



2018-03-01

The Use of Evidence-Based Design in Hospital Renovation Projects

David S. Whitaker
Brigham Young University

Follow this and additional works at: <https://scholarsarchive.byu.edu/etd>

 Part of the [Construction Engineering and Management Commons](#)

BYU ScholarsArchive Citation

Whitaker, David S., "The Use of Evidence-Based Design in Hospital Renovation Projects" (2018). *All Theses and Dissertations*. 6692.
<https://scholarsarchive.byu.edu/etd/6692>

This Thesis is brought to you for free and open access by BYU ScholarsArchive. It has been accepted for inclusion in All Theses and Dissertations by an authorized administrator of BYU ScholarsArchive. For more information, please contact scholarsarchive@byu.edu, ellen_amatangelo@byu.edu.

The Use of Evidence-Based Design
in Hospital Renovation Projects

David S. Whitaker

A thesis submitted to the faculty of
Brigham Young University
in partial fulfillment of the requirements for the degree of
Master of Science

Evan D. Bingham, Chair
Justin E. Weidman
Jay P. Christofferson

School of Technology
Brigham Young University

Copyright © 2018 David S. Whitaker

All Rights Reserved

ABSTRACT

The Use of Evidence-Based Design in Hospital Renovation Projects

David S. Whitaker
School of Technology, BYU
Master of Science

Since the 1960s, researchers have been exploring how the design of the built environment impacts the health and well-being of occupants and users. By the 1980s, further research began to focus on healthcare facilities in particular and how design could influence patient healing and medical staff performance (Alfonsi, 2014). Evidence-Based Design (EBD) is “the process of basing decisions about the built environment on credible research to achieve the best possible outcomes” (CHD, 2016). The desired outcomes of Evidence-Based Design recommendations include improvements in the following: patient healing, patient experience and comfort, medical staff performance, and medical staff job satisfaction (CHD, 2017). Extensive research has been done on the subject of EBD; however, the question remains whether or not the latest research findings are being utilized by the design and construction industries in practice. The purpose of this research is to determine whether or not the latest scientific knowledge and research findings are being implemented into hospital renovation projects by the healthcare design and construction industries. A list of recommendations from existing EBD literature was compiled. Construction documents from 30 recent healthcare facility renovation projects across the United States were then obtained and analyzed. The findings indicate that EBD recommendations are being adopted in practice at consistently high levels. These findings also reveal that there are still areas of potential improvement which could inform those who influence or determine building and design codes, standards, and guidelines. The results are instructive to owners, designers, and contractors by providing a glimpse into how well the industry is recognizing and implementing known best practices. The findings likewise open up new opportunities for further research which could lead to additional improvement in the healthcare facilities of the future.

Keywords: evidence-based design, healthcare construction, hospital construction, healthcare design, hospital design, EBD in healthcare, healthcare design and construction, hospital design and construction, David S. Whitaker

ACKNOWLEDGEMENTS

First, I extend my heartfelt appreciation to the entire Brigham Young University family in general, which includes inspired founders and leaders, fellow students, dedicated instructors and administrators, and the multitude of donors and supporters who, through their generosity, help put higher education within the reach of people like me. I thank my graduate committee in particular for their guidance, encouragement, and enthusiasm for this work. I acknowledge my employer for supporting my educational goals by giving me the needed schedule flexibility to meet all of my obligations, a gesture which was both unexpected and unprecedented, and will not be forgotten.

To my impressive and talented children who I expect will surpass me in every measure of character development and educational achievement: your unconditional love and admiration has given me the inner drive to improve myself through higher education in hopes that you will do the same. I am delighted to have a front row seat to witness each of you reach your own goals.

Most importantly, I recognize my dear wife, Elizabeth, who is my superior in nearly every way, most notably in intellect and self-discipline. This endeavor would have been impossible on my part if not for my good fortune that her strengths seem to be rubbing off on me. The credit goes to her for seeing more potential in me than I could see in myself. I will always cherish her personal contribution to this work through her unwavering faith, generous (and always timely) encouragement, and incalculable sacrifice.

TABLE OF CONTENTS

TABLE OF CONTENTS.....	iv
LIST OF TABLES.....	vi
LIST OF FIGURES	vii
1 Introduction	1
1.1 Progress and Improvement in Healthcare Facilities.....	1
1.2 The Challenges of Making Improvements in Healthcare Facilities.....	2
2 Review of the Literature.....	4
2.1 Introduction to the Literature Review	4
2.2 Hospitals in the United States	4
2.3 The History of Evidence-Based Design.....	5
2.4 Evidence-Based Design Research.....	6
2.5 Evidence-Based Design Recommendations.....	8
2.5.1 Reduction of Errors.....	9
2.5.2 Increasing Safety and Security.....	9
2.5.3 Enhancing Control	12
2.5.4 Privacy	13
2.5.5 Comfort.....	14
2.5.6 Summary of the Literature	15
3 Methodology.....	17
3.1 The Analysis of Evidence-Based Design Principles in Renovation Projects.....	17
3.2 Selecting Evidence-Based Design Recommendations to Study	18
3.3 The Data Itself.....	20
3.4 Data Analysis Methods	22
3.4.1 Reduction of Errors.....	23
3.4.2 Increasing Safety and Security.....	26
3.4.3 Enhancing Control	30
3.4.4 Privacy	33
3.4.5 Comfort.....	35
3.5 Methodology Summary.....	36
4 Findings.....	37
4.1 Introduction to Findings.....	37

4.2	Extent of Findings	38
4.3	Consistency of Findings.....	39
4.4	Other Variables	41
4.5	Summary of the Findings.....	43
5	Conclusions and Recommendations.....	44
5.1	The Impact of This Research	44
5.2	Suggestions for Further Research in Healthcare Design and Construction	45
5.3	Suggestions for Further Research in Other Industries	46
5.4	Suggestions for Changes in Design and Construction Education.....	47
	REFERENCES	48

LIST OF TABLES

Table 2-1: Desired Evidence-Based Design Outcomes and Recommendations	7
Table 3-1: Evidence-Based Design Recommendations Included in This Study	19
Table 3-2: The Variety of Influencing Factors Within the Data.....	20
Table 3-3: Comprehensive Listing of Influencing Factors	22
Table 4-1: Extent of Evidence-Based Design Implementation.....	39
Table 4-2: Consistency of Evidence-Based Design Findings by Project	40
Table 4-3: Project Variables and Evidence-Based Design Implementation.....	42

LIST OF FIGURES

Figure 3-1: Identical and Mirrored Rooms	24
Figure 3-2: Non-Identical Room Beside Mirrored Rooms	24
Figure 3-3: Two Light Fixture Specifications	25
Figure 3-4: Patient Beds with Curtains and Doors for Entry and Privacy	26
Figure 3-5: Safety Rails and Accessories in Patient and Staff Restrooms	27
Figure 3-6: Single-Bed and Dual-Bed Patient Rooms	28
Figure 3-7: Floor Finish Plan Which Notes Flooring Types	29
Figure 3-8: Wristblade and Electronic Faucet Specifications.....	30
Figure 3-9: Patient Rooms with Individual Thermostats.....	31
Figure 3-10: Patient Room with Light Control Near the Bed.....	32
Figure 3-11: Patient Rooms Featuring Window Coverings.....	33
Figure 3-12: Visitor Waiting Area Separated from Work Areas by Doors	34
Figure 3-13: Outdoor Seating Area.....	36

1 INTRODUCTION

1.1 Progress and Improvement in Healthcare Facilities

Progress comes as a result of taking the ever-advancing knowledge and technology available to us and putting it to good use. This is certainly true when it comes to healthcare facilities. Over the years, hospitals and clinics have been able to deliver care with increasingly better outcomes. In order to continue to achieve improvements in patient care, it is important to constantly evaluate current means and methods. One element that influences the delivery of care is the design and construction of healthcare facilities themselves. The practice of researching, evaluating, and incorporating the most effective strategies in healthcare facility design and construction is known as Evidence-Based Design (EBD). The question is: to what extent and to what consistency are EBD principles being put to use in healthcare construction projects today?

Evidence-Based Design (EBD) as defined by The Center for Health Design is “the process of basing decisions about the built environment on credible research to achieve the best possible outcomes” (CHD, 2016). Research focusing on how the design of health care facilities could influence patient healing and medical staff performance has been ongoing since the 1980s (Alfonsi, 2014). While a review of the literature reveals many studies related to Evidence-Based Design for healthcare facilities, there is a gap in the literature pertaining to the implementation of EBD recommendations in practice.

The question remains whether or not, or to what extent, EBD recommendations are being put to use by the design and construction community for healthcare facilities. The intent of this paper is to determine whether or not renovated hospitals are implementing the design elements that have been scientifically proven to improve healing and comfort for patients as well as improve performance and satisfaction for medical staff.

In order to answer the question above and provide the appropriate context for this study, a summary of healthcare facility statistics will be provided. Critical information relating to Evidence-Based Design research and recommendations will follow. Next, the methodology of this research will be explained in detail. From there the findings will be shared along with some commentary. The paper will close with a discussion of the conclusions reached, the impact of this research, and suggestions for further research.

1.2 The Challenges of Making Improvements in Healthcare Facilities

Research and literature support full implementation of Evidence-Based Design (EBD) principles; however, there are many challenges which can prevent full adoption by the industry. First, the building standards and codes which govern construction projects across the country have not been adopted consistently by Authorities Having Jurisdiction (AHJ). For full EBD adoption from a building code standpoint each municipality or AHJ would first need to be aware of the most recent scientific findings and then decide the findings were compelling enough to be enforced as a minimum standard from that point forward. Second, supposing some EBD standards are not deemed to be code-enforceable changes, each healthcare design firm would need to be willing to design to a higher standard than code requires. Next, even if designers fully implemented all EBD recommendations into their work, budget and constructability constraints

still remain. Many projects undergo a value engineering phase to help bring an owner budget in alignment with the design. It is possible that during this point in the life of a project some EBD design elements are removed in order to keep a project on budget. In the case of renovation projects, a fourth obstacle is introduced in the form of the constraints inherent in the existing structure that may prohibit implementation of otherwise desirable EBD recommendations.

Due to the variety of variables which influence hospital design, including local building code jurisdictions, design firms, owners, and the existing facilities themselves, much can stand between EBD research and their inclusion in actual construction documents. An analysis of final construction documents for hospital renovation projects from various locations, design firms, and owners is a straightforward way to discover an answer to this question: To what extent and to what consistency are EBD principles being put to use in healthcare construction projects today? The results of this study will be instructive to owners, designers, and contractors by providing a glimpse into how well the industry is recognizing and implementing known best practices. The findings likewise open up new opportunities for further research which could lead to additional improvement in healthcare facilities of the future. A summary of current healthcare facility statistics as well as the latest findings in EBD literature will provide the context this study seeks to build upon.

2 REVIEW OF THE LITERATURE

2.1 Introduction to the Literature Review

In order to best evaluate the use of Evidence-Based Design (EBD) in healthcare renovation projects, it is first helpful to have an understanding of a few key elements. First, some high-level healthcare facility statistics and trends will be shared. Next, a brief history of how Evidence-Based Design emerged will then be provided. These two introductory subjects provide the necessary context to dive deep into the latest EBD recommendations. A summary of each EBD recommendation will be included in this work.

2.2 Hospitals in the United States

As of 2016 (the latest data available at the time of this writing) there were 5,534 hospitals in the U.S. registered with the American Hospital Association (AHA), which contain a total of 894,574 staffed beds (AHA, 2018). That number is down from 1975, the earliest year for which data is available, when there were 7,156 hospitals in the U.S. (Statista, 2018) and over 1.465 million beds (Statista, 2018). The number of hospitals and beds steadily declined in a mostly linear fashion between 1975 and 2000. Since 2000, the number of hospitals and beds has been declining at a much slower rate.

The 22% decline in the number of hospitals and 40% decline in the number of hospital beds during the 41 years spanning from 1975 to 2016 contrasts sharply with the population of the

United States during that same period. The U.S. population was 216 million in 1975 and grew to 323 million by 2016, an increase of nearly 50% (Google, 2018). The life expectancy of American citizens has also increased from 72.60 years to 78.74 years over these same 41 years (Google, 2018). In summary, we have a much larger population that lives on average six years longer, yet there are significantly fewer hospitals and hospital beds in service today.

The reduction in U.S. hospitals is best explained by the improvement of medical technology and care, which results in shorter patient stays in hospitals. In addition, more health procedures are offered as out-patient services, further reducing the demand on hospital space for longer stays (Evans, 2015). Another factor that contributes to a lower demand on hospital space is the improvement of healthcare facilities themselves. Evidence presented later in this research suggests that making changes in the design and construction of hospitals is a scientifically proven way to improve health outcomes for hospital patients, thus requiring fewer hospitals and beds.

2.3 The History of Evidence-Based Design

In conjunction with improvements in medicine and care, the design of healthcare facilities has improved in the past 50 years. Beginning in the 1960s, the first studies analyzing the link between building design and user health and well-being were conducted by the Environmental Design Research Association (EDRA). The purpose of the EDRA is “to advance and disseminate research, teaching, and practice toward improving an understanding of the relationships among people, their built environments, and natural eco-systems” (EDRA, 2018).

In the 1980s, thanks primarily to Dr. Robert S. Ulrich, an increasing body of research began to focus on the built environment of health care facilities in particular. In 1993 the Center

for Health Design (CHD) was founded. This organization “advances best practices and empowers healthcare leaders with quality research that demonstrates the value of design to improve health outcomes, patient experience and care, and provider/staff satisfaction and performance” (CHD, 2017). Over the years, awareness of Evidence-Based Design (EBD) principles steadily increased in the industry. In 2009 an accreditation and certification program sponsored by the CHD became available for professionals in the field (The Center for Health Design, 2018). In theory, these trained professionals deliver the latest medical EBD research from the scholars to the healthcare design community for implementation.

2.4 Evidence-Based Design Research

In 2006, a systematic review of existing research related to healthcare environments and their effects on users was completed by Karin Dijkstra. In that review, over 500 potentially relevant studies on the subject were identified after a search through eight different databases. In the end, 30 studies were found to meet inclusion criteria.

“Studies were included if they concerned interventions involving health effects of environmental stimuli in healthcare settings on patients and were based on controlled clinical trials published in peer-reviewed journals. Both clinical and psychological outcome measures were included” (Dijkstra, 2006).

In 2012 a similar systematic review was conducted by Huisman. Through a computerized search of three databases using relevant keywords, 798 papers were found on the subject of Evidence-Based Design (EBD). Search results were limited to papers published in the English language between 1984 and 2011. Of those papers, 186 articles were included for further selection and analysis. Those were narrowed down to 65 papers which met the criteria of academic rigor as described in the systematic review procedures of the study (Huisman, 2012).

The body of knowledge supporting EBD principles, as evidenced by the two above-referenced systematic reviews, is substantial enough to merit industry adoption and standardization. Both Dijkstra and Huisman make such recommendations within their papers. Organizations such as the CHD aim to do just that. The Huisman recommendations, which are both more comprehensive and more recent, were selected for this research. The list of EBD recommendations from the Huisman study are shown in Table 2-1, organized by the desired outcome each recommendation seeks to achieve.

Table 2-1: Desired Evidence-Based Design Outcomes and Recommendations

Desired Outcome	EBD Recommendations
Reduction of Errors	Identical rooms
	Lighting
Increasing Safety and Security	No slippery floors
	Appropriate door openings
	Correct placement of rails and accessories
	Correct toilet and furniture height
	Single-bed rooms
	Easy-to-clean surfaces
	Automated sinks
	Smooth edges in rooms
Enhancing Control	Control over bed position
	Control over air temperature
	Control over lights
	Control over sound
	Control over natural light
Privacy	Single-bed rooms
	Design of waiting rooms
Comfort	Single-bed rooms
	Materials without glare
	Windows with a view
	Daylight
	Wayfinding

2.5 Evidence-Based Design Recommendations

Roger S. Ulrich, a pioneer in the field of Evidence-Based Design (EBD), makes a strong case for improving the design of healthcare facilities by utilizing EBD recommendations. He asserts that “there is increasing scientific evidence that poor design works against the well-being of patients and in certain instances can have negative effects on psychological indicators of wellness. The effects of supportive design are complementary to the healing effects of drugs and other medical technology and foster the process of recovery” (Ulrich, 1991).

The benefits of implementing EBD principles are not limited to patient outcomes. Ulrich goes on to point out that there are economic benefits as well.

“Further, there are instances when research findings concerning health-related effects of good design can be linked to dollar savings in healthcare costs. Therefore, research that yields credible evidence of the role of design in fostering or hindering wellness can create a greater awareness among healthcare decision-makers of the need to give high priority to psychologically supportive design in retrofitting or constructing new facilities” (Ulrich, 1991).

The dual advantage of reduced costs of care and increased benefits to patients makes for a compelling argument in favor of the implementation of EBD principles.

With the advantages of EBD implementation fresh in mind, the next step is to understand what the recommendations are. A brief summary and background for each EBD recommendation which the Huisman study published is provided below. The Huisman recommendations are organized into five categories which represent the various desired patient outcomes. The five categories are: reduction of errors, increasing safety and security, enhancing control, privacy, and comfort.

2.5.1 Reduction of Errors

2.5.1.1 Identical Rooms

“The standardization of patient rooms and equipment makes routine tasks simpler and decreases errors by staff. When the facility has identical rooms, the nursing staff encounter exactly the same distribution, layout and lighting in every room” (Huisman, 2012).

2.5.1.2 Lighting

Two studies found that lighting levels play a role in errors made by hospital staff. Booker & Roseman found at a hospital in Alaska that after controlling for several factors, 58% of all medication errors over the course of five years occurred between January 1 and March 31. They further concluded that “medication errors appear to follow a pattern that is closely associated with the annual cycle of daylight and darkness” (Booker, 1995). Buchanan et. al. studied three different illumination levels and how they related to pharmacist errors. The study concluded that “the rate of prescription dispensing errors was associated with the level of illumination. Ergonomics can affect the performance of professional tasks” (Buchanan, 1991).

2.5.2 Increasing Safety and Security

2.5.2.1 No Slippery Floors

The Huisman paper lists no slippery floors as a design feature with enough evidence to merit inclusion; however, no specific reference relating to a study of slippery floors was given (Huisman, 2012). That said, one study noted “higher microorganism counts on carpeted floors than on bare floors” and that “air above carpeting contained more consistent concentrations of organisms than air above the bare flooring” (Huisman, 2012).

2.5.2.2 Appropriate Door Openings

In a study of bacteria counts on bed curtains it was found that “patients and medical staff can contaminate and be contaminated by bacteria which may be a source of cross-infection” (Palmer, 1987). Inasmuch as bed curtains serve the primary purpose of providing patient privacy, the utilization of single-bed rooms with doors, which are easier to disinfect than curtains, can also serve to increase safety and security.

2.5.2.3 Correct Placement of Rails and Accessories

Studies cited by Huisman noted that a high percentage of patient falls were related to the use of the restroom (Huisman, 2012). The recommendation to use rails and accessories is aimed at providing assistance to patients during activities involving higher risk.

2.5.2.4 Correct Toilet and Furniture Height

Other studies noted by Huisman observed that a large percentage of patient falls and injuries occurred while changing posture or moving around the patient room after long periods of lying down (Huisman, 2012). Proper toilet and furniture height contributed to reducing the frequency of such accidents.

2.5.2.5 Single-Bed Rooms

Common infection rates were compared between open wards and single-bed rooms. The Huisman paper noted that “single-bed rooms and good air quality substantially reduce infection rates and reduce mortality” (Huisman, 2012). The recommendation to use private patient rooms in hospital design offers many other benefits which will be discussed in subsequent sections.

Interestingly, this recommendation is found in three of the five categories of desired outcomes outlined in the Huisman study.

2.5.2.6 Easy-to-Clean Surfaces

Contamination of surfaces such as overbed tables, bed privacy curtains, computer keyboards, infusion pump buttons, door handles, bedside rails, blood pressure cuffs, chairs and other furniture, and countertops occurs near infected patients and can spread when staff or visitors spread the contaminants. One study showed that while vinyl and fabric surfaces are equally likely to become contaminated, contaminants are more easily removed from vinyl surfaces than from fabric or upholstered surfaces (Huisman, 2012). Fabric surfaces are discouraged while smooth surfaces which can be easily disinfected are recommended.

2.5.2.7 Automated Sinks

Larson performed a study in which the practice of hand washing by hospital staff using an automatic sink was observed at two different sites. “For both sites, hands were washed significantly better but significantly less often with the automated sink” (Larson, 1991). While a lower frequency of hand washing was observed with the automated sink, the fact that the washing was more thorough prompted Huisman to recommend the use of automated sinks.

2.5.2.8 Smooth Edges in Rooms

Huisman noted that smooth edges in hospitals are easier to clean than tight corners. This recommendation made the list; however, it should be noted that no reference accompanied that statement. While that statement could very well be true, and the recommendation could lead to positive outcomes, it is unclear to this author how the Huisman paper drew that conclusion.

2.5.3 Enhancing Control

Hospital patients recovering from illness or injury are under significantly more stress than usual. First, the patient is dealing with the stress associated with the illness or injury itself as well as the recovery process. On top of that, there is additional stress related to not being at home and in a normal, familiar environment. “In healthcare contexts, lack of control is a pervasive problem that increases stress and adversely affects wellness. Patients’ sense of control can be markedly reduced by health facilities that are often, for instance, noisy, confusing from the standpoint of wayfinding, invade privacy, and prevent personal control over lighting and temperature” (Ulrich, 1991). Giving patients control over the following environmental variables reduces stress and improves wellness (Huisman, 2012). Those five variables are bed position, air temperature, lights, sound, and natural light.

2.5.3.1 Control Over Bed Position

As noted in section 2.4.3 above, giving patients control over bed position reduces stress and improves wellness.

2.5.3.2 Control Over Air Temperature

As noted in section 2.4.3 above, giving patients control over air temperature in the patient room reduces stress and improves wellness.

2.5.3.3 Control Over Lights

As noted in section 2.4.3 above, giving patients control over the lights in the patient room reduces stress and improves wellness.

2.5.3.4 Control Over Sound

As noted in section 2.4.3 above, giving patients control over the sound in the patient room reduces stress and improves wellness.

2.5.3.5 Control Over Natural Light

As noted in section 2.4.3 above, giving patients control over the natural light coming into the patient room reduces stress and improves wellness. This is primarily accomplished by providing window coverings which the patient can adjust autonomously.

2.5.4 Privacy

2.5.4.1 Single-Bed Rooms

The benefits of single-bed rooms as they relate to safety and security are outlined in section 2.4.2.5. There are also benefits for single-bed rooms as it relates to privacy. In a study comparing patients in four-bed rooms to single-bed rooms it was noted that ward residents feel less secure and have less control over social interaction taking place within their rooms in comparison to patients of single-bed rooms (Huisman, 2012). Another study highlighted the great need for privacy among adolescent patients, especially when using the restroom, showering and grooming. Further, the study noted a strong preference for a quiet personal space or room to read or do homework (Huisman, 2012).

2.5.4.2 Design of Waiting Rooms

Patient privacy in one sense can be described as a physical area protected from the unwanted intrusion of others. When it comes to the design of waiting rooms, the context changes to privacy in the sense of control over personal information. One observational study of medical personnel noted that 100% of the health care team committed confidentiality and privacy breaches during the periods of observation. The study concluded that architecture and floor plans affect the confidentiality and privacy of patients. The study recommended that waiting rooms should be designed to be physically apart from work areas such as reception desks and nurse stations where sensitive conversations commonly take place. The use of background music or physical barriers could also reduce privacy violations (Mlinek, 1997).

2.5.5 Comfort

2.5.5.1 Single-Bed Rooms

Single-bed rooms contribute to patient privacy as well as safety and security as noted in sections 2.4.4.1 and 2.4.2.5, respectively. When it comes to patient comfort, the environmental influence on patient well-being is better in single-bed rooms than in multi-bed rooms (Huisman, 2012).

2.5.5.2 Materials Without Glare

Burton observed that “reflective or shiny surfaces [are] perceived as wet and slippery” (Burton, 2007). Furthermore, the Huisman paper notes that “polished floors are a common source of glare and pose problems for people with visual impairments. Therefore, the use of matte surfaces is not only convenient but also solves the problem of glare” (Huisman, 2012).

2.5.5.3 Windows with a View

The benefits to patients with a view of nature out of the window in their room (as opposed to a view of a brick building wall) include shorter postoperative stays, the taking of fewer pain medications, and more positive comments in nurses' notes (Huisman, 2012).

2.5.5.4 Daylight

Studies show that patients staying in sunny rooms have shorter hospital stays than those in dimly lit rooms. Mortality for both men and women is higher in dim rooms. Another study suggests that morning light is more beneficial than afternoon light (Huisman, 2012).

2.5.5.5 Wayfinding

Gardens in healthcare facilities serve the dual purpose of assisting the healing process as well as helping occupants navigate and orient themselves within the building. "There is increasing evidence that simply viewing gardens can mitigate pain. In addition to reducing stress and pain, gardens can heighten satisfaction and facilitate wayfinding or navigation in healthcare buildings for patients and visitors (Huisman, 2012).

2.5.6 Summary of the Literature

In summary, the number of hospitals and hospital beds in the U.S. are declining and have been for decades. Influencing factors include a higher emphasis on out-patient services as well as improvements in medical technology and care, part of which is influenced by improvements in healthcare facility design and construction. Hundreds of studies relating to best practices in healthcare facility design and construction have recently been compiled and analyzed by researchers. Their findings have been organized into five areas of emphasis and

recommendations have been issued for industry adoption and implementation. There is no shortage of literature relating to EBD principles; however, the body of literature is silent on whether or not these recommendations have been put to use, and if so, to what extent and with what consistency. This study aims to fill the gap in the literature by conducting an analysis of EBD use in recently designed healthcare renovation projects. An understanding of how well the EBD recommendations are being implemented in hospital renovation projects today will be valuable in the ongoing effort to make progress toward increasingly better healthcare outcomes.

3 METHODOLOGY

3.1 The Analysis of Evidence-Based Design Principles in Renovation Projects

Progress requires the application of the most recent knowledge and technology. When it comes to the design and construction of healthcare facilities, the latest knowledge comes in the form of Evidence-Based Design (EBD) research. While extensive EBD research has been published, no studies have been done to verify that these best practices are being implemented. Without any studies verifying the real-world application of the latest knowledge and technology, it is unclear whether the industry has progressed to the point of reaching its current maximum potential. An analysis of final construction documents for hospital renovation projects from various locations, design firms, and owners was a straightforward way to discover an answer to the question: To what extent and to what consistency are EBD principles being put to use in healthcare construction projects today? The answer to this question reveals the true progress achieved by healthcare facilities for the benefit of patients and other users.

The analysis of construction documents to verify the implementation of EBD principles provided a perspective second only to actual site visits to completed projects. With a large enough sample size of projects, this method provided a glimpse into many recent healthcare renovation projects across the United States without the expense of travel to the facilities themselves. The results of this research relied upon the assumption that the EBD recommendations found in the construction documents were unchanged through project

completion and were utilized in the completed operational facilities. There is a risk that EBD recommendations shown in the construction documents were not actually put into place during construction. On the other hand, it remains uncertain whether EBD recommendations not shown in construction documents were actually added after the fact. The study proceeded under the assumption that these two uncertainties offset each other, and that construction documents for this purpose could be relied upon. The analysis of construction documents provided compelling evidence of the degree to which the latest healthcare research has influenced the healthcare design and construction community.

3.2 Selecting Evidence-Based Design Recommendations to Study

At the outset, this study aimed to verify the entire list of Evidence-Based Design (EBD) recommendations in the Huisman study as listed in Table 2-1. Unfortunately, construction documents do not consistently contain all of the information needed to do a complete analysis. For example, construction documents do not generally contain information related to the patient beds. Consequently, without a physical visit to each facility it was not possible to find out to what degree patients have control over their bed position. EBD recommendations not shown in construction documents fall outside of the scope of this study for two reasons. Primarily, the EBD recommendations that did not appear in construction documents, regardless of whether or not they appeared in completed hospital renovations, would reveal how the *end users* utilize the latest EBD research, not the design and construction industry. Secondly, the research question was tested by analyzing the construction documents of recently designed hospital renovation projects. EBD recommendations that do not appear in construction documents would need to be verified by physically visiting each project. While this would have been ideal, due to the great distance between the locations of the projects obtained for this research, it was impractical due to

cost and time constraints. Further, some of the construction projects included in this study were not yet completed.

A list of each EBD recommendation provided by Huisman is shown in Table 3-1, with the recommendations in bold representing those which were able to be analyzed by using construction documents. A description of the methodology used to analyze each recommendation follows.

Table 3-1: Evidence-Based Design Recommendations Included in This Study

Desired Outcome	EBD Recommendations Included (bold)
Reduction of Errors	Identical rooms
	Lighting
Increasing Safety and Security	No slippery floors
	Appropriate door openings
	Correct placement of rails and accessories
	Correct toilet and furniture height
	Single-bed rooms
	Easy-to-clean surfaces
	Automated sinks
	Smooth edges in rooms
Enhancing Control	Control over bed position
	Control over air temperature
	Control over lights
	Control over sound
	Control over natural light
Privacy	Single-bed rooms
	Design of waiting rooms
Comfort	Single-bed rooms
	Materials without glare
	Windows with a view
	Daylight
	Wayfinding

3.3 The Data Itself

To perform a proper analysis of whether or not Evidence-Based Design (EBD) findings are fully implemented in practice, a review of construction documents for healthcare facility renovation projects is required. Construction documents for 30 projects were obtained from the archives of a general contracting firm. This firm is among the top ten largest healthcare contractors in the United States as ranked by Modern Healthcare. It is also ranked in the 2017 ENR top 100 list of general contractors. This general contracting firm was selected due to the large variety of data contained in the archives, which is due to its large national footprint of operations and the proximity of its corporate headquarters to the author.

Inasmuch as the articles in the Huisman paper were published between 1984 and 2011, the construction documents obtained for the purpose of this paper were limited to those archived by the general contractor in 2012 and later (Huisman, 2012). Care was taken to ensure the data set included diversity among healthcare organization, design team, project location, and project type to ensure that the results are not influenced by any one of those factors in particular. Table 3-2 details the variety of these variables represented within data obtained for this study.

Table 3-2: The Variety of Influencing Factors Within the Data

Influencing Factor	Count
Renovation Projects	30
Project Locations (State)	13
Project Types	9
Governing Building Code	9
Designed in 2012 or Later	27
Project Owner and/or End User	23
Architecture Firms	20
Mechanical Engineering Design Firms	16
Electrical Engineering Design Firms	16

Of the 30 projects for which construction documents were obtained for analysis, there exists diversity among many factors that could influence the findings. The renovation projects were located across 13 different states, including Alaska (2), Arizona (2), California (8), Colorado (1), Florida (1), Hawaii (1), Nevada (1), Ohio (1), Oklahoma (1), Oregon (1), Texas (1), Utah (9), and Wyoming (1). Eight different project types are represented: emergency department (5), general patient rooms (3), rehabilitation (3), surgical (8), behavioral health (3), intensive care (5), women's health (2), and imaging (1). Nine different building codes governed the various projects, ranging from the International Building Code (IBC) 2006 edition all the way through IBC 2012, as well as non-IBC codes governing projects in California, Florida, and Ohio.

While all 30 projects were archived by the general contractor in 2012 or later, three projects were actually designed earlier than 2012. For unknown reasons to this author, the general contractor did not get involved in the project until 2012. Of the projects designed earlier than 2012, two were designed in 2011 and one was designed in 2008. The other 27 projects were designed between 2012 and 2016. The 30 projects in the analysis were designed on behalf of 23 different owners or end users by 20 different architecture firms. Those architecture firms utilized the services of 16 different mechanical engineering (ME) firms and 16 different electrical engineering (EE) firms. With the diversity just mentioned, this author is satisfied that the results obtained will provide an accurate picture of how well the industry in general has adopted EBD recommendations. See Table 3-3 for a comprehensive listing of influencing factors.

Table 3-3: Comprehensive Listing of Influencing Factors

Project	State	Year	Type	Code	Architect	Owner	ME	EE
1	Alaska	2014	Emergency Department	IBC 2009	Architect A	Owner A	ME A	EE A
2	Arizona	2012	General Patient Rooms	IBC 2006	Architect A	Owner B	ME A	EE A
3	California	2008	Emergency Department	UBC 1997	Architect B	Owner C	ME B	EE B
4	Florida	2012	Rehabilitation	FL BC 2007	Architect C	Owner D	ME C	EE C
5	Nevada	2012	Surgical	IBC 2009	Architect A	Owner E	ME A	EE A
6	Utah	2013	Surgical	IBC 2006	Architect D	Owner F	ME D	EE D
7	Utah	2012	Behavioral	IBC 2009	Architect E	Owner G	ME E	EE D
8	Alaska	2014	Surgical	IBC 2012	Architect F	Owner H	ME F	EE F
9	Arizona	2013	General Patient Rooms	IBC 2006	Architect G	Owner I	ME G	EE G
10	California	2013	Behavioral	IBC 2009	Architect H	Owner J	ME H	EE H
11	California	2013	Surgical	IBC 2009	Architect I	Owner K	ME I	EE I
12	Colorado	2013	Women's Health	IBC 2009	Architect J	Owner L	ME G	EE G
13	California	2015	Rehabilitation	IBC 2012	Architect K	Owner M	ME G	EE G
14	Oklahoma	2014	Emergency Department	IBC 2003	Architect L	Owner N	ME J	EE J
15	Utah	2014	Intensive Care	IBC 2012	Architect M	Owner O	ME K	EE K
16	Utah	2016	Intensive Care	IBC 2012	Architect L	Owner P	ME G	EE G
17	Utah	2015	Intensive Care	IBC 2012	Architect N	Owner Q	ME D	EE D
18	Utah	2015	Women's Health	IBC 2012	Architect D	Owner F	ME D	EE D
19	Utah	2014	Surgical	IBC 2009	Architect O	Owner G	ME G	EE G
20	Wyoming	2015	General Patient Rooms	IBC 2006	Architect P	Owner L	ME L	EE L
21	California	2011	Emergency Department	IBC 2006	Architect Q	Owner R	ME M	EE M
22	California	2011	Intensive Care	IBC 2006	Architect Q	Owner R	ME M	EE M
23	California	2015	Rehabilitation	IBC 2012	Architect K	Owner M	ME G	EE G
24	California	2015	Surgical	IBC 2009	Architect R	Owner S	ME N	EE B
25	Ohio	2015	Behavioral	ICC/ANSI 2003	Architect S	Owner T	ME O	EE N
26	Oregon	2015	Surgical	IBC 2012	Architect A	Owner U	ME A	EE A
27	Utah	2015	Intensive Care	IBC 2012	Architect E	Owner Q	ME E	EE O
29	Hawaii	2016	Emergency Department	IBC 2006	Architect T	Owner V	ME P	EE P
30	Texas	2016	Imaging	IBC 2006	Architect A	Owner W	ME A	EE A

3.4 Data Analysis Methods

With the construction documents in hand, the next step in the methodology was to determine how each Evidence-Based Design (EBD) recommendation could be analyzed. Most of the EBD recommendations selected for analysis were related in some way to the patient rooms of the facilities. The first action taken with each set of construction drawings was a thorough floor plan review to quantify patient rooms or bed locations and to organize by type. Once room counts were established, the EBD recommendations were evaluated. After all of the documents

were analyzed for the identified EBD recommendations, the results were tabulated and conclusions were drawn.

During the data analysis it was discovered that one of the 30 projects for which documents were obtained was actually a high-level executive summary of a future project under contemplation. No construction documents were developed to date, and the executive summary did not contain any information regarding plans to implement any of the EBD principles selected for analysis. Excluding that project, the final total of projects with sufficient data to contribute to this study was 29. The methods used to analyze each EBD recommendation, or an explanation of why certain recommendations were left out of this study, follows.

3.4.1 Reduction of Errors

3.4.1.1 Identical Rooms

Each patient room was compared to others designed for the same purpose and grouped into two categories: Identical or Mirrored Room, or Non-Identical Room. Identical rooms are exactly alike in every way in regards to distribution, layout, and lighting as recommended by Huisman (Huisman, 2012). All aspects of the mirrored rooms are exactly identical, the only exception being that the layout is mirrored with the adjacent room. Since the EBD recommendation specifies that the distribution, layout, and lighting are to be identical, it was determined that mirrored rooms met this standard and were thus included with identical rooms as results were tabulated (see Figure 3-1). Non-identical rooms generally vary in size and layout, usually for ADA or specialized care purposes. These rooms were found to be different in distribution, layout, and lighting and were therefore counted separately (see Figure 3-2). The project was

determined to be compliant with this EBD recommendation if all non-specialty rooms in the same department of care were found to be identical or mirrored.

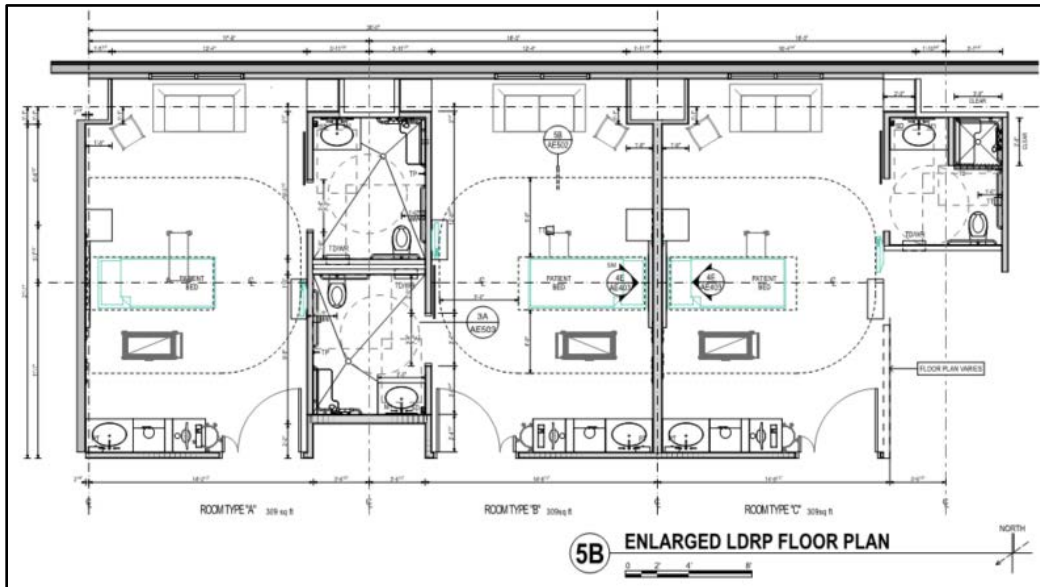

Figure 3-1: Identical and Mirrored Rooms

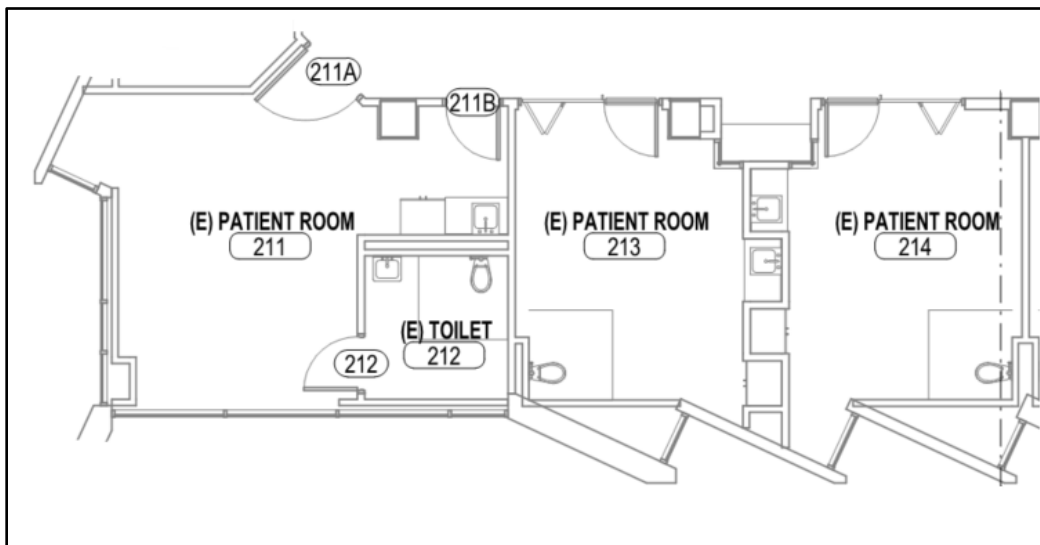

Figure 3-2: Non-Identical Room Beside Mirrored Rooms

3.4.1.2 Lighting

To determine if adequate lighting was provided at the point of care, the light fixture specification for the fixture located above the patient bed was found. Inasmuch as “an illuminance of 1570 lx was associated with a significantly lower error rate” in pharmacy work, this was the standard used for patient bed lighting for this study (Huisman, 2012). Once the specified light fixture and lamps were found, the lumen output of the fixture was then calculated and converted to lux, which is 1 lumen per square meter. An area of two square meters was used to represent the patient bed. Patient rooms with illuminance of 3140 lx or greater (2 square meters x 1570 lx) at the point of care were determined to be in compliance with this recommendation. Figure 3-3 gives two examples of a lighting specification which indicate the lamp type required for the specified fixture. The patient bed light fixture in the top image requires a 33W 3500K LED lamp. The patient bed light fixture in the bottom image requires two 56W T5 RE841 lamps. In both cases, the lumen output of the specified lamps could be determined after a quick internet search of the product.

PE-1	48" PATIENT BED LIGHT CEILING COMBINATION EXAM, READING/AMBIENT LIGHT WHIT PWDR ANTIMICROBIAL FINISH PROVIDE LOW VOLTAGE CONTROLLER TO CONNECT TO NURSE CALL FLANGE MOUNT	LED 3500K	33W	277/120V	KENALL	MPCADE24 F 45L/90L35K DCC DV HD AMF LRL LVC IF
G-2	2X4, 2-LAMP.	2-T5 RE841	56W	277/120V	PINN FOCAL POINT CORELITE	CJ24A 2T5 G UNV W FEQ 24 B 2T5 UNV XX L835 WH Z3WL2N5 1 C UNV 24 T1

Figure 3-3: Two Light Fixture Specifications

3.4.2 Increasing Safety and Security

3.4.2.1 No Slippery Floors

A slip coefficient or other standard to determine whether or not a floor was slippery was not given along with this EBD recommendation. Without clear parameters compliance could not be determined and this item was therefore not included in this study.

3.4.2.2 Appropriate Door Openings

Each room type was checked and designated as either having a door or a curtain as the primary means of entry and privacy. Figure 3-4 shows eight patient areas with curtains (dotted lines) as the primary means of entry and privacy, whereas the two rooms on the right have doors.

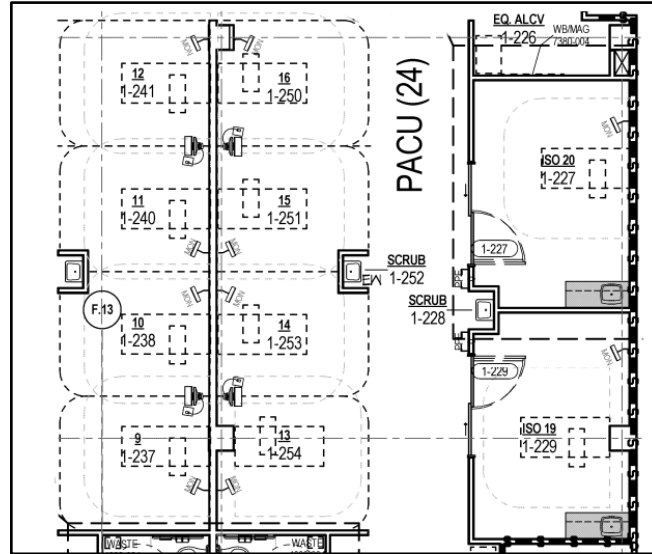

Figure 3-4: Patient Beds with Curtains and Doors for Entry and Privacy

3.4.2.3 Correct Placement of Rails and Accessories

Each restroom within a patient room was checked for safety rails and accessories. In the case that patient rooms did not feature a private restroom, the nearest restroom to the patient room was checked. In addition, all other restrooms accessible to patients or visitors were checked for safety rails and accessories. Figure 3-5 shows two restroom types which feature the recommended safety rails and accessories along the walls.

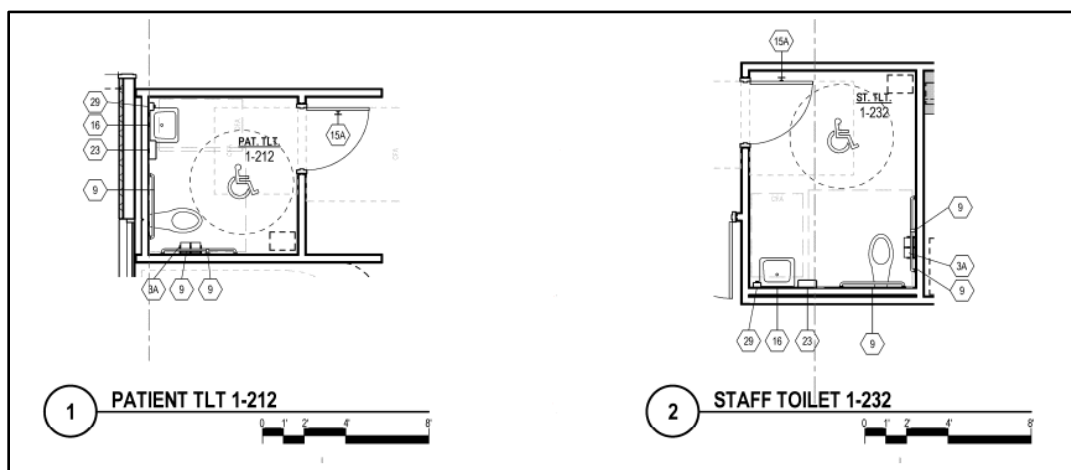

Figure 3-5: Safety Rails and Accessories in Patient and Staff Restrooms

3.4.2.4 Correct Toilet and Furniture Height

The Huisman study recommended that the correct toilet height should be used in order to increase safety and security; however, no recommended height was given. A furniture height recommendation was also not provided, which proved to be irrelevant since construction documents do not contain specifications for patient beds or other furniture (as they are typically provided by the owner or end user). For these reasons this recommendation was not included in this study.

3.4.2.5 Single-Bed Rooms

Each patient bed in the floor plans was identified as single-bed or not. Figure 3-6 gives an example of adjacent patient rooms with one dual-occupancy room (above) and one single-bed room (below).

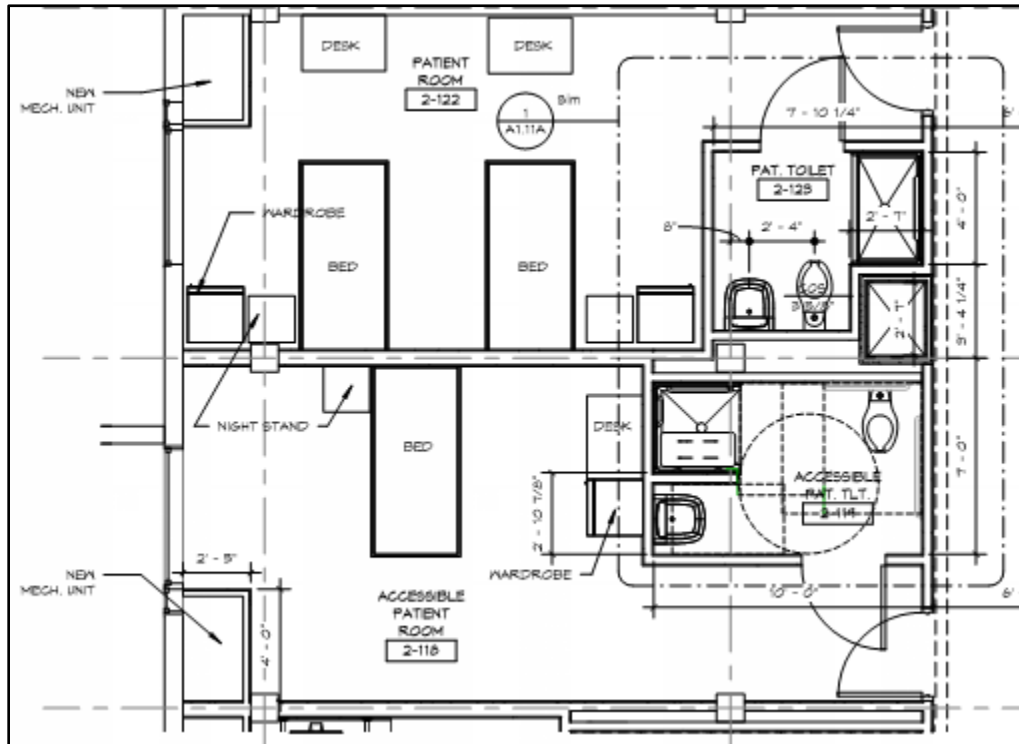

Figure 3-6: Single-Bed and Dual-Bed Patient Rooms

3.4.2.6 Easy-to-Clean Surfaces

The surfaces shown in construction documents that should be easy to clean (no fabrics) per the recommendations are limited to door hardware, countertops, and flooring materials. Without the need to verify, this author determined that 100% of the facilities would utilize door hardware and countertops made from materials other than fabric. To verify that the flooring specified met the recommendation, the floor finish plans of each project were referenced and the flooring type

specified for use in patient rooms was noted. Carpet in patient rooms was determined to be non-compliant. Figure 3-7 indicates sheet vinyl flooring (SV-1) with integral base (IB-1) for patient room floors.

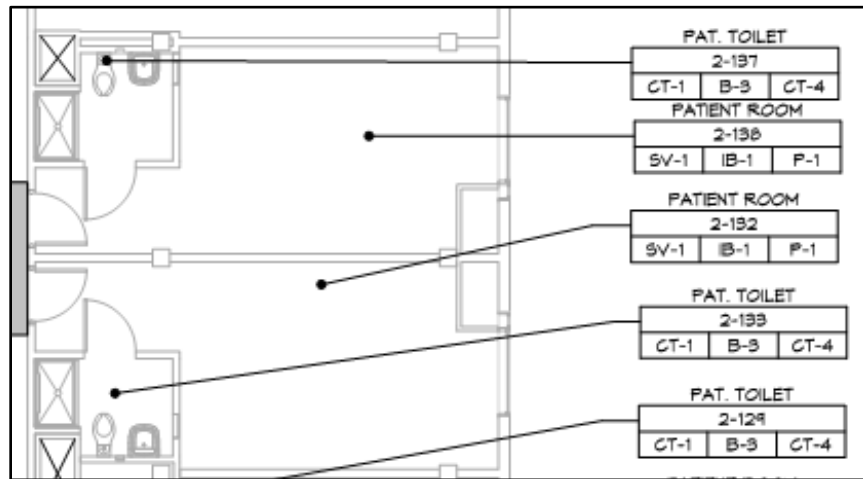

Figure 3-7: Floor Finish Plan Which Notes Flooring Types

3.4.2.7 Automated Sinks

Each patient room and patient restroom was checked for a handwashing sink. Plumbing drawings and specifications were checked to determine whether automated faucets were specified for use. Figure 3-8 gives an example of a sink specification calling for manually controlled wristblade faucet control levers (above) and an example of a specification calling for an electronic faucet with no levers (below).

SELF RIMMING STAINLESS STEEL, JUST SLF-1815-A-GR
CHICAGO FAUCET: 786-E29VPCP, DECK MOUNTED, 8" FIXED CNETERS, 4"WRISTBLADE

WALL HUNG AMERICAN STANDARD "LUCERNE" #0355.012,
CHICAGO FAUCET: HYTRONIC.116.103.AB.1, 12V AC, ELECTRONIC GOOSENECK FAUCET, PROVIDE 12 V AC
TRANSFORMER, NON-AERATOR, w/ADJUSTABLE TEMPERATURE CONTROL MIXER

Figure 3-8: Wristblade and Electronic Faucet Specifications

3.4.2.8 Smooth Edges in Rooms

This recommendation lacked enough information to determine what observations could be made in order to verify. It is not included in this analysis.

3.4.3 Enhancing Control

3.4.3.1 Control Over Bed Position

Patient bed specifications are not provided in construction documents and therefore this recommendation could not be verified in this study. The author did note that all patient room headwalls feature electrical outlets which could be used to power a patient bed with the recommended features.

3.4.3.2 Control Over Air Temperature

The mechanical plans and specifications were analyzed to determine whether or not a thermostat was placed within each patient room or not. Those patient rooms containing a dedicated thermostat were determined to be in compliance with the EBD recommendation of giving patients control over air temperature. The four patient rooms shown in Figure 3-9 each

have their own thermostat near the entrance, allowing each patient to adjust the temperature to meet their individual preferences without impacting others.

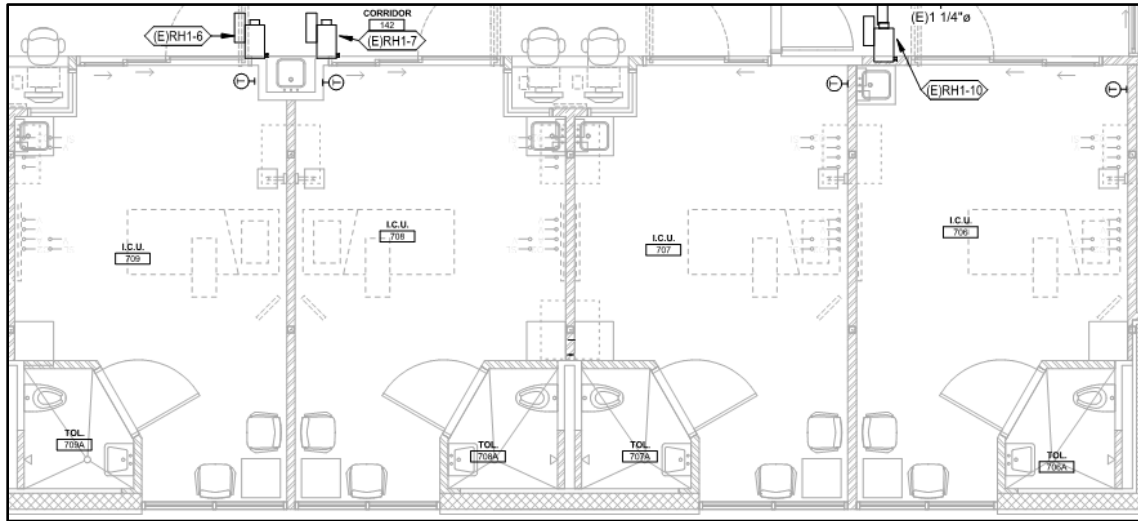

Figure 3-9: Patient Rooms with Individual Thermostats

3.4.3.3 Control Over Lights

To determine whether patients had control over their room lighting, the electrical plans were checked for light switches within the patient room either near the bed location or at the room entrance. The patient room in Figure 3-10 features a light switch at the head of the patient bed which controls the light fixture overhead.

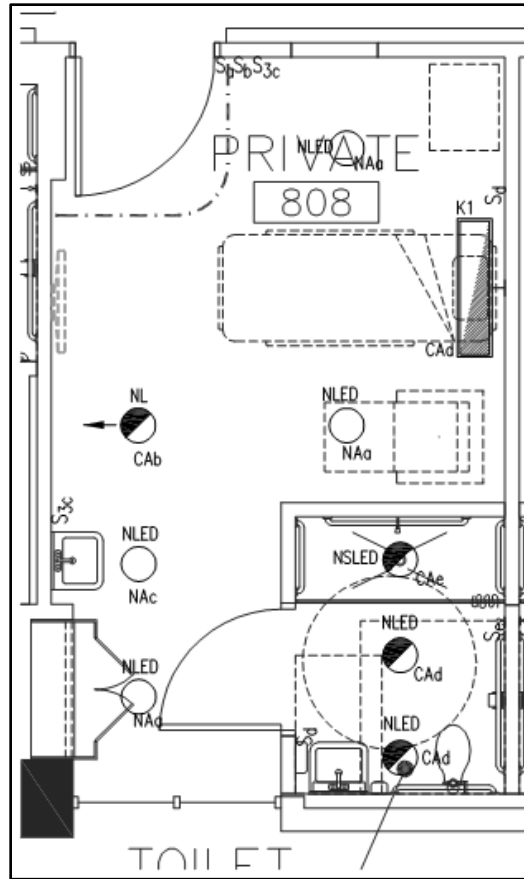

Figure 3-10: Patient Room with Light Control Near the Bed

3.4.3.4 Control Over Sound

For this recommendation, the Huisman study referenced control over music and television (Huisman, 2012). These features are not typically shown in construction documents so this element was not included in this analysis.

3.4.3.5 Control Over Natural Light

The construction drawings were checked for window coverings. This author is unaware of any window covering product which is not able to be manipulated by a user in one form or

another. If window coverings were specified, it was determined that this recommendation was satisfied. Figure 3-11 shows that Keynote 26 calls for window coverings in the patient rooms.

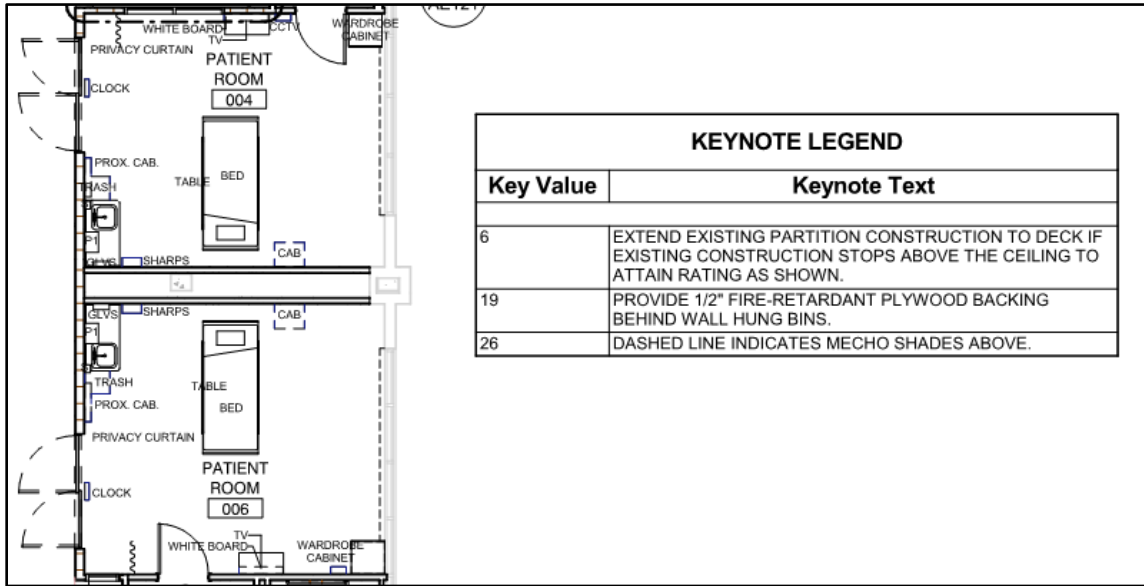

Figure 3-11: Patient Rooms Featuring Window Coverings

3.4.4 Privacy

3.4.4.1 Single-Bed Rooms

Each patient bed in the floor plans was identified as single-bed or not.

3.4.4.2 Design of Waiting Rooms

Each set of drawings was searched and waiting areas were identified. The Huisman study did not provide specific parameters on how to determine whether the waiting areas were separate from work areas, such as reception desks and nurse stations, other than “audibly secure” and “physical barrier” (Huisman, 2012). Without clear direction, it was determined that if the waiting

area was a distinctly separate space on the floor plan than the work areas, it was audibly secure and the recommendation was met. If a wall separated the two spaces it was determined to be EBD compliant. If the waiting and reception space blended together architecturally then it was concluded that the recommendation was not met. Figure 3-12 gives an example of a visitor waiting area that meets the recommendation criteria. An example of a non-compliant layout would place the waiting area inside of the hallway doors with no physical barriers between the waiting room and the patient rooms and nurse stations.

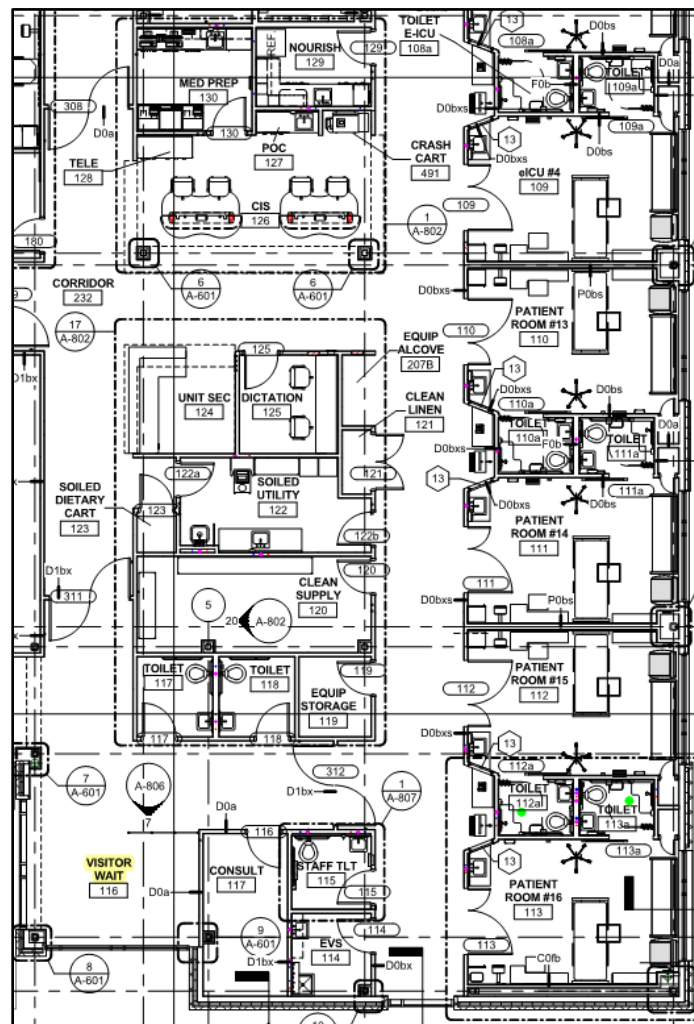

Figure 3-12: Visitor Waiting Area Separated from Work Areas by Doors

3.4.5 Comfort

3.4.5.1 Single-Bed Rooms

Each patient bed in the floor plans was identified as single-bed or not.

3.4.5.2 Materials Without Glare

No standard was given to determine whether or not a flooring surface caused glare in the Huisman paper other than “polished” (Huisman, 2012). Lacking clear direction, this recommendation was not included in the analysis.

3.4.5.3 Windows with a View

Each patient room was checked for a window to the exterior of the building. None of the projects analyzed were located in dense urban areas with little space between buildings. Each patient room with a window to the exterior which could be seen from the patient bed was determined to be compliant with the recommendation.

3.4.5.4 Daylight

Each patient room was checked for a window to the exterior of the building. The presence of a window was evidence enough that the patient would be exposed to daylight, whether or not they could see out the window from the bed.

3.4.5.5 Wayfinding

The wayfinding recommendation makes reference to the presence of a garden available for patient enjoyment. Each project was checked for a garden or outdoor seating areas. Those

projects with these features were determined to be compliant with the recommendation. Figure 3-13 provides an example of an outdoor seating area added during the renovation of a hospital.

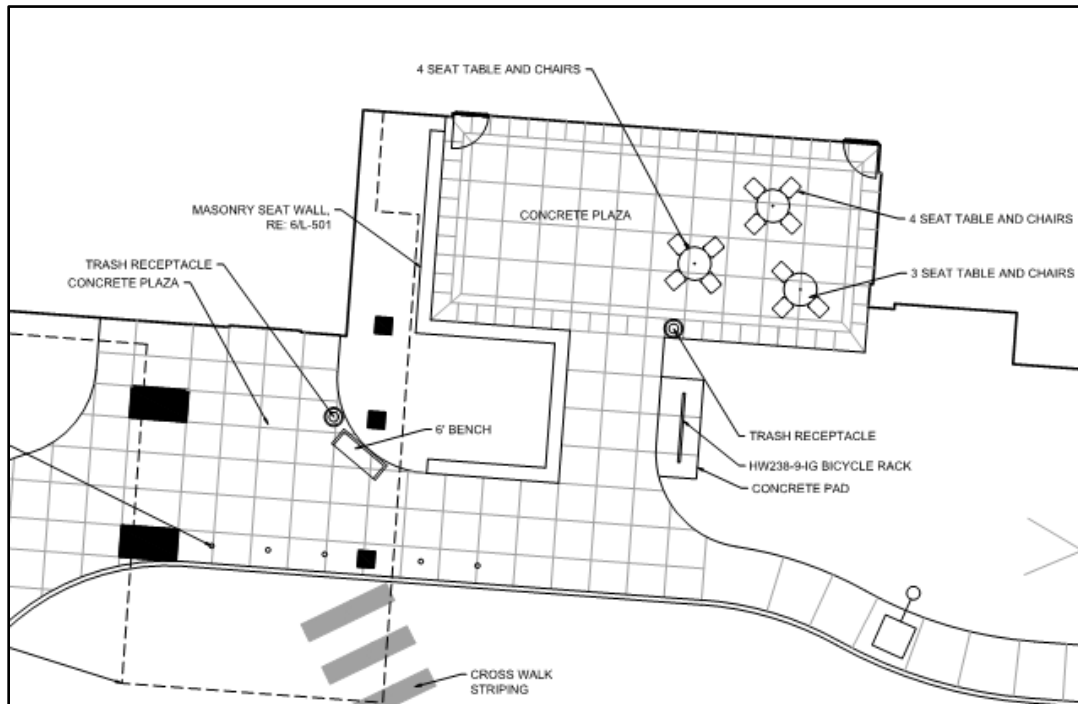

Figure 3-13: Outdoor Seating Area

3.5 Methodology Summary

In summary, the construction documents for 29 recent hospital renovation projects were obtained and analyzed. Key project information was compiled for the purpose of sorting the results once the analysis was complete. Each Evidence-Based Design recommendation which could be found within the documents was noted and tabulated. After the analysis was complete and all of the information was organized, it was then possible to sort the data in order to extract the findings, observe patterns and trends, and draw conclusions.

4 FINDINGS

4.1 Introduction to Findings

At the outset it was stated that the purpose of this research was to determine to what extent and to what consistency proven Evidence-Based Design (EBD) principles are being put to use in healthcare facility renovation projects today. In order to best show this, the findings will first be presented in a manner to show the *extent* of industry adoption. Next, the same results will be presented in a format which best articulates the *consistency* of EBD utilization.

To best understand extent, the results were tabulated by each of the 15 distinct EBD recommendations used for analysis. The extent of industry adoption was manifest by how many of the projects in the analysis included the recommendation in the design. The higher the adoption rate of any given recommendation among all projects, the greater the extent.

To best understand consistency, the results were compiled by each of the projects analyzed. The consistency of industry adoption was apparent by how many of the 15 EBD recommendations chosen for analysis were included in the design of each project. A project exhibited greater consistency when most, if not all, EBD principles were found in the design. Low consistency was evident in projects which featured only a few EBD recommendations.

4.2 Extent of Findings

In response to the research question posed, the use of Evidence-Based Design (EBD) recommendations was found to be extensive. Table 4-1 contains the data that shows the extent to which the design and construction industry has adopted each EBD recommendation from the Huisman paper selected for analysis in this study. The data shows that five recommendations have been adopted extensively by the industry and were detected in 100% of the plans analyzed. Those recommendations are a minimum lighting of 1570 lx at the point of care, rails and accessories in hallway restrooms, easy to clean flooring surfaces, patient control over natural light, and a window providing daylight in each patient room. In contrast, one recommendation had very sparse adoption: only 21% of facilities (6 out of 29) in this study added or modified a garden or outdoor seating area to assist with wayfinding and patient well-being within the renovation scope. The nine other recommendations in between the very high and the very low findings skew to the high side. Six recommendations are adopted at a rate of between 86% and 96%. These include: identical or mirrored rooms, entry door rather than a curtain, safety accessories in patient room restrooms, single-bed rooms, patient control over lights, and waiting areas apart from work areas. The remaining three recommendations, which appeared in just over half of the projects studied, include windows with a view, patient control over air temperature, and automated sinks in patient rooms.

Table 4-1: Extent of Evidence-Based Design Implementation

Recommendation	Total Projects with Sufficient Data	Total Projects Meeting Recommendation	Percentage Meeting Recommendation
Reduction of Errors			
Identical or Mirrored Rooms	28	25	89%
Lighting - Minimum 1570 lx at Point of Care	25	25	100%
Increasing Safety and Security			
Door Provides Entry and Privacy (No Curtains)	29	25	86%
Rails and Accessories in Patient Restrooms	28	27	96%
Rails and Accessories in Hallway Restrooms	29	29	100%
Single-Bed Rooms	29	26	90%
Easy-to-Clean Surfaces (No Carpet Flooring)	27	27	100%
Automated Sinks	27	14	52%
Enhancing Control			
Control Over Air Temperature	28	16	57%
Control Over Lights	25	23	92%
Control Over Natural Light	4	4	100%
Privacy			
Single-Bed Rooms	29	26	90%
Design of Waiting Rooms - Apart from Work Areas	27	24	89%
Comfort			
Single-Bed Rooms	29	26	90%
Windows with a View (See Window from Bed)	29	17	59%
Daylight (Window in the Patient Room)	29	29	100%
Wayfinding - Garden or Outdoor Seating Area	29	6	21%

The findings indicate extensive industry use of EBD principles. One third (5 of 15, or 33%) of the recommendations observed in the data collected had total industry adoption. Nearly three-quarters (11 of 15, or 73%) of the Huisman recommendations analyzed were included at a high rate of 86% or more of the projects in the data set. One-fifth (3 of 15, or 20%) were found in roughly half of the projects (ranging from 52% to 59%) included for analysis. Only one recommendation (1 of 15, or 7%) appeared in a low 21% of projects.

4.3 Consistency of Findings

In response to the question this study set forth to answer, the consistency of Evidence-Based Design (EBD) use is high. Table 4-2 contains the data that reveals how consistently certain projects incorporated each of the 15 EBD recommendations into design. The range of

consistency falls between three projects with a high EBD inclusion rate of 93% and one project with a low EBD inclusion rate of 57%. 19 projects included EBD principles at a rate higher than 80%. Seven projects included EBD principles at a rate between 70% and 79%. One project exhibited an EBD adoption rate of between 60% and 69% with the final two just below 60%. The average adoption rate of all 29 projects included in the data is 81%. The findings revealed a high rate of consistency wherein most of the recommendations known were included in the design.

Table 4-2: Consistency of Evidence-Based Design Findings by Project

Project	Identical Rooms	Lighting	Doors (no curtains)	Rails (Patients)	Rails (General)	Single-Bed Room	Floor (no carpet)	Auto Sinks	Temp Control	Light Control	Window Coverings	Separate Waiting Area	View	Daylight	Gardens	EBD Percentage
1	no	yes	yes	yes	yes	yes	yes	yes	no	yes	n/a	yes	no	yes	no	71%
2	yes	yes	no	yes	yes	yes	yes	no	no	no	n/a	yes	no	yes	no	57%
3	yes	n/a	yes	yes	yes	yes	yes	yes	n/a	n/a	n/a	yes	no	yes	no	82%
4	yes	yes	yes	yes	yes	yes	yes	no	yes	yes	n/a	no	yes	yes	yes	86%
5	yes	yes	yes	yes	yes	yes	yes	no	yes	yes	n/a	no	yes	yes	no	79%
6	yes	yes	no	yes	yes	no	yes	no	no	yes	n/a	n/a	no	yes	no	58%
7	yes	n/a	yes	yes	yes	yes	yes	yes	yes	yes	n/a	yes	no	yes	no	85%
8	yes	yes	yes	yes	yes	yes	yes	yes	no	yes	n/a	yes	no	yes	yes	86%
9	yes	yes	yes	yes	yes	yes	yes	no	yes	yes	n/a	yes	yes	yes	no	86%
10	yes	n/a	yes	yes	yes	no	n/a	n/a	no	n/a	yes	yes	yes	yes	yes	82%
11	yes	yes	no	yes	yes	yes	yes	yes	no	yes	n/a	yes	no	yes	yes	79%
12	yes	yes	yes	yes	yes	yes	yes	no	yes	yes	n/a	yes	yes	yes	yes	93%
13	yes	yes	yes	yes	yes	yes	yes	yes	no	yes	n/a	yes	yes	yes	no	86%
14	yes	yes	yes	yes	yes	yes	yes	no	no	yes	n/a	n/a	no	yes	no	75%
15	no	yes	yes	yes	yes	yes	yes	yes	yes	yes	n/a	yes	yes	yes	no	93%
16	no	yes	yes	yes	yes	yes	yes	no	yes	yes	yes	no	yes	yes	no	73%
17	no	yes	yes	n/a	yes	yes	yes	yes	yes	yes	yes	yes	yes	yes	no	86%
18	yes	yes	yes	yes	yes	yes	yes	no	yes	yes	n/a	yes	yes	yes	no	86%
19	yes	yes	yes	yes	yes	yes	yes	yes	yes	n/a	n/a	yes	no	yes	no	85%
20	yes	yes	yes	yes	yes	yes	yes	no	yes	yes	n/a	yes	yes	yes	no	86%
21	yes	yes	no	yes	yes	yes	yes	yes	no	yes	n/a	yes	no	yes	no	71%
22	yes	yes	yes	no	yes	yes	yes	yes	yes	yes	n/a	yes	yes	yes	no	86%
23	yes	yes	yes	yes	yes	yes	yes	yes	no	yes	n/a	yes	yes	yes	no	86%
24	yes	n/a	yes	yes	yes	yes	n/a	yes	yes	n/a	n/a	yes	yes	yes	no	91%
25	yes	yes	yes	yes	yes	no	yes	yes	yes	yes	n/a	yes	yes	yes	yes	93%
26	yes	yes	yes	yes	yes	yes	yes	no	yes	yes	n/a	yes	yes	yes	no	88%
27	yes	yes	yes	yes	yes	yes	yes	n/a	no	yes	yes	yes	yes	yes	no	86%
28	n/a	n/a	n/a	n/a	n/a	n/a	n/a	n/a	n/a	n/a	n/a	n/a	n/a	n/a	n/a	n/a
29	yes	yes	yes	yes	yes	yes	yes	no	no	yes	n/a	yes	no	yes	no	71%
30	n/a	yes	yes	yes	yes	yes	yes	no	yes	no	n/a	yes	no	yes	no	69%

4.4 Other Variables

The data collected for this study, when sorted, could possibly provide an explanation as to what factors most contribute to the findings. Some notable results were tabulated and are shown in Table 4-3. Of the 13 states where the projects were located, two states, California and Utah, had enough variety of projects to perform further analysis of the findings. When the eight projects located in California were sorted, the average Evidence-Based Design (EBD) implementation rate is 83%, which is close to the overall average of 81%. The eight projects located in Utah had an average EBD inclusion rate of 82%, also very close to the overall average. All other states contained either one or two projects, which is not enough information to detect any trends. The project location does not seem to play a significant factor in how consistently EBD principles were utilized.

Project type is another potential variable which could influence the findings. When sorted by project type, the EBD implementation rates ranged from a high (90%) to a low (69%), relatively close to the overall average of 81%. Four project types scored above the average: Women's Health (2 projects averaging 90%), Behavioral Health (3 projects averaging 87%), Intensive Care (5 projects averaging 85%), and Rehabilitation (3 projects averaging 85%). It is possible that facilities that provide this type of care place a higher emphasis on improved patient outcomes and experience. Further research would be required to determine that for sure.

Sorting the results by the Building Code governing the project design produced interesting results. Eight projects analyzed fell under the International Building Code (IBC) 2006. Another eight projects fell under IBC 2009. Nine projects were governed by IBC 2012. The remaining projects each cited a separate building code unique to the data set. The noteworthy observation is that the average EBD implementation rate improved over time from 73% under IBC 2006, to

83% under IBC 2009, and 85% under IBC 2012. It is possible that over time, the new edition of IBC standards has included additional EBD principles as a minimum standard. It is also possible that facility design standards could be influencing this observed trend. IBC standards generally come into play for the purpose of promoting public safety, while facility design standards may address issues related to patient comfort and staff performance. While this observation of improvement is encouraging, more research is needed in order to determine whether this trend could be replicated. Research could also be done to determine which codes and standards are adopting (or not adopting) EBD recommendations. It is worth noting that facility design standards (if any) that apply to a given project are not generally referenced on construction documents; therefore, any potential influence could not be definitively determined in this study. For a summary of key variables and their corresponding rate of EBD adoption, see Table 4-3.

Table 4-3: Project Variables and Evidence-Based Design Implementation

Filter	No. of Projects	EBD %
All Projects	29	81%
<i>Project Location</i>		
California	8	83%
Utah	8	81%
<i>Project Type</i>		
Behavioral Health	3	87%
Emergency Department	5	74%
General Patient Rooms	3	76%
Imaging	1	69%
Intensive Care	5	85%
Rehabilitation	3	85%
Surgical	7	81%
Women's Health	2	90%
<i>Governing Code</i>		
IBC 2006	8	73%
IBC 2009	8	83%
IBC 2012	9	85%

While the building code showed the EBD implementation rate improving over time, the data did not reflect this same trend when sorted by the year the project was designed. An analysis of how the owner or end user possibly impacted the EBD results likewise did not reveal any noticeable patterns. The same holds true after sorting the data by architect, mechanical engineering firm, and electrical engineering firm. The large variety of owners and designers represented in this set of data incumbers an analysis of how those variables may influence the results. This fact is advantageous to this study because the wide variety of projects offers a glimpse into what the design and construction industry is doing as a whole. The absence of any trends when the data is sorted by owner, architect, mechanical engineer, or electrical engineer strengthens the confidence that the data selected for this study is suitable for its intended purpose.

4.5 Summary of the Findings

The analysis of the data collected for this study indicated that Evidence-Based Design recommendations are found extensively and consistently in recent healthcare facility renovation project construction documents. Some recommendations are found in all projects, while others appear in most. Projects implement an average of 81% of the known EBD recommendations. Sorting the data by different influencing variables provided additional insight into industry trends. After the findings were analyzed, the next step was to evaluate the impact of this study and explore possibilities for future research.

5 CONCLUSIONS AND RECOMMENDATIONS

5.1 The Impact of This Research

The purpose of this study was to compare the design of recent healthcare renovation construction projects with fundamental Evidence-Based Design (EBD) principles to determine whether or not the latest research is being utilized by the healthcare design and construction industry in practice. A comprehensive literature review was conducted in order to determine and compile the latest known EBD recommendations. Construction documents for recent healthcare facility renovation projects were obtained for analysis. The extent and consistency of compliance with EBD recommendations was documented. The data was sorted in order to extract results and draw conclusions. Judging from the results contained herein, it was overwhelmingly evident that the Evidence-Based Design recommendations identified in the body of scientific research since 1984 are being put to use by the healthcare design and construction community.

The extensive and consistency of EBD use today informs us that the known benefits to healthcare facility users are being realized. Similarly, the cost savings which result from better patient and medical staff outcomes are also being realized by the organizations that deliver healthcare. The findings in this study also reveal that there are areas of potential improvement which could inform those who influence or determine building and design codes, standards, and guidelines. The results are instructive to owners, designers, and contractors, and provide a glimpse into how well the industry is currently recognizing and implementing best practices.

These results likewise open up new opportunities for further research which could lead to additional improvement in healthcare facilities of the future.

5.2 Suggestions for Further Research in Healthcare Design and Construction

While the above results are encouraging, and definitive conclusions can be drawn due to the size of the sample obtained for this research, further research into this topic is warranted. Many opportunities exist to expand on this effort. Further research into the Evidence-Based Design (EBD) recommendations made by Huisman but not included within this study is necessary. Further research should be conducted to determine if additional EBD criteria have emerged since the Huisman paper was published. More recently designed projects can be analyzed to determine whether or not the design industry has taken note. Studies of construction documents produced pre-2011 (prior to the publication of the Huisman recommendations), pre-2005 (prior to the publication of the Dijkstra study) , and pre-1984 (prior to any EBD research) may also shed light on when industry adoption of EBD principles took hold.

The construction documents analyzed for this study came from projects with a variety of owners, designers, and locations; however, the projects came from one general contractor source and were all renovation projects. Research from multiple other general contractor sources with still more owner, designer, and location variety should be completed to ensure these results can be replicated. Future research should include new hospitals and other types of healthcare facilities. Research can also be done to determine if EBD adoption differs between publicly administered healthcare facilities and privately owned and operated facilities.

Additional research can be conducted to further understand why such high use of EBD principles were observed in this paper. A thorough analysis of the International Building Code in

2006, 2009, and 2012 may reveal what EBD recommendations, if any, have become the national minimum standard and when those standards were adopted, if at all. An investigation of the differing standards, if any, unique to specific hospitals or specialized care units within hospitals may explain the differing rates of EBD adoption observed among different project types. A better understanding of how facility design standards govern the design and construction of healthcare facilities could also prove to be instructive.

It is possible that patient satisfaction has become a greater focus in the industry, which is impacting the design and use of healthcare infrastructure outside of building codes or design standards. Further study into owner and end user objectives and how they have evolved over the years may provide further insight. While it is evident from this research that EBD principles have been noticed and implemented in practice, there is still room for improvement. Additional inquiry into the previously mentioned subjects may help uncover some of the challenges or roadblocks which are preventing further improvement. While progress appears to be going in the right direction, it is now known, as a result of this research, that not all scientifically proven best practices are currently being incorporated into all hospital designs.

5.3 Suggestions for Further Research in Other Industries

It should further be noted that Evidence-Based Design (EBD) principles may also be applicable to industries outside of healthcare and wellness. Further research into how the design of the built environment impacts the well-being of users and occupants in several other areas may prove to be valuable. If changes in design elements can improve healing and satisfaction for hospital patients and users, surely similar outcomes can occur in other sectors of the built

environment such as office, institutional, retail, education, government & municipality, religious, and residential.

5.4 Suggestions for Changes in Design and Construction Education

Furthermore, academic institutions may seek to participate in more Evidence-Based Design (EBD) research as a means of contributing to the design and construction practices associated with improving the end user experience in all sectors of the built environment. Researchers in the medical field can collaborate with design and construction researchers to find new ways in which designs can help improve patient outcomes. Design and construction researchers can work in partnership with medical researchers to determine how the latest design and building technology can be put to use to improve healthcare environments. In addition, design and construction courses with heavy emphasis in Evidence-Based Design research, whether in healthcare or any other industry, will bridge the gap between the researchers making new discoveries and the future professionals tasked with the ultimate implementation of those findings in practice.

Progress comes as a result of taking the ever-advancing knowledge and technology available to us and putting it to good use. Enhanced cooperation between researchers and industry professionals across disciplines and specialties can accelerate progress healthcare facilities and in all sectors of the built environment.

REFERENCES

- American Hospital Association. (2018, February 27). *Fast Facts on US Hospitals*. Retrieved from American Hospital Association: <https://www.aha.org/statistics/fast-facts-us-hospitals>
- E. Alfonsi, S. C. (2014). Evidence-based design and healthcare: an unconventional approach to hospital design. *Ann Ig*, 137-143.
- E. Burton, J. T. (2007). Designing environments suitable for older people. *CME Journal Geriatric Medicine*, 39-45.
- E. Larson, D. K. (1991). Effect of an automated sink on handwashing practices and attitudes in high-risk units. *Infection Control & Hospital Epidemiology*, 422-428.
- E.J. Mlinek, J. P. (1997). Confidentiality and privacy breaches in a university hospital emergency department. *Academic Emergency Medicine*, 1142-1146.
- E.R.C.M. Huisman, E. M. (2012). Healing environment: A review of the impact of physical environmental factors on users. *Building and Environment*, 70-80.
- Evans, M. (2015, February 21). *Hospitals face closures as 'a new day in healthcare' dawns*. Retrieved February 27, 2018, from modernhealthcare.com: <http://www.modernhealthcare.com/article/20150221/MAGAZINE/302219988>
- Google. (2018, February 27). *United States of America / Life expectancy*. Retrieved from google.com: https://www.google.com/search?rlz=1C1GGRV_enUS752US752&ei=3NSVWvjaDsLm0gLNy5K4Bg&q=life+expectancy+in+us&oq=life+ex&gs_l=psy-ab.1.2.0i20i265k1j0i131i20i265k1j0i67k114j0i67k112j0.178332.179641.0.181995.7.7.0.0.0.115.712.3j4.7.0..3..0...1.1.64.psy-ab..0
- Google. (2018, February 27). *United States of America / Population 1975*. Retrieved from google.com: https://www.google.com/search?q=us+population+in+1975&rlz=1C1GGRV_enUS752US752&oq=us+population&aqs=chrome.3.69i57j012j35i39j012.6055j1j7&sourceid=chrome&ie=UTF-8

- JM Booker, C. R. (1995). A seasonal pattern of hospital medication errors in Alaska. *Psychiatry Research*, 251-257.
- K. Dijkstra, M. P. (2006). Physical environmental stimuli that turn healthcare facilities into healing environments through psychologically mediated effects: systematic review. *Journal of Advanced Nursing*, 166-181.
- Palmer, R. (1987). Bacterial contamination of curtains in clinical areas. *Nursing Standard*, 33-35.
- Statista. (2018, February 27). *Number of all hospital beds in the U.S. from 1975 to 2015*. Retrieved from statista.com: <https://www.statista.com/statistics/185860/number-of-all-hospital-beds-in-the-us-since-2001/>
- Statista. (2018, February 27). *Number of federal and nonfederal hospitals in the U.S. from 1975 to 2015*. Retrieved from statista.com: <https://www.statista.com/statistics/185852/number-of-federal-and-nonfederal-hospitals-in-the-us-since-2001/>
- T.L. Buchanan, K. B. (1991). Illumination and errors in dispensing. *American Journal of Hospital Pharmacy*, 2137-2145.
- The Center for Health Design. (2016, December 15). *healthdesign.org/about*. Retrieved from healthdesign.org: <https://www.healthdesign.org/about>
- The Center for Health Design. (2017, September 25). *healthdesign.org/about-us*. Retrieved from healthdesign.org: <https://www.healthdesign.org/about-us>
- The Center for Health Design. (2018, February 27). *Certification & Outreach / About*. Retrieved from healthdesign.org: <https://www.healthdesign.org/certification-outreach/edac/about>
- The Environmental Design Research Association. (2018, February 27). *Mission, Value, History*. Retrieved from erda.org: <http://www.edra.org/page/missionvaluehistory>
- Ulrich, R. (1991). Effects of interior design on wellness. Theory and recent scientific research. *Journal of Health Care Interior Design*, 97-109.