



## Food Profiles of Indigenous Households in Brazil: Results of the First National Survey of Indigenous Peoples' Health and Nutrition

James R. Welch , Aline Alves Ferreira , Mirian Carvalho De Souza & Carlos E. A. Coimbra Jr

To cite this article: James R. Welch , Aline Alves Ferreira , Mirian Carvalho De Souza & Carlos E. A. Coimbra Jr (2020): Food Profiles of Indigenous Households in Brazil: Results of the First National Survey of Indigenous Peoples' Health and Nutrition, Ecology of Food and Nutrition, DOI: [10.1080/03670244.2020.1781105](https://doi.org/10.1080/03670244.2020.1781105)

To link to this article: <https://doi.org/10.1080/03670244.2020.1781105>



© 2020 The Author(s). Published with license by Taylor & Francis Group, LLC.



Published online: 17 Jun 2020.



Submit your article to this journal [↗](#)



Article views: 532







View related articles [↗](#)



View Crossmark data [↗](#)

# Food Profiles of Indigenous Households in Brazil: Results of the First National Survey of Indigenous Peoples' Health and Nutrition

James R. Welch <sup>a</sup>, Aline Alves Ferreira <sup>b</sup>, Mirian Carvalho De Souza <sup>c</sup>,  
and Carlos E. A. Coimbra Jr <sup>a</sup>

<sup>a</sup>Escola Nacional De Saúde Pública, Fundação Oswaldo Cruz, Rio De Janeiro, Brazil; <sup>b</sup>Instituto De Nutrição Josué De Castro, Universidade Federal Do Rio De Janeiro, Rio De Janeiro, Brazil; <sup>c</sup>Divisão De Pesquisa Populacional, Instituto Nacional De Câncer, Rio De Janeiro, Brazil

## ABSTRACT

The objective of the present study was to characterize the food profiles in Indigenous households participating in the First National Survey of Indigenous People's Health and Nutrition in Brazil. Multiple correspondence analysis was used to estimate distances between regions and foods from three sources (local Indigenous production, purchased, and external donation), in addition to "not consumed." The combined distribution of the first two dimensions revealed three distinct profiles of food acquisition. Observed proximities between geopolitical regions and distinct modes of food acquisition speak to regional contrasts in food sovereignty among the Indigenous population that are closely linked to historical occupation and economic expansion in the country. Considering the concept of food sovereignty as involving rights to dietary autonomy, healthy diets, and resource management, our data suggest Brazil's North region is the closest of the four regions analyzed to these goals. Food sovereignty in the Northeast and South/Southeast regions is reduced due to greater monetarization and proximity to market economy resources. The advance of agribusiness in the Amazon has been a hallmark of the Brazilian government's current environmental policy, directly threatening the survival of Indigenous peoples living in that region.

## KEYWORDS

Food sovereignty;  
indigenous food systems;  
indigenous peoples; food  
policy; Brazil

## Introduction

Poor diets and dietary health disorders are particularly insidious because their determination involves macro factors well beyond the control of the individual, such as market availability of foods and limited access to primary health services, and micro factors that also are only difficultly modified by individual behavioral means, such as highly caloric foods consumption and physical inactivity. Addressing dietary problems require new public health tools sensitive to situational factors at all scales, including sociocultural, environmental, and economic realities. As argued by Damman et al. (2008, 135),

**CONTACT** James R. Welch  [welch@ensp.fiocruz.br](mailto:welch@ensp.fiocruz.br)  Escola Nacional De Saúde Pública, Fundação Oswaldo Cruz, Rio De Janeiro, RJ, 21041-210, Brazil

© 2020 The Author(s). Published with license by Taylor & Francis Group, LLC.  
This is an Open Access article distributed under the terms of the Creative Commons Attribution License (<http://creativecommons.org/licenses/by/4.0/>), which permits unrestricted use, distribution, and reproduction in any medium, provided the original work is properly cited.

Indigenous peoples' chronic disease risk tends to increase as a result of government policies that infringe on indigenous peoples' livelihoods and territories, undermining their economic system, values and solidarity networks. Policies intended to increase food security, including food aid, may also fuel the nutrition transition.

The “right to food perspective” advocated for by Damman et al. recognizes that the westernization of diets that accompanies the nutrition transition from chronic undernutrition to overweight and obesity is partially due to forms of discrimination that affect lifestyles broadly, including structural racism. One of their effects is reduced reliance of traditional food production and acquisition and increased consumption of processed and ultraprocessed market foods rich in fast-acting carbohydrates, sodium, and saturated fats.

Food sovereignty is a diverse but established and growing agenda based on principles of self-determination and food revitalization, rooted in generalized rights of all peoples to healthy locally produced foods (Grey and Patel 2015; Wittman 2010). Among the directives of the Brazilian National Policy for Food Security are the human rights to adequate food and food sovereignty (Presidency of the Republic 2006, 2010). Recent efforts to “indigenize” food sovereignty appeal to not only rights, but also responsibilities for people to regain sustainable and healthy dietary relationships with their environments (Coté 2016; Delormier and Marquis 2019). The food sovereignty movement transcends indigeneity but shares with it a view of food as interconnected with more generalized dynamics such as human rights, ethnic identity, market insertion, traditional knowledge systems, sustainability, and well-being.

Globalization of food systems and access to market foods may not overtly require household decision makers to purchase or furnish unhealthy exogenous diets, but they do bring about this effect through abundant extrinsic factors ranging from public policies to local market access. Such conditions cause households to lack real food production and consumption options, which is to lack food sovereignty. For many Indigenous peoples, such key intervening factors include preservation of ethnic identity and access to traditional territories, natural resources, and traditional ecological knowledge (Power 2008; Rocha and Liberato 2013). The food sovereignty model provides a framework for understanding built-in structural challenges to maintaining healthy diets through local investment in sociocultural, economic, and environmental well-being. In this sense it improves on the food security concept by emphasizing the need for social change to improve the broader circumstances and rights that contribute to how people decide what is produced and consumed, such as access to landscape and biodiversity resources and participation in policy discourse (Jarosz 2014; Patel 2009). A notable limitation to the food sovereignty movement is its failure to engage in adequate dialog with health equity literature (Weiler et al. 2015). This paper aims to contribute to this gap by addressing interregional inequities in the context of household food profiles among Indigenous peoples in Brazil.

Indirect indicators suggest that contemporary Indigenous diets in Brazil are lacking in quality to different degrees and in different ways depending on the region. For example, results of the First National Survey of Indigenous People's Health and Nutrition in Brazil (henceforth, the National Survey) show the prevalence of obesity among women > 14 years differed by region, with the highest value in the South/Southeast (22.6%), and the lowest in the North (6.1%). Besides region, significant determinant factors included higher socioeconomic status, market-integrated living conditions, and less reliance on local food production (Coimbra Jr. et al. 2020). In contrast, the same study also showed low height-for-age (stunting) in children < 5 was most prevalent in the North (40.8%) and least in the Northeast (13.9%), with significant determinant factors including region, socioeconomic status, access to sanitation services, and prior hospitalization (Horta et al. 2013). Women's and children's anemia were higher in the North (46.3% and 66.4%, respectively) and lower in the Northeast (22.8% and 41.1%, respectively) (Borges et al. 2016; Leite et al. 2013). These results suggest a double burden of malnutrition among Indigenous peoples in Brazil, with the South/Southeast most burdened by obesity and anemia in adults (Borges et al. 2016; Coimbra et al. 2020) and the North most burdened by stunting and anemia in children under five years (Horta et al. 2013; Leite et al. 2013).

These findings are determined by complex factors and cannot be reduced to diet alone. For example, among the most important determinant factors for high stunting prevalence in children in the North is lack of sanitation services and prior hospitalization due to preventable infectious diseases, usually diarrhea. According to the National Survey, diarrhea during the prior week was most prevalent in the North (38.1%) and the least prevalent in the South/Southeast (15.9%) (Escobar et al. 2015). Other studies highlight the occurrence in the North of other endemic infectious and parasitic diseases such as malaria and tuberculosis, which contribute to child undernutrition (Coimbra Jr. et al., 2013; Coimbra Jr. and Basta 2007; Leandro-Reguillo 2015; Walker, Sattenspiel, and Hill 2015). However, the high prevalence of obesity among Indigenous women in the South/Southeast, on par with the national non-Indigenous population in Brazil, and low prevalence among those in the North, may be more directly related to household dietary economies and thus to food sovereignty.

The objective of the present study was to describe the food profiles and joint relationships between national regions and sources of foods consumed in Indigenous households participating in the National Survey. Multiple correspondence analysis was used to estimate proximities and distances between regions and foods from three sources (local Indigenous production, purchased, and external donation), in addition to "not consumed." The resulting regional food profiles are compared considering regional differences in food production autonomy, territorial access, and health equity.

## Methods

The objective of the National Survey was to characterize nutritional status and other health indicators in Indigenous children < 5 years and Indigenous women 14–49 years, based on a representative probabilistic sample of the Indigenous population residing in federally recognized Indigenous reserves in Brazil. The multi-stage sample was stratified by four major geopolitical regions. The final target sample included 123 villages, of which 65 were in the North, 14 in the Central-West, 23 in the Northeast, and 21 in the South/Southeast. Households in selected villages were investigated by census or sample depending on their estimated populations. In selected households, one representative responded to the household questionnaire, which addressed such topics as physical characteristics of the house, sanitation, durable household goods, sources of monetary income, food production and consumption, and food seasonality (Coimbra Jr et al. 2013).

For the present study, frequencies were calculated for selected household variables and food items (Tables 1 and 2). Chi-squared homogeneity test and Fisher's exact test were not performed due to insufficient numbers of cases.

To describe household food acquisition profiles, multiple correspondence analysis was performed. This descriptive analytical technique permitted evaluation of similarities between a set of categorical data (Carvalho and Struchiner 1992; Greenacre and Blasius 2006), which in this case included regions and household food items. For each food item, interviewees were asked whether it is

**Table 1.** Distribution of household food acquisition practices by geopolitical region. First National Survey of Indigenous Peoples' Health and Nutrition, Brazil, 2008–2009.

	All regions		Region							
			North		Central-West		Northeast		South/Southeast	
Residents consume	n	%	n	%	n	%	n	%	n	%
<b>Household garden products or livestock</b>										
Yes	4389	83.2	1637	89.4	946	87.3	1049	71.7	757	84.6
No	884	16.8	195	10.6	137	12.7	414	28.3	138	15.4
<b>Community garden products or livestock</b>										
Yes	484	9.2	222	12.1	59	5.4	62	4.2	141	15.8
No	4788	90.8	1610	87.9	1024	94.6	1401	95.8	753	84.2
<b>Food derived from household hunting or fishing</b>										
Yes	2434	87.7	1392	98.2	301	87.0	502	70.5	239	79.9
No	340	12.3	25	1.8	45	13.0	210	29.5	60	20.1
<b>Food derived from household collecting</b>										
Yes	3638	69.0	1565	85.4	674	62.2	878	60.0	521	58.2
No	1635	31.0	267	14.6	409	37.8	585	40.0	374	41.8
<b>Food derived from community hunting, fishing, or collecting</b>										
Yes	686	13.0	340	18.6	77	7.1	103	7.0	166	18.5
No	4586	87.0	1492	81.4	1006	92.9	1359	93.0	729	81.5
<b>Purchased foods</b>										
Yes	5081	96.4	1682	91.8	1060	97.9	1452	99.2	887	99.1
No	192	3.6	150	8.2	23	2.1	11	0.8	8	0.9
<b>Staple foods donations (cesta básica)</b>										
Yes	2168	41.1	64	3.5	960	88.6	448	30.6	696	77.8
No	3105	58.9	1768	96.5	123	11.4	1015	69.4	199	22.2
<b>Other donations from outside the village</b>										
Yes	335	6.4	48	2.6	15	1.4	167	11.4	105	11.7
No	4937	93.6	1784	97.4	1068	98.6	1296	88.6	789	88.3

**Table 2.** Distribution of household food acquisition practices for 13 food items by geopolitical region. First National Survey of Indigenous Peoples' Health and Nutrition, Brazil, 2008–2009.

	Region									
	All regions		North		Central-West		Northeast		South/Southeast	
	n	%	n	%	n	%	n	%	n	%
Residents customarily consume										
<b>Rice</b>										
No	206	3.9	190	10.4	14	1.3	2	0.1	0	0.0
Yes, Indigenous production	356	6.8	112	6.1	86	7.9	119	8.1	39	4.4
Yes, purchase	4242	80.5	1524	83.3	564	52.1	1327	90.7	827	92.5
Yes, receive from outside village/community	465	8.8	3	0.2	419	38.7	15	1.0	28	3.1
<b>Maize or products</b>										
No	701	13.3	412	22.5	124	11.4	119	8.1	46	5.2
Yes, Indigenous production	2572	48.8	1041	56.9	495	45.7	502	34.3	534	59.9
Yes, purchase	1697	32.2	374	20.4	210	19.4	821	56.1	292	32.7
Yes, receive from outside village/community	298	5.7	3	0.2	254	23.5	21	1.4	20	2.2
<b>Manioc or products</b>										
No	127	2.4	10	0.5	20	1.8	55	3.8	42	4.7
Yes, Indigenous production	3980	75.5	1741	95.2	909	83.9	680	46.5	650	72.7
Yes, purchase	1063	20.2	71	3.9	144	13.3	675	46.1	173	19.4
Yes, receive from outside village/community	99	1.9	7	0.4	10	0.9	53	3.6	29	3.2
<b>Potatoes and tubers</b>										
No	748	14.2	222	12.1	214	19.8	214	14.6	98	11.0
Yes, Indigenous production	3033	57.6	1361	74.4	665	61.4	501	34.2	506	56.6
Yes, purchase	1445	27.4	242	13.2	199	18.4	725	49.6	279	31.2
Yes, receive from outside village/community	44	0.8	5	0.3	5	0.5	23	1.6	11	1.2
<b>Beans</b>										
No	276	5.2	249	13.6	20	1.8	3	0.2	4	0.4
Yes, Indigenous production	1679	31.9	470	25.7	181	16.7	642	43.9	386	43.3
Yes, purchase	2752	52.3	1106	60.5	358	33.1	801	54.8	487	54.7
Yes, receive from outside village/community	559	10.6	4	0.2	524	48.4	17	1.2	14	1.6
<b>Fruits</b>										
No	173	3.3	46	2.5	56	5.2	42	2.9	29	3.2
Yes, Indigenous production	3080	58.5	1638	89.6	536	49.5	482	32.9	424	47.5
Yes, purchase	1994	37.9	144	7.9	484	44.7	931	63.6	435	48.7
Yes, receive from outside village/community	21	0.4	1	0.1	7	0.6	8	0.5	5	0.6
<b>Nuts</b>										
No	1304	24.7	247	13.5	545	50.3	234	16.0	278	31.1
Yes, Indigenous production	2988	56.7	1419	77.5	300	27.7	918	62.7	351	39.3
Yes, purchase	931	17.7	156	8.5	232	21.4	286	19.5	257	28.7
Yes, receive from outside village/community	47	0.9	8	0.4	6	0.6	25	1.7	8	0.9
<b>Vegetables and greens</b>										
No	1048	19.9	682	37.3	198	18.3	81	5.5	87	9.7
Yes, Indigenous production	961	18.2	466	25.5	124	11.4	104	7.1	267	29.9
Yes, purchase	3241	61.5	680	37.2	754	69.6	1268	86.7	539	60.3
Yes, receive from outside village/community	18	0.3	0	0.0	7	0.6	10	0.7	1	0.1
<b>Milk and products (cheese, etc.)</b>										
No	655	12.4	356	19.5	49	4.5	129	8.8	121	13.5
Yes, Indigenous production	429	8.1	109	6.0	50	4.6	158	10.8	112	12.5
Yes, purchase	3152	59.8	1356	74.1	325	30.0	999	68.3	472	52.9
Yes, receive from outside village/community	1032	19.6	8	0.4	659	60.8	177	12.1	188	21.1
<b>Eggs</b>										
No	478	9.1	241	13.2	128	11.8	59	4.0	50	5.6
Yes, Indigenous production	2035	38.6	689	37.7	553	51.1	312	21.3	481	53.8
Yes, purchase	2732	51.9	898	49.1	399	36.9	1080	73.8	355	39.7
Yes, receive from outside village/community	23	0.4	1	0.1	2	0.2	12	0.8	8	0.9
<b>Chicken, turkey, or duck</b>										
No	256	4.9	186	10.2	35	3.2	27	1.8	8	0.9
Yes, Indigenous production	2051	39.0	749	41.0	578	53.5	280	19.2	444	49.8
Yes, purchase	2929	55.7	887	48.5	465	43.1	1141	78.0	436	48.9
Yes, receive from outside village/community	25	0.5	5	0.3	2	0.2	14	1.0	4	0.4
<b>Beef, goat, pork, etc.</b>										
No	788	15.0	632	34.5	50	4.6	59	4.0	47	5.3

(Continued)

**Table 2.** (Continued).

	Region									
	All regions		North		Central-West		Northeast		South/Southeast	
	n	%	n	%	n	%	n	%	n	%
Residents customarily consume										
Yes, Indigenous production	310	5.9	176	9.6	32	3.0	30	2.1	72	8.1
Yes, purchase	4150	78.8	1016	55.5	994	91.8	1370	93.6	770	86.2
Yes, receive from outside village/community	21	0.4	6	0.3	7	0.6	4	0.3	4	0.4
<b>Fish</b>										
No	413	7.8	9	0.5	195	18.0	71	4.9	138	15.4
Yes, Indigenous production	3014	57.2	1664	91.1	453	41.9	506	34.6	391	43.7
Yes, purchase	1807	34.3	152	8.3	432	39.9	862	58.9	361	40.4
Yes, receive from outside village/community	32	0.6	2	0.1	2	0.2	24	1.6	4	0.4
<b>Game meat</b>										
No	2288	43.5	152	8.3	716	66.1	873	59.7	547	61.4
Yes, Indigenous production	2462	46.8	1303	71.3	343	31.7	515	35.2	301	33.8
Yes, purchase	436	8.3	354	19.4	21	1.9	42	2.9	19	2.1
Yes, receive from outside village/community	78	1.5	19	1.0	3	0.3	32	2.2	24	2.7

customarily consumed in the household and, if so, from where it was generally obtained. Thus, each food item was classified as not consumed (n) or obtained through purchase (p), Indigenous production (i), or external donation (d). These analytical techniques utilized the household as the unit of analysis, although the National Survey was designed for national representativeness for women and children. Thus, this study is representative of participant households, not of all Indigenous households nationally.

Results obtained by multiple correspondence analysis are presented in a graphical scatterplot format (Figure 1) permitting visualization of the combined distribution of studied variables, which can be interpreted in terms of approximate proximity or similarity and distance or difference. This technique assists in the succinct visual identification of patterns for large numbers of variables, which the frequency tables do not permit. Each response category (n, p, i, d; North, Central-West, Northeast, South/Southeast) of each variable (food item; region) is represented as a point. The distances between points represent the proximities between variable response categories (Carvalho and Struchiner 1992; Greenacre and Blasius 2006). Additionally, a dendrogram (Figure 2) of the mean of the coordinates obtained via multiple correspondence analysis was used as a complementary graphical format to facilitate identification of similarities not visually apparent in the scatterplot (Maechler et al. 2019). In both graphical representations, proximity is to be interpreted as similarity in the combined distribution of the first two dimensions but does not imply uniformity. In other words, association of a variable response category with a profile does not preclude the possibility that a substantial number of households in that profile reported acquiring that food according to different response categories.

Analyzes were performed using R software version 2.6.0 (R Core Team 2007) with the supplementary library multiple and joint correspondence analysis and IBM SPSS 21.0 (IBM Corp 2012).

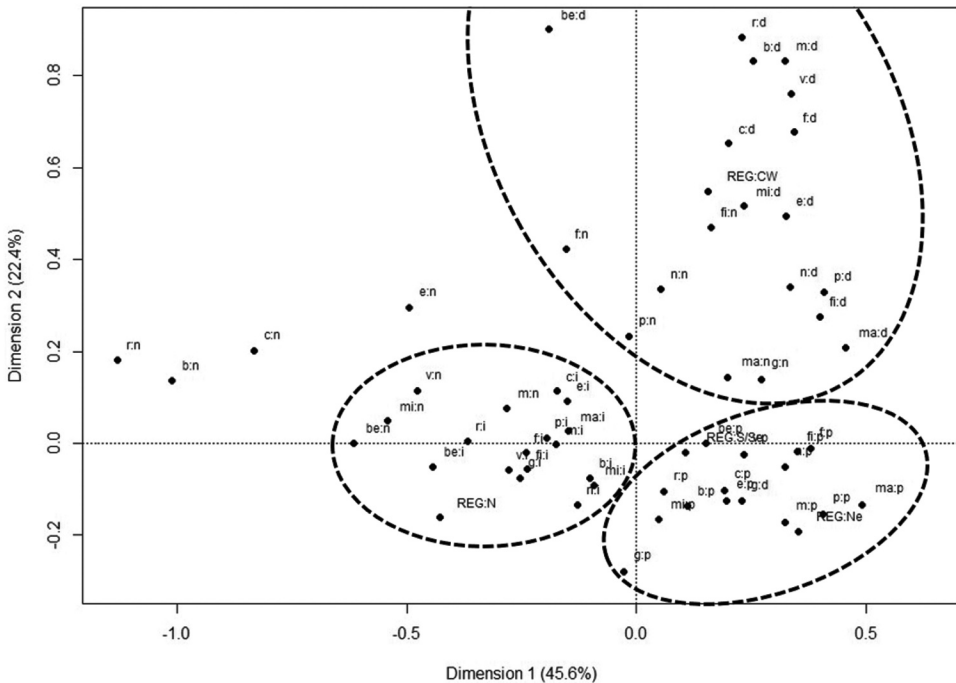

**Figure 1.** Scatterplot of combined distribution of first two dimensions of multiple correspondence analysis, according to characteristics of Indigenous household food economies. First National Survey of Indigenous Peoples' Health and Nutrition, Brazil, 2008–2009. **d** donation from outside village/community; **i** Indigenous production; **n** Not consumed; **p** Purchase; **REG** Region; **CW** Central-West region; **N** North region; **Ne** Northeast region; **S/Se** South/Southeast region; **b** Beans; **be** Beef, goat, pork, etc.; **c** Chicken, turkey, or duck; **e** Eggs; **fi** Fish; **f** Fruits; **g** Game meat; **m** Maize or products; **ma** Manioc or products; **mi** Milk and products (cheese, etc.); **n** Nuts; **p** Potatoes and tubers; **r** Rice; **v** Vegetables and greens.

The National Survey was authorized by the Brazilian National Research Ethics Commission and the National Indian Foundation. Permission was obtained from community leaders according to local protocols for community decision-making. A Collective Free and Informed Consent form was presented in detail and signed if consent was provided. Any particular village or household was allowed to decline to participate at any stage of fieldwork. During household visits, any additional questions about the study were answered before conducting research.

## Results

Of the target sample of 123 villages, 113 (91.9%) participated in the study. Nonparticipation was due to declination, data error in target village list, lack of access due to weather and flu outbreak, cost, and data loss by postal service. Of the 5674 Indigenous households sampled, 369 (6.5%) were not interviewed, 5.9% due to absence and 0.6% to declination. Of the interviewed households, 5235 (98.7%) had adequate data for inclusion in analyses for the present study.



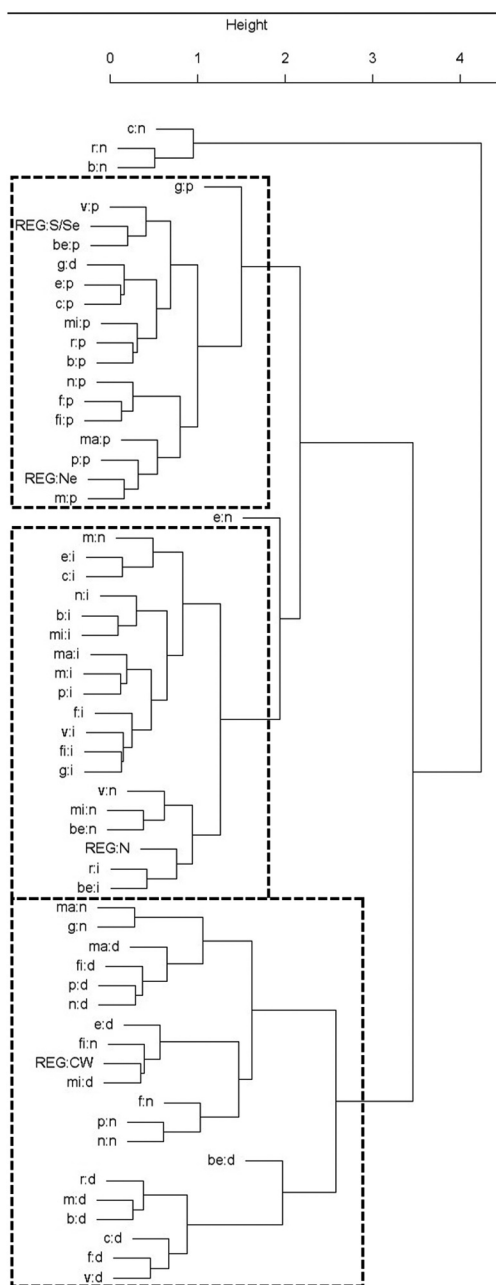

**Figure 2.** Dendrogram of first two dimensions from multiple correspondence analysis, according to characteristics of Indigenous household food economies. First National Survey of Indigenous Peoples' Health and Nutrition, Brazil, 2008–2009. **d** donation from outside village/community; **i** Indigenous production; **n** Not consumed; **p** Purchase; **REG** Region; **CW** Central-West region; **N** North region; **Ne** Northeast region; **S/Se** South/Southeast region; **b** Beans; **be** Beef, goat, pork, etc.; **c** Chicken, turkey, or duck; **e** Eggs; **fi** Fish; **f** Fruits; **g** Game meat; **m** Maize or products; **ma** Manioc or products; **mi** Milk and products (cheese, etc.); **n** Nuts; **p** Potatoes and tubers; **r** Rice; **v** Vegetables and greens.

Very high frequencies exceeding 90% or more of households in all regions reported customarily consuming purchased foods (Table 1), with the Northeast (99.2%) and South/Southeast (99.1%) presenting the highest values and the North presenting the lowest (91.8%). Elevated frequencies exceeding 70% or more of households in all regions reported customarily consuming garden products or livestock and food derived from household hunting or fishing, with the highest values observed in the North (89.4% and 98.2%, respectively) and the lowest in the Northeast (71.7% and 70.5%, respectively). Majority frequencies of 60% or more were observed in all regions for food obtained by means of household collecting, with the highest value observed in the North (85.4%) and the lowest in the South/Southeast (58.2%). Consistently lower frequencies (under 20% in all regions) were observed for the variables community garden products or livestock; food derived from community hunting, fishing, or collecting; and other donations from outside the village. Staple food donations (*cesta básica*) presented considerable variability, with the highest value observed in the Central-West (88.6%) and the lowest in the North (3.5%).

The distribution of individual food item acquisition varied pronouncedly between regions (Table 2). For example, rice was generally purchased, but was not consumed by 10.4% of households in the North and was predominantly received from outside the village or community (donation) in 38.7% of households in the Central-West. Maize was least consumed in the North (22.5% of households reported not consuming maize) while simultaneously being most frequently acquired through Indigenous production in the South/Southeast (59.9%) and North (56.9%). Although manioc products were substantially acquired through Indigenous production in all regions, only in the North did the value surpass 90%. The North region had the highest proportion of households acquiring these foods through Indigenous production: manioc, potatoes and tubers; fruits; nuts; beef, goat, pork, etc.; fish; and game meat. The Central-West stood out for receiving donations from outside the village or community pronounced proportions of rice, maize, beans, and dairy products. The Northeast and South/Southeast showed elevated rates of purchasing: rice; maize; manioc; potatoes and tubers; beans; fruits; vegetables and greens; dairy products; eggs; poultry; beef, goat, pork, etc.; and fish.

In the multiple correspondence analysis, the first two dimensions explained 68.0% of the total variability (45.6% + 22.4%). Visual inspection of the combined distribution of the first two dimensions (Figures 1 and 2) revealed three distinct profiles of food acquisition in Indigenous households, characterized as follows:

- Acquisition of foods by means of Indigenous production: formed by domiciles in the North region (*REG:N*) that produce domestically many of the consumed foods, as well as other foods that are not consumed, including eggs (*e:n*), maize (*m:n*), vegetables and greens (*v:n*), milk and other dairy products (*mi:n*), and beef, goat, pork, etc. (*be:n*).

- Acquisition of foods by means of purchase: including domiciles in the geopolitical regions Northeast (*REG:Ne*) and South/Southeast (*REG:S*), this profile includes a large proportion of foods obtained by purchase and several other foods, such as game meat (*g:d*), which were obtained by donation from outside the village or community.
- Acquisition of foods by means of donation from outside the village or community: comprised of domiciles in the Central-West region (*REG: CW*) that were distinguished by receiving various foods in pronounced proportions by means of external donations, and not consuming manioc (*ma:n*), game meat (*g:n*), fish (*fi:n*), fruits (*f:n*), potatoes and tubers (*p:n*), and nuts (*n:n*).

## Discussion

### Overview

This paper presents the results of the most extensive study ever carried out in Brazil on Indigenous food economies, as it is based on household data collected by the National Survey, which examined a representative sample of Indigenous women and children in each of the country's geopolitical regions. As we discuss below, the findings derived from the study are closely linked to historical occupation patterns of the territory and expansion of the economic and demographic frontiers of Brazil, marked by the usurpation and dramatic reduction of Indigenous lands, the ramifications of which are still felt by the great majority of the Indigenous population today in a lack of food sovereignty and security.

The distributions of household responses to food acquisition questions shown in [Table 1](#) reveal a general pattern whereby the North region presented comparatively high frequencies of household and community subsistence activities, including horticulture, hunting or fishing, and collecting. In contrast, with few exceptions, the Northeast and South/Southeast regions tended to present lower frequencies of household subsistence activities. Notably, the South/Southeast presented frequencies of community subsistence activities comparable with the North region. Although all regions presented elevated frequencies of purchasing foods, only in the Northeast and South/Southeast did this figure reach approximately 100% of households. Finally, the Central-West stood out for nearly 90% of households reporting receiving staple food donations (*cesta básica*). Other forms of donations from outside the villages were much less frequent for all regions. These patterns help explain the results of the multiple correspondence analysis.

The three regional food acquisition profiles – local Indigenous production, purchased, and external donation – that resulted from multiple correspondence analysis exhibit dramatic contrasts that help make sense of how Brazil's immense socioenvironmental diversity affects Indigenous household food economies. The

most notable pattern is that the Northeast and South/Southeast were most proximal to purchasing certain foods, while the North was grouped with the Indigenous production of many foods, and the Central-West was distinguished by the presence of many foods acquired by donation from outside the village. The similarities between these results and the patterns observed in [Table 1](#) deserve attention given their probable interrelatedness. For example, the association of the North region with Indigenous production of agricultural and wild foods is congruent with the prevalence of household and community subsistence activities in this region. Similarly, the proximity between the Central-West region and foods received by donation is congruent with the pronounced observed prevalence of receiving staple food donations (*cesta básica*).

The proximities of several food response categories in the multiple correspondence analysis results deserve special note. In the first profile, which included the Northeast and South/Southeast, all food response categories were purchased, with one exception. Along with such typical purchased foods as beef, eggs, chicken, milk, rice, and maize, this profile included both purchased and donated game meat. However, the prevalence of households reporting acquiring game meat by purchase or from outside the village/community was extremely low (< 3%), suggesting they were not substantial food items. In the second profile, highlighting the North and foods acquired by Indigenous production, four foods (maize, vegetables, dairy products, and beef) appeared in proximity with one another in different response categories: Indigenous production and not consumed. This apparent contradiction can make sense if one recalls that proximity does not suggest exclusivity. In other words, not consuming these foods and producing them within the household or community were both proximate conditions with the North considering the overall data distribution. In the third profile, the set of foods acquired by external donation were proximate to a set of foods that were not consumed (manioc, game meat, fish, fruits, potatoes and tubers, and nuts). As can be observed in [Table 3](#), these foods were consumed in the Central-West region, but not with the same frequencies as some other regions.

External to all three profiles (and all four regions) were the non-consumption of rice, beans, chicken, and eggs. In other words, in all four regions, these four foods were eaten, whether acquired by Indigenous production, purchase, or external donation. Consistent with the patterns described above, these foods were predominantly reported to have been acquired by Indigenous production in the North, purchase in the Northeast and South/Southeast, and from outside the village/community in the Central-West ([Table 2](#)).

These acquisition profiles should be interpreted in a manner consistent with the methodology employed, which approximates similarities and differences, but does not purport to sketch the comprehensive food economy of each region. Also, proximity between variable response categories and a profile does not suggest that households in a given region do not also acquire foods located at

greater distances. As observed above, the association of a given food and acquisition response category with a geopolitical region reveals proximity but does not imply an exclusive relationship. This interpretive approach permits a reading of patterns while avoiding overly deterministic conclusions. This caveat is especially important because the many of the local food economies analyzed here are hybrid (Altman 2009; Altman, Buchanan, and Biddle 2006), involving Indigenous production, market participation, and government inputs. They are multifaceted economies and Indigenous subsistence systems in transition, which differ substantially from locale to locale. Thus, the proximity of a particular set of foods and response categories to a geopolitical region should be interpreted as the features that most distinguish it from other regional profiles, not necessarily the most prevalent forms of food access in the region.

### **Regional contexts**

The distinguishing feature of the North region documented in this study, characterized by greater consumption of dietary items produced in the context of Indigenous subsistence systems (i.e., Indigenous agriculture, hunting, fishing, and collecting of nondomesticated products) may be explained, at least in part, by the fact that approximately 98% of the area occupied by federally recognized Indigenous reserves in Brazil are located in the Legal Amazon, which includes the entire North region and the northern portion of the Central-West region, as well as the western portion of the state of Maranhão. Additionally, the great majority of Indigenous reserves in this region are much larger than those present in the rest of the country, with much greater access to arable land, water, and plant and animal biodiversity with dietary potential (Clement 2006; Ricardo 2001; Smith 1999). This tendency is due to more recent histories of contact along with late twentieth century public policies more favorable to the recognition of Indigenous land rights and the preservation of larger Indigenous reserves. Considering that access to local Indigenous production systems requires access to landscapes with natural and anthropogenic resources, these historical geographical circumstances are congruent with our finding that the North was grouped in the profile with the Indigenous production of many foods. In other words, the region where Indigenous peoples have the greatest access to land and healthy forest environment was also the most closely associated with food derived from Indigenous subsistence systems. This interpretation finds support in recent studies emphasizing the link between food security and healthy landscapes in other parts of the world (Sunderland 2011; Vinceti et al. 2013).

The other 2% of Indigenous reserves by area are scattered throughout the other major geopolitical regions, with the Northeast and South/Southeast concentrating the smallest and least continuous lands that were the first to be settled by people of European descent. In the central and southern portions

of the Central-West region, where the regional economy is dominated by agribusiness, most Indigenous lands are too small to support their human populations through sustainable subsistence activities, with very low potential for Indigenous production of foods due to lack of space for gardens and reduced biodiversity. Many of these Indigenous reserves are circumscribed by large cattle ranches and farms dominated by soy and sugarcane monoculture with minimal native vegetation cover, limited to small patches dispersed among fields and rangelands, many of which become covered with invasive African grass species when abandoned. These characteristics not only limit the potential for collecting, fishing, and hunting, but also favor the occurrence of destructive and extensive wildfires during the dry season (Welch and Coimbra Jr. 2019).

Regarding the Northeast and South/Southeast regions, which our results showed proximity to a predominance of purchased foods, ethnographic literature recalls the importance of money for attending basic daily food needs of households even in the presence of some subsistence agriculture. For the most part, this money is derived from governmental cash transfer and other social programs, prominent among which are family stipends (*bolsa família*) and retirement pensions. Additionally, some individuals receive pay for work (for example, schoolteachers, community health agents, farm workers, etc.). Especially in touristic areas, money may be earned from the direct sale of crafts to tourists and panhandling. According to observation by Tempass among the Mbyá-Guarani (Tempass 2012, 344), “When a visitor is arriving in a *tekoá* [village], along the way he or she will probably see a child or adolescent going to or returning from the store with bags. Purchases are constant.” This pattern of obtaining food strongly determined by the purchasing power of each family or household suggests a scenario of economic dependence and severe food insecurity, even in the areas considered to be the richest in the country, namely in the South/Southeast states and in some Northeast areas (Gerum and Doppler 2012; Melo 2009; Pacheco and Xavier 2015; Scalco and Rodrigues 2013; Segall-Corrêa et al. 2018).

The State Diagnosis of Sustainable Food and Nutritional Security of the Indigenous Peoples of Minas Gerais State located in the South/Southeast region, carried out in 2009, approximately at the same time as this National Survey, clearly delineated the recurring socioeconomic and environmental scenario in the Indigenous reserves of the South/Southeast and Northeast (Weitzman 2013, 145):

Degradation of lands and the high level of deforestation, attributed to invasion by ranchers and squatters [...], has provoked demand for the use of various supplies and technologies that were not used in agricultural activities [...]. Regarding food habits, growing acquisition of industrialized foods derived from the external market was reported in the greater part of villages.

In the 2000 s, the Central-West region was marked by acute conditions of hunger and mortality of Indigenous children in specific Indigenous reserves and communities. Extreme food insecurity, acute malnutrition, and high infant mortality was experienced by such ethnic groups as the Xavante, Bororo, Terena, Guarani, and Kaiowá, among others (Braga-Neto, Moraes, and Skowronski 2014; Brand and Pícoli 2006; Fávaro et al. 2007). According to research carried out by the Indigenous Missionary Council (Conselho Indigenista Missionário – CIMI) in Guarani and Kaiowá villages in the state of Mato Grosso do Sul (Franceschini 2016, 68),

[...] there is a direct relationship between the hunger of the Indigenous people and the lack of land ownership [...]. In 76% of households, the interviewee stated that in the previous month there were days when the children and young people of the house ate nothing and went to sleep hungry because there was no food in the house.

In turn, the Terena report “[...] participating in the state government’s assistance program, where they receive monthly food baskets. For some families, the foods received are essential and often represent the only source of food” (Lemos et al. 2014).

These events were well publicized nationally and internationally as a public scandal, mobilizing several federal and state public agencies, as well as churches and non-governmental organizations to implement mitigations measures. As a result of this crisis, the Federal Public Ministry determined that the Ministry of Health should implement at the national level a food and nutrition program that prioritized Indigenous children, nursing mothers, and pregnant women in situations of food and nutritional insecurity. The Central-West region was especially targeted due to successive child hunger and death crises documented by academics (M. L. M. Corrêa 2005b; Pícoli, Carandina, and Ribas 2006; Souza and Santos 2001) and journalists (H. Corrêa 2005a; Fernandes 2015; Gonçalves 2016; Moncau and Pimentel 2010) mainly in the states of Mato Grosso and Mato Grosso do Sul. During the years that followed, hundreds of thousands of staple food donations called “basic food baskets” (*cesta básica*) were distributed by the various agencies involved.

Considering the very high prevalence of basic food baskets in the Central-West region (Table 1), this single factor may help explain the strong proximity between this region and food donations from outside villages in the multiple correspondence analysis. It is possible that with changes in public policy regarding these food distributions, this proximity may not continue to the present day.

### **Food sovereignty**

The observed proximities between geopolitical regions and distinct modes of food acquisition speak to regional contrasts in food sovereignty among the

Indigenous population. Given the concept of food sovereignty as involving rights to dietary autonomy, healthy diets, and resource management (Wittman 2011), our data suggest Brazil's North region is the closest of the four regions analyzed to these goals. Not only are many foods in the North region produced at the domestic level through small-scale agriculture and collecting, but this occurs in contexts of comparably larger and less deforested Indigenous reserves, conditions that favor Indigenous landscape management and conservation (Clement 2006; Constantino, Benchimol, and Antunes 2018; Peres 1994; Schwartzman et al. 2013; Welch et al. 2013). Simultaneously, northern households often have less local access to large supermarkets, banks, and other conveniences of external market economies. While this condition limits choice of purchased foods (diversity), it does not meaningfully reduce purchasing as an acquisition strategy (91.8% of households in the North reported purchasing foods).

Food sovereignty in the Northeast and South/Southeast regions is mitigated by the close association between these regions and food purchasing, which derives from access to money or income and proximity to market economy resources, such as employers, banks, and supermarkets. Due to easier access to regional centers, which may be accessed by roadways serviced by local buses and other means of transport, such as bicycles, residents in these regions also have more affordable and consistent access to government services, including those articulating cash transfer programs and other social benefits that contribute to a household's overall income. Greater access to the means of purchasing diverse market foods in these two regions suggests compromised food sovereignty. It implies that dietary options are dominated by the external market economy rather than local and traditional production activities, such as horticulture, fishing, hunting, and gathering. This condition directly increases reliance on industrialized and ultraprocessed foods, and therefore reduces the right to healthy diets. It further suggests that subsistence activities are reduced when compared to the North region and, therefore, that the small Indigenous reserves are not as effectively manageable for conservation and food production.

A similar scenario may be described for the Central-West region, with its disproportionate access to donated foods deriving from "basic food baskets." Our data show that many households in this region continue to produce and extract food locally (for example, 87.3% of households engaged in plant or animal agriculture), and continue to purchase foods (97.9% of households), while also receiving external donations of rice (38.7% of households), maize (23.5%), beans (48.4%), and dairy products (60.8%). Although our study did not capture this information, it is also typical for these food baskets to contain refined sugar, coffee, salt, vegetable cooking oil, pasta, and canned tomato paste, which promote diets rich in fast-acting carbohydrates, sodium, and saturated fats. Such donations, especially with such compositions, directly reduce food sovereignty as they strongly influence dietary choice and, consequently, rights to food autonomy and healthy diets.



Considering all four regions, our data suggest Indigenous households in Brazil engage in what has been described for Aborigines in Australia as a hybrid food economy involving local production, purchasing, and government inputs (Altman 2009; Altman, Buchanan, and Biddle 2006). Thus, independently of observed regional differences, many households engage in all three modes of food acquisition. What our results show is that Brazil's geopolitical regions are dissimilar in their emphases on these three modes, and therefore also in their degrees of food sovereignty.

### **Public policies**

Within the scope of public policies, Brazil has a historical trajectory of combating hunger and malnutrition in children. Over the years, several programs were developed and managed by different government agencies, including specific programs for food supplementation, safe milk banks, school meals, and nutritional surveillance, among others (Leão and Castro 2007). An important advance in this area consists of the National System of Food and Nutritional Security (Sistema Nacional de Segurança Alimentar e Nutricional – SISAN), created by Law 11,346/2006 (Presidency of the Republic 2006), which aims to ensure “[...] everyone’s right to regular and permanent access to quality food, in sufficient quantity [...], based on health-promoting food practices that respect cultural diversity and that are environmentally, culturally, economically, and socially sustainable”. Attention to sociocultural diversity in policy formulation in the sphere of food and nutrition opens up a scenario of diversified initiatives that, theoretically, could meet the multiple demands of Indigenous peoples in Brazil, taking into account the specificities of their food cultures. In 2013, the development of the national food security policy incorporated the concept of food sovereignty, defined as “a crucial principle for the guarantee of food and nutritional security” ensuring the “[...] right of peoples to define policies, with autonomy over what to produce, for whom to produce, and under what conditions to produce” (Machado 2017).

Unfortunately, despite advances in the field of policy formulation and management aimed at ensuring food security for the Brazilian population in general, recent assessments carried out in different Indigenous communities report high frequencies of families in situations of food insecurity, very far from reaching the ideal food sovereignty (Rocha and Liberato 2013; Segall-Corrêa et al. 2018). According to anthropologist Maria Emília Pacheco, former president of the National Council for Food Security in the Ministry of Social Development, it is not possible to talk about food security and sovereignty of Indigenous communities in Brazil without questioning the government’s policy of demarcating and possessing Indigenous peoples’ land in regions that do not always ensure adequate conditions for the physical and cultural survival of the populations (Andrade 2019).

## Final considerations

As if the dilemmas challenging promotion of food sovereignty in the Indigenous population in Brazil were not enough, the governmental situation in the country today represents an important setback. The advance of agribusiness in the Amazon has been a hallmark of the Brazilian government's current environmental policy, directly threatening the survival of Indigenous peoples living in that region. According to a recent editorial published in *The Lancet* journal, “Bolsonaro’s presidency represents the most serious threat to Brazil’s Indigenous population since the 1988 Constitution granted Indigenous people the right to exclusive use of their land” (*The Lancet* 2019). For anthropologists Carino and Diniz (2019, 2241),

The accelerating pillaging of the Amazon rainforest has deadly effects on climate justice and human rights, particularly those of women and girls [...] Diminishing resources such as water and food affect a woman’s ability to care for her family and increase her workload. At the same time, the influx of foreign mining and development companies can have devastating consequences for the human rights of women and girls.

These alarming environmental and Indigenous policies have the potential, if continued, to further transform the food acquisition profile of the North region. They have the potential to transform household economies based significantly in food production and acquisition on Indigenous lands into greater reliance on market-based purchasing as observed in the Northeast and South/Southeast. The potential inequity of this kind of transformation has been appropriately called “ethno-biased poverty” (Begotti and Peres 2019, 592).

## Declaration of interest statement

No conflicts declared.

## Funding

This work was funded by the Wellcome Trust (grant 203486/Z/16/Z) and the Foundation for Scientific and Technological Development in Health (TED/FIOTEC 175/2018, project no. 25380.102279/2018-04). The authors also thank the Brazilian National Council for Scientific and Technological Development (CNPq) for the concession of research fellowships for Welch and Coimbra.

## ORCID

James R. Welch  <http://orcid.org/0000-0002-9094-5491>

Aline Alves Ferreira  <http://orcid.org/0000-0001-5081-3462>

Mirian Carvalho De Souza  <http://orcid.org/0000-0001-7516-1974>

Carlos E. A. Coimbra Jr  <http://orcid.org/0000-0003-4085-1080>

## References

- Altman, J. C. 2009. The hybrid economy and anthropological engagements with policy discourse: A brief reflection 1. *The Australian Journal of Anthropology* 20 (3):318–29. doi:10.1111/j.1757-6547.2009.00039.x.
- Altman, J. C., G. Buchanan, and N. Biddle. 2006. The real ‘real’ economy in remote Australia. In *Assessing the Evidence on Indigenous Socioeconomic Outcomes*, CAEPR Monograph No. 26, ed. B. H. Hunter, 139–52. Canberra: Australian National University (ANU) Press.
- Andrade, L. 2019. *Território e Soberania Alimentar: Desafios para povos Indígenas em São Paulo*. São Paulo: Comissão Pró-Índio de São Paulo.
- Begotti, R. A., and C. A. Peres. 2019. Brazil’s Indigenous lands under threat. *Science* 363 (6427):592. doi:10.1126/science.aaw3864.
- Borges, M. C., R. V. Romina Buffarini, A. M. Santos, J. R. Cardoso, L. G. Welch, E. Carlos, A. Coimbra Jr, and B. L. Horta. 2016. Anemia among Indigenous women in Brazil: Findings from the First National Survey of Indigenous People’s Health and Nutrition. *BMC Women’s Health* 16 (1):7. doi:10.1186/s12905-016-0287-5.
- Braga-Neto, J. A., T. S. Moraes, and L. Skowronski. 2014. Reflexões nutricionais sobre a alimentação dos índios Kaiowa e Guarani de Caarapó-MS: Algumas preparações características. *Tellus* 3 (5):107–20.
- Brand, A. J., and R. P. Pícoli. 2006. Mortalidade infantil entre os Kaiowá e Guarani de Mato Grosso do Sul. In *Povos Indígenas no Brasil: 2001-2005*, ed. B. Ricardo and F. Ricardo, 795–98. São Paulo: Instituto Socioambiental.
- Carino, G., and D. Diniz. 2019. Deforestation and Brazil’s Indigenous Population. *The Lancet* 394 (10216):2241. doi:10.1016/S0140-6736(19)32620-0.
- Carvalho, M. S., and C. J. Struchiner. 1992. Análise de correspondência: Uma aplicação do método à avaliação de serviços de vacinação. *Cadernos De Saúde Pública* 8 (3):287–301. doi:10.1590/S0102-311X1992000300008.
- Clement, C. R. 2006. Fruit trees and the transition to food production in Amazonia. In *Time and Complexity in Historical Ecology: Studies in the Neotropical Lowlands*, ed. W. L. Balée and C. L. Erickson, 165–85. New York: Columbia University Press.
- Coimbra, C. E. A., Jr., and P. C. Basta. 2007. The burden of tuberculosis in Indigenous peoples in Amazonia, Brazil. *Transactions of the Royal Society of Tropical Medicine and Hygiene* 101 (7):635–36. <https://10.1016/j.trstmh.2007.03.013>.
- Coimbra, C. E. A., Jr., R. V. Santos, J. R. Welch, A. M. Cardoso, M. C. Souza, L. Garnelo, E. Rassi, M.-L. Follér, and B. L. Horta. 2013. The First National Survey of Indigenous People’s Health and Nutrition in Brazil: Rationale, methodology, and overview of results. *BMC Public Health* 13 (1):52. doi:10.1186/1471-2458-13-52.
- Coimbra, C. E. A., Jr, F. G. Tavares, A. A. Ferreira, J. R. Welch, B. L. Horta, A. M. Cardoso, and R. V. Santos. 2020. Prevalence of excess weight and obesity and associated factors among Indigenous women: Findings from the First National Survey of Indigenous People’s Health and Nutrition in Brazil. In *Public Health Nutrition*. First view. doi:10.1017/S1368980020000610.
- Constantino, P. A. L., M. Benchimol, and A. P. Antunes. 2018. Designing Indigenous lands in Amazonia: Securing Indigenous rights and wildlife conservation through hunting management. *Land Use Policy* 77:652–60. doi:10.1016/j.landusepol.2018.06.016.
- Corrêa, H. 2005a. Desnutrição também mata 5 crianças Xavantes. *Folha de São Paulo*, March 1, 2005, sec. Brasil. <https://www1.folha.uol.com.br/fsp/brasil/fc0103200519.htm>
- Corrêa, M. L. M. 2005b. *Situação de Alimentação e Nutrição dos Bororo da Terra Indígena Perigara: Perspectivas de Segurança Alimentar*. Masters in Public Health, Cuiabá: Universidade Federal de Mato Grosso.

- Coté, C. 2016. 'Indigenizing' food sovereignty. Revitalizing Indigenous food practices and ecological knowledges in Canada and the United States. *Humanities* 5 (3):57. doi:10.3390/h5030057.
- Damman, S., W. B. Eide, and H. V. Kuhnlein. 2008. Indigenous peoples' nutrition transition in a right to food perspective. *Food Policy* 33 (2):135–55. doi:10.1016/j.foodpol.2007.08.002.
- Delormier, T., and K. Marquis. 2019. Building healthy community relationships through food security and food sovereignty. *Current Developments in Nutrition* 3 (Supplement 2):25–31. doi:10.1093/cdn/nzy088.
- Escobar, A. L., C. E. A. Coimbra Jr., J. R. Welch, B. L. Horta, R. V. Santos, and A. M. Cardoso. 2015. Diarrhea and health inequity among Indigenous children in Brazil: Results from the First National Survey of Indigenous People's Health and Nutrition. *BMC Public Health* 15 (1):191. doi:10.1186/s12889-015-1534-7.
- Fávaro, T., D. L. B. Ribas, J. R. Zorzatto, A. M. Segall-Corrêa, and G. Panigassi. 2007. Segurança alimentar em famílias indígenas Teréna, Mato Grosso do Sul, Brasil. *Cadernos De Saúde Pública* 23 (4):785–93. doi:10.1590/S0102-311X2007000400006.
- Fernandes, S. 2015. Cercada por latifúndios, população Xavante resiste, mas exige políticas públicas. *Rede Brasil Atual*, January 18, 2015.
- Franceschini, T. 2016. *O Direito Humano à Alimentação Adequada e à Nutrição do Povo Guarani e Kaiowá: Um Enfoque Holístico*. Brasília: FIAN Brasil and Conselho Indigenista Missionário (CIMI).
- Gerum, Á. F. A., and W. Doppler. 2012. Distribuição da terra, renda familiar e uso dos recursos produtivos: O caso Fulni-ô. In *Cultura, Identidade e Território no Nordeste Indígena: Os Fulni-ô*, ed. P. Schröder, 165–85. Recife: Editora da Universidade Federal de Pernambuco.
- Gonçalves, J. 2016. Pesquisa Aponta Que Falta de Território Causa Desnutrição de Indígenas Guarani Kaiowá. *Brasil de Fato*, August 17, 2016. <https://www.brasildefato.com.br/2016/08/17/pesquisa-aponta-que-falta-de-territorio-causa-desnutricao-de-indios-guarani-kaiowa/>.
- Greenacre, M. J., and J. Blasius. 2006. *Multiple Correspondence Analysis and Related Methods*. Boca Raton: Chapman & Hall/CRC.
- Grey, S., and R. Patel. 2015. Food sovereignty as decolonization: Some contributions from indigenous movements to food system and development politics. *Agriculture and Human Values* 32 (3):431–44. doi:10.1007/s10460-014-9548-9.
- Horta, B. L., R. V. Santos, J. R. Welch, A. M. Cardoso, J. V. Dos Santos, M. O. A. Ana, P. C. I. Lira, and C. E. A. Coimbra Jr. 2013. Nutritional status of Indigenous children: Findings from the First National Survey of Indigenous Peoples Health and Nutrition in Brazil. *International Journal of Equity in Health* 12 (1):23. doi:10.1186/1475-9276-12-23.
- IBM Corp. 2012. *IBM SPSS Statistics for Windows, Version 21.0*. Armonk, NY: IBM Corp.
- Jarosz, L. 2014. Comparing food security and food sovereignty discourses. *Dialogues in Human Geography* 4 (2):168–81. doi:10.1177/2043820614537161.
- Lancet, T. 2019. Bolsonaro Threatens Survival of Brazil's Indigenous Population. *The Lancet* 394 (10197):444. doi:10.1016/S0140-6736(19)31801-X.
- Leandro-Reguillo, P., R. Thomson-Luque, W. M. Monteiro, and M. V. G. Lacerda. 2015. Urban and architectural risk factors for malaria in Indigenous Amazonian settlements in Brazil: A typological analysis. *Malaria Journal* 14 (1):284. doi:10.1186/s12936-015-0806-0.
- Leão, M. M., and I. R. R. Castro. 2007. Políticas públicas de alimentação e nutrição. In *Epidemiologia Nutricional*, ed. G. Kac, R. Sichieri, and D. P. Gigante, 519–41. Rio de Janeiro: Editora Fiocruz.
- Leite, M. S., A. M. Cardoso, C. E. A. Coimbra Jr, J. R. Welch, S. A. Gugelmin, P. C. I. Lira, B. L. Horta, R. V. Santos, and A. L. Escobar. 2013. Prevalence of anemia and associated factors among Indigenous children in Brazil: Results from the First National Survey of Indigenous People's Health and Nutrition. *Nutrition Journal* 12 (1):69. doi:10.1186/1475-2891-12-69.

- Lemos, E. F., D. L. B. Ribas, M. C. B. Pessoa, and M. H. V. B. Concone. 2014. Cozinha Terena: Novas práticas alimentares em tempos de mudança. *Espaço Ameríndio* 8 (2):87. doi:10.22456/1982-6524.48897.
- Machado, R. L. A. 2017. Conceitos: Segurança Alimentar e Nutricional e Soberania Alimentar. In Conselho Nacional de Segurança Alimentar e Nutricional. 29, 2017. <http://www4.planalto.gov.br/consea/ acesso-a-informacao/institucional/conceitos>.
- Maechler, M., P. Rousseeuw, A. Struyf, M. Hubert, and K. Hornik. 2019. *Cluster: Cluster Analysis Basics and Extensions. R Package Version 2.1.0*. <https://cran.r-project.org/web/packages/cluster/>.
- Melo, Maria, O. 2009. *Situação de (in)Segurança Alimentar e Nutricional em Índios Karapotó da Aldeia Plak-ô em São Sebastião, Estado de Alagoas*. Masters thesis in Nutrition, Maceió: Universidade Federal de Alagoas.
- Moncau, J., and S. Pimentel. 2010. O genocídio surreal dos Guarani-Kaiowá. *Povos Indígenas no Brasil*, October 13, 2010, sec. Notícias. <https://pib.socioambiental.org/pt/Not%c3%adcias?id=93465>.
- Pacheco, S. Q. M., and K. O. Xavier. 2015. Food practices of the Kariri-Xocó Indigenous group from Lauro de Freitas-BA: Sustainability and challenges in times of change. *Demetra: Alimentação, Nutrição & Saúde* 10 (3):649–62. doi:10.12957/demetra.2015.16082.
- Patel, R. 2009. Food sovereignty. *The Journal of Peasant Studies* 36 (3):663–706. doi:10.1080/03066150903143079.
- Peres, C. A. 1994. Indigenous reserves and nature conservation in Amazonian forests. *Conservation Biology* 8 (2):586–88. doi:10.1046/j.1523-1739.1994.08020586.x.
- Pícoli, R. P., L. Carandina, and D. L. B. Ribas. 2006. Saúde materno-infantil e nutrição de crianças Kaiowá e Guaraní, Área Indígena de Caarapó, Mato Grosso do Sul, Brasil. *Cadernos De Saúde Pública* 22 (1):223–27. doi:10.1590/S0102-311X2006000100025.
- Power, E. M. 2008. Conceptualizing food security for Aboriginal people in Canada. *Canadian Journal of Public Health* 99 (2):95–97. doi:10.1007/BF03405452.
- Presidency of the Republic. 2006. *Lei Nº 11.346, de 15 de Setembro de 2006*. [http://www.planalto.gov.br/ccivil\\_03/\\_Ato2004-2006/2006/Lei/L11346.htm#art3](http://www.planalto.gov.br/ccivil_03/_Ato2004-2006/2006/Lei/L11346.htm#art3).
- Presidency of the Republic. 2010. *Decreto Nº 7.272, de 25 de Agosto de 2010*. [http://www.planalto.gov.br/ccivil\\_03/\\_Ato2007-2010/2010/Decreto/D7272.htm](http://www.planalto.gov.br/ccivil_03/_Ato2007-2010/2010/Decreto/D7272.htm)
- R Core Team. 2007. *R: A Language and Environment for Statistical Computing*. Vienna, Austria: R Foundation for Statistical Computing. <https://www.R-project.org>.
- Ricardo, B. 2001. A sociodiversidade nativa ontemporânea No brasil e a biodiversidade na Amazônia. In *Biodiversidade na Amazônia Brasileira: Avaliação e Ações Prioritárias para a Conservação, Uso Sustentável e Repartição de Benefícios*, ed. J. P. R. Capobianco, A. Veríssimo, A. Moreira, D. Sawyer, I. Santos, and L. P. Pinto, 194–204. São Paulo: Estação Liberdade and Instituto Socioambiental.
- Rocha, C., and R. S. Liberato. 2013. Food sovereignty for cultural food security: The case of an Indigenous community in Brazil. *Food, Culture & Society* 16 (4):589–602. doi:10.2752/175174413X13673466712047.
- Scalco, N., and E. Rodrigues. 2013. Changes in the acquisition and consumption of food plants and their relationship with Indigenous perceptions of health in a Guarani village, São Paulo, Brazil. *Public Health Nutrition* 16 (10):1820–26. doi:10.1017/S136898001200434X.
- Schwartzman, S., A. Villas-Boas, K. Y. Ono, M. G. Fonseca, J. Doblas, B. Zimmerman, P. Junqueira, A. Jerolimski, M. Salazar, R. P. Junqueira, et al. 2013. The natural and social history of the Indigenous lands and protected areas corridor of the Xingu River basin. *Philosophical Transactions of the Royal Society B: Biological Sciences* 368 (1619):20120164. doi:10.1098/rstb.2012.0164.

- Segall-Corrêa, A. M., L. Marín-Leon, M. M. A. Azevedo, M. B. R. Ferreira, D. R. Gruppi, D. F. M. Camargo, R. P. T. Vianna, and P.-E. Rafael. 2018. The Brazilian food security scale for Indigenous Guarani households: Development and validation. *Food Security* 10 (6):1547–59. doi:10.1007/s12571-018-0847-7.
- Smith, N. J. H. 1999. *The Amazon River Forest: A Natural History of Plants, Animals, and People*. New York: Oxford University Press.
- Souza, L. G., and R. V. Santos. 2001. Perfil demográfico da população Indígena Xavante de Sangradouro-Volta Grande, Mato Grosso (1993-1997), Brasil. *Cadernos De Saúde Pública* 17 (2):355–65. doi:10.1590/S0102-311X2001000200010.
- Sunderland, T. C. H. 2011. Food security: Why is biodiversity important? *The International Forestry Review* 13 (3):265–74. doi:10.1505/146554811798293908.
- Tempass, M. C. 2012. *A Doce Cosmologia Mbyá-Guarani: Uma Etnografia de Saberes e Sabores*. Curitiba: Editora Appris.
- Vinceti, B., C. Termote, A. Ickowitz, B. Powell, K. Kehlenbeck, and D. Hunter. 2013. The contribution of forests and trees to sustainable diets. *Sustainability* 5 (11):4797–824. doi:10.3390/su5114797.
- Walker, R. S., L. Sattenspiel, and K. R. Hill. 2015. Mortality from contact-related epidemics among Indigenous populations in Greater Amazonia. *Scientific Reports* 5 (1):14032. doi:10.1038/srep14032.
- Weiler, A. M., C. Hergesheimer, B. Brisbois, H. Wittman, A. Yassi, and J. M. Spiegel. 2015. Food sovereignty, food security and health equity: A meta-narrative mapping exercise. *Health Policy and Planning* 30 (8):1078–92. doi:10.1093/heapol/czu109.
- Weitzman, R. 2013. As práticas alimentares ‘tradicionais’ no contexto dos povos indígenas de Minas Gerais. *Estudos Sociedade E Agricultura* 21 (1):140–59. <https://revistaesa.com/ojs/index.php/esa/article/view/362>.
- Welch, J. R., E. S. Brondízio, S. S. Hetrick, and C. E. A. Coimbra Jr. 2013. Indigenous burning as conservation practice: Neotropical savanna recovery amid agribusiness deforestation in Central Brazil. *Plos One* 8 (12):e81226. doi:10.1371/journal.pone.0081226.
- Welch, J. R., and C. E. A. Coimbra Jr. 2019. Indigenous fire ecologies, restoration, and territorial sovereignty in the Brazilian Cerrado: The case of two Xavante Reserves. *Land Use Policy* (October):104055. doi:10.1016/j.landusepol.2019.104055.
- Wittman, H. 2010. reconnecting agriculture and the environment: Food sovereignty and the agrarian basis of ecological citizenship. In *Food Sovereignty. Reconnecting Food, Nature and Community*, ed. -A.-A. Desmarais, N. Wiebe, and H. Wittman, 91–105. Vancouver: Fernwood Publishing.
- Wittman, H. 2011. Food sovereignty: A new rights framework for food and nature? *Environment and Society* 2 (1):87–105. doi:10.3167/ares.2011.020106.