

The Islamic university – Gaza
Graduate studies deanery
College of education
Curricula and English teaching
Methods department



**The Effect Of Using Concept Maps On Achieving
English Grammar Among Ninth Graders
In Gaza Governorate**

Thesis

Submitted by
Mazen Khalil Abu Nada

Supervised by
Dr . Awad Soliman Keshta

Thesis submitted to the curricula and English teaching methods department
Faculty of education in partial fulfilment of the
requirement for master degree of education

June 2008

DEDICATION

To all who carried the candles to light my way

To my parents my sisters

To my wife my sons and daughters

To my uncle Muhanna

ACKNOWLEDGMENT

IN THE NAME OF ALLAH , THE MOST GRACIOUS , THE MOST MERCIFUL .

All thanks for Allah , the one to whom all dignity , honor and glory are due , the Unique with perfect attributes , who begets not , nor is he begotten . He has no equal but he is Almighty and Omnipotent ,Peace and blessing of Allah be upon all the prophets and messengers , especially on Mohammed , the last of the prophets and on all who follow him in righteousness until the Day Of Judgment .All praise to Allah for enabling me to write t his research . As prophet Mohammed , peace be upon him , said " he who is thankless to people , is thankless to God " .

All appreciation to those kindness , patience and support who lit the candles that enlightened my way towards success .

My appreciation and respect first must go to my parents whose prayers guided , helped and supported me to carry out this work .

My gratitude is deeply paid to my advisor , Dr Awad Keshta for his generosity , guidance and advice . Of course especial thanks to Dr Mo hamed Hamdan and Dr Ezzo Affana for accepting to discuss this study .

Special thanks are due to the Islamic University and its staff for all the facilities , help and advice they offered .

My gratitude is deeply paid to my family , especially my wife who endured a lot during my research , and whose love , affection and supplications stimulated me to complete this work .

" The Effect Of Using Concept Maps On achieving English Grammar Among Ninth Graders
In Gaza Governorate "

ABSTRACT

The study aimed to investigate the effect of using concept maps on achieving English grammar among the ninth graders in Gaza governorate. For answering the questions of the study , the researcher adopted the experimental approach . The sample of the study consisted of (113) male students from AL-Zaitun prep (A) school . The concept maps strategy was used in teaching the experimental group , while the traditional method was used with the control one in the first term of the school year (2007 – 2008) . An achievement test of five scopes with (49) items was designed and validated to be used as a pre and post test .

The data of the study were analyzed , using (T – test) and Mann Whitney test pre- post test was used to identify the direction of the effect. Effect size technique was used to measure the effect size of concept maps strategy on the experimental group in each scope of the test .The study indicated that there are statistically significant differences in the ninth grades' achievement of English grammar due to the method in favor of concept maps strategy .

Based on those findings , the study recommended the necessity of implementing concept maps strategy in teaching English grammar to bring about better outcomes in students' achievement of English grammar .It also was suggested that further researches should be conducted on the effect of concept maps on different dimensions of achieving English language and other school subjects .

ملخص الدراسة

لقد هدفت الدراسة إلى التعرف على أثر استخدام خرائط المفاهيم على : قواعد اللغة الانجليزية لدى طلبة الصف التاسع الإعدادي في محافظات غزة .

و للإجابة عن أسئلة الدراسة، استخدم الباحث المنهج التجريبي، حيث توزعت عينة الدراسة و التي تكونت من (113) طالبا من مدرسة الزيتون الإعدادية (أ) إلى مجموعتين (ضابطة و تجريبية) . و استخدمت إستراتيجية خرائط المفاهيم في تدريس المجموعة التجريبية بينما استخدمت الطريقة التقليدية في تدريس المجموعة الضابطة و ذلك في الفصل الدراسي الأول من العام (2007 - 2008) . و لقد قام الباحث ببناء اختبار تحصيلي مكون من (49) سؤال ، و لقد تم تحليل نتائج الدراسة باستخدام (اختبار ت) و (اختبار مان و وتي) بالإضافة إلى معادلة حجم الأثر و ذلك لقياس حجم اثر خرائط المفاهيم على المهارات المختلفة في قواعد اللغة الانجليزية . و خلصت الدراسة إلى وجود فروق ذات دلالة إحصائية بين المجموعة التجريبية و المجموعة الضابطة تعزى إلى طريقة التدريس لصالح إستراة خرائط المفاهيم.

هذا و قد أوصت الدراسة بضرورة استخدام إستراتيجية خرائط المفاهيم في :
قواعد اللغة الإنجليزية ، لتحقيق نتائج أفضل في تحصيل الطلبة و اقترح الباحث ضرورة
إجراء المزيد من الدراسات للتعرف على اثر خرائط المفاهيم على الجوانب المختلفة في
اللغة ا تجليزية و غيرها من المواد الدراسية .

TABLE OF CONTENTS

DEDICATION.....	I
ACKNOWLEDGMENT	II
ABSTRACT IN ENGLISH	IV
ABSTRACT IN ARABIC	VI
TABLE OF CONTENTS	VII
LIST OF APPENDICES.....	X
LIST OF TABLES	XI

Chapter page

I. INTRODUCTION

1.1 Study statement and background	1
1.2 Statement of problem.....	4
1.3 Research questions.....	5
1.4 Research hypotheses.....	6
1.5 The purpose of the study.....	6
1.6 The significance of the study.....	7
1.7 Definitions of variables and operational terms.....	7

II. LITERATURE REVIEW

2.1 Learning and acquisition	9
2.1.1 Definition of learning	10
2.1.2 Language acquisition.....	11
2.1.3 The conditions of learning	13
2.1.4 The principles of learning	14
2.1.5 The benefits of learning	15
2.1.6 Effective learning	16
2.1.7 Language learning process	17
2.1.8 Learning strategies	19
2.2 Grammar.....	22
2.2.1 Definitions of the term grammar	22
2.2.2 What is grammar.....	26
2.2.3 Why study grammar	29
2.2.4 The uses of grammar	30
2.2.5 Grammar and written language	31
2.2.6 Grammar and spoken language	32
2.2.7 Grammar and communication	33
2.2.8 Types of Grammar.....	34
2.2.9 Grammar and language	38
2.2.10 Teaching Grammar	46

2.2.11 Attitudes to Grammar	47
2.3 Concept maps.....	59
2.3.1 What are concept maps	59
2.3.2 Definitions of concept maps	60
2.3.3 Basic principles of concept maps	62
2.3.4 The uses of concept maps	63
2.3.5 Reasons of using concept maps	66
2.3.6 Concept maps in the Holly Quran.....	68
2.4 Related studies concerning using concept maps in achievement.....	70
2.5 Related studies concerning using concept maps in teaching and learning.....	80
2.6 Commentary on the previous studies	92

III METHODOLOGY

Introduction

3.1 Research design	96
3.2 The population of study	96
3.3 The sample of study	96
3.4 The variables of study.....	97
3.5 Instrumentation.....	98
3.6 the pilot study	100

III	METHODOLOGY (continued)	
	3.7 The validity of the study.....	100
	3.8 Controlling the variables.....	106
	3.9 The statistical analysis	113
	3.10 Limitations of the study	113
	3.11 Data collection procedures	114

IV DATA ANALYSIS

Introduction

4.1 Data analysis.....	115
------------------------	-----

V FINDINGS , DISCUSSION , CONCLUSION AND RECOMMENDATIONS

Summary.....	124
--------------	-----

5.1 Findings.....	125
-------------------	-----

5.2 Discussion	125
----------------------	-----

5.3 Conclusion.....	129
---------------------	-----

5.4 Recommendations	130
---------------------------	-----

References	133
------------------	-----

LIST OF APPENDIX

APPENDIX (A) TOOLS OF THE STUDY	152
APPENDIX (A .1) The general objectives of the content	153
APPENDIX (A . 2) The content analysis.....	155
APPENDIX (A . 3) Test specification.....	156
APPENDIX (A . 4) Achievement test.....	157
APPENDIX (A . 5) Difficulty coefficient of the test items	171
APPENDIX (A . 6) Discrimination coefficient of the test items	172
APPENDIX (A . 7) Correlation coefficient of the test items	173
APPENDIX (B) Concept Maps	176
APPENDIX (B.1)Suggested lesson plan for teaching concept maps ...	177
APPENDIX (B.2) Trained concept maps	180
APPENDIX (C) Concept map in the Holy Quran.....	186
APPENDIX (D).....	188
APPENDIX (D.1)Referee Committee.....	189

LIST OF TABELS

Table	page
1- The distribution of the sample according to the groups	97
2- Correlation coefficient of the scopes of the test	101
3- Reliability coefficient by Alpha Cronbach technique	102
4- Reliability coefficient by Split-half technique	102
5- T- test result of controlling age variable	107
6- Mann and Whitney test result of controlling age variable	107
7- T-test result of controlling general achievement variable	108
8- Mann and Whitney test result of controlling English achievement variable	108
9- T-test result of controlling general achievement in English variable.....	109
10- Mann and Whitney test results of controlling general achievement variable	109
11- T-test result of controlling pre test in English variable ...	110
12- T-test results of controlling pre test in English variable	110
13- Mann and Whitney test result of controlling pre test in English variable according to Bloom levels	111

LIST OF TABLES (continued)

Table	page
14- Mann and Whitney test result of controlling pre test in English variable	112
15- T-test result of differences between experimental and control groups in the Bloom level	116
16-The table referee to determine the level of size effect (η^2) and (d)..	117
17- "T" value, Eta square " η^2 ", and "d" for each scope and the total degree	117
18- T.test results of differences between experimental and control groups in contents of the test.....	118
19- "t" value, Eta square " η^2 ", and "d" for each scope and the total degree	118
20- Mann-Whitney U test of differences of learning in English variable.....	119
21- Mann-Whitney U of differences of achieving in English variable.....	120
22- Mann-Whitney U of differences of achieving in English variable.....	121
23- Mann-Whitney U of differences of achieving in English variable.....	122

LIST OF TABELS (continued)

Table	page
24- The table of specification	156
25- Difficulty coefficient for each items of the test	171
26- Discrimination coefficient for each items of the test	172
27- Correlation coefficient of knowledge items	173
28- Correlation coefficient of comprehension items	174
29- Correlation coefficient of applying items	175
30- Correlation coefficient of analyzing items	175

I

INTRODUCTION

1.1 Study statement and background

Language is one of the main features that human being is characterized with , so it is a social as well as an individual phenomenon that enables man to express his feelings , thoughts and culture . In the age of globalization where the world has become a small vill age , people tend to learn each others languages . The demand for learning English language increased , however the history of teaching and learning foreign languages often appears to have been a history of failure (Kara : 1992 ; 9-21).Though many theories, studies and researches tackled th is issue , each tried to provide teachers and learners with better way of learning foreign languages (Lewis and Hill :1995 ;22)

English being the most wide spread language becomes an issue of interest that increases rapidly . In Palestine we can find different centers for teaching English , some of them are foreign and they provide programs for English language in almost every centre ,to increase its possibility of dissemination . Also the governments in the Middle East including the Palestinian Authority provide programs for English language in every educational place (Keshta : 2000 ; 4) .Realizing the importance of English, the Palestinian Authority began its project of teaching English

from the first elementary class , but in fact we can notice the low level of our learners achievement in English language (Hamad : 2005 ; 3) . The researcher , being an English teacher , noticed this problem , such a problem may relate to curriculum , materialistic resources , evaluation, instruments and strategies used in the teaching-learning process .New authentic technique may contribute in solving this problem .

Palmer (1971 : 7) believes grammar is being taught in the schools from early ages , many learners think that grammar is a boring school subject and children usually spared the boredom because the teaching of grammar in schools depends on teaching the rules . Kohli (1999 : 138) sees that grammar is the subject of criticism , because there is no correlation between teaching grammar and learners improvement in writing English , Teachers also were criticized because of the ways , techniques or methods that they use in teaching grammar . Lewis (1986 : 18) sees that teachers of foreign languages usually commit a mistake when they think that the most important part of their job is to explain the rules of grammar .

Fromkin and Rodman (1993 :13) claim human being who speaks a language knows its grammar , and knowing the grammar of the target language will help you as a communicator to communicate easily with

others, so knowledge of grammar enhances communication which is the ultimate goal of teaching any language .

The researcher sees that learning grammar is the most difficult skill rather than any other skill of English language, this is why teachers have different perceptions of the term grammar which will later affect the learners attitudes in learning . Some of the teachers look at the grammar as the rules that govern the language (Brinto : 2000 ; 8) . Others see it is either an instrument of judgment on the validity of the learners' speech and writing or to what we can find in the students books written down or learnt by heart (Palmer :1995 ; 2) .

Leou and Liu (2004) suggested that learning can be enhanced if the learning involves interaction , student-centred and engaging activities when learners construct their understanding rather than more traditional methods of teacher-centred direct instruction in order to make learning organised and meaningful . Based on the constructive learning theory whose main principle is that new knowledge should be integrated into existing structures in order to be remembered and receive meaning , concept maps stimulates this process by making it explicit and requiring the learner to pay attention to the relationship between concepts (Fitzgeraled:1999 ;153) . So concept maps became more prevalent in educational programme ,

Instruction begins to explore ways to utilize them more effectively to facilitate student learning (Love : 2004 ; 17).

Elorriaga (2006 : 12) says that in recent years it has become apparent to many educational researchers that representing knowledge in a visual format allows one to better recognize and understand incoming information. It is easier for the brain to interpret data when information is presented in visual formats; visual symbols are quickly and easily recognized . Fonseca (2004 ; 122) indicates that concept maps is a tool of meaningful learning , because it identifies the important concept from a subject and describes the relationship between those concepts within linking words .

The researcher is trying to examine the effect of using concept maps strategy for achieving English grammar to help learners to achieve English grammar easily and to tune the teachers attention to the importance of using concept maps strategy in teaching grammar .

1.2 Statement of the problem :

In the age of globalization where the world has become a small village , especially in age of the satellites , technology , information and internet , the demand of learning English increased and it became a necessary need for individuals who tend to follow up the vast changes in this world . However, learning English grammar is not an easy job for the majority of

our students , especially within our schools limited possibilities . A lot of obstacles such as crowded classes , difficult curricula and traditional evaluation instruments force teachers to modify or even change their techniques to overcome these obstacles towards the targeted objectives . The students low achievement level in English language in general and its grammar in particular requires a serious research for alternative techniques that may improve our students' level .

The purpose of this study is to investigate the effect of using concept maps on achieving English grammar among ninth graders in Gaza governorate .

1.3 Research Question :

The problem is stated in the following major question

What is the effect of using concept maps on achieving English grammar among ninth graders in Gaza govern orate ?

The minor questions :

1) Are there statistically significant differences at (0.05) between achieving English grammar by using concept maps between the experimental group and achieving English grammar by the traditional method in the control one ?

2) Are there statistically significant differences at (0.05) in achieving English grammar between high achievers in the experimental group and their counterparts in the control one ?

3) Are there statistically significant differences at (0.05) in achieving English grammar between low achievers in the experimental group and their counterparts in the control one ?

1.4 Research hypotheses :

1) There are no statistically significant differences at (0.05) between achieving English grammar by using concept maps in the experimental group and achieving English grammar by the traditional method in the control one .

2) There are no statistically significant differences at (0.05) in achieving English grammar between high achievers in the experimental group and their counterparts in the control one .

3) There are no statistically significant differences at (0.05) in achieving English grammar between low achievers in the experimental group and their counterparts in the control one .

1.5 The purpose of the study :

The study aimed to achieving the following objectives

1- Identifying the effect of using concept maps on achieving grammar among ninth graders in Gaza governorate .

2- Familiarizing English language teachers with the basic principles of designing , and using concept maps in teaching English grammar .

3- Measuring the changes in ninth graders in achieving grammar as a result of using concept maps .

1.6 The significance of the study :

The study may benefit

The teachers :-

The study may help English language teachers organize effective teaching-learning environment in the light of implementing concept maps .

The supervisors :-

The study stimulate specialists' and supervisors' interests in conducting training courses for their teachers to enhance the use of concept maps in teaching grammar .

Syllabus designers :-

They may benefit from this study to modify , organize and enrich English language curricula with activities based on concept maps .

1.7 Definition of variables and operational terms :

1) **Concept Maps :-** Is an educational strategy which has different shapes and it is arranged hierarchically with the super ordinate concept at the top and subordinate at the bottom , and there are some links among concepts to represent the relationships between the concepts .

- 2) **English grammar** :- is a set of rules which govern the language , these rules organize and fit words together to help learners to use the language correctly and accurately .
- 3) **Traditional method** :- It is a conventional method used by teachers in Gaza . It is a teacher centered method , where the teacher is the main source of teaching and demonstrates the scene while learners are passive recipients .
- 4) **Achievement** :- it is information , experience and skills of English language introduced in curriculum and acquired by the learner during a certain period . achievement is measured by the marks the learner gets in the examination .
- 5) **Effect** :- The degree of improvements in the students achievement level in English grammar as a result of learning English grammar .
- 6) **High achievers** :- students whose total score on the achievement test lies among the highest 25% of other students score .
- 7) **Lower achievers** :- students whose total score on the achievement test lies among the lowest 25% of other students score .
- 8) **Statistical style** :- it refers to the analysis that the researcher is going to use to measure the differences between groups

II

LITRETURE REVIEW

2.1 Learning and acquiring

Introduction

Language is one of the most important things that we can give to our children . Some people feel that there is a strong relation between learning and acquisition (Stevick : 1982 ;21) , but others find it is difficult to differentiate between acquisition and learning . The term learning is related to the conscious process of accumulating knowledge of the vocabulary and grammar of language (Yule :1996 ;191) .

Wikipedia (2008) sees that learning is the acquisition and development of memories and behaviours , including skills , knowledge , understanding , values and wisdom , and it is the product of experience and the goal of education .Smith (1994 : 11) believes that acquisition is associated with the informal models of learning .

Learning was used in two ways first to describe the mental activities that are involved when we acquire new meanings for stimuli , and the second use refers to situations in which we developed (Gordon : 1989 ; 5) . AL- Aza (2002 : 12) stated that learning is a dynamic continuous process . It may happen inside or outside the classroom (Knight and Lindsay : 2006 ; 3) ,

So that it is necessary to know how learners learn the language and to prepare suitable situations and environment for learners to have an effective learning , in these situations learners should feel secure . Security is needed in the classroom , it helps learners to learn more effectively (Kristmanson : 2000 , 1-5) .

2.2 Definition of learning :

The word **learning** covers a range of different meaning for people , Harlen (2006 : 3) says that there are two views of what learning means .

- 1- Adding more knowledge and skills as a result of being taught .
- 2- Making sense of new experience by learners themselves, in collaboration with others .

Carnell and Lodge (2002 : 8) added some views to what it means

- 3- Memorizing and reproducing
- 4- Applying facts or procedures .
- 5- Understanding .
- 6- Changing as a person .

From these views different definitions were given to the term learning . We can notice that most of these definitions concentrated on the changes that happen with the learners' behaviour as a result of experience .

Catania (1992 : 1) believes that learning can be defined as a relatively permanent change in behaviour resulting from experience .

Abed AL – Khalek (2001 : 20) sees that learning is an intended process which aims to make a relatively permanent change in the learners' behaviour as a result of experience .

Seidel et .al (2005 : 12) think learning is a relatively permanent change in behavioural tendency ... based on ... reinforcement practice .

Sluckin (1972 : 101) maintains learning refers to the relatively lasting changes in behaviour resulting from practice .

2.3 Language acquisition :

Language with all its complexity is one of the most greatest gifts that we can give to our learners , Wikipedia (2008) says that language acquisition is the process by which the language capability develops in a human , first language acquisition concerned with development of language in children , while second language acquisition focuses on language development in adults , so language acquisition is a product of exposure to the natural language .

Wilkins (1974 : 26) maintains the term language acquisition refers to the process where a language is acquired as a result of natural and largely random exposure to language . Yule (1996 : 191) assumes acquisition refers to the gradual development of ability in a language by using it naturally in communicative situations .

Bruce (2006 : 18) sees that language acquisition is a product of active and repetitive and complex learning , "So the two processes are essentially related to each other but in fact they are essentially different " (Garcia : 2003 ; 35) .

Stevick (1982 : 21-23) believes that the term acquisition used for the former and learning for what goes in the classroom . In acquisition , the person who is doing the acquiring meets words in the full context of some kind of genuine human communication , there is no special presentation of new item , no organised drilling and no testing in the academic sense , so language acquisition has some advantages

- 1- What has been acquired is relatively permanent .
- 2- What has been acquired serves directly as the basis for smooth production either of speech or for writing .
- 3- Children can use what they acquired such as grammar , definite and indefinite article , choice of the right preposition or verb tenses in their real life communication correctly .

2.4 What are the difference between learning and acquisition :

Garcia (2003 : 35) mentioned some certain differences between learning and acquisition

- 1- Learning occurs in formal situations , while acquisition occurs in informal situations.

- 2- Learning is the product of direct teaching , but acquisition is the result from trying to communicate .
- 3- Learning involve learning rules while acquisition involves learning for real purpose .
- 4- Learning can be tasted , while acquisition can be used .
- 5- Learning is a conscious process , while acquisition is sub -conscious .

Oxford (1990 : 4) suggested that learning can't contribute to acquisition , that to mean conscious gains in knowledge can't influence subconscious development of language . Moreover, some elements of language use are at first conscious and then become unconscious or automatic through practice.

2.5 The conditions of learning :

Abu AL Hijah (2001 : 18 – 20)believes that learning refers to the changes that happen in the human behaviour every minute , and it is a result of the teaching process which would happen through the positive interaction between the teacher and the learner .

Abed AL Khalek (2001 : 26 – 28) mentioned three main conditions for the effective learning .

1. Maturity : - which refers to the internal changes that happen with creatures . These changes include the change s in the organs .

2. Practice :- it means the training on the material that they learnt to be able to implement and use later in different situations .
3. Motivation :- motivation is an important factor in successful learning .
The student how is highly motivated can achieve greater success than the more intelligent students who is not well motivated
(Reece and Walker : 2003 ; 78) .

2.6 The principles of learning :

Many different principles of learning were devised by researchers , but in general many of these principles apply to learning and teaching , but clearly some are especial for learning . The American Association for the Advancement of Science (AAAS) (1990) determined the principles of learning .

1. Learning is not necessarily an outcome of teaching .
2. What learners learn is influenced by their existing ideas .
3. Progression in learning is usually from the concrete to the abstract .
4. Effective learning by students require s feedback .
5. Expectations affect performance .

Novicki (1996 : 145) added some other principles

6. Learning needs an environment that supports it .
7. Learning by doing is more powerful than memorising . (you hear , you forget . you see ,you remember . you do, you understand)

8. Some times the best learning is unlearning .

9. Learning is fundamentally social.

2.7 The benefits of learning :

Every learner has his own purpose of learning , some of them learn to add more knowledge , others learn to work and to earn money , so people don't learn things unless there is a purpose to learning especially in the work context .

Different people seek different benefits (Mumford : 1999 ; 187) . Carnell and Lodge (2006 : 10) mentioned that recently United Nations Educational Scientific And Cultural Organisation (UNESCO) stressed the need for every one to learn for four purposes .

1) learning to know :

Everyone needs to know how to deal with different situations in his life especially in the future , learners need to know how to find , evaluate , sort and correct informal learning to make improvement in their knowledge and to the new areas of skill (Mumford : 1999 ; 188) .

2) learning to do :-

learners may find that it is not easy to respond to changes that have already occurred , but that they need to anticipate further needs . So learning means to manage the changes and to develop the skills for self-directed learning .

3) Learning to live together :-

Stiles (2000 : 17) sees that learning is a social process , so people need learning to live together and to equip them to live in uneasily complex world .

4) Learning to be :-

This purpose is relating to what people want to be in the future. Mumford (1999 : 187) said some people are learning to improve the personal satisfaction that they get from their work .

2.8 Effective learning :

Learning is a process , it is built upon steps and can be by memorising, reading , speaking ,summarizing or other methods (Har len : 2006 ; 5-7) . Effective learning focuses on how we learn , it gives invaluable insights into how you can develop your portfolio of skills and knowledge by managing and improving your ability to learn positively and systematically, practical exercises and clear guidance are given on :

1. Recognising the importance of achieved learning .
2. Understanding the learning process , the learning cycle and learning style performances .
3. Taking best advantage of learning opportunities .
4. Creating and implementing a personal development plan .
5. Encouraging and managing a learning culture .

Carnell (2002: 18-20) said that effective learning involves outcomes , these outcomes are necessary for people to remain active learners .

1. Higher-order skills , strategies and approaches .
2. Action towards greater complexity and more learning .
3. Positive emotions , excitement and enthusiasm .
4. Exchange sense of self .
5. More sense of connection with others .
6. Further learning strategies .
7. Greater affiliation to learning .
8. Personal significance and change .

2.9 Language learning process :

Language learning is a natural phenomenon , it occurs even without intervention (Genesee:2000 ; 121) .If it is a natural phenomenon so it is a part of our life . Jenen (2003 : 25-28) said that life is a process of learning and every activity in life can be considered as an apparently to learn .

Learning was observed to involve adding or accumulating knowledge (Miller : 2006 ;3) and this knowledge should be organised to be used when and where people want . Lindsay and Knight (2006 : 11 - 12) divided the process of language learning into five stages .

1- Input :- It refers to all language that the learner is exposed to either spoken or written language , inside or outside the classroom , formal or informal . The sources of input such as (the teacher , friends ,TV) .

2- Noticing :- Learners can notice the language that they are exposed to , some of these are already known by them and some may be new . So learners can notice a gap in their learning or it may be brought to their attention by their teachers .

3- Recognising patterns and rules making :-

Through practising learners can notice that the pattern of the verb can be used to refer to the past , so they start to develop rules for themselves. Teachers also may tell them the rule and then give them a chance to use it in a writing or speaking activity .

4- Use the rule modification :-

In this stage learners start to generate their own rules by producing their own sentences , learners may commit some mistakes because these rules don't include the exceptions of grammar , but later they might correct and modify the rule to include these exceptions .

5- Automating :- In this stage learners will be able to use the language with its complexity and exceptions especially in grammar without consciously thinking of these difficulties. At this point the language has become automatic , this means that the language has to be stored in the memory ,

learners need to keep using new rules and language in order to mention this stage .

2.10 Learning strategies :

Introduction

Learning strategies are mainly related with learners , learners try to find different procedures in order to facilitate learning and to escape from the dependence on their teachers (Cook : 1991 ;81) .

learning strategies are different ;some are inherently more effective than the others , and some are appropriate in particular contexts of learning or for individuals with different aptitudes and learning style (Saville-troike:2006 ;91).

2.10.1 Definition of learning strategies :

Oxford (1990 : 8) believes that learning strategies are specifications taken by the learners to make learning faster , easier , more enjoyable , more self-directed ,more effective and more transferable to new situations.

Hismonoglu (2008 : 14) sees learning strategies refer to the intentional behaviour and thoughts used by learners during learning so as to better help them understand , learn or remember new information .

2.11 Taxonomy of learning strategies :

Brown (2007 : 134 -135) classified learning in three main types .

2.11.1 Cognitive learning :-

Cognitive leaning strategies involves conscious ways of takin g learning such as note-taking re-sourcing and elaborating (Oxford : 1990 ; 81) .

Brown mentioned eleven main cognitive learning strategies contributing directly to learning .

- Translation
- Grouping
- Note taking
- Deduction
- Imagery
- Auditory representation
- Key word
- Elaborating
- Transfer
- Recombination
- Inferencing

2.11.2 Metacognitive learning :

Hismonoglu (2008 : 16) sees these strategies are used to regulate self language learning and it involves different process .Brown mentioned eight strategies of metacognition .

- ◆ Advanced organiser
- ◆ Direct attention
- ◆ Self – management
- ◆ Functional planning
- ◆ Self monitoring
- ◆ Delayed production
- ◆ Self – evaluation
- ◆ Selective attention

2.11.3 Socioaffective strategies :

These strategies are related with social mediating activity and transacting with others , cooperation and question for clarification are the main socioaffective strategies .

3.1 GRAMMAR

Introduction

Grammar has been a familiar part of the school teaching language for many years , and its familiarity has given rise to some inconsistencies in the same use of the word grammar . Some elementary grammar books introducing a foreign language are entitled English Grammar or Grammar in use (Robins:1980,142) ,For several last years English grammar teaching in schools has been a the subject of criticism , some people believe that there is no correlation between teaching grammar and pupils' improvement in writing of English (Kohli:1999,138) .

Protherough and King (1995 :106) didn't prefer the narrow definition of grammar as the analysis of parts of speech and sentence structure , as they believed that these definitions will encourage bad practice of teaching grammar exercise .

3.2 Definitions of the term grammar :

Different definitions of the term grammar were given i n different ages , the differences are important . Some of these definitions refer to the theoretical or practical point of view , Barnard (1858 : 755) said that a lot of writers defined grammar as the art of speaking and writing correctly whereas others believed that grammar is a guide to a correct understanding of language through its words and forms of speech .

Theoretical point of view saw grammar as the science of language (Sweet : 2005 ,1) saw the role of grammar as every science is to observe the facts and phenomena with which it has to deal and to classify and state them methodically .

Williams (2005 :26) used the term grammar to when teachers and administrators grow frustrated over errors in students' writing , they often return the term to the " basics" which are defined as grammar , Williams also mentioned that the term grammar refers to how are people speak .

Palmer (1995 : 2) sees that grammar describes the native spoken language of people , grammar does not refer to what we can find in the students books written down or learnt by heart .

Woods (1995 : 2) maintains that grammar helps us how to make use of words and to be able to choose the words , you have to be familiar with the principles and rules

Protherough and King (1995 : 106) said that the definition of the term grammar should be wider , it should consider :-

1. The change in the language to suit the listener and audience form and purpose .
2. The different effect which can be achieved in speech and writing .
3. The reasons why some languages are structurally ambiguous or misleading .

4. The study of elements larger than sentences .

5. The introduction of specialist terminology in context for purpose .

Nasr (1980 :2) sees that grammar consists of means by which the relationships between words are shown , these means include inflection , word order and grammatical words .

Some linguists defined grammar as a set of rules or principles which govern the language system .

Harmer (2001 : 12) maintained that grammar is a description of ways in which words change their forms and can be combined into sentences .

Cross (1992 : 26) defined grammar as a body of rules which govern the structure of words to form clauses and sentences that are acceptable to the native speakers .

Jespersen (1969 :15) sees that grammar deals with structures of the target language and each language has its own system .

Fromkin and Rodman (1993 :13) believe that grammar is the rules that combine words to form sentences . For Fromkin and Rodman grammar is what people know . It represents the linguistic competence which leads people to understand the nature of the language and the set of the rules which is part of every grammar of every language .

Thornbury (2004 : 1) grammar is the study of forms and structures of a language and description of rules which govern how a language sentences are formed .

Kohli (1999 : 138) sees that grammar to linguists means the total set of signals by which a given language expresses meaning and the total structure of a language , But for learners it is the analytical and terminological study of sentences .

Brinto (2000 : 8) maintained that grammar is a term used to refer to rules or principles by which languages work their system or structure .

Yule (1996 : 87) believes that grammar is the description of the structure of phrases , sentences and their rules .

Williams (2005 : 27) grammar is the formal study of the structure of a language and it describes how words organized and fit together in meaningful constructions .

Wikipedia (2008) maintained that grammar is a branch of linguistics and it is the study of the rules governing the use of a language .

Lock (2002 : 1) sees that grammar is a set of rules which specify the grammatical structures of the language .

From the previous definitions it can be noticed that the term grammar was defined in different ways to mean different things . From the researcher point of view the term grammar is a set of rules which govern

the language , these rules organize and fit words together to help learners to use the language correctly and accurately .

3.3 What is grammar ?

The term grammar has been used in different ways. Some people see grammar as the rules which govern the language system , for others grammar refers to the language that the native speaker use to convey his message correctly and accurately .

Lewis (1986 : 9 -12) maintained there are three kinds of grammar

1- Facts :-

grammar is the matter of fact , that means grammar has information which is generally accepted by all native speakers .

English grammar for instance contains twelve nouns ending in (f) or (-fe) and to make plural from them you have to drop the (f) or (-fe) and to add (-ves) . Close (1992 : 1) sees that grammar is a matter of facts which we should develop to use in appropriate ways .

The information is non-generative that means , learners can't follow the same patterns that they used with some certain words to suit other words even if it has the same endings , so each bit needs to be learnt separately .

English curriculum aims to make learners more comprehensive , therefore, we can find different verbs , words , structures and tenses in the students book , some of these are more important to the foreign language learners

than other , so teachers will face difficulties in teaching grammar because they try to be more comprehensive , but in fact learners learn a small amount of useful information hidden in comparison to the useless material .

2- Patterns :-

The second kind of grammar helps learners to reduce their load of memory , here learners may follow some certain patterns to help them in their learning, these patterns can be generalized . In English grammar for example foreign learners can generalize how to form question tag either by considering a sufficiently large rang of examples or by given the pattern in a formulation and these generalization can be used by reflexive pronouns , but sometimes teachers face some problems with the “ exception” and the best solution for this problem is to put these items belong to lexicon rather than grammar .

3- Primary semantic distinctions :-

Language makes some certain distinctions which may occur in words and structures . Distinctions divide the meaning into two parts , it makes difference between personal and impersonal .

In English language the distinction is clear between the pronouns “ he “ and “ it “ , the divisions are essentially semantic ; they are concerned with meaning , to be noticed that the distinction is different from language to language , at the same time it is not easy to define it because they are

deeply associated with meaning , so the most general problem that may face foreign learners is the basic structure of the verb .

Woods (1995 : 15 _ 18) says that grammar as rules , forms and resources .

4- Grammar as rules :-

Woods (1995 : 16) believed that learning grammar is the learning of rules and learners should have an intellectual knowledge of grammar , this knowledge will provide basis on which learners can build their knowledge, these bases will act as the generative base .

4.1 Are rules important ?

Some writers argued that the rules are not important , because native speakers make mistakes in their language but they can convey their message, also they argue that children learn their native language and they use its own grammar without learning the rules , so learning grammar is not necessary , but Woods (1995 :17) believed that children may not be conscious to learn the rules but if they use incorrect regular verb instead of irregular verb ,that means children has unconsciously hypothesized the rules and they need more time to be aware of rules .

5- Grammar as form :-

Grammar was defined as a set of rules which are considered how forms are composed and used (Woods : 1995 ; 16) . Many teachers refer

grammar to the form of structures , how to arrange and order the words correctly to form a grammatical structure , but the problem is how to deal with the syntactic rules .If teachers don't concentrate on the errors of low level-syntax , that means learners will commit mistakes and they will form ill-formed sentences , at the same time if the errors are pointed out , the communicative quality will be lost and students will focus on grammar and rules instead of communication .

6- Grammar is a resource :-

Grammar is one of the resources that language include , it helps learners to communicate . Choosing the correct form is as important as choosing the lexical items that will help speakers to say and expect their listener and reader interpret to what they are saying .

3.4 Why study grammar ?

Finegan (1998 :470) said that "all creatures had their own language to communicate , some of these creatures make meaningful sounds to make links between sounds and meaning " , we as human beings spend a lot of our life speaking , listening , reading and writing , at the same time we also need a link to make meaningful communication with others. This link is grammar (Palmer : 1971;7-8) .

Kohli (1999 :139) sees that grammar is a very important aspect in teaching .

A person can't learn and practice foreign language accurately without having knowledge of grammar .

Principles of practicing grammar :

1. Grammar will be as a reference when the linguistic habits fail the learners .
2. It helps learners to arrange and consolidate forms and structures that they have already learnt .
3. “ It offers a set of labor saving rules , explanations and patterns which economize effort in language . “
4. It helps learners to monitor the performance .
5. Grammar is preventive and corrective , it gives learners a usual feedback to the points or words – use which are especially liable to error
6. It helps learners in the improvement of written work , it makes them understand how to link sentences .
7. Teaching grammar will lead learners to more practice over a wide range of valuable practice .
8. Grammar helps learners to express their thoughts correctly either in speaking or in writing . (Woods : 1995 ; 3) .

3.5 The uses of grammar

Woods (1995 :5) sees that the term grammar used in different ways to mean different things , it may come in a form of a book to mean the rules

of the language or a subject that teachers teach in the school to their learners to use the language correctly or it can be an approach to analyze and describe the language . Kohli (1999 : 139) had the same belief for the use of grammar , he said that the term grammar for school students means the terminological study of sentences , but to linguistics it is the structures of a language or " the set of signals by which a given language expresses meaning" .Leech et.al (1982 : 4) believed that grammar is the core of the language which relates the semantic with phonology .

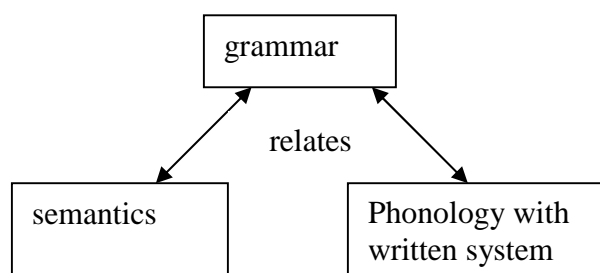

Figure 1

1- Grammar and written language

Ridout and Clarke (1970 : 146) the word grammar was derived from the Greek meaning " the science of letters " . Thornbury (2004 : 8) grammar in the recent days presented to the learners is essentially based on written grammar . Leech and et .al (1982 : 184) said that having knowledge of grammar will improve the style of writing and it will help learners to criticize and discuss their own writing .

Leech put four principles for good writing .

1. The language should be easy to follow .
2. It should be clear (avoiding ambiguities) .
3. Writers should be economical (avoiding unnecessary words) .
4. Writers should be effective .

2- Grammar and spoken language

Children learn the spoken language naturally from their parents , so the spoken form is learnt before the written one . Jespersen (1969 : 19) mentioned three characteristics of the speech activity .

1. Expression which treats the language that the speakers give Suppression which treats the language that the speaker didn't give .
2. Impression which deals with the receiver or the listener of the language .
3. Suppression it deals with the speakers ability of expressing things .

So we can notice that the speaker of the language has different choices in using the language in expression , while in suppression some speakers may want to express something but they couldn't and this will effect the listeners impression .

Eyres (2000 : 6) sees that grammar is something that speakers of language need to know , and he mentioned that there are two kinds of knowledge of grammar .

1. Implicit knowledge , it enables speaker to form sentences grammatically ,and it also allows them to differentiate between grammatical and un grammatical sentences .
2. Explicit knowledge , It helps speakers to identify and describe the errors , and to state which of the rules have been broken through terminology .

3- Grammar and communication

Woods (1995 :2) said that "grammar teaches how to use words , it teaches us how to use these words correctly and appropriately " .

Lock (1996 : 266-267) said that "communicative competence is not just the ability to of producing correct sentences , but to know when , where and with whom to use them" . Lock also mentioned that there are prerequisites for communication :

1. To represent what you need to talk about and to locate it in time .
2. To make content interpersonally relevant and appropriate .
3. To make good organisation for the message and to relate it to the previous and to the situational context .

For Lock grammatical competence is an essential part of communicative competence and the development of the communication is the result from the relation between grammar and communication . Purpura (2004 : 53) assumes grammatical competence is the knowledge of the rules of phonology , the lexicon, syntax and semantics.

Purpura mentioned three competences that people need in communication .

1. Sociolinguistic competence :- It means the using of the language functionally within the social context (Hamdan :1991 ; 6)
2. Strategic competence :-which refers to the ways that we use to get our meaning across (e.g. body language) (Woods :1995 ; 26) .

Hamdan (1991 : 6) sees that strategic competence refers to verbal or non verbal strategies used to enhance communication .

3. Discourse competence : it refers to the strategies of constructing and interpreting the text (Woods :1995 ;26)

3.6 Types of grammar :

There are two types of grammar ;descriptive and prescriptive grammar

1- Descriptive grammar :

All the speakers of the language have a mental grammar that is a form of internal knowledge , this knowledge operates naturally without learning .

There may be some differences between the speakers knowledge of grammar , but in fact there is a shared knowledge between them which will help them to communicate and understand each other (Yule :1996;87) .

(Fromkin and Rodman : 1993 ; 13). So it can be said that descriptive grammar doesn't mean the way that the speakers should speak the language , but it describes the basic linguistic knowledge . Eyres (2000 : 6)

mentioned that descriptive grammar may be used as prescriptive way through teaching the foreign grammar .

2- Prescriptive grammar :

This type of English grammar is an old traditional type , it deals with the rules of the language and how speakers should use these rules in their speaking and writing correctly (Eyres : 2000 ; 5) .

Kohli (1999 :140) sees that prescriptive grammar tries to perform the legislative function of the language , so it is not allowed to neglect the rules of the language .

The differences between descriptive and prescriptive grammar

- 1- Prescriptive grammar deals with rules which should be acquired by the speakers , while descriptive grammar deals with the use of the language without concentration on these rules .
- 2- Descriptive grammar is dynamic . It takes into account the fact that the language is changeable , while prescriptive didn't allow the ignorance of rules (Kohli : 1999 ; 140) .
- 3- Fromkin and Rodman (1993 : 13) sees descriptive grammar deals with sounds , words , phrases , and sentences of the language .
- 4- Eyres (2000 ; 6) sees prescriptive grammar deals with structures or words as correct or incorrect . It is concentrating on the areas of the

language which are considered to be necessary , and it may be used in a prescriptive way especially in teaching grammar to foreign learners .

3.7 Functional and formal grammar :

Grammar is also classified as functional and formal grammar :-

1- Functional grammar :

Kohli (1999 : 141) sees that functional grammar is " incidental grammar " which is acquired by learners naturally or unconsciously . He believes that grammar can be learnt through the process of learning and it could be learnt by imitation or consciously by observation and deduction . For him functional grammar gives the learner the ability to speak and write correctly .

Lock (1996 : 1) sees the main purpose of a language is communication and analyzing grammar to allow the speakers and the writers to exchange the meanings where ever it is possible and necessary .

2- Formative grammar :

Grammar has been described as a set of rules that govern the language system , so formal grammar deals with rules and forms which should be organized to be used later . Kohli (1999 :141) sees that formal grammar deals with terminology , it describes and analyzes the language . Brown and Miller and Brown (1980 :60) assume formal grammar refers to the

description of forms , but not to the sense of individual forms nor to the meaning of the whole statement .

Lapalombara (1976 :54) concluded the relation between the two types of grammar. She believes that it is not possible to separate between functional and formal grammar . Both types deal with words and word groups , so forms can make different functions and functions can not be achieved without forms .

3.8 Traditional grammar :

Traditional grammar was widely used by teachers in the classroom through giving definitions for the part of speech or by giving the systematic rules of grammar (Woods :1995 ;6) .Guth (1973 : 41) said that traditional grammar concentrates on the good organization of words and relationships between the words in a sentence , so it deals with the syntactic organization of words in a sentence .

3.8.1 Criticism of traditional grammar :

Traditional grammar faced some criticism , Kohli (1999: 143) and Guth (1973 : 46) said that :

1. Traditional grammar is based on Latin grammar , but the two languages have different structure features, so it is not allowed to adopt the same rules in different languages .

2. Some of the traditional grammar schools are based on the written rather than spoken language and they consider the language as "logical", while traditional English grammar is based on its concepts and definitions of meaning which is a very subjective and shaky foundation.

3.9 Grammar and language :

Nasr (1980 : 52) sees grammar is a part of a language and it is not acceptable to speak the language without understanding its grammar .

Nasr mentioned that the language consist of three major parts .

1- Phonology :- the study of sounds and sound patterns

2- Vocabulary :- are the words that the speaker of the language uses .

3- Grammar :- which refers to the rules or to the means that make a good relationship between words .

1. morphology :-

Todd (1992 :41) mentions that morphology is the science of studying morpheme , which is the smallest significant unit of grammar .

Nasr (1980 : 53) assumes morpheme has a meaning and a sound or more than one .

Types of morphemes :

There are two types of morpheme :

1. Free morpheme :- It refers to the morphemes which can occur freely , Nasr said that free morphemes "refer to the morpheme which can stand by itself" , and he called it " independent morpheme "
2. Bound morpheme :- for Nasr it is "independent morpheme " which can't stand by itself . Todd (1992 :41) sees bound morpheme refers to that morpheme which occurs as " affixes " , Todd (1992 : 41 -42) and Nasr (1980 : 177 -179) said that bound morpheme are divided into

two types :

- 1 Prefix : - refers to the affix which occur at the beginning of the word and changes its meaning such as (un – dis –im –il – ir -in)
- 2 Suffix :- refers to affix which appears at the end of the word and change its type from verb to noun or from adjective to adverb.

2. Phonology:

People all over the world utter different words , these words help them to communicate together . Words exist from the human mouth in a form of sounds , these sounds appear as signals by which human being introduce them together to form meanings , so phonology is the science of studying the speech sounds and it deals with linguistic patterning of sounds in human language (Spencer 1996 :1) , while phonetics is one of the

phonology studies which is the study of sounds and sounds patterns (Todd : 1992 ; 13) .

Nasr (1980 :2) sees that phonology is the features sounds in a language which is systematically structures , for Nasr these features are divided into :

- 1 Segmental features which includes consonants and vowel s .
- 2 Supra-segmental which include stress , intonation ,pause , junct ure and rhythm and pitch .

3. lexicology:

Fromkin and Rodman (1993 :35) sees lexicon is a Greek word to mean dictionary . Todd (1992 :49) sees it is the science that studies words .

What do we mean by word ?

Todd (1992 : 50) sees that there is no exact definition for the (word) some writers said that word can stand in isolation while others said it contains meaning .

Smith and Wilson (1979 : 52-53) knowing a word requires having at least three kinds of information :

- 1 Phonological :- which refers to the sounds the word contains and their understanding .
- 2 Semantic :- it deals with the meanings of the word .
- 3 syntactic :- refers to the category that the word belong s to .
- 4 Morphological :- which deals with how words related together .

4. Syntax :

The word syntax meant " arrangement " or " a setting together " in the Greek language , it was defined by the modern grammarians to mean concentration on the structure and ordering of components within a sentence (Yule : 1996 : 100) . Some grammarians see the word to mean having a knowledge of language , this knowledge includes the ability of arrangement and using the words together to form sentences or phrases to express our needs (Fromkin and Rodman : 1993 ;73) .

1- The phrase :

Todd (1992 : 60-62) sees that phrase is a group of words which work as a unit with exception to the verb phrase which doesn't contain a finite verb.

The phrase could be :

1. Noun phrase :- it is a group of words which has a noun as a head word .
2. Adjective phrase :- it refers to words which modify nouns as adjectives these words either attributive or predicative .
3. Adverb phrase :- a group of words which function like adverbs . It tells about when , where , why and how things happened .
4. Preposition phrase :- refers to the words which begins with a preposition.

2- The sentence :

Finegan (1992 : 118 -119)said that "sentence can be classified into four major types ."

1. Simple sentences :- refer to the kind of sentences which contain only one clause .
2. Coordinate sentences or compound :- refer to the sentences which contain two clauses or joined by a coordinating conjunction .
3. Complex sentences :- is a kind of sentences which contain two or more clauses and one of these clauses functions as grammatical part of the other one .
4. compound complex sentences :- is a sentence made up of more than one main clause and at least one subordinate clause. It is the combining of a compound sentence with a complex sentence.

3.10 Parts of speech :

Huddleston (1988 : 23) said that "the part of speech can be divided into two major classes" . These are open and closed .

The open class includes verb , noun , adjective and adverb , while the closed class includes the rest , preposition , determinative , coordinator and subordinator .

1. The open clauses :-

1.1. **Verb** :- Nasr (1980 : 189) defended the word verb to refer to a word or a group of words that can tell about what something or someone is , or does and it should be related to tense .

Finegan (1992 : 79) sees that there are different subcategories for verbs :

1-1-1 Transitive verbs :- Refer to that verbs which take a noun phrase after them .

1-1-2 Intransitive verbs :- Verbs which don't require noun phrase .

1-1-3 Ditransitive verbs :- Verbs which have two noun phrases .

1-1-4 complex transitive verb : A verb that takes a direct object plus an object complement.

1.2 Nouns :- nouns are usually known as a name of a person , thing , place , animal or a state (Todd :1992 ; 53) .

Finegan (1992 :80) sees that there are some features for nouns

1.2.1. Number :- nouns can be singular or plural

1.2.3 Case :- English nouns has a possessive form .

1.2.4 Gender :- it deals either sex , male or female , nouns occur in different classes each class has its own case and number marks .

1-3 Adjectives :- words which describe nouns . Finegan (1992 : 80) see s that adjectives can be marked for two degrees :

1.3.1 Comparative :- adding (-er) to the adjectives or (more)

(Adjective +er) or (more + adjective) + than

1.3.2 Superlative :-putting (the) before the adjective and adding (est) to the adjectives or (the most) .

1-4 Adverbs :- English adverbs are usually formed by adding "ly " to the adjectives , but not all adverbs are formed in this way and not all adverbs have related adjectives .

Todd (1992 : 56) and Finegan (1998 : 83) see that adverb is a word that modifies , a verb , an adjective , a sentence or another adverb .

2- closed classes :-

2-1 Conjunctions :- It is a joining word like . Nasr (1980 : 170) sees that it is a word which relates parts of sentences , phrases .Todd (1992 : 57) sees that coordinators or conjunctions have two forms .

2-1-1 Subordinating :- it is a conjunction which relates the subordinate clause to the main clause .

2-1-2 Coordinating :- it relates units of equal significance in sentence .

2.1.3 Preposition :- Nasr (1980 : 176) maintains that it is a word which can be found with nouns or pronouns or (ing) form to show its connection with another word . Yule (1996 : 88) believes that prepositions are words used with nouns in phrases , they provide information about when , where and other connectors involving actions and things .

2.1.4 Determinative :- Nasr (1980:171) sees that the function of the determinative is to limit the meaning of the noun and it comes before the words that describe the same word .

Todd (1992 : 53) sees determiner is a word like an adjective , it precedes and follows nouns and adjective.

Huddleston (1988 : 32) and Todd (1992 : 54) see that there are five main kinds of determiners .

2.1.5 Articles :- in English there are three kinds of articles, they are (a , an , the and the zero article) .

2.1.6 Demonstrative :- such as (this , that , these and those) .

2.1.7 Possessives :- in English we have six possessive pronouns they are (my , his , her, our , their ,its) .

2.1.8 Numbers :- when they precede nouns such as one boy , t wo boys

2.1.9 Indefinite demonstrative :-

Singular Indefinite Pronouns :

(any , anybody , anything , anyone , anybody , each , either , another ,everyone , everybody, everything, neither , something, someone ,some body , none ,anything) .

Plural Indefinite Pronouns :

Plural indefinite pronouns include both, few, several, some, many.

3.11 Teaching grammar :

Palmer (1971 : 7) sees Grammar is central to the teaching and learning of languages. It is also one of the most difficult aspects of language to teach well . Many people, including language teachers, hear the word "grammar" and think of a fixed set of word forms and rules of usage. They associate "good" grammar with the prestige forms of the language, such as those used in writing and in formal oral presentations, and "bad" or "no" grammar with the language used in everyday conversation or used by speakers of no prestige forms. . Kohli (1999 : 138) sees that Language teachers who focus on grammar as a set of forms and rules. Teachers teach grammar by explaining the forms and rules and then drilling students on them. This results in bored, disaffected students who can produce correct forms on exercises and tests, but consistently make errors when they try to use the language in context . Garacia (2003 : 35) believed that Other language teachers, influenced by recent theoretical work on the difference between language learning and language acquisition, tend not to teach grammar at all. Believing that children acquire their first language without overt grammar instruction, they expect students to learn their second language the same way. They assume that students will absorb grammar rules as they hear, read, and use the language in communication activities. This approach does not allow students to use one of the major tools they

have as learners; their active understanding of what grammar is and how it works in the language they already know.

Byrd (2004 : 144) sees that the goal of grammar instruction is to enable students to carry out their communication purposes. This goal has three implications:

- Students need overt instruction that connects grammar points with larger communication contexts.
- Students do not need to master every aspect of each grammar point, only those that are relevant to the immediate communication task.
- Error correction is not always the instructor's first responsibility.

3.12 Attitudes to grammar :

Attitudes were defined in psychological books to refer to feelings that people form towards something or someone .

Morgan et al (1999 : 450) see that attitude implies a favorable or unfavorable evaluation which is likely to affect ones responses towards the person or object concerned .

Atkinson (1993 : 725) sees that attitudes are like and dislike , favorable or unfavorable evaluations which make a reactions to objects , people or different aspects of the world including ideas and social policies .

Lewis (1986 : 12) sees that children in the first classes in schools find the foreign language something fun , and teachers can notice that learners have positive attitudes towards learning the language , but later after learning the language they find that learners attractive will decrease , and the negative attitudes will increase from the difficulties that learners may face during learning . Teachers sometimes make division during teaching and these divisions in grammar would be helpless for learner s to build a picture for the important points that they should concentrate on .

Cakir (2004 ; 105-109) states that most children come to school ready and willing to learn and the majority of their learning time is spent in school and as such the climate of the school is important for the creation of effective learning environments. If a student feels alienated and disengaged from the learning contexts in school, their potential to master fundamental skills and concepts and develop effective learning skills is likely to be reduced . Creating a suitable atmosphere would help learners to learn the target language , no matter how difficult it is . It is a psychological secure setting in the classroom that would enhance learning through enjoyment and pleasure .

3.12.1 Teachers attitudes to grammar :

Teachers should have positive attitudes towards teaching grammar more importantly ,they should have a clear strategy for teaching it .

Hussin et.al (2000 : 2) believe that teachers can play crucial role in driving children to learn language , if they provide them with activities that are pleasant ,meaningful and relevant to their life and experience . Lewis (1986 : 12 -13) sees that teachers should have an approach to make learning grammar more useful , so he suggests five ideas to make grammar lesson more attractive .

1. Teachers can communicate with their learners without discussing or explaining the rules of grammar .
2. Teachers can use attractive and discovery methods with learners .
3. Teachers should keep in their minds the problems that may learners face during learning grammar , because these problems are more difficult and important , but learners may learn grammar without explanation of these problems.
4. The syllabuses and textbooks are full off categories and catalogue approach to grammar , but in fact the texts are not related to each other , so learners will face difficulties in learning grammar separately , and it will give the learners an impression that learning grammar in this way is impossible .
5. learners will be affected by teachers attitude to grammar , some teachers may consider English grammar is a rough skill or difficult , so teachers must have positive attitudes to the skill .

3.13 Methods of teaching grammar :-

The word methodology was used to mean different things :

Abu Jalalh and Al- Elimat (2001 :33) see that it refers to the necessary procedures and steps that the teachers prepare for the process of teaching to achieve the aims which will achieve learning later .

Yassen (2005 : 26) believes it refers to a group of the practical procedures , practices and activities that the teacher is making inside the classroom to teach a certain lesson to link learners with the concepts , facts and information .

Al Hussari and Al Enizi (2005 :27) see that it is the linked procedures and activities which the teachers are planning to practice it inside or outside the classroom , that allow him to achieve a group of aims in a perfect way.

1. The grammar translation method :

This method is not new , it had different names it was called the classical method because . It was used to teaching the classical languages , then the method was used to helping learners to use and practice the foreign languages . The philosophy of this method is to help learners to study the grammar of the language by using their native language (Freeman: 2000 ; 11)

Woods (1995 : 52) said that the idea of this method is based on teaching grammar by using the native language .

Principles of the grammar translation method :

- 1- Freeman (2000: 15) sees that translation from one language to another is the most important goal in order to achieve a successful learning , and learners should be able to translate from one language to another .
- 2- Kohli (1999 : 48) the structure of the target language would be learnt successfully when it is compared with the mother language structure .
- 3- Communication is not the main goal of foreign language instruction .

Advantages and disadvantages of grammar translation method

Advantages :

Kohli (1999 : 49) there are some advantages when this method is used by teachers .

- 1- Translation saves efforts and time especially when teachers teach vocabulary and phrases of the foreign language .
- 2- Teachers labor is saved , the method is easy to follow , and it suits average of students and teachers .
- 3- Comprehension is not easily tasted , teachers may ask their students to tell them what they have learnt in their mother tongue . This strategy suit the learners in the early stages .

Disadvantages of this method :

Freeman (2000 : 17 -19) said the disadvantages of this method are :

- 1- The process of learning is teacher centered, the teacher has the authority in the classroom and he plays the main role during the process of learning and teaching .
- 2- The method doesn't take in consideration the feelings of the learners .
- 3- The method is concentrating on vocabulary and grammar , and there is much less attention given to speaking and listening .
- 4- Teachers supply the errors of the students directly with the correct answer without giving them chance to correct themselves or to make pair correction .

2. The Direct method :

The direct method is an old method , and it took its name from the fact that meanings can be conveyed directly in the target language through the use of practice , demonstration and visual aids (Freeman : 2000 ; 23) .

The principles of the direct method :

Woods (1995 : 62) sees the direct method is known as a natural method and it is based on the idea of teaching grammar through activities that the teacher uses in the classroom , where there is no translation and no focusing on explanation and analyzing of the rules of the language .

Kohli (1999 : 51) sees that the basic principle of this method is that learners think directly in the foreign language. It teaches language through conversation , discussion and reading in the language directly without translation , drilling and studying the terminology .

Freeman (2000: 26-28) mentioned some certain principles :

- 1- Reading can be developed through speaking .
- 2- Visual aids and different instruments should be used to help learners to understand the meaning.
- 3- There is no place for the native language in the classroom .
- 4- It makes great demand on demonstrating learning .
- 5- The purpose of language learning is communication .

Advantages and disadvantages of the direct method

Advantages :

Kohli (1999 : 52) said that this method has some characteristics :

1. The method is natural , it makes a great demand on demonstration and practice in learning a foreign language , the same way in which learners learn their native language .
2. It makes use of the audio-visual aids .It emphasizes the use of the instruments and aids in the classroom to help learners to understand and practice the language .(Freeman :2000;26)

3. Teaching through conversation, the method neglects translation , explanation and analyzing of the rules of the language .
4. It facilitates reading and writing . It concentrates on speaking and conversation , so naturally that it will improve writing and it will increase love for reading .

The disadvantages of the direct method :

Freeman (2000: 28) and Kohli (1999 :52) mentioned some disadvantages of this method :

- 1- The method is not complete . It focuses on speech and conversation , while writing and reading don't receive due attention .
- 2- It needs competent teachers who have the ability of pronunciation and speaking the language correctly and perfectly .
- 3- It is not suitable for all learners .
- 4- It is difficult in explanation .

3. The Audio-lingual method :

Woods (1995 : 65) Audio-lingual method is related to the behaviourist approach , It is an oral-based approach . The idea of this method is that the language is divided into structures which learners practice through drilling . Teachers drill the structure and learners learn from over drilling rather than describing the rules of the language .

The principles of audio-lingual method :

Nunan (1991 : 230-231) and Freeman (2000: 42-45) mentioned the principles of this approach

- 1- Language learning is a process of habit formation .
- 2- Language is speech not writing .
- 3- Languages are different .
- 4- Teach the language not the rules of it .
- 5- The main source of the language is from its native speaker .

Advantages and disadvantages of audio-lingual method

Advantages :

Freeman (2000:42-45) said that the teacher in audio-lingual method is a leader-conducting , guiding and controlling the students behaviour in the target language .

- 1- The method emphasises speech ,So learners will be able to learn vocabulary and structure .
- 2- It emphasises the good relation between learners through chain drills or when learners take different roles in dialogue .
- 3- Teacher emphasises the use of the target language ,So there is no use of the native language .

The disadvantages of audio-lingual method

Nunan (1991 : 230-231) mentioned some disadvantages of this method :

- 1- Learners like parrots . They imitate their teachers .
- 2- Audio-lingual method rejects mistakes that learners may commit during the process of learning , for them these mistakes are not acceptable .
- 3- It emphasises (speaking) more than the other skills .
- 4- There are no considerations for the learners feelings .
- 5- Drilling of the language and structures will affect learners, and they may feel bored and easily forgotten (Abbott : 1981 ; 281) .

4. The communicative approach :

Communication is a humanistic feature , where people use words to convey their messages . Todd (1992 : 6) defined language as a set of signals by which we communicate . So human language communication is not a vocal system only as it can be expressed by writing .

Expressing needs , feelings , opinions and thoughts need words and these words should be sorted in a good form , therefore , grammar is important to help learners to convey their message . Woods (1995 : 52) sees that grammar teaches how to use words correctly and appropriately .

Principles of communication approach

Hamdan (1991 : 6) and woods (1995 :65) mentioned some principles of the communicative approach :

- 1- Teachers are responsible to establish the situation of communication .
- 2- Learners should have a chance to express their feelings , interests and thoughts .
- 3- Grammar and vocabulary which are taught are functional not structural .
- 4- Learners errors are the result of communication Nunan (1991 : 233) .
- 5- Games are very important to enhance real life communication Nunan (1991 : 243) .
- 6- It emphasises the use of the four competences .

Advantages and disadvantages of the communication approach

Advantages

Hamdan (1991 :9) mentioned some advantages and disadvantages of the communicative approach :-

- 1- It emphasises the use of the four competences in the real life communication with concentration on the social competence .
- 2- It gives the learners chance to use the language for their own purpose .
- 3- They are more tolerant with learners mistakes . They believe that these mistakes are the outcome of communication (Nunan : 1991 ; 233) .
- 4- It takes care of the learners feeling , so learners will enjoy learning .

The disadvantages of the communicative approach :

- 1- Communicative approach doesn't offer security for teachers in the text book .
- 2- It is more difficult to evaluate .
- 3- It makes a great demand on professional practice , training and competences .
- 4- It doesn't meet withhold learners and teachers .

4.1 Concept Maps

Introduction

Concept maps first suggested by Joseph Novak , who has studied the education field as an aid for learners to increase understanding (Richardson et . al : 2005) . The strategy was born out of the constructivist theory of learning which holds that the learner constructs or builds his own knowledge as opposed to the previous one (Basso and Margarita : 2004) .

The idea was based on the Ausubels' assimilation theory of cognitive learning who sees that the meaningful learning takes place when new knowledge is consciously incorporated into the concepts and ideas previously acquired by the learner (Clark and James : 2004 ; 224) . Ausubels advocates the use of the advanced organiser which is based on the idea that the teacher is given a short description to the new material before the lesson to prepare the students to accept the new material (Reece and Walker : 2003 ; 87) .

4.2 What are concept maps ?

concept map is visualised through a graphical representation. Concepts are usually depicted by circles or boxes , forming the nods of the new work by labelled links (Buzzetto -More :2007 ;61) .

Juall and Moyet (2005 : 7) maintain that concept maps are an educational technique that uses diagrams to demonstrate the relation of one concept or situation , by linking a central concept to another one , to help the learners to understand the central concept better . So concept maps are presented as a pyramids seen from above and they are arranged hierarchically with the super ordinate concepts at the top of the map and subordinate at the bottom which are less inclusive than higher ones (Ahlberg and Vukko : 2004 ;25) .

Novak and Can s (2006 : 17) sees that concept maps are graphical tools for organising and representing knowledge . They includes concepts usually closed in circles or boxes of some type and relationships between concepts indicated by connecting or linking two concepts or words on line , referred to as linking words or linking phrase . The link between the concepts can be one-way or non-directional . The concepts and the links may be categorized and the concept may show temporal or casual relationships between concepts (Fitzgerald : 1999 ; 81) .

4.3 Definitions of concept maps

The researchers in the field of education studied concept maps as a means to facilitate the quick and effective learning .Concept maps was defined by Novak and Gowin (1984: 32) as graphical representations of

knowledge that are comprised of concepts and the relationships between them .

Rubin and Babbie (2005 : 537) see that concept mapping is the relationships among concepts in graphical format .

Vanides et.al (2005 : 27) maintain concept map is the graphical representation of the relationships between terms .

Vakilifard and Armand (2006) see that concept map is a graphic representation which not only transmits basic information , but also presents relationships between the concepts .

Talebinezhad (2007 : 2) maintains concept maps for Novak represent the relation among concepts , with the visual representation of key words. Students can identify main issues of text and organise these key issues of text and organise these key issues in a meaningful way .

Jeresa and Jorge (2006 : 13) see that Concept map is a graphic organiser which uses schematic representation to hierarchically organise a set of concepts connected by means of words in order to build meaningful statements . Showing meaningful relationships between concepts in a shape of prepositions , the concept map reveals students' comprehension and knowledge structure .

From the previous definitions the researcher sees that concept maps are an educational strategy which has different shapes and it is arranged

hierarchically with the super ordinate concept at the top and subordinate at the bottom , and there are some links among concepts to represent the relationships between the concepts .

4.4 Basic principles of concept maps :

Novak (2001 : 74) believes concept maps is a tool for organising and presenting knowledge . This knowledge is mostly semantic (Asan : 2007 ; 11) ,So it needs to be organised and presented hierarchically from the most general concept to the most specific one .

Pill and et .al (2005 : 40) mentioned the main principles of concept maps .

- 1) Key ideas are presented in a hierarchy , which moves from the most general ideas to the most specific .
- 2) Key ideas are additionally arranged in domains or clusters , which visually define their association and related boundaries .
- 3) The nature of the interrelationships between the key ideas are identified through the use of relationship lines . These lines are annotated to clearly indicate the nature of these relationships within discrete sections of the map and between the different domains .
- 4) The lowest point of hierarchical representation of ideas is illustrated by the use of relevant examples .

4.5 The use of concept maps :

Leou and Liu (2004 : 22) suggest that learning can be enhanced if learning involves interaction , student-centred and engaging activities when learners construct their understanding rather than more traditional methods of teacher-centred direct instruction in order to make learning organised and meaningful . So concept maps became more prevalent in educational programme . Instructors began to explore ways to utilize them more effectively to facilitate student learning (Love et .al : 2004 ; 11) .

4.5.1 Concept maps and teaching

Concept maps were used in different ways .They could reach all the fields of education .

Affana and AL Khozendar (2007 : 135) suggested some certain steps that the teacher can follow inside the classroom to have an effective teaching and learning .

- 1- Teachers tell their learners about the item or the subject that he is going to teach with identification for the main concepts in the lesson .
- 2- Teachers identify the sub concepts which are in relation to the main one. Teachers can write them on the board to give the students the chance to know them .
- 3- Teachers find key words or link-words between the sub-concepts in order to make a meaningful relation between these concepts .

- 4- Teacher organises the concepts in a pyramid form and puts the link-words on the arrows .
- 5- Teacher explains the sub-concepts by giving examples , so that teacher can transfer his students from main concepts at the top of the map to subordinate at the bottom .
- 6- Teacher asks students to make concept maps in the subject matter either individually or groups .

4.5.2 Concept maps during the process of teaching :

AL Hwidi (2005 : 310) suggested that the concept map can be used in three ways during the process of learning .

1. Pre- teaching :- Teachers can survey the concept maps in front of the students as an advanced organiser ,either by drawing the map on the board or by using the over head projector .
2. During- teaching:- Students may use concept maps during -learning , when teacher copies the map and gives every one a copy to benefit from.
3. Post- teaching:- Teachers can ask individuals or groups of learners to build up concept maps for the lesson or for the unit , then he checks it to know the places of weakness and the places of strength to help them to overcome the weakness later .

4.5.3 Concept map as an assessment tool

Ozdemir (2005 : 11) believes that concept maps can be typically used as an evaluation method before and after teaching . (Francis : 2006 ; 2) concept maps can be used as an assessment tool in education and it provides the faculty of interesting and effective ways to assess learning by students in all academic areas .

Ruiz –Primo (2000 : 33-34) assume researchers use the term assessment to reflect the belief that reaching judgment about individuals' achievement , in a domain requires an integration of several pieces of information , therefore, concept maps as an assessment tool is characterized by :

1. A task that invites a student to provide evidence bearing on his or her knowledge structure in a domain .
2. A format for the students' response .
3. A scoring system by which the students' concept map can be accurately and consistently evaluated .

Kommers (2004 : 53) suggested that concept maps can be used in educational assessment and described two main purposes .

1. Formative evaluation of teaching and teaching materials .

Daley (2006 : 48) sees that formative evaluation where the teachers can assess the students' learning at a particular point . Veccia and Pedroni (2007 : 308) see that this kind of evaluation plays as a diagnostic role

in that it is geared towards defining the compensatory intervention should the monitoring operations show that the learner is having difficulties progressing through his or her training programme .

2. Using concept maps as part of achievement tests , then who concludes that concept maps provides a theoretically powerful and psychological sound tool for assessing conceptual change in experimental and classroom setting .

4.6 Reasons of using concept maps :

Pill and et. al (2005 : 40) mentioned some reasons for using concept maps on the base that they can .

1. Facilitate the development of self-directed learning within which conceptual and prepositional relationships can be reflectively and critically explored .
2. Enhance problem-solving practically in the context of acquisition and sequencing of the new information .
3. Aid the development of deep meaningful teaching moving towards critical thinking rather than more surface approaches .
4. Have potential value in assessment during students' learning journey .

Fitzgerald (1999 : 81) added some uses for concept maps to :

5. Generate ideas .
6. Design complex structure .

7. Communicate complex ideas .
8. Aid learning by explicitly integrating new and old knowledge .
9. Assess understanding or diagnose misunderstanding .

advantages of concept maps :

Fitzgerald (1999 : 82) mentioned some certain advantages for concept maps .

- 1- Visual symbols are quickly and easily recognized .
- 2- Minimum use of text makes it easy to scan for a word , phrase or general idea .
- 3- Visual representation allows for development of holistic understanding , that words alone can't convey .

Kommers (2004 : 53) added some advantages of using concept maps

- 4- Concept maps can be used as an advanced organizer to improve learners' achievement .
- 5- It provides teacher with a meaningful and practical structured approach .
- 6- Concept maps is also gaining in roads as a tool of problem solving in education .
- 7- Concept maps also allows for students to reflect on their own misunderstanding and take ownership of their learning (Novak and Gowin : 1984 : 74) .

Daley (2006 : 12) added :

8- Concept maps has the possibility to measure a students' evolving knowledge framework .

Ruiz-Primo (2005 : 28) sees concept maps may give students an opportunity to :

1. Think about the connection between the terms being learned .
2. Organize their thoughts and visualize the relationships between the key concepts in semantic way .
3. Reflect on their understanding . In sum concept maps allow to think deeply about the content by helping them to better understand and organize what they learned .

4.7 Concept maps in the holly Quran

Allah said in the holly Quran " مَا فَرَّطْنَا فِي الْكِتَابِ مِنْ شَيْءٍ " we have neglected nothing in the Book " (Al-an m : 38), This verse is a strong evidence that the holly Quran includes all the fields of science , especially education .

We as Moslems believe in the holy Quran and we consider it as a reference and a guide to our life . Also we believe in that this Book covers every thing in our life from birth to post death .

The researcher will introduce an evidence for the use of the concept maps in the holly Quran , to say that the holy Quran is the first which used

concept maps (before Ausubels' advanced organizer and Joseph Novak)
to tune our attention for the importance of the concept maps to facilitate
and explain the natural things around us .

اللَّهُ نُورُ السَّمَاوَاتِ وَالْأَرْضِ مِثْلُ نُورِهِ كَمِشْكَاةٍ فِيهَا مِصْبَاحٌ الْمِصْبَاحُ فِي زُجْجَةٍ الزُّجْجَةُ كَأَنَّهَا
كَوْكَبٌ دُرِّيٌّ يُوقَدُ مِنْ شَجَرَةٍ مُبَارَكَةٍ زَيْتُونَةٍ لَّا شَرْقِيَّةٍ وَلَا غَرْبِيَّةٍ يَكَادُ زَيْتُهَا يُضِيءُ وَلَوْ لَمْ
تَمْسَسْهُ نَارٌ نُورٌ عَلَى نُورٍ يَهْدِي اللَّهُ لِنُورِهِ مَنْ يَشَاءُ وَيَضْرِبُ اللَّهُ الْأَمْثَالَ لِلنَّاسِ وَاللَّهُ بِكُلِّ
شَيْءٍ عَلِيمٌ

Allah is the light of the heavens and the earth , the parable of his light is
as (if there were) . niche and within a lamp , the lamp is in a glass the
glass as it were a brilliant star lit from blessed tree , an olive , neither of
the east (i.e. neither it gets sun-rays only in the morning) nor of the west
(i.e. nor it gets sun-rays only in the afternoon . But it is exposed to the
sun all day along) whose oil would almost glow forth (of itself) ,
though no fire touched it , Light upon light ! Allah guides to his light
whom he wills , and Allah sets forth parables for mankind , and Allah all-
knower of every thing (AL nour , verse : 35) . See appendix (C .1)

REVIEW RELEATED LITERATURE

Introduction

English is a world language , and its one of the six languages which are used in the United Nations. Therefore , English has become a necessary need for human beings to communicate with others all over the world especially in the age of globalization where the world became a small village where the demand of English increased .

People everywhere deal with this language in their specialization and nowadays we can find different associations in different areas requesting English as one of the main conditions for applying to different jobs. Different methods and strategies were used to teach English language and one of these strategies is concept maps which are a basic principle to build up new knowledge with reference to the previous one .

Concept maps were used to enhance communication , learning ,teaching and to bring about good achievement .

A - Concept maps as a tool for achievement

Esiobu and Soyibo (2006)

This study verified the efficiency of concept and V ee mapping heuristics under cooperative (CP), cooperative-competitive (CP-CM) and individualistic whole (IW) class learning conditions in improving students' achievement in ecology and genetics. A total of 808 tenth -grade students

were involved in the study. The results showed that the experimental groups taught with concept and vee mappings under the three learning modes achieved significantly better than the control group . Students in the CP-CM condition in all groups achieved significantly better than their counterparts in the other two groups, whereas the CP -CM experimental group students achieved significantly best. A significant interaction between treatment and ability suggested that an element of competition, when combined with small group cooperation, favored students of lower ability .

Stoddart (2006)

This study describes the use of concept maps to assess the understanding of science concept and science language production of elementary students who are English language learners (ELL) , The research assessment of sciences content understanding in ELL students i s particularly challenging because it is difficult to determine whether students' performance reflects their understanding of the concepts or their language proficiency , concept maps allow students to demonstrate what they have learned in their primary or second language or both , in a task where the linguistics demands or minimized , a method is described which evaluates 400 grades 2 -5 ELL students' performance in four categories : (1) number of propositions , (2) scientific accuracy , (3) depth of explanation and (4) science vocabulary ,

the results show that the concept maps can be used to assess growth in ELL understanding of science concepts .

Pankratius (2006)

The investigation of the effect of the degree of concept mapping on achievement physics was the purpose of this study. Six intact high school physics classes taught by this investigator took part in the study. Two classes were control groups and received standard instruction. Four classes received six weeks of concept-mapping instruction prior to the unit under study. Two of these four classes were the low-level treatment group and were required to submit concept maps at the conclusion of the instruction. The other two classes were the high-level treatment group and were required to submit concept maps at the beginning and at the conclusion of the unit under study. One class from each treatment group took a pretest prior to instruction. An analysis of the posttest results revealed no pretest sensitization. A one-way analysis of covariance indicated a significant main effect for the treatment level at the $p < 0.05$ level. A pair of single -df comparisons of the adjusted treatment means resulted in significant differences ($p < 0.05$) between the control group and the average of the treatment means as well as between the two experimental groups. It can be concluded that for this sample (upper-middle-class high school physics

students) mapping concepts prior to, during, and subsequent to instruction led to greater achievement as measured by posttest scores.

Willerman and Harg (2006)

The objective of this study was to determine if a concept map used as an advance organizer can improve the science achievement of eighth -grade students. Eighty-two eighth-grade students in four science classes participated in this study. The experimental group completed the concept map at the beginning of the science unit under the teacher's supervision. At the end of the two-week unit a science test was administered to the experimental and the control group. The results of a one-tailed t test indicated that there was a significant difference between the two groups. The effect size is 0.40. It appears that the concept map can provide the classroom teachers with a meaningful and practical structured approach for using advance organizers in their classes.

Rice and et . al (1998)

In the study, a method of scoring concept maps was developed to assess knowledge and comprehension levels of science achievement. By linking scoring of concept maps to instructional objectives, scores were based upon the correctness of propositions. High correlations between the concept map scores and unit multiple choice tests provided strong evidence of the content validity of the map scores. Similarly, correlations between map

scores and state criterion-referenced and national norm-referenced standardized tests were indicators of high concurrent validity. The approach to concept map scoring in the study represents a distinct departure from traditional methods that focus on characteristics such as hierarchy and branching. A large body of research has demonstrated the utility of such methods in the assessment of higher-level learning outcomes. The results of the study suggest that a concept map might be used in assessing declarative and procedural knowledge, both of which have a place in the science classroom. One important implication of these results is that science curriculum and its corresponding assessment need not be dichotomized into knowledge/comprehension versus higher-order outcomes.

Snead and Young (2003)

This study reports on the results of a nine-week investigation that examined the effectiveness of concept mapping on science achievement of 182 African American middle grade science students distributed into eight intact earth science classes (by ability levels). Ability level was examined as a covariate on student achievement. For this sample of students, analyses of covariance indicated no significant overall effects of treatment on science achievement. A statistically significant effect was found between concept mapping and student achievement among the average students measured by combined performance assessment items. The results suggest

that concept mapping has a positive effect on average (lower) ability level African American science students.

Wang and Dwyer (2004)

This study attempts to examine the instructional effects of three concept mapping strategies used to facilitate student achievement in physics. One hundred fifty-six college level students participated in this study. Extra credit points were awarded for participation. Students were randomly assigned to one of the four treatment groups: (a) Treatment 1 (the control group); (b) Treatment 2 (the concept identifying mapping strategy group); (c) Treatment 3 (the proposition identifying mapping group); and (d) Treatment 4 (the student generated mapping group). There were statistically significant differences found between the control group and the concept identifying mapping strategy group in all criterion tests. The significant differences were also found between the control group and the student generated mapping strategy group in the identification, terminology and total criterion tests. There were no statistical significances found among the three concept mapping strategy groups.

Snead and snead (2004)

This study examined the effects of concept mapping on the science achievement of middle grade science students. The subjects were 182

eighth-grade students, distributed into eight intact earth science classes by ability levels. The ability level variable also was examined as a possible effect on student achievement. Two teachers were involved in teaching a unit on weather for nine weeks. An objective weather test and six performance assessment items were used to measure achievement. For this group of students, analyses indicated no significant overall effects of treatment on science achievement. A statistically significant effect was found between concept mapping and student achievement among the average students, as measured by combined performance assessment items. The results suggest that the effect of concept mapping on science achievement is not clear, but that lower ability students appear to have better success with concept mapping than higher ability students.

Attieh and Boujaouda (2003)

This study explores the effect of using concept maps as study tools on achievement in chemistry. Tenth grade students engaged in building concept maps as homework to investigate the correlation between their mastery of concept mapping skills and their achievement in chemistry, and gender differences in using concept mapping as a homework tool. This study provides some insight into the use of concept mapping as a homework tool and provides significant results concerning its different effects on different sex groups where females achieved higher scores than

males on chemistry tests, especially on questions at the knowledge and comprehension levels. The results also show that concept mapping helped low achievers achieve higher in chemistry. Students exhibited positive attitudes toward using concept maps in chemistry .

Guastello and et. al (2000)

This study investigates the effects of concept mapping on science content comprehension of low-achieving inner-city seventh graders , low-achieving seventh-grade students from an urban parochial school were randomly assigned to two equally sized groups (n = 62, each group). One group was taught by a read-and-discuss, teacher-directed method, and the second group, given the some type of introductory lesson as the first, followed a model of concept mapping that connected major and minor concept ideas. A criterion-referenced test based on the content of a science chapter served as the dependent variable. Prior to any teaching, a pretest was administered. An analysis of covariance with pretest scores as the covariate showed a statistically significant difference in comprehension between the pretest and posttest for the experimental group. Effect size estimates revealed that concept mapping can be expected to improve comprehension scores of low-achieving seventh graders by approximately six standard deviations over a traditional instructional technique. When students lack background information on a topic to aid comprehension, the

active participation in constructing semantic or concept maps may help students form a cognitive schema to assimilate and relate the new topic information .

AL Wsimi (2001)

This is aiming to determine the effectiveness of using the concept maps strategy on achievement ,long term learning and developing the attitudes toward science in the prep stage in Saudi Arabia . The sample of the study was a group of (100) students who were divided into two groups (50) for experimental group and (50) for control group . The researcher designed and made use of achievement test instrument .The test was used as pre and post tests . Research findings revealed that there were statistically significant differences between the scores of the experimental group and those of control group in the post-test regarding to the use of concept maps. The researcher recommended using the concept maps strategy in teaching science in prep classes .

Party (2004)

This study was aimed at verifying if students well develop metacognition and the ability to reflect on one's own cognitive process to significant degree , the research was done with subjects in a 10th grade physical sciences course and the sample was (38) for experimental group and (35) for control group . The researcher used three types of tests such as

questionnaire and metacognition (predictive self – evaluation of exam results) and thinking aloud problem solving session . The result of the research revealed that there were no significant differences between the subjects who had a short term training in concept mapping without an explicit accent on metacognitive behavior and those who had not , and the researcher recommended that the short term training in concept mapping had no apparent effect on the development of metacognition .

Riley and Ahlberg (2004)

The study focuses on the effects that an ICT (information and communications technologies)-based concept mapping intervention has on creativity and writing achievement in 10–11-year-old primary stage pupils. The data shows that pupils using a concept mapping intervention significantly improve their NFER non-verbal reasoning age-standardised scores over a control group with a higher baseline whose scores remain constant. Evidence linking this with using ICT-based concept mapping remains inconclusive. Correlation studies show that writing achievement and creativity are linked and that writing achievement and concept mapping connectivity are linked. However, there is no conclusive evidence for linking concept mapping connectivity with creativity. Findings show that concept mapping components increase post-test and that concept mapping ability can be evaluated using a connectivity index that may have

some predictive value in assessing writing achievement. The findings suggest that ICT-based concept mapping provides a reliable framework from which to structure writing and that ICT enhances learning and use of this representational technique provides opportunities for developing innovative and educationally valid practices.

B) Concepts maps as a teaching - learning tool

Odom and Kelly (2001)

This study explores the effectiveness of concept mapping, the learning cycle, expository instruction, and a combination of concept mapping/learning cycle in promoting conceptual understanding of diffusion and osmosis. Four high school biology classes were taught diffusion and osmosis concepts with the aforementioned treatments. Conceptual understanding was assessed immediately and seven weeks after instruction with the Diffusion and Osmosis Diagnostic Test (DODT). The results indicated the concept mapping/learning cycle and concept mapping treatment groups significantly outperformed the expository treatment group in conceptual understanding of diffusion and osmosis. There was no significant difference among the learning cycle group and other treatments.

Lonning and Marko (1998)

The problem addressed by this study is that first-year college chemistry students learn little of the conceptual material associated with chemistry experiments they perform. The thesis of this research is that the construction of prelab and postlab concept maps help students understand the concepts involved in the experiments they perform. The study was conducted using 32 non-science majors enrolled in a first-year chemistry course. The experimental group constructed prelab and postlab concept maps, while the control group wrote essays explaining the conceptual chemistry of the four experiments used in this study. Both groups took 25-item achievement tests 1 week after each experiment. Prelab and postlab concept maps were scored and evaluated for significant differences. Five students were interviewed to investigate their perceptions regarding the usefulness of concept maps in chemistry laboratories. No significant differences were found between treatment groups with respect to students' conceptual understanding as determined by the multiple choice achievement tests. Students responded very positively toward the use of concept maps in the laboratory. They felt strongly that constructing prelab and postlab concept maps helped them understand the conceptual chemistry of the experiments.

Chularu and DeBacker (2004)

This study investigated the effectiveness of concept mapping used as a learning strategy with students in English as a Second Language classrooms. Seventy-nine ESL students participated in the study. Variables of interest were students' achievement when learning from English-language text. Students' reported use of self-regulation strategies (self-monitoring and knowledge acquisition strategies), and students' self-efficacy for learning from English-language text. A randomized pre-test–post-test control group design was employed. The findings showed a statistically significant interaction of time, method of instruction, and level of English proficiency for self-monitoring, self-efficacy, and achievement. For all four outcome variables, the concept mapping group showed significantly greater gains from pre-test to post-test than the individual study group. The findings have implications for both practice and research.

Talebinezhad (2007)

This paper has investigated the effectiveness of concept mapping as a learning strategy on students' self-regulation (metacognitive self-regulation, time and study environment, effort regulation, peer learning, and help seeking). Sixty university students who were randomly selected, participated in the study and were randomly assigned to one control group

and one experimental group, each including thirty students. They were at the intermediate level of English proficiency and studying English either as Translation or Literature. Their language proficiency was determined by the Michigan Test of English Language Proficiency. The instrument to collect data on students' self-regulation was Motivated Strategies for Learning Questionnaire (Printrich et al., 1991), the findings revealing that students gained higher self-regulation as the result of concept mapping strategy teaching. These findings have implications for pedagogy as well as for research.

Keraro and et. al (2007)

This study investigated the effects of using the cooperative concept mapping (CCM) teaching approach on secondary school students' motivation in biology. A non equivalent control group design under the quasi-experimental research was used in which a random sample of four co-educational secondary schools was used. The four schools were randomly assigned to four groups. Each school provided one Form Two class. The study sample was comprised of 156 second grade students in the secondary school cycle (Form Two students) in Gucha District, Kenya. Students in all the groups were taught the same biology content but two groups. The experimental groups were taught using the CCM approach while the other two control groups were taught using regular teaching

methods. Two groups, one experimental and one control, were pre -tested prior to the implementation of the CCM intervention. After four weeks, all four groups were post-tested using the students motivation questionnaire (SMQ). Data were analysed using the t-test, ANOVA and ANCOVA. The results show that students exposed to the CCM approach have significantly higher motivation than those taught through regular methods. The results further indicate that there is no statistically significant gender difference in motivation towards the learning of biology among secondary school students exposed to CCM. The researchers concluded that CCM was an effective teaching approach, which biology teachers needed to incorporate in their teaching.

Lian (1998)

This study used concept map content analysis and interviews to gain insights into the knowledge organization and knowledge processing of pre -service teachers. Forty-eight preservice teachers of elementary science from a teachers' training college in Sarawak, Malaysia, participated in this study. Correlations between achievement and five concept map characteristics showed that there were significant positive correlations ($p < .01$) between achievement and the number of appropriate links , the average number of appropriate concepts per cluster; and, the hierarchy score of subjects' concept maps, and significant negative correlations

($p < .01$) between achievement and: the number of inappropriate links; and, the average number of inappropriate concepts per cluster. Interviews with high-achievers and low achievers revealed that there were differences in the way they processed knowledge during concept mapping. The high-achievers were more thorough than were the low-achievers in cognitive processing of knowledge, taking time to make sense of concepts, sort and group concepts, form relevant links between concepts, and organize concepts hierarchically. Active cognitive processing of knowledge seems to be related to more complex, well-integrated cognitive structures for the material learned.

Pegg (2007)

This study explores concepts of learning used by leaders, focusing on learning for leadership through day-to-day workplace experiences. The participants were drawn from the senior management team within a school, the chair of governors of the school and the local authority school improvement advisor. Concept mapping was used as a participatory research method. Maps were created by the participants and linkages discussed. The maps indicated that learning for leadership from experience was multifaceted. The language used to describe concepts of learning reflected generic and everyday concepts, rather than the language of pedagogy or concepts used in professional training/the literature. The study

alerts us to the difficulties in embedding concepts used in formal training in the everyday life of educational professionals. It also highlights the use of concept mapping as a technique for exploring workplace learning.

Valentina and Sunikumar (2006)

This study describes and demonstrates the use of electronic visual learning tool Open Mind in the classroom to create concept mapping. The concept maps are used either at the beginning of starting a new topic in the classroom to assess prior knowledge or at the end to summarize student's new learning. It develops the critical thinking skills, explores understanding of concepts and links to their future learning. The instructor can also create the concept maps and each box can be electronically linked to add images, pictures, Flash, audio, video, clipart, text, and power point documents. Finally the completed concept map can be exported to Microsoft word, power point, or HTML and can be used as a document or Web page. This software can also be used to make electronic portfolios. The lesson plan and other documented maps serve as links to the electronic portfolio or the portfolio itself.

Brandt, and et .al (2001)

The aim of this study was to examine whether the construction of integrated knowledge structures by students can be stimulated by concept

mapping and by better visualization of concepts and their interrelationships. The investigation was carried out in regular teaching settings: chemistry courses in secondary schools in Flanders, in the domain of electrochemistry. A significant positive effect of extra attention to visualization on the learning achievement of students was found. However, significant effects of concept mapping as an instruction method could not be detected under the given research conditions.

Daley and et. al (2006)

The purpose of this study was to investigate the ways in which the use of concept maps influenced the learning processes of third year internal medicine studies in the context of medical education , sixty – three students were taught to use concept mapping as a learning strategy at the beginning of their internal medicine rotation , the first and final concept maps created by these students were collected and scored , the results indicate that there was a significant difference in the concept maps scores of student during their clerkship rotation .

Saber (2003)

This is aiming to determine the effectiveness of using the concept maps strategy in teaching psychology on acquiring some concepts and developing the attitudes towards it with students in the second grade in the secondary stage .The sample of the study was a group of (77)female

students who were divided into (38) students in the experimental group and (39) student in the control group. The researcher designed and made use of cognitive achievement test and the test was used as pre – and post tests , The research findings revealed that there were statistically significant differences between the scores of the experimental subjects and those of the control subjects in the post - test regarding the use of concept maps. The researcher recommended using the concept maps strategy in teaching psychology in order to acquire some concepts and to develop the attitudes towards it .

Vakilifard and Armand (2006)

The study aims at observing the effects of an instructional sequence , based on the most effective approaches tested in first languages , on informative text comprehension in French as a second language . The sample of the study was (18) students who are selected from the adults students of various mother tongues school of the universitê du Québec Montréal , the researcher divided the sample of two equivalent groups (9) for experimental group and (9) for control group . The researchers used questions as an instrument . The result obtained with comprehension questionnaires on the reading text specific to each meeting indicated that the experimental group obtained a better performance than the group that had used the traditional approach .

Hung, Manh (2006)

In this thesis, it is proposed that concept mapping and sentence diagramming are two techniques that have the potential to effectively solve the inefficient concept manipulation and the structural language ambiguity problems of natural language narrative. The purpose of this research is therefore to offer a solution to the language ambiguity and inefficient concept manipulation problem existing in the traditional narrative technical documents. Specifically, it seeks to answer the question: is it possible to create a new technical writing technique that has its structure similar to the sentence diagramming technique, but is simpler for readers to understand, and can help readers to efficiently manipulate concepts in a text in a manner similar to that of a concept map? A developmental research method approach was adopted. The research was conducted in two phases. The first phase was to develop a new and more effective technical writing technique called 'spatial technical writing' (STW) based on concept mapping and sentence diagramming techniques. The second phase was to conduct a small exploratory study using students to compare the STW technique with traditional narrative. The exploratory study used a small pilot experiment with basic quantitative and qualitative measurements. The quantitative result showed that students achieved a slightly higher mark on comprehension of the narrative text test than the spatial text test. The

probability analysis showed that the pilot experiment was not significant. The qualitative result revealed that the main reason that students did not do as well on the spatial text test was because they did not thoroughly understand the STW symbols used in the pilot experiment. Due to the lack of an experimental budget; the pilot experiment couldn't test all STW symbols, and the students didn't receive enough training to understand STW sufficiently.

Novak (2005)

This research describes the methods and outcomes of a 12-year longitudinal study into the effects of an early intervention program, while reflecting back on changes that have occurred in approaches to research, learning and instruction since the preliminary inception stages of the study in the mid 1960s. The study began to challenge the prevailing consensus at the time that primary school children were either preoperational or concrete operational in their cognitive development and they could not learn abstract concepts. The research based on Ausubelian theory, suggested otherwise. The paper describes the development and implementation of a Grade 1 –2 audio tutorial science instructional sequence, and the subsequent tracing over 12 years, of the children's conceptual understandings in science compared to a matched control group. During the study the concept map was developed as a new tool to trace children's conceptual development.

The researcher found that students in the instruction group far outperformed their non-instructed counterparts, and this difference increased as they progressed through middle and high school. The data clearly support the earlier introduction of science instruction on basic science concepts, such as the particulate nature of matter, energy and energy transformations. The data suggest that national curriculum standards for science grossly underestimate the learning capabilities of primary -grade children. The study has helped to lay a foundation for guided instruction using computers and concept mapping that may help both teachers and students become more proficient in understanding science.

Roberts and Joiner (2007)

In this study , they report the outcomes of a naturalistic experiment in which they investigated the utility of concept mapping as an educational strategy with pupils diagnosed with an autistic spectrum disorder (ASD). Theoretical arguments supporting the use of concept mapping with a n autistic population are outlined in the paper. A tutor group of ten pupils with ASD, aged between 11 and 14 years, took part in the study. Concept mapping tasks were integrated within National Curriculum science lessons in collaboration with the school's science teacher. The study found that the increase in pupil performance in subject -specific questionnaires was nearly four times greater in the concept mapping condition than after a more

conventional teaching intervention. Veronica Roberts and Richard Jo inter tentatively draw out the implications of their work for staff who work with pupils with ASD and make recommendations for further research into the use of these learning strategies.

Hsu and RN (2004)

This study is examining the effects of adopting concept mapping in problem-based learning scenario discussions on the improvement of students' learning outcomes in a nursing course. ... Concept mapping can promote problem-solving and critical thinking to help students organize complex patient data, process complex relationships and offer holistic care to patients. The conclusions. Concept mapping strategies may be useful for analysis of individual student's thinking processes for (1) emphasizing key concepts or main ideas, (2) understanding relationships between different concepts, including cause-effect and part-whole relationships, (3) reviewing propositions, hierarchies and cross -links in a logically scientific way, and (4) revising concept structures to agree with theory and experience .

Commentary on the previous studies :

Having studied the literature , the researcher could extract that implementation of concept maps brings about good results in different dimension . This is clear not only in the students achievement and

understanding in different school subjects , but also positive effects on teaching and learning processes .

Some studies like Esiobu and Saoyibo (2006) , Pankratius (2006) , Willerman and Harg (2006) , Rice et.al (1998) , Snead and Young (2003) , Dwyer and Wang (2004) , Snead and Snead (2004) , Attieh and Boujaouda (2003) , Guastello at el (2000) , AL wisimi (2001) , Party (2004) and Riley and Ahleberg (2004) investigated the effect of using concept maps on achievement .

Odom and Kelly (2001) , Lonning and Marko (1998) ,Chularu and DeBacker (2004) ,Talebinezhad (2007) , Keraro et.al (2007) ,Lian (1998) , Pegg (2007) , Valentina and Sunikumar (2006) , Brandt and et . al (2001) , Daley and et.al (2006) , Saber (2003) , Vakilifard and Armand (2006) ,Hung and Manh (2006) , Novak (2005) Roberts and Joiner (2007) and Hsu and Rn (2004) investigated the effect of using concept maps on teaching and learning .

Stoddart (2006) investigated the effect of using concept maps on understanding .

Some of the studies were conducted in the Middle East area , others in other countries , however , no study in Gaza tackled the effect of concept maps on learning English grammar .

Studies in different subjects benefited the researchers in the sense that the core of concept maps as a strategy is to facilitate learning and to increase achievement .

This study may differ from the other studies in three points :

The place :- As it is the first study in Gaza refugees schools (with their special conditions) which studies the effect of concept maps on achieving English grammar .

The Palestinian context in Gaza strip

The context in Gaza strip is different from other places in the world , a lot of unemployed people who suffer a lot because of the surrounding and poverty , those people are making great demand on the services that improved by the UNRWA , in general , the economical situation is very difficult and miserable because of the Israeli occupation . The target group:- administrating the experiment on the ninth graders , the significance of this grade is that ,it is in the middle between primary and secondary stages , so the researcher can generate the results on the other two stages .

Summary

This chapter consisted of two sections ; literature review and previous studies .

Literature review included three important scopes :

The first scope a brief idea about learning and acquisition as two main processes of practising language and strategies of learning to give a justification for adapting the suitable strategy for teaching our learners the foreign language .

The second scope is a detailed idea about grammar , definitions , the benefit , uses , types , its relation with language and different methods of teaching grammar , that's to help teachers to know the specifics about English grammar .

The third scope is about concept maps as a strategy which can be used in education , the scope includes different definitions , types ,uses , principles , and advantages of the strategy .

Previous studies includes two scopes :

The use of concept maps as a tool for good achievement and understanding results.

The use of the strategy as an effective tool for teaching and learning

III

Methodology

Introduction :

This chapter contains the procedures followed through out the study . It introduces a complete description of the methodology of the study , the population , the sample , the instrumentation , the pilot study , a description of concept maps used in the study , Moreover , it introduces the statistical treatment for the study finding .

3.1 Research design

The study adopts the experimental approach which requires two groups of students ; an experimental group and control one . The strategy of concept maps was used in teaching the subjects of the experimental group while the traditional method was used with the control group subjects .

3.2 The population of the study :

The population of the study consisted of all ninth graders in UNRWA schools in Gaza governorate for the school year (2007 – 2008) . The population of the study was (2497) male students.

3.3 The sample of the study:

The sample of the study consisted of (113) male students distributed into two groups . One experimental group which consisted of (56) students , and one control group consisted from (57) students .The researcher used

a purposive sample from AL- Zaitun prep boys (A) school . The researcher himself administrated the experiment where he is a teacher in the same school .

Table (1)

The distribution of the sample according to the groups

Group	Experimental	Control
MALE	56	57

The subjects were equivalent in the economic , cultural and social levels . They were equivalent in their general achievement in accordance with statistics of their results in the mid -first term exam of the school year (2006-2007) .They were equivalent in their English language achievement in accordance with the statistical treatment of the ir results in the first term exam of the school year (2007 - 2008) . Age variable of the sample also was controlled before the experiment application .

3.4 The variables of the study :

The study included the following variables .

A – The independent variables represented in :

1- the teaching method

1.1 concept maps

1.2 the traditional method

2- The students general ability of English language :

2.1 High achievers

2.2 Low achievers

B- The dependent variable represented in :

The students learning in English grammar .

3.5 Instrumentation :

To achieve the aims of the study , the researcher used the following tool :

3.5.1 Achievement test :

A pre- post achievement test prepared by the teacher to measure the subjects achievement .It was used as a pre-test applied before the experiment and as post test applied after the experiment .(Appendix A .4 page 157).

1. The general aims of the test :

The test aimed at measuring the effect of concept maps strategy on achieving English grammar among the ninth graders . It was built according to the criteria of the test specification .

2. The items of the test :

The items of the test fell into five scopes :

A – knowledge :

This scope includes ten items that measure the subjects knowledge , learners have to read the sentence and to choose one of the correct answers between brackets .

B- comprehension :

This scope includes eight items that measure student comprehension the students have to correct the underlined words if necessary .

C- Applying :

This scope includes fifteen items that measure students comprehension and understanding . Students have to use the word between brackets and to form a new sentence .

D- Analyzing :

This scope includes seven items that measure knowledge and comprehension . Students have to analyze the sentences to show their understanding .

E – Concept Maps :

This scope includes three items with nine questions :

- The first item measures students knowledge and understanding , students have to put the concepts in the correct box to build a meaningful concept .
- The second item the students have to put the connectors on the suitable arrows , to show the relation between concepts .
- The third item students have to put the concepts and the connectors on the suitable places to make a meaningful and understandable concept maps .

3.6 The pilot study :

To examine the appropriateness of the tests items as well as their validity and reliability .The test was administered on a random sample of (28) students from AL-Zaitun prep boys (A) school . The results were recorded and statistically analyzed . The necessary revisions and recommendations were made in the light of the statistical result .

3.7 The validity of the test :

Al Agha (2004: 104) states that valid test is the test that measures what it is designed to measure. The study used the referee validity and the internal consistency validity .

A) The Referee Validity :

The test was introduced to a panel of specialists in English language and methodology in Gaza universities, Ministry of Education and experienced supervisors and teachers in UNRWA schools . The items of the test were modified according to their recommendations. Appendix (D.1 page 189)

B) The content validity :

The test specification was designed according to the general objectives of the content (appendix A.1) (p.156) , the content analysis (appendix A.2) (p 155) and the weight of each skill and the objectives of the test , the ninth grade syllabus consists of (10) units each consists of (5) lessons ; reading lesson ; writing lesson; listening lesson ; speaking

(communication skills) and grammar . The researcher took the last five units to apply the expert on four of Blooms levels where it represented in the test specification and therefore their items in the test . The test items for each level accord with the general objectives of the skill and its nature according to the syllabus .

(C) The internal consistency validity

Al Agha (2004: 110) refers that the internal consistency validity indicates the correlation of the degree of each item with the total average of the test . It also indicates the correlation of the average of each scope with the total average. This validity was calculated by using Pearson Equation . The correlation coefficient of each item within its scope is significant at levels (0.01) and (0.05) appendix (A. 7 pages 173 -175) shows the correlation coefficient of each scope with the whole test.

Table (2)
Correlation coefficient of the scopes of the test

Scope	Total	Knowledge	understanding	application	analyzing
Total	1				
knowledge	0.795	1			
Comprehension	0.912	0.742	1		
applying	0.913	0.557	0.788	1	
analyzing	0.847	0.606	0.690	0.775	1

Table (2) shows the correlation coefficient of each scope with the whole test and each scope with other scopes . Tables in appendix (A. 7 pages 173-175) show the correlation coefficient between each item from the

degree of the scopes, it can be concluded that the test is highly consistent and valid as a tool for the study.

6- Reliability of the test :

The test is reliable when it gives the same results if it is reapplied in the same conditions.(AL Agha : 2004 ; 104) The reliability of the test was measured by Alpha Cronbach and the Spilt- half techniques .

Table (3)

Reliability coefficient by Alpha Cronbach Technique

Scope	NO. of the items	Reliability coefficient
knowledge	11	0.766
Comprehension	13	0.760
Applying	18	0.758
analyzing	7	0.767
total	49	0.912

Table (4)

Reliability coefficient by Spilt –half Technique

scope	NO. OF THE ITEMS	Reliability Coefficient
knowledge	*11	0.685
Comprehension	*13	0.796
applying	18	0.790
analyzing	*7	0.694
total	*49	0.849

* for the singular No. of the items the researcher used Gutman.

According to tables (3) and (4) , the test is proved to be reliable . Alpha Cronbach coefficient is (0.912) and the Split- half coefficient is (0.849)

3.8 Difficulty coefficient

Difficulty coefficient is measured by finding out the percentage of the wrong answers of each item made by the student .Difficulty coefficient of each item was calculated according to the following formula :

$$\text{Co of Difficulty} = \frac{\text{No. of students who gave wrong answers}}{\text{total number of the student}} \times 100$$

The difficulty coefficient varied between (0.31 – 0.69) with a total mean (0.44), thus all items were acceptable or in the normal limit of difficulties according to view of point of assessment and evaluation specialist. See appendix (A. 5)

3.9 Discrimination coefficient:

The discrimination coefficient was calculated according to the following formula.

$$\text{Discrimination Coefficient} = \frac{\text{No. of the student who has the correct answer from the high achievers}}{\text{No. of high achievers students}} - \frac{\text{No. of the student who has the correct answer from the low achievers}}{\text{No. of low achievers students}}$$

The discrimination coefficient varied between (0.30 – 0.70) with a total mean (0.49), thus all the items are acceptable or in the normal limit of

discrimination according to view of point of assessment and evaluation specialist. See appendix (A.6 page 172)

3.10 The using of "concept maps" in the study:

In this study, concept maps was developed by the researcher from different sources e.g. Holy Quran , literature review and the experience of the researcher in teaching English. The aim was using concept mapping to teach the first five units of "English Hello! 5 " for both experimental and control group.

3.11 The validity of the method

To test the methods validity, the researcher submitted this method first design to a group of English Language supervisors and teachers. The researcher did the needed adjustment according to their recommendations . They fall into seven categories :

1- choose the correct answer

Learners have to choose the correct answer from the brackets . This task depends on their knowledge and the aim of this task is to emphasize remembering of the rules of different tenses .

2- Correct the mistakes :-

In this exercise learners have to correct the underlined words , these words are incorrect . The aim of this exercise is of evaluate their

comprehension to grammar according to what they have learned during the experiment .

3- use the words between brackets :-

learners in this exercise face different sentences they have to use the words between brackets and to rewrite the sentence again . The aim of this exercise is to check their comprehension .

4- Analyze the following sentences

In this exercise learners have to analyze the sentences . They have to show that they can differentiate between the types of conditions , time clause , and different tenses .

5- Put the words in the suitable box :

This is a group of words which relate to the map -tense .Students have to put these words in the suitable place to make a meaningful concept . These words are well known words they taught to them by the expert . The aim of these maps is to show learners ability in constructing maps from the more general concept to the more specific one . Through this activity the teacher aims to check the learners knowledge and to identify their ability in constructing maps.

6- Putting the connectors on the suitable place

This is a group of connectors it given to the learners during the ir study . Learners have to put the connectors on the suitable arrows , to show the

relationships between the concepts .This exercise needs a high level of comprehension . learners have to think and to find these relationships to show how are the sub- concepts related to each others and to the general one . The teacher here is checking their understanding and trying to know their abilities in finding these interrelationships.

7- Putting words and connectors in the suitable place :

In this exercise the learners face a constructive map made by the teacher and they have to put the words and connectors which were given to them. Learners here have to construct the map depending on their knowledge and understanding of concept mapping . Learners have to put t he words in the boxes and the connectors on the arrows . The aim of this exercise is to activate their knowledge and comprehension to construct a map and from another hand to make sure that learners can build up maps if we give them concepts and connectors. see (Appendix A. 4) page (P 162 -170) .

3.12 Controlling the variables :

To assure the results and avoid any , marginal interference the researcher tried to control some variables before the study .

1- Age variable

The researcher recorded the students age from their school files at the beginning of the school year (2007 – 2008) T-test and Mann Whitney test were used to measure any statistical differences .

A: The two groups

table (5)
T-test results of controlling age variable

scope	group	N	Mean	Std. Deviation	t	Sig. value	sig. level
Age	experimental	56	15.449	0.588	1.078	0.284	No sig.
	control	57	15.548	0.374			

“t” table value at (111) d f. at (0.05) sig. level equal 1.98

“t” table value at (111) d f. at (0.01) sig. level equal 2.58

B: The high and low achievers:

Table (6)
Mann Whitney test results of controlling age variable

scope	Groups	N	Mean Rank	Sum of Ranks	Mann Whitney U	Sig. value	Sig. level
Age	high achievers in experimental	15	16.033	240.500	104.500	0.737	No sig.
	high achievers in control	15	14.967	224.500			
Age	low achievers in experimental	15	12.867	193.000	73.000	0.100	No sig.
	low achievers in control	15	18.133	272.000			

Tables (5)- (6) indicate that there were no statistically significant differences at (0.05) level between the experimental and control group according to age variable .

2- General achievement variable :

T-test and Mann Whitney test were used to measure the statistical differences between the groups due to their general achievement .The subjects results in the second term test of the school year (2006 – 2007) were recorded and analysed

A: The two groups:

Table (7)
T-test results of controlling general achievement variable

scope	group	N	Mean	Std. Deviation	t. value	Sig. value	sig. level
general achievement	experimental	56	682.214	119.348	0.769	0.444	No sig.
	control	57	663.930	133.063			

“t” table value at (111) d f. at (0.05) sig. level equal 1.98

“t” table value at (111) d f. at (0.01) sig. level equal 2.58

B: The high and low achievers:

Table (8)
Mann-Whitney Test results of controlling English achievement variable

scope	Groups	N	Mean Rank	Sum of Ranks	Mann-Whitney U	Sig. value	Sig. level
general achievement	high achievers in experimental	15	13.767	206.500	86.500	0.281	No sig.
	high achievers in control	15	17.233	258.500			
general achievement	low achievers in experimental	15	17.767	266.500	78.500	0.158	No sig.
	low achievers in control	15	13.233	198.500			

Tables (7)- (8) show that they were no statistical significances at (0.05) between the experimental and the control subjects due to the general achievement variable .

3- General achievement in English language variable :

T-test and Mann-Whitney Test were used to measure the statistical differences between the groups due to their general achievement . The subjects results in the final test of the school year (2006 -2007) were recorded and analyzed .

A: the two groups:

Table (9)
T-test results of controlling general achievement in English variable

scope	group	N	Mean	Std. Deviation	t. value	Sig. value	sig. level
general achievement	experimental	56	682.214	119.348	0.769	0.444	No sig.
	control	57	663.930	133.063			

“t” table value at (111) d f. at (0.05) sig. level equal 1.98

“t” table value at (111) d f. at (0.01) sig. level equal 2.58

B: The high and low achievers:

Table (10)
Mann-Whitney Test results of controlling general achievement variable

scope	Groups	N	Mean Rank	Sum of Ranks	Mann-Whitney U	Sig. value	Sig. level
English achievement	high achievers in experimental	15	15.733	236.000	109.000	0.884	No sig.
	high achievers in control	15	15.267	229.000			
English achievement	low achievers in experimental	15	16.367	245.500	99.500	0.589	No sig.
	low achievers in control	15	14.633	219.500			

Tables (9) – (10) show that there were no statistical differences at (0.05) between the experimental and control subjects due to the general achievement in English variable .

4- Previous learning variable :

To make sure that the sample subjects are equivalent in their previous English language achievement . The researcher applied the pre - achievement test . The results of the subjects were recorded and statistically analyzed by using T-test and Mann-Whitney Test .

A: the two groups:

A/1) According to Bloom levels:

Table (11)
T-test results of controlling pre- test in English variable

scope	group	N	Mean	Std. Deviation	t	Sig. value	sig. level
knowledge	experimental	56	10.607	3.037	0.131	0.896	No sig.
	control	57	10.526	3.516			
Comprehension	experimental	56	9.821	5.153	0.272	0.786	No sig.
	control	57	10.070	4.551			
applying	experimental	56	12.411	5.416	0.082	0.935	No sig.
	control	57	12.491	4.986			
Analyzing	experimental	56	3.125	1.926	0.929	0.355	No sig.
	control	57	2.807	1.705			
total degrees	experimental	56	35.964	12.264	0.031	0.975	No sig.
	control	57	35.895	11.552			

“t” table value at (111) d f. at (0.05) sig. level equal 1.98

“t” table value at (111) d f. at (0.01) sig. level equal 2.58

A/2) According to content of the test :

Table (12)
T-.test results of controlling pre- test in English variable

scope	group	N	Mean	Std. Deviation	t	Sig. value	sig. level
FUTURE	experimental	56	10.839	3.697	0.074	0.941	No sig.
	control	57	10.789	3.488			
PAST	experimental	56	13.571	4.663	0.156	0.876	No sig.
	control	57	13.439	4.396			
condition	experimental	56	11.554	3.949	0.157	0.876	No sig.
	control	57	11.667	3.710			
Total degrees	experimental	56	35.964	12.264	0.031	0.975	No sig.
	control	57	35.895	11.552			

“t” table value at (111) d f. at (0.05) sig. level equal 1.98

“t” table value at (111) d f. at (0.01) sig. level equal 2.58

**B: the high and low achievers:
B/1) According to Bloom levels:**

Table (13)

Mann-Whitney Test results of controlling pre- test in English variable

scope	Groups	N	Mean Rank	Sum of Ranks	Mann-Whitney U	Sig. value	Sig. level
knowledge	high achievers in experimental	15	14.133	212.000	92.000	0.391	No sig.
	high achievers in control	15	16.867	253.000			
	low achievers in experimental	15	16.633	249.500	95.500	0.477	No sig.
	low achievers in control	15	14.367	215.500			
Comprehension	high achievers in experimental	15	15.267	229.000	109.000	0.884	No sig.
	high achievers in control	15	15.733	236.000			
	low achievers in experimental	15	14.700	220.500	100.500	0.616	No sig.
	low achievers in control	15	16.300	244.500			
applying	high achievers in experimental	15	16.667	250.000	95.000	0.465	No sig.
	high achievers in control	15	14.333	215.000			
	low achievers in experimental	15	14.833	222.500	102.500	0.676	No sig.
	low achievers in control	15	16.167	242.500			
analyzing	high achievers in experimental	15	16.933	254.000	91.000	0.350	No sig.
	high achievers in control	15	14.067	211.000			
	low achievers in experimental	15	15.067	226.000	106.000	0.778	No sig.
	low achievers in control	15	15.933	239.000			
Total degrees	high achievers in experimental	15	16.200	243.000	102.000	0.662	No sig.
	high achievers in control	15	14.800	222.000			
	low achievers in experimental	15	15.300	229.500	109.500	0.901	No sig.
	low achievers in control	15	15.700	235.500			

B/2) According to content of the test :

Table (14)

Mann-Whitney Test results of controlling pre- test in English variable

scope	Groups	N	Mean Rank	Sum of Ranks	Mann Whitney U	Sig. value	Sig. level
FUTURE	high achievers in experimental	15	16.667	250.000	95.000	0.463	No sig.
	high achievers in control	15	14.333	215.000			
	low achievers in experimental	15	15.533	233.000	112.000	0.983	No sig.
	low achievers in control	15	15.467	232.000			
PAST	high achievers in experimental	15	16.200	243.000	102.000	0.660	No sig.
	high achievers in control	15	14.800	222.000			
	low achievers in experimental	15	15.633	234.500	110.500	0.933	No sig.
	low achievers in control	15	15.367	230.500			
condition	high achievers in experimental	15	15.233	228.500	108.500	0.866	No sig.
	high achievers in control	15	15.767	236.500			
	low achievers in experimental	15	15.333	230.000	110.000	0.917	No sig.
	low achievers in control	15	15.667	235.000			
Total degrees	high achievers in experimental	15	16.200	243.000	102.000	0.662	not sig.
	high achievers in control	15	14.800	222.000			
	low achievers in experimental	15	15.300	229.500	109.500	0.901	No sig.
	low achievers in control	15	15.700	235.500			

Tables (11) (12) (13) and (14) show the mean and the standard deviation of each group in English previous achievement .The results analysis indicated that there were no statistically significant differences

between the experimental and control groups at (0.05) level due to their pre- test achievement in English grammar before the experiment .

3.13 The statistical analysis

The data were collected and computed by using (SPSS) Statistical Package for social Science , Spearman correlation, Alpha Cronbach Technique and Split –half Technique were used to confirm the test validity and reliability.

On the other hand, T-test was used to measure the statistical differences in means between the experimental and the control groups due to the teaching method.

Mann-Whitney Test was used to measure the statistical differences in mean rank between the low and high achievers in the experimental and control groups.

Eta square was used to calculate the size effect.

3.14 Limitations of the study

- The study aimed to develop English grammar achieving for the ninth graders in UNRWA schools in Gaza governorate .
- The study was applied in the first semester of the school year (2007 – 2008) .
- The study was limited to teaching English language textbook " Hello 5 " units (6-7-8-9-10) through implementing the concept maps strategy .

- The experiment lasted seven weeks in November and December (2007) .

3.15 Data collection procedures

- Studying researches and studies conducted on concept maps in general and the implementation of concept maps in teaching foreign languages .
- Analyzing the content of the suggested units .
- Preparing a teacher guide based on using concept maps in teaching the content of the suggested units .
- Designing achievement test with the help of a group of good teachers .
- Consulting experts in English grammar to assure the test statistical validity .
- Having regular meetings with supervisors to explain the goals and the procedures for administrating the experiment .
- Applying pre-test recording and interpreting the results .
- Teaching the content based on the teachers guide based on concept mapping strategy with the experimental group and traditional method with the control group .
- Applying the post test , recording and interpreting the results .
- Presenting recommendations and suggestions in the light of the study findings .

IV

DATA ANALYSIS

Introduction

The study aimed at investigating the effect of using concept maps on achieving English grammar among ninth graders in Gaza governorate.

This chapter includes the statistical treatment of the groups results and data analysis as well as its statistical significance .T-test and Mann-Whitney Test in addition to mean . Standard Deviation and "t" value, Eta square "²", tests were used to test the hypotheses of the study .

4.1 Data analysis

1- The first hypothesis

There are no statistically significant differences at (0.05) between achieving English grammar by using concept mapping in experimental group and achieving English grammar by the traditional method in the control one .

To investigate the second hypothesis , mean and standard deviation of the experimental and control groups results were computed . (T-test) was used to measure the significant of differences .

A) According to Bloom levels:

Table (15)

T.test results of differences between experimental and control groups in Bloom levels

scope	group	N	Mean	Std. Deviation	t	Sig. value	sig. level
knowledge	experimental	56	17.125	4.725	6.540	0.000	sig. at 0.01
	control	57	11.702	4.071			
comprehension	experimental	56	18.679	8.052	6.205	0.000	sig. at 0.01
	control	57	10.965	4.781			
applying	experimental	56	21.750	6.360	8.163	0.000	sig. at 0.01
	control	57	12.895	5.115			
analyzing	experimental	56	4.696	2.182	4.641	0.000	sig. at 0.01
	control	57	3.035	1.581			
Total degrees	experimental	56	62.250	20.169	7.544	0.000	sig. at 0.01
	control	57	38.596	12.284			

“t” table value at (111) d f. at (0.05) sig. level equal 1.98

“t” table value at (111) d f. at (0.01) sig. level equal 2.58

Table (15) shows that "t" computed value is larger than "t" table value in all scopes and the total degree . This means that there are significant differences in favor of the experimental group due to the concept maps strategy . As a result the hypothesis is totally rejected .

To specify the effect size of the concept maps the researcher used Eta square " η^2 " using the following equation:

$$\eta^2 = \frac{t^2}{t^2 + df}$$

Also the researcher calculated "d" value by using the following equation:

$$d = \frac{2t}{\sqrt{df}}$$

Table (16)
the table referee to determine the level of size effect (η^2) and (d)

Test	Effect volume		
	Small	Medium	Large
η^2	0.01	0.06	0.14
d	0.2	0.5	0.8

Table (17)
"t" value, Eta square " η^2 ", and "d" for each scope and the total degree

Scope	t value	η^2	d	Effect volume
knowledge	6.540	0.278	1.241	Large
Comprehension	6.205	0.258	1.178	Large
Applying	8.163	0.375	1.550	Large
analyzing	4.641	0.163	0.881	large
total	7.544	0.339	1.432	Large

The result of (η^2) and (d) values shown in table (17) indicate large effect of concept maps strategy in almost of Blooms levels . Thus the suggested strategy has a large effect and improve the skills for the experimental group according to their counterparts in the control group.

B) According to content of the test :

Table (18)

T.test results of differences between experimental and control groups in contents of the test

scope	group	N	Mean	Std. Deviation	t	Sig. value	sig. level
FUTURE	experimental	56	18.732	6.077	7.503	0.000	sig. at 0.01
	control	57	11.649	3.691			
PAST	experimental	56	23.446	7.654	7.549	0.000	sig. at 0.01
	control	57	14.491	4.610			
condition	experimental	56	20.071	6.461	7.538	0.000	sig. at 0.01
	control	57	12.456	4.018			
SUM	experimental	56	62.250	20.169	7.544	0.000	sig. at 0.01
	control	57	38.596	12.284			

“t” table value at (111) d f. at (0.05) sig. level equal 1.98

“t” table value at (111) d f. at (0.01) sig. level equal 2.58

Table (18) shows that there are statistically significant differences between the experimental group and their counterparts in the control in favor of the experimental group during the method in the content of the syllabus and the total degree. Thus the suggested strategy has a positive effect on improving the skills for the experimental group.

Table (19)

"t" value, Eta square " η^2 ", and "d" for each scope and the total degree

Scope	t value	η^2	d	Effect volume
Future	7.503	0.337	1.424	Large
Past	7.549	0.339	1.433	Large
Condition	7.538	0.339	1.431	Large
total	7.544	0.339	1.432	large

To specify the effect size of the concept maps the researcher used Eta square " η^2 " table (19) shows that:

The result of (η^2) and (d) values shown in table (19) indicate large effect of concept maps strategy in most of content of the syllabus . Thus the suggested strategy has a large effect and improve the skills for the experimental group compared to their counterparts in the control group.

2. The second hypothesis :

There are no statistically significant differences at ($\alpha = 0.05$) on achieving English grammar between high achievers in the experimental group and their counterparts in the control one .

To answer this question the researcher used Mann-Whitney U test the following table show that:

A) According to Bloom levels:

Table (20)
Mann-Whitney U test of differences of achieving in English variable

scope	Groups	N	Mean Rank	Sum of Ranks	Mann-Whitney U	Sig. value	Sig. level
knowledge	high achievers in experimental	15	23.000	345	0	0.000	sig. at 0.01
	high achievers in control	15	8.000	120			
comprehension	high achievers in experimental	15	23.000	345	0	0.000	sig. at 0.01
	high achievers in control	15	8.000	120			
applying	high achievers in experimental	15	23.000	345	0	0.000	sig. at 0.01
	high achievers in control	15	8.000	120			
analyzing	high achievers in experimental	15	22.533	338	7	0.000	sig. at 0.01
	high achievers in control	15	8.467	127			
Total degrees	high achievers in experimental	15	23.000	345	0	0.000	sig. at 0.01
	high achievers in control	15	8.000	120			

Table (20) shows that there are statistically significant differences between the high achievers in the experimental group and their counterparts in the control one in favor of the high achievers in the experimental group in all Blooms levels and the total degree, thus the suggested strategy has a positive effect on improving the skills for the experimental group.

B) According to content of the test :

Table (21)
Mann-Whitney U of differences of achieving in English variable

scope	Groups	N	Mean Rank	Sum of Ranks	Mann Whitney U	Sig. value	Sig. level
FUTURE	high achievers in experimental	15	23.000	345	0	0.000	sig. at 0.01
	high achievers in control	15	8.000	120			
PAST	high achievers in experimental	15	23.000	345	0	0.000	sig. at 0.01
	high achievers in control	15	8.000	120			
condition	high achievers in experimental	15	23.000	345	0	0.000	sig. at 0.01
	high achievers in control	15	8.000	120			
Total degrees	high achievers in experimental	15	23.000	345	0	0.000	sig. at 0.01
	high achievers in control	15	8.000	120			

Table (21) shows that there are statistically significant differences between the high achievers in the experimental group and their counterparts in the control one in favor of the high achievers in the experimental group in the content of the test and the total degree, thus the suggested strategy has a

positive effect on improving the skills for the high achievers in experimental group.

3. The third hypothesis:

There are no statistically significant differences at (0 .05) on achieving English grammar between low achievers in the experimental group and their counterparts in the control one

A) According to Bloom levels:

Table (22)
Mann-Whitney U of differences of achieving in English variable

scope	Groups	N	Mean Rank	Sum of Ranks	Mann Whitney U	Sig. value	Sig. level
knowledge	low achievers in experimental	15	18.833	282.50	62.500	0.037	sig. at 0.05
	low achievers in control	15	12.167	182.50			
comprehension	low achievers in experimental	15	18.233	273.50	71.500	0.082	not sig.
	low achievers in control	15	12.767	191.50			
applying	low achievers in experimental	15	21.000	315.00	30.000	0.001	sig. at 0.01
	low achievers in control	15	10.000	150.00			
Analyzing	low achievers in experimental	15	16.700	250.50	94.500	0.440	not sig.
	low achievers in control	15	14.300	214.50			
Total degrees	low achievers in experimental	15	19.567	293.50	51.500	0.011	sig. at 0.05
	low achievers in control	15	11.433	171.50			

Table (22) shows that there are statistically significant differences between the low achievers in the experimental group and their counterparts in the control one in favor of the low achievers in the experimental group in all the Bloom levels and the total degrees, Except two levels (comprehension

and analyzing) there are no statistically significant differences between two groups. Thus the suggested strategy has a positive effect on improving the skills for the low experimental group in Blooms levels and the total degrees of the test except understanding and analyzing. The researcher attributed this result to the nature of low achievers being unserious students especially , if they know that they are not competing others . Low achievers of both groups ; the experimental group and the control didn't pay enough efforts to achieve marks .

B) According to content of the test:

Table (23)
Mann-Whitney U of differences of achieving in English variable

scope	Groups	N	Mean Rank	Sum of Ranks	Mann Whitney U	Sig. value	Sig. level
FUTURE	low achievers in experimental	15	19.467	292.00	53.000	0.013	sig. at 0.05
	low achievers in control	15	11.533	173.00			
PAST	low achievers in experimental	15	19.633	294.50	50.500	0.010	sig. at 0.05
	low achievers in control	15	11.367	170.50			
condition	low achievers in experimental	15	19.767	296.50	48.500	0.008	sig. at 0.01
	low achievers in control	15	11.233	168.50			
Total degrees	low achievers in experimental	15	19.567	293.50	51.500	0.011	sig. at 0.05
	low achievers in control	15	11.433	171.50			

Table (23) shows that there are statistically significant differences between the low achievers in the experimental group and their counterparts in the control one in favor of the low achievers in the experimental group in all

the content of the syllabus and the total degrees. Thus the suggested strategy has a good effect to improve the skills for the low experimental group

Summary

Chapter four dealt with data analysis and its results .The results of each hypothesis was analyzed statistically using different statistical techniques .

The results of the first hypothesis showed differences of statistical significant between the experimental group and the control one in favor of the experimental group due to the teaching method . The results of the second hypothesis indicated significant differences between the two groups in favor of the experimental group high achievers . The results of the third hypothesis indicated differences of statistical significance between the two groups in favor of the experimental group low achievers except in comprehension and analyzing levels .

V

FINDINGS , DISCUSSION , CONCLUSION AND RECOMMENDATIONS

Summary :

The purpose of this study was to examine the effect of using concept maps on achieving English grammar among ninth graders in Gaza governorate . To collect data pre – post test was employed .A panel of specialists agreed that the instrument was valid .The items of the instrument had an alpha coefficient of (.912) and Split- half coefficient is (0.849) for the test as a whole .The data were tested through the application of T -test and Mann Whitney test .

In this study , this chapter deals with the interpretation of the statistically analyzed data of the hypotheses of the study presented in chapter four .In the light of the statistical results , the researcher concludes the following findings .

5.1 Findings :

1- There were statistical significant differences in achieving English grammar between the experimental group and the control one due to the method in favor of concept maps strategy .

2- There were statistically significant difference between the high achievers in the experimental group and their counterparts in the control one in favor of the high achievers in the experimental group .

3- There were statistically significant differences between the low achievers in the experimental group and their counterparts in the control one in favor of the low achievers in the experimental group .

5.2 Discussion :

1- Results of the first hypothesis :

1) There are no statistically significant differences at (0.05) between achieving English grammar by using concept maps in the experimental group and achieving grammar by the traditional method in the control one . To this hypothesis , mean and standard deviation of the experimental and the control groups results were computed . (T-test) was used to measure the significant of differences . Moreover "d" and " η^2 " values were computed to estimate the effect size of the concept maps strategy .

The findings of the study were limited to the experiment " concept maps strategy " since all variables such as age , general achievement and general achievement in English language were controlled before the experiment .

Table (17) showed that "t " computed value is larger than " t " table value in all scopes of the test and the total degrees . This meant that there were significant differences in favor of the experimental group due to the concept maps strategy .

This result agreed with the results of almost all the previous studies like ; Esiobu and Soyibo (2006) , Pankratius (2006) , Willerman and Harg (2006) Chularu and DeBacker (2004) , Snead and Snead (2004) , Saber (2003) ,Pegg (2007) , Valentina and Sunikumar (2006) that revealed the effect of using concept mapping on achieving different subjects . Riley and Ahlberg (2004) reveled that concept maps may have some predictive value in assessing writing achievement .Talbinezhad (2007) revealed that students gained higher self-regulation as the result of concept maps strategy .

Odom and Kelly (2001) revealed that concept mapping/learning cycle and concept mapping treatment groups significantly outperformed the expository treatment group in conceptual understanding of diffusion and osmosis. Keraro et .al (2007) who investigated the effects of using the cooperative concept mapping (CCM) teaching approach on secondary

school students' motivation in biology , showed that students exposed to the CCM approach have significantly higher motivation than those taught through regular methods

Lonning and Marko (1998) revealed that no significant differences were found between treatment groups with respect to students' conceptual understanding as determined by the multiple choice achievement tests. Students responded very positively toward the use of concepts maps in the laboratory .

Daley and et.al (2006) investigated the ways in which the use of concept maps influenced the learning processes of third year internal medicine studies in the context of medical education . The results indicated that there was a significant difference in the concept maps scores of student during their clerkship rotation .

Vakilifard and Armand (2006) and Hung and Manh (2006) who used concept maps in teaching comprehension text their studies revealed that concept mapping has a positive effect on comprehension . And agreed with Party(2004) in that concept maps have a positive effect on metacognition Stoddart (2006) who investigated the effect of concept mapping to assess the understanding of science concept and science language production of elementary students .Novak (2005) supported the earlier introduction of science instruction on basic science concepts .

According to "d" and " r^2 " values shown in table (19) , it was observed that the effect size of concept mapping strategy was larger on the students achievement including knowledge , comprehension , applying and analyzing .

2- Results of the second hypothesis

There are no statistically significant differences at (0.05) in achieving English grammar between high achievers in the experimental group and their counterparts in the control one .

(Mann-Whitney test) results showed that there were differences of statistical significant in the favor of the experimental high achievers in all (Bloom levels) . According to "d" and " r^2 " values , it was observed that the effect size of the concept maps strategy was large in all the levels .

These results agreed with Brandt, and et.al (2001) , Lian (1998) , Rice and et .al (1998) which indicated positive effect of using concept mapping with the higher achievers in achievement and in cognitive processing of knowledge .

3- Results of the third hypothesis

There are no statistically significant differences at (0,05) in achieving English grammar between low achievers in the experimental group and their counterparts in the control one .

(Mann-Whitney test) results showed that there were statistically significant differences between the low achievers in the experimental group and their counterparts in the control one, in favor of the low achievers in the experimental group in all the Bloom levels and the total degree, except two levels (comprehension and analyzing) there are no statistically significant differences between the two groups. Thus the suggested strategy has a positive effect on improving the skills for the low achievers in the experimental group in Blooms levels . This study agreed with Lian (1998) and Snead and Young (2003) , however the results disagreed with Guastello and et . al (2000) who revealed that concept maps can be expected to improve comprehension scores of low -achieving . The researcher attributed this result to the differences between learners culture , economic situation , number of the students within the same class and to their age .

5.3 Conclusion

Based on the findings , delivered from the results of this study the following conclusions were reached .

1. Concept maps strategy has a superiority over the traditional method in learning English grammar .
2. Concept maps provides students with a better learning environment which reflects on their learning to English grammar .

3. Concept maps stimulates students towards an independent practice of English language instead of direct instruction .
4. Concept maps develops the cooperative learning within the same group and competition with other groups .
5. Through concept maps learners play different roles as , thinkers , problem solvers , and researchers . These roles help them acquire and employ English language in different t situations more easily .
6. Concept maps strategy is very effective in motivating students to think more deeply .
7. Concept maps also allows students to reflect on their own misunderstanding and take ownership of their learning .
8. Concept maps as a visual representation allows for development of holistic understanding that words alone can't convey .

5.4 Recommendations :

According to the conclusion of the study , the following recommendations are offered :

Curriculum designers and decision makers are recommended to :

- enhance the Palestinian curriculum with different concept maps that tackle different tenses in English grammar .
- supply schools with different materials for employing concept maps strategy .

Supervisors are recommended to :

- prepare and distribute instructional materials that increase teachers awareness of concept maps strategy significance and necessity of using this strategy in teaching English grammar .
- emphasize the fact that concept maps is a strategy of teaching that should be used with different tenses of English grammar .
- conduct training courses that help teachers enhance their competencies of implementing the concept maps strategy in their classes .
- conduct workshops that aim at familiarizing teachers of how to build concept maps in their classes .

English language teachers are recommended to :

- shift from the traditional teaching methods to communicative approach that is based on the students real environment in teaching – learning process .
- use concept maps strategy to create an appropriate learning environment.
- enrich the curriculum with concept maps that enhance students use of English grammar .
- consider students individual differences and learning styles while using concept mapping strategy .
- help students to use English in " life – like "situations .

- adapt modern techniques that enhance students participation and interaction .
- change their role from instructors who dominate the class into educators whose role is to help , guide and support the students to acquire language .

5.5 Recommendations and further studies :

Education in Palestine still needs a lot of researches that touch all the inputs of the educational system . These inputs are represented in ; the strategies , the teacher , the students , the curriculum , the administration and local community . The researcher suggests the following titles for further studies.

1. The effect of using concept mapping in teaching punctuation .
2. The effect of using concept mapping in developing students critical thinking .
3. Using concept maps as an assessment tool for students comprehension.
4. Using concept mapping as a tool for teaching religion .
5. Using concept maps to assess language production of English language learners.

REFERANCES

AAAS . (1990) : **Effective learning and teaching** , From :

www.project2061.org/.../rsl/online/GUIDE/CH2/TPELT.PDF

Abbott , G. and et. al (1981) : **The Teaching Of English has An**

International Language , A Practical Guide , English As An

International Language , Great Britain .

Ahlberg , M and , Vukko , A. (2004) : **Six Years Of Design**

Experiments Using Concept Mapping At The Beginning Of The End

Of Each Of Learning Projects .

From : <http://cmc.ihmc.us/CMC2004Programa.html>

Asan , A (2007) : **Concept Mapping In Science Class : A Case Study**

Of Fifth Grade Students , Educational Technology And Society ,

Vol (10) , No (1) .

Atkinson , R . and et. al (1993) : **Introduction To Psychology** , Eleventh

Edition , Harcourt Brace College Publisher , United States Of America .

Attieh , M and Boujaouda , S (2003) : **The Effect of Using Concept**

Maps as Study Tools on Achievement in Chemistry , Reports - Research;

Speeches/Meeting Papers.

From : www.Eric.com

Barnard , H. (1858) : **Definition Of Grammar** , The American Journal Of Education . From : <http://books.google.com>

Basso, S. and Margarita, S. (2004) : **Teaching By Doing With Concept Maps : Integrating Plone and Cmaptools** .

From : <http://cmc.ihmc.us/CMC2004Programa.html>

Brandt and et .al (2001) : **The impact of concept mapping and visualization on the learning of secondary school chemistry students**

,International Journal Of Science Education , Vol (12) , Issue (23) .

Brinto , L. J. (2000) : **The Structure Of Modern English : A Linguistic Introduction**, John Benjamin , Amsterdam .

From : <http://books.google.com>

Brown, D .H .(2007) : **Principles Of Language Learning And Teaching** , Fifth Edition , Longman , United State s Of America .

Bruce , P . (2006) : **How Young Children Learn Language** , Early Childhood Today , Canada , Retrieved 3 . April . 2008 .

From : <http://content.scholastic.com/>

Buzzetto-More , N . A. (2007) : **Advanced Principles Of Effective E-Learning** , Information Science press , California .

Cakir .I (2004) : **Designing Activities For Young Learners In EFL Classroom** .GU ,Gasi Egitim Dergisi , Vol (24) , No (3) .

Catania . Ch .A . (1992) : **Learning** , Third Edition , Prentice Hall ,
Englewoods Cliffs , New Jersey .

Byrd . P (2004) : **Grammar In The Foreign Language Classroom :
Making Principled Choices** , Grace Stovall Burkart, Ed.; Washington,
DC: Center For Applied Linguistics .

Retrieved From : <http://www.nclrc.org/essentials/grammar/grindex.htm>

Chularu , P. and DeBacker , K. T.(2004) : **The influence of concept
mapping on achievement, self-regulation, and self-efficacy in students
of English as a second language**, Contemporary Educational Psychology
journal , Volume 29, Issue 3 .

Clark , I .F and James , P.R. (2004) : **Using Concept Maps To Plan An
Introductory Structural Geology Course** , Journal Of Geoscience
Education , V (52) , No (3) .

Close , R.A. (1992) : **A Teachers Grammar ; An Approach To The
Central Problems Of English** , Language Teaching Publishing , London.

Cook . V. (1991) : **Second Language Learning And Language
Teaching** ,Chapman And Hall Inc , Great Britain .

Cross , D. (1992) : **A Practical ; Handbook Of Language Teaching** ,
Prentice Hall International Limited , UK .

Daley , B. (2006) : **Advancing Teaching And Learning In Medical
Education Through The Use Of Concept Maps** .

From : <http://cmc.ihmc.us/cmc2006papers/cmc2006-p7a-pdf> .

David, S. and David, V. (2006): **Visual Learning Through Concept Mapping**, In E. Pearson and P. Bohman (Eds.), Proceedings of World Conference on Educational Multimedia , Hypermedia and Telecommunications .

Elorriaga , J.A . (2006) : **Applications Of A Concept Mapping Tool**..

From : <http://cmc.ihmc.us/cmc2006Papers/cmc2006.pdf>

Esiobu ,O .G. and Soyibo , K. (2006) : **Effects of concept and vee mappings under three learning modes on students' cognitive achievement in ecology and genetics** , Journal of Research in Science Teaching , Volume 32, Issue 9 .

Eyres , I. (2000) : Developing Subject Knowledge ; Primary English , Paul chpman , London .

Finegan , E. (1998) : **Language Its Structure and Use** ,Second Edition , Harcourt Brace College , USA .

Fizgeraled , M. A. (1999) : **Educational Media And Technology** , Libraries Unlimited , USA . From : <http://books.google.com>

Fonseca , A. P. (2004) : **Concept Mapping : A Strategy For Meaningful Learning In Medical Microbiology** .

From : <http://cmc.ihmc.us/CMC2004Programa.html>

Francis , R. .W (2006) : **Using Concept Maps As An Assessment Tools : Defining Understanding** . College Quarterly , Vol (9) , No (3) .

Retrieved 3rd . April . 2008 . from : <http://www.senecac.on.ca/quarterly>

Fred , N. and et .al (2007) : **Effects of Cooperative Concept Mapping Teaching Approach on Secondary School Students' Motivation in Biology in Gucha District**

Freeman ,D. L. (2000) : **Techniques and Principles in Language Teaching** , Oxford University press , New York .

Fromkin , V. and Rodman R. (1993) : **An Introduction To Language** , Holt Rinchart and Winston , United States Of America .

Garcia , G . G . (2003) : English Learners : Reaching The Highest Level Of English Literacy , International Reading Association , New Jersey.

Genesee , F.(2000) : **Brain Research : Implications For Second Language Learning , Online Resources : Digests** , Retrieved 21 . March . 2008 .

From : <http://www.cal.org/resources/digest/0012brain.html>

Gordon , W .C. (1989) : **Learning and Memory** , Books/Cole Publishing Company . California .

Guastello, E. F. (2000) : **Concept Mapping Effects on Science Content Comprehension of Low -Achieving Inner-City Seventh Graders** , Remedial and Special Education .

Guth , H. p. (1973) : **English For New Generation** , McGraw-Hill Book Company , United States Of America .

Hamad , I . (2005) : **The Effect Of Using Role Play Strategy On The Eighth Graders Achievement In English Language** . (Unpublished M.A Thesis) , AL-A zhar University .

Hamdan , J. (1991) : **Communicative Language Teaching** , UNRWA , Amman .

Harlen , W. (2006) : **Teaching , Learning and Assessing Science** , Forth Edition , Sage Publications , London .

Harmer .J (2001) : The Practice Of English Language Teaching , Longman ,England .

Hismanoglu , M. (2008) : **Language Learning Strategies In Foreign Language Learning And Teaching** , Retrieved 21 . March . 2008.

From : <http://iteslj.org/articles/Hismanoglu-strategies.html>

Hsu , L. and RN , E. (2004) : **Developing Concept Maps From Problem-Based Learning Scenario Discussions** , Journal of Advanced Nursing , Vol, (48) , No (5) .

Huddleston , R. (1988) : **English Grammar An Outline** , Cambridge University Publishing , Great Britain .

International Journal Of Leadership In Education , V(10) , N(3) .

Hung ,H. and Manah.m (2006) : **The development of a spatial technical writing technique: the application of concept mapping and sentence diagramming**, University of Wollongong , Australian Digital Theses Program .

From: <http://www.library.uow.edu.au/adt-NWU/public/adt-NWU20070212.134504/index.html> .

Hussin , et.al (2000) : **Sustaining An Interest In Learning English And Increasing The Motivation To Learn English : An Enrichment Program**, paper presented at the millennium MICELT 2000, 3rd malaysia intrnational Conference For English Language Teaching , Melaka , Putra Malaysia University , The International Internet TESL , Journal Vol (7) , No(5) Retrived May 15th , 2008 . From :

<http://iteslj.org/Techniques/Hussin-motivation/>

Jenen, J. (2003) : **The Process Of Learning** , Virtual Book Publishing . United States Of America .

Jespersen , O. (1969) : **Essentials Of English Grammar** ,George Allen and Unwin Ltd , London .

Juall , L. and Moyet , C. (2005) : **Understanding The Nursing Process : Concept Mapping And Care Planning** , Williams And Eilkins , USA .

From : <http://books.google.com>

Kara , R . (1992) : **Language Learning And Teaching , Basic Premises** ,
Al Fateh University Publishing , Tripoli .

Keshta , A .S. (2000) : **Alternative Approaches For Teaching English
Literature To Undergraduate Students In Gaza Strip** , Houston ,
University Of Houston , Texas .

Knight , P. and Lindsay , C. (2006) : **Learning And Teaching English** ,
Oxford University Press . UK .

Kohli .A.L (1999) : **Techniques Of Teaching English , For B. Ed .
Students** , Fifteen Edition , Dhanpat Rai Publishing Company (P) Ltd ,
New Delhi .

Kommers ,P . A. M . (2004) : **Cognitive Support For Learning :
Imagining The Unknown** , Ios Press , England .

From : <http://books.google.com>

Kristmanson , P . (2000) : **Affect In The Second Language ; How To
Create An Emotional Climate** , Reflexion , Vol . 19 , No 2 .

Lapalombara , L . E . (1976) : **An Introduction To Grammar :
Traditional , Structural , Transformational** , Winthrop , Cambridge .

Leech , G. and et.al (1982) : **English Grammar For Today ; A New
Introduction** , The Macmillan Press In Conjunction With The English
Association ,London .

Leou , Sh. and Liu, J. C (2004) : **The Study Of Concept Map Implementation For Enhancing Professional Knowledge Of High School Mathematics Teacher . From :**

<http://cmc.ihmc.us/CMC2004Programa.html>

Lewis , M. (1986) : **The English Verb ; An Exploration Of Structure And Meaning** , Michael Lewis Language Teaching Publications , London.

Lian . M. and Wong , S. (1998) : **An Investigation Into High-Achiever And Low-Achiever Knowledge Organization And Knowledge**

Processing In Concept Mapping: A case Study , Research in Science Education journal , Volume 28, Number 3 .

Lindsay . C and Knight . P (2006) : Learning And Teaching , Oxford University Press .UK.

Lock ,G. (1996) : **Functional English grammar : an introduction for second language teachers** , Cambridge university press , UK .

Lock , G. (2002) : **Functional English Grammar : An Introduction For Second Language Teachers** , Cambridge university press , UK .

Lodge ,Caroline and Carnell ,Eileen (2002) : **Supporting Effective Learning** , Paul Chapman Publication , London .

Love , K. (2004) : **Facilitating Learning Of Cmaptools Software Using A Learning Project** . From : <http://cmc.ihmc.us/CMC2004Programa.html>

Lewis , M. And Hill ,J (1995) : Practical Techniques For Language Teaching , Commercial Colour Press , London .

Markow . G. P. and Lonning .A . R. (1998) : **Usefulness Of Concept Maps In College Chemistry Laboratories: Students' Perceptions And Effects On Achievement** , Journal of Research in Science Teaching , Volume 35, Issue 9 .

McClure . R , and et .al (1999) : **Concept Map Assessment Of Classroom Learning: Reliability, Validity, And Logistical Practicality** , Journal of Research in Science Teaching , Volume 36, Issue 4 .

McMurray . M . A (2008) : **Introduction to Concept Mapping** , Henderson Community College, Henderson, KY . Retrieved , May 2nd , 2008 From : <http://www.synapseadaptive.com/inspiration/cm.html>

Miller . J, E and Brown . E. K. (1980) : **Syntax : A Linguistic Introduction To Sentence Structure** , Hutchinson , London .

Miller. P. J. (2006) : **Learning For Many Educators Involves Adding Or Accumulating Knowledge , Education For Wisdom And Compassion : Creating Conditions For Timeless Learning** , Corwin press , California .

Morgan , C .T and et.al (1999) : **Introduction To Psychology** , Sixth Edition , Tata McGraw-Hill , New Delhi .

Mumford , A. (1999) : **Effective Learning** , Book Marquee Ltd , Great Britain . From : <http://books.google.com>

Nasr , R. T. (1980) : **The Essentials Of Linguistic Science** , Longman , Great Britain .

Novak , J. (2001) : **Concept Maps : What The Heck Is This ?** ,

Retrieved 21 . March . 2008 . From : <http://camp.coginst.uwf.edu/info/>

Novak , J. ,D and Ca as , A. J . (2006) : **The Theory Underlying Concept Maps And How To Construct Them** .

From:<http://cmap.ihmc.us/Publications/ResearchPapers/TheoryCmaps/TheoryUnderlyingConceptMaps.htm>

Novak , J.D and Bob G. (1984) : **Learning How To Learn** , Cambridge University Press , USA .

From : <http://books.google.com>

Novak . J . D (2005) : **Results And Implications Of 12-Year**

Longitudinal Study of Science Concept Learning , Journal Of Research In Science Education , Vol (35) , No (1) .

Novicki , Ch. (1996) : **Principles For Learning** ,

From : Fast Company.Com .

Nunan , D. (1991) : **Language Teaching Methodology A Textbook For Teachers** , Prentice Hall, UK .

Odom . L. A. and Kelly ,V. P. (2001) : **Integrating Concept Mapping And The Learning Cycle To Teach Diffusion And Osmosis Concepts To High School Biology Students** , Science Education Journal , Volume (41) , Issue (6) .

Oxford .L. R (1990) : Language Learning Strategies , Heinle and Heinle Publishers , United States Of America .

Ozdemir , A . G . (2005) : Analyzing Concept Maps As An Assessment (Evaluation) Tool In Teaching Mathematics , Journal Of Social Sciences , Vol (1) , No (3) .

Palmer , F. (1971) : **Grammar** , Penguin Books , England .

Pankratius , W . J. (2006) : **Building An Organized Knowledge Base: Concept Mapping And Achievement In Secondary School Physics** , Journal of Research in Science Teaching , Volume 27, Issue 4 .

Patry , J. (2004) : **Effects Of Short Term Training Iin Concept – Mapping On The Development Of Metacognition**

From : <http://cmc.ihmc.us/CMC2004Programa.html>

Pegg .A. E. (2007) : **Learning For School Leadership: Using Concept Mapping To Explore Learning From Everyday Experience**, International Journal Of Leadership In Education .

http://www.accessmylibrary.com/coms2/summary_0286-1889286_ITM

Pill , M. and et .al (2005) : **Enhancing Teaching In Higher Education** ,
Routledge , USA.

Purpura , J . E . (2004) : *Assessing Grammar* , Cambridge University ,
United Kingdom .

Rebecca . O. L . (1990) : **Language Learning Strategies : What Every
Teacher Should Know** , Heinle And Heinle Publishers , United States Of
America .

Reece , I. and , Walker S.(2003) : **Teaching , Training And Learning** ,
(Fifth Edition) Business Education Publishers Limited , Great Britain .

Rice. C. Diana , and at. el . (1998) : **Using Concept Maps To Assess
Student Learning In The Science Classroom: Must Different Methods
Compete?** , Journal of Research in Science Teaching , Volume (35), Issue
(10) .

Richardson , R. and et. at (2005) : **Evaluating Concept Maps As A
Cross –Language Knowledge Discovery Tool For NDLTD** .

From : <http://adt.caul.edu.au/etd2005/papers/061Richardson.pdf>

Ridout , R. and Clarke , W. (1970) : **A Reference Book Of English ; A
General Guide For Foreign Students Of English** , Macmillan , London.

Riley . N. R and Ahlberg. M. (2004) : **Investigating The Use Of ICT-
Based Concept Mapping Techniques On Creativity In Literacy Tasks**,
Journal of Computer Assisted Learning , Volume (20) , Issue (4).

Robins .R .H . (1980) : **General Linguistics , An Introductory Survey** ,
Longman , London .

Rubin , A.and Babbie , E.R . (2005) : **Research Methods For Social
Work** , Thomson Learning , USA. From: <http://books.google.com>

Ruiz-Primo , M. A. (2000) : **On The Use Of Concept Maps As An
Assessment Tool In Science : What We Have Learned So Far** , Revista
Elect nica De Investigac n Educativa , Vol (12) , No (1) .

Saville-T. M. (2006) : **Introducing Second Language Acquisition** ,
Cambridge University Press , UK .

Seidel , R. J (2005) : **From Principles Of Learning To Strategies For
Instruction : Empirically Based , Springer Science + Business Media** ,
Inc , U.S.A. From : <http://books.google.com>

Sluckin . W . (1972) : **Imprinting And Early Learning** , Methuen And
Co Ltd , London .

Smith , M. Sh. (1994) : **Second Language Learning : Theoretical Part** ,
Longman Group , UK .

Snead , D. and Young , B. (2003) : **Using Concept Mapping To Aid
African American Students' Understanding In Middle Grade Science** ,
The Journal of Negro Education, Vol. 72, No. 3, pp. 333-343.

Snead .V.L and Snead .D (2004) : **Concept Mapping And Science Achievement Of Middle Grade Students** , Journal of Research in Childhood Education, V18 , N4 .

Spencer , A. (1996) : **Phonology Theory And Description** , Blackwell , USA .

Stevick . W . E. (1982) : **Teaching And Learning Language** , Cambridge University Press , United Kingdom .

Stiles .M .J . (2000) : **Effective Learning And The Virtual Learning Environment** , European Universities Information System Congress – EUNIS . From www.staffs.ac.uk .

Stoddart ,T. (2006) : **Using Concept Maps To Assess The Science Understanding And Language Production Of English Language Learners** , Second International Conference On Concept Mapping .
From : <http://cmc.ihmc.us/cmc2006Papers/cmc2006-p103.pdf>

Sweet , H. (2005) : **A New English Grammar : Logical And historical. Part (1) , introduction phonology and accidence** , adamant media Corporation , London . From : <http://books.google.com>

Talebinezhad, M. R. (2007) : **The Effect of Explicit Teaching of Concept Mapping in Expository Writing on EFL Students' Self - Regulation** , The Linguistic Journal , Volume (2) , Issue (1).

Teresa , S. M. and Jorge ,V.(2006) : **Using Concept Maps As A Strategy To Teach Physics , In Particular The Topic Of Acoustics** .From:

<http://cmc.ihmc.us/cmc2006papers/cmc2006-p7a-pdf> .

Thornbury , S.(2004) **How To Teach Grammar** , Longman , England.

Todd , L.(1992) : **An Introduction To Linguistics** , Longman , Great Britain .

Vakilifard , A. and Armand , F. (2006) : **The Effects Of Concept Mapping On Second Language Learner Comprehension Of**

Informative Text . from:<http://cmc.ihmc.us/cmc2006papers/cmc2006-p7a-pdf> .

Vanides , J. and et .al (2005) : **Using Concept Maps In The Science Classroom** , National Science Teachers Association , Vol (28) , No (8) .

Vecchai , L. L. and Pedroni , M. (2007) : **Concept Maps As A Learning Assessment Tool** , Issues In Informing Science And Information Technology , Vol (4) .

Veronica , R. and Richard J. (2007) : **Investigating The Efficacy Of Concept Mapping With Pupils With Autistic Spectrum Disorder,**
British Journal of Special Education 34 (3) .

Wang . Ch . X. and Dwyer . F. (2004) : **Effect Of Varied Concept Mapping Strategies On Student Achievement Of Different Educational Objectives,** International Journal of Instructional Media,V(31), N (4) .

Wikipedia , The Free Encyclopedia, **Grammar** : Retrieved 3rd, April, 2008 .

Wikipedia , the Free Encyclopedia, **Language Acquisition** : Retrieved 3rd. April. 2008 .

Wikipedia , the Free Encyclopedia, **Learning** : Retrieved 31st. March. 2008 from <http://en.wikipedia.org/wiki/Learning> .

Wilkins , A .(1974) : **Second – Language Learning And Teaching** , Edward Arnold Ltd , Great Britain .

Willerman , M. and Harg. R. A. M.(2006) : **The Concept Map As An Advance Organizer**, Journal of Research in Science Teaching , Volume (28), Issue (8) .

Williams , J . D . (2005) : **The Teachers Grammar Book** , Lawrence Erlbaum Associates , New Jersey . From : <http://books.google.com>

Wilson , D. and Smith , N. (1979) : **Modern Linguistics The Results Of Chomsky's Revolution** , Penguin Books , Great Britain .

Woods , E. (1995) : **Introducing Grammar** , Penguin Books , USA .

Yule , G. (1996) : **The Study Of The Language** ,Second Edition , Cambridge University Press , United Kingdom .

المراجع العربية

القرآن الكريم ، سورة الأنعام ، الآية (38) .

القرآن الكريم ، سورة النور ، الآية (25) .

أبو الهيجا ، فؤاد حسن (2001) : أساليب التدريس و مهاراته و طرقه العامة ، دار المناهج ، عمان .

أبو جلاله ، صبحي حمدان و عليمات ، محمد مقبل (2001) : أساليب التدريس العامة المعاصرة ، مكتبة الفلاح ، الكويت .

الأغا، إحسان، و الأستاذ ، محمود (2004) مقدمة في تصميم البحث التربوي، ط3، مطبعة المقداد.

الحصري ، منير على (2005) : طرق التدريس العامة ، مكتبة الفلاح ، الكويت .

الوسيمي ، عماد الدين عبد المجيد (2001) : أثر استخدام إستراتيجية خرائط المفاهيم على

التحصيل و الاحتفاظ بالتعلم و تنمية الاتجاهات نحو مادة العلوم لدى تلاميذ المرحلة المتوسطة

بالمملكة العربية السعودية ، دراسات في المناهج و طرق التدريس ، العدد(75) .

العزة ، سعيد حسنى (2002) : صعوبات التعلم (المفهوم ، التشخيص ، الأسباب) اساليب

التدريس و استراتيجيات العلاج ، الدار العلمي الدولية و دار الثقافة ، عمان .

الهوري ، زيد (2005) : الأساليب الحديثة في تدريس العلوم، دار الكتاب الجامعي ،

العين.

صابر، ملكة حسين (2003) : اثر استخدام خرائط المفاهيم في تدريس علم النفس على

اكتساب بعض المفاهيم و تنمية الاتجاه نحوه لدى طالبات السنة الثانية الثانوية ، مجلة القراءة

و المعرفة ، العدد (22) .

عبد الخالق ، احمد محمد (2001) : مبادئ التعلم ، الطبعة الثانية ، دار المعرفة الجامعية ،

الإسكندرية .

عفانه ، عزو اسماعيل و الخزندار ، نائلة نجيب (2007) : التدريس الصفي بالذكاوات

المتعددة ، دار المسيرة ، عمان .

منصور . رشدي (1997) : حجم التأثير الوجه المكمل للدلالة الإحصائية المجلة المصرية

للدراستات النفسية، العدد 16، المجلد السابع (1) .

ياسين ، محمد رياض (2005) : إستراتيجية التدريس العامة ، جامعة الأقصى ، غزة .

APPENDIX (A)
TOOLS OF THE STUDY

APPENDIX (A -1)

Future :-

1. Remember the forms of the future with (will) and (going to) and to use these future tenses correctly .
2. revising the future with (will) and (going to) .
3. Use the future tense (will) and (going to) for different purposes .
4. Use the future tense with negative forms .
5. Use the future tense (will) and (going to) in question .
6. Identifying the different uses between will and going to .

Past tense

A :- Past simple tense

1. Identify the uses of past simple tense .
2. Remember the two forms of past simple tense (regular and irregular verbs) and revise (used to) .
3. Remember the key words that used with the past simple tense Use the past tense in negative .
4. Use the past tense in question form .

B:- past perfect tense :

5. Identify the uses of past perfect tense .
6. Learning the form of past perfect tense .
7. Remember the key words that used with the past perfect tense .

8. Use the past perfect in negative .
9. Use the past tense in question form .
10. Write sentences combining the past simple tense and the past perfect tense with time clause .

conditions :-

conditional if

1. Remember the first , second and third conditionals .
2. Learning first , second and third conditionals .
3. Revise and use the first , second and third conditionals .
4. Practice first , second and third conditionals .

APPENDIX (A . 2)

Unit	Aims	Structure	Vocabulary
Unit six lesson (2 + 4)	<p>Asking and answering about plans for the future . revising the future with (will) and (going to) . Use the future tense (will) and (going to) for different purposes . Use the future tense with negative forms . Use the future tense (will) and (going to) in question . Identifying the different uses between will and going to . Remember the two forms of past simple tense (regular and irregular verbs)and revise used to .</p>	<p>Future tense with questions and short answers Did he used to...? Yes , he used to ... He didn't use to ...</p>	<p>Intention, plan, decision , prediction promise , facts , quick decision , threat Used to</p>
Unit seven lessons (3+4)	<p>Identify the uses of past simple tense . Remember the key words that used with the past simple tense . Use the past tense in negative . Use the past tense in question form . Identify the uses of past perfect tense . Learning the form of past perfect tense Remember the key words that used with the past perfect tense . Use the past perfect in negative . Use the past tense in question form . Write sentences combining the past simple tense and the past perfect tense with time clause .</p>	<p>By the time the police arrived , the thief had escaped. When I arrived at Hassan house , he had gone out . As soon as I had finished , I switched on the TV . After he had learned to use a computer , he practised every day .</p>	<p>Yesterday , last , ago , in the past by the time , when , as soon as , after before</p>
Unit eight lessons (1+ 3 + 4)	<p>Giving warning , promise – advice - regret –predictions</p>	<p>If you study hard you will succeed If I were you I would accept this job .</p>	<p>if , will , would , warning , promise – advice - regret – predictions</p>
Unit nine lesson (4)	<p>Talking about Impossible things regret</p>	<p>If I had trained hard we would have won If we hadn't trained hard we wouldn't have won .</p>	<p>If , had , past participle , would have , Impossible things regret</p>

APPENDIX (A . 3)

A -The table of specification :

Table (24)

Bloom Level Skill weight	Knowledge 20%	Comprehension 25%	Applying 37.5%	Analyzing 17.5%	Total
future 30%	4	4	5	2	15
past 38%	5	5	6	3	19
condition 32%	4	4	5	2	15
Total 100%	13	13	16	7	49

APPENDIX (A . 4)

Achievement test

بِسْمِ اللَّهِ الرَّحْمَنِ الرَّحِيمِ

Zaitun prep boys school

Pre and post test

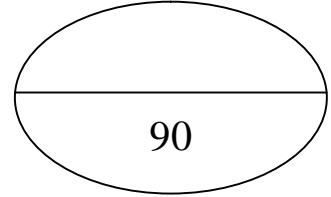

Name:-

Class:-

1- choose the correct answer

(8 marks)

After he had finished his homework , he football .

- a) plays b) played c) is playing d) was playing

If he drives quickly , he will an accident .

- a) make b) is making c) made d) had made

If she slowly , she would be late.

- a) walk b) walks c) is walking d) walked

Samy a book yesterday .

- a) read b) is reading c) was reading d) reads

she picked the flowers when the farmer

- a) went b) is going c) had gone d) was going

I fish tomorrow .

- a) will b) was going to c) am going to d) go

you the cinema if you finish your homework early.

- a) will b) would c) would have d) will not

Soha the west bank next week.

- a) goes b) was going c) is going to d) will go

* Samy is going to plays tennis next week .

.....

* She draws the picture last month .

.....

* He is watching T.V when his friend arrived.

.....

* He will not smoking .

.....

* If he wrote his lessons his teacher will thank him .

.....

* If he climb this tree he will fall down.

.....

* As soon as she had sat on the chair the telephone rang.

.....

* If they had finished their homework early they would have sleep early.

.....

* They were going to the university next Saturday .

.....

* Al- Ahli wins this team two years ago .

.....

3-make sentences by using the words between brackets :- (15 marks)

1) They have a party ,so they are going to invite me . (1st if)

.....

2) I didn't get high marks because , I didn't study hard . (2nd if)

.....

3) Soha usually visits us every Friday . (will)

.....

4) While I was reading a book , my mother came . (when)

.....

5) I was watching TV when, the police came . (after)

.....

6) I arrived, then the bus had gone . (by the time)

.....

7) we had finished the meal then we watched T.V . (as soon as)

.....

8) We were playing computer games , when the telephone rang. (while)

.....

9) I am flying to Cairo next week . (going to)

.....

10) I think he should accept this job . (2nd if)

.....

11) He decided not to smoke . (won't)

.....

12) He is going to fish tomorrow . (negative)

.....

13) He is writing his lessons . (yesterday)

.....

14) They climbed the tree then they caught oranges . (as soon as)

.....

15) We pray in El Omary mosque every Friday . (last)

.....

4 – Analyze the following sentences :- (7 marks)

A) If I were you I'd be very careful .

Type of Condition:- past simple:-

The use of the condition :-

a) promise b) advice c) impossible thing

B) if it rains , I'll take an umbrella .

Type of Condition :- Infinitive :-

The use of the condition :-

a) prediction b) advice c) impossible thing

C) by the time he came , I had switched off the light .

Connector :- past simple :-

past perfect :-

D) while we were watching T.V , Ali slept .

Connector :- past simple :-

past continuous :-

E) I'll lend you money .

Future:- infinitive :-

The use of the future :-

a) promise b) threat c) fact

F) I'm going shopping next Monday .

Future :- Key word of the future :-

The use of the future :-

- a) intentions and plan
- b) actions or events that are about to happen
- c) quick decision

G) Soha wrote her homework yesterday .

Past simple :- key word for the past :-

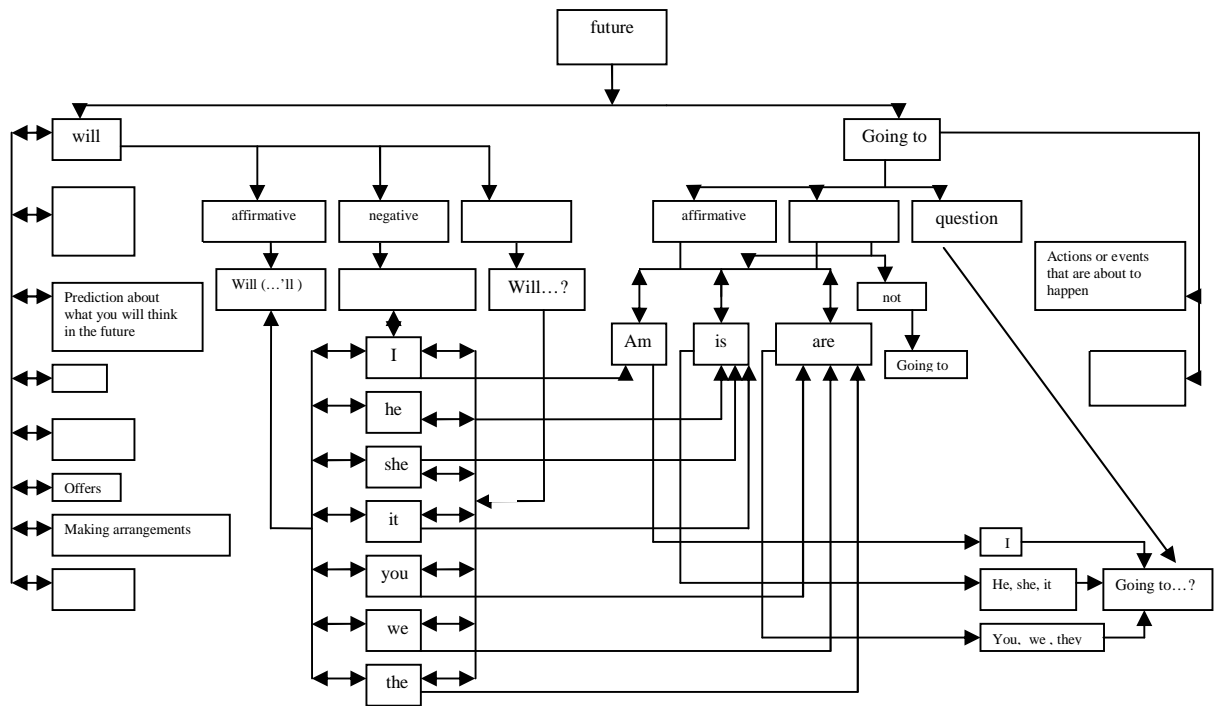

1) Put the following concepts in the suitable place (4 marks)
 (promise , facts , quick decision , threat , intentions and plans , negative ,question , will not)

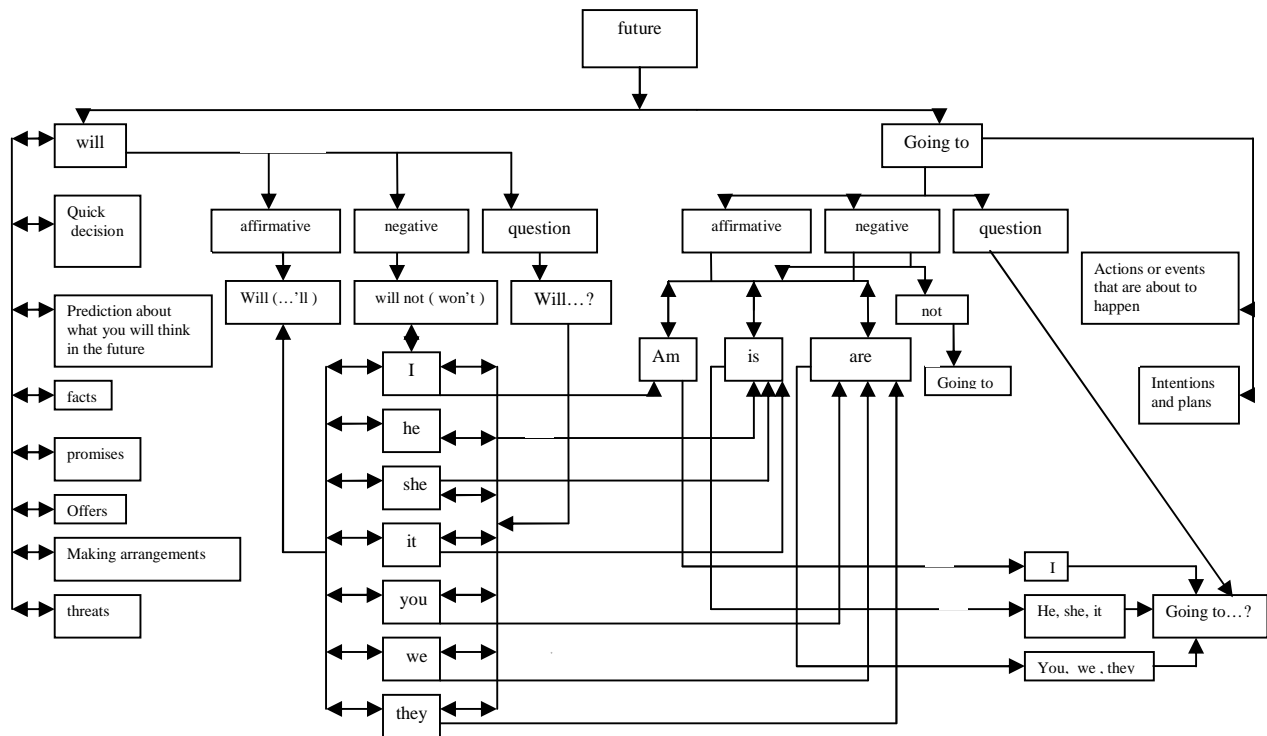

2) Put the following connectors in the suitable place (6 marks)
 (and , + , could be , is , use)

7) put the following concepts and connectors in the suitable place (7 marks)

Concepts	Intentions and plans , affirmative , ...not going to , infinitive
Connecters	Used for , Could be , and , +

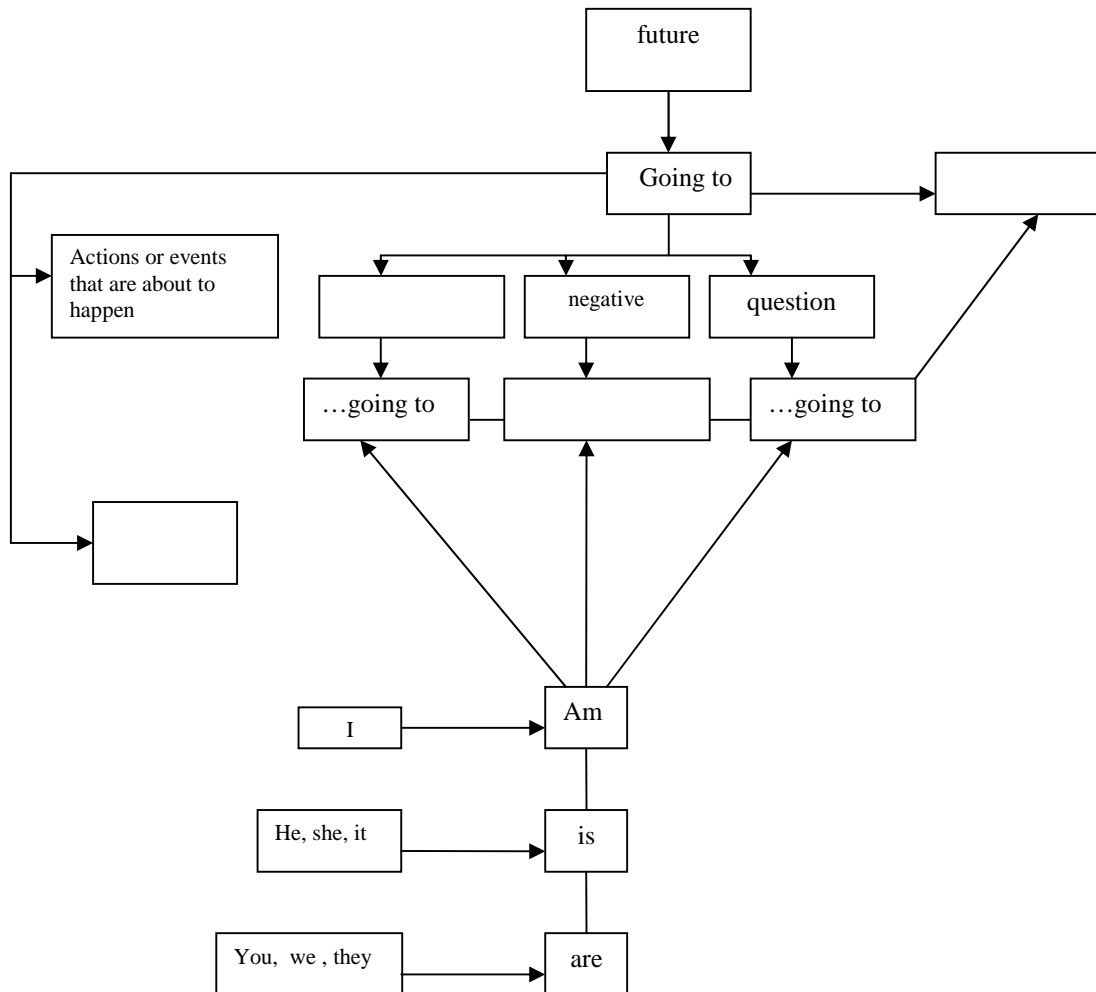

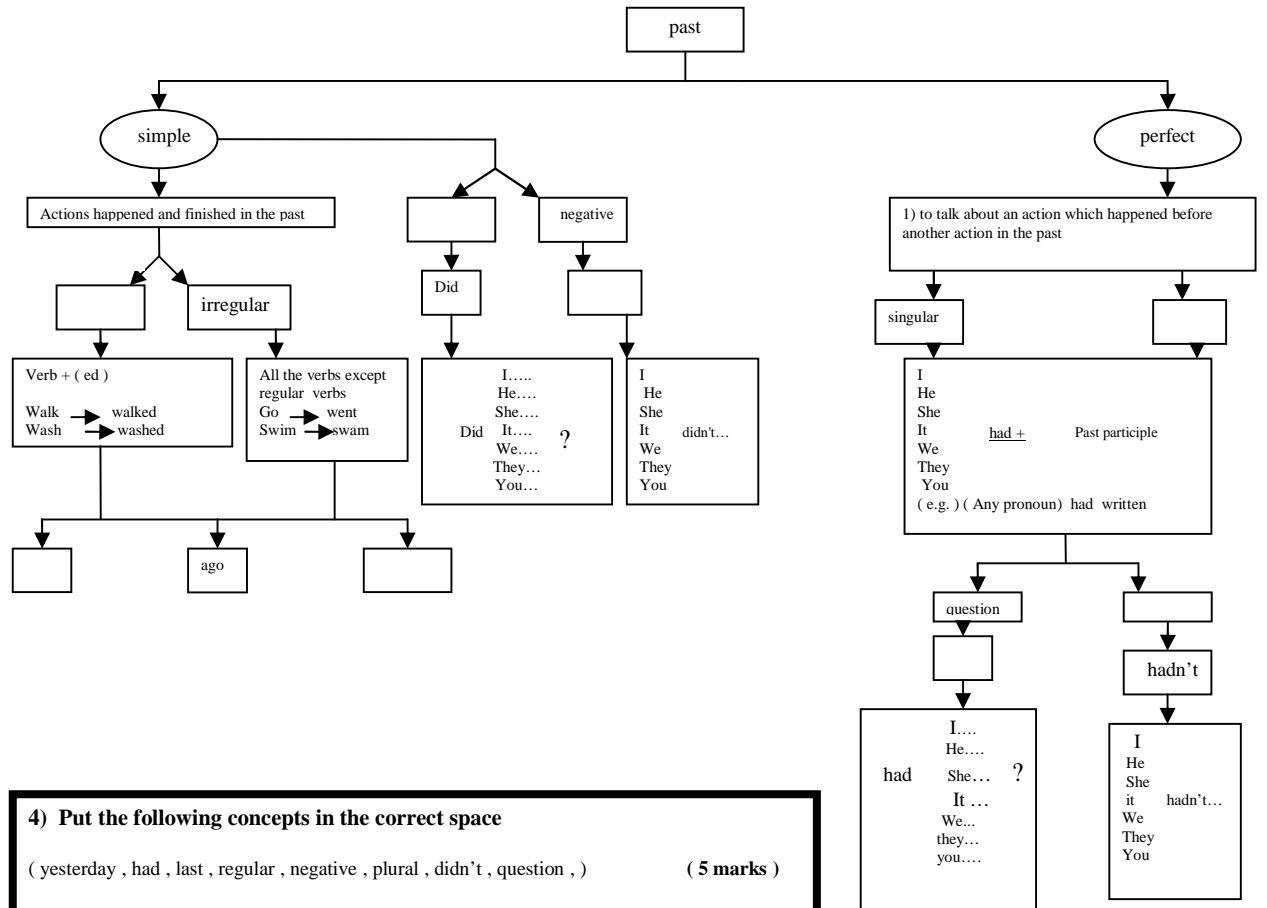

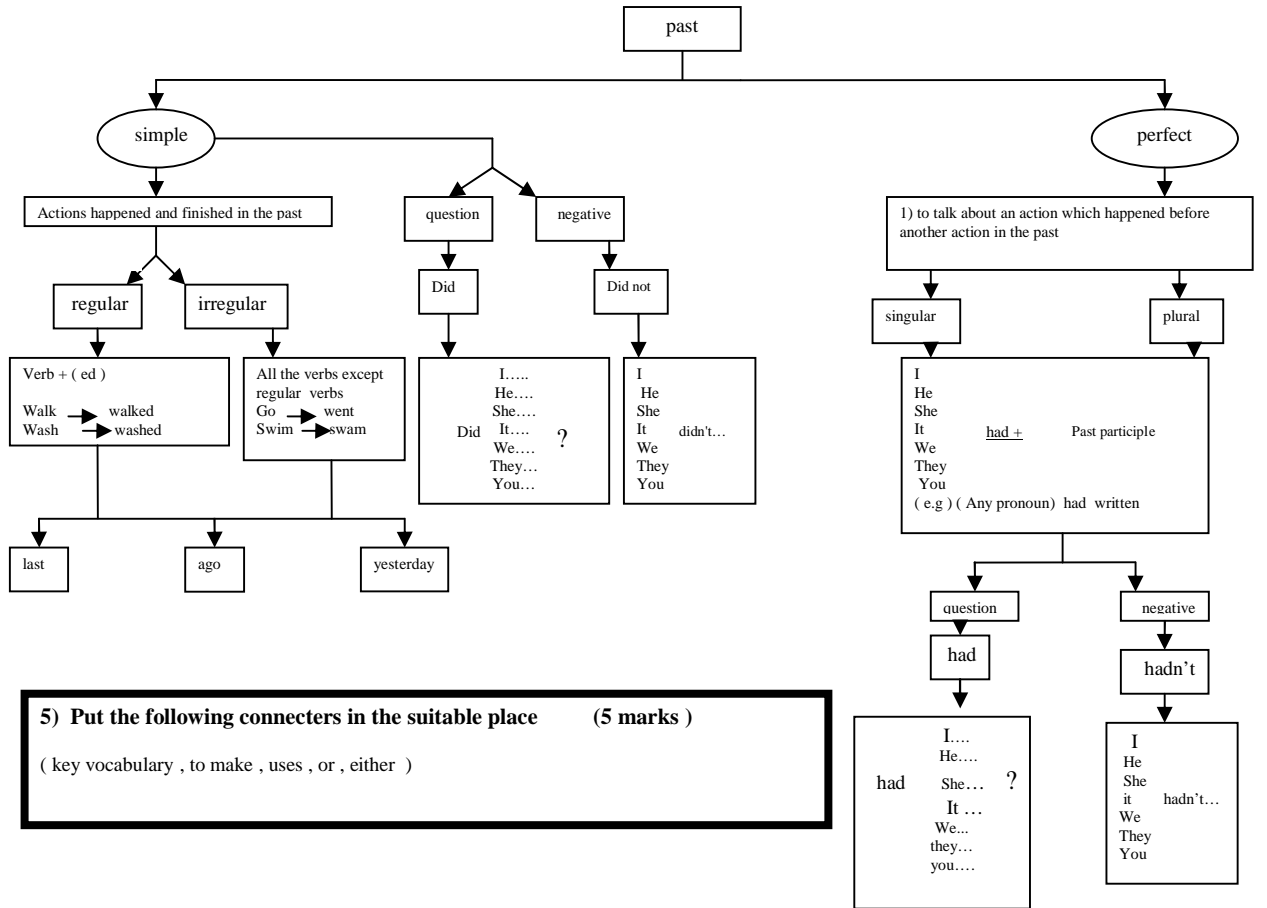

6) Make concept mapping by using the following concepts (8 marks)

(negative , did ... ? , didn't , irregular , verb _ (ed) , verbs without (ed) , ago , yesterday)

Use the following connectors

(to make , either , or , is , key vocabulary)

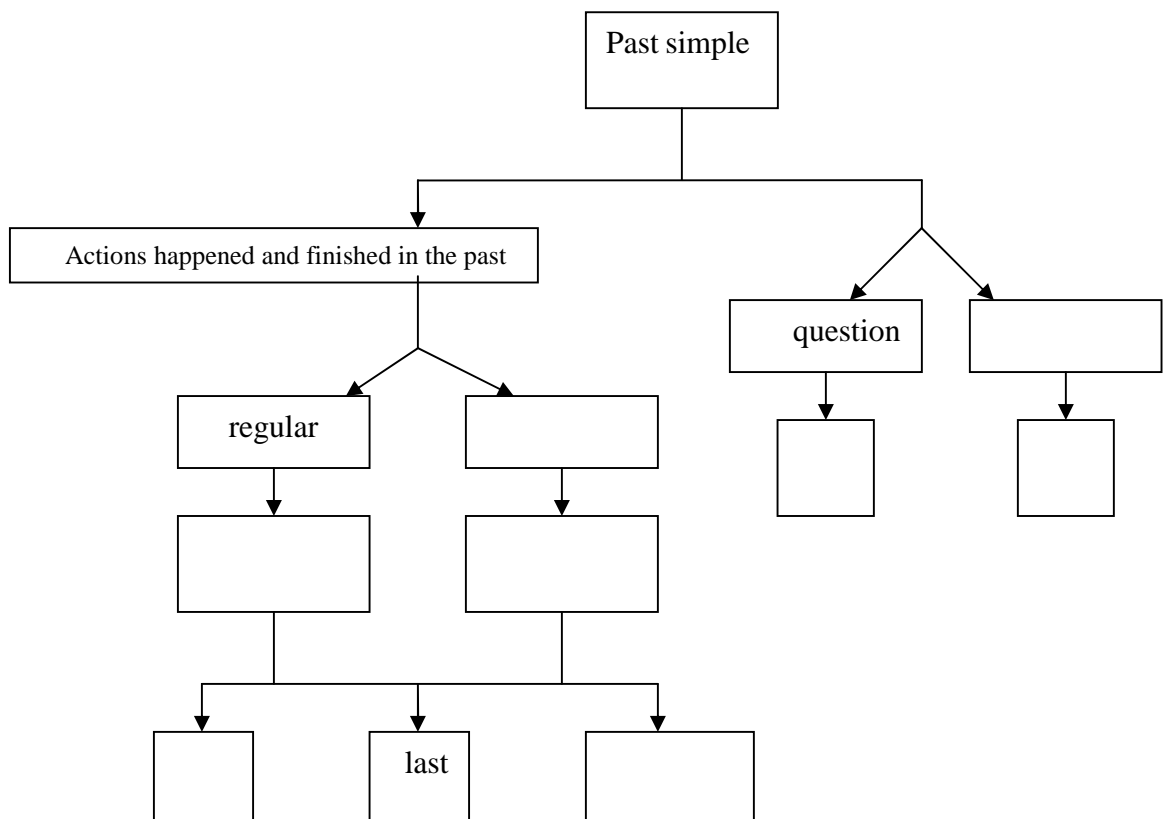

5 marks

7) Put the following concepts in the suitable place

(present simple – would + - past participle – would have + past participle – past simple – promise – advice - regret –predictions)

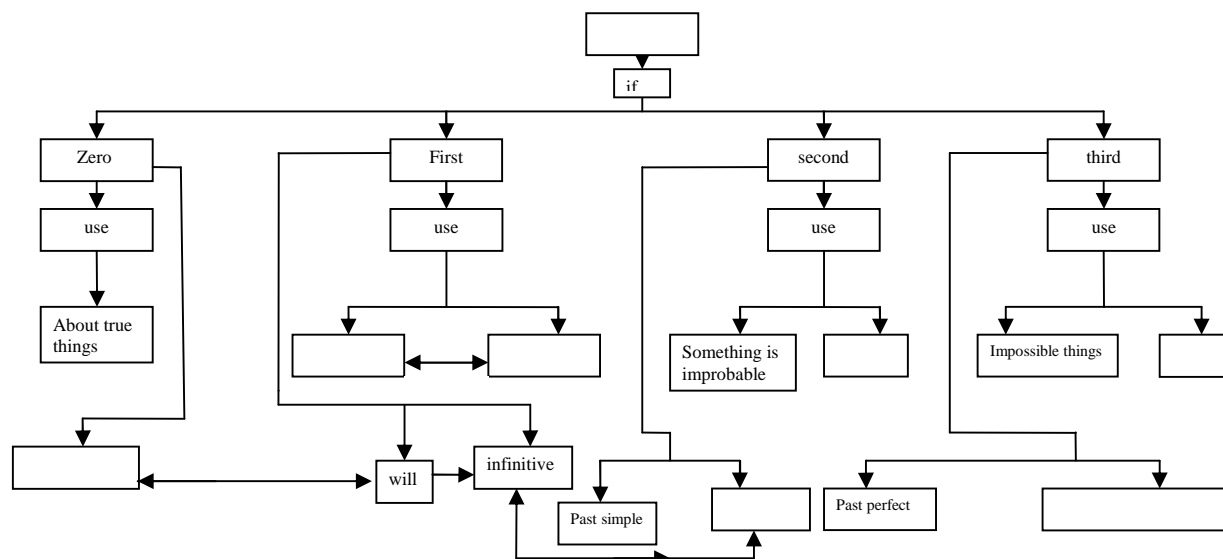

8) put the connectors in the suitable place

5 marks

(to talk – to make to give – talk about – to express – consist of)

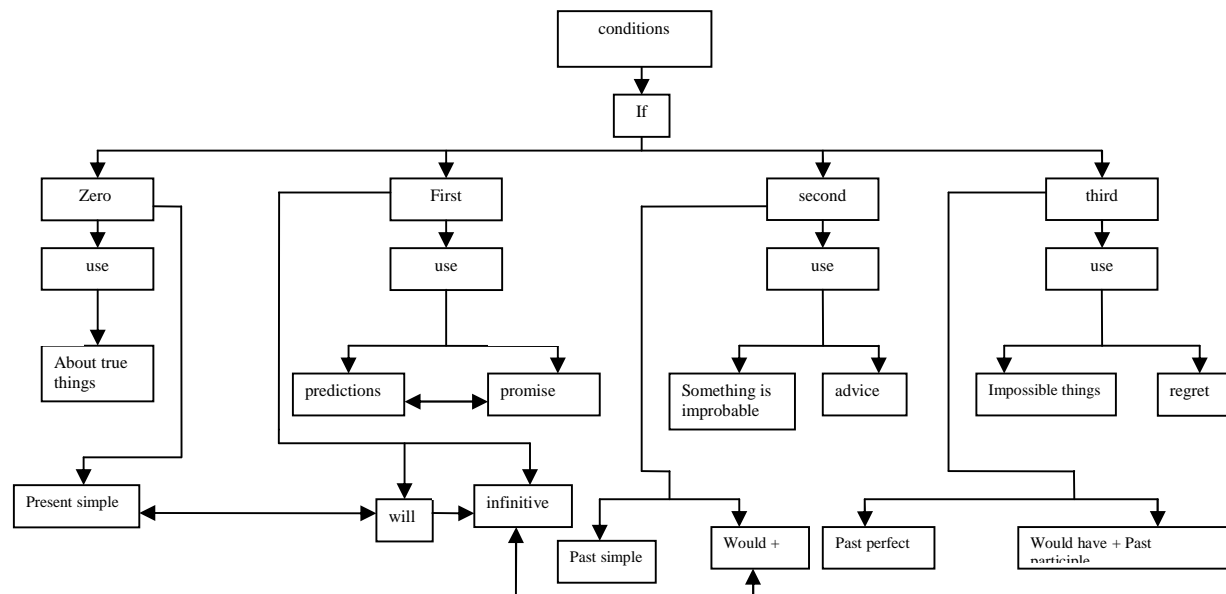

9) use the following concepts and connectors to make concept mapping

(used – impossible things –past perfect –past participle)

The connectors

(to talk about – to express – consist of)

5 marks

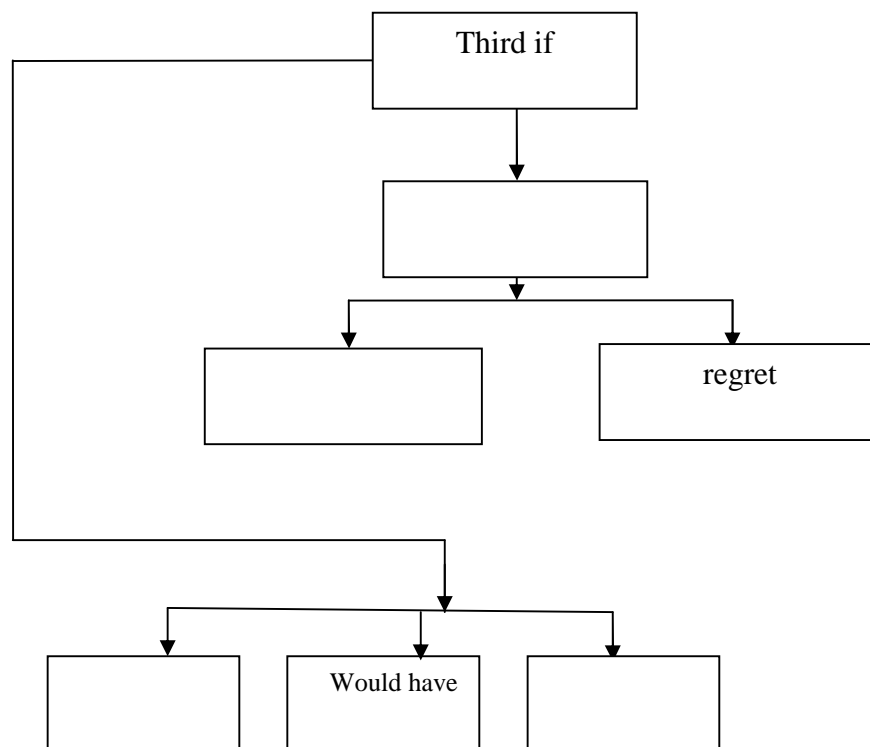

APPENDIX (A.5)

Table (25)

Difficulty coefficient for each items of the test

No.	Difficulty coefficient	No.	Difficulty coefficient
1	0.44	26	0.44
2	0.56	27	0.44
3	0.56	28	0.31
4	0.69	29	0.31
5	0.56	30	0.63
6	0.56	31	0.38
7	0.44	32	0.31
8	0.31	33	0.50
9	0.69	34	0.50
10	0.44	35	0.56
11	0.44	36	0.69
12	0.63	37	0.69
13	0.56	38	0.69
14	0.56	39	0.69
15	0.56	40	0.69
16	0.44	41	0.47
17	0.56	42	0.29
18	0.63	43	0.46
19	0.31	44	0.35
20	0.31	45	0.43
21	0.44	46	0.34
22	0.31	47	0.58
23	0.44	48	0.43
24	0.31	49	0.39
25	0.44		
Total difficulty coefficient		0.44	

APPENDIX (A .6)

Table (26)

Discrimination coefficient for each items of the test

No.	Discrimination coefficient	No.	Discrimination coefficient
1	0.38	26	0.63
2	0.38	27	0.63
3	0.63	28	0.38
4	0.38	29	0.63
5	0.63	30	0.50
6	0.38	31	0.50
7	0.38	32	0.63
8	0.63	33	0.50
9	0.63	34	0.50
10	0.38	35	0.38
11	0.38	36	0.63
12	0.50	37	0.63
13	0.63	38	0.63
14	0.63	39	0.38
15	0.63	40	0.63
16	0.63	41	0.31
17	0.38	42	0.36
18	0.50	43	0.63
19	0.38	44	0.60
20	0.38	45	0.70
21	0.63	46	0.30
22	0.38	47	0.45
23	0.38	48	0.70
24	0.38	49	0.43
25	0.38		
Total discrimination coefficient			0.49

APPENDIX (A. 7)

Table (27)

Correlation coefficient of knowledge items

Items	Pearson correlation	Sig.
A1	0.772	0.000
A2	0.605	0.001
A3	0.694	0.000
A4	0.695	0.000
A5	0.670	0.000
A6	0.592	0.001
A7	0.608	0.001
A8	0.619	0.000
Cm1	0.417	0.027
Cm4	0.742	0.000
Cm7	0.746	0.000

Table (28)

Correlation coefficient of comprehension items

Items	Pearson correlation	Sig.
B1	0.566	0.002
B2	0.563	0.002
B3	0.603	0.001
B4	0.513	0.005
B5	0.561	0.002
B6	0.583	0.001
B7	0.632	0.000
B8	0.463	0.013
B9	0.381	0.045
B10	0.378	0.047
Cm2	0.646	0.000
Cm 5	0.807	0.000
Cm 8	0.840	0.000

Table (29)

Correlation coefficient of applying items

Items	Pearson correlation	Sig.
C1	0.691	0.000
C2	0.735	0.000
C3	0.586	0.001
C4	0.408	0.031
C5	0.647	0.000
C6	0.748	0.000
C7	0.534	0.003
C8	0.612	0.001
C9	0.586	0.001
C10	0.419	0.026
C11	0.593	0.001
C12	0.723	0.000
C13	0.419	0.026
C14	0.515	0.005
C15	0.481	0.010
Cm 3	0.570	0.002
Cm 6	0.546	0.003
Cm 9	0.532	0.004

Correlation coefficient of analyzing items

Table (30)

Items	Pearson correlation	Sig.
D1	0.536	0.003
D2	0.541	0.003
D3	0.834	0.000
D4	0.834	0.000
D5	0.671	0.000
D6	0.562	0.002
D7	0.535	0.003

APPENDIX (B)

CONCEPT MAPS

APPENDIX (B.1)

Suggested lesson plan for teaching concept maps

Objectives : to learn different tenses and conditions

Group size : ninth graders

Material : sheets of papers that have concept maps , over head projector

Lesson phase : pre-requisite

Language focus : future with will and going to

A suggested lesson plan prepared by McMurray (2008)

in class

1. Explain to the students that a concept map is a written representation of the relationships among major concepts, ideas, objects or activities. Then model the creation of a map for them ..

- the teacher divides the class into groups of four .
- ask the students to make a list of major concepts to include on the map.
- Under each major concept, list more specific concepts to form a cluster of related ideas.
- Draw links connecting the major ideas to one another.
- Write labels on the lines that describe how one concept links to another.
- Draw cross-links that relate concepts in one part of the map to concepts in another part of the map. Cross -links should have an arrowhead that indicates the intended direction of the relationship.

- Label these lines to describe the connections.
2. Explain that there are many correct ways to map the same set of concepts. The better the students understand the concepts and how they are related, the better the map students can draw. Studying and thinking about the concepts they want to map will make the map richer as well as more accurate .
 3. Teacher split the students pairs , the teacher can operate on the over head projector for the whole class.
 4. Each group generates some of the most important concepts related to the topic to be mapped, then contributes to a list that the teacher (or a student) records in Inspiration. Then, again in pairs , the students come up with ten or twelve terms that they deem most important to include in their concept map of the topic.
 5. The students direct the teacher to arrange and rearrange the concepts they've chosen and then to draw links connecting concepts to show relationships. Encourage them to note when arrows are needed to clarify the direction of a relationship.
 6. Throughout this process, encourage discussion about which concepts should be included, which should not, and in what ways they can relate.
 7. Ask them to save the map on files .

Follow-up activities

1. At the conclusion of the lesson, have the students critique this map. In small groups or as a class, have them alter or add to the map to reflect their enhanced learning.
2. Assign students to map additional topics as independent assignments .

APPENDIX (B .2)

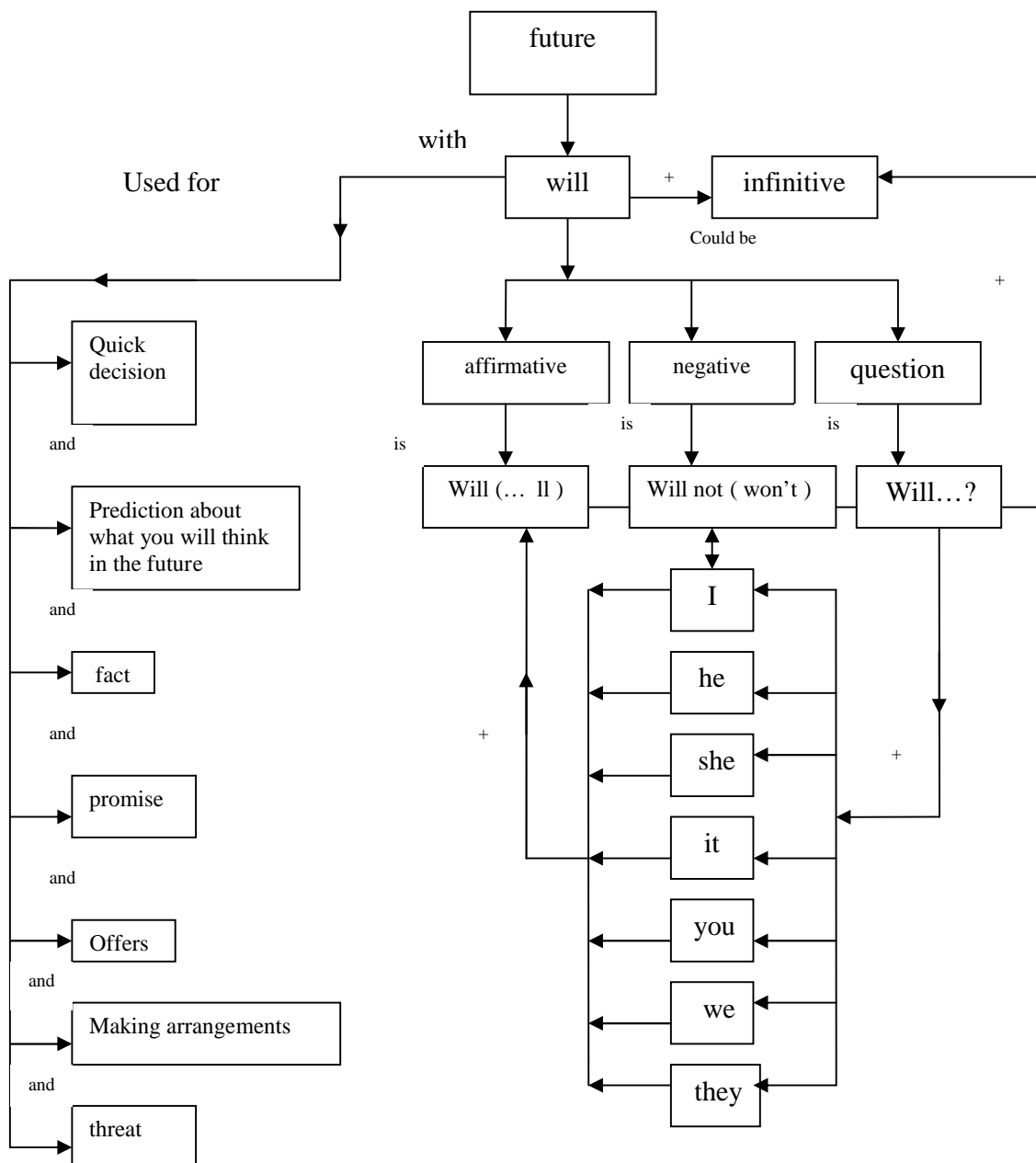

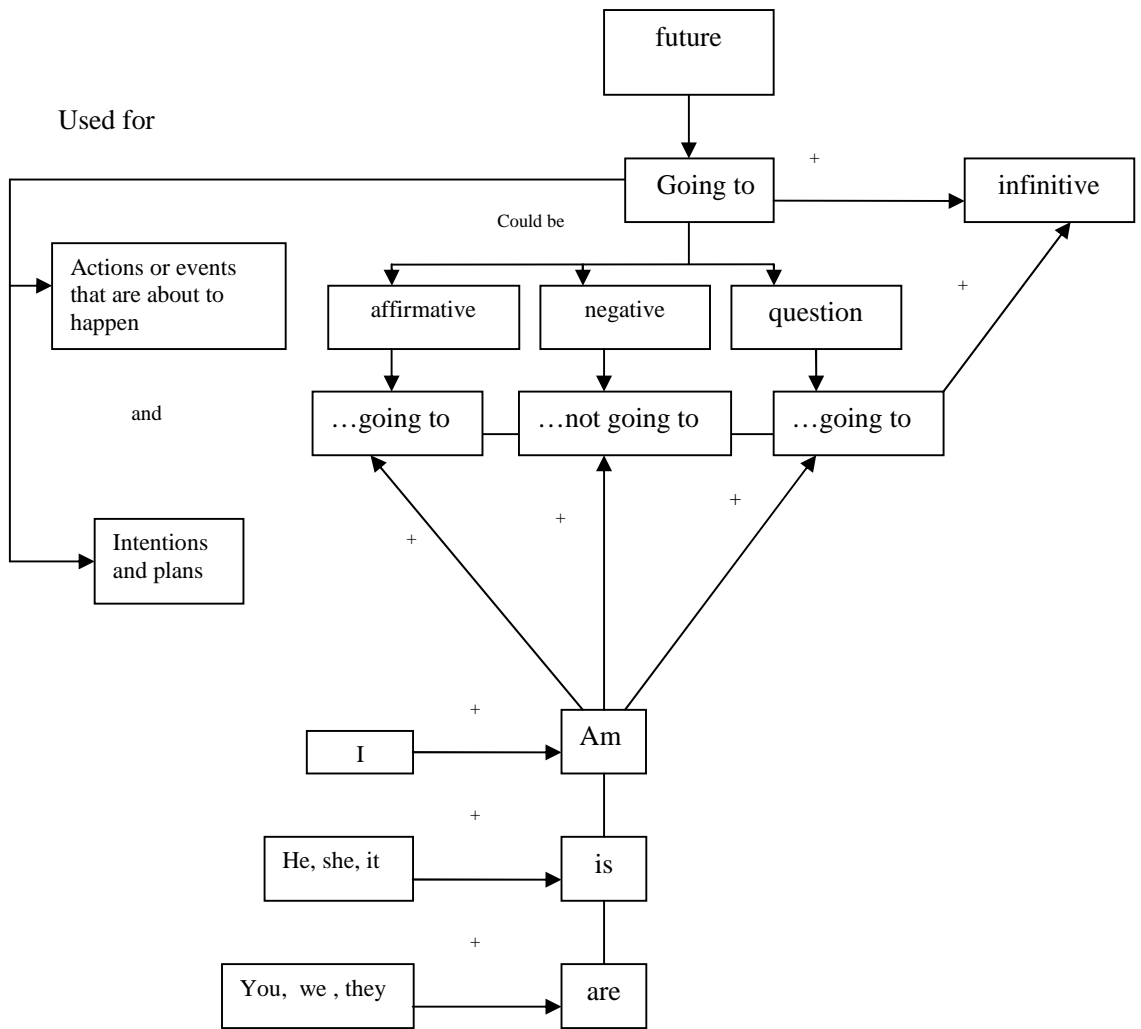

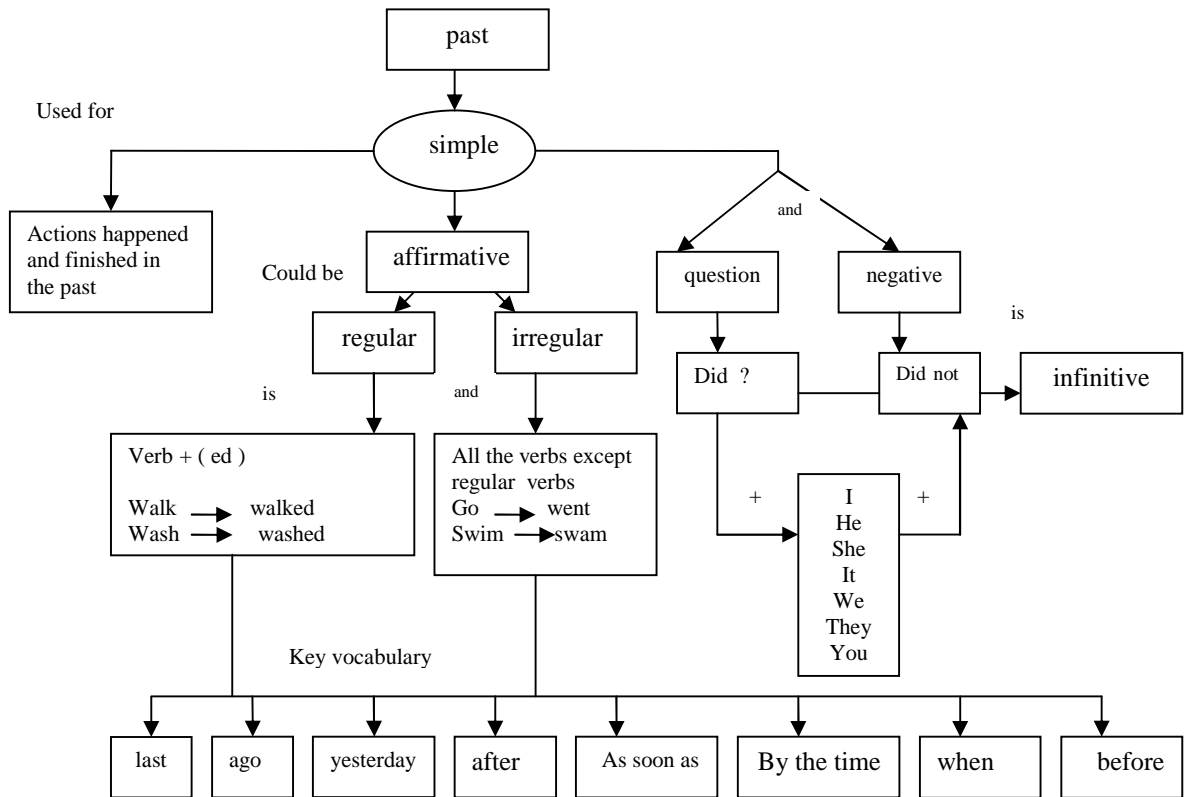

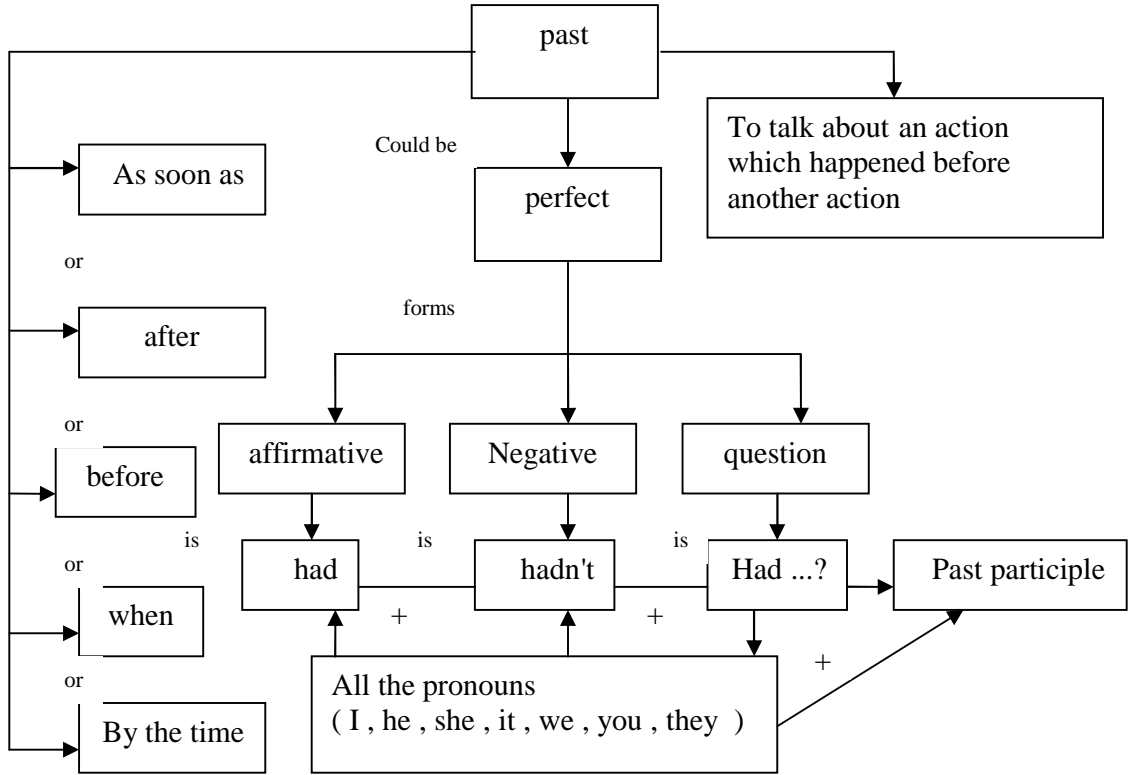

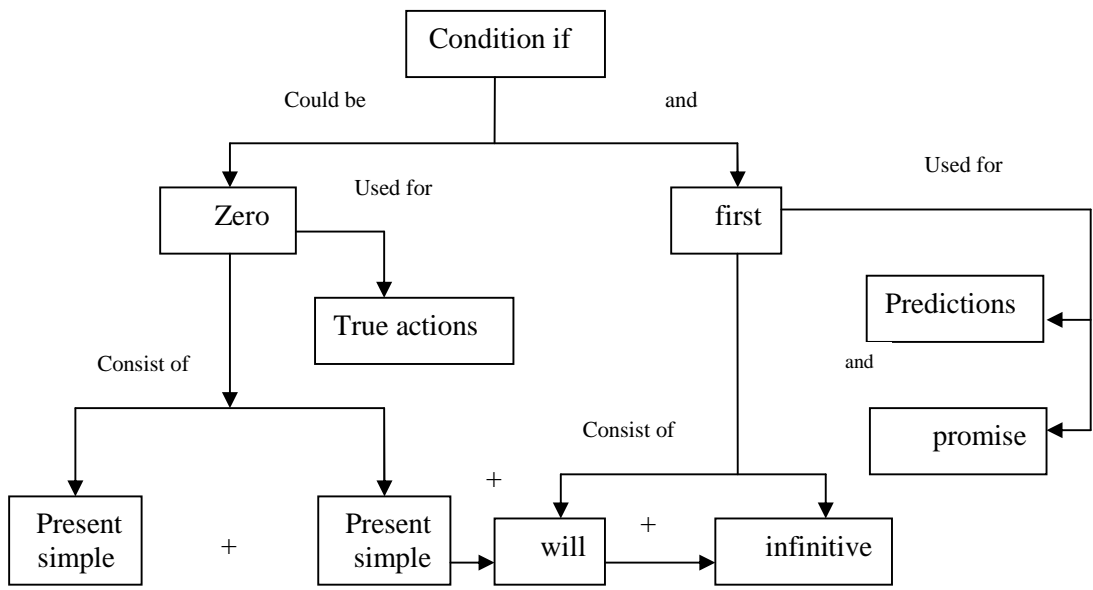

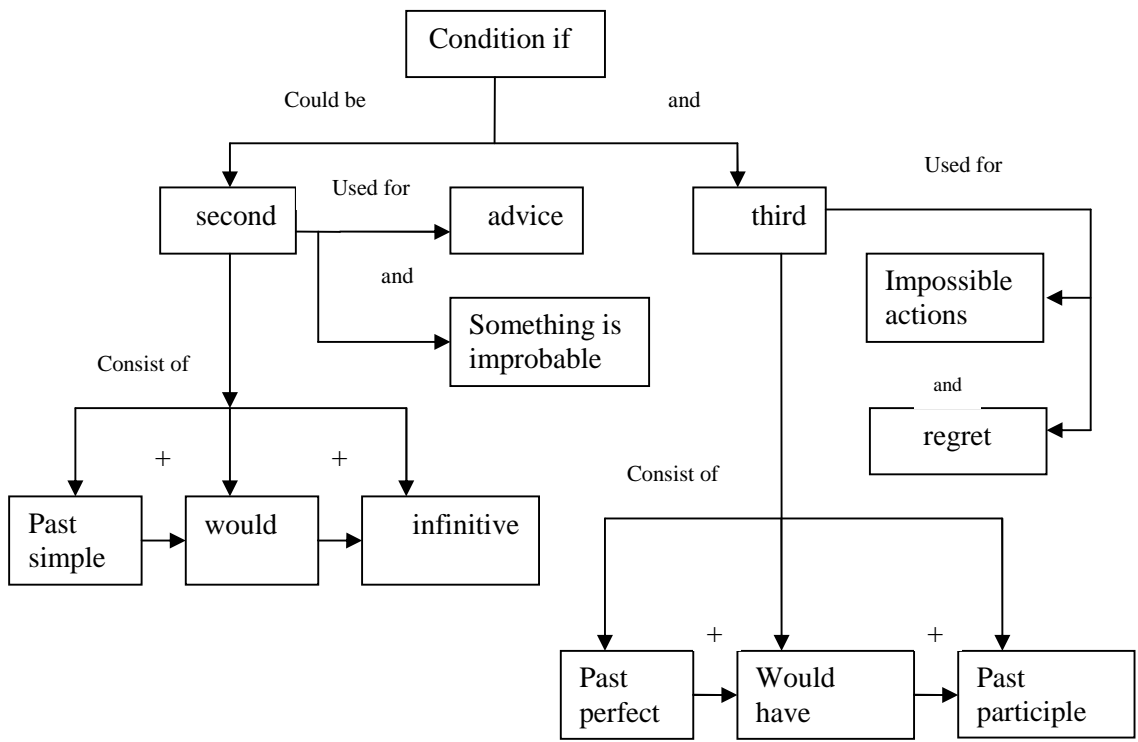

APPENDIX (C)
CONCEPT MAPS IN THE HOLY QURAN

APPENDIX (D)

APPENDIX (D . 1)

REFEREE COMMITTEE

- 1- **Prof . Ezzo Affana** *The Islamic university*
- 2- **Prof . Mohamed Askool** *The Islamic university*
- 3- **Dr . Awad Keshta** *The Islamic university*
- 4- **Dr. Abed Al- Moati Al –Gaa** *The Islamic university*
- 5- **Dr . Nazmi Al-Masri** *The Islamic university*
- 6- **Dr. Khader Khader** *The Islamic university*
- 7- **Dr . Akrm Habieb** *The Islamic university*
- 8- **Dr. Hassan Al- Nabeh** *The Islamic university*
- 9- **Prof . Saed Abd Al-Wahed** *Al – Azhar university*
- 10- **Dr . Basel Skiek** *Al – Azhar university*

CURRICULUM VITE

C.V

Mazen Khalil Diab Abu Nada
AL-sheikh rdwan , AL- Jlaa Street
Mazenkha@hotmail.com
mazenabunada@yahoo.com

Tel : 2858189 mobile 0599604041

Personal Information

Name : Mazen Khalil Diab Abu Nada

Gender : Male

Data Of Birth : 18/12/1974

Marital Status : Married

City and Country of Birth : Palestine

Current Country Of Citizenship : Palestine

I.D : 00216227

Education

- General Certification Of Education : 1992
- Special Diploma in Russian Language From Keeve
- BA of English Language (Islamic University)
- Special diploma of education (Islamic University)
- MA of Methodology " The Effect Of Using Concept Maps On Achieving English grammar Among Ninth Graders In Gaza Governorate "

Professional Experience

Teacher of English language (Gaza UNRWA schools)