

Old Dominion University

ODU Digital Commons

Electrical & Computer Engineering Theses &
Dissertations

Electrical & Computer Engineering

Fall 2019

Pulse Power Effects on Transient Plasma Ignition for Combustion

David Wayne Alderman II

Old Dominion University, dalde001@odu.edu

Follow this and additional works at: https://digitalcommons.odu.edu/ece_etds



Part of the [Electrical and Computer Engineering Commons](#), and the [Plasma and Beam Physics Commons](#)

Recommended Citation

Alderman, David W.. "Pulse Power Effects on Transient Plasma Ignition for Combustion" (2019). Master of Science (MS), Thesis, Electrical/Computer Engineering, Old Dominion University, DOI: 10.25777/skjc-8882 https://digitalcommons.odu.edu/ece_etds/209

This Thesis is brought to you for free and open access by the Electrical & Computer Engineering at ODU Digital Commons. It has been accepted for inclusion in Electrical & Computer Engineering Theses & Dissertations by an authorized administrator of ODU Digital Commons. For more information, please contact digitalcommons@odu.edu.

PULSE POWER EFFECTS ON TRANSIENT PLASMA IGNITION FOR COMBUSTION

By

David Wayne Alderman II
B.S. December 2018, Old Dominion University

A Thesis Submitted to the Faculty of
Old Dominion University in Partial Fulfillment of the
Requirements for the Degree of

MASTER OF SCIENCE

ELECTRICAL AND COMPUTER ENGINEERING

OLD DOMINION UNIVERSITY
October 2019

Approved by:

Chunqi Jiang (Director)

Shu Xiao (Member)

Linda Vahala (Member)

Jason Sanders (Member)

ABSTRACT

PULSE POWER EFFECTS ON TRANSIENT PLASMA IGNITION FOR COMBUSTION

David Wayne Alderman II
Old Dominion University, 2018
Director: Dr. Chunqi Jiang

Transient plasma ignition (TPI) uses highly non-equilibrium plasmas, driven by less than 100 nanosecond, high-voltage pulses, to initiate combustion. The effects of pulse repetition frequency (PRF) and ultrashort nanosecond rise times on TPI are investigated in this work using lean, stoichiometric, and rich air-fuel mixtures at atmospheric pressure. Experimental data show the transient plasmas driven by ultrashort rise time, high voltage pulses at high PRF's enhance the combustion of lean or stoichiometric air-methane mixtures in a static chamber. In particular, increasing PRF enhances the combustion performance by means of reduced delay times independent of the equivalence ratio of the air-fuel mixture. Plasmas driven by shorter rise time pulses improve combustion performance by reducing ignition delay time and increasing peak pressure in lean and stoichiometric mixtures. As TPI promises improved combustion efficiency and reduced emission, this study provides important pulse power parameter information to optimize TPI for combustion.

Copyright, 2019, by David Wayne Alderman II, All Rights Reserved.

ACKNOWLEDGEMENTS

This thesis would have not been possible without the support and guidance of many people who helped me to complete my master's degree. I would like to thank my advisor, Prof. Chunqi Jiang, for allowing me to be a part of her research group. I appreciate all the opportunities, knowledge, and wisdom that she shared with me. I would like to thank my committee members Prof. Jason Sanders, Prof. Shu Xiao, and Prof. Linda Vahala. Prof. Sanders provided me technical support with respect to pulse power. Prof. Xiao provided me with understanding of voltage measurement techniques for high voltage nanosecond pulses. Prof. Vahala helped me gain deeper understanding of my project with respect to electromagnetics. I would also like to acknowledge my friends and colleagues, Christopher Tremble, James Hornef, and Shutong Song for all their help and support.

TABLE OF CONTENTS

LIST OF FIGURES	vi
1 INTRODUCTION	1
1.1 ORGANIZATION & CONTRIBUTION	1
1.2 BACKGROUND.....	2
1.3 EXPERIMENTAL SETUP.....	9
1.4 EXPERIMENTAL METHODOLOGY	13
2 EXPERIMENTAL RESULTS & DISCUSSION	21
2.1 VOLTAGE CURRENT & ENERGY	21
2.2 VOLTAGE RISE TIME EFFECT	26
2.3 MODE CHANGE	30
2.4 ROTATIONAL TEMPERTURE.....	32
3 CONCLUSIONS	35
4 REFERENCES	37
5 VITA.....	39

LIST OF FIGURES

Figure

1 constant volume chamber for combustion by transient plasma ignition.....	9
2 conventional spark plug electrode to the left and zoomed in diagram of the high and low voltage electrode geometry to the right.	11
3 the combustion chamber design drawn in inventor	13
4 fused quartz window O-ring sealed when bolted to the chamber	14
5 illustrates how the pressure trace is analyzed by the MATLAB algorithm.....	17
6 schematic of the triggering system used to align and capture each pulse of a burst.....	19
7 Pressures of combustion corresponding OH(X) emission at a range of pulse repetition frequencies. Combustion was initiated with the 10 ns rise time plasmas. Importantly, notice that as PRF is increased delay time is reduced.	24
8 Pressure delay time reducing as pulse repetition frequency is increased.	25
9 Emission of OH(X) that has a reduction in delay time similar to pressure.	26
10 Rich mixtures ignited by four pulse bursts with different voltage rise times.	28
11 Stoichiometric mixture ignited by bursts with different voltage rise times.	29
12 Lean mixture ignited by bursts with different voltage rise times.	30
13 Rotational temperature model compared with experimental data	32

CHAPTER

1 INTRODUCTION

1.1 ORGANIZATION & CONTRIBUTION

This thesis explores the effects of nanosecond plasma with respect to rise time and pulse repetition frequency for combustion ignition. Transient plasma discharges driven by voltage pulses with 5 ns and 10 ns rise times are used for combustion ignition. To clarify terminology in this study the shorter rise time pulse corresponds to the 5 ns and the longer to 10 ns. The transient plasma discharges are applied at a range of pulse repetition frequencies. Combustion pressure waveforms are compared for relative performance differences and discussed. The data produced in this work and its interpretation contribute new information to the field of plasma assisted combustion.

This thesis is organized as follows. First an introduction to the topic and a comprehensive review of prior research work. Next, the experimental setup, i.e. specific equipment for the measurement of pressure, optical emission, voltage, and current are discussed in detail. Following that, experimental procedures and methodology are explained with respect to the equipment used in the study. Then, experimental results are presented in detail. Voltage and current waveforms are used to discuss the different plasmas. Pressure and OH waveforms are used to discuss combustion performance. The effects of two different plasma are compared. Plasma driven by nanosecond pulses with different rise times for combustion ignition are compared with respect to combustion enhancement. Then, rotational temperature of the second positive system of nitrogen is investigated, and the results are correlated with the two different plasmas for combustion ignition and their related combustion performance enhancement. Finally, the conclusions of this research are presented.

1.2 BACKGROUND

One way to improve the efficiency of combustion is to improve ignition systems. Improved ignition systems can help with combustion challenges such as increasing thermal efficiency, reducing fuel consumption, and reducing hazardous emissions. Continued development of more efficient ignition systems is needed, along with an understanding of specific effects when applied across a wide range of operating conditions. Traditionally mixtures are ignited by high temperature air and high compression ratios in diesel engines and spark discharges in gasoline engines. The focus of this study will be combustion by transient plasma ignition and the application would ultimately be for gasoline engines. Transient plasma ignition is a viable option that has shown improved lean-fuel combustion and improved rate of combustion with potentially reduced emissions such as nitrogen monoxide also known as nitric oxide [1, 2]. It utilizes nanosecond, high voltage pulses to generate, low temperature, highly non-equilibrium plasmas for combustion ignition [3]. Nanosecond plasma enables more voluminous ignition and differs from arc plasma which initiates combustion through thermal decomposition [4, 5]. During a typical TPI process a more turbulent ignition kernel is developed which propagates faster leading to reduced ignition delay times [6]. The faster propagation of flame fronts leads to a more complete burn of fuel air mixtures enabling leaner mixtures. Leaner mixtures help to reduce harmful combustion byproducts such as NO_x . Reducing ignition delay time and extending the lean-fuel misfire limit reduces burn time and increases fuel economy, both of which are important to applications in internal combustion engines or any combustion-driven propulsion systems [1].

In 1976 the effect of frequency was studied with bursts of two pulse [7]. The purpose of the study was to investigate the effects of discharge frequency. The experimental setup consisted

of a 58 cm³ cylindrical combustion chamber. The electrode ends were fitted with spherical balls for the purpose of keeping the break-down voltage constant. The inner electrode gap was varied between 1.5 – 3.0 mm. Spark duration was obtained from the voltage traces and are presented as a function of frequency, inductance, and capacitance. From the results, it was concluded that spark frequency was critical with ignition by capacitive sparks. An optimum interval between sparks increased igniting capability. With a discharge frequency of 100 kHz (10 μs pulse duration), the stated plug gap, the optimum spark interval is between 10 – 50 kHz.

In 1979 the initiation of flame fronts by three different modes of a discharge was studied (breakdown, arc, and glow) [8]. The breakdown phase is characterized by very high peak voltages and currents (≈ 10 kV and ≈ 200 A), short duration of 1 – 10 ns, and a cold cathode. During this early stage a cylindrical channel is formed, and a rapid temperature rise occurs. The molecules in the cylindrical channel are fully ionized and dissociated. The electrical energy is coupled to the plasma with almost no loss. The pressure surges due to the intense almost instantaneous heating and a shockwave is formed. Only following a breakdown is a conductive path created that can facilitate a glow discharge formed. If the electric field is maintained for a sufficient period of time an arc can form. The study revealed that there was no benefit to prolonged energy input to a fuel air mixture. Therefore, reducing the spark duration and rise time would more efficiently couple energy into the plasma.

In 1984 the different modes of plasma were studied with a capacitive discharge ignition system (CDI) [9]. The experimental setup was composed of a combustion chamber of unknown size with an electrode gap of 1 mm. Mixtures were ignited at 300 K and atmospheric pressure. The purpose of the study was to better understand the modes of discharges. In the pre-breakdown phase, the fuel-air mixture between the electrodes represents a perfect insulator. Once the pulse

is applied the randomly existing electrons produced by hard, ionizing radiation from the cosmos can gain energy in the rising electric field and are accelerated toward the anode. The number of electrons and ions increase like an avalanche. If the ionizing processes produce less electrons than required for making the discharge self-sustaining this phase is called the pre breakdown phase. If the ionizing processes produces enough electrons to make the discharge self-sustaining, a conductive channel is formed between the electrodes, and a breakdown occurs. When breakdown occurs, current rises until any further increase is limited by the impedance of the discharge. At this stage the voltage across the gap as well as the electric field drop rapidly. Electrical energy will be efficiently coupled from the gap capacitor via electric field to electrons and the ions. Electronic excitation occurs with a massive increase in gas temperature. Due to the extremely rapid transition in gas temperature the pressure inside the channel rises instantaneously causing the emission of a supersonic shock wave. Because of the extremely fast processes there are almost no thermal losses, the cathode remains cold and cannot absorb any appreciable amount of heat via conduction. A prolonged duration of a high current flow would lead to heating and signify the end of the breakdown phase and the start of the arc regime. An arc is sustained once the electrical conductivity is sufficiently increased during the breakdown phase. An arc is characterized by high current being only limited by the impedance of the plasma. The electrode becomes hot, approximately 3000 K. Electrons are emitted from the hot electrodes and are required to sustain the arc. The high temperature causes heavy evaporation or erosion of cathode material. This study provides a clear understanding of the stages the plasma goes through over time.

In 2005 transient plasma ignition of quiescent and flowing mixtures was studied [1]. Transient plasmas exist during the formative phase of a pulse ignited atmospheric pressure

discharge or the breakdown phase and are primarily composed of streamers. Non-equilibrium electrons exist in the head of the streamer, they can have reduced electric fields greater than 100 Townsend, and are responsible for direct electron impact excitation, ionization and dissociation. In this study, quiescent mixtures at atmospheric pressure are ignited in a cylindrical stainless-steel chamber that is 633 cm³. Fuel air mixtures were ignited with peak voltage of 80 kV, and pulse duration of 50 ns. The results of the investigation showed that transient plasma ignition compared with spark ignition resulted in shorter ignition delay times and pressure rise times. This corresponds with the research in 1979. The benefits were most prominent in lean mixtures which leads to cleaner combustion. Higher peak pressures can also be achieved by transient plasma ignition indicating that nanosecond plasmas for ignition result in more efficient combustion.

In 2006 ignition by burst of nanosecond discharges of a range of mixtures at pulse repetition frequency were examined [10]. Pulses with duration of 10 ns, peak voltage of 10 kV, and pulse repetition frequency of 30 kHz were examined. Stoichiometric, lean, and nitrogen diluted mixtures were examined. Previous investigations show that the best combustion results, highest energy densities, and temperature gradients occurred, when the ignition energy is delivered in the shortest time period possible. The experimental setup for the study consisted of a 60 cm³ test chamber and a point to plane electrode geometry with 1.5 mm gap. The burst was categorized into two groups of pulses. The first group of pulses carry relatively low amounts of current and produce weak emission which is a typical characteristic of pulsed corona discharges. The second group of pulses carry high currents and a strong emission of N, N⁺, O, and O⁺ atomic species. The gas temperature was found to raise to 1000 K after the first break down, which would be signified by a large spike in current, and the temperature would stabilize around 3000

K in the subsequent pulses. It was found that the use of nanosecond discharge plasmas becomes easier at higher pressures. The minimal energy for a fixed pressure and gap depends on the partial pressure of the combustible gas. It is expected that increasing pulse repetition frequency would continue to reduce combustion delay time.

In 2011 the role of non-thermal transient plasma for enhanced flame ignition was investigated [3]. In 1984 different modes of plasma were studied over a long time period, i.e. millisecond, in this study the time period investigated is over nanoseconds. Two distinct phases of nanosecond discharges are studied, an initial non-equilibrium plasma phase and a spatially distributed thermal phase. In the initial non-equilibrium phase energetic electrons transfer energy into electronically excited species that accelerate reaction rates. In the spatially distributed thermal phase exothermic fuel oxidation reactions occur that result in ignition. The investigation shows that ignition kernels are formed at the ends of the spatially separated streamer channels creating a larger volume of radicals. A significant amount of the energy from the plasma is coupled to the molecules via electronic excitation. The specific reason for the reduction in delay time and rise time is due to the larger production of the excited species of oxygen. A larger volume of species is produced because multiple streamers that are spatially separated.

In 2013 a spectroscopic study of the mechanisms of nanosecond repetitively pulsed discharges was conducted [11]. More specifically the mechanisms between the nanosecond discharge that lead to the ultrafast heating and dissociation of oxygen were examined. Plasmas driven by 10 ns duration, 5.7 kV peak voltage, and 10 kHz pulse repetition frequencies across a 4 mm electrode gap. The electrode is a point to point geometry and the discharges are examined at atmospheric pressure. The air for the study is preheated to 1000 K, in other studies the mixtures were ignited at 300 K or room temperature. The investigation found the mechanism of ultrafast

heating is impacted by the reduced electric field. With a reduced electric field of less than 200 Townsend the dissociation of oxygen is the main route for heating and occurs through electron impact and the dissociative quenching by O_2 of electronically excited nitrogen molecules. A reduced electric field greater than 400 Townsend, the ultrafast heating is due to electron impact dissociation of N_2 and process involving charged particles, e.g. ion-molecule reactions, electron-ion, and ion-ion recombination. The discharge was found to dissociate about 50% of molecular oxygen within 20 ns and to increase temperature to approximately 900 K. This work was in close agreement with numerical simulations [12-14].

In 2017 burst of nanosecond discharges at a wide range of frequencies was studied [2]. Experiments were performed in a constant volume combustion chamber that was 98 cm^3 and filled with lean mixtures to 29 psi. The mixtures were ignited with a pin to pin electrode geometry, at a peak voltage of 10 kV, a pulse duration of 10 ns, at pulse repetition frequencies from 2 – 90 kHz. The reduced electric fields in the study were between 400 – 465 Townsend for the 1.2 mm electrode gap and 180 – 230 Townsend for the 3 mm electrode gap. This study was of considerable interest because of the comparison of the 2 different plug gaps. Recall, the study from 2006, that increasing pulse repetition frequency would simply continue to enhance combustion. Recall the study from 1976, there was an optimum interval between discharges. In this study pulse repetition frequency was enhanced to a point depending on the electrode gap. When a gap of 3 mm is used the reduced electric field is reduced and the optimum pulse repetition rate is shifted to approximately 30 kHz. When a gap of 1.2 mm is used the reduced electric field is increased and the optimum pulse repetition rate is shifted to approximately 60 kHz. The pulse repetition rate corresponds with the flow that occurs between the electrodes. From the study in 1984 we know when a discharge occurs an intense shock wave is created

about the axis of the stream ejecting excited radicals away. As this occurs a circulation effect is created, and fresh gas fills the low-pressure area between the electrodes. Then, when the next well-timed discharge occurs the fresh gas is excited and ejected in the same way. The cycle repeats until there are enough oxygen radicals to develop an ignition kernel that can transition into a self-sustaining flame front. Therefore this investigation agrees with the study of 1976 in the fact that there is an optimum time interval between discharges. It also states that the time interval is impacted by the electrode gap.

This study builds upon and differs from previous works by investigating the effects of pulse rise time and PRF of transient plasma for combustion ignition. The purpose of the study is to further understand effects on combustion with relatively small changes to the high voltage pulses that drive transient plasma for ignition. To use this understanding and acknowledge practical challenges with implementing the technology such as plug erosion and energy for combustion and discuss possible solutions.

In this study plasmas with constant pulse duration, i.e. 10 ns full width half maximum (FWHM), but with different rise times, i.e. 5 ns and 10 ns, are examined. The different rise times are explored at a range of pulse repetition frequencies (PRF's). Another significant difference in this study is the use of a conventional spark plug, generally tungsten electrodes with specific radii are used to better control breakdown. A conventional spark plug was investigated so that contrast can be drawn between this work and others with more ideal electrode geometries. High voltage pulses are applied to the spark plug electrode in a static combustion chamber containing methane and dry air mixtures at atmospheric pressure. Combustion performance based on pressure traces of lean, stoichiometric, and rich mixtures were evaluated and compared. Combustion performance is measured in terms of ignition delay time, rise time, and peak

pressure. The high voltage pulses to drive plasmas were analyzed by their voltage and current traces. Total energy for bursts and energy for each pulse in a burst are examined. Spectra of the second positive system of nitrogen was recorded and rotational temperature evaluated.

1.3 EXPERIMENTAL SETUP

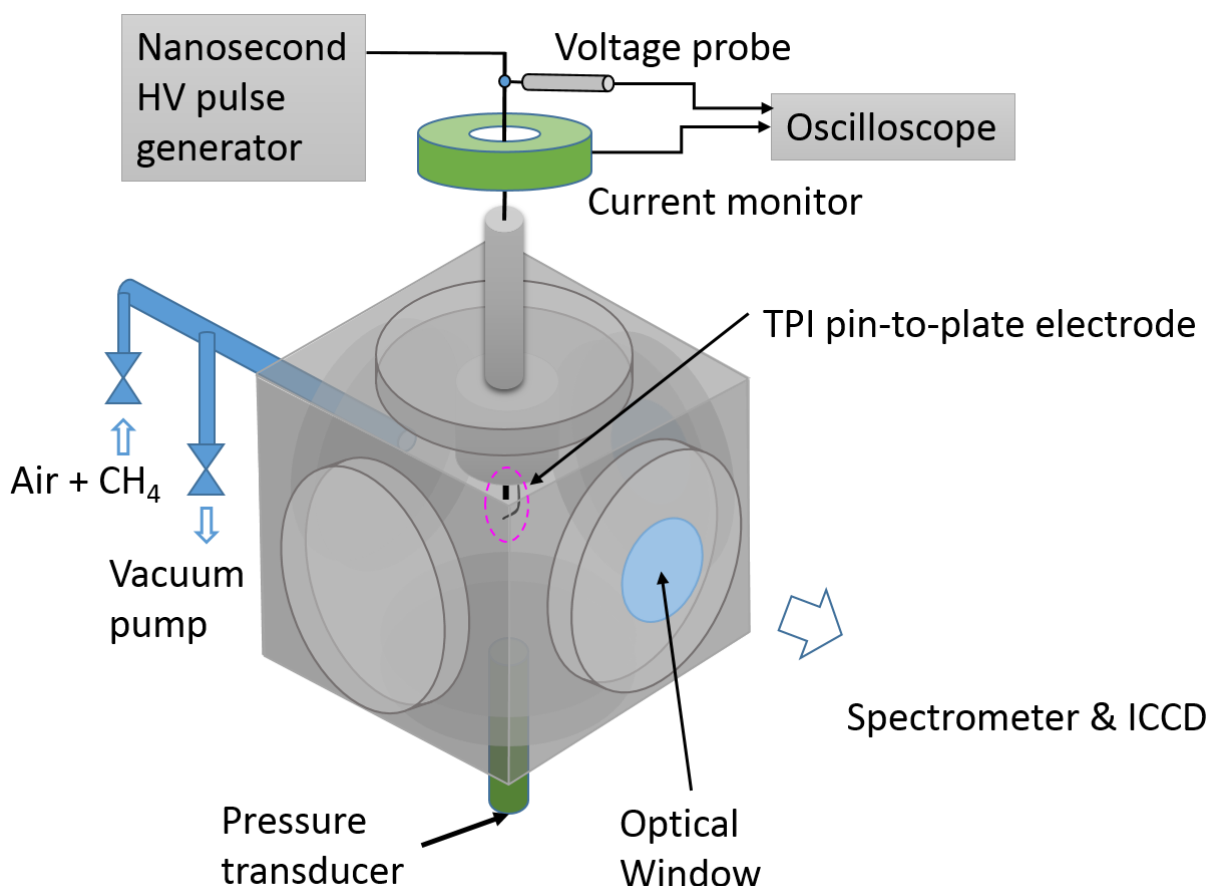

Figure 1 constant volume chamber for combustion by transient plasma ignition.

This project was an excellent example of recycling previous projects that are now obsolete. The test combustion chamber was constructed almost entirely from components in the lab. The strength of the chamber or the forces that it needed to withstand were calculated based on expected combustion pressure based on other similar works [1-3, 7, 10]. The diagram of the experimental setup and its features are presented in Figure 1. Experiments were conducted in a

700 cm³ test chamber constructed of stainless steel that was equipped with a fused quartz window. Before each run, the combustion chamber was evacuated to a pressure of less than 1 mbar (0.015 psi) by an Alcatel 2008A rotary vane vacuum pump and then filled with the working mixture up to a maximal pressure of 1 bar (14.5 psi). The gas filling and pressure in the chamber were monitored and controlled by a low-pressure gauge (Snap-on EEPV511) and manual turn needle and ball valves.

Combustion system design focuses on operation with a variety of mixtures: stoichiometric, lean, and rich fuel air mixtures. Some designs also consider mixtures diluted by exhaust gas, however that is beyond the scope of this paper. Methane (AirGas, 99.5% methane) and dry air (AirGas, <7 ppm H₂O) were used to create the combustible mixtures. For the purpose of comparative analysis, the mixtures used in this study were:

- 1) Dry air: N₂ and O₂ (0.79:0.21 ratio)
- 2) Lean air-CH₄ mixture ($\lambda = 1.033$)
- 3) Stoichiometric air-CH₄ mixture ($\lambda = 1$)
- 4) Rich air-CH₄ mixture ($\lambda = 0.967$)

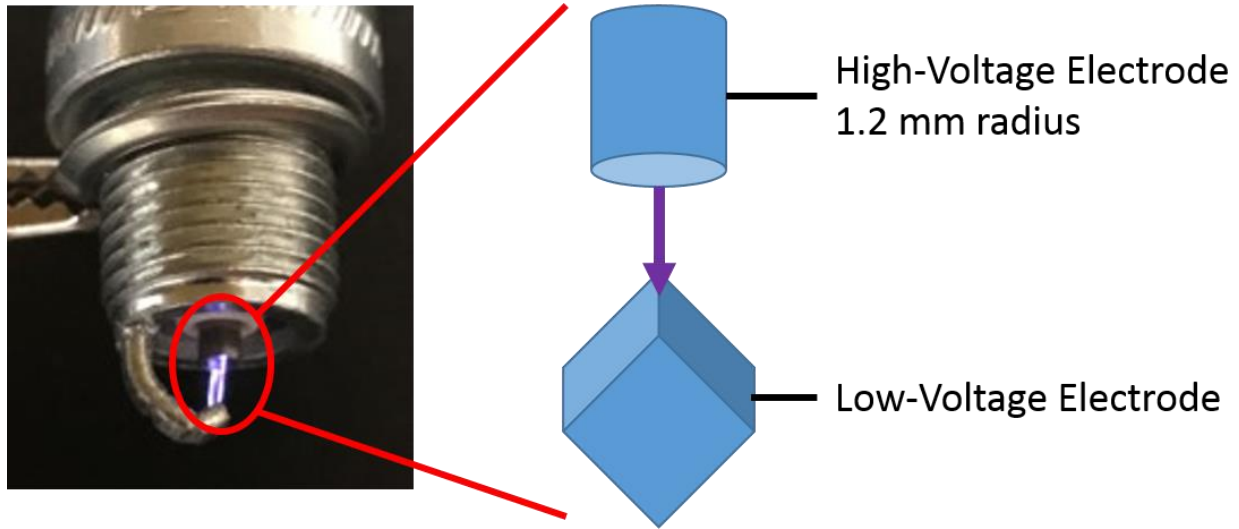

Figure 2 conventional spark plug electrode to the left and zoomed in diagram of the high and low voltage electrode geometry to the right.

Voltage measurements were made with the help of a custom high-voltage probe (600 MHz cutoff frequency) [15, 16]. Current measurements were made with a Pearson current monitor (Model 6585, 200 MHz cutoff frequency, 1.5 ns usable rise time, peak current of 500 A). Synchronization of the probes was achieved by probe placement within a shielded V-I measurement device. Measurements were made by the V-I device where the coaxial cable was soldered to the electrode. All electrical signals were recorded by high-speed digital oscilloscope (Model Tektronix DPO 5204, 2 GHz). The energy delivered by each pulse, E_p , was calculated as a function of the integral over the pulse duration, Δt , of the product of voltage $V(t)$ and current $i(t)$ (1).

$$E_p = \int_0^{\Delta t} (V(t) \cdot i(t)) dt \quad (1)$$

The displacement current contributed little to the overall energy when compared with the magnitude of conduction current and was neglected [2, 11, 17]. The total energy, E_t , was calculated as the sum of each pulse in a four-pulse burst (2).

$$E_t = \sum_{i=0}^4 E_p \quad (2)$$

An Omega Model PX409 piezo resistive pressure transducer (0 – 250 PSIG, cutoff frequency 1.5 kHz) was used to measure the pressure trace directly during combustion. A Hamamatsu photomultiplier tube (PMT) Model R928 with a TECHSPEC bandpass filter ($\lambda_0 = 310$ nm, $\Delta\lambda = 10$ nm) was used to determine the time characteristics of OH emission during the combustion process. A Stanford Research Systems pulse delay generator (Model DG645) was used for triggering and synchronization of the setup when configured with the PMT.

Spectroscopic measurements were performed with a Princeton Instruments SpectraPro High Resolution Spectrograph (Model Acton SP2750, 75 cm focal length, 900 groove/mm grating blazed at 500 nm) coupled with a Princeton Instruments intensified charge coupled device (ICCD) camera (PI-MAX 4, 1024×1024 pixels, 32MHz fps). Measurements were performed between 300 – 800 nm with a spectral resolution of 0.02 nm (0.2 Å). The system was calibrated by means of an ORIEL HG (A) UV pencil lamp. Capturing emission of each pulse was challenging and required a combination of function generators (two Stanford Research Systems Model: DG645 and one Stanford Research Systems Model: DG535) to achieve a jitter of $2 \text{ ns} \pm 0.84 \text{ ns}$.

1.4 EXPERIMENTAL METHODOLOGY

This project was an excellent example of recycling previous projects that are now obsolete. The combustion chamber was constructed almost entirely from components in lab. Materials were gathered and researched for their strength properties. The combustion chamber was drawn in inventor and the necessary modifications, i.e. hole for pressure transducer, O-ring grooves for a mating surfaces, hole for electrode, and electrode height adjustment, that needed to be made to the chamber were added. The model in inventor helped to save much time because each component could be inspected in an assembly format and tolerances could be verified for necessary machining before taking to the machine shop. Also, because everything was drawn in inventor the necessary information for machining of each component was readily available and expedited the process with the machine shop.

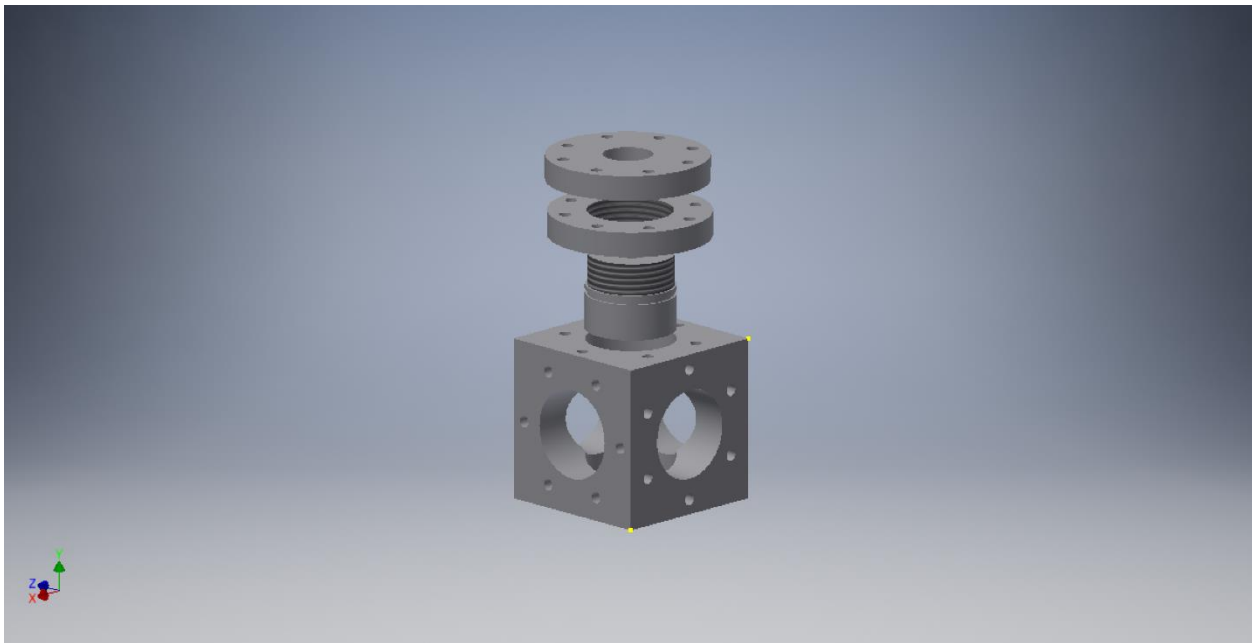

Figure 3 the combustion chamber design drawn in inventor

A study of previous works revealed mixtures ignited at 1 bar (~14.7 psi) were required to withstand peak combustion pressures of approximately 7 bar (~100 psi). The chamber was designed with a safety factor of 2 and could withstand combustion pressures of 14 bar (~200 psi). The 700 cm³, final chamber volume was not the biggest and not the smallest chamber as compared with other works [1, 3]. The chamber was repurposed from left over vacuum equipment. It had walls that were 25 mm thick and a volume of approximately 800 cm³. The chamber was equipped with knife seals designed to be used in conjunction with large crush washers to seal the chamber for very low pressure. The working pressures of the seal were not provided for positive pressure therefore the chamber was adapted with O-rings to ensure its seal.



Figure 4 fused quartz window O-ring sealed when bolted to the chamber

The test chamber was equipped with a window for spectroscopic measurements. The window was made of optical grade, fused quartz. The second positive system of nitrogen will be investigated in this study and has a 310 nm spectrum, the fused quartz permitted greater than 90% transmission from 300 – 1000 nm. The thickness of the window was critical to the design, it had to be able to withstand the pressures of combustion. The modulus of rupture (M) for fused quartz is 482 bar. The unsupported diameter (d) of the window was 40 mm and the unsupported area (A) was 12.6 cm². A pressure (P) of 14 bar and safety factor (S) of 7 were used. The minimum thickness (T) was calculated to be 9 mm using equation (3). A 12.7 mm window was used, it was a standard thickness option.

$$T = \sqrt{\frac{P \cdot A \cdot F}{3.12 \cdot M}} \quad (3)$$

Before each run, the combustion chamber was evacuated to a pressure of less than 1 mbar (0.015 psi) by a vacuum pump and then filled with the working mixture up to a maximal pressure of 1 bar (~14.7 psi). Evacuating and filling with purified gases removed possible instabilities that can be caused by moisture and unknown particles in unfiltered atmosphere.

In this study each plasma in a sequence to initiate combustion was investigated. Each combustion event was initiated with a sequence of four nanosecond type pulses. Two different pulsers, capable of generating pulses with different rise times, were used to initiate combustion. Nanosecond type pulses with two different rise times are compared i.e. pulses with 4.86 ns ± 0.42 ns rise times and 10.04 ns ± 0.62 ns rise times. Peak voltages of the initial pulses in the sequences were fixed to approximately 10 kV ± 567 V. The reason for the large standard deviation was due to use of a conventional spark-plug electrode. The spark-plug electrode is of

interest because it would be the practical implementation, however it does not have an ideal geometry, precise radii at the anode and cathode, which would more accurately control breakdown voltage.

Pulse repetition frequencies of 1 – 6 kHz of the short rise time pulse and PRF of 1 – 10 kHz of the longer rise time pulse were studied. The difference in PRF's were due to equipment limitations. Energy of the first pulse, with the shorter rise time characteristic, was $5 \text{ mJ} \pm 0.2 \text{ mJ}$. Energy of the first pulse, with the longer rise time characteristic, was $3.8 \text{ mJ} \pm 0.2 \text{ mJ}$. Energy for subsequent pulses, with both rise time characteristics, varied depending on the plasma mode change. The mode change transition can be seen in the energy fluctuations of the second and third pulses in the sequence as non-resistive) electrode, as shown in Figure 1. The experimental setup consisted of the electrode, a gas flow control system, and a view port allowing optical diagnostics.

A custom-built high voltage probe with a bandwidth up to 600 MHz was inserted between the spark-plug electrode and the coaxial transmission line that delivered the nanosecond pulses [16]. The pulsed current was measured at the same location using a current probe connected to a high-speed digital oscilloscope. Voltage (V) and current (I) measurements were made and then the data was imported into MATLAB where an algorithm was written to process large batches of data and then send a text message once the processing was complete. The algorithm determined peak voltage, voltage rise time, FWHM, energy per pulse, and energy per burst. For example, ten combustion events would be executed, and the data recorded. Next, the data would be put into MATLAB for processing while simultaneously running the next set of ten experiments. The algorithm also evaluated the statistics of data in a batch, this provided feedback on how repeatable aspects were.

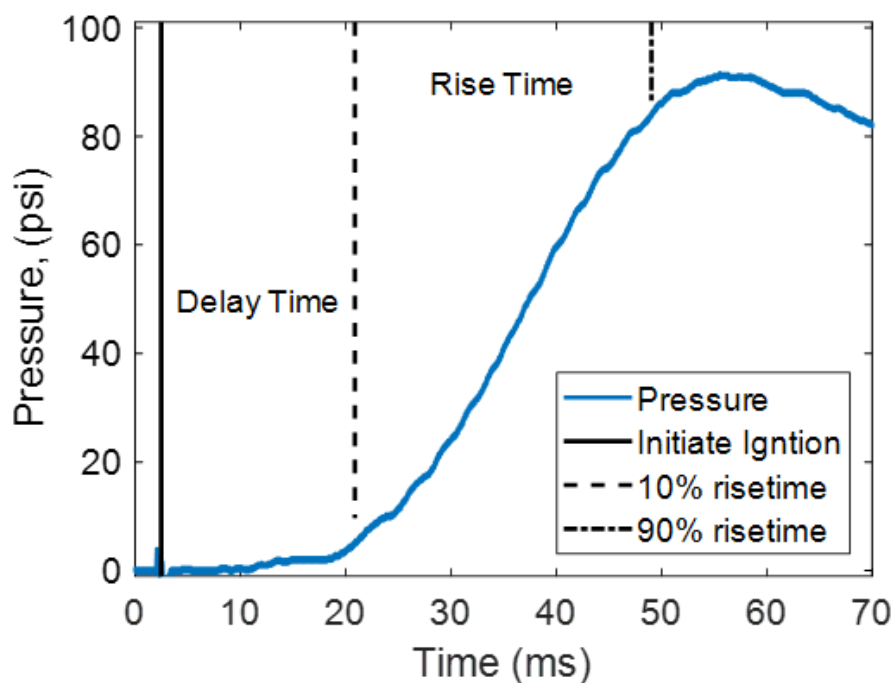

Figure 5 illustrates how the pressure trace is analyzed by the MATLAB algorithm.

The gas filling control system included stainless steel tubing, a pressure transducer, low pressure gauge, valves, and a vacuum mechanical pump. For each test, the combustion chamber was first evacuated to < 1 mbar (0.015 psi) using the low-pressure gauge. Different mixtures of dry air and methane were delivered to the chamber to reach a total pressure of 1 bar (14.7 psi). Total combustion chamber volume was 700 mL once the device that allowed for electrode height adjustment was fitted to the chamber. The pressure transducer, with a range of 0 – 250 PSIG, and reaction time of less than 1 ms was used to directly measure the pressure of each combustion event. There was a separate algorithm that evaluated combustion data for delay time, rise time, peak pressure, and statistics like the ones for voltage and current. This helped to look for outliers where combustion did not follow the trend of the rest of the events, usually due to a mixture issue during the filling stage.

A photo multiplication tube (PMT) placed behind a bandpass filter was aligned to the spark-plug electrode, through the optical window, to measure the relative OH(X) emission during each combustion event as illustrated in Figure 7. To make optical emission spectroscopy (OES) measurements the chamber was moved and aligned in a similar fashion to a spectrometer. Optical emission of the second positive system of nitrogen was measured through the optical window. Capturing the emission of each pulse was challenging and required a combination of function generators (two Stanford Research Systems Model: DG645 and one Stanford Research Systems Model: DG535). A schematic of the system is shown in Figure 6. This system was devised for three reasons. First, the ICCD camera is controlled by a PC and if the delay feature is used for a lengthy time interval 200 – 600 ns of jitter is introduced. Therefore timing the camera to the second third and fourth pulses is impossible in that configuration. Second, the ICCD camera has a limit of frames it can record per second based on the size of the window, for example 1024×1024 would be the full sensor window and 256×256 would be the smallest window. If the window size were optimized, the fastest the ICCD can take images is 200 Hz. Third, there is approximately 100 – 200 ns of jitter between the TPS trigger and the high-voltage output making capturing the second, third, and fourth pulses not possible.

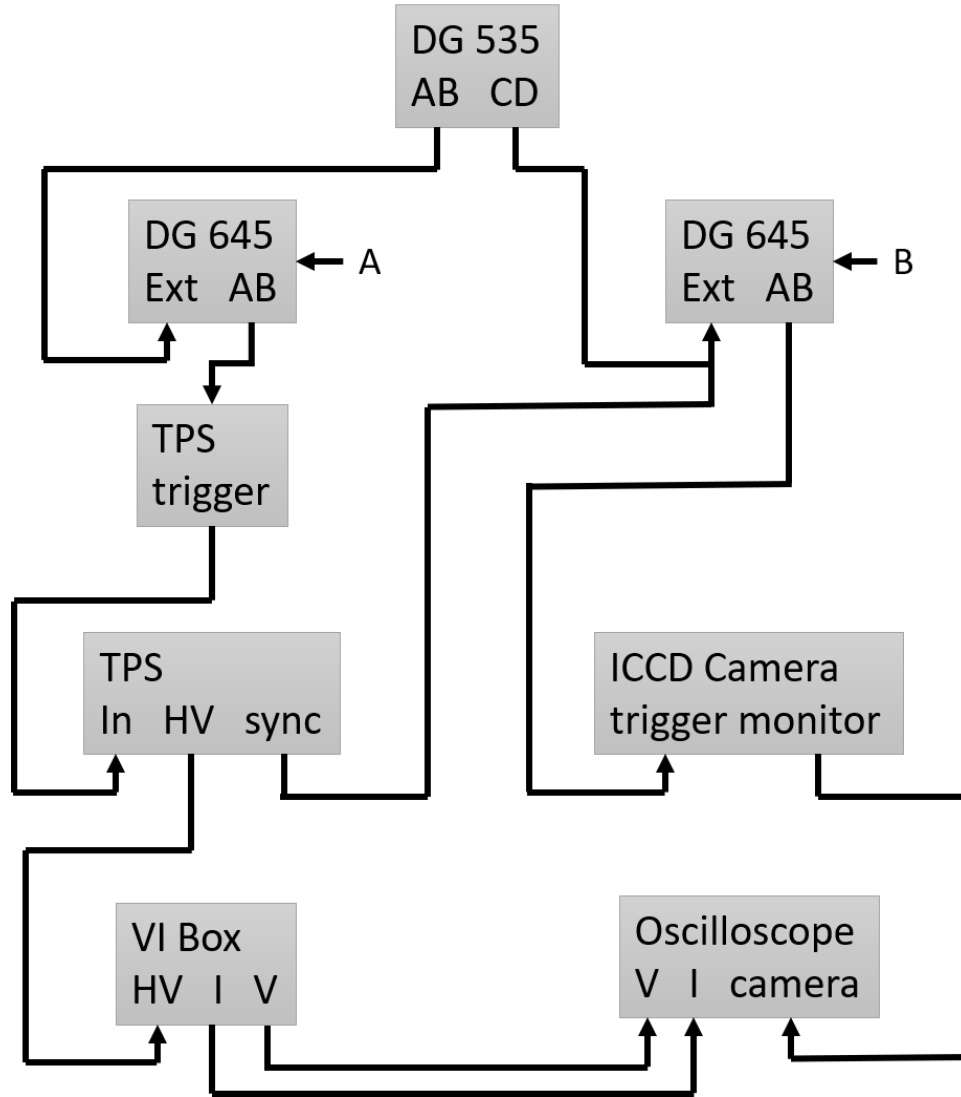

Figure 6 schematic of the triggering system used to align and capture each pulse of a burst

A system of function generators was used to time the ICCD to each voltage pulse used to drive the plasmas of a burst. The DG 535 sent a signal to each DG 645 to synchronize the beginning of an event. The DG 645 A sent a four-pulse burst to the TPS optical trigger. The optical trigger drove the high voltage pulse generator that was equipped with a synchronization output with 500 fs of jitter. The sync was connected to DG 645 B. The DG 535 was connected to DG 645 B so the hold feature could be activated which is important for capturing the second,

third, and fourth pulses. The hold feature tells the DG 645 to ignore any input for a period, i.e. the camera would ignore the trigger of the first pulse, the hold period would expire, and the second pulse would trigger the camera. The only consequence of this is that the camera takes two photos for every event and the first photo is a throwaway and the second captures the emission data. With the system configured as shown in Figure 6 a jitter of $2 \text{ ns} \pm 0.84 \text{ ns}$ was achieved. All the photos were processed for background subtraction and cosmic radiation. Then the batch, which includes ten combustion events, and twenty photos was exported to a .csv format. Again, a MATLAB algorithm was written to analyze the .csv spread sheet and gather the photos with the emission data and combine the frames.

Two separate oscilloscopes were used simultaneously to record plasma and combustion characteristics. The evolution of combustion occurred on the millisecond time scale, PRF occurred from the microsecond time scale to the millisecond time scale, and plasma pulse occurred on the nanosecond time scale. It is important to point out that the oscilloscope with high resolution was used to record voltage and current traces otherwise the rise time, peak voltage, and FWHM could not be accurately measured. The oscilloscope with the lower resolution was used to accurately record the OH(X) emission and pressure traces.

2 EXPERIMENTAL RESULTS & DISCUSSION

2.1 VOLTAGE CURRENT & ENERGY

In this investigation each combustion event was initiated with a burst of four high voltage pulses. Energy for combustion and plug erosion are two crucial aspects directly affected by PRF and the number of pulses in a burst. Plug erosion occurs once a highly conductive ionization channel is established between the anode and cathode of the spark plug electrode and large currents can pass [9]. Understanding the minimum number of pulses needed to initiate combustion is critical to reducing erosion and extending the life of the spark plug electrode. At the same time, applying the minimum number of pulses reduces energy per event. Next, the reduced electric field is calculated using equation (4). Applied voltage and plug gap are straight forward parameters but we also need the number density of the gas. Number density of gas is calculated using equation (5). It is based on the number of moles, Avogadro's number, and the volume of the chamber. The number of moles in the chamber is dependent upon temperature, pressure, the gas constant, and chamber volume. With the three equations the reduced electric field is effected by applied voltage, electrode gap, temperature, and pressure as shown in equation (7). Considering the applied voltage ($V = 10$ kV), the inner electrode gap ($d = 3$ mm), temperature (293.15 K), and pressure ($P = 1$ bar), we will examine the reduced electric field, measured in Townsend, Td, with equation (4). For the plug gap and combustion chamber conditions in this study the reduced electric field is approximated to be 135 Td.

$$\frac{E}{N} = \frac{V_d}{N \cdot d} \quad (4)$$

$$N = \frac{n \cdot N_A}{V} \quad (5)$$

$$n = \frac{P \cdot V}{R \cdot T} \quad (6)$$

$$\frac{E}{N} = \frac{V_d \cdot T \cdot R}{d \cdot P \cdot N_A} \quad (7)$$

In the review of prior research different reduced electric fields result in excitation by different mechanisms [11]. If the field is below 400 Td, the effect is a result of electron impact dissociation of oxygen. If the field is above 400 Td, the effect is a result of ion and electron impact dissociation of oxygen. This is important to understand now because later, when the rotational temperature is analyzed this will give insight as to what to look for, what to expect, and why.

Pulse repetition frequencies of 1 – 6 kHz of the short rise time pulse and PRF of 1 – 10 kHz of the longer rise time pulse at 1 kHz intervals were examined. The difference in PRF's were due to limitations of the high voltage pulse generators. Energy of each pulse was determined from the voltage and current traces and equation (1). Energy of the first pulse, with the 10 ns rise time, was $5 \text{ mJ} \pm 0.2 \text{ mJ}$. Energy of the first pulse, with the 10 ns rise time, was $3.8 \text{ mJ} \pm 0.2 \text{ mJ}$.

The energy of subsequent pulses, with both rise time characteristics, varied depending on the change in conductivity of the plasma channel created between the electrodes. Conductivity increased with each pulse in this study. The conductivity seemed to stabilize by the third or fourth pulse based on PRF and interpretation of the voltage and current traces. The 5 ns rise time pulse coupled a higher amount of energy into the plasma than that of the longer rise time pulse. The internal impedance of the two high voltage pulse generators was different and may have

been a contributing factor to the different energies being coupled into the different plasmas. The shorter rise time pulser had an internal impedance of 400 – 500 Ω as compared to the 10 ns rise time pulser which had an internal impedance of 100 Ω .

The total energy per event was analyzed and showed that as PRF increased, energy decreased. Results corresponded with previous work performed with similar nanosecond discharges at higher applied voltages (12 kV) [18]. The energy for ignition was less than the applied energy when pulses that were not contributing to combustion were removed. Reducing the number of pulses for combustion ignition is important for reducing electrode erosion and energy for combustion especially if they do not contribute to combustion.

A separate set of experiments were performed to compare combustion initiated with single plasmas driven by two different rise time pulses. The plasma driven by the 10 ns rise time pulse required a 23 kV pulse and the plasma with the 5 ns rise time pulse required a 21 kV pulse to initiate combustion. The energy for single shot ignition was calculated to be 7.9 mJ and 6.2 mJ respectively. Single shot ignition used half of the energy that was required for bursts, however breakdown issues and electromagnetic noise become a prevalent challenge. Using multiple pulses, peak voltage can be reduced to less than half of what is needed to ignite a mixture with a single pulse. This is significant because implementing the technology into automobiles is going to require the components to be as small and lightweight as possible. There won't be room for special or bulky high voltage and electromagnetic shielding.

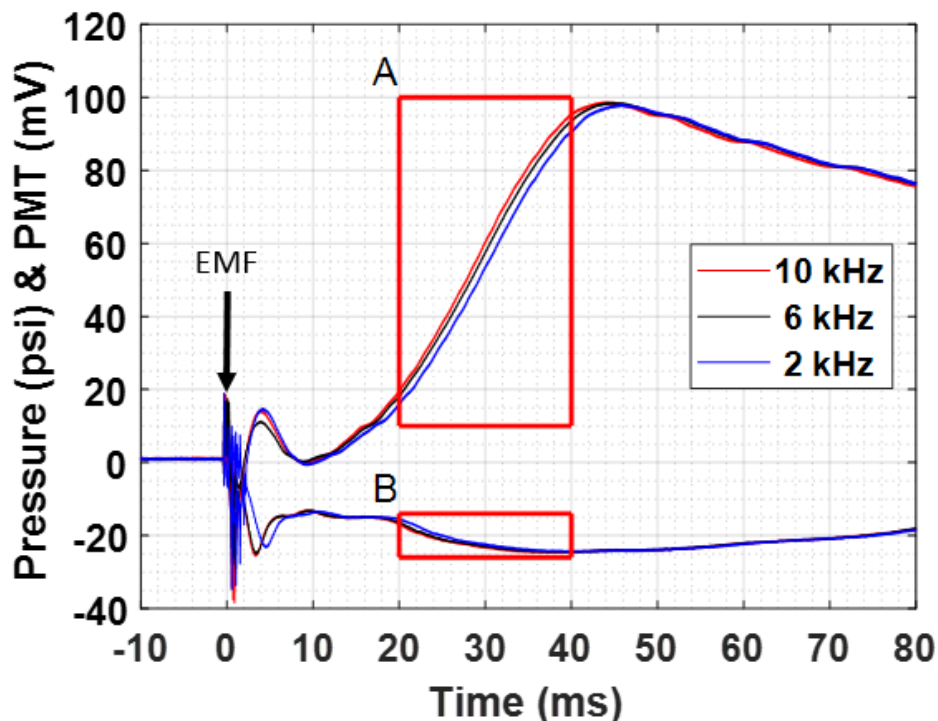

Figure 7 Pressures of combustion corresponding OH(X) emission at a range of pulse repetition frequencies. Combustion was initiated with the 10 ns rise time plasmas. Importantly, notice that as PRF is increased delay time is reduced.

Previous research has shown that pulse repetition frequency is effected by spark-plug gap [2]. A 3 mm spark-plug gap was used for this study and based upon previous work we expected that as PRF is increased combustion performance (delay time, rise time, peak pressure) would be enhanced to a point, then as PRF is increased again the benefits will decay. Experimental results showed as PRF was increased delay time was reduced Figure 7. Notice the electromagnetic noise in the pressure signal induced by the burst of 10 kV pulses. The noise seems relatively low however the oscilloscope recording the pressure has a relatively long sample period (0.08 ms) and this is not an accurate representation of the magnitude of the true noise. All that to say, even at the applied voltage of 10 kV there is EM noise. Noise analysis is beyond the scope of this

study but is important to consider for implementing the technology into a vehicle. The reduction in pressure delay time is more clearly represented in Figure 8. Further analysis of the delay time trend followed a second order polynomial decay. The decay corresponds with the previous works. The decay in performance gain with each increase in pulse repetition frequency aligns with previous work because we expect there to come a point where there is not further benefit to combustion. The decay in performance is not seen because PRF could not be further increased due to equipment limitations.

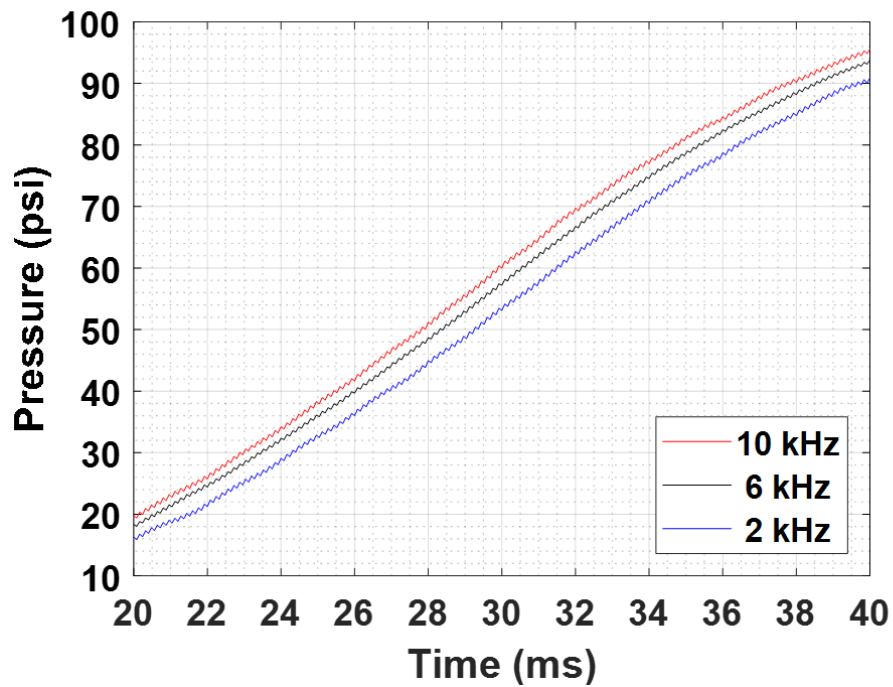

Figure 8 Pressure delay time reducing as pulse repetition frequency is increased.

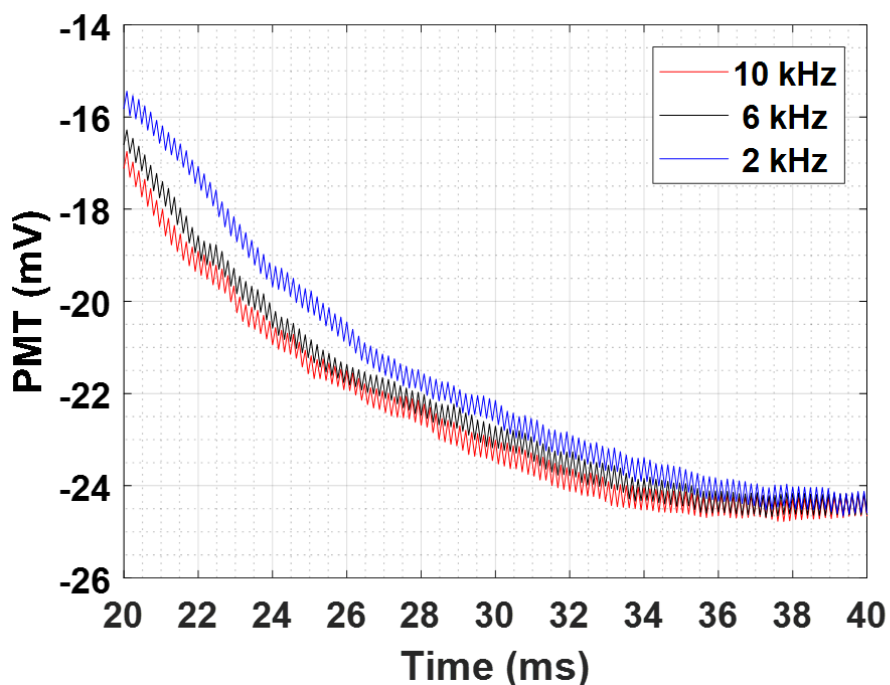

Figure 9 Emission of OH(X) that has a reduction in delay time similar to pressure.

The OH(X) emission measurements produced a similar trend to that seen in pressure with respect to delay time. Figures 10 – 12 are the combustion traces of stoichiometric mixtures. Peak pressures were similar and measured $98.72 \text{ psi} \pm 0.36 \text{ psi}$ and were considered negligible when compared with respect to PRF. Pressure rise time was sustained at $21.95 \text{ ms} \pm 0.23 \text{ ms}$. The prevalent advantage to increasing PRF was reduced pressure delay time. Similar trends were seen for all mixture conditions, independent of rise time.

2.2 VOLTAGE RISE TIME EFFECT

In this study the effect of high voltage pulses with rise times of 5 ns and 10 ns were investigated. Combustion initiated with plasmas driven by high voltage pulses with short rise times, i.e. $4.86 \text{ ns} \pm 0.42 \text{ ns}$ were compared with long rise times, i.e. $10.04 \text{ ns} \pm 0.62 \text{ ns}$ pulses. In previous research, single pulse transient plasma ignition with two different rise times was

compared and the shorter risetime high voltage pulse regularly produced combustion with greater peak pressure and reduced delay time [19]. In this investigation, plasma driven with the shorter rise time high voltage pulse, independent of the PRF, enhanced combustion in different ways depending on the mixture. Each pressure trace represents the average of ten combustion events with a fixed mixture and fixed rise time plasma. Combustion performance of the different mixtures ignited by the same rise time plasma are compared in Figures 10 – 12.

Combustion of a stoichiometric mixture always resulted in the best combustion performance when compared with lean and rich mixtures. The rich mixture has a shorter delay time relative to the lean mixture when ignited with plasmas driven by 10 kV and 10 ns rise time pulses. When ignited with plasmas driven by 10 kV and 5 ns rise time pulses the behavior is opposite, the lean mixture has a shorter delay time than the rich mixture. Igniting leaner mixtures is important to increasing engine efficiency and reducing fuel consumption. Rich mixtures are important to include as well because there are circumstances when the engine is normally operated with a rich mixture such as acceleration and during warm up, therefore performance characteristics in all conditions need to be known.

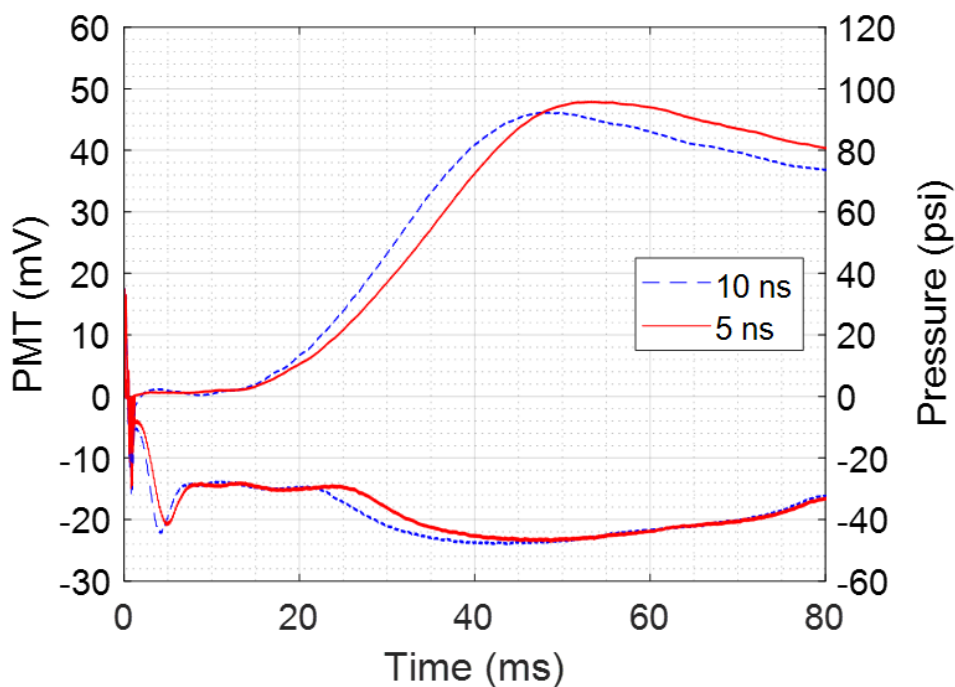

Figure 10 Rich mixtures ignited by four pulse bursts with different voltage rise times.

Rich mixtures were ignited and compared; combustion initiated with the 5 ns rise time pulses had a higher peak pressure but longer delay time. Combustion initiated with the 10 ns rise time pulses had shorter delay time but a lower peak pressure. Combustion initiated by the plasmas with the 10 ns rise time pulse had a combustion delay time that was $4.42\% \pm 0.71\%$ shorter than that of the combustion generated by the plasmas driven by the 5 ns rise time pulse. Peak pressure of combustion initiated by the plasmas with the shorter rise time pulses was $3.63\% \pm 0.12\%$ higher than combustion generated by plasmas driven by the 10 ns rise time pulse as shown in Figure 10. The behavior was independent of PRF.

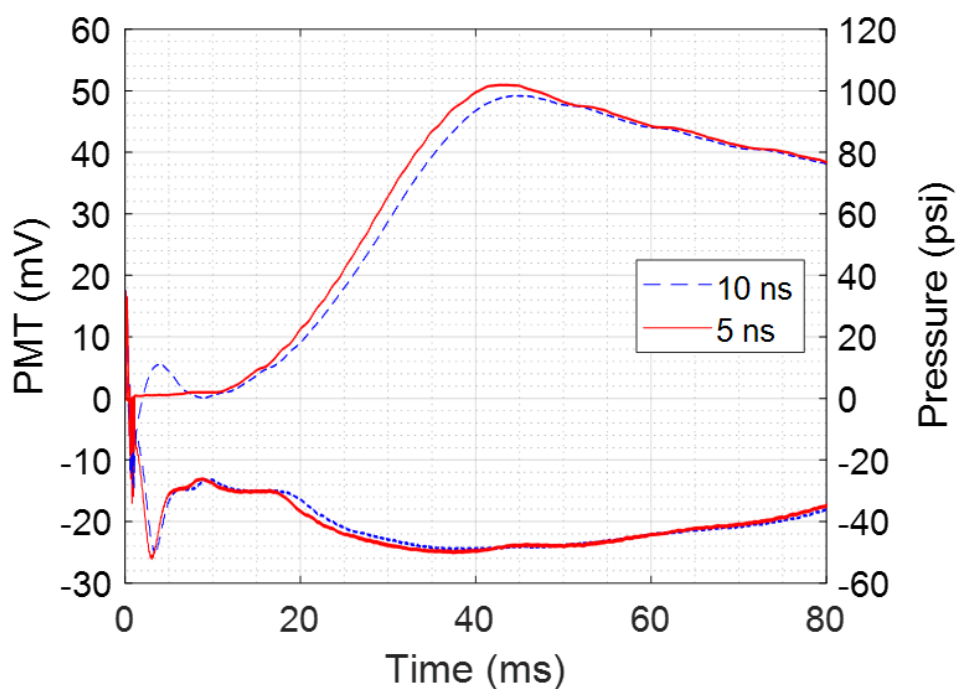

Figure 11 Stoichiometric mixture ignited by bursts with different voltage rise times.

The best combustion pressure performance occurred with stoichiometric mixtures when compared with the rich and lean mixtures. When a stoichiometric mixture was ignited with a burst of plasmas driven by the shorter rise time pulse, combustion consistently had higher peak pressure and shorter delay time as compared to the plasma driven by the longer rise time pulse. Plasmas driven by 5 ns rise time pulses reduced combustion delay time by $4.97\% \pm 2.78\%$ and increased peak pressure $3.5\% \pm 0.21\%$.

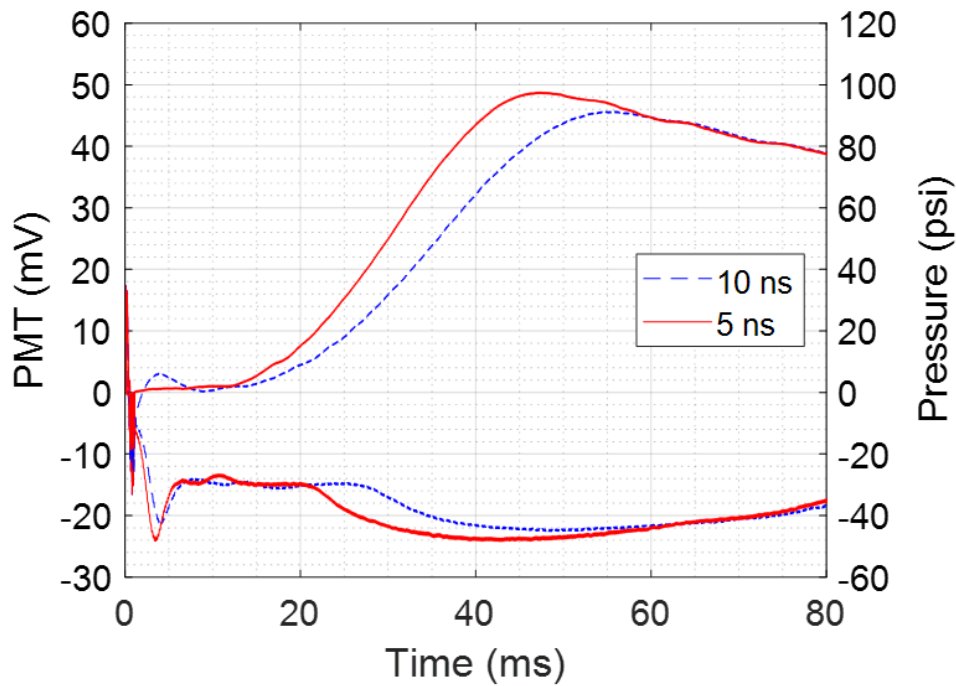

Figure 12 Lean mixture ignited by bursts with different voltage rise times.

Transient plasma ignition of lean mixtures yielded the greatest relative performance gains when ignited by plasma driven with the 5 ns rise time pulse. The 5 ns rise time plasma consistently produced combustion with higher peak pressures and significantly reduced delay times, Figure 12. Peak pressure was increased $5.66\% \pm 1.59\%$ and pressure delay time reduced $15.71\% \pm 0.37\%$. The relative OH(X) emission measured indicated similar trends when compared with pressure. More reactive species are efficiently generated by the shorter rise time pulse characteristic.

2.3 MODE CHANGE

Plasma mode change occurs when a weakly ionized, highly non-equilibrium plasma transitions to an abnormal glow with higher conductivity resulting in reduced peak voltage and

increased peak current. The voltage and current of each pulse at two different PRFs, 2 kHz and 6 kHz, are contrasted. At 2 kHz PRF, the first two pulses have peak currents of approximately 75 amps. On the third pulse, a large increase in peak current occurs, peak current jumps to approximately 150 amps. The fourth pulse is similar to the fourth pulse. At 6 kHz PRF a large increase in current occurs sooner, on the second pulse. Interpretation of the voltage and current traces indicate that ignition occurred on the third pulse at 2 kHz PRF and on the second pulse at 6 kHz PRF. Next, observe where the large increase in current occurs for the longer rise time pulse characteristic as compared to that of the shorter rise time pulse characteristic. Voltage current traces indicate ignition occurred on the fourth pulse at 2 and 6 kHz PRF.

A separate set of experiments was performed to confirm the interpretation of voltage current traces, at 1 – 6 kHz PRF, for both pulses rise times. The results at 2 kHz will be described in detail and can be applied to the results of other PRF's in this study. Results of the experiments showed that with the shorter rise time pulse characteristic ignition never occurred, at 2 kHz, with two pulses applied. At 2 kHz, ignition occurred every time, with three pulses applied. Results at 2 kHz, with four pulses applied ignition occurred every time and with the same combustion characteristics as observed with three pulses. That is, there was no further enhancement of combustion characteristics (delay time, rise time, or peak pressure) with the extra pulse after ignition had occurred. For completeness, the same experiments were performed with the longer rise time pulse characteristic at 2 kHz and the results indicated the same interpretation of the voltage and current traces could be applied. If three pulses were applied with the longer rise time pulse the mixture was never ignited. If four pulses were applied the mixture was ignited every time. Again, subsequent pulses applied after the mode change occurred did not

contribute to combustion performance and they consumed more energy. A significant take away from the mode change phenomena is that combustion closely follows the large increase in peak current. Interpreting a drop in voltage is not always an accurate way to verify ignition occurred. Also, the interpretation would have to be verified at higher pressure combustion to be sure that the interpretation does not differ. Reducing voltage rise time permitted combustion with less pulses. Increasing PRF also allowed combustion with less pulses. Electrode life and ignition energy are important factors in ignition systems and using less pulses to initiating combustion will increase electrode life and reduce energy demand. Increasing electrode life allows for practical maintenance intervals of the spark plug. Reducing energy allows the electronic components to drive plasmas to be physically smaller.

2.4 ROTATIONAL TEMPERATURE

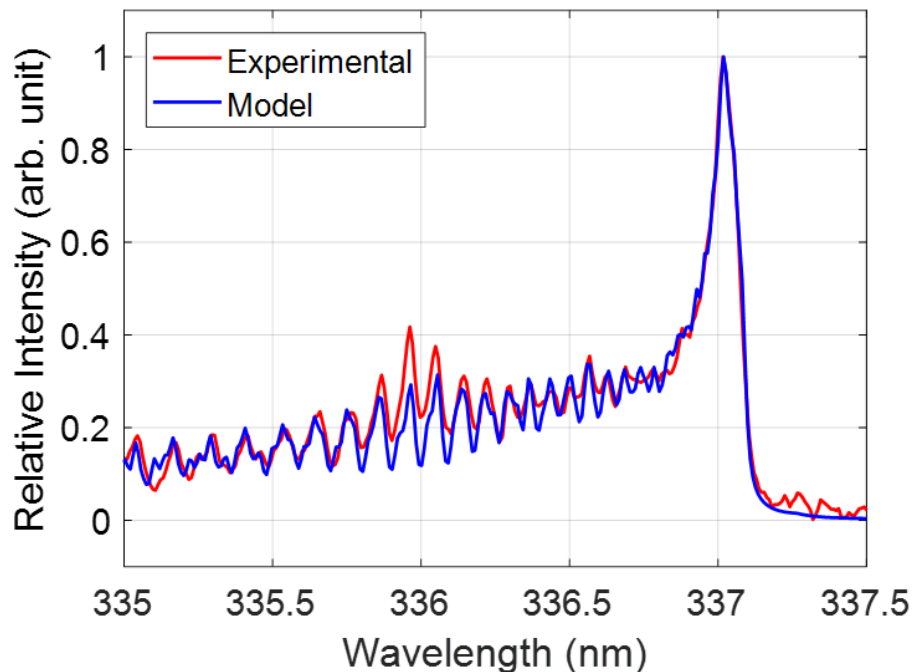

Figure 13 Rotational temperature model compared with experimental data

Optical emission spectroscopy was used to investigate each plasma in a four-pulse burst for combustion ignition. This study differs from other research where the temperature of the evolution of combustion is investigated. The second positive system of nitrogen was investigated to identify the rotational temperature of each plasma in a burst. Bursts from 2 – 10 kHz PRF, at an interval of 2 kHz were investigated. An accumulation of ten images was recorded for each condition, i.e. each pulse at each frequency, and was averaged. LightField (version 4.10) was used to process images for cosmic radiation and background subtraction. A Matlab script was used to retrieve the useful emission data from the batch and then the frames combined. Spatially, the full length of the plasma between the electrodes was observed. An ICCD camera in combination with multiple function generators was used to image each plasma. The slit width of the spectrometer was fixed to 40 μm and the system had an optical resolution of 0.2 \AA . Each plasma was imaged with a 100 ns exposure time. Emission from each pulse was recorded and the rotational temperature was determined. Temperature was determined by comparing the experimental spectra intensity with the model spectra intensity using Specair (version 2.2), Figure 13.

On the first pulse no emission was observed, and room temperature assumed. With the emission from the second, third, and fourth plasmas rotational temperatures could be deduced. The average rotational temperature of the second pulse – 1080 K, third pulse – 1640 K, and fourth pulse – 1840 K [20]. Temperature of each plasma was unaffected by PRF in the range of frequencies investigated. Recall, plasma driven by the shorter rise time pulse characteristic, at 2 kHz PRF, combustion was initiated on the third pulse and at 6 kHz combustion was initiated on the second pulse. With increased PRF, in combination with shorter rise time, not only was the number of pulses reduced, the temperature at which combustion was initiated was reduced by

560 K as compared to the third pulse and 760 K as compared to the fourth pulse. This means that the energy is being more efficiently coupled into the plasma.

3 CONCLUSIONS

Transient plasmas driven by repetitively pulsed, 10 kV, 10 ns pulses, with rise times of 5 ns and 10 ns were produced with a conventional, non-resistive, spark-plug electrode in different methane-dry air mixtures at atmospheric pressure. Ignition delay time was reduced when shorter rise time pulses, 5 ns, were used in conjunction with stoichiometric and lean mixtures. Increasing PRF from 1 kHz to 10 kHz, decreased delay time logarithmically for all mixture conditions. Importantly, fuel-air mixtures that were ignited by shorter rise time pulses or higher PRFs were able to reduce the energy necessary for ignition and improve the thermal efficiency of energy transfer between the plasma and molecules. The combination of shorter rise time and increased PRF reduced energy for ignition and lower gas temperature. The combination would also reduce electrode erosion and hence be beneficial to the lifetime of the combustion system. In addition, high repetition rate multi pulse bursts for TPI helped to reduce peak voltage to less than half of what was needed for single-shot TPI, which simplifies system design and makes the high-voltage nanosecond-pulsed implementation more achievable.

Transient plasmas generated from nanosecond pulses were used to ignite methane-air mixtures and combustion was enhanced. Combustion delay time was reduced when shorter rise time pulses were used in conjunction with stoichiometric and lean mixtures. Delay time was further reduced when pulse repetition frequency was increased for all mixture conditions. By using shorter rise time pulses mixtures were ignited with less pulses at a lower rotational temperature. Furthermore, reducing the number of pulses for ignition would reduce energy and reduce electrode erosion. Another important characteristic, the impedance of the pulser needs to closely match the plasma impedance which was affected by electrode geometry and chamber

conditions. Employment of multiple-pulse ignition helped to reduce peak voltage to less than half of what was needed for single shot ignition making implementation more achievable.

4 REFERENCES

- [1] F. Wang *et al.*, "Transient plasma ignition of quiescent and flowing air/fuel mixtures," (in English), *Ieee Transactions on Plasma Science*, vol. 33, no. 2, pp. 844-849, Apr 2005.
- [2] S. Lovascio *et al.*, "Effects of pulsation frequency and energy deposition on ignition using nanosecond repetitively pulsed discharges," (in English), *Proceedings of the Combustion Institute*, vol. 36, no. 3, pp. 4079-4086, 2017.
- [3] D. Singleton, S. J. Pendleton, and M. A. Gundersen, "The role of non-thermal transient plasma for enhanced flame ignition in C₂H₄-air," (in English), *Journal of Physics D-Applied Physics*, vol. 44, no. 2, Jan 19 2011.
- [4] B. Lewis and G. Von Elbe, *Combustion, flames, and explosions of gases*, 3rd ed. Orlando: Academic Press, 1987, pp. xxiv, 739 p.
- [5] C. D. Cathey, T. Tang, T. Shiraishi, T. Urushihara, A. Kuthi, and M. A. Gundersen, "Nanosecond plasma ignition for improved performance of an internal combustion engine," (in English), *Ieee Transactions on Plasma Science*, vol. 35, no. 6, pp. 1664-1668, Dec 2007.
- [6] J. Liu, P. D. Ronney, and M. A. Gundersen, "Premixed flame ignition by transient plasma discharges," 2001. [Online]. Available.
- [7] M. Kono, S. Kumagai, and T. Sakai, "Ignition of gases by two successive sparks with reference to frequency effect of capacitance sparks," *Combustion and Flame*, vol. 27, pp. 85-98, 1976/08/01/ 1976.
- [8] R. Maly and M. Vogel, "Initiation and propagation of flame fronts in lean CH₄-air mixtures by the three modes of the ignition spark," *Symposium (International) on Combustion*, vol. 17, no. 1, pp. 821-831, 1979/01/01/ 1979.
- [9] R. Maly, "Spark Ignition: Its Physics and Effect on the Internal Combustion Engine," Boston, MA: Springer, 1984.
- [10] S. V. Pancheshnyi, D. A. Lacoste, A. Bourdon, and C. O. Laux, "Ignition of Propane-Air Mixtures by a Repetitively Pulsed Nanosecond Discharge," *IEEE Transactions on Plasma Science*, vol. 34, no. 6, pp. 2478-2487, 2006.
- [11] D. L. Rusterholtz, D. A. Lacoste, G. D. Stancu, D. Z. Pai, and C. O. Laux, "Ultrafast heating and oxygen dissociation in atmospheric pressure air by nanosecond repetitively pulsed discharges," (in English), *Journal of Physics D-Applied Physics*, vol. 46, no. 46, Nov 20 2013.
- [12] N. L. Aleksandrov, S. V. Kindysheva, M. M. Nudnova, and A. Y. Starikovskiy, "Mechanism of ultra-fast heating in a non-equilibrium weakly ionized air discharge plasma in high electric fields," *Journal of Physics D: Applied Physics*, vol. 43, no. 25, p. 255201, 2010/06/08 2010.
- [13] N. Popov, "Kinetic processes initiated by a nanosecond high-current discharge in hot air," *Plasma Physics Reports*, Article vol. 37, no. 9, pp. 807-815, 2011.
- [14] N. A. Popov, "Fast gas heating in a nitrogen-oxygen discharge plasma: I. Kinetic mechanism," *Journal of Physics D: Applied Physics*, vol. 44, no. 28, p. 285201, 2011/06/24 2011.
- [15] J. Sanders, C. Jiang, A. Kuthi, and M. A. Gundersen, "Broadband Power Measurement of High-Voltage, Nanosecond Electric Pulses for Biomedical Applications," in *2008 IEEE International Power Modulators and High-Voltage Conference*, 2008, pp. 350-353.

- [16] C. Tremble, D. Alderman, J. Sanders, D. Singleton, and C. Jiang, "Broadband Power Measurements of High-Voltage, 10-ns Pulses for Plasma Ignition for Combustion," presented at the IEEE Pulse Power & Plasma Science Conference, Orlando, Florida, June 23, 2019.
- [17] D. Pai, "Nanosecond Repetitively Pulsed Plasmas in Preheated Air at Atmospheric Pressure," Ecole Centrale Paris, France, 2008.
- [18] D. Alderman, C. Tremble, S. Song, and C. Jiang, "Plasma Kinetics Study of a Repetitive 10-ns Pulsed Plasma Ignition for Combustion," in *IEEE Pulse Power & Plasma Science Conference*, Orlando, Florida, 2019.
- [19] D. Alderman, C. Tremble, J. Sanders, D. Singleton, and C. Jiang, "Initial Evaluation of Pulse Risettime on Transient Plasma Ignition for Combustion," in *IEEE International Power Modulator and High Voltage Conference*, 2018.
- [20] D. Alderman, C. Tremble, D. Singleton, J. Sanders, and C. Jiang, "Effects of Pulse Rise Time and Repetition Frequency on Nanosecond Pulsed Plasma Ignition for Combustion," *to submit to IEEE Transactions on Plasma Science*, 2020.

5 VITA

David Wayne Alderman II

Department of Electrical and Computer Engineering

Old Dominion University

Norfolk, VA 23529

EDUCATION

Bachelor of Science in Electrical Engineering

Old Dominion University Fall 2018

Norfolk, VA 23529

PUBLICATIONS

D. Alderman, C. Tremble, S. Song, and C. Jiang, "Plasma Kinetics Study of a Repetitive 10-ns Pulsed Plasma Ignition for Combustion," to appear in *IEEE Pulse Power and Plasma Science Conference*, 2019, in press.

D. Alderman, C. Tremble, J. Sanders, D. Singleton, and C. Jiang, "Initial Evaluation of Pulse Risettime on Transient Plasma Ignition for Combustion," in *IEEE International Power Modulator and High Voltage Conference*, 2018.

EXPERIENCE

David Alderman has worked in the automotive industry for ten years. He worked as a master certified BMW technician for four years then decided to pursue higher education.