



January 2012

# Analysis Of The Role Of Amphetamine In The Induction Of Changes In Histone Modifications Of Dopaminergic Pathway Genes

Amritendu Chakraborty

Follow this and additional works at: <https://commons.und.edu/theses>

---

## Recommended Citation

Chakraborty, Amritendu, "Analysis Of The Role Of Amphetamine In The Induction Of Changes In Histone Modifications Of Dopaminergic Pathway Genes" (2012). *Theses and Dissertations*. 1341.  
<https://commons.und.edu/theses/1341>

This Thesis is brought to you for free and open access by the Theses, Dissertations, and Senior Projects at UND Scholarly Commons. It has been accepted for inclusion in Theses and Dissertations by an authorized administrator of UND Scholarly Commons. For more information, please contact [zeinebyousif@library.und.edu](mailto:zeinebyousif@library.und.edu).

ANALYSIS OF THE ROLE OF AMPHETAMINE IN THE INDUCTION OF  
CHANGES IN HISTONE MODIFICATIONS OF DOPAMINERGIC PATHWAY  
GENES

by

Amritendu Chakraborty  
Masters of Science, University of Calcutta (2008)

A Thesis

Submitted to the Graduate Faculty

of the

University of North Dakota

in partial fulfillment of the requirements

for the degree of

Master of Science

Grand Forks, North Dakota  
December 2012

**Copyright 2012 Amritendu Chakraborty**

This thesis, submitted by Amritendu Chakraborty in partial fulfillment of the requirements for the Degree of Master of Science from the University of North Dakota, has been read by the Faculty Advisory Committee under whom the work has been done and is hereby approved.

---

Dr. Joyce E. Ohm, Chairperson

---

Dr. Barry Milavetz

---

Dr. Lucia Carvelli

This thesis is being submitted by the appointed advisory committee as having met all of the requirements of the Graduate School at the University of North Dakota and is hereby approved.

---

Dr. Wayne Swisher,  
Dean of the Graduate School

---

Date

## PERMISSION

Title            Analysis of the Role of Amphetamine in the Induction of Changes in  
Histone Modifications of Dopaminergic Pathway Genes

Department    Biochemistry and Molecular Biology

Degree         Master of Science

In presenting this thesis in partial fulfillment of the requirements for a graduate degree from the University of North Dakota, I agree that the library of this University shall make it freely available for inspection. I further agree that permission for extensive copying for scholarly purposes may be granted by the professor who supervised my thesis work or, in their absence, by the chairperson of the department or the dean of the Graduate School. It is understood that any copying or publication or other use of this thesis or part thereof for financial gain shall not be allowed without my written permission. It is also understood that due recognition shall be given to me and to the University of North Dakota in any scholarly use which may be made of any material in my thesis.

Name: Amritendu Chakraborty

Date: December 01, 2012

## TABLE OF CONTENTS

LIST OF FIGURES .....	viii
LIST OF TABLES .....	ix
ACKNOWLEDGEMENTS .....	x
ABSTRACT .....	xi
CHAPTERS	
I.    INTRODUCTION .....	1
The concept of Addiction.....	1
Amphetamine .....	1
Evolution of Amphetamine as an abusive drug .....	2
Dopamine .....	3
Biosynthesis of Dopamine .....	3
Association of Amphetamine to Dopamine .....	6
Effect of Amphetamine on Vesicular Monoamine Transporters .....	7
Effect of Amphetamine on Dopamine Transporter .....	8
Advantages of the <i>Caenorhabditis elegans</i> as a model organism .....	10
<i>Caenorhabditis elegans</i> Life Cycle .....	11
<i>Caenorhabditis elegans</i> Neurobiology .....	14
Role of Dopamine Signaling in <i>C.elegans</i> .....	14
Effect of Amphetamine on the Dopamine Signaling Pathway .....	17
Epigenetics .....	19

	Importance of Epigenetics .....	23
	Epigenetics and Addiction .....	25
	Transcription Factors Associated with addiction.....	25
	Histone Tail Modifications Associated With Addiction.....	27
II.	MATERIALS AND METHODS.....	31
	Cell Culture.....	31
	Protein Extraction .....	31
	Immunoblot.....	32
	Synchronization of worm cultures .....	34
	Worm Egg Isolation.....	34
	Treatment with Amphetamine .....	35
	Worm Protein Preparation .....	36
	Chromatin Immunoprecipitation.....	36
	RNA Isolation.....	39
III.	RESULTS .....	41
	Protein Expression of Histone Modifications.....	41
	Amphetamine administration induces changes in the global expression of histone modifying enzymes .....	45
	Enrichment of Histone Modifications tri-methylated H3K4, H3K27 and H3K36 around the transcription start site of dopamine pathway genes .....	51
	Amphetamine treatment induces changes in the expression of genes in the dopaminergic pathway.....	63
IV.	DISCUSSION .....	65

V. REFERENCES .....72



## LIST OF FIGURES

Figure	Page
1. Schematic model of a <i>C. elegans</i> DA neuron containing known and predicted genes involved in DA biosynthesis and metabolism.....	5
2. Life cycle of <i>C. elegans</i> .....	13
3. Schematic of <i>C. elegans</i> Dopaminergic neurons .....	16
4. Average enrichment profiles of histone modifications .....	21
5. Protein Expression of H3K4me3, H3K27me3 and H3K36me3 in control and Amphetamine treated samples .....	43
6. Amphetamine treatment induces changes in the expression of histone methyltransferases and histone demethylases.....	46
7. Enrichment of tri-methylated H3K4, H3K27 and H3K36 around the transcription start sites of dopaminergic pathway genes in control and amphetamine treated worms .....	56
8. Amphetamine treatment induces changes in the expression of genes in the dopaminergic pathway.....	63

## LIST OF TABLES

Table	Page
1. Nucleotide sequence of the primers used in the chromatin immunoprecipitation analysis .....	52

## ACKNOWLEDGMENTS

I would like to express my appreciation towards my advisor Dr. Joyce Ohm for her guidance and positive attitude over the past couple of years. I would also like to thank my committee members: Dr. Barry Milavetz for his encouragement, the racquet ball sessions and our conversations which gave me the impetus to work harder and Dr. Lucia Carvelli for being generous with her time and believing in me. I owe special thanks to Dr. Kathy Sukalski for her support throughout my journey. My fellow graduate students: Les Kallested has been helpful with experimental design, Mahmoud L. Soliman has been instrumental in the data analysis and providing positive outlook, and Promisree Choudhury conferred constant support and positive research attitude which made my work less stressful and more fun.

Ultimately, my heartfelt gratitude goes out to my family members for their love and support without whom, my endeavor would not have been a success, especially my elder brothers Arkadyuti Chakravarty and Ajitava Chakravorty for being my source of inspiration.

## ABSTRACT

Amphetamine and cocaine has long been known as drug of abuse. These drugs impart their physiological manifestations by regulating the reward circuitry of the brain which is controlled primarily by the dopaminergic pathway where they control the release of dopamine. It has been found that repeated cocaine administration changes histone acetylation patterns at the promoter sequences of several important genes. Sirtuin proteins are histone deacetylases that regulate important biological functions have also been found to be elevated in the nucleus accumbens after cocaine administration. Although there have been several studies that have tried to elucidate the mode of action of amphetamine, it is still not known whether the drug of abuse, induces heritable histone modifications at affects each of the genes of the dopaminergic pathway by inducing changes at the promoter regions of these genes. Therefore, in order to better understand the mechanism of the action of amphetamine, the goal of the present study is to look into the effect of amphetamine in stimulation of epigenetic changes by the induction of histone modifications at the promoters of genes of the dopaminergic pathway. We chose *Caenorhabditis elegans* (*C. elegans*) as our experimental model system for our study. Dopamine is synthesized in eight sensory neurons (4 CEP, 2 ADE and 2 PDE) and modulates locomotion, learning and egg laying activity. All the known dopaminergic components involved in DA synthesis, vesicle storage, release and reuptake are highly conserved between the worm and mammals.

In order to identify the histone modifications that are affected by amphetamine administration, immunoblot followed by mRNA expression was performed which revealed that amphetamine indeed affects the expression of histone modifications. For, gene specific investigation, chromatin immunoprecipitation was employed. Chromatin immunoprecipitation revealed that amphetamine treatment down regulates the expression of *dat-1*, the dopamine transporter and *cat-1*, vesicular monoamine transporter by reducing the enrichment of tri-methylated H3K4. Amphetamine treatment also increases the expression of *cat-2*, tyrosine hydroxylase by reducing the enrichment of tri-methylated H3K27. Our results also showed that amphetamine treatment has no effect on the expression of *bas-1*, the aromatic amino acid decarboxylase. We further confirmed our results by mRNA expression. These results indicate the role of amphetamine in inducing changes in the histone modifications, though further research is needed to confirm the observations.

RS

To my Rev. Acharya Dev, my Father and Mother

For everything that I am today

## **Chapter 1**

### **Introduction**

#### **The concept of Addiction**

Addictive drugs have been in usage for thousands of years. For example, there has been evidence that shows that clinical opium was considered as a “joy plant” in Sumeria in 5000BC, where opium was generally used as opium vapors. The Chinese had the concept of “recreational opium smoking” since early 1600s. The concept of addiction (uncontrollable drug habit) was developed in 1822 by Thomas De Quincey in “Confessions of an English Opium Eater” (1).

Addiction became rampant with the introduction of the hypodermic syringe during the American Civil War, which increased the appeal for the usage of morphine and opium. After morphine, came the use of cocaine. Cocaine was introduced by modern chemists in the 19<sup>th</sup> century. Cocaine was used in the soft drink coca-cola in 1886. The concept of cocaine as an addictive drug was raised in 1887 by an American physician.

#### **Amphetamine**

Amphetamine is a psychostimulant drug that has been used for the treatment of a variety of disorders including Attention Deficit Hyperactivity disorder (ADHD), obesity, brain injury and others because of its ability to release catecholamine(2).

## **Evolution of Amphetamine as an abusive drug**

Amphetamine has been in significant use since synthetic amphetamine was invented in 1887 by a Romanian chemist, Lazar Edeleano. Since then chemists and researchers have developed wide range of synthetic derivatives of Amphetamine. Synthetic amphetamine was introduced commercially by Smith Kline and French, as an inhaler form and marketed as 'Benzedrine', in the early 1930s for the treatment of narcolepsy. Use of Amphetamine was rampant among various military personnel around the world in order to promote alertness (3). Millions of tablets were supplied to various military troops during the Second World War for increasing alertness. It was especially common amongst the Air Force personnel.

As the usage of the drug increased, so did its abuse. Initial abuse of amphetamine usage started among students in various universities followed by artists, musicians, the armed forces, and truck drivers in order to increase alertness(3). Since then, amphetamine abuse has increased in epidemic proportions in United States and around the world. As of 2000, the U.S Drug Enforcement Agency (D.E.A) has identified methamphetamine (METH) as the most illicitly used controlled manufactured substance (3).

## **Abusive property of Amphetamine and the Effects**

The addictive potential of amphetamine was mentioned as early as 1937, although the reasons behind it were obscure. It was only in the early 1960s, when the initial reports of central nervous system neurotoxicity induced by amphetamines appeared, that amphetamine was widely recognized as an addictive substance.



The dependence on amphetamine arose from the fact that acute amphetamine administration can cause a wide range of behavioral effects in a dose dependent manner, including increased alertness, anorexia, hyperactivity and emotional effects including a state of elation and euphoria (3).

### **Dopamine**

Dopamine, a member of the catecholamine family, is an important neurotransmitter in the brain. The chemical structure of dopamine consists of an amine group attached to dihydroxyphenylalanine. Dopamine plays several important roles in the human brain. Its major roles include the regulation of behavior, voluntary movement, motivation and reward, mood changes, attention, and learning. Dopaminergic neurons are the neurons that transmit dopamine. They are found predominantly in the Ventral Tegmental Area (VTA) of the mid brain, the Substantia Nigra pars Compacta, and the arcuate nucleus of the Hypothalamus.

### **Biosynthesis of Dopamine**

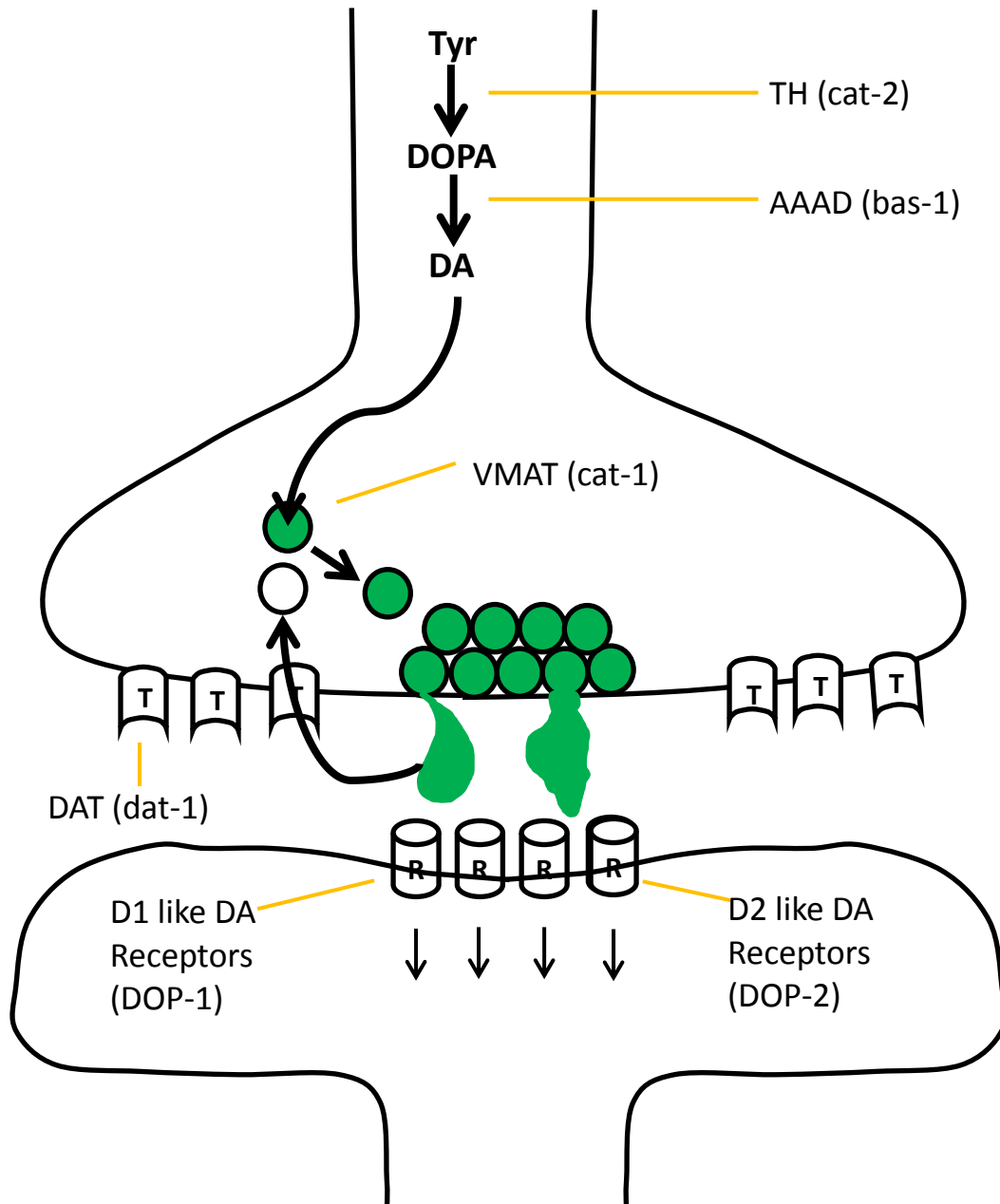
Biosynthesis of dopamine starts with tyrosine. Tyrosine is an essential amino acid that is found in surplus amounts in the diet. A low affinity amino acid transport system transports tyrosine up to the brain and from the brain extracellular fluid into dopaminergic neurons. Once inside the dopaminergic neurons, L-tyrosine is converted into dihydroxyphenylalanine (L-DOPA), by hydroxylation of L-tyrosine. This is done by the cytosolic enzyme, Tyrosine Hydroxylase (TH)(4). This conversion of Tyrosine to L-DOPA is the rate limiting step in the biosynthesis of Dopamine. Another enzyme that is indirectly responsible for the production of L-DOPA is dihydropteridine hydroxylase,

which catalyzes the recycling of the essential cofactor tetrahydrobiopterine to dihydrobiopterine.

The next step in the biosynthesis of dopamine is the cytosolic conversion of L-DOPA to dopamine. This conversion is carried out by the enzyme Aromatic Amino Acid Decarboxylase (AADC) (4). The rate of conversion of L-DOPA to dopamine is so swift that there is almost no L-DOPA left in the brain under normal conditions.

Following the biosynthesis of dopamine, dopamine is transported from the cytoplasm to specialized vesicles by an active transport mechanism, and these vesicles store dopamine until it is released by exocytosis (4). These specialized vesicles are derived from the endosomal compartment. An active transport mechanism is used to transport dopamine into the vesicles, and is regulated by the Vesicular Monoamine Transporter (VMAT).

The dopaminergic system is one of the major targets of addictive drugs. This is because dopamine is the primary neurotransmitter involved in the reward circuitry of the brain.



**Figure 1: Schematic model of a *C.elegans* DA neuron containing known and predicted genes involved in DA biosynthesis and metabolism - TH, tyrosine hydroxylase; AAAD, aromatic L-amino acid decarboxylase; VMAT, vesicular monoamine transporter; DAT-1, dopamine transporter; DOP1, D1-like DA receptor; DOP2, D2-like DA receptor.**

## **Association of Amphetamines to Dopamine**

It has been a known fact that most addictive drugs function by increasing the synaptic dopamine via various synaptic modulations, which are significantly distinct from regular physiological circumstances (1). Amphetamine stands out from other addictive drugs in the manner by which it regulates the increase of synaptic dopamine. Amphetamine achieves the increase of extracellular dopamine by promoting efflux from synaptic terminals (5). Acute administration of amphetamine induces phosphorylation of cAMP response element-binding protein (CREB) and increases expression of a number of immediate early genes (IEGs), such as c-fos (6). On the other hand, chronic exposure to amphetamine induces delta FosB ( $\Delta$ FosB), which plays an essential role in long-term adaptive changes in the brain (7). Amphetamine affects dopamine signaling in multiple ways. It has been shown that amphetamine is a transporter substrate of DAT that is dependent on temperature. It was shown that the accumulation of amphetamine was prevented by the presence of DAT reuptake inhibitors like cocaine (8). Galli and coworkers showed that amphetamine can stably efflux dopamine through DAT.

The first series of studies on the mode of action of amphetamines showed that amphetamines could release dopamine in cells that expressed dopamine transporter (DAT) (9) and that this release was greatly increased in cells that co-expressed VMAT, suggesting a role for both DAT and VMAT in the release of dopamine. Studies using knockout mice and cyclic voltammetry showed that knockout mice that did not express DAT were unable to exhibit AMPH mediated dopamine release (10, 11). Moreover, AMPH mediated dopamine release was reduced by 65% in VMAT knockout animals (12).

### *Effect of Amphetamine on Vesicular Monoamine Transporters*

It has been widely accepted that vesicular monoamine Transporter (VMAT) is an important mediator of amphetamine mediated dopamine release. There are two basic mechanisms which have been suggested on how AMPH exerts its effects on the monoamine transporters: The Weak Base Hypothesis and Redistribution of VMAT (2).

#### *The Weak Base Hypothesis*

Amphetamines are lipophilic weak bases with a pK of 9.9. It has been suggested that the interior of the catecholaminergic vesicles is acidic, like that of the chromaffin granules (pH 5.5). Therefore it is assumed that once amphetamine gains access inside the vesicles, it starts accepting protons, which in turn alkalizes the interior of the vesicles (2). According to the weak base hypothesis, AMPH enters the cells through diffusion and from there it gains access inside the vesicles. Once inside the vesicles, it disrupts the proton electrochemical gradient that is required by the vesicles in order to sequester the cytosolic dopamine. The disruption of the electrochemical gradient leads to inability of the vesicle to sequester intracellular dopamine, which finally leads to increased accumulation of intracellular dopamine. High concentration of cytosolic dopamine and a disrupted concentration gradient leads to reverse transport of dopamine via the dopamine transporter (DAT) (13). The mode of action of amphetamines according to the weak base hypothesis depends solely on the weak base properties of AMPH and does not require the direct action of amphetamines on dopamine transporters (2). This mechanism is widely accepted although there are several questions that still need to be answered before this model can be unanimously accepted.

### *Redistribution of VMAT*

Apart from being responsible for disrupting the proton gradient, amphetamines also appear able to hamper the ability of VMAT to uptake dopamine. It has been found that administration of a high dose of amphetamine and its derivatives (METH and MDMA) can rapidly reduce the ability of VMAT to uptake dopamine. This occurs along with a reduction in the ability of VMAT ligands like dihydrotetrabenazine (DHTBZ) to bind to VMAT (14). It was also found by immunohistochemistry studies that immediately after high dose administration of METH, a decrease in the immunoreactivity of VMAT from the cytosolic fraction to a location that was not retained in the preparation of the synaptosomes with a concurrent decrease in the vesicular dopamine (15, 16). This suggests that there is a redistribution of dopaminergic vesicles in addition to a decrease in the amount of dopamine in the vesicles, although clear mechanism is yet to be known.

### ***Effect of Amphetamines on Dopamine Transporter***

Vesicular neurotransmitters transporters like plasma membrane transporters use electrochemical energy from ion gradients. In principle, membrane transporters should possess at least one mechanism, known as a gating mechanism, which acts to alter their conformation and prevents superfluous substrates from diffusing through the membrane.

A study conducted using low concentration of radiolabelled amphetamine, showed that Dopamine transporter blockers such as methylphenidate, cocaine and methamphetamine were able to block the accumulation of amphetamine. This suggested that amphetamine is indeed a substrate of DAT (8).

Further studies using transfection of DAT into cells have confirmed the fact that amphetamine is a substrate of DAT (3). DAT blockers such as cocaine act by inhibiting inward current as a result of Na<sup>+</sup> co-transport, but amphetamine activates inward currents, which identifies amphetamine as a substrate as it activates co-transport (17).

The most widely accepted model used to explain the uptake of amphetamine release at plasma membrane transporters is the facilitated exchange diffusion model. The concept was introduced by Stein in 1967 in order to explain glucose transport. According to the *facilitated exchange diffusion model*, in order to aggregate cellular glucose, the binding site acquires a molecule of glucose extracellularly and then translocates the molecule across the plasma membrane in order to release the molecule in the cytosol. In case of reverse transport, the binding site facing the cytosol binds another molecule of cytosolic glucose and releases this molecule extracellularly after it re-traverses to the external site.

In 1969, Bogdanski and Bogie extended this idea to catecholamine transporters. Now the facilitated exchange diffusion is the most prominent model used to explain the effect of catecholamine release by amphetamines at the plasma membrane uptake transporters.

In order to explain action of amphetamine on membrane transporters, the facilitated exchange diffusion model states that amphetamine induces the release of dopamine by translocation of amphetamine as a substrate of DAT and suggesting that the DAT binding site faces the cytosol. Dopamine, having a higher concentration in the cytosol, binds to the DAT binding site and increasing the rate of reverse transport of Dopamine. A molecule of dopamine released by the reverse transport is followed by the

uptake of an amphetamine molecule. Thus, there would be one molecule of dopamine released per molecule of amphetamine that is acquired. Although the facilitated exchange diffusion model is widely used to explain the action of dopamine release, it is not yet sufficient enough to explain all the mechanisms that are associated with amphetamine and dopamine release (1).

### **Advantages of the *Caenorhabditis elegans* as a model organism**

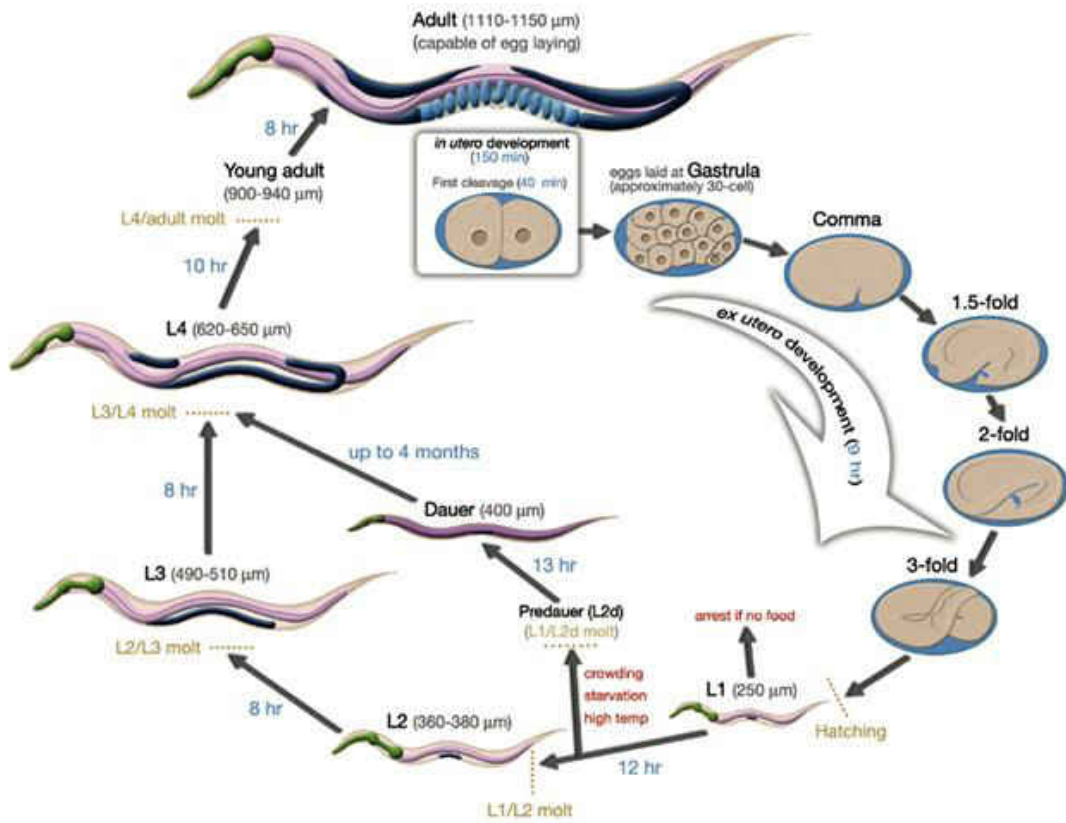
The present study was conducted on the invertebrate *Caenorhabditis elegans*, a nematode commonly known as the round worm. The worm has several characteristics that make it an ideal candidate for neurological studies. First, the worm can be easily maintained in the laboratory. They are generally grown in agar plates that have been pre-seeded with bacteria. It has a large brood size which yields around three hundred worms per hermaphrodite animal within a short span of three days. This rapid growth of the worms and their large brood size allows for a wide variety of molecular, genetic and cellular studies. Another advantage of using *C.elegans* is the fact that the animal is transparent. This transparency helps in the studying various morphological features of the organism. Reporter genes can be easily constructed in *C.elegans* and this helps in better understanding the neurological morphology and also aids in the examination of protein expression. It is also very easy to perform gene-knock out studies in *C.elegans* using RNA-mediated interference (RNAi) technology (18).



### *Caenorhabditis elegans* Life Cycle

The life cycle of *C. elegans* is comprised of three basic stages which include the embryonic stage, larval stage, and adult worm and takes 3 days to complete (figure 2). The larval stage has four sub-stages (L1-L4) which include the synthesis of a stage specific cuticle layer with the subsequent shedding of the old stage (19). The embryonic stage lasts for 9 hours. Immediately after the hatching of the egg, the L1 larval stage sets in. In the L1 larval stage, the nervous system, reproductive system, and the coelomocyte system starts to develop. The L1 larval stage lasts for about 12 hours, after which the larva enters the second L2 larval stage which may last upto 8 hours. There are a few cell divisions during the L2 stage, during which the nervous system and the reproductive system are further developed. At the end of L2 stage, the animal may enter an arrested state called the dauer larva stage. This happens when the environmental conditions are not favorable for further growth. The environmental factors include population density, absence of food or starvation, and high temperature. If any of the environmental factors are present, a pheromone is secreted that act as a signal to trigger the formation of a morphologically distinct L2 stage larva designated L2d. The critical period for this dauer signal begins after the middle of the first larval stage. The L2d larva retains the potential to form either a dauer larva or an L3 larva depending on the environmental parameters. If the environment continues to be disadvantageous, L2d molts into a dauer. The dauer state is a non-aging state, as its duration does not affect postdauer life span. During the dauer state, feeding is arrested indefinitely and locomotion is reduced. The dauer state ends with the onset of favorable environmental conditions.

In the L4 larval stage, which starts 7 hours after the hatching of the egg, the gonadogenesis is completed. Approximately at 45-50 hrs post hatch at 22-25°C, a newly matured hermaphrodite lays its first cells, hence completing its 3-day reproductive life cycle. The adult hermaphrodite produces oocytes for about 4 days and after this fertile period of 3-4 days, the mature adult lives for an additional 10-15 days.



**Figure 2: Life cycle of *C. elegans*.** 0 min is fertilization. Numbers in blue along the arrows indicate the length of time the animal spends at a certain stage. First cleavage occurs at about 40 min. post-fertilization. Eggs are laid outside at about 150 minutes post-fertilization and during the gastrula stage. The length of the animal at each stage is marked next to the stage name in micrometers.

Reprinted with permission from David H Halle at [www.wormatlas.org](http://www.wormatlas.org)

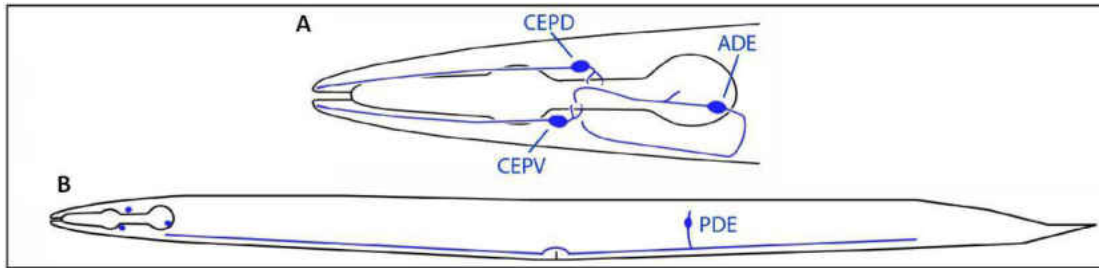
### **Caenorhabditis elegans Neurobiology**

One of the major advantages is the fact that *C.elegans* has only 302 neurons. All of the 302 neurons of the worm have been mapped and characterized. Moreover, the major interactions between the neurons are also known. The neurobiology of *C.elegans* is very similar to that of mammals and the worm shares a significant amount of conservation of neuronal pathways with its mammalian counterpart. The *C.elegans* nervous system constitutes of ion channels, neurotransmitters, receptors synaptic components and vesicular transporters which are very similar with mammals (18, 20). *C.elegans* has eight dopaminergic neurons. Four of the dopaminergic neurons are symmetrically arranged in the cephalic cells (CEPS), two dopaminergic neurons are present bilaterally in the anterior derids (ADE) in the head, and two neurons are present bilaterally in the posterior derids (PDE) (Figure 3).

### **Role of Dopamine Signaling in C.elegans**

Dopamine plays several important roles in *C.elegans*. Dopamine is essential for locomotion, egg-laying, defecation, basal motor activity, sensation/response to food sources, habituation to touch, and several other mechanisms in worms. Exposure of animals to dopamine has been found to affect locomotion, feeding, and egg-laying behavior in worms by decreasing it. This hypothesis has been confirmed by data showing that when the uptake of dopamine is blocked by the use of dopamine receptor antagonists like haloperidol and chlorpromazine, it reversed the effect by resuming normal locomotion and egg-laying (21). Moreover, mutation studies on genes that affect dopamine storage and uptake have shown that the locomotion of the animals is not

affected by the presence or absence of a food source, whereas under normal physiological conditions, the worms move at a slower pace when food source is present. In the absence of an adequate food source, the worms tend to move faster (22). Dopamine signaling also seems to play a role in the mating behavior of worms. It has been found that laser ablation of the male tail dopaminergic neurons makes the males unable to locate the vulva and results in failure in copulation. Similarly *cat-1*, *cat-4*, *bas-1* and *cat-2* mutant male worms have been found to have less interest in mating while encountering a hermaphrodite compared to wild type worm (18).



**Figure 3: Schematic of *C. elegans* Dopaminergic neurons.** A- head showing dopaminergic (DA) neurons on one side; each neuron has a bilaterally symmetric partner. **CEPD: dorsal cephalic neuron; CEPV: ventral cephalic neuron; ADE: anterior deirid neuron.** B- Schematic of *C. elegans* body showing locations of DA neurons, including the **PDE: posterior deirid neuron.**

Reprinted by permission from BMC Neurosci., 2010, 11, 22, England: "A comparison of experience-dependent locomotory behaviors and biogenic amine neurons in nematode relatives of *Caenorhabditis elegans*." Rivard,L.; Srinivasan,J.; Stone,A.; Ochoa,S.; Sternberg,P.W.; Loer,C.M. copyright 2010 by BioMed Central.

## **Effect of Amphetamine on the Dopaminergic Signaling Pathway**

The general mode of action of amphetamine is increasing the amount of dopamine in the synaptic cleft which finally heightens the response of the post synaptic neurons. The mode of action of amphetamine in dopamine released has been studied by various independent research groups. Initial studies using cocaine as the Dopamine transporter (DAT) blocker and other AMPH antagonists suggested that although cocaine works by binding directly to DAT (11), the mode of action of AMPH is more complex. A significant effect of amphetamine administration is that it causes reverse transport of dopamine via the DAT (23). As we know from previous sections, the main function of the dopamine transporter is to pump dopamine that is not up taken by the dopaminergic receptors back to the cytosol for vesicular storage and future release. Amphetamine reverses the function of DAT where DAT is unable to transport any dopamine back to the synapses. This effect of AMPH on DAT was shown in mice lacking DAT, where amphetamines were not able to increase the levels of dopamine in the synapses (11). Sulzer et.al have also shown that amphetamines can release monoamines by the redistribution of the dopamine transporter from a vesicular to cytoplasmic pool, which in turn promotes the reverse transport of dopamine from cytosol to the synapses(13). When amphetamine is administered it does not have any charge; as it gradually traverses the vesicle membrane, amphetamine gains a charge because of the lower pH of the synaptic vesicles. As the concentration of amphetamine increases, the vesicular pH gradient decreases. As the pH decreases, the energy required by the dopamine transporter to uptake extracellular dopamine also decreases. Finally, amphetamine competes with the

dopamine for protons. This results in the diffusion of uncharged dopamine from the vesicle. This reduced vesicular monoamine concentration and increased substrate concentration creates a concentration gradient across the plasma membrane which leads to the release of dopamine through reverse transport (9).

Amphetamine induces a manifestation in *C.elegans* known as SWIP (Swimming Induced Paralysis). This manifestation is the outcome of increased dopamine in the extracellular space which is not being cleared by the DAT. McDonald et al. was one of the first groups to show the phenomenon. They showed when well-fed wild type and *dat-1* mutant worms were placed in liquid environment like water or M9 buffer, the wild-type worms showed sustained thrashing even after 30 minutes in water. In contrast, when *dat-1* mutant worms were placed in the same liquid environment, they demonstrated symptoms consistent with paralysis within 6 minutes (24).



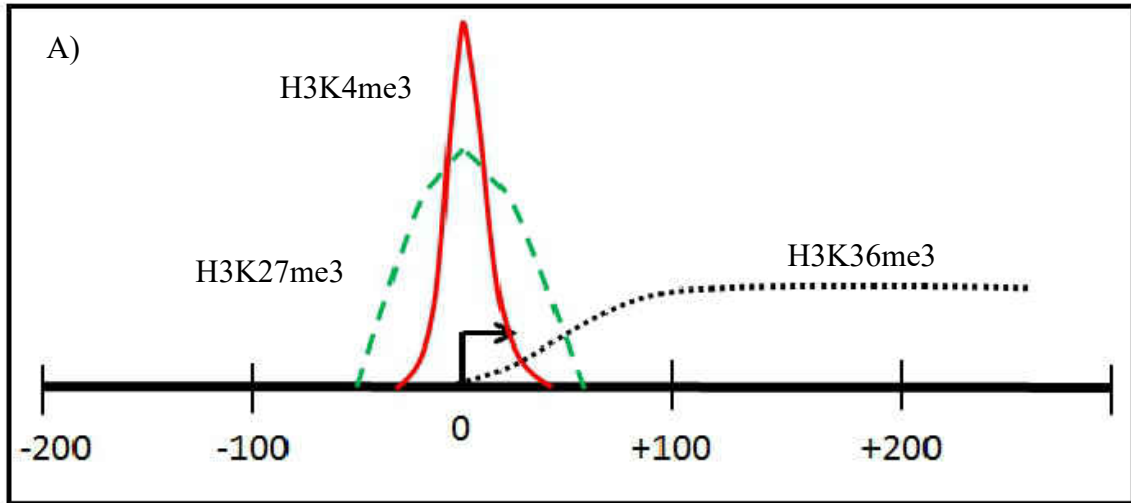
## **Epigenetics**

Epigenetics is a word that was coined by C.H. Waddington in 1942. The word Epigenetics is derived from the Greek word ‘epi’, and roughly translates as above the genome. In practice, the term epigenetics is used to refer to functional modifications of the genome that do not involve a change in the overall nucleotide sequence of the organism. Examples of functional epigenetic modifications include methylation, acetylation, phosphorylation, ubiquitylation and others.

Epigenetic modifications can be broadly divided into two basic categories. One group of modifications target DNA directly. Here, DNA can be directly modified at the cytosine residues by either methylation or hydroxymethylation. In terms of regulation of gene expression, cytosine residues may be predominantly situated in a cytosine-guanine (CG) dinucleotide rich area, referred to as CpG islands in vertebrates. CpG islands are regions in the genome where there is a high frequency of CpG sites, and these islands are often localized around gene promoters. The “p” here refers to the phosphodiester bond between cytosine and guanine indicating that the Cytosine and the guanine residue are in the same strand, next to each other connected by a phosphodiester bond. The mechanism by which a DNA methylation affects transcription is a two-step process. First, the methylation of the DNA at the CpG site by specific proteins known as DNA methyltransferases (DNMT) (25). Second, DNA methylation may directly interfere with the sequence-specific binding of some of the transcription factors, thereby reducing transcriptional activation. Another method by which the DNA methylation can directly affect transcriptional regulation is by the specific recognition of methylated DNA by the

methyl-CpG-binding domain (MBD) proteins that can cause transcriptional repression. (26).

A second mode of epigenetic modifications involves chromosomal proteins such as histones. These modifications are covalently carried on the histone tails and the modifications can be stable enough that they may be passed on to multiple generations (27, 28). Histones are a class of highly conserved alkaline proteins that package the DNA in an ordered manner into structural units known as nucleosomes. The core of the nucleosome is made up of four histones namely, H2A, H2B, H3 and H4. This octameric histone protein complex is made up of two H2A and H2B heterodimers and two H3 and H4 tetramers. Each of the histone proteins consist of a structural domain and an amino-terminal tail domain. This amino-terminal tail domain is the site of major epigenetic histone modifications (29). Histone modifications have a major impact on the functioning of the organism. Known regulatory roles associated with histone modifications include the regulation of cell division, cell differentiation, transcription, gene activation, and gene repression. Histone modifications are essential during cellular differentiation where they help direct a cell to know which genes are to be turned on and turned off (27). Histone modifying enzymes are required to alter the histone modifications like methylation, acetylation etc. Some of the histone modifying enzymes are Histone methyltransferases (HMTs), Histone acetyltransferase (HATs), Histone demethylases and Histone deacetylases (HDACs) to name a few. These enzymes add or remove acetyl groups or methyl groups at the tail of the specific histone proteins and the resulting histone code plays a role in the regulation of gene expression. The addition of a methyl group or an acetyl group can lead to the gene activation or gene repression depending on the specific



B)

	Histone Methyl Transferase	Histone Demethylase
H3K4me3	set-16	rbr-2
H3K27me3	mes-2	utx-1
H3K36me3	met-1	jmjd-2

**Figure 4: Average enrichment profiles of histone modifications** A) Average enrichment profiles of histone modifications associated with active genes around the transcription start site. B) Histone Modifying Enzymes (Histone Methyltransferase and histone demethylase) of H3K4me3, H3K27me3 and H3K36me3 in *C.elegans*.

histone residue being modified. There are certain histone marks that are associated with gene activation while there are other histone marks that are associated with gene repression. Active marks are predominantly associated with the euchromatin where the chromosomal structure is such that it allows the transcription factors and other associated proteins to access the genes and allows for the transcription of the genes. Repressive marks are predominantly associated with heterochromatin, regions of chromatin where the chromatin is compacted and reduces the ability of the transcriptional machinery to bind to the chromatin and reducing gene transcription. Examples of several of the activation marks are H3K4me3 (trimethylation on lysine 4 of histone H3)(30), and H3K36me3 (trimethylation on lysine 36 of Histone H3). Repressive histone modifications include H3K9me2/3 (di/trimethylation on lysine 9 on Histone H3) and H3K27me3 (trimethylation on lysine 27 of Histone H3), among others. In higher organisms, heterochromatin is a region that is enriched in the repressive histone marks which include H3K27me3, H3K9me2/3. Euchromatin is enriched with active histone marks such as H3K4me3. The pattern of enrichment of histone marks (active or repressive) with the specific chromatin is highly conserved in eukaryotes from flies to mammals (31). The chromatin modifying enzymes that bring about the histone modifications have been found to play an important role in the development of an organism at all stages of the development of the organism.

## **Importance of Epigenetics**

Stable histone modifications play an important role in deciding various factors in the development and the functioning of an organism. Histone modifications have been known to impart roles in vulval cell fate specification, lifespan determination, genomic stability, embryonic and germline development in various organisms. H3K27me<sub>3</sub>, a repressive histone mark that is associated with facultative heterochromatin, is known for increasing the lifespan in *C.elegans* (32). It has been found that UTX-1 increases the lifespan in *C.elegans* in a manner that is dependent on insulin signaling pathway (32). The knockdown of UTX-1, an H3K27me<sub>3</sub> demethylase enzyme, increases the levels of H3K27me<sub>3</sub>. This high level of H3K27me<sub>3</sub> maintains the chromosomal repression and this transcriptional repression is thought to play a role in increasing the lifespan. This is also backed by the finding that as an organism ages, the enrichment levels of H3K27me<sub>3</sub> falls. Another important role of the H3K27me<sub>3</sub> histone modification is that it is essential for the transmission of specific chromatin and gene expression patterns from the mother to the daughter cells (33, 34).

H3K36me<sub>3</sub> is an active histone mark that has several important functions. The H3K36me<sub>3</sub> modification is enriched on histones associated with the gene bodies of actively transcribing genes. This suggests that the H3K36me<sub>3</sub> modification is associated with the transcription process. While H3K9me<sub>3</sub> a repressive histone mark is often enriched at the promoter regions of silent genes. Another important role of the H3K36me<sub>3</sub> modification is thought to be its role in splicing (35). Splicing is modification of pre-mRNA where non-coding sequences of the nucleotides within a gene (introns) are removed and the coding sequences (exons) are joined in order to form the mature mRNA

that can be utilized by the translational machinery to make proteins. In 2009, Kolasinska-Zwierz et.al conducted a genome-wide map of histone H3 tail methylations in order to gain deeper insight in to the chromatin function in *C.elegans*. They found that the H3K36me3 histone modification is present preferentially on the exons, but reduced on histones associated with intronic regions (36). They also found that the H3K36me3 exon marking is dependent on transcription and it is found at a lower level on exons that are alternatively spliced (36). This suggests that the H3K36me3 has a patterning mechanism that is dependent on splicing. They also found that this splicing dependent patterning mechanism of the H3K36me3 modification is present not only in *C.elegans* but is conserved evolutionarily in mice and humans.

The H3K4me3 histone modification is considered to be an activating histone mark. It is associated with the activation of transcription (30). The H3K4me3 histone mark plays an important role in the development of an organism. It has been found that the H3K4me3 mark is sometimes associated with the repressive histone mark H3K27me3 at select gene loci. These loci are generally associated with the developmentally regulated transcription factors that need to be activated at certain appropriate times only (37, 38). H3K4me3 plays another important role in the development of an organism apart from gene activation. It has been found in *C.elegans* that the H3K4me3 mark is also responsible for controlling the lifespan of the organism and that this epigenetic information is carried to multiple generations in *C.elegans* (39). Recent study has shown that a deficiency in H3K4me3 chromatin modifiers can increase the lifespan of the progeny through three subsequent generations (39).

There is a high degree of conservation between the chromatin modifications and the enzymes that regulate these modifications (methylase, demethylase and others) across species. Keeping the high degree of conservation in mind, genetic approaches used in *C.elegans* are expected to shed light in the functional importance of epigenetic gene regulation in normal development and trans-generational inheritance in other species, including humans. In this study, *C.elegans* is used as a model organism to study the effect of drugs on these chromatin modifiers.

### **Epigenetics and Addiction**

It has been hypothesized that environmental stimuli may induce epigenetic changes which can then be inherited by future generations. Addiction is a known human disease with clear trans-generational impact and susceptibility, but lack of a defining genetic change that can explain this phenomenon. To date, only limited data exists suggesting a link between addictive drug use and epigenetic changes in the brain. Specifically, drugs of abuse are known to induce changes in histone acetylation patterns in the brain and cocaine has been found to globally increase the acetylation levels of Histone H3 and H4 in Nucleus accumbens in the brain (40, 41).

### ***Transcription Factors Associated With Addiction***

There are several key transcription factors that are associated with addiction, and modulation of transcription factors are one of the classical mechanisms of gene expression regulation. Psychostimulant drugs and opiates are known to regulate gene expression through their action on key transcription factors. These regulatory actions can lead to further consequences like increased self-administration of drugs, changes in the

rewarding effects of the drug, etc. Some of the key transcription factors that are known to be associated with drug addiction are as follows:

*ΔFosB*- It is encoded by the *fos B* gene and shares homology with other Fos family of proteins. Fos family transcription factors are essential for the cell proliferation, differentiation etc.  $\Delta$ fos B heterodimerizes with Jun family of proteins to form the Activator protein (AP-1). AP-1, later on binds to AP-1 sites in genes in order to regulate transcription.

It has been found that psychostimulant drugs like cocaine affect *ΔfosB* that leads to a long lasting expression.  $\Delta$ FosB has been found to be induced in the Nucleus Accumbens and in the dorsal striatum (42).  $\Delta$ FosB is a C-terminal truncation of FosB which is generated by the alternative splicing. This alternative spliced product lacks the degron domains. This alternative splicing and phosphorylation at several sites increases the stability of the protein (43). It has been found that overexpression of  $\Delta$ FosB in the Nucleus Accumbens and dorsal striatum causes increased locomotor sensitivity to cocaine and this may lead to increased cocaine self-administration (44). Studies using virus-mediated overexpression have shown that induction of  $\Delta$ FosB by cocaine aids in the ability of cocaine to induce the cognition-disrupting effects of acute drug exposure. Moreover, overexpression of  $\Delta$ JunD, which is an antagonist of  $\Delta$ FosB in the Nucleus Accumbens blocks the effects of  $\Delta$ FosB mediated effects of cocaine (43).

*CREB (cyclic AMP response element binding protein)* - CREB is a transcription factor that has multiple functions in the brain. It is responsible for the formation of long-term memory in the brain (45). In mice, it has been found that deletion of CREB in the embryo leads to death immediately after birth. CREB acts as a transcription factor only after it



has been phosphorylated at Serine 133 and binds to a cAMP response Element (CRE). It has been found that cocaine and amphetamine increases CREB activity both acutely and chronically in both the Nucleus Accumbens and in the dorsal striatum in the brain (46). It has also been found through various studies that overexpression of CREB decreases the rewarding effects of cocaine and that of opiates in the D1-D2 Medium Spiny Neurons (MSN) in the Nucleus Accumbens, an effect that increases the self-administration of drug through negative reinforcement (47).

There are other transcription factors like NF $\kappa$ B (nuclear factor  $\kappa$ B), MEF-2 (myocyte enhancing factor-2) and others that have been found to be regulated by drugs of abuse and also by nicotine and alcohol.

### ***Histone Tail Modifications associated with Addiction***

Unraveling the histone code is an ongoing challenge in the epigenetic field. The challenge is based on the need to understand both the significant number of possibilities of complex histone modification patterns that may exist in a genome, and reconcile this data with the possibility that a particular pattern may have diverse meaning depending on the individual gene in question. In the recent years, there has been a dramatic acceleration of progress in the development of various new tools and techniques for mapping of the epigenetic state of any particular gene and the genome as a whole. This emergence of new technology has dramatically increased our understanding of the functional role of the histone code, and aided in deciphering the functionality of epigenetic signatures as they pertain to gene expression.

Drugs of abuse have also been found to be associated with changes in the epigenome. Evidence has started to accumulate regarding the effect of various drugs of

abuse in inducing histone acetylation in the brain. At the global level, studies have shown that acute or chronic exposure to cocaine increases the acetylation of H3 and H4 in the Nucleus Accumbens (40, 41). Although there is an increase in the acetylation of H3 and H4 at the global level, interestingly though, there is decrease in the acetylation after chronic cocaine at the local level for many genes. Simultaneously, another case study associated with alcohol withdrawal has shown that there is an increase in the levels of Histone Deacetylase (HDAC) activity which is associated with reduction in histone acetylation in mouse (48). The above examples emphasize the fact that there is a need for further research in order to define the effect of drug of abuse on histone acetylation in the brain and also to pinpoint the specific histone modifying enzymes that mediate this regulation.

Recent findings have pointed towards the fact that the change in the acetylation of H3 and H4 with cocaine usage has been linked to sirtuin proteins which are a class of Histone deacetylases. Genome wide studies at the chromatin level in the Nucleus Accumbens after chronic cocaine administration revealed the upregulation of two sirtuin proteins SIRT1 and SIRT2. The induction of sirtuin protein is associated with increased H3 acetylation and also with an increase in the binding of  $\Delta$ FosB at its gene promoters (49).

Histone methylation has also been linked to regulation by drugs of abuse. Chronic cocaine has been known to reduce the global levels of Histone 3 lysine 9 dimethylation (H3K9me<sub>2</sub>) in the nucleus accumbens, which is thought to be mediated by the down regulation of the two histone methyltransferase G9a, and the G9alike proteins (GLP) (50). Although there is a decrease in the global levels of H3K9me<sub>2</sub> in the NAc, interestingly,

genomewide screening revealed significant decreases in the enrichment of H3K9me2 at the promoters of various genes, further suggesting that the epigenetic mark at a specific gene is not a true representation of the changes at the global level (49).

Chronic cocaine is also known to downregulate the repressive histone mark H3K9me3 (histone 3 lysine 9 trimethylation) in the NAc. The H3K9me3 is a mark that is predominantly associated with heterochromatin. This decrease in the H3K9me3 levels is associated with a decrease in the total amount of heterochromatin in the NAc (51). The above observations draw light towards the profound effects that drugs of abuse can exert on the epigenome, although the functional implications of this regulation is not clearly understood.

It is now widely accepted that epigenetic modifications lead to heritable, but reversible, changes in gene expression without causing alterations in DNA sequences. Studies have shown that a deficiency in trimethylated H3K4me3 chromatin modifiers can increase the lifespan of the progeny until three subsequent generations (39). As previously discussed; environmental influence has been known to induce changes in epigenetic modifications. This suggests that drugs of abuse might also induce changes in epigenetic modifications. Studies by Renthal et al. in 2009 (51) have shown that repeated administration of cocaine alters gene regulation by inducing changes in histone modifications. They showed that chronic use of cocaine alters transcription by changing the acetylation states of histones H3/H4 and also the methylation states of H3K9 and H3K27. This observation advocates that drug of abuse can alter gene expression by inducing changes in epigenetic modifications.

Amphetamine treatment has been shown to induce a phenotype known as SWIP (Swimming Induced Paralysis) in *C.elegans* (24). Recent SWIP study indicates that animals exposed to amphetamine during embryogenesis/developmental stage show Swimming Induced Paralysis in F0 and this phenotype is also observed in F1-F3 generations. Moreover, Carvelli et al (5) has indicated that DAT plays an important role in the ability of amphetamine to increase extracellular dopamine. They showed that amphetamine treatment produces SWIP in “a time- and dose-dependent manner” in wild-type worms but this ability to produce SWIP is greatly hampered in DAT-1 knockout animals. This observation leads us to hypothesize that amphetamine treatment might induce changes in histone modifications, specifically histone methylation at the promoter of the genes involved in dopamine synthesis and uptake, as drugs of abuse have been known to induce histone modifications as shown by Renthal et al. We propose that an epigenetic mechanism may be responsible for the altered response to amphetamine observed by Carvelli et.al. in subsequent generations of worms (unpublished data).

## **Chapter 2**

### **Materials and Methods**

#### **Cell Culture**

HT1080 (fibrosarcoma) cells were obtained from American Type Culture Collection (ATCC, Rockville, MD) and used as a control in several studies. The HT1080 cells were grown on 75cm<sup>2</sup> canted neck cell culture flasks. The cells were grown in Eagle's Minimum Essential Medium (EMEM) supplemented with 10% Fetal Bovine Serum (FBS). The cell cultures were maintained at 37<sup>0</sup>C in a 5%CO<sub>2</sub>: 95% air atmosphere and fed with fresh growth medium every three days. Upon reaching confluency, the cell culture medium was discarded; the cells were rinsed briefly with Phosphate Buffered Saline (PBS). 3.0ml of Trypsin-EDTA solution (0.25%w/v) was added and the flasks were observed under microscope until the cell layer was dispersed. Following dispersion, the cells were subcultured with fresh media (EMEM) at 1:4 ratios or harvested for RNA, DNA, or protein extraction.

#### **Protein Extraction**

Cytoplasmic and nuclear protein extracts from HT1080 cells were prepared using NE-PER Nuclear and Cytoplasmic Reagents (Pierce Biotechnology, Rockford IL). The NE-PER Nuclear and Cytoplasmic Reagents kit allows stepwise separation of cytoplasmic and nuclear extracts from mammalian cells or tissues. HT1080 cell lysates

were prepared by adding Trypsin-EDTA solution (0.25%w/v) for the detachment of the cells from the surface of the culture flasks. The cells were then collected by pipetting and then centrifugation at 1000 times g for five minutes. The cell pellets were stored at -80°C for further use. 20 µl of cell lysate was used to make the protein extracts. The cell pellet was washed with Phosphate Buffered Saline (PBS) by centrifugation at 500 x g for five minutes. After Phosphate Buffered Saline was removed by pipetting, 200 µl of Cytoplasmic Extraction Reagent I (CER I) was added and the cells were vortexed for 15 seconds. After incubating the cell pellet on ice for 10 minutes, 22 µl of Cytoplasmic Extraction Reagent II (CER II) was added and the tube was vortexed for 5 seconds and incubated on ice for 1 minute. The cells were vortexed again for 5 seconds and centrifuged at highest speed ( $\geq 16000xg$ ). Immediately after the centrifugation, the supernatant was carefully transferred to fresh pre-chilled 1.5ml centrifuge tube and stored at -80°C for further use. 100 µl of Nuclear Extraction Reagent (NER) was added to the cell pellet and vortexed for 15 seconds after 10 minutes incubation on ice for a total of 40 minutes. The tubes were then centrifuged at highest speed ( $\geq 16000xg$ ) for 10 minutes. Immediately after the centrifugation, the supernatant was carefully transferred into pre-chilled 1.5ml centrifuge tubes and stored at -80°C for further use.

### **Immunoblot**

Western blots were performed using pre-cast (4-20%) Tris – glycine gels from Bio-Rad, Inc. The gels lanes were loaded with 15µg of nuclear and cytoplasmic protein fractions. Laemlli buffer (Bio-Rad, Inc.) was used for sample prep prior to electrophoresis. Electrophoresis was conducted using running buffer (1gm SDS, 100ml

10X Tris Glycine Buffer, 900ml Distilled water) for 1 hour at 100 constant volts. The gels were immersed in running buffer for 20 minutes.

After 20 minutes, the gels were subjected to transfer on Polyvinylidene fluoride membrane (PVDF membrane). The preferred method of transfer was the semi-dry transfer method. Transfer was conducted for 1 hour at 100 constant milliamps. Since PVDF membrane has high affinity for proteins and it can bind to both target and non-specific proteins, in order to prevent the binding of non-specific proteins, the remaining binding surface of the membrane must be blocked in order to prevent the non-specific binding of the antibodies. Therefore, after the transfer, the PVDF membranes were incubated overnight in blocking buffer at 4<sup>0</sup>C with agitation. Two different blocking buffers were used. For the detection of anti-histone H3 antibody (Abcam 1791), milk (5% milk, 0.05% Tween 20 1X Tris Buffered Saline) was used as the blocking buffer and for the detection of antibodies against histone modifications {(Anti-histone H3K27me3 (Millipore 07-449); Anti-histone H3K4me3 (Millipore 07-443) and Anti-histone H3K36me3 (Abcam 9050)}, BSA was used as the preferred blocking buffer (5% BSA, 0.05% Tween 20 1X Tris Buffered Saline). In order to visualize the protein of interest, the membranes were incubated with the primary antibody (Anti-Histone H3 1:1000; Anti-histone H3K4me3 1:5000; Anti-histone H3K27me3 1:2500; anti-Histone H3K36me3 1:1000) for 1 hour in a solution of either BSA blocking buffer or milk blocking buffer with agitation. Membranes were then rinsed and washed thrice in wash buffer (0.1% tween 20, 1X Tris buffered Saline) for 20 minutes each. Affinity purified goat anti-rabbit IgG Horse Radish Peroxidase-linked secondary antibody was diluted to 1:1000 in either Milk or BSA blocking buffer and applied to the membranes for 1 hour at

room temperature with agitation. The membranes were then rinsed and washed thrice in wash buffer (0.1% tween 20, 1X Tris buffered Saline) for 20 minutes each. The protein bands were developed using Immun-Star WesternC Chemiluminescent Kit (Biorad).

### **Synchronization of worm cultures**

Isolated eggs were resuspended in 100-200 ul of sterile water and seeded onto NGM agar plates without bacteria. The eggs were hatched by incubating the plates at 20-24°C for 12-16 hours. After hatching, the larvae were rinsed off the plates into a 15 ml conical tube with sterile water or M9 buffer. The worms were pelleted by brief centrifugations and then resuspended in a small volume of sterile water. Finally, 15mm Petri plates were seeded with washed larvae. The larvae were then allowed to grow until reaching the young adult stage.

### **Worm Egg isolation**

Adult synchronized worms were washed off agar plates with Milli-Q water into a 15 milliliter sterile conical tube such that 7 petri plates of worms were washed into one 15 ml conical tube. The contents of the tubes were mixed thoroughly and the tubes were then centrifuged at 1200 rpm (~450 g) for one minute in a swinging bucket rotor. The pellet was washed 5 times with Milli-Q water until the supernatant becomes clear. After the last wash the worms were lysed with bleach and NaOH (Fresh Clorox 2.0mL, 10N NaOH 0.5mL and sterile water 7.5mL). The worms were rocked gently during lysis. Finally, the lysis was monitored by viewing the worm suspension under the microscope. The lysis reaction was stopped when ~50% of the worms were lysed (approximately 6 minutes of



lysis). The lysis reaction was stopped by mixing the worm suspension with egg buffer and immediately spinning the worm suspension at 1200 rpm for 3 minutes.

The supernatant was decanted using a sterile plastic pipette and the pellet was washed three times by re-suspending the pellet with egg buffer and spinning the tubes at 1200 rpm for three minutes. After the last centrifugation, the excess buffer was carefully removed using a sterile transfer pipette. The eggs were removed from the cell debris by centrifugation in a 60% sucrose solution. For this, the lysed cell debris along with eggs was re-suspended in 5mL of sterile water and 5mL of 60% sterile sucrose solution. The mixture was vortexed and then centrifuged at 1200 rpm for 6 minutes using a swinging bucket rotor. After the centrifugation, the eggs were collected from the top layer (near the meniscus) using a sterile transfer pipette and transferred to a new 15mL conical tube.

The collected eggs were washed thrice using sterile water. Then the eggs were re-suspended in 6mL M9 buffer and washed vortexing the tubes and then spinning the tubes at 1200 rpm for two minutes. After the centrifugation, the tubes supernatant was discarded and the eggs were transferred into a single tube.

### **Treatment with amphetamine**

One half of the eggs were treated with Amphetamine (100mM Amphetamine stock was used to a final concentration of 1mM) for 15 hours till the worms reached L4 stage. After treatment, all of the worms were collected by washing with M9 buffer from the petri plates in order to make sure that no *e.coli* was collected.

## **Worm Protein Preparation**

A small amount of worms were taken in a centrifuge tube and briefly centrifuged in a mini centrifuge in order to remove excess media. The pellet size was roughly measured and to it an equal volume of 1X PBS was added. Then an equal volume of 2X Laemmli buffer containing DTT was added. The mixture was boiled for 5 minutes and then immediately cooled at  $-80^{\circ}\text{C}$ . Later on the mixture was sonicated in a Branson sonicator for 15 minutes at the highest setting for 30 minutes on and 30 minutes off cycle.

## **Chromatin Immunoprecipitation (ChIP)**

### *Crosslinking*

100ul of worms were flash-frozen in liquid nitrogen and ground to a fine powder in liquid nitrogen using a mortar and pestle to a fine powder. The worm powder was incubated in PBS containing 1% formaldehyde for 10-15 minutes at room temperature. The reaction was quenched by addition of 2.5M glycine to a final concentration of 125mM for 10-15 minutes with shaking at room temperature. The mixture was centrifuged at 1000 rpm for 5 minutes. Then the pellet was washed three times with 1X PBS having protease inhibitor cocktail. After the pellet was centrifuged, the pellet was frozen in liquid Nitrogen and stored at  $-80^{\circ}\text{C}$ .

### *Sonication*

The worm pellet was re-suspended in 900ul SDS lysis buffer with Protease Inhibitor Cocktail. Then the pellet was sonicated in a Bioruptor water bath (Diagenode) at maximum power for 30secs on and 30secs off for a total of eight pulses on. After the sonication, the homogenate was centrifuged at 14,000 rpm for 15-20 minutes at  $4^{\circ}\text{C}$  in

order to remove cellular debris. The sample purity was quantified by measuring the 260/280 ratio on a Biotek Epoch spectrophotometer. 3uL of the sheared chromatin sample was run on 1% agarose gel in order to determine the resulting DNA fragment size. The supernatant containing the sheared chromatin (chromatin extract) was frozen in liquid nitrogen, and kept at  $-80^{\circ}\text{C}$  for immunoprecipitation.

#### *Immunoprecipitation*

The chromatin extract was thawed and  $\sim 100\mu\text{g}$  was distributed into individual tubes. The chromatin was diluted with  $500\mu\text{l}$  of chip dilution buffer. The chromatin was pre-cleared for 1 hour at  $4^{\circ}\text{C}$  with  $120\mu\text{l}$  of 1:1 slurry of Protein A agarose beads.  $50\mu\text{l}$  of the pre-cleared chromatin extract was stored separately as Input sample at  $-20^{\circ}\text{C}$ . After the pre-clearing, the tubes were centrifuged at 2000 rpm for 2-3 minutes.  $400\mu\text{l}$  of cleared chromatin extract was taken in in 15 mL conical tubes and to each tube 3.6mL of ChIP dilution buffer containing Protease Inhibitor cocktail was added.

To each tube the specific antibodies were added. The antibodies used were Anti-histone H3K27me3 (Millipore 07-449); Anti-histone H3K4me3 (Millipore 07-443), Anti-histone H3K36me3 (Abcam 9050) and Anti- Histone H3 (Abcam 1791). The cleared chromatin containing antibody was incubated overnight at  $4^{\circ}\text{C}$  in a rotator.

#### *Preparation of magnetic beads*

$50\mu\text{l}$  of Protein G and  $150\mu\text{l}$  of Protein A magnetic beads were taken in a 1.5ml centrifuge tube. To it, 1ml of blocking solution (0.5%BSA in1X PBS) was added and mixed properly. The tube was placed in a magnetic stand and the after the beads settled to the side of the tubes, the blocking solution was discarded. This step was repeated twice

before finally re-suspending the magnetic beads in 1ml of blocking buffer. The 1.5ml tube containing the magnetic beads was incubated overnight at 4°C with rotation.

#### *Immunoprecipitation*

The next day, 100µl of magnetic beads was added to each 15ml conical tube containing the chromatin extract and the antibody and the conical tube was incubated for 3 hours in a rotator at 4°C.

After 3 hours of incubation with the magnetic beads, 1ml of the mixture was transferred to a pre-chilled 1.5ml centrifuge tube and the tube was left to sit on the magnetic rack for a minute so that all the magnetic beads could bind to the walls of the tube. Once, all the magnetic beads were able to bind to the side of the tube, the supernatant was discarded. This step was repeated until all of the beads were collected.

#### *Washes*

The magnetic beads were washed for 10 minutes at 4°C with wash buffers. After 10 minutes the tubes were placed in the magnetic rack. The wash buffers used were commercially available Low Salt Immune Complex Wash Buffer, High Salt Immune Complex Wash buffer, Tris-EDTA Buffer (Millipore, Inc.)

#### *Elution and Reverse Cross linking*

After the last wash, the tubes were centrifuged at 960g for 3 minutes at 4°C in order to remove any residual TE buffer. 210µl of Elution buffer was added and the mixture was eluted for 15 minutes at 65°C. The tubes were then centrifuged at 16000 g for a minute at room temperature. 200µl of the supernatant containing the chromatin was transferred to a new 1.5ml centrifuge tube. The tubes were subjected to reverse crosslinking in elution buffer for overnight at 65°C.

The next day, 200µl of TE buffer was added to each tube and 8µl of 10mg/ml of RNase A was added before the tubes were incubated at 37°C for 2 hours. 8µl of 10mg/ml of Proteinase K was added to the tubes and the tubes were incubated at 55°C for 2 hours.

#### *DNA extraction using Qiagen PCR Purification columns*

5 volumes of buffer PB was added to the tubes and mixed properly. The mixture was then applied to the column and the tubes were centrifuged at 13000 rpm for 1 minute. The columns were washed with 750µl of PE buffer. The tubes were again centrifuged for 1 minute at 13000 rpm. Then 50µl of elution buffer EB was added to the tubes and the tubes were centrifuged at 13000 rpm for 1 minute. The elution step was repeated again.

### **RNA Isolation**

#### *Homogenization*

The samples were mixed with 1ml of TRIZOL reagent and the samples were frozen in liquid Nitrogen. The tubes were vortexed for 30 seconds and again replaced in liquid Nitrogen. After the tubes had frozen, the tubes were thawed at 37°C. This step of freezing and re-thawing was repeated for 3-6 times. The tubes were checked under the microscope to see if most of the worms were disrupted. Most worms (not 100%) should appear disrupted under a dissecting microscope.

#### *Phase Separation*

The samples were incubated for 5 minutes at 15 to 30°C to permit the complete dissociation of nucleoprotein complexes. Then 0.2 ml of chloroform per 1 mL of TRIZOL Reagent was added. The samples were shaken vigorously by hand for 15 seconds and incubated at 15 to 30°C for 2 to 3 minutes. The samples were then centrifuged at 12,000 x g for 15 minutes at 2 to 8°C.

### *RNA Precipitation*

Following centrifugation, the mixture separated into a lower red, phenol-chloroform phase, an interphase, and a colorless upper aqueous phase. The aqueous phase containing the RNA was transferred to a fresh tube.

RNA was precipitated from the aqueous phase by mixing with isopropyl alcohol. For this 0.5 mL of isopropyl alcohol per 1 mL of TRIZOL Reagent was added to the tubes. The samples were incubated at 15 to 30°C for 10 minutes and then centrifuged at 12,000 x g for 10 minutes at 2 to 8°C. The RNA precipitated and formed a pellet on the side and bottom of the tube.

### *RNA Wash*

The supernatant was removed and the RNA pellet was washed once with 1ml of 75% ethanol per 1 mL of TRIZOL Reagent. The samples were mixed by vortexing and then centrifuged at 7,500 x g for 5 minutes at 2 to 8°C.

### *Redissolving the RNA*

RNA pellet was air dried for not more than 2 minutes before dissolving the RNA in RNase-free water by passing the solution a few times through a pipette tip, and then incubating for 10 minutes at 55 to 60°C. The dissolved RNA sample was stored at -80°C for further use.

## Chapter 3

### **RESULTS**

For all our experiments, we used *C.elegans* that were treated with 1mM Amphetamine solution. For this, we first made sure that all the worms were grown synchronously by starving the worms at L1 larval phase. The starvation ensures that the worms will all enter the dauer larva stage. After the worms are in the dauer larval stage, the worms were introduced to bacteria for feeding and this synchronization procedure results in all of the worms bring in the same growth phase for the duration of the experiment. After this, the worms were allowed to grow to adult stage. Then adult worms were collected by washing the plates with M9 buffer, and then the eggs were collected. Half of the eggs were treated with M9 and the other half were treated with 1mM amphetamine solution and the worms were then allowed to grow for 15-16 hours till they reached L4 larval stage when they were collected and the effects of amphetamine exposure were studied.

#### **Protein Expression of Histone Modifications**

The primary goal of this study was to investigate whether exposure to amphetamine induces changes in histone modifications at the promoters of key genes within the dopaminergic pathway. First, however, we wanted to investigate whether there were any global changes in the protein expression levels of the histone modifications that will be investigated in this study (H3K4me3, H3K27me3 and H3K36me3). In order to

achieve this, the worms were treated with either 1mM Amphetamine or with vehicle control for 15 hours. Protein lysates were isolated and western blot analysis performed. The blots were probed for anti-H3K4me3, anti-H3K36me3 and anti-H3K27me3 and for anti-Histone H3 as a loading control.

In Figure 5A, the blot intensity of the western blot analysis shows that there was no change in the expression levels of H3K4me3 in amphetamine treated samples compared to vehicle control.

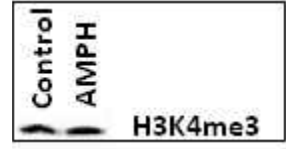
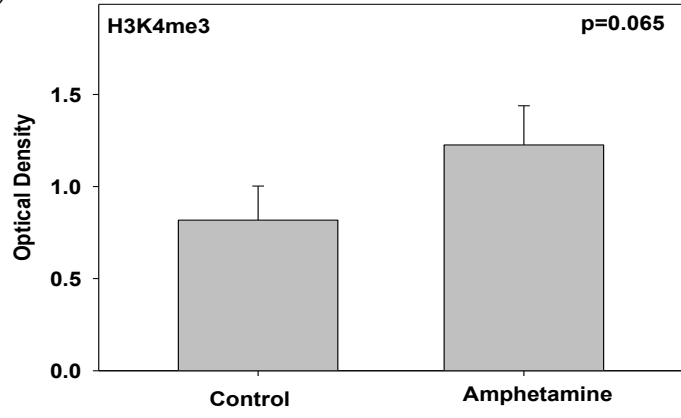
In figure 5B, the blot intensity of the western blot analysis shows that there is a statistically significant increase in the protein expression levels of H3K27me3 in the amphetamine treated samples compared to the control samples.

Figure 5C shows that there is a statistically significant increase in the protein levels of H3K36me3 in amphetamine treated samples as compared to control samples.

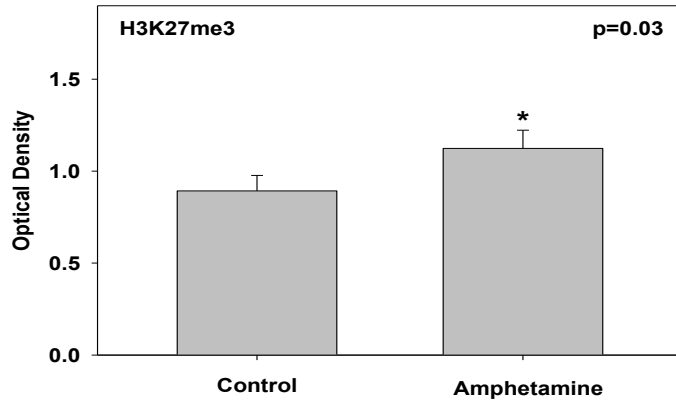


**Figure 5: Protein Expression of H3K4me3, H3K27me3 and H3K36me3 in control and Amphetamine treated samples.** The worms were exposed to vehicle control or 1mM amphetamine for 15 hours and then Western blot analysis was performed. Briefly, the worm samples were boiled in 1X PBS containing 2X Laemmli Buffer and DTT. The samples were sonicated and electrophoresed on a 4-20% SDS polyacrylamide gel. The resultant blot intensity was normalized to Histone H3 and are shown as a relative protein expression  $\pm$  SD (n=3). Statistical analysis was performed using Student's unpaired *t*-test, with statistical significance set at  $p \leq 0.05$ .

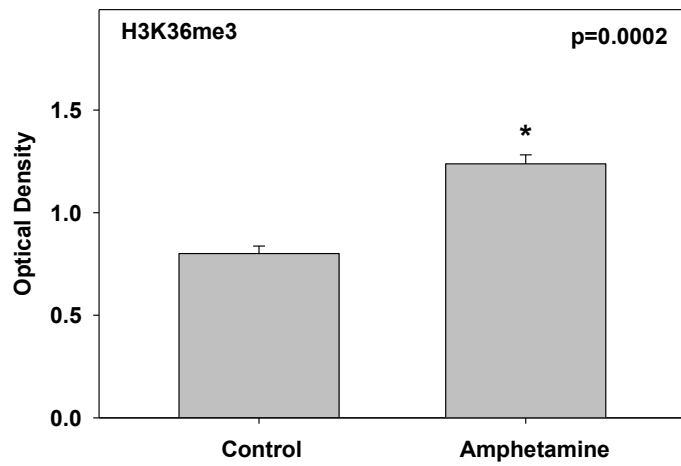
A)



B)



C)

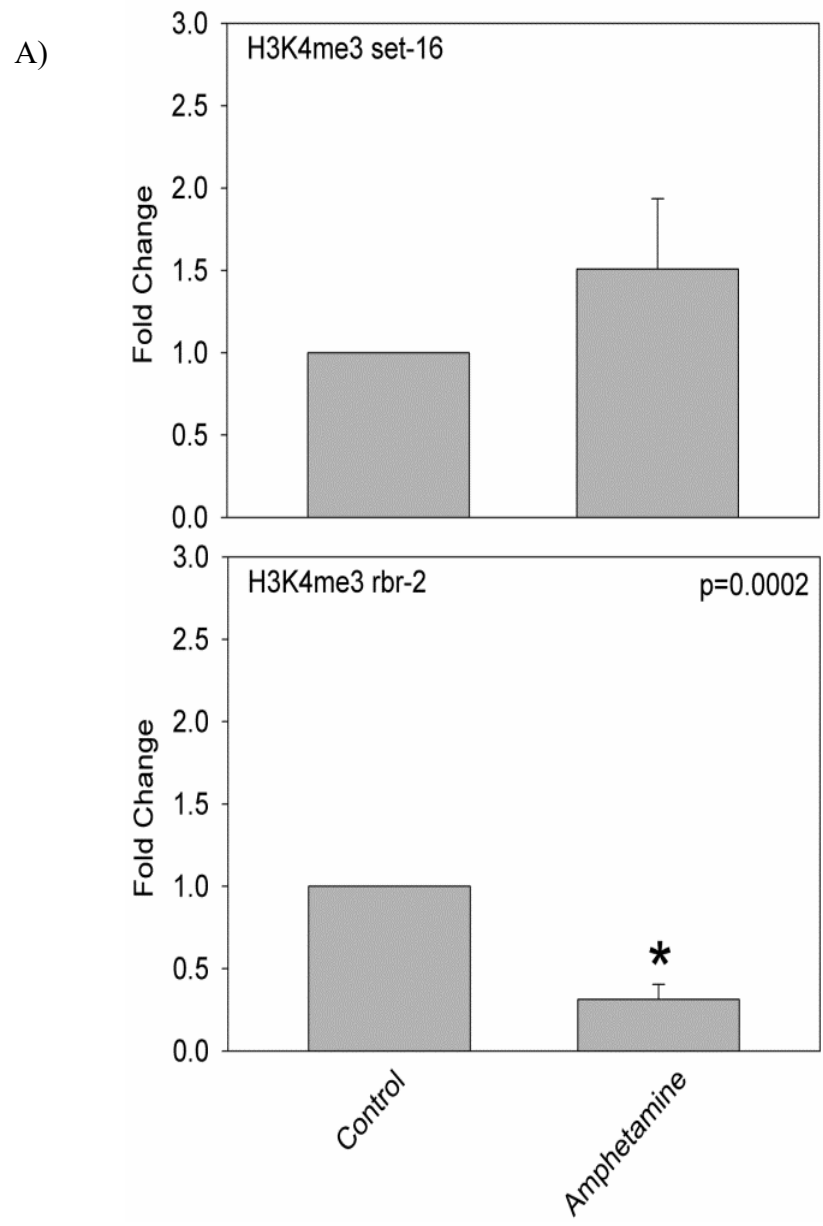


**Amphetamine administration induces changes in the global expression of histone modifying enzymes.**

Our western blot analysis revealed the fact that amphetamine induces changes in the global enrichment of the histone modifications H3K4me3, H3K27me3 and H3K36me3. In order to confirm our findings and determine whether this was due to changes in the expression of known histone modifying enzymes, we wanted to investigate the mRNA expression of these known corresponding histone modifying enzymes. Histone lysine methyltransferases and histone demethylases are responsible for the addition or removal of methyl groups at the specific amino acid in a histone protein, respectively. By adding and removing methyl groups, the histone modifying enzymes may affect the expression of a gene. We used quantitative real time PCR to look at the mRNA expression of MET-1, MES-2 and SET-16 histone methyl transferases and UTX-1, JMJD-2, RBR-2 histone demethylases in amphetamine treated samples. We found that there was a statistically significant decrease in the expression of H3K4me3 histone demethylase RBR-2 in amphetamine treated samples but there was no change in the expression of H3K4me3 histone methyltransferase SET-16 compared to control samples (Figure 6A). The mRNA analysis of H3K27me3 histone methyltransferase MES-2 revealed a significant decrease in MES-2 expression in amphetamine treated samples compared to control, but the histone demethylase UTX-1 was also decreased (Figure 6B). There was no change in the expression of H3K36me3 histone methyl transferase MET-1, but rather, there was a significant decrease in the expression of the histone demethylase JMJD-2 (Figure 6C). The above data suggests that amphetamine treatment induces

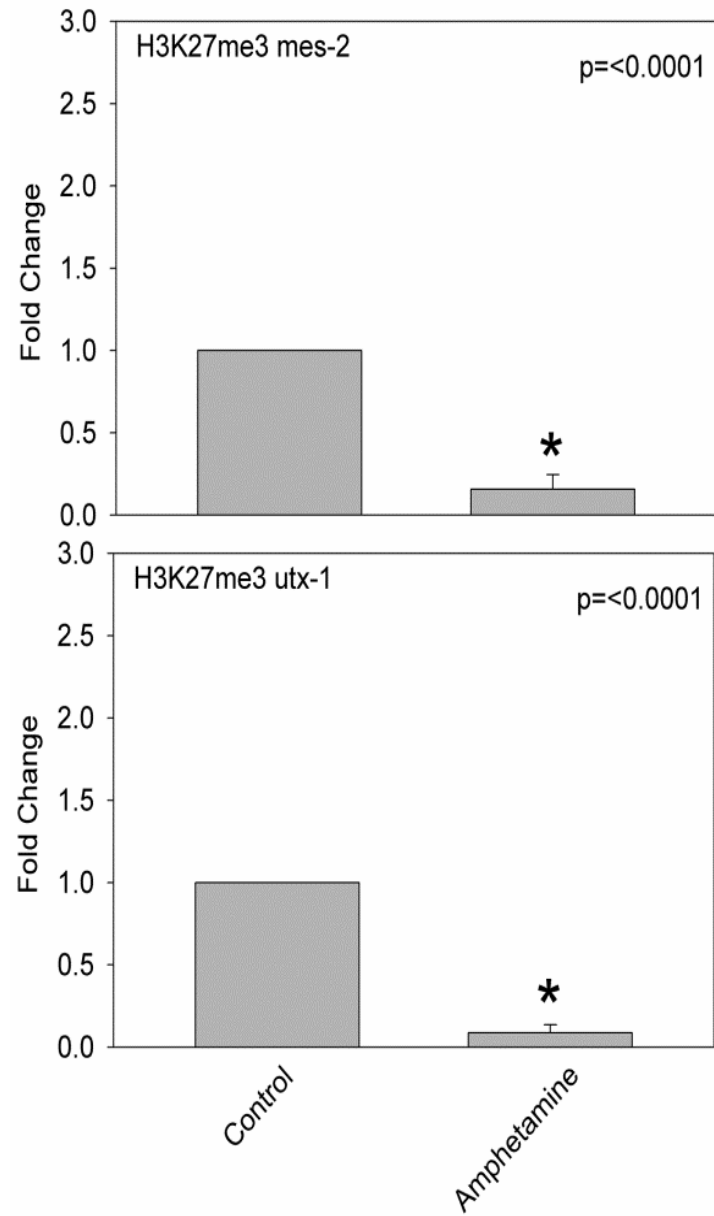
changes in the expression of histone modifying enzymes which in turn affects the expression of histone modifications.

**Figure 6: Amphetamine treatment induces changes in the expression of histone methyltransferases and histone demethylases.** The effect of amphetamine treatment on the expression of the histone modifying proteins was determined by quantitative real-time PCR using cDNA prepared from the transcriptome of wild type and amphetamine treated worms. Figure shows fold change of SET-16 and RBR-2 (5A), MES-2 and UTX-1 (5B), MET-1 and JMJD-2 (5C) over wild type control. All data was normalized to *actin-1* and are shown as a relative fold change  $\pm$  SD (n=3). Statistical analysis was performed using Student's unpaired *t-test*, with statistical significance set at  $p \leq 0.05$ .



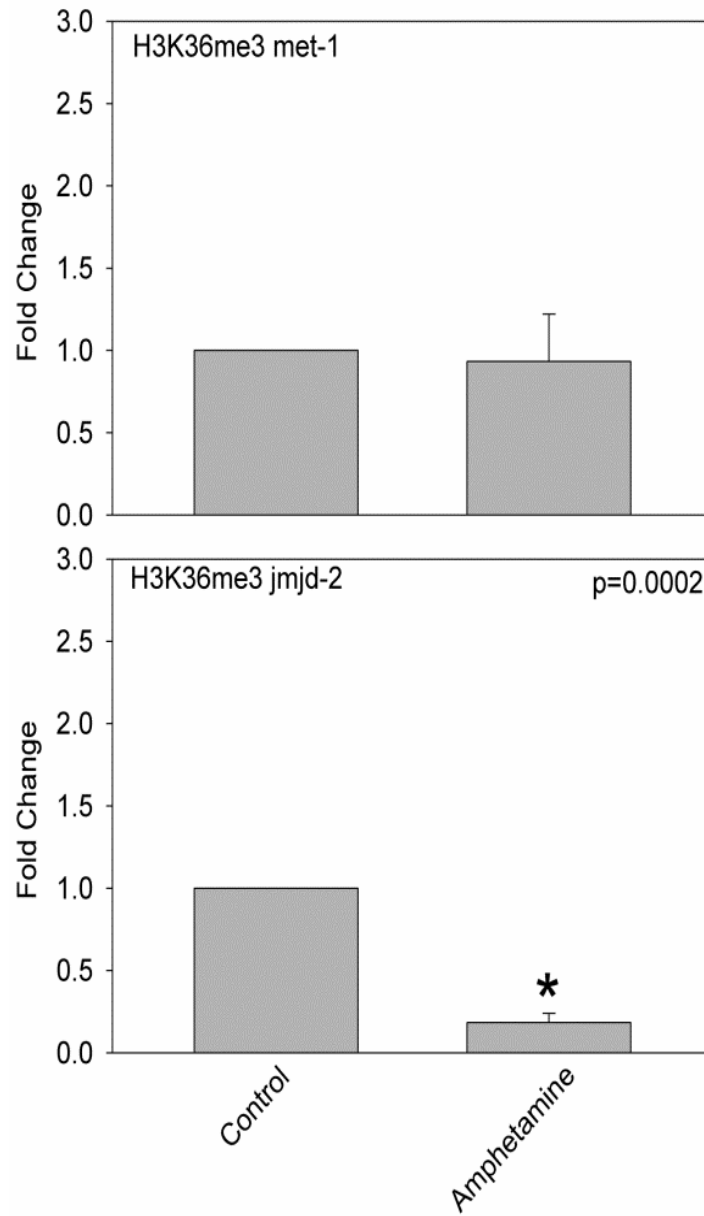
Figure#6 Cont.

B))



Figure#6 Cont.

C))





**Enrichment of histone modifications tri-methylated H3K4, H3K27 and H3K36  
around the transcription start sites of dopaminergic pathway genes.**

Epigenetic modifications have been previously shown to be affected by chronic exposure to addictive drugs. Rental et al. (43) has recently shown that chronic cocaine administration can induce changes in the acetylation of Histone H3/H4 at the promoters of significant number of genes. Histone lysine methylation has long been associated with either gene activation or gene repression by affecting the transcriptional machinery. Since our previous finding suggested that acute administration of amphetamine induces changes in histone modifications at the global level, we wanted to assess if acute amphetamine administration is able to induce changes in histone modifications at the promoters of the genes of the dopaminergic pathway. For this, the enrichment of tri-methylated H3K4, H3K27 and H3K36 around the promoters of *bas-1*, *cat-1*, *cat-2*, *dat-1* and *dop-2* genes was measured using chromatin immunoprecipitation (ChIP). Four different primer sets were prepared for each of these genes, spanning different genomic stretches between -750 base pairs and +250 base pairs (Table 1).

Amphetamine treatment produced no change in the enrichment of H3K4me<sub>3</sub>, H3K27me<sub>3</sub> and H3K36me<sub>3</sub> in *bas-1* gene compared to the control (Figure 7A). There was a statistically significant decrease in the enrichment of H3K4me<sub>3</sub> in amphetamine treated samples in *cat-1* gene, but there was no change in the enrichment levels of H3K27me<sub>3</sub> and H3K36me<sub>3</sub> (Figure 7B). In *cat-2* gene, there was a statistically significant decrease in the enrichment levels of H3K4me<sub>3</sub> and H3K36me<sub>3</sub>, but there was no change in the enrichment of H3K27me<sub>3</sub> (Figure 7C). At the *dat-1* gene promoter, there was statistically significant decrease in the enrichment of H3K4me<sub>3</sub> but there was no

change in the enrichment of H3K27me3 and H3K36me3 (Figure 7D). Amphetamine induced a decrease in the enrichment of H3K4me3, H3K27me3 and H3K36me3 at the cat-2 gene promoter (Figure 7E). These data suggest that amphetamine treatment alters histone modifications at the promoters of genes involved in the dopaminergic pathway, and that these changes which may potentially influence the mode of action of amphetamine by increasing the efflux of the catecholamine dopamine in the synapses.

**Table 1: Nucleotide sequence of the primers used in the chromatin**

**immunoprecipitation analysis.** Table listing the nucleotide sequence of the primers used in the chromatin immunoprecipitation analysis. During the preparation of these primer sets, we used the nematode genome browser of the University of California, Santa Cruz at <http://genome.ucsc.edu/cgi-bin/hgGateway>; the December 2011 assembly. To calculate the properties of the primers (length, melting temperature, and GC content), we used the online oligonucleotide properties calculator available at <http://www.basic.northwestern.edu/biotools/oligocalc.html>. For each gene, we designed 2 primer sets spanning genomic sequences upstream to the transcription start site (up to 500 base pairs), 1 primer set spanning genomic sequences downstream to the transcription start site (up to 250 base pairs) and one primer set spanning the transcription start site.

Gene	Primer set		Sequence	Length	Melting temperature (°C)	Amplicon size (bp)
<i>dat1</i>	Primer set #1	Forward	TTC CCA AAT CTT TTC CTG TCC TTT	23	60.3	127bp
		Reverse	TTC TTT TTC TAC ATT TAT CCG AGC TA	26	60.1	
	Primer set #2	Forward	TAT CCA CCG CAC CGT AGT CT	20	60.5	146bp
		Reverse	TAG ATG TGG TGG CAT GTC GAA T	22	60.1	
	Primer set #3	Forward	TTC GGT TTT TTT GTT CTG ACA AGA AA	26	60.1	153bp
		Reverse	TCG AGT AAA CCG TAG CGG GA	20	60.5	
	Primer set #4	Forward	TTG CCC GAC TCT TAT TTA TCT GTA	26	60.3	154bp
		Reverse	ACC GCT ATT GTA TCA TAT TCT TTG TT	26	60.1	

Gene	Primer set		Sequence	Length	Melting temperature (°C)	Amplicon size (bp)
<i>cat1</i>	Primer set #1	Forward	TAA AAT TTC TCT ATC TAT TCC GGG AA	26	60.1	85bp
		Reverse	AGG GTG AAC ACT GGT AAT GAC A	22	60.1	
	Primer set #2	Forward	TTC CTT TTT TTC GCG GAC TCC A	22	60.1	151bp
		Reverse	TAG ATT CCC ACG GTC TGA AAA ATT	24	60.3	
	Primer set #3	Forward	TCA GTT TTG TTA TCA CAT TTC TCA CA	26	60.1	148bp
		Reverse	AAA GTA GAA TTT TCC TAT TGT TCC GA	26	60.1	
	Primer set #4	Forward	ACA GTT GGT AAG TTT CTG GAA ACA	21	60.3	136bp
		Reverse	TTT TGA GAG TTG TGA CTG AAC AGA	24	60.3	

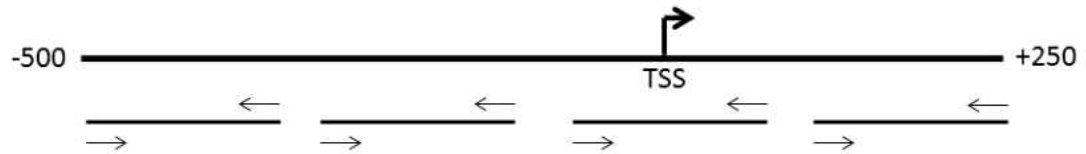
Table 1 Continued

Gene	Primer set		Sequence	Length	Melting temperature (°C)	Amplicon size (bp)
<i>cat2</i>	Primer set #1	Forward	TTC ATA TGC TGG GTT ATC AGT TCT	24	60.3	118bp
		Reverse	ACG TTC ACC GCC GCA ATT AG	20	60.5	
	Primer set #2	Forward	TCG TCA CTA ACC AAC AAT ACT TTC A	25	60.9	176bp
		Reverse	AGG TTC TTC CTC CTA GAA ATT GAA A	25	60.9	
	Primer set #3	Forward	TGG TGC ACC AAG CGA GTT GT	20	60.5	130bp
		Reverse	ACA AGA GCT TGT ATG GAT TAC TGT A	25	60.9	
	Primer set #4	Forward	TTC CGA CGA TTC AGA TTC TCC A	22	60.1	114bp
		Reverse	TTG GGT CAG TGG AAG TGA GAA T	22	60.1	

Gene	Primer set		Sequence	Length	Melting temperature (°C)	Amplicon size (bp)
<i>dop2</i>	Primer set #1	Forward	GCT TAA TGT GTG CTT TGT GTT AGA	24	60.3	139bp
		Reverse	TTC TTT ACC AAT GCT CAG ATG ACT	24	60.3	
	Primer set #2	Forward	AGA TTC TTT CTG TTA TCG AGT CTA AA	26	60.1	112bp
		Reverse	AAC GTA ATA GAT TTT AGT TTC TCA GA	26	58.4	
	Primer set #3	Forward	ACA CCT TTG TTT TTA CCT TCT TCA A	25	59.2	141bp
		Reverse	AAG AGA GGG TGG AGG CCA TT	20	60.5	
	Primer set #4	Forward	TGA ACT ACG CTG GAC TTT CTC T	22	60.1	94bp
		Reverse	ATT TTT TAA CTG ACA ATT GAA CTC TAA C	28	59.9	

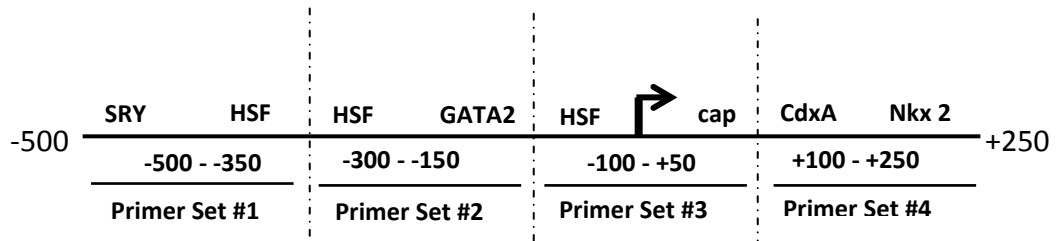
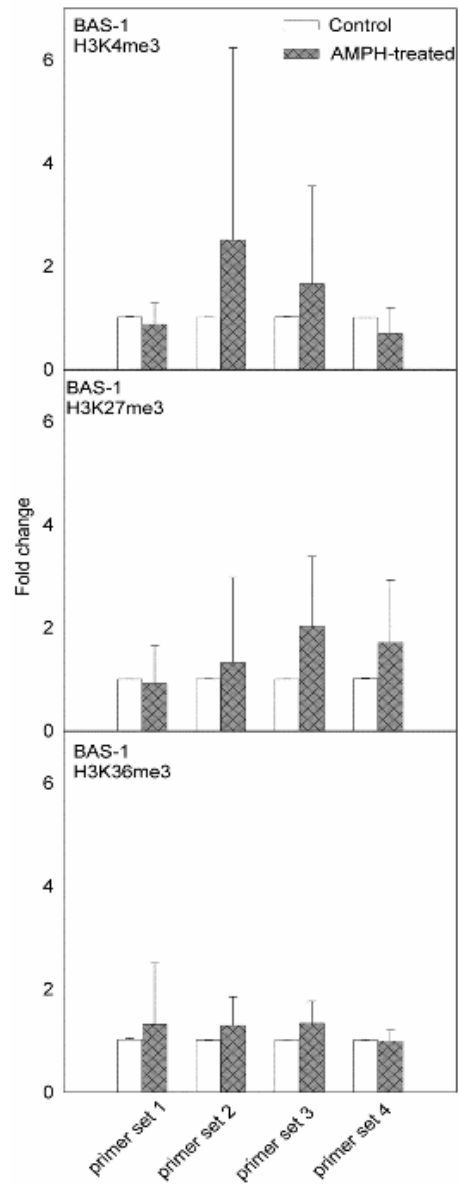
Table 1 Continued

Gene	Primer set		Sequence	Length	Melting temperature (°C)	Amplicon size (bp)
<i>bas1</i>	Primer set #1	Forward	TGC CGA CGC TCA TCA TCA CT	20	60.5	193 bp
		Reverse	TGT CAA AAG TTC TGA AAA CGG AAA TA	26	60.1	
	Primer set #2	Forward	TTT CTG CAG CCA ATT CTT TTT CTC	24	60.3	154bp
		Reverse	ATA CCT ATC CAT CTA TGC GCG A	22	60.1	
	Primer set #3	Forward	TCC CCT CAT TTC TCT TAT TTT CCT	24	60.3	171bp
		Reverse	AGT AGT CCG CCA CAA AAT CCA	21	59.5	
	Primer set #4	Forward	ACC ACT GCC TGA TGT TAA ACC A	22	60.1	133bp
		Reverse	TCG GCT CGT GGC CTA GTA AA	20	60.5	



**Figure 7: Enrichment of tri-methylated H3K4, H3K27 and H3K36 around the transcription start sites of dopaminergic pathway genes in control and amphetamine treated worms.** Figure shows the fold changes in the levels of enrichment of tri-methylated H3K4, H3K27 and H3K36 at *bas-1* (A), *cat-1* (B), *cat-2* (C), *dat-1* (D), and *dop-2* (E) genes measured by chromatin immunoprecipitation analysis followed by qrt-PCR, in *C.elegans* treated with 100mM amphetamine for 15 hours, with water as control. The cartoon in the bottom shows the possible Transcription Factor binding sites based on sequence specificity calculated from <http://www.Cbrc.jp/research/db/TFSEARCH.html> Bars represent means  $\pm$  SD (n=3) where statistical analysis was performed using Student's unpaired *t-test*, with statistical significance set at  $p \leq 0.05$ .

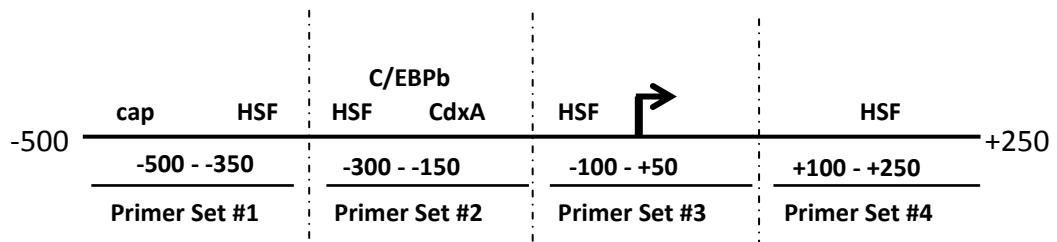
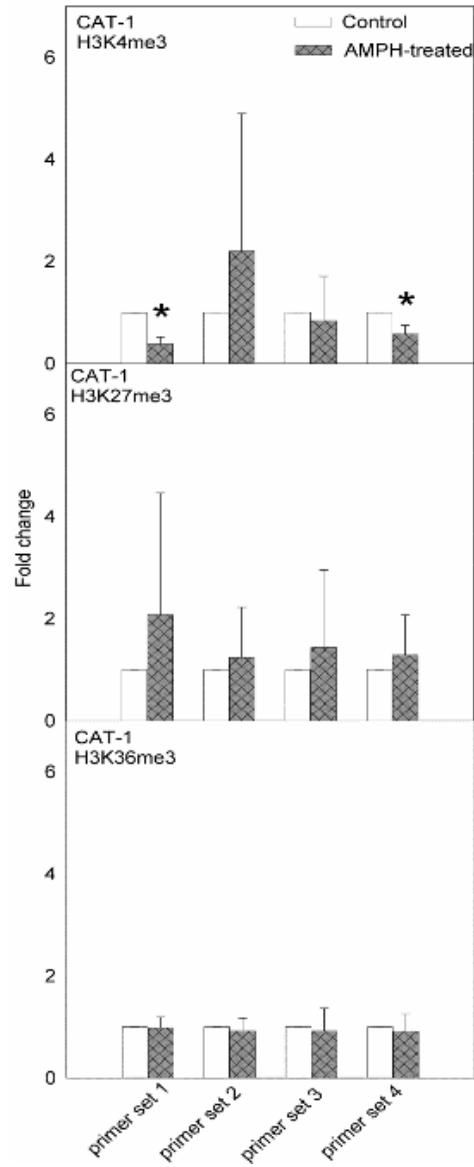
A)





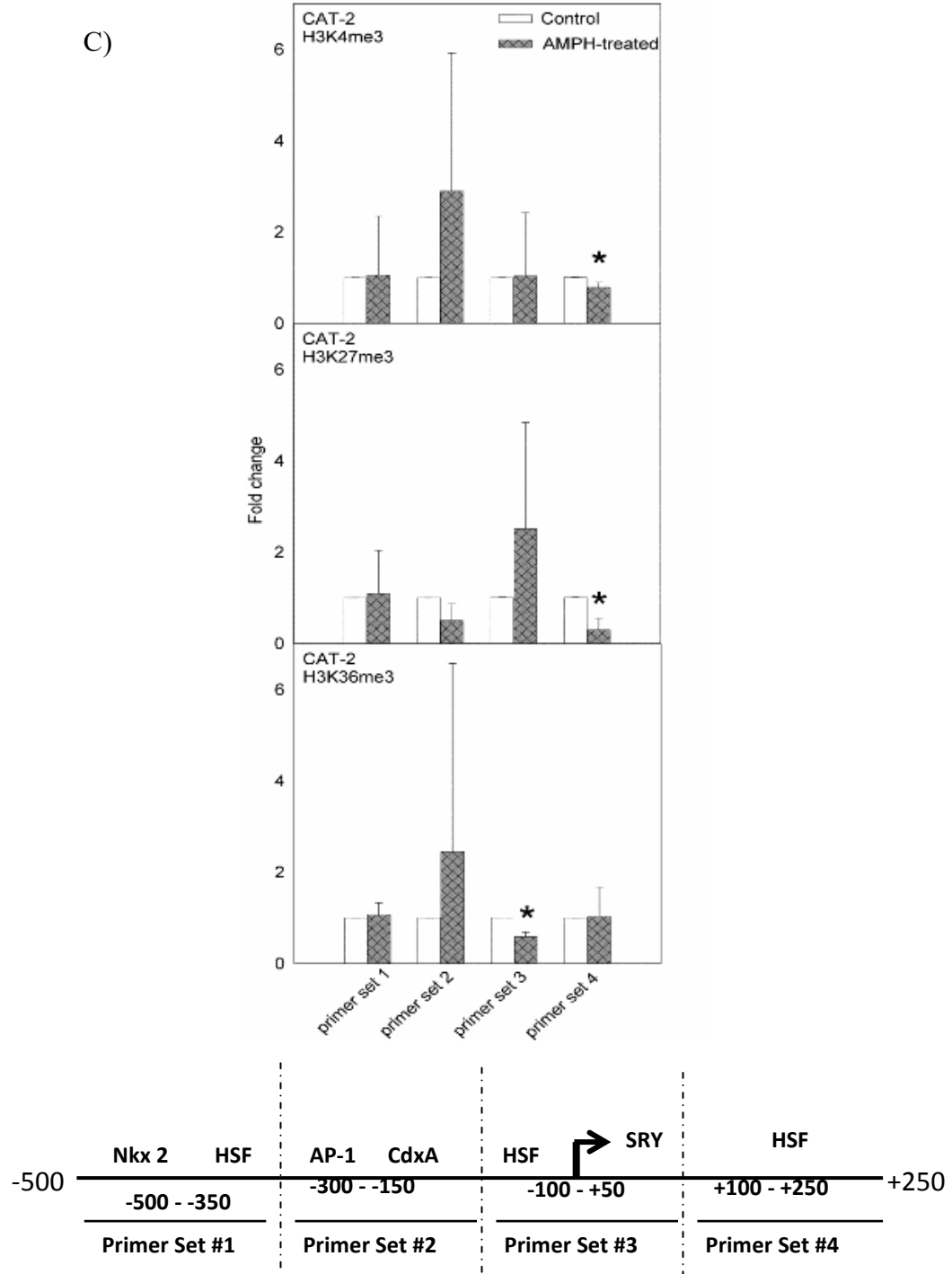
Figure#7 Cont.

B)



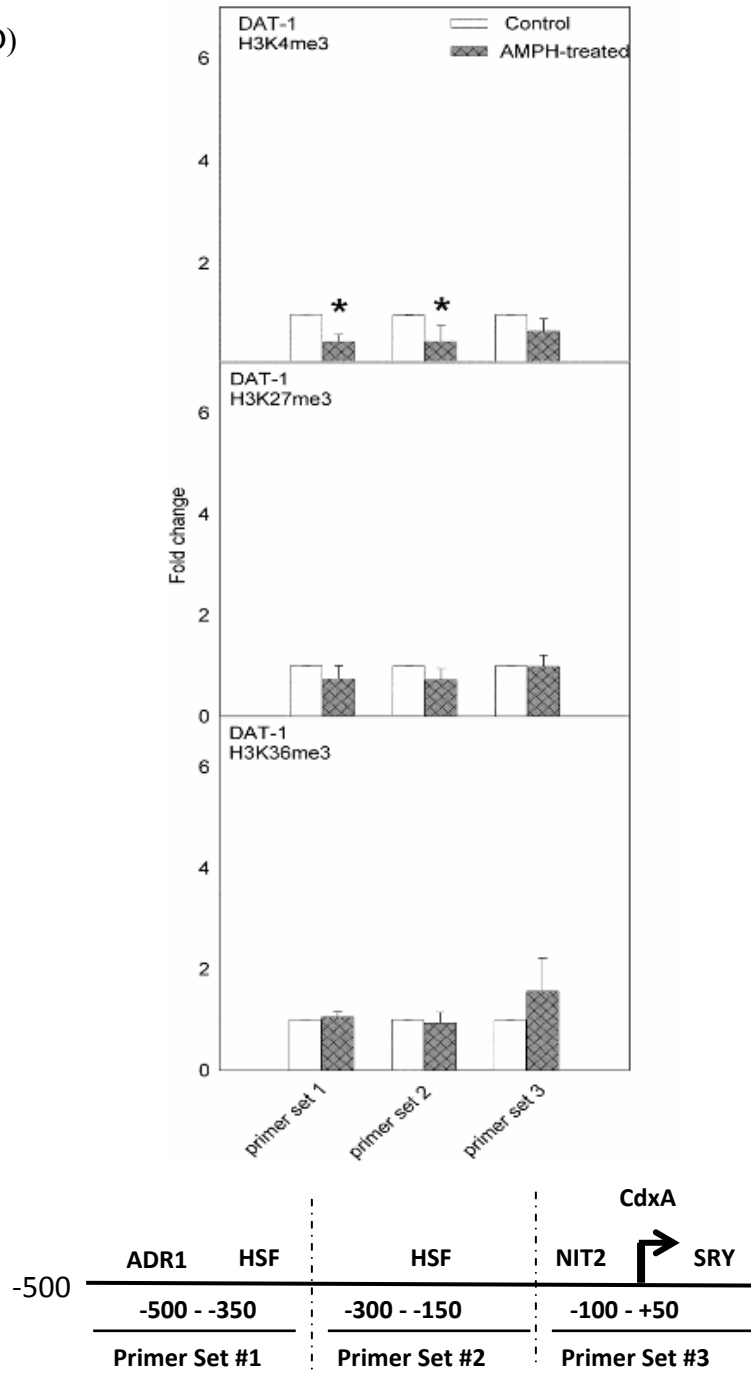
Figure#7 Cont.

C)



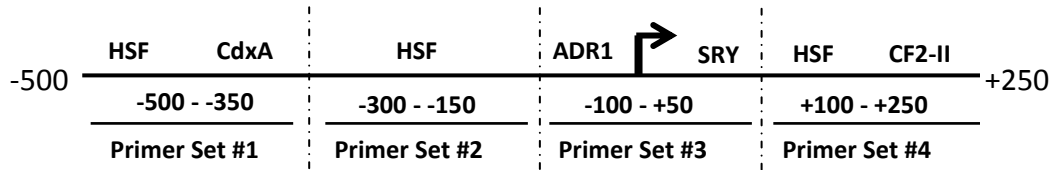
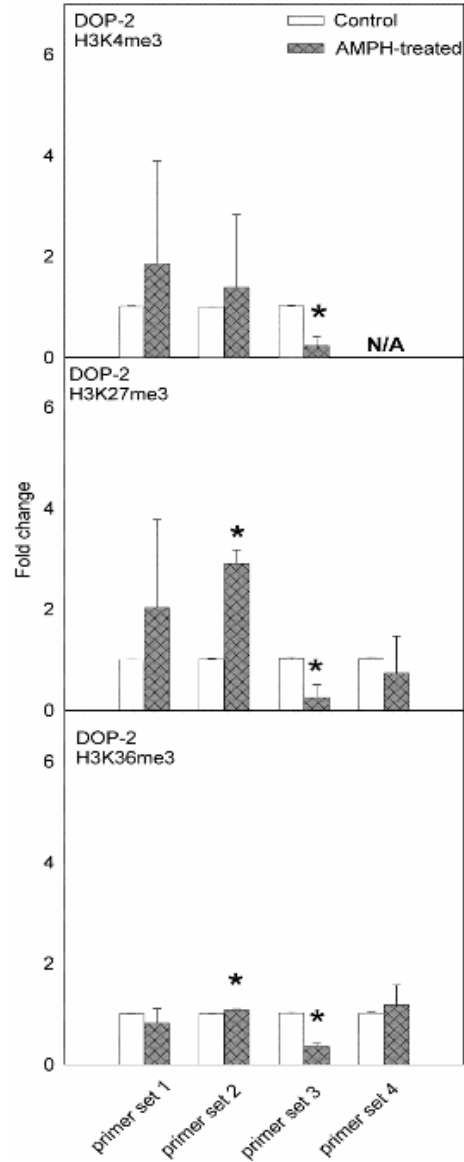
Figure#7 Cont.

D)



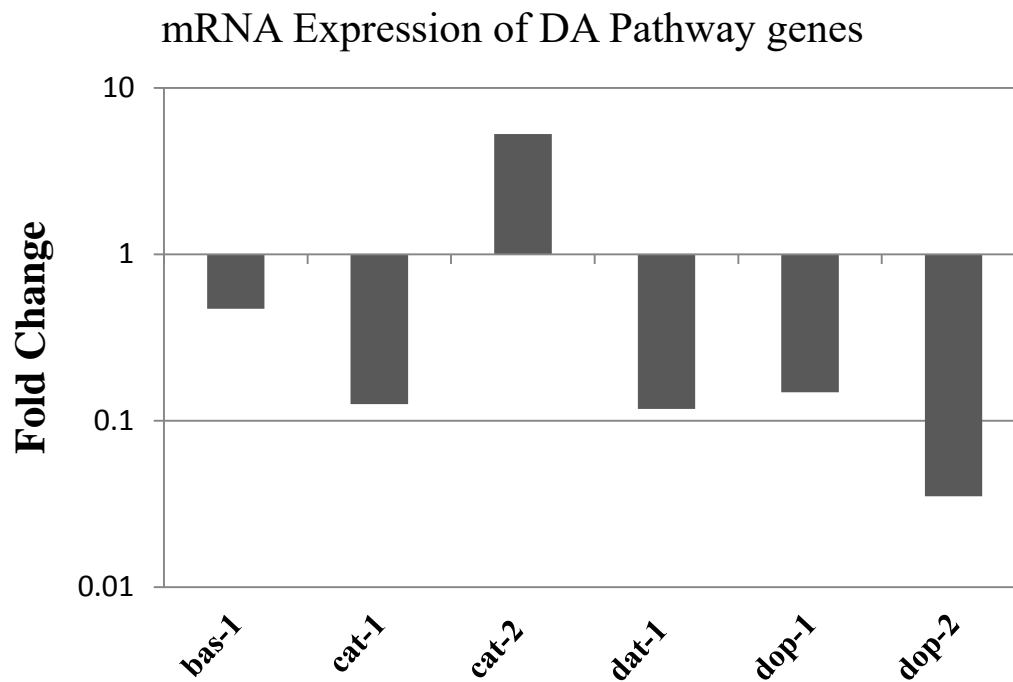
Figure#7 Cont.

E)



**Amphetamine treatment induces changes in the expression of genes in the dopaminergic pathway.**

We addressed the question of whether acute amphetamine treatment alters gene expression in the dopaminergic pathway. Using qrt-PCR, we looked at the effect of amphetamine on individual genes of the dopamine signaling pathway which included *bas-1*, *cat-1*, *cat-2*, *dat-1*, *dop-1* and *dop-2*. Our qrt-PCR analysis revealed that amphetamine treatment decreases the expression of *bas-1*, *cat-1*, *dat-1*, *dop-1* and *dop-2*, but increases the expression of the *cat-2* gene which encodes the protein tyrosine hydroxylase (Figure 8). These results support the findings that amphetamine treatment alters the expression of the genes involved in the dopaminergic pathway, an effect that might help shed light onto complex mechanism of action by which of amphetamine induces efflux of cellular dopamine in the synapses.



**Figure 8: Amphetamine treatment induces changes in the expression of genes in the dopaminergic pathway.** The effect of amphetamine treatment on the expression of the genes of the dopaminergic pathway was determined by quantitative real-time PCR using cDNA prepared from the transcriptome of wild type and amphetamine treated worms. Figure shows fold change of individual genes over wild type control. Data was normalized to *actin-1*.

## Chapter 4

### **DISCUSSION**

Epigenetic modifications, which include histone modifications like acetylation, phosphorylation and methylation, have been known to play important roles in the development and the differentiation of an organism. Epigenetic modifications are also known to be affected by environmental stimuli such as heavy metals and pesticides. Zhou et al. showed that arsenic disrupts epigenetic events by altering histone modifications (52). Addictive drugs have also been known to induce changes in the epigenetic modifications. Recent study by Renthall et al. revealed that cocaine treatment induces changes in the acetylation states of H3/ H4 (49), an effect that was associated with the sirtuin family of proteins.

The main goal of this study was to determine if exposure to amphetamine is able to induce changes in histone modifications at the promoters of the key genes of the dopaminergic pathway. Our western blot analysis shows that there is a significant increase in the expression of H3K27me3 and H3K36me3 at the global level in amphetamine treated samples.

This suggests that there is an increase in the protein expression of H3K27me3 and H3K36me3 at the global level in amphetamine treated samples compared to control samples. Trimethylation of lysine 27 on histone 3 (H3K27me3) is a mark that is known to be associated with the repression of transcription in a cell type specific manner. A global

increase in the protein expression levels of H3K27me3 may be associated with an increase in the formation of heterochromatin, which is characteristic of transcriptionally silent chromatin.

Trimethylation of lysine 36 on Histone 3 (H3K36me3) is considered as a marker of transcriptional elongation, as this mark is mainly co-enriched with the Ser2-phosphorylated elongating form of RNA polymerase (Pol) II at the coding region (CR) of the gene body. Therefore, a global increase in the protein expression of H3K36me3 is associated with increased transcription status.

Although the western blot analysis revealed that there was a change in expression levels of H3K27me3 and H3K36me3 at the global level, this observation does not necessarily correlate with the fact that there will be a similar observation at the gene level for the genes of interest in this study. This may be because histone post translational modification is a dynamic process; it undergoes dynamic changes at various stages of life. For example, Lander et al. have shown that methylation of CpGs undergo extensive changes during cellular differentiation. Moreover, histone methylation patterns are correlated with DNA methylation patterns (53). This suggests that histone methylation is a dynamic process and may vary across the genome. The western blot analysis revealed several important pieces of information. First, exposure to amphetamine disturbs the epigenetic pattern in a way that it brings about changes in the global levels of these covalent modifications. This supports our hypothesis so far that exposure to amphetamine may induce changes in histone modifications at the promoter region of genes.



In order to further study the changes in the histone modifications by amphetamine, we looked at the protein levels of the various histone modifying enzymes using mRNA expression. Our mRNA expression study showed that exposure to amphetamine leads to a statistically significant decrease in the levels of H3K4me3 histone demethylase RBR-2 and H3K36me3 histone demethylase JMJD-2, but that there was no change in the expression levels of the histone methyltransferases of the above mentioned modifications from wild type worms. Although there was a statistically significant increase in the expression of H3K27me3 in our western blot analysis, the protein levels the histone methyltransferase MES-2 and histone demethylase UTX-1 were both found to be decreased in amphetamine treated samples compared to the control samples. This suggests that the H3K27me3 mark might have a lesser role in the regulation of gene expression in amphetamine treated samples or as the worms develop, although further work is warranted to confirm this. These results indicate that amphetamine treatment increases the expression of H3K4me3 and H3K36me3 modifications by reducing the protein levels of the histone demethylases.

The next phase of the study was to examine whether exposure to amphetamine induces changes in histone modifications in the promoter region of the genes of the dopaminergic pathway. Amphetamine has been known to exert its behavioral effect primarily by increasing the extracellular levels of dopamine. This effect is thought to be elicited by the reversal of the dopamine transporter (DAT) and thereby modification of dopamine signaling (5). The dopamine signaling pathway consists of tyrosine hydroxylase *cat-1*, aromatic amino acid decarboxylase *bas-1*, vesicular monoamine transporter *cat-2*, dopamine transporter *dat-1* and dopamine receptors *dop-1* and *dop-2*. We wanted to

examine if amphetamine exerts its effects by manipulating various histone modifications at these key gene promoters. For, this we measured the enrichment of H3K4me3, H3K27me3 and H3K36me3 at the promoter regions of the genes of the dopaminergic pathway using chromatin immunoprecipitation (ChIP). We find that amphetamine treatment has no effect on the amino acid decarboxylase *bas-1* (Figure 7A). Chromatin immunoprecipitation analysis of *cat-1* reveals that amphetamine treatment significantly decreases the enrichment of tri-methylated H3K4me3, but there was no change in the enrichment of H3K27me3 and H3K36me3 (Figure 7A). *cat-1* encodes for vesicular monoamine transporter which packages cellular dopamine from the cytoplasm into specialized vesicles, by an active transport mechanism and stores dopamine until it is released by exocytosis into the synapses. This result implies that amphetamine reduces the expression of VMAT, which might indicate the increased cytoplasmic dopamine levels. Previous studies have shown that amphetamine affects vesicle storage of dopamine in synaptic vesicles by reducing the ability of VMAT to store the neurotransmitter, possibly by synaptic vesicle localization (15, 54) which suggests that amphetamine treatment might induce changes in the expression of the vesicular monoamine transporter by introducing changes in the histone modifications in the promoter region such that the protein expression is altered. We find that amphetamine treatment significantly decreases the enrichment of both H3K4me3 and H3K27me3, while increasing expression of tyrosine hydroxylase *cat-2* gene (Figure 7C). This may be partially explained by the fact that we find that although there is a significant decrease in the H3K4me3 enrichment in primer set 4, we find a greater decrease in the enrichment of H3K27me3 in primer set 4. The primer set 4 is located closer to the transcription start

site, and as we can see in Figure 4A, the H3K4me3 and H3K27me3 marks are highly enriched around the transcription start site. This suggests that the greater reduction in the enrichment of H3K27me3 compared to the H3K4me3 may be the primary regulatory factor in terms of gene activation at this promoter. Since, *cat-2* encodes the tyrosine hydroxylase gene, this suggests that amphetamine increases the expression of tyrosine hydroxylase, which then increases the synthesis of dopamine. We hypothesize that since we have seen earlier that amphetamine decreases the expression of VMAT, and that this suggests that as there is an increase in the synthesis of dopamine, the VMAT may not be able to efficiently package the excess dopamine, thereby increasing the concentration of cytosolic dopamine. This may then be funneled out to the pre-synaptic space through the dopamine transporter. The enrichment of H3K4me3 in *dat-1* (Figure 7D) shows a statistically significant decrease in primer set 2 and 3 which suggests that there might be a reduction in the enrichment of H3K4me3. We find no change in the enrichment of H3K27me3 and H3K36me3, and this might indicate a reduction in the expression of dopamine transporter. Recent work by Carvelli et al. has indicated that DAT plays an important role in the ability of amphetamine to increase extracellular dopamine (5). We suggest that this decrease in the expression of *dat-1* leads to increased concentration of extracellular dopamine as the lower expression of DAT prevents the shuttling of extracellular dopamine inside the neuron, which is a manifestation of the action of amphetamine. Recent work by German et al. has showed that *in vivo* amphetamine treatment decreases DAT function (55). *dop-2* shows reduced enrichment of H3K4me3, H3K27me3 and H3K36me3 (Figure 7E). This might suggest a reduced expression of the type II dopaminergic neurons.

Our next goal was to confirm our observations in the chromatin Immunoprecipitation. For this we wanted to see the mRNA expression of the genes of the dopaminergic pathway. We looked at the transcriptional levels of the various components of the dopaminergic pathway using mRNA expression (Figure 8). Our mRNA expression study showed that exposure to amphetamine lead to decrease in the expression of *dat-1*, *cat-1*, *bas-1*, *dop-1* and *dop-2* but there was an increase in the expression of *cat-2* which encodes tyrosine hydroxylase. This is largely in agreement with our chromatin immunoprecipitation reaction observations.

To our knowledge, no studies have been done to date on the role of amphetamine in inducing changes in histone modifications at the promoter region of the genes of the dopaminergic pathway. Our results show that amphetamine treatment induces changes in the expression of the dopaminergic pathway genes by controlling various histone modifications at the promoter region of these genes. We find that amphetamine brings about its manifestation of increasing extracellular/synaptic dopamine by the down regulation of vesicular monoamine transporter, which becomes unable to package dopamine, thereby increasing the concentration of cellular dopamine. This increase in cellular dopamine may be exported out of the neurons by action of amphetamine on the reverse transport of the dopamine transporter. The main role of the dopamine transporter is to pump back extra dopamine that has net been picked up by the dopaminergic receptors in the post-synaptic neurons, and restore dopamine levels in the pre-synaptic neuron. Amphetamine also seems to down regulate the dopamine transporter, which suggests that the function of the dopamine transporter is affected in a way that the ability of DAT to funnel synaptic dopamine is hampered. Finally we say that as this study was

performed on *Caenorhabditis elegans*, further analysis is necessary in order to correlate the data with clinical outcomes.

## References

1. Sulzer D. How addictive drugs disrupt presynaptic dopamine neurotransmission. *Neuron*. 2011 Feb 24;69(4):628-49.
2. Fleckenstein AE, Volz TJ, Riddle EL, Gibb JW, Hanson GR. New insights into the mechanism of action of amphetamines. *Annu Rev Pharmacol Toxicol*. 2007;47:681-98.
3. Sulzer D, Sonders MS, Poulsen NW, Galli A. Mechanisms of neurotransmitter release by amphetamines: A review. *Prog Neurobiol*. 2005 Apr;75(6):406-33.
4. Elsworth JD, Roth RH. Dopamine synthesis, uptake, metabolism, and receptors: Relevance to gene therapy of parkinson's disease. *Exp Neurol*. 1997 Mar;144(1):4-9.
5. Carvelli L, Matthies DS, Galli A. Molecular mechanisms of amphetamine actions in *Caenorhabditis elegans*. *Mol Pharmacol*. 2010 Jul;78(1):151-6.
6. Konradi C, Cole RL, Heckers S, Hyman SE. Amphetamine regulates gene expression in rat striatum via transcription factor CREB. *J Neurosci*. 1994 Sep;14(9):5623-34.
7. Renthal W, Carle TL, Maze I, Covington HE, 3rd, Truong HT, Alibhai I, et al. Delta FosB mediates epigenetic desensitization of the *c-fos* gene after chronic amphetamine exposure. *J Neurosci*. 2008 Jul 16;28(29):7344-9.
8. Zaczek R, Culp S, De Souza EB. Interactions of [<sup>3</sup>H]amphetamine with rat brain synaptosomes. II. active transport. *J Pharmacol Exp Ther*. 1991 May;257(2):830-5.
9. Sulzer D, Maidment NT, Rayport S. Amphetamine and other weak bases act to promote reverse transport of dopamine in ventral midbrain neurons. *J Neurochem*. 1993 Feb;60(2):527-35.
10. Jones SR, Gainetdinov RR, Wightman RM, Caron MG. Mechanisms of amphetamine action revealed in mice lacking the dopamine transporter. *J Neurosci*. 1998 Mar 15;18(6):1979-86.
11. Giros B, Jaber M, Jones SR, Wightman RM, Caron MG. Hyperlocomotion and indifference to cocaine and amphetamine in mice lacking the dopamine transporter. *Nature*. 1996 Feb 15;379(6566):606-12.
12. Fon EA, Poos EN, Sun BC, Killeen N, Sulzer D, Edwards RH. Vesicular transport regulates monoamine storage and release but is not essential for amphetamine action. *Neuron*. 1997 Dec;19(6):1271-83.
13. Sulzer D, Chen TK, Lau YY, Kristensen H, Rayport S, Ewing A. Amphetamine redistributes dopamine from synaptic vesicles to the cytosol and promotes reverse transport. *J Neurosci*. 1995 May;15(5 Pt 2):4102-8.

14. Hogan KA, Staal RG, Sonsalla PK. Analysis of VMAT2 binding after methamphetamine or MPTP treatment: Disparity between homogenates and vesicle preparations. *J Neurochem.* 2000 May;74(5):2217-20.
15. Riddle EL, Topham MK, Haycock JW, Hanson GR, Fleckenstein AE. Differential trafficking of the vesicular monoamine transporter-2 by methamphetamine and cocaine. *Eur J Pharmacol.* 2002 Aug 2;449(1-2):71-4.
16. Sandoval V, Riddle EL, Hanson GR, Fleckenstein AE. Methylphenidate alters vesicular monoamine transport and prevents methamphetamine-induced dopaminergic deficits. *J Pharmacol Exp Ther.* 2003 Mar;304(3):1181-7.
17. Sonders MS, Zhu SJ, Zahniser NR, Kavanaugh MP, Amara SG. Multiple ionic conductances of the human dopamine transporter: The actions of dopamine and psychostimulants. *J Neurosci.* 1997 Feb 1;17(3):960-74.
18. Nass R, Blakely RD. The *Caenorhabditis elegans* dopaminergic system: Opportunities for insights into dopamine transport and neurodegeneration. *Annu Rev Pharmacol Toxicol.* 2003;43:521-44.
19. Cassada RC, Russell RL. The dauerlarva, a post-embryonic developmental variant of the nematode *Caenorhabditis elegans*. *Dev Biol.* 1975 Oct;46(2):326-42.
20. Calahorra F, Ruiz-Rubio M. *Caenorhabditis elegans* as an experimental tool for the study of complex neurological diseases: Parkinson's disease, Alzheimer's disease and autism spectrum disorder. *Invert Neurosci.* 2011 Dec;11(2):73-8.
21. Weinshenker D, Garriga G, Thomas JH. Genetic and pharmacological analysis of neurotransmitters controlling egg laying in *C. elegans*. *J Neurosci.* 1995 Oct;15(10):6975-8.
22. Sawin ER, Ranganathan R, Horvitz HR. *C. elegans* locomotory rate is modulated by the environment through a dopaminergic pathway and by experience through a serotonergic pathway. *Neuron.* 2000 Jun;26(3):619-31.
23. Carvelli L, McDonald PW, Blakely RD, Defelice LJ. Dopamine transporters depolarize neurons by a channel mechanism. *Proc Natl Acad Sci U S A.* 2004 Nov 9;101(45):16046-51.
24. McDonald PW, Hardie SL, Jessen TN, Carvelli L, Matthies DS, Blakely RD. Vigorous motor activity in *Caenorhabditis elegans* requires efficient clearance of dopamine mediated by synaptic localization of the dopamine transporter DAT-1. *J Neurosci.* 2007 Dec 19;27(51):14216-27.
25. Li E, Bestor TH, Jaenisch R. Targeted mutation of the DNA methyltransferase gene results in embryonic lethality. *Cell.* 1992 Jun 12;69(6):915-26.

26. Klose RJ, Bird AP. Genomic DNA methylation: The mark and its mediators. *Trends Biochem Sci.* 2006 Feb;31(2):89-97.
27. Jenuwein T, Allis CD. Translating the histone code. *Science.* 2001 Aug 10;293(5532):1074-80.
28. Zhang Y, Reinberg D. Transcription regulation by histone methylation: Interplay between different covalent modifications of the core histone tails. *Genes Dev.* 2001 Sep 15;15(18):2343-60.
29. Biswas M, Voltz K, Smith JC, Langowski J. Role of histone tails in structural stability of the nucleosome. *PLoS Comput Biol.* 2011 Dec;7(12):e1002279.
30. Litt MD, Simpson M, Gaszner M, Allis CD, Felsenfeld G. Correlation between histone lysine methylation and developmental changes at the chicken beta-globin locus. *Science.* 2001 Sep 28;293(5539):2453-5.
31. Wenzel D, Palladino F, Jedrusik-Bode M. Epigenetics in *C. elegans*: Facts and challenges. *Genesis.* 2011 Aug;49(8):647-61.
32. Maures TJ, Greer EL, Hauswirth AG, Brunet A. The H3K27 demethylase UTX-1 regulates *C. elegans* lifespan in a germline-independent, insulin-dependent manner. *Aging Cell.* 2011 Dec;10(6):980-9.
33. Margueron R, Justin N, Ohno K, Sharpe ML, Son J, Drury WJ, 3rd, et al. Role of the polycomb protein EED in the propagation of repressive histone marks. *Nature.* 2009 Oct 8;461(7265):762-7.
34. Muller J, Verrijzer P. Biochemical mechanisms of gene regulation by polycomb group protein complexes. *Curr Opin Genet Dev.* 2009 Apr;19(2):150-8.
35. Kolasinska-Zwierz P, Down T, Latorre I, Liu T, Liu XS, Ahringer J. Differential chromatin marking of introns and expressed exons by H3K36me3. *Nat Genet.* 2009 Mar;41(3):376-81.
36. Kolasinska-Zwierz P, Down T, Latorre I, Liu T, Liu XS, Ahringer J. Differential chromatin marking of introns and expressed exons by H3K36me3. *Nat Genet.* 2009 Mar;41(3):376-81.
37. Agger K, Cloos PA, Christensen J, Pasini D, Rose S, Rappsilber J, et al. UTX and JMJD3 are histone H3K27 demethylases involved in HOX gene regulation and development. *Nature.* 2007 Oct 11;449(7163):731-4.
38. Ruthenburg AJ, Allis CD, Wysocka J. Methylation of lysine 4 on histone H3: Intricacy of writing and reading a single epigenetic mark. *Mol Cell.* 2007 Jan 12;25(1):15-30.



39. Greer EL, Maures TJ, Ucar D, Hauswirth AG, Mancini E, Lim JP, et al. Transgenerational epigenetic inheritance of longevity in *Caenorhabditis elegans*. *Nature*. 2011 Oct 19;479(7373):365-71.
40. McQuown SC, Wood MA. Epigenetic regulation in substance use disorders. *Curr Psychiatry Rep*. 2010 Apr;12(2):145-53.
41. Kumar A, Choi KH, Renthall W, Tsankova NM, Theobald DE, Truong HT, et al. Chromatin remodeling is a key mechanism underlying cocaine-induced plasticity in striatum. *Neuron*. 2005 Oct 20;48(2):303-14.
42. Perrotti LI, Weaver RR, Robison B, Renthall W, Maze I, Yazdani S, et al. Distinct patterns of DeltaFosB induction in brain by drugs of abuse. *Synapse*. 2008 May;62(5):358-69.
43. Robison AJ, Nestler EJ. Transcriptional and epigenetic mechanisms of addiction. *Nat Rev Neurosci*. 2011 Oct 12;12(11):623-37.
44. Kelz MB, Chen J, Carlezon WA, Jr, Whisler K, Gilden L, Beckmann AM, et al. Expression of the transcription factor deltaFosB in the brain controls sensitivity to cocaine. *Nature*. 1999 Sep 16;401(6750):272-6.
45. Bourtchuladze R, Frenguelli B, Blendy J, Cioffi D, Schutz G, Silva AJ. Deficient long-term memory in mice with a targeted mutation of the cAMP-responsive element-binding protein. *Cell*. 1994 Oct 7;79(1):59-68.
46. Carlezon WA, Jr, Thome J, Olson VG, Lane-Ladd SB, Brodtkin ES, Hiroi N, et al. Regulation of cocaine reward by CREB. *Science*. 1998 Dec 18;282(5397):2272-5.
47. Larson EB, Graham DL, Arzaga RR, Buzin N, Webb J, Green TA, et al. Overexpression of CREB in the nucleus accumbens shell increases cocaine reinforcement in self-administering rats. *J Neurosci*. 2011 Nov 9;31(45):16447-5.
48. Pandey SC, Ugale R, Zhang H, Tang L, Prakash A. Brain chromatin remodeling: A novel mechanism of alcoholism. *J Neurosci*. 2008 Apr 2;28(14):3729-37.
49. Renthall W, Kumar A, Xiao G, Wilkinson M, Covington HE, 3rd, Maze I, et al. Genome-wide analysis of chromatin regulation by cocaine reveals a role for sirtuins. *Neuron*. 2009 May 14;62(3):335-48.
50. Maze I, Covington HE, 3rd, Dietz DM, LaPlant Q, Renthall W, Russo SJ, et al. Essential role of the histone methyltransferase G9a in cocaine-induced plasticity. *Science*. 2010 Jan 8;327(5962):213-6.

51. Maze I, Feng J, Wilkinson MB, Sun H, Shen L, Nestler EJ. Cocaine dynamically regulates heterochromatin and repetitive element unsilencing in nucleus accumbens. *Proc Natl Acad Sci U S A*. 2011 Feb 15;108(7):3035-40.
52. Zhou X, Sun H, Ellen TP, Chen H, Costa M. Arsenite alters global histone H3 methylation. *Carcinogenesis*. 2008 Sep;29(9):1831-6.
53. Meissner A, Mikkelsen TS, Gu H, Wernig M, Hanna J, Sivachenko A, et al. Genome-scale DNA methylation maps of pluripotent and differentiated cells. *Nature*. 2008 Aug 7;454(7205):766-70.
54. Riddle EL, Fleckenstein AE, Hanson GR. Role of monoamine transporters in mediating psychostimulant effects. *AAPS J*. 2005 Dec 20;7(4):E847-51.
55. German CL, Hanson GR, Fleckenstein AE. Amphetamine and methamphetamine reduce striatal dopamine transporter function without concurrent dopamine transporter relocalization. *J Neurochem*. 2012 Nov;123(2):288-97.