



January 2016

Factors That Influence The Adoption Of Geographic Information Systems In A Professional Work Environment: A Study Of The Property Assessment Profession

Daniel J. Fasteen

Follow this and additional works at: <https://commons.und.edu/theses>

Recommended Citation

Fasteen, Daniel J., "Factors That Influence The Adoption Of Geographic Information Systems In A Professional Work Environment: A Study Of The Property Assessment Profession" (2016). *Theses and Dissertations*. 2015.
<https://commons.und.edu/theses/2015>

This Dissertation is brought to you for free and open access by the Theses, Dissertations, and Senior Projects at UND Scholarly Commons. It has been accepted for inclusion in Theses and Dissertations by an authorized administrator of UND Scholarly Commons. For more information, please contact zeinebyousif@library.und.edu.

FACTORS THAT INFLUENCE THE ADOPTION OF GEOGRAPHIC
INFORMATION SYSTEMS IN A PROFESSIONAL WORK ENVIRONMENT: A
STUDY OF THE PROPERTY ASSESSMENT PROFESSION

by

Daniel J. Fasteen
Bachelor of Science, University of North Dakota, 2008
Master of Arts, University of North Dakota, 2010

A Dissertation

Submitted to the Graduate Faculty

of the

University of North Dakota

In partial fulfillment of the requirements

for the degree of

Doctor of Philosophy

Grand Forks, North Dakota
December
2016

This dissertation, submitted by Daniel J. Fasteen in partial fulfillment of the requirements for the Degree of Doctor of Philosophy from the University of North Dakota, has been read by the Faculty Advisory Committee under whom the work has been done, and is hereby approved.



Steven D. LeMire, Ph.D., Chair



Robert Stupnisky, Ph.D.

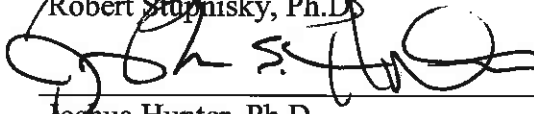

Joshua Hunter, Ph.D.

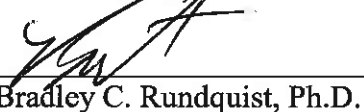

Bradley C. Rundquist, Ph.D.

This dissertation is being submitted by the appointed advisory committee as having met all of the requirements of the School of Graduate Studies at the University of North Dakota and is hereby approved.

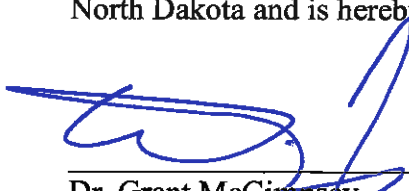

Dr. Grant McGimpsey,
Dean of the School of Graduate Studies

December 1, 2016
Date

PERMISSION

Title Factors that Influence the Adoption of Geographic Information Systems in
 a Professional Work Environment: A Study of the Property Assessment
 Profession

Department Educational Foundations and Research

Degree Doctor of Philosophy

In presenting this dissertation in partial fulfillment of the requirements for a graduate degree from the University of North Dakota, I agree that the library of this University shall make it freely available for inspection. I further agree that permission for extensive copying for scholarly purposes may be granted by the professor who supervised my dissertation work or, in her/his absence, by the Chairperson of the department or the dean of the Graduate School. It is understood that any copying or publication or other use of this dissertation or part thereof for financial gain shall not be allowed without my written permission. It is also understood that due recognition shall be given to me and to the University of North Dakota in any scholarly use which may be made of any material in my dissertation.

Daniel J. Fasteen
December 1, 2016

TABLE OF CONTENTS

LIST OF FIGURES	viii
LIST OF TABLES	ix
ACKNOWLEDGMENTS	xi
ABSTRACT	xii
CHAPTER	
I. INTRODUCTION	
Importance of GIS Technology for Knowledge Acquisition.....	3
GIS Technology in Property Assessment Valuation	4
Statement of the Problem.....	5
Research Purpose and Objectives	6
A Theoretical Model of Technology Acceptance.....	7
Importance of the Study.....	8
Overview of the Dissertation	9
II. LITERATURE REVIEW	
Models of Acceptance and Adoption of Technology	10
Innovation Diffusion Theory (DOI).....	11
Theory of Reasoned Action (TRA).....	13
Theory of Planned Behavior (TPB)	15
Technology Acceptance Model (TAM) for Explaining User Adoption....	17

Extensions of the TAM.....	19
Applications of the TAM.....	21
Applications of the TAM with Geographic Information Systems	23
Geographic Information Systems (GIS)	24
Development of GIS	24
Application of GIS in Professional Work Environments	26
Application of GIS in Local Government.....	27
GIS in the Property Assessor’s Office	29
Barriers to GIS Technology in the Assessor’s Office.....	32
Adoption of GIS Technology for Decision Support.....	33
GIS as a Decision Support System in the Assessor’s Office	34
Summary.....	35

III. METHODOLOGY

Methodological Approach	37
Research Model Design.	38
Endogenous Variables	42
Intent to use GIS Technology	42
Attitude	42
Perceived Usefulness	43
Exogenous Variables	43
Perceived Ease of Use.....	44
Social Influence	44
Efficiency.....	45

Instrument	46
Procedure	46
Data Analysis Plan.....	47
Validity and Reliability of the Instrument and Analysis	51
Summary.....	53

IV. RESULTS

Research Questions.....	54
Demographic Analysis.....	55
Analysis of Adoption Statements and Constructs.....	57
Construct Scores	61
Bivariate Correlations	61
Reliability Analysis.....	64
Explaining GIS Technology Adoption Using the TAM.....	64
CFA for the Perceived Usefulness Construct	66
CFA for the Perceived Ease of Use Construct.....	68
CFA for the Efficiency Construct.....	70
CFA for the Attitude Construct.....	72
CFA for the Social Influence Construct.....	74
CFA for the Intention to Use Construct.....	76
Structural Equation Model for Predicting Intention to Use GIS Technology	78
Tests of SEM Hypothesis.....	83
Quality of Training	85
Defined Uses of GIS Technology.....	86

Summary	88
V. CONCLUSIONS	
Discussion	89
Levels of Agreement on Adoption Constructs.....	90
Technology Acceptance Model to Predict Adoption.....	90
Perceived Quality of Training.....	94
Actual GIS Technology Use	95
Limitations	96
Implications for Practice	97
Implications for Further Study.....	99
APPENDICES	101
REFERENCES	114

LIST OF FIGURES

Figure	Page
1. Theory of reasoned action.....	14
2. Theory of planned behavior	16
3. The technology acceptance model	18
4. Proposed TAM structural model.....	41
5. Measurement model for perceived usefulness with factor loadings	67
6. Revised measurement model for perceived usefulness with factor loadings	68
7. Measurement model for perceived ease of use with factor loadings	69
8. Revised measurement model for the perceived ease of use construct with factor loadings	70
9. Measurement model for the efficiency construct with factor loadings.....	71
10. Revised measurement model for the efficiency construct with factor loadings	72
11. Measurement model for the attitude construct with factor loadings.....	73
12. Revised measurement model for the attitude construct with factor loadings	74
13. Measurement model for the social influence construct with factor loadings	75
14. Revised measurement model for the social influence construct with factor loadings	76
15. Measurement model for the intent to use construct with factor loadings	77
16. Revised measurement model for the intent to use construct with factor loadings.	78
17. Theoretical structural model with standardized regression weights	81
18. Revised structural model with standardized regression weights	82
19. GIS technology usage among survey respondents.....	87

LIST OF TABLES

Table	Page
1. Summary of technology used in TAM research adopted by Lee et al. (2003) review of the literature	22
2. Subscale items within each of the defined TAM constructs.....	40
3. Demographic question on age and experience in years	56
4. Demographic results on usage of GIS technology.....	56
5. Level of agreement on respondent has received quality training on the use and functionality of GIS	57
6. Descriptive statistics of each of the variables within their defined constructs	60
7. Ranking of levels of agreement from low to high between all constructs.....	61
8. Correlation matrix for perceived usefulness	62
9. Correlation matrix for perceived ease of use	62
10. Correlation matrix for social influence	62
11. Correlation matrix for Efficiency.....	63
12. Correlation matrix for Attitude	63
13. Correlation matrix for Intention to Use	63
14. Correlations and measures of internal consistency between all constructs	63
15. Goodness-of-fit criterion used to assess the measurement and structural model ..	65
16. Parameter estimates for perceived usefulness.....	67
17. Goodness-of-Fit statistics for perceived usefulness.....	67
18. Parameter estimates for perceived ease of use.....	69
19. Goodness-of-Fit statistics for perceived ease of use.....	69

20. Parameter estimates for the efficiency construct	71
21. Goodness-of-Fit statistics for the efficiency construct	72
22. Parameter estimates for the attitude construct	73
23. Goodness-of-Fit statistics for the attitude construct	73
24. Parameter estimates for the social influence construct	75
25. Goodness-of-Fit statistics for the social influence construct	75
26. Parameter estimates for the intent to use construct.....	77
27. Goodness-of-Fit statistics for the intent to use construct.....	77
28. Parameter estimates for the SEM.....	80
29. Goodness-of-Fit statistics for the SEM.....	83
30. Mean comparison and significance of the perception of receiving quality training on the use and functionality of GIS and adoption constructs	86

ACKNOWLEDGMENTS

I would like to thank all of my friends, family, and colleagues who have supported me throughout this research and program over the last four years. I am very grateful to the assessor's offices in the City of Fargo, ND and Dakota County, MN for being so flexible in allowing me to work on this program. Additionally, I am very grateful to my advisor and mentor Dr. Steven LeMire, who has always believed in me from the very beginning as an undergraduate. I don't know anyone who has ever given me any better advice both personally and professionally in a competitive work environment. I would also like to thank my committee with Dr. Steven LeMire, Dr. Rob Stupinski, Dr. Josh Hunter, and Dr. Brad Rundquist for bearing with me while finishing this dissertation while I have been working full time in local government. It has been a long road.

Furthermore, I would like to thank the International Association of Assessing Officers (IAAO), specifically executive director Ron Worth for allowing me the opportunity to conduct research on the members. This organization has afforded me so many opportunities for exploration of my skills in research and has produced colleagues and friendships that will be everlasting.

Finally I'd like to acknowledge my wife Angela and amazing son, Riley who has had to endure missing out on hanging with daddy due to the time spent working on this project, I love you so much with all my heart!

ABSTRACT

The adoption of Geographic Information Systems (GIS) Technology has been emerging in many professional work environments — including the property assessment discipline. Although many uses of GIS have been thoroughly documented throughout the literature in a variety of disciplines, there has been little research on the perceived factors that influence its adoption in professional work settings. The purpose of this research is to assess factors that influence the adoption of geographic information systems technology in a professional work environment. The work environment being studied is the property assessment profession. An online survey was sent out to property assessment professionals from around the United States and other countries that have access to International Association of Assessing Officers (IAAO) correspondence which collected data on constructs of perceived ease of use, perceived usefulness, efficiency, attitude, social influence, and intent to use GIS technology. A structural equation model was constructed based on an extension of the theoretical framework of the technology acceptance model (TAM). After minor revisions, the extended TAM accounted for 86% of the variance within the model indicating good fit in predicting assessment professional's intent to use GIS technology. Additionally, perceived quality of training was found to be a significant determinant of success with regard to all adoption constructs, and simple GIS applications used for visualization and land records management were the most utilized in the field. With these findings, organizations such as the IAAO would be able to design best practices and educational opportunities within

the professional work environment and provide adequate guidance and support. This in turn may produce a positive impact on the innovation and influx of GIS usage within the property assessment field to produce more accurate and equitable assessments.

CHAPTER I

INTRODUCTION

Technology has been at the forefront of increasing efficiencies of and access to information for many professional organizations throughout the United States, including local governments (Ho, 2002; Nedovic-Budic & Godschalk, 1996). Geographic Information Systems (GIS) technology can be defined by Wade and Sommer (2006, p. 90) as, “an integrated collection of computer software and data used to view and manage information about geographic places, analyze spatial relationships, and model spatial processes. A GIS provides a framework for gathering and organizing spatial data so that it can be displayed and organized.” Spatial phenomena are events that are spread across space and have geographic coordinates associated with them, such as locations of crime or points of interests on a vacation. GIS technology has been emerging over the last several decades as one of the fastest-growing technologies in professional disciplines outside of Geography (Gatheru & Nyika, 2015; Ventura, 1995). It has been used to solve several problems within the context of various local government entities such as planning and zoning to understand issues associated with ordinances.

Adoption of GIS technology, defined as the instance of choosing to use the technology has been widespread in professional work environments (Lee et al., 2003). The actual use of GIS technology, defined as the extent to which it is employed for a particular purpose has been well documented throughout the literature (Lee et al., 2003).

The usage of GIS technology has grown beyond typical thematic mapping and parcel geometry, to being used for such tasks as advanced spatial overlay, routing, and statistical analysis of large data sets, among several other uses (Fleming, 2013; Kebede, 2007; Crossland et al., 1995). Its adoption has been embedded into many disciplines, such as planning, business, environmental science, mathematics, engineering, history, language arts, biology, chemistry, government, etc. With a growing reliance and use of GIS technology to extract patterns and distributions from data, it is becoming more important to identify the factors that influence its adoption in professional work environments. Full adoption of GIS technology into professional settings has been met with some resistance, possibly given the advancement in its technological capabilities, advanced learning curve and complex functionality for accomplishing specific tasks (Kebede, 2007; FaithiZahraei, 2015; Budic & Godschalk, 1996; Davis, Bagozzi, and Warshaw, 1989). There is a growing need to understand factors that influence adoption and usage to develop proper education and training in the context of the professional work environment (Baker et al., 2012). This research will seek to understand those influences within the property assessment discipline.

This chapter will discuss the importance of understanding the adoption of GIS technology in professional work environments, while introducing a theoretical framework that can be used to model adoption within an information systems context. An overview of GIS technology in the context of the property assessment profession will also be discussed, followed by the problem statement, research objectives, and discussion of the critical need for research in this area. Finally, a general summary of the dissertation is presented.

Importance of GIS Technology for Knowledge Acquisition

The application of GIS technology has been shown to be effective through the use of both web-based and desktop methodologies and has revolutionized the way in which meaning is derived from complex data (Lee & Bednarz, 2009). This is not just limited to advanced or professional users of the technology; it has been studied at the K-12 and postsecondary level. A subfield of geography called GIS education research has been developed that specifically focuses on the enhancement of GIS technology for knowledge acquisition in all environments (Baker et al., 2012). Several of these studies have looked into both the effectiveness of GIS technology in enhancing student learning as well as adult and professional development (Baker and White, 2003; Nielsen, Oberle, & Sugumaran, 2011; West, 2003; Kerski, 2003).

Professional development in the form of training and hands on workshops on the application and use of GIS technology are critical within the context of adoption, as it serves as the foundation upon which GIS may be perceived as useful or easy to use (Baker and White, 2003; Davis, 1989). Therefore an operational understanding of individual user perceptions on the application and use of this technology will prove to be useful in the development of curriculum and design of instruction (Baker and White, 2003). It is beneficial to extract these significant factors before designing instruction to provide the most benefit to the individuals that receive any kind of training or other professional development on GIS technology.

GIS technology has been adopted for research and knowledge gain by professionals in industry for several decades. These studies have provided many insights into how professionals come to spatially understand our world better through the

conceptual base of geography. It also provides meaning in the form of visualization and aggregation of phenomena at various spatial scales and how professionals utilize that information to make decisions (Crossland et al., 1995). Although many uses of GIS technology have been thoroughly documented throughout the literature in a variety of disciplines, there has been little research on the perceived factors that influence its adoption in professional work environments, including that within the property assessment valuation profession.

GIS Technology in Property Assessment Valuation

Much like several of the disciplines named above, GIS technology adoption within the context of the property assessment profession has been growing drastically over the last several decades (Walters, 2013; Thrall, 1998, Ventura, 1995). A property tax assessor is a local government official responsible for identifying, valuing, and classifying property for property tax purposes (Thimgan, 2010). The growing interest and adoption of GIS technology in local governments have made this technology readily available to assessors who in turn have built significant web and desktop GIS programs to visualize property data. As GIS technology continues to evolve within the assessment profession, understanding how it improves work performance, valuation equitability, and staff efficiency will be essential for designing efficient and useful applications within the work environment that facilitate its use as a methodological tool for data discovery and decision support. Since GIS has many benefits to the assessor for understanding both spatial and non-spatial phenomena for acquiring professional knowledge and increasing performance of assessments; it is critical for organizations such as the International Association of Assessing Officers (IAAO) to have working knowledge of factors that

influence adoption of this technology within the profession to develop proper training and support.

Statement of the Problem

In any general business process, there is usually some resistance to new or unfamiliar technology, and the adoption of GIS technology is not any different (Davis et al., 1989). The integration of technologies such as GIS technology into normal work tasks has been a barrier for many professional organizations, mainly at the individual level. To predict success of technology use, it is important to understand the user's perceptions of adoption of such technology (Nedovic-Budic & Godschalk, 1996). Sometimes implementations of assessor-focused GIS technology applications are contained and planned out by an Information Systems department without consult with subject matter experts or users (Tomlinson, 2007). Other times, the use of GIS technology to perform job tasks is met with inadequate training, lack of self-efficacy, or inexperience with technology. As a result, a lack of buy in or underexposure by office staff can lead to non-use of the system, thus failing to improve efficiencies as intended (Tomlinson, 2007). Hu, Lin, & Chen (2005) suggested that users should employ an adopted technology as its intended use, based on existing conceptual knowledge of the problem that the technology is attempting to solve. If proper education and training are in place, and users are adequately consulted on how that technology would best solve the problem, users would then most likely voluntarily employ it for its intended use. (Hu, Lin, & Chen, 2005). Therefore, in order for a GIS technology to be adopted and used over obsolete methods, it is important to understand the influence of a user's needs, expectations, and perceptions, along with other constructs of human psychology regarding the use of new technology in

professional work environments (Ajzen & Fishbein, 2005; Hu, Lin, & Chen, 2005; Tomlinson, 2007; Nedovic-Budic & Godschalk, 1996). With an understanding of potential influences of use and adoption of GIS technology, organizations such as the IAAO can design best practices and educational opportunities to help assessors' offices better manage the adoption of GIS through providing adequate guidance and support. This in turn may produce a positive impact on the innovation and influx of GIS technology usage within the professional work environment to ensure accurate and equitable assessments.

Research Purpose and Objectives

The purpose of this research is to assess factors that influence the adoption of GIS technology within the property assessment professional work environment. In other words, how do assessment professionals as individuals perceive GIS technology as being useful within the context of their everyday work environment? This research will assess a structural model of factors that could potentially influence the use and adoption of GIS technology. The research will also assess the perceived quality of training as it relates to the individual constructs of GIS technology adoption as well as understand some of the actual uses of GIS technology across the discipline. Using an extended version of the Technology Acceptance Model (TAM) as a theoretical framework, the objectives of this research is to answer the following:

1. What is the overall level of support on each potential construct for evaluating individual user adoption of GIS technology in the property assessment profession?

2. Does the proposed extended technology acceptance model (TAM) structural model provide an adequate framework for explaining GIS technology adoption within the property assessment profession?
3. What effect does perceived quality of training with regard to the use and functionality of GIS technology have on factors of adoption?
4. What are some of the defined uses of GIS technology within the context of the property assessment profession?

A Theoretical Model of Technology Acceptance

This research will analyze an extension of the widely used technology acceptance model (TAM). The TAM, originally conceptualized by Davis (1989) is a theory used for studying user acceptance of information technology. The model is integrated with the theory of reasoned action (TRA) which is a psychological theory that seeks to explain behavior. The premise of the TRA is that, “..an individual’s behavior is determined by one’s intention to perform the behavior, and thus intention is influenced jointly by the individual’s attitude and subjective norms (Dillion and Morris, 1996, p. 9).” The TAM is based on two major factors that incorporate part of the TRA in perceived ease of use and perceived usefulness, which determines one’s behavioral intention to use technology.

The TAM by itself has proven to be a simple yet valid theoretical model by much of the published research (Liu, 2010; McFarland and Hamilton, 2006). It’s been argued that improvement in its predictive strength could be increased if additional external factors are utilized to account for the influences that alter a user’s acceptance (Liu, 2010; Moon and Kim, 2001). There are various studies that have extended and modified the use of the TAM due to limitations regarding the explanation of perceived ease of use, and

perceived usefulness including the lack of social influences in explaining adoption and usage of technology (Venkatesh, 2000, Venkatesh & Davis, 2000, Liu, 2010). This research will construct and explore an extended version of a TAM framework theorized based on the literature to analyze factors that influence the adoption of GIS technology.

Importance of the Study

There could be tremendous value with this research in its methodology and results to effectively understand the factors that influence the adoption of GIS technology in the property assessment profession. Knowledge of specific influential factors will provide a base upon which to design effective education for assessors and assessment professionals. With the emergence of GIS technology in the property assessment profession, eliciting influences and motivations for using it as a method to understand data and as a way to analyze outcomes and make important decisions provides additional value to this research. Spatial decision support systems (SDSS) built within GIS and its interaction with Computer Assisted Mass Appraisal (CAMA) systems are growing gradually within the profession (Crossland et al., 1995). Organizations such as the IAAO will be able to develop training and professional development opportunities with GIS for its membership. Such opportunities could include GIS/CAMA standardized integration practices, incorporation of specialized GIS tools for the analysis of data, and valuation methodologies utilizing GIS technology. Additionally, the structural model developed and tested in this research could be utilized for research in other professional work environments to understand the factors that influence the use of GIS technology in those professions. This data may also prove to be very useful for individual local governments, as there has been a rapid movement toward the application of GIS in new ways. Having

an understanding of the influences affecting use and adoption of GIS technology along with data on emerging trends may provide insight into implementation, education, and application strategies.

Overview of the Dissertation

The purpose of this research is to assess factors that influence adoption of GIS technology in the property assessment professional work environment. GIS technology has been a widely used technology in several disciplines; however, factors that affect its adoption have not been well studied within the property assessment profession. This research will propose and examine an extended version of the Technology Acceptance Model (TAM) to assess potential factors of adoption. The subsequent chapters will explore this research beginning with an overview of TAM and GIS technology literature, followed by details of the research methodology in chapter three. The results of the data analysis are presented in chapter four, while the last chapter is dedicated to the conclusions and discussion of the results, including limitations and implications for future research.

CHAPTER II

LITERATURE REVIEW

Geographic information systems (GIS) technology has had a prominent presence throughout literature in many professional disciplines. This chapter will overview the theoretical framework of user acceptance, including the theories of planned behavior, reasoned action, innovation diffusion, and technology acceptance. The technology acceptance model (TAM) framework will be analyzed along with an overview of its emergence and effectiveness for modeling factors of adoption for information technology and its potential for usage within GIS technology. Additionally, a discussion of the background and the emergence of GIS technology will be provided in addition to its relevance and context within property assessment. Furthermore, the chapter will review how the adoption or usage of GIS technology has been emerging as a method of decision support in acquiring knowledge to effectively understand phenomena. It will summarize where the property assessment work environment stacks up in relation to other disciplines that use GIS technology.

Models of Acceptance and Adoption of Technology

User acceptance as defined by Dillon and Morris (1996, p. 4) is, “the demonstrable willingness within a user group to employ information technology for the tasks it is designed to support.” To understand the benefit that technology has on its intended users, it is of interest to discover constructs that are inherent in adopting

technology for a particular subset of individuals or groups in order to predict intention or usage. It is important for organizations to assess particular factors due to the growing reliance that humans have on its usage to solve complex problems (Park, 2009; Dillon & Morris, 1996). Much of the underlying theory behind these models originates from the disciplines of sociology, psychology, and education while drawing on literature from innovation diffusion, technology design and implementation, human-computer interaction and information systems to explain an individual or group intent to adopt a particular technology (Dillon & Morris, 1996; Davis et al., 1989; Taylor & Todd, 1995; Venkatesh et al., 2003). Technology adoption modeling has been around since the 80's and has matured significantly (Venkatesh et al., 2003). Several Models have been proposed and examined in the literature, many of which are inconsistent on the constructs that are utilized within each model as well as their causal relationships. In Venkatesh et al. (2003) review of the literature, they categorized two paths of inquiry in technology acceptance literature; that of individual acceptance and that of organizational acceptance. The following section overviews literature from the more popular theoretical models in technology adoption, specifically the evolution of the technology acceptance theory. These models are often used to explain an individual's intent to adopt technology.

Innovation Diffusion Theory (DOI)

Innovation diffusion theory or diffusion of innovation (DOI) is one of the most influential theories applied to acceptance analysis. According to Dillon and Morris (1996, p. 6), the premise behind DOI is "to provide an account of the manner in which any technological innovation moves from the stage of invention to widespread use (or not)." DOI takes into account potential adopter perceptions of technology and its impact on

influencing overall adoption (Moore & Benbasat, 1991). Understanding the potential adopter's perceptions has been identified as a key issue within the DOI literature. Rogers (1983, 2003) has been cited several times throughout the literature for describing characteristics of innovation that affect the diffusion of a technology. They are relative advantage, compatibility, trialability, and observability. They are defined below within the context of technology adapted from Rogers (2003).

- Relative advantage is the extent to which a technology offers improvement over another technology. There are many variables that can affect relative advantage including cost, satisfaction, and social status.
- Compatibility described by Rogers (2003), is the degree to which a technology is perceived as consistent with the existing values, needs, and past experiences of potential adopters.
- Complexity refers to the ease of use of a technology. Rogers (2003) denotes that an innovation (technology) should not be challenging or require skills beyond the typical knowledge base of a potential adopter.
- Trialability is the opportunity to try a technology or innovation before committing to use it. This may also lead to the process of reinvention as ideas to enhance the technology are adopted (Rogers, 2003).
- Observability refers to the extent that the technology's outputs and gains are observable to others. Rogers (2003) states that peer adoption will diffuse at a faster rate if the results are visible to others.

Several studies within the DOI literature have found that only three of Rogers (1983) characteristics had great influence on the adoption of technology, compatibility, and

relative advantage. These were all positively related to adoption, whereas complexity was negatively related only to a slight degree of significance (Lee et al, 2011; Rogers; 2003; Karahanna et al., 1999).

Based on existing research and a clear lack of reliable constructs that accounts for much variability to predict adoption, Moore and Benbasat (2001) defined a new instrument using constructs that were rigorously tested. Instead of focusing on the primary usage, they focused on the perceived characteristics of innovations or perceived usage. They state that an individual's behavior with regard to technology is based more on how they perceive the primary attributes (Moore and Benbasat, 2003). Meaning that everyone's perceptions of a particular phenomenon may be different based on past experiences, socioeconomic status, beliefs, etc. Thus, it is better to understand the relative attributes regarding the phenomena to derive a perception of the primary attribute.

Research conducted by Lee et al. (2011) combined the three DOI characteristics that had shown to have the greatest influence with the TAM with some success accounting for 51% of the variance in predicting intent to use. Many of the characteristics of DOI share some key constructs with the TAM which have been used to increase the credibility and effectiveness of the research (Hardgrave et al., 2003; Wu & Wang, 2005; Chang & Tung, 2008). DOI does a great job in accounting for the impact of potential users based on their perceptions of existing technology; however it does little to provide an explicit treatment of user adoption of new technology (Dillon & Morris, 1996).

Theory of Reasoned Action (TRA)

The theory of reasoned action (TRA) has been widely used to predict a behavioral intention with regard to adoption of technology. It is one of the most fundamental and

influential theories of human behavior and has been widely used in technology acceptance literature (Ajzen & Fishbein, 1980; Fishbein & Ajzen, 1975; Venkatesh et al., 2003; Madden et al., 1992). The TRA states that behavioral intentions are predictors of actual behavior and thus provide insight into technology adoption (Davis et al., 1989). The theoretical framework states that the behavioral intention is determined by an individual's attitude and subjective norms concerning the behavior as shown in Figure 1.

Behavioral intention as defined by Fishbein and Ajzen (1975) is the measure of strength of an individual to perform a specific behavior. As noted above behavioral intention is a function of attitude and subjective norms and influences actual behavior. Attitude refers to an individual's feelings toward performing a certain behavior (Davis et al., 1989). Subjective norm refers to "the person's perception that most people who are important to him think he should or should not perform the behavior in question (Fishbein and Ajzen, 1975)."

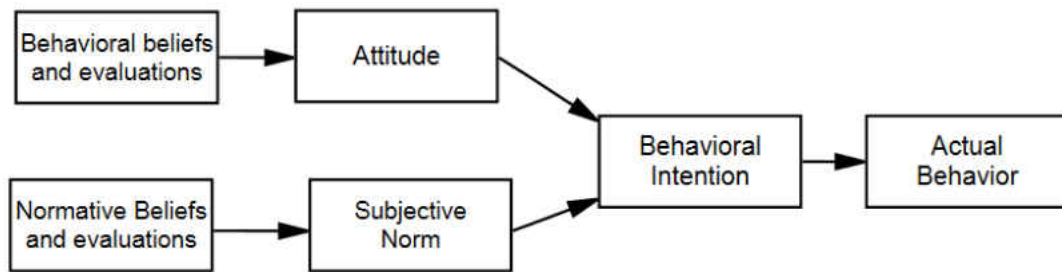

Figure 1. Theory of reasoned action (Fishbein & Ajzen, 1975)

This model has been utilized extensively throughout the literature spanning a wide array of disciplines including technology adoption. Its support has been thoroughly tested in various situations including the presence of choice and alternatives on attitude and subjective norms (Dillon & Morris, 1996; Shepard et al., 1988).

The limitations of this model have also been thoroughly documented in looking at its key assumptions and posing refinements and extensions. Modifications have included the inclusion of personal norms, moral obligations, and competing attitudes (Fishbein, 1980; Gorsuch & Ortberg, 1983; Zuckerman & Reis, 1978). Some studies have also argued that only attitude and subjective norms do not fully capture an individual's behavior, and other variables such as ability, habits, and cultural factors might also affect behavior (Venkatesh et al., 2003). It also had shown to limit predictability in situations where intention and behavior are highly correlated (Yousafzai et al., 2010). Additionally it had been argued that intention might only account for accomplishing a goal and not capture a behavior that will actually be performed (Sheppard et al., 1988). In response to this, Ajzen (1991) had proposed an extension of the TRA to account for perceived control over intention.

Theory of Planned Behavior (TPB)

The theory of planned behavior (TPB) was developed by Icek Ajzen (1991) as an extension of the theory of reasoned action to account for the limitation of perceived behavioral control (Dillion and Morris, 1996; Madden et al., 1992). As shown in Figure 2, behavioral intention, which directly affects behavior, is influenced by both attitude and normative influences while adding perceived behavioral control as an additional component (Ajzen, 2002). Perceived behavioral control is characterized by an individual's perception of resources, skills, and opportunities they believe to possess as well as their importance in achieving outcomes (Ajzen, 1991).

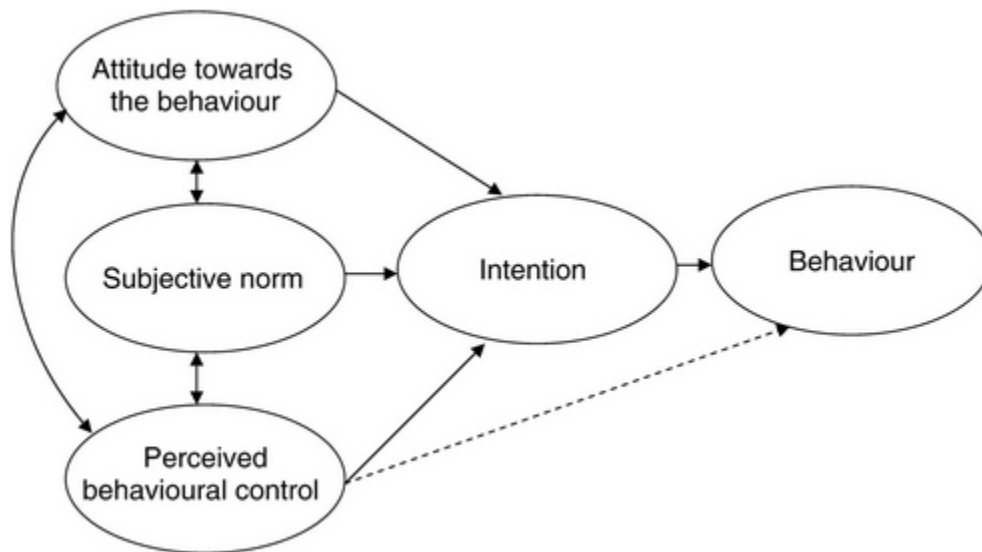

Figure 2. Theory of planned behavior (Ajzen, 1991).

According to the TPB model, three types of considerations affect human behavior, behavioral beliefs, normative beliefs, and control beliefs. Behavioral beliefs concern the attitudes about the likely outcomes of a favorable or unfavorable behavior and the evaluations of those outcomes (Ajzen, 1991; Yousafzai et al., 2010). Normative beliefs concern the individual's perception or expectations of others and the motivation to meet those expectations. Finally, control beliefs refer to the opportunities or skills that an individual possesses to perform a particular behavior (Ajzen, 2002; Dillion & Morris, 1996). The makeup of the TPB, allows perceived behavioral control to have both an indirect and direct effect on behavior. This model has been utilized in a variety of technology contexts including the use of instant messaging, internet banking, use of technology in education, online video sharing, among several others with varying degrees of success (Lu et al., 2009, Yousafzai et al., 2010, Lee, Cerreto, & Lee, 2010). Several of these studies, such as that of Mathieson (1991) found that TPB did not result in as much variance explained as the Technology Acceptance Model.

As has been shown in some studies, behavior was not always directly affected by intention or perceived behavioral control (Matheson, 1991; Ajzen, 1991). While introducing the TPB, Ajzen (1991) noted that it might be able to accommodate the inclusion of additional variables if they capture a substantial amount of the variance in intent or behavior after the existing variables have been taken into account. This in turn led to various extensions of the TPB and decomposed theories of the TPB to further identify particular factors that might affect attitude, subjective norms, or perceived behavioral control (Taylor & Todd, 1995).

Technology Acceptance Model (TAM) for Explaining User Adoption

The technology acceptance model (TAM) has been considered throughout the information systems literature to be one of the most commonly used models for describing an individual's adoption of technology (Lee et al., 2003; Venkatesh et al., 2003). The TAM was originally proposed by Davis (1989) as a means to find better measures in predicting and explaining voluntary technology adoption (Figure 3). Davis (1989) concentrated on two major variables from the theory of reasoned action (TRA): perceived usefulness (PU) and perceived ease of use (PEU). Perceived usefulness as defined within TAM is "a belief that using the technology will increase the performance" and perceived ease of use is "the degree to which a person believes that using a particular technology would be free of effort (Davis, 1989, p. 320)". The significance of these two factors is what Davis (1989) said can affect an individual's perception toward either adoption or rejection. It has been shown that the TAM has outperformed the TRA or has accounted for a similar amount of causality as the DOI in a majority of studies (Taylor & Todd, 1995, Davis et al., 1989).

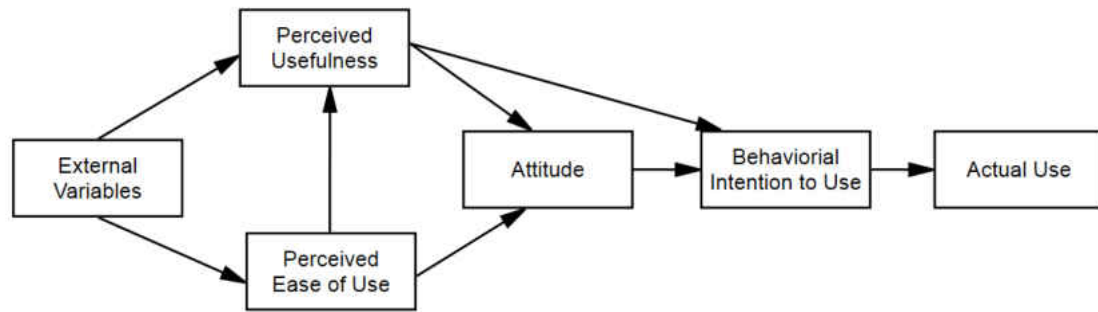

Figure 3. The technology acceptance model (Davis et al. 1989)

As is shown in Figure 3, actual use is determined through intent to use. Many studies use intention as the dependent variable due to the significant correlation that it has with predicting actual usage (Davis et al. 1989; Taylor & Todd, 1995; Lee et al., 2003; Dillion and Morris, 1996). Actual usage has also been used; however it has been shown to be more distorted and prone to common method bias which exaggerates the causal relationship between constructs (Agarwal & Prasad, 1999; Jackson et al., 1997; Sheppard et al., 1988).

The TAM according to Taylor and Todd (1995) can be considered a special case of the TRA with the belief that when someone forms an intention to act that they will be free to act without limitation (Taylor & Todd, 1995; Davis, 1989; Davis et al., 1989; Lee et al., 2003; Venkatesh et al., 2003). Thus, the TAM postulates a direct effect from perceived usefulness to intention that violates the TRA model, which claims that attitude alone mediates the relationship between all factors and intention. The rationale for this is that the likeness of a particular technology may be irrelevant if the perceived usefulness exceeds the ease of use regardless of attitude (Davis et al., 1989). In other words, a professional may dislike the technology, but would still use it if it provides efficiency and productivity toward job performance (Taylor & Todd, 1995).

There have been many comparisons between TAM and other acceptance models. Moore and Benbasat (1991) discussed several parallels between the DOI and TAM. The complexity and relative advantage characteristics from the DOI are similar to TAM's perceived ease of use and perceived usefulness constructs. There are several studies that have compared the TPB and TAM and discovered that both models can be successful in predicting adoption or use of technology (Yousafzai et al., 2010; Mathieson, 1991; Lee et al. 2003). The only difference is that the TPB has better controls on the prediction of an individual's behavior due to its inclusion of constructs such as subjective norms and perceived behavioral control, which adds complexity to the model. The simplicity of the TAM is a reason why it has been popular in predicting usage of technology (Lee et al., 2003; Davis, 1989; Davis et al., 1989).

Extensions of the TAM

The TAM has undergone various adaptations and configurations throughout the literature, however adding additional variables or extenuations have also proven to help account for additional causality within the model. According to Davis et al. (1989), external factors or factors that are not explicitly part of the model are expected to impact usage through perceived ease of use and perceived usefulness. External variables might include system design characteristics, training, documentation, decision maker characteristics and other types of support to improve the model fit to understand use. Venkatesh and Davis (2000) examined the use of external factors on the TAM calling it TAM2 to include social influence and cognitive instrumental processes. They found that TAM2 was strongly supported with external factors explaining up to 60% of the variance in perceived usefulness with subjective norms having a significant amount of influence

(Venkatesh & Davis, 2000). Lucas and Spittler (1999) extended the TAM through the use of social norms, organizational factors, and characteristics of a particular technology which were all significant in predicting use. Liu (2010) added three variables to the TAM in self-efficacy, anxiety, and perceived behavioral control in measuring use of educational wikis. The behavioral control construct was considered to have a direct impact on intention, but was not significant. Liu (2010) explained this because she was measuring perceived behavioral control and not actual behavioral control. A general rule with regard to social norms is that the greater the perceived behavioral control, the more likely the individual will perform the behavior under consideration (Ajzen 1991).

The use of social influence constructs has been somewhat controversial within the literature. There have been arguments both for and against the inclusion of this construct in the TAM to account for the social norms or outside influences on an individual (Venkatesh et al., 2003). The literature has shown that social influence was a significant construct when the focus of the research was either on mandatory settings, women in early stages of experience, or older workers (Taylor & Todd, 1995, Thompson et al., 1991; Venkatesh & Davis, 2000; Hartwick & Barki, 1994; Venkatesh & Morris, 2000). Venkatesh et al. (2003) verified the effects of the use of this construct and found that social influences did have an impact on all older professionals, particularly women as well as professionals that are in the early stages of adoption.

Extensions on perceived usefulness and perceived ease of use, as explained, may help account for added variance in the model. Several other extensions are explained in Lee et al's.(2003) meta-analysis review. The most frequently introduced variables to

extend the TAM according to Lee et al. (2003) were system quality, training, compatibility, anxiety, and self-efficacy.

Applications of the TAM

The TAM has been utilized in various IT contexts such as in communication systems (e.g., email, voicemail, and fax), general purpose systems (e.g., computers and workstations), office systems (e.g., spreadsheets, word processing, database programs, and presentation software) as well as specialized business systems (e.g. hospital programs, other special computer applications) among others as discussed below.

Lee et al. (2003) conducted a meta-analysis using the aforementioned categories to classify the types of technology used in TAM research. They found that the context for which the TAM is used has been evenly distributed across most all technologies, especially e-mail and word processing. Though TAM has been applied within the context of all of these technologies, the purpose, subject, and tasks have been different (Lee et al., 2003). Table 1 adopted from Lee et al. (2003) examines many of the research studies that have been conducted over the last several decades. This also includes the contexts with which they were measured.

The concept of user acceptance and resistance to adoption is an important topic within the information systems literature because it helps explain what factors are contributing to nonuse in a professional work environment. Agawar and Prasad (1998) state that in order to understand projected productivity gains, users must accept and appropriately use the technology as intended. There have been debates over whether new technology is actually being used to its fullest extent in professional work environments

(Carlos Sanchez-Prieto, 2016; Chung & Vogel, 2013; Dillion & Morris, 1996). If it is not, then the likelihood of rejection of that technology becomes more realistic.

Table 1. Summary of technology used in TAM research adopted by Lee et al. (2003) review of the literature.

Type	# of IS	Systems of each category	References
Communication Systems	25 (20%)	E-mail (13)	Karahanna & Straub (1999), Straub (1994)
		Voicemail (6)	Karahanna & Limayem (2000)
		Fax (1)	Straub (1994)
		Dial-up Systems (1)	Subramanian (1994)
		Others (e.g., cellular)	Kwon and Chidambaram (2000)
General Purpose Systems	34 (28%)	Windows (1)	Karahanna et al. (1999)
		PC (or Microcomputer) (9)	Igbaria et al. (1995), Agarwal & Prasad (1999)
		Website (e-commerce) (17)	Gefen & Straub (2000)
		Workstation (3)	Lucas & Spitler (1999, 2000)
		Computer Resource Center (2)	Taylor & Todd (1995)
Office Systems	33 (27%)	Groupware (2)	Lou et al. (2000)
		Word Processor (16)	Adams et al. (1992), Hubona & Geitz (1997)
		Spreadsheet (7)	Mathieson (1991), Venkatesh & Davis (1996)
		Presentation (6)	Doll et al. (1998), Hendrickson et al. (1993)
		Database Programs (2)	Szajna (1994), Doll et al. (1998)
Specialized Business Systems	30 (25%)	Groupware (2)	Malhotra & Galletta (1999), Lou et al. (2000)
		Computerized Model (1)	Lu et al. (2001)
		Case Tools (4)	Xia & Lee (2000), Dishaw & Strong (1999)
		Hospital IS (telemedicine) (5)	Lu & Gustafson (1994), Rawstorne et al. (2000)
		DSS, GSS, GDSS	Sambamuthy & Chin (1994), Vreede et al. (1999)
		Expert Support System (2)	Gefen & Keil (1998), Keil et al. (1995)
		Others	Gefen (2000)

Many studies have extended and modified the TAM as a framework as described earlier to predict use. Other research and applications of TAM have found issues with the original TAM structure such as the Hu et al. (1999) study that found that perceived ease of use was not a significant determinant of technology use within the telemedicine field. Venkatesh and Morris (2000) added a control to measure the impact of perception by

gender and found that women are more affected by social norms and ease of use while men are more affected by perceived usefulness.

Venkatesh et al. (2003) conducted a review of user acceptance models and theories while formulating their own model called the unified theory of technology acceptance. They provide four main factors of intention to use technology including performance expectancy, effort expectancy, social influence, and facilitating conditions.

Applications of the TAM with Geographic Information Systems

There have been very few applications of the TAM within specialized local government contexts and none to the researcher's knowledge that exist with regard to GIS technology adoption in professional work environments. A thorough search found applications of TAM on GIS technology adoption within education. These studies utilize the basic TAM structure to understand the perceived ease of use and perceived usefulness to boost teaching performance and understand student engagement with GIS technology (Lay et al., 2013).

Other adoption type research in professional work environments with regard to GIS has been either descriptive or demographic. Many governments are pushing the adoption of GIS technology all over the world due to the robust nature of using spatial data (Ventura, 1995). A lack of studies in GIS technology adoption in local governments confirms the need for additional research within professional work environments using the TAM or other acceptance models.

The implications of technology adoption are very much geared toward training and education of technology usage within the professional work environment. Adequate training on the benefits of using the technology can be tested and developed into a

training initiative for a particular technology in an organization (Wallace & Sheetz, 2014). Additionally developers and software engineers can use the results to evaluate the user friendliness of software and identify what factors contribute to its potential non-use. Most professional organizations are interested in the ability of using GIS technology to enhance work performance and the use of the TAM could predict how well an integration program would work

Geographic Information Systems

Geographic Information Systems have been at the forefront of much modern local government process improvements over the last several decades (Fleming, 2014; Kebede, 2007; Wadsworth, 2006; Hockey, 2007). GIS within the context of this dissertation is defined as, “An integrated collection of computer software and data used to view and manage information about geographic places, analyze spatial relationships, and model spatial processes. A GIS provides a framework for gathering and organizing spatial data and related information so that it can be displayed and analyzed (Wade & Sommer, 2006). The following section reviews the emergence and application of GIS technology.

Development of GIS

As an evolutionary technology, GIS had its roots in the mid-20th century and has since evolved into a giant enterprise that has been well integrated into several professional disciplines, especially government organizations (Fleming, 2014; Kebede, 2007; Nedovic-Budic & Godshalk, 1996). GIS was originally conceptualized by Roger Tomlinson in 1962 who wanted to develop a computer system to process multiple types of geographic information as part of the Canadian Land Inventory (Aguirre, 2014). Soon thereafter the U.S. Bureau of the Census and the Harvard laboratory for computer

graphics were pioneering new technology programs to conduct address matching and as well as general mapping respectively. Jack Dangermond founded the Environmental Systems Research Institute (ESRI) in 1969 in the effort to, “provide one mechanism by which people of different organizations, different levels of government, different countries and different disciplines to come together to solve common problems (Holt-Jensen, 2006, p. 180).” The development of GIS systems was not without limitations, especially with regard to slow processing speeds and limited disk storage capacities on mainframe computers (Foresman, 1998).

The 1960’s and 1970’s saw many innovative developments in computer graphics however, in the late 1970’s rapid development in performance, storage capacity, and processing proved to be pivotal to making software more usable and affordable to more users of the technology. This sparked a major influx in development from users and companies alike to take advantage of refined spatial databases and advancements in computer graphics and spatial analysis for various professional disciplines (Foresman, 1998; Coppock & Rhind, 1991; Goodchild, 2000).

In the decades following, computers became much more affordable and GIS and computer mapping had become more popular. GIS applications grew rapidly especially through the internet. The rapid diffusion of GIS applications had made it into a worldwide enterprise in various professional disciplines and in various countries (Goodchild, 2000). GIS has evolved from a command line interface, to a complex desktop application, and now to an interactive web based platform to provide a way for everyone, regardless of experience or tech savviness, to use the technology.

Application of GIS in Professional Work Environments

Due to its robustness with regard to organizing, analyzing, visualizing, and integrating spatial data, GIS technology has been at the forefront for the use of many professional industries including agriculture, geology, business, urban planning, health care, etc. The uses within these fields have created new ways with which to interact with data that is geographically aware. Some industry related examples are below.

Advertising – GIS aids in the decision making process through providing analysis of areas where consumers would be more likely to buy products.

Medical – GIS in the medical field provides information on the spread of diseases, infections, or model potential outbreak areas. This could help decision makers on where to concentrate their resources and mitigate the situation.

Environment – Environmental science provides scientists assistance with resource management, mapping, surveying, forestry management, and impact analysis. It could also identify areas of invasive plants or understand the impact of climates on physical change.

Natural Disaster or Hazards – GIS can aid with natural disasters in not only modeling potential impact areas but also analyzing the destruction afterward. It can provide visualization and analysis with regard to financial and social impact as well.

As is shown in some of the stated examples, the need and adoption of GIS has grown globally and continues to allow decision makers to make accurate and more effective decisions for solving complex problems (Smelcer & Carmel, 1997). Over the last decade a growing number of research studies have focused on the impact of spatial reasoning on presenting complex and multi-dimensional information to decision makers.

They've shown that spatial information processing is more useful if not complementary to the use of standard media in analyzing more in depth geographical relationships between phenomena (Dransch, 2000; Denis & Carte, 1998).

Visual representation of phenomenon has become more important and has grown in popularity due to the simplicity of comparing data. Visualization is a simple method for looking at relationships among multiple variables of complex data (Dransch, 2000). Overlay and proximity analysis of data can include a more analytical and quantitative reasoning to provide even more finite decision making capabilities. As an example, this may be the case in deriving suitable locations for a business where a professional may overlay layers of spatial data consisting of lifestyle data on product demands, economic data based on census, in addition to neighborhood and zoning data to find a feasible area to locate. GIS provides the ability to show only the suitable areas based on the queries of each of these variables to show possible locations (Flemming, 2014).

GIS based analysis is especially powerful for predictive analytics as the use of geospatial modeling is becoming more and more popular within the environmental sciences as well as in local governments. The use of clustering, regression and 3D modeling capabilities is becoming much more simplistic through the use of web-based and integration with open source technologies (Harder, 2015).

Applications of GIS in Local Government

The use of GIS technology for government consumption has taken off as one of the fastest growing areas in GIS adoption due to the amount of data that local governments collect. Data is the most important component of a GIS and the strength of spatial data has had a profound impact on the way that local governments build and store

their data (Fleming, 2014). Over the last decade, local governments have understood the need to expand beyond the use of mapping and parcel data inventory and move into the realm of finding patterns and understanding relationships inherent within the data (Nedovic-Budic, 1998; Fleming, 2014). Moreover, recently, as big data analytics are becoming commonplace in local government, and more educated professionals are beginning to work with the data, decisional applications are gradually being constructed to solve a business need and create much needed efficiencies across many government departments (Tomlinson, 2007). Local governments are using these databases for land and city planning for parks, subdivisions, bike trails and roadways (Yeh, 1999).

Additionally, GIS is being utilized for environmental and asset management in tracking harmful atmospheric contaminants as well as the locations of snowplows, police and fire trucks, etc. (Fleming, 2014). Interactive or public participation uses are also growing, where citizens are communicating with local governments through web applications on the location of particular phenomena such as the locations of potholes or even crimes as well as contributing thoughts on potential policy decisions (Ganapati, 2011).

GIS in local government continues to evolve with the increase in spatial data support systems (SDSS) which will be discussed in a later section, but is essentially a GIS based tool or application that local governments can use to make efficient decisions on a multitude of issues ranging from planning, environmental, political, as well as taxation and property assessment (Hockey, 2007).

GIS in the Property Assessor's Office

Property tax assessors are the heart and soul of local government data, and the use of GIS technology within this professional work environment is essential to acquiring knowledge in an efficient manner. A property tax assessor is a local government official responsible for identifying, valuing, and classifying property for ad valorem tax purposes (Thimgan, 2010). Assessment jurisdictions may vary depending on the state or country as there are tax assessors for township, city, county, and statewide (Renne, 2003). There may also be a state oversight agency that provides direction to tax assessors in interpreting state laws and policies. The assessor must take into account data of many different kinds throughout the assessment cycle to appropriately value and classify property. Assessors collect data on property characteristics, building permits, ownership, transfer documents, sale information, plats, income and expenses, community and economic data, etc. in order to value properties (Thimgan, 2010). The goal of any assessor's office is to maintain fair and equitable valuations when conducting mass appraisal analysis. Mass appraisal is the development of appraisal models that are then applied to groups of properties in a land records database (Gloude-mans & Almy, 2011). To measure how fair and equitable valuations are, the assessor uses statistics looking at the assessed value to sale price ratio to determine how close the valuation model is to market. Other statistics include measures of dispersion through analysis of the average absolute deviations from the median of a group of sales (Gloude-mans & Almy, 2011). Several valuation methodologies exist to generalize sale information to other properties through either a comparison of a subject property to those that have sold, extraction of building costs taking into account depreciation over time, and analyzing the income

generated by a property and comparing to sale value to develop a capitalization rate (Gloude-mans & Almy, 2011). Another emerging method is the use of multiple regression analysis which takes into account all variables and looks at their contribution to value.

Wadsworth (2006) noted that there is a spatial component to just about every assessment activity making the use of GIS and its integration with Computer Assisted Mass Appraisal (CAMA) software, which stores property data, an important part of a local government system that is utilized by the entire organization. Sales can be geocoded on latitude and longitude coordinates. Parcels are drawn out as lines using deeded land descriptions and can be extracted into polygon geometry. The data associated with this geometry is the basis upon the visualization or analysis conducted.

GIS technology has been introduced to the field of local government property valuation with varying degrees of usage. Local tax assessors have been progressively increasing adoption over the last several years. Most assessors' offices have some form of GIS component within their departments (Gatheru & Nyika, 2015). There has been numerous applications of GIS usage within the assessor's office documented throughout the literature and various conference presentations.

The most basic use of GIS within the assessor's office is that of general mapping of property data to display on a map. Assessors map out property to understand their spatial relationship with other property. Bhatt and Singh (2013) define cartography and mapping qualitative and quantitative characteristics as the top needs for an assessor's office. Quality assurance of data is essential for adequate valuations (Gloude-mans & Almy, 2011). Bhatt and Singh (2013) also note that visualization, meaning mapping

significant effects with regard to more advanced (e.g., proximity and overly, cluster) analysis is also important. Payton (2006) suggested several methods to analyze property tax equity in Indiana using clustering at various spatial scales.

The use of hedonic multiple regression modeling within the assessment field has been used significantly by CAMA and GIS professionals within the property valuation profession in order to understand contributing variables that affect property value (Gatheru, & Nyika, 2015; Case et al., 2004; Gloudemans, 2002). Models have refined modeling methods over time and progressed into the geographic arena with the use of dummy variables, spatial lag models as well as geographically weighted regression (GWR) as a method to account for additional model variance (Bidanset & Lombard, 2014; Quintos, 2013). Modeling using GWR has been used for modeling foreclosures, effects of environmental contaminants, or even modeling property tax equity among various other valuation problems (Bidanset et al., 2016;).

The use of imagery has also had a tremendous impact within the profession as the International Association of Assessing Officers (IAAO) had written into their standards the ability to collect data through imagery. According to Walters (2013), almost 89% of assessor's offices use aerial imagery while 41% use oblique imagery. This is significant as there have been much efficiency that has arisen from imagery based applications, especially those embedded in GIS. Imagery has been utilized for measurement of not only land, but also structures and other amenities, assessment of quality and condition of properties and neighborhoods, in addition to looking at the comparability of sale properties with subject properties. Images can be utilized in concert with GIS, CAMA, and sketching to provide a full desktop assessment review (Kebede, 2007). Imagery

based assessment is called desktop review by many vendors within the profession. Desktop review is an assessment methodology that allows an appraiser to analyze properties that might not have significantly changed through the use of aerial imagery, oblique aerial imagery, street level imagery, and other desktop tools from their offices (Kebede, 2007; Skaff & Murphy, 2000).

Another idea that has been very popular within the assessment profession is the integration between computer assisted mass appraisal systems (CAMA) and GIS technology. Wadsworth (2006) wrote that CAMA systems need to be fully immersed in GIS in order to provide an effective assessment solution. This is an idea that has been very difficult to attain over the decades due to the disconnect between GIS and CAMA databases. This idea would allow spatial data to enhance the assessment process to improve work efficiency, visualize location and discovery of property, explore outliers, and spatial patterns, and various others (Wadsworth, 2006).

There are many examples where assessor's offices have successfully adopted GIS applications and technology. Maricopa County, AZ had worked with a vendor and successfully implemented a full desktop review methodology using GIS, CAMA, sketching, and all forms of imagery. However the problem of adoption still lies in actual usage as well as tracking the benefits of that usage within the professional work setting (Ventura, 1995). Compared to other professional environments, GIS technology within the property assessor's office faces certain barriers.

Barriers to GIS Technology Adoption in the Assessor's Office

There are several barriers to the adoption and application of GIS technology within the assessor's office. Ventura (1995) divides barriers into individual and

organizational barriers. Organizational barriers include the aging demographic of assessment professionals and assessor related staff (Walters, 2013). Intergovernmental relations within and between organizations where technology must be shared may present barriers in the form of communication and collaboration issues. Another issue may include technical and IT issues, where a jurisdiction may not have the resources to maintain a system. Training also can be a barrier where an improperly trained staff may not have the know how to use the technology appropriately and thus rejects it. This is often the case with technology that is poorly implemented, not well documented, or too complicated (Ventura, 1995). Many times, the biggest individual barrier to GIS technology adoption is fear of change, accepting new methods, or having difficulty learning (Ventura, 1995; Nedovic-Budic & Godschalk, 1996). Having adequate training and support from peers or experts in the technology is important to successful individual adoption (Ventura, 1995).

Adoption of GIS Technology for Decision Support

It has been shown that GIS technology has been adopted for a number of various applications within local government. The massive amount of data associated with local governments is stored in a database for consumption, but is often not adequately taken full advantage of (Ventura, 1995). A decision support system (DSS) is an “interactive computer-based system designed to support a user in achieving a highest effectiveness of decision making while solving a semi-structured decision problem (Halbich & Votrovsky, 2011, p.68; Sugumaran & Degroote, 2010).” Adding location based coordinates to the data ultimately makes decision support a spatial decision support system (SDSS). Crossland et al. (1995) in a study on the use of a DSS through the

integration of a GIS technology component had shown that it had reduced decision time and increased the accuracy of decision makers.

Decision support systems are often utilized in situations where complex and diverse factors influence an analysis, and the volume of data and information involved is overwhelming for someone without technical skills to perform. Building a DSS would be essential for these types of problems, as it would increase efficiency and productivity as well as standardize analysis across the professional work environment (Natividade-Jesus et al., 2006).

There have been numerous examples of SDSS within the literature that solve a multitude of complex problems. De Meyer et al. (2013) created a SDSS to analyze various complex scenarios of land use planning. The SDSS took into account many variables to plan for various cases including agriculture, forestry and pasture which allowed for many scenarios to solve land use planning problems and situations (DeMeyer et al., 2013). Other systems include simple push button systems that help policy makers or executives make quick location decisions with regard to permitting, demographics, economics or other public notifications within local governments (Narasimhan et al., 2005).

GIS as a Decision Support System in the Assessor's Office

A spatial decision support system application within the assessor's office would provide a means for efficient analysis of data by non-technical professionals. As explained by Crossland et al. (1995), a SDSS would allow assessment professionals to conduct simple focused, potentially even web-based analysis to visualize variables and analyze the relationship between and among other variables. Additionally, SDSS would

also assist professionals in discovering spatial patterns in order to make critical decisions about the assessment for fair and equitable valuations.

Adoption of GIS technology as a SDSS enables a professional to acquire knowledge of a specific phenomenon that they would otherwise not be able to do themselves. Advanced, but focused applications of GIS technology have been proven through various case studies where ease of use and training, not just on GIS application itself, but on how to understand the output, provides huge benefits. Interpreting output is essential to comparing with existing theory, and understanding the conceptual ideas or patterns behind the data. Natividade-Jesus et al. (2006) implemented a multicriteria SDSS that took into account several variables to analyze and evaluate housing markets. The SDSS was multi-functional, meaning that it could perform several types of analysis methodologies based on good logic and theory. The system was very versatile, flexible, and user friendly, providing structured information to both experts and non-experts.

The need for training on GIS technology for assessment professionals is paramount to understanding how GIS technology can be adopted into everyday business procedures for decision support (Bhatt & Singh, 2013). The future of SDSS adoption in assessor's offices is dependent upon how well local governments can advocate business needs to benefit the organization and individual professionals within the organization (Natividade-Jesus et al., 2006).

Summary

GIS technology adoption within professional work environments is essential to efficient and effective decision making, especially in the assessor's office. The concept of acceptance has produced many theoretical models such as the theory of reasoned action

(TRA), the theory of planned behavior (TPB), and the innovation diffusion theory (DOI) that can be used to understand adoption. The technology acceptance model (TAM) provides the most simple and robust method for explaining adoption of GIS technology for assessment professionals. GIS technology has evolved over the last several decades to become one of the most essential technologies for viewing and analyzing spatial data. Its uses span across all disciplines and professional work environments. There have been both organizational and individual barriers documented within the literature with regard to GIS technology adoption. Training has been shown to be one of the most important individual barriers to adopting GIS technology as well as an organization's ability to provide proper documentation and support. Spatial Decision Support Systems (SDSS) have been documented to provide an efficient and suitable method of complex analysis in professional work environments for users that require less technical skills. This research will present a case study of the property valuation profession on factors that influence the adoption of GIS technology to understand the main facets that impact an assessment professional's use of GIS in their everyday work environment.

CHAPTER III

METHODOLOGY

Given the vast array of information systems technologies that have been developed (e.g., email, word processing, spreadsheets, etc.), various forms of user acceptance models have been created to explain adoption within different contexts as described by the literature in the previous chapter. The Technology Acceptance Model (TAM) has proven to be the most significant contributor given its simplicity and the number of information systems research studies that have utilized this theoretical model (Liu, 2010; Lee et al., 2003; Legris et al., 2003). Very few, if any research studies have utilized the TAM for GIS technology research. This study will help expand the literature in that area of information systems research. This chapter will focus on the methodology employed to understand factors that influence adoption of GIS technology within the property assessment professional work environment. The chapter begins with an explanation of the methodological approach used in this study, followed by a description of the theoretical constructs that will be conceptualized in the measurement model. Next, a detailed account of the population sampling, instrument used for measuring variables, data analysis approach, and validity will follow.

Methodological Approach

This research will explore the use of a modified TAM to assess the factors that influence the adoption of GIS technology in the property assessment professional work

environment. The research methodology will focus mainly on understanding the theoretical constructs that make up the overall measurement model to predict the intent to adopt GIS technology. The measurement model was conceived through careful examination of the information systems literature. Perceived usefulness of GIS technology and perceived ease of use from the theory of reasoned action (TRA) model have shown to be major constructs that influence intention to use and overall use (Davis, 1989). Efficiency and social influence were utilized to account for other external variability captured through time savings and human emotion respectively (Liu, 2010, Venkatesh & Davis, 2000). In order to capture the perceptions of influence that may be present on adopters or users of GIS technology, an affective survey questionnaire was designed and made available to assessors throughout the United States and other countries that have an IAAO membership presence.

Research Model Design

The TAM has been widely used as a model for studying user acceptance throughout the information systems literature (Wallace & Sheetz, 2014; Cheung & Vogel, 2013). As noted in the previous chapter, there have been many cases where the TAM has been modified or extended to help explain additional variance not captured in the traditional model. Several variables within the literature have been used to extend the model, especially as it relates to social influence and self-efficacy (Cheung & Vogel, 2013; Liu, 2010, Venkatesh and Davis, 2000, Wu and Wang, 2005, Legris et al., 2003). The theoretical model used in this study will use six constructs to explain factors that influence the adoption GIS technology (Table 2). Based on the findings of the Venkatesh and Davis (2000) as well as the Legris et al. (2003) research, this model will also include

a construct that accounts for human and social influence to measure the effect on the behavioral intention of an assessment professional to use GIS technology. It will also utilize an efficiency construct to account for the possible time savings and effect that GIS technology has on visualizing and analyzing spatial data (Davis, 1989; Davis et al., 1989; Moore and Benbasat, 1991).

The integration of the theories discussed in the previous chapter such as the TAM, TRA, and the theory of planned behavior (TPB), should increase the effectiveness of the measurement and may account for additional variability while possibly eliminating much of the limitations presented in previous studies. The comprehensiveness of all of the theories may have a high level of explanatory power than each theory individually (Venkatesh et al., 2003). The proposed structural model is expected to provide a comprehensive examination of the behaviors regarding an individual property assessor's intent to use or adopt GIS technology (Figure 4). The operational definitions of the constructs in the model are explained in the next section along with a causal hypothesis of their relationship to other constructs in the model. Results of the model hypothesis will provide a clear understanding of the causal factors and their influence on a property assessment professional's intention to adopt GIS technology.

Table 2. Subscale items within each of the defined TAM constructs.

Construct	#	Item	Description
<i>Perceived Usefulness</i> Adopted from Davis (1989), Davis et al. (1989), Moore and Benbasat (1991)	10A_1	PU1	Using GIS applications improves my job performance.
	10A_2	PU1	Using GIS improves my quality of work.
	10A_3	PU3	Using GIS gives me greater control over my work.
	10A_4	PU4	Using GIS in my position increases my task capacity.
	10A_5	PU5	Overall, I find GIS applications to be useful in my position.
<i>Perceived Ease of Use</i> Adopted from Davis (1989), Davis et al. (1989), Moore and Benbasat (1991)	10A_6	PEU1	My understanding of GIS technology is clear.
	10A_7	PEU2	Using a GIS application does not require a lot of skill.
	10A_8	PEU3	Using a GIS application does not require a lot of mental effort.
	10A_9	PEU4	Learning to operate a GIS application is easy for me.
	10A_10	PEU5	I find GIS applications flexible to interact with.
	10A_11	PEU6	Overall, I believe that GIS applications are easy to use.
<i>Social Influence</i> Adopted from Thompson et al. (1991), Venkatesh et al. (2003)	10A_12	SI1	My supervisors and managers think that I should use GIS.
	10A_13	SI2	My colleagues think that I should use GIS.
	10A_14	SI3	The senior management of my department supports the use of GIS technology.
	10A_15	SI4	In general, the organization supports the use of GIS technology.
<i>Efficiency</i> Adopted from Davis (1989), Davis et al. (1989), Moore and Benbasat (1991)	10B_1	EFF1	Using GIS reduces the time I spend on completing other job-related tasks.
	10B_2	EFF2	Using GIS saves me time.
	10B_3	EFF3	Using GIS allows me to complete my tasks in much less time.
	10B_4	EFF4	GIS allows me to accomplish tasks using less staff.
	10B_5	EFF5	Overall, using GIS increases task efficiency.
<i>Attitude</i> Adopted from Taylor and Todd (1995), Thompson et al. (1991), Venkatesh et al. (2003)	10B_6	ATT1	I like working with GIS technology.
	10B_7	ATT2	GIS makes work more interesting.
	10B_8	ATT3	Working with GIS is enjoyable.
	10B_9	ATT4	In property assessment, using GIS is a good idea.
<i>Intention to Use</i> Adopted from Venkatesh and Davis (1996), Venkatesh and Davis (2000), Agarval and Prasad (1997)	10B_10	IU1	When I have access to GIS, I intend to use it in my job.
	10B_11	IU2	Whenever possible, I would use GIS for my tasks.
	10B_12	IU3	Even outside of my job I would use GIS applications to do different things.
	10B_13	IU4	I intend to increase my use of GIS applications for work in the future.

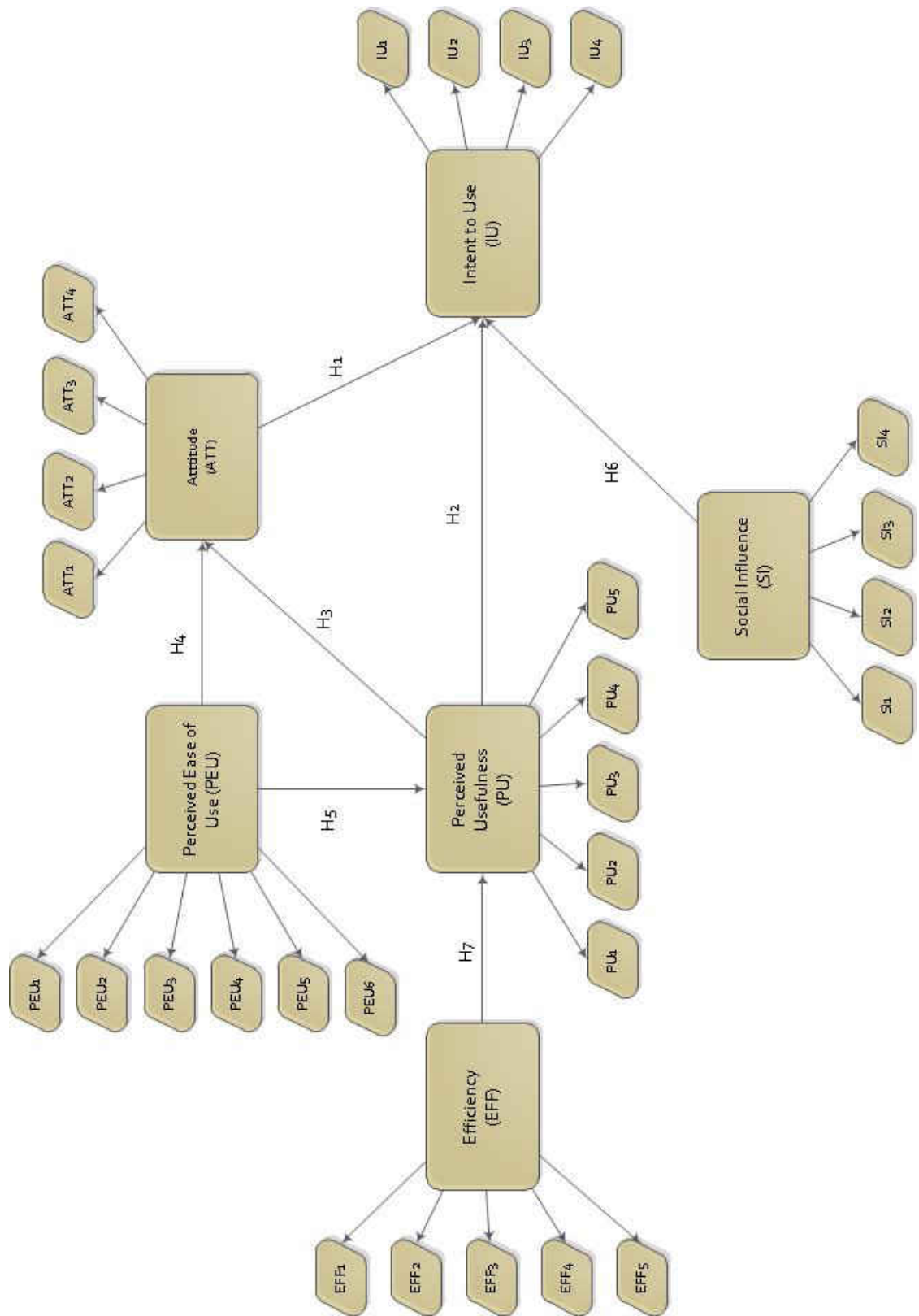

Figure 4. Proposed TAM structural model.

Endogenous Variables

The endogenous variables used within the model are perceived usefulness, attitude, and intent to use. Endogenous variables are those that are, “predicted to be causally affected by other variables in the model (Hatcher, 1994, p.146).” These variables are similar to dependent variables in which they are affected by other variables, but do not co-vary with any other variable in the model. These variables are explained below along with a hypothesis on their causality between other constructs in the proposed structural model.

Intent to use GIS Technology

The dependent variable of the research study, intent to use (IU), has been used and empirically tested in various other research studies (Hu et al., 2005; Venkatesh & Davis, 2000; Ajzen, 1991; Fishbein & Ajzen 1975). It has shown to be an important precursor to behavior and has proven to be influenced by the perception of the technology, especially regarding the advantages and disadvantages, word of mouth, reviews, and other social interactions. Since this research is analyzing and attempting to assess the factors that influence the adoption of GIS technology, intent to use would serve as the dependent variable. Actual use, which will also be captured in the data collection, will not be used as a variable in the model due to the variability and inconsistencies present in self-reporting (Lee et al., 2003).

Attitude

The Attitude (ATT) variable within the TAM is shown in the literature to be directly affected by perceived ease of use and perceived usefulness. Attitude explains the

users' beliefs about the usage of GIS technology, which also may include preconceived ideas or ideas learned over time (Davis, 1989).

H1: An assessor's attitude toward using GIS technology has a positive influence on their intention to use it to do their jobs.

Perceived Usefulness

Davis (1989, p. 320) defined perceived usefulness (PU) as, "the degree to which a person believes that using a particular technology would enhance his or her job performance." PU explains technology effectiveness as it relates to performance. Essentially if an assessment professional finds GIS technology to increase productivity while decreasing the amount of time spent on a project than the user will have a positive "use-performance" relationship as denoted by Davis (1989, p. 320).

H2: PU has a positive influence on the intention of property assessment valuation professionals using GIS technology.

H3: PU has a positive influence on the attitude of property assessment valuation professionals using GIS technology

Exogenous Variables

In order to measure the impact on perceived usefulness and intent to use, exogenous variables are used as latent constructs to better determine the amount of influence they exert. This may improve the predictive accuracy of the measurement model. The exogenous variables defined within the model are effectiveness, perceived ease of use, and social influence. Exogenous variables are, "constructs that are influenced only by variables that lie outside of the causal model (Hatcher, 1994, p. 146)." These variables are explained below along with a hypothesis on their causality between other constructs in the model.

Perceived Ease of Use

Davis (1989, p. 320) defines perceived ease of use (PEU) as, “the degree to which a person believes that using a particular technology would be free of effort.” Based on the structure and theory of the TAM, PEU has a significant direct effect on both perceived usefulness and attitude (Lee et al., 2003; Liu, 2010). Thus, if property assessment professionals perceive GIS technology as easy to use, they will more than likely adopt it more readily within the scope of their work and accept it as a methodology or tool. Subsequently, if property assessment professionals perceive GIS technology as easy to use, their attitude will also affect their perception.

H4: PEU has a positive influence on property valuation professional's attitudes using GIS technology.

H5: PEU has a positive influence on the PU of property valuation professional's using GIS technology.

Social Influence

Social influence (SI) is defined as “the degree to which an individual perceives that other important individuals believe that he or she should use the technology (Venkatesh et al., 2003, p. 451).” This is essentially a social norm variable that accounts for the subjectivity within the users’ environment. SI, which is heavily entrenched in the TRA and TPB literature, has been shown as a direct determinant of behavioral intention through variables of subjective norms, social factors, and image (Ajzen, 1991; Davis et al., 1989; Fishbein & Azjen, 1975; Mathieson, 1991; Taylor & Todd, 1995; Thompson et al., 1991; Moore and Benbasat, 1991).

Having a strong social or positional status is important for any property assessment professional within the field among peers and colleagues. Thus, a manager, supervisor, or someone with a strong social status could potentially have an impact on

other subordinate users and possibly influence their perception of GIS technology. Social influences may include others that might not have influence, but have strong perceptions on the use of GIS technology in the professional work environment. Since local government office staff is usually organized based on a traditional hierarchy, social influence could be an important determinant of property assessment professional's adoption of GIS technology.

H6: Social influence has a positive influence on intention of property assessment professionals use of GIS technology.

Efficiency

Efficiency (EFF) is defined within this research as, “the degree to which a property assessment professional perceives his or her task performance as being improved with the usage of GIS technology (Hu et al., 2005, p. 238).” Efficiency is an important determinant of use within the context of technology, as its use is dependent upon the time savings and the task efficiency gained as a result. Within the context of GIS technology, several studies have outlined the use of GIS as a spatial decision support system (SDSS) (Crossland et al., 1995). Not only does GIS technology create an environment where spatial and non-spatial information is acquired and stored for analysis, but also provides a means for which decisions can be made regarding a particular phenomenon, such as property assessment valuation problems (Gloudemans & Almy, 2011; Payton, 2006). GIS technology could improve the ability to solve these problems and provide more accurate results while accounting for spatial variability and potentially decreasing the time and expertise needed (Crossland et al., 2005). Thus, it is more than likely that property assessment professionals would consider the use of GIS T when they know that it will increase their task performance.

Instrument

A survey instrument consisting of ten total questions was developed, broken into three main parts (Appendix D). The first part consisted of eight demographic questions asking the respondent their education level, age, years of professional experience, years of GIS experience, state they live in, jurisdiction size, and frequency of GIS usage. The second part asked the respondents to check all the types of GIS usage that they most frequently interacted with during their day-to-day work experiences. The third part consisted of 28 statements, requesting the respondents to rate their level of agreement on each. A six-point Likert-type scale of agreement was utilized, ranging from “1 = strongly disagree” to “6 = strongly agree.” Neutral was not utilized in this questionnaire in order to solicit some form of agreement with the statement. All of the scale questions were validated in prior research and adapted to use with GIS technology within this research (See references in Table 2).

Procedure

In alliance with the International Association of Assessing Officers (IAAO), an online survey questionnaire was administered to the organization’s membership through Qualtrics online survey software by means of a convenience sample. The data collection timeframe was from May 18th through June 10th, 2016. A web link along with a brief explanation of the research purpose was sent out through a weekly emailed newsletter called *Assessing Info*. This e-newsletter was sent out to 12,000 email addresses made up of local government assessors, private fee appraisers, and sale vendors. Additional follow up included advertisements in a valuation webinar conducted by the researcher, social media postings, postings to the IAAO website, as well as postings on an online

collaboration portal used by IAAO members called *AssessorNet*. Overall all 7,461 members of IAAO were informed of the questionnaire in addition to many other non-member individuals and groups. The estimated response rate for this research was about 3% based on the 12,000 potential respondents of the email newsletter. The questionnaire was voluntary and was not contingent upon IAAO membership. Approval was acquired through both the University of North Dakota's Institutional Review Board (IRB) and the IAAO executive director to conduct this research study (see Appendix A and B).

Data Analysis Plan

The data gathered from the online survey questionnaire was coded in Qualtrics and extracted into the Statistical Package for the Social Sciences (SPSS) statistics version 19 to be analyzed. Descriptive statistics were analyzed on each of the demographic variable attributes, including the frequency, total percent response and cumulative percent response for each attribute. Responses were compiled and descriptive statistics were analyzed at the construct level. The reliability of the instrument was evaluated using Cronbach's alpha statistic to look at the internal consistency of each of the defined constructs. An overview of the analysis conducted for each of the research questions is discussed below.

1. What is the overall level of support on each potential construct for evaluating individual user adoption in the property assessment profession?

In order to assess the overall level of support on each of the theoretical factors that influence adoption of GIS technology, the mean of each level of agreement was observed on the sub-construct items. The overall mean of some type of agreement, some type of disagreement, standard deviations, and percentage of some type of

agreement/disagreement for each construct was calculated to form a construct score that provided a unit of comparison. The reliability of each of the items was explored within each construct to ensure internal consistency (Cronbach alpha statistic). In order to derive the highest perception of influence in the adoption of GIS technology, all construct means were ranked. It is hypothesized that the constructs of attitude and efficiency will have the greatest amount of perceived influence as the excitement grows within the property assessment field to have a better understanding of the capabilities of GIS technology as was demonstrated by Bhatt & Singh (2013) and Payton (2006).

2. Does the proposed extended technology acceptance model (TAM) structural model provide an adequate framework for explaining GIS technology adoption within the property assessment profession?

Correlations were calculated on all subscale-construct items to look for multicollinearity between and within constructs. In order to explore variation and covariation within the formation of constructs, confirmatory factor analysis (CFA) was conducted to see if the proposed indicators within the measurement model fit the data. The measurement model consisted of the relationship between the latent factors and the indicator variables (Hatcher, 2005). In this case the indicator variables are the individual statements. Once the model was confirmed, a structural latent path model or structural equation model (SEM) was analyzed to explore the relationships between the intent to adopt GIS technology as the dependent variable, and all the other factors as the predictors. Goodness of fit statistics such as chi-square, comparative fit index (CFI), standardized root mean square residual (SRMR), and the root mean square error of approximation (RMSEA) statistics were calculated to assess how well the model fits the

data. A well accepted convention in the use of CFA and SEM analysis is that there is never one best goodness-of-fit index that has been developed that will provide all the various forms of model fit. The types of indices that were analyzed within this model were absolute fit, incremental fit, and parsimonious fit (Byrne, 2016; Wan, 2002).

Reliability and validity analysis was also conducted as discussed in the next section. SEM was a good approach for this analysis in that it provided an assessment of convergent and discriminant validity of the measures as well as explained the causal structure of GIS technology adoption based on the constructs defined within the theoretical framework (Hatcher, 2005).

It is hypothesized that based on the vast literature found in developing a TAM instrument from other information systems research, that the proposed modified TAM will be adequate for explaining the intent to adopt GIS technology (Wallace & Sheetz, 2014; Davis, 1989, Venkatesh et al., 2003; Moore & Benbasat, 1991, Venkatesh & Davis, 2000; Lee et al., 2003; Legris et al., 2003). The additional external factors of efficiency and social influence should also help account for the additional variance to better fit the model as was the case in several research studies where external factors were used to reflect that result (Venkatesh and Davis, 2000, Wu and Wang, 2005, Legris et al., 2003; Park, 2009; Liu, 2010).

3. What effect does perceived quality of training with regard to the use and functionality of GIS technology have on factors of adoption?

Perceived quality training is an important component to the success of individuals in any professional environment. Without training in the use of any technology, users will likely not adopt it (Tomlinson, 2001). “The adoption of a technology is reflective of the

relationships established between an individual and the technology (Nedovic-Budic & Godshalk, 1996, p.555).” In order to assess if there was a difference of agreement vs. disagreement on each adoption construct for having received quality training on the use, functionality, and adoption of GIS technology, each level of some form of agreement and disagreement were assigned to its respective grouping thereby serving as the independent variable in the analysis. Each grouping was then compared to the dependent variables consisting of the six adoption constructs used within the model with a t-test analysis to assess mean differences.

The role of technological change on more experienced and older professionals is an issue that many professional work environments have been struggling with, especially that of assessment offices (Walters, 2014, Rizzuto, 2011). Considering the mean and median age of assessment professionals, and the possible role that experience and training have on adoption, this research hypothesizes that having a greater agreement on the constructs of perceived usefulness and social influence may have the greatest level of agreement for receiving quality training in GIS technology (Walters, 2014; Nedovic-Budic, 1998).

4. What are some of the defined uses of GIS technology within the context of the property assessment profession?

The final question with regard to current personal GIS technology usage will be directly measured and discussed within the context of other demographic items from the questionnaire such as length and frequency of GIS technology usage. This may provide further insight in the extent of how GIS is being utilized within the property assessment discipline. Summaries were tabulated based on the frequency of responses from the

questionnaire. It is hypothesized based on the types of published research studies and periodicals, that GIS technology is mainly being used for data visualization and land records management in the assessor's office (Bhatt & Singh, 2013). More advanced analysis, such as specific uses of modeling with GIS will be shown to be underutilized in the property assessment professional environment, as they are suited for more specialist type of positions (Bidanset, 2014).

Validity and Reliability of the Instrument and Analysis

Creswell (2012, p. 159) elaborated on the importance of validity by stating that, "...if instrument scores are not reliable then they will not be valid." Validity concerns the soundness, legitimacy and relevance of a research theory and its investigation (Creswell, 2012, 159). It is important to possess evidence to support the results of the research to ensure its accuracy (O'leary, 2004, p. 61). Becker (1993) proposed that all measures be backed and confirmed by a valid conceptual framework. The TAM has proven to be a reliable framework within the literature for modeling factors that influence intent to use. There are several types of validity outlined in Creswell (2012, p. 159) that exist to ensure that measures are accurate and useful. A few of these measures are discussed regarding this research.

Content validity ensures that any measured content is conceptually valid. The instrument questions must be relevant to the phenomena being researched. Previous research must be carefully consulted and cross-referenced with other similar studies to verify its validity as it relates to the defined constructs. Within this research, the questionnaire included questions adapted from the literature whose content validity had

already been established. Therefore it was expected that the questionnaire would give consistent and uniform results.

Response validity refers to how accurate the responses of an instrument are compared to an individual's actual response (Creswell, 2012, p. 163). In this research, some of the items (i.e., perceived ease of use) within the questionnaire are worded negatively to ensure validity is maintained (Creswell, p. 2012). Additionally, the responses were cross referenced with other similar questions surveyed by other organizations or within the literature. Throughout the pilot process and instrument generation stages, items were modified and retested if the responses were significantly different than the anticipated response. This indicated that the respondent did not adequately understand the question. Additional feedback was sought after from the preliminary pilot respondents to elaborate on why they would have chosen a particular answer.

Construct validity refers to how consistently the scores stack up against the conceptual and operational definitions of each construct. In other words, did the scores of the instrument reflect the anticipated scores that were internally consistent with the conceptual framework? A pilot tested instrument should reveal internally consistent responses for questions under each construct. In this research, the conceptual definitions within the literature identified the TAM as the conceptual model for understanding factors that influence the use of GIS technology. There were six factors (constructs) identified and the scores would reflect consistency within each if the instrument is to be reliable. The underlying factor structure was objectively tested using confirmatory factor analysis (Hatcher, 1994, 59). The Cronbach's alpha coefficient was used to assess the

internal consistency of each construct (Hatcher, 1994). A Chronbach alpha above .70 was the standard used in this research (Hatcher, 1994). A higher alpha coefficient indicates that all the included items or statements may be measuring the same construct.

Summary

This research will explore the constructs of an extended technology acceptance model (TAM) using efficiency and social influence in order to assess factors that influence the adoption of GIS technology among property assessment professionals. The proposed structural model is expected to explain a majority of the variance on the intent to adopt GIS technology and a confirmatory factor analysis is expected to provide evidence that the measurement model constructs will hold up in a structural model. If so, the structural model will be assessed. The analysis will also look at perceived quality training to determine if there is a difference in an assessor having received quality training on each of the adoption constructs. Finally, the research will also look at defined usage of GIS technology to understand how it is being used within the profession.

CHAPTER IV

RESULTS

The purpose of this research was to assess factors or constructs that influence the adoption of Geographic Information Systems technology in a professional work environment. The property assessment profession was the professional work environment used in this study. The theoretical framework employed in this research was an extension of the technology acceptance model (TAM) with the dependent variable being intent to adopt GIS technology. The results will have implications in the field of property assessment on the adoption of GIS technology, and how GIS technology would be utilized to acquire knowledge within the functions of the assessor work environment. The following chapter will present the findings of the data analysis. It will begin by looking at the general demographics of the research sample followed by analyzing the construct items. Next, it will go into detail with regard to the results of the research questions as described, ending with a summary of the results.

Research Questions

The results of this study were placed within the context of the following research questions which will guide the results:

1. What is the overall level of support on each potential construct for evaluating individual user adoption of GIS technology in the property assessment profession?

2. Does the proposed extended technology acceptance model (TAM) structural model provide an adequate framework for explaining GIS technology adoption within the property assessment profession?
3. What effect does perceived quality of training with regard to the use and functionality of GIS technology have on the factors of adoption?
4. What are some of the defined uses of GIS technology within the context of the property assessment profession?

Demographic Analysis

The sample collected from the online questionnaire yielded 450 total responses, which also included incomplete responses. Once the data were cleaned it was determined that there were 394 valid responses that included GIS technology usage questions. Of the 394, only 377 of those responses were fully complete to analyze the factor structure. Therefore, within the context of this analysis, the sample total will be $n = 377$. An estimated response rate of 3% was calculated based on the 12,000 subscribers of the email newsletter *AssessingInfo*. Since this survey was given through a convenience sample which ended up snowballing to other groups (i.e., word of mouth, email from colleagues, state listserves, etc), many respondents may have not been members of the IAAO.

A majority of the sample was collected from the state of Minnesota as shown in the map and tables in Appendix E, consisting of about 42% of the overall responses, followed by Iowa at 15%. A possible reason for the high response rate within the state of Minnesota is because it is the researcher's home state and the survey was distributed through the state assessing organization listserve. At least one response was collected

from 37 of the 50 states representing 74% of the United States. The survey also received responses from Canada (1.6%).

Table 3. Demographic question on age and experience in years.

Variable	Mean	Median	SD
Age	48.4	50	11.3
Experience in Profession	16.2	14	11.3
Experience with GIS Technology	9.9	10	6.2

Table 4. Demographic results on usage of GIS technology.

Variable	Attributes	Frequency	%	Cumulative %
Hours a week that Respondents Use GIS Technology	Less than 2	50	13.3	13.3
	Between 2 and 5	90	23.9	37.1
	Between 5 and 7	63	16.7	53.8
	Between 8 and 10	57	15.1	69.0
	More than 10	115	30.5	99.5
	Do not use GIS	2	.5	100
Totals		377	100	

The sample contained a majority of respondents with Bachelor’s degrees (49%), followed by some college (35%) and about 8% with advanced degrees. A majority of the respondents were between the ages of 51 and 60 (34%). The median age of the respondents in the sample was 50 years old with a mean average of 48 years old (Table 3). This can be further analyzed by looking at years of assessment experience where the mean average number of years of experience is 16.2 years. With regard to experience with GIS technology, the mean years of experience is ten years with 30% using GIS technology more than ten hours per week. These results are shown in Table 4 with additional breakdowns in Appendix E. A majority of respondents (77%) were from Counties, 16% from Cities, where 41% were from jurisdictions that had between 10,000 and 50,000 land parcels.

A measure was also collected regarding the perception of the respondent on if they had received quality training on the use and functionality of GIS technology. As shown in Table 5, 68.4% had some form of agreement in that they did receive quality

GIS technology training while 31.6% had some form of disagreement on quality training. This is fairly higher than expected, but on par with many other professions development of quality training on GIS technology (ESRI).

Table 5. Level of agreement on respondent has received quality training on the use and functionality of GIS.

	Frequency	Percent	M	SD
Some Form of Agreement	258	68.4		
Some From of Disagreement	119	31.6		
Totals	377	100.0	5.0	.92

Analysis of Adoption Statements and Constructs

It was hypothesized that the constructs of attitude and efficiency would have the highest levels of agreement compared to other constructs due to the growing excitement in the field for adopting GIS technology. In order to assess the levels of agreement within and between each of the adoption constructs descriptive means, standard deviations as well as the percentage of some form of agreement or disagreement were calculated based on the six point Likert scale (Table 6).

Perceived usefulness (PU) is defined as “the degree to which a person believes that using a particular technology would enhance his or her job performance (Davis, 1989, p. 320).” Technology effectiveness as it relates to performance is explained within this construct and consisted of five statements. The average means for this construct were all in the 5 range. The highest form of some form agreement with 98.9% of responses came from the statement “Overall, I find GIS applications to be useful in my profession.”

Perceived ease of use (PEU) included six statements and is defined as the “degree to which a person believes that using a particular technology would be free of effort (Davis, 1989, p. 320). This is an important factor affecting an individual’s attitude toward the use of technology, or in this case GIS technology. The mean scores within this

construct were between 3.6 and 4.5 with the lowest score coming on the statement, “Using a GIS application does not require a lot of mental effort” (M = 3.6, SD = 1.2) with 56.5% of the respondents marking some form of agreement. Additionally, the statement, “Using a GIS application does not require a lot of skill” (M = 3.8, SD = 1.2) also stood out as only 62.1% marked some form of agreement. Many of the questions in this construct were lower than expected.

Social influence (SI) included four statements and is defined as “the degree to which an individual perceives that important others believe that he or she should use the technology (Venkatesh et al., 2003, p.451).” The mean scores within this construct were between 5.1 and 5.3 on the six point Likert-type scale. The highest responses on some form of agreement at 97.1% were on the statements, “My colleagues think that I should use GIS” and “In general, the organization supports the use of GIS technology.”

Efficiency (EFF) included five statements within the questionnaire and is defined as the degree to which a property assessment professional “perceives his or her task performance as being improved with the usage of GIS technology (Hu et al., 2005, p. 238).” Efficiency is an important construct because it dictates how useful a technology would be for solving a particular problem. The mean scores ranged from 4.7 to 5.0 on the six Point Likert-type scales. The lowest response on some form of agreement with 79.6% was on the statement, “GIS allows me to accomplish tasks using less staff.”

Attitude (ATT) included four statements and is defined as the users’ beliefs about the usage of technology (Davis, 1989). The mean scores in the attitude construct ranged from 5.0 to 5.5 on the six point Likert-type scale, with at least 95% or more of respondents having some form of agreement on each statement.

Intent to adopt is the main construct or dependent variable of the study in predicting GIS technology adoption. The construct is measured by four statements with a mean range between 4.6 and 5.5 on the six Point Likert-type scales. The items indicated that professionals had a positive behavior with regard to the use of GIS technology overall.

Table 6. Descriptive statistics of each of the variables within their defined constructs.

Construct	Indicator	Question	Some Form of Agreement (%)	Some Form of Disagreement (%)	M	SD
<i>Perceived Usefulness</i>	PU1	Using GIS applications improves my job performance.	98.7	1.3	5.5	.75
	PU1	Using GIS improves my quality of work.	97.9	2.1	5.4	.76
	PU3	Using GIS gives me greater control over my work.	97.3	2.7	5.2	.87
	PU4	Using GIS in my position increases my task capacity.	96.8	3.2	5.2	.91
	PU5	Overall, I find GIS applications to be useful in my position.	98.9	1.1	5.5	.72
<i>Perceived Ease of Use</i>	PEU1	My understanding of GIS technology is clear.	88.6	11.4	4.5	1.0
	PEU2	Using a GIS application does not require a lot of skill.	62.1	37.9	3.8	1.2
	PEU3	Using a GIS application does not require a lot of mental effort.	56.5	43.5	3.6	1.2
	PEU4	Learning to operate a GIS application is easy for me.	85.1	14.9	4.5	1.1
	PEU5	I find GIS applications flexible to interact with.	79.8	20.2	4.3	1.1
	PEU6	Overall, I believe that GIS applications are easy to use.	81.7	18.3	4.3	1.1
<i>Social Influence</i>	SI1	My supervisors and managers think that I should use GIS.	93.4	6.6	5.1	1.0
	SI2	My colleagues think that I should use GIS.	97.1	2.9	5.1	.87
	SI3	The senior management of my department supports the use of GIS technology.	96.6	3.4	5.3	.87
	SI4	In general, the organization supports the use of GIS technology.	97.1	2.9	5.3	.82
<i>Efficiency</i>	EFF1	Using GIS reduces the time I spend on completing other job-related tasks.	88.9	11.1	4.7	2.0
	EFF2	Using GIS saves me time.	93.9	6.1	5.0	.98
	EFF3	Using GIS allows me to complete my tasks in much less time.	91.0	9.0	4.8	1.0
	EFF4	GIS allows me to accomplish tasks using less staff.	79.6	20.4	4.4	1.2
	EFF5	Overall, using GIS increases task efficiency.	94.4	5.6	5.0	.95
<i>Attitude</i>	ATT1	I like working with GIS technology.	97.1	2.9	5.2	.85
	ATT2	GIS makes work more interesting.	95.8	4.2	5.1	.96
	ATT3	Working with GIS is enjoyable.	95.0	5.0	5.0	.97
	ATT4	In property assessment, using GIS is a good idea.	97.9	2.1	5.5	.79
<i>Intention to Use</i>	IU1	When I have access to GIS, I intend to use it in my job.	98.9	1.1	5.5	.74
	IU2	Whenever possible, I would use GIS for my tasks.	97.3	2.7	5.2	.85
	IU3	Even outside of my job I would use GIS applications to do different things.	85.8	14.1	4.6	1.2
	IU4	I intend to increase my use of GIS applications for work in the future.	96.0	4.0	5.0	.97

n=377

Construct Scores

In order to determine the overall level of agreement on each of the six adoption constructs, the levels of agreement were ranked using the construct means. The levels of agreement on each of the statements within each of the constructs were averaged to obtain a dimensional or construct score. Table 7 shows the ranked means and standard deviations for each construct from lowest to highest. All of the mean scores were above 4.0 with the lowest being perceived ease of use ($M = 4.2$, $SD = .88$), followed by efficiency ($M = 4.8$, $SD = .92$). The highest mean score was perceived usefulness ($M = 5.4$, $SD = .70$), followed by social influence ($M = 5.2$, $SD = .88$). All variances were within 1 point of the mean construct score.

Table 7. Ranking of levels of agreement from low to high between all constructs.

Construct	Mean	SD	Variance
Perceived Ease of Use (PEU)	4.2	.88	.77
Efficiency (EFF)	4.8	.92	.85
Intention to Use (IU)	5.1	.72	.52
Attitude (ATT)	5.2	.77	.61
Social Influence (SI)	5.2	.77	.59
Perceived Usefulness (PU)	5.4	.70	.49

Bivariate Correlations

Correlation matrices using the Pearson product-moment correlation coefficient were analyzed on each scale for all statements within and between each of the six constructs. The Pearson's is one of the most widely used measures of correlation in the social sciences. It provides a standardized measurement of the strength of relationship between two variables. Hatcher (1994) iterated that correlations that are too high may cause estimation problems when conducting latent variable analysis and should be removed because they redundantly measure the same thing. The maximum recommended correlation that was consistent throughout the literature is .85 (David, 1998). As is seen in

Tables 8, 9 and 10, for the PU, PEU, and SI constructs all correlations seem to be below that .85 mark. The highest is PU2 with PU1 which asks if GIS technology improves job performance vs. improving quality of work, which could possibly be interpreted similarly.

Table 8. Correlation matrix for perceived usefulness.

Statement	PU1	PU2	PU3	PU4
PU1				
PU2	.85			
PU3	.72	.76		
PU4	.63	.69	.67	
PU5	.72	.77	.64	.64

*Correlations are significant to the .01 level (2-tailed)

Table 9. Correlation matrix for perceived ease of use.

Statement	PEU1	PEU2	PEU3	PEU4	PEU5
PEU1					
PEU2	.36				
PEU3	.32	.85			
PEU4	.63	.54	.47		
PEU5	.53	.53	.47	.67	
PEU6	.52	.64	.59	.74	.77

*Correlations are significant to the .01 level (2-tailed)

Table 10. Correlation matrix for social influence.

Statement	SI1	SI2	SI3
SI1			
SI2	.76		
SI3	.66	.48	
SI4	.64	.49	.81

*Correlations are significant to the .01 level (2-tailed)

Correlations for EFF, ATT, and IU as shown in Tables 11, 12, and 13 also show fairly good Pearson's scores with the exception of the interaction of EFF3 with EFF2 (.90) indicating some multicollinearity. Herein again the statements may have been interpreted by the respondent as the same with the wording that "Using GIS saves me time" verses "Using GIS allows me to complete my task in much less time." A few other variables that have over .80 were EFF5 and EFF3 as well as ATT2 and ATT3. Overall, all but one interaction was below .85 suggesting limited multicollinearity problems. It

may be necessary to eliminate variable EFF3 or EFF2 as stated by David (1998). The variable in which to eliminate will be decided by looking at the reliability analysis for each of the constructs to determine how well each variable contributes to internal consistency.

Table 11. Correlation matrix for Efficiency.

Statement	EFF1	EFF2	EFF3	EFF4
EFF1				
EFF2	.74			
EFF3	.74	.90		
EFF4	.55	.65	.67	
EFF5	.67	.81	.82	.72

*Correlations are significant to the .01 level (2-tailed)

Table 12. Correlation matrix for Attitude.

Statement	ATT1	ATT2	ATT3
ATT1			
ATT2	.75		
ATT3	.77	.83	
ATT4	.59	.57	.51

*Correlations are significant to the .01 level (2-tailed)

Table 13. Correlation matrix for Intention to Use.

Statement	IU1	IU2	IU3
IU1			
IU2	.69		
IU3	.36	.50	
IU4	.49	.50	.47

*Correlations are significant to the .01 level (2-tailed)

Table 14. Correlations and measures of internal consistency between all constructs.

Construct	PU	PEU	SI	EFF	ATT	Cronbach α
Perceived Usefulness (PU)						.92
Perceived Ease of Use (PEU)	.37					.88
Social Influence (SI)	.50	.36				.88
Efficiency (EFF)	.73	.47	.47			.93
Attitude (ATT)	.72	.45	.39	.70		.89
Intention to Use (IU)	.69	.40	.41	.69	.77	.80

*Correlations are significant to the .01 level (2-tailed)

Construct correlations were calculated based on the mean scores of the statements within each construct. As shown in Table 14, all correlations were positive and

significant, falling within the acceptable range indicating no multicollinearity problems. The highest correlation was between IU and ATT constructs at .77.

Reliability Analysis

Cronbach's alpha reliability method was employed to determine if each construct had strong internal consistency of the statements used within the research. An index measure of between .70 and .95 was used as the criteria by which to determine if the statements within each construct are correlated with each other (Cronbach, 1951). As shown in Table 14, the alphas were all above the threshold value of .70 and in fact were all above .85 indicating that all statements measured very well within each of their respective constructs.

Overall based on the descriptive results, the constructs which were assembled from theory based on existing literature, held up quite well. The highest level of agreement within the constructs was on social influence and perceived usefulness. Next, the latent structure of each of the constructs was assessed for model fit to ensure that they were adequate.

Explaining GIS Technology Adoption using the TAM

Confirmatory factor analysis (CFA) was used to examine the latent structure of each of the measurement models in order to further evaluate their adequacy within the structural model to predict intent to adopt GIS technology (Mertler & Vannatta, 2005). Since the scale reliability was verified, the next step was to confirm its validity. This research will follow the guidelines written by Wan (2002), who proposes a three stage analysis along with guidance from Lei & Wu (2007), Schreiber et al. (2006) and Byrne (2016). These guidelines are summarized as follows:

First measurement models based on the theoretical foundations were developed and checked for significance at the .05 level (two tailed). The critical ratios will be used to determine significance ($CR \pm 1.96, p < .05$) (Hatcher, 1994; Lei & Wu, 2007). Hair et al. (2009) suggested that the factor loadings of each of the items be ideally greater than .70 or higher and anything less than .5 is recommended to be removed from the model. This will be considered on a case by case basis within this study to determine if the indicator for the factor would be left in the measurement model.

The second stage was to assess measurement model fit. IBM SPSS AMOS 24 was used to evaluate each measurement model. Many of the models indicated that despite the high internal reliability and significant factor loadings and critical ratios, that the model would still not meet the goodness-of-fit measures. The goodness-of-fit measures used in this research are summarized in Table 15.

Table 15. Goodness-of-fit criterion used to assess the measurement and structural model.

Index	Adequate Fit	Excellent Fit
Chi-square (χ^2)	Low	Low
Degrees of Freedom (df)	≥ 0	≥ 0
Likelihood Ratio (χ^2/df)	< 4.0	< 4.0
Standardized Root Mean Square Residual (SRMR)	$< .10$	$< .05$
Comparative Fit Index (CFI)	$\geq .90$	$\geq .95$
Root Mean Square Error of Approximation (RMSEA)	$\leq .08$	$\leq .06$

Hatcher (1994), Lei & Wu (2007), as well as Byrne (2016) all note that poor performing indicators must be identified by the goodness-of-fit statistics, and then be addressed through modification indices. Thus, the third step was to improve model fit. The modification index is commonly used to “estimate the magnitude of decrease in the model chi-square when the fixed or constrained parameter is freely estimated (Lei & Wu, 2007; Byrne, 2016, p.103).” The modification indices in this research was analyzed based on the covariance structures looking at the error terms of each of the constructs to

determine if there were any potential items that were strongly correlated with each other. The covariance structure represents the strength of association between two error terms (Byrne, 2016). If this is the case than the model should be revised to account for it to improve overall fit of the measurement model.

The process defined by Wan (2002) was applied to all measurement and structural models until a satisfactory model fit was attained based on the goodness of fit statistics. All latent models were measured using a six point Likert-type scale ranging from strongly disagree (1) to strongly agree (6). A discussion of each measurement model fit is provided.

CFA for the Perceived Usefulness Construct

Perceived usefulness was one of the three endogenous variables used in the theoretical model, according to the TAM literature to have a direct effect on the intent to use as well as have an indirect effect through attitude. The measurement model is shown in Figure 5 and was analyzed for model fit. All parameter estimates on the measurement model were significant ($CR \pm 1.96, p < .05$). Factor loadings on the latent construct and its indicator items were strong and ranged from .75 to .94. All of the items of the latent construct remained in the measurement model.

In spite of the high critical ratios as shown in Table 16, and strong factor loadings, the evaluation of the measurement model was still not satisfactory based on the goodness-of-fit statistics as shown in Table 17. Thus the measurement model was modified based on the results of the modification indices to improve model fit.

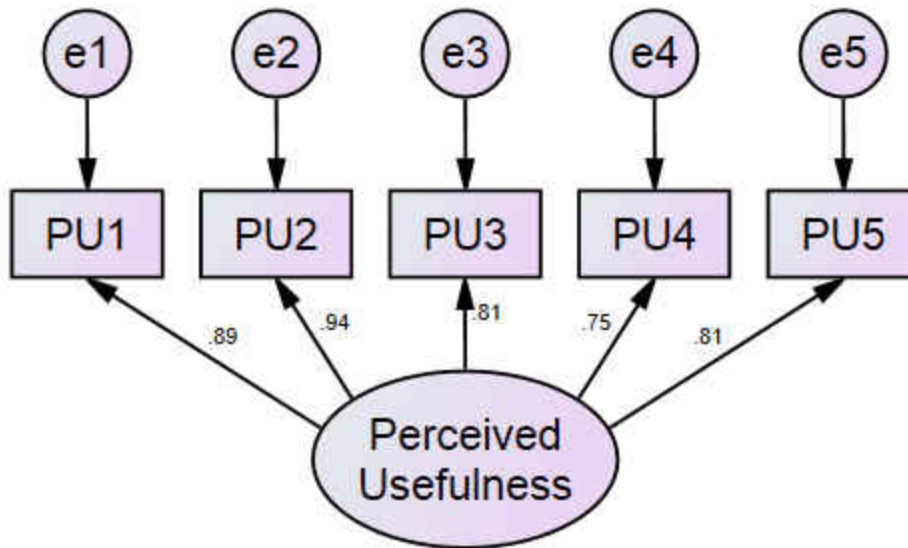

Figure 5. Measurement model for perceived usefulness with factor loadings.

Table 16. Parameter estimates for perceived usefulness.

Indicator	Theoretical Model					Revised Model				
	URW	SRW	SE	CR	P	URW	SRW	SE	CR	P
PU1←PU	1.00	.888				1.00	.889			
PU2←PU	1.071	.944	.038	28.48	***	1.075	.948	.038	28.66	***
PU3←PU	1.063	.813	.050	21.07	***	1.049	.803	.051	20.62	***
PU4←PU	1.017	.746	.056	18.08	***	.998	.732	.057	17.55	***
PU5←PU	.882	.814	.042	21.09	***	.879	.812	.042	21.08	***
e3←e4						.062	.194	.019	3.265	***

*** $p < .05$

Table 17. Goodness-of-Fit statistics for perceived usefulness.

Index	Theoretical Model	Revised Model
Chi-square (χ^2)	18.67	6.88
Degrees of Freedom (df)	5	4
Lilkihood Ratio	3.73	1.72
Standardized Root Mean Square Residual (SRMR)	.020	.012
Comparative Fit Index (CFI)	.788	.999
Root Mean Square Error of Approximation (RMSEA)	.085	.044

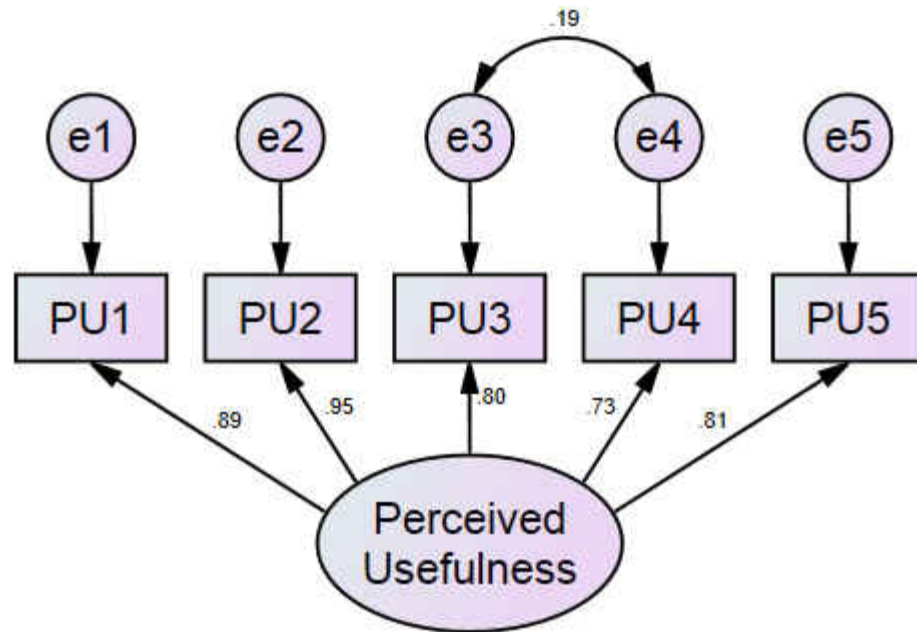

Figure 6. Revised measurement model for perceived usefulness with factor loadings.

As indicated by the revised model in Figure 6, the parameter estimates were similar to the theoretical model; however the goodness-of-fit indices indicated a better fit with a covariance between the error terms of PU3 and PU4. It is possible that the question for PU3 in asking, “Using GIS gives me greater control over my work,” was interpreted by the respondents similarly to, “using GIS in my position increases my task capacity.”

CFA for the Perceived Ease of Use Construct

The perceived ease of use construct is one of the exogenous variables in the model and is theorized as an indirect predictor of intent to use through attitude, perceived usefulness as well as through both perceived usefulness and attitude. The measurement model, as shown in Figure 7, had six latent indicators that made up the construct and was assessed for model fit. Factor loadings on the construct ranged from .61 to .91 but with

significant critical ratios (Table 18). The factor loadings indicated that revisions were necessary.

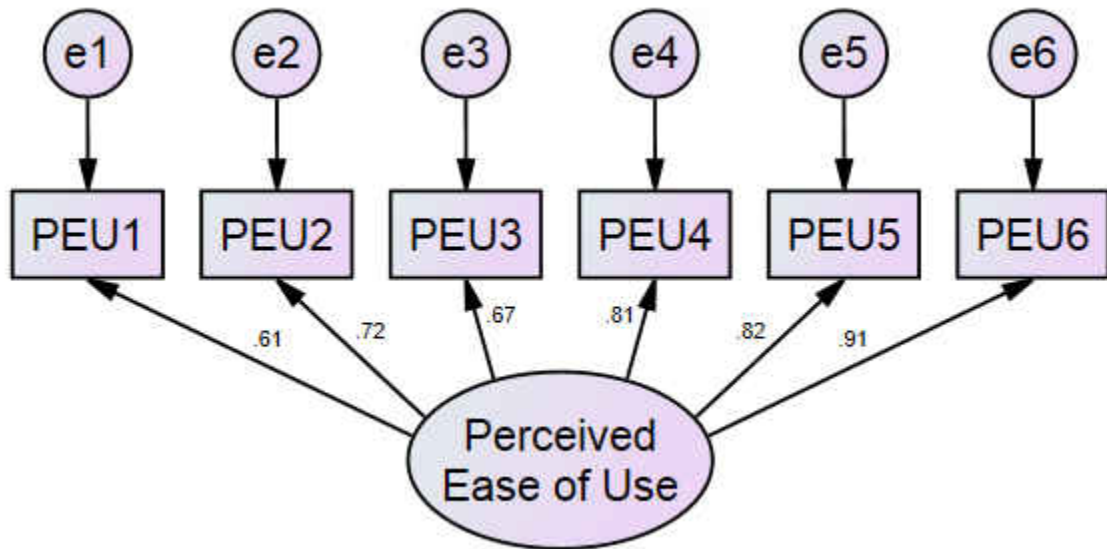

Figure 7. Measurement model for perceived ease of use with factor loadings.

Model fit was also outside the acceptable tolerances as shown in the goodness-of-fit statistics in Table 19. The chi-square was high at 332 with a likelihood ratio well outside of acceptable range. Thus modification indices were utilized to determine a better fit.

Table 18. Parameter estimates for perceived ease of use.

Indicator	Theoretical Model					Revised Model				
	URW	SRW	SE	CR	P	URW	SRW	SE	CR	P
PEU1←PEU	1.00	.609								
PEU2←PEU	1.36	.723	.119	11.41	***	1.00	.672			
PEU3←PEU	1.30	.669	.121	10.79	***					
PEU4←PEU	1.41	.809	.114	12.34	***	1.10	.793	.080	13.72	***
PEU5←PEU	1.40	.822	.112	12.47	***	1.12	.827	.079	14.22	***
PEU6←PEU	1.54	.905	.117	13.19	***	1.26	.935	.082	15.28	***

*** $p < .05$

Table 19. Goodness-of-Fit statistics for perceived ease of use.

Index	Theoretical Model	Revised Model
Chi-square (χ^2)	332.90	2.73
Degrees of Freedom (df)	9	2
Likelihood Ratio	36.99	1.36
Standardized Root Mean Square Residual (SRMR)	.094	.001
Comparative Fit Index (CFI)	.991	.998
Root Mean Square Error of Approximation (RMSEA)	.31	.031

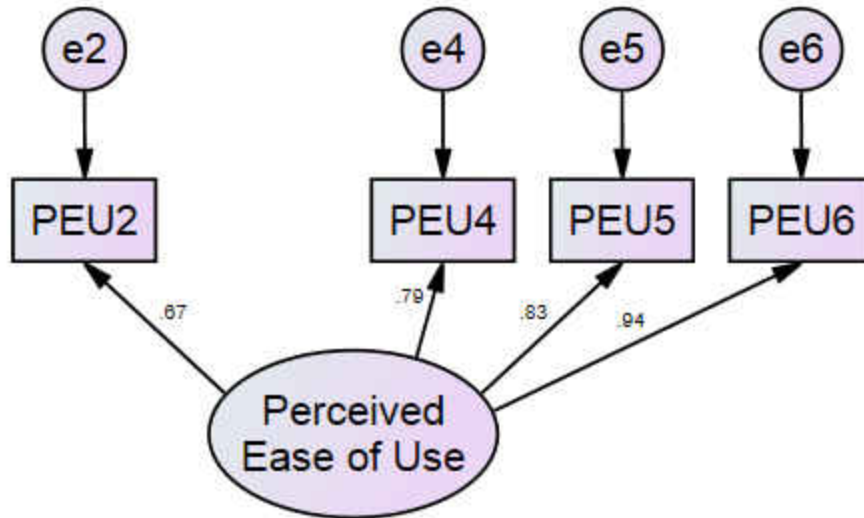

Figure 8. Revised measurement model for the perceived ease of use construct with factor loadings.

In revising the model to create a better fit, several iterations were conducted to determine the best modification structure. It was determined that since PEU1 had the lowest factor loading of .61 and PEU3 had a loading of .67, that a better fit might be obtained if these indicators were deleted from the model (Figure 8). PEU2 and PEU3 may have been misinterpreted by respondents as it had a large amount of variance with a standard deviation of 1.01 and 1.16 respectively. Indicators for PEU1 were also highly loading on PEU6, thus PEU1 was eliminated from the revised model. Through testing and analysis, it was determined that the overall fit was improved considerably as the goodness-of-fit statistics in the revised column of Table 19 show that the chi-square, likelihood ratio and RMSEA are all within the specified tolerance.

CFA for the Efficiency Construct

The efficiency construct is an exogenous variable which was one of the two extension latent constructs added to the original TAM model for predicting intent to use GIS technology. Efficiency within this model directly affects perceived usefulness in

predicting intent. The measurement model of efficiency consisted of five indicators as shown in Figure 9. Factor loadings between the latent construct and the indicators were within tolerance which ranged from .72 to .94 as shown in Table 20. All parameter estimates on the measurement model were significant ($CR \pm 1.96, p < .05$). Therefore, all items remained in the model.

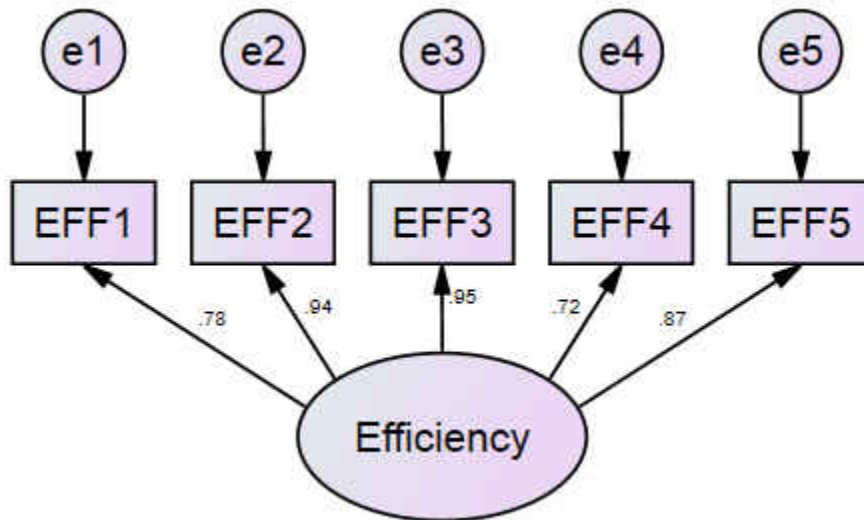

Figure 9. Measurement model for the efficiency construct with factor loadings.

In spite of the high critical ratios as shown in Table 20 and strong factor loadings, the evaluation of the measurement model was still not satisfactory based on the goodness of fit statistics shown in Table 21. Thus, the measurement model was modified based on the modification indices to improve model fit.

Table 20. Parameter estimates for the efficiency construct.

Indicator	Theoretical Model					Revised Model				
	URW	SRW	SE	CR	P	URW	SRW	SE	CR	P
EFF1 ← EFF	1.00	.781				1.00	.782			
EFF2 ← EFF	1.08	.942	.050	21.47	***	1.08	.945	.050	21.57	***
EFF3 ← EFF	1.13	.948	.052	21.66	***	1.13	.950	.052	21.73	***
EFF4 ← EFF	.991	.715	.066	14.99	***	.963	.695	.067	14.46	***
EFF5 ← EFF	.969	.870	.050	19.28	***	.958	.860	.050	19.00	***
e4 ← e5						.132	.321	.025	5.23	***

*** $p < .05$

Table 21. Goodness-of-Fit statistics for the efficiency construct.

Index	Theoretical Model	Revised Model
Chi-square (χ^2)	35.28	.748
Degrees of Freedom (df)	5	4
Likelihood Ratio	7.06	.187
Standardized Root Mean Square Residual (SRMR)	.026	.002
Comparative Fit Index (CFI)	.982	1.00
Root Mean Square Error of Approximation (RMSEA)	.127	.00

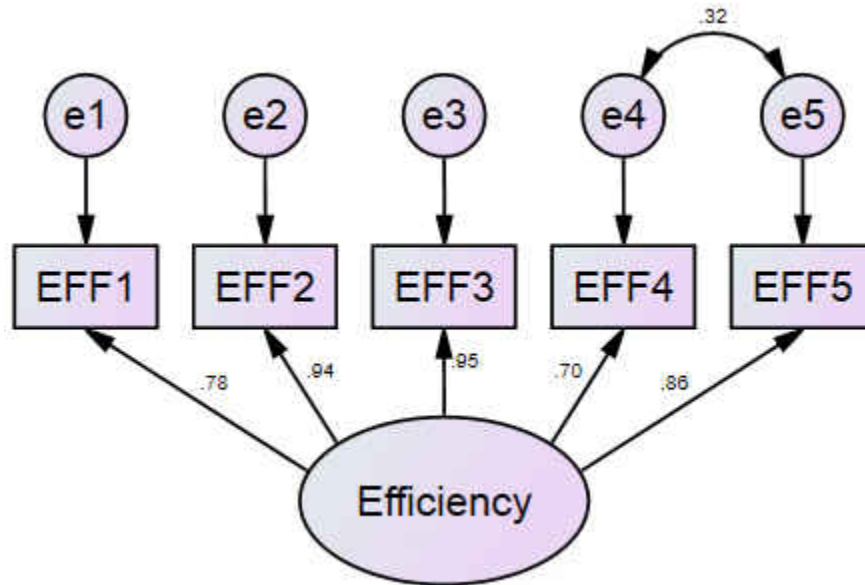

Figure 10. Revised measurement model for the efficiency construct with factor loadings.

The revised model was improved slightly based on the modification indices showing a slight covariance between EFF4 and EFF5 based on the improvement in the goodness-of-fit statistics in Table 21. It is possible that the wording of the question in the items for EF4 and EFF5 may yield very similar responses as they describe increases in task efficiency as well as accomplishments of tasks using less staff. Figure 10 shows the revised model along with the factor loadings with the added covariance estimate.

CFA for the Attitude Construct

The attitude construct is an endogenous construct which based on the TAM has a direct effect on the intent to use GIS technology. The attitude construct is made up of four indicators as shown in the measurement model in Figure 11. All parameter estimates

on the measurement model were significant ($CR \pm 1.96, p < .05$) as shown in Table 22. Factor loadings on the latent construct and its indicator items were high with the exception of ATT4 which had a loading of .62. All indicators were left in the model as the model was assessed for fit.

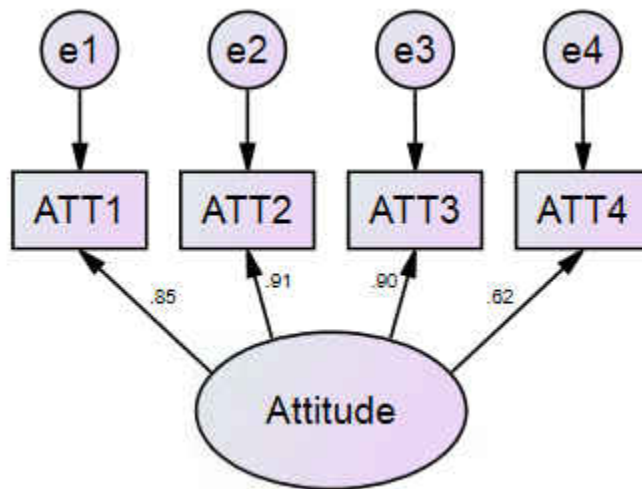

Figure 11. Measurement model for the attitude construct with factor loadings.

Much like the other measurement models, the goodness-of-fit indices were slightly out of tolerance as shown in the theoretical model column of Table 23. The model was revised based on the results of modification indices to improve model fit.

Table 22. Parameter estimates for the attitude construct.

Indicator	Theoretical Model					Revised Model				
	URW	SRW	SE	CR	P	URW	SRW	SE	CR	P
ATT1←ATT	1.00	.847				1.00	.845			
ATT2←ATT	1.20	.908	.053	22.71	***	1.180	.891	.052	22.60	***
ATT3←ATT	1.21	.901	.054	22.51	***	1.235	.920	.054	22.73	***
ATT4←ATT	.678	.619	.052	13.05	***	.731	.665	.053	13.79	***
e3←e4						-.082	-.374	.018	-4.61	***

*** $p < .05$

Table 23. Goodness-of-Fit statistics for the attitude construct.

Index	Theoretical Model	Revised Model
Chi-square (χ^2)	23.79	3.98
Degrees of Freedom (df)	2	1
Likelihood Ratio	11.90	3.98
Standardized Root Mean Square Residual (SRMR)	.028	.012
Comparative Fit Index (CFI)	.978	.997
Root Mean Square Error of Approximation (RMSEA)	.170	.089

As shown in the revised model (Figure 12), a covariance was added between ATT3 and ATT4 which improved model fit. The indicator of ATT3 asked if working with GIS is “enjoyable” and ATT4 asked if “using GIS is a good idea” within the field. The result was a negative covariance which might have indicated an inverse relationship between the two items. Some respondents may have responded in that working with GIS might have been enjoyable, but perhaps not a good idea within the field and vice versa.

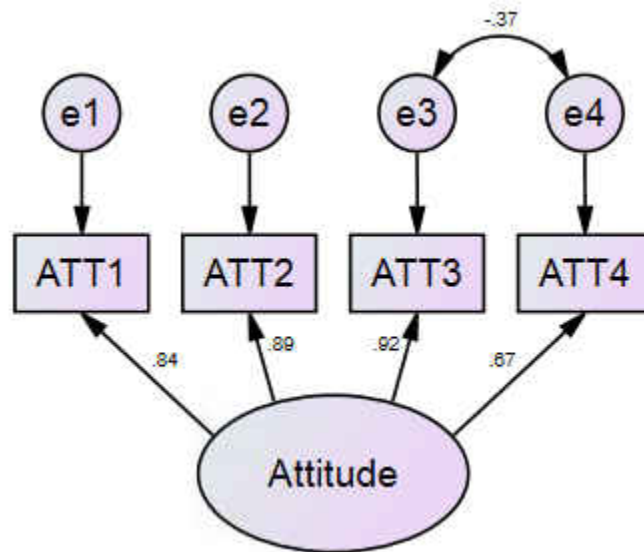

Figure 12. Revised measurement model for the attitude construct with factor loadings.

CFA for the Social Influence Construct

The social influence construct is utilized as an exogenous variable in the model and was applied as an extension of the TAM to account for outside personal influences on individuals intending to adopt GIS technology. The social influence construct was originally set up to have a direct effect on the intent to adopt as was shown in the TPB. Figure 13 shows the measurement model of the social influence construct containing four indicators. All parameter estimates were statistically significant ($CR \pm 1.96, p < .05$) and

factor loadings were all high with the exception of SI2 at .63 as shown in Table 24. All indicators remained in the measurement model as model fit was assessed.

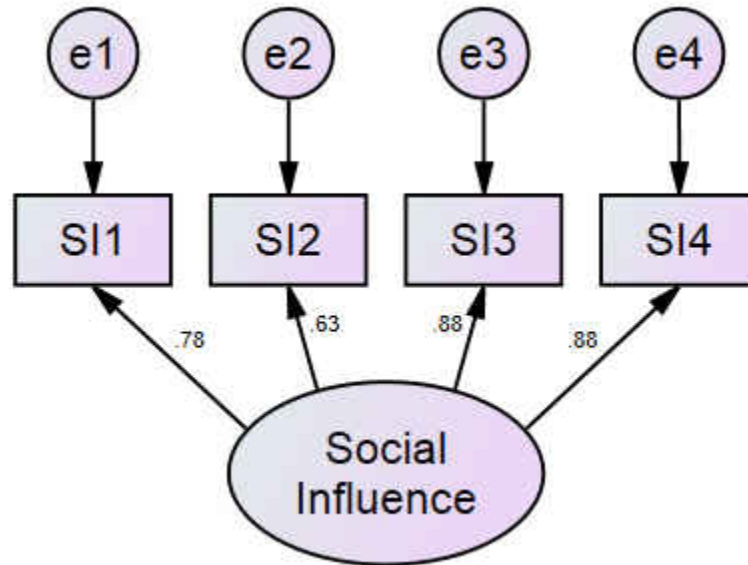

Figure 13. Measurement model for the social influence construct with factor loadings.

Table 24. Parameter estimates for the social influence construct.

Indicator	Theoretical Model					Revised Model				
	URW	SRW	SE	CR	P	URW	SRW	SE	CR	P
SI1 ← SI	1.00	.777				1.00	.720			
SI2 ← SI	.681	.627	.056	12.25	***	.628	.536	.042	15.02	***
SI3 ← SI	.963	.883	.054	17.95	***	1.076	.914	.067	16.18	***
SI4 ← SI	.902	.877	.050	17.86	***	.983	.886	.061	16.15	***
e1 ← e2						.331	.631	.035	9.41	***

*** $p < .05$

Table 25. Goodness-of-Fit statistics for the social influence construct.

Index	Theoretical Model	Revised Model
Chi-square (χ^2)	168.83	2.41
Degrees of Freedom (df)	2	1
Likelihood Ratio	84.41	2.41
Standardized Root Mean Square Residual (SRMR)	.092	.007
Comparative Fit Index (CFI)	.825	.999
Root Mean Square Error of Approximation (RMSEA)	.471	.061

The revised model (Figure 14) for the social influence construct was improved through the addition of a covariance between SI1 and SI2 to raise the goodness-of-fit statistics to an acceptable range. The items on SI1 and SI2 relate to either managers or coworkers believing that an individual should use GIS which could have been interpreted

similarly by the respondents. The chi-square was significantly decreased and the remaining goodness-of-fit statistics were within an acceptable range as shown in the revised column in Table 25.

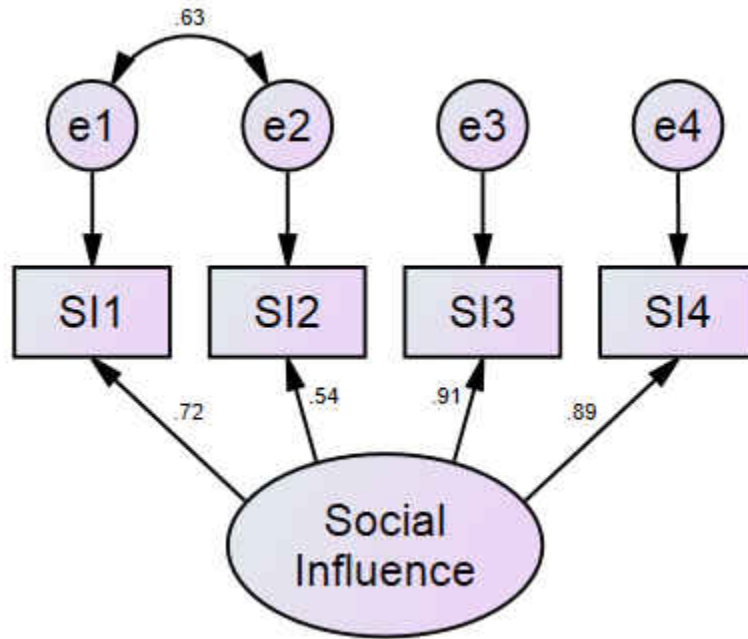

Figure 14. Revised measurement model for the social influence construct with factor loadings.

CFA for the Intention to Use Construct

The main endogenous variable within this study was intention to use GIS technology which was made up of four indicators. The measurement model is shown in Figure 15. Parameter estimates were all significant ($CR \pm 1.96, p < .05$) as shown in Table 26 however, a few of the factor loadings were weak. The lowest estimates were on IU3 and IU4 at .56 and .62 respectively while there were acceptable estimates on IU1 and IU2 all above .70. All indicators remained in the final model to account for degrees of freedom. The goodness of fit statistics as shown in Table 27 indicated that the model was in need of significant revision.

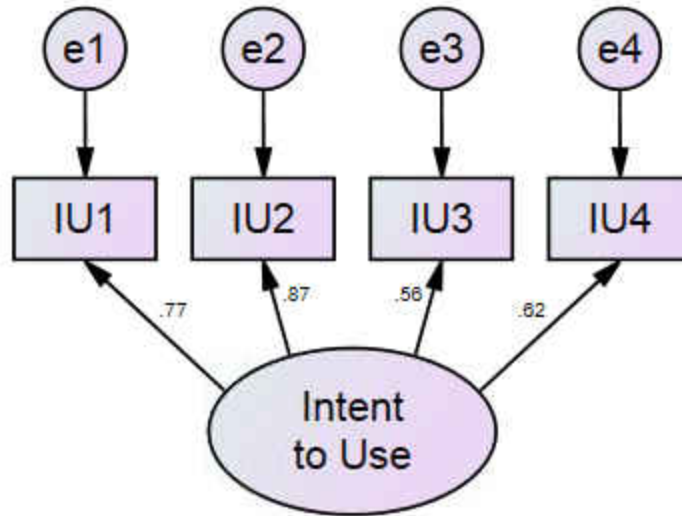

Figure 15. Measurement model for the intent to use construct with factor loadings.

Table 26. Parameter estimates for the intent to use construct.

Indicator	Theoretical Model					Revised Model				
	URW	SRW	SE	CR	P	URW	SRW	SE	CR	P
IU1←IU	1.00	.774				1.00	.836			
IU2←IU	1.31	.874	.092	14.17	***	1.11	.806	.085	13.09	***
IU3←IU	1.14	.563	.110	10.33	***	1.22	.653	.117	10.43	***
IU4←IU	.99	.616	.087	11.36	***	.929	.626	.083	11.15	***
e1←e3						-.160	-.453	.034	-4.65	***

*** $p < .05$

Table 27. Goodness-of-Fit statistics for the intent to use construct.

Index	Theoretical Model	Revised Model
Chi-square (χ^2)	27.40	6.22
Degrees of Freedom (df)	2	1
Likelihood Ratio	13.70	6.22
Standardized Root Mean Square Residual (SRMR)	.048	.024
Comparative Fit Index (CFI)	.950	.990
Root Mean Square Error of Approximation (RMSEA)	.184	.118

Figure 16 shows the revised measurement model which included four indicators. A covariance was added between the IU1 and IU3 error terms based on the modification indices. This resulted in a negative covariance which might indicate an inverse association between the two items. Although a respondent has access to GIS and use it consistently within their job (IU1), they might not want to use GIS outside of their regular job function (IU3). IU1 and IU2 loaded strong at .84 and .81 respectively, however IU3 and IU4 were still low, but improved. All parameter estimates were

significant ($CR \pm 1.96, p < .05$) as shown in Table 26. The revised goodness-of-fit statistics as shown in Table 27 were slightly improved bringing the chi-square down to 6.22 but the RMSEA still remained higher than acceptable indicating a poor fit. Despite the poor fit on the IU measurement model, it was determined that an examination of the structural model would still yield informative results.

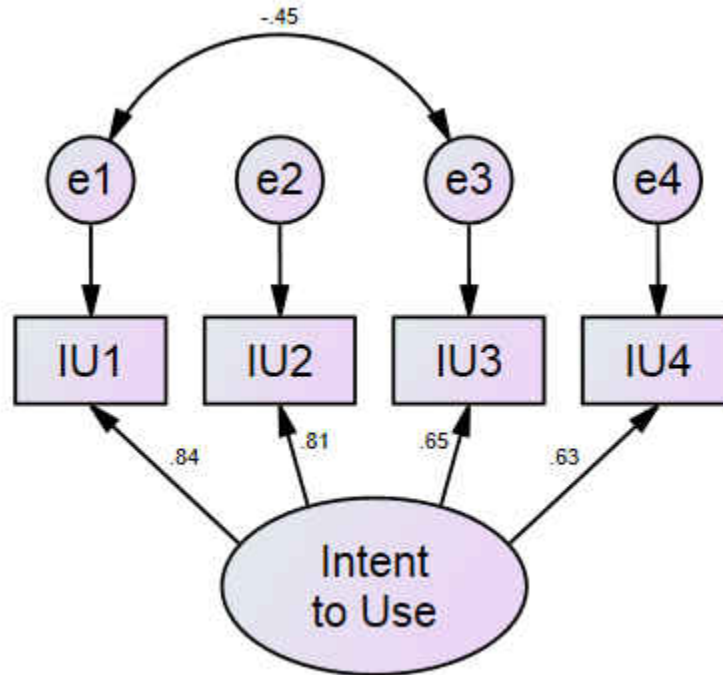

Figure 16. Revised measurement model for the intent to use construct with factor loadings.

Structural Equation Model for Predicting Use of GIS Technology

Based on the results of the measurement models and the confirmatory factor analysis, a structural equation model (SEM) was next defined to test the causal relationship between all factors and the dependent variable of intent to use GIS technology. A generic SEM was developed based on the results of the exogenous and endogenous measurement models which were validated using CFA (Figure 17).

The same approach that was used with the CFA was used for the SEM analysis. The generic model was developed and significance levels on the critical ratios and factor loadings were analyzed. The theoretical path between PEU and PU was insignificant due to a low factor loading score of .03 as shown in Table 28. This may be due to the fact that the efficiency construct had accounted for most of PEU on PU. All other critical ratios and regression path coefficients were significant ($CR > \pm 1.96, p < .05$).

The goodness-of-fit statistics for the theoretical model suggested good fit, although the chi-square was very high and significant as shown in Table 29. The likelihood ratio was below four which is good for absolute fit. The CFI was above .90 which was okay for incremental fit and the RMSEA was below .10 which is acceptable for parsimonious fit. Although the model fit okay, it could be better. Therefore the modification indices were analyzed to determine if the SEM could be revised.

After the removal of the insignificant regression path between PEU and PU, the model was run again, but the fit was improved only slightly with regard to the likelihood ratio. After analyzing the regression paths, it was evident that although the SI and IU regression path was significant, it had a very low parameter estimate. It was shown in the modification indices that a stronger association existed between SI and PU. Theoretically this would make sense since social influence may have a direct effect on someone's belief system (Davis, 1989). This effect has shown in the literature that SI as an external variable might have a bigger impact on IU through PU rather than directly on IU due to various social norms that may not be accounted for in the model (Davis, 1989). Thus, the model was modified to eliminate the regression path between SI and IU and a path was created between SI and PU. The model modification indices were again analyzed for

correlations and covariance and were modified accordingly. It's presumed that the rationale for the correlations between items is due to the tone of the questions being similar. Meaning respondents presume they are asking the same thing. The revised model as shown in Figure 18 shows that the model had improved slightly with a lower chi-square value and a slightly higher CFI and lower RMSEA to indicate good fit (Table 29).

Table 28. Parameter estimates for the SEM.

Indicator	Theoretical Model					Revised Model				
	URW	SRW	SE	CR	P	URW	SRW	SE	CR	P
PU←EFF	.624	.781	.042	14.90	***	.561	.730	.039	14.56	***
PU←SI						.132	.157	.035	3.74	***
PU←PEU	.004	.005	.038	.113	.910					
ATT←PEU	.233	.246	.041	5.69	***	.183	.185	.039	4.74	***
ATT←PU	.741	.665	.053	13.97	***	.873	.720	.058	15.09	***
IU←PU	.336	.357	.053	6.40	***	.388	.390	.059	6.54	***
IU←SI	.073	.089	.029	2.51	.012					
IU←ATT	.480	.567	.049	9.74	***	.468	.570	.050	9.42	***
PEU2←PEU	1.00	.671				1.00	.671			
PEU4←PEU	1.12	.809	.081	13.85	***	1.11	.807	.080	13.86	***
PEU5←PEU	1.14	.838	.080	14.26	***	1.31	.836	.079	14.26	***
PEU6←PEU	1.24	.916	.082	15.13	***	1.24	.919	.082	15.18	***
EFF5←EFF	1.00	.869				1.00	.869			
EFF4←EFF	.993	.693	.053	18.66	***	.994	.694	.053	18.66	***
EFF3←EFF	1.15	.938	.042	27.51	***	1.15	.939	.042	27.62	***
EFF2←EFF	1.13	.950	.040	28.32	***	1.12	.950	.040	28.31	***
EFF1←EFF	1.04	.786	.053	19.45	***	1.04	.786	.053	19.46	***
PU1←PU	1.00	.882				1.00	.849			
PU2←PU	1.07	.934	.038	27.83	***	1.08	.909	.037	28.86	***
PU3←PU	1.07	.811	.051	20.78	***	1.11	.812	.058	19.13	***
PU4←PU	1.03	.753	.057	18.23	***	1.10	.770	.062	17.64	***
PU5←PU	.900	.825	.042	21.47	***	.945	.833	.047	20.04	***
ATT1←ATT	1.00	.863				1.00	.902			
ATT2←ATT	1.12	.865	.050	22.56	***	1.02	.822	.047	21.75	***
ATT3←ATT	1.26	.885	.051	22.92	***	1.09	.864	.046	23.47	***
ATT4←ATT	.798	.742	.047	16.89	***	.855	.823	.051	16.92	***
IU1←IU	1.00	.846				1.00	.857			
IU2←IU	1.11	.809	.060	18.39	***	1.09	.808	.058	18.94	***
IU3←IU	1.08	.581	.102	10.57	***	1.06	.579	.099	10.68	***
IU4←IU	.946	.644	.070	13.49	***	.925	.639	.068	13.57	***
SI1←SI	1.00	.731				1.00	.731			
SI2←SI	.642	.556	.041	15.59	***	.644	.559	.041	15.65	***
SI3←SI	1.05	.903	.063	16.70	***	1.04	.898	.062	16.71	***
SI4←SI	.975	.891	.059	16.62	***	.978	.895	.059	16.69	***

*** $p < .05$

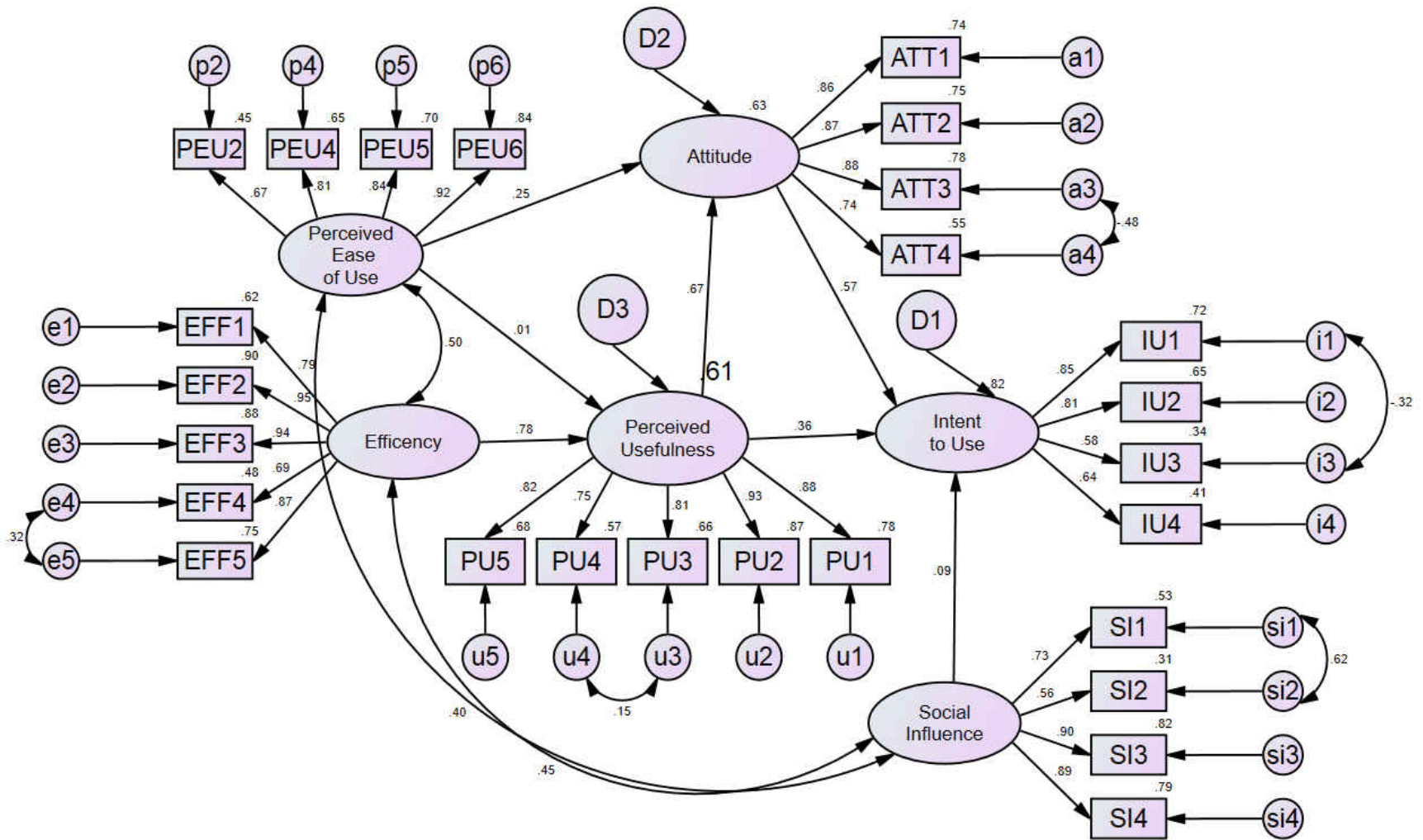

Figure 17. Theoretical structural model with standardized regression weights.

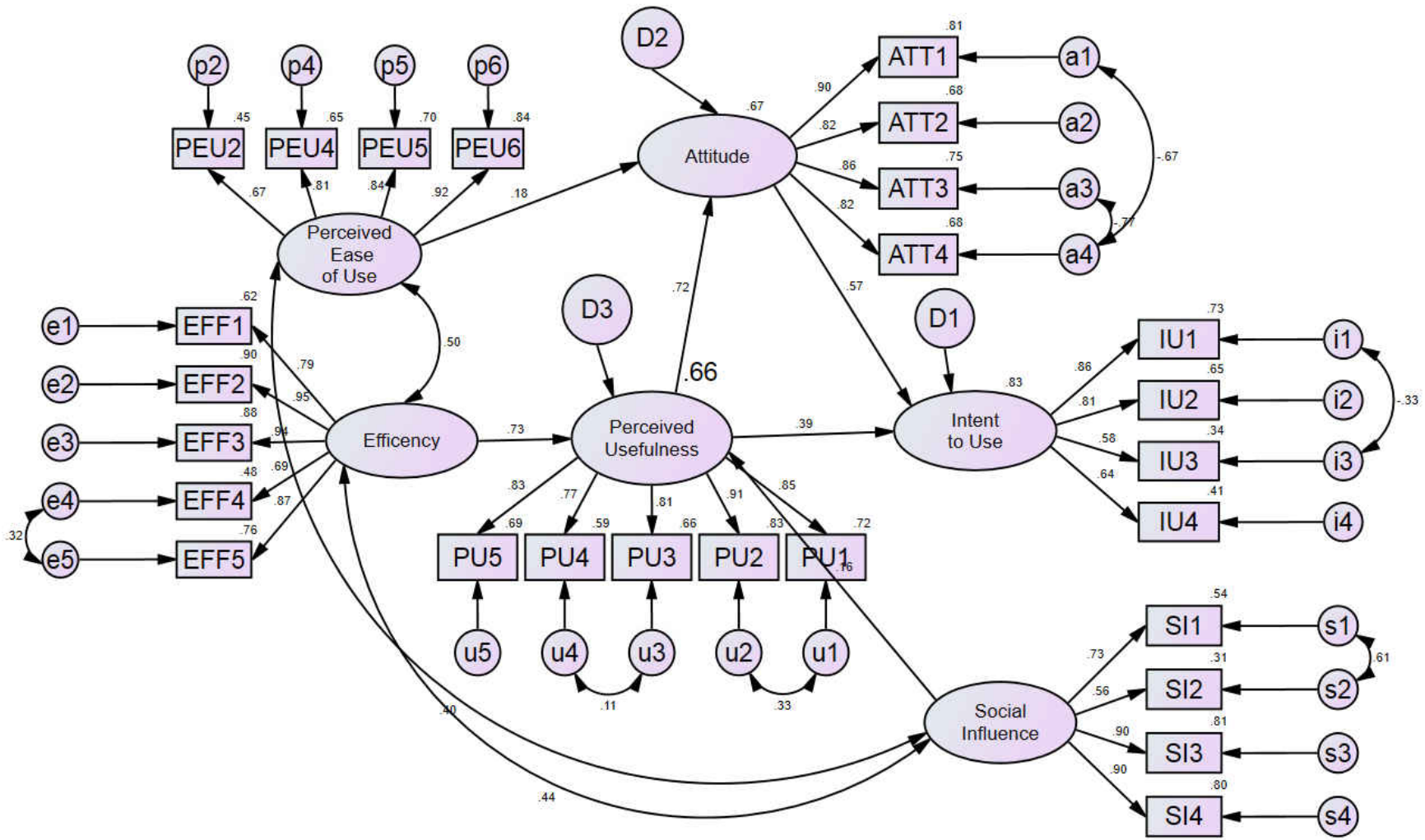

Figure 18. Revised structural model with standardized regression weights.

Table 29. Goodness-of-Fit statistics for the SEM.

Index	Theoretical Model	Revised Model
Chi-square (χ^2)	962.87	894.57
Degrees of Freedom (df)	284	283
Likelihood Ratio	3.39	3.16
Standardized Root Mean Square Residual (SRMR)	.082	.071
Comparative Fit Index (CFI)	.918	.926
Root Mean Square Error of Approximation (RMSEA)	.080	.076

The revised model in Figure 18, indicated that efficiency (.73) had the highest regression weight on perceived usefulness, followed by perceived usefulness on attitude (.72), attitude on intent (.57), perceived usefulness on intent (.39), and social influence (.16) respectively. All critical ratios and regression path coefficients were significant ($CR > \pm 1.96, p < .05$) as shown in the revised column of Table 28. Overall, the independent predictor variables accounted for 83% of the variance in intent to use, 67% variance in attitude, and 66% variance in perceived usefulness. The outcome of this analysis indicated that the factors in this model provided an acceptable explanation of GIS technology adoption for property valuation professionals. Hypothesis testing based on the results of the analysis is next discussed.

Tests of SEM Hypothesis

Several hypothesis tests were posed for the theoretical model and the below describes the results of each.

H1: An assessor's attitude toward using GIS technology has a positive influence on their intention to use it to do their jobs.

This hypothesis was supported based on the results of the revised model ($\beta = .57, p < .05$), which indicated that there was a statistically positive relationship between the attitude of property valuation professionals toward the use and adoption of GIS technology. Meaning that the stronger the attitude of property valuation professionals, the

more likely a property valuation professional will intend to use or adopt the use of GIS technology.

H2: PU has a positive influence on the intention of property assessment valuation professionals using GIS technology.

This hypothesis was also supported ($\beta = .39, p < .05$) from the analysis. This indicated that intent to use GIS technology is directly and positively influenced by perceived usefulness of the technology. Thus, one standard unit increase in PU results in a 39% increase in adoption or use of GIS technology.

H3: PU has a positive influence on the ATT of property assessment valuation professionals using GIS technology

This hypothesis was supported and showed that the perceived usefulness of GIS technology had a very strong positive influence on individual attitudes toward use ($\beta = .72, p < .05$).

H4: PEU has a positive influence on property valuation professional's attitudes using GIS technology.

The fourth hypothesis was also supported in that perceived ease of use of GIS technology does have a positive influence on the attitude of property valuation professionals ($\beta = .18, p < .05$). Thus, the easier that a GIS technology is perceived for usage, the more likely they will have a better attitude toward its use thus, actually adopt it.

H5: PEU has a positive influence on the PU of property valuation professional's using GIS technology.

This regression path was shown to not be statistically significant and thus did not support the hypothesis of a relationship between PEU and PU.

H6: Social influence has a positive influence on intention of property assessment professionals use of GIS technology.

The results of the analysis suggested that this could be supported, but did not have a very strong significant direct relationship between social influence and intent to use GIS technology. This was reexamined to show that there is an indirect relationship through the perceived usefulness construct. Therefore, this hypothesis could not be supported.

H7: Efficiency has a positive influence on the PU of property assessment professionals using GIS technology.

The final hypothesis could be supported in that efficiency does have a positive influence on perceived usefulness ($\beta = .73, p < .05$). This means that efficiency of GIS technology could be more perceived as useful to GIS professionals. This was the highest relationship of any of the constructs in the structural model.

Quality of Training

The third research question examined each respondent's perceived quality of training on the use and functionality GIS technology as it relates to each of the factors of adoption. This was an important question because the more that a user understands a technology through experience or training; the more likely they are to utilize or adopt it more regularly (Wallace & Sheetz, 2014; Nedovic-Budic, 1998; Nedovic-Budic & Godshalk, 1996). Since 30.5% of respondents indicated that they use GIS technology more than ten hours a week, it was possible that they have had better quality training than those who use it less. It was hypothesized that perceived usefulness and social influence would have the greatest impact from receiving quality training. Table 30 shows the comparison of each level of some form of agreement on each of the six adoption constructs. A larger mean represents a higher construct score on agreement or disagreement. The mean differences were significant on all constructs meaning that there

was a difference in agreement vs. disagreement on the perception of training on each adoption construct.

Table 30. Mean comparison and significance of the perception of receiving quality training on the use and functionality of GIS and adoption constructs.

Construct	Yes		No		t	p	Cohen's d
	M	SD	M	SD			
Perceived Usefulness (PU)	5.5	.66	5.2	.76	-3.8	.00*	.42
Perceived Ease of Use (PEU)	4.4	.77	3.6	.88	-8.6	.00*	.97
Social Influence (SI)	5.3	.71	5.0	.85	-4.0	.00*	.38
Efficiency (EFF)	4.9	.85	4.4	.96	-5.3	.00*	.55
Attitude (ATT)	5.3	.73	4.9	.81	-4.4	.00*	.52
Intention to Use (IU)	5.2	.67	4.8	.78	-4.5	.00*	.55

* $p < .05$ (2-tailed)

According to the results, all the mean scores were higher on the “Yes” cohort for all constructs, meaning that property assessment professionals were more likely to perceive to have had quality training in GIS technology if they had higher levels of agreement within each of the adoption constructs. As was mentioned earlier, approximately 32% listed that they did not receive some form of quality training on the use and functionality of GIS. The highest mean in the analysis according to Table 30, is perceived usefulness ($t(375) = -3.77, p < .05$) followed by social influence ($t(375) = -4.04, p < .05$) and attitude ($t(375) = -4.35, p < .05$). This test performed as expected and hypothesized.

Defined Uses of GIS Technology

The final research question examined responses to GIS usage among individual assessment professionals, in addition to their level of usage. It was hypothesized that GIS was mainly being used for data visualization land records identification based on examples from existing literature. The responses, graphically shown in Figure 19, show that a majority of assessment professionals use GIS technology for land records management with 85% saying they always or often use.

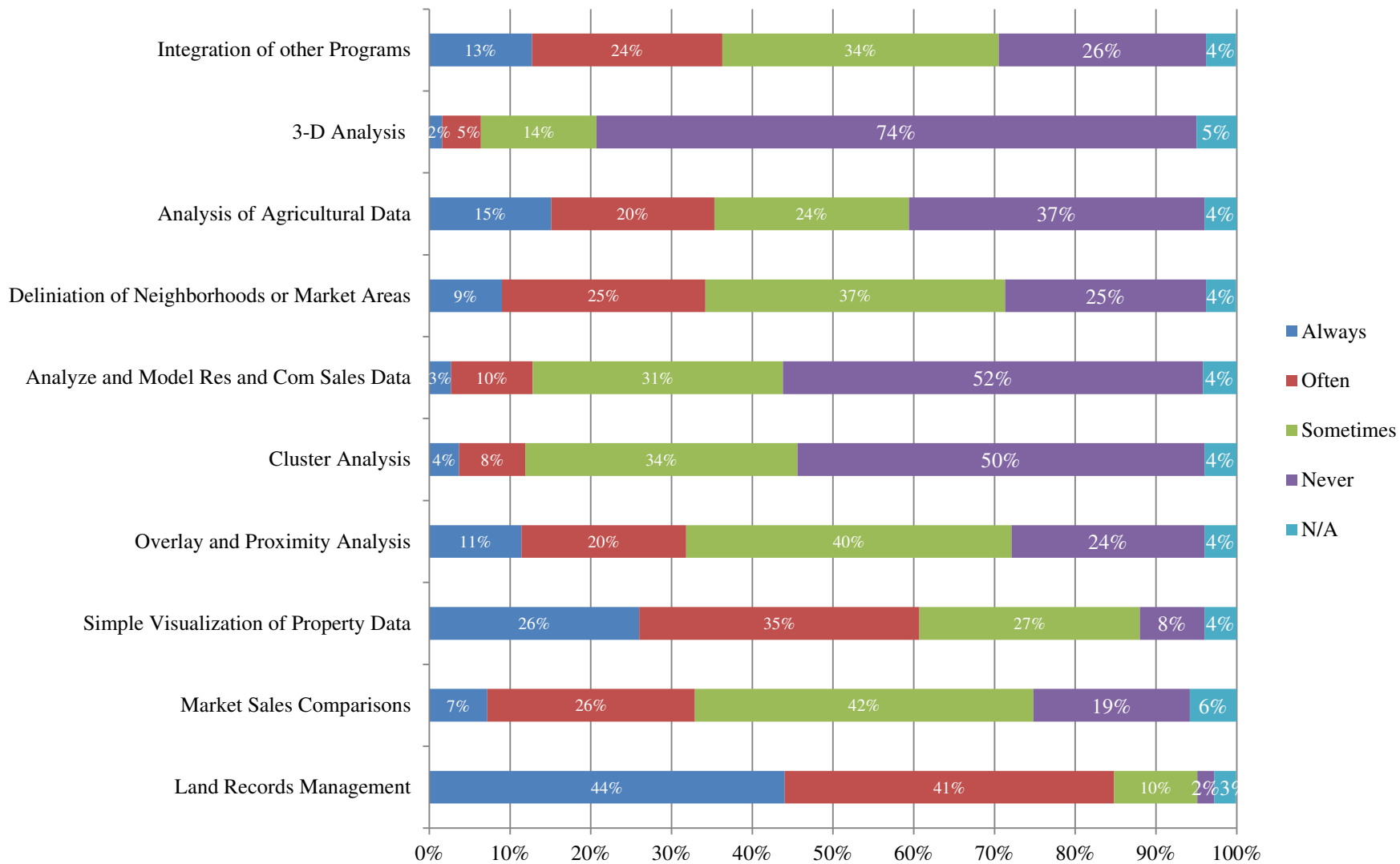

Figure 19. GIS technology usage among survey respondents.

The least amount of GIS use was 3D analysis, as was expected with only 7% indicating that they always or often use. Simple visualization of property data was the second highest with 26% always using and 35% often using. The integration of other programs was next highest with 37% at least often or always using, followed by the analysis of Ag Data at 35%. The use of market comparisons was surprisingly lower than anticipated based on the researcher's knowledge of the profession at 33% always or often using, in addition to the use of overlay and proximity analysis at 31%.

Summary

This chapter provided a detailed overview of the results of the analysis conducted to answer each of the four research questions. General demographics of the respondents show that the property valuation profession according to the sample is aging, and although GIS training was high, it could be better especially with regard to types of usage (Walters, 2014). Descriptive data indicated that perceived usefulness and social influence had the highest level of support among each of the constructs. The factors posed in the theoretical model worked well after some revision to predict the intent for an individual to use GIS technology within the property valuation profession and supported five of the seven hypotheses that were tested. Additionally, the perception of quality training did have a significant impact on each of the adoption factors listed in the theoretical model. Finally, this research had indicated that land records management and simple visualization are being used more than any other form of GIS analysis within the assessor's office. The next chapter will break down some of the results and put them into context with regard to the existing literature as well as its implications on education and the property valuation field.

CHAPTER V

CONCLUSIONS

This research has provided an analysis of factors that influence the adoption of geographic information systems technology within the property assessment professional work environment. This final chapter will provide a discussion and review the general findings as well as their implications on the property assessment professional work environment. Additionally, the limitations of the research will be discussed and recommendations for future research in this topic area will be proposed.

Discussion

Though the technology acceptance model (TAM) had been around for several decades however its use for GIS technology adoption had not been adequately studied. The use of the TAM for this research was based on the strong theoretical framework as well as the many supporting and reliable studies within the literature on various information systems. Therefore, this research took into account the basic TAM model and had modified it with two extension variables. Understanding these factors and their contribution to individual adoption and usage of the technology will be important to facilitate appropriate training and guidance on the adoption of GIS technology in the assessor's office.

Levels of Agreement on Adoption Constructs

The first research question asked about the level of support on each potential construct for evaluating individual user adoption of GIS technology in the property assessment profession. The analysis indicated that all factors had high internal consistency and correlated well within each construct as shown in Table 2. All of the statements that were used in the questionnaire were designed and tested through much of the existing literature and theory, so it was no surprise that the measures were reliable on each construct. It was hypothesized that the constructs of attitude and efficiency would have the highest levels of agreement compared to other constructs due to the growing excitement in the property assessment field for adopting GIS technology. This hypothesis was not supported.

The results showed that perceived usefulness had the highest level of agreement ($M = 5.37$) followed by social influence ($M = 5.20$). Perceived usefulness (PU) is well documented within the literature as being the most important construct in predicting intention or usage of technology. Lee et al. (2003) writes that the PU construct is the strongest because users are willing to use the technology if it has useful functionality and increases their task performance. Davis et al. (1989), Wallace and Sheetz (2014), Yousafzai et al. (2010) among many other adoption based studies had also supported this finding.

Technology Acceptance Model to Predict Adoption

Overall the factors in the model explained 83% of the total variance in predicting an assessment professional's intention of using GIS technology. Seven causal hypotheses were built to examine the model of factors that influence the adoption of GIS technology

(See Figure 4). Five of the seven hypotheses were supported with the revised model, while two were not supported. Discussion of the path hypothesis followed by an overall summary of the research hypothesis is below.

The findings of the analysis show among the constructs, efficiency (EFF) through the perceived usefulness (PU) construct to have the highest path estimate ($\beta=.730, p < .05$) supporting hypothesis seven. Efficiency was one of the extensions that were added to perceived usefulness to account for the amount of time that would be saved through task performance. This was found to be consistent with the literature. Hu et al. (2005) denotes task performance as a critical course to determine the usefulness of the technology. Davis et al. (1989, p.320) describes enhanced performance as “instrumental to achieving various rewards that are extrinsic to the content of the work itself.” Additionally, Davis et al. (1989) stated that “people form intentions toward behaviors they believe will increase their job performance over and above whatever positive or negative feelings may be evoked toward the behavior per se.” Efficiency has found to be associated with improved problem solving capacity, decreased problem solution time, and increased decision making capacity, especially with adequate technology (Crossland & Wynne, 1994).

Perceived usefulness (PU) was significant on attitude with the second highest parameter estimate ($\beta = .72, p < .05$) which supported hypothesis three. PU, according to the literature was a belief and primary determinant of user acceptance (Davis et al., 1989). PU also had a significant direct effect on IU ($\beta = .39, p < .05$) which substantiated that claim and supported hypothesis two in the model. The more that professional’s view GIS technology as being useful to enhance their job performance, the more likely they would adopt it within their work environment even if they dislike the technology (Davis,

1989). This was a violation of the theory of reasoned action, but was substantiated in this research using the TAM. PU also had a significant indirect effect on IU through ATT as a mediator. As individuals saw the technology as useful they were generally happier to use the technology conforming to what Davis (1989) wrote "...people form intentions to perform behaviors toward which they have a positive effect." The TAM in this research also showed the power of PU in explaining up to 66% of the variance with EFF as an extension, which verified PU as a very powerful construct in predicting IU.

Perceived ease of use was the other primary construct in determination of intent to use. PEU had a significant, albeit small, direct effect on ATT, which confirmed hypothesis four ($\beta = .18, p < .05$). It also has a significant direct effect on IU mediated through ATT. Individuals will intend to adopt the technology more if they had a positive impression on the simplicity of its functions (Yousafzai et al., 2010).

PEU on PU was not significant and did not support hypothesis five, meaning that ease of use of the technology did not significantly impact how respondents would use the technology. This could be due to the fact that individuals held a more positive view of the technology without regard to its ease of use. It is also possible that the efficiency construct could have accounted for much of the PEU, since it had a high regression coefficient path on PU. This was an interesting but not surprising finding. Even though many studies captured a tremendous amount of influence from PEU on PU, the influence had been very low and not as useful to the point where many in the literature had questioned its role in the TAM (Lee et al., 2003; King and He, 2006; Davis et al., 2000). Of the 101 studies reviewed by Lee et al. (2003) only 13% of the paths between PEU and PU were not significant.

Attitude (ATT) was also found to have a significant direct impact on intent to use which supported hypothesis one ($\beta = .57, p < .05$). In most studies, ATT was found to be the strongest predictor of intention when key predictors of performance and effectiveness were excluded from analysis (Venkatesh et al., 2003). This proved to be the same and also accounted for 67% of the overall variance of the PEU and PU constructs.

The addition of the social norm factor of social influence (SI) as a direct effect on intent was added to determine if social influence had an effect on intention due to the high median age of the profession, suggested by Venkatesh et al. (2003) and Morris and Venkatesh (2000). This path (hypothesis six), was found to be not significant and thus could have been excluded, however research by Morris & Venkatesh (2000) suggested that social influence might have an indirect effect through PU if use or adoption was mandated by the organization. SI might influence an individual's perception of a technology based on what peers, colleagues, or subordinates convey. Thus, the revised model included the regression line to PU to discover if SI was a major determinant of intent. The result was significant ($\beta = .16, p < .05$), but accounted for a lower than expected parameter estimate. Although many assessors' offices within the sample had a high median age, they may not be mandated to use the technology, which was an important theoretical consideration when using this extension (Lee et al., 2003; Venkatesh & Davis, 2000). Venkatesh et al. (2003), noted that social influence constructs were not significant in any previous studies where use of technology was not mandatory.

Overall, the structural model which used the constructs of PEU, PU, EFF, ATT, and SI explained 83% of the total variance in intent to use GIS technology. This supported the research hypothesis in that the TAM had a high predictive ability with GIS

technology adoption within professional work environments. The research provided support for the TAM as a versatile framework for modeling acceptance within the property assessment profession.

Perceived Quality of Training

It was important to understand how individuals perceive quality of training on each of the constructs to identify areas of improvement. The more that a user understood a technology through experience or training; the more likely they were to utilize or adopt the technology more regularly (Wallace & Sheetz, 2014; Nedovic-Budic, 1998; Nedovic-Budic & Godshalk, 1996). These constructs could help identify areas where additional training and support may be needed from an organizational standpoint (Ventura, 1995). According to the results of the research, all constructs were statistically higher on, “yes,” quality training was received. The highest mean was on PU which was to be expected and supported the hypothesis.

Spatial thinking had shown to improve analytical capabilities as well as their task performance (Lee & Bednarz, 2009). Therefore having an understanding of the value of spatial thinking as it relates a profession will be critical. Within the property tax assessor’s office almost all data may be referenced as geographic data, since most of the data is pertinent to a piece of property that has been identified, listed, and valued (Wadsworth, 2006). Training on how GIS technology could be used to leverage analysis of sales or even analysis of the spatial distribution of new construction would make for big efficiency gains for professionals. If professionals do not receive adequate training or support in thinking spatially, they would most certainly reject the usage of any GIS technology until they could perceive the benefit.

Actual GIS Technology Use

Analysis of actual technology usage within the field showed that land records management and visualization were the highest according to Figure 19. This was not surprising given the simplicity that this type of visualization had within assessor's offices. This supported the original hypothesis and the existing literature (Bhatt & Singh, 2013; Wakaba & Nyika, 2015).

Although the analysis component with GIS technology was low in terms of usage across the study area (13% either always or often use), there was considerable growth within a niche area of subject matter experts or CAMA specialists that have been using this technology for many years. With the growing nature of spatial decision support systems, and the integration of these advanced tools within CAMA systems, individuals without a strong technical background can take advantage of these types of analyses as well (Demeyer et al., 2013; Natividade-Jesus et al., 2006). A lot of technical literature has also focused on the increased accuracy of spatial modeling (Bidanset & Lombard, 2014; O'Connor, 2013). Open source technology has also made this much more prominent and easier for integration into CAMA systems as well as other commercial software products. Business intelligence software has been growing prominently within the assessment market as well where several data sources may be connected and analyzed together. 3D analysis software has become more popular as well as the need to understand the value of view from high rise structures, which is more of an issue in larger cities. These types of analysis in combination with user friendly spatial decision support systems (SDSS) will help with the creation of fair and equitable valuations within the assessment jurisdiction.

Limitations

This research presented several limitations that must be considered when taking the results into account. The first and most apparent limitation of this research was the response rate of the population. It was possible that only the top assessment professionals within the organizations with experience and knowledge of GIS technology responded to the questionnaire and thus may have biased the results. The response rate of this research must be taken into consideration with regard to external validity.

As with any structural equation model study, the causality of the influences of each of the constructs are open to interpretation, though the model was based on sound theory and produced a good fit to the data to support the conclusions that were made (Byrne, 2016; Liu, 2010).

Additionally, it may have been possible within this research that respondents had preconceived notions on the usage and adoption of GIS technology which may have had an impact on the results. Since the TAM excludes the influence of social and personal control factors, ATT acted as a mediator between PEU and PU the possible removal of the attitude construct may provide a stronger link between PU and IU. This was shown to be effective in Yousafzai et al. (2010) and could potentially be relevant here since beliefs may have had a larger effect on IU.

Fourth, the generalizability of this research may also be questioned due to the fact that it was only a snapshot in time. Since the data was collected at only one time period, it might have been more beneficial to collect data at various time periods to conduct a longitudinal study and ensure that results were consistent and generalizable as users perceptions can and do change over time (Lee et al., 2003). The sample collected was

also a convenience sample that was geared to all IAAO members and their affiliates. Future studies may dive deeper into particular office hierarchies such as appraisers vs. CAMA specialists etc.

The fifth limitation was found in testing the measurement models. Confirmatory factor analysis was conducted only on each individual measurement model and not with all factors covarying. This was done due to the simplicity of analyzing the measurement models. This may present differences in the specification of the final structural model and affect the significance of the revised model.

It was possible that significant factors were excluded from the model, and thus did not account for those effects on IU. This might produce omitted variable bias to the research. As explained in Lee et al. (2003), there are many variables that can be extended with PU and PEU. This research looked at theoretically sound variables that make sense in describing and explaining GIS technology adoption within the context of the assessor's office (Byrne, 2016).

Finally, since the research relied upon self-reported measures on an affective scale, there was always the chance that bias or error of some form was present (Lee et al., 2003). Self-report measures always assume that respondents were aware of their emotional experiences and that they reported objectively on their own observations of their behavior (Byrne, 2016; Liu, 2010).

Implications for Practice

There are implications for practice to consider with this research. This study presented perhaps one of the first known uses of the TAM with GIS technology to understand adoption. The results of the study were shown to be successful for using the

TAM in a GIS technology professional environment. The TAM literature was rich with studies of various forms of technology under different conditions, tasks, and methodologies with a multitude of purposes (Lee et al., 2003). Davis (1989) mentioned that the evolution of the TAM must take into account how other variables generalize on PU and PEU with the prediction of use and acceptance of technology. Additional research is needed in the field of GIS technology using various constructs to gain a better understanding of additional factors that influence its use. This could be done in any professional environment and not just the property assessment professional environment.

Additionally, from a property assessor perspective, this research also has implications on how assessors approach the adoption of GIS technology within their organizations. Since an assessment professional's intent to use GIS technology was dependent upon the perceived usefulness and attitude, it may have been beneficial for assessment organizations to provide quality information on GIS technology functionality and provide better direction on the usefulness of that technology within the context of their jobs. Additionally, to account for attitude toward the intent to adopt, possible inclusion of assessment staff in the decision making process through surveys or focus group interviews might be necessary for GIS technology buy in. Local government assessment offices are often bogged down by inefficiencies and strapped by budgets or other impediments. Organizational and institutional factors may always be a greater barrier to GIS technology adoption than the technical constraints (Ventura, 1995).

Understanding both the organizational and institutional barriers to GIS adoption in local government assessor's offices would provide rational or business needs for training, technology, or other related components for adoption.

On an individual level, the analysis of these factors in predicting adoption would provide for the understanding of a professional's level of competence and training within the organization. Diving into each of these individual factors would provide a means for understanding how training could impact adoption. Training will have a tremendous impact on PEU but will also produce more positive individual attitude toward the adoption of the technology at various levels within the organization. Designing a hierarchical training program that provides various levels of complexity from beginner concepts through more advanced concepts, based on an individual's knowledge level may provide the most amount of support and knowledge gain within an organization.

The assessment of factors of adoption using user perceptions of GIS technology was shown to be useful with regard to professional development and training. Professionals that had higher levels of agreement on the adoption constructs were more likely to have received quality training. This has implications on the way that professional development should potentially be conducted, such as hands-on or problem based training. The factors that were elicited showed that perceived usefulness and perceived ease of use were important in predicting intent to adopt. Organizations such as the IAAO can utilize these causal factors for designing potential instruction with regard to the use or training in GIS technology.

Implications for Further Study

There are implications for future research on the adoption of GIS technology in general. Since this was one of very first research studies on the usage of the TAM for GIS adoption research, more effort should be concentrated on other external factors that might account for more variability within the model. Davis (1989) noted that future studies with

TAM should address how other variables affect PU and PEU. Perhaps even removing the external variables and running the theoretical model to understand causality would be acceptable. This was not conducted in this research. Other constructs such as training, self-efficacy, relevance to job, complexity, etc could also account for additional variance (Lee et al., 2003).

Additionally, longitudinal studies over time could also look at the trending of GIS technology adoption within an assessor's office to understand how well training programs are working as well as the role of GIS technology takes on in a professional environment over time.

GIS adoption could also be divided into specialized areas that concern everyday users of web-based spatial decision support systems versus those data science experts or CAMA specialists who analyze the data with special tools such as desktop GIS. Also, issues such as gender or age differences may also be interesting to understand within GIS technology adoption for future research.

Finally, since the current research indicated that the TAM was a robust theoretical framework, and could be applied to understanding adoption within the context of GIS technology in the property assessor professional work environment. It would be interesting in future studies on GIS technology adoption to see how this model would generalize to other professional work environments as well.

APPENDICIES

APPENDIX A
IRB Approval Letter



DIVISION OF RESEARCH & ECONOMIC DEVELOPMENT

UND.edu

Institutional Review Board
Twamley Hall, Room 106
264 Centennial Dr Stop 7134
Grand Forks, ND 58202-7134
Phone: 701.777.4279
Fax: 701.777.6708

May 11, 2016

Principal Investigator(s):	Daniel J. Fasteen
Project Title:	Factors that Influence the Adoption of Geographic Information Systems Technology (GIST) in a Professional Work Environment: A Study of the Property Assessment Profession
IRB Project Number:	IRB-201605-385
Project Review Level:	Exempt 2
Date of IRB Approval:	05/11/2016
Expiration Date of This Approval:	05/10/2019

The application form and all included documentation for the above-referenced project have been reviewed and approved via the procedures of the University of North Dakota Institutional Review Board.

If you need to make changes to your research, you must submit a Protocol Change Request Form to the IRB for approval. No changes to approved research may take place without prior IRB approval.

This project has been approved for 3 years, as permitted by UND IRB policies for exempt research. You have approval for this project through the above-listed expiration date. When this research is completed, please submit a Termination Form to the IRB.

The forms to assist you in filing your project termination, adverse event/unanticipated problem, protocol change, etc. may be accessed on the IRB website: <http://und.edu/research/resources/human-subjects/>

Sincerely,

Michelle L. Bowles, M.P.A., CIP
IRB Coordinator

MLB/sb

Cc: Steven LeMire, Ph.D.

APPENDIX B
International Association of Assessing Officers (IAAO) Letter of Support



February 19, 2016

Daniel J. Fasteen
PhD Candidate
Educational Foundations and Research
University of North Dakota
17849 Fielding Way
Lakeville, MN 55044

Dear Mr. Fasteen,

The International Association of Assessing Officers gives their full support to your dissertation research. The IAAO has granted you permission to survey our association's membership.

The IAAO believes your research that attempts to further identify learning patterns in the technical field of geographical information systems will ultimately benefit our professional membership.

Research findings could assist the IAAO in the development of continuing education formats for assessment professionals who need to fully understand GIS technologies and their capacity to streamline operational workflows.

The IAAO looks forward to participating in your research, and we appreciate the academic contribution you are personally making to enhance our organization's mission.

Sincerely,

A handwritten signature in black ink, appearing to read 'Ron Worth', is written over a light blue horizontal line.

Ron Worth
Executive Director

APPENDIX C Online Survey Informed Consent Page



Please read the below statement of informed consent. Completion of the survey implies that you have read the information on this page and consent to participate in the research. Please click the arrow below to begin the survey.

FACTORS THAT INFLUENCE THE ADOPTION OF GIST IN A PROFESSIONAL WORK ENVIRONMENT: A STUDY OF THE PROPERTY ASSESSMENT PROFESSION

Purpose of the Study:

The purpose of this research study is to assess factors that influence the adoption of GIS Technology in a professional work environment. In this case the property assessment professional work environment.

Procedures to be Followed:

You will be asked to answer a short survey with ten questions. Nine are demographic questions and one asks you to provide your level of agreement to the statements provided.

Risks:

There are no risks in participating in this research beyond those experienced in everyday life.

Benefits:

- This research will provide insight into the individual factors that influence the adoption of GIST to design future educational opportunities that would benefit the IAAO and professional property assessors alike.
- It will provide data to look at efficiency, perceived ease of use, perceived usefulness, attitude, social influence and intent to use on professional experience and educational level.
- It will set up and test a structural model that could be used to predict intent to adopt GIST in the property assessment field.
- It will provide trends on actual uses of GIST in the property assessment profession.

Duration:

It will take approximately 5 to 10 minutes to complete the survey questions.

Statement of Confidentiality:

The questionnaire does not ask for any information that would identify who the responses belong to. Therefore, your responses are recorded anonymously. If this research is published, no information that would identify you will be included since your name is in no way linked to your responses. All survey responses that we receive will be treated confidentially and stored on a secured server. However, given that the surveys can be completed from any computer (e.g., personal, work, school), we are unable to guarantee the security of the computer on which you choose to enter your responses. As a participant in this study, please be aware that certain "key logging" software programs exist that can be used to track or capture data that you enter and/or websites that you visit.

Right to Ask Questions:

The researcher conducting this study is Daniel Fasteen. If you later have questions, concerns, or complaints about the research please contact Daniel at (218) 791-3439 during the day or at daniel.fasteen@und.edu. Otherwise you may contact the dissertation adviser, Dr. Steven LeMire at (701) 777-3158 or at steven.lemire@und.edu.

If you have questions regarding your rights as a research subject, you may contact The University of North Dakota Institutional Review Board at (701) 777-4279. You may also call this number with problems, complaints, or concerns about the research. Please call this number if you cannot reach research staff, or if you wish to talk with someone who is an informed individual who is independent of the research team.

General information about being a research subject can be found on the Institutional Review Board website "Information for Research Participants" <http://und.edu/research/resources/human-subjects/research-participants.cfm>

Compensation:

You will not receive compensation for your participation.

Voluntary Participation:

You do not have to participate in this research. You can stop your participation at any time. You may refuse to participate or choose to discontinue participation at any time without losing any benefits to which you are otherwise entitled. You do not have to answer any questions you do not want to answer. You must be 18 years of age or older to consent to participate in this research study.

Completion of the the survey implies that you have read the information in this page and consent to participate in the research.

Please click the arrow to begin the survey.



APPENDIX D
Online Survey Page 1 Screenshots



Thank you for participating in this research. This questionnaire will only take about five minutes to complete and can be relevant to any environment of GIS technology that you use.

The purpose of this research is to assess factors that influence the adoption of GIS technology. Please take a moment to answer the questions below to the best of your ability. The responses to the questions will be confidential.

GIS within this research is defined as "computerized software used to view and manage information about geographic places, analyze spatial relationships, and model spatial processes (ESRI)."

What is your Education level?

- Less than High School
- High School
- Some College
- Bachelors Degree
- Masters Degree
- Ph.D.

What is your age?

How many years of experience do you have in the property assessment profession.

How many years of experience do you have with GIS Technology?

What State do you work in?

If you work outside of the United States please mark International.

What type of jurisdiction do you work for?

- City
- Township
- State
- District
- County
- Proviencoe
- Other (Please explain)

APPENDIX D
Online Survey Page 1 Screenshots Continued

What is your Jurisdiction Size?

- 0 -10,000 parcels
- 10,000 - 50,000 parcels
- 50,000 - 100,000 parcels
- 100,000 - 150,000 parcels
- 150,000 - 500,000 Parcels
- Greater than 500,000 parcels

How often (in hours per week) approximately do you use GIS Technology (Can be any GIS environment such as web or desktop)

- Less than 2 hours
- Between 2 and 5 hours
- Between 5 and 7 hours
- Between 8 and 10 hours
- More than 10 hours
- I do not use GIS



APPENDIX D
Online Survey Page 2 Screenshots



What do you (personally) use GIS for?

	Please indicate your level of usage			
	Always	Often	Sometimes	Never
Land Records Management (i.e., parcel management or viewing attributes on a property)	<input type="radio"/>	<input type="radio"/>	<input type="radio"/>	<input type="radio"/>
Market Sales Comparisons	<input type="radio"/>	<input type="radio"/>	<input type="radio"/>	<input type="radio"/>
Simple Visualization of Property Data (Spatial uniformity of property characteristics, values, ratios, or other interval data)	<input type="radio"/>	<input type="radio"/>	<input type="radio"/>	<input type="radio"/>
Overlay and Proximity Analysis (i.e., find sales within a given distance of a roadway or visualize multiple attributes at once)	<input type="radio"/>	<input type="radio"/>	<input type="radio"/>	<input type="radio"/>
Cluster Analysis (i.e., significant hot or cold spots of ratios or other phenomena)	<input type="radio"/>	<input type="radio"/>	<input type="radio"/>	<input type="radio"/>
Analyze and Model Data (i.e., regression, interpolation) of residential and commercial sales data	<input type="radio"/>	<input type="radio"/>	<input type="radio"/>	<input type="radio"/>
Delineation of neighborhood or market areas	<input type="radio"/>	<input type="radio"/>	<input type="radio"/>	<input type="radio"/>
Analysis of agricultural data	<input type="radio"/>	<input type="radio"/>	<input type="radio"/>	<input type="radio"/>
3-D Analysis (Condos, High Rise)	<input type="radio"/>	<input type="radio"/>	<input type="radio"/>	<input type="radio"/>
Integration with other programs	<input type="radio"/>	<input type="radio"/>	<input type="radio"/>	<input type="radio"/>
Other (Please Explain) <input type="text"/>	<input type="radio"/>	<input type="radio"/>	<input type="radio"/>	<input type="radio"/>



APPENDIX D
Online Survey Page 3 Screenshots



Please rate each of the statements below based on your level of agreement to the statements.

	Strongly Disagree	Disagree	Somewhat Disagree	Somewhat Agree	Agree	Strongly Agree
Using GIS applications improves my job performance.	<input type="radio"/>	<input type="radio"/>	<input type="radio"/>	<input type="radio"/>	<input type="radio"/>	<input type="radio"/>
Using GIS improves my quality of work.	<input type="radio"/>	<input type="radio"/>	<input type="radio"/>	<input type="radio"/>	<input type="radio"/>	<input type="radio"/>
Using GIS gives me greater control over my work.	<input type="radio"/>	<input type="radio"/>	<input type="radio"/>	<input type="radio"/>	<input type="radio"/>	<input type="radio"/>
Using GIS in my position increases my task capacity.	<input type="radio"/>	<input type="radio"/>	<input type="radio"/>	<input type="radio"/>	<input type="radio"/>	<input type="radio"/>
Overall, I find GIS applications to be useful in my position.	<input type="radio"/>	<input type="radio"/>	<input type="radio"/>	<input type="radio"/>	<input type="radio"/>	<input type="radio"/>
My understanding of GIS technology is clear.	<input type="radio"/>	<input type="radio"/>	<input type="radio"/>	<input type="radio"/>	<input type="radio"/>	<input type="radio"/>
Using a GIS application does not require a lot of skill.	<input type="radio"/>	<input type="radio"/>	<input type="radio"/>	<input type="radio"/>	<input type="radio"/>	<input type="radio"/>
Using a GIS application does not require a lot of mental effort.	<input type="radio"/>	<input type="radio"/>	<input type="radio"/>	<input type="radio"/>	<input type="radio"/>	<input type="radio"/>
Learning to operate a GIS application is easy for me.	<input type="radio"/>	<input type="radio"/>	<input type="radio"/>	<input type="radio"/>	<input type="radio"/>	<input type="radio"/>
I find GIS applications flexible to interact with.	<input type="radio"/>	<input type="radio"/>	<input type="radio"/>	<input type="radio"/>	<input type="radio"/>	<input type="radio"/>
Overall, I believe that GIS applications are easy to use.	<input type="radio"/>	<input type="radio"/>	<input type="radio"/>	<input type="radio"/>	<input type="radio"/>	<input type="radio"/>
My supervisors and managers think that I should use GIS.	<input type="radio"/>	<input type="radio"/>	<input type="radio"/>	<input type="radio"/>	<input type="radio"/>	<input type="radio"/>
My colleagues think that I should use GIS.	<input type="radio"/>	<input type="radio"/>	<input type="radio"/>	<input type="radio"/>	<input type="radio"/>	<input type="radio"/>
The senior management of my department supports the use of GIS technology.	<input type="radio"/>	<input type="radio"/>	<input type="radio"/>	<input type="radio"/>	<input type="radio"/>	<input type="radio"/>
In general, the organization supports the use of GIS technology.	<input type="radio"/>	<input type="radio"/>	<input type="radio"/>	<input type="radio"/>	<input type="radio"/>	<input type="radio"/>

APPENDIX D
Online Survey Page 4 Screenshots



Please rate each of the statements below based on your level of agreement to the statements.

	Strongly Disagree	Disagree	Somewhat disagree	Somewhat Agree	Agree	Strongly agree
Using GIS reduces the time I spend on completing other job-related tasks.	<input type="radio"/>	<input type="radio"/>	<input type="radio"/>	<input type="radio"/>	<input type="radio"/>	<input type="radio"/>
Using GIS saves me time.	<input type="radio"/>	<input type="radio"/>	<input type="radio"/>	<input type="radio"/>	<input type="radio"/>	<input type="radio"/>
Using GIS allows me to complete my task in much less time.	<input type="radio"/>	<input type="radio"/>	<input type="radio"/>	<input type="radio"/>	<input type="radio"/>	<input type="radio"/>
GIS allows me to accomplish tasks using less staff.	<input type="radio"/>	<input type="radio"/>	<input type="radio"/>	<input type="radio"/>	<input type="radio"/>	<input type="radio"/>
Overall, using GIS increases task efficiency.	<input type="radio"/>	<input type="radio"/>	<input type="radio"/>	<input type="radio"/>	<input type="radio"/>	<input type="radio"/>
I like working with GIS Technology.	<input type="radio"/>	<input type="radio"/>	<input type="radio"/>	<input type="radio"/>	<input type="radio"/>	<input type="radio"/>
GIS makes work more interesting.	<input type="radio"/>	<input type="radio"/>	<input type="radio"/>	<input type="radio"/>	<input type="radio"/>	<input type="radio"/>
Working with GIS is enjoyable.	<input type="radio"/>	<input type="radio"/>	<input type="radio"/>	<input type="radio"/>	<input type="radio"/>	<input type="radio"/>
In property assessment, using GIS is a good idea.	<input type="radio"/>	<input type="radio"/>	<input type="radio"/>	<input type="radio"/>	<input type="radio"/>	<input type="radio"/>
When I have access to GIS, I intend to use it in my job.	<input type="radio"/>	<input type="radio"/>	<input type="radio"/>	<input type="radio"/>	<input type="radio"/>	<input type="radio"/>
Whenever possible, I would use GIS for my tasks	<input type="radio"/>	<input type="radio"/>	<input type="radio"/>	<input type="radio"/>	<input type="radio"/>	<input type="radio"/>
Even outside my job I would use GIS applications to do different things	<input type="radio"/>	<input type="radio"/>	<input type="radio"/>	<input type="radio"/>	<input type="radio"/>	<input type="radio"/>
I intend to increase my use of GIS applications for work in the future.	<input type="radio"/>	<input type="radio"/>	<input type="radio"/>	<input type="radio"/>	<input type="radio"/>	<input type="radio"/>
I have received quality training on the use and functionality of GIS	<input type="radio"/>	<input type="radio"/>	<input type="radio"/>	<input type="radio"/>	<input type="radio"/>	<input type="radio"/>

APPENDIX E
Descriptive Results of Demographic Variables

Variable	Attributes	Frequency	%	Cumulative %
Education Level	Less than High School	0	0	0
	High School	28	7.4	7.4
	Some College	133	35.3	42.7
	Bachelor's Degree	186	49.3	92.0
	Master's Degree	28	7.4	99.5
	Ph.D.	2	.5	100.0
Totals		377	100.0	
Age	Less than 21	0	0	0
	Between 21 and 30	26	6.9	6.9
	Between 31 and 40	83	22.0	28.9
	Between 41 and 50	86	22.8	51.7
	Between 51 and 60	129	34.2	85.9
	More than 61	53	14.1	100.0
Totals		377	100.0	
Years of Experience in the Assessment Profession	Less than 6	81	21.5	21.5
	Between 6 and 10	64	17.0	38.5
	Between 11 and 15	64	17.0	55.4
	Between 16 and 20	41	10.9	66.3
	Between 21 and 25	34	9.0	75.3
	Between 26 and 30	46	12.2	87.5
	More than 31	47	12.5	100.0
Totals		377	100.0	
Years of Experience with GIS Technology	Less than 6	116	30.8	30.8
	Between 6 and 10	117	31.0	61.8
	Between 11 and 15	85	22.5	84.4
	Between 16 and 20	44	11.7	96.0
	Between 21 and 25	11	2.9	98.9
	Between 26 and 30	2	.5	99.5
	More than 31	2	.5	100.0
Totals		377	100.0	
Type of Jurisdiction	City	61	16.2	16.2
	Township	7	1.9	18.0
	State	9	2.4	20.4
	District	2	.5	21.0
	County	289	76.7	97.6
	Province	2	.5	98.1
	Other	7	1.9	100.0
Totals		377	100.0	

Other Responses: Borough, Town, Metropolitan Government, Multiple Jurisdictions

APPENDIX E
Descriptive Results of Demographic Variables Continued

Number of Parcels in the Jurisdiction	Under 10,000	46	12.2	12.2
	10,000 – 50,000	154	40.8	53.1
	50,000 – 100,000	62	16.4	69.5
	100,000 – 150,000	31	8.2	77.7
	150,000 – 500,000	59	15.6	93.4
	Greater than 500,000	25	6.6	100.0
Totals		377	100.0	
Variable	Attributes	Frequency	%	Cumulative %
Hours a week that Respondents Use GIS Technology	Less than 2	50	13.3	13.3
	Between 2 and 5	90	23.9	37.1
	Between 5 and 7	63	16.7	53.8
	Between 8 and 10	57	15.1	69.0
	More than 10	115	30.5	99.5
	Do not use GIS	2	.5	100.0
Totals		377	100.0	

Level of agreement on the question: I have received quality training on the use and functionality of GIS technology.

	Frequency	Percent	M	SD
Some Form of Agreement	258	68.4		
Some From of Disagreement	119	31.6		
Totals	377	100.0	5.04	.92

APPENDIX E
Descriptive Results of Demographic Variables Continued

State	Frequency	%
Minnesota	159	42.2
Iowa	57	15.1
North Dakota	23	6.1
Florida	15	4.0
Virginia	15	4.0
Arizona	14	3.7
Arkansas	10	2.7
Missouri	10	2.7
Alaska	6	1.6
International	6	1.6
Illinois	5	1.3
Kansas	5	1.3
Wisconsin	5	1.3
New York	4	1.1
North Carolina	4	1.1
Ohio	4	1.1
Indiana	3	.8
Michigan	3	.8
Connecticut	2	.5
Montana	2	.5
Nebraska	2	.5
New Hampshire	2	.5
New Jersey	2	.5
Oregon	2	.5
South Dakota	2	.5
Utah	2	.5
West Virginia	2	.5
California	1	.3
Colorado	1	.3
Georgia	1	.3
Idaho	1	.3
Louisiana	1	.3
Massachusetts	1	.3
Nevada	1	.3
New Mexico	1	.3
Rhode Island	1	.3
Tennessee	1	.3
Texas	1	.3

APPENDIX E
 Descriptive Results of Demographic Variables Continued

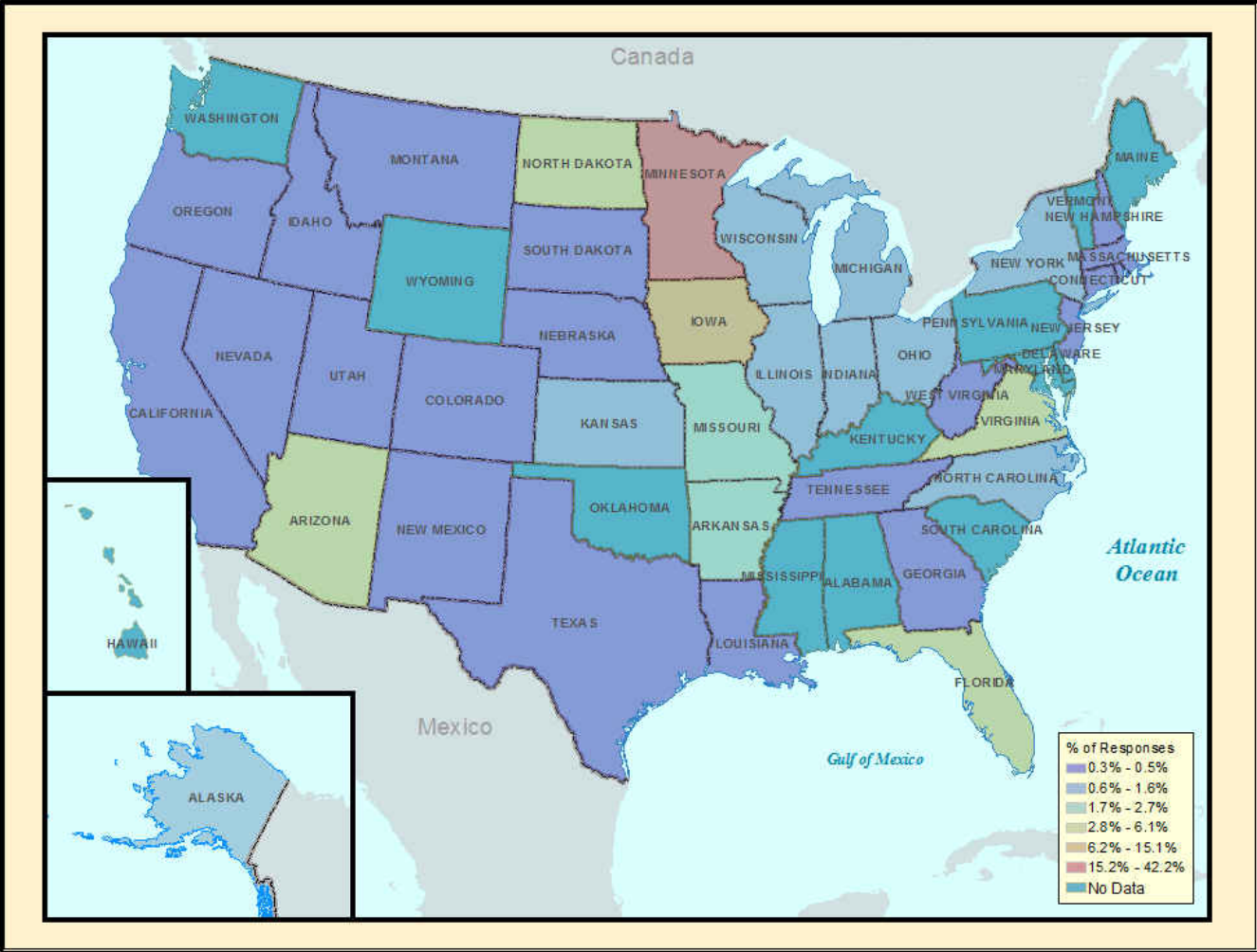

Location of responses across the United States.

References

- Adams, D.A., Nelson, R.R., Todd, P.A. (1992). Perceived usefulness, ease of use, and usage of information technology: A replication. *MIS Quarterly* 16(2), p.227-247.
- Agarwal, R., & Prasad, J. (1998). Are individual differences germane to the acceptance of new information technologies? *Decision Sciences*, 30(2), p. 361-391.
- Aguirre, J.C. (2014, June). The unlikely history of the origins of modern maps. *Smithsonian.com*. Retrieved from <http://www.smithsonianmag.com/history/unlikely-history-origins-modern-maps-180951617/?no-ist>.
- Ajzen, I. (1991). The theory of planned behavior. *Organizational Behavior and Human Decision Making Processes*, 50 (2), p.179-211.
- Ajzen, I., & Fishbein, M. (2005). The influence of attitudes on behavior. In D. Albarracín, B.T. Johnson, & M.M.P. Zanna (Eds.), *The handbook of attitudes*. Mahwah, NJ: Erlbaum.
- Ajzen, I., & Fishbein, M. (1980). *Understanding attitudes and predicting social behavior*. Englewood Cliffs, NJ: Prentice-Hall.
- Baker, T.R., Kerski, J.J., Huynh, N.T., Viehrig, K., & Bednarz, S.W. (2012). Call for an agenda and center for GIS education research. *Review of International Geographical Education Online*, 2(3), p. 254-288.
- Baker, T.R., & White, S.H. (2003). The effects of GIS on students' attitudes, self-efficacy and achievement in middle school science classrooms. *Journal of Geography*, 102, p. 243-254.
- Bidanset, P.E., Mccord, M., & Davis, P. (2016). Spatially accounting for spillover effects of foreclosures in automated valuation models to promote accuracy and uniformity of property tax assessments. *Journal of Property Tax Assessment & Administration*, 13(1), p. 5-19.
- Bidanset, P.E., & Lombard, J.R. (2014). Evaluating spatial model accuracy in mass real estate appraisal: A comparison of geographically weighted regression and the spatial lag model. *Cityscape*, 16(3), p. 169-182.
- Bidanset, P. (2014). Moving automated valuation models out of the box: The global geography of AVM's. *Fair & Equitable*, 12(7), p. 3-7.

- Case, B., Clapp, J., Durbin, R., & Rodriguez, M. (2004). Modeling spatial and temporal house price patterns: A comparison of four models. *The Journal of Real Estate Finance and Economics*, 29(2), p. 167-191.
- Chang, S.C., & Tung, F.C. (2008). An empirical investigation of students' behavioural intentions to use the online learning course websites. *British Journal of Educational Technology*, 39 (1), p. 71-83.
- Cheung, R., & Vogel, D. (2013). Predicting user acceptance of collaborative technologies: An extension of the technology acceptance model for e-learning. *Computers and Education*, 63, p. 160 – 175.
- Coppock, J.T., Rhind, D.W. (1991). The History of GIS. In: Maguire, D.J., Goodchild, M.F., Rhind, D.W. (Eds.), *Geographical Information Systems: Principles and Applications*, Longman Scientific and Technical, London, pp. 21–43.
- Crossland, M.D., Wynne, B.E., & Perkins, W.C. (1995). Spatial decision support systems: An overview of technology and a test of efficacy. *Decision Support Systems*, 14, p. 219-235.
- David, A.K. (1998). Multiple factor models. Retrieved August 8, 2016 from <http://davidakenny.net/cm/mfactor.htm>.
- Davis, F.D. (1989). Perceived usefulness, perceived ease of use, and user acceptance of information technology. *MIS Quarterly*, 13(3). P. 319-340.
- Davis, F.D., Bagozzi, R.P., & Warshaw, P.R. (1989). User acceptance of computer technology: A comparison of two theoretical models. *Management Science*, 35(8), p. 982-1003.
- Dennis, A.R., & Carte, T.A. (1998). Using geographical information systems for decision making: Extending cognitive fit theory to map-based presentations. *Information Systems Research*, 9(2), p. 194-203.
- Dillion, A., & Morris, M.G. (1996). User acceptance of information technology: Theories and models. *Annual Review of Information Science and Technology*, 31, p. 3-32.
- Dishaw, M.T., & Strong, D.M. (1999). Extending the technology acceptance model with task technology fit constructs. *Information and Management*, 36(1), p. 9-21.
- Doll, W.J., & Hendrickson, A., & Deng, X. (1998). Using Davis's perceived ease of use instruments for decision making: A confirmatory and multigroup invariance analysis. *Decision Sciences*, 29(4), p. 839-869.
- Dransch, D. (2000). The use of different media in visualizing spatial data. *Computers and Geosciences*, 26(1), p. 5-9.

- Farrell, A. (1994). Structural equation modeling with longitudinal data: Strategies for examining group differences and reciprocal relationships. *Journal of Consulting and Clinical Psychology*, 62(3), p. 477-487.
- FathiZahraei, M., Marthandan, G., Raman, M., & Asadi, A. (2015). Reducing risks in crisis management by GIS adoption. *Natural Hazards*, 76, p. 83-98.
- Fishbein, M., & Ajzen, I. (1975). Belief, attitude, intention, and behavior: An introduction to theory and research. Boston: Addison-Wesley.
- Fishbein, M. (1980). A theory of reasoned action: Some applications and implications, in *Nebraska Symposium on Motivation* H.Howe and M.Page (eds.). Lincoln, NB: University of Nebraska Press.
- Fleming, C. (2014). The GIS guide for elected officials. Redlands, CA, ESRI Press.
- Foresman, T.W. (1998). *The history of geographic information systems: Perspectives from the pioneers*. Upper Saddle River, NJ: Prentice Hall Press.
- Ganapati, S. (2011). Uses of public participation geographic information systems in e-government. *Public Administration Review*, 71(3), p. 425-434.
- Gathery, S.W., & Nyika, D. (2015). Application of geographic information system in property valuation. *International Journal of Scientific & Technology Research*, 4(8), p. 61-71.
- Gefen, D., & Straub, D.W. (2000). The relative importance of perceived ease of use in IS adoption: A study of e-commerce adoption. *Journal of the Association for Information Systems 1*.
- Gefen, D., & Keil, M. (1998). The impact of developer responsiveness on perceptions of usefulness and ease of use: An extension of the technology extension model. *Data Base*, 29(2), p. 35-49.
- Gloudemans, R.J. (2002). Comparison of three residential regression models: Additive, multiplicative and nonlinear. In *Vision Beyond Tomorrow, Integrating GIS & CAMA*, proceedings of the 2002 annual conference. Chicago: IAAO.
- Gloudemans, R., & Almy, R. (2011). Fundamentals of mass appraisal. Kansas City, MO: International Association of Assessing Officers.
- Goodchild, M. (2000). The current status of GIS and spatial analysis. *Journal of Geographical Systems*, 2 (1), p. 5 – 10.
- Hair, J.F., Black, W.C., Babin, B.J., & Anderson, R.E. (2009). *Multivariate Data Analysis* (7th ed). Upper Saddle River, NJ: Prentice Hall.

- Hardgrave, B., Davis, F., & Riemenschneider, C. (2003). Investigating determinants of software developers intentions to follow methodologies. *Journal of Management Information Systems*, 20 (1), p. 123-151.
- Hartwick, J., & Barki, H. (1994). Explaining the role of user participation in information systems use. *Information Systems Research*, 8(2), p. 440-465.
- Hatcher, L. (1994). *A step-by-step approach to using SAS for factor analysis and structural equation modeling*. Cary, NC: SAS Publishing.
- Hendrickson, A.R., & Collins, M.R. (1996). An assessment of structure and causation of IS usage. *Data Base*, 27(3), p. 61-67.
- Hockey, A. (2007). Towards a framework for supporting GIS competencies in local governments. *Proceedings of the CBRE Built Environment Education Conference*, p.1-15.
- Holt-Jensen, A. (2006). *Geography: History and concepts*. Thousand Oaks, CA: SAGE.
- Hu, P.J., Lin, C., & Chen, H. (2005). User acceptance of intelligence and security informatics technology: A study of COPLINK. *Journal of the American Society for Information Science and Technology*, 56 (3), p. 235-244.
- Hu, P.J., Chau, P.Y.K, Sheng, O.R.L., & Tam, K.Y. (1999). Examining the technology acceptance model using physician acceptance of telemedicine technology. *Journal of Management Information Systems*, 16(2). P. 91-112.
- Hubona, G.S., & Cheney, P.H. (1994). System effectiveness of knowledge-based technology: The relationship of user performance and attitudinal measures. Proceedings of the 27th annual Hawaii International Conference on System Sciences.
- Igbaria, M., Livari, M.J., & Maragahh, H. (1995). Why do individual use computer technology? A Finnish case study. *Information & Management*, 29(5), p. 227-238.
- Jackson, C.M., Chow, S., & Leitch, R.A. (1997). Toward an understanding of the behavioral intention to use an information system. *Decision Sciences*, 28(2), p. 357-389.
- Karahanna, E., Straub, D.W., & Chervany, N.L. (1999). Information technology across time: A cross-sectional comparison of pre-adoption beliefs. *MIS Quarterly*, 23, p. 183-213.
- Karahanna, E., & Straub, N.L. (1999). Information technology adoption across time: A cross sectional comparison of pre-adoption and post adoption beliefs. *MIS Quarterly*, 23(2), p.183-213.

- Karahanna, E., & Limayem, M. (2000). E-mail and V-mail usage: Generalizing across technologies. *Journal of Organizational Computing and Electronic Commerce* 10(1). p. 49-66.
- Kebede, L. (2007). Web-based GIS and digital oblique imagery: Considerations and examples for successful implementation of appraisal-focused technology. *Journal of Property Tax Assessment and Administration*, 4(2), p. 5-22.
- Keil, M, Beranek, P.M., & Konsynski, B.R. (1995). Usefulness and ease of use: Field study evidence regarding task considerations. *Decision Support Systems*, 13(1), p. 75-91.
- Kerski, J.J. (2003). The implementation and effectiveness of geographic information systems technology and methods in secondary education. *Journal of Geography*, 102, p. 128-137.
- Lee, J., Cerreto, F.A., & Lee, J. (2010). Theory of planned behavior and teachers' decisions regarding the use of educational technology. *Educational Technology and Society*, 13 (1), p. 152-164.
- Lee, J. & Bednarz, R. (2009). Effect of GIS learning on spatial thinking. *Journal of Geography in Higher Education*, 33(2), p.183-198.
- Lee, Y., Kozar, K.A., & Larsen, K.R.T. (2003). The technology acceptance model: Past, present, and future. *Communications of the Association for Information Systems*, 12 (50), p. 752-780.
- Lee, Y., Hsieh, Y., & Hsu, C. (2011). Adding innovation diffusion theory to the technology acceptance model: Supporting employees intentions to use e-learning systems. *Educational Technology & Society*, 14 (4), p. 124-137.
- Legris, P., Ingham, J., & Collerette, P. (2003). Why do people use information technology? A critical review of the technology acceptance model. *Information and Management*, 40, p. 191-204.
- Liu, X. (2010). Empirical testing of a theoretical extension of the technology acceptance model: An exploratory study of educational wikis. *Communication Education*, 59(1), p. 52-69.
- Lou, H., Luo, H.W., & Strong, D. (2000). Perceived critical mass effect on groupware acceptance. *European Journal of Information Systems* 9(2), p. 91-103.
- Lu, H., Yu, H., & Lu, S.S.K (2001). The effects of cognitive style and model type on DSS acceptance: An empirical study. *European Journal of Operational Research*, 13(1), p. 649-663.

- Lu, Y., Zhou, T., & Wang, B. (2009). Exploring Chinese users' acceptance of instant messaging using the theory of planned behavior, the technology acceptance model, and the flow theory. *Computers in Human Behavior*, 25, p. 29-39.
- Lu, H., & Gustafson, H. (1994). An empirical study of perceived usefulness and perceived ease of use on computerized support system use over time. *International Journal of Information Management*, 14(5), p. 317-329.
- Lucas, H.C., & Spitzer, V.K. (1999) Technology use and performance: A field study of broker workstations. *Decision Sciences*, 30(2), p. 291-311.
- Madden, T.J., Ellen, P.S., & Ajzen I. (1992). A comparison of the theory of planned behavior and the theory of reasoned action. *Personality and Social Psychology Bulletin*, 18 (1), p. 3-9.
- Malhotra, Y., & Galletta, D.F. (1999). Extending the technology acceptance model to account for social influence theoretical bases and empirical validation. Proceedings of the 32nd Hawaii International Conference on System Sciences.
- Mathieson, K. (1991) Predicting user intentions: Comparing the technology acceptance model with the theory of planned behavior. *Information Systems Research*, 2 (3), p.173-191.
- McFarland, D.J., & Hamilton, D. (2006). Adding contextual specificity to the technology acceptance model. *Computers in Human Behavior*, 22, 427.
- Mertler, C.A., & Vannatta, R.A. (2005). *Advanced and multivariate statistical methods* (3ed). Glendale, CA: Pyrzak Publishing.
- Moon, J.W., & Kim, Y.G. (2001). Extending the TAM for a world wide web context. *Information and Management*, 38, p. 217-230.
- Moore, G.C., & Benbasat, I. (1991). Development of an instrument to measure the perceptions of adopting an information technology innovation. *Information Systems Research*, 2 (3), p. 192-222.
- Narasimhan, R., Talluri, S., Sarkis, J., & Ross, A. (2005). Efficient service location design in government services. A decision support system framework. *Journal of Operations Management*, 23, p. 163-178.
- Nedovic-Budic, Z. (1998). The impact of GIS Technology. *Environment and Planning B: Planning and Design*, 25, p. 681-692.
- Nielsen, C.P., Oberle, A., & Sugumaran, R. (2011). Implementing a high school level geospatial technologies and spatial thinking course. *Journal of Geography*, 110, p. 60-69.

- Payton, S. (2006). A spatial analytic approach to examining property tax equity after assessment reform in Indiana. *The Journal of Regional Analysis and Policy*, 36(2), p. 182-193.
- Persico, D., Manca, S., & Pozzi, F. (2014). Adapting the technology acceptance model to evaluate the innovative potential of e-learning systems. *Computers in Human Behavior*, 30, p. 614-622.
- Quintos, C. (2013). Spatial weight matrices and their use as baseline values and location adjustment factors in property assessment models. *Cityscape*, 15(3), p.5-28.
- Rawstorne, P., Jayasuriya, R., Caputi, P. (2000). Issues in predicting and explaining usage behaviors with the technology acceptance model and the theory of planned behavior.
- Renne, J.S. (2003). Valuation methodologies for the assessment function, current and past practices. *Journal of Property Tax Assessment and Administration*. 10(4), p. 103-108.
- Rogers, E.M. (1983). *Difusion of Innovations* (Third Ed.). New York, NY: Free Press.
- Rogers, E.M. (2003). *Diffusion of Innovations* (Fifth Ed.). New York, NY: Free Press.
- Sambamuthy, V., & Chin, W.W. (1994). The effects of group attitudes toward alternative GDSS designs on the decision-making performance of computer supported groups. *Decision Sciences*, 25(2), p. 215-241.
- Schreiber, J.B., Stage, F.K., King, J., Nora, A., & Barlow, E.A. (2006). Reporting structural equation modeling and confirmatory factor analysis results: A review. *The Journal of Educational Research*, 99 (6), p.323 – 337.
- Sheppard, B.H., Hartwick, J., & Warsaw, P.R. (1988). The theory of reasoned action: A meta-analysis of past research with recommendations for modifications and future research. *Journal of Consumer Resarch*, 15(3), p. 325-343.
- Skaff, M.S., & Murphy, J.G. (2000). The role of GIS in imaging in assessment administration. *Assessment Journal*,
- Smelcer, J.B., & Carmel, E. (1997). The effectiveness of different representations for managerial problem solving: Comparing tables and maps. *Decision Sciences*, 28(2), p. 3901-420.
- Straub, D.W. (1994). The effect of culture on IT diffusion e-mail and FAX in Japan and the U.S. *Information Systems Research*, 5(1), p. 23-47.

- Subramanian, G.H. (1994). A replication of perceived usefulness and perceived ease of use measurement. *Decision Sciences* 25(5/6), p. 863-874.
- Szajna, B. (1994). Software evaluation and choice predictive validation of the technology acceptance instrument. *MIS Quarterly*, 18(3), p. 319-324.
- Taylor, S., & Todd, P. (1995). Understanding information technology usage: A test of competing models. *Information Systems Research*, 6 (2), p.144-176.
- Taylor, S., & Todd, P. (1995). Assessing IT usage: The role of prior experience. *MIS Quarterly*, 19 (4), p. 561-570.
- Thrall, G.I. (1998) GIS applications in real estate and related industries. *Journal of Housing Research*, 9 (1), p. 33-59.
- Thimgan, G.E. (2010) Property assessment valuation. Kansas City, MO: International Association of Assessing Officers.
- Thompson, R.L., Higgins, C.A., & Howell, J.M. (1991). Personal computing: Toward a conceptual model of utilization. *MIS Quarterly*, 15 (1), p. 125-143.
- Tomlinson, R. (2010). Thinking about GIS. *ESRI Press*: Redlands, CA
- Venkatesh, V. (2000). Determinants of perceived ease of use: Integrating control, intrinsic motivation, and emotion into the technology acceptance model. *Information Systems Research*, 11, p. 342-365.
- Venkatesh, V., Morris, M.G., Davis, G.B., & Davis, F.D. (2003). User acceptance of information technology: Toward a unified view. *MIS Quarterly*, 24(1), p. 425-478.
- Venkatesh, V., & Morris, M.G. (2000). Why don't men ever stop to ask for directions? Gender, social influence, and their role in technology acceptance and usage behavior. *MIS Quarterly*, 24(1), p. 115-139
- Venkatesh, V., & Davis, F. (2000). A theoretical extension of the technology acceptance model: Four longitudinal field studies. *Management Science*, 46(2), p. 186-204.
- Venkatesh, V., & Davis, F. (1996). A model for the antecedents of perceived ease of use development and test. *Decision Sciences*, 27(3). p. 451-481.
- Ventura, S.J. (1995). The use of geographic information systems in local government. *Public Administration Review*, 55 (5), p.461-467.
- Vreede, G.D., Jones, N., & Mgaya, R.J. (1999). Exploring the application and acceptance of group support systems in Africa. *Journal of Management Information Systems*, 15(3), p. 197-234.

- Wade, T., & Sommor, S. (2006). *A to Z GIS*. Redlands, CA: ESRI Press
- Wadsworth, W.M. (2006). CAMA/AA Immersion in GIS: The future is here. *Journal of Property Tax Assessment & Administration*, 3 (1), p. 33 – 43.
- Wallace, L.G., & Sheetz, S.D. (2014). The adoption of software measures: A technology acceptance model (TAM) perspective. *Information and Management*, 51, p. 249-259.
- West, B.A. (2003). Student attitudes and the impact of GIS on thinking skills and motivation. *Journal of Geography*, 102, p. 267-274.
- Wu, J., & Wang, S. (2005). What drives mobile commerce? An empirical evaluation of the revised technology acceptance model. *Information and Management*, 42 (5), p.719-729.
- Xia, W., & Lee, G. (2000). The influence of persuasion, training, and experience on user perceptions and acceptance of IT innovation. *Proceedings of the 21st International Conference on Information Systems*. p. 371-384.
- Yeh A, (1999). Urban planning and GIS In Longley, PA, Goodchild MF, Maguire, D.J. (eds) *Geographical Information Systems*, vol II, p. 877-888, John Wiley & Sons, New York, NY.
- Yousafzai, S.Y., Foxall, G.R., & Pallister, J. (2010). Explaining internet banking behavior: Theory of reasoned action, theory of planned behavior, or technology acceptance model? *Journal of Applied Social Psychology*, 40 (5), p. 1172-1202.