

Electronic Theses and Dissertations, 2004-2019

2017

The Contribution of Educators' Levels of Inspiration and Compassion for Others to Their Degree of Burnout

Samuel Bierbrauer
University of Central Florida

 Part of the [Counselor Education Commons](#), and the [Education Commons](#)
Find similar works at: <https://stars.library.ucf.edu/etd>
University of Central Florida Libraries <http://library.ucf.edu>

This Doctoral Dissertation (Open Access) is brought to you for free and open access by STARS. It has been accepted for inclusion in Electronic Theses and Dissertations, 2004-2019 by an authorized administrator of STARS. For more information, please contact STARS@ucf.edu.

STARS Citation

Bierbrauer, Samuel, "The Contribution of Educators' Levels of Inspiration and Compassion for Others to Their Degree of Burnout" (2017). *Electronic Theses and Dissertations, 2004-2019*. 5612.
<https://stars.library.ucf.edu/etd/5612>

THE CONTRIBUTION OF EDUCATORS' LEVELS OF INSPIRATION AND COMPASSION
FOR OTHERS TO THEIR DEGREE OF BURNOUT

by

SAMUEL LOGAN BIERBRAUER
B.A., Colorado Mesa University, 2012
M.C., Arizona State University, 2015

A dissertation submitted in partial fulfillment of the requirements
for the degree of Doctor of Philosophy
in the Department of Child, Family, and Community Sciences
in the College of Education and Human Performance
at the University of Central Florida
Orlando, Florida

Summer Term
2017

Major Professors: Glenn W. Lambie & Sejal M. Barden

ABSTRACT

This study investigated the directional relationship between educators' levels of inspiration and compassion for others to their degree of burnout. Specifically, the investigation tested the hypothesized directional relationship that educators' who report higher levels of inspiration (as measured by the *Educator Inspire Scale*, EIS; Lambie, Barden, & Bierbrauer, 2016) and compassion for others (as measured by the *Compassion for Others Scale*; COS; Pommier, 2010) would score at lower levels of burnout (as measured by the three components of burnout [emotional exhaustion, depersonalization, personal accomplishment] on the *Maslach Burnout Inventory – Educator Survey*; MBI-ES; Maslach, et al., 1996). In addition, the investigation examined the relationship between educators' levels of inspiration, compassion for others, and burnout and their reported demographic information (e.g., age, years of experience, type of school, etc.).

A review of the literature along with empirical support for the tested theoretical model of the three constructs of interest (educator inspiration, compassion for others, and burnout) is presented. A correlational research design was used to investigate the hypothesized structural model and exploratory research questions (Tabachnick & Fidell, 2012). Structural equation modeling (SEM) was used to test the hypothesized structural model. The results found an acceptable model fit with these data. Specifically, the results yielded statistically significant relationship between educator inspiration and burnout, with educator inspiration accounting for approximately 17%, 15%, and 33% of variance in emotional exhaustion, depersonalization, and personal accomplishment, respectively. Study limitations and implications of this study are discussed.

Dedicated to my mother, Suzanne Bierbrauer

ACKNOWLEDGEMENTS

Ah, the acknowledgements section – without a doubt *the most* difficult portion of this dissertation for me to write. Not because I thought the dissertation itself was easy (FAR from it), but simply for the fact that there are no words to express the amount of honor and gratitude that I have for the people who have helped me along this journey. Nonetheless, there are a select few who, if not for their support, guidance, and “tough love”, I do not believe I would have finished the doctoral program. The following is my sincerest and most heart-felt expression of my thankfulness and gratitude.

First and foremost, I would not have even had the opportunity to begin this journey without the love and support of my immediate family. Dad, Fofi, Lonnie, Rebecca, Micho, Ayla, Mia, and baby Rooney: I love you all so very much and would not be the man that I am today without all of your support and encouragement. To Jim and Flo and all of the “cousins”, I appreciate all of your support and could not have done this without you. You all mean more to me than words can express and I am grateful for you all.

Similarly, I owe my deepest amount of gratitude to my co-chairs – Dr. Glenn Lambie and Dr. Sejal Barden, without each of your support and guidance, I would not have completed this project. In addition to the time and energy you both put forth in helping me with this dissertation, you both displayed a level of commitment in me that I will forever be indebted to you for - you each believed in me when I lost all belief in myself. You both showed me what it means to be a competent and effective counselor educator, while maintaining a balanced perspective and sense

of humanity. For all of your guidance, support (both academic and personal), and wisdom, I will be forever grateful that the two of you served as my co-chairs. Thank you.

To my committee – Dr. Bai, Dr. Hundley, and Dr. Taylor – thank you all for your support, feedback, and most importantly, your *patience* with me throughout this project! Dr. Bai, thank you very much for all of your support and feedback in making my dissertation as strong and statistically sound as it could be. Drs. Hundley and Taylor, thank you both very much for your support, both academic and emotional, as you each have a unique and humorous way of putting things back into perspective when I inevitably catastrophize everything!

Last, but *certainly* not least, to my cohort, “The Scholarly Survivors”, I could not have done this without each of you; you all have done more for me than you probably know, and I will always be grateful it was the five of you who I had the pleasure of experiencing this process with. You all, in your own personal and unique ways, helped me grow into the man and counselor educator that I am. Naomi – I always said that you were Superwoman; without you knowing it, you inspired me to persist even through the most difficult of times. Coralis – thank you very much for your support and encouragement; being so far from home, your hospitality helped us all become our own family. Shay – thank you very much for your positivity and unique ability to calm me down in the most stressful of times (not to mention for teaching me the benefits of using a planner!). Elizabeth – you were always there to listen to me vent and then turn around and offer some hilarious feedback that never failed to make me die from laughter. Chris – I looked up to you like a little brother looks up to his big brother; I couldn’t have asked for a better role model, not just as a counselor educator, but as a hilarious meme creator as well! I am so proud to have been a part of this cohort and am excited to see you all flourish in this field!

TABLE OF CONTENTS

LIST OF FIGURES	x
LIST OF TABLES	xii
CHAPTER ONE: INTRODUCTION.....	1
Statement of the Problem.....	1
Significance of the Study	2
Theoretical Framework.....	3
Burnout	3
Compassion.....	4
Educator Inspiration.....	5
Research Hypothesis and Exploratory Questions	10
Research Hypothesis.....	10
Exploratory Research Question One.....	12
Exploratory Research Question Two	12
Exploratory Research Question Three	12
Research Design.....	12
Research Method	13
Population and Sampling	13
Data Collection Procedures.....	14
Instrumentation	15
General Demographic Questionnaire.....	15
Educator Inspire Scale	16
Compassion for Others Scale.....	18
Maslach Burnout Inventory – Educator Survey.....	23
Marlow-Crowne Social Desirability Scale – Form X1.....	24
Data Analysis	25
Ethical Considerations	26
Potential Limitations of the Current Study	26
Chapter Summary	27
CHAPTER TWO: LITERATURE REVIEW	28

The Educational System in the United States	28
Burnout	29
Theoretical Foundation of Burnout.....	30
Empirical Research on Educator Burnout.....	31
Compassion.....	37
Theoretical Foundation of Compassion	38
Empirical Research on Compassion and Educator Burnout	39
Inspiration	43
Empirical Research on the Phenomenon of Inspiration.....	45
Empirical Research on Inspiration in Education	48
Educator Inspiration.....	51
Evocation and Educator Inspiration.....	51
Transcendence and Educator Inspiration	53
Approach Motivation and Educator Inspiration	55
Empirical Research on Educator Inspiration	56
Relationship Between Educator Inspiration, Compassion, and Burnout.....	57
Chapter Summary	59
CHAPTER THREE: METHODS.....	60
Population and Sampling Procedures	61
Data Collection Procedures.....	63
Instrumentation	64
General Demographic Questionnaire.....	65
Educator Inspiration Scale	65
Compassion for Others Scale.....	68
Mashlach Burnout Inventory – Educator Survey.....	72
Marlow-Crowne Social Desirability Scale – Form X1.....	77
Research Design.....	79
Threats to Validity	79
Research Hypothesis and Exploratory Questions.....	82
Research Hypothesis.....	82
Exploratory Research Question One.....	87

Exploratory Research Question Two	87
Exploratory Research Question Three	87
Data Analysis	87
Research Hypothesis	88
Exploratory Research Questions	92
Ethical Considerations	92
Potential Limitations of the Current Study	93
Chapter Summary	94
CHAPTER FOUR: RESULTS	95
Sampling and Data collection Procedures	96
Response Rate	97
Descriptive Data Results	99
Participant Demographic Information	99
Educator Inspiration	103
Compassion for Others	104
Burnout	107
Social Desirability	109
Data Screening and Statistical Assumptions in SEM	111
Sample Size	111
Missing Data	112
Outliers	113
Normality	115
Multicollinearity	131
Linearity Between Variables	133
Homoscedasticity	137
Estimation Techniques	137
Model Specification and Identification	138
Confirmatory Factor Analysis of the EIS	139
Confirmatory Factor Analysis of the COS	141
Confirmatory Factor Analysis of the MBI-ES	145
Secondary Analysis of the Complete Measurement Model	148

Complete Measurement Model.....	153
Analysis of the Research Hypothesis and Exploratory Questions.....	155
Research Hypothesis.....	155
Chapter Summary.....	165
CHAPTER FIVE: DISCUSSION.....	166
Study Summary.....	166
Descriptive Statistics.....	167
Confirmatory Factor Analyses of the EIS, COS and MBI-ES.....	168
Primary Research Hypothesis and Exploratory Questions.....	170
Discussion of the Results.....	171
Study Limitations.....	172
Research Design Limitations.....	173
Sampling Limitations.....	174
Instrumentation Limitations.....	174
Recommendations for Future Research.....	175
Implications of the Current Investigation.....	177
Implications for Educators, School, and Training Programs.....	177
Implications for Instrument Development.....	179
Chapter Summary.....	180
APPENDIX A: INFORMED CONSENT.....	182
APPENDIX B: DEMOGRAPHIC QUESTIONNAIRE.....	185
APPENDIX C: EDUCATOR INSPIRE SCALE (EIS).....	188
APPENDIX D: MASLACH BURNOUT INVENTORY – EDUCATOR SURVEY (EIS).....	193
APPENDIX E: COMPASSION FOR OTHERS SCALE (COS).....	195
APPENDIX F: MARLOWE-CROWNE SOCIAL DESIRABILITY SCALE – X1 (MCSDS-X1)	198
REFERENCES.....	200

LIST OF FIGURES

Figure 1: Hypothesized Structural Model.....	11
Figure 2: Measurement Model - EIS	83
Figure 3: Measurement Model - COS.....	84
Figure 4: Measurement Model – MBI-ES	85
Figure 5: Histogram - EIS: ML.....	116
Figure 6: Normal Q-Q Plot - EIS: ML.....	116
Figure 7: Histogram - EIS: EP.....	117
Figure 8: Normal Q-Q Plot - EIS: EP.....	117
Figure 9: Histogram - EIS: RS.....	118
Figure 10: Normal Q-Q Plot - EIS: RS.....	118
Figure 11: Histogram - EIS: PS	119
Figure 12: Normal Q-Q Plot - EIS: PS	119
Figure 13: Normal Q-Q Plot - EIS: PS	120
Figure 14: Normal Q-Q Plot - EIS: EI.....	120
Figure 15: Histogram - COS-R: DS.....	121
Figure 16: Normal Q-Q Plot - COS-R: DS.....	121
Figure 17: Histogram - COS-R: KD.....	122
Figure 18: Normal Q-Q Plot - COS-R: KD	122
Figure 19: Histogram - COS-R: CH	123
Figure 20: Normal Q-Q Plot - COS-R: CH	123
Figure 21: Histogram - COS-R: CT.....	124
Figure 22: Normal Q-Q Plot - COS-R: CT.....	125
Figure 23: Histogram - MBI-ES-R: EE	125
Figure 24: Normal Q-Q Plot - MBI-ES: EE	126
Figure 25: Histogram - MBI-ES-R: DP	126
Figure 26: Normal Q-Q Plot - MBI-ES: DP	127
Figure 27: Histogram - MBI-ES-R: PA	127
Figure 28: Normal Q-Q Plot - MBI-ES: PA	128
Figure 29: Normal P-P Plot - MBI-ES: EE.....	134
Figure 30: Normal P-P Plot - MBI-ES: DP	135
Figure 31: Normal P-P Plot - MBI-ES: PA	136
Figure 32: CFA - EIS	140
Figure 33: CFA - COS	143
Figure 34: CFA - 3 Factor COS.....	144
Figure 35: CFA – MBI-ES.....	146
Figure 36: CFA - MBI-ES-R	147

Figure 37: Measurement Model - EIS	149
Figure 38: Measurement Model - COS-R.....	150
Figure 39: Measurement Model - MBI-ES-R.....	151
Figure 40: Modified Hypothesized Structural Model.....	152
Figure 41: Complete Measurement Model	154
Figure 42: Modified Structural Model 1	158
Figure 43: Modified Structural Model 2.....	160

LIST OF TABLES

Table 1: Factor Structure - EIS	17
Table 2: Factor Structure - COS	20
Table 3: Inter-correlations Between Factors on COS	69
Table 4: Reliability and Measures of Central Tendency - COS	71
Table 5: Categorization of MBI-ES Scores	74
Table 6: Measures of Central Tendency of MBI-ES Scores.....	75
Table 7: Fit Indices – Social Desirability Measures	78
Table 8: Descriptions of Fit Indices.....	91
Table 9: Response Rate via Data Collection Methods.....	99
Table 10: Participant Demographic Information	101
Table 11: Measures of Central Tendency – Satisfaction, Stress, Support, Effectiveness	103
Table 12: Measures of Central Tendency - EIS.....	104
Table 13: Measures of Central Tendency - COS	106
Table 14: Range of Experienced Burnout.....	107
Table 15: Measures of Central Tendency – MBI-ES	108
Table 16: Measures of Central Tendency – MCSDS-X1	109
Table 17: Influence of Social Desirability on EIS, COS, and MBI-ES Scores	110
Table 18: Univariate Outliers.....	114
Table 19: Tests of Normality	128
Table 20: Tests of Normality – Transformed Variables	130
Table 21: Correlations Between Constructs of Interest	132
Table 22: Tolerance and VIF Values for EIS, COS, and MBI-ES Scores.....	133
Table 23: Model Fit - EIS	141
Table 24: Model Fit – COS & COS-R.....	145
Table 25: Model Fit – MBI-ES & MBI-ES-R	148
Table 26: Model Fit – Complete Measurement Model.....	155
Table 27: Model Fit – Structural Models.....	161
Table 28: Pearson’s Product-Moment Correlations.....	162

CHAPTER ONE: INTRODUCTION

The purpose of this research study was to investigate the directional relationship between educators' levels of inspiration and compassion to their degree of burnout. The hypothesized theoretical model that was examined was that educators' levels of inspiration (as measured by the *Educator Inspire Scale* [EIS]; Lambie, Barden, & Bierbrauer, 2017) and compassion (as measured by the *Compassion for Others Scale* [COS]; Pommier, 2010) contributed to their levels of burnout (as measured by the three dimensions [emotional exhaustion, depersonalization, personal accomplishment] of the *Maslach Burnout Inventory – Educator Survey* [MBI-ES]; Maslach, Jackson, Leiter, Schaufeli, & Schwab, 1996). Specifically, the hypothesized structural model tested the directional relationship that educators who report higher levels of inspiration and compassion for others scored at lower levels of burnout (emotional exhaustion, depersonalization, personal accomplishment). Further, the study investigated the relationship between educators' levels of inspiration, compassion, and burnout and their reported demographic information (e.g., gender, type of position, current school).

Statement of the Problem

Educator turnover has continued to be a problem for school districts and policy makers. Ingersoll and Smith (2003) reported that 40-50% of educators ($N = 7,429$) leave the profession within the first five years. In addition, educator turnover costs the United States approximately 2.2 billion dollars per year (Alliance for Excellent Education, 2014). Moreover, Ronfeldt, Loeb, and Wyckoff (2013) reported that as educator turnover increases, students' math and English language arts (ELA) scores decrease by an average of 9.2% and 5.45% respectively. As educator turnover continues to be a significant problem in the educational system, many researchers have

continued to investigate the phenomena of burnout and how to mitigate the effects of burnout in the profession of education (e.g., Abenavoli, Jennings, Greenberg, Harris, & Katz, 2013; Byrne, 1994; Maslach, 2003).

Burnout is a well-established construct that first emerged in the 1970s and has since been the topic of over 6,000 scholarly publications (Schaufeli, Leiter, & Maslach, 2008). However, despite the magnitude of investigations into burnout with educators, it continues to be a pervasive phenomenon that affects educators at all grade levels (Schubert-Iratorza & Fabry, 2014). Recent research has implemented a positive psychological approach to burnout, conceptualizing the phenomena as “the erosion of a positive psychological state” rather than assuming a strictly negative approach to burnout research (Schaufeli et al., 2008, p. 215). However, investigations into interventions that address burnout are limited due to difficulties with implementation and longitudinal follow-up studies, and focus more on interventions at the individual-level as opposed to an organizational-level (Maslach, 2003). Therefore, the following section outlines how this study can address this limitation and contribute to the burnout literature.

Significance of the Study

The findings of the current study contribute to: (a) the advancement of educator inspiration as an explicit construct; (b) increased awareness of the benefits of implementing compassion into an academic setting; (c) further understanding of the relationship between educator inspiration, compassion for others, and burnout; and (d) inform undergraduate and graduate training programs of the qualities that contribute to future educators’ levels of inspiration. In addition, the current investigation is the first empirical study to examine educator inspiration and compassion as they relate to the personal qualities of educators and burnout.

Furthermore, the present study provides empirical support for the psychometric properties of two theory-driven instruments (*Educator Inspire Scale*; Lambie et al., 2016; *Compassion for Others Scale*; Pommier, 2010).

There is a dearth of knowledge in the educational literature that addresses educator inspiration. The majority of investigations into educator inspiration are qualitative (e.g., Acker, 2003; Bradley, Kirby, & Madriaga, 2015) and lack an operational definition of inspiration. However, with the development of the *Educator Inspire Scale* (EIS; Lambie et al., 2017), this investigation addressed the lack of quantitative research into educator inspiration as well as contributed further understanding of the directional relationship between educator inspiration, compassion for others, and burnout. Furthermore, the investigation identified educator variables (inspiration and compassion) that mitigate the effects of burnout, supporting the understanding of developmental characteristics and behaviors of educators that can be incorporated into educator training programs as preventative measures to burnout.

Theoretical Framework

Burnout

Burnout was first conceptualized as an individual experience that developed over time in which negative changes occurred in: (a) attitudes and decision-making; (b) physiological states; (c) mental, emotional and behavioral health; and (d) occupational motivation (Freudenberger, 1974). Further developments of the burnout construct have included societal and organizational contributors to its development (Maslach et al., 1996). Although research burnout research began in the helping professions (i.e., Freudenberger, 1974; Maslach, 1976), burnout has been investigated across many disciplines, such as *nursing* (i.e., Bakker, Killmer, Siegrist, &

Schaufeli, 2000), *counseling* (e.g., Kottler & Hazler, 1996; Lambie, 2007; Wilkerson & Bellini, 2006); *business* (i.e., Maslach & Leiter, 2008); and *education* (e.g., Crosmer, 2008; Skaalvik & Skaalvik, 2010) as well as in different countries across the world (Schaufeli et al., 2008). Since burnout has been investigated across many disciplines, Maslach and colleagues (1996) broadened the definition of burnout as, “a state of exhaustion in which one is cynical about the value of one’s occupation and doubtful of one’s capacity to perform” (p. 20).

Maslach and Jackson (1981) extended the research on burnout as a multidimensional model and found three factors of burnout: (a) emotional exhaustion; (b) depersonalization; and (c) personal accomplishment. The presence of burnout in educators has received much attention given the moderate to high percentage of educators (30% - 75%) who report moderate to high levels of burnout (Cano-Garcia, Padilla-Munoz, & Carrasco-Ortiz, 2005). There are multiple factors that contribute to educator burnout, such as: (a) low self-efficacy (i.e., Skaalvik & Skaalvik, 2010); (b) poor school climate (i.e., Grayson & Alvarez); and (c) role ambiguity and work overload (i.e., Byrne, 1994). Prolonged symptoms of educator burnout can lead to impairment and increase helping professionals (e.g., educators) susceptibility to physical and mental disabilities, alcoholism, and substance abuse as well as absenteeism and increased student misbehavior (Freudenberger, 1984; Pas, Bradshaw, & Hershfeldt, 2012).

Compassion

Compassion has philosophical roots in Buddhism and is focused on the mindful approach to alleviating the suffering of others (Pommier, 2010). Neff (2003a) defined compassion as, “being touched by the suffering of others, opening one’s awareness to others’ pain and not avoiding or disconnecting from it, so that feelings of kindness towards others and the desire to alleviate their suffering emerge” (pp. 86-87). There is a dearth of literature focused on

compassion as a distinct construct – one reason for limited research on compassion is the conceptual similarities with other constructs, namely empathy (Brown, 1996). However, for this investigation, empathy is considered a building block for compassion (Gilbert, 2005). Further, whereas empathy depends on individuals’ abilities of perspective-taking (Eisenberg, 1991), compassion arises from individuals’ morals, values, and views of humanity (Dalai Lama, 1995).

Neff (2003a; 2003b) and Pommier (2010) are the seminal authors on the construct of compassion. Neff (2003) focused on the construct of self-compassion and Pommier (2010) extended her work to focus on compassion for others. Specifically, there are three components to compassion: (a) kindness; (b) common humanity; and (c) mindfulness. Kindness refers to the quality of understanding that people offer those who experience suffering as opposed to being critical or indifferent (Pommier, 2010). Common humanity in the sense of compassion refers to the continual recognition that the suffering of others is an aspect of the human experience and is not limited to isolated incidences. Mindfulness is the foundation of compassion as it requires individuals to become aware and remain open to the suffering of others despite their own personal reactions to the suffering. Compassion correlates with: (a) feelings of social connectedness; (b) compassionate love; and (c) empathy (Pommier, 2010). Moreover, Neff, Kirkpatrick, and Rude (2007) found that self-compassion was associated with enhanced psychological well-being.

Educator Inspiration

Inspiration is defined as when, “[an individual] apprehends something ordinarily beyond his or her capacities, because of an influence from beyond the self, and he or she is moved to communicate or implement that which is newly apprehended (Thrash & Elliot, 2004, p. 957). Inspired individuals are not driven by external rewards; rather, they are driven by a deep sense of

mission and purpose (Kerfoot, 2001). Thrash and Elliot (2003) identified three components of inspiration: (a) evocation; (b) transcendence; and (c) approach motivation. Evocation refers to the fact that inspiration occurs from experiencing something external of the self. Transcendence describes the experience of an inspired individual rising above his or her current preoccupations or perceived limitations. Approach motivation refers to the implementation of that which is newly apprehended. However, there is limited research focused on inspiration in education and no operational definition that focus on educators' inspirational qualities.

The partnership between the T. Denny Sanford Foundation and the Department of Child, Family, and Community Sciences at the University of Central Florida aimed to address the lack of empirical research on inspiration in education (Lambie et al., 2017). Thus, the goal of the partnership was to develop and validate an instrument that would measure educators' inspirational qualities. After a thorough review of the literature, and using the three components of inspiration proposed by Thrash and Elliot (2003; evocation, transcendence, approach motivation), Lambie and colleagues (2016) concluded that there were seven, theoretically-supported characteristics that would constitute an inspirational educator: (a) leadership; (b) motivation; (c) passion; (d) self-efficacy; (e) empathy; (f) academic optimism; and (g) resilience.

Operational Definitions

Burnout

For the purpose of this investigation, burnout was defined as, “overwhelming exhaustion, feelings of frustration, anger, and cynicism [towards students and colleagues], and a sense of ineffectiveness and failure” (Maslach & Goldberg, 1998, p. 64).

Emotional Exhaustion

Emotional exhaustion was defined as, “feelings of being emotionally overextended and depleted of one’s emotional resources” (Maslach & Goldberg, 1998, p. 64).

Depersonalization

Depersonalization was defined as, “an unfeeling and impersonal response towards recipients of one’s care or service (e.g., students)” (Maslach & Jackson, 1981, p. 101).

Personal Accomplishment

Personal accomplishment was defined as, “feelings of competence and successful achievement in one’s work with people (e.g., students)” (Maslach & Jackson, 1981, p. 101).

Compassion

For the purpose of this investigation, compassion was defined as, “being touched by the suffering of others, opening one’s awareness to others’ pain and not avoiding or disconnecting from it, so that feelings of kindness towards others and the desire to alleviate their suffering emerge” (Neff, 2003a, p. 86-87).

Kindness

Kindness was defined as, “being warm and understanding to others as opposed to being harshly critical or judgmental” (Pommier, 2010, p. 2).

Indifference

Indifference refers to the threat response an individual feels that “creates a barrier for the natural response of kindness” (Pommier, 2010, p. 22).

Common Humanity

Common humanity was defined as, “the recognition of shared human experience that allows for a sense of connection to others” (Pommier, 2010, p. 2 – 3).

Separation

Separation refers to the threat response in which individuals are unable to perceive others’ suffering as a common part of humanity and, “foregoes a compassionate response to [others’] instances of suffering” (Pommier, 2010, p. 25).

Mindfulness

Mindfulness was defined as, “a nonjudgmental, receptive mind state in which individuals observe their thoughts and feelings as they arise without trying to change them or push them away” (Neff, 2003b, p. 224).

Disengagement

Disengagement refers to as a dissociative response to the suffering of others (Pommier, 2010).

Inspiration

For the purpose of this investigation, inspiration was defined as an affective state that is evoked rather than self-generated which causes individuals to direct their goal-oriented behavior towards a cause that requires them transcend their ordinary preoccupations or limitations in pursuit of something beyond self-interest (Thrash & Elliot, 2003).

Educator Inspiration

For the purpose of this investigation, educator inspiration refers to educators that possess the self-efficacy and ability to create and maintain empathic relationships with students, families, and colleagues as a means to resiliently lead them in pursuit of an academically-focused vision that extends beyond their current circumstances and self-interest (Lambie et al., 2017).

Educator

For the purpose of this investigation, educators were defined as a professional in a school setting (e.g., K-12 educators, administrators, school counselors) who provides direct academic services to students.

Educator-in-training

For the purpose of this investigation, educator-in-training was defined as a student who is providing direct academic services as part of their degree requirements (e.g., clinical experience, internship, student-teachers).

Research Hypothesis and Exploratory Questions

The purpose of the investigation was to examine the strength and directional relationship between educators' levels of inspiration, compassion for others, and burnout. The following section presents the: (a) primary research question; (b) research hypothesis; and (c) exploratory questions.

Research Hypothesis

Educators scoring at higher levels of inspiration (as measured as measured by the *Educator Inspire Scale* [EIS]; Lambie et al., 2017) and compassion for others (as measured by the *Compassion for Others Scale* [CS]; Pommier, 2010) contribute to lower levels burnout (as measured by the three dimensions [lower emotional exhaustion (EE) scores, lower depersonalization (DP) scores, and higher personal accomplishment (PA) scores] of the *Maslach Burnout Inventory – Educator Survey* [MBI-ES]; Maslach et al., 1996). (see Figure 1 for the hypothesized theoretical model).

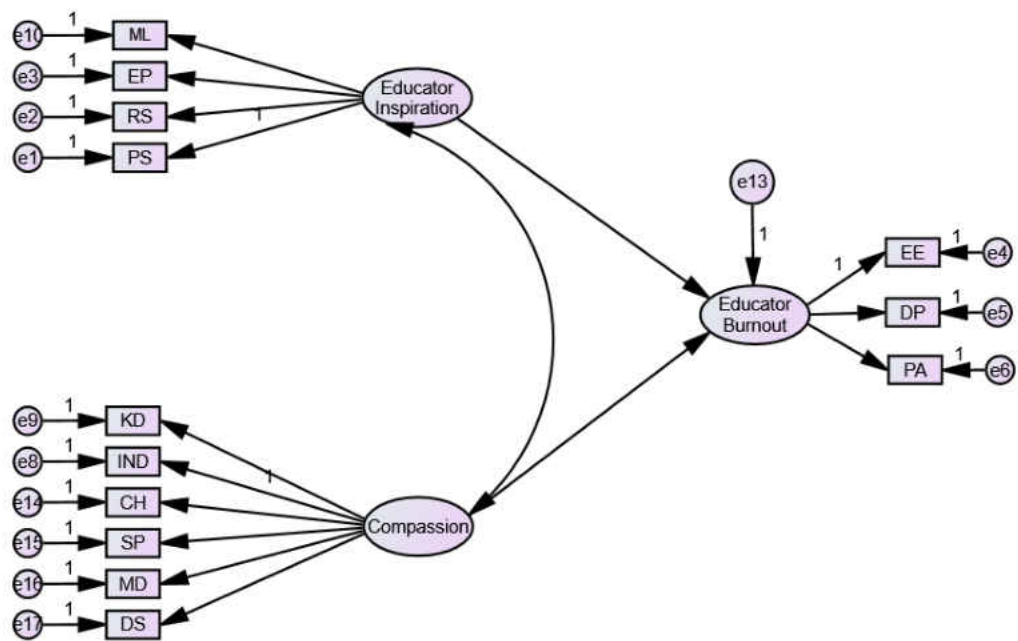

Figure 1: Hypothesized Structural Model

Exploratory Research Question One

What is the linear relationship between educators' reported demographic information (e.g., gender, age, years of experience, etc.) and their levels of burnout (as measured by the three subscale scores [emotional exhaustion, depersonalization, personal accomplishment] of the MBI-ES; [Maslach et al., 1996])?

Exploratory Research Question Two

Are there statistically significant relationships between educators' levels of burnout (as measured by the three subscales scores [emotional exhaustion, depersonalization, personal accomplishment] of the MBI-ES; Maslach et al., 1996) and their reported demographic variables (e.g., type of school, current position, years of experience, gender, etc.)?

Exploratory Research Question Three

Are there statistically significant relationships between educators' level of inspiration (as measured by the EIS; Lambie et al., 2017), compassion for others (as measured by the COS; Pommier, 2010) and their reported demographic variables (e.g., type of school, current position, years of experience, gender, etc.)?

Research Design

A correlational research design was used to test the research hypothesis and exploratory questions. Correlational research investigates the strength and direction of linear relationship between one or more variables (Gall et al., 2007); however, correlational research does not determine causal relationships between variables (Graziano & Roulin, 2006). As such, more

advanced correlational analyses (i.e., SEM) are recommended to explain complex relationships between variables (Crockett, 2012). SEM is a confirmatory analysis that allows researchers to test theoretical models composed of latent constructs (i.e., unobserved variables) within a causal framework (Lambie, 2007; Ullman, 2007).

Research Method

Population and Sampling

The identified target population was defined as educators and educators-in-training who provide direct educational services to students (e.g., K-12 educators, school counselors, student-teachers). However, given random sampling from the target population *was not feasible*, criterion sampling was used which is a process that, “involves the selection of cases that satisfy an important criterion” (Gall et al., 2007, p. 184). The criterion that needed to be met for participation was participants’ active involvement in providing direct educational services to students. The rationale for including administrators and school counselors in the final sample educators was due to their active involvement in students’ academic and socio-emotional needs. In addition, the norm sample ($N = 11,067$) of the *Maslach Burnout Inventory – Human Services Survey* (HSS; Maslach et al., 1996) included educators and administrators (i.e., K – 12) and mental health professionals (i.e., psychologists, counselors) and when separated by profession, burnout scores were comparable between educators and mental health professionals, suggesting the experience and rate of burnout is comparable across settings (i.e., academic and clinical). Educators and educators-in-training from the following three states comprised the final sample: (a) Florida; (b) Louisiana; and (c) Texas.

When determining adequate sample size for quantitative research it is important to consider population validity as well as the type of analysis that will be used (Gall et al., 2007). There are approximately six million educators and educators-in-training in the United States (U.S. Department of Labor, 2014). Determining an appropriate sample size a priori for SEM research is necessary to avoid Type II error (i.e., failing to reject a false null hypothesis; Balkin & Sheperis, 2011). According to MacCallum and colleagues (1996), given that the study had $df = 102$ (136 [observations] – 34 [parameters]; Kline, 2016, p. 128) and an approximate statistical power of .8, a sample size of 200 was sufficient for the study. Moreover, Kim (2005) provides an equation for calculating minimum sample size as a function of fit indices (i.e., root mean square error of approximation [RMSEA]). Based on the equation, $N_e = \frac{\delta_{1-\beta}}{\varepsilon^2 df} + 1$, where $\delta_{1-\beta} = 40.8892$, $\varepsilon^2 = .05$, and $df = 102$, in order to achieve an $RMSEA \leq .05$, the minimum sample size for the current study was 162 participants. Taken together, a minimum sample size that exceeds 200 was sufficient for this investigation (MacCallum et al., 1996).

Data Collection Procedures

Approval of all documentation (e.g., Human Research Protocol form, informed consent) from the university's Institutional Review Board (IRB) was obtained prior to any recruitment or data collection procedures. The data that was analyzed was part of a separate study funded by T. Denny Sanford Foundation. In the separate study, 4,000 data collection packets were printed which included: (a) an informed consent that outlines the purpose of the study; (b) a general demographic questionnaire; (c) the *Educator Inspire Scale* (EIS); (d) the *Compassion for Others Scale* (COS); (e) the *Maslach Burnout Inventory – Educator Survey* (MBI-ES); and (f) the *Marlowe-Crowne Social Desirability Scale – XI* (MCSDS-X1; Strahan & Gerbasi, 1972). In

addition, a pen was provided in each packet - small incentives such as a pen have been shown to increase response rates by up to 70% (Dillman, Smyth, & Christian, 2014).

Criterion sampling was used to obtain the required sample size for the study. Criterion sampling is a method in which participants who satisfy an important criterion are recruited for participation in a study (Gall et al., 2007). The data collection packets were disseminated via two face-to-face methods. First, data collection packets were disseminated to schools who employ practicing educators or educators-in-training throughout a large school district in a large southeastern state upon approval from the Superintendent. The second face-to-face method of data collection consisted of two parts: (a) contacting colleagues who have direct access to educators and/or educators-in-training (e.g., K-12 educators, school counselors, student-teachers, etc.) and then mailing data collection packets to the identified colleagues who then disseminated the data collection packets and returned the completed packets; and (b) attending classes, workshops, and career fairs that potential participants who meet the criteria for participation (i.e., educator or educator-in-training) were in attendance and distributing data collection packets to voluntary participants.

Instrumentation

General Demographic Questionnaire

The *General Demographic Questionnaire* is a self-report measure of the participants' demographic information (e.g., gender, age, marital status, geographic location, ethnicity, highest earned degree, years of experience as an educator, current position, and setting and type of school currently employed in). In addition, the questionnaire includes four Likert scale questions that asked participants to rank from 1 to 5: (a) *current level of satisfaction* (1 = very not satisfied,

5 = very satisfied); (b) *current level of stress* (1 = very stressed, 5 = very unstressed); (c) *current level of support at school* (1 = very unsupportive, 5 = very supportive) and (d) *current level of perceived effectiveness as an educator* (1 = very ineffective, 5 = very effective).

Educator Inspire Scale

The *Educator Inspire Scale* (EIS; Lambie et al., 2016) was used to measure educator inspiration. The EIS is an 18-item self-report measure with 4 subscales: (a) motivational leadership; (b) empathy; (c) resilience; and (d) passion. All of the items on the EIS are positively worded; hence, higher scores on the EIS indicate higher levels of inspiration. Response options for the EIS are on a Likert scale from 1 (strongly disagree) to 7 (strongly agree).

The EIS was developed in collaboration with the T. Denny Sanford Foundation to quantitatively measure educators' inspirational qualities. The purpose of the partnership was to develop an instrument with sound psychometric features that would measure educators' inspirational qualities. The instrument developers followed best practices outlined by DeVellis (2017) for instrument development and concluded that there were seven characteristics of inspirational educators (leadership, motivation, passion, self-efficacy, empathy, academic optimism, resilience). The initial instrument was sent to a panel of external reviewers who were experts in the fields of scale development and/or education for their feedback which was implemented into the final version of the EIS. Table 1 presents the factor structure ($N = 776$) of the EIS (Lambie et al., 2017)

Table 1
Factor Structure – EIS

EDUCATOR INSPIRE SCALE (EIS)	Factor			
	1	2	3	4
Motivational Leadership				
EIS20: I always encourage my students to achieve their academic goals.	.759			
EIS26: I have a genuine concern for my students.	.713			
EIS37: I work to have trusting relationships with all of my students	.560			
EIS49: I have confidence in my students' capacity to do well.	.642			
EIS53: I always strive to promote my students' success.	.839			
EIS56: I always urge my students to reach their personal aspirations.	.764			
EIS62: I care significantly about my students as individuals.	.767			
Empathy				
EIS5: I am always comfortable talking with students about their emotional concerns.		.768		
EIS33: I possess the ability to assess my students' emotional concerns.		.803		
EIS41: I am confident in my ability to communicate with students when they are emotionally distressed.		.854		
EIS69: I am always able to respond appropriately to my students' emotional concerns.		.723		
Resilience				
EIS25: I believe in my ability to work with challenging colleagues.			.579	
EIS28: I am flexible when confronted with difficult and/or changing situations.			.803	
EIS35: When faced with stressful situations as an educator, I am able to adapt very well.			.754	
EIS64: I possess the ability to accommodate to demanding conditions in the workplace.			.716	
Passion				
EIS10: I always participate in activities to continuously improve my work as an educator.				.517
EIS31: I regularly attend professional conferences and workshops in order to maintain educational best practices.				.942
EIS46: I frequently attend professional development workshops to be a stronger educator.				.938

Psychometric Properties of the EIS Scores

Although the EIS is in the early stages of development, the instrument has reported acceptable internal reliability coefficients. Lambie and colleagues (*unpublished*) reported the following Cronbach's α for the EIS and its subscales ($N = 770$): (a) *total* (18 items; $n = 727$; $\alpha = .901$); (b) *motivational leadership* (7 items; $n = 747$; $\alpha = .887$); (c) *empathy* (4 items; $n = 746$; $\alpha = .874$); (d) *resilience* (4 items; $n = 750$; $\alpha = .816$); and (e) *passion* (3 items; $n = 755$; $\alpha = .853$). In addition, scores on the EIS were positively and negatively related to scores on the COS, $r = .409$, $p < .001$, supporting the convergent validity of the EIS data. Furthermore, scores on the EIS were significantly associated with the burnout (as measured by the three dimensions of the MBI-ES [emotional exhaustion, depersonalization, personal accomplishment]; Maslach et al., 1996): (a) emotional exhaustion ($r = -.340$, $p < .001$); (b) depersonalization ($r = -.463$, $p < .001$); and (c) personal accomplishment ($r = .575$, $p < .001$), supporting both convergent and divergent validity.

Compassion for Others Scale

The *Compassion for Others Scale* (COS; Pommier, 2010) was used to measure educators' levels of compassion. The COS was developed and validated as part of a dissertation investigation. Pommier (2010) adapted the theoretical factor structure of the *Self-Compassion Scale* (SCS; Neff, 2003b). Similar to the SCS, the COS is comprised of three core components, each of which possess an opposite that create a continuum: (a) kindness vs. indifference; (b) common humanity vs. separation; and (c) mindfulness vs. disengagement. Kindness refers to a

warm and understanding disposition towards others. Common humanity refers to the recognition that suffering is experienced by all humans. Mindfulness refers to an emotional balance that prevents disengagement from others (Pommier, 2010). Items range on a five point Likert scale from 1 (almost never) to 5 (almost always); however, response options 2, 3, and 4 do not have specific descriptions. Table 2 represents the factor structure of the COS (Pommier, 2010).

Table 2
Factor Structure - COS

Compassion for Others Scale (COS)	Factor					
	1	2	3	4	5	6
Kindness						
COS6: If I see someone going through a difficult time, I try to be caring toward that person.	.74					
COS8: When others feel sadness, I try to comfort them.	.73					
COS16: I like to be there for others in times of difficulty.	.72					
COS24: My heart goes out to people who are unhappy.	.61					
Indifference						
COS2: Sometimes when people talk about their problems, I feel I don't care.		.69				
COS12: When others are feeling troubled, I usually let someone else attend to them.		.64				
COS14: Sometimes I am cold to others when they are down and out.		.58				
COS18: I don't concern myself with other people's problems.		.56				
Common Humanity						
COS11: Everyone feels down sometimes, it is part of being human.			.83			
COS15: It is important to recognize that all people have weaknesses and no one's perfect.			.71			
COS17: Suffering is just part of the common human experience.			.56			
COS20: Despite my differences with others, I know everyone feels pain just like me.			.54			

Table 2

Separation	
COS3: I don't feel emotionally connected to people in pain.	.73
COS5: I can't really connect with other people when they're suffering.	.73
COS10: When I see someone feeling down, I feel like I can't relate to them.	.68
COS22: I feel detached from others when they tell me their tales of woe.	.51
Mindfulness	
COS4: I tend to listen patiently when people tell me their problems.	.72
COS9: I pay careful attention when other people talk to me.	.72
COS13: I notice when people are upset, even when they don't say anything.	.67
COS22: When people tell me about their problems, I try to keep a balanced perspective on the situation.	.55
Disengagement	
COS1: When people cry in front of me, I often don't feel anything at all.	.68
COS7: I don't think much about the concerns of others.	.65
COS19: I often tune out when people tell me about their troubles.	.64
COS23: I try to avoid people who are experiencing a lot of pain.	.58

Note. Table adapted from Pommier, 2010, p. 121 – 122.

Psychometric Properties of the COS Scores

The theoretical foundation of the COS was adapted from the *Self-Compassion Scale* (SCS; Neff, 2003b) whose subscales have been shown to have acceptable reliability coefficients: (a) self-kindness, $\alpha = .78$; (b) self-judgment, $\alpha = .85$; (c) common humanity, $\alpha = .79$; (d) isolation, $\alpha = .77$; (e) mindfulness, $\alpha = .66$; and (f) over-identification, $\alpha = .75$ (Thompson & Waltz, 2008). The only theoretical difference between the COS and the SCS is that compassion on the COS is directed towards others whereas compassion on the SCS is directed towards the self. Pommier (2010) reported mixed results for the internal reliability scores for the six subscales on the COS: (a) Kindness, $\alpha = .77$; (b) Indifference, $\alpha = .68$; (c) Common Humanity, $\alpha = .70$; (d) Isolation, $\alpha = .64$, (e) Mindfulness, $\alpha = .67$; and (f) Disengagement, $\alpha = .57$; however, the total reliability score for the COS was sound, $\alpha = .90$. It is possible that the low reliability coefficient for the ‘Disengagement’ subscale is due to poor correlation between items and/or the low number of items (Tavakol & Dennick, 2011). The split-half reliability of the COS was also sound, $r = .90$ (Pommier, 2010). Overall, the COS is a new instrument that could benefit from further investigation into the reliability of the scores; it is possible that the opposing subscales (indifference, isolation, disengagement) share a significant amount of the variance for the compassion subscales (kindness, common humanity, mindfulness) which can limit the observed variance in the scores on the COS.

Maslach Burnout Inventory – Educator Survey

The *Maslach Burnout Inventory- Educator Survey* (MBI-ES Maslach et al., 1996) was used to measure educators' levels of burnout. The MBI-ES is a self-report, 22-item measure that consists of three dimensions: (a) emotional exhaustion; (b) depersonalization; and (c) personal accomplishment. Emotional exhaustion is the depletion of emotional resources to the extent that individuals no longer feel they can be fully invested in their work. Depersonalization refers to the physical and/or emotional detachment from others as well as cynical feelings that develop towards students, colleagues, and one's career. Personal accomplishment is defined as educators' feeling like their work contributes and enhances the learning and development of students. Response options assess the frequency with which educators experience certain aspects of burnout and are recorded on a six point Likert-scale. The MBI-ES was adapted from the *Maslach Burnout Inventory – Human Services Survey* (MBI-ESS; Maslach & Jackson, 1981); however, the only difference between the two instruments is that the MBI-ES changed the word "recipient" to "student" to better suited educators.

Psychometric Properties of the MBI-ES Scores

A full review of the development and validation of the MBI-ES are reported in the *MBI Training Manual* (Maslach et al. 1996). Maslach and colleagues (1996) reported sound internal consistency reliability coefficients (Clark & Watson, 1995) for the three dimensions of burnout: (a) emotional exhaustion, $\alpha = .90$; (b) depersonalization, $\alpha = .79$; and (c) personal accomplishment, $\alpha = .71$. Recent investigations using the MBI-ES have produced similar

reliability coefficients - Lim and Eo (2014) investigated burnout in a sample of 367 educators using the MBI-ES and reported sound/acceptable reliability coefficients: (a) emotional exhaustion, $\alpha = .88$; (b) depersonalization, $\alpha = .69$; and (c) personal accomplishment, $\alpha = .85$. Grayson and Alvarez (2008) used the MBI-ES to investigate educator burnout ($N = 320$ educators) and also found acceptable reliability coefficients for the three factor structure: (a) emotional exhaustion, $\alpha = .88$; (b) depersonalization, $\alpha = .80$; and (c) personal accomplishment, $\alpha = .64$. Furthermore, test-retest reliability with a one-year interval also supports the reliability of the MBI-ES: (a) emotional exhaustion, $r = .60$; (b) depersonalization, $r = .54$; and (c) personal accomplishment, $r = .57$. Overall, scores on the MBI-ES reliably measure educator burnout (Maslach et al., 1996).

Marlow-Crowne Social Desirability Scale – Form XI

Crowne and Marlow (1960) developed the *Marlowe-Crowne Social Desirability Scale* (MCSDS) to measure the amount of influence social desirability has on self-report measures. The original version of the MCSDS was normed on a sample of 76 undergraduate students and showed strong internal consistency, $\alpha = .88$, and test-retest reliability, $r = .89$ (Crowne & Marlowe, 1960); however, the length of the original instrument has resulted in the development multiple short forms of the MCSDS (e.g., Strahan & Garbasi, 1972; Reynolds, 1982) which has led to some disagreement amongst scholars as to which version is the strongest (Loo & Thorpe, 2000). Fischer and Fick (1993) investigated the psychometric properties of the six short forms the MCSDS and their relation to the original version to determine the best measure of social desirability. Overall, the authors reported acceptable fit indices for all of the short forms and

original form; however, Fischer and Fick (1993) concluded the *Marlowe-Crowne Social Desirability Scale – X1* (MCSDS-X1; Strahan & Gerbasi, 1972) was “scale of choice” among the various forms of the MCSDS (Fischer & Fick, 1993, p. 423).

Data Analysis

The completed data collection packets included: (a) the *General Demographic Questionnaire*; (b) EIS (Lambie et al. 2016); (c) COS (Pommier, 2010); (d) MBI-ES (Maslach et al. 1996); and (e) MCSDS-X1 (Strahan & Gerbasi, 1972). The completed packets were collected and entered into *Statistical Program Systems Software 23rd edition* (SPSS, 2015) and analyzed with SPSS, and *Analysis of Moment Structure* (AMOS, 2011). AMOS is a statistical modeling program that translates mathematical equations into visual representations (i.e., path diagrams) that represent the theoretical relationships (including measurement error) between the latent (i.e. unobserved) variables (Crockett, 2012).

Specifically, SEM was used to address the research hypothesis and exploratory questions for this study. SEM is a confirmatory procedure that uses a combination of multiple regression, path analysis, and confirmatory factor analysis (Byrne, 2016). In addition, SEM is often used to test the directionality of relationships between variables within a causal framework (Lambie, 2007; Ullman, 2007). Further, the following statistical assumptions were tested and met to ensure the data is appropriate for SEM: (a) normality; (b) homogeneity; (c) multicollinearity; and (d) relative variances (Kline, 2016).

Ethical Considerations

The ethical considerations that were considered by the IRB at the researcher's university and the dissertation committee were:

1. All of the data was collected anonymously to protect the identity of each participant.
2. Participation in the study was completely voluntary.
3. Each participant was given an informed consent which detailed their rights and purpose of the study. The informed consent that each participant received was approved by the IRB at the researcher's university.
4. Permission to use the MBI-ES (Maslach et al. 1996) was given by the developers of the instrument. The other instruments did not require permission to use in educational research.
5. The current investigation was conducted upon approval from the dissertation co-chairs, committee members, and the IRB at the researcher's university.

Potential Limitations of the Current Study

1. Although efforts were made to limit threats validity (e.g., construct, internal, and external), implicit limitations to descriptive correlational research remain.
2. The *Educator Inspire Scale* is a new instrument and the psychometric properties of the data need further validation.
3. The *Compassion for Others Scale* is a new instrument and the psychometric properties of the data need further validation.

4. All of the data collection instruments were self-report; hence, the scores on each may contain bias that could influence the results.
5. Given the sampling methods used in the current study, there is potential for the occurrence of sampling bias.

Chapter Summary

This chapter introduced the constructs of interest for the current investigation (educator inspiration, compassion for others, and burnout). The research methods were reviewed along with ethical considerations and potential limitations to the study. It is important for the research to address the directional relationship between educator inspiration, compassion for others, and burnout as the directional relationship between the constructs of interest has not been addressed in the current literature. Therefore, there is a need to address this gap in research to further our understanding of the theoretical model for this investigation.

CHAPTER TWO: LITERATURE REVIEW

This chapter introduced the constructs of interest for the current investigation (educator inspiration, compassion for others, and burnout). The research methods were reviewed along with ethical considerations and potential limitations to the study. It is important for the research to address the directional relationship between educator inspiration, compassion for others, and burnout as the directional relationship between the constructs of interest has not been addressed in the current literature. Therefore, there is a need to address this gap in research to further our understanding of the theoretical model for this investigation.

The Educational System in the United States

The educational system in the United States has utilized a standardized management paradigm in which assessment-based accountability measures (e.g., high-stakes testing) and prescribed curricula are the primary focus (Kesson & Henderson, 2010). The use of assessment-based accountability measures has increased since the *No Child Left Behind Act* was passed in 2001 and they have two primary objectives: (a) provide reliable information about student performance; and (b) motivate educators to enhance their teaching by attributing their students' test scores to their performance as educators (Neal, 2013). However, students' advancement and educators' salaries and tenure opportunities are contingent upon satisfying predetermined accountability measures (Amrein & Berliner, 2003; Harris & Adams, 2007). Increased emphasis on accountability measures leads to mechanical behaviors on the part of teachers and, "bleeds school children of their natural love of learning" (Sacks, 1999, p. 256 – 257). As a result, educators become conflicted between meeting their students' diverse learning needs and teaching

to the test (Greene, Caskey, Musser, Samek, Casbon, & Olson, 2008). Along with additional organizational conditions such as non-competitive wages and minimal administrative support, the educational climate that solely emphasizes accountability measures often contributes to educator attrition and burnout (Hansen, 2006; Ingersoll, 2001).

The United States spends approximately 2.2 billion dollars per year due to educator attrition (Alliance for Excellent Education, 2014). Goldring, Taie, and Riddles (2014) investigated educator attrition in the United States during the 2011-2012 academic year; results indicated that 16% of all educators ($N = 4,400$) in the United States were not teaching at the same school the following year. Furthermore, Ingersoll and Smith (2003) reported that 40-50% of educators ($N = 7,429$) leave the profession within the first five years. In sum, educator attrition is a significant concern in the United States; one of the most common contributors to educator attrition is burnout (Hansen, 2006; Skaalvik & Skaalvik, 2010). For the purpose of this investigation, educator is defined as a professional who provides direct educational services to students. Therefore, the term educator is used to encompass: (a) educators-in-training; (b) Pre K-12 educators and administrators; and (c) school counselors. The following section reviews the theoretical foundation of burnout as well as provide a thorough review of research on burnout.

Burnout

Burnout was first used to describe the negative behavioral and emotional responses of staff personnel at a free health clinic (Freudenberger, 1974). Maslach (1978) further developed the concept of burnout and characterized the multidimensional phenomenon. Since the work of Freudenberger (1974; 1975) and Maslach (1978), burnout has been a central focus of research

across many disciplines such as *nursing* (i.e., Bakker, Killmer, Siegrist, & Schaufeli, 2000), *counseling* (e.g., Kottler & Hazler, 1996; Lambie, 2007; Wilkerson & Bellini, 2006); *business* (i.e., Maslach & Leiter, 2008); and *education* (e.g., Crosmer, 2008; Skaalvik & Skaalvik, 2010). For the purpose of the current review, educator burnout was defined as, “overwhelming exhaustion, feelings of frustration, anger, and cynicism [towards students and colleagues], and a sense of ineffectiveness and failure” (Maslach & Goldberg, 1998, p. 64).

Theoretical Foundation of Burnout

Burnout occurs when helping professionals are unable to meet their own needs as well as their clients’ needs in a high-pressure society (Freudenberger, 1975). Burnout does not develop overnight - rather it develops over time, usually within a year of beginning one’s career (Freudenberger, 1989). Freudenberger (1974; 1986; 1990) observed and identified common symptoms of burnout, such as negative changes in: (a) attitudes and decision-making; (b) physiological states; (c) mental, emotional and behavioral health; and (d) occupational motivation.

Around the same time that Freudenberger (1974; 1986; 1990) developed his theory of burnout, Maslach (1976) conducted interviews to understand helping professionals’ experiences and responses to burnout, identifying three themes that characterized participants’ descriptions of their experiences: (a) emotional exhaustion; (b) depersonalization; and (c) low personal accomplishment. Emotional exhaustion is the depletion of emotional resources to the extent that individuals no longer feel they can be fully invested in their work. Depersonalization occurs when individuals develop cynical attitudes towards others and detaches physically and/or

emotionally from others. Lack of personal accomplishment describes individuals' decreased efficacy and negative evaluations which both contribute to lower satisfaction and meaning in their work. Maslach later used the three themes of burnout to develop the multidimensional model of burnout and the *Maslach Burnout Inventory* (MBI; Maslach & Jackson, 1981). Expanding Freudenberger's theory of burnout and other job stress theories, Maslach's multidimensional model of burnout addresses the experience of overwhelming stress as well as the responses and effects of the overwhelming stress (i.e., depersonalization and lack of personal accomplishment).

Empirical Research on Educator Burnout

The following section of the chapter reviews the empirical research on educator burnout within two domains: (a) external contributors to educator burnout (e.g., student misbehaviors, school climate, administrative support) and (b) internal contributors to educator burnout (e.g., self-efficacy, coping strategies, personal characteristics).

Educator Burnout: External Contributing Factors

Student misbehavior is a strong contributor to educator burnout (McCormick & Barnett, 2011). McCormick and Barnett (2011) utilized hierarchical linear regression modeling (HLM) to investigate the relationship between external stressors and educators' levels of burnout.

Educators ($N = 372$) from 38 high schools in Australia completed surveys that assessed: (a) demographic variables; (b) educator burnout; and (c) the intensity of stress caused by specific factors (e.g., personal, student, school, government). After accounting for educators' demographic variables, student misbehavior positively related to educators' feelings of

depersonalization ($\beta = .56, p < .05$) and emotional exhaustion ($\beta = .71, p < .05$). In contrast, student misbehavior negatively related to educators' feelings of personal accomplishment ($\beta = -.14, p < .05$). However, the results from McCormick and Barnett (2011) must be interpreted cautiously as the sample was limited to individuals from Australia and directionality of the relationship between student misbehavior and educator burnout was not examined. Nevertheless, increased levels of poor student misbehavior in school is a strong predictor of high levels of educator burnout.

Aloe and colleagues (2016) conducted a multivariate meta-analysis of studies ($k = 19$) investigating the relationship between student misbehavior and educator burnout. The researchers included studies that were: (a) written in English; (b) quantitative; (c) used a sample of in-service educators; and (d) utilized Person's correlations (or a statistic that could be converted to a Pearson's correlation). The researchers reported student misbehavior was consistently related to: (a) emotional exhaustion, $r = .44, SE = .0333, p < .001$ (19.36% of the variance explained); (b) depersonalization, $r = .36, SE = .0405, p < .001$ (12.96% of the variance explained); and (c) personal accomplishment was, $r = -.31, SE = .0366, p < .001$ (9.61% of the variance explained). However, only 36% of the studies explicitly identified the *Maslach Burnout Inventory – Educator Survey* (MBI-ES; Maslach, Jackson, & Schwab, 1986) as the primary instrument to measure educator burnout. Further, the studies that were reviewed by Aloe and colleagues (2016) did not investigate *causal* relationships between student misbehavior and educator burnout. Nonetheless, the research findings consistently identified significant relationships between student misbehavior and the three dimensions of educator burnout (emotional exhaustion, depersonalization, personal accomplishment).

In a correlational investigation, Lim and Eo (2014) used SEM to examine the directional relationship between school climate and educators' ($N = 367$) levels of burnout. Specifically, the researchers examined the influence of *reflective dialogue* (i.e. frequent conversations about teaching and learning between educators) and *organizational politics* with the school (i.e. educators' behaviors that promote self-interest rather than organizational goals) on educator burnout (as measured by the MBI-ES; Maslach, et al., 1996). In addition, the researchers examined the mediation effect of collective teacher efficacy on the relationship between reflective dialogue, organizational politics, and educator burnout in a sample of South Korean educators. The results indicated that reflective dialogue and collective teacher efficacy negatively affected educator burnout ($\gamma = -.31$; $\gamma = -.46$, respectively) together accounting for 43% of the variance in educator burnout ($R^2 = .43$). Moreover, collective teacher efficacy mediated the relationship between organizational politics and educator burnout. However, the researchers transformed the MBI-ES from a seven-point Likert scale to a five-point Likert scale to account for the differences in language between Korean and English. Consequentially, educators who do not engage one another in reflective dialogue, do not believe in one another's abilities to influence student achievement, and place personal interest over collective goals experience higher levels of educator burnout.

In a correlational study, Byrne (1994) used SEM to examine the influence of external factors, such as role conflict, work overload, and classroom climate contribute to educators' ($N = 3,044$) levels of burnout. Educators from two large metropolitan areas in central Canada completed the MBI-ES (Maslach et al., 1986), the *Teacher Stress Scale* (TSS; Pettegrew & Wolf, 1982), and the *Classroom Environment Scale* (CES; Bacharach, Bauer, & Conley, 1986) to

measure educators' levels of role conflict, work overload, educator burnout, and perceptions of classroom climate. Role conflict contributed to higher levels of emotional exhaustion for elementary and intermediate educators ($\beta = .570, p < .001$; $\beta = .659, p < .001$, respectively) as well as higher levels of depersonalization for secondary educators ($\beta = .125, p < .001$). Work overload contributed to higher levels of emotional exhaustion in secondary ($\beta = .621, p < .001$) educators. On the other hand, classroom climate negatively contributed to emotional exhaustion and depersonalization, regardless of school setting: (a) *elementary*; $\beta_{E; EE} = -.197, p < .001$; $\beta_{E; DEP} = -.267, p < .001$; (b) *intermediate*; $\beta_{I; EE} = -.228, p < .001$; $\beta_{I; DEP} = -.331, p < .001$; and (c) *secondary*; $\beta_{S; EE} = -.210, p < .001$; $\beta_{S; DEP} = -.367, p < .001$. Results from Byrne (1994) must be interpreted with caution as the study was conducted over 20 years ago; therefore, the results may not represent current levels of educator burnout. Further, potential differences may exist between the educational systems of the United States and Canada that would influence how external factors contribute to educator burnout. Nevertheless, increased workloads, role conflict, and negative classroom climates contribute to higher levels of educator burnout.

Educator Burnout: Internal Contributing Factors

Maslach (1982) outlined specific characteristics of individuals who are at-risk to experience burnout, including individuals who: (a) have low confidence and self-esteem; (b) lack of self-awareness about capabilities; (c) have unrealistic expectations for achievement; (d) lack autonomy and control in their career; and (e) lack emotional control. Although educators with several (or all) of these characteristics are not the only educators at-risk of burnout, it is important to consider how educators' internal or interpersonal factors contribute to their burnout.

Cano-Garcia, Padilla-Munoz, and Carrasco-Ortiz (2005) investigated the relationship between personality traits (as measured by the NEO-FFI; Costa & McCrae, 1999) and educators' ($N = 99$) level of educator burnout. The researchers surveyed special education and elementary educators from both public and private institutions in Sevilla, Spain. The results indicated that higher levels of neuroticism and agreeableness influenced educator burnout. Specifically, the results indicated that neuroticism and emotional exhaustion were positively related ($\beta = .72, p < .001; R^2 = .13$) whereas agreeableness was positively related to personal accomplishment ($\beta = .58, p < .001, R^2 = .34$) and negatively related to depersonalization ($\beta = -.37, p < .03, R^2 = .11$). However, the sample size for the investigation was small ($N = 99$) and consisted of special education and elementary educators from one province in Spain. Nonetheless, educators who score higher as neurotic, introverted and disagreeable score higher in burnout; thus, it is plausible educators who are rigid, keep to themselves, and do not get along with others will experience higher levels of burnout.

In a correlational study, Skaalvik and Skaalvik (2010) used SEM to examine the directional relationship between educators' ($N = 2,249$) perceived self-efficacy (as measured by the *Norwegian Teacher Self-Efficacy Scale*; NTSES; Skaalvik & Skaalvik, 2007) and educator burnout. Specifically, the researchers investigated how educators perceived abilities to instruct, motivate, adapt, discipline, cooperate, and cope related to emotional exhaustion and depersonalization in a sample of elementary and middle school educators in Norway. The results indicated negative and reciprocal relationships between self-efficacy and emotional exhaustion ($\beta = -.29$) and depersonalization ($\beta = -.41$). However, the researchers adapted the scoring scale on the MBI-ES to a six-point Likert scale with options that range from 1 (False) to 6 (True) and

did not use the personal accomplishment subscale of the MBI-ES; although the authors reported acceptable reliability coefficients for emotional exhaustion and depersonalization, $\alpha = .88$, and $\alpha = .70$, respectively. Therefore, educators with higher perceived self-efficacy experience less emotional exhaustion and depersonalization.

In a correlational study, Fernet, Guay, Senecal, and Austin (2012) used SEM to examine the mediating effect of changes in educators' intrinsic motivation and self-efficacy on the relationship between school factors and educator burnout ($N = 806$). Specifically, the researchers examined how changes in educators' motivation and self-efficacy mediate the relationship between educators' perceptions of: (a) overload; (b) decision latitude; (c) principals' leadership behaviors; and (d) students' disruptive behaviors on educator burnout in a sample of elementary and high school teachers from Quebec, Canada. The results indicated that educators' levels of motivation and self-efficacy decreased over an academic year (Δ Motivation = $-.72$, $p < .01$; Δ Self-efficacy = $-.08$, $p < .01$). In addition, the results indicated that the decreases in educators' motivation and self-efficacy were positively related to emotional exhaustion ($r = .40$, $p < .01$ and $r = .39$, $p < .01$, respectively) and depersonalization ($r = .20$, $p < .01$ and $r = .40$, $p < .01$, respectively). In contrast, increases in educators' motivation and self-efficacy were positively related to personal accomplishment ($r = .22$, $p < .01$ and $r = .68$, $p < .01$, respectively). Moreover, the researchers reported that classroom overload and student misbehavior had a negative impact on educator motivation ($\beta = -.29$, $p < .01$; $\beta = -.24$, $p < .05$, respectively), indicating a statistically significant indirect effect between classroom overload and student misbehavior on emotional exhaustion through educator motivation ($\beta = -.28$, $p < .05$). Further, the results indicated a negative relationship between student misbehavior and self-efficacy ($\beta = -$

.46, $p < .01$), indicating a statistically significant indirect effect between student misbehavior and emotional exhaustion ($\beta = -.37, p < .01$), depersonalization ($\beta = -.38, p < .01$) and personal accomplishment ($\beta = .63, p < .01$) through self-efficacy. However, it is important to note that not all participants who participated in the first data collection time-point participated in the second data collection time-point even though the researchers determined the two samples were not qualitatively different. Hence, Fernet and colleagues' (2012) findings underscore the importance of educators' motivation and sense of self-efficacy in protecting against educator burnout.

Compassion

Compassion is a core component of Buddhist philosophy (Dalai Lama, 1995) and is defined by Neff (2003a) as, "being touched by the suffering of others, opening one's awareness to others' pain and not avoiding or disconnecting from it, so that feelings of kindness towards others and the desire to alleviate their suffering emerge" (p. 86-87). Compassion has received limited empirical attention, possibly due to interrelatedness with constructs such as empathy which is presumed to be a building block for compassion (Brown, 1996; Gilbert, 2005, Zhou et al., 2003). However, compassion does not depend on individuals' ability of perspective-taking whereas perspective-taking is vital to empathy (Eisenberg, 1991); rather, compassionate feelings arise from individuals' morals, values, and views of humanity (Dalai Lama, 1995). Therefore, given the dearth of empirical research on compassion as a distinct construct, it is important to note that several studies reviewed in the subsequent sections will focus on empathy and caring as similar constructs to compassion in relation to educator burnout.

Theoretical Foundation of Compassion

Neff (2003a; 2007) is a leading pioneer in compassion research; specifically, self-compassion. Neff identified three distinct components, each of which occur on a continuum, that work symbiotically to create compassion: (a) kindness; (b) common humanity; and (c) mindfulness. Kindness refers to the quality of understanding that people offer those who experience suffering as opposed to being critical or indifferent (Pommier, 2010). Common humanity, in the context of compassion, refers to the continual recognition that the suffering of others is an aspect of the human experience and is not limited to isolated incidences. Mindfulness is the foundation of compassion as it requires individuals to become aware and remain open to the suffering of others. As such, kindness was proposed to be the opposite of indifference; common humanity was the opposite of separation; and mindfulness was the opposite of disengagement. Pommier (2010) conducted a correlational study using factor analysis to examine the factor structure of the *Compassion Scale* (CS; 2010), which was adapted from the *Self-Compassion Scale* (SCS; Neff, 2003b). Using the factor structure of the SCS, the researcher developed the initial 80-item, self-report instrument and administered it to undergraduate students ($N = 439$) who were randomly selected from an educational psychology subject pool at a large southwestern university. Results from a confirmatory factor analysis (CFA) supported the six-factor construct of compassion: (a) kindness; (b) indifference; (c) common humanity; (d) separation; (e) mindfulness; and (f) disengagement, $CFI = .97$; $NNFI = .96$; $SRMR = .05$; and $RMSEA = .05$. Further higher-order factor analysis provided acceptable support for a single factor (i.e., compassion), which explained the inter-correlations between the six factors, $CFI = .96$; $NNFI = .95$; $SRMR = .06$; $RMSEA = .06$. Furthermore, the final CS showed high

convergent validity with the Empathic Concern subscale of the *Davis Interpersonal Reactivity Index* (IRI; Davis, 1980), $r = .65, p < .01$, with 42% shared variance between the CS and Empathic Concern subscale of the IRI. However, an initial exploratory factor analysis (EFA) was not conducted and the sample consisted of undergraduates from one university. Nevertheless, the results from Pommier (2010) provide empirical support for the theoretical framework of compassion, consisting of six factors and highlight the similarities between compassion and empathy. Given the empirical support (i.e., Pommier, 2010) for the theoretical framework of compassion, the following section reviews the research focused on various aspects of compassion as they relate to educator burnout.

Empirical Research on Compassion and Educator Burnout

Teven (2007) investigated the relationship between educators' ($N = 48$) levels of caring and their levels of burnout (as measured by the MBI; Maslach & Jackson, 1981). Forty-eight faculty members from a medium-sized Southwestern university completed assessment packets that assessed perceived levels of caring for others and educator burnout. Teven (2007) reported that educators' levels of caring negatively related to emotional exhaustion ($r = -.39, p < .01$), depersonalization ($r = -.56, p < .001$), and loss of personal accomplishment ($r = -.26, p < .05$). It is important to note that the sample size for the investigation was small, consisting of faculty members from one university. Additionally, the reliability of the educators' reports of caring for others is subject to bias given that educators are less likely to report that they do not care for their students. The findings identified relationships between educators' levels of caring for others and lower scores of educator burnout (Teven, 2007).

Wróbel (2013) investigated the mediation effect of educators' ($N = 168$) emotional labor between their levels of empathy and emotional exhaustion. Participants from elementary, intermediate, and high schools in Poland completed surveys that included the *Mood Regulation Scale* (MRS; Wojciszke, 2003) and the Polish version of the emotional exhaustion subscale of the MBI (Maslach & Jackson, 1986). Results indicated that educators' empathy was positively related to positive mood induction ($\beta = .23, p < .01$), which in turn was negatively associated with emotional exhaustion ($\beta = -.17, p < .05$) with educators' mood regulation strategies, accounting for 20.39% of the variance in emotional exhaustion. However, the researcher only used one subscale of the MBI and surveyed educators in Poland. Nevertheless, the results from Wróbel (2013) indicate that educators' positive mood regulatory strategies (i.e., kindness in compassion) can mitigate the effects of emotional exhaustion.

Bibou-Nakou, Stogiannidou, and Kiosseoglou (1999) investigated the differences between educators' ($N = 200$) attributions to student misbehavior and their levels of educator burnout (as measured by the MBI; Maslach & Jackson, 1986). Elementary teachers were sampled from Northern Greece and were divided into two groups based on their attributions of whether student misbehavior was caused by internal or external factors related to the student. The results indicated that educators who attributed misbehavior as student-focused (i.e., something wrong with the student) reported more emotional exhaustion ($t = 2.03, p < .05$) and less personal accomplishment ($t = 2.01, p < .05$). On the other hand, educators who attributed misbehavior as a response to external events reported lower levels of depersonalization ($t = 2.76, p < .05$). However, the sample consisted of only educators in Greece and the researchers did not specify whether the educator version of the MBI was used. Nevertheless, the results indicated

that educators who attributed student misbehavior as externally student-related (arguably reflective of common humanity worldview found in compassion) experienced less emotional exhaustion and depersonalization and more feelings of personal accomplishment.

In a correlational study, Jennings (2015) investigated the relationship between educators' ($N = 35$) levels of self-compassion (as measured by the *Self-Compassion Scale*; SCS; Neff, 2003b), emotional climate of their classrooms (as measured by the Pre-K version of the *Classroom Assessment Scoring System*; CLASS; Pianta, La Paro, & Hamre, 2008), and educator burnout (as measured by the MBI-ES; Maslach et al., 1996). The researchers used the CLASS as an observational measure to assess the classroom climate across three domains: (a) emotional support; (b) classroom organization; and (c) instructional support while the educators completed the self-report instruments. The results indicated that educators' self-report measures of self-compassion accounted for 14.4% of the variance in their emotional support of their students. Further, emotional support was negatively related to emotional exhaustion ($R^2 = .1225, p < .05$) and depersonalization ($R^2 = .2116$). However, the sample size was small ($N = 35$) and the inter-rater reliability of the CLASS was not provided. Nevertheless, the results indicated that educators who have higher levels of self-compassion created a more emotionally supportive classroom environment which in turn negatively related to educator burnout. Therefore, it is plausible to assume that educators who are more self-compassionate express more compassion for others and thus would provide comparable emotional support for their students and protect against educator burnout.

Mindfulness (a component of compassion) has also been shown to be effective in buffering educator burnout. Roeser and colleagues (2013) investigated the effects of mindfulness

training (MT) on educators' ($N = 113$) levels of burnout in a randomized experimental study. Participants were randomly assigned to one of two conditions: (a) MT group; or (b) waitlist control group and participated in three data collection points: (a) baseline; (b) post-treatment; and (c) 3-month follow-up. The MT was an eight week, 11-session program with main foci on mindfulness and self-compassion techniques to help teachers deal with burnout more effectively while promoting emotional resilience. The researchers reported a significant main effect of MT on educator burnout post-treatment, $F(1, 108) = 14.96, p < .01, d = -.76$ and showed significant lasting effects at the three-month follow-up, $F(1, 94) = 10.26, p < .01, d = -.68$; which indicates a large effect of MT on educator burnout. However, the waitlist control group reported higher levels of educator burnout at baseline compared to the MT group and educator burnout was aggregated as one score rather than three separate scores (i.e., emotional exhaustion, depersonalization, and personal accomplishment). Nonetheless, the results indicated that educators who receive MT experience less educator burnout. Therefore, given mindfulness has been shown to be a theoretical component of compassion (i.e., Pommier, 2010), it is plausible to assume that educators' compassionate feelings will also mitigate the effects of educator burnout.

In a correlational study, Abenavoli, Jennings, Greenberg, Harris, and Katz (2013) investigated the relationship between mindfulness and educators' ($N = 64$) levels of educator burnout. The participants were sampled from two middle schools in Pennsylvania and completed a battery of assessments that included: (a) *Interpersonal Mindfulness in Teaching Scale* (IMTS; Greenberg, Jennings, & Goodman, 2010); (b) the *Five Facet Mindfulness Questionnaire* (FFMQ; Baer, Smith, Hopkins, Krietemeyer, & Toney, 2006); and (c) the MBI-ES (Maslach et al., 1986). After controlling for gender and years of experience, there were significant negative

relationships between educators' mindfulness (as measured by the IMTS) and emotional exhaustion, $\beta = -.58, p < .05$, depersonalization, $\beta = -.54, p < .05$, and low personal accomplishment, $\beta = -.56, p < .05$. However, it is important to note that an overwhelming majority of the sample ($n = 98\%$) identified as Caucasian and that the results do not indicate a causal relationship between educator mindfulness and educator burnout. Nevertheless, the results from Abenavoli and colleagues (2013) provide further support that educators who possess higher levels of mindfulness (a core component of compassion) experience less educator burnout.

Taken together, reviews of the empirical research provide support for the proposed negative association between educators' levels of compassion and educator burnout. Caring (i.e., Teven, 2007), empathy (i.e., Wróbel, 2013), mindfulness (Roser et al., 2013), and self-compassion (Jennings, 2015) have all been shown to negatively correlate with educator burnout. On the other hand, it is important to note that there is potential for there to be a positive relationship between compassion and burnout (i.e., compassion fatigue; Berg, Harshbarger, Ahlers-Schmidt, & Lippoldt, 2016). However, the theoretical foundation of compassion fatigue is qualitatively different from that of compassion in the current study. Therefore, it is assumed that as educators' levels of caring, empathy, mindfulness, common humanity, and self-compassion (i.e., compassion) increase, their levels of educator burnout decrease.

Inspiration

Inspiration is a complex construct and has different meanings depending on the context and/or discipline in which the term is used (Thrash & Elliot, 2003). Inspiration relates to many professional disciplines, including psychology (i.e., Hart, 1998; Thrash & Elliot, 2003; 2004),

theology (i.e., Canale, 1994), management (i.e., Bass & Avalio, 1994), and engineering (i.e., Beer, Quin, Chiel, & Ritzmann, 1997). The word inspiration is often used interchangeably with the term intrinsic motivation (i.e., Bowman, 2011); however, for the purpose of the current study, there are several distinctions between inspiration and intrinsic motivation that need to be made. First, intrinsic motivation refers to the act of doing something because it is inherently enjoyable (Ryan & Deci, 2000); thus personal gains (e.g., joy, satisfaction, personal competence, etc.) are the main determinants of engagement in a particular task. On the other hand, inspiration involves purposeful behavior that transcends beyond personal gains when engaging in a task, although these experiences are likely by-products (Thrash & Elliot, 2003). Second, intrinsic motivation can be theoretically lost for a number of reasons, such as decreased interest or fulfillment when engaging in an activity. However, given the transcendental qualities of inspiration, interest is trivial with regards to being inspired; rather, inspiration implies a link between the task and the purpose for one's life. Hence, if individuals become uninspired, it is not simply a loss of interest that they have experienced – it is the loss of purpose and meaning in their life. Furthermore, intrinsic motivation can be self-generated whereas inspiration is evoked from factors external of an individual (Thrash & Elliot, 2003).

The original conception of inspiration referred to a supernatural influence on an individual to deliver divine truths; however, sources of inspiration vary, from music, literature, and nature (i.e., Thrash & Elliot, 2003) to counselor-client relationships (i.e., Freeman & Hayes, 2002). Thrash and Elliot (2003; 2004) are the first researchers to begin operationally defining inspiration as a psychological construct. The authors reviewed literature from various sources on inspiration and concluded three common features: (a) transcendence; (b) evocation; and (c)

approach motivation. Transcendence refers to individuals rising above their ordinary preoccupations and limitations. Additionally, inspiration is evoked rather than self-generated; hence, something outside the individual must occur prior to experiencing inspiration. Moreover, inspiration implies that upon evocation and transcendence, inspired individuals experience motivation as the need to express, create, or engage in that which is newly apprehended (Thrash & Elliot, 2003). However, it is important to note that the limited empirical research that has focused on inspiration, whether as a distinct phenomenon or in an educational context, lacks a clear theoretical foundation and operational definition. Nonetheless, the following section reviews empirical investigations focused on inspiration as a general phenomenon, and more specifically as it relates to educators' inspirational characteristics.

Empirical Research on the Phenomenon of Inspiration

Hart (1998) conducted phenomenological interviews focused on participants' ($N = 70$) experiences of inspiration. The researcher interviewed participants from diverse professions, ages, and socioeconomic statuses and the semi-structured interviews had two primary foci: (a) the participants' various experiences of being inspired and how they differed from similar experiences (i.e., being motivated); and (b) the participants' experiences in the *absence* of inspiration. The final analysis of the interviews resulted in four phenomenological themes of inspiration: connection, opened, clarity, and energy. *Connection* was the most common theme described by participants and described "the perceived alteration of one's personal boundaries and an accompanying shift in a feeling of self-separateness" (p. 13). *Opened* was another theme associated with inspiration and described experiences of heightened a receptivity that occurred

from the experience. *Clarity* described participants' heightened sense of cognitive, emotional, and physical awareness. *Energy* described an immediate shift in emotional and physical energy, which translated into feelings of "excitement", "joy", and "being at peace" (p. 20). Moreover, participants described feeling physically rejuvenated and cleansed from their inspirational experience. On the other hand, common descriptions of participants feeling uninspired were "depression", "isolated", "hopeless", and experiences of "worry" and "self-doubt" (p. 22). However, it is important to note that the results only capture the experiences of the interviewed participants and cannot be generalized to the population. Moreover, inspiration was not operationally defined for participants before being interviewed; therefore, participants' personal conceptualizations of inspiration may have influenced what they shared during the interviews. Nonetheless, the results from Hart (1998) support that inspiration is a distinct and powerful phenomenon that is evoked and results in individuals pursuing goals that transcend beyond their personal interests.

Thrash and Elliot (2003) conducted a Confirmatory Factor Analysis (CFA) to develop the *Inspiration Scale* (IS) in a sample of undergraduate students ($N = 333$). The IS consisted of four items (e.g., "I feel inspired to do something") on a seven-point Likert scale from one (strongly disagree) to seven (strongly agree). In addition, each item contained two parts (i.e. frequency and intensity) such that participants would respond to how often they feel inspired to do something as well as the degree to which they are inspired to do something. The results supported the factor structure of the IS, CFI = .99, TLI = .98, RMSEA = .07. However, the development sample consisted only of undergraduate students who received extra credit in a psychology course for their participation. In addition, the IS does not have a sound theoretical foundation as the

researchers' primary goal was to develop an instrument that is, "straight-forward and face valid" (Thrash & Elliot, 2003, p. 874). Nonetheless, the results from Thrash and Elliot (2003) are important to underscore as they are among the first quantitative studies to investigate inspiration as a distinct phenomenon.

In a correlational study, Thrash and Elliot (2003) investigated the relationship between inspiration (as measured by the IS; Thrash & Elliot, 2003), approach-avoidance motivation (as measured by the *Behavioral Inhibition System/Behavioral Approach System Scale*; BIS/BAS; Carver & White, 1994), intrinsic-extrinsic motivation (as measured by the *Work Preference Inventory*; WPI; Amabile, Hill, Hennessey, & Tighe, 1994), and personality traits (as measured by the *NEO Five Factor Inventory*; NEO-FFI; Costa & McCrae, 1992) in a sample of undergraduates ($N = 152$) who received extra credit in exchange for completed questionnaire packets. The results indicated that inspiration was positively correlated with intrinsic motivation, $r = .43, p < .001$ (18.5% of the variance in intrinsic motivation explained by inspiration), approach motivation, $r = .18, p < .05$ (3.24% of the variance in approach motivation explained by inspiration), and negatively correlated with extrinsic motivation, $r = -.17, p < .05$ (2.89% of the variance in extrinsic motivation accounted for by inspiration). However, the sample consisted of only undergraduate students and the IS (Thrash & Elliot, 2003) has limited empirical research to support its psychometric properties. Nonetheless, the results provide further support for inspiration as a similar yet distinct construct from intrinsic motivation.

Empirical Research on Inspiration in Education

There is a limited research examining inspiration in an educational context; however, the studies that have investigated inspiration in education used qualitative methods to address their research questions. Consequently, the findings from qualitative investigations into inspiration in education lack generalizability. Nevertheless, qualitative inquiries provide researchers with the beginnings of rich and meaningful data into the phenomena of educator inspiration (Gall et al., 2007).

In a qualitative study, Burke and Nierenberg (1998) investigated students' ($N = 116$) perspectives of the qualities that make an educator inspirational. Specifically, the participants were instructed to respond to three questions: (a) Who was your best teacher? (b) What was he or she like? and (c) What did he or she do? (p. 341). The participants' responses to the three guiding questions were collected and analyzed for common themes. The researchers concluded that above all other qualities, inspirational educators were perceived to care for their students' emotional, mental, social, physical and academic welfare. Another common theme that emerged was inspirational educators' maintained positive attitude towards their students and life in general. Moreover, inspirational teachers seemed to maintain their positivity even in challenging circumstances. One participant thought her sixth-grade teacher was inspirational because, "She taught us that every child has his or her bad days; however, every child is still good inside. She loved even the worst of us...She always made time to laugh or to say something positive and nice" (p. 348). Therefore, inspirational teachers not only maintain a positive attitude towards their students, but their positive attitude is unconditional and expressed towards all of their students. Further, participants described their inspirational educators as dedicated – not only in

the classroom but beyond the classroom as well. One participant described their inspirational teacher: “[He] went to hundreds of seminars to learn new activities to do in class. He always believed he could become a better teacher” (p. 349). However, the results are limited to only the participants’ interpretations of inspirational educators that varied in in their profession (i.e., not all participants chose to write specifically about educators). Nonetheless, the results from Burke and Nierenberg (1998) identify that inspirational teachers are able to cultivate compassionate relationships with their students. Specifically, inspirational teachers seem to care and support students mental, emotional, and academic needs. Furthermore, inspirational teachers are dedicated to the profession of teaching and engage in professional development activities to help them become better teachers. Taken together, inspirational teachers facilitate positive and caring relationships with their students which can serve as a catalyst for students to transcend their current views of school to a more meaningful future derived from a quality education (DiBara, 2007).

In qualitative study, Bradley, Kirby, and Madriaga (2015) analyzed students’ ($N = 2,300$) perceptions of inspirational teachers who were nominated for inspirational teaching awards at a large university in the United Kingdom. The survey asked students to nominate and explain why they nominated educators who were inspirational. The researchers identified three distinct themes from the participants’ descriptions of inspirational educators: (a) student engagement with learning, (b) rapport with students, and (c) vocational. The theme *student engagement with learning* described the type of teaching style inspirational educators embodied such as passionate, encouraging, up-to-date, and motivational. The *rapport with students* theme referred to the quality of relationships that educators facilitated with their students. The *vocational* theme

referred to the ways in which inspirational educators served as positive role models in their specific profession. However, interpretation of the results warrants consideration given that the sample was undergraduate students from one university and did not operationally define inspiration. Nonetheless, inspirational educators were described as positive and engaging when establishing strong relationships with their students, serving as positive role models in their chosen profession.

Acker (2003) conducted a qualitative study examining how criminal justice scholars ($N = 21$) describe their best educators as undergraduate students. Among the common themes in participants' descriptions, inspirational educators were said to have high standards for student performance. One participant recalled a time when his professor (with whom he had a good relationship with) gave him an 'F' on a paper because it was clear the student did not put forth his best effort. However, it is important to note that the document analysis procedures and demographic information of the sample was not reported. Nevertheless, inspirational educators cultivate and maintain caring and positive relationships with their students; their high standards are not compromised even at the expense of the teacher-student relationships. Furthermore, the high standards of inspirational educators can help students transcend their current abilities to achieve higher goals.

The purpose of the current section was to present the theory of inspiration as a distinct phenomenon and review empirical research focused on inspiration both general and educational contexts. However, it is important to note that the empirical investigations of inspiration in an educational context lacked a sound theoretical foundation and operational definition. Therefore,

the following section provides a brief overview into the first theoretically-driven definition of educator inspiration.

Educator Inspiration

Lambie and colleagues (2016) utilized Thrash and Elliot's (2003) conceptualization of inspiration (evocation, transcendence, approach motivation) to develop the first theoretically-driven operational definition of educator inspiration. The following section contains two components: (a) an overview of the development of the theoretical foundation of educator inspiration; and (b) a review of the development and validation of the first empirical investigation into the construct of educator inspiration.

Evocation and Educator Inspiration

Evocation refers to the concept that, "one does not feel directly responsible for becoming inspired" (Thrash & Elliot, 2003, p. 957). The presence of evocation serves as a clear distinction between inspiration and motivation. For instance, although both inspiration and motivation are considered affective states, motivation can be self-generated; hence, individuals can become under direct control of whether they become motivated (Ryan & Deci, 2000). Alternatively, inspiration is not considered under the direct control of an individual; rather, something external of an individual must occur prior to arousing feelings of inspiration (Thrash & Elliot, 2003).

In an educational context, educators serve as the evocative change agents within their schools and communities as they are role models for students and colleagues (Bandura, 1997). Given the dynamic roles that educators are expected to perform at any given time (Grayson & Alvarez, 2008), there are three behaviors that educators engage in that can evoke inspiration

from their colleagues and students: (a) leadership; (b) empathy; and (c) academic optimism. Leadership has been defined as, “the moving of followers beyond their self-interests for the good of the group, organization, or society” (Bass, 1997, p. 130). Effective leaders communicate a clear and inspirational vision that their followers can believe in (Joshi, Lazarova, & Liao, 2009). In an educational context, the “vision” that inspirational educators communicate to their students and colleagues must have an academic focus and optimism that inspires them (Hoy, Tarter, & Woolfolk Hoy, 2006). Specifically, Lim and Eo (2014) identified that reflective dialogue among educators (i.e., “in-depth conversations about teaching and learning”; p. 139) negatively contributed to educator burnout ($\gamma = -.31$) and positively contributed to collective teacher efficacy ($\gamma = .32$), which in turn negatively contributed to educator burnout ($\gamma = -.46$). Further, reflective dialogue and collective teacher efficacy accounted for 43% of the variance in educator burnout. Thus, educators who provide a clear and inspirational vision for their students and colleagues that is academically optimistic can evoke inspiration from their students and colleagues. In addition, relationship quality (e.g., trusting and empathic) is an important contributor to collective efficacy between leaders and followers (Joshi et al., 2009). Barr (2011) investigated the relationship between educators’ empathy (as measured by the *Interpersonal Reactivity Index* [IRI]; Davis, 1980) and perceptions of school climate (as measured by the *School Culture Scale*, Higgins-D’Alessandro & Sath, 1997) in a sample of educators ($N = 100$). The results indicated that educators’ self-reported perspective-taking skills were positively associated with their perceptions of: (a) student-peer relationships, $r = .20, p < .05$; (b) educational opportunities, $r = .20, p < .05$; and (c) school norms, $r = .23, p < .05$. Therefore, inspirational educators evoke inspiration from their colleagues and students by serving as

empathic leaders who provide a clear and academically-focused vision which creates a positive and optimistic school climate for educators and students to excel.

Transcendence and Educator Inspiration

Transcendence as it relates to inspiration asserts that, “inspiration orients one toward something that is better or more important than one’s usual concerns; one sees better possibilities” (Thrash & Elliot, 2004, p. 957). As such, inspiration requires individuals to overcome their usual concerns (i.e., barriers) in pursuit of something greater than themselves. Moreover, inspiration orients individuals towards a larger perspective that is driven by a deep sense of mission and purpose for their lives (Kerfoot, 2001). Taken together, there are two qualities that inspirational educators possess: (a) passion; and (b) resilience. Passion is characterized as, “a strong inclination toward an activity that individuals like (or even love) that they find important, and in which they invest time and energy” and is internalized into their identity (Vallerand, Mageau, Elliot, Dumais, Demers, & Rousseau, 2008, p. 374). Much of the research on passion focuses on skill acquisition in a variety of sports (e.g., Baker, Horton, Robertson-Wilson, & Wall, 2003; Starkes & Ericsson, 2003); however, research findings identify that inspirational educators possess passion for education. For example, Vallerand and colleagues (2008) investigated the theoretical model that passion (as measured by the *Passion Scale*, Vallerand et al., 2003) would contribute to deliberate practice in a sample of high school basketball players ($N = 184$), which positively related to basketball performance. The hypothesized model showed acceptable fit, $CFI = .96$, $RMSEA = .05$, supporting the hypothesis that passion relates to deliberate practice, $\beta = .50$, $p < .05$, which in turn related to performance,

$\beta = .35, p < .05$. For educators, “deliberate practice” may translate to attending additional workshops, conferences, and educational sessions to continuously improve upon their effectiveness and performance educators. However, it is important to acknowledge that educators are required to perform multiple tasks and roles under varying degrees of external influence and circumstances (Allison, 2011; Byrne, 1994); thus, passion is fruitless without resilience. Academic resilience has been defined as, “the capacity to cope with difficulty and remain academically engaged” (Sosa & Gomez, 2012, p. 877). Day (2014) interviewed principals ($N = 12$) about their experiences being in schools from lower socioeconomic communities in England and Wales who had limited academic resources and found many principals spoke of their ability to be resilient. One participant spoke of being resilient in the face of external challenges:

I felt each step I took was being scrutinized by so many people who were all expecting me to do what, in their minds at least, they thought I should be doing...I can't look my pay check in the eye, let alone the children, the staff and my own family, if I do things that I know, deep down, are fundamentally the wrong things to do...even if everyone is telling me to do them... (Day, 2014, p. 648)

The previous quote from one principal in the study not only exemplified resilience, but it also highlighted the importance of transcendence – the principal's job was not to collect a paycheck, rather it seemed the principal had a sense of purpose and duty to the students and their families that transcended his own personal interests in pursuit of higher academic excellence. Therefore, inspirational educators possess passion for education and resilience to overcome the many external contributors that contribute to educator burnout.

Approach Motivation and Educator Inspiration

Thrash and Elliot (2004) contend approach motivation in inspiration, involves a desire to, “express or make manifest that which is newly apprehended” (p. 957). As such, motivational theory (e.g., Ryan & Deci, 2000) is relevant to inspiration; however, only after experiences of evocation and transcendence have occurred (Thrash & Elliot, 2003). Thus, approach motivation as it relates to inspiration implies that inspirational educators are motivated to accomplish a goal that is beyond their sense of self-satisfaction (Kerfoot, 2001; Koltko-Rivera, 2006). Therefore, inspirational educators possess two qualities that have a reciprocal relationship: (a) motivation, and (b) self-efficacy (Bandura, 1997).

Fernet and colleagues (2012) investigated the mediating effects of educator motivation and self-efficacy between external factors (overload, decision latitude, principals’ leadership behavior, students’ disruptive behavior) and educator burnout (emotional exhaustion, depersonalization, personal accomplishment) in a sample of educators ($N = 806$). The results identified that increases in motivation and self-efficacy were negatively related to: (a) emotional exhaustion, $r = -.40, p < .01$; $r = -.39, p < .01$, respectively; and (b) depersonalization, $r = -.20, p < .01$; $r = -.40, p < .01$, respectively; on the other hand, changes in motivation and self-efficacy were positively related to personal accomplishment, $r = .22, p < .01$ and $r = .68, p < .01$, respectively. Therefore, inspirational educators are able to maintain their levels of motivation and self-efficacy, which negatively relate to educator burnout.

Empirical Research on Educator Inspiration

Lambie and colleagues (2016) developed the *Educator Inspire Scale* (EIS) to address the need for a quantifiable measure of educator inspiration given a clear operational definition. Upon a thorough review of the literature that focused on the inspirational qualities of educators, the researchers identified seven common characteristics of inspirational educators: (a) leadership, (b) motivation, (c) self-efficacy, (d) empathy, (e) passion, (f) academic optimism, and (g) resilience. Once the initial EIS was developed by using best practices of instrument development outlined by DeVellis (2017), it was reviewed by 15 experts in educational research and/or scale development to provide content-related evidence for the instrument. The final version of the EIS consisted of 70 items, 10 items per the 7 different domains comprising the construct of educator inspiration. Next, the researchers tested the factor structure of the EIS with a large sample of educators as well as the convergent and divergent validity of the assessment.

The final version of the EIS was an 18-item, four factor structure: (a) motivational leadership; (b) empathy; (c) resilience; and (d) passion. Cronbach's α for the EIS was .901. Internal reliability coefficients for the four subscales were: (a) motivational leadership (7 items; $n = 747$; $\alpha = .887$); (b) empathy (4 items; $n = 746$; $\alpha = .874$); (c) resilience (4 items; $n = 750$; $\alpha = .816$); and (d) passion (3 items; $n = 755$; $\alpha = .853$), all of which are good for beginning research (Nimon, Zientek, & Henson, 2012). Further, convergent validity of the EIS was supported: educator inspiration (as measured by the EIS; Lambie et al., 2016) positively and significantly ($r = .409, p < .001$) related to compassion (as measured by the COS; Pommier, 2010), accounting for 16% of variance in compassion scores. Moreover, divergent validity of the EIS was supported: educator inspiration negatively related to educator burnout (as measured by the MBI-

ES; Maslach et al., 1996). Specifically educator inspiration scores negatively related to emotional exhaustion ($r = -.340, p < .001$) and depersonalization ($r = -.463, p < .001$), accounting for 11.56% and 21.43% of the variance for emotional exhaustion and depersonalization scores, respectively. In addition, educator inspiration scores positively related to personal accomplishment ($r = .575, p < .001$), accounting for 33% of variance in personal accomplishment scores. Therefore, the convergent and divergent validity of EIS scores are supported.

Relationship Between Educator Inspiration, Compassion, and Burnout

Educator burnout continues to be a problem; approximately 30 – 75% of educators reporting moderate to high levels of burnout (Cano-Garcia et al., 2005). Educator burnout is a strong contributor to attrition (Hansen, 2006; Skaalvik & Skaalvik, 2010), which costs the United States approximately 2.2 billion dollars per year (Alliance for Excellent Education, 2014). Unfortunately, there is limited research that investigates the direct relationships between burnout, compassion for others, and educator inspiration; yet the existing literature supports the theoretical model that educators with higher levels of inspiration (as measured by the EIS; Lambie et al., 2016) and compassion for others (as measured by the COS, Pommier, 2010) will have lower levels of burnout (as measured by the three factors [emotional exhaustion, depersonalization, personal accomplishment] as measured by the MBI-ES; Maslach et al., 1996). For example, student misbehavior is one of the strongest contributors to educator burnout, particularly to the dimension of depersonalization (McCormick & Barnett, 2011). However, compassion emphasizes kindness, common humanity, and mindfulness; recognizing that

suffering (i.e., student misbehavior) is not a student-focused problem; rather student misbehavior is a common occurrence for schoolchildren and instead of depersonalizing students and becoming emotionally exhausted, educators should react with mindful kindness, which protects the educators against burnout. Moreover, Bibou-Nakou and colleagues (1999) found that educators who attribute student misbehavior as an internal problem (i.e., increased separation as opposed to common humanity in compassion) reported more emotional exhaustion, $t = 2.03, p < .05$, and less personal accomplishment, $t = 2.01, p < .05$, compared to educators who attributed student misbehavior to external factors (i.e., increased common humanity as opposed to separation in compassion). Conversely, educators who attributed student misbehavior to external factors reported less depersonalization compared to educators who attributed student misbehavior to internal problems, $t = 2.76, p < .05$. Therefore, educators who possess more compassion for others theoretically experience less burnout. In addition, educators with higher levels of inspiration experience less burnout (Lim & Eo, 2014). Specifically, Lim and Eo found that educators who perceived their school climates as having more reflective dialogue and organizational goals reported less burnout. It is plausible then to contend that the school climate which was negatively related to burnout (e.g., Lim & Eo, 2014) is characterized as having a high degree of academic optimism and empathy contributes to educators' inspirational qualities (e.g., Hoy et al., 2006; Joshi et al., 2009). Moreover, inspirational educators possess high levels of passion and resilience, protecting them from experiencing burnout (e.g., Day, 2014; Vallerand et al., 2009). Further, Fernet and colleagues (2012) identified that educator inspiration negatively correlates with burnout, given the inverse relationship between motivation, self-efficacy, and

burnout. Therefore, educators who possess more inspirational qualities and compassion for others experience less burnout.

Chapter Summary

Chapter two presented an overview of the constructs that create the theoretical framework for the model in this study (burnout, compassion, and educator inspiration). Specifically, burnout was discussed and empirical studies were evaluated to support the necessity of research that addresses the issue of burnout in educators. In addition, the theoretical framework of compassion was presented and empirical studies were reviewed to support the inverse relationship between compassion for others and burnout. Further, the concept of inspiration was reviewed as it relates to education in order to provide a clear operational definition of educator inspiration. Moreover, the theory of educator inspiration was presented along with empirical research to support the theoretical model that was investigated in this study. Therefore, the proposed investigation addresses the lack of research focused on the direct relationship between educator inspiration, compassion for others, and burnout.

CHAPTER THREE: METHODS

Chapter three presents the research design, methodology, and procedures for the current investigation. The purpose of the current study was to investigate the directional relationship between educators' levels of inspiration, compassion, and burnout. The present study tested the theoretical model that educators' inspiration (as measured by the *Educator Inspire Scale* [EIS; Lambie et al., 2016]) and compassion for others (as measured by the *Compassion for Others Scale* [CS; Pommier, 2010]) scores contribute to their levels of burnout (as measured by the *Maslach Burnout Inventory – Educator Survey* [MBI-ES; Maslach et al., 1996]). Specifically, this investigation examined the hypothesized directional relationship that educators with higher inspiration and compassion for others scores would have lower levels of burnout (lower emotional exhaustion and depersonalization and higher feelings of personal accomplishment subscale scores).

The current study utilized a correlational research design to determine the directional relationships between educators' levels of inspiration, compassion for others, and burnout without manipulation of scores (scores occurring naturally; Fraenkel, Wallen, & Hyun, 2011). Structural Equation Modeling (SEM) was used to examine the directionality and strength of the relationships between the constructs of interest (Tabachnick & Fidell, 2013). Further, the current chapter presents the following components of the investigation: (a) population and sampling procedures; (b) data collection methods; (c) measurement instrumentation; (d) research design; (e) research questions and hypotheses; (f) data analysis procedures; (g) ethical considerations; and (h) limitations to the current study.

Population and Sampling Procedures

For the purpose of the investigation, the target population was defined as educators and educators-in-training who provide direct educational services to students; thus, potential participants range from preschool educators, elementary, middle, and high school educators, administrators, and school counselors. The rationale for including administrators and school counselors in the final sample educators was due to their active involvement in students' academic and socio-emotional needs. In addition, the norm sample ($N = 11,067$) of the *Maslach Burnout Inventory – Human Services Survey* (HSS; Maslach et al., 1996) included educators and administrators (e.g., K – 12 educators) as well as mental health professionals (e.g., psychologists, counselors), however, when the samples were separated by profession, the measures of central tendency for the burnout scores were comparable, suggesting educators have similar experiences and rates of burnout compared to other helping professions. Further, educators and educators-in-training (completing their clinical experiences) were chosen as the target population because more research is needed on developmental educator characteristics that protect against burnout (Abenavoli et al., 2014; Ma Roeser et al., 2013; Schaefer, Long, & Clandinin, 2012). However, when access to the target population is infeasible, it is appropriate to draw samples from an accessible population (Gall et al., 2007). An accessible population includes all participants who could realistically be included in the sample (Gall et al. 2007). The accessible population for the current investigation was educators and educators-in-training from: (a) Florida; (b) Louisiana; and (c) Texas.

Determining an adequate sample size that supports population validity is essential for sound quantitative research (Gall et al. 2007). Population validity refers to the extent to which

the results derived from a specific sample can be generalized to a larger population (Gall et al., 2007). There are approximately six million educators and educators-in-training in the United States (U.S. Department of Labor, 2014). In addition, determining an adequate a priori sample size that is appropriate for SEM research is also necessary to help avoid Type II error (i.e., failing to reject a false null hypothesis; Balkin & Sheperis, 2011). In SEM, a minimum sample of 200 participants is considered the “golden standard” (Crockett, 2012, p. 43), although there are other factors that need to be considered such as effect size, statistical power, the number of latent and observed variables, and the significance level (Kline, 2016). Schumacker and Lomax (2010) recommend using a sample size calculator (i.e., www.Danielsoper.com) to determine the minimum sample size required when using SEM. According to the website, in a model with three latent variables and 13 manifest variables at the probability of $p < .05$ with a high power (0.8), a minimum sample size of 119 participants was needed to observe a moderate effect effect size (0.3). MacCallum, Browne, and Sugawara (1996) provide another method for determining minimum sample size based on degrees of freedom (df) and statistical power estimates. According to MacCallem and colleagues (1996), given the study has $df = 102$ (136 [observations] – 34 [parameters]; Kline, 2016, p. 128) and an approximate statistical power of .8, a sample size of 200 was sufficient for the study. Moreover, Kim (2005) provides an equation for calculating minimum sample size as a function of fit indices (i.e., root mean square error of approximation [RMSEA]). Based on the equation, $N_{\varepsilon} = \frac{\delta_{1-\beta}}{\varepsilon^2 df} + 1$, where $\delta_{1-\beta} = 40.8892$, $\varepsilon^2 = .05$, and $df = 102$, in order to achieve an $RMSEA \leq .05$, a sample size of 162 participants was sufficient for this study. Furthermore, Raykov and Marcoulides (2006) suggested that a desirable sample size would be at least 10 times the number of free model parameters (10×34 [free model

parameters] = 340). Taken together, the sample size of 580 was sufficient for the current investigation (MacCallum et al., 1996).

Data Collection Procedures

Prior to any recruitment of participants and data collection, the researchers received approval from their university's Institutional Review Board (IRB). The researchers submitted an application to IRB including (a) Human Research Protocol form, (b) a copy of informed consent, and (c) all measurement and assessment instruments including the demographic form. The data used in the current investigation was part of a larger study funded by the T. Denny Sanford Foundation. In the larger study, a total of 2,060 data collection packets were disseminated. Specifically, each assessment packet contained: (a) an informed consent that outlines the purpose of the study; (b) a general demographic questionnaire; (c) the *Educator Inspire Scale* (EIS); (d) the *Maslach Burnout Inventory – Educator Survey* (MBI-ES); (e) the *Compassion for Others Scale* (COS); and (f) the *Marlowe-Crowne Social Desirability Scale – XI* (MCSDS-X1; Strahan & Gerbasi, 1972). Permission and the purchasing of the necessary instruments (i.e., *Maslach Burnout Inventory – Educator Survey*) was obtained prior to the distribution of the assessment packets. Further, each participant was provided with a pen as an incentive for participation in the investigation. Small incentives such as a pen have been shown to increase response rates by up to 70% (Dillman, Smyth, & Christian, 2014).

The current study utilized criterion sampling methods to obtain the required sample size from the accessible population. Criterion sampling is a method in which participants who satisfy an important criterion are recruited for participation in a study (Gall et al., 2007). Two methods

of face-to-face data collection were used to sample from the accessible population. First, data collection packets were disseminated to schools who employ practicing educators or educators-in-training throughout a large school district in a large southeastern state upon approval from the Superintendent. The second face-to-face method of data collection consisted of two parts: (a) contacting colleagues who have direct access to educators and/or educators-in-training (e.g., K-12 educators, school counselors, student-teachers, etc.) and then mailing data collection packets to the identified colleagues who disseminated the data collection packets and returned the completed packets to the researchers; and (b) the researcher attended classes, workshops, and career fairs that potential participants who meet the criteria for participation (i.e., educator or educator-in-training) were in attendance and distributing data collection packets to voluntary participants.

Therefore, to account for the threat to population validity, colleagues with direct access to educators and/or educators-in-training in the following states were sent data collection packets: (a) Florida; (b) Louisiana; and (c) Texas. Additionally, follow-up e-mails and telephone calls were made to ensure the appropriate number of participants were attained. Once the completed data collection packets were returned, they were entered into SPSS for future analyses.

Instrumentation

The following constructs and instruments were used in the investigation: (a) educator inspiration (EIS; Lambie et al., 2016); (b) compassion for others (COS; Pommier, 2010); and (c) burnout (MBI-ES; Maslach et al. 1996]. Additionally, a *General Demographic Questionnaire* was used, including four questions focused on the participants' self-reported levels of: (a) current

job satisfaction; (b) current job stress; (c) perceived support at school; and (d) perceived effectiveness as an educator. The following section provides a review of the instruments that were used in the study.

General Demographic Questionnaire

The *General Demographic Questionnaire* was created for this investigation and is a self-report measure of the participants' demographic information (e.g., gender, age, marital status, geographic location, ethnicity, highest earned degree, years of experience as an educator, current position, and setting and type of school currently employed in). In addition, the questionnaire includes four Likert scale questions that asked participants to rank from 1 to 5: (a) *current level of satisfaction* (1 = very not satisfied, 5 = very satisfied); (b) *current level of stress* (1 = very stressed, 5 = very unstressed); (c) *current level of support at school* (1 = very unsupportive, 5 = very supportive) and (d) *current level of perceived effectiveness as an educator* (1 = very ineffective, 5 = very effective). The demographic questionnaire was reviewed for face content validity and deemed appropriate for this investigation

Educator Inspiration Scale

The EIS (Lambie et al., 2017) was used to measure educator inspiration. The development of the EIS began as an initiative by the T. Denny Sanford Foundation whose main focus was to develop and train inspirational educators. As such, the Sanford Inspire program partnered with a large university in the southern United States to develop the first psychometrically tested instrument aimed to measure educators' inspirational qualities.

The EIS is an 18-item self-report measure with four subscales: (a) motivational leadership; (b) empathy; (c) resilience; and (d) passion. Motivational leadership is defined as “the act of developing trusting interpersonal relationships with students, families, and colleagues by establishing clear expectations and support as a means to influence them to transcend their own limitations and commit to a larger vision” (Lambie et al., 2016, *unpublished*). A sample item from the *motivational leadership* subscale is, “I always strive to promote my students’ success”. Empathy was defined as “educators’ ability to facilitate a personal and supportive relationship with students and other stakeholders by expressing genuine concern for students’ personal and academic lives in order to understand their experiences” (Lambie et al., 2016, *unpublished*). A sample item from the *empathy* subscale is, “I am always comfortable talking with my students about their emotional concerns”. Resilience was defined as “educators’ abilities to persist and remain engaged in activities even in the presence of adversity” (Lambie et al., 2016, *unpublished*). A sample item from the *resilience* subscale is, “When faced with stressful situations as an educator, I am able to adapt very well”. Passion was defined as “an educator’s inclination towards an activity that fulfills and contributes meaning to his or her life” (Lambie et al., 2016, *unpublished*). A sample item for the *passion* subscale is, “I regularly attend professional conferences and workshops in order to maintain educational best practices”. Response options of the EIS are on a Likert scale from 1 (strongly disagree) to 7 (strongly agree). There are two ways to score the EIS: (a) average each of the subscales for four separate scores; or (b) calculate a *grand mean* for an overall educator inspiration score. Higher scores on the EIS (and its subscales) indicate higher levels of educator inspiration. Table 1 represents the items and factor loadings of the EIS.

Psychometric Properties of EIS Scores

The initial EIS was a 70-item instrument with seven subscales: (a) leadership; (b) motivation; (c) passion; (d) empathy; (e) self-efficacy; (f) academic optimism; and (g) resilience. Subsequent EFA, parallel analysis (PA), and CFA procedures reduced the EIS to an 18-item instrument comprised of four subscales: (a) motivational leadership; (b) empathy; (c) resilience; and (d) passion.

Cronbach's α for the EIS was .901. Internal reliability coefficients for the four subscales were: (a) motivational leadership (7 items; $n = 747$; $\alpha = .887$); (b) empathy (4 items; $n = 746$; $\alpha = .874$); (c) resilience (4 items; $n = 750$; $\alpha = .816$); and (d) passion (3 items; $n = 755$; $\alpha = .853$), all of which are good for beginning research (Nimon, Zientek, & Henson, 2012). Convergent and divergent validity were supported for the EIS: educator inspiration (as measured by the EIS; Lambie et al., 2016) positively and significantly ($r = .409, p < .001$) related to compassion for others (as measured by the COS; Pommier, 2010) and accounted for roughly 16% of variance in compassion scores. In addition, educator inspiration was significantly related to the three dimensions of burnout as measured by the MBI-ES (Maslach et al., 1996): (a) emotional exhaustion ($r = -.340, p < .001$); (b) depersonalization ($r = -.463, p < .001$); and (c) personal accomplishment ($r = .575, p < .001$). Further, educator inspiration accounted for 11.56%, 21.43%, and 33% of variance in emotional exhaustion, depersonalization, and personal accomplishment, respectively.

Compassion for Others Scale

The COS (Pommier, 2010) was used to measure educators' levels of compassion.

Pommier (2010) developed the COS and tested the psychometric features of COS scores as part of her dissertation investigation. The COS was adapted from the *Self-Compassion Scale* (SCS; Neff, 2003). There are three components of compassion, each of which comprise of two factors that occur on a continuum: (a) *kindness* (four COS items; e.g., "I like to be there for others in times of difficulty") vs. *indifference* (four COS items; e.g., "Sometimes I am cold to others when they are down and out"); (b) *common humanity* (four COS items; e.g., "Everyone feels down sometimes, it is part of being human") vs. *separation* (four COS items; e.g., "I don't feel emotionally connected to people in pain"); and (c) *mindfulness* (four COS items; e.g., "I pay careful attention when other people talk to me") vs. *disengagement* (four COS items; e.g., "I don't think much about the concerns of others"). Response options are on a Likert scale and range from 1 ("Almost Never") to 5 ("Almost Always"); however, there are not indicator labels for options that range from 2 to 4. The constructs of the COS are not mutually exclusive; for example, higher scores on the construct 'kindness' does not directly result in lower scores on 'indifference'; rather, subscale scores are allowed to act independently of each other. The scores on the COS can be examined separately or aggregated into a single compassion score; however, if a total compassion score is computed, scores on: (a) indifference; (b) separation; and (c) disengagement need to be reversed scored.

Compassion is considered a continuous construct in which higher total scores on the COS indicate higher levels of compassion, although given the COS is in early stages of development, cut-off scores are not provided. Given the COS was adapted from the SCS (Neff, 2003), a

traditional EFA was not conducted on the initial 80-item COS; rather factor analyses were conducted on each subscale separately in a developmental sample of $N = 439$ undergraduate students (males; $n = 153$; females; $n = 286$; $M = 20.6$ years, $SD = 1.82$) who were randomly assigned from an educational-psychology subject pool at a large Southwestern university in the United States. The results of the EFA reduced the original COS from an 80-item instrument to a 24-item instrument. Table 2 presents a description of the items and factor loadings for the final version of the COS. A CFA was then conducted to confirm the six-factor structure of the final 24-item COS (Pommier, 2010) and indicated acceptable goodness of fit indices (Hu & Bentler, 1999), CFI = .97; NNFI = .96; SRMR = .05; and RMSEA = .05. Furthermore, Pommier conducted a higher-order factor analysis to provide support for assertion that a single higher order factor (i.e., compassion) would explain the inter-correlations between the six subscales. Table 3 presents the inter-correlations between the six factors of the COS.

Table 3
Inter-Correlations Between Factors on the COS

	F1	F2	F3	F4	F5	F6
Kindness (F1)	1.00					
Indifference (F2)	-.66	1.00				
Common Humanity (F3)	.48	.28	1.00			
Separation (F4)	-.55	-.56	-.41	1.00		
Mindfulness (F5)	.57	.45	.49	.46	1.00	
Disengagement (F6)	-.65	-.64	-.36	-.61	-.51	1.00

Note. Table adapted from Pommier, 2010, p. 123.

According to the Hu and Bentler (1999) criteria, the higher-order factor analysis produced mixed results – two fit indices indicated acceptable fit, CFI = .96; NNFI = .95; however, two fit indices indicated only a marginal fit, RMSEA = .06; SRMR = .06. Therefore, a total compassion score can be computed or subscale scores can be computed separately (Pommier, 2010).

Psychometric Properties of the COS Scores

The theoretical foundation of the COS was adapted from the SCS (Neff, 2003b). Neff (2003b) investigated the factor structure of the SCS in a sample of 391 undergraduate students (males; $n = 166$; females; $n = 225$; $M = 20.91$ years, $SD = 2.27$) who were randomly selected from an educational-psychology pool from a large Southwestern university in the United States. The reliability of the total SCS score was supported, $\alpha = .92$. Thompson and Waltz (2008) investigated the relationship between PTSD symptoms and self-compassion using the SCS in a sample of 210 undergraduate students and found strong reliability for the total score on the SCS, $\alpha = .90$, as well as the subscales of the SCS: (a) self-kindness, $\alpha = .78$; (b) self-judgment, $\alpha = .85$; (c) common humanity, $\alpha = .79$; (d) isolation, $\alpha = .77$; (e) mindfulness, $\alpha = .66$; and (f) over-identification, $\alpha = .75$. Given the COS was developed from the theoretical framework of the SCS, Pommier (2010) found initial support for the reliability of the total score on the CS as well as the subscale scores. Table 4 presents the reliability coefficients, means, and standard deviations of the scores on the COS in a sample of 439 undergraduate students.

Table 4
Reliability and Measures of Central Tendency - COS

	α	M	SD
Compassion	.90	3.84	.60
Kindness	.77	3.90	.64
Indifference	.68	3.60	.60
Common Humanity	.70	4.06	.63
Isolation	.64	3.72	.58
Mindfulness	.67	3.96	.57
Disengagement	.57	3.82	.56

The reliability coefficients of the subscales of the COS range from acceptable to strong except for the ‘Disengagement’ subscale ($\alpha = .57$). It is possible that the low reliability coefficient for the ‘Disengagement’ subscale is due to poor correlation between items and/or the low number of items (Tavakol & Dennick, 2011). Additionally, Pommier (2010) investigated the split-half reliability of the COS. Split-half reliability involves dividing an instrument into two equivalent halves and correlating the scores (DeVellis, 2012). The split-half reliability of the COS showed strong reliability, $r = .90$. Overall, the COS is a new instrument that needs further investigation of the reliability of the scores. It is possible that the three opposing subscales to compassion (i.e., indifference, isolation, disengagement) share a significant amount of variance with the three subscales of compassion (i.e., kindness, common humanity, mindfulness), which may limit the observed variance in scores on the COS.

Pommier (2010) also investigated multiple sources of validity for the COS: (a) content validity; (b) convergent validity; and (c) discriminant validity. Content validity was established by sending the initial 118-item COS to a panel of eight experts in the field of scale development or constructs similar to compassion. The feedback from the panel of experts was incorporated and resulted in the 80-item measure that was used in the EFA and CFA analyses. Convergent validity was examined by correlating scores on the COS with scores on similar instruments, such as: (a) feelings of social connection as measured by the *Social Connectedness Scale* (Lee & Robbins, 1995), $r = .41, p < .01$; (b) compassionate love as measured by the *Compassionate Love Scale* (Sprecher & Fehr, 2005), $r = .30, p < .01$; and (c) empathy as measured by the *Mehrabian Questionnaire of Empathic Tendency* (Mehrabian & Epstein, 1972), $r = .59$. Moreover, discriminant validity of the CS was supported as indicated by the low correlation ($r = .09$) between the COS and the *Southampton Mindfulness Questionnaire* (Chadwick et al. 2008); thus supporting the distinction between compassion and mindfulness. However, it is important to note that there was a small relationship between the scores on the COS social desirability scores (Strahan & Gerbasi, 1972), $r = .19, p < .01$; in other words, approximately 3% of the scores on the COS are accounted for by participants responding in a socially desirable way.

Maslach Burnout Inventory – Educator Survey

The MBI-ES (Maslach, et al., 1996) was used to measure educators' levels of burnout along three dimensions: (a) emotional exhaustion; (b) depersonalization; and (c) personal accomplishment. Emotional exhaustion is characterized as educators' feelings of being

emotionally drained and unable to do their best work at their job. There are nine MBI-ES items that measure emotional exhaustion, such as “I feel emotionally drained from work”.

Depersonalization is characterized as when educators hold negative views towards their students and distance themselves from students and/or colleagues. There are five MBI-ES items that measure depersonalization, such as “I feel I treat some students as if they were impersonal objects”. Personal accomplishment is defined as educators’ feeling like their work contributes and enhances the learning and development of students. There are eight MBI-ES items that measure personal accomplishment, such as “I can easily understand how my students feel about things”. The MBI-ES is a 22-item, adapted version of the Human Services Survey (HSS; Maslach & Jackson, 1981) with the only difference between the two being the change in wording from “recipient” to “student”. Items on the MBI-ES focus on the frequency in which educators experience the three dimensions of burnout and are recorded on a Likert-scale: 0 = Never, 1 = A few times a year or less, 2 = Once a month or less, 3 = A few times a month, 4 = Once a week, 5 = A few times a week, and 6 = Every day.

Burnout is considered a continuous construct in which scores can range from low to high (Maslach et al. 1996). A high degree of burnout is indicated by high scores on the emotional exhaustion and depersonalization subscales and low scores on the personal accomplishment subscale. A moderate degree of burnout is indicated by average scores on the three subscales. A low degree of burnout is indicated by low scores on the emotional exhaustion and depersonalization subscales and high scores on the personal accomplishment subscale. Maslach and colleagues (1996) recommend that an aggregate score of burnout should not be calculated; hence, scores on each subscale should be calculated separately. Maslach and colleagues (1996, p.

6) provide cut-off points based on a sample of 4,163 teachers (K-12; see Table 5). Further, Maslach and colleagues (1996, p. 8) provide means and standard deviations for the MBI subscales in an overall sample of 11,067 (see Table 6).

Table 5
Categorization of MBI-ES Scores

Range of Experienced Burnout			
Educator (K-12)	Low	Average	High
Emotional Exhaustion	≤ 16	17-26	≥ 27
Depersonalization	≤ 8	9-13	≥ 14
Personal Accomplishment	≥ 37	36-31	≤ 30

Table 6
Measures of Central Tendency – MBI-ES

	Emotional Exhaustion	Depersonalization	Personal Accomplishment
Overall Sample (<i>N</i> = 11,067)			
<i>M</i>	20.99	8.73	34.58
<i>SD</i>	10.75	5.89	7.11
Educators (<i>N</i> = 4,163)			
<i>M</i>	21.25	11.00	33.54
<i>SD</i>	11.01	6.19	6.89

Psychometric Properties of MBI-ES Scores

A full review of the development and validation of the MBI-ES are reported in the *MBI Training Manual* (Maslach et al. 1996). The MBI-ES was adapted from the MBI-HSS which began as a 47-item instrument; however, a CFA reduced the model to a three factor model, consisting of 22-items. The MBI-ES has sound internal consistency reliability coefficients: (a) emotional exhaustion, $\alpha = .90$; (b) depersonalization, $\alpha = .79$; and (c) personal accomplishment, $\alpha = .71$. Lim and Eo (2014) investigated burnout in a sample of 367 educators using the MBI-ES and reported sound/acceptable reliability coefficients: (a) emotional exhaustion, $\alpha = .88$; (b) depersonalization, $\alpha = .69$; and (c) personal accomplishment, $\alpha = .85$. Grayson and Alvarez (2008) investigated burnout in a sample of 320 educators using the MBI-ES and also found

sound/acceptable reliability coefficients for the three-factor structure: (a) emotional exhaustion, $\alpha = .88$; (b) depersonalization, $\alpha = .80$; and (c) personal accomplishment, $\alpha = .64$. Furthermore, test-retest reliability with a one-year interval also supports the reliability of the MBI-ES: (a) emotional exhaustion, $r = .60$; (b) depersonalization, $r = .54$; and (c) personal accomplishment, $r = .57$. Overall, the MBI-ES has shown to produce reliable measures of educators' emotional exhaustion, depersonalization, and personal accomplishment.

Maslach and colleagues (1996) investigated the validity of scores derived from the MBI-HSS which, as noted, only differs from the MBI-ES in wording; hence it is plausible to assume the validity measures of the MBI-HSS are comparable to the MBI-ES. Convergent validity was supported by correlating participants' scores on the MBI-HSS and colleagues' behavioral ratings of the same individual. Participants who reported higher scores on emotional exhaustion were reported by colleagues as appearing to be: (a) emotionally drained, $r = .28, p < .05$; and (b) physically fatigued, $r = .42, p < .01$. In addition, participants who reported higher scores of depersonalization were reported by colleagues as appearing to be: (a) emotionally drained, $r = .56, p < .001$; (b) physically fatigued, $r = .55, p < .001$; and (c) complaining about clients, $r = .32, p < .05$ (Maslach et al. 1996). Moreover, discriminant validity of the MBI-ES has been supported – Wang, Hall, and Rahimi (2015) reported moderate correlations between job satisfaction and the three dimensions of burnout: (a) emotional exhaustion, $r = -.55, p < .01$; (b) depersonalization, $r = -.36, p < .01$; and (c) personal accomplishment, $r = .40, p < .01$, which all support the discriminate hypothesis that the dimensions of burnout are negatively related to job satisfaction in the expected directions. Kokkinos (2006) conducted a CFA to investigate the factor structure of the MBI-ES in a sample of $N = 771$ educators in Greece and found moderate

support for the three factor model of the MBI-ES, $\chi^2 = 978.64$ (206), $p > .05$; CFI = 0.83; RMSEA = .08; SRMR = .08. Although the CFI was lower than the .90 value determined to indicate good fit (i.e., Mueller, 1996), the RMSEA and SRMR values reported by Kokkinos (2006) fall within the cut-off points recommended by Hu and Bentler (1999), indicating an acceptable fit. Furthermore, Maslach and colleagues (1996) reported that the MBI-HSS is not influenced by social desirability as measured by the *Social Desirability Scale* (SDS; Crowne & Marlowe, 1960), indicating that the scores on the MBI-HSS are a reliable measure of burnout and are not subject to response bias. Therefore, it may be inferred that scores on the MBI-ES are not influenced by social desirability.

Marlow-Crowne Social Desirability Scale – Form XI

Crowne and Marlow (1960) developed the *Marlowe-Crowne Social Desirability Scale* (MCSDS) to measure the amount of influence social desirability has on self-report measures. The original version of the MCSDS was normed on a sample of 76 undergraduate students and showed strong internal consistency, $\alpha = .88$, and test-retest reliability, $r = .89$ (Crowne & Marlowe, 1960); however, the length of the original instrument has resulted in the development of multiple short forms of the MCSDS (e.g., Strahan & Garbasi, 1972; Reynolds, 1982).

Variations of the short form of the MCSDS have been used in hundreds of studies (Barger, 2002); however, there is some disagreement as to whether the short forms are stronger assessments than the original (Loo & Thorpe, 2000). Fisher and Fick (1993) investigated the psychometric properties of six short forms of the MCSDS and their relation to the original version of the MCSDS to determine the best measure of social desirability in a sample of 390

undergraduate students. Table 7 presents the goodness-of-fit indices for the social desirability scales.

Table 7
Fit Indices – Social Desirability Measures

SD Form	# of Items	Assessment of Fit						
		AGFI	RMS	Chi Sq.	<i>df</i>	BBI	ALPHA	<i>r</i>
Standard	33	.396	.054	673	495	.500	.963	
Form A	11	.958	.039	65	4	.787	.863	.941
Form B	12	.949	.040	70	54	.825	.875	.965
Form C	13	.916	.047	103	65	.775	.891	.965
Form XX	20	.781	.051	236	170	.648	.937	.976
Form X1	10	.968	.035	32	35	.831	.876	.958
Form X2	10	.949	.044	47	35	.751	.880	.908

Note. Table adapted from Fischer and Fick (1993, p. 419)

Standard (Crowne & Marlowe, 1960)

Form A (Reynolds, 1982) items: 3, 6, 13, 15, 16, 19, 21, 26, 28, 30, 33

Form B (Reynolds, 1982) items: 3, 6, 13, 15, 16, 19, 21, 26, 28, 30, 33, 12

Form C (Reynolds, 1982) items: 3, 6, 13, 15, 16, 19, 21, 26, 28, 30, 33, 12, 10

Form XX (Strahan & Gerbasi, 1972) items: 2, 4, 6, 11, 12, 14, 15, 16, 17, 19, 20, 21, 22, 23, 24, 25, 26, 28, 30, 33

Form X1 (Strahan & Gerbasi, 1972) items: 11, 15, 16, 17, 19, 22, 23, 25, 26, 33

Form X2 (Strahan & Gerbasi, 1972) items: 2, 4, 6, 12, 14, 20, 21, 24, 28, 30

r: Correlation with the standard 33-item Social Desirability Scale

Overall, Fischer and Fick's (1993) results support the MCSDS model fit as well as the reliability and validity of the scores in a sample of undergraduate students. For the purpose of the current study, the MCSDS-X1 (Strahan & Gerbasi, 1972) was chosen to measure social desirability – given its shortened length, high internal consistency and correlation with the original version, it is referred to as the, “scale of choice” among the various forms of the MCSDS (Fischer & Fick, 1993, p. 423).

Research Design

A correlational research design was used to address the investigation's hypotheses and research questions. Correlational research investigates the strength and direction of linear relationship between one or more variables (Gall et al., 2007); however, correlational research does not determine causal relationships between variables (Graziano & Roulin, 2006). As such, more advanced correlational analyses (i.e., SEM) are recommended to explain complex relationships between variables (Crockett, 2012). SEM allows researchers to examine the relationships between latent constructs (i.e., unobserved variables) within a causal framework (Murnane & Willet, 2011; Tabachnick & Fidell, 2012). Therefore, SEM was used to address the research hypothesis and questions, providing a better understanding of the strength and direction of the relationship between the constructs of interest within a causal framework.

Threats to Validity

Validity refers to the extent to which appropriate inferences can be made from test scores (Gall et al., 2007). There are inherent threats to validity in correlational research designs that need to be addressed, including: (a) construct validity; (b) internal validity; and (c) external

validity. Construct validity is defined as, “the extent to which a set of measured variables actually represent the theoretical latent construct they are designed to measure” (Hair, Black, Babin, & Anderson, 2010, p. 613). In the current study, construct validity was addressed by providing clear operational definitions of the constructs of interest which was derived from a thorough review of the theoretical and empirical research associated with each. Moreover, a CFA was conducted to support the conclusion that the instruments that were used to measure the constructs fit the data collected for the investigation.

Internal validity addresses how well causal inferences can be made between independent and dependent variables and relates to the instruments used in an investigation (Murnane & Willet, 2011). The first threat to internal validity in the present study is the potential for an ambiguous temporal precedence (Murnane & Willet, 2011) between the measured variables. In order to address the potential for ambiguous temporal precedence, the researcher specified the model a priori based on a theory-driven review of the empirical research focused on the constructs of interest. The second threat to internal validity is characteristic correlation which is the potential for a third variable (e.g., demographics, prior knowledge, etc.) to influence the relationship between the variables being measured (Brewer, 2000). The study collected demographic information (e.g., gender, position, years of experience, etc.) in order to examine their potential influence on the relationship between the constructs of interest. The third threat to internal validity in the study is instrumentation, which describes the possibility that the psychometric properties of the instruments being used are weak (Murnane & Willet, 2011). The researcher conducted CFAs on the instruments being used to ensure that the data appropriately reflects the validity of the scores for the sample. The fourth threat to internal validity is testing

which refers to participants becoming familiar with the nature of the items and responding randomly (Gall et al., 2007). The study implemented a test item to detect whether participants were responding to the questions at random (i.e., “If you are reading this item, please select rating number 4”). The fifth threat to internal validity is attrition which refers to the possibility that participants drop out of a study (Murnane & Willet, 2011). The data collection packet consisted of 142 total items; hence, it is possible participants dropped out midway through completing the assessment packets. To address the threat of attrition, an informed consent was provided to each participant which outlined the approximate time it would take to complete the data collection packet. The last threat to internal validity is the self-report nature of the data that was collected. However, to address the threat to internal validity that is posed by self-report measures, the MCSDS – X1 (Strahan & Gerbasi, 1972) was used to examine the relationship between social desirability and scores on the other data collection instruments.

External validity is the extent to which the results can be applied across individuals and settings beyond the participants in the sample (Murnane & Willet, 2011) and is comprised of two types of validity: (a) population validity; and (b) ecological validity. Population validity refers to the extent to which the results from the sample can be generalized to a larger group that is similar to the sample (Gall et al., 2007). The first threat to population validity is generalizing results from an accessible population to a target population. In addition, personal characteristics of participants who volunteer to participate can threaten population validity in that more inspirational educators chose to participate in the study which can limit the variance within the data (Gall et al., 2007). Further, the study focused on personal attributes of educators; therefore, self-report bias can potentially limit the generalizability of the results. Ecological validity refers

to the extent to which the results can be generalized to different environmental conditions (Gall et al., 2007). In order to address potential threats to ecological validity, demographic information was collected (e.g., type of school, school setting, current position, etc.) and used to determine whether the theoretical model is consistent across different settings.

Research Hypothesis and Exploratory Questions

The purpose of the current investigation was to examine the directional relationship between educators' levels of inspiration, compassion, and burnout. The purpose of the current section outlines the research hypothesis and questions.

Research Hypothesis

The research hypothesis that was tested in the current investigation was: Educators' inspiration (as measured by the EIS; Lambie et al. 2016) and compassion for others (as measured by the CS; Pommier, 2010) scores contribute to their levels of burnout (as measured by the MBI-ES; Maslach et al. 1996). Specifically, educators' levels of inspiration and compassion for others will negatively relate to educators' levels of burnout

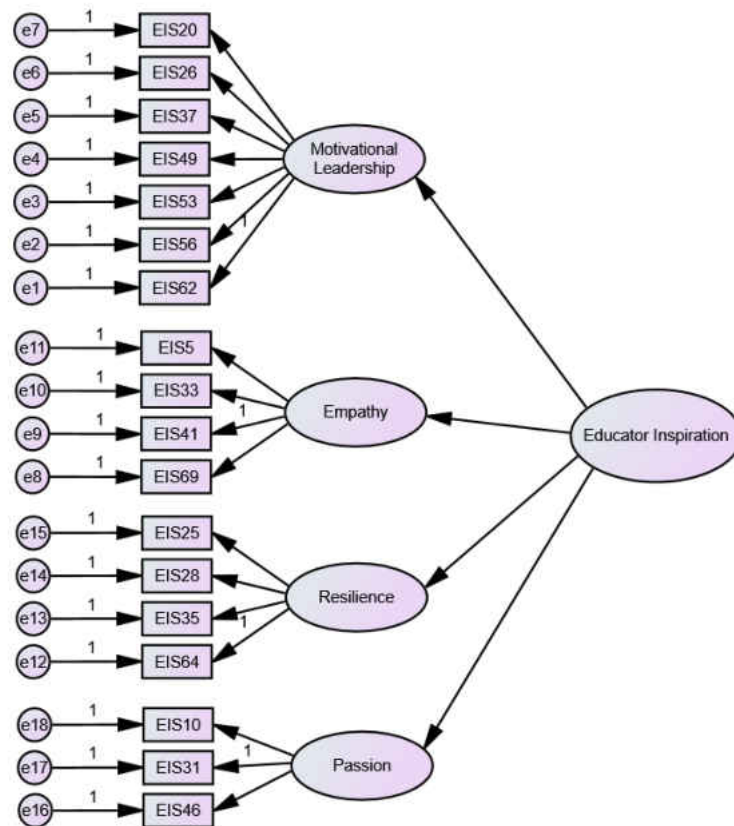

Figure 2: Measurement Model - EIS

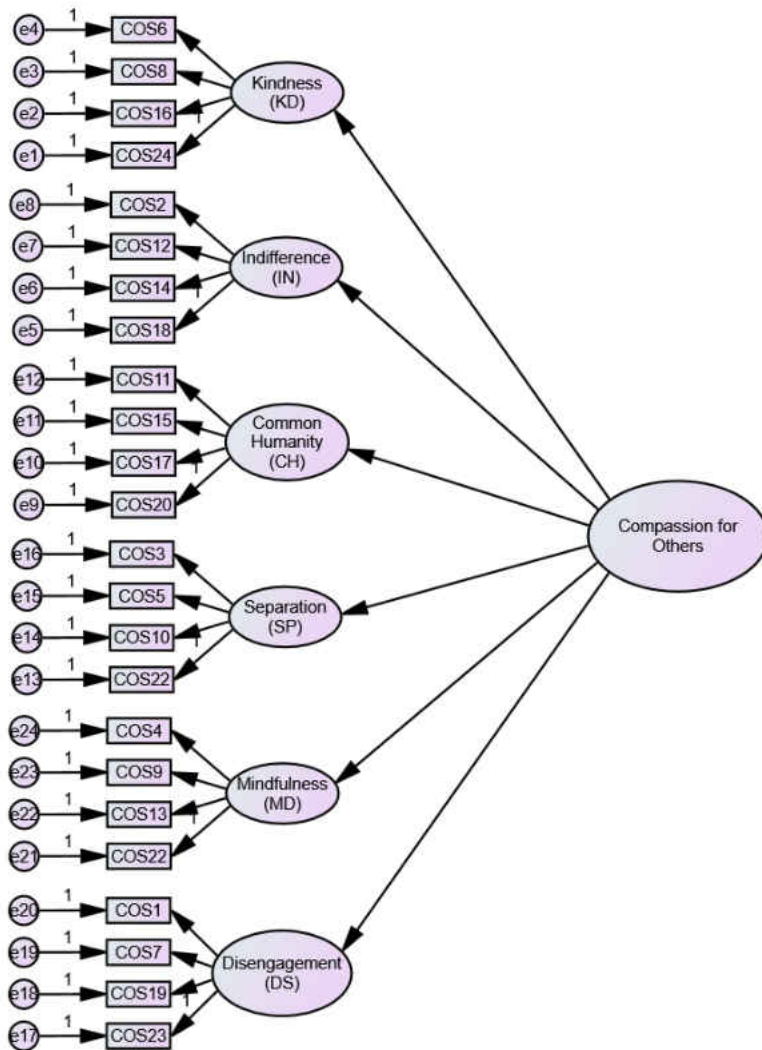

Figure 3: Measurement Model - COS

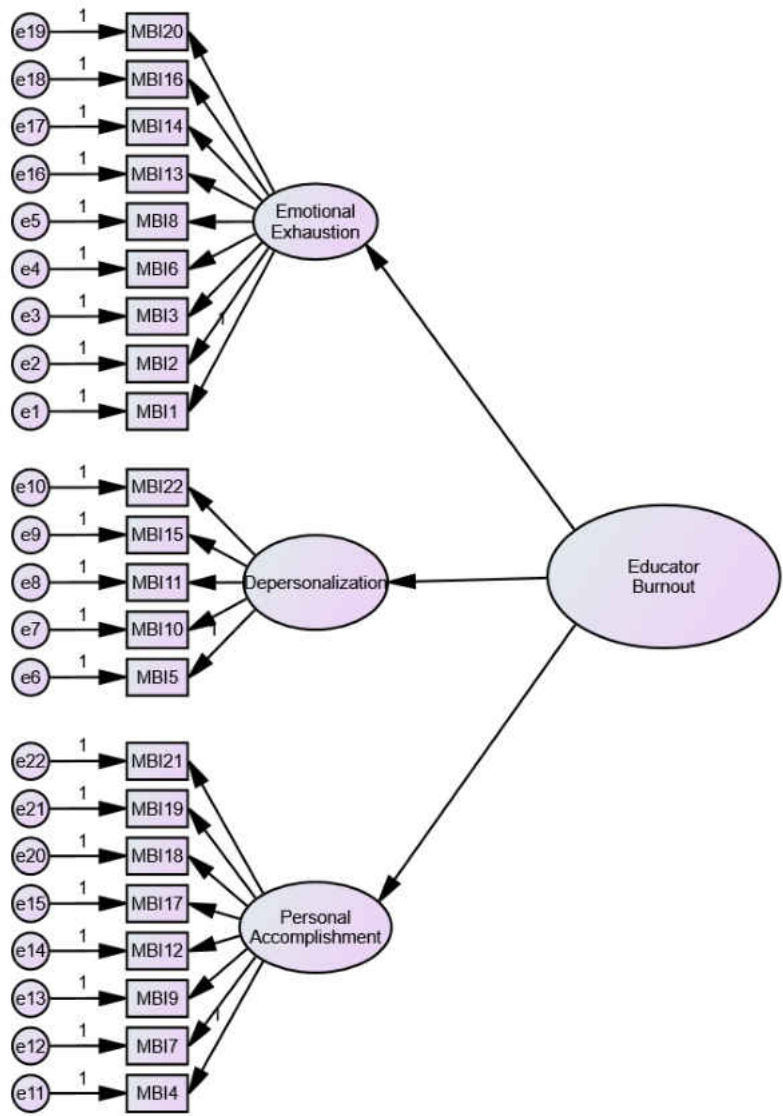

Figure 4: Measurement Model – MBI-ES

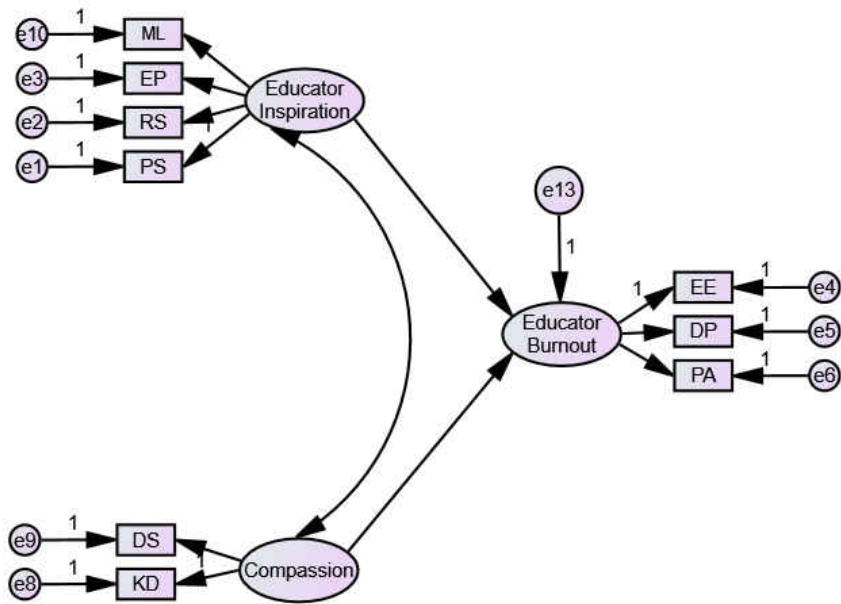

Figure 1: Hypothesized Structural Model

Exploratory Research Question One

What is the linear relationship between educators' reported demographic information (e.g., gender, age, years of experience, etc.) and their levels of educator inspiration (as measured by the EIS; [Lambie et al., 2017], compassion for others (as measured by the COS; [Pommier, 2010]), and burnout (as measured by the MBI-ES; [Maslach et al., 1996])?

Exploratory Research Question Two

Are there statistically significant differences in educators' levels of burnout (as measured by the MBI-ES; [Maslach et al., 1996]) based on their reported demographic variables (e.g., type of school, current position, years of experience, gender, etc.)?

Exploratory Research Question Three

Are there statistically significant differences in educators' level of inspiration (as measured by the EIS; [Lambie et al., 2017]) and compassion for others (as measured by the COS; [Pommier, 2010]) based on their reported demographic variables (e.g., type of school, current position, years of experience, gender, etc.)?

Data Analysis

The data analysis was conducted based on the completed assessment packets which included a *General Demographic Questionnaire* and the four instruments: (a) EIS (Lambie et al. 2016); (b) COS (Pommier, 2010); and (c) the MBI-ES (Maslach et al. 1996); and (d) MCSDS-X1 (Strahan & Gerbasi, 1972). The data was entered into *Statistical Program Systems Software*

23rd edition (SPSS, 2015) and analyzed with SPSS, *Analysis of Moment Structure* (AMOS, 2011), and Mplus. AMOS and Mplus are statistical modeling programs that translate mathematical equations into visual representations (i.e., path diagrams) that represent the theoretical relationships (including measurement error) between the latent variables as well as address missing data, outliers, and variable transformations within a data set (Crockett, 2012). Further, in order to determine the collected data is appropriate for SEM analysis, statistical assumptions such as normality, homogeneity, and relative variances were tested and satisfied (Kline, 2016). The following section outlines the steps in the data analysis that addressed the research questions and hypothesis.

Research Hypothesis

The study utilized SEM to address the research hypothesis. SEM is a collection of statistical techniques that allows researchers to test the relationships between directly observed variables and underlying a priori theoretical models (Crockett, 2012). SEM was chosen over other methods of analysis, such as path analysis or multiple regression, because it is an optimal method to investigate the strength and directionality of multi-factor latent variables within a causal framework (Kline, 2016; Lambie, 2007).

Crockett (2012) outlines five steps to SEM research when conducting counseling research: (a) model specification; (b) model identification; (c) model estimation; (d) model evaluation; and (e) model modification. The following sections applies the five steps to SEM research outlined by Crockett (2012) to the proposed investigation.

Model Specification

Model specification is the most important step to SEM research (Kline, 2016) and requires researchers to diagram the theoretical relationships between the constructs of interest. The researcher has reviewed the literature of the three constructs of interest (educator inspiration, compassion, and burnout) and the hypothesized structural model is presented in Figure 4.

Model Identification

Model identification determines whether it is theoretically possible for SEM software (AMOS) to extract a unique estimate for each model parameter (Kline, 2016). There are two components that need to be identified: (a) measurement model; and (b) structural model. The measurement model is the relationship between the observed measures and the latent variable (Byrne, 2016). The structural model is the relationship between the latent variables (Byrne, 2016). Bollen (1989) described a two-step identification rule for fully latent models: (a) the measurement model is identified if it has two or more factors that each have two or more indicators; and (b) the structural model is identified if it is specified as recursive. Figures 1, 2, and 3 represent the measurement models of the three constructs in the study and indicate that there are two or more factors that comprise the latent variable, each of which have a minimum of two indicators. Figure 4 represents the structural model and shows that it is recursive (i.e., there are not any feedback loops in the model). Furthermore, in order for the hypothesized model to be identified, it is necessary that the model degrees of freedom (df_M) is at least 0. In the study, the $df_M > 0$, $(136 \text{ [observed variables]} - 34 \text{ [free parameters]} = 102 \text{ [} df_M \text{)})$.

Model Estimation

Model estimation involves “determining the value of the unknown parameters and the error associated with the estimated value” (Weston & Gore, 2006, p. 737). Thus, researchers determine an appropriate fitting function to use (e.g., Maximum Likelihood [ML], Generalized Least Squares [GLS]) that generates a theoretical covariance matrix, Σ , whose parameter values minimize the difference between the theoretical covariance matrix and the observed covariance matrix, S (Crockett, 2012). ML and GLS are considered the most popular fitting functions (Crockett, 2012); however, it should be noted that while GLS is better for non-normal data, ML is most commonly used with complex models and unequal group sizes (Kline, 2016).

Model Testing

Crockett (2012) described model testing as “the analysis of both the measurement and structural models in order to determine (a) the global fit of the entire model and (b) the fit of individual model parameters” (p. 34). It is best practice to analyze multiple fit indices such as: (a) absolute fit indices (e.g., χ^2 test, RMSEA, AGFI); (b) comparative fit indices (e.g., CFI, NNFI); and (c) parsimonious fit indices (e.g., PNFI, PGFI; Crockett, 2012). Table 8 presents a description of the fit indices along with cutoff criteria.

Table 8
Description of Fit Indices

Fit Indices	Description	Cutoff Criteria
Chi-Square (χ^2)	Determines whether the observed covariance matrix is significantly different from the predicted covariance matrix with the goal being that the model predicts the matrix.	Non-significant χ^2 values indicate acceptable fit.
Comparative Fit Index (CFI)	Compares the discrepancy between a target model and an alternate model. Most common alternate model requires making all latent variables and indicators uncorrelated.	CFI \geq .95 indicates a good fit
Root Means Squared Error of Approximation (RMSEA)	Identifies the amount of variance in the hypothesized model. Sensitive to <i>df</i> .	RMSEA \leq .08 is acceptable
Goodness of Fit Index (GFI)	Determines the degree of variance and covariance in the observed sample matrix which is predicted by the model covariance matrix.	GFI \geq .90 indicates a good fit
Normed Fit Index (NFI)	Indicates the percentage of improvement from a baseline model to the theoretical model.	NFI \geq .90 indicates a good fit

Note. Chart adapted from: Bloom, 2016; Crockett, 2012; Hu & Bentler, 1999; Mullen, 2014

Model Modification

Model modification requires researchers to adjust the parameters of the theoretical model with the intention to increase the goodness-of-fit between the model and the data (Schumacker & Lomax, 2010). Analyses such as the Lagrange Multiplier test or Wald test are used to determine if the model fit would improve with the addition or subtraction of specific paths in the model (Kline, 2016).

Exploratory Research Questions

The exploratory research questions were analyzed using: (a) descriptive statistics; (b) Spearman's Rho Correlations; (c) Multivariate Analysis of Covariance (MANCOVA); and; and (d) Multiple Regression. The purposes of the exploratory research questions are: (a) examine whether there is a relationship between reported demographic information and educators' levels of inspiration (as measured by the EIS; Lambie et al., 2016) and compassion for others (as measured by the COS; Pommier, 2010); and (b) examine whether there is a relationship between reported demographic information and educators' levels of burnout (as measured by the MBI-ES; Maslach et al. 1996).

Ethical Considerations

The ethical considerations that were considered by the researcher's university and the investigator's dissertation committee were:

1. All of the data was collected anonymously to protect the identity of each participant.
2. Participation in the study was completely voluntary.

3. Each participant was given an informed consent which detailed their rights and purpose of the study. The informed consent that each participant received was approved by the IRB at the researcher's university.
4. Permission to use the MBI-ES (Maslach et al. 1996) was given by the developers of the instrument. The other instruments did not require permission to use in educational research.
5. The current investigation was conducted upon approval from the dissertation co-chairs, committee members, and the IRB at the researcher's university.

Potential Limitations of the Current Study

1. Although efforts were made to limit threats validity (e.g., construct, internal, and external), implicit limitations to descriptive correlational research remain.
2. The *Educator Inspire Scale* is a new instrument and the psychometric properties are still being developed.
3. The *Compassion for Others Scale* is a new instrument and the reliability of scores on some subscales (i.e. Disengagement) are questionable.
4. All of the data collection instruments were self-report; hence the scores on each may contain bias (e.g., social desirability) that could influence the results.
5. Given the sampling methods used in the current study (i.e. criterion and convenience sampling), there is potential for the occurrence of sampling bias.

Chapter Summary

Chapter Three presented the research methods that were used to examine the theoretical structural model that educators with higher levels of inspiration (as measured by the EIS; Lambie et al., 2016) and compassion for others (as measured by the COS; Pommier, 2010) score at lower levels of burnout (as measured by the MBI-ES; Maslach et al., 1996). Chapter Three also outlined: (a) the population and sampling procedures; (b) the data collection; (c) the instrumentation; (d) the research design; (e) the research hypothesis and exploratory questions; and (f) the data analysis. Furthermore, ethical considerations were reviewed and potential limitations to the study were presented.

CHAPTER FOUR: RESULTS

Chapter four presents the results from the investigated research hypothesis and questions. The purpose of the current research investigation was to examine the directional relationship between educators' levels of educator inspiration and compassion for others to their degree of burnout. The investigation tested the theoretical model that educators' levels of educator inspiration (as measured by the *Educator Inspire Scale* [EIS]; Lambie et al., 2016) and compassion for others (as measured by the *Compassion for Others Scale* [COS]; Pommier, 2010) contributes to their levels of burnout (as measured by the three dimensions [emotional exhaustion, depersonalization, personal accomplishment] of the *Maslach Burnout Inventory – Educator Survey* [MBI-ES]; Maslach et al., 1996). Specifically, the investigation tested the hypothesized directional relationship that educators' scoring at higher levels of educator inspiration and compassion for others have lower reported levels of burnout (lower emotional exhaustion, lower depersonalization, and higher personal accomplishment scores). In addition, the current investigation examined the relationship between educators' inspiration, compassion for others, and burnout scores and their reported demographic information (e.g., gender, current position, and years of experience).

The research hypothesis was analyzed using structural equation modeling (SEM). Specifically, a combination of multiple regression, path analysis, and confirmatory analysis were conducted (Ullman, 2007). The exploratory questions were addressed using: (a) descriptive statistics; (b) Pearson's product-moment correlations; (c) multiple regression; and (d) Spearman's Rho correlations. The results of the current investigation are presented in the

following order: (a) sampling and data collection procedures; (b) descriptive statistics; and (c) data analyses for the primary research hypothesis (SEM; measurement and structural models) and exploratory questions.

Sampling and Data collection Procedures

The data that was analyzed was part of a study funded by T. Denny Sanford Foundation. In the original study, 2,060 data collection packets were printed which included: (a) an informed consent that outlines the purpose of the study; (b) a general demographic questionnaire; (c) the EIS; (d) the COS; (e) the MBI-ES; and (f) the *Marlowe-Crowne Social Desirability Scale – XI* (MCSDS-X1; Strahan & Gerbasi, 1972). In addition, a pen was provided in each data collection packet - small incentives such as a pen have been shown to increase response rates by up to 70% (Dillman, Smyth, & Christian, 2014).

Criterion sampling was used to obtain the required sample size for the current study. Criterion sampling is a method in which participants who satisfy an important criterion are recruited for participation in a study (Gall et al., 2007). The data collection packets were disseminated via two face-to-face methods. First, data collection packets were disseminated to schools who employ practicing educators and/or educators-in-training throughout a large school district in a large southeastern state upon approval from the Superintendent. The second face-to-face method of data collection consisted of two parts: (a) contacting colleagues who have direct access to educators and/or educators-in-training (e.g., K-12 educators, school counselors, student-teachers, etc.) and then mailing data collection packets to the identified colleagues who

then disseminated the data collection packets and returned the completed packets; and (b) attending classes, workshops, and career fairs that potential participants who meet the criteria for participation (i.e., educator or educator-in-training) were in attendance and distributing data collection packets to voluntary participants.

Response Rate

As noted, there were three face-to-face methods of data collection that were utilized for the current study. The following section presents the response rate per each of the three data collection method employed.

School District Distribution

The researcher identified 13 elementary, middle, and high schools throughout a large school district in a large southeastern state in the United States that had access to potential educator participants. Upon receiving approval from the school district's superintendent's office, the researcher delivered boxes of data collection packets with specific instructions for the study, including that participation was: (a) voluntary; (b) data was anonymous; and (c) the purpose of the research is to better understand educators' and educators-in-training experiences relating to burnout. Each school was given approximately two weeks to disseminate the data collection packets to voluntary participants, at which point a colleague of the researcher drove to each of the 13 participating schools to collect the completed data collection packets. In total, 1,500 data collection packets were distributed to the 13 schools. Of the 1,500 data collection packets that were distributed, the researcher received a total of 243 data collection packets in return; however,

15 data collection packets were not filled completed, resulting in 228 completed data collection packets (15.2% usable responses rate).

Mailing Distribution

With the help of a senior faculty member, the researcher identified a colleague in a large southeastern state of the United States with access to potential participants who were educators and/or educators-in-training. A total of 200 data collection packets were mailed to the identified colleague at the large university to distribute to educators and educators-in-training throughout her state. A total of 62 data collection packets were completed and returned to the researcher, resulting in a 31% usable response rate.

Classes, Workshops, and Career Fairs Distributions

The researcher identified classes, workshops, and career fairs that occurred at a large university in a southeastern state where potential participants attended these events. First, a career fair for educators and/or educators-in-training was held at the university in the fall of 2015. The researcher attended the career fair and disseminated 230 data collection packets to voluntary participants, resulting in 160 completed data collection packets (69.56% usable response rate). In addition, with the help of a senior faculty member, 20 data collection packets were given to colleagues with access to educators-in-training at the university who requested their students participate in the current study, yielding an addition 20 completed data collection packets (100% usable response rate). Moreover, the researcher attended three workshops for educators and/or educators-in-training and disseminated 100 data collection packets to voluntary

participants, yielding 100 completed data collection packet (100% usable responses rate). Table 9 represents the usable response rate obtained via each data collection method.

Table 9
Response Rate via Data Collection Methods

	Data packets distributed	Data packets returned	Response rate	# of incomplete data packets	Usable Response Rate
School District	1,500	243	16.20 %	15	15.20 %
Mailing	200	62	31.00 %	0	31.00 %
Classes	20	20	100%	0	100%
Workshops	100	100	100%	0	100%
Career Fair	230	160	69.56%	0	69.65%

Note. $N = 580$.

Total Response Rate = 29.02%

Total Usable Response Rate = 28.29%

Descriptive Data Results

Participant Demographic Information

Data collection resulted in a final sample of 580 participants with complete assessment data (usable response rate of 28.15%). The majority of participants self-identified as “Female” ($n = 469$; 80.9%), while ($n = 108$; 18%) identified as “Male”, and ($n = 1$; .2%) identified as “Other”. Participants’ ages ranged from 18 to 75 years ($M = 36.8$, $SD = 14.1$, $Mdn = 33.00$). The

majority of participants self-identified as “White/Non-Hispanic” ($n = 431$; 74.1%) whereas 10.2% ($n = 59$) identified as “African-American”, 1.6% ($n = 9$) as “Asian-American”, 10.5% ($n = 61$) as “Hispanic”, 1.2% ($n = 7$) as “Multiracial”, .2% ($n = 1$) as “Native-American”, .5% ($n = 3$) as “Pacific/Islander”, and 1.2% ($n = 7$) as “Other”. Half of the sample ($n = 290$; 50.0%) reported being married/partnered/living together, while ($n = 174$; 30.0%) reported being single, and the remaining sample reporting as dating ($n = 74$; 12.4%), divorced/widowed ($n = 37$; 6.4%), or “other” ($n = 1$; .2%). The majority of participants reported that their highest degree completed was a Bachelor’s degree ($n = 202$; 34.8%) as opposed to participants who reported currently earning their Bachelor’s degree ($n = 160$; 27.6%), Master’s degree ($n = 178$; 30.7%), Educational Specialist ($n = 12$; 2.1%), Doctorate of Philosophy ($n = 6$; 1.0%), and Doctorate of Education ($n = 15$; 2.6%). Participants’ years of experience ranged from 0 years (educators-in-training) to 52 years ($M = 9.9$ years, $SD = 11.1$, $Mdn = 6.00$). Additional participant demographic data are presented in Table 10 and Table 11.

Table 10
Participant Demographic Information

Characteristic	<i>n</i>	Total Percent
Gender		
Female	469	80.9%
Male	108	18.6%
Other	1	.2%
Ethnicity		
African-American	59	10.2%
Asian-American	9	1.6%
Hispanic	61	10.5%
Native-American	7	1.2%
Multiracial	1	.2%
Pacific/Islander	3	.5%
White/Non-Hispanic	431	74.3%
Other	7	1.2%
Marital Status		
Married/Partnered/Living together	290	50.0%
Currently Dating	74	12.8%
Single	174	30.0%
Divorced/Widowed	37	6.4%
Other	1	.2%
Highest Degree Completed		
Earning Bachelor's Degree	160	27.6%
Bachelor's	202	34.8%
Master's	178	30.7%
Educational Specialist	12	2.1%
Doctorate of Philosophy	6	1.0%
Doctorate of Education	15	2.6%
State Currently Employed		
Florida	504	86.9%
Louisiana	62	10.7%
Texas	1	.2%

Table 10

Setting of Current School		
Rural	35	6.0%
Suburban	357	61.6%
Urban	162	27.9%
Other	6	1.0%
Type of School Currently Employed		
Regular	466	80.3%
Vocational	7	1.2%
Special Education	10	1.7%
Alternative Education	5	.9%
Other	43	7.4%
Current Position		
Educator-in-Training	145	25.0%
Elementary School Teacher	133	22.9%
Middle School Teacher	52	9.0%
High School Teacher	134	23.1%
School Administrator	9	1.6%
School Counselor	14	2.4%
Other	54	9.3%

Table 11
Measures of Central Tendency – Satisfaction, Stress, Support, Effectiveness

	<i>M</i>	<i>Mdn</i>	<i>SD</i>	<i>Min. – Max.</i>
Current Satisfaction	4.06	4	.979	1.00 – 5.00
Current Stress	2.78	3	1.11	1.00 – 5.00
Perceived Support	3.81	4	1.01	1.00 – 5.00
Perceived Effectiveness	4.32	4	.679	1.00 – 5.00

Note. Scores were recorded on a five-point Likert scale:

1 = “very not satisfied/ very stressed/ very unsupportive/ very ineffective”

2 = “not satisfied/ stressed/ unsupportive/ ineffective”

3 = “somewhat satisfied/ somewhat stressed/ somewhat supportive/ somewhat effective”

4 = “satisfied/ not stressed/ supportive/ effective”

5 = “very satisfied/ very unstressed/ very supportive/ very effective”

Educator Inspiration

The EIS (Lambie et al., 2016) was used to measure educators’ levels of inspiration. The EIS is an 18-item instrument that ranges on a seven-point Likert scale from 1 (*Strongly Disagree*) to 7 (*Strongly Agree*). In addition, the EIS contains four subscales: (a) *Motivational Leadership* (items 20, 26, 37, 49, 53, 56, and 62); (b) *Empathy* (items 5, 33, 41, and 69); (c) *Resilience* (items 25, 28, 35, and 64); and (d) *Passion* (items 10, 31, and 46). EIS subscale scores were calculated by averaging the scores on each of the four subscales. Further, a total mean score can be calculated to reflect an overall educator inspiration score. In general, the educators in the current sample ($N = 580$) reported similar scores on the EIS across all of the subscales. Therefore, further analyses should be interpreted with caution as the current sample consists of above average inspirational educators ($M = 6.26$). Table 12 represents the measures of central tendency for the EIS.

The initial examination of the internal consistency reliability of the EIS was good ($\alpha = .904$; $n = 554$). Cronbach's α for the subscales of the EIS also reflected sound internal consistency reliabilities: (a) *Motivational Leadership* ($\alpha = .888$; $n = 568$); (b) *Empathy* ($\alpha = .869$; $n = 568$); (c) *Resilience* ($\alpha = .825$; $n = 572$); and (d) *Passion* ($\alpha = .853$; $n = 573$).

Table 12
Measures of Central Tendency - EIS

EIS	<i>n</i>	<i>M</i>	<i>SD</i>	<i>Mdn.</i>	<i>Min. - Max</i>
<i>Motivational Leadership</i>	579	6.66	.493	6.85	2.86 – 7.00
<i>Empathy</i>	580	6.01	.931	6.25	2.00 – 7.00
<i>Resilience</i>	579	6.16	.783	6.25	2.50 – 7.00
<i>Passion</i>	580	5.79	1.10	6.00	1.33 – 7.00
<i>Total Educator Inspiration</i>	580	6.26	.581	6.39	3.61 – 7.00

Compassion for Others

The COS (Pommier, 2010) was used to measure educators' levels of compassion. The COS is a 24-item measure with a five-point Likert scale that ranges from 1 ("Almost Never") to 5 ("Almost Always"); however, there are not indicator labels for options that range from 2 to 4. The COS consists of six subscales: (a) *kindness* (items 6, 8, 16, and 24); (b) *indifference* (items 2, 12, 14, and 18); (c) *common humanity* (items 11, 15, 17, and 20); (d) *separation* (items 3, 5, 10, and 22); (e) *mindfulness* (items 4, 9, 13, and 21); and (f) *disengagement* (items 1, 7, 19, and 23). It is important to note that the COS subscales are not mutually exclusive; for example, higher scores on the subscale 'kindness' does not directly result in lower scores on 'indifference'; rather, subscale scores are allowed to score independently of each other. Subscale

scores were calculated by examining the mean of each subscale (e.g., *kindness* is the mean value of items 6, 8, 16, and 24). In order to calculate a *total* compassion score, subscales *indifference* (items 2, 12, 14, and 18), *separation* (items 3, 5, 10, and 22), and *disengagement* (items 1, 7, 19, and 23) were first reversed scored, then a total mean was calculated from the six subscales.

In general, educators in the current sample reported higher compassion scores ($M = 4.27$, $SD = .49$) as compared to the compassion scores of the norm sample ($N = 439$; $M = 3.84$, $SD = .60$). Specifically, educators in the current sample ($N = 580$) reported higher scores on: (a) *kindness* ($M = 4.36$, $SD = .69$) as compared to the norm sample scores of kindness ($M = 3.90$, $SD = .64$); (b) *common humanity* ($M = 4.30$, $SD = .58$) as compared to the common humanity scores of the norm sample ($M = 4.06$, $SD = .63$); and (c) *mindfulness* ($M = 4.31$, $SD = .57$) as compared to the mindfulness scores of the norm sample ($M = 3.96$, $SD = .57$). However, it is important to note that the norm sample of the COS consisted of only undergraduate students majoring in psychology and should be interpreted with caution. Table 13 presents the measures of central tendency for the COS.

Table 13
Measures of Central Tendency - COS

	<i>M</i>	<i>SD</i>	<i>Mdn</i>	<i>Range</i>
Kindness ^a	4.36	.69	4.50	1.25 – 5.0
Indifference ^a	1.86	.72	1.75	1.0 – 4.5
Common Humanity ^b	4.30	.58	4.50	2.0 – 5.0
Separation ^a	1.81	.76	1.75	1.0 – 5.0
Mindfulness ^b	4.31	.57	4.5	2.25 – 5.0
Disengagement ^a	1.76	.72	1.5	1.0 – 4.75
Total Compassion ^b	4.27	.49	4.33	2.67 – 5.0

Note. ^a*n* = 577; ^b*n* = 578

The initial examination of the internal consistency reliability of the COS data was acceptable for early development research ($\alpha = .571$; Streiner, 2003). Cronbach's α for the *kindness* (KD) subscale was .725 and the *indifference* (ID) subscale was .714, both of which are acceptable. Cronbach's α for the remaining subscales on the COS with these data were: (a) *common humanity* (CH; $\alpha = .583$; $n = 573$); (b) *separation* (SP; $\alpha = .675$, $n = 563$); (c) *mindfulness* (MD; $\alpha = .542$; $n = 575$); and (d) *disengagement* (DS; $\alpha = .697$; $n = 569$). Given the COS is in the early stages of development, lower (i.e., $\alpha = .675$ and $\alpha = .697$) internal consistency scores are acceptable (Nimon, Zientek, & Henson, 2012), although the others (i.e., $\alpha = .583$ and $\alpha = .542$) are questionable and should be interpreted with caution (Hair et al., 2006).

Burnout

The MBI-ES (Maslach et al., 1996) was used to measure participants' levels of burnout along three dimension: (a) *emotional exhaustion* (EE); (b) *depersonalization* (DP); and (c) *personal accomplishment* (PA). The MBI-ES is a 22-item, self-report instrument that measures participants' levels of burnout. Participants respond to each item on a seven-point Likert scale: 0 = Never; 1 = A few times a year or less; 2 = Once a month or less; 3 = A few times a month; 4 = Once a week; 5 = A few times a week; and 6 = Every day. *Emotional exhaustion* scores are the sum of items 1, 2, 3, 6, 8, 13, 14, 16, and 20. *Depersonalization* scores are the sum of items 5, 10, 11, 15, and 22. *Personal accomplishment* scores are the sum of items 4, 7, 9, 12, 17, 18, 19, and 21. Tables 14 and 15 represent the range of reported experienced burnout and the measures of central tendency for the subscales of the MBI-ES (EE, DP, and PA).

Table 14
Range of Experienced Burnout

	Range of Experienced Burnout					
	Low		Average		High	
	<i>n</i>	Percent	<i>n</i>	Percent	<i>n</i>	Percent
Emotional Exhaustion	239	41.2%	165	28.4%	171	29.5%
Depersonalization	466	80.3%	61	10.5%	46	7.9%
Personal Accomplishment	59	10.2%	80	13.8%	434	74.8%

Note. *N* = 580.

Table 15
Measures of Central Tendency – MBI-ES

	<i>M</i>	<i>SD</i>	<i>Mdn</i>	<i>Range</i>
Emotional Exhaustion ^a	20.16	12.01	19	0 - 52
Depersonalization ^b	4.53	5.16	3	0 - 28
Personal Accomplishment ^c	40.05	6.52	41	16 - 48

Note. ^a*n* = 568; ^b*n* = 563; ^c*n* = 557

The current sample of educators reported similar levels of EE ($M = 20.16$, $SD = 12.01$) as compared to the reported levels of EE in the norm sample of educators ($N = 4,163$; $M = 21.25$, $SD = 11.01$). However, the current sample reported lower scores of DP ($M = 4.53$, $SD = 5.16$) as compared to the norm sample of educators' levels of DP ($M = 11.00$, $SD = 6.19$) and higher levels of PA ($M = 40.05$, $SD = 6.52$) as compared to the norm sample of educators' levels of PA ($M = 33.54$, $SD = 6.89$). Overall, the scores on the MBI-ES for the current sample identified that participants reported lower levels of burnout as compared to the norm sample of educators.

The initial examination of the internal consistency reliability of the entire MBI-ES (22 items) was good ($\alpha = .914$; $n = 550$). Cronbach's α for the EE (nine items) was .912, DP (five items) was .746, and PA (eight items) dimension was .798; all of which indicate acceptable internal consistency (Hair, et al., 2006).

Social Desirability

The MCSDS-X1 (Strahan & Gerbasi, 1972) was used to account for possible response bias and to promote internal validity (Reynolds, 1982). The MCSDS-X1 is a 10-item, true/false instrument that has been described as the, “scale of choice” among the various forms of the MCSDS (Fischer & Fick, 1993, p. 423). The MCSDS-X1 is a one-factor assessment that yields a composite score which indicates participants’ levels of social desirability. Participants receive a 1 point for every “true” statement on items 1, 2, 3, 4, and 5 and 1 point for every “false” statement on items 6, 7, 8, 9, and 10. Higher scores on the MCSDS-XI identify that participants are responding in a socially desirable way rather than a truthful way. Initial Cronbach’s α for the MCSDS-XI (10 items, $n = 573$) was .682, which is acceptable for the purpose of the current research (Nunnally, 1967). Table 16 presents the measures of central tendency for the MCSDS-XI.

Table 16
Measures of Central Tendency – MCSDS-XI

	<i>M</i>	<i>SD</i>	<i>Mdn.</i>	<i>Min. – Max.</i>
MCSDS-X1	5.91	2.25	6.00	0 - 10

Note. $N = 580$.

In order to assess the influence of social desirability on participants’ responses on the MBI-ES-R, COS-R, and EIS, the researcher opted to conduct a multiple regression analysis to examine the potential influence social desirability had on the participants’ responses. Table 17 represents the results from the multiple regression analysis for participants’ scores on the

MCSDS-X1 and: (a) MBI-ES-R (EE, DP, and PA); (b) COS-R (compassion total); and (c) EIS (motivational leadership, empathy, resilience, passion).

Table 17
Influence of Social Desirability on EIS, COS, and MBI-ES Scores

	β	t	Sig.	d
ML	.028	.529	.597	.056
EP	.063	1.237	.217	.126
RS	.167	3.272	.001	.339
PS	.006	.133	.896	.012
EE	-.199	-2.356	.019	.406
DP	-.169	-3.158	.002	.343
PA	-.052	-1.045	.296	.104
CT ^a	-.073	-1.806	.071	.146

Note. ^aN = 578.

Results from the multiple regression analysis indicate that RS, EE, and DP were influenced by social desirability, although the effect sizes were small to medium. Furthermore, results from independent-samples t-tests revealed: (a) statistically significant differences in MCSDS-X1 scores between participants who reported *high EE* scores (i.e., ≥ 27 ; $n = 171$; $M = 5.14$, $SD = 2.14$) and participants who reported *low to average EE* scores (i.e., < 26 ; $n = 409$; $M = 6.23$, $SD = 2.22$), $t(578) = 5.48$, $p < .001$; and (b) statistically significant differences in MCSDS-X1 scores between participants who reported *high DP* scores (i.e., ≥ 14 ; $n = 46$; $M = 2.34$, $SD = .874$) and participants who reported *low to average DP* scores (i.e., < 13 ; $n = 534$; $M = 3.01$, $SD = 1.13$), $t(58.82) = 4.802$, $p < .001$. Implications of the influence of social desirability on the participants' RS, EE, and DP scores is discussed in chapter five.

Data Screening and Statistical Assumptions in SEM

When conducting quantitative research, it is necessary to screen the data to ensure that the statistical assumptions are met (Osborne, 2013). Specifically, the following were screened and checked to ensure appropriateness for SEM analyses: (a) adequate sample size; (b) missing data; (c) outliers; (d) univariate and multivariate normality; (e) multicollinearity; (f) linearity between variables; and (g) homoscedasticity (Kline, 2016).

Sample Size

Determining an adequate sample size that supports population validity is essential for sound quantitative research (Gall et al. 2007). In addition, determining an adequate a priori sample size that is appropriate for SEM research is also necessary to help avoid Type II error (i.e., failing to reject a false null hypothesis; Balkin & Sheperis, 2011). In SEM, a minimum sample of 200 participants is considered the “golden standard” (Crockett, 2012, p. 43), although there are other factors that need to be considered such as effect size, statistical power, the number of latent and observed variables, and the significance level (Kline, 2016). Kim (2005) provides an equation for calculating minimum sample size as a function of fit indices (i.e., root mean square error of approximation [RMSEA]). Based on the equation, $N_{\epsilon} = \frac{\delta_{1-\beta}}{\epsilon^2 df} + 1$, where $\delta_{1-\beta} = 40.8892$, $\epsilon^2 = .05$, and $df = 73$, in order to achieve an RMSEA = .05, the minimum sample size for the current study is 162 participants. MacCallum, Browne, and Sugawara (1996) provide another method for determining minimum sample size based on degrees of freedom (df) and statistical power estimates. According to MacCallum and colleagues (1996), given the current study has $df = 73$ (105 [observations] – 32 [parameters]; Kline, 2016, p. 128) and an approximate

statistical power of .8, a sample size of 200 is sufficient for this study. Further, Raykov and Marcoulides (2006) suggested that a desirable sample size would be at least 10 times the number of free model parameters (10×32 [free model parameters] = 320). Taken together, with a final sample size of 580 participants, the researcher achieved an acceptable sample size to conduct SEM research (MacCalllem et al., 1996; Raykov & Marcoulides, 2006).

Missing Data

Missing data is a common issue for researchers and can occur for a variety of reasons; however, although missing data is common, it is important to first check the severity of missing data as it can skew the results and affect generalizability (Osborne, 2013). Kline (2016) acknowledges that although missing data is common, missing values less than 5% on a single variable (i.e., construct of interest) is of little concern. Thus, in order to retain the largest dataset possible, the researcher examined the presence of missing data within the three constructs of interest (educator inspiration, compassion for others, and burnout). Each data packet contained a total of 51 possible data points (MBI-ES-R = 17 items; COS-R = 16 items; EIS = 18 items) per packet yielding a total amount of 29,580 possible data points (51 possible data points per packet x 580 participants). The researcher examined frequency tables of each data collection instrument to determine the amount of data points were missing for each instrument. Overall, 524 data points were missing (EIS = missing 62 total data points, COS = missing 111 total data points, and MBI-ES = missing 195 total data points); thus, the completed data packets were determined to be 99.99% complete. Given the large sample size (e.g., > 200) and the minimal amount of

missing data, Maximum Likelihood (ML) estimation produced the least bias imputations (Byrne, 2016).

Outliers

Outliers are generally defined as, "... data point[s] that [are] far outside the norm for a variable or population" (Osborne, 2013, p. 140). Outliers are problematic in that they increase error variance by altering the skewness and kurtosis of certain variables, in addition to influencing central tendency estimates of variables (i.e., constructs of interest; Osborne, 2013). In addition, it is important to determine the presence of univariate outliers (i.e., single score on a variable) and multivariate outliers (i.e., extreme scores on two or more variables; Kline, 2016). As such, Pallant (2013) suggests examining graphs (e.g., histograms, scatterplots) to detect the presence of univariate outliers. Table 18 presents the presence of univariate outliers for the constructs of interest (educator inspiration, compassion for others, and burnout).

Table 18
Univariate Outliers

	<i>n</i>	Percentage
EIS		
<i>Motivational Leadership^b</i>	28	4.82%
<i>Empathy^a</i>	13	2.24%
<i>Resilience^b</i>	11	1.89%
<i>Passion^a</i>	16	2.75%
<i>Educator Inspiration^a</i>	15	2.59%
COS – R		
<i>Disengagement^d</i>	2	0.34%
<i>Kindness^c</i>	9	1.55%
<i>Common Humanity^c</i>	9	1.55%
<i>Compassion^c</i>	3	0.52%
MBI-ES-R		
<i>Emotional Exhaustion^e</i>	0	0.00%
<i>Depersonalization^f</i>	23	3.96%
<i>Personal Accomplishment^f</i>	18	3.10%

Note. ^a*n* = 580; ^b*n* = 579; ^c*n* = 578; ^d*n* = 577; ^e*n* = 575; ^f*n* = 573

In addition, multivariate outliers were examined by calculating Mahalanobis distance and Cook’s distance, indicating “the distance in variance units between the profile of scores for that case and the vector of sample means, correcting for intercorrelations” (Kline, 2016, p. 73). Overall, there were four participant responses that were determined to be multivariate outliers according to Mahalanobis distance values; on the other hand, there was not a Cook’s distance value larger than 1, suggesting the presence of multivariate outliers had minimal influence on these data (Tabachnick & Fidell, 2013). Further, Osborne (2013) suggests that as datasets become larger and more representative of the population from which the sample is attained, the likelihood of legitimate extreme values increases. Therefore, in order to retain the largest sample possible, the researcher chose to keep the univariate and multivariate outliers as the sample size

was large (i.e., > 200); thus, the outliers can be assumed to be legitimate. However, as deciding to keep outliers in the final data set can potentially affect the skewness and kurtosis of the data, the researcher performed several transformations (e.g., Square Root, Logarithmic) to mitigate the influence of outliers and non-normal data.

Normality

Multivariate statistics assume univariate and multivariate normality, that is the data is distributed along a “bell-shape” curve (Kline, 2016). Normality was assessed by visually inspecting the Q-Q plots and histograms (Tabachnick & Fidell, 2013) and observed positive skewness (i.e., most scores are below the mean), negative skewness (i.e., most scores are above the mean), and leptokurtic distributions (i.e., higher peaks and heavier tails; see Figures 6 – 39). In addition, the researcher calculated a Kolmogorov-Smirnov statistic, all of which were statistically significant; therefore, the data was determined to be non-normally distributed (see Table 24).

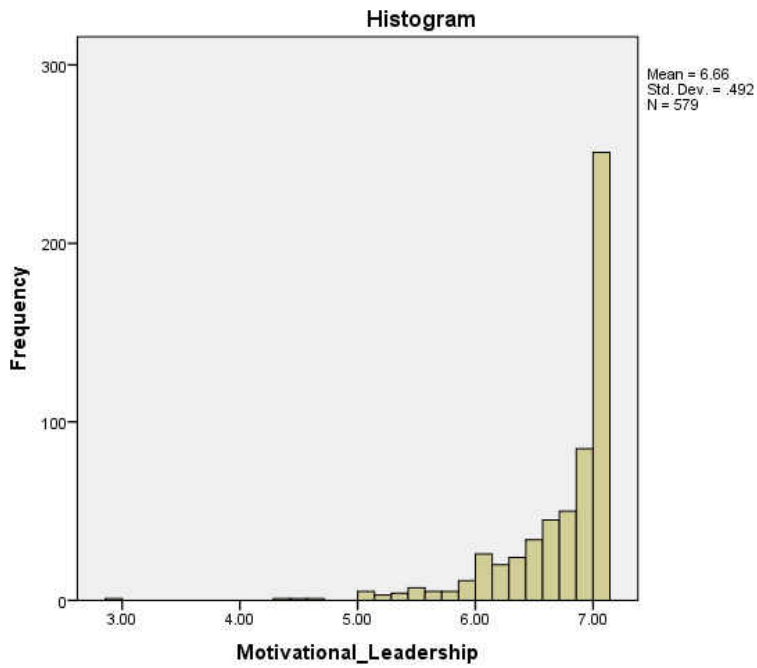

Figure 5: Histogram - EIS: ML

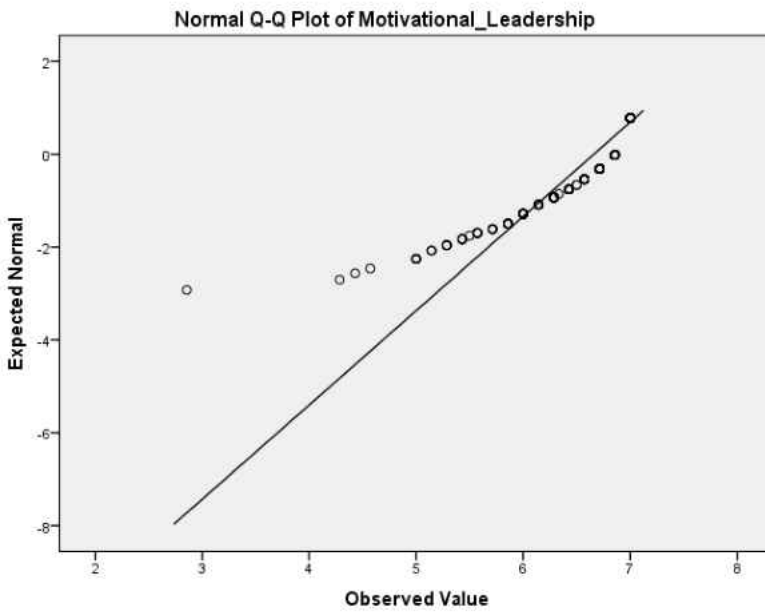

Figure 6: Normal Q-Q Plot - EIS: ML

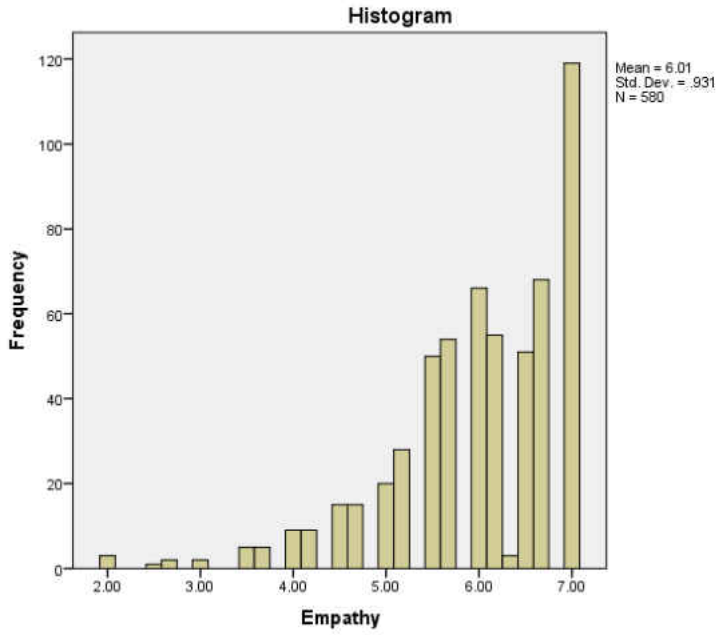

Figure 7: Histogram - EIS: EP

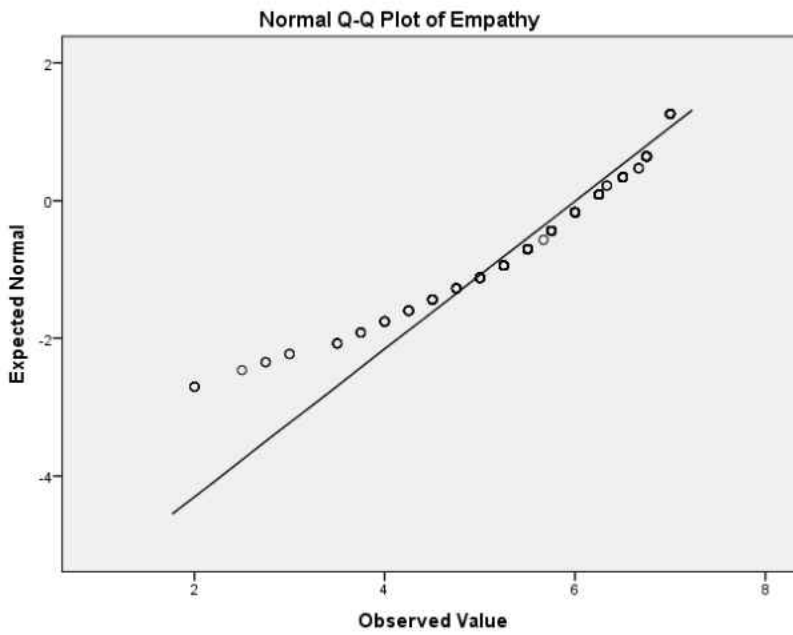

Figure 8: Normal Q-Q Plot - EIS: EP

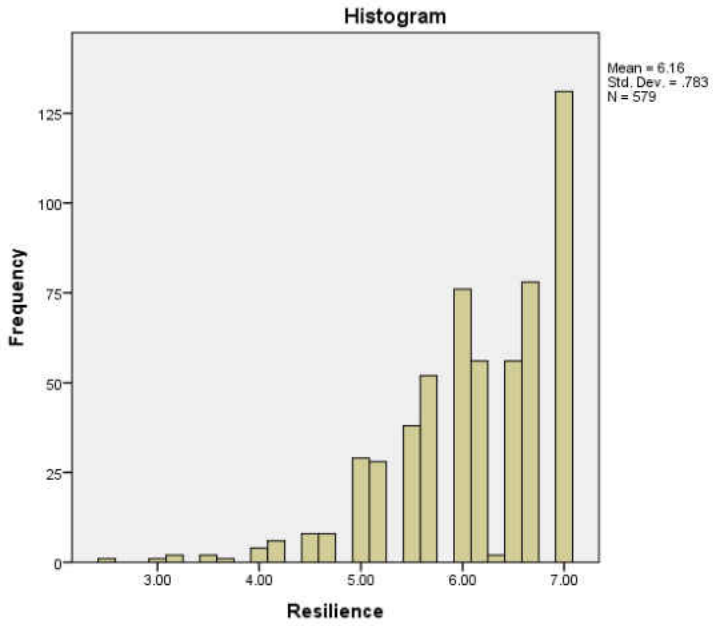

Figure 9: Histogram - EIS: RS

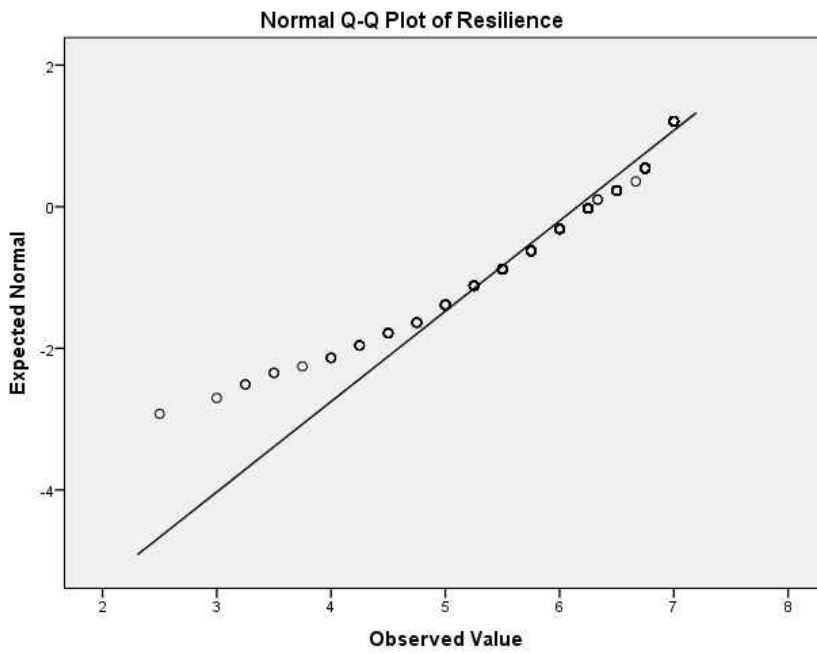

Figure 10: Normal Q-Q Plot - EIS: RS

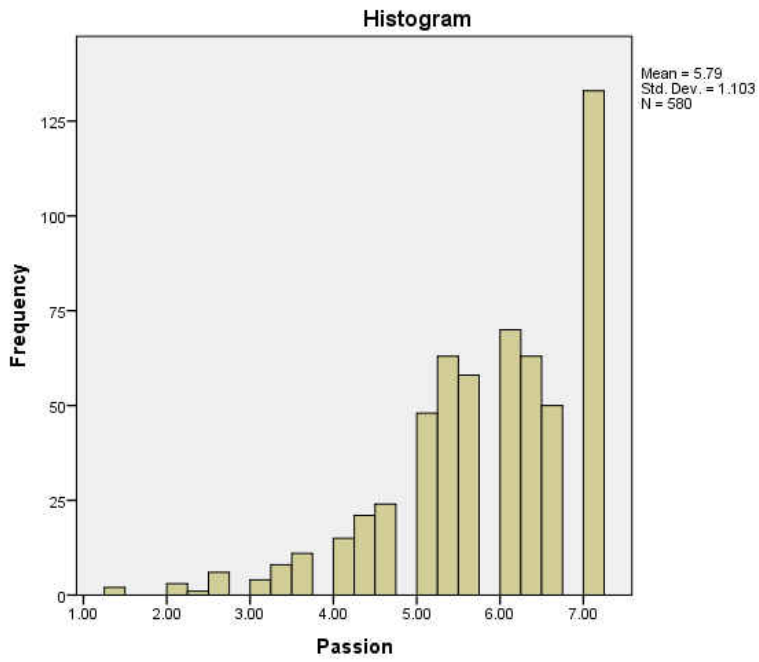

Figure 11: Histogram - EIS: PS

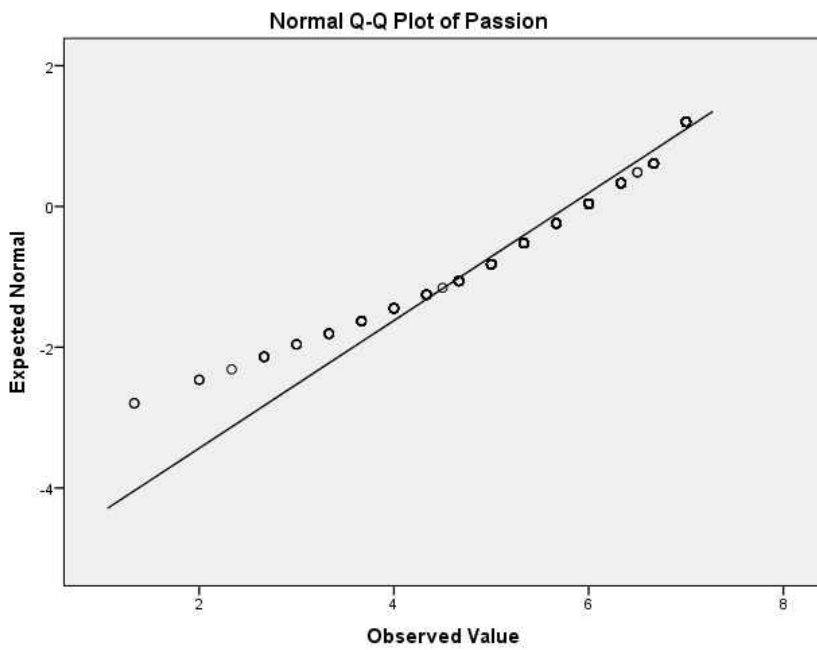

Figure 12: Normal Q-Q Plot - EIS: PS

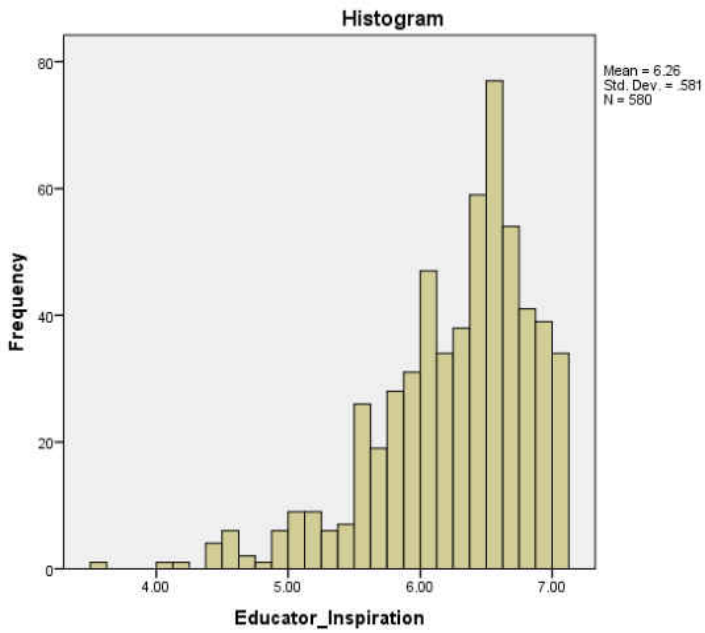

Figure 13: Normal Q-Q Plot - EIS: PS

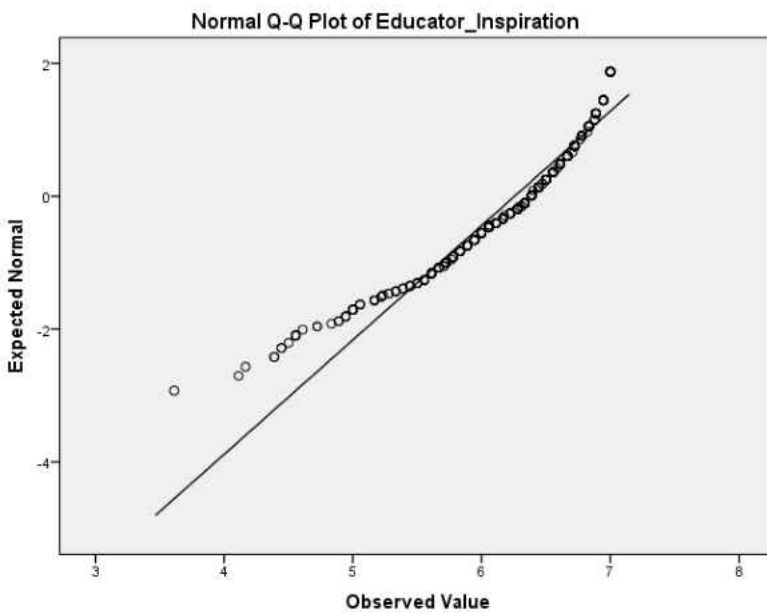

Figure 14: Normal Q-Q Plot - EIS: EI

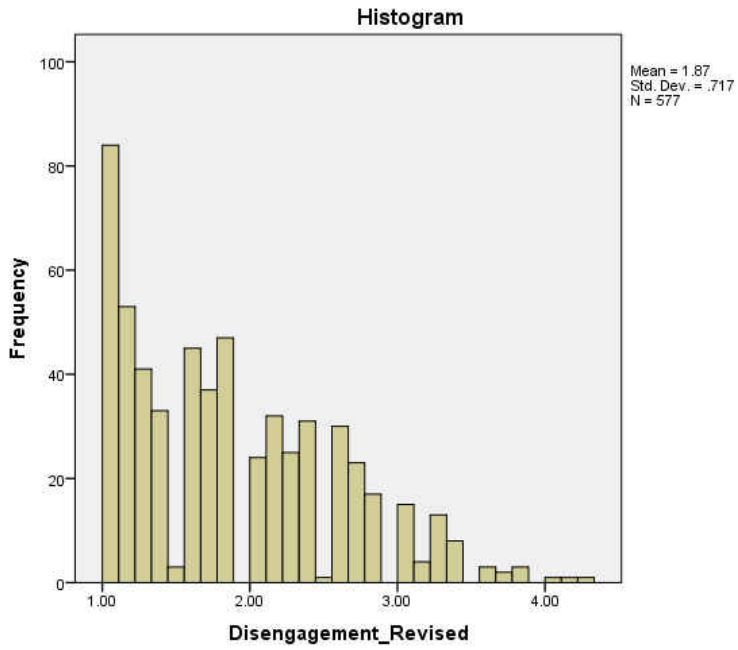

Figure 15: Histogram - COS-R: DS

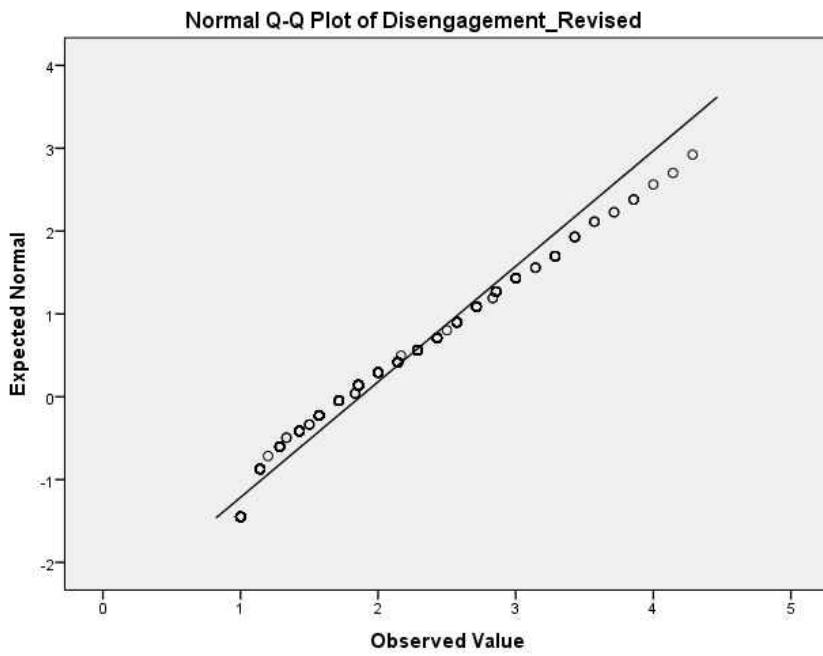

Figure 16: Normal Q-Q Plot - COS-R: DS

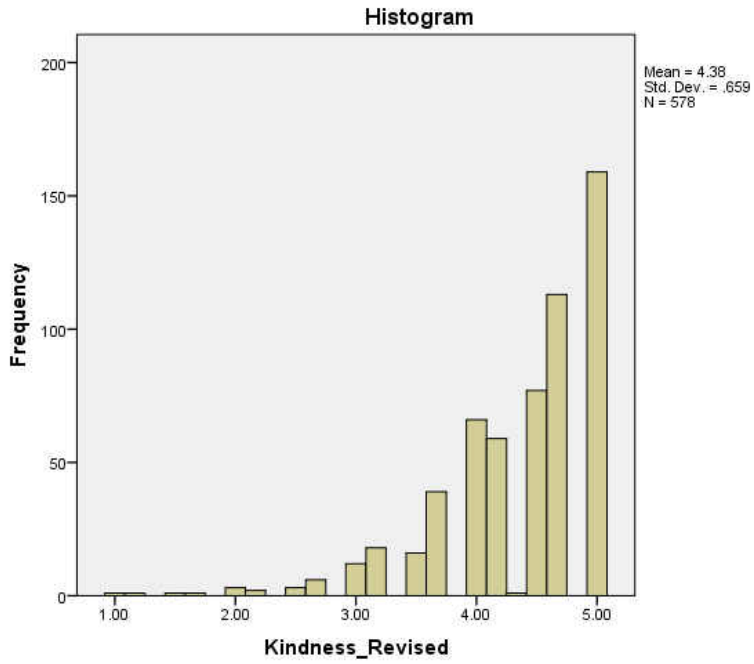

Figure 17: Histogram - COS-R: KD

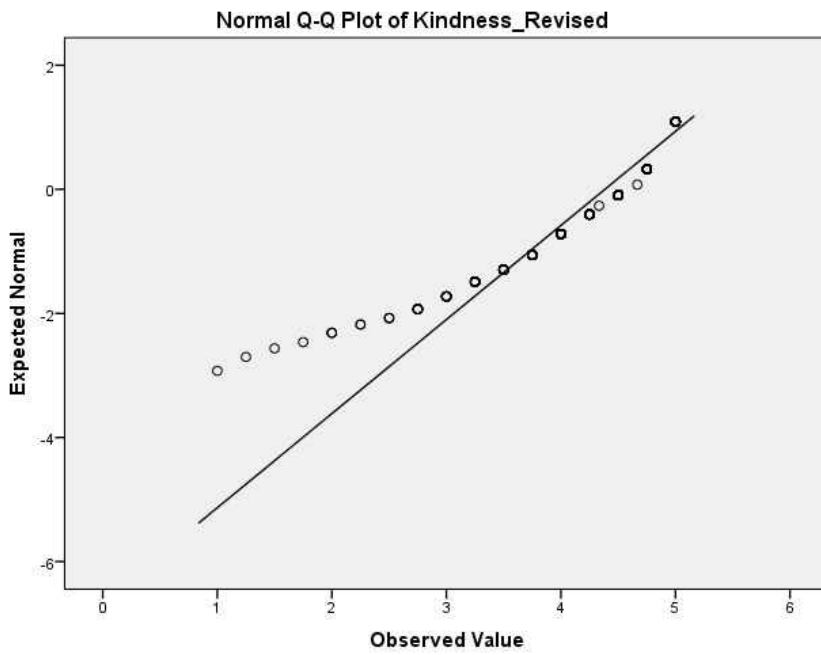

Figure 18: Normal Q-Q Plot - COS-R: KD

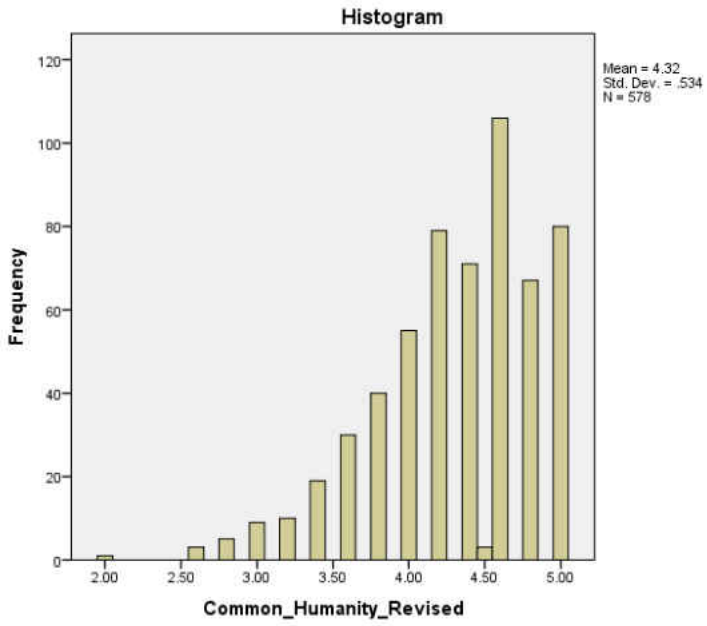

Figure 19: Histogram - COS-R: CH

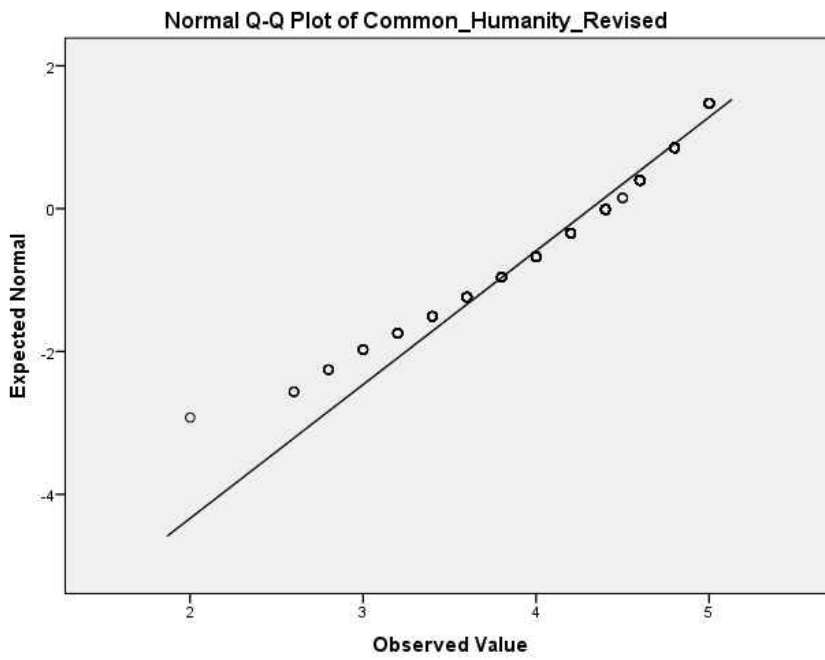

Figure 20: Normal Q-Q Plot - COS-R: CH

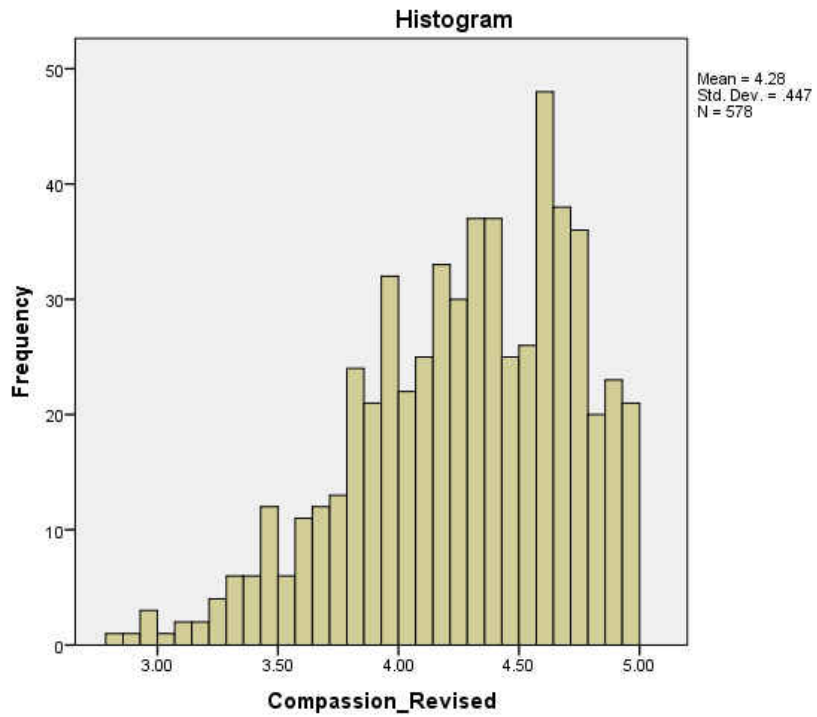

Figure 21: Histogram - COS-R: CT

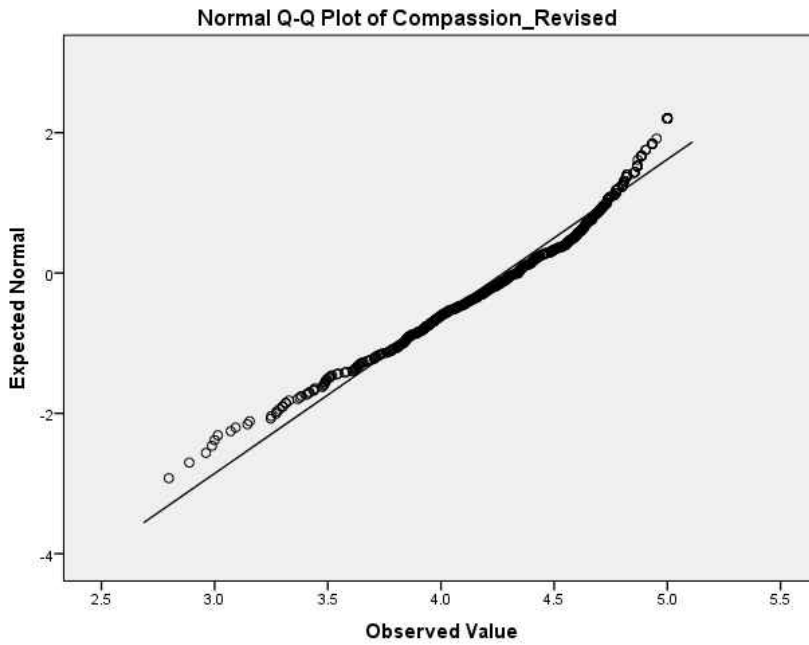

Figure 22: Normal Q-Q Plot - COS-R: CT

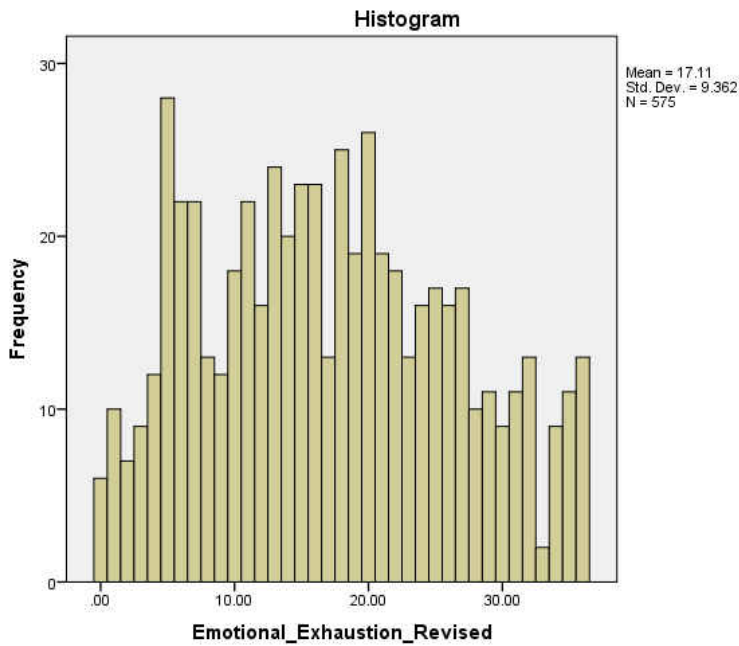

Figure 23: Histogram - MBI-ES-R: EE

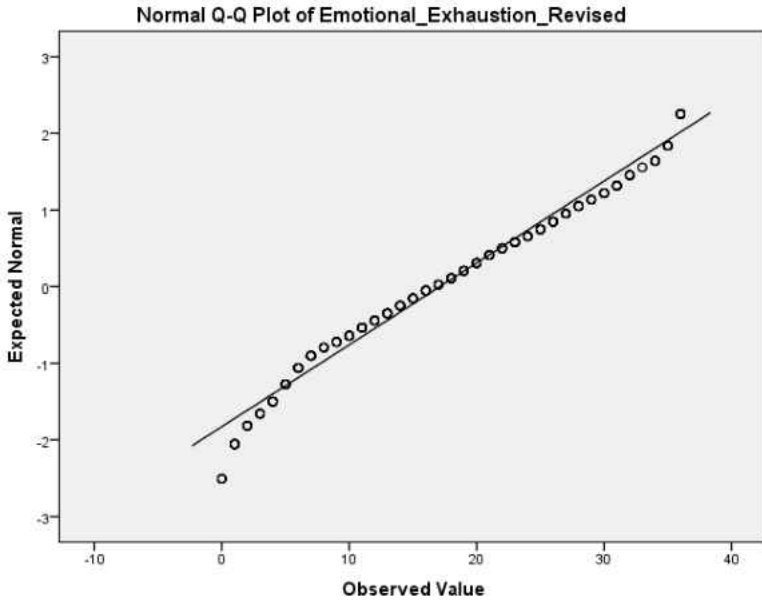

Figure 24: Normal Q-Q Plot - MBI-ES: EE

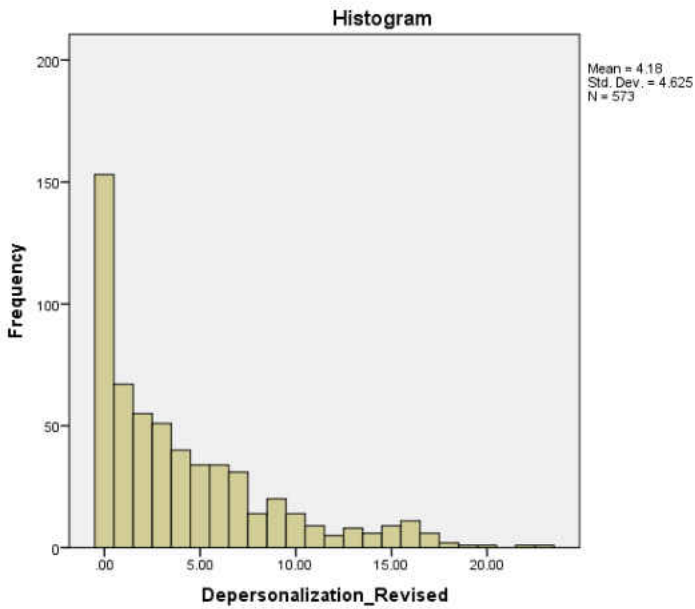

Figure 25: Histogram - MBI-ES-R: DP

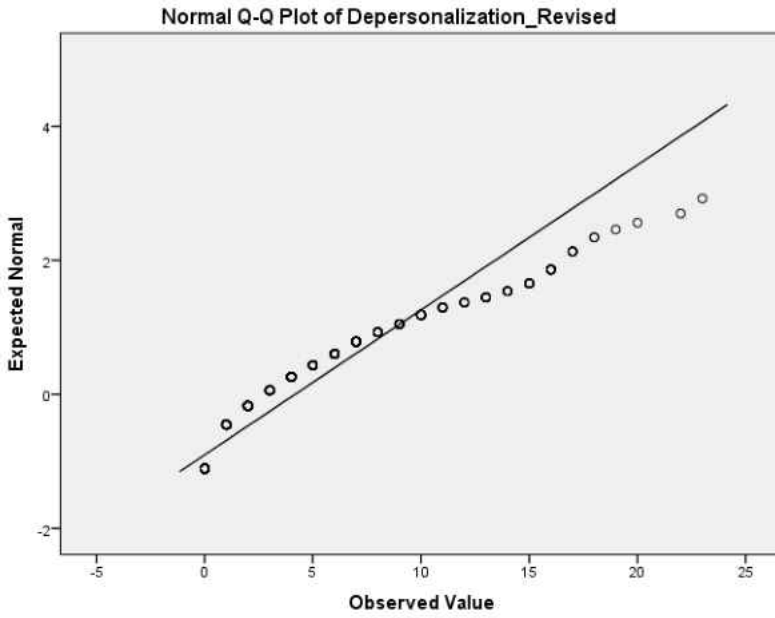

Figure 26: Normal Q-Q Plot - MBI-ES: DP

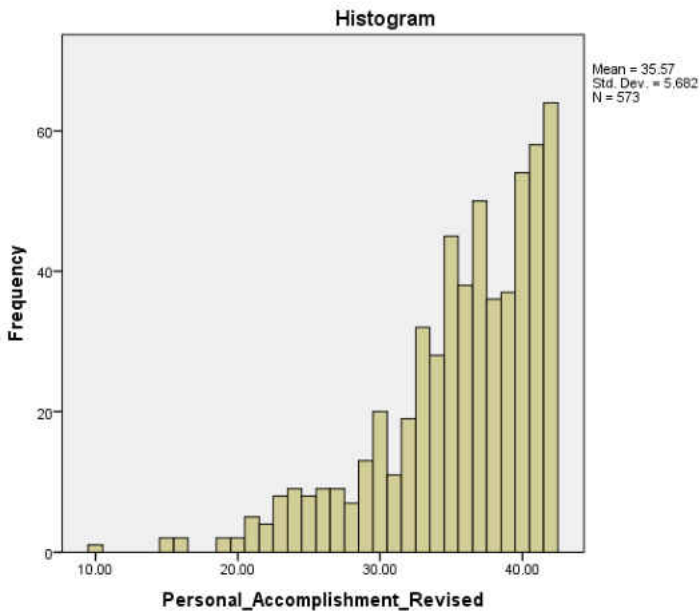

Figure 27: Histogram - MBI-ES-R: PA

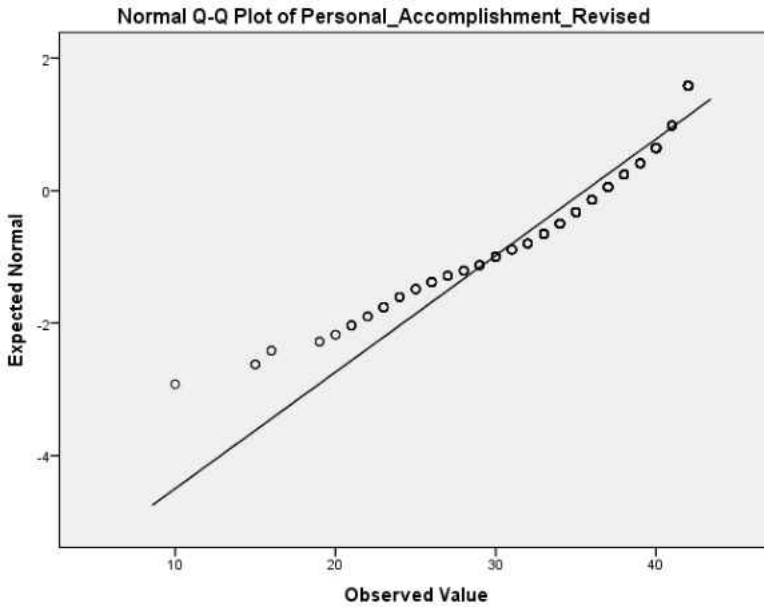

Figure 28: Normal Q-Q Plot - MBI-ES: PA

Table 19
Tests of Normality

Subscale	Kolmogorov-Smirnov		
	Statistic	<i>df</i>	Sig.
EIS			
<i>Motivational Leadership</i>	.245	579	.001
<i>Empathy</i>	.143	580	.001
<i>Resilience</i>	.141	579	.001
<i>Passion</i>	.136	580	.001
<i>Educator Inspiration</i>	.115	580	.001
COS-R			
<i>Disengagement</i>	.112	577	.001
<i>Kindness</i>	.179	578	.001
<i>Common Humanity</i>	.141	578	.001
<i>Compassion</i>	.076	578	.001
MBI-ES-R			
<i>Emotional Exhaustion</i>	.062	575	.001
<i>Depersonalization</i>	.183	573	.001
<i>Personal Accomplishment</i>	.129	573	.001

Overall, participants' scores on the three data collection instruments (EIS, COS-R, and MBI-ES-R) reflect a non-normal distribution. Specifically, educators in the current sample reported higher scores of educator inspiration and compassion for others compared to their respective norm samples. In addition, educators in the current sample reported lower scores of EE and DP, as well as higher scores on PA (i.e., lower levels of burnout) than the norm sample of educators for the MBI-ES. Due to the non-normal distribution of the data, Pallant (2013) suggests transforming the variables to reflect a more normal distribution of the data. Transformations (e.g., Square Root, Logarithm, Inverse) are mathematical modifications to raw scores that are applied to mitigate the skewness and kurtosis of non-normal data (Pallant, 2013). However, prior to transforming variables of interest, Kline (2016) recommends considering whether normality is a reasonable expectation given the nature of the construct (e.g., educator inspiration, compassion for others, and burnout). For example, it is plausible that participants who volunteered to participate in the study had lower levels of burnout compared to participants who chose not to participate in the study; thus, positively skewing the data. Nevertheless, appropriate transformations were conducted on each variable per Pallant (2013, p. 97). Table 25 presents the results of the test of normality for the transformed variables along with the type of transformation that was conducted.

Table 20
Tests of Normality – Transformed Variables

Subscale	Transformation	Kolmogorov-Smirnov		
		Statistic	<i>df</i>	Sig.
EIS				
<i>Motivational Leadership</i>	Reflect & Inverse	.189	580	.001
<i>Empathy</i>	Reflect & Inverse	.153	580	.001
<i>Resilience</i>	Reflect & Square Root	.139	579	.001
<i>Passion</i>	Reflect & Square Root	.094	580	.001
<i>Educator Inspiration</i>	Reflect & Logarithm	.071	580	.001
COS-R				
<i>Disengagement</i>	Logarithm	.155	577	.001
<i>Kindness</i>	Reflect & Inverse	.223	577	.001
<i>Common Humanity</i>	Reflect & Logarithm	.115	578	.001
<i>Compassion</i>	Reflect & Square Root	.084	578	.001
MBI-ES-R				
<i>Emotional Exhaustion</i>	None	.070	575	.001
<i>Depersonalization</i>	Reflect & Inverse	.331	573	.001
<i>Personal Accomplishment</i>	Reflect & Logarithm	.108	573	.001

Despite the implementations of various transformations, visual representations and normality statistics (e.g., Kolmogorov-Smirnov) remain significant, suggesting non-normal data (see Table 15). Therefore, given the limited affect the transformations had on the variables of interest, the researcher decided to analyze the original variables as with SEM with large samples (e.g., > 200), the influence of significant skewness and kurtosis are diminished (Tabachnick & Fidell, 2013). Furthermore, because multivariate normality requires the presence of univariate normality (Hair et al., 2006), the researcher was not able to assume the presence of multivariate normality with these data. Therefore, the results of the statistical analyses with these data are to be interpreted with caution and are further discussed in the following section.

Multicollinearity

Multicollinearity is the presence of high correlations (e.g., $r \geq .90$) between independent and dependent variables (Tabachnick & Fidell, 2013). In order to determine the presence of multicollinearity between the constructs of interest (educator inspiration, compassion for others, and burnout), bivariate correlations were conducted to determine whether there was a correlation between the variables greater than .90 (see Table 26). In addition, Tolerance and the Variance Inflation Factor (VIF) were calculated to address potential multicollinearity between the variables. Tolerance is, “an indicator of how much of the variability of the specified independent is not explained by the other independent variables in the model” (Pallant, 2013, p. 164). Tolerance values below .10 or VIF values above 10 suggest multicollinearity between variables. Table 27 presents the Tolerance and VIF values for the variables. The researcher examined bivariate correlations between the constructs and failed to find a correlation between any construct that exceeded .90. In addition, all of the Tolerance values were larger than .10 and all VIF values were less than 10. Thus, the researcher concluded that multicollinearity was not present in this data.

Table 21
Correlations Between Constructs of Interest

	ML	EP	RS	PS	EI	DS	KD	CH	CT	EE	DP	PA
ML	1.00											
EP	.556**	1.00										
RS	.476**	.553**	1.00									
PS	.382**	.332**	.375**	1.00								
EI	.794**	.812**	.775**	.673**	1.00							
DS	-.361**	-.329**	-.279**	-.120**	-.357**	1.00						
KD	.346**	.339**	.315**	.124**	.370**	-.400**	1.00					
CH	.140**	.052	.072	.018	.090*	-.109**	.144**	1.00				
CT	.419**	.364**	.333**	.132**	.409**	-.775**	.764**	.527**	1.00			
EE	-.231**	-.247**	-.353**	-.101*	-.301**	.195**	-.209**	.083*	-.176**	1.00		
DP	-.361**	-.357**	-.379**	-.143**	-.427**	.289**	-.280**	.034	*.281**	.589**	1.00	
PA	.550**	.508**	.441**	.239**	.570**	-.343**	.394**	.083*	.412**	-.344**	-.444**	1.00

Note. * Correlation significant at the .05 level (two-tailed). ** Correlation significant at the .01 level (two-tailed). ML = Motivational Leadership. EP = Empathy. RS = Resilience. PS = Passion. EI = Educator Inspiration. DS = Disengagement. KD = Kindness. CH = Common Humanity. CT = Compassion Total. EE = Emotional Exhaustion. DP = Depersonalization. PA = Personal Accomplishment.

Table 22
Tolerance and VIF Values for the EIS, COS-R, and MBI-ES-R

	Emotional Exhaustion		Depersonalization		Personal Accomplishment	
	Tolerance	VIF	Tolerance	VIF	Tolerance	VIF
EIS						
<i>Motivational Leadership</i>	.577	1.733	.577	1.732	.577	1.732
<i>Empathy</i>	.569	1.757	.570	1.755	.570	1.755
<i>Resilience</i>	.627	1.596	.625	1.599	.625	1.599
<i>Passion</i>	.801	1.249	.802	1.247	.802	1.247
<i>Educator Inspiration</i>	.821	1.218	.823	1.216	.823	1.216
COS-R						
<i>Disengagement</i>	.761	1.314	.764	1.310	.764	1.310
<i>Kindness</i>	.756	1.322	.758	1.319	.758	1.319
<i>Common Humanity</i>	.965	1.036	.965	1.037	.965	1.037
<i>Compassion</i>	.821	1.218	.823	1.216	.823	1.216

Linearity Between Variables

Linearity between continuous variables are a component of the multivariate normality assumption (Kline, 2016). One way to detect linearity between variables is to examine normal P-P plots of the continuous variables' standardized residuals (Kline, 2016). Observing a non-linear relationship between standardized residuals suggest a curvilinear relationship between variables; however, providing that there is an adequate sample size during data analysis (e.g., $N > 200$), it is safe to proceed with further analysis (Pallant, 2013). Figures 40, 41, and 42 are normal P-P plots between the continuous independent variables' standardized residuals (e.g., subscales of the EIS and COS) and the dependent variables' standardized residuals (EE, DP, and PA).

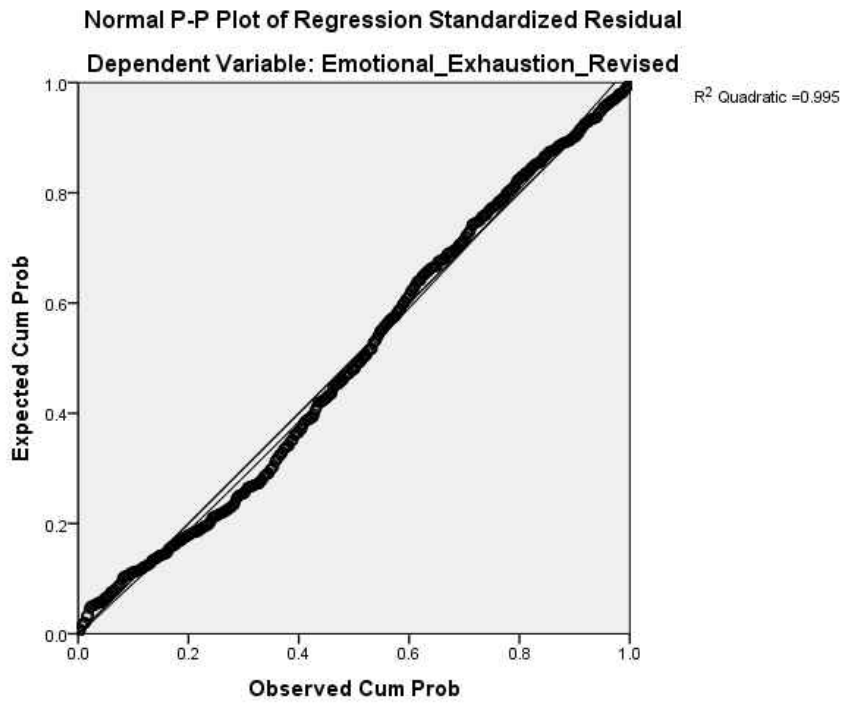

Figure 29: Normal P-P Plot - MBI-ES: EE

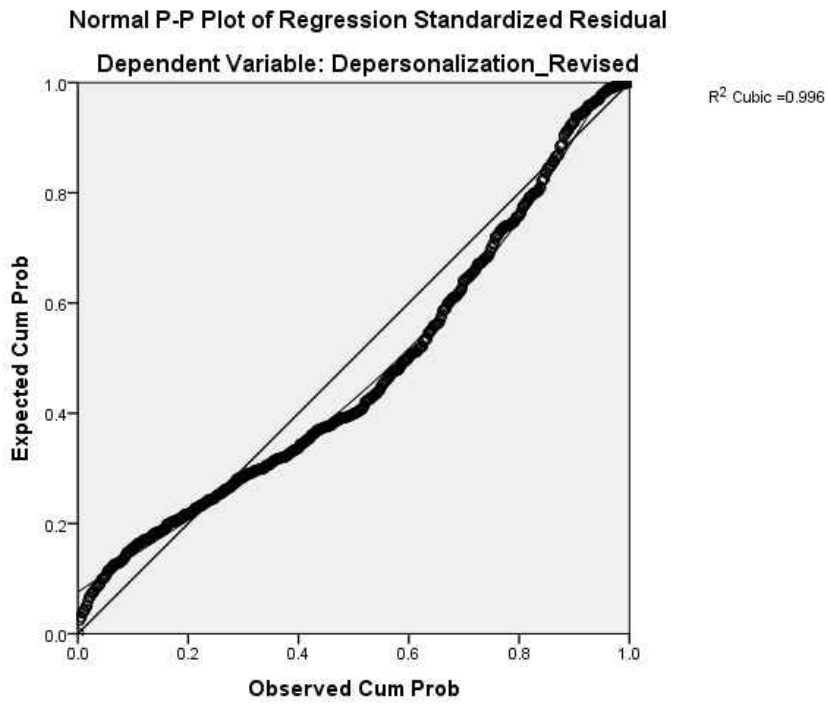

Figure 30: Normal P-P Plot - MBI-ES: DP

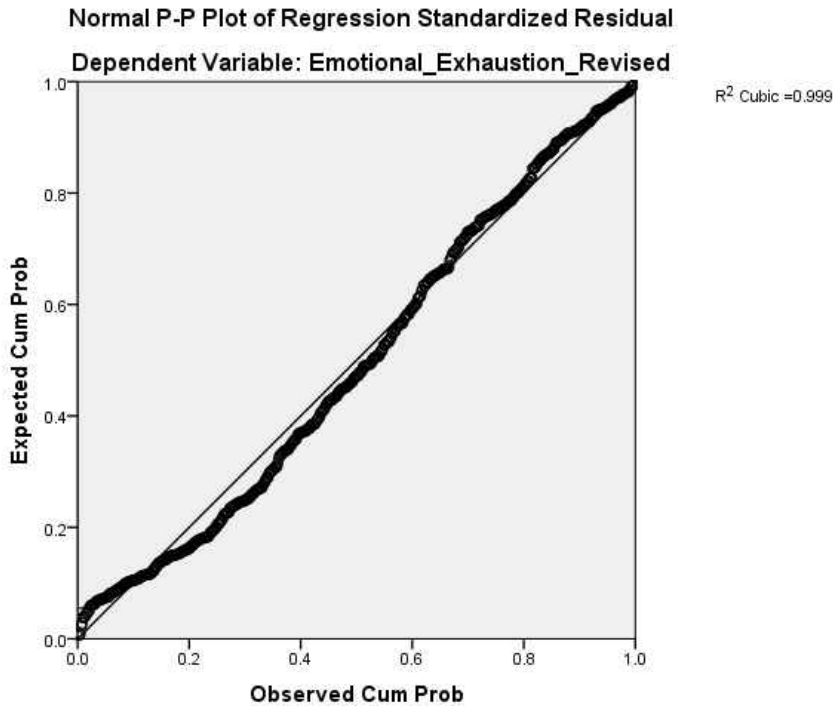

Figure 31: Normal P-P Plot - MBI-ES: PA

After examining the normal P-P plots of the standardized residuals between continuous variables, the researcher determined that there is a linear relationship between independent variables (e.g., subscales on the EIS and COS) and EE and curvilinear relationships between independent variables (e.g., subscales on the EIS and COS) and both DP and PA. Nonetheless, as it was noted earlier, despite the presence of curvilinear relationships between variables, adequate sample sizes (e.g., $N > 200$) make future analysis appropriate (Pallant, 2012).

Homoscedasticity

Homoscedasticity refers to the assumption that variance in scores on a given variable (e.g., EE) will be roughly similar to the variance in scores on another variable (e.g., compassion; Tabachnick & Fidell, 2013). Given homoscedasticity is related to the assumption of normality, the data was assumed to be heteroscedastic. Bivariate scatterplots between the variables were analyzed and confirmed unequal variance in participants' responses on the three measures of interest (EIS, COS, and MBI-ES). However, Tabachnick and Fidell (2013) note that even when the assumption of homoscedasticity is not met, "...the analysis is weakened, but not invalidated" (p. 85). Therefore, the data was not manipulated to address heteroscedasticity, although the potential influence of heteroscedasticity is discussed in following chapter.

Estimation Techniques

Prior to conducting SEM analyses, it is important to address various assumption violations (e.g., normality; Tabachnick & Fidell, 2013). For severely non-normal data, Kline (2016) suggests utilizing estimation techniques such as generalized least squares (GLS), which is a method similar to fully weighted least squares (WLS) estimation. However, maximum likelihood (ML) is the default estimation technique in many SEM programs (e.g., AMOS) and is generally the preferred estimation method (Byrne, 2016). The underlying principle of ML is to, "...maximize the likelihood that the data (the observed covariances) were drawn from [the] population" (Kline, 2016, p. 235); thus, the ML estimation method supports the generalizability of the results. However, it is important to note that for severely non-normal data, Kline (2016) suggests considering alternative estimation methods. Nonetheless, after careful consideration

between GLS and ML methods of estimation, the researcher decided to utilize ML as the estimation method and discussed the potential limitations of the non-normal data in the interpretation of the results.

Model Specification and Identification

Prior to conducting SEM, it is essential for researchers to specify a structural model that has sound theoretical rationale (Schumacker & Lomax, 2010). Therefore, before data analysis, the researcher reviewed the literature focused on educator inspiration, compassion for others, and educator burnout and built a model specifying the anticipated relationship between the constructs of interest (see Figure 1). Following model specification, the next step in SEM is model identification (Kline, 2016). Whether a model is identified depends upon whether or not the specified model can produce a unique solution (Schumacker & Lomax, 2010). Prior to the identification of a structural model, each measurement model within the structural model must first be identified (Crockett, 2012). Crockett (2012) specified two conditions in which measurement models are most likely identified: (a) there are at least two latent variables, each of which contain at least three indicators that load only on one factor and whose errors are uncorrelated; or (b) there are at least latent variables whose variance and covariance equal zero; in addition, one factor (i.e., latent variable) contains *only* two indicators, with each indicator loading on only one factor and the indicators' errors are uncorrelated. Thus, the researcher performed confirmatory factor analyses (CFA) on each measurement model (i.e., instrument) to ensure the structural model met the criteria for model identification per Crockett (2012; See Table 8).

Confirmatory Factor Analysis of the EIS

The EIS (Lambie et al., 2016) was used to measure educators' levels of inspiration. The researcher conducted a CFA on the EIS and observed moderate (.64) to high (.92) factor loadings with an acceptable model fit, $\chi^2 (129, N = 580) = 455.058$, $CMIN/df = 3.528$, $CFI = .942$, $RMSEA = .066$, $TLI = .923$, $NFI = .921$. Given the acceptable model fit of the original EIS with these data, the researcher determined additional modifications to the EIS were not necessary. Cronbach's α for the EIS was acceptable (.904). The reliability coefficients of the EIS subscales were acceptable for early research purposes: (a) *Motivational Leadership* (ML), $\alpha = .888$; (b) *Empathy* (EP), $\alpha = .869$; (c) *Resilience* (RS), $\alpha = .825$; and (d) *Passion* (PS), $\alpha = .853$. Figure 33 and Table 23 represent the results from the CFA of the EIS.

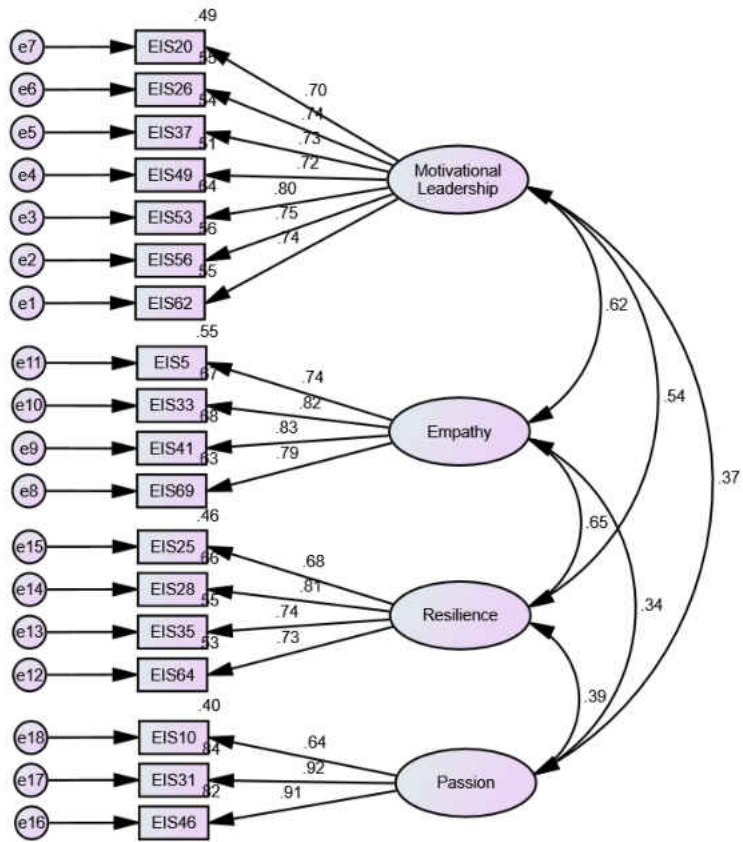

Figure 32: CFA - EIS

Table 23
Model Fit - EIS

	X^2	df	p	CMIN/ df	CFI	RMSEA	TLI	NFI
EIS	455.058	129	.001	3.528	.942	.066	.923	.921

Note. $N = 580$

Confirmatory Factor Analysis of the COS

The *Compassion for Others Scale* (COS; Pommier, 2010) was used to measure educators' levels of compassion for others. A CFA was conducted for the 24-item COS to examine its fit for these data (see Figure 35). Results from the CFA for the COS exhibited acceptable fit to these data, $\chi^2(237, N = 580) = 905.399$, $CMIN/df = 3.820$, $CFI = .842$, $RMSEA = .070$, $TLI = .800$, $NFI = .800$; however, the results were inadmissible. Specifically, the results produced inadmissible results (i.e., Heywood case) in which there were correlations between factors that exceeded 1.0. One of the most common causes of inadmissible solutions is a specification error (Chen, Bollen, Paxton, Curran, & Kirby, 2001). Therefore, the researcher consulted the theoretical framework of compassion to understand the specification error. Upon the review of the theoretical framework of compassion, the researcher determined that the subscales for *indifference*, *separation*, and *disengagement* were unnecessary to include in the measurement model because as Pommier (2010) notes, the main components of compassion are *kindness*, *common humanity*, and *mindfulness*. However, *indifference*, *separation*, and *disengagement* were included in the original COS to maintain the face validity of the instrument, as it was adopted from the *Self-Compassion Scale* (Neff, 2003). After removing the subscales *indifference*, *separation*, and *disengagement*, the researcher conducted a CFA on the three-factor

COS (i.e., COS-R; *kindness, common humanity, mindfulness*), which corrected the Heywood case, although it produced a poor model fit with these data, $\chi^2 (52, N = 580) = 334.368$, $CMIN/df = 6.430$, $CFI = .801$, $RMSEA = .097$, $TLI = .701$, $NFI = .777$ (see Figure 36). Despite the poor fit of the revised COS, the researcher determined that it was appropriate to include in the hypothesized structural model to maintain the integrity of the theoretical framework of compassion. The limitations will be discussed in Chapter five. Table 24 presents the fit indices of the COS and the COS-R.

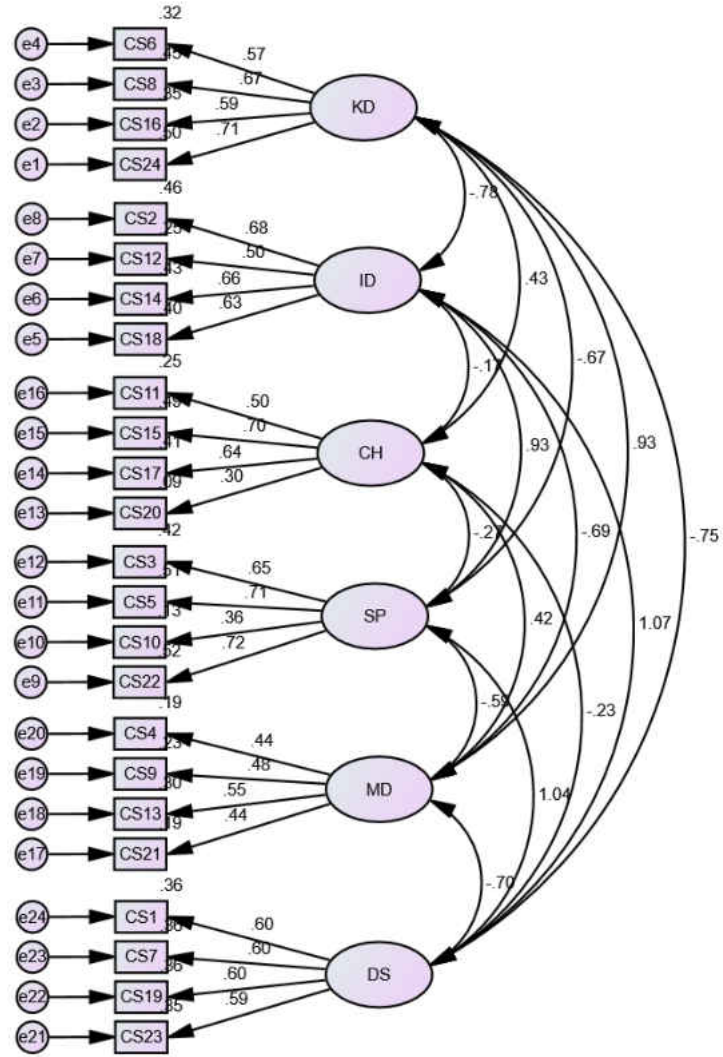

Figure 33: CFA - COS

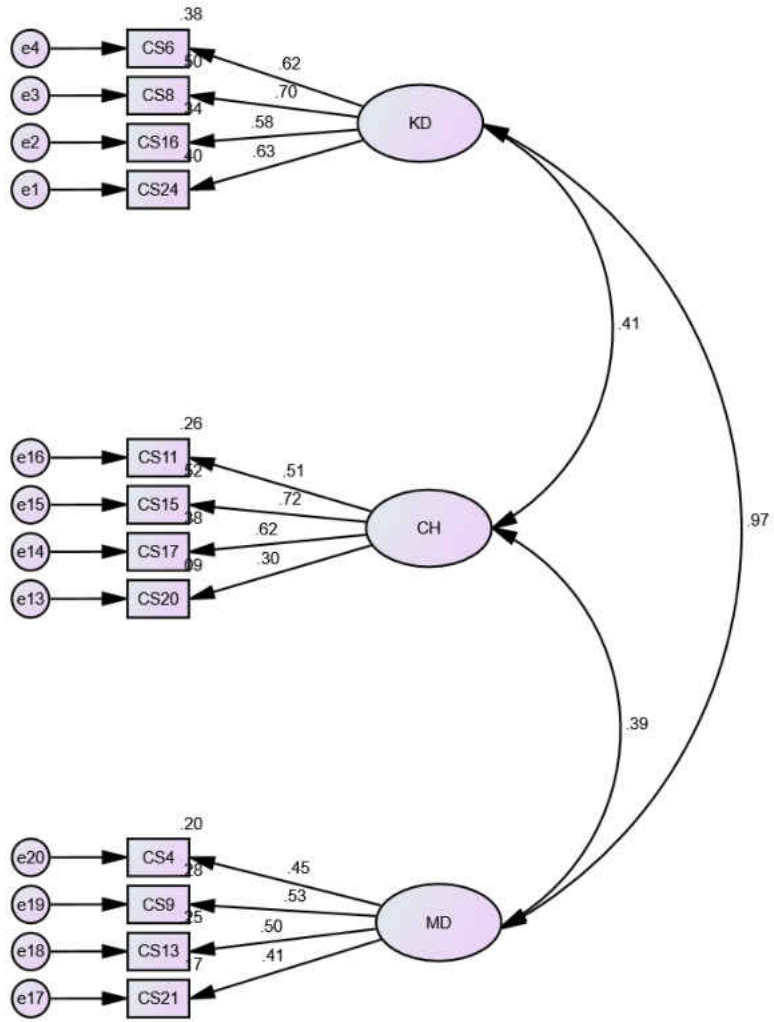

Figure 34: CFA - 3 Factor COS

Table 24
Model Fit - COS & COS-R

	X^2	<i>df</i>	<i>p</i>	CMIN/ <i>df</i>	CFI	RMSEA	TLI	NFI
COS*	905.399	237	.000	3.820	.842	.070	.800	.800
COS-R	334.368	57	.000	6.430	.801	.097	.701	.777

Note. * = Heywood case. N = 580.

Confirmatory Factor Analysis of the MBI-ES

The MBI-ES (Maslach et al., 1996) measured educators' levels of burnout. The MBI-ES is a 22-item instrument comprised of three dimensions: (a) EE, (b) DP, and (c) PA. A CFA was conducted on the 22-item MBI-ES to examine the model fit for these data (see Figure 10). Initial results from the CFA exhibited a poor fit of the MBI-ES to these data, χ^2 (206, $N = 580$) = 1187.806, CMIN/*df* = 5.766, CFI = .835, RMSEA = .091, TLI = .798, NFI = .809 (see Figure 35). In order to improve the model fit of the MBI-ES, the researcher consulted past research that has used the MBI-ES (e.g., Byrne, 1993; 1994). Specifically, the researcher determined it was appropriate to correlate the error terms of items 1 and 2, 6 and 16, and 10 and 11 (see Figure 36; MBI-ES-R). The results of the CFA of the MBI-ES-R produced a better fitting model, χ^2 (203, $N = 580$) = 822.599, CMIN/*df* = 4.052, CFI = .896, RMSEA = .073, TLI = .871, NFI = .868. Table 25 represents the model fit of the MBI-ES and the MBI-ES-R.

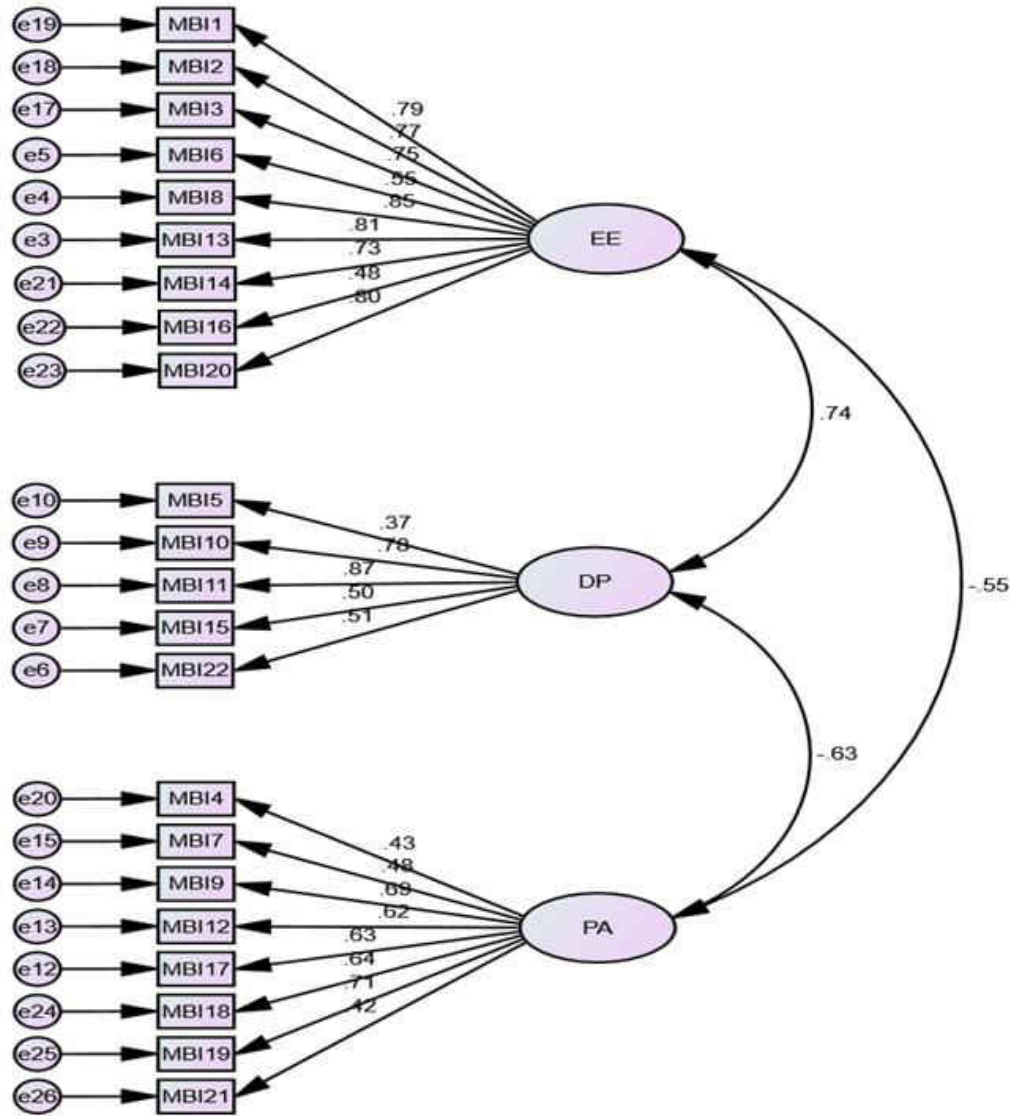

Figure 35: CFA – MBI-ES

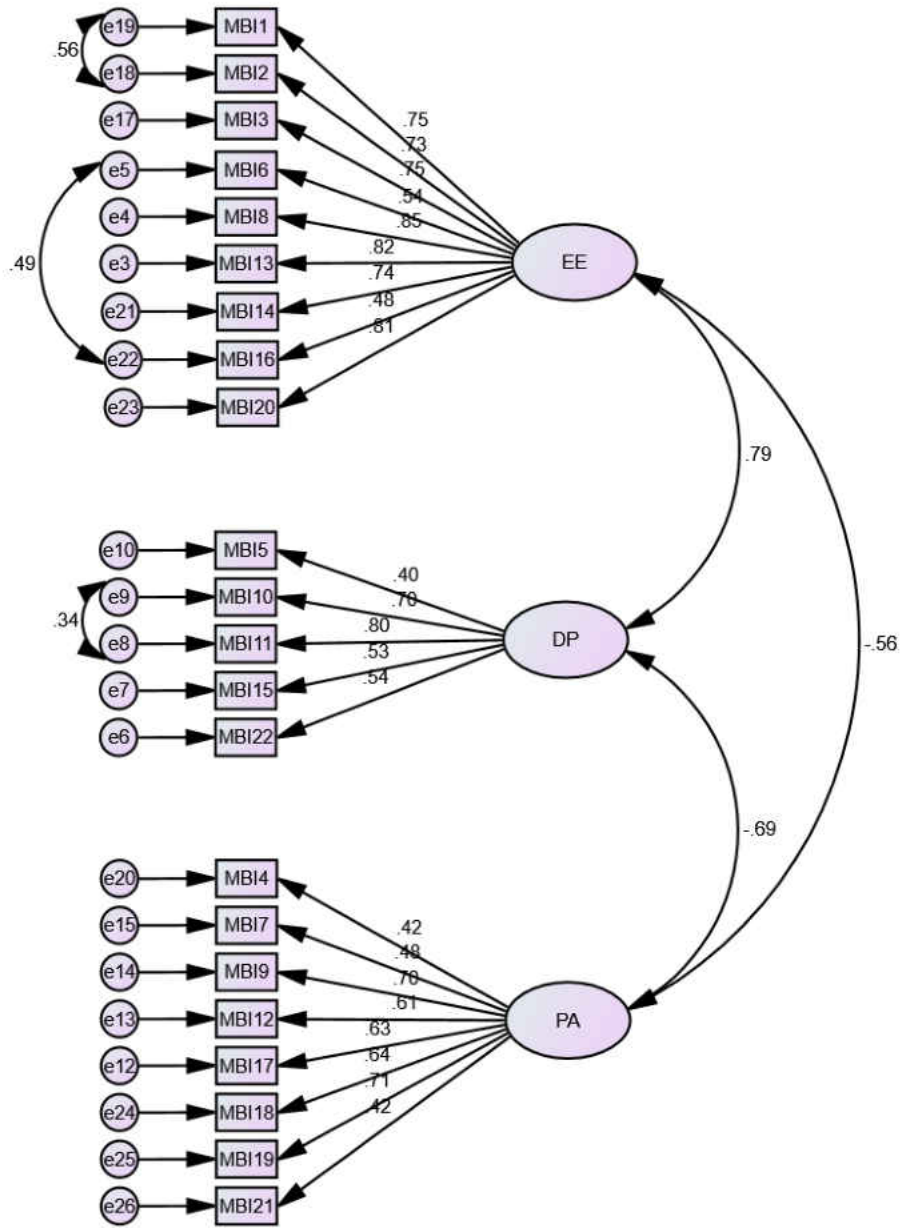

Figure 36: CFA - MBI-ES-R

Table 25
Model Fit - MBI-ES & MBI-ES-R

	X^2	<i>df</i>	<i>p</i>	CMIN/ <i>df</i>	CFI	RMSEA	TLI	NFI
MBI-ES	1187.806	206	.000	5.766	.835	.091	.798	.809
MBI-ES-R	822.599	203	.000	4.052	.896	.073	.871	.868

Note. N = 580.

Secondary Analysis of the Complete Measurement Model

The researcher conducted CFAs on all measurement models to ensure acceptable fit to the current data. All of the measurement models were modified, considering factor loadings, communalities, and standardized residual covariance to achieve the best fit to these data. Figures 42 – 44 present the modified measurement models that comprise the hypothesized structural model to be tested (see Figure 45).

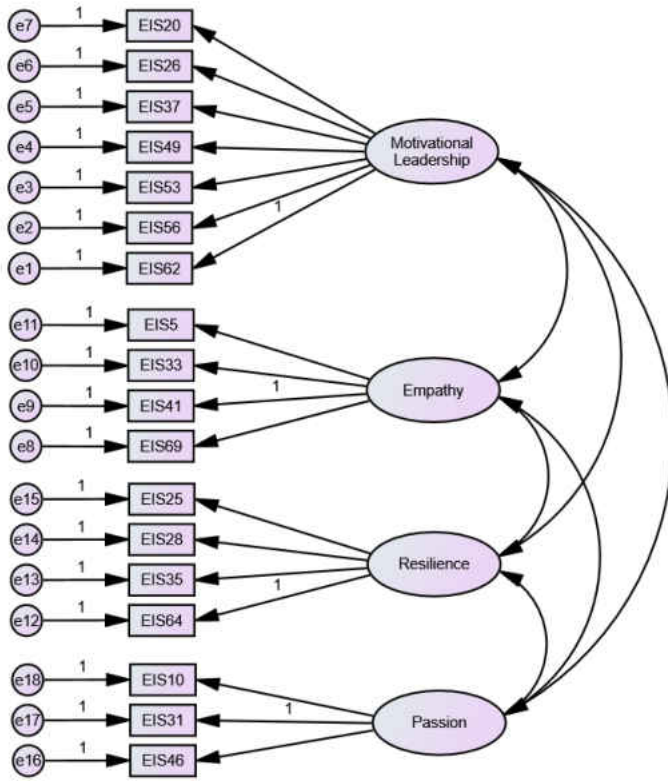

Figure 37: Measurement Model - EIS

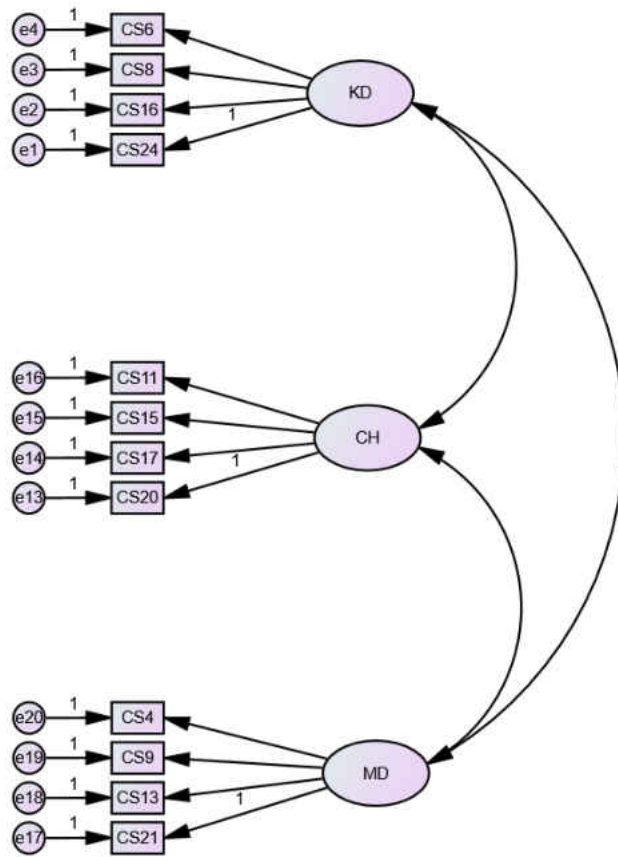

Figure 38: Measurement Model - COS-R

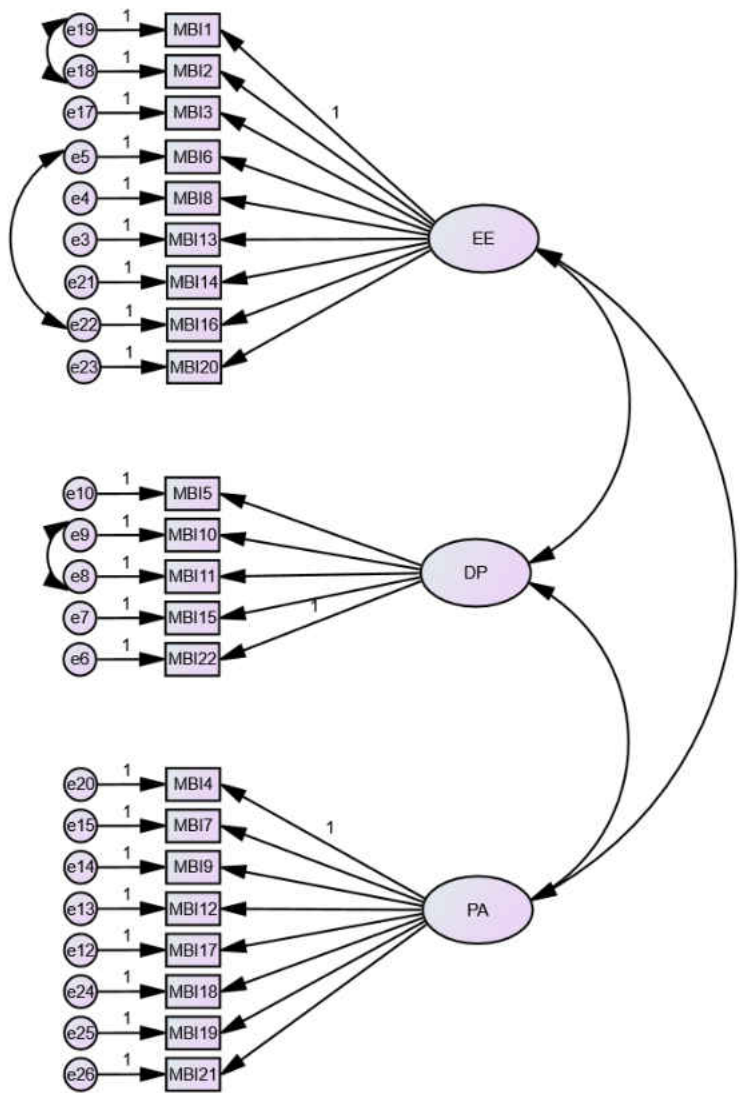

Figure 39: Measurement Model - MBI-ES-R

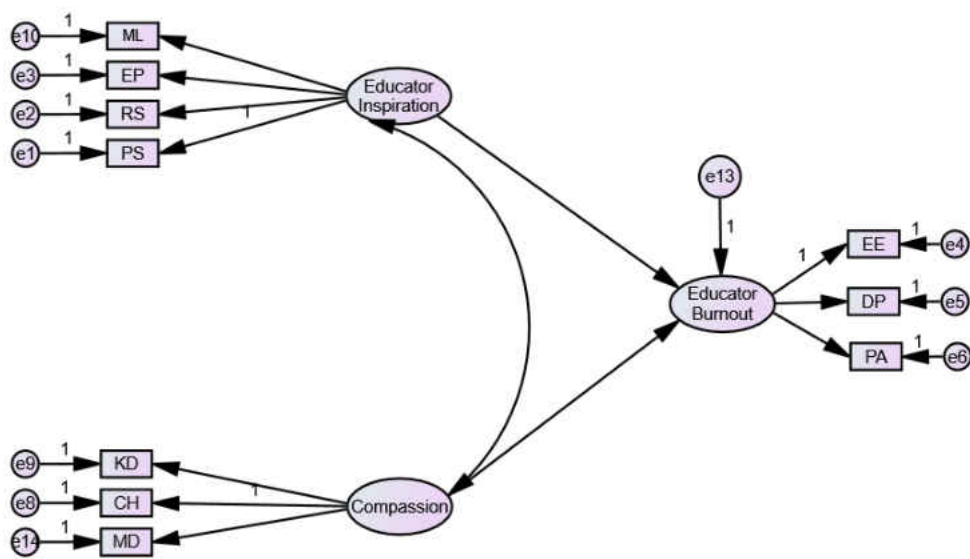

Figure 40: Modified Hypothesized Structural Model

Complete Measurement Model

In order to examine the relationship between the indicators and latent variables, the researcher tested the model fit of the complete measurement model (i.e., all constructs of interest; Byrne, 2016; see Figure 41). The complete measurement model exhibited good fit with these data; therefore, no additional modifications were needed (see Table 26).

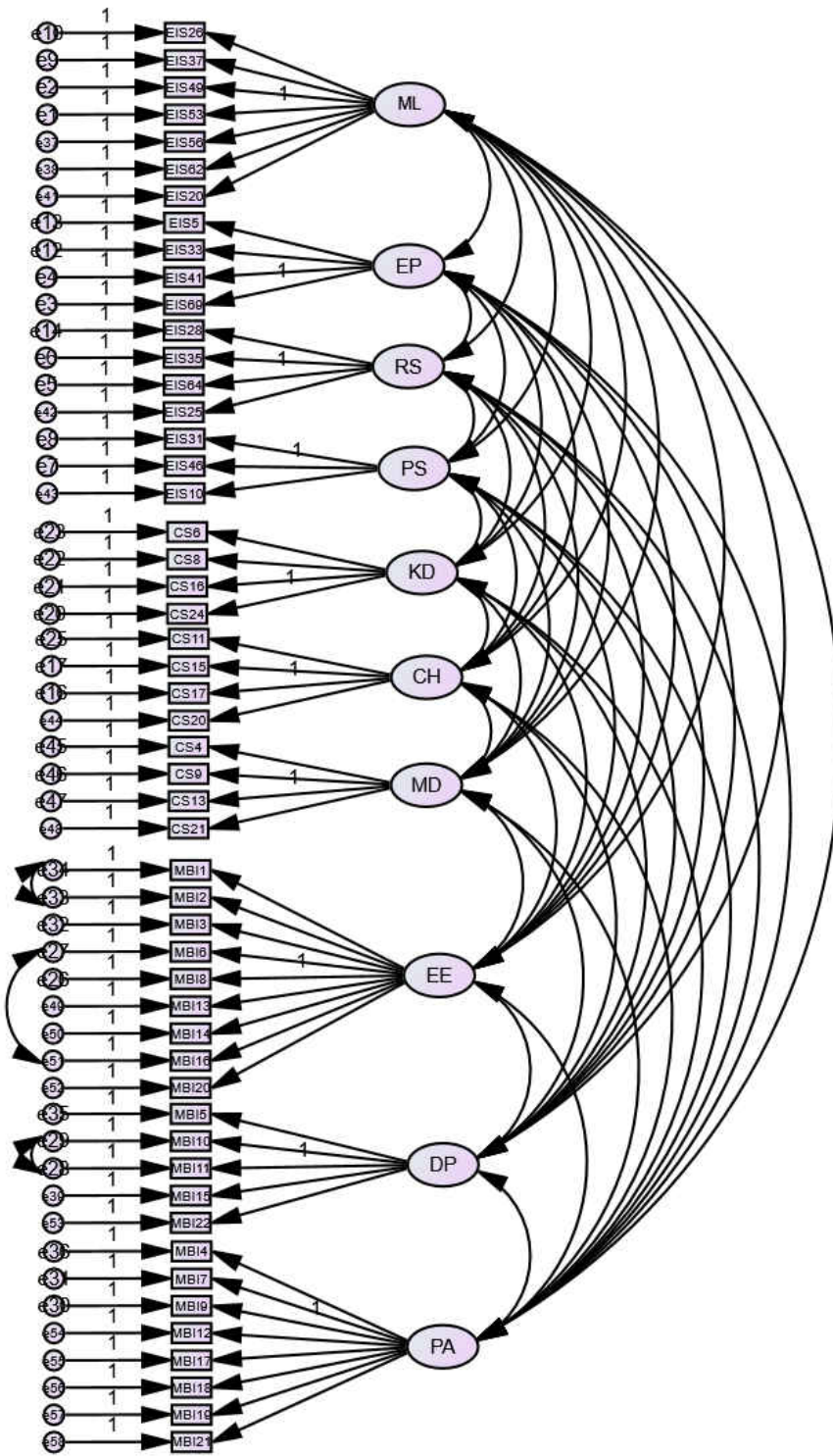

Figure 41: Complete Measurement Model

Table 26
Model Fit Indices - Complete Measurement Model

	X^2	<i>df</i>	<i>p</i>	CMIN/ <i>df</i>	CFI	RMSEA	TLI	NFI
Complete Measurement Model	2896.156	1226	.001	2.362	.881	.049	.866	.812

Note. $N = 580$.

Analysis of the Research Hypothesis and Exploratory Questions

The investigation examined the influence of educator inspiration and compassion for others on burnout. Specifically, the investigation examined the directional relationship between educators' levels of inspiration, compassion for others, and burnout. The researcher utilized *Statistical Package for the Social Science* (SPSS, Version 21) and the *Analysis of Moment Structures* (AMOS, Version 21) to analyze the data. The researcher utilized the following statistical analyses to address the research hypothesis and exploratory questions: (a) SEM; (b) descriptive statistics; (c) Spearman's Rho Correlations; (d) multiple regression; and (e) ANOVA. In addition, the researcher utilized both EFA and CFA procedures to facilitate SEM. The following sections detail the resulting data analyses for the primary research hypothesis and exploratory questions.

Research Hypothesis

The study utilized SEM to address the research hypothesis. SEM is a collection of statistical techniques that allows researchers to test the relationships between directly observed variables and underlying a priori theoretical models (Crockett, 2012). SEM was chosen over

other methods of analysis, such as path analysis or multiple regression, because it is an optimal method to investigate the strength and directionality of multi-factor latent variables within a causal framework (Kline, 2016; Lambie, 2007).

Crockett (2012) outlines five steps to SEM research when conducting counseling research: (a) model specification; (b) model identification; (c) model estimation; (d) model evaluation; and (e) model modification. The following sections applies the five steps to SEM research outlined by Crockett (2012) to the proposed investigation.

Primary Research Hypothesis

The research hypothesis that was tested in the current investigation was: Educators' inspiration (as measured by the EIS; Lambie et al. 2016) and compassion for others (as measured by the CS; Pommier, 2010) scores contribute to their levels of burnout (as measured by the MBI-ES; Maslach et al. 1996). Specifically, educators' levels of inspiration and compassion for others will negatively relate to educators' levels of burnout (see Figure 40).

Structural Model

The researcher specified that educator inspiration and compassion for others will influence educator burnout. Specifically, both educator inspiration and compassion for others were specified as exogenous variables (i.e., independent variables) and educator burnout specified as endogenous (i.e., dependent variable). The review of the literature focused on the constructs of interest (educator inspiration, compassion for others, and educator burnout) informed the researcher to specify the structural model between the variables as such. Further, the research hypothesized that educator inspiration and compassion for others would negatively

relate to educator burnout. Maximum likelihood (ML) was the estimation technique used for the hypothesized structural model.

The initial results of the CFA of the hypothesized structural model exhibited poor fit to these data, $\chi^2 (32, N = 580) = 228.890$, $CMIN/df = 7.153$, $CFI = .896$, $RMSEA = .103$, $TLI = .821$, $NFI = .882$. In order to improve the model fit, the researcher determined it was necessary to re-specify educator burnout to consist of three, first-order latent factors (see Figure 42). Results of the CFA on the modified structural model indicated a moderately acceptable fit, $\chi^2 (364, N = 580) = 1279.588$, $CMIN/df = 3.515$, $CFI = .879$, $RMSEA = .066$, $NFI = .840$, $TLI = .856$. Specifically, the model indicated that educator inspiration accounted for 15.21% of the variance in emotional exhaustion scores (standardized regression weight = $-.390$, $p < .001$), 14.52% of the variance in depersonalization (standardized regression weight = $-.381$, $p < .001$), and 26.32% of the variance in personal accomplishment (standardized regression weight = $.513$, $p < .001$). On the other hand, educators' levels of compassion did not account for statistically significant ($p < .001$) amounts of variance in emotional exhaustion (standardized regression weight = $-.044$, $p = .526$, .19% of variance), depersonalization (standardized regression weight = $-.035$, $p = .551$, .12% of variance), or personal accomplishment (standardized regression weight = $.112$, $p = .050$, 1.25% of variance). Further, educator inspiration and compassion for others shared approximately 40% of variance (standardized covariance = $.630$, $p < .001$).

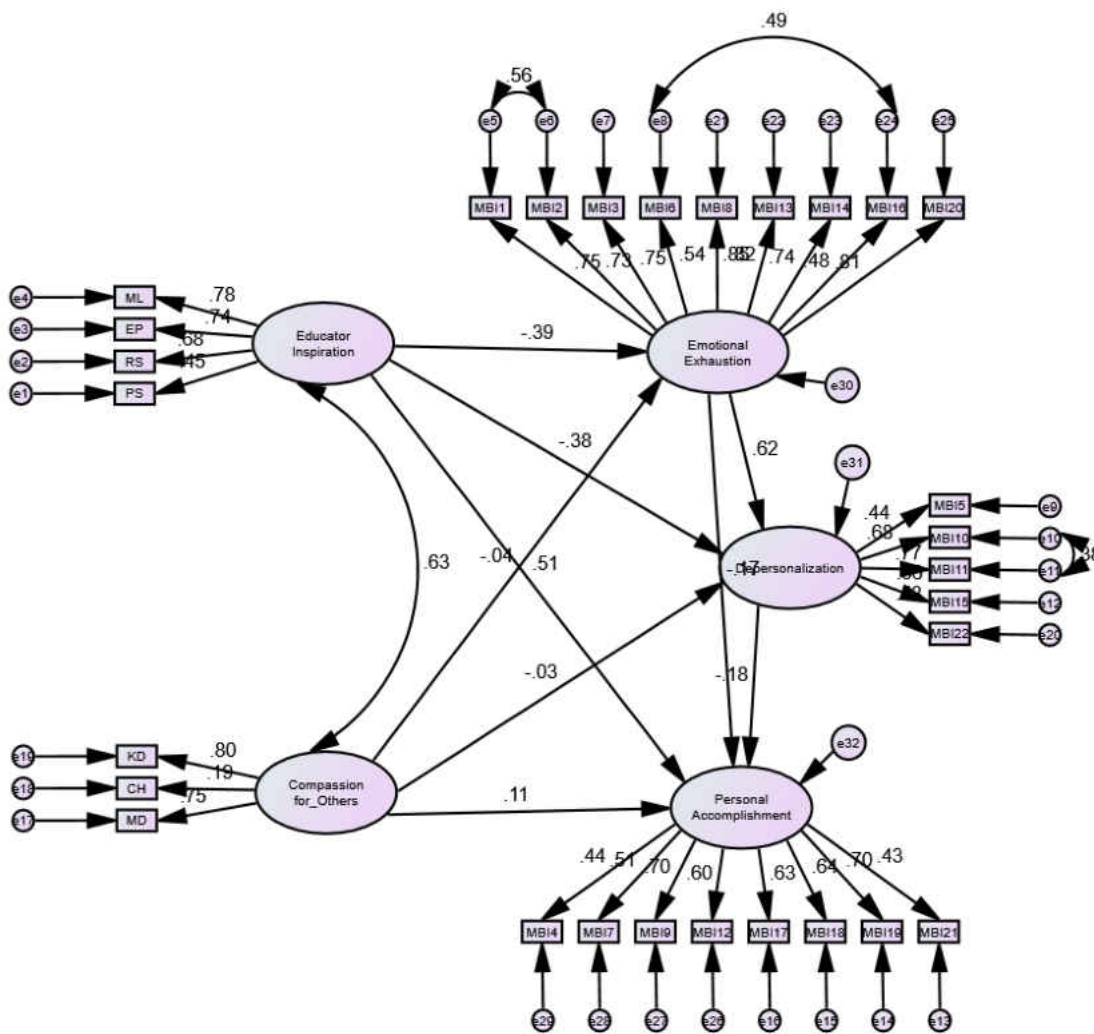

Figure 42: Modified Structural Model 1

Given educators' levels of compassion did not contribute a statistically significant amount of variance to the three dimensions of educator burnout (EE, DP, and PA), the researcher removed the construct (compassion for others) from the structural and re-examined the model fit. The removal of the compassion for others construct did not significantly affect the model fit, producing a moderately acceptable fit for these data, $\chi^2 (290, N = 580) = 1162.706$, $CMIN/df = 4.009$, $CFI = .877$, $RMSEA = .072$, $NFI = .844$, $TLI = .851$ (see Figure 43). It is important to note that although the RMSEA of the current structural model meets the model fit criteria (see Table 8), the CFI, NFI, and TLI values are all below the acceptable model fit recommendations; thus, the current model fit and results should be interpreted with caution. Nonetheless, the structural model indicates that educator inspiration accounted for 17.64% of the variance in EE (standardized regression weight = $-.420$, $p < .001$), 15.76% of the variance in DP (standardized regression weight = $-.397$, $p < .001$), and 33.29% of the variance in PA (standardized regression weight = $.577$, $p < .001$).

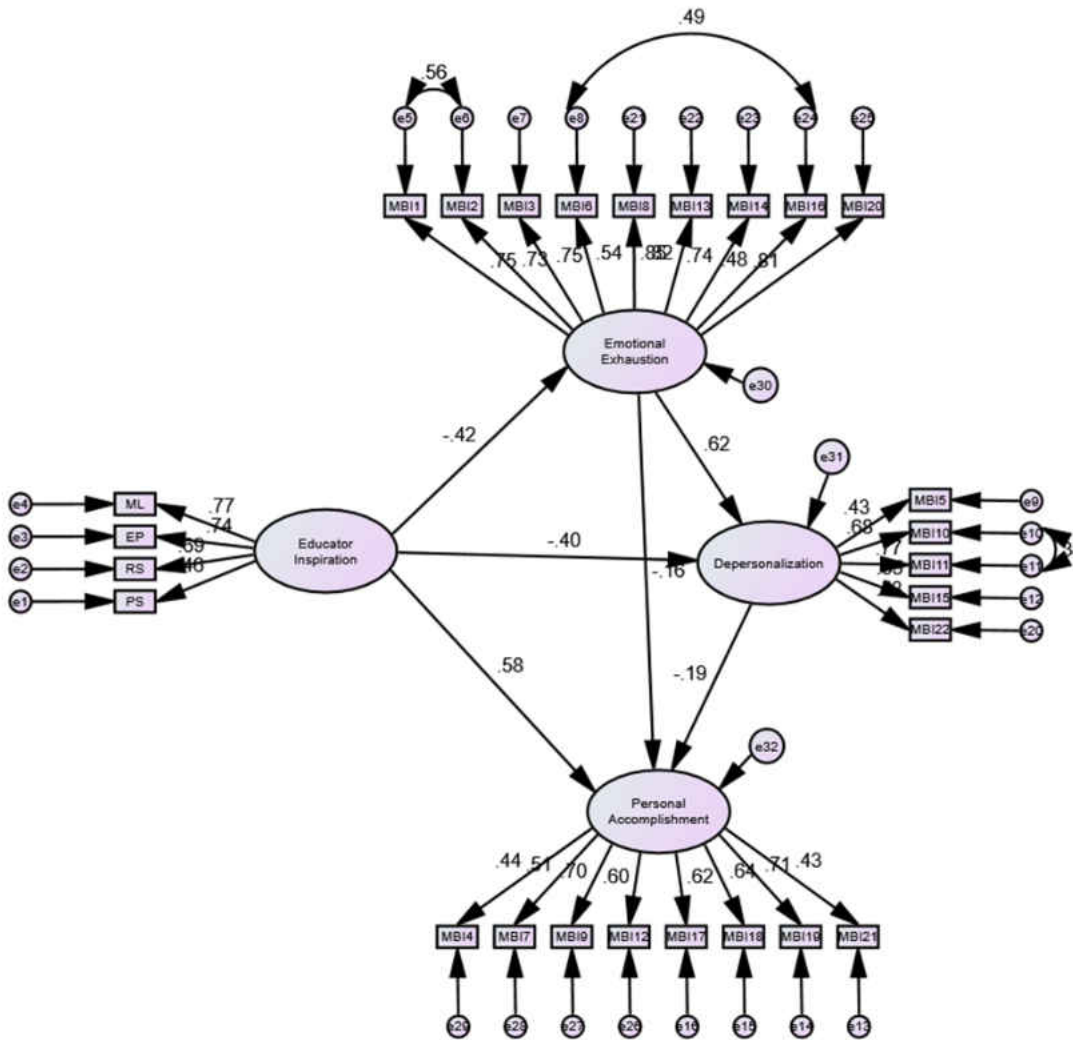

Figure 43: Modified Structural Model 2

Table 27
Fit Indices - Structural Models

	X^2	<i>df</i>	<i>p</i>	CMIN/ <i>df</i>	CFI	RMSEA	TLI	NFI
Hypothesized Structural Model	228.890	32	.001	7.153	.896	.103	.821	.882
Modified Structural Model 1	1279.588	364	.001	3.515	.879	.066	.840	.856
Modified Structural Model 2	1162.706	290	.001	4.009	.877	.072	.844	.851

Note. $N = 580$.

Exploratory Research Question One

The purpose of exploratory research question one was to investigate the linear relationships between the variables of interest. Specifically, the researcher opted to analyze Spearman’s Rho (only for highest degree completed) and Pearson’s Product-Moment correlations to determine the statistical relationships between educator inspiration (ML, EP, RS, PS), compassion for others (KD, CH, MD), educator burnout (EE, DP, PA) and educators’ demographic information (e.g., gender, ethnicity, position, etc.). Table 28 represents the results from the Pearson’s Product-Moment correlational analysis. Although there were statistically significant relationships between certain variables (e.g., gender and ML, EP, and PS, etc.), the effect sizes of the correlations were small to medium (Cohen, 1988).

Table 28
Pearson's Product-Moment Correlations

	ML	EP	RS	PS	KD	CH	MD	EE	DP	PA
GEN	-.17**	-.17**	-.01	-.15**	-.24**	-.01	-.11**	-.03	-.10*	.01
AGE	-.02	-.07	.03	.20**	-.05	-.01	.01	.07	.01	-.06
ETH	-.05	-.08*	-.05	.02	-.03	-.06	-.04	.10*	.10*	.03
DEG	-.04	-.05	-.02	.17**	-.12**	-.05	-.08*	.18**	.10*	-.08
YRS	-.01	-.06	.01	.16**	-.04	-.03	-.01	.12**	.02	-.06
SET	.05	.01	.02	.08	.00	.04	.03	.06	.02	.02
POS	-.06	-.02	-.03	-.05	.01	-.03	-.02	-.10*	.01	.01
TYPE	.05	.07	-.01	.03	.04	-.01	.04	-.10*	-.06	.05

Note.

*. Correlation significant at the .05 level (two-tailed).

**. Correlation significant at the .01 level (two-tailed).

GEN = Gender

AGE = Age

ETH = Ethnicity

DEG = Highest degree completed

YRS = Years of experience

SET = Setting of current school

POS = Current Position

TYPE = Type of current school

Exploratory Research Question Two

The purpose of exploratory research question two was to investigate the differences in educator burnout based on educators' demographic information. Specifically, exploratory research question two examined the differences in educator burnout (EE, DP, PA) across educators' reported demographic information, after accounting for their current levels of job satisfaction, stress, perceived support, and perceived effectiveness.

The researcher conducted a series of multivariate analysis of covariance (MANCOVA) to examine the differences in educators' EE, DP, and PA scores across their reported *categorical* demographic information, after accounting for educators' current levels of job satisfaction, stress, perceived support, and perceived effectiveness. In addition, the researcher opted to utilize multiple regression analysis to determine whether the *continuous* variables (i.e., age and years of experience) contributed to statistically significant changes in EE, DP, and PA.

After controlling for educators' current levels of job satisfaction, stress, perceived effectiveness, and perceived support, results from a series of MANCOVA indicated that there was not a statistically significant ($p < .001$) difference in EE, DP, and PA scores based on educators': (a) *gender*, $F(6, 938) = 1.309$, $p = .250$, $\eta^2 = .008$; (b) *ethnicity*, $F(21, 1410) = 1.210$, $p = .232$, $\eta^2 = .018$; (c) *highest degree completed*, $F(15, 1410) = 1.104$, $p = .348$, $\eta^2 = .012$; (d) *current position*, $F(18, 1374) = 1.432$, $p = .107$, $\eta^2 = .018$; (e) *setting of current school*, $F(9, 1374) = 2.202$, $p = .022$, $\eta^2 = .014$; or (f) *type of current school*, $F(4, 458) = .132$, $p = .156$, $\eta^2 = .012$. In addition, neither age nor years of experience contributed to statistically significant ($p < .001$) changes in educators' EE, DP, or PA scores.

Exploratory Research Question Three

The purpose of exploratory research question three was to investigate the differences in educator inspiration and compassion for others based on educators' demographic information. Specifically, exploratory research question #3 examined the differences in ML, EP, RS, PS, and CT scores based on educators' demographic information, after controlling for their current levels of job satisfaction, stress, perceived support, and perceived effectiveness

The researcher conducted a series of MANCOVAs to examine the differences in educators' ML, EP, RS, PS, MD, CH, and MD scores across their reported *categorical* demographic information. In addition, the researcher utilized a multiple regression analysis to investigate the statistical relationship between educators' levels of ML, EP, RS, PS, and CT and their reported *continuous* demographic information (age and years of experience).

The results from a series of MANCOVA indicated that after controlling for educators' current levels of job satisfaction, stress, perceived support, and perceived effectiveness, there was not a statistically significant ($p < .001$) in educators' levels of inspiration (ML, EP, RS, PS) and compassion (KD, CH, MD) based on their: (a) *gender*, $F(14, 930) = 1.484, p = .110, \eta^2 = .022$; (b) *ethnicity*, $F(49, 3290) = .807, p = .830, \eta^2 = .012$; (c) *highest degree completed*, $F(35, 2340) = 1.414, p = .069, \eta^2 = .021$; (d) *current position*, $F(42, 2748) = 1.166, p = .216, \eta^2 = .018$; (e) *setting of current school*, $F(21, 1375) = 1.533, p = .061, \eta^2 = .023$; or (f) *type of current school*, $F(28, 1824) = 1.143, p = .074, \eta^2 = .021$. In addition, results from a multiple regression analysis indicated that neither age nor years of experience contributed to a statistically significant ($p < .001$) change in educators' levels of inspiration or compassion for others.

Chapter Summary

Chapter four presented the statistical results of the current investigation. Specifically, the researcher presented the results to: (a) sampling and data collection procedures; (b) initial descriptive statistics; (c) data screening and statistical assumptions; (d) confirmatory factor analyses of the measurement models; (e) analysis of the hypothesized structural model; (f) analysis of alternative structural models; and (g) analysis of exploratory research questions. SEM was used to analyze the hypothesized structural models as well as the alternative structural models (Byrne, 2016). The exploratory research questions were addressed using: (a) descriptive statistics; (b) multivariate analysis of covariance (MANOVA); and (c) standard multiple regressions (SMR).

CHAPTER FIVE: DISCUSSION

Chapter five provides an overview of the study, research methods and data analyses, and the implications of the results from the current investigation. Specifically, chapter five reviews the results for the primary research question (i.e., the hypothesized structural model and alternative models) as well as exploratory research questions and discusses the limitations of this study. Furthermore, the chapter offers implications of the current study's findings as they relate to clinical practice, counselor education, and instrument development.

Study Summary

Educator turnover continues to be problematic for schools, school districts, and policy makers with an average of 40-50% of educators leaving the profession within their first five years (Ingersoll & Smith, 2003), costing the United States (U.S.) approximately 2.2 *billion* dollars per year (Alliance for Excellent Education, 2014). One of the most common contributors to the educator turnover problem is burnout (Hansen, 2006; Richards et al., 2016). Although there is a plethora of research that has examined the *contributors* to burnout, recent paradigm shifts in burnout research have begun to focus on the *protective factors* to educator burnout (Schaufeli et al., 2008). Nevertheless, the existing research on educator characteristics that protect against burnout has focused mainly on rather stable traits (i.e., educators' personality; Cano-Garcia et al., 2005) rather than more developmental characteristics that can protect against educator burnout at the individual-level as well as the contextual-level (Maslach, 2003).

Therefore, this study investigated the influence of educators' inspirational qualities and levels of compassion on the three dimensions of educator burnout. Specifically, the researcher utilized SEM to investigate the contribution of educators' levels of educator inspiration (as measured by the EIS; Lambie et al., 2017) and compassion (as measured by the COS; Pommier, 2010) to their levels of burnout (as measured by the three dimensions of burnout; *emotional exhaustion* [EE], *depersonalization* [DP] and, *personal accomplishment* [PA] on the MBI-ES; Maslach et al., 1996). Prior to address the current investigation's primary research question, the researcher examined the descriptive statistics and conducted confirmatory factor analysis (CFA) on the EIS, COS, and MBI-ES.

Descriptive Statistics

In the current investigation, most of the educators identified as white ($n = 431$; 74.3%), females ($n = 469$; 80.9%), and having earned a Bachelor's degree ($n = 202$; 34.8%). The majority of educators were employed in the state of Florida ($n = 89.1%$) at regular ($n = 466$; 80.3%), suburban schools ($n = 357$; 61.6%). Educators-in-training (EIT), elementary school educators, and high school educators were equally represented ($n = 145$ [25.0%]; $n = 133$ [22.9%]; $n = 134$ [23.1%], respectively); however, middle school educators ($n = 52$; 9.0%), school administrators ($n = 9$; 1.6%), and school counselors ($n = 14$; 2.4%) were less represented. The demographic information of the participants in the current investigation was similar to that of other studies investigating educator burnout (e.g., Aloe et al., 2016; Byrne, 1994; Skaalvik & Skaalvik, 2010).

Confirmatory Factor Analyses of the EIS, COS and MBI-ES

CFA were conducted to ensure each measurement model was appropriate for these data. The results from the CFA on the EIS (Lambie et al., 2016) indicated an acceptable model fit to these data, $\chi^2 (129, N = 580) = 455.058$, $CMIN/df = 3.528$, $CFI = .942$, $RMSEA = .066$, $TLI = .923$, $NFI = .921$, with each of the subscales yielding acceptable internal reliability measures (i.e., Cronbach's α ; Streiner, 2003). The acceptable model fit of the EIS is consistent with prior research; however, it is important to note that the current investigation shared approximately 75% of the data with prior research (i.e., Lambie et al., 2017).

The initial results of the CFA on the COS (Pommier, 2010) yielded inadmissible (i.e. Heywood case). The most common explanation for a Heywood case is a specification error, which directly relates to the theoretical framework (i.e., construct validity) of an instrument. The researcher reviewed the development and validation of the COS and determined that although the instrument has appropriate *face* validity, the *construct* validity was questionable. Specifically, Pommier (2010) adopted the factor structure of the COS from the *Self-Compassion Scale* (Neff, 2003) under the assumption that compassion for one's self would manifest similarly in compassion for others. The researcher determined it was necessary to remove the subscales *indifference*, *separation*, and *disengagement*, which did not affect the integrity of the theoretical framework of compassion (Pommier, 2010). The modification corrected the Heywood case, although the three-factor COS yielded a poor model fit to these data, $\chi^2 (52, N = 580) = 334.368$, $CMIN/df = 6.430$, $CFI = .801$, $RMSEA = .097$, $TLI = .701$, $NFI = .777$. The poor model fit for the COS scores offers several implications to this finding. First, the results indicate that

compassion for others (as measured by the COS) is better suited as a three-factor instrument. Moreover, the poor model fit of the three-factor COS to these data identified that compassion for others manifests differently in educators compared the developmental sample of the COS (i.e. undergraduate psychology students). Future researcher should continue to develop the theoretical framework of the COS and consider modifying the instrument specifically for educators and educators-in-training.

The results from the CFA on the MBI-ES (Maslach et al., 1996) indicated that the model fit of the MBI-ES fit poorly to these data, $\chi^2 [206, N = 580] = 1187.806$, $CMIN/df = 5.766$, $CFI = .835$, $RMSEA = .091$, $TLI = .798$, $NFI = .809$. However, the researcher modified the MBI-ES to achieve an acceptable fit ($\chi^2 [203, N = 580] = 822.599$, $CMIN/df = 4.052$, $CFI = .896$, $RMSEA = .073$, $TLI = .871$, $NFI = .868$), which is common when using the MBI-ES with a sample of educators (Byrne, 2016). In addition, the measures of central tendency for the MBI-ES indicated that educators in the current sample reported low levels of educator burnout (i.e., low EE and DP scores; high PA scores). Specifically, educators in the current sample scored at: (a) *lower* levels of EE ($M = 20.16$, $SD = 12.01$) compared to the norm sample of educators for the MBI-ES ($M = 21.25$, $SD = 21.25$; $d = .09$); (b) *lower* levels of DP ($M = 4.53$, $SD = 5.16$) compared to the norm sample of educators for the MBI-ES ($M = 11.00$, $SD = 6.19$; $d = 1.065$); and (c) *higher* levels of PA ($M = 40.05$, $SD = 6.52$) compared to the norm sample of educators for the MBI-ES ($M = 33.54$, $SD = 6.89$, $d = .951$). On the other hand, results from a multiple regression analysis indicated that educators' scores on the MBI-ES had a statistically significantly relationship their social desirability scores; however, the effect sizes were small to medium: (a) EE, $d = .4$; (b) DP, $d = .3$, and (c) PA, $d = .1$ (Cohen, 1988). Nonetheless, the influence of social desirability on

educators' reports of burnout warrant further consideration given that research focused on protecting against educator burnout requires educators to respond to their experiences of burnout honestly.

Primary Research Hypothesis and Exploratory Questions

Initial examination of the modified hypothesized structural model did not fit the data; however, when educator burnout was re-specified as three first-order latent variables, the model yielded a moderately acceptable fit to these data, $\chi^2 (364, N = 580) = 1279.588$, $CMIN/df = 3.515$, $CFI = .877$, $RMSEA = .066$, $NFI = .841$, $TLI = .851$. Educator inspiration reported statistically significant ($p < .001$) negative direct effects on EE and DP, and a statistically significant ($p < .001$) positive relationship with PA. However, COS did not yield a statistically significant ($p < .001$) relationship with any of the three dimensions of educator burnout and was subsequently removed and the model was re-analyzed. Overall, the final structural model (i.e., without the compassion for others construct) indicated a moderately acceptable fit to these data, $\chi^2 (290, N = 580) = 1162.706$, $CMIN/df = 4.009$, $CFI = .877$, $RMSEA = .072$, $NFI = .844$, $TLI = .851$. Specifically, the final model indicated that educator inspiration accounted for 17.64% of the variance in EE scores, 15.76% of the variance in DP scores, and 33.29% of the variance in PA scores ($p < .001$). Overall, the results indicate that increasing educator inspiration (as measured by the EIS) can protect against educator burnout by decreasing educators' experiences of EE and DP while increasing their feelings of PA.

Discussion of the Results

The results from the current investigation are the first to examine the directional relationship between educator inspiration and burnout. The researcher found that educator inspiration is negatively related to educators' feelings of EE and DP and positively related to their feelings of PA. Specifically, the results identified that educator inspiration (as measured by the EIS) can protect against and/or mitigate the effects of EE and DP while promoting educators' feelings of PA. On the other hand, compassion for others did not contribute a statistically significant amount of variance to the model, which did not support prior research. Whereas past research has reported that components of compassion (e.g., empathy, caring, mindfulness) are negatively related to educator burnout (e.g., Abenovoli et al., 2013; Teven, 2007). One possibility for the inconsistent results is that COS (Pommier, 2010) measure had limited construct validity. As noted, the development of the COS was based on the assumption that compassion for others would manifest similarly to that of compassion for the self. As such, although the COS has adequate *face* validity, there is potential that the instrument does not adequately measure compassion for others. In addition, it is possible that educator compassion is different compared the compassion that was measured in the developmental sample. The COS broadly measured compassion (e.g., "When I see someone struggling, my heart goes out to them"); thus, it is possible that educator compassion is specifically associated with their students and would benefit from modifying the items to address educators' compassion for their students (e.g., "When I see *my students struggling academically*, my heart goes out to them").

The results from this investigation are the first to address developmental characteristics of educators (i.e., educator inspiration) that have the potential to protect against the effects of educator burnout. Lim and Eo (2014) reported a statistically significant negative relationship between *reflective dialogue* (i.e., frequent discussion between educators about teaching and learning) and educator burnout. The results from this investigation support that finding in that educators with higher levels of inspiration would theoretically be more likely to engage in reflective dialogue, thus negatively influencing experiences of educator burnout. Moreover, Lambie and colleagues (2017) reported a statistically significant relationship between educator inspiration and educator burnout, further establishing discriminant validity for the EIS. Given that there is limited amount of research in this particular area of educator burnout, there are many suggestions for future research that are discussed later in the chapter.

Study Limitations

Despite efforts to reduce threats to internal and external validity of this investigation, there were several limitations to the current study. Specifically, the results of the current study were limited by: (a) research design; (b) sampling methodology; and (c) instrumentation (Gall et al., 2007).

Research Design Limitations

A correlational research design was used to address the primary research question for this investigation. Specifically, SEM was used to examine the relationship between latent constructs (i.e., unobserved variables) within a causal framework (Murnane & Willet, 2011; Tabachnick & Fidell, 2013); however, results from SEM analyses do not determine a purely causal relationship between variables (Gall et al., 2007). Therefore, even though the researcher attempted to mitigate the influence of extraneous and/or confounding variables by examining the relationship between educators' demographic information and the constructs of interest, other extraneous and confounding variables may have influenced the tested relationship between the constructs of interest. Further, there is inherent limitations to the results of studies that utilize self-report instruments (Gall et al., 2007). The researcher attempted to mitigate this potential influence by utilizing the MCSDS – X1 (Strahan & Gerbasi, 1972) and examining the relationships between social desirability and the constructs of interest. The researcher determined that social desirability *did* have an influence on educators' responses, albeit small to medium effect sizes: (a) EE, $d = .4$; (b) DP, $d = .3$; and (c) PA, $d = .1$. Nonetheless, the researcher decided to include social desirability in the final retained model.

Sampling Limitations

The researcher used criterion sampling and multiple data collection methods to obtain the largest and most diverse sample possible (Tabachnick & Fidell, 2013). In addition, when access to the entire population is not available, convenience sampling methods are appropriate (Gall et al., 2007). As such, another limitation to the results of this investigation is the lack of generalizability to the entire population. Specifically, the majority of this investigation's sample were employed in the state of Florida ($n = 517$; 89.1%); therefore, the results from the current study may not generalize to educators in different states. In addition, the majority of the sample identified as white and female; however, it is important to note that this demographic representation is comparable across the United States (*National Center for Education Statistics* [NCES]; 2014). Further, it is important to note that environmental factors may have influenced participants' responses. Specifically, due to the different data collection methods (e.g., mailing, school distribution, and classes/workshops), it is possible educators may have experienced different types of pressure (i.e., class distribution) when participating in the study.

Instrumentation Limitations

Although the results of this investigation supported the primary research hypothesis, it is important to note that the results are limited to the instruments that were used, specifically for the

EIS and COS scores. The EIS and COS are relatively new instruments that are still in their early stages of development; thus, it is important to note that participants' scores should be interpreted with caution. Nonetheless, the researcher reported acceptable internal consistency measures for instruments being used in early developmental research (Streiner, 2003). In addition, it is important to note that each of the instruments that were used in this investigation (EIS, COS, MBI-ES) are self-report instruments. In order to mitigate the effects of self-report bias, the researcher utilized the MCSDS – X1 to measure the influence of social desirability of participants' responses on each instrument. The researcher determined that although the effect size of the relationship between social desirability and educators' scores on the EIS, COS, and MBI-ES, it was prudent to include social desirability in the final retained model to further researchers' understanding of the relationship between the constructs of interest (educator inspiration, compassion for others, and burnout).

Recommendations for Future Research

The researcher recommends future research consider the limitations to the current study. Specifically, this investigation utilized a correlational research design and could not establish a causal relationship between the constructs of interest; thus, future research should examine the causal relationship between educators' levels of inspiration and compassion and burnout. In addition, while the current study utilized criterion and convenience sampling methods, future research should consider obtaining a random sample that is both large and more geographically and demographically diverse. Moreover, future research should address the issue of social desirability in burnout literature in the education profession. While the current study accounted

for the influence of social desirability, the sample included educators that, in general, did not report high levels of burnout. As a result, it is possible that educators who experience burnout are *less* likely to volunteer to be research participants, particularly with regards to burnout studies.

Although educator inspiration is a new construct with limited empirical support, the findings from this study provide a plethora of implications for future research in preventing educator burnout. Specifically, there are many well-established contributors to educator burnout, both internal and external to educators. Common external contributors to educator burnout are *student misbehavior* (e.g., Aloe et al., 2016; McCormick & Barnett, 2011), *organizational politics* (e.g., Lim & Eo, 2014), and *work overload* (e.g., Byrne, 1994). In addition, common internal contributors to educator burnout are *low intrinsic motivation* (e.g., Fernet et al., 2010) and *low self-efficacy* (e.g., Skaalvik & Skaalvik, 2010). As such, it is possible that educator inspiration can mediate the effects of the common contributors to educator burnout, thus helping protect against the deleterious effects of burnout. For instance, Fernet and colleagues (2010) reported that educators' intrinsic motivation significantly decreases over the academic year, which in turn contributes to increased experiences of burnout. As such, it is possible that the promotion of educator inspiration can mediate the relationship between changes in motivation and burnout by reinforcing the inspirational qualities measured by the EIS (*motivational leadership, empathy, resilience, and passion*). Similarly, student misbehavior and work overload increase educator burnout (e.g., Aloe et al., 2016; Byrne, 1994). Thus, it is possible that educator inspiration can mediate the effects of these external job demands by promoting inspirational qualities that negatively relate to educator burnout. Furthermore, future research should continue

to develop the psychometric properties of the EIS as the instrument has empirical support for protecting against educator burnout.

Implications of the Current Investigation

Implications for Educators, School, and Training Programs

The results from the current study offer implications for educators, school administrators, policy makers, and educator training programs. Educator burnout continues to be a central focus in educational research, and until recently, has focused on the *contributors* to burnout rather than the *protective factors* to burnout (Maslach, 2003). The results from this investigation found that educator inspiration was related to lower levels of burnout; thus, the results imply that as educators increase their levels of inspiration, they experience lower degrees of burnout. Specifically, educators who experience lesser degrees of burnout have more emotional investment devoted in their jobs (i.e., less EE), experience an increased engagement with their students and colleagues (i.e., less DP), and experience a greater sense of satisfaction with their careers (i.e., more PA), further reinforcing their levels of inspiration. In turn, as educators experience less burnout (and more inspiration), it is possible that the rate of educator turnover may decrease, a problem that continues to cost the United States 2.2 billion dollars per year (Alliance for Excellent Education, 2014). In fact, if raising educators' levels of inspiration decreases their degrees of burnout, not only may it save the United States millions of dollars per year, it may have positive impacts on student achievement. Hansen (2006) reported that students

in schools that experience higher rates of turnover report lower standardized Math and English scores; hence, raising inspiration protects against burnout, which decreases educator turnover, and ultimately promoting students' academic performance.

Furthermore, just as educators' affective responses to their demanding job conditions (i.e., burnout) contribute to educator turnover (Billingsley, 2004); inadequate teacher preparation has been argued to further exacerbate the rate of educator turnover (Ingersoll & Smith, 2003). The results from this investigation have implications for teacher preparation, namely for the utilization of the EIS in teacher preparation programs to mitigate the educators' degree of burnout. The EIS is an empirically-tested, theoretically-driven instrument that measures educators' levels of inspiration across four domains (motivational leadership, empathy, resilience, passion; Lambie et al., 2017), which this investigation found to negatively relate to educators' degrees of burnout. As such, the EIS affords teacher preparation programs the opportunity to utilize the EIS to assess the levels of inspiration in educators-in-training and intervene when appropriate. Specifically, the EIS allows teacher preparation programs to focus on the development and maintenance of educator inspiration prior to educators-in-training entering the field of education, thus protecting against burnout prior to its manifestation. In turn, as noted, decreasing educators' degrees of burnout (via increasing educator inspiration) has the potential to mitigate the rate of educator turnover.

Implications for Instrument Development

The researcher utilized three instruments to measure educators' levels of inspiration, compassion for others, and burnout. The EIS (Lambie et al., 2017) was used to measure educators' levels of inspiration. The current investigation is the first empirical research study to examine the relationship between educator inspiration and burnout. The EIS performed well with these data; however, the empathy scale did not directly relate to the three dimensions of burnout (EE, DP, and PA), which contradicts prior research (e.g., Teven, 2007). As such, future research should consider re-wording the items on the *empathy* subscale to reflect more empathic *responses* as opposed to educators' comfort level with addressing emotional concerns with students. Nonetheless, the results from this investigation regarding the psychometric features of the EIS scores as consistent with prior research (Lambie et al., 2017), bolstering the support for the construct validity of the EIS scores.

In addition, the COS (Pommier, 2010) was used to measure educators' levels of compassion for others; however, it did not perform well with these data. One possibility for the low performance of the COS with this sample is that the items did not directly pertain to educators' levels of compassion *for their students*; rather, the items measured educators' general levels of compassion (e.g., "When others feel sadness, I try to comfort them."). It is possible that more items on the original 24-item COS would be retained if the future research re-words the items to directly pertain to educators' levels of compassion for their students.

Further, the MBI-ES (Maslach et al., 1996) was used to measure educators' levels of burnout. After several modifications to the original 22-item instrument, the model produced a

strong fit to these data. As it is common for the initial fit of the MBI-ES to be poor in samples of educators, it is possible that the results from this investigation found a need to re-examine the factor structure of the MBI-ES. Whereas the MBI-ES has been extensively used to measure burnout for the past 30 years (Maslach, 2003), it is possible that the implications from this investigation suggest the construct of burnout has changed along with the educational context in the United States. The researcher recommends for future research to continue exploring the psychometric properties of the MBI-ES prior to assessing model fit.

Chapter Summary

In chapter five, the researcher provided a brief overview of the findings presented in chapter four and compared these results to past research on the constructs of interest. The results from this investigation indicated that educators' levels of inspiration negatively relate to EE and DP, and positively relate to PA. The researcher examined the alternate model which specified the EIS as a consisting of four first-order dimensions (motivational leadership, empathy, resilience, passion) rather than one second-order factor (i.e., educator inspiration), which produced a strong fit with these data. While the COS did not account for a noteworthy amount of variance in EE, DP, or PA, it is important to note that the results indicated the relationships were in the expected directions and recommendations for future research using the COS with samples of educators was provided. Further, the researcher presented the implications of this study's results as they

relate to educators, schools, educational policy, and instrument development. Overall, this investigation's findings contribute to the growing body of literature focused on educator inspiration, compassion for others, and burnout.

APPENDIX A: INFORMED CONSENT



University of Central Florida Institutional
Review Board Office of Research &
Commercialization
12201 Research Parkway, Suite 501
Orlando, Florida 32826-3246
Telephone: 407-823-2901 or 407-882-2276
www.research.ucf.edu/compliance/irb.html

Approval of Exempt Human Research

From: **UCF Institutional Review Board
#1 FWA00000351, IRB00001138**

To: **Glenn William Lambie and Co-PIs: Samuel L. Bierbrauer, Sejal Barden**

Date: **February 05, 2016**

Dear Researcher:

On 02/05/2016, the IRB approved the following activity as human participant research that is exempt from regulation:

Type of Review: Exempt Determination
Project Title: The Educator Inspire Scale (EIS): Development and Validation
Investigator: Glenn William Lambie
IRB Number: SBE-16-11992
Funding Agency:
Grant Title:
Research ID: N/A

This determination applies only to the activities described in the IRB submission and does not apply should any changes be made. If changes are made and there are questions about whether these changes affect the exempt status of the human research, please contact the IRB. When you have completed your research, please submit a Study Closure request in iRIS so that IRB records will be accurate.

In the conduct of this research, you are responsible to follow the requirements of the [Investigator Manual](#). On behalf of Sophia Dziegielewski, Ph.D., L.C.S.W., UCF IRB

Chair, this letter is signed by:

A handwritten signature in black ink that reads "Joanne Muratori".

Signature applied by Joanne Muratori on 02/05/2016

04:24:34 PM EST IRB Manager

APPENDIX B: DEMOGRAPHIC QUESTIONNAIRE

Directions: Please complete items in the following general demographics questionnaire (all responses are anonymous).

Gender (Select the appropriate answer):

- Female
- Male
- Other (please specify): _____

Age: _

Please indicate your current marital status:

- Married/Partnered/Living together
- Currently Dating
- Single
- Divorced/Widowed
- Other (please specify): _____

What state do you currently work in as an educator? __

What school district do you currently work in as an educator? _____

Ethnicity (Select the single most appropriate answer):

- African-American
- Asian-American
- Hispanic
- Multiracial
- Native-American
- Pacific / Islander
- White (Non-Hispanic)
- Other: (please specify): _____

What is the highest degree you have completed to date (Select the single most appropriate answer)?

- Earning Bachelors' Degree
- Bachelors
- Masters
- Educational Specialist
- Doctorate of Philosophy (Ph.D.)
- Doctorate of Education (Ed.D.)

How many years, including the current school year, have you worked as an educator (Educators-in- training, please use "0")?

What setting is your school located?

- Rural
- Suburban
- Urban
- Other (please specify): _____

What is your current position (Select the single most appropriate answer):

- Elementary School Teacher
- Educator-in-Training
- High School Teacher
- Middle School Teacher
- School Administrator (e.g., Assistant Principal, Dean, Principal)
- School Counselor
- Other (please specify): _____

What type of school do you work in?

- Regular
- Vocational
- Special Education
- Alternative Education
- Other (please specify): _____

Please rate your current level of satisfaction in being an educator or educator-in-training:

1 Very Not Satisfied	2 Not Satisfied	3 Somewhat Satisfied	4 Satisfied	5 Very Satisfied
-------------------------	--------------------	-------------------------	----------------	---------------------

Please rate your current level of stress you experience being an educator or educator-in-training:

1 Very Stressed	2 Stressed	3 Somewhat Stressed	4 Not Stressed	5 Very Unstressed
--------------------	---------------	------------------------	-------------------	----------------------

Please rate the level of support your experience at your school:

1 Very Unsupportive	2 Unsupportive	3 Somewhat Supportive	4 Supportive	5 Very Supportive
------------------------	-------------------	--------------------------	-----------------	----------------------

Please rate your current level of effectiveness as an educator or educator-in-training:

1 Very Ineffective	2 Ineffective	3 Somewhat Effective	4 Effective	5 Very Effective
-----------------------	------------------	-------------------------	----------------	---------------------

APPENDIX C: EDUCATOR INSPIRE SCALE (EIS)

Educator Inspire Scale (EIS) ©

(Lambie, Barden, &
Bierbrauer, 2016)

The *Educator Inspire Scale*© (EIS) is designed for educators-in-training (completing their clinical experiences / student-teaching) and practicing educators to evaluate their own levels of inspirational qualities. The seven primary areas measured by the EIS include educators' levels of: (a) leadership; (b) motivation; (c) passion; (d) self-efficacy; (e) empathy; (f) academic optimism; and (g) resilience.

Using the 7-point Likert scale provide below, please indicate the degree to which you agree or disagree with each statement about yourself as an educator-in-training or practicing educator *within the last month*.

Strongly Disagree 1	Moderately Disagree 2	Mildly Disagree 3	Neither Agree or Disagree 4	Mildly Agree 5	Moderately Agree 6	Strongly Agree 7					
Items					Rating						
1. I work to develop cooperative relationships with my students.					1	2	3	4	5	6	7
2. I find being an educator rewarding.					1	2	3	4	5	6	7
3. I invest extra time and energy into being an effective educator.					1	2	3	4	5	6	7
4. I am confident in my abilities to be an effective educator.					1	2	3	4	5	6	7
5. I am always comfortable talking with students about their emotional concerns.					1	2	3	4	5	6	7
6. I focus on students' strengths rather than their limitations.					1	2	3	4	5	6	7
7. I employ coping strategies to maintain professional wellness.					1	2	3	4	5	6	7
8. I always provide students with clear guidelines that delineate my expectations.					1	2	3	4	5	6	7
9. I am internally driven to be the best educator as possible.					1	2	3	4	5	6	7
10. I always participate in activities to continuously improve my work as an educator.					1	2	3	4	5	6	7
11. I believe I can set attainable professional goals.					1	2	3	4	5	6	7
12. I always work to build supportive relationships with my students.					1	2	3	4	5	6	7
13. I believe in students' ability to succeed.					1	2	3	4	5	6	7

14. I always reframe setbacks into positive learning experiences.							1	2	3	4	5	6	7
15. I continuously challenge my students to increase their skills and abilities.							1	2	3	4	5	6	7
16. I believe being an educator is important.							1	2	3	4	5	6	7
Strongly Disagree 1	Moderately Disagree 2	Mildly Disagree 3	Neither Agree or Disagree 4	Mildly Agree 5	Moderately Agree 6	Strongly Agree 7							
Items							Rating						
17. I am determined to be the best educator I can to support my students' learning.							1	2	3	4	5	6	7
18. I trust my ability to be effective in managing potential difficult situations with students.							1	2	3	4	5	6	7
19. I appreciate that my students may have different perspectives than I do.							1	2	3	4	5	6	7
20. I always encourage my students to achieve their academic goals.							1	2	3	4	5	6	7
21. I am very persistent in completing challenging work-related tasks (e.g., grading, lesson planning, etc.).							1	2	3	4	5	6	7
22. I always collaborate with my students to support their learning.							1	2	3	4	5	6	7
23. I set high expectations for myself as an educator.							1	2	3	4	5	6	7
24. I work to understand my students' personal needs.							1	2	3	4	5	6	7
25. I believe in my ability to work with challenging colleagues.							1	2	3	4	5	6	7
26. I have a genuine concern for my students.							1	2	3	4	5	6	7
27. I have a positive career outlook.							1	2	3	4	5	6	7
28. I am flexible when confronted with difficult and/or changing situations.							1	2	3	4	5	6	7
29. I frequently acknowledge my students' efforts to achieve their goals.							1	2	3	4	5	6	7
30. I always reward myself when I achieve my goals.							1	2	3	4	5	6	7
31. I regularly attend professional conferences and workshops in order to maintain educational best practices.							1	2	3	4	5	6	7
32. I always seek challenges to increase my professional competence.							1	2	3	4	5	6	7
33. I possess the ability to assess my students' emotional concerns.							1	2	3	4	5	6	7
34. I always forgive my students when they make academic mistakes.							1	2	3	4	5	6	7
35. When faced with stressful situations as an educator, I am able to adapt very well.							1	2	3	4	5	6	7
36. If you are reading this item, please select rating number "4".							1	2	3	4	5	6	7

37. I work to have trusting relationships with all of my students.							1	2	3	4	5	6	7
38. I firmly believe being an educator is what I am meant to do.							1	2	3	4	5	6	7
39. I am devoted to being an educator, while maintaining a balance within my life.							1	2	3	4	5	6	7
40. I believe I can always inspire my students.							1	2	3	4	5	6	7
Strongly Disagree 1	Moderately Disagree 2	Mildly Disagree 3	Neither Agree or Disagree 4	Mildly Agree 5	Moderately Agree 6	Strongly Agree 7							
Items							Rating						
41. I am confident in my ability to communicate with students when they are emotionally distressed.							1	2	3	4	5	6	7
42. I employ strength-based strategies with my students (i.e., building upon students' strengths).							1	2	3	4	5	6	7
43. I continuously work to sustain my personal well-being.							1	2	3	4	5	6	7
44. I always provide direct communication to my students about the goals and/or objectives of our work together.							1	2	3	4	5	6	7
45. I am very comfortable with the autonomy of being an educator.							1	2	3	4	5	6	7
46. I frequently attend professional development workshops to be a stronger educator.							1	2	3	4	5	6	7
47. I trust my ability to achieve my professional aspirations.							1	2	3	4	5	6	7
48. I always work to develop positive relationships with my students' caregivers.							1	2	3	4	5	6	7
49. I have confidence in my students' capacity to do well.							1	2	3	4	5	6	7
50. I am always able to reconfigure challenging experiences into learning opportunities.							1	2	3	4	5	6	7
51. I constantly encourage my students to continuously develop and grow.							1	2	3	4	5	6	7
52. I see working in education as a very valuable profession.							1	2	3	4	5	6	7
53. I always strive to promote my students' success.							1	2	3	4	5	6	7
54. I utilize effective strategies to address difficult classroom management circumstances.							1	2	3	4	5	6	7
55. I understand that my students have diverse perspectives about education (e.g., importance of education).							1	2	3	4	5	6	7
56. I always urge my students to reach their personal aspirations.							1	2	3	4	5	6	7

57. I am determined to work through challenging academic circumstances.							1	2	3	4	5	6	7
58. I frequently collaborate with colleagues to support students' learning.							1	2	3	4	5	6	7
59. I always set clear professional goals that I work towards.							1	2	3	4	5	6	7
60. I am very committed to know my colleagues personally.							1	2	3	4	5	6	7
61. I am very confident in my ability to work through the challenging educational bureaucracy.							1	2	3	4	5	6	7
62. I care significantly about my students as individuals.							1	2	3	4	5	6	7
Strongly Disagree	Moderately Disagree	Mildly Disagree	Neither Agree or Disagree	Mildly Agree	Moderately Agree	Strongly Agree							
1	2	3	4	5	6	7							
Items							Rating						
63. I always maintain an optimistic view of my students.							1	2	3	4	5	6	7
64. I possess the ability to accommodate to demanding conditions in the workplace.							1	2	3	4	5	6	7
65. I always celebrate my students' accomplishments.							1	2	3	4	5	6	7
66. I always use positive reinforcement to support my professional aspirations.							1	2	3	4	5	6	7
67. I continuously work to maintain an active involvement in various educational professional associations.							1	2	3	4	5	6	7
68. I am very confident in my ability to implement effective strategies that meet my students' diverse learning needs.							1	2	3	4	5	6	7
69. I am always able to respond appropriately to my students' emotional concerns.							1	2	3	4	5	6	7
70. I am very compassionate towards my students.							1	2	3	4	5	6	7
71. I have strong professional stress management skills.							1	2	3	4	5	6	7

Thank you for completing the EIS!

**APPENDIX D: MASLACH BURNOUT INVENTORY – EDUCATOR
SURVEY (EIS)**

MBI-Educators Survey

How often:	0	1	2	3	4	5	6
	Never	A few times a year or less	Once a month or less	A few times a month	Once a week	A few times a week	Every day

How Often

0-6

Statements

1. ___ I feel emotionally drained from my work.
2. ___ I feel used up at the end of the workday.
3. ___ I feel fatigued when I get up in the morning and have to face another day on the job.
4. ___ I can easily understand how my students feel about things.
5. ___ I feel I treat some students as if they were impersonal objects.
6. ___ Working with people all day is really a strain for me.
7. ___ I deal very effectively with the problems of my students.
8. ___ I feel burned out from my work.
9. ___ I feel I'm positively influencing other people's lives through my work.
10. ___ I've become more callous toward people since I took this job.
11. ___ I worry that this job is hardening me emotionally.
12. ___ I feel very energetic.
13. ___ I feel frustrated by my job.
14. ___ I feel I'm working too hard on my job.
15. ___ I don't really care what happens to some students.
16. ___ Working with people directly puts too much stress on me.
17. ___ I can easily create a relaxed atmosphere with my students.
18. ___ I feel exhilarated after working closely with my students.
19. ___ I have accomplished many worthwhile things in this job.
20. ___ I feel like I'm at the end of my rope.
21. ___ In my work, I deal with emotional problems very calmly.
22. ___ I feel students blame me for some of their problems.

APPENDIX E: COMPASSION FOR OTHERS SCALE (COS)

Compassion Scale

HOW I TYPICALLY ACT TOWARDS OTHERS

Please read each statement carefully before answering. To the right of each item, indicate how often you feel or behave in the stated manner, using the following scale:

Almost					Almost
Never					Always
1	2	3	4	5	

Statements	Rating				
1. When people cry in front of me, I often don't feel anything at all.	1	2	3	4	5
2. Sometimes when people talk about their problems, I feel like I don't care.	1	2	3	4	5
3. I don't feel emotionally connected to people in pain.	1	2	3	4	5
4. I pay careful attention when other people talk to me.	1	2	3	4	5
5. I feel detached from others when they tell me their tales of woe.	1	2	3	4	5
6. If I see someone going through a difficult time, I try to be caring toward that person.	1	2	3	4	5
7. I often tune out when people tell me about their troubles.	1	2	3	4	5
8. I like to be there for others in times of difficulty.	1	2	3	4	5
9. I notice when people are upset, even if they don't say anything.	1	2	3	4	5
10. When I see someone feeling down, I feel like I can't relate to them.	1	2	3	4	5
11. Everyone feels down sometimes, it is part of being human.	1	2	3	4	5
12. Sometimes I am cold to others when they are down and out.	1	2	3	4	5
13. I tend to listen patiently when people tell me their problems.	1	2	3	4	5
14. I don't concern myself with other people's problems.	1	2	3	4	5
15. It's important to recognize that all people have weaknesses and no one's perfect.	1	2	3	4	5
16. My heart goes out to people who are unhappy.	1	2	3	4	5
17. Despite my differences with others, I know that everyone feels pain just like me.	1	2	3	4	5
18. When others are feeling troubled, I usually let someone else attend to them.	1	2	3	4	5

19. I don't think much about the concerns of others.	1	2	3	4	5
20. Suffering is just a part of the common human experience.	1	2	3	4	5
21. When people tell me about their problems, I try to keep a balanced perspective on the situation.	1	2	3	4	5
22. I can't really connect with other people when they're suffering.	1	2	3	4	5
23. I try to avoid people who are experiencing a lot of pain.	1	2	3	4	5
24. When others feel sadness, I try to comfort them.	1	2	3	4	5

Pommier, E. A. (2011). The compassion scale. *Dissertation Abstracts International Section A: Humanities and Social Sciences*, 72, 1174.

**APPENDIX F: MARLOWE-CROWNE SOCIAL DESIRABILITY SCALE –
X1 (MCSDS-X1)**

Marlowe Crowne Social Desirability Scale – X1 (MCSDS – X1)

Directions: Listed below are 10 statements concerning personal attitudes and traits. Please read each item and decide whether the statement is “ True ” or “ False ” as it pertains to you personally.		
1. I’m always willing to admit it when I make a mistake.	True	False
2. I always try to practice what I preach.	True	False
3. I never resent being asked to return a favor.	True	False
4. I have never been irked when people expressed ideas very different from my own.	True	False
5. I have never deliberately said something that hurt someone’s feelings.	True	False
6. I like to gossip at times.	True	False
7. There have been occasions when I took advantage of someone.	True	False
8. I sometimes try to get even rather than forgive and forget.	True	False
9. At times I have really insisted on having things my own way	True	False
10. There have been occasions when I felt like smashing things.	True	False

Strahan, R., & Gerbasi, K. (1972). Short, homogenous version of the Marlowe-Crowne Social Desirability Scale. *Journal of Clinical Psychology*, 28, 191-193.

REFERENCES

- Abenavoli, R. M., Jennings, P. A., Greenberg, M. T., Harris, A. R., & Katz, D. A. (2013). The protective effects of mindfulness against burnout among educators. *Psychology of Education Review, 37*, 57-69.
- Acker, J. R. (2003). Class acts: Outstanding college teachers and the difference they make. *Criminal Justice Review, 28*(2), 215-231.
- Allison, E. (2012). The Resilient Leader. *Educational Leadership, 69*(4), 79-82.
- Aloe, A. M., Shisler, S. M., Norris, B. D., Nickerson, A. B., & Rinker, T. W. (2014). A multivariate meta-analysis of student misbehavior and teacher burnout. *Educational Research Review, 12*, 30-44.
- Amrein, A. L., & Berliner, D. C. (2003). The effects of high-stakes testing on student motivation and learning. *Educational Leadership, 60*(5), 32-38.
- Baker, J., Horton, S., Robertson-Wilson, J., & Wall, M. (2003). Nurturing sport expertise: Factors influencing the development of elite athlete. *Journal of Sports Science and Medicine, 2*, 1-9.
- Balkin, R. S., & Sheperis, C. J. (2011). Evaluating and reporting statistical power in counseling research. *Journal of Counseling & Development, 89*(3), 268-272.
- Bandura, A. (1997). *Self-efficacy: The exercise of control*. New York: Freeman.
- Barr, J. J. (2011). The relationship between teachers' empathy and perceptions of school culture. *Educational Studies, 37*(3), 365-369.
- Bass, B. M. (1997). Does the transactional–transformational leadership paradigm transcend organizational and national boundaries? *American Psychologist, 52*(2), 130 – 139.

- Bentler, P. M., & Chou, C. P. (1987). Practical issues in structural modeling. *Sociological Methods & Research, 16*, 78-117.
- Bibou-Nakou, I., Stogiannidou, A., & Kiosseoglou, G. (1999). The relation between teacher burnout and teachers' attributions and practices regarding school behavior problems. *School Psychology International, 20*(2), 209-217.
- Billingsley, B. S. (2004). Special education teacher retention and attrition: A critical analysis of the research literature. *The Journal of Special Education, 38*, 39-55.
- Bloom, Z. D. (2016). *The influence of online dating on emerging adults' levels of empathy, objectification of others, and quality of romantic relationships*. (Unpublished doctoral dissertation). University of Central Florida, Orlando, FL.
- Bollen, K. A. (1989). A new incremental fit index for general structural models. *Sociological Methods & Research, 17*, 303-316.
- Bradley, S., Kirby, E., & Madriaga, M. (2015). What students value as inspirational and transformative teaching. *Innovations in Education and Teaching International, 52*(3), 231-242.
- Brewer, M. B. (2000). Research design and issues of validity. *Handbook of research methods in social and personality psychology, 3-16*.
- Burke, R. W., & Nierenberg, I. (1998). In search of the inspirational in teachers and teaching. *Journal for a Just and Caring Education, 4*(3), 336-354.
- Byrne, B. M. (1991). The Maslach Inventory: Validating factorial structure and invariance across intermediate, secondary, and university educators. *Multivariate Behavioral Research, 26*, 583-605.

- Byrne, B. M. (1993). The Maslach Inventory: Testing for factorial validity and invariance across elementary, intermediate, and secondary teachers. *Journal of Occupational and Organizational Psychology, 66*, 197-212.
- Byrne, B. M. (1994). Burnout: Testing for the validity, replication, and invariance of causal structure across elementary, intermediate, and secondary teachers. *American Educational Research Journal, 31*, 645-673.
- Byrne, B. M. (2016). *Structural equation modeling with AMOS: Basic concepts, applications, and programming* (3rd ed.). New York: Routledge.
- Cano-García, F. J., Padilla-Muñoz, E. M., & Carrasco-Ortiz, M. Á. (2005). Personality and contextual variables in teacher burnout. *Personality and Individual Differences, 38*(4), 929-940.
- Chadwick, P., Hember, M., Symes, J., Peters, E., Kuipers, E., & Dagan, D. (2008). Responding mindfully to unpleasant thoughts and images: Reliability and validity of the Southampton Mindfulness Questionnaire (SMQ). *The British Journal of Clinical Psychology, 47*(4), 451-455.
- Cohen, J. (1988). *Statistical power analysis for the behavioral sciences* (2nd ed.). Mahwah, N.J: Erlbaum.
- Clark, L. A., & Watson, D. (1995). Constructing validity: Basic issues in objective scale development. *Psychological Assessment, 7*(3), 309-319.
- Crockett, S. A. (2012). A five-step guide to conducting SEM analysis in counseling research. *Counseling Outcome Research and Evaluation, 3*, 30-47.

- Crowne, d. P., & Marlowe, D. (1960). A new scale of social desirability independent of psychopathology. *Journal of Consulting Psychology, 24*, 349-354.
- Davis, M. H. (1980). A multidimensional approach to individual differences in empathy. *Catalogue of Selected Documents in Psychology, 10*, 85 – 102.
- Day, C. (2014). Resilient principals in challenging schools: The courage and costs of conviction. *Teachers and Teaching, 20*(5), 638 – 654.
- Day, C. (2004). The passion of successful leadership. *School Leadership & Management, 24*(4), 425-437.
- DeVellis, R. F. (2012). *Scale development: Theory and applications* (3rd ed.). Los Angeles, CA: Sage.
- Dillman, D. A., Smyth, J. D., & Christian, L. M. (2014). *Internet, phone, mail, and mixed-mode surveys: The tailored design method*. Hoboken, N.J: John Wiley & Sons.
- Eisenberg, N. (1991). Values, sympathy, and individual difference: Toward a pluralism of factors influencing altruism and empathy. *Psychological Inquiry, 2*(2), 128-131.
- Fernet, C., Guay, F., Senécal, C., & Austin, S. (2012). Predicting intraindividual changes in teacher burnout: The role of perceived school environment and motivational factors. *Teaching and Teacher Education, 28*(4), 514-525.
- Fischer, D. G., & Fick, C. (1993). Measuring social desirability: Short forms of the Marlowe Crowne Social Desirability Scale. *Educational and Psychological Measurement, 53*, 417-424.
- Fraenkel, J., Wallen, N., Hyun, H. (2011). *How to design and evaluate research in education* (8th ed.). New York: McGraw-Hill Companies, Inc.

- Freudenberger, H. J. (1974). Staff burn-out. *Journal of Social Issues*, 30, 159-165.
- Freudenberger, H. J. (1975). The staff burn-out syndrome in alternative institutions. *Psychotherapy: Theory, Research and Practice*, 12, 73-82.
- Freudenberger, H. J. (1986). The issues of staff burnout in therapeutic communities. *Journal of Psychoactive Drugs*, 18, 247-251.
- Freudenberger, H. J. (1989). Burnout: Past, present, and future concerns. *Loss, Grief, & care*, 3, 1-9.
- Freudenberger, H. J. (1990). Hazards of psychotherapeutic practice. *Psychotherapy in Private Practice*, 8, 31-34.
- Gall, M. D., Gall, J. P., & Borg, W. R. (2007). *Educational research: An introduction* (8th ed.). Boston: Pearson/Allyn & Bacon.
- Gilbert, P. (2005). *Compassion: Conceptualizations, research, and use in psychotherapy*. New York: Routledge.
- Goldring, R., Taie, S., & Riddles, M. (2014). *Teacher attrition and mobility: Results from the 2012-2013 teacher follow-up survey* (NCES 2014-077). U.S. Department of Education. Washington, DC: National Center for Education Statistics. Retrieved: June 28, 2016 from <http://nces.ed.gov/pubsearch>.
- Grayson, J. L., & Alvarez, H. K. (2008). School climate factors relating to teacher burnout: A mediator model. *Teaching and Teacher Education*, 24(5), 1349-1363.
- Graziano, A. M., & Raulin, M. L. (2006). *Research methods: A process of inquiry* (6th ed.). Boston, MA: Pearson.

- Greene, W. L., Caskey, M. M., Musser, P. M., Samek, L. L., Casbon, J., & Olson, M. (2008). Caught in the middle again: Accountability and the changing practice of middle school teachers. *Middle Grades Research Journal*, 3(4), 41-72.
- Hair, J. F., Black, W. B., Babin, B. J., & Anderson, R. E. (2010). *Multivariate data analysis* (7th ed.). Upper Saddle River, NJ: Prentice Hall.
- Hansen, A. (2006). *No child left behind: High-stakes testing and teacher burnout in urban elementary schools*. (Unpublished doctoral dissertation). University of Phoenix.
- Harris, D. N., & Adams, S. J. (2007). Understanding the level and causes of teacher turnover: A comparison with other professions. *Economics of Education Review*, 26(3), 325-337.
- Hart, T. (1998). Inspiration: Exploring the experience and its meaning. *Journal of Humanistic Psychology*, 38(3), 7-35.
- Hermida, R. (2015). The problem of allowing correlated errors in structural equation modeling: Concerns and considerations. *Computational Methods in Social Sciences*, 3, 5-17.
- Higgins-D'Alessandro, A., & Sadh, D. (1997). The dimensions and measurement of school culture: Understanding school culture as the basis for school reform. *International Journal of Educational Research*, 27, 553 – 569.
- Hoy, W. K., Tarter, C. J., & Hoy, A. W. (2006). Academic optimism of schools: A force for student achievement. *American Educational Research Journal*, 43(3), 425-446.
- Hu, L. T., & Bentler, P. M. (1999). Cutoff criteria for fit indexes in covariance structure analysis: Conventional criteria versus new alternatives. *Structural Equation Modeling*, 6, 1-55.
- Ingersoll, R. M. (2001). The teacher shortage: A case of wrong diagnosis and wrong prescription. *NASSP Bulletin*, 86(631), 16-31.

- Ingersoll, R. M., & Strong, M. (2011). The impact of induction and mentoring programs for beginning teachers a critical review of the research. *Review of Educational Research, 81*(2), 201-233.
- Jackson, D. L. (2003). Revisiting sample size and number of parameter estimates: Some support for the N:q hypothesis. *Structural Equation Modeling, 10*, 128-141.
- Joshi, A., Lazarova, M. B., & Liao, H. (2009). Getting everyone on board: The role of inspirational leadership in geographically dispersed teams. *Organization Science, 20*, 240-252.
- Kerfoot, K. (2001). On leadership: From motivation to inspiration leadership. *Dermatology Nursing, 14*(2), 126 – 127.
- Kesson, K. R., & Henderson, J. G. (2010). Reconceptualizing professional development for curriculum leadership: Inspired by John Dewey and informed by Alain Badiou. *Educational Philosophy and Theory, 42*(2), 213-229.
- Kim, K. H. (2005). The relation among fit indexes, power, and sample size in structural equation modeling. *Structural Equation Modeling, 12*(3), 368-390.
- Kline, R. B. (2016). *Principles and practice of structural equation modeling* (4th ed.). New York: The Guilford Press.
- Kokkinos, C. M. (2007). Job stressors, personality and burnout in primary school teachers. *British Journal of Educational Psychology, 77*, 229-243.
- Krejcie, R. V., & Morgan, D. W. (1970). Determining sample size for research activities. *Educational and Psychological Measurement, 30*(3), 607-610.
- Lambie, G. W. (2007). The contribution of ego development level to burnout in school

- counselors: Implications for professional school counseling. *Journal of Counseling & Development*, 85(1), 82-88.
- Lee, R. M., & Robbins, S. B. (1995). Measuring belongingness: The social connectedness and social assurance scales. *Journal of Counseling Psychology*, 42(2), 232-241.
- Lim, S., & Eo, S. (2014). The mediating roles of collective teacher efficacy in the relations of teachers' perceptions of school organizational climate to their burnout. *Teaching and Teacher Education*, 44, 138-147.
- Loo, R., & Thorpe, K. (2000). Confirmatory factor analyses of the full and short versions of the Marlowe-Crowne Social Desirability Scale. *Journal of Social Psychology*, 140, 628-635.
- Martins, D., Nicholas, N. A., Shaheen, M., Jones, L., & Norris, K. (2013). The development and evaluation of a compassion scale. *Journal of Health Care for the Poor and Underserved*, 24(3), 1235-1246.
- Maslach, C., & Jackson, S. E. (1981). The measurement of experienced burnout. *Journal of Organizational Behavior*, 2(2), 99-113.
- Maslach, C., Jackson, S. E., Leiter, M. P., Schaufeli, W. B., & Schwab, R. L. (1996). *Maslach burnout inventory manual* (3rd ed.). Palo Alto, CA: Consulting Psychologist Press.
- MacCallum, R. C., Browne, M. W., & Sugawara, H. M. (1996). Power analysis and determination of sample size for covariance structure modeling. *Psychological Methods*, 1(2), 130-149.
- McCormick, J., & Barnett, K. (2011). Teachers' attributions for stress and their relationships with burnout. *International Journal of Educational Management*, 25(3), 278-293.

- Mehrabian, A., & Epstein, N. A. (1972). A measure of emotional empathy. *Journal of Personality, 40*(4), 523-543.
- Mullen, P. R. (2014). *The contribution of practicing school counselors' self-efficacy and professional quality of life to their programmatic service delivery* (Unpublished doctoral dissertation). University of Central Florida, Orlando, FL.
- Murnane, R., & Willett, J. (2011). *Methods matter: Improving causal inference in educational and social science research*. New York: Oxford University Press.
- Musser, P. M., Caskey, M. M., Samek, L. L., Kim, Y. M., Greene, W. L., Carpenter, J. M., & Casbon, J. (2013). Imagine a place where teaching and learning are inspirational: A decade of collected wisdom from the field. *Middle School Journal, 44*(4), 6-13.
- Neal, D. (2013). The consequences of using one assessment system to pursue two objectives. *The Journal of Economic Education, 44*(4), 339-352.
- Neff, K. D. (2003). The development and validation of a scale to measure self-compassion. *Self and Identity, 2*(3), 223-250.
- Pommier, E. A. (2010). *Development of a scale to measure compassion* (Doctoral dissertation). Retrieved from: http://gateway.proquest.com/openurl?url_ver=Z39.88-2004&res_dat=xri:pqdiss&rft_val_fmt=info:ofi/fmt:kev:mtx:dissertation&rft_dat=xri:pqdiss:3445994&_ga=1.137832564.516030118.1475605875
- Reynolds, W. M. (1982). Development of reliable and valid short forms of the Marlowe-Crowne Social Desirability Scale. *Journal of Clinical Psychology, 38*, 119-125.
- Roeser, R. W., Schonert-Reichl, K. A., Jha, A., Cullen, M., Wallace, L., Wilensky, R.,... & Harrison, J. (2013). Mindfulness training and reductions in teacher stress and burnout:

- Results from two randomized, waitlist-control field trials. *Journal of Educational Psychology*, 105(3), 787-804.
- Ryan, R. M., & Deci, E. L. (2000). Intrinsic and extrinsic motivations: Classic definitions and new directions. *Contemporary Educational Psychology*, 25, 54-67.
- Sacks, P. (1999). *Standardized minds: The high price of America's testing culture and what we can do to change it*. Cambridge, MA: Perseus Books.
- Schaefer, L., Long, J. S., & Clandinin, D. J. (2012). Questioning the research on early career teacher attrition and retention. *Alberta Journal of Educational Research*, 58, 106-121.
- Schubert-Irastorza, C., & Fabry, D. L. (2014). Job satisfaction, burnout and work engagement in higher education: A survey of research and best practices. *Journal of Research in Innovative Teaching*, 7, 37-50.
- Schumacker, R. E., & Lomax, R. G. (2010). *A beginner's guide to structural equation modeling*. Mahwah, N.J: L. Erlbaum Associates.
- Skaalvik, E. M., & Skaalvik, S. (2010). Teacher self-efficacy and teacher burnout: A study of relations. *Teaching and Teacher Education*, 26(4), 1059-1069.
- Sosa, T., & Gomez, K. (2012). Connecting teacher efficacy beliefs in promoting resilience to support of Latino students. *Urban Education*, 47(5), 876 – 909.
- Sprecher, S., & Fehr, B. (2005). Compassionate love for close others and humanity. *Journal of Social and Personality Relationships*, 22(5), 629-651.
- Strahan, R., & Gerbasi, K. C. (1972). Short, homogeneous versions of the Marlowe-Crowne Social Desirability Scale. *Journal of Clinical Psychology*, 28, 191-193.

- Tabachnick, B. G., & Fidell, L. S. (2013). *Using multivariate statistics* (6th ed.). Upper Saddle River, N.J: Pearson.
- Tavakol, M., & Dennick, R. (2011). Making sense of Cronbach's alpha. *International Journal of Medical Education*, 2, 53-55.
- Thompson, B. L., & Waltz, J. (2008). Self-compassion and PTSD symptom severity. *Journal of Traumatic Stress*, 21(6), 556-558.
- Thrash, T. M., & Elliot, A. J. (2003). Inspiration as a psychological construct. *Journal of Personality and Social Psychology*, 84(4), 871-889.
- Thrash, T. M., & Elliot, A. J. (2004). Inspiration: Core characteristics, component processes, antecedents, and function. *Journal of Personality and Social Psychology*, 87(6), 957-973.
- Vallerand, R. J., Blanchard, C., Mageau, G. A., Koestner, R., Ratelle, C., Léonard, M.,... & Marsolais, J. (2003). Les passions de l'ame: On obsessive and harmonious passion. *Journal of Personality and Social Psychology*, 85(4), 756 – 767.
- Vallerand, R. J., Mageau, G. A., Elliot, A. J., Dumais, A., Demers, M. A., & Rousseau, F. (2008). Passion and performance attainment in sport. *Psychology of Sport and Exercise*, 9(3), 373-392.
- Vallerand, R. J., & Reid, G. (1984). On the causal effects of perceived competence on intrinsic motivation: A test of cognitive evaluation theory. *Journal of Sport Psychology*, 6, 94-102.
- Wang, H., Hall, N. C., & Rahimi, S. (2015). Self-efficacy and causal attributions in teachers: Effects on burnout, job satisfaction, illness, and quitting intentions. *Teaching and Teacher Education*, 47, 120-130.

Weston, R., & Gore, P. A. (2006). A brief guide to structural equation modeling. *The Counseling Psychologist, 34*(5), 719-751.

Zhao, Y. (2009). *Catching up or leading the way: American education in the age of globalization*. ASCD.