



Are Current U.S. Nuclear Power Plants Grid Resilience Assets?

Sherrell R. Greene

To cite this article: Sherrell R. Greene (2018) Are Current U.S. Nuclear Power Plants Grid Resilience Assets?, Nuclear Technology, 202:1, 1-14, DOI: [10.1080/00295450.2018.1432966](https://doi.org/10.1080/00295450.2018.1432966)

To link to this article: <https://doi.org/10.1080/00295450.2018.1432966>



© Sherrell R. Greene. Published with license by Taylor & Francis.



Published online: 15 Mar 2018.



Submit your article to this journal [↗](#)



Article views: 2123



View related articles [↗](#)



View Crossmark data [↗](#)



Citing articles: 3 View citing articles [↗](#)



Are Current U.S. Nuclear Power Plants Grid Resilience Assets?

Sherrell R. Greene *

Advanced Technology Insights, 12113 Valley Trail, Knoxville, Tennessee 37934

Received November 20, 2017

Accepted for Publication January 23, 2018

Abstract — *This paper examines the concept of Grid resilience in the context of the North American electricity supply system and the role existing (Generation II) light water-cooled nuclear power plants (NPPs) play in enabling and enhancing Grid resilience. (Because of similarities in technology and plant design, it is likely that most of the discussion in the paper is also relevant to Generation III and Generation III+ light water NPP designs. The applicability of the analysis to Canadian CANDU and Russian VVER technology has not been assessed.) The paper asks and answers three compound questions: (1) what is Grid resilience, and what is a resilient Grid? (2) what is a resilient nuclear power plant (rNPP), and what are the basic functional requirements of rNPPs? and in light of the answers to these questions, (3) are today's U.S. NPPs significant Grid resilience assets? The conclusion reached is that existing U.S. commercial NPPs are safe and efficient capacity, energy, and reliability assets and they have demonstrated some Grid resilience benefit during regional weather events. However, today's NPPs do not deliver the Grid resilience benefits nuclear power can and should provide the nation. The author argues that nuclear power's unique fuel security (an attribute that could allow NPPs to energize the Grid during extended periods in which fuel could not be delivered to other types of power plants) is a compelling reason to develop future rNPPs that would deliver strategic Grid resilience benefits in the face of evolving hazards and threats to the U.S. Grid.*

Keywords — *Critical infrastructure resilience, Grid resilience, resilient nuclear power plant.*

Note — *Some figures may be in color only in the electronic version.*

I. INTRODUCTION

The concept of societal resilience in a world of growing human populations, limited natural resources, seemingly intensifying natural hazards, and expanding man-made threats has become a matter of global importance.¹ Within this context, society's ever-increasing dependence on several key critical infrastructures is a matter of concern for both governmental and private sectors.² Critical infrastructures are societal assets, systems, and networks so vital that their incapacitation or destruction would have a debilitating effect

on national security, economic prosperity, public health and safety, etc. The U.S. electric power system or the "Grid" can arguably be viewed as the most critical of America's critical infrastructures because it is the foundation upon which virtually every other critical infrastructure depends. The Grid consists of the integrated bulk electric system (comprising electricity generation and transmission networks) and the distribution system that delivers electricity over the "last mile" to the end user.³ Indeed, in many ways the Grid is the "umbilical cord" of modern society. Resilient modern societies require resilient Grids. Given society's dependence on electricity, the subject of Grid resilience is a matter of great relevance to U.S. economic, energy, homeland, and national security.⁴

The U.S. Grid consists of some 7700 operating electric power generation facilities with capacities of 1 MW (electric) or larger, over 700 000 miles of high-voltage transmission lines (240 000 miles of which operate at or above 230 kV),

*E-mail: srg@ATInsightsLLC.com

This is an Open Access article distributed under the terms of the Creative Commons Attribution-NonCommercial-NoDerivatives License (<http://creativecommons.org/licenses/by-nc-nd/4.0/>), which permits non-commercial re-use, distribution, and reproduction in any medium, provided the original work is properly cited, and is not altered, transformed, or built upon in any way.

approximately 56 000 substations, and 6.5 million miles of local distribution lines.⁵ Of these 7700 operating power plants, 99 are commercial nuclear power reactors located in 61 nuclear power plants⁶ (NPPs). These reactors produced approximately 20% of the total electrical energy generated in the United States in 2016 (Ref. 7). When considered in terms of their contribution to Grid reliability and greenhouse gas emissions avoidance, it is clear these NPPs play a much larger role in the nation's electricity supply strategy than their numbers would otherwise suggest.

This paper explores the concept of Grid resilience in the context of the U.S. and North American electricity supply system; the role current Generation II, light water-cooled reactor (LWR) NPPs play in enhancing Grid resilience; and the role a new type of NPP—a resilient NPP (rNPP)—could play in enabling and enhancing Grid resilience. The analysis is applicable to both pressurized water reactor (PWR) and boiling water reactor (BWR) concepts. The general principles of Grid resilience discussed here are believed to be broadly relevant around the globe. However, the applicability of this analysis to any specific region other than the United States has not been assessed. Additionally, because of similarities in technology and plant design, much of the discussion here is believed to be relevant to existing Generation III and Generation III+ light water-cooled NPP designs. The applicability of this analysis to Canadian CANDU and Russian light water reactors (VVER) technology has not been assessed.

Section II presents a working definition of Grid resilience that is useful for exploring the characteristics of NPPs that impact Grid resilience. Based on the definition of Grid resilience provided in Sec. II, Sec. III provides a definition of a generic resilient power plant (rPP) and a rNPP, the two key attributes of rNPPs, and the functional requirements of rPPs and rNPPs in particular. Section IV discusses the response of today's NPPs to Grid disruptions in terms of their ability to absorb and adapt to Grid anomalies. Given the likelihood that today's NPPs will shut down in response to major Grid anomalies, Sec. V identifies and explores the principal Grid resilience implications of NPP shutdown in such situations. Section VI discusses the role of today's NPPs in Grid recovery operations. Based on the evidence presented in Secs. II through VI, Sec. VII presents the conclusion that NPPs in the United States do not deliver the Grid resilience benefits today that nuclear power can and should provide the nation. However, the story does not end there. Section VIII discusses the fact that all NPPs possess one unique characteristic that should provide great motivation for enhancing the resilience of future NPPs. Finally, and in light of the analysis presented in the foregoing sections,

Sec. IX presents a challenge for the designers and operators of future NPPs and the Grid they will serve.

II. GRID RESILIENCE: A DEFINITION

Given modern society's growing dependence of critical infrastructure and the Grid in particular, it is perhaps surprising that a consensus definition of Grid resilience has not yet evolved. What is resilience? And precisely, what is Grid resilience?

II.A. Basic Concepts of System Resilience

Resilience as an engineering term is one whose definition is surprisingly difficult to articulate in a precise manner. Resilience is typically defined and measured at the system level. One recent working definition of resilience is “the ability of a system to withstand a change or a disruptive event by reducing the initial negative impacts (absorptive capability), by adapting itself to them (adaptive capability), and by recovering from them (restorative capability).”⁸

Many of the basic elements of system resilience are captured in a system resilience curve (SRC). Figure 1 is an illustrative generic SRC (adapted from Ref. 8) that depicts a system's time-dependent performance in response to a disruptive event. The units of time and performance plotted in Fig. 1 are arbitrary and obviously depend both on the system and the event under examination. The time period upon which the resilience curve is based begins at the far left of the curve, with the system operating within some nominal steady-state performance (functionality) range. The specific disruptive event of interest is assumed to begin at point 1 in Fig. 1. The system's initial response is to absorb the disturbance within its nominal band of operation. System performance, as viewed from the outside of the system, is still nominal. As a consequence, it is quite possible no one (including the system's operators) would even be aware of the disturbance. However, in this case the disturbance is assumed to continue to point 2 (time duration Δt_0) and to be of such severity that the system can no longer absorb the stressor without perceptible impact on the system's performance. The normal operations phase of the event ends at point 2.

Unable to cope with the stressor event while maintaining nominal system performance, the system's event response cascade is triggered at point 2 and proceeds to point 3 (time duration Δt_1), at which time the damage is complete. This shock and response cascade is the second phase of the event sequence. The shock and response cascade may consist of a diverse set of preplanned and unplanned actions inherent to the system architecture and

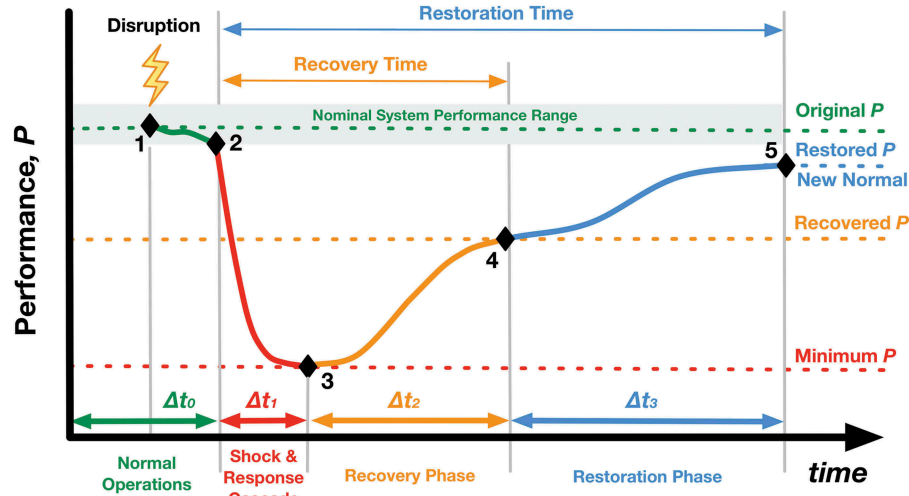

Fig. 1. Generic SRC (adapted from Ref. 8).

composition, automatic control system actions, and human operator interventions, all of which impact the terminal point of the system’s response cascade, the magnitude of performance loss, the shape of the system response curve between points 2 and 3, and the duration Δt_1 of the response cascade.

The third or recovery phase of the event commences at the time the system performance has reached its minimum level (point 3 and minimum P) and ends at a point in time in which some minimally acceptable and stable level of system performance has been recovered through adaptive actions by the system and its human operators (point 4 and recovered P). The recovered P at point 4 in Fig. 1 reflects restoration of some intermediate level of system performance in which the system’s high-priority functionalities are recovered and from which the system can be further reconstituted, reconfigured, and restored.

The restoration phase of the event commences at point 4 and ends at point 5 with the system performance at restored P . As previously mentioned, the timescale depicted in Fig. 1 (especially for the restoration phase) may not be linear as depicted. The duration of this restoration phase is Δt_3 , which may often be much longer than the duration of the recovery phase Δt_2 . Depending on the damage inflicted on the system, the restored P might be higher, the same, or lower than the original system performance, original P . For cases in which system functionality is not restored to its original predisturbance value, system operators and those who are served by the system must become accustomed to a “New Normal” (typically reduced) level of system functionality.⁹ The achievement of any stable New Normal can be a demanding long-term societal undertaking.

II.B. Limitations of SRCs

System resilience curves are useful for visualizing and discussing the basic dynamics of system resilience, but they have many limitations. First, SRCs do not actually plot resilience; they plot system performance (however defined) versus time. The physical significance of the integral of performance over time (or conversely the performance decrement represented by the area between the nominal system performance curve and the disturbed system performance curve) is open to debate and in any event depends on the units (metrics) employed for performance. SRCs do not define or depict how performance is measured or the individual metrics that constitute performance.

Major challenges faced by those seeking to employ SRCs for real-world engineered systems include the development of a meaningful definition of the performance plotted in the SRC, the development of approaches to predict performance in response to a specified disturbance, and the development of methods for testing and measuring this performance for disturbances of interest (particularly for systems that cannot easily be taken off-line for testing). In order to be useful, the performance plotted in the SRC must be a function of parameters and metrics that can be measured, estimated from prior experience, or simulated via computational modeling. For instance, consider the hypothetical case of a U.S. commercial airline operating out of three major hubs with connecting flights through a dozen connecting airports and providing customer service to 40 destination locations. In this case, the disruptive event might be the closure of one of the connecting airports due to extreme weather. The performance plotted on the ordinate axis in this case might be the average delay in destination arrival

time for all of the airline’s customers as a function of time from the onset of the weather event.

Finally, an SRC is a product of many unique time-dependent factors such as (1) the nature of the disruptive event (its type, magnitude, persistence, etc.), (2) the system’s evolving (time-dependent) composition as individual system elements respond to the event, (3) the system’s evolving configuration as individual system elements respond to the event, and (4) the system’s automatic and manual control protocols and how they are implemented through time in response to the disruptive event. Because items 2, 3, and 4 all depend on both intrinsic (to the system) actions and those of the system’s human maintainers and operators, the SRC actually masks most of the engineering details required to understand the “why” of what is transpiring as the system responds to the disruption.

II.C. Grid Resilience

Application of the resilience concept to both the Grid and to the NPPs it hosts is a nontrivial exercise. Arghandeh et al.¹⁰ recently offered one possible working definition for “power system cyber-physical resilience”: “the system’s ability to maintain continuous electricity flow to customers given a certain load prioritization scheme.” The authors do not propose specific metrics by which Grid resilience can be measured or by which different systems can be compared. Their definition captures many system resilience considerations but appears to focus primarily on *preventing* interruptions in electricity flow.

The National Academy of Sciences, Engineering and Medicine recently released the report, “Enhancing the Resilience of the Nation’s Electricity System,”⁴ which offers the following observation regarding Grid resilience: “Resilience is not the same as reliability. While minimizing the likelihood of large-area, long-duration outages is important, a resilient system is one that acknowledges that outages can occur, prepares to deal with them, minimizes their impact when they occur, is able to restore service quickly, and draws lessons from the experience to improve performance in the future.”⁴ In light of the National Academy’s observation (i.e., the concept of capturing prevention, recovery, and restoration in the definition of Grid resilience), the author has proposed the following working definition of Grid resilience: “**Electric Grid resilience is the system’s ability to minimize interruptions of electricity flow to customers given a specific load prioritization hierarchy.**”¹¹

The National Academy’s report briefly reviews a variety of potential Grid resilience metrics, which are primarily those proposed by the U.S. Department of Energy’s (DOE’s) Grid

Modernization Laboratory Consortium. These include metrics such as cumulative customer hours of outages, cumulative critical customer hours of outages, time to recovery, loss of utility revenue, and several other direct and indirect consequences. However, the report does not recommend specific metrics by which Grid resilience should be measured. Rather, it states the following: “Unlike reliability, there are no generally agreed upon resilience metrics that are used widely today.”⁴ The report goes on to recommend (Recommendation 2.2) that the DOE, the North American Electric Reliability Corporation, and others collaborate in the development and operationalization of appropriate resilience metrics.

Because Grids are composed of linked generation, transmission, and distribution elements, Grid resilience truly is a weakest-link issue. Ideally, every element of the Grid must possess essential resilience attributes: the ability to withstand, absorb, adapt to, and quickly recover from offending disturbances and disruptions. Alternatively, less resilient elements of the Grid must be buffered or isolated in some manner from offending disturbances by other more resilient elements of the system. Thus, an optimally designed and operated Grid should function in a manner in which every system element is resilient and each element also reduces the stress placed on the other elements of the system by offending Grid disturbances.

The customer-focused definition of Grid resilience offered here is arguably the most relevant approach for defining Grid resilience from the societal perspective. However, the use of such a definition is greatly complicated by the reality that neither the ownership and operation nor the regulation of the Grid’s generation, transmission, and distribution assets is vertically integrated in today’s deregulated electricity markets. Because of the mosaic of regional transmission organizations and independent system operators, and because many entities own and operate only generation or transmission or distribution assets (or two of the three), an enormous challenge confronts those seeking to enhance the resilience of the U.S. electricity supply system. (This is a matter of great importance but one that is beyond the scope of this paper.)

Figure 2 presents a simplified Grid resilience curve that follows directly from the concepts captured in the generic SRC in Fig. 1 and the definition of Grid resilience offered above. The simplified Grid disruption behavior depicted in Fig. 2 assumes the Grid operator has designated three load prioritization classes (high priority, middle priority, and low priority)—hence “3-step”—and that the system ultimately regains its predisturbance functionality. The Grid’s generation, transmission, and distribution subsystems (and the interfaces between them) all play a role in shaping the Grid’s SRC.

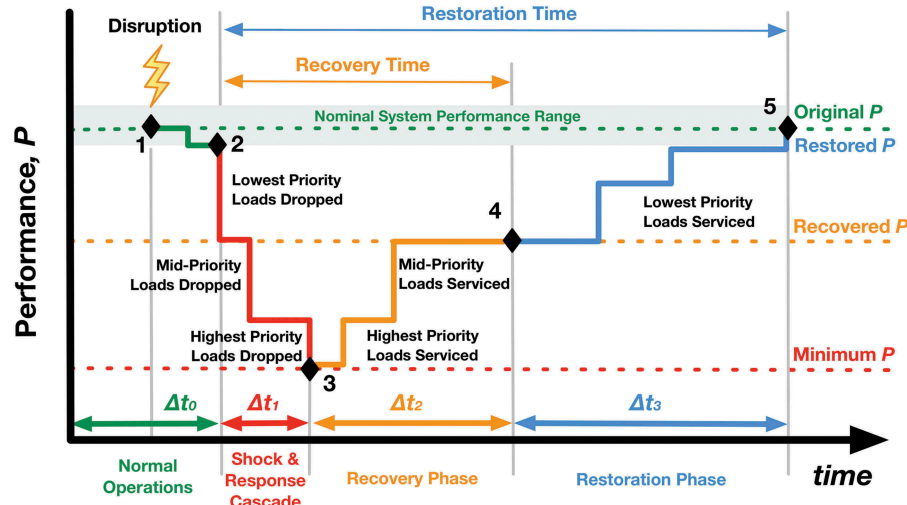

Fig. 2. Notional 3-step Grid resilience curve (SRC).

The basic disruption response depicted in Fig. 2 is one in which low-priority loads would be actively interrupted or passively surrendered first, as the system’s performance/functionality decays or descends between points 2 and 3. Loads of increasing priority are interrupted as the performance descends to minimum P at point 3. Truly essential “must run” critical loads would all lie in the region beneath point 3 in Fig. 2 and (at least theoretically) would never be interrupted. As is the case in Fig. 1, Fig. 2 illustrates the reality that the time to recovery and to restore complete system functionality can be much longer than the duration of the original Grid disturbance. The serial impact of Hurricanes Irma and Maria on the island of Puerto Rico’s Grid during September 2017 (and their continuing aftermath) are grim reminders that the recovery and restoration phases of a system may last much longer than the duration of the disturbance that originally stressed the system. The aftermath of these storms also graphically illustrates that the New Normal system performance may be greatly degraded in comparison with the system’s predisturbance performance.

Figure 2 also reflects the difficulty in applying SRCs to real systems. What exactly is the performance being plotted in Fig. 2? A fundamental difficulty in the application of resilience curves arises when system performance is not obviously a single number or a simple mathematical combination of multiple computed or observed metrics. This indeed is the case with respect to Grid resilience. The plotted performance should embody the metrics by which Grid resilience is measured. But, as previously discussed, there is no single measure of Grid resilience. The performance plotted in Fig. 2 might be a function of a weighted combination of expected frequency and duration of load loss or failure to serve for each class of loads in the operator’s

load prioritization scheme. Or, the performance plotted in Fig. 2 might be related to the percentage of total load being served at any moment in time. However, given that it is more acceptable to drop low-priority loads than high-priority loads (in keeping with the utility’s load prioritization hierarchy), the abscissa scale would not be linear in this case. The difficulty in defining a single performance metric for Grid resilience is evident and will be the subject of continuing debate and research in the future.

Finally, Fig. 2 is not simply the artifact of a managed load shedding protocol. It also reflects a system damage function. The magnitude of performance degradation or gain (and the shape of each segment of the SRC between points 2 and 5) would also be a complex function of a host of voluntary and involuntary actions involving the response and behavior of individual elements of interconnected generation, transmission, and distribution subsystems.

II.D. Utility of SRCs as Grid Resilience Assessment Tools

If the challenges discussed above could be overcome to construct credible Grid SRCs, the tool could be applied to provide many useful insights to Grid operators, planners, and regulators. In the case of existing systems, SRCs might be employed by operators to optimize emergency operating procedures and Grid recovery and restoration procedures as well as to maximize the marginal resilience benefit of incremental investments in the Grid. Grid designers and planners might utilize SRCs to conduct comparative analyses of different potential Grid architectures and technologies, including the siting of key Grid assets such as new generating plants, substations, etc. Regulating authorities might employ

SRCs to inform decisions regarding rate structures and to create incentives that enable infrastructure owners and operating entities to monetize system resilience, thereby creating a mechanism for financing system resilience investments. Unfortunately, for all their potential utility, SRCs are currently more valuable as qualitative tools for discussing high-level Grid resilience issues than as quantitative Grid analysis and planning tools. Only time will tell whether SRCs will become useful tools for Grid resilience analysis and planning.

III. DEFINITION, KEY ATTRIBUTES, AND FUNCTIONAL REQUIREMENTS FOR rPPs AND rNPPs

What does the definition of Grid resilience discussed in [Sec. II](#) imply with respect to the electrical generating plants (particularly the NPPs) embedded in the Grid? Indeed, what is a rNPP? Given the definitions of critical infrastructure and Grid resilience discussed in [Sec. II](#), the author has proposed the following definition of a rNPP ([Ref. 11](#)): “A resilient rNPP is one whose performance attributes and functionalities enable and enhance Grid resilience—the system’s ability to minimize interruptions of electricity flow to customers given a specific load prioritization hierarchy.”

Based on this definition of a rNPP, the author has also defined¹¹ two essential attributes of rNPPs:

1. *rNPP attribute 1*: rNPPs enable the Grid to absorb and adapt to a broad spectrum of Grid anomalies and upsets.
2. *rNPP attribute 2*: rNPPs enhance the Grid’s ability to quickly recover from upsets and to restore electric service in a manner consistent with the system operator’s load prioritization hierarchy.

It should be noted that both the definition of a rNPP and the two defining attributes of rNPPs are equally applicable to all types of rPPs. Thus, one could also speak of a rPP as one that also exhibits the two rNPP attributes defined above. In any event, rNPPs are NPPs defined not by the technologies they employ, nor their size, etc., but by the resilience value and impact they deliver to the Grid they serve. The design, siting, method of interface to the Grid, and operational characteristics of the rPP or rNPP would all impact the plant’s value as a Grid resilience asset.

Given the foregoing discussion, what are the generic operational characteristics (functionalities) of power plants that would enable them to be major Grid resilience assets? [Table I](#) summarizes a key list of functional capabilities the author believes would characterize an

TABLE I
Idealized Generic Resilient Power Plant (rPP) Capabilities

Capability	Relevant Resilience Characteristic(s)
1. Capable of supplying power to the Grid anytime the plant is called on to do so	Absorptive Adaptive Restorative
2. Capable of rapidly maneuvering over any power range between the plant’s housekeeping load and its rated capacity	Absorptive Adaptive Restorative
3. Capable of operating indefinitely at any dispatched power level	Absorptive Adaptive
4. Capable of riding through (tolerating) any Grid anomaly (aberration in load and off-site power magnitude or quality) without incurring damage, without isolating from the Grid, and without shutting down	Absorptive Adaptive Restorative
5. Capable of operating in an island mode (completely isolated from Grid) indefinitely if/when forced to detach from the Grid	Adaptive Restorative
6. Capable of independently maintaining a safe shutdown state indefinitely without drawing power or other resources from the Grid or off-site if/when the plant is required to shut down	Adaptive Restorative
7. Capable of independently cranking (starting up) without drawing power or other resources from the Grid or off-site if/when the plant is required to shut down	Restorative

ideal, generic rPP, along with the specific resilience attribute(s) they support. Of course, no existing technology and power plant design can deliver all of these idealized functionalities. Nevertheless, it is useful to consider the real-world implications of this list of idealized generic power plant capabilities with respect to rNPPs. Table II lists the Six Functional Requirements the author considers to be essential to enable a NPP to satisfy the definition of a rNPP and that, as a package, distinguish rNPPs from today’s NPPs.

Each of the Six rNPP Functional Requirements in Table II addresses more than one resilience attribute category. (Because of space constraints, a detailed discussion of Tables I and II will be deferred to a forthcoming paper.) rNPP Functional Requirement 1 implies a rNPP is capable of functioning in modes beyond traditional baseload operations when called upon by system dispatchers to do so. Functional Requirements 2 and 3 assure the rNPP is not rendered inoperable by events that trigger the Grid’s need for the resilience contribution of the rNPP. Functional Requirement 4 reduces the time required for a rNPP to reload and support the Grid in extreme conditions that have necessitated the plant’s disconnection from the Grid. Functional Requirement 5 assures the rNPP is not a distraction or burden to Grid operators when it is not available, especially during emergencies involving reconstitution and recovery of Grid operations in the wake of a major blackout or other Grid disturbances. Finally, Functional Requirement 6 enables the rNPP to restart independent of off-site power supplies and without placing demands on an already stressed Grid during Grid recovery and restoration operations.

TABLE II
Six Functional Requirements of rNPPs

Functional Requirement
1. Robust load-following
2. Immunity to damage from external events (including Grid anomalies)
3. Ability to avoid plant shutdown (reactor scram) in response to Grid anomalies
4. Ability to operate indefinitely in island mode (i.e., without connection to off-site transmission load and electric power supply)
5. Unlimited independent safe shutdown cooling capability (i.e., requiring no off-site power or resupply of diesel fuel from off-site)
6. Independent self-cranking blackstart capability (i.e., the ability to start with no off-site power supply from the Grid)

IV. TODAY’S NPPs HAVE LIMITED ABILITY TO ABSORB AND ADAPT TO GRID ANOMALIES

Given the discussion in Secs. II and III, it is natural to ask the following question: What is the contribution of today’s nuclear power plants to Grid resilience? The answer to this question depends, in turn, on the answer to the following set of lower-level questions. How do modern commercial NPPs respond to changing conditions around them? How do they respond to disturbances and disruptions in the Grid? Do they enable and enhance the Grid’s ability to absorb, adapt to, and rapidly recover from Grid anomalies? Do they enhance the Grid’s ability to minimize interruptions in electric flow to customers in the face of major Grid disturbances? The answers to these questions reveal much about the true value of today’s NPPs in terms of their contribution to Grid resilience.

There is no question that electrical generation facilities (nuclear and nonnuclear) are impacted by events that occur in the Grid. A cursory search of the U.S. Nuclear Regulatory Commission’s (NRC’s) online Licensee Event Report (LER) database¹² for the period 2000 to 2017 returned 26 reports in which a Grid disturbance was a contributing cause to a reported event at a U.S. commercial NPP. A similar search with the keywords “transmission line” yielded 31 reports in which issues associated with the NPP transmission lines resulted in reported events. [It is relevant to note that a single wide-area or regional event (e.g., a weather event) can lead to multiple reported events in the NRC’s LER database. This occurs when a single external (to the NPP) event impacts multiple reactors at a single site or multiple NPP sites.¹³]

Many aspects of a particular NPP’s response to a Grid anomaly would depend on plant-specific issues, including the manner in which the NPP is interfaced to the Grid (Fig. 3) and the Grid architecture beyond the interfaces.¹⁴ Figure 3 is a highly simplified, generic depiction of the interfaces between a typical NPP and its surroundings. The Grid anomaly can appear at one, some, or all three of the NPP-Grid interfaces depicted on the right side of the drawing (i.e., the main power transformer, the startup transformer that energizes the plant’s startup systems, and the engineered safety feature transformer). The NPP’s response to the Grid anomaly (especially in the short term) will be heavily influenced by which NPP-Grid interfaces are involved and the specific nature of the Grid anomaly.

IV.A. The Response of Today’s NPPs to Anticipated Grid Anomalies

For cases in which an NPP operator receives advance notice of an impending Grid disruption, today’s NPP

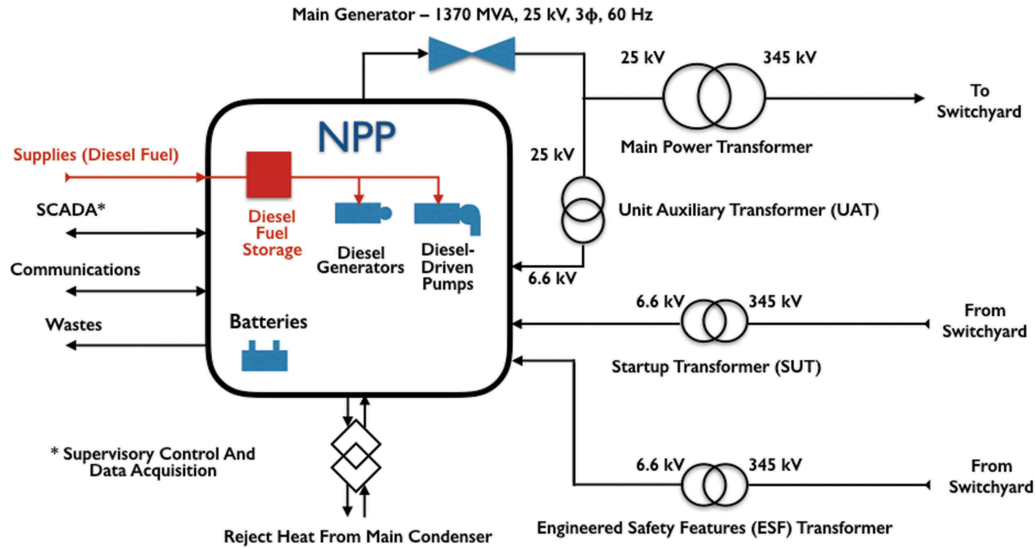

Fig. 3. Simplified NPP-Grid interfaces.¹⁴

operators would take prudent preemptive action to protect the power plant. Such advance notice might originate through federally issued alerts from the space weather network, the plant's supervisor control and data acquisition (SCADA) system, or other means. *Theoretically*, plant operators might respond to such alerts in four ways¹⁴:

1. *Watchful waiting*: The NPP continues to operate as normal but enters a state of heightened situational awareness. Precautionary and prudent steps are taken to assure the plant is prepared to rapidly execute one of the other three actions described below if the plant is presented with boundary conditions it cannot otherwise accommodate.

2. *Manual runback or cutback*: The NPP reduces its power level but remains attached to the Grid via transmission lines and off-site power connections to the plant's switchyard. Every effort is taken to maximize and maintain situational awareness as the plant continues to operate at a reduced power level.

3. *Initiation of island mode operations*: The plant operators both cut back reactor power and isolate the plant from the Grid. [This mode of operation is not allowed in the current NRC regulatory regime but is employed (indeed required) of at least some NPPs in Europe. As discussed below, many—perhaps most—U.S. NPPs are not designed to enable true island mode operations.] Power levels in island mode would likely be as close as possible to the plant's housekeeping load level while maintaining stable operation of the plant. This low power level is difficult to maintain for long periods in large power reactors due to operational

stability issues and the stresses such operation imposes on hardware (the main condenser system, feedwater systems, etc.).

4. *Manual shutdown*: The NPP operators manually shut down the plant (trip the reactors) and transition them to normal shutdown decay heat removal, possibly combined with managed (preemptive) transition at some point to on-site diesel-driven power systems if there is reason to believe the anticipated Grid disruption could result in a loss of off-site power (LOOP). This action might be taken to avoid the possibility of unnecessarily harsh transitions in the event the anticipated Grid anomaly dictates rapid plant response.

The choice of which of these four actions to execute depends on several factors, such as the nature of the anticipated Grid disruption and the warning time given to the NPP operators, the potential for direct damage to the NPP plant and equipment from the external initiating event, or the period of time off-site power might be unavailable (in the event of a Grid deenergization) to the NPP, etc. The selection of any of the actions other than the watchful waiting option results in a loss of some, or all, of the NPP's generation capacity from the Grid for a period of time that depends both on the NPP's individual response to the Grid disturbance and the response of the remainder of the Grid to the disturbance.

IV.B. Response of Today's NPPs to Unanticipated Grid Anomalies

In contrast to anticipated Grid disturbances, unanticipated Grid disturbances would initially be "sensed" by

a NPP as an anomaly in one or more of its NPP-Grid interfaces (voltage and frequency perturbations, phase angle/power factor anomalies, load perturbations, etc.) at the NPP-Grid interfaces depicted in Fig. 3. The plant's initial response to the event would depend on the manner in which it was first sensed: Which NPP-Grid interface detects the anomaly and the specific anomalous parameter that is detected (load or supply voltage, frequency, and phase angle perturbations; power factor and real/reactive power perturbations; etc.).^{14–16} Note that in the case of a complete Grid deenergization, all three transient responses discussed below would progress to the so-called LOOP event:

1. *Partial load rejection:* A load rejection is a sudden reduction in electric power demand at the NPP generator's terminals (see Fig. 3). Such events can be caused by faults in transmission lines or the opening of interconnections between parts of the Grid experiencing a load rejection. While some Generation II LWR plants designed by Combustion Engineering were designed to accommodate 85% or greater load rejection without tripping the reactor, U.S. NPPs typically can manage load rejections of up to ~50% by reducing power (run-back) and dumping excess steam as necessary to the unit's main condenser [assuming alternating-current (ac) power is still available at that point to drive the pumps that supply water to the secondary side of the condenser].

2. *Complete loss of load:* In this case, the NPP might experience a momentary or short-term partial load rejection that quickly evolves to a complete (100%) load rejection, i.e., a loss of load event that is ultimately sensed by the NPP at its generator terminals (see Fig. 3). This loss of load event could descend on the NPP with little advance warning. The NPP's normal response to the loss of load would be to open breakers at the generator output, isolating the NPP's main generator from the Grid. In such cases, it might be possible for the NPP to rapidly run back its power level to that required to supply its own housekeeping electrical loads, provided (once again) that ac power is available to drive the pumps that supply water to the secondary side of the condenser. (It is the author's understanding that only a few U.S. NPPs were designed with main generator output breaker configurations that enable the unit to separate from the Grid while maintaining electrical feed to the unit's auxiliary transformers (see Fig. 3). Thus, most NPPs in the United States today are probably incapable of transitioning to island mode operations.) In any event, if the (rapid) power reduction and delicate balancing operation cannot be managed, the reactor will be tripped.

3. *Voltage and frequency perturbation-induced reactor trips:* North American Grid ac frequency is typically controlled to within ± 0.05 Hz (Ref. 17). The initial stage of a widespread Grid anomaly or blackout would involve large variations in system voltage and frequency as load shedding and real or reactive power supply-demand mismatches cascade throughout the Grid. NPPs have voltage limits that are more restrictive than the standard Grid voltage control limits employed by many regional transmission operators.¹⁸ A NPP senses Grid ac voltage and frequency via several mechanisms. Changes in Grid ac voltage and frequency produce electromagnetic-induced stresses within the NPP's turbine-generator system (Fig. 3) as it seeks to remain in synchronization with the Grid. These Grid voltage and frequency perturbations also directly impact the speed of ac motor-driven pumps used to circulate cooling water through the reactor, steam generators (if a PWR), feedwater to the reactor's condenser, etc. The thermodynamic balance of the plant can be significantly impacted by Grid ac voltage and frequency perturbations. The core protection calculator (CPC) systems in U.S. NPPs (especially Westinghouse and Combustion Engineering designs) are very sensitive to and intolerant of reactor coolant pump (RCP) speed variations resulting from Grid frequency perturbations—more sensitive than typical European Generation II LWR designs. In addition, most ac motor-driven pumping systems are protected by breakers designed to open under unacceptable voltage and frequency perturbations that could cause motor overheating due to excessive current demands. (Though, as just described, the CPC system would almost certainly act to trip the reactor before the RCP protection systems would initiate a reactor trip.) The control band for these protection systems is relatively narrow. Given all of these design features, excessive Grid voltage and frequency perturbations would trigger the NPP's protection systems to rapidly trip the reactor and transition it to on-site or off-site ac-powered shutdown cooling.

V. FOUR IMPLICATIONS OF NPP SHUTDOWN WITH RESPECT TO GRID RESILIENCE

The implication of the three NPP transient response scenarios discussed in Sec. IV is that the ultimate response of today's NPPs to major Grid anomalies (those involving significant disruptions in the plant's sensed transmission load or quality of off-site power) will most likely be to trip the reactors and shut down the plant. A reactor trip and plant shutdown in the event of a Grid anomaly introduces four concerns that are relevant to Grid resilience:

(1) maintenance of safe shutdown cooling for the NPP (reactor and spent-fuel pool), (2) avoidance of cascading Grid collapse, (3) time delay intrinsic to NPP restart, and (4) provision of the off-site power required to crank (start up) the NPP.

V.A. Maintenance of NPP Safe Shutdown Cooling Is a Burden on Grid Operators

Once tripped, the NPP's reactor(s) would be rapidly transitioned to the shutdown decay heat removal mode. Depending on the circumstances, safe shutdown cooling could be accomplished via several systems¹⁹: (1) ac-powered pumping systems if off-site power is available, (2) diesel generator/inverter-driven ac-powered pumping systems, (3) steam turbine-driven pumping systems (as long as the reactor remains pressurized), and (4) direct diesel-driven pumping systems. The period of time the plant can remain in a safe shutdown state obviously depends on the reliability of these pumping systems (and in the case of diesel-driven systems, the inventory of diesel fuel available). Regardless of their on-site shutdown cooling capabilities, NPPs are considered to be among the highest-priority critical loads to which electric service must be restored in the event of a Grid blackout. Regional transmission system operators in the United States typically seek to restore off-site power to the NPPs within 4 h of its loss.²⁰ Thus, once the Grid has gone dark, the NPP actually constitutes a burden on Grid operators rather than an asset. It is a facility that demands immediate attention and draws power from the Grid rather than producing power and contributing in meaningful ways to early Grid recovery operations.

V.B. Avoidance of a NPP Shutdown-Induced Cascading Grid Collapse Is a Real Concern for Grid Operators

For cases in which the NPP carries a significant portion of the Grid's electric load, the loss of the plant's generating capacity can result in additional Grid voltage and/or frequency perturbations. The abrupt removal of a large block of generating capacity from an (already) stressed Grid is not a recipe for Grid stability. If not quickly corrected by the addition of other generating capacity, NPP shutdown in the face of a Grid anomaly can lead to the shutdown of other generation and transmission assets and a cascading collapse of larger portions of the Grid.¹⁵ Such was the case during the Northeast blackout in 2003, when nine NPPs in the United States, and seven in Canada, rapidly and automatically shut down or disconnected from the Grid, robbing the Grid of generating capacity and contributing to the cascading spread of the

blackout.²¹ (Such scenarios also plunge the NPP into a complete LOOP event if the plant is not already in such a state.)

V.C. Postblackout NPP Restart Timeline for Current NPPs Undermines Their Value as Grid Recovery Assets

Speaking strictly from the standpoint of internal (to the NPP) considerations, how quickly might an NPP that has shut down (either manually in anticipation of a Grid disruption or automatically in response to an unanticipated event) return to service?

The startup of a NPP is a carefully choreographed exercise involving a series of diverse actions and activities including holds for tests and verification of required conditions, along with conditional gates beyond which the process cannot proceed unless required conditions are met.²² Commercial NPPs have several operating modes and rules for transitioning between these modes. This operational framework determines the ability of and schedule for an NPP's return to service if it shuts down in the event of a major Grid disruption. The definition of the NPP operating modes differs between reactor types and reactor vendors.^{23,24} Traditional Generation II PWRs have six operational modes, while BWRs have only five modes. However, in all cases, a particular mode is defined by a unique combination of reactor thermal power level, reactor average coolant temperature, and status (tension) of the reactor closure head bolts (for modes in which the reactor is shut down).

The relevance of reactor operating modes with respect to major Grid anomalies and blackouts is that the operating mode that the plant is in at the time of the Grid disruption (or the operating mode that is the terminal point of the plant's response to the disruption) dictates the starting point for restart of the NPP and the time required to return the plant to service. This is true because the plant's technical specifications dictate a diverse set of limiting conditions for operation (LCOs), surveillances, checks, tests, and conditions that must be executed or confirmed as prerequisites for evolving between operating modes.

LCOs identify the lowest functional capability or performance level of equipment required for safe operation of the facility. In addition, the manner in which a NPP evolved to its present operating mode (e.g., whether the plant was automatically tripped or whether the plant was manually shut down in a controlled manner) and the reactor's operating history (e.g., reactor fuel burnup) also impact the operating mode evolution protocol. It is clear a NPP's operating modes, LCOs, and operating history are of great importance with

respect to its ability to (and schedule for) return to service and thus its value as a Grid recovery asset in the wake of a major Grid disruption. Because of these considerations, current (Generation II) LWR plants would probably require a minimum of several hours to perhaps even a couple of days to return to service—even for cases in which the plant is not damaged by the Grid anomaly that precipitated the plant shutdown.

V.D. Startup Cranking Power for Today's NPPs Must Be Supplied by the Grid

The cranking power requirements of commercial NPPs are largely a function of the size [MW(thermal)] of the power plant. This is an artifact of the power demands of electric-driven pumps that provide the motive force for cooling of the reactor core, generation of steam, power conversion, and rejection of waste heat to the environment. An LWR-based NPP's total housekeeping and cranking power load is dominated by the power demand of its RCPs and the circulating water pumps (CWPs). The RCPs typically represent over 40% of the total fixed load, while the CWPs contribute ~20% of the total fixed load. Thus, these two systems are responsible for ~60% of the NPP's total fixed load. The combined real and reactive power demand of electrically driven pumps is much larger while they are starting and accelerating to operating speed.

While all of the plant's systems and components do not simultaneously start and operate as the plant is being cranked, several systems do. Thus, cranking power requirements are reasonably approximated by fixed electrical housekeeping loads. Today's large GW(electric)-class NPPs typically require ~30 to 40 MW(electric) of cranking power. The actual cranking power demand for a specific plant depends on plant size [MW(thermal) and MW(electric)], whether the plant is a PWR (higher loads) or a BWR, and a variety of other plant-specific considerations. Cranking power demands of this magnitude are beyond that which can be supplied by emergency diesel generators (because the emergency diesel generators are sized primarily to power engineering safety features and shutdown cooling systems). The implication is that today's plants require substantial off-site power to start up—power that often is not available in the earliest stages of the Grid recovery process.

VI. THE ROLE OF TODAY'S NPPs IN GRID RECOVERY AND RESTORATION

Rapid recovery of the Grid system and restoration of electricity service to customers is of paramount importance if

significant social and economic consequences are to be avoided in the wake of a major Grid anomaly. Therefore, it is relevant to ask, "Do today's NPPs contribute in meaningful ways to rapid restoration of a stable Grid?" The answer from decades of operational experience is clear. Adibi et al.²⁵ provided an analysis of NPP requirements during power system restoration as an activity of the Institute of Electrical and Electronics Engineers Power System Restoration Working Group in 1995. Adibi and Fink²⁶ integrate some of the conclusions of Adibe et al. into a broader discussion of postblackout Grid restoration procedures. Sroka and Grzadzielski²⁷ echo many similar observations. The following major points are conveyed in Refs. 25, 26, and 27:

1. A NPP's plant technical specifications detail the conditions that must exist before a NPP that has automatically tripped or has been manually taken off-line can restart. The optimal mode for NPP restart following a Grid disruption is hot standby.

2. NPPs that have been manually taken off-line in a controlled manner might return to service within 24 to 48 h. Plants that automatically trip in response to external stimuli could take considerably longer to return to service. For these reasons, current Grid restoration plans focus on providing assured off-site power to the NPPs in order to maintain their safe shutdown condition while restoring as much of the service area load as possible without any assistance from the NPPs. Therefore, full customer restoration may not be achievable for an extended period in areas in which nuclear power constitutes a significant fraction of the generation mix.

3. Grid restoration strategies involving NPPs must incorporate real-time knowledge about the NPP's generation (mode) status and must facilitate intimate and continuous communications between the NPP operator and the Grid system operator.

4. Grid restoration is typically a bottoms-up approach. NPPs interface with the Grid via extra high voltage transmission lines that are neither available nor stable early in the Grid restoration process. Given the power maneuvering limitations of large Generation II NPPs, the ability to rebuild a sufficient amount of stable load for the NPP is a crucial constraint on the speed with which NPPs can return to service and contribute to the Grid restoration process.

5. Premature attempts to reload large NPPs can result in systemwide voltage and frequency perturbations that can trigger automatic NPP and Grid system protection measures resulting in generating unit trips and Grid refragmentation (i.e., premature attempts to restart/reload large NPPs can make matters worse rather than better).

It is clear today's NPPs do not play a significant role in the early stages of Grid recovery and restoration in the wake of major Grid disruption.

VII. CONCLUSION: CURRENT U.S. NPPs ARE NOT SIGNIFICANT GRID RESILIENCE ASSETS

Modern commercial NPPs are remarkable feats of engineering. They have (with a few notable exceptions) proven to be safe, reliable, and efficient means of producing massive amounts of emissions-free electricity. They are major Grid capacity, energy, and reliability assets. Indeed, they are substantial societal assets in an electricity-dependent world concerned with local air quality and global climate change.

However, today's Generation II LWR NPPs are intolerant of Grid disturbances. Once shut down, they are not typically capable of rapidly restarting. They have large cranking power requirements that must be supplied from off-site. Their large size requires the Grid operator to rebuild large blocks of transmission capability and stable load to enable the NPP to power up and reload. Beyond these considerations, the Grid operator's concern that a premature attempt to reload the NPP could trigger a shutdown of the NPP and a cascading Grid collapse inhibits the use of NPPs in the early stages of Grid recovery following a major Grid disruption.

The analysis presented here supports the conclusion that although today's NPPs are safe and reliable, the design and operational approaches adopted to achieve these safety and reliability objectives have resulted in plants that are not significant Grid resilience assets. For all of their virtues, today's NPPs are not rNPPs. They are not plants that enable the Grid to absorb and adapt to major Grid disruptions nor do they enable the Grid to rapidly recover and restore electric service to its customers.

VIII. NUCLEAR POWER'S FUEL SECURITY PREMIUM: A MOTIVATION FOR ENHANCING THE RESILIENCE OF NUCLEAR POWER

This paper begins with an observation that modern society is utterly dependent on the smooth functioning of several critical infrastructures, virtually all of which either depend on or are involved in the production of electricity. Thus, at the end of the day, Grid resilience is a matter of energy, economic, and homeland security. There are a number of natural hazards and man-made threats that have the potential to disrupt the Grid and other critical infrastructures.¹⁴ The recovery and restoration phases of these disruptive events could last for months, or even years

in some extreme scenarios. It is in precisely those "very-bad-day" scenarios that the nation might benefit most from one of nuclear power's unique attributes: its fuel security.

Unlike other steam cycle power plants that have only hours to days (natural gas-fired plants), days to weeks (oil-fired plants), or weeks to a few months (coal-fired plants) of fuel on-site, NPPs have many months to perhaps 2 years of fuel in the tank. Thus, NPPs have sufficient fuel reserves to operate for extended periods when the delivery of fuel to other steam cycle plants would be difficult or even impossible. NPPs must be capable of operating in harsh environments if their fuel security benefit is to be accessed. This capability was aptly demonstrated during the Southwest Cold Weather Event of February 2011 in Texas and New Mexico and the Polar Vortex Event of January 2014 (that impacted vast regions of the United States), when NPPs in the affected areas continued to operate while numerous oil-fired, gas-fired, and coal-fired power plants were forced to shut down due to lack of fuel supply and/or a variety of other issues intrinsic to their use of fossil fuels.^{28,29} The 2011 and 2013–2014 U.S. weather events clearly demonstrate nuclear power's short-term or tactical Grid resilience benefit for such regional weather events. This short-term resilience benefit was delivered because the NPPs in the affected regions (1) had the fuel to operate through the event and (2) were capable of operating. The NPPs were not presented with Grid interface anomalies that they could not accommodate nor were they directly damaged in any significant way by the weather event itself.

As previously noted,¹⁴ there are a variety of man-made and natural events that have the potential to create much greater challenges for the Grid and its NPP operators than the short-term weather events discussed above. It is precisely in such very-bad-day scenarios that the long-term strategic Grid resilience value of nuclear power would be of maximum benefit to society. But, this potential benefit can be accessed only if the NPPs and the Grid in which they are embedded are sufficiently resilient to operate in the challenging conditions that accompany such worst-case scenarios.

Unfortunately, the analysis presented in [Secs. II through VII](#) demonstrates that the fuel security benefit of today's NPPs would be largely inaccessible precisely at the time society might benefit most from it. This reality should be a major motivation for enhancing the resilience of future commercial NPPs.

IX. THE FUTURE: rNPPs ENABLING RESILIENT ELECTRIC GRIDS?

Fortunately, there is nothing intrinsic to nuclear power that prevents it from becoming a major strategic Grid and

societal resilience asset. It may not be feasible from the technical and economic standpoints to modify most existing NPPs to achieve the resilience capabilities discussed in this paper. It *is* possible to envision plant designs and technology bundles that could enable rNPPs in the future. Indeed, designers of future NPPs can and should explicitly incorporate Grid resilience considerations into the design of tomorrow's plants. Tomorrow's rNPPs would be NPPs that are intentionally designed, cited, interfaced, and operated in a manner to enhance the resilience of the Grid they serve. Given the dependence of life today on sustained access to electricity, the resilience of modern society in the 21st century may depend on such innovations. Who will take up the challenge?

Acknowledgments

The work described in this paper has been conducted by the author in partial fulfillment of the requirements for the PhD in Energy Science and Engineering at the University of Tennessee Knoxville (UTK). The author gratefully acknowledges the encouragement and support of Howard L. Hall, Director, Institute for Nuclear Security, and Governor's Chair Professor of Nuclear Engineering at UTK—with whom the author is working to explore the nexus of Grid resilience, nuclear power, and national and homeland security.

ORCID

Sherrell R. Greene  <http://orcid.org/0000-0003-4661-4705>

References

1. *Proc. 1st Int. Symp. Societal Resilience*, Fairfax, Virginia, November 30–December 2, 2010, Homeland Security Studies and Analysis Institute (2010); http://www.anser.org/docs/Social_Resilience_BOOK.pdf (current as of Nov. 20, 2017).
2. “Presidential Policy Directive—Critical Infrastructure Security and Resilience,” PPD-221, The White House Office of the Press Secretary (2013); <https://obamawhitehouse.archives.gov/the-press-office/2013/02/12/presidential-policy-directive-critical-infrastructure-security-and-resil> (current as of Nov. 20, 2017).
3. “Glossary of Terms Used in NERC Reliability Standards,” North American Electric Reliability Corporation (Jan. 25, 2016); http://www.nerc.com/files/Glossary_of_Terms.pdf (current as of Nov. 20, 2017).
4. “Enhancing the Resilience of the Nation's Electricity System,” The National Academies of Sciences, Engineering, and Medicine; <https://doi.org/10.17226/24836>.
5. “Transforming the Nation's Electricity System: The Second Installment of the Quadrennial Energy Review (QER 1.2),” U.S. Department of Energy (2017); <https://energy.gov/epsa/quadrennial-energy-review-second-installment> (current as of Nov. 20, 2017).
6. “How Many Nuclear Power Plants Are in the United States, and Where Are They Located?” U.S. Energy Information Administration; <https://www.eia.gov/tools/faqs/faq.php?id=207&t=3> (current as of Nov. 20, 2017).
7. “What Is U.S. Electricity Generation by Energy Source?” U.S. Energy Information Administration; <https://www.eia.gov/tools/faqs/faq.php?id=427&t=3> (current as of Nov. 20, 2017).
8. G. SANSVINI, “Engineering Resilience in Critical Infrastructures,” SET-NAV Project (Apr. 2017); <http://www.set-nav.eu/content/set-nav-discussion-paper> (current as of Nov. 20, 2017).
9. “Severe Impact Resilience: Considerations and Recommendations,” North American Electric Reliability Corporation Severe Impact Resilience Task Force (2012).
10. R. ARGHANDEH et al., “On the Definition of Cyber-Physical Resilience in Power Systems,” *Renew. Sustain. Energy Rev.*, **58**, 1060 (2016); <https://doi.org/10.1016/j.rser.2015.12.193>.
11. S. R. GREENE, “Enhancing Electric Grid and Critical Infrastructure Resilience with Resilient Nuclear Power Plants (rNPPs),” *Trans. Am. Nucl. Soc.*, **117** (2017).
12. “Licensee Event Report Search (LERSearch) Database,” U.S. Nuclear Regulatory Commission; <https://lersearch.inl.gov/Entry.aspx> (current as of Nov. 20, 2017).
13. N. JOHNSON and J. A. SCHROEDER, “Analysis of Loss-of-Offsite-Power Events 1987–2015,” INL/EXT-16-39575, Idaho National Laboratory (2016).
14. S. R. GREENE, “Nuclear Power: Black Sky Liability or Black Sky Asset?” *Int. J. Nucl. Security*, **2**, 3 (2016); <https://doi.org/10.7290/V78913SR>.
15. J. H. BICKEL, “Grid Stability and Safety Issues Associated with Nuclear Power,” Nautilus Institute for Security and Sustainability; <http://nautilus.org/wp-content/uploads/2011/12/Bickel.pdf> (current as of Nov. 20, 2017).
16. “Interfacing Nuclear Power Plants with the Electric Grid: The Need for Reliability Amid Complexity,” International Atomic Energy Agency; https://www.iaea.org/About/Policy/GC/GC53/GC53InfDocuments/English/gc53inf-3-att5_en.pdf (current as of Nov. 20, 2017).
17. B. J. KIRBY et al., “Frequency Control Concerns in the North American Electric Power System,” ORNL/TM-2003/41, Oak Ridge National Laboratory (2002).
18. “PJM Manual 39: Nuclear Plant Interface Coordination,” Rev. 10, PJM Interconnection (2015).
19. S. R. GREENE, “The Canary, the Ostrich, and the Black Swan: A Historical Perspective on Our Understanding of

- BWR Severe Accidents and Their Mitigation,” *Nucl. Technol.*, **186**, 115 (2014); <https://doi.org/10.13182/NT13-44>.
20. “PJM Manual 36: System Restoration,” Rev. 19, PJM Interconnection (2013).
 21. “Final Report on the August 14, 2003 Blackout in the United States and Canada: Causes and Recommendation,” U.S.-Canada Power System Outage Task Force (2004).
 22. S. R. GREENE, “Nuclear Power’s Role in Black Sky Grid Recovery—A Literature Review,” ATI-TR-2016-17, Advanced Technology Insights LLC (2016).
 23. “Standard Technical Specifications, Westinghouse Plants, Revision 4.0, Volume 1, Specifications,” NUREG-1431, pp. 1.1–7, U.S. Nuclear Regulatory Commission; <http://www.nrc.gov/docs/ML1210/ML12100A222.pdf> (current as of Nov. 20, 2017).
 24. “Standard Technical Specifications, General Electric BWR/4 Plants, Revision 4.0, Volume 1, Specifications,” NUREG-1433, pp. 1.1–7, U.S. Nuclear Regulatory Commission; <http://www.nrc.gov/docs/ML1210/ML12104A192.pdf> (current as of Nov. 20, 2017).
 25. M. M. ADIBI et al., “Nuclear Plant Requirements During Power Restoration,” *IEEE Trans. Power Syst.*, **10**, 3 (1995); <https://doi.org/10.1109/59.466499>.
 26. M. M. ADIBI and L. H. FINK, “Overcoming Restoration Challenges Associated with Major Power System Disturbances,” *Power and Energy Magazine, IEEE*, **4**, 68 (2006); <https://doi.org/10.1109/MPAE.2006.1687819>.
 27. K. SROKA and I. GRZADZIELSKI, “Nuclear Power Plants During Blackout,” *ActaEnergetica*, No. 1/2011 (Mar. 21, 2011); <http://actaenergetica.org/article/en/nuclear-power-plants-during-blackout.html> (current as of Nov. 20, 2017).
 28. “Severe Weather Event of February, 2011 and Its Cascading Impacts on NM Utility Service,” New Mexico Public Regulation Commission (2011); http://www.nmprc.state.nm.us/utilities/docs/2011-12-21_Final_Report_NMPRC.pdf (current as of Nov. 20, 2017).
 29. “Polar Vortex Review,” North American Electric Reliability Corporation (2014); http://www.nerc.com/pa/rrm/January%202014%20Polar%20Vortex%20Review/Polar_Vortex_Review_29_Sept_2014_Final.pdf (current as of Nov. 20, 2017).