

Summer 2019

Early Information Access to Alleviate Emergency Department Congestion

Anjee Gorkhali
Old Dominion University, anje.gorkhali@gmail.com

Follow this and additional works at: https://digitalcommons.odu.edu/businessadministration_etds



Part of the [Databases and Information Systems Commons](#), [Health and Medical Administration Commons](#), and the [Theory and Algorithms Commons](#)

Recommended Citation

Gorkhali, Anjee. "Early Information Access to Alleviate Emergency Department Congestion" (2019). Doctor of Philosophy (PhD), Dissertation, Info Systems/Dec Sciences, Old Dominion University, DOI: 10.25777/5768-ne76
https://digitalcommons.odu.edu/businessadministration_etds/123

This Dissertation is brought to you for free and open access by the College of Business (Strome) at ODU Digital Commons. It has been accepted for inclusion in Theses and Dissertations in Business Administration by an authorized administrator of ODU Digital Commons. For more information, please contact digitalcommons@odu.edu.

**EARLY INFORMATION ACCESS TO ALLEVIATE EMERGENCY DEPARTMENT
CONGESTION**

By

Anjee Gorkhali

A Dissertation Submitted to the Faculty of

Old Dominion University in Partial Fulfillment of the

Requirement for the Degree of

DOCTOR OF PHILOSOPHY

INFORMATION TECHNOLOGY

August 2019

Approved by:

Ling Li (Director)

Li Xu(Member)

Kayoung Park

ABSTRACT

Early Information Access to Alleviate Emergency Department Congestion

Alleviating Emergency Department (ED) congestion results in shorter hospital stay which not only reduces the cost of medical procedure but also increase the hospital performance. Length of patient stay is used to determine the hospital performance. Organization Information Processing (OIPT) Theory is used to explain the impact of information access and availability on the information processing need and ability of a hospital. Technical devices such as RFID that works as “Auto Identification tags” is suggested to increase the information availability as well as the information processing capability of the hospitals. This study suggests that the OIPT needs to be further broken down into its entity form and then the impact of these entities is measured separately. On the other hand, institutional factors such as employee behavior towards the new technology is studied to analyze the impact of human factors in the implementation of these technical devices in the ED procedures. It can be implied from this study that early information access does increase the use of supporting EMR implementation. However, the importance of the use of EMR decreases with time on hospital performance. Moreover, other factors such as management policies related to IT positively moderates the relationship between information availability and the processing capability of a hospital ED.

© Copyright by

Anjee Gorkhali

2019

Dedication

To. Dr. Ling, my advisor and a wonderful mentor, who encouraged me towards excellence throughout my Doctoral program in Old Dominion University. To Dr. Li Xu and Dr. Kayoung Park, for reading and providing valuable insights on my work.

To my parents and brother.

Thank you all for supporting and encouraging me.

Acknowledgements

I would like to thank SPARCS and HIMSS, who helped me with this research for providing data.

Table of Contents

LIST OF TABLES.....	VII
LIST OFF FIGURES.....	VIII
LIST OF ABBREVIATIONS.....	IX
CHAPTER 1.....	1
1. INTRODUCTION.....	1
1.1 EMERGENCY DEPARTMENT IN U.S.....	1
1.2 EMERGENCY DEPARTMENT IN THE U.S.A: AN OVERVIEW ON CURRENT SITUATION.....	3
1.3 PROBLEM STATEMENT.....	4
1.3.1 DECREASING CAPACITY.....	4
1.3.2 INCREASING DEMAND.....	6
1.3.3 HEALTHCARE PERFORMANCE.....	7
1.3.3.1 HISTORY OF HEALTHCARE LEGISLATION IN THE U.S.....	7
1.3.3.2 IMPACT OF HEALTHCARE LEGISLATION IN THE ED PERFORMANCE.....	10
1.4 RESEARCH OBJECTIVE.....	11
1.4.1 AN EXAMPLE WITH RFID.....	12
1.5 ORGANIZATION OF THIS PAPER.....	15
CHAPTER 2.....	17
LITERATURE REVIEW.....	17
2.1 BEFORE AFFORDABLE CARE ACT (ACA).....	17
2.2 AFTER AFFORDABLE CARE ACT (ACA).....	25
2.3 DEVELOPMENT OF RFID TECHNOLOGY.....	30
2.4 HEALTH INFORMATION EXCHANGE.....	34
CHAPTER 3.....	35
THEORETICAL BACKGROUND AND HYPOTHESIS.....	35
3.1 ORGANIZATION INFORMATION PROCESSING THEORY.....	35
3.1.1 OIPT IN ENTITY FORM.....	37
3.1.2 DECREASING UNCERTAINTY WITH INFORMATION PROCESSING THEORY.....	38
3.1.3 DECREASING INFORMATION AMBIGUITY AMONGST PROVIDER WITH THE HELP OF EARLY INFORMATION.....	43
3.1.4 EARLY INFORMATION ACCESS AND INFORMATION COORDINATION.....	46
3.2 EARLY INFORMATION ACCESS AND ORGANIZATIONAL FACTORS.....	49
3.2.1 THEORY OF REASONED ACTION AND THEORY OF PLANNED BEHAVIOR.....	50
3.2.2 EARLY INFORMATION ACCESS AND SUCCESS OF NEW TECHNOLOGY.....	51
3.2.3 EARLY INFORMATION ACCESS AND USE OF SUPPORTING IT COMPONENTS.....	53
3.3 EARLY INFORMATION ACCESS, RESOURCE BASED VIEW AND HOSPITALS IT POLICIES/PLANS.....	54
3.3.1 RESOURCE BASED VIEW.....	54
3.4 IMPACT OF WORKPLACE TRAININGS ON HOSPITAL PERFORMANCE.....	57
3.5 CONCEPTUAL MODEL OF THE STATED HYPOTHESIS.....	62
CHAPTER 4.....	64
METHODOLOGY AND RESEARCH DESIGN.....	64
4.1 DATABASES.....	64
4.2 DATABASE INTEGRATION.....	66
4.3 DATA SELECTION.....	66

4.4 DATA REDUCTION.....	68
4.5 DATA DESCRIPTION	70
4.6 VARIABLES.....	72
4.7 STATISTICAL TOOL.....	77
4.8 HYPOTHESES TESTING.....	78
4.8 HYPOTHESIS TESTING SETUP.....	94
CHAPTER 5.....	96
RESULTS.....	96
CHAPTER 6.....	99
DISCUSSION.....	99
6.1 FUTURE IMPLICATIONS.....	100
6.2 RESEARCH CONTRIBUTION.....	101
6.3 LIMITATIONS	104
REFERENCES	106
APPENDICES.....	132
A. DISTRIBUTION OF INITIAL SELECTED 132 HOSPITALS IN THE STATE OF NEW YORK.....	132
B. DISTRIBUTION OF SELECTED 45 HOSPITALS IN THE STATE OF NEW YORK.....	133
C. SPARCS 2014 SELECTION VARIABLES	134
D. LIST OF VARIABLES AND SOURCES	135
APPENDIX E.....	136
E. RANGE OF EACH VARIABLE.....	136
F. TABLE TYPES OF IS SKILLS PROVIDED TO STAFF.....	137
G. LIST OF FULLY OPERATIONAL EMR UNITS.....	138
H. TYPES OF IS PLANS	139
I. UNITS WITH FULLY OPERATIONAL RFID.....	140
J. SIMULATION PARAMETERS	141
K. ARENA SIMULATION MODEL.....	142
L. GRAPHS 1A, 2A, 3A1, 3A2, 1B, 2B, 3B.....	146
M. SPSS RESULTS.....	149
N. HYPOTHESIS TESTING RESULT FOR SIMULATION METHOD.....	153
O. LISREL NOTATION.....	154
P. PATH MODEL FOR THE HYPOTHESIS TESTING	155
Q. PATH MODEL SHOWING THE RESULT OF HYPOTHESIS TESTING	156
R. PATH MODEL FIT TEST	157
S. TEST RESULTS WITH ESTIMATES AND P-VALUE.....	158
T. HYPOTHESIS TESTING RESULTS FOR PATH MODEL.....	160
VITA.....	161

LIST OF TABLES

Table 1.1 History of Healthcare Legislation in the U.S	10
Table 1.2 Different Fields of Applications of RFID.....	14
Table 2.1 Key Findings Before ACA	25
Table 2.2 Key Findings After ACA.....	28
Table 3.1 Proposed Hypothesis Relationship.....	63
Table 4.1: List of Methods Used in Healthcare Research.....	80

LIST OFF FIGURES

Figure 1.1 ED Visit Rate (per 1000 population)	3
Figure 3.2 Interactions of system, technology, organization capabilities and organizational requirements.	40
Figure 3.3 RBV for Early Information Access.....	61
Figure 3.4 Early Information Access in Hospital Information System	62
Figure 4.1 Flow Chart for Data Selection	67
Figure 4.2 Flow Chart for Data Reduction.....	71
Figure 4.3 Path Flow for the Patient with Early Information Access.....	83
Figure 4.4 Path Flow for the Patients without Early Information Access	84
Figure 4.5 Seize Delay Release Process	85
Figure 4.6 Comparison of the Number of Medical Procedure for RFID Patient Vs Regular Patient.....	87
Figure 4.7 Comparison of the Number of Patients Discharged for RFID Patient Vs Regular Patient.....	89

LIST OF ABBREVIATIONS

ACA	Affordable Care Act
RFID	Radio Frequency Identification
EIA	Early Information Access
ED	Emergency Department
OIPT	Organization Information Processing Theory
RBV	Resource Based View
TRA	Theory of Reasoned Action
TPB	Theory of Planned Behavior
IT	Information Technology
IS	Information Systems
EMR	Electronic Medical Records
MMA	Multi-Methodological Analysis
SEM	Structural Equation Modeling
SPARCS	Statewide Planning and Research Cooperative Systems
HIMSS	Healthcare Information and Management Systems Society
IFI	Bollen's Incremental Fit Index
TLI	Tucker-Lewis Index
RMSEA	Root Mean Square of Error Approximation
CFI	Comparative Fit Index
GFI	Goodness of Fit
NFI	Bentler-Bonett Nonnormed Fit Index

CHAPTER 1

1. INTRODUCTION

1.1 Emergency Department in U.S

Hospital is a complex system with different components working together to provide quality service to its customers, known as patients. Healthcare is the world's largest industry (Janz et al. 2005), and its market size is growing continuously (Wilson and Lankton 2004). Data from the OECD show that the U.S. spent 17.1% of its gross domestic product (GDP) on health care in 2013. This was almost 50 % more than the next-highest spender France (11.6% of GDP) and almost double what was spent in the U.K. (8.8%). U.S. spent \$9,086 (not adjusted to inflation) per person per person. Studies conducted by Squires and Anderson (2015), suggests that the U.S spends highest per capita amongst other developed countries. The highest per capita spending is a result of new set of rules and regulations which needs to be integrated in the healthcare industry. Therefore, healthcare industry has been making major transformations in its information technology (IT) base (Wilson and Lankton 2004; Li et al. 2008) and in addition to that it is also incorporating IT to deliver a higher business value and quality of care. Even though the healthcare market is expanding, the cost of healthcare is also growing simultaneously, hospitals are under immense pressure to provide the same quality service in a lower cost as well as reduce its overall cost. Therefore, hospitals are relying on IT to provide with unique and optimum ways to deliver quality care on a budget to its customers. However, it is not always possible and one of the areas where the cost cut has created problem is in Emergency Department (ED).

The number of ED patients is growing and therefore, the cost cut in ED has created additional stress in the ED system (Shen and Wang, 2015). Hernandez-Boussard, et al., 2014, suggest that increase in ED visits is primarily the result of an increase in illness-related diagnoses and not because of the additional trauma-related injuries. The authors further attribute the increase to the lack of private health insurance, in particular, uninsured people and Medicaid patients are the largest contributor to the increase in rates of ED use, compared to patients with private insurance. Moreover, Medicaid patients have experienced decreasing access to primary care, which might have led them to use the ED as a main source of health care (Hernandez-Boussard et al., 2014). Hence, increasing the ED congestion.

Since, the patients in ED arrive without any appointment, it is difficult to predict the actual resources required to operate the ED smoothly (Green & Liu, 2015; Shen & Wang, 2015). There are many studies in the recent past that have tried to predict the optimum resources required to run an ED smoothly (Alleon, Deo & Lin, 2013; Ghanes et al., 2015). Some studies are focused on streamlining the patient flow in the ED when the patients arrive using different queuing mechanism (Elalouf & Watchel, 2015; Huang et al., 2015; Srikanth & Arivezhagan). Similarly, there are studies that claim that the patient streamlining before they arrive in the ED is key to managing the congestion in ED, for example ambulance diversion (Chen et al., 2016; Hoot & Aronsky, 2008; Saghafian et al., 2012). However, some studies point that ambulance diversion cause other ED's in the area to be congested and results in poor care for the patients and also in higher death rate amongst patients with severe health problems (Green & Liu, 2015). One important flaw with ambulance diversion is the lack of real time interaction between patient's medical condition and the diversion scheme. This results in an inefficient diversion scheme which might have critical

patients getting diverted to other ED's in the vicinity. Moreover, this type of diversion scheme might also create a silo effect thereby putting almost all ED's in a certain area in diversion mode.

1.2 Emergency Department in the U.S.A: An overview on current situation

ED serves as the main entry point to healthcare for patients who do not have any other health coverage. Since, ED's have to treat patients with or without the ability to pay for their hospital stay and medical procedure, ED's are considered to be one of the measures to gauge the level of public health. The National Center for Health Statistics reports that there were 44.5 ED visits per 100 persons in the United States in 2015, and 12% of these encounters resulted in hospitalization. In every community, EDs play an important social role, guaranteeing assistance to vulnerable populations, including uninsured and low-income individuals. Thus, EDs are an essential contributor to the health of a population and it is used as a well-defined measure of this contribution. The Figure 1.1 below depicts the ED visits rate per 1000 population in the state of California, from the year 2005-2015 (Hsia et al., 2018).

Table 1 California ED visit rates (per 1000 population), 2005–2015													
	2005	2006	2007	2008	2009	2010	2011	2012	2013	2014	2015	% Change	P values
Total ED visit rate	284.3	282.4	289.0	294.4	315.3	309.8	317.3	326.0	331.1	344.9	363.5	27.8%	<0.001

Figure 1.1 ED Visit Rate (per 1000 population)

It can be concluded from Figure 1 that the emergency department use has been steadily increasing over the year. However, the resources are limited and, in some cases, even decreasing, therefore there is need to study on optimizing ED resources.

Schafermeyer et al 2003, emphasize that emergency department (ED) crowding has been reported in the USA for over a decade (Andrulis et al., 1991). However, this problem was first encountered

in literature as early as late 1980's and early 1990's. Back then, policymakers attributed this problem to urban safety net hospitals and patients visiting ED's for minor conditions. The emergency medicine community did raise their concern towards the boarding of inpatients in the ED as the primary cause for ED crowding, it was not until mid 1990's when this was given a thought (Lynn et al., 1991; Kellermann, 1991). Although ED crowding did not simply go away during this time period, the issue was not perceived as a crisis within the emergency medicine community. The reasons for this are not entirely clear; however, the rapid growth in managed care penetration did result in a transient levelling off in the growth of ED visits in the middle of the decade. Furthermore, hospitals and emergency providers made operational adjustments to cope with capacity problems, and finally, crowded ED became, at least to a certain extent, accepted as the status quo (Burt and McCaig, 2001).

1.3 Problem Statement

Healthcare in the U.S is facing growing challenges due to changing government policies such as introduction of "Affordable Care Act" which has led to a series of changes in hospital management policies to create efficient cost structure (Rosoko et al., 2018). The Affordable Care Act (ACA) enable the largest expansion of public health insurance coverage in decades (Duggan et al., 2017). The Patient Protection and Affordable Care Act (ACA) was signed into law in March 2010 and was phased in different levels till its full practice in 2014. hence, the largest expansion of publicly funded health insurance coverage was introduced, since the Medicare and Medicaid in the 1960s (Duggan et al., 2017). The changing scenario of ED's in the U.S can be summarized from both the "capacity change" as well as "demand change".

1.3.1 Decreasing Capacity

A large number of hospitals, inpatient beds, and ED have closed during the past 20 years in the USA. In 1992 there were around 6000 hospitals with ED (McCaig and Ly, 2002) and the number decreased to 5,273 by 2015 according to the Emergency Medicine Network “The 2015 National ED Inventory-USA (NEDI-USA)”. In most cases, the entire facility was closed; however, in some cases they close their ED but remain open for elective admissions. This trend has been particularly prominent in California. In addition to hospital and ED closures, there have been a significant decrease in the number of beds and wings in their facilities. These closures were not accidental but rather carefully planned and processed in a stepwise manner. In early 1990’s, the reason behind surging healthcare costs was attributed to an excess supply of hospital beds (Lambe et al., 2002). Not only this but a series of market and policy interventions has resulted in downsizing of hospitals. For example: The Balanced Budget Act of 1997, dramatically divided provider payments into public programs like Medicare and Medicaid (Kasich, 1997). It was not prominent and vivid in its initial year of conception, however now it is evident that hospitals may have downsized too rapidly in many areas of the country which resulted in the problem of ED congestion. Another example of the impact of legislation on ED congestion is that of Affordable Care Act (ACA), which was signed into law on 23rd of March 2010 with several objectives such as: to increase access to health care; to introduce new consumer protections, and to lower the cost and to improve the quality of health care. It was implied that ACA would be able to decrease the ED visits since more Americans would have health insurance, enabling them to visit their doctors of choice and not rely on ED (Duggan et al., 2017). The authors emphasize that even though, ACA came into effect on January 1, 2014, it has not resulted in any significant decrease in the ED use but the number of ED’s are steadily decreasing.

1.3.2 Increasing Demand

It was a paradoxical situation where hospitals were flexing to decrease the excess number of inpatient beds but the demand for ED care rose steadily. The annual number of ED visits from 1992 to 2001 increased from 89.8 to 108 million (Burt and McCaig, 2001). The most growth in ED visits occurred between 1997 and 2000, when ED visits increased by 14% attributing to a change from 94.9 to 108 million (McCaig and Ly, 2002). Recently Nikpay et al. (2017). This implies that due to the lack of health insurance amongst a large population, the total number of ED patients increased. Even though, ACA has increased the number of populations with health insurance, the total number of patients using the ED has not decreased significantly.

In addition to that availability of inpatient bed when needed to transfer the ED patients to inpatient ward is also creating additional demand in the ED. When an inpatient bed isn't available, or when the bed is available but there is no nurse to staff it, patients wait in the ED. This period of 'boarding' in the ED can last from hours to days. In fact, some patients wait so long that they complete their 'hospital admission' and are discharged from the ED without ever reaching an inpatient bed. It should come as no surprise that the combination of rapid downsizing in hospital capacity, higher ED utilization and increasing patient acuity has resulted in serious problems meeting the demand for emergency hospital admissions. While some areas of the USA have been affected more seriously than others (particularly the coasts), almost every state has reported problems with boarding of inpatients in the ED. Inpatient boarding is the most frequently cited reason for ED crowding within the emergency medicine community. An American Hospital Association (AHA) survey in April 2002 confirmed all of these trends (Henry, 2001, Viccellio, 2011). A majority of hospital ED in this survey perceived that they were at or over capacity. Wesson et al (2018), mention that close to 50% of all inpatient hospital admissions began in the ED in the year 2013,

and the total cost of these inpatient stay is estimated to be \$697 billion for that year. Furthermore, the authors also mention that for every hospital admission, there are five treat-and-release visits in the ED, at an estimated cost of \$101.9 billion in the year of 2013. Hence, it can be inferred that even though most of the ED patients belong to treat-and-release category, the huge portion of total estimated cost in the ED fall for the patient who stay longer in the ED. ED use increased 15 percent from 2004 to 2014, while inpatient hospital admissions were stable during that period (Wesson et al., 2018).

1.3.3 Healthcare Performance

1.3.3.1 History of Healthcare legislation in the U.S

The nature of US health care delivery system is different from that of other developed nations. There are three key differences: this system relies heavily on multiple sources of private financing, it does not cover everyone and is selective covers, and it costs much more than other nations healthcare delivery system. In 2013, the USA spent the equivalent of \$8713 per person on health compared to the OECD average of \$3453 (Organization for Economic Co-operation and Development [OECD] 2015). It is reported in the data released by OECD 2015, that the total US health expenditures is equal to 16.4 % of gross domestic product (GDP) compared to the OECD country average of 8.9 % (OECD 2015). Out of this expenditure in the US, 52% of expenditures were privately financed, for example by insurers, corporations, and consumers which is more than twice of that to other OECD nations at a 25% average. However, more Americans (15.5 %) were without health coverage for a basic set of services than the people from other countries. Only Greece was lower than the US, where 21% of the total population lacked health coverage (OECD 2015). In fact, most of the OECD countries provided its population with universal coverage (OECD 2015).

The lack of health coverage amongst the general population is not historical in nature. In fact, back in 1964, roughly 75 % of the population had hospital insurance and 50 % had medical insurance (Bureau of the Census 1964). However, increasing premiums and out-of-pocket costs to see a doctor of their choice, kept certain groups out of the market, including low-income workers and aged population (Maioni 1998). The government did try to solve this issue by extending government insurance to military dependents starting from the year 1956. Furthermore, health benefits were extended to federal employees in 1960 to bring more population under coverage, but not all of the population could get coverage. So, in 1960, Congress created a program with the help of the Kerr-Mills Act that provided federal grants to states for the purpose of extending medical expenses for low-income population.

However, Kerr-Mills program, faced much opposition, hence the government acted towards bringing more elderly population under coverage started the Medicare and Medicaid programs via the Social Security Act in 1965 (Maioni 1998). Medicare is a national social insurance program that provides hospital and medical insurance (and prescription drug benefits as of 2006) to aged individuals. Medicaid is slightly different from Medicare in that, it is a joint federal-state program that provides matching funds to participating states that provide health insurance to categories of low-income individuals in accordance with federal requirements.

These two programs did fill the major gaps in the private insurance system held in the US, but there was still some residual as well as newer gaps that needed to be fulfilled. These gaps pertained to coverage, access, and quality. With this gap in sight, Congress amended Medicare and Medicaid to cover the disabled individuals in 1970's. Similarly, in 1973, Congress passed a law encouraging the development of health maintenance organizations to manage insured persons' care, thereby

limiting the total government expenditure in healthcare. A year later, the Employee Retirement Income Security Act (ERISA) was introduced which set minimum standards for private health plans. The 80's were pretty much same but in 1997, Congress passed the Balanced Budget Act to enable Medicare and state Medicaid programs to place more beneficiaries in managed care programs. This Act gave states right to participate in the newly created joint federal-state Children's Health Insurance Program (CHIP), which can be described as a hybrid between Medicaid and private insurance to cover the increasing numbers of uninsured low-income children who were not eligible to obtain Medicaid coverage. The most recent Act was laid out in in 2010, by the Veto of President Obama, Congress passed the Affordable Care Act (ACA), to overcome the worsening condition of healthcare coverage, access, quality, and cost problems in the US healthcare system. Since, this was a massive overhaul, Congress phased the changes in a period of 4-years.

The US healthcare system consists of seven major sources of coverage: employer-sponsored (ESI), individual direct purchase, Medicare, Medicaid and CHIP, the Veterans Health Administration (VHA), the military, and the Indian Health Service (IHS). The benefits provided by each differ from the other and mostly they do not overlap with each other. For example, Medicaid covers custodial care in nursing homes, but Medicare does not, hence gradually eligible individuals often draw from multiple sources to maximize their coverage. A brief timeline of healthcare legislative changes in the U.S presented in the table 1.1 below.

Year	Act
1854	Bill for benefit of Indigent Insane
1933	Social Security Act
1949	Proposal of Universal Healthcare

1951	IRS ruled group premiums paid by employer as tax-deductible business expenses
1965	Medicare and Medicaid signed into law
1980's	Consolidated Omnibus Budget Reconciliation Act of 1985 or COBRA
2000's	Medicare Modernization Act
2014	Affordable Care Act

Table 1.1 History of Healthcare Legislation in the U.S (Balasubramaniam, 2017; Simpson, 2016)

1.3.3.2 Impact of Healthcare Legislation in the ED Performance

The USA has always relied predominantly on market forces to finance health care services. While it is true that specific demographic groups receive publicly financed health care, the country has never enacted universal health care coverage despite multiple debates on the topic. Because of this reality, approximately 40 million USA residents are uninsured. Carrasquillo et al (1999) implied that there is a lack of insurance coverage means that these individuals, as well as others who have inadequate private or public insurance, and must rely on a diverse and poorly organized system of care referred to as the health care safety net. A key part of the USA health care safety net is a guarantee for emergency care regardless of one's ability to pay. Despite society's inability to come to consensus over a scheme for providing universal coverage, emergency care is provided to all via an unfunded Federal mandate (Asplin, 2001). While virtually all agree that it is good public policy to provide emergency care without demanding a source of payment, the lack of funding has contributed significantly to the inadequate supply of staffing and beds in USA hospitals (Fields et al., 2001). Recently studies investigating the impact of medical cost sharing requirements, referred to as out-of-pocket (OOP) medical spending has implied that OOP constrains the demand for health care, and therefore its cost (Baird, 2016). The author further assert that such practices can

result cost-related reductions in medical care, and hence contribute to worse health outcomes and financial burdens. A recent Commonwealth Fund study comparing the health care systems in 11 countries placed the United States last in terms of both access and equity, rankings in large part due to the United States' high OOP spending requirements (Baird, 2016). Moreover, lack of health insurance forced many patients to avoid seeing doctors and visit the ED's as the last option. Therefore, these three factors of supply, demand and performance constraint is impacting the ED performance and increasing ED congestion.

1.4 Research Objective

This research points out the gap in the current ED management system to overcome congestion. For example, the current literature suggests ambulance diversion mechanism as a solution to overcome ED congestion. However, the limitations of this solution is that, a total ambulance diversion is not possible. In addition to that, there are those patients who arrive on their own hence the ED might still keep on getting patient. Above all the major issue is that, it might create a domino effect where the other nearby ED's also gets in congestion. Hence, a more concrete solution should be provided. In this regard, the current literature is missing one crucial variable in the ED management, "time". It is very important to note that "time" plays an important aspect in a complex process as medical process to provide quality service to patients. If the triage nurses have enough time to process the patient information, both the incoming and existing patients, then it will be easier in the decision-making process. This research highlights the importance of the time that patient information is made available to the hospital staff in particular to the triage nurse. The early information is going to make the decision-making process much easier and hence, help in the reduction of ED congestion.

One of the reason for “time” being of essence in ED is due to “Length of stay (LOS)” which is perceived as an important indicator of quality of care in EDs and increased LOS at EDs may contribute to systematic problems in the delivery of efficient and high quality medical care in the U.S which also mean that patients wait longer to see ED physicians and to obtain critical treatments and test results (Karcer et al., 2012). According to queuing theory, as occupancy increases, wait times and service delays increase exponentially (Cesta et al., 2013). Since, organizations have started to recognize the association between patient flow and quality care and there is more than a causal relationship between LOS and cost of care. Wrong medications or treatments, including over-utilization of medications and treatment; misuse of product or personnel resources; delays in care processes, including core measures has been shown to affect the care given to a patient in the ED (Cesta et al., 2013). Hence, this study aims to reduce the total length of stay so as to improve quality of care, and while doing so the ED congestion will decrease since length of stay is an indicator to the total wait time during medical procedure (Karcer et al., 2012; Green and Liu, 2015).

1.4.1 An Example with RFID

Radio frequency identification (RFID) is a recent innovation which is considered to be the next big thing in the IT revolution (Tzeng et al. 2008; Umar 2005; Zang et al. 2008). Emergence of RFID has dramatically affected a number of industries particularly in the field of supply chain (Curtin et al. 2007; Ngai et al. 2008). It has been adopted in industries such as logistics (Ngai et al. 2007a, b), manufacturing (Swedberg 2006), food safety management (McMeekin et al. 2006; Kelepouris et al. 2007), transportation (Caputo et al. 2003) and as potential key enabler to improved patient safety (Ngai et al., 2009). RFID (Radio Frequency Identification) technology has been widely used in the Healthcare sector for better and more reliable information transfer

mechanism that can provide secure quality services (Yao et al., 2012). In its present state, RFID systems have been extensively integrated into hospital information systems for full automation of patient identification, staff allocation, patient's medication and patient management (Yazici, 2009). RFID's generated information has been illustrated for its potential applications in healthcare environment. In short, RFID acts as a tool that helps in secured and seamless communication mechanism within different units of a hospital.

RFID till date has been used as a tool for inventory management, its specialization has been to track products and devices in the supply chain. Some of major areas that the RFID has been implemented are: construction (Valero et al., 2015), Food supply chain (Biji et al., 2015), libraries (He et al., 2014; Singh and Mahajan, 2014), Industrial applications (Rantasila et al., 2014), agricultural sector (Costa et al., 2014) and healthcare (Chong et al., 2015). The table 1.2 below lists the focus of the above-mentioned studies and their key findings in the applications and impact of RFID. It is time to realize that the RFID can be used for much more significant process in the supply chain system compared to its current use.

Reference	Focus of Review	Key Findings
Chong et al., (2015)	RFID adoption in healthcare supply chain	Discusses the importance of RFID adoption in the supply chain size of the healthcare. In particular in transferring and reusing of medical equipments
Valero et al. (2015)	A review of RFID applications in construction	Highlights the existing developments, limitations and gaps. The review highlights the use of RFID in four main stages of the lifecycle of a facility: planning and design, construction and commission and operation and maintenance
Biji et al. (2015)	A review of RFID-enabled packaging systems for the food industry	Reviews the implementation of RFID in smart packaging and tracing of products within the food supply chain
He et al. (2014)	RFID application research for discrete manufacturing	Highlights the applications, benefits, and challenges of

		implementing RFID in the broad industry of discrete manufacturing
Singh and Mahajan (2014)	A review of RFID and its use in libraries	Highlights the applications, benefits and challenges of deploying RFID systems in libraries
Rantasila et al. (2014)	A survey of the Finnish RFID sector	Highlights the applications of RFID in different industries in Finland
Costa et al. (2013)	RFID research publications in the agriculture-cum-food sector	An overview of developments in RFID research in the agricultural and food sectors. It identifies and evaluates the current and potential applications of RFID in the production and distribution of agricultural produce and products.

Table 1.2 Different Fields of Applications of RFID

This seamless and secured communication mechanism provided by RFID helps in obtaining real-time and reliable feedback from different units in a hospital which when used from the initial stage of patient pick up point (ambulance), can help in seamless ambulance diversion mechanism and help in alleviating not only the congestion in ED's but also to generate better quality care for patients. As emphasized by control theory, feedback (both external and internal) is crucial to maintain the smooth running of the system. This research proposes the use of RFID as the communication mechanism for the hospital system. RFID is used as the first point of communication between the patients and the hospital even before the patients arrive in the ED. RFID is used by the ambulance staff as soon as they get to the patient to transfer as much information about the patient as possible at the pick-up point. This information is then directly transferred to the nearest ED where the station nurse checks the ED occupancy (both the ED as well as inpatient occupancy if there is a possibility to clear ED by transferring some ED patients to inpatient department). Since this process is carried out in real time and automatically by the station nurse without the patients having to be physically present, the ambulance will have more time to divert to another closest ED or skip the ED and be taken to other healthcare providers, thus saving valuable time for the patient and hence aiding in providing better quality of care for patients.

The objective of this research is to establish that “time of information availability” to the triage nurses plays an important role in minimizing ED congestion. “Time of information availability” is termed as “Early Information Access”, and if it is positive that is, if the patient information is provided to triage nurses earlier (as soon as possible using RFID devices), then it will have a positive impact on reducing information ambiguity, information coordination and reducing information uncertainty hence, decreasing ED congestion.

Furthermore, this research also aims to study if there are any moderators that impacts the effect of “early information access” on reducing ED congestion. If the impact is positive or negative and what are those moderating factors will also be discussed. In short, this research aims to contribute both the healthcare practitioners as well as researchers. In terms of healthcare practitioners, this research aims to identify the additional technology as well as employee support that needs to be implemented to reduce the congestion. For the healthcare researchers, this research will analyze the existing theories (organization information processing theory, theory of planned behavior and theory of reasoned action) and identify “time of information availability” or as termed “Early information access” is an important factor that needs to be included in the above mentioned theory when applying it in the field of healthcare studies since, “time” plays a crucial role in determining the quality and performance of a healthcare system.

1.5 Organization of this paper

The paper discusses the current literature in the hospital ED congestion, its resolution and existing use of RFID in section 2, section 3 will discuss about the theories used (OIPT, RBV, TRA and TPB) and explain how these theories can be extended in this study as well as modification needed to these theories to explain the phenomena of ED congestion, furthermore section 3 also extends

to explain support to the proposed hypothesis based on the theoretical development explained earlier in this section. Section 4 will discuss about the methodology, section 5 will list the results obtained from the path analysis, section 6 will provide a discussion of the results obtained, section 7 will provide future implication along with both the theoretical as well as practical contribution of this study and finally in section 8, limitation of this study will be discussed.

CHAPTER 2

LITERATURE REVIEW

The overcrowding of Emergency department (ED) has been noted as a growing problem in the United States (Committee on the Future of Emergency Care in the United States 2007; McCaig and Ly 2002; Burt and Schappert 2004; Derlet, Richards, and Kravitz 2001). The Committee on the Future of Emergency Care reports that there has been a steady rise of 11.4% in the wait time to see an ED physician between 1997-2004. The median wait time for patients diagnosed with pre-existing medical conditions such as: acute myocardial infarction (AMI) increased from eight minutes in 1997 to 20 minutes in 2004, with even more longer waits reported for the urban areas and the teaching hospitals (Wilper et al. 2008). In the U.S.A, the Affordable Care Act 2014, brought about a major change in terms of change in the nature of healthcare cost coverage for both patients and hospitals. This did impact the hospitals revenue and their perspective of patients toward using healthcare services. In addition to that hospitals modeled its cost structure to match the Affordable Care Act (ACA). Therefore, our analysis divides the existing literature in two sections: before ACA and after ACA.

2.1 Before Affordable Care Act (ACA)

Some previous research tries to alleviate the congestion in ED through different mechanism. McClain (1976) reviews research on models for evaluating the impact of bed assignment policies on utilization, waiting time, and the probability of turning away patients. Also, Nosek and Wilson (2001), review the use of queuing theory in pharmacy applications with particular attention to improve customer satisfaction. Customer satisfaction is improved by predicting and reducing

waiting times and adjusting staffing. Jacobson et al., (2006) is dedicated to improving health care through reducing the delays experienced by patients. One aspect of this goal is to improve the flow of patients, so that they do not experience unnecessary waits as they proceed through a health care system. Another aspect is ensuring that services are closely synchronized with patterns of patient demand. Green (2006) presents the theory of queuing as applied in health care. The author discusses the relationship between delays, utilization, and the number of servers; the basic M/M/s model, its assumptions, and extensions; and the applications of the theory to determine the required number of servers. Singh (2006) analyses the theory and instances of use of queuing theory in health care organizations around the world and the benefits accrued from the same. A hypothetical simplistic queuing model is also demonstrated in the literature analysis section to illustrate the point. Creemers, Lamberecht and Vandaele (2007) explain how a queuing model offers an excellent tool to analyze and to improve the performance of health care systems. Mehandiratta (2011) analyses the theory (queuing) and instances of use of queuing theory in health care organizations around the world and benefits acquired from the same. Patient scheduling, resource scheduling, and ambulance services are likely the most extensively referenced management problems in health care. Bell and Allen (1969) use a multiple-server queuing model to determine the number of ambulances needed to achieve specified response rates. The hypercube model which is a spatially distributed queuing model based on Markovian approximations has been one of the most popular techniques to model emergency vehicle systems (Burwell, Jarvis and McKnew, 1993; Larson, 1974). Burwell, Jarvis and McKnew (1992) develop an extension of the hypercube model that contains preference ties and apply the proposed model to the emergency medical system of Greenville County, South Carolina. They conclude that the proposed model could provide good estimates of the emergency system performance when the input parameters are accurately

specified.

Taylor and Templeton (1980) model an emergency anesthetic department operating with a priority queuing discipline. They are interested in the probability that a patient would have to wait more than a certain amount of time to be seen. Haussmann (1970) investigates the relationship between the composition of prioritized queues and the number of nurses responding to inpatient demands. The research finds that slight increases in the number of patients assigned to a nurse and/or a patient mix with more high-priority demands result in very large waiting times for low-priority patients. Taylor and Templeton (1980) consider a priority queue in a steady state with N servers, with two different streams of customers, and a threshold cut-off for measuring service discipline. In this system, a patient with “low-priority” are subjected to cut off” (refused immediate service) and are placed in a queue if “ N_1 ” or more servers are in a “busy-state”, so that “ $N - N_1$ ” servers stays free for “high-priority” arrivals. The patient arrival rate is considered to be a Poisson distribution function and the distribution function for each of its several classes is considered to be “exponential”. The two models considered are such that: one has high-priority customers queue for service and the other has a mechanism where all is lost if all servers are busy at an arrival process. The probability for each of the “ N ” busy servers are along with the expected low-priority waiting time, and a complete low-priority waiting time distribution. The results of this experiment when applied to determine the optimum number of ambulances required to serve both emergency calls as well as low-priority patient transfers implied that low-priority patient transfers took collectively more time than the “high-priority” patients. However, McQuarrie (1983) shows that whenever possible, giving priority to low-priority patients than high-priority patients decreases the service time. This phenomenon can be explained using the idea of shortest processing time first where the removal of shortest processing time task from a queue increases the ability of a queue

to lessen the total service time. In another study, Siddharthan, Jones and Johnson (1996) investigate the impact of patients seeking non-emergency or primary care visiting ED on increased waiting time and costs. The authors propose a need for prioritizing different patient categories and then a first-in–first-out queue for each of these categories. They find that prioritizing of services to patients reduces the average wait time for all patients. However, the results also imply that while the wait time for higher-priority patients is found to be reduced, the impact on the lower-priority patients is that the average waiting time is still lengthier. Au-Yeung et al. (2006) develop a multi-class Markovian queuing network model of patient flow for ED visits of a major London hospital. They use real-time patient data to generate parameters for the model and use discrete-event simulation to solve for the functions of the patient response for the wait time. Fiems et al. (2007) investigate the effect of emergency requests on the waiting times of scheduled patients with deterministic processing times. It is a preemptive repeat priority queuing system in which the emergency patients interrupt the scheduled patients and the latter's service is restarted as opposed to being resumed. However, these are the techniques that have been implemented after the patients arrive in the ED. The question remains that what if the ED is congested when the patients arrive, and they have to be routed to different ED. This technique called "ambulance diversion" is frequently utilized to mitigate emergency department congestion, where the central dispatcher diverts incoming ambulances to other hospitals (McCaig and Ly 2002).

However, ambulance diversions are found to be the cause for increase delays for medical care in several conditions. The American Hospital Association reports that 36% of all hospitals, 56% of urban hospitals, and 64% of teaching hospitals experienced periods of ambulance diversion in 2007. Furthermore, it was found that January was the month with the greatest number of diversions, this was concluded from the data of January 2007 published in American Hospital

Association on 2009. It was found that such diversion was found to be 13% more than other regular hospitals and it was 20% higher than in the month January, when diversions often become a particular problem due to higher hospital occupancy levels (American Hospital Association 2009). Therefore, it can be concluded from these researches, that the existing solutions provided to alleviate ED congestion does not provide optimum solution.

Some research direct towards implementing RFID to streamline patient flow. Radio Frequency Identification Device (RFID) is a wireless automatic identification and data capture technology (AIDC) device that saves lives, prevents errors, saves costs and increases security and therefore improved organizational performance (Wamber et al., 2013). While there is a growing interest in the use of this technology in health care setting, there is little, or no pilot studies performed in many departments to visualize the benefits associated with the use of this technology (Huang et al., 2011). There are several factors that challenge effective use of RFID in healthcare setting such as high implementation costs, substantial gap between technology implementation costs and the RFID-enabled benefits, lack of common standard of usage/data analysis and low operational performance level in a harsh environment (Wamber et al., 2013). One of the challenges that concern the potential use of RFID is its utilization and return from implementation of RFID. This is due to the fact that hospitals have not completely utilized the potential of RFID implementation. However, RFID has not been implemented to communicate the patient information from the patient pick up point to the nurse triage center. This can actually save valuable time when ED's are congested and serve to properly divert ambulances that are bringing in patients with acute disease. The goal of these emerging technologies is to support decision-makers with relevant, timely information that they can quickly interpret at the time and location in which they must decide.

RFID device has been installed throughout the ED in Mayo Clinic, Rochester campus and enables real-time monitoring and tracking of physicians, nurses, allied health staff, patients, medical devices including the ED bed etc. within the ED. RFID data are collected and automatically stored in a database which can be retrieved for offline analysis.

Currently RFID in hospitals have applications that can be grouped under three categories: asset control and management, people monitoring, and asset and people integration (Mogre, Gadh, & Chattopadhyay, 2009). Some of the reported benefits of RFID are: reduced amount of rental, lost or stolen equipment, reduced time spent locating missing equipment, optimized inventory levels and better managed consignment stock, expired products and recall notifications with RFID, reduce shrinkage and ensure high-value items do not expire before use (Reyes et al., 2012). Increased equipment utilization is also demonstrated with simulated data, using a Markov Chain Model (Qu et al., 2011). However, the use is still limited to tracking medical equipment and tracking the medicines given to patients rather than trying to transfer patient information to triage nurses as soon as possible. Along with RFID comes information, in the case of ED, triage nurses receive this information. However, it is also equally important to understand how the information received is used. In most of the cases, the information is received, however it is late. It can be said that “it is not too little too late, but too much too late”.

As the hospitals were already struggling with ED congestion, a new healthcare act called “Affordable Care Act” was introduced in 2014. This act meant that more people were covered therefore the patients who has to visit ED as last resort can now visit doctor’s office and not have to wait in line for ED. However, the reality was far from this scenario. The ED visits for patients with chronic conditions did decrease but the overall ED visits increased (Hernandez-Boussard, et al., 2014).

One other factor crucial to alleviating ED congestion is the rate at which patients can be transferred from ED to IW (inpatient ward) Mandelbaum et al (2012). The authors conduct a study to identify the factors that can instigate a faster patient transfer rate from ED to IW. Furthermore, the study enforces the notion that there is a need to identify the critical factors that impact patient flow, with the ultimate goal being the process of designing and implementing policies, processes, and procedures. Designing and Implementing policies, plans and procedures will help in tracking, monitoring, and improving patient flow throughout hospitals. The empirical analysis presented suggest that an inverted-V queueing model is appropriate for describing the transfer of patients from ED-to-IW. Furthermore, the authors also quantify operational fairness toward medical staff and introduce two major metrics of hospital performance: bed occupancy levels and bed turnover. These metrics serve as operational proxies for fairness, which is an intricate concept. Operational proxies relate to operations, are easy to measure, and they approximate notions that are hard to quantify. However, the major limitation to this study is that, it only studies the fairness metrics using bed-based model, instead it can be studied using another complex staff-based model as well. This staff-based model will enable to study the impact on individual level rather than on firm level. Overall fairness can be achieved by enforcing fairness both at the inter- and intra- ward levels.

Dobson et al., (2013), presents a system that models customer processing using three steps and two resources. The two resources are: investigator and the back office. The three steps are: information collection, decision making and providing of information. In the first step: an investigator collects information from the customers and transfers the information to second step. In second step, analysis is conducted in the information received from first stage in the back office. Finally, in the third step, the investigator will organize the new information and forward it to the

customers. The authors implement this system in ED such as: physician is considered to be the investigator and the lab or radiology as back office.

The physician as an investigator performs the initial examination of a patient and orders further tests in the first step. The tests are conducted by back office such as radiology and lab and conduct analysis on it and returns the additional information to the customer (patients). This information is then carried back to the investigator to get final results using the knowledge base of investigator.

This system can be used to model any overloaded system, such as an ED. Hence, the main objective is to analyze the impact of the investigator's choices on the system performance.

In this study, the main point of view is from that of ED physician, the process of treating a patient has two steps: the initial physical examination including the ordering of tests and the decision-making process after the tests results are received. Since, ED's are almost always crowded, physicians had to decide on how to organize their workflow. Physicians faced situations where they had to choose between examining a new patient or completing the additional analysis work that would enable a patient's discharge. On one hand, this type of prioritization lowered the wait time to see a doctor for a new patient but on the other side, it increased the total stay time of a patient in the ED before being discharged. Furthermore, it also meant that the physical capacity of an ED needed to be raised as well as the capacity of a physician to see a patient simultaneously. This result further supported the claim that task interruptions in ED is a regular phenomenon and the number of task interruptions is correlated to the number of patients currently present in the ED (Chisholm et al., 2000). Some of the most popular studies in ED healthcare is presented below in table 2.1.

Authors	Theories	Research Focus	Key Findings
---------	----------	----------------	--------------

Nosek and Wilson (2001)	Queuing Theory	Pharmacy with high-volume outpatient workload	Reducing wait times is key to customer satisfaction. Queuing theory can help in decision making on various factors of operations management.
Jacobson et al., (2006)	Discrete Event Simulation	Reducing delays in patient care	Discrete event simulation helps to optimize the resources in emergency department
Green (2006)	Queuing Theory	Setting up priority queue to prioritize incoming patients	Patient prioritizing leads to high acuity patients getting early access. Queuing tool is key tool in estimating capacity requirement including demand surges.
Singh (2006)	Queuing Theory	Minimize hospital expense	There is a tradeoff between patient wait time and cost to the hospital for resources.
Creemers et al., (2007)	Queuing Theory	Patient flow management	Increasing capacity utilization will have inverse effect on patient wait time. High degree of variability negatively impacts hospital performance.
Huang et al., (2011)	Behavior Theory Technology Acceptance Model	Impact of technology in healthcare	Information quality and service quality impact use of new technology.
Mehandiratta (2011)	Queuing Theory	Health service capacity planning	Synchronization of work among service stages, scheduling resources and constant system monitoring helps to improve service quality
Qu et al., (2011)	Markov chain model	hospital equipment usage	RFID technology helps in tracking medical devices Optimization of medical devices helps in increasing hospital performance.
Wamber et al., (2013)			Challenges to RFID use results from unclear return on investment from RFID

Table 2.1 Key Findings Before ACA

2.2 After Affordable Care Act (ACA)

The ACA Medicaid expansions were associated with higher rates of insurance coverage, improved quality of coverage, increased utilization of some types of health care, and higher rates of diagnosis

of chronic health conditions for low-income adults (Wherry and Miller, 2016). The authors emphasize that after the implementation of ACA, the main focus was optimizing resources. In this aspect the obstacles that hospitals face while providing quality care to patients is attributed to the delays that arise routinely in various settings (Chan et al., 2016). According to the authors, delays in the context of hospitals are a result of the inherent, highly variable requirements and the overwhelming demand to fulfill these requirements in the form of the services provided by hospitals. (Chan et al., 2016) illustrates that delay in receiving care in intensive care setting can result in longer length of stay in the intensive care unit (ICU). This result further supports the claim that it is very important to provide timely care for the patients in ICU or the ones with acute medical conditions. It can be concluded that the problem with ED congestion is a result of delay in providing services. In recent years, most notably after the implementation of ACA, researches seem to be more focused on optimizing hospital resources and services provided to the patient (Wherry and Miller, 2016). Therefore, the solution such as ambulance diversion is viewed as lesser means to solve the issue. Hence, it became even more important to have an accurate timely information of the incoming patient condition to the ED triage nurses. Since, there was a high probability that resources could be taken by patients with less acute condition. In addition to that Green and Liu (2015) concluded from their research that ambulance diversion has a negative impact on the care of patients with acute condition. It became even more important Therefore, even though ambulance diversion is a frequently implemented method to overcome ED congestion, their needs to be a better communication when diverting ambulance between ED nurse triage system and the ambulance to have optimum output from this method.

Another factor that has gained more focus due to the introduction of ACA is “Length of stay (LOS)” which is perceived as an important indicator of quality of care in EDs and increased LOS

at EDs may contribute to systematic problems in the delivery of efficient and high quality medical care in the U.S which also mean that patients wait longer to see ED physicians and to obtain critical treatments and test results (Karcner et al., 2012). Earlier research conducted before the introduction of ACA has already established that ED crowding compromises patient dignity, privacy, and completeness of care (Boyle et al., 2012). According to queuing theory, as occupancy increases, wait times and service delays increase exponentially (Cesta et al., 2013). Since, organizations have started to recognize the association between patient flow and quality care and there is more than a causal relationship between LOS and cost of care. Wrong medications or treatments, including over-utilization of medications and treatment; misuse of product or personnel resources; delays in care processes, including core measures has been shown to affect the care given to a patient in the ED (Cesta et al., 2013). Therefore, in the era of post ACA, a second and faster communication channel is highly sought after. Few of the key literature in ED healthcare after the ACA was introduced in table 2.2 below.

Authors	Theories	Research Focus	Key Findings
Karaca et al., (2012)	Observational study	Length of stay as indicator to hospital performance	The duration of T&R ED visits varied significantly by admission hour, day of the week, patient volume, patient characteristics, hospital characteristics and area characteristics.
Cesta (2013)		Patient Flow	By taking a proactive approach to patient flow, the number of days your hospital will be bottlenecked can be reduced.
Rousek et al., (2014)		RFID and return on investment	RFID helps to improves efficiency and reduce cost of equipment
Yom-Tov and Mandelbaum (2014)	Queuing Model	Utilized Erlang R model for both the normal as well as mass casualty situation.	A time-varying square-root staffing policy helps to optimize the staff level in an emergency department.

			This works for both the normal as well as mass casualty situation.
Wherry and Miller (2016)	Observational study	State Medicaid impacts on insurance coverage	Introduction of ACA increased health coverage
Chan et al., (2016)	Queuing theory	Service and interarrival delays need to be incorporated in the queuing model.	an effect of system load on work that grows much faster than the traditional $1/(1 - \rho)$ relationship
Boyle et al., 2012	Literature Review	Causes of ED crowding, possible interventions and the results from the interventions	The ED crowding is caused not just because of the high volume of patient but also due to the type of care and level of acuity of the incoming patients. ED is considered to be crowded when the occupancy reaches 90%
Batt and Terwiesch (2015)	Queuing Theory	Emergency Department Crowding	Patients leave if the wait time is higher. Patients react to being jumped in line when waiting in ED.
Terweiesch (2017)	Queuing Theory	Emergency Department	The ED queue should be treated as a finite length queue since ED actually work in shifts. Patients total treatment time depends on the physician's work shift attending the particular patient.

Table 2.2 Key Findings After ACA

Batt and Terwiesch (2015), discuss the reason and impact of queue abandonment (also known as renegeing) and its importance. The authors state that abandonment is undesirable in most service provider settings since it leads to a combination of lost revenue and negative image of the service provider. In a hospital emergency department, abandonment is even more potent since it might result in the added risk of a patient suffering an adverse medical event. Although the blame might not fall completely on the hospital, an adverse medical condition on a patient is clearly not a desirable situation if it can be avoided. An empirical analysis was conducted on a hospital emergency department. In this analysis patients were allowed to watch the waiting room, but they

were unaware of the happenings in the service-delivery section also known as the treatment rooms. Moreover, even though patients were able to observe the waiting room, they were not given a clear information about the waiting time or their queue number. Other important factors with which the patients can deduct their relative wait time for example: arrival order, priority level, assignment to separate service channels, and the required service time of others were also not provided. This experiment analyzed how a particular patient's observation and experience regarding their waiting exposure impacts their decision to abandon the queue. The authors used a detailed time-stamp data of 180,000 patient visits that were obtained from the ED's electronic patient tracking system, they were able to reconstruct a set of variables that patients created themselves to reach their decision of abandonment or non-abandonment. The results showed that patients observe and consider two variables: stock variables and flow variables to make their decision of abandonment or non-abandonment.

In another study, Batt and Terwiesch (2017) study a multistage service process that adapts to system occupancy level. The authors argue that by using operational data from more than 140,000 patient visits to a hospital emergency department, they were able to conclude that the system-level performance of the emergency department is an aggregation of several simultaneous server-level workload response mechanisms. They imply that "*early task initiation*" is a "between-stage" adaptive response mechanism that occurs when an upstream stage initiates tasks normally assigned for a downstream stage. Furthermore, the authors state that it is always fruitful to have some additional diagnostic tests performed during the triage process since it reduces treatment time on average by 20 minutes. However, the disadvantage of too many tests during triage period might lead to an increase in the total number of tests performed on the patient. Moreover, other response

mechanisms such as queuing delays impact processes such as medication delivery resulting in nurses spending relatively less time with patients when the queue length is longer.

2.3 Development of RFID Technology

Furthermore, the evolution from passive RFID tags to smarter sensing platforms promises a new world in healthcare IT applications as fine-grained real-time data becomes available. Healthcare applications using RFID technologies are a new trend as patients are able to monitor themselves with telemedicine, track their activities. The term called “hospital of the future” uses RFID technologies to track patients, staff, and equipment, as demonstrated in the Healthcare Information and Management Systems Society Conference (HIMSS). In addition to that, decision support systems will also benefit from the faster, finer-grained, and highly accurate technology. There is also the case of unstructured application domains, known as Emergent Knowledge Processes (EKPs), that can gain from access to more real-time information. One area of healthcare that can leverage the benefits from EKPs is the intelligent machine learning that is based on clinical support systems. This can be used to diagnose complex medical conditions. Both the static (traditional tracking of patients, care providers, and equipment/supplies) as well as dynamic (data driven EKPs) healthcare IT applications, will benefit from a wide range of RFID technology and applications. The use of RFID device has been attributed to a decrease in health care costs, to improve patient safety and to provide an overall efficiency in process flow in health care delivery systems (Rousek et al., 2014).

One way to offer a seamless and secured communication line is through the use of RFID and different departments of hospitals are already using it, then why not implement it as soon as the

patients are picked up by the ambulance rather than wait till the patients reach the ED. With the modification of several aspects of categorization, (Green and Liu, 2015) employed a classification of three major subgroups of queuing research models applied in health care management: (1) health care system design, (2) health care system operation, and (3) health care system analysis. In case of a medical emergency, it is very important for ambulance services to reach the site as quickly as possible. Patient waiting time in this situation is a key indicator for ambulance system performance.

Furthermore, the delay in the ED is mostly attributed to lack of proper information flow amongst the service providers within the realm of the hospital. For example, the delay in the information flow from incoming patients to triage nurses cause the delay in decision making process and can impact the possible clearance of hospital resources to accommodate the incoming patient. Therefore, there is a need to implement devices or system that can speed up the process of information transfer, for example RFID.

There has been research on how to track the patients, how to streamline the patient flow and optimize hospital resources. However, there is negligible research on tracking information flow. Since, all these hospitals use electronic system, using electronic tracking of patient flow should be one avenue where more research should be focused. The impact of information availability on the rate at which patient is admitted in ED or transferred from ED to inpatient ward is an important factor that needs to be studied.

The high volume of ED congestion contributes to not only higher usage of physical resources but also higher usage of human resources. In past, suggestions like hiring more nurses were provided (Yom-Tov and Mandelbaum, 2014), but since the hospitals are in all resource optimization path, human resource is also considered for optimization. Triage nurses have immense work load, so to

get them to work near perfectly or close to perfection or motivate them, it is important to develop a sense of positive attitude towards the technology. In absence of such positive attitude, these technologies will fail to justify its implementation and hence will not result in the desired impact making it redundant. Therefore, in addition to installing information processing systems, it is equally important to provide support for the implementation of such systems including timely information access and staff trainings on how to use these systems. A system is as good as the staff using it. As discussed by Demerouti and Bakker (2011), the Job-Demand Resource (JD-R) Model describes that the implementation and success of any novel technology in an organization is related to the perception of the employees towards the technology. The perception of employees towards the employee determines their behavior towards the use of it. There are various factors that impact the perception of employees. One of the factors discussed is quality or number of additional helps that is provided to employees to use the new technology. This can be provided in terms of workplace trainings related the new technology.

Furthermore, JD-R model also provides a relationship that establishes that employee satisfaction helps in increasing employee output. Employee satisfaction can be increased by providing easier work place environment, that is by providing ample support and technologies to employees to make their working condition and procedure easier. In addition to that, providing supporting trainings when newer technologies are introduced helps to create a positive perception towards the newer technologies. Employees will have lesser trepidation towards using the technology and hence the use of technology increases and so the desired outcome increases. Therefore, evaluating the employee perception by introducing variables such as the number of trainings provided to the employees are equally important to understand when analyzing a better output from a use of a new technology. Therefore, this study aims to find additional factors other than lack of “timely

information” that might impact the proper use of RFID and therefore help in reducing ED congestion.

Another major issue in the current ED congestion scenario is the lack of proper theoretical based research. Most of these studies are based on mathematical models ED as a standalone entity, very few research ventures into ED as a socio technical model where there is interaction amongst the technological system and human. One key aspect to explaining the ED congestion is lack of proper information at the right time (early information) is through the use of Organization Information Processing theory. Organization processing theory states that the information requirement needed by the organization is fulfilled by the organization by increasing its information processing capacity or it decreases its information requirement. In addition to that, OIPT also states that the key reasons behind the mismatch between the information processing capacity and information requirement of an organization is the result of three factors: information uncertainty, information ambiguity and information coordination. If these three factors are properly managed, then an organization can match its information processing capacity and information requirement.

In short, the existing literature seems to fall short in explaining the reasons behind the congestion in ED. The research seems to be highly concentrated in solving the issue using queuing models and introducing new technology, however does not discuss the importance of human-computer interaction or the lack of it in the existing scenario. This results in slow information transfer and inadequate information processing which results in ED congestion. Hence, by outlining this gap in existing literature, this research aims to provide potential solution to the ED congestion by utilizing organization processing theory and the theory of reasoned action and theory of planned behavior.

2.4 Health Information Exchange

Health information exchanges (HIEs) is one of the latest technologies introduced in healthcare systems that are expected to improve information coordination in emergency departments (EDs) Ayer et al (2019). However, there is a lack of concession amongst the healthcare management teams on how to optimally use HIE's in their respective systems. Ayer et al., (2019), studies the relationship between HIE and length of stay (LOS) and find that introduction of HIE in a hospital resulted in a 10.2% decrease in LOS furthermore, it was also found that the decrease in LOS was further 14.8% when the hospital was a part of an integrated health system. Moreover, the impact was more prominent in teaching hospitals compared with non-teaching hospitals. In addition to that it was found that the LOS in ED for patients with severe or multiple comorbid conditions was lowered. Therefore, it can be concluded that introduction of HIE resulted in shorter LOS and the benefits were found to be even higher for individual hospitals.

CHAPTER 3

THEORETICAL BACKGROUND AND HYPOTHESIS

3.1 Organization Information Processing Theory

Organization Information Processing Theory (OIPT) has been used in various organization settings to explain the interaction between organization settings and information requirements of an organization. Galbraith (1973, 1977) emphasize that firms should organize and use information effectively when executing tasks that involve uncertainty and interdependence. Srinivasan and Swink (2015), implement OIPT in leveraging supply chain settings and use Galbraith ‘mechanistic model’ to coordinate actions, rules, hierarchy, targets and goals to resolve exception scenarios. An organization’s structure serves to “coordinate the interdependent subtasks which result from the division of labor” (Galbraith, 1973, p.3). The authors explain “exception scenarios” with an example of firms may encounter uncertainties in supply due to capacity problems faced by an upstream supplier. Galbraith suggests that such an unanticipated event can be resolved by referring the problem to a manager that oversees the boundary-spanning employees. However, such a mechanistic approach can quickly become overwhelmed in highly uncertain situations, where the frequency of exception scenarios is dramatically increased. From an OIPT perspective, the firm can contend with the increased frequency of “exception scenarios” either by decreasing its *information processing needs* or by increasing its *information processing capacity*. An organization can reduce its information processing needs by creating slack resources or by creating self-contained tasks. For example, when the focal firm faces supply fluctuations, it can minimize its information processing needs by carrying additional inventory (i.e., safety stock). Alternatively,

the organization can increase its information processing capacity by investing in both lateral relations and vertical information systems. Examples of lateral relations include the organizational processes and relationships (e.g., direct contacts, liaison roles, teams) associated with *customer integration* and *supplier integration* externally, and *internal integration* across different functions within a firm. Hence, from the view of OIPT, firms that engage in SCI efforts can be seen as choosing a path of increasing their information processing capacity through extending lateral relations. Vertical information systems, Galbraith's other means for increasing information processing capacity, are mechanisms that allow an organization to process information during task performance in ways that do not overload hierarchical communication channels. In other words, vertical information systems allow an organization to adjust or make new plans rapidly, with minimal resource costs. SCMS are examples of such systems. Importantly, from an OIPT perspective, SCMS define decision frequency, the formalization of language, and the types of decision mechanisms and logic; these are the primary design elements of Galbraith's vertical information systems.

OIPT is used in this study, since the congestion in ED setting is due to high volume of incoming patient. In literature review section it has been established that previous studies conduct different analysis to overcome the ED congestion. Most of the studies tried to queue patients and optimize its resources. However, none of those studies tried to analyze the congestion from the perspective of information congestion. The incoming patients in an ED, bring information with them and the hospitals have to process that information to provide services to the patient. Hence, using OIPT in an ED setting to explain the congestion, can help to understand and solve the congestion. The congestion is not due to high volume of patients, but rather due to lack of hospital's ability to align

its information processing capacity with its information need. Although, a perfect alignment might not be able to be met, a somewhat perfect alignment can help to reduce the ED congestion.

3.1.1 OIPT in Entity Form

Even though, OIPT has been used to analyze the information need of an organization (cite), it has seldom been used to explain the phenomena of information need in an ED. Therefore, the novelty of this study is in extending OIPT in the healthcare sector. Literature in ED congestion studies mainly based on queuing theory (cite), however patients bring in information and hence, being able to explain the information congestion is needed to understand and solve ED congestion. Furthermore, even when studies use OIPT to define the information processing phenomena in an organization, they apply it as whole without breaking it down into its entity form. There are three different entities of the information processing, and this study identifies the need to analyze each of these entities separately to establish the actual nature of OIPT. Since, OIPT has three entities, it is not necessary that all three entities behave in the same manner. This study proposes that each entity has a separate and different impact both in terms of sign and magnitude on the information processing capacity of an organization.

The entities of OIPT: information uncertainty, information ambiguity and information coordination has individual impact on the information processing capacity of an organization as shown in figure 1. When studied together, it is unclear as to which entity has higher impact and which one has lower, these entities will not always have same impact and cannot be measured using same underlying variable. Hence, this study first works towards breaking down OIPT into entity level and then analyze its impact as shown in figure 3.1 below.

Therefore, this study sought out to breakdown the OIPT into its three entities and establish each entity as a separate factor that helps an organization to align its information need with its information processing capacity.

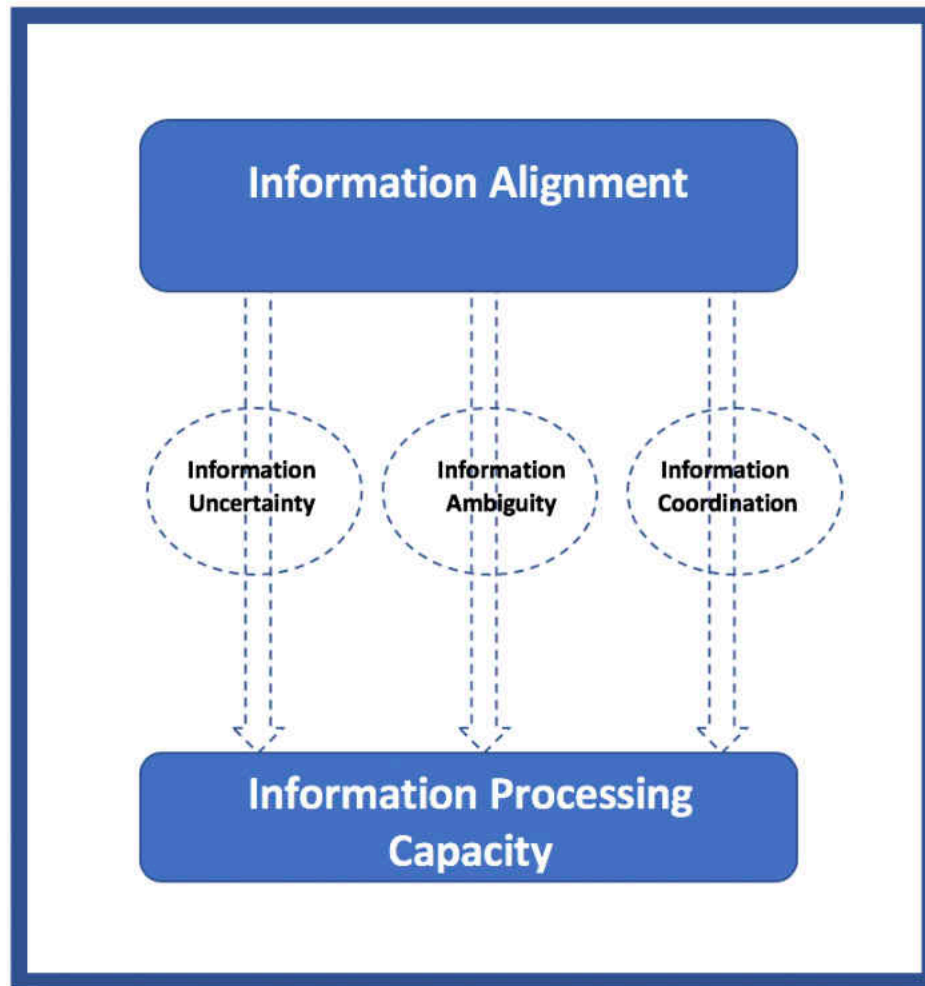

Figure 3.1 Organization Information Processing Theory Breakdown For Emergency Department Scenario

3.1.2 Decreasing Uncertainty with Information Processing Theory

According to OIPT, organizations face different levels of uncertainty, i.e., "the difference between the amount of information available and the amount of information required to perform the task at the desired level of performance" (Galbraith, 1973). This difference characterizes the information

processing requirements of the task. Bento (2006), presents a model that illustrates various interaction in an organization from socio-technical point of view. This study adopts this model and extends it in an ED scenario. The rightmost column in Figure 3.2 shows three factors (Information uncertainty, information coordination and information ambiguity) which is based on OIPT. According to OIPT these three factors influence the information processing requirements that an organization must meet. These three factors influence information processing based on: industry, scope of operations, and size of the organization. Bento (2006) shows that not all industries are same in terms of: velocity and predictability of change. This results in varying levels of uncertainty hence, resulting in different information requirements. Similarly, uncertainty resulting from information requirements also changes as an organization expands, therefore it has a direct relationship with the size of an organization. In addition to that, geographic scope of operations (regional, national, international, or global) and size (small, medium, large) organizations impact the uncertainty level faced by an organization therefore resulting in different information requirements. OIPT states that an organization can cope with increasing information processing requirements by reducing the level of uncertainty using mechanisms such as “buffering” or by increasing their information processing capacity through structural mechanism or improved information flow. The two middle columns in the model in Figure 3.2 represent those two ways of increasing information processing capabilities. The column labeled "Organizational Capabilities" includes factors such as:

1. Employee size to help enhance the organization's capabilities to process information;
2. the degree to which management's decision-making style affects information flow by introducing supporting IS policies to facilitate proper information processing (IS Policies) or by relying mostly on one-way vertical communications (Command and Control styles).

The column labeled "Technological Capabilities" includes factors such as:

1. The types of technology used in the performance management system to generate and process information: Electronic Medical Records (ERM) or specialized tools (RFID, DSS-Decision Support Systems);
2. The level of use wireless connectivity to facilitate the flow of information.

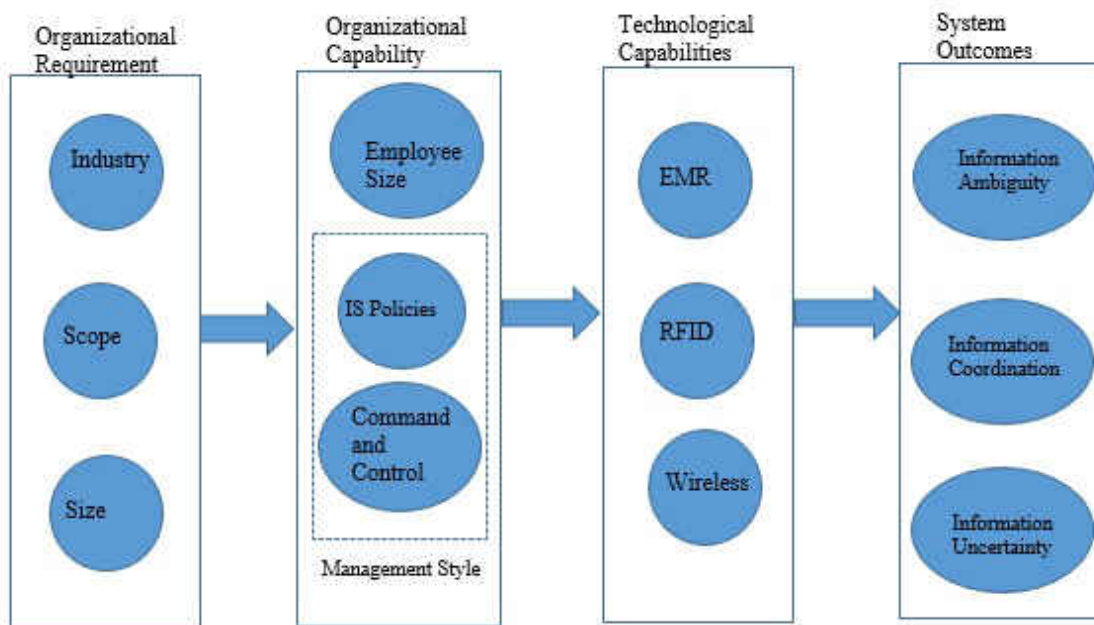

Figure 3.2 Interactions of system, technology, organization capabilities and organizational requirements.

Information ambiguity is defined in the literature as the degree to which value and meaning of same information differ from one user to another. The actual information ambiguity is widely considered an important measure of IT success in organizations and has been found to have a strong correlation with the perceived usefulness of a system by the user (Mahmood, Hall and Swanberg, 2001).

Information Coordination is the degree to which the sub system delivers its intended results i.e, the interface of each sub systems transfers information seamlessly, so that the sub systems receive information in the language they can understand and process.

Information Uncertainty is a result of combination of information coordination and information ambiguity. In addition to that, size of information also plays a vital role in information uncertainty. The factors identified in the model in Figure 1 were inspired by Organizational Information Processing Theory, or OIPT (Galbraith, 1973, 1977, 1980; Gattiker and Goodhue, 2004; Premkumar, Ramamurthy and Saunders, 2005).

Information processing has been defined as “the gathering, interpreting, and synthesis of information in the context of organizational decision making” (Tushman and Nadler, 1978, p. 614). Information processing theory (IPT) was developed by Galbraith (1973) by integrating the work of several scholars such as: Burns and Stalker (1961), Lawrence and Lorsch (1976), and others. The main focus of OIPT is to figure out how an organization can structure its need for information and how an organization can apply that information. Galbraith expanded OIPT to understand the phenomena of how reducing the task uncertainty would help in increasing the impact of application of the information in an organization. The organizations were differentiated based on its information needs. The result supported the initial claim made by Galbraith that difference in organizational structure correlates with the amount and type of information required to reduce task uncertainty. Therefore, it can be claimed that task uncertainty is the result of imbalance in organization structure.

There are a number of sources that results in task uncertainty and Tushman and Nadler (1978) identify three sources of task uncertainty and these are typical occurrence in a hospital setting. The three sources are as follows: task characteristics; sub-unit task environment and inter-unit task

interdependence. Task characteristics include task complexity and intra-unit task interdependence. The sub-unit task environment is the degree to which the external environment is outside the unit's control, in addition to that, it also measures the degree to which the environment is static vs. dynamic. Finally, inter-unit task interdependence is the degree to which the sub-unit must interact with other units to exchange and coordinate information. Galbraith (1973) and Tushman and Nadler (1978) imply that uncertainty in organizations can be reduced by implementing an iterative process in which managers analyze situations using highly specific questions which are narrowed down with each iteration. They are then utilized to shape their respective actions based on the responses received, which is then conducted throughout successive iterations. In other words, it can be implied that more information (abundance of information) is helpful to reduce information uncertainty.

In an ED where there is high uncertainty due to all three sources, since there is both task complexity as well as inter-unit dependency. The ED task is complicated not only due to the unknown number of patients arriving but also due to its dependency on other factors like how soon the patients can be transferred to inpatient department or how soon doctors and another provider can facilitate the incoming patient. Therefore, to minimize this uncertainty, the decision makers should be able to follow an iterative process that provides a way to generate responses and then use those responses to make future decisions. In the case of ED, the decision makers are the triage nurses who make the decision to divert ambulances. In addition to that, providing information as soon as possible to the concerned party be it triage nurse or other clinical staff is of utmost important. Since, this helps in making knowledgeable decision. In terms of making a proper decision based on iterative process, early information helps since, it helps in comparing the results from the iterative process and hence crucial time can be saved. Therefore, to make a diversion decision that results in

optimum quality of care resulting in less unnecessary diversions requires both the past data as well as current resources usage and available at their disposal. A system that can predict the actual condition of ED resource usage is what they need, however they need to be able to gauge the current situation as well. The past data can be readily available and if the current usage as well as required resources is made available then the diversion decision have less error. Since, this paper proposes the use of RFID at the patient pick up point rather than when the patient reaches the ED. The nurses at the triage station will be able to get real time resource requirement information from different incoming ambulances. Hence, it will be easier for them to review all the required resources and the patient condition in transit. Therefore, the use of RFID at the patient pick up point will provide nurses at the triage much needed look into the number of incoming patients and the probable resources that they will require. Hence, giving them the additional time to make the diversion decision. This will then lead to decrease in the unnecessary ambulance diversion during the ED congestion.

Hypothesis 1a: Early information access tends to decrease information uncertainty and, this leads to lower “average number of wait days for a procedure to be performed”, and in turn lower ED congestion

Hypothesis 1b: Lower Information Uncertainty tends to increase hospital performance i.e, lower “average number of wait days for a procedure to be performed”, tends to lower the length of stay.

3.1.3 Decreasing information ambiguity amongst provider with the help of early information

Hospital ED has many providers working together to provide service to patients. One of the issues is that each of these providers have different set of information and knowledge, which is important

to be communicated properly to provide quality care for patients. This becomes even more crucial during ED congestion. As (Lawrence, 1976) explained the differentiation, in that providers involved (nurses, physicians, technicians) embody different bodies of knowledge, technical language and perspectives that can lead to differences of opinion, therefore a technology like RFID that helps as a shared platform to exchange information as well as integrate these information from different providers as well as have these information accessible to each provider in their own format will help to decrease the additional time that can help in providing quality care for patients during ED congestion, hence smooth running of ED and timely transfer of patients to inpatient department.

Knowledge ambiguity is defined by the degree to which knowledge can be transferred. In short, the ease or difficulty of knowledge transfer is what creates level of knowledge ambiguity. It has been defined in various literature and this study will also borrow the same definition as construed by: ambiguity (Nouraei et al., 2015), causal ambiguity (Reed and DeFillippi, 1990; Mosakowski, 1997), difficulty to imitate (Foss et al., 1995; Amuna et al., 2017), inertness of knowledge (Kogut and Zander, 1992), internal stickiness (Szulanski, 1996), sticky information (von Hippel, 1994), and transferability (Grant, 1996b; Nouraei et al., 2015). Similar to the notion of causal ambiguity, knowledge ambiguity also encapsulates a similar lack of understanding of the various logical linkages present between actions and outcomes, inputs and outputs, and furthermore between causes and effects that are related to technological or process. Causal ambiguity due to its difficulty in skill and resource deployment are considered to be the sources of competitive advantages since it creates barriers to imitation (Reed and DeFillippi, 1990). In a similar fashion, casual ambiguity can also be considered as competitive advantage in the context of strategic alliances, where it diminishes the effect of learning from a partner.

Tacit, asset specificity, prior experiences, prior experience, complexity, partner protectiveness, organizational distance and cultural distance are found to be the attributes of information ambiguity. However, in an ED situation the factors that interferes the most are: tacit, specificity, complexity and experience. Reed and DeFillippi (1990) define tacit as the implicit and non-codifiable collection of skills that depends on learning by doing. Tacit knowledge, in short is a knowledge that is possessed by an individual, which cannot be easily communicated and shared. It is deeply rooted in action and personal experience. These depends on an individual's involvement within a specific context. On the other hand, knowledge specificity can be described as the transaction cost required for knowledge asset transfer. Knowledge complexity can be defined as the number of inter dependent technologies, since more inter-dependence requires a wider and complex knowledge base as well as knowledge transfer session. Experience is defined as the level of degree to which the learner can seek information. Experience can be defined as a sub-set of tacit knowledge.

Early information access makes information available in a much earlier phase of the process, which leads to ample time for the concerned stakeholders to be able to overcome all four of the antecedents of the information ambiguity. Tacit nature of information cannot be reduced easily, however, reserving the resources (doctors and nurses or equipment's) required for the particular patient can be carried out easily if pre-notification of the resources can be transferred to the concerned parties. Anderson (2015) imply that in most cases, the delay in hospitals are not due to lack of resources but rather due to lack of optimized usage of the resources. Hence, early information access can lead to the early knowledge of the required resources and thus can lead to decreasing information ambiguity. This will lead to freeing up of ED resources, therefore less requirement for ambulance diversion.

Hypothesis 2a: Early information access tends to increase information coordination and, this leads to lower “average number of patients discharged from ED”, and in turn lower ED congestion.

Hypothesis 2b: Higher Information coordination tends to increase hospital performance i.e, higher “average number of patients discharged from ED”, tends to lower the length of stay.

3.1.4 Early Information Access and Information Coordination

OIPT implies that iterative process helps in accommodating information processing requirement. However, there are other factors that needs to be included as well, these factors are: planning comprehensiveness, planning processes. In terms of information coordination, planning comprehensiveness plays a crucial role. Planning comprehensiveness is one such factor that has been in use and study since at least early 1980’s. This factor was studied by various scholars in different fields, such as: strategic management (Fredrickson, 1984; Fredrickson & Mitchell, 1984; e.g., Fredrickson & Iaquinto, 1989), information systems management (e.g., Segars & Grover, 1999) and supply chain operations management (Fawcett, Stanley, & Smith, 1997; Cachon & Fisher, 2000; Papke-Shields et al., 2006; Hall, Skipper,&Hanna, 2010). The scholars in strategic management were key to provide a proper and well-grounded definition to this term “planning comprehensiveness”. One such definition explains it as the “extent to which organizations attempt to be exhaustive or inclusive in making and integrating strategic decisions.” (Fredrickson & Mitchell, 1984, p. 399).

“Planning processes” is defined as process that includes: goal-setting, scanning the environment, and searching and evaluating alternatives (Fredrickson & Mitchell, 1984; Powell, 1992; Papke-Shields et al., 2006). This process can be conducted on a limited scale with the information already available or on a wider scale where additional information is mined. Moreover, it can be

characterized by an organization use of formalized, systematic processes to set short-term and long-term goals and priorities as well as its objection towards performing various activities such as: scanning information alternatives and analyzing risks and benefits of the information mining process (Powell, 1992; Fawcett et al., 1997). Furthermore, the authors also classify the planning process based on behaviors such as: scrutiny of wide ranging alternatives, survey of a range of objectives, careful weighing of costs and risks of different consequences, intensive search for information to evaluate alternative actions, objective evaluation of the information that is gathered, reexamining the pros and cons of all the alternatives, and making detailed plans that explicitly address the contingencies for implementing the chosen action (Janis & Mann, 1977). It is claimed that performing all of the above seven steps can reduce information uncertainty to a certain extent since these steps provide a better information latency and value for the new information.

From an OIPT perspective, planning comprehensiveness and the steps taken during planning processes reduces information uncertainty. Daft and Lengel (1986) highlight that a second source of information uncertainty indicator is “equivocality”. The authors define equivocality as the existence of multiple and conflicting interpretations of any particular organization scenario. Equivocality is such a factor that cannot be diminished simply by collecting more data or conducting iterative actions. However, equivocality can be resolved by performing additional processing that can facilitate idea creation and exchange amongst peers (Daft and Lengel, 1986).

Information uncertainty is a result of lack of information coordination. Information coordination is vital since seamless information exchange results in reduced overall time to execute a medical process. It is implied that better information access leads to faster service provided to the patients and hence this leads to shorter length stay. The problem in an ED environment is that, there are multiple clinicians that provide service to a single patient. They all work in different platform; the

information requirement might not be very different but the way it is provided is different. This leads to all of the clinical service providers having different information platform and presentation styles. When a patient moves from one service provider to another, their information should be transferred as well. However, this handover of information has some time lag. This time lag adds additional time to the patient's clinical procedure. Hence, a system that can provide a platform to exchange information over there different platforms will lead to a better required information access to the respective clinicians. This leads in the scenario of ED the equivocality mainly results from different operating platform used by different clinical practitioner involved in the medical process. This is due to different practitioner needing different information and the sensitive nature of the information involved. Therefore, during ED congestion, predicting the level of resource required is next to impossible. This task is not only highly uncertain, but also ambiguous due to different parameters involved. For example: in case of ambulance diversion, there are multiple parameters involved. Firstly, when to start the diversion process? Do hospitals set up a threshold number of ED occupancy before starting diversion? How about probability of moving patients from ED to inpatient wards? Is there a probability of freeing up ED occupancy? If so then how soon is it possible? Additionally, how about patients with acute medical condition? Is it feasible to keep on diverting ambulance carrying patients with acute medical conditions?

Therefore, utilizing the IPT it can be predicted that if additional information processing mechanism is established in the current system, then the diversion of ambulance will not lead to decrease in quality of care for patients with acute medical conditions. Since, RFID helps track the patient medical procedure, in case of patients with acute medical conditions, the RFID system helps in getting the patients previous records as soon as the ambulance personnel get to the patient, therefore providing more information about the patient even before they reach the hospital. In

addition to that, RFID helps in providing real-time interactive information which in turn helps in more accurate prediction of the hospital resource requirement over a period of time in comparison to other current technologies used in hospitals. Therefore, it can be predicted that the use of RFID provides more optimum resource required in any given day in a ED.

Hypothesis 3a: Early information access tends to decrease in information ambiguity and, this leads to lower “average number of medical procedures performed for patients in ED”, and in turn lower ED congestion.

Hypothesis 3b: Lower Information ambiguity tends to increase hospital performance i.e, lower “average number of medical procedures performed for patients in ED”, tends to lower the length of stay.

3.2 Early Information Access and Organizational Factors

It can be suggested from the above discussion that early information access leads to higher hospital performance, however, early information access is the result of introduction of new technology (RFID in our study). The introduction of new technology and its impact on organization output cannot be explained by a direct relationship alone. Organization environment and organizational factors play an important role in the success of the implementation of new technology (Sykes, 2015). Hence, it is important to study these factors when studying the impact of information processing behavior of an organization. One of the organizational factors identified is the employees and their behavior towards the use of the new technology. Theory of Reasoned Action and Theory of Planned behavior is used to analyze the impact of their behavior in the success of the said new technology.

3.2.1 Theory of Reasoned Action and Theory of Planned Behavior

The Theory of Reasoned Action (TRA) and the Theory of Planned Behavior (TPB) are two such theory that define the phenomena of describing how individual motivational factors determine the inclination towards a certain behavior. TRA and TPB states that there are certain theoretical constructs that determine that individual motivational factors determine the likelihood of performing a specific behavior. The best predictor of a behavior is individual behavioral intention which is determined by an individual's attitude towards a certain behavior and their perceptions towards certain social norms.

Various meta-analyses and reviews have stated that both the TRA and TPB, focuses on the determining constructs that align with attitude, subjective norm, and perceived control. These constructs help to explain the major determinants of the variance present in the behavioral intention and hence is able to predict different behaviors which includes health behaviors (Armitage and Conner, 2001; Albarracin, Johnson, Fishbein, and Muellerleile, 2001; Albarracin and others, 2003; Albarracin, Kumkale, and Johnson, 2004; Albarracin and others, 2005; Downs and Hausenblas, 2005; Durantini and others, 2006; Hardeman and others, 2002; Sheeran and Taylor, 1999; Webb and Sheeran, 2006). However, both TRA and TPB are not above criticism, and there has been some studies that question the validity of the results using TRA and TPB (Weinstein, 2007), there are many studies that are proponents of the constructs of TRA and TPB (Albarracin and others, 2003, 2005; Jemmott, Jemmott, and Fong, 1992; Kamb and others, 1998; Kalichman et al., 2007). In the field of healthcare, TRA and TPB have been used successfully to predict various behavioral intention towards individual health such as: smoking, drinking, health services utilization, exercise, sun protection, breastfeeding, substance use, HIV/STD-prevention and use of contraceptives, mammography, safety helmets, and seatbelts (Albarracin, Fishbein, and Goldstein

de Muchnik, 1997; Albarracin, Johnson, Fishbein, and Muellerleile, 2001; Bogart, Cecil, and Pinkerton, 2000). Hence, this study does not claim to be the first study to bring these two theories in the field of healthcare, but it is the first one to enhance this theory to predict employee's behavior towards the use of new technology.

This study adopts these two theories because, TPB states that perceived control is an independent determinant of behavioral intention, along with attitude toward the behavior and subjective norm. It can be concluded from these discussions that, TRA and TPB explains an employee's behavior towards the implementation of any IT systems. Therefore, when discussing the impact of implementation of any IT systems, an employee's attitude towards the use and importance of the said IT systems/components need to be studied to convey its overall impact.

3.2.2 Early Information Access and Success of New Technology

Since, TRA implies that one of the major attributes of behavior is behavioral intention, it can be concluded that attitude towards performing a certain task and their subjective norm associated with that attitude is the direct determinants of individuals' behavioral intention. Furthermore, TPB includes another important factor of behavioral intention which is the "perceived control". In fact, TPB postulates that "perceived control" takes precedence over behavioral intention to complete a certain task.

Some studies (Ajzen, 1991; Ajzen and Driver, 1991; Ajzen and Madden, 1986) intervened in the favor of TRA and added *perceived behavioral control* to TRA to accommodate the additional factors that impact intentions and behaviors and thus bring back relevance to TRA. As shown in the figure 4, "control beliefs" is the attribute behind "perceived control" and in turn perceived

control impacts the presence or absence of facilitators and barriers to behavioral performance.

Therefore, TRA and TPB jointly concludes that a particular individual is more likely to behave in a certain way under the following conditions:

- a person has a strong intention to perform it and the knowledge and skill to do so
- there is no serious environmental constraint preventing performance
- the behavior is salient
- the person has performed the behavior previously

There is also the presence of moderators such as skills and environmental constraints that impact the behavioral intentions and these are represented in the figure 4, which depicts that behavioral intentions are determined by three constructs: attitude toward the behavior, subjective norms and perceived control (Triandis, 1980; French and others, 2005). Attitude towards the behavior or just affect is described by (Fishbein et al., 2007) as the individual's emotional response to the perception towards performing a behavior recommended by authority or rule. It was shown by the authors that an individual that has a strong positive emotional response to the behavior are more likely to perform it and vice versa.

The second construct "perceived norm" represents the social pressure an individual feel towards performing or not performing a particular behavior. Fishbein (2007) describes that subjective norm is a normative belief and interprets it as what others think one should do and this motivates an individual to comply by the norms. This does not necessarily completely capture normative influence at its truest form. This construct is also used as an indicator of normative influence (Bagozzi and Lee, 2002; Triandis, 1980; Triandis and others, 1988).

The third construct, "personal agency", is based on the definition provided by Bandura (2006) and

based on the author's description it is an individual's influence to bear on their own functioning and environmental events.

3.2.3 Early Information Access and Use of Supporting IT Components

In any organization, one of the important aspects that determines the use of IT to enhance the performance is directly related to the perception or the behavior of employees using it (Chae and Lanzara 2006; Gibson 2003; Robey et al. 2002). Furthermore, employees are the entities in any organization who actually use the system or technology to enhance the organization procedure/process. It has been already established in previous discussion of TRA and TPB that employee's behavior towards a new technology impact the successful implementation of the said technology. There are a number of organizational factors that impact employee's behavior, some of these factors are using of supporting IT components. Furthermore, employee's perception towards a new technology and subsequently towards its use is impacted by the availability of other supporting IT components that help in making the use of the new technology easier (Bandurra, 2006). Therefore, the success of the use of RFID which results in easy access to information is related to other supporting IT components such as Decision Support System (DSS), Electronic Medical Records (EMR) that can automatically input the information generated by RFID and process it and provide proper reports to the triage nurses. In the case of ED, the employees are the ED physicians, triage nurses and other related technicians that are related to various medical procedures like ultrasound, x-ray etc. technicians. In ED, where the work environment is hectic as well as ambiguous due to lack of information coordination and information ambiguity, it is reported that the ED employees find high stress in their work environment. They necessarily do not report a lack of job satisfaction since most are well paid and love their job for self-satisfaction

of helping other people in need. However, these employees do report added stress due to lack of proper training or additional technologies to support their work (Chang and Chang, 2007).

In an ED, triage nurses will have to make multiple decisions regarding the routing of incoming patients, if they have early information access regarding the nature of medical process the patients require or a real time medical condition of the patient as soon as possible, then it will help the triage nurses to make more knowledgeable decisions in routing the patients. This means that the triage nurses and in turn ED's will be better prepared to handle the patients hence providing better medical treatment for the patients. This will lead to comparatively shorter length of stay for the patients and better performance output of the hospital. Therefore, use of supporting IT components has been identified as an additional factor by this research. The early information access will alleviate the anxiety that employees face due to lack of information in high performance, high risk work environment such as ED and result in high hospital performance. However, the relationship is not a simple direct one, instead there is a moderating variable (use of supporting IT components).

Hypothesis 4: Early information access tends to increase the use of supporting IT components.

Hypothesis 5: Higher use of supporting IT components leads to higher hospital performance.

3.3 Early Information Access, Resource Based View and Hospitals IT Policies/Plans

3.3.1 Resource Based View

Resource based view (RBV) is a managerial framework based on strategic management that is used to determine the strategic resources that can provide an organization with a potential comparative advantage (Wernerfelt, 1984). The RBV of the firm states that firms compete on the basis of "unique" resources that are valuable, rare, difficult to imitate, and non-substitutable by other resources for the firms in the same level (Barney 1991; Conner 1991; Schulze 1992). The

RBV theory assumes that resources are heterogeneously distributed and all firms competing at the same level will need this particular resource to become successful. This resource further supports the firm at managerial level to entertain unique strategies (Barney 1991). Furthermore, RBV states that these resources are above any imitation as these are protected using various mechanisms (Rumelt 1984) such as time-compression diseconomies, historical uniqueness, embeddedness and causal ambiguity (Barney 1991; Dierickx and Cool 1989; Peteraf 1993).

The original RBV defines these unique resources in a broad stroke, that can include: assets, knowledge, capabilities, and organizational processes. However, Grant (1991) adds to the original RBV resource definition by distinguishing between resources and capabilities and classifies resources into three categories: tangible, intangible, and personnel-based resources. Tangible resources are financial capital and the physical assets of the firm such as factory, equipment, and stocks of raw materials. Intangible resources include assets such as: brand image, and product quality. Similarly, personnel-based resources include technical knowledge and organization dimensional knowledge such as: organizational culture, employee training, loyalty. While resources are the basic unit of analysis in RBV, the major contributor to competitive advantage in RBV is how these resources enhance organizational capabilities. Organizational capabilities, is defined as an organization's ability to assemble, integrate, and deploy unique resources (Amit and Schoemaker 1993; Russo and Fouts 1997; Schendel 1994). Capabilities enhance organizational competencies (Prahalad and Hamel 1990) and are dimension of business routines and processes. Moreover, Grant and Baden-Fuller (1995) also enhance RBV by introducing hierarchy of organizational capabilities. Capabilities are further divided into functional capabilities such as marketing, manufacturing, and IT capabilities. Functional capabilities are a part of cross-functional capabilities such as new product development capability and customer support capability.

RBV is well established in IT field since, various IT related resources can serve as potential resources for competitive advantage. For example, Mata et al. (1995) argue that managerial IT skills are firm specific and unique to the particular firm hence can be rarely substitutable or imitated, therefore managerial skills can serve as a means to obtain sustainable competitive advantage. Ross et al. (1996) point out that IT skills (human IT asset), and reusable technology base (technical asset) as well as strong partnering relationship between a firm's IT and business unit management can attribute to a firm's ability to leverage strategic advantage using IT. For example, in a study conducted by Chatfield and Bjørn- Andersen (1997) based on an airline company in Japan, its inter- organizational system (a physical capital resource) and its people (human capital resource) were found to be the primary sources of its business growth and improved competitiveness, which acted as competitive advantage for the airlines.

A firm's *IT capability* can be defined as its ability to mobilize and deploy IT-based resources in combination with other resources and capabilities to generate competitive advantage. Grant (1991) provides a classification of IT-based resources as follows: The first step comprises of the tangible resource that includes the physical *IT infrastructure* components, then comes the *human IT resources* which includes the technical and managerial IT skills, and finally is the *intangible IT-enabled* resources such as knowledge assets, customer orientation, and synergy. The idea of IT as a competitive advantage was first established in a study conducted on the Provident National Bank of Philadelphia. In this study it was found that the bank had (1) a flexible IT infrastructure (2) competent IT skill base and (3) a strong customer orientation which acted as an intangible knowledge base. This study found that the bank was more successful in adopting newer features that the customers were demanding. This resulted in higher customer satisfaction as well as higher

profit turnover for the bank compared to its competitors. This result further supported the claim that IT can be used as a resource to achieve competitive advantage.

IT is used mainly as an organization capability to enhance firm's performance. Higher the number of IT units in use, higher is the firm's financial performance. In high paced environment like ED, where time is of essence, IT units can help medical employees to make quick decisions and speed up the medical process and transfer of patients, resulting in lower ED congestion. However, it is seen that most of these ED's and ED employees rely less on IT units that are already installed. In an ED, it is not just about making correct decision, and doing the right process but it is also about speeding up the process. The reason why IT units are used less is because they do not provide with faster information which can be used to make fast, educated decisions. Therefore, if these IT units can be provided to information sooner about the patients using RFID tags and other such devices, then the use of IT units will grow and hence, the performance of the hospital.

The management style does impact the use of these IT units. Since, the management make IT plans. Therefore, it can be hypothesized that higher number of IT plans/policies lead to the positive use of these systems.

Hypothesis 4A: Number of IS Plans by management positively moderates the relationship between early information access and use of supporting IT components.

3.4 Impact of Workplace Trainings on Hospital Performance

Knowledge sharing amongst physicians in a hospital is key to not just higher performance but also in some cases for the survival of a patient (O'Dell & Grayson, 1998). Since, physicians are knowledge-intensive and principal professional group in hospitals. Hence, the knowledge base they carry both in terms of theory and practice is key to provide better care for the patients.

Moreover, in some cases: like that of tertiary hospitals, knowledge sharing is considered to be even more crucial since physicians are involved not just in-patient care but also in research-oriented, environment, and need to be ready to accept new challenges like learning new medical technologies and procedures that can be obtained from various organizational learning mechanisms (OLMs) (Popper and Lipshitz, 2000). This emphasizes that physician's knowledge sharing behavior attributes to increasing quality and efficiency in a hospital.

Knowledge sharing behavior is viewed as the degree to which physicians actually share their knowledge with their colleagues for professional tasks (Ryu et al 2003). The authors highlight that knowledge sharing has two parts: one is behavioral knowledge sharing and the other being technological knowledge sharing. (Davenport & Prusak, 1988) imply that one does not just share knowledge, instead they need to find that knowledge sharing is valuable and important. A survey conducted by Ruggles (1998), concludes that the biggest challenge an organization face in terms of knowledge management is to change people's behavior towards the concept of knowledge sharing. This result is further supported by the study conducted by Robertson (2002), by comparing two knowledge sharing systems where human activity and understanding the humans sharing the knowledge is the most crucial step to the success of such knowledge sharing systems. In general, it can be concluded that there are several contextual factors other than just sharing of knowledge that impact the success of knowledge sharing systems/knowledge sharing behavior. Some of these factors are: attention to the team structure and workflow issues; collaboration practices; the nature of documents being shared; task structure and leadership style and factors facilitating physician's OLMs in hospitals (Popper and Lipshitz, 2000; Robertson, 2002).

In the past, knowledge sharing amongst physicians has mainly been carried out in non-scientific methods such as: by word of mouth among peers and colleagues, and across personal relationships

built upon mutual respect, trust, and shared interests (Kaye, Heeney, Hawkins, De Vries, & Boddington, 2009). However, the emergence of the newer communication technologies has enabled the knowledge sharing process to be carried out in more scientific manner and the process of knowledge dissemination is becoming more easier, faster and secured (Neumann & Prusak, 2007). This type of technology used has brought forward new mechanism of “Knowledge networking”, which is defined as “a special case of social networks in which the links of the network represent shared or related knowledge” (Burton-Jones, 2001). This mechanism has increasingly become more prevalent across different types of process such as: data-intensive technical and scientific domains including computer as well as healthcare sector.

In the field of health and life sciences, knowledge networking can be used to enhance the research communities (De Silva & Vance, 2017). Knowledge networking is found to enable scientists to confirm research findings with minimal processes (Kratzwohl, 1993; Neumann & Prusak, 2007). It is also well-suited for encouraging collaborative scientific discovery and creativity in research communities (De Silva & Vance, 2017; Neumann & Prusak, 2007; Ward, Schmieder, Highnam, & Mittelman, 2013). Some studies have found that knowledge networking helps to reduce the cognitive burdens of scientists associated with uncertainty and data complexity (Neumann & Prusak, 2007; Ward et al., 2013).

Although many studies have cited the tacit-explicit classification of knowledge, the terms implicit and tacit knowledge are often incorrectly used interchangeably. Explicit knowledge can be defined as the type of knowledge that can be expressed, formalized, documented and codified in the form of visual (e.g., text, tables, diagrams, or documents) artifacts (Alavi & Leidner, 2001; Cabrera & Cabrera, 2002; Nickols, 2000a). Hence, the matter of explicit knowledge can be relatively easy to search and share with other practitioners and scientists as compared to tacit and implicit knowledge

(Cabrera & Cabrera, 2002). The examples of explicit knowledge are as follows: documented best practices, formalized standards, mathematical formulas, training manuals, instructions, or simple factual information are some common examples of explicit knowledge (Epstein and Roy 2000; Nickols, 2000b; Zack, 1999).

Tacit knowledge is the type of knowledge that is derived from individuals' actions, experiences, and values (Alavi & Leidner, 2001). These typw of knowledge cannot be dictated and codified in similar manner to that of explicit knowledge (Hislop, 2002; Nickols, 2000b). Polanyi (1997) explains the nature of tacit knowledge by saying that, “we can know more than we can tell”. Implicit knowledge is also supported by experience, practical skills, and know-how (Cortada & Woods, 2000), but it can be adequately articulated and codified which cannot be done in the case of tacit knowledge.

In a situation like ED, employees’ knowledge of its surrounding and awareness plays a crucial role in there and the process success. In an ED process where using IT units are crucial for better work performance, only installing such units are not enough to provide high job satisfaction for employees. It is equally important to provide them with enough trainings to use these IT units. Therefore, the positive relationship of early information access and employee job satisfaction is impacted by number of job-related IT trainings are provided to the respective staffs using those IT units.

As shown in figure 3.3 below, RBV can be used to explain the phenomena of obtaining comparative advantage in an ED. Similar to any other organizations, hospitals also have some objective. These objectives might not be monetary gain and are more to do with providing better care for patients, optimizing its resources and so on. In this scenario, optimizing its performance which is length of stay of a patient is taken as a comparative advantage. Therefore, RBV is used

to explain the comparative advantage an ED can achieve by “early information access” and utilizing its already present resources such as IS structure and components.

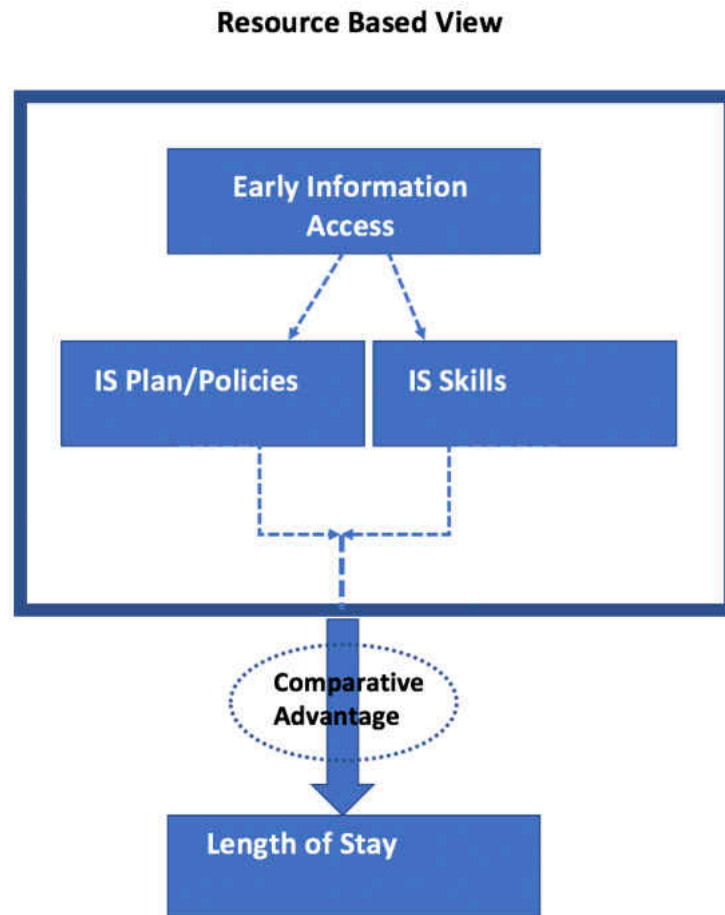

Figure 3.3 RBV for Early Information Access

Hence, it can be concluded that if additional work place trainings can be provided to the ED employees in using the technology that helps them to make their work easier or safer than they will have positive perception towards the technology. This will result in better employee job satisfaction and in turn better output from the employees can be attributed to the work place trainings.

Hypothesis H4b: Workplace related IT trainings moderate the relation between early information access and the use of supporting IT components.

3.5 Conceptual Model of the Stated Hypothesis

Based on the theoretical discussion in section 3.1-3.4, a conceptual model is presented below in figure 3.4, which shows all of the proposed hypothesis.

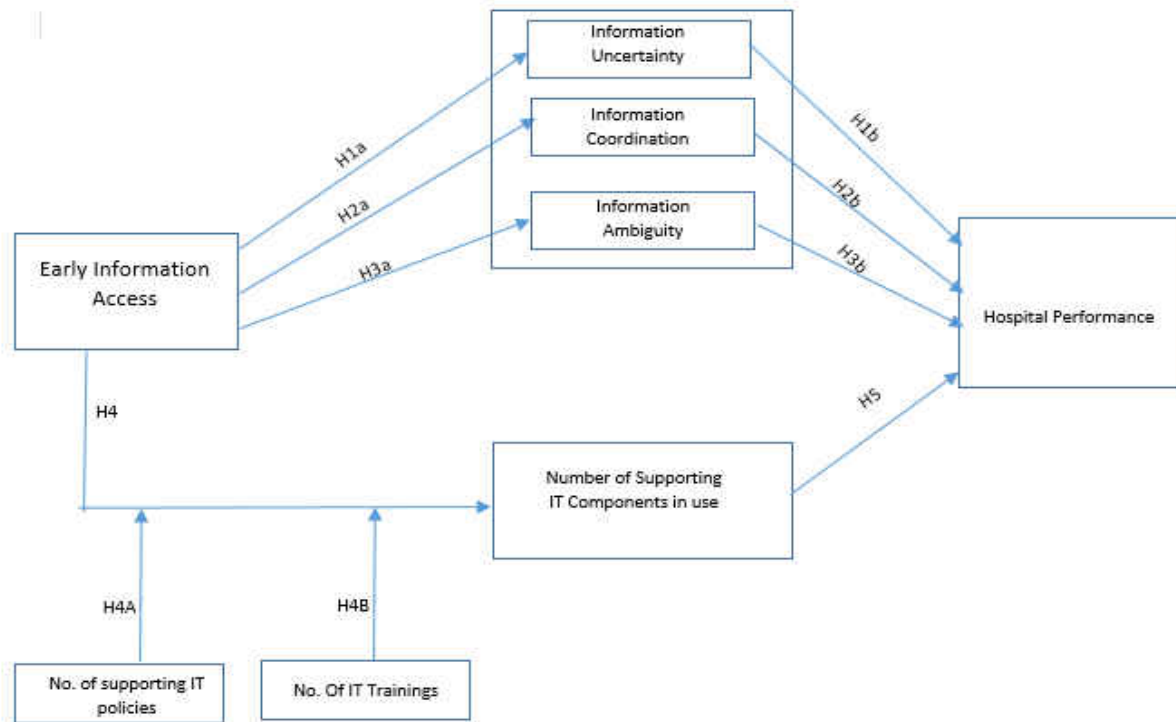

Figure 3.4 Early Information Access in Hospital Information System

H1a, H2a and H3a are the three hypothesis that illustrated the relationship between early information access (RFID) and the three entities of OIPT. H1b, H2b and H3b are the three-hypothesis representing the relationship between the three entities of OIPT and hospital performance (LOS). Similarly, hypothesis H4 shows the relationship between early information access and EMR use (number of supporting It components in use), and H5 represents the relationship between EMR use and hospital performance. H4A and H4B represents the moderating variables for IS skills and IS plans/policies. In the proposed model, the hypothesis are supposed to

have following relationship as presented in table 3.1:

Hypothesis	Expected Result
H1 A	Negative Relationship
H2A	Positive Relationship
H3A	Negative Relationship
H1B	Positive Relationship
H2B	Negative Relationship
H3B	Positive Relationship
H4	Negative Relationship
H4A	Positive Relationship
H4B	Positive Relationship
H5	Positive Relationship

Table 3.1 Proposed Hypothesis Relationship

CHAPTER 4

METHODOLOGY AND RESEARCH DESIGN

Since, this research addresses the ED congestion, we will be using the dataset from one of the biggest cities with record of ED congestion. The state of New York is the sample that we will study in this research since it is very crowded and past study shows that it has severe ED congestion issue. It will use two popular health-based databases HIMSS and SPARCS. There were over 6.4 million visits to NYS emergency departments by NYS residents in 2013 at a rate of 328.07 ER visits per 1,000 population. The most common conditions seen in the ER included ‘Superficial injury; contusion’, ‘Other upper respiratory infections’, and ‘Sprains and strains’ while the most commonly performed procedures were blood tests and X-Rays. Individuals who visited the ER more than five times in 2013 represented 1.92% of patients but 11.75% of all visits. The high number of ER visits coupled with nearly 72% of these visits being classified by 3M grouper logic as potentially preventable indicates that the ER is a usual source of care for the population, often for clinical conditions that could have been treated or prevented through access to high quality primary care settings.

4.1 Databases

4.1.1 HIMSS

The HIMSS Analytics® Database is the most comprehensive collection of the best intelligence in the industry. It is available to healthcare participants nationwide, it is a resource built by, and for, healthcare professionals. The sharing of institution details, accomplishments, goals, and progress has resulted in the most detailed snapshot of the state of healthcare IT today. Available only

through HIMSS Analytics, this collective contribution provides exclusive insight that is vital to the advancement of healthcare industry. It is also considered as a global healthcare advisor, providing guidance and market intelligence solutions that move the industry forward with insight to enable better health through the use of information and technology. It collects data that focuses in collaboration with hospitals and clinical practices to track and benchmark their EMR adoption and utilization goals since 2005 -- through the EMR Adoption Model (EMRAM). We will use this database to obtain the RFID usage, number of IT trainings provided to the staff, number of IT plans and policies made on managerial level and the number of IT units fully installed in the hospital. The HIMSS database selected is for the year 2014.

4.1.2 New York State hospital patient database

The next source of data is the Statewide Planning and Research Cooperative System (SPARCS), which collects detailed information on patient characteristics, diagnoses and treatments, services, discharge information, and charges for every hospital discharge, ambulatory surgery patient, and emergency department admission in New York state. This research will use the data where the patients are identified with an acute medical condition. The total length of stay for such patient outside of non-acute procedure will be studied for this analysis. This study will use variables: length of stay, average number of medical procedures conducted on a patient, average number of days to complete all the additional medical procedures and the average number of patients discharged per day. The datasets selected are for the 2014 which has the data for all 132 hospitals selected from the HIMSS database.

4.2 Database Integration

In this study, there are two databases that are used to generate the required data. The two databases: HIMSS and SPARCS as described above have different data types stored, therefore the first and foremost step is to find the way to integrate these two databases. The two databases were studied carefully, and its data variables matched with each other. Since, SPARCS stores data such as patient admit day, discharge day, procedure day, number of procedure and so on. HIMSS stores data such as hospital size, number of physicians and nurses, IS plans and policies, EMR use, RFID units in use, employee trainings and so on. The two common data variables in these two databases were found to be “hospital name” and “hospital address”. So, using these two data variables, the two databases were joined, and the common hospital data were included in our data subset. Since, SPARCS contains data from the hospitals in the state of NY only, we sorted the HIMSS database based on the “state” and it helped us to easily join the two databases. Finally, matching for the common “hospital name” and “hospital address”, we found 132 common hospitals.

4.3 Data Selection

The first step in data selection is to join the two databases: HIMSS and SPARCS. The data sets required has variables from both the database, therefore it is needed to join these two databases using a unique identifier. In this study, since the two databases are not in sync when assigning unique key for each hospital, so the hospital identifier is determined to be the hospital name, address and zip code as joint variable. Once, the two databases were joined, only the hospitals in the state of NY were included. Even though the HIMSS database has data for hospitals from all 50 states in the U.S, the SPARCS database only collects data from the hospitals from the state of NY. The state of NY was selected because NY is one of the most populated state in the U.S.A

along with it being the state with the highest population density. Once the hospitals in the state of NY is identified in the HIMSS database, the required variables: RFID Use, EMR Use, IS Skills and IS Plans were selected. This process flowchart is modeled in Appendix A.

The selected hospitals were then populated in a new dataset where a unique hospital identifier was assigned to each hospital. There were in total 132 hospitals in the state of NewYork, that were included in both the HIMSS database and the SPARCS databases.

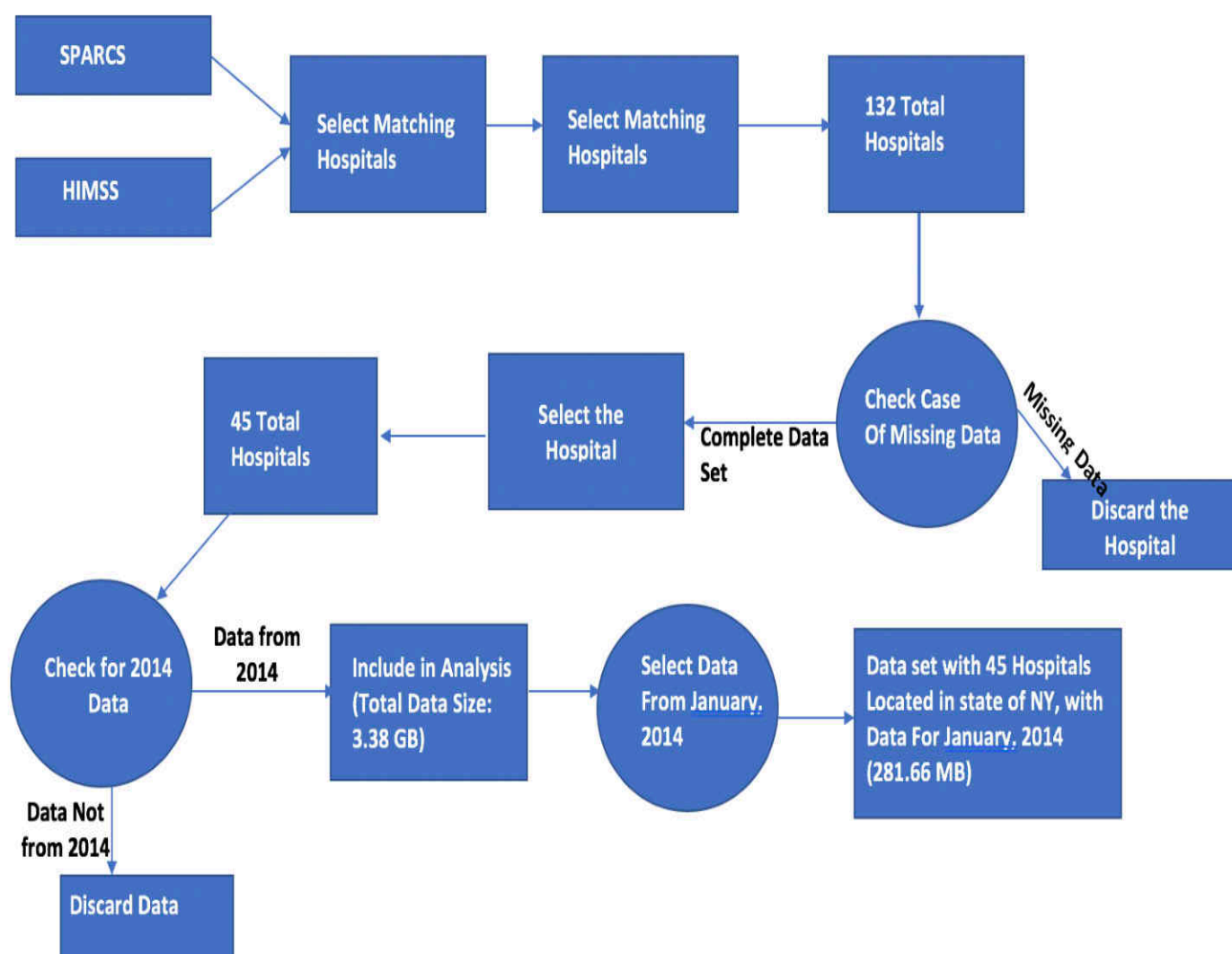

Figure 4.1 Flow Chart for Data Selection

Therefore, this first set of datasets generated had all 132 hospitals in the state of NY. The hospitals

included in this dataset each had their emergency department unit. In addition to that, it was also verified that these hospitals had a significant use of EMR and RFID. These hospitals also had it IS plans and policies announced and listed. A complete list of hospitals is depicted in the figure 4.1 above.

The Appendix A shows the distribution of hospitals throughout different cities and township in the state of New York. It can be seen that most of the cities have 1 emergency department while the big cities do have multiple emergency departments. This goes to support the earlier mentioned problem of ED congestion due to its decreasing number. In this first list, Brooklyn has the highest number of ED's at 12, closely trailed by New York city with 9 ED's.

Once, the 132 hospitals in the state of NY, that were to be included in this study were identified, the data analysis process was started. The total size of the data was found to be 3.68 Gigabyte's. This was a huge data set to be analyzed, hence there was a need for data reduction.

4.4 Data Reduction

Selection of Year and Month: The process of data reduction was not just conducted because, the size of data collected was huge but also due to the need of this study. The data reduction process was conducted on the basis of extant literature and the history of legislative history of healthcare in the U.S.A. One of the recent legislations of "Affordable Care Act", which claimed to result in higher health coverage was introduced in the year 2014. Moreover, this claim implied that with higher insurance coverage, the number of patients visiting ED would decrease as explained in the literature review section of this study. Hence, the data collected in this study is for the year 2014 to check for the effect of ACA in the overcrowding of the ED. The data sets selected from both the HIMSS and SPARCS database were adjusted for the year 2014, HIMSS has the technical data

whereas SPARCS has the medical data. Furthermore, another reduction was conducted by reducing the study time frame, by only including the data for the month of January. The month of January was selected since, the first month of the year would be the first time ACA was rolled out and the initial effect of insurance coverage would take place in this month. This can also be explained as the “first mover” advantage since most of the insurance provider would want to benefit from ACA and would have already rolled out their lucrative healthcare plans. Hence, more patients would have insurance coverage and not have to resort to visit ED for their health issues.

Selection of Final List of Hospitals: After the 132 hospitals were selected, further analysis of the data showed that there were number of missing variables from various hospitals in the HIMSS database. Therefore, the hospitals were sorted based on number of incoming patients and the top 45 hospitals were selected as they were the only hospitals with full set of data for each of the variables that is analyzed in this study. Therefore, the final set of data in this study came down to 45 hospitals in the state of New York.

Selection of data points in SPARCS: In case of SPARCS, for each hospital the patient data were aggregated. Before aggregating the required variables, the patient data were selected based on some criteria. SPARCS data had some variables such as AMIWarning, AgeWarning and others as listed in Appendix C. Any patient that had any one of these warning variables as positive was discarded before the aggregating each of the variables. The reason behind removing patient data that had these warning in positive is because, it is implied that older patients might require longer length of stay due to them having other medical conditions other than the one they were admitted for (Joseph et al., 2016). Similarly, other pre-existing medical conditions such as AMI and HIV also impact the length of stay (Morris et al., 2016). Therefore, it can be concluded that the length of stay of these patients are not just the ED congestion, but their pre-existing medical condition

might increase their length of stay. Furthermore, other variables such as PStatus is checked as PStatus provides information on whether the patients were a same day discharge or stayed in for more than a day to count in for length of stay. Another variables was used to filter out the patient data in the SPARCS database is “Service Category”, this variable indicates whether the patient needed high level of medical procedure or not. There were in total 5 level of service category. Service 5 being the highest level and 1 the lowest. Service 5 is mostly listed for patients that have high medical acuity therefore will require longer stay in hospital. Hence, patients with service 5 were also excluded so as not to have biased analysis from other pre-existing medical condition.

4.5 Data Description

The data collected from the 45 hospitals shows that the hospitals are from cities across New York where Oneida is the city with the lowest population and New York is the one with the highest population. New York and Rochester have the highest (3) hospitals each in this study and the other cities have 1 hospital each as shown in figure 4.2. The operating expenses range from \$8936556-\$1750443000. The IS budget the hospitals have allocated are in a ratio of .0053 - .090 of their total budget. Hence, it can be seen that the IS budget is less than 10% of a hospital’s total budget. The number of physicians range from 65-413 and that of nurses range from 337-1269. The number of physicians reflect both the full time resident as well as resident physicians. The number of hospital bed range from 56-543. The hospitals selected were from 41 distinct towns and cities from the state of NY, with the New York city being the most populated city with a population of 8,175,133 where 3 of the hospitals in this study is based on. On the other hand, the least populated town in this study is Oneida with a population of 234,878 and it has only 1 hospital in this study. The three hospitals in the most populated city NY, were also the largest hospital in terms of operating expenses and size.

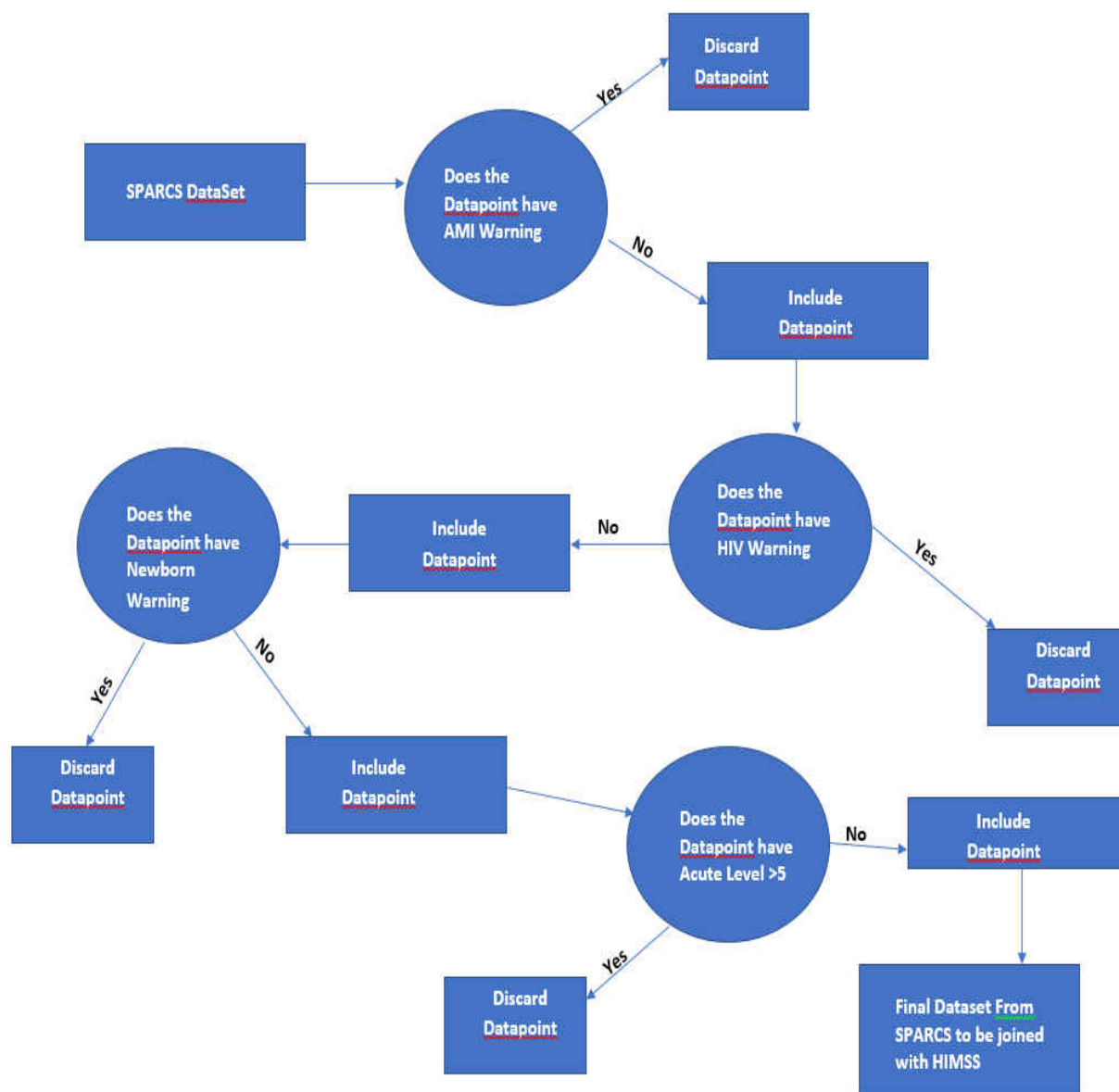

Figure 4.2 Flow Chart for Data Reduction

The total number of incoming patients ranged from 1234 to 23456, with hospitals in city of NY receiving the highest number of patients. In addition to that, these hospitals in the city of NY also had an average of length of stay lower than other hospitals in this study.

4.6 Variables

4.6.1 Independent Variables

1. **Average Number of Process (Avg_Proc):** It is defined as the average number of medical procedures that needs to be performed for each incoming patient in lieu with the original emergency department visit in each hospital (Kassin et al., 2012). This variable is listed in Appendix D, and according to the data dictionary of SPARCS 2014, a hospital's number of procedures is calculated by adding the total number of medical process required by each incoming patient to complete their medical procedures. It has been aggregated for each individual hospital for the month of January. It is used to measure the information ambiguity and this variable is collected from the SPARCS database. Based on SPARCS database, it can be stated that that highest number of procedures performed on a patient is 5.909 and the lowest is 1.149. A complete set of range value for all the variables in provided in Appendix E.
2. **Average Number of Patients Discharged (Avg_Discharge):** It is defined as the average number of patients discharged from a hospital in one month of January (Elliot et al., 2016). This variable is listed in Appendix D and, and according to the data dictionary of SPARCS 2014, a hospitals number of Discharge per day is calculated by adding the total number of patients discharged on a particular. It has been aggregated for each individual hospital for the month of January. It is used to measure the information coordination and this variable is collected from the SPARCS database. Based on SPARCS database, the lowest value is 3.525 and the highest value is 49.796. A complete set of range value for all the variables in provided in Appendix E.

3. **Average Procedure Day (ProcDay):** It is defined as the average number of wait days for a patient to complete all of their required procedures in lieu with the original emergency department visit (Dolton and Pathania, 2016). This variable is listed in Appendix D, and according to the data dictionary of SPARCS 2014, a hospital's ProcDay is calculated by averaging the total number of days required by each incoming patient to complete their medical procedures. It has been aggregated for each individual hospital for the month of January. It is different from length of stay since length of stay shows the overall hospital stay time period whereas average procedure day variable shows the total days that was needed by patients to get their turn to undergo their medical procedure. It is used to measure the information uncertainty and this variable is collected from the SPARCS database. Based on SPARCS database, the lowest is 31 and the highest is 172. A complete set of range value for all the variables is provided in Appendix E.
4. **Information Technology Training (ISSkill):** This variable represents the total trainings provided by an organization to its employees that is related to use of IT components to enhance daily organization work. This variable is provided by the HIMSS database. According to the HIMSS 2014 database, this variable is average number of trainings provided to medical employees in a hospital in the year of 2014. This variable is adopted from Pazos et al. (2013). This variable is listed in Appendix D and, based on the HIMSS database, it can be noted that on average the hospitals have provided 5 different types of IS trainings, hence this value ranges from 1-5. A complete set of range value for all the variables is provided in Appendix E. The list of different types of IS Skills provided to the staff are listed in detail in Appendix F.
5. **EMR Units Used (EMR):** This variable collected from the HIMSS represents the total

number of fully installed/implemented and running EMR units. The units that are only installed but not running are not counted in this variable. This variable is adopted from Pazos et al. (2013) and it is the average number of EMR units that were fully operational each month in the year 2014. A hospital might have a number of EMR units installed, however only the fully operational EMR units are only able to realize its full potential (Gastaldi, et al., 2017). Therefore, those units that are not fully operational are not included in aggregating this variable. This variable is listed in Appendix D and, based on the HIMSS 2014 database, it can be noted that on average there were 9 different EMR Units installed and so this variable ranged from 1-9 for the year of 2014. A complete set of range value for all the variables in provided in Appendix E. The list of different types of EMR units fully operating is listed in detail in Appendix G.

6. **Total number of Information Systems Plans (ISPlan):** This variable collected from the HIMSS database, represents the average number of both long term and short term IS plans announced by the hospital management. This variable is adopted from Pazos et al. (2013). This variable is listed in Appendix D and, based on HIMSS 2014 database, for the year of 2014, there were 5 different types of IS Plans rolled out by the management and so the lowest value for the average IS Plans is 1 and the highest is 5. A complete set of range value for all the variables in provided in Appendix E. The list of IS Plans made by managerial team is listed in detail in Appendix H.
7. **Use of Auto Identification Technology (RFIDUse):** This variable measures the average number of RFID units fully operational in a hospital. As implemented by Dimick et al (2001) and more recently by Heyland et al (2015), this variable is calculated by adding the total number of departments in a hospital that have a fully operational RFID unit. This

variable is listed in Appendix D and is extracted from the HIMSS database and it can be noted that this variable ranged from 1-7 as shown in Appendix E, since there were 7 different types of units with RFID use. The list of units fully equipped with RFID is listed in Appendix I.

4.6.2 Dependent Variables

1. **Total Length of Stay (LOS):** This variable measures the average total length of stay of patient in a hospital. As implemented by Dimick et al (2001) and more recently by Green and Liu (2015), this variable is calculated by adding the days a patient spends in ED with the days spent in inpatient ward till they get discharged and is listed in Appendix D. This variable has been aggregated for the month of January for each hospital. This variable is extracted from SPARCS database and ranges from 3.525 to 39.746 as listed in Appendix E.

4.6.3 Control Variables

1. **Size of the Hospital:** This variable is defined as the total number of beds available in the hospital including both the ED and inpatient ward. As implemented by Dimick et al (2001) and more recently by Lin et al., (2015), this variable is controlled since hospitals with larger number of beds might have a better ability to absorb incoming patients than a hospital with lower bed number. Studies such as Lin et al., (2015) consider hospital bed as control variable and mention that this variable is not a bottleneck in their analysis. Similar to past studies, this analysis considers hospital bed as unlimited resource hence, it will be considered as control variable.

2. **Number of Physicians and nurses:** As implemented by Dimick et al (2001) and more recently by Dodek et al (2015), this variable is controlled in this analysis, since a hospital with higher number of physicians and nurses have higher capability to provide patients with proper treatment faster than a hospital that is struggling to have enough resources in terms of physicians and nurses. Since, number of physicians and nurses are a considered as a traditional control variable in most previous studies, therefore this study also continues the same tradition. Based on both the SPARCS 2014 and HIMSS 2014 database this variable ranges from 87-208 for physicians and 116-452 for nurses as listed in Appendix E.
3. **Location of the Hospital:** Location of the hospital is also used as control variable in this research because it is considered that a hospital in urban location will definitely get a higher number of patient than a hospital in rural area in both ED and inpatient ward. This difference is attributed to the population size of the respective location. Green and Liu (2015), explains this phenomenon and similar to it, this study also considers location of the hospital as a control variable. In this study, it can be seen that the hospitals included in the analysis are from cities/towns that have population that ranges from 8,175,133 to 234,878. In this regard, the hospitals located in cities with higher population density will get more patients in ED compared to cities with lower population density. Therefore, this variable is controlled in this study.

4.7 Statistical Tool

4.7.1. ARENA Simulation Software

ARENA simulation software is one of the many simulation software available to model systems. It is easy to use and has graphical user interface. There are studies such as Chan and Currie (2016) that uses ARENA simulation in the healthcare analysis. A simulation is an approximate [imitation](#) of the operation of a process or system; the act of simulating first requires a model is developed. This model is a well-defined description of the simulated subject, and represents its key characteristics, such as its behavior, functions and abstract or physical properties. The model represents the system itself, whereas the simulation represents its operation over time. In this study, the ED of a hospitals is modeled using the ARENA software. Each entity can be modeled using a process and then assigned to another process. There must be a closure to every loop that is opened. In this study, ARENA is used for a pilot study to establish the impact of early information system. The whole ED can be modeled using ARENA, however since we have a detailed data for each hospital, this study uses the actual data collected from hospitals rather than the data generated from a simulation model to test the proposed model. Hence, only a part of ED is modeled to conduct the pilot study. The first entry point of the ED which is the patient transfer from their entry till they get a bed assigned/admitted in the ED is modeled.

4.7.2. AMOS

It is a statistical tool to represent structural equation model. It helps in graphically representing structural relations among observed variables; all observed variables are assumed to have been measured without error. It also helps to design confirmatory factor analytical models which shows the relationship between latent variables (also called factors or constructs) and the observed

variables designed to measure them. Such observed variables are often referred to as “indicators” of the corresponding factor. Structural regression models, also called hybrid models or general structural equation models combines measurement models with structural relations between latent variables.

In general, structural equation modeling is considered to be a very powerful *multivariate* technique that is a specialized versions of other analysis methods. The major applications of SEM are as follows: casual modeling or path analysis; confirmatory factor analysis; second order factor analysis; covariance structure models and correlation structure models.

1. Causal modeling or path analysis, which hypothesizes causal relationships among variables and test the causal models with linear equation systems. These models can involve either observed variables, latent variables, or both.

4.8 Hypotheses Testing

4.8.1 Multi-Method Approach

Research method classification has been distinctly identified by Sodhi and Tang (2014). The authors present analytical modelling, quantitative analysis and qualitative case studies were the methods discussed by the authors. However, these three are not the only analysis methods available in the field of MMA in OM. Other behavioral research (with human subjects) has been reviewed by (Croson et al. 2013, Gans and Croson 2008) and is also considered multi-methodological by nature therefore, implying that multi-method approach can be conducted using either of the methods in combination. Some of the examples of these studies are as follows: Caro and Gallien (2010) uses qualitative method to understand inventory management practice and then used the inventory data to conduct quantitative analysis.

Multi-methodological analysis is not a new concept in the field of OM, it is in fact rather classical. It can be seen that, as early as 1950s, MMA was in practice in OM studies. The first step was taken by Ackoff (1956), when he proposed a scientific framework for conducting OM studies through MMA. This framework includes 6 steps:

- Step 1 – formulating the problem
- Step 2 – constructing a mathematical model
- Step 3 – deriving a solution from the model
- Step 4 – testing the model and solution
- Step 5 – establishing controls
- Step 6 – implementing the solution.

Furthermore, the author mentions that it is important to consider organizational behavior, which can be learned by conducting organizational survey, when designing the research model for making decisions in the organization. Similarly, the use of “operational experiments” and “operational gaming” were critically important in order to generate insights into the organizational behavior. Finally, statistical testing methods were employed to obtain a more sophisticated analysis.

The popularity of MMA has been growing rapidly however, there are some issues that needs to be addressed before MMA can be used regularly are listed below: It is difficult for a researcher to master multiple methods with equal competence and employ them in the same piece of research. Similarly, limitations of time and resources; there is no need to do so because a good paper using a single method is already publishable; probability of bias; Paradigm shift is another issue and has been discussed by Carter et al. (2008) as a tendency for shifting the focal point from empirical data

based research to econometric modelling research and only one research method “survives” finally. Despite all these issues, MMA is still very much sought after since, with the advances of information and communications technology, it is much easier to find research collaborators around the world. It is also very convenient for researchers that have diversified backgrounds and master different research methodologies to work together. Thus, the popularity of multi-methodological OM research will definitely increase.

In the field of healthcare, popular studies commonly adopt single method approach, for example: simulation approach (Chan et al., 2017) or statistical approach (Hsia et al., 2017). While conducting a literature review, this study was unable to find any study that implemented MMA in the healthcare analysis. In the table 4.1 below, is listed the studies and the approach each of them implemented.

Authors	Method
Chan et al., 2017	Simulation (math model)
Hsia et al., 2017	Statistical Analysis
Mandelbaum and Momcilovic (2017)	Simulation (math model)
Saghafian et al., (2012)	Simulation (math model)
Shen and Wang (2015)	Simulation
Yom-Tov and Mandelbaum (2015)	Simulation
Batt and Terwiesch (2015)	Empirical Study
Batt and Terwiesch (2016)	Empirical Study

Table 4.1: List of Methods Used in Healthcare Research

Due to the growing importance of MMA, this study implements simulation and statistical analysis, to bring multi-method approach in the field of healthcare analysis.

4.8.2 Multi- Study (Simulation and Path Analysis)

4.8.2.1 Study 1: Simulation Modeling Approach

Before testing hypothesis, a pilot test is conducted to establish the impact of early information access. It is considered that, before proceeding with the actual data analysis to establish the proposed model, it is crucial to test whether the assumption that early information access increases hospital performance is true or not. To establish this experimental setup, a simulation study was conducted. A complete ED model was not demonstrated in the simulation study, due to the complicated nature of ED settings, big data structure and also due to time constraint. Therefore, only the transfer of patient from ambulance to admitting the patient (assigning a ED bed) process was modeled. The first step in every patient's visit, the wait time before being assigned a hospital bed is simulated. There are 2 different cases of incoming patient as per patients using "early information access" and patients without "early information access".

In the case of "early information access": A patient is brought into a ED from ambulance and as soon as the patient is picked up, their medical information is transferred to the triage nurse, therefore there is no delay caused due to the process of information transfer when they are in the triage area. Hence, the total wait time in this case is the time taken by triage nurses to access their condition and assign them a bed in ED. This scenario is shown in figure 4.3. Therefore, there is no delay caused due to the process of information transfer when they are in the triage area.

However, in the case of patient without "early information access": A patient is brought into a ED from ambulance and as dropped off in the waiting area, the triage nurse access their condition, obtains their other medical information, transfers the medical information to the hospital system

and then assigns them a ED bed. Hence, there is a delay caused due to the process of information transfer when they are in triage area.

This is modeled by having two streams of incoming patient “PatientArrival_RFID” and “PatientArrival”. “PatientArrival_RFID” indicates the stream of patient with “early information access” and the “PatientArrival” indicates patient without “early information access”. The patients are then accessed by the triage nurse in the “Triage Nurse” process and then based on their information transfer condition, they are assigned to their respective process. In the case of patients with “early information access”, they are just assigned to “RFIDPatientProcess” where they go on to get a assigned bed “AssignBed”, and their transfer is complete from ambulance to ED. However, in the case of patients without “early information access”, they will have to complete two processes “PatientProcess” and “InfoTransfer”. The additional “InfoTransfer” process is needed to transfer patient’s medical reports and vitals to the hospital system.

Based on SPARCS database for the selected hospital in the state of NewYork, the stream of incoming patient is modeled as poisson distribution with a mean of 15 minutes. It is calculated that the average time at a nurse triage is 15 minutes. However, the time to transfer information in the triage ranges from 0 to 120 minutes and it is a uniform distribution. This delay is modeled for the patient without “early information access” only. The total number of triage nurses is taken as 125. This number is collected from the HIMSS database for one of the 45 hospital selected in this analysis. The simulation was initially performed using the parameters generated using SPARCS database. The results from this first stage of simulation analysis was then used to generate parameters for the second stage of simulation analysis. Hence, the parameters used to obtain our results were randomly created. The parameters used to simulate the final model were as: Information transfer time: 11.997 minutes, regular patient process time: 11.234 minutes, RFID

patient process time: 11.379 minutes and triage nurse process time: 11.578 minutes. Both the list of initial and final parameters is listed in Appendix J. The iterations were conducted in a step-wise manner to obtain model stability. First, the model was run for 100 iterations, then 150 iterations and finally at 200 iterations, the model stability was achieved and the results from these 200 iterations were used to conduct the t-test analysis. It can be seen from the ARENA simulation model that, the total wait time for the patients with “early information access” is the sum of time taken in “Triage Nurse” and the “RFIDPatientProcess”. The total wait time for the patients without “early information access” is the sum of time taken in “Triage Nurse”, “PatientProcess” and “InfoTransfer”. The path flow of patients with early information access is shown in figure 9 and that for patients without early information access is shown in figure 4.4. The total wait time for patients with early information access is shown in equation 1 and that for the patients without early information access is shown in equation 2.

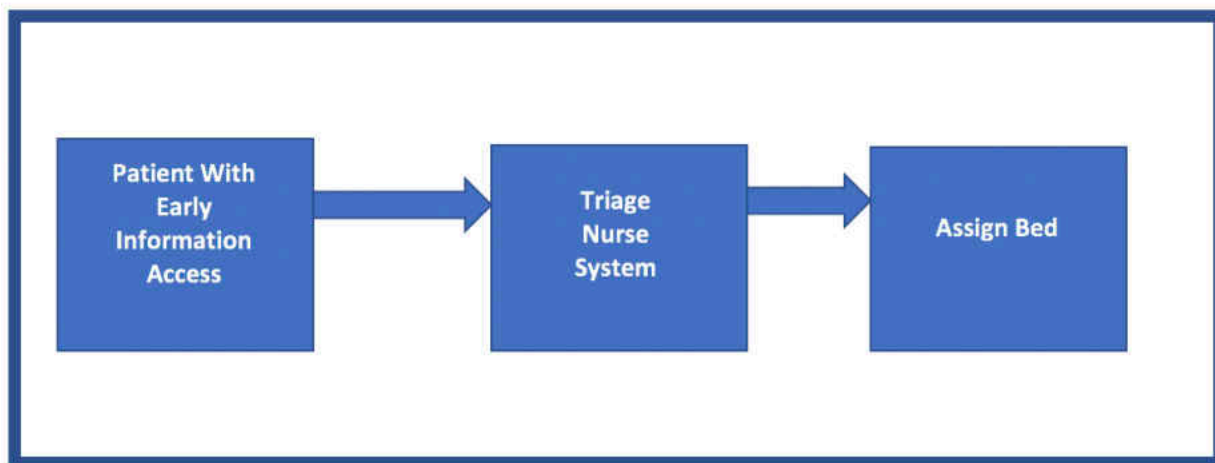

Figure 4.3 Path Flow for the Patient with Early Information Access
Equation 1: depicts the total wait time for the patient with “Early information access”.

$$\textit{Total Wait Time} = \textit{RFIDPatientProcess} - - - \textit{Equation 1}$$

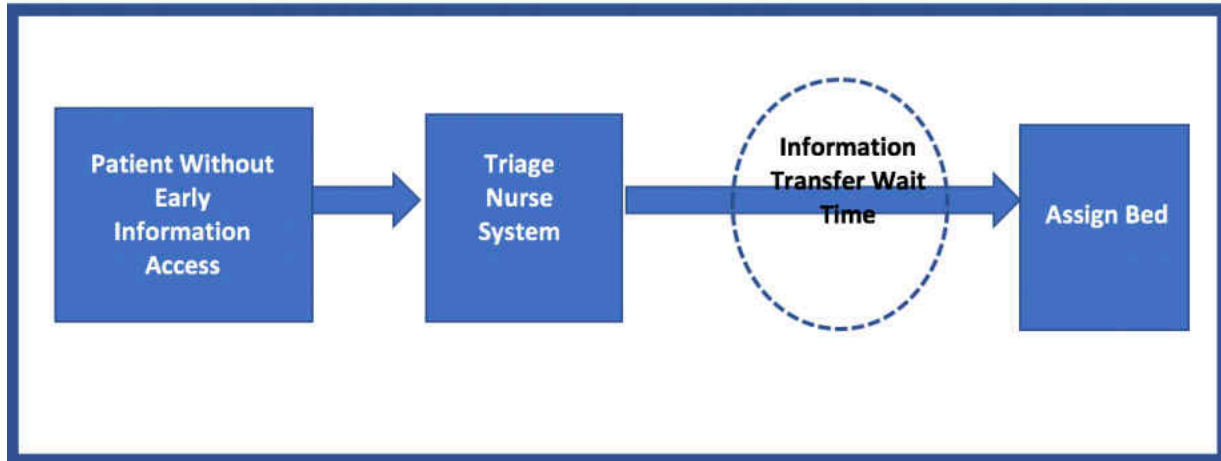

Figure 4.4 Path Flow for the Patients without Early Information Access
Equation 2: depicts the total wait time for the patient without “Early information access”.

$$\text{Total Wait Time} = \text{PatientProcess} + \text{InfoTransfer} \text{ --- Equation 2}$$

The processes such as triage nurse can be either modeled with the help of the “Action field” option, selected from the pull-down menu, is Seize Delay Release, which stands for a sequence of SEIZE, DELAY, and RELEASE SIMAN blocks. SEIZE and RELEASE blocks are used to model contention for a resource possessing a capacity (e.g., machines). When resource capacity is exhausted, the entities contending for the resource must wait until the resource is released. Thus, the SEIZE block operates like a gate between entities and a resource. When the requisite quantity of resource becomes available, the gate opens and lets an entity seize the resource; otherwise, the gate bars the entity from seizing the resource until the requisite quantity becomes available. Note that the resource quantity seized should be an integer; otherwise Arena truncates it. The processing (holding) time of a resource (Machine in our case) by an entity is specified via the DELAY block within the Process module.

For example, in the case of “Triage Nurse” process, 1 nurse is assigned to complete that process, therefore for every incoming patient when they are in the “TriageNurse” process they will have 1 nurse each. Hence, if one patient is in the “Triage Nurse” process then the total number of nurses available for other patients comes down to 124 from the initial number of 125 nurses. Similar occurrence is in the other three processes: “RFIDPatientProcess”, “PatientProcess” and “InfoTransfer”. The seize delay release process is shown in figure 4.5 below:

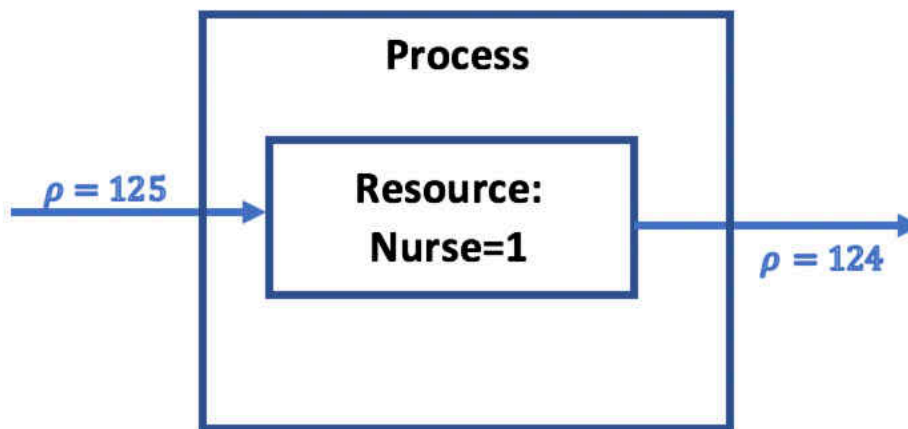

Figure 4.5 Seize Delay Release Process

4.8.2.1.1 Simulation Result

The ARENA simulation was set up for a 30 replication with the time measured in minutes. The only resource used in this pilot study is “Nurses” and there were 125 nurses made available. Each patient in the “Triage Nurse”, “RFIDPatientProcess”, “PatientProcess” and “InfoTranfer” will take 1 nurse each time and release the nurse after the process is completed. It is ED and hence is opened for 24 hours.

Test of 1A: Early information access decreases the average number of medical procedures required on a patient reversely it enables ED’s to complete comparatively higher number of

medical procedures overall.

The simulation model presented in Appendix K under model 1A, is used to test this hypothesis. In this model, an additional decision parameter is added, which is a 2 way by chance to select patients that will need additional medical procedures. This is modeled as “by-chance” because the probability whether an incoming patient will require additional procedure and if so then how many cannot be predicted. Furthermore, there is a counter added after the patients require additional medical process. This counter counts up all the returning patients that require additional medical procedures. This decision parameter and the counter is added for both streams of incoming patients: with early information access and patients without early information access. The difference between the total number of medical procedures conducted for both the patients with early information access and patients without early information access is shown in figure 12, for each respective iteration. The comparison of the average number of medical process completed for the two sets of patients for iterations is shown in Appendix L under graph 1A. There were in total 165.49 medical procedures conducted on patients with early information access in comparison to the total number of 86.7350 medical procedures conducted on patients without early information access through the two processes “PatientProcess” and “infoTransfer”. This number is presented in figure 4.6 below with red representing RFID patient which is for the patients with early information access and blue represents regular patients which is for the patients without early information access.



Figure 4.6 Comparison of the Number of Medical Procedure for RFID Patient Vs Regular Patient

The results from each iteration for both sets of patients were recorded and an Independent samples t-test was conducted. The statistics is provided in Appendix M under Results 1A. There were total of 60 samples with a mean of 163.22 for patients with early information access and 88.22 for patients without early information access. In addition to that the standard deviation reported 12.536 and 8.443 respective for patients with and without early information access. The Levine's test conducted had a significance value of .003 which is less than .05, thus the assumption of equal variances cannot be supported. Therefore, the test will be conducted with the results based on Equal variances is not assumed. This test result shows that the t-value is 38.437 at the significance level of .000 which is less than .05, thus the assumption that the difference is mean between two samples is statistically significant. Hence, it can be concluded that the two samples had a statistically significant different mean with a mean difference of 75 and standard error difference of 1.951. This result thus supports the proposed hypothesis 1A which states that the use of RFID (early information access) leads to decreased number of medical procedures that needs to be conducted on a particular patient or reversely since a smaller number of medical procedure needs to be conducted on a particular patient, overall more number of medical procedure can be

conducted on the overall incoming patient.

Test of 2A: Early information access increases the average number of patients discharged per day:

The simulation model presented in Appendix K under model 2A is used to test this hypothesis. In this model, a counter is added after the “RFIDPatientProcess” and “InfoTransfer” process to count on which process results in higher number of patients getting assigned bed in the ED. The difference between the total number of patients discharged for both the patients with early information access and patients without early information access is shown in figure 13, for respective iterations. The comparison of the average number of patients discharged for the two sets of patients for iterations is shown in Appendix L under graph 2A. There were 332.85 total patients with early information access through the “RFIDPatientProcess”, that were discharged compared to 209.59 total patients were discharged without early information access through the two processes “PatientProcess” and “infoTransfer”. This number is presented in figure 4.7 below, with red representing RFID patient which is for the patients with early information access and blue represents regular patients which is for the patients without early information access.



Figure 4.7 Comparison of the Number of Patients Discharged for RFID Patient Vs Regular Patient

The results from each iteration for both sets of patients were recorded and an Independent samples t-test was conducted. The statistics is provided in Appendix M under Results 2A. There were total of 60 samples with a mean of 334.87 for patients with early information access and 307.55 for patients without early information access. In addition to that the standard deviation reported is 15.177 and 15.238 respective for patients with and without early information access. The Levine's test conducted had a significance value of .679 which is greater than .05, thus the assumption of equal variances is supported. Therefore, the test will be conducted with the results based on Equal variances assumed. This test result shows that the t-value is 45.855 at the significance level of .000 which is less than .05, thus the assumption that the difference is mean between two samples is statistically significant. Hence, it can be concluded that the two samples had a statistically significant different mean with a mean difference of 127.317 and standard error difference of 2.777. This result thus supports the proposed hypothesis 2A which states that the use of RFID (early information access) leads to increase in the average number of patients being discharged on a daily basis.

Test of 3A: Early information access decreases the average number of days required to complete all the additional medical procedure required.

The simulation model presented in Appendix k under model 3A is used to test this hypothesis. The simulation result showed that there is a significant difference in the wait time for the two streams of patients. The patients with "early information access" wait much less in comparison to the patients without "early information access". The results for the wait time in each process was collected and a t-test for sample means was conducted using SPSS. The results of the t-test are shown in Appendix M under results 3A. The SPSS analysis suggest that the mean wait time for

patients with “early information access” is 29.6102 minutes with a standard deviation of 1.3059 minutes compared to that for the patients without “early information access” is 59.6953 minutes with a standard deviation of .965 minutes. This simple data analysis implies that the wait time is significantly higher for patients without “early information access” just for the first step in their ED process. The wait time for all of the three processes “InforTransfer”, “RegularPatientProcess” and “RFID Patient Process” is shown in Appendix L under graph 3A1. It can be concluded from this graph that the time difference between the “Regular PatientProcess” and the “RFID Patient Process” is not that different, however when added the time for “InfoTransfer” process, the wait time for the regular patient is significantly higher than that for the RFID patients as shown in Appendix L under graph 3A2.

Furthermore, the wait time results were subjected to independent samples test and to test for the statistical significance in the difference in means. The first part of the test which is the Levene’s Test for equality of variances show that the p-value is .252 which is $>.05$, thus the assumption of equal variances cannot be supported and so for further analysis the results under the “equal variances not assumed” section will be utilized. Under this section, the p-value is .000 which is $<.05$, therefore the difference in mean between the two groups (patients with early information access and without early information access), is statistically significant, the difference in mean is found to be 30.085 minutes with a standard error difference of .209. Therefore, hypothesis 3A is supported.

This pilot study conducted on the first stage of ED process for a patient supports our assumption that, patient information transfer does take significant amount of time and if that process can be automated and made non-repeatable, then the overall length of stay can be reduced significantly. Hence, the positive impact of “early information access” is established and a much-detailed

analysis using full dataset as well as statistical analysis (Path analysis) is conducted to test the proposed hypothesis.

Test of 1B-3B: Early information access decreases the length of stay through lower information uncertainty, higher information coordination and lower information ambiguity.

The simulation model presented in Appendix k under model 1B-2B-3B is used to test this hypothesis. The simulation result showed that there is a significant difference in the time interval between the first point of contact at the triage nurse and the patient being discharged for the two group of patients. The model was setup for 200 iterations and the iterations results are shown in Appendix M under table 1B-2B-3B. For the patients with early information access this time interval is 62.361 days and for patients without early information access, this is 63.423 days. The patients with “early information access” stay less time in the system in comparison to the patients without “early information access”. The results for this stay time in each process was collected for 200 different iterations and a t-test for sample means was conducted using SPSS. The results of the t-test are shown in Appendix M under results 1B-2B-3B. The SPSS analysis suggests that the mean length of stay for patients with “early information access” is 62.361 with a standard deviation of .481 compared to that for the patients without “early information access” is 63.423 with a standard deviation of .623. This sample data analysis implies that the patient stay time is higher for patients without “early information access”. The difference between the total stay time interval for both the patients with early information access and patients without early information access is shown in Appendix L under graph 1B-2B-3B, for each of the 200 iterations.

Furthermore, the wait time for iterations were subjected to independent samples test and to test for the statistical significance in the difference in means. The first part of the test which is the Levine’s Test for equality of variances show that the p-value is .149 which is $>.05$, thus the assumption of

equal variances cannot be supported and so for further analysis the results under the “equal variances not assumed” section will be utilized. Under this section, the p-value is .000 which is $<.05$, therefore the difference in mean between the two groups (patients with early information access and without early information access), is statistically significant, the difference in mean is found to be 1.061 days with a standard error difference of .101. Therefore, hypothesis 1B, 2B and 3B is supported. Even though the difference in length of stay is only 1.061 days in this experiment, it should be noted that the model only simulates the first section of the hospital and does not include for the complicated medical procedures during the patient’s entire stay in the hospital. Therefore, it can be concluded that overall the impact will be compounded and hence, the use of early information access will have a significant impact on length of stay of a patient and consequently on the hospital performance.

This pilot study conducted on the first stage of ED process for a patient supports our assumption that, patient information transfer does take significant amount of time and if that process can be automated and made non-repeatable, then the overall length of stay can be reduced significantly. Hence, the positive impact of “early information access” is established and a much-detailed analysis using full dataset as well as statistical analysis (Path analysis) is conducted to test the proposed hypothesis. Appendix N lists all the hypothesis testing conducted using simulation and its results.

4.8.2.2 Study 2: Path Analysis

Since, the impact of early information access is established through the pilot study, a detailed impact of early information access through different factors is conducted. This study will use a type of structural equation modeling technique called path model to test all of its hypothesis. "structural relationship model". The path analysis is also sometimes referred as Causal Modeling

as it is used to test a specific pattern of relationship among variables in which some are assumed to be the cause of the other(s). However, this label is a misnomer since a cause - effect relationship cannot be established in true sense using path analysis.

In simple terms, the Path analysis involves testing a theoretically or empirically determined specific pattern of relationship among a set of variables. Say, we are working with four variables A, B, C, and D. Then using path analysis, we can test the relationship among these variables as defined by some theory or hypothesis based on prior experience or empirical evidences.

In this study, there are 8 variables: RFID Use, Avg_Proc, Proc_Day, Avg_Discharge, LOS, EMR Use, IS Skill and IS Plans. Out of these 8 variables based on the hypothesis proposed above, RFID causes changes to Avg_Proc, Proc_Day and Avg_Discharge and these three variables cause changes in LOS. In addition to that, RFID also causes change in EMR Use and EMR Use cause changes in LOS. There are two interaction terms IS Skills and IS Plans which cause moderation effect on the path between RFID and EMR Use.

Furthermore, using these variables, a path model is designed using AMOS, the data selected from joining and parsing both the SPARCS and HIMSS database is saved in a SPSS file. This file is loaded into the AMOS and the model designed based on the proposed by hypothesis and the conceptual model. The path model is designed to represent the conceptual model. The two moderators: IS Skills and IS Plans in the relationship between RFID Use and EMR Use are modeled after creating two new variables respectively. Each of the variables are separately multiplied with RFID Use and two resulting variables “IS Skills * RFID Use” and “IS Plans * RFID Use” were created. These two variables were then correlated with RFID Use and represented as independent variables for EMR Use. Appendix P shows the complete Path model to test the proposed conceptual model and test the hypothesis.

A simple multiple regression would not be able to show the impact of all three indicators at the same instant since there are multiple causal relationship in this model. Therefore, structural model with one independent variable, four intermediate dependent variables which impact the dependent variable, length of stay. In addition to that there are two moderating variables.

The data collected will be from two different databases. The unique hospital identifier is used to connect these two databases and generate the mapping of desired variables. RFID use, number of IT training provided, number of IT plans and policies and number of IT units fully installed are obtained from HIMSS database. Length of stay, average number of medical procedures conducted on a patient, average number of days to complete the additional procedure and average number of patients discharged per day is obtained from the SPARCS database. All of these data will be collected for the hospitals in the state of NY.

4.8 Hypothesis Testing Setup

- Hypothesis 1A, average number of medical procedures conducted is the effect variable and RFID is the causal variable.
- Hypothesis 1B, average number of patients discharged per day is the effect variable and RFID is the causal variable.
- Hypothesis 1C, average number of days required to complete all the additional medical procedure required is the effect variable and RFID is the causal variable.
- Hypothesis 2A, average length of stay is the effect variable and average number of medical procedures conducted is the causal variable.
- Hypothesis 2B, average length of stay is the effect variable and average number of patients discharged per day is the causal variable.

- Hypothesis 2C, average length of stay is the effect variable and average number of days required to complete all the additional medical procedure required is the causal variable.
- Hypothesis 3A, average number of EMR units fully operational is the effect variable and RFID is the causal variable.
- Hypothesis 3B, average length of stay is the effect variable and average number of EMR units fully operational is the causal variable.
- Hypothesis 4, average number of IS Skill is the moderating variable for the direct relationship between RFID and average number of EMR units fully operational.
- Hypothesis 5, average number of IS Plans is the moderating variable for the direct relationship between RFID and average number of EMR units fully operational.

These hypothesis testing equations are represented using Lisrel notation and is shown in Appendix O. The linear equation for representing each of the path is shown under the equation, there are altogether 9 equations. The coefficient matrix is shown as A, and the endogenous matrix represented by X and the error matrix by E.

CHAPTER 5

RESULTS

The results from the run of the AMOS for the path model is shown in Appendix R. The path model analysis results indicate that the model proposed has a good fit. This good fit result is referred in Appendix R. It has a normed chi-square of 1.018 and the P-value is .433. The degree of freedom is shown to be 15. In addition to that, the good fit of the model is further supported by the RMSEA value of .020 which is lower than the .08 cutoff value as well as PCLOSE is high at .545 (Kline, 2015). This path model is recursive and hence is identifiable. Since, the path model has no feedback loops and no correlation between the disturbance terms for the corresponding endogenous variables that have direct paths between them. The value of NFI (.956), RFI (.917), IFI (.999), TLI (.998) and CFI (.999) are all greater than .9, indicating a good fit of the model. Furthermore, the Goodness of Fit (GFI) is also higher than .9 indicating a good fit model. These initial results imply that the model is a good fit and hence, further analysis is performed to test the hypothesis.

In further analysis, the results presented in Appendix S, indicate that the RFID use has a negative and statistically significant impact on both the average number of procedure and average number of procedures wait day. Average number of procedures represented by (Avg_Proc) is used to measure the information uncertainty and Average procedure wait day represented by (ProcDay) is used to measure information ambiguity. Therefore, as proposed in hypothesis 1a and 1c, it can be implied that higher the use of RFID, both the information uncertainty and information ambiguity is comparatively lower. It can be concluded that, for every 1 unit increase in RFID use, there is a

.606 unit decrease in average number of procedures that has to be performed in a patient. Similarly, the results indicate that for every 1 unit increase in RFID use, there is an 8.052 unit decrease in the average number of days a patient has to wait for their medical procedure to start. However, the proposed hypothesis on information coordination which states that increased use of RFID increases information coordination resulting in lower length of stay (indicator for higher hospital performance). In this analysis, it can be seen that this result is not statistically significant. On the other hand, both the information uncertainty and information ambiguity are shown to have a direct positive and statistically significant relationship with length of stay. Therefore, hypothesis 2 is also partly supported since only one of the indicator variables (information coordination has no statistical significance in this relationship). The case of average number of discharges not having a statistically significant impact implies that even if the increased RFID use increased information coordination, it does not have a statistical significance since the number of discharges can relate to any of the reasons where the patients just had a minor issue and could have been discharged with a little medical help or could have stayed in longer due to some medical issues. Therefore, being completely insignificant relationship in response to the use of RFID. Similarly, the average discharge also does not have a statistical significance in length of stay since, the patient discharge day does not necessarily mean shorter length of stay since, they can come back for additional medical procedures or any medical process that might require variety of discharge day which cannot be attributed to the use of RFID use and hence the direct relationship to length of stay. In addition to that the SMC's presented in Appendix S, show that all of the variables have except for "Avg_Discharge" has a very low SMC (.010). This indicate that "Avg_Discharge" has a potential lack of fit in this analysis.

Furthermore, the results indicate that increase in RFID use also increases the use of IT components

and this relationship is shown to be statistically significant as well. It can be concluded that for every 1 unit increase in the use of RFID, there is a 1.140 unit increase in the use of IT components. This variable is represented by EMR_Use. There are two moderating variables IS Skills, which represents the number of IT related trainings to the employees and IS Plan, which represents the number of plans and policies rolled out by the management regarding installation and maintenance of IT equipment. IS skills do not have any statistically significant impact however, IS plans seems to have a positive and statistically significant moderating impact on the relationship between RFID and the number of IT components in use. This shows that the increasing use of RFID helps in realizing the objective of hospitals to have an increased use of EMR components and make its transactions and operations completely electronic. However, it is also noticeable that, higher EMR use does not necessarily mean higher hospital performance. Therefore, it can be concluded that higher use of RFID does decrease length of stay through decreasing information ambiguity and information uncertainty, however increased EMR use does not decrease the length of stay. Even in this case, increased use of RFID is still desirable since, it helps in increased use of EMR use which helps to make the medical process completely paperless and hence can enhance the patient experience. There needs to be further analysis on this relationship. The results of the complete list of hypothesis decisions is presented in Appendix T.

CHAPTER 6

DISCUSSION

The results imply that, early information access through the use of information transfer technology such as RFID tends to decrease the ED congestion. Therefore, it can be concluded that the ED congestion is a result of lack of proper information transfer mechanism that results in improper information alignment in ED. Improper information alignment is represented by entities such as higher information uncertainty and information ambiguity as well as lower information coordination. The solutions proposed in healthcare literature to reduce ED congestion included the management of hospital bed, other hospital resources as well as diverting the incoming patients. In contrast this study, proposes that the ED congestion is due to the lack of information alignment between information processing capacity of the ED and the information need (due to the increasing number of patients in ED). Therefore, rather than diverting the patients, or just focusing on managing physical resources in hospital, if the information alignment problem is tackled then the ED congestion can be tackled as well, and this can be a long-term solution. This solution can be used not just in the ED but in overall supply chain literature to resolve the congestion issue.

In terms of information alignment, this study provided the breakdown of information processing entities into three parts: information uncertainty, information ambiguity and information coordination. This helps in understanding that, information alignment is alignment of all three aspect of information processing. These three entities do not necessarily pertain to the same factor but are different. This study is successful in implying that since, only two of the three entities

(information uncertainty and information ambiguity) shows statistical significance while information coordination does not. Hence, this study helps in establishing an additional factor to the existing OIPT that the three entities need to be studied separately and there is an entity level analysis necessary to explain the information alignment issues.

Furthermore, the early information access also helps in increasing the use of other EMR units in the ED. This relationship implies that the success of implementation and maintenance of any IT components in a healthcare setup is not an insulated concept but is a organic one that is built on other IT components supplementing its operations. Furthermore, the moderating factors IS plans also support this theory. It can be seen that IS plans help to enhance the use of EMR units when it is supported by use of early information access. This concept is not just supportive in an ED setting but throughout the setup of any organization. An organization purchases and installs newer IT components but does not support the components by developing managerial policies. In addition to that, the use of IT components needs to be facilitated by providing proper information transfer mechanism that is crucial for the growth and sustainability of the new IT components installed.

6.1 Future Implications

- 1) Comparative Advantage of Technology use decreases with time:

The use of new technology can bring in better performance if used in a proper manner with better support from the management in terms of plans/policies and employee motivation, however the effect of the new technology on the firm's performance is not perpetual. It will decrease with time. As mentioned by Lee et al., (2016), if a firm's IT investment is aligned with its business, then firm's performance increases with the investment in IT. However, this study shows that the EMR use was able to impact a hospital's performance

in 2012, whereas its impact was not statistically significant for the year 2014. Therefore, it can be concluded that any IT investment made by a firm only has a diminishing return on investment over time. However, to have a better support for this hypothesis, a time series analysis of the datasets from 2012, 2014 and some latest year say 2016-2018 can be conducted. In addition to that, studying the rate of saturation of technology in various industries, or the causes of saturation is a topic that has not been studied as of yet with a proper time series analysis.

- 2) Organization Information Processing Theory and interaction with human resource of the organization:

It is seen that till date the studies are only focused on the information side of this theory. This study expands the theory by dissecting different parts of this theory and using it as a stand-alone entity to understand the impact of each entity on firm's performance. In future, additional factors such as interaction terms of human aspect of the firm such as employee skills, employee behavior, managerial plans can be introduced to study the interactive pattern of these variables on the total output which is the firm's performance.

6.2 Research Contribution

6.2.1 Theoretical Contribution

- a. Organization Information processing Theory: This study expands the use of OIPT in healthcare settings by using patients as information. The increase in patient corresponds to the increase in need of information processing capacity. It divides the three different entity of OIPT: information ambiguity, information coordination and information uncertainty; into an individual entity in itself. This will help in

analyzing OIPT through each of the individual entity and implies that all three entities of OIPT does not necessarily need to act together to increase the information processing capacity. Instead as per the requirement of ability of a firm, managing each entity separately can also lead to increase in information processing capacity. Hence, this study provides a breakdown of OIPT in entity form.

- b. Multi-Method Data Analysis Approach: In the field of healthcare/ED congestion, most studies conduct a single method approach to support their hypothesis: For example, simulation approach (Chan et al., 2017; Shen and Wang, 2015; Reyes et al., 2012) and empirical approach (Batt and Terweisch, 2016; Batt and Terweisch, 2015; Hsia et al., 2017). It is not commonly used in the healthcare IS sector, however other fields have started to merge towards multi-method approach (Choi et al., 2016). The authors imply that this multi-method approach provides “Methodological validation” which goes on to further strengthen the support for the proposed hypothesis.

In this study, a “multi-method” approach is conducted by using both simulation study as well as statistical study (path model) to validate the support for the proposed hypothesis. Hence, it can be implied that one of the major theoretical contribution of this study is to provide a “multi-method” approach in the field of healthcare IS/ED congestion. For example, in this study, all of the first 6 hypothesis were supported by the simulation study and supporting the claim that all three entities of OIPT had statistically significant impact on hospital performance (LOS). However, path analysis showed that “information coordination” entity did not have any statistical impact on the hospital performance. Therefore, a more detailed study

must be conducted to understand the impact of this entity.

6.2.2 Contribution to Practitioners

- a. **Increasing Information processing Capacity:** This study proves that only increasing the information processing capacity as a whole does not help to meet the firm's goal of information need, since there are three different entities that make up information processing capacity. Therefore, it is important to align each of the entity to the firm's need to obtain a satisfactory information processing capacity. Hence, this study concludes that aligning information need is as equally important as increasing information processing capacity.
- b. **Managerial Plans and Policies Vs Employee Trainings:** Employees use the technology to make it a success and studies show that employee trainings focused on the use of the said technology is highly crucial for the successful implementation of the technology, this study shows that employee trainings do not significantly impact the relationship. This points towards a need for a much deeper analysis of the type of technology the trainings are based on. Technology trainings by itself are not significant and there needs to be additional study on the way trainings are delivered. In fact, this study supports the claim by Caramel and Agarwal (2006), that method of deliverance of trainings related to technology is crucial in the learning behavior of employees and hence the success of the implementation of the said technology. On the other hand, managerial plans and policies regarding the initiation/implementation and maintenance of the technology is a significant factor in the success of the technology. Therefore, this study implies that the focus should

be in creating and promoting managerial plans and policies. In terms of trainings, it is not just the number that matters but the method of delivery of trainings is much more important and focus should be on quality of trainings rather than quantity.

- a. **Data Reduction:** This study started with a 3.68 GB of data in the beginning of analysis. It was huge data to conduct any analysis and generate a meaningful trends and results from without using some form of big data analysis tool. Big data analysis tool was not feasible in this study due to the privacy of the patient and the act to be followed for the SPARCS database. Hence, a data extraction and reduction mechanism are followed in this study. A flow chart is created to make sure that the final data had all the necessary elements of the original data as well as the data was small enough to be analyzed upon. Many practitioners face this challenge of analyzing big data in the field of healthcare hence, this study provides a data reduction flowchart that was successfully implemented.

6.3 Limitations

Methodology: The data collected has been aggregated for one month only due to the big volume of data. The statistical method used in this study is not capable to analyzing the full data set at one time as a whole. Some big data analytics tool such as R or Google Fusion Table would have been helpful to analyze the trend in this data for the full year or even conduct a time series analysis for different years and study the trend over time in some of the relationship in the model. However, due to the patient privacy and security clause when using SPARCS database, we were not able to use most of the big data analysis tools to maintain the data usage clause. Therefore, it can be stated that the analytical tool used is one of the biggest limitations of this research.

Data: Due to lack of availability of data, only the state of NY has been considered. A nation-wide study could have helped to analyze the real impact of “early information access”, in emergency department with different population density, different level of access to the emergency department, different level of concentration of emergency department and different income distribution. This kind of analysis gives a more detailed and real impact of the “early income access” in reducing emergency department congestion.

Simulation Pilot Study: In the simulation pilot study, due to lack of big data analysis tool, only a part of ED was simulated and not the whole ED system to support the positive impact of early information access. If the whole ED system were modeled, then the pilot study could have been more impactful, and a detailed analysis could have been predicted on the early information access on stage level. For example: is the impact more on earlier stages of ED process, or is it more impactful on recurring stages like monitoring medications to staff and so on. This type of analysis can present an insightful prediction for the use of early information access on whether to use it throughout the overall ED process or just some process needs to use it. This can be more useful when doing a cost-benefit analysis.

Theory: Additional interaction variables to moderate the relationship between EMR use and length of stay. The relationship between EMR use and length of stay is considered to be a direct causal relationship which does not show any statistically significant impact in this research. There is a need for a study that analyzes the impact of interaction variables that moderate this relationship and presents a theoretical understanding of the factors that impact this direct relationship and test whether, those additional factors can play a role in making this direct relationship statistically significant or not, is crucial in this field of study. This area has not been studied theoretically in this study.

REFERENCES

- Abu Amuna, Y., Al Shobaki, M., Abu Naser, S., & Badwan, J. (2017). Understanding Critical Variables for Customer Relationship Management in Higher Education Institution from Employee Perspective. *International Journal of Information Technology and Electrical Engineering*, 6(1), 10-16.
- Ackoff, R. L. (1956). The development of operations research as a science. *Operations Research*, 4(3), 265-295.
- Ajzen, I. (1991). The theory of planned behavior. *Organizational behavior and human decision processes*, 50(2), 179-211.
- Ajzen, I., & Driver, B. L. (1991). Prediction of leisure participation from behavioral, normative, and control beliefs: An application of the theory of planned behavior. *Leisure sciences*, 13(3), 185-204.
- Ajzen, I., & Madden, T. J. (1986). Prediction of goal-directed behavior: Attitudes, intentions, and perceived behavioral control. *Journal of experimental social psychology*, 22(5), 453-474.
- Alavi, M., & Leidner, D. E. (2001). Knowledge management and knowledge management systems: Conceptual foundations and research issues. *MIS quarterly*, 107-136.
- Albarracin, D., Fishbein, M., & de Muchnik, E. G. (1997). Seeking Social Support in Old Age as Reasoned Action: Structural and Volitional Determinants in a Middle-Aged Sample of Argentinean Women 1. *Journal of Applied Social Psychology*, 27(6), 463-476.
- Albarracin, D., Johnson, B. T., Fishbein, M., & Muellerleile, P. A. (2001). Theories of reasoned action and planned behavior as models of condom use: a meta-analysis. *Psychological bulletin*, 127(1), 142.

- Albarracín, D., Kumkale, G. T., & Johnson, B. T. (2004). Influences of social power and normative support on condom use decisions: a research synthesis. *AIDS care*, *16*(6), 700-723.
- Downs, D. S., & Hausenblas, H. A. (2005). The theories of reasoned action and planned behavior applied to exercise: A meta-analytic update. *Journal of Physical Activity and Health*, *2*(1), 76-97.
- Allon, G., Deo, S., & Lin, W. (2013). The impact of size and occupancy of hospital on the extent of ambulance diversion: Theory and evidence. *Operations Research*, *61*(3), 544-562.
- Ajami S, Carter MW. The advantages and disadvantages of Radio Frequency Identification (RFID) in Health-care Centers; approach in Emergency Room (ER). 2013.
- Anderson, S. (2015). Publicness, goal ambiguity and patient safety: exploring organizational factors in hospital practice. *International Journal of Privacy and Health Information Management (IJP HIM)*, *3*(2), 1-26.
- Amit, R., & Schoemaker, P. J. (1993). Strategic assets and organizational rent. *Strategic management journal*, *14*(1), 33-46.
- Amuna, Y. M. A., Al Shobaki, M. J., & Naser, S. S. A. (2017). The Role of Knowledge-Based Computerized Management Information Systems in the Administrative Decision-Making Process. *International Journal of Information Technology and Electrical Engineering*, *6*(2), 1-9.
- Andrulis, D. P., Kellermann, A., Hintz, E. A., Hackman, B. B., & Weslowski, V. B. (1991). Emergency departments and crowding in United States teaching hospitals. *Annals of emergency medicine*, *20*(9), 980-986.
- Ann Sykes, T. (2015). Support structures and their impacts on employee outcomes: A longitudinal field study of an enterprise system implementation. *MIS quarterly*, *39*(2).

- Armitage, C. J., & Conner, M. (2001). Efficacy of the theory of planned behaviour: A meta-analytic review. *British journal of social psychology*, 40(4), 471-499.
- Asplin, B. R. (2001). Tying a knot in the unraveling health care safety net. *Academic Emergency Medicine*, 8(11), 1075-1079.
- Baird, K. E. (2016). The financial burden of out-of-pocket expenses in the United States and Canada: How different is the United States?. *SAGE open medicine*, 4, 2050312115623792.
- Bagozzi, R. P., & Lee, K. H. (2002). Multiple routes for social influence: The role of compliance, internalization, and social identity. *Social Psychology Quarterly*, 226-247.
- Bandura, A. (2006). Toward a psychology of human agency. *Perspectives on psychological science*, 1(2), 164-180.
- Barney, J. (1991). Firm resources and sustained competitive advantage. *Journal of management*, 17(1), 99-120.
- Batt, R. J., & Terwiesch, C. (2015). Waiting patiently: An empirical study of queue abandonment in an emergency department. *Management Science*, 61(1), 39-59.
- Balasubramanian, S. (2017). Executive Dynamism in Healthcare: A Rich History of the Executive Branch and Its Use of Power in Public Health and Access to Care Initiatives. *Faulkner L. Rev.*, 9, 61.
- Batt, R. J., & Terwiesch, C. (2016). Early task initiation and other load-adaptive mechanisms in the emergency department. *Management Science*, 63(11), 3531-3551.
- Bell, C. E., & Allen, D. (1969). Optimal planning of an emergency ambulance service. *Socio-Economic Planning Sciences*, 3(2), 95-101.

- Biji, K. B., Ravishankar, C. N., Mohan, C. O., & Gopal, T. S. (2015). Smart packaging systems for food applications: a review. *Journal of food science and technology*, 52(10), 6125-6135.
- Bogart, L. M., Cecil, H., & Pinkerton, S. D. (2000). Hispanic adults' beliefs, attitudes, and intentions regarding the female condom. *Journal of Behavioral Medicine*, 23(2), 181-206
- Boyle, A., Beniuk, K., Higginson, I., & Atkinson, P. (2012). Emergency department crowding: time for interventions and policy evaluations. *Emergency medicine international*, 2012.
- Burns, T., & Stalker, G. M. (1961). *The Management of Innovation* (London, Tavistock Publications). *BurnsThe Management of Innovation1961*.
- Burt, C. W., & Schappert, S. M. (2004). Ambulatory care visits to physician offices, hospital outpatient departments, and emergency departments: United States, 1999--2000. *Vital and health statistics. Series 13, Data from the National Health Survey*, (157), 1-70.
- Burt, C. W., & McCaig, L. F. (2001). Trends in hospital emergency department utilization; United States, 1992-99.
- Burton-Jones, A. (2001). Knowledge capitalism: Business, work, and learning in the new economy. *Oup Catalogue*.
- Burwell, T. H., Jarvis, J. P., & McKnew, M. A. (1993). Modeling co-located servers and dispatch ties in the hypercube model. *Computers & Operations Research*, 20(2), 113-119.
- Burwell, T. H., McKnew, M. A., & Jarvis, J. P. (1992). An application of a spatially distributed queuing model to an ambulance system. *Socio-Economic Planning Sciences*, 26(4), 289-300.
- Cabrera, A., & Cabrera, E. F. (2002). Knowledge-sharing dilemmas. *Organization studies*, 23(5), 687-710.

- Cachon, G. P., & Fisher, M. (2000). Supply chain inventory management and the value of shared information. *Management science*, 46(8), 1032-1048.
- Caputo, A. C., Pelagagge, P. M., & Scacchia, F. (2003). Integrating transport systems in supply chain management software tools. *Industrial Management & Data Systems*, 103(7), 503-515.
- Caro, F., & Gallien, J. (2010). Inventory management of a fast-fashion retail network. *Operations Research*, 58(2), 257-273.
- Carter, C. R., & Rogers, D. S. (2008). A framework of sustainable supply chain management: moving toward new theory. *International journal of physical distribution & logistics management*, 38(5), 360-387.
- Carver, C. S., & Scheier, M. F. (1982). Control theory: A useful conceptual framework for personality—social, clinical, and health psychology. *Psychological bulletin*, 92(1), 111.
- Carrasquillo, O., Himmelstein, D. U., Woolhandler, S., & Bor, D. H. (1999). Going bare: trends in health insurance coverage, 1989 through 1996. *American Journal of Public Health*, 89(1), 36-42.
- Cesta, T. "Managing length of stay using patient flow--part 1." Hospital case management: the monthly update on hospital-based care planning and critical paths 21, no. 2 (2013): 19-22.
- Chae, B., & Francesco Lanzara, G. (2006). Self-destructive dynamics in large-scale technochange and some ways of counteracting it. *Information Technology & People*, 19(1), 74-97.
- Chan, C. W., Farias, V. F., & Escobar, G. J. (2016). The impact of delays on service times in the intensive care unit. *Management Science*.

- Chang, C. S., & Chang, H. H. (2007). Effects of internal marketing on nurse job satisfaction and organizational commitment: Example of medical centers in southern Taiwan. *The journal of nursing research: JNR*, 15(4), 265-274.
- Chalfin, D. B., Trzeciak, S., Likourezos, A., Baumann, B. M., Dellinger, R. P., & DELAY-ED study group. (2007). Impact of delayed transfer of critically ill patients from the emergency department to the intensive care unit. *Critical care medicine*, 35(6), 1477-1483.
- Chatfield, A. T., & Bjørn-Andersen, N. (1997). The impact of IOS-enabled business process change on business outcomes: transformation of the value chain of Japan airlines. *Journal of Management Information Systems*, 14(1), 13-40.
- Chen, J., Li, K., Tang, Z., Bilal, K., & Li, K. (2016). A parallel patient treatment time prediction algorithm and its applications in hospital queuing-recommendation in a big data environment. *IEEE Access*, 4, 1767-1783.
- Conner, K. R. (1991). A historical comparison of resource-based theory and five schools of thought within industrial organization economics: do we have a new theory of the firm?. *Journal of management*, 17(1), 121-154.
- Cortada, J. W., & Woods, J. A. (2000). *The knowledge management yearbook 2000-2001*. Taylor & Francis.
- Costa, C., Antonucci, F., Pallottino, F., Aguzzi, J., Sarria', D., & Menesatti, P. (2013). A review on agri-food supply chain traceability by means of RFID technology. *Food and Bioprocess Technology*, 6(2), 353–366. doi:10.1007/s11947-012-0958-7.
- Creemers, S., Lambrecht, M., & Vandaele, N. (2007). Queueing models in healthcare. *Tijdschrift voor Economie en Management*, 52(3), 471-497.

- Croson, R., Schultz, K., Siemsen, E., & Yeo, M. L. (2013). Behavioral operations: the state of the field. *Journal of Operations Management*, 31(1-2), 1-5.
- Curtin, J., Kauffman, R. J., & Riggins, F. J. (2007). Making the “most” out of RFID technology: A research agenda for the study of the adoption, usage, and impact of RFID. *Information Technology and Management*, 8(2), 87–110.
- Daft, R. L., & Lengel, R. H. (1986). Organizational information requirements, media richness and structural design. *Management science*, 32(5), 554-571.
- Davenport, T. H., & Prusak, L. (1998). *Working knowledge: How organizations manage what they know*. Harvard Business Press.
- De Luca, G., Suryapranata, H., Ottervanger, J. P., & Antman, E. M. (2004). Time delay to treatment and mortality in primary angioplasty for acute myocardial infarction. *Circulation*, 109(10), 1223-1225.
- De Silva, P. U., & Vance, C. K. (2017). Preserving the quality of scientific research: peer review of research articles. In *Scientific Scholarly Communication* (pp. 73-99). Springer, Cham.
- Demerouti, E., & Bakker, A. B. (2011). The job demands-resources model: Challenges for future research. *SA Journal of Industrial Psychology*, 37(2), 01-09.
- Derlet, R. W., & Richards, J. R. (2000). Overcrowding in the nation’s emergency departments: complex causes and disturbing effects. *Annals of emergency medicine*, 35(1), 63-68.
- Derlet, R. W., Richards, J. R., & Kravitz, R. L. (2001). Frequent overcrowding in US emergency departments. *Academic Emergency Medicine*, 8(2), 151-155.
- Dierickx, I., & Cool, K. (1989). Asset stock accumulation and sustainability of competitive advantage. *Management science*, 35(12), 1504-1511.

- Dimick, J. B., Pronovost, P. J., Heitmiller, R. F., & Lipsett, P. A. (2001). Intensive care unit physician staffing is associated with decreased length of stay, hospital cost, and complications after esophageal resection. *Critical care medicine*, 29(4), 753-758.
- Dobrzykowski, D. D., & Tarafdar, M. (2015). Understanding information exchange in healthcare operations: Evidence from hospitals and patients. *Journal of Operations Management*, 36, 201-214.
- Dobson, G., Tezcan, T., & Tilson, V. (2013). Optimal workflow decisions for investigators in systems with interruptions. *Management Science*, 59(5), 1125-1141.
- Dolton, P., & Pathania, V. (2016). Can increased primary care access reduce demand for emergency care? Evidence from England's 7-day GP opening. *Journal of Health Economics*, 49, 193-208.
- Duggan, M., Gupta, A., & Jackson, E. (2017). The Impact of the Affordable Care Act: Evidence from California's Hospital Sector.
- Duncan, N. B. (1995). Capturing flexibility of information technology infrastructure: A study of resource characteristics and their measure. *Journal of management information systems*, 12(2), 37-57.
- Durantini, M. R. (2006). others. "Conceptualizing the Influence of Social Agents of Change: A Meta-Analysis of HIV Prevention Interventions for Different Groups.". *Psychological Bulletin*, 132, 212-248.
- Elalouf, A., & Wachtel, G. (2015). An alternative scheduling approach for improving patient-flow in emergency departments. *Operations Research for Health Care*, 7, 94-102.
- Elliott, K., Klein, J. W., Basu, A., & Sabbatini, A. K. (2016). Transitional care clinics for follow-up and primary care linkage for patients discharged from the ED. *The American journal*

- of emergency medicine*, 34(7), 1230-1235.
- Epstein, M. J., & Roy, M. J. (2000). Strategic evaluation of environmental projects in SMEs. *Environmental Quality Management*, 9(3), 37-47.
- Fawcett, S. E., Stanley, L. L., & Smith, S. R. (1997). Developing a logistics capability to improve the performance of international operations. *Journal of business logistics*, 18(2), 101.
- Fiems, D., Koole, G., & Nain, P. (2007). Waiting times of scheduled patients in the presence of emergency requests. *Technisch rapport*. URL [http://www. math. vu. nl/koole/articles/report05a/art. pdf](http://www.math.vu.nl/koole/articles/report05a/art.pdf), (Accessed on 18/12/2012), 1-19.
- Fishbein, M., & Stasson, M. (1990). The Role of Desires, Self-Predictions, and Perceived Control in the Prediction of Training Session Attendance 1. *Journal of Applied Social Psychology*, 20(3), 173-198.
- Fishbein, M., Ajzen, I., Albarracin, D., & Hornik, R. (2007). A reasoned action approach: Some issues, questions, and clarifications. *Prediction and change of health behavior: Applying the reasoned action approach*, 281-295.
- French, N. P., McCarthy, H. E., Diggle, P. J., & Proudman, C. J. (2005). Clustering of equine grass sickness cases in the United Kingdom: a study considering the effect of position-dependent reporting on the space–time K-function. *Epidemiology & Infection*, 133(2), 343-348.
- Forero, R., Hillman, K. M., McCarthy, S., Fatovich, D. M., Joseph, A. P., & Richardson, D. B. (2010). Access block and ED overcrowding. *Emergency Medicine Australasia*, 22(2), 119-135.
- Foss, S. K., & Griffin, C. L. (1995). Beyond persuasion: A proposal for an invitational rhetoric. *Communications Monographs*, 62(1), 2-18.

- Fredrickson, J. W. (1984). The comprehensiveness of strategic decision processes: Extension, observations, future directions. *Academy of Management journal*, 27(3), 445-466.
- Fredrickson, J. W., & Mitchell, T. R. (1984). Strategic decision processes: Comprehensiveness and performance in an industry with an unstable environment. *Academy of Management journal*, 27(2), 399-423.
- Fredrickson, J. W., & Iaquinto, A. L. (1989). Inertia and creeping rationality in strategic decision processes. *Academy of management journal*, 32(3), 516-542.
- Galbraith, J. R. (1973). *Designing complex organizations*. Addison-Wesley Longman Publishing Co., Inc..
- Gans, N., & Croson, R. (2008). Introduction to the special issue on behavioral operations. *Manufacturing & Service Operations Management*, 10(4), 563-565.
- Gardner, J. W., Boyer, K. K., & Gray, J. V. (2015). Operational and strategic information processing: Complementing healthcare IT infrastructure. *Journal of Operations Management*, 33, 123-139.
- Gastaldi, L., Segato, F., Radaelli, G., Lettieri, E., & Corso, M. (2017). Professionals' Use of IT in Hospitals: Evidence of User Acceptance and Institutional Factors for the EMRs in Italy. In *18th International Continuous Innovation Network (CINet) Conference "Digitalization and Innovation: Designing the Organization of the Future"* (pp. 188-201).
- Gattiker, T. F., & Goodhue, D. L. (2004). Understanding the local-level costs and benefits of ERP through organizational information processing theory. *Information & management*, 41(4), 431-443.
- Ghanes, K., Wargon, M., Jouini, O., Jemai, Z., Diakogiannis, A., Hellmann, R., ... & Koole, G.

- (2015). Simulation-based optimization of staffing levels in an emergency department. *Simulation*, 91(10), 942-953.
- Gibson, C. F. 2003. "IT-Enabled Business Change: An Approach to Understanding and Managing Risk," *MIS Quarterly Executive* (2:2), pp. 104-115.
- Gowen, C. R., Mcfadden, K. L., Hoobler, J. M., & Tallon, W. J. (2006). Exploring the efficacy of healthcare quality practices, employee commitment, and employee control. *Journal of Operations Management*, 24(6), 765-778.
- Grant, R. M. (1996). Toward a knowledge-based theory of the firm. *Strategic management journal*, 17(S2), 109-122.
- Grant, R. M., & Baden-Fuller, C. (1995, August). A knowledge-based theory of inter-firm collaboration. In *Academy of management proceedings* (Vol. 1995, No. 1, pp. 17-21). Briarcliff Manor, NY 10510: Academy of Management.
- Grant, R. M. (1991). The resource-based theory of competitive advantage: implications for strategy formulation. *California management review*, 33(3), 114-135.
- Green, L. (2006). Queueing analysis in healthcare. *Patient flow: reducing delay in healthcare delivery*, 281-307.
- Green, L. V., & Liu, N. (2015). A study of New York City obstetrics units demonstrates the potential for reducing hospital inpatient capacity. *Medical Care Research and Review*, 72(2), 168-186.
- Groves, P. S., Bunch, J. L., Cram, E., Farag, A., Manges, K., Perkhounkova, Y., & Scott-Cawiezell, J. (2017). Priming patient safety through nursing handoff communication: A simulation pilot study. *Western journal of nursing research*, 39(11), 1394-1411.

- Hall, D. J., Skipper, J. B., & Hanna, J. B. (2010). The mediating effect of comprehensive contingency planning on supply chain organisational flexibility. *International Journal of Logistics: Research and Applications*, 13(4), 291-312.
- Hall, J. E. (2010). *Guyton and Hall Textbook of Medical Physiology E-Book: with STUDENT CONSULT Online Access*. Elsevier Health Sciences.
- Hardeman, W., Sutton, S., Griffin, S., Johnston, M., White, A., Wareham, N. J., & Kinmonth, A. L. (2005). A causal modelling approach to the development of theory-based behaviour change programmes for trial evaluation. *Health education research*, 20(6), 676-687.
- Hardeman, W., Johnston, M., Johnston, D., Bonetti, D., Wareham, N., & Kinmonth, A. L. (2002). Application of the theory of planned behaviour in behaviour change interventions: A systematic review. *Psychology and health*, 17(2), 123-158.
- Hausmann, R. D. (1970). Waiting time as an index of quality of nursing care. *Health services research*, 5(2), 92.
- He, C., Zheng, Y., Wang, L., & Ma, D. (2014). RFID application research for discrete manufacturing. *Computer Integrated Manufacturing Systems*, 20(5), 1160–1170. doi: 10.13196/j.cims.2014.05.hechangpeng.1160.11.20140519.
- Hernandez-Boussard, T., Burns, C. S., Wang, N. E., Baker, L. C., & Goldstein, B. A. (2014). The Affordable Care Act reduces emergency department use by young adults: evidence from three states. *Health Affairs*, 33(9), 1648-1654.
- Heyland, D., Cook, D., Bagshaw, S. M., Garland, A., Stelfox, H. T., Mehta, S., ... & Turgeon, A. F. (2015). The very elderly admitted to ICU: a quality finish?. *Critical care medicine*, 43(7), 1352-1360.

- Hislop, D. (2002). Mission impossible? Communicating and sharing knowledge via information technology. *Journal of Information Technology*, 17(3), 165-177.
- Hoot, N. R., & Aronsky, D. (2008). Systematic review of emergency department crowding: causes, effects, and solutions. *Annals of emergency medicine*, 52(2), 126-136.
- Hsia, R. Y., Sabbagh, S. H., Guo, J., Nuckton, T. J., & Niedzwiecki, M. J. (2018). Trends in the utilisation of emergency departments in California, 2005–2015: a retrospective analysis. *BMJ open*, 8(7), e021392.
- Huang, YC., & Chu, CP. (2011). RFID Applications in hospitals – A case study for emergency department. *Journal of Communication and Computer*, 8(7), 1-8.
- Huang, J., Carmeli, B., & Mandelbaum, A. (2015). Control of patient flow in emergency departments, or multiclass queues with deadlines and feedback. *Operations Research*, 63(4), 892-908.
- Jacobson, S. H., Hall, S. N., & Swisher, J. R. (2006). Discrete-event simulation of health care systems. In *Patient flow: Reducing delay in healthcare delivery* (pp. 211-252). Springer US.
- Jaffe, R., Nash, R. A., Ash, R., Schwartz, N., Corish, R., Born, T., ... & Working Group on Healthcare Transparency, A. S. I. M. P. (2006). Healthcare transparency: opportunity or mirage. *Journal of Management Development*, 25(10), 981-995.
- Janis, I. L., & Mann, L. (1977). *Decision making: A psychological analysis of conflict, choice, and commitment*. Free press.
- Janz, B. D., Pitts, M. G., & Otondo, R. F. (2005). Information systems and health care-II: Back to the future with RFID: Lessons learned-some old, some new. *Communications of the Association for Information Systems*, 15(1), 7.

- Jemmott 3rd, J. B., Jemmott, L. S., & Fong, G. T. (1992). Reductions in HIV risk-associated sexual behaviors among black male adolescents: effects of an AIDS prevention intervention. *American journal of public health, 82*(3), 372-377.
- Joseph, B., Zangbar, B., Pandit, V., Fain, M., Mohler, M. J., Kulvatunyou, N., ... & Rhee, P. (2016). Emergency general surgery in the elderly: too old or too frail?. *Journal of the American College of Surgeons, 222*(5), 805-813.
- Kamb, M. L., Fishbein, M., Douglas Jr, J. M., Rhodes, F., Rogers, J., Bolan, G., ... & Kent, C. (1998). Efficacy of risk-reduction counseling to prevent human immunodeficiency virus and sexually transmitted diseases: a randomized controlled trial. *Jama, 280*(13), 1161-1167.
- Kalichman, S. C., Eaton, L., White, D., Cherry, C., Pope, H., Cain, D., & Kalichman, M. O. (2007). Beliefs about treatments for HIV/AIDS and sexual risk behaviors among men who have sex with men, 1997–2006. *Journal of Behavioral Medicine, 30*(6), 497-503.
- Karaca, Z., Wong, H. S., & Mutter, R. L. (2012). Duration of patients' visits to the hospital emergency department. *BMC emergency medicine, 12*(1), 1.
- Krathwohl, D. R. (1993). *Methods of educational and social science research: An integrated approach*. Longman/Addison Wesley Longman.
- Kasich, J. H. R. (1997). Balanced Budget Act of 1997. *Washington, DC: US House of Representatives*.
- Kassin, M. T., Owen, R. M., Perez, S. D., Leeds, I., Cox, J. C., Schnier, K., ... & Sweeney, J. F. (2012). Risk factors for 30-day hospital readmission among general surgery patients. *Journal of the American College of Surgeons, 215*(3), 322-330.

- Kaye, J., Heeney, C., Hawkins, N., De Vries, J., & Boddington, P. (2009). Data sharing in genomics—re-shaping scientific practice. *Nature Reviews Genetics*, *10*(5), 331.
- Kelepouris, T., Pramataris, K., & Doukidis, G. (2007). RFID-enabled traceability in the food supply chain. *Industrial Management & data systems*, *107*(2), 183-200.
- Kellermann, A. L. (1991). Too sick to wait. *Jama*, *266*(8), 1123-1125.
- Kline, R. B. (2015). *Principles and practice of structural equation modeling*. Guilford publications.
- Kogut, B., & Zander, U. (1992). Knowledge of the firm, combinative capabilities, and the replication of technology. *Organization science*, *3*(3), 383-397.
- Lambe, S., Washington, D. L., Fink, A., Herbst, K., Liu, H., Fosse, J. S., & Asch, S. M. (2002). Trends in the use and capacity of California's emergency departments, 1990-1999. *Annals of emergency medicine*, *39*(4), 389-396.
- Larson, R. C. (1974). A hypercube queuing model for facility location and redistricting in urban emergency services. *Computers & Operations Research*, *1*(1), 67-95.
- Lawrence, Paul R. and Jay W. Lorsch 1967 "Differentiation and integration in complex organizations." *Administrative Science Quarterly* 12:1-47.
- Li, L., Xu, L., Jeng, H. A., Naik, D., Allen, T., & Frontini, M. (2008). Creation of environmental health information system for public health service: A pilot study. *Information Systems Frontiers*, *10*(5), 531-542.
- Lin, C. H., Kao, C. Y., & Huang, C. Y. (2015). Managing emergency department overcrowding via ambulance diversion: A discrete event simulation model. *Journal of the Formosan Medical Association*, *114*(1), 64-71.
- Ly, N., & McCaig, L. F. (2002). National Hospital Ambulatory Medical Care Survey: 2000

- outpatient department summary. *Advance data*, (327), 1-27.
- Lynn, S. G., & Kellermann, A. L. (1991). Critical decision making: managing the emergency department in an overcrowded hospital. *Annals of emergency medicine*, 20(3), 287-292.
- Mahmood, N., Shah, A., Waqas, A., Bhatti, Z., Abubakar, A., & Malik, H. A. M. (2014, November). RFID based smart hospital management system: A conceptual framework. In *Information and Communication Technology for The Muslim World (ICT4M), 2014 The 5th International Conference on* (pp. 1-6). IEEE.
- Manchikanti, L., Helm, S. I., Benyamin, R. M., & Hirsch, J. A. (2017). Evolution of US Health Care Reform. *Pain physician*, 20(3), 107-110.
- Mandelbaum, A., Momčilović, P., & Tseytlin, Y. (2012). On fair routing from emergency departments to hospital wards: QED queues with heterogeneous servers. *Management Science*, 58(7), 1273-1291.
- Marcozzi, D., Carr, B., Liferidge, A., Baehr, N., & Browne, B. (2018). Trends in the contribution of emergency departments to the provision of hospital-associated health care in the USA. *International Journal of Health Services*, 48(2), 267-288.
- Mata, F. J., Fuerst, W. L., & Barney, J. B. (1995). Information technology and sustained competitive advantage: A resource-based analysis. *MIS quarterly*, 487-505.
- McClain, J. O. (1976). Bed planning using queuing theory models of hospital occupancy: a sensitivity analysis. *Inquiry*, 13(2), 167-176.
- McMeekin, T. A., Baranyi, J., Bowman, J., Dalgaard, P., Kirk, M., Ross, T., ... & Zwietering, M. H. (2006). Information systems in food safety management. *International journal of food microbiology*, 112(3), 181-194.
- McQuarrie, D. G. (1983). Hospitalization utilization levels. The application of queuing. Theory

- to a controversial medical economic problem. *Minnesota Medicine*, 66(11), 679-686.
- Mehandiratta, R. (2011). Applications of queuing theory in health care. *International Journal of Computing and Business Research*, 2(2), 2229-6166.
- Miraglia, M., & Johns, G. (2016). Going to work ill: A meta-analysis of the correlates of presenteeism and a dual-path model. *Journal of Occupational Health Psychology*, 21(3), 261.
- Mogre, R., Gadh, R., & Chattopadhyay, A. (2009). Using survey data to design a RFID centric service system for hospitals. *Service Science*, 1(3), 189-206.
- Morris, P. E., Berry, M. J., Files, D. C., Thompson, J. C., Hauser, J., Flores, L., ... & Bakhru, R. N. (2016). Standardized rehabilitation and hospital length of stay among patients with acute respiratory failure: a randomized clinical trial. *Jama*, 315(24), 2694-2702.
- Mosakowski, E. (1997). Strategy making under causal ambiguity: Conceptual issues and empirical evidence. *Organization Science*, 8(4), 414-442.
- Neumann, E., & Prusak, L. (2007). Knowledge networks in the age of the Semantic Web. *Briefings in bioinformatics*, 8(3), 141-149.
- Ngai, E. W., Poon, J. K. L., Suk, F. F. C., & Ng, C. C. (2009). Design of an RFID-based healthcare management system using an information system design theory. *Information Systems Frontiers*, 11(4), 405-417.
- Ngai, E. W., Cheng, T. E., Au, S., & Lai, K. H. (2007). Mobile commerce integrated with RFID technology in a container depot. *Decision Support Systems*, 43(1), 62-76.
- Ngai, E. W. T., Cheng, T. C. E., Lai, K. H., Chai, P. Y. F., Choi, Y. S., & Sin, R. K. Y. (2007). Development of an RFID-based traceability system: experiences and lessons learned from an aircraft engineering company. *Production and operations management*, 16(5), 554-568.

- Ngai, E. W. T., Moon, K. K., Riggins, F. J., & Candace, Y. Y. (2008). RFID research: An academic literature review (1995–2005) and future research directions. *International Journal of Production Economics*, *112*(2), 510-520.
- Nickols, F. (2000). The knowledge in knowledge management. *The Knowledge Management Yearbook, 2000–2001*, *12*, 21.
- Nikpay, S., Freedman, S., Levy, H., & Buchmueller, T. (2017). Effect of the Affordable Care Act Medicaid expansion on emergency department visits: evidence from state-level emergency department databases. *Annals of emergency medicine*, *70*(2), 215-225.
- Nosek, R. A., & Wilson, J. P. (2001). Queuing theory and customer satisfaction: a Review of terminology, trends, and applications to pharmacy practice. *Hospital pharmacy*, *36*(3), 275-279.
- Nouraei, S. A. R., Virk, J. S., Hudovsky, A., Wathen, C., Darzi, A., & Parsons, D. (2015). Accuracy of clinician-clinical coder information handover following acute medical admissions: implication for using administrative datasets in clinical outcomes management. *Journal of Public Health*, *38*(2), 352-362.
- O'dell, C., & Grayson, C. J. (1998). If only we knew what we know: Identification and transfer of internal best practices. *California management review*, *40*(3), 154-174.
- Papke-Shields, K. E., Malhotra, M. K., & Grover, V. (2006). Evolution in the strategic manufacturing planning process of organizations. *Journal of Operations Management*, *24*(5), 421-439.
- Pazos, P., Gorkhali, A., & DelAguila, R. (2013). The Role of IS Infrastructure and Organizational Context on Implementation of Electronic Health Records Systems. In *Proceedings of the 2013 Industrial and Systems Engineering Research Conference* (pp. 676-681).

- Peng, Y., Han, Y., & Gardner, D. J. (2012). Spray-drying cellulose nanofibrils: effect of drying process parameters on particle morphology and size distribution. *Wood and Fiber Science, 44*(4), 448-461.
- Peteraf, M. A. (1993). The cornerstones of competitive advantage: a resource-based view. *Strategic management journal, 14*(3), 179-191.
- Pines, J. M., Pilgrim, R. L., Schneider, S. M., Siegel, B., & Viccellio, P. (2011). Practical implications of implementing emergency department crowding interventions: summary of a moderated panel. *Academic Emergency Medicine, 18*(12), 1278-1282.
- Polanyi, L. (1997, September). Discourse structure and discourse interpretation. In *Annual Meeting of the Berkeley Linguistics Society* (Vol. 23, No. 1, pp. 492-503).
- Popper, M., & Lipshitz, R. (2000). Organizational learning: Mechanisms, culture, and feasibility. *Management learning, 31*(2), 181-196.
- Powell, T. C. (1992). Research notes and communications strategic planning as competitive advantage. *Strategic Management Journal, 13*(7), 551-558.
- Prahalad, C. H., & Hamel, G. (1990). G.(1990).-“The Core Competence of the Corporation”. *Harvard Business Review, 68*(3), 295-336.
- Premkumar, G., Ramamurthy, K., & Saunders, C. S. (2005). Information processing view of organizations: an exploratory examination of fit in the context of interorganizational relationships. *Journal of Management Information Systems, 22*(1), 257-294.
- Qu, X., Simpson, L. T., & Stanfield, P. (2011). A model for quantifying the value of RFID-enabled equipment tracking in hospitals. *Advanced Engineering Informatics, 25*(1), 23-31.
- Rantasila, K., Hinkka, V., Pilli-Sihvola, E., & Permala, A. (2014). Unveiling the RFID business: A survey of the Finnish RFID sector. *International Journal of Radio Frequency*

- Identification Technology and Applications, 4(3), 244–259. doi: 10.1504/IJRFITA.2014.063917.
- Reed, R., & DeFillippi, R. J. (1990). Causal ambiguity, barriers to imitation, and sustainable competitive advantage. *Academy of management review*, 15(1), 88-102.
- Renaud, B., Santin, A., Coma, E., Camus, N., Van Pelt, D., Hayon, J., ... & Brun-Buisson, C. (2009). Association between timing of intensive care unit admission and outcomes for emergency department patients with community-acquired pneumonia. *Critical care medicine*, 37(11), 2867-2874.
- Reyes, P. M., Li, S., & Visich, J. K. (2012). Accessing antecedents and outcomes of RFID implementation in health care. *International Journal of Production Economics*, 136(1), 137-150.
- Robertson, S. (2002). A tale of two knowledge-sharing systems. *Journal of Knowledge Management*, 6(3), 295-308.
- Robey, D., Ross, J. W., and Boudreau, M. 2002. "Learning to Implement Enterprise Systems: An Exploratory Study of the Dialectics of Change," *Journal of Management Information Systems* (19:1), pp. 17-46.
- Robinson, C., Verrall, C., Houghton, L., & Zeitz, K. (2015). Understanding the patient journey to the emergency department—a South Australian study. *Australasian Emergency Nursing Journal*, 18(2), 75-82.
- Rosko, M., Goddard, J., Al-Amin, M., & Tavakoli, M. (2018). Predictors of Hospital Profitability: A Panel Study Including the Early Years of the ACA. *Journal of Health Care Finance*, 44(3).

- Ross, J. W., Beath, C. M., & Goodhue, D. L. (1996). Develop long-term competitiveness through IT assets. *Sloan management review*, 38(1), 31-42.
- Rousek, J. B., Pasupathy, K., Gannon, D., & Hallbeck, S. (2014). Asset management in healthcare: Evaluation of RFID. *IIE Transactions on Healthcare Systems Engineering*, 4(3), 144-155.
- Ruggles, R. (1998). The state of the notion: knowledge management in practice. *California management review*, 40(3), 80-89.
- Rumelt, R. (1984). 1984, Towards a strategic theory of the firm. *Competitive strategic management*, 556-570.
- Russo, M. V., & Fouts, P. A. (1997). A resource-based perspective on corporate environmental performance and profitability. *Academy of management Journal*, 40(3), 534-559.
- Ryu, C. M., Farag, M. A., Hu, C. H., Reddy, M. S., Wei, H. X., Paré, P. W., & Kloepper, J. W. (2003). Bacterial volatiles promote growth in Arabidopsis. *Proceedings of the National Academy of Sciences*, 100(8), 4927-4932.
- Saghafian, S., Hopp, W. J., Van Oyen, M. P., Desmond, J. S., & Kronick, S. L. (2012). Patient streaming as a mechanism for improving responsiveness in emergency departments. *Operations Research*, 60(5), 1080-1097.
- Schafermeyer, R. W., & Asplin, B. R. (2003). Hospital and emergency department crowding in the United States. *Emergency Medicine*, 15(1), 22-27.
- Schendel, D. (1994). Introduction to 'Competitive organizational behavior: toward an organizationally-based theory of competitive advantage'. *Strategic Management Journal*, 15(S1), 1-4.

- Schickler, A., Maioni, A., Katznelson, I., Shefter, M., & Skocpol, T. (1998). *Parting at the crossroads: the emergence of health insurance in the United States and Canada* (Vol. 66). Princeton University Press.
- Schulze, W. S. (1992, August). THE TWO RESOURCE-BASED MODELS OF THE FIRM: DEFINITIONS AND IMPLICATIONS FOR RESEARCH. In *Academy of Management Proceedings* (Vol. 1992, No. 1, pp. 37-41). Briarcliff Manor, NY 10510: Academy of Management.
- Segars, A. H., & Grover, V. (1999). Profiles of strategic information systems planning. *Information Systems Research, 10*(3), 199-232.
- Shen, X., & Wang, X. (2015). Improving the health-care delivery process at hospital emergency services by a better use of inpatient bed information. *Electronic Commerce Research and Applications, 14*(1), 14-22.
- Sheeran, P., & Taylor, S. (1999). Predicting Intentions to Use Condoms: A Meta-Analysis and Comparison of the Theories of Reasoned Action and Planned Behavior 1. *Journal of Applied Social Psychology, 29*(8), 1624-1675.
- Siddharthan, K., Jones, W. J., & Johnson, J. A. (1996). A priority queuing model to reduce waiting times in emergency care. *International Journal of Health Care Quality Assurance, 9*(5), 10-16.
- Simonin, B. L. (1999). Ambiguity and the process of knowledge transfer in strategic alliances. *Strategic management journal, 20*(7), 595-623.
- Simpson, D. O. (2016). Healthcare programs and fighting healthcare fraud in the united states of america. *United States Attorneys' Bulletin, 64*(6), 1-6.

- Singh, N. K., & Mahajan, P. (2014). Application of RFID technology in libraries. *International Journal of Library and Information Studies*, 4(2), 1-9.
- Singh, V. (2006). Use of queuing models in health care. *The Selected Works of Vikas Singh*.
- Sodhi, M. S., & Tang, C. S. (2014). Supply-chain research opportunities with the poor as suppliers or distributors in developing countries. *Production and operations management*, 23(9), 1483-1494.
- Statewide Planning and Research Cooperative System. (2014). *Inpatient output data element table of contents*. Retrieved from <http://www.health.ny.gov/statistics/sparcs/sysdoc/iptable.htm>
- Speier, C., Valacich, J. S., & Vessey, I. (1999). The influence of task interruption on individual decision making: An information overload perspective. *Decision Sciences*, 30(2), 337-360.
- Squires, D., & Anderson, C. (2015). US health care from a global perspective: spending, use of services, prices, and health in 13 countries. *The Commonwealth Fund*, 15, 1-16.
- Srikanth, K. (2017). An Efficient Patient Inflow Prediction Model For hospital Resource Management. *Indonesian Journal of Electrical Engineering and Computer Science*, 7(3), 809-817.
- Srinivasan, R., & Swink, M. (2015). Leveraging supply chain integration through planning comprehensiveness: An organizational information processing theory perspective. *Decision Sciences*, 46(5), 823-861.
- Swedberg, C. (2006). Crown saves manufacturing costs via RFID. *RFID Journal*.
- Szulanski, G. (1996). Exploring internal stickiness: Impediments to the transfer of best practice within the firm. *Strategic management journal*, 17(S2), 27-43.
- Taheri, P. A., Butz, D. A., & Greenfield, L. J. (2000). Length of stay has minimal impact on the

- cost of hospital admission. *Journal of the American College of Surgeons*, 191(2), 123-130.
- Taylor, I. D. S., & Templeton, J. G. C. (1980). Waiting time in a multi-server cutoff-priority queue, and its application to an urban ambulance service. *Operations Research*, 28(5), 1168-1188.
- Triandis, H. C. (1980). Reflections on trends in cross-cultural research. *Journal of cross-cultural psychology*, 11(1), 35-58.
- Tushman, M. L., & Nadler, D. A. (1978). Information processing as an integrating concept in organizational design. *Academy of management review*, 3(3), 613-624.
- Tzeng, S. F., Chen, W. H., & Pai, F. Y. (2008). Evaluating the business value of RFID: Evidence from five case studies. *International Journal of Production Economics*, 112(2), 601-613.
- Umar, A. (2005). IT infrastructure to enable next generation enterprises. *Information Systems Frontiers*, 7(3), 217-256.
- Valero, E., Adán, A., & Cerrada, C. (2015). Evolution of RFID applications in construction: A literature review. *Sensors*, 15(7), 15988-16008.
- Von Hippel, E. (1994). "Sticky information" and the locus of problem solving: implications for innovation. *Management science*, 40(4), 429-439.
- Vikas, S. (2006). Use of Queuing Models in Health Care. *University of Arkansas for Medical Sciences, Department of Health Policy and Management*.
- W. Australian Institute of Health and Welfare, A. I. O. H. A. (Ed.), Australian Hospital Statistics 2013–14: Emergency Department Care. Health Services Series no. 58. Cat. no. HSE 153. AIHW, Canberra, ed, 2014.

- Wamba, S. F., Anand, A., & Carter, L. (2013). A literature review of RFID-enabled healthcare applications and issues. *International Journal of Information Management*, 33(5), 875-891.
- Ward, R. M., Schmieder, R., Highnam, G., & Mittelman, D. (2013). Big data challenges and opportunities in high-throughput sequencing. *Systems Biomedicine*, 1(1), 29-34.
- Webb, T. L., & Sheeran, P. (2006). Does changing behavioral intentions engender behavior change? A meta-analysis of the experimental evidence. *Psychological bulletin*, 132(2), 249.
- Wesson, D., Kitzman, H., Halloran, K. H., & Tecson, K. (2018). Innovative Population Health Model Associated With Reduced Emergency Department Use And Inpatient Hospitalizations. *Health Affairs*, 37(4), 543-550.
- Wernerfelt, B. (1984). A resource-based view of the firm. *Strategic management journal*, 5(2), 171-180.
- Westbrook, J. I., Woods, A., Rob, M. I., Dunsmuir, W. T., & Day, R. O. (2010). Association of interruptions with an increased risk and severity of medication administration errors. *Archives of Internal medicine*, 170(8), 683-690.
- Wherry, L. R., & Miller, S. (2016). Early coverage, access, utilization, and health effects of the affordable care act medicaid expansions: A quasi-experimental study. *Annals of internal medicine*, 164(12), 795.
- Wilper, A. P., Woolhandler, S., Lasser, K. E., McCormick, D., Cutrona, S. L., Bor, D. H., & Himmelstein, D. U. (2008). Waits to see an emergency department physician: US trends and predictors, 1997–2004. *Health Affairs*, 27(2), w84-w95.
- Wilson, E. V., & Lankton, N. K. (2004). Interdisciplinary research and publication opportunities

- in information systems and health care. *The Communications of the Association for Information Systems*, 14(1), 51.
- Yao, W., Chu, C. H., & Li, Z. (2012). The adoption and implementation of RFID technologies in healthcare: a literature review. *Journal of medical systems*, 36(6), 3507-3525.
- Yom-Tov, Galit B., and Avishai Mandelbaum. "Erlang-R: A time-varying queue with reentrant customers, in support of healthcare staffing." *Manufacturing & Service Operations Management* 16.2 (2014): 283-299.
- Yazici, H. J. (2014). An exploratory analysis of hospital perspectives on real time information requirements and perceived benefits of RFID technology for future adoption. *International Journal of Information Management*, 34(5), 603-621.
- Zack, M. H. (1999). Developing a knowledge strategy. *California management review*, 41(3), 125-145.
- Zang, C., Fan, Y., & Liu, R. (2008). Architecture, implementation and application of complex event processing in enterprise information systems based on RFID. *Information Systems Frontiers*, 10(5), 543-553.

APPENDICES

APPENDIX A

A. DISTRIBUTION OF INITIAL SELECTED 132 HOSPITALS IN THE STATE OF NEW YORK

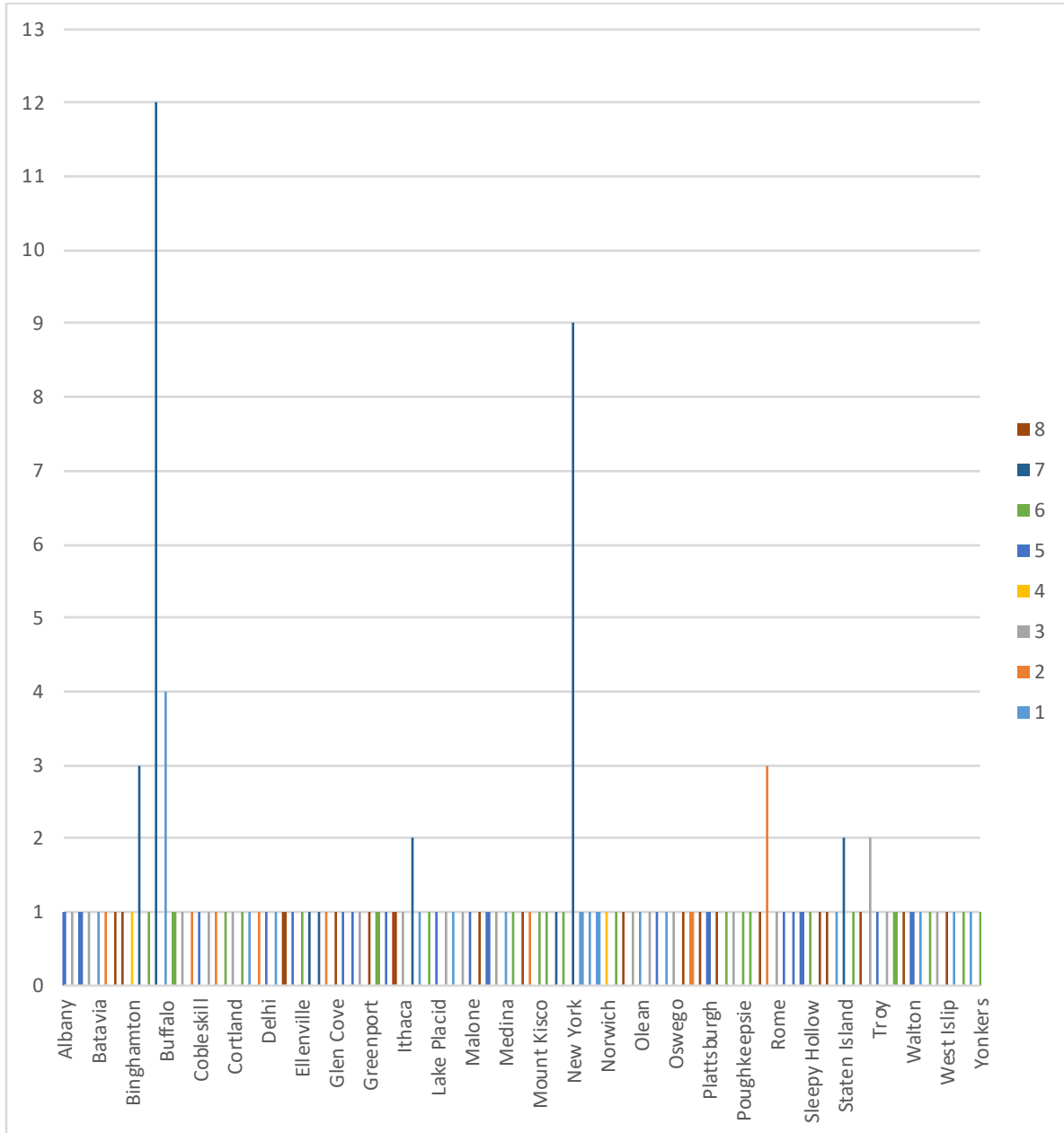

APPENDIX B

B. DISTRIBUTION OF SELECTED 45 HOSPITALS IN THE STATE OF NEW YORK

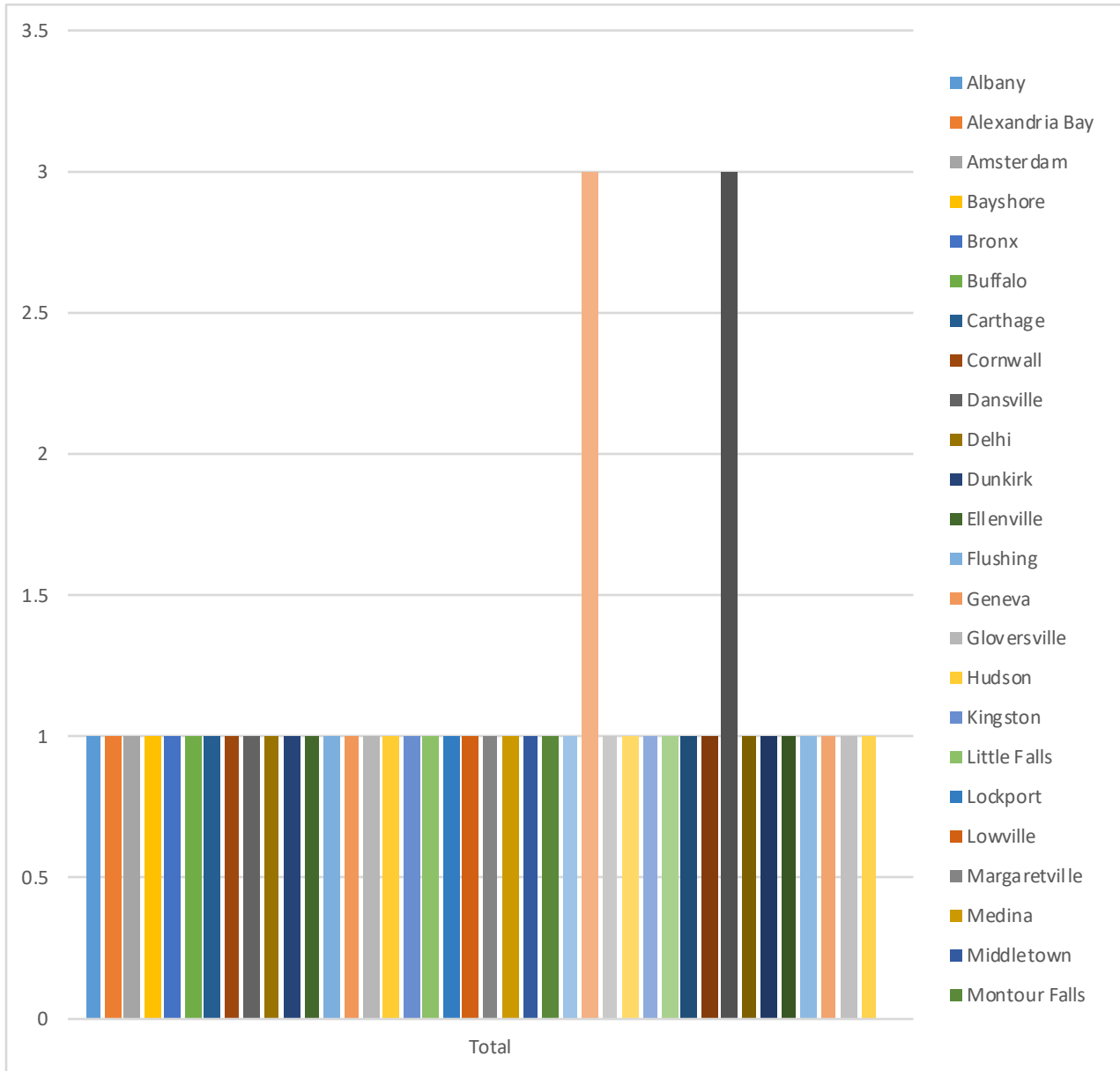

APPENDIX C

C. SPARCS 2014 SELECTION VARIABLES

Variables	Source	Definition
PICDCCode (Principal ICD Code)	SPARCS	Identifies the inpatient principal procedure performed at claim level during period covered by this event
PStatus	SPARCS	Patient Status on discharge
ServiceCat	SPARCS	Service category provided to each patient. It ranges from 1 to 5, 1 being for the low acute patient and 5 being the highest.
TypeAdmission	SPARCS	Code indicating manner the patient was admitted "1" = Emergency "2" = Urgent "3" = Elective "4" = Newborn "5" = Trauma "9" = Information not available
POrigin	SPARCS	Patient pickup: either by ambulance or walk in
AgeWarning	SPARCS	1 if patient is above
AMIWarning	SPARCS	Acute Myocardial Infarction (AMI) Warning Indicator "1" = AMI code reported/"0" = No AMI code reported.
AHIV	SPARCS	1 if patient has HIV, 0 if they do not.
AdmitUrgency	SPARCS	Flags conflict between reported diagnosis and ICD-CM reference file's Age-specific edits. 1 = conflict, blank = no conflict
FACNAME	SPARCS	Name of the hospital
HAS	SPARCS	Unique hospital identifier
EUPIDE	SPARCS	Unique ID for each patient

APPENIDX D

D. LIST OF VARIABLES AND SOURCES

Variables	Source	Type
RFID Use	HIMSS	Independent
EMR Use	HIMSS	Independent
IS Skills	HIMSS	Interaction
IS Plans	HIMSS	Interaction
Average Procedure	SPARCS	Independent
Average Procedure Day	SPARCS	Independent
Average Discharge	SPARCS	Independent
Length of Stay	SPARCS	Dependent
Number of Doctors	HIMSS	Control
Number of Nurses	HIMSS	Control
Location of Hospital	SPARCS/HIMSS	Control
Size of hospital	HIMSS	Control

APPENDIX E**E. RANGE OF EACH VARIABLE**

Variable	Lower Limit	Upper Limit
RFID Use	1	7
Proc Day	31	172
Avg_Proc	1.1497	5.9091
Avg_Discharge	3.525065	49.7964
LOS	3.322034	39.746929
EMR Use	1	9
IS Skills	1	4
IS Plans	1	5
Number of Doctors	87	208
Number of Nurses	116	452

APPENDIX F**F. TABLE TYPES OF IS SKILLS PROVIDED TO STAFF**

Number	IS Trainings
1	Health Information Exchange
2	Patient Portal
3	Nurse Call System
4	Document Management
5	Emergency Department Information System
6	Ambulatory EMR

APPENDIX G**G. LIST OF FULLY OPERATIONAL EMR UNITS**

EMR Use
Access Diagnostic Results
Clinical Documentation Charting
Personal Health Records
Electronic Signatures
Billing
Scheduling
Retrieving Diagnostic Results
Pre-registration
Entering Orders

APPENDIX H**H. TYPES OF IS PLANS**

Number	Type
1	Computerized Patient Record
2	Integration Issues
3	Decreasing Medical Errors
4	Migrating Towards a Paperless Environment
5	Reducing the Number of Software Vendors

APPENDIX I**I.UNITS WITH FULLY OPERATIONAL RFID**

Number	Units Fully Equipped with RFID
1	Fixed Assets/ Equipment Management
2	Laboratory
3	Material management
4	Medication Administration
5	Patient Registration
6	Pharmacy
7	Radiology

APPENDIX J

J. SIMULATION PARAMETERS

Parameter	Value
Iterations	200
Patient Arrival Distribution	Exponential
Number of Nurses	125
RFID Patient Process Time	15 Minutes
Regular Patient Process Time	15 Minutes
Information Transfer	0-120 Minutes
Measurement Unit	Minutes
Replication Length	200
Hours Per Day	24 Hours

Table: Initial Simulation Parameter

Parameter	Value
Iterations	200
Patient Arrival Distribution	Exponential
Number of Nurses	125
RFID Patient Process Time	11.3794 Minutes
Regular Patient Process Time	11.2347 Minutes
Information Transfer	11.9979 Minutes
Measurement Unit	Minutes
Replication Length	200

APPENDIX K

K. ARENA SIMULATION MODEL

Emergency Department Simulation

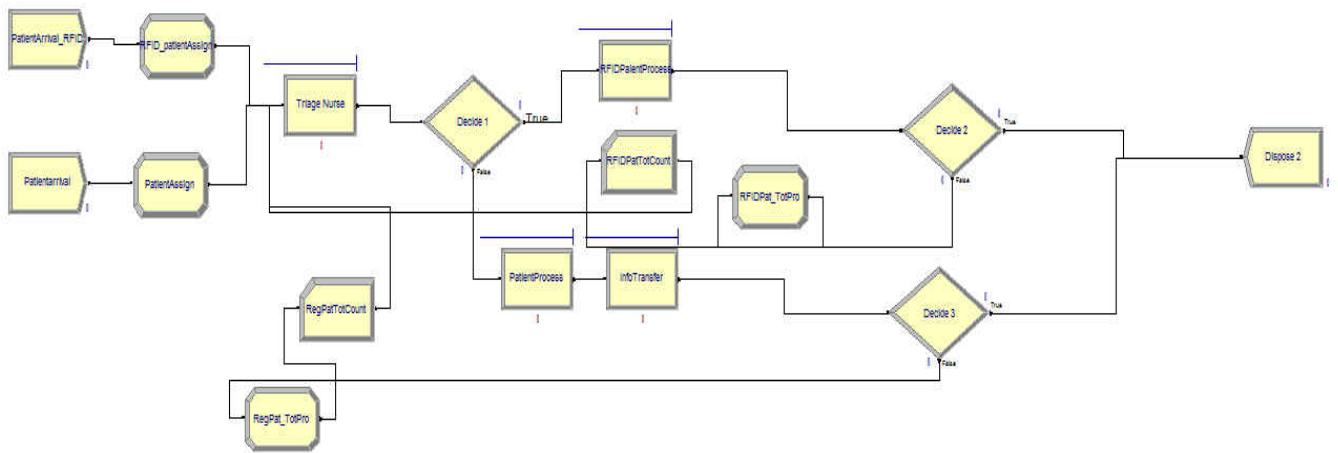

Model 1A:

Emergency Department Simulation

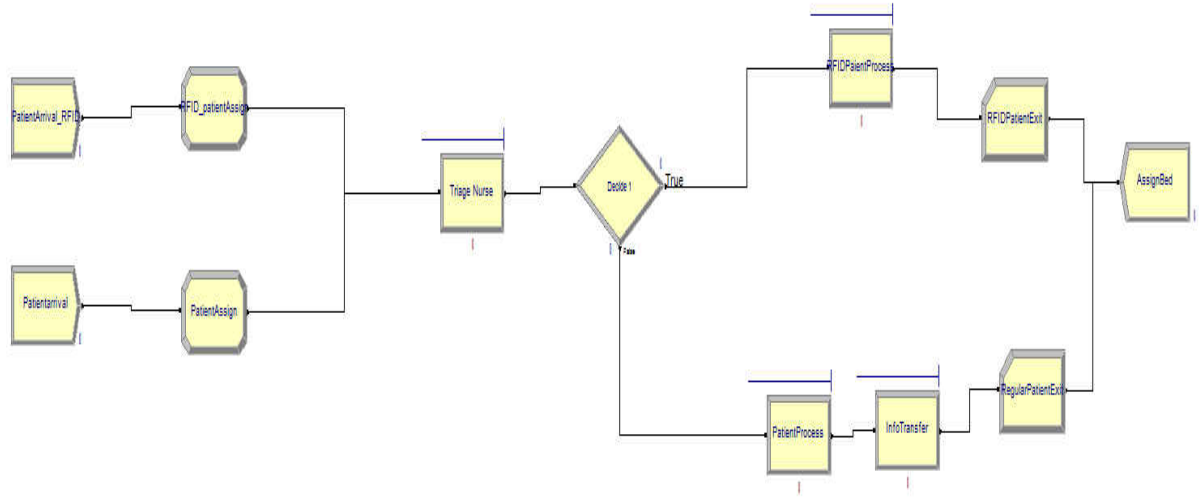

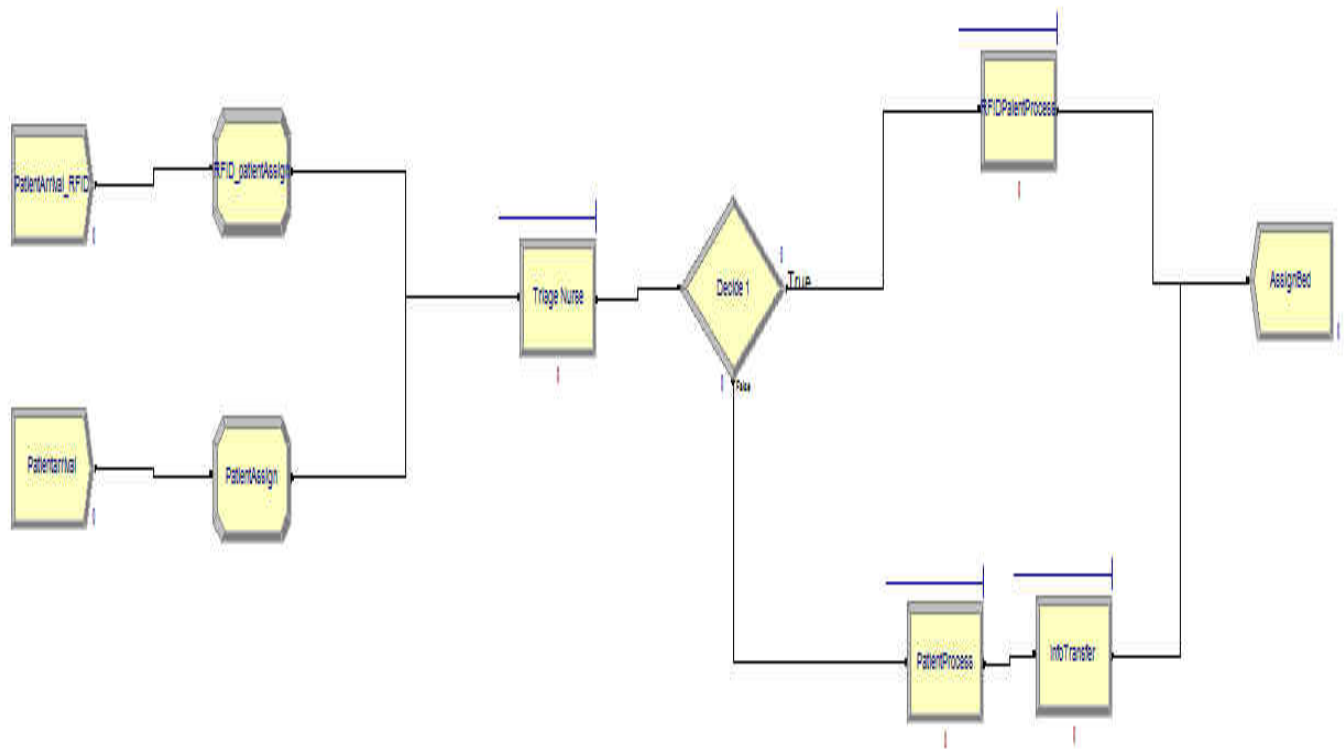

Model 1C:

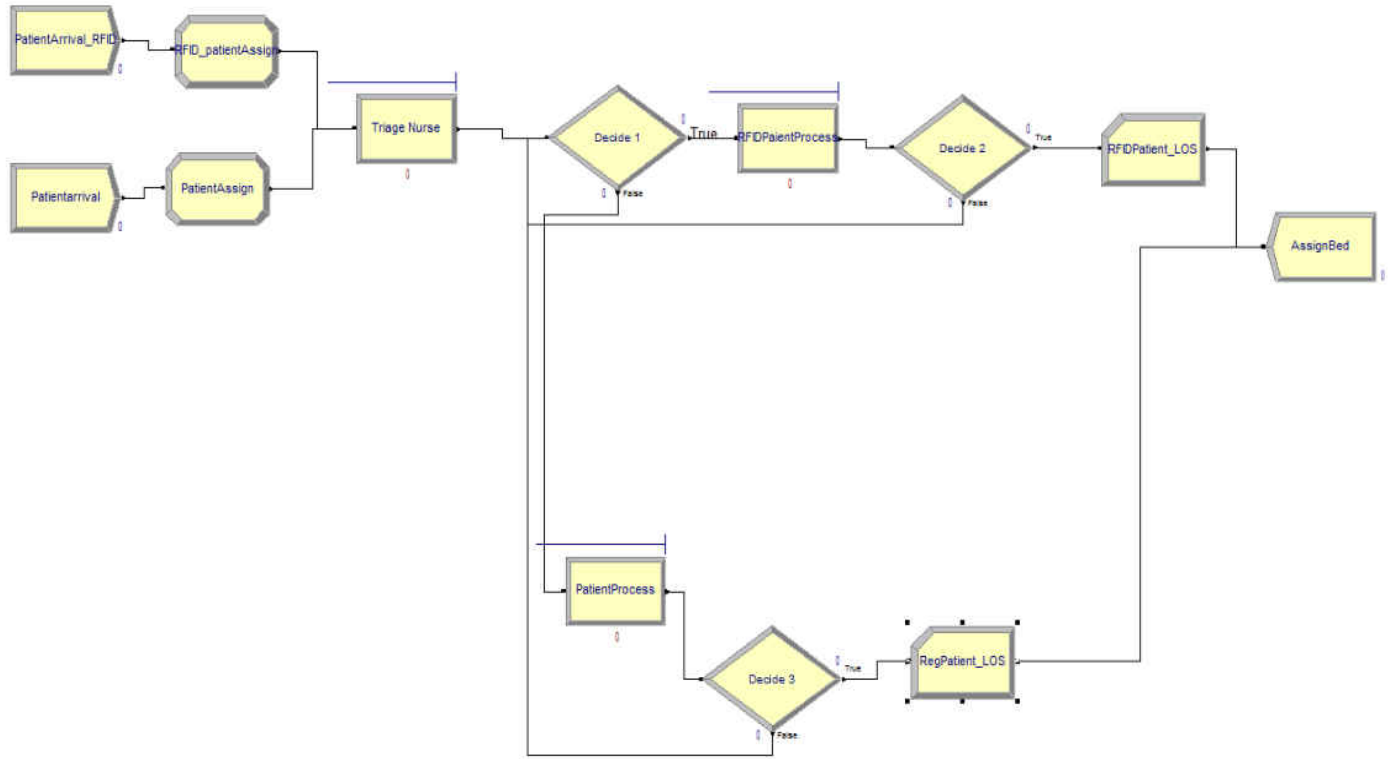

Model 1B-2B-3B

APPENDIX L

L. GRAPHS 1A, 2A, 3A1, 3A2, 1B, 2B, 3B

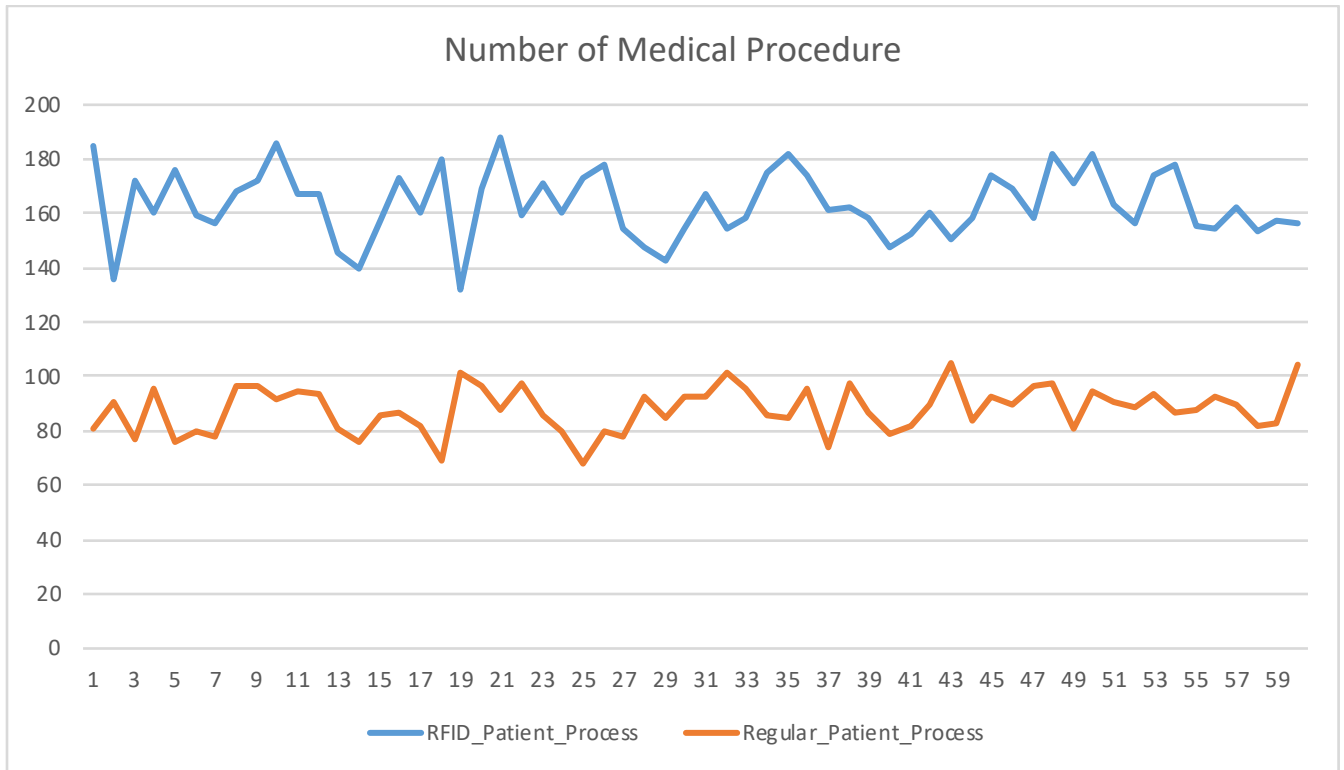

Graph 1A

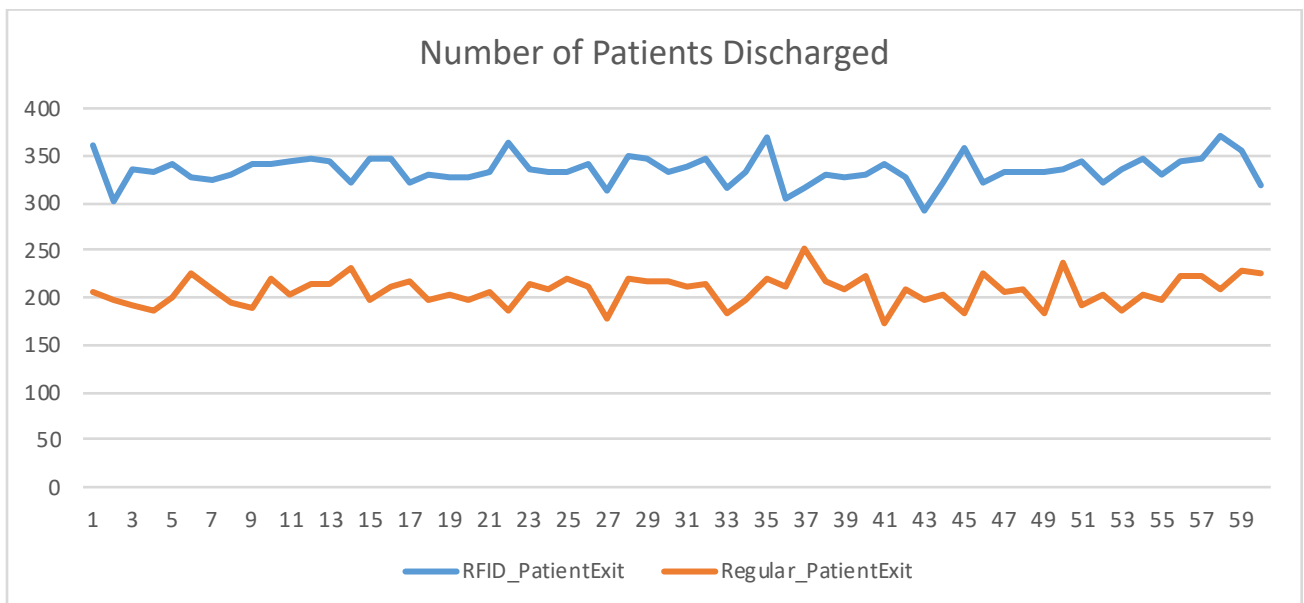

Graph 2A

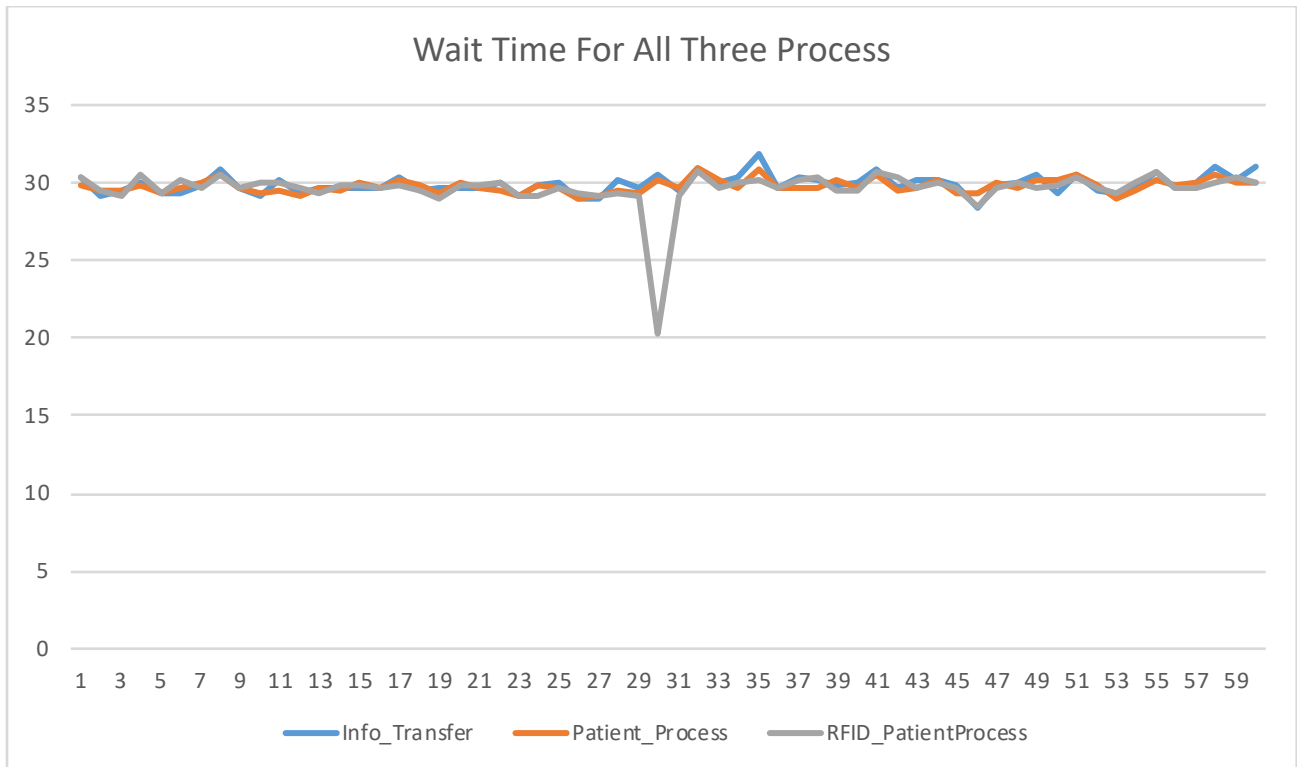

Graph 3A1

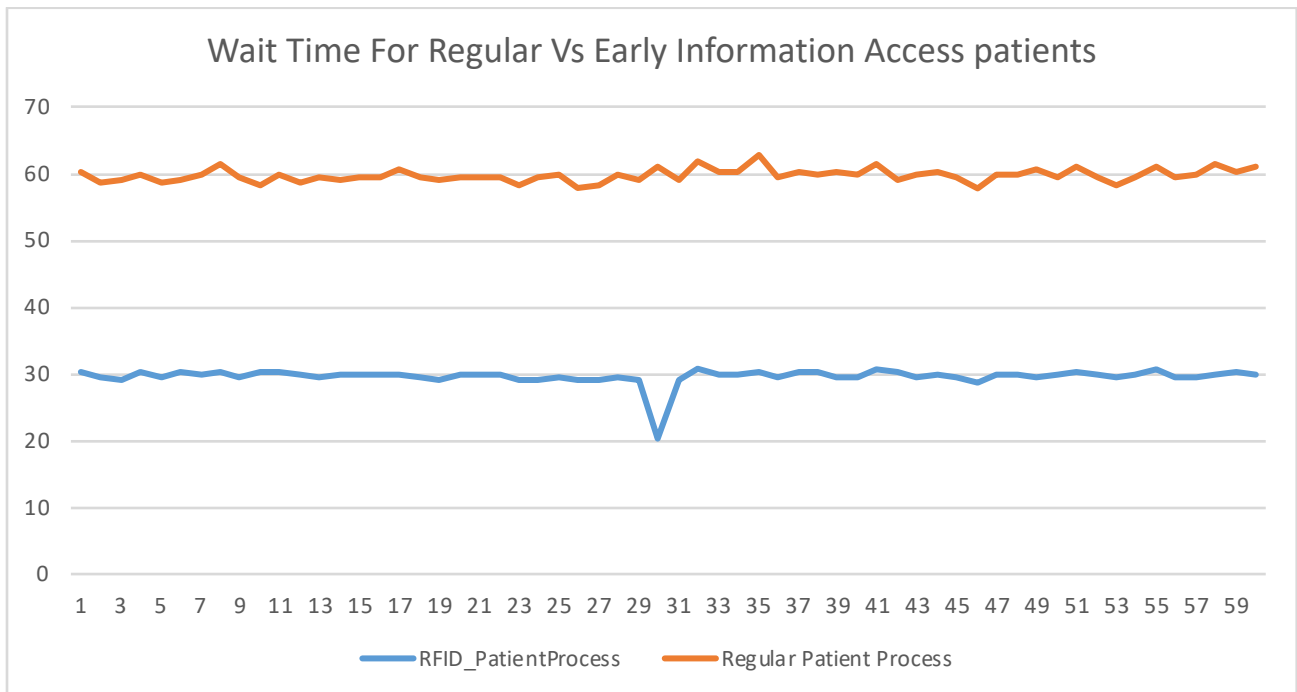

Graph 3A2

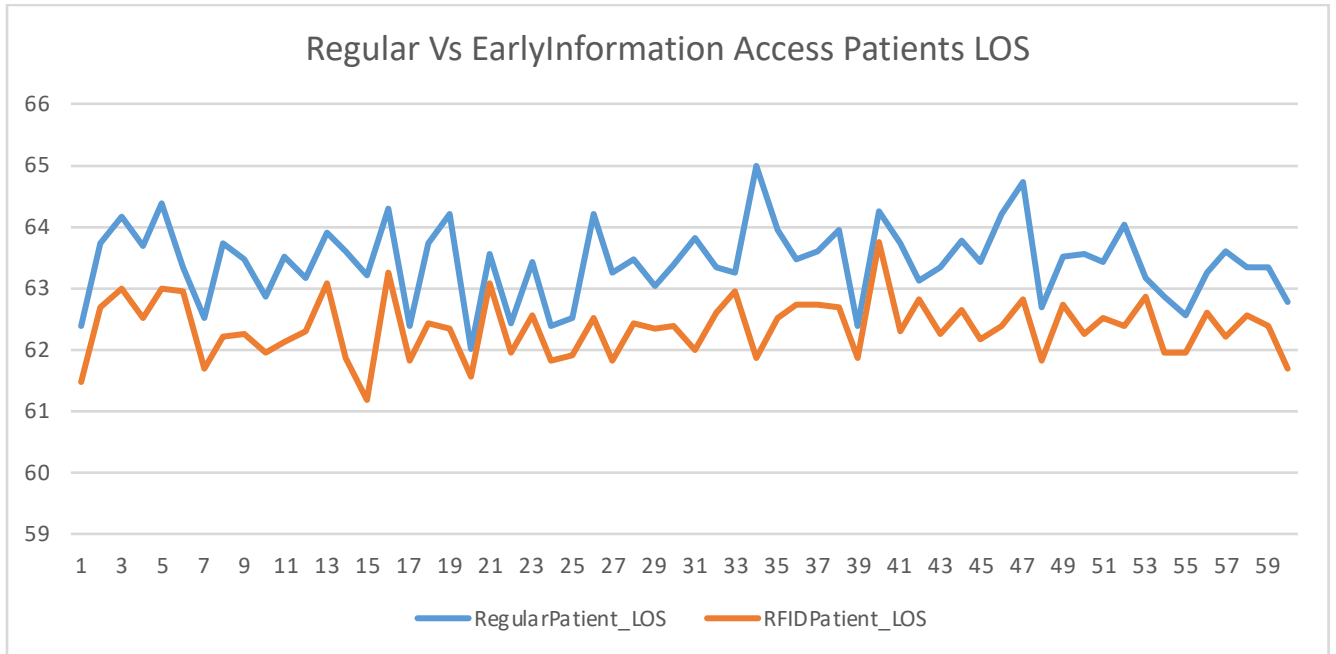

Graph 1B, 2B, 3B

APPENDIX M

M. SPSS RESULTS

Group Statistics

	Category	N	Mean	Std. Deviation	Std. Error Mean
RFIDPatientProcess	RFID	60	163.22	12.536	1.618
	REGULAR	60	88.22	8.443	1.090

Independent Samples Test

		Levene's Test for Equality of Variances		t-test for Equality of Means						
		F	Sig.	t	df	Sig. (2-tailed)	Mean Difference	Std. Error Difference	95% Confidence Interval of the Difference	
									Lower	Upper
RFIDPatient Process	Equal variances assumed	9.278	.003	38.437	118	.000	75.000	1.951	71.136	78.864
	Equal variances not assumed			38.437	103.393	.000	75.000	1.951	71.130	78.870

Results 1A

Group Statistics

	Category	N	Mean	Std. Deviation	Std. Error Mean
RFIDPatientExit	RFID	60	334.87	15.177	1.959
	REGULAR	60	207.55	15.238	1.967

Independent Samples Test

		Levene's Test for Equality of Variances		t-test for Equality of Means					95% Confidence Interval of the Difference	
		F	Sig.	t	df	Sig. (2-tailed)	Mean Difference	Std. Error Difference	Lower	Upper
RFIDPatientExit	Equal variances assumed	.173	.679	45.855	118	.000	127.317	2.777	121.818	132.815
	Equal variances not assumed			45.855	117.95	.000	127.317	2.777	121.818	132.815

Result 2A

Group Statistics

	PatientCategory	N	Mean	Std. Deviation	Std. Error Mean
RFIDPatientProcess	RFID	60	29.6102	1.30597	.16860
	REGULAR	60	59.6953	.96588	.12469

Independent Samples Test

		Levene's Test for Equality of Variances		t-test for Equality of Means					95% Confidence Interval of the Difference	
		F	Sig.	t	df	Sig. (2-tailed)	Mean Difference	Std. Error Difference	Lower	Upper
RFIDPatientProcess	Equal variances assumed	1.322	.252	-143.467	118	.000	-30.08517	.20970	-30.50043	-29.66990
	Equal variances not assumed			-143.467	108.681	.000	-30.08517	.20970	-30.50080	-29.66953

Results 3A

Group Statistics

	Patient_Group	N	Mean	Std. Deviation	Std. Error Mean
RegPatientLOS	RFID	60	62.3617	.48171	.06219
	REGULAR	60	63.4232	.62338	.08048

Independent Samples Test

		Levene's Test for Equality of Variances		t-test for Equality of Means						
		F	Sig.	t	df	Sig. (2-tailed)	Mean Difference	Std. Error Difference	95% Confidence Interval of the Difference	
									Lower	Upper
RegPatientLOS	Equal variances assumed	2.109	.149	-10.437	118	.000	-1.06150	.10171	-1.26290	-.86010
	Equal variances not assumed			-10.437	110.941	.000	-1.06150	.10171	-1.26304	-.85996

Result :1B, 2B, 3B

APPENDIX N**N. HYPOTHESIS TESTING RESULT FOR SIMULATION METHOD**

Hypothesis	Decision
H1 A	Statistically Significant Support
H1B	Statistically Significant Support
H1C	Statistically Significant Support
H2A	Statistically Significant Support
H2B	Statistically Significant Support
H2C	Statistically Significant Support
H3A	Statistically Significant Support
H3B	Statistically Significant Support

APPENDIX O

O. LISREL NOTATION

Equation:

$$X_4 = \beta_{41} * X_1 + e_1$$

$$X_5 = \beta_{51} * X_1 + e_2$$

$$X_6 = \beta_{61} * X_1 + e_3$$

$$X_7 = \beta_{71} * X_1 + \beta_{72} * X_2 + \beta_{73} * X_3 + e_4$$

$$X_8 = \beta_{84} * X_4 + \beta_{85} * X_5 + \beta_{86} * X_6 + \beta_{87} * X_7 + e_5$$

Coefficient Matrix: A =

$$\begin{pmatrix} 0 & 0 & 0 & 0 & 0 & 0 & 0 & 0 \\ 0 & 0 & 0 & 0 & 0 & 0 & 0 & 0 \\ 0 & 0 & 0 & 0 & 0 & 0 & 0 & 0 \\ \beta_{41} & 0 & 0 & -1 & 0 & 0 & 0 & 0 \\ \beta_{51} & 0 & 0 & 0 & -1 & 0 & 0 & 0 \\ \beta_{61} & 0 & 0 & 0 & 0 & -1 & 0 & 0 \\ \beta_{71} & \beta_{72} & \beta_{73} & 0 & 0 & 0 & -1 & 0 \\ 0 & 0 & 0 & \beta_{84} & \beta_{85} & \beta_{86} & \beta_{87} & -1 \end{pmatrix}$$

Error Terms, $[E_1] = \begin{pmatrix} 0 \\ 0 \\ 0 \\ -e_1 \\ -e_2 \\ -e_3 \\ -e_4 \\ -e_5 \end{pmatrix}$

Endogenous Variable Matrix, $[X_1] = \begin{pmatrix} X_1 \\ X_2 \\ X_3 \\ X_4 \\ X_5 \\ X_6 \\ X_7 \\ X_8 \end{pmatrix}$

Matrix Notation of the simultaneous equation

$$[X_1] = [A] [X_1] + [E_1]$$

APPENDIX P

P. PATH MODEL FOR THE HYPOTHESIS TESTING

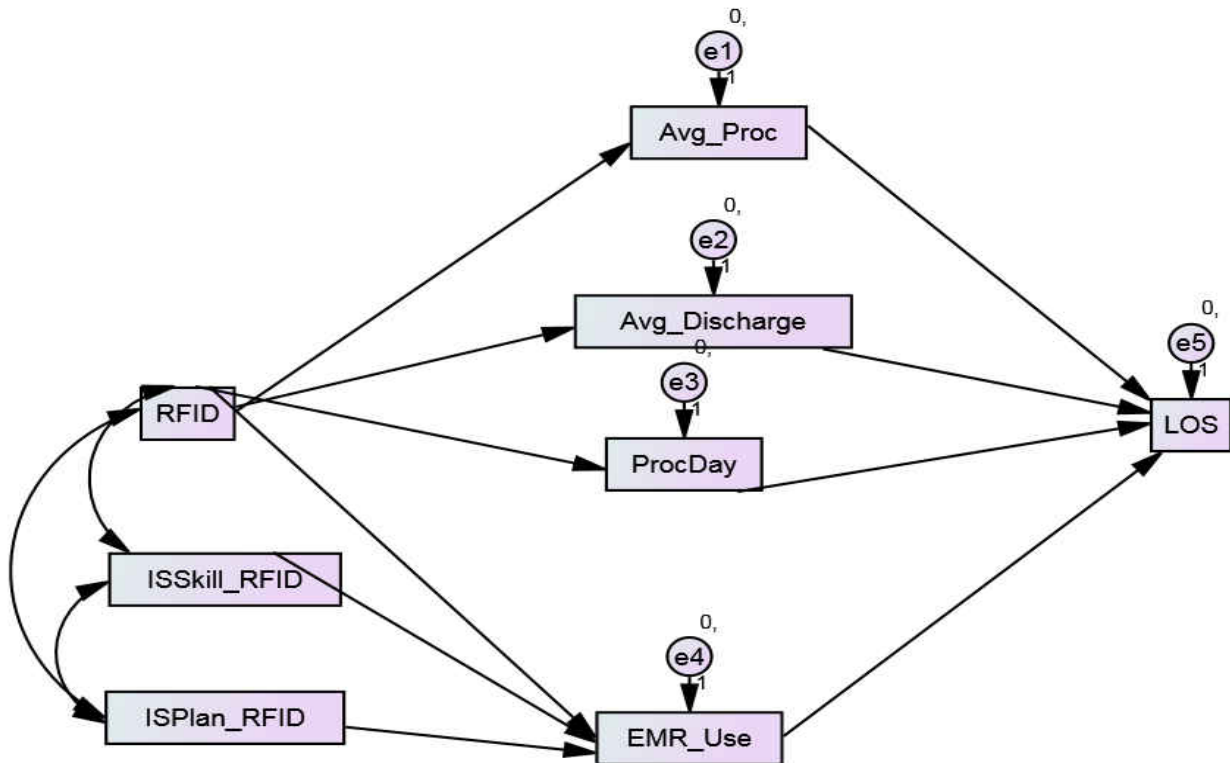

APPENDIX Q

Q. PATH MODEL SHOWING THE RESULT OF HYPOTHESIS TESTING

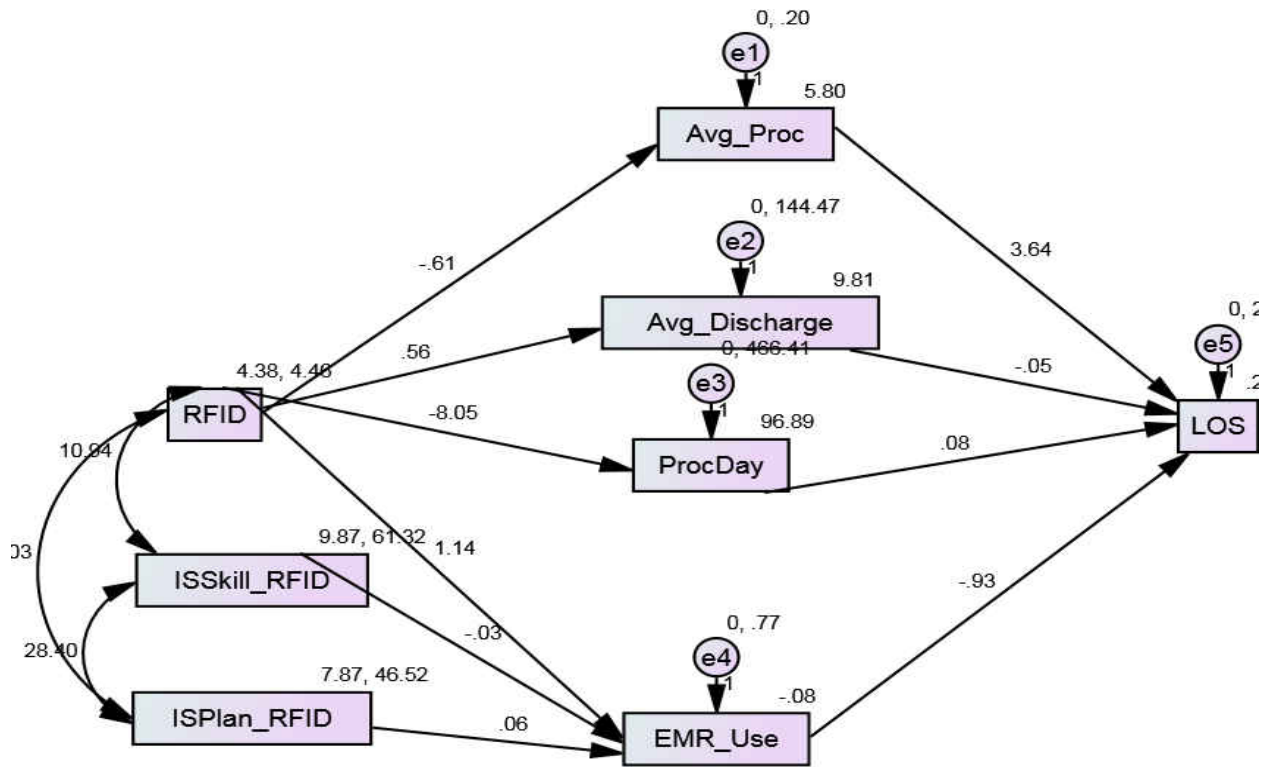

APPENDIX R

R. PATH MODEL FIT TEST

Measure of Fit	Value
CMIN	15.264
P	.433
CMIN/DF	1.018
NFI	.956
RFI	.917
IFI	.999
TLI	.998
CFI	.999
NCP	.264
FMIN	.347
RMSEA	.020
PCLOSE	.545

APPENDIX S

S. TEST RESULTS WITH ESTIMATES AND P-VALUE

Estimates

Dependent Variable		Independent Variable	Estimate	S.E.	C.R.	P	Label
Avg_Proc	<---	RFID	-.606	.032	-18.943	***	
Avg_Discharge	<---	RFID	.564	.858	.657	.511	
ProcDay	<---	RFID	-8.052	1.542	-5.222	***	
EMR_Use	<---	RFID	1.140	.093	12.314	***	
EMR_Use	<---	ISSkill_RFID	-.034	.023	-1.464	.143	
EMR_Use	<---	ISPlan_RFID	.059	.025	2.333	.020*	
LOS	<---	Avg_Proc	3.638	1.205	3.020	.003**	
LOS	<---	Avg_Discharge	-.049	.063	-.783	.434	
LOS	<---	ProcDay	.083	.034	2.442	.015*	
LOS	<---	EMR_Use	-.930	.611	-1.522	.128	

*p<.05, **p<.01, ***p<.001

Covariances

			Estimate	S.E.	C.R.	P	Label
ISSkill_RFID	<-->	ISPlan_RFID	28.404	9.119	3.115	.002	
RFID	<-->	ISPlan_RFID	9.028	2.562	3.524	***	
RFID	<-->	ISSkill_RFID	10.939	2.988	3.660	***	

SMC

	Estimate
EMR_Use	.891
ProcDay	.383
Avg_Discharge	.010
Avg_Proc	.891
LOS	.759

Total Effects

	ISPlan_RFI D	ISSkill_RFI D	RFID	EMR_Us e	ProcDa y	Avg_Discharg e	Avg_Pro c
EMR_Use	.059	-.034	1.140	.000	.000	.000	.000
ProcDay	.000	.000	8.052	.000	.000	.000	.000
Avg_Discharg e	.000	.000	.564	.000	.000	.000	.000
Avg_Proc	.000	.000	-.606	.000	.000	.000	.000
LOS	-.055	.031	3.964	-.930	.083	-.049	3.638

APPENDIX T**T. HYPOTHESIS TESTING RESULTS FOR PATH MODEL**

Hypothesis	Decision
H1 A	Statistically Significant Support
H2A	Not Supported
H3A	Statistically Significant Support
H1B	Statistically Significant Support
H2B	Not Supported
H3B	Statistically Significant Support
H4	Statistically Significant Support
H3B	Not Supported
H4A	Statistically Significant Support
H4B	Not Supported
H5	Not Supported

VITA

Anjee Gorkhali

agork001@odu.edu
757 822 0088
5510 Monroe Place #281A,
Norfolk, VA 23508

EDUCATION

Old Dominion University, Norfolk, VA

Ph.D Business Administration, May 2019; **Awards: Outstanding IT Student 2017-2018**

Ph.D Dissertation: Early Information Access To Alleviate Emergency Department Congestion

Old Dominion University, Norfolk, VA

Master of Science, Engineering Management, December 2012

Master's Thesis: Electronic Health Records System: The factors behind a successful implementation of electronic health records system.

Tribhuvan University, Kathmandu, Nepal

Bachelors of Science in Computer Engineering, May 2008

PUBLICATION

Journal Publications

- Gorkhali, A., & Xu, L. D. (2018). Systems Science and Systems Design: A Systemic View Approach. *Journal of Industrial Integration and Management*.
- Gorkhali, A., & Xu, L. D. (2017). Enterprise architecture: a literature review. *Journal of Industrial Integration and Management*, 2(02), 1750009.
- Gorkhali, A., & Xu, L. D. (2016). Enterprise Application Integration in Industrial Integration: A Literature Review. *Journal of Industrial Integration and Management*, 1(04), 1650014.
- Chen, Y., Chen, H., Gorkhali, A., Lu, Y., Ma, Y., & Li, L. (2016). Big data analytics and big data science: a survey. *Journal of Management Analytics*, 3(1), 1-42.

Conference Proceedings

- Gorkhali, A & Shrestha, A (2018). From Cost to Strategic Focused Offshore Information Systems Investment: The Impact Of Specialized Trainings In The Context Of National Culture. Decision Science Institute Conference
- Pazos, P, Gorkhali, A & DelAguila, R (2013). The Role of IS Infrastructure and Organizational Context on Implementation of Electronic Health Records Systems. Proceedings of the 2013 Industrial and System Research Conference. **Award: Top 5 Best Paper Award**

TEACHING EXPERIENCE

Old Dominion University, Department of IT & Decision Sciences - **Adjunct Faculty** 08/16 – 08/19

RESEARCH EXPERIENCE

National Science Foundation Funded Project- Pair Programming

08/18 – Present

Research Assistant/VB.NET Instructor