Electronic Theses and Dissertations, 2004-2019

2008

Motorcycle Conspicuity: The Effects Of Age And Vehicular Daytime Running Lights

Lorenzo Torrez
University of Central Florida

 Part of the [Psychology Commons](#)

Find similar works at: <https://stars.library.ucf.edu/etd>

University of Central Florida Libraries <http://library.ucf.edu>

This Doctoral Dissertation (Open Access) is brought to you for free and open access by STARS. It has been accepted for inclusion in Electronic Theses and Dissertations, 2004-2019 by an authorized administrator of STARS. For more information, please contact STARS@ucf.edu.

STARS Citation

Torrez, Lorenzo, "Motorcycle Conspicuity: The Effects Of Age And Vehicular Daytime Running Lights" (2008). *Electronic Theses and Dissertations, 2004-2019*. 3757.

<https://stars.library.ucf.edu/etd/3757>

MOTORCYCLE CONSPICUITY:
THE EFFECTS OF AGE AND VEHICULAR DAYTIME RUNNING LIGHTS

by

LORENZO I. TORREZ
B.A. Adams State College, 2000
M.S. University of Central Florida, 2008

A dissertation submitted in partial fulfillment of the requirements
for the degree of Doctor of Philosophy
in the Department of Psychology
in the College of Sciences
at The University of Central Florida
Orlando, Florida

Spring Term 2008

Major Professor: Janan Smither

© 2008 Lorenzo I. Torrez

ABSTRACT

Research has shown that riding a motorcycle can potentially be much more dangerous than operating a conventional vehicle. There are factors inherent in driving or riding a small two wheeled vehicle, such as a motorcycle, moped or even bicycle that can potentially decrease their ability to be seen or noticed by other drivers. This disadvantage is reflected in the disproportionate overrepresentation of injuries and/or fatalities incurred by this particular driving group. This creates a significant problem which deserves dedicated evaluation as to causative factors and/or influential variables. The following research was conducted with intentions to investigate the topic of motorcycle conspicuity so as to further explain the variables which positively contribute to a motorcycle being seen and to supplement the body of knowledge that currently exists on this topic. This study specifically evaluated the influence of sex, age, motorcycle lighting conditions, and vehicular daytime running lights upon one's ability to effectively detect a motorcycle within a "high fidelity" simulated environment. This research additionally sought to examine the feasibility and validity of using a novel fixed base "high fidelity" simulator for the evaluation of motorcycle conspicuity. The results from this research clearly indicate a link between vehicular DRLs and the effective detection of motorcycles and also support previous research as to the effectiveness of motorcycle DRLs. Additionally, these results suggest that as one ages, certain degradations in vision, cognition, and physiology occur which decrease one's performance in detecting and responding to a motorcycle. These findings additionally provide support for the use of a "high definition" fixed base simulator as a valid technology for the evaluation of motorcycle conspicuity.

This work is dedicated to my parents Jesse and Sarah as well as my brother, Jesse J. and my sister Laura. Without their continual inspiration and dedicated support, the completion of this dissertation would not have been attainable. Thanks for helping me through the process and for continually believing that I would succeed.

ACKNOWLEDGMENTS

The views expressed in this document are those of the author and do not necessarily reflect those of the organizations with which the author is affiliated. The research reported in this dissertation was partially supported by funding through the Motorcycle Safety Foundation (MSF), an internationally recognized not-for-profit organization. The intention of this research was to address issues specified in the National Agenda for Motorcycle Safety (NAMS), which is a continuing effort developed by the Motorcycle Safety Foundation in conjunction with government and industry support.

First and foremost, I would like to officially express recognition and gratitude toward my program advisor and committee chair, Dr. Janan Smither. Throughout this entire process, she stood by my side and continually pushed me to achieve this accomplishment. I would additionally like to acknowledge my committee members, Dr. Edward Rinalducci, Dr. Mustapha Mouloua and Dr. Gene Lee for all of their support and guidance in bringing these ideas into fruition.

I must also extend my gratitude toward a close friend of mine and an incomparable assistant, Bryan Sanders. Without the ingenuity, creativity and resourcefulness brought forth by “Sanders”, much of this work would have ceased to exist. The same can be said for Larry Foor, who saved the day when all hope was lost. The experiment would literally not have even begun, had Larry not come through with his Triumph Bonneville and his motorcycling and “cross walking” skills. Additionally, I would like to devote a special thanks to Alice Cornejo, Lyndsay Doll, Amanda Kane, Shazia Mirza, and Jessica Sollazzo for their dedicated assistance with scheduling, recruiting, and data collection. I would also like to express gratitude to James Alford, whose insight and brilliance helped clarify my views on the analysis of this data. Last but

certainly not least, I would like to thank Amy, for her unconditional support during times when I needed it most.

TABLE OF CONTENTS

LIST OF FIGURES	ix
LIST OF TABLES	x
INTRODUCTION	1
Motorcycle Conspicuity: Literature Review.....	1
Motorcycle Conspicuity.....	5
Physical Conspicuity – Vehicular.....	6
Motorcycle Lighting	7
Daytime Running Lights.....	7
Flashing Lights – Headlight Modulators	9
Auxiliary Lighting	13
Other Vehicle Characteristics – Fairings/Bodywork, Tires, & License Plates.....	13
Operator Conspicuity – The Motorcyclist	17
Cognitive Conspicuity – The Other Motorist	17
Motorist Expectation – Expectancy Phenomenon	19
Expectancy and Daytime Running Lights	22
Individual Differences	27
Experience and Familiarity	29
Hazard Perception.....	33
Hazard Perception and Motorcycle Conspicuity	35
Hazard Perception – Motorcyclist versus Motorist	36
Older Adults and Motorcycle Conspicuity	38
Accident Involvement.....	39
Visual, Cognitive, Perceptual Changes and the Older Adult.....	40
Vision Issues.....	40
Cognitive Issues.....	42
Mobility Issues.....	44
Conspicuity and the Older Adult	44
Road Sign Conspicuity	44
Pedestrian Conspicuity	46
Motorcycle Conspicuity.....	49
Evaluative Methodologies	51
METHOD	54
Participants.....	54
Materials	55
Video Recording and Presentation.....	55

Motorcycle and Conspicuity Conditions	57
Procedure	59
RESULTS	63
Main Effects.....	65
Differences by Age (Young/Middle/Older).....	65
Differences by Sex (Male/Female)	68
Motorcycle Conspicuity Conditions	71
Vehicle Following Conditions	72
Interaction Effects.....	73
Motorcycle Conspicuity Condition x Vehicle Following Condition.....	73
DISCUSSION.....	81
Hypotheses.....	81
Age Differences	93
Male/Female Differences.....	95
Motorcycle Conspicuity and High Definition Simulation	96
Conclusion and Future Research	98
APPENDIX A: PRE-TEST PARTICIPANT SCREENER.....	105
APPENDIX B: DRIVING HABITS QUESTIONNAIRE	108
APPENDIX C: MOTION SICKNESS HISTORY QUESTIONNAIRE.....	115
MOTION SICKNESS HISTORY QUESTIONNAIRE	116
APPENDIX D: INFORMED CONSENT FORM.....	120
APPENDIX E: PSYCHOLOGY RESEARCH EXPERIENCE EVALUATION FORM FOR PARTICIPANTS.....	124
APPENDIX F: EXPERIMENTAL ROAD-WAY CONDITION	127
APPENDIX G: GE-I-SIM SIMULATOR.....	129
APPENDIX H: EXPERIMENTAL APPARATUS RESPONSE CONTROL BOX	131
APPENDIX I: EXPERIMENTAL TEST VEHICLES.....	133
APPENDIX J: MOTORCYCLE HEADLIGHT MODULATORS.....	135
APPENDIX K: MOTORCYCLE CONSPICUITY TEST CONDITIONS.....	137
APPENDIX L: NHTSA-DOT SEC 571.108 STANDARD NO. 108	141
APPENDIX M: VEHICULAR DAYTIME RUNNING LIGHTS	143
APPENDIX N: MOTORCYCLE DRY SURFACE BRAKING RESULTS	145
APPENDIX O: REACTION TIME-TO-DISTANCE CONVERSION	147
APPENDIX P: IRB HUMAN SUBJECTS PERMISSION LETTER.....	149
REFERENCES	151

LIST OF FIGURES

Figure 1: Traffic Scenarios use (Olson, Halstead-Nussloch, & Sivak, 1981)	11
Figure 2: Chevron Pattern used on police vehicles.....	15
Figure 3: Chevron Pattern at night – Reflectors	16
Figure 4: Model of the integral role of hazard perception in the safe detection and response to risky/dangerous/hazardous traffic situations (Haworth, Mulvihill, & Symmons, 2005).....	34
Figure 5: Age Differences.....	66
Figure 6: Age Differences x Motorcycle Conditions.....	67
Figure 7: Age Differences x Vehicle Conditions.....	68
Figure 8: Differences by Sex	69
Figure 9: Differences by Sex – Trend across all 4 vehicle conditions.....	70
Figure 10: Differences by Sex – Trend across all 3 motorcycle conditions	70
Figure 11: RT at 3 Motorcycle Conspicuity Treatment Conditions	71
Figure 12: Vehicle Following Conditions.....	72
Figure 13: Vehicle x Motorcycle Interaction.....	73
Figure 14: Vehicle x Motorcycle Interaction (All 4 Vehicle Following Conditions).....	74
Figure 15: RT with a Following Vehicle	75
Figure 16: Motorcycle Reaction Time x Vehicle Following Conditions (collapsed).....	76
Figure 17: Motorcycle Reaction Time when followed by a Vehicle with DRL or Low Beam	77
Figure 18: RT to Motorcycle with No Vehicle Present	78
Figure 19: RT to Motorcycle with Vehicle Following (no headlights)	79
Figure 20: RT to Motorcycle with Vehicle Following with Low Beams	79
Figure 21: RT to Motorcycle with Vehicle Following with DRLs.....	80

LIST OF TABLES

Table 1: Participant Demographic Data.....	64
Table 2: Age Differences.....	66
Table 3: Differences by Sex.....	69
Table 4: Motorcycle Conspicuity Treatment.....	71
Table 5: Vehicle Following Conditions.....	72
Table 6: Vehicle/Motorcycle Interaction – Descriptive Statistics.....	77
Table 7: Paired Samples Statistics.....	78

INTRODUCTION

Motorcycle Conspicuity: Literature Review

Operating a motorcycle or moped is very different in many ways when compared to operating a conventional vehicle such as a car, truck or van. Aside from the more obvious differences such as physical placement of gas, brake, clutch controls, or environmental operating variables such as reduced protection/increased exposure to the elements, there are differential factors that dramatically influence the safe operation of the machine and the overall safety of the operator at hand. Specifically, there are factors inherent in driving or riding a small two wheeled vehicle, such as a motorcycle, moped or even bicycle that can potentially decrease their ability to be seen or noticed by other drivers. These differences include physical characteristics of the motorcycle and rider, such as size, shape, color, lighting/luminance, and orientation on the road (Cole & Hughes, 1984; Cole & Jenkins 1984; Hendtloss, 1992; Thomson, 1980; Wulf, Hancock, & Rahimi, 1989). Additionally, there are variables associated with operators of other vehicles (non-motorcycle) that can negatively influence their ability to “detect” a motorcycle, such as reduced expectancy or expectation for motorcyclists (Gibson, 1966; Thomson, 1980; Wulf, Hancock, & Rahimi, 1989). Of equal, if not greater, importance is the ever growing “older adult” population and the degree to which one’s “detection” capabilities suffer as a function of the inevitable aging process (Department for Transport, 2006; Keskinen, Ota, & Katila, 1998; Kline, Kline, Fozard, Kosnik, Schieber, & Sekular, 1992; Transportation Research Board, 1999). When combined, these elements of human sensation, perception and cognition all play a pivotal role in the effective detection and response to small vehicles on the road. This decreased ability to

be seen or noticed is generally categorized as an issue of conspicuity, which is the ability to effectively attract attention and to be located with ease (Engel, 1971; Engel 1977). Motorcycle conspicuity is a significant issue that accompanies one's decision to operate a motorcycle and ultimately leads to a disproportionate increase in the amount of injuries and/or fatalities incurred by this subsection of the driving population. This problem is further compounded when coupled with the under-representation of motorcycles on the road as well as the overrepresentation of motorcyclist fatalities within the United States and abroad, creating a significant quandary which deserves dedicated evaluation as to causative factors and/or influential variables (Motorcycle Safety Foundation, 2000; Hurt, Oullet, & Thom, 1981; Wulf, Hancock, & Rahimi, 1989). This inquiry is essential so as to determine the most effective means by which motorcycle conspicuity can be increased, motorcyclist injury and fatality decreased and overall motorcycle safety enhanced.

The end result of ineffectively detecting a motorcycle on the road, whether it be due to the physical attributes of the motorcycle or cognitive aspects of the motorist, is ultimately an accident between motorcycle and motorist. Of these accidents, there has been a disproportionate number reported whereby the motorist claims that the accident occurred because he/she simply did not see the motorcycle (Hurt, Oullet & Thom, 1981; Wulf, Hancock, & Rahimi, 1989). This idea was first formally elucidated by Reiss & Haley (1968) who claimed that a good majority of motorcycle accidents were attributable to the other motorist who most likely didn't see the motorcycle until it was too late. This notion has recently been updated to formally capture the accident typology as the "looked but failed to see" phenomenon (Hills, 1980; Langham et al., 2002; Langham & McDonald, 2004; Labbett & Langham, 2006; Mack & Rock, 2000). That is the failure to

detect and respond accordingly to oncoming motorcycles due to misjudgments in distance and speed caused primarily by the characteristics of the motorcycle and more importantly by cognitive characteristics of the motorist, such as visual search strategy, expectation or even perceptual differences that are unique to the individual (Herslund, & Jorgensen, 2003; Hills, 1980; Wulf, Hancock, & Rahimi, 1989).

Conspicuity: Origins and Vision Research

Conspicuity has been operationalized by a variety of researchers in a variety of ways and although differing mildly in specificity, what has been agreed upon is that in order to be conspicuous, the object of interest must stand out from its surroundings (Engel, 1971; Hughes & Cole, 1984; Langham & Moberly, 2003; Williams & Hoffman, 1979). Engel (1971) originally defined conspicuity as the ability of an object to effectively grab the attention of the perceiver with regard to the objects background (Engel, 1977). In these early studies, elements such as background complexity and luminance were emphasized as contributory toward the capture of one's attention (Engel, 1971; Engel, 1977). Additionally this term was operationally quantified as the time taken to effectively identify and respond to a given stimulus within a specified area (radius from fixation point) presented for a short period of time (Cole & Jenkins, 1980; Engel, 1971; Engel, 1977). This quantifying metric was successively termed "conspicuity area" in reference to the visual area surrounding a pre-determined fixation point necessary for effective target detection (Engel, 1971; Engel, 1977; Hughes & Cole, 1986; Jenkins & Cole, 1982). This research has since been progressively built upon by investigators interested in determining causative factors and further operationalizing the term in regards to specific situations, environmental factors/background complexity, behavioral

patterns, cognitive styles, individual perceptions, and methods of quantification (Cole & Hughes, 1984; Kooi & Toet, 1999; Langham, 1999; Langham & Moberly, 2003). Most researchers conclude with similar assumptions of conspicuity citing that an emphasis be placed upon an object's visual contrast from its surrounding background. Cole and Jenkins (1980) have somewhat simplified the operational term of conspicuity proposed by Engel (1971) and state that if an object is conspicuous, then it should be detected and responded to with an accurate degree of certainty ($p < 1.0$), regardless of eccentricity from the observers fixation point (Cole & Hughes, 1984). Additionally, Cole & Jenkins (1984) termed the phrase "glance conspicuity" in reference to the short duration with which an object should be detected without the need for visual search (250 ms).

Extracting further specificity in operationalizing the term conspicuity, Cole and Hughes (1984), examined the formal historical definition of the term and found two distinct aspects that deserve recognition. An essential aspect of detecting an object is its ability to attract attention and to jump out at the observer. That is, conspicuity that requires no further cognitive or perceptual faculties but is more automatic in nature, as opposed to conspicuity that requires further visual search. They termed this type of conspicuity "attention conspicuity", as it requires very little effort to detect and is more automatic in nature (Cole & Hughes, 1984). The latter type of conspicuity that requires a more effortful approach by the observer in order to consciously find and locate an object has been termed "search conspicuity" (Cole & Hughes, 1984). This distinction is extremely important to the study of conspicuity, specifically in regards to the type of evaluative method used for analysis throughout the following research conducted on motorcycle conspicuity.

Motorcycle Conspicuity

Throughout history, there have been many attempts made to effectively pronounce the presence of motorcycles on the road, increase the detection of motorcycles, and positively illuminate issues affecting motorcycle conspicuity (Motorcycle Safety Foundation, 2000; Thomson, 1980; USPTO, 2004). Specific focus has been placed on both vehicle and operator characteristics and research has most recently seen a shift towards influential factors attributable to the other driver or operators of conventional vehicles who also share the road (Wulf, Hancock, & Rahimi, 1989). In an effort to improve motorcycle conspicuity and increase visibility, a great deal of research has focused on vehicle characteristics such as lighting, fairings/body work, and tires. Vehicular variables such as headlights/running lights, signals, beacons and strobe lights have all been focal areas of emphasis for countless studies, as have patterned, fluorescent and reflective/retro-reflective body panels and tires (Gerathewohl, 1954; Hendtlass, 1992; Janoff & Cassel, 1971; Perlot & Prower, 2003; smith 1991; Tenkink & Walraven, 1987; Thomson, 1980; Tijerina, 2003; Williams and Hoffman, 1979). Similar emphasis has also been placed on the operator of the motorcycle where aspects such as the patterns, color, and reflectance of helmets, gloves, boots, pants, and jackets have all been examined for their contributory influence to conspicuity (Cook & Quigley, 1998; Kirkby & Stroud, 1978; Kwan & Mapstone, 2004; Michon, Ernst & Koutstoal, 1969; Sivak, 1987; Williams & Hoffman, 1979). It must be noted that there are additionally significant environmental factors which influence the degree of significance each of the aforementioned implements have upon conspicuity. Aside from

characteristics specific to particular geographical locations, there are properties inherent in daytime and nighttime situations which greatly differentiate the effectiveness of the equipment being tested, and ultimately influence both vehicular and operator aspects of motorcycle conspicuity (Forester, 2004; Gerathewohl, 1954; Gerathewohl, 1957; Henttloss, 1992; Sivak, 1987; Woltman & Austin, 1974).

Physical Conspicuity – Vehicular

Being seen while operating a motorcycle, scooter or bicycle in an environment where other motorists exist is imperative to one's safety and longevity, but this seeming necessity is all too often ineffectively accomplished. Operating a motorcycle or scooter in particular, places one in an environment of extreme danger compared to conventional vehicles due to a variety of factors. First and foremost are aspects of the motorcycle itself that consequently lead to insufficient conspicuity. In order to combat this lack of, or reduced conspicuity, a great deal of research has been dedicated toward vehicular augmentation/modification and fabrication. In order to increase motorcycle conspicuity, particular emphasis has been placed on physical properties of the motorcycle that make it stand out from its background creating a certain degree of contrast with the environment. The following research has focused on elements of conspicuity by evaluating the effects of headlights, flashing lights, colored lights, beacons, strobes, bright vehicular colors, patterned colors, and reflectors for both day and night time environments. Most important here are the type of lights, the intensity, size, shape, orientation, location, direction, as well as quantity found on the motorcycle, which all influence the degree of conspicuity.

Motorcycle Lighting

Daytime Running Lights

Virtually every street-bike manufactured for use and sold in the United States comes hard wired from the factory, with automatic on headlamps or daytime running lights (DRL) (Motorcycle Safety Foundation, 2000). This trend started with the states of Arkansas and Montana in 1967, which were the first to mandate the use of DRLs (Hendtlass, 2004). Since then many more states have followed suit (22 total) basing their decisions on both field and laboratory research, which has found the use of DRL to increase motorcycle conspicuity and decrease accident involvement (Hendtlass, 2004). One of the first studies to formally examine the effectiveness of DRLs in vehicular use was conducted by Allen (1965) who evaluated accident occurrence for a bus company. Results from this study indicated that the compulsory use of DRLs by the bus company evaluated decreased the accident rate per million miles in daylight conditions by 40% compared to the previous year prior to implementation. When transferred to motorcycle use, similar results have been found. In a historical study attempting to determine the overall effectiveness of trial regulations/laws mandating the use of DRL on motorcycles in Indiana, Montana, Oregon and Wisconsin, Janoff et al. (1970) performed accident evaluations before and after implementation of the law to determine efficacy. This evaluation is also known as the Franklin Institute Report and has predominately been used as a basis for justifying the need and mandate of DRLs for manufacturers as well as the 21 other states that currently regulate DRL use. Their research concluded that the use of high beam and low beam headlights dramatically increased the conspicuity of

motorcycles, as was evident in their decreased accident involvement (Janoff et al., 1970). In an effort to further illuminate the issue, Williams and Hoffman (1979) conducted laboratory experiments utilizing conditions of both day and night, where they tested participants using simulations of real life situations.

In this experiment, participants were shown slides 20 degrees off a focal fixation point in their periphery vision. This was pre-determined by Williams and Hoffman (1977) in a previous study to be similar to the most prevalent types of motorcycle accidents that occurred either directly head on or slightly to the side of oncoming traffic. The slides were presented for a short duration in a search conspicuity type of scenario, where the participants were told to keep a watch out for the motorcyclist and to indicate when it had been detected. Each slide contained pictures of a motorcyclist at an approximate distance of 30m in either cluttered or uncluttered scenarios (complex/basic background). The motorcycle was equipped with a white frontal fairing, high beam headlights, low beam headlights, or the rider was wearing a fluorescent jacket. These situations were compared to a control situation where the motorcycle was equipped with none of the aforementioned implements. This experiment evaluated the conspicuity of these implements and response time as well as detection accuracy were used as metrics of conspicuity. The results found that overall conspicuity was increased when high and low beam headlight conditions were compared to no light conditions in both cluttered and uncluttered environments and that compared to all the other implements tested, the high beam was most effective (Williams & Hoffman, 1979). Although some researchers believe that the effectiveness of DRLs on motorcycles is diminishing due to the prevalence of DRLs by other vehicles, most agree that the compulsory use of DRLs by

motorcycle manufacturers significantly reduces accident involvement and thus increases overall conspicuity (Hendtlass, 1992; Horberg & Rumar, 1979; Olson, 1984; Olson, Halstead-Nussloch & Sivak, 1981; Perlot & Prower, 2003; Rumar, 1980; Thomson, 1980). It must be noted however that the effectiveness of motorcycle DRLs dramatically decreases as the observer line of sight approaches and exceeds 30 degrees from the focal point of the DRL (Donne & Fulton, 1985; Huang & Preston, 2004).

Flashing Lights – Headlight Modulators

There is evidence to suggest that a disproportionate amount of motorcycle accidents occur when other motorists fail to detect a motorcycle approached from a degree off center in the periphery. Williams and Hoffman (1977) found a significantly higher amount of motorcycle-vehicle collisions occur slightly angled from directly head on. This would suggest that in order to detect the presence of motorcycles, certain emphasis should be placed upon aspects of conspicuity that recognize this constraint. The human visual system has evolved over time so as to create specialized features that makes the periphery of the visual area more receptive to the detection of motion (Levine, 2000). The rods which constitute the periphery are much more receptive to motion, including flashes, which may be an influential factor increasing conspicuity through the use of flashing devices.

Early research on conspicuity in regard to visual performance, has established that flashing lights cause objects to stand out from their background more than static sources of illumination. Studies published as early as 1953 have determined that a relationship exists between the duration of the flash, the frequency of the flash as well as the intensity of the source of illumination (Gerathewohl, 1953; Rinalducci & Higgins, 1971).

Gerathewohl (1954) established that as the frequency of the flash increases, and the shorter the flash duration, the less intensity is required of the observer to detect it at low levels of contrast. A critical duration of flash was additionally found in this study. That is, a critical point in flash duration where conspicuity diminishes, which they suggested was in the range of 10 Hz (Gerathewohl, 1954). This threshold was also examined by Long (1951), and psycho-physiologically by Johnson & Bartlett (1956), who confirmed that if a flash duration exceeded 10 Hz or 100 msec, it suddenly became constant, ultimately diminishing conspicuity. Recognition of this early work is important in determining an optimal flash duration with which to implement into a system designed to increase conspicuity. This work has been carried over into modern systems and into modern evaluations of conspicuity increasing devices.

There are predominately two types of flashing systems that have been created with intentions of increasing conspicuity, one using a strobe like effect and the other relying on a rotating beacon set-up (Smith, 1991; Tijerina, 2003). These devices have traditionally been employed by emergency vehicle manufacturers but due to their seeming success, have recently been considered for application as modulators in motorcycle headlights. There are currently laws that prevent the use of beacons for commercial vehicles, including motorcycles, but these systems must be evaluated for their effectiveness in conspicuity research regardless. In order to determine the effectiveness of headlight modulators, in addition to fluorescent garments (discussed later), Olson, Halstead-Nussloch, & Sivak (1981) tested the detection/reaction times of participants in real world driving situations.

The authors used a proven method previously employed by Kirkby & Stroud (1978) with regards to motorcycle conspicuity, which is called the gap acceptance paradigm. This evaluative methodology uses a pre-determined gap in traffic (between cars), where the participant is given the option to accept, or reject that gap as if pulling onto a busy street and merging with traffic from a side street (Olson, Halstead-Nussloch, & Sivak, 1981). Participants were extensively tested under three pre-determined scenarios where motorcycle accident involvement has been predominately overrepresented (as shown in figure 1).

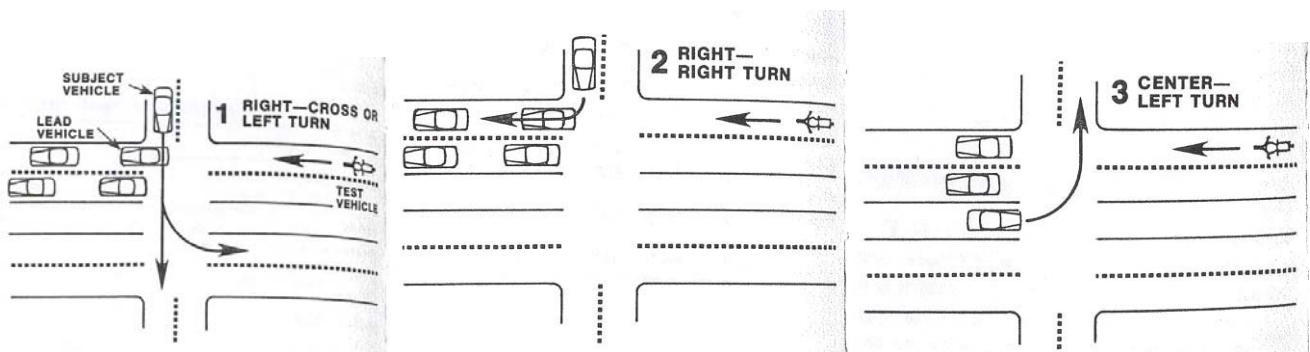

Figure 1: Traffic Scenarios used in study (Olson, Halstead-Nussloch, & Sivak, 1981)

In this study an actual motorcycle was equipped with various implements used to increase conspicuity such as fluorescent garments (discussed later in paper), running lights, high/low beam headlights, and modulating headlights (3 Hz) as well as respective coding devices. The results from this study indicate that during daytime conditions, both low and high beam headlights as well as modulating headlights significantly improved conspicuity. This was additionally found during the nighttime situations among all conditions tested.

In regards to emergency vehicle use, Smith (1991) suggests that rotating beacons be employed as opposed to strobe light devices, claiming a beacon is advantageous because it can be seen within a 360 degree radius and that it reflects off the ground and other objects, further increasing conspicuity. A more recent study performed by ICE Ergonomics (2002) a consultation group based in the United Kingdom revealed a number of subjective criteria important to the study of strobe light/beacon use. According to their findings, warning beacons were preferred over strobe light devices when a greater sense of urgency was necessary and that rotating beacon systems were found to be less annoying and preferred when glare is an issue (ICE, 2002). Additionally, they found that a flash rate of 4 Hz improved detection time of warning beacons in both day and night conditions as opposed to lower frequencies tested. They also tested systems with multiple beacons and found that when used, simultaneous flashes were preferred to alternating and that as beacon quantity increased, so too did discomfort, glare, and annoyance (ICE, 2002).

Although the use of beacons and strobe type conspicuity devices have been determined to effectively increase conspicuity under the right conditions set at frequencies between 3 Hz and 10 Hz, negative consequence of use must also be considered. Most specifically, epileptogenic response must be taken into consideration. Although quite rare, epileptic seizures as a result of flashing lights or eyestrain, discomfort or headaches by those with epilepsy must all be recognized when considering the implementation and use of the aforementioned devices. Medical researchers have found that flashing lights with frequencies in the range of 10 – 20 Hz are most likely to induce an epileptogenic response and likely cause seizure in those with photo-sensitive

epilepsy (Plaster, Lodge, & Mulvaney, 1979; Watanabe, Imada, & Nihei, 2002).

Subsequently, it is suggested that flash rates not exceed 5 Hz when exposure to a large variety of individuals is probable as is the case with motorcycle lighting (ICE, 2002).

Auxiliary Lighting

In addition to strobe/beacon style flashing lights, side marker lights, auxiliary lights, and running lights have also been investigated for their positive contributions toward increasing vehicle conspicuity. Although the use of side marker lighting has been mandatory since 1969 in all vehicles made for use in the United States, it was only until just recently that a formal, experimental investigation as to their positive influence on conspicuity was conducted. Theeuwes and Alferdinck (1997) conducted a study in which participants were shown slides of various vehicles at various angles and distances in nighttime conditions (complex/basic) with and without side marker lamps. Their findings offer indisputable support for the use of side marker lamps as an effective tool for increasing conspicuity in vehicles when viewed at angles between 0 and 20 degrees perpendicular to the side of the vehicle. These results occurred across all conditions, in all situations, and at all distances suggesting a great deal of benefit if implemented on motorcycles (Theeuwes & Alferdinck, 1997).

Other Vehicle Characteristics – Fairings/Bodywork, Tires, & License Plates

In keeping true to the necessities of conspicuity, which require an object to be effectively differentiated from its surrounding so that sufficient contrast is created and the object seemingly pops out from the background, one must additionally recognize other physical variables of the motorcycle. Elements of the fairing/bodywork and tires such as color, reflectance, and patterns equally contribute to making a motorcycle more

noticeable to other drivers. The colors white, crème, and lime yellow have all been found to be more conspicuous than any other color of vehicle in studies evaluating accident involvement (Allen, 1970; Solomon, 1990). The results from these studies are questionable as there is a high degree of validity as to confounding variables such as individual behavioral characteristics and color selection (do safer drivers choose white cars). In a more controlled setting, Williams and Hoffman (1979) tested a variety of conspicuity aides to determine effectiveness and found rather interesting results when comparing the effectiveness of an all white frontal fairing installed on motorcycles in both complex and simple traffic settings/backgrounds. When participants were exposed to situations where a motorcycle fitted with this fairing was in very sparse traffic or the simple background, detection rates were comparable to those exposed to high beam headlights. This indicates significantly higher amounts of conspicuity. However, these results changed when the same fairing was viewed in more dense traffic/complex background situations, where the authors noted a camouflaged effect or inability to produce effective contrast from the surroundings (Williams & Hoffman, 1977). Additionally, there is physiological evidence to support the probability of increased conspicuity and color detection when employing these colors as rods in the periphery have developed to be more sensitive to the aforementioned colors (Levine, 2000; Tijerina, 2003).

Evidence has also been found to suggest that certain types of patterns displayed on fairings or body work might advantageously contribute to increased conspicuity if applied to motorcycles, by creating an effective contrast from the surrounding background. In the field of emergency vehicle design, it is extremely important in

increase conspicuity as much as possible due to the particular types of situations and traffic these vehicles must navigate. In doing so, a large amount of research has been directed toward patterned vehicle applications, mostly overseas (Tijerina, 2003). One such potentially promising pattern is the Chevron pattern, or Harlequin “Battenburg Livery” as it is called in Europe (See Figure 2). This pattern apparently plays off of human perceptual cues by representing similarity to a horizontal barricade or bridge abutment, and consequently increasing conspicuity when applied to emergency vehicles (CVPI, 2004).



Figure 2: Chevron Pattern used on police vehicles

Additionally, this pattern has been found to be effective in both day and night time conditions (Figure 3), if applied with reflective paint/colorization (Saunders & Gough, 2003; Tijerina, 2003).



Figure 3: Chevron Pattern at night – Reflectors

Although the aforementioned examples of patterned paint schemes on bodywork have directly been applied to emergency vehicles, and specifically the rear end of emergency vehicles, there is great potential for this type of application in motorcycle conspicuity. Unfortunately as of date, this correlation has yet to be established.

As can be seen in figure 3, and what has largely been recognized by manufacturers of pedestrian and bicyclist clothing, manufacturers of bicycles, mopeds, motorcycles, and virtually all motorized vehicles, the use of reflectors is extremely important to nighttime conspicuity. Across virtually every study conducted on the matter, it has been found that reflectors dramatically increase one's conspicuity at night (Ashford, Stroud & Kirk, 78; Burg & Beers, 1978; Cairney, 1999; Green, Kubacki, Olson, & Sivak, 1979; for review see Kwan & Mapstone, 2004; Wulf, Hancock, & Rahimi, 1989). Whether applied to the tire sidewalls (Burg & Beers, 1978), vehicle body, license plates (for review see Kubacki, Olson, & Sivak, 1979), or rider (discussed in next section), the use of reflectors has significantly been found to be effective in promoting increased conspicuity at night.

Operator Conspicuity – The Motorcyclist

In addition to physical systems characteristic to the vehicle such as lighting and reflectors, of equal importance are variables specific to the operator of the motorcycle, or the motorcyclist. Similar results to research specific to body fairings and tires with reflectors have been found with regards to operator helmets, jackets, pants, and boots. All of which positively influence the conspicuity of the motorcyclist, especially in nighttime conditions (Blomberg, Hale & Preusser, 1986; Kwan & Mapstone, 2004; Owens & Antonoff, 1994; Woltman & Austin, 1973; Williams & Hoffman, 1976). In a study conducted by (Woltman & Austin, 1973), motorcyclists equipped with fluorescent garments were detected much quicker than those wearing conventional colors under a variety of backgrounds, at a variety of angles. This was especially true under environmental conditions of dust and or dim illumination. As mentioned earlier in regards to vehicular lighting, Olson, Halstead-Nussloch, & Sivak (1981) additionally tested the effectiveness of fluorescent garments on motorcycle detection and found their use to effectively distinguish the motorcyclist from their surroundings via a gap acceptance paradigm. These findings have been supplemented by support from research on pedestrian and bicyclist conspicuity, where virtually every study done has concluded that both fluorescent and retro-reflective garments drastically improve conspicuity (for an exhaustive review see Kwan & Mapstone, 2004).

Cognitive Conspicuity – The Other Motorist

As with most areas of research and/or inquiry, in order to fully attempt at understanding the intricacies of a topic, one must approach that topic from as many angles as possible. Although the physical properties of both motorcycle and motorcyclist

are indisputably influential in effectively increasing overall motorcycle conspicuity, additional variables associated with motorists must be recognized (Hole, Tyrrell, & Langham, 1996). More recent inquiry into motorcycle conspicuity has shifted focus to a more globalized perspective emphasizing not only the motorcycle or motorcyclist, but also, other drivers who share the road (motorists). In doing so, aspects of human cognition such as decision making, information processing and cognitive schemas/expectation as well as perceptual aspects such as size discrimination, hazard perception and judgment have all been the focus of recent research (Hills, 1980; Langham, Hole, Edwards, & O'Neil, 2002; Langham & McDonald, 2004; Labbett & Langham, 2006; Mack & Rock, 2000; Wulf, Hancock, & Rahimi, 1989). Focus on these aspects of cognition and perception, as they relate to the effective detection of objects within vehicular traffic, have been termed "cognitive conspicuity" (Langham & McDonald, 2004). They involve not only the physical properties of a motorcycle or motorcyclist, but directly address certain cognitive and perceptual qualities of other motorists, which impact one's ability to effectively detect the presence of a motorcycle.

It is seemingly obvious, but the size, shape and orientation of a motorcycle or scooter, is extremely different from what many consider conventional and from what many motorists have come to expect to encounter while driving (Gibson, 1966; Olson, Halstead-Nussloch & Sivak, 1981; Thomson, 1980). The physical size of a motorcycle is significantly smaller than a conventional vehicle. The frontal silhouette of a motorcycle is approximately 30 – 40% smaller than a conventional vehicle. This number is increasingly becoming larger as conventional vehicle size continues to grow (Hendtlass, 1992; Huang & Preston, 2004; RSC, 1992). Woltman and Austin (1974) evaluated the

impact that size might have on accident rates involving motorcycles and conventional vehicles. They systematically performed accident analysis on motorcycle collisions with other vehicles comparing aspects such as size and frontal silhouette of motorcycles. They concluded their research by claiming that the smaller size of motorcycles in general as well as their frontal silhouette of a motorcycle compared to a car, significantly lead to inconsistent expectations of other motorists. This consequently leads to the probability of higher accident rates for motorcyclists (Woltman & Austin, 1974). Additionally judgments of speed and distance are determined by size and expectation so that those operating conventional vehicles might have a more difficult time perceiving an accurate distance and speed judgment for those oncoming motorcycles.

Motorist Expectation – Expectancy Phenomenon

This brings about concern for what has been termed the “expectancy” phenomenon, or defiance of pre-established schemas or expectations as to how things operate (Gibson, 1966; Hendtlass, 1992; Langham & McDonald, 2004; Labatt & Langham, 2006). Rumar as cited in Langham and McDonald (2004) states that motorists lack necessary expectations for smaller and less common vehicles such as motorcycles. Thus far, theories explaining this condition have focused primarily around the formation of perceptual schemas and patterns of visual scanning. One explanation that has been proposed, suggests that motorists tend to develop a “perceptual set” that incorporates an increased expectancy for common vehicles encountered while driving and places less importance on the detection of less common vehicles, such as motorcycles, bicycles or even pedestrians (Hole & Tyrrell, 1995). In their study, Hole and Tyrrell (1995) found that participants were less likely to notice the presence of a motorcycle without

headlights, once they had been exposed to conditions where the majority of motorcycles had their headlights in the ON position. These results suggest that motorists are inclined to create perceptual associations for vehicles on the road and consequently establish expectations, whether accurate or not, that can negatively influence the conspicuity of less common vehicles. In this case, participants that had established the expectancy for all motorcycles to have their lights on, consequently detected motorcycles at a slower rate, that did not comply with this particular expectation.

Langham and McDonald (2004) support a supplementary theory and suggest that motorists employ inadequate scanning strategies for motorcycles and conversely devote the majority of their visual scanning to larger vehicles and other more common or “expected” hazards. Summala, Pasanen, Rasanen, and Sievanen (1996) conducted a study on bicycle conspicuity in which visual scanning was recorded and found results that directly support this concept. These researchers monitored the visual scanning of motorists situated at a busy intersection, who were instructed to turn right, and to scan for any hazards as a bicycle approached from the right. These researchers found that the majority of these motorists failed to effectively detect the bicycle, concluding that they visually scan for hazards that are common and expected, but fail to scan for less common objects such as bicycles (Summala, Pasanen, Rasanen, & Sievanen, 1996). Herslund and Jorgensen (2003) have also concluded with similar findings in an experiment utilizing a gap acceptance paradigm, whereby participants were exposed to different combinations of bicycle and car. These researchers suggest that experienced motorists develop visual scanning behavior that allows them to look in a seemingly automatic manner, for expected objects in expected areas of the road way, and if these expected objects (cars)

are not present, then minimal concern for hazard or risk is exerted (Herslund & Jorgensen, 2003). Although the aforementioned research has been conducted using bicycles in a somewhat different context than studies involving motorcycles, what can be generalized is the transfer of expectancy and the degree to which expectation plays a role in the effective detection of less common objects while in traffic.

When discussing motorist expectation, it is also important to discuss some of the perceptual qualities related to expectation, such as meaningfulness, recognition, as well as prior experience with motorcycles (Hancock & Rahimi, 1989; Hole & Tyrrell, 1995; Hole, Tyrrell & Langham, 1996; Langham and McDonald, 2004; Shinar, 1985).

Although it is true that certain properties of a motorcycle can be modified to increase the likelihood that a motorcycle will be seen by other motorists, motorists must additionally be able to effectively extract meaning from the presence of a motorcycle and to “recognize” a motorcycle as an object within traffic that is inherently smaller, faster and of a higher level of “risk” than other vehicles (Hole, Tyrrell & Langham, 1996; Langham & McDonald, 2004). This concept posits that if a motorcycle has been assigned some type of identifier which establishes meaning and recognition as a “potential hazard” or a vehicle with “increased risk”, then the probability of a motorists’ expectation for encountering a motorcycle on the road has potential to increase as does their overall awareness and conspicuity for motorcycles (Shinar, 1984). Thomson (1980) has suggested that motorist expectation for motorcycles can effectively be enhanced through the standardized design of a conspicuity aiding implement for motorcycles that markedly differentiates them from other vehicles on the road. He refers to this as “positive information”, which can potentially serve to indicate the presence of a motorcycle

(Thomson, 1980). That is, by employing a unique, unusual and standardized identifier on motorcycles, meaning and recognition can be established for motorists, which holds great potential in enhancing the overall expectation and conspicuity of motorcycles. Shinar (1985) supports this mindset suggesting that in the context of pedestrian conspicuity, the implementation of a standardized, consistent and easily recognized symbol, in this case a reflective hang-tag, could potentially aid in increased driver detection. In a research study, Shinar (1985) found that participants having had pre-exposure to the meaning and recognition of such pedestrian hang-tags were much more likely to detect pedestrians both earlier and quicker than those without prior exposure. In this study, Shinar (1985) further discussed the importance of establishing meaning, recognition and significance within the driving population and claimed that the benefits of conspicuity aiding devices are minimal, unless an meaningful association between these devices and a potential hazard/increased caution can be established (Shinar, 1985). That is until motorists are able to effectively develop expectations and meaningful associations between devices which aid in conspicuity and potential hazard or increased caution, the effectiveness of these devices remains somewhat limited.

Expectancy and Daytime Running Lights

The idea behind the assignment of hazard recognition to motorcycles is by no means novel and is a concept that has in fact been implemented into every single road legal motorcycle in the United States since as far back as 1967 (Hendtlass, 2004; Motorcycle Safety Foundation, 2000). What is being referred to here is the implementation of daytime running lights (DRL) on motorcycles both in the United States as well as many European Countries and elsewhere. Currently, only 22 states in

the US mandate DRLs, however, every motorcycle that is imported or built in the US comes standard with DRLs hardwired into the ignition that automatically turn ON, whenever the motorcycle is operated (Williams & Lancaster, 1995). When the implementation of this technology was first mandated for motorcycles in the states of Arkansas and Montana in 1967, it was done so because both lab and field studies at the time supported increased safety and conspicuity through the use of DRL (Hendtlass, 2004). At this time, motorcycles were exclusive in their use of DRL and very rarely were other vehicles on the road seen using such a technology. When DRLs were first implemented, they were unique to motorcycles and it is highly possible that this uniqueness allowed motorists to perceptually establish a link between this unique identifier and motorcycles. Since this time, more than forty years have transpired, times have changed, laws have changed, technology has advanced and ultimately, so too has the prevalence of DRL that are seen on the road, both for motorcycles as well as other four wheeled vehicles. The question now becomes, to what degree has the widespread implementation of Daytime Running Lights on vehicles other than motorcycles, negatively influenced the effectiveness of Daytime Running Lights as an implement of conspicuity on motorcycles. That is, what if any adverse effects to motorcycle conspicuity have resulted from DRLs being implemented into other vehicles on the road. The topic of DRLs has been discussed in detail in a previous section of this document (Daytime Running Lights) and will be discussed further in this section as it relates to aspects of cognitive conspicuity. The following topics will specifically be focused on: hazard perception, recognition, association and the potential for diminished effectiveness on motorcycles, brought on by motorist habituation and overexposure.

The consensus of research conducted on this topic has shown that DRLs used on motorcycles increase the probability of being detected by other motorists as has been discussed in a previous section of this document entitled “Daytime Running Lights” (Allen, 1965; Hendtlass, 1992; Horberg & Rumar, 1979; Koornstra, Bijlefeld & Hagenzieker, 1997; Olson, 1984; Olson, Halstead-Nussloch & Sivak, 1981; Perlot & Prower, 2003; Rumar, 1980; Thomson, 1980; Williams & Hoffman, 1979). However, there is concomitant evidence to suggest that the effectiveness of DRLs on motorcycles has been negatively influenced by the increasing use of DRLs in other vehicles besides motorcycles. This evidence suggests that motorcycle conspicuity provided by DRLs has potential to decrease as a result of masking effects caused by the ever growing prevalence of DRLs on other vehicles that share the road (Brouwer, Janssen, & Theeuwes, 2004; Hendtlass, 1992; Hole & Tyrrell, 1995; Perlot & Prower, 2003). Additionally, there is evidence to suggest that the widespread use of DRLs in the majority of vehicles will also lead to decreased motorcycle conspicuity due to a sense of habituation by motorists (Perlot & Prower, 2003). While motorcycles were once exclusive in their use of DRLs on the road, there are now many other vehicles that also use DRLs and it is this increased prevalence which has the potential to lead to a decrease in motorcycle conspicuity. What started on some GM models in 1995 has now evolved to include standard “hard-wired” DRLs on vehicles produced by a large number of manufacturers including General Motors, Jeep, Mercedes Benz, Lexus, Saab, Subaru, Suzuki, Volkswagen, and Volvo, as well as some models produced by Toyota (IIHS, 2006; Williams & Lancaster, 1995).

There has been a great deal of speculation and conjecture applied to the topic of motorcycle conspicuity and degradations caused by other vehicle DRLs, but very few

studies have actually come to fruition in order to examine this issue (Binder, Perel, Pierowicz, Gawron, & Wilson, 2005; Brouwer, Janssen & Theeuwes, 2004; Horberg & Rumar, 1979; Koornstra, Bijlefeld & Hagenzieker, 1997; Perlot & Prower, 2003; Williams & Lancaster, 1995) . Early research on this topic suggested that vehicles with DRLs would mask those without DRLs and lead to decreased conspicuity for such vehicles, while more recent research has focused on masking due to motorcycles with DRLs amongst other vehicles with DRL. In an early study conducted by Horberg and Rumar (1979) an inadvertent finding was that vehicles with DRL might potentially mask vehicles without DRL. Some early research had participants view vehicles with lights OFF among those with lights ON, where it was found that those in the OFF conditions were much more difficult to detect (Hendtlass, 1992). These findings were hypothesized to be a result of masking from vehicles in the ON condition. Hole and Tyrrell (1995) continued with this line of thought and hypothesized that the majority of motorcycles with lights ON would lead to a decrease in conspicuity for those who voluntarily rode without headlights (OFF). These researchers used a slide presentation and a forced choice paradigm, where participants were required to decide whether a motorcycle was present or absent in each slide as quickly as possible. Although the authors found that participants were quicker and more accurate in detecting motorcycles in the ON condition as opposed to the OFF condition, they also found evidence to support their main hypothesis. These authors found that the more participants were exposed repeatedly to motorcycles in the ON condition, the more detection times increased for motorcycles in the OFF condition. That is, participants were perceptually influenced by the conditions where the majority of motorcycles had their headlights ON, so as to establish expectancy

for this condition, which thus decreased the conspicuity of other motorcycles that did not match this level of expectation (OFF condition). Perlot and Prower (2003) refer to this perceptual inadequacy as masking by confusion, where the detection of a vehicle (OFF condition) can potentially be masked by the established expectation for another vehicle (ON expectation). According to Perlot and Prower (2003) masking by confusion is a condition that is inevitably caused by other vehicles with DRLs and can be linked to decreased motorcycle conspicuity and inevitably to motorcycle crash causation.

The inclusion of the aforementioned research on DRLs is not to suggest that vehicles other than motorcycles should not be produced with DRLs, but rather to point out some of the adverse effects that have been influenced by the increased number of vehicles with DRLs. It is likely that DRLs that were once only used on motorcycles have potentially decreased in their effectiveness due to such prevalence. When originally they were used only on motorcycles, it was this exclusive application that allowed motorists to develop expectations and meaningful associations between DRLs and motorcycles. The results from the research presented in this section suggest that such association has diminished in recent times. It is at this point that a standardized, easily recognizable device for conspicuity must be developed for motorcycles as has been suggested by Shinar (1985), as mentioned in the previous section (Expectancy). There are a variety of ways that manufactures could potentially go about designing such an implement. Paine, Haley, and Cockfield (2005) support this notion and have suggested that color should be used as this identifier and such an identifier should only be allowable on motorcycles. These authors claim that the implementation of such a device could result in a potential reduction in fatal motorcycle crashes by as much as 13% (Paine, Haley, & Cockfield

2005). This ideology is additionally supported by the International Commission on Illumination (1990), who have suggested the implementation of a standard, recognizable, easily associated identifier, which in this case is a triangular configuration of lighting, created by the addition of two auxiliary driving lights. These are just a few examples that can be incorporated in current motorcycle design so as to establish expectancy among motorists as to the recognition and meaningful association with a motorcycle. However the implementation of such a device exclusively, standalone, will do little more than what is currently available on motorcycles, for it is necessary that motorists recognize and associate such a device with increased caution and/or risk. Additional work must be done in order to establish an awareness among motorists as to the hazard and increased caution that must be associated with motorcycles on the road, which is a perception that currently exists minimally for motorists on the road (refer to section on Hazard Perception).

Individual Differences

As with many aspects of human performance, variables that are inherent in the individual can ultimately affect one's performance when driving and ultimately impact motorcycle safety. Thus when examining motorcycle conspicuity and motorcycle accident attribution, it is imperative to include differences that are unique to the individual. Such individualities include variances in perceptual and cognitive styles, as well as human aging and the ways in which aging influences such functions.

Wulf, Hancock and Rahimi, (1989) and Langham (1999) support this notion and have suggested that focus be placed upon characteristics of the other driver and influential variables inherent in individual perceptions and cognitive styles. One such cognitive characteristic that is divisive among individuals is that of field

dependence/independence. Witkin (1950) originally proposed an idea positing that individual differences existed in regards to one's ability to distinguish items from their background. He termed this individual attribute "field dependence/independence". Field dependence involves the effective perceptual differentiation of objects from their background, where those with field dependence have much more difficulty doing so than those categorized as field independent (Thomson, 1980). This perceptual individuality places those with field dependence at a much higher risk of involvement in vehicular accidents than those that are field independent. In a recent study, Langham (1999) shed some light on the influence that field dependence/independence has on motorcycle conspicuity. These researchers first administered an Embedded Figures Test to determine field dependence/independence of each participant and then had them watch a video of a traffic situation. The video contained the inclusion or absence of a motorcycle with/without headlights on, in either a cluttered or uncluttered environment. Additionally, perceived distance from the motorcycle varied between 50 and 100 meters. In this experiment, participants were required to correctly report the detection of a motorcycle and the probability of correct detection was measured. Along with supporting previous findings regarding the positive influence headlights have on conspicuity and the effects of background complexity, the findings of this study suggest a distinct difference between reaction times for field dependent and independent individuals. This was an initial study examining the effects of field dependence on motorcycle conspicuity but the findings clearly indicate the extent to which individual differences such as this can and do contribute to motorcycle conspicuity. As a concluding remark, the author suggests that this topic is a viable concern that should be further addressed and points out the

importance of empirically examining attributes that are unique to the individual (Langham, 1999).

Experience and Familiarity

One additional variable that has been found to correlate with motorcycle accident causation and motorcycle conspicuity is individual experience and familiarity with motorcycles (Brooks, 1991; Brooks & Guppy, 1990; Horswill & Helman, 2003; Magazzu, Comelli, & Marinoni, 2006; Olson, 1989; Wulf, Hancock and Rahimi, 1989. This concept posits that those who have had meaningful exposure or experience with motorcycles and have thus established familiarity as to the operation and characteristics of the machine/operator, are more inclined to notice other motorcycles on the road and less inclined to be involved in motorist-motorcycle accidents (Brooks, 1991; Brooks & Guppy, 1990; Magazzu, Comelli, & Marinoni, 2006). This idea was first noted by Hurt, Oullet and Thom (1981), who included the category of “motorcycle experience” in a survey they used to evaluate motorcycle crash causation. Although no correlation was found at the time, Brooks and Guppy (1990) took note of this concept and advanced this line of research in a formal report that was presented at the annual Motorcycle Safety Conference. To this day, this report is still widely cited as it is one of only a small number of research endeavors that have been dedicated to this topic (Motorcycle Safety Foundation, 2000). In this report, Brooks and Guppy (1990) sought to reveal the relationship between past/current motorcycle rider experience and one’s involvement in motorcycle crash involvement in addition to defining the degree to which one’s experience influences motorcycle crash involvement. Brooks and Guppy (1990) established a framework to evaluate these hypotheses that divided motorcycle experience

into two separate categories. The first category of motorcycle experience is Technical Awareness, or the degree to which one has knowledge as to the operating characteristics and complexities and vulnerabilities involved with riding a motorcycle (Brooks, 1991; Brooks & Guppy, 1990). The second category of motorcycle experience is Social Awareness, which Brooks and Guppy (1991) defined as the degree to which one understands the relationship between motorists and motorcyclists who share the road. In order to evaluate their hypothesis, Brooks and Guppy (1990) performed multiple regression analysis on crash data statistics and results from a motorcycle experience survey, to obtain predictive criteria. What these authors found was that the single most significant variable for predicting accident involvement with a motorcycle was that of direct motorcycling experience, specifically first hand Technical Awareness. That is, actually having ridden a motorcycle and obtaining the knowledge first hand as to the intricacies of motorcycle operation was found to predict one's involvement in an accident with a motorcycle (motorist-motorcycle). The authors additionally found significant prediction from both past as well as current motorcycle experience and indicated that even those with less than 18 months direct motorcycle experience were still less likely to be involved in an accident with a motorcycle. Also noted was the long standing endurance of Technical Awareness, as there was evidence to show that the participants crash involvement continued to be minimal for up to 10 years after first being obtained. The authors concluded with an emphasis placed upon education and driver awareness campaigns directed at enhancing the knowledge base of Motorcycle Awareness throughout the population. Based on the results from this evaluation, Brooks and Guppy (1990) suggest that motorists must be made more aware as to the prevalence of

motorcycles on the road and suggest that components of motorcycle awareness be implemented into driver education courses as well as driver licensure testing, so as to reduce the overrepresentation of motorcycle accidents and motorcyclist fatalities.

In another study directed at motorist/motorcyclist behavior and accident involvement, Horswill and Helman (2003) inadvertently found similar results as those uncovered by Brooks and Guppy (1990). In this study, Horswill and Helman (2003) set out to compare motorcyclists and motorists to see if any correlations existed between behavioral attitudes and levels of accident risk (Horswill & Helman, 2001). They observed each group in a naturalistic setting and found that motorcyclists tended to take greater risks involving speed and traffic maneuvers. However all participants were additionally evaluated in a “car” driving simulator, and the authors found that those in the motorcycle group tended to have higher levels of hazard perception than those in the car group (McKenna & Horswill, 1999). Although this group markedly took more risks while riding a motorcycle, than when behind the wheel of a car, they were significantly quicker at the detection of hazards when compared to participants that had no prior or current motorcycle experience (Horswill & Helman, 2003). The authors inferred that the increased levels of hazard perception that they encountered in the motorcycle group can be generalized to overall accident involvement and motorcycle conspicuity, where they conceivably see where a correlation might potentially exist (Horswill and Helman, 2001).

One final research project directed at further establishing a correlation between motorcycle experience and accidents involving motorcycles was performed by Magazzu, Comelli and Marinoni (2006). In their article titled “Are car drivers holding a motorcycle license less responsible for motorcycle-car crash occurrence”, the authors further explored

the findings of Brooks and Guppy (1990) and attempted to link motorcycle accident involvement with motorcycle experience. In order to evaluate this correlation, the authors limited motorcycle experience to those currently licensed to operate motorcycles. Crash data from the Motorcycle In-Depth Study (MAIDS, 2006) was then analyzed using a classification and regression tree technique (CART), which generated logistic regression models. The regression analysis used, revealed that those who currently possess a motorcycle license had a significantly lower probability of being involved in a car-motorcycle crash than those who did not possess a motorcycle license (Magazzu, Comelli & Marinoni, 2006). The authors conclude that there is something inherent in the experience obtained from riding a motorcycle that ultimately reduces one's probability of being involved in an accident with a motorcycle. The findings from this research directly support the findings from both Brooks and Guppy (1990) as well as Horswill and Helman (2003).

When combined, there is significant evidence to support the concept linking motorcycling experience and familiarity with a reduced probability of motorcycle accident involvement. What has been evaluated thus far includes the evaluation of crash data by Brooks and Guppy (1990) as well as Magazzu, Comelli and Marinoni (2006) and hazard perception by Horswill and Helman (2003). This research can further be generalized to support the notion that experience and technical knowledge of motorcycles can potentially increase one's ability to detect a motorcycle on the road and be used a predictor of motorcycle conspicuity. However, what has thus been excluded from this particular type of research is the relationship between motorcycle experience and motorcycle conspicuity. This is a topic that deserves further inquiry through both lab and

field studies so as to supplement current accident data analysis and to evaluate the extent to which motorcycle experience contributed to one's ability in detecting a motorcycle on the road.

Hazard Perception

The findings obtained from the study by Horswill and Helman (2003) are unique and original in that they suggest a positive correlation exists between the operation of a motorcycle and that of Hazard Perception. This study is unique in that the findings apply the concept of hazard perception to motorcycle operation, which up to this point, is a pairing of concepts, which has not explicitly been linked. When coupled with the results obtained by Brooks and Guppy (1990) and those from Magazzu, Comelli and Marinoni (2006) who found that having operated a motorcycle leads to greater motorcycle conspicuity, it can be inferred that Hazard perception can also be linked to motorcycle conspicuity. That is, if operating a motorcycle leads to increased hazard perception and operating a motorcycle also leads to increased motorcycle conspicuity, then it can be conjectured that increased motorcycle conspicuity can be correlated with increased hazard perception.

Hazard perception has been defined as one's ability to effectively identify and detect situations within traffic that can potentially contribute to increased danger, caution, risk, or accidents (Grayson & Sexton, 2002; Haworth, Mulvihill, & Symmons, 2005; Sagberg & Bjornskau, 2006). Hazard perception has been found to correlate with driving experience and has in particular, been found to increase as a function of exposure and experience to driving in general (Haworth & Mulvihill, 2006). Hazard perception is an integral component to safe driving and is necessary for not only the detection of

dangerous situations within traffic, but the safe response and outcome as well (Haworth, Mulvihill, & Symmons, 2005). Hazard perception is extremely important for safe driving and can be viewed as one of the steps involved in the detection and response to dangerous situations encountered while driving. However, hazard perception is only one of the steps involved in the cognitive/behavioral process that is necessary for safely identifying, and responding to danger and risk when driving. Haworth and Mulvihill (2006) additionally clarify that physical characteristics of the motorcycle/motorcyclists should be viewed as an influential component of hazard perception as these are perceived as “modifying factors” in the detection-response paradigm of hazard perception. (refer to Figure 4.)

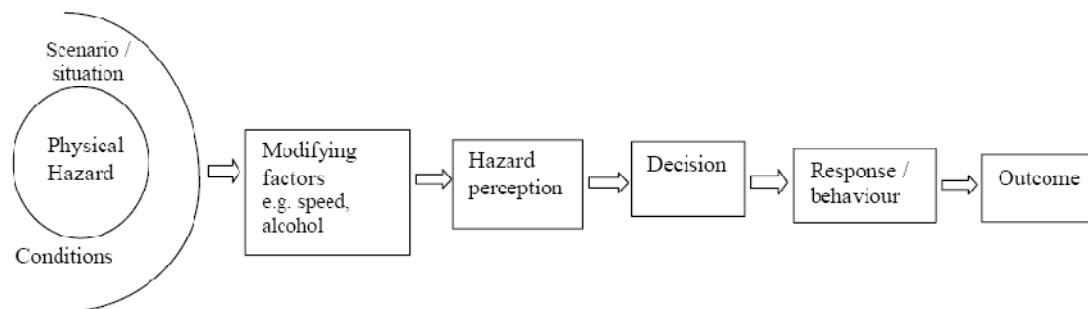

Figure 4: Model of the integral role of hazard perception in the safe detection and response to risky/dangerous/hazardous traffic situations (Haworth, Mulvihill, & Symmons, 2005).

In past research, hazard perception ability has been strongly correlated with accident involvement and crash causation (Fitzgerald & Harrison, 1999; Grayson & Sexton, 2002; Horswill & Helman, 2003; Sagberg & Bjornskau, 2006). It has been found that those who score low on hazard perception evaluations, have a higher probability of being involved in accidents (Grayson & Sexton, 2002; Horswill & Helman, 2003). Thus

hazard perception has been widely accepted as a key component to safe driving and has recently been adopted as standard criteria for driving licensure in countries such as Australia, New Zealand as well as England (Fitzgerald, & Harrison, 1999; Grayson & Sexton, 2002; Haworth, Mulvihill & Symmons, 2005). As such, there has been great effort placed toward the development of a standardized, computer based testing methodology by which one's hazard perception can be accurately assessed. The assessment of hazard perception involves the ability of a driver to detect potential hazards within the driving environment (Haworth, Mulvihill & Symmons, 2005). In the case of more recent computerized assessments, the driver completes a computer driving simulation which mimics a real-life driving situation in which various hazards are introduced, requiring the drivers' accurate detection and response (Fitzgerald & Harrison, 1999; Grayson & Sexton, 2002). This particular type of evaluation provides the instructor and driver with a cumulative hazard perception score, which can then be evaluated to determine overall driving skills. Since hazard perception has been positively correlated with accident involvement and causation, it can be seen as an important predictor to overall detection of risk on the road as well as driving safety in general.

Hazard Perception and Motorcycle Conspicuity

Hazard perception involves the effective detection of risky or hazardous situations within traffic and is an important step in safely identifying and responding to potential dangers while driving. Motorcycle conspicuity involves the safe and effective recognition and detection of a motorcycle, which can also be considered to possess characteristics which could potentially create higher levels of risk or hazard. Motorcycles in traffic have been shown to require increased levels of caution and are

incontrovertibly considered risky, dangerous and hazardous in particular contexts (Bellaby & Lawrenson, 2001; Magazzu, Comelli, & Marinoni, 2006). Hazard perception can thus be viewed as a component of motorcycle conspicuity. Hazard perception involves elements of cognition and perception such as detection, identification, recognition, decision making and situational awareness, all of which are additionally required for effective motorcycle conspicuity (Haworth & Mulvihill, 2006; Haworth, Mulvihill, & symmons, 2005; Horswill & Helman, 2003). If motorcycles are adequately associated with risk, caution, and potential hazard, as they inherently are when sharing the road, then the concept of hazard perception can be applied accordingly.

Hazard Perception – Motorcyclist versus Motorist

The operation of a motorcycle in particular is perceived to be a risky activity and to involve high levels of danger. One method to combat this high level of risk, which has been implemented by most motorcycle safety courses, is that involving explicit instruction on hazard perception and awareness (Motorcycle Safety Foundation, 2000). Aside from more recent efforts by European and Australian licensing agencies, the responsibility of hazard perception has in the past been placed exclusively on the motorcyclist, despite evidence citing a disproportionate number of accidents that have been attributed to other motorists (Motorcycle Safety Foundation, 2000; Hurt, Oullet, & Thom, 1981; Wulf, Hancock, & Rahimi, 1989). Motorcycle safety instruction goes so far as to outline hazards that are inherent in the other driver and teaches motorcyclists to have a high degree of awareness so as to avoid un-attentive, stressed, impatient drivers as well as to expect that other drivers won't see them at intersections or roundabouts (Motorcycle Safety Foundation, 2000; Haworth & Mulvihill, 2006). Many programs

teach motorcyclists to “look ahead” and expect that motorists will not see them, some going so far as to instruct motorcyclists to assume they are invisible while on the road (Motorcycle Safety Foundation, 1999). Thus far, hazard perception training has been taught extensively to motorcyclists while motorists, who have been found to be more likely at fault in accidents with motorcycles, are simply not being educated or evaluated for hazard perception, nor are they being made aware as to the risks, dangers, and hazards associated with motorcycles. In order to fully understand motorcycle conspicuity and the extent to which hazard perception influences one’s ability to effectively detect a motorcycle, this dichotomous approach to hazard perception must be evaluated and modified if necessary.

There are still many questions that remain unanswered in regard to hazard perception and motorcycle conspicuity. Since there is potentially a link between hazard perception and one’s ability to detect a motorcycle, it is necessary to examine the specifics of this particular relationship (Horswell & Helmann, 2003). Additionally there are issues surrounding hazard perception and the discrepancy between motorists and motorcyclists, where motorists appear to receive much less emphasis than do motorcyclists. It would be interesting to first examine motorist perceptions as to the risks, dangers and hazards associated with motorcycles. It would appear that motorists do not currently view nor recognize motorcycles as faster, quicker, or smaller, nor are they viewed as deserving of increased levels of risk and caution. The question now arises as to how prevalent this perspective is among motorists as well as the causative factors associated with motorists not viewing motorcycles as an increased risk, or “hazard” on the road, when it is apparent that they pose a marked degree of risk and deserve adequate

levels of caution. There is very little research that has thus far provided a significant link between hazard perception and motorcycle conspicuity, excluding the aforementioned study by Horswell & Helmann (2003). It is for this reason that additional empirical evaluation of this topic is needed for a more solid foundation on the link between hazard perception and motorcycle conspicuity. Unfortunately at this point, validated hazard perception tests are region specific and are limited exclusively to areas outside the United States such as England, Australia and New Zealand. While the driving task may be similar, there are specifics to roadway configuration, road signage, and environmental conditions that make these tests regions specific, thus the first step would involve the creation/validation of such a test that is applicable to driving in the United States.

Older Adults and Motorcycle Conspicuity

Motorcycle conspicuity has been found through research and analysis of accident statistics, to be an extremely important aspect in the safe operation of a motorcycle. Research has thus far found that motorcycle conspicuity is highly impacted by the physical characteristics of the motorcycle, cognitive characteristics of the motorist as well as attributes inherent in the individual. One such attribute that has thus far been minimally examined within the literature is the degree to which deficits brought about through chronological age influence one's ability to effectively detect a motorcycle. The question then arises as to how motorcycle conspicuity differs between older adults and younger adults and what aspects of age influence these differences. This is an extremely important topic of analysis, due to the dramatically increasing population of older adults in the coming future. It has been estimated that by the year 2030, the population of older adults will increase by more than two-thirds the current number, which will result in

more than 20 percent of the population being over the age of 65 (Dulisse, 1997; Harris, 1999; Transportation Research Board, 1999). This is of significant concern because a great deal of what is currently known within the literature suggest that as one ages, certain levels of physiology, cognition, perception and mobility decrease, which ultimately result in poorer levels of driving capability (Department for Transport, 2006; Keskinen, Ota, & Katila, 1998; Kline, Kline, Fozard, Kosnik, Schieber, & Sekular, 1992; Transportation Research Board, 1999). It is well known that certain decrements in visual and cognitive performance occur as one ages, and it can be inferred that such decrements can potentially influence one's ability to detect a motorcycle. Additionally, there is evidence to suggest that the type of accidents older adults are disproportionately involved in are those which motorcyclists are commonly overrepresented in, those which violate the right of way.

Accident Involvement

It has been reported that for cumulative miles driven, older adults have a disproportionately larger number of accidents than does any other age group (Owsley, Ball, & Sloan, 1991). Additionally, crash data has provided evidence to suggest that crash typologies for older adults vary markedly from those of younger adults (Dulisse, 1997; Hakamies-Blomqvist, 2004; Keskinen, Ota, & Katila, 1998; Lord, Smiley & Haroun 1998). On average, older adults have a disproportionately higher probability of being involved in an accident at an intersection than do younger adults (Hakamies-Blomqvist, 2004; Lord, Smiley & Haroun, 1998). Keskinen, Ota, and Katila (1998) suggest that this is directly linked to cognitive and perceptual decrements ordinarily associated with age such as reaction, attention and decision making. According to Lord,

Smiley and Haroun (1998), older adults are much more likely than younger adults to be involved in accidents related to violating the right of way of traffic, such as left-hand turn violations. Hakamies-Blomqvist (2004) state that this is largely in part due to older adults claiming they did not see the other car coming and ultimately failed to yield the right of way. This particular type of traffic violation has been reported as a highly prevalent cause of motorcycle accidents (Thomson, 1980; Williams & Hoffman, 1979). Older adults are additionally involved in a disproportionate number of accidents that involve other vehicles, and have also been shown to have a higher probability of causative attribution than do younger adults (Hakamies-Blomqvist, 2004; Keskinen, Ota, & Katila, 1998). The causes of such accidents can directly be related to aspects of the natural aging process, which inevitably results in decreased performance within areas associated with vision, cognition, perception as well as mobility (Fisk & Rogers, 1997).

Visual, Cognitive, Perceptual Changes and the Older Adult

Vision Issues

Driving is a very intense visual, cognitive, and perceptual task, but the most important sensory mechanism used in driving is unquestionably that of vision. Researchers have estimated that between 90% and 95% of information processed throughout the task of driving is inherently visual in nature (Kline, Kline, Fozard, Kosnik, Schieber, & Sekular, 1992; Owsley, Ball, Sloane, Roenker, & Bruni, 1991; Shina & Schieber, 1991). This becomes an issue with older drivers due to both the degeneration of visual function commonly encountered with age, as well as visual diseases, which are also commonly encountered as one ages (Rousseau, Lamson, & Rogers, 1998). Common physiological changes associated with vision and aging include

the yellowing of the lens, which results in a reduction of the overall amount of light that is able to reach the retina (Corso, 1981; Fisk & Rogers, 1997). This can ultimately result in disruption to color discrimination, particularly in the shorter wavelengths, such as green, violet, or blue (Shinar & Schieber, 1991). There are a variety of visual conditions associated with age that can negatively impact one's overall visual acuity, contrast sensitivity, temporal resolution, susceptibility to glare as well as peripheral vision (Noyce, 1999, Owsley, Ball, Sloane, Roenker, & Bruni, 1991). As one ages, the ability to focus on objects becomes reduced due to loss of elasticity in the lens as well as an overall reduction in receptor cells within the eye (Corso, 1981; Fisk & Rogers, 1997). This results in an overall reduction in visual acuity for both static and dynamic situations and can severely impact one's driving capability, particularly during nighttime conditions (Luoma, Schuman, & Traube, 1996). Susceptibility to glare is another issues that commonly accompanies age, where increased opacity of the lens results in a dramatic increase in the recovery time necessary from exposure to glare (Fisk & Rogers, 1997). This is particularly important in motorcycle conspicuity due to issues with motorcycle headlights and modulated headlights, where recovery times from exposure can be critical, particularly in high density traffic (Olson-Nussloch, & Sivak, 1981; Smith, 1991; Tijerina, 2003). Contrast sensitivity has also been found to decrease as one ages, where the ability to distinguish between light and dark can diminish as one gets older (Harris, 1999; Shinar & Schieber, 1991). This poses a great concern for the effectiveness of physical motorcycle conspicuity implements that strive to create contrast between motorcycle and background. An additional visual component that declines with age is the speed and accuracy with which one is able to visually scan an environment. This

process is referred to as visual search or visual localization (Shinar & Schieber, 1991). It has been found in both lab and field research that older adults take longer and are more inaccurate than younger adults in identifying specified targets that are located among distracting stimuli or within complex visual scenes, especially in dynamic environments (Department for Transport, 2006; Lord, Smiley, & Haroun, 1998; Owsley, Burton-Danner, & Jackson, 2000; Shinar & Schieber, 1991). Motorcycle conspicuity relies on the effective detection of a motorcycle within a driving environment that can potentially be very complex, with potential distractors existing such as other vehicles, pedestrians, bicycles. A component of visual search that also diminishes as one ages is the visual area with which information can be obtained, which is referred to as the Useful Field of View or UFOV (Owsley, Ball, McGwin, Sloane, Roenker, White, & Overley, 1998). To a degree, narrowing of the visual field usually accompanies age, which results in an increased inability to detect objects in the periphery, which can severely impact the detection of motorcycles. UFOV has been found to be an important component of safe driving and is primarily visual in nature, but is also related to cognitive problems associated with divided and selective attention as well as information processing.

Cognitive Issues

While vision is undeniably the most utilized sensory input in the driving process, issues associated with cognition such as memory, attention, problem solving skills and reaction time, must also be considered when evaluating the influence of aging upon motorcycle conspicuity. All of these cognitive factors influence one's ability when driving and for older adults, there is evidence to suggest that similarly to vision, certain decrements also occur for cognitive faculties (Fisk & Rogers, 1997; Masha & Shinar,

1999; Rousseau, Lamson, & Rogers, 1998; Shinar & Schieber, 1991). One particularly prevalent decline found to coincide with aging is capacity for working memory, which is also related to recognition and meaning. This function is critical for the safe operation of a vehicle within traffic and for motorcycle conspicuity, this can be even more important as many driving tasks such as left-turns require the efficient processing of relevant information for accurate decisions and responses (Noyce, 1999; Rousseau, Lamson, & Rogers, 1998). Also of concern are decreased levels of selective and divided attention performance as well as sustained attention, which have also been found to decline as one ages (Corso, 1981; Fisk & Rogers). The topic of visual search was discussed in a previous section on visual decrements and aging, and one component of visual search is the ability to concentrate on a specified target while driving. This ability to focus in on a singular target in the presence of distracting stimuli is a cognitive faculty referred to as selective attention (Harris, 1999; Fisk & Rogers, 1997). Results indicate that both the efficiency and the accuracy with which older adults are able to extract a target from a back ground decreases with age (Corso, 1981; Harris, 1999). Although selective attention is a primary component in safe driving, so too is one's ability to process multiple items at one time, or the ability to divide attention. As with selective attention, divided attention performance decreases as one ages. This is especially important in driving, where a driver must process many things at one time and in the case of motorcycle conspicuity is extremely important as a motorcycle is merely one of many items encountered within the driving process. Although it has been found that older adults utilize various methods to compensate for particular cognitive decrements, it is

important to recognize that these forms of decreased performance commonly accompany age and can potentially impact the effective detection of a motorcycle.

Mobility Issues

In addition to decreased performance in both visual and cognitive functions, older adults also suffer from decreased mobility as a result of age. Older adults in particular incur losses to muscle fiber and stiffness from ailments such as arthritis, which can reduce and limit movement (Department for Transportation, 2006; Fisk & Rogers).

Conspicuity and the Older Adult

Road Sign Conspicuity

In a study conducted by the U.S. Department of Transportation and the Federal Highway Administration, the conspicuity of roadway signs was evaluated for both younger ($M = 26$), middle aged ($M = 49$) and older adults ($M = 68$) (Dewar, Kline, Schieber & Swanson, 1997). All participants were exposed to 18 common road signs, presented randomly, one at a time in a slide type format. In a search conspicuity paradigm, participants were required to respond to whether a sign was present or not as quickly as they could. In this study, the authors examined factors associated with conspicuity such as contrast sensitivity, search time and response accuracy (Dewar, Kline, Schieber & Swanson, 1997). The authors found that older adults had a considerably longer search time for all 18 signs, than both the middle aged group and the young adult group. In this particular study, there were no significant findings related to response accuracy. The authors conclude by suggesting that the longer times measured for older adults searching for signs might be indicative of certain compensatory strategies. They suggest that older adults might compensate for certain visual and

cognitive deficiencies by taking longer to evaluate a roadway scene (Dewar, Kline, Scheiber, & Swanson, 1997).

In another study examining the relationship between age and sign conspicuity, Schieber and Goodspeed (1997) found that older participants ($M = 72$) performed markedly worse than younger participants ($M = 32$) in detecting signs with increased background complexity. The authors had participants complete a driving task in a nighttime road scene simulator who were instructed to detect a speed limit and business district sign. Both background complexity and sign brightness were varied within the simulator. The authors found no significant differences in conditions where signs were situated in conditions with low background complexity, however in conditions where signs were situated in conditions with high background complexity, older participants took significantly longer to respond. A surprising result was that as the luminance of the target sign was increased, response time for detection showed a marked decrease. The authors suggest that these findings indicate that for older adults, the negative effects caused by complex sign background can potentially be alleviated by increasing the overall brightness of the sign (Schieber & Goodspeed, 1997). However the degree to which increasing overall sign brightness can be beneficial was not indicated.

Background complexity is an important concept in the study of conspicuity and has in particular been found to correlate with motorcycle conspicuity (Cole & Hughes, 1984; Engel, 1977; Jenkins & Cole, 1982). Background complexity and conspicuity is especially an issue for older adults who potentially face certain decrements in visual performance as a result of age (Owsley, Ball, Sloane, Roenker, & Bruni, 1991). To examine this issue further, Ho, Scialfa, Caird, and Graw (2001) conducted a study where

they hypothesized that older adults ($M = 65$) would perform worse than younger adults ($M = 23$) in a sign conspicuity task as a result of increased background complexity. The authors first had participants categorize digital images of traffic scenes as either high or low in visual clutter. Participants were then presented digital images of both high/low background complexity with embedded road signs and asked to identify the presence of a particular road sign by pressing either a “present” or “absent” button. The authors found significant differences between younger and older adults, specifically that older adults took longer in the detection of road signs and were also less accurate than younger participants. Ho, Scialfa, Caird, and Graw (2001) further suggest that these results can be generalized to real life scenarios and can conceivably be used to explain why older adults might have increased difficulty detecting/identifying road signs on a busy street.

Pedestrian Conspicuity

The safety of pedestrians is a major concern and is somewhat compromised on many of today’s roads. More specifically the conspicuity of pedestrians by motorists at intersections, cross walks, and road sides is a topic often cited within the literature as a contributive to decreased pedestrian safety (Langham & Moberly, 2003). According to Wood, Tyrrell, and Carberry (2005), in the US alone, over 70,000 pedestrians sustained injury and 4,747 died in 2003, most of these occurred during nighttime conditions. This is a topic that has been discussed in previous sections of this document, however all previous research has found this to be an issue specifically pertinent to young adults. This research has exclusively evaluated young adults who are free from decrements and/or disorders associated with cognition, perception or mobility (Blomberg, Hale & Preusser, 1986; Kwan & Mapstone, 2004; Langham & Moberly, 2003; Owens &

Antonoff, 1994; Shinar, 1985). Although pedestrian conspicuity has been found to be a significant issue with young(er) adults, the effects of age on pedestrian conspicuity have been shown to be even more significant.

Luoma, Schuman, and Traube (1996) sought to explore the correlation between age and pedestrian conspicuity in a study that looked at the influence of reflector positioning on pedestrians at night. The authors tested both young ($M = 23$) and older adults ($M = 67$) and had them observe pedestrians that were placed throughout a test track. Participants were instructed to press a hand held response button as soon as they detected the presence of a pedestrian. Pedestrians were fitted with varying levels of conspicuity treatments, in this case, reflective garments. The results indicated that older adults significantly had more difficulty detecting pedestrians in all conspicuity conditions. The main finding was that older adults required more time to recognize pedestrians, which reflected in their distance to recognition, where those in the older adult group were much shorter than those in the younger adult group (Luoma, Schuman & Traube, 1996). The authors found that older adults specifically had trouble recognizing pedestrians when pedestrian movement was limited, as was the case when pedestrians were approaching the vehicle as opposed to crossing its path (Luoma, Schuman & Traube, 1996).

Wood, Tyrrell, and Carberry (2005) conducted a similar study to specifically examine the effects of age on one's ability to detect pedestrians walking on the side of the road at night. The authors had both younger adults ($M = 28$), and older adults ($M = 68$) drive on a closed circuit track where pedestrians with varying levels of conspicuity treatments were placed strategically in locations along the side of the road. Participants

were required to press a button on the dashboard as soon as they detected the presence of a pedestrian and both the probability of correct recognition and response distance were recorded. The authors found that the probability of correct recognition of pedestrians in all conspicuity conditions was significantly worse for the older adult group than the younger group. Participants in the younger adult group were found to have correctly recognized 84% of pedestrians along the track, while those in the older adult group correctly recognized only 53% (Wood, Tyrrell, & Carberry, 2005). Additionally, older adults were found to have shorter recognition distances than younger adults, where those in the older adult group recognized pedestrians at a distance that was only 58% that of the younger adult group (Wood, Tyrrell, & Carberry, 2005). These results support the findings of Luoma, Schumann and Traube (1996), who found very similar results in their study.

Although pedestrian conspicuity has been found to be a concern for pedestrians at intersections, cross walks, and during night-time conditions, of equal, if not more risk, are pedestrians employed in work zones along roads and highways. In a study conducted by Sayer and Mefford (2004), the conspicuity of work zone pedestrians at night was evaluated for both young adults ($M = 25$) as well as older adults ($M = 69$). Participants were instructed to drive a test vehicle around a test track at night, where road workers were situated in a road work zone, with various levels of conspicuity enhancing garments. Participants were instructed to indicate verbally, the moment they detected the presence of a road worker and detection distance was recorded by the experimenters. In a similar fashion to research on pedestrian conspicuity and the older adult, the authors found that those in the older adult group had significantly shorter detection distances than

those in the younger adult groups in detecting road workers (Sayer & Mefford, 2004). This result was found in all conditions, regardless of conspicuity garments. The authors suggest that road workers should be made more aware as to the limitations of older adults. The authors also suggest that road workers should also recognize that the effectiveness of current implements for increased conspicuity, such as reflective vests might potentially be limited for older drivers.

Motorcycle Conspicuity

Thus far there has been very little research published that has been dedicated to the topic of motorcycle conspicuity and the older adult. The research that has been conducted, while being valuable, is nonetheless incomplete as it only examines a segment of particular topic. Most of the research that has been conducted on this topic has dealt with the analysis of accident statistics/crash data, while there has been no empirical research obtained by lab and/or field study. One study that examined statistics on motorcycle crash involvement and the effects of age was conducted by Magazzu, Comelli, and Marinoni (2006). These authors specifically set out to develop a correlation between motorcycle operation and motorcycle accident involvement, but as a supplementary to their main objective, also evaluated the probability of age as a predictor of motorcycle crash involvement (refer to section on Experience and Familiarity). These authors examined statistics on motorist age and accident causation within a large scale compendium of European crash statistics involving motorcycles, called the Motorcycle Accident In-Depth Study (MAIDS, 2006). Through this evaluation, the authors found age to be a significant predictor of accident involvement with motorcycles. The authors also found that older adults (> 55) had a higher probability of car-motorcycle crash

causation than those in the middle adult group (22 – 54). The authors suggest that these findings significantly impact motorcycle safety and should be further investigated to assess the degree of such impact (Magazzu, Comelli, and Marinoni, 2006).

It is clearly evident that there are significant effects of age on the conspicuity of road signs, pedestrians and road workers. With age come certain decrements in visual, cognitive, perceptual, and motor abilities. All of these faculties are essential to the safe operation of a motor vehicle and specifically for the effective conspicuity of road signs, pedestrians, road workers, and motorcycles. Although there has been minimal research conducted on the relationship between age and motorcycle conspicuity, what has been found within past studies on the conspicuity of road signs, pedestrians and road workers, linking age to decreased conspicuity performance, can easily be generalized to the detection of motorcycles. When past research on age and the conspicuity of road signs, pedestrians, and road workers is combined with more recent research on motorcycle conspicuity and the older adult, it becomes apparent that there is also a correlation between age and motorcycle conspicuity. Thus far, there has only been one study specifically devoted to the topic of motorcycle conspicuity and the older adult which found age to be a significant predictor of motorcycle crash involvement/causation (Magazzu, Comelli, and Marinoni, 2006). The intentions of this dissertation are to further explore the relationship between age and motorcycle conspicuity. This dissertation will specifically assess the degree to which age influences one's ability to effectively detect a motorcycle at varying levels of conspicuity.

Evaluative Methodologies

In examining the issue of motorcycle conspicuity and evaluating the effectiveness of various implements designed to improve detection rates/accuracy by other motorists, researchers have used a variety of testing methodologies. These methodologies can generally be divided between statistical accident analysis, experimental laboratory trials, experimental field studies and naturalistic observations (Cole & Hughes, 1984; Cole & Jenkin, 1980; Hole, Tyrell & Langham, 1996; Kooi & Toet, 1999; Langham, 1999; Langham & Moberly, 2003; Thomson, 1982). Many of the aforementioned studies have relied upon metrics dealing with search and reaction time, recall, verbalizing what was seen and using subjective ratings such as perceived distance, visibility and speed. Some older experiments relied upon images of motorcycles presented in the periphery on tachistoscopes or slides where the participants were required to report whether having seen a motorcycle or not after the experiment was over (Langham, 1999). Aside from generalizability issues regarding the ecological validity of using slides and static images as well as employing memory as a factor, these studies have provided a clearer understanding of motorcycle conspicuity (Thomson, 1982). Additional studies have been based on the evaluation of attention conspicuity where the participant was within a vehicle driving in a designated area and after the experiment, they were asked if they had seen a motorcyclist which was strategically positioned (Wulf, Hancock & Rahimi, 1989). The authors suggest that these types of testing paradigms lack validity and that certain confounding variables were not accounted for. An additional method whereby a seeming sense of ecological validity remains intact is that employed by Williams and Hoffman (1977), which has previously been described. This study is unique because unlike many

others, it is a field study that actually uses motorcyclists and tests real world driving situations such as those over-represented by motorcycle-conventional vehicle accidents. Unfortunately, this particular study has its drawbacks and has been criticized as not representing a real traffic scenario, since the participants were situated in search conspicuity paradigm. Thomson (1982) claims that this type of situation is not real and sets the participants up for what to expect, which is unlike what is usually encountered when driving. One of the most popular methods for evaluating conspicuity is through the use of the gap-acceptance technique as previously described and employed by Olson, Halstead-Nussloch, & Sivak (1981). These types of tests are usually configured so that conspicuity is measured by the participant's decision to either accept or reject a pre-determined space between a car and motorcycle as adequate to perform the maneuver required. That is, the participant must decide whether it is safe to merge into traffic or not. Although it would seem that these types of metrics adequately measure conspicuity, Thomson (1982) has a rather negative critique of these methods suggesting a lack of visual realism and the presence of confounding variables that are unaccounted for. Most of these studies, however, especially some of the early paradigms using slides and tachistoscopes, could potentially be made much more visually realistic through the use of more modern high definition recording/playback equipment for the reproduction of traffic scenes. One of the major critiques of these early studies is that they lacked visual realism and visual fidelity due to the technology available at the time, but it is highly possible that this could be remedied through the use of modern day equipment for both recording and playback. One solution to these early inadequacies would be to utilize technology brought forth through high definition recording and playback, which provides

dramatically increased quality of picture, clarity and contrast. Some high definition systems are even able to provide a brightness ANSI level up to 12,000 lumens, a resolution of up to 1920 x 1080 pixels and a contrast ratio of 2000:1 (Christie, 2006). Comparative to systems used in earlier studies, the use of high definitions systems could potentially solve many issues associated with contrast and visual realism, thus increasing ecological validity to a much higher level than previous studies.

METHOD

Participants

Seventy-five male and female participants took part in this experiment. This experiment included three groups of equal numbers (25) that were separated by age. One group of younger adults (18 – 35 yrs), one of middle aged adults (40 – 55 yrs), and one of older adults (65 yrs and above) participated in this study. All participants were screened for visual acuity, using a STEREO OPTEC 2000 vision testing system, where only participants with 20/40 (corrected or uncorrected) for far visual acuity were included. Additionally, participants completed a static contrast sensitivity test, where only those who fell within the population norm were retained for this study (refer to Appendix B). Participants were also screened for cataracts and/or other visual impairments/conditions/diseases prior to participation as well as mobility issues that might potentially impair driving (Appendix A). Only participants who were free from visual impairments/conditions/diseases (which affect driving) in addition to mobility issues (which affect driving) were included. All participants were also screened for motorcycle experience (Appendix A). Only participants without prior first hand motorcycle experience were included in this study. Motorcycle experience was defined in this experiment as current/past operation of a motorcycle or moped and/or close relations with an individual with current/past experience operation of a motorcycle or moped (refer to Appendix A). Participants in the younger adult group were granted “Experimental Course Credit” and \$20 for their participation and those in the middle aged and older adult group were granted \$20 remuneration for participating in this experiment.

Materials

Video Recording and Presentation

This experiment used dynamic video clips of a real road-way, captured using a Sony HDR-FX1 High Definition Video Recording system in HDV format at a resolution of 1080i (1440x1080). Video clips were captured on a closed, four-way intersection located in the Central Florida area, which was surrounded by buildings/trees and grass on each side (Appendix F). All video was captured on a single cloudless, sunny day, between 2:00 pm and 3:00 pm in the afternoon. The video camera was attached to a stable tripod positioned as closely to the drivers' perspective as possible (facing on-coming traffic). The test vehicle was positioned in the left hand turning lane, as if preparing to turn left (Appendix F). Each video segment from each test condition (i.e. lights on/off/modulated) was recorded on the same portion of roadway, under the same conditions on the same day. The overall illumination was evaluated using a GOSSEN PANLUX electronic footcandle meter. The contrast between motorcycle and background was recorded, using a MINOLTA LS-110 spot metering system, to ensure consistency across all conditions. There was a total of 12 test conditions (motorcycle present), each 3 seconds long, which were looped in a randomized order among 12 non-test conditions (motorcycle absent). Non-test conditions consisted of the following: 4 pedestrian video clips (motorcycle absent), 4 traffic cone clips (motorcycle absent), 2 regular traffic clips, 2 empty road clips. Each of the 12 test conditions were presented four times (randomized) for a total of 48 test condition video clips. Traffic clips consisted of ordinary traffic on the same segment of road (motorcycle absent). Pedestrian clips consisted of a pedestrian crossing the street via the crosswalk (motorcycle absent). Each

of the video clips (motorcycle present/motorcycle not present) were 3 seconds in length. Participants were instructed to place their hand on the bottom of the steering wheel of the simulator and to watch for the following hazards: pedestrians, motorcycles, and traffic cones. Participants were also instructed to place their hand on the bottom of the steering wheel prior to each video clip, and to continue holding it in this position until a target is detected. Participants were instructed to press the YELLOW button located in the middle of the steering wheel when they detected a target. Participants were also instructed to identify what they saw as either a motorcycle, a pedestrian, or traffic cones by pressing the appropriate button on the handheld remote control (refer to Appendix H). If a participant saw a motorcycle they pressed the BLUE button, if they saw a pedestrian they pressed the GREEN button, and if they saw traffic cones, they pressed the RED button (refer to Appendix G, H). The detection of traffic cones and pedestrians were not used for evaluation, but rather intended to minimize participant expectation for motorcycles and increase external validity by more closely matching the tasks of this simulation to those of real driving. Participants were presented with a blank “visual noise” slide between video clips. The blank slide contained a background of “visual noise” and a green fixation point located directly in the middle of the screen.

Post processing of video capture was attained using SONY VEGAS 7.0c. All video clips were presented in digital format using a custom designed, Multi-Media Desktop Computer, with a Dual Core Pentium D processor rated at 3.6 GHZ (per processor) with 2 GB of RAM installed, running Windows XP. This computer system was equipped with a Nvidia GeForce 7300 512MB PCI-e Video card with one DVI output and one VGA output for dual output to the simulator system and to the operator

control console. Video was presented using a GE PatrolSim II+ driving simulator (refer to Appendix G). This particular driving simulator has a steering wheel, brake pedal, full dash, full driving controls, and is set up to replicate the interior of a 1995 Ford Crown Victoria. This particular driving simulator was equipped with a high definition Samsung Multimedia Rear Projection monitor HLT5075S rated at a resolution of 1280 x 720 with a contrast ratio of 2,500:1 (Samsung, 2007).

Motorcycle and Conspicuity Conditions

The motorcycle that was used in this experiment was a black 2006 Triumph Bonneville T100 motorcycle (APPENDIX I). The motorcyclist was dressed in all flat black protective clothing and helmet. The motorcycle was fitted with a standard H4, 45W low beam halogen dipped headlight. The motorcycle traveled at a consistent speed of 25 miles per hour in the opposite lane of traffic for all experimental conditions. There were 12 experimental conditions used in this study. The 12 experimental conditions were as follows (refer to Appendix K for more detail):

Motorcycle Only:

1. Motorcycle Headlight-OFF
2. Motorcycle Headlight-ON
3. Motorcycle Headlight-Modulated

Motorcycle + Vehicle:

4. Motorcycle Headlight-OFF/Vehicular-DRL-OFF
5. Motorcycle Headlight-ON/Vehicular-DRL-OFF
6. Motorcycle Headlight-Modulated/Vehicular-DRL-OFF

Motorcycle + Vehicle w/Headlights:

7. Motorcycle Headlight-OFF/Vehicular-DRL-ON (Low)
8. Motorcycle Headlight-ON/Vehicular-DRL-ON (Low)
9. Headlight-Modulated/Vehicular-DRL-ON (Low)

Motorcycle + Vehicle w/DRLs:

10. Motorcycle Headlight-OFF/Vehicular-DRL-ON (Dedicated)
11. Motorcycle Headlight-ON/Vehicular-DRL-ON (Dedicated)

12. Headlight-Modulated/Vehicular-DRL-ON (Dedicated)

For the headlight-modulated condition, the motorcycle was fitted with a “KISAN Technologies P115W Pathfinder” Single headlight modulator kit, which is factory set at a modulation of 4 HZ and complies with The United States, Department of Transportation, National Highway Transportation Safety Administration, Sec. 571.108 Standard No. 108 of the Federal Motor Vehicle Standards (refer to Appendix J, Kisan, 2006; NHTSA, 2006). For the headlight-OFF/Vehicular-DRL-OFF, headlight-ON/Vehicular-DRL-OFF and Headlight-Modulated/Vehicular-DRL-OFF conditions, the motorcycle was trailed by a 2006 Chevrolet TrailBlazer SUV without any daytime running lights. For the headlight-ON/Vehicular-DRL-ON(Low) and Headlight-Modulated/Vehicular-DRL-ON (Low) conditions, the motorcycle was trailed by a 2006 Chevrolet TrailBlazer SUV equipped with L/R Daytime Running Lights (standard Low Beams), each rated at 45W. For the headlight-ON/Vehicular-DRL-ON(DEDICATED) and Headlight-Modulated/Vehicular-DRL-ON (DEDICATED) conditions, the motorcycle was trailed by a 2006 Chevrolet TrailBlazer SUV equipped with L/R Dedicated Daytime Running Lights (reduced wattage Low beams rated at 25W (250cd). The 2006 Chevrolet TrailBlazer SUV used in this study was Dark Burgundy in color. This vehicle followed at a consistent distance of 25ft for all vehicle following conditions. In order to accurately ensure distance across all conditions, a Leica Disto A8 Laser Distance Meter was affixed to the vehicle dash, calibrated accordingly and used to monitor distance (Leica Geosystems, 2007).

Procedure

Each participant was tested individually. The experimenter explained to participants that the intentions of the study were to identify potential hazards that might be encountered while driving. Participants were then tested for visual acuity, contrast sensitivity and were required to fill out a past driving history questionnaire with embedded questions related to motorcycle experience as well as visual impairments which might potentially affect driving ability (refer to Appendix B). These questions were asked to ensure that participant information obtained during recruitment was accurate. Participants were then asked to complete a hazard perception questionnaire (included in driving habits questionnaire) where they were required to select potential objects from a list that they perceive to pose a possibility of hazard and/or risk while driving (refer to Appendix B). The driving habits questionnaire was used primarily to document participant driving background and as a screening tool for exclusion of participants who did not meet criteria or who were found to be outliers. The hazard perception questionnaire was used to supplement the “distractor” task paradigm and to reinforce the idea that participants would be looking for “hazards” as opposed to exclusively motorcycles. Participants were also required to complete a motion sickness history questionnaire (MHQ) to determine their susceptibility to motion sickness (Kennedy, Fowlkes, Berbaum, & Lilienthal, 1992; refer to Appendix C). Those who scored “high” on the MHQ were notified of their susceptibility to motion sickness and dismissed from the study without penalty. All participants were notified that they would be allowed to withdraw at any time throughout the study, for any reason, without penalty.

At this point, participants were asked to seat themselves within the driving simulator and to prepare as if they were about to take the vehicle for a drive. The experimenter then explained to participants that they were about to watch a series of short video clips of road-way traffic and that they would be allowed to take a short break every 5 minutes or sooner if desired. The experimenter then explained to participants that once each of the video clips begins, they were to place their hand on the bottom of the steering wheel and observe the roadway for all hazardous situations such as pedestrians, motorcycles and “ORANGE” traffic cones. Participants were then instructed to press a “YELLOW” button on the steering wheel as quickly as they can, whenever they detect a target. Participants were then shown a screen with the following text: “*Please Identify what you just saw*”. This screen included pictures of a motorcycle, pedestrian, and traffic cones, which were each associated with a colored button on the button box. Participants were instructed to select what they had seen by using a remote button box with color coded buttons (refer to Appendix H). That is, if a participant saw motorcycle they were instructed to press the BLUE button, if they saw a pedestrian, to press the GREEN button, and if they saw traffic cones, to press the RED button (refer to Appendix H). Participants were also told that between video clips, they will see a 5 second slide, which contains a GREEN fixation point, located in the middle of the screen. Participants were instructed to focus their visual attention on the green dot between video clips and to place their hand on the bottom of the steering wheel until they detected a motorcycle, pedestrian, or traffic cones. Prior to the test conditions, participants were given a series of 24 randomized practice trials. The practice trials contained 12 clips where

motorcycles were present and 12 clips where motorcycles were not present. The practice trials included the following 12 conditions where a motorcycle was not present.

- 1) Traffic 1 (cross traffic)
- 2) Traffic 2 (oncoming traffic)
- 3) Pedestrian 1
- 4) Pedestrian 2
- 5) Pedestrian 3
- 6) Pedestrian 4
- 7) Traffic Cone 1
- 8) Traffic Cone 2
- 9) Traffic Cone 3
- 10) Traffic Cone 4
- 11) Empty Roadway
- 12) Empty Roadway

The practice trials also included the following 12 conditions where a motorcycle was present:

Motorcycle Only:

1. Motorcycle Headlight-OFF
2. Motorcycle Headlight-ON
3. Motorcycle Headlight-Modulated

Motorcycle + Vehicle:

4. Motorcycle Headlight-OFF/Vehicular-DRL-OFF
5. Motorcycle Headlight-ON/Vehicular-DRL-OFF
6. Motorcycle Headlight-Modulated/Vehicular-DRL-OFF

Motorcycle + Vehicle w/Headlights:

7. Motorcycle Headlight-OFF/Vehicular-DRL-ON (Low)
8. Motorcycle Headlight-ON/Vehicular-DRL-ON (Low)
9. Headlight-Modulated/Vehicular-DRL-ON (Low)

Motorcycle + Vehicle w/DRLs:

10. Motorcycle Headlight-OFF/Vehicular-DRL-ON (Dedicated)
11. Motorcycle Headlight-ON/Vehicular-DRL-ON (Dedicated)
12. Headlight-Modulated/Vehicular-DRL-ON (Dedicated)

The contents of each video clip were explained to participants and participants were allowed to ask questions at this point prior to the actual test. When all questions

were answered and participants adequately understood the process, the experimenter initiated the test conditions and commenced the experiment.

RESULTS

A mixed model 2 (Sex) x 3 (Age) x 3 (Motorcycle Conspicuity Treatment) x 4 (Vehicle Following Condition), multivariate Analysis of Variance (MANOVA) was performed using SPSS 15.0, where data was analyzed at the .05 level unless otherwise stated. Both Sex (male/female) and Age (young, middle, older) were analyzed as between subjects variables (refer to Table 1 for Demographic Data). Motorcycle Conspicuity Treatment (No Headlights/DRL/Modulated Headlights) and Vehicle Following Condition (No Veh/Veh. No Headlights/Veh.Low Headlights/Veh.DRL) were all evaluated as within subjects variables. The dependent variable was Reaction Time for all conditions evaluated. Additionally, hits, misses, and false alarms were calculated across all conditions. There was an extremely low number of misses (.2%) and False Alarms (.6%) and this data was excluded from further analysis.

All Reaction Time data was evaluated for normality, homogeneity of variance and sphericity prior to formal analysis. This analysis revealed moderate levels of positive skew for each of the Dependent Variables (Reaction Time scores). Although positive skew is a common outcome associated with reaction time measures (McCormack & Wright, 1964), in order to better accommodate the assumptions of MANOVA, all data within each of these DV's was transformed using a Logarithmic Transformation(Log10). Wilks' Lambda was used for interpretation of all multivariate tests of significance unless otherwise noted.

Table 1: Participant Demographic Data

Age Group	Sex	M	SD	N
Young Adult	Male			13
	Female			12
	Total	20.92	3.24	25
Middle Adult	Male			10
	Female			15
	Total	46.28	5.26	25
Older Adult	Male			14
	Female			11
	Total	70.24	5.23	25
Total	Male	46.65	21.96	37
	Female	45.00	19.85	38
	Total	45.81	20.79	75

Multivariate tests revealed 4 significant main effects for Age, Sex, Motorcycle Conspicuity Condition and Vehicle Following Condition. These results suggest that there was significant main effect found for both of the between subjects variables, Age, $F(2, 69) = 10.40, p. < .005, \text{partial } \eta^2 = .086$ and for Sex, $F(1, 69) = 9.372, p. < .005, \text{partial } \eta^2 = .086$. The results also indicate a main effect for the 4 vehicle following conditions, Wilks' Lambda, $F(3, 67) = 15.51, p. < .005, \text{partial } \eta^2 = .410$. Additionally, these results indicate a significant main effect for the 3 motorcycle conspicuity conditions, Wilks' Lambda, $F(2, 68) = 3.19, p. < .05, \text{partial } \eta^2 = .086$. There were also a variety of interaction effects found between motorcycle conspicuity conditions and vehicle following conditions Wilks' Lambda, $F(6, 64) = 6.96, p. < .005, \text{partial } \eta^2 = .395$. Specifically, an interaction effect was found between motorcycle conditions (all 3 collapsed) and the presence of a following vehicle without lights $F(1, 69) = 42.72, p. < .005, \text{partial } \eta^2 = .382$. Additionally an interaction effect was found between the motorcycle conditions with DRLs or Headlight Modulators and those with a vehicle following in general (all 3 vehicle conditions collapsed) $F(1, 69) = 21.19, p. < .005,$

partial $\eta^2 = .235$. An interaction effect was also found between conditions where a motorcycle with DRLs or Headlight Modulators was followed by a vehicle with DRLs or Low Beam headlights $F(1, 69) = 10.77, p. < .005, \text{partial } \eta^2 = .135$.

Main Effects

Multivariate analysis was performed and revealed 4 significant main effects for the following variables evaluated in this experiment: Age, Sex, Motorcycle Conspicuity Condition and Vehicle Following Condition.

Differences by Age (Young/Middle/Older).

These results suggest that there was a significant main effect found for the between subjects variable, Age, $F(2, 69) = 10.40, p. < .005, \text{partial } \eta^2 = .086$. A planned pairwise comparison was subsequently conducted to clarify this result and Age was found to significantly affect reaction time measures where younger adults ($M = 886.72, SD = 165.99$) were found to be significantly faster than middle aged adults ($M = 984.90, SD = 169.27$) at a level of $p < .05$ across all conditions (refer to Figure 5, Table 2). This analysis also revealed that younger adults ($M = 886.72, SD = 165.99$) were significantly faster than older adults ($M = 1100.01, SD = 167.06$) at a level of $p < .005$ across all conditions (refer to Figure 5, Table 2). Additionally the results indicate that middle aged adults ($M = 984.90, SD = 169.27$) were significantly faster than older adults ($M = 1100.01, SD = 167.06$) at a level of $p < .05$. This trend was found to be similar for all motorcycle conspicuity and following vehicle conditions evaluated (refer to Figure 6, 7).

An independent samples t-test was also conducted between the young and older adult groups to provide more detail on the specific conditions between motorcycle-

ON/Vehicular DRL-ON. The results revealed a significant difference between the two age groups for this particular condition $t(48) = -3.21, p = .002$

Table 2: Age Differences

AGE	N	Mean	Std. Error	SD
YOUNG	25	886.716	33.197	165.99
MIDDLE	25	984.897	33.854	169.27
OLD	25	1100.011	33.412	167.06

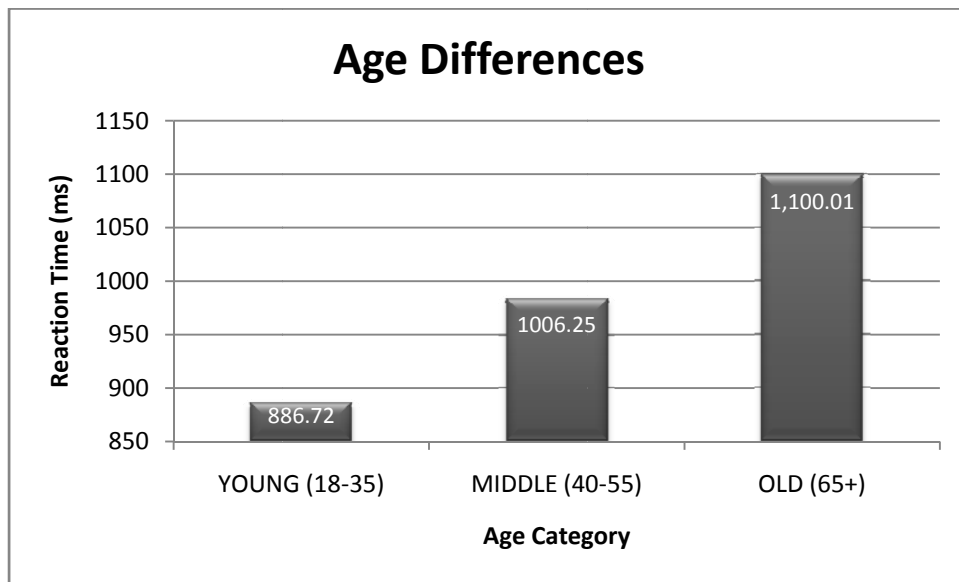

Figure 5: Age Differences

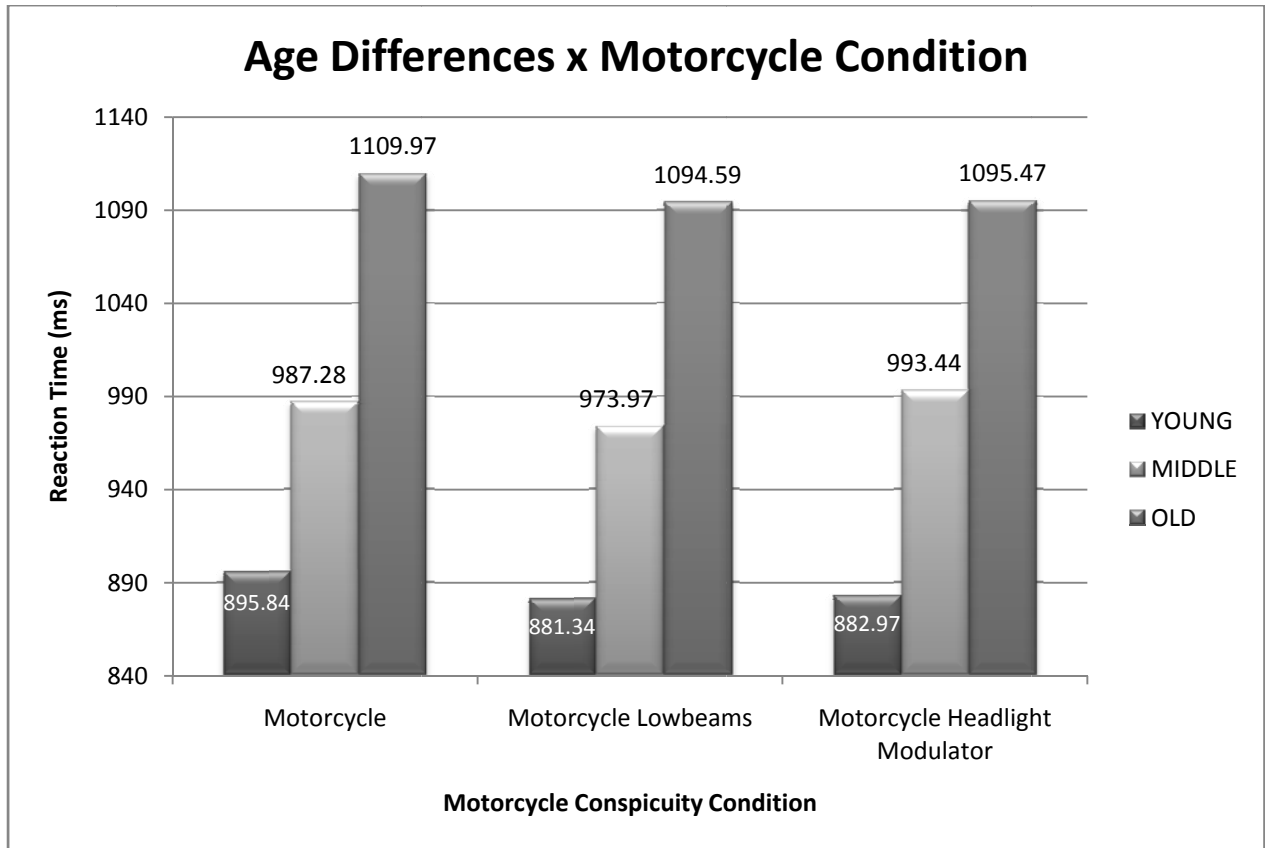

Figure 6: Age Differences x Motorcycle Conditions

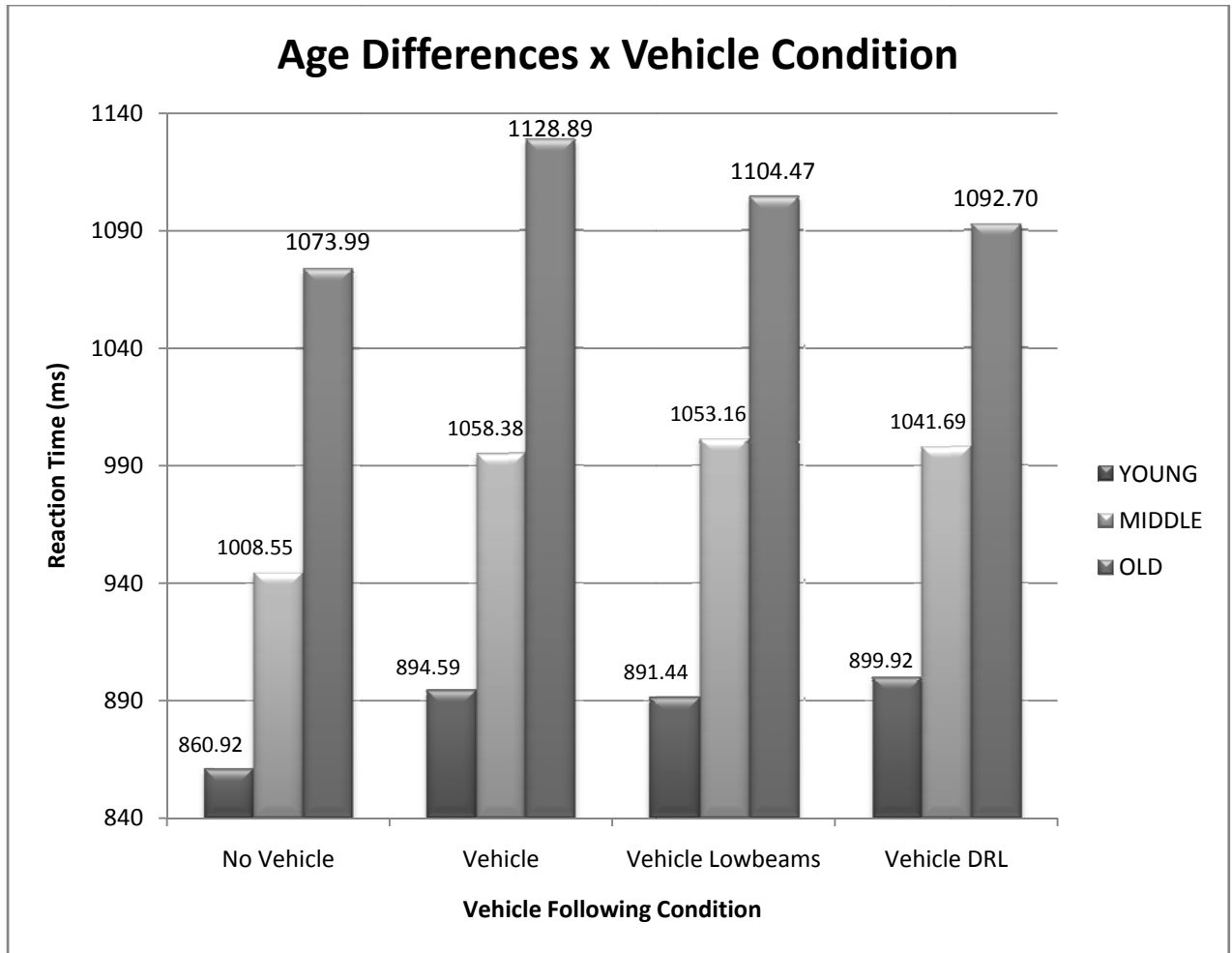

Figure 7: Age Differences x Vehicle Conditions

Differences by Sex (Male/Female)

Analysis also revealed that participant sex (male/female) was found to be a significant factor in the detection time of motorcycles $F(1, 69) = 9.372, p < .005$, partial $\eta^2 = .086$. To better understand the level of significance between these two groups, a pairwise comparison was conducted between males and females. This analysis showed that males ($M = 940.64, SD = 167.58$) were significantly faster at detecting motorcycles than females ($M = 1040.45, SD = 167.27$) throughout all conditions evaluated at a $p < .005$ level (refer to Figure 8, Table 3)

Table 3: Differences by Sex

Sex	Mean	Std. Error	SD
MALE	940.637	27.550	167.58
FEMALE	1040.446	27.135	167.27

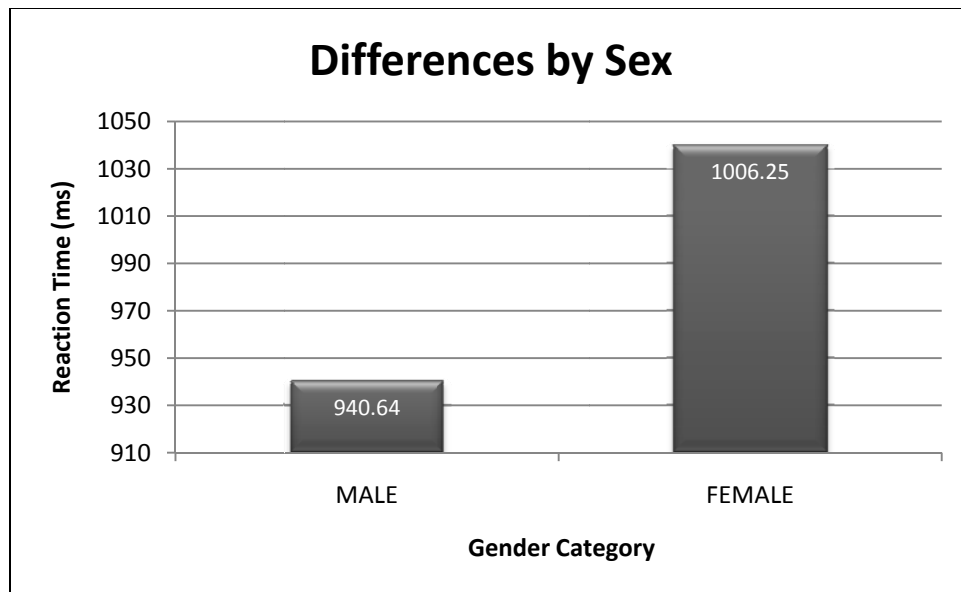

Figure 8: Differences by Sex

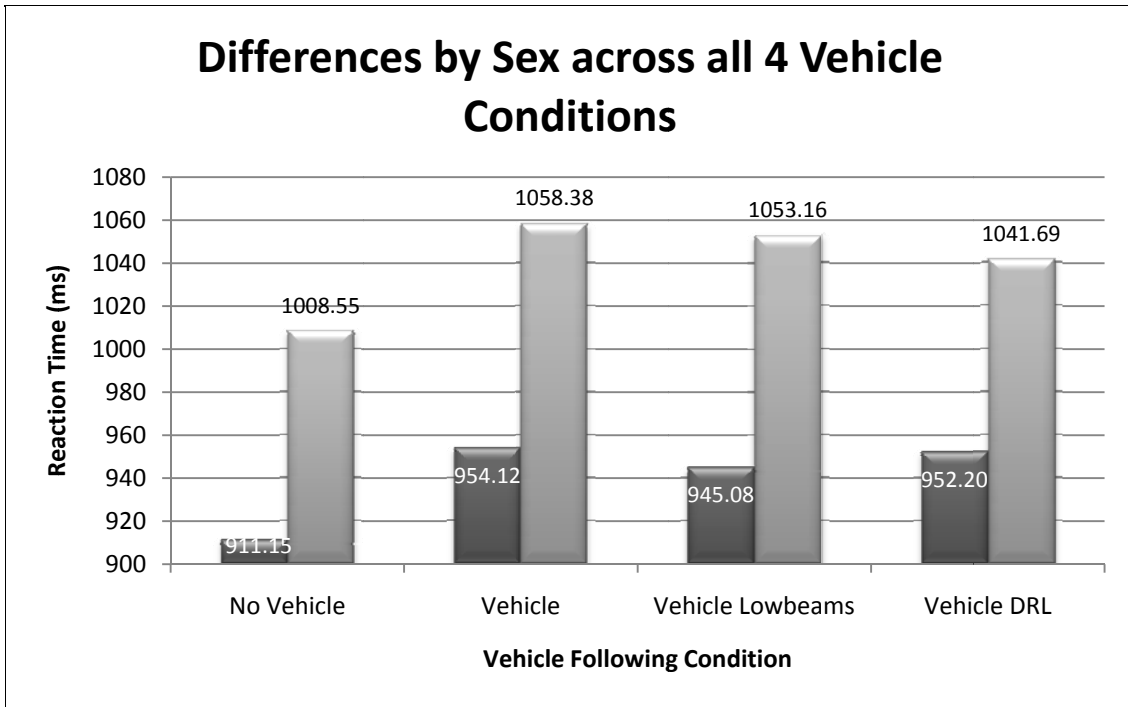

Figure 9: Differences by Sex – Trend across all 4 vehicle conditions

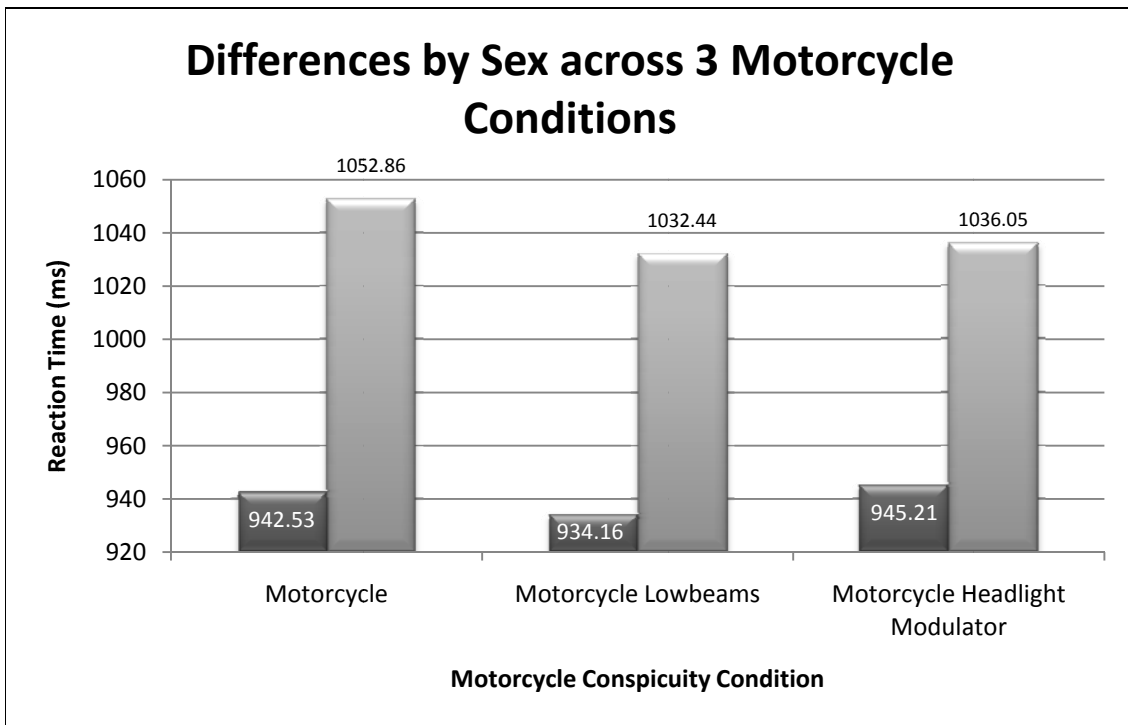

Figure 10: Differences by Sex – Trend across all 3 motorcycle conditions

Motorcycle Conspicuity Conditions

These results additionally indicated a significant main effect for the 3 motorcycle conspicuity conditions, Wilks' Lambda, $F(2, 68) = 3.19$, $p < .05$, partial $\eta^2 = .086$. In order to further explain the significant main effect found for the motorcycle conspicuity conditions, a planned pairwise comparison was conducted and revealed a significant difference between the motorcycle "no lights" condition ($M = 997.70$, $SD = 171.32$) and the motorcycle with DRL (Low Beams) condition ($M = 983.30$, $SD = 171.53$) at the $p = .05$ level (refer to Table 4 and Figure 11).

Table 4: Motorcycle Conspicuity Treatment

Motorcycle Condition	Mean	Std. Error	SD
Motorcycle	997.6957	19.78247	171.32
Motorcycle DRL	983.2994	19.80707	171.53
Motorcycle Modulator	990.629	19.72597	170.83

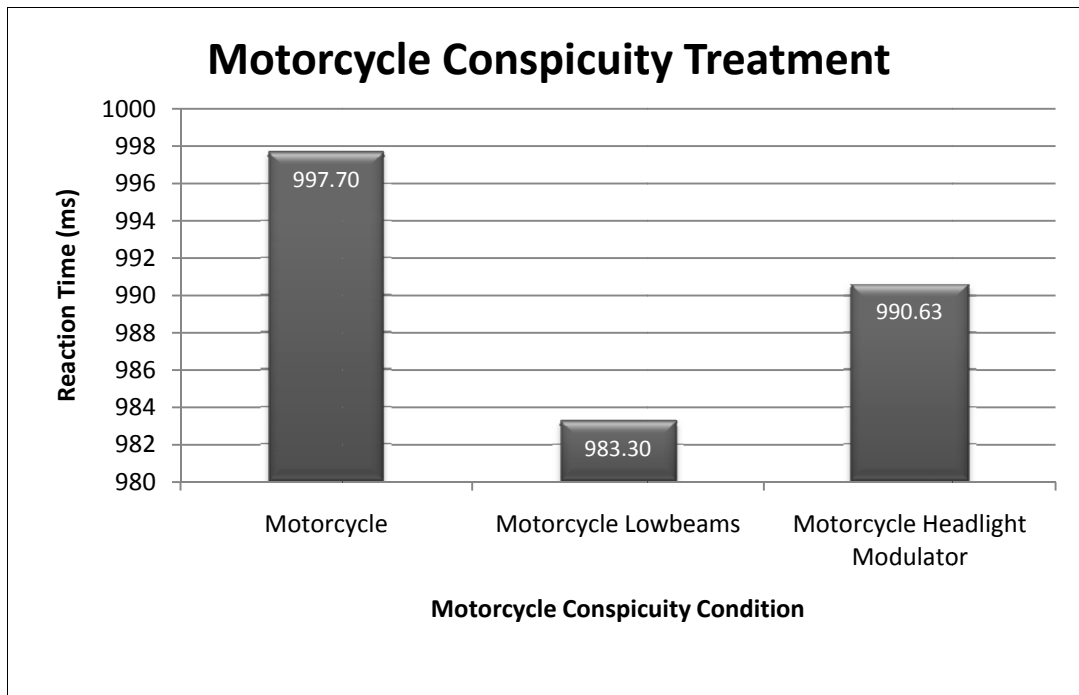

Figure 11: RT at 3 Motorcycle Conspicuity Treatment Conditions

Vehicle Following Conditions

The results also indicated a significant main effect for the 4 vehicle following conditions evaluated in this study, Wilks' Lambda, $F(3, 67) = 15.51, p. < .005$, partial $\eta^2 = .410$. In order to better understand this significance, a planned pairwise comparison was carried out. This analysis revealed a significant difference between motorcycle conditions without a vehicle ($M=959.85, SD=162.47$) compared to those where a vehicle was present ($M=1006.25, SD=189.20$), those with a vehicle with Low Beam headlights ($M=999.12, SD=173.45$), and those with vehicles with DRLs ($M=996.94, SD=166.44$) (refer to Table 5, Figure 12).

Table 5: Vehicle Following Conditions

Vehicle Condition	Mean	Std. Error	SD
No Vehicle	959.847	18.761	162.47
Vehicle Present	1006.253	21.847	189.20
Vehicle w/Low Beams	999.121	20.028	173.45
Vehicle w/DRL	996.944	19.219	166.44

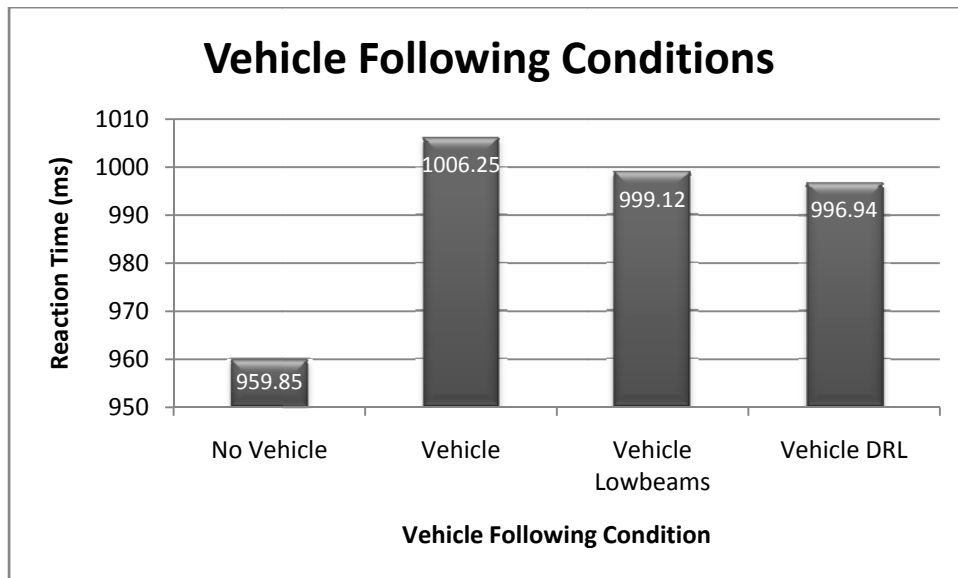

Figure 12: Vehicle Following Conditions

Interaction Effects

Motorcycle Conspicuity Condition x Vehicle Following Condition

The results from this study also revealed a significant interaction effect between the Motorcycle Conspicuity Treatment Conditions and conditions where a Vehicle was Following. The results suggest that the interaction between these two variables significantly influences one's ability to detect a motorcycle, Wilks' Lambda, $F(6, 64) = 6.96$, $p < .005$, partial $\eta^2 = .395$ (refer to Figure 13, 14).

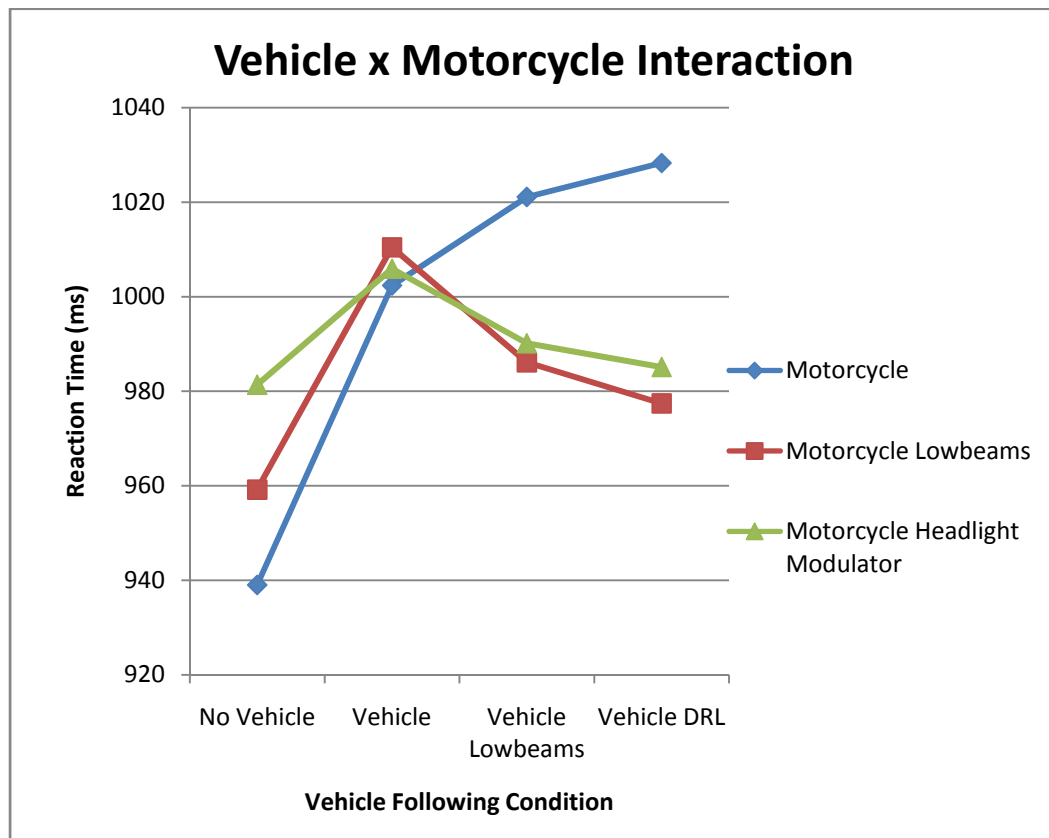

Figure 13: Vehicle x Motorcycle Interaction

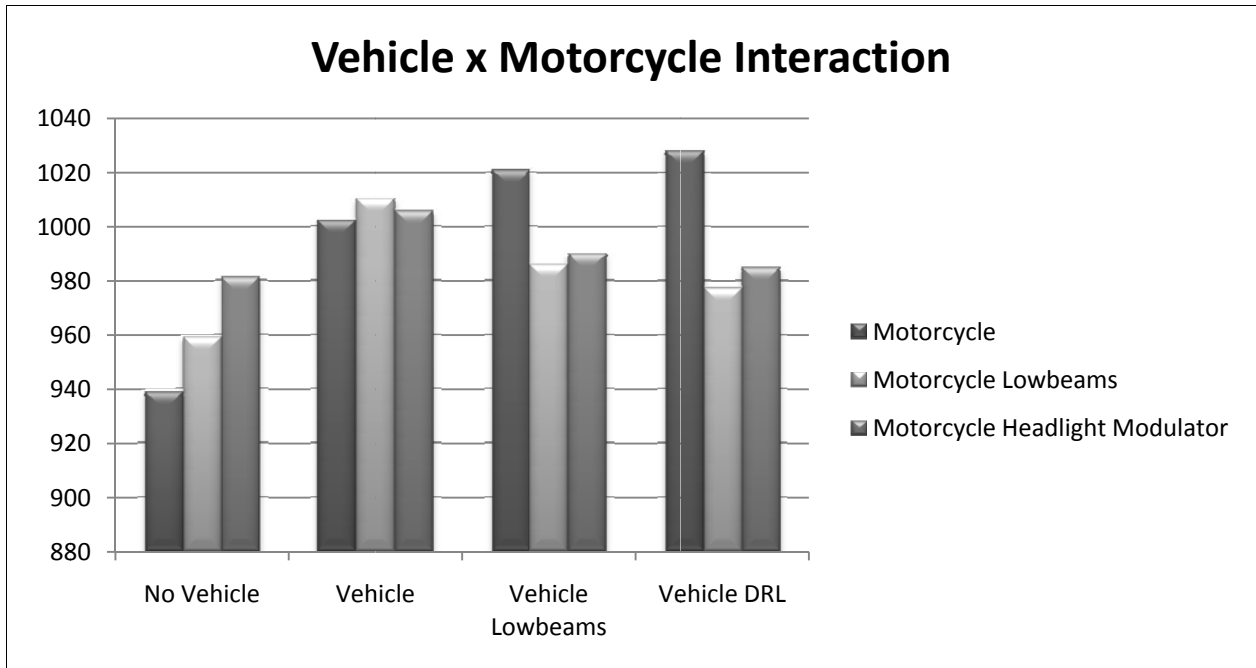

Figure 14: Vehicle x Motorcycle Interaction (All 4 Vehicle Following Conditions)

These multivariate effects were further explained through the use of an orthogonal planned contrast comparison. When motorcycle conditions were collapsed this analysis showed that the general presence of a following vehicle behind a motorcycle significantly decreased ones reaction time in detecting a motorcycle $F(1, 69) = 42.72, p. < .005,$ partial $\eta^2 = .382$ (refer to Figure 15, 16, and Table 6).

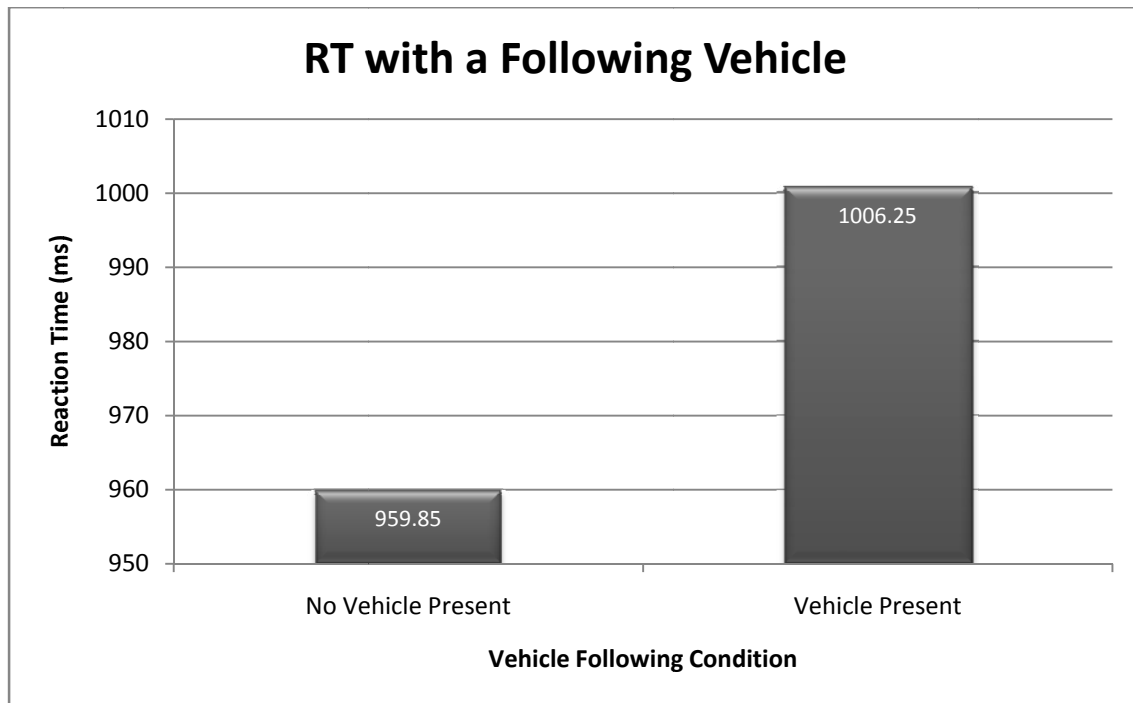

Figure 15: RT with a Following Vehicle

More specifically, this analysis showed that when all 3 vehicle following conditions were collapsed (vehicle following in general), a motorcycle with DRLs or Headlights Modulated is more quickly detected than a motorcycle without headlights On or without headlights modulated $F(1, 69) = 21.19, p. < .005, \text{partial } \eta^2 = .235$ (refer to figure 16).

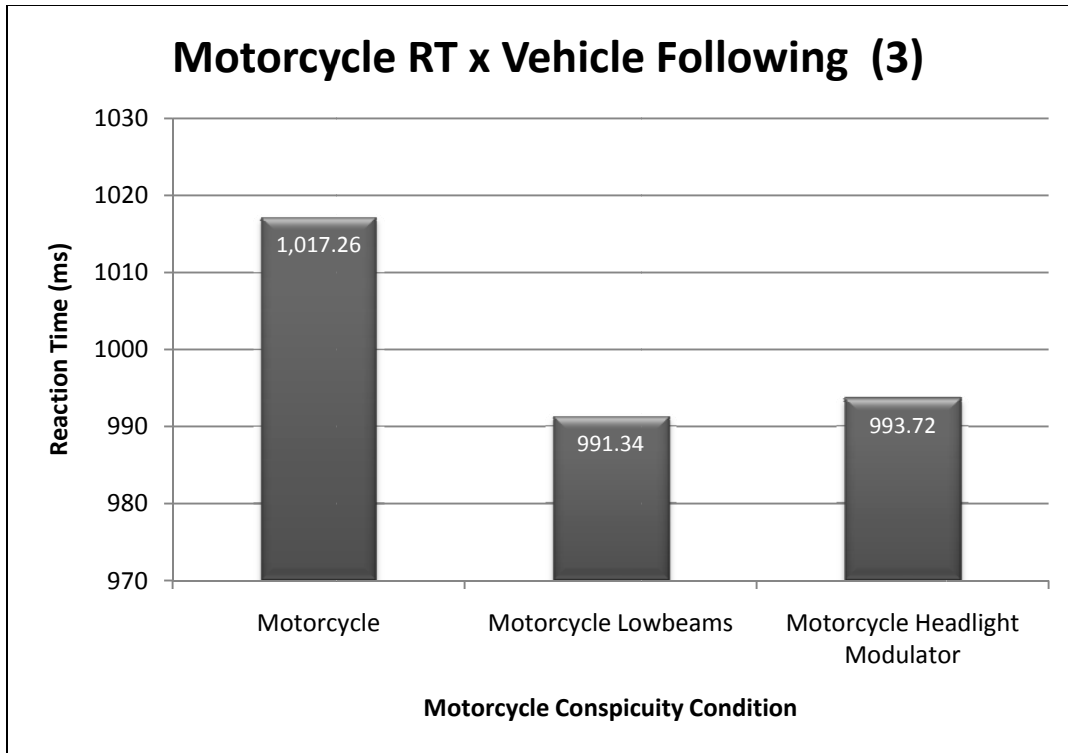

Figure 16: Motorcycle Reaction Time x Vehicle Following Conditions (collapsed)

An interaction effect was also found between conditions with a motorcycle running DRLs or a Modulator and the presence of a following vehicle with either its DRLs or Headlights On. The results suggest that when followed by a vehicle with Low Beams, or DRLs on, a motorcycle that has its Headlights On or Headlights Modulated is more quickly detected than a motorcycle without headlights On/Modulated $F(1, 69) = 10.77, p. < .005, \text{partial } \eta^2 = .135$ (refer to Figure 17, Table 6).

Table 6: Vehicle/Motorcycle Interaction – Descriptive Statistics

Vehicle Condition	Motorcycle Condition	Mean	S.E.	S.D.
Vehicle Low Beams	Motorcycle	1021.102	22.13	191.65
Vehicle Low Beams	Motorcycle Low Beams	986.1241	21.95	190.09
Vehicle Low Beams	Motorcycle Headlight Modulator	990.1357	19.63	170.00
Vehicle DRL	Motorcycle	1028.296	20.14	174.42
Vehicle DRL	Motorcycle Low Beams	977.4271	20.19	174.85
Vehicle DRL	Motorcycle Headlight Modulator	985.11	20.10	174.07

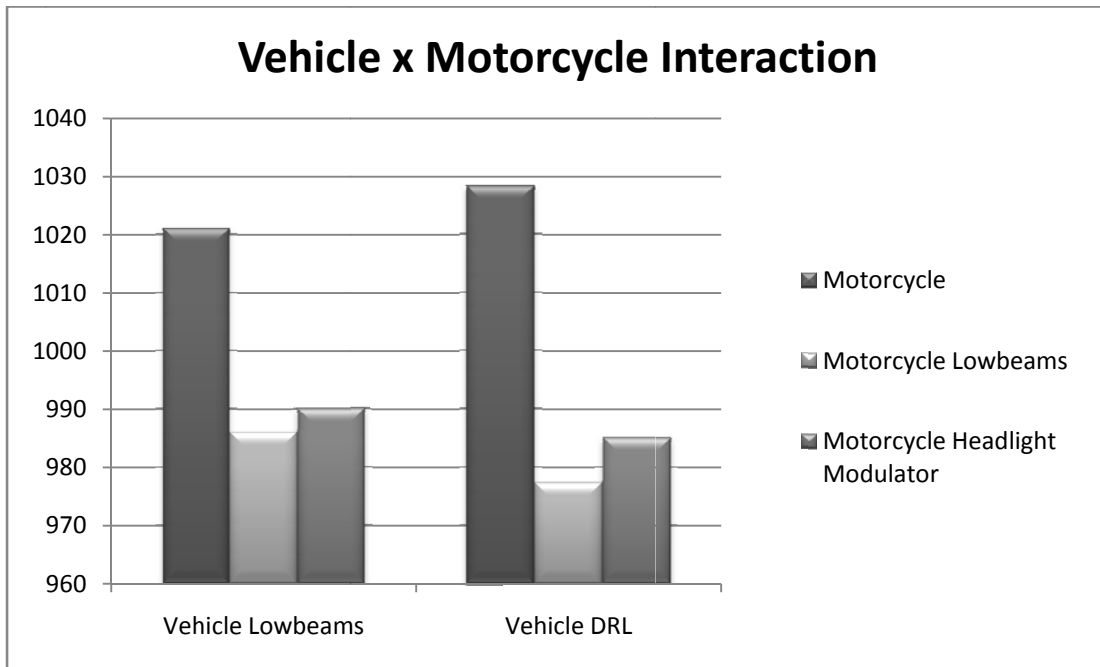

Figure 17: Motorcycle Reaction Time when followed by a Vehicle with DRL or Low Beam

In order to further understand the relationship between vehicular DRLs and motorcycle conspicuity, an additional paired samples t-test was conducted between the following conditions: Pair 1 - Motorcycle Headlight ON – No Vehicle Present (MONVOFF) and Motorcycle Headlight ON – Vehicle w/DRLs (MONVDAY), Pair 2 – Motorcycle Headlight OFF – Vehicle Present (MOFFVOFF) and Motorcycle Headlight

OFF – Vehicle DRL (MOFFVDAY). This analysis revealed a significant difference between MONVOFF and MONVDAY, $t(74) = -2.2$, $p = .048$ and a significant differences between MOFFVOFF and MOFFVDAY, $t(74) = 2.45$, $p = .017$.

Table 7: Paired Samples Statistics

		Mean	N	Std. Deviation	Std. Error Mean
Pair 1	MOnVDay	983.853	75	191.5614	22.1196
	MOnVOff	1012.384	75	231.7006	26.7545
Pair 2	MOffVDay	1033.795	75	203.5248	23.5010
	MOffVOff	1007.345	75	226.9173	26.2021

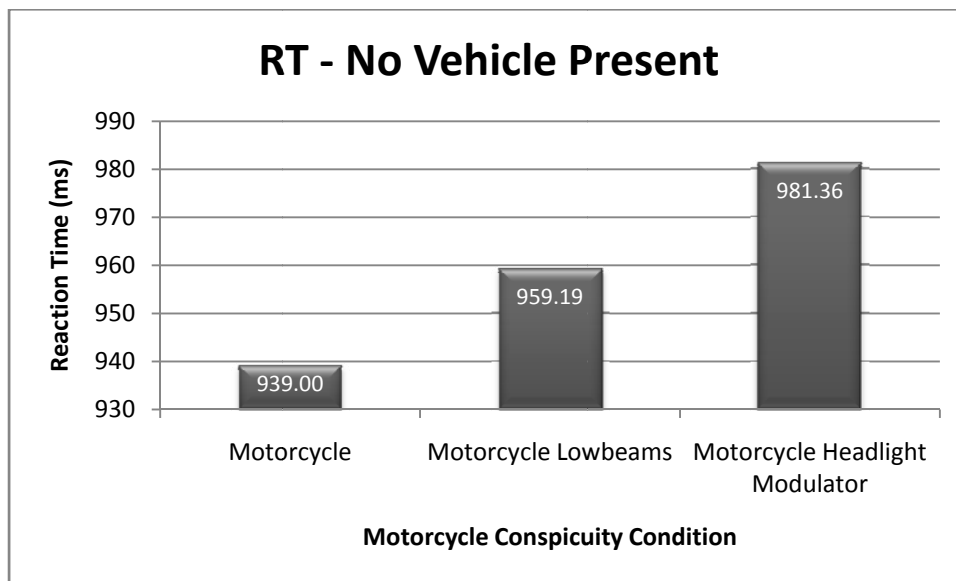

Figure 18: RT to Motorcycle with No Vehicle Present

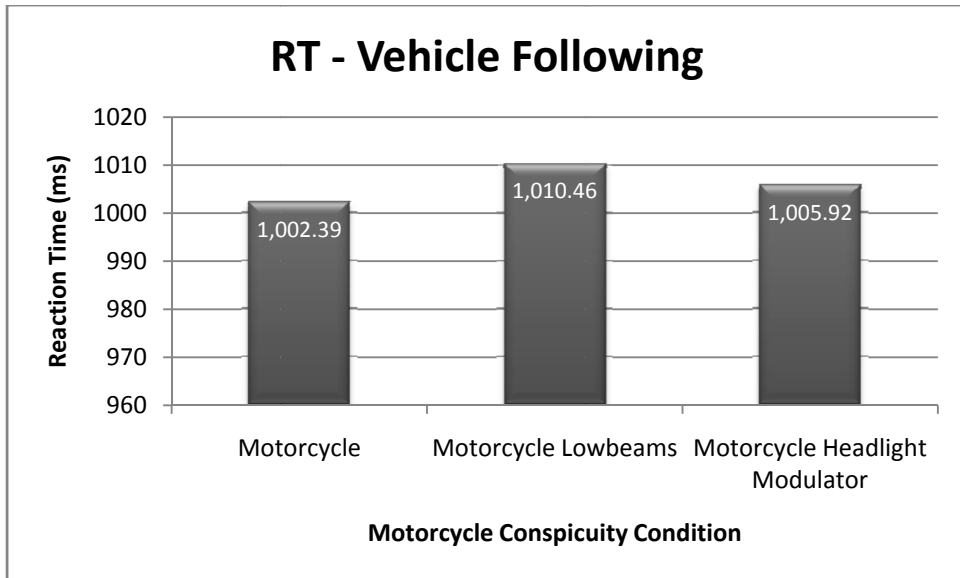

Figure 19: RT to Motorcycle with Vehicle Following (no headlights)

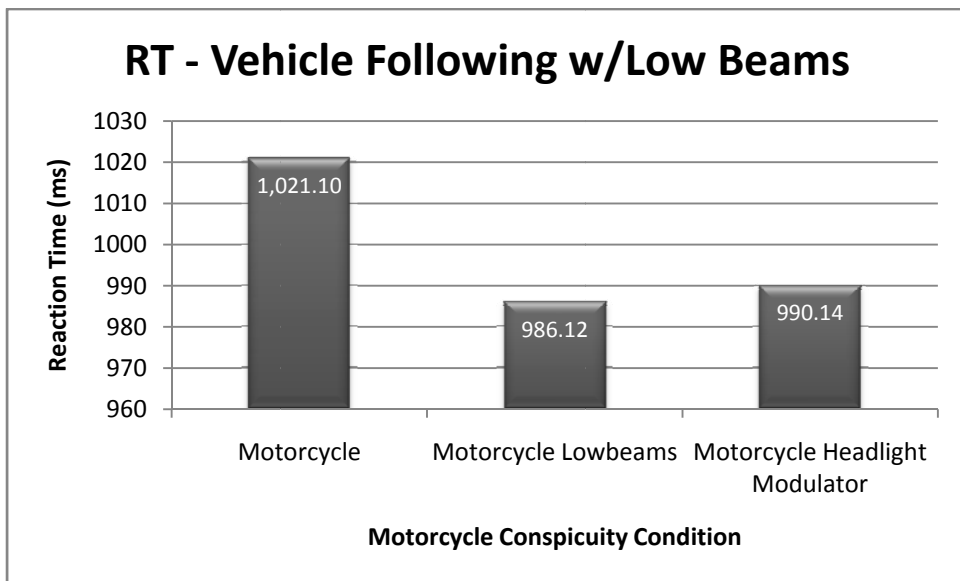

Figure 20: RT to Motorcycle with Vehicle Following with Low Beams

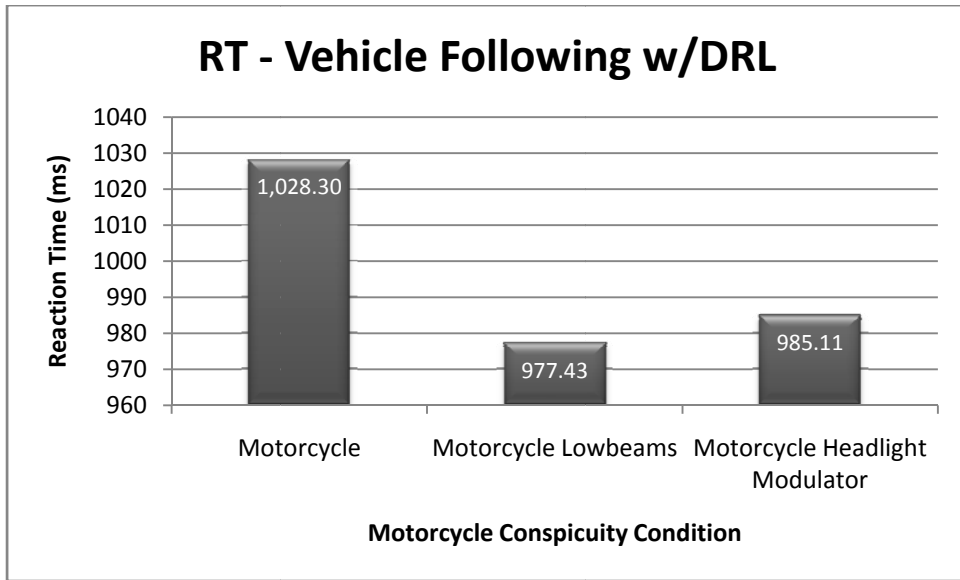

Figure 21: RT to Motorcycle with Vehicle Following with DRLs

DISCUSSION

Hypotheses

The primary intention of this research was to investigate the topic of motorcycle conspicuity so as to further explain the variables which positively contribute to a motorcycle being seen and to supplement the body of knowledge that currently exists on this topic. This study specifically evaluated the influence of sex, age, motorcycle lighting conditions, and vehicular daytime running lights upon one's ability to effectively detect a motorcycle within a "high fidelity" simulated environment. This research additionally sought to examine the feasibility and validity of using a novel fixed base "high fidelity" simulator for the evaluation of motorcycle conspicuity. The following hypotheses were used as a basis for this research and a summary of their outcomes is outlined in the following section.

- 1. Those in the (younger/middle) adult groups will have greater levels of performance for motorcycle conspicuity than those in the older adult group.***

The results from this study directly support the hypothesis that the younger and middle aged groups would perform better than the older adult group. A main effect was found for Age, where further analysis revealed significant differences between all three groups.

- 2. Those in the Older adult group will have slower Reaction Time measures than those in the younger adult and middle aged groups in detecting motorcycles***

Age was found to significantly influence one's ability to detect and respond to a motorcycle. Of the three age groups tested, older adults were found to have the poorest performance in detecting a motorcycle.

- 3. Those in the Older adult group will have shorter detection distance measures than those in the younger adult and middle aged groups in detecting motorcycles.***

Although detection distance was not directly evaluated as a dependent variable, it was subsequently equated with reaction time metrics as a measure of distance to collision (refer to Appendix O). This was done so by calculating the distance travelled at a rate of 25 MPH and associating it with Reaction Time measures in ms (.036 ft/ms). When equated with reaction time measures, it was found that those in the older adult group took longer to detect a target and thus had shorter detection distance measures than those in the other two groups.

- 4. There will be faster reaction time measures and greater detection distance measures for all groups (young/middle/older) exposed to the motorcycle headlight-ON conditions compared to reaction time/detection distance measures found for the motorcycle headlight-OFF condition.***

This hypothesis held true for all groups evaluated. There was a main effect found for the motorcycle conspicuity condition, which upon further analysis revealed a significant difference between the headlight ON condition and the headlight OFF condition for all participants evaluated.

- 5. There will be faster reaction time measures and greater detection distance measures for all groups (young/middle/older) exposed to the motorcycle headlight-modulated group compared to reaction time/detection distance measures found for the motorcycle headlight-OFF condition.***

This hypothesis was found to be primarily supported in the results from this study. The following 4 vehicle conditions were tested: No Vehicle, Vehicle, Vehicle with DRLs and Vehicle with Low Beam Headlights. Each of these vehicle conditions contained a motorcycle headlight modulated condition and a motorcycle headlight off condition. There were no significant differences found between the motorcycle Modulated group and the motorcycle OFF group for conditions where the motorcycle was exclusive. There were, however, significant differences found between the motorcycle Modulated group and the motorcycle OFF group when followed by a vehicle with Low Beam Headlights or a vehicle with DRLs.

- 6. There will be faster reaction time measures and greater detection distance measures for all groups (young/middle/older) exposed to the motorcycle headlight-modulated group compared to reaction time measures found for the motorcycle headlight-ON condition.***

The results indicate that there was not a significant difference between the headlight modulated condition and the headlight ON condition. This was likely the result of the environmental conditions tested in this study (clear day/rural

intersection). Research shows that headlight modulators are most effective when used in inclement weather and congested areas.

7. ***There will be faster reaction time measures and greater detection distances for all groups (young/middle/older) exposed to the motorcycle headlight-ON/Vehicular-DRL-OFF condition compared to reaction time/detection distance measures for the motorcycle headlight-ON/Vehicular-DRL-ON condition.***

There was a significant difference found for conditions with a motorcycle with DRLs which was either followed by a Vehicle with DRLs or a Vehicle in general. However, the direction of results was the opposite of that predicted. Where it was hypothesized that the motorcycles followed by a vehicle without DRLs would be more quickly detected than those followed by vehicles with DRLs, the results indicate the opposite. This could potentially be explained by the “masking by confusion” phenomenon where an unanticipated masking effect may have been imposed by the DRL-OFF condition. This might also be explained through participant expectancy where increased RT in the DRL-ON condition might be attributed to expectancy for vehicle/motorcycle lights in general.

8. ***There will be faster reaction time measures and greater detection distances for all groups (young/middle/older) exposed to the motorcycle headlight-Modulated/Vehicular-DRL-ON condition compared to reaction time/detection distance measures for the motorcycle headlight-ON/Vehicular-DRL-ON condition.***

There were no significant differences found between the motorcycle headlight modulated group and the motorcycle DRL group for any of the vehicle following conditions. This was likely the result of the environmental conditions tested in this study (clear day/rural intersection) as research shows that headlight modulators are most effective when used in inclement weather and congested areas.

- 9. Those in the older adult group will have slower reaction time measures and shorter detection distances than those in the (younger/middle) adult groups when exposed to motorcycle headlight-ON/Vehicular-DRL-ON.***

There was a significant difference found between the younger and the older group for this specific motorcycle/vehicle condition, however, there was not a significant difference found between the middle and older groups.

- 10. There will be faster reaction time measures and greater detection distances for those in the Older adult group that are exposed to the motorcycle headlight-Modulated condition compared to reaction time/detection distance measures for the motorcycle headlight-ON condition.***

There was not a significant difference between the headlight modulated group and the motorcycle DRL group for any of the vehicle following conditions or age groups evaluated in this study. It has been shown in previous studies, that as weather worsens and visibility conditions become less than ideal, the overall effectiveness of headlight modulators increases. This however, would have to be confirmed in future research.

One of the core underpinnings behind this research involves the issue of motorcycle conspicuity and the benefits of supplementary motorcycle lighting. It is well established that a disproportionate number of motorcycle accidents are attributed to “non-motorcycling” motorists failing to see the motorcycle until it is too late (Hills, 1980; Langham et al., 2002; Langham & McDonald, 2004; Labbett & Langham, 2006; Mack & Rock, 2000). In an attempt to better “illuminate” motorcycles on the road, daytime running lights (DRLs) have been mandated on all production motorcycles in the United States since 1967. As a result, there have been many attempts to determine the efficacy of DRLs and thus far, both lab and field research have found benefit in the usage of DRLs (Allen, 1965; Janoff et al., 1970; Williams & Hoffman, 1979; Wulf, Hancock, & Rahimi, 1989). This current research sought to supplement these previous findings by determining the difference in the conspicuity of a motorcycle without headlights to that of a motorcycle with headlights (DRLs). The current research found a significant main effect for the motorcycle conspicuity conditions evaluated and subsequent post-hoc analysis revealed a significant difference between motorcycle conditions with DRLs and those without DRLs. The results suggest that a motorcycle driving with headlights on is significantly more likely to be detected faster by oncoming motorists than a motorcycle without any headlights on. These results directly fall in-line with previous research conducted on this topic and support the compulsory requirement for motorcycles to operate with “hard-wired” DRLs. These results also support one of the main hypothesis proposed at the onset of this study: that with the use of a DRL, the conspicuity of a motorcycle is positively affected.

An additional hypothesis that was evaluated in this study was that headlight modulators would increase motorcycle conspicuity and would decrease the detection time of a motorcycle throughout all conditions evaluated. Although it was hypothesized that headlight modulators would positively affect the conspicuity of a motorcycle, regardless of context and regardless of whether or not the motorcycle was being followed by a vehicle, the results from this study reveal a somewhat different story. When all conditions are collapsed and only the three motorcycle conditions are evaluated (Lights OFF, ON, Modulated), without taking into consideration the impact of a vehicle being present, there does not appear to be a significant difference between the Modulated group ($M = 990.63$, $SD = 170.83$) and the Motorcycle without Lights group ($M = 997.70$, $SD = 171.32$) (refer to figure 11). These results seemingly contradict the proposed hypothesis, but these results are not entirely exclusive to this study as similar findings have been presented and there are additionally, likely explanations for these unanticipated findings.

There are a variety of reasons why this outcome may have transpired as it did, however, under no circumstances should these results be interpreted to suggest that headlight modulators are an ineffective method to increase motorcycle conspicuity. First and foremost, this study was developed so as to be representative of the most “commonly reported” environmental and contextual conditions for potential motorcycle accidents (Thomson, 1980; Williams & Hoffman, 1979; MAIDS, 2006). Thus the video clips presented in this study utilized a vehicular left-turn scenario, where the observer was situated as if they were about to turn left in front of a motorcycle on a fairly clear, afternoon day in a very “low traffic” rural environment (refer to Appendix F). Additionally there is evidence to suggest that motorcycle headlight modulators perform

optimally within dense, urban traffic situations where enhanced differentiation and calling out of attention is the key (Olson, Halstead-Nussloch, & Sivak, 1981; Williams & Hoffman, 1977; Williams & Hoffman, 1979). It has also been suggested that motorcycle headlight treatments are dramatically affected by environmental conditions such as those where there is fog, smoke, shadows, or in twilight conditions (Williams & Hoffman, 1977; Williams & Hoffman, 1979). These results consequently indicate the need for further research that takes into account these environmental and contextual traffic variables and tests them accordingly. However one primary reason why there was not a significant difference found between collapsed conditions of the 3 motorcycle groups exclusively, is because this “initial” analysis does not take into account the influence of a following vehicle upon one’s ability to detect a motorcycle.

When these interaction effects are examined more closely using a planned orthogonal comparison, a more comprehensive understanding is presented and it becomes clear how influential a following vehicle can be upon the conspicuity of a motorcycle. These comparisons also reveal the effects that both motorcycle DRLs and Headlight Modulators have upon motorcycle conspicuity. An initial multivariate test revealed that the mere presence of a vehicle significantly influenced the detection time of a motorcycle, regardless of motorcycle headlight condition. These results were further confirmed with the use of the planned orthogonal comparison.

Although it would appear that headlight modulators or even a motorcycle with Low Beams do not have a positive (significant) influence upon motorcycle conspicuity in the absence of a vehicle (Figure 18), the story dramatically changes once a following

vehicle appears (Figure 15) and even more so, when that vehicle has Low Beams or DRLs (Figure 16)

The planned comparison revealed a significant interaction effect between the presence of a following vehicle and the motorcycle headlight conditions, suggesting both contribute to the conspicuity and detection time of a motorcycle. This initial analysis suggests that when followed by a vehicle in general, the effectiveness of DRL use on a motorcycle becomes apparent. That is, when a motorcycle is traveling alone on a visually uncluttered roadway, there is a minimal issue with the conspicuity of this motorcycle and thus, reaction times for detection are fairly quick (refer to Figure 15).

However, once a vehicle is introduced into this equation and the motorcycle is now being followed, the visual environment now becomes much more cluttered, a visual masking of sorts transpires and there is much more visual stimuli to sort through before making a determination as to whether or not a motorcycle is present. This consequently results in extended time necessary for the detection of a motorcycle and ultimately equates to decreased motorcycle conspicuity. In this particular type of situation, the results from this study suggest the imperative nature of motorcycle DRLs in effectively differentiating a motorcycle from its surroundings and ultimately making it more conspicuous. This effect can be seen in the following image (refer to Figure 16), where participant reaction time is literally reversed from that where no vehicle is present.

More specifically, these findings revealed an interaction for motorcycles that have DRLs or modulated headlights. This interaction analysis revealed a direct relationship between a motorcycle that is traveling with its headlights ON or Modulated when that motorcycle is followed by a vehicle with Low Beams or DRLs. In figure 14, it can be

seen that when a motorcycle is followed by a vehicle in general it does not matter whether a motorcycle has DRLs, a Modulator or is traveling without lights, the time to detect a motorcycle is fairly even. These results suggest that when a large, dark vehicle is following a motorcycle at a fairly close range of 25ft, the mere presence of a vehicle makes it difficult to distinguish a motorcycle, where neither motorcycle DRLs or Modulators make a difference comparative to a motorcycle without lights. This is supported in the statistical analysis where there was no significant difference found between the three motorcycle conditions when followed by a vehicle without lighting. This trend shifts dramatically once said vehicle turns on their Low Beam Headlights or DRLs (Vehicle Low Beams/Vehicle DRL), where it can now be seen that the motorcycle without DRLs/Modulators becomes increasingly harder to detect and the motorcycle with DRLs and/or Modulators becomes easier to detect (refer to figures 20, 21). These results suggest that if a motorcycle without lights, is followed by a vehicle with DRLs or Low Beams headlights, that motorcycle becomes significantly harder to distinguish and to detect. Conversely if a motorcycle has DRLs or Headlight Modulators and is followed by a vehicle with Low Beams headlights or DRLs, the motorcycle is significantly more likely to be detected quicker than if it had no headlights under these conditions. That is, DRLs and/or Headlight modulators were shown to increase motorcycle conspicuity in a more pronounced manner, when a motorcycle is followed closely (25ft) by a vehicle with DRLs or Low Beams. More importantly, these results directly support the notion that vehicular DRLs do in fact play a role in the effective detection of motorcycles (Allen, 1965; Hendtlass, 1992; Horberg & Rumar, 1979; Koornstra, Bijlefeld & Hagenzieker, 1997; Olson, 1984; Olson, Halstead-Nussloch & Sivak, 1981; Perlot & Prower, 2003;

Rumar, 1980; Thomson, 1980; Williams & Hoffman, 1979). In the particular context of this research, it can be inferred that vehicular DRLs and/or headlights on a vehicle directly following a motorcycle (25 ft), can potentially impose a negative effect upon the conspicuity of a motorcycle if that motorcycle does not have DRLs or Headlight Modulators.

It was originally hypothesized that a motorcycle with DRLs would be more quickly detected when followed by a vehicle without DRLs as opposed to one with DRLs. The results from this study did not find this to be true, but conversely indicate that when followed by a vehicle with DRLs, a motorcycle with DRLs is detected faster than if it were followed by a vehicle that had no headlights or DRLs. Although these findings contradict the predicted outcome, they can potentially be explained by a concept proposed by Perlot and Prower (2003), masking by confusion. The authors suggest that when closely followed by a vehicle, a motorcycle becomes much more susceptible to decreased conspicuity due to the size, orientation and lighting conditions of the following vehicle (Perlot & Prower, 2003). Although this can be assumed to influence motorcycle conspicuity for all conditions where a vehicle is following a motorcycle, the results of this study, suggest that this becomes more pronounced in conditions where the following vehicle does not have DRLs or low beam headlights. Thus it would appear that a motorcycle with DRLs becomes more easily confused with the following vehicle when that following vehicle does not have any lights on as opposed to when it has DRLs or headlights on. Additionally, it is probable that participant expectancy played a role in this unanticipated result.

These results can also be explained by participant expectancy or an association between a motorcycle headlight condition and the presence of a following vehicle with either DRLs or headlights on. Although this variable was controlled for as much as possible in the design of this experiment through the use of “distraction” conditions such as blank slides, slides with random traffic, pedestrians and traffic cones, it cannot be completely ruled out, that expectancy contributed to this phenomenon. The results show that participants were significantly faster at detecting a motorcycle with DRLs, when followed by a vehicle with DRLs as opposed to one without any lights. It can potentially be inferred that participants may have developed an expectancy for motorcycles based on the presence of a vehicle that also had lights so as to influence these results in this manner.

Despite the aforementioned findings, it is clear from these results, vehicular DRLs and vehicular Low Beam headlights definitively have an effect upon the conspicuity of a motorcycle. The results specifically indicate a more pronounced negative effect occurs when a motorcycle does not have DRLs or Modulators, and is followed by a vehicle that does have DRLs or Low Beam headlights. This is a situation that is very common today, as many newly manufactured vehicles are more commonly being produced with various implementations of daytime running lights. Although the findings from this research suggest that vehicular DRLs have a more significantly negative effect for only motorcycles without DRLs or headlight modulators, the trends in this study also suggest a potential benefit for motorcycles fitted with DRLs or headlight modulators. Since a positive trend was seen in the current research, it can be conjectured that under different environmental conditions (dusk/cloudy/foggy) this trend could potentially be increased

where the probability of a motorcycle fitted with DRLs and/or headlight modulators could potentially be found to increase overall motorcycle conspicuity.

Age Differences

The results from this research predominately matched the a-priori predictions made in regards to Age and motorcycle conspicuity. It is well documented, that as one ages, certain decrements occur within the visual, cognitive, physiological systems which can dramatically impact driving performance and decrease reaction and performance metrics (Department of Transport, 2006; Keskinen, Ota & Katila, 1998; Kline, et. al., 1992; Transportation Research Board, 1999). The results from this study serve as confirmation that as one chronologically ages, certain changes occur that have a dramatic influence upon one's driving performance, reaction time and conspicuity for motorcycles. The results from this study definitively indicate a significant decline in reaction time performance to the visual stimuli presented, which can be inferred as having a potentially negative effect upon their ability to detect motorcycles. This research has found that for all conspicuity conditions evaluated, younger adults performed significantly better than both middle aged adults and older adults. Additionally, it was found that middle aged adults performed better than older adults on all conspicuity conditions.

More importantly is that this trend was repeated across all motorcycle conspicuity and vehicle following conditions evaluated. In this study, as well as other reaction time studies, a progressive decline in RT performance was seen to accompany age. On average, there was a 20ms difference between younger adults and middle aged adults and more than 200ms difference between younger adults and older adults.

As with the younger adult and middle aged groups, there was unfortunately no positive effects seen with the use of headlight modulators for the older adult group. The use of headlight modulators was hypothesized to have a beneficial effect on the detection time of motorcycles for the older adult group, as the 4 hz flashing light was predicted to decrease the time needed to respond to a motorcycle comparative to the headlight on condition. The results however suggested very little difference between the 3 motorcycle conditions for the older adult group (refer to Figures 15, 16, 17). One explanation might lie in the speed/accuracy tradeoff that has been reported to commonly occur with the older adult population (Smith & Brewer, 1995). That is, for this particular group, it has been found that in order to obtain a higher degree of accuracy, often times what is sacrificed is the overall speed of a reaction to a target. In this particular study, it would appear as if this group opted to spend more time in accurately selecting a target as opposed to quickly responding, which can be seen for virtually all conditions evaluated (extremely low False Alarm and MISS rates for all groups).

It must additionally be noted that although there have been research efforts applied toward aging and conspicuity of pedestrians and road signs, up to this point there has been little if any attempt made to understand the relationship between age and motorcycle conspicuity. This research has thus taken the first step and has been the first to specifically outline the difference in motorcycle conspicuity as a function of age. The results from this study definitively indicate that as one ages, a certain degree of declination transpires which ultimately affects performance in detecting and responding to motorcycles within a simulated environment.

Male/Female Differences

Although there was no hypothesis directed toward, nor initial intent to include participant sex as an evaluative variable, a preliminary analysis revealed a very large disparity between conspicuity reaction time scores for males and females. The results from this study showed that males were significantly faster than females throughout all of the conditions evaluated (refer to Figure 8, 9, 10). Although this result was not originally anticipated, it is an interesting outcome that can be attributed to a number of different variables.

Throughout time, there have been great efforts placed on determining sex differences with regards to reaction time and driving performance (Lahtela, Niemi, & Kuusela, 1985). Although there have been quite a few studies applied to this topic, the results have unfortunately been fairly contradictory, some suggesting males are faster than females and some saying the opposite. A more appropriate way to examine this issue is to focus on the specific sex differences as a function of the task, as opposed to general performance and reaction time. Research has found that males are faster and more accurate than females when they are involved in tasks that contain a high degree of spatial targets (Lahtela, Niemi, & Kuusela, 1985; Caird & Hancock, 1994; Adam, et. al., 1999). Additionally one particular driving study found that males were more accurate in judging distances of oncoming vehicles when placed in a “left turn” driving scenario (Caird & Hancock, 1994). The current research had participants locate a spatial target (motorcycle) within a dynamic environment, while situated at an intersection and instructed to “act” as if they were about to make a left turn. It can be inferred that under these contextual constraints, it is possible that males could potentially perform better than

females at detecting and responding to the presence of a motorcycle. That is, the discrepancy between reaction time performances for males and females could potentially be attributed to the contextual and environmental conditions employed within this study.

An additional explanation for these unanticipated results could be associated with participant experience, comfort, and familiarity as they relate to the specific testing apparatus used in this research. It is clear that through participant feedback obtained in this study, males were more pronounced in their common reference to the testing apparatus as a “video game”, whereas females were much less likely to make this association. It is possible that male participants, who, for the most part are more likely to have experience and familiarity with video games than females, may have had faster reaction times for the conditions evaluated due to their experience, familiarity and comfort with a simulator such as that used in this research. It must however be noted that participants were not screened for video game or simulator experience so at this point, this is mere conjecture however this is a topic that could be screened for and further explored in future studies.

It must be additionally noted that participants were not screened for sex and there is a slight possibility this may have influenced the results. Although overall sample sizes for males (N=37) and females (N=38) were fairly equal, samples sizes for each age group (young, middle, older) were not equalized. The young group included 13 males, N12 females, the middle group included 10 males, 15 females and the older adult group included 14 males and 11 females.

Motorcycle Conspicuity and High Definition Simulation

The main intentions of this study were to identify factors which contribute to the increased conspicuity of a motorcycle and to explore the implications with which vehicular daytime running lights impact the conspicuity of a motorcycle. However, this study also sought to explore the usability of a novel technology for the display and assessment of motorcycle conspicuity metrics. The apparatus used in this study consisted of a GE I-Sim Fixed base simulator modified to incorporate a 50” High Definition digital monitor which displayed high definition video recorded at a resolution of 1080i. This resolution currently ranks among the highest visual fidelity available, doubling that of conventional DVD quality, and surpassed only by the most expensive display systems. Prior to this point, the presentation and evaluation of motorcycle conspicuity has been achieved by using static 35mm film slides or by using low fidelity video or projection units. All of these methods have been seemingly effective in evaluating motorcycle conspicuity however one extremely important variable has been lacking with these previous technologies, which ultimately plays an integral role within the real world conspicuity of a motorcycle. This variable is the highly detailed visual fidelity of the motorcycle and surrounding environment.

The underlying goal of “simulation” is to re-create, as closely as possible, the conditions and variables that constitute the object being simulated. In the case of motorcycle conspicuity, while in the field (i.e. real world), there are many variables that contribute toward the detection of a motorcycle, but those most salient are related to vision and the visual system. The environment where the majority of motorcycle accidents take place is composed of many highly visual details such as traffic signs/devices, roadway traffic, surrounding buildings and vegetation as well pedestrians

and other objects. Thus it is extremely important to recognize these elements when attempting to re-create an environment for the evaluation of motorcycle conspicuity. What this research has demonstrated is that when replicated, at this high level of resolution (1080i), this technology can potentially be used to gauge driver performance as it relates to motorcycle conspicuity. However like all research of this nature, the extent of these findings has a limitation. In order to fully understand the implications and significance of the results obtained through the use of a high definition digital video display system, it is truly necessary to corroborate these findings with real world data obtained via field studies.

Conclusion and Future Research

The current research has sought to provide clarity on issues associated with the effective detection and response to motorcycles under common conditions where motorcycle accidents occur. Through the use of “high definition” digital video and a fixed base simulator, the current research has produced significant findings that further explain the core issues regarding causative factors behind motorcycles not being seen on the roadway. This study specifically looked at issues of sex, age, vehicular DRLs and motorcycle headlight treatments as contributory factors and the results do indeed suggest these all play a role in the effective detection and response to motorcycles. One of the more notable findings in this current research was that concerning the effectiveness of motorcycle DRLs, which fell directly in-line with previous research. This is an important finding because it clearly supplies support for the widespread usage of motorcycle DRLs and indicates that by using them, motorcycles clearly become more conspicuous. This is especially true in certain situations where standing out from one’s surroundings becomes

imperative, such as high density traffic situations or as this research has shown, when closely followed by a large vehicle. This also holds true for motorcycle headlight modulators. Although motorcycles equipped with modulators were not found to be significantly detected quicker than motorcycles with DRLs in general, they were however found to be more noticeable than motorcycles without lights, especially when followed by a vehicle that had its headlights on or DRLs. This is important because the likelihood of being followed by a vehicle with DRLs or headlights is becoming increasingly greater as more and more vehicles are coming equipped with DRLs or turning on their headlights during the day. More research would have to be conducted on the effectiveness of motorcycle headlight modulators, but this technology does hold potential, especially in “real world” settings such as those with high density traffic, or under adverse environmental conditions such as fog, rain, or during twilight hours.

An additional finding that is worth noting as it relates to the safety of driving a motorcycle is that involving age. This research found that it takes older adults over the age of 65 over 200ms longer to detect a motorcycle than younger adults. This is not only significant statistically, but when evaluated in terms of real world applicability, this equates to approximately 7-10 feet of distance for a motorcycle traveling at a rate of 25MPH (refer to Appendix O). If a motorcycle is traveling at 25MPH and it takes an older adult 200ms longer to respond to a motorcyclist, this poses a greater likelihood of accident for these vehicles since the motorcycle will be approximately 7-10 feet closer to the vehicle. This is especially dangerous when taking into consideration the type of crash typology evaluated, where the driver is situated in a left turn scenario. In this type of situation 200ms can mean the difference between initiating a left hand turn where the

vehicle is in the left hand turning lane and actually making a left hand turn, where the vehicle is now in the path of an oncoming motorcycle. This impact is further compounded when taking into consideration that it takes a motorcycle an average of 22' to come to a full stop when traveling at a rate of 25MPH (Green, 2006; refer to Appendix N). It is extremely important that the influence of age upon motorcycle conspicuity be further investigated as the population of those over 65 is rapidly increasing and as this research has shown, with age also comes declination in performance as associated with the effective detection and response to motorcycles on the road.

Although there were significant findings revealed for each of the aforementioned variables, this study, like any other lab oriented study, is limited in nature, and can consequently be improved and supplemented in future iterations. The nature of a lab study or a simulation study inherently involves a certain level of control over confounding variables. These variables that are controlled for include factors such as the environment, traffic conditions, participant selection, and roadway selection among other variables.

In this particular study, motorcycle conspicuity was tested under very controlled environmental conditions including the use of a rural roadway with very light, “uncongested” traffic conditions on a somewhat clear and sunny afternoon day. Future research might benefit if some of these variables were modified so as to encompass a broader perspective of factors that contribute to motorcycle conspicuity. One example would be to modify the environmental conditions of this test and incorporate adverse weather conditions such as fog, rain, snow, and to test the same variables in the current research under day, night or even twilight conditions. Traffic conditions could also be

adjusted where it can be conjectured that increased traffic might lead to differing performance in detecting and responding to the presence of a motorcycle. It is also very possible that properties of the test vehicles indirectly influenced the outcomes of the current research.

The test vehicles used in this study were designed to have colors and equipment that minimizes contrast, distraction, and decreased the overall vehicular conspicuity so that the target treatments (modulator, DRL) could better be evaluated. The test vehicles in this study included a “standard” single headlight equipped “flat black” motorcycle, ridden by a test driver dressed all in black, who in some conditions was followed by a “large” SUV painted a very dark burgundy color, equipped with Standard 45W Low Beam Headlights and a specialized, reduced wattage DRL. Additionally in video clips containing a following vehicle, the distance between motorcycle and trailing vehicle was standardized at 25ft across all conditions of this nature. In future research, vehicular conditions such as the motorcycle color, headlight configuration, or operator clothing could be modified to evaluate their contribution toward motorcycle conspicuity. Distance between motorcycle and trailing vehicle could also be adjusted to determine the effects of vehicular following distance on the detection of a motorcycle. Also, factors associated with the following vehicle could be adapted such as the size, color and type of vehicle, which could include compact vehicles and conventional cars, mini-vans and other motorcycles as opposed to just large SUV’s. One interesting variable would be to test the difference in conspicuity between a motorcycle followed by a vehicle with DRLs as opposed to a motorcycle followed by other motorcycles with DRLs. One other notable item would be the particular type of DRLs evaluated on the trailing in this current study.

The DRLs tested in the current study were 25W reduced wattage variations of the 45W Low Beam Dipped Headlight manufactured by General Motors. This is only one of many types of DRLs currently on the market for production automobiles. Although the current research did not find significant differences between RT's for vehicular DRLs as opposed to Low Beam headlights, it would be extremely interesting to see if these results hold true for vehicles equipped with other variants of the vehicular DRL. It would equally be interesting to see the effects of these modified vehicular and motorcycle variables upon the detection and response of motorcycles by those within the aging population.

One of the main variables evaluated in this study was the influence that age has upon performance in detecting motorcycles on the road. The results indicate that as one ages, performance in detecting motorcycles decreases significantly. This can definitively be said to hold true only for the conditions tested in the current research and it would be very interesting to see if such results held consistent if vehicular variables or motorcycle lighting/operator conditions were adjusted. The ultimate goal of this type of research is to determine how, if at all, it is possible to increase the conspicuity of motorcycles for all motorists on the road, which includes the increasingly growing population of those over 65 years of age. The current research did not find any significant increase in motorcycle detection performance for older adults as a result of headlight modulators, but it would be interesting to see if other technologies purported to increase conspicuity had a beneficial effect for this particular group. In future research it would be advantageous to evaluate the effectiveness of rider clothing (fluorescent), motorcycle coloring/reflectivity/patterns, auxiliary headlights and flashing beacons as they relate to the motorcycle conspicuity

performance of this higher risk group. Additionally, the extent to which vehicular DRLs influence the detection and response to motorcycles for the older adult population needs to be further investigated so as to better understand this relationship.

An additional variable that was evaluated was the difference in performance for detecting a motorcycle based upon the sex of the observer. This research found that males were significantly faster at detecting and responding to motorcycles than were females. Previous research suggests that this may have been influenced by the tendency for males to perform better at tasks involving temporal target identification such as a moving vehicle. An additional explanation for this phenomenon could potentially lie in the general, overall increased experience and familiarity that males have with video games and simulation comparative to females. The current research did not screen for this potentially confounding variable. In future research it is important that this be screened for to determine the correlation, if any, that this type of experience and familiarity has with motorcycle conspicuity that is tested within a simulated “game-like” environment.

As can be seen, there are indeed certain boundaries and limitations to the type of research that is performed in a lab under simulated conditions. As with any research, in order to obtain as accurate of an understanding as possible, the questions must be approached from as many directions as are applicable. In order to fully understand the “real world” implications of these current findings, they must be corroborated with data obtained through directed field studies which employ similar paradigms for the detection and response to motorcycles. It is only through this multi-faceted approach, that a true understanding of the factors which increase the detection and response to motorcycles on

the road can be achieved. Although this is a cumulative effort, as our understanding of the underlying variables that influence motorcycle conspicuity become more refined, so too does the potential to positively decrease the number of motorcycle accidents and fatalities incurred. The current research has been conducted in an attempt to positively contribute to understanding the complex variables that impact a motorcycle being seen on the road and can positively be seen as a foundation for future research with these goals in mind.

APPENDIX A: PRE-TEST PARTICIPANT SCREENER

The following screener will be administered to all participants prior to participation in the experiment. This screener will be administered via email and/or telephone.

Driving Experience/Vision Screener:

1. How many years have you been driving? _____

2. Do you currently have a valid Drivers license? Yes/No

Yes = CONTINUE

NO = EXCLUDE

3. Do you currently have any visual conditions/diseases that might potentially impair your driving ability? Yes/No. If so, what visual conditions do you have? _____

Yes = EXCLUDE (unless they have 20/40 or better visual acuity)

NO = CONTINUE

4. Do you have cataracts? Yes/No

Yes = EXCLUDE (unless they have had corrective surgery – 20/40)

NO = CONTINUE

5. Which of the following most closely matches your age?

(18 – 35)

(40 - 55)

(65+)

6. How often do you drive? (pick one)

Daily

Weekly

Monthly

Less often than above

7. Which of the following do you currently drive or have you driven in the past?

Car

Van

Truck

- Motorcycle
- Moped
- Bus
- Other please specify _____

Motorcycle = EXCLUDE

8. Which of the following do you most often drive:

- Car
- Van
- Truck
- Motorcycle
- Moped
- Bus
- Other please specify _____

9. Have you ever been involved in an accident? Yes/No

If so, how long ago was your last accident? _____

If so, were you at cause or was the other motorist at fault? _____

10. Do you know anyone that rides a motorcycle or moped? Yes/No

If so what is your relationship to this person? _____

**If Yes, Distant Relationship (distant family member, distant friend, acquaintance)
= CONTINUE**

**If Yes, Close Relationship (immediate family member, close friend, boyfriend/girlfriend)
= EXCLUDE**

APPENDIX B: DRIVING HABITS QUESTIONNAIRE

Participant #: _____

Driving Habits Questionnaire

Please complete the following questionnaire by filling in the blanks or circling the appropriate answers for each item. If you should have any questions, please ask the researcher for assistance.

Name: _____	Date: _____	
Sex: Male Female	Height: ___ft___in	Date of Birth: _____
Do you currently own a valid driver's license? Yes No		
Have you ever had a motorcycle endorsement? Yes No		
Driver's License Number _____		
Are there any restrictions on your driver's license? Yes No		
If Yes, please specify: _____		

1. What is your primary language? _____
2. Starting with the first grade, how many years of schooling have you completed? _____ years of schooling.
3. Do you currently drive? Yes No
4. Are you the primary household driver? Yes No
5. Do you wear glasses or contacts when you drive? Yes No
6. Which way do you prefer to get around? (Please circle one)
 - a. I prefer to drive myself.
 - b. I prefer to have someone else drive me.
 - c. I prefer to use public transportation or a taxi.
7. When compared to the general flow of traffic, do you drive:
 - a. Much faster
 - b. Somewhat faster
 - c. About the same
 - d. Somewhat slower
 - e. Much slower
8. Over the past year, has anyone suggested that you limit your driving or stop driving? Yes No
 - a. If Yes, for what reason? _____
9. How would you rate the quality of your driving? (Please circle one)

Excellent Good Average Fair Poor

10. In an average week, how many days to you drive? _____ days per week
11. Over the past year, how many crashes have you been involved in while you were driving? _____ Crashes
12. Over the past year, how many times have you been pulled over by the police, whether or not you received a ticket? _____ Times
13. In the past five years, how many traffic tickets (other than parking tickets) have you received, whether or not you were at fault? _____ Tickets
14. Have you fallen within the last 6 months? Yes No
15. Have you fallen within the last 12 months? Yes No
16. Do you currently have any visual conditions/diseases that might potentially impair your driving ability? Yes No
- a. If so, what visual conditions do you have? _____
17. Do you currently have any neurological conditions/diseases that might potentially impair your driving ability?
- a. If so, what neurological conditions do you have? _____
18. Do you currently have any mobility conditions that might potentially impair your driving ability?
- a. If so, what mobility conditions do you have? _____
19. For each of the following health conditions, please check "Yes" if you have this condition, or "No" if you do not.

Health Condition	Yes	No
Arthritis		
Heart Problems		
High Blood Pressure		
Parkinson's		
Diabetes		
Seizures		
Depression		
Other: (please specify)		

Hazard Perception Questionnaire

What is your definition of a “driving hazard”?

Which of the following do you consider to be a driving hazard?

Potential Driving Hazard	Yes/No	Comments
Horse on Side of Road		
Horse entering roadway		
Bicyclist on side of road		
Bicyclist entering roadway		
Jogger on side of road		
Jogger crossing roadway		
Pedestrian at Crosswalk		
Pedestrian Crossing Road (crosswalk)		
Motorcycle/Moped in oncoming traffic		
Motorcycle/Moped on side of road		
Motorcycle/Moped entering traffic		
Motorcycle/Moped in opposing traffic		
Presence of Motorcycle/Moped		
Car in oncoming traffic		
Car parked on side of road		
Car crossing the middle lane		
Car travelling on shoulder of road		
Car stalled in roadway		
Car on side of road (drivers door open)		

Downed tree in roadway		
Traffic Cones in Roadway		
Other		

***Please return this information packet to the Experimenter
The following is to be filled out by the Experimenter:***

Participant NO: _____

Glasses/Contacts: Yes No

Experimenter Name: _____

Date: _____

Static Visual Acuity TEST #1:

Ensure the participant is wearing glasses or contacts if they regularly wear them. Have the participant stand on the red line (20ft away from chart) and read each line from left to right. Start at the large E at the top of the chart. Participants must read the ENTIRE LINE CORRECTLY in order to score at that acuity level.

Visual Acuity Rating: 20/ _____ (last line read correctly)

FAR POINT Visual Acuity TEST #2:

Ensure the participant is wearing glasses or contacts if they regularly wear them. Have the participant look into the Keystone Visual Testing Machine and read each line from left to right. Start at the large F at the top of the chart and read Column A from left to right..

Visual Acuity Rating: 20/ _____ (last line read correctly)

NEAR POINT Visual Acuity TEST #3:

Ensure the participant is wearing glasses or contacts if they regularly wear them. Have the participant look into the Keystone Visual Testing Machine and read each line from left to right. Start at the large S at the top of the chart and read column C from left to right.

Visual Acuity Rating: 20/ _____ (last line read correctly)

Contrast Sensitivity:

Ensure the participant is wearing glasses or contacts if they regularly wear them. Have the participant stand on the red line (10ft away from chart) and instruct them to “please read the direction that the top of each line is pointing aloud. Lines can point: LEFT, RIGHT, UP/DOWN. Start on line A, #1 and read from left to right. Place an X over each incorrect response. The white area of the table represents Normal Contrast Sensitivity.

	1	2	3	4	5	6	7	8	9
A	U	U	L	R	U	L	L	L	B
B	U	L	R	U	R	L	U	U	B
C	U	L	U	R	L	R	U	R	B
D	U	U	U	R	R	L	U	L	B
E	U	R	U	L	R	U	R	R	B

Reaction Time Tests:

These reaction times will be gathered after computerized reaction time tests are administered.

Computer Reaction Time Test: ____ms

Motorcycle Conspicuity Reaction Time Test: _____ms

APPENDIX C: MOTION SICKNESS HISTORY QUESTIONNAIRE

MOTION SICKNESS HISTORY QUESTIONNAIRE

Developed by Robert S. Kennedy & colleagues under various projects. For additional information contact:

Robert S. Kennedy, RSK Assessments, Inc., 1040 Woodcock Road, Suite 227, Orlando, FL 32803 (407) 894-5090

Subject Number: _____ **Date:** _____

1. Approximately how many total flight hours do you have? _____ hours
2. How often would you say you get airsick (please check ONE)?
Always___(4) Frequently___(3) Sometimes___(2) Rarely___(1) Never___(0)
3. a) How many total flight simulator hours? _____ Hours
b) How often have you been in a virtual reality device? _____ Times _____ Hours
4. How much experience have you had at sea aboard ships or boats?
Much ___ Some ___ Very Little ___ None _____
5. From your experience at sea, how often would you say you get seasick?
Always___(4) Frequently___(3) Sometimes___(2) Rarely___(1) Never___(0)
6. Have you ever been motion sick under any conditions other than the ones listed so far?
No___(0) Yes___(1) If so, under what conditions?
7. In general, how susceptible to motion sickness are you?
Extremely___(4) Very___(3) Moderately___(2) Minimally___(1) Not at all___(0)
8. Have you been nauseated FOR ANY REASON during the past eight weeks?
No ___ Yes ___ If yes, explain
9. When you were nauseated for any reason (including flu, alcohol, etc.), did you vomit?
Easily ___ Only with difficulty ___ Retch and finally vomited with great difficulty _____
10. If you vomited while experiencing motion sickness, did you:
a) Feel better and remain so?
b) Feel better temporarily, then vomit again?
c) Feel no better, but not vomit again?
d) Other - specify
11. If you were in an experiment where 50% of the subjects get sick, what do you think your chances of getting sick would be?
Almost _____ Almost _____

certainly would ____ (3)	Probably would ____ (2)	Probably would not ____ (1)	Certainly would not ____
-----------------------------	----------------------------	--------------------------------	-----------------------------

(0)

12. Would you volunteer for an experiment where you knew that: (Please answer all three)

- a) 50% of the subjects did get motion sick? Yes ___ No ____
- b) 75% of the subjects did get motion sick? Yes ___ No ____
- c) 85% of the subjects did get motion sick? Yes ___ No ____

13. Most people experience slight dizziness (not a result of motion) three to five times a year. The past year you have been dizzy:

More than this ___ The same as ___ Less than ___ Never dizzy ___

14. Have you ever had an ear illness or injury which was accompanied by dizziness and/or nausea? Yes ___ No ____

15. Listed below are a number of situations in which some people have reported motion sickness symptoms. In the space provided, check (a) your PREFERENCE for each activity (that is, how much you like to engage in that activity), and (b) any SYMPTOM(s) you may have experienced at any time, past or present.

SITUATIONS	PREFERENC E			SYMPTOMS												
	LI KE (0)	NE U R A L (1)	DI S L I K E (2)	V O M I T E D	N A U S E A	S T O M A C H A W A R E N E S S *	I N C R E A S E D S A L I V A T I O N	D I Z Z I N E S S	D R O W S I N E S S	S W E A T I N G	P A L L O R	V E R T I G O * *	A W A R E N E S S O F B R E A T H I N G	H E A D A C H E	O T H E R S Y M P T O M S	N O N E
Aircraft						12										
Flight simulator	1 3	1 3	13		14	15		1 6								
Roller Coaster																
Merry-Go-Round																
Other carnival devices																
Automobiles																
Long train or bus trips																
Swings																
Hammocks																
Gymnastic Apparatus																
Roller / Ice Skating																
Elevators																
Cinerama or Wide-Screen Movies																

Motorcycles																		
-------------	--	--	--	--	--	--	--	--	--	--	--	--	--	--	--	--	--	--

*Stomach awareness refers to a feeling of discomfort that is preliminary to nausea.

**Vertigo is experienced as loss of orientation with respect to vertical upright.

END OF MOTION HISTORY QUESTIONNAIRE

RSKA Form MHQ-2 (Rev. 5/01) © 1985-2001 RSK Assessments, Inc.

Motion History Questionnaire (MHQ) Scoring

Enter the Scores for the Following Questions:

#	Questions	S C O R E
2	Airsickness	
5	Seasickness	
6	Previous Motion Sickness	
7	Motion Sickness Susceptibility	
11	Chances of getting sick	
12	Stomach Awareness in Airplane (None =0, Felt =1)	
13	Flight Simulator: Preference (Like=0,Neutral=1,Dislike=2)	
14	Nauseous in Flight Simulator (None =0, Felt =1)	
15	Stomach Awareness in FS (None =0, Felt =1)	
16	Dizziness in Flight Simulator ((None =0, Felt =1)	
	TOTAL:	

APPENDIX D: INFORMED CONSENT FORM

Please read this consent document carefully before you decide to participate in this study.

Project Title: Visual Performance and the Detection of Road-way Hazards.

Purpose of the research study: The purpose of this study is to measure participants' detection abilities for hazards such as pedestrians crossing the road, Orange Traffic Cones and motorcycles on the road, under varying conditions, within a driving simulator.

What you will be asked to do in this study: Volunteer participation in this research project will take place in the UCF Department of Applied Experimental Human Factors' new Driving Simulator Laboratory located in Room 215 (Visual and Driving Performance Lab) in Howard Phillips Hall. Following an informal briefing about the UCF driving simulator, you will be given an opportunity for practice trial runs to become familiar with the controls and get acclimated to the virtual environment. After a short rest period, you will be asked to view a series of short video clips of road-way traffic, where you are to identify hazardous situations in the road such as pedestrians, red traffic lights, and motorcycles as quickly as possible. You will be asked to press the brake pedal as soon as you detect one of these hazardous situations and to announce what was detected. You will be allowed to take a short break every 5 minutes or sooner if desired. During each session, the research team will be recording information related to your driving behavior (steering, gas and brake pedal inputs) as well as location of the simulator vehicle and its proximity to certain objects in the visual scene.

Time Required: Approximately 60minutes

Risks: There is a small risk of subjects developing what is ordinarily referred to a simulator sickness. It occurs infrequently to subjects who are exposed to prolonged continuous testing in simulated environments. Symptoms consist of nausea and a feeling of being light headed. The risk is minimized as a result of the short duration of each session in the simulator. Five-minute breaks will be given at intervals if needed and participants will be allowed to withdraw from the experiment at any point without penalty. Potential side effects of virtual environment (VE) use include stomach discomfort, headaches, sleepiness, and mild degradation of postural stability. However, these risks are no greater than the sickness risks participants may be exposed to if they were to visit an amusement park such as Disney Quest (Disney Quest is a VE based theme park), or the Disney World or Universal Studios parks and ride attractions such as roller coasters. Participants will be administered a motion sickness history questionnaire (MHQ) prior to participation and those who score "high" as defined by the standardized test will be dismissed from further participation in the study. The simulator sickness questionnaire (SSQ) will also be administered throughout the study to assess the possibility of simulator sickness.

Benefits/Compensation: There is no direct benefit to you from participation in this study. All volunteers in this experiment will receive \$20 each for their time and effort in

completing this study. Participants attending UCF will also receive experimental course credit for their participation.

Privacy: Your identity will be kept confidential. Your name will not be used in any report. The recorded data will be assigned a code number. A list correlating participant names and code numbers will be locked up in the office of the principal investigator from UCF.

Voluntary participation: Your participation in this study is voluntary. You have the right to withdraw from this study at any time without consequence. Anyone not able to complete the study will receive \$10 regardless of what percentage of the tasks were completed. UCF Students who are not able to complete the study will receive half experimental course credit in addition to \$10 for partial completion in this study.

More information: For more information or if you have questions about this study, contact

Lorenzo I. Torrez
Principal Investigator
Applied Experimental Human Factors
425-296-6886
ltorrez@ucf.edu

or

Dr. Janan Smither
Faculty Supervisor/Coordinator
Applied Experimental Human Factors
407-823-5889
smither@ucf.edu

If you believe you have been injured during participation in this research project, you may file a claim with UCF Environmental Health & Safety, Risk and Insurance Office, P.O. Box 163500, Orlando, FL 32816-3500 (407) 823-6300. The University of Central Florida is an agency of the State of Florida for purposes of sovereign immunity and the university's and the state's liability for personal injury or property damage is extremely limited under Florida law. Accordingly, the university's and the state's ability to compensate you for any personal injury or property damage suffered during this research project is very limited.

Research at the University of Central Florida involving human participants is carried out under the oversight of the Institutional Review Board. **Information regarding your rights as a research volunteer may be obtained from:**

Institutional Review Board (IRB)

University of Central Florida
Office of Research & Commercialization
12201 Research Parkway, Suite 501
Orlando, FL 32826-3246
Telephone: (407) 823-2901

- I have read the procedure described above
- I voluntarily agree to participate in the procedure
- I am at least 18 years of age or older

Participant

Date

Principal Investigator

Date

APPENDIX E: PSYCHOLOGY RESEARCH EXPERIENCE EVALUATION FORM
FOR PARTICIPANTS

Psychology Research Experience Evaluation Form for Participants

Please complete this form to evaluate your experience as a participant in _____ Study conducted by _____ (Researcher)

Your Current Psychology Course(s): _____

This is important to our educational efforts and the feedback you provide will aid in the evaluation and possible modification of the research participation experience. Your answers are anonymous. When you have completed this form, return it to the Psychology Department Main Office (Howard Phillips Hall, Room 302).

For each question, please circle the statement that best indicates your response.

Do you clearly understand the purpose of this study?

<p>The researcher did not explain the purpose. I did not receive a written or oral explanation of the study.</p>	<p>The researcher explained the purpose or gave me a written explanation of the study, but did not give me a way to ask further questions.</p>	<p>The researcher explained the purpose, gave me a chance to ask questions, and answered the questions I had.</p>	<p>The researcher explained the purpose, gave me a chance to ask questions, and answered the questions I had, and made sure I understood the purpose and implications of the study.</p>
--	--	---	---

Was participating in this study a learning experience for you?

<p>I completed the study, but did not receive any additional</p>	<p>I furthered my learning about the research process (informed consent, debriefing, etc.) OR this specific</p>	<p>I gained information about the research process and this specific study.</p>	<p>I gained information about the research process, this specific study, and research that supports this</p>
--	---	---	--

information.	study (not both).		study.
--------------	-------------------	--	--------

Were you treated with courtesy and respect?

The researcher did not treat me with courtesy and respect.	The researcher treated me with some courtesy and respect.	The researcher treated me with an acceptable level of courtesy and respect.	The researcher treated me with a great deal of courtesy and respect.
---	--	--	---

Additional comments (continue on back if necessary):

APPENDIX F: EXPERIMENTAL ROAD-WAY CONDITION

The experimental road-way conditions used in this study was a 2-lane urban segment of closed road-way located within the Central Florida area. The following image represents the road-way condition and the vehicular left turn paradigm that was used in this study.

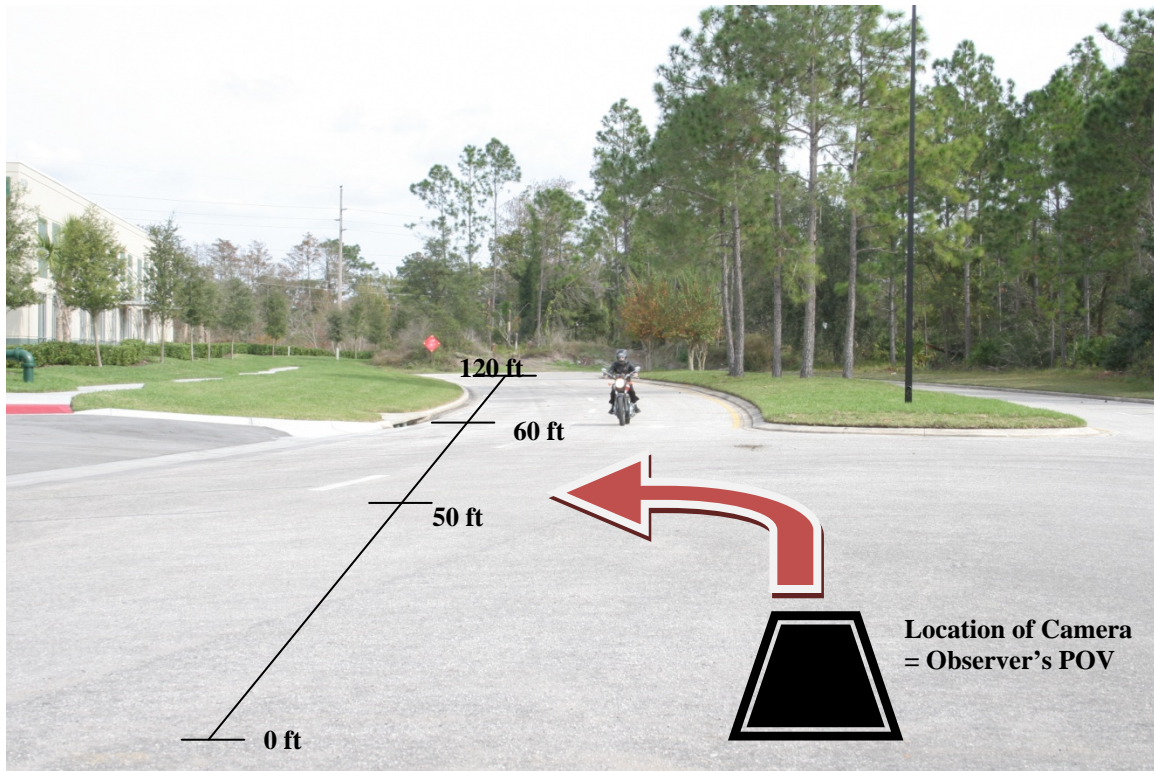

APPENDIX G: GE-I-SIM SIMULATOR

Video was presented using a GE PatrolSim II+ driving simulator. This particular driving simulator has a steering wheel, brake pedal, full dash, full driving controls, and is set up to replicate the interior of a 1995 Ford Crown Victoria. The driving simulator used in the current study is equipped with a Samsung HL-T5075S 50" Widescreen DLP High Definition Monitor.



SPECIFICATIONS

Height: 83 inches (2.11 meters)
Width: 119 inches (2.94 meters)
Depth: 63 inches (1.7 meters)
Weight: 1200 pounds (544 Kg)
Power Requirements:
60Hz, 20-amp, 115vac - Simulator
60Hz, 15-amp, 115vac - OpCon
Minimum Room Size;
10 feet by 10 feet by 8 feet high
Cooling BTU per hour: 12,000

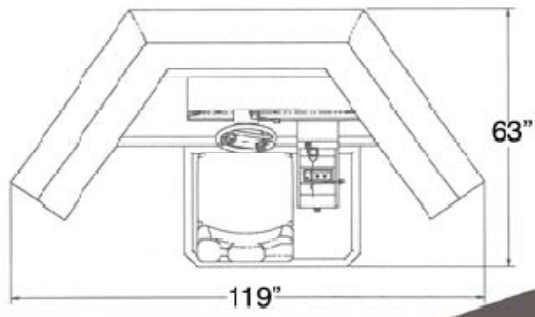

APPENDIX H: EXPERIMENTAL APPARATUS RESPONSE CONTROL BOX

Experimental Apparatus: Remote Selection Button Box



APPENDIX I: EXPERIMENTAL TEST VEHICLES

Experimental Test Vehicles



2006 Triumph Bonneville T100 motorcycle



2006 Chevrolet Trailblazer SUV

APPENDIX J: MOTORCYCLE HEADLIGHT MODULATORS

The following images are linked to animated gif file that demonstrate the overall appearance of a headlight modulated at a frequency of 4 HZ.



<http://www.kriss.com/#>

APPENDIX K: MOTORCYCLE CONSPICUITY TEST CONDITIONS

Motorcycle Conspicuity: Experimental Conditions

The following 12 experimental conditions were evaluated in this study.

Motorcycle Only:



Motorcycle Headlight-OFF



Motorcycle Headlight-ON



Motorcycle Headlight-Modulated

Motorcycle + Vehicle:



Motorcycle Headlight-OFF/Vehicular-DRL-OFF



Motorcycle Headlight-ON/Vehicular-DRL-OFF



Motorcycle Headlight-Modulated/Vehicular-DRL-OFF

Motorcycle + Vehicle w/Low Beam Headlights:



Motorcycle HeadlightOFF
/VehicularLowbeams



Motorcycle HeadlightON
/VehicularLowbeams



HeadlightModulated
/VehicularLowbeams

Motorcycle + Vehicle w/DRLs:



Motorcycle HeadlightOFF
/Vehicular-DRL-



Motorcycle HeadlightON
/Vehicular-DRL-



Headlight-Modulated
/Vehicular-DRL-ON

The following images are examples of the following two experimental conditions in this study: *Headlight-ON/Vehicular-DRL-OFF* and *Headlight-ON/Vehicular-DRL-ON*



Headlight-ON/Vehicular-DRL-OFF



Headlight-ON/Vehicular-DRL-ON



Vehicular-DRL-ON (LOW)



Vehicular-DRL-ON (Reduced Wattage DRL)

APPENDIX L: NHTSA-DOT SEC 571.108 STANDARD NO. 108
MOTORCYCLE HEADLIGHT MODULATION SYSTEM (2007)

TITLE 49 TRANSPORTATION
CHAPTER V NATIONAL HIGHWAY TRAFFIC SAFETY ADMINISTRATION, DEPARTMENT OF
 TRANSPORTATION
PART 571 FEDERAL MOTOR VEHICLE SAFETY STANDARDS

Subpart B--Federal Motor Vehicle Safety Standards
Sec. 571.108 Standard No. 108;

Lamps, reflective devices, and associated equipment - S7.9.4 Motorcycle headlamp modulation system.

S7.9.4.1 A headlamp on a motorcycle may be wired to modulate either the upper beam or the lower beam from its maximum intensity to a lesser intensity, provided that:

- (a) The rate of modulation shall be 240 <plus-minus> 40 cycles per minute.
- (b) The headlamp shall be operated at maximum power for 50 to 70 percent of each cycle.
- (c) The lowest intensity at any test point shall be not less than 17 percent of the maximum intensity measured at the same point.
- (d) The modulator switch shall be wired in the power lead of the beam filament being modulated and not in the ground side of the circuit.
- (e) Means shall be provided so that both the lower beam and upper beam remain operable in the event of a modulator failure.
- (f) The system shall include a sensor mounted with the axis of its sensing element perpendicular to a horizontal plane. Headlamp modulation shall cease whenever the level of light emitted by a tungsten filament light operating at 3000 deg. Kelvin is either less than 270 lux (25 foot-candles) of direct light for upward pointing sensors or less than 60 lux (5.6 foot-candles) of reflected light for downward pointing sensors. The light is measured by a silicon cell type light meter that is located at the sensor and pointing in the same direction as the sensor. A Kodak Gray Card (Kodak R-27) is placed at ground level to simulate the road surface in testing downward pointing sensors.
- (g) When tested in accordance with the test profile shown in Figure 9, the voltage drop across the modulator when the lamp is on at all test conditions for 12 volt systems and 6 volt systems shall not be greater than .45 volt. The modulator shall meet all the provisions of the standard after completion of the test profile shown in Figure 9.
- (h) Means shall be provided so that both the lower and upper beam function at design voltage when the headlamp control switch is in either the lower or upper beam position when the modulator is off.

S7.9.4.2(a) Each motorcycle headlamp modulator not intended as original equipment, or its container, shall be labeled with the maximum wattage, and the minimum wattage appropriate for its use. Additionally, each such modulator shall comply with S7.9.4.1 (a) through (g) when connected to a headlamp of the maximum rated power and a headlamp of the minimum rated power, and shall provide means so that the modulated beam functions at design voltage when the modulator is off.

(b) Instructions, with a diagram, shall be provided for mounting the light sensor including location on the motorcycle, distance above the road surface, and orientation with respect to the light.

APPENDIX M: VEHICULAR DAYTIME RUNNING LIGHTS

The following images demonstrate different types of vehicular Daytime Running Lights.



Reduced Wattage DRLs



Dedicated DRLs (separate light within headlight housing)

APPENDIX N: MOTORCYCLE DRY SURFACE BRAKING RESULTS

Dry Surface Braking Results (Green, 2006)

Table 2: Dry Surface Braking Results

			Honda VFR800			BMW F650			BMW R1150R			Yamaha FJR 1300		
Brake System Operation			with ABS and CBS	w/o ABS, with CBS		with ABS, w/o CBS	w/o ABS, w/o CBS		with ABS and CBS	w/o ABS, w/o CBS		with ABS, w/o CBS	w/o ABS, w/o CBS	
Brakes	Test Weight	Speed (km/h)	Dist. (m)	Dist. (m)	Diff. (%)	Dist. (m)	Dist. (m)	Diff. (%)	Dist. (m)	Dist. (m)	Diff. (%)	Dist. (m)	Dist. (m)	Diff. (%)
Both	Lightly loaded	48.3	11.37	11.18	-1.7	11.89	11.53	-3.0	12.30	10.79	-12.3	12.64	10.40	-17.7
		128.8*	70.67	71.84	+1.7	58.24	65.26	+12.0	68.12	71.82	+5.4	79.21	67.46	-14.8
	Loaded	48.3	13.60	13.44	-1.2	13.09	13.11	+0.1	13.70	13.36	-2.5	12.51	14.90 ⁽²⁾	+19.1
		128.8*	93.43 ⁽¹⁾	90.09	-3.6	63.06	66.08	+4.8	89.49 ⁽¹⁾	94.07	+5.1	78.00 ⁽¹⁾	93.33 ⁽²⁾	+19.7
Front	Lightly loaded	48.3	11.72	12.76	+8.9	13.74	13.55	-1.4	11.89	10.85	-8.7	14.90	12.89	-13.5
		128.8*	77.66	82.12	+5.7	65.98	66.14	+0.2	68.56	74.12	+8.1	84.14	74.41	-11.6
	Loaded	48.3	14.12	13.75	-2.6	14.67	15.76	+7.4	12.85	12.79	-0.5	14.39	13.91	-3.3
		128.8*	99.38 ⁽¹⁾	94.15	-5.3	70.98	85.07 ⁽²⁾	+19.8	78.01 ⁽¹⁾	90.21	+15.6	84.30	86.70	+2.8
Rear	Lightly loaded	48.3	13.78	16.54 ⁽²⁾	+20.0	22.25	23.45	+5.4	22.89	23.65	+3.3	25.86	25.74	-0.5
		128.8*	85.59	111.46 ⁽²⁾	+30.2	109.32	113.34	+3.7	134.71	158.23	+17.5	152.76	160.28	+4.9
	Loaded	48.3	16.24	17.57	+8.2	22.92	23.38	+2.0	22.77	24.83	+9.0	24.68	25.61	+3.8
		128.8*	105.63 ⁽¹⁾	122.03	+15.5	109.90	120.0	+9.2	134.66	183.48 ⁽²⁾	+36.3	143.46	164.12	+14.4

* Top speed of BMW F650 being 157 km/h, its test speed was 117.8 km/h (75% of 157 km/h).

Notes:

(1) Minimal or no ABS operation.

(2) Results most likely to improve with additional test runs.

(3) Average values listed for stops w/ABS, best result values listed for stops w/o ABS.

APPENDIX O: REACTION TIME-TO-DISTANCE CONVERSION

Reaction Time (ms)	Distance (Ft)
0	0
10	0.366667
20	0.733333
30	1.1
40	1.466666
50	1.833333
60	2.2
70	2.566666
80	2.933333
90	3.299999
100	3.666666
110	4.033333
120	4.399999
130	4.766666
140	5.133332
150	5.499999
160	5.866666
170	6.233332
180	6.599999
190	6.966665
200	7.333332
210	7.699999
220	8.066665
230	8.433332
240	8.799998
250	9.166665
260	9.533332
270	9.899998
280	10.26666
290	10.63333
300	11

APPENDIX P: IRB HUMAN SUBJECTS PERMISSION LETTER



January 9, 2007

Janan Al-Awar Smither, Ph.D. and
Lorenzo Torrez
University of Central Florida
Department of Psychology
PH 309G
Orlando, FL 32816-1390

Dear Dr. Smither & Mr. Torrez:

With reference to your protocol #06-4053 entitled, "Motorcycle Conspicuity: The Effects of Age and Vehicular Daytime Running Lights," I am enclosing for your records the approved, expedited document of the UCFIRB Form you had submitted to our office.

This study was approved on 01/09/2007. The expiration date for this study will be 01/08/2008. Should there be a need to extend this study, a Continuing Review form must be submitted to the IRB Office for review by the Chairman or full IRB at least one month prior to the expiration date. This is the responsibility of the investigator.

Please be advised that this approval is given for one year. Should there be any addendums or administrative changes to the already approved protocol, they must also be submitted to the Board through use of the Addendum/Modification Request form. Changes should not be initiated until written IRB approval is received. Adverse events should be reported to the IRB as they occur.

Should you have any questions, please do not hesitate to call me at 407-823-2901.

Please accept our best wishes for the success of your endeavors.

Cordially,

A handwritten signature in cursive script that reads 'Joanne Muratori'.

Joanne Muratori
(FWA00000351 Exp. 5/13/07, IRB00001138)

Copies: IRB File

JM:jt

REFERENCES

- Adam, J. J., Paas, F. G, Buekers, M. J., Wuyts, I. J., Spukers, W. A. C., & Wallmeyer, P. (1999). *Ergonomics*, 42(2), 327 – 335.
- Allen, M. J. (1970). *Vision and highway safety*. Philadelphia: Chilton.
- Bellaby, P., & Lawrenson, D. (2001). Approaches to the risk of riding motorcycles: Reflections on the problem of reconciling statistical risk assessment and motorcyclists' own reasons for riding. *Sociological Review*, 49(3), 368 – 388.
- Binder, S., Perel, M., Pierowicz, Gawron, V., & Wilson, G. (2005). Motorcycle conspicuity and the effects of motor vehicle fleet daytime running lights (DRLs). *Proceedings of the 6th International Symposium on Automotive Lighting*, Munchen, 6, 2 – 10.
- Blomberg, R. D., Hale, A., & Preusser, D. F. (1986). Experimental evaluation of alternative conspicuity-enhancement techniques for pedestrians and bicyclists. *Journal of Safety Research*, 17, 1 -12.
- Brooks, P. (1991). *Preventing driver error and motorcycle accident causation: An empirical investigation* (College of Aeronautics Report No. 9106). Cranfield-Bedford, England: Applied Psychology Unit – College of Aeronautics, Cranfield Institute of Technology.
- Brooks, P., & Guppy, A. (1990). Driver awareness and motorcycle accidents. *Proceedings of The International Motorcycle Safety Conference*, II, 10-27 – 10-56.
- Brouwer, R.F.T., Janssen, W.H., Duistermaat, M. & Theeuwes, J. (2004). *Do other road users suffer from the presence of cars that have their daytime running lights on?*

- Investigation of possible adverse effects of daytime running lights.* (TNO Report TM-04-C001). TNO Human Factors, Soesterberg.
- Burg, A., & Beers, J. (1978). Reflectorization for night-time conspicuity of bicycles and motorcycles. *Journal of Safety Research*, 10, 69 – 77.
- Caird, J.K., & Hancock, P.A. (1994). The perception of arrival time for different oncoming vehicles at an intersection. *Ecological Psychology*, 6(2), 83 – 109.
- Cairney, P. T. (1999). The conspicuity of bicycle lighting under on-road conditions. In A. G. Gale, I. D. Brown, C. M. Halegrave & Taylor S. P (Eds.), *Vision in Vehicles VI* (pp185 - 190). Oxford, England: Elsevier Science Ltd.
- Comagination (2006). Headlight modulator and solid state relay kit: Specifications. Retrieved on October 19, 2006 from <http://www.comagination.com/relay-kit-headlight-modulator.htm> ,
<http://www.webbikeworld.com/images/comagination/headlight-modulator.mov>
- Cook, S., & Quigley, C. (1998). *Motor vehicle and pedal cycle conspicuity: Part 3 – Retro-reflective and fluorescent materials*. Retrieved November 21, 2004, from http://www.lboro.ac.uk/research/esri/ttec/pdf_files/Vehicle_conspicuity.pdf
- Cole, B. L., & Hughes, P. K. (1984). A field trial of attention and search conspicuity. *Human Factors*, 26, 299 – 313.
- Cole, B. L., & Jenkins, P. K. (1984). The effect of variability of background elements on the conspicuity of objects. *Vision Research*, 24, 261 – 270.
- Corso, J.F. (1981) *Aging Sensory Systems and Perception*. Praeger: New York.

- CVPI. (2004) *Countermeasures: Crown Victoria Police Interceptor Conspicuity*. Retrieved December 3, 2004, from http://www.cvpi.com/pdfs/BRP_Report_Out_Countermeasures.pdf
- Department for Transport (2006). *Older drivers: A literature review*. (DFT Publication No. 25). London, UK: Department for Transport.
- Dewar, R., Kline, D., Scheiber, F., & Swanson, A. (1997). Symbol signing design for older drivers. Springfield, VA. (NTIS No. FHWA-RD-94-069).
- Donne, G. L., & Fulton, E. J. (1985). *The evaluation of aids to the daytime conspicuity of motorcycles* (Report No. LR 1137). Crowthorne, England; Department of Transportation, Transport and Road Research Dept.
- Dulisse, B. (1997). Older drivers and risk to other road users. *Accident Analysis and Prevention*, 29(5), 573 – 582.
- Engel, F. L. (1971). Visual conspicuity, directed attention and retinal locus. *Vision Research*, 11, 261 – 270.
- Engel, F. L. (1977). Visual conspicuity, visual search and fixation tendencies of the eye. *Vision Research*, 17, 95 – 108.
- Fitzgerald, E. S., & Harrison, W. A. (1999). Hazard perception and learner drivers: A theoretical discussion and an in-depth survey of driving instructors (Technical Report No. 161). Victoria, Australia: Monash University Accident Research Center.
- Forester, J. (2004). *Bicycle nighttime protective equipment: Literature presented to the consumer product safety commission*. Retrieved November 26, 2004 from <http://johnforester.com/articles/lights/cpsc pap.htm>

- Gerathewohl, S. J. (1954). Conspicuity of flashing light signals of different frequency and duration. *Journal of Experimental Psychology*, 48, 247 – 251.
- Gerathewohl, S. J. (1957). Conspicuity of flashing and steady light signals: Variation in contrast. *Journal of The Optical Society of America*, 47, 27 – 29.
- Gibson, J. J. (1966). *The senses considered as perceptual systems*. Boston: Houghton Mifflin.
- Grayson, G. B., & Sexton, B. F. (2002). The development of hazard perception testing (Research Report No: TRL558). Crowthorne, UK: TRL Limited.
- Green, D. (2006). A comparison of stopping distance performance for motorcycles equipped with ABS, CBS and conventional hydraulic brake systems. *Proceedings of International Motorcycle Safety Conference*, Long Beach, California, March 28th – 30th, 2006.
- Green, P., Kubacki, M., Olson, P.L., and Sivak, M. (1979). *Accidents and the Nighttime Conspicuity of Trucks* (Technical Report UM-HSRI-79-92). Ann Arbor, MI: The University of Michigan Highway Safety Research Institute.
- Hakamies-Blomqvist, L. (2004). Safety of older persons in traffic. *Proceedings of Transportation in an Aging Society*, Bethesda, Maryland, 27, 22 - 35.
- Harris, P. (1999). Vision and driving in the elderly. *Journal of Optometric Vision Development*, 30(4), 188 – 197.
- Haworth, N., Mulvihill, C., & Symmons, M. (2005). Hazard perception and responding by motorcyclists: Background and literature review (Technical Report No. 235). Victoria, Australia: Monash University Accident Research Center.

- Haworth, N. & Mulvihill, C. (2006, March). *A comparison of hazard perception and responding in car drivers and motocyclists*. Paper presented at the 2006 International Motorcycle Safety Conference , California USA.
- Christie. (2006) *High definition: Christie HD12K*. Retrieved on October 23, 2006 from <http://www.christiedigital.com/AMEN/Products/christieRoadsterHD12K.htm>
- Hendtlass, J. (1992). *Appendix C: Literature Review*. Retrieved November 30, 2004, from <http://www.parliament.vic.gov.au/rsc/1992cycle/appendC.html>
- Herslund, M. B., & Jorgensen, N. O. (2003). Looked-but-failed-to-see-errors in traffic. *Accident Analysis and Prevention*, 35, 885 – 891.
- Hills, B. L. (1980). Vision, visibility and perception in driving. *Perception*, 9, 183-216.
- Ho, G., Scialfa, C. T., Caird, J. K., & Graw, T. (2001). Visual search for traffic signs: The effects of clutter, luminance, and aging. *Human Factors*, 43(2), 194 – 207.
- Hole, G. J., & Tyrrell, L. (1995). The influence of perceptual set on the detection of motocyclists using daytime headlights, *Ergonomics*, 38(7), 1326 – 1341.
- Hole, G. J., Tyrrell, L., & Langham, M. (1996). Some factors affecting motocyclists' conspicuity, *Ergonomics*, 39(7), 946 – 965.
- Horberg, U. & Rumar, K. (1979). The effect of running lights on vehicle conspicuity in daylight and twilight. *Ergonomics*, 22, 165 – 173.
- Horswill, M. S., & Helman, S. (2001). *A comparative approach to differential accident liability: Motocyclists versus car drivers*. In G. B. Grayson (Ed), *Behavioral research in road safety: 11th Seminar* (pp 215 – 228). London: Department of Environmental Transport, and the Regions.

- Horswill, M. S., & Helman, S. (2003). A behavioral comparison between motorcyclists and a matched group of non-motorcycling car drivers: Factors influencing accident risk. *Accident Analysis and Prevention*, 35, 589 – 597.
- Huang, B., & Preston, J. (2004). *A literature review on motorcycle collisions: Final report*. Retrieved November 4, 2004, from <http://www.mpi.mb.ca/PDFs/MotorcycleRiskStudy/Appendix%205.2%20Oxford%20Univ.pdf>
- Hughes, P. K., & Cole, B. L. (1984). Search and attention conspicuity of road traffic control devices. *Australian Road Research Board*, 14, 1 – 9.
- Hurt, H.H., Ouellet, J.V. and Thom, D.R (1981). *Motorcycle Accident Cause Factors and Identification of Countermeasures*, Volume 1: Technical Report No. DOT HS-5-01160. Los Angeles, California: University of Southern California, Traffic Safety Center.
- ICE Ergonomics (2002). *Motor vehicle conspicuity: Warning beacons*. Retrieved December 2, 2004, from <http://www.unece.org/trans/main/wp29/wp29wgs/wp29gre/greinfdoc/48inf02.pdf>
- IIHS (2006). *Insurance Institute of Highway Safety: Daytime running light Q & A*. Retrieved October 10, 2006, from <http://www.iihs.org/research/qanda/drl.html>
- Janoff, M. S., Cassel, A., Fertner, K. S., & Smierciak, E. S. (1970). *Daytime motorcycle headlight and taillight operation* (Technical Report No. F-C 2588). Philadelphia, PA: Franklin Institute Research Laboratories.
- Janoff, M. S., & Cassel, A. (1971). Effect of daytime motorcycle headlight laws on motorcycle accidents. *Highway Research Record*, 377, 53 – 63.

- Johnson, E. P., & Bartlett, N. R. (1956). Effect of stimulus duration on electrical responses of the human retina. *Journal of the optical Society of America*, 46, 167 – 171.
- Kennedy, R. S., Fowlkes, J. E., Berbaum, K. S., & Lilienthal, M. G. (1992). Use of a motion sickness questionnaire for prediction of simulator sickness. *Aviation, Space and Environmental Medicine*, 63(7), 588 -593.
- Keskinen, E., Ota, H., & Katila, A. (1998). Older drivers fail in intersections: Speed discrepancies between older and younger male drivers. *Accident Analysis and Prevention*, 30(3), 323 – 330.
- Kirkby, C. & Stroud, P. G. (1978). Effects of motorcyclists high-visibility aids on driver gap acceptance. *Traffic Engineering and Control*, 19, 401 – 403.
- Kline, D. W., Kline, T. J. B., Fozard, J. L., Kosnik, W., Schieber, F., & Sekular, R. (1992) Vision, aging, and driving: The problems of older drivers. *Journal of Gerontology: Psychological Sciences*, 47(1), 27 – 34.
- Kwan, I. & Mapstone, J. (2004). Visibility aids for pedestrians and cyclists: A systematic review of randomized controlled trials. *Accident Analysis and Prevention*, 36, 305 – 312.
- Kooi, F. L., & Toet, A. (1999). Conspicuity: An efficient alternative for search time. In A. G. Gale, I. D. Brown, C. M. Halegrave & Taylor S. P (Eds.), *Vision in Vehicles VII* (pp 451 – 462).
- Koornstra, M., Bijleveld, F. & Hagenzicker, M. (1997). *The safety effects of daytime running lights: A perspective on daytime running lights (DRL) in the EU*. (Tech Rep. R-97-36). The Netherlands: SWOV Institute for Road Safety Research.

- Jenkins, S. E. & Cole, B. L. (1982). The effect of density of background elements on the conspicuity of objects. *Vision Research*, 22, 1241 – 1252.
- Labbett, S., & Langham, M. (2005). Training can make the problem worse. *Proceedings of the 70th Annual Royal Society for the Prevention of Accidents: Road Safety Congress*. Brighton, UK.
- Langham, M. P. (1999). Effects of cognitive style on motorcycle conspicuity. In A. G. Gale, I. D. Brown, C. M. Halegrave & Taylor S. P (Eds.), *Vision in Vehicles VI* (pp191 – 200).
- Langham, M., Hole, G., Edwards, J., & O’Neil, C. (2002). An analysis of “looked but failed to see” accidents involving parked police vehicles. *Ergonomics*, 45(3), 167 – 185.
- Langham, M., & McDonald, N. (2004, May). Now you see me, now you don’t. *Proceedings of the IPWEA NSW Division Annual Conference*, Sydney, Australia.
- Langham, M. P., & Moberly, N. J. (2003). Pedestrian conspicuity research: A review. *Ergonomics*, 46, 345 – 363.
- Lahtela, K., Niemi, P., & Kuusela, V. (1985). Adult visual choice-reaction time, age, sex, and preparedness. *Scandinavian Journal of Psychology*, 26, 357 – 362.
- Leica Geosystems (2007). Leica Disto A8. Retrieved on February 3rd, 2007 from http://www.leica-geosystems.com/cpd/en/ndef/lgs_64226.htm
- Levine, M. W. (2000). *Levine and Shefner’s fundamentals of sensation and perception* (3rd ed.). New York, NY: Oxford University Press.

- Long, G. E. (1951). The effect of duration on onset and cessation of light flash on the intensity-tiem relation in the peripheral retina. *Journal of the Optical Society of America*, 41, 743 – 747.
- Lord, D., Smiley, A., & Haroun, A. (1998, January). *Pedestrian accidents with left-turning traffic at signalized intersections: Characteristics, human factors and unconsidered issues*. Paper presented at the 77th Annual Transportation Research Board Meeting. Washington, DC.
- Luoma, J., Schumann, J., & Traube, E. C. (1996). Effects of retroreflector positioning on nighttime recognition of pedestrians. *Accident Analysis and Prevention*, 28(3), 377 – 383.
- Magazzu, D., Comelli, M., & Marinoni, A. (2006). Are car drivers holding a motorcycle license less responsible for motorcycle-car crash occurrence? A non-parametric approach. *Accident Analysis and Prevention*, 38, 365 – 370.
- Mack, A., & Rock, A. (2000). *Inattentional blindness*. Cambridge, MA: The MIT Press.
- MAIDS (2006). In-depth investigations of accidents involving powered two wheelers: Final report version 1.2. Retrieved on October, 20, 2006 from <http://maids.acembike.org/MAIDS%20Report%201.2-2nd%20September%202004.pdf>
- Masha, M. & Shinar, D. (1999). Eye movements of younger and older drivers. *Human Factors*, 41(1), 15 – 25.
- McCormack, P. D., Wright, N. M. (1964). The positive skew observed in reaction time distributions. *Canadian Journal of Psychology Revue*, 18(1), 43-51.

- McKenna, F. P., & Horswill, M. S. (1999). Hazard perception and its relevance for driver licensing. *Journal of the International Association for Traffic Safety Science*, 23(1), 26 – 41.
- Michon, J. A., Ernst, J. T. & Koutstoal, G. A. (1969). Safety clothing for human traffic obstacles. *Ergonomics*, 12, 61 – 70.
- Motorcycle Safety Foundation. (1999). *Motorcycle Safety* (DOT HS 807 - 709). Washington DC: U.S. Department of Transportation, National Highway Traffic Safety Administration.
- Motorcycle Safety Foundation. (2000). *National Agenda for Motorcycle Safety* (DOT HS 809 156). Washington DC: U.S. Department of Transportation, National Highway Traffic Safety Administration.
- National Highway Traffic Safety Administration (2006). *PART 571--FEDERAL MOTOR VEHICLE SAFETY STANDARDS*. Retrieved October 19, 2006 from http://a257.g.akamaitech.net/7/257/2422/12feb20041500/edocket.access.gpo.gov/cfr_2004/octqtr/pdf/49cfr571.108.pdf
- Noyce, D. A. (1999). *Human factors considerations in the selection of a uniform protected/permitted left-turn signal display*. Madison, WI: The Wisconsin Traffic Operations and Safety (TOPS) Laboratory, University of Wisconsin-Madison
- Olson, P. L. (1984). Motorcycle conspicuity. In G. A. Peters and B. J. Peters (Eds.), *Automotive Engineering and Litigation: Vol 1*. New York, NY: Garland Publishing.

- Olson, P. L., Halstead-Nussloch, R. & Sivak, M. (1981). The effect of improvements in motorcycle/motorcyclist conspicuity on driver behavior. *Human Factors*, 23, 237 – 248.
- Owens, D. A., & Antonoff, R. J. (1994). Biological motion and nighttime pedestrian conspicuity. *Human Factors*, 36, 718 – 732.
- Owsley, C., Ball, K., Sloane, M. E., Roenker, D. L., & Bruni, J. R. (1991). Visual/cognitive correlates of vehicle accidents in older drivers. *Psychology and Aging*, 5(3), 403 – 415.
- Owsley, C., Burton-Danner, K., & Jackson, G. R. (2000). Aging and spatial localization during feature search. *Gerontology*, 46, 300- 305.
- Paine, D., Haley, J., & Cockfield, S. (2005) Daytime running lights for motorcycles. *Proceedings of the 19th International Conference on the Enhanced Safety of Vehicles - Washington DC*, 19, 1-8.
- Perlot, A., & Prower, S. (2003). *Review of the evidence for motorcycle and motorcar daytime lights*. Retrieved December 1, 2004, from <http://www.safespeed.org.uk/~dadrl/Perlot%20&%20Prower%202003.pdf>
- Plaster, G. A., Lodge, K. J., & Mulvaney, D. E. (1979) Effect of distance of photostimulation on a photosensitive epileptic subject. *Psychological Reports*, 45, 271-274.
- Reiss, M. L., & Haley, J. A. (1968). *Motorcycle safety*. Airborne Instruments Lab; NY. (NTIS No. PB/178/332)
- Rinalducci, E. J. & Higgins, K. E. (1971). An investigation of the effective intensity of flashing lights at threshold and supra-threshold levels. *In Proceedings of the*

- International Symposium of Imperial College of London: The Perception and Application of Flashing Lights*. London, 113-125.
- Road Safety Committee (1992), *Social Development Committee Inquiry into Motorcycle Safety in Victoria*. Retrieved November 29, 2004, from <http://www.parliament.vic.gov.au/rsc/1992cycle/motorcycle.htm>
- Rousseau, G. K., Lamson, N., & Rogers, W. A. (1998). Designing warnings to compensate for age-related changes in perceptual and cognitive abilities. *Psychology of Marketing*, 15(7), 643 – 662.
- Rumar, K. (1980). Running lights: Conspicuity, glare, and accident reduction. *Accident Analysis and Prevention*, 12, 151 – 157.
- USPTO. (2004). *The United States Patent and Trademark Office*. Retrieved November 4, 2004, from <http://www.uspto.gov/>
- Sagberg, F., & Bjornskau, T. (2006). Hazard perception and driving experience among novice drivers. *Accident Analysis and Prevention*, 38, 407 – 414.
- Samsung (2007). *Samsung HL-T5075S 50” Widescreen DLP HDTV Monitor*. Retrieved July 21, 2007, from http://www.samsung.com/us/consumer/detail/detail.do?group=televisions&type=televisions&subtype=dlptv&model_cd=HLT5075SX/XAA
- Saunders, G. & Gough, A. (2003). Emergency ambulances on the public highway linked with inconvenience and potential danger to road users. *Emergency Medical Journal*, 20, 277-280

- Sayer, J. R., & Mefford, M. L. (2004). High visibility safety apparel and nighttime conspicuity of pedestrians in work zones. *Journal of Safety Research*, 35, 537 – 546.
- Shinar, D., & Schieber, F. (1991). Visual requirements for safety and mobility of older drivers. *Human Factors*, 35(5), 507 – 519.
- Sivak, M. (1987). Human factors and road safety: Overview of research at the University of Michigan Transportation Research Institute between 1977 and 1986. *Applied Ergonomics*, 18, 289 – 296.
- Schieber, F. & Goodspeed, C. H. (1997). Nighttime conspicuity of highway signs as a function of sign brightness, background, complexity and age of observer. *In Proceedings of the Human Factors and Ergonomics Society*, 1362 – 1366.
- Shinar, D. (1985). The effects of expectancy, clothing reflectance, and detection criterion on nighttime pedestrian visibility, *Human Factors*, 27(3), 327 – 333.
- Smith, A. G. (1991). Effective warning lights. *Law and Order*, 39, 57 – 62.
- Smith, G. A., & Brewer, N. (1995). Slowness and Age: Speed-Accuracy Mechanisms. *Psychology and Aging*, 10, 2, 238 – 247.
- Solomon, S. S. (1990). Lime-Yellow color as related to reduction of serious fire apparatus accidents: The case for visibility in emergency vehicle accident avoidance. *Journal of the American Optometric Association*, 61, 827 – 831.
- Summala, H., Pasanen, E, Rasanen, M, & Sievanen, J. (1996). Bicycle accidents and drivers visual search at left and right turns. *Accident Analysis and Prevention*, 28(2), 147 – 153.

- Tenkink, E. & Walraven, J. (1987). Conspicuity of flashing warning lights at dutch open-level realroad crossings. In A. G. Gale, M. H. Freeman, C. M. Halegrave, P. Smith & Taylor S. P (Eds.), *Vision in Vehicles II* (pp 167 –175).
- Theeuwes, J., & Alferdinck, J. (1997). The effectiveness of side marker lamps: An experimental study. *Accident Analysis and Prevention*, 29, 235 – 245.
- Thomson, G. A. (1980). The role frontal motorcycle conspicuity has in road accidents, *Accident Analysis and Prevention*, 12, 165 – 178.
- Thomson, G. A. (1982). Do measurements of motorcycle conspicuity really measure conspicuity effects? *Ergonomics*, 25, 771 – 782.
- Tijerina, L. (2003, February). *Committee Report: Conspicuity enhancement for police interceptor rear-end crash mitigation*. The Blue Ribbon Panel Committee on Lighting and Conspicuity- Ford, Dearborn, MI.
- Watanabe, K. Imada, T., & Nihei, K. (2002) Neuromagnetic responses to chromatic flicker: Implications for photosensitivity. *Rapid Communication of Neuroscience Research*,13, 2161-2165.
- Williams, M. J., & Hoffman, E. R.(1976). *Improvement of frontal conspicuity of motorcycles*. Melbourne, Australia; The University of Melbourne, Department of Mechanical Engineering.
- Williams, M. J., & Hoffman, E. R. (1977). *The influence of motorcycle visibility of traffic accidents*. The Department of Transport Report. Melbourne: University of Melbourne.
- Williams, M. J., & Hoffman, E. R. (1979). Conspicuity of motorcycles. *Human Factors*. 21, 619 – 626.

- Williams, A. F., & Lancaster, K. A. (1995). The prospects of daytime running lights for reducing vehicle crashes in the United States. *Public Health Report*, 110(3), 233 – 239.
- Witkin, H. A. (1950). Individual differences in ease of perception of embedded figures. *Journal of Personality*, 19, 1 – 15.
- Woltman, H. L., & Austin, R. L. (1973). *Some day and night time visual aspects of motorcycle safety*. Paper presented at the 2nd International Congress on Automotive Safety.
- Woltman, H. L., & Austin, R. L. (1974). Some day and nighttime visual aspects of motorcycle safety. *Transportation Research Record*, 502, 1 – 8.
- Wood, J. M., Tyrrell, R. A., & Carberry, T. P. (2005). Limitations in drivers' ability to recognize pedestrians at night. *Human Factors*, 47(3), 644 – 655.
- Wulf, G., Hancock, P. A., & Rahimi, M. (1989). Motorcycle conspicuity: An evaluation and synthesis of influential factors. *Journal of Safety Research*, 20, 153 – 176.