



Collection of soot particles into aqueous suspension using a particle-into-liquid sampler

Anna Wonaschuetz, Theresa Haller, Eva Sommer, Lorenz Witek, Hinrich Grothe & Regina Hitzemberger

To cite this article: Anna Wonaschuetz, Theresa Haller, Eva Sommer, Lorenz Witek, Hinrich Grothe & Regina Hitzemberger (2019) Collection of soot particles into aqueous suspension using a particle-into-liquid sampler, *Aerosol Science and Technology*, 53:1, 21-28, DOI: [10.1080/02786826.2018.1540859](https://doi.org/10.1080/02786826.2018.1540859)

To link to this article: <https://doi.org/10.1080/02786826.2018.1540859>



© 2018 The Author(s). Published with license by Taylor & Francis Group, LLC



Published online: 06 Dec 2018.



Submit your article to this journal [↗](#)



Article views: 1363



View related articles [↗](#)



View Crossmark data [↗](#)



Citing articles: 2 View citing articles [↗](#)



Collection of soot particles into aqueous suspension using a particle-into-liquid sampler

Anna Wonaschuetz^a , Theresa Haller^a, Eva Sommer^a, Lorenz Witek^a, Hinrich Grothe^b, and Regina Hitznerberger^a

^aUniversity of Vienna, Faculty of Physics, Vienna, Austria; ^bTU Wien, Institute of Materials Chemistry, Vienna, Austria

ABSTRACT

Steam collection devices collecting aerosol particles into liquid samples are frequently used to analyze water-soluble particulate material. The fate of water-insoluble components is often neglected. In this work, we show that fresh soot particles can be suspended into pure water using a steam collection device, the particle-into-liquid sampler (PILS, Weber et al. 2001). The overall collection efficiency of freshly generated soot particles was found to be on the order of 20%. This shows that, depending on the analytic technique employed, the presence of insoluble, and/or hydrophobic particles in liquid samples from steam collection cannot be neglected.

ARTICLE HISTORY

Received 28 May 2018
Accepted 18 September 2018

EDITOR

Kihong Park

Introduction

Steam collection devices are used for collecting aerosol particles into a liquid sample. While details vary from instrument to instrument, the basic principle of operation is the mixing of the aerosol with hot steam, followed by cooling and droplet formation (with the aerosol particles serving as condensation nuclei) and transfer of the droplets into a liquid sample for analysis. A number of analysis methods of the liquid sample are described in the literature: on-line bulk chemical composition measurements using ion chromatography (Weber et al., 2001; Khlystov, Wyers, and Slanina 1995; Poruthoor and Dasgupta 1995; Löflund et al. 2001; Timonen et al. 2010), determination of water-soluble organic carbon (WSOC) by TOC analysis (Sullivan et al. 2004), atomic absorption spectrometry (Kidwell and Ondov 2004), measurement of aerosol acidity (Ito et al., 1998), fluorometric measurements (Poruthoor and Dasgupta 1998), and other liquid-phase chemical analysis methods (Sierau et al. 2003; Parshintsev et al. 2010; Saarnio et al. 2013; Clark et al. 2013; Violaki et al. 2016; Zhang et al. 2016).

The collection of particles in steam collection devices is based on their ability to act as condensation nuclei at the supersaturation achieved in the cooling section of the instrument. If insoluble particles are hygroscopic

(this includes hydrophobic matter that has acquired a hygroscopic surface film, for example, soot particles with a sulfate coating), at sufficient supersaturation, water will condense on them, and the particles will enter the liquid sample. Supersaturations in steam collecting devices tend to be very high: Khlystov, Wyers, and Slanina (1995) report over 200% for their steam jet aerosol collector (SJAC); Kidwell and Ondov (2004) report a maximum theoretical saturation ratio of 1.8 in their instrument. They also state that a saturation ratio of 1.25 is needed to grow hydrophobic particles as small as 0.010–5 μm within 0.03 s (residence time in device is 0.5 s). For the Particle-Into-Liquid-Sampler (PILS), Sullivan et al. (2004) report that water vapor condenses on all atmospheric particles larger than 10–30 nm. Assuming that this includes insoluble, completely wettable particles, this would place a lower boundary on the PILS supersaturation in the range of 7–23% (Kelvin diameter between 10 and 30 nm). Given these conditions, the collection of insoluble, even hydrophobic, material into a liquid sample is possible. Also, the generation of samples of insoluble particles in aqueous suspension without the use of any other solvent has practical applications, for example, in ice nucleation experiments (Zolles et al. 2015; Augustin et al. 2013; Häusler et al. 2017).

CONTACT Anna Wonaschuetz anna.wonaschuetz@univie.ac.at University of Vienna, Faculty of Physics, Boltzmannngasse 5, Vienna 1090, Austria.

© 2018 The Author(s). Published with license by Taylor & Francis Group, LLC

This is an Open Access article distributed under the terms of the Creative Commons Attribution-NonCommercial-NoDerivatives License (<http://creativecommons.org/licenses/by-nc-nd/4.0/>), which permits non-commercial re-use, distribution, and reproduction in any medium, provided the original work is properly cited, and is not altered, transformed, or built upon in any way.

The capability of steam collection devices to collect insoluble and/or hydrophobic material is described in the literature, although usually not in much detail: For the Steam Jet Aerosol Collector (SJAC), Slanina et al. (2001) state a sampling efficiency for carbon black particles ($d_p > 10$ nm) of 99.9%, but do not describe how this was determined. Ito et al. (1998) explicitly state that “solid material remains suspended,” but do not comment on its fate in the analytical system. Kidwell and Ondov (2004) describe their liquid sample as a slurry containing both soluble and hydrophobic components, both of which were analyzed without physical separation. For the PILS (a version of which is used in this study), Weber et al. (2001) describe the sample as a “liquid containing particles.” For a later version of the PILS, Orsini et al. (2003) state that the “final exiting flow is a solution containing the soluble ions of the collected aerosol particles.” The solubility of particles is discussed as a potential source for artifacts, but insolubles are not discussed specifically. In a more detailed investigation, Zhang et al. (2016) report the sampling of slightly water-soluble compounds in a PILS system: Using organic standards of variable solubility, and employing a mixture of isopropanol and water as wash flow (which may increase solubility of some substances), they find a solubility threshold of 1 g L^{-1} , above which a mass collection efficiency of > 0.6 is achieved. In some works, insolubles are stated to be removed by an in-line liquid filter placed into the liquid sample flow line (Timonen et al. 2010; Rastogi et al. 2015; Satish et al. 2017), and often, a pore size is given: $0.45 \mu\text{m}$ (Rastogi et al. 2015; Satish et al. 2017), or $0.5 \mu\text{m}$ (Sullivan et al. 2004). However, this technique may not be sufficient to remove insolubles for every type of aerosol sample. For example, fresh combustion particles, consisting mostly of insoluble material, are on the order of tens of nanometers in diameter, much smaller than the reported pore size. The actual percentage of particles retained by an inline filter is usually not reported in the PILS literature. In many other studies, the possible presence of insoluble material is not mentioned at all.

An experiment determining explicitly the sampling efficiency of insoluble and hydrophobic material in steam collection devices is missing from the literature to the best of our knowledge. In this work, we examine the possible transfer of insoluble and partially hydrophobic aerosol particles into a PILS liquid sample. We determine the collection efficiency of CAST generated soot by comparing black carbon (BC) concentrations entering and exiting the PILS, using the

Integrating Sphere method (Hitzenberger, Dusek, and Berner 1996, Wonaschütz et al. 2009) to analyze both the ingoing aerosol and the liquid PILS sample.

Methods

Soot particles were generated with a Combustion Aerosol STandard (CAST) Generator (MiniCAST 5201, Jing 1999); full characterization by Moore et al. (2014). In the CAST, particles are produced in a diffusion flame, with propane (C_3H_8) as combustion gas (combustion gas flow rate $Q_{\text{C}_3\text{H}_8}$), and filtered pressurized air as oxidation gas (oxidation gas flow rate Q_{ox}). Nitrogen can be added (Q_{N_2}) to the mix of propane and oxidation gas. The aerosol exiting the combustion chamber is quenched by adding N_2 (7.5 lpm, Q_q) into the flow, stabilizing the particle size distribution, and diluted by filtered pressurized air (air flow rate Q_p), which compensates for the variations in the amount of soot produced by the CAST at the different combustion conditions. By varying the gas flow rates $Q_{\text{C}_3\text{H}_8}$ and Q_{ox} , the carbon/oxygen (C/O) ratio of the combustion process is changed, which in turn influences the physical and chemical properties of the soot particles produced (Moore et al. 2014; Kim et al. 2015). This will be termed “C/O setting” for the remainder of this article.

The detailed design of the PILS (Model 4001, Brechtel, Inc.) is described in the literature (Weber et al. 2001; Orsini et al. 2003; Sorooshian et al. 2006). The aerosol enters the instrument via an impactor with a lower cut diameter of $2.5 \mu\text{m}$ aerodynamic equivalent diameter. In the instrument, the aerosol is mixed with steam at a temperature of about $97.5\text{--}100^\circ\text{C}$. In the condensation chamber, the particles grow into droplets. The droplets are then transported to, and impacted on a quartz plate. The air flow passes through an internal critical orifice (13.4 lpm), and leaves through the pump exhaust. The impacted droplets are transferred into a wash flow along a mesh wick at the perimeter of the quartz plate. The liquid sample is then collected into flexible tubing attached at the bottom of the mesh wick/quartz plate and transported by a peristaltic pump (flow rate: 0.5 ml/min). The sample passes through a debubbler, which removes any remaining air, and is finally collected in a vial. The reported lower collection limit of particle size is $d_p = 30 \text{ nm}$ for sulfate particles (Orsini et al. 2003), or between 10 and 30 nm for atmospheric particles (Sullivan et al. 2004).

Figure 1 shows the experimental setup. Soot aerosol generated by the CAST passes through a valve and is

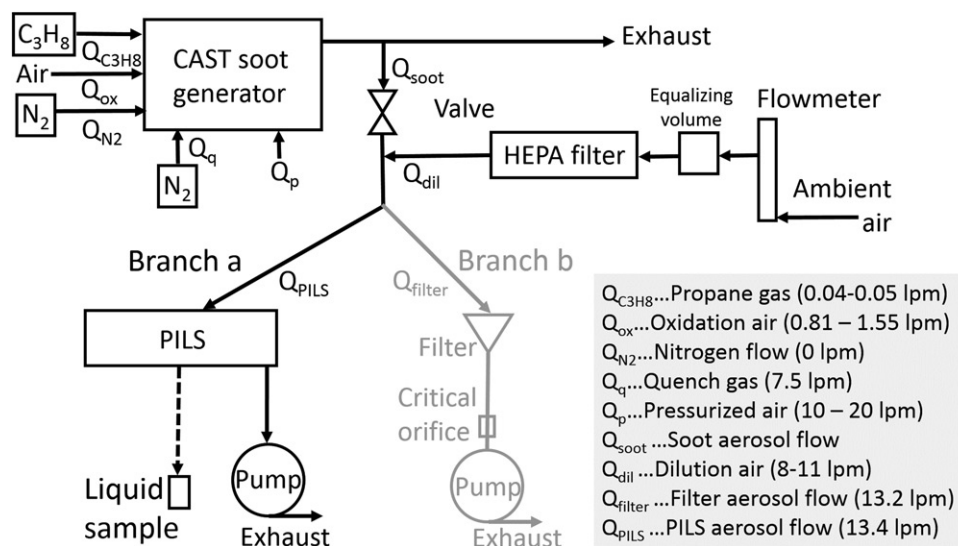

Figure 1. Experimental setup. Branch a: Sampling of soot aerosol by the Particle-Into-Liquid Sampler, Branch b: Filter sampling of the soot aerosol.

diluted with filtered pressurized air (dilution flow rate Q_{dil} ; HEPA filter, Pall Corporation). The aerosol then passes to one of two branches, which are operated alternately, by physical attachment/removal: in Branch a (black in Figure 1), the aerosol flow (Q_{PILS}) is controlled by the PILS internal critical orifice. The aerosol enters the PILS, where it is collected into the liquid sample as described above. In Branch b, the particles are collected on a quartz fiber filter (Pallflex Tissuquartz, Pall Corporation, 47 mm diameter, sample area: 40 mm diameter). The filters had been pre-baked for 1 h at 450 °C and equilibrated for 24 h at room temperature in a water-saturated atmosphere to remove adsorbed OC (Jankowski et al. 2008). The aerosol flow rate in the filtration branch (Q_{filter}) is controlled by a separate critical orifice. Filter samples were stored in a freezer after loading and brought to room temperature immediately before analysis. The measured flow rates (flowmeter, Figure 1) Q_{PILS} and Q_{filter} were (13.4 ± 0.2) lpm and (13.2 ± 0.3) lpm, respectively. The possible Q_{dil} and C/O settings were bracketed by the necessity to obtain BC and/or BrC concentrations above the detection limits of the integrating sphere (IS) method ($1-10 \mu\text{g BC/sample}$) and, on the other hand, minimizing PILS cleaning efforts (see also below). Optimum working conditions were found in test measurements and comprised (i) two alternative amounts of sampled liquid (12 and 2 ml), (ii) Q_{dil} ranging from 7.5 to 12 lpm, (iii) the C/O settings shown in Table 1. Nitrogen was not added to the mix of propane and oxidation gas ($Q_{N_2}=0$). At these settings, no decrease of Q_{PILS} was observed within the sampling time.

Two experiments were conducted to determine the collection efficiency CE for the soot particles: (1) determination of CE at different C/O settings with constant dilution for each setting; (2) determination of CE at different dilutions (i.e., different soot concentrations) for C/O setting 2.

For Experiment 1, the following measurement procedure was employed for each C/O setting: The flow rate in Branch b was measured by closing the valve and reading the total flow rate from the flowmeter. After this, an appropriate Q_{dil} was set by opening the valve. The aerosol was sampled on a filter for two to five minutes (depending on the dilution). Meanwhile, the PILS was sampling filtered air. The setup was then switched to Branch a, and the total flow rate was measured (valve closed). The valve was opened and adjusted to the desired dilution flow; then, one (for settings 1 and 6) or two (for all other settings) PILS samples were taken with sampling times of 24 min (12 ml of sample) or 4 min (2 ml of sample), respectively. This procedure was repeated five times (three times for setting 6), followed by a last filter sample. The PILS was then rinsed by sampling filtered air for a minimum of 1 h. Previous test measurements showed that after 45 min no more soot was detectable by the IS method in the PILS sample. As soot deposits accumulated within the PILS components over time, in spite of the rinsing, a rigorous cleaning schedule (impactor surface, mesh wick, debubbler membrane, air flow critical orifice) was kept, which depended on the CAST settings. For example, for settings 2, 3, and 4, around fifteen samples were taken between each cleaning; for setting 5, cleaning was necessary after only 1–2 samples. The components were cleaned in

an ultrasonic bath, using isopropanol and/or ultrapure water as solvents.

In Experiment 2, C/O setting 2 was chosen to evaluate the collection efficiency CE. The measurement procedure was analogous; a series of 70 measurements was conducted by varying the dilution air flow rate (Q_{dil}), effecting different incoming soot concentrations. Q_{dil} was varied between 8 and 11 lpm in steps of 0.5 lpm (10 measurements for each Q_{dil} setting).

The analysis of liquid samples with the IS method (Heintzenberg 1982; Hitznerberger, Dusek, and Berner 1996) allows for the detection of black and brown carbon (Wonaschütz et al. 2009; Reisinger et al. 2008). A detailed description of the method can be found in the study by Wonaschütz et al. (2009). Briefly, a sample vial containing a filter piece immersed in a liquid, or containing a liquid suspension (see below for sample preparation), is placed into the illuminated integrating sphere. The change in the light signal caused by the sample (relative to light signal with an empty vial) is measured and evaluated against calibration standards (suspensions of carbon black and humic acid sodium salt) to obtain the masses of black (BC) and brown (BrC) carbon in the sample. The signals caused by BrC and BC are separated with an iterative procedure using the difference in wavelength dependence of light absorption by the two materials. Concentrations of BC and BrC aerosol are calculated from the area of the analyzed filter piece, the area of the filter deposit, and the flow rates in the experimental setup.

The filter samples were prepared for IS analysis as follows: a circular filter punch (diameter: 10–12 mm, depending on the loading of the filter) was inserted into a 5 ml PE vial (50 ml vial for settings 1 and 6), and immersed in 5 ml (18 ml for settings 1 and 6) of a mixture of 50% acetone, 40% water, and 10% isopropanol. For the liquid samples from the PILS, the organic solvents were added in the appropriate ratios, for example, 0.5 ml of isopropanol and 2.5 ml of acetone to 2 ml of liquid sample (settings 2, 3, and 4) and 3 ml of isopropanol and 15 ml of acetone to 12 ml of liquid sample (settings 1 and 6).

The concentration of BC in Q_{PILS} at the time of the PILS sampling (BC_{in}) is calculated on the basis of the filter measurements. We assume that the CAST generator produces a constant aerosol concentration for each C/O setting, and that the filter sampling efficiency is 1. We also assume that the light absorption properties of the CAST soot particles collected on the filter remain unchanged after passing through the

PILS into the liquid sample. BC_{in} concentrations are expressed with respect to the PILS-in flow rate, i.e.

$$[BC_{\text{in}}] = [BC_{\text{CAST-out}}] * (Q_{\text{PILS}} - Q_{\text{dil}}) / Q_{\text{PILS}}, \quad (1)$$

where $BC_{\text{CAST-out}}$ is the BC concentration in the undiluted CAST output flow determined by filter sampling:

$$[BC_{\text{CAST-out}}] = BC_{\text{filter}} / (t_{\text{filter}} * (Q_{\text{filter}} - Q_{\text{dil}})). \quad (2)$$

Here, BC_{filter} is the total amount of BC collected on the filter during the filter sampling time t_{filter} . The BC concentration in Q_{PILS} as detected by PILS sampling (BC_{out}) is also expressed with respect to the PILS-in flow, that is:

$$[BC_{\text{out}}] = BC_{\text{PILS}} / (Q_{\text{PILS}} * t), \quad (3)$$

where BC_{PILS} is the total BC amount in the liquid sample.

In order to determine the collection efficiency CE of the PILS, the BC concentration as determined by PILS sampling ($[BC_{\text{out}}]$), was compared with that determined by filter sampling ($[BC_{\text{in}}]$):

$$CE = [BC_{\text{out}}] / [BC_{\text{in}}]. \quad (4)$$

Over the course of the measurements for Experiment 2 (different dilution for the same C/O setting), it was found that the measurement error incurred by the setting of the flow rates was negligible in comparison to that incurred by uneven filter loading (i.e., variability in the BC loading of different filter punches of the same filter was comparable to the BC loading of punches of different filters). A mean value of $BC_{\text{CAST-out}} = 3.05 \pm 0.6 \text{ mg/m}^3$ was therefore calculated and used in Equation (3).

Auxiliary measurements were conducted to characterize the ingoing soot aerosol and help with the interpretation of the results: Number size distributions of the particles produced at the six different C/O settings were measured: The CAST output was diluted by a factor of 32.5 and passed to a custom-built DMPS System: a Vienna-type DMA (configuration described by Burkart et al. 2011), equipped with a soft x-ray charger (TSI, Inc.) and coupled to a CPC (Model 3776, TSI, Inc.). The number size distributions were recorded for a size range of 10–926 nm and converted into mass size distribution assuming a nominal density of 0.8 g/cm^3 , an estimate based on the effective densities of mini-CAST soot reported by Moore et al. (2014). For each C/O setting, two loaded filters were also randomly chosen for determination of OC-EC: two or three punches (1.5 cm^2) of each filter were analyzed in an OC-EC aerosol analyzer (Sunset Laboratory Inc.), set to the EUSAAR protocol (Cavalli et al. 2010).

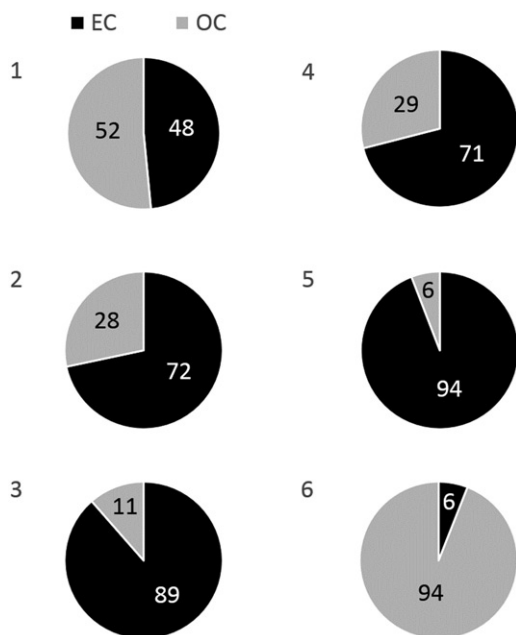

Figure 2. Fraction of OC and EC for the six C/O settings.

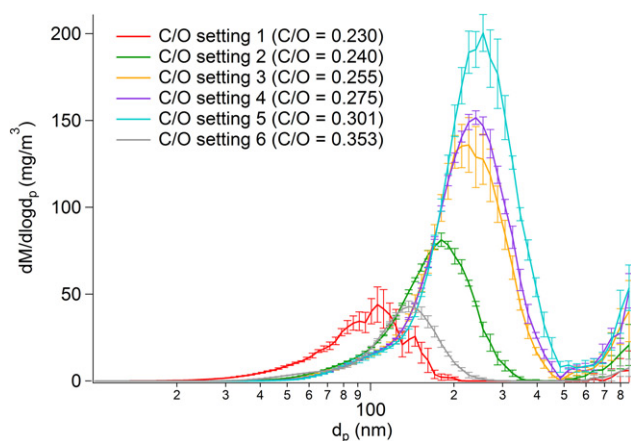

Figure 3. Mass size distributions of CAST soot for the six C/O settings as measured by a DMPS (number size distribution converted assuming a density of 0.8 g/cm^3).

Results and discussion

In this section, we discuss the properties of the incoming soot aerosol, followed by the results and discussion of the PILS collection efficiency for these particles. Figure 2 shows the contributions of OC and EC in the aerosol generated at the different settings. Evidently, the carbonaceous particulate matter of setting 6 consists mostly (94%) of OC; for setting 1, 52% OC were found. For all other settings, EC is the dominant component, varying between 71 and 94%. Mass size distributions (Figure 3) of the soot particles at the different settings clearly show that settings 1 and 6 have smaller modal diameters (99 and 139 nm, respectively), and the distribution is generally shifted to smaller diameters. The other settings, in turn, have larger modal diameters (184, 238, 248, and

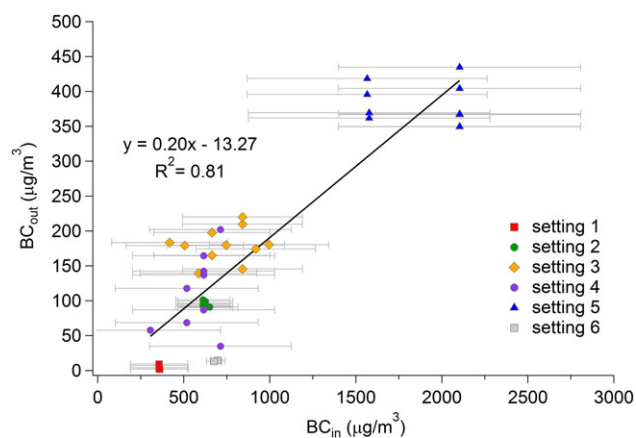

Figure 4. BC_{out} concentrations detected by the PILS vs. calculated BC_{in} concentrations based on filter measurement for the six different CAST C/O settings.

262 nm for settings 2, 3, 4, and 5, respectively). The particle size range is consistent with the findings by Moore et al. (2014), who operated their miniCAST at slightly different settings ($Q_{C_3H_8} = 0.06 \text{ lpm}$, $Q_{dil} = 20 \text{ lpm}$, $Q_{oxi} = 0.6\text{--}1.8 \text{ lpm}$), but also found modal sizes $>90 \text{ nm}$ for the range of C/O ratios used here (0.23–0.35). They also report an increasing OC/TC ratio with decreasing particle size: in their experiments, OC/TC varies from less than 0.3 for soot modal sizes $>100 \text{ nm}$ to over 0.8 for modal sizes $<50 \text{ nm}$ (Moore et al. 2014).

Qualitatively, this trend is reproduced here, in that it is the settings with smaller overall size ranges (i.e., settings 1 and 6), that show the larger OC/TC ratios (0.94 and 0.52).

The result of Experiment 1 is shown in Figure 4: The determined overall collection efficiency CE for the CAST soot is 0.20. There is variability in the CE for the different C/O settings: Settings 1 and 6 clearly have a much lower CE than the other four settings. Looking at the size distribution in Figure 3, it is evident that these are the settings with the smallest modal diameter and overall size range. Figure 5 shows $[BC_{out}]$ vs. $[BC_{in}]$ for different BC_{in} concentrations at C/O setting 2. A collection efficiency of 0.26 was determined for a $[BC_{in}]$ concentration range of $469\text{--}1200 \mu\text{g/m}^3$ (R^2 of 0.94), largely consistent with the result shown in Figure 4.

The low collection efficiency is entirely expected, given the insoluble and/or hydrophobic nature of fresh soot. It compares well to the PILS collection efficiencies of <0.2 for the least soluble organic standards presented by Zhang et al. (2016), and it is lower than the PILS CE of 50–94% (particle sizes of 25–300 nm) for water-soluble ions reported by Weber et al. (2001). The majority of the soot did not enter the PILS liquid sample. Possible mechanisms are the following: (i) particles do not activate at

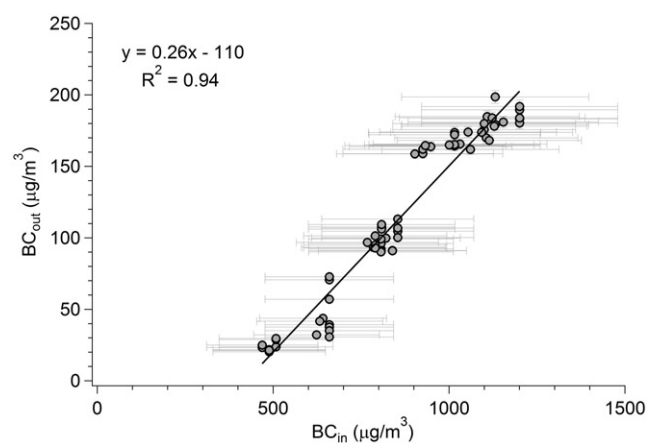

Figure 5. BC_{out} concentrations detected by the PILS vs. calculated BC_{in} concentrations based on filter measurement for C/O setting 2.

all, (ii) activated particles may fail to grow large enough to impact on the quartz plate, as suggested by Zhang et al. (2016), (iii) wall losses of collected particles in the liquid sampling line. In cases (i) and (ii), soot particles end up in the exhaust air instead of the liquid sample. After our experiments, accumulated dark deposits were clearly visible in bends of the exhaust air-line, showing that mechanisms (i) and/or (ii) are effective. Given the high supersaturation in the PILS, mechanism (i) would effectively require the particles to have an entirely hydrophobic surface. This is not implausible: Henning et al. (2012) find neither CCN activation nor hygroscopic growth of miniCAST soot, regardless of OC content. For fresh aircraft combustion soot, Hitznerberger et al. (2003) find activation ratios smaller by a factor 10^3 than those of insoluble, but wettable particles of the same size. Popovicheva et al. (2008), however, observe increasing water adsorption with increasing organic content of CAST soot, along with more oxygen-containing groups on the particle surface. Moore et al. (2014) report a hygroscopicity (κ) of miniCAST soot between 0 and 10^{-3} (C/O ratios between 0.21 and 0.29), indicating that soluble compounds are present, depending on the exact combustion settings. In combination with the high supersaturations in the PILS, this indicates that some particles may still activate. Subsequently, mechanism (ii) can take effect and may explain the smaller CE of settings 1 and 6: Zhang et al. (2016) show that hydrophobic components in the particles slow down droplet growth, with negative effects on CE: droplets may not reach the critical size for impaction within the residence time (1 s) in the supersaturated environment in the PILS. In our experiment, this effect may be limiting to the collection of the smaller particles in settings 1 and 6. Finally, black deposits were also observed in the liquid sample path, in particular the impactor surface and the debubbler membrane. This

indicates that a fraction of soot particles that were successfully transferred into the liquid sample had been lost during transport in the liquid lines (mechanism (iii)).

Conclusions

We find an appreciable collection of insoluble and hydrophobic material by the PILS. With an overall BC collection efficiency of about 20%, the presence of insoluble and hydrophobic particles in PILS samples should not be assumed to be negligible under all circumstances, especially when sampling at high concentrations. Care must be taken when relying on PILS sampling for definitions of water-soluble components of aerosols. For example, in the original method description (Sullivan et al. 2004) for WSOC analysis of PILS samples (PILS-TOC), WSOC is operationally defined as “the fraction of particulate organic carbon that has been collected in water by the PILS, and at a given liquid concentration, penetrates a $0.5 \mu\text{m}$ filter and liquid transport tubing, and is detected.” As mentioned above, and as shown in Figure 3, insoluble, fresh combustion particles can be much smaller than $0.5 \mu\text{m}$ and may pass such a filter. In the TOC analyzer, total organic carbon is determined by oxidation using UV irradiation and ammonium persulfate $((\text{NH}_4)_2\text{S}_2\text{O}_8)$, followed by conductivity detection of dissolved CO_2 . It remains unclear whether a physical separation of soluble and insoluble material is achieved.

In atmospheric samples, the PILS sample should be expected to contain hydrophobic and insoluble material, as mixed particles (soluble and insoluble components) are a common occurrence (e.g., Okada and Hitznerberger 2001). In general, the relevance of insolubles depends on the analysis method used on the PILS sample, but care must be taken not to view the PILS sample as a liquid containing exclusively soluble material.

Funding

We gratefully acknowledge financial support from the Austrian Science Foundation (FWF), project number P26040.

ORCID

Anna Wonaschuetz  <http://orcid.org/0000-0002-4687-8623>

References

Augustin, S., H. Wex, D. Niedermeier, B. Pummer, H. Grothe, S. Hartmann, L. Tomsche, T. Clauss, J.

- Voigtländer, K. Ignatius, and F. Stratmann. 2013. Immersion freezing of birch pollen washing water. *Atmos. Chem. Phys.* 13(21):10989–11003. doi:10.5194/acp-13-10989-2013.
- Burkart, J., G. Steiner, G. Reischl, and R. Hitznerberger. 2011. Long-term study of cloud condensation nuclei (CCN) activation of the atmospheric aerosol in Vienna. *Atmos. Environ.* 45(32):5751–5759. doi: 10.1016/j.atmosenv.2011.07.022.
- Cavalli, F., M. Viana, K. E. Yttri, J. Genberg, and J.-P. Putaud. 2010. Toward a standardized thermal-optical protocol for measuring atmospheric organic and elemental carbon: the EUSAAR protocol. *Atmos. Meas. Tech.* 3(1):79–89. doi: 10.5194/amt-3-79-2010.
- Clark, C. H., S. Nakao, A. Asa-Awuku, K. Sato, and D. R. Cocks. 2013. Real-time study of particle-phase products from α -Pinene Ozonolysis and isoprene photooxidation using particle into liquid sampling directly coupled to a time-of-flight mass spectrometer (PILS-ToF). *Aerosol Sci. Technol.* 47 (12):1374–1382. doi: 10.1080/02786826.2013.844333.
- Häusler, T., L. Witek, L. Felgitsch, R. Hitznerberger, and H. Grothe. 2017. Freezing on a chip—a new approach to determine heterogeneous ice nucleation of micrometer-sized water droplets. *Atmosphere* 9(4):140. doi:10.3390/atmos9040140.
- Heintzenberg, J. 1982. Size-segregated measurements of particulate elemental carbon and aerosol light absorption at remote arctic locations. *Atmos. Environ.* 16(10): 2461–2469.
- Henning, S., M. Ziese, A. Kiselev, H. Saathoff, O. Moehler, T. F. Mentel, A. Buchholz, C. Spindler, V. Michaud, and M. Monier. 2012. Hygroscopic growth and droplet activation of soot particles: uncoated, succinic or sulfuric acid coated. *Atmos. Chem. Phys.* 12:1680–7324. doi: 10.5194/acp-12-4525-2012.
- Hitznerberger, R., U. Dusek, and A. Berner. 1996. Black carbon measurements using an integrating sphere technique. *J. Geophys. Res.* 101(D14):19601–19606.
- Hitznerberger, R., H. Giebl, A. Petzold, M. Gysel, S. Nyeki, E. Weingartner, U. Baltensperger, and C. W. Wilson. 2003. Properties of jet engine combustor particles during the PartEmiss experiment. Hygroscopic properties at supersaturated conditions. *Geophys. Res. Lett.* 30(14): 1779. doi:10.1029/2003GL017294
- Ito, K., C. C. Chasteen, H.-K. Chung, S. K. Poruthoor, Z. Genfa, and P. K. Dasgupta. 1998. A continuous monitoring system for strong acidity in aerosols. *Anal. Chem.* 70(14):2839–2847.
- Jankowski, N., C. Schmidl, I. L. Marr, H. Bauer, and H. Puxbaum. 2008. Comparison of methods for the quantification of carbonate carbon in atmospheric PM10 aerosol samples. *Atmos. Environ.* 42(34):8055–8064.
- Jing, L. 1999. Standard Combustion Aerosol Generator (SCAG) for Calibration Purposes, in 3rd ETH Workshop on Nanoparticle Measurement, CD-ROM.
- Khlystov, A., G. P. Wyers, and J. Slanina. 1995. The steam-jet aerosol collector. *Atmos. Environ.* 29(17):2229–2234.
- Kidwell, C. B., and J. M. Ondov. 2004. Elemental analysis of sub-hourly ambient aerosol collections. *Aerosol Sci. Technol.* 38(3):205–218. doi: 10.1080/02786820490261726.
- Kim, J., H. Bauer, T. Dobovičnik, R. Hitznerberger, D. Lottin, D. Ferry, and A. Petzold. 2015. Assessing optical properties and refractive index of combustion aerosol particles through combined experimental and modeling studies. *Aerosol Sci. Technol.* 49(5):40–350. doi: 10.1080/02786826.2015.1020996.
- Löflund, M., A. Kasper-Giebl, W. Tschewenka, M. Schmid, H. Giebl, R. Hitznerberger, G. Reischl, and H. Puxbaum. 2001. The performance of a gas and aerosol monitoring system (GAMS) for the determination of acidic water soluble organic and inorganic gases and ammonia as well as related particles from the atmosphere. *Atmos. Environ.* 35(16):2861–2869.
- Moore, R. H., L. D. Ziemba, D. Dutcher, A. J. Beyersdorf, K. Chan, S. Crumeyrolle, T. M. Raymond, K. L. Thornhill, E. L. Winstead, and B. E. Anderson. 2014. Mapping the operation of the miniature combustion aerosol standard (Mini-CAST) soot generator. *Aerosol Sci. Technol.* 48(5):467–479. doi: 10.1080/02786826.2014.890694
- Okada, K., and R. Hitznerberger. 2001. Mixing properties of individual submicrometer aerosol particles in Vienna. *Atmos. Environ.* 35(32):5617–5628.
- Orsini, D., Y. Ma, A. Sullivan, B. Sierau, K. Baumann, and R. J. Weber. 2003. Refinements to the particle-into-liquid sampler (PILS) for ground and airborne measurements of water soluble aerosol composition. *Atmos. Environ.* 37(9-10):1243–1259. doi: 10.1016/S1352-2310(02)01015-4.
- Parshintsev, J., M. Kivilompolo, J. Ruiz-Jimenez, K. Hartonen, M. Kulmala, and M.-L. Riekkola. 2010. Particle-into-liquid sampler on-line coupled with solid-phase extraction–liquid chromatography-mass spectrometry for the determination of organic acids in atmospheric aerosols. *J. Chromatogr. A* 1217(33):5427–5433. doi:10.1016/j.chroma.2010.06.026.
- Popovicheva, O. B., N. M. Persiantseva, V. Tishkova, N. K. Shonija, and N. A. Zubareva. 2008. Quantification of water uptake by soot particles. *Environ. Res. Lett.* 3(2): 025009. doi: 10.1088/1748-9326/3/2/025009
- Poruthoor, S. K., and P. K. Dasgupta. 1995. Continuous automated measurement of the soluble fraction of atmospheric particulate matter. *Anal. Chem.* 67(1):71–78.
- Poruthoor, S. K., and P. K. Dasgupta. 1998. Automated particle collection and analysis. Near-real time measurement of aerosol cerium (III). *Anal. Chim. Acta* 361(1-2): 151–159.
- Rastogi, N., A. Patel, A. Singh, and D. Singh. 2015. Diurnal variability in secondary organic aerosol formation over the Indo-Gangetic plain during winter using online measurement of Water-Soluble organic carbon. *Aerosol Air Qual. Res.* 15(6):2225–2231. doi: 10.4209/aaqr.2015.02.0097.
- Reisinger, P., A. Wonaschütz, R. Hitznerberger, A. Petzold, H. Bauer, N. Jankowski, H. Puxbaum, X. Chi, and W. Maenhaut. 2008. Intercomparison of measurement techniques for black or elemental carbon under urban background conditions in wintertime: Influence of biomass combustion. *Environ. Sci. Technol.* 42 (3):884–889. doi: 10.1021/es0715041
- Saarnio, K., K. Teinilä, S. Saarikoski, S. Carbone, S. Gilardoni, H. Timonen, M. Aurela, and R. Hillamo. 2013. Online determination of levoglucosan in ambient aerosols

- with a particle-into-liquid sampler – high-performance anion-exchange chromatography – mass spectrometry (PILS-HPAEC-MS). *Atmos. Meas. Tech.* 6(10): 2839–2849. doi: [10.5194/amt-6-2839-2013](https://doi.org/10.5194/amt-6-2839-2013).
- Satish, R., P. Shamjad, N. Thamban, S. Tripathi, and N. Rastogi. 2017. Temporal characteristics of brown carbon over the Central Indo-Gangetic plain. *Environ. Sci. Technol.* 51(12):6765–6772. doi: [10.1021/acs.est.7b00734](https://doi.org/10.1021/acs.est.7b00734).
- Sierau, B., F. Stratmann, M. Pelzing, C. Neusüß, D. Hofman, and M. Wilck. 2003. A condensation-growth and impaction method for rapid off-line chemical characterization of organic submicrometer atmospheric aerosol particles. *J. Aerosol. Sci.* 34(2):225–242. doi: [10.1016/S0021-8502\(02\)00159-3](https://doi.org/10.1016/S0021-8502(02)00159-3).
- Slanina, J., H. M. ten Brink, R. P. Otjes, A. Even, P. Jongejan, A. Khlystov, A. Waijers-Ijpelaar, M. Hu, and Y. Lu. 2001. The continuous analysis of nitrate and ammonium in aerosols by the steam jet aerosol collector (SJAC): extension and validation of the methodology. *Atmos. Environ.* 35(13):2319–2330.
- Sorooshian, A., F. J. Brechtel, Y. L. Ma, R. J. Weber, A. Corless, R. C. Flagan, and J. H. Seinfeld. 2006. Modeling and characterization of a particle-into-liquid sampler (PILS). *Aerosol. Sci. Technol.* 40(6):396–409. doi: [10.1080/02786820600632282](https://doi.org/10.1080/02786820600632282).
- Sullivan, A. P., R. J. Weber, A. L. Clements, J. R. Turner, M. S. Bae, and J. J. Schauer. 2004. A method for on-line measurement of water-soluble organic carbon in ambient aerosol particles: Results from an urban site. *Geophys. Res. Lett.* 31:L13105. doi: [10.1029/2004gl019681](https://doi.org/10.1029/2004gl019681).
- Timonen, H., M. Aurela, S. Carbone, K. Saarnio, S. Saarikoski, T. Makela, M. Kulmala, V. M. Kerminen, D. R. Worsnop, and R. Hillamo. 2010. High time-resolution chemical characterization of the water-soluble fraction of ambient aerosols with PILS-TOC-IC and AMS. *Atmos. Meas. Tech.* 3(4):1063–1074. doi: [10.5194/amt-3-1063-2010](https://doi.org/10.5194/amt-3-1063-2010).
- Violaki, K., T. Fang, N. Mihalopoulos, R. Weber, and A. Nenes. 2016. Real-Time, online automated system for measurement of Water-Soluble reactive phosphate ions in atmospheric particles. *Anal. Chem.* 88(14):7163–7170. doi: [10.1021/acs.analchem.6b01264](https://doi.org/10.1021/acs.analchem.6b01264).
- Weber, R. J., D. Orsini, Y. Daun, Y.-N. Lee, P. J. Klotz, and F. Brechtel. 2001. A particle-into-liquid collector for rapid measurement of aerosol bulk chemical composition. *Aerosol. Sci. Technol.* 35(3):718–727. doi: [10.1080/02786820152546761](https://doi.org/10.1080/02786820152546761).
- Wonaschütz, A., R. Hitzemberger, H. Bauer, P. Pouresmaeil, B. Klatzer, A. Caseiro, and H. Puxbaum. 2009. Application of the integrating sphere method to separate the contributions of black and brown carbon in atmospheric aerosols. *Environ. Sci. Technol.* 43(4):1141–1146.
- Zhang, X., N. F. Dalleska, D. D. Huang, K. H. Bates, A. Sorooshian, R. C. Flagan, and J. H. Seinfeld. 2016. Time-resolved molecular characterization of organic aerosols by PILS + UPLC/ESI-Q-TOFMS. *Atmos. Environ.* 130: 180–189. <http://dx.doi.org/10.1016/j.atmosenv.2015.08.049>.
- Zolles, T., J. Burkart, T. Häusler, B. Pummer, R. Hitzemberger, and H. Grothe. 2015. Identification of ice nucleation active sites on feldspar dust particles. *J. Phys. Chem. A* 119 (11):2692–2700. doi: [10.1021/jp509839x](https://doi.org/10.1021/jp509839x).