

Old Dominion University

ODU Digital Commons

Mechanical & Aerospace Engineering Theses & Dissertations

Mechanical & Aerospace Engineering

Summer 2017

Development of the Compact Jet Engine Simulator From Concept to Useful Test Rig

Henry H. Haskin
Old Dominion University

Follow this and additional works at: https://digitalcommons.odu.edu/mae_etds



Part of the [Acoustics, Dynamics, and Controls Commons](#), and the [Aerospace Engineering Commons](#)

Recommended Citation

Haskin, Henry H.. "Development of the Compact Jet Engine Simulator From Concept to Useful Test Rig" (2017). Master of Science (MS), thesis, Mechanical & Aerospace Engineering, Old Dominion University, DOI: 10.25777/bv0y-1154
https://digitalcommons.odu.edu/mae_etds/176

This Thesis is brought to you for free and open access by the Mechanical & Aerospace Engineering at ODU Digital Commons. It has been accepted for inclusion in Mechanical & Aerospace Engineering Theses & Dissertations by an authorized administrator of ODU Digital Commons. For more information, please contact digitalcommons@odu.edu.

DEVELOPMENT OF THE COMPACT JET ENGINE SIMULATOR FROM CONCEPT TO USEFUL TEST RIG

by

Henry H. Haskin

B.S. March 1979, Virginia Polytechnic Institute and State University

A Thesis Submitted to the Faculty of
Old Dominion University in Partial Fulfillment of the
Requirements for the Degree of

MASTER OF SCIENCE

AEROSPACE ENGINEERING

OLD DOMINION UNIVERSITY

August 2017

Approved by:

Arthur Taylor (Director)

Robert Ash (Member)

Michael Doty (Member)

ABSTRACT

DEVELOPMENT OF THE COMPACT JET ENGINE SIMULATOR FROM CONCEPT TO USEFUL TEST RIG

Henry H. Haskin
Old Dominion University, 2017
Director: Dr. Arthur Taylor

NASA had a goal to develop a set of modeling tools for designing next generation civil transport aircraft with reduced noise, emissions and increased fuel efficiency by 2016. To verify the models, a database of aerodynamic and acoustic data was needed for an unconventional flying wing design that was predicted to meet the goals. A Compact Jet Engine Simulator (CJES) was needed as the jet source for the 5.8% scale model. Ultra-Compact Combustor Technology from the Air Force Research Laboratory was used to reduce the conventional burner acoustic test rigs down to the required scale size. The Air Force design had to be modified for compactness and safety standards for testing in a wind tunnel. The combustor liner, plug-vane and flow conditioner components were built in-house at the NASA Langley Research Center. The CJES units were built and integrated incorporating a control system for operation in the NASA Langley Low Speed Aeroacoustic Wind Tunnel. The operational envelope of the combustor was mapped, and improvements were developed to moderate combustor instability tones and rig flow noise. The final concept was unchanged, but the internal hardware evolved throughout the process. The Compact Jet Engine Simulator as a standalone unit demonstrated acceptable acoustic rig performance compared to the Boeing Low Speed Acoustic Facility rig. An integrated aerodynamic and acoustic test using the Compact Jet Engine Simulators was performed in the 14- by 22- Foot Subsonic Tunnel in 2012/13, and the results proved the goals were met with a score of 96%. The Compact Jet Engine Simulator is modular and can be used to test subsonic engine nozzles in the bypass ratio range from 5 to 10. The CJES units can be used for acoustic testing or studying the integration of the engine propulsion

flow with an aircraft. This thesis focuses on the design and hardware development of the CJES units for which the author was primarily responsible.

ACKNOWLEDGMENTS

There are many people who have contributed to the successful completion of this work. I extend many thanks to my committee members for their patience and hours of editing this manuscript.

The author sincerely thanks the Environmentally Responsible Aviation Project for funding this work. The efforts of the Jet Noise Lab researcher Michael Doty and technical staff (John Swartzbaugh, Shaun Reno, Clint Reese, Butch Allen, and Mike Carr) are gratefully acknowledged. Additionally, Les Yeh, Mark Carpenter, and Mike Henshaw are acknowledged for CJES control implementation; Robert Andrews, Michael Powers and Mark Griffith for their support in additive manufacturing and ceramics; and Governor's School student Megan Beisser for her assistance in the swirl velocity measurements. Lastly, the author acknowledges the excellent support of the NASA Langley Research Center fabrication and welding services, as well as the welding services of Bill Clemens at the Thomas Jefferson National Accelerator Facility.

I have to give special credit and thanks to my wife, Betty Haskin. I would not have finished this program without her support.

NOMENCLATURE

14x22-Tunnel	14-by 22- Foot Subsonic Tunnel
AFRL	Air Force Research Laboratory
APCRC	Atmospheric-Pressure Combustion Research Complex
ATK/Micro Craft	Alliant Techsystems Inc., Missile Subsystems & Components Division, Micro Craft Operations
CAEP	Committee on Aviation Environmental Protection (part of ICAO)
CAD	Computer Aided Design
CJES	Compact Jet Engine Simulator
DMLS	Direct Metal Laser Sintering
ERA	Environmentally Responsible Aviation
FAA	Federal Aviation Administration
Fr	Froude number
g_c	Gravitational constant
GRC	Glenn Research Center (NASA)
HFJER	High Flow Jet Exit Rig (GRC)
HWB	Hybrid Wing Body
ITB	Inter Turbine Burner
ICAO	International Civil Aviation Organization
JLab	Jefferson Laboratory
JES	Jet Engine Simulator
LaRC	Langley Research Center (NASA)

LSAF	Low Speed Acoustic Facility (Boeing)
LSAWT	Low Speed Aeroacoustic Wind Tunnel (LaRC)
MIT	Massachusetts Institute of Technology
Mwt	Wind Tunnel Mach number
NACA	National Advisory Committee on Aeronautics
NASA	National Aeronautics and Space Administration
NPR	Nozzle Pressure Ratio (core / fan)
NRA	NASA Research Announcement
NTR	Nozzle Temperature Ratio (core / fan)
r	Local cavity radius
SAJF	Small Anechoic Jet Facility (LaRC)
SLA	Steriolithography
TIG	Tungsten Inert Gas Welding
UCC	Ultra-Compact Combustor
UCI	University of California Irvine
UTRC	United Technologies Research Center
V_{tan}	Swirl velocity

TABLE OF CONTENTS

	Page
LIST OF TABLES.....	ix
LIST OF FIGURES.....	x
 Chapter	
I. Introduction.....	1
II. Overview.....	3
III. Literature Search	10
IV. General Arrangement Evolution.....	20
V. Implementation of AFRL Concept.....	24
VI. Swirl Air and Flow Conditioner Study	27
VII. Final Design/Build Contract	29
VIII. Ceramic Combustor Liner and Plug-Vane Development.....	30
IX. Direct Metal Laser Sintered Fabrication of Combustor Liner and Plug-Vane.....	38
X. Initial Testing of the CJES.....	48
XI. Combustion Instability Issue.....	61
XII. Metallic Component Part Life.....	67
XIII. Results Summary	72
XIV. Conclusions.....	75
XV. Future Work.....	78
BIBLIOGRAPHY	82

APPENDICES

A. Infrastructure to Support HWB Acoustic Test 88

B. Variations of the CJES and HWB during Development..... 93

C. CJES Combustor Liner, Plug-Vane and Flow Conditioner FY 2011-2012 102

VITA..... 103

LIST OF TABLES

Table	Page
1. Environmentally Responsible Aviation, Integrated Systems Research Program Goals	2
2. Take-Off Sizing Mass Flows and Temperatures for the CJES Design	6

LIST OF FIGURES

Figure	Page
1. The 14' by 22' Subsonic Wind Tunnel Test Section Configured for the HWB test.....	3
2. Comparative Size of the CJES to "state of the art" Acoustic Test Rigs.....	5
3. Initial CJES Concept Sudden Expansion Burner and Hybridburner.com, $\frac{3}{4}$ " T-Rex Burner	8
4. Boeing Nozzle Test Rig in 1989.....	11
5. NASA Glenn High Flow Jet Exit Rig	12
6. NASA Langley JES Acoustic Test Rig Cross Section	13
7. The Effect of Flame Impingement on a Flow Conditioner	14
8. The Effect of Flame Impingement on a Temperature Rake and Supersonic Nozzle Test in LSAWT	16
9. A 2-Passage Dome/2-Vortex Cavity Trapped Vortex Combustor and Schematic.....	17
10. Schematic Axial View of UCC and Side View	18
11. Boeing Concept of the Hybrid Wing Body Aircraft.....	21
12. CFD Results Showing Streamlines and Surface Pressure	22
13. The Compact Jet Engine Simulator in Cross Section	23
14. Swirl Air Configuration of the CJES Combustor.....	24
15. Comparison of Air and Fuel Supplies Between CJES and AFRL's UCC/ITB	26
16. Swirl Air Valve Calibration Test and Data.....	27
17. Views of the Combustor Liner Showing Features to be Cast	30
18. First Combustor Mold Version	32
19. Wax Core Insert Cutting Fixture and a Wax Core.....	33
20. Failed Ceramic Combustor Liners, New Coarse Material and New Fine Material	35

Figure	Page
21. Ceramic Plug-Vane Mold Details	36
22. CJES Flow Conditioners, Upstream Face and Downstream Face	39
23. DMLS Failed Fan Flow Conditioners and Core Flow Conditioner	41
24. Sintered Screen Electron Beam Weld Samples; Tensile test samples a), Flow Conditioner Welds b), Prepared Parts before E-beam Welding.....	43
25. DMLS Combustor Liner on the CNC Lathe; a) showing the Machine set-up with the built in index feature, b) Close up of the Combustor Annulus and a Flame Holder Groove	44
26. Finished CoCr Combustor Liner	46
27. DMLS Plug-Vane Parts. a) The build failed due to support failure then deflection; b) is a batch of four units with CAD generated supports	47
28. Initial testing Configuration of CJES Combustor in the Jet Noise Laboratory	49
29. CJES First Light and Combustion in the Annulus from Aft Camera	50
30. a)Angular Velocity Probe Installed in Glow Plug Port, b) Modified Combustor Liner with Larger Swirl Nozzles, c), d) Probe Details	51
31. Swirl Air Velocity in the Combustor Annulus	53
32. Froude Number for Cracked and New Combustor Liners	53
33. Combustion Switching Outside of the Annulus in the Plug-Vane	54
34. Propane Injector Modifications; a) Pressure Dropping Screen, b) Diverter Loop, c) Cross Drilled Holes.....	55
35. Soot Buildup in the CJES Unit after the First Flow Conditioner Run, a) Soot on the Propane Manifold, b) Soot Deposits on the Combustor Liner Inlet Ports, c) Carbon Tracks in the Combustor Annulus..	56
36. Failure of the Sintered Screen Flow Conditioner	57

Figure	Page
37. Combustor Liner after first Flow Conditioner Failure; a) Soot Structures in Flame Holder Grooves, b) Ceramic Erosion in the Combustion Annulus	58
38. Second Screen Flow Conditioner Failure.....	59
39. Section View of CJES with Alternate Fan Flow Conditioner and Fan Plenum Diverter	60
40. Combustion Driven Tones in the Core ~ 25dB Above Broadband Levels.....	61
41. Some of the Combustor Change Variations tried to eliminate the Combustor Instability; a) Spot Welded Straps, b) Trailing Edge Fins on the Plug-Vane, c) Double Sinusoid Upstream Face on the Honeycomb Flow Conditioner, d) Staggered Screens to Replace the Honeycomb, e) Baseline Honeycomb with Flow Blocking Wedges, f) Single Sinusoid Flow Conditioner, g) Flat Faced Honeycomb with an Elliptical Dimple, h) Sintered Screen with Hole Patterns for Different Percent Open Areas, i) Location of the Sintered Screen Ahead of the Combustor.....	64
42. CJES Configuration that Eliminated Combustor Tones; a) Schematic UCC including non-uniform downstream flow conditioner and perforated screen upstream, b) Elimination of Combustion Tones	65
43. Hybrid Wing Body Model in 14x22 Tunnel with the CJES Units and Model Support.....	66
44. Thermal Stress Cracks and Oxidation of Plug-Vane after 35 hours of Operations	68
45. Cobalt Chrome Combustor Liner after Six Hours of Testing	69
46. Cobalt Chrome Combustor Liner after Thirty Hours of Testing	70
47. Cobalt Chrome Combustor Liner after Fifty Hours of Testing.....	70

Figure	Page
48. Far-field one-third octave acoustic spectra with CJES and LSAF operating at nominal original cutback condition: $NPR_{core}=1.285$, $NPR_{fan}=1.508$, $NTR_{core}=2.792$, $NTR_{fan}=1.135$, $Mwt =0.10$. A 10 dB addition to 90° spectra and a 20 dB addition to 140° spectra were applied to better visualize the data, as is the case for the remaining spectral figures	73
49. Far-field acoustic spectra with axisymmetric nozzles and CJES operating at updated cutback condition: $NPR_{core}=1.240$, $NPR_{fan}=1.461$, $NTR_{core}=2.721$, $NTR_{fan}=1.124$, $Mwt =0.10$ showing a) spectral and b) directivity differences between CJES units.....	74
50. Core Flow Conditioners Exhibiting Nonuniform Heating. Pictures a) and b) show upstream and downstream view of the same part, c) shows a Single Sinusoid, d) shows a Concave Unit	79
51. a) Combustor Modified for Pressure Taps, b) Axial Viewport with a Flow Conditioner	81

CHAPTER I

INTRODUCTION

One of NASA's goals in the 2006 NASA Strategic Plan was "By 2016, develop multidisciplinary analysis and design tools and new technologies enabling better vehicle performance in multiple flight regimes and within a variety of system architectures."⁽¹⁾ In 2010 the Environmentally Responsible Aviation (ERA) Project was started.^(2, 3) The overall goal was to develop an integrated approach for designing the next generation of aircraft, so it had to include reduced aircraft noise and engine emissions and increased fuel efficiency. It is no longer appropriate to optimize one factor without including all the related improvements because margins for isolated improvement were no longer sufficient for that methodology to work. The system metrics for the ERA project are displayed in Table 1.

A NASA Research Announcement (NRA) contract, NNL07AA54C, ⁽⁴⁾ was awarded to Boeing Company as the prime contractor in October 2007. The NRA team consisted of Boeing Phantom Works, Massachusetts Institute of Technology (MIT), and the University of California Irvine (UCI) with NASA Langley and Glenn Research Centers. Boeing designed a Hybrid Wing Body (HWB) vehicle to meet the performance goals of the N+2 ERA goals based on MIT's earlier design and built a wind tunnel model for verification. UCI developed noise prediction methods for partially shielding jet noise. MIT developed the initial aircraft lines as the Cambridge-MIT "Silent Aircraft Initiative" SAX-40 to meet International Civil Aviation Organization (ICAO) annex 14 code E span limits⁽⁴⁾ (<65m). MIT also provided code modules to the NASA Langley Aircraft Noise Prediction Program (ANOPP2) for unconventional aircraft. NASA Glenn Research Center provided the engine design. NASA Langley Research Center provided the test facility, Compact Jet Engine Simulators (CJES), and the phased array data system to perform the wind tunnel test for validation data. United Technologies Research Corporation, Pratt & Whitney provided jet engine consultation and rounded out the HWB team.

When the ERA project started, the selected test site, the NASA Langley 14x22-Tunnel, lacked the infrastructure to support the validation tests. Data collection system and facility improvements were required to perform the test. Appendix A summarizes the efforts that were part of this multi-million dollar project. To ensure that the test in the 14x22-Tunnel went smoothly, subsystems were developed and proof tested beforehand in risk reduction efforts.

NASA System Level Metrics

.... technology for dramatically improving noise, emissions, & performance



CORNERS OF THE TRADE SPACE	N+1 = 2015*** Technology Benefits Relative To a Single Aisle Reference Configuration	N+2 = 2020*** Technology Benefits Relative To a Large Twin Aisle Reference Configuration	N+3 = 2025*** Technology Benefits
Noise (cum below Stage 4)	-32 dB	-42 dB	-71 dB
LTO NO _x Emissions (below CAEP 6)	-60%	-75%	better than -75%
Performance: Aircraft Fuel Burn	-33%**	-40%**	better than -70%
Performance: Field Length	-33%	-50%	exploit metro-plex* concepts

***Technology Readiness Level for key technologies = 4-6

** Additional gains may be possible through operational improvements

* Concepts that enable optimal use of runways at multiple airports within the metropolitan area

Table 1 Environmentally Responsible Aviation, Integrated Systems Research Program Goals (shown in green box) ⁽²⁾

CHAPTER II

OVERVIEW

The Compact Jet Engine Simulator provides the hot gas streams required to simulate the jet engines of a 5.8% scale model in the NASA Langley Research Center's 14x22-Tunnel. The test section of the 14x22-Tunnel configured for the HWB test is shown in Figure 1. Testing in the 14x22-Tunnel costs more than ten times the cost of operating the Low Speed Aeroacoustic Wind Tunnel (LSAWT). Performing development work for the CJES in the LSAWT was a cost effective way to reduce the risk facilitating a successful test in the 14x22-Tunnel. This thesis was part of the risk reduction efforts to provide test hardware for wind tunnel validation test data collection.

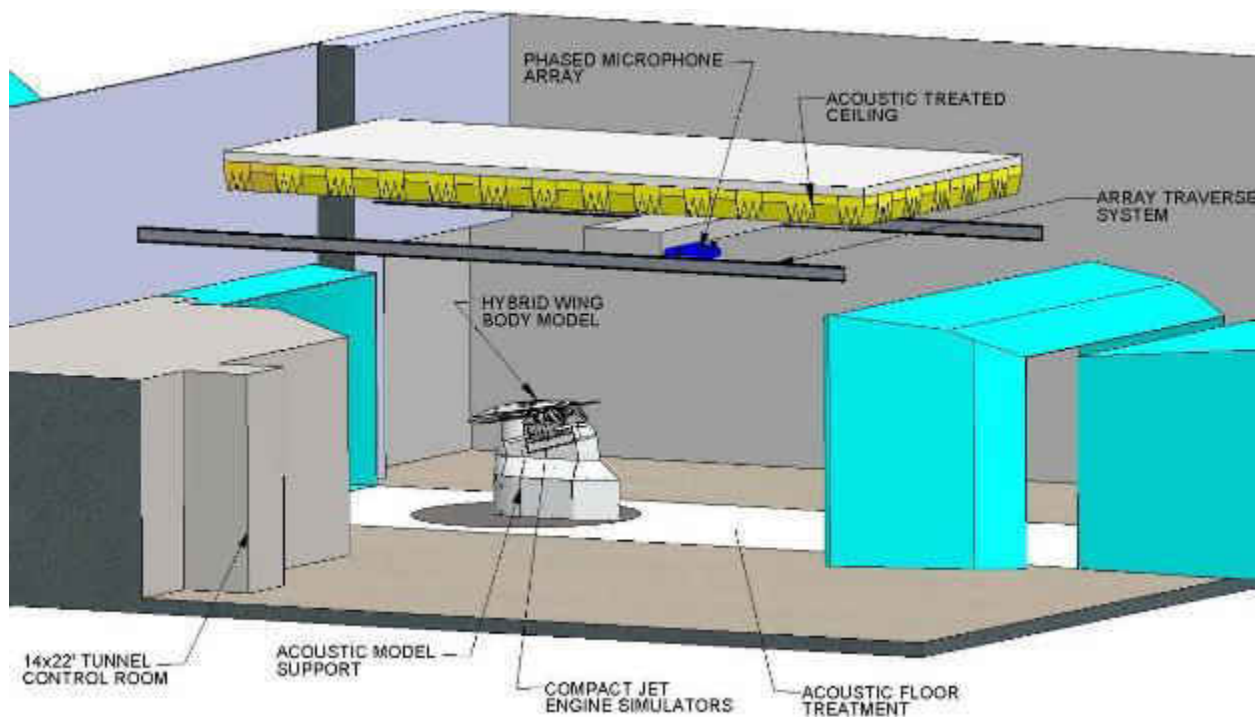

Figure 1 The 14' by 22' Subsonic Wind Tunnel Test Section Configured for the HWB test. ⁽⁵⁾

The Compact Jet Engine Simulator (CJES) simulates subsonic transport jet engines with bypass ratios (ratio of fan mass/core mass) ranging from 5:1 to 15:1. As the aircraft model design progressed through many iterations, it became clear that a bypass ratio of 10:1 would be used for the N+2 configuration, and the CJES design was capped at that bypass ratio because the nacelle for a larger nozzle would interfere with the model fuselage. The goal was to build a dual stream test rig with a hot gas generator for nozzle testing that was roughly 1/3 the size of the “state of the art” rigs. In Figure 2 a) the Langley Jet Engine Simulator (JES) is shown with the CJES in the Low Speed Aeroacoustic Wind Tunnel (LSAWT). The JES is shown without a nozzle set and is 8.33 feet long compared with the CJES without fairing, which was 2.58 feet long. Boeing’s Low Speed Aeroacoustic Facility (LSAF) is shown in Figure 2 b), with their acoustic test rig performing a jet shielding study using the CJES baseline nozzle set. The burners are located in the base of the vertical strut, 12 feet below the nozzle centerline. The large coannular flow duct had to be necked down and ducted away from the main rig to minimize flow interference with the wing. Figure 2 c) shows the reduction in diameter required to obtain the scale distance from the wing. The wing and vertical tails shown simulated part of the HWB model since a full fuselage would interfere with the test rig.

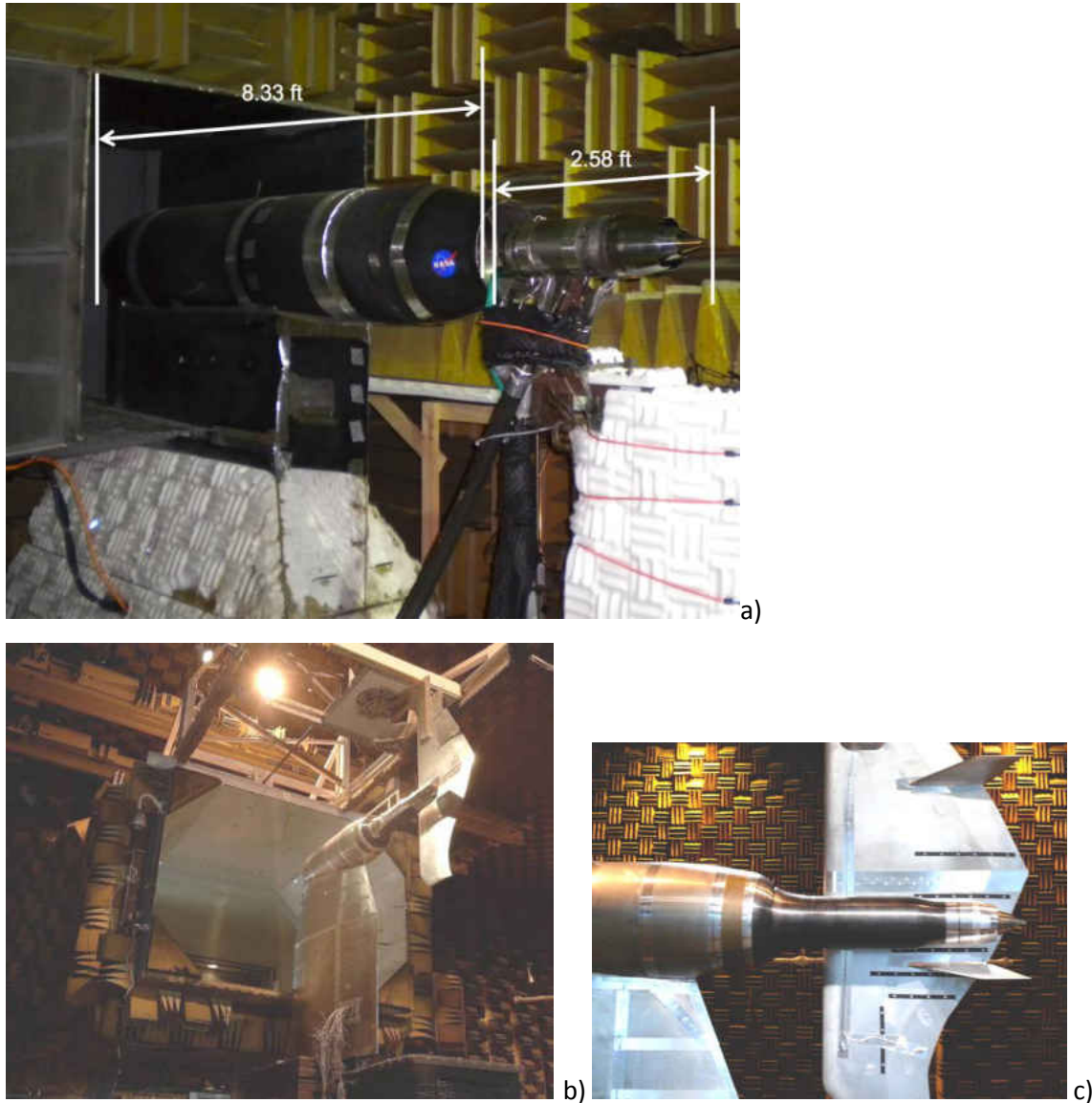

Figure 2 Comparative Size of the CJES to “state of the art” Acoustic Test Rigs.⁽⁶⁾

These existing rigs are 8 to 12 feet long and are about the same length as the entire HWB model. The blockage effects utilizing those rigs would compromise the flow over the model and invalidate any test data.

The project engine design data was provided by NASA Glenn Research Center's engine performance program, and the scaled take-off conditions are shown in Table 2 below ⁽⁶⁾. The red highlighted items became the sizing conditions for the CJES.

	BPR-15			BPR-10			BPR-5		
	Mass (#/s)	Flow	Temp (°F)	Mass Flow (#/s)	Temp (°F)	Mass Flow (#/s)	Temp (°F)	Mass Flow (#/s)	Temp (°F)
Fan	12.25		90	7.10	130	5.793		150	
Core	0.842		960	0.70	1047	1.225		1510	

Table 2. Take-Off Sizing Mass Flows and Temperatures for the CJES Design.⁽⁶⁾

The initial concept was to copy elements from the large Jet Engine Simulator (JES) in the Low Speed Aeroacoustic Wind Tunnel using a burner for the core stream and facility-supplied steam heat for the fan stream. The first goal was to shorten the flame length for the maximum flow condition. Due to the model dimensions duct sizes were limited and the air velocities higher than desired. In the JES at high air mass flows, the flame was stretched because the air velocity exceeded the flame speed. In the core stream, flame impingement occurred 13 feet downstream from the burner (this happened during a supersonic nozzle test in 1996 that this author designed and built). This condition caused flame impingement on flow conditioners and associated instrumentation with a resulting loss of the probes. This is also the reason that the "state-of-the-art" rigs are three to four times longer than practical lengths for the HWB tests. More of the CJES concept development is discussed in Appendix B.

The initial design was proposed to the HWB team, and the other aspects of the aircraft design progressed. Concurrently, the design for the required infrastructure to operate burners safely in the wind tunnel was started. There were major concerns about locating the propane fuel storage, run tanks, the nitrogen purge bottle trailer and an outside test stand for operator training and certification. The use of national design codes and NASS safety concerns controlled many of the design choices for the facility and the CJES.

A conventional dump or sudden expansion burner design was developed in parallel with a literature search (refer to the next section) for more compact combustor concepts. The initial concepts for the CJES were based on a dump combustor and turbulence generating devices ⁽⁸⁻¹⁰⁾. The first of a series of variations used a premixed fuel air concept of an “off-the-shelf” burner from a Navy project ⁽¹¹⁾ as shown in Figure 3. Calculation of the fuel required for heating the Hybrid Wing Body core flow test conditions revealed that the desired low temperatures could not be met using a premixed configuration. The highest test temperature resulted in fuel-air ratios well below the flammability limit, so fuel injection at the sudden expansion was necessary to operate the burner. Thus, if the fuel did not burn in the combustor, it could not burn.

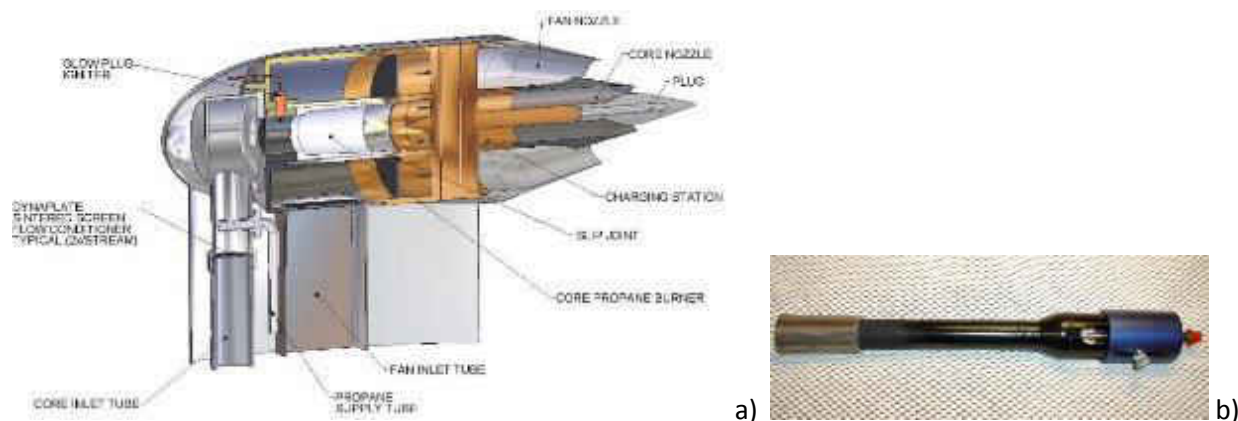

Figure 3 a) Initial CJES Concept Sudden Expansion Burner ⁽⁵⁾, b) and Hybridburner.com, $\frac{3}{4}$ " T-Rex Burner. ⁽¹²⁾

This finding played a critical role in simplifying the overall system design. The NASA Langley Fire Chief did not require an active fire suppression system in the facility because of the self-extinguishing capability of the combustor.

The remainder of this thesis will document the evolution of the CJES design development starting from a marginally operating prototype to a useful research test rig. The following list of events describes the chronology of the CJES development.

1. The literature search revealed the pathway to a compact burner configuration.
2. The parallel development of the wind tunnel model by the model team introduced changes in the general arrangement.
3. The literature search along with direct contact with Air Force Research Lab (AFRL) personnel adapted the Air Force concepts into the CJES design.
4. Due to security restrictions, the lack of AFRL open literature data prompted swirl air and flow conditioner studies to fill in information gaps.

5. The concept was finalized and a contract awarded for the final design and build of the CJES.
6. None of the model supply contractors had experience with ceramic components, so the fabrication of the ceramic combustor and plug-vane parts became an in-house development effort led by the author. After a year of effort that only yielded 30% acceptable ceramic components, a direct metal laser sintering fabrication effort was initiated to produce the combustor liner and plug-vane.
7. The initial testing of the CJES and related hardware was done in the Low Speed Aeroacoustic Wind Tunnel.
8. When back pressuring devices (flow conditioners and a nozzle) were added to the CJES assembly, raising the combustor pressure, combustor instability was discovered and eliminated.
9. The metallic combustor components were found to have a thermal cycle limited life.

Finally, the paper will conclude with results, and conclusions and recommendations for future work will be provided.

CHAPTER III

Literature Search

A Google search of “combustor design” resulted in 1.7 million results. For the high flow rates in the CJES, fully turbulent flames were expected. Most turbulent combustors use variations on the basic sudden expansion flame holding technique. The fuel is introduced into the incoming air stream a short distance ahead of a step increase in the duct size. The aft facing step creates a flow recirculation region that holds the flame front and enhances the fuel mixing for better combustion. Slotted can burners and perforated shell burners are variations of the simple step expansion. In another variation, jet engine afterburners inject the fuel ahead of a V-shaped flame holder gutter. ^(7,8)

The author began working with combustion test rigs in 1989 while working as a contractor for NASA, as the lead project engineer to design the Jet Engine Simulator and the LSAWT for the Jet Noise Lab. Boeing was given a task contract to perform a preliminary design of the JES based on their nozzle test rig.



Figure 4 Boeing Nozzle Test Rig in 1989, (NASA photo L-89-10230)

The Boeing rig used a General Electric J79 jet engine (a 1950s turbojet with a series of combustors, “cans” in a ring) combustor can to supply heat to the core flow and electric heat for the fan flow. The LaRC Jet Noise Lab principal researcher, Jack Seiner, did not want to be limited by the design of the air-cooled burner (lower temperature <1300°F and life < 2000 hours). Dr. Seiner had a water-cooled dump combustor in service as a single flow heat source for ten years (>5000 hours). The author

combined the Boeing concept with the water-cooled commercial burner to achieve the reliability and long rig life provided by a water-cooled combustor.

NASA Glenn Research Center (GRC) has an Aero-Acoustic Propulsion Laboratory with a Nozzle Acoustic Test Rig as another example of a combustor heated test rig. NASA GRC employs a Pratt & Whitney J58 engine combustor can for heating the core flow and steam heat for the fan flow. ⁽⁹⁾ The combustor was housed in a 16 inch diameter pipe and exhausted into a lower manifold assembly of tubes transporting the combustion products up to the upper plenum. Past the upper plenum, there was a 4 to 6 foot long nozzle adapter section. This rig was very large and not adaptable to the CJES requirements because of the remote combustor design. Figure 5 shows a diagram of the NASA GRC High Flow Jet Exit Rig.

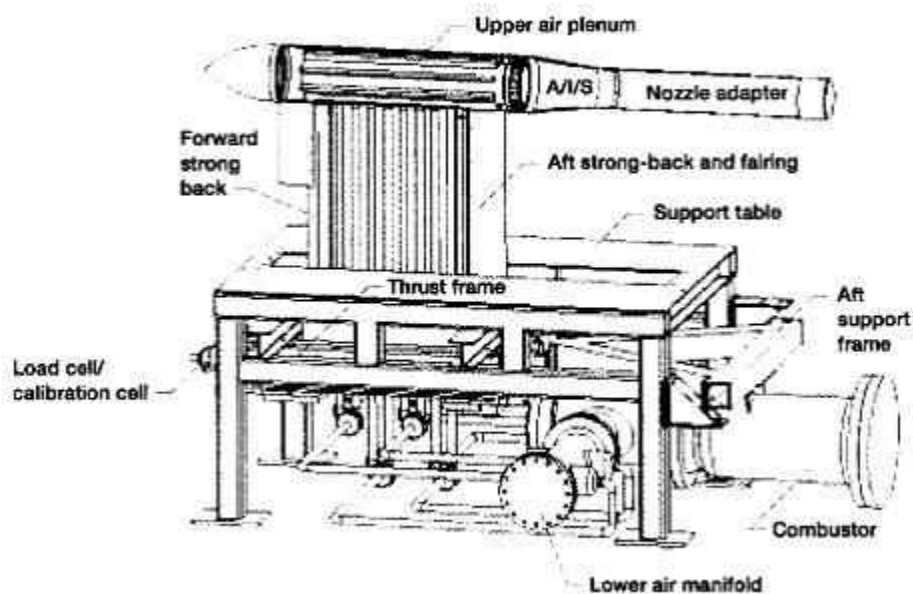

Figure 5 NASA Glenn High Flow Jet Exit Rig. ⁽⁹⁾

The large flow rig in the NASA LaRC Low Speed Aeroacoustic Wind Tunnel (LSAWT) utilizes Sudden Expansion Burners from the Mardquardt Co. ⁽¹¹⁾ These units were rated to supply 20 pounds/second of air at 3000°F, and the JES had been in service since 1994. The JES uses water-cooled orifices called turbulators (by Mardquardt) to eliminate burner acoustic resonance. The lab found that burner resonance would occur with a 10 foot run of pipe before a flow restriction like a test nozzle or turn. The resonance produced a pressure oscillation of $\pm 25\%$ of the total pressure, enough to shake the control room electronics racks. Figure 6 shows a view of the JES with a subsonic transport nozzle installed.

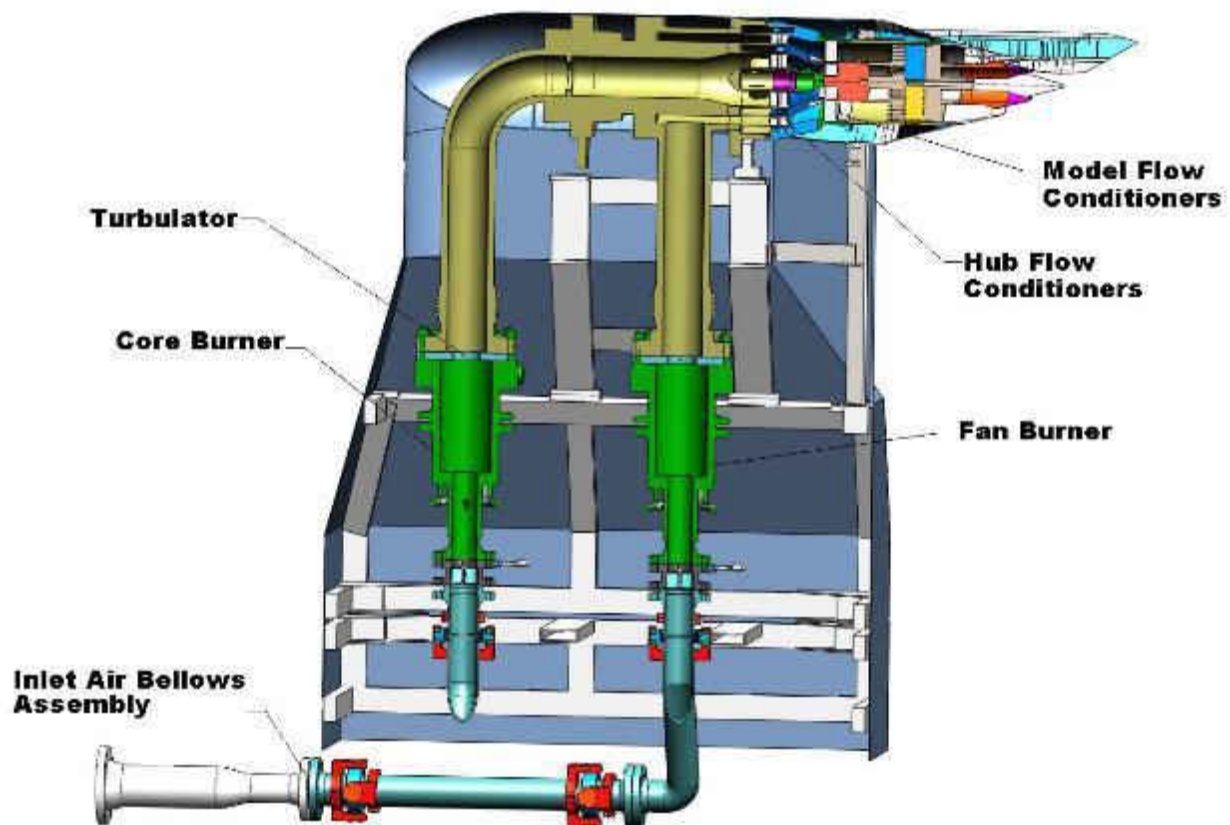

Figure 6 Langley JES Acoustic Test Rig Cross Section. ⁽⁵⁾

The stretching of the flame due to high velocity air flow and flame impingement problems was due to these burners. To provide clean flow to a nozzle for acoustic testing, one needed to supply uniform temperature and pressure flow to the nozzle. The best way to achieve this was with a low noise pressure reducing flow conditioner. At the LSAWT, brazed corrugated and wound nickel super alloy foil flow conditioners performed the best. They were similar to a low backpressure automobile catalytic converter. In Figure 7, a) illustrates a flow conditioner with about 200 hours of use at temperatures below 1500°F. In Figure 7, b) depicts a new flow conditioner. One can see in picture 7a) the foil has slipped, and the corrugations were no longer uniform (due to creep of the braze joints). The thermally exposed unit shed flakes of oxidized metal when squeezed manually. In addition, the loss of material in the center of the picture is evident. The nickel super alloy had oxidation resistance to 2100°F and had been used for nozzles that operate at 2000°F with an operating life of 100 hours.

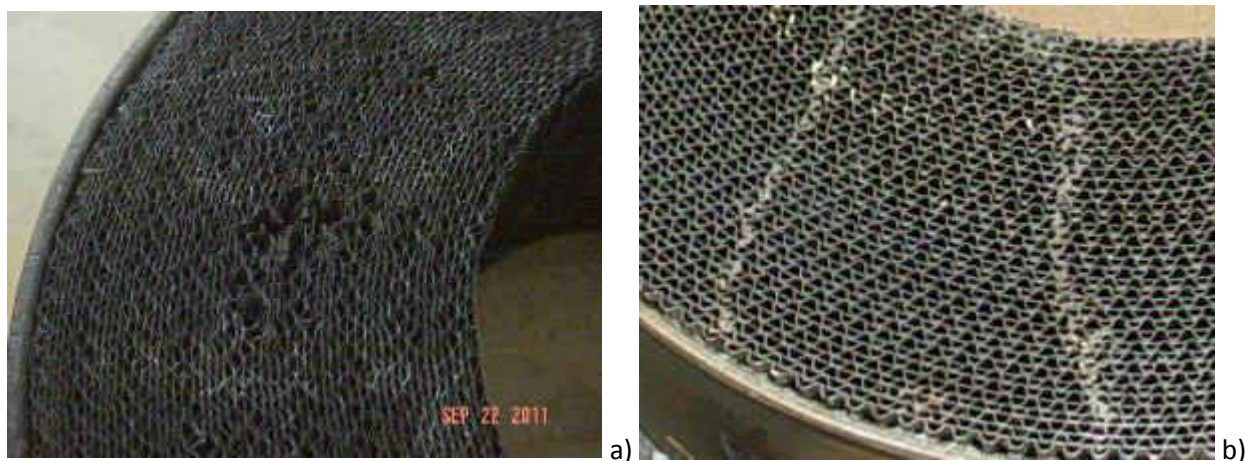

Figure -7 The Effect of Flame Impingement on a Flow Conditioner. ⁽¹²⁾

Similar to flame impingement on the flow conditioners, flame impingement on instrumentation was very destructive. Figure 8 a) shows a thermocouple rake after 3 to 5 seconds of flame impingement. The Inconel sheathed thermocouples fared better than the pressure probe rakes. The pressure tubes were burned off. The flow conditioners and rakes were located about 14 feet from the flame holder section of the sudden expansion burner in the JES. Figure 8 b) shows the supersonic model, where the rakes were burnt up, in the LSAWT for testing. The rakes were to the right of the red stripe (round to square transition). In the Compact Jet Engine Simulator, the flow conditioner was 7.8 inches from the combustion section. A fresh idea was needed to correct the deficiencies of the dump combustor outside of the author's experience.

Researchers at the Air Force Aero Propulsion Laboratory have reported extensively on Dump Combustors.⁽¹³⁻¹⁹⁾ These references form a database for scaling dump combustors used in ramjet missile development. For example, Stull and Craig,⁽¹³⁾ found that short combustors with length to diameter ratios (L/D) < 4.5 exhibited substantial increases in combustor efficiency with a well-designed flame holder: from 60% with no flame holder up to 80% with a flame holder. The addition of a flame holder significantly increased the pressure loss (40-50%). An L/D ratio of 2.25, without a flame holder, was the shortest ratio L/D combustor this study found to operate in a stable manner, with 40-60% efficiency. The CJES design required a combustor with a length to diameter ratio of 1.85. After further research of the AFRL work, it became evident that some other combustor type would be required to achieve the goal of shortening the combustor to an acceptable length. The author could not find any dump type combustor papers that claimed successful operation of a lower L/D ratio unit.



Figure 8 a) The Effect of Flame Impingement on a Temperature Rake, b) High Speed Research Model where the Rake was used. ⁽¹²⁾

Swirling flow combustion can produce the required increase in flame speed to achieve the CJES rig length goal. The HWB team agreed that the CJES could be twice the length of the scaled engine nacelle. The nacelle length was 20 inches, so the maximum length for the CJES was 40 inches. A paper by Lewis ⁽²⁰⁾ documented a test of centrifugal loading on flame propagation in 1971. In a subsequent contractor report for the Air Force, Lewis found that the flame propagation speed could be increased by a factor of four or more. ⁽²¹⁾

According to Lewis ⁽²²⁾

There are two commonly accepted means of spreading flame through a combustible mixture in practical combustion systems. The first of these, laminar flame propagation, depends on heat conduction and the diffusion of chemically active species into the adjacent fuel-air mixture to propagate the fire. One foot per second is a typical laminar flame speed for stoichiometric hydrocarbon-air mixtures. The second, turbulent flame propagation, adds the turbulent

transport of small elements of flame a short distance into the unburned mixture to act as new ignition sources. Turbulent flame speeds in hydrocarbon-air mixtures typically range from 2 to about 20 feet per second. In the past, when attempts have been made to increase the turbulent flame speed to higher values, the pressure drop required to produce the turbulence has been prohibitive for practical applications, or flame stabilization problems prevented operation at higher velocities. Recently, tests in a combustion centrifuge have demonstrated that centrifugal force can be used to increase flame propagation rates by an additional factor of 4 or more.

As part of Lewis's contractor study, a scale afterburner was built and tested. The testing results indicated that a full-scale afterburner could be shortened by 1/3. This was additional confirmation that a high swirl combustor was the appropriate design direction.

Additional research identified a test facility at the Wright Patterson Air Force Research Lab, the Atmospheric-Pressure Combustion Research Complex (APCRC) that was applying one of Lewis's concepts.⁽²⁵⁾ The APCRC has been developing two types of combustors: Trapped Vortex Combustion technology and an Ultra-Compact Combustor (UCC). The Trapped Vortex Combustor, shown in Figure 9, provides improved combustion performance and reduced nitrogen oxide production.

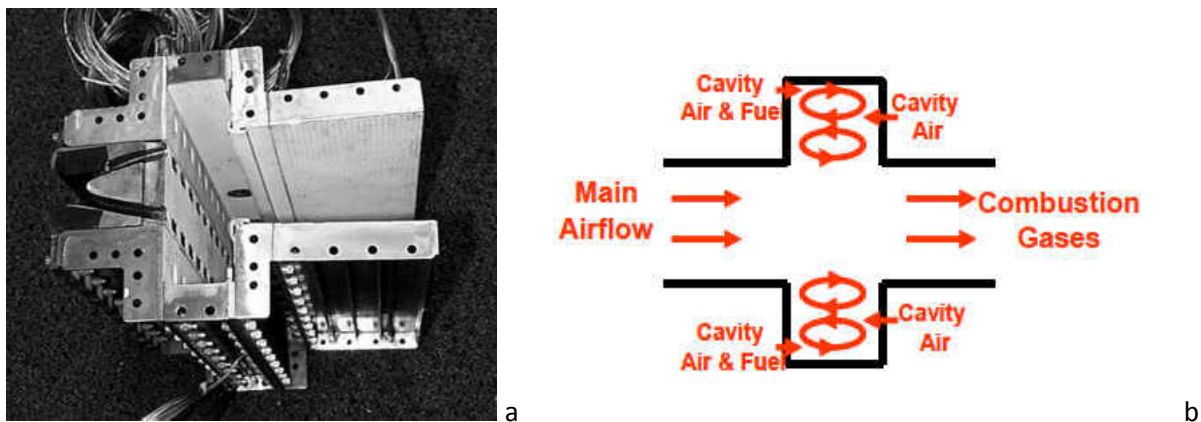

Figure 9. A 2-Passage Dome/2-Vortex Cavity Trapped Vortex Combustor and Schematic.⁽²⁵⁾

The main air supply is split into two streams, and additional air is injected in the cavities to form a pair of vortices in each cavity. Figure 9a shows a 12-inch section of a working combustor while Figure 9b is a schematic for the flow. The combusting products swirl for a short time in the outer vortex then transfer to the inner trapped vortex and then mix with the main air stream to continue burning downstream of the cavity. The main advantage of this design was the rich burn-rapid quench combustion. This was efficient and produced low nitrous-oxide emissions. However, this style of combustor was two dimensional in nature with a short flame residence and was not adaptable to the CJES.

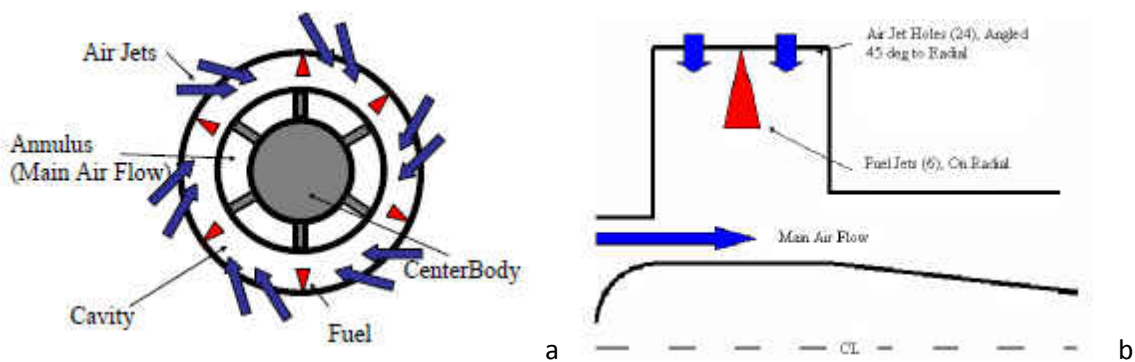

Figure 10. Schematic Views of UUC; a) Axial View and b) Side View. ⁽²⁷⁾

The Ultra Compact Combustor, shown in Figure 10, had similar advantages to the Trapped Vortex Combustor, and combustion occurred mainly in the annular passage. A combustible air-fuel mixture swirls around the main air flow to generate high centrifugal loading and provide residence time for the flame without adding axial length. The higher-density fuel and cool air circulated around the

annulus until it burned; then the lighter high temperature combustion products migrated to the inner radius of the annulus and mixed with the main air stream. The prototype versions of the UCC were similar in size to that required for the HWB test rig. ⁽²⁶⁻³³⁾ A preliminary design was developed by the author and sent to Joseph Zelina, the head of the APCRC in 2009. His comments were incorporated into the design and explained in the section Implementation of the AFRL UCC Concept.

CHAPTER IV.

General Arrangement Evolution

Flow rigs to test acoustic performance of jet nozzles were designed to minimize the impact of delivering the desired air flow to the nozzle. For the test to be relevant, one had to match the air stream temperature and pressure ratios to that of the engine with the scaled mass flow rate. This applied to both the core and bypass air streams. If the model size is not limiting, large duct sizes could be used to minimize the flow noise and provide a large contraction ratio for good flow uniformity. The large duct size reduced the flow velocity, which also reduced flow turbulence and the associated noise in the duct. A large contraction ratio nozzle accelerated the flow and reduced the boundary layer and associated turbulence intensity just ahead of the test article exit. For the CJES, the flow rig also had to match nominally the scale engine nacelle size. The free stream air flow over the HWB would have been adversely affected by a large duct, so the large duct concept was not viable. Hence, contraction ratios for the nozzles were consistent with typical engine nozzles. Therefore, flow conditioners and pressure reducing grids were added to provide the flow uniformity and reduce rig flow noise by pressurizing the system to raise the density and reduce velocity.

While the CJES design was underway, the airframe geometry was changing as the engine location was being adjusted. The engines were mounted over the wing causing the wing to shield ground observers from noise subsequently an element of the HWB test was to evaluate these shielding effects. For that reason the engine nacelle height above the fuselage and the distance from the trailing edge were varied. At one point in the design cycle, the CJES included a 20° bend to clear the fuselage. Fortunately, cross flow from the wing over the fuselage drove the required nacelle height upward in order to minimize the flow separation at the nacelle inlet and eliminated a supersonic separation bubble

at cruise speed to allow an inline CJES design. Eventually, the airframe design was frozen and the nacelle design was finalized in late 2009. The final model configuration is shown in Figure 11.



Figure 11. Boeing Concept of the Hybrid Wing Body Aircraft. ⁽⁵⁾

The initial UCC design in the Compact Jet Engine Simulator drove the model nacelle size down to 1.5 times the scale nacelle length. Computational Fluid Dynamics (CFD) modeling demonstrated that a stagnation pressure bubble on the wing/body caused by the CJES nacelle disturbed the flow over the wing (see Figure 12).

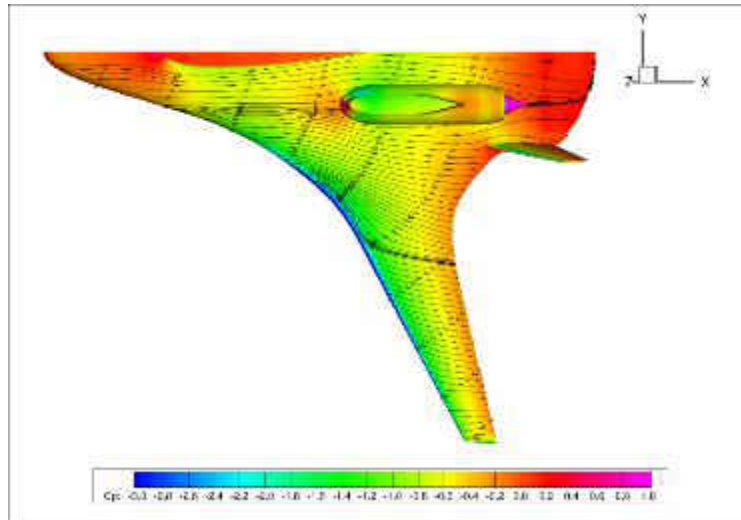

Figure 12 CFD Results Showing Streamlines and Surface Pressure (Craig Hunter NASA LaRC 8-24-2010)

The nacelle was modified with a longer forward taper to eliminate the blunt body produced excessive surface pressures and the nacelle grew to be 1.8 times the scale engine nacelle length. The stagnation pressure resulted from the CJES not ingesting the incoming air flow like an engine and the front was closed off. The final CJES configuration is shown in Figure 13. The CJES units were track mounted on the model support so the axial location can be varied without rebuilding the model. This arrangement allowed the air and fuel supply hoses to avoid interference with balance measurements in the main model.

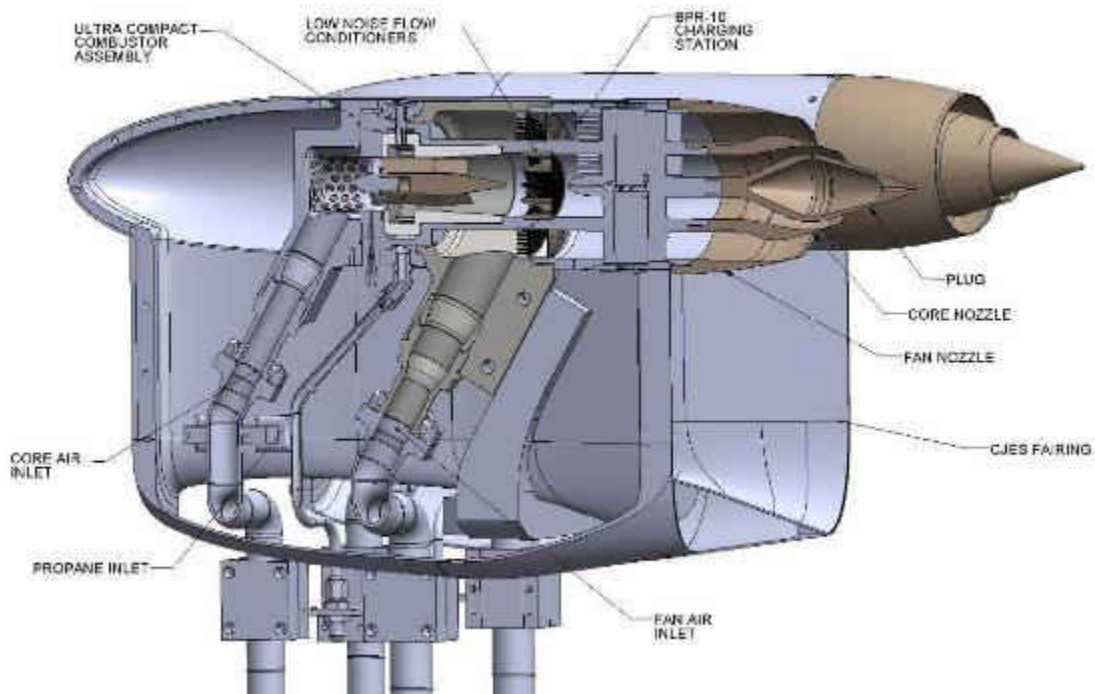

Figure 13. The Compact Jet Engine Simulator in Cross Section. ⁽⁵⁾

The final engine size varied during the design iteration process and resulted in the values shown in Table 1 (page 5). The scaled nacelle ended up being 8 inches on the outer diameter. Trying to achieve contraction ratios of 1.5 for both streams while maintaining the duct Mach number below 0.3, for a low noise rig, proved to be challenging. The CJES units had to translate axially (1/2 a fan diameter aft of the trailing edge to 2.5 diameters forward) to study the shielding effect of the wing and integrate with the model support, which was being supplied by a separate vendor. Several changes to the AFRL design were needed to adapt the concept to NASA's application and are described in the next section.

CHAPTER V.

Implementation of the AFRL UCC Concept

The AFRL concept used a separate swirl air feed. This added another variable to the combustor control that was necessary for combustor studies but not for a space-constrained wind tunnel model system. The swirl air for the CJES was provided from the main core air stream. A sintered-screen flow-conditioner supplied uniform flow into the main core air passage and a pressure differential. Two annular ports fed swirl air to the swirl air plenum around the combustor liner utilizing manually controlled globe valves. The swirl air plenum also provided air cooling to the high temperature section of the combustor liner. The swirl air supply is shown in Figure 14.

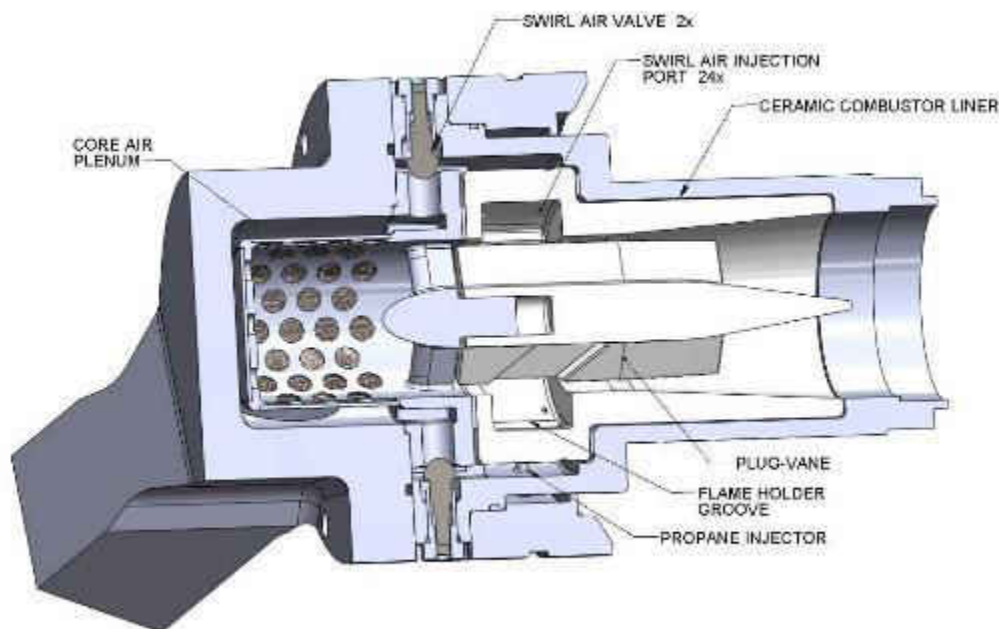

Figure 14

Swirl Air Configuration of the CJES Combustor. ⁽⁵⁾

To achieve the design goal of an 8" outside diameter on the CJES fairing and match the Boeing model, the fuel and air supplied to the combustor had to be nested in coannular manifolds. Figure 15 compares the CJES in Figure 15a with the AFRL UCC/ Inter Turbine Burner (ITB) in Figure 15b. The CJES employs an outer annular propane manifold with fuel injectors protruding radially into the combustor liner. The swirl air manifold is inside the propane manifold. Twelve of the 24 air injection ports that induce the swirl in the combustor annulus can be seen. The AFRL rig had separate fuel and air feeds; this made studying the combustion process easier, but the design was large, on the order of 3 feet in diameter. Based on the results of the AFRL studies, the ratio of swirl air to main core air was known and the NASA design did not need the extra variables nor could they be fitted into the confined space available.

The NASA UCC design utilized gaseous propane as the fuel instead of liquid jet fuel as was the case for the AFRL system. This addressed several safety concerns. Using gas phase fuel, the supply was to be cut off in close proximity with the combustor and purged in an emergency stop condition. Using liquid fuel, the reaction time to bring the system to an inert state was much longer (mass of fuel is larger), and some fuel remained trapped in the system because it cannot be dumped. With propane vapor, the combustion must occur in the combustor annulus. If combustion did not occur, then the main core flow mixes with the combustor flow and the resulting mixture is below the flammability limit for propane by the time the flow reached the flow conditioner. The flow conditioner was a flame stop. Using liquid jet fuel, the fuel was able to run out of the combustor and produced flammable mixture outside of the combustor as well as permitting a fuel spill to occur. The Fire Chief would have required active fire suppression in the 14x22- Tunnel if a combustible mixture left the CJES.

Due to security restrictions, AFRL would not provide any drawings or dimensions of the configurations they had tested other than what was published in open access papers. Using that data,

the author picked sizes for the combustor annulus and integrated them into the design. Joseph Zelina, from AFRL gave some general comments and sizing suggestions in e-mails in the July-September 2009 timeframe. With the third version, Mr. Zelina indicated the design was similar to what AFRL had tested; consequently, the internal geometry was frozen and the design proceeded. The plug in the CJES was approximately half the diameter of the AFRL version. ⁽²⁶⁻³³⁾ The CJES design departed from the AFRL version and needed verification that the new design would work.

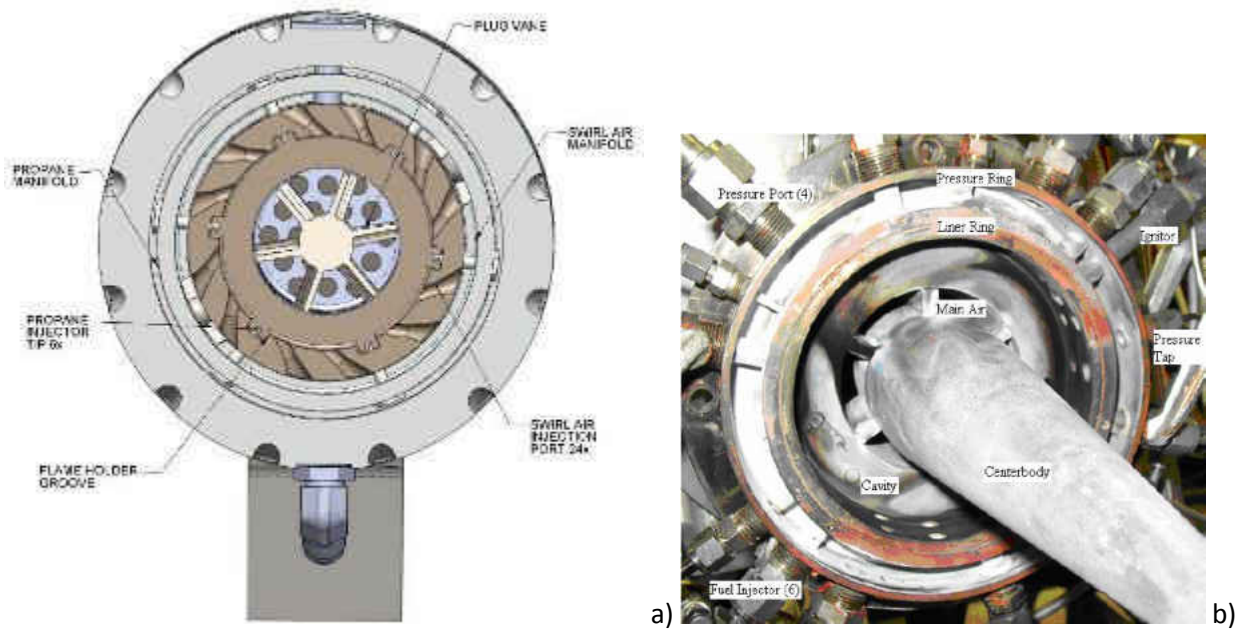

Figure 15 Comparison of Air and Fuel Supplies between a) CJES ⁽⁵⁾ and b) AFRL's UCC/ITB. ⁽²⁵⁾

Chapter VI.

Swirl Air and Flow Conditioner Study

To verify sizing of the swirl air passages and the initial valve settings, a test was designed for the Small Anechoic Jet Facility (SAJF) to simulate the swirl air valve conditions. ⁽³⁵⁾ The test rig for studying flow conditioners was modified by adding a flanged Swirl Air Valve Calibration Rig into the Flow Conditioner Test hardware (see Figure 16). Employing this setup, the inlet flow conditioner was evaluated, and the initial valve settings for the swirl air nozzles could be determined. In order for 14.5% of the core air to flow through the swirl air nozzles, a valve position of 2.75 turns of the valve were required.

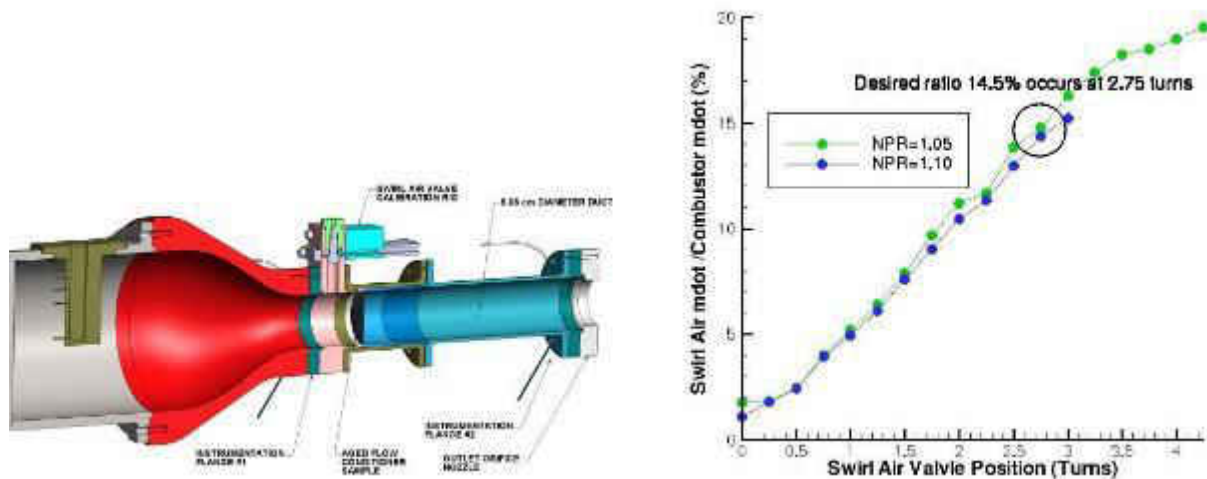

Figure 16 Swirl Air Valve Calibration Test and Data. ⁽³⁵⁾

The CJES unit was small compared with similar acoustic test rigs in other facilities, so the probability that there would be rig noise issues was high. Consequently noise attenuation flow

conditioners had to be found. Before the flow conditioners were selected, a test was planned in the NASA Small Anechoic Jet Facility (SAJF) to determine what types of flow conditioners could attenuate the noise and provide good flow quality. ⁽³⁴⁾ This testing was documented by Doty and Haskin. ⁽³⁵⁾ That study concluded that low porosity honeycomb (15.6% open area) and a fine sintered wire mesh provided 20 dB of broadband noise attenuation with minimal self-noise. The sintered screen used commercially as a 20 μ filter media was a product of Martin Kurz corporation and was designated DP450661.

Chapter VII.

Final Design/Build Contract

The final CJES concept was released on contract for detail design and construction. Alliant Techsystems Inc., Missile Subsystems & Components Division, Micro Craft Operations (ATK/Micro Craft) was awarded the contract and built the hardware. Since none of the contractors on the NASA LaRC models contract had any experience casting ceramics, LaRC was to supply the combustor liner and the plug/vanes in ceramic material to complete the assembly.

Chapter VIII.

Ceramic Combustor Liner and Plug Development

The ceramic cast combustor liner concept had many challenging features (see Figure 17): incorporating 31 through holes, an undercut annulus, a cylinder, and a conical section. To develop a mold for this part, the author worked with a team of technicians, an additive manufacturing specialist and two ceramic casting specialists. The mold had to have either a removable core or use consumable core inserts to generate the desired final shape. Several computer models were developed by this author and discussed as options before any mold components were made.

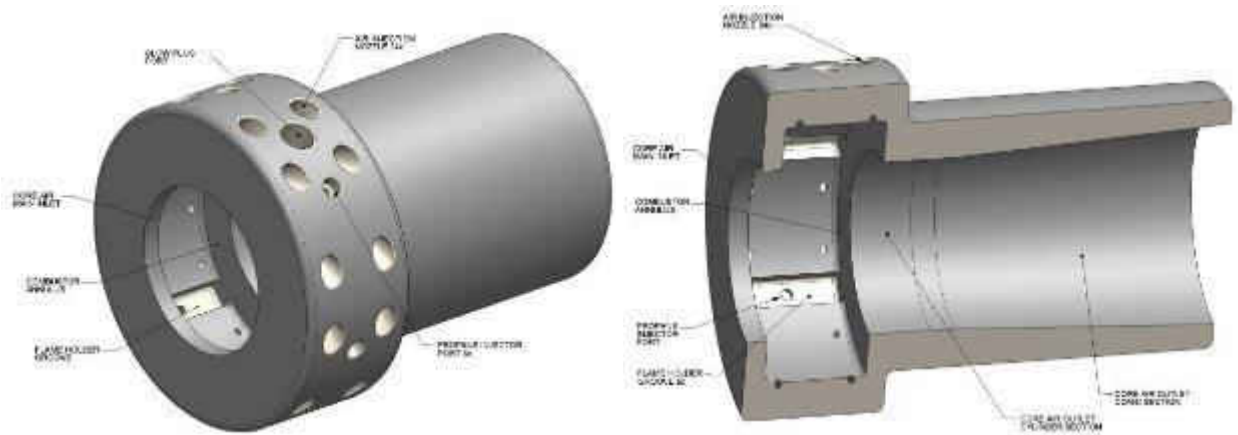

Figure 17 Views of the Combustor Liner Showing Features to be Cast in Ceramic. ⁽⁵⁾

Typically, a rubber core insert can form an internal feature that collapses for removal (see Figure 18). This was tried on the first mold iteration; the combustion annulus was formed utilizing a soft silicone rubber insert. To support the thin insert, twelve plastic blocks were installed through the core

main air inlet. An aluminum plug held the blocks in place. Over the downstream section of the plug, a second rubber core formed the cylindrical and conical outlet geometry. The propane, air injection ports and glow plug igniter port were formed with aluminum inserts through the outer split mold. The outer mold halves were Stereolithography assembly (SLA) plastic parts. The hole in the left face of the outer mold was a fill port for the ceramic mixture. The classic mold technique was very hard to remove from a green ceramic casting without damage to the part.

The technicians suggested employing a consumable wax insert to form the combustor annulus. These inserts were made using an in-house wax printer. The wax printing provided a simpler mold, but substantial wax shrinkage necessitated several iterations on the CAD model to achieve the desired core geometry. A simple scaling operation applied to the CAD file was not satisfactory, and each feature had to be scaled separately. The wax part had a uniform wall outer shell and thin rib supports on the interior. The 3% shrinkage rate had to be applied to each length of the part. The inner conical surface had to match the aluminum plug cone angle and allow the plug to fully seat axially. After eight trials, a successful wax core was produced.

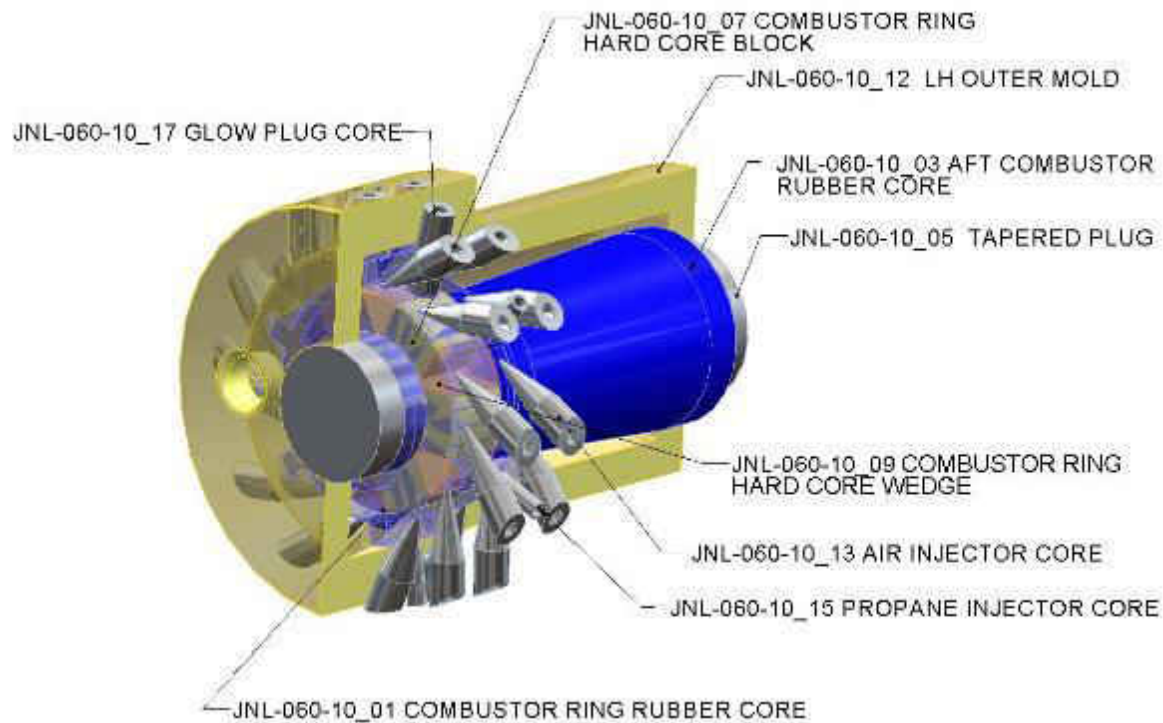

Figure 18 First Combustor Mold Version. ⁽⁵⁾

To avoid ceramic material protrusion (flash) into the 31 ports, the inserts had to fit into sockets in the wax core. These features could not be printed. The wax was printed on a plate and built up vertically. Any round features not parallel to the vertical axis became elliptical due to the liquid wax fusing and shrinking. To circumvent this problem, a SLA fixture and a set of cutters were made (see Figure 19). The wax core is shown in Figure 19a, mounted in the cutting fixture with single tooth aluminum cutters for the glow plug, air injection port and propane injector port tools. A wax core is shown in figure 19b. This gave consistent insert seating avoiding cleanup of the ceramic cast part ports after firing the ceramic.

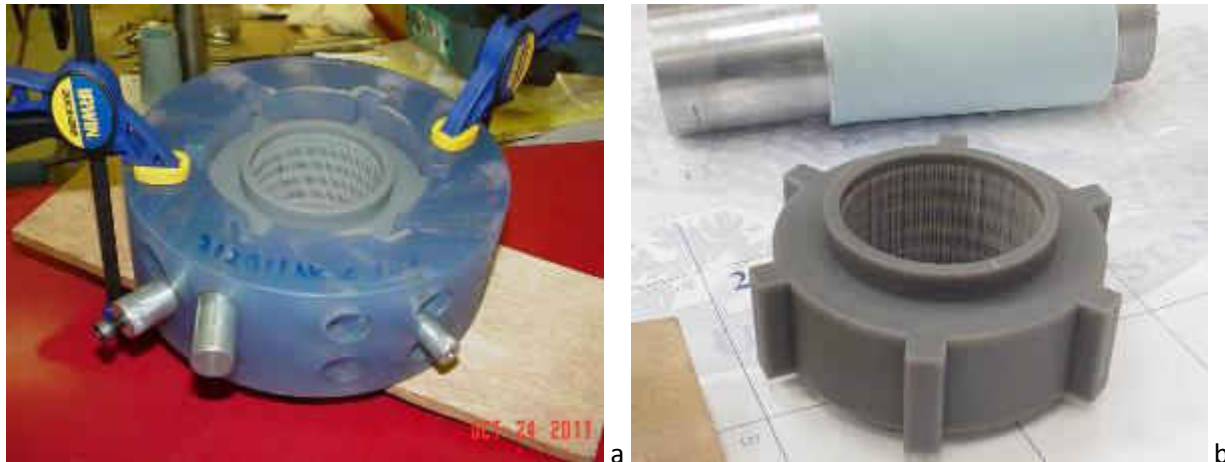

Figure 19 Wax Core Insert Cutting Fixture and a Wax Core. ⁽¹²⁾

Once the mold was complete, casting system evaluation and development was initiated. The selected combustor liner material was Cotronics Rescor 760, a Zirconia Oxide with a colloidal silica binder. This material had been used before on ceramic flame holders (see Appendix B). The ceramic casting technicians used their standard practice and cast the first liner.

The first casting had several problems: the ceramic material had a 10 minute working life before it started to set; once it started to set, it would not flow; the material would also segregate into coarse and fine grain volumes that would fracture at the transition; a frothy jelly formed at the top of the mold making the top wall unusable; a new mold was made with the fill ports at the downstream end of the part to allow for the froth to form beyond the usable part. The material segregation issue could not be solved with a mold change so a different material was tried.

The second casting material was Aremco 646, which is a Zirconia Oxide, utilizing a magnesia phosphate binder. The different chemistry presented a new set of problems. This material would set by a chemical reaction after enough water had evaporated out of the mixture. While setting, the material initially expanded then shrank. The technicians observed that the casting had to sit in a warm place for

three days before it could successfully be removed from the mold. After one day the aluminum plug and all 31 of the port inserts could be removed to help the water escape.

Several standard mold release agents were tried, and petroleum jelly was found to be superior. Fine bubbles were observed in all of the ports in the casting. Discussion with the Aremco revealed that the manganese phosphate binder reacted with aluminum and certain plastics. Instead of remaking the 32 aluminum parts and the mold, the author suggested painting them so the metal and plastic did not come in contact with the ceramic during casting. The first ceramic casting, after the above changes, cracked when fired at 1200°F per the manufacturer's directions. Additional discussions between this author and the manufacturer resulted in reducing the water content of the mixture (below the printed instructions) to potentially resolve the cracking problem. Those changes resulted in one acceptable part in three casting attempts. The amount of shrinkage for the ceramic material was dependent on the percentage of water in the mixture. The modified water proportion reduced the shrinkage rate and provided some acceptable castings, but the viscous paste would not pour into the mold.

Aremco was contracted to perform a study of ceramic grain size distribution versus shrinkage and develop a NASA formulation with lower shrinkage. Two formulas were submitted for evaluation. The coarse version proved to be too thick for effective vacuum outgassing at the lower water levels required for reduced shrinkage. The trapped air in the material caused the part to fail while curing (see Figure 20). The fine-grained version released the air and withstood firing. During firing the part developed fine cracks on the surface (crazing). Reducing the water content further (an inability to charge the mold defined the lower limit) improved the castings. Figure 20 b shows the results of the improved material and water proportions.



Figure 20 Failed Ceramic Combustor Liners, a) New Coarse Material, and b) New Fine Material. ⁽¹²⁾

After a year of working to develop a casting technique that produced a 50% part yield, an alternate approach to produce a metallic combustor liner and plug/vanes in parallel with the ceramic effort was initiated. The additive manufacturing process of direct metal laser sintering of cobalt chrome material was considered the best in-house option. The same team of technicians would be working this solution because they knew the problem well.

The purpose of the plug-vane was to redirect the swirling flow out of the combustor annulus and mix it with the main core flow. Ideally, one would generate a non-swirling flow with uniform temperature and velocity profiles. Figure 14 (page 24) shows the plug-vane location within the CJES

combustor. The plug vane is secured with a 1/8 turn twist lock. This retention method aligns the vanes with the flame holder grooves in the combustor liner. The mold was manufactured in six segments (symmetry split along vane centerline planes) as shown in Figure 21.

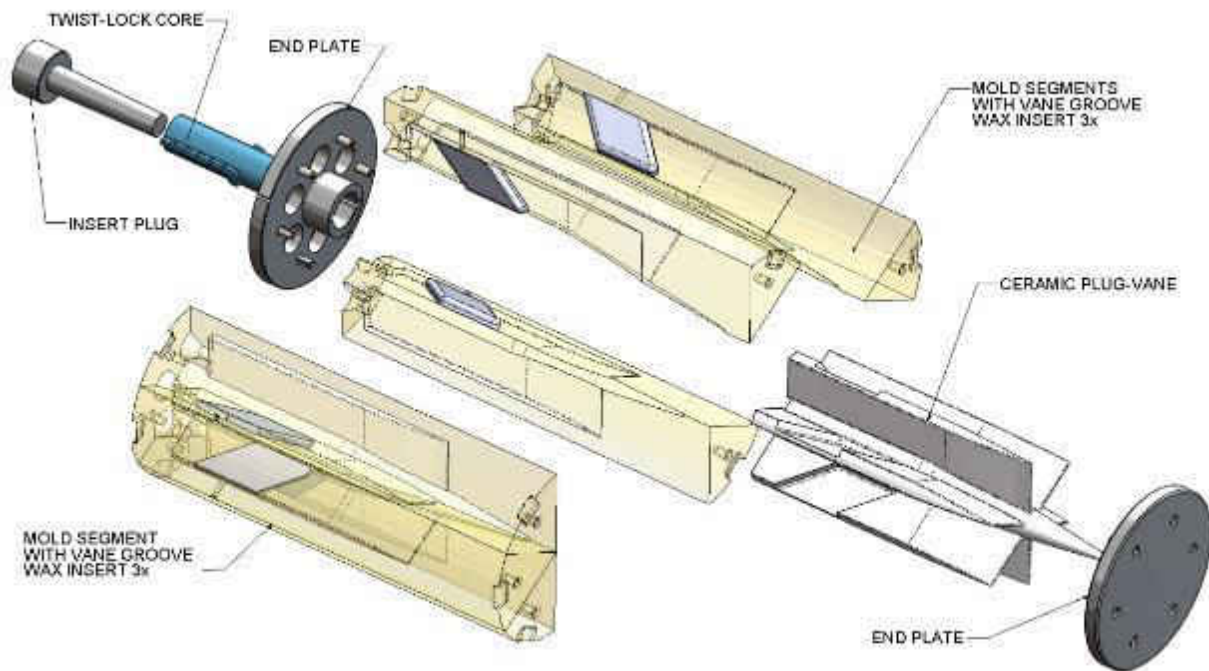

Figure 21 Ceramic Plug-Vane Mold Details. ⁽⁵⁾

The end plate with the twist lock core included the filler holes. The wax vane groove inserts were retained with pins. The wax inserts were also made on the wax printer after it proved to be much faster than cutting them from wax sheet stock. This casting had similar issues with the ceramic materials (paint the aluminum and plastic parts). This mold was tighter than the combustor liner mold and took

five days to outgas enough water for the Aremco material to set up. The Cotronics material was tested only once, and the part quality was so bad no changes were attempted to make that material work.

Four mold variations for the plug-vane casting were explored to reduce the cracking during shrinkage. The plug diameter was increased; the radii on the twist lock were enlarged; the groove insert radii were also enlarged; and the segment locking arrangement/end plates were changed. With the improved Aremco material, a good surface finish was obtained, but the parts still developed fine cracks through the twist-lock grooves and were unacceptable. At this point a decision was made, the ceramic versions were determined to be not viable and concentrate on the metallic component development. A slide presentation covering this development (part of a letter of accommodation for the technicians' efforts) is included in Appendix C.

CHAPTER IX

DIRECT METAL LASER SINTERED FABRICATION OF COMBUSTOR LINER AND PLUG-VANE

Additive manufacturing was starting to become a mainstream technology in 2011. The hardware and software were making large step improvements. NASA LaRC Fabrication Directorate had purchased from 3D Systems a

Sinterstation® Pro DM250, a Direct Metal Laser Sintered (DMLS) fabrication machine. Earlier work the author had done on this machine for flow conditioner fabrications had required two firmware updates to be written for the Sinterstation and doubling the machine memory. The Realizer translation software (from CAD to Sinterstation) also required a revision. All of the computer-related changes were due to the extreme feature-rich nature of the flow conditioners. The file sizes of the larger flow conditioners were in excess of 4GB before translation to the machine sliced file format. The DOS 6.2 based machine required some workarounds to deal with the geometry.

The detail design/build contract with ATK-Microcraft supplied one set of flow conditioners with each CJES unit provided. At least one set of spare flow conditioners was needed for the test. Past experience in the Jet Noise Laboratory had shown that 5 μ filters in the airline did not ensure that the flow conditioners would not clog with dust and dirt from the old pipes upstream of the model. In addition, the combustor produced soot at some operating conditions. The proposed 20 μ filter media for noise attenuation could easily plug with a light layer of soot. Having spare flow conditioners was necessary for a test in the 14x22 Tunnel, which is an expensive facility to run.

The fan flow conditioner had a nominal 6.50" outer diameter, a 3.85" inner diameter and a length of 1.50". It was a 0.50" thick honeycomb with 15.6% open area followed by thin walls to support the sintered screen. Figure 13 shows the locations in the CJES and Figure 22 shows the flow conditioners. The honeycomb holes were .025" across the flats of the hexagons. This part had to be built

using the DMLS because the 2500+ holes would have to be burned one at a time on an Electrical Discharge Machining (EDM) machine. That process would require custom tooling and several months of schedule. The cost for that feature alone was prohibitive. The hexagonal holes were selected over round holes because the translation file from SolidWorks to the DMLS format converted the solid surfaces into triangles. A hexagonal hole could be defined with 12 triangles, but a round hole depends on the resolution needed to define the hole. The part file, on the coarsest setting, was two orders of magnitude larger with round holes versus hexagonal holes at the same resolution. Since software/hardware limits were a challenge with the number of features, hexagonal holes had to be used.

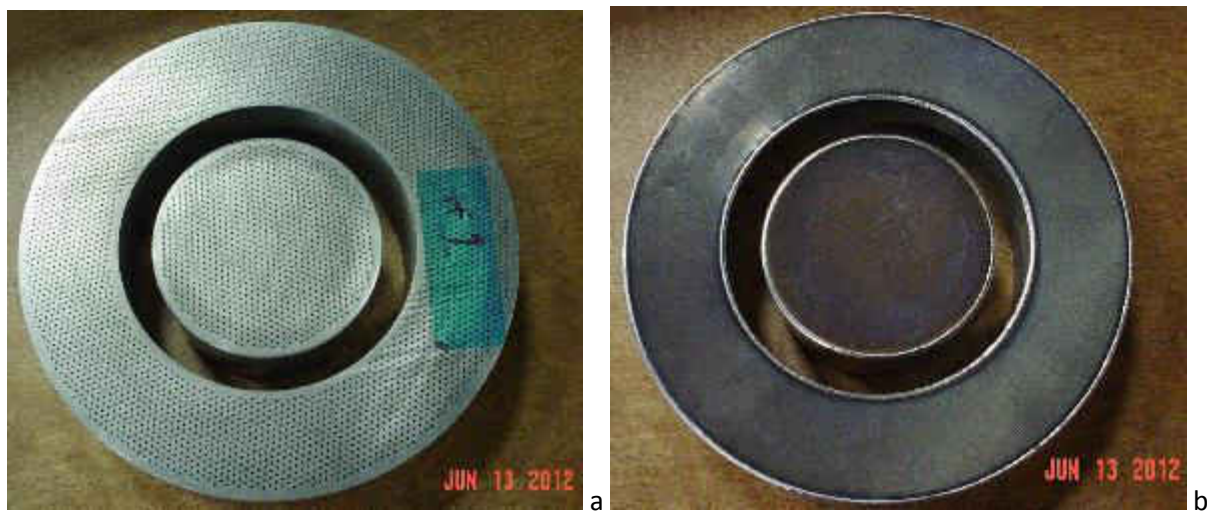

Figure 22 CJES Flow Conditioners, a) Upstream Face, b) Downstream Face. ⁽¹²⁾

The CJES fan flow conditioner is not a very large part, it has an outer diameter of 6.52", an inner diameter of 3.85" and is 1.50" thick. Attempts to utilize the DMLS centered on the process to fabricate fan flow conditioners failed for a variety of reasons as shown in Figure 23. In Figure 23 a and c, the machine failed to cross hatch fill in between the wall edges. The part shown in Figure 23 b had many

material defects due to lack of fusion between the layers, resulting in a porous material. The core flow conditioner parts shown in, Figures d & e, document that the top surface did not always fuse with the solid below and the surface curled up and jamming the machine and preventing it from depositing the next layer of metal powder. This was a new problem for 3D Systems field technician, and a member of the original design team from Germany had to be consulted. The problem required a replacement laser, complete realignment of the optics, new laser cavity seals and additional argon purge of the laser cavity (metal powder leaked in and had coated the optics) additionally the powder drop wiper blades were upgraded latest revision. Eventually one acceptable fan flow conditioner blank was fabricated using this machine. The second part was built in Germany on their developmental machine. That effort generated further software/hardware updates. The core flow conditioners were not a problem after the fan flow conditioner development. There were minor tuning issues resulting from the shift from stainless steel to cobalt chrome. The machine had only processed stainless steel until this project arrived. In the CJES unit both materials would be required. The stainless steel would suffice for the lower temperature flow, and the cobalt chrome would handle the high temperature core flow.

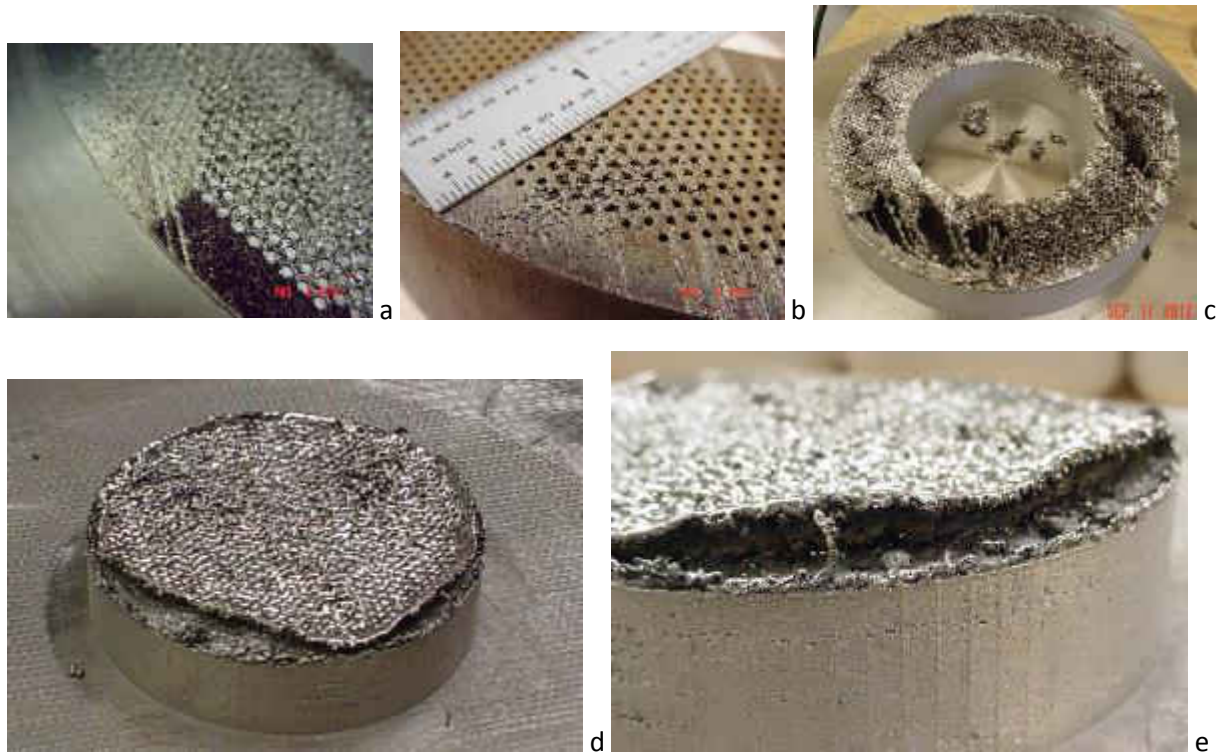

Figure 23 Failed DMLS Fan Flow Conditioners and Core Flow Conditioner. ⁽¹²⁾

The fan flow conditioners were designed to operate with flow temperatures ranging from 0°F up to 150°F as the cold air supply pipes heat up from a steam heat exchanger and reach a steady state. 316 stainless steel can be used in this application, and it is less expensive and easier to weld to the same material sintered screen. The core flow conditioners can experience temperatures ranging from 0°F to 1500°F since they are directly downstream of the combustor. The control software is programmed to shut off burner if the rake temperature exceeds 1200°F. The DMLS machine requires different operating parameters for the laser to properly fuse the powder for each material (pulse power level, duration, spot overlap, etc.). The company supplies baseline parameters for each material, but samples have to be run, requiring adjustments, within the specified ranges to achieve the desired material properties.

The next fabrication challenge was to attach the fine sintered screen to the flow conditioners. The sintered screen material was 0.018" thick 316L stainless steel wire mesh. Conventional Tungsten Inert Gas (TIG) welding burned through the thin screen leaving gaping holes or unfused sections. Brazing was not an option because the braze alloy wicks into the screen, filling it. Electron beam welding the screen to the flow conditioners offered the best thermal control to the screen and base part. Unfortunately, the NASA LaRC fabrication shop lacked an appropriate electron-beam welder, and outsourcing the welding was the only option. Through the researcher exchange program with the Department of Energy, Thomas Jefferson National Accelerator Facility (JLab), it was discovered that the JLab fabrication shop had electron beam welding capability required for welding their superconducting alloy parts in their Continuous Electron Beam Accelerator facility.

NASA LaRC was granted permission to use their equipment and the JLab operator. In order to utilize this capability, the author worked with the E-Beam welding technician in order to develop the process for welding the screen to the flow conditioners. The flow conditioner had step in the wall to position the screen, which had to be adjusted. The bottom of the step acted as a beam stop to prevent excessive melting. It was found that a filler wire had to be added to the joint in order to fabricate a complete joint because the screen was too porous (when the screen melted it left a large gap). The JLab machine did not have automated wire feed. The NASA LaRC shop used a water jet to cut the screen material, to a tight fit, which was then cleaned for oxygen service. The Jet Noise Lab Technicians spot welded the screen in place and then spot welded the TIG wire filler to the joint. After four sample trials, the team was able to weld the sintered screen to the flow conditioners. The welding samples that were subjected to tensile tests are shown in Figure 24a. The screen-to-screen welds failed due to lack of filler metal (samples 1A & 1B). The screen to sheet metal welds (simulated screen to flow conditioner welds)

survived even after the screen failed. Figure 24 b) shows a completed flow conditioner weld. Figure 24 c) shows the flow conditioner, sintered screen and the TIG weld wire spot welded in place ready for E-beam welding.

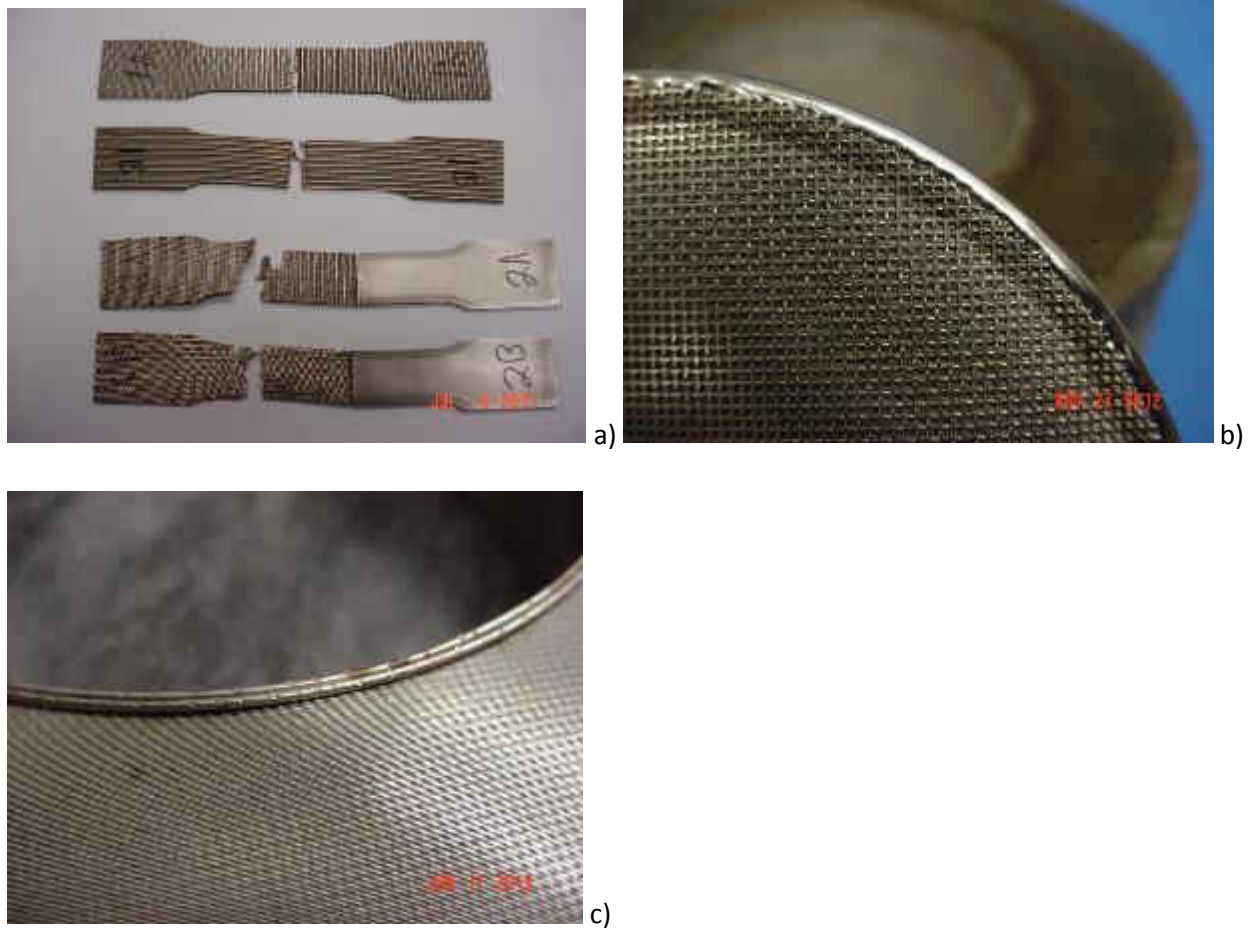

Figure 24 Sintered Screen Electron Beam Weld Samples; a) Tensile test samples, b) Flow Conditioner Welds, c) Prepared Parts before E-beam Welding. ⁽¹²⁾

The next parts to be manufactured by DMLS were the combustor liner and the plug-vane. The combustor liner design required a separate fabrication file, in addition to the CAD file, allowing all of the finished part details to be manufactured. Similar to the wax printer parts, holes not aligned with the build axis had to be omitted and Computer Numeric Control (CNC) machined after DMLS manufacture. The combustor annulus and flame holder grooves were built in the part. An indexing tab was required to permit CNC lathe setup aligning all the holes to the flame holder grooves (see Figure 25a below the tool). In the DMLS fabrication process, the combustor annulus and flame holder grooves were filled with a web like structural supports to secure the outlet duct (remains of the supports are visible in Figure 25b to the right).

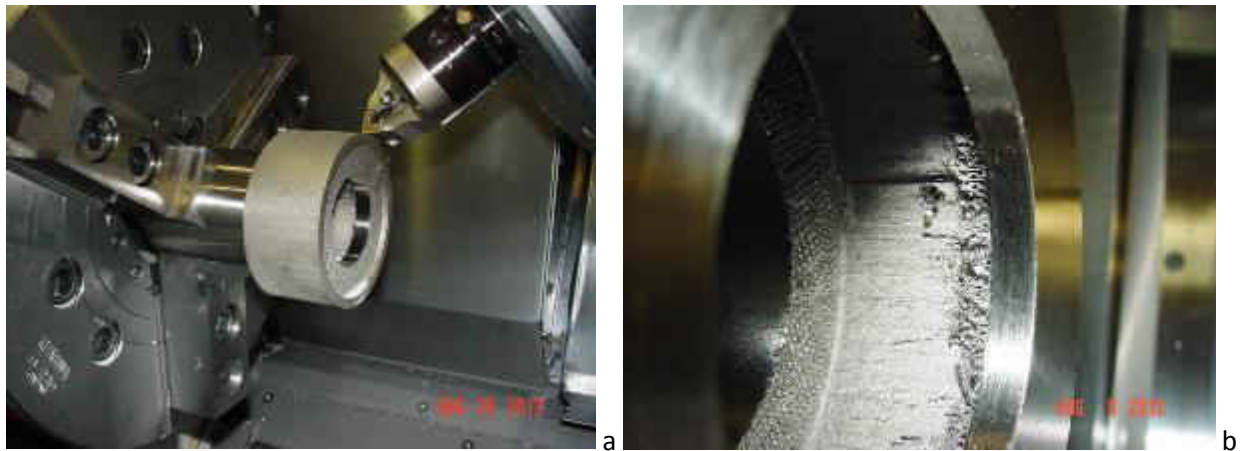

Figure 25 DMLS Combustor Liner on the CNC Lathe; a) showing the Machine set-up with the built in index feature, b) Close up of the Combustor Annulus and a Flame Holder Groove. ⁽¹²⁾

The propane injector and glow plug ports were bored. The air injection nozzles required special tooling. A flat bottom end mill produced the indexing reference and a solid carbide drill bit was

employed to produce a pilot hole. A custom set of single flute straight tapered solid carbide cutters finished the air injection nozzles. The outer diameter of the combustor liner and the combustion annulus were left in the “as built” condition for reasons of economy.

All of the DMLS parts were subjected to solution annealing heat treatment cycle in a furnace. Early sample DMSL tensile tests produced erratic results. To insure that DMLS parts had consistent properties, the parts were solution annealed. This process finishes sintering the powder metal part into a solid and softens the so it can be machined with regular tooling. In addition, pull samples were made with each batch and tested in a lab for material property documentation. As a result of this effort, these requirements have been incorporated in the Langley Model Systems Criteria for wind tunnel model testing. A finished combustor liner is shown in Figure 26.



Figure 26 Finished CoCr Combustor Liner. ⁽¹²⁾

The plug-vane development was less complicated than the combustor liner. However, several unique challenges were encountered. The twist-lock feature was made as a sample part so that the fit could be evaluated on the mating part. Since the inner diameter of the twist-lock is 0.6", it was too small to finish machine the interior features. The "as-built" finish and tolerances had to conform to the mating part. The part was modified to build the plug-vane, starting from the trailing edge plug cone tip. This approach eliminated the need for interior supports from within the twist lock feature. The first trials proved that the supports from the translation software were too weak. They failed and the part tilted during fabrication leading to a failed part (see Figure 27a). The author added .025" thick webs and .050"

ribs between the build plate and the trailing edges of the vanes. These supports produced a successful part as shown in Figure 27b. The plug tip support was reduced from the part outer diameter to 3/8" diameter. It was then possible to construct four plug-vanes simultaneously.

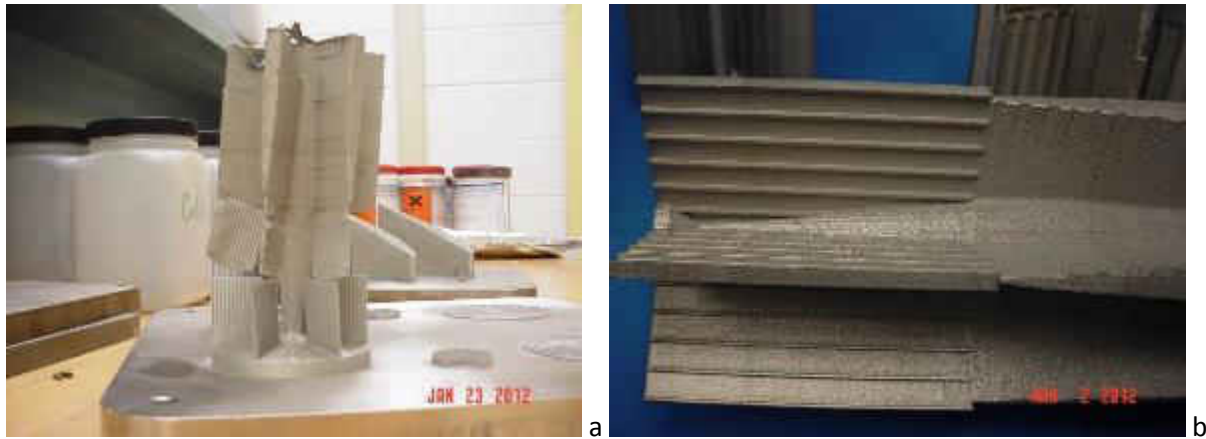

Figure 27 DMLS Plug-Vane Parts. The build in a) the left failed due to support failure then deflection. In b) is a batch of four units with CAD generated supports. ⁽¹²⁾

CHAPTER X

INITIAL TESTING OF THE COMPACT JET ENGINE SIMULATOR

The combined purpose of CJES testing was to:

- 1) Evolve CJES design from an untried burner concept into a functioning aero acoustic test rig.
- 2) Develop a reliable operating procedure for the CJES.
- 3) Document the operating envelope of the CJES.
- 4) Demonstrate the safe operation of the CJES using the hardware, as designed to operate it in the 14x22-Tunnel.
- 5) Evaluate the control software to an operational state.
- 6) Comply with the safety reviews required by LaRC to allow testing of this hardware in the 14x22-Tunnel.

Several steps were required in preparation for CJES testing. These included:

1. Modify the liquid propane supply to provide gas to the CJES valve pallet.
2. Modify the air supplies to the large Jet Engine Simulator to supply the CJES.
3. Wire in the CJES control PLC to the facility.
4. Integrate the CJES controls with the JNL controls and safety interlocks.
5. Write an operating procedure.
6. Operate the CJES with air and nitrogen to simulate operation and demonstrate all of the facility safety interlocks.
7. Produce a documentation package and present it to a safety review panel for release to begin testing.

The initial configuration run included only the burner section with no flow conditioner. A ceramic liner was used because the metal part was not fabricated yet. A set of thermocouples and a total pressure probe replaced the instrumentation section for the first runs so the assembly could avoid damage during burner checkout. The arrangement is shown in Figure 28. The large blue cylinder houses the propane control valve assembly. It is enclosed in a purged container because the 14x22 tunnel is not rated for fuel use. It was more economical to place the hardware in a purged container than to upgrade the 1970s vintage wind tunnel. The propane vaporizer was visible, a green cylinder, between the Jet Engine Simulator (acoustic foam covered burner rig on the left) and the CJES stand fairing.



Figure 28 Initial testing Configuration of CJES Combustor in the Jet Noise Laboratory. ⁽¹²⁾

Numerous modifications and adjustments were required before continuous combustion was demonstrated. For example, a check valve required for safety considerations had to be removed from the vaporizer liquid feed line to enable continuous fuel flow to the CJES. For the vaporizer to work, it had to maintain a constant liquid level height in the vaporizer tank, and the check valve had prevented that. The vaporizer would shut down in less than a minute of CJES operation. The control software was modified numerous times. While it was possible to light the burner, the flame did not stay in the combustor annulus. See Figure 29 a).

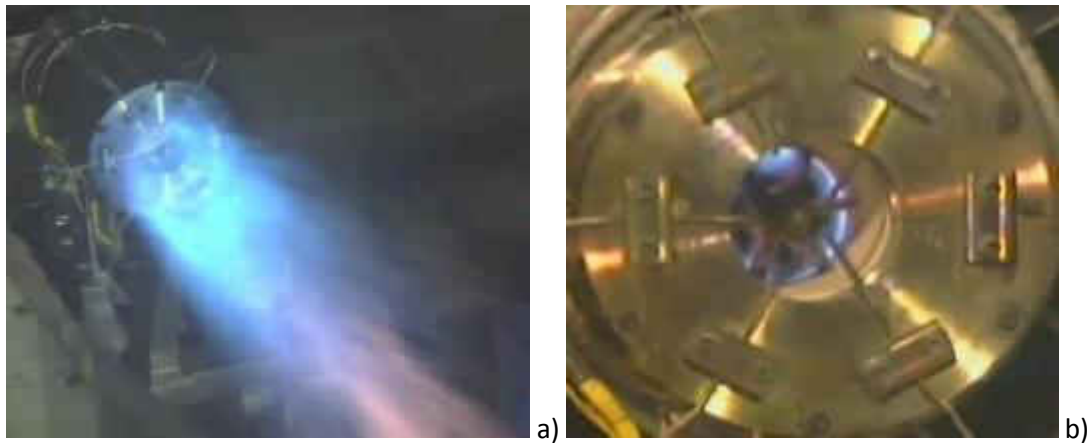

Figure 29 a) CJES First Light, b) Combustion in the Annulus from Aft Camera. ⁽¹²⁾

Another camera had to be added, in the tunnel diffuser, to view the exhaust of the CJES and verify the desired combustion operation. The initial combustion attempts could only cover a very small range of the desired overall operating envelope. More instrumentation was needed to achieve

acceptable combustor diagnostics. Ramping up the fuel and air to achieve higher mass flow rates blew the flame out of the annulus to burn on the plug-vane or a flame out. The author designed a total pressure rake that could replace the glow plug in the CJES unit (see Figure 30). This allowed running air through the CJES unit and the ability to measure the swirl rate in the annulus. Unstable combustion in the annulus was due possibly to inadequate centrifugal loading in the annulus resulting in incomplete combustion in the annulus. In addition, the amount of swirl air was not constant with the accumulating run time on a combustor liner.

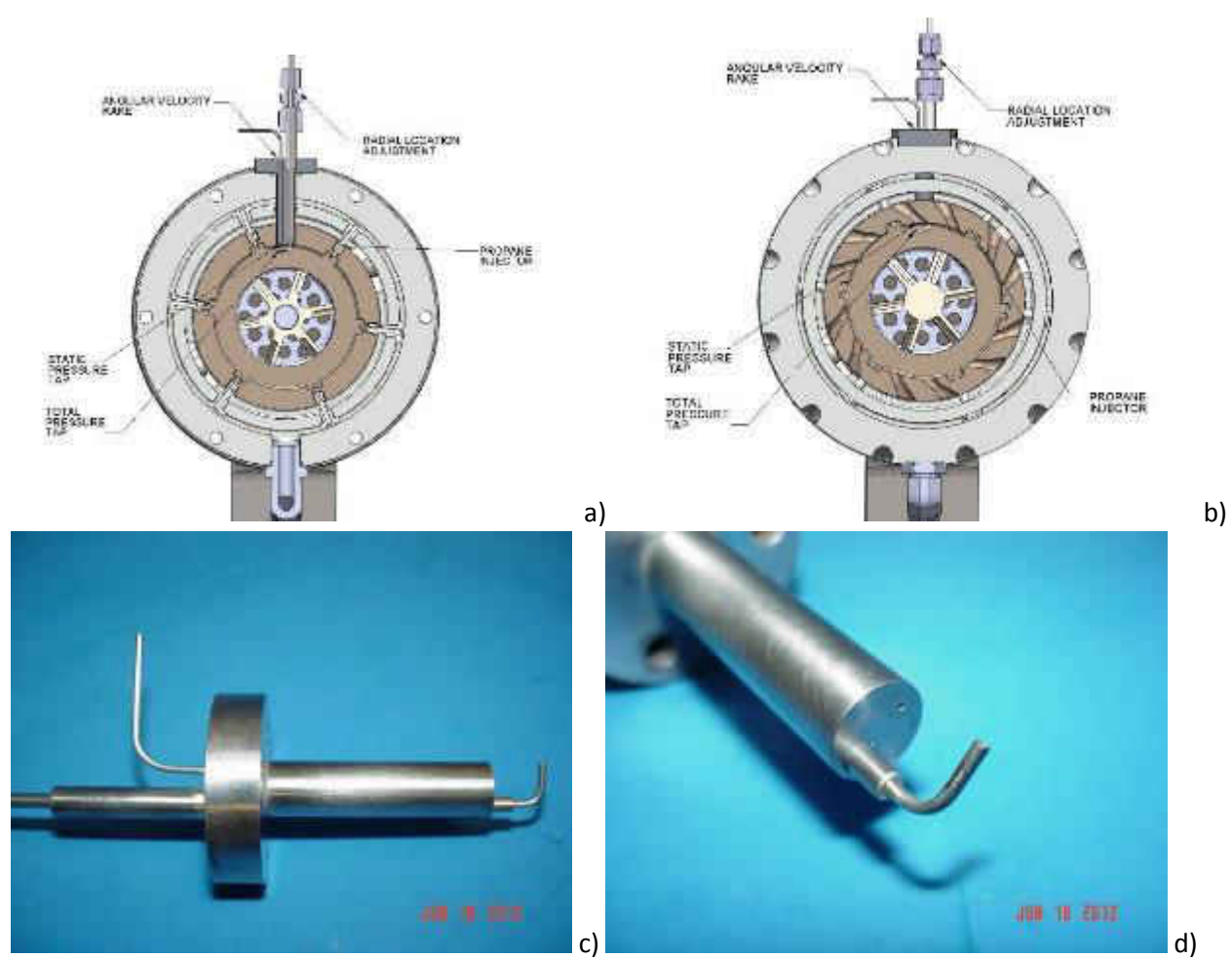

Figure 30 a) Angular Velocity Probe Installed in Glow Plug Port, b) Modified Combustor Liner with Larger Swirl Nozzles,⁽⁵⁾ c) & d) Probe Details.⁽¹²⁾

Current combustor liners were manufactured from ceramic and cracked after only several hours of use. The useful life was on the order of eight hours or less. The angular velocity probe provided data that showed as the liner cracked, the swirl air leaked through the cracks instead of swirling in the annulus. Lewis⁽²²⁾ observed that the peak flame speed for propane occurred around a Froude number of $Fr=3500$ dropped with increasing Fr . AFRL reported^(24, 27, 31) that the Froude number range of 2000-3000 was ideal for their Ultra-Compact Combustor. The tangential velocity distributions displayed in Figures 31 and 32 show the tangential velocity decreased by 50% or more with a cracked liner. The resulting Froude numbers were depressed to the point that combustion was not complete in the annulus. However, it was also noted that the swirl air velocity in a new liner could be lowered to bring the Froude number into the preferred range. This was done by enlarging the swirl air nozzle outlet diameter to .243 inches in diameter. This also allowed a larger volume of swirl air to achieve higher temperatures by adding more fuel. Figure 30 b) shows the modified swirl air nozzles. With this modification, the takeoff conditions for the Hybrid Wing Body Test were attainable.

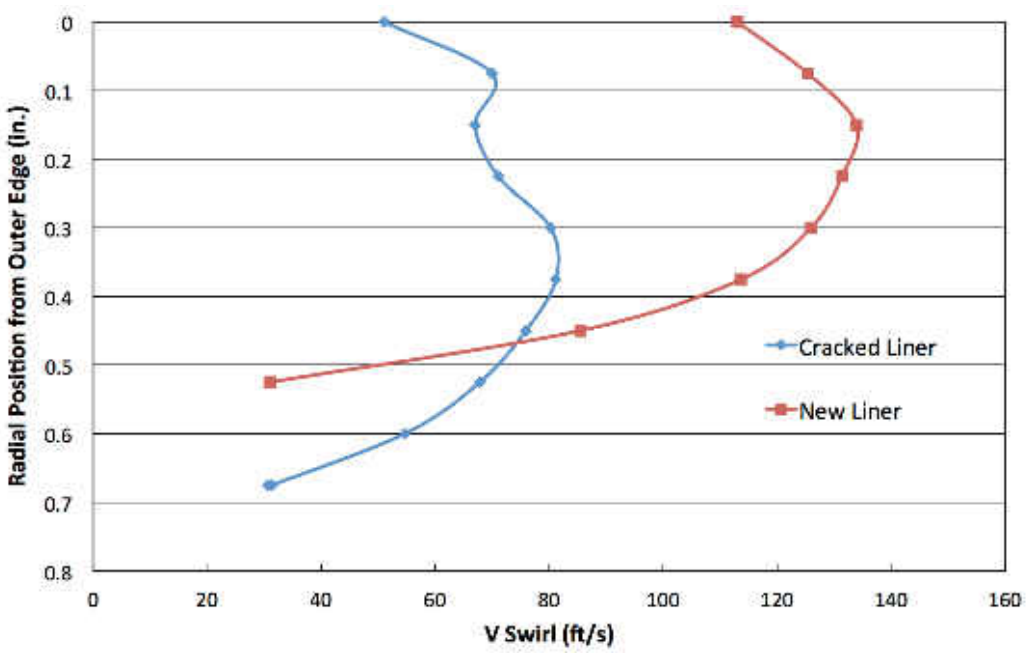

Figure 31 Swirl Air Velocity in the Combustor Annulus.⁽³⁶⁾

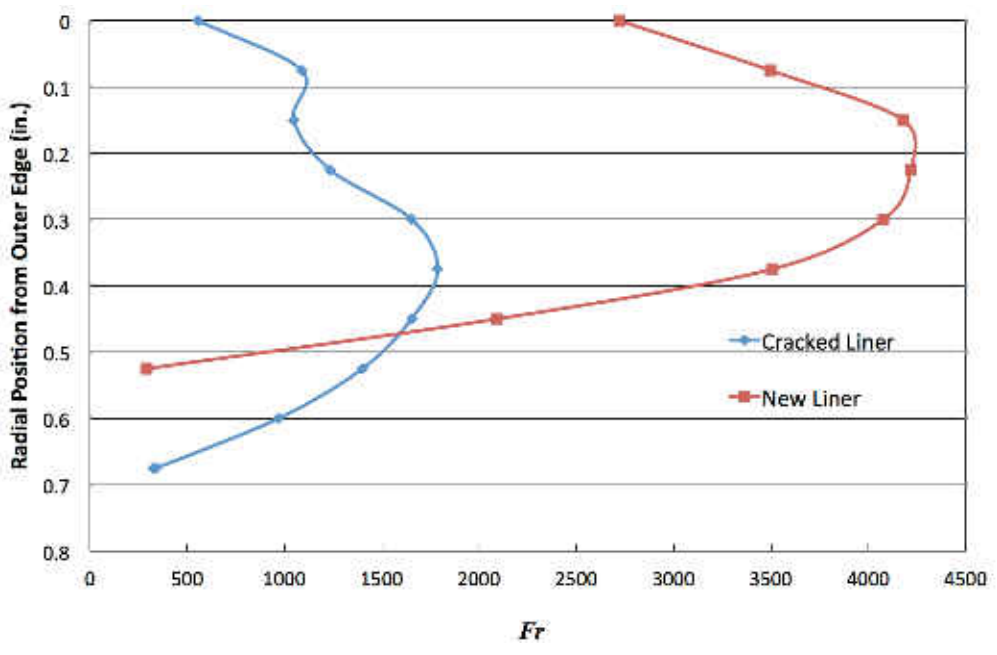

Figure 32 Froude Number for Cracked and New Combustor Liners.⁽³⁶⁾

Where $Fr = \frac{V_{tan}^2}{g_c r}$

Fr- Froude number, V_{tan} – swirl velocity, g_c – gravitational constant, r - local cavity radius

The increase in the swirl air nozzle size reduced the combustion switching in the plug as shown in Figure 33. While addressing the swirl air loading, it was determined that the propane injectors produced a very high jet velocity for the gaseous propane, which enhanced combustion in the plug-vane area. Part of this problem was due to gaseous propane fuel and a resulting lack of control of the gas supply pressure.

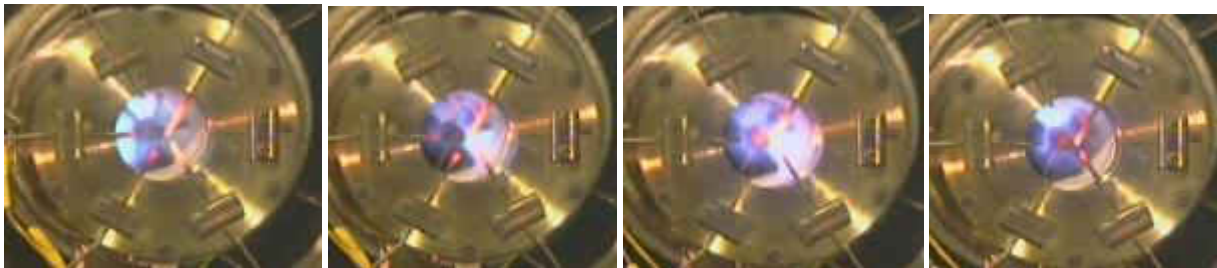

Figure 33 Combustion Switching Outside of the Annulus in the Plug-Vane. ⁽¹²⁾

The vapor pressure for propane at the tank temperature of 110F (propane tank in the sun August 2012) was 220 psi. The burner was operating at a static pressure of 15 to 20 psi. A differential pressure of 50-60 psi would have been better for mixing the fuel with the air for combustion. The fuel injector orifice size was changed to the maximum for the size of the part (.093") but resulted in little to no improvement, and as a result, a layer of sintered screen over the inlet of the injectors was tested (Figure 34 a). This modification was to ensure that the propane manifold pressure was uniform for all of the injectors while reducing the injection pressure. This provided no benefit to the operations so a

Nichrome strap over the tip of each injector was installed to divert the flow to the sides aligned with the flame holder groove (Figure 34 b).

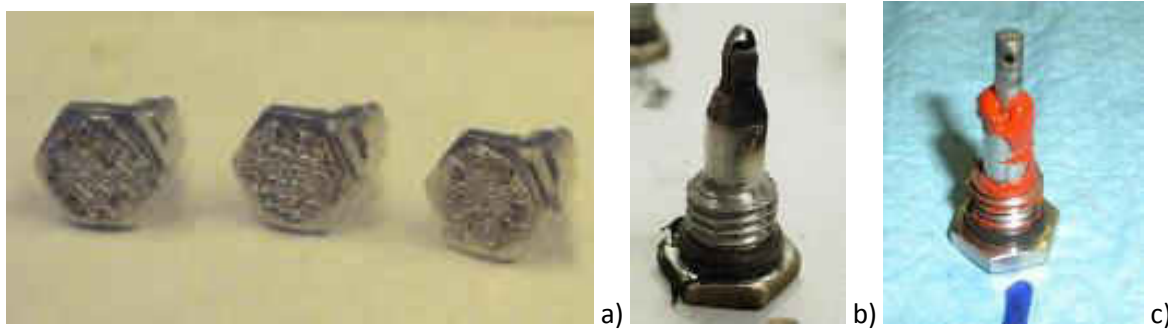

Figure 34 Propane Injector Modifications; a) Pressure Dropping Screen, b) Diverter Loop, c) Cross Drilled Holes. ⁽¹²⁾

This improved the temperature profile and burner stability. The burner operated consistently but the flame was not stable at the level desired. The final configuration extended the tip of the injector with a cross-drilled exit holes (Figure 34 c). This configuration provided the most stable operation across the mass flow and temperature range required for the HWB testing.

At this point, the CJES control software was validated demonstrating operation of the burner at test set points, and the ability to alternate between the set points with the burner exhausting to atmosphere. The next stage in development was to apply back pressure the combustor by adding flow conditioners and the test article nozzle. As a result of increasing the back pressure, the operating characteristics of the burner were altered.

The first back pressured runs were made with the 15.6% open area flow conditioner honeycomb. The unit started attained the lower test set points of approach and cutback, but did not attain the test set point of takeoff. It was assumed that the ceramic liner had cracked and had lost

burner efficiency. Upon disassembly and inspection of the unit (Figure 35), it was found that the liner had cracked and the increased backpressure had heated the propane manifold sufficiently to coke the propane. Carbon deposits were found in the propane manifold area where there was no air for combustion (Figure 35a). The propane injectors were coated in carbon on the injector inlet side. Soot was evident on the outside (Figure 35 b) and the inside of the combustor liner (Figure 35 c).

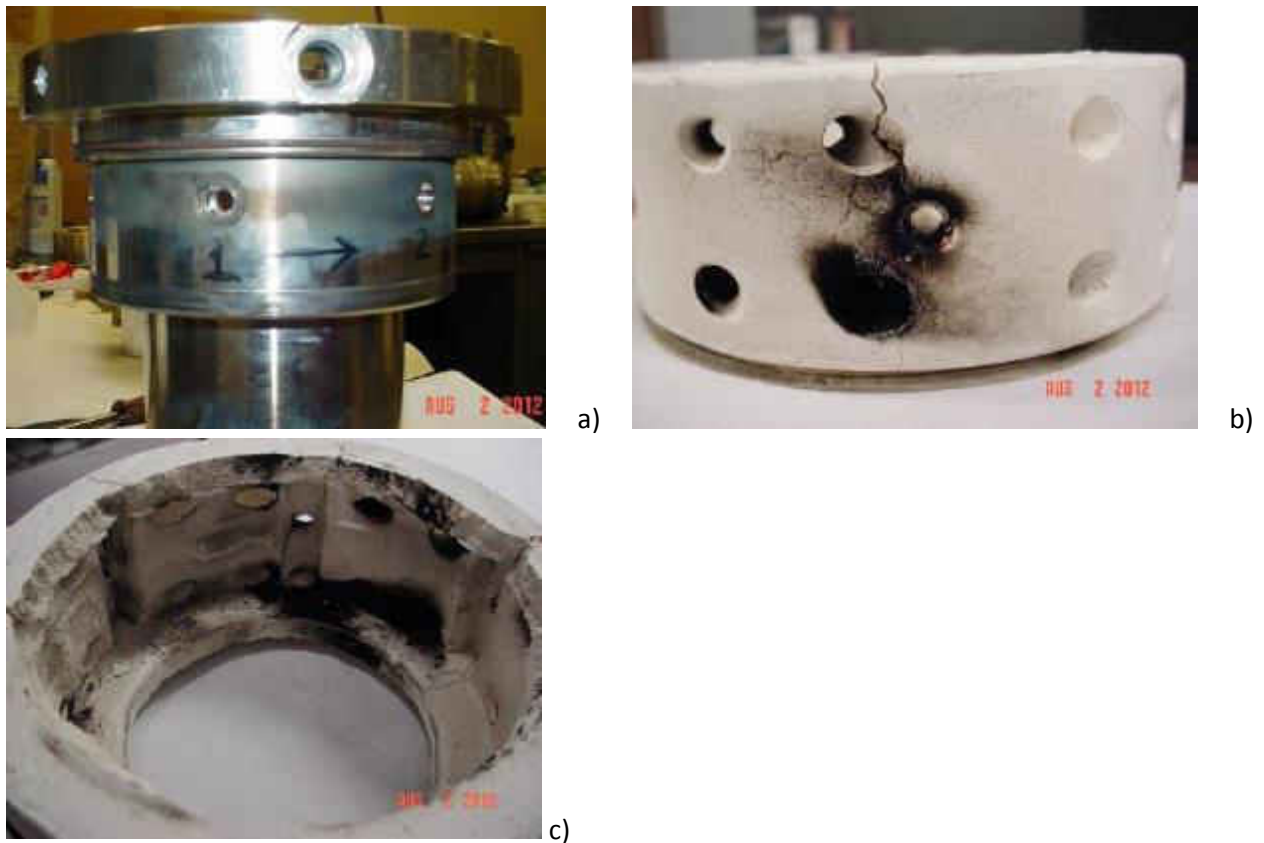

Figure 35 Soot Buildup in the CJES Unit after the First Flow Conditioner Run, a) Soot on the Propane Manifold, b) Soot Deposits on the Combustor Liner Inlet Ports, and c) Carbon Tracks in the Combustor Annulus. ⁽¹²⁾

The flow conditioner displayed carbon and fragments of the combustor liner. The unit was cleaned and reassembled along with a new liner. The sintered screen failed on the second run utilizing a full flow conditioner set (honeycomb and screen). Selected frames from the video showing the screen failure sequence are shown in Figure 36.

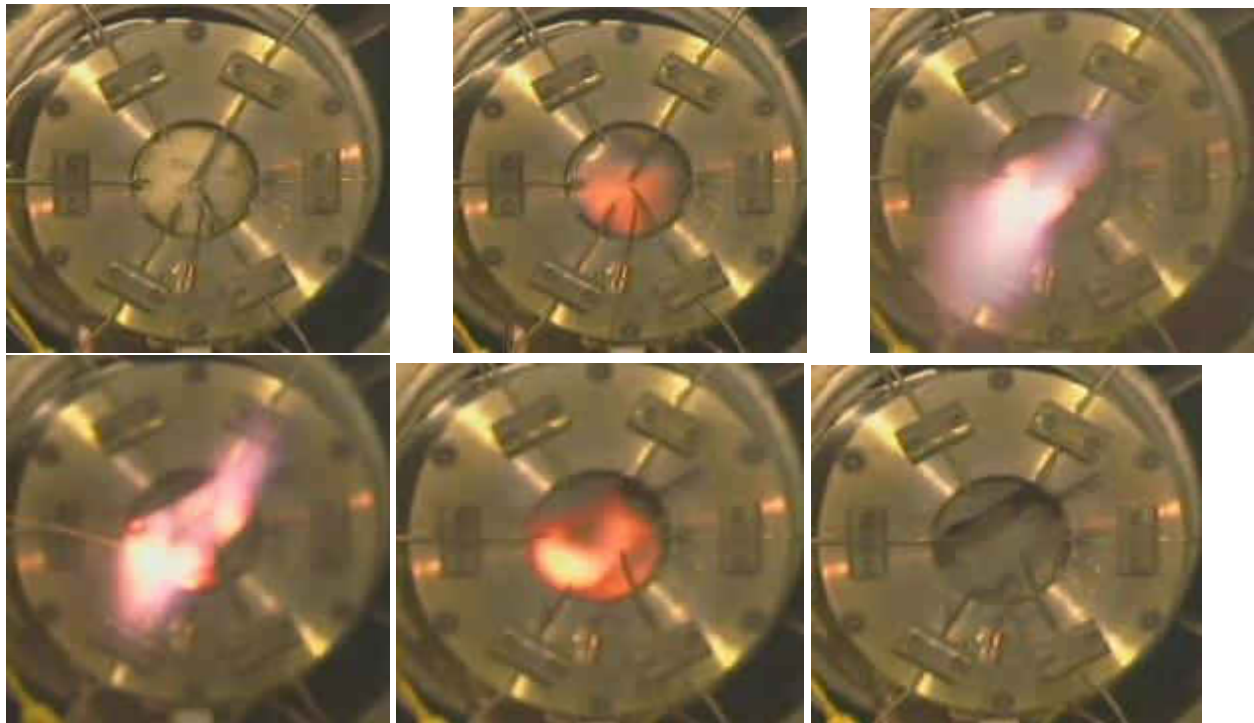

Figure 36 Failure of the Sintered Screen Flow Conditioner. ⁽¹²⁾

Examination of the screen showed evidence of excessive heat, and the video images suggested that soot deposits had built up on the screen and then ignited, causing an overpressure to blow out the

screen. The combustor liner had large deposits of carbon formed over the flame holder grooves (Figure 37 a). In addition, significant ceramic erosion of the annulus was observed (Figure 37 b).

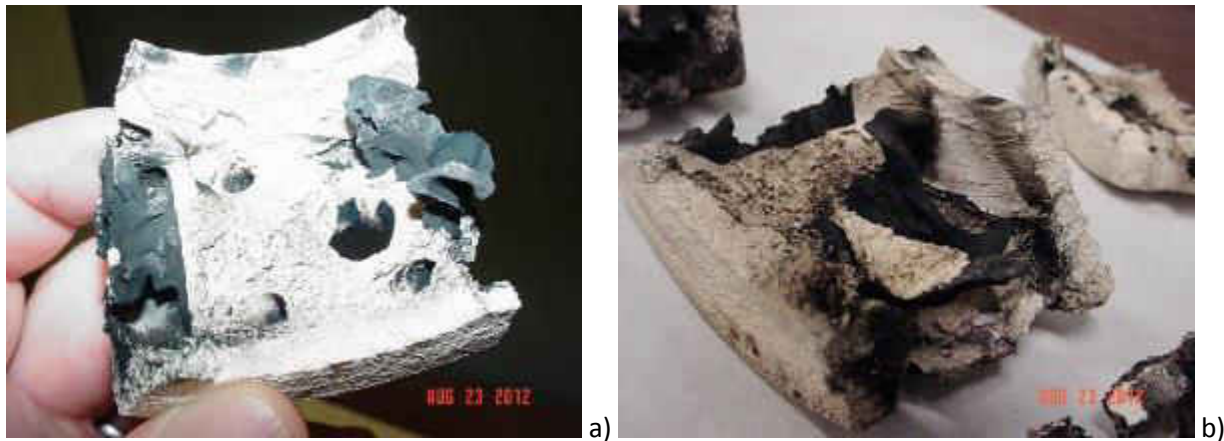

Figure 37 Combustor Liner after first Flow Conditioner Failure; a) Soot Structures in Flame Holder Grooves, b) Ceramic Erosion in the Combustion Annulus. ⁽¹²⁾

The second flow conditioner failed as a consequence of the ceramic liner cracking, then shedding ceramic particles that plugged the screen until it ruptured from excess pressure forces (see Figure 38). At this point, there were no additional spare sintered screen flow conditioners. Alternate flow conditioner options were therefore tested. The cobalt chrome DMLS combustor liner was manufactured and put into service. The metallic liner could at least eliminate the ceramic dust clogging observed in the core flow conditioner.



Figure 38 Second Screen Flow Conditioner Failure. ⁽¹²⁾

To begin checking out the fan flow operations, the combustor was integrated with the fan plenum and the associated instrumentation section to measure the temperature and pressure profiles produced by both the fan and core streams and measure the acoustic characteristics of the rig. Since JLab capability to electron beam weld the sintered screens had to be scheduled, they were in short supply. Tungsten Inert Gas (TIG) welding of the screen material to stainless steel support rings was tried. This provided both samples for the lab to test with cold flow and the welders' practice parts needed to develop their technique. Eight fan support frames and different sintered screens were cut using a water jet. While testing the flow conditioners, it was found that the old air lines and electric heaters were shedding rust flakes and accumulated dirt. These deposits collected on the 20 μ filter media (sintered screen) causing pressure spikes. Once a low noise flow conditioner was contaminated, it took three days to cycle it through a cleaning process for reuse. The first alternate fan flow conditioner failed due to inadequate fusion in the TIG weld. The welder washed melted stainless steel over the screen but did not fuse it to the screen (the welder was too careful not to burn through the screen (.025" thick)). The

higher porosity alternate screens did not supply an adequate pressure drop for uniform flow into the test nozzle.

In addition, the close coupling of the fan air inlet to the bottom of the fan flow conditioner produced a velocity flow asymmetry from the bottom to the top of the nozzle (high velocity at the bottom reducing with distance from the bottom). A cross section of the CJES unit showing the alternate flow conditioner arrangements is shown in Figure 39. The flow diverter prevented jet impingement from the incoming fan air across the alternate flow conditioner. The alternate flow conditioners did not have the 15.6% open area honeycomb and allowed the inlet air to impinge on the screen. The fan plenum diverter reduced the flow asymmetry but did not eliminate it, unlike the low noise flow conditioner. A larger pressure drop was required to achieve uniform plenum flow.

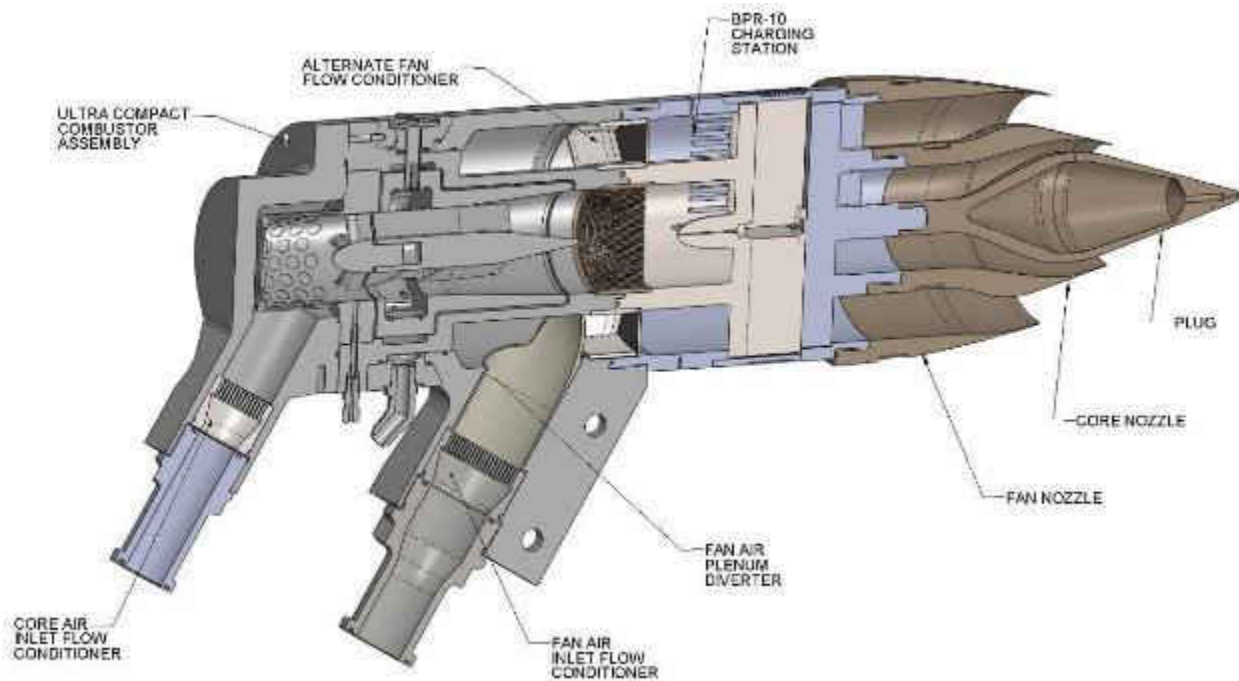

Figure 39 Section View of CJES with Alternate Fan Flow Conditioner and Fan Plenum Diverter. ⁽⁵⁾

CHAPTER XI.

Combustion Instability Issue

In early September 2012, the metallic combustor liner was received, and testing resumed with only a honeycomb flow conditioner in the core and a sintered screen in the fan stream. The CJES unit could achieve all of the HWB test conditions. The acoustic spectra exhibited a burner tone that had not been observed before as shown in Figure 40. Raising the pressure in the combustor as a result of the honeycomb had changed the combustion characteristics of the assembly.

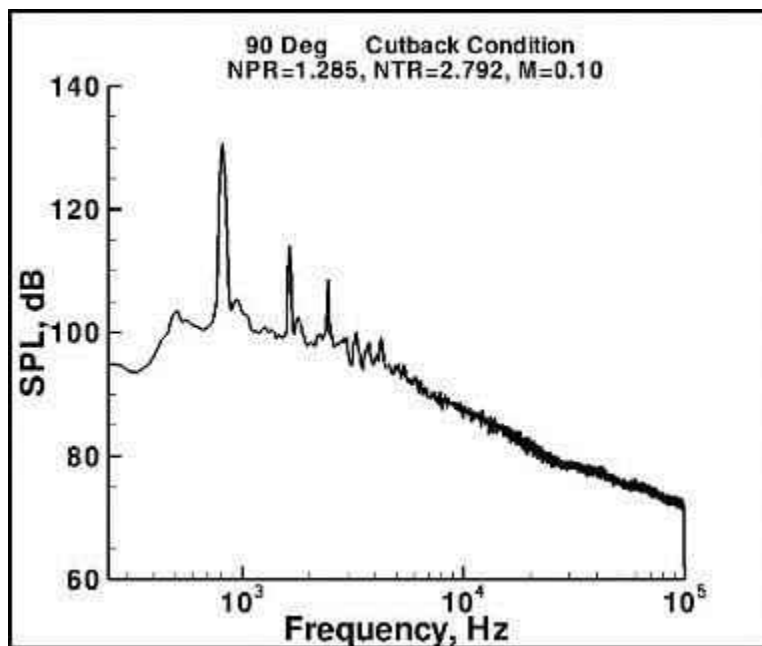

Figure 40 Combustion Driven Tones in the Core ~ 25dB Above Broadband Levels.⁽³⁷⁾

The tone had a first fundamental at 820 Hz with related harmonics. The core mass flow and temperature were varied changing the peak frequency only slightly. "The combustion driven acoustic

instability resulted from a resonant interaction between the heat release and airflow within the combustor cavity and the length of the combustor section. Much like a Sondhauss tube³⁸, it was found that the quarter wavelength of the tone frequency was closely related to the combustor length. In fact, by switching the downstream flow conditioner and spacer ring positions, and effectively changing the length of the combustor, the tone frequency was altered in a corresponding manner.⁽³⁶⁾ There were two characteristics of combustor instability that would eliminate the problem: disrupt the planar wave or change the cavity length to detune the standing wave.

The fixed length of the CJES limited the modifications that could be made to the combustor length so attempting to break up the planar wave was first method attacked. The first variations were made by modifying the existing hardware as shown in Figure 41 a, b & e. The versions in a & e blocked sections of flow through the flow conditioner. Version b had flaps welded to the trailing edges of the plug's vanes. The wave could pass over the upstream angled faces and would be reflected back on the return wave. The initial versions were not effective in reducing the resonance. The second stage of variations used flow conditioners with a nonplanar front face. The DMLS core flow conditioners shown, in Figure 41, took 30 hours to build and another four hours to remove the part from the build plate with a wire EDM followed by 3-5 hours on the lathe to turn the outer diameter to size. Optimizing the fabrication process to reduce the time required, by the third iteration the part file had been tuned so the outer diameter did not need lathe work and could be just cut to length on the wire EDM. It was found that one could not turn or mill the honeycomb because the material would form a burr over the holes that was very difficult to remove. Finally, the excess material requirement was reduced from .250" down to .06" and the build time was reduced by four hours. Close collaboration between engineering, DMLS technicians, and machinists allowed the team to produce three versions a week. The second versions did reduce the intensity of the tone, but did not eliminate it.

Examination of the CJES assembly showed a location within the combustor where a sintered screen could be inserted to change the cavity length. There was a gap between the plug-vane and the upstream support where the .075" thick sintered screen would fit.



Figure 41 Selected Combustor Change Variations intended to eliminate the Combustor Instability; a) Spot Welded Straps, b) Trailing Edge Fins on the Plug-Vane, c) Double Sinusoid Upstream Face on the Honeycomb Flow Conditioner, d) Staggered Screens to Replace the Honeycomb, e) Baseline Honeycomb with Flow Blocking Wedges, f) Single Sinusoid Flow Conditioner, g) Flat Faced Honeycomb with an Elliptical Dimple, h) Sintered Screen with Hole Patterns for Different Percent Open Areas, i) Location of the Sintered Screen Ahead of the Combustor. ⁽¹²⁾

After more than 24 variations of flow conditioners and screens, the most effective design is shown in Figure 41 g), h), and i). The concave honeycomb flow conditioner downstream of the combustor liner with the 15.1 % open area HFM 600 sintered screen, installed upstream of the plug-vane eliminated the tone. This combination changed the combustor cavity length and broke-up the planar acoustic wave eliminating the instability. Figure 42 shows the final arrangement with the modifications in blue.

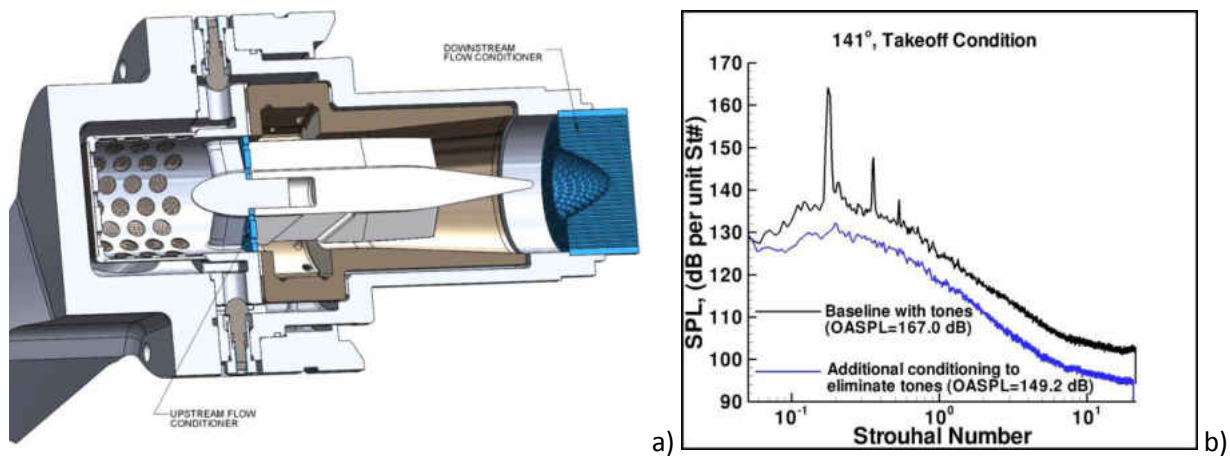

Figure 42 CJES Configuration that Eliminated Combustor Tones; a) Schematic UCC including non-uniform downstream flow conditioner and perforated screen upstream, b) Elimination of Combustion Tones. ⁽³⁴⁾

Once the combustion instability tones were eliminated, the other rig noise sources could be isolated. Leakage around the fan flow conditioner was one source that appeared intermittently and that source was eliminated by applying high temperature silicone sealant to the outer and inner diameters. The inlet pipes had short radius elbows and high velocity separated flows and were controlled by adding

70% open area honeycomb flow conditioners in the CJES inlets (see Figure 39) and at the pipe connection flanges. During testing within LSAWT the option was available to use rubber hoses and straight connections. In the 14x22-Tunnel test, the CJES units must use the pipes because of space constraints, see Figure 43.



Figure 43 Hybrid Wing Body Model in 14x22' Tunnel with the CJES Units and Model Support. ⁽¹²⁾

CHAPTER XII.

Metallic Component Part Life

The plug-vane component was a cobalt chrome DMLS part from the start of testing. The ceramic castings all cracked through the attachment feature during firing because the wall thickness changes and ceramic shrinkage exceeded the material survival. The metal version of the plug-vane also had a finite life (see Figure 44). Upon examining the parts after 35 hours of use, the first part was retired because thermal stress cracks had grown on five out of the six vanes. The oxidation patterns indicated that the upstream end remained cold (Sharpie marks remained). The section under the combustor and downstream experienced high temperatures causing thermal stress failure.

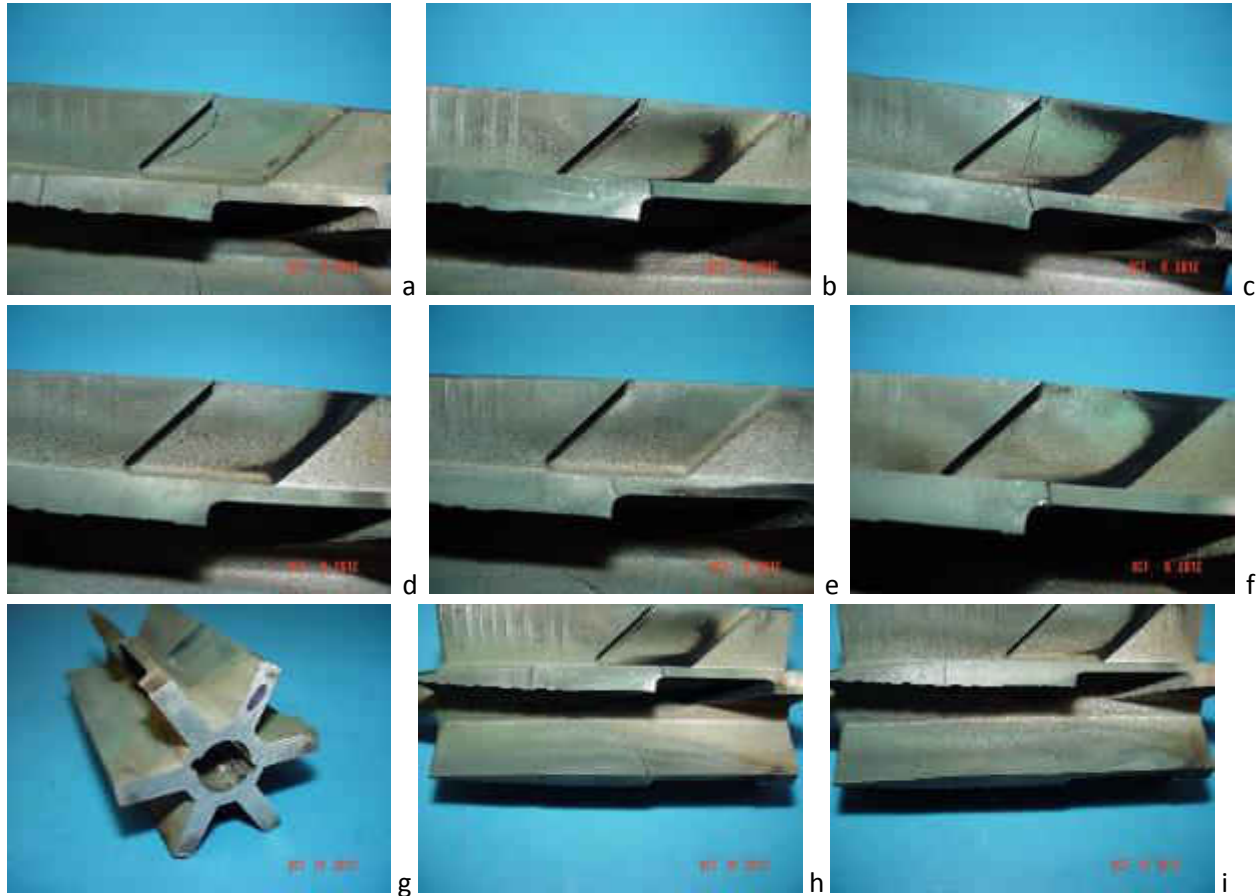

Figure 44 Thermal Stress Cracks and Oxidation of Plug-Vane after 35 hours of Operations. ⁽¹²⁾

Figure 44 shows the six vanes after 35 hours of use. Note the differences in soot accumulation. Combustion was not uniform around the annulus as evidenced by the soot patterns in the vane grooves. Photograph 42g shows the upstream end with the Sharpie index mark. Photographs h and i show the oxidation patterns on the backsides of vanes “c” and “e”. The chrome started oxidizing at 500°F. The plug vane color was dependent on temperature, time of exposure and atmosphere content. Photograph h indicates that the temperature remained below 500°F from the upstream right end outer surface going at an angle to the plug body at the end of the groove (silver color transitioning to green). The darker the oxide, the higher the temperature. The heat pattern indicated that high temperature flow was pulled to the plug body. Photograph i) indicates that azimuthal location was cooler because the dark

oxide did not reach the plug. This indicated that there was less combustion at this azimuthal location. The thermal stress through the thin web of the vane groove at the higher temperature locations caused stress cracks to form.

The metallic combustor liner also had a limited life due to thermal stress cracks. The first metal liner was solution annealed, and the interior surfaces were coated subsequently with ceramic coatings (from International Technical Ceramics, Inc.). ITC-213 is a primer ceramic that was used to reduce oxidation scaling on metal parts in a furnace environment. A second coating, ITC-100HT, is an infrared reflective coating used as a thermal barrier applied over the primer. The combustor liner is shown in Figures 45 through 47. The ceramic coatings did not adhere to turned (smooth) surfaces and only partially adhered to the as-fabricated surfaces. The ceramic coating was not used again because it did not yield a noticeable benefit, and the ceramic flakes tended to plug the flow conditioner. After the first days of testing, the liner showed no deterioration.

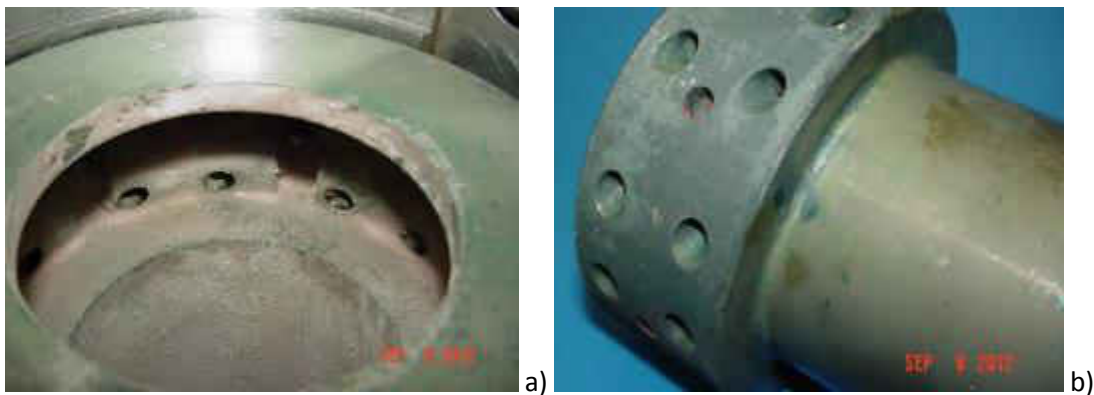

Figure 45 Cobalt Chrome Combustor Liner after Six Hours of Testing. ⁽¹²⁾

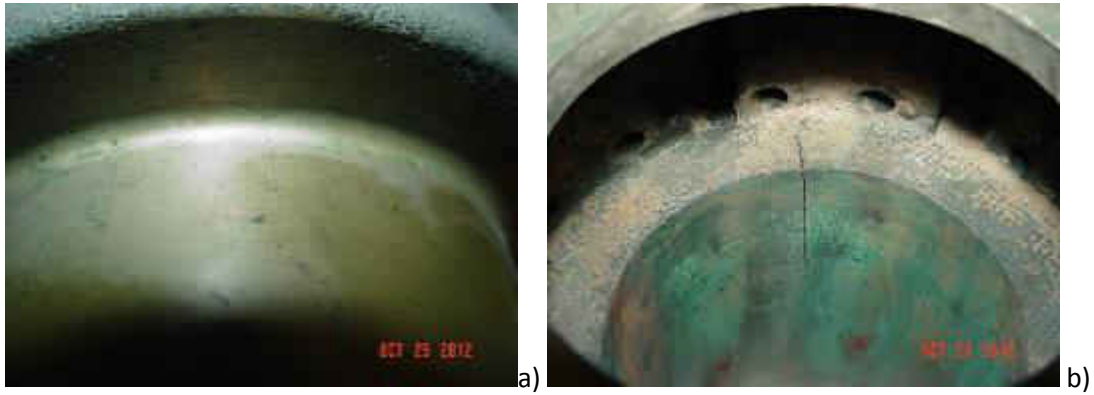

Figure 46 Cobalt Chrome Combustor Liner after Thirty Hours of Testing.

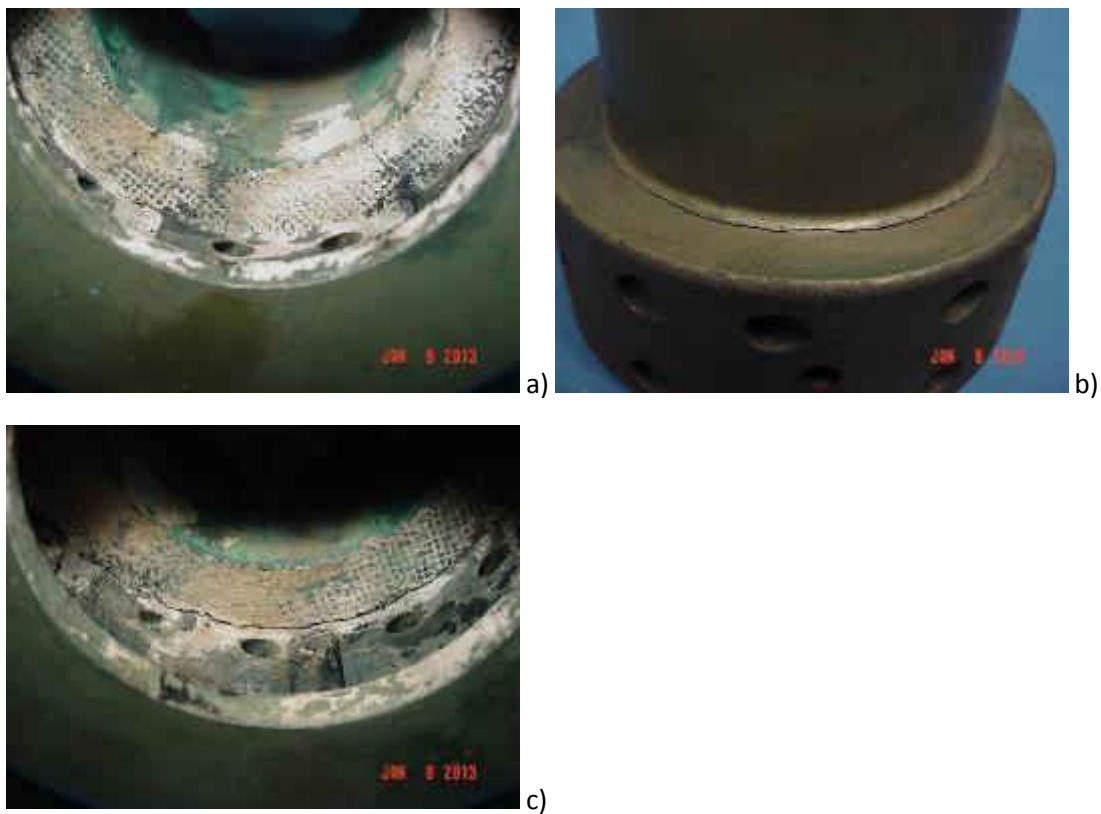

Figure 47 Cobalt Chrome Combustor Liner after Fifty Hours of Testing. ⁽¹²⁾

After thirty hours of testing, thermal stress cracks appeared. Figure 46 a) and b) shows the inside and outside views of a single Y shaped crack. This was one of two axial cracks that were present at

the 30 hour inspection. At the 50 hour inspection, the two axial cracks had not changed visible, (Figure 47a). A circumferential crack that spanned 150 degrees of arc had appeared as shown in Figure 47 b) and c). This crack was at the junction of the annulus wall and the downstream face. This crack would likely have resulted in a fracture on further use. The lifespan of the metallic liner was set at 40 hours. The location of the crack would not have produced a catastrophic failure if it separated the liner. There were a fillet radius and a rim that would not allow the liner to shift downstream, and the flow conditioner also captured the downstream segment. Because the HWB test was only scheduling 32 hours of CJES operation, the team was confident a major rebuild of the units would not be required during the test cycle.

Detailed modeling of the combustion, temperature profiles, and internal flow of the CJES were not attempted because the short development cycle prior the test schedule did not allow for it. In addition, there was no budget to outsource this effort.

CHAPTER XIII

RESULTS SUMMARY

The acoustic performance of the CJES units was compared with Boeing's Low Speed Aeroacoustic Facility (LSAF), as shown in Figure 48. Boeing designed the low noise nozzles to be used in the HWB test and had a set of baseline nozzles to test. The LaRC Jet Noise Lab data could then be compared to the Boeing data. The spectra compare very well in the mid frequency range. The 2-3 dB difference in the low frequency range could be due to the treated fuel pallet positioned below the microphones and may have shielded the downstream microphones. The LSAF facility employed a vacuum pump to remove the external boundary layer over the fan nozzle, which could explain the reduced low frequency of upstream noise for the CJES.

The 5-10 dB rise in high frequency noise at all angles was a concern. The behavior of the spectra was very similar to the high frequency lift observed from self-noise of the honeycomb flow conditioners¹⁹ observed before the fine sintered screen was used downstream. In that study the fine screen always attenuated the honeycomb self-noise. However, the previous study was at a much smaller scale and had a straight line flow path. Furthermore, the core stream does not have the fine screen to filter the honeycomb self-noise.

Before proceeding with the HWB test in the 14x22-Tunnel, it was necessary to check the consistency of the noise produced by the two CJES units. Large differences between them would invalidate twin engine jet noise shielding and interaction tests. Each CJES unit was tested separately with its own control system. There was one exception; the second set of final flow conditioners had not yet been built, so the initial set was used for both units. Figure 49 "shows the consistency between the two separate units tested over a month apart as two different simulator build-ups, both using axisymmetric nozzles. The spectral comparisons are quite close with the exception of a mid-frequency difference

between units at aft angles. Similarly, the directivity comparison of Fig. 49 b) shows consistency within 0.5 dB OASPL, providing confidence for repeatability in further HWB testing.”⁽³⁶⁾

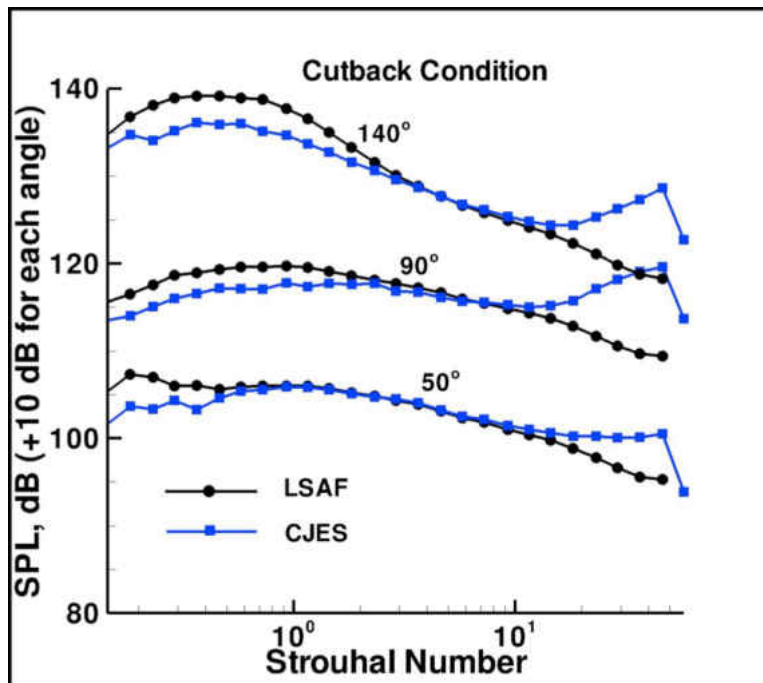

Figure 48 Far-field one-third octave acoustic spectra with CJES and LSAF operating at nominal original cutback condition: $NPR_{core}=1.285$, $NPR_{fan}=1.508$, $NTR_{core}=2.792$, $NTR_{fan}=1.135$, $Mwt=0.10$. A 10 dB addition to 90° spectra and a 20 dB addition to 140° spectra were applied to better visualize the data, as is the case for the remaining spectral figures.⁽³⁶⁾

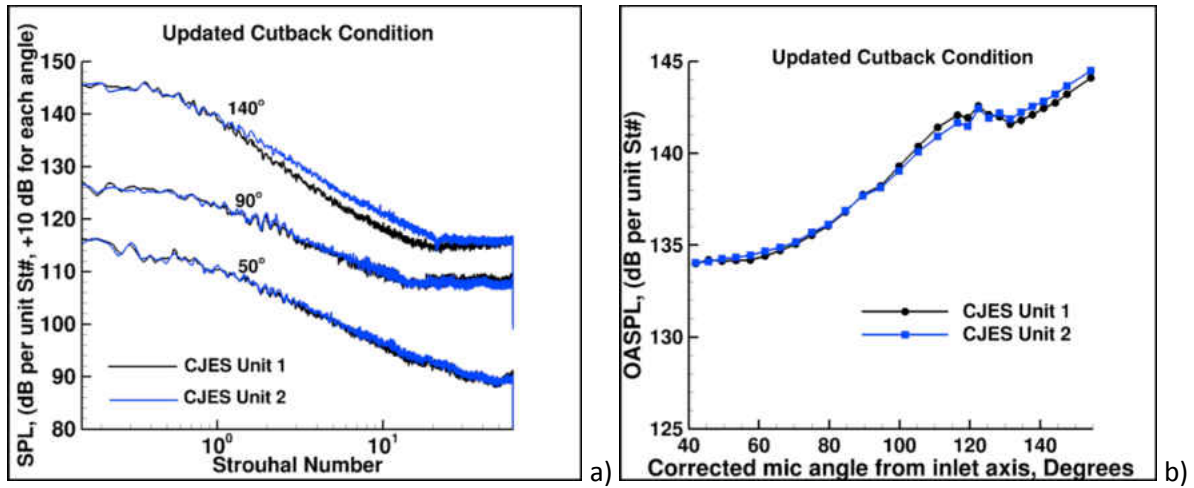

Figure 49 Far-field acoustic spectra with axisymmetric nozzles and CJES operating at updated cutback condition: $NPR_{core}=1.240$, $NPR_{fan}=1.461$, $NTR_{core}=2.721$, $NTR_{fan}=1.124$, $M_{wt} = 0.10$ showing a) spectral and b) directivity differences between CJES units.⁽³⁶⁾

CHAPTER XIV

CONCLUSIONS

The Compact Jet Engine Simulator became a viable tool for studying integrated aircraft engine acoustics and propulsion integration effects on scaled models in a wind tunnel. The difficulty of the effort to develop the CJES into a working system was compounded by a very tight schedule. Initially the schedule had 20 months for refinement, but the contractor delivery of the CJES units was 18 months late. This was mitigated by the tunnel entry date that was delayed due to other tests. First ignition of the burner occurred on May 29, 2012, and delivery of the units to the wind tunnel occurred on December 10, 2012. The control valve units had to be installed in the basement of the tunnel before the model support cart. The CJES units ran in the HWB test in February of 2013. During the 14 week test (of which the CJES testing was only a couple of weeks), up to 120 terabytes of data were collected per day which created a huge acoustic and aerodynamic database. ⁽³⁹⁻⁴¹⁾

Since the test was completed, the data has been processed and the analysis of it has just started; the initial results showed model tested achieved a cumulative noise reduction of 38.7 dB⁽³⁹⁾ compared to the project goal of 42 dB. The CJES testing showed that baseline nozzle noise shielding achieved 2 dB of noise reduction, and when the “low noise nozzle” was used, a total of 6 dB of reduction was achieved. The portion of engine noise dropped below other noise sources such as the landing gear and high lift devices. Improvements in aircraft noise control since the 1970s have eliminated the loudest sources, and now the integration of the aircraft systems (Propulsion Airframe Integration) is affecting further possible noise reductions. The test schedule did not allow for several other low noise treatments to be tested, such as partial main gear fairings or flap side edge treatments, which could have helped meet the cumulative goal. The total noise reduction of 42dB is realistic technically, but additional development is required to make it cost effective for implementation by the industry.

Propulsion Airframe Integration (PAI) has become a crucial part of developing a new aircraft design. The interaction of the engine flow with the wings and fuselage is complex, and the current Computational Fluid Dynamics (CFD) codes require validation experiments, and the CJES units can be an integral part of that validation process. The legacy noise prediction codes were based on an empirical database, but the Aircraft NOise Prediction Program (ANOPP2) framework can use CFD results, thus, it also requires validation data from wind tunnel tests using the CJES or flight testing.

A large team effort was required to proceed from final concept to test ready hardware. In the evolutionary process, manufacturing techniques were invented, unproductive ceramic parts development was eliminated, and alternate materials and manufacturing techniques were developed. An unexpected combustion instability was overcome. Having a large pool of ideas from a diverse group of people allowed the project to quickly react to progress or problems.

The ability to reach out to other national labs (AFRL & JLab) provided time and cost savings in achieving the project goals. The work by AFRL on the UCC formed the basis for the CJES concept. Follow on consultations guided the design concept and saved years' worth of effort in what would have been a parallel effort. Finding the electron-beam welding capability at the local Department of Energy funded Jefferson Laboratory was a project saver. Setting up a by-the-hour fabrication support contract usually takes a year through the LaRC acquisition system. Having an experienced operator that was used to research hardware and developing welding processes saved six months of schedule time to produce parts. Since JLab is a federal laboratory with a cooperative agreement in place with NASA, there were no issues with funding for a "favor" resulting in cost savings. The CJES development could not have met the project goals or schedule without the collective support of these federal laboratories.

Ceramic components offered a longer thermal cycle life if they could be made. General Electric Aviation (GE) has developed composite ceramic matrix components they are installing in the Leap1a

engines. ⁽⁴²⁻⁴⁴⁾ GE's process would be prohibitively expensive for prototype work like the CJES. GE claims a proprietary coating for the fiber that allows it to bond to the matrix, and their ceramic is silicon carbide. The processing for silicon carbide is beyond the fabrication capabilities available at LaRC. When the commercially available cast material could not be made to work, the fabrication technicians suggested adding chopped fiber reinforcement. Past in-house work took six months to years to complete, and the test schedule only left five months. This author decided to change direction for the fabrication of the combustor liner and plug-vane to additive manufactured metal to meet the schedule.

The author had several years of experience working with the in-house additive manufacturing group (which also fabricated the ceramics). The original flow conditioner fabrication effort revised the hardware and software to the point where the combustor parts were possible. If the combustor liner had to be conventionally machined, it would require at least three parts. The rough machined parts would need to be brazed together then final machined. The additive manufactured part eliminated two thirds of the time and half of the hours compared to conventional machining. There was a similar savings on the plug-vane. The use additive manufacturing has allowed single parts to be built that would have required an assembly if conventionally machined for a reduced cost and shorter schedule. The limited part life in a combustor rig has been accepted at the LSAWT for years. As new materials and processing technology become available, they are put to use to decrease cost and improve the reliability of the hardware.

CHAPTER XV

FUTURE WORK

The capabilities of the CJES units have been barely tapped. The rapid work up to the HWB test left a wide expanse of unknowns about the combustor and the CJES workings. Funding and time will be required to continue the exploration of this new test rig. A short list of future work areas is given below:

- Implement acoustic improvements
 - Fan Flow Conditioners
 - Core Flow Conditioners (solve the self-noise without a filter media that clogs from soot)
 - Modified fan plenum (to eliminate flow across the flow conditioners)
- Investigate the burner operation / development
 - Combustor uniformity (azimuthally)
 - Temperature profile uniformity (radially)
 - Hot section life cycle improvements
- Expand the operating envelope of the burner to reach the BPR 5 core goals
- Develop a model support mast that will support Propulsion Airframe Integration (PAI) studies

The acoustic improvements were initially described in the results summary. Lowering the high frequency noise levels will provide higher quality sound measurements. These improvements may mean expanding the size of the unit (for larger settling chamber sizes) and incorporating more flow conditioner inserts in the air supply system. The additional flow conditioners could be removed if low noise testing is not required.

Flow conditioner studies have been ongoing since wind tunnels were first built. Additional studies for acoustic treatment would benefit from the larger scale of the Compact Jet Engine Simulator over the Small Anechoic Jet Facility rig. The combustion products' increased temperature range also

changes the mixing physics compared to low temperature air tests. Investigating the burner operation is a rich area for future research. Examining the plug-vanes and flow conditioners shows that the combustion is not uniform around the annulus as shown in Figure 50.



Figure 50 Core Flow Conditioners Exhibiting Nonuniform Heating. Pictures a) and b) show upstream and downstream view of the same part, c) shows a Single Sinusoid, d) shows a Concave Unit.⁽¹²⁾

In Figure 50, the non-uniform oxidation color distributions indicate nonuniform heating through the core flow conditioners. Note that the thickness variation of the honeycomb does not affect the patterns in pictures b) and d). Both flow conditioners have a 'branched' shaped low temperature pattern. The top section d) had burnt metal, and the stainless steel could be scratched into flakes. That same 'Y' pattern is not quite so obvious in Figure 50 c). What is the cause of the combustion non-uniformities around the combustor? The first stage of combustor investigation would be to instrument the propane plenum with pressure taps and measure the pressure uniformity around the manifold. The same would be done with the swirl air manifold.

Another useful tool to investigate the combustor would be to modify the core inlet plenum to add a window on the burner axis, see Figure 51b. This would allow one to observe the spectral fluence of combustion light with the back pressuring devices in place. This would allow a mapping measurement of the OH in the combustor to determine how the fuel mixes with the air, indicating combustion efficiency. Direct infrared measurements could be made along with high speed video of the flame motion.

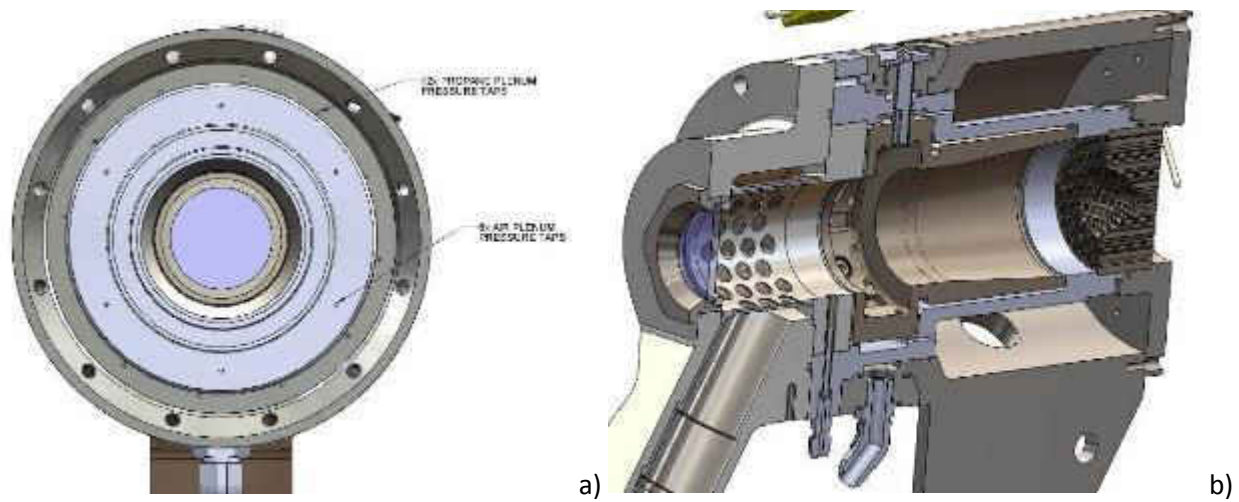

Figure 51 a) Combustor Modified for Pressure Taps, b) Axial Viewport with a Flow Conditioner. ⁽⁵⁾

With those modifications one could retune the combustor by varying the swirl air and fuel distribution and improve the combustion stability and temperature uniformity. Expansion of the burner operation up to the design point of 1.25 lbm/sec and 1250°F would be the next step. Discussions with the Advanced Measurement and Data Systems Branch indicate that it is possible to perform Particle Image Velocimetry and OH fluorescence tests in a highly modified combustor.

BIBLIOGRAPHY

- 1) "2006 NASA Strategic Goals", NP-2006-02-423-HQ, NSAS Headquarters, Washington DC 20546
- 2) Wahls Rich, "Environmentally Responsible Aviation: Snapshot of a New NASA Project for 2010 and Beyond", AIAA 27th Applied Aerodynamics Conference, San Antonio, TX, June 22, 2009, AIAA 2009-4315.
- 3) Collier, Fayette, "Overview of NASA's Environmentally Responsible Aviation (ERA) Project", 48th AIAA Aerospace Sciences Meeting, January 4, 2010
- 4) Kawai Ron, Brown Derrell, Boeing Phantom Works; Spakovsky Zoltan, MIT; Papamoschou Dimitri, UCI, "Acoustic Prediction Methodology and Test Validation for an Efficient Low-Noise Hybrid Wing Body Subsonic Transport", NASA Contract No. NNL07AA54C, Final Report September 2008
- 5) Author generated CAD image on SolidWorks at NASA Langley Research Center 1998-2012
- 6) Thomas Russell H., Casey Burley L., "Recent Experience with Noise Assessment of Hybrid Wing Body Aircraft", 1st Joint DLR & TU Delft Aviation Noise Workshop, Harz, Germany, October 6-8, 2014.
- 7) CJES parameters, e-mail from James Bridges (GRC-RTA0)
- 8) Mattingly, Jack D.; Heiser, William H.; Daley Daniel H. "Aircraft Engine Design" AIAA Education Series, 1987
- 9) Edited by Oates Gordon C "Aircraft Propulsion Systems Technology and Design" AIAA Education Series, 1989
- 10) Castner, Raymond S., Wolter, John D., "design and Checkout of a High Speed Research Nozzle Evaluation Rig" NASA TM-113179, AIAA-98-0711, October 1997
- 11) US Patent 3,074,469, Sudden Expansion Burner Having Step Fuel Injection. January , 1963

- 12) Photographs taken by the author at NASA LaRC, 1995-2012
- 13) Stull, F.D., Craig, R.R., Hojnacki J.T.; "Dump Combustor Parametric Investigation" AFAPL-TR-74-90, AF Aero Propulsion Laboratory (RJT) Wright-Patterson AFB, Ohio, 1974
- 14) Barclay Lewis P. Capt. USAF, "Pressure Losses in Dump Combustors" AFAPL-TR-72-57, AF Aero Propulsion Laboratory (RJT) Wright-Patterson AFB, Ohio, 1972
- 15) Stull, F.D., Craig, R.R.; "Investigation of Dump Combustors with Flame Holders" AFAPL-TR-76-15, AF Aero Propulsion Laboratory (RJT) Wright-Patterson AFB, Ohio, 1976
- 16) Drewry James E.; "Characterization of Sudden-Expansion Dump Combustor Flow Fields", AFAPL-76-52, AF Aero Propulsion Laboratory (RJT) Wright-Patterson AFB, Ohio, 1976
- 17) Craig R.R., Buckley P.L., Stull F.D.; "Large Scale Low Pressure Dump Combustor Performance", AFAPL-TR-76-53, AF Aero Propulsion Laboratory (RJT) Wright-Patterson AFB, Ohio, 1976
- 18) Schmotolocha Stephen N.; "Experimental Investigation of Ignition, Combustion and Stability Characteristics of a Coaxial Sudden Expansion Burner", AFOSR-TR-1603 AD787879 Prepared by General Applied Science Laboratories, INC. for Air Force Office of Scientific Research, Arlington VA, 1974
- 19) Davis D.L., "Coaxial Dump Ramjet Combustor Combustion Instabilities Part I- Parametric Test Data", AFWAL-TR-81-2047
- 20) Lewis George D.; "Combustion in a Centrifugal-Force Field", 13th Symposium on Combustion, Volume 13, Issue 1, pages 625-629, 1971
- 21) Lewis George D.; "Swirling Flow Combustion – Fundamentals and Application" AIAA Paper 73-1250. AIAA / SAE 9th Propulsion Conference, 1973

- 22) Lewis George D., Smith Clifford E.; "Investigation of Centrifugal Force and Reynolds Number Effects on Combustion Processes", AFOSR-TR-75-1167, Pratt & Whitney Aircraft/United Technologies CORP. for Air Force Office of Scientific Research /NA. 1975
- 23) Lewis George D., "Centrifugal-Force Effects on Combustion", 14th Symposium (International) on Combustion, Vol 14, Issue 1, 1973, Pgs. 413-419.
- 24) Sturgess J.G., Syed S.A., "Calculation of Confined Swirling Flows", AIAA 23rd Aerospace Sciences Meeting January 14-17, 1985, Reno NV, AIAA 1985-0060.
- 25) Shouse Dale T., "Trapped Vortex Combustion Technology", MITE Workshop, December 4-5, 2000.
- 26) Zelina J., Ehret J., Hancock R.D., Shouse D.T., Roquemore, AFRL, WPAFB, OH 45433, Sturgess G.J., Innovative Scientific Solutions Inc., Dayton OH 45440-3638, "Ultra-Compact Combustion Technology Using High Swirl for Enhanced Burning Rate", 38th AIAA/ASME/SAE/ASEE Joint Propulsion Conference & Exhibit, July 7-10 2002, Indianapolis IN, AIAA 2002-3752
- 27) Quaale, Ryan J. Captain, USAF, "Experimental Results for a High Swirl, Ultra Compact Combustor for Gas Turbine Engines", AFIT/GAE/ENY/03-5, Air Force Institute of Technology, Wright-Patterson Air Force Base, Ohio
- 28) Zelina, Joseph, Sturgess, G. J., Shouse, Dale T., "The Behavior of an Ultra-Compact Combustor (UCC) Based on Centrifugally Enhanced Turbulent Burning Rates", 40th AIAA/ASME/SAE/ASEE Joint Propulsion Conference and Exhibit, 11-14 July, Fort Lauderdale FL. AIAA 2004-3541
- 29) Zelina Joseph, Sturgess G.J., Mansour Adel, Hancock Robert D., " Fuel Injection Design Optimization For An Ultra-Compact Combustor", Presented at 16th International Symposium on Air Breathing Engines, September 2003

- 30) Anisko Jonathan, 2nd LT, USAF, "Numerical Investigation of Cavity-Vane Interactions Within the Ultra Compact Combustor", AFIT/GAE/ENY/06-M, 01, Air Force Institute of Technology, Wright-Patterson Air Force Base, Ohio
- 31) Zelina Joseph, Greenwood R. T., Shouse D. T., "Operability and Efficiency Performance of Ultra-Compact, High Gravity (g) Combustor Concepts", Proceedings of ASME TURBO EXPO '06 51st ASME International Gas Turbine and Aeroengine Congress and Exposition, May 2006, Barcelona Spain, GT2006-90119
- 32) Thornburg Hugh, Mississippi State University; Sekar Balu, Zelina Joseph, Greenwood Roger, US AFRL, Propulsion Directorate, Turbine Engine Division, Wright-Patterson AFB, OH, "Effect of Curved Radial Vane Cavity Arrangements on Predicted Inter-Turbine Burner Performance", HPCMP Users Group Conference 2007 (HPCMP-UGC 2007) 0-7695-3088-05/07 © 2007 IEEE
- 33) Zelina Joseph, Shouse Dale T., Neuroth Craig, Air Force Research Laboratory, WPAFB, Ohio, 45433, "High-Pressure Tests of a High-g, Ultra-Compact Combustor", 41st AIAA/ASME/SAE/ASEE Joint Propulsion Conference & Exhibit, 10 - 13 July 2005, Tucson, Arizona, AIAA 2005-3779
- 34) Kinzie Kevin W., Henderson Brenda S., Haskin Harry H., "Aeroacoustic Characteristics of Model Jet Test Facility Flow Conditioners", 11th AIAA/CEAS Aeroacoustics Conference (26th AIAA Aeroacoustics Conference) 23 - 25 May 2005, Monterey, California, AIAA 2005-3055
- 35) Doty, Michael J., Haskin, Henry H., "Investigation of Flow Conditioners for Compact Jet Engine Simulator Rig Noise Reduction". 17th AIAA/CEAS Aeroacoustics Conference, 05-08 June 2011, Portland OR. AIAA 2011-2791
- 36) Doty, Michael J., Haskin, Henry H., "Acoustic Characterization of Compact Jet Engine Simulator Units", 19th AIAA/CEAS Aeroacoustics Conference May 27-29, 2013, Berlin, Germany, AIAA 2013-2035

- 37) Doty, Michael J., Haskin, Henry H., Ultra-Compact Combustor Shakedown Testing in Preparation for HWB Acoustic Test”, Acoustics Technical Working Group Meeting, October 23, 2012, NASA Langley Research Center, Hampton VA
- 38) Eisinger, F. L., and Sullivan, R. E., “Avoiding Thermoacoustic Vibrations in Burner/Furnace Systems,” *Transactions of the ASME*, Vol. 124, November 2002, pp. 418-424.
- 39) Stephanie L Stephanie L. Heath, Thomas Brooks, Florence Hutcheson, Michael J. Doty, Henry H. Haskin, Taylor Spalt, Christopher Bahr, Casey Burley, Scott Bartram, William Humphreys, Charles B. Lunsford, Thomas Popernack and Scott Colbert, *NASA Langley Research Center, Hampton, VA, 23681*, Danny Hoad, Lawrence Becker and Daniel Stead, *Northrop Grumman*, Dennis Kuchta and Les Yeh, *Jacobs Sverdrup ROME, NASA Langley Research Center, Hampton, VA, 23681*, “Hybrid Wing Body Aircraft Acoustic Test Preparations and Facility Upgrades”, 28th AIAA Aerodynamic Measurement Technology, Ground Testing, and Flight Testing Conference, 24 - 27 June 2013, San Diego, California, AIAA 2013-2623
- 40) Gatlin Gregory M., Vicroy Dan D., Carter Melissa B., “Experimental Investigation of the Low-Speed Aerodynamic Characteristics of a 5.8-Percent Scale Hybrid Wing Body Configuration”, 30th AIAA Applied Aerodynamics Conference, June 25-28 2012, New Orleans LA, AIAA-2012-2669.
- 41) Burley Casey L., Brooks Thomas F., Hutcheson Florence V., Doty Michael J., Lopes Leonard V., Nickol Craig L., Vicroy Dan D., NASA Langley Research Center, Pope Stuart D., Analytical Services and Material, “Noise Scaling and Community Noise Metrics for the Hybrid Wing Body Aircraft”. 20th AIAA/CEAS Aeroacoustics Conference, 16-20 June, 2014, Atlanta, GA. AIAA 2014-2626
- 42) General Electric Aviation, “Ceramic Matrix Composites/Advanced Materials”,
<https://www.youtube.com/watch?v=666VH25FeG0> ,

43) GE Aviation and the Ceramic Matrix Composite Revolution,

<https://www.youtube.com/watch?v=is1BBilkyUM>

44) General Electric Aviation, "What is Additive Manufacturing?" ,

<https://www.youtube.com/watch?v=l0SXlkrmyzw>

45) Eaton Daron S., "Allegany Ballistics Lab Sensor Test Target System", SPIE Defense Security +

Sensing Conference, Marriot World Center, Orlando FL, April 27, 2011

APPENDIX A

INFRASTRUCTURE TO SUPPORT HWB ACOUSTIC TEST

The Validation Test Project at NASA Langley to support the ERA project involved a massive effort to build an infrastructure to allow the test to occur. The 14x22-Tunnel had never tested with combustion in the facility, the phased array instrument was twice the size of previous versions, the tunnel needed a traverse system to position all of the microphones and more. Figure A-1 shows the major subprojects that all formed the final test.

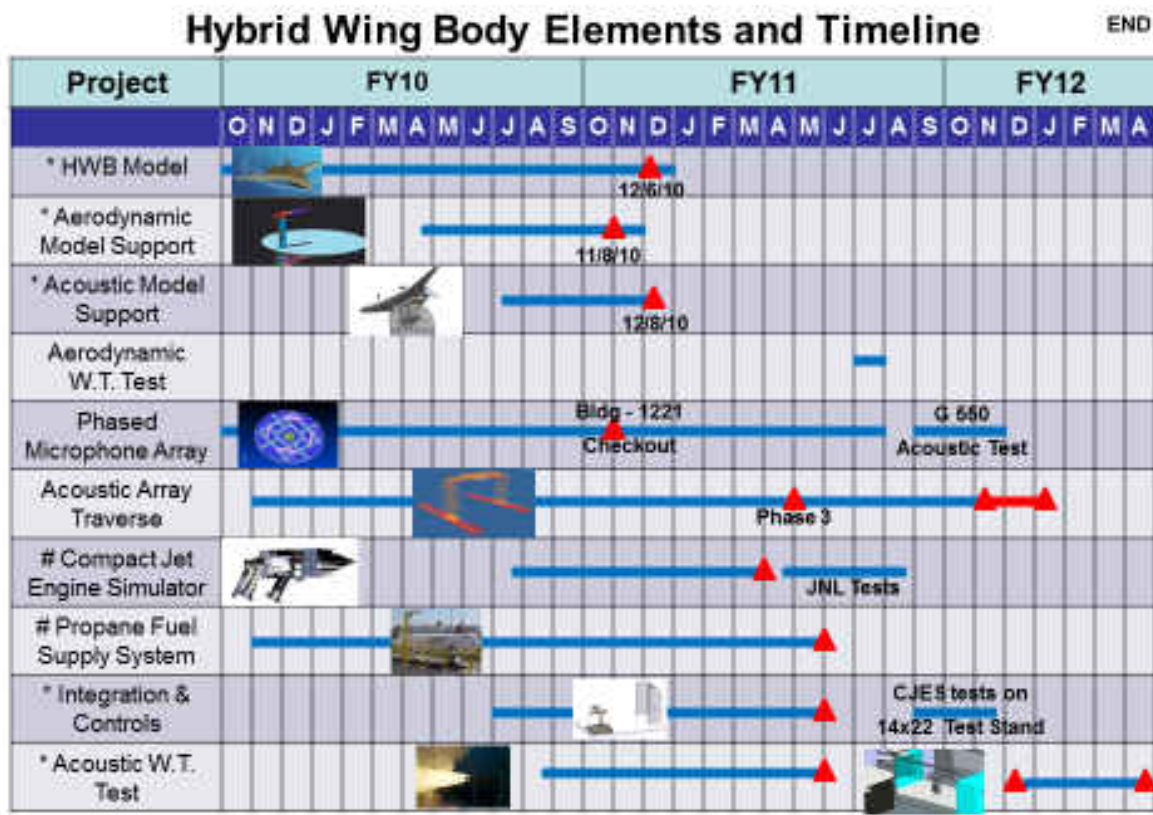

Figure A-1 Work Breakdown Structure for HWB Test Preparations. * Author Supported, # Author Team Lead. (Slide from Critical Design Review, 10/14/2010 at NASA LaRC, Danny Hoad)

One of the major selling points in the plan to test in the 14x22-Tunnel was the risk reduction efforts at the Jet Noise Laboratory to develop the Compact Jet Engine Simulator, the controls, operating program, procedures and safety interlock verifications before entering the 14x22 Tunnel. In addition, once the system was running, the LSAWT provided operator training and certification prior to operations in the significantly more costly 14x22 Tunnel. This supplied a great cost savings to the program.

The CJES control system was a single rack for each unit. Figure A-2 shows one of the racks in the LSAWT control room. The fuel control valves were pallet mounted as shown in Figure 26. This allows for each unit to operate independently if the test calls for only one unit.



Figure A-2 LSAWT Control Room, CJES standalone console on the left. ⁽¹²⁾

The wind tunnel required new acoustic treatment on the floor and walls. The old material (15-20 years old) had broken down over time. Figure A-3 shows the 29 sideline and overhead microphones along with the 97 microphone phased array. The phased array data can be used for determining noise source locations from the model. Airframe sources such as flap edges are generated by vorticity from flap edges and are close to point sources. Jet noise, on the other hand, is a distributed source (several jet diameters long) smeared downstream along the jet plume. The processing program can isolate the multiple sources and reject wind tunnel noise as well. Figure A-4 shows the HWB model with the CJES units installed.

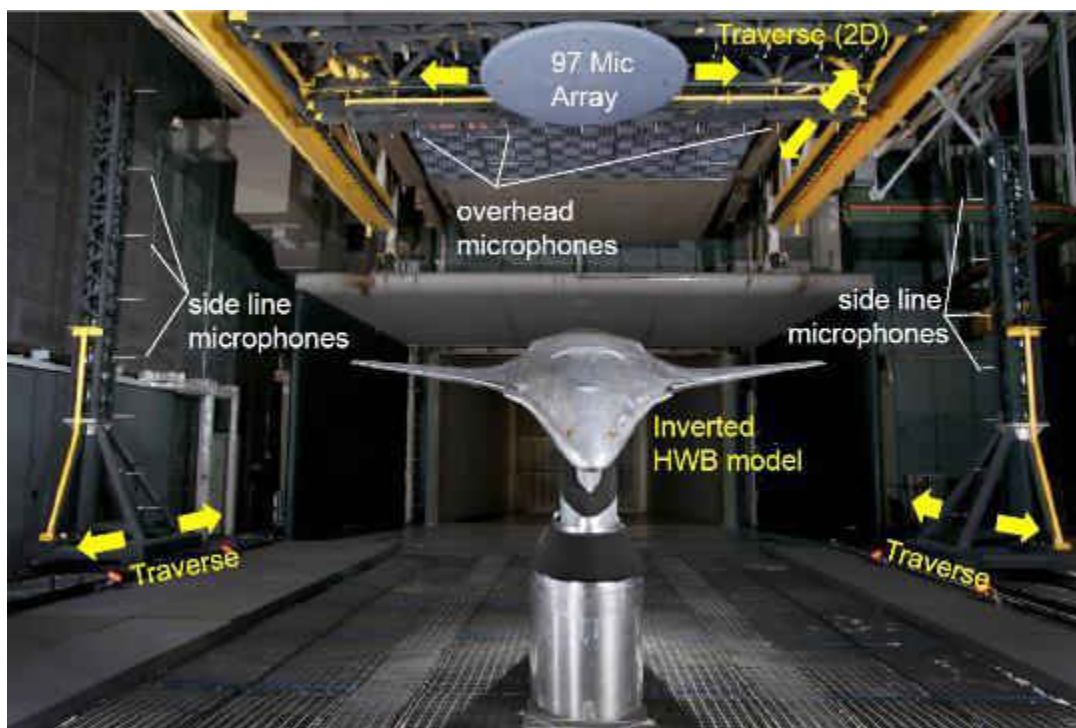

Figure A-3 Acoustic Validation Test in the 14x22' Subsonic Wind Tunnel, Microphone Configuration.⁽³⁹⁾



Figure A-4 Aft View of the Hybrid Wing Body Showing the CJES Units. ⁽³⁹⁾

Before the acoustic testing could be done, an aerodynamic test was completed to obtain the performance of the isolated airframe. From the static pressure tap information over the model surface, the acoustic model's orientation (pitch, yaw and roll) in the open jet configuration could be adjusted to match the aerodynamic test results and compensate for the CJES hardware. Figure A-5 shows the aerodynamic test in the 14x22 Tunnel. In addition to force, moment and pressure data, oil flow was used to map the surface flow direction over the HWB. Figure A-6 shows the oil flow result with the leading edge droop and trailing edge flaps deployed. Earlier CFD results predicted that the inboard leading edge droop end vortex would either be sucked into the engine or hit the vertical tail. The first result would stall the engine at takeoff, and the second would cause a loss of control authority for the tail. The leading edge droop inboard edge was moved outboard to eliminate the problem.



Figure A-5 Aerodynamic Test of the HWB in the 14x22' Subsonic Wind Tunnel. ⁽⁴⁰⁾



Figure A-6 Oil Flow Visualization of Surface Flow Patterns. ⁽⁴⁰⁾

APPENDIX B

VARIATIONS OF THE CJES AND HWB DURING DEVELOPMENT

The roots of the Compact Jet Engine Simulator go back to the original Jet Engine Simulator in the NASA Langley Research Center's Jet Noise Lab (JNL). The author worked with Jack Seiner (Principal Investigator) and the team at Boeing's Low Speed Aeroacoustic Facility (LSAF). The LSAF had a dual stream coannular rig in their facility that Dr. Seiner wanted to beat. The Boeing design used General Electric J79 jet engine burner cans to heat the air for engine simulation. The disadvantages were non-uniform temperature and pressure profiles in the flow streams leading to the test nozzles and a temperature limit of 1500°F. Above that temperature, the burner cans began rapid oxidation of the Hastelloy-X material and burner failure. The JNL wanted to reach afterburner temperatures of 3000°F. The lab had a water cooled Sudden Expansion Burner (SUE) from Marquardt Company. The concept was to use two burners, one for each stream, and build up a coaxial flow rig. The goal was to build a rig that could provide 20 pounds per second at 2000°F per stream. The water cooled SUE burners could provide 3000°F capability, but the uncooled nozzle hardware could only survive below 2000°F. This design was completed in 1994 and brought into service. It has been in service for 22 years without a major failure. The general arrangement is shown in Figure B-1.

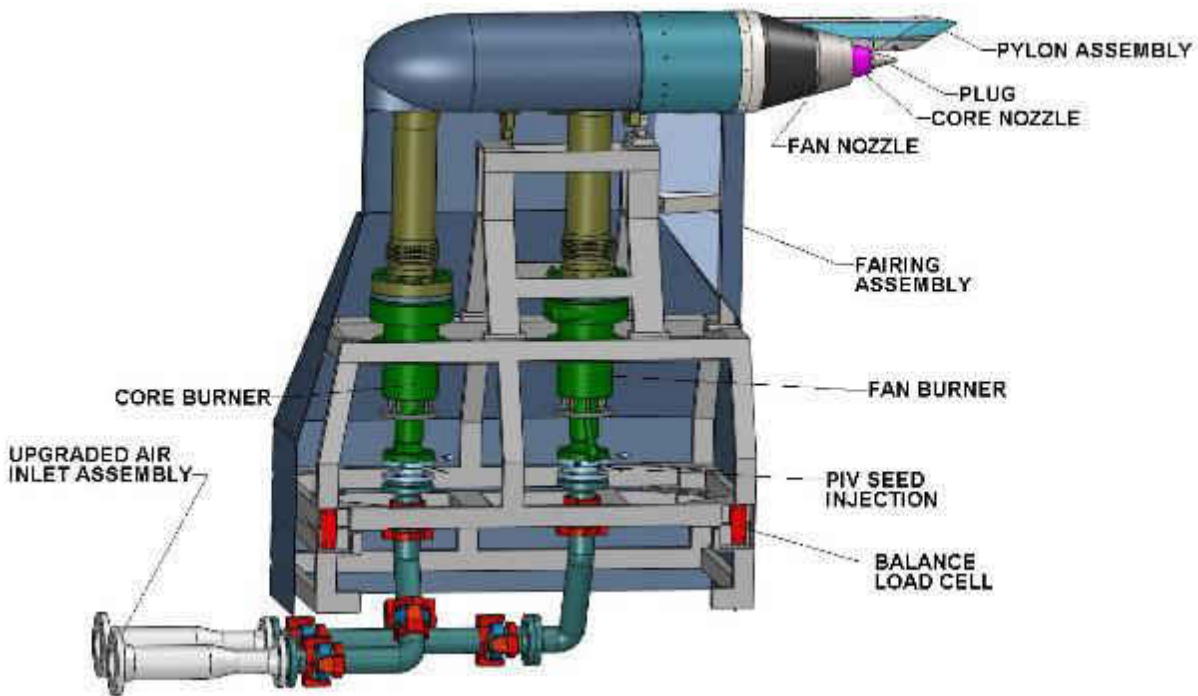

Figure B-1 Jet Engine Simulator in Subsonic Transport Engine Configuration. ⁽⁵⁾

The JES rig brought a spin-off customer to Langley in August of 2005. An aerospace convention with an acoustics session caught the attention of a Navy commander. A JNL paper on Fluidic Chevrons described the lab's test rig as a jet engine simulator. The Navy was looking for infrared target source to develop new seeker heads and wanted to procure six units. After several phone calls, the correct scale of their project was determined and collaboration was begun. The end result used modified off-the-shelf propane torches to meet their requirements. The original burner is shown in Figure B-2, and the final configuration is shown in Figure B-3.



a)



Figure B-2 a) Commercial Off The Shelf (COTS) Torch, b) Torch in a NAVSEA Project Mock-up, c) Ceramic Flame Holder. ⁽¹²⁾



Figure B-3 NAVSEA Jet Engine Simulator- Infrared JES-IR Final Configuration ⁽⁴⁵⁾

The initial design effort was completed in 2007 and the first generation hardware built in 2008. The systems have been in operation since 2011.

The Compact Jet Engine Simulator concept started in early 2008. The initial design was a simple premixed combustor. Then that changed to a dump combustor with fuel injection just upstream of the step ⁽¹³⁻¹⁷⁾. The next attempt to increase flame speed was turbulence generators, then swirl vanes. By the end of the year, the literature review made it clear that a dump combustor was not going to meet the short overall length requirement. The fully turbulent flame speeds of 20-100 ft. /sec would need 9 feet of travel length to not impinge on the flow conditioners and rakes. The CJES design had less than 8.5

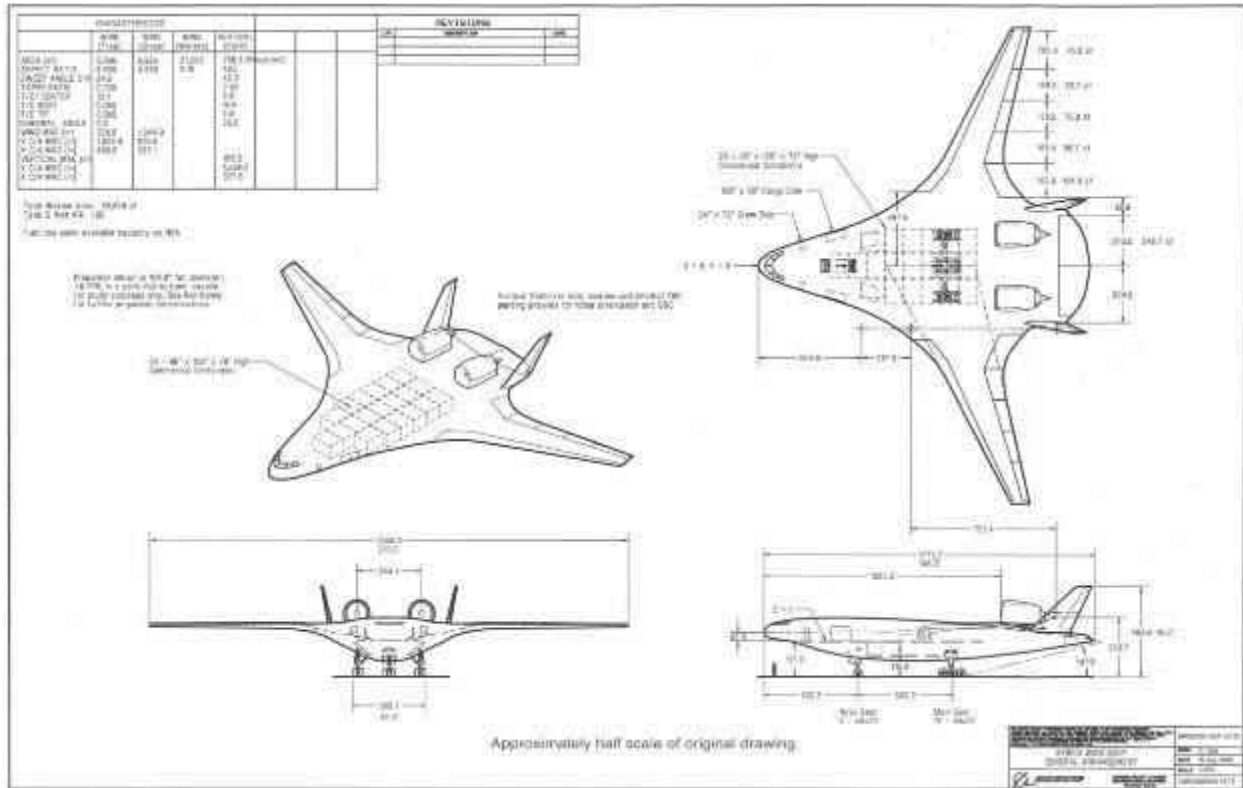

Figure B-5 Boeing N2A-EXT Aircraft Concept, NASA Contract Number NNL07AA54C ⁽⁴⁾

Figure B-6 shows the cargo layout of the podded engine configuration. The design study showed that the outer wing tanks were all that was needed for a 6000 NM range, the inboard tanks (upper left image) were dropped. The ERA project was in the headlines of the aviation industry; Aviation Week had several articles on the project. Aerospace Testing International 2010 Showcase had an article that included CAD images from the author.

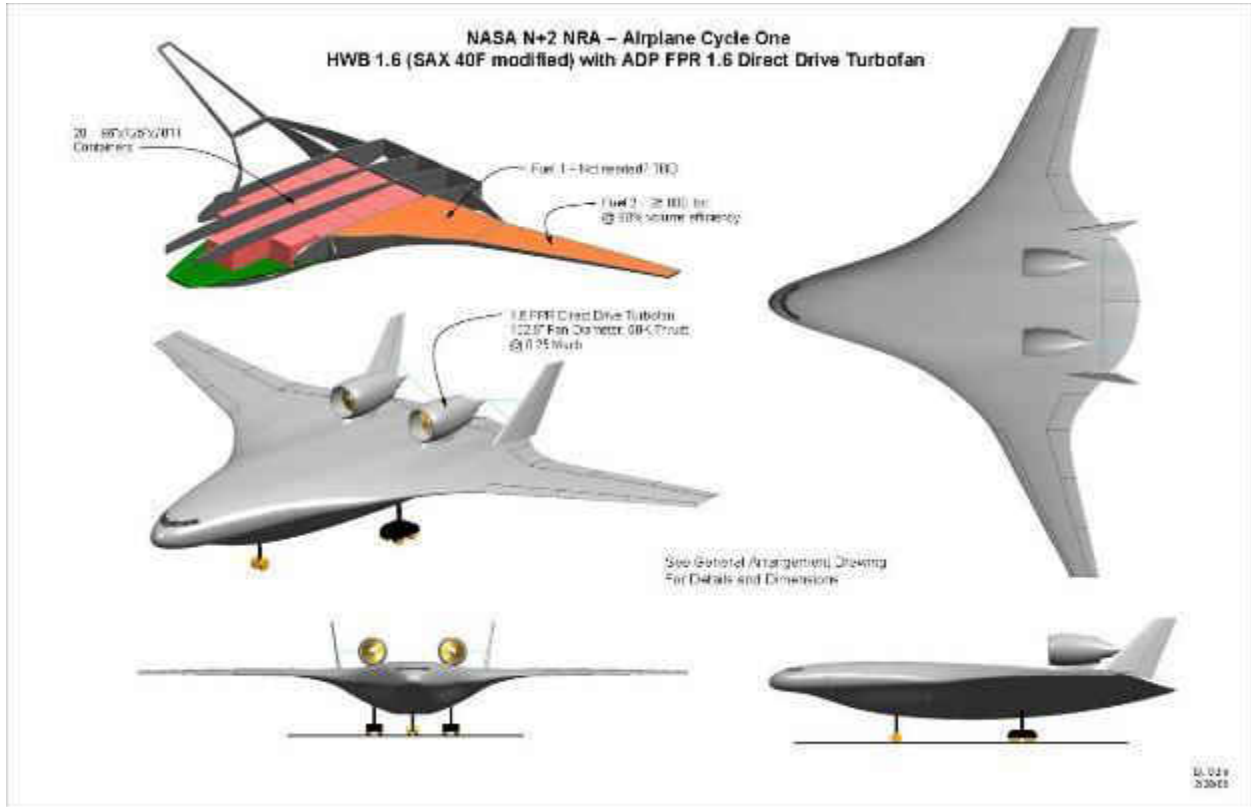

Figure B-6 Boeing N2A Cargo Configuration ⁽⁴⁾

APPENDIX C

CJES COMBUSTOR LINER, PLUG-VANE AND FLOW CONDITIONER FY 2011-12



Jet Noise Lab

Langley Research Center

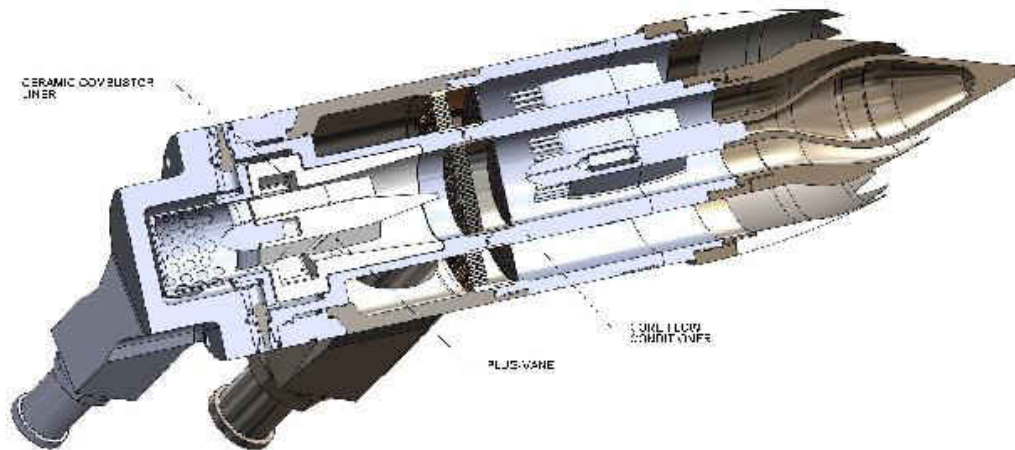

CJES Combustor Liner, Plug-Vane & Flow Conditioner FY 11-12

Harry Haskin, Mike Powers, Mark Griffith, Rob Andrews
5-11-2012

Place Holder see separate PFD file

VITA

Henry H. Haskin
 957 Heathland DR.
 Newport News, VA 23602
 Work Phone: 757-864-6939
 Home Phone: 757-813-5171

email: henry.h.haskin@nasa.gov
hhask002@odu.edu

Education:

Old Dominion University
 Mechanical & Aerospace Engineering
 238 Kaufman Hall
 Norfolk, VA 23529
 Master of Science in Aerospace Engineering 2016

Virginia Polytechnic Institute and State University
 Bachelor of Science in Mechanical Engineering 1979

Work Experience:

NASA, Langley Research Center	1990-present
Aeroacoustics Branch, Research Directorate	1996-present
12B Langley Boulevard, Hampton VA 23681-2199	
Jet Noise Laboratory, Facility Engineer/Safety Head	
Facilities Engineering Branch, Facilities Systems Engineering Division	1990 to 1996
1 North Dryden Street, Hampton VA 23681	
Project Manager	
Planning Research Corp	1989 to 1990
303 Butler Farm Road, Hampton, VA 23666	
Project Engineer	
Micro Craft Inc.	1985 to 1989
3130 North Armistead Avenue, Hampton VA 23666	
Project Engineer	
Engineering Incorporated	1981 to 1985
41 Research Drive, Hampton VA 23666	
Project Engineer	
Goodyear Tire & Rubber Co	1979 to 1981
1144 Market Street Akron, Ohio 44316	
Machine Designer	