

Systems Science & Control Engineering

An Open Access Journal

ISSN: (Print) 2164-2583 (Online) Journal homepage: <https://www.tandfonline.com/loi/tssc20>

Micro grid fault diagnosis based on redundant embedding Petri net

Xiangmin Chen, Xingzhen Bai & Qingqing Zhang

To cite this article: Xiangmin Chen, Xingzhen Bai & Qingqing Zhang (2018) Micro grid fault diagnosis based on redundant embedding Petri net, Systems Science & Control Engineering, 6:3, 289-296, DOI: [10.1080/21642583.2018.1554801](https://doi.org/10.1080/21642583.2018.1554801)

To link to this article: <https://doi.org/10.1080/21642583.2018.1554801>



© 2018 The Author(s). Published by Informa UK Limited, trading as Taylor & Francis Group



Published online: 05 Dec 2018.



Submit your article to this journal [↗](#)



Article views: 274



View related articles [↗](#)



View Crossmark data [↗](#)

Micro grid fault diagnosis based on redundant embedding Petri net

Xiangmin Chen^{a,b}, Xingzhen Bai^a and Qingqing Zhang^a

^aCollege of Electrical Engineering and Automation, Shandong University of Science and Technology, Qingdao, People's Republic of China;

^bRizhao Power Supply Company, State Grid Shandong Electric Power Company, Rizhao, People's Republic of China

ABSTRACT

On account of the variable topology and multi-terminal power supply in micro-grid, the fault diagnosis faces more and more challenges. Traditional fault location criteria are unsuitable and fault diagnosis modelling is complex or poor versatility. Further on, the fault reasoning operation is time-consuming. A high transplantable fault diagnosis model aiming at the fault features in micro-grid is established in this paper, and a simple inference algorithm with good error-detecting capability is proposed. Firstly, the fault location criterion based on current magnitude, current phase and Distributed Generation's current direction information is proposed, and the fault transient component is adopted as a supplementary criterion. Secondly, a hierarchical Petri net model utilizing the electrical information, relays' and circuit breakers' state information is accomplished. The model consists of fault location layer and fault clearance layer. In order to increase the portability of the model, the collective processing for the breakers is implemented. Moreover, 'bidirectional arrowhead arc' is introduced to reduce the number of places to optimize the Petri net model well. An improved redundant coding Petri net reasoning algorithm is proposed based on the fault clearance layer of the Petri net model. Finally, the validity of the method is verified through case analysis and comparison.

KEYWORDS

Micro-grid; fault diagnosis; fault location criteria; hierarchical modelling; redundancy coding theory

1. Introduction

In recent years, various types of distributed power sources are pollution-free and renewable, for example, photovoltaic power generation and wind power generation. And their penetration rate in smart grids is increasing (Zhang & Wang, 2016). The traditional distribution network is a medium and low voltage system with single-end power supply. The distribution network is changed into double-end or multi-end power supply due to the distributed power supplies' access. In addition, the network topology and power flow direction of the distribution network are changed. It leads to the traditional relay protection strategy not meet the requirement of timely fault resection. In order to complete fault location timely and accurately, the protection technology applicable to the micro-grid and the corresponding fault diagnosis methods need to be adjusted accordingly (Oureilidis & Demoulias, 2016; Sun & Cheng, 2015). Therefore, a diagnosis method which can locate fault elements and discriminate the incorrect action information of protection and circuit breaker is more significant, thereby facilitating the efficient control on the system (Sheng, Zhang, & Gao, 2014).

Artificial intelligence technology has been widely used in fault diagnosis due to its strong processing ability and

learning capability. For instance, expert systems, neural networks, genetic algorithms and so on. However, these intelligent methods have some limitations when they are applied to fault diagnosis in micro-grid (Wang, Wu, & Wang, 2016). Petri net is an ideal tool to deal with discrete and parallel events. It is widely used in power grid fault diagnosis due to its graphical representation and matrix operational reasoning. As early as 1991, Petri net was applied to fault diagnosis of power system. Lo, Ng, and Trecat (1997) proposed a new method based on Petri net model to detect fault location of power grid. This method can adapt to changing power grid structure and configuration, and the reasoning process is greatly simplified. Furthermore, the fault processing time is shortened by using the Petri net reasoning algorithm. In literature (Calderaro, Hadjicostis, Piccolo, & Siano, 2011), the fault location in smart grid utilizing the Petri net is carried out. The misoperation and refusal of relays or circuit breakers are inferred and discriminated by simple matrix operation. In this study, the influence of DG' current direction on fault location is considered, but the influence of DG' number and position is not considered. A hierarchical Petri net model based on the line protection information with strong adaptability is established (Liu, Xuan, Wei, & Tian, 2016), and the scale of the fault diagnosis model is

CONTACT Xingzhen Bai  xzbai@sdu.edu.cn

reduced greatly. Moreover, the intelligent weighted fuzzy Petri net theory is used to make weight adaptive adjustment, which greatly improves the accuracy of fault diagnosis results in this paper. A fault diagnosis method based on improved fuzzy time Petri net is proposed and the relays and circuit breakers action probability measurement are defined (Liu, Gao, & Wang, 2016). Moreover, to make the diagnosis more accurate, the matrix inference algorithm with time information is used to discriminate the relays and circuit breakers' action information.

In order to solve the following problems: (a) the fault location criteria in traditional distribution network is not applicable or the fault location criteria in micro-grid is not complete; (b) the fault diagnosis Petri net model is complex and poor universality; (c) the timing information for relays and circuit breakers are ignored, and the fault reasoning is complex and time-consuming. In this study, a more concise hierarchical Petri net model is built, and the fault reasoning algorithm appropriate for micro-grid based on redundancy embedded Petri net is proposed.

2. Petri net and its modelling and inference

The static structure of the system in Petri net is called base net, including three elements: place, transition and flow relation. The base net is defined as $\mathbf{N}_1 = (\mathbf{P}, \mathbf{T}, \mathbf{F})$, and the marked net (Wu, 2006) is defined as $\mathbf{N}_2 = \{\mathbf{P}, \mathbf{T}, \mathbf{F}, \mathbf{K}, \mathbf{W}, \mathbf{M}\}$, where $\mathbf{P} = \{p_1, p_2 \dots p_n\}$ is the set of places, $\mathbf{T} = \{t_1, t_2 \dots t_m\}$ is the set of transitions, and $\mathbf{F} = \{f_1, f_2 \dots f_n\}$ is the directional arc between place and transition, \mathbf{K} is the capacity of a place which means the maximum number of tokens contained in it, \mathbf{W} is the set of weights and the weight represents the token number consumed and passed to place after a transition occurs (Yang, Heng, & Zang, 2010), \mathbf{M} is the marking of a Petri net, which denotes the number of tokens contained in each place. A simple Petri net diagram is shown in Figure 1.

In the Petri net modelling, the occurrence of transition is also called firing. The firing represents the token in a place is passed to another place, which means the tokens' consumption. The Petri net matrix operation reasoning is used to infer the system state at any time utilizing state evolution equation and the transition firing sequence.

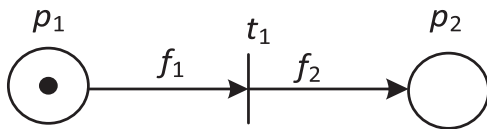

Figure 1. The schematic diagram of basic Petri net.

The state evolution equation of a Petri net is defined as follows:

$$\mathbf{M}_i = \mathbf{M}_0 + \mathbf{A}^T \mathbf{X}_i \quad (1)$$

where $\mathbf{A} = \mathbf{A}^+ - \mathbf{A}^-$, here, \mathbf{A} is the correlation matrix, $\mathbf{A}^+ = (a_{ij}^+)_{n \times m}$ is the input matrix and $\mathbf{A}^- = (a_{ij}^-)_{n \times m}$ is the output matrix (Wu, 2006). a_{ij}^+ and a_{ij}^- are expressed as follows:

$$a_{ij}^+ = \begin{cases} 1, & \text{If there is a directed arc from } t_i \text{ to } p_j \\ 0, & \text{other} \end{cases} \quad (2)$$

$$a_{ij}^- = \begin{cases} 1, & \text{If there is a directed arc from } p_j \text{ to } t_i \\ 0, & \text{other} \end{cases} \quad (3)$$

3. Study on fault location criteria of micro-grid

Based on the wide area information, the fault location criteria suitable for micro-grid are proposed. The criteria include current amplitude and current phase, DG's current direction and transient current component.

3.1. Fault location criteria based on current amplitude and phase

A three-terminal power supply micro-grid system is as shown in Figure 2. The current amplitude and phase fault location criteria based on the wide area information are given as follows:

$$Q_1 : \text{current phase criteria} : \left| \arg \frac{\dot{I}_{AB}}{\dot{I}_{AC}} \right| \leq 90^\circ \quad (4)$$

$$Q_2 : \text{current amplitude criteria} : |\dot{I}_1| > |\dot{I}_2| \quad (5)$$

If Q_1 is satisfied, then the fault is located in the upstream line. If Q_1 is not satisfied but Q_2 is satisfied, then the fault is on the line 1, otherwise on the line 2. If there are passive branches, whether the fault current (which exceeds a certain threshold) flows through should

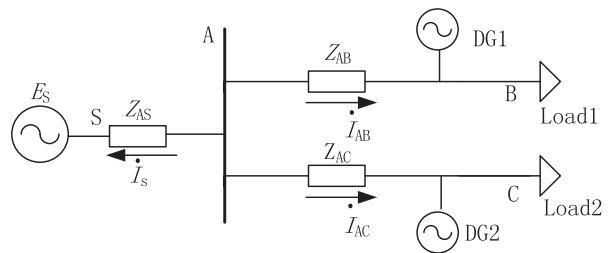

Figure 2. A three-terminal power supply system.

be determined. For multiple branches, the above location method can be used between every two branches.

The current amplitude and phase fault location criteria are translated into the '0-1' 0-1 status information for modelling. When modelling, '0' or '1' means there is no or one token in the place. They are expressed as follows:

$$P_1 = \begin{cases} 1, & \text{The current phase satisfies} \\ & \text{the criterion } Q_1 \\ 0, & \text{The current phase dissatisfies} \\ & \text{the criterion } Q_1 \end{cases} \quad (6)$$

$$P_2 = \begin{cases} 1, & \text{The current amplitude} \\ & \text{satisfies the criterion } Q_2 \\ 0, & \text{The current amplitude} \\ & \text{dissatisfies the criterion } Q_2 \end{cases} \quad (7)$$

3.2. Fault location criteria based on DG's current direction

Another criterion based on the DG's current direction is proposed. Relying on this criterion, the fault location can be more specific; furthermore, it can locate the fault at the specific location on a branch.

A DG current information unit is defined to express all DG information related to a certain line. The place P_{DG} represents the 'union' of current direction information on all lines with DG access and it is expressed as follows:

$$P_{DG} = \begin{cases} 1, & \text{The current on the line connected with} \\ & \text{DG flows to the fault line} \\ 0, & \text{The current on the line connected with} \\ & \text{DG doesn't flow to the fault line} \end{cases} \quad (8)$$

If there is no DG access on the branch or the DG exits, whether fault current flows through the branch will be judged. It is expressed as follows:

$$P_C = \begin{cases} 1, & \text{There is faulty current flows through} \\ 0 & \text{There isn't faulty current flows through} \end{cases} \quad (9)$$

3.3. Fault location criteria based on transient current component

The distributed generation is fluctuant and it has some volatility. The uncertainty of its power and current will affect the current amplitude and phase criterion proposed in this paper. So the criteria based on transient current component are proposed. On account of the Kirchhoff's law, the amplitude of zero sequence current mutation on fault line is equal to the sum of zero

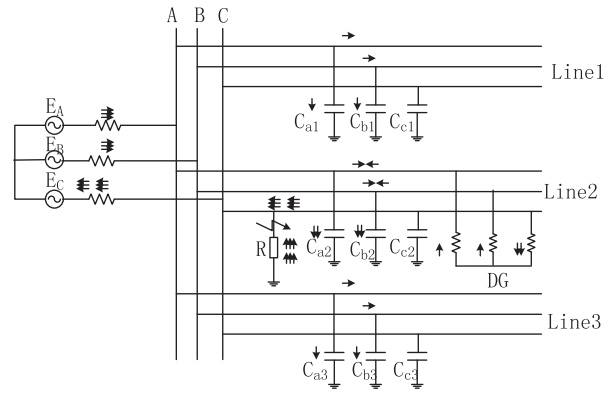

Figure 3. The capacitive current flow direction.

sequence current amplitude of non-fault line, which has nothing to do with the current. So when current criterion fails, based on the fault transient component, the fault location can still accomplish correctly.

In network as shown in Figure 3, when a single-phase ground short circuit fault occurs, the polarity of zero sequence current mutation on fault line is opposite to that on non-fault line. According to Kirchhoff's law, the amplitude of zero sequence current mutation on fault line is equal to the sum of zero sequence current amplitude of non-fault line (Lei et al., 2016). The position of the power source is changed, so the distribution of capacitive current is changed. But the transient zero sequence current through the fault line 2 changed little. It is not affected by DG access position and still values the sum of zero sequence current on non-fault line.

Therefore, the location criterion based on fault transient component can be transformed into '0-1' state quantity information, which is shown as follows:

$$P_{zt} = \begin{cases} 1, & \text{The zero sequence current flowing to the bus} \\ & \text{is equal to the sum of others' capacitance} \\ & \text{current to the earth and reverse} \\ 0, & \text{The zero sequence current flowing to the bus} \\ & \text{isn't equal to the sum of others' capacitance} \\ & \text{current to the earth or synclastic} \end{cases} \quad (9)$$

4. Micro-grid fault diagnosis hierarchical Petri net model

4.1. Hierarchical Petri net model

Combined with electrical information collected by wide area measurement system and state information from SCADA system, the weak robustness of online fault diagnosis system can be solved to a certain extent (Zhong

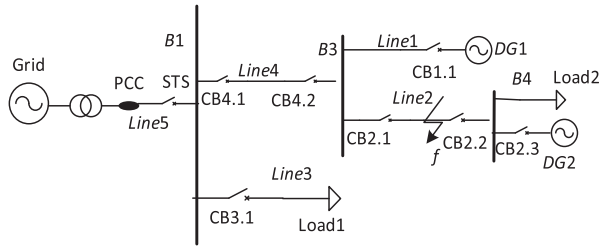

Figure 4. The schematic diagram of a 10 kV micro-grid.

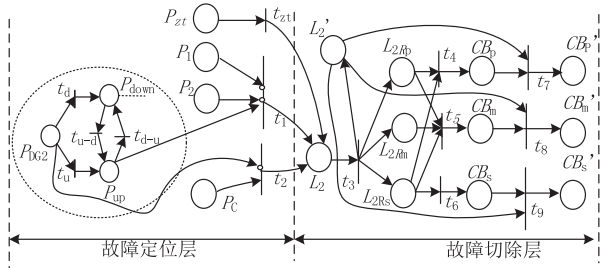

Figure 5. The fault diagnosis Petri net model of Line 2.

et al., 2015). Therefore, a layered modelling method utilizing the electrical and state information is proposed in this paper. A simple micro-grid is shown in Figure 4, and it is taken as an example to build the Petri net model.

As shown in Figure 5, the fault diagnosis Petri net model is divided into two layers which includes fault location layer and fault removal layer. The fault location layer is built by utilizing current criterion, DG's current direction criterion and the fault transient component criterion. The fault removal layer is built by using the logical relationship between relays and circuit breakers. It should be noted that the directional arc between P_2 and t_1 in Figure 5 is an inhibitory arc. Unlike ordinary arc, no token in the place is the necessary condition for transition firing.

In order to increase the portability of the model, the integrated circuit breaker is processed in this paper. That is, according to the junction analysis, the circuit breakers associated with a certain component are classified according to the corresponding main protection, local backup protection and remote backup protection, respectively. And they are written into different sets. The set \overline{CB}_m , \overline{CB}_p and \overline{CB}_s are defined to be the collection of circuit breakers corresponding to the main protection, local backup protection, remote backup protection. And they are respectively corresponding to the place CB_m , CB_p and CB_s in the Petri net model. For example, in Figure 3, \overline{CB}_m is the set of $CB_{2.1}$ and $CB_{2.2}$. The main protection and the local backup protection are considered to be non-expansive protection and they send trip signal to same circuit breakers, so \overline{CB}_p is also the set of $CB_{2.1}$ and $CB_{2.2}$. Remote backup protection is an expanded protection, so

Table 1. The temporal information of transitions.

Number	Transition	Time constraint (ms)
1	$t_u, t_d, t_{u-d}, t_{d-u}$	0
2	t_1, t_2, t_3	0
3	t_4	[260, 340]
4	t_5	[10, 40]
5	t_6	[950, 1070]
6	t_7, t_8, t_9	[20, 40]

the corresponding circuit breakers $CB_{4.2}$, $CB_{1.1}$ and $CB_{2.3}$ are included in \overline{CB}_s . After collection processing, the overall logical relationship between the protection relays and the circuit breakers in the fault removal layer remains unchanged. When the power grid structure changes, only the information about circuit breakers inside the collection can be updated.

4.2. Model optimization

In order to make a fault diagnosis model more perfect, the transition' time information of a Petri net model is set up by referring to the relay protection configuration principle in traditional distribution network (Zhang, Zhang, Wen, & Li, 2014). The temporal information of transitions is shown in Table 1.

In order to verify the correctness of the fault removal layer model, a test is completed. The transitions' firing delay time is set as follows: t_3 fires immediately; the firing delay of t_4, t_5, t_6 is 260, 10 and 950 ms, respectively; the firing delay of t_7, t_8, t_9 is 20 ms. It should be noted that there is no state evolution interruption in the process of simulation and only the final results of simulation are presented to illustrate the evolution state of the model for lack of space. The simulation result is shown in Figure 6.

In Figure 6, the delay is 20 ms and the transition t_8 is triggered. The tokens in CB_m and L_2' are consumed, at the same time, a token is output to CB'_m . That is, the fault is cleared by the circuit breakers corresponding to the main

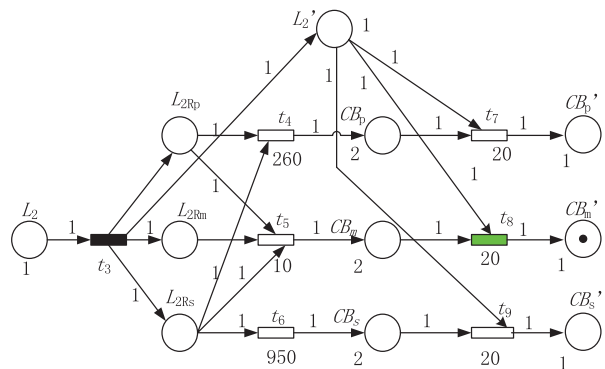

Figure 6. The state of Petri net at 30 ms.

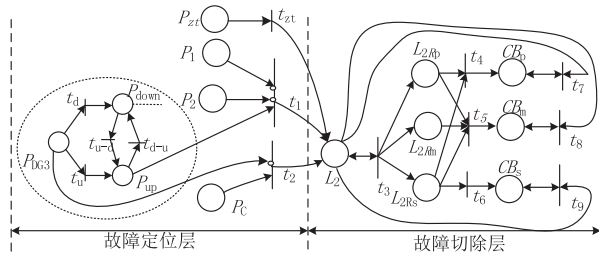

Figure 7. The simplified fault diagnosis model of Line 2.

protection. Therefore, it can be verified that the process of fault clearance can be described correctly.

In order to further simplify the model, a ‘bidirectional arrowhead arc’ is defined in this paper. It means that when the transition fires, there will be tokens output to the pre-place and the post-place, respectively.

A simplified model using a bidirectional arrowhead arc is shown in Figure 7. And the bidirectional arc between L_2 and t_3 accurately expresses that the online fault has not been removed when the relay starts, the failure is removed only when the corresponding circuit breakers act. The bidirectional arc between CB_m and t_8 expresses that the circuit breakers corresponding to main protection act to remove the failure. At the same time, a token is output to the place CB_m , which indicates the fault is removed by the circuit breaker CB_m finally. Obviously, it can be seen that although the simplification reduces the number of places, it does not affect the description of fault removal process.

5. Improved redundant coding Petri net fault reasoning

Based on the coding theory (Zhao & Liu, 2009), appropriate redundancy places are embedded in original Petri net in order to supervise the transition or place error in state evolution. Finally, through calculating the check matrix, the misoperation of protections or breakers are discriminated (Ji, Liang, Yu, Bai, & Wu, 2016). In order to make the transition fault in the model correspond to the signal loss or false action in the actual system, the following two kinds of transition faults are introduced (AIMuhaini & Heydt, 2012).

The post-condition failure: the transition occurs and the token in the pre-place has been consumed, but no token is placed in the post-place.

The pre-condition failure: the transition occurs and the token is output in the post-place, while token in the pre-place is not consumed.

Because the bidirectional arrowhead arc is introduced in micro-grid fault diagnosis model, the action of relays and circuit breakers can be described perfectly only by the

transitions’ firing with temporal information. The pre-condition failure of $t_4(t_5, t_6)$ is that the local backup protection (main, remote backup protection) acts but the corresponding circuit breakers fails to start. And the post-condition failure of $t_4(t_5, t_6)$ is that the local backup protection (main, remote backup protection) doesn’t act or the action information is not collected by monitoring centre, but the corresponding circuit breakers start without delay. The pre-condition failure of $t_7(t_8, t_9)$ is that the circuit breakers corresponding to local backup protection (main, remote backup protection) act and the fault is cleared, but the action information of circuit breakers can’t be collected. And the post-condition failure of $t_7(t_8, t_9)$ is that the circuit breakers corresponding to local backup (main, remote backup) protection does not operate and the fault was not removed, but the action information of the breakers can’t be collected by the monitoring centre.

It can be seen that the transition firing will be enough to express the action information of protections and breakers and the logical relationship between them. Therefore the place fault check does not have to be carried out on account of the improving the reasoning method in this paper.

5.1. The Redundant coding inference method

The transformation relation between original net S and redundant Petri net H is:

$$q_h(t) = \begin{bmatrix} I_n \\ C^* \end{bmatrix} q_s(t) \quad (11)$$

In normal state, the evolution equation of redundant Petri net H is:

$$q_h[t+1] = q_h[t] + \begin{bmatrix} A^+ \\ C^*A^+ - D^* \end{bmatrix} X(t) - \begin{bmatrix} A^- \\ C^*A^- - D^* \end{bmatrix} X(t) \quad (12)$$

When post-condition failure or pre-condition failure occurs, the evolution equations are respectively formula (13) and (14):

$$[q_h[t+1] = q_h[t] - \begin{bmatrix} A^+ \\ C^*A^+ - D^* \end{bmatrix} e^-] \quad (13)$$

$$q_h[t+1] = q_h[t] + \begin{bmatrix} A^- \\ C^*A^- - D^* \end{bmatrix} e^+ \quad (14)$$

where $q_h(t)$ and $q_s(t)$ are the state vector of the net H and the state vector of net S respectively, I_n is a unit matrix, A^+ and A^- are input and output matrix, respectively, $X(t)$ is the transition firing sequence, e^- and e^+

are the fault indicator vectors, \mathbf{C}^* is a generator matrix which can be constructed referring to literature (Wu & Hadjicostis, 2005), \mathbf{D} is the vandermonde matrix (Jia, Yang, Zheng, & Bi, 2017), and p is the minimum prime which both greater than the row and the column.

$$\mathbf{D} = \begin{bmatrix} 1 & 2 & 3 & \dots & m \\ 1 & 2^2 & 3^2 & \dots & m^2 \end{bmatrix} \text{ mod } p \quad (15)$$

$$\mathbf{D}^* = -p \cdot \mathbf{D} \quad (16)$$

The transition fault representation vector \mathbf{S}_T and the check matrix \mathbf{S} are respectively defined as follows:

$$\mathbf{S}_T = \mathbf{D} \cdot (e^+ - e^-) \quad (17)$$

$$\mathbf{S} = [-\mathbf{C}^* \quad \mathbf{I}_d] \cdot q_f[k] \quad (18)$$

Finally, the vector \mathbf{S} and \mathbf{S}_T are compared with \mathbf{D}^* or $-\mathbf{D}^*$ respectively to find out the same columns or the sum of several columns. Then, the transition corresponding to this column or several columns has a fault. The transition corresponding to column in \mathbf{D}^* represents the refusal action, while the transition corresponding to column in $-\mathbf{D}^*$ represents the malfunction.

5.2. Case study

Case 1: The alarm from SCADA are L_{2Rm} acts at 53 ms, L_{2Rp} acts at 360 ms, L_{2Rs} acts at 375 ms, B_{3m} acts at 50 ms, $CB1.1$ acts at 105 ms, $CB2.1$ acts at 384 ms, $CB2.2$ acts at 135 ms and 391 ms, $CB4.2$ does not act.

(1) The information collective processing:

The information related to *Line2* are $R_1 = \{L_{2Rm}, L_{2Rp}, L_{2Rs}, CB2.1, CB2.2, CB4.2\}$, $\overline{CB_m} = \{CB2.1, CB2.2\}$, $\overline{CB_p} = \{CB2.1, CB2.2\}$ and $\overline{CB_s} = \{CB4.2\}$. The information related to *Bus3* are $B_3 = \{B_{3m}, L_{2Rp}, CB1.1, CB2.1, CB4.2\}$, $\overline{CB_{3m}} = \{CB1.1, CB2.1, CB4.2\}$.

Conclusions can be drawn from the alarm information time inference: L_{2Rm} and L_{2Rp} act, but only relying on the information collected the real action of the circuit breakers corresponding to main protection are unknown. The circuit breakers corresponding to the local backup protection act. And the remote backup protection L_{2Rs} acts, but CB_s does not act.

(2) According to the state evolution of redundant Petri nets, the final state is as formula (19).

$$q_h(6) = [0 \quad -1 \quad 0 \quad 0 \quad 1 \quad 0 \quad 0 \quad -17 \quad 22]^T \quad (19)$$

(3) Finally, its check matrix and transition fault representation vector are calculated as follows:

$$\mathbf{S} = (-\mathbf{C}^* \quad \mathbf{I}_d) \cdot q_h(6) = [-22 \quad 22]^T \quad (20)$$

$$\begin{aligned} \mathbf{S}_T &= \mathbf{S} = [-22 \quad 22]^T = -\mathbf{D}^*(:, 4) + \mathbf{D}^*(:, 6) \\ &= [44 \quad 55]^T + [-66 \quad -33]^T \end{aligned} \quad (21)$$

By comparison, it can be seen that: \mathbf{S}_T is equal to the sum of the fourth column of $-\mathbf{D}^*$ and the sixth column of \mathbf{D}^* , which means that the circuit breaker CB_m refuses to act and the relay L_{2Rs} fails to act. Therefore, the diagnosis results are as follows: L_{2Rm} acts, and CB_m refuses to act, L_{2Rp} and CB_p act, then the fault is removed, but the remote backup protection relay misoperates.

Case 2: L_{2Rm} acts at 53 ms, L_{2Rp} acts at 360 ms, $CB1.1$ acts at 105 ms, $CB2.2$ acts at 135 ms, $CB4.2$ acts at 210 ms, $CB2.1$ acts at 384 ms, $CB2.2$ acts at 391 ms.

Conclusions can be drawn from the alarm information time inference: the information related to Line 2 is that L_{2Rm} , L_{2Rp} and CB_p act, the state of CB_m is unknown. Therefore, there may still be information loss or refusal information, although the timing information is correct.

The check matrix \mathbf{S} and transition fault representation vector \mathbf{S}_T are finally obtained based on redundant Petri nets reasoning:

$$\mathbf{S} = (-\mathbf{C}^* \quad \mathbf{I}_d) \cdot q_h(5) = [-66 \quad -33]^T \quad (22)$$

$$\begin{aligned} \mathbf{S}_T &= \mathbf{S} = [-66 \quad -33]^T = \mathbf{D}^* \cdot \\ &[0 \quad 0 \quad 0 \quad 0 \quad 0 \quad 1 \quad 0]^T \end{aligned} \quad (23)$$

By comparison, the sixth column of \mathbf{D}^* equals the vector \mathbf{S}_T . That is, the main protection acts, but $CB2.1$ and $CB2.2$ refuse to act at the correct delay interval. The fault is removed by the breakers corresponding to the local backup protection.

To illustrate the advantages, the method proposed in this paper is compared with the traditional fault reasoning method and fault diagnosis method based on the redundant embedded Petri net but uninvolved sequence information, the results are as shown in Tables 2 and 3.

The diagnosis results utilizing the traditional method are uncertain and only one possible diagnosis result is listed in Table 3. However, the reasoning methods not making full use of temporal information may get wrong diagnosis results and have poor error-detecting capacity. The method presented in this paper can discriminate mal-operation of the relays and breakers only by carrying out the transition fault reasoning. Correct results which are consistent with the actual cases can be obtained. So the

Table 2. Comparison of the method with other methods.

Methods	Criteria	Model object	Reasoning process
The traditional method	The current direction and current direction of distributed power supply	A certain line	Place and transition fault reasoning should be done, complex reasoning process
Method based on the redundant embedded Petri net without time	Short circuit power direction and status information of protections and circuit breakers	Considering the location and quantity of distributed power access	Constant revision, slow reasoning
Methods of this paper	Current phase and amplitude, current direction information of distributed power supply and fault transient information	The upstream and downstream connected with the same bus	Identify protection or breaker's misoperation effectively and only carry out transition fault reasoning; simply the calculation process

Table 3. Reasoning results of different methods.

Methods	Diagnosis results of case 1	Diagnosis results of case 2
The traditional method	L_{2Rm} and L_{2Rp} act correctly, CB_m acts the fault is removed by $CB_{2.1}$ and $CB_{2.2}$, L_{2RS} malfunction.	L_{2Rm} and L_{2Rp} act correctly, CB_m acts fault is removed by $CB_{2.1}$ and $CB_{2.2}$, CB_p malfunction.
Method based on redundant embedded Petri net without time	L_{2Rm} acts correctly CB_m acts, the fault is removed by $CB_{2.1}$ and $CB_{2.2}$, L_{2Rm} and L_{2RS} malfunction.	L_{2Rm} acts correctly, L_{2Rp} malfunction, CB_m acts correctly the fault is removed by $CB_{2.1}$ and $CB_{2.2}$.
Methods of this paper	L_{2Rm} and L_{2Rp} acts correctly CB_m refuses to act the fault is removed by CB_p , L_{2RS} malfunction.	L_{2Rm} and L_{2Rp} acts correctly CB_m refuses to act the fault is removed by CB_p .

method proposed in this paper has better error-detecting ability.

6. Conclusion

In order to achieve the fault diagnosis in micro-grid, the electrical criteria are proposed for fault location. At the same time the incorrect state information can be discriminated. A micro-grid fault diagnosis Petri net model is established and it is divided into fault location layer and fault removal layer. Temporal information is considered, and the Petri net fault reasoning based on redundant encoding theory is improved in this paper. Only the transition fault reasoning is implemented to obtain reliable diagnosis results by the improved method. Finally, through case studies and method comparison, the model is proved to be simple and visualized, and the reasoning method has strong error-detection Capacity.

Disclosure statement

No potential conflict of interest was reported by the authors.

References

- Al-Muhaini, M., & Heydt, G. T. (2012). Minimal, cut sets, Petri nets, and prime number encoding in distribution system reliability evaluation. *Proceedings of the IEEE Power Engineering Society Transmission and Distribution Conference, 2012*, 1–8.
- Calderaro, V., Hadjicostis, C., Piccolo, A., & Siano, P. (2011). Failure identification in smart grids based on petri net modeling. *IEEE Transactions on Industrial Electronics*, 58(10), 4613–4623.
- Ji, X., Liang, Y., Yu, Y., Bai, X., & Wu, N. (2016). An approach of fault diagnosis for power network based on redundant embedded petri net. *Journal of Anhui University (Natural Science Edition)*, 40(5), 50–56.
- Jia, X., Yang, D., Zheng, W., & Bi, Y. (2017). Distribution network fault diagnosis method based on multi-factor hierarchical petri net. *Power System Technology*, 41(3), 1015–1021.
- Lei, Q., Ji, X., Wen, F., Liu, Z., Yu, Y., & Xu, H. (2016). Fault diagnosis of distribution system with distributed generation employing transient component. *Electric Power Construction*, 37(2), 42–49.
- Liu, X., Gao, Y., & Wang, Z. (2016). Method of power distribution network fault diagnosis based on improved time fuzzy petri net. *Journal of Northeastern University: Natural Science*, 37(11), 1526–1529.
- Liu, K., Xuan, W., Wei, S., & Tian, L. (2016). A method of micro grid fault diagnosis based on high-level petri net. *Power System Protection and Control*, 44(15), 106–111.
- Lo, K., Ng, H., & Trecat, J. (1997). Power systems fault diagnosis using Petri nets. *IEEE Proceedings Generation, Transmission and Distribution*, 144(3), 231–236.
- Oureilidis, K., & Demoulias, C. (2016). A fault clearing method in converter-dominated micro grids with conventional protection means. *IEEE Transactions on Power Electronics*, 31(6), 4628–4640.
- Sheng, L., Zhang, W., & Gao, M. (2014). Relationship between Nash equilibrium strategies and H_2/H_∞ control of stochastic Markov jump systems with multiplicative noise. *IEEE Transactions on Automatic Control*, 59(9), 2592–2597.
- Sun, M., & Cheng, J. (2015). Discussion on special problem solutions for relay protection in micro grid. *Automation of Electric Power System*, 39(19), 137–141.
- Wang, D., Wu, X., & Wang, Z. (2016). Fault location for distribution network with distributed power based on improved genetic algorithm. *Journal of Northeast Dianli University (Natural Science Edition)*, 36(1), 1–7.
- Wu, Z. (2006). *An introduction to Petri nets*. Beijing: China Machine Press.
- Wu, Y., & Hadjicostis, C. (2005). Algebraic approaches for fault identification in discrete-event systems. *IEEE Transactions on Automatic Control*, 50(12), 2048–2055.

- Yang, J., Heng, Z., & Zang, T. (2010). Power system fault-diagnosis method based on directional weighted fuzzy petri nets. *Proceedings of the CSEE*, 30(34), 42–49.
- Zhang, D., & Wang, J. (2016). Research on construction and development trend of micro-grid in China. *Power System Technology*, 40(2), 451–458.
- Zhang, Y., Zhang, Y., Wen, F., & Li, J. (2014). Power system fault diagnosis with enhanced fuzzy petri net accommodating temporal constraints. *Automation of Electric Power System*, 38(5), 66–72.
- Zhao, Q., & Liu, R. (2009). *Coding theory*. Beijing: Beihang University Press.
- Zhong, J., Zhang, Y., Wen, F., Yang, M., Zhang, X., & Zhu, H. (2015). An improved petri net model for power system fault diagnosis employing electrical data and temporal constraints. *Automation of Electric Power System*, 39(11), 152–159.