



The relationships between the use of smart mobile technology, safety knowledge and propensity to follow safe practices at work

Andrzej Jan Olak, Irena Hejduk, Waldemar Karwowski, Przemyslaw Tomczyk, Jan Fazlagić, Paweł Gac, Hubert Hejduk, Sylvia Sobolewska, Erman Çakıt & Omar A. Alrehaili

To cite this article: Andrzej Jan Olak, Irena Hejduk, Waldemar Karwowski, Przemyslaw Tomczyk, Jan Fazlagić, Paweł Gac, Hubert Hejduk, Sylvia Sobolewska, Erman Çakıt & Omar A. Alrehaili (2019): The relationships between the use of smart mobile technology, safety knowledge and propensity to follow safe practices at work, International Journal of Occupational Safety and Ergonomics, DOI: [10.1080/10803548.2019.1658398](https://doi.org/10.1080/10803548.2019.1658398)

To link to this article: <https://doi.org/10.1080/10803548.2019.1658398>



© 2019 Central Institute for Labour Protection – National Research Institute (CIOP-PIB). Published by Informa UK Limited, trading as Taylor & Francis Group



Published online: 11 Oct 2019.



Submit your article to this journal [↗](#)



Article views: 1889



View related articles [↗](#)



View Crossmark data [↗](#)



Citing articles: 1 View citing articles [↗](#)

The relationships between the use of smart mobile technology, safety knowledge and propensity to follow safe practices at work

Andrzej Jan Olak^{a*}, Irena Hejduk^{b†}, Waldemar Karwowski^{b,c}, Przemysław Tomczyk^{b,d}, Jan Fazlagić^e, Paweł Gac^f, Hubert Hejduk^g, Sylvia Sobolewska^h, Erman Çakıt^{b,i} and Omar A. Alrehaili^j

^aThe Bronisław Markiewicz State Higher School of Technology and Economics in Jarosław, Poland; ^bSGH Warsaw School of Economics, Poland; ^cUniversity of Central Florida, USA; ^dAkademia Leona Koźmińskiego, Poland; ^ePoznań University of Economics and Business, Poland; ^fSafety consultant, Poland; ^gAvaleo, Poland; ^hSGH Warsaw School of Economics, Poland; ⁱDepartment of Industrial Engineering, Gazi University, Turkey; ^jTaibah University Faculty of Engineering, Saudi Arabia

The main objective of this study was to investigate the relationships between the use of smart technology (mobile phones) and the implicit (tacit) and explicit safety knowledge of employees and their propensity to follow safe practices at work. A survey was performed with seven constructs: (a) use of mobile technology; (b) tacit safety knowledge; (c) explicit safety knowledge of unsafe behaviors; (d) attitudes toward safety: emotional aspects; (e) safety culture: behavioral and psychological aspects of work; (f) safety culture: aspects of work; (g) safety culture: regulations at work. Workers from three manufacturing companies located in southeastern Poland completed a paper-based survey. The results revealed that using mobile technology positively influenced the explicit safety knowledge of employees, as well as their assessed safety culture, in terms of behavioral aspects and their attitudes toward safety expressed through the psychological aspects of safety culture.

Keywords: mobile technology; use of smartphones; safety; knowledge management; safe work practices; structural equation modeling

1. Introduction

The use of mobile personal communication devices such as smartphones and tablets is currently widespread in both daily activities as well as in a variety of working environments, including formal and informal training and learning [1–3]. For example, Pimmer and Pachler [4] discussed the value of mobile learning for work-based education and pointed out that, similar to other technological innovations, mobile devices have the potential to enhance existing educational practices and can be widely used for learning in informal contexts. The authors also concluded that the affordances of mobile devices at work enable cross-contextual learning by sharing content such as multimedia material, learning at work through competence development, engaging in social mobile networking and education in informal settings, which can lead to a significant increase in workers' active participation in the learning process. Mobile devices have also been increasingly used for safety training and education in a variety of occupational settings, including road safety [5], healthcare [6–8] and construction sites [8–10], to increase workers' ability to identify safety risks and improve real-time communication between employees and managers.

As recently discussed by Srivastava [11], in light of the rapid expansion of mobile technology, it is important to consider the effect of such technology on society, in general, and to explore the extent to which mobile phones affect our daily lives, and, in particular, how they affect our social behaviors. For example, the excessive use of mobile technology by individuals at large has been linked to anti-social behavior [12]. Furthermore, Bianchi and Phillips [13] suggested that people who are attached to their mobile phones also tend to take risks more often. People with significant mobile phone usage are also more likely to use the phones inappropriately despite recognized safety concerns, formal and informal bans against their use at the risk of fines and penalties, and a knowledge of the potential dangers to self and others due to such use. Notably, Yang et al. [14] provided evidence that behavioral beliefs, social influences and personal traits are salient factors for the adoption and use of mobile technology.

Smartphones are pervasive and rapidly developing communication tools currently used in everyday life; however, very little is known about their effect on work environments from the social and cultural points of view [11]. Therefore, this study focused on exploring the potential

*Corresponding author. Email: aolak@onet.eu

†Deceased.

association between the use of mobile devices in general and the propensity of workers to follow safety rules, regulations and policies in the workplace. The main purpose of this research was to investigate the relationships between the general tendency to use smart mobile technology, employee safety knowledge and safe practices at work while considering the safety culture and employees' attitudes toward safety.

2. Background

2.1. Safety culture

Three interrelated concepts of safety culture include behavioral, psychological and situational aspects [15]. The behavioral (organizational) aspect focuses on the behaviors of employees, activities and actions related to safety within the organization, i.e., what 'people do' in an organization regarding safety. The organizational context of safety culture can be measured using a set of indicators, including engagement, managerial commitment and employees' empowerment, awards and a reporting system [16]. The psychological aspect considers 'what people feel' about safety and its management at all levels of the organization. Worker attitudes and perceptions are important aspects of corporate safety culture [17]. The situational (or corporate) aspect relates to a corporation's policies, instructions, procedures, management system and communication flow, and explains 'what an organization obtains' [18].

2.2. Safety knowledge management

According to Vecchio-Sudus and Griffiths [19], promoting strong safety practices can positively affect safety culture in an organization. Management support of safety training includes informing workers about safety, in general, and adherence to safety procedures, in particular [20]. Safety training that focuses on safety accountability increases employee safety knowledge and compliance, influences worker behaviors and attitudes regarding occupational and safety rules [21–23], and is considered one of the most effective aspects of a safety program [24,25].

Employee training should lead to a comprehensive level of safety-relevant knowledge [26,27]. Such knowledge includes both the explicit (structural) safety knowledge that is codified into safety documents, including national and international and national safety standards, regulations, rules or instructions, as well as workers' tacit (hidden) knowledge regarding safety based on her/his individual experience and prior safety performance [27]. As discussed by Nonaka et al. [28,29], while explicit knowledge is a codified knowledge that is formal, objective and easy to transmit, process and share, tacit knowledge is personal and context specific and is therefore very difficult to communicate, formalize or codify. In other words, tacit knowledge is typically transferred through anecdotes

in personal communications that take place in face-to-face interactions between individuals, in meetings or through electronic tools, such as email and online chats. It should be noted that new knowledge is also created during interactions between individuals based on their understanding of different content and possessing different types of explicit and tacit knowledge [29]. Furthermore, effective organizational knowledge creation involves continuous and dynamic processes of conversion from tacit knowledge to explicit knowledge [30]. Unfortunately, many organizations today focus their training efforts exclusively on the transfer of formal or explicit knowledge that includes governmental and corporate policies [31,32]. However, such an approach does not account for the great variability of the mostly dynamic nature of hazards and unsafe conditions at work. Therefore, comprehensive safety management systems should utilize both explicit and tacit (hidden) safety knowledge. Tacit employee safety knowledge is strongly tied to the work context, and although tacit knowledge is difficult to formalize and verbalize, nonetheless it can be acted upon and utilized during work processes and is critical to ensuring the use of safety practices [30].

3. Methods and procedures

3.1. Study variables

The primary focus of the present study was on the relationships between the tendency to use smart mobile technology, employee safety knowledge and safe work practices at work while considering the safety culture and employees' attitudes toward safety. As a first step, the main constructs of the proposed model were designed based on the previously reported literature discussed earlier. Principal component analysis (PCA) of the data extracted 38 items that represent the safety knowledge dimensions. As a result, the remaining 38 items were used for further analyses. A final set of variables (a total of 38 items) used in model development were categorized and named as follows:

- Use of mobile technology (smartphones) (TECH) (six items).
- Tacit knowledge (TK) (eight items).
- Explicit safety knowledge of unsafe behaviors (EKUB) (three items).
- Attitudes toward safety emotional aspects (ASEA) (five items).
- Safety culture: behavioral and psychological aspects of work (SCBPA) (four items).
- Safety culture: aspects of work (SCAW) (seven items).
- Safety culture: regulations at work (SCW) (five items).

Here, tacit and explicit safety knowledge pertains to safety knowledge, and the remaining factors including TECH,

Table 1. Model constructs with corresponding item measures and descriptions after principal component analysis.

Item number	Model construct	Description
Factor 1 – use of mobile technology (TECH)		
152	TECH1	When I urgently need information, I use the search engine on my smartphone
150	TECH2	When I get lost in the city, I use my smartphone's navigation system
154	TECH3	I cannot imagine my life without a smartphone
153	TECH4	In the event of a breakdown or accident, I look for information about their causes on the Internet using my smartphone
151	TECH5	When I need to contact someone urgently, I use social media on my smartphone
149	TECH6	I like to be up to date with mobile technological innovations
Factor 2 – tacit safety knowledge (TK)		
12	TK1	To avoid accidents, it is best to see how an experienced employee performs a given task
11	TK2	If I have to learn a new task quickly, I observe how someone else does it safely
15	TK3	It is best to warn others of a hazardous device at work, telling them the history of the accidents related to the use of this device
13	TK4	Before I start working on new equipment, I will ask an experienced worker to explain to me the potential safety hazards
18	TK5	I like to observe how experienced employees perform their jobs
113	TK6	It is best to teach young employees about safe behaviors by having older employees tell them what safety hazards to watch out for
14	TK7	My coworkers help me maintain a safe workplace
148	TK8	I feel good knowing that I can help someone work safely
Factor 3 – explicit safety knowledge of unsafe behaviors (EKUB)		
115	EKUB1	To make employees more attentive to safety at work, it is best to organize a meeting at the beginning of the day and ask them to focus on working safely all the time
116	EKUB2	Employees who work in an unsafe manner and do not care about the safety of their coworkers should be required to take safety training to change their unsafe behaviors
114	EKUB3	Employees can be taught to unlearn their bad safety habits by sharing with them a movie that shows what they are doing that is unsafe
Factor 4 – attitude toward safety: emotional aspects (ASEA)		
144	ASEA1	I feel safer after taking my safety training
147	ASEA2	I am willing to share my knowledge in the field of health and safety with others
146	ASEA3	I am happy to ask others about issues related to work safety
138	ASEA4	Occupational health and safety training enriches my knowledge of working safely
143	ASEA5	Health and safety knowledge is important to me
Factor 5 – safety culture: behavioral and psychological aspects of work (SCBPA)		
120	SCBPA1	I feel responsible for the safety of customers and visitors to my workplace
122	SCBPA2	I feel personally responsible for the safety of my coworkers
124	SCBPA3	I put away the tools left in the wrong place by another employee
119	SCBPA4	I know the benefits of safe work at my company
Factor 6 – safety culture: aspects of work (SCAW)		
129	SCAW1	I use personal protection equipment recommended by my company at my workstation
117	SCAW2	I know the safety hazards at work that might affect my life and health
121	SCAW3	I know how to behave in the event of an accident at work
123	SCAW4	I report my observations regarding the safety hazards that I see at work
118	SCAW5	I feel responsible for the safety requirements in my workplace
134	SCAW6	I inform my superiors about any potential threats to working safely that I observe
137	SCAW7	I can recognize the safety hazards that are present at my workplace
Factor 7 – safety culture regulations at work (SCW)		
128	SCW1	I disregard health and safety regulations, especially when I do a job that I know very well
130	SCW2	I disregard some health and safety regulations to get my job done faster
125	SCW3	Sometimes I use machines, devices or tools whose technical condition may endanger my personal safety
133	SCW4	I do not use equipment that in my opinion may pose a safety hazard
139	SCW5	Employees with extensive experience do not have to comply with health and safety rules

ASEA, SCBPA, SCAW and SCW are related to safety practice.

The survey statements for each of the study variables are presented in Table 1.

3.2. Survey questionnaire

All questionnaire statements were measured on a 5-point response Likert scale: 1 = *strongly disagree*; 2 = *disagree*; 3 = *neither agree nor disagree*; 4 = *agree*;

Table 2. Study hypotheses.

Identifier	Hypothesis
H_1	TECH has a significant influence on safety culture: aspects of work (SCAW)
H_2	TECH has a significant influence on tacit knowledge (TK)
H_3	TECH has a significant influence on attitudes toward safety: emotional aspects (ASEA)
H_4	TECH has a significant influence on safety regulations at work (SCW)
H_5	TECH has a significant influence on safety culture: behavioral and psychological aspects (SCBPA)
H_6	TECH has a significant influence on explicit safety knowledge of unsafe behaviors (EKUB)

Note: TECH = use of mobile technology.

5 = *strongly agree*. To minimize the potential impact of respondent inertia, several items were presented on a reversed scale. Furthermore, the order of all statements in the questionnaire was randomized.

3.3. Participants

Empirical data collection was carried out in three large industrial enterprises in southeastern Poland. A total of 436 respondents (78.1% male workers and 21.9% female workers) provided valid survey responses (a response rate of 54%). The study participants performed a large variety of manufacturing and fabrication jobs with a mix of physical (60%) and cognitive (40%) task components. A standardized interview method was implemented using a paper self-administered questionnaire.

3.4. Study hypotheses

The proposed study hypotheses are depicted in Table 2 and represented in Figure 1. In total, six hypotheses were developed to examine the plausible relationships between the use of smart mobile technology, employee safety knowledge, tacit and explicit knowledge, safety regulations and safe practices at work with due consideration given to safety culture and employees' attitudes toward safety.

4. Model development and analysis

4.1. Overview of statistical analyses

The statistical analyses were performed using SPSS version 25 for Windows and AMOS version 24 [33]. These analyses consisted of PCA, unidimensionality analysis, reliability analysis and structural equation modeling (SEM) to analyze the relationships among the model factors.

4.2. Principal component analysis

Prior to performing the factor extraction through PCA, the commonalities involved were extracted. Commonalities are very useful in representing the total amount that an original variable shares with all other variables included in the analysis [34]. According to Field [34], this is critical in deciding which variables to finally extract into the various

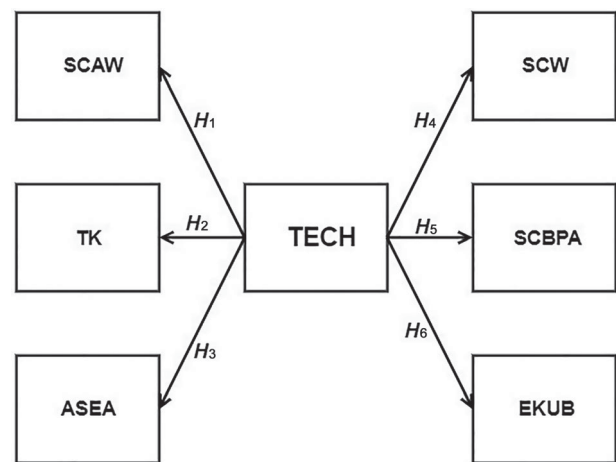

Figure 1. The hypothesized study model.

Note: For postulated hypotheses H_1 – H_6 , see Table 2.

ASEA = attitudes toward safety: emotional aspects;

EKUB = explicit knowledge of unsafe behaviors;

SCAW = safety culture: aspects of work; SCBPA = safety

culture: behavioral and psychological aspects; SCW = safety

culture regulations at work; TECH = use of mobile technology;

TK = tacit knowledge.

items. In general, in commonality values, the extraction of values that are greater than 0.5 at the initial iteration indicates that the variable is significant and should be included in the data for further analysis, or otherwise should be removed [34]. From our data, we have extracted seven items with values less than 0.5 (items 11, 27, 31, 32, 36, 42 and 45) prior to conducting the factor extraction through PCA.

In this study, a principal component together with varimax rotation, an eigenvalue greater than 1 and a cut-off factor loading of 0.4 were used for factor analysis. Data are deemed appropriate for analysis based on the Kaiser–Meyer–Olkin sampling adequacy value of 0.917. Bartlett's test of sphericity is significant ($\chi^2 = 9025.605$, $p < 0.001$), which indicates that correlations exist among certain response categories. After the first run of the principal component factor analysis, several factors remained unchanged, whereas other questions had to be redistributed between the factors, in comparison to the structure of the original questionnaire. We named these factors in an appropriate way. Table 3 presents the results of the PCA,

Table 3. Seven key components were extracted from the principal component analysis.

Item	Principal component						
	PC1 (SCAW)	PC2 (TK)	PC3 (TECH)	PC4 (ASEA)	PC5 (SCW)	PC6 (SCBPA)	PC7 (EKUB)
I29	0.749	—	—	—	—	—	—
I17	0.731	—	—	—	—	—	—
I21	0.682	—	—	—	—	—	—
I23	0.681	—	—	—	—	—	—
I18	0.539	—	—	—	—	—	—
I34	0.494	—	—	—	—	—	—
I37	0.488	—	—	—	—	—	—
I2	—	0.742	—	—	—	—	—
I1	—	0.741	—	—	—	—	—
I5	—	0.630	—	—	—	—	—
I3	—	0.526	—	—	—	—	—
I8	—	0.522	—	—	—	—	—
I13	—	0.496	—	—	—	—	—
I4	—	0.406	—	—	—	—	—
I48	—	0.405	—	—	—	—	—
I52	—	—	0.799	—	—	—	—
I50	—	—	0.794	—	—	—	—
I54	—	—	0.758	—	—	—	—
I53	—	—	0.744	—	—	—	—
I51	—	—	0.659	—	—	—	—
I49	—	—	0.487	—	—	—	—
I44	—	—	—	0.739	—	—	—
I47	—	—	—	0.706	—	—	—
I46	—	—	—	0.683	—	—	—
I38	—	—	—	0.589	—	—	—
I43	—	—	—	0.469	—	—	—
I28	—	—	—	—	0.821	—	—
I30	—	—	—	—	0.781	—	—
I25	—	—	—	—	0.731	—	—
I33	—	—	—	—	0.480	—	—
I39	—	—	—	—	0.467	—	—
I20	—	—	—	—	—	0.746	—
I22	—	—	—	—	—	0.717	—
I24	—	—	—	—	—	0.521	—
I19	—	—	—	—	—	0.439	—
I15	—	—	—	—	—	—	0.710
I16	—	—	—	—	—	—	0.622
I14	—	—	—	—	—	—	0.615

Note: ASEA = attitudes toward safety: emotional aspects; EKUB = explicit knowledge of unsafe behaviors; PC = principal component; SCAW = safety culture: aspects of work; SCBPA = safety culture: behavioral and psychological aspects; SCW = safety culture regulations at work; TECH = use of mobile technology; TK = tacit knowledge.

grouping the 38 items into seven key factors, accounting for 63.8% of total variance.

4.3. Unidimensionality and reliability analysis

While performing a statistical analysis, unidimensionality should always be considered first, prior to conducting reliability and validity analysis [35]. This is thought to reduce the possibility of misspecifications [36], because the analysis of reliability and validity is based on the assumption of unidimensionality [37]. A comparative fit index (CFI) of 0.9 or greater for the model indicates strong evidence of unidimensionality [33,38]. To test for

the unidimensionality of the instrument used in the current study, a CFI was conducted on measurements for each of the seven items. In relation to this study, the CFI values were found to be greater than the 0.9 level, as presented in Table 4, which indicates strong evidence of unidimensionality for all of the scales.

Reliability is known as the consistency of the measurement [39]. The reliability expressed by Cronbach's α was greater than the cut-off criterion of 0.7, which indicates the achievement of internal consistency among the latent variables [40]. In this study, the results presented in Table 4 show that the internal consistency of all factors was good to excellent (Cronbach's α from 0.71 to 0.87).

Table 4. Results of confirmatory factor analysis: unidimensionality and reliability coefficients.

Safety management measure	Number of items	Comparative fit index	Cronbach's α
Use of mobile technology (TECH)	6	0.96	0.82
Tacit safety knowledge (TK)	8	0.93	0.83
Explicit safety knowledge of unsafe behaviors (EKUB)	3	0.97	0.71
Attitudes toward safety emotional aspects (ASEA)	5	0.92	0.87
Safety culture: behavioral and psychological aspects of work (SCBPA)	4	0.98	0.76
Safety culture: aspects of work (SCAW)	7	0.95	0.86
Safety culture regulations at work (SCW)	5	0.94	0.77

4.4. Structural equation modeling

The SEM approach was used to determine the degree to which the hypothesized model in this study was supported by the empirical data. SEM as a statistical method determines the relationships and directional influence, either direct or indirect, between the model's latent variables, each of which has a set of observed variables in the conceptualized study model [33]. SEM has been commonly and successfully employed in most survey research in the behavioral and social sciences because of its ability to improve and validate the latent constructs or unobserved variables in measurement models [41]. The SEM methodology mainly consists of two parts: the measurement model and the structural model. The structural model associates latent variables to measure the relationships between them, such as the direct and indirect effects, as well as the explained and unexplained variances accounted for in each latent variable [42].

4.5. Model fit indices

The goodness of fit for each measurement was assessed using five indices: the relative χ^2 ratio over the df , the CFI, the Tucker–Lewis index (TLI), the goodness-of fit index (GFI) and the root mean square error of approximation (RMSEA) index. A lower χ^2 index value is preferable because such a value indicates better model fitness for the data. A ratio of 5 or less is an acceptable fit between a hypothetical model and the sample data. The CFI and TLI indices, also called relative or comparative fit indices, express the relative improvement in fit of the hypothetical model compared with the sample data. The GFI indicates the proportion of variance accounted for by the predicted population covariance [43]. CFI, GFI and TLI values greater than 0.90 are generally considered acceptable model fits. Finally, the RMSEA relates a model's residual and is considered one of the most informative criteria in covariance structure modeling. Values of RMSEA range from 0 to 1. A smaller RMSEA value, particularly a value less than 0.06, is an indication of a good fit [44]. According to Hooper et al. [45], validating each construct or latent factor individually is the most reliable way to assess any possible weaknesses in model fit. Successful fit

values were reached after checking the factor loading of the observed variables and the critical ratios.

5. Results and discussion

5.1. Confirmatory factor analysis

After validating each construct as already shown, the hypothesized study model was validated using confirmatory factor analysis (CFA). CFA was applied to the model shown in Figure 1. All fit values after model revisions were within an acceptable range of values (see Table 4). CFA was applied to validate the measurement model for each construct in the model as well as to validate the hypothesized study model. Fit indices were examined to analyze the data fit values, and the model fit was reached after several alterations and modifications to reach the best acceptable fitting values for the fit indices.

5.2. Development of the final structural equation model

SEM was used to extract the structured model and to test the relationships among the study variables. The last step was to validate the measurement model for each construct as well as with respect to the whole hypothesized study model. Path analysis [36] was employed using each latent indicator to test the connections between each latent variable as well as the postulated hypotheses of the study. Comparison of fit indices for the initial and final model parameters are presented in Table 5.

For the initial model, only one fit index met the acceptability criteria, with GFI = 0.709, CFI = 0.725, TLI = 0.707, RMSEA = 0.084 and χ^2/df = 4.309. After eliminating the insignificant regression paths, the final structural model satisfied all fit criteria with the following values: GFI = 0.902, CFI = 0.907, TLI = 0.915, RMSEA = 0.056 and χ^2/df = 2.332.

5.3. Hypothesis testing

The results of hypothesis testing, as presented in Table 6, were used to draw the following conclusions. Tendency to use mobile technology affected all variables, with the

Table 5. Summary of fit indices: comparison for the initial and final models.

Fit index	Fit criteria	Initial model	Final model
χ^2 statistic	Low	2839.5	1410.8
df	≥ 0	659	605
χ^2/df	≤ 5	4.309	2.332
Tucker–Lewis index	> 0.90	0.707	0.915
Comparative fit index	> 0.90	0.725	0.907
Goodness-of-fit index	> 0.90	0.709	0.902
Root mean square error of approximation	$< 0.05-0.08$	0.084	0.056
Probability (p_{close})	> 0.05	0.00	0.061

Table 6. Results of the final model relationships.

Relationship	p	Test results/hypothesis
SCAW \leftarrow TECH	0.008	H_1 : supported
TK \leftarrow TECH	0.008	H_2 : supported
ASEA \leftarrow TECH	0.008	H_3 : supported
SCW \leftarrow TECH	0.009	H_4 : supported
SCBPA \leftarrow TECH	0.008	H_5 : supported
EKUB \leftarrow TECH	0.009	H_6 : supported

Note: p is significant at the 0.05 level. For postulated hypotheses H_1-H_6 , see Table 2. ASEA = attitudes toward safety: emotional aspects; EKUB = explicit knowledge of unsafe behaviors; SCAW = safety culture: aspects of work; SCBPA = safety culture: behavioral and psychological aspects; SCW = safety culture regulations at work; TECH = use of mobile technology; TK = tacit knowledge.

p values for all relationships being less than 0.05; thus, all postulated hypotheses (H_1, H_2, H_3, H_4, H_5 and H_6) were supported by the survey results.

All relationships in the structural model shown in Figure 2 were significant at the level of $p = 0.05$. These analyses provided the following results:

- Using mobile technology (TECH) had a significant positive effect on safety culture: aspects of work (SCAW) (standardized weight = 0.94; $p < 0.05$), which supports H_1 .
- A positive effect of using mobile technology (TECH) on tacit knowledge (TK) was identified in Polish industrial enterprises (standardized weight = 0.91; $p < 0.05$), which supports H_2 .
- Using mobile technology (TECH) positively influenced personnel attitudes toward safety emotional aspects (ASEA) in Polish industrial enterprises (standardized weight = 0.88; $p < 0.05$), which supports H_3 .
- The effect of using mobile technology (TECH) on safety culture regulations at work (SCW) in Polish industrial enterprises was statistically significant (standardized weight = 0.58; $p < 0.05$), which supports H_4 .
- Using mobile technology (TECH) had a significant positive effect on safety culture: behavioral and psychological aspects of work (SCBPA) (standardized weight = 0.85; $p < 0.05$), which supports H_5 .

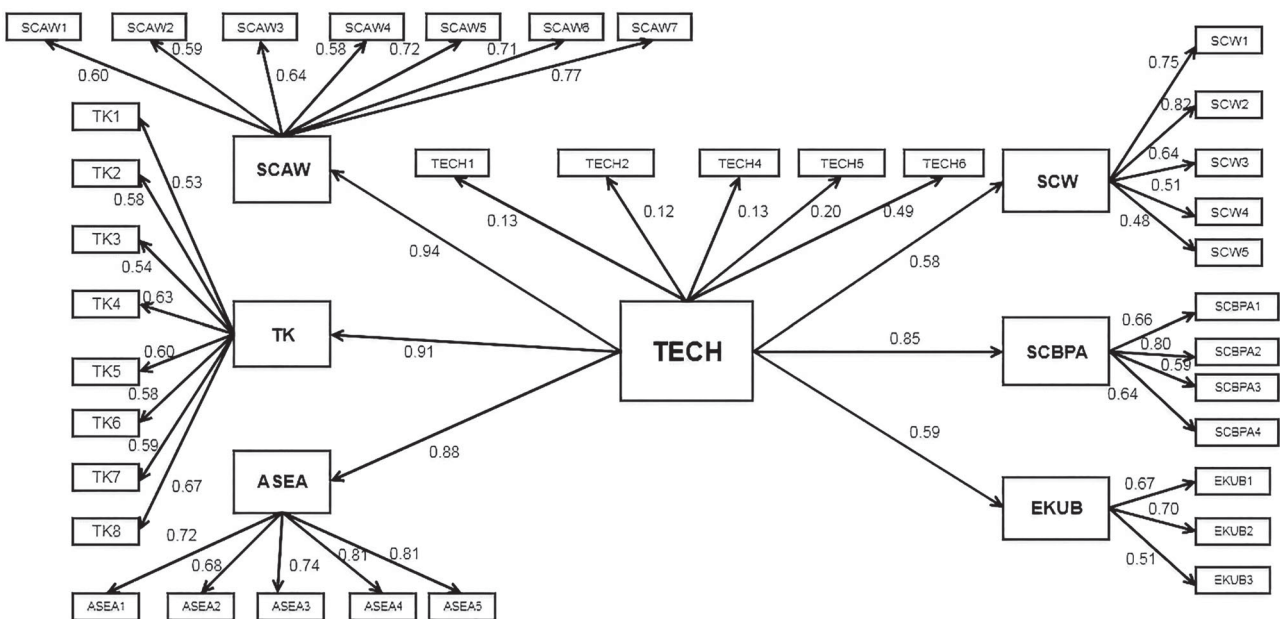

Figure 2. A final structural model with standardized path coefficients.

Note: ASEA = attitudes toward safety: emotional aspects; EKUB = explicit knowledge of unsafe behaviors; SCAW = safety culture: aspects of work; SCBPA = safety culture: behavioral and psychological aspects; SCW = safety culture regulations at work; TECH = use of mobile technology; TK = tacit knowledge.

- A positive effect of using mobile technology (TECH) on explicit safety knowledge of unsafe behaviors was identified in Polish industrial enterprises (standardized weight = 0.59; $p < 0.05$), which supports H_6 . The significance of all direct effects shown in the model was confirmed at $p < 0.05$ through bootstrapping analysis [45].

Based on these hypothesis results, our positive findings are in contrast to the findings of Phillips et al. [12] and Bianchi and Phillips [13]. Phillips et al. [12] focused on the questions ‘estimating the average weekly amount of time spent playing games’ and the ‘degree of interest in new features of mobile phones’. Other questions elicited ‘estimates of the time spent on the mobile’ and ‘the types of mobile phone use’ (e.g., business, incoming/outgoing calls, social, wanted/unwanted calls, SMS). Bianchi and Phillips [13] used the mobile phone problem usage scale (MPPUS), which includes six measures of mobile phone use: ‘duration of mobile phone ownership’; ‘weekly frequency of usage’; ‘frequency of text messaging’; ‘number of persons called’; ‘type of usage (social, business, or other)’; ‘average mobile phone expenses’. Thus, it is likely that the main reason for the difference between the outcomes in our work versus those of Bianchi and Phillips [13] is the difference in the measurements.

6. Conclusions

This study examined the relationships between the use of smart mobile technology, employee safety knowledge and safe practices at work with due consideration given to safety culture and employees’ attitudes toward safety. The tendency to use smartphones outside work, in general, and in the workplace, in particular, was associated with a greater propensity to follow safety regulations and safe practices at work. The results also indicate that using mobile technology positively influenced the explicit safety knowledge of employees, as well as their assessed safety culture in terms of behavioral aspects and their attitudes toward safety expressed through the psychological aspects of safety culture. Similarly, a positive effect of using mobile technology on participants’ explicit safety knowledge of unsafe behaviors was identified in Polish industrial enterprises. Furthermore, the use of mobile technology positively influenced personnel attitudes toward safety emotional aspects, safety culture: aspects of work and safety culture regulations at work. These results could be used in future to develop a safety knowledge management system that optimizes employees’ tacit and explicit knowledge to improve overall safety performance. Further studies are also needed to better understand the intricacies of safety knowledge management for employees with differing education backgrounds and to examine the effects of age, gender and relevant job experience.

Recently, Pimmer and Pachler [4] pointed out that even though the use of mobile phones is gaining increased attention in the fields of professional learning and work-based education, there is relatively little research regarding how mobile devices can be used effectively for learning and competence development in real work contexts. As discussed by Attewell [1], mobile learning is unique in that it allows truly anywhere, anytime, personalized learning and can provide the following important benefits: (a) help learners improve their literacy and numeracy skills and recognize their existing abilities; (b) encourage both independent and collaborative learning experiences; (c) help learners identify areas where they need assistance and support; (d) help combat resistance to the use of information and communications technology (ICT) and help bridge the gap between mobile phone literacy and ICT literacy; (e) help remove some of the formality from the learning experience and engage reluctant learners; (f) help learners remain more focused for longer periods; (g) help increase self-esteem and self-confidence. It seems plausible that these benefits would be equally applicable to the current state-of-the-art in mobile-based learning of safety in the workplace and for the quest to improve the effectiveness of safety training. Indeed, more research in this area in the near future is very much needed.

Disclosure statement

No potential conflict of interest was reported by the authors.

Funding

This research was partially supported by the Central Institute for Labour Protection – National Research Institute (CIOP-PIB), Poland [grant number: IV.P.09].

ORCID

Waldemar Karwowski  <http://orcid.org/0000-0002-9134-3441>

Przemyslaw Tomczyk  <http://orcid.org/0000-0002-7069-6918>

Erman Çakat  <http://orcid.org/0000-0003-0974-5941>

References

- [1] Attewell J. Mobile technologies and learning. London: Learning and Skills Development Agency; 2005.
- [2] Ally M, editor. Mobile learning: transforming the delivery of education and training. Athabasca (AB): Athabasca University Press; 2009.
- [3] Peng H, Su YJ, Chou C, et al. Ubiquitous knowledge construction: mobile learning re-defined and a conceptual framework. *Innov Educ Teach Int.* 2009;46(2):171–183. doi:10.1080/14703290902843828
- [4] Pimmer C, Pachler N. Mobile learning in the workplace: unlocking the value of mobile technology for work-based education. In: Ally M, Tsinakos A, editors. *Increasing access through mobile learning.* Vancouver (BC): Commonwealth of Learning and Athabasca University; 2014. p. 193–203.
- [5] Reychar I, Wu D. Exploring mobile tablet training for road safety: a uses and gratifications perspective. *Comput*

- Educ. 2014;71:43–55. doi:10.1016/j.compedu.2013.09.005
- [6] Chatterjee S, Chakraborty S, Sarker S, et al. Examining the success factors for mobile work in healthcare: a deductive study. *Decis Support Syst.* 2009;46(3):620–633. doi:10.1016/j.dss.2008.11.003
- [7] Jen WY, Chao CC. Measuring mobile patient safety information system success: an empirical study. *Int J Med Informat.* 2008;77(10):689–697. doi:10.1016/j.ijmedinf.2008.03.003
- [8] Prgomet M, Georgiou A, Westbrook JI. The impact of mobile handheld technology on hospital physicians' work practices and patient care: a systematic review. *J Am Med Informat Assoc.* 2009;16(6):792–801. doi:10.1197/jamia.M3215
- [9] Izkara JL, Pérez J, Basogain X, Borro D. Mobile augmented reality, an advanced tool for the construction sector. In: Proceedings of the 24th W78 conference; 2007 Jun 27–29; Maribor; 2007 [cited at 2018 Oct 1]; p. 190–202. Available from: <https://www.semanticscholar.org/paper/Mobile-augmented-reality%2C-an-advanced-tool-for-the-Izkara-P%2C%20A9rez/b2d5e8c2aa74787ac99467b2b9df77761138a141>
- [10] Le QT, Pedro AK, Lim CR, et al. A framework for using mobile based virtual reality and augmented reality for experiential construction safety education. *Int J Eng Educ.* 2015;31(3):713–725.
- [11] Srivastava L. Mobile phones and the evolution of social behaviour. *Behav Inf Technol.* 2005;24(2):111–129. doi:10.1080/01449290512331321910
- [12] Phillips JG, Butt S, Blaszczynski A. Personality and self-reported use of mobile phones for games. *CyberPsychol Behav.* 2006;9(6):753–758. doi:10.1089/cpb.2006.9.753
- [13] Bianchi A, Phillips JG. Psychological predictors of problem mobile phone use. *CyberPsychol Behav.* 2005;8(1):39–51. doi:10.1089/cpb.2005.8.39
- [14] Yang S, Lu Y, Gupta S, et al. Mobile payment services adoption across time: an empirical study of the effects of behavioral beliefs, social influences, and personal traits. *Comput Human Behav.* 2012;28(1):129–142. doi:10.1016/j.chb.2011.08.019
- [15] Cooper D. Towards a model of safety culture. *Saf Sci.* 2000;36(2):111–136. doi:10.1016/S0925-7535(00)00035-7
- [16] Guldenmund FW. The nature of safety culture: a review of theory and research. *Saf Sci.* 2000;34(1):215–257. doi:10.1016/S0925-7535(00)00014-X
- [17] Michael JH, Evans DD, Jansen KJ, et al. Management commitment to safety as organizational support: relationships with non-safety outcomes in wood manufacturing employees. *J Saf Res.* 2005;36(2):171–179. doi:10.1016/j.jsr.2005.03.002
- [18] Wiegmann DA, Zhang H, Von Thaden TL, et al. Safety culture: an integrative review. *Int J Aviat Psychol.* 2004;14(2):117–134. doi:10.1207/s15327108ijap1402_1
- [19] Vecchio-Sadus AM, Griffiths S. Marketing strategies for enhancing safety culture. *Saf Sci.* 2004;42(7):601–619. doi:10.1016/j.ssci.2003.11.001
- [20] Choudhry RM, Fang D, Mohamed S. The nature of safety culture: a survey of the state-of-the-art. *Saf Sci.* 2007;45(10):993–1012. doi:10.1016/j.ssci.2006.09.003
- [21] Ho CL, Dzeng RJ. Construction safety training via e-learning: learning effectiveness and user satisfaction. *Comput Educ.* 2010;55(2):858–867. doi:10.1016/j.compedu.2010.03.017
- [22] Vinodkumar M, Bhasi M. Safety management practices and safety behaviour: assessing the mediating role of safety knowledge and motivation. *Accid Anal Prev.* 2010;42(6):2082–2093. doi:10.1016/j.aap.2010.06.021
- [23] Floyde A, Lawson G, Shalloe S, et al. The design and implementation of knowledge management systems and e-learning for improved occupational health and safety in small to medium sized enterprises. *Saf Sci.* 2013;60:69–76. doi:10.1016/j.ssci.2013.06.012
- [24] Wu X, Liu Q, Zhang L, et al. Prospective safety performance evaluation on construction sites. *Accid Anal Prev.* 2015;78:58–72. doi:10.1016/j.aap.2015.02.003
- [25] Al-Refaie A. Factors affect companies' safety performance in Jordan using structural equation modeling. *Saf Sci.* 2013;57:169–178. doi:10.1016/j.ssci.2013.02.010
- [26] Arezes PM, Miguel AS. Risk perception and safety behaviour: a study in an occupational environment. *Saf Sci.* 2008;46(6):900–907. doi:10.1016/j.ssci.2007.11.008
- [27] Sherehiy B, Karwowski W. Knowledge management for occupational safety, health, and ergonomics. *Hum Factor Ergon Man Serv Ind.* 2006;16(3):309–319. doi:10.1002/hfm.20054
- [28] Nonaka I, Takeuchi H. The knowledge-creating company: how Japanese companies create the dynamics of innovation. New York (NY): Oxford University Press; 1995.
- [29] Nonaka I, Umemoto K, Senoo D. From information processing to knowledge creation: a paradigm shift in business management. *Technol Sci.* 1996;18:203–218. doi:10.1016/0160-791X(96)00001-2
- [30] Nonaka L, Takeuchi H, Umemoto K. A theory of organizational knowledge creation. *Int J Technol Manag.* 1996;11(7–8):833–845. doi:10.4324/9780203699416-2
- [31] Thomas JC, Kellogg WA, Erickson T. The knowledge management puzzle: human and social factors in knowledge management. *IBM Syst J.* 2001;40(4):863–884. doi:10.1147/sj.404.0863
- [32] Domingues JP, Sampaio P, Arezes PM. Analysis of integrated management systems from various perspectives. *Total Qual Manag Bus.* 2015;26(11–12):1311–1334. doi:10.1080/14783363.2014.931064
- [33] Byrne BM. Structural equation modeling with Mplus: basic concepts, applications, and programming. London: Routledge; 2013.
- [34] Field A. Discovering statistics using SPSS for windows. London: SAGE; 2005.
- [35] Hair J, Anderson R, Tatham R, et al. Multivariate data analysis with readings. Englewood Cliffs (NJ): Prentice-Hall International; 1995.
- [36] Gerbing DW, Anderson JC. An updated paradigm for scale development incorporating unidimensionality and its assessment. *J Marketing Res.* 1988;25(2):186–192. doi:10.1177/002224378802500207
- [37] Nunnally J, Bernstein I. Psychometric theory. New York (NY): McGraw-Hill; 1994.
- [38] Issac G, Rajendran C, Anantharaman RN. An instrument for the measurement of customer perceptions of quality management in the software industry: an empirical study in India. *Software Qual J.* 2006;14(4):291–308. doi:10.1007/s11219-006-0037-2
- [39] Hair J, Black W, Babin B, et al. Multivariate data analysis. Saddle River (NJ): Prentice Hall; 2010.
- [40] Cortina JM. What is coefficient alpha? An examination of theory and applications. *J Appl Psychol.* 1993;78(1):98–104. doi:10.1037/0021-9010.78.1.98
- [41] Lomax RG, Schumacker RE. A beginner's guide to structural equation modeling. New York (NY): Psychology Press; 2004.

- [42] Molenaar KR, Park JJ, Washington S. Framework for measuring corporate safety culture and its impact on construction safety performance. *J Constr Eng Manag.* 2009; 135(6):488–496. doi:10.1061/(ASCE)0733-9364(2009)135:6(488)
- [43] Tabachnick BG, Fidell LS, Ullman JB. *Using multivariate statistics.* Vol. 5. Boston (MA): Pearson; 2007.
- [44] Hu LT, Bentler PM. Cutoff criteria for fit indexes in covariance structure analysis: conventional criteria versus new alternatives. *Struct Equ Model.* 1999;6(1):1–55. doi:10.1080/10705519909540118
- [45] Hooper D, Coughlan J, Mullen M. Structural equation modelling: guidelines for determining model fit. *Electr J Bus Res Method.* 2008;6(1):53–60.