

# Systems Science & Control Engineering: An Open Access Journal

ISSN: (Print) 2164-2583 (Online) Journal homepage: <https://www.tandfonline.com/loi/tssc20>

## Research on a chaotic circuit based on an active $\text{TiO}_2$ memristor

Wei Wang, Guangyi Wang & Xiaoyuan Wang

To cite this article: Wei Wang, Guangyi Wang & Xiaoyuan Wang (2014) Research on a chaotic circuit based on an active  $\text{TiO}_2$  memristor, Systems Science & Control Engineering: An Open Access Journal, 2:1, 740-744, DOI: [10.1080/21642583.2013.879842](https://doi.org/10.1080/21642583.2013.879842)

To link to this article: <https://doi.org/10.1080/21642583.2013.879842>



© 2014 The Author(s). Published by Taylor & Francis.



Published online: 20 Feb 2014.



Submit your article to this journal [↗](#)



Article views: 1230



View related articles [↗](#)



View Crossmark data [↗](#)



Citing articles: 2 View citing articles [↗](#)

## Research on a chaotic circuit based on an active TiO<sub>2</sub> memristor

Wei Wang\*, Guangyi Wang and Xiaoyuan Wang

School of Electronics Information, Hangzhou Dianzi University, Hangzhou, People's Republic of China

(Received 8 September 2013; final version received 30 December 2013)

The memristor is the fourth fundamental circuit element besides the resistor, inductor and capacitor. As a two-terminal nonlinear resistor, the memristor has a broad application prospect. In this paper, a negative memconductance expression of a flux-controlled memristor is derived from the relationship between voltage and current for the Hewlett-Packard memristor. By replacing Chua's diode with the active flux-controlled TiO<sub>2</sub> memristor, a chaotic circuit is obtained. By means of the conventional dynamic analysis method, dynamic behaviors of the chaotic circuit are investigated. Software simulation and theoretical analysis all indicate that this active memristor-based chaotic circuit has more complex behaviors. Furthermore, the integrated circuit experiment on the digital signal processor chip of this circuit was also realized.

**Keywords:** TiO<sub>2</sub> memristor; Chua's oscillator; chaotic system; dynamic analysis

### 1. Introduction

In 1971, Leon O Chua of UC Berkeley first proposed the memristor as the fourth fundamental circuit element besides the resistor, inductor and capacitor (Chua, 1971; Tour & He, 2008). Almost four decades from then on, the actual memristor had not been manufactured, which prevents the development of memristor research and application. Fortunately, in 2008, a research team in the Hewlett-Packard (HP) Company fabricated a nanometer-sized TiO<sub>2</sub> memristor (Strukov et al., 2008), which not only confirms the existence of the memristor, but also spirits the research upsurge of the memristor like the  $i-v$  characteristics studying and modeling of the memristor (Hu et al., 2011), using the memristor model to structure a memcapacitor circuit (Wang, Fitch, Iu, Sreeram, & Qi, 2012), chaotic circuit building based on memristor (Bao, Liu, & Xu, 2010; Itoh & Chua, 2008; Muthuswamy, 2009; Qi, Bian, & Li, 2011; Wang, Qi, & Wang, 2012; Wang, Wang, Chen, & Tan, 2011; Wang, Wang, & Tan, 2011), memristor-based analog circuits (Batas & Fiedler, 2011; Mutlu & Karakulak, 2010) and so on. The arrangement of this paper is as follows: in the next section, we review the proposal of the memristor and focus on the structure and formulas of the HP memristor, and as well as the theoretical foundation of the memristor model building help to derive the negative memristor model in this paper. In Section 3 by replacing Chua's diode with the active memristor, a chaotic system was built and theoretical simulation with Matlab was shown to confirm the chaotic behavior of this system. In Section 4, the digital signal processor (DSP) realization is done.

### 2. Memristor and TiO<sub>2</sub> memristor

As one of the four fundamental circuit element, the memristor has different characteristics from the traditional circuit devices, especially in memory character, which enables it to be used in neural network (Kim, Sah, Yang, & Chua, 2012; Jo et al., 2010) and non-volatile random access memory (Duan, Hu, Wang, Li, & Mazumder, 2012). The memristor is an element proposed to indicate the direct relations between magnetic flux  $\phi$  and charge  $q$ , as is shown in Figure 1. The symbol of the memristor and the simplified structure of TiO<sub>2</sub> memristor are shown in Figure 2.

The relationship between voltage across the memristor  $v$  and current  $i$  through it in both charge-controlled memristor and flux-controlled memristor can be described by the following equation (Wang, Fitch et al. 2012)

$$\begin{aligned}v &= M(q)i, \\i &= W(\phi)v,\end{aligned}\quad (1)$$

where  $M(q)$  is the memristance of a memristor and  $W(\phi)$  is memconductance in each kind of definitions. As shown in Figure 2, by analyzing the moving process inside the solid-state HP memristor, the following  $i-v$  relationship can be obtained (Kim et al., 2012; Strukov et al., 2008):

$$v(t) = \left( R_{\text{ON}} \frac{w(t)}{D} + R_{\text{OFF}} \left( 1 - \frac{w(t)}{D} \right) \right) i(t), \quad (2)$$

where  $R_{\text{ON}}$  and  $R_{\text{OFF}}$  represent the resistances of the doped region and undoped region,  $w(t)$  is assigned as the width

\*Corresponding author. Email: [zouwei2924@126.com](mailto:zouwei2924@126.com)

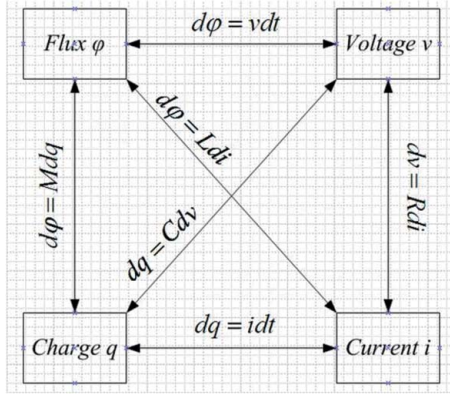

Figure 1. Relationship between fundamental circuit variables and the memristor.

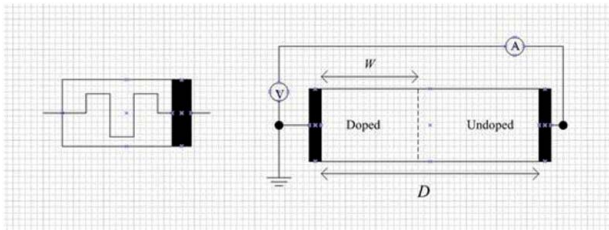

Figure 2. Symbol of the memristor and structure of the TiO<sub>2</sub> memristor.

of the doped region and  $D$  is the total width of the titanium dioxide film. In the TiO<sub>2</sub> memristor,  $w(t)$  ranges from 0 to  $D$  and is determined by the following equation:

$$\frac{dw(t)}{dt} = \mu_V \frac{R_{ON}}{D} i(t), \quad (3)$$

where  $\mu_V$  is the dopant mobility.

By resolving Equation (3), we can obtain

$$w(t) = \mu_V \frac{R_{ON}}{D} \int_{-\infty}^t i(\tau) d\tau = \mu_V \frac{R_{ON}}{D} q(t) + w_0, \quad (4)$$

where  $w_0$  is the initial width of  $w$  (Kim et al., 2012). Applying Equation (4) to Equation (2), we can rewrite Equation (2) as the following relation:

$$v(t) = \left( \frac{R_{ON}}{D} \left( \mu_V \frac{R_{ON}}{D} q(t) + w_0 \right) + R_{OFF} - \frac{R_{OFF}}{D} \left( \mu_V \frac{R_{ON}}{D} q(t) + w_0 \right) \right) i(t). \quad (5)$$

Integrating both sides of Equation (5), we can obtain

$$\phi(t) = R_{OFF} \left\{ q(t) \left[ 1 + \frac{w_0}{D} \left( \frac{R_{ON}}{R_{OFF}} - 1 \right) \right] - \frac{\mu_V R_{ON}}{2D^2} \left( 1 - \frac{R_{ON}}{R_{OFF}} \right) q(t)^2 \right\} + \phi_0. \quad (6)$$

Now, let  $a = 1 + (w_0/D)(R_{ON}/R_{OFF} - 1)$ ,  $b = (\mu_V R_{ON}/2D^2)(1 - R_{ON}/R_{OFF})$ , Equation (6) will be simplified

as

$$\phi(t) = R_{OFF} [aq(t) - bq(t)^2] + \phi_0. \quad (7)$$

Combining Equation (7) with the definition of memductance,  $W(\phi)$  can be derived as

$$W(\phi) = \frac{dq(\phi)}{d\phi} = \pm \frac{1}{R_{OFF}} \left[ a^2 - \frac{4b}{R_{OFF}} (\phi - \phi_0) \right]^{-1/2}. \quad (8)$$

In terms of the characteristics of the TiO<sub>2</sub> memristor, and under the assumption of  $R_{ON} \ll R_{OFF}$  and  $w_0/D \approx 0$ , we can obtain

$$a \approx 1, \quad b \approx \frac{\mu_V R_{ON}}{2D^2}. \quad (9)$$

So Equation (8) can be simplified as

$$W(\phi) = \pm \frac{1}{R_{OFF}} \left[ 1 - \frac{2\mu_V R_{ON}}{R_{OFF} D^2} (\phi - \phi_0) \right]^{-1/2}. \quad (10)$$

Let  $a_1 = 1/R_{OFF}$ ,  $a_2 = 2\mu_V R_{ON}/R_{OFF} D^2$ ,  $a_3 = \phi_0$ , then Equation (10) can be described as

$$W(\phi) = \pm a_1 [1 - a_2(\phi - a_3)]^{-1/2}. \quad (11)$$

As the memconductance has been obtained, and in this paper we only discuss when using the negative value of Equation (11) as the mathematic model of the memristor in Chua's circuit instead of the nonlinear diode, to see what the dynamic characteristics will appear.

### 3. Construction of the memristor-based chaotic circuit

In 2008, Chua derived several oscillators based on the memristor whose characteristics were described by a monotone-increasing piecewise-linear curve (Wang, Fitch et al., 2012). In Muthuswamy (2009), the author used a monotone-increasing cubic model of the memristor built a chaotic circuit. And in Wang, Qi et al. (2012), a novel memristor-based chaotic system was proposed, and the mathematic model used as the memristor is based on the memristive system definition. All of these chaotic circuits based on the memristor are by means of replacing Chua's diode with a memristor. So in the same way, we replace Chua's diode with an active flux-controlled TiO<sub>2</sub> memristor model which is shown in Equation (11), and a five-order chaotic oscillator based on an active memristor is derived as shown in Figure 3.

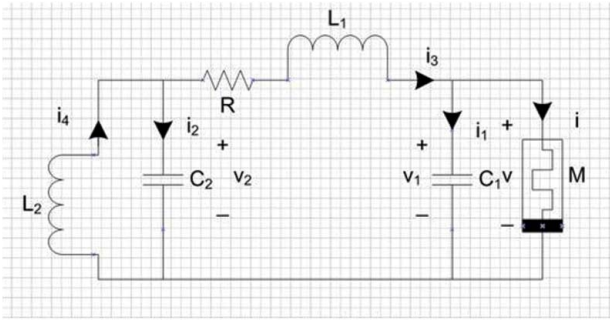

Figure 3. A five-order chaotic oscillator based on the TiO<sub>2</sub> memristor.

Applying Kirchoff's laws to the system in Figure 3, we can obtain

$$\begin{aligned} \frac{dv_1}{dt} &= \frac{1}{C_1}[i_3 - W(\phi)v_1], \\ \frac{dv_2}{dt} &= \frac{1}{C_2}(-i_3 + i_4), \\ \frac{di_3}{dt} &= \frac{1}{L_1}(v_2 - v_1 - Ri_3), \\ \frac{di_4}{dt} &= -\frac{1}{L_2}v_2, \\ \frac{d\phi}{dt} &= v_1. \end{aligned} \tag{12}$$

If  $x = v_1, y = v_2, z = i_3, w = i_4, u = \phi$ , then Equation (12) can be transformed as the following:

$$\dot{x} = p(z - W(u)x),$$

$$\begin{aligned} \dot{y} &= -z + w, \\ \dot{z} &= q(y - x - z), \\ \dot{w} &= -ry, \\ \dot{u} &= x. \end{aligned} \tag{13}$$

Let  $R = 1, C_2 = 1, p = 1/C_1 = 8.985, q = 1/L_1 = 15.125, r = 1/L_2 = 24.625$ , and  $a_1 = 1/1.2, a_2 = 0.98$  and

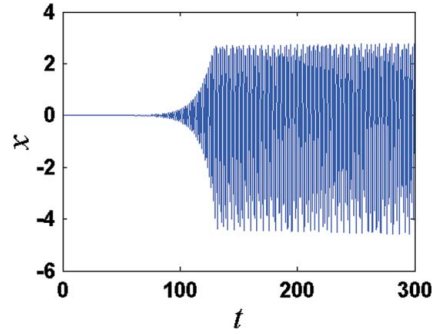

Figure 5.  $x$  time domain waveform.

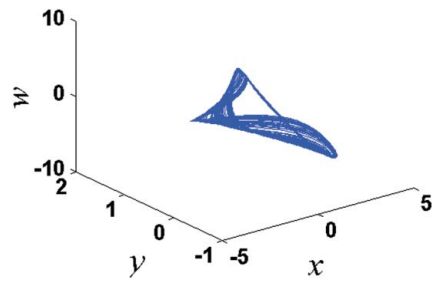

Figure 6.  $x-y-w$ .

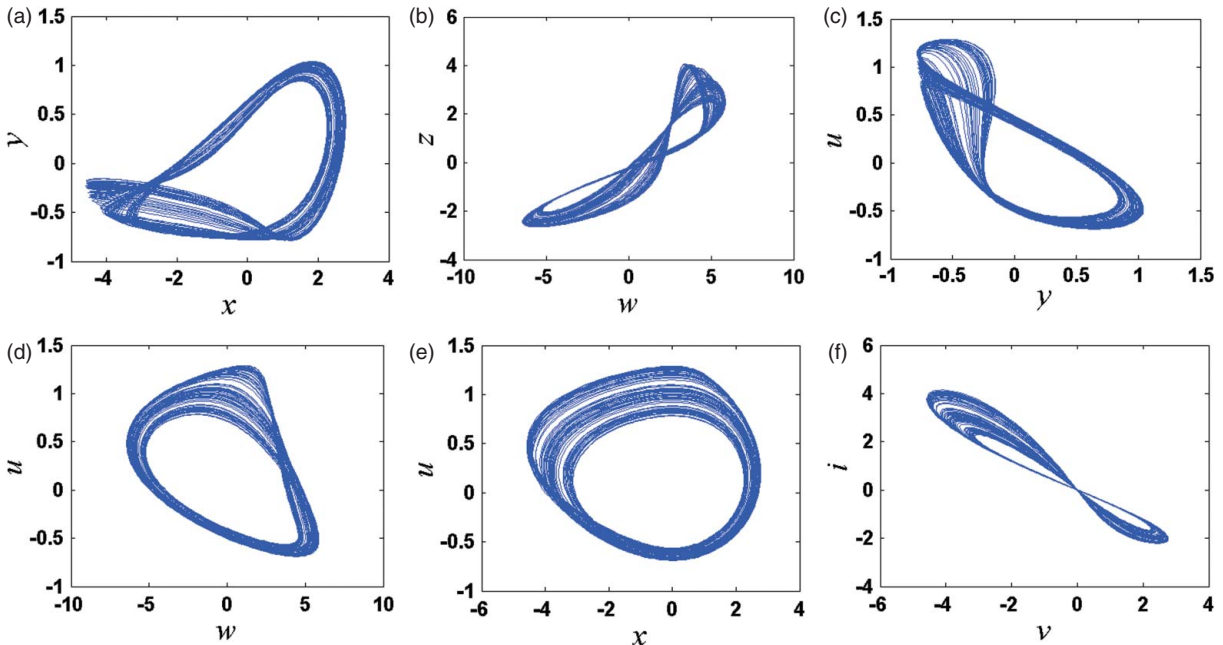

Figure 4. Chaotic attractors of the memristor-based circuit.

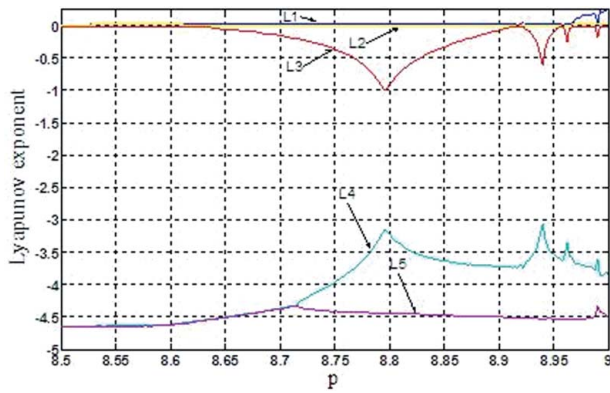

Figure 7. Lyapunov exponents with a changing  $p$ .

$a_3 = 0.5$ , the system shown in Figure 3 has a chaotic attractor as shown in Figure 4. Also, the  $x$  time domain waveform and the 3-D phase trajectory are shown in Figures 5 and 6. By means of the Jacobi method, the Lyapunov exponents are obtained, they are  $L_1 = 0.2315$ ,  $L_2 = 0.0043$ ,  $L_3 = -0.0014$ ,  $L_4 = -3.4515$  and  $L_5 = -4.5058$ , which confirms that the system is a chaotic dynamic one. The Lyapunov exponents diagram is shown in Figure 7, and it is obvious that when  $p$  changes there are two exponents more than zero, three are negative, and the summary of these five exponents is negative, which satisfies the feature of the chaotic system.

**4. DSP realization of the chaotic system**

To realize the above circuit with DSP, we use Euler’s formula method as the discretization method. With the help of

the core processor, a 16-bit fixed-point digital signal processor TMS320C5509 and a two channels analog oscilloscope, the chaotic attractors shown in Figure 8 were observed in the oscilloscope, which coincides with the results in Figure 4.

**5. Conclusions**

In this paper, an active memristor model based on the HP memristor was formed, and by replacing Chua’s diode with this active memristor, a five-order chaotic circuit is derived. By means of the conventional dynamic analysis, the dynamic characteristics of this system are discussed in detail. Simulation results as well as theoretical analysis indicate that such an active memristor-based chaotic system easily generates complex chaotic dynamic behaviors. Finally, the DSP experiment results were shown.

**Acknowledgements**

This work was supported by the National Nature Science Foundation of China (Grant No: 61271064) and the National Natural Science Foundation of Zhejiang province (Grant No: LZ12F01001).

**References**

Bao, B.-C., Liu, Z., & Xu, J.-P. (2010). Dynamical analysis of memristor chaotic oscillator. *Acta Physica Sinica*, 59, 3785–3793.  
 Batas, D., & Fiedler, H. (2011). A memristor SPICE implementation and a new approach for magnetic flux-controlled memristor modeling. *IEEE Transactions on Nanotechnology*, 10, 250–255.  
 Chua, L. O. (1971). Memristor – The missing circuit element. *IEEE Transactions on Circuit Theory*, CT-18, 507–519.

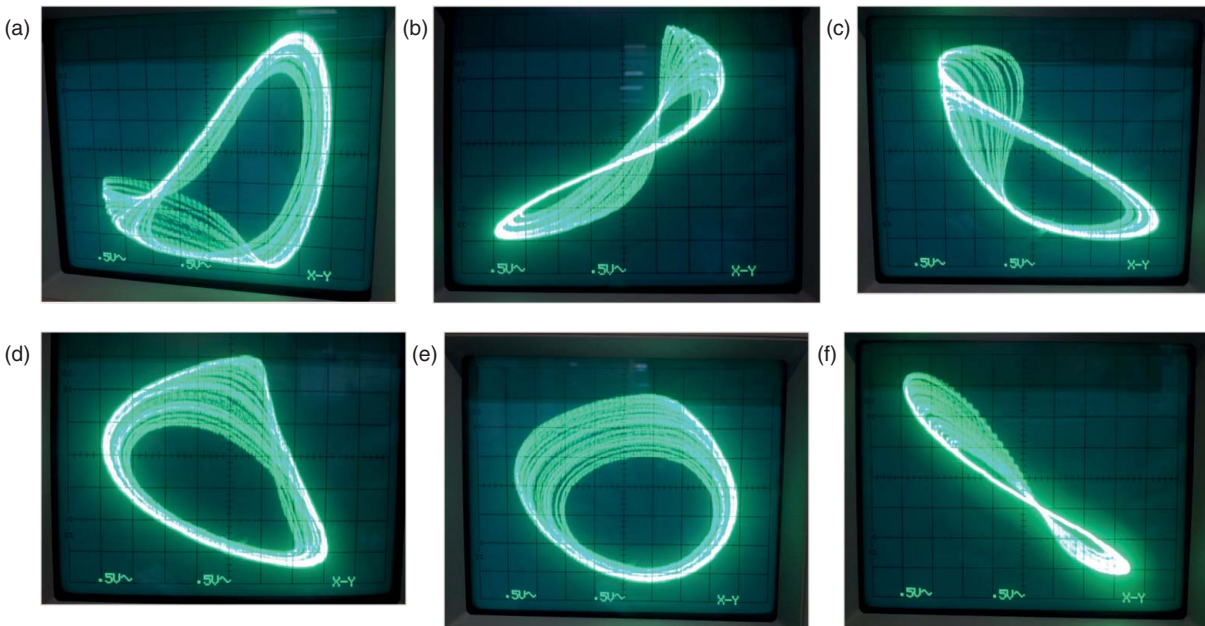

Figure 8. Chaotic attractors observed in the oscilloscope.

- Duan, S.-K., Hu, X.-F., Wang, L.-D., Li, C.-D., & Mazumder, P. (2012). Memristor-based RRAM with applications. *Science China Press*, *42*, 754–769.
- Hu, B.-L., Wang, L.-D., Huang, Y.-W., Hu, X.-F., Zhang, Y.-Y., & Duan, S.-K. (2011). Simulink modeling and graphical user interface design for a memristor. *Journal of Southwest University (Natural Science Edition)*, *33*, 50–56.
- Itoh, M., & Chua, L. O. (2008). Memristor oscillators. *International Journal of Bifurcation and Chaos*, *18*, 3183–3206.
- Jo, S. H., Chang, T., Ebong, I., Bhadviya, B. B., Mazumder, P., & Lu, W. (2010). Nanoscale memristor device as synapse in neuromorphic systems. *Nano Letters*, *10*, 1297–1301. doi:10.102/nl904092h
- Kim, H., Sah, M. Pd., Yang, C., & Chua, L. O. (2012). Neural synaptic weighting with a pulse-based memristor circuit. *IEEE Transactions on Circuits and Systems*, *59*, 148–158.
- Muthuswamy, B. (2009). *Memristor-based chaotic circuits*. Retrieved from <http://www.eecs.berkeley.edu/Pubs/TechRpts/2009/EECS-2009-6.html>
- Mutlu, R., & Karakulak, E. (2010). *Emulator circuit of TiO<sub>2</sub> memristor with linear dopant drift made using analog multiplier*. Electrical, Electronics and Computer Engineering (ELECO), 2010 National Conference on, 380–384.
- Qi, A.-X., Bian, L., & Li, W.-B. (2011). Realization of Chua's chaotic circuit based on the memristor and dynamic performance analysis. *Periodical of Ocean University of China*, *41*, 119–124.
- Strukov, D. B., Snider, G. S., Stewart, D. R., & Williams, R. S. (2008). The missing memristor found. *Nature*, *453*, 80–83. doi:10.1038/nature0693
- Tour, J. M., & He, T. (2008). The fourth element. *Nature*, *453*, 42–43.
- Wang, G.-Y., Wang, C.-L., Chen, W., & Tan, D. (2011). A magnetic-controlled memristor based chaotic circuit and its FPGA realization. *Journal of Circuits and Systems*, *16*, 114–119.
- Wang, X. Y., Fitch, A. L., Iu, H. H. C., Sreeram, V., & Qi, W. G. (2012). Design of a memcapacitor emulator based on a memristor. *Physics Letters A*, *376*, 394–399.
- Wang, X. Y., Qi, W. G., & Wang, X. Y. (2012). Novel circuit of memristor and its chaotic dynamics characteristics. *Journal of Beijing University of Aeronautics and Astronautics*, *38*, 1–5.
- Wang, W., Wang, G., & Tan, D. (2011). *A new memristor based chaotic circuit*. The Fourth International Workshop on Chaos-Fractals Theories and Applications, Hangzhou.