

إقرار

أنا الموقع أدناه مقدم الرسالة التي تحمل العنوان:

A study of the daylighting performance in the multi-storey residential buildings of Gaza Strip

دراسة أداء الإضاءة الطبيعية للمباني السكنية متعددة الطوابق في قطاع غزة

أقر بأن ما اشتملت عليه هذه الرسالة إنما هو نتاج جهدي الخاص، باستثناء ما تمت الإشارة إليه حيثما ورد، وإن هذه الرسالة ككل أو أي جزء منها لم يقدم من قبل لنيل درجة أو لقب علمي أو بحثي لدى أي مؤسسة تعليمية أو بحثية أخرى.

DECLARATION

The work provided in this thesis, unless otherwise referenced, is the researcher's own work, and has not been submitted elsewhere for any other degree or qualification

Student's name:

اسم الطالب/ة: امانى يوسف الشرفا

Signature:

التوقيع: 

Date:

التاريخ: 2016 / 02 / 15

The Islamic University Gaza
Deanery of Graduate Studies
Faculty of Engineering
Architecture Department
Master of Architecture Program



**A study of the daylighting performance in the multi-storey
residential buildings of Gaza Strip**

دراسة أداء الإضاءة الطبيعية للمباني السكنية متعددة الطوابق في قطاع غزة

By

Amany Yousef Hassan Al-Shurafa

Supervisor

Dr. Omar S. Asfour

**“A Thesis Submitted in Partial Fulfillment of the Requirements for the
Degree of Master in Architectural Engineering, Faculty of Engineering,
The Islamic University of Gaza, Gaza– Palestine”**

1437ھ–2016



نتيجة الحكم على أطروحة ماجستير

بناءً على موافقة شئون البحث العلمي والدراسات العليا بالجامعة الإسلامية بغزة على تشكيل لجنة الحكم على أطروحة الباحثة/ امانى يوسف حسن الشرفا لنيل درجة الماجستير في كلية الهندسة قسم الهندسة المعمارية وموضوعها:

دراسة أداء الإضاءة الطبيعية للمباني السكنية متعددة الطوابق في قطاع غزة A study of the daylighting performance in the multi-storey residential buildings in Gaza Strip

وبعد المناقشة التي تمت اليوم الأحد ٢١ ربيع الآخر ١٤٣٦ هـ، الموافق ٣١/٠١/٢٠١٦م الساعة التاسعة صباحاً، اجتمعت لجنة الحكم على الأطروحة والمكونة من:

.....
.....
.....

د. عمر سعيد عصفور مشرفاً و رئيساً
أ.د. محمد علي الكحلوت مناقشاً داخلياً
د. مصطفى كامل الفسرا مناقشاً خارجياً

وبعد المداولة أوصت اللجنة بمنح الباحثة درجة الماجستير في كلية الهندسة / قسم الهندسة المعمارية.

واللجنة إذ تمنحها هذه الدرجة فإنها توصيها بتقوى الله ولزوم طاعته وأن تسخر علمها في خدمة دينها ووطنها.

والله ولي التوفيق ،،،

نائب الرئيس لشئون البحث العلمي والدراسات العليا

.....

أ.د. عبد الرؤوف علي المناعمة



Dedication :

This research is lovingly dedicated...

To our respective parents who have been our constant source of inspiration. They have given us the drive and discipline to tackle any task with enthusiasm and determination.

To Palestine, land and human ...

To our martyrs blood ...

To the Islamic University of Gaza ...

To all who helped us ...

We dedicate this modest research and we hope to obtain pride.

Acknowledgement

In the first place... My deep thanks to Allah.....His generosity and bountifulness, the bulk of the credit help me to complete this work. I am grateful to my supervisor **Dr. Omar S. Asfour** for patiently listening and offering valuable advice throughout the research process. For his help and encouragement since I have started; for guidance and wisdom during this research; for keeping me focus while navigating through numerous obstacles.

Another big thanks send to Department of Architectural Engineering in Islamic university...

I am eternally grateful for its teaching staff help, support, and encouragement.

Abstract

Natural lighting in dwelling units is very important considering its effects on the visual comfort of occupants, and its role in energy saving. This design issue is more challenging in the crowded housing environments, where environmental and spatial design requirements have to be balanced. This is true in the case of Gaza Strip. Gaza Strip is a narrow strip stretching along the Mediterranean Sea. With its limited area and natural resources, urban areas are characterized with a high housing density. As a result, the quality of natural lighting in the residential buildings became questionable. This is because architects are under constant pressure from the developers and clients to design multi-unit residential buildings with maximum space utilization, in the face of rising land prices and scarcity.

Thus, the challenge is to get daylight into rooms on lower floors that are overshadowed by adjacent structures. This depends on some internal factors such as size and position of the windows, the depth and shape of the rooms and the colours of the internal surface, and some external factors such as light reflected from the ground and opposite obstruction.

Thus, this study aims to highlight the situation of daylighting in the multi-storey residential buildings at Gaza Strip, and to propose design recommendations to improve it. In order to achieve that, an parametrical study is carried out by "Radiance" program to assess the current situation in those buildings.

The research concludes that a direct relationship between the illuminance levels that reaches inner spaces with window and well design. The study found significant effects of plan orientation, area, light well surfaces material reflectance, and opening area passes the light to the spaces on the illuminance level in the tested spaces. Light shelf has effective results on improving quality distribution of light

Therefore, the research recommends applying natural lighting window and light well design strategies, Further studies are necessary which provide more data, and investigate more variables. Further work needs to be done to investigate the other daylight variables.

المخلص

من المهم جدا النظر في آثار الإضاءة الطبيعية في الوحدات السكنية على الراحة البصرية للمستخدمين, ودورها في توفير الطاقة. هذه المسألة التصميمية أكثر تحديا في البيئات السكنية المكتظة , حيث أن المتطلبات التصميمية المكانية والبيئية بحاجة إلى الموازنة بينهم; كما في حالة قطاع غزة, قطاع غزة شريط ضيق يمتد على طول البحر الأبيض المتوسط ذو مساحة وموارد طبيعية محدودة. وتتميز المناطق الحضرية أنها ذات كثافة سكانية عالية, ونتيجة لذلك , فإن نوعية الإضاءة الطبيعية في المباني السكنية تصبح محل تساؤل, وذلك لأن المهندسين المعماريين تحت ضغط مستمر من المستثمرين والعملاء لتصميم مباني سكنية متعددة الوحدات باستخدام أقصى مساحة ممكنة, في ظل ارتفاع أسعار الأراضي وندرته.

وبالتالي, فإن التحدي هو الحصول على ضوء النهار إلى الغرف في الطوابق السفلى التي غطتها المباني المجاورة , هذا يعتمد على بعض العوامل الداخلية مثل حجم وموضع النوافذ, عمق وشكل الغرف وألوان السطوح الداخلية , وبعض العوامل الخارجية مثل الضوء المنعكس من الأرض ومعينات الانعكاس.

لذلك تهدف هذه الدراسة إلى تسليط الضوء على حالة ضوء النهار في المباني السكنية متعددة الطوابق في قطاع غزة, واقتراح توصيات لتحسين التصميم. من أجل تحقيق ذلك, تم دراسة هذه العوامل باستخدام برنامج "Radiance" لتقييم الوضع الحالي في تلك المباني.

ويخلص البحث إلى وجود علاقة مباشرة بين مستويات الإضاءة التي تصل الفراغات الداخلية مع تصميم النوافذ وتصميم المنور. ووجدت الدراسة تأثيرات هامة لتوجه المسقط الأفقي أو المساحة أو الانعكاس المادي للسطوح, والمساحات, ودرجة انعكاس الضوء من الأسطح الداخلية للمنور, ومساحة فتحة الشبابيك التي تمرر الضوء للفراغات التي تم دراستها , الرف الضوئي ذو أثر فعال على تحسين كفاءة توزيع الضوء, لذا يوصي البحث بتطبيق استراتيجيات تصميم الضوء للشبابيك والمناور, كما يوصي البحث بضرورة عمل دراسات إضافية تقدم معلومات إضافية لمتغيرات أخرى.

List of Contents

Dedication	V
Acknowledgement	II
Abstract	III
المخلص	IV
List of Contents	V
List of Tables	VIII
List of Figures	IX
Chapter 1: General Introduction	1
1.1 Background	1
1.2 Research Statement	2
1.3 Research Hypothesis	2
1.4 Importance of the Research	2
1.5 Research Aims	3
1.6 Research Objectives	3
1.7 Methodology	3
1.8 Research Limits	4
1.9 Previous Studies	4
Chapter 2: Daylighting design in Buildings: An Overview	7
2.1 Introduction	7
2.2 The Global Energy Problem	7
2.3 Energy Efficient Building Design	8
2.4 Building Envelope and Daylight	9
2.4.1 The Nature of Light	9
2.4.2 Daylighting	12
2.4.3 Daylight and Architecture	12
2.4.4 Daylight and Energy	14
2.5 Design Tools	15
2.6 Daylight Availability and Sky Condition	17
2.7 Daylighting Technologies	19
2.8 Conclusion	28

Chapter 3: Energy situation and the need of daylighting in Gaza Strip residential buildings	29
3.1 Introduction	29
3.2 Overview on Gaza Strip	29
3.2.1 Location and Topography	29
3.2.2 Population	30
3.2.3 General Characters of Urban Geometry in Gaza	31
3.2.4 Climate	32
3.3 Energy Situation in Gaza Strip	34
3.4 Renewable energy sources	37
3.5 Residential complexes in Gaza Strip	38
3.6 The need of daylighting	40
3.7 Conclusion	41
Chapter 4: Results Of Simulation Process	42
4.1 introduction	42
4.2 Building Simulation	42
4.2.1 Desktop RADIANCE	44
4.3 The Case Description	48
4.4 Study Variables	52
4.5 The Results of living Room Simulation Process	52
4.5.1 The Results of Plan Redirection Simulation Process	52
4.5.2 The Results of Increasing of Window Area Simulation Process	54
4.5.3 The Results of Material Reflectance Simulation Process	57
4.5.4 The Results of Adding A Light Shelf to The Window Simulation Process	59
4.6 light well window	60
4.6.1 The Results of Plan Redirection Simulation Process	60
4.6.2 The Results of Increasing of Plan Area Simulation Process	62
4.6.3 The Results of Material Reflectance Simulation Process	65
4.6.4 The Results of Opening area Simulation Process	67
4.7 Conclusion	71
Chapter 5: Conclusions and Recommendations	72
5.1 Introduction	72

5.2 Conclusions	72
5.2.1 Daylighting design in Buildings	72
5.2.2 Energy situation and the need of daylighting in Gaza Strip residential buildings	73
5.2.3 The Study of Effective Parameters on The Daylight Performance.	73
5.3 Recommendations	75
5.4 Further Studies	75
References	76

List of tables

Table No.	Table title	page
Table (2.1)	Five Sample Definitions for Daylighting	16
Table (3.1)	Zoning district regulations in Gaza Strip	47
Table (4.1)	Different cases of window area, simulated in the study. Multiplying the dimensions of the light well	62
Table (4.2)	Material reflectance cases names	65
Table (4.3)	Different cases of plan area, simulated in the study. Multiplying the dimensions of the light well.	69
Table (4.4)	Material reflectance cases names	72
Table (4.5)	Opening area cases names	74

Figure No.	Figure title	Page
Figure. (1.1)	Map showing the location of Gaza Strip	5
Figure (2.1)	Global fuel mix by decade	11
Figure (2.2)	Electromagnetic spectrum showing the location of the visible spectrum	13
Figure (2.3)	Typical illuminances on different surfaces under the noonday sun in temperate climates	15
Figure (2.4)	Diffuse sky radiation distribution under clear sky conditions	25
Figure (2.5)	Diffuse sky radiation distribution under overcast sky conditions	25
Figure (2.6)	Courtyard	27
Figure (2.7)	Atrium	28
Figure (2.8)	Atrium	29
Figure (2.9)	Clerestory	31
Figure (2.10)	Clerestory	31
Figure (2.11)	Sun ray guided by light shelf in winter and summer time	32
Figure (2.12)	Properties of a mirror reflective louvre	33
Figure (2.13)	Prismatic panels	34
Figure (2.14)	Light-guiding shade (LGS)	34
Figure (2.15)	Laser cut panel light guiding principle	35
Figure(2.16)	Lightpipe guiding principle	36
Figure (2.17)	Anidolic system principle	37
Figure (3.1)	Gaza Strip plan	39
Figure (3.2)	Street and parcels orientations in Gaza Strip	40
Figure (3.3)	The annual average temperature (C°) in Gaza Strip	42
Figure (3.4)	The annual average relative humidity (%) in Gaza Strip	42
Figure (3.5)	the annual average wind speed (m/s) in Gaza Strip	43
Figure (3.6)	The percentage of consuming imported Energy by sectors in 2005	44
Figure (3.7)	Electricity consumption in Palestine territory (GWh) from 1994-2005	45
Figure (3.8)	Energy Consumption in Residential Sector by Fuel (2001-2005)	45
Figure (3.9)	The average duration of solar radiation in Gaza City in year 2011	46
Figure (3.10)	View of residential building in Gaza city	49
Figure (4.1)	Represents the typical plan of the case study building and simulated rooms.	54
Figure (4.2)	Shows the bathroom which the research studied the daylight environment in. The room with a window which opening on the light well	55
Figure (4.3)	Reference grid for illuminance level calculated.	57
Figure (4.4)	AutoCAD R-14 is used as a front end to the Desktop Radiance modules	59
Figure (4.5)	The Simulation Manager allows users to manage and control multiple simulation runs quickly and easily	59
Figure (4.6)	Represents the plan of the base case A and the reorientation A1, A2 and A3.	61
Figure (4.7)	Represents the illuminance level in the simulated room at 12:00pm, in March under the cases A, A1, A2 and A3.	61
Figure (4.8)	Represents the illuminance level in the simulated room 12:00pm in March, under different window areas.	63
Figure (4.9)	A sketch of case B3 plan and section	64

Figure (4.10)	Represents the illuminance level in the simulated room 12:00pm in March, under different material reflectance	65
Figure(4.11)	A section of the window with the light shelf	66
Figure (4.12)	Represents the illuminance level in the simulated room 12:00pm in March, under different material reflectance	67
Figure (4.13)	Represents the plan of the base case A and the reorientation A1.	68
Figure (4.14)	Represents the illuminance level in the simulated room at 12:00pm, in March under the cases A and A1.	68
Figure (4.15)	Represents the illuminance level in the simulated room 12:00pm in March, under different light well plan areas	71
Figure (4.16)	A sketch of case B4 plan and section	72
Figure (4.17)	Represents the illuminance level in the simulated room 12:00pm in March, under different material reflectance	73
Figure (4.18)	A sketch of the plan and section for C4 as a base case	74
Figure (4.19)	Represents the illuminance level in the simulated room 12:00pm in March, under different cases of opening area	76

CHAPTER 1: INTRODUCTION

1.1 Background

Natural lighting has an essential role In architectural design. This is not limited to the physical aspect; rather, it is related to the aesthetic sensation of the users. Yet when we attempt to analyze the role of light in contemporary architecture, we find a great challenge.

Thus, it is essential for the architectural profession to recover the systematic use of natural light. To this end, designers should be made aware of how spaces work in conjunction with light. The principle is to the practice of natural light in design with greater efficiency than would be the case with the technology of particular solutions and systems (Serra, 1998).

In modern architecture, daylighting is an important issue affecting the functional arrangement of spaces and occupants' comfort. Daylight is considered as the best source of light for good color rendering. Also, its quality is the one that most closely matches human visual response. It gives a sense of cheeriness and brightness that can have a significant positive impact on people. The amount of daylight penetrating a building is mainly through window openings, allowing people to maintain visual contact with the outside environment. All of this makes people desire good natural lighting in their living environments(Li, 2006).

Being one of the most densely populated cities in the world, Gaza Strip has faced many challenges in tackling the housing needs. In addition, Gaza Strip suffers from a serious problem in energy and The electricity sector suffers from many electrical problems such as high electrical deficit rate Hence, the quality and quantity of daylight inside the building interior may be restricted, particularly for flats on the lower floors which would have to rely on supplementary artificial lighting even at the daytime with high daylight intensity.

There is a clear lack in electricity supply to Gaza Strip, the electricity energy has been aggravated since 2007 because of the siege imposed on the Strip (Musalam, 2013). As It is acknowledged that by maximizing the use of natural lighting a significant reduction in artificial lighting and thus primary energy consumption can be achieved.

Natural light entering a building depends on both internal and external factors. Indoor environment includes the size and position of the windows, the depth and shape of the rooms and the colors of the internal surfaces(Lam,1994). Externally, the light reflected from the ground and opposite facades can be important sources of interior lighting (Tsangrassoulis,*et al.*2003). This research studies the daylighting performance in multi-storey residential buildings using computer simulation techniques, presents the key building variables affecting the interior daylight level in Gaza Strip and discusses the impacts of various techniques on the indoor daylight availability and the implications for daylighting performance and electric lighting use in residential sectors.

Finally, providing a building with natural light is more than just the solution of a problem of energy consumption. Natural light in architecture must be part of a more general philosophy that reflects a more respectful, sensitive attitude in human beings towards the environment in which they live.

1.2 Problem Statement

Gaza Strip is a narrow strip stretching along The Mediterranean Sea. With its limited area and natural resources, urban areas are characterized with a high housing density. Thus the multi-storey residential building design dominated by achieving the maximum profit especially for apartment buildings. Also Gaza Strip has been suffering from a real shortage in electricity supply. This led to scheduled cuts of electricity supply for several hours per day which has negatively affected all aspects of the Palestinians life and made it very hard to go about normal life. Under this stress, considerable options to solve this problem are available in Gaza Strip, this includes improving natural lighting investing, where several buildings are designed without adequate lighting conditions. For that, this research aims to examine this problem in a scientific approach, in order to arrive at recommendations that help solving this problem.

1.3 Research Hypothesis

This study assumes that several design solutions can be effectively implemented to improve the internal lighting environment in the multi-storey residential buildings in Gaza Strip. On one side, this reduces the need for providing lighting using artificial lighting, which is energy-consuming. On the other side, this improves the visual quality of this environment. In this context, several design recommendations are quantitatively examined and compared.

1.4 Importance of the Research

There are several researches about daylighting performance in buildings and analyzing methods of daylighting quality. Also there are various researches about daylighting simulations focusing on enhancing natural lighting indoors. However, there is a lack of such studies considering Gaza climate and built environment.

The importance of this research can be summarized as mentioned in the following points:

- Keeping up with the tendency all over the world to reduce the dependence on conventional energy in buildings, and to use more renewable energy.
- Highlighting the design of residential buildings in Gaza Strip in an attempt to find solutions for improving the residential daylighting design and enhance the comfort conditions.

- Finding solutions and practical steps to assist improving and investing natural lighting in buildings in Gaza Strip.

1.5 Research Aim

The research aims to improve daylighting performance in the multi-storey residential buildings at Gaza Strip, and to propose design recommendations in this regard.

1.6 Research Objectives

1. To identify the problem of energy shortage in Gaza Strip.
2. To explain the great importance for daylighting in building design.
- 3- To study the influence of the urban environment on the availability of daylighting in the multi-storey residential buildings in Gaza Strip, and
- 4-To propose design recommendations that help improving natural lighting in those buildings in terms of quality and quantity.

1.7 Methodology

The research is carried out using both quantitative and qualitative approach in the following steps:

1.7.1 Literature Review:

A literature review on natural lighting performance and design techniques in buildings is carried out as a theoretical background. This is done with reference to Gaza Strip conditions.

1.7.2 Studying the current situation of daylighting in the reference case:

Studying and analyzing the current situation of daylighting in the multi-storey residential buildings in Gaza Strip to find the design problems and to determine the levels of natural light indoors.

1.7.3 Parametric study:

Also the research has carried out a parametric simulation study using computerized Program "Radiance" to provide quantitative results. Residential buildings with different architectural and urban configurations have been analyzed. The results have been evaluated in order to reach the most suitable solutions for daylighting that are adequate for Gaza Strip.

1.8. Research limits

This research examines the residential buildings in Gaza Strip, it focuses on the Multi-storey residential building, which suffers from natural lighting design problems.

Gaza Strip is located within the solar belt countries and considered as one of the highest solar potential energy, the climate conditions of Palestine is sunny about 300 days a year (Hussein,*et al.* 2011).).And the climate of Gaza Strip is characterized by its location in hot humid region specifically on longitude 34° 26' east and latitude 31° 10' north (Elaydi,*et al.* 2013).



Figure (1.1): Map showing the location of Gaza Strip
Source: (acsa-craa.org, date)

1.9 Previous studies

Several Studies have investigated the daylighting performance in buildings. For example:

1. Li *et al.* (2006). A study of the daylighting performance and energy use in heavily obstructed residential buildings via computer simulation techniques

This paper studies the daylighting performance and energy use for residential flats facing large sky obstructions via computer simulations. The daylighting performance for typical interior rooms was investigated in terms of illuminance level and daylight factor. The daylight levels of residential flats can be severely reduced by neighboring buildings and hence the externally reflected component would be the main source of natural light. The indoor daylight levels for kitchen and living, dining facing large neighboring buildings were found always less than the standard maintenance

illuminance during daytime period. These imply that many residential flats in Hong Kong would have to rely on supplementary electric lighting.

2. **Husin, *et al.* (2011). The Performance of Daylight through Various Type of Fenestration in Residential Building**

This study focused on the various types and materials of the glass and window, in order to identify the quantity and quality of daylight that penetrate into the residential buildings. Based on a series of measurement, it was identified that type of glazing and window gives major significant on the performance of daylight and thermal performance in residential buildings.

3. **Li *et al.* (2007). An analysis of daylighting performance for office buildings in Hong Kong.**

This paper studied the daylighting performance and energy implications for office buildings. A total of 35 commercial buildings have been selected in the survey. Two typical office blocks were further analyzed based on RADIANCE simulation program. The daylighting performance was evaluated in terms of daylight factor, room depth and glare index. It has been found that the daylighting performance for office buildings is quite effective. About one-third of the office areas that are near the perimeter regions have an average daylight factor of 5%. For inner region of deep plan offices, some innovative daylighting systems such as light redirecting panels and light pipe could be used to improve the daylighting performance. In general, the office building envelop designs are conducive to effective daylighting and proper daylight linked lighting controls could save over 25% of the total electric lighting use.

4. **Kim, *et al.* (2009). Healthy-daylighting design for the living environment in apartments in Korea.**

In this article, healthy residential environment is discussed as an architectural field of light. It is focused the discussion on two areas of action: providing healthy light and eliminating harmful light within apartments. When a balcony is eliminated, thus, there is a larger glass area of the window in the field of human view. Eliminating the balcony also removes the overhangs structure which works as an obstruction to block the excessive penetration of sunlight. This results in the advent of harmful light in quantitative and qualitative ways; too much light, uncomfortable glare, and UV penetration. This paper discusses issues related to light and healthy living environment. Initially, it deals with the establishment of all design elements in terms of light and surveys examples of current designs. Architectural and optical solutions both to attenuate the harmfulness of light and to improve the visual satisfaction are given issued and their performance is reviewed.

5. **Freewan, (2010). Maximizing the light shelf performance by interaction between light shelf geometries and a curved ceiling.**

This research investigated the interaction between different light shelf geometries combined with a curved ceiling using RADIANCE, to maximize the daylight performance of a light shelf. Two main performance parameters were investigated; illuminance level and distribution uniformity in a large space located in a sub-tropical climate region like Jordan. It was found that a curved light shelf could improve the daylight level by 10% compared to a horizontal light shelf. A curved light shelf help to bounce more daylight deep into a space thus improve the illuminance level and uniformity level. The best light shelf shapes found are curved and chamfered light shelves compared to horizontal light shelves.

6. **Suriansyah, (2013). Daylight Quality Potency at Sarijadi Mass Public Housing in Bandung Indonesia.**

Apartment Sarijadi Bandung (ASB) is intended as mass public housing for the lower middle income. ASB designed as cluster typology with one staircase lined to four dwelling units. This study aims to determine the extent of a natural lighting at ASB that is designed with optimization approach of the natural lighting. This study used quantitative methods. Field surveys conducted to obtain data of (1) physical spatial configurations of architectural elements, and (2) illuminant of the residential units, which will be used for analyzing how much the natural lighting potential in the residential units at ASB. The finding is the innovations of disclosure of influence factors of the architectural physic-spatial configuration to day lighting potential in vertical residential building typology as in the ASB. It is a useful new finding to be applied in supporting the development of science and technology and procurement related to vertical housing that provide opportunities for better life quality and energy efficiency in urban areas.

Some Previous studies were reviewed and they can be summarized in the following points:

- 1- The daylight levels of residential flats can be severely reduced by neighboring buildings and hence the externally reflected component would be the main source of natural light according to Li et al. (2006).
- 2- Type of glazing and window gives major significant on the performance of daylight and thermal performance in residential buildings. (Husin, et al. ,2011).
- 3- The office building envelop designs are conducive to effective daylighting could save over 25% of the total electric lighting use. (Li et al., 2007).
- 4- Architectural and optical solutions both are important to attenuate the harmfulness of light and to improve the visual satisfaction are given issued and their performance according to Kim, et al. (2009) and Suriansyah, (2013).
- 5- The best light shelf shapes found are curved and chamfered light shelves compared to horizontal light shelves. (Freewan, 2010).

CHAPTER 2: DAYLIGHTING DESIGN IN BUILDINGS: AN OVERVIEW

2.1 Introduction

There are several ways in which natural lighting can play an important role in sustainable design. In a world becoming increasingly concerned with reducing CO₂ carbon emissions, the planned use of natural light in residential and non-residential buildings is an important strategy in improving energy efficiency and sustainability by minimizing lighting, heating and cooling loads. An innovative approach is the introduction of advanced daylighting strategies and systems, which can considerably reduce a building's electricity consumption and also significantly improve the quality of light in an indoor environment. Daylighting systems serving multiple functions with a mix of strategies (e.g. the redirection of direct sunlight and the use of controlled shading devices), may be much more economical than using photovoltaic electricity.

Providing a building with natural light is more than just the solution of a problem of energy consumption; more, even, than an aesthetic resource easily incorporated into the architecture. Natural light in architecture must be part of a more general philosophy that reflects a more respectful, sensitive attitude in human beings towards the environment in which they live (Serra, 1998).

This chapter introduces a literature review about daylighting design in buildings. It discusses the issue of the global energy problem. Then, it is carried out to identify the energy efficient building design. After that the chapter discusses the building envelope and daylight. Also the chapter shows daylighting design tools. Then, the chapter discusses the daylight availability and sky condition. At the end of the chapter, it discusses several daylighting technologies to improve daylighting quality in buildings.

2.2 The global energy problem

Our world runs on energy, it's fundamental to our way of life and growing our economy. But the world is changing. An expanding population, economic growth, new technology development and changes of energy nature.

The Outlook for Energy: A View to 2040 (2013) contains global projections through 2040. And it includes:

- The world's population will rise by more than 25 percent from 2010 to 2040, reaching nearly 9 billion. An additional 2 billion people worldwide by 2040 means growing mobility requirements, rising electricity needs for homes and other buildings, and increasing energy supplies to power industry.
- The global economy is expected to grow at an annual average rate of 2.8 percent from 2010 to 2040. Economic growth, and the improved living standards it enables, will require more energy.
- Heavy duty transportation demand grows 65 percent by 2040.

- Over the next 30 years, industrial energy demand will continue to grow. Producing the materials modern society needs like steel, cement, plastics and chemicals takes an enormous amount of energy.
- Global electricity demand will grow by 85 percent from 2010 to 2040. This growth is driven primarily by an increase in the industrial sector of more than 75 percent, followed by residential/ commercial.

Globally, from 2010 to 2040, the rate of increase of CO2 emissions will be about half that of energy demand growth. Two factors impact this: the wise and efficient use of energy and a shift to less carbon-intensive fuels. Of these factors, the most important over the future relates to improving efficiency of energy use as people continue to improve their living standards.

Energy sources will continue to evolve and diversify as global energy demand surges. The most significant developments shown in figure (2.1) Oil, gas, nuclear and renewables grow, while coal experiences a decline by 2040.

In the other hand Our world's energy supplies have changed throughout history. The most dramatic changes occurred in the past 50 to 60 years, as advances in our productivity and a dramatic evolution of technology enabled higher living standards and created better lifestyles for people. Today, the world consumes about 25 times the amount of energy used 200 years ago.

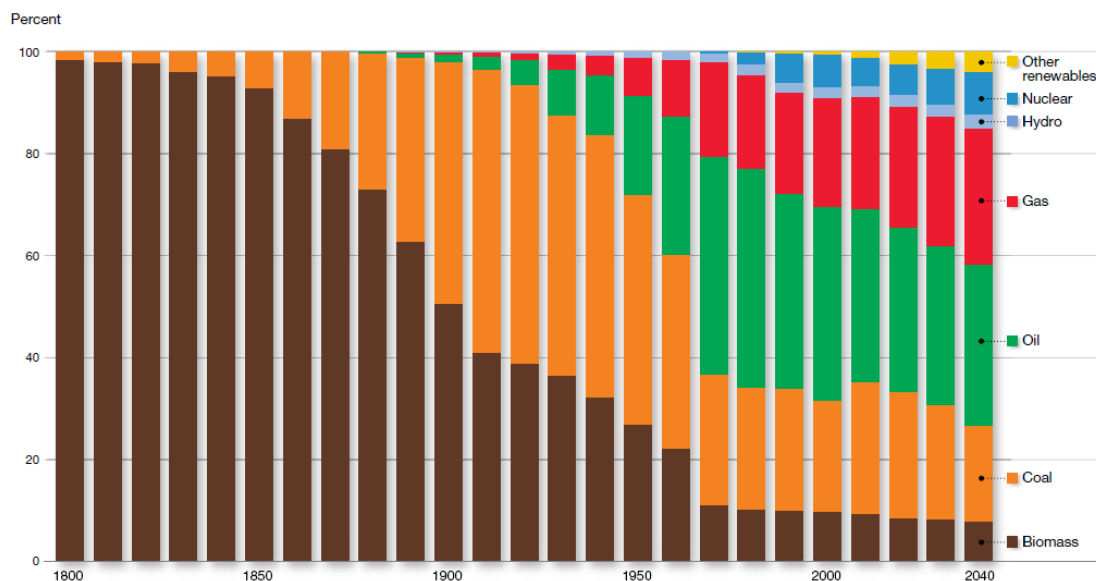

Figure (2.1): Global fuel mix by decade
Source: (The Outlook for Energy: A View to 2040, 2013)

2.3 Energy Efficient Building Design

It is clear from the above section that energy efficiency in buildings is vital for many reasons. Having justified the needs for energy efficiency it is now important to focus on the basic principles that can bring about energy efficiency in residential buildings. An extensive literature review consisting of different journals, books, researches and related

websites was undertaken to establish the basic passive principles for designing energy efficient residential buildings (Ahsan, 2009). Ahsan (2009) presented a list of aspects for energy efficient residential buildings,

1. Planning aspects:

- Site analysis
- Building form
- Building orientation
- Room orientation
- Landscaping

2. Building envelope:

- External wall
- Thermal insulation
- Building material
- Roof
- Windows
 - Size
 - Orientation
 - Shading device
 - Natural ventilation
 - Daylight

2.4 building envelope and Daylighting

As it is clear in the previous section the building envelope includes everything that separates the interior of a building from the outdoor environment, including the windows, walls, foundation, ceiling, roof, and insulation. Windows in buildings establish contact with nature through a direct view and admit daylight inside. Adequate provisions of daylight in buildings through a proper planning for windows in respect of the position, area and shape, are therefore an important aspect of a good building design. Daylight integration helps reduce dependence on artificial lighting and thus help reduce electricity consumption of the building (Majumda, 2002).

2.4.1 The Nature of Light.

Light is the part of the energy spectrum of electromagnetic radiation emitted by the sun within the visible waveband that is received at the surface of the earth after absorption and scattering. The figure (2.2) shows how electromagnetic waves of varying frequencies, produce different effects such as radio, light, and X-rays (Andrews, 2014). The small colored bands show the range that represents visible light. This visible spectrum extends from a wavelength of approximately 380 nanometers to 780 nanometers (Boyce, 2003).

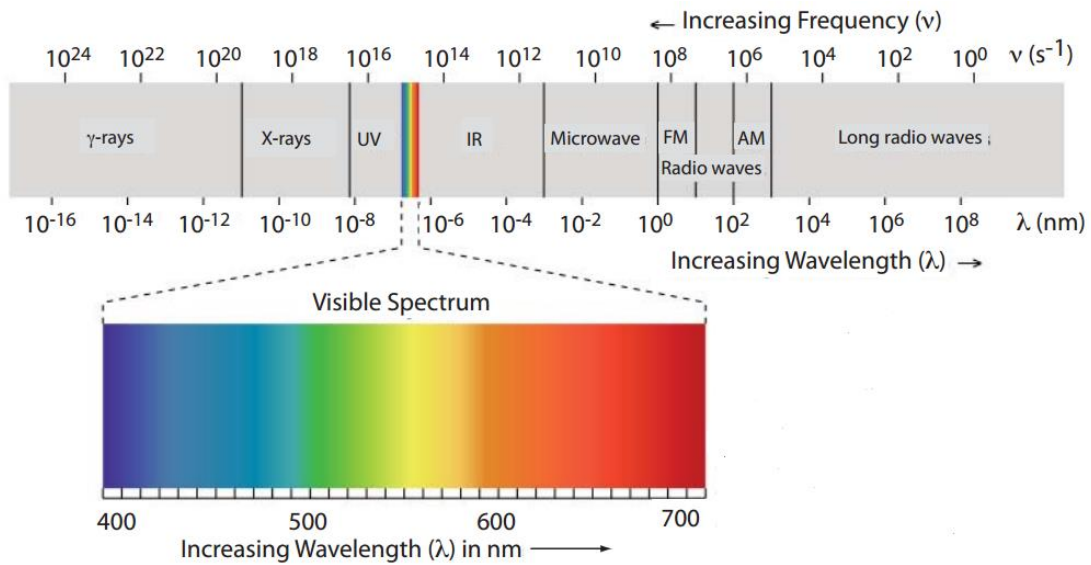

**Figure (2.2): Electromagnetic spectrum showing the location of the visible spectrum
Source: (Harvey,2006)**

The measurement of light — photometry

According to Stork & Mathers (2009) light sources emit electromagnetic waves in the Ultra Violet (UV), visible and infra-red spectrum. Measurement of all these is called radiometry. Photometry is a special branch of radiometry in which we only measure visible light.

Four terms are used to describe light:

- Luminous Intensity (candela)
- Luminous Flux (lumen)
- Illuminance (lux)
- Luminance (candela/m²)

Luminous Intensity

Luminous intensity is the luminous flux emitted/unit solid angle, in a specified direction. Solid angle is given by area divided by the square of the distance and is measured in steradians. An area of 1 square meter at a distance of 1 meter from the origin subtends one steradian. The unit of measurement of luminous intensity is the candela, which is equivalent to one lumen/steradian. Luminous intensity is used to quantify the distribution of light from a luminaire (Boyce & Raynham, 2009).

Luminous flux

The most fundamental measure of the electromagnetic radiation emitted by a source is its radiant flux. This is the rate of flow of energy emitted and is measured in watts. The most fundamental quantity used to measure light is luminous flux. Luminous flux is radiant flux multiplied, wavelength by wavelength, by the relative spectral sensitivity of the human visual system, over the wavelength range 380 nm to 780 nm.

The radiant flux is measured in watts (W) and the luminous flux in lumens (lm) (Stork & Mathers, 2009).

Illuminance

Illuminance is the luminous flux falling on unit area of a surface. The unit of measurement of illuminance is the lumen/m² or lux. The illuminance incident on a surface is the most widely used electric lighting design criterion. Figure (2.3) shows some typical illuminances on different surfaces under the noonday sun in temperate climates (Boyce & Raynham, 2009).

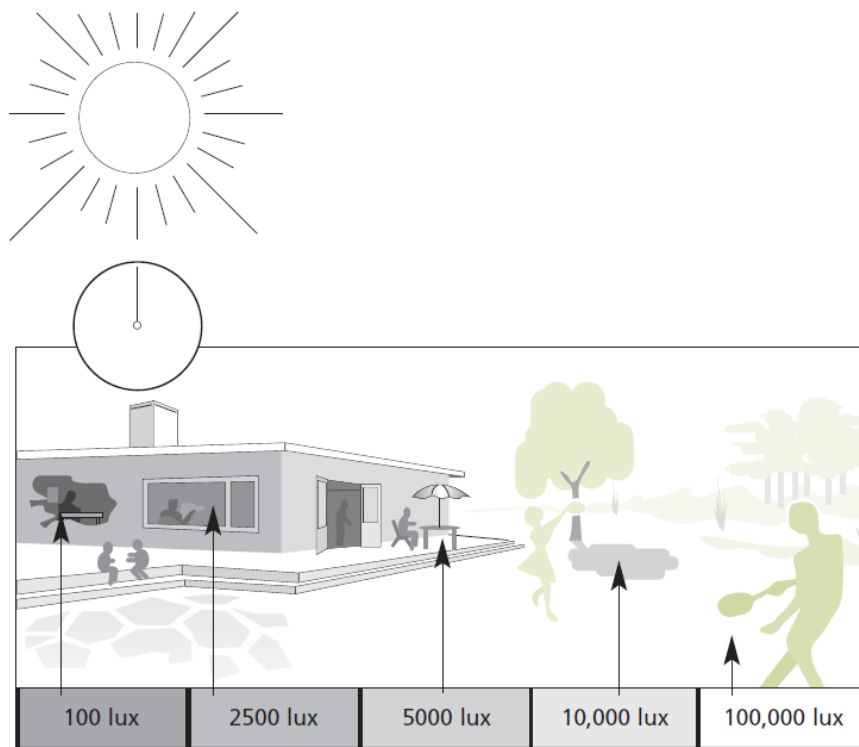

Figure (2.3): Typical illuminances on different surfaces under the noonday sun in temperate climates

Source: (Boyce & Raynham, 2009)

Luminance

The luminance of a surface is the luminous intensity emitted per unit projected area of the surface in a given direction. The unit of measurement of luminance is the candela/m². Luminance is widely used to define stimuli presented to the visual system (Stork & Mathers, 2009).

2.4.2 Daylighting

Daylight is a source which can save the energy and able to create a pleasant visual environment for occupants. According to Illuminating Engineering Society of North America (IESNA), daylighting is a technique to bring natural light into a room by manipulating this free resource to achieve required illumination level in that room. By having a good daylighting strategy, it helps to create a visually stimulating and productive environment for building occupants (Husin, & Harith, 2012).

Daylighting is the use of direct, diffuse, or reflected daylight to provide full or supplemental lighting for building interiors (Abboushi, 2013).

According to Reinhart & Galasiu (2006) cited in Reinhart *et al.* (2006) One of the difficulties of pinpointing good daylighting may be that different professions concentrate on different aspects of daylighting. Table (2.1) presents a five sample list of definitions for daylighting that were presented to participants in a recent survey on the use of daylighting in sustainable building design (Reinhart & Galasiu 2006).

Table (2.1) Five Sample Definitions for Daylighting

Source: (Reinhart & Galasiu, 2006)

<i>Architectural definition:</i> the interplay of natural light and building form to provide a visually stimulating, healthful, and productive interior environment
<i>Lighting Energy Savings definition:</i> the replacement of indoor electric illumination needs by daylight, resulting in reduced annual energy consumption for lighting
<i>Building Energy Consumption definition:</i> the use of fenestration systems and responsive electric lighting controls to reduce overall building energy requirements (heating, cooling, lighting)
<i>Load Management definition:</i> dynamic control of fenestration and lighting to manage and control building peak electric demand and load shape
<i>Cost definition:</i> the use of daylighting strategies to minimize operating costs and maximize output, sales, or productivity

2.4.3 Daylight and Architecture: The perception of light in architecture

"No space, architecturally, is a space unless it has natural light." - Louis Kahn

"Light and illumination are inseparable components of form, space and light. These are the things that create ambiance and feel of a place, as well as the expression of a structure that houses the functions within it and around it. Light renders texture, illuminates surface, and provides sparkle and life." - Le Corbusier

Vision is the main role of lighting in architecture. Phillips (2000) encapsulated this by saying "light enables us to perform, and without it the building would cease to function". Before the appearance of electrical lighting, building design responded to the climatic parameters and daylight conditions of a place, in order to achieve adequate lighting levels in the interior for visual performance. Phillips (2000) also added that "it is light that can make a building bright and airy or dull and gloomy".

When an architect imagines the architecture that he is beginning to design, he pictures in his brain the forms of the building he is creating, from overviews of the building to specific details of its facades. If he is sensitive to interior space, he will also imagine how the interior forms of its building will be when it is inhabited, thus becoming much more closely involved in the future architectural experience. Very few architects, however, are sensitive enough to imagine and design in their mind the light being planned for these spaces (Serra, 1998).

The natural light is one of the most important factors which are taken in consideration during the conceptual phase of architectural design, when the building configuration and fenestration are formulated. The problem with new buildings is that they generally have large depth to height ratios to maximize the area of floors and therefore the rental area that produces gloomy, Littlefair (1990) discussed the basic principles of daylighting for comfortable ambient lighting, and he suggested these principles:

- Configure the building so that most of the floor area occupied by people is within the daylight zone. The typical daylight zone is about 5m deep from the window wall or the top floor of a building with skylights.
- Locate critical visual tasks near the building's perimeter.
- Bring the light in high. Windows higher on the wall will allow the light to penetrate further into the space.
- Admit daylight from more than one side of a space where possible. Bilateral lighting, for example, increases uniformity and balances the brightness within the room.
- Control the direct sun. Bounce the direct sun horizontal elements, window blinds and other non-specular surfaces to distribute and diffuse the light.
- Use light-colored interior surfaces. Light surfaces reduce the luminance contrast between the windows and surrounding surfaces, increasing visual comfort.
- Locate workstations and computer screens perpendicular to the windows to reduce reflected glare in the screens or visual discomfort.

The previous principles will assist designers to solve this problem and to reach a good daylighting while they are designing such buildings, creating design feature, admitting daylight in indoor areas to make it more pleasing and comfortable environment for occupants. Also applying these principles can improve visual performances and enhance visual comfort since daylight has essential components, which give occupants a greater satisfaction level when introduce into indoor environments (Kim & Kim, 2009).

Daylighting has the potential to improve human health, mood, performance and productivity (Poyceet *al.*, 2003). Daylight provides high illuminance and permits excellent color discrimination and color rendering Consequently, economic potential of daylight is achieved not only by saving energy, but also by increasing workers' productivity in offices, factories, schools and retail premises (Heschong, 1999; Bommel&Beld, 2004). The

quality of the indoor environment depends significantly on several aspects of lighting including the illuminance, the amount of glare, and the spectrum of the light (Gibson, 2008). Lighting characteristics influence the quality of vision and can have psychological influences on mood and on perceptions about the pleasantness of a space (Croom, 2003). Using daylighting in buildings is more than providing buildings with ambient daylight and improving visual environment, it contributes greatly to human wellbeing. Therefore, building design and especially lighting design need to take into consideration not only functional requirements, but also biological and psychological needs (Freewan, 2010).

2.4.4 Energy

Over the past few decades, there has been a growing concern about climate change and global warming, In nitrogen oxide. Irreversible damages on environment have been caused by those air pollutants wimsot developed countries, energy is generated by burning fossil fuels and the process simultaneously emits air pollutants and greenhouse gases such as Sulphur dioxide and tch still keep on increasing. Promoting daylight is one of the feasible solutions to reduce the fossil fuels consumption as well as the greenhouse gases emission (Lun, 2008).

Lighting accounts for between 5 and 15% of residential energy use and up to 30% of commercial building energy use, and continues to increase. In certain business types, for example the retail sector, lighting can account for up to 80% of energy use. This is due to long operating hours and the need to “keep things bright” and stand out from the competition (Stork & Mathers, 2009), and according to (Capeluto, 2003; Garcia-Hansen *et al.*, 2002; Greenup *et al.*, 2001; Ihmet *et al.*, 2009; West, 2001). Lighting represents 20-60% of buildings electricity consumption in buildings.

Practical experience and calculation have shown that daylight can replace up to 50% of the electric lighting energy used in buildings with daytime occupancies. (Goulding *et al.*, 1992). X. Efficient use of daylighting is reflected on the amount of energy used for lightening in significant, it reduces the energy needed by (30% - 77%), (Doulos *et al.*, 2008, Ihm *et al.*, 2009, Li *et al.*, 2006) and according to Boubekri Mohamad (2008), by (20 – 40%) of the electricity used in lighting and cooling can be achieved with the proper use of daylight photo sensors along with other energy-saving systems.

Neural light is more efficient than electrical light, by providing more light for less heat than artificial light (Leung, 2011). For example, at a given level of illumination, tungsten light produces between 5 and 14 times more heat than daylight (Baker & Steemer, 2000).

As a consequence, daylight also lowers the cooling requirements of a building up to 15% (Muhs, 2000).

Energy savings cannot be realized in daylight buildings unless the electric lights are dimmed or switched to correspond with the amount of available daylight. An evaluation of currently available responsive control systems has shown that energy savings of up to 40%, compared to a noncontrolled system, have been found in daylit zones. (Ruck *et al.* 2000)

The challenge facing daylighting practice is the cost. Costs have always been an important consideration for lighting applications, the balance between first and operating costs changing as the price of electricity has changed. The price of electricity varies with the source of fuel. In the UK, recent increases in demand for oil and gas and reductions in supply have resulted in dramatic increases in the price of electricity. Whatever the cause, any increase in the cost of electricity implies a shift in emphasis to operating costs and enthusiasm for technologies that minimize electricity consumption and maximize energy efficiency, together with a closer examination of the basis of many lighting recommendations. (Boyce & Raynham, 2009).

2.5 Design Tools

Design tools play a significant role in the decision-making process that characterizes daylighting design in a building project. These tools must fit the most significant phases of an architectural project, where important decisions regarding daylighting strategies are taken. The large number of tools existing today gives the building designers the possibility of selecting the one most appropriate for their needs. According to (Ruckert *et al.*, 2000) Daylighting design tools include:

- Simplified tools, which are probably more applicable in the early design phases and are best suited for basic design problems (simple openings)
- Computer based tools, which can handle advanced daylighting systems and provide a vast variety of different deliverables (image rendering, visual comfort calculation, etc.); and
- Physical models, which are well mastered and shared by building design professionals.

Currently available daylighting design tools can provide:

- Visualization of a luminous environment of a given daylighting design
- Prediction of daylighting factors in a space lit by diffuse daylight
- Identification of potential glare sources and evaluation of visual comfort indexes
- Prediction of potential energy savings achievable through daylighting; and
- Control of the penetration of sunrays and visualization of the dynamic behavior of Sunlight.

2.5.1 Simplified tools

The simplified design tools available use a large variety of calculation techniques and performance evaluation methods, ranging from rules of thumb and mathematical formulas to simple experimental equipment based on easy-made scale models. Most of the available simplified design tools reflect the days where daylighting design had to be approached without the support of any computer technology: this is the case for empirical equations, tables, nomograms, diagrams and protractors. With the advent of computers at almost every workspace, a certain number of simplified methods benefited from the advantage offered by this technology and have been adapted to that purpose.

Most of the simplified tools however, have significant drawbacks for practitioners, in that:

- They are limited in the complexity they can handle and can cope only with simple rectangular spaces
- They consider only simple openings, like rectangular windows and skylights, and no advanced daylighting systems; and
- They usually use daylight factor calculations, which suppose a standard overcast sky.

Consequently, computer based design tools have gained more importance in the last few years and have led to new developments and improved deliverables for their users.

2.5.2 Computer based tools

Computer based tools offer fewer limitations regarding the geometry and the photometry of the modeled architectural spaces, and allow larger and richer graphic outputs (illuminance contours and mapping). Image based daylighting computer tools have even improved these output features by providing synthetic imaging of the modelled spaces: they belong today to the common architectural design practice. Most of these tools have now been transferred to the PC world, and some of them have been linked to common CAD programs of the architectural domain, which lead to easier input and handling of geometric data.

Three simulation packages have been compared using a realistic situation, Lightscape, Specter and Radiance. The resulting luminances demonstrated similar results although on average, Radiance was the better performer (Khodulev & Kopylov, 1996).

Most of the packages give useful results. The Radiance package produces a consistent level of accuracy. There are now several plug-in packages for AutoCAD, which provide the connection between the CAD drawing and the data requirements for Radiance.

2.5.3 Physical models

Physical models are used extensively for daylighting design. The main advantages of this approach compared to other design methods are that:

- Building design professionals can use scale models as design tools to study various aspects of the building; and
- When properly constructed, scale models portray the distribution of daylight within the model room almost exactly as in a full size room, due to the extremely small size of light wavelengths. The scale chosen will depend on the function of the daylighting purpose.

Sky simulators offer reliable and reproducible conditions that simulate daylight under real skies. Some new sky simulator configurations, such as those used in the International Energy Agency's research, are based on a scanning process (Tregenza, 1989, Michel et al., 1995). These types of simulators have numerous advantages as compared with other sky simulators, including a close match to the sky measuring format of the International Daylighting Measuring Program (IDMP), reproductions of all existing standards or statistical sky models and contributing to lower construction, maintenance and operation costs.

No design tool will ever replace designers themselves, who must make the choices involved in the daylighting design of a building. However, these tools can accompany the designer in a creative process of devising an enjoyable and productive built environment while saving energy through the use of daylighting.

2.6 Daylight Availability and Sky Condition

The condition of daylight can be very dependent on the outdoor environment. The location of building, orientation, external ground reflectance, surrounding obstacles and sky conditions all contribute to the differences in the daylighting condition. Among those mentioned above, climatic conditions and sky conditions are closely related to daylight availability.

All daylight technologies require luminance distribution from the sun. The sun and its rays which are scattered over the sky produce direct and diffuse daylight. Some of the daylight goes to buildings; some is reflected off the ground. The daily and seasonal movements of the sun are predictable. The pattern of daylight luminance through cloud modulating can also be recognizable. Therefore, the availability of sunlight at any time can be determined by examining different daylight parameters, such as solar azimuth angle, latitude, orientation of the building, climate and specific weather data.

Skylight is diffuse light caused by the refraction and reflection of sunlight as it passes through the atmosphere. Under clear skies, the very small size of the atmospheric particles causes only the wavelengths of light in the blue portion of the spectrum to be refracted (440–490 nm), imparting a blue color to the sky (around 12,000 - 20,000 K color temperature). Under overcast skies the relatively larger water particles diffusely refract/reflect all wavelengths equally in all directions. This results in a white colored sky, about three times brighter at the zenith than at the horizon.

Unless sunlight has been re-directed, direct sunlight itself is not a practical source of illumination, since it is far too intense and produces a high degree of glare. As a result, only sky radiation can be considered as the light source. A bright summer sky with white clouds may have an average total luminance of up to 20000 cd m⁻², whereas a stormy overcast sky may have as little as 2000 cdm⁻², a ratio of 10 to 1 (Robbins 1986).

Clear and overcast sky conditions provide different characteristic lighting patterns. Generally, overcast skies provide deeper penetration of skylight into a room. However, the light from overcast skies provides a softer set of shadow patterns and sometimes more glare than from a clear sky. Glare is caused by the extreme brightness of the overcast sky extending to the horizon. Clear sky conditions, on the other hand, provide a source of light that establishes sharp shadow patterns. Glare is usually caused by excessive contrast between the window aperture and the surrounding surfaces (Leung, 2011).

CIE Sky conditions

The Commission International de l'Eclairage (CIE) models for clear and overcast sky conditions are theoretical representations of standard clear and overcast skies, and predict sky luminance rather than exterior illuminance falling on a horizontal or vertical surface (CIE Standard 1973, 2003). It has been used worldwide as a standard for all kinds of daylighting evaluations.

The CIE has defined two basic sky conditions. The overcast sky may have uniform or non-uniform luminance distribution, as defined by the (CIE Standard 1973). The clear sky with sun has a luminous distribution that can be divided into two quantities: the diffuse sky brightness, which is independent of orientation; and the circumsolar component, which is dependent upon solar location and atmospheric conditions (Kittler, 1965). The direct component (the sunlight) is usually considered separately and is dependent upon solar location and atmospheric conditions (CIE Standard 1973). The CIE overcast sky model was proposed by Moon and Spencer (1942) as a basis for design in climates of the world where overcast conditions were sufficiently prevalent to justify using an overcast sky model as the critical design condition.

Figure (2.4) shows an anisotropic picture describing clear sky condition. The figure can be compared with Figure (2.5) which is an overcast sky condition scenario. In Figure (2.4) , direct radiation under clear skies is refracted and reflected as it passes through the atmosphere. The coefficients range from 5 to 1 where the greatest is at the sun and the least is ninety degrees from the sun.

The overcast sky condition in Figure (2.5) is different. Large water particles attenuate all wavelengths of the direct beam equally in all directions, resulting in solar radiation between zeniths to horizon decreasing in such a way that the zenith is three times brighter than the horizon (Leung, 2011).

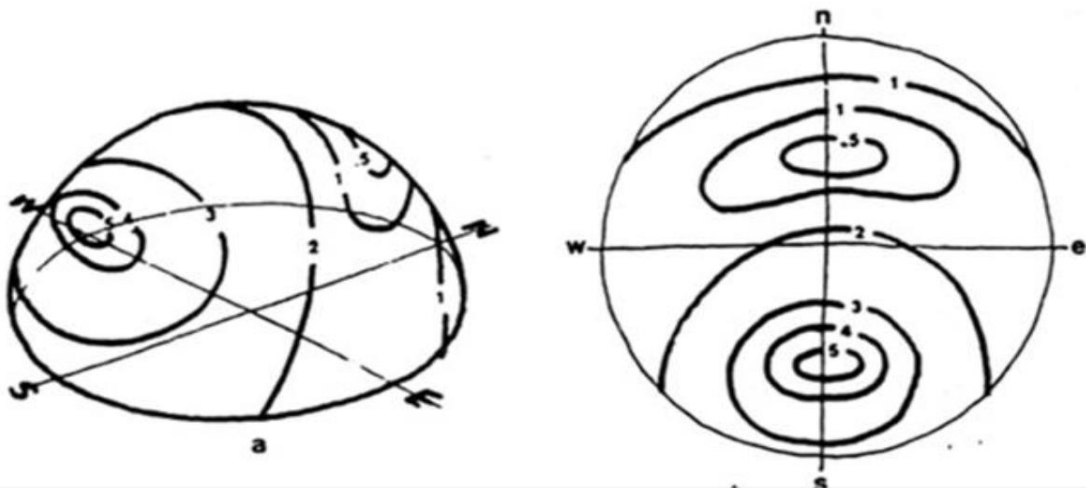

Figure 2.4: Diffuse sky radiation distribution under clear sky conditions

Source: (Moore, F 1991)

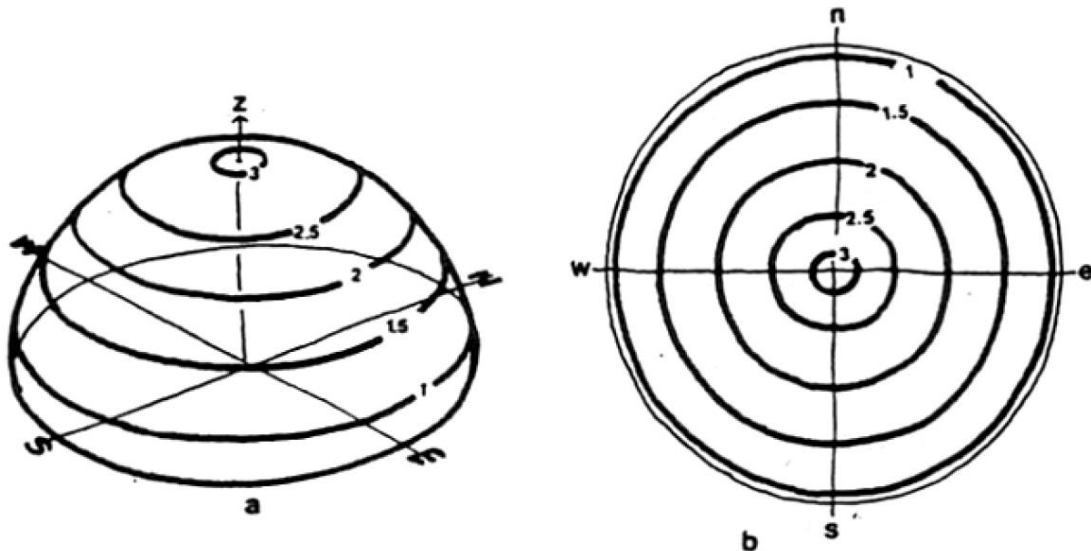

Figure 2.5: Diffuse sky radiation distribution under overcast sky conditions
Source: (Moore, F. 1991)

2.7 Daylighting technologies

Numerous lighting technologies and devices have been designed and developed, from simple windows to advanced technology like fiber optics.

The increasing number of highly sophisticated daylight devices and the dependence of these devices on many building parameters make it hard for building designers to easily choose and utilize them. Freewan (2014) presents a new matrix of daylight devices to help building designers correctly choose the most proper device in the right time during the building design process.

The new system matrix includes four levels for categorizing the daylighting technologies:

- 1- The first level divides the technologies into:
 - conceptual technologies;
 - design element technologies synthesis stage; and
 - Adding the devices to the design during the evaluation stage.
- 2- The second level divides the design elements into:
 - wall technologies and
 - Roof technologies.
- 3- The third level divides the wall and roof technologies into:
 - Perimeter daylighting technologies, which are related to direct entering technologies and
 - Deep daylighting technologies, which include guiding and trans-ported technologies.
- 4- The fourth level shows the working mechanism of the devices. This level shows how a device utilizes the daylight such as; transmittance, reflection, transportation via reflection. Working mechanism is involved in the following explanation variables:
 - Direct means; utilizing the daylight directly in a space depends mostly on light transmittance.

- Indirect means; depending on reflection and/or transport as well as on light transmittance.
- Dependent means; the device depends on other building elements to perform its functions.
- Independent means: the device does not depend on other parameters to utilize the light.
- Design process; shows when a designer needs to think of using the devices.
- Building elements; building elements that the devices will be installed and integrated with.

Thus the architect can select the appropriate strategy to light interior spaces being designed according to the stage in design process. The solution could take two forms: conceptual design based on daylighting, or easy selection of a system for a problem a designer faces while designing a building.

2.7.1 Conceptual decision and elements

These include technologies that need consideration at the conceptual stages in the design process. Therefore, they have a direct effect on the form, plan and facade of the building being designed. Such as courtyard, atrium, light well, building layout and orientation.

2.7.1.1. Courtyard

The courtyard is an unroofed space within a building that brings light and ventilates surrounded spaces. It is a traditional device used for ventilation and privacy, daylighting, heat gain control and social functions.

Using courtyard as a daylight device requires a decision in the early stages of the design process. it helps light deep spaces by creating open areas in large area buildings Fig. (2.6). The courtyard area, wall height, wall and floor materials and colors, walls shape, and orientation are the main parameters to be considered when designing the courtyard as a daylight device (Aldawoud& Clark, 2008; Belakehal, TabetAoul, &Bennadji, 2004).

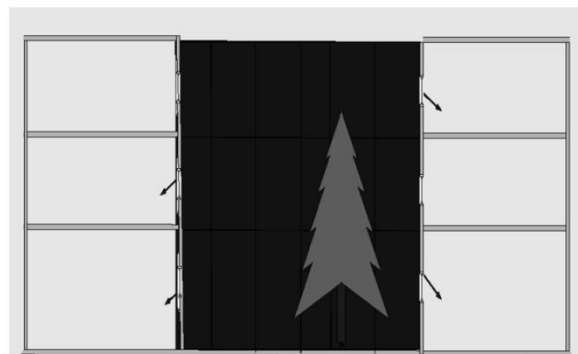

Figure 2.6: Courtyard
Source: (Moore, F. 1991)

2.7.1.2. Atrium

The modern atrium is a controlled courtyard used in high, large buildings Fig. (2.7). The atrium requires a decision in the early stage of design process, because it has direct effects on a building form, relation to outdoor environment, external walls area, circulation systems and spatial relations. It helps light the lower floors by creating open glazed areas in large area buildings. Littlefair (2002); Calcagni&Paroncini (2004); Samant and Yang (2007) studied the main characteristics of the atrium's shape affect its daylighting performance. The atrium area, wall height, wall and floor materials and colours, walls shape, and orientation are the main parameters to be considered when designing the atrium as a daylight device.

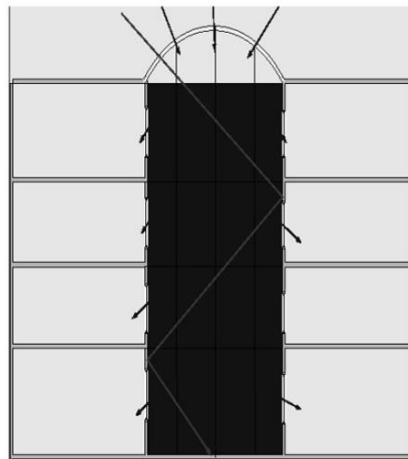

Figure 2.7: Atrium
Source: (Moore, F. 1991)

2.7.1.3. Light-well

A light-well is an open space, with a small area, reaching from the roof down several storeys to the ground floor or basement level. It is used to light spaces without a direct connection to outside. It can be used for lighting and ventilation, and also to increase the depth of buildings Fig. (2.8). It requires a decision in the early stage of design process because it has direct effects on how designers solve ventilation and light issues in intermediate spaces. It helps light lower floors by creating open glazed areas in large area buildings.

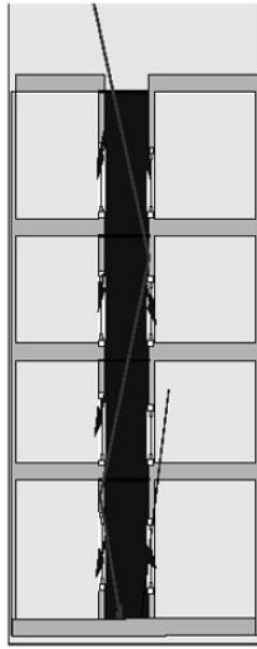

Figure 2.8: Atrium

Source: (Moore, F. 1991)

2.7.1.4. Building form and orientation

Building form has a great influence on the daylight environment inside spaces. Increasing a building's exterior surface area enlarges the area exposed to daylight and the sky component, thus enhancing the daylight level inside the building. In addition, building forms with self-shading could improve the daylight environment by excluding direct sunrays and increasing the sky and diffuse components. On the other hand, forms with small exterior wall area decrease the daylight level in building spaces and create spaces without direct contact to outside. Building orientation could affect the quality and quantity of day-light. Building surfaces oriented towards the south will be more exposed to direct sun rays, so shading devices are needed to exclude the direct sun to avoid overheating and glare. On the other hand, north-facing surfaces can make use of daylight without direct sunrays; increasing window area improves daylight quantity without overheating. East- and west-facing face, ads need more attention to avoid overheating and glare in the morning and evening, respectively.

2.7.1.5. Building elements

Building elements include those that can be installed into building surfaces like walls, ceilings and floors. Elements could be installed inside building surfaces or attached to the surfaces. Entering technologies are used to utilize the space with daylight using direct contact with outside, like windows. Reflecting technologies are used to serve spaces by reflecting or redirecting the light to the space, like light shelves. Transporting technologies are used to transport light over a long distance deep into spaces without direct contact with outside, like light pipes, and light rods.

2.7.1.6. Direct entry device

1. Window

The traditional daylighting system, the window is the simplest daylight technology and has many functions. It is used for ventilation and view, as well as for daylighting. Al-Sallal (1998) studied the optimum window size to achieve integration between the three functions of the window. Saridar&Elkadi (2002) studied the impact of facade configuration in terms of window-to-wall ratio, fenestration factor, effective apertures on daylighting, and energy used in buildings. It requires an external wall with direct contact with outdoor environment. Its width, height, shape and location are the main variables need to be considered when designing a window.

2. Clerestory

An opening in the upper part of an exterior wall Fig.(2.9). It helps to increase the illuminance level deep in a space (IEA-Task-21, 1999). Hayter, Torcellini, Eastment, &Judkoff (2000) showed that a clerestory helps to improve the daylighting environment and retail sale. It is a high window above the roof and can light deep spaces. It requires high building, an external wall and a large area.

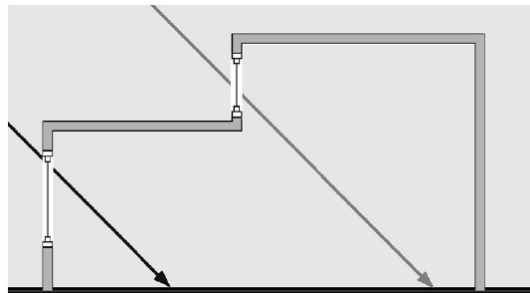

Figure 2.9: Clerestory
Source: (Leung, 2011)

3. Skylight

A roof opening used to utilize the daylight through the roof for the upper floors or single floor buildings Fig. (2.10). IEA-Task-21 (1999) provides a full detailed description on how to use the skylight, including size, spacing and glazing properties. Its selection depends on its orientation, shape, size and placement on the roof.

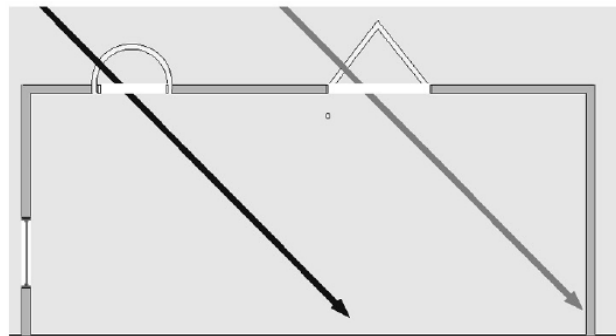

Figure 2.10: Clerestory
Source: (Leung, 2011)

2.7.1.7. Reflection technologies

These include devices like light shelves, louvres and laser-cutpanels (LCPs) used to reflect the light deep into a space and provide shade to frontal building parts.

1. Lightshelf

A horizontal or inclined plane projected over a view window. It may be external, internal, one or both with a considerable reflective upper surface Fig. (2.11). As a shading device, it blocks direct sunlight from entering the room, thus reducing heat gain and glare. Its working mechanism depends on reflecting the light to the ceiling then to the working plane. The variables influencing its performance are reflectance factor, width, height, ceiling height and shape.

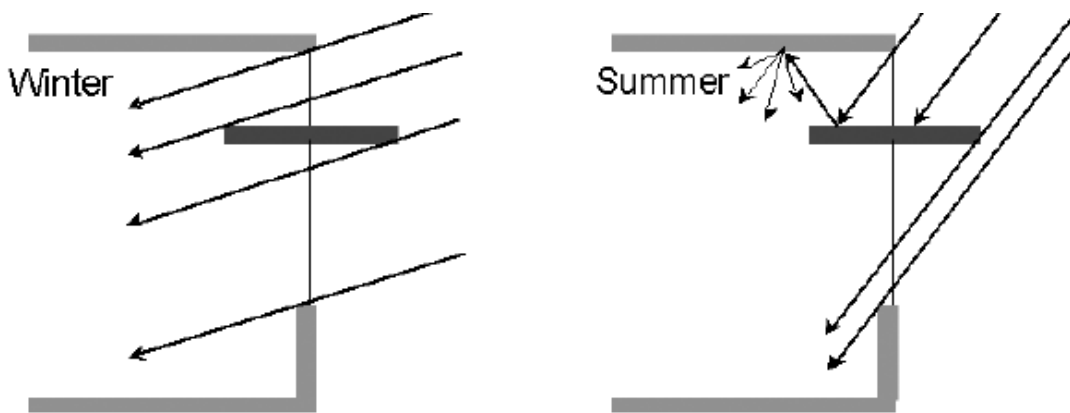

Figure 2.11: Sun ray guided by light shelf in winter and summer time

Source: (Ruck *et al.*, 2000)

2. Louvres

Louvres are composed of multiple horizontal, vertical, or sloping slats with different shapes and surface finishes Fig. (2.12). Louvres and blinds may be external or internal, and partially or completely obstruct the sun's rays and view. They can be used in any direction and latitude. Louvres help to control excessive sun rays, reflecting daylight to the ceiling. Variables affecting louvre daylight performance include width, distance between louvres, orientation and ceiling height.

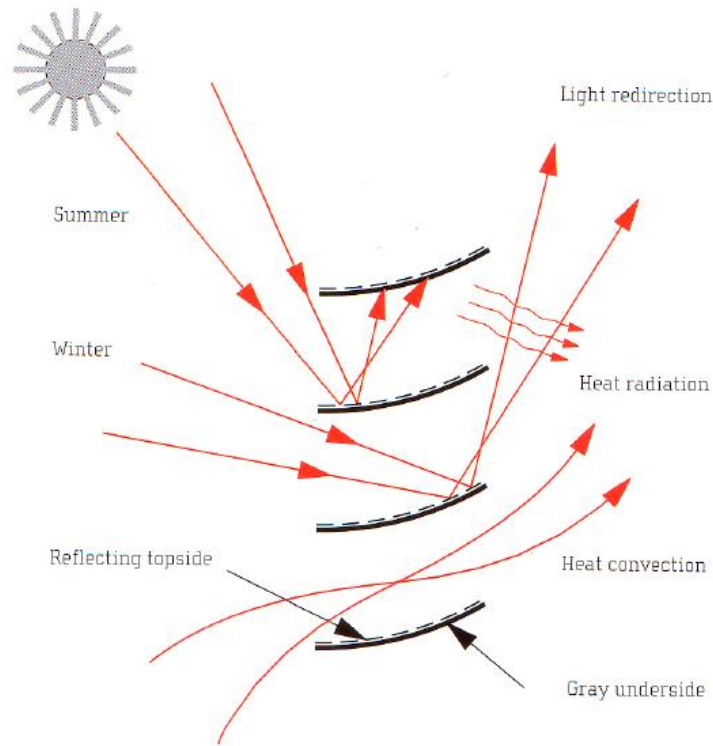

Figure 2.12: Properties of a mirror reflective louvre

Source: (Koster, 2004)

3. Prismatic panels

These are thin, planar, sawtooth devices made of clear acrylic that are used in temperate climates to redirect or refract daylight. These can be used as shading and daylighting devices as they can refract direct sunlight while transmitting diffuse skylight and redirecting the light to the rear part. They can be fixed or sun-tracking, and can be applied in any direction (IEA-Task-21, 1999). The design of prismatic panels depends on solar angles, sawtooth dimension, depth and the angle of the panels. Prismatic panels can improve the uniformity and redirect light to the rear part, thus increasing the illuminance level in the rear of the space. The panels can be used under clear and overcast sky conditions Fig. (2.13).

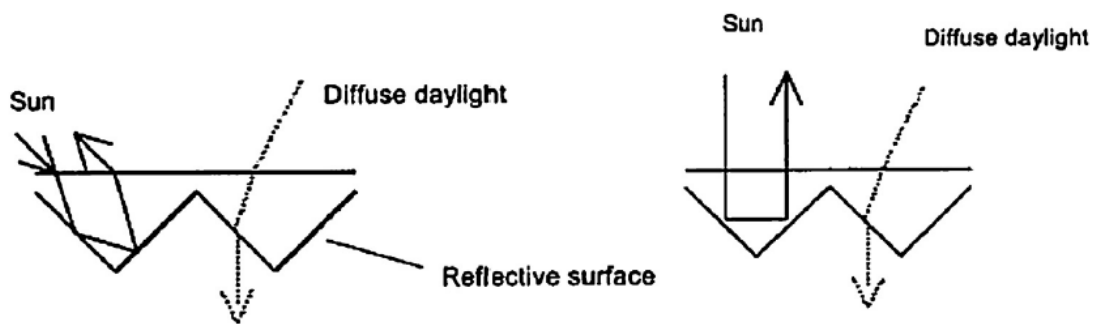

Figure 2.13: Prismatic panels

Source: (Ruck et al., 2000)

4. Light-guiding shade (LGS)

An external shading system that redirects sunlight and skylight onto the ceiling, LGS consists of a diffusing glass aperture and two reflectors designed to direct the diffuse light from the aperture into a building at angles within a specified angular range. The device was created in response to the need for daylighting technologies that can utilize direct sunlight while maintaining visual and thermal comfort in sub-tropical buildings (Greenup & Edmonds, 2004). Edmonds and Greenup (2002) showed that the LGS has high efficiency, typically about 50%, and it reflects light to the ceiling, which in turn reflects it to working surfaces as diffuse light. Building height, ceiling reflectance, orientation and LGS material reflectance affect the LGS daylight performance (Fig. 2.14).

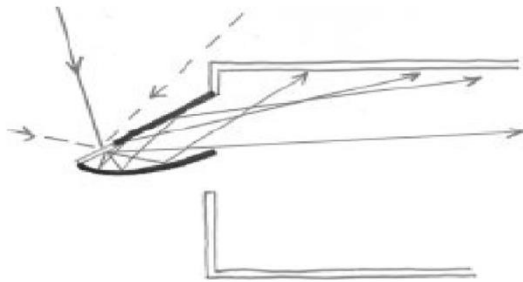

Figure 2.14: Light-guiding shade (LGS)

Source: (Ruck et al., 2000)

5. Sun-directing glass concave

An acrylic element stacked vertically within a double-glazed unit, sun-directing glass concave can redirect direct sunlight from all angles of incidence onto the ceiling, thus working both as a shading and a daylighting system (IEA-Task-21, 1999). An important part of the system is the ceiling, which receives the redirected light and reflects it down to the task areas. Tilted reflective elements to the ceiling can be used to concentrate the reflected light to specific task areas. A simple white ceiling also works well in redirecting light; the resulting illumination will be more diffuse. It works better under clear sky conditions, as it improves the uniformity and redirects light to the rear part, while it decreases the illuminance level under overcast conditions.

6. Laser cut panel (LCP)

An innovative daylight system used to redirect high-angle light upwards towards the ceiling by total interior reflections and to redirect low-angle light or diffuse it downwards by internal refractions (Fig. 2.15), LCP is used to reflect light deep into rooms. LCP is an optical material produced by making fine parallel laser cuts in a sheet of thin panel of clear acrylic material (Edmonds, 1993; Reppel & Edmonds, 1998; Edmonds & Pearce, 1999). Panel width and distance between lines in addition to ceiling height affect its performance.

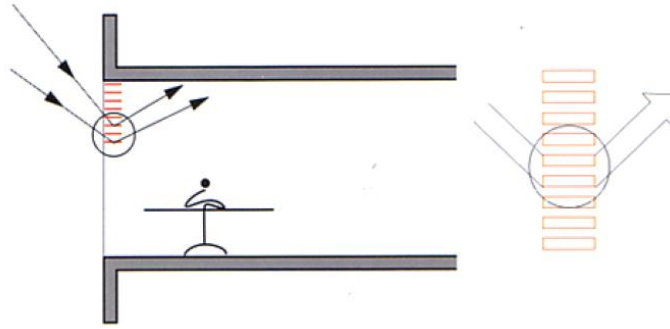

Figure 2.15: Laser cut panel light guiding principle

Source: (Koster, 2004)

2.7.1.8. Transport technologies

Light pipes, light rods and anidolic technologies are used to transport light over a long distance to non-perimeter zones. All of them transport light by reflection into deep zones independently.

1. Lightpipe

Lightpipe is an advanced daylighting technology used to bring light to a space with no direct contact to outside Fig. (2.16). Oakley, Riffat, & Shao (2000) investigated the effect of a light pipe's length, diameter, bend and shape of luminaire and space characteristics on the performance of the light pipe. Light pipe length, diameter and reflectance affect its performance

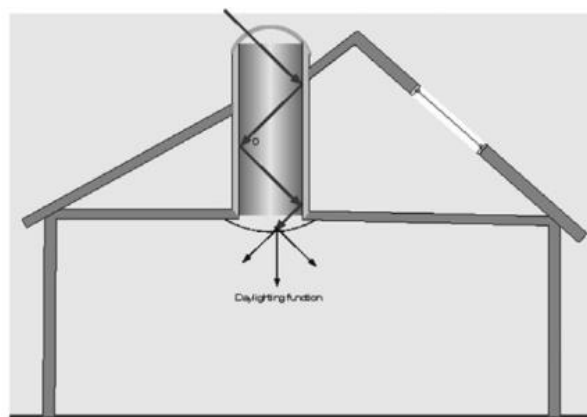

Figure 2.16: Lightpipe guiding principle

Source: (Leung, 2011)

2. Anidolic system

Anidolic system Fig. (2.17) depends on non-optical materials and total reflections to collect daylight and transport it deep into the space. (Wittkopf, 2007).The anidolic system shows a good improvement in the day-light level in the back part of a room and improves the uniformityof distribution in climates of high luminosity. The openingsize, reflectance materials, and channels depth affect its daylightperformance.

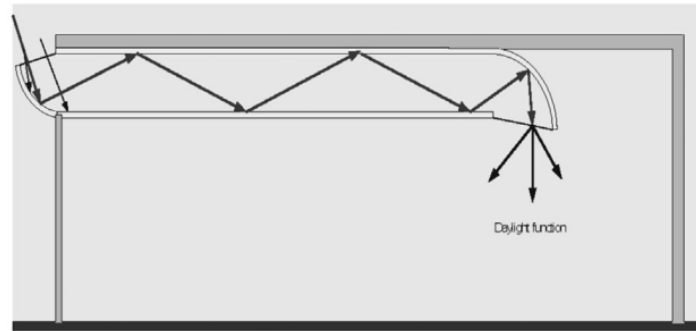

Figure 2.17: Anidolic system principle

Source: (Leung, 2011)

2.8 Conclusion

Chapter 2 has affirmed The Global Energy Problem, and The Role of Building and window to increase maximum daylighting gains

This Chapter has presented the benefits of sunlight on human well-being and work productivity in daylighting spaces. There are so many daylighting systems that contribute to the improvement of lighting level and its distribution. Building design with the aid of advanced daylighting system can make the interior space more comfortable, happier, pleasing and also productive. This will have an impact on the building operating cost and eventually also reduce the energy consumptions.

Chapter 3: Energy situation and the need of daylighting in Gaza Strip residential buildings

3.1 Introduction

Many challenges face the residential sector in Gaza. The main problem is that Gaza strip has almost no conventional energy sources, wherefore Gaza Strip is almost totally dependent on the electricity and fossil fuel imported from Israel (Electricity Distribution Company for Gaza provinces, 2014). Gaza Strip has been suffering from a serve energy deficit and a worsening balance between supply and demand in recent years. It is evident that using fossil fuel to produce energy has adverse impacts on the environment and human health through emission of greenhouse gases.

In other hand, atmospheric environment in Gaza Strip doesn't have any follow ups, or studies that enable the researcher & planner to put a hand on its fact in a correct scientific way. Generally, environmental problems include desertification, salination of fresh water, sewage treatment, water-borne disease, soil degradation and depletion and contamination of underground water resources, (Central Intelligence Agency, 2012).

This chapter is carried out to identify the energy situation in Gaza Strip especially in the domestic sector and to explain the need of daylighting in residential buildings in Gaza Strip.

3.2 Overview on Gaza Strip Situation

Gaza strip is a small area in the world that has special environment features and problems. This study summarizes these features and the environmental problems including location and topography, population density, climate, urban geometry and environmental issues.

3.2.1 Location and topography

Gaza Strip lies on the Eastern coast of the Mediterranean Sea, at 31, 25° N and 34, 20° E. As shown in figure (3.1) the Strip borders are: Egypt on the southwest with 11km long, occupied lands on the east and north, 51km long. It is about 40 kilometers long, and between 6 and 12 kilometers wide, with a total area of 360 square kilometers. The terrain

roughly, is flat or rolling, with dunes near the coast. The height from sea level does not increase more than 50 m generally and in some areas 10m, (Ministry of local government, 2004).

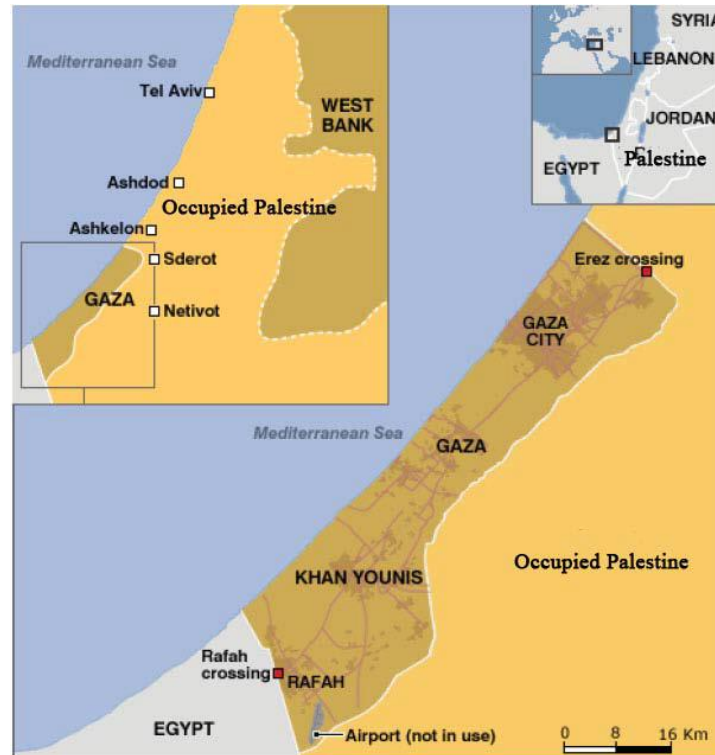

Figure (3.1): Gaza Strip plan, (Droege, 2009) adapted by author

3.2.2 Population Density

The population of Gaza Strip census is about 1.85 million people, most of them descendants of refugees. One million of the population roughly was considered refugees, although the vast majority of them were actually born in Gaza Strip, Population growth is 3.4 percent per year, (Palestinian Central Bureau of statistics, 2015). Therefore, Gaza Strip is one of the highest densities in the world. According to the ministry of local government, the issued constructions permits by municipalities increased a double from year 2000 to year 2011. The municipality of Gaza alone issued 1400 permits in year 2000, this number increased to 3500 permits in year 2011, (Ministry of local government, 2012). As a result, buildings are in a compact urban setting. The residential building surfaces in Gaza, mostly built in concrete, have very high heat storage capacity especially due to low albedo level. After sunset, sensible heat flux from these do not drop rapidly due to high thermal capacity

of the combined mass of buildings. This leads to warming of air and a rise in nocturnal UHI.

3.2.3 General Characters of Urban Geometry in Gaza

Gaza city is considered the main city in Gaza Strip. It has the main view to the northern western direction where the Mediterranean Sea is the main mark of the region. The urban geometry complexes of Gaza are considered as dense in construction, high degree of impervious surfaces (asphalt, concrete, cement, and interlock), very low density of vegetation within the micro-environment, high heat storage capacity of construction material, and the geometry block can easily traps the radiation that create air stagnation. Generally, street takes parallel and perpendicular orientations to the sea coast. See figure (3.2). Thus, land plots and buildings take the same orientations. The main forms of buildings range between the square and rectangular as the rectangular shape is the most popular shape in parcels, (Abed, 2012).



Figure (3.2): Street and parcels orientations in Gaza Strip, (open street map, 2015) (Street and parcels take parallel and perpendicular orientations to the sea coast in Gaza Strip.)

The urban fabric may have different characteristics from a small village than a city or a refugee camps, but all cities, villages, and refugee camps have common elements and components forming an urban fabric. Downtowns and neighborhoods are the two main types of development for urban areas; others may include educational institutions, industrial areas or individual buildings. Neighborhoods are primary residential areas, but

also include commercial uses such as grocery stores, restaurants, and small offices. Neighborhoods have many types of buildings: detached houses, villas, and apartments. Landscape elements are less effective especially for those high buildings and for the absence of outdoor functions in apartment buildings and office building, (Hadid, 2002).

3.2.4 Climate

Gaza Strip forms transitional zone between humid costly area and dry desert area. Gaza Strip is located within the solar belt countries and considered as one of the highest solar potential energy, the climate conditions of Palestine is sunny about 300 days a year (Hussein, et al. 2011).)and the climate of Gaza Strip is characterized by its location in hot humid region specifically on longitude 34° 26' east and latitude 31° 10' north (Elaydi, et al. 2013). And according to Köppen climate classification (the most widely used climate classification systems), Gaza Strip has a moderate Mediterranean climate, with rainy, mild, short winters, unpredictable springs and autumns, and dry, warm, hot, long summer.

For most parts of the year Gaza Strip climate remains enjoyable. The Palestinian atmosphere is fresh and the air is unadulterated at the region. Main radiant temperature of Gaza Strip ranges from 25°C in the summer season to 13°C in the winter season, see figure (3.3). Comfort level is measured in Gaza Strip by mean air temperature that ranges from 15-20 °C, (Ministry of local government, 2004). Rainfall in Gaza Strip is very restricted which mostly occurs in the months of November through February. It varies from north (450 mm) to south (200 mm). Rain is the main source of water in Palestine as it provides the underground water reservoir.

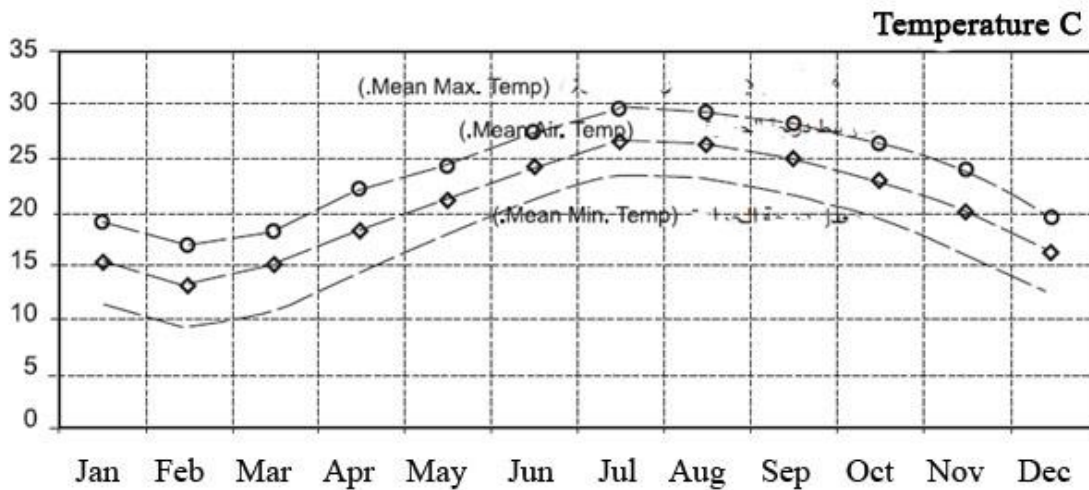

Figure (3.3): The annual average temperature (C°) in Gaza Strip, (Ministry of local government, 2004) adapted by author Also, as shown in figure (3.4), relative humidity ranges in the summer from 65% in day and 85% at night. It ranges in the winter from 60% in day and 80% at night, (Ministry of local government, 2004).

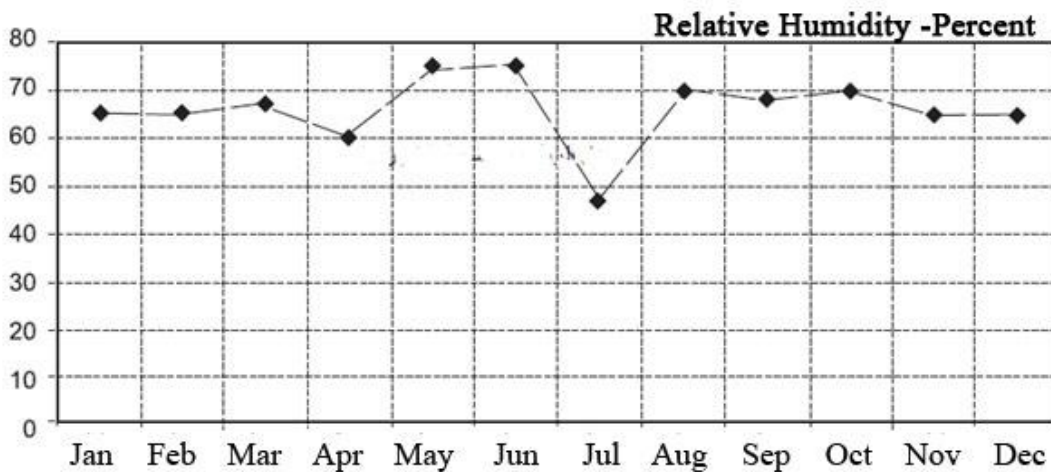

Figure (3.4): The annual average relative humidity (%) in Gaza Strip, (Ministry of local government, 2004) adapted by author Prevailing wind in the summer is northern western wind. Its speed ranges from 3.9 m/s in the afternoon and soon lowers in the night to half of daily speed. In the winter the direction of wind change to southern western and its speed reach in sometimes to 18 m/s, (Ministry of local government, 2004). Show figure (3.5)

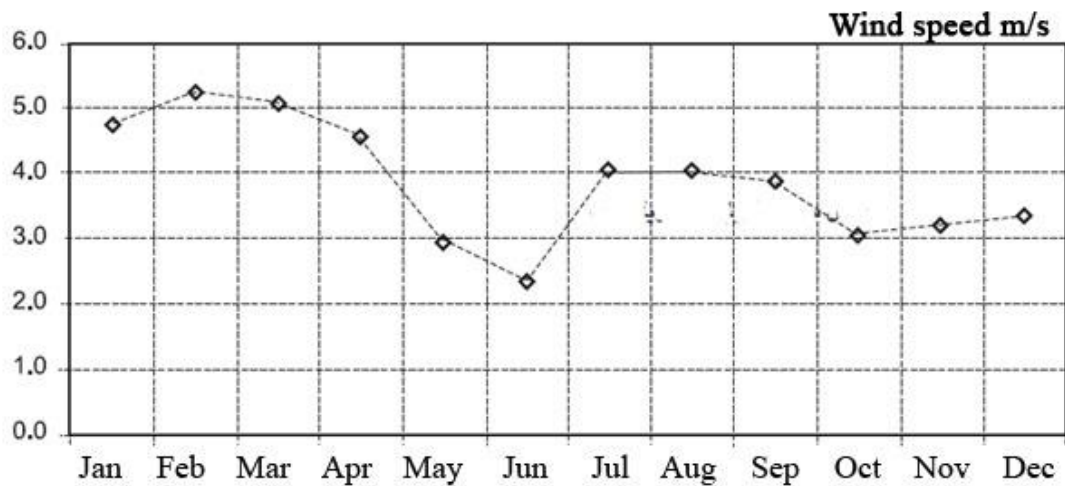

Figure (3.5): the annual average wind speed (m/s) in Gaza Strip, (Ministry of local government, 2004) adapted by author Solar radiation is large in summer, but in winter it less than one-third the amount of radiation in summer. It has approximately 2861 annual sunshine hours throughout the year. The daily average solar radiation on a horizontal surface is about 222 W/m² and this value varies during the day and the year, (Ministry of local government, 2004).

3.3 Energy Situation in Gaza Strip

The main natural resources in Gaza Strip are arable lands that forms about a third of the Strip, and recently natural gas was discovered, (Central Intelligence Agency, 2012). The energy sector plays a significant role in improving the national economy and providing employment opportunities in Palestine. Generally, energy sources consist of the energy generated by petroleum and natural gas, electricity, and renewable energy (including solar power, wind power, and energy generated from burning wood, peat, etc.). With the exception of renewable energy, the Palestinian energy sector has special resources and in the same time inability to fully exploit available ones, causing it to largely depend on imported fossil fuels from Israel, (Abu-Hafeetha, 2009). Gaza Strip is considered as one of the poorest countries in energy resources and consumption compared to developed countries. Beside unusual position for Gaza Strip, energy demand increase as the increase of population, services, and welfare means. Energy generated by gas and petroleum derivate forms 51% of total consumption in the local market. A major portion of this energy is used as fuel by transportation, residential, and factories sectors. Large part of this fuel (benzene and diesel) is used by Gaza Electricity Generation Plant for electricity production for previous sectors, (Palestinian national plan, 2011). Liquefied petroleum gas

for cooking and heating gas is used largely in domestic sector because residential buildings form greater percentage of buildings in Gaza strip, (ministry of local government, 2012). As shown in following diagram (3.6) Residential sector is the first sector that consumed the imported energy from 1996 to 2005 in total Palestine with roughly 64%, (Abu-Hafeetha, 2009). Residential buildings in Gaza Strip are the largest consumer of energy that was estimated as 70% of the total amount energy consumed, (PENRA, 2012).

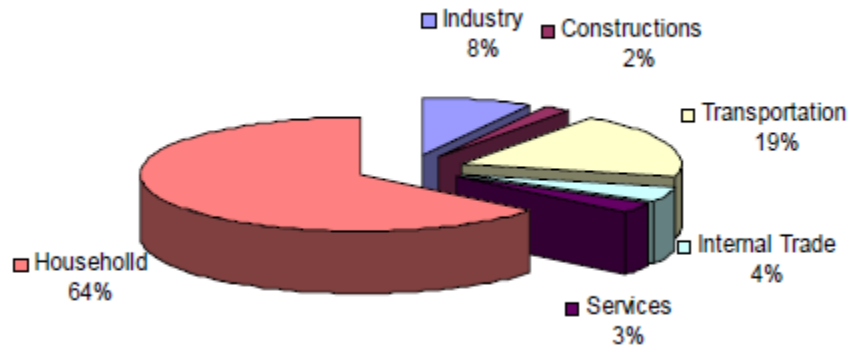

Figure (3.6): The percentage of consuming imported Energy by sectors in 2005, (Abu-Hafeetha, 2009)

Electricity: There is a clear lack in electricity supply to Gaza Strip, the electricity energy has been aggravation since 2007 because of the economic siege imposed on the Strip (Musalam, 2013). Statistics show that Gaza Strip needs 500 MW of electricity. In reality, the Strip receives only 152 MW. The Israeli Electricity Company provides 120 MW, Egypt provides 32 MW which allocated to Rafah province according to electricity technical nature, Egypt only provides half of Rafah needs. On the other hand, Gaza Power Plant does not provide anything (after the last war at 2014). But when repaired, it will provide 60 MW. Therefore, Gaza Strip shortage of electricity is about 70% (Electricity Distribution Company for Gaza provinces, 2014).

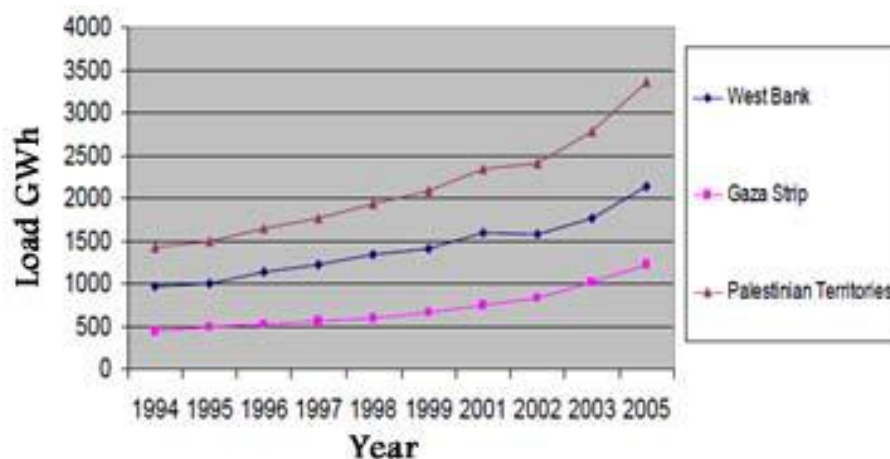

Figure (3.7): Electricity consumption in Palestine territory (GWh) from 1994-2005, (Yasin, 2008)

Fossil fuels: In 2000, liquefied petroleum gas (LPG) was discovered in the Palestinian Territories at large quantities. Two fields in the Mediterranean Sea were discovered in the cost of Gaza Strip. One of them is entirely within the regional waters while 67% of the second field is located in the Palestinian territory and 33% in areas controlled by Israel, (Abu-Hafeetha, 2009). This gas is not used by Palestinians because of occupation. Generally, petroleum products (gas, kerosene, gasoline, diesel, oil, and liquefied petroleum gas (LPG)) are imported from Israel or Egypt. As seen in the following diagram (3.8), using the much of it go to domestic activities or use as electricity that generated directly from electrical distribution company.

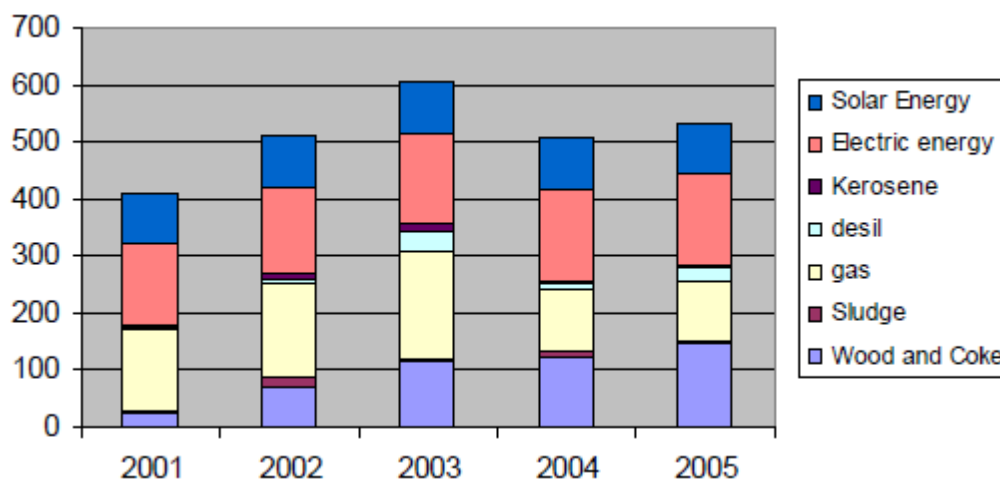

Figure (3.8): Energy Consumption in Residential Sector by Fuel (2001-2005), (Abu-Hafeetha, 2009) Gaza shortage of electricity and the increase in consumption of it motivate the architects towards looking for alternatives that contribute to reduce the dependence on air conditioner that increases usage of electricity in the last years.

3.4 Renewable Energy in Gaza Strip

Solar energy is considered the main renewable source of energy available in Gaza Strip because its geographic location nears the hot dry climate. Figure (3.9) shows the average duration of solar radiation in Gaza City. It is noticed that the mean sunshine duration range between (8-11) hours in summer period and between (5-7) hours in winter period which is useful for many applications. Solar heaters which are used to heat water are the most applicable application in Gaza houses, in addition to using it for lighting

during daylight hours. According to the Palestinian central bureau of statistics (2011), about 60.5 % of housing units in Gaza Strip use solar heaters.

There is a growing market to use Photovoltaic units, these units aren't frequently used in Gaza buildings due to its initial high cost which results in a high cost of electricity which estimated to be 3-5 times more than that obtained from the grid. Wind energy is another renewable source in Gaza Strip. The low annual average wind speed which is 3.8 m/s can't be used for considerable generation of electricity. However, it may be suitable for small wind turbines to be installed in residential buildings (Muhaisen, 2007). Also, the biomass energy (wood and agricultural waste) is only used in cooking and heating in rural areas (Ibrik, 2009).

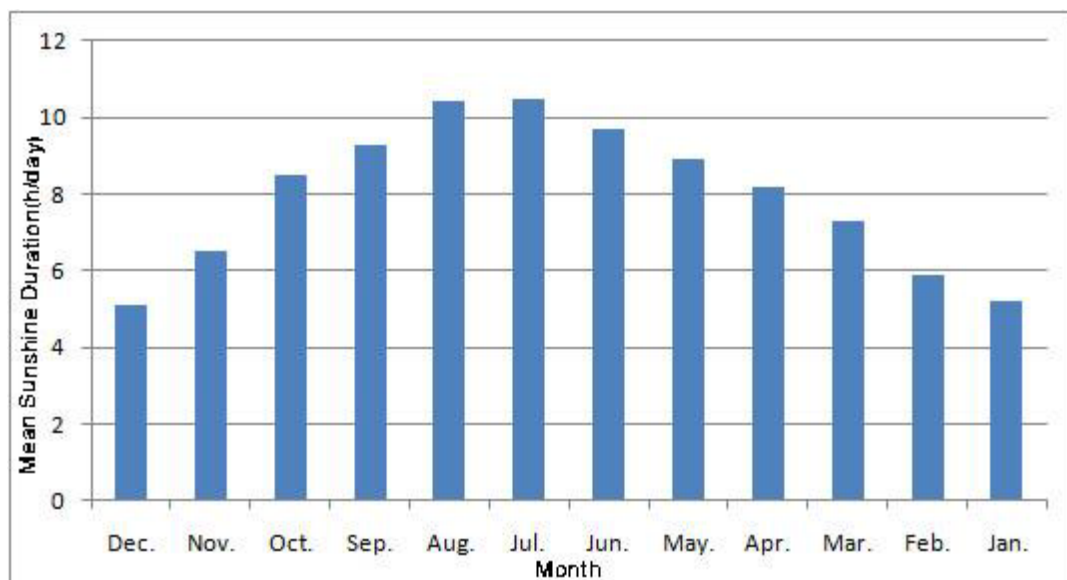

Figure (3.9): The average duration of solar radiation in Gaza City in year 2011

Source: Palestinian Meteorological Department, (2011)

3.5 Residential complexes in Gaza Strip

Residential buildings are considered the main sector in Gaza buildings. Detached buildings are the most commonly used style in residential complexes. The attached style is only found in the old town in Gaza city and it doesn't used in the present architecture of Gaza Strip. Building's density, height, area and spacing between them are determined according to the zoning district regulations. The maximum built site coverage ranges between 50% in multi storey buildings and 60% in zoning district (b) and 80% in zoning

district (c). The minimum area of parcel range between 250 m² in zoning district (b) and (c) and 1000 m² in multi-storey buildings. Spacing between buildings is determined according to the side and rear setback. Table (3.1) illustrates the main zoning district regulations in Gaza Strip (Alkahloot, 2006).

Table (3.1): Zoning district regulations in Gaza Strip
Source: Alkahloot (2006).

Area	The maximum built site coverage	Number of floors	Top	The minimum area of parcel	The front setbacks	The side and rear setbacks
Zoning district (b)	60%	5	3	250	3m	2/2/2m
Zoning district (c)	80%	5	4	250	2m	1/1/1m
Multi-storey buildings	50%	1.5*streets width	0.5*1.5* streets width	1000	3m	Side back= 10% of height and 15% of height

According to Hadid, (2002) residential buildings can be classified into two main types which are separate house and apartment building:

a. Separate House

The separate house is a popular style in the cities, towns and campus of Gaza Strip. The area of this style can be determined according to the owner ability and to accommodate the main functions which are 2-3 bedrooms, 1-2 bathrooms, kitchen, guest room, setting room, and balconies. Simple forms are using and the main materials are the concrete and hollow blocks walls, which are plastered and painted from both sides with light colors. Ventilation is the most characteristic of this style as the building is exposed to the environment from the four facades. Due to the absence of insulation, the upper floor usually gains much heat in summer time and losses heat in winter. A villa house is another type of this style for rich families. The area of such type is variable starting from 200 m² up to 500 m². Different forms can be utilized to create shades on the elevations.

b. Apartments Buildings

Residential apartment is a new concept in the Palestinian society. The needs of housing increased especially in cities and some villages. The areas for building purposes are small comparing to the demand of housing needs, especially in cities. This is another reason for the vertical expansion in apartments which can be classified as low-apartment building and tower-apartment. The areas of apartments vary from 80m² up to 180 m² with the same functions as in the separate house functions.

The design and form varies depending on number of apartments in the same floor. In most of the low-apartment buildings, 1, 2, or 3 apartments in the same level is the typical example, while the number of floors can reach 6 floors. Each apartment has three facades open to the natural environment in the best cases for ventilation and natural lighting. The building material is concrete. The number of floors can reach more than 15 floors in the tower apartments. Generally, The tower buildings are cool (with humidity) and windy (open to the west – the sea) in summer time, and cold in winter. Figure (3.10) shows a view of residential building in Gaza city.



Figure (3.10): View of residential building in Gaza city

Source: Hadid, (2002)

3.6 The need of daylighting

Most of multi-storey residential buildings are located in densely populated areas; the availability of daylight in these certain areas can be difficult due to the influence of the surrounding environment. Moreover, increasing building density inside cities forces designer to use all the allowed area of a building site. Therefore, prevent much space from direct contact to outside. In addition, the flats are positioned back to back and sometimes have only one or two outer walls.

All of that create inner spaces with no direct contact with outside natural light, for that reason it is imperative to develop new design guidelines for designing built environment considering not only the conditions of the daylight come from out windows, but also transport daylight to the inner spaces and lower storey.

Our research has investigated the daylighting performance of new window and light well design.

3.7 Conclusion

The chapter addressed the reality of the residential sector in Gaza Strip, which it was clear that it is suffering from various problems especially the land scarcity for construction in light of the rising population and the high cost of construction due to poor economic conditions.

The researcher showed the situation of the energy in Gaza Strip and the potential of using renewable energy in Gaza Strip and, at the end, the chapter discussed Residential Building types which used in Gaza Strip.

Chapter Four: Simulation Study of Daylighting Performance

4.1 introductions

It has been derived from the previous chapter the situation of daylighting in multi-storey buildings in Gaza Strip, and the need for natural lighting

Thus, improving daylight quality requires controlling design variable which can make change. A number of variables concerning natural lighting design and elements will be tested in this chapter, these variables were classified into two main groups; the first regarding the living room space. The second one regarding the light well.

Illuminance level will be used in this research which indicates the quality of the indoor daylighting. The minimum acceptable horizontal illuminance for the workplane is 300 lx, as required by Israeli standards, while the upper limit illuminance is 4000 lx (Ochoa and Capeluto, 2005).

The simulation software "Radiance" is used to carry out the study and to calculate daylighting levels of building in different cases. Then, comparison of the obtained results is performed to find the best solutions

4.2 Building Simulation

Simulation is a technique that utilizes computer program to analyze, formulate and give solutions to problems of the method. Daylighting Simulation is a complex task, involving many parameters, but it is an important step in design buildings, especially when the main purpose is to conserve energy and make buildings more comfortable. For

architects, simulation is still something far from the professional practice, due to software complexities, difficulties to use software's interface, hard interpretation of the results and many so other reasons. Christakou and Amorim(2008), in their book "Advances in Computer and Information Sciences and Engineering" analyzed and compared 4 daylighting software: Desktop Radiance, Rayfront, Relux 2004 Vision and Lightscape.

The purpose behind writing the book was to find the main advantages and limits of each one, taking into account the priorities for the use of the software by the architects in their professional practice. Some criteria like interface, flexibility, help manuals, and others are analyzed, in order to establish a frame of the main points to be considered when choosing daylighting software for architects use, both in architecture schools and offices.

The book illustrated RELUX PRO 2004 VISION is the most adequate for architect's use and that RAYFRONT and DESKTOP RADIANCE are more complex to be used in the design process. Both programs showed similar level of difficulties and friendly use limitations. DESKTOP RADIANCE has the advantage of being enclosed in AUTOCAD, a graphical interface well known to architects. Moreover, it uses dialogue boxes to materials and glass selection and visualization with synthetic cameras. LIGHTSCAPE has a user-friendly interface, but is not as intuitive as RELUX.

In present study Desktop Radiance will be used for the simulation process to develop a complete computerized outline that can be used to investigate a bigger number of variables and so to develop a new model of more efficient natural lighted spaces.

4.2.1 Desktop RADIANCE

RADIANCE was developed as a research tool for predicting the distribution of visible radiation in illuminated spaces. It takes as input a three-dimensional geometric model of the physical environment, and produces a map of spectral radiance values in a color image. The technique of ray-tracing follows light backwards from the image plane to the source. Because it can produce realistic images from a simple description, RADIANCE has a wide range of applications in graphic arts, lighting design, computer-aided engineering and architecture (Larson and Shakespeare, 1998, Mistrick, 2000).

RADIANCE development started in 1984 primarily by Greg Ward Larson at the Lawrence Berkeley Laboratory (Kay, 2003). In 1990 the LESO-PB in Lausanne, Switzerland (Laboratoire d'Energie Solaire et de Physique du Bâtiment) initiated a project on daylighting simulation tools. Greg Ward, the principal author of RADIANCE, joined that project for 9 months during which he greatly extended the capabilities of the software especially for daylighting simulation purposes. In parallel, RADIANCE has been included into the ADELIN software developed within an IEA task. Since then, RADIANCE has been available in two versions: the original one as free software for UNIX workstations and a slightly limited MS-DOS version included within ADELIN (Compagnon, 1997).

Compagnon(1997) explained the physical basis of RADIANCE, which is based on the backward ray tracing algorithm. This means that light rays are traced in the opposite direction to that which they naturally follow. The process starts from the eye (the viewpoint) and then traces the rays up to the light sources taking into account all physical interactions (reflection, refraction) with the surfaces of the objects composing the scene. Polarisation of light rays is not taken into account. RADIANCE uses a geometrical

description of the "scene" based on the boundaries of objects. The volumes enclosed by these surfaces are always empty. Surfaces have definite orientation.

The objects composing the scene are described using a Cartesian coordinate system (X, Y, Z). Originally the X axis is directed towards the East, the Y axis towards the North and the Z axis towards the zenith. It is usually much more convenient to align the principal planes of the scene (e.g. the walls of a rectangular room) along the X, Y, Z axes and then to rotate the sky description around the Z axis in order to correctly orient the scene. Coordinates can be given in any unit of length. Each single ray "carries" a certain amount of radiance (hence the name of the software) expressed in (W/m²sr). The radiance is divided into three "channels" corresponding to the red, green and blue primary colors. This method of handling colors relates to a perceptual model which is unable to fully account for spectrally dependent properties. Compared to programs where the spectral distribution of the light is modelled using many channels covering narrow wavelength bands, RADIANCE is less precise and is unable to model all possible colors. This disadvantage is far outweighed by the fact that color data for materials are much more frequently available as colorimetric values, than as detailed spectral curves. In addition, for our type of application spectral effects are rather limited since colors commonly used in buildings are not very saturated (i.e. their spectral reflection curves are smooth) (Compagnon, 1997).

ADELINÉ was designed to be used under the UNIX operating system and it lacks a user-friendly interface (Papamichael, 1999, Ward, 1994). It expects the description of building geometry, surface material properties, glazing properties, electric lighting luminaires geometry, position and photometric characteristics, etc., in an input file, using specific keywords and syntax.

Radiance then processes the input file through a variety of UNIX commands, depending on the type of simulation desired. The requirement of a UNIX workstation and the complexity of using Radiance are the two major barriers in realizing a more widespread use of the software by building designers.

There are, however, two basic approaches to computing the distribution of light in a scene: ray tracing, and radiosity.

Desktop Radiance includes links to AutoCAD, a popular commercial CAD software package, and electronic libraries of materials, glazing, electric lighting luminaries and furniture. Desktop Radiance users specify the geometry of the building surfaces using the AutoCAD software. Then they can access all of Desktop Radiance functionality through a single “Radiance” menu in AutoCAD’s menu bar. Through a graphical user interface, Desktop Radiance allows users to select materials from a library and attach them to the AutoCAD surfaces (Ward, 1994).

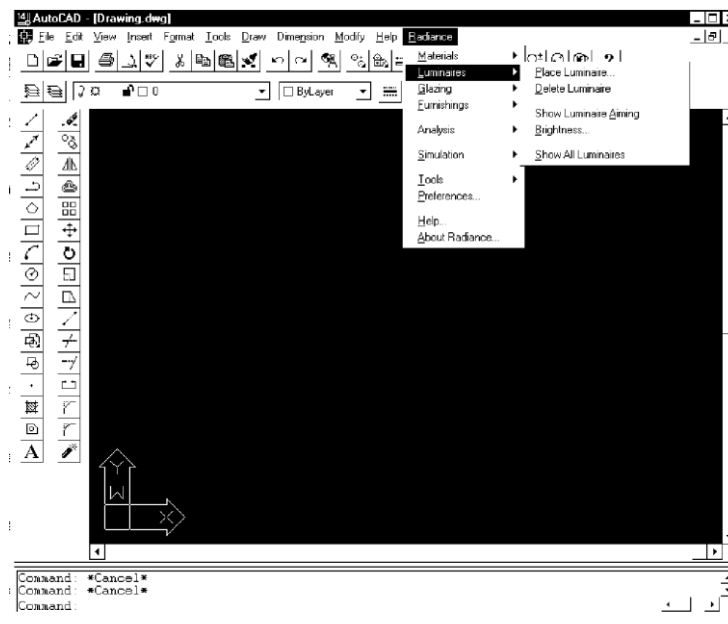

Figure 4.1: AutoCAD R-14 is used as a front end to the Desktop Radiance modules (Papamichael, 1999).

The users can select and place glazing, as well as electric lighting luminaries and furniture items, and they can place “cameras” and “light sensors” into the AutoCAD scene and request Radiance computations, specifying location, time of the year, sky condition, desired accuracy, etc.. (Ward, 1994, Papamichael, 1999).

The Desktop Radiance software automatically prepares the Radiance input file and activates the Radiance algorithms for the computation of the desired output, which is also controlled through a graphical user interface. Through a “simulation manager,” it supports easy management of multiple simulations, storing all input specifications and results into a project database.

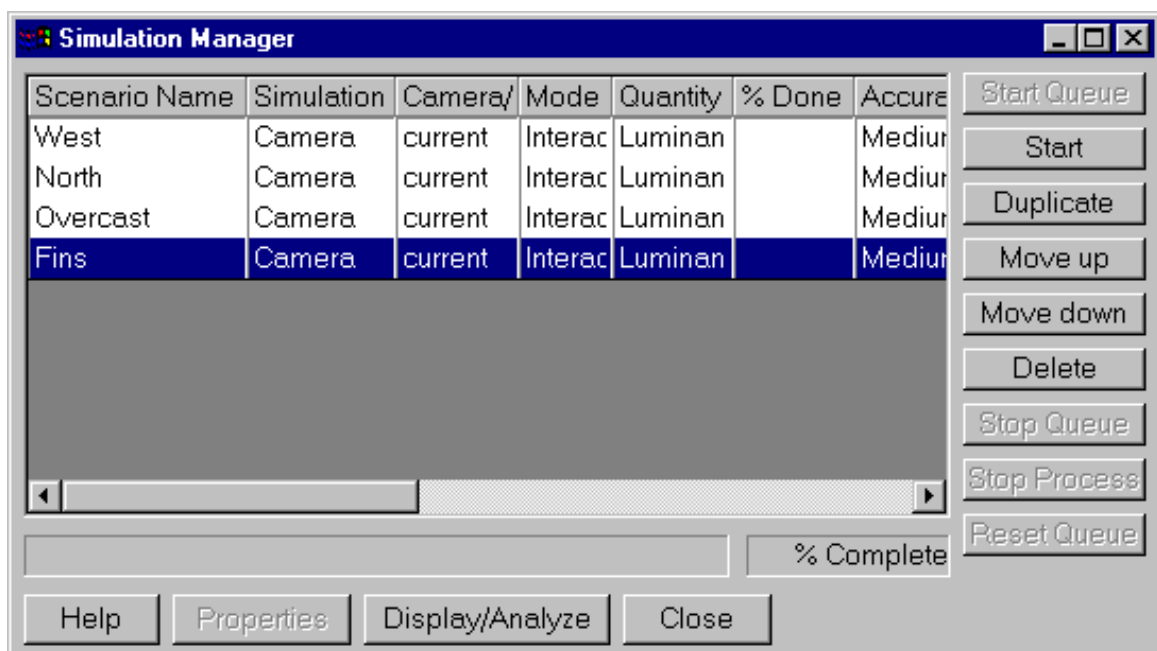

Figure 4.2: The Simulation Manager allows users to manage and control multiple simulation runs quickly and easily (Papamichael, 1999).

The Radiance output can be further manipulated to display quantitative and qualitative information in different ways, such as by superimposed illuminance/luminance iso-contours, false color displays and adjustment of images to account for the sensitivity and adaptation of the human eye (Ward, 1994).

4.3 The Case Description

The study case was a building composed of 5 residential floors and commercial ground floor, it's located in Gaza-Palestine with a geographical coordinates of (31°10'00"N) latitude and (34°26'00"E) longitude and UTC / GMT +2 time zone. The building consists of 5 flats in each repeated storey, and it has four light wells not contacting the outside. (Fig 4.3)

Only one living room and one of the light wells was included in the present research (see Fig. 4.3), to carry out the measurements and to study the variables which will be a core stone in designing and specifying the elements of windows and light wells. As mentioned in chapter two, indoor daylighting can be assessed through many indicators one of them is illuminance level which indicates the quality of the indoor daylighting. Due to that the focus of the study was drown to the windows and light wells' components that affecting the level of illuminance.

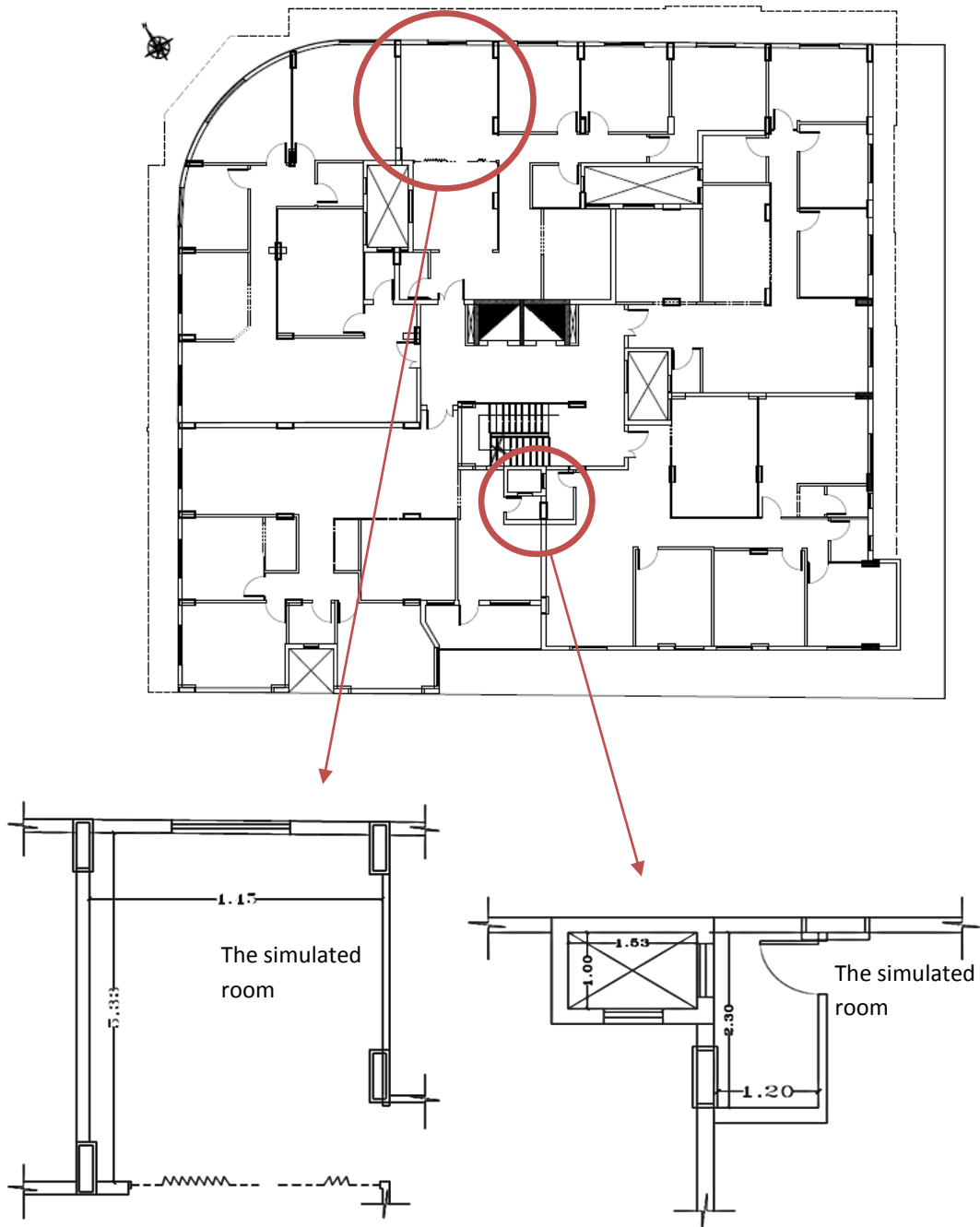

Figure 4.3: Represents the typical plan of the case study building and simulated rooms.

In the case study, RADIANCE was used to evaluate indoor daylighting in the simulated room at the five different floors. A reference grid was assigned in the simulated room by putting sensors grid at 0.85 m above the floor. A specific date 21st march and time 12:00 pm were selected to take many measurements as simulation conditions. Studies usually consider overcast sky as a worst scenario, however, it is usually clear in Gaza Strip so it may good choice to simulate under a clear sky condition.

The first simulated room is a typical living room in all the floors with North direction, has vertical walls, with 5.33m long by 4.45m width and 2.85m high. All walls and ceiling are concrete with 65% reflectance material walls, 35% reflectance material floor and 68% reflectance material ceiling; it has a 1.8m by 1.1m window (Figure 4.3).

The second simulated room is a typical bath room in all the floors, with 2.3m long by 1.2m width and 2.85m high. All walls and ceiling are concrete (Figure 4.4), it has a 0.6m by 0.6m window.

The simulated room is a bathroom opens on a simple light well with East _ West direction with 1.53m tall by 1. 0m width and 30% gray reflectance walls. The bathroom with 2.30m length by 1.20m width, with 80% reflectance material walls, 35% reflectance material floor and 68% reflectance material ceiling.(Figure 4.3, 4.4).

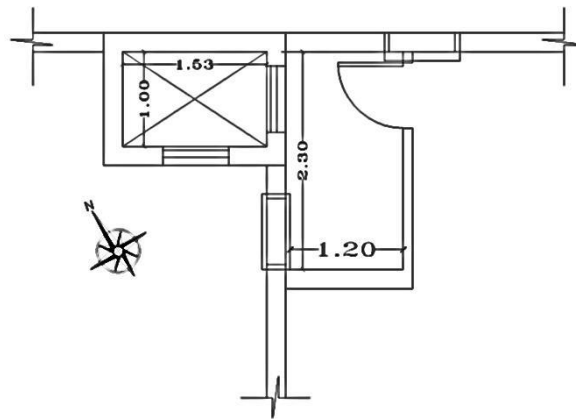

Figure 4.4: Shows the bathroom which the research studied the daylight environment in. The room with a window which opening on the light well

In all the cases, a grid of nine sensors was used to calculate illuminance, the medial line of the grid adopted as the average. The sensors were placed on 0.85m height from the floor. Figure 4.5 shows the grid of the sensors in the simulated room.

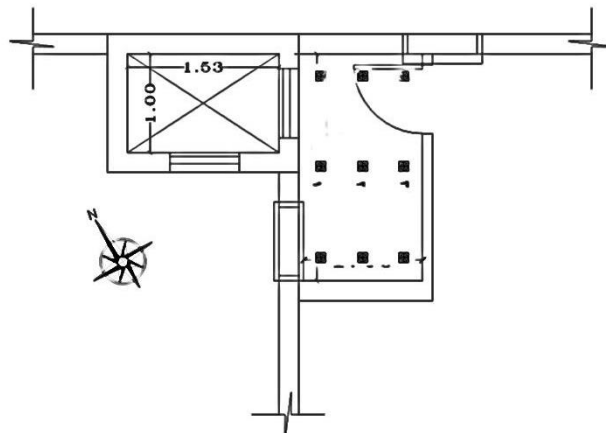

Figure 4.5: Reference grid for illuminance level calculated.

4.4 Study Variables

The research assessed the daylight performance of a living space and a light well in multi-storey residential building,

A number of variables concerning natural lighting design and elements were tested, these variables were classified into two main groups; the first regarding the living room space, In this group the orientation, window-to-wall ratio, material reflectance and adding a shelf device were tested. The second one regarding the light well.this group was divided into three groups; orientation, area, material reflectance, and opening space area.

4.5 The Results of living Room Simulation Process

4.5.1 The Results of Plan Redirection Simulation Process

As mentioned before, the first group considered the orientation of the space. The simulation depended on changing the orientation of the plan facing four directions (N, E, S and W)

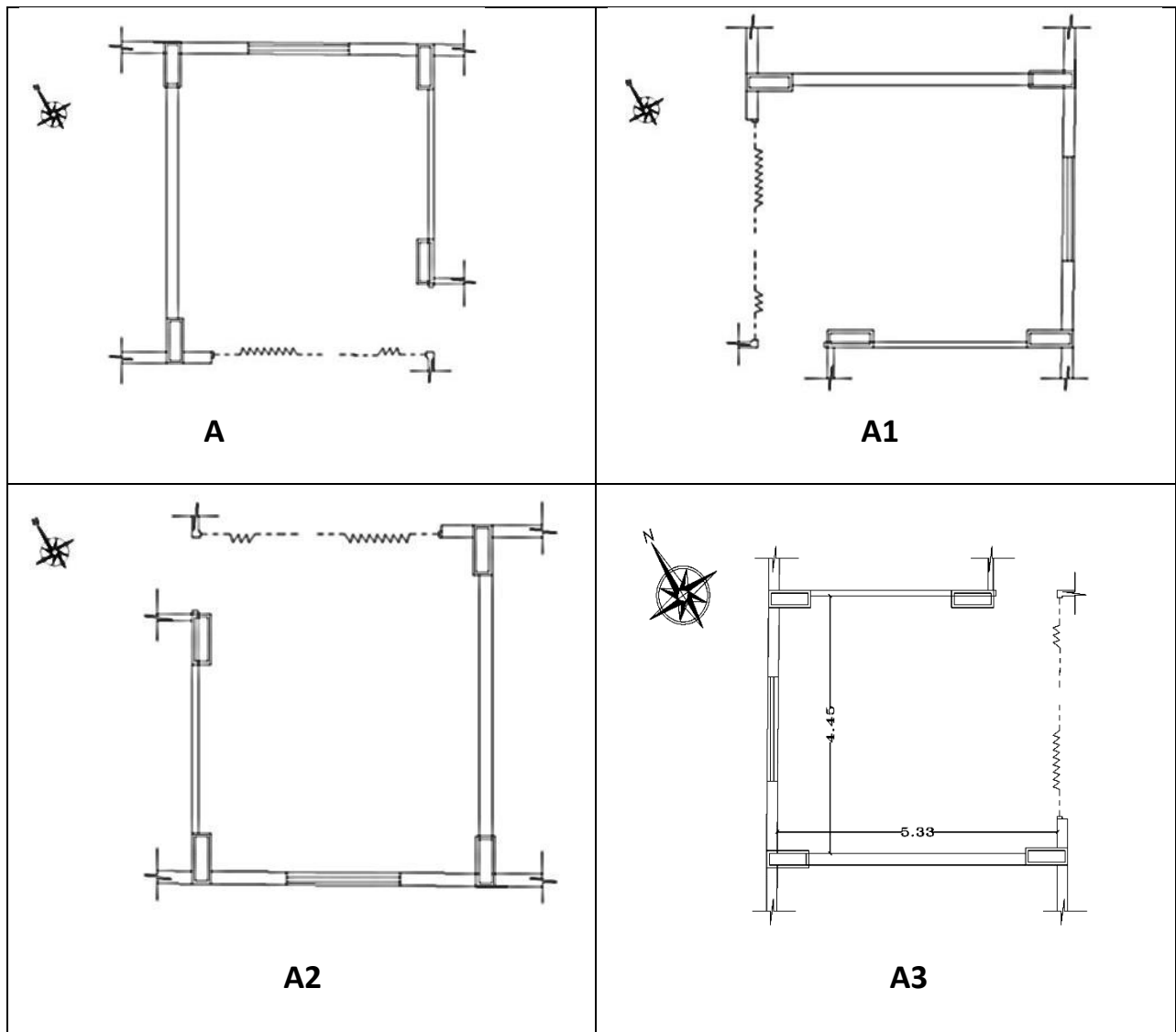

Figure 4.6: Represents the plan of the base case A and the reorientation A1, A2 and A3.

In this group we investigated the significance of the plan orientation and its effect on the illuminance level in the simulated room. Figure 4.7 represents the illuminance level in the simulated room under the cases A and A1, A2 and A3 at 12:00pm in March 21st, and under clear sky. However, it is usually clear in Gaza Strip so it may good choice to simulate under a clear sky condition

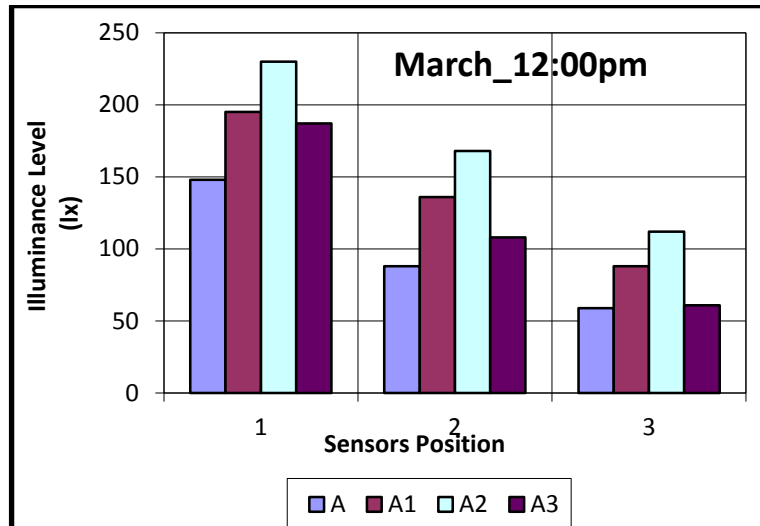

Figure Error! Use the Home tab to apply Heading 3 to the text that you want to appear here..7:Represents the illuminance level in the simulated room at 12:00pm, in March under the cases A, A1, A2and A3.

The results showed that case A2 is better than case A, A1 and A3, so that southern orientation is the best.

4.5.2 The Results of Increasing of Window Area Simulation Process

The simulation of this group was done to investigate the effect of window area on the illuminance level in the simulated room. four cases with different areas were tested in addition to A2 as a base case. The cases are showing in Table 4.1

Table (4.1): Different cases of window area, simulated in the study. Multiplying the dimensions of the light well.

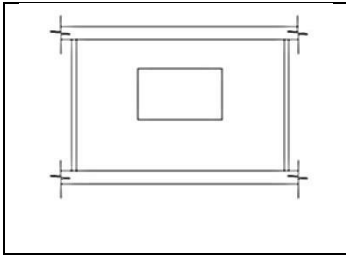
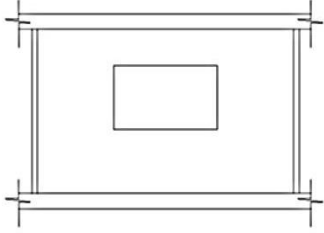
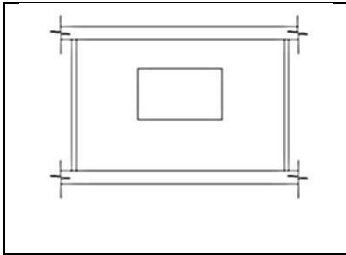
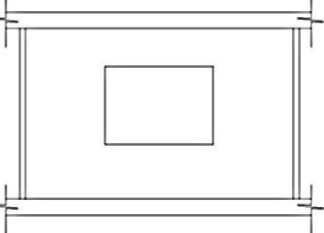
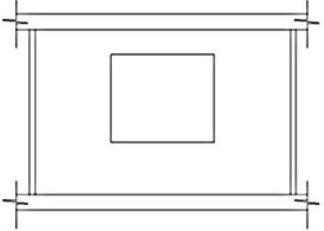
Base Case	Window-to-Wall Ratio	New Dimensions	Sketch of the plan
<p>1.1m*1.8m</p> 	30%	1.1m*1.8m	<p>A2</p> 
	35%	1.3m*1.8m	<p>B1</p> 
	40%	1.5m*1.8m	<p>B2</p> 

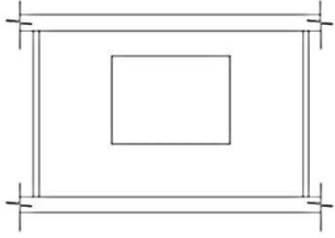
	45%	1.5m*2.0m	B3 
--	-----	-----------	--

The following figures illustrate the results that represent the effect of the window area on the illuminance level. The names of columns refer to the cases of window areas, mentioned in the previous Table, respectively.

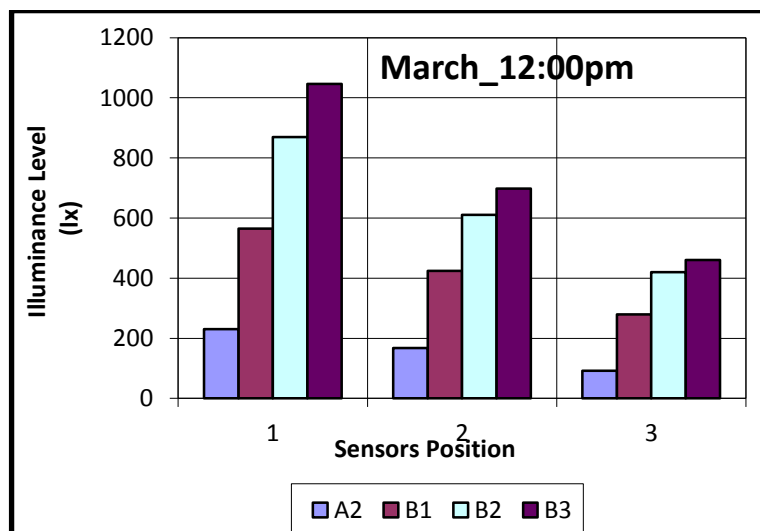

Figure Error! Use the Home tab to apply Heading 3 to the text that you want to appear here..8:Represents the illuminance level in the simulated room 12:00pm in March, under different window areas.

Although the results of simulation showed an increase in the illuminance level, this increase reach the minimum standard required level. Despite of that the

results made a significant effect on the illuminance level due to the change in the window area.

4.5.3 The Results of Material Reflectance Simulation Process

To achieve appropriate illuminance level, the material reflectance had been investigated. In order to do that a window of 1.5m high and 2.0m width, south-west orientation, and 65% material reflectance was chosen as a base case (given the name B3), then the simulation was carried out by changing the material reflectance starting from 65% increasing it 5% each time till we reached 85%. The chosen material reflectance were named as C1, C2, C3 and C4 respectively as shown in the Table 4.2, all were applied to B3 case, and compared with the original base case.

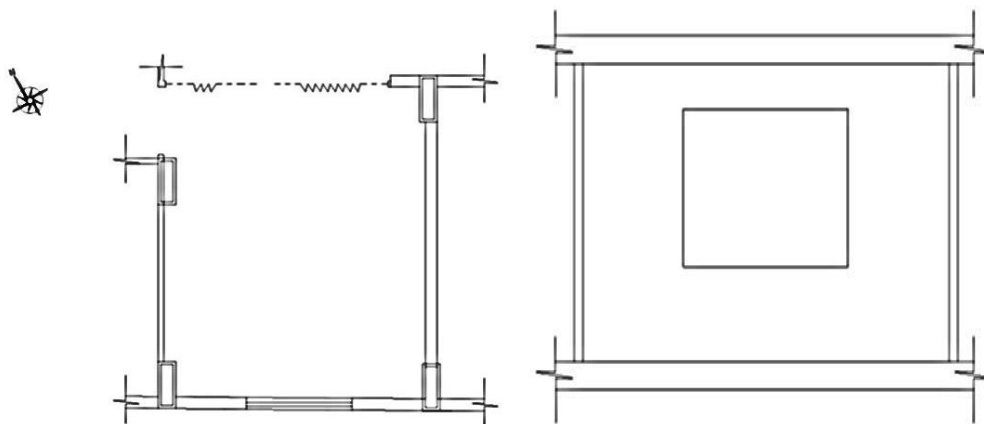

Figure 4.9: A sketch of case B3 plan and section

The chosen materialsreflectance was named as C1, C2, C3 and C4 respectively as shown in the Table 4:2.

Table 4.2: Material reflectance cases names

Name	Material Reflectance
C1	70%
C2	75%
C3	80%
C4	85%

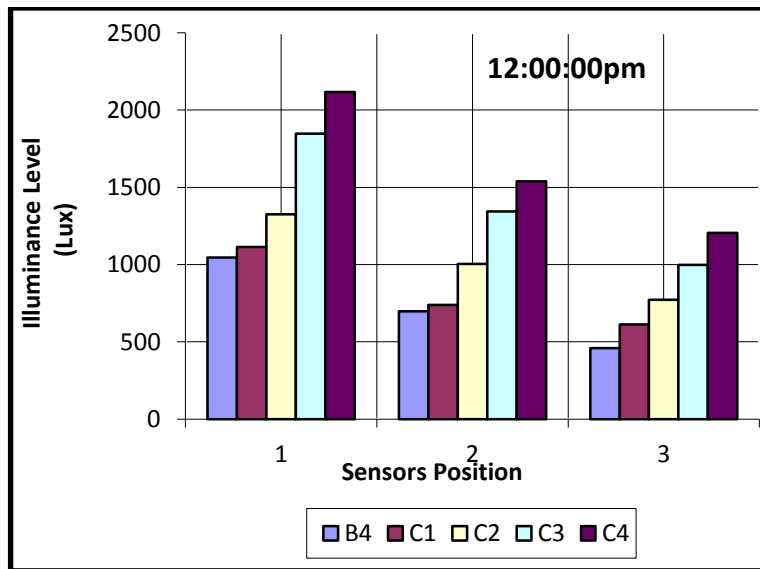

Figure Error! Use the Home tab to apply Heading 3 to the text that you want to appear here..10:Represents the illuminance level in the simulated room 12:00pm in March, under different material reflectance.

Generally, the result clarified that the increase in the material reflectance helped to improve the daylight environment in simulated space. The illuminance level increased gradually and systematically. The use of C4 made increased the illuminance level to around the standard. Therefore, the difference between the

illuminance level deep in the room and near windows is reduced, which led to improve the daylight quality by increasing the uniformity level.

4.5.4 The Results of Adding A Light Shelf to The Window Simulation Process

To achieve appropriate illuminance level, a light shelf has been added to the window then the illuminance had been investigated. In order to do that the window was chosen as a base case (given the name B4), then the simulation was carried out as shown in the figure 4.10, it was applied to C4 case, and compared with the original base case.

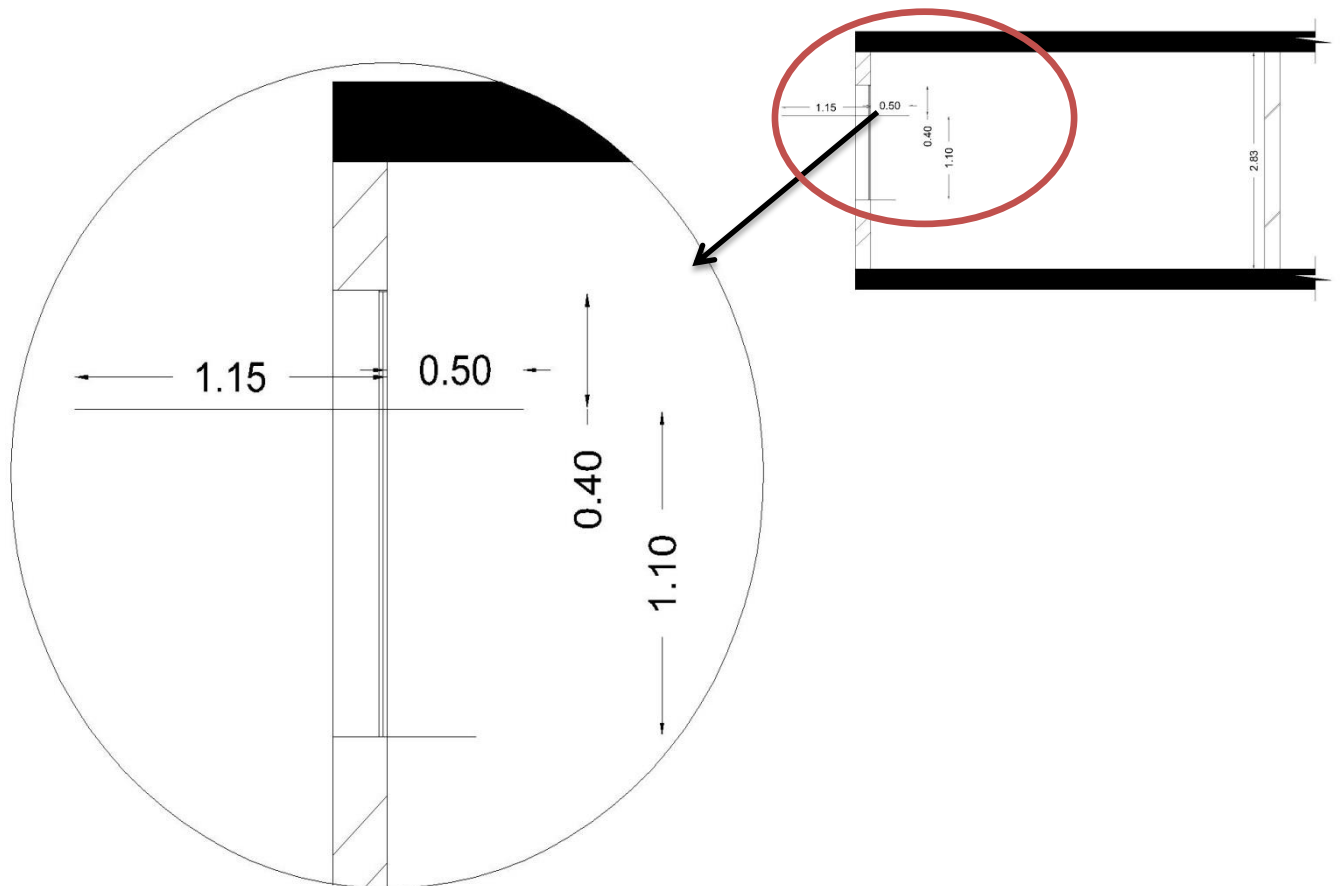

Figure 4.11: A section of the window with the light shelf

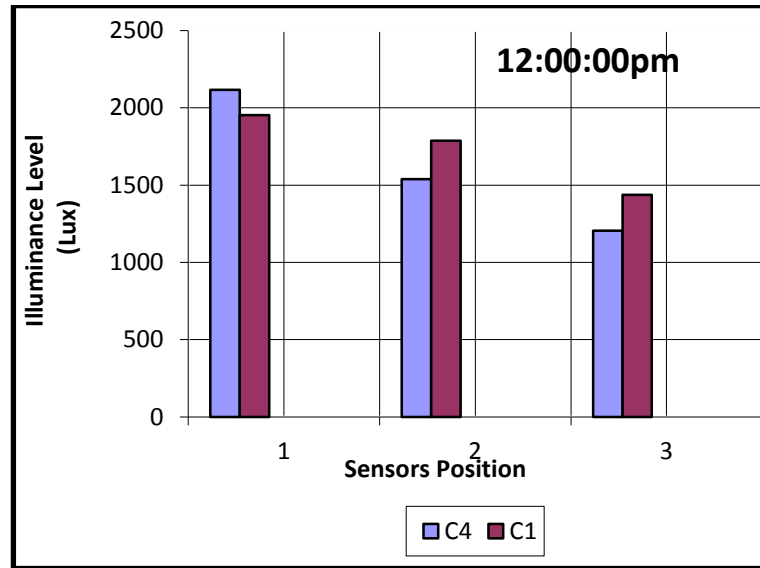

Figure Error! Use the Home tab to apply Heading 3 to the text that you want to appear here..12:Represents the illuminance level in the simulated room 12:00pm in March, under different material reflectance.

Generally, the result clarified that the lightshelf helped to improve the daylight environment in simulated space. Therefore, the difference between the illuminance level deep in the room and near windows is reduced much more than previous case C4, which led to improve the daylight quality by increasing the uniformity level and much more illuminance deep inside the plan.

4.6 light well window

4.6.1 The Results of Plan Redirection Simulation Process

As illustrated before, the second group considered the orientation of the light well plan. The simulation depended on changing the orientation of the light well plan to build up a new light well.

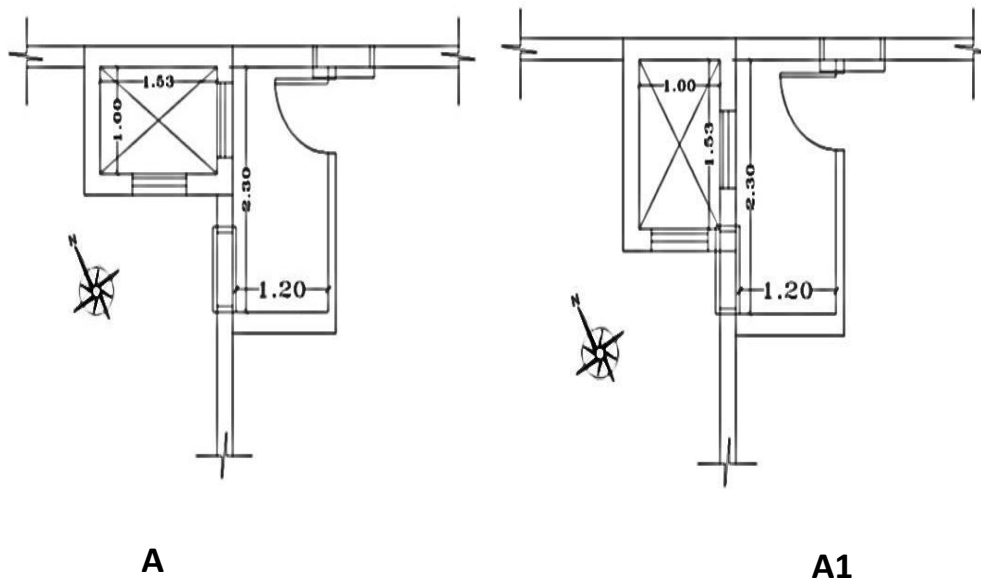

Figure 4.13: Represents the plan of the base case A and the reorientation A1.

In this group we investigated the significance of the plan orientation and its effect on the illuminance level in the simulated room. Figure 4.12 represents the illuminance level in the simulated room under the cases A and A1 at 12:00pm in March 21st, and under clear sky.

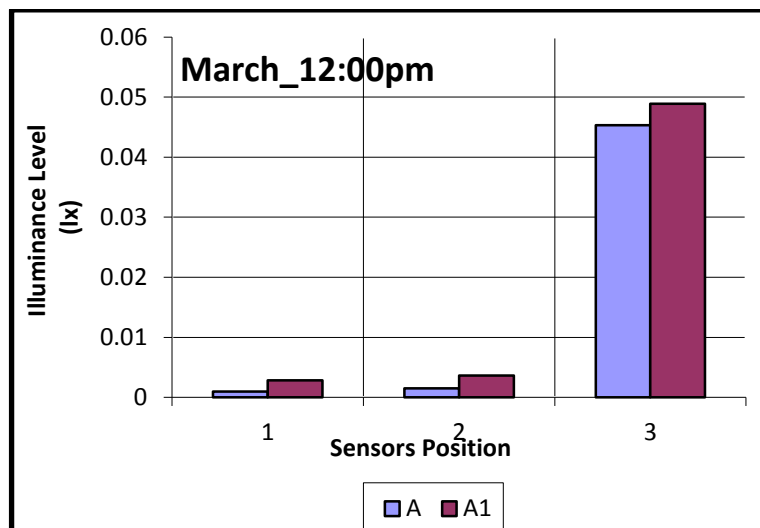

Figure Error! Use the Home tab to apply Heading 3 to the text that you want to appear here..14:Represents the illuminance level in the simulated room at12:00pm, in March under the cases A and A1.

The results showed that case A1 is better than case A, where the lighting level increased. The noticed increase could be a result of the difference in the distance traveled by light before hitting the surface, which is longer in the second case, that leads to a reduction in the number of reflections the light had before reaching the lower floors.

4.6.2 The Results of Increasing of Well Area

The simulation of this group was done to investigate the effect of light well plan area on the illuminance level in the simulated room. four cases with different plan areas were tested in addition to A1 as a base case. The cases are showing in Table 4.3

Table (4.3): Different cases of plan area, simulated in the study. Multiplying the dimensions of the light well.

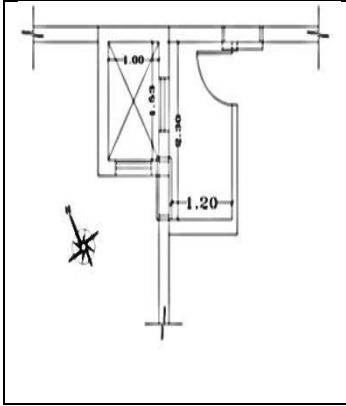
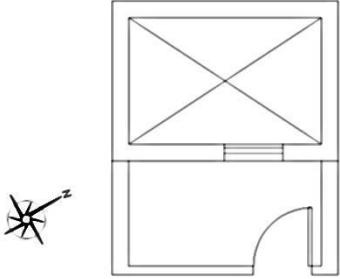
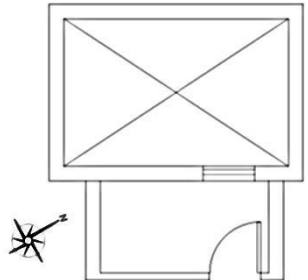
Base Case	Multiplying Factor	New Dimensions	Sketch of the plan
<p data-bbox="316 792 485 824">1.53m*1.00m</p> 	1.5	2.29m*1.50m	<p data-bbox="1241 479 1278 510">B1</p> 
	2	3.06m*2.00m	<p data-bbox="1241 1072 1278 1104">B2</p> 
	2.5	3.82m*2.50m	<p data-bbox="1241 1666 1278 1697">B3</p>

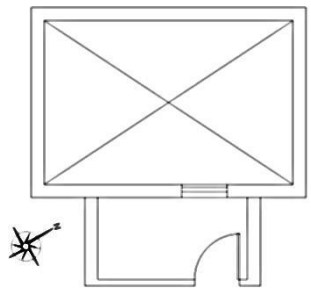
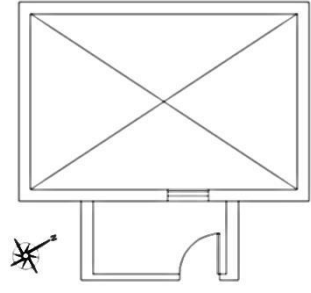
			
	3	4.59m*3.00m	<p style="text-align: center;">B4</p> 

The following figures illustrate the results that represent the effect of the light well area on the illuminance level. The names of columns refer to the cases of plan areas, mentioned in the previous Table, respectively.

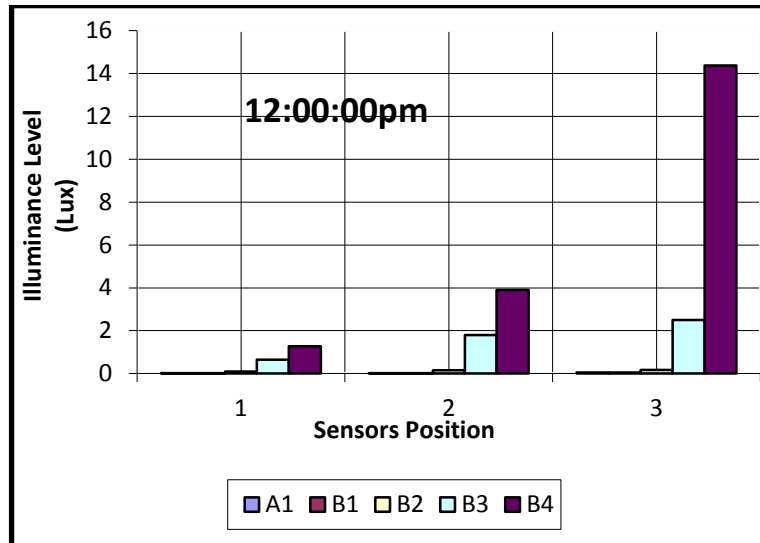

Figure Error! Use the Home tab to apply Heading 3 to the text that you want to appear here..15:Represents the illuminance level in the simulated room 12:00pm in March, under different light well plan areas.

Although the results of simulation showed an increase in the illuminance level, this increase didn't reach the standard required level. Despite of that the results retrieved a significant effect on the illuminance level due to the change in the light well area.

4.6.3 The Results of Material Reflectance Simulation Process

To achieve appropriate illuminance level, the material reflectance had been investigated. In order to do that a light well of 4.59m length and 3.00m width, north south orientation, 0.60m by 0.60m opening area and 65% material reflectance was chosen as a base case (given the name B4), then the simulation was carried out by changing the material reflectance starting from 70% increasing it 5% each time till we reached 85%. The chosen material reflectance were named as C1, C2, C3 and C4

respectively as shown in the Table 4.4, all were applied to B4 case, and compared with the original base case.

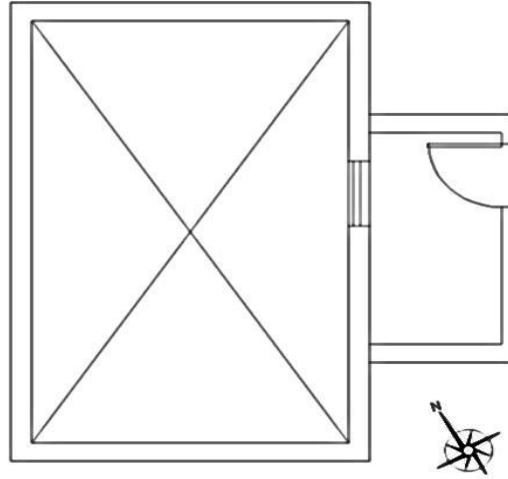

Figure 4.16: A sketch of case B4 plan and section

The chosen material reflectance was named as C1, C2, C3 and C4 respectively as shown in the Table 4:4.

Table 4.4: Material reflectance cases names

Name	Material Reflectance
C1	70%
C2	75%
C3	80%
C4	85%

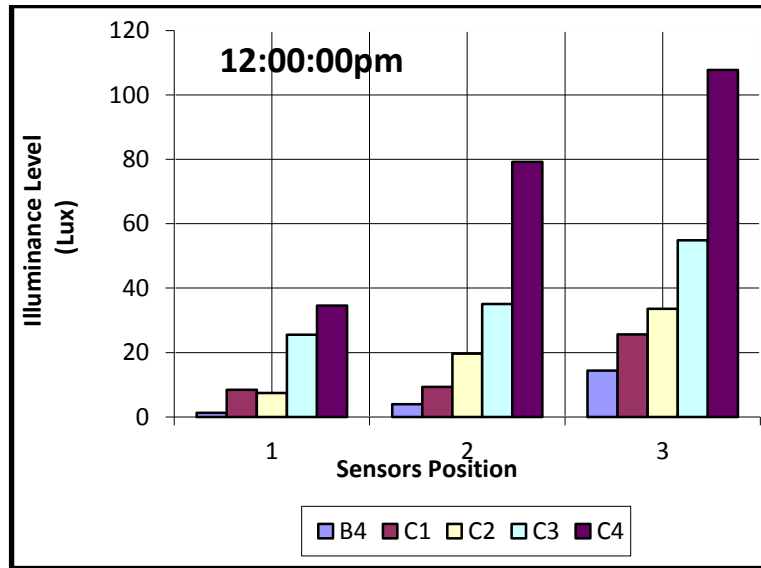

Figure Error! Use the Home tab to apply Heading 3 to the text that you want to appear here..17:Represents the illuminance level in the simulated room 12:00pm in March, under different material reflectance.

Generally, the result clarified that the increase in the material reflectance helped to improve the daylight environment in simulated space. The illuminance level increased gradually and systematically. The use of C4 made a quantity leap reduced the illuminance level to around the standard. Therefore, the difference between the illuminance level deep in the room and near windows is reduced, which led to improve the daylight quality by increasing the uniformity level.

4.5.4 The Results of Opening area Simulation Process

In the previous simulation process illuminance level reduced nears the standards. In this part the opening area which passes the light to the space were investigated. The case C4 was chosen to be a base case. The opening area was increased by multiplying the widow diminutions with 50% of the base dimensions. Table 4:5 shows the base case opening area and the new opening areas with their names.

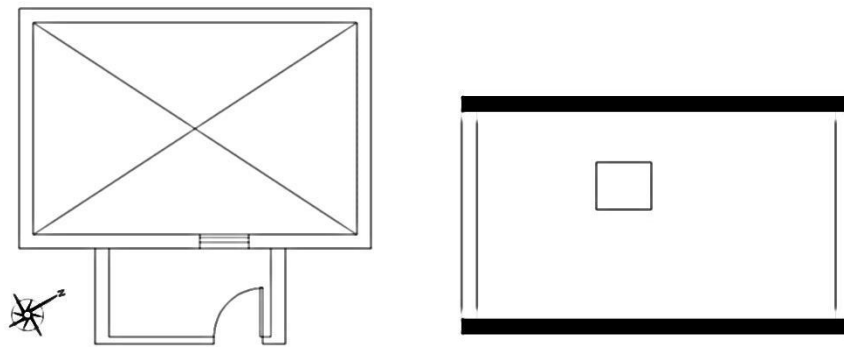
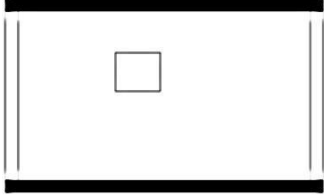
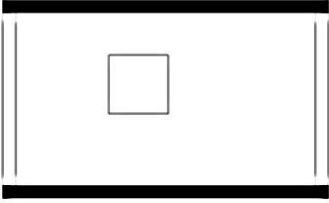
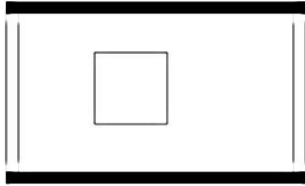
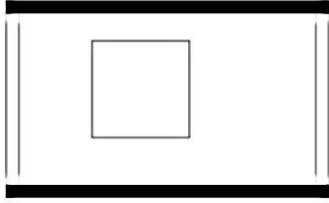

Figure 4.18: A sketch of the plan and section for C4 as a base case

Table(5.4): Opening area cases names

Name	Multiplying Factor	New dimensions	Sketch of the elevation
C4	1	0.60m*0.60m	

D1	1.5	0.90m*0.90m	
D2	2	1.20m*1.20m	
D3	2.5	1.50m*1.50m	

The results of simulation are represented in the following figures. three cases was studied (D1-D3) in addition to the base case C4. The names of columns refer to the cases of section configuration, which mentioned in the Table 4.5, respectively.

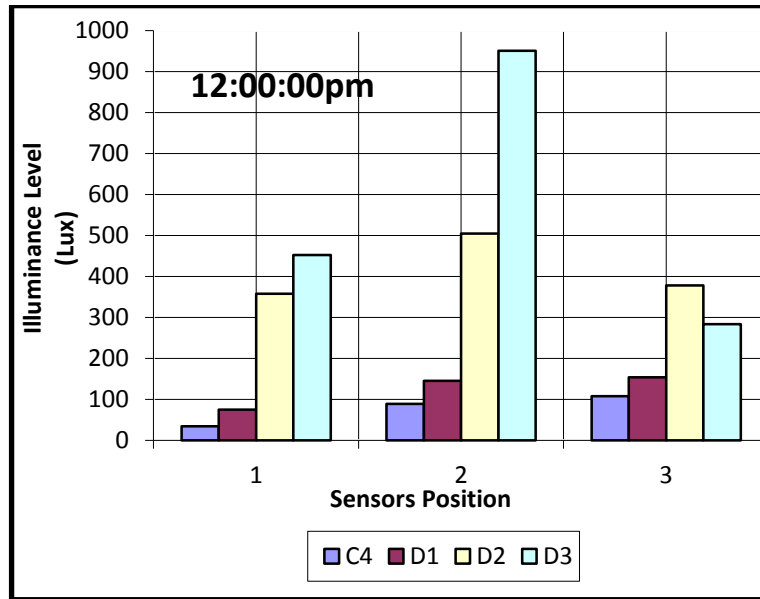

Figure Error! Use the Home tab to apply Heading 3 to the text that you want to appear here..19:Represents the illuminance level in the simulated room 12:00pm in March, under different cases of opening area

The increase in the opening area in general helped to improve the daylight environment in the simulated space. The illuminance level increased and not just reached the standard required level but also and exceeded it in some cases. As the case in the material reflectance simulation the difference between the illuminance level deep in the room and near windows is reduced, which led to improve the daylight quality by increasing the uniformity level.

4.6 Conclusion

This chapter discussed the impact of windows and light wells design on illuminance level which indicates the quality of the indoor daylighting, to carry out the measurements and to study the variables which will be a core stone in designing and specifying the elements of windows and light wells.

Chapter 5: Conclusions and Recommendations

5.1 Introduction

Using fossil fuel for lighting, cooling and heating buildings produces CO₂, which consequently causes environmental degradation. Buildings consume a large amount of energy for lighting and consequent space cooling. Therefore, using daylighting in buildings will contribute significantly to the environment and economy. Moreover, daylighting has the potential to improve human health, mood, performance and productivity.

Gaza Strip faces a great challenge in this regard considering its limited resources, the purpose of this research was to maximize the daylighting performance for multi-storey building, in regions with high luminous conditions, such as Palestine, the study focused on the effect of study parameters on illuminance level in the climatic conditions in Gaza Strip, several strategies can be used in building design including passive and active ones.

5.2 Conclusions

The main findings of the theoretical study are classified into three sections:

5.2.1 Daylighting design in Buildings

- Using natural light in residential and non-residential buildings is an important strategy in improving energy efficiency and sustainability by minimizing lighting, heating and cooling loads.
- The introduction of advanced daylighting strategies and systems is an innovative approach which can considerably reduce a building's electricity

consumption and also significantly improve the quality of light in an indoor environment

- Providing a building with natural light is more than just the solution of a problem of energy consumption; more, even, than an aesthetic resource easily incorporated into the architecture.

5.2.2 Energy situation and the need of daylighting in Gaza Strip residential buildings

- The residential sector in Gaza faces many challenges, the main problem is that Gaza strip has almost no conventional energy sources.
- Gaza Strip is almost totally dependent on the electricity and fossil fuel imported from Israel.
- Residential buildings are considered the main sector in Gaza buildings there are two main types which are separate house and apartment building. Detached buildings are the most commonly used style in residential complexes
- Residential sector in Gaza Strip is suffering from various problems especially the land scarcity for construction in light of the rising population and the high cost of construction due to poor economic conditions.

5.2.3 The Effect of Study Parameters on the Daylight Performance:

- This study explored the effects of the living space orientation, window-to-wall ratio, material reflectance and adding a light-shelf device on the daylight performance.
- In addition, the effect of light well direction, area, opening area and surfaces material type on the illuminance level in the core spaces in the lower floors of multi-storey residential buildings have been examined.

- The study confirmed a direct relationship between the illuminance level that reaches inner spaces through window with window design, and the illuminance level that reaches lower spaces with light well design.
- The research assessed the daylight performance of a living space and a light well in multi-storey residential building. A number of variables concerning natural lighting design and elements were tested. The illuminance level in The simulated living room from increased from about 200lx to about 2000lx, and in the space which opens on lightwell the illuminance level increased from less than 0.05 lx to 950lx

The suggested design measures are expected to help enhance the illuminance level in the inner spaces in the multi-storey residential buildings. Cases like A2 which demonstrate the strategy of the plan orientation and its effect on the illuminance level indoor, Southern Orientation is the best. B3 with 1.5m*2.0m Dimensions was the best window area, the illuminance level in case C4 increased the illuminance level to around the standard, D1 which led to improve the daylight quality by increasing the uniformity levels and much more illuminance deep inside the plan. ,those cases are highly recommended. The second group considered the light well design. Cases like A1 which demonstrate the strategies of orientation, North – South seems good, B4 represent the effect of the light well area on the illuminance level, which showed an increase in the illuminance level by increasing plan area. C4 showed results of an increase in the illuminance level, this increase didn't reach the standard required level. D3 showed that The increase in the opening area in general helped to improve the daylight environment in the simulated space. Those cases are highly recommended to use in high illuminance regions with clear

sky and direct sun rays. Tables (5.1) and (5.2) show the suggestions window and light well design elements.

Table(5.1): The suggestions window design elements

	Orientation	Window-wall Ratio	Material Reflectance	Lightshelf
Window Design	Southern Orientation	40%	85%	Add Lightshelf

Table(5.2): The suggestions light well design elements

	Orientation	Light Well Plan area	Material Reflectance	Opening Area
Light Well Design	Nortn-South	3.00m*4.59m	85%	1.50 m*1.50m

5.3 Recommendations

In building design, the emphasis is placed on construction and maintenance cost. People will be living and working in these buildings, so their psychological and physiological well-being should be given more consideration. An understanding of the effects of various elements for window and light well will provide the basis for manipulating form to achieve adequate lighting levels.

For effective daylighting design and to achieve suitable illuminance level, and based on the presented results and conclusion, the following recommendations are suggested to provide more successful design:

- The orientation of the window and light well should be more concerned, because it has a significant effect on illuminance levels.
- The reflectance values of space and light well surfaces must be considered because it can increase the illuminance level values in the space, despite the good design of the space.

- The local authorities should provide facilities in the licensing procedures to encourage citizens to use the suitable areas for windows light wells.
- Encourage the studies about lighting during the design process.

5.4 Further Studies

Further studies are necessary to provide more data, and investigate more variables.

As explained in the second chapter, this study began with some limitations and delimitations. Further work is needed to investigate the other daylight variables and to find solutions for the uniformity of daylight over the space.

In addition, there is also a need to investigate the result of simulation process for urban daylighting.

References

- Abboushi, Belal Khalid. (2013). "The Effects Of Adaptive Shading And The Selective Reflector Light Shelf On Office Building Energy Efficiency And Daylight Performance In Hot Arid Regions". MA. thesis, College of Architecture, Planning, and Landscape Architecture , The University of Arizona.
- Abed H., 2012, effects of building form on the thermal performance of residential complexes in the Mediterranean climate of Gaza Strip, master thesis, architecture program, Islamic University, Gaza.
- Abu-Hafeetha M., 2009, Planning for Solar Energy as an Energy Option for Palestine, master program, An-Najah National University, Nablus, Palestine.
- Ahsan, T. (2009). "passive design features for energy-efficient residential buildings in tropical climates". MA. thesis, KTH, Department of Urban Planning and Environment, Stockholm University.
- Aldawoud, A., & Clark, R. (2008). Comparative analysis of energy performance between courtyard and atrium in buildings. *Energy and Buildings*, 40(3), 209–214.
- Al-Sallal, K. A. (1998). Sizing windows to achieve passive cooling, passive heating, and daylighting in hot arid regions. *Renewable Energy*, 14, 365–371.
- Andrews, David L (1999). Electromagnetic Radiation: Encyclopedia of Spectroscopy and Spectrometry (2nd Ed.). 451-455, doi:10.1016/B978-0-12-409547-2.11153-9
- Applied Research Institute (ARIJ), September 2003, Climatic Zoning for Energy Efficient Buildings in the Palestinian Territories (the West Bank and Gaza), Technical Report.
- Baker, N. and Seemers, K. (2000). Energy and environment in Architecture. *A Technical Design Guide*, E & FN SPON, London.
- Belakehal, A., TabetAoul, K., & Bennadji, A. (2004). Sunlighting and daylighting strategies in the traditional urban spaces and buildings of the hot arid regions. *Renewable Energy*, 29(5), 687–702.
- Boubekri, M. (2008). Daylighting, Architecture and Health Building Design Strategies, Amsterdam, Linacre House, Jordan Hill, Oxford OX2 8DP, UK.
- Boyce & Raynham (2009). SII in Stuart Boreham and Hadley. *CIBSE*. Balham High Road, London SW12 9BS.
- Boyce, P, Hunter, C &Howlett, O (2003). The benefits of daylight through Windows. *capturing the daylight dividend program*, Rensselaer Polytechnic Institute, New York, U.S.A.

- C. E. Ochoa & I. G. Capeluto, (2005). Evaluating visual comfort and performance of three natural lighting systems for deep office buildings in highly luminous climates. *Building and Environment*.
- Calcagni, B., & Paroncini, M. (2004). Daylight factor prediction in atria building designs. *Solar Energy*, 76(6), 669–682.
- Callow, J. M., & Shao, L. (2003). Air-clad optical rod daylighting system. *Lighting Research and Technology*, 35, 31–38.
- Capeluto, I. G. (2003). The influence of the urban environment on the availability of daylighting in office buildings in Israel. *Building and Environment*, 38, 745-752.
- Central Intelligence Agency, April 11 2012, the world fact book: Gaza Strip, available at: [Uhttps://www.cia.gov/library/publications/the-world-factbook/geos/gz.html](https://www.cia.gov/library/publications/the-world-factbook/geos/gz.html)U, accessed in: May 12 2012.
- Christakou, D. E. & Amorim, C. N. D. (2008). Comparison of softwares for architect's utilization advances in computer and information sciences and engineering 1st edition ed. Brazil, Springer Netherlands.
- CIBSE (1999). *SLL Lighting guide 10: Daylighting and window design*. Chartered Institution of Building Services Engineers.
- CIBSE (2009). *SLL lighting handbook*, The Society of Light and Lighting, Chartered Institution of Building Services Engineers: entiveon Ltd., London.
- CIE (1987). *International Lighting Vocabulary*, France, International Electrotechnical Commission.
- CIE Standard (1973). Standardization of luminous distribution on clear skies. *Commission Internationale de l'Éclairage Publication*, vol. 22. (TC 4.2), Commission Internationale de l'Éclairage, Vienna, Austria.
- CIE Standard (2003). *Spatial distribution of daylight-CIE standard general sky*. Commission Internationale de l'Éclairage, Vienna, Austria, CIE S 011/E:2003
- Compagnon, R. (1997). *Radiance: a simulation tool for daylighting systems*
- CROOM, D. (2003). *Environmental quality and the productive workplace*. E&FN Spon. London.
- D.H.W. Li, S.L. Wong, C.L. Tsang, Gary H.W. Cheung, A study of the daylighting performance and energy use in heavily obstructed residential buildings via computer simulation techniques, 2006.
- Danny Li, Ernest Tsang, An analysis of daylighting performance for office buildings in Hong Kong, 2007.
- Doulos, L., Tsangrassoulis, A. & Topalis, F. (2008). Quantifying energy savings in daylight responsive systems: The role of dimming electronic ballasts. *Energy and Buildings*, 40, 36-50.

- Droege P., 2009, project S4G-solar for Gaza, institute of architecture and planning, Hochschule Liechtenstein, Germany.
- Edmonds, I. R. (1993). Performance of laser cut light deflecting panels in daylighting applications. *Solar Energy Materials and Solar Cells*, 29(1), 1–26.
- Edmonds, I. R., & Greenup, P. J. (2002). Daylighting in the tropics. *Solar Energy*, 73(2), 111–121.
- Edmonds, I. R., & Pearce, D. J. (1999). Enhancement of crop illuminance in high latitude greenhouses with laser-cut panel glazing. *Solar Energy*, 66(4), 255–265.
- Freewan, (2010). Maximizing the lightshelf performance by interaction between light shelf geometries and a curved ceiling.
- Freewan, A. A. (2010). Modifying courtyard wall geometries to maximize daylight performance of courtyard. SEB-10, Briton - UK, Springer.
- Freewan, A.A. (2014). Developing daylight devices matrix with special integration with building design process. *Sustainable Cities and Society*. Retrieved from: <http://dx.doi.org/10.1016/j.scs.2014.11.003>.
- Garcia-Hansen, V., Esteves, A. & Pattini, A. (2002). Passive solar systems for heating, daylighting and ventilation for rooms without an equator-facing facade. *Renewable Energy*, 26, 91-111.
- GIBSON, F. (2008). Green design and sustainability in sport and recreation facilities. *The Smart Journal*, 4, 27-33.
- Greenup, P. J., & Edmonds, I. R. (2004). Test room measurements and computer simulations of the micro-light guiding shade daylight redirecting device. *Solar Energy*, 76(1–3), 99–109.
- Greenup, P., Bell, J. M. & Moore, I. (2001). The importance of interior daylight distribution in buildings on overall energy performance. *Renewable Energy*, 22, 45-52.
- Hadid A., 2002, Architectural Styles Survey in Palestinian Territories, Establishing, Adoption, and Implementation of Energy Codes for Building.
- Hayter, S., Torcellini, P., Eastment, M., & Judkoff, R. (2000). Using the whole building design approach to incorporate daylighting into a retail space.
- HESCHONG (1999) Daylighting in schools. *George Loisos Pacific Gas and Electric Company*.

- Husin ,Sharifah, &HarithZarina (2011). The performance of daylight through various type of fenestration in residential building. *Social and Behavioral Sciences*, Published by Else Procedia 36, 196 – 203.
- Ibrik, Imad (2009). Energy profile and the potential of renewable energy sources in Palestine. In Mason, Michael and Mor, Amit (eds) *Renewable Energy in the Middle East : Enhancing Security Through Regional Cooperation* (NATO Science for Peace and Security Series C: Environmental Security). London, Springer Science+ Business Media B.V, p: 71- 81.
- IEA-Task-21. (1999). Daylighting in buildings.
- IESNA (1987). *Lighting Handbook*, New york, Illuminating Engineering Society of North America, USA.
- IESNA (2004). *American National Standard Practice for Office Lighting*, Illuminating Engineering Society of North America, New York, U.S.A., ANSI/IESNA RP-1-04.
- Ihm, P., Nemri, A. &Kartti, M. (2009). Estimation of lighting energy savings from daylighting. *Building and Environment*, 44, 509-514.
- In The Martin Centre For Architectural And Urban Studies, U. O. C. D. O. A. (Ed.) 6 Chaucer Road, Cambridge CB2 2EB, UK. Cambridge, UK.
- International Energy Agency Solar Heating and Cooling Programme (IEA).
- James, P. A. B., &Bahaj, A. S. (2005). Smart glazing solutions to glare and solar gain:A ‘sick building’ case study. *Energy and Buildings*, 37(10), 1058–1067.
- KAY, A. W. (2003). Lighting Simulation with Radiance. Linux journal.
- Kim, et al. (2009). Healthy-daylighting design for the living environment in apartments in Korea. *Building and Environment*.
- KIM, G. & KIM, J. T. (2009). Healthy-daylighting design for the living environment in apartments in Korea. *Building and Environment*, 45, 287-294.
- Kittler, R. (1965, 5-9 April). 'Standardization of outdoor conditions for the calculation of daylight factor with clear skies', in Proceedings of CIE Conference on Sunlight, Newcastle upon Tyne, U. K.
- Kottek M, Grieser J., Beck C., Rudolf B., and Rubel F., 2006, World Map of the Köppen-Geiger climate classification updated, *MeteorologischeZeitschrift*, Vol. 15, No. 3, P: 259-263.

- Larson, G., W. & Shakespeare, R. A. (1998). *Rendering with Radiance The Art and Science of Lighting Visualization*, San Francisco, California, Morgan Kaufmann Publishers.
- Leung, Tony (2011). Performance study of a daylight guiding system in an office building. MA Thesis of Architecture, Deakin University.
- Li, D. H. W., Cheung, G. H. W. & Lau, C. C. S. (2006). A simplified procedure for determining indoor daylight illuminance using daylight coefficient concept. *Building and Environment*, 41, 578-589.
- Littlefair, P. (2002). Daylight prediction in atrium buildings. *Solar Energy*, 73(2), 105–109.
- LITTLEFAIR, P. J. (1990). Review Paper: Innovative daylighting: Review of systems and evaluation methods. *Lighting Research and Technology*, 22, 1-17.
- LUN, TANG HO (2008), A Study of standard skies classification, MA thesis, City University Of Hong Kong.
- Majumda, M. (2002). *Energy -efficient building in India*. Published by Tata Energy Research Institute, Darbari Seth Block, India.
- Michel, L, Roecker, C, & Scartezini, JL (1995). Performance of a new scanning sky simulator. *Lighting Research and Technology* 27 (4), 197-207.
- Ministry of Local Government, 2004, *Palestinian Guidelines for Energy Efficient*, Bailasan company-Ramallah, Palestine.
- MISTRICK, R. (2000). *Desktop Radiance Overview*. Pennsylvania Pacific Gas & Electric.
- Mohan, N. K., Islam, Q. T., & Rastogi, P. K. (2006). Recent developments in holographic optical elements (HOEs). *Optics and Lasers in Engineering*, 44(9), 871–880.
- Moon, P. and Spencer, D. E. (1942). 'Illumination from a non-uniform sky', *Illuminating Engineering*, vol. 37(10), 707–726.
- Moore, F. (1991). *Concepts and practice of architectural daylighting*, Van Nostrand Reinhold, New York, U.S.A.
- Muhaisen A., 2007, “the energy problem in Gaza Strip and its potential solution”, Energy and environment protection in sustainable development conference ICEEP, Palestine polytechnic university, Hebron, Palestine.
- Muhs, J. D. (2000). Design and Analysis of Hybrid Solar Lighting and Full-Spectrum solar energy systems, Proceedings of American Solar Energy Society "Solar 2000 Conference", Madison, Wisconsin.

- Oakley, G., Riffat, S. B., & Shao, L. (2000). Daylight performance of lightpipes. *SolarEnergy*, 69(2), 89–98.
- Open street map, 2012, available at: [Uhttp://www.openstreetmap.org/U](http://www.openstreetmap.org/U), accessed in: 13 October 2012.
- Palestinian Central Bureau of Statistics, Nov. 2009, Brochure results of population-Population, Housing & Establishment Censuses, 2007, available at: [Uhttp://www.pcbs.gov.ps/DesktopDefault.aspx?tabID=3354&lang=enU](http://www.pcbs.gov.ps/DesktopDefault.aspx?tabID=3354&lang=enU), accessed in: May 12 2012.
- Palestinian national plan, 2011, energy sector strategy, Report to Palestinian authority.
- Papamichael, K. (1999). Desktop Radiance. Environmental Energy Technologies Division News. Berkeley.
- PENRA (Palestinian Energy and Natural Resources Authority), 06-07-2012, interview with EngAwniNaeim.
- Reinhart, C. F., J. Mardaljevic, and Z. Rogers. (2006). Dynamic daylight performance metrics for sustainable building design. *Leukos*, 3(1): 7 – 3 1.
- Reppel, J., & Edmonds, I. R. (1998). Angle-selective glazing for radiant heat control in buildings: Theory. *Solar Energy*, 62(3), 245–253.
- Ruck, N. C., Aschehoug, O., Aydinli, A., Christoffersen, J., Courret, G., Edmonds, I. R., Jakobiak, R., Kischkoweit-Lopin, M., Klinger, M., Lee, E., Michel, L., Scartezzini, J. L. and Selkowitz, S. (2000). Daylight in buildings: a source book on daylighting systems and components, International Energy Agency, Lawrence Berkeley National Laboratory, California, U.S.A.
- Ruck, Nancy (2001). Daylighting of buildings. *BDP Environment Design Guide* : The Royal Australian Institute of Architects.
- Samant, S., & Yang, F. (2007). Daylighting in atria: The effect of atrium geometry and reflectance distribution. *Lighting Research and Technology*, 39(2), 147–157.
- Saridar, S., & Elkadi, H. (2002). The impact of applying recent facade technology on daylighting performance in buildings in eastern Mediterranean. *Building and Environment*, 37(11), 1205–1212.
- SERRA, R. (1998). Chapter 6: Daylighting. *Renewable and Sustainable Energy Reviews*, 2, 115-155.
- Shao, L., & Callow, J. M. (2003). Daylighting performance of optical rods. *Solar Energy*, 75(6), 439–445.
- Sharifah Husin, ZarinaHarith, The Performance of Daylight through Various, 2011.

- Stork, Trevor & Mathers, Moira. (2009). The basics of efficient lighting: A Reference Manual for Training in Efficient Lighting Principles. Australia ,The National Framework for Energy Efficiency.
- The outlook for energy:a view to 2040 (2013). Exxon mobil corporation. U.S.A. : Las Colinas Blvd.
- Tregenza, PR. (1989). Daylight measurement in models: new type of equipment. *Lighting Research and Technology* (21) 4, 193-194.
- Ward, G. J. (1994). The radiance lighting simulation and rendering system. Siggraph Conference. Orlando, Florida.
- West, S. (2001). Improving the sustainable development of building stock by the implementation of energy efficient, climate control technologies. *Building and Environment*, 36, 281-289.
- Wittkopf, S. K. (2007). Daylight performance of anidolic ceiling under different sky conditions. *Solar Energy*, 81(2), 151–161.
- Yasin A., 2008, Optimal Operation Strategy and Economic Analysis of Rural Electrification of Atouf Village by Electric Network, Diesel Generator and Photovoltaic System, master program, Najah National University, Nablus- Palestine.
- Yasmin Suriansyah, Daylight Quality Potency at Sarijadi Mass Public Housing in Bandung Indonesia, 2013.

Arabic References

- الكلوت, محمد (2006) مخالفات البناء التنظيمية وأثرها على البيئة العمرانية في قطاع غزة ,مجلة الجامعة الإسلامية (سلسلة الدراسات الطبيعة والهندسية)المجلد الرابع عشر ,العدد الأول،ص: 301