

2017

Techno-Economic Analysis (TEA) and Environmental Impact Assessment (EIA) of corn biorefinery and bioprocessing operation

Weitao Zhang
Iowa State University

Follow this and additional works at: <https://lib.dr.iastate.edu/etd>

 Part of the [Agriculture Commons](#), and the [Bioresource and Agricultural Engineering Commons](#)

Recommended Citation

Zhang, Weitao, "Techno-Economic Analysis (TEA) and Environmental Impact Assessment (EIA) of corn biorefinery and bioprocessing operation" (2017). *Graduate Theses and Dissertations*. 16247.
<https://lib.dr.iastate.edu/etd/16247>

This Dissertation is brought to you for free and open access by the Iowa State University Capstones, Theses and Dissertations at Iowa State University Digital Repository. It has been accepted for inclusion in Graduate Theses and Dissertations by an authorized administrator of Iowa State University Digital Repository. For more information, please contact digirep@iastate.edu.

**Techno-Economic Analysis (TEA) and Environmental Impact Assessment (EIA)
of corn biorefinery and bioprocessing operation**

by

Weitao Zhang

A dissertation submitted to the graduate faculty
in partial fulfillment of the requirements for the degree of
DOCTOR OF PHILOSOPHY

Major: Agricultural and Biosystems Engineering

Program of Study Committee:
Kurt A Rosentrater, Major Professor
Carl Joseph Bern
Tong Wang
Thomas J Brumm
Chenxu Yu

The student author, whose presentation of the scholarship herein was approved by the program of study committee, is solely responsible for the content of this dissertation. The Graduate College will ensure this dissertation is globally accessible and will not permit alterations after a degree is conferred.

Iowa State University

Ames, Iowa

2017

Copyright ©Weitao Zhang, 2017. All rights reserved.

DEDICATION

I dedicate this dissertation to:

My country --- China

&

Mai Wu and our angel Krystal

TABLE OF CONTENTS

	Page
LIST OF FIGURES	viii
LIST OF TABLES	xi
NOMENCLATURE	xii
ACKNOWLEDGMENTS	xiv
ABSTRACT	xv
CHAPTER 1 LITERATURE REVIEW	1
1.1. Techno-Economic Analysis (TEA).....	2
1.1.1. Introduction to TEA	2
1.1.2. Methodology	4
1.1.2.1. Static Cost Benefit Assessment	5
1.1.2.2. Annuity Method	5
1.1.2.3. Net Cash Flow Table	6
1.1.2.4. Net Present Value	6
1.1.2.5. Internal Rate of Return.....	7
1.1.3. Applications	7
1.2. Environmental Impact Assessment (EIA)	12
1.2.1. Introduction to EIA	12
1.2.2. Methodology	13
1.2.3. Applications	15
1.3. Corn-Based Ethanol Industry.....	17
1.3.1. Introduction.....	17
1.3.2. Ethanol Process.....	18
1.3.2.1. Dry milling.....	19
1.3.2.2. Wet milling	20
1.3.3. Distillers Dry Grains Solubles (DDGS).....	21
1.3.3.1. Basic Properties of DDGS	21

1.3.4. DDGS Separation Methods.....	22
1.3.5. Industrial Simulation.....	24
1.4. Integrated Corn and Soybean Biorefinery	26
1.4.1. Soybean Oil Process	26
1.4.2. EAEP Process	27
References	28
CHAPTER 2 OBJECTIVES AND OVERVIEW	39
2.1. Objectives	39
2.2. Dissertation Organization	40
CHAPTER 3 TECHNO-ECONOMIC ANALYSIS (TEA) TO MODEL THE COSTS PROCESS OF A CORN-BASED ETHANOL PLANT	43
3.1. Introduction.....	43
3.2. Materials and Methods.....	45
3.2.1. Computer Model	45
3.2.2. Simulation Scenarios	46
3.2.3. Data Analysis	47
3.3. Results and Discussion	48
3.3.1. Capital Costs	48
3.3.2. Annual Operating Costs.....	50
3.3.2.1. Facility Costs	51
3.3.2.2. Labor Costs	51
3.3.2.3. Material Costs	52
3.3.2.4. Utility Costs	52
3.3.3. Annual Revenues	53
3.3.3.1. Ethanol	54
3.3.3.2. DDGS.....	54
3.3.3.3. Distillers Wet Grains (DWG)	55
3.3.3.4. Distillers Corn Oil (DCO).....	55
3.3.4. Gross Operating Margins and Payback Time	56
3.3.5. Multiple Linear Regression.....	57

3.4. Conclusion	60
References	60
CHAPTER 4 TECHNO-ECONOMIC ANALYSIS (TEA) OF A 120 MILLION GALLON CORN-BASED ETHANOL PLANT	84
4.1. Introduction.....	84
4.2. Materials and Methods.....	85
4.2.1. Computer Model	85
4.2.2. Simulation Scenarios	87
4.2.3. Data Analysis	88
4.3. Results and Discussion	88
4.3.1. Capital Costs	88
4.3.2. Annual Operating Costs.....	90
4.3.2.1. Facility Costs	91
4.3.2.2. Labor Costs	92
4.3.2.3. Material Costs	92
4.3.2.4. Utility Costs	93
4.3.3. Annual Revenues	93
4.3.2.1. Ethanol.....	94
4.3.2.2. DDGS.....	94
4.3.3.3. Distillers Corn Oil (DCO).....	94
4.3.4. Gross Operating Margins and Payback Time	95
4.3.5. Multiple Linear Regression.....	96
4.4. Conclusion	98
References	98
CHAPTER 5 TECHNO-ECONMIC ANALYSIS (TEA) OF INTEGRATED SOYBEAN BIOREFINERY PRODUCTS INTO CORN-BASED ETHANOL PRODUCTION	114
5.1. Introduction.....	114
5.2. Materials and Methods.....	116

5.2.1. Computer Model	116
5.2.2. Simulation Scenarios	117
5.3. Results and Discussion	119
5.3.1. Capital Costs	119
5.3.2. Annual Operating Costs	120
5.3.2.1. Facility and Labor Costs	120
5.3.2.2. Material Costs	121
5.3.2.3. Utility Costs	121
5.3.3. Annual Revenues	122
5.3.2.1. Ethanol	122
5.3.2.2. DDGS	123
5.3.3.3. Distillers Corn Oil (DCO)	123
5.3.4. Gross Operating Margins and Payback Time	123
5.4. Conclusion	124
References	125
CHAPTER 6 ENVIRONMENTAL IMPACT ASSESSMENT (EIA) OF 40 AND 120 MILLION GALLONS CORN-BASED ETHANOL PLANTS	134
6.1. Introduction	134
6.2. Materials and Methods	135
6.2.1. Methodology	135
6.2.2. Components Classification	137
6.2.3. Environmental Impact	137
6.3. Results and Discussion	138
6.3.1. Input Components	138
6.3.1.1. Classification of Impact Groups and Categories	138
6.3.1.2. Environmental Impact Indices of Input Components	139
6.3.2. Output Components	140
6.3.2.1. Classification of Impact Groups and Categories	140
6.3.2.2. Environmental Impact Indices of Output Components	141

6.4. Conclusion	142
References	142
CHAPTER 7	TECHNO-ECONOMIC MODELING OF USING A DESTONER
TO FRACTIONATE DISTILLERS DRIED GRAINS WITH SOLUBLES (DDGS)	158
7.1. Introduction.....	158
7.2. Materials and Methods.....	160
7.2.1. Computer Model	160
7.2.2. Simulations	161
7.3. Results and Discussion	163
7.3.1. Capital Costs	163
7.3.2. Annual Operating Costs.....	163
7.3.3. Annual Revenues	165
7.3.4. Profits.....	166
7.4. Conclusion	167
References	168
CHAPTER 8	CONCLUSIONS AND FUTURE WORK
8.1 Overall Conclusion	180
8.2 Future Work	183
References	184

LIST OF FIGURES

	Page
Figure 1.1 Process flow diagram for enzyme-assisted aqueous extraction processing of soybeans.....	38
Figure 3.1 Process of flow diagram for 40 million gallons corn-based ethanol model.....	63
Figure 3.2a Capital cost from corn-based ethanol process without distillers wet grains or distillers corn oil	64
Figure 3.2b Capital cost from corn-based ethanol process with distillers wet grains (no distillers corn oil)	65
Figure 3.2c Capital cost from corn-based ethanol process with distillers wet grains and distillers corn oil	66
Figure 3.3a Operating cost from corn-based ethanol process without distillers wet grains or distillers corn oil	67
Figure 3.3b Operating cost from corn-based ethanol process with distillers wet grains (no distillers corn oil)	68
Figure 3.3c Operating cost from corn-based ethanol process with distillers wet grains and distillers corn oil	69
Figure 3.4a Total annual revenue from corn-based ethanol process without distillers wet grains or distillers corn oil.....	70
Figure 3.4b Total annual revenue from corn-based ethanol process with distillers wet grains (no distillers corn oil)	71
Figure 3.4c Total annual revenue from corn-based ethanol process with distillers wet grains and distillers corn oil	72
Figure 3.5a Gross operating margin from corn-based ethanol process without distillers wet grains or distillers corn oil.....	73
Figure 3.5b Gross operating margin from corn-based ethanol process with distillers wet grains (no distillers corn oil)	74
Figure 3.6 Gross operating margin from corn-based ethanol process (without DCO or DWG, 2010-2015) and gross operating margin from corn-based ethanol process with DCO (without DWG).....	75

Figure 3.7a Unit production cost, unit production revenue and payback time from corn-based ethanol process without DWG and oil extraction	76
Figure 3.7b Unit production cost, unit production revenue and payback time from corn-based ethanol process with DWG (no oil extraction).....	77
Figure 3.8 Unit production cost, unit production revenue and payback time from corn-based ethanol process with oil extraction and without oil extraction (2010-2015).....	78
Figure 4.1 Process of flow diagram for 120 million gallons per year corn-based ethanol process	100
Figure 4.2a Capital cost from 120 million gallons per year corn-based ethanol process without distillers corn oil	101
Figure 4.2b Capital cost from 120 million gallons per year corn-based ethanol process with distillers corn oil	102
Figure 4.3a Operating cost from 120 million gallons per year corn-based ethanol process without distillers corn oil	103
Figure 4.3b Operating cost from 120 million gallons per year corn-based ethanol process with distillers corn oil	104
Figure 4.4a Total annual revenue from 120 million gallons per year corn-based ethanol process without distillers corn oil	105
Figure 4.4b Total annual revenue from 120 million gallons per year corn-based ethanol process with distillers corn oil.....	106
Figure 4.5. Gross operating margin from 120 million gallons per year corn-based ethanol process without distillers corn oil	107
Figure 4.6 Gross operating margin from 120 million gallons per year corn-based ethanol process with oil extraction and no oil extraction (2010-2015)..	108
Figure 4.7 Unit production cost, unit production revenue and payback time from 120 million gallons per year corn-based ethanol process without DCO	109
Figure 4.8 Unit production cost, unit production revenue and payback time from 120 million gallons per year corn-based ethanol process with DCO.....	110
Figure 4.9 Unit production cost, unit production revenue and payback time for 40 and 120 million gallon corn-based ethanol process (2010-2015).....	111

Figure 5.1 Process of flow diagram for EAEP integrated corn-based ethanol process	127
Figure 5.2 Capital cost from integrated EAEP with corn-based ethanol process.	128
Figure 5.3 Operating cost from integrated EAEP with corn-based ethanol process	129
Figure 5.4 Material cost from integrated EAEP with corn-based ethanol process. ...	130
Figure 5.5 Annual total revenues from integrated EAEP with corn-based ethanol process.....	131
Figure 5.6 Profit analysis from integrated EAEP with corn-based ethanol process.	132
Figure 5.7 Unit analysis and payback time from integrated EAEP with corn-based ethanol process.....	133
Figure 6.1 Structure of the environmental impact assessment	144
Figure 6.2 Impact categories, impact groups & environmental factors for input and output components	145
Figure 6.3 Mass index of input components.....	146
Figure 6.4 Environmental impact of input components: multiplying system.....	147
Figure 6.5 Environmental impact of input components: averaging system.....	148
Figure 6.6 General environmental impacts of input components	149
Figure 6.7 Mass index of output components for 40 million corn-based ethanol model.....	150
Figure 6.8 Environmental impact of output components: multiplying system.....	151
Figure 6.9 Environmental impact of output components: averaging system.....	152
Figure 6.10 General environmental impacts of output components.....	153
Figure 7.1 SuperPro model for DDGS production with 118,880 metric tons per year	171
Figure 7.2 SuperPro model for DDGS production with 297,000 metric tons per year	172
Figure 7.3 SuperPro model for DDGS production with 445,500 metric tons per year	173
Figure 7.4 Annual revenues of various DDGS for various scales (Million \$ per year)	174

LIST OF TABLES

	Page
Table 3.1 Price of Raw Material & Products to Corn-based Ethanol Process (1982-2016)	79
Table 3.2 Net Profit & Payback Time for Scenario I and Scenario II	80
Table 3.3 Multiple Linear Regression for 40 Million Gallons Ethanol Process Without DWG and DCO.....	81
Table 3.4 Multiple Linear Regression for 40 Million Gallons Ethanol Process Without DCO	82
Table 3.5 Multiple Linear Regression for 40 Million Gallons Ethanol Process Without DWG.....	83
Table 4.1 Multiple Linear Regression for 120 Million Gallons Ethanol Process Without DCO.....	112
Table 4.2 Multiple Linear Regression for 120 Million Gallons Ethanol Process with DCO	113
Table 6.1 The Mass Flow of Input & Output Components.	154
Table 6.2 Parameters & Class Limits for Impact Category Classification.	155
Table 6.3 Classification of Impact Groups & Categories for Input Components.....	156
Table 6.4 Classification of Impact Groups & Categories for Output Components..	157
Table 7.1 Data for Various Destoner Capacities.	175
Table 7.2 Fixed Capital Estimate Summary	176
Table 7.3 Process Summary of Annual Operating Cost	177
Table 7.4 Profitability Analysis of Using a Destoner to Fractionate DDGS	178
Table 7.5 Executive Summary of Using a Destoner to Fractionate DDGS.....	179

NOMENCLATURE

CDS	Condensed Distillers Solubles
CFC	Contractor's Fee & Contingency
CO ₂	Carbon Dioxide
DCO	Distillers corn oil
DDC	Degermed Defibered Corn
DDGS	Distillers Dry Grains Solubles
DFCC	Direct Fixed Capital Cost
DWG	Distillers Wet Grains
EAEP	Enzyme-Assisted Aqueous Extraction
EI	Environmental Index
EIA	Environmental Impact Assessment
EF	Environmental Factors
GEI	General Effect Impact
GHG	Greenhouse Gas
IRR	Internal Rate of Return
LCA	Life Cycle Assessment
LMAA	Low-Moisture Anhydrous Ammonia
MBtu	Million British Thermal Unit
MI	Mass Index
MGY	Million Gallons per Year
MLR	Multiple Linear Regression
MP	Main Product

MTG	Methanol-To-Gasoline
NPV	Net Present Value
OECD	Organization for Economic Co-operating and Development
PC	Process Condensate
TEA	Techno-Economic Analysis
TPDC	Total Plant Direct Cost
TPIC	Total Plant Indirect Cost
USDA	U.S. Department of Agriculture
UIF	Untreated Insoluble Fiber
WAR	Waste Reduction

ACKNOWLEDGMENTS

I would like to appreciate everyone who has been part of my research and graduate career at Iowa State University. It is a pleasure to thank the many people who made this dissertation possible.

Firstly, I would like to appreciate my major professor Dr. Kurt Rosentrater for his continuous guidance, support, patience and enthusiasm. When I was abandoned by someone, it was Dr. Rosentrater who offered me the graduate study opportunity at Iowa State University and the financial support. What's more, he appreciated my talent and hard work so I always felt a sense of belonging while working with him. Dr. Rosentrater is like sunshine to me, making me full of power and energy every day.

Also, I would like to appreciate Dr. Carl Bern, Dr. Thomas J Brumm, Dr. Chenxu Yu and Dr Tong Wang for their instruction and insightful comments. In addition, I would like to thank all staffs of Agricultural and Biosystems Engineering, who gave me a lot of help both in work and life.

My great appreciation goes to my wife for always being there when I needed help, with personal advice and patient care. And our baby Krystal brought me a lot of magic power during this hard period that I will never forget in my life. I would also like to appreciate Ming-Hsun Cheng, Minliang Yang, Xuefei Zhao, Mingjun Ma and Jasreen for their support and friendship.

Finally, I want to dedicate this dissertation to my parents, who are always showing their support and encouragement. Their unlimited love and sacrifices gave me the strength to finish my degree. I greatly appreciate their perspective and understanding.

ABSTRACT

With the rapid development of agricultural biorefinery and bioprocessing, economic efficiency and environmental effects have gradually been very popular studies in the advanced research of industrial process. As an important section of bioprocessing, the corn-based ethanol industry and oil refinery processes have been discussed fully, with details of technology, including material, reaction control, equipment and industrial applications. However, there are few studies of engineering economy and environmental effects on these processes and related products. In addition, most bioprocess research separately treats either economic efficiency or environmental effect, which lacks efficiency and comprehensiveness. Because of these obstacles, an efficient tool and software for engineering economics and environmental research is still being investigated.

Due to the reasons above, this dissertation focused on techno-economic analysis (TEA) and environmental impact assessment (EIA) on the industrial corn-based ethanol process, advanced corn-soybean bio-refining and distillers dried grains with solubles (DDGS) separation process. This dissertation is prepared in a paper format, and is comprised of six chapters, as follows:

The first chapter conducted initial techno-economic analysis (TEA) for a corn-based ethanol plant using data from 1982 to 2016. This study tested various procedures to assess the factors that affect ethanol plant profit, such as cost of corn, DDGS, ethanol, gas, electricity and so on. By using the updated U.S. Department of Agriculture (USDA) model, this study demonstrated the bioprocess modeling used to assess the economic performance of bioethanol plant systems, which provided a starting point for the analysis of advanced corn-soybean biorefinery.

The second chapter expanded the scale of the first study model from 40 million gallons of ethanol per year to 120 million gallons of ethanol per year, and compared the effects to efficiency and profits during various scales. Similar to the first manuscript, this model was constructed using SuperPro Designer, and considered purchase and sale prices of materials and products, as well as estimated fixed costs, capital costs, revenues, and profits. This study provided a starting point for the analysis of advanced corn-soybean bio-refining in the future.

The third chapter focused on advanced corn-soybean bio-refining using techno-economic analysis (TEA). By using the data of enzyme-assisted aqueous extraction processing (EAEP), this study demonstrated using the updated USDA model to simulate the corn-soybean bio-refining systems, and discuss the feasibility of industrial application for this technology. In addition, this chapter explored the difference in economic effects with original corn-based ethanol plants.

The fourth chapter collected processing data from the previous three manuscripts, and utilized a method with a simple structure to easily assess environmental impacts. This method focused on the material or process steps that caused most of the potential environmental burden. Environmental impact assessment (EIA) concentrated more on the corn-based ethanol process itself, and was less time-consuming than complicated life cycle assessment (LCA).

The fifth chapter determined techno-economics analysis of DDGS fractionation using a destoner to separate nutrients. Mathematical models were built for conducting techno-economic analysis (TEA), which allowed for estimations of capital costs, annual operating costs, annual revenues, and net profits. The techno-economics of the base case ethanol plant

were examined by adjusting material and market costs, and estimating fractionation efficiencies and fraction prices based on protein content. This study demonstrated the possibility of using a destoner to fractionate DDGS to produce higher economic returns.

CHAPTER 1: INTRODUCTION AND LITERATURE REVIEW

1. Overview

In modern agricultural and biosystems engineering, biorefinery and bioprocessing are very popular topics for research as they efficiently improve the quality of human life. Biorefinery can be considered a facility that utilizes biomass conversion processes and equipment to produce new energy or material from biomass, which includes fuels, electricity, thermal energy, and value-added chemicals (Rosendahl, 2013). During the conversion of biomass feedstock, the objective of biorefinery is to obtain maximum, valuable chemical product and energy with minimal waste and emissions (Rosendahl, 2013). Different from biorefinery, bioprocessing contains a much wider range of design and development of equipment and processes for the manufacturing of products, such as food, feed, agriculture and chemical products. Bioprocessing is an engineering process which requires consideration of its industrial applications, such as applications in industry optimization, large-scale production, and quality of the end product. In addition, transportation of energy and mass is a fundamental problem during biorefinery and bioprocessing, which is related to device design, pollution control and carbon dioxide emission (Liu, 2016). The effect of environmental aspects on biorefinery and bioprocessing is increasingly becoming a popular research topic, with various assessment methods invented in recent years.

This literature review is divided into four sections: (1) techno-economic analysis (TEA), (2) environmental impact assessment (EIA), (3) an introduction to the corn-based ethanol industry and (4) an introduction to integrated corn/soybean biorefinery processes.

1.1. Techno-economic analysis (TEA)

Techno-economic analysis (TEA) is an engineering method used to provide both quantitative and qualitative understanding of financial viability, which combines process modeling and engineering design with economic evaluation (Gnansounou & Dauriat, 2010). With wide TEA applications on hybrid, solar, network and other industrial areas (Celik, 2003; Yang et al., 2009; Frias & Pérez, 2012), TEA was used as an efficient and important method of analyzing biorefinery and bioprocessing. By applying TEA methods, biorefinery and bioprocessing in the industrial setting were studied to explore economic feasibility, including corn-based ethanol production, distillers dried grain with solubles (DDGS) separation and other agricultural processes.

1.1.1. Introduction to TEA

Generally, techno-economic analysis is used to compare a set of well-established processes with existing or developing technology to discuss whether market-driven prices can be achieved and economic feasibility can be determined from economic aspects or not (Swanson et al., 2010). TEA is a widely used method for cost-benefit comparison, the objectives of which include to investigate economic feasibility, evaluate cash flows, explore the difference of various technology scales and compare the efficiency of different technology applications (Caves et al., 1982). In all objectives of techno-economic analysis, efficiency of a production process is the keystone, which is reflected on the compounds of input efficiency, productivity level, the transformation rates of energy and materials used in the process (Jorgenson & Griliches, 1967).

In all engineering areas, input efficiency is considered an important factor of efficiency, both at the technical and economic level (Färe & Hunsaker, 1986). Generally, the indicator of input efficiency is shown as the average unit cost of the main product or variations of the cost of other systems (Caves et al., 1982). Input efficiency is a beginning point for efficiency analysis, and is difficult to measure in most processes (Coticchia et al., 1993). According to Cowing and Stevenson (1981), productivity was seen as a useful but limited tool to evaluate efficiency in the 1980s. In the 21st century, it would probably be considered the main index to assess efficiency. The reason for this change was that the new economic and industrial revolution caused rapid improvement during the performance of inputs and outputs in all industries, breaking traditional economic rules and evaluation systems (Clews & Leonard, 1985). Similar to input efficiency, productivity has traditionally been used to evaluate transformation rates of energy and materials used in engineering processes, which has no evident change in any specific theoretical contributions (Wheelwright & Clark, 1988).

When applied specifically to engineering, TEA is mostly concerned with cost engineering analysis, which includes the economic and financial assessment of a process. TEA in engineering is divided into several parts like cost estimates, income estimates, estimates of the return on investment, depreciation and other aspects (Ahuja & Walsh, 1983). As mentioned before, raw materials and energy used in the production processes are the most difficult parts to measure, caused by high instability of various periods in the market. To account for this instability, it would be necessary to develop a feasible method that could both estimate raw material and energy costs by considering the fluctuation of prices in the market, as well as forecast the trend of future prices (Blank & Tarquin, 1998). Different from

the usage of raw materials and energy, labor and maintenance costs are calculated based on values referring to depreciation share, which is considered more reliable, especially in mature product technology and industrial applications (Ahuja & Walsh, 1983).

Compared with cost estimate, income estimate is partial arbitrary and harder to evaluate, which is reflected on obtainable unit prices and saleable quantities (Ahuja & Walsh, 1983). Due to the properties of income estimate, a detailed operative process of estimates is the key to control accuracy and precision, which includes how products will be sold and the requirement on destination markets. In addition, risks and errors are important obstructions to income estimates, which ask to use methods of consolidated statistical calculation, adjusted estimates, equally objectives and realistic criteria to obtain probability values to risk and error estimate (Himmelblau, 1978). It is possible to approach a reliability of values with the methods mentioned above, but modifying the aspects and variables are always required so the estimate obtains a more reliable result.

Net profits and net cash flows are key points to estimate the return of an investment, which utilize several indexes to reflect the process conditions including payout time, rate of return, net present worth and discounted cash flow. Making fair criteria and discount rates are the hardest problems on the return of an investment, which requires a different set of hypotheses (Himmelblau, 1978).

1.1.2. Methodology

Techno-economic analysis (TEA) is a complicated but useful method to obtain various objectives, which include cost estimate, income estimate, risk estimate, depreciation and other items (Ahuja & Walsh, 1983). To achieve the objectives, several TEA methods

have been developed and utilized in current industrial production, including static cost benefit assessment, annuity method, net cash flow table, net present value and internal rate of return.

1.1.2.1. Static cost benefit assessment

Static cost benefit assessment is an easy and convenient method to do a comparison of cost and profit in one average year (Pearce, 1994). The weakness of this method is lack of precision, which ignores the effect of interest rates and inflation rates. The more deviation to the real value is reflected on the conditions of high interest rates or a huge difference between interest rate and inflation rate (Wills, 1993). Generally, this method is utilized in the preliminary check to explore the feasibility of a project.

1.1.2.2. Annuity method

Similar to static cost benefit assessment in principle, annuity method is another convenient method to simple TEA, which includes an interest rate for paybacks of the investment in the calculation of the annuity (Perimenis et al., 1994). The main content of annuity is composed with the capital payback and the interest, which possesses a fixed and constant annual payment during the whole project's lifetime. By utilizing a hypothesized interest rate to spread the initial investment cost over the whole project, annuity method regards the net benefit of project operation annually as the static method does (Perimenis et al., 1994). At a normal inflation and interest rate, this method easily shows economic results and rapidly compares different projects. The limitation of this method is that it is hard to explore the variations in costs and benefits within a year unit, which is caused by setting the

same net benefit every year. Another weakness of this method is it has a blind spot between the investment and early period regular operations.

1.1.2.3. Net cash flow table

Net cash flow table is an efficient method to illustrate the development of profits and the cash flow over the development stage and technical lifetime of a project. The advantages of this method include an expectation of how long it takes a project to get positive cash flow, an indication on questions of financing and presents the overall situation of a project. While disadvantages are also evident, this method can only work efficiently on a project with detailed, available information on all benefit and cost issues. In addition, this method is not sensitive enough for comparative technology assessment and is difficult to investigate economic viability of a technology application, which requires calculation of the net present value of the cash flows over the years (West & Riggs, 1986). Comparing with profit or loss that only focuses on income and expenses at a certain point in time, net cash flow table is more dynamic, which required to consider with the movement of money in and out of a project and considered with the time at which the movement of the money takes place.

1.1.2.4. Net present value

The net present value is another method utilized in TEA, which presents an indication of how the project will change in current money value over a certain period. This method is widely used for all engineering projects, especially long project phases, high inflation rates and non-linear developments in prices (Zimmermann & Jørgensen, 2015). The net present value (NPV) should contain the value of zero; and all investment cost should be exact

recoups over the lifetime of a project, such as utilizing the hypothesized discount rate. If the NPV is positive, the investor's property will continuously grow by this value over the whole investment process (Lier & Grünwald, 2011). But for a negative value of NPV, the project is hard to realize without suffering losses, considering the hypothesized discount rate. Similar with the net cash flow table, net present value (NPV) works efficiently when evaluating very specific projects with all simulation data available, and has a better performance when used to compare different projects.

1.1.2.5. Internal rate of return

Different from the method above, the internal rate of return (IRR) is a graphic method to evaluate the economic quality of a project (Magni, 2013). If several potential projects need to be compared to each other at the same time, this method judges independent factors (project size and technology), and indicates the optimal project with the highest profit. The structure of this method utilizes an amount of judgments of the efficacy on the project. If the IRR is lower than the rate of bank cash deposits, it is dangerous to open an investment on a project where the capital is unsafe and the payback is doubtful to recoup the rate of return. After considering degrees of risk associated with the investment, investors can conveniently explore an attractive project, where the IRR is higher than other options.

1.1.3. Applications

As an efficient method to evaluate the financial viability, techno-economic analysis has been utilized in various areas, including civil engineering, chemical engineering and

other engineering areas (Ims et al., 1996). In this chapter, techno-economic analysis is limited and discussed only on bioprocess and biorefinery engineering.

A corn-based ethanol process was a popular topic to be discussed and simulated. Early in 2004, a degermed defibered corn (DDC) based dry mill ethanol process was evaluated by a modeling platform with a production of 15 and 40 million gallons per year (Srinivasan et al., 2005). This study created a simplified economic analysis, which contained capital costs, operating costs, revenues, profits, and payback time for each individual model. On this basis, a corn-based dry grind processing model used to produce ethanol with the production of 119 million kg per year (40 million gallons per year) was investigated as a research tool to evaluate new processing applications and products from starch-based material (Kwiatkowski et al., 2006). To examine the effect of new value added use for ethanol coproducts, an advanced simulation model was built to observe the sensitivity and changes of a corn-based ethanol plant model in input prices and various coproduct processing (Christine et al., 2006). According to simulation results, corn price made the greatest contribution on the annual operating costs, coproducts played significant roles in capital cost and mass of products produced, and the market price of ethanol had the greatest performance on annual revenues. To increase economic feasibility, the integrated corn biorefinery with an add-on facility processing corn DDGS to hydrocarbons was attempted in the simulation, and TEA was chosen to evaluate the possibility (Wang et al., 2015). The results showed the minimum fuel selling price for the integrated scenario was \$2.27 per gallon, and the minimum fuel selling price for the stand-alone scenario was \$2.18 per gallon.

Corn stover was another popular material for ethanol production and related bioprocess application, and had a strong requirement for exploring economic viability. Most

TEA for the corn stover bioprocess discussed the feasibility for new method application, which was different from TEA used to discuss the industrial efficiency for corn-based ethanol processes. Low-moisture anhydrous ammonia (LMAA) pretreatment for corn stover fermentation used TEA to conduct a cost analysis and estimate the breakeven point in large-scale production, which showed the lowest unit cost obtained from this method was \$3.86/gal, and was higher than 2015 gasoline prices (Yang & Rosentrater, 2015). Corn stover fungal fermentation was also attempted in recent studies. TEA assessed the process economics of ethanol production from lignocellulosic feedstock by fungi to identify promising opportunities. Results showed Recombinant *S. cerevisiae* provided the most attractive process economics with an ethanol cost of \$2.51 per gallon, and co-producing organic acids improved the process economics, reducing the ethanol cost to \$2.22 per gallon in the lab scale (Meyer et al., 2013). Combining two or more bioprocesses to reduce cost was another popular topic in recent research, which TEA explored using the change of efficiency. With existing corn stover industrial production, minimum ethanol selling price was \$5.64 per gasoline gallon equivalent. After combining with a corn-based ethanol process, the lowest minimum ethanol selling price for cellulosic ethanol was \$5.47 per gasoline gallon in 2014 (Ou et., 2014). In addition, techno-economic analysis has been utilized to discuss the possibility for corn stover to supply heat and energy for a corn-based ethanol plant in the corn stover biomass supply chain system (Sokhansanj et al., 2010; Shah, 2013).

With the exception of analyzing the process of bioethanol from corn and corn stover, TEA also works for other biomasses conversions to fuel in biorefinery and bioprocesses, which include softwood, hardwood and other agricultural residue (Sassners et al., 2008).

Gasification and pyrolysis are popular technical attempts used to treat lignocellulose biomass in recent years, which means there are strong requirements to investigate the economic feasibility of these processes. As an efficient method to evaluate and compare alternative processes, TEA has been utilized to analyze for biomass gasification syngas conversion to fuels systems with final products of hydrogen, methanol, ethanol, or electricity (Mueller-Langer et al., 2007; Clausen et al., 2010; He & Zhang, 2011; McIlveen-Wright et al., 2011). Jones and Zhu (2009) investigated a woody biomass gasification based fixed-bed methanol-to-gasoline system. TEA was utilized to estimate a two-step S2D process and investigated the gasoline production cost at \$3.20 per gallon, which included methanol synthesis from syngas and fixed bed methanol-to-gasoline (MTG) processes. In this study, the major capital cost areas included the syngas cleanup and the S2D synthesis processes. Different from the study by Jones and Zhu (2009), Phillips et al. (2011) utilized TEA to explore the feasibility of a biomass gasification based MTG system, which combined improved syngas cleanup and fluidized bed MTG technologies. The evaluation of this study showed new technology obtained a gasoline production cost of \$1.95 per gallon.

In addition, pyrolysis was another pathway to produce ethanol from biomass, and TEA was also utilized to estimate its economic feasibility. Thilakaratne et al. (2014) found mild catalytic pyrolysis could achieve fuel yield of 17.7 wt% and 39% energy conversion, which meant this bioprocess obtained a probable fuel cost of \$3.03 per gallon. Similar with Thilakaratne et al. (2014), Hu et al. (2016) explored the techno-economic feasibility of three product portfolios from a biomass fast pyrolysis biorefinery, which showed minimum product-selling prices were \$3.09 per gallon for biofuel, \$0.434 per kg for biochemical and \$0.774 per kg for hydrocarbon chemicals. Some studies used the TEA method to evaluate

the economic feasibility of biohydrogen production between bio-oil gasification and bio-oil reforming (Zhang et al., 2013).

Excluding the thermochemical method used to treat biomass, researchers used biochemical pathway with specific microorganisms to investigate and explore economic feasibility. Pham et al. (2010) utilized a mixed culture of acid-forming microorganisms to convert biomass components; and the TEA study showed a hydrocarbon production cost was \$2.56 per gallon. TEA also explores the economic viability of some specific material including palm empty fruit bunches and vegetable oils (Apostolakou et al., 2009; Do et al., 2014)

Different from the process to produce bioethanol, algae biodiesel is a promising alternative fuel to petro-diesel. Thilakaratne et al. (2014) developed a techno-economic analysis of microalgae remnant pyrolysis biofuels, which compared partial mechanical drying and thermal drying scenarios with subsequent energy flow analyses. Study results showed microalgae remnant biofuel varied in price between \$5.64 and \$6.81 per gallon, and the economic feasibility was strongly influenced by fuel yields, feedstock prices, and capital costs. Unlike the results above, Nagarajan et al. (2013) utilized an updated comprehensive techno-economic analysis to conduct optimized processes and improved cost estimations. The final costs of biodiesel were in the range of \$1.59–3.67 per gallon, which showed a single step biodiesel production process was close to commercial reality. In addition, Davis et al. (2011) used TEA to explore micro-algal-derived biofuels in an open pond and closed tubular photo bioreactor system. The results of fuel costs were equal to \$9.84 per gallon (open pond production) and \$20.51 per gallon (closed tubular photo bioreactor production), which showed both systems were far from industrial production. Better micro-algal strains

and maximizing algal lipid content were the primary means to reduce production cost, which may cause these methods to be more competitive in commercial reality. Excluding traditional TEA methods, some specific TEA math models, like real option analysis, were utilized in the investigation, which attempted to quantify the value of greater product flexibility at algal biofuel production facilities (Kern et al., 2017).

Techno-economic analysis can also be utilized to evaluate biomass-fueled combined heat and power, bioenergy supply chain configuration and integrating sorghum milling, which help researchers explore the economic feasibility of new technology in industrial application (Wood et al., 2014; Cutz et al., 2014; Li & Hu, 2016).

1.2. Environmental impact assessment (EIA)

1.2.1. Introduction to EIA

Environmental impact assessment (EIA) is activity designed to assess and forecast the impact of a project on the environment and human health. It is recommended that decision makers make appropriate measures and operational procedures to minimize the impact (Hung et al., 2012). Similar with TEA, EIA is related to the multi-disciplinary background, which requires researchers to utilize synthesis applications to obtain results of complicated assessments. After its initial definition mentioned in the USA in 1970, it has developed for nearly fifty years, and widely spread to most developed countries and some developing countries (Morgan, 1998). Generally, EIA includes three basic steps of identifying, predicting and evaluating, which is related with biological, physio-chemical, ecological, social, health, economic and other correlative subjects (Glasson et al., 2013). Before the EIA procedure starts, related regulations should be checked and most important affected factors

listed. Areas of less concern should be ignored to define the scope of EIA. For the identification step, the existing environmental system and components of the project should be described, and possible environmental modifications caused by the project also need to be explored. Similar to the identification step, the prediction step also works on two aspects of project and environmental effect. Required EIA can forecast the quality and quantity of change in an environment and estimate the probability of impacts on a time scale. In the evaluating step, uncertainty and risks are the significant affected factors for final conclusion. In addition, depth of analysis and alternative comparisons are also very important to the success of EIA, which supplies a sufficiently detailed and complete comparison of the various alternative conditions and a reasonable sufficient depth of analysis for users and the public.

The main purpose of EIA is to identify the possible negative impacts to the environment resulting from a proposed project according to detailed environmental study and public comments (Holder, 2004). Based on this purpose, EIA also requires a detailed plan to reduce the negative effects of a project and minimize the level of environmental degradation. To measure and monitor the parameters of plan implementation and effectiveness, simulations are widely used in EIA for identifying the degree of uncertainty and investigating the potential risks.

1.2.2. Methodology

As an important and efficient tool for environmental assessment, the method of EIA must be significantly free from assessors' bias, and be economical in terms of costs, investigating time, equipment and facilities. To achieve the objectives above, several EIA

methods have been developed and utilized in current industrial production, including the ad hoc method, checklists method, matrices method, networks method, overlays method, environmental index using factor analysis, benefit analysis and predictive simulation methods (Canter et al., 1997; Dec, 1973; Fischer & Davies, 2013; Johnson & Bell, 1975; Lohani et al., 1997; Wathern, 2013; Westman, 1985).

The ad hoc method is simply based on subjective environment impacts, which can provide broad areas of possible impacts by showing each composite environmental characteristic. This method focuses on each environmental aspect separately, and can be utilized for tough assessment of total impacts. It is useful when there are time constraints and lack of expert resources and other necessities. Due to parameters mentioned above, the ad hoc method is weak when handling a comprehensive set of all relevant environmental factors and lacks consistency in analysis, which requires a continuing effort to modify and collect an appropriate panel for each assessment (Johnson & Bell, 1975). Different from the ad hoc method, the checklists method is strong on impact identification, which is a very significant fundamental function of EIA. This method ranges from listing environmental aspects according to their importance weighting of various factors, which is easy for site selection and priority. However, it is hard to link action and impact with this method and it is weak on distinguishing between direct and indirect impacts (Fischer & Davies, 2013). Unlike ad hoc and checklists methods, the overlay method involves a set of transparent maps with various environmental characteristics, which include biological, ecological, social, health, economic and other relevant aspects. These maps are overlaid to produce a composite so critical environmental features are reflected at the same scale (Lohani et al., 1997). This method is easy to understand and good for site selection settings, and is widely used for preparing

combined mapping with an assessment on sensitive areas and ecological carrying capacities. The weakness of this method is the limited number of overlaid transparencies that can be used, making it hard to address impact duration and probability. Excluding the three methods listed above, there are still other methods commonly used in EIA, including the matrices method, networks method, and benefit analysis. In a complicated EIA project, different assessment stages require various methods and techniques to be utilized cooperatively so final assessments are accurate and convincing.

1.2.3. Applications

As an efficient method to evaluate the environmental effect, environmental impact assessment has been utilized in various areas, including industrial design, civil engineering, environmental engineering, chemical engineering and other engineering areas (Koller, 2000; Jia et al., 2004).

As a renewable replacement for petroleum fuels, biofuel is considered a positive beneficial product in the economy, but some are still doubtful of biofuel's environmental benefits (Menetrez, 2010). To investigate this doubt, EIA is widely utilized as an efficient method to explore the effects of biofuel production on the environment. In 2014, bioethanol and bioethanol-blended gasoline fuel was discussed with EIA and it was concluded using bioethanol significantly reduced petroleum use and exhaust greenhouse gas (GHG) emission (Sadeghinezhad et al., 2014). In addition, this study illustrated that bioethanol from sugar cane was essentially a cleaner fuel than petroleum-derived gasoline in reducing GHG emissions and improving air quality. Excluding traditional bioethanol material like corn and sugarcane, other biomass was discussed by the EIA method to explore feasibility on

environmental effects. Sun et al (2013) used EIA to explore the effect of rinse water and recovered sulfuric acid on ethanol production from bamboo. This study claimed condensate without acetate could be reused as elution water in acid–sugar separation, and 86.3% of the process water and 77.6% of the sulfuric acid could also be recycled. Similar with bioethanol production, biogas production was unclear in its environmental effects, which required researchers to use various tools to explore the truth. In 2015, Morero et al presented a comparison between EIA and a life cycle assessment (LCA), analyzing the upgrade of biogas production. The LCA results showed water produced a minor impact in most of the considered categories, whereas the high impact in the process with amines was the result of its high energy consumptions. What's more, positive results obtained in the EIA made the project feasible, and all negative impacts were mitigated by preventive and remedial measures. After considering the strengths and weaknesses of each tool, this study indicated the EIA was a procedure that complemented the LCA.

Excluding analysis of the processes of biofuel and biorefinery, EIA also works for other engineering processes, which include fermentation, product design and chemical process (Hendershot, 1997; Koller, 2000). To explore the optimum method from three different fermentation processes for fructooligosaccharides, EIA was utilized to evaluate and compare the environmental impact (Mussatto et al., 2015). This study showed solid-state fermentation (SSF) was the most attractive process in environmental aspects since it was more favorable environmentally, causing a lower carbon footprint (0.73 kg per kg, expressed in mass of CO₂ equivalent per mass of FOS) and the lowest wastewater generation. Similar to the research of Mussatto et al (2015), EIA also worked to compare the various chemical processes with potential environmental impacts. Young et al (2004) utilized EIA with a waste

reduction (WAR) algorithm to compare three modified chemical processes, which EIA partitioned into impacts of the non-product streams and impacts of the energy generation/consumption process. This study demonstrated EIA was helpful to illustrate the consequences of decision making in the design of environmentally friendly processes. Environmental impact assessment was also utilized to assess continuous chemical processes, clean design, and pollution prevention progress, which helped researchers explore the environmental effect of new industrial applications (Elliott et al., 1996; Stephan et al., 1994).

1.3. Corn-based ethanol industry

1.3.1. Introduction

With increased demand for fossil fuels, bioethanol was utilized as a fuel additive and continuously increased to reach the market requirements for fuel (Schnepf & Yacobucci, 2010). As a renewable bioenergy resource, ethanol has the potential to partially replace fossil fuels like petrol, which has fewer negative effects on the environment and a relatively stable price (Alinia et al., 2010). In addition, the development of bio-based industries helps the U.S. domestic economies as well as its feed and energy security. In fact, the corn-based ethanol industry and related upstream and downstream industries are the most important part of the US ethanol industry, and had a rapid development to in last 20 years (Renewable Fuels Association, 2012). In 2015, United States fuel ethanol production reached 14.7 billion U.S. liquid gallons (55.6 billion liters), and was predicted to reach 16 billion U.S. liquid gallons production in 2022 (Renewable Fuels Association, 2016; Conti et al., 2015). To total energy consumption, liquid biofuel increased 65 times from 0.02 to 1.31 quadrillion Btu between 1982 and 2014 (Conti et al., 2015).

1.3.2. Ethanol process

As the earliest product of value-added processing in human history, ethanol has been produced from starch plant or sugar-based feedstocks including corn, wheat and other plants since the 12th century (Pimental, 1991). The producing process of ethanol kept similar steps for both in beverage production and industrial production, while starch-based industrial ethanol process significantly increased yield and efficiency for ethanol production (Hahn-Hägerdal et al., 2006). Of all starch-based ethanol production, the corn-based ethanol process was the most common one in U.S. ethanol industry, which developed series of pathways to increase ethanol yield and decrease negative effects on the environment. With the technological innovations in recent years, fractionation and low heat fermentation have been utilized in industrial production, which significantly increased the yield of ethanol production (Wildschut et al., 2013). By exploring the feasibility of biomass gasification, corn stover can be utilized as another raw material to produce ethanol and coproducts. What's more, oil extraction has been widely used in corn-based ethanol plants, which made it possible to produce value-added products (Chien et al., 1990). In addition, various types of coproducts, including DWG, DDG, DDGS and corn syrup, made a positive contribution on the feed industry (Kim et al., 2008). In modern industrial ethanol production, milling is an important process to affect the quality and quantity of ethanol production. The corn milling industry has grown in its 150 years of existence into the most diversified and integrated of all grain processing industries (Uriyapongson, & Rayas-Duarte, 1994). There are two main distinct processes for processing corn: wet-milling and dry-milling, and each process generates unique coproducts.

1.3.2.1. Dry milling

Both in dry milling and wet milling process, corn kernels are required to clean for removing stone and dust. Then corn is grounded into flour to have a better performance when reacting with enzymes in next steps. After slurring with water, various enzymes are added into the mash mixture so that long chain starches can be broken into dextrose and glucose. Lime, ammonia or sulfuric acid are used for pH control in the industrial process, and the mash is heated to reduce contamination by bacteria and other microorganisms (Verser & Eggeman, 2011). After cooling down the mash, the mixture is transferred to fermenters and specific yeast is added, which can convert the simple structure sugar into ethanol and carbon dioxide.

The residence time of fermentation generally takes 36 to 72 hours, which depends on the condition of slurry, enzymes and yeasts (Kelsall & Lyons, 2003). The fermentation slurry is transferred to stripping column after fermentation, which contains between 10% and 15% ethanol. With a heated multiple-column distillation system, the ethanol content is separated from the stillage, then concentrated to 190 proof with conventional distillation (Verser & Eggeman, 2011). 200 proof ethanol can be obtained with the microporous beads of the molecular sieve system, which adsorb the water vapor from ethanol. To separate from beverage alcohol, a 5% denaturant like octane is added into ethanol so that it is undrinkable.

By utilizing the centrifuge, the whole stillage separates the coarse grain from the solubles. Thin stillage with high concentration of water and wet cake, or DWG, is used as a dewatered product. By evaporating the solubles, it is concentrated to around 30% solids, which is defined as condensed distillers solubles (CDS) or syrup (Verser & Eggeman, 2011).

If corn-based ethanol plants directly dry DWG, the final product is distillers dried grains (DDG). However, the majority of corn-based ethanol plant mix and dry CDS with DWG to produce dried distillers grains with solubles (DDGS), which offers a nutritious benefit in livestock feed (Verser & Eggeman, 2011). In addition, CO₂ released in the fermentation process can be added into soft drinks or beers and assigned a market value (Hunt et al., 2010).

1.3.2.1. Wet milling

In wet milling, corn is soaked in water around 50°C for 24 to 48 hours, with sulphur dioxide added to the water to decrease the contamination of bacterial (Johnson & May, 2003). This process is called steeping, which separates the whole grain into its many component parts. After steeping, the corn slurry flows to the germ separators to divide out the corn germ, which contains 85% oil content of the corn (Freeman, 1973). The germ is collected and dried for further processing to extract the oil content. With using the grinding, three components of starch, gluten and fiber content are separated from the corn slurry. The fiber content stays on fixed concave screens but the starch and gluten pass through. The starch-gluten mixture is transferred to the starch separators, and the collected fiber content is collected and dried for animal feed.

By utilizing a centrifuge, the two contents of mixture are easily separated due to the density of gluten. Gluten can be collected and utilized for animal feed. What's more, the starch can be washed to remove a small percentage of protein, creating 99.5% pure starch as a high value added product (Singh & Eckhoff, 1996). The starch can be dried as corn starch or modified to turn into other products, such as corn sweeteners, corn syrups, dextrose and

fructose (Haros & Suarez, 1997). Another pathway for using starch is to ferment it into ethanol. The fermentation process for ethanol is very similar to the dry mill process mentioned above. In addition, steeping liquor with evaporation can be sold as corn gluten feed in the livestock industry.

1.3.3. Distillers dried grains with solubles (DDGS)

Dried Distillers Grains with Solubles (DDGS) are wet distillers grains (WDG) that are dried with concentrated thin stillage to 10~12% moisture. In corn-based fuel manufacturing, bioethanol, distillers dried grains with solubles (DDGS) (or other coproducts), and carbon dioxide are the three main products. Among all products from the bioethanol industry, DDGS is the most important ingredient, and is packaged and traded as a commodity feed product in US.

1.3.3.1. Basic properties of DDGS

Common physical properties of DDGS include particle size, loose bulk density, packed bulk density, and angle of repose. These influence how much of the product can be stored in a given volume (Ileleji et al., 2008). In addition, moisture content, water activity and shear strength also affect the storability and material milling properties of DDGS. However, large variations in physical properties have been reported by different research groups over the years. (Shurson, 2005; Rosentrater, 2006; Ileleji et al., 2007).

DDGS is mainly composed of protein, fiber, and fat and is a dry mix of particulate materials. Due to various particle compositions, with high protein and high fiber particles, a method dividing DDGS into high protein and high fiber fractions contribute extra economic

benefits (Renewable Fuels Association, 2012). A high protein fraction has greater value as feed to animals (Belyea et al., 2004), and a high fiber fraction has more potential for corn fiber gum or raw material for lignocellulose ethanol production (Singh et al., 2002). Marketing of DDGS as an ingredient is directly related to sustainability of a dry grind plant, and is sold at a varying market price (US\$85–300 per metric ton) (Liu, 2008).

1.3.4. DDGS separation methods

As a potential value added mixed product, DDGS has requirements for efficient methods to fractionate into different value added products. After fractionation, DDGS will separate into high protein and fat DDGS and high fiber DDGS. Higher protein and fat content is considered to enhance nutritional value, which is used in non-ruminant animal diets with a higher market value (Belyea et al., 2004). High fiber DDGS has also been studied to investigate extra value, which includes the possibility of ingredients in human foods, material for bioplastic and substrates for biofuel (Baboi et al., 2008; Bechen, 2008; Dien et al., 2008).

Due to the potential value of DDGS, various methods have been investigated in the last decade, including aspiration, elutriation, sieving and destoner fractionation (Liu, 2009; Garcia & Rosentrater, 2008). Aspiration is a common method attempted by researchers (Garcia & Rosentrater, 2008). Using screenings and air classifications to separate a variety of sizes, an aspirator separates DDGS into high and low terminal velocity fractions. Combining the undersize fraction and existing low velocity fraction, final DDGS products are substantially enriched in protein. Similar to aspiration, sieving is another possible method to fractionate the various components of DDGS. Liu (2009) found sieving was effective in

producing fractions with varying compositions, and showed particle size had a negative correlation with protein and ash contents. In addition, elutriation also separated DDGS particles using an upward flowing stream of fluid. Combined with the aspiration method, Srinivasan et al. (2005) concluded that elutriation improved the fractionation efficiency on DDGS, based on combined effects of density, shape, and size characteristics. This study showed larger sizes of DDGS with appropriate air flow velocities were more effective than sieving alone in separating fiber from DDGS. Similar to the results above, Srinivasan et al. (2009) designed another experiment to sieve DDGS into four fractions, which showed nearly 12.4% of DDGS was separated into fiber products, and two high protein products with low fiber contents.

Differently from the methods above, the destoner fractionation process is a new pathway for separating DDGS with various compositions. A destoner is a simple structure machine with high efficiency in fractionation, and was originally used to remove stones and soil from grains. By using air flow and shaking to separate, a destoner keeps the stone or heavy part on the top of the screen and the grains or light part falls through (Heiland & Kozempel, 1988). Due to convenience and inexpensive operation, destoner is a potential tool for DDGS fractionation, and very appropriate for industrial application. Zhang and Rosentrater (2013) utilized the destoner process to separate DDGS, and found it somewhat efficient and effective on the fractionation process. Results showed particle size distribution had a positive correlation coefficient (0.93) with oil parameters and a negative correlation coefficient (-0.96) with moisture parameters.

Though amounts of research have been done to explore fractionation of DDGS, these methods only reached partially success, which were ambiguous in efficiency and economic

benefits. They were far from the goal of sustainable industrial production, which required TEA and EIA to explore the feasibility in economic and environmental aspects.

1.3.5. Industrial simulation

Industrial simulation is the imitation of the operation of a physical, mathematical, or otherwise logical representation of an industrial system or process, which can develop data as a basis for managerial or technical decision making (Balci, 1997; Bank et al., 2001). Industrial simulation was widely used in two situations, which were high uncertainty without enough data and to replace the real experimentation with a high risk or high cost environment (Banks, 1998). Compared to other approaches on solving industrial problems, industrial simulation had the advantages of strong forecasting power, universality on specific topics and high cost effects (Schmidt & Taylor, 1970). Supported by a correct theory and responsible frame design, industrial simulation would have a high predictive power, which could forecast the scenarios outside of historical bounds. Industrial simulation supported highly flexible techniques for solving various similar industrial problems, while the limitation of simulation was hard to formalize and required large amounts of update and modification. In addition, industrial simulation tested similar scenarios with different variables, which caused less time and resources usage than real experiments or producing in industrial production. However, the weakness of industrial simulation was forecasting the future. Researchers always suspected events that never happened affected simulations, especially on accuracy and precision

In biorefinery and bioprocesses, industrial simulation programs were widely used to determine feasibility, which explored how different operations affected the overall

production costs and the effects of each environmental impact. SuperPro Designer (Intelligen, Inc., Scotch Plains, NJ), ASPEN PLUS (Aspen Technology, Inc., Burlington, MA) and CHEMCAD (Chemstations, Inc., Houston, TX) were widely utilized as a tool of techno-economic analysis and environmental impact assessment for industrial simulation (Haas et al, 2006; Kwiatkowski et al, 2006). By using techno-economic analysis with related software to build models, researchers explored the various possible affected factors, which included material price, labor cost, energy consumption, product revenue and process profit. In addition, industrial simulation made it possible to investigate the feasibility and efficiency improvement for new industrial technology usage. What's more, industrial simulation supplied an approach to obtain the effects of production to ecological systems and maximized recycling of materials and waste.

During recent research, industrial simulation from SuperPro Designer was widely used in the bioethanol process and related industrial processes, which included corn-based ethanol, lignocellulosic ethanol and oil extraction (Wood et al., 2014; Yang & Rosentrater, 2015; Cheng & Rosentrater, 2015). USDA has built a basic simulation model for corn-based ethanol process, and more details are available in Kwiatkowski (2006) and Wood (2014). Similar to SuperPro Designer, Aspen Plus was another common software for industrial simulation in biorefinery and bioprocesses, which attempted to explore the feasibility of biohydrogen, bio-oil gasification, biodiesel, syngas and microalgae fuel production (Hu et al., 2016; Apostolakou et al., 2009; Zhang et al., 2013; Davis et al, 2011; Gnansounou & Dauriat, 2010; Zhu et al). In addition, ChemCAD was also chosen to evaluate the economic feasibility of lignocellulosic ethanol and integrated hydrocarbon fuels form corn and microalgae (Wang et al, 2015; Thilakaratne et al, 2014; Meyer et al., 2013; Ou et al, 2009).

Beside these, there were other software applied for industrial simulation (Mani et al, 2010; Kern et al., 2017)

1.4. Integrated corn and soybean biorefinery

1.4.1. Soybean oil process

The U.S. soybean crush is about 90 million MT (3.3 billion bushel), with more than 20 billion lbs. of soybean oil produced in the U.S. (ERS, 2013). Nearly all (>97%) soybean oil was produced using hexane extraction. Hexane extraction has two significant shortcomings: safety issues due to extreme volatility and flammability, and production of volatile organic compounds and hazardous air pollutants. Industry losses of hexane range from 0.2 to 0.5 gallon per metric ton of soybeans (Wu et al, 2009). Considering today's plants process at least 3,000 metric ton per day, these losses are quite large. The U.S. Environmental Protection Agency enacted very stringent emission standards (EPA, 2001) and imposed financial penalties on hexane losses.

Today, most fuel ethanol production is achieved using dry grind processes with corn grain, and as much as 15 billion gallons of capacity are available. Thus, more than 10% of the 150 billion gallons of annual motor fuel consumption are met with corn-derived ethanol. This amount of production meets the mandated level in the 2007 Energy Independence and Security Act. Most of corn-based ethanol plants kept the positive profitability in last decade, but more efficient methods of production were desperately required by the corn-based ethanol industry to obtain higher profits.

1.4.2. EAEP process

Enzyme-assisted aqueous extraction processing (EAEP) is a new oil extraction process, which utilizes enzymes and water to recover either free oil or oil stabilized as natural oleosomes, protein and fiber-rich fractions (De Moura et al., 2009; De Moura et al., 2011; Majoni et al., 2011). There are four main portions in the EAEP process, which are mechanical pretreatment, enzyme-assisted aqueous extraction, separation of cream and coproducts and demulsification of the cream fraction (De Moura et al., 2011). A process flow diagram of the soybean EAEP process is shown in Figure 1.1. The main function of mechanical pretreatment is to breakdown raw material cell walls, which is helpful for subsequent aqueous fractionation. There are various amounts of factors affecting the rate of separating oil and protein, which includes solids to liquid ratio, temperature, pH, enzyme usage and residence time (De Moura et al., 2011). Solids are efficiently separated from skim and cream by using a three-phase horizontal decanter centrifuge. After the extraction process, the main contents in the liquid stream are cream, skim and insoluble fiber, which utilize centrifugation and fractionation to separate. Reducing the volume of skim and the amount of enzyme usage are key points in this separation. With demulsifying by enzyme and heat treatment, the free oil yield from cream fraction achieves 97% (De Moura et al., 2011). In addition, protein can be collected from the stream and anti-nutritional factors are inactivated.

In previous studies, surplus amounts of skim and insoluble fiber were a limitation to the EAEP process in profit analysis. However, with the high content of hydrolyzed protein and soluble sugars, soy skim was an effective nutrient source for corn soybean integrated fermentation, which increased the fermentation rate and the DDGS value with a higher protein content (Yao et al., 2011; Yao et al., 2012). In addition, fiber fractions from soybean

EAEP process contained 60-70% moisture, while solids were mainly cellulose, hemicellulose and insoluble proteins (De Moura et al., 2011). Due to this characteristic, insoluble fiber was a potential lignocellulosic feedstock for ethanol production, which helped corn-based ethanol processes increase ethanol production. Sekhon et al (2011) indicated that adding soybean skim and insoluble fiber from EAEP significantly increased ethanol production rate and ethanol yield. Under optimal conditions, modified corn fermentation increased 20% of ethanol yield and 3% of ethanol production rate in the lab scale.

EAEP is generally more environmentally friendly and more suitable for converting soybean products into products replacing petroleum. Compared with the expelling and hexane processes, EAEP reduces environmental impacts by maintaining high oil recovery. High energy consumption is one limitation for the EAEP process in industrial application (Cheng et al., 2016a). In addition, high oil extraction yield made the EAEP process keep economic feasibility in an industrial scale, which was suitable for farmer-owned cooperatives with lower investment costs (Cheng et al., 2016b).

References

- Ahuja, H. N., & Walsh, M. A. (1983). *Construction management and engineering: Successful methods in cost engineering*. Mississauga, Canada: John Wiley & Son Inc.
- Alinia, R., Zabihi, S., Esmailzadeh, F., & Kalajahi, J. F. (2010). Pretreatment of wheat straw by supercritical CO₂ and its enzymatic hydrolysis for sugar production. *Biosystems Engineering* 107(1), 61-66.
- Apostolakou, A. A., Kookos, I. K., Marazioti, C., & Angelopoulos, K. C. (2009). Techno-economic analysis of a biodiesel production process from vegetable oils. *Fuel Processing Technology*, 90(7), 1023-1031.
- Baboi, M., Grewell, D., & Srinivasan, G. (2008, May). Proceedings from ANTEC: *Feasibility study of the use of DDGS plastic composites*.

- Balci, O. (1997). Proceedings of the 29th Conference on Winter Simulation: *Verification validation and accreditation of simulation models*, 135-141.
- Banks, J. (Ed.). (1998). *Handbook of simulation: Principles, methodology, advances, applications, and practice*. Mississauga, Canada: John Wiley & Sons.
- Banks, J., Carson, J. S., Nelson, B. L., & Nicol, D. M. (2001). Verification and validation of simulation models. *Discrete-event system simulation (3rd ed.)*, (367-397). Upper Saddle River, NJ: Prentice-Hall.
- Bechen, A. M. (2008). *The glycemic response of distillers dried grains as a human food ingredient*. Brookings SD: South Dakota State University.
- Belyea, R. L., Rausch, K. D., & Tumbleson, M. E. (2004). Composition of corn and distillers dried grains with solubles from dry grind ethanol processing. *Bioresource Technology* 94(3): 293-298.
- Blank, L., & Tarquin, A. (1998). *Engineering economy*. New York, NY: WCB/McGraw-Hill.
- Canter, L., Sadler, B., & Lee, N. (1997). A tool kit for effective EIA practice: Review of methods and perspectives on their application. *Project Appraisal*, 12(4), 266.
- Caves, D. W., Christensen, L. R., & Diewert, W. E. (1982). Multilateral comparisons of output, input, and productivity using superlative index numbers. *The Economic Journal*, 92(365), 73-86.
- Celik, A. N. (2003). Techno-economic analysis of autonomous PV-wind hybrid energy systems using different sizing methods. *Energy Conversion and Management*, 44(12), 1951-1968.
- Cheng, M. H., & Rosentrater, K. A. (2015). Techno-economic analysis of soybean oil expelling process from 1980-2014. In *2015 ASABE Annual International Meeting* (p. 1). American Society of Agricultural and Biological Engineers.
- Cheng, M. H., Zhang, W., Rosentrater, K. A., Sekhon, J. J., Wang, T., Jung, S., & Johnson, L. A. (2016a). Environmental impact analysis of soybean oil production from expelling, hexane extraction and enzyme assisted aqueous extraction. In *2016 ASABE Annual International Meeting* (p. 1). American Society of Agricultural and Biological Engineers.
- Cheng, M. H., Zhang, W., Rosentrater, K. A., Sekhon, J. J., Wang, T., Jung, S., & Johnson, L. A. (2016b). Techno-economic analysis of integrated enzyme assisted aqueous extraction of soybean oil. In *2016 ASABE Annual International Meeting* (p. 1). American Society of Agricultural and Biological Engineers.
- Chien, J. T., Hoff, J. E., Lee, M. J., Lin, H. M., Chen, Y. J., & Chen, L. F. (1990). Oil extraction of dried ground corn with ethanol. *The Chemical Engineering Journal*, 43(3), B103-B113.
- Clausen, L. R., Houbak, N., & Elmegaard, B. (2010). Technoeconomic analysis of a methanol plant based on gasification of biomass and electrolysis of water. *Energy*, 35(5), 2338-2347.
- Clews, G., & Leonard, R. (1985). *Technology and production*. Rossendale, United Kingdom: Philip Allan.

- Conti, J. J., Holtberg, P. D., Diefenderfer, J. R., Napolitano, S. A., Schaal, A. M., Turnure, J. T., & Westfall, L. D. (2015). Annual energy outlook 2015. *US Energy Information Administration*, 14.
- Coticchia, M. E., Crawford, G. W., & Preston, E. J. (1993). *CAD/CAM/CAE systems: Justification, implementation, productivity measurement*. Boca Raton, FL: CRC Press.
- Cowing, T. G., & Stevenson, R. E. (Eds.). (1981). *Productivity measurement in regulated industries*. New York, NY: Academic.
- Cutz, L., & Santana, D. (2014). Techno-economic analysis of integrating sweet sorghum into sugar mills: The Central American case. *Biomass and Bioenergy*, 68, 195-214.
- Davis, R., Aden, A., & Pienkos, P. T. (2011). Techno-economic analysis of autotrophic microalgae for fuel production. *Applied Energy*, 88(10), 3524-3531.
- Dec, N. (1973). Environmental evaluation system for water resources planning. *Water Resources Research*, 9(3), 523-535.
- De Moura, J. M. L. N., & Johnson, L. A. (2009). Two-stage countercurrent enzyme-assisted aqueous extraction processing of oil and protein from soybeans. *Journal of the American Oil Chemists' Society*, 86(3), 283-289.
- De Moura, J. M. L. N., Maurer, D., Jung, S., & Johnson, L. A. (2011). Pilot-plant proof-of-concept for integrated, countercurrent, two-stage, enzyme-assisted aqueous extraction of soybeans. *Journal of the American Oil Chemists' Society*, 88(10), 1649.
- Dien, B. S., Ximenes, E. A., O'Bryan, P. J., Moniruzzaman, M., Li, X. L., Balan, V., Dale, B. & Cotta, M. A. (2008). Enzyme characterization for hydrolysis of AFEX and liquid hot-water pretreated distillers' grains and their conversion to ethanol. *Bioresource Technology*, 99(12), 5216-5225.
- Do, T. X., Lim, Y. I., & Yeo, H. (2014). Techno-economic analysis of biooil production process from palm empty fruit bunches. *Energy Conversion and Management*, 80, 525-534.
- Elliott, A. D., Sowerby, B., & Crittenden, B. D. (1996). Quantitative environmental impact analysis for clean design. *Computers & Chemical Engineering*, 20, S1377-S1382.
- Environmental Protection Agency (EPA). (2011). National emission standards for hazardous air pollutants: Solvent extraction for vegetable oil production. *Federal Register*, 66(71), 19005-19026
- ERS, U. (2013). Food access research atlas.
- Färe, R., & Hunsaker, W. (1986). Note— notions of efficiency and their reference sets. *Management Science*, 32(2), 237-243.
- Fischer, D. W., & Davies, G. S. (1973). An approach to assessing environmental impacts. *Journal of Environmental Management*, 1(3), 207-227.

- Freeman, J. E. (1973). Quality factors affecting value of corn for wet milling. *Transactions of the ASAE*, 16(4), 671-0678.
- Frias, Z., & Pérez, J. (2012). Techno-economic analysis of femtocell deployment in long-term evolution networks. *EURASIP Journal on Wireless Communications and Networking*, 2012(1), 1-15.
- Garcia, R. A., & Rosentrater, K. A. (2012). Fractionation of distillers dried grains with solubles (DDGS) through a narrowing of particle size distribution followed by aspiration. *Food and Bioprocess Technology* 5(6): 2623-2629.
- Glasson, J., Therivel, R., & Chadwick, A. (2013). *Introduction to environmental impact assessment*. London, United Kingdom: Routledge.
- Gnansounou, E., & Dauriat, A. (2010). Techno-economic analysis of lignocellulosic ethanol: a review. *Bioresource Technology*, 101(13), 4980-4991.
- Haas, M. J., McAloon, A. J., Yee, W. C., & Foglia, T. A. (2006). A process model to estimate biodiesel production costs. *Bioresource Technology*, 97(4), 671-678.
- Hahn-Hägerdal, B., Galbe, M., Gorwa-Grauslund, M. F., Lidén, G., & Zacchi, G. (2006). Bio-ethanol—the fuel of tomorrow from the residues of today. *Trends in Biotechnology*, 24(12), 549-556.
- Haros, M., & Suarez, C. (1997). Effect of drying, initial moisture and variety in corn wet milling. *Journal of Food Engineering*, 34(4), 473-481.
- He, J., & Zhang, W. (2011). Techno-economic evaluation of thermo-chemical biomass-to-ethanol. *Applied Energy*, 88(4), 1224-1232.
- Heiland, W. K., & Kozempel, M. (1988). A mechanical destoner for small processing plants. *American Journal of Potato Research* 65(9): 543-546.
- Hendershot, D. C. (1997). Measuring inherent safety, health and environmental characteristics early in process development. *Process Safety Progress*, 16(2), 78-79.
- Himmelblau, D. M. (1978). *Fault detection and diagnosis in chemical and petrochemical processes* (Vol. 8). Amsterdam, Netherlands: Elsevier Science Ltd.
- Holder, J., (2004), *Environmental assessment: The regulation of decision making*. New York, NY: Oxford University Press.
- Hu, W., Dang, Q., Rover, M., Brown, R. C., & Wright, M. M. (2016). Comparative techno-economic analysis of advanced biofuels, biochemicals, and hydrocarbon chemicals via the fast pyrolysis platform. *Biofuels*, 7(1), 57-67.
- Hung, Y. T., Wang, L. K., & Shamma, N. K. (Eds.). (2012). *Handbook of environment and waste management: Air and water pollution control* (Vol. 1). World Scientific.
- Hunt, A. J., Sin, E. H., Marriott, R., & Clark, J. H. (2010). Generation, capture, and utilization of industrial carbon dioxide. *ChemSusChem*, 3(3), 306-322.

- Ims, L. A., Olsen, B. T., Myhre, D., Lahteenoja, M., Mononen, J., Ferrero, U., & Zaganlaris, A. (1996). Multiservice access network upgrading in Europe: A techno-economic analysis. *IEEE Communications Magazine*, 34(12), 124-134.
- Ileleji, K. E., Prakash, K. S., Stroshine, R. L., & Clementson, C. L. (2007). An investigation of particle segregation in corn processed dried distillers grains with solubles (DDGS) induced by three handling scenarios. *Bulk Solids Powder Sci. Technol.* 2: 84–94.
- Ileleji, K. E., & Rosentrater, K. A. (2008). On the physical properties of dried distillers grains with solubles (DDGS). *ASABE Paper*, (084576).
- Jia, X. P., Han, F. Y., & Tan, X. S. (2004). Integrated environmental performance assessment of chemical processes. *Computers & chemical engineering*, 29(1), 243-247.
- Johnson, F. L., & Bell, D. T. (1975). Guidelines for the identification of potential environmental impacts in the construction and operation of a reservoir. *For Res Rep Agric Exp Stn Univ III*.
- Johnson, L. A., & May, J. B. (2003). Wet milling: the basis for corn biorefineries. *Corn: Chemistry and technology*, (Ed. 2), 449-494.
- Jones, S. B., & Zhu, Y. (2011). Techno-economic analysis for the conversion of lignocellulosic biomass to gasoline via methanol-to-gasoline (MTG) process, PNNL-18481. Richland, WA: Pacific Northwest National Laboratory. Retrieved from http://www.pnl.gov/main/publications/external/technical_reports/PNNL-18481.pdf
- Jorgenson, D. W., & Griliches, Z. (1967). The explanation of productivity change. *The Review of Economic Studies*, 34(3), 249-283.
- Kelsall, D. R., & Lyons, T. P. (2003). Grain dry milling and cooking procedures: Extracting sugars in preparation for fermentation. *The Alcohol Textbook*, (4th ed.). (9-21). Nottingham, United Kingdom: Nottingham University Press.
- Kern, J. D., Hise, A. M., Characklis, G. W., Gerlach, R., Viamajala, S., & Gardner, R. D. (2017). Using life cycle assessment and techno-economic analysis in a real options framework to inform the design of algal biofuel production facilities. *Bioresource Technology*, 225, 418-428.
- Kim, Y., Mosier, N. S., Hendrickson, R., Ezeji, T., Blaschek, H., Dien, B., & Ladisch, M. R. (2008). Composition of corn dry-grind ethanol by-products: DDGS, wet cake, and thin stillage. *Bioresource Technology*, 99(12), 5165-5176.
- Koller, G. (2000). Identification and assessment of relevant environmental, health and safety aspects during early phases of process development, *Dissertation ETH Nr. 13607 (ETH Zurich, Zurich, Switzerland)*.
- Kwiatkowski, J. R., McAloon, A. J., Taylor, F., & Johnston, D. B. (2006). Modeling the process and costs of fuel ethanol production by the corn dry-grind process. *Industrial Crops and Products*, 23(3), 288-296.
- Li, Q., & Hu, G. (2016). Techno-economic analysis of biofuel production considering logistic configurations. *Bioresource Technology*, 206, 195-203.

- Lier, S., & Grünewald, M. (2011). Net present value analysis of modular chemical production plants. *Chemical Engineering & Technology*, 34(5), 809-816.
- Liu, K. (2009). Effects of particle size distribution, compositional and color properties of ground corn on quality of distillers dried grains with solubles (DDGS). *Bioresource Technology* 100(19): 4433-4440.
- Liu, S. (2016). *Bioprocess engineering: Kinetics, sustainability, and reactor design*. Amsterdam, Netherlands: Elsevier.
- Lohani, B. N., Evans, J. W., Everitt, R. R., Ludwig, H., Carpenter, R. A., & Tu, S. L. (1997). *Environmental impact assessment for developing countries in Asia. 1. Overview. 2. Selected case studies*. Asian Development Bank.
- Madu, C. N. (2001). Life Cycle Assessment. In Handbook of environmentally conscious manufacturing (pp. 385-416). New York, NY: Springer US.
- Magni, C. A. (2013). The internal rate of return approach and the AIRR paradigm: A refutation and a corroboration. *The Engineering Economist*, 58(2), 73-111.
- Majoni, S., Wang, T., & Johnson, L. A. (2011). Enzyme treatments to enhance oil recovery from condensed corn distillers solubles. *Journal of the American Oil Chemists' Society*, 88(4), 523-532.
- Mani, S., Sokhansanj, S., Tagore, S., & Turhollow, A. F. (2010). Techno-economic analysis of using corn stover to supply heat and power to a corn ethanol plant—Part 2: Cost of heat and power generation systems. *Biomass and Bioenergy*, 34(3), 356-364.
- McIlveen-Wright, D. R., Moglie, M., Rezvani, S., Huang, Y., Anderson, M., Redpath, A. D., & Hewitt, N. J. (2011). A techno-economic analysis of biomass gasifiers integrated with high and intermediate temperature solid oxide fuel cells. *International Journal of Energy Research*, 35(12), 1037-1047.
- Menetrez, M. Y. (2010). The potential environmental impact of waste from cellulosic ethanol production. *Journal of the Air & Waste Management Association*, 60(2), 245-250.
- Meyer, P. A., Tews, I. J., Magnuson, J. K., Karagiannis, S. A., & Jones, S. B. (2013). Techno-economic analysis of corn stover fungal fermentation to ethanol. *Applied Energy*, 111, 657-668.
- Morero, B., Rodriguez, M. B., & Campanella, E. A. (2015). Environmental impact assessment as a complement of life cycle assessment. Case study: Upgrading of biogas. *Bioresource technology*, 190, 402-407.
- Morgan, R. K. (1998). *Environmental impact assessment*. Hoboken, NJ: John Wiley & Sons, Ltd.
- Mueller-Langer, F., Tzimas, E., Kaltschmitt, M., & Peteves, S. (2007). Techno-economic assessment of hydrogen production processes for the hydrogen economy for the short and medium term. *International Journal of Hydrogen Energy*, 32(16), 3797-3810.

- Mussatto, S. I., Aguiar, L. M., Marinha, M. I., Jorge, R. C., & Ferreira, E. C. (2015). Economic analysis and environmental impact assessment of three different fermentation processes for fructooligosaccharides production. *Bioresource Technology*, *198*, 673-681.
- Nagarajan, S., Chou, S. K., Cao, S., Wu, C., & Zhou, Z. (2013). An updated comprehensive techno-economic analysis of algae biodiesel. *Bioresource Technology*, *145*, 150-156.
- Ou, L., Brown, T. R., Thilakarathne, R., Hu, G., & Brown, R. C. (2014). Techno-economic analysis of co-located corn grain and corn stover ethanol plants. *Biofuels, Bioproducts and Biorefining*, *8*(3), 412-422.
- Pearce, D. (1994). The greening of the GATT: Some economic considerations. *Trade and The Environment: The Search For Balance*, *1*, 20-38.
- Perimenis, A., Walimwipi, H., Zinoviev, S., Müller-Langer, F., & Miertus, S. (2011). Development of a decision support tool for the assessment of biofuels. *Energy Policy*, *39*(3), 1782-1793.
- Pham, V., Holtzapple, M., & El-Halwagi, M. (2010). Techno-economic analysis of biomass to fuel conversion via the MixAlco process. *Journal of Industrial Microbiology & Biotechnology*, *37*(11), 1157-1168.
- Phillips, S. D., Tarud, J. K., Bidy, M. J., & Dutta, A. (2011). Gasoline from woody biomass via thermochemical gasification, methanol synthesis, and methanol-to-gasoline technologies: A technoeconomic analysis. *Industrial & Engineering Chemistry Research*, *50*(20), 11734-11745.
- Pimentel, D. (1991). Ethanol fuels: Energy security, economics, and the environment. *Journal of Agricultural and Environmental Ethics*, *4*(1), 1-13.
- Renewable Fuels Association. (2012). 2012 Ethanol industry outlook: Accelerating industry innovation: 3, 8, 10 22 and 23. *Renewable Fuels Association: Washington D.C.*. Retrieved from <http://www.ethanolrfa.org/>.
- Rosendahl, L. (Ed.). (2013). *Biomass combustion science, technology and engineering*. Amsterdam, Netherlands: Elsevier.
- Rosentrater, K. A. (2006). Some physical properties of distillers dried grains with solubles (DDGS). *Applied Engineering in Agriculture* *22*(4): 589-595.
- Rajagopalan, S., Ponnampalam, E., McCalla, D., & Stowers, M. (2005). Enhancing profitability of dry mill ethanol plants. *Applied Biochemistry and Biotechnology*, *120*(1), 37-50.
- Sassner, P., Galbe, M., & Zacchi, G. (2008). Techno-economic evaluation of bioethanol production from three different lignocellulosic materials. *Biomass and Bioenergy*, *32*(5), 422-430.
- Sadeghinezhad, E., Kazi, S. N., Badarudin, A., Togun, H., Zubir, M. N., Oon, C. S., & Gharehkhani, S. (2014). Sustainability and environmental impact of ethanol as a biofuel. *Reviews in Chemical Engineering*, *30*(1), 51-72.
- Schmidt, J. W., & Taylor, R. E. (1970). *Simulation and analysis of industrial systems*. New York, NY: Richard D. Irwin.

- Schnepf, R., & Yacobucci, B. D. (2010, July). Renewable Fuel Standard (RFS): overview and issues. *CRS Report for Congress* (No. R40155).
- Sekhon, J. K., Jung, S., Wang, T., Rosentrater, K. A., & Johnson, L. A. (2015). Effect of co-products of enzyme-assisted aqueous extraction of soybeans on ethanol production in dry-grind corn fermentation. *Bioresource technology*, *192*, 451-460.
- Shah, Ajay. (2013). Techno-economic analysis and life cycle assessment of the corn stover biomass feedstock supply chain system for a Midwest-based first-generation cellulosic biorefinery. *Graduate Theses and Dissertations*. 13493. Retrieved from <http://lib.dr.iastate.edu/etd/13493>
- Shurson, G. C. (2005). Issues and opportunities related to the production and marketing of ethanol by-products. *Agricultural Outlook Forum* (Vol. 24).
- Singh, N., & Eckhoff, S. R. (1996). Wet milling of corn-A review of laboratory-scale and pilot plant-scale procedures. *Cereal chemistry*, *73*(6), 659-667.
- Singh, V., Moreau, R. A., Hicks, K. B., Belyea, R. L., & Staff, C. H. (2002). Removal of fiber from distillers dried grains with solubles (DDGS) to increase value. *Transactions of the ASAE*, *45*(2), 389.
- Srinivasan, R., Moreau, R. A., Rausch, K. D., & Belyea, R. L. (2005). Separation of fiber from distillers dried grains with solubles (DDGS) using sieving and elutriation. *Cereal Chemistry* *82* (5), 528-33.
- Srinivasan, R., To, F., & Columbus, E. (2009). Pilot scale fiber separation from distillers dried grains with solubles (DDGS) using sieving and air classification. *Bioresource Technology*, *100*(14), 3548-3555.
- Stephan, D. G., Knodel, R. M., & Bridges, J. S. (1994). A "Mark I" measurement methodology for pollution prevention progress occurring as a result of product design decisions. *Environmental Progress & Sustainable Energy*, *13*(4), 232-246.
- Sun, Z. Y., Tang, Y. Q., Morimura, S., & Kida, K. (2013). Reduction in environmental impact of sulfuric acid hydrolysis of bamboo for production of fuel ethanol. *Bioresource technology*, *128*, 87-93.
- Swanson, R. M., Platon, A., Satrio, J. A., & Brown, R. C. (2010). Techno-economic analysis of biomass-to-liquids production based on gasification. *Fuel*, *89*, S11-S19.
- Thilakaratne, R., Brown, T., Li, Y., Hu, G., & Brown, R. (2014). Mild catalytic pyrolysis of biomass for production of transportation fuels: A techno-economic analysis. *Green Chemistry*, *16*(2), 627-636.
- Thilakaratne, R., Wright, M. M., & Brown, R. C. (2014). A techno-economic analysis of microalgae remnant catalytic pyrolysis and upgrading to fuels. *Fuel*, *128*, 104-112.
- Uriyapongson, J., & Rayas-Duarte, P. (1994). Comparison of yield and properties of amaranth starches using wet and dry-wet milling processes. *Cereal Chemistry*, *71*(6), 571-577.

- Verser, D. W., & Eggeman, T. J. (2011). *U.S. Patent No. 7,888,082*. Washington, DC: U.S. Patent and Trademark Office.
- Wang, K., Ou, L., Brown, T., & Brown, R. C. (2015). Beyond ethanol: A techno-economic analysis of an integrated corn biorefinery for the production of hydrocarbon fuels and chemicals. *Biofuels, Bioproducts and Biorefining*, 9(2), 190-200.
- Wathern, P. (Ed.). (2013). *Environmental impact assessment: Theory and practice*. London, United Kingdom: Routledge.
- West, T. M., & Riggs, J. L. (1986). Engineering economics, (4th ed.) (781-789). New York, NY: McGraw-Hill Inc.
- Westman, W. E. (1985). *Ecology impact assessment and environmental planning*. Hoboken, NJ: John Wiley & Sons.
- Wheelwright, S. C., & Clark, K. B. (1988). *Dynamic manufacturing: Creating the learning organization*. New York, NY: Simon and Schuster.
- Wildschut, J., Smit, A. T., Reith, J. H., & Huijgen, W. J. (2013). Ethanol-based organosolv fractionation of wheat straw for the production of lignin and enzymatically digestible cellulose. *Bioresource Technology*, 135, 58-66.
- Wills, W. P. (1993). The search for the rule in article 30 EEC: Much ado about nothing?. *European Law Review*, 18(6), 475-492.
- Wood, C., Rosentrater, K. A., & Muthukumarappan, K. (2014). Techno-economic modeling of a corn-based ethanol plant in 2011/2012. *Industrial Crops and Products*, 56, 145-155.
- Wood, S. R., & Rowley, P. N. (2011). A techno-economic analysis of small-scale, biomass-fuelled combined heat and power for community housing. *Biomass and Bioenergy*, 35(9), 3849-3858.
- Wu, J., Johnson, L. A., & Jung, S. (2009). Demulsification of oil-rich emulsion from enzyme-assisted aqueous extraction of extruded soybean flakes. *Bioresource Technology*, 100(2), 527-533.
- Yang, H., Wei, Z., & Chengzhi, L. (2009). Optimal design and techno-economic analysis of a hybrid solar-wind power generation system. *Applied Energy*, 86(2), 163-169.
- Yang, M., & Rosentrater, K. A. (2015). Techno-economic analysis (TEA) of low-moisture anhydrous ammonia (LMAA) pretreatment method for corn stover. *Industrial Crops and Products*, 76, 55-61.
- Yao, L., Wang, T., & Wang, H. (2011). Effect of soy skim from soybean aqueous processing on the performance of corn ethanol fermentation. *Bioresource Technology*, 102(19), 9199-9205.
- Yao, L., Lee, S. L., Wang, T., de Moura, J. M., & Johnson, L. A. (2012). Effects of fermentation substrate conditions on corn-soy co-fermentation for fuel ethanol production. *Bioresource Technology*, 120, 140-148.

- Young, D., Scharp, R., & Cabezas, H. (2000). The waste reduction (WAR) algorithm: Environmental impacts, energy consumption, and engineering economics. *Waste Management*, 20(8), 605-615.
- Zhang, W., & Rosentrater, K. A. (2013). Fractionation of distillers dried grains with solubles (DDGS) through a destoner. In *2013 Kansas City, Missouri, July 21-July 24, 2013* (p. 1). American Society of Agricultural and Biological Engineers.
- Zhang, Y., Brown, T. R., Hu, G., & Brown, R. C. (2013). Comparative techno-economic analysis of biohydrogen production via bio-oil gasification and bio-oil reforming. *Biomass and Bioenergy*, 51, 99-108.
- Zhu, Y., Jones, S. B., Bidy, M. J., Dagle, R. A., & Palo, D. R. (2012). Single-step syngas-to-distillates (S2D) process based on biomass-derived syngas—A techno-economic analysis. *Bioresource Technology*, 117, 341-351.
- Zimmermann, F., & Jørgensen, C. (2015). Bioeconomic consequences of fishing-induced evolution: A model predicts limited impact on net present value. *Canadian Journal of Fisheries and Aquatic Sciences*, 72(4), 612-624.

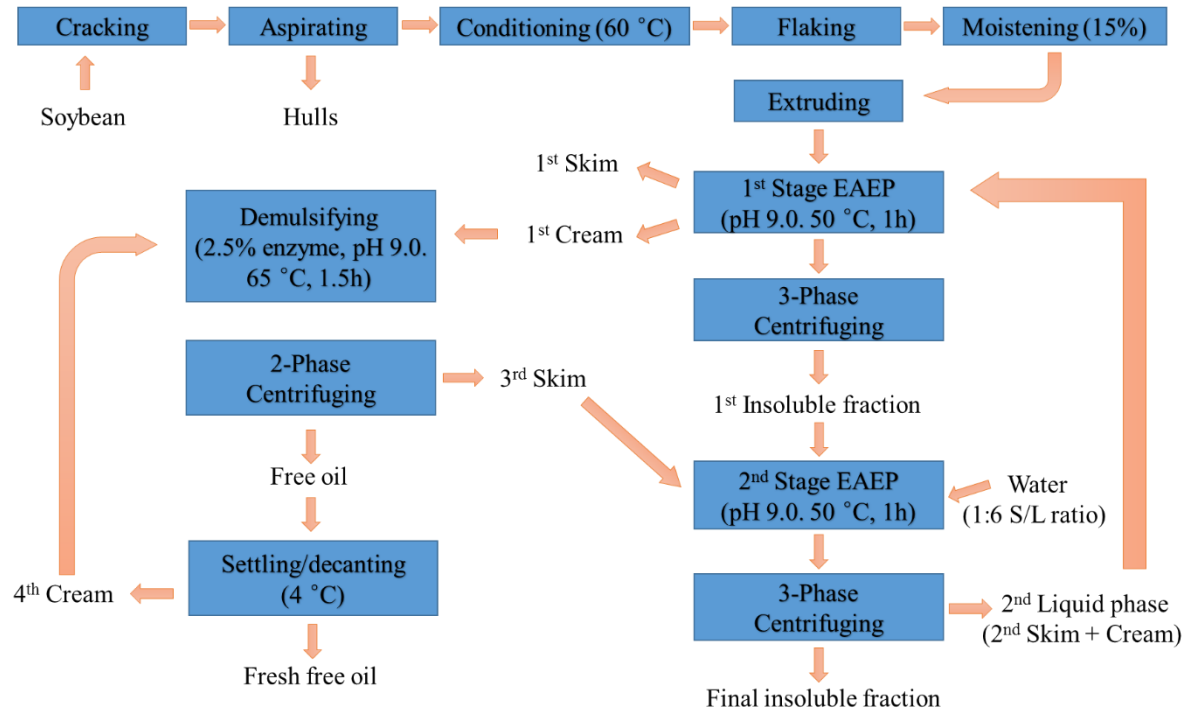

Figure 1.1. Process flow diagram for enzyme-assisted aqueous extraction processing of soybeans (de Moura et al., 2010)

CHAPTER 2: OBJECTIVES AND OVERVIEW

This dissertation focuses on the study of techno-economic analysis (TEA) and environmental impact assessment (EIA), and contains the related research on industrial corn-based ethanol processes, advanced corn-soybean bio-refining and distillers dried grains with solubles (DDGS) separation processes. Through investigating the basic properties of techno-economic analysis (TEA) and environmental impact assessment (EIA), this dissertation explores the feasibility of various agricultural biorefinery and bioprocesses, and compares the production efficiency and economic profits to a series of new technologies in an industrial applications.

2.1. Objectives

The research objectives for this dissertation are listed below:

1. Investigate techno-economic analysis (TEA) on basic properties of corn-based ethanol with a modified USDA model. By using the USDA and EIA data collected from 1982 to 2016, the first objective is to assess the factors that affect ethanol plant profit, such as cost of corn, DDGS, ethanol, gas and electricity. Additionally, this objective investigated the effect of the wet distillers grains (WDG) on final profits during the corn-based ethanol industrial production.
2. Compare the effects to efficiency and profits during various scales between the model of 40 million gallon ethanol per year and the model of 120 million gallon ethanol per year. This objective explores the effect of the oil extraction technology to final profits

during industrial production. This study provides a starting point for the analysis of advanced corn-soybean bio-refining in the future.

3. Investigate basic properties of techno-economic analysis (TEA) on advanced corn-soybean bio-refining. This objective discusses the feasibility of industrial application for the combination of two bio-refining process. In addition, this chapter explores the difference in economic effects with original corn-based ethanol plant.
4. Utilize the data collected from the above three parts to make an environmental impact assessment (EIA) for the modified corn-based ethanol process and corn-soybean bio-refining process. This objective also attempts to compare the difference between the original corn-based ethanol plant model and the corn-based ethanol with oil extraction process.
5. Techno-economics analysis of DDGS fractionation using a destoner to separate nutrients. Techno-economics of the base case ethanol plant were examined by adjusting material and market costs, and estimating fractionation efficiencies and fraction prices based on protein content. Additionally, this objective demonstrates the possibility of using a destoner to fractionate DDGS to produce higher economic returns.

2.2. Dissertation organization

The body of this dissertation is divided into eight chapters, and contains one chapter of literature review, one chapter of objectives and overview, five chapters of descriptive procedures and results, one chapter of overall conclusions and future work, as well as cited references and acknowledgements.

Chapter 1 is a literature review that includes techno-economic analysis (TEA), environmental impact assessment (EIA), corn-based ethanol processes and an integrated corn/soybean bio-refinery process. This chapter mainly focuses on background information for the content of this dissertation. Chapter 2 is an introduction that includes the objectives, organization of this dissertation, and author's role. Chapter 3 entitled "Techno-economic analysis to model the process of a corn-based ethanol plant from 1982 to 2016" is a research article modified from a manuscript submitted to the conference of ASABE 2014. In this work, techno-economic analysis (TEA) explored the basic properties of corn-based ethanol with a modified USDA model. Chapter 4 entitled "Techno-economic analysis (tea) of a 120 million gallon corn-based ethanol plant" is a report using the 120 million gallon ethanol per year model to compare the TEA effects during various industrial scales. This chapter is modified from a manuscript submitted to the conference of ASABE 2015. Chapter 5 is research on techno-economic analysis (TEA) of biofuels production with integrated corn and soybean biorefinery. This is a research article modified from a manuscript submitted to the conference of ASABE 2016. The sixth chapter is a research paper in environmental impact assessment (EIA) of corn-based ethanol processes and biofuel productions with integrated corn and soybean biorefinery. In this work, the various factors influencing environmental effects are discussed, including raw material, chemicals and products. This chapter is modified from a manuscript submitted to the conference of ASABE 2015 and ASABE 2016. The seventh chapter entitled "Techno-economic modeling of using a destoner to fractionate distillers dried grains with solubles (DDGS)" is a report modified from a manuscript submitted to the conference of ASABE 2013. In this study, techno-economic analysis (TEA) explores the

feasibility of using a destoner to separate DDGS fractionation in the industrial production.

Chapter 8 is an overall conclusion of research and recommendations for future work.

CHAPTER 3: TECHNO-ECONOMIC ANALYSIS (TEA) TO MODEL THE COSTS PROCESS OF A CORN-BASED ETHANOL PLANT

3.1. Introduction

With the increased demand for fossil fuels, bioethanol as a fuel additive continues its rapid growth in the United States. According to Renewable Fuels Association (2016), more than 95% of U.S. fuel ethanol plants use corn as a major raw material to produce ethanol, and most U.S. bioethanol manufacturers use a dry grind process, contributing more than 90% of current ethanol production (Renewable Fuels Association, 2016). Corn is mainly treated with grinding and slurring in the dry grind process, then enzymes are added to transform starch into monosaccharides for yeast fermentation (Singh et al., 2001).

Corn-based fuel manufacturing has three main byproducts: bioethanol, distillers dried grains with solubles (DDGS) (or other similar coproducts), and carbon dioxide. As the most popular renewable fuel in recent years, bioethanol has a long history of being used as fuel for vehicles produced from agricultural feedstock, including sugarcane and corn (Inderwildi & King, 2009). Excluding feedstock, bioethanol is also generated from a variety of other sources, including plant biomass, waste wood and algae (Balat et al., 2008). Sugarcane and corn are the most common materials used in first generation biofuel production. The main processes for converting sugar and starch from feedstocks to ethanol are well established, which make them possible to be utilized in industrial scale production (Balat & Balat, 2009). Second generation feedstocks mainly consist of cellulosic biomass, such as corn stover, short rotation woody crops and perennial grasses. This type of bioethanol

process is still not mature, and the technology is still unstable during the pretreatment stage, resulting in a lower efficiency of enzymolysis when converting these materials to sugar. Due to these factors, the lignocellulose process is far from industrial application and production (Hamelinck, et al., 2005; Dwivedi et al., 2009). This study focuses on the first generation bioethanol process, which is mainly related to the corn-based ethanol process.

DDGS is the most important coproduct of the dry grind process. It is directly related to profit and sustainability of the dry grind ethanol plant, and is sold at a varying market price (\$85–140 dollars per metric ton) (Liu, 2008). In 2013, 37.8 million metric tons (mmt) of high-quality feed were generated, which was 2.3 million metric tons increase from 2012 (Renewable Fuels Association, 2014a). DDGS is mainly composed of protein (25-35%), fiber (7-10%), and fat (3-14%) as a dry mix of particulate materials, making it ideal material for feed (Bhadra et al., 2009; Rosentrater & Muthukumarappan, 2006; Shurson & Alhamdi, 2008; Srinivasan et al, 2005; Zhang & Rosentrater, 2013a, 2013b). In 2013, 48% of DDGS was used for beef cattle; 31% used for dairy cattle and 12% used for swine (Renewable Fuels Association, 2014a). In recent years, increased production of DDGS caused prices to decrease in relation to other feed ingredients, such as soybean meal. Manufacturers considered alternative ways to add value to DDGS to be cost competitive; and oil extraction of DDGS was a possible way of doing so (Bals et al., 2006).

Petrides (2011) mentioned that computer models make economical predictions more accurately with enough data of parameters and simulation. ASPEN PLUS (Aspen Technology, Inc., Burlington, MA) and SuperPro Designer (Intelligen, Inc., Scotch Plains, NJ) were utilized as a tool of cost analysis in the bio-ethanol industry (Haas et al, 2006; Kwiatkowski et al, 2006). Thus, this study used an modified model from the USDA, which

was a 40 million gallon dry grind corn to ethanol process used to determine economic feasibility of a DDGS fractionation system. The main objective of this research was to calculate the cost and profits of the operations and equipment from economic analysis of corn-based ethanol plants from 1982 to 2013. In addition, this model attempted to test various possible affected factors (price of corn, DDGS, ethanol, gas and electricity) and searched for optimal conditions of a corn-based ethanol plant.

3.2. Materials and methods

3.2.1. Computer model

SuperPro Designer (Intelligen, Inc., Scotch Plains, NJ) is an industrial design software with facilitate modeling, evaluation and optimization of integrated processes in a wide range of industries. The combination of manufacturing and environmental operation models in the same package enables the user to practice the simulation of waste minimization via pollution prevention, control concurrent designs and evaluate manufacturing and end-of-pipe treatment processes. By defining flow rate, composition, physical characteristics and cost for each stream, this software determines mass and economic balances for the individual unit operations and whole systems. In a previous study, Kwiatkowski et al (2006) created a 40 million gallon per year ethanol plant model using SuperPro, which used a generic dry grind plant comprised of all individual unit operations required to convert raw corn into ethanol. This model was then updated by McAloon and Yee (2011) and reflected new ethanol processing technologies and current economic values of equipment and materials.

This study used the structure and framework of the modified model (McAloon & Yee, 2011) to calculate current economic values of equipment and materials (Figure 3.1).

The model of this study was designed with 330 days per year of production to mirror the real industry process, which generally operates 24 hours per day year round. All annual calculations were based on these factors and were included in the range of reports available through the program. After setting basic data into the model, SuperPro produced a variety of reports based on simulation data changed on each scenario; which facilitated the judging of economic feasibility for the model. These reports were produced and compared to estimate scenarios for each year, and sensitivity to each affected factor. The design frame and structure of dry grind ethanol from corn processing is shown in Figure 3.1.

3.2.2. Simulation scenarios

Scenarios were updated and modified based on the basic corn-based ethanol process plant model developed by McAloon and Yee (2011). Three scenarios were set and described below: Distillers Corn Oil

I. Corn-based ethanol process with 40 million gallons ethanol per year, which excluded distillers wet grains (DWG) and distillers corn oil (DCO).

II. Corn-based ethanol process with 40 million gallons ethanol per year, which included distillers wet grains (DWG) but excluded distillers corn oil (DCO).

III. Corn-based ethanol process with 40 million gallons ethanol per year, which excluded distillers wet grains (DWG) but included distillers corn oil (DCO).

Simulations were run based on modifying various prices of materials and products that affected corn-based bioethanol factories. Three different variables were considered in this model:

(1) Market price of corn, ethanol, DDGS, and distillers wet grains (DWG) from 1982 to 2016 (Table 1) (McAloon & Yee, 2011; USDA 2016). All prices used in the scenarios are listed in Table 3.1.

(2) Market prices of distillers corn oil from 2010 to 2016 (The Jacobsen, 2016). These prices for the scenarios are listed in Table 3.1.

(3) Industrial prices of natural gas and electricity from 1982 to 2016 are set in Table 3.1 (McAloon & Yee, 2011; EIA 2016a; EIA 2016b). Labor cost and inflation rate were set according to data from the U.S. Department of Labor.

This study focused on the three series of affected factors described above. The other factors including physical property, material combination and other indexes were set with the same data as the modified model (McAloon & Yee, 2011). Installation costs depended on various types of equipment, so the loan interest was set at 7.0% per year as a common assumption. During all final reports, there were three important tables for all three scales, which included capital cost summary, operating cost and profitability analysis. Annual operating cost composed of raw materials, labor-dependent, facility-dependent and utilities. For profitability analysis, the unit production cost, unit production revenue, net profit and payback time were the most important results of this study.

3.2.3. Data analysis

Multiple linear regression is a statistic method used to model the relationship between two or more explanatory variables and a response variable, which requires a linear equation to fit observed data (Tranmer & Elliot, 2008). This study utilized multiple linear regression (MLR) to interpret how the prices of corn, ethanol, DDGS, and oil impacted profit of the

corn-based ethanol process. SPSS v.22 software program (IBM Corp. Released 2013) was used to conduct the statistical analysis. Excel was used to manage the raw data and import data to SPSS.

3.3. Results and discussion

3.3.1. Capital costs

Capital costs are the expenditures of initial investments on all direct and indirect costs with additional amounts for a contractor's charge; which include construction cost, process piping, utilities production, equipment cost and inventories (Porrás, 2011). Capital costs are different from labor costs and operating costs, which are independent from the level of output in the whole project. In this study, the sum of capital cost was composed of individual process parts: grain handling and milling, starch to sugar conversion, fermentation, ethanol processing, coproduct processing and common support systems. For each individual process capital cost, the final result was determined based on the equipment purchase price, a setting material factor by the model and an installation factor. For simplifying some indirect supported equipment, steam generation and cooling water equipment were not included in the capital cost, and were treated as purchased utilities. All these settings were based on previous model data from McAloon and Yee (2011), which efficiently reflected the effect of new technology applications on a corn-based ethanol plant.

The effect each of these scenarios on total capital are presented in Figure 3.2a, Figure 3.2b and Figure 3.2c. In scenario I, capital cost ranged from 33.82 to 62.89 million dollars, which was mainly caused by the inflation rate and gradually increased year by year. Despite the effect of the inflation rate on all sections, the percentages for each section did not change

drastically. Coproduct processing contributed from 41.23% to 42.50% of the total capital cost in all 34 years. This contribution was larger than the sum of contribution of fermentation and ethanol processing, which was around 19.82% and 16.71%, respectively. Grain handling and milling, starch to sugar conversion and common support systems separately made a contribution of approximately 7.25%, 8.60% and 5.80%, respectively.

In scenario II, capital cost ranged from 33.34 to 62.07 million dollars, which increased year by year but had a slight decrease compared with scenario I. The reason for this change was the equipment used for treating DWG to DDGS had a lower flow rate and purchase cost, causing the cost of coproduct processing to decrease. Similar to scenario I, the percentage of each section did not have a significant change in 34 years. Coproduct processing contributed from 40.49% to 41.74% of the total capital cost in all 34 years, which was a little less than scenario I. This contribution was also twice as large as the fermentation step (20.07%) or ethanol processing (16.92%). In addition, grain handling and milling, starch to sugar conversion and common support systems also had a similar contribution of approximately 7.35%, 8.71% and 5.88%, which decreased when compared with scenario I and resulted from the decrease of total capital costs.

Unlike the two scenarios above, capital cost of scenario III ranged from 67.95 to 74.76 million dollars, which was a significant increase. One reason for the increase was the oil extraction technology applied in industrial production beginning in 2010, which had a higher starting base than the inflation rate. Another reason for increased cost was extra oil extraction equipment cost increased the total cost of production in all 6 years. Based on cost evaluation of this scenario, coproduct processing contributed from 51.45% to 51.63% of the total cost, which was 10% more than scenario I and II. The oil extraction process cost was

the main reason for this increase, which also made other sections rates decrease. The fermentation step made a contribution of 17.01%, with around a 3% decrease of scenario I and II. Ethanol processing took 14.34% of total capital cost with around a 2.5% decrease of scenario I and II. Grain handling and milling, starch to sugar conversion and common support systems also had a slight decrease of capital cost, which made a contribution of 6.23%, 7.38% and 3.51%.

3.3.2. Annual operating costs

Annual operating costs are the sum of all expenses needed to run a facility in one calendar year, which is related to the operation of a device, component, pieces of equipment and facility. In this model, the whole operating costs consisted of labor, facility, utility costs and raw material costs for all three scenarios. Consumables, advertising, running royalties and failed product disposal were not estimated in this model's techno-economic analysis.

For scenario I, annual operating cost ranged from 40.22 to 123.93 million dollars in the simulation over 34 years. According to Figure 3.3a, this indicated material cost had the largest impact on the overall operating cost (average 72.20%) followed by utilities (average 14.43%). Similar to scenario I, scenario II ranged from 39.63 to 123.23 million dollars in the simulation over 34 years, with savings mainly from utility costs (Figure 3.3b). The largest percentage of annual operating cost was still material cost at 72.95% followed by utilities (average 13.68%). For scenario III, the average annual operating cost was 98.91 million dollars, which included the average 76.61% contribution from raw materials (Figure 3.3c). Differently from scenario I and II, facility (average 10.86%) was the second highest contributor in scenario III rather than utilities cost (average 9.95%). All three scenarios

results are a slight lower than the results of Ag Decision Maker (Ag Decision Maker, 2016). The reasons for the differences are from the difference in assumption for the models, which reflected on percent debt, length of loan, interest rate, water usage and ethanol yield.

3.3.2.1. Facility costs

Facilities were composed of maintenance cost, equipment depreciation, interest on debt, insurance, taxes, and other industrial expenses. Based on basic parameters set by McAllon and Yee (2011), maintenance expenses were determined as 3% of capital costs, while insurance and other industrial expenses were set to 0.8% and 0.75% of capital cost. Depreciation was set as an initial index by SuperPro Designer, and taxes were set as 24% for green and renewable energy plants. The tax rate for corn-based ethanol plants were kept lower than the tax for chemical industrial plants (Damodaran, 2012). In all three scenarios, the facility kept a relatively stable rate around 10%, and ranged from 7% to 14% of total operating costs (Figure 3.3a, Figure 3.3b and Figure 3.3c).

3.3.2.2. Labor costs

The cost of labor was determined based on a lump estimate of number of working hours per year (330 day per year), which assumed the rest of time was used for maintenance. The hourly wage for 30 years was collected from the U.S. Department of Labor minimum wage, which has not changed in the last 7 years (Index, 2012). The model multiplied the minimum wage rate by the number of estimated workers, automatically creating labor cost for all scenarios. For scenarios I and II, the minimum annual labor cost was 1.142 million in

1982, and the maximum was 2.471 million in 2015. Due to no change of minimum wages in the last 7 years, the labor cost was estimated with 2.471 million per year in scenario III.

3.3.2.3. Material costs

According to McAllon and Yee (2011), the materials of corn-based ethanol processes included corn, water, yeast, caustic, lime, octane, ammonia, sulfuric acid, gluco-amylase and alpha-amlyose. To control the amount of independent factors, only the corn price was set according to the year, which made a contribution of more than 90% of cost in corn-based ethanol process expenses (Wood et al., 2014; McAllon & Yee, 2011). Another reason to follow the price of corn was due to its volatility, which changed more than 4 times between the maximum value (\$0.06 per kg) and minimum value (\$0.27 per kg) in the last 34 years. Through the price peak occasionally existed, the high volatility of corn price made it affect as an important factor. As shown in Figure 3.3a, material costs made a contribution of 62.49% (2005) to 83.68% (2012) in annual operating cost for scenario I, with the average value of 72.20%. Compared to scenario I, the rate of material cost in operating cost slightly increased in scenario II, with the mean value of 72.95% (Figure 3.3b). Scenario III had the average rate of material cost increase to 76.61%, which reflected the increasing trend of material cost and corn price (Figure 3.3c).

3.3.2.4. Utility costs

In this model, utility costs consisted of the costs of electricity, natural gas, steam, and chilled water. Steam and chilled water were already changed during the simulation. The price of electricity ranged from \$0.044 to \$0.071 per kW·h, and natural gas wavered between

\$2.48 and \$9.65 per MBtu (million British thermal unit). Due to the large volatility of electricity and natural gas, all three scenarios had a larger range of 6.92% to 20.74% in annual operating costs.

3.3.3. Annual revenues

Annual revenues are defined as the total income generated from the sale of total products in one financial year and do not subtract miscellaneous charges, costs and other expenses. According to McAllon and Yee (2011), the simulated model of corn-based ethanol process produced five products: carbon dioxide (CO₂), ethanol, corn oil, DWG, and DDGS. Though CO₂ could be added into soft drinks or beer and assigned a market value, it was not collected for resale in this model to simplify the simulation (Hunt et al., 2010).

In scenario I, ethanol and DDGS were used to determine the total annual revenue for the simulation, with ethanol defined as the main product (MP). In scenario II, ethanol was also defined as the main product, while coproducts included DDGS and DWG. Compared with scenario I, scenario III chose DDGS and distillers corn oil as coproducts. The market prices for ethanol were set to reflect market values from 1982 to 2016 (\$0.99-2.66 per gallon EtOH (\$0.32-0.87 per kg)) (USDA, 2016). As the most important coproduct, market prices of DDGS were collected from the USDA (2016), which ranged from \$0.08 to \$0.26 per kg with an average value of \$0.13 per kg. DWG prices varied from \$0.02 to \$0.08 per kg during the last 34 years (USDA, 2016). The data of distillers corn oil was collected from the Jacobsen Company (2016) and ranged between \$0.84 per kg and \$1.04 per kg from 2010 to 2016. (Table 3.1)

3.3.3.1. Ethanol

During this model, ethanol was approximately 30% of the total mass weight produced annually by the ethanol process in all years, but contributed more than 70% of the total annual revenue for all three scenarios. In scenario I (Figure 3.4a), ethanol made the maximum revenue contribution in 2005, and took 90.81% of all revenues. But in 1995, only 72.49% of total revenues were from ethanol. The mean values of total revenue percentage from ethanol were 79.51% from 1982 to 2016. Through adding the coproduct of DWG in scenario II, ethanol contribution kept similar levels on total revenues, which were from 72.92% to 91.05% with a mean value of 79.94% (Figure 3.4b). Differently from scenario I and II, scenario III discussed the years between 2010 and 2015, and added distillers corn oil as the coproduct (Figure 3.4c). With the effects of year and oil component, ethanol contribution on annual revenues had a mean value of 75.50%, which was around 1.5% less than scenario I and II.

3.3.3.2. DDGS

DDGS made up about 25% of the total mass weight produced by the ethanol plant, with prices determined by USDA data (2016). In scenario I, DDGS worked as the only coproduct in production, and made an average 20.49% contribution to total revenues (Figure 3.4a). After adding DWG as another coproduct in scenario II, the contribution of DDGS had an evident decrease of about 3%. DWG was directly collected as a product instead of the raw materials used for DDGS (Figure 3.4b). Similar with scenario I, scenario III had a similar level of DDGS (average 19.18%) contribution on revenues, which reflected oil extraction did not affect DDGS production significantly (Figure 3.4c).

3.3.3.3. Distillers wet grains (DWG)

In this study, only scenario II had production of DWG, which made up about 13% of total mass weight produced by the ethanol plant. The rate of DWG in scenario II was set as half of the production of DDGS, which was similar to the Renewable Fuels Association report (DWG 30%; DDGS & DDG 56%) in 2016 (Renewable Fuels Association, 2016). The reason for setting a lower production rate of DWG was due to its physical property of 60% moisture, creating a limited shelf life. High moisture content in DWG made shipping less cost-effective (Anderson et al., 2006).

Due to the lower product price, DWG made a contribution of 2.75% on annual revenues in scenario II, ranging from 1.20% to 3.84% during the last 34 years (Figure 3.4b). Lower DWG was utilized as raw material for DDGS resulting in a utility cost decrease, which was reflected in less usage of electricity to dry DDGS and discussed more in the gross operating margin section of this dissertation.

3.3.3.4. Distillers corn oil (DCO)

The industrial production rate was 75% in 2012, and the lab scale of oil extraction was over 95% recently (Pragya et al., 2013). In this study, the oil extraction rate was set at 80%, which was a reasonable rate for current industrial production. Scenario III was set with production of DCO, which made up about 2% of the total mass weight produced by the ethanol plant. However, DCO made an important contribution on annual revenue, which ranged from 4.75% to 5.92% (Figure 3.4c). The contribution to revenue caused more and more ethanol plants to produce this technology, with 85% of dry mill corn-based ethanol processes extracting oil currently (Renewable Fuels Association, 2016).

3.3.4. Gross operating margins and payback time

Gross operating margin is defined as the annual revenue minus the annual operating cost. A payback period is the length of time required to recover the cost of an investment. Gross operating margins are seen in Figures 3.5a, 3.5b and 3.6, showing capital cost, operating cost, revenue, and profits in million dollars per year. Unit production cost, unit production revenue and payback time are shown in Figures 3.7a, 3.7b, and 3.8. For all three scenarios, capital investment cost had an evident trend of increasing, which fit the inflation rate change between 1982 and 2016. Both annual revenues and operating cost were very volatile, which were mainly determined by market price of raw material and production.

In scenario I, the highest profit year was 2005, arriving at \$ 51.31 million per year, while the lowest profit year was 2015 at \$ 4.98 million per year. Compared with scenario I, scenario II had a better performance in most years except 2012 and 2015 (Table 3.2). Though it had the limitation of transportation and storage life, DWG was a better economic coproduct to a corn-based ethanol plant. Through Figure 3.6, all years showed the corn-based ethanol process with DCO had a better performance on net profit, supplying around \$3 million per year.

The annual operating cost and annual revenue was divided into a \$/kg ethanol basis, which directly reflected the efficiency of how costs related to each kilogram of ethanol produced by the plant. Comparing scenario I with scenario II concluded that DWG slightly increased the unit production cost and slightly decreased the unit production revenue, resulting in a 2% increase in profits. As shown in Figure 3.8, scenario III had a significantly higher unit revenue cost than scenario I, which showed a corn-based ethanol process with DCO was an efficient method to improve the economic effect.

3.3.4. Multiple linear regression

This study used profit of the corn-based ethanol process as a response variable, which was calculated by SuperPro modeling. For scenario I, the response variable was analyzed against three explanatory variables, which included the prices of corn, ethanol and DDGS. Different from scenario I, the response variable of scenario II was analyzed against four explanatory variables with the prices of corn, ethanol, DDGS, and DWG. The response variable of scenario III was analyzed against four explanatory variables with the price of corn, ethanol, DDGS, and oil. The results of statics on scenario I is listed in Table 3.3. An unstandardized coefficient was used to analyze the amount changes in profit if explanatory variables changed by one unit, keeping the other three independent variables constant. Therefore, the equation between profits and explanatory variables for scenario I is shown as Equation 3.1 below:

$$\begin{aligned} \text{Profits} = & -243.727 \times \text{Corn price} + 73.615 \times \text{Ethanol price} + \\ & 45.503 \times \text{DDGS price} \end{aligned} \quad (3.1)$$

In Equation 3.1, the unit of profits is millions of U.S. dollars per year, and the unit of corn, ethanol and DDGS is U.S. dollars per kilogram. Partial correlation was used to measure the strength and direction of the linear relationship between each explanatory variable and profit respectively by controlling the effect of the other two dependent variables. The results of partial correlation for scenario I indicated that corn had a strong negative effect on profits, while ethanol had a strong positive effect on the profits and DDGS had a moderate positive effect on profits.

The results of statics on scenario II are listed in Table 3.4, and the equation between profits and explanatory variables for scenario II are shown as Equation 3.2 below:

$$\text{Profits} = -249.421 \times \text{Corn price} + 75.685 \times \text{Ethanol price} - 54.370 \times \text{DDGS} + 295.734 \times \text{DWG price} \quad (3.2)$$

In Equation 3.2, the unit of profit is millions U.S. dollars per year, and the units of corn, ethanol, DDGS and DWG are U.S. dollars per kilogram. The partial correlation between profits and corn price by controlling the prices of ethanol, DDGS and DWG was -0.944, which was slightly lower than that of scenario I. That result indicated the negative effect of corn had been strengthened when adding DWG into the model. The value of partial correlation for ethanol was 0.984, which was slightly higher than that in scenario I and indicated the positive effect of ethanol was strengthened when adding DWG into the model. The value of partial correlation for DDGS and DWG was -0.276 and 0.487, which reflected DDGS had a weak negative effect on profits; but DWG had a moderate, positive effect on profits in scenario II. Compared with scenario I, it indicated that DWG had a more positive effect on profits than DDGS, which meant corn-based ethanol plants obtained more profits from DWG production. Due to more than 50% moisture content in DWG, the shelf life of DWG was very limited, and shipping large quantities of water had a low cost–performance ratio (Renewable Fuels Association, 2007). These results explained why the wet and modified wet distillers grains production in the U.S. remained around 40% of total distillers grains production (Renewable Fuels Association, 2016; Renewable Fuels Association, 2017).

The results of statics on scenario III are listed in Table 3.5, and the equation between profits and explanatory variables for scenario III are shown as Equation 3.3 below:

$$\text{Profits} = -231.630 \times \text{Corn price} + 80.743 \times \text{Ethanol price} + 34.682 \times \text{DDGS} - 0.339 \times \text{DCO price} \quad (3.3)$$

In Equation 3.3, the unit of profit is millions of U.S. dollars per year, and the units of corn, ethanol, DDGS and DWG are US dollars per kilogram. The value of partial correlation for corn was -0.817, which was higher than that in of scenario I and II. Results indicated the negative effect of ethanol on profits was weakened when adding DCO into the model, which was helpful for corn-based ethanol plants to decrease their sensitivity on corn price. Partial correlation between profits and corn price when controlling the prices of corn showed, DDGS and DCO was 0.625, which was significantly lower than scenario I and II. Results indicated the positive effect of ethanol was weakened when adding DCO into the model. The value of partial correlation for DDGS and DCO was 0.142 and -0.005, which reflected DDGS had a weak positive effect on profits. DCO had a very weak, negative effect on the profits for the 40 million gallon ethanol per year model. Compared with scenario I and II, scenario III indicated DCO significantly affected the whole relationship between profits and each explanatory variable. Through DCO had a very weak, negative effect on profits of a small industrial scale corn-based ethanol plant, it significantly weakened the sensitivity of both the price of corn and products. That outcome explained why more and more corn-based ethanol plants added oil extraction to industrial production. DCO helped corn-based ethanol plants decrease market risk due to large changes of one or more product prices.

3.4. Conclusion

To perform economic calculations for new fractionation systems, SuperPro Designer was used for techno-economic modeling. According to simulation results from the model, the corn-based ethanol plant had positive net profits from 1982 to 2016 but had larger volatility due to market price. The model did not consider government support and other factors. Distillers wet grains made a 2% increase in profits and distillers corn oil made an extra \$3 million in profits per year. When distillers wet grains and DDGS are produced together in the corn-based ethanol process, the former co-product had a better economic performance than DDGS, and the model with distillers corn oil extraction significantly decreased the market risk for corn-based ethanol plant.

References

- Ag Decision Maker. (2016, July). *Monthly Profitability of Ethanol Production*. Retrieved from <https://www.extension.iastate.edu/agdm/refirst.html>.
- Anderson, J. L., Schingoethe, D. J., Kalscheur, K. F., & Hippen, A. R. (2006). Evaluation of dried and wet distillers grains included at two concentrations in the diets of lactating dairy cows. *Journal of Dairy Science*, 89(8), 3133-3142.
- Bals, B., B. Dale & V. Balan. 2006. Enzymatic hydrolysis of distillers dry grain and solubles (DDGS) using ammonia fiber expansion pretreatment. *Energy & Fuels* 20: 2732–2736.
- Balat, M., H. Balat & C. Oz. (2008). Progress in bioethanol processing. *Prog. Energy Combust. Sci.*, 34(5), 551–573.
- Balat, M., & H. Balat. (2009). Recent trends in global production and utilization of bio-ethanol fuel. *Appl. Energy*, 86(11), 2273–2282.
- Bhadra, R., K. Muthukumarappan, & K. A. Rosentrater. 2009. Flowability properties of commercial distillers dried grains with solubles (DDGS). *Cereal Chem.* 86(2): 170-180.
- Damodaran, A. (2012). *Investment valuation: Tools and techniques for determining the value of any asset* (Vol. 666). Hoboken, NJ: John Wiley & Sons.

- Dwivedi, P., J. R. R. Alavalapati. & P. Lal. 2009. Cellulosic ethanol production in the United States: Conversion technologies, current production status, economics, and emerging developments. *Energy Sustainable Dev.* DOI: 10.1016/j.esd.2009.06.003. Published online September 2009.
- EIA (U.S. Energy Information Administration). 2016a. U.S. Natural Gas Wellhead Price. Retrieved from <http://www.eia.gov/dnav/ng/hist/n9190us3a.htm>.
- EIA (U.S. Energy Information Administration). 2016b. Average retail price of electricity to ultimate customers. Retrieved from <http://www.eia.gov/electricity/data.cfm#traderel>.
- Haas, M.J., A. McAloon, W. C. Yee, & T. A. Fog. 2006. A process model to estimate biodiesel production costs. *Bioresource Tech.* 97: 671-678.
- Hamelinck, C. N., G. V. Hooijdonk & A. P. C. Faaij. 2005. Ethanol from lignocellulosic biomass: Techno-economic performance in short, middle and long-term. *Biomass Bioenergy*, 28(4), 384-410.
- Hunt, A. J., Sin, E. H., Marriott, R., & Clark, J. H. (2010). Generation, capture, and utilization of industrial carbon dioxide. *ChemSusChem*, 3(3), 306-322.
- Inderwildi, O. R. & King, D. A. (2009). "Quo Vadis Biofuels". *Energy & Environmental Science* 2(4): 343-356.
- Index, C. P. (2012). Bureau of Labor Statistics, U.S. Department of Labor. Washington, D.C. Retrieved from <http://data.bls.gov/cgi-bin/surveymost/>.
- Kwiatkowski, J. R., A. McAloon, F. Taylor, & D. B. Johnston. (2006). Modeling the process and costs of fuel ethanol production by the corn dry-grind process. *Ind. Crops and Products* 23: 288-296.
- Liu, K. (2008). Particle size distribution of distillers dried grains with solubles (DDGS) and relationships to compositional and color properties. *Bioresource Technology*. 99(17): 8421-8428.
- McAloon, A., & W. Yee. (2011). *Ethanol plant model*. Wyndmoor, P.A.: USDA, ARS.
- Petrides, D., C. Siletti, J. Jimenez, P. Psathas, & Y. Mannion. (2011). Optimizing the design of operation of fill-finish facilities using process simulation and scheduling tools. *Pharmaceutical Eng.* 31(2).
- Porras, E. R. 2011. The cost of capital. Eva R. Porras. Basingstoke, Hampshire, England, New York: Palgrave Macmillan.
- Pragya, N., Pandey, K. K., & Sahoo, P. K. (2013). A review on harvesting, oil extraction and biofuels production technologies from microalgae. *Renewable and Sustainable Energy Reviews*, 24, 159-171.
- Renewable Fuels Association. (2009). *Industry Resources Co-products: 2009 ethanol industry outlook*. Washington DC: Renewable Fuels Association.

- Renewable Fuels Association. (2014a). *Falling walls & rising tides, 2014 ethanol industry outlook*. Washington, D.C.: Renewable Fuels Association. Retrieved from <http://www.ethanolrfa.org/page/-/rfa-association-site/Resource%20Center/2014%20Ethanol%20Industry%20Outlook.pdf?nocdn=1>.
- Renewable Fuels Association. (2014b). *Pocket guide to ethanol 2014*. Washington, D.C.: Renewable Fuels Association. Retrieved from <http://www.ethanolrfa.org/page/-/rfa-association-site/Resource%20Center/2014%20Pocket%20Guide%20to%20Ethanol.pdf?nocdn=1>
- Renewable Fuels Association. (2016). *Fueling a high octane future: 2016 ethanol industry outlook*. Washington, DC: Renewable Fuels Association.
- Renewable Fuels Association. (2017). *Building partnerships and growing markets: 2017 ethanol industry outlook*. Washington, DC: Renewable Fuels Association.
- Rosentrater, K. A. (2006). Some physical properties of distillers dried grains with solubles (DDGS). *Applied Engineering in Agriculture*. 22(4): 589–595.
- Rosentrater, K. A., & K. Muthukumarappan. (2006). Corn ethanol coproducts: Generation, properties, and future prospects. *Int. Sugar J.* 108(1295): 648-657.
- Schnepf, R., & B. D. Yacobucci. (2013). Renewable Fuel Standard (RFS): Overview and issues. Retrieved from <http://www.epa.gov/otaq/fuels/renewablefuels/index.htm>.
- Shurson, J. & Alhamdi, A. S. (2008). Quality and new technologies to create corn co-products from ethanol production. In Babcock, B. A., Hayes, D. J., and Lawrence, J. D. (Ed.), *Using distillers grains in the U.S. and international livestock and poultry industries*, (pp. 231-256). Ames, IA.: Iowa State University.
- Singh, V., K. Rausch, P. Yang, H. Shapouri, R. L. Belyea, & M. E. Tumbleson. (2001). *Modified dry grind ethanol process*. Urbana, IL: University of Illinois at Urbana-Champaign Agricultural Engineering Department.
- Srinivasan, R., R. Moreau, K. Rausch, R. Belyea, M. Tumbleson, & V. Singh. (2005). Separation of fiber from distillers grains with solubles (DDGS) using sieving and elutriation. *Cereal Chem.* 82(5): 528-533.
- The Jacobsen. (2016, July). *Distillers corn oil*. Retrieved from The Jacobsen Research database.
- Tranmer, M., & Elliot, M. (2008). Multiple linear regression. *The Cathie Marsh Centre for Census and Survey Research (CCSR)*.
- USDA (United States Department of Agriculture) (2016). Fuel ethanol, corn and gasoline prices, marketing year. Retrieved from <http://marketnews.usda.gov/portal/lg>
- Zhang, W. & K. A. Rosentrater. (2013a). Fractionation of distillers dried grains with solubles (DDGS) through a destoner. Paper No. 1593288. Kansas City, MO: ASABE.
- Zhang, W. & K. A. Rosentrater. (2013b). Some properties of evolving distillers dried grains with solubles (DDGS) in 2012. Paper No. 1593267. Kansas City, MO: ASABE.

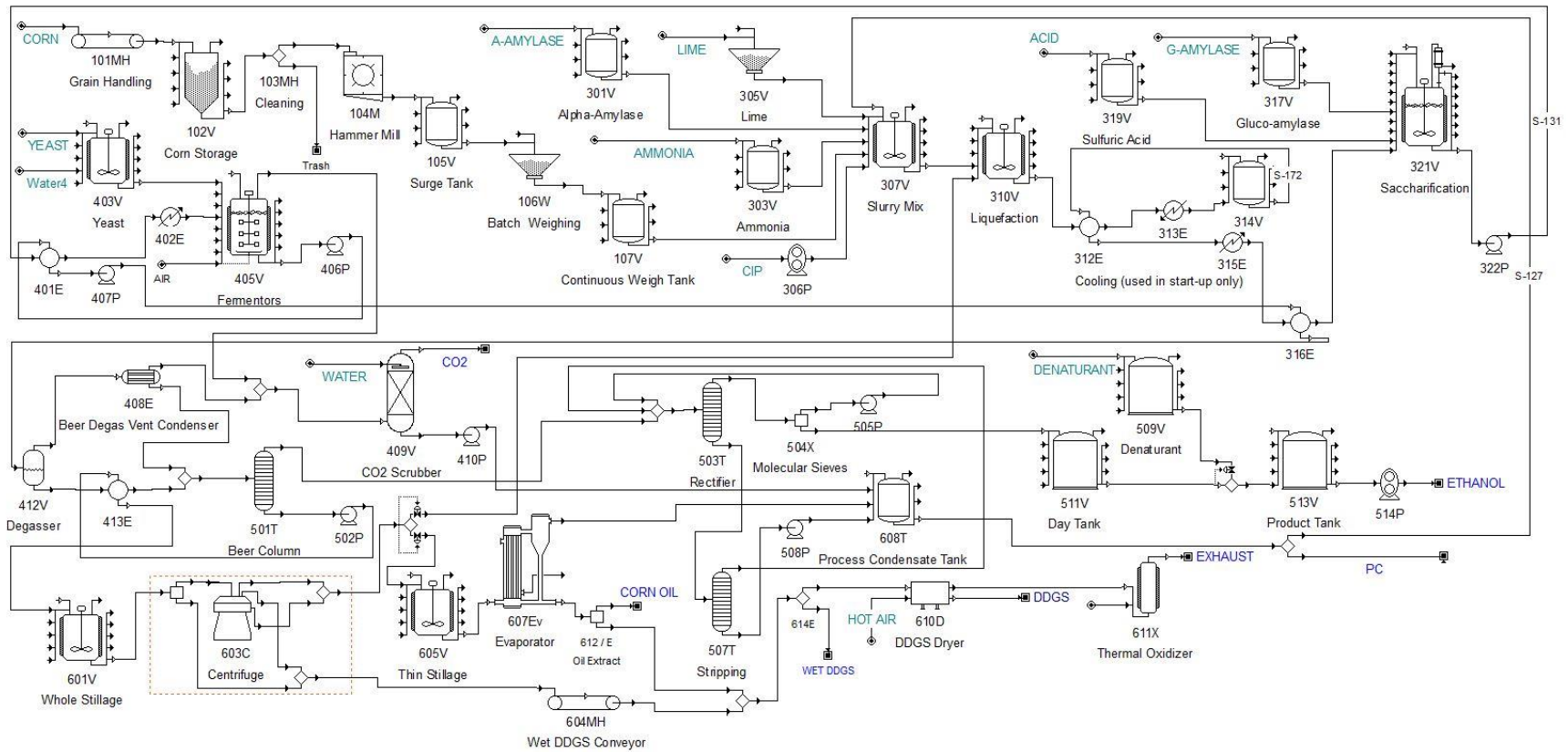

Figure 3.1. Process of flow diagram for 40 million gallons per year corn-based ethanol model.

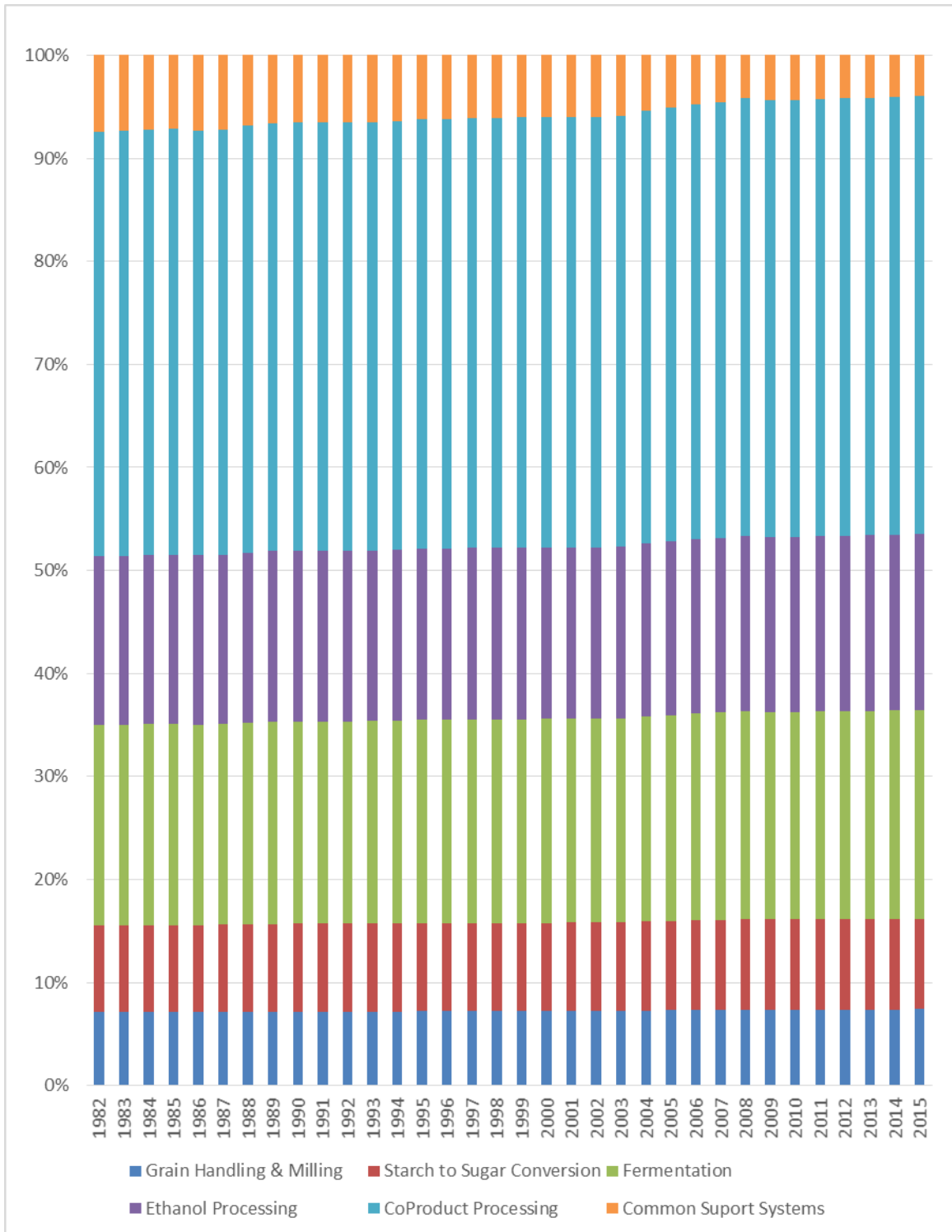

Figure 3.2a. Capital cost from corn-based ethanol process without distillers wet grains or distillers corn oil.

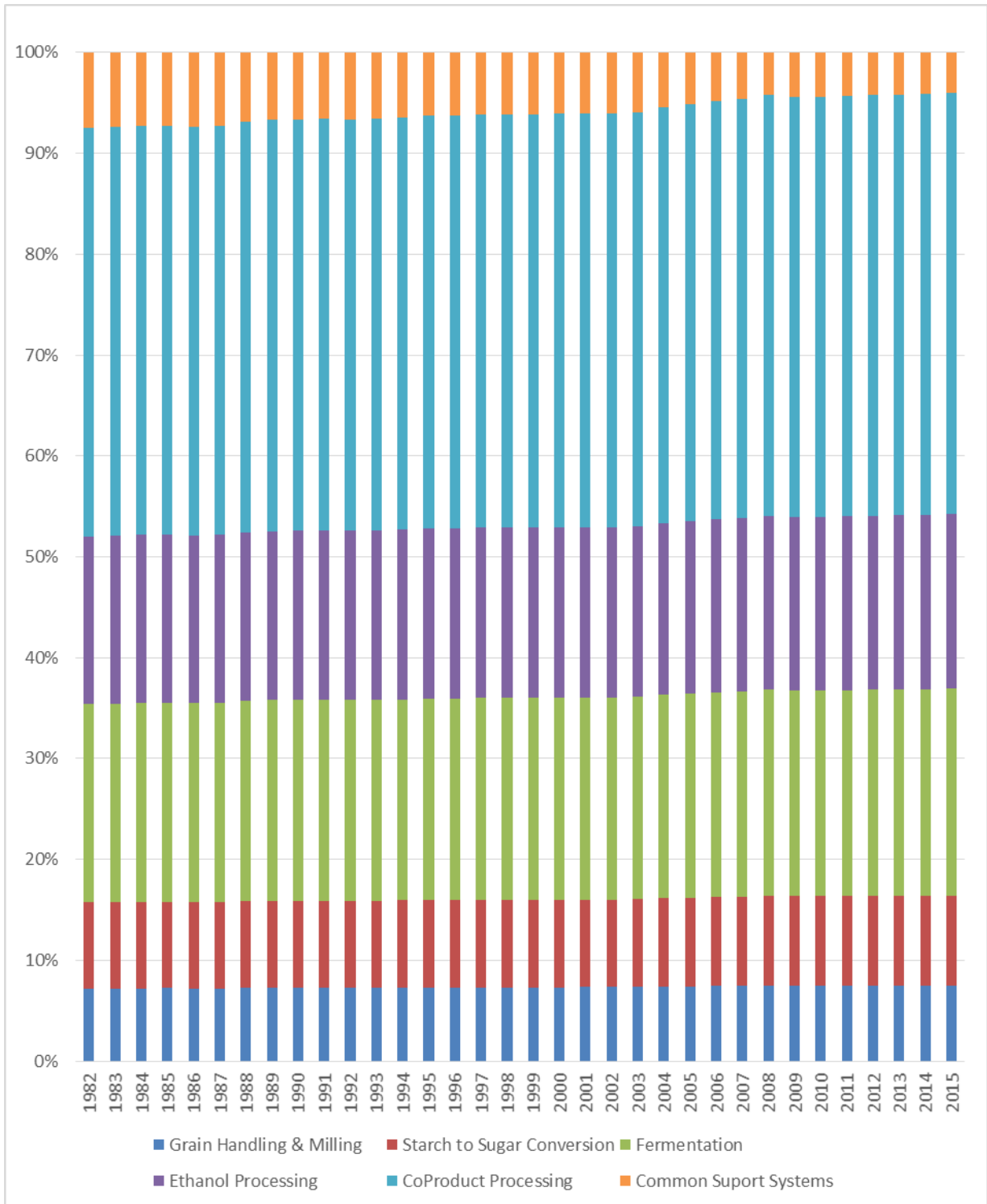

Figure 3.2b. Capital cost from corn-based ethanol process with distillers wet grains (no distillers corn oil)

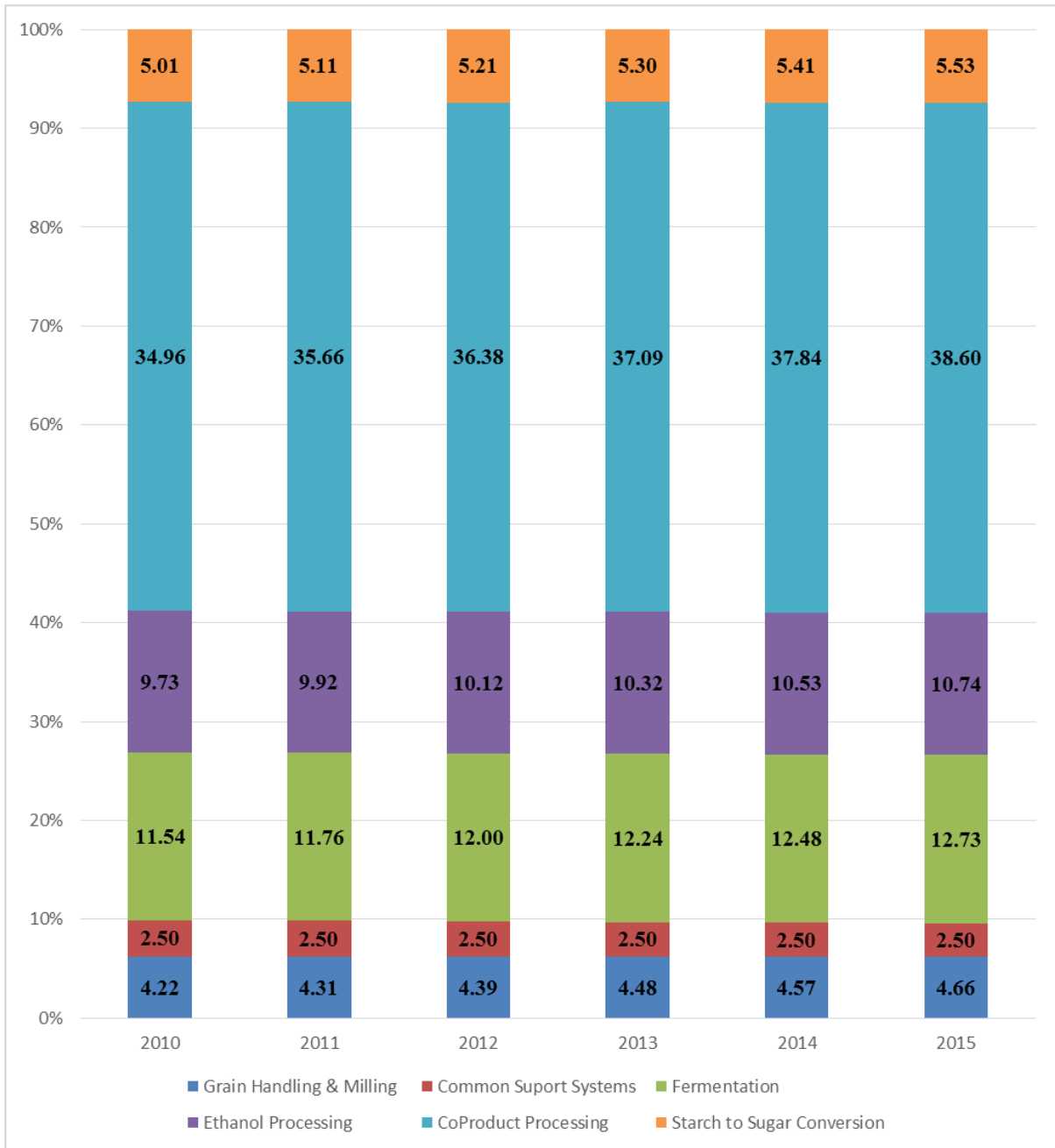

Figure 3.2c. Capital cost from corn-based ethanol process with distillers wet grains and distillers corn oil*.

*The unit of data in the bar is millions of dollars

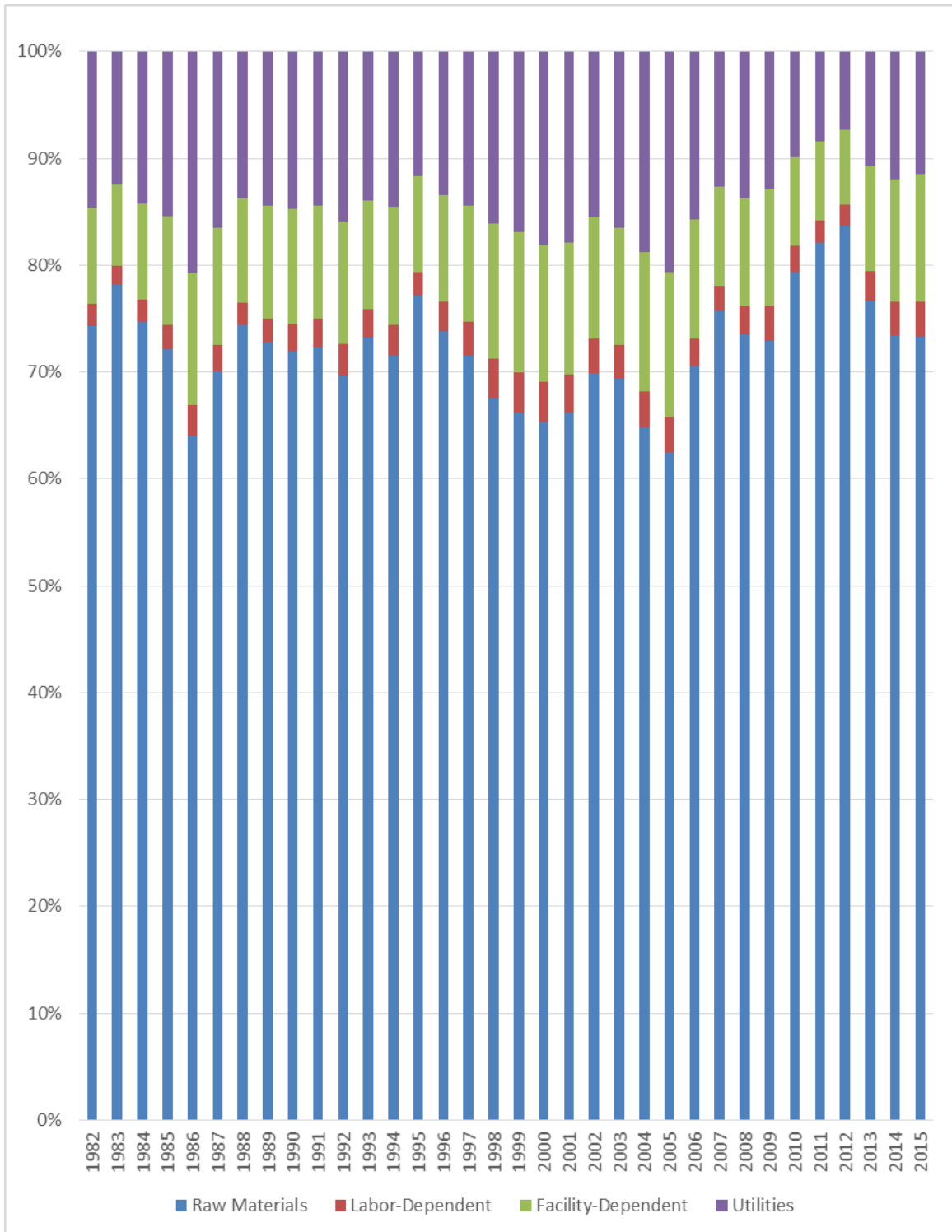

Figure 3.3a. Operating cost from corn-based ethanol process without distillers wet grains or distillers corn oil.

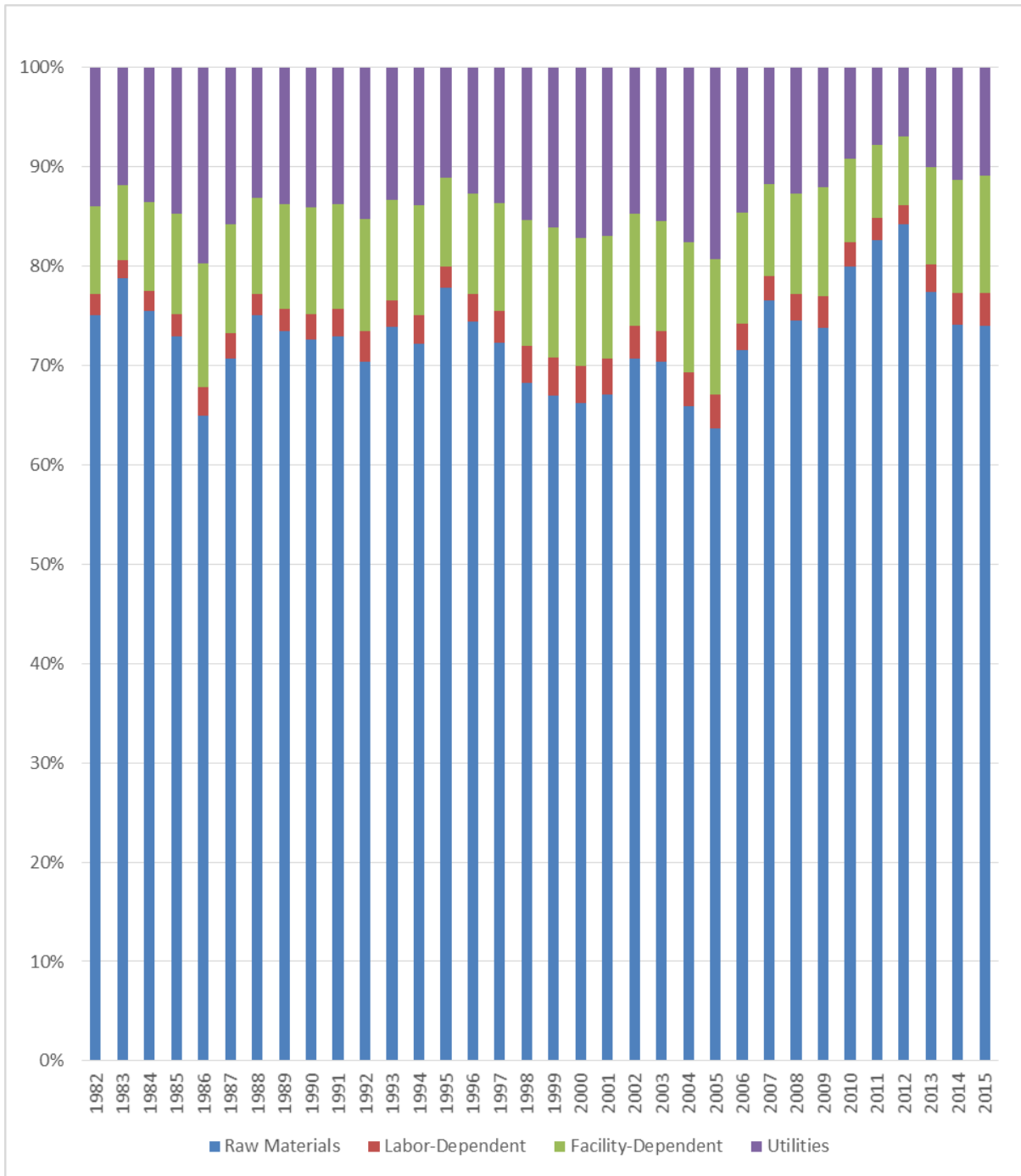

Figure 3.3b. Operating cost from corn-based ethanol process with distillers wet grains (no distillers corn oil).

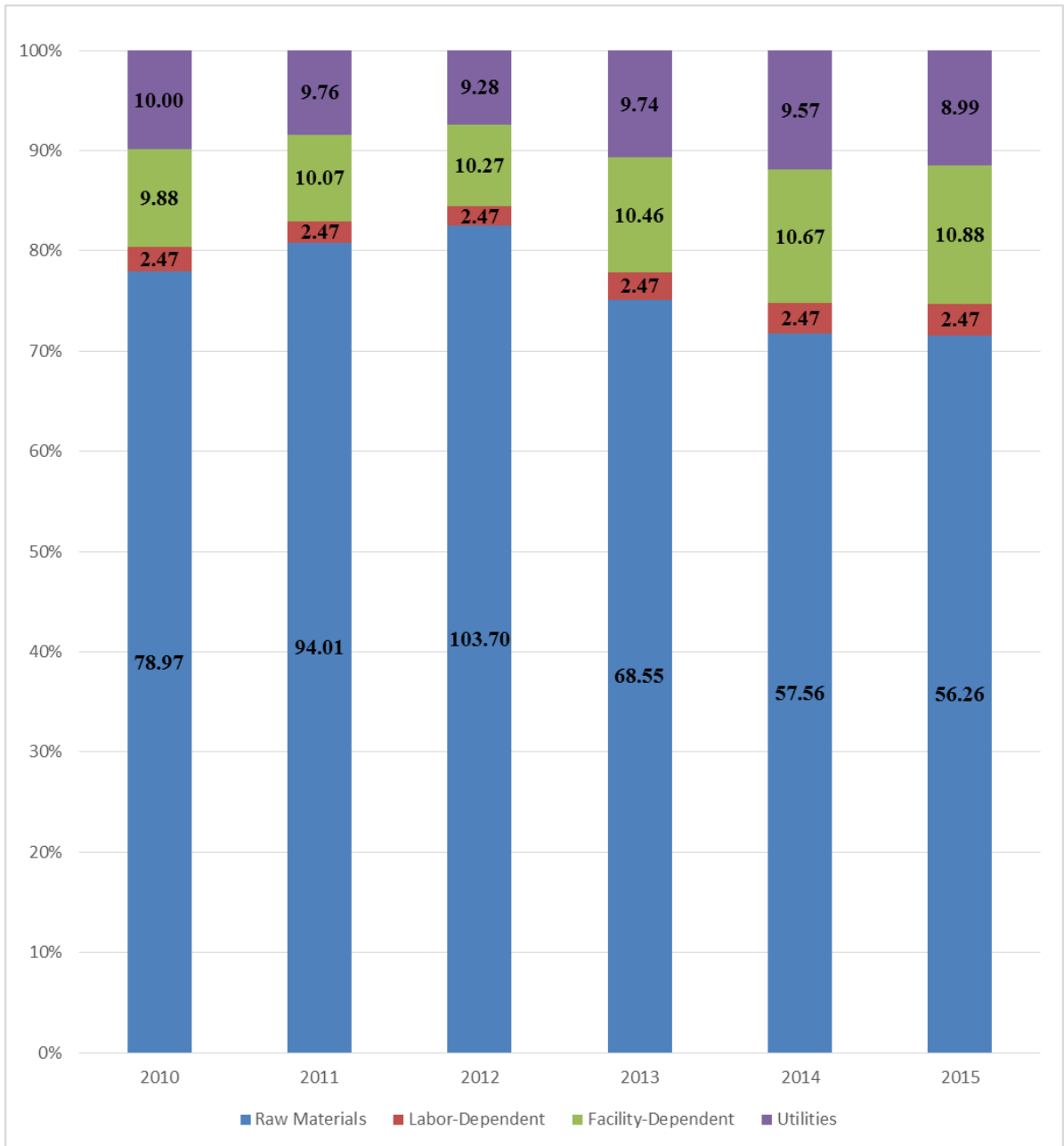

Figure 3.3c. Operating cost from corn-based ethanol process with distillers wet grains and distillers corn oil*.

*The unit of data in the bar is millions of dollars per year

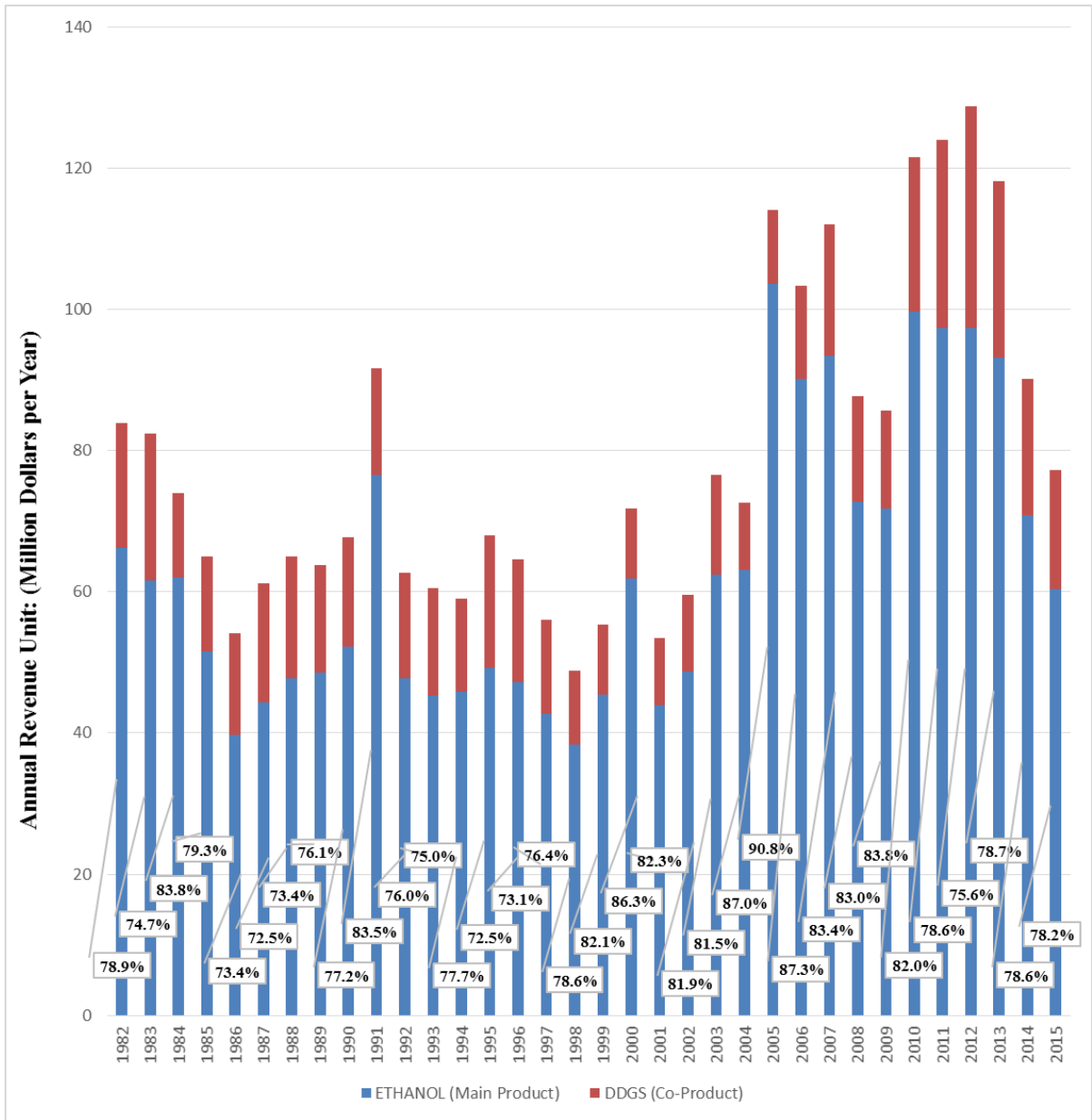

Figure 3.4a. Total annual revenue from corn-based ethanol process without distillers wet grains or distillers corn oil.

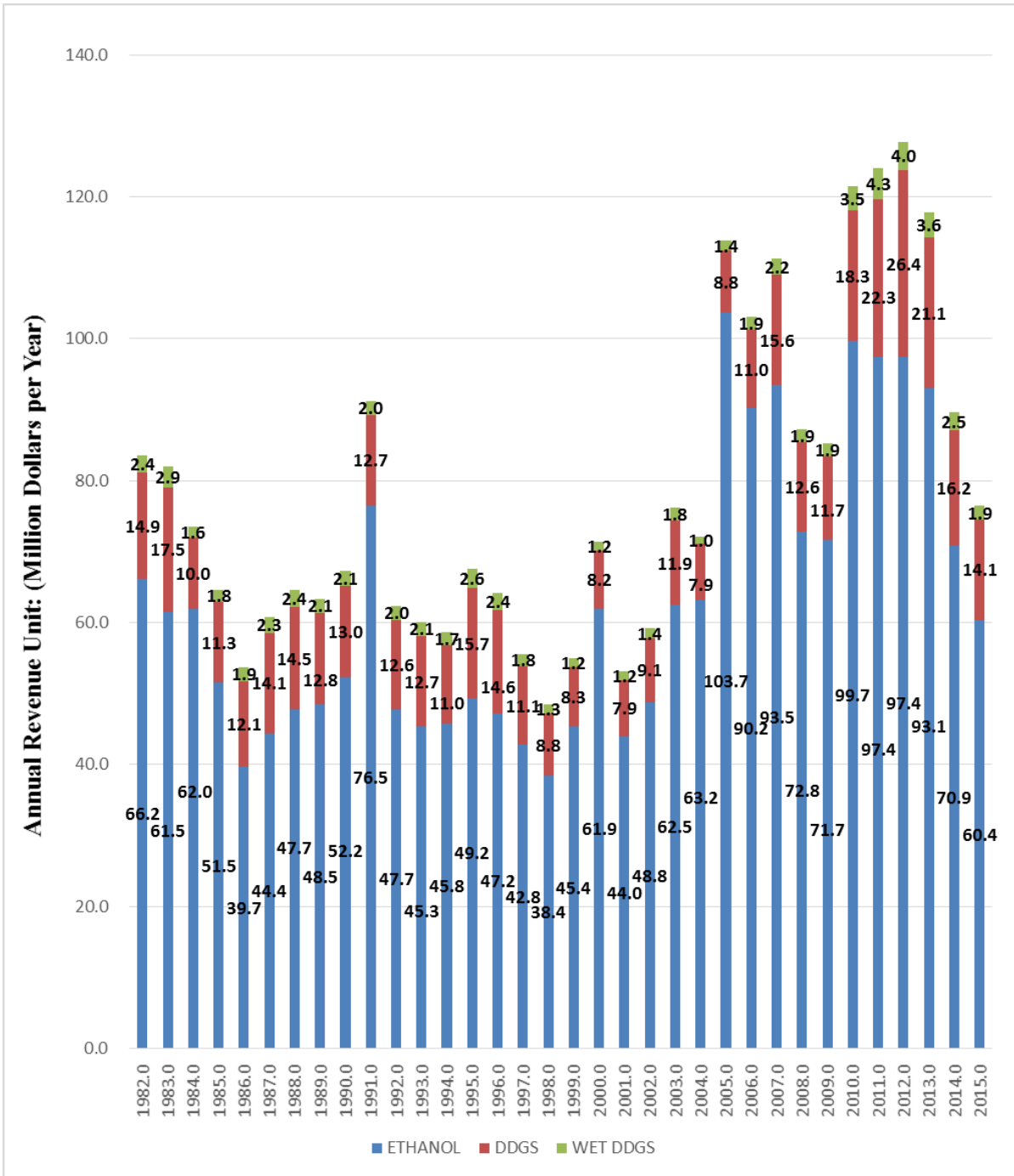

Figure 3.4b. Total annual revenue from corn-based ethanol process with distillers wet grains (no distillers corn oil).

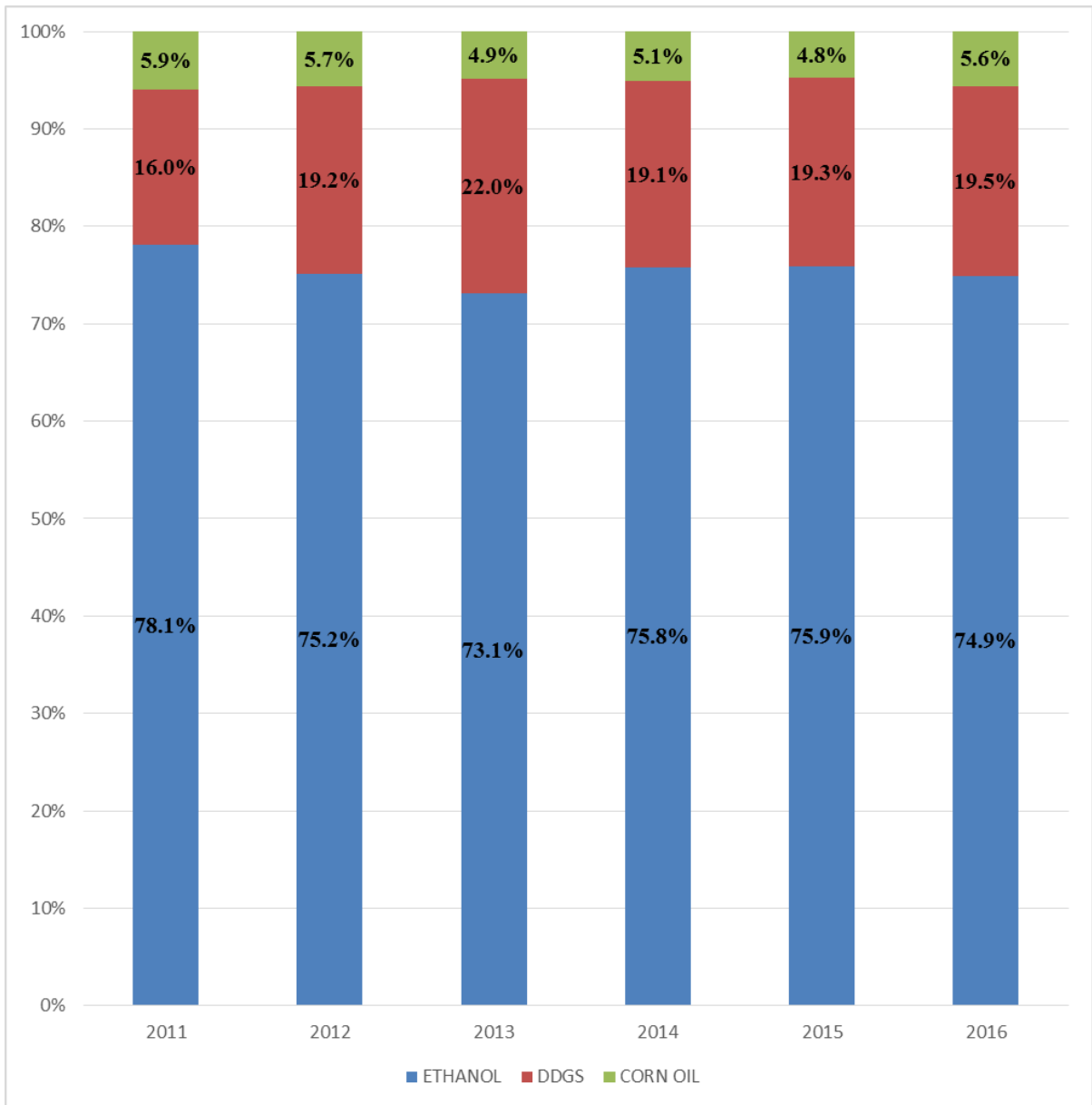

Figure 3.4c. Total annual revenue from corn-based ethanol process with distillers wet grains and distillers corn oil*.

*The unit of data in the bar is millions of dollars per year

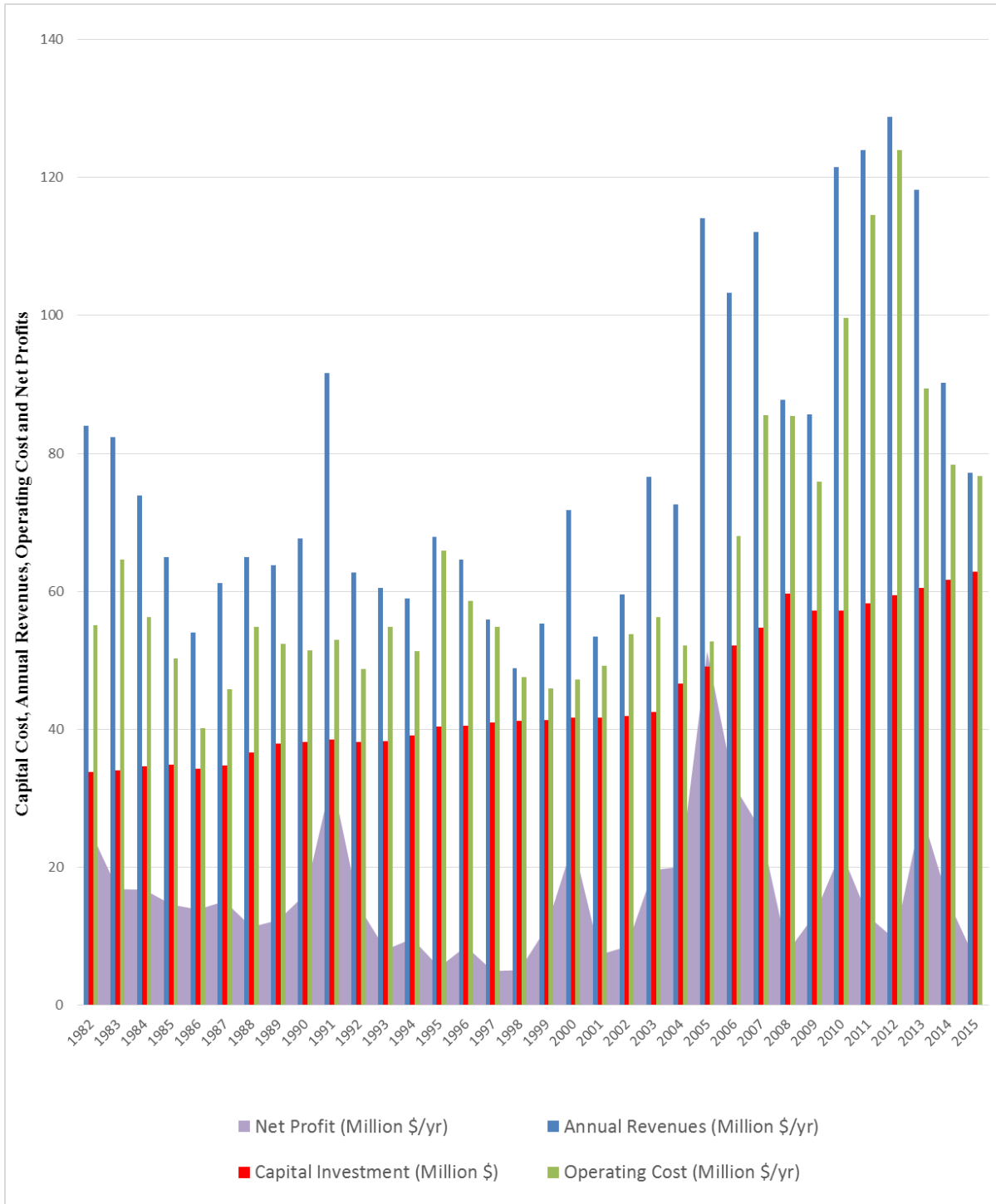

Figure 3.5a. Gross operating margin from corn-based ethanol process without distillers wet grains or distillers corn oil.

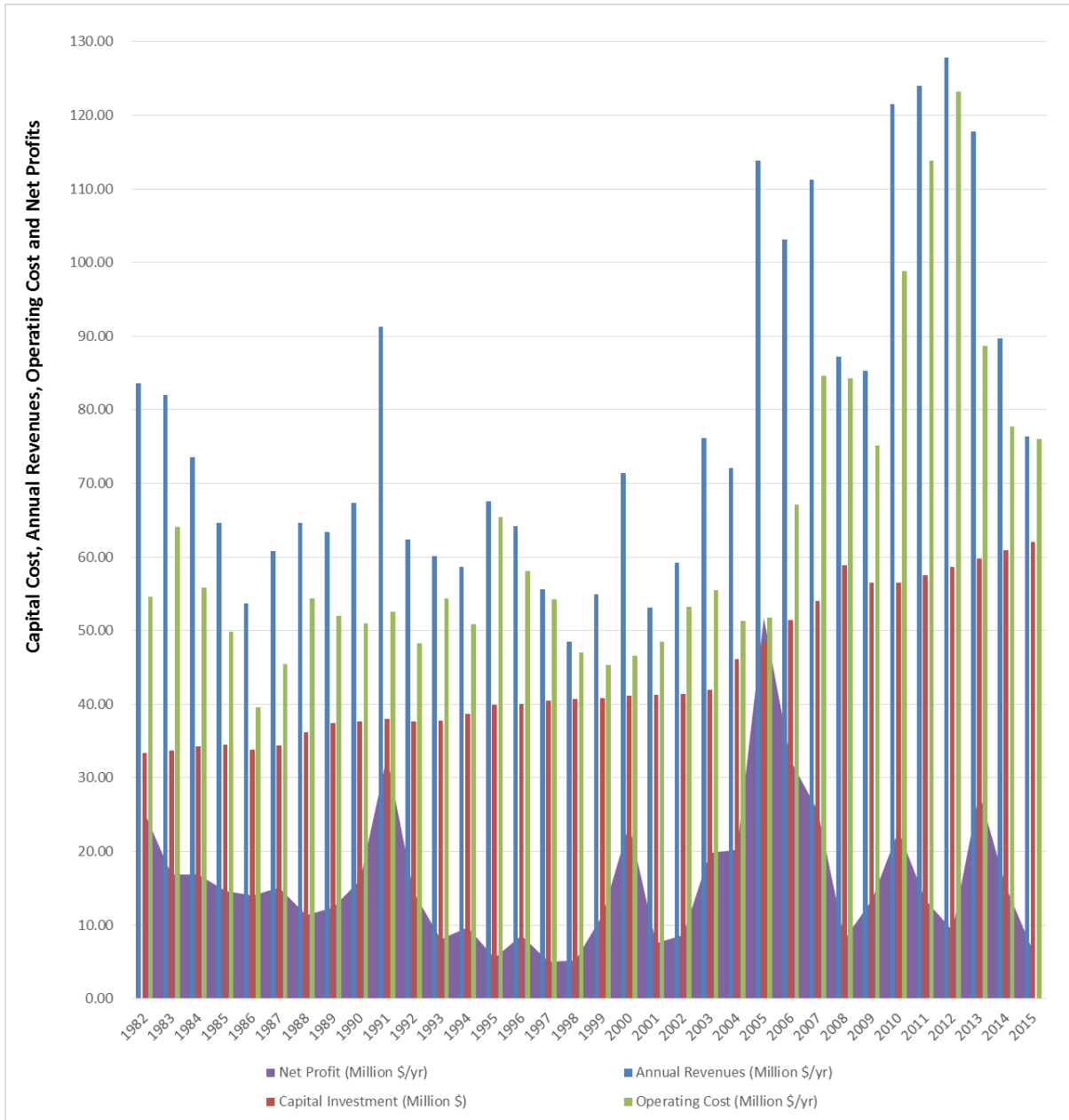

Figure 3.5b. Gross operating margin from corn-based ethanol process with distillers wet grains (no distillers corn oil).

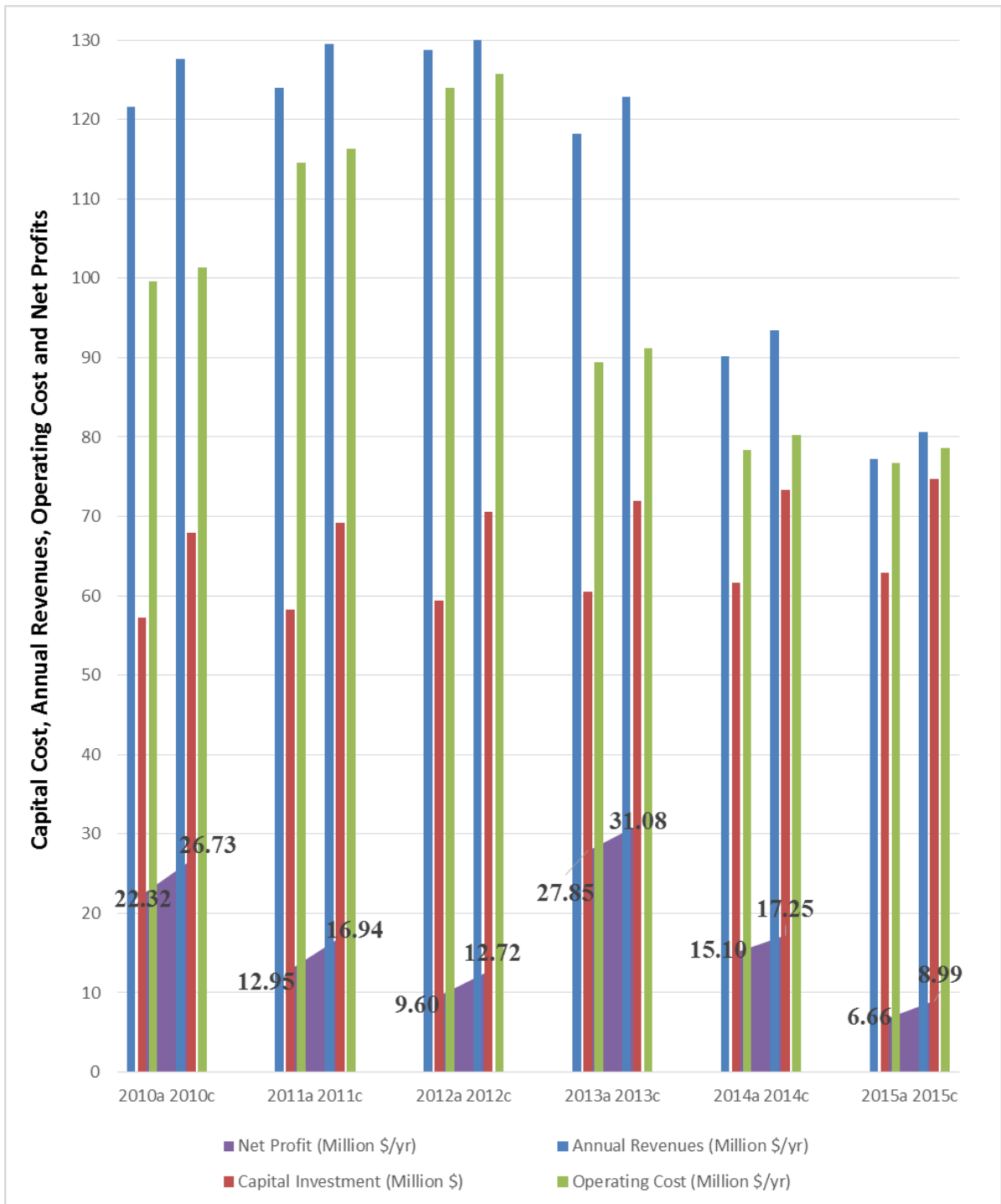

Figure 3.6. Gross operating margin from corn-based ethanol process (without DCO or DWG, 2010-2015) and gross operating margin from corn-based ethanol process with DCO (without DWG).

*a present scenario I, and c present scenario III

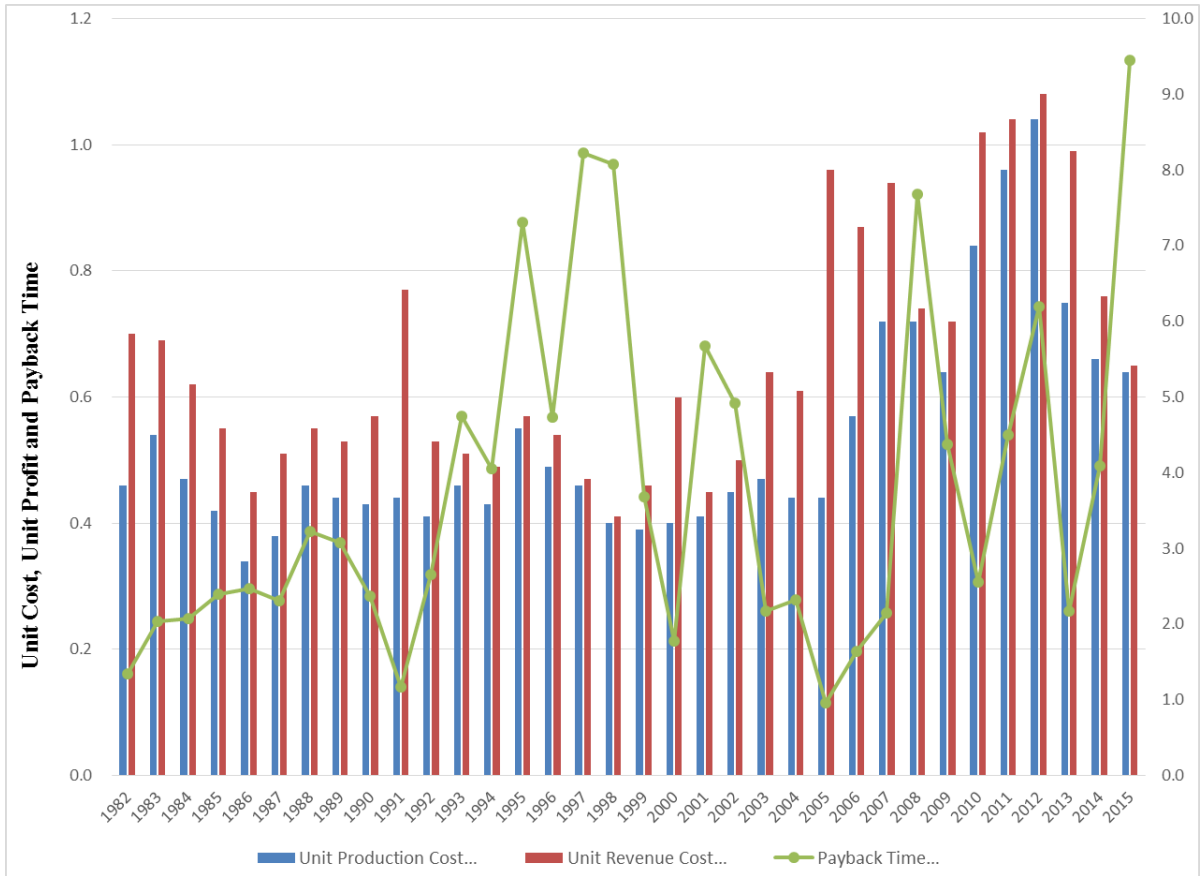

Figure 3.7a. Unit production cost, unit production revenue and payback time from corn-based ethanol process without DWG and oil extraction.

*The unit of unit production cost and unit production revenue are reflected on the left axes, and payback time is reflected on the right axes.

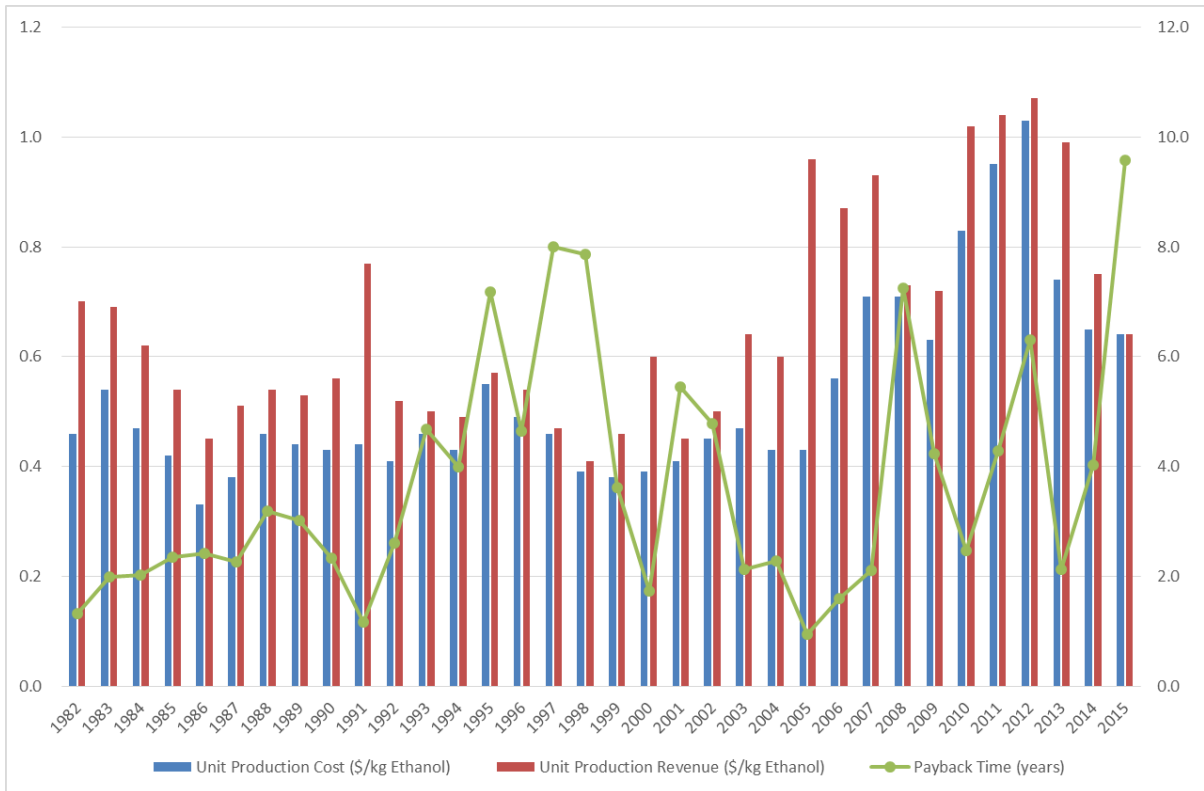

Figure 3.7b. Unit production cost, unit production revenue and payback time from corn-based ethanol process with DWG (no oil extraction).

*The unit of unit production cost and unit production revenue are reflected on the left axes, and payback time is reflected on the right axes.

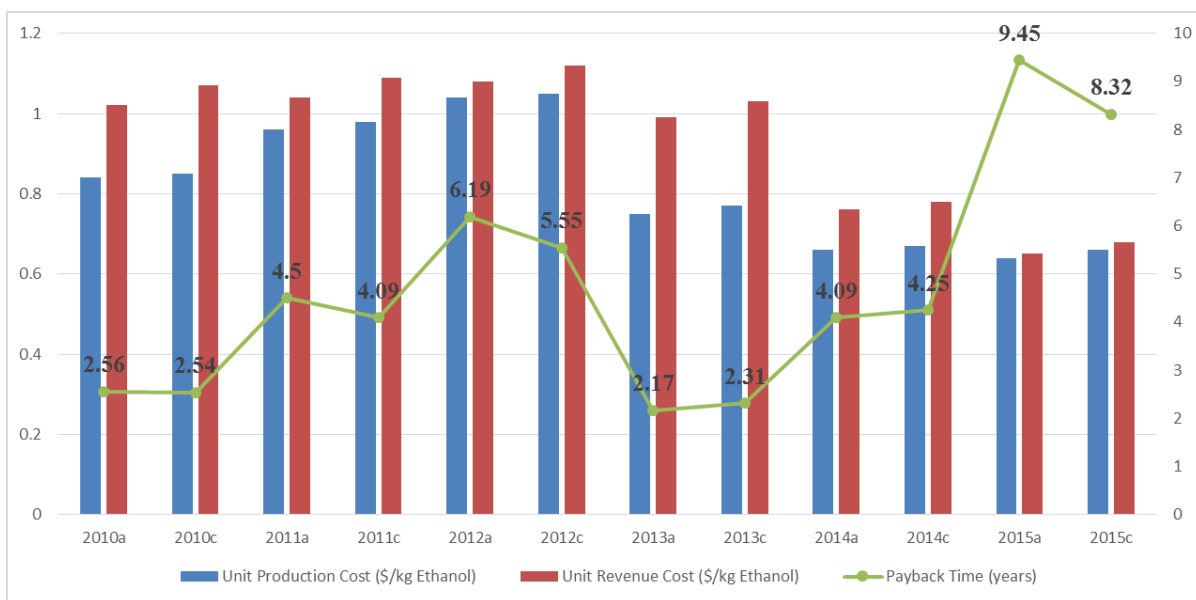

Figure 3.8. Unit production cost, unit production revenue and payback time from corn-based ethanol process with oil extraction and without oil extraction (2010-2015).

*a present scenario I, and c present scenario III

Table 3.1

Price of Raw Material & Products to Corn-based Ethanol Process (1982-2016)

Marketing Year	Corn	Ethanol	DDGS	DWG	Distillers corn oil	Natural Gas	Electricity
	\$ / kg	\$ / kg.	\$ / kg	\$ / kg	\$ / kg	\$ / MBtu	\$ / kW·h
1982/83	0.1004	0.5557	0.1446	0.0484		3.4956	0.0500
1983/84	0.1264	0.5165	0.1699	0.0579		3.5638	0.0483
1984/85	0.1035	0.5199	0.0975	0.0310		3.4177	0.0497
1985/86	0.0878	0.4326	0.1099	0.0356		2.8627	0.0493
1986/87	0.0591	0.3331	0.1172	0.0383		2.5998	0.0477
1987/88	0.0764	0.3726	0.1372	0.0457		2.6193	0.0470
1988/89	0.1000	0.4004	0.1411	0.0471		2.6193	0.0472
1989/90	0.0929	0.4072	0.1242	0.0409		2.6388	0.0474
1990/91	0.0898	0.4383	0.1260	0.0416		2.5706	0.0483
1991/92	0.0933	0.6423	0.1230	0.0404		2.6680	0.0483
1992/93	0.0815	0.4004	0.1226	0.0403		2.9601	0.0485
1993/94	0.0984	0.3805	0.1235	0.0406		2.7751	0.0477
1994/95	0.0890	0.3846	0.1071	0.0346		2.4830	0.0466
1995/96	0.1276	0.4132	0.1524	0.0514		3.0867	0.0460
1996/97	0.1067	0.3961	0.1418	0.0474		3.4956	0.0453
1997/98	0.0957	0.3587	0.1078	0.0348		3.5900	0.0448
1998/99	0.0764	0.3222	0.0852	0.0264		3.1400	0.0443
1999/00	0.0717	0.3811	0.0806	0.0247		3.1200	0.0464
2000/01	0.0728	0.5197	0.0800	0.0245		4.4500	0.0505
2001/02	0.0776	0.3688	0.0771	0.0234		5.2400	0.0488
2002/03	0.0913	0.4091	0.0881	0.0275		4.0200	0.0511
2003/04	0.0953	0.5241	0.1155	0.0361		5.8900	0.0525
2004/05	0.0811	0.5301	0.0767	0.0194		6.5300	0.0573
2005/06	0.0787	0.8697	0.0856	0.0271		8.5600	0.0616
2006/07	0.1197	0.7570	0.1070	0.0374		7.8700	0.0639
2007/08	0.1654	0.7842	0.1515	0.0430		7.6800	0.0683
2008/09	0.1598	0.6110	0.1220	0.0368		9.6500	0.0681
2009/10	0.1398	0.6020	0.1133	0.0374		5.3300	0.0677
2010/11	0.2039	0.8368	0.1781	0.0691	1.0410	5.4900	0.0682
2011/12	0.2449	0.8172	0.2168	0.0843	1.0109	5.1300	0.0667
2012/13	0.2713	0.8172	0.2559	0.0800	0.8956	3.8900	0.0682
2013/14	0.1756	0.7812	0.2049	0.0708	0.8600	4.6600	0.0706
2014/15	0.1457	0.5949	0.1576	0.0496	0.6113	4.4533	0.0691
2015/16	0.1421	0.5066	0.1372	0.0380	0.6203	3.3400	0.0674

(1) Each marking year starts from September to August of the following year

Table 3.2

Net Profit & Payback Time for Scenario I and Scenario II

Year	Net Profit(a)	Net Profit(b)	DWG vs DDGS	Payback Time(a)	Payback Time(b)	Payback shorten time
	(Million \$/yr)	(Million \$/yr)	(Million \$/yr)	(years)	(years)	
1982	25.210	25.277	0.067	1.34	1.32	1.49%
1983	16.842	16.890	0.048	2.03	1.99	1.97%
1984	16.781	16.874	0.093	2.07	2.03	1.93%
1985	14.626	14.679	0.053	2.39	2.35	1.67%
1986	13.901	14.022	0.121	2.47	2.41	2.43%
1987	15.091	15.105	0.014	2.31	2.27	1.73%
1988	11.371	11.384	0.013	3.22	3.18	1.24%
1989	12.360	12.386	0.026	3.07	3.02	1.63%
1990	16.077	16.101	0.024	2.37	2.34	1.27%
1991	32.872	32.902	0.030	1.17	1.16	0.85%
1992	14.390	14.438	0.048	2.65	2.61	1.51%
1993	8.066	8.100	0.034	4.75	4.67	1.68%
1994	9.674	9.701	0.027	4.05	3.99	1.48%
1995	5.536	5.563	0.027	7.31	7.18	1.78%
1996	8.557	8.610	0.053	4.74	4.65	1.90%
1997	4.979	5.059	0.080	8.23	8.00	2.79%
1998	5.118	5.187	0.069	8.07	7.86	2.60%
1999	11.239	11.317	0.078	3.68	3.61	1.90%
2000	23.505	23.679	0.174	1.78	1.74	2.25%
2001	7.362	7.566	0.204	5.67	5.45	3.88%
2002	8.519	8.657	0.138	4.92	4.78	2.85%
2003	19.632	19.800	0.168	2.17	2.12	2.30%
2004	20.082	20.238	0.156	2.32	2.28	1.72%
2005	51.313	51.755	0.442	0.96	0.94	2.08%
2006	31.882	32.370	0.488	1.64	1.59	3.05%
2007	25.485	25.531	0.046	2.15	2.11	1.86%
2008	7.771	8.125	0.354	7.68	7.25	5.60%
2009	13.062	13.333	0.271	4.38	4.24	3.20%
2010	22.323	22.852	0.529	2.56	2.47	3.52%
2011	12.945	13.456	0.511	4.50	4.28	4.89%
2012	9.597	9.302	-0.295	6.19	6.31	-1.94%
2013	27.849	28.011	0.162	2.17	2.13	1.84%
2014	15.096	15.134	0.038	4.09	4.02	1.71%
2015	6.657	6.489	-0.168	9.45	9.57	-1.27%

Table 3.3

Multiple Linear Regression for 40 Million Gallons Ethanol Process Without DWG and DCO ^{a,b}

Model		Unstandardized Coefficients		Standardized Coefficients	t	Sig.	Correlations
		B	Std. Error	Beta			Partial
1	Corn	-243.727	17.786	-1.637	-13.704	.000	-.926
	Ethanol	73.615	2.825	2.180	26.060	.000	.978
	DDGS	45.503	15.468	.328	2.942	.006	.467

a. This table was obtained from the data of Scenario I, in which the dependent variable was profit and predictors were corn, ethanol and DDGS.

b. Linear regression through the no-intercept model. According to unstandardized coefficients, the model can be formulated as below:

$$\text{Profit} = -243.727 * \text{corn price} + 73.615 * \text{ethanol price} + 45.503 * \text{DDGS price}$$

Table 3.4

Multiple Linear Regression for 40 Million Gallons Ethanol Process Without DCO ^{a,b}

Model		Unstandardized Coefficients		Standardized Coefficients	t	Sig.	Correlations
		B	Std. Error	Beta			Partial
1	Corn	-249.421	15.841	-1.662	-15.745	.000	-.944
	Ethanol	75.685	2.533	2.224	29.884	.000	.984
	DDGS	-54.370	34.609	-.389	-1.571	.127	-.276
	DWG	295.734	96.711	.702	3.058	.005	.487

a. This table was obtained from the data of Scenario II, in which the dependent variable was profit and predictors were corn, ethanol, DDGS and DWG.

b. Linear regression through the no-intercept model. According to unstandardized coefficients, the model can be formulated as below:

$$\text{Profit} = -249.421 * \text{corn price} + 75.685 * \text{ethanol price} - 54.370 * \text{DDGS price} + 295.734 * \text{DWG}$$

Table 3.5

Multiple Linear Regression for 40 Million Gallons Ethanol Process Without DWG ^{a,b}

Model		Unstandardized Coefficients		Standardized Coefficients	t	Sig.	Correlations
		B	Std. Error	Beta			Partial
1	Corn	-231.630	115.408	-2.301	-2.007	.183	-.817
	Ethanol	80.743	71.295	2.910	1.133	.375	.625
	DDGS	34.682	171.428	.332	.202	.858	.142
	DCO	-.339	47.734	-.014	-.007	.995	-.005

a. This table was obtained from the data of Scenario III, in which the dependent variable was profit and predictors were corn, ethanol, DDGS and DCO.

b. Linear regression through the no-intercept model. According to unstandardized coefficients, the model can be formulated as below:

$$\text{Profit} = -231.630 * \text{corn price} + 80.743 * \text{ethanol price} + 34.682 * \text{DDGS price} - 0.339 * \text{DCO}$$

CHAPTER 4: TECHNO-ECONOMIC ANALYSIS (TEA) OF A 120 MILLION GALLON CORN-BASED ETHANOL PLANT

4.1. Introduction

The U.S. ethanol industry has expanded rapidly in recent years (Schnepf & Yacobucci, 2013). In 2015, 14.7 billion gallons of ethanol were produced by nearly 200 operating plants, which was a new record of production and 2.7% higher than the production of 2014 (Renewable Fuels Association, 2016). What's more, ethanol's share of the gasoline pool rose from 3% (2005) to 10% (2014), becoming gradually more important during the last 10 years (Renewable Fuels Association, 2014a). Production levels of distillers' grains increased between 35 and 40 million metric tons in 2014, and currently feed approximately 30% of domestic and exported products (11.3 million metric tons) (Renewable Fuels Association, 2015). Distillers grains are widely used in animal feed, primarily in beef and dairy diets, but are increasingly being used in swine and poultry diets. As the ethanol industry gradually became more mature in technology, individual plants began to implement new production processes; which increased efficiencies, diversified coproduct streams, and improved profit margins (Hoffman and Baker, 2011; Liu and Rosentrater, 2011). Many corn-based ethanol plants attempted fractionated products, like high-protein DDGS, DDGS, and low-fat DDGS, and distillers corn oil from stillage streams (Schnepf & Yacobucci, 2013; Renewable Fuels Association, 2015). Even though distillers coproducts were effectively used as feed ingredients for decades, the livestock and ethanol industries faced a severe lack of information, especially during the recent exponential growth phase of the ethanol industry (NASS, 2007). In addition, the efficiency and profitability of new products and new

technology are still unclear, requiring urgently techno-economic analysis for a corn-based ethanol plant.

Similar to chapter 3, this study utilized a SuperPro Designer, corn-based ethanol model to explore the difference between various possible affected factors (price of corn, DDGS, ethanol, gas, electricity, labor and inflation rate) and the effect of corn-based ethanol plants profits and energy consumption. Additionally, this study used a model to investigate the efficiency improvements associated with new technology usage (like pure DDGS production and oil extraction). Finally, this study attempted to compare the efficiency and profit change between the models of 40 and 120 million gallon ethanol plants.

4.2. Materials and methods

4.2.1. Computer Model

Similar to chapter 3, this chapter also chose SuperPro Designer (Intelligen, Inc., Scotch Plains, NJ) as the main software used to simulate the corn-based ethanol process. As mentioned in chapter 3, SuperPro Designer helps researchers rapidly facilitate modeling and evaluate and optimize integrated processes in a wide range of industries. In addition, it has a strong capacity for simulating a large database of specific chemical compounds and unit operations, which allows the possibility of evaluating economic performance indexes. SuperPro Designer simplifies the process of scale-up, and also compares different scale processes through integrated material, equipment sizing and utility requirements (Toumi et al., 2010; Kawachale & Kumar, 2011; Misailidis et al., 2009).

According to previous research regarding a 40 million gallon per year corn-based ethanol plant model (Kwiatkowski et al., 2006; McAloon & Yee, 2011), chapter 3 updated

the model of a dry grind ethanol plant, and explored the effect of various rates of coproducts on economic values and the possibility of new technology like oil extraction. The model in this chapter was updated for a corn-based plant with 120 million gallons of ethanol per year production. This study used a similar structure and frame as the modified model (McAloon & Yee, 2011), but all equipment scales and other property was reset so the new model kept appropriate capacity and volume for a larger scale.

The model of this study was designed with 330 working days per year to mirror real industry process, which generally operates 24 hours per day year round. This model assumed the rest of time was used for maintenance. All equipment volume rose to 1.8 ~ 3 times larger than the 40 million gallon ethanol model, which depended on the requirement of flow rate date. The purchase price of equipment was also updated according to the change in volume and flow rate. In addition, the requirement of power for the equipment was updated so that new capacity fitted for larger flow rate, including small piece equipment like pumps. Heat exchange was also reset, and the system was balanced during the updated recycling process. Based on these modified factors, all annual calculations were decided using the new data simulation. A variety of reports from SuperPro Designer were produced to reflect the economic feasibility of the new model simulation. These reports were produced and compared to estimate for each year with a 120 million gallons ethanol scenario, which included exploration of sensitivity on each affected factor. The design frame and structure of 120 million gallons of dry grind ethanol from corn processing is shown in Figure 4.1.

4.2.2. Simulation scenarios

Scenarios were updated and modified on the basic corn-based ethanol process plant model developed by McAloon and Yee (2011). Two scenarios were set:

IV. Corn-based ethanol processes with 120 million gallons of ethanol per year, which excluded distillers wet grains (DWG) and distillers corn oil.

V. Corn-based ethanol process with 120 million gallons of ethanol per year, which excluded distillers wet grains (DWG) but included distillers corn oil.

Simulations were run based on modifying various prices of materials and products that affected corn-based bioethanol factories. The marketing prices of raw materials and products were the same as the 40 million gallons ethanol model and all data is cited in Table 3.1. Three different variables were considered in this model:

(1) Market price of corn, ethanol, DDGS, and distillers wet grains (DWG) from 1982 to 2016 (Table 3.1) (McAloon & Yee, 2011; USDA, 2016). All price scenarios are listed in Table 3.1.

(2) Market price of distillers corn oil from 2010 to 2016 (The Jacobsen, 2016). These price scenarios are listed in Table 3.1.

(3) Industrial price of natural gas and electricity from 1982 to 2016 are set in Table 3.1 (McAloon & Yee, 2011; EIA, 2016a; EIA, 2016b). Labor cost and inflation rates were set according to the data from the U.S. Department of Labor.

Similar to chapter 3, this study focused on the three series of affected factors mentioned above. All other variables were the same as the modified model in chapter 3 including physical property, material combination and other basic indices. Installation cost depended on various types of equipment, and loan interest was set at 7.0% per year as a

common assumption. In addition, annual operating cost was shown as an important content of process summary, which included raw materials, labor, facility and utilities. Among profitability analysis, the unit production cost, unit production revenue, net profit and payback time were the most important results to explore the difference between the two scenarios.

4.2.3. Data analysis

Multiple linear regression was an efficiency statistic method utilized to model the relationship between two or more explanatory variables and a response variable, which required a linear equation to fit to observed data (Tranmer & Elliot, 2008). This study utilized multiple linear regression (MLR) to interpret how the prices of corn, ethanol, DDGS, and oil impacted the profit of the corn-based ethanol process. SPSS v.22 was the software program used to conduct the statistical analysis. Excel was used to manage the raw data and import data to SPSS.

4.3. Results and discussion

4.3.1. Capital costs

Capital costs are generally defined as the initial investments for all direct and indirect costs, including construction cost, process piping, utilities production and equipment cost. (Gallaher et al., 2005). Different from labor cost and operating cost, capital cost is independent from the level of output in the whole project. The main objective of capital cost is to provide project analysis and evaluation, which helps researchers select alternative designs, plan the appropriation funding and supply a basic project cost control. Similar to

chapter 3, the capital cost of this study mainly contained several individual process parts: grain handling and milling, starch to sugar conversion, fermentation, ethanol processing, coproduct processing and common support systems. Using a similar model frame and simulation, each individual process capital cost was simulated from the data of equipment purchase price, model material factor and installation factors. To simplify some indirect supported equipment, steam generation and cooling water equipment were not calculated in capital cost. The results of scenarios on capital cost are presented in Figure 4.2a and Figure 4.2b.

For scenario IV, the capital cost continuously increased from 71.86 to 136.57 million dollars, which was nearly double the change of the last 34 years. The main reason for this change was the effect of inflation rates and market requirements. Compared to the model in chapter 3, this scenario required around 2.17 times the capital cost to finish 120 million gallons of ethanol production. Through utilizing a similar simulation frame with the 40 million gallon ethanol model, the percentage of each section had a significant change especially on coproduct processing. In this scenario, coproduct processing contributed from 50.65% to 51.42% of the total capital cost in all 34 years, which was nearly a 10% increase than scenario I in chapter 3. Due to scale-up, the contribution of the fermentation process slightly increased (from 20.30% to 20.69%), but the ethanol processing section had a small decrease (from 12.02% to 12.24%). The reason for these changes were coproducts, like DDGS and WDG, needed more steps and more equipment to treat, increasing the rate in capital cost. In addition, grain handling and milling, starch to sugar conversion and common support systems kept a similar level of contribution in capital cost, which was approximately 6.59%, 7.08% and 2.66%.

Similar to the change in chapter 3, scenario V had a significant increase on capital cost, which varied from 130.14 million (2010) to 143.40 million (2015). The extra oil extraction equipment made a contribution on the increase of coproduct processing, which was approximately a 3% increase from scenario I. In contrast, other process parts kept the same level of cost so the percentage of contribution decreased. The fermentation process made a contribution of 19.68%, and ethanol processing took 11.65% of total capital cost, which both had 1% decrease compared to scenario IV. Grain handling and milling, starch to sugar conversion and common support systems also had a slight decrease of capital cost, making contributions around 6.33%, 6.80% and 1.83%.

4.3.2. Annual operating costs

In this chapter, annual operating costs are composed of labor, facility, utility costs and raw material costs. To keep similar comparability, both scenarios excluded consumables, advertising, running royalties and failed product disposal, which kept the same conditions as the previous study. Due to the scale up from the 40 to 120 million gallon ethanol model, annual operating cost had a significant increase in both scenarios. For scenario IV, annual operating cost ranged from 108.65 (1985) to 355.09 (2012) million dollars, which was approximately 2.82 times more than scenario I in chapter 3. Similar to the previous study, Figure 4.3a indicates material cost had the largest impact on overall operating cost (average 77.23 %), which was 5% larger than scenario I in chapter 3. The reason for this change was the larger requirement for raw materials. The volatility of corn prices were magnified to reflect in the annual operating cost. Due to the data collected from 2010 and the effect of the inflation rate, annual operating cost in scenario V reached from 214.77 to 356.22 million

dollars per year, which included an average 82.27% contribution from raw materials (Figure 4.3b). Similar to scenario IV, utilities cost (average 9.30 %) was the second highest contributor other than facility cost (average 7.51%) in scenario V, with labor contribution around 1% in scenario IV and scenario V. Both scenarios results are a slight lower than the results of Ag Decision Maker (Ag Decision Maker, 2016). The reasons for the differences are from the difference in assumption for the models, which reflected on percent debt, length of loan, interest rate, water usage and ethanol yield.

4.3.2.1. Facility costs

Facilities were composed of maintenance cost, equipment depreciation, interest on debt, insurance, taxes, and other industrial expenses. Based on basic parameters set by McAllon and Yee (2011), maintenance expenses were determined as 3% of capital costs, while insurance and other industrial expenses were set to 0.8% and 0.75% of capital cost. Depreciation was set at a default index, and tax was set at 24% due to the renewable energy policy (Damodaran, 2012). Compared to scenario I in chapter 3, scenario IV had a narrow contribution range of around 8% ($\pm 2\%$), which was affected by more important contributions from raw material (Figure 4.3a). Similar to IV, scenario V kept a relatively stable rate and ranged from 5.52 % to 9.71 % of the total operating costs (Figure 4.3b). The small variation in both scenarios was mainly caused by the addition of oil extraction equipment in coproduct systems.

4.3.2.2. Labor costs

The cost of labor was estimated based on the number of working hours and the hourly wage. Both scenarios set working hours as 24 hours per day and 330 days per year. The hourly wage for 30 years was collected from the U.S. Department of Labor minimum wage, which gradually increased in the last 34 years (Index, 2012). This model multiplied the minimum wage by the labor amount to automatically create labor cost for all scenarios. The mean value for 34 years in scenario IV was 1.717 million dollars per year, and the mean value for scenario V was 2.471 million dollars per year. Both scenarios were approximately 1% of annual operating cost.

4.3.2.3. Material costs

According to the McAllon and Yee (2011), the materials of a corn-based ethanol process includes corn, water, yeast, caustic, lime, octane, ammonia, sulfuric acid, gluco-amylase and alpha-amlyose. To control the amount of independent factors, only corn price was set according to the year, which contributed more than 90% of cost in corn-based ethanol process (Wood et al., 2014; McAllon & Yee, 2011). Another reason to follow the price of corn was due to its volatility, which changed more than 4 times between the maximum value (\$0.06 per kg) and minimum value (\$0.27 per kg) in the last 34 years. As shown in Figure 4.3a, material cost made a contribution ranging from 68.19% (2005) to 87.31% (2012) on the annual operating cost in scenario IV, where the average value was 77.23%. For scenario V, the average rate of material cost increased to 82.27%, which reflected the increasing trend of material cost and corn price (Figure 4.3b). Compared to the 40 million gallon ethanol model, both 120 million gallons models increased the rate of material cost on total operating cost.

4.3.2.4. Utility costs

In this model, utility costs consisted of the costs of electricity, natural gas, steam, and chilled water. Steam and chilled water were changed for these utilities during the simulation. The price of electricity ranged from \$0.044 to \$0.071 per kW·h, and natural gas wavered between \$ 2.48 and \$ 9.65 per MBtu (million British thermal unit). Due to the large volatility of electricity and natural gas, both scenarios had a larger range: 6.71% to 19.94% in annual operating costs (Figure 4.3a and 4.3b).

4.3.3. Annual revenues

Annual revenues are defined as the total income generated from the sale of total products in one financial year without considering any miscellaneous charges, costs and other expenses. Both of the models produced three products: carbon dioxide (CO₂), ethanol, and DDGS. Though CO₂ can be used as a raw material to produce soft drinks or beers, it was still not estimated with a market value in this study. In addition, distillers corn oil was extracted as a coproduct in scenario V. Both scenarios chose ethanol as the main product, or MP for short. The market prices for ethanol were set to reflect market values from 1982 to 2016 (\$0.99-2.66 per gallon EtOH (\$0.32-0.87 per kg)) (USDA, 2016). As the most important coproduct, the market prices of DDGS were collected from the USDA (2016), which ranged from \$0.08 to 0.26 per kg, and the average value was \$0.13 per kg. The data of distillers corn oil was collected from The Jacobsen Company (2016), and ranged between \$0.84 per kg and \$1.04 per kg from 2010 to 2016 (Table 3.1).

4.3.3.1. Ethanol

During this model, ethanol contributed more than 80% of the total annual revenue in both scenarios, which was nearly 10% higher than the 40 million gallon ethanol model and reflected the increase of product efficiency with a larger scale. Similar to scenario II, scenario IV simulated that ethanol made the maximum contribution to total revenue in 2005 and a minimum contribution in 1995, which took 90.81% and 72.49% of total annual revenues (Figure 4.4a). Due to the application limit on industrial oil extraction, scenario V only discussed the years between 2010 and 2015, and added the distillers corn oil as a coproduct (Figure 4.4b). With the effects of the year and oil components, ethanol contribution on annual revenues had a mean value of 75.41%, which was around 4% less than scenario IV. The reason for this was distillers corn oil made an important contribution on final annual revenues with a lower production amount.

4.3.3.2. DDGS

DDGS made up around 20% of total revenues produced by the ethanol plant in scenario IV, which kept a similar level compared to the 40 million gallon ethanol model. Similar to scenario IV, scenario V made an average 19.18% contribution to revenues, which indicated oil extraction had a small negative effect on DDGS production and revenue (Figure 4.4b).

4.3.3.3. Distillers corn oil (DCO)

The oil extraction rate was set at 80% in scenario V, which was a reasonable rate for current industry production. With around 2% of the total mass increased, DCO made an

approximate contribution of 5% on annual revenue, which was helpful to keep a stable profit for an ethanol plant, especially in some extreme years (Figure 4.4b). DCO explained why more and more ethanol plants included this technology in their production, with 85% of dry mill corn-based ethanol processes currently extracting oil from DDGS (Renewable Fuels Association, 2016).

4.3.4. Gross operating margins and payback time

Gross operating margins are seen in Figure 4.8, which shows capital cost, operating cost, revenue, and profits in millions of dollars per year. Unit production cost, unit production revenue and payback time are shown in Figure 4.5 and Figure 4.6. For both scenarios, capital investment cost had an evident trend of increasing, which fit the inflation rate change between 1982 and 2016. Both annual revenues and operating costs were very volatile, which was mainly determined by the market price of raw materials and products.

In scenario IV, the most profitable year was 2005, arriving at \$ 159.47 million per year, nearly 3.1 times larger than the 40 million gallon ethanol model. The annual operating cost and annual revenue was divided into a \$/kg ethanol basis, which directly reflected the efficiency of how costs are related to each kilogram of ethanol produced by the plant. As shown in Figure 4.8, scenario V had a significantly higher unit revenue cost than scenario IV, which showed DCO was an efficient method to improve the economic effect.

Comparing with 40 million gallons per year corn-based ethanol model, 120 million gallons per year corn-based ethanol model kept the similar level of unit revenue. But due to the scale up, unit production cost in 120 million gallons per year corn-based ethanol model slightly decreased, which caused the shorter payback time than 40 million gallons per year

corn-based ethanol model (Figure 4.9). Similar with the effect of scale up, oil extraction technology had a better performance on gross operating margins. Though the unit cost increased due to extra equipment required, more total annual revenues made the model obtain more profits so that payback time were decreased in both 40 and 120 million gallons per year ethanol model. As a conclusion, this study showed larger scale and oil extraction had a better performance on the corn-based ethanol production.

4.3.5. Multiple linear regression

This study used the profit of the 120 million gallons corn-based ethanol process as response variable, which was calculated by SuperPro modelling. For scenario IV, the response variable was analyzed against three explanatory variables, which include the prices of corn, ethanol and DDGS. Considering DCO in scenario V, the response variable of scenario V was analyzed against four explanatory variables with the price of corn, ethanol, DDGS, and DCO. The results of statics on scenario I is listed in Table 4.1. An unstandardized coefficient was used to analyze the amount changes in profit when explanatory variables changed by one unit while keeping the other three independent variables constant. Therefore, the equation between profits and explanatory variables for scenario I are shown as Equation 4.1 below:

$$\begin{aligned} \text{Profits} = & -723.122 \times \text{Corn price} + 226.063 \times \text{Ethanol price} + \\ & 147.794 \times \text{DDGS price} \end{aligned} \quad (4.1)$$

In Equation 4.1, the unit of profit is millions of U.S. dollars per year, and the unit of corn, ethanol and DDGS is U.S. dollars per kilogram. The partial correlation between profits

and corn price by controlling the prices of ethanol and DDGS was -0.945, which was slightly lower than scenario I of chapter 3 and r-square value is more than 0.9. These results indicated that the negative effect of corn was strengthened in the 120 million gallons ethanol process model, which reflected the 120 million gallons corn-based ethanol process was more sensitive in material price change than the 40 million gallons corn-based ethanol process. The value of partial correlation for ethanol was 0.985 and the value of partial correlation for DDGS was 0.560, which was slightly higher than scenario I of chapter 3. The results indicated positive effects of ethanol and DDGS were strengthened with the 120 million gallons ethanol process.

The results of statics on scenario V are listed in Table 4.2, and the equation between profits and explanatory variables for scenario V is shown as Equation 4.2 below:

$$\begin{aligned} \text{Profits} = & -721.533 \times \text{Corn price} + 245.562 \times \text{Ethanol price} + 138.065 \times \text{DDGS} + \\ & 3.352 \times \text{DCO price} \end{aligned} \quad (4.2)$$

In Equation 4.2, the unit of profit is millions of U.S. dollars per year, and the units of corn, ethanol, DDGS and DCO are US dollars per kilogram. The partial correlation between profits and corn price when controlling the prices of ethanol, DDGS and DCO was -0.880, which was lower than scenario III of chapter 3. Similar to the results above, the negative effect of corn was strengthened in the 120 million gallons ethanol process model, and larger industrial scales were more sensitive to corn price changes. The value of partial correlation for ethanol was 0.714 and the value of partial correlation for DDGS was 0.232; both of which were higher than scenario III of chapter 3. That indicated the positive effects of ethanol and DDGS on profits were strengthened in the 120 million gallons ethanol process model. Differently from the results above, the partial correlation between profits and DCO was

0.021 when controlling the prices of corn, ethanol and DDG. Results indicated a slight positive effect of DCO on profits, which was different from the negative value of DCO in scenario III of chapter 3. This result also suggested corn-based ethanol plants with a larger industrial scale should increase DCO production to obtain optimal profits.

4.4. Conclusion

To perform economic calculations for a 120 million gallon ethanol process, SuperPro Designer was used for techno-economic modeling. According to simulation results from the model, the 120 million gallon corn-based ethanol plant had positive net profits from 1982 to 2016 but larger volatility due to market price. Compared to a 40 million gallons ethanol process, the 120 million gallons ethanol model had a better performance in unit production. By adding oil extraction, a 120 million gallon ethanol model had higher efficiency on unit production revenue, which had a lower payback compared to the 120 million gallons ethanol model without oil extraction and the 40 million gallons ethanol model with oil extraction. To the corn-based ethanol production, larger industrial scale and oil extraction usage will be efficient strategies for both in investment and engineering.

References

- Ag Decision Maker. (2016, July). *Monthly Profitability of Ethanol Production*. Retrieved from <https://www.extension.iastate.edu/agdm/refirst.html>.
- Damodaran, A. (2012). *Investment valuation: Tools and techniques for determining the value of any asset* (Vol. 666). Hoboken, NJ: John Wiley & Sons.
- EIA (U.S. Energy Information Administration). (2016a). U.S. natural gas wellhead price. Retrieved from <http://www.eia.gov/dnav/ng/hist/n9190us3a.htm>.
- EIA (U.S. Energy Information Administration). 2016b. Average retail price of electricity to ultimate customers. Retrieved from <http://www.eia.gov/electricity/data.cfm#traderel>.

- Gallagher, P. W., Brubaker, H., & Shapouri, H. (2005). Plant size: Capital cost relationships in the dry mill ethanol industry. *Biomass and Bioenergy*, 28(6), 565-571.
- Hoffman, L. A. & A. Baker. 2011. Estimating the substitution of distillers' grains for corn and soybean meal in the U.S. feed complex, FDS-11-I-01. Washington, D.C: Economic Research Service, United States Department of Agriculture.
- The Jacobsen. (2016, July). *Distillers corn oil*. Retrieved from The Jacobsen Research database.
- Kawachale, N., & Kumar, A. (2011). Simulation, scale-up and economics of adsorption and membrane based processes for isoflavones recovery. *Chemical Engineering Research and Design*, 89(4), 428-435.
- Kwiatkowski, J. R., A. McAloon, F. Taylor, & D. B. Johnston. (2006). Modeling the process and costs of fuel ethanol production by the corn dry-grind process. *Ind. Crops and Products* 23: 288-296.
- Liu, K. & K. A. Rosentrater. (2011). *Distillers grains: production, properties, and utilization*. Boca Raton, FL: CRC Press .
- Misailidis, N., Campbell, G. M., Du, C., Sadhukhan, J., Mustafa, M., Mateos-Salvador, F., & Weightman, R. M. (2009). Evaluating the feasibility of commercial arabinoxylan production in the context of a wheat biorefinery principally producing ethanol: Part 2. Process simulation and economic analysis. *Chemical Engineering Research and Design*, 87(9), 1239-1250.
- McAloon, A., & W. Yee. (2011). *Ethanol plant model*. Wyndmoor, P.A.: USDA, ARS.
- National Agricultural Statistics Service (NASS). (2007). Ethanol co-products used for livestock feed. United States Department of Agriculture.
- Renewable Fuels Association. (2015). *2015 ethanol industry outlook: Going global: 2, 4 and 7*. Washington D.C.: Renewable Fuels Association. Retrieved from http://www.ethanolrfa.org/wp-content/uploads/2015/09/c5088b8e8e6b427bb3_cwm626ws2.pdf.
- Schnepf, R., & B. D. Yacobucci. (2013). *Renewable Fuel Standard (RFS): Overview and issues*. Retrieved from <http://www.epa.gov/otaq/fuels/renewablefuels/index.htm>.
- Tranmer, M., & Elliot, M. (2008). Multiple linear regression. *The Cathie Marsh Centre for Census and Survey Research (CCSR)*.
- Toumi, A., Jurgens, C., Jungo, C., Maier, B., Papavasileiou, V., & Petrides, D. (2010). Design and optimization of a large scale biopharmaceutical facility using process simulation and scheduling tools. *Pharmaceutical Engineering*, 30(2), 1-9.
- USDA (United States Department of Agriculture) (2016). *Fuel ethanol, corn and gasoline prices, marketing year*. Retrieved from <http://marketnews.usda.gov/portal/lg>
- Wood, C., Rosentrater, K. A., & Muthukumarappan, K. (2014). Techno-economic modeling of a corn-based ethanol plant in 2011/2012. *Industrial Crops and Products*, 56, 145-155.

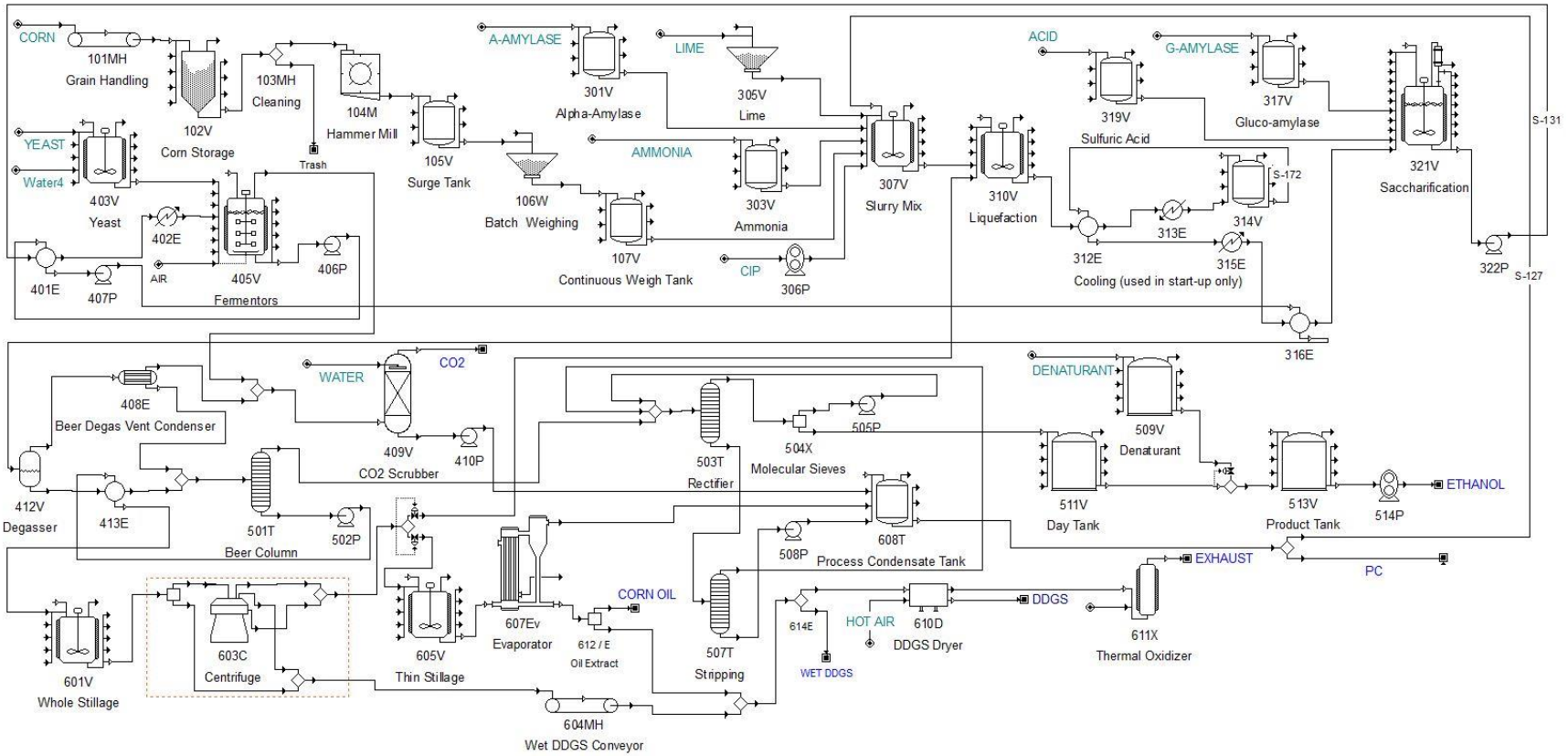

Figure 4.1. Process of flow diagram for 120 million gallons per year corn-based ethanol process.

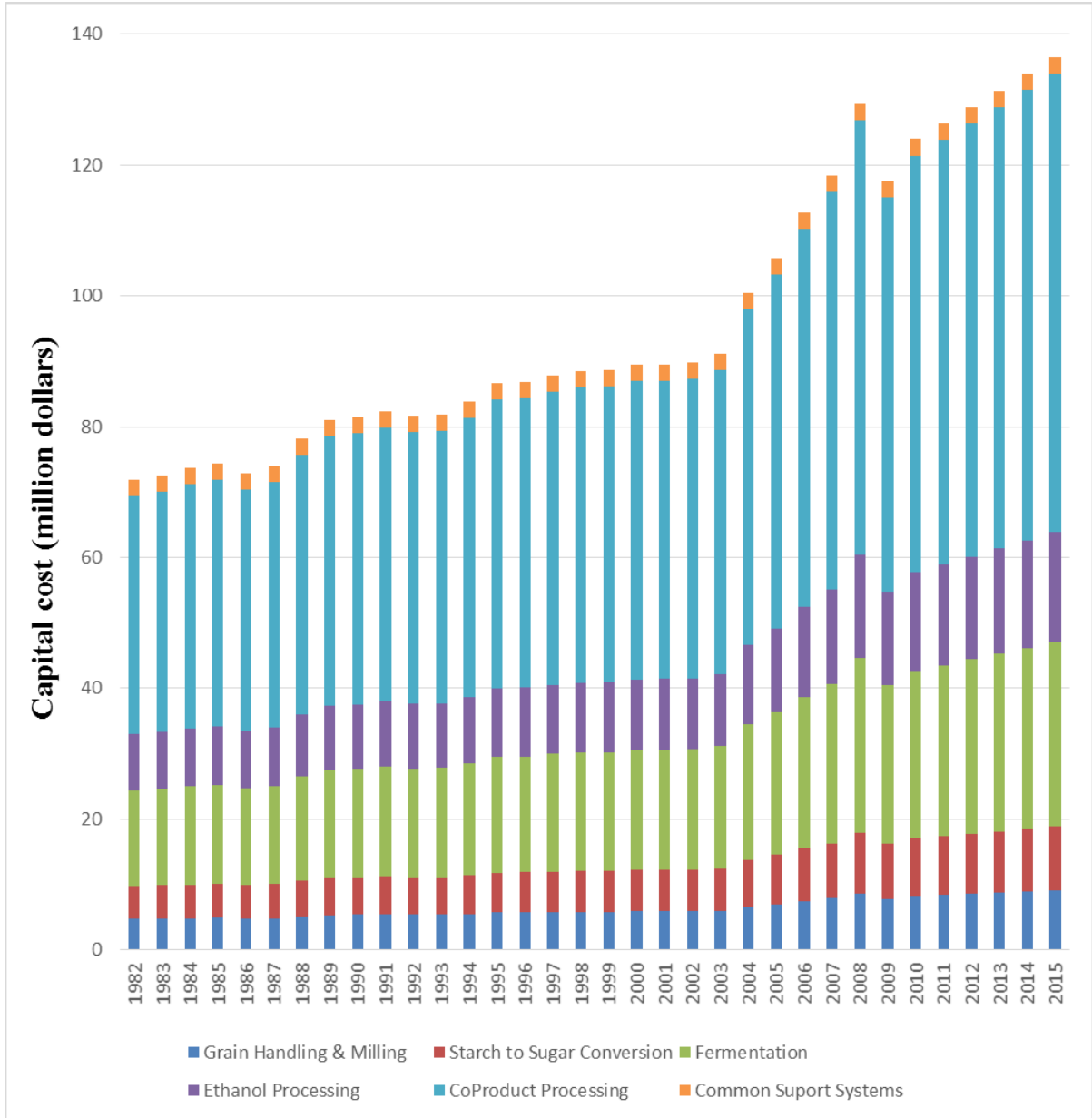

Figure 4.2a. Capital cost from 120 million gallons per year corn-based ethanol model without distillers corn oil.

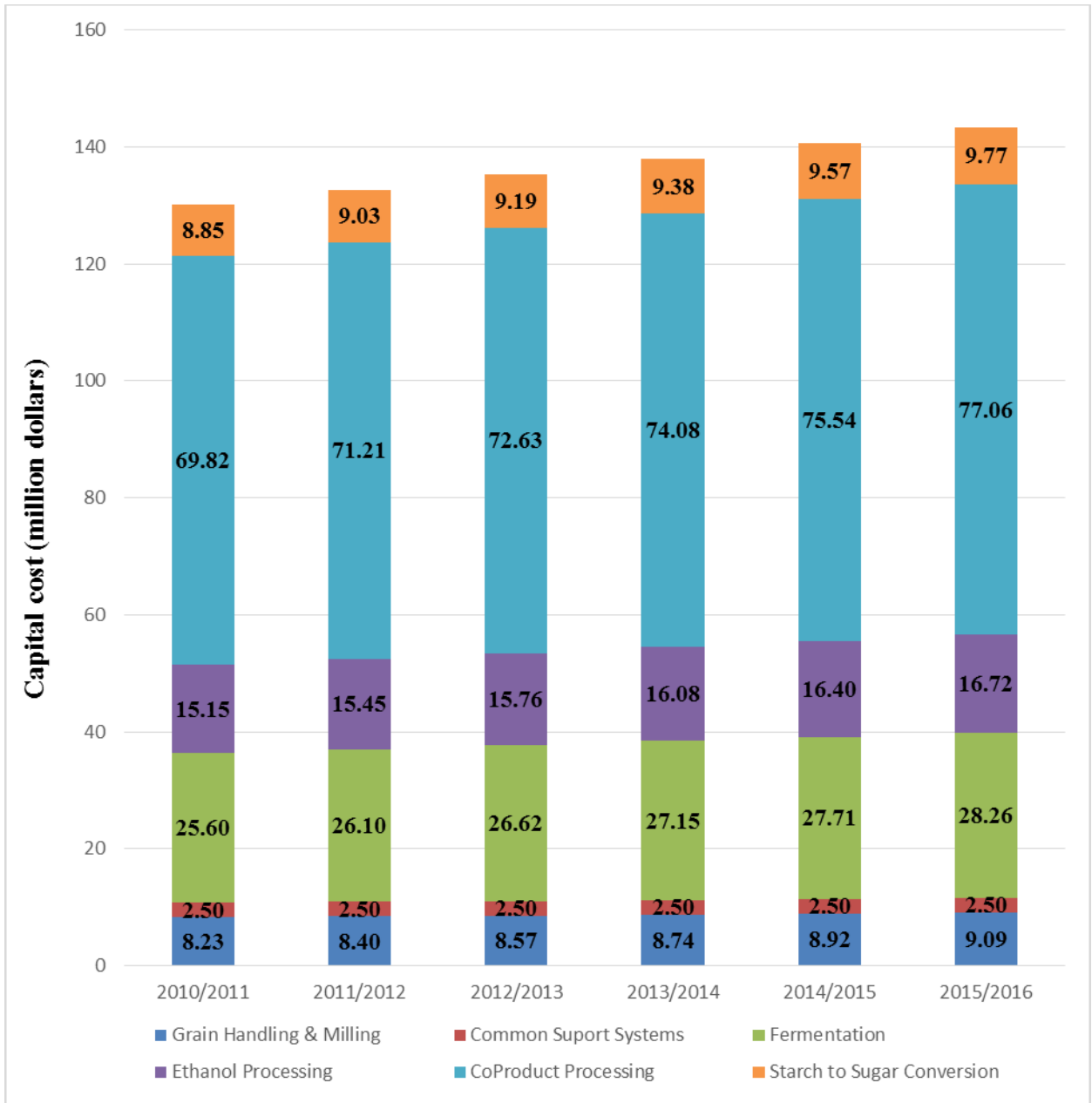

Figure 4.2b. Capital cost from 120 million gallons corn-based ethanol model with distillers corn oil.

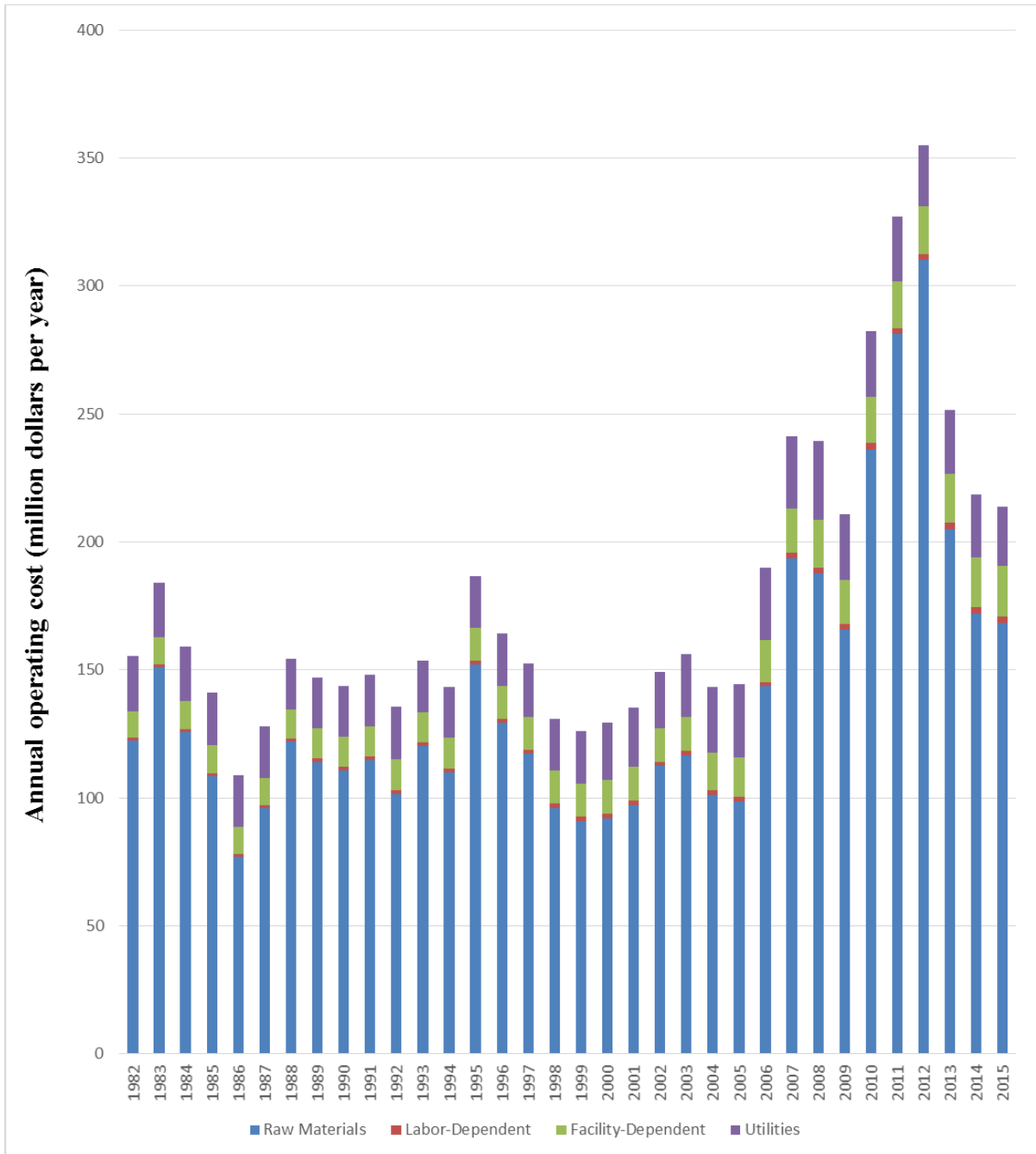

Figure 4.3a. Operating cost from 120 million gallons per year corn-based ethanol process without distillers corn oil.

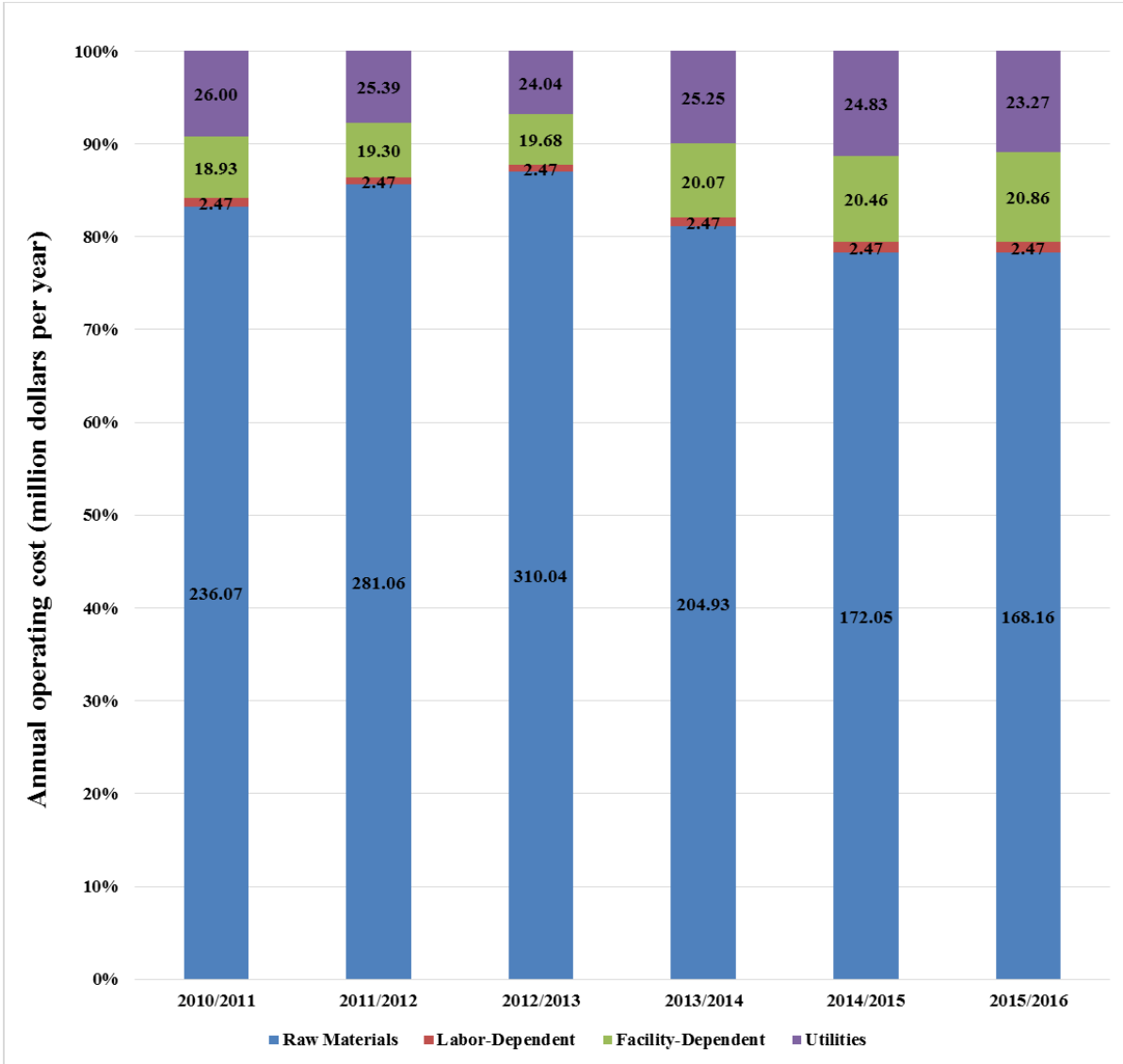

Figure 4.3b. Operating cost from 120 million gallons per year corn-based ethanol process with distillers corn oil.

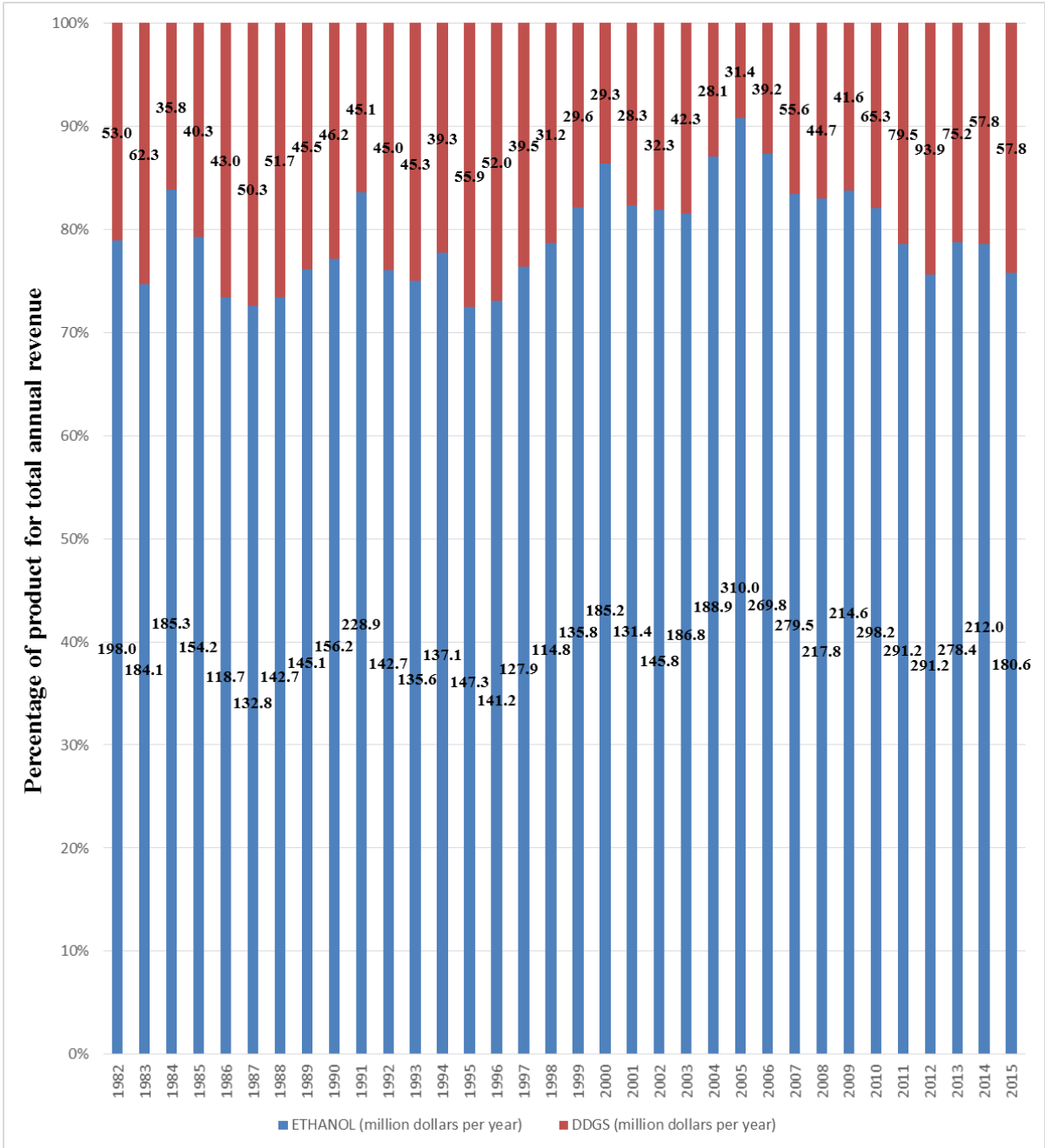

Figure 4.4a. Total annual revenue from 120 million gallons per year corn-based ethanol process without distillers corn oil.

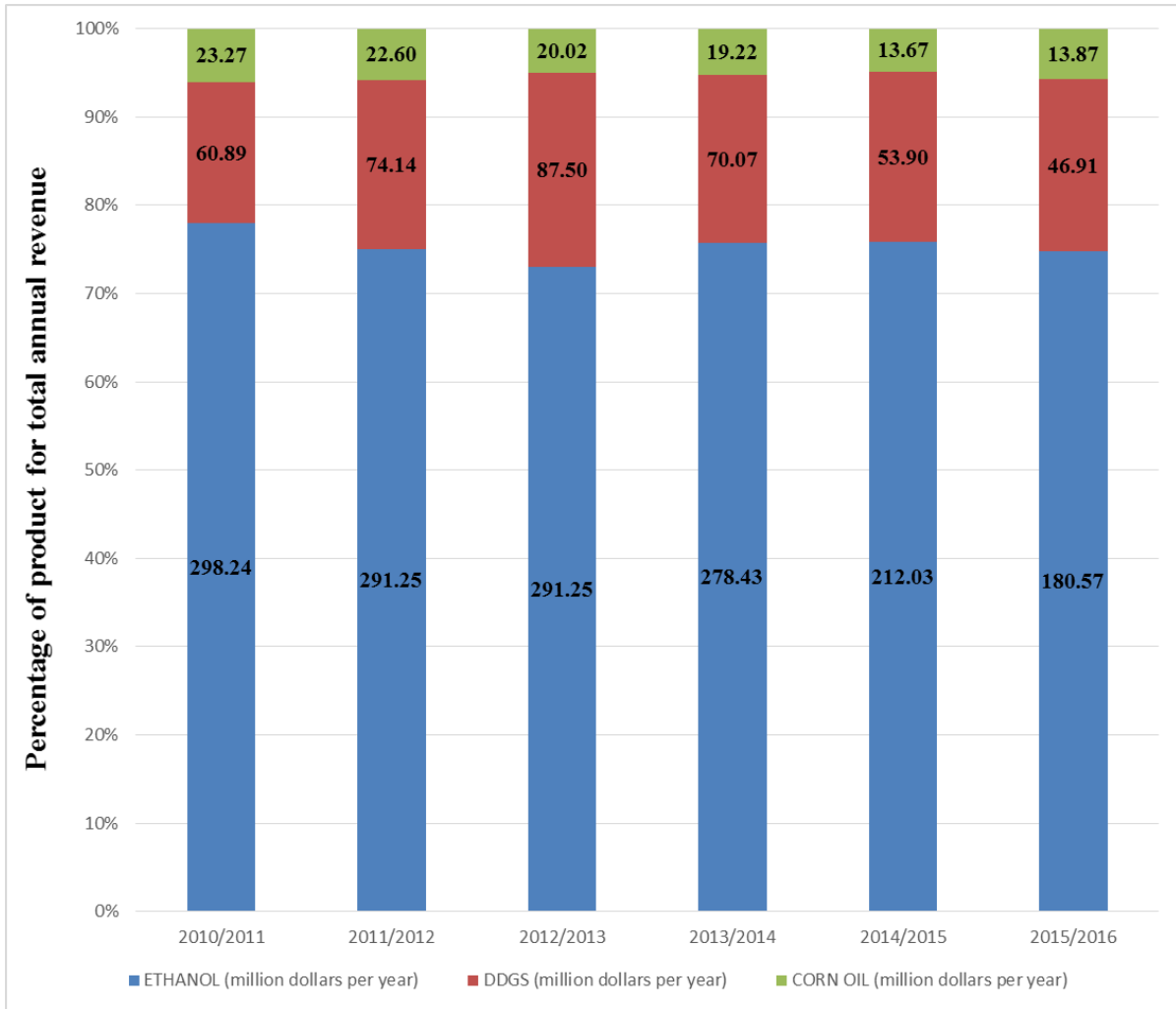

Figure 4.4b. Total annual revenue from 120 million gallons per year corn-based ethanol process with distillers corn oil.

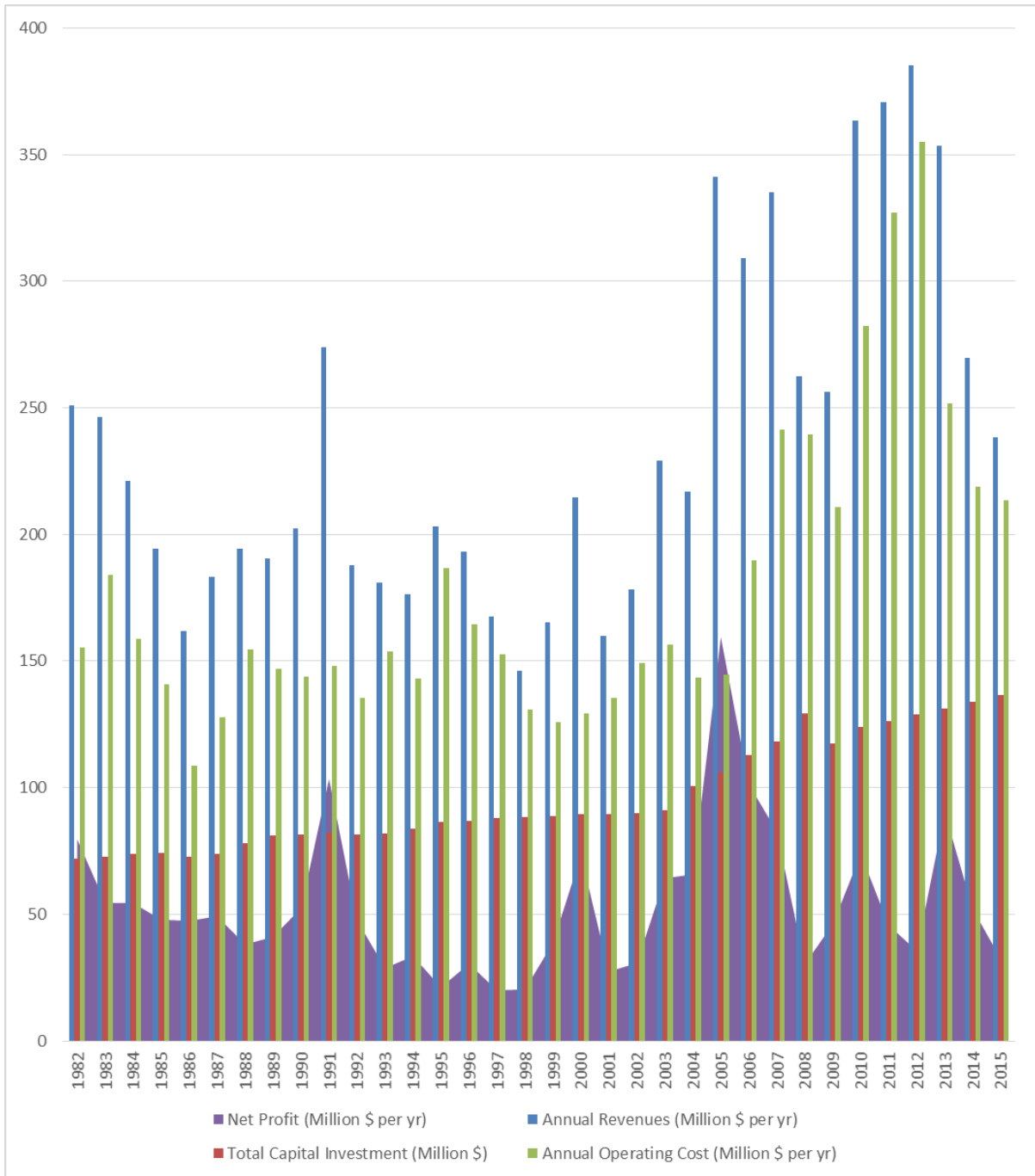

Figure 4.5. Gross operating margin from 120 million gallons per year corn-based ethanol process without distillers corn oil.

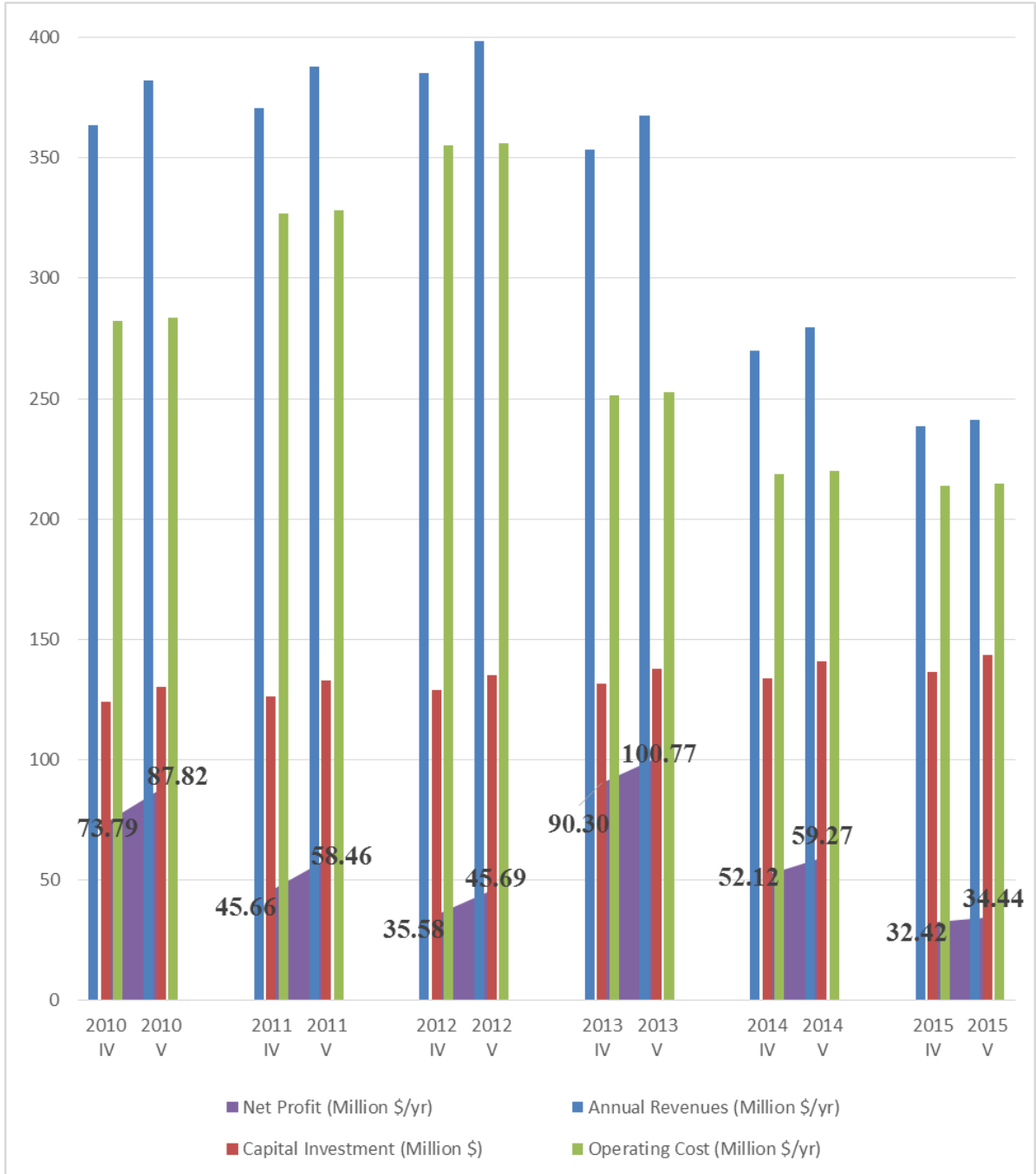

Figure 4.6. Gross operating margin from 120 million gallons per year corn-based ethanol process with oil extraction and no oil extraction (2010-2015).

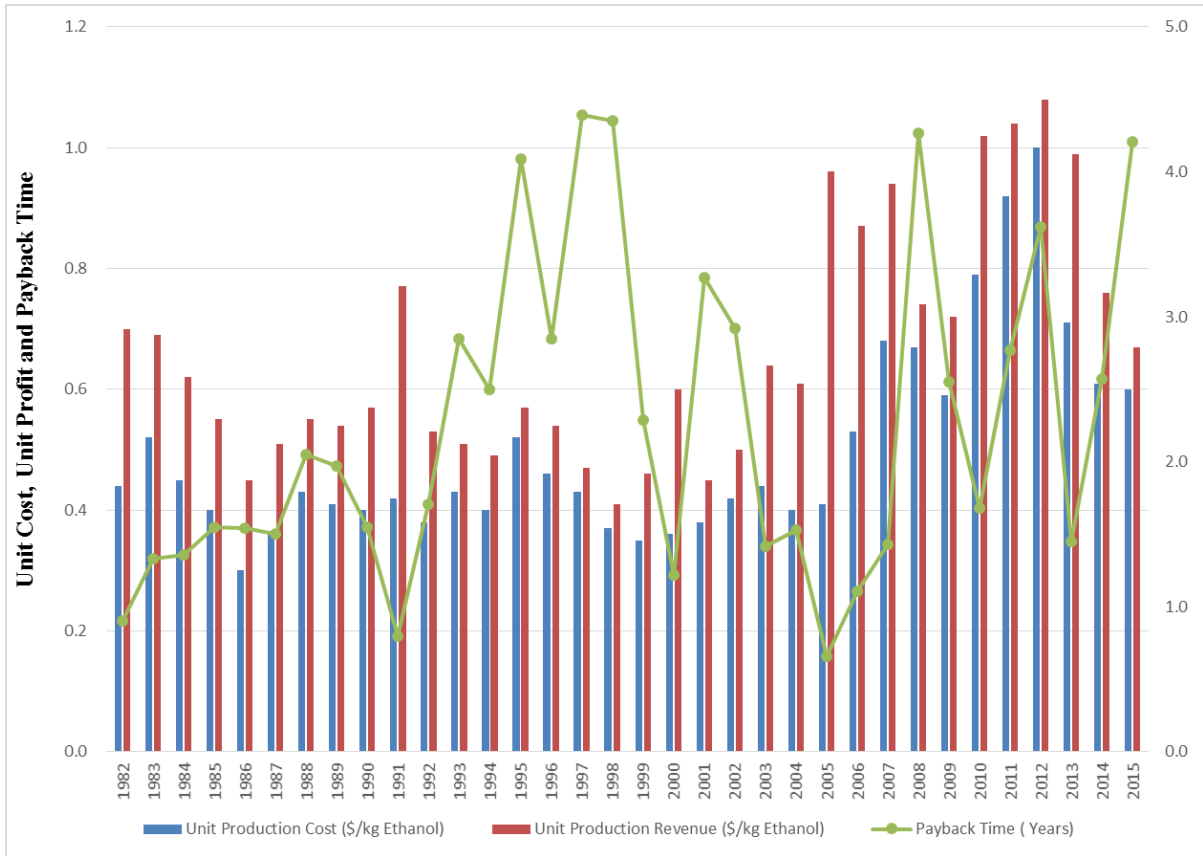

Figure 4.7. Unit production cost, unit production revenue and payback time from 120 million gallons per year corn-based ethanol process without DCO.

*The unit of unit production cost and unit production revenue are reflected on the left axes, and payback time is reflected on the right axes.

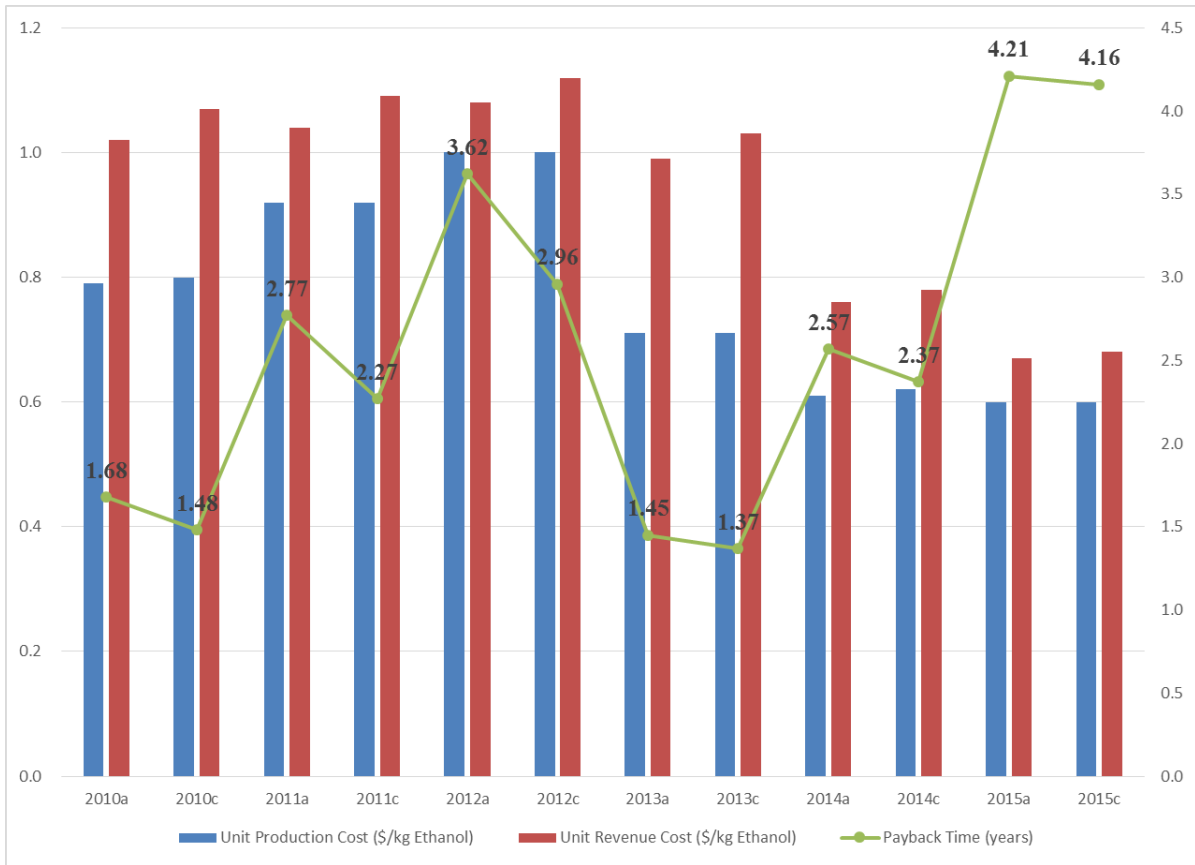

Figure 4.8. Unit production cost, unit production revenue and payback time from 120 million gallon per year corn-based ethanol process (2010-2015).

*The unit of unit production cost and unit production revenue are reflected on the left axes, and payback time is reflected on the right axes; a present scenario IV, and c present scenario V

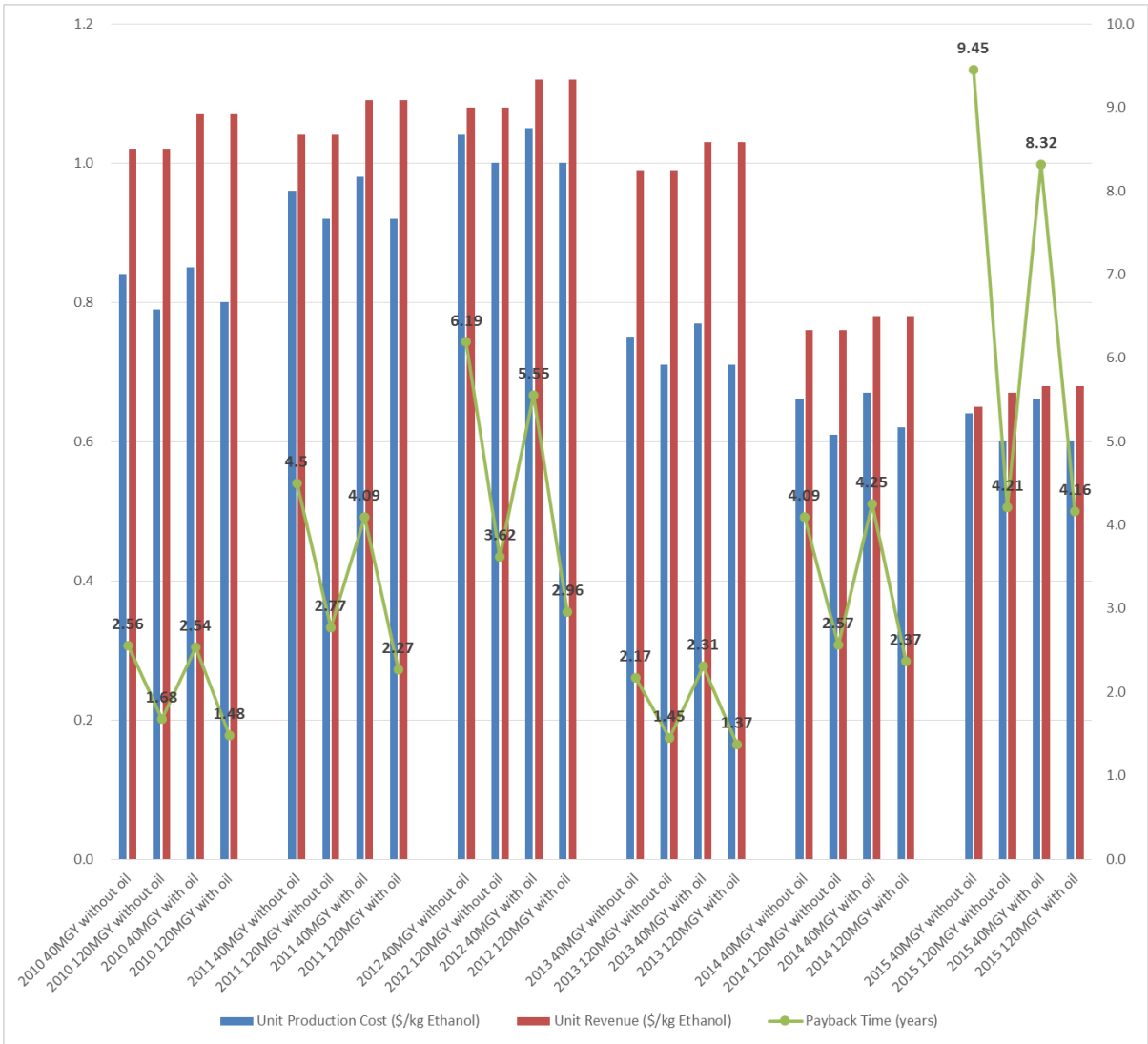

Figure 4.9. Unit production cost, unit production revenue and payback time for 40 and 120 million gallon corn-based ethanol process (2010-2015).

*The unit of unit production cost and unit production revenue are reflected on the left axes, and payback time is reflected on the right axes.

Table 4.1

Multiple Linear Regression for 120 Million Gallons Ethanol Process Without DCO ^{a,b}

Model		Unstandardized Coefficients		Standardized Coefficients	t	Sig.	Correlations
		B	Std. Error	Beta			Partial
1	Corn	-723.122	45.100	-1.495	-16.034	.000	-.945
	Ethanol	226.063	7.163	2.061	31.560	.000	
	DDGS	147.794	39.224	.328	3.768	.001	

a. This table was obtained from the data of Scenario IV, in which the dependent variable was profit and predictors were corn, ethanol and DDGS.

b. Linear regression through the no-intercept model. According to unstandardized coefficients, the model can be formulated as below:

$$\text{Profit} = -723.122 * \text{corn price} + 226.063 * \text{ethanol price} + 147.794 * \text{DDGS price}$$

Table 4.2

Multiple Linear Regression for 120 Million Gallons Ethanol Process with DCO^{a,b}

Model		Unstandardized Coefficients		Standardized Coefficients	t	Sig.	Correlations
		B	Std. Error	Beta			Partial
1	Corn	-721.533	275.588	-2.142	-2.618	.120	-.880
	Ethanol	245.562	170.250	2.645	1.442	.286	.714
	DDGS	138.065	409.361	.395	.337	.768	.232
	DCO	3.352	113.986	.042	.029	.979	.021

a. This table was obtained from the data of Scenario V, in which the dependent variable was profit and predictors were corn, ethanol, DDGS and DCO.

b. Linear regression through the no-intercept model. According to unstandardized coefficients, the model can be formulated as below:

$$\text{Profit} = -721.533 * \text{corn price} + 245.562 * \text{ethanol price} + 138.065 * \text{DDGS price} + 3.352 * \text{DCO}$$

CHAPTER 5: TECHNO-ECONOMIC ANALYSIS (TEA) OF INTEGRATED SOYBEAN BIOREFINERY PRODUCTS INTO CORN-BASED ETHANOL PRODUCTION

5.1. Introduction

As a renewable energy resource, ethanol worked as a partial replacement to gasoline fuel. It was harmless to the environments, made a contribution to the feed industry and provided energy security for U.S. agriculture (Alinia et al., 2010). In fact, the corn-based ethanol industry and related upstream and downstream industries were the most important portions of the U.S. ethanol industry, which has attempted various new technologies to increase economic feasibility. To obtain better efficiency and lower unit production, it was popular to combine the corn-based ethanol process with other product processes. If the biorefinery process made several types of products, it lowered costs for the combined products to produce together rather than separated. Oil refineries produced fuels and ingredients for an estimated 6,000 products, which had the potential to obtain 44 gallons of products from every 42-gallon barrel of crude oil. In the soybean oil extraction process, enzyme-assisted aqueous extraction processing (EAEP) was a new method to obtain oil, which used water as an extraction media to remove oil from ground soybeans.

Due to cell walls and pseudo-membranes around oil and protein bodies creating barriers to freeing oil and protein, EAEP utilizes the insolubility of oil in water and used water as a media to fractionate oil, protein and fiber. Enzymes were added to assist in breaking down cell walls (Lamsal et al., 2006). EAEP denatured proteins and destabilized the cream, which increased the final oil extraction yield to around 90% (Chabrand & Glatz,

2009). The enzyme in the skim was recycled in the extraction process, which enabled treated soy skim to be used as a water replacement in the corn-based ethanol process. In addition, soy skim worked as an effective nutrient source, which increased ethanol yield and the protein content in final coproducts (Yao et al., 2011; Yao et al., 2011). The high fiber content of soybean fiber from the extraction process was another advantage of EAEP, which was pretreated in oil extraction and directly used in saccharification for the next step in ethanol fermentation. During soybean EAEP, fiber fractions produced contained 60-70% moisture and the solids were mainly cellulose, hemicellulose and insoluble proteins.

Due to these advantages, combining EAEP with a corn-based ethanol processes became a possibility to improve the efficiency for producing ethanol. Sekhon et al (2015) finished lab scale research using coproducts from EAEP on ethanol production in dry grind corn fermentation. This study indicated that adding soy skim and untreated insoluble fiber from EAEP significantly increased ethanol production rates and ethanol yields.

Even though integrated corn-soybean fermentation was effectively used for corn-based ethanol production, it still faced a severe lack of economic information on efficiency and profit. It urgently needs more techno-economic analysis for combining corn and soybean biorefinery processes. The objective of this study was to use techno-economic analysis (TEA) for developing complete estimates of all costs associated with construction and operation of these types of systems, which included all capital and operational costs. In addition, this study compared integrated corn and soybean biorefinery with the original corn-based ethanol process in economic performance to explore the effect of new applications on the corn-based ethanol production under 40 and 120 million gallon ethanol scales.

5.2. Materials and methods

5.2.1. Computer model

Similar to previous research, SuperPro Designer v8.5 (Intelligen, Inc., Scotch Plains, NJ) was applied to conduct biofuels production with integrated corn and soybean biorefinery. This industrial design software facilitated modeling, evaluation and optimization of integrated processes in a wide range of industries (Ngo et al., 2015). Based on the structure and frame of an modified model (McAloon & Yee, 2011), this model was updated by adding the untreated insoluble fiber (UIF) and skim for integrated corn and soybean biorefinery. Due to the UIF and skim added as raw material, the energy and mass balances for the individual unit operations was reset, and the recycling index was also updated so the system obtained the mass and economic balances for the entire process.

The model of this study was designed with 330 working days per year to mirror the real industry process, which generally operates 24 hours per day year round. All annual calculations were based on these factors and were included in the range of reports available through the program. After setting basic data into the model, SuperPro produced a variety of reports based on simulation data changes on each scenario, and facilitated judging for economic feasibility of the model. These reports were produced and compared to estimate for each year scenario, and sensitivity to each affected factor. The design frame and structure of dry grind ethanol from corn processing is shown in Figure 5.1.

5.2.2. Simulation scenarios

Scenarios were updated and modified based on the basic corn-based ethanol process plant model, which was developed by McAloon and Yee (2011). Two scenarios were set below:

VI. Integrated EAEP with corn-based ethanol process producing 40 million gallons ethanol per year with distillers corn oil.

VII. Integrated EAEP with corn-based ethanol process producing 120 million gallons ethanol per year with distillers corn oil.

Based on the research of de Moure et al (2011), 75 kg of soybeans in the EAEP process produced 14.28 kg oil, 50.64 kg UIF and 363.81 kg skim. According to previous studies, Sekhon et al (2015) indicated maximum ethanol production was achieved when UIF and skim were mixed together with the rate of corn-to-UIF ratio 1:0.16 and skim-to-UIF ratio 6.5:1. To be appropriate for the scale of 40 and 120 million gallons ethanol production, the 75 kg per hour soybean pilot scale with EAEP process was scaled up to medium and commercial scales, which were 17 million and 51 million kg annual soybean oil production (Cheng et al., 2016). According to the study of Minghusn et al (2016), medium scale of EAEP produced UIF of 7596 kg per hour and soy skim of 54572 kg per hour; while commercial scale produced UIF of 22788 kg per hour and soy skim of 163716 kg per hour. After adding UIF and soy skim in the process, the ratio of water-to-solids in the fermenter increased from 2.0:1 to 2.5:1, which obtained optimal ethanol yield and maximum ethanol production (Sekhon et al., 2015; McAloon & Yee, 2011).

In this model, operating cost included raw material cost, labor cost, facility cost and utility cost. Corn, UIF and skim were the main resources for integrated EAEP with a corn-

based ethanol process, which made a significant contribution on raw material cost. The market price of corn was \$145.67 per metric ton, and untreated insoluble fiber was \$30.66 per metric ton in 2015 (USDA, 2016; Alibaba, 2016). The market price of soy skim was unavailable due to lack of data, and was generally disposed of as waste trash. In this model, the price of soy skim was treated as water with a price of \$0.04 per metric ton in 2015, and was mainly used to reduce the water requirement in the fermentation process (EIA 2016a). For the utility cost, steam was mainly utilized as a heat transfer agent, while natural gas and electricity were used as the energy resource. In this model, steam was set as \$12.86 per metric ton, while the industrial price of natural gas and electricity in 2015 was set as \$4.4533 per MBtu and \$0.0691 per kW·h (EIA, 2016a; EIA, 2016b). Labor cost and inflation rate were set according to data from the U.S. Department of Labor. Installation cost depended on various types of equipment. Loan interest was set at 7.0% per year as a common assumption.

Ethanol was the main product of the whole process, with DDGS and oil extracted from WDG treated as coproducts for revenue estimation. The market prices of ethanol (\$594.91 per metric ton) and DDGS (\$157.64 per metric ton) were collected from the USDA database in 2015. Corn distillers oil (\$611.32 per metric ton) from the oil extraction process was collected from The Jacobsen Company (The Jacobsen, 2016). In addition, physical property, material combination and other basic indices kept a similar level as the original corn-based ethanol model. Among profitability analysis, the unit production cost, unit production revenue, net profit and payback time were the most important results to explore between the two scenarios.

5.3. Results and discussion

5.3.1. Capital costs

In this chapter, the sum of capital cost was composed with the following individual process parts: grain handling and milling, starch to sugar conversion, fermentation, ethanol processing, coproduct processing and common support systems. For each individual process' capital cost, the final result was determined based on the equipment purchase price, a setting material factor by the model and an installation factor. For simplifying some indirect supported equipment, steam generation and cooling water equipment were not included in capital cost, and were treated as purchased utilities. All these settings were based on previous model data from McAloon and Yee (2011), which efficiently reflected the effect of new technology applications on the corn-based ethanol plant.

The effect each of these scenarios had on total capital are presented in Figure 5.2. The simulation data indicated the process of starch to sugar conversion decreased in the integrated EAEP with the corn-based ethanol model due to skim partially replacing the water requirement, and caused a decrease of reactor requirements. In contrast, the capital cost in fermentation, ethanol processing and coproduct processing increased, which was caused by more products produced with extra UIF and skim from EAEP. The total capital cost increased in 40 and 120 million gallon integrated EAEP with corn-based ethanol scales, which increased to 95.27 million and 162.78 million dollars. The coproduct processing took the largest portions of fixed capital costs in the 40 and 120 million gallon integrated EAEP.

5.3.2. Annual operating costs

Similar to the previous study, annual operating costs in this chapter consisted of labor, facility, utility costs and raw material costs in all three scenarios. In this model, consumables, advertising, running royalties and failed product disposal were not estimated in the techno-economic analysis. Due to added skim and UIF from the EAEP process, integrated EAEP with a corn-based ethanol process required more operating costs. The 40 and 120 million gallon integrated EAEP with corn-based ethanol scales required 86.71 million and 233.80 million dollars per year, which was around 8% more than other models (Figure 5.3). Differently from original corn-based ethanol models and corn-based ethanol with oil extraction processes, integrated EAEP with a corn-based ethanol process had lower portions of operating costs in raw material but higher rates in facility and utility. The reason for this was integrated EAEP with corn-based ethanol processes required higher liquid to solid condition in fermentation, which meant more DDGS was treated in coproduct processing.

5.3.2.1 Facility and labor costs

Similar to previous studies, the facility in this chapter was composed of maintenance cost, equipment depreciation, interest on debt, insurance, taxes, and other industrial expenses. Based on basic parameters set by McAllon and Yee (2011), maintenance expenses were determined as 3% of total capital costs, while insurance and other industrial expenses were set to 0.8% and 0.75% of the capital cost. Depreciation was set as an initial index and taxes were set as 24% because corn-based ethanol plants belonged to green & renewable energy and kept a lower tax rate than basic chemical industrial plants (Damodaran, 2012). A portion

of the facility in scenario VI was 15.98%, and the portion of the facility in scenario VII was 10.13% (Figure 5.3). Both scenarios were around 3% higher than other scenarios.

The cost of labor was determined based upon a lump estimate of number of working hours per year (330 day per year). The hourly wage for all 30 years was collected from U.S. Department of Labor minimum wage data, which did not change in the last 7 years (Index, 2012). This model multiplied the minimum wage by available workers and automatically created labor cost for all scenarios. Compared to other indexes of operating cost, labor cost was relatively stable in all scenarios, which was around 2% of total operating cost (Figure 5.3).

5.3.2.2. Material costs

Differently from the previous study, the material of integrated EAEP with a corn-based ethanol process included corn, water, yeast, caustic, lime, octane, ammonia, sulfuric acid, gluco-amylase, alpha-amylase, untreated insoluble fiber and skim from EAEP. All material prices were set with marketing prices of 2015. The simulation results are shown in Figure 5.4. Differently from other scenarios, untreated insoluble fiber made a significant contribution to the annual material cost in scenario VI and scenario VII. Instead, the corn portion cost was decreased in two scenarios, which was replaced by the coproduct from EAEP.

5.3.2.4. Utility costs

Similar to the previous study, utility costs were mainly from electricity, natural gas, steam, and chilled water. The price of electricity was set at \$0.0691 per KW·h, and natural

gas was set at \$4.4533 per MBtu (million British thermal unit). According to Figure 5.3, utility costs increased slightly in two scenarios, and was required to treat more DDGS coproduct. Due to the relatively stable rate of composition for utility, integrated EAEP with a corn-based ethanol process had a slight effect on the portion of utility in annual operation cost.

5.3.3. Annual revenues

In this chapter, annual revenues were defined as the total income from all the final products and coproducts, which included ethanol, distillers corn oil, and DDGS. The average corn price was \$594.91 per metric ton in 2015, and the average DDGS price was \$157.64 per metric ton in 2015 (USDA, 2016). According to data from the Jacobsen Company (2016), the marketing price of distillers corn oil was \$611.32 per metric ton in 2015 (Table 3.1).

5.3.3.1 Ethanol

During this model, ethanol was approximately 30% of the total mass weight produced annually by the ethanol process in all years, but contributed more than 70% of the total annual revenue in all scenarios. Compared with corn-based ethanol models and corn-based ethanol with oil extraction processes, scenario VI and scenario VII produced more ethanol than the similar scale, which was a 7.5% increase for ethanol production (Figure 5.5). The main reason for this increase was UIF supported more carbon sources for fermentation, and integrated EAEP with a corn-based ethanol process increased the ethanol yield and production.

5.3.3.2. DDGS

DDGS made up about 55% of the total mass weight produced by the ethanol plant. Price was determined by USDA data (2016). Comparing corn-based ethanol models and corn-based ethanol with oil extraction processes, the revenue of DDGS in scenario VI and scenario VII significantly increased, which was a 20% increase for DDGS annual revenue (Figure 5.5). The main reason for this increase was skim and UIF supplied more carbon sources and other indexes for DDGS production.

5.3.3.3. Distillers corn oil (DCO)

Similar to the previous study, oil extraction rates in this chapter were set as 80%, which was a reasonable rate for current industrial production. Compared to corn-based ethanol with an oil extraction process, the revenue of oil in scenario VI and scenario VII significantly increased, which was around a 23% increase for the oil annual revenue (Figure 5.5). The main reason was skim and UIF from EAEP processes supplied extra oil content, which ceased oil extraction from obtaining more oils from thin stillage.

5.3.5. Gross operating margins and payback time

Similar to previous study, gross profit was defined as the annual revenue minus the annual operating cost. The payback period was the length of time required to recover the cost of an investment. Gross operating margins are seen in Figure 5.6, which contains capital cost, operating cost, revenue, and profits in millions of dollars per year. Figure 5.6 clearly indicates scenario VI and scenario VII had higher amounts in capital investment and operating cost, which was directly affected by the extra skim and UIF from the EAEP

process. However, due to more resources for fermentation and coproduct processes, the integrated EAEP with corn-based ethanol process obtained more revenues from the higher amounts of ethanol, DDGS and distillers corn oil production. Scenario VI obtained \$23.33 million per year in the scale of a 40 million gallons ethanol model process, and scenario VII obtained \$77.17 million per year in the 120 million gallons ethanol model process scale. The results of net profit indicated that scenario VI and scenario VII had a better performance, while corn-based ethanol models with oil extraction also obtained more profit than the original corn-based ethanol process.

The annual operating cost and annual revenue were divided into one dollar per kg ethanol basis, which directly reflected the efficiency of how costs are related to each kilogram of ethanol produced by the plant. Unit production cost, unit production revenue and payback time are shown in Figure 5.7. Due to scale-up, the unit production cost decreased when increasing the scale. The integrated EAEP with corn-based ethanol process required more capacity of equipment and utility, causing the small increase of unit production. Due to the addition of UIF and skim from EAEP, unit production revenue increased with more ethanol and other coproducts. Payback time also indicated the integrated EAEP with a corn-based ethanol process had economic feasibility in industrial applications. In addition, larger scales owned a higher efficiency on unit production.

5.4. Conclusion

To perform economic calculations for integrated EAEP with a corn-based ethanol processes, SuperPro Designer was used for techno-economic analysis on the industrial scale application. According to the simulation results from the model, the integrated EAEP with

corn-based ethanol process required more capacity for equipment and utility, causing the small increase of unit production. Due to the addition of UIF and skim from EAEP, unit production revenue increased with more ethanol and other coproducts. Payback time also indicated the integrated EAEP with corn-based ethanol process had economic feasibility in industrial applications.

References

- Alibaba. (2016). *Alibaba.com*. Retrieved from untreated insoluble fiber: <http://www.alibaba.com/showroom/untreatedinsolublefiber.html>
- Alinia, R., Zabihi, S., Esmailzadeh, F., & Kalajahi, J. F. (2010). Pretreatment of wheat straw by supercritical CO₂ and its enzymatic hydrolysis for sugar production. *Biosystems Engineering* 107(1), 61-66.
- Chabrand, R. M., & Glatz, C. E. (2009). Destabilization of the emulsion formed during the enzyme-assisted aqueous extraction of oil from soybean flour. *Enzyme Microb. Technol.* 45, 28-35.
- Cheng, M. H., & Rosentrater, K. A. (2015). Techno-economic analysis of soybean oil expelling process from 1980-2014. In *2015 ASABE Annual International Meeting* (p. 1). American Society of Agricultural and Biological Engineers.
- Damodaran, A. (2012). *Investment valuation: Tools and techniques for determining the value of any asset* (Vol. 666). Hoboken, NJ: John Wiley & Sons.
- EIA (U.S. Energy Information Administration). (2016a). *U.S. natural gas wellhead price*. Retrieved from <http://www.eia.gov/dnav/ng/hist/n9190us3a.htm>.
- EIA (U.S. Energy Information Administration). (2016b). *Average retail price of electricity to ultimate customers*. Retrieved from <http://www.eia.gov/electricity/data.cfm#traderel>.
- Index, C. P. (2012). Bureau of Labor Statistics, U.S. Department of Labor. Washington, D.C. Retrieved from <http://data.bls.gov/cgi-bin/surveymost/>.
- Lucas, E. W., Lawhon, J. T., & Rhee, K. C. (1982). Producing edible oil and protein from oilseeds by aqueous processing. *Oil Mill Gazetteer*, 86, 28-33.
- Lamsal, B. P., Murohy, P. A., & Johnson, L. A. (2006). Flaking and extrusion as mechanical treatments for enzyme-assisted aqueous extraction of oil from soybeans. *J. Am. Oil Chem. Soc.*, 83, 973-979.
- McAloon, A., & Yee, W. (2011). *Ethanol plant model*. Wyndmoor, P.A.: USDA, ARS.

- Morrone, M. (2009). *Production process and technical change*. Cambridge, United Kingdom: Cambridge University Press.
- Ngo, H. L., Yee, W. C., McAloon, A. J., & Haas, M. J. (2014). Techno-economic analysis of an improved process for producing saturated branched-chain fatty acids. *Journal of Agricultural Science*, 6(10), 158.
- Sekhon, J. K., Jung, S., Wang, T., Rosentrater, K. A., & Johnson, L. A. (2015). Effect of co-products of enzyme-assisted aqueous extraction of soybeans on ethanol production in dry-grind corn fermentation. *Bioresource Technology*, 192, 451-460.
- The Jacobsen. (2016, July). *Distillers corn oil*. Retrieved from The Jacobsen Research database.
- USDA (United States Department of Agriculture) (2016). *Fuel ethanol, corn and gasoline prices, marketing year*. Retrieved from <http://marketnews.usda.gov/portal/lg>
- Yao, L., Wang, T., & Wang, H. (2011). Effect of soy skim from soybean aqueous processing on the performance of corn ethanol fermentation. *Bioresource Technology*. 120, 9199–9205.
- Yao, L., Lee, S. L., Wang, T., de Moura, J. M., & Johnson, L. A. (2012). Effects of fermentation substrate conditions on corn-soy co-fermentation for fuel ethanol production. *Bioresource Technology*. 120, 140–148.
- Yusoff, M. M., Gordon, M. H., & Niranjana, K. (2015). Aqueous enzyme assisted oil extraction from oilseeds and emulsion de-emulsifying methods: A review. *Trends Food Sci. Tech.*, 41, 60-82.

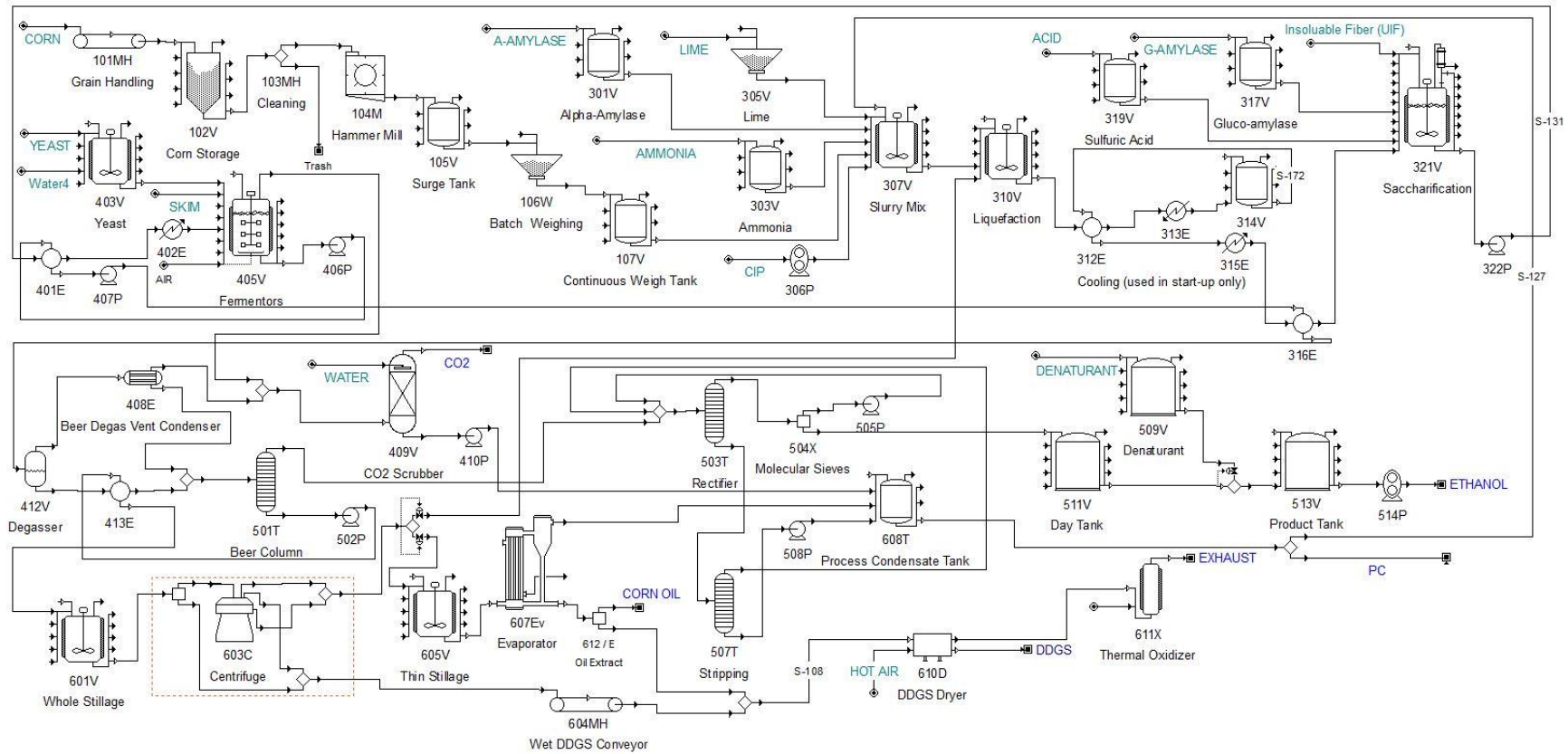

Figure 5.1. Process of flow diagram for EAEP integrated corn-based ethanol process.

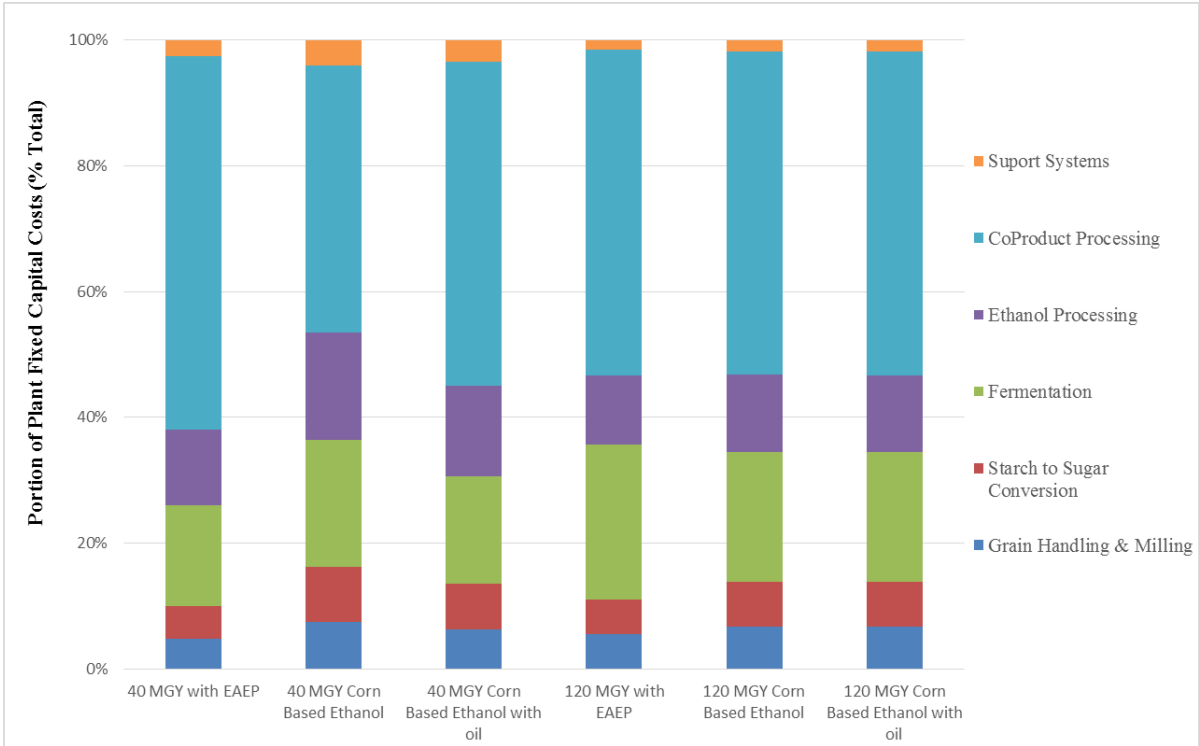

Figure 5.2. Capital cost from integrated EAEP with corn-based ethanol process.

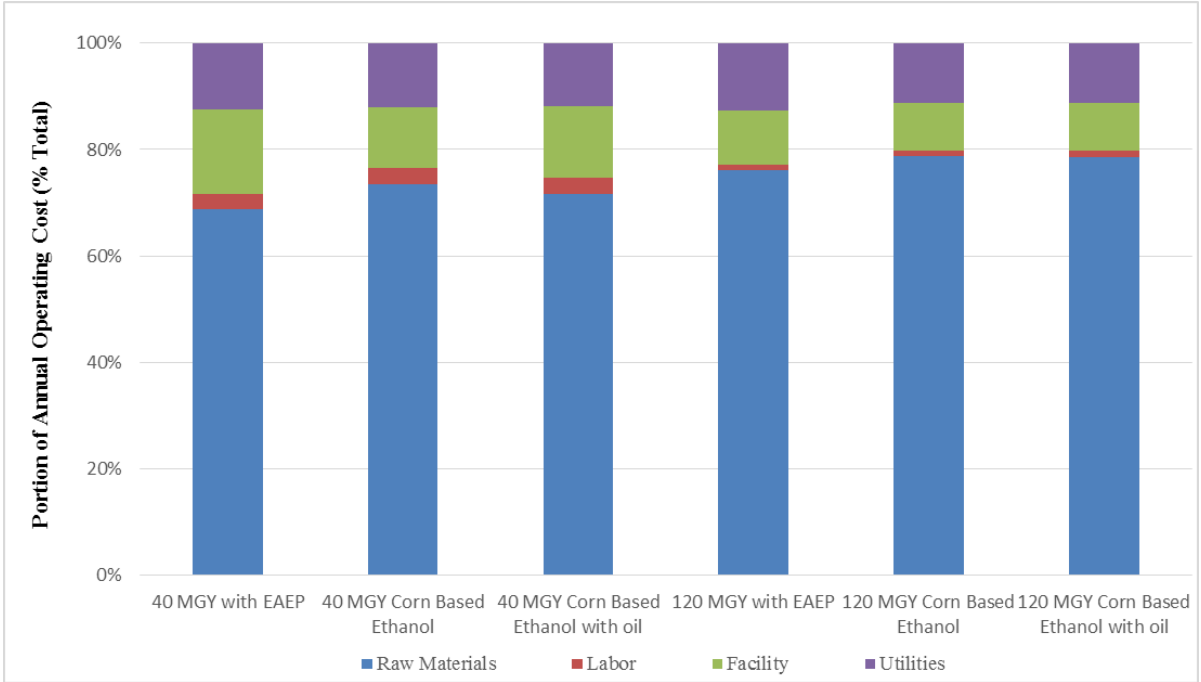

Figure 5.3. Operating cost from integrated EAEP with corn-based ethanol process.

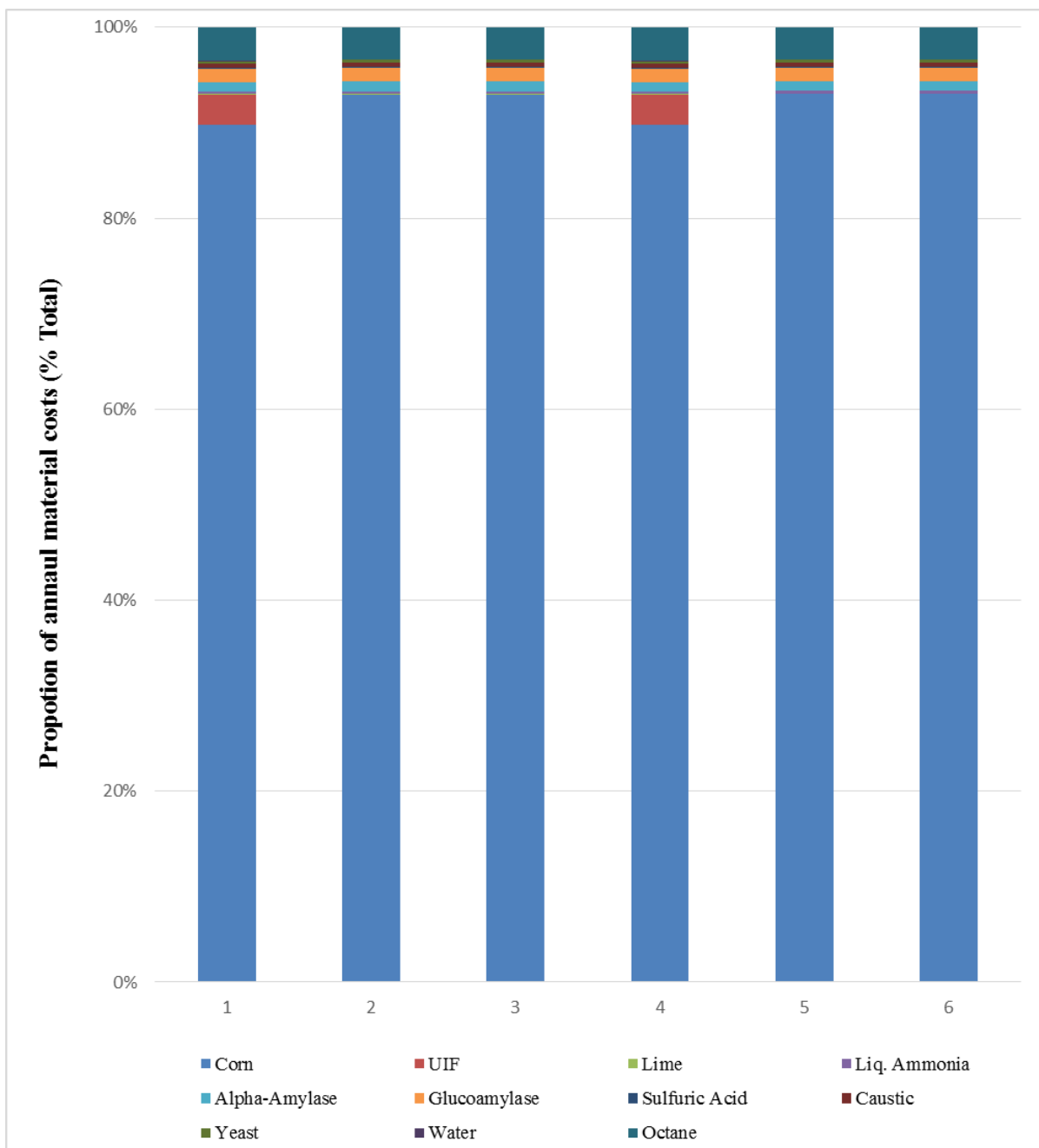

Figure 5.4. Material cost from integrated EAEP with corn-based ethanol process.

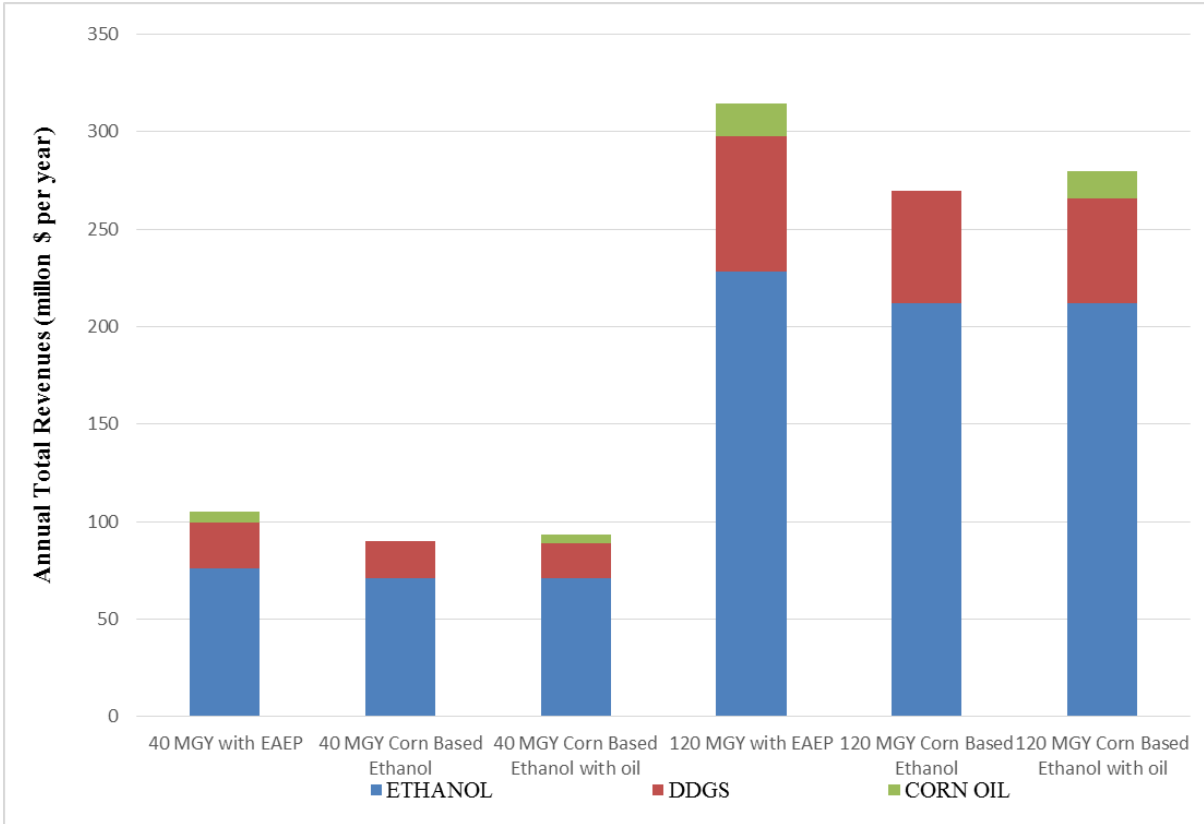

Figure 5.5. Annual total revenues from integrated EAEP with corn-based ethanol process.

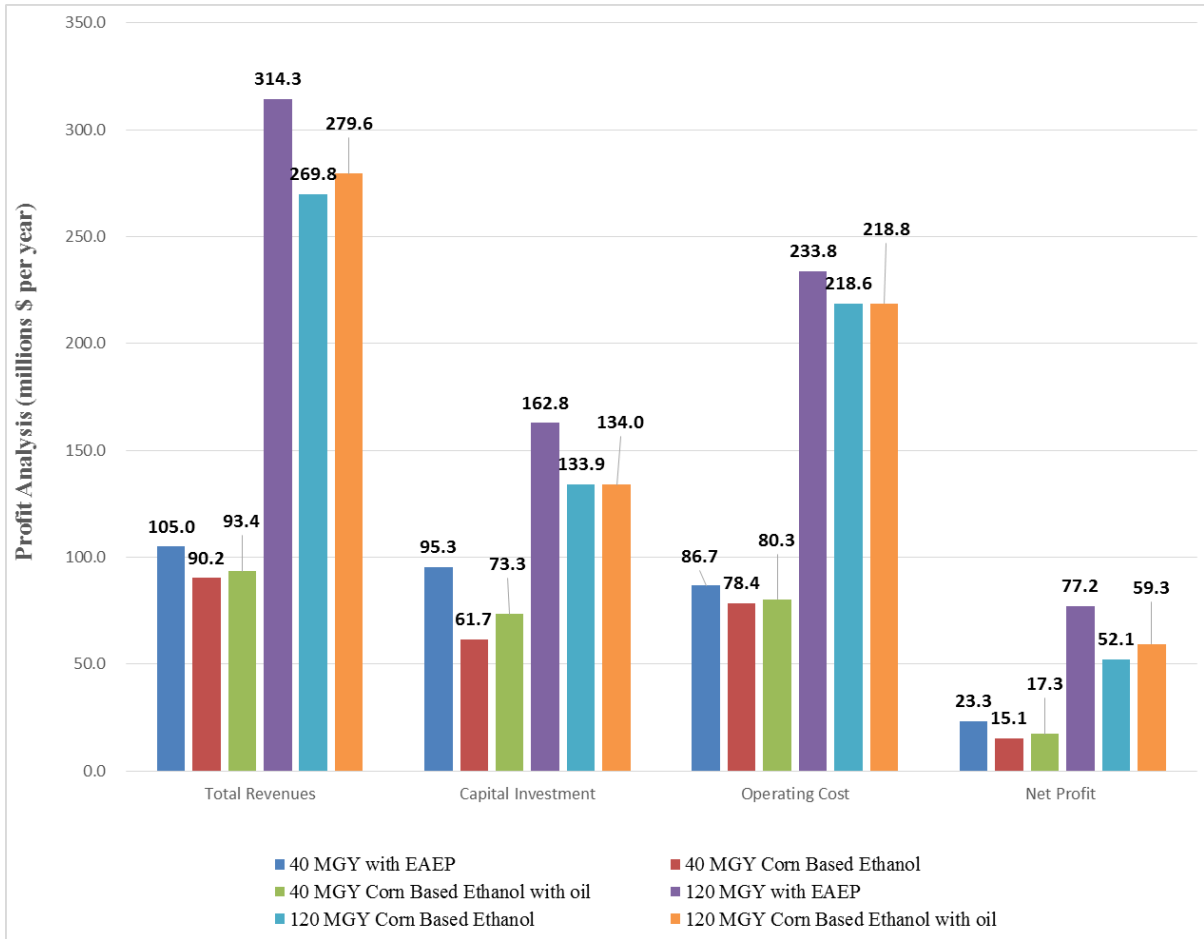

Figure 5.6. Profit analysis from integrated EAEP with corn-based ethanol process.

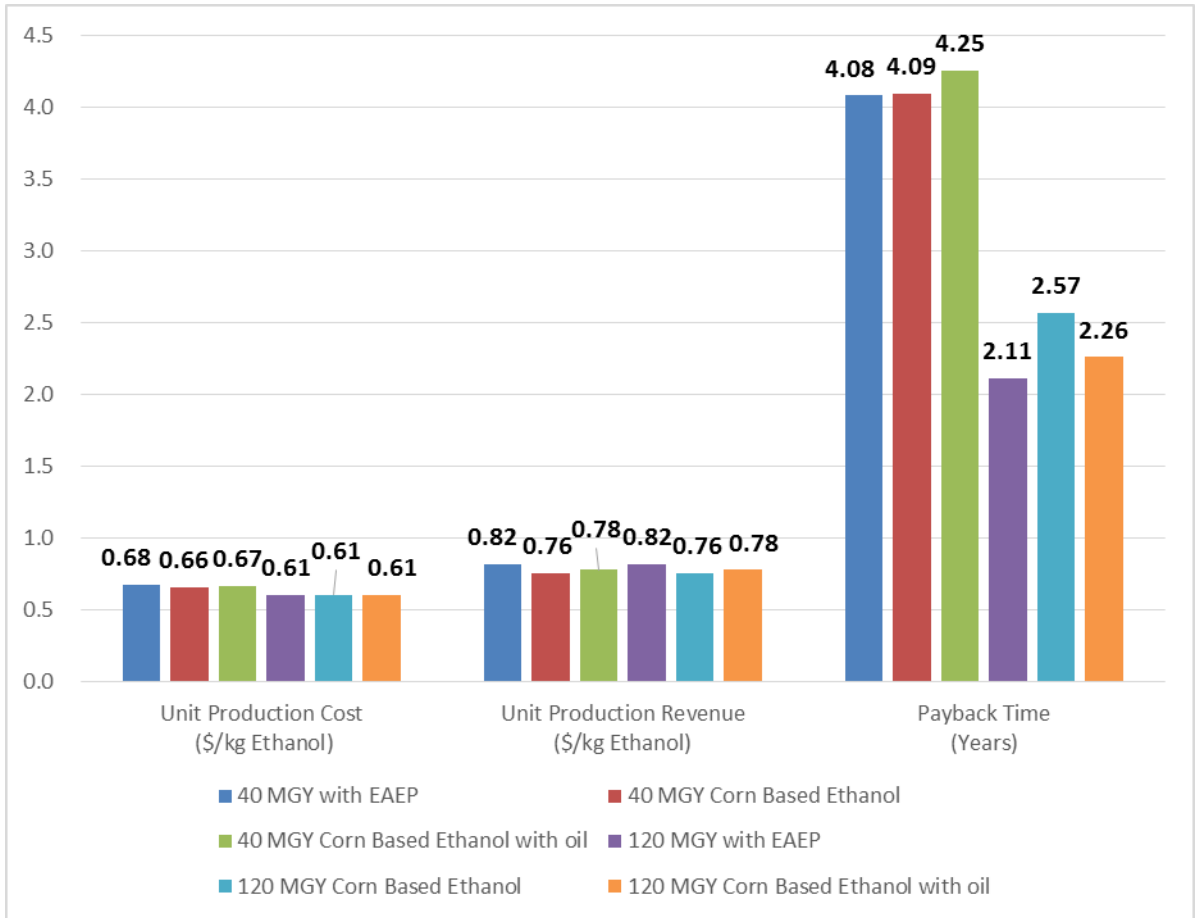

Figure 5.7. Unit analysis and payback time from integrated EAEP with corn-based ethanol process.

CHAPTER 6: ENVIRONMENTAL IMPACT ASSESSMENT (EIA) OF 40 AND 120 MILLION GALLONS CORN-BASED ETHANOL PLANTS

6.1. Introduction

As mentioned above, techno-economic analysis (TEA) is used as an efficient and important method to analyze corn-based ethanol processes. TEA compares a set of well-established processes with the factors of capital investment, operational cost, revenue, profits and payback time (Swanson et al., 2010). However, seeking economic feasibility is not a unique target for a corn-based ethanol simulation model. Environmental impacts to natural and societal environments should also be considered in the process model (Gomes, 2011). Similar to TEA as an evaluation method, environmental impact assessment (EIA) is the formal process used to assess the potential environmental impact of a proposed plan, policy, program, or project, and includes an assessment of both short and long term effects on the natural and social environment (Madu, 2001). The main purpose of an environmental impact assessment is to help decision makers consider environmental values and justify decisions according to simplified environmental assessment and public comments on the potential environmental impacts. EIA contains several assessments to quantify the energy, materials, products, wastes and pollutants flow during the producing process (Gomes, 2011; Holder, 2004). In fact, EIA has been widely used to estimate energy consumption and pollutant emissions during biorefinery processes, which are related to chemical processes, industrial applications and oil extractions. (Salomone & Ioppolo, 2012; Heinzle et al., 1998).

Estimating environmental impact has become a popular topic with the rapid development of bioethanol industry. By collecting data from the simulation model, the environmental impact assessment was completed for a simplified dry grind ethanol from corn process (McAloon et al., 2000; Taylor et al., 2000). In addition, the Organization for Economic Co-operating and Development (OECD) suggested the results of EIA could be utilized as an important index to assess the sustainability of industrial processing (OECD, 2001). However, few studies focused on the environmental impact assessment of new technology application in the corn-based ethanol industry, especially comparing the environmental effect of different final products. This study mainly focused on comparing the environmental impacts between the existing corn-based ethanol process and two modified bioethanol processes. In addition, the mass flow including raw materials usage, main product (ethanol), coproducts (DDGS and crude oil) and waste were also investigated in this chapter.

6.2. Materials and methods

6.2.1. Methodology

Figure 6.1 illustrates the simplified structure of the environmental assessment method used in this chapter. This method was mainly composed of two aspects: mass index (MI) and environmental factors (EF), which were calculated and evaluated for all input and output components. For input materials, the MI showed how much of a component was consumed to produce a unit of the main product. For the output component, MI indicated how much of a component was formed per unit main product. The sum of all input or output MI determined the mass index of the process. Due to the different environmental relevance of each component, defining the degree and effect of each component became the next step to the

assessment. The method used in this chapter separated input and output in 15 impact categories. For each category a component was allocated to the class A, B or C, which represented the effect of high, medium and low relevance on the environment. For a multiplying system, class A, B and C represented the values of 4, 1.3 and 1, respectively. The values of 1, 0.3 and 0 were defined for class A, B and C of an averaging system (Heinzle et al., 2007). All related equations were shown below:

$$EF_{\text{mult}} = \prod_1^j G_j \quad (6.1)$$

$$EF_{\text{mv}} = \frac{G_1 + G_2 + G_3 + G_4}{j} \quad (6.2)$$

$$MI_{p, \text{in}} = \sum_1^i \frac{m_i}{m_p} \quad (6.3)$$

$$MI_{p, \text{out}} = \sum_1^i \frac{m_i}{m_p} - 1 \quad (6.4)$$

$$EI_i = EF_i \times MI_i \quad (6.5)$$

$$EI_p = \sum_1^i EI_i \quad (6.6)$$

$$GEI = \frac{EI_p}{MI_p} \quad (6.7)$$

After defining the impact categories, this method combined these categories into six impact groups, each of which represented an important field for environmental, human health or safety aspects. The next step was to link the amount of components in the mass balance with the potential environmental impact by multiplying their MI with their EF, which was defined as environmental index (EI). The EI of the process was the summation for all EIs, which can represent the environmental relevance of all projects. The general effect impact

(GEI) was defined by the ratio of EI_p to MI_p , which indicated a weighted average effect of all components on the environment.

6.2.2. Components classification

For environmental groups, input components included resources, grey input, component risk and organisms; while output components included component risk, organisms, air and water/soil. The details about the impact categories and impact groups are shown in Figure 6.2. The components classification was defined with three classifications (A, B and C), which were determined by the level of environmental impact caused by each component in the process. Table 6.2 shows details regarding how to judge classification levels (Heinzle et al., 2007).

6.2.3. Environmental impact

The environmental impacts were based on input and output components, and these indexes were also calculated by mass balance of the process. Because the corn-based ethanol process is complicated, mechanical and chemical processes were considered for various sections. In this chapter, the EIA boundary was set as the whole ethanol and DDGS producing process and did not include steam generation equipment, cooling water equipment, corn harvest, transportation and final product transportation. The basic mass data was simulated and collected from the three models in chapters 3 and 5, which included a series of chemical components, mixture and resource databases. The mass data of basic corn-based ethanol process and the modified process with oil extraction were based on research from chapter 3, while the mass data of integrated EAEP with a corn-based ethanol process was

collected from chapter 5. The input components, output components and the main product are shown in Table 6.1 with their quantity, which was the basic data for environmental indices calculations.

6.3. Results and discussion

6.3.1. Input components

6.3.1.1. Classification of impact groups and categories

Results for the classification of impact groups and categories for input components are shown in Table 6.3. The content of three corn-based models was similar, and included corn, water, hot air, alpha-amylase, gluco-amylase, yeast, sulfuric acid, liquid ammonia, lime, caustic and octane. Only integrated EAEP with a corn-based ethanol process added untreated insoluble fiber and skim as input content. Corn, water and air were generally considered as noncritical compounds involved, which caused them to belong to class C. Through alpha-amylase, gluco-amylase and yeast did not contain critical compounds, all required more than three steps to synthesize, which caused them to belong to class B for grey input. Due to the property of sulfuric acid, it belonged to class B in most impact categories, except on chronic toxicity, which was in the range of class A. Caustic was mainly composed of NaOH, and lime was composed of calcium carbonate. Owing to the application of NaOH led to acute toxicity and was allocated into class B due to its R-phrase of 35 (Sodium Hydroxide, 2016). Ammonia and octane obtained similar conditions so both belonged to class B. The protein and oil in untreated insoluble fiber, caused it to allocate to class B on raw material and complexity synthesis. The skim was used as a water replacement and was treated as the water property.

6.3.1.2. Environmental impact indices of input components

According to calculations of the mass index for each component, results in Figure 6.3 reflected the conditions of materials' applications for each process. The corn-based ethanol with oil extraction process was slightly lower than corn-based ethanol without extraction caused by the small change in air usage. Integrated EAEP with corn-based ethanol processes had the highest mass index among these three processes because large amounts of skim and UIF were added to make the fermentation condition optimal.

Based on calculations of EF and MI, the results of two systems (multiplying and averaging) are shown in Figure 6.4 and Figure 6.5. Integrated EAEP with corn-based ethanol process had the highest EI in both calculation systems. The usage of water in integrated EAEP with a corn-based ethanol process decreased. Large amounts of skim worked as a water replacement, causing the environmental impact of input components to increase. Optimal conditions for integrated EAEP with corn-based fermentation required more water, which increased the air usage to treat coproducts like DDGS.

As the EI of each component was calculated, the GEI was obtained and regarded as the index for evaluating the environmental impact potential for the process. According to the results (Figure 6.6), integrated EAEP with a corn-based ethanol process had the highest general impact potential than others in both systems. For the corn-based ethanol with oil extraction process, the impact potential was almost the same as original corn-based ethanol, which was slightly lower than the former. Compared to oil extraction technology, combining the EAEP process had a more significant effect on the input component to environmental impact for a corn-based ethanol system. Though new technology increased the negative

effects, all three models kept a relatively low effect on the environment. For example, the results of the chemical process for producing 6-aminopenicillanic from penicillin G was $GEI_{(Mult)}$ 5.7 and $GEI_{(Mv)}$ 0.36, which was seriously higher than the three ethanol models. Even compared to the soybean oil extraction process, the input component GEI of integrated EAEP with a corn-based ethanol process was equal to the level of expelling and EAEP process, which was much lower than the hexane process.

6.3.2. Output components

6.3.2.1. Classification of impact groups and categories

Results of the classification of impact groups and categories for output components are shown in Table 6.4. Due to the similar structure and frame of model simulating, the main product of all three models was ethanol, the main coproduct was DDGS, and exhaust and CO_2 were considered the waste. In addition, oil was the final output for corn-based ethanol with oil extraction and integrated EAEP with a corn-based ethanol process. Carbon dioxide directly affected global warming, which was determined by class B in impacted groups of air. Ethanol existed in process condensate (PC), causing a B classification determined in the impact categories of thermal risk and acute toxicity. Exhaust was mainly composed of air and water steams, which caused all categories to belong to class C. With very small amounts of acid existing in DDGS, it was judged as class A or class B for component risk and organisms. Checking the property of distillers corn oil, a class B was determined on thermal risk and acute toxicity.

6.3.2.2. Environmental impact indices of output components

Products, coproducts and wastes produced by each process and the mass index of output components are shown in Figure 6.7. DDGS was the main coproduct of all three models, and oil was another important coproduct for corn-based ethanol with oil extraction and integrated EAEP with corn-based ethanol processes. In addition, exhaust and CO₂ made an important contribution on the mass index considered. Due to the change of water or skim usage, more air was required to treat DDGS for drying, which caused significant increases in the exhaust as an output component.

Based on the calculations of EF and MI, the results of two systems (multiplying and averaging) are shown in Figure 6.8 and Figure 6.9. Integrated EAEP with a corn-based ethanol process still had the highest EI in both calculation systems. However, the difference between the two systems was evident. The reason was the components without environmental impacts were also considered in the environmental impact multiplying system. As the most important output component in quantity, exhaust made an important contribution on the multiplying system with the effects of multiplying expanding. Whereas, exhaust had no environmental impact effect on an average system, causing DDGS to make a significant contribution on total environmental impact. This result illustrates why this study chose two systems to assess the environmental impact, to avoid any one component in final output to determine the total environmental impact of the process.

As the EI of each component was calculated, the GEI was obtained and used to evaluate the environmental impact potential for the process. According to the results (Figure 6.10), GEI of integrated EAEP with corn-based ethanol processes had the lowest value in both systems, which was 1.254 in multiplying systems and 0.038 in average systems. The

value of corn-based ethanol with an oil extraction process was slightly lower than original corn-based ethanol in both systems. This means corn-based ethanol with oil extraction and combinations with EAEP products helped decrease the effect on the output component to the environment. All of these results indicated oil extraction processes helped the bioethanol industry decrease the negative effects of environmental impact. Combination of the products from EAEP with a corn-based ethanol process further decreased the negative effect on the environment, and supplied environmental feasibility to utilize this application in industry.

6.4. Conclusion

From the results of the environmental impact, the corn-based ethanol industry was considered an environmental friendly industry, and corn-based ethanol with oil extraction processes had the best performance on the input component to environment. In addition, integrated EAEP with a corn-based ethanol process had the best performance on the output component to environment. This study explored the environmental feasibility of oil extraction and integrated EAEP with corn-based ethanol processes in an industrial application.

References

- Budavari, S., O'Neil, M. J., & Smith, A. (1989). *The Merck Index: An encyclopedia of chemicals, drugs and biologicals*. Rahway, NJ: Merck and Co.
- Castells, F., Aelion, V., Abeliotis, K. G., & Petrides, D. P. (1994). Life cycle inventory analysis of energy loads in chemical processes. In *AIChE Symposium Series* (pp. 161-161). American Institute of Chemical Engineers.
- Derwent, R. G., Jenkin, M. E., & Saunders, S. M. (1996). Photochemical ozone creation potentials for a large number of reactive hydrocarbons under European conditions. *Atmospheric Environment*, 30(2), 181-199.

- Derwent, R. G., Jenkin, M. E., Saunders, S. M., & Pilling, M. J. (1998). Photochemical ozone creation potentials for organic compounds in northwest Europe calculated with a master chemical mechanism. *Atmospheric environment*, 32(14), 2429-2441.
- Elliott, A. D., Sowerby, B., & Crittenden, B. D. (1996). Quantitative environmental impact analysis for clean design. *Computers & Chemical Engineering*, 20, S1377-S1382.
- Elvers, B. (1989). *Ullmann's encyclopedia of industrial chemistry* (pp. 173-174). S. Hawkins, & W. Russey (Eds.). Weinheim, Germany: Verlag Chemie.
- Gomes, L., Troiani, E. P., & Nozaki, J. (2011). Analysis of the environmental impact on a stream: Is only tannery to blame. *Environmental Monitoring and Assessment*, 173(1-4), 489-498.
- Haas, M.J., McAloon, A., Yee, W. C., & Fog, T. A. (2006). A process model to estimate biodiesel production costs. *Bioresource Technology*, 97: 671-678.
- Heinzle, E., Biwer, A. P., & Cooney, C. L. (2007). *Development of sustainable bioprocesses: Modeling and assessment*. Hoboken, NJ: John Wiley & Sons.
- Holder, J. (2004). *Environmental assessment: The regulation of decision making*. New York, NY: Oxford University Press.
- Houghton, J. T., Ding, Y. D. J. G., Griggs, D. J., Noguer, M., van der Linden, P. J., Dai, X., & Johnson, C. A. (2001). *Climate change 2001: The scientific basis*. Cambridge, United Kingdom: The Press Syndicate of the University of Cambridge.
- Jensen, A. A. (1998). *Life cycle assessment (LCA): A guide to approaches, experiences and information sources* (No. 6). European Communities.
- Kwiatkowski, J. R., McAloon, A., Taylor, F., & Johnston, D. B. (2006). Modeling the process and costs of fuel ethanol production by the corn dry-grind process. *Ind. Crops and Products* 23: 288-296.
- Madu, C. N. (2001). Life cycle assessment. In *Handbook of environmentally conscious manufacturing* (pp. 385-416). New York, NY: Springer US.
- McAloon, A., Taylor, F., & Yee, W. (2000). *Determining the cost of producing ethanol from corn starch and lignocellulosic feedstocks*, NREL Report TP-580-28893. Golden, CO: National Renewable Energy Laboratory.
- OECD. (2001). *OECD environmental indicators: Toward sustainable development*. Paris, France.
- Swanson, R. M., Satrio, J. A., Brown, R. C., Platon, A., & Hsu, D. D. (2010). *Techno-economic analysis of biofuels production based on gasification*. Golden, CO: National Renewable Energy Laboratory.
- Taylor, F., Kurantz, M. J., Goldberg, N., McAloon, M. J., & Craig Jr., J. C. (2000). Dry grind process for fuel ethanol by continuous fermentation and stripping. *Biotechnol. Prog.* 16, 541-547.
- SuperPro Designer. (2014). SuperPro Designer® Intelligen, Inc. Products catalog. Retrieved from http://www.intelligen.com/superpro_overview.html.

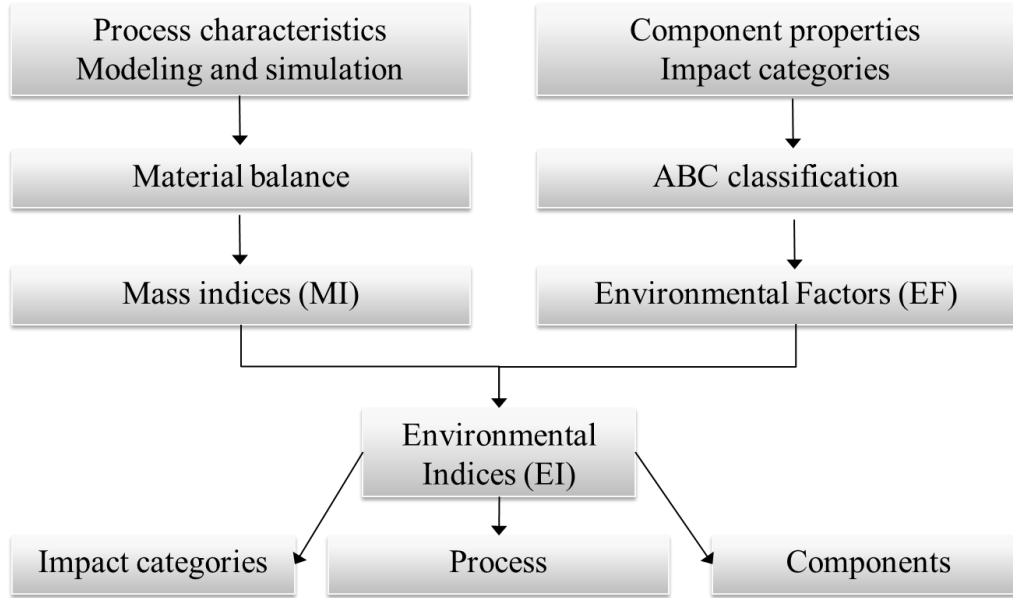

Figure 6.1. Structure of the environmental impact assessment.

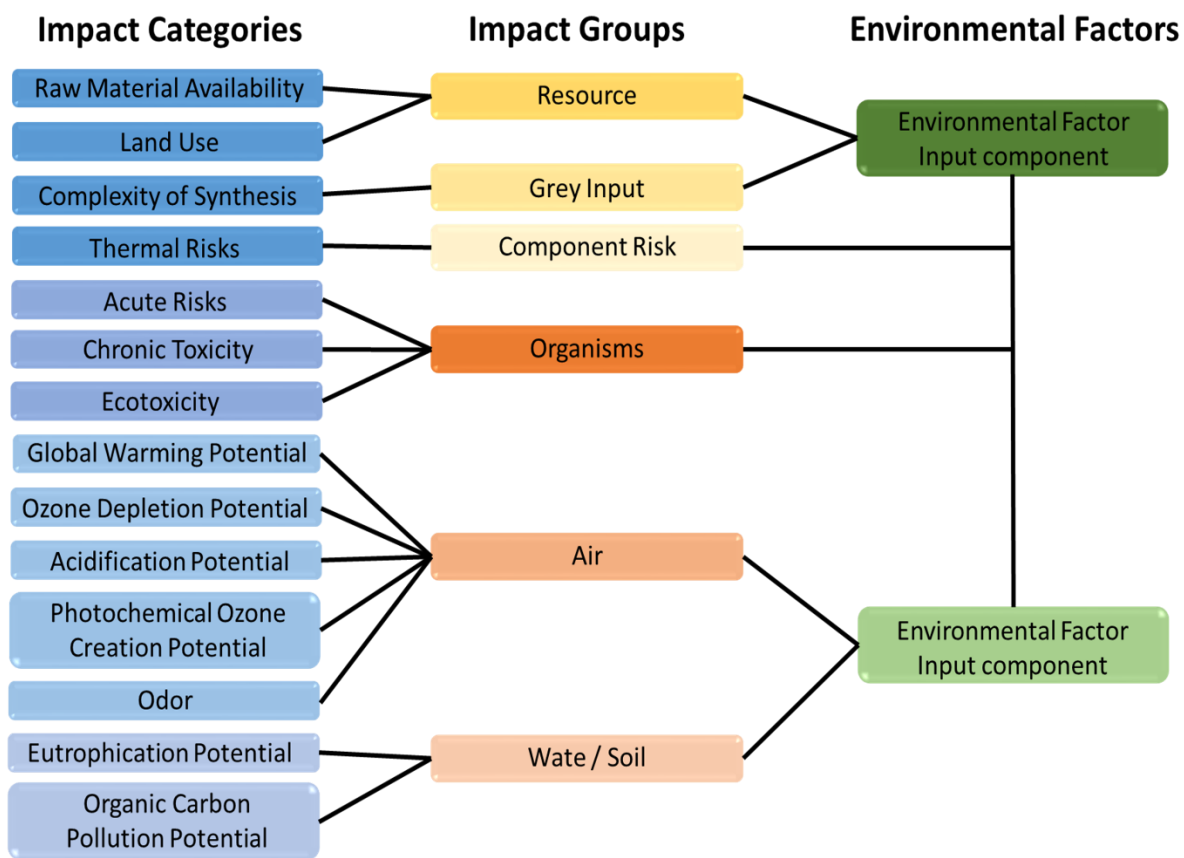

Figure 6.2. Impact categories, impact groups & environmental factors for input and output components (Heinzle et al., 2007).

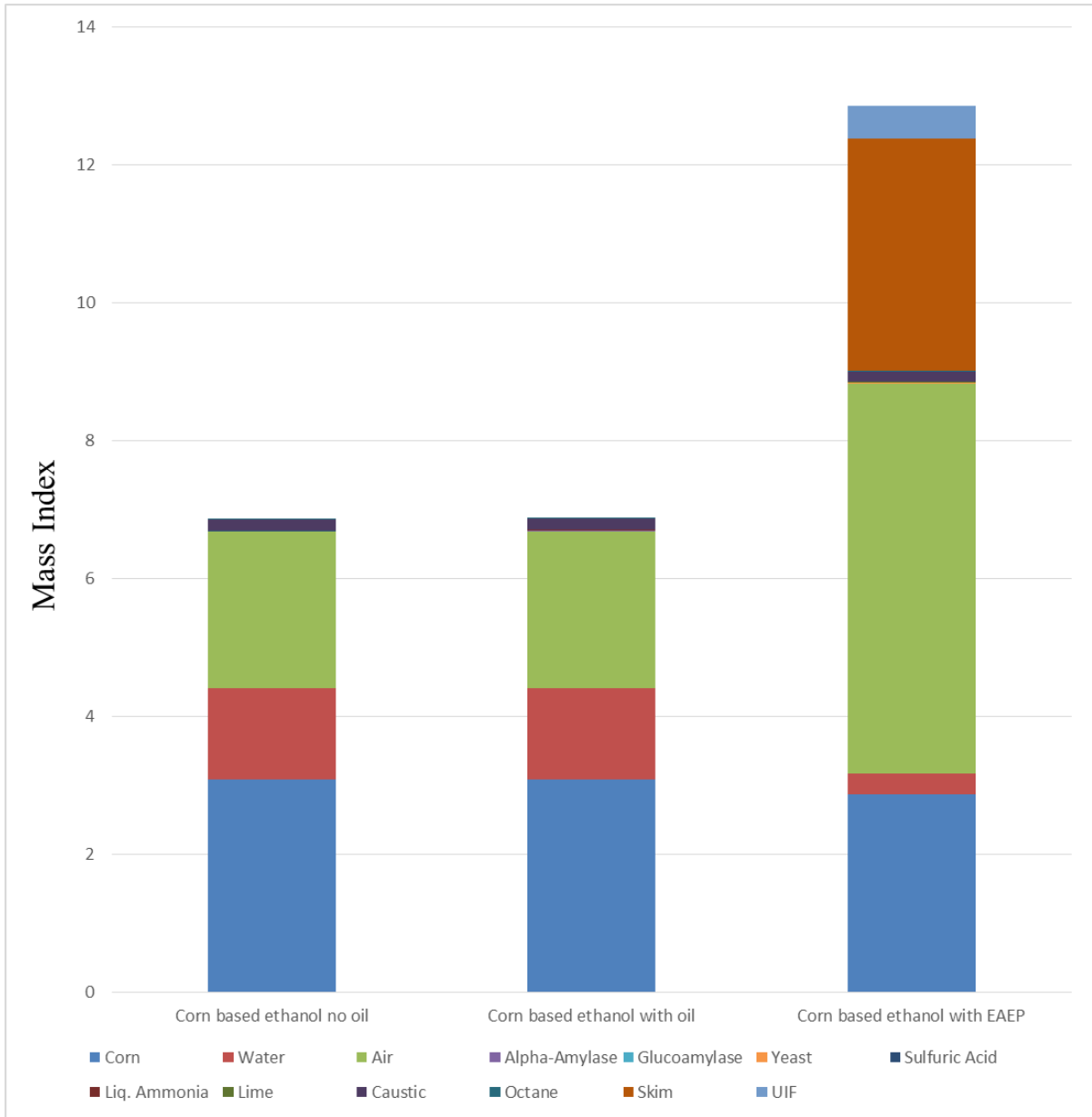

Figure 6.3. Mass index of input components ^(a).

(a) Corn-based ethanol no oil is the model from scenario I, corn-based ethanol with oil is the model from scenario III, and corn-based ethanol with EAEP is the model from chapter 5.

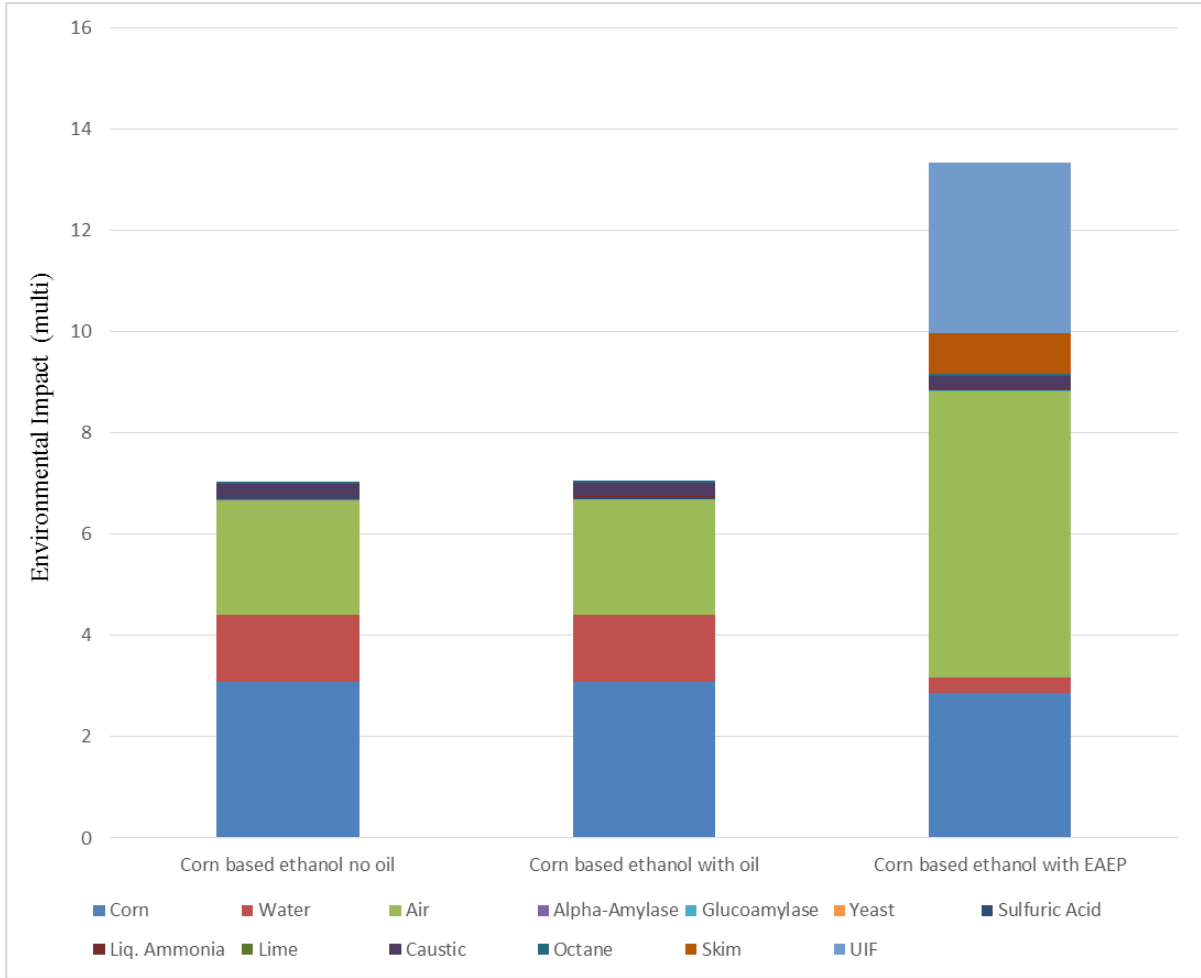

Figure 6.4. Environmental impact of input components: multiplying system ^(a).

(a) Corn-based ethanol no oil is the model from scenario I, corn-based ethanol with oil is the model from scenario III, corn-based ethanol with EAEP is the model from chapter 5.

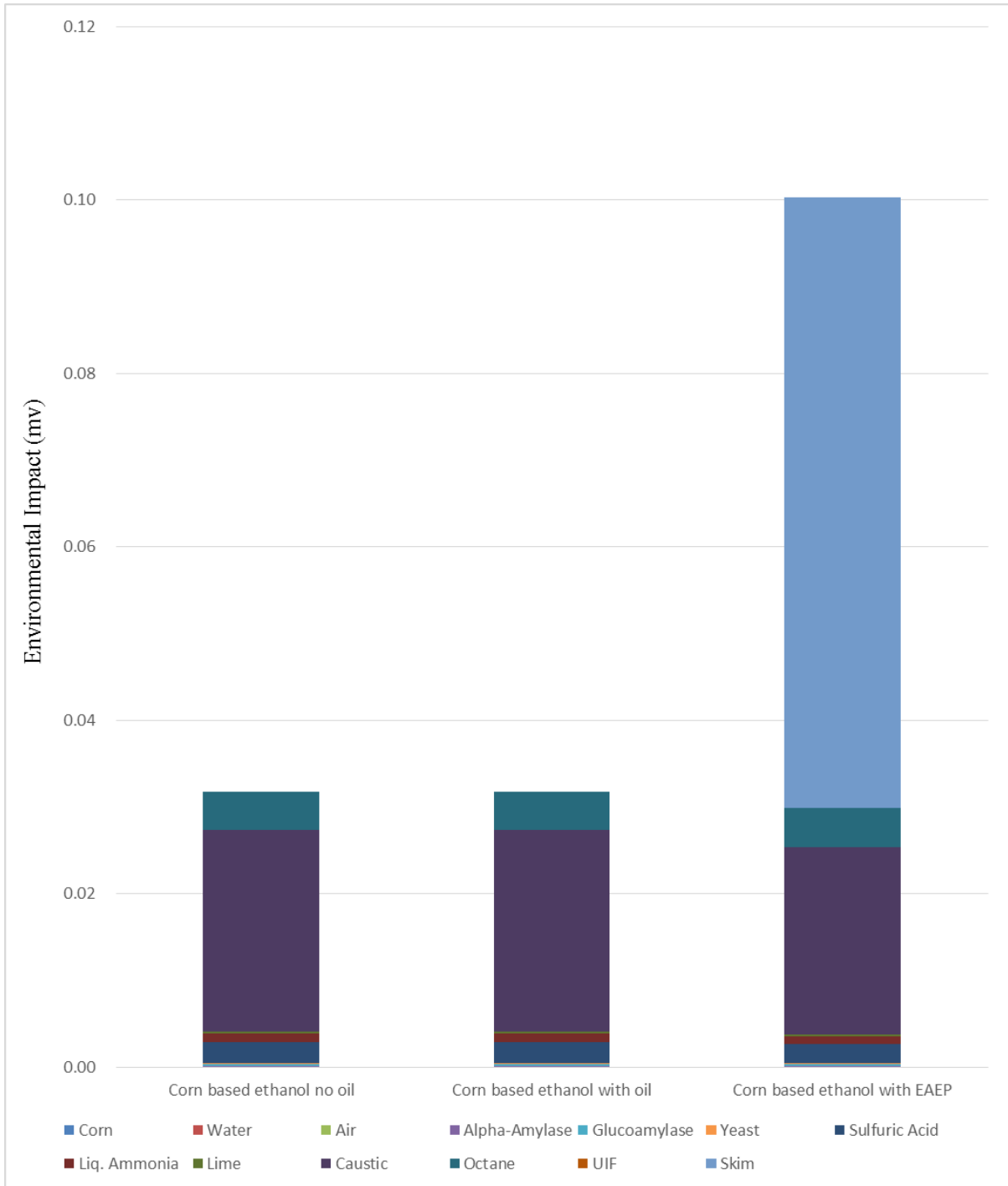

Figure 6.5. Environmental impact of input components: averaging system ^(a).

(a) Corn-based ethanol no oil is the model from scenario I, corn-based ethanol with oil is the model from scenario III, corn-based ethanol with EAEP is the model from chapter 5.

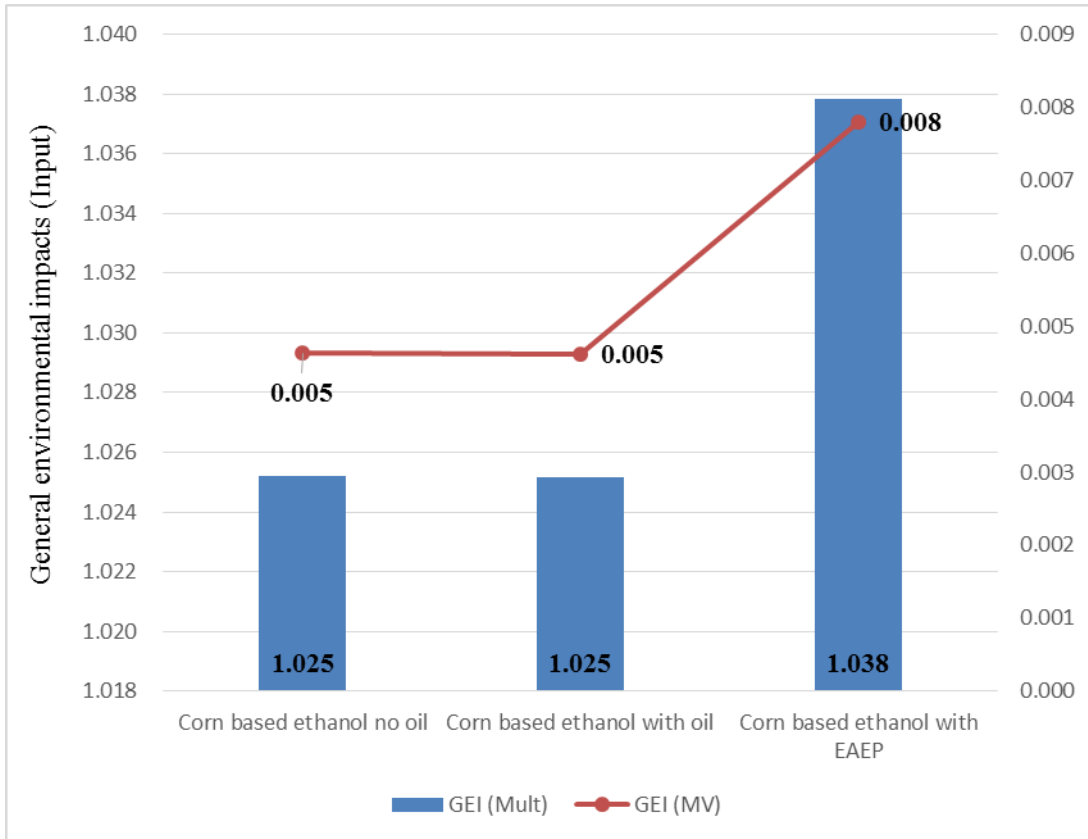

Figure 6.6. General environmental impacts of input components ^(a).

(a) Corn-based ethanol no oil is the model from scenario I, corn-based ethanol with oil is the model from scenario III, corn-based ethanol with EAEP is the model from chapter 5.

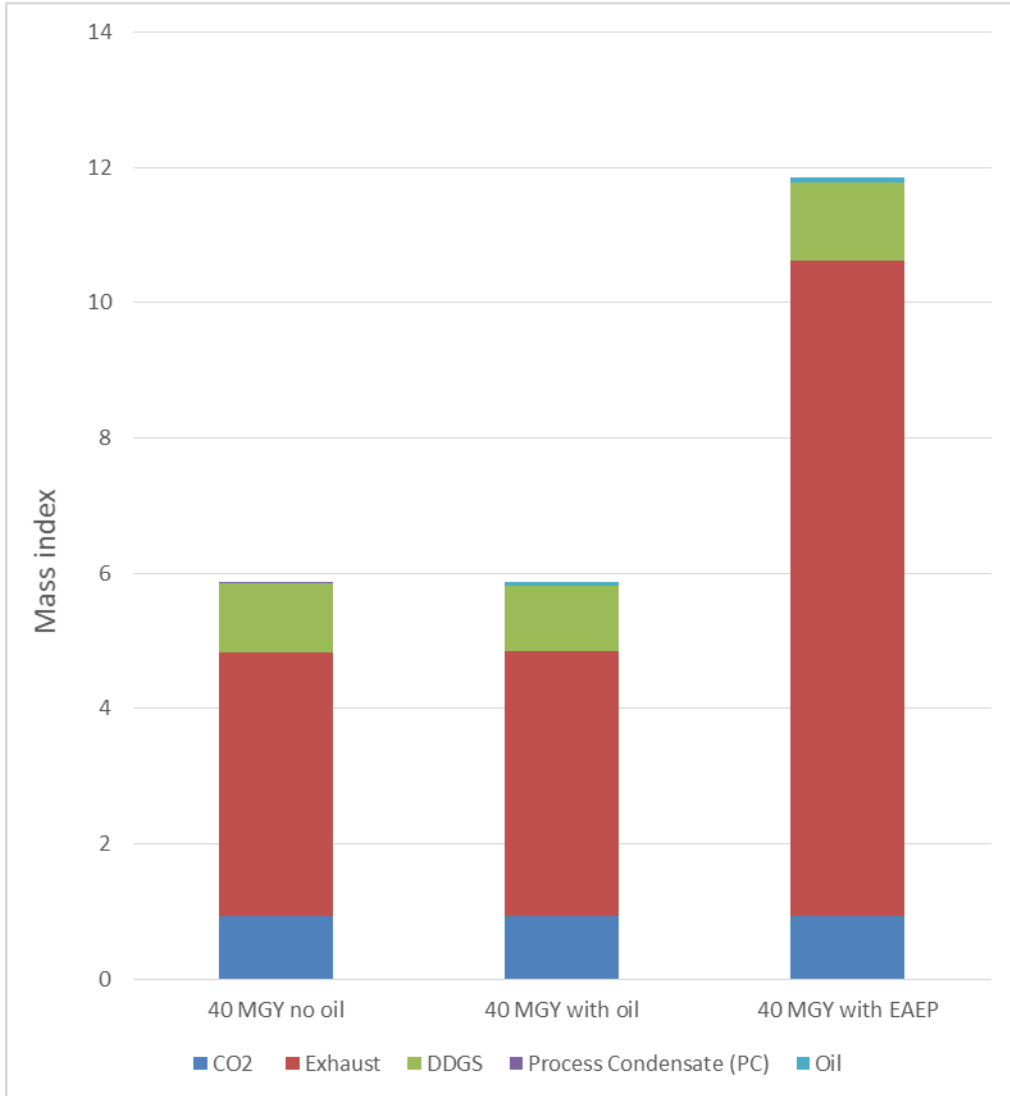

Figure 6.7. Mass index of output components for 40 million corn-based ethanol model ^(a).

(a) 40 MGY no oil is the model from scenario I, 40 MGY with oil is the model from scenario III, 40 MGY with is the model from chapter 5.

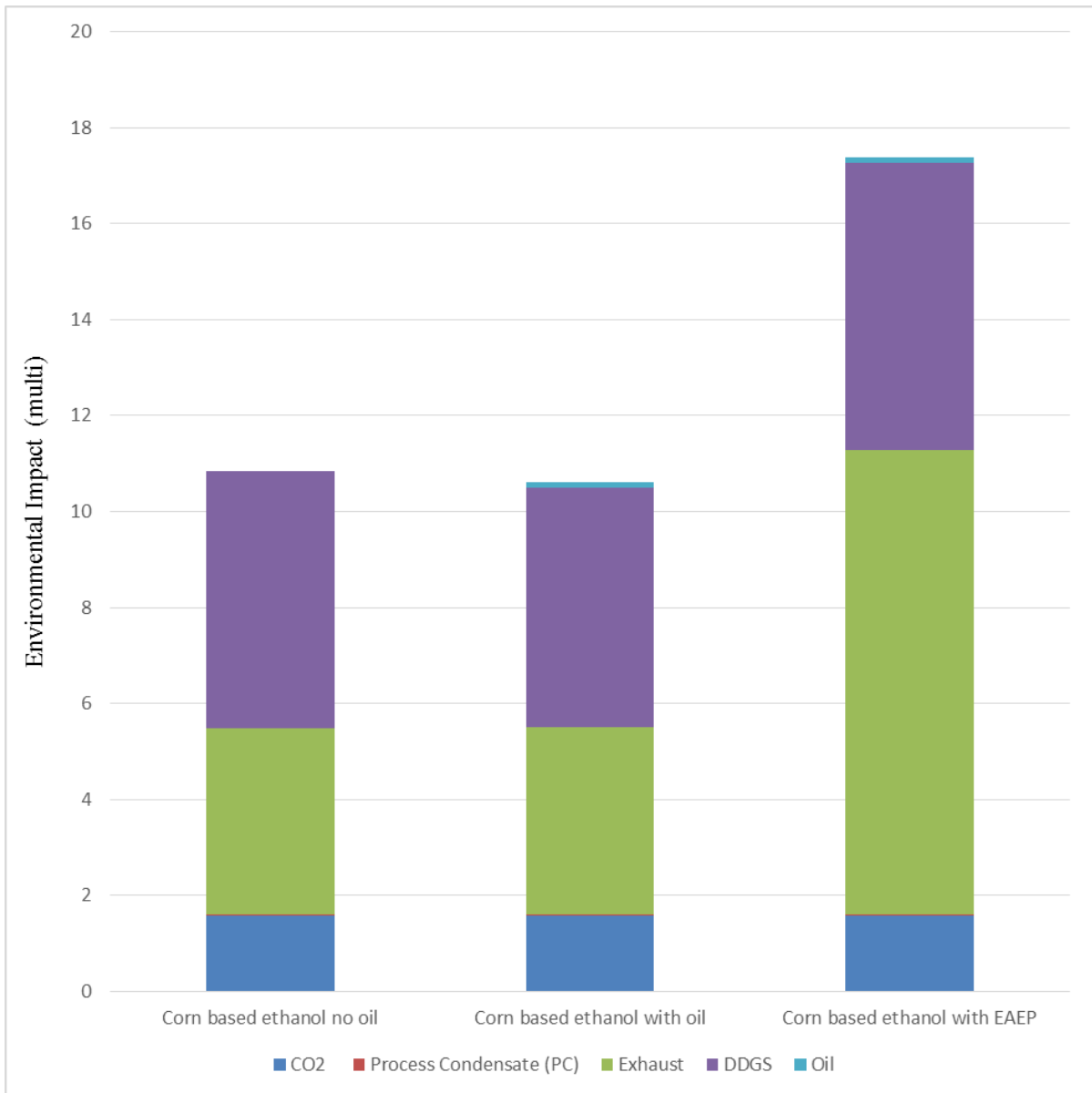

Figure 6.8. Environmental impact of output components: multiplying system.

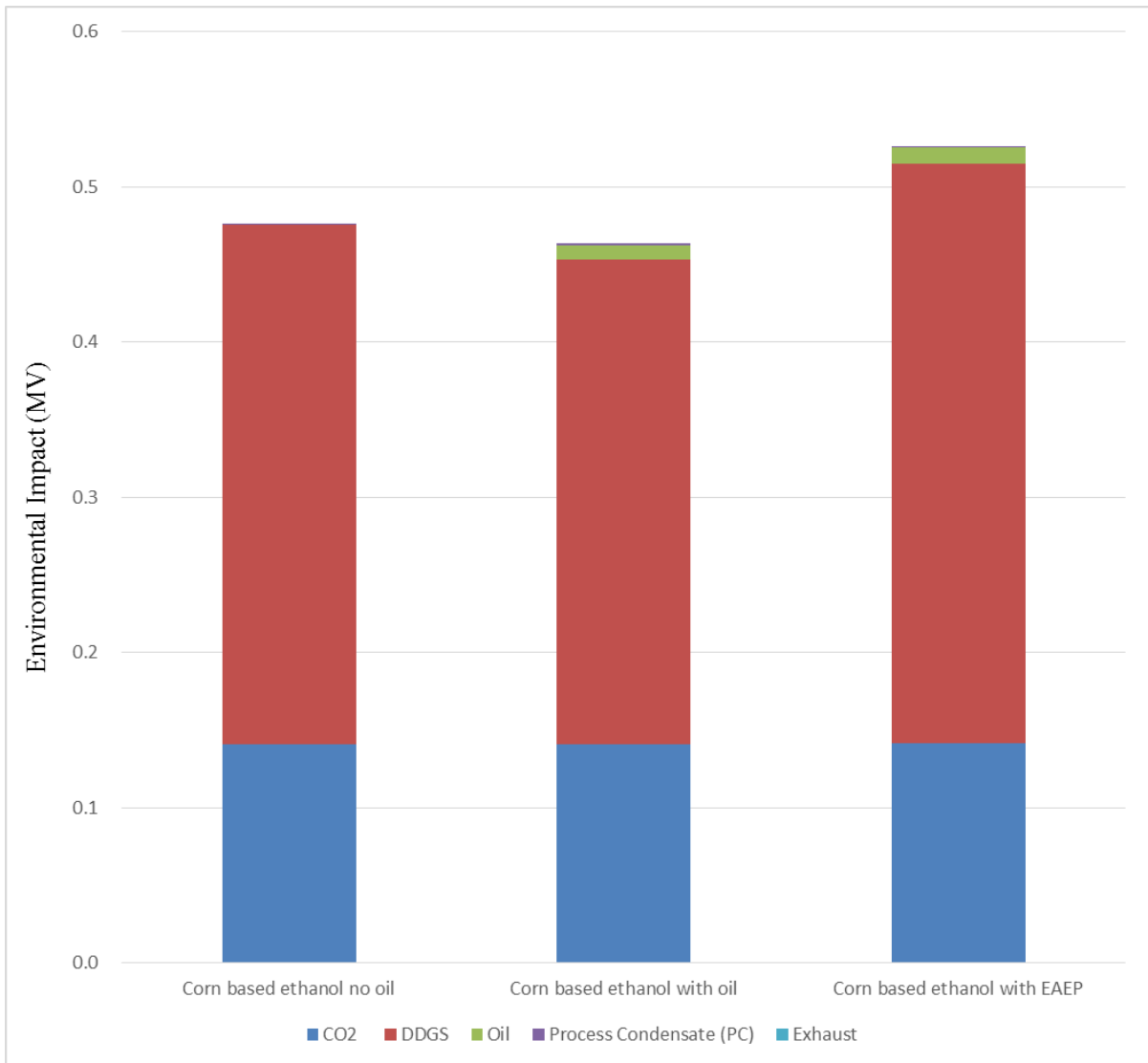

Figure 6.9. Environmental impact of input components: averaging system.

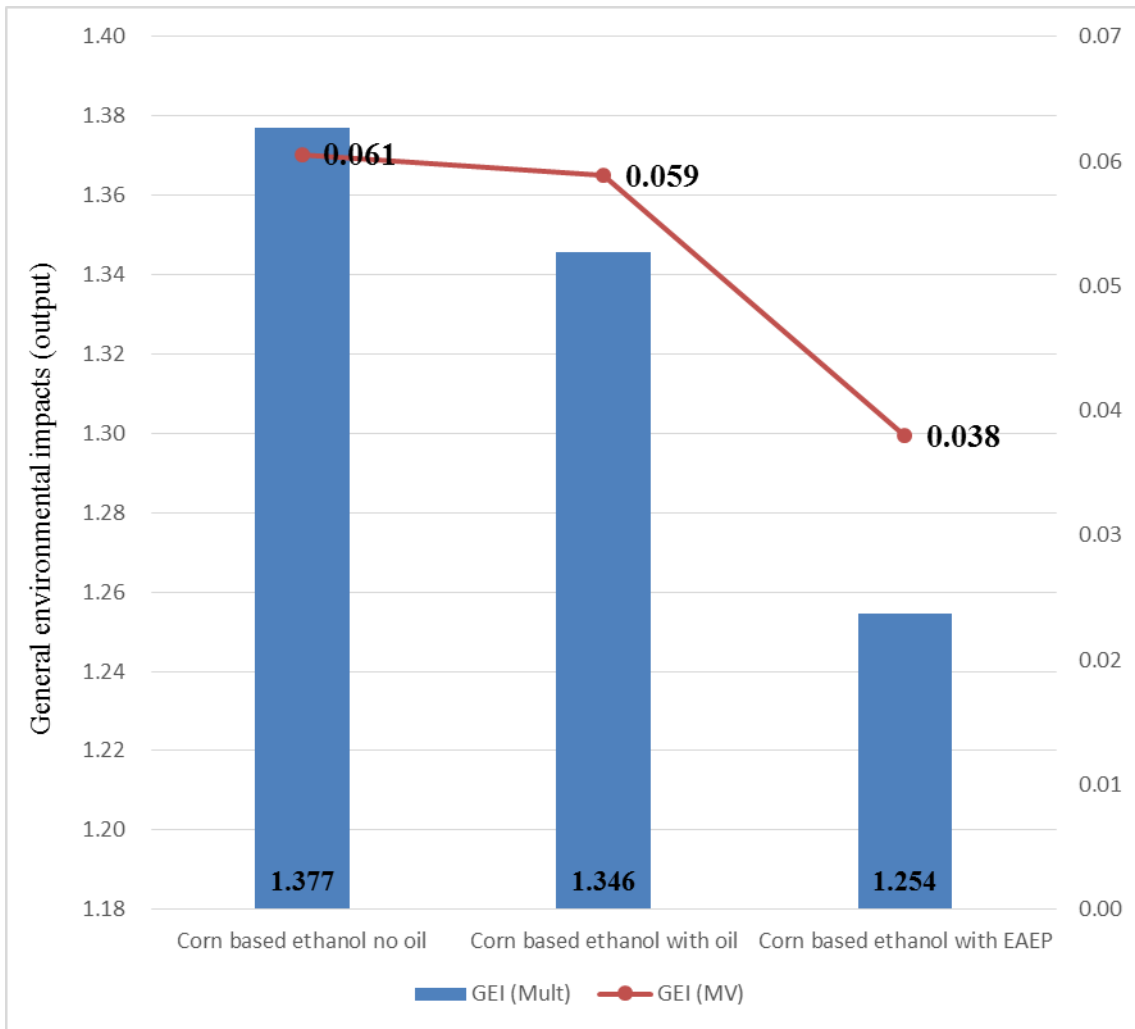

Figure 6.10. General environmental impacts of output components.

Table 6.1

The Mass Flow of Input & Output Components

Input	Input/Output (I/O)	Mass flow (kg per year) of each material		
		Corn-based ethanol	Corn-based ethanol with oil extraction	Integrated EAEP with corn-based ethanol
Corn	I	367327562	367327562	367327562
Water	I	157642888	157642745	39607920
Air	I	270724010	271856450	724683165
Alpha-Amylase	I	257139	257139	257139
Glucosylase	I	371408	371408	371408
Yeast	I	96466	96466	96466
Sulfuric Acid	I	733337	733337	733337
Liq. Ammonia	I	733337	733337	733337
Lime	I	438190	438190	438190
Caustic	I	18423742	18423742	18423742
Octane	I	2383459	2383459	2564177
Untreated Insoluble Fiber (UIF)	I	0	0	60156518
Skim	I	0	0	432210240
CO ₂	O	111981751	111981750	120708437
Process Condensate (PC)	O	646454	646454	577479
Exhaust	O	463610878	465550169	1241182800
DDGS	O	122619727	114549848	147317839
Oil	O	0	7262891	8935077
Ethanol	Main product	119172941	119172941	128208872

Table 6.2

Parameters & Class Limits for Impact Category Classification

Impact Category	Class A	Class B	Class C
Raw Material Availability	Fossil derived, exhaustion with 30 years	Fossil derived, exhaustion with 30-100 years	Exclusively renewable or long term supply
Critical Material	Heavy metal, AOX, PCB used or produced in stoichiometric amounts	Involved in sub-stoichiometric amounts	No critical components involved
Complexity of Process	>10 stages	3-10 stages	<3 stages
Thermal Risk	R 1-4,9,12,15-17,44; EU:F+,E; NFPA F+R:3,4	R 5-8,10,11,14,18,19,30; EU:F,O; NFPA F+R:2	NFPA F+R: 0, 1
Acute Toxicity	EU:T+;R 26-28,32; CH-poison class:1,2; NFPA H:4; WGK 3;	R 20-25,29,31,34-39,41-43, 65-67; EU: T, Xn, Xi, C; CH-poison class:3,4; NFPA H:2,3; WGK 2,	CH-poison class: 5; NFPA H:0,1; WGK 1;
Chronic Toxicity	MAK:<1 mg/m ³ , IARC:1,2A; R 45-49,60-61,64	MAK:1-10 g/m ³ ,IARC:2B,3; R 33,40,62,63; EU:T,T+,Xn; CH-poison class:1,2	MAK:>10mg/m ³ ,IARC:4; CH-poison class:3,4,5
Ecotoxicity	EU: N; R 50; WGK 3	R 51-58; WGK 2	WGK 1 or no water hazard
Global Warming Potential	>20	<20	N/A
Ozone Depletion Potential	>0.5	<0.5	N/A
Acidification Potential	>0.5	<0.5	N/A
Photochemical Ozone Creation Potential	>30 or NOx	2-30	<2 or no effect
Odor		Threshold < 300 mg/m ³	Threshold > 300 mg/m ³
Eutrophication Potential	N-content>0.2 or Pcontent>0.05	N-content < 0.2 and Pcontent < 0.05	No N and P
Organic Carbon Pollution Potential		ThOD > 0.2g O ₂ /g substrate	ThOD <0.2 g O ₂ /g substrate or no organic compound

Table 6.3

Classification of Impact Groups & Categories for Input Components

Impact Groups	Impact Categories	Corn	Water	Hot Air	Alpha-Amylase	Glucosylase	Yeast	Sulfuric Acid	Liquid Ammonia	Lime	Caustic	Octane	UIF	Skim
Resources	Raw Material	C	C	C	C	C	C	B	B	B	B	B	B	C
	Critical Material	C	C	C	C	C	C	B	B	B	B	B	C	C
Grey Input	Complexity Synthesis	C	C	C	B	B	B	C	C	C	C	C	B	C
Component Risk	Thermal Risk	C	C	C	C	C	C	B	C	C	C	B	C	C
Organisms	Acute Toxicity	C	C	C	C	C	C	B	B	C	B	B	C	C
	Chronic Toxicity	C	C	C	C	C	C	A	C	C	B	C	C	C
	Ecotoxicity	C	C	C	C	C	C	B	B	C	C	B	C	C

Table 6.4

Classification of Impact Groups & Categories for Output Components

		CO ₂	PC	Exhaust	DDGS	Oil
Component Risk Organisms	Thermal Risk	C	B	C	B	B
	Acute Toxicity	B	B	C	B	B
	Chronic Toxicity	C	C	C	A	C
	Exotoxicity	C	C	C	B	C
Air	Global Warming Potential	B	B	C	C	C
	Ozone Depletion Potential	C	C	C	C	C
	Acidification Potential	C	C	C	C	C
	Photochemical Ozone Creation Potential	C	C	C	C	C
	Odor	C	C	C	C	C
	Water / Soil	Eutrophication Potential	C	C	C	C
Organic Carbon Pollution Potential		C	C	C	C	C

CHAPTER 7: TECHNO-ECONOMIC MODELING OF USING A DESTONER TO FRACTIONATE DISTILLERS DRIED GRAINS WITH SOLUBLES (DDGS)

7.1. Introduction

With increased demand for fossil fuels in recent years, the supply of ethanol as a fuel additive has increased, and the U.S. ethanol industry has grown rapidly (Schnepf & Yacobucci, 2013). In 2013, 13.3 billion gallons of ethanol were produced by nearly 200 operating plants, which was a little higher than the production of 2012. Ethanol's share of the gasoline pool has gradually become important, and rose from 3% in 2005 to 10% today (Renewable Fuels Association, 2014). Most of the bio-ethanol plants have chosen dry grind processing, which treats corn by grinding and slurring, and then adds enzyme to transform starch into monosaccharide for yeast fermentation (Singh et al., 2001).

There are three products generated from corn-based fuel manufacturing: bioethanol, distillers dried grains with solubles (DDGS) (or other coproducts), and carbon dioxide. In 2013, 37.8 million metric tons (mmt) of high-quality feed was generated, which increased to 2.3 million metric tons compared to 2012 (Renewable Fuels Association, 2014). Marketing of DDGS as an ingredient was directly related to sustainability of a dry grind plant, and sold with a varying market price (US\$85–300 per metric ton) (Liu, 2008). DDGS was composed largely of protein (25-35%), fiber (7-10%), and fat (3-14%) as a dry mix of particulate materials, which made it an ideal material for feed (Bhadra et al., 2009; Rosentrater & Muthukumarappan, 2006; Shurson & Alhamdi, 2008; Srinivasan et al, 2009; Zhang & Rosentrater, 2013a; Zhang & Rosentrater, 2013b). In 2013, 48% of DDGS was used for beef

cattle; 31% for dairy cattle and 12% for swine (Renewable Fuels Association, 2014). Due to various particle compositions, especially high protein and high fiber particles, an efficient method of separating DDGS into high protein and high fiber fractions contributed extra economic benefit to producers (Renewable Fuels Association, 2012; Srinivasan et al., 2005). The high protein portions had greater value as feed to animals (Belyea et al., 2004), while the high fiber fractions had more potential for corn fiber gum or as raw material for lignocellulose ethanol production (Singh et al., 2002; Rosentrater, 2007; Rosentrater & Krishnan, 2006; Srinivasan et al., 2005).

Numerous methods were tried to fractionate various components of DDGS, including sieving and aspiration (Liu, 2009; Srinivasan et al. 2009; Garcia & Rosentrater, 2008). All methods mentioned thus far, however, were suboptimal in efficiency and economy which are the hallmarks of sustainable industrial production. A destoner was a simple and efficient machine that used air flow and shaking to separate, and removed stones and soil from grains. In previous research, destoner fractionation was proven as a somewhat efficient method to separate fractions of DDGS (Zhang & Rosentrater, 2013a). The convenience and inexpensive operation were the greatest advantages to using a destoner, which made it appropriate for industrial production (Heiland & Kozempel, 1988). Most studies of fractionation of DDGS by destoner were done on a small scale, but no research had been done to study the possibility and economic analysis of an industry scale (Zhang & Rosentrater, 2013a). As it is known, the feasibility of experimental and industrial scales are completely different. Equipment costs, fluctuating prices of material and other process parameters play an important role in the whole process, which was not necessary to be considered in experimental scales. For this reason, it was very important to predict accurately with various

affected factors in an industrial scale for detecting the feasibility of fractionation of DDGS through a destoner.

Petrides (2011) mentioned computer models made economical predictions more accurate with enough data of parameters and simulation. ASPEN PLUS (Aspen Technology, Inc., Burlington, MA) and SuperPro Designer (Intelligen, Inc., Scotch Plains, NJ) were utilized as tools for cost analysis in the bio-ethanol industry (Haas et al, 2006; Kwiatkowski et al, 2006). This study used portions of a TEA model (McAloon & Yee, 2011), which was a 40 million gallon dry grind ethanol from corn process to determine the economic feasibility of a DDGS fractionation system. The main objective of this research was to explore technoeconomics of three different scales using a destoner process to fractionate DDGS, and to determine how effectively they obtained revenue and profit.

7.2. Material and methods

7.2.1. Computer model

SuperPro Designer® (Intelligen, Inc., Scotch Plains, NJ) is an industrial design software, which can facilitate modeling, evaluation and optimization of integrated processes in a wide range of industries (SuperPro Designer, 2014). In general, SuperPro Designer® includes a series of chemical components, equipment, mixture and resource databases. By defining flow rate, composition, physical and economic characteristics for each stream, this software determines mass and economic balances for the individual unit operations and whole systems. This study used the original model designed by the USDA in 2011, Wood et al (2014) updated the model in 2013 for a 40 million gallons per year ethanol plant. This study collected the data from Wood (2013) and assumed another two scales, which are 100

and 150 million gallons per year ethanol plants. These models were operational 330 days per year, 24 hours per day. The price of a destoner was collected from Table 7.1 (Alibaba, 2013). After setting basic data into the model, SuperPro Designer produced a variety of reports based on each simulation, and the design of the three scales are shown in Figure 7.1, Figure 7.2 and Figure 7.3.

7.2.2. Simulations

Simulations were run based on modifying how various scales of destoner were used. Two different variables were considered in this model:

- 1) Quantity of DDGS treated in one year (118,880 metric ton per year DDGS in a yearly 40 million gallons ethanol plant; 297,000 metric ton per year DDGS in a yearly 100 million gallon ethanol plant; 445,500 metric ton per year DDGS in a yearly 150 million gallon ethanol plant).
- 2) Prices of various DDGS fractions were determined by various protein percentages (Original DDGS was \$200 per metric ton; medium protein DDGS was \$214.45 per metric ton; high protein DDGS was \$222.27 per metric ton). The calculation of final DDGS prices is shown in the Equation 7.1:

$$\text{Final DDGS price} = \text{Original DDGS price (\$)} + \text{Protein percent over original DDGS (\%)} * \$10 \text{ per percent (\$/\%)} \quad (7.1)$$

For the design of the model, the flow rate of DDGS and destoner capacity were the only limitations to model building. Because the destoner had a limited flow rate, the medium and larger scale processes had to split DDGS into two flows to increase amounts of destoner

capacities to fractionate DDGS. In this model, the price of DDGS was only judged by protein percentage, which was commonly used as a main factor for pricing of DDGS. According to the previous study (Zhang & Rosentrater, 2013), the protein in DDGS is about 29.03%; the medium protein DDGS is about 30.52%, and high protein DDGS is about 31.30%. Though the lighter protein part of DDGS had a lower protein, it was still higher than the lowest DDGS basic level, which meant it had the same price as unfractionated DDGS. This study simulated original DDGS at \$200 per metric ton with a \$10 change to every 1 % point of protein increase, which resulted in medium protein DDGS of \$214.45 per metric ton and high protein DDGS of \$222.27 per metric ton (Wood et al, 2013).

The standard electrical power was \$0.046 per kW·h, and labor cost was \$23.66 per hour, which was from the 2013 USDA model (Wood et al. 2013). Installation costs depended on various types of equipment, and storage cost depended on storage volume. The cost of destoner depended on throughput, which is shown in Table 7.1. Loan interest was set at 7.0% per year. For model outputs, there were three important tables to consider, which included fixed capital estimate summary, process summary and profitability analysis. The fixed capital estimate summary consisted of three portions: total plant direct cost, total plant indirect cost and contractor's fee & contingency (Table 7.2). Annual operating cost consisted of raw materials, labor, facility-dependent and utilities (Table 7.3). Among profitability analysis, the unit production cost, unit production revenue, net profit and payback time were the most important results for this study (Table 7.4). All three tables were combined in an executive summary (Table 7.5).

7.3. Results and discussion

7.3.1. Capital costs

Capital costs are independent of the level of output, and are costs associated with the capital or investment expenditures on land, plant, equipment and inventors (CIEL, 2013). Direct fixed capital cost (DFCC) was composed of total plant direct cost (TPDC), total plant indirect cost (TPIC) and contractor's fee & contingency (CFC). Total plant direct cost was mainly affected by the total equipment purchase costs and maintenance cost for the individual process, which included equipment purchase cost, installation, process piping, instrumentation, insulation, electrical supplies, buildings, yard improvement and auxiliary facilities. Annualized equipment and installation costs for all three scales, in U.S. dollars per year, are shown in Table 7.2. Based on cost evaluations of all scenarios, installation contributed to about 20% of equipment costs, while equipment contributed to the remaining 33%. In this model of TPDC, TPIC was used as capital costs calculations for the whole plant, including engineering and construction.

7.3.2. Annual operating costs

Annual operating costs in the industry are composed of equipment operation, component, equipment purchase and facilities in one calendar year (Nichols, 1933). In this model, the destoner process consisted of expenses related to utilities, facilities, labor, and raw materials. Table 7.3 shows how each of these costs impacted annual operating costs as a whole in every scale. In every scenario, annual operating costs were largely impacted by raw material costs, which had an average of 97% of total annual operating costs. Only 3% of annual operating costs were decided by other categories.

Facility costs were composed of maintenance costs, insurance, local taxes and factory expenses, which accounted for about 1.2% in all scales. Labor costs were estimated based on the number of working hours needed per year, and were decided by the scales and equipment numbers. All scales for set labor cost at the same unit cost which was \$23.66 per hour, nearly three times the cost of the lowest salary requirement in Iowa. The total annual labor working time for the small scale was 2,138 hours, which resulted in \$50,595 for labor cost. Medium and large scale labor costs kept the same size and structure in the SuperPro model, which resulted in labor costs of \$783,278 per year.

In this study, the majority of annual operating cost came from raw materials. Raw material costs were determined by various DDGS with different percentages of proteins. Original DDGS was set at \$200 per metric ton as a base price, with \$10 added to the base price for every one percentage increase in protein change. Three scales used 118,880, 297,000 and 445,550 metric tons of DDGS based on the USDA model results (Wood et al, 2013). Annual costs for the three scales were \$23,760,000; \$59,400,000 and \$89,100,000, which are shown in Table 7.3.

Due to the destoner process, utility costs in this study were mainly related to the costs of electricity, with standard power set at \$0.046 per kW·h. When all three scales were compared, utilities of the whole cost were always less than 0.3% and had little effect on costs, which only took \$16,942; \$41,231 and \$61,847 for 118,880, 297,000 and 445,550 metric tons of DDGS scales.

7.3.3. Annual revenues

The destoner process produced three marketable products: low protein DDGS, medium protein DDGS and high protein DDGS. Due to low protein DDGS keeping the same price as raw materials, the annual revenue of the destoner process was only determined by medium protein DDGS and high protein DDGS. The initial DDGS market prices were set at \$200 / metric ton for low protein DDGS. Medium and high protein DDGS prices were calculated by the computer model based upon their protein concentration, which assumed initial DDGS was 29.03% protein (Zhang & Rosentrater, 2013a). The market value of protein (\$1.05 per kg) was determined based upon a previous study, and resulted in medium and high protein DDGS prices of \$214.45 per metric ton and \$222.27 per metric ton (Wood et al, 2013).

Table 7.4 shows the values of small, medium and large fractionation processes on plant revenues for the Jan-Dec 2013 period. Small scale fractionation revenue was 2.178 million dollars per year for high protein DDGS, 10.289 million dollars per year for medium protein DDGS, and 12.15 million dollars per year for low protein DDGS, which totally obtained 24.618 million dollars per year. As scales increase, total revenues also increased from the initial \$24.6 million (small scale) to \$61.544 million (medium scale) to \$92.316 million (large scale). Though low protein had the largest total revenue, the system still judged high protein DDGS as the main revenue in all three scales. The possible reason for this was that high protein DDGS had a higher unit revenue rate, which was determined by protein percentage. Of the production of three products, high protein DDGS contributed an extra 12.14% revenue than the low protein DDGS. Figure 7.4 shows how each product affects the overall annual revenue of the plant. According to Figure 7.4, same scale contributed similar

percentages of total revenues, which was less affected by model scale and only determined by destoner separation rates for protein in DDGS.

7.3.4. Profits

Gross profits are seen in Table 7.5, which shows capital cost, operating cost, revenue, and profit in million dollars per year. In addition, unit production cost and unit production revenue are shown in Table 7.5. Undoubtedly, 445, 550 metric tons of DDGS scale (large scale) had the largest gross profit of 1.228 million dollars per year. However, 118,880 metric tons of DDGS scale (small scale) had the highest efficient gross profit, and the smallest unit production cost (\$2.49 per kg) of all three scales. The possible reason for this condition was that the small scale process had the most simplified design with the smallest amount of destoner and other accessory equipment, which contributed a larger cost in total equipment cost. For unit production revenue, it was easily found that all scales did not have an evident change. The reason for this condition was that unit production revenue was determined by unit revenue of every product, which was set with the same data in all scales. After considering taxes and interest, the three scales of return on investment were 11.08%, 7.32% and 9.03%, which represented a payback time of 9.03 years, 13.67 years and 11.08 years. In general, all scales of payback time were positive, which meant they were valuable investment projects. However, payback time of all scales was still too long for investors, who were always interested in investing with higher efficient profits and less payback time. Increasing destoner efficiency and decreasing the equipment costs may be a better solution to increase unit profit and decrease payback time. Another factor was oil content. In this study, models calculated the change of protein, which determined DDGS prices in most agricultural trade

markets. In recent years, oil extraction became very popular at plants, and improved the value of coproducts in corn-based ethanol productions. In 2012, the price of oil from a bio-refinery reached \$1.173 per kg, which was approximately two times more than the price of \$0.520 per kg in 2005 (Index Mundi, 2012). A destoner also had the ability to concentrate oil in the DDGS (Zhang & Rosentrater, 2013a). Increasing unit profits and decreasing payback time has possible feasibility. Showing productions using a destoner to fractionate DDGS at an industrial scale is realistic.

7.4. Conclusion

To perform economic calculations for new fractionation systems, SuperPro Designer was used for techno-economic modeling. The process of using a destoner to fractionate distillers dried grains with solubles (DDGS) resulted in three types of DDGS, and provided additional revenue to the ethanol plant. Through the simulated scenarios, it was concluded that destoner fractionation has the potential to play a vital role in increasing the market value of DDGS. The fractionation systems incorporated in this study increased the capital costs associated with the facility, but did not greatly affect the overall annual operating costs. The addition of fractionation, such as high protein DDGS, added revenue and improved the profits of the plant. The overall profits of a destoner process in all scales were positive, but the net profit was still very low. In the future, increasing destoner efficiency and decreasing equipment costs should be examined so fractionation can be better utilized in the industry. Oil extraction to produce high and medium protein DDGS could also be considered.

References

- Alibaba. (2013). *Alibaba.com*. Retrieved from destoner: <http://www.alibaba.com/showroom/destoner.html>
- Belyea, R. L., Rausch, K. D., & Tumbleson, M. E. (2004). Composition of corn and distillers dried grains with solubles from dry grind ethanol processing. *Bioresource Technology*, 94(3): 293-298.
- Bhadra, R., Muthukumarappan, K., & Rosentrater, K. A. (2009). Flowability properties of commercial distillers dried grains with solubles (DDGS). *Cereal Chem.*, 86(2): 170-180.
- CIEL (The Center for International Environmental Law). (2013). Climate Change Glossary. Global Warming. Retrieved from: <http://www.ciel.org/Publications/climatechangeglossary.pdf>.
- Garcia, R. A., & Rosentrater, K. A. (2012). Fractionation of distillers dried grains with solubles (DDGS) through a narrowing of particle size distribution followed by aspiration. *Food and Bioprocess Technology*, 5(6): 2623-2629.
- Haas, M.J., McAloon, A., Yee, W. C., & Fog, T. A. (2006). A process model to estimate biodiesel production costs. *Bioresource Technology*, 97: 671-678.
- Heiland, W. K., & Kozempel, M. (1988). A mechanical destoner for small processing plants. *American Journal of Potato Research*, 65(9): 543-546.
- Index Mundi. (2012). Soybean oil futures end of day settlement price. Retrieved from www.indexmundi.com/commodities.
- Kwiatkowski, J. R., McAloon, A., Taylor, F., & Johnston, D. B. (2006). Modeling the process and costs of fuel ethanol production by the corn dry-grind process. *Ind. Crops and Products*, 23: 288-296.
- Liu, K. (2008). Particle size distribution of distillers dried grains with solubles (DDGS) and relationships to compositional and color properties. *Bioresource Technology*, 99(17): 8421–8428.
- Liu, K. (2009). Effects of particle size distribution, compositional and color properties of ground corn on quality of distillers dried grains with solubles (DDGS). *Bioresource Technology*, 100: 4433–4440.
- McAloon, A., & Yee, W. (2011). *Ethanol plant model*. Wyndmoor, PA: USDA, ARS.
- Nichols, W. B. (1933). *In The brewing industry: A brief survey of markets, distribution methods, operating costs, and capital requirements*. New York, NY: Primo-Alephloc.
- Petrides, D., Siletti, C., Jimenez, J., Psathas, P., & Mannion, Y. (2011). Optimizing the design of operation of fill-finish facilities using process simulation and scheduling tools. *Pharmaceutical Eng*, 31(2).

- Renewable Fuels Association. (2012). 2012 Ethanol industry outlook: Accelerating industry innovation: 3, 8, 10 22 and 23. *Renewable Fuels Association*: Washington D. C.. Retrieved from <http://www.ethanolrfa.org/>.
- Renewable Fuels Association. (2014). Falling walls & rising tides, 2014 ethanol industry outlook. Washington, D.C.: Renewable Fuels Association. Retrieved from: <http://www.ethanolrfa.org/page/-/rfa-association-site/Resource%20Center/2014%20Ethanol%20Industry%20Outlook.pdf?nocdn=1>.
- Rosentrater, K. A. (2007). Corn ethanol coproducts – some current constraints and potential opportunities. *Int. Sugar J.*, 109(1307): 2-11.
- Rosentrater, K. A., & K, Muthukumarappan. (2006). Corn ethanol coproducts: generation, properties, and future prospects. *Int. Sugar J.*, 108(1295): 648-657.
- Rosentrater, K. A., & Krishnan, P. (2006). Incorporating distillers grains in food products. *Cereal Foods World*, 51(2): 52-60.
- Schnepf, R., & Yacobucci, B. D. (2013). *Renewable Fuel Standard (RFS): Overview and issues*. Retrieved from: <http://www.epa.gov/otaq/fuels/renewablefuels/index.htm>.
- Shurson, J. & Alhamdi, A. S. (2008). Quality and new technologies to create corn co-products from ethanol production. In Babcock, B. A., Hayes, D. J., and Lawrence, J. D. (Ed.), *Using distillers grains in the U.S. and international livestock and poultry industries*, (pp. 231-256). Ames, IA.: Iowa State University.
- Singh, V., Rausch, K., Yang, P., Shapouri, H., Belyea, R. L., & Tumbleson, M. E. (2001). *Modified dry grind ethanol process*. Urbana, IL: University of Illinois at Urbana-Champaign Agricultural Engineering Department.
- Singh, V., Moreau, R. A., Hicks, K. B., Belyea, R. L., & Staff, C. H. (2002). Removal of fiber from distillers dried grains with solubles (DDGS) to increase value. *Transaction of the ASAE*, 45: 389–392.
- Srinivasan, R., To, F., & Columbus, E. (2009). Pilot scale fiber separation from distillers dried grains with solubles (DDGS) using sieving and air classification. *Bioresource Technology.*, 100: 3548-3555.
- Srinivasan, R., Moreau, R., Rausch, K., Belyea, R., Tumbleson, M., & Singh, V. (2005). Separation of fiber from distillers grains with solubles (DDGS) using sieving and elutriation. *Cereal Chemistry*, 82(5): 528-533.
- SuperPro Designer. (2014). SuperPro Designer® Intelligen, Inc. Products catalog. Retrieved from http://www.intelligen.com/superpro_overview.html.
- Wood, C. R., Rosentrater, K. A., & Muthukumarappan, K. (2013). Techno-economic modeling of coproduct processing in a corn based ethanol plant in 2012. In *2013 Kansas City, Missouri, July 21-July 24, 2013* (p. 1). American Society of Agricultural and Biological Engineers.

- Zhang, W., & Rosentrater, K. A. (2013). Fractionation of distillers dried grains with solubles (DDGS) through a destoner. In *2013 Kansas City, Missouri, July 21-July 24, 2013* (p. 1). American Society of Agricultural and Biological Engineers..
- Zhang, W., & Rosentrater, K. A. (2013). Some properties of evolving distillers dried grains with solubles (DDGS) in 2012. In *2013 Kansas City, Missouri, July 21-July 24, 2013* (p. 1). American Society of Agricultural and Biological Engineers.

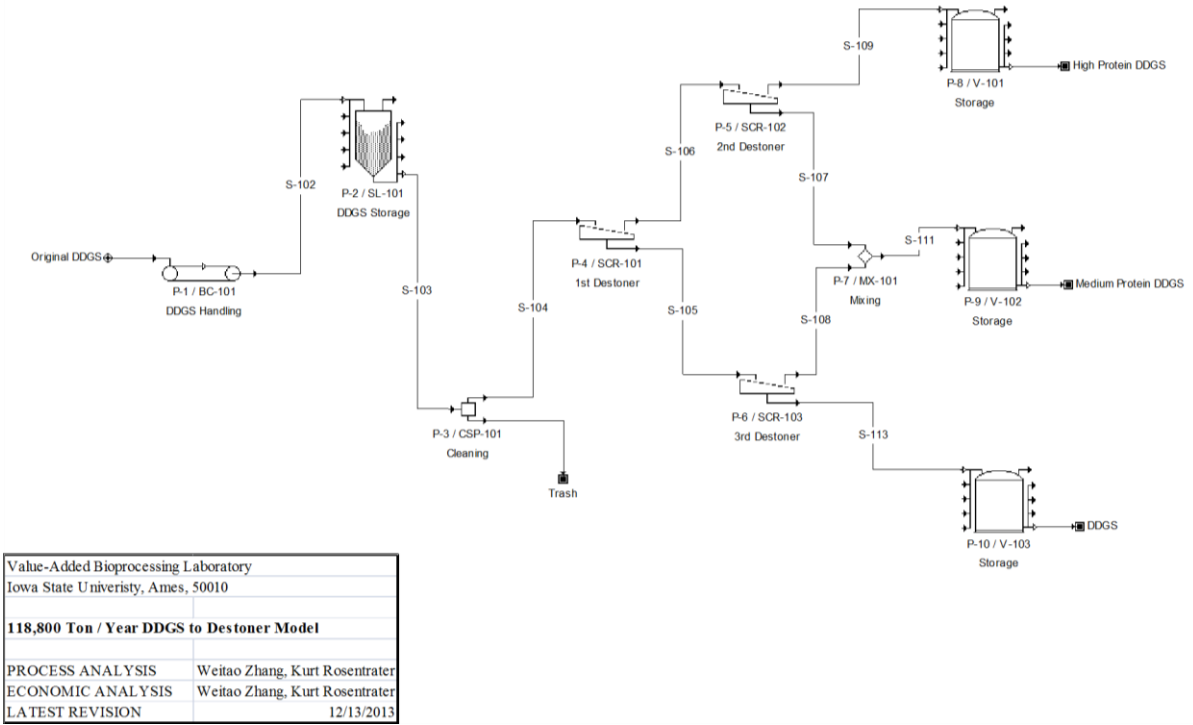

Figure 7.1. SuperPro model for DDGS production with 118,880 metric tons per year.

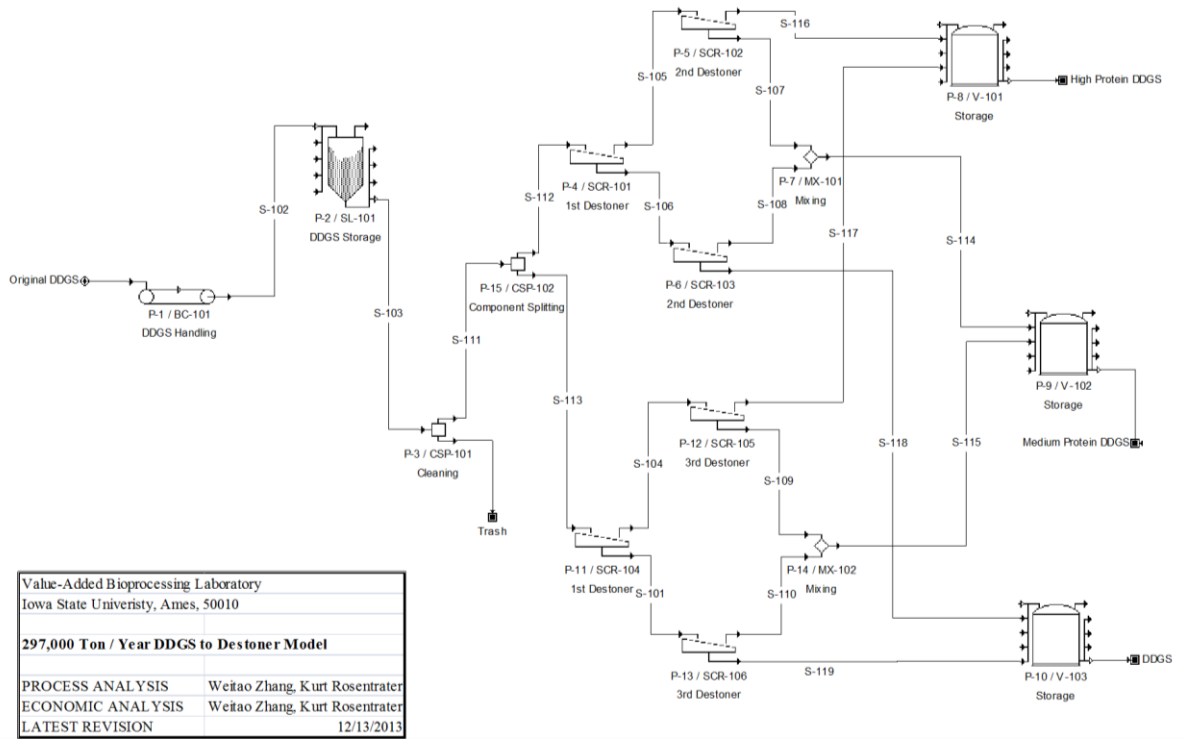

Figure 7.2. SuperPro model for DDGS production with 297,000 metric tons per year.

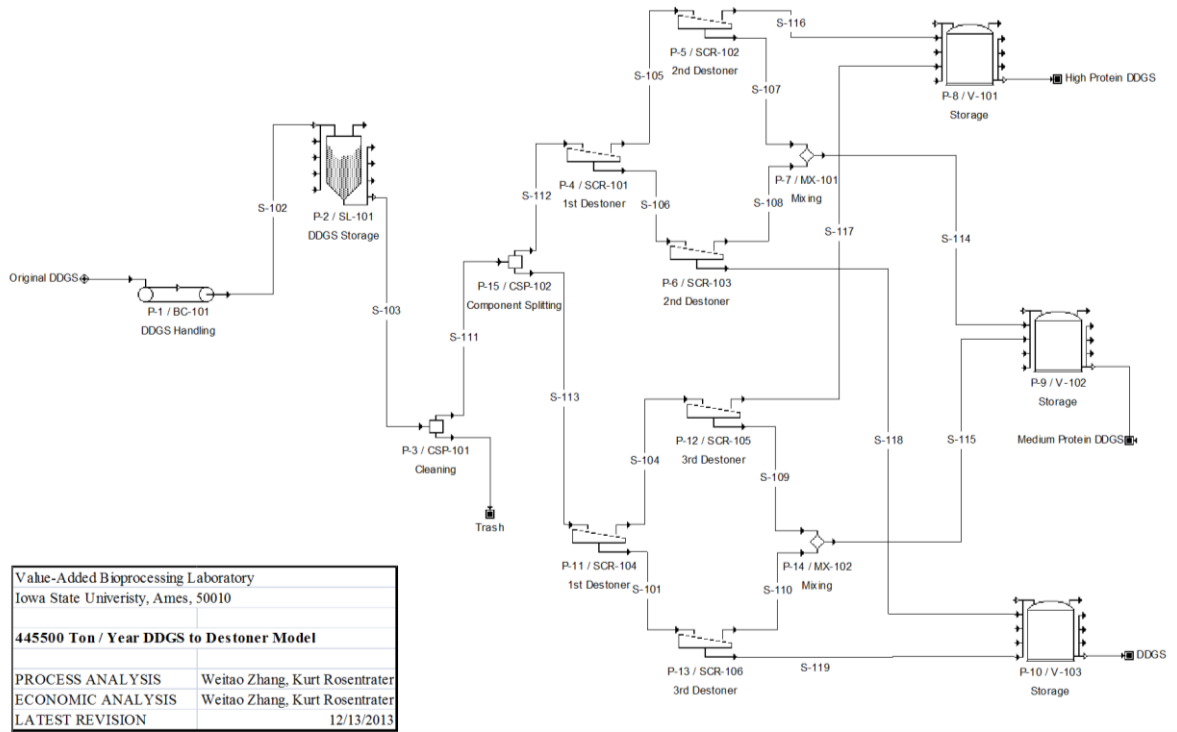

Figure 7.3. SuperPro model for DDGS production with 445,500 metric tons per year.

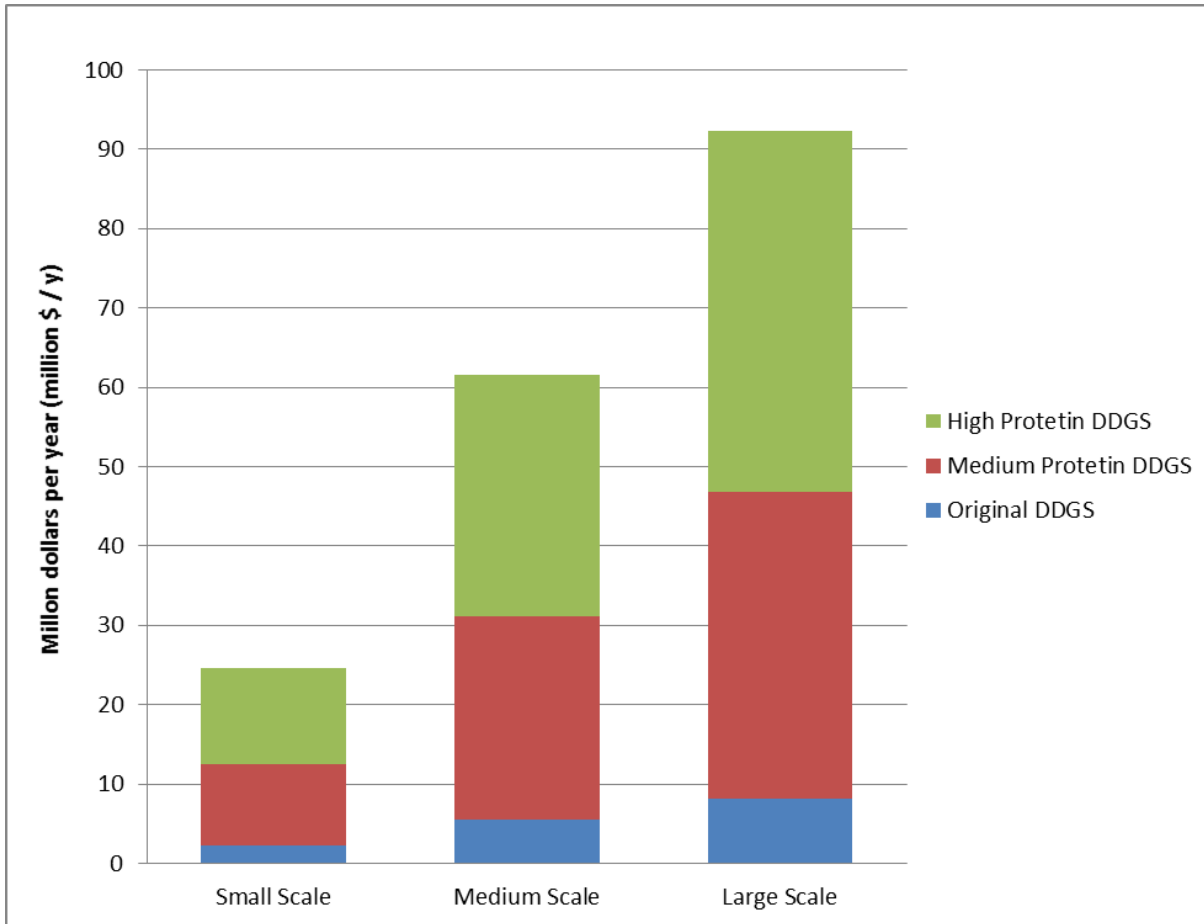

Figure 7.4. Annual revenues of various DDGS for various scales (Million \$ per year)^(a).

(a) Small scale is 118,880 metric tons of DDGS production per year. Medium scale is 297,000 metric tons of DDGS production per year. Large scale is 445,500 metric tons of DDGS production per year.

Table 7.1

Data for Various Destoner Capacities (Alibaba, 2013)

Model	Power (kW)	Price (\$)	Capacity (metric ton per hour)	Capacity (metric ton per day)
FBF40	0.5	2000	2	48
FBF50	0.5	12000	5	120
FBF63	0.5	15000	6	144
FBF80	0.5	22000	8	192
FBF100	0.5	28000	10	240
FBF125	0.5	42000	14	336
FBF150	0.74	45000	15	360
FBF175	0.74	65000	21	504
FBF250	0.74	85000	27	648

Table 7.2.

Fixed Capital Estimate Summary ^(a)

Total Plant Direct Cost (TPDC)	Small Scale ^(b)	Medium Scale ^(c)	Large Scale ^(d)
1. Equipment Purchase Cost	195,000	522,000	785,000
2. Installation	286,000	710,000	1,093,000
3. Process Piping	68,000	183,000	275,000
4. Instrumentation	78,000	209,000	314,000
5. Insulation	6,000	16,000	24,000
6. Electrical	20,000	52,000	78,000
7. Buildings	88,000	235,000	353,000
8. Yard Improvement	29,000	78,000	118,000
9. Auxiliary Facilities	78,000	209,000	314,000
TPDC	849,000	2,212,000	3,354,000
Total Plant Indirect Cost (TPIC)			
10. Engineering	212,000	553,000	838,000
11. Construction	297,000	774,000	1,174,000
TPIC	509,000	1,327,000	2,012,000
Total Plant Cost (TPC = TPDC+TPIC)			
TPC	1,358,000	3,540,000	5,366,000
Contractor's Fee & Contingency (CFC)			
12. Contractor's Fee	68,000	177,000	268,000
13. Contingency	136,000	354,000	537,000
CFC = 12+13	204,000	531,000	805,000
Direct Fixed Capital Cost (DFC = TPC+CFC)			
DFC	1,562,000	4,071,000	6,171,000

(a) The prices are from 2013 and are shown in \$ USD.

(b) Small scale is 118,880 metric tons of DDGS production per year.

(c) Medium scale is 297,000 metric tons of DDGS production per year.

(d) Large scale is 445,500 metric tons of DDGS production per year.

Table 7.3.
Process Summary of Annual Operating Cost ^(a)

Process Summary	Small scale ^(b)	Medium Scale ^(c)	Large Scale ^(d)
Labor Cost			
Unit Cost (\$ per hour)	23.66	23.66	23.66
Annual Amount	2,138	33,106	33,106
Annual Cost	50,595	783,278	783,278
Materials Cost			
Unit Cost (\$ per metric ton)	200	200	200
Annual Amount (metric ton)	118,800	297,000	445,500
Annual Cost (\$)	23,760,000	59,400,000	89,100,000
Utilities Cost			
Unit Cost (\$ per kW·h)	0.046	0.046	0.046
Annual Amount (kW·h)	361,680	904,200	1,356,300
Annual Cost (\$)	16,492	41,231	61,847
Annual Operating Cost			
Raw Materials	23,760,000 (98.34%)	59,400,000 (97.38%)	89,100,000 (97.82%)
Labor-Dependent	51,000 (0.21%)	783,000 (1.28%)	783,000 (0.86%)
Facility-Dependent	289,000 (1.20%)	754,000 (1.24%)	1,143,000 (1.25%)
Utilities	16,000 (0.26%)	41,000 (0.10%)	62,000 (0.07%)
TOTAL	24,161,000 (100%)	60,999,000 (100%)	91,088,000 (100.00%)

(a) The prices are from 2013 and are shown in \$ USD.

(b) Small scale is 118,880 metric tons of DDGS production per year.

(c) Medium scale is 297,000 metric tons of DDGS production per year.

(d) Large scale is 445,500 metric tons of DDGS production per year.

Table 7.4

Profitability Analysis of Using a Destoner to Fractionate DDGS ^(a)

	Small Scale ^(a)	Small Scale ^(b)	Small Scale ^(c)
Direct Fixed Capital	1,562,000 \$	4,071,000 \$	6,171,000 \$
Working Capital	2,170,000 \$	5,477,000 \$	8,177,000 \$
Startup Cost	78,000 \$	204,000 \$	309,000 \$
Total Investment	3,810,000 \$	9,751,000 \$	14,656,000 \$
Investment Charged to Project	3,810,000 \$	9,751,000 \$	14,656,000 \$
Revenue Rates			
High Protein DDGS (Main Revenue)	9,711 MT /y	24,279 MT /y	36,418 MT /y
Medium Protein DDGS (Revenue)	47,980 MT /y	119,951 MT /y	179,927 MT /y
Low Protein DDGS (Revenue)	60,752 MT /y	151,879 MT /y	227,819 MT /y
Revenue Price			
High Protein DDGS (Main Revenue)	224.27 \$/MT	224.27 \$/MT	224.27 \$/MT
Medium Protein DDGS (Revenue)	214.45 \$/MT	214.45 \$/MT	214.45 \$/MT
Low Protein DDGS (Revenue)	200.00 \$/MT	200.00 \$/MT	200.00 \$/MT
Revenues			
High Protein DDGS (Main Revenue)	2,178,000 \$/y	5,445,000 \$/y	8,167,000 \$/y
Medium Protein DDGS (Revenue)	10,289,000 \$/y	25,723,000 \$/y	38,585,000 \$/y
Low Protein DDGS (Revenue)	12,150,000 \$/y	30,376,000 \$/y	45,564,000 \$/y
Total Revenues	24,618,000 \$/y	61,544,000 \$/y	92,316,000 \$/y
Annual Operating Cost (AOC)	24,161,000 \$/y	60,999,000 \$/y	91,088,000 \$/y
Unit Production Cost / Revenue			
Unit Production Cost	2.49 \$/kg	2.51 \$/kg	2.50 \$/kg
Unit Production Revenue	2.53 \$/kg	2.53 \$/kg	2.53 \$/kg
Gross Profit (J-K)	456,000 \$/y	545,000 \$/y	1,228,000 \$/y
Taxes (40%)	182,000 \$/y	218,000 \$/y	491,000 \$/y
Net Profit	422,000 \$/y	713,000 \$/y	1,323,000 \$/y
Gross Margin	1.85%	0.88%	1.33%
Return On Investment	11.08%	7.32%	9.03%
Payback Time	9.03 years	13.67 years	11.08 years

(a) The prices are from 2013 and are shown in \$ USD.

(b) Small scale is 118,880 metric tons of DDGS production per year.

(c) Medium scale is 297,000 metric tons of DDGS production per year.

(d) Large scale is 445,500 metric tons of DDGS production per year.

Table 7.5

Executive Summary of Using a Destoner to Fractionate DDGS ^(a)

	Small scale ^(b)	Medium Scale ^(c)	Large Scale ^(d)
Total Capital Investment (\$)	3,810,000	9,751,000	14,656,000
Operating Cost (\$ per year)	24,161,000	60,999,000	91,088,000
Total Revenues (\$ per year)	24,618,000	61,544,000	92,316,000
Cost Basis Annual Rate (kg per year)	9,711,456	24,278,641	36,417,962
Gross Profit (\$ per year)	456,000	545,000	1,228,000
Unit Production Cost (\$ per one kg DDGS)	2.49	2.51	2.50
Unit Production Revenue (\$ per one kg DDGS)	2.53	2.53	2.53
Gross Margin	1.85%	0.88%	1.33%
Return On Investment	11.08%	7.32%	9.03%
Payback Time	9.03 years	13.67 years	11.08 years
IRR (After Taxes)	8.36%	3.52%	5.55%
NPV (\$)	317,000	2,158,000	1,452,000

(a) The prices are from 2013 and are shown in \$ USD.

(b) Small scale is 118,880 metric tons of DDGS production per year.

(c) Medium scale is 297,000 metric tons of DDGS production per year.

(d) Large scale is 445,500 metric tons of DDGS production per year.

Charter 8: CONCLUSIONS AND FUTURE WORK

8.1. Overall Conclusion

This dissertation represents a summary of the research project “Application of techno-economic analysis (TEA) and environmental impact assessment (EIA) in the agricultural biorefinery and bioprocess.” With pressure from the shortage of fossil fuels, bioethanol as a fuel additive has gradually increased to reach the demand for fuel. Conversion of corn to ethanol is a very efficient method in the US ethanol industry, and has grown rapidly in recent years. More than 95% of U.S. fuel ethanol plants use corn as a major raw material to produce ethanol. In corn-based fuel manufacturing, bioethanol, distillers dried grains with solubles (DDGS), and carbon dioxide are three main products. With the rapid development of the ethanol industry, various research on new technical applications of economic and environmental feasibility has been done in recent years.

Chapter 2 was a literature review that discussed related background information about four major topics: techno-economic analysis (TEA), environmental impact assessment (EIA), corn-based ethanol industry and integrated corn/soybean biorefinery. For the TEA and EIA topics, this dissertation chose background information and application to discuss the previous study. In the third topic, this dissertation chose five common physics properties, including background information, ethanol process, distillers dry grains solubles (DDGS) process and distillers dry grains solubles (DDGS) to discuss the results of previous study. Finally, the literature review discussed the application of integrated corn/soybean biorefinery and EAEP processes.

Chapter 3 attempted to calculate the cost and profits of the operations and equipment, which determined economic analysis for corn-based ethanol plants from 1982 to 2013. To perform economic calculations for new fractionation systems, SuperPro Designer was used for this techno-economic modeling. According to simulation results from the model, the corn-based ethanol plant had positive net profits from 1982 to 2016, but had larger volatility due to market price, which did not consider government support and other factors. Distillers wet grains made a 2% increase in profits and distillers corn oil made an extra \$3 million in profits per year.

To explore the difference of various possible affected factors, chapter 4 focused on comparing the efficiency and profit changes between the models of 40 and 120 million gallons ethanol plants. According to simulation results from the models, the 120 million gallons corn-based ethanol plant had positive net profits from 1982 to 2016 but had larger volatility due to market price. Compared to the 40 million gallons ethanol process, the 120 million gallons ethanol model had a better performance in unit production. By adding oil extraction, the 120 million gallons ethanol model had a higher efficiency on unit production revenue, which had the shortest payback time compared to the 120 million ethanol model without oil extraction and 40 million ethanol model with oil extraction.

Chapter 5 used techno-economic analysis (TEA) for developing complete estimates of all costs related to integrated corn and soybean biorefinery. This study also compared integrated corn and soybean biorefinery with the original corn-based ethanol process in economic performance to explore the effects of new applications on corn-based ethanol plants under 40 and 120 million gallon ethanol scales. According to the simulation results from the model, the integrated EAEP with corn-based ethanol process required more capacity

of equipment and utility, which caused a small increase of unit production. Adding the UIF and skim from EAEP, unit production revenue increased with more ethanol and other coproducts. Payback time also indicated the integrated EAEP with corn-based ethanol process had economic feasibility in an industrial application.

Chapter 6 focused on comparing the environmental impacts between the existing corn-based ethanol process and two modified bioethanol processes. In addition, the mass flow including raw materials usage, main product (ethanol), coproducts (DDGS and crude oil) and waste were also investigated. From the results of environmental impacts analysis, the corn-based ethanol industry was considered an environmental friendly industry, and a corn-based ethanol with oil extraction process had the best performance on the input component to environment. In addition, an integrated EAEP with corn-based ethanol process had the best performance on the output component to environment. This study explored the environmental feasibility of oil extraction and integrated EAEP with corn-based ethanol process in industrial applications.

To explore techno-economics of three different scales using a destoner process to fractionate DDGS, chapter 7 focused on the process of using destoner to fractionate distillers dried grains with solubles (DDGS) and resulted in three types of DDGS, which provided additional revenue to the ethanol plant. Through the simulated scenarios, it was concluded that destoner fractionation had the potential to play a vital role in increasing the market value of DDGS. The fractionation systems incorporated in this study increased the capital costs associated with the facility, but did not greatly affect the overall annual operating costs. The addition of fractionation, such as high protein DDGS, added revenue and improved the

profits of the plant. The overall profits of a destoner process in all scales were positive, but the net profit was still very low.

8.2. Future Work

In this dissertation, chapter 3 and chapter 4 simulated the corn-based ethanol process and explored the relationship between corn cost and ethanol plant profits. Research is still far from meeting the requirements of market forecasting in the bioethanol industry. However, amounts of studies explored that corn prices were partly determined by the weather and corn yield, which were mainly related to three key points: precipitation, temperature and carbon dioxide concentration (Diffenbaugh et al., 2012; Dixon et al., 1994; Lewis, 2010). More precipitation was positive to the corn field at similar climate factors, especially in the higher latitudes area (Wang et al., 2004; Kucharik & Serbin, 2008). Similar to precipitation, higher temperature was helpful to increase corn yield trends in higher latitude areas, while different stages of corn required various temperature levels to make final productions of the best quality and quantity (Jones et al., 1986). As a C4 plant, corn yield is sensitive to the change of carbon dioxide concentration. It is possible to investigate the relationship between weather conditions and corn price, which can help bioethanol plants forecast the trend of corn price and ethanol plant profit in advance.

Chapter 6 compared the environmental impacts between the existing corn-based ethanol process and two modified bioethanol processes. The main purpose of EIA in this dissertation was to ensure decision makers considered environmental values and justified decisions according to simplified environmental assessment and public comments on potential environmental impacts. EIA had a lack of capacity to supply reliable research on

net environmental impact from a global perspective. Life cycle assessment should be attempted to explore the effect of corn-based ethanol process on net environmental impact.

In this dissertation, the model simulation focused on the corn-based ethanol process, which included techno-economic analysis and environmental impact assessment. Similar to corn-based ethanol, cellulosic ethanol process was another popular topic in recent years. Amounts of cellulosic ethanol plants have been built in U.S. recently, which reflected the feasibility of cellulosic ethanol process in industrial production (Lynd et al., 2017). However, techno-economic analysis and environmental impact assessments on cellulosic ethanol processes are still lack of data and research in the industrial scale. What's more, both corn kernels and corn stover originate from the same plant, which created the possibility to study combinations of two types of bioethanol in industrial scale.

References

- Diffenbaugh, N. S., Hertel, T. W., Scherer, M., & Verma, M. (2012). Response of corn markets to climate volatility under alternative energy futures. *Nature Climate Change*, 2, 514.
- Dixon, B. L., Hollinger, S. E., Garcia, P., & Tirupattur, V. (1994). Estimating corn yield response models to predict impacts of climate change. *Journal of Agricultural and Resource Economics*, 58-68.
- Jones, C. A., Kiniry, J. R., & Dyke, P. T. (1986). *CERES-Maize: A simulation model of maize growth and development*. College Station, TX: Texas A& M University Press.
- Kucharik, C. J., & Serbin, S. P. (2008). Impacts of recent climate change on Wisconsin corn and soybean yield trends. *Environmental Research Letters*, 3(3), 034003.
- Lewis, K. E. (2010). *The impact of ethanol on corn market relationships and corn price basis levels*. East Lansing, MI: Michigan State University.
- Lynd, L. R., Liang, X., Bidy, M. J., Allee, A., Cai, H., Foust, T., ... & Wyman, C. E. (2017). Cellulosic ethanol: Status and innovation. *Current Opinion in Biotechnology*, 45, 202-211.
- Wang, R. Y., Zhang, Q., Wang, Y. L., Yang, X. G., Han, Y. X., & Yang, Q. G. (2004). Response of corn to climate warming in arid areas in Northwest China. *Acta Botanica Sinica*, 46(12), 1387-1392.