

2011

# Single-pass corn stover harvest system productivity and cost analysis

Keith Webster  
*Iowa State University*

Follow this and additional works at: <http://lib.dr.iastate.edu/etd>



Part of the [Bioresource and Agricultural Engineering Commons](#)

---

## Recommended Citation

Webster, Keith, "Single-pass corn stover harvest system productivity and cost analysis" (2011). *Graduate Theses and Dissertations*. 10411.

<http://lib.dr.iastate.edu/etd/10411>

This Thesis is brought to you for free and open access by the Graduate College at Iowa State University Digital Repository. It has been accepted for inclusion in Graduate Theses and Dissertations by an authorized administrator of Iowa State University Digital Repository. For more information, please contact [digirep@iastate.edu](mailto:digirep@iastate.edu).

**Single-pass corn stover harvest system productivity and cost analysis**

by

**Keith Edward Webster**

A thesis submitted to the graduate faculty  
in partial fulfillment of the requirements for the degrees of  
**MASTER OF SCIENCE**

Co-majors: Industrial and Agricultural Technology and Biorenewable Resources and  
Technology

Program of Study Committee:

Mathew Darr, Major Professor

D. Raj Raman

Stuart Birrell

William Edwards

Iowa State University

Ames, Iowa

2011

Copyright © Keith Edward Webster, 2011, All rights reserved.

## Table of Contents

List of Tables .....	v
List of Figures.....	viii
List of Equations.....	xv
Acknowledgements .....	xviii
Abstract.....	xix
Chapter 1.0 Introduction.....	1
Chapter 2.0 Literature Review .....	5
2.1 Introduction .....	5
2.2 Development of Single-pass Harvest Systems.....	5
2.2.1 Single-pass Cob Harvesting Systems .....	5
2.2.2 Single-Pass Bulk Harvesting Systems.....	7
2.2.3 Single-Pass Bale Harvesting Systems .....	8
2.3 Single-Pass Harvest System Performance Analysis .....	8
2.3.1 Single-Pass Bulk Harvest Systems.....	8
2.3.2 Single-Pass Baling Harvest Systems .....	10
2.4 Harvest Economics.....	11
2.4.1 Single-Pass Harvest Systems .....	11
2.4.2 Multi-Pass Harvest Systems.....	11
Chapter 3.0 Objectives .....	13
Chapter 4.0 Data Logging .....	16
4.1 Introduction .....	16
4.2 Materials and Methods.....	16
4.2.1 CyCAN Data Logger.....	16
4.2.2 Data Parameters.....	20
4.2.2.1 CAN Data .....	20
4.2.2.2 Serial Data .....	27
4.2.3 Data Processing .....	28
4.2.3.1 CAN Data .....	28

4.2.3.2 Serial Data .....	29
4.3 Results .....	31
4.4 Conclusions .....	32
<b>Chapter 5.0 Single-Pass Harvest System Productivity.....</b>	<b>33</b>
5.1 Introduction .....	33
5.2 Materials and Methods .....	33
5.2.1 Combine and Header .....	33
5.2.1.1 Combine .....	33
5.2.1.2 Header.....	35
5.2.2 Harvest System Testing Configurations.....	37
5.2.2.1 Conventional Harvest System .....	37
5.2.2.2 Single-Pass Bulk Harvest System .....	38
5.2.2.3 Single-Pass Baling Harvest System.....	42
5.2.3 Data Logging.....	46
5.2.4 Data Processing .....	46
5.2.4.1 Ag Leader SMS Advanced.....	47
5.2.5 In-Field Testing .....	50
5.2.5.1 In-Field Test Setup .....	50
5.2.5.2 In-Field Test Procedure .....	56
5.2.5.3 Yield Monitor Calibration .....	57
5.2.6 Productivity Statistical Analysis .....	58
5.3 Results .....	64
5.3.1 Productivity Analysis Results .....	64
5.3.1.1 System Productivity Analysis.....	64
5.3.1.2 Amount Harvested Analysis.....	65
5.3.2 Productivity Prediction Equation .....	68
5.4 Conclusions .....	69
<b>Chapter 6.0 Single-Pass Harvest System Performance .....</b>	<b>70</b>
6.1 Introduction .....	70
6.2 Materials and Methods.....	70
6.2.1 Field Speed and Fuel Consumption .....	70

6.2.2 Power Analysis.....	71
6.3 Results .....	72
6.3.1 Fuel Consumption Analysis .....	72
6.3.2 Speed Analysis .....	75
6.3.3 Power Analysis.....	77
6.3.4 Baler Power Analysis .....	79
6.4 Conclusions .....	84
Chapter 7.0 Single-Pass Baling Economics .....	85
7.1 Introduction .....	85
7.2 Material and Methods .....	85
7.2.1 Input Page.....	86
7.2.2 Output: Combine .....	95
7.2.3 Output: Grain Cart and Tractor .....	100
7.2.4 Outputs: Baler and Collection .....	102
7.2.5 Output: Cumulative Costs .....	105
7.2.6 Output: Total Gross Loss .....	107
7.3 Results .....	109
7.3.1 Cumulative Costs .....	109
7.3.2 Stover Removal System Costs .....	111
7.3.3 Machine Cost Breakdown .....	115
7.4 Conclusions .....	121
Chapter 8.0 Conclusions.....	124
8.1 Results .....	124
8.2 Recommendations .....	126
8.3 Future Work .....	127
Chapter 9.0 Bibliography .....	128

## List of Tables

Table 1: Treatment factors and detailed levels of testing performed during fall 2010 harvest machine testing and model based cost analysis of single-pass baling of corn stover.....	14
Table 2: Diagnostic descriptions that refer to the LED's embedded within the CyCAN's logger. ....	18
Table 3: CAN database for specific data messages referenced by PGN, the sample rate (Hz), description of placement in the message, conversion factors, and engineering units for the combine.....	22
Table 4: CAN database for specific data messages referenced by PGN, the sample rate (Hz), description of placement in the message, conversion factors, and engineering units for the combine.....	23
Table 6: CAN database for specific data messages referenced by PGN, the sample rate (Hz), description of placement in the message, conversion factors, and engineering units for the tractor.....	24
Table 5: CAN database for specific data messages referenced by PGN, the sample rate (Hz), description of placement in the message, conversion factors, and engineering units for the combine.....	24
Table 7: CAN database for specific data messages referenced by PGN, the sample rate (Hz), description of placement in the message, conversion factors, and engineering units for the tractor.....	25
Table 8: CAN database for specific data messages referenced by PGN, the sample rate (Hz), description of placement in the message, conversion factors, and engineering units for the Baler Engine. ....	25
Table 9: CAN database for specific data messages referenced by PGN, the sample rate (Hz), description of placement in the message, conversion factors, and engineering units for the Baler Monitor.....	26
Table 10: Sample of CAN data messages logged by the data logger. ....	28
Table 11: Breakdown of the serial data for the scale and GPS data over the two serial channels of data.....	30

Table 12: Summary of serial channels and filter components to process serial data. ....	30
Table 13: List of machine configurations and settings for the systems used during the testing of the machines.....	45
Table 14: Final summary of the total test passes harvested by the harvest configuration and amount of stover collected based upon header setting. ....	55
Table 15: Variables into the economic model used to analyze single-pass baling. Data from the 2010 harvest was used to set the boundaries of this model but not tied directly to the output of the model. ....	86
Table 16: Inputs factored into the economic model for the determination of the single-pass baling system harvest cost. These input were based off of typical machines industry today or in field data from the 2010 harvest. ....	87
Table 17: Inputs factored into the economic model for the determination of the single-pass baling system harvest cost. These input were based off of typical machines industry today or in field data from the 2010 harvest. ....	88
Table 18: List of fuel consumption inputs into the economic model for analysis. ....	89
Table 19: Coefficients for determine machine salvage value from the ASABE Standard 497.7. (ASABE, 2011).....	91
Table 20: Estimated lifespan of purchased equipment for harvest. Based upon the average lifespan of equipment from the ASABE Standard D497.7. (ASABE, 2011) .....	92
Table 21: Capital prices for machinery for determining capital costs based upon the 2010 harvest. ....	92
Table 22: Rental cost for tractors which were considered a multi-use machine over the year besides harvesting and the self-propelled bale collector which was could be used to move bales at different times of the year. ....	94
Table 23: Repair factors and estimated life expectancy of machine for calculating machine repair cost based upon ASABE standard D496.3 (ASABE, 2006). Repair factors were used with no adjustment for corn stover harvest. ....	100

Table 24: The assigned cost categories that each machine was analyzed for based upon how they were factored for cost either rental cost or capital purchase cost. .... 105

Table 25: Summary of combine productivity analysis of the different harvest systems at harvest rates from 0-12 rows of collection. As harvest rates increase the productivity is reduced and productivity is reduced when the baler is pulled behind the combine. .... 125

Table 26: Summary of cost based on the 2010 harvest documented harvest and productivity reduction rates. Lower productivity reduction rates will have less cost but less stover will also be collected to offset these cost. .... 126



## List of Figures

Figure 1-1: A comparison of the cut height for a single-pass and the multi-pass harvest. ....	3
Figure 2-1: AGCO corporation's Challenger single-pass baler harvest system.....	6
Figure 2-2: John Deere's and Hillco's single-pass cob harvester system developed in collaboration with Iowa State University. ....	6
Figure 2-3: Vermeer Manufacturing's single-pass cob harvester system.....	7
Figure 2-4: Shinners et al. analysis of machine performance versus cut height or amount of stover harvested. ....	9
Figure 4-2: ISOBUS CAN diagnostic port connector (right) and associated pin out used to plug into compatible machines. Pins A, B, C, and D were used. ....	17
Figure 4-1: The CyCAN datalogger used for logging data in-field during testing.....	17
Figure 4-3: The compact flash card the CyCAN data logger used to record captured data to.....	18
Figure 4-4: Example CAN data file. Each line of data is segmented into one second intervals in the processing sheet and represents the real time performance of the machine. ....	20
Figure 4-5: Resulting data file of test data after processing of CAN and serial data captured from testing. ....	31
Figure 4-6: Plot from data processing Excel Macro displaying data from a test pass.....	32
Figure 5-1: John Deere 9860 test combine used in field tests. ....	34
Figure 5-2: Detail pathway of the major grain and stover processing areas of the conventional combine used in testing. ....	34
Figure 5-4: Interval plot graph of the stover yield for each row configuration tested in the bulk harvest test cases. ....	36
Figure 5-5: Range of harvested dry tons per hour of stover removed. ....	36
Figure 5-6: Example of stover left behind in the field due to not having the hydraulic spreaders on the combine.....	37

Figure 5-7: Detailed pathway of corn plant pathway through the combine, stalks and residue are left on the ground at the header and grain and MOG are passed through the separator.....	38
Figure 5-8: View of combine chopper to bulk attachment's blower drive pulley, the drive belt connects these two pulleys when the bulk harvest system was operating and was disconnected when it was not used. ....	39
Figure 5-9: Detailed pathway of material from combine chopper through blower and out the spout or directing material onto the ground. ....	39
Figure 5-10: Combine in bulk stover collection configuration conveying stover into the Oxbo 1516 cart being towed by a John Deere tractor. This was one of the configurations tested. ....	41
Figure 5-11: Detail diagram of the power distribution and pathway for the corn stover through the combine and the bulk harvest attachment.....	41
Figure 5-12: Pathway of stover and grain from entering the combine through the header to the grain tank and through the back of the combine into the baler. ....	42
Figure 5-13: General layout of the components of the baler along with the modified components (conveyor and engine) for single-pass corn stover harvesting. ....	43
Figure 5-15: The John Deere 9860 with the AGCO 4790 single-pass baler harvesting grain and stover.....	44
Figure 5-14: Block diagram showing the power distribution through the combine from the combine engine and baler engine along with showing the pathway of the stover and grain through the combine and baler. ....	44
Figure 5-15: Testing area layout displaying the variation in the yield across the field and why the yield was a factor in machine productivity calculation. Green shaded areas are higher yielding areas and red shaded areas are lower yielding areas. ....	48
Figure 5-16: Single test pass laid out in SMS advanced prior to trimming the data for steady state determination of the performance of the machine.....	49
Figure 5-17: Separate layout of the higher-moisture grain field harvested for testing the combine. Each pass was laid out and assigned a number which is in the	

lower portion of the pass description was the running total of passes assigned throughout testing. .... 51

Figure 5-18: Layout of the field for testing the combine, baler, and bulk harvest systems with estimations of the layout of the field and adjusted after the field was opened and crop conditions were assessed. .... 52

Figure 5-20: Recorded precipitation for the 2010 fall harvest season demonstrating the below average rainfall received for the month in Ames, Ia. (National Oceanic and Atmospheric Administration's, 2011). .... 53

Figure 5-20: Average crop flow data recorded by the combine's yield monitoring system during testing. The conventional test shows a decreased crop flow compared to the bulk and baling configurations which was not a predicted outcome. .... 60

Figure 5-21: Average speed of the combine during the test from the combine. Speed is more consistent across the configurations and shows a predicted drop off as more stover is harvested. .... 61

Figure 5-22: Estimated average yield of the test passes from the combine's yield monitoring system. The conventionally harvested passes are lower than the bulk and baling configurations. .... 62

Figure 5-23: Combine engine loading % @ speed (engine rpm), for the test passes the lower harvest rates show that the engine is not loaded fully until more stover is introduced. The engine loading also increases when the baler is being towed by the combine. .... 63

Figure 5-24: Plot of normalized productivity of the combine in each harvest system over 3 different harvest rates. This shows the combine's productivity is reduced as the amount of corn stover is increased and when the baler is towed behind the combine. .... 65

Figure 5-28: Diagram of header row unit the stalk will reach the back of the stripper plates before it is completely pulled down by the stalk roll. When this happens the entire stalk will push over instead of straight down. .... 67

Figure 6-1: Fuel consumption of the combine, tractor, and baler in liters per hour based on harvest system configuration and stover collection rate. The fuel consumption reflects the loading of the engine loading, when the loading is higher the fuel consumption will reach close to the maximum fuel consumption for the machine..... 73

Figure 6-2: The typical breakdown of grain and stover harvested per acre by collection configuration and header rows. The total yield reflects the maximum capacity of the combine. .... 74

Figure 6-3: Fuel consumption of the combine, baler, and tractor based upon total tons of material harvested. The combine- grain and stover; tractor and baler- stover. As the combine is slowed by collecting a higher concentration of corn stover the fuel consumption is increased. .... 75

Figure 6-4: Actual combine speed from in-field testing versus predicted speed if combine was not head limited. This shows that the header is a larger limiting factor in productivity than the baler..... 76

Figure 6-5: Total horsepower used by the combine, tractor, and baler in grain harvest and corn stover collection. This reflects a similar trend to fuel consumption because horsepower is a direct calculation from fuel consumption. .... 77

Figure 6-6: Horsepower used to by the combine, tractor, and baler just to collect corn stover. The horsepower requirements increase as more rows of stover are harvested and the amount of material passing through the combine increases. .... 78

Figure 6-7: Number of plunges the plunger of the baler made each new flake. As the collection rate increases the number of plunges per flake decrease as more the stuffer conveys more material into the baler. The ideal plunges per flake number for a baler is near 1 plunge per flake. .... 79

Figure 6-8: Time-series plot for 0 row collection stover collection for the towed baler. The plot show the variability in power output of the engine as the baler was in operation due to varying rates stover being fed into the baler and different plunger loads based on those rates. .... 80

Figure 6-10: Time-series plot for 12 row collection stover collection for the towed baler. As the baler requires more power to operate from the higher rates of stover being collected the engine load will approach 100% but also consistently stay higher on the cyclical load because of the higher loads on the baler..... 81

Figure 6-9: Time-series plot for 6 row collection stover collection for the towed baler. As the harvest rate increases the power consumption of the baler will become raise and also grow closer together due to plunges being closer together. .... 81

Figure 6-11: Normal distribution curve for the 0 row collection collection rate of the baler engine power load. At lower collection rates the baler power required was lower to operate the baler as shown in the curve..... 82

Figure 6-12: Normal distribution curve for the 6 row collection collection rate of the baler engine power load. As the power requirement of the baler increased due to the higher rates of stover collection the curve became better distributed..... 83

Figure 6-13: Normal distribution curve for the 12 row collection collection rate of the baler engine power load. As the higher rates of stover intake were experienced the baler required more power, this power requirement was cyclical based upon the plunger position and stuffer actuation. .... 83

Figure 7-1: The average trend in harvest progress for Iowa for the last 11 years based upon culmulative progress of the corn harvest. Markers are placed 10% for early harvest progress and 90% for late harvest progress. 80% of the crop is removed in under 30 days. .... 90

Figure 7-3: Total cumulative cost per ton for grain and stover harvest in the conventional configuration. As the harvest rate increases (ton/acre) the cost to harvest decreases as more cost was distributed amongst the higher rates of stover..... 110

Figure 7-2: Total cumulative cost per acre for grain and stover harvest in the conventional configuration. The cost to normally harvest corn remains steady

while the cost to harvest the stover varies according to the productivity of the combine..... 110

Figure 7-5: Cost per ton for harvesting stover at harvest rates between .5 tn/ac and 2.5 tn/ac with the factor of productivity reduction on the combine. Productivity reductions are not tied to a specific combine..... 112

Figure 7-4: Cost per acre for harvesting stover at harvest rates between .5 tn/ac and 2.5 tn/ac with the factor of productivity reduction on the combine. Productivity reductions are not tied to a specific combine. .... 112

Figure 7-6: Total cost per acre for each machine system based upon the amount of stover harvested (tn/ac) and the reduction in productivity (%) for a combine harvesting stover. .... 114

Figure 7-7: Total cost per ton for each machine system based upon the amount of stover harvested (tn/ac) and the reduction in productivity (%) for a combine harvesting stover. .... 114

Figure 7-8: Total cost per ton for the combine to harvest stover broken down into seven cost categories for analysis based upon cost data from the ASABE D497 standard and current machine prices. .... 115

Figure 7-9: Total cost per ton for the grain cart and tractor to harvest stover broken down into seven cost categories for analysis based upon cost data from the ASABE D497 standard and current machine prices..... 117

Figure 7-10: Total cost per ton for the single-pass baler to harvest stover broken down into eight cost categories for analysis based upon cost data from the ASABE D497 standard and current machine prices..... 118

Figure 7-12: Total cost per acre for the single-pass baler to harvest stover broken down into eight cost categories for analysis based upon cost data from the ASABE D497 standard and current machine prices..... 120

Figure 7-11: Total cost per ton for the single-pass baler to harvest stover broken down into eight cost categories for analysis based upon cost data from the ASABE D497 standard and current machine prices..... 120

Figure 7-13: Comparison of the average amount of bales per hour collected versus  
the average amount of bales per hour produced by the baler by harvest rate  
and productivity reduction interval. .... 121

## List of Equations

Equation 1: General formula for calculation of bits of data in a CAN message. ....	29
Equation 2: Productivity Index Equation.....	58
Equation 3: Regression equation for predicted Productivity Index .....	68
Equation 4: Determination of the Fuel Equivalent Power. (Goering & Hansen, 2004) .....	71
Equation 5: Calculation for determining the actual mechanical power used by the stover harvest machines in the analysis. ....	72
Equation 6: Salvage Value Equation based upon ASABE factors salvage values (ASABE, 2011).....	91
Equation 7: Calculation for determining the salvage value price for a machine based upon the ASABE Salvage Value Equation and capital value of a machine for the 2010 harvest. ....	92
Equation 8: Calculation for determining the depreciation for a machine Turhollow et al (2009). ....	93
Equation 9: Calculation for determining interest for a machine Turhollow et al (2009). ....	93
Equation 10: Time per hour spent harvesting based upon time for turning machine, unloading grain while harvesting, and miscellaneous stops. ....	96
Equation 11: Calculation for determining the percent of the hour used for grain unloading based upon the ratio of grain entering the combine and the amount of grain being unloaded and percent of time the combine is stopped to unload.....	97
Equation 12: Calculation for determining bushels per hour harvested by the combine base upon the total time per hour spent harvesting and crop flow into the combine. ....	97
Equation 13: Calculation for determination of acres per hour harvested by the combine based upon the total bushels per hour harvested and the average yield inputted into the model. ....	98
Equation 14: Calculation for the determination of acres per day harvested by the combine based upon the average working hours per day and the acres per hour harvested. ....	98



Equation 15: Calculation for the determination of acres per year harvested by the combine based upon the average working days in Iowa for corn harvest and the average acres per day harvested..... 98

Equation 16: Calculation for the determination of fuel consumption on a per acre basis based upon the estimated fuel per hour consumed and the acres per hour harvested. .... 99

Equation 17: Repair and maintenance cost equation from the ASABE standard D496.3. (ASABE, 2006)..... 99

Equation 18: Calculation for the amount of time spent filling the grain cart based upon the unload capacity of the combine and the total bushels per hour harvested by the combine..... 100

Equation 19: Calculation for the determination of the number of cycles the grain cart would make in one hour based upon the amount of grain harvested and the grain cart capacity. .... 101

Equation 20: Calculation for the determination of travel time in-field for the grain cart and tractor based upon in-field travel speed of the grain cart and tractor to and from the combine and the dump site. .... 101

Equation 21: Calculation for the determination of time to unload the grain cart based upon the grain cart’s capacity, unload rate and the number of time per hour it will need to unload..... 102

Equation 22: Calculation for determining the total amount of time spent waiting by the grain cart and tractor per hour for the combine to be ready to unload based upon the grain cart unload time, time for the combine to fill the cart, and the travel time of the grain cart. .... 102

Equation 23: Calculation for determining the number of bales per acre made by the baler based upon the density, size, and tons per acre of stover harvested. .... 103

Equation 24: Calculation for determining the number of bales per hour being produced based upon the average bales per acre produced and the acres per hour harvested. .... 103

Equation 25: Calculation for determining the cost of the string per bale based upon the string cost, length of string used on the bale and in the roll, and bale size. ....	104
Equation 26: Calculation for the determination of acres per hour covered by the bale collector based upon the average amount of bales per hour collected and the bales per acre produced by the baler. ....	104
Equation 27: Calculation for determining the cost per hour of fuel consumption based upon the average fuel consumption per hour, fuel cost, and the surcharge for lubrication based upon ASABE standards. ....	106
Equation 28: Calculation for determining cost per acre of the stover harvest machines for fuel as based in Equation 27 and for other hourly costs as well. ....	106
Equation 29: Calculation for determining cost per ton of the stover harvest machines based off of the cost per hour in Equation 27 and the tons per hour of stover harvested. ....	107
Equation 30: Calculation for determining the stover harvest cost of the combine found by taking the cost to operate a normal harvest from the additional cost to harvest stover. ....	108
Equation 31: Calculation for determining the stover harvest cost of the grain cart and tractor which was found by taking the cost to operate a grain cart under normal harvested condition and subtracting it from the cost to operate when harvesting stover. ....	108
Equation 32: Calculation for determining the stover harvest cost of the grain cart and tractor which was found by adding the cost difference of the operation of the combine, baler, bale collection machine, and grain cart. ....	109

## Acknowledgements

I would like to thank the North Central Regional Sun Grant Center at South Dakota State University through a grant provided by the US Department of Energy Office of Biomass Programs under award number DE-FG36-08GO88073 for providing funding for this work. Dr. Mathew Darr provided direction, assistance, and guidance throughout this project. I would also like to acknowledge Dr. D Raj Raman, Dr. Stuart Birrell, and Dr. William Edwards for their help and guidance.

I would also like to thank the following industry partners and representatives for providing the machines for testing as well as technical support. John Deere: Mark Chaney, Seth Williams, Aaron Bruns, Kevin Ehrecke, and Aj Mertz. AGCO Corporation: Brian Olander, Pat Kendrick, and Maynard Herron. Stinger Ltd: Justin Matlack and Karl Matlack.

The following facilities and facility employees should also receive mention for their logistic support: BioCentury Research Farm, Andy Suby, Iowa State Research Farms, Kent Berns, Agricultural Engineering and Agronomy Farm, Jeff Erb, Richard Vandepol, and Mike Fiscus.

Finally, I would like to recognize the numerous graduate students who worked countless hours during fall testing including Curt Thoreson, Robert McNaull, Jeremiah Johnson, Jonathon Roth, Jeff Zimmerman, and John Kruckeberg. Also a special mention should also go to “Big Matteo” Matteo Zuchelli who helped tremendously during the 2009 harvest. There were numerous undergrads that provided support at some point as well: Kent Thoreson, Joe Klaes, Levi Powell, Eric Fredickson, Karl Moritz, Chris Hoffman, and Kevin Cordray. There also are numerous others whom I have forgotten and would like to acknowledge.

My family should also be thanked for their steadfast support of my graduate education.

## Abstract

To supply a cellulosic ethanol plant that can produce upwards of 30 million gallons of fuel annually, it will take over 300,000 tons of clean corn stover a year. To supply this stover demand, a combination of multi-pass and single-pass harvest systems will be required. Harvesting this amount of corn stover has never been achieved at a commercial scale before. Multi-pass systems are typically used in the harvest of hay and forage crops as well as for some small-scale corn stover collection for livestock feed and bedding. Furthermore, the baseline costs and the productivity effects of multi-pass machines on grain and stover harvest are known. In contrast, such knowledge has not been developed for single-pass stover harvest systems.

Two single-pass stover harvest systems have been identified as potentially viable: bulk harvesting and baling, each of which has distinct advantages and disadvantages. However, single-pass baling has inherent logistical benefits over bulk harvesting that make it more desirable for future development. The objective of this research was to explore and document the effects of additional corn stover passing through currently designed combines on productivity. Another objective was to use the knowledge base to develop cost functions for harvesting corn stover and delivering it to the field edge. Together, these objectives provide a critical cost and performance data not currently available for production level machinery.

## Chapter 1.0 Introduction

Corn grain ethanol has been a staple in the renewable energy portfolio of the United States for many years. From its initial start to present it has undertaken a long and tenuous process of trial and error with the rapid development of the industry only coming in the last 10 years since 2000. The Energy Independence and Security Act of 2007 (EISA, 2007) mandated that advanced biofuels such as cellulosic ethanol be produced at a rate of 79.38 billion liters (21 billion gallons) per year by 2022. In 2011, renewable fuels including corn grain ethanol were only mandated to produce 52.9 billion liters (13.95 billion gallons) of fuel. Of this amount, advanced biofuels including cellulosic biofuels were to produce 5.1 billion liters (1.35 billion gallons) of that total. Cellulosic biofuels were mandated to produce .95 billion liters (.25 billion gallons) of fuel. Cellulosic biofuels must develop methods and build up infrastructure that will support the production of 60.5 billion liters (16 billion gallons) of the 136 billion liters (36 billion gallons) of total renewable fuels made in the United States by 2022 or in the next 11 years. Compare this to corn grain ethanol which has been subsidized since the start of the National Energy and Conservation Act of 1978 (California Energy Commission, 2004). It was produced on a smaller scale initially which allowed it to develop a supply infrastructure. Cellulosic biofuel infrastructure development will need to be much more rapid. Cellulosic biofuels while not a new idea have had far less time to perfect its supply infrastructure with movement to large scale production only beginning to be developed. Not only do feedstocks need to be identified that can produce biofuels efficiently, but systems must be developed to harvest the feedstock, transport the feedstock to the plant, and process the feedstock into a convertible product. One feedstock, corn stover, has been identified as a potential feedstock in the Midwest United States due to its wide availability (Hettenhaus & Wooley, 2000). Research is now under way to efficiently collect, transport and process corn stover.

Corn stover has been mainly relegated to ground fodder in current harvest systems. Harvesting technology has evolved since removing the plant and ear from the field using a corn binder in the early 1900s and storing the bundles (Gray, 1898). The next method for harvest was using an ear corn harvester for harvesting the ear of corn. Now current combines

harvest and separate the kernels of corn from the cob. Once, the corn grain is harvested the leftover corn stover is either returned to the ground and allowed to deteriorate for next year's planting or collected in small multi-pass systems for use as animal feed and bedding.

Most plant material is returned to the soil in current corn cropping systems. While it is the least labor intensive method of getting rid of the excess material it does present challenges. Development of higher yielding and more resistant varieties of corn to disease and insects has in many producers' opinions made it more difficult to breakdown the remaining plant residue over the winter period and hampers new crop planting in the spring. Now some producers will take additional passes over the field with extra tillage or shredders in order to enhance material breakdown either in the fall or spring (Hanna & Al-Kaisi, 2008).

The current design of the multi-pass collection systems for livestock systems emphasizes quantity rather than quality of material harvested. However, for the renewable energy future this thinking must be changed to improve quality and to address sustainability concerns. New constraints to harvesting will be introduced such as moisture content and quality much like corn grain is currently subjected to. One way to improve material quality is to use a single-pass harvest and collection system. Single-pass systems take the higher portion, which has less nutrient value and more stable moisture content than other sections of the plant (Karlen, 2008). Multi-pass system will harvest almost all of the lowest part of the plant that has the highest moisture and nutrient levels (Johnson, et al., 2010). Single-pass harvest systems have a selectable height and therefore infinite harvest rate with the typical harvest height of within one foot below the ear as shown in Figure 1-1. Single-pass harvest systems have been under development for many years now. The initial single-pass harvester was developed (Rosenthal, 1950) and continues in development today. The two systems that have emerged as possible solutions to maximize collection and harvest of corn are a bulk harvest system and a baling harvest system.

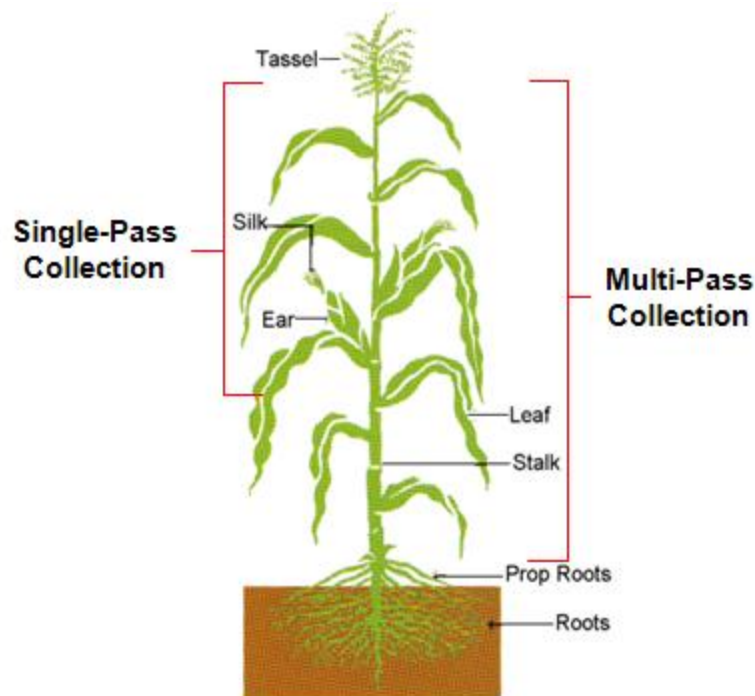

**Figure 1-1: A comparison of the cut height for a single-pass and the multi-pass harvest.**

The towed bale system or single-pass baling harvest system has been analyzed but no production scale economic studies have been produced that can be used by the producer or end user to determine the applicability of this technology. Production scale economic and productivity data will help establish the predicted economic value of corn stover to the producer to ensure a profit for the extra work that will come along with collecting corn stover. There was also very little data collected to evaluate the effects of the additional stover harvested, weather conditions, and collection systems on the productivity of the combine. The lack of this information can lead to inaccurate predictions of collection costs. It can also hinder further investigation into systems which can improve harvesting.

Some of these questions and lack of knowledge was addressed by quantifying performance data from prototype single-pass harvest machines, productivity of bale collection machinery, and cost to harvest and collect corn stover to the field edge. The testing conducted at the BioCentury Research Farm, Agricultural Engineering and Agronomy Farm, Iowa State Research and Demonstration Farms, and Iowa State Agricultural and

Biosystems Engineering Department produced a comprehensive dataset of machine performance factors which provided a basis to make these quantifications. This data along with a predictive model will attempt to quantify reduction in overall machine performance, cost of the performance reduction, cost of stover collection, and the significant factors for improvements in machine performance.



## Chapter 2.0 Literature Review

### 2.1 INTRODUCTION

Corn stover harvesting is still in its infancy in terms of supplying a commercial scale biorefinery. Initial commercialization methods have started with multiple pilot scale commercial harvests. Single-pass harvesting which is potentially the next step in the development of the new era in corn stover collection has just started with new machinery design concepts. Testing and analysis of the machines' in-field productivity will develop a baseline database which performance can be measured and improved. It will also help determine the cost of production in the single-pass harvest configuration.

### 2.2 DEVELOPMENT OF SINGLE-PASS HARVEST SYSTEMS

#### 2.2.1 SINGLE-PASS COB HARVESTING SYSTEMS

One of the most challenging issues in the cellulosic biofuel industry was determining what needed to be developed first; the plant and process to make the fuel or the equipment to harvest the material. POET Biorefining started Project Liberty which was due to open in 2012 and produce 94.75 million liters (25 million gallons) per year of cellulosic ethanol from corn cobs (POET Biorefining, 2011). The promotion and anticipated opening of this plant has led to the development and commercialization of biomass harvesting equipment. This plant supply strategy was largely based around commercial cob harvesting initially. The next step beyond corn cobs was corn stover which was investigated throughout the industry and is headed towards commercialization by DuPont Danisco Cellulosic Ethanol in 2013 (Dupont Danisco Cellulosic Ethanol LLC, 2011).

Today there are many single-pass harvest systems that are nearing commercial production. AGCO Corporation of Duluth, Georgia currently is developing a single-pass baling harvest system that will bale material other than grain (MOG) which consists primarily of husks and cobs from their production combine. The Challenger LB34B single-

pass baler can produce 1.2 x .875 m (4 x 3 ft) bales at various lengths up to 2.7 m (8 feet) (AGCO Corporation, 2010).



**Figure 2-1: AGCO corporation's Challenger single-pass baler harvest system.**

Another single-pass harvest system nearing commercial production is the Hillco Technologies Cob Collection Attachment. This system attaches to the back of a John Deere STS series combine. Unlike the Challenger Baler, Hillco Cob Attachment collects cob material and MOG through a modified chopper and blower system that conveys material either into a towed cart or a cart that is towed by a tractor beside the combine (Hillco Technologies, 2010).



**Figure 2-2: John Deere's and Hillco's single-pass cob harvester system developed in collaboration with Iowa State University.**

The final system currently nearing commercial release is from Vermeer Manufacturing in Pella, Iowa. This combine-towed system collects cobs and MOG by collecting the material as it exits the back of the combine. Like the Hillco Technologies cob attachment it collects a loose bulk material that has low bulk density. Unlike the AGCO Challenger baler or the Hillco Technologies Cob Attachment this system is self-contained with an 86 kW (115 hp) motor attached to the machine and does not take power from the combine for operation (Vermeer Manufacturing, 2009).



**Figure 2-3: Vermeer Manufacturing's single-pass cob harvester system.**

### 2.2.2 SINGLE-PASS BULK HARVESTING SYSTEMS

The dual stream single-pass corn stover harvest systems that exist, beyond the current cob harvest systems, are currently still in a preproduction research phase. At Iowa State University development of an attachment that will attach to the back of a combine that will convey stover into a wagon that is towed by a tractor is currently being investigated (Schlesser, 2007). This system has been analyzed and developed at both Iowa State University by Dr. Stuart Burrell and at the University of Wisconsin Madison by Dr. Kevin Shinnars.

Beyond this system, the closest commercially developed machinery available today is a single-pass forage harvester. Numerous companies commercially produce these units that will process corn or other crop and convey it into an awaiting collection vehicle. These systems can have large engine systems consisting of one or more engines like the CLAAS Jaguar 980 which is powered by two 12.8 L engines (640 kW, 857 hp) (CLAAS, 2011). One undesirable trait for corn stover collection is that there is no separation of grain from the

material stream. To separate the grain from the wet material stream would be very hard even though it is one of the least expensive forms of collection as Shinnars et al. (2003) reported.

### 2.2.3 SINGLE-PASS BALE HARVESTING SYSTEMS

The implementation of the single-pass baling harvest system started in the 2000's on the Glenvar Farm in Western Australia. The Glenvar Farm was originally looking for a way to collect wheat straw from the back of the combine in order to catch weed seed that had become hard to control in their fields. The first single-pass baler developed was a small square baler which worked successfully but was limited by the overall throughput of the machine and collection logistics. Later the farm moved to a large square baler in order to achieve the desired throughput, higher bale densities, and bigger bales (Glenvar Bale Direct, 2007). A partner company, Tuthill Drive Systems, has now started marketing and selling the balers in the United States for the same purposes. These systems are being used to produce anywhere from 0.9 - 3.2 Mg (1 – 3.5 ton) of wheat straw per acre. The baler draws its power completely from the combine's engine and chopper drive system while material is conveyed from the rear of the combine into the baler by a conveyor system. Tuthill Drive System has now started to enter the corn stover harvesting market by using the same configuration in the Midwest and marketing to corn cob producers (Mud Hog, 2011).

## 2.3 SINGLE-PASS HARVEST SYSTEM PERFORMANCE ANALYSIS

### 2.3.1 SINGLE-PASS BULK HARVEST SYSTEMS

Single-pass corn stover harvest systems have been available for analysis in the past; some of the first analysis of performance of modern single-pass combines set to collect stover was performed by Shinnars et al. (2005). The test field was prepared by removing the headlands and laying out twelve 150 m (500 ft) long by 4.6 m (15 ft) wide passes in which the four treatments could be replicated three times. The combine then harvested the test strips in which the ground speed was varied in order to keep engine speed at 2260 rpm for similar loading of the machine. Time across the plot was recorded to calculate average ground speed, stover mass flow, and grain mass flow.

Results from this testing showed stover mass flow rates increased as the whole crop header height decreased. This was done until the combine had to slow down in order to maintain its engine speed. This showed that stover mass flow was a limiting factor in performance. As header height increased and less stover was taken in by the whole crop head and the conventional ear snapper head, grain flow became a limiting factor for combine performance. The two corn heads produced a comparable difference in stover mass flow. The whole crop head obtain a stover mass flow of 13.5 kg per second (30 lbs per second) dry matter while the ear-snapper head produced 8.1 kg per second (17.8 lbs per second) dry matter. This is further demonstrated in Figure 2-4 as this chart shows how as the combine was slowed by either increased stover mass flow or increased grain mass flow. It also demonstrated that productivity was tied to stover mass flow and grain mass flow. Overall, harvesting stover with the whole crop head at its lowest height was shown to reduce combine productivity by 50%.

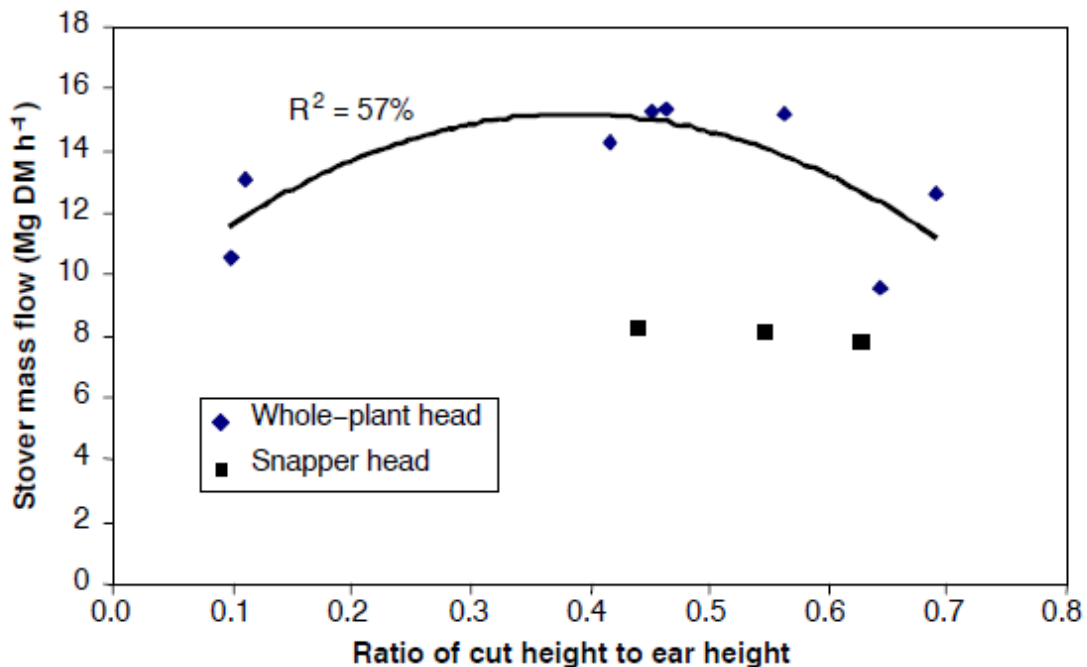

Figure 2-4: Shinnars et al. analysis of machine performance versus cut height or amount of stover harvested.

Shinners et al. (2009) followed up this research by modifying the current combine design and also testing new header concepts. Similar results were seen in performance between the ear-snapper head and the whole-plant head. While the adapted stalk-gathering head did allow for better productivity, it also experienced plugging issues due to stalks being lodged into the spout. The whole-plant head consumed the most fuel in both a per unit mass (42% greater) and per unit area basis (96% greater). The analysis of machine performance versus ground speed yielded that the combine was unable to achieve the top level speed desired and only reached 3.5 kph for the whole-plant head and 6.0 kph for the ear-snapper head. At these maximum speeds the combine was able to process 32% more stover and grain while using 40% less fuel per unit area (20% less fuel per unit mass).

Schessler's analysis of the blower and chopper in the John Deere 9750 STS combine showed a maximum power consumption of 10.5 kW (14 hp) for the blower. The power required for the chopper to operate was maximized at about 30 kW (40 hp) for the flail chopper and 17 kW (23 hp) for the shear chopper.

### 2.3.2 SINGLE-PASS BALING HARVEST SYSTEMS

Very little published work has been completed to provide a database on actual single-pass baling machine performance. In economic models the combine and baler system was estimated to have a 300 kW (400 hp) engine and consume 120 L/h (31.7 gph) of fuel (Shinners, 2003). Earlier analysis of data from the 2009 harvest at Iowa State University suggests a 15% drop in combine productivity while towing a baler during harvest (Webster et al. (2010)).

## 2.4 HARVEST ECONOMICS

### 2.4.1 SINGLE-PASS HARVEST SYSTEMS

Economic analysis of single-pass harvesting system is difficult due to a lack of true machine performance data under production scale conditions. Shinnars et al. (2003) found that corn harvest alone cost \$7.80 per dry Mg (\$7 per dry ton) to harvest compared to \$7.50 per dry Mg (\$6.75 per dry ton) for both an integrated single-pass baler and for a chopper unit to be attached to a combine. To harvest and transport corn grain and stover to a storage site cost \$106 per ha (\$42.40 per acre), \$182 per ha (\$72.80 per acre), and \$219 per ha (\$87.60 per acre) for a conventional grain combine, a single-pass bulk harvest system, and a single-pass baling harvest system respectively. While the single-pass bulk harvest system did provide a cheaper method of harvest and initial transport from the field it was found that long-term storage for bulk material was more expensive than storing bales.

### 2.4.2 MULTI-PASS HARVEST SYSTEMS

Numerous commercial scale multi-pass harvest systems have been tested in the past 15 years in order to develop a working knowledge of the system. An analysis of current custom harvest practices showed a cost of \$21.60 per dry Mg (\$19.44 per dry ton) for square bales and \$23.60 per dry Mg (\$21.24 per dry ton) for a round bale system (Sokhansanj & Turhollow, 2002). This included a transport cost for 8 km (5 miles) of travel which was responsible for part of the cost assigned to the transport cost in their research of \$6.10 and \$8.60 for round and square baling respectively. The cost was analyzed using shredding, raking, and baling passes separately.

Perlack and Turhollow (2002) analyzed four systems similar to current production practices. The systems were divided into multi-pass bulk and multi-pass baling. The multi-pass bulk system consisted of a forage harvester towed by a tractor and a tractor mounted blower that left the stover unprocessed. Each of these systems would convey stover into a 31.2 cu m (1092 cu ft) or 62 cu m (1935 cu ft) wagon that would compress the stover to double the packing density. The bulk system cost ranged from about \$27.5 - \$42.90 per dry

Mg (\$25 - \$39 per dry ton) delivered to a processing facility that used between 454.5 – 3636 dry Mg (500 – 4000 dry tons) per day. The range of the biomass cost was dependent on the hauling system. The unprocessed system was from \$22 – \$38.5 per dry Mg (\$20 - \$35 per dry ton) delivered which mainly was attributed to the lower capital equipment cost associated with the blower. The other system analyzed was a baling system consisting of square baling and round baling. When hauled to a similar facility large round bales cost \$24.20 - \$27.50 per dry Mg (\$22 - \$25 per dry ton) to bale and transport while large square bales had a higher cost from \$26.4 – \$30.8 per dry Mg (\$24 - \$28 per dry ton).

Work completed at the Oak Ridge National Laboratory developed a cost analysis model using many of the American Society of Agriculture and Biological Engineers and American Agricultural Economics Association adapted standards for equipment costing. This analysis took into account all fixed and variable costs associated with biomass collection. The model was tied into the Integrated Biomass Supply Analysis and Logistics model (IBSAL) which allowed for estimation of equipment needs and optimization of equipment for herbaceous crops and agricultural residues (Turhollow, (2009)). The model included assumptions and calculations to provide estimates for machine productivity and provided a breakdown of supply chain costs. This work clearly highlighted the need for improved estimates on actual machine productivity associated collection and transportation of biomass feedstocks.



## Chapter 3.0 Objectives

Corn stover harvest has been an unrefined and underutilized segment of the corn production system. As technology develops to process cellulosic material into ethanol to meet the goal set forth by the Renewable Fuel Standard 2, corn stover will become one of the many feedstocks that will help meet the 60 billion liters (16 billion gallons) of cellulosic ethanol goal (EISA, (2007)). Single-pass harvest systems have shown great promise in early development. Some analysis of single-pass (Shinners, (2003)) and multi-pass (Sokhansanj and Turhollow, (2001)) harvest systems have provided baseline costs for corn stover collection systems. The need now is to develop a more thorough understanding of the machinery productivity impact from corn stover harvesting in order to improve cost estimates of single-pass and multi-pass systems. This will allow producers to determine if the operating cost of collecting corn stover outweighs the price achieved from the sale of corn stover. If the producer does choose to collect corn stover, an analysis of cost will be helpful in determining the fair price between the producer and processor.

The current practice for collecting corn stover is to use a multi-pass system based upon practices used in most hay and forage systems in the livestock industry. Equipment in this system typically only has a single use. Application of the equipment in another operation would amortize the capital cost of the machine further. For most operations though corn stover is only baled in small quantities at the farmer's discretion as to not hinder harvest operations in the fall. The multi-pass collection system does seem to be easiest for most producers to implement. However, quality requirements at a cellulosic processing plant and harvest and collection timeliness could dictate single-pass harvest systems as the optimal harvesting option.

The following objectives and Table 1 further detail the tests performed to understand the impact of harvesting corn stover on the combine and the cost basis for harvesting the stover with the extra power consumed from the combine for stover harvest factored into the cost of harvest.

Objective 1: Quantify the impact of single-pass harvesting systems on the productivity of traditional grain production. Experimental harvest performance data will be used to fulfill the requirements of this objective.

Objective 2: Integrate harvest productivity results into biomass production cost analysis and determine the cost of the single-pass baling harvest system. An analysis of the single-pass baling harvest system and sensitivity to its production parameters will be used to complete this objective.

Test	Treatment Factors	Treatment Levels
Combine Productivity		
	Rows of Stover Collected	Rows
		0 6 12
	Collection Configuration	
		Conventional Bulk Baling
Stover Collection Costs		
	Productivity Reduction Levels	%
		0 15 30 45
	Collection Configurations	
		Baling Conventional

**Table 1: Treatment factors and detailed levels of testing performed during fall 2010 harvest machine testing and model based cost analysis of single-pass baling of corn stover.**

To determine the combine productivity a series of replicated tests in different harvest configurations was conducted. Explained in further detail in Chapter 5 the combine was tested in a baling configuration, bulk configuration, and conventional configuration. Along with the different harvest configurations the combine header also collected different number of rows of stover to vary the collection rate of the combine. Tests were conducted with different moisture contents of the grain to obtain a higher moisture corn stover and in a variety of weather and crop conditions to obtain the full spectrum of performance factors that the combine could encounter during a normal harvest period.

To determine costs of harvesting corn stover performance data from in field testing was used to build a model. The model which is explained in further detail in chapter 7 used the infield data to set parameters for a combine baling corn stover using the single-pass method. At predetermined collection rates and predetermined productivity reductions the cost was model for a combine with similar performance curves as the combine used in the 2010 fall harvest tests.

Data collected during testing is unique to previous research because of the implementation of real-time data logging of vehicle performance and logistics in the field during the harvest season. The completion of this analysis allows producers to make rational decisions on whether to collect stover in a single-pass operation or in a multi-pass system. This data also helps agricultural equipment companies set performance goals to meet for equipment in single-pass harvest systems.

## Chapter 4.0 Data Logging

### 4.1 INTRODUCTION

The development and implementation of CAN Bus systems in equipment allowed for a new method of data collection as compared to older techniques which relied on more labor intensive and less accurate methods. This new method provided the ability to plug into the CAN system on any ISOBUS compliant machine and log the performance data of the machine in real time. Accessing CAN electronic vehicle information was achieved through implementation of the CyCAN data logging system at Iowa State University.

Data in this system was logged by the CyCAN logger and recorded for processing after the completion of the test. Parameters analyzed during the harvest testing were:

- Vehicle CAN Performance Parameters
- GPS Serial Data
- Biomass Cart Weight Serial Data

### 4.2 MATERIALS AND METHODS

#### 4.2.1 CYCAN DATA LOGGER

The CyCAN data logger was developed at Iowa State University by Dr. Matthew Darr. The logger worked by uploading a program to filter the CAN messages that populated the CAN Bus system on machine. The logger, which is shown in Figure 4-1, consisted of a custom built circuit board, custom software, an external case, a CAN cable to connect to the CAN diagnostic port, and a 2 gb compact flashcard for recording data to a solid state device. This device was developed and tested prior to installing the data loggers on the machines but it was the first use of the logger for long term machine performance monitoring.

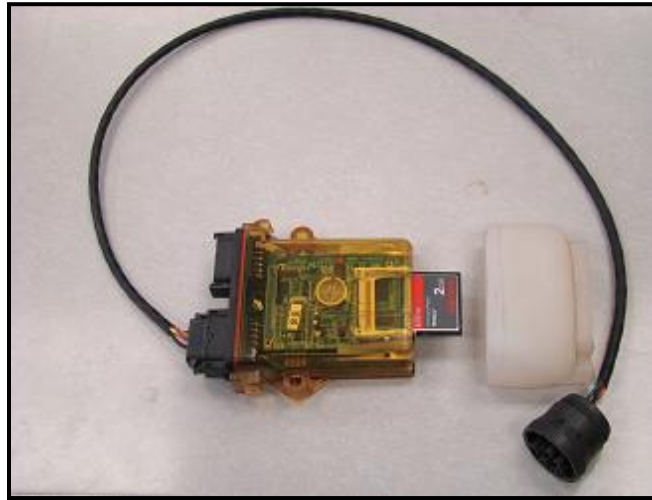

Figure 4-2: The CyCAN data logger used for logging data in-field during testing.

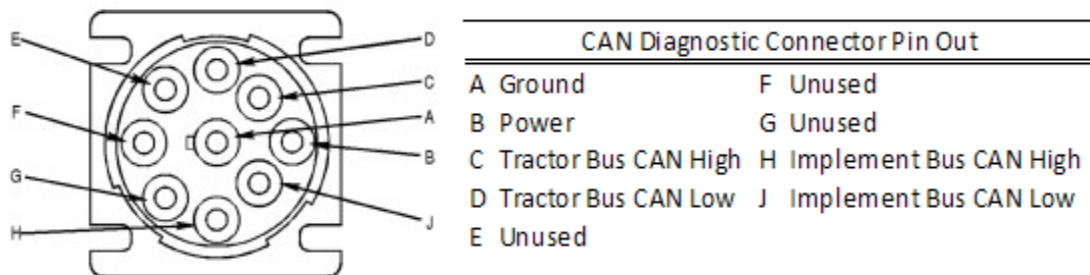

Figure 4-1: ISOBUS CAN diagnostic port connector (right) and associated pin out used to plug into compatible machines. Pins A, B, C, and D were used.

The logger was powered from the 12 volt connection within the CAN Bus System. Power was controlled to the logger in one of two ways. The first was disconnecting the logger either at the CAN diagnostic port, standard in all ISOBUS compatible machines, or by disconnecting the CAN cable from the logger itself. The second option was to put a switch in line with the CAN 12 volt power or ground and cycle power with the switch. The first option was used during the testing reported in this document. By manually controlling the power cycle individual logging files were created for each unique test treatment. The logger contained four LED's, each was programmed to light up during operation, the LED's worked as diagnostic aids to the operator during testing. The functionality of the lights is further described in Table 2. The clear case allowed the LED's to be seen during operation from

their mounting point on the custom circuit board. After initial startup the LED's assume a 'heartbeat' mode and switch on and off every second. This operation allowed the operator to visually ensure that each data channel was being captured. If one of the LED's started to blink erratically, the channel that the light was tied to was not properly logging data.

LED Descriptions	
LED	Function Monitored
1	Heart Beat
2	Scale data received successfully
3	Data is written to compact flash card successfully
4	Flash every second if CAN data is received

**Table 2: Diagnostic descriptions that refer to the LED's embedded within the CyCAN's logger.**

The compact flash card used in the logger was the SanDisk Ultra Compact Flash 2 gb card. The logger could be configured either to log all CAN data or filters could be setup which would only record specific CAN signals at specific time intervals.



**Figure 4-3: The compact flash card the CyCAN data logger used to record captured data to.**

The data logger was capable of logging data from 1 CAN channel, 2 serial channels, 2 digital channels, and 4 analog data channels. The different types of communication configurations and each of their respective channels were setup in an Excel based macro. The chosen signals, the rate of sampling, and any filters were placed into the excel spreadsheet. When complete the sheet produced a text file (.txt file) with the messages to be recorded that would be used in the CyCAN data logger to filter messages. This setup process was completed for each desired channel of communication and also used to set the internal board time stamp, if needed.

Once the compact flash cards were setup with the proper configuration files they were placed into the CyCAN data logger for validation. Validation took place prior to harvest at the BioCentury Research Farm (BCRF). This consisted of installing loggers into each machine and going through a set procedure for data confirmation. The validation procedures for engine data such as load, RPM, and fuel consumption were tested by starting a logging sequence. While stationary the machine's throttle position was changed to high idle then returning to low idle. The data was then processed to confirm that the throttle positions recorded in the CyCAN data matched the timing and output from the engine during the test. To test the GPS and speed, the combine was driven around the BCRF yard. The data was analyzed to confirm the vehicle path and speed matched the test scenario. Similar engine and GPS test procedures were conducted with the baler hooked to the combine to test the baler's engine and baling functions. Most baler functions were tested without the presence of stover in the machine by manually triggering limit switches and sensors from the ground while stopped. To test the yield monitor and moisture sensor actual crop material had to pass through the machine. A weigh wagon and separate moisture sensor was used to confirm and adjust each of these measurements for calibration.

The data collected from a single experimental test or treatment pass created one data text file. The file was incrementally labeled automatically by the CyCAN logger with the logger ID number and file number. This provided an organized approach to data collection but did not explicitly link the test data file to a specific test pass or test machine. The text

files were removed and processed after each test in order to not lose the operational context of the data. This also allowed for confirmation that the proper data was collected by quickly reviewing the processed data file.

To process the data an Excel spreadsheet was setup with a macro that would process the raw data from the text file, combine the various channels of data, down sample the data into one second intervals and break the various messages into specific data points depending on the engineering units assigned to the data. This will be discussed later in the chapter and is shown in Figure 4-4.

1	Time	Logger ID	File Date	File Time	Engine Speed (rpm)	Engine Torque (%)	Wheel Based Vehicle Speed (km/hr)	Latitude	Longitude
2	1	52	9/13/2010	17:50:16	1200.5	130	0	42.0188656	-93.7819413
3	2	52	9/13/2010	17:50:16	1200.5	130	0	42.0188656	-93.7819413
4	3	52	9/13/2010	17:50:16	1189	130	1.625	42.0188644	-93.7819413
5	4	52	9/13/2010	17:50:16	1202.75	130	3.75390625	42.018854	-93.7819408
6	5	52	9/13/2010	17:50:16	1203	130	4.23828125	42.0188399	-93.7819398
7	6	52	9/13/2010	17:50:16	1184	130	5.8515625	42.0188245	-93.7819391
8	7	52	9/13/2010	17:50:16	1192.5	130	7.76171875	42.0188007	-93.781937
9	8	52	9/13/2010	17:50:16	1205	130	9.1796875	42.0187709	-93.7819346
10	9	52	9/13/2010	17:50:16	1198.25	130	9	42.0187404	-93.7819326
11	10	52	9/13/2010	17:50:16	1201	130	9.109375	42.0187103	-93.7819317
12	11	52	9/13/2010	17:50:16	1202.5	130	9.21484375	42.0186794	-93.7819313
13	12	52	9/13/2010	17:50:16	1201	130	9.05078125	42.0186492	-93.7819308
14	13	52	9/13/2010	17:50:16	1201.5	130	9.00390625	42.0186192	-93.7819306

**Figure 4-4: Example CAN data file. Each line of data is segmented into one second intervals in the processing sheet and represents the real time performance of the machine.**

## 4.2.2 DATA PARAMETERS

### 4.2.2.1 CAN DATA

Most performance data collected from the tests came from the CAN Bus on each machine. To collect this data the data logger was connected to the CAN Bus via the CAN diagnostic port shown in Figure 4-2. There were two methods in which data was recorded. First, if no configuration setup file was present then all available CAN messages on the machine's CAN Bus were logged. If the CAN configuration file was loaded, the logger recorded and filtered messages that were present in the configuration files based on a specific parameter group number (PGN). The PGN was further filtered and broken into specific data messages by the source address and the command bytes. The exact location of signals within the CAN message was dependent on the standard used to define the message.



Messages are filtered first by the PGN which contained one group of specific messages on CAN bus. To differentiate between controllers that were sending out messages with the same PGN, the source address was used to separate out the microcontroller that sent the message. The microcontrollers in each ISOBUS compliant machine were assigned a unique source address number that ranges from 0 - 255. When the PGN had been identified, command bytes were used to further designate out messages within PGNs with a specific source address. Prior to harvest data parameters were identified that were desired for the productivity analysis. The messages were a mixture of standard messages as listed in SAE J1939 and ISO 11783 while others were proprietary messages provided by John Deere and AGCO Corporation for each respective piece of machinery. The messages listed in the following table list the source of where each was found.

CAN Message Database												
Combine CAN												
PGN	Parameter Group Label	Message	Rate (Hz)	Source Address	D0	D1	D2	Start Bit	Length (bits)	Resolution	Offset	Units
65256	Vehicle Direction/Speed		2									
		Compass Bearing (degrees)						0	16	0.0078125	0	deg
		Navigation Based Vehicle Speed (km/hr)						16	16	0.00390625	0	km/h
		Pitch (°)						32	16	0.0078125	-200	deg
		Altitude (Meters)						48	16	0.125	-2500	m
65254	Time/Date		2									
		Seconds						0	8	0.25	0	s
		Minutes						8	8	1	0	min
		Hours						16	8	1	0	h
		Month						24	8	1	0	day
		Day						32	8	0.25	0	month
		Year						40	8	1	1985	year
		Local Hour Offset						56	8	1	-125	h
65267	Vehicle Position		2									
		Latitude (°)						0	32	0.0000001	-210	deg
		Longitude (°)						32	32	0.0000001	-210	deg
61443	Electronic Engine Controller 2		2									
		Engine Percent Load (%) at Speed						16	8	1	0	%
61444	Electronic Engine Controller 1		2									
		Requested Engine Torque (%)						8	8	1	-125	%
		Engine Torque (%)						16	8	1	-125	%
		Engine Speed (rpm)						24	16	0.125	0	rpm
65265	Cruise Control/Vehicle Speed		2									
		Wheel Based Vehicle Speed (km/hr)						8	16	0.00390625	0	km/h
65266	Fuel Economy (Liquid)		2									

**Table 3: CAN database for specific data messages referenced by PGN, the sample rate (Hz), description of placement in the message, conversion factors, and engineering units for the combine.**

CAN Message Database												
Combine CAN												
PGN	Parameter Group Label	Message	Rate (Hz)	Source Address	D0	D1	D2	Start Bit	Length (bits)	Resolution	Offset	Units
65535	Proprietary		2									
		Header Width In Use (ft)			24			8	16	1	0	
		Actual Header Width			24			24	16	1	0	
		Number Rows in Cut			24			32	8	1	0	
		Number Rows on Header			24			48	8	1	0	row
		Crop Row Spacing (in.)			24			56	8	1	0	cm
		Combine Separator Speed (RPM)			46					0.125	0	rpm
		Combine Thresher Speed (RPM)			46					0.125	0	rpm
65534	Proprietary		2									
		Average Harvested Area Rate (ac/hr)			101			40	16	1	0	
		Harvest Rate Pressure			102			8	16	1	0	
		Fuel Efficiency (%)			102			24	16	1	0	
		Feeder House Height (%)		234	71					0.4	0	%
		4 Wheel Drive High Engaged			52					1	0	
		4 Wheel Drive Low Engaged			52					1	0	
		Chaffer Position (mm)			50			8	8	1	-125	mm
		Sieve Position (mm)			50			16	8	1	125	mm
		Clean Grain Elevator Speed			60			8	16	1	0	rpm

**Table 4: CAN database for specific data messages referenced by PGN, the sample rate (Hz), description of placement in the message, conversion factors, and engineering units for the combine.**

CAN Message Database												
Combine CAN												
PGN	Parameter Group Label	Message	Rate (Hz)	Source Address	D0	D1	D2	Start Bit	Length (bits)	Resolution	Offset	Units
65097	Ground-based Speed and Distance		2									
		Ground Based Speed (km/hr)						0	16	0.001	0	m/s
		Ground Based Implement Distance (m)						16	24	0.001		meters
61439	Proprietary		2									
		Grain Mass Flow (kg/sec)		211	79	9				0.01	0	kg/sec
		Grain Moisture (%)		211	79	9				0.01	0	%

**Table 6: CAN database for specific data messages referenced by PGN, the sample rate (Hz), description of placement in the message, conversion factors, and engineering units for the combine.**

CAN Message Database												
Tractor CAN												
PGN	Parameter Group Label	Message	Rate (Hz)	Source Address	D0	D1	D2	Start Bit	Length (bits)	Resolution	Offset	Units
61443	Electronic Engine Controller 2		2									
		Engine Percent Load (%) at Speed						16	8	1	0	%
61444	Electronic Engine Controller 1		2									
		Requested Engine Torque (%)						8	8	1	-125	%
		Engine Torque (%)						16	8	1	-125	%
		Engine Speed (rpm)						24	16	0.125	0	rpm
65265	Cruise Control/Vehicle Speed		2									
		Wheel Based Vehicle Speed (km/hr)						8	16	0.00390625	0	km/h
65266	Fuel Economy (Liquid)		2									
		Fuel Rate (L/hr)						0	16	0.05	0	L/h

**Table 5: CAN database for specific data messages referenced by PGN, the sample rate (Hz), description of placement in the message, conversion factors, and engineering units for the tractor.**

CAN Message Database												
Tractor CAN												
PGN	Parameter Group Label	Message	Rate (Hz)	Source Address	D0	D1	D2	Start Bit	Length (bits)	Resolution	Offset	Units
65256	Vehicle Direction/Speed		2									
		Compass Bearing (degrees)						0	16	0.0078125	0	deg
		Navigation Based Vehicle Speed (km/hr)						16	16	0.00390625	0	km/h
		Pitch (°)						32	16	0.0078125	-200	deg
		Altitude (Meters)						48	16	0.125	-2500	m
65254	Time/Date		2									
		Seconds						0	8	0.25	0	s
		Minutes						8	8	1	0	min
		Hours						16	8	1	0	h
		Month						24	8	1	0	day
		Day						32	8	0.25	0	month
		Year						40	8	1	1985	year
		Local Minute Offset						48	8	1	0	min
		Local Hour Offset						56	8	1	-125	h
65267	Vehicle Position		2									
		Latitude (°)						0	32	0.0000001	-210	deg
		Longitude (°)						32	32	0.0000001	-210	deg

**Table 7: CAN database for specific data messages referenced by PGN, the sample rate (Hz), description of placement in the message, conversion factors, and engineering units for the tractor.**

CAN Message Database												
Baler Engine CAN												
PGN	Parameter Group Label	Message	Rate (Hz)	Source Address	D0	D1	D2	Start Bit	Length (bits)	Resolution	Offset	Units
61443	Electronic Engine Controller 2		2									
		Engine Percent Load (%) at Speed						16	8	1	0	%
61444	Electronic Engine Controller 1		2									
		Requested Engine Torque (%)						8	8	1	-125	%
		Engine Torque (%)						16	8	1	-125	%
		Engine Speed (rpm)						24	16	0.125	0	rpm

**Table 8: CAN database for specific data messages referenced by PGN, the sample rate (Hz), description of placement in the message, conversion factors, and engineering units for the Baler Engine.**

CAN Message Database												
Baler Monitor CAN												
PGN	Parameter Group Label	Message	Rate (Hz)	Source Address	D0	D1	D2	Start Bit	Length (bits)	Resolution	Offset	Units
61443	Electronic Engine Controller 2		2									
		Engine Percent Load (%) at Speed						16	8	1	0	%
61444	Electronic Engine Controller 1		2									
		Requested Engine Torque (%)						8	8	1	-125	%
		Engine Torque (%)						16	8	1	-125	%
		Engine Speed (rpm)						24	16	0.125	0	rpm
59008			2									
		Bale Cylinder Pressure			168	252		32	16	1	0	PSI
		Baler Counter			168	239		32	16	1	0	bale
		Flake Counter			168	249		32	16	1	0	Flakes
		Pressure Control			168	253		32	16	1	0	PSI
		Flywheel Speed			168	251		32	16	1	0	RPM
		Left-hand Plunger Force			168	82		32	16	1	0	PSI
		Right-hand Plunger Force			168	81		32	16	1	0	PSI
		Plunges/Flake			168	248		32	16	1	0	Plunges

**Table 9: CAN database for specific data messages referenced by PGN, the sample rate (Hz), description of placement in the message, conversion factors, and engineering units for the Baler Monitor.**

#### 4.2.2.2 SERIAL DATA

Two parameters were recorded through the serial channels on the logger. The Oxbo 1516 hydraulic side dump cart, which was used to collect bulk stover, was outfitted with Digi-Star spindle load cell scales with an EZ 2400V display. The display was outfitted with a RS-232 serial port which allowed serial communications from the display to another device, in this case the data logger. By changing the output configuration within the scale indicator from print to automatic output at one second intervals to any device connected to the RS-232 port. The CyCAN logger would accept the messages and synchronize the data to other data that was recorded.

The second serial data stream recorded was the GPS NEMA data strings. This NEMA data was divided in the combine cab between the three loggers present in the cab for recording data from the combine, baler function monitor, and baler engine. The baler data loggers required GPS data from an alternate source because the baler did not have its own GPS. Since every time the baler was in operation it also was attached to the combine the combine's StarFire iTC RTK receiver was used to provide GPS data to both machine's data logger. The serial cable on the GPS receiver was split, with the signal going to the three loggers. The tractor used in bulk collection was also configured in the same manner to record the GPS NEMA string from its StarFire iTC receiver. The data from the NEMA string provided two types of information. First, it provided an alternate set of Latitude and Longitude points versus the set of points on the CAN bus, these were ultimately chosen to use because the points were common amongst all machines. Secondly, it provided a standard time output in order to synchronize data by the UTC time output. UTC time or Greenwich Mean Time was the universal time that was output by all GPS satellites, using this time ensures that all files being processed and merged will coincide with other companion files from the same test pass.

To configure a logger to receive both of these channels a configuration text file was made using the Excel configuration macro. A text file was setup exclusively for each

channel, which set the baud rate for data collection. If no file was created the data from the channels was not collected.

#### 4.2.3 DATA PROCESSING

An Excel macro was created in order to divide and process data that was recorded by the loggers. The macro referenced a database for each type of data logged. The macro allowed for one data file produced from one test pass to be processed. Once processed the data was available to be reviewed by the operator for validation.

##### 4.2.3.1 CAN DATA

CAN data was processed by the macro, which used a filter that contained the same command bytes and source addresses that were used in the configuration setup file. Depending on the message a combination of these filters were used to break the messages into the desired data strings.

Type	ID1	ID2	ID3	ID4	D1	D2	D3	D4	D5	D6	D7	D8	PDU_FORMAT	PDU_SPECIFIC	SOURCE_ADDRESS	PGN	Timestamp (msec)
C:	103	128	32	0	240	255	255	130	37	255	255	255	240	4	0	61444	1000
C:	103	128	24	0	255	0	9	255	255	255	255	255	240	3	0	61443	1036
C:	199	247	136	184	255	0	0	255	255	255	255	255	254	241	23	65265	1085
C:	199	247	144	0	56	0	255	255	255	255	255	255	254	242	0	65266	1096
C:	103	247	48	224	216	30	0	11	9	24	255	255	254	230	28	65254	1111
C:	103	127	255	176	13	250	255	250	79	35	240	255	239	255	246	61439	1185
C:	103	128	32	0	240	255	255	134	37	255	255	255	240	4	0	61444	2023
C:	103	128	24	0	255	0	9	255	255	255	255	255	240	3	0	61443	2084

**Table 10: Sample of CAN data messages logged by the data logger.**

A typical CAN message was captured from the Bus contained information similar to that in Table 10. Each line of data contained information that was recorded from the Bus and filtered. In this case most messages only contained one piece of information. The position of this data within the message was known and could be referenced in the CAN database for the macro. The information in the macro database contained general information such as the PGN but also more specific data such as the source address and command bytes. To



specifically pick out the data from a message the start byte and stop byte were referenced. The length in bits was also determined using Equation 1.

**Equation 1: General formula for calculation of bits of data in a CAN message.**

$$Bits = \frac{CAN[D_1 - D_8] \text{ AND Data Mask}}{2^{Start \text{ Bit}}}$$

Where as

Bits = Number of bits of in data

$D_1$  = Lowest byte of data in message

$D_8$  = Highest byte of data in message

Data Mask = Location of desired bits in the data ( $2^n$ )

Start Bit = Position of the first byte of data for the message (by every 8 bits)

Once the number of bits was calculated for the message, the data resolution of the signal was accounted for. Then the offset factor was also applied to yield engineering data units. The end result of this conversion yielded a single unit of engineering data which was placed into the excel macro worksheet. The macro was setup so that data was down sampled to one data point per second. The last data point in each one second interval was used to provide the data values for the message.

#### 4.2.3.2 SERIAL DATA

The two serial port channels 0 and 1, which contained data from the Digi-Star Scale and the GPS respectively, were processed at the same time using the same Excel Macro workbook that was processing the CAN data. A reference database of serial data was placed into the macro. The macro then used the database to convert the serial data into useful data. This data was synchronized with the CAN data into one second interval and displayed on another page in the workbook.

Serial Channel	Sentence Identifier	Time	Latitude	Longitude	GPS Fix Quality	Number of Satellites in View	HDOP	Altitude	Geoid Height	Time since last DGPS update	DGPS Reference Station	Checksum
S1	\$GPGGA	174416	4159.379433 N	9341.227391 W	2	10	1	314.907 M	-31.326 M	3	104	*77
S1	\$GPRMC	174416	A	4159.379433 N	9341.227391 W	0.03	89.8	181010			0 E	D*13
S1	\$GPVTG		89.8 T	M		0.03 N					0.05 K	D*37
S0			Scale Mass									
			-60									

**Table 11: Breakdown of the serial data for the scale and GPS data over the two serial channels of data.**

Serial Breakdown						
Channel	Data Logged	Baud	Data Bits	Parity	Start Bit	Stop Bit
Serial 0	GPS	9600	8	N		1
Serial 1	Scale	1200	7	E	1	1

**Table 12: Summary of serial channels and filter components to process serial data.**

The database contained information to filter the incoming data according to the designated message type. Data was filtered first by distinguishing which channel of data was captured. Depending upon the channel captured the data processed differently. For the GPS data, a NMEA data string contained a sentence identifier. Of the numerous sentence identifiers, only three were used in testing: \$GPGGA, \$GPRMC, and \$GPVTG. Each string of data contains specific information including the position and status of the receiver and ultimately the vehicle. The \$GPGGA string contained the time, Latitude and Longitude, GPS signal quality data, altitude, and correction data statistics. The \$GPRMC identifier contained the time, Latitude and Longitude, speed data, and the date. The \$GPVTG identifier provided tracking status data as well as the speed in kilometers. To convert the strings into useable data, the values for each string were sub-divided and converted to engineering units. Each identifier has its own set of adjustments and multipliers for each identification string.

Data from the scale upon entry into the processor was filtered using the serial channel 0. The data which was sent from the indicator required no resolution change or offset

adjustment once in the processor and was placed in the excel output worksheet under a predetermined column.

### 4.3 RESULTS

Once the CyCAN loggers had been validated and verified to be working correctly testing started. Of the 98 test passes that were completed only one file was not collected properly, which was due to operator error by not plugging in a data logger. Data processing did slow overall testing productivity and adjustments were made by upgrading computational capacity for data processing. The data processing sheet and plot which are shown in Figure 4-5 and Figure 4-6, provided quick feedback on whether there were data collection errors or not. It also allowed for better grouping of separate files for each machine to be grouped into the correct test pass file.

Time	Logger ID	File Date	File Time	Engine Percent Load (%) at Speed	Engine Speed (rpm)	Engine Torque (%)	Wheel Based Vehicle Speed (km/hr)	Latitude	Longitude	Requested Engine Torque (%)	Compass Bearing (degrees)
1	64	10/11/2010	18:21:03	12	1200.75	130	0	41.992389	-92.9542417	130	287.46875
2	64	10/11/2010	18:21:03	12	1199	130	0	41.9923889	-92.9542417	130	287.4609375
3	64	10/11/2010	18:21:03	12	1199.25	130	0	41.9923889	-92.9542417	130	287.4453125
4	64	10/11/2010	18:21:03	12	1199.25	130	0	41.9923889	-92.9542417	130	287.53125
5	64	10/11/2010	18:21:03	12	1198.75	130	0	41.9923888	-92.9542417	130	287.5390625
6	64	10/11/2010	18:21:03	12	1198.75	130	0	41.9923889	-92.9542417	130	287.5390625
7	64	10/11/2010	18:21:03	10	1200.5	130	0	41.992389	-92.9542418	130	287.59375
8	64	10/11/2010	18:21:03	10	1200.5	130	0	41.9923889	-92.9542418	130	287.6328125
9	64	10/11/2010	18:21:03	10	1200.5	130	0	41.9923889	-92.9542418	130	287.5859375
10	64	10/11/2010	18:21:03	10	1200.75	130	0	41.992389	-92.9542418	130	287.53125
11	64	10/11/2010	18:21:03	10	1200.25	130	0	41.9923888	-92.9542419	130	287.5703125
12	64	10/11/2010	18:21:03	10	1200.5	130	0	41.9923888	-92.9542419	130	287.578125
13	64	10/11/2010	18:21:03	10	1200.75	130	0	41.9923888	-92.9542419	130	287.609375
14	64	10/11/2010	18:21:03	10	1200.5	130	0	41.9923888	-92.954242	130	287.546875
15	64	10/11/2010	18:21:03	10	1200.75	130	0	41.9923887	-92.954242	130	287.5625
16	64	10/11/2010	18:21:03	10	1200.75	130	0	41.9923887	-92.954242	130	287.4296875

Figure 4-5: Resulting data file of test data after processing of CAN and serial data captured from testing.

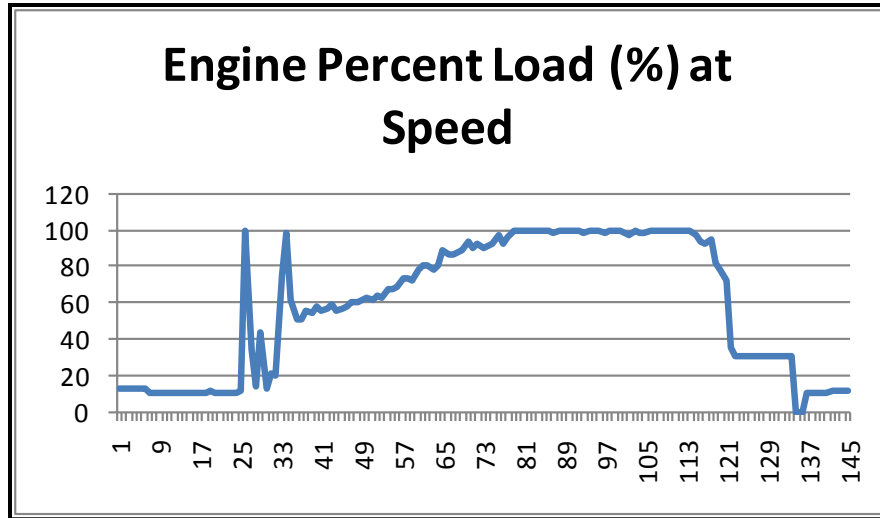

Figure 4-6: Plot from data processing Excel Macro displaying data from a test pass.

#### 4.4 CONCLUSIONS

To capture the amount of data that was logged with the CyCAN data logger, numerous sensors and a large processing capacity would have been required. The CyCAN logger in ISOBUS 11783 compatible machines allowed the logging of data such as fuel usage and engine loading. The data logger's adaptability and design for widespread use with numerous digital, analog CAN, and frequency channels made it ideal for machinery productivity testing. The ability to process this data in an Excel macro allowed for variation in the number and configuration of the messages that were captured by the logger. The messages that were captured by the logger produced specific engineering units of data. Serial data which consisted of GPS NEMA strings and scale data from the Oxbo 1516 cart were processed according to its given message structure and placed sequentially with the CAN data.

The use of these robust loggers resulted in 97 of 98 test having full results of CAN data, GPS coordinates, and scale data when applicable. The data was then further processed in Ag Leader SMS Advanced software and statistically analyzed which will be discussed further in Chapter 5.0.

## Chapter 5.0 Single-Pass Harvest System Productivity

### 5.1 INTRODUCTION

Two different methods of single-pass corn stover collection were identified in Chapter 1 as potential means for collecting corn stover in the field during corn grain harvest. The additional corn stover collected through the combine will slow harvest productivity in each system. The objective of this section is to quantify the following:

- The effects of corn stover collection on the combine's productivity
- The effect of each corn stover harvest system on overall harvest productivity.

### 5.2 MATERIALS AND METHODS

#### 5.2.1 COMBINE AND HEADER

##### 5.2.1.1 COMBINE

A John Deere 9860 STS was selected to perform all tests for the 2010 harvest season. The combine was outfitted with a 12.5 L engine, four wheel drive, and a twelve row corn head with selectable row configurations for stover collection. The combine was classified as a Class 8 (279+ kW; 375+ hp) machine with an engine horsepower output ranging from 360 – 380 kW (480 – 514 hp). The clean grain elevator capacity of the combine was 41.3 kg per second (91 lbs per second), the grain hopper capacity was 300 bushels, and the maximum unload rate was 3.3 bushels per second.



Figure 5-1: John Deere 9860 test combine used in field tests.

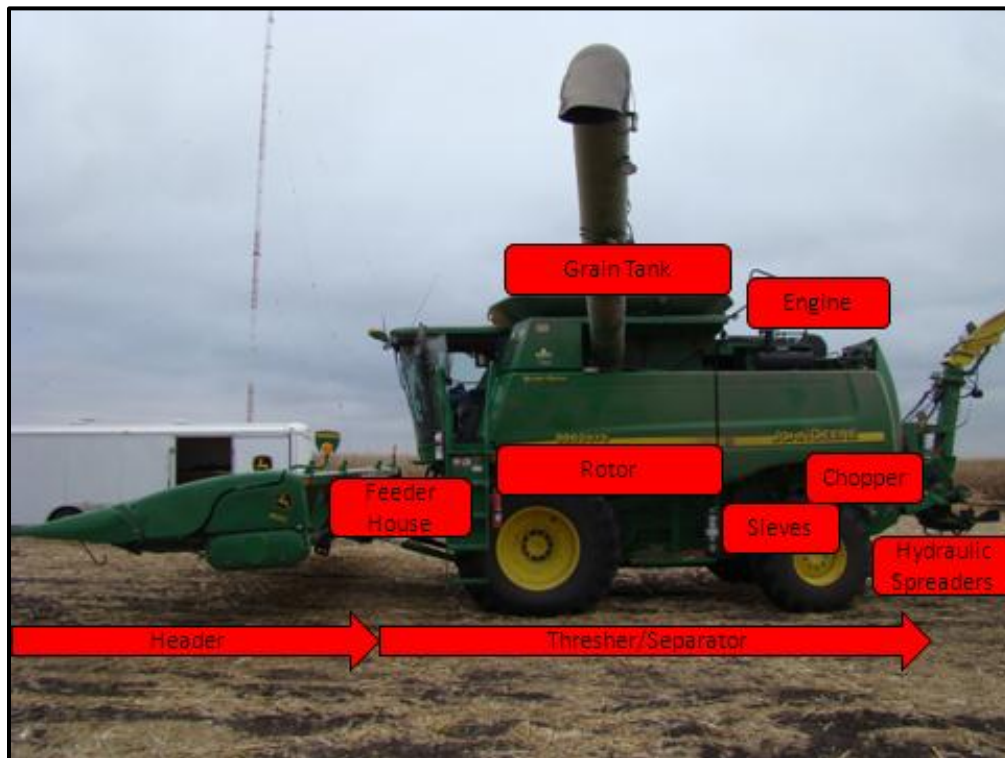

Figure 5-2: Detail pathway of the major grain and stover processing areas of the conventional combine used in testing.

### 5.2.1.2 HEADER

By switching any of the twelve rows of the header to either a conventional harvest system or a stover harvest setting, the rate of stover collected by the combine was varied. The configurations tested in the 2010 harvest were zero rows of stover collection chains, six rows of stover collection chains and six rows of conventional chains, and twelve rows of stover collection chains. These row configurations corresponded to the varying rates of collection, about 1.1 Mg/ha (.5 tn/ac) for zero row, 2.5 Mg/ha (1 tn/ac) for six row collection and 4 Mg/ha (1.75 tn/ac) for twelve row collection. These rates were variable, mainly dependent on overall crop conditions such as plant height; Figure 5-4 showed how variable the stover yield was in the tests.

Figure 5-5 shows the average range of stover that could have been collected in a production setting on a per hour basis. The data was calculated by using the recorded machine productivity (ha per hour; acre per hour) estimation from the yield monitor and the estimated collection rate (Mg/ha; tn/ac). This produced the estimated dry tons per hour removed shown in the figure.

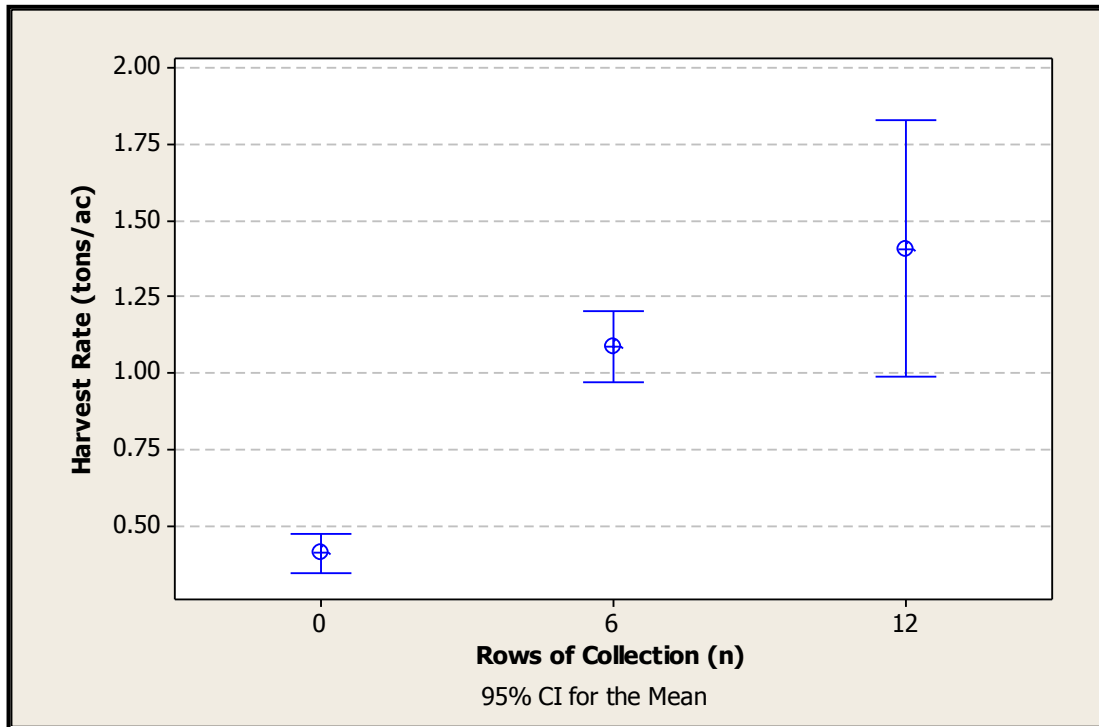

Figure 5-3: Interval plot graph of the stover yield for each row configuration tested in the bulk harvest test cases.

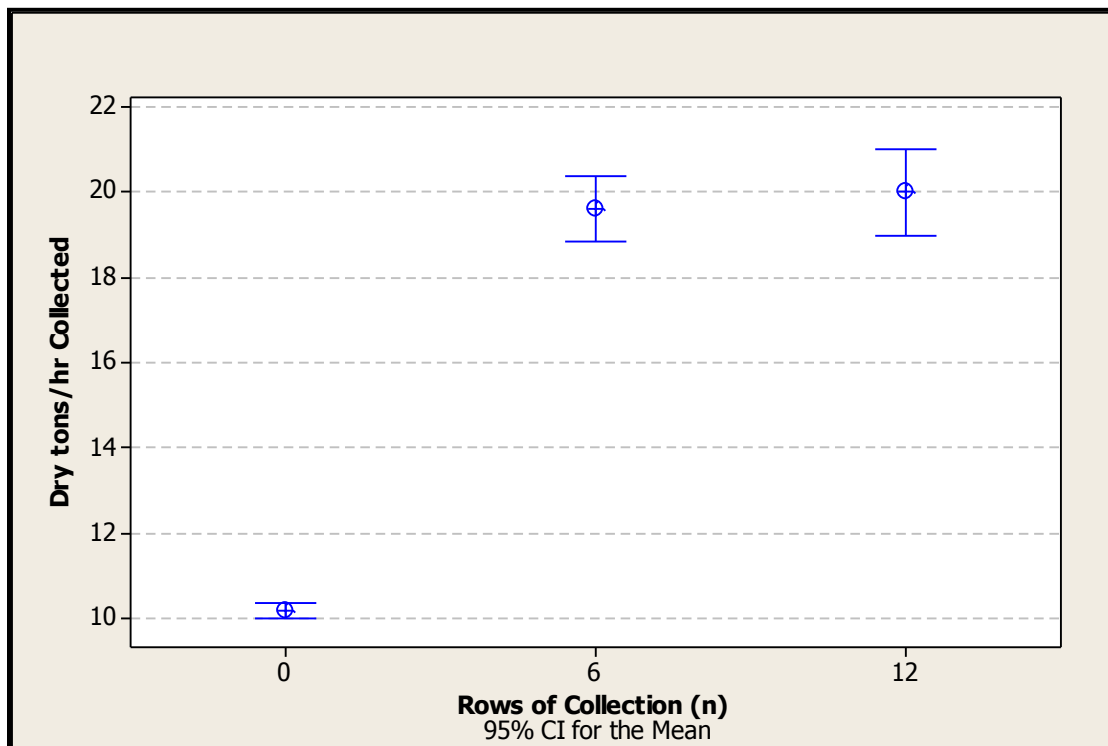

Figure 5-4: Range of harvested dry tons per hour of stover removed.



## 5.2.2 HARVEST SYSTEM TESTING CONFIGURATIONS

### 5.2.2.1 CONVENTIONAL HARVEST SYSTEM

To collect baseline performance data, the combine was configured to the normal (conventional) operating system. This entailed disabling power to the blower section of the bulk harvest system which was attached to the back of the combine by means of removing the drive belt between the chopper and blower further detailed in Figure 5-8. Once the blower was disabled, the straw spreaders were re-attached to the back of the machine and powered hydraulically. The spreaders kept residue from windrowing as it came out the back of the machine and preventing interference with standard tillage practices, as shown in Figure 5-6.



**Figure 5-5: Example of stover left behind in the field due to not having the hydraulic spreaders on the combine.**

The conventional harvest system used the corn head to strip as much biomass material away from the ear of corn prior to gathering the ear for threshing inside of the combine. As shown in Figure 5-7 most stalk and plant residue was processed by the head and left on the ground to deteriorate or be harvested for stover in a multi-pass harvest system. The combine then threshed and separated the grain from the material other than grain (MOG) and elevated the grain to the combine's hopper. The MOG was then conveyed by the chopper out the back of the machine onto the spreaders to be returned to the soil.

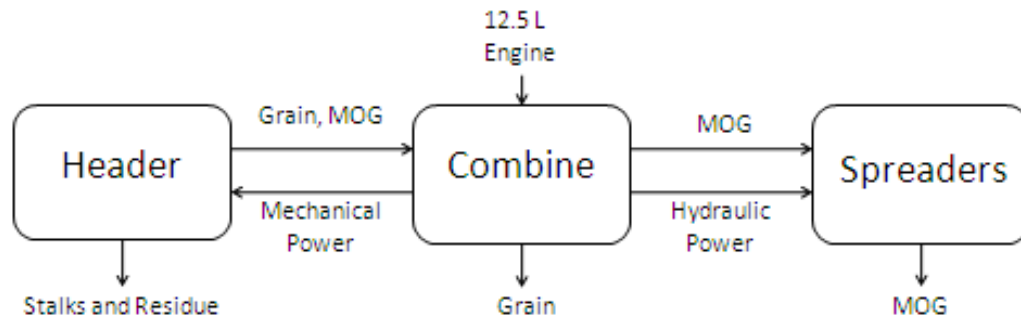

**Figure 5-6: Detailed pathway of corn plant pathway through the combine, stalks and residue are left on the ground at the header and grain and MOG are passed through the separator.**

#### 5.2.2.2 SINGLE-PASS BULK HARVEST SYSTEM

The single-pass bulk harvest system that was tested consisted of the John Deere combine with the bulk stover attachment and an Oxbo model 1516 hydraulic side dump cart towed by a John Deere 8245R tractor. The 30 cu m (1100 cu ft) cart was outfitted with digital scales in order to track the weight of corn stover being removed from the field during a test. This allowed for determination of stover mass flow from the combine.

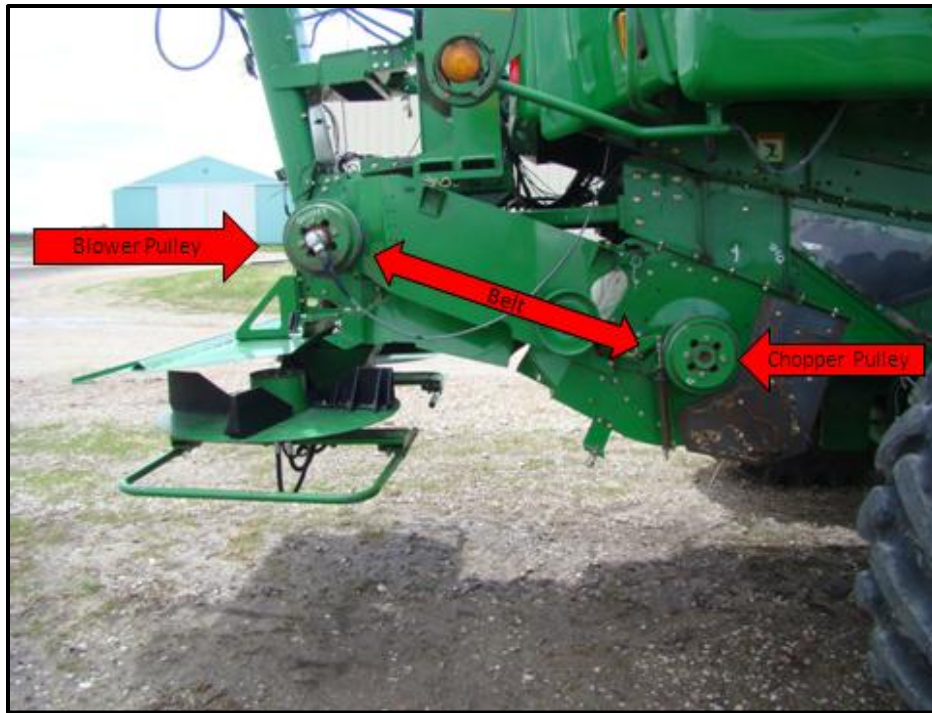

Figure 5-7: View of combine chopper to bulk attachment's blower drive pulley, the drive belt connects these two pulleys when the bulk harvest system was operating and was disconnected when it was not used.

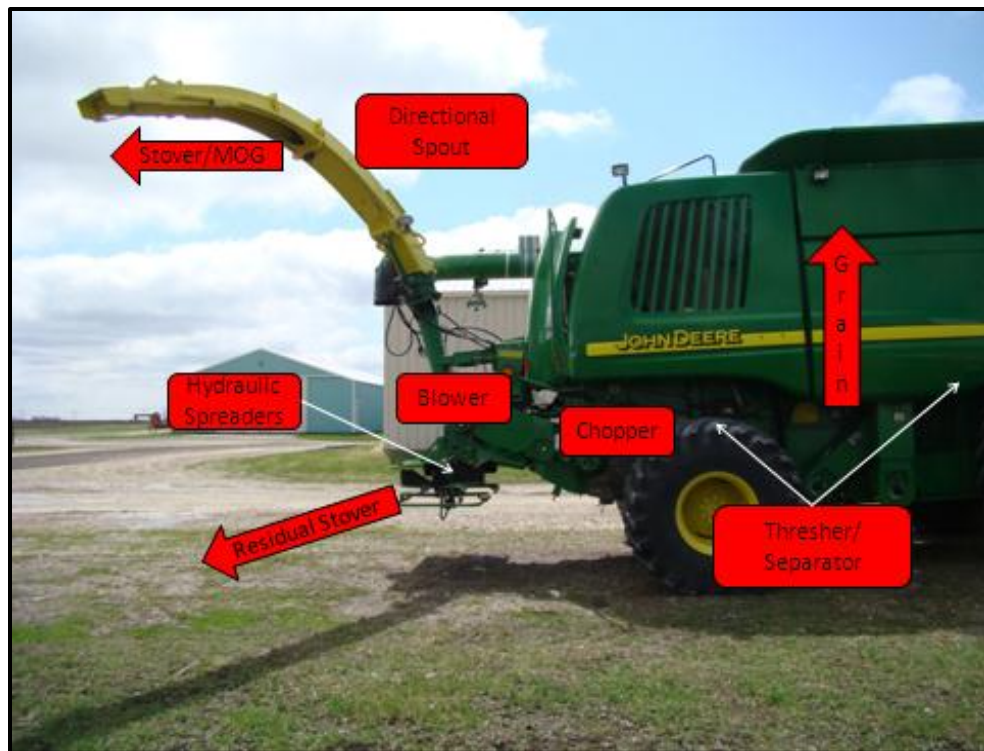

Figure 5-8: Detailed pathway of material from combine chopper through blower and out the spout or directing material onto the ground.

As mentioned in section 5.2.2.1, to go between the conventional harvest system and bulk harvest system the drive belt that powered the bulk attachment's blower must be removed in order to stop any material from going through the blower. The belt was also removed when using the single-pass baling system. To remove the belt, the shield, which is not pictured in Figure 5-8, was removed, the belt was de-tensioned, and the belt was removed from both pulleys.

Once configured to harvest in the bulk stover harvest system the stover, MOG, and grain collected at the header was fed into the combine and passed through the threshing cylinder. In the threshing cylinder and separator, grain and stover were separated by the rotor and the sieves. The clean grain was then elevated to the grain tank while the corn stover was handed to the chopper. After the stover and MOG passed through and was accelerated by the chopper, it was blown towards the blower and spreaders. At the blower, low pressure created by a vacuum from the blower blades and the velocity of the material coming out of the chopper forced material to enter the throat of the blower. The material was then conveyed into the cart which was towed by a tractor traveling next to the combine. Corn stover that was not captured by the blower was then passed onto the spreaders which spread the stover back onto the ground. Examples and descriptions of the bulk system are shown in Figure 5-10 and Figure 5-11.





Figure 5-9: Combine in bulk stover collection configuration conveying stover into the Oxbo 1516 cart being towed by a John Deere tractor. This was one of the configurations tested.

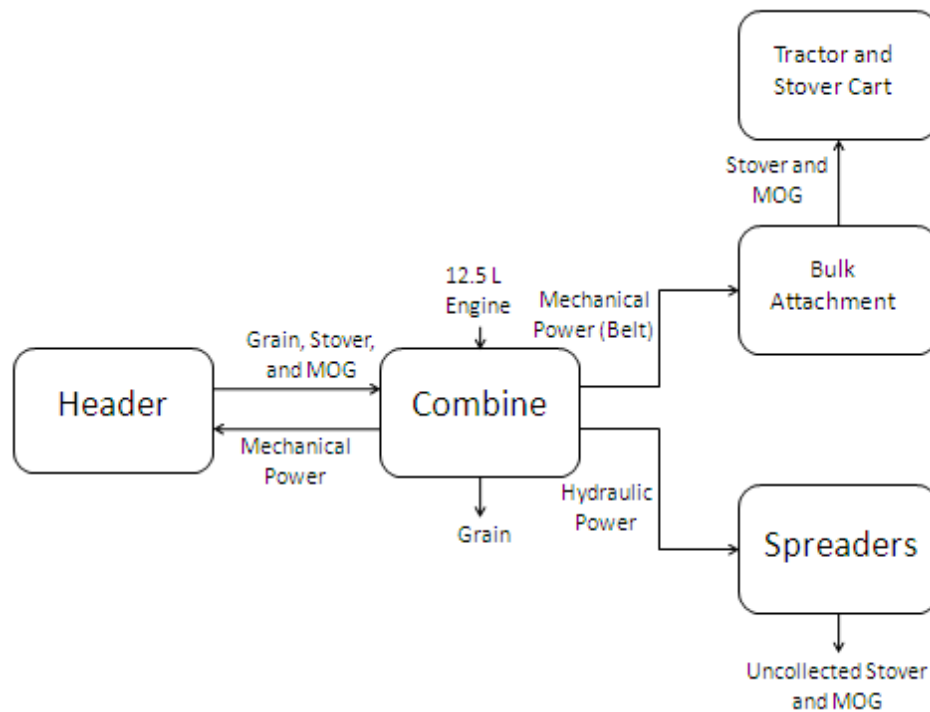
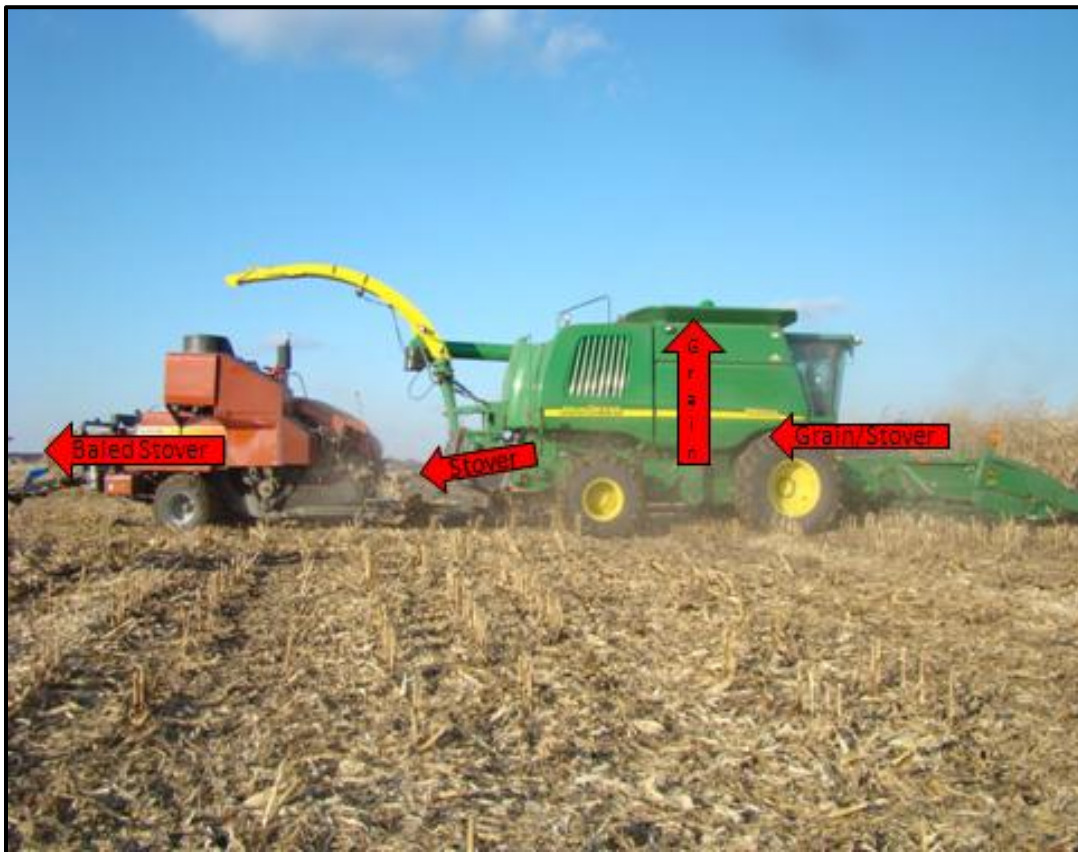

Figure 5-10: Detail diagram of the power distribution and pathway for the corn stover through the combine and the bulk harvest attachment.

### 5.2.2.3 SINGLE-PASS BALING HARVEST SYSTEM

The single-pass baling system consisted of the John Deere 9860 STS combine and an AGCO Hesston 4790 single-pass baler. The combine was outfitted with a custom built hitch that allowed it to tow the baler through the field during harvest. Like the conventional system, the bulk harvest drive belt was disconnected from the chopper. This prevented any material from being conveyed through the bulk system. The baling configuration also called for the hydraulic spreaders to be removed as well. Spreader removal was necessary to allow for the baler's conveyor to achieve minimal interference between the rear of the blower on the combine and the baler.



**Figure 5-11: Pathway of stover and grain from entering the combine through the header to the grain tank and through the back of the combine into the baler.**

Corn stover and grain were harvested by the combine just like the single-pass bulk harvest system. However, the blower was not powered and the spreaders were removed. Stover and MOG were dropped onto a conveyor located on the tongue at front of the baler. The conveyor was powered by the same hydraulic circuit that powered the spreaders. It conveyed the stover to another conveyor which was built into the baler and was powered by the baler hydraulically. At the back end of this conveyor the stuffer fingers grabbed the material to fill the stuffer chute. As material filled the stuffer chute stover would push out on limit switches which triggered the stuffer arm to convey material into the bale chamber. Inside the bale chamber stover was compressed by the plunger. The amount of force the stover was compressed varied by how much pressure was applied to the bale in front of the stover. Typically bale chamber pressures of 6,900 – 13,800 kpa (1000 - 2000 psi) were used with a plunger force of 2100 kpa (300 psi) max desired. At a predetermined length a trip arm triggered the baler needles to pull string from the bottom of the bale and be tied off to string on the top side of the bale. The bale then was pushed out as more stover was collected from the back of the combine. This bale was then used as back pressure just like others had been used prior in forming the bale until it was clear of the bale chamber and pushed off the back of the baler onto the ground.



Figure 5-12: General layout of the components of the baler along with the modified components (conveyor and engine) for single-pass corn stover harvesting.

The baler was powered by an integrated Perkins diesel 4 cylinder, 4.4 L turbocharged diesel engine. The baler was controlled over a dedicated CAN system with displays and controls in the combine cab to allow the operator to control and monitor both the combine and baler simultaneously during harvesting operations.

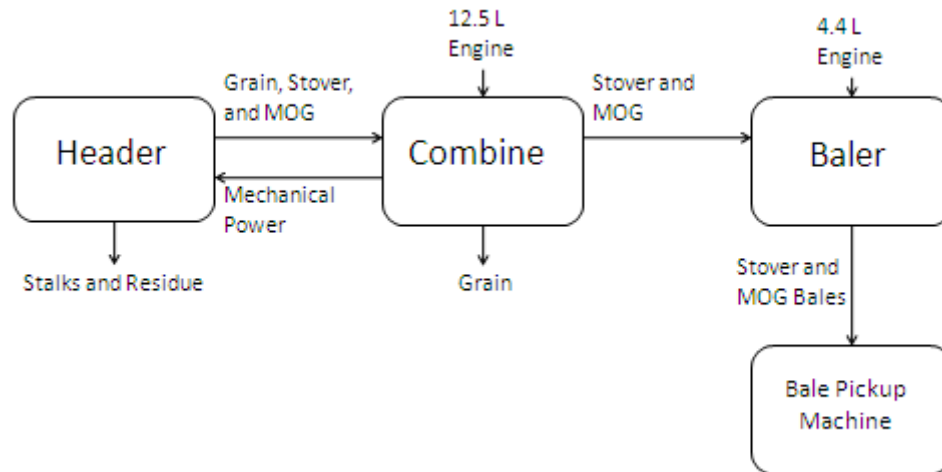

**Figure 5-14: Block diagram showing the power distribution through the combine from the combine engine and baler engine along with showing the pathway of the stover and grain through the combine and baler.**



**Figure 5-13: The John Deere 9860 with the AGCO 4790 single-pass baler harvesting grain and stover.**



---



---

Machine Configurations and Settings

---



---

Conventional System		
Combine		
Cleaning Fan Speed (RPM)		800 - 1000
Chaffer Setting		13 - 15
Sieve Setting		7 -10
Chopper Speed (RPM)		1600 RPM
Header Backshaft Speed (RPM)		600 - 700
Bulk System		
Combine		
Cleaning Fan Speed (RPM)		1300
Chaffer Setting		15 - 18
Sieve Setting		5-8
Chopper Speed (RPM)		1600 RPM
Header Backshaft Speed (RPM)		700
Blower Speed (RPM)		900
Baling System		
Combine		
Cleaning Fan Speed (RPM)		1300
Chaffer Setting		15 - 18
Sieve Setting		5-8
Chopper Speed (RPM)		1600 RPM
Header Backshaft Speed (RPM)		700
Baler		
Baler Engine (RPM)		2500
Operational Temperature degrees F		180 - 210
Baler PTO (RPM)		1000
Baler Auto Pressure Setting		
MOG		210-250
1 - 2.5 tons		240 - 295
Chamber Operational Pressure Ranges (PSI)		1000 -2500
Plunger Force	ideal	less than 300
Plunges per flake	ideal	1 - 3
Flakes per bale	dependent on bale length	20-30

**Table 13: List of machine configurations and settings for the systems used during the testing of the machines.**

### 5.2.3 DATA LOGGING

Data logging was conducted throughout each trial using the CyCAN loggers detailed further in Chapter 4.0. Loggers for the combine and baler were placed inside the cab to allow the operator to monitor the loggers during each test. Loggers were turned on and logged data only during the test run. The operator would plug the loggers into their respective CAN diagnostic ports prior to starting the combine separator. At the conclusion of the test the operator would unplug the loggers after the separator was turned off. This allowed the logger to capture a full cycle for each experimental trial. In the event that in the middle of the test run that the combine had to be stopped or shutdown loggers were unplugged and stopped recording and plugged back in after startup of the machine. Data points from multiple files were merged during post processing if required. This procedure worked well for the conventional and baling harvest system tests because the only loggers that were active were inside the cab with the operator. In bulk harvest system tests an additional data logger was placed in the tractor's cab that towed the Oxbo 1516 cart. The data logger was also configured to read the cart scale output that was displayed in the tractor cab from the Oxbo cart. Data from the scale and tractor were merged into one data file. This allowed for an estimation of the corn stover mass flow through the combine.

Once the logger was unplugged and the test was complete data was removed from the compact flash card in the CyCAN logger and uploaded to a laptop. The raw data files were then processed in the field and sorted accordingly by the test pass number and combine configuration. Data files were processed using the CyCAN extraction and processing program further detail in Chapter 4.0. Once testing was completed, data was further broken down into each configuration: conventional, single-pass baling, and single-pass bulk.

### 5.2.4 DATA PROCESSING

Data from the loggers was extracted and processed with Microsoft Excel. Once the data was processed into an Excel file it was ready to be merged together in order to provide a synchronized timeline for each of the data files that were produced in each test run. An

Excel macro was developed that would synchronize the UTC time among the files and combine the files into a single comprehensive file. From this process a Comma Delimited file (.csv file) was produced which was the file format that was required to upload data into the Ag Leader SMS Advanced spatial management software.

#### 5.2.4.1 AG LEADER SMS ADVANCED

The Ag Leader SMS Advanced spatial management software was chosen for data processing due to previous working experience with the software and its ability to import custom files with non-traditional data such as data from the biomass harvesting experiments. First, all data files were converted to a CSV file in order to be uploaded to the program. In these files specific data attributes were set to specific data columns, blank cells were removed from the edges of the data in order to create a uniform set of data points for each file. This allowed for multiple files of the same configuration data to be uploaded at once by using the software's batch upload command. In the batch upload command the capability of setting up a template to upload other files with similar data was setup decreasing overall data processing time.

For each combine harvest configuration a separate template file was created that would match that file's specific data attributes. The template simply configured the software to read in data attributes and then display the preferred data in the software's main data display screens.

Yield monitor data was also imported into SMS Advanced software. This data was logged by the yield monitoring system on the combine and recorded to the GreenStar 2 Display located in the combine cab. Data was removed from the display via a compact flashcard at the conclusion of harvest testing. The data from this was uploaded to a computer and then processed by the SMS Advanced software using preset data templates provided by Ag Leader specifically for the John Deere GreenStar 2 data format.

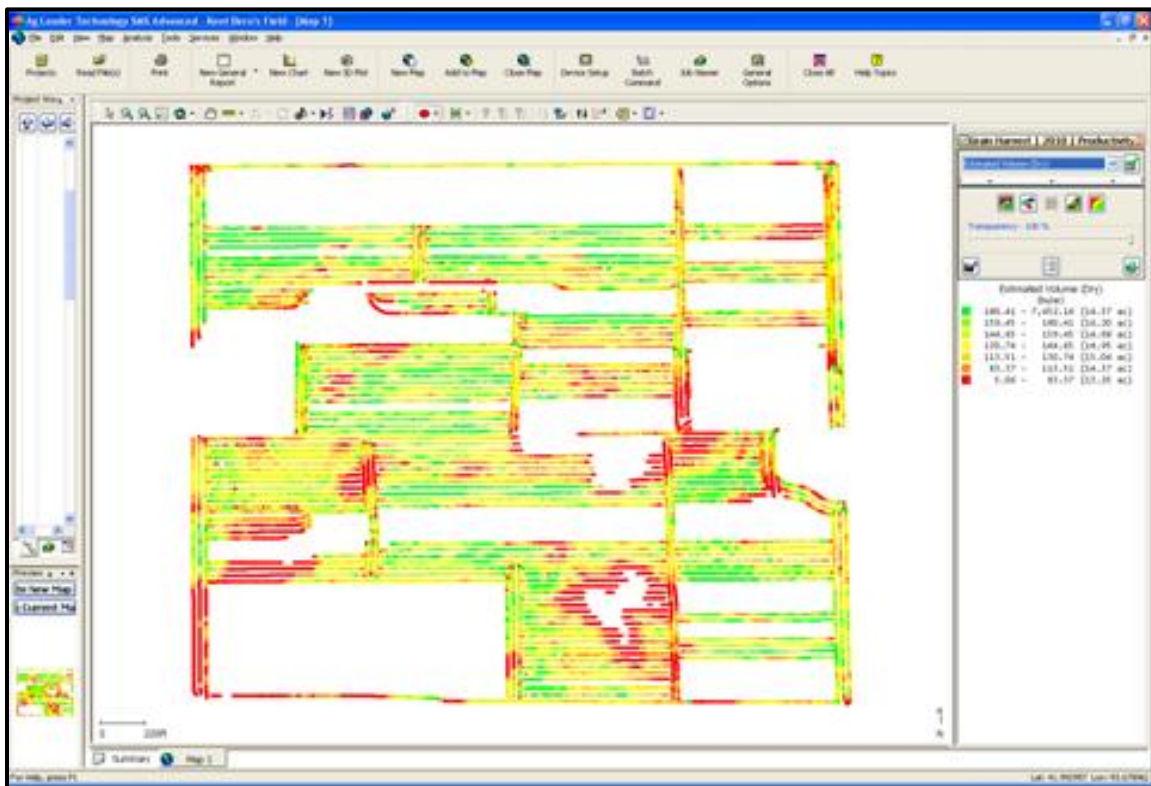

**Figure 5-15: Testing area layout displaying the variation in the yield across the field and why the yield was a factor in machine productivity calculation. Green shaded areas are higher yielding areas and red shaded areas are lower yielding areas.**

Each dataset needed to be trimmed due to high variation of yield through the test area which had many wet areas which reduced yield and crop flow through the combine. Also crop flow data at the start and finish of each test pass that was affected by lag time of crop going through the machine was removed. Crop flow lag through a combine affected the first 5 – 10 seconds of a pass due to grain needing to pass through the separator of the combine before impacting the sensor at the top of the clean grain elevator. At the start of a harvest

pass a reduced crop flow was registered. This anomaly was repeated at the end of a pass as the combine separator emptied unless the header was lifted above a predefined cutoff threshold. Figure 5-16 shows how at the ends of the test pass yield will lag compared to the center with more representative data. Also, the red highlighted area of the pass was a demonstration of the yield variation effect seen throughout the due to wet field conditions. In this pass each of these areas would be excluded. Using a common boundary for both the performance data and the yield monitor ensures that the same data points are used in both files. This was due to the previously mentioned fact that SMS uses the latitude and longitude points which represent the same area covered by the combine.

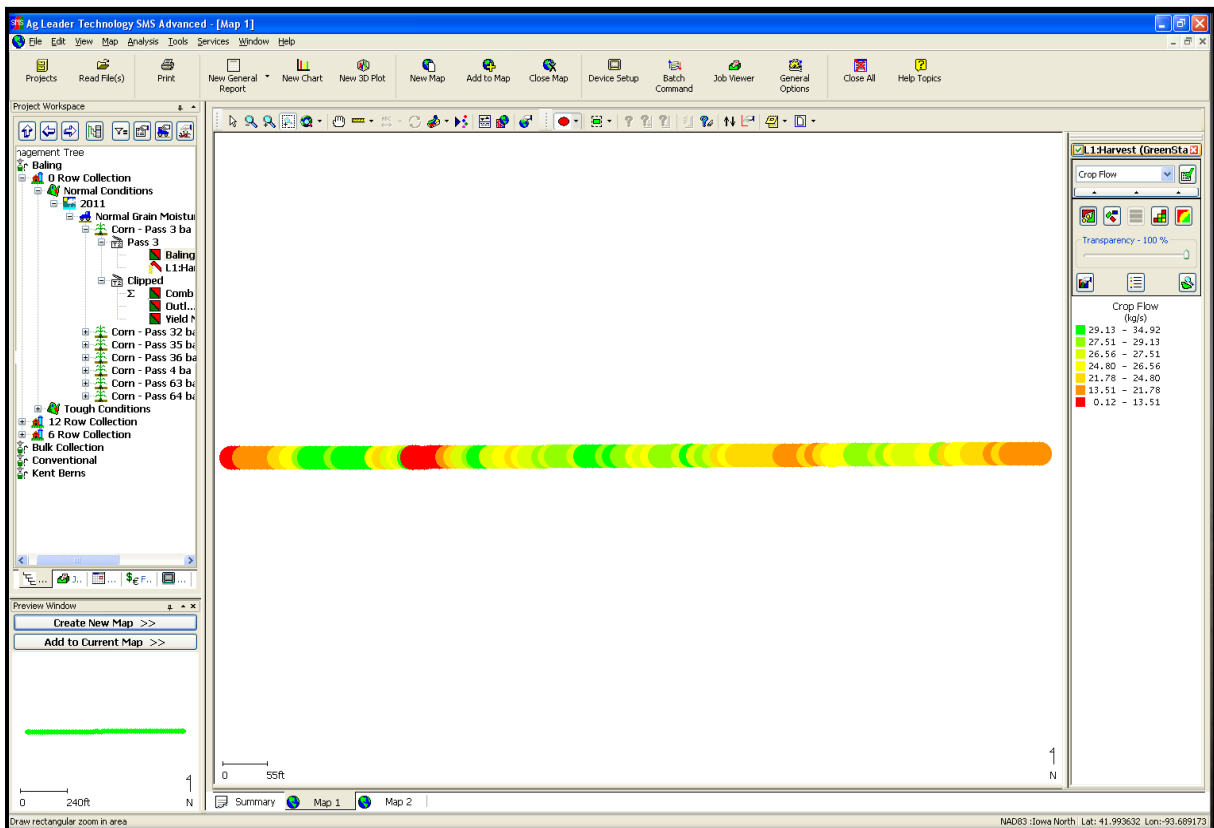

**Figure 5-16: Single test pass laid out in SMS advanced prior to trimming the data for steady state determination of the performance of the machine..**

The next step in processing the data was to summarize the data from each pass into an average for the dataset. SMS Advance's general report function was used to build these custom generated reports. The reports broke down each pass's attributes, reporting the

average of each attribute in the pass. Once reported the data was then transferred to an excel file for further processing and statistical analysis in Minitab.

## 5.2.5 IN-FIELD TESTING

### 5.2.5.1 IN-FIELD TEST SETUP

The Iowa State Research and Demonstration Farms provided five possible farms for testing to occur at. Beginning in mid-August corn was hand shelled and tested for moisture in order to determine a reasonable start time for harvest. The first farm chosen was the Bass Farm, at the Iowa State University's Agricultural Engineering and Agronomy farms, which had 10.1 ha (25 acres) of harvestable corn. The moisture of this corn was 21.0% which was the highest moisture content at the start of harvest and represented the desirable high moisture conditions required for testing. The 76.9 hectares (190 acres) Bennett Farm on the Iowa State University Research Farms 1 mile south of Ames, Iowa was selected as the second test field. This corn averaged 15.4% moisture, which was one of the driest fields at the beginning of the harvest tests. This provided the normal test conditions desired.

Upon identification of the test fields an Ag Leader SMS Mobile handheld unit was used to map the field's perimeter. In each field, specific areas were identified that were restricted due to other research experiments being conducted, waterways, or wet areas. From this an excel document was created that provided a general layout of the field for the initial test plan layout. The combine was then used to remove the headlands prior to beginning of testing. Using the original field layout each field was set up with passes that varied in length from 150 m (500 ft) to 300 m (1000 ft). The test layout was then adjusted accordingly to account for any field areas that were not identified as restricted or wet. At the completion of the field mapping 98 passes were predefined with a few set aside in case a pass was logged incorrectly. High moisture grain testing was conducted on September 30, 2010 and October 1, 2010. Testing within the Bennett field began on October 9, 2010 and carried on through November 8, 2010. The test layout for each field is further detailed in Figure 5-17 and Figure 5-18.



Figure 5-17: Separate layout of the higher-moisture grain field harvested for testing the combine. Each pass was laid out and assigned a number which is in the lower portion of the pass description was the running total of passes assigned throughout testing.

90 ft headland	3	Bale - 0 Row	Normal	picked headland 90 ft	63	Bale - 0 Row	Normal	picked headland 90 ft	161	Bale 6 Row hill	90 ft headland
90 ft headland	4	Bale - 0 Row	Normal	picked headland 90 ft	64	Bale - 0 Row	Normal	picked headland 90 ft	155	Bale 6 Row hill	90 ft headland
90 ft headland	5	Bulk - 0 Row	Normal	picked headland 90 ft	65	Bulk - 0 Row	Normal	picked headland 90 ft	156	Bale 12 Row	90 ft headland
90 ft headland	6	Bulk - 0 Row	Normal	picked headland 90 ft	66	Bulk - 0 Row	Normal	picked headland 90 ft	157		90 ft headland
90 ft headland	7	Bulk - 12 Row	Normal	picked headland 90 ft	67	Bulk - 12 Row	Normal	picked headland 90 ft	150		90 ft headland
90 ft headland	8	Bulk - 12 Row	Normal	picked headland 90 ft	68	Bulk -12 Row	Normal	picked headland 90 ft	151	Conventional - 0 row	90 ft headland
90 ft headland	9	Bale - 12 Row	Normal	picked headland 90 ft	69	Bale - 12 Row	Normal	picked headland 90 ft	152	Conventional - 6 row pass 174	90 ft headland
90 ft headland	10	Bale - 12 Row	Normal	picked headland 90 ft	70	Bale - 12 Row	Normal	picked headland 90 ft	153	Conventional - 0 row	90 ft headland
90 ft headland	11			picked headland 90 ft	71			picked headland 90 ft	154	Conventional - 12 row	90 ft headland
90 ft headland	12			picked headland 90 ft	72			picked headland 90 ft	155	Bale - 6 Row	90 ft headland
90 ft headland	13			picked headland 90 ft	73			picked headland 90 ft			90 ft headland
90 ft headland	14			picked headland 90 ft	74			picked headland 90 ft			90 ft headland
90 ft headland	15			picked headland 90 ft	75			picked headland 90 ft			90 ft headland
90 ft headland	16			picked headland 90 ft	76			picked headland 90 ft			90 ft headland
90 ft headland	17			picked headland 90 ft	77			picked headland 90 ft	Hill		90 ft headland
90 ft headland	18			picked headland 90 ft	78			picked headland 90 ft	158	Bale 12 Row	91 ft headland
90 ft headland	19			picked headland 90 ft	79			picked headland 90 ft	159	Conventional - 12 row	92 ft headland
90 ft headland	20			picked headland 90 ft	80			picked headland 90 ft	160	Conventional - 6 row pass 174	93 ft headland
90 ft headland	470ft	21	Bale - 12 Row	Tough	picked headland 90 ft	Conventional - 0 row pass 170	tough	picked headland 90 ft	161	Bale - 6 Row	94 ft headland
90 ft headland		22	Bale - 12 Row	Tough	picked headland 90 ft	Conventional - 0 row pass 171	tough	picked headland 90 ft			
90 ft headland		23	Bale - 6 Row	Tough	picked headland 90 ft	Conventional - 12 row pass 172	Normal				
90 ft headland		24	Bale - 6 Row	Tough	picked headland 90 ft	Conventional - 12 row pass 173	Normal				
90 ft headland		25	Bulk - 6 Row	Tough	picked headland 90 ft	Conventional - 6 row pass 174	Normal				
90 ft headland		26	Bulk - 6 Row	Tough	picked headland 90 ft	Conventional - 6 row pass 175	Normal				
90 ft headland		27	Bale - 6 Row	Normal	picked headland 90 ft	Conventional - 0 row pass 176	normal				
90 ft headland		28	Bale - 6 Row	Normal	picked headland 90 ft	Conventional - 0 row pass 177	normal				
90 ft headland		29	Bulk - 6 Row	Normal	picked headland 90 ft	Conventional - 12 row pass 178	Tough				
90 ft headland		30	Bulk - 6 Row	Normal	picked headland 90 ft	Conventional - 12 row pass 179	Tough				
90 ft headland		31	Bale - 0 Row	Tough	picked headland 90 ft	Conventional -6 row pass 180	Tough				
90 ft headland		32	Bale - 0 Row	Tough	picked headland 90 ft	Conventional -6 row pass 181	Tough				
90 ft headland		33	Bulk - 0 Row	Tough	picked headland 90 ft	Extra-750 ft 16 passes					
90 ft headland	425 ft	34	Bulk - 0 Row	Tough	picked headland 90 ft						
90 ft headland		35	Bale - 0 Row	Normal	picked headland 90 ft			picked headland 90 ft	-300 ft/picked headland 90 ft		
90 ft headland		36	Bale - 0 Row	Normal	picked headland 90 ft			picked headland 90 ft	-300 ft/picked headland 90 ft		
90 ft headland		37	Bulk - 0 Row	Normal	picked headland 90 ft			picked headland 90 ft	-300 ft/picked headland 90 ft		
90 ft headland		38	scratch		picked headland 90 ft			picked headland 90 ft	-300 ft/picked headland 90 ft		
90 ft headland		39	Bulk - 12 Row	Normal	picked headland 90 ft			picked headland 90 ft	-300 ft/picked headland 90 ft		
90 ft headland		40	Bulk -12 Row	Normal	picked headland 90 ft			picked headland 90 ft	-300 ft/picked headland 90 ft		
90 ft headland		41	Bale - 12 Row	Normal	picked headland 90 ft			picked headland 90 ft	-300 ft/picked headland 90 ft		
90 ft headland		42	Bale - 12 Row	Normal	picked headland 90 ft			picked headland 90 ft	-300 ft/picked headland 90 ft		
90 ft headland		43	Bale - 6 Row	Normal	picked headland 90 ft			picked headland 90 ft	-320 ft	90 ft headland	
90 ft headland		44	Bale - 6 Row	Normal	picked headland 90 ft			picked headland 90 ft	-320 ft	90 ft headland	
90 ft headland		45	Bulk - 6 Row	Normal	picked headland 90 ft			picked headland 90 ft	-320 ft	90 ft headland	
90 ft headland		46	Bulk - 6 Row	Normal	picked headland 90 ft			picked headland 90 ft	-320 ft	90 ft headland	
90 ft headland		47	Bale - 0 Row	Tough	picked headland 90 ft			picked headland 90 ft	-660 ft	Extra	90 ft headland
90 ft headland		48	Bale - 0 Row	Tough	picked headland 90 ft			picked headland 90 ft	-660 ft		90 ft headland
90 ft headland		49	Bulk - 12 Row	Tough	picked headland 90 ft			picked headland 90 ft	-660 ft		90 ft headland
90 ft headland		50	Bulk - 0 Row	Tough	picked headland 90 ft			picked headland 90 ft	Conventional - 12 row-200	tough	90 ft headland
90 ft headland		51	Bulk - 0 Row	Tough	picked headland 90 ft			picked headland 90 ft	Conventional - 12 row-201	tough	90 ft headland
90 ft headland		52			picked headland 90 ft			picked headland 90 ft	Conventional - 6 row -202	tough	90 ft headland
90 ft headland		53			picked headland 90 ft	Bulk - 6 Row	Normal	picked headland 90 ft	Conventional - 6 row-203	tough	90 ft headland
90 ft headland		54			picked headland 90 ft	Bulk - 6 Row	Normal	picked headland 90 ft	Bulk - 12 Row-204	Tough	90 ft headland
90 ft headland		55			picked headland 90 ft			picked headland 90 ft	Bulk -12 Row-205	Tough	90 ft headland
90 ft headland		56			picked headland 90 ft			picked headland 90 ft	Bale - 12 Row-206	Tough	90 ft headland

Figure 5-18: Layout of the field for testing the combine, baler, and bulk harvest systems with estimations of the layout of the field and adjusted after the field was opened and crop conditions were assessed.



The layout of the field was planned with the goal of having two passes next to each other as much as possible to shorten testing time to within a reasonable harvest window. Test conditions which were identified prior to laying out the field dictated the amount of passes that were to be fitted into the field layout. A minimum of four passes per configuration were designed into the field layout initially and adjusted after the final field layout was confirmed. Table 14 shows the final amount of passes that were achieved during testing. Most of the normal conditions were fully tested, however due to restrictions in some areas, testing on the hillside had to be reduced. Also, due to abnormally long and favorable weather conditions during harvest some of the tough condition scenarios were untested due to lack of rainfall during the 2010 harvest season

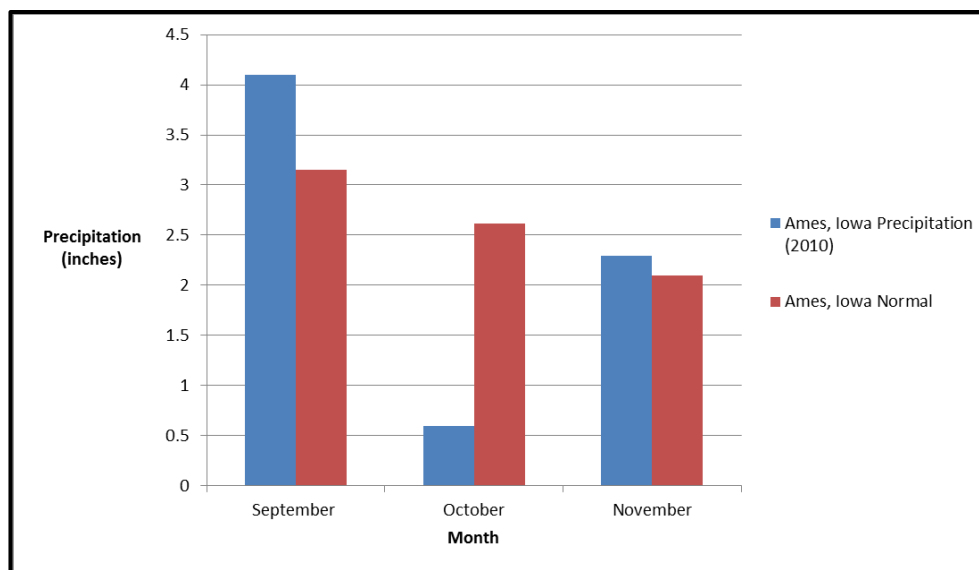

**Figure 5-19: Recorded precipitation for the 2010 fall harvest season demonstrating the below average rainfall received for the month in Ames, Ia. (National Oceanic and Atmospheric Administration's, 2011).**

The two major variables tested during the harvest were the effects of each harvest system on the productivity of the grain harvest operation and then the effects of the different corn stover collection rates. Also investigated were the effects various crop and field conditions including some terrain effects, tough conditions, high moisture grain conditions, and normal or ideal crop conditions. This was done with the hopes of determining the overall effect on combine performance that each condition had. The normal production tests,

simulated typical crop conditions and grain moisture during a fall harvest day when it was dry and sunny. Higher grain moisture was targeted with the assumption that higher plant tissue moisture would be harvested at the same time. No corn stover harvest attachment was used at the high moisture treatment because of the availability of high moisture grain. Instead tests were performed with the combine which provided a baseline data for performance, the effects of the single-pass bulk and single-pass baling system were then quantified a direct loss above the baseline performance of the machine. Tough crops conditions were analyzed. These conditions were experienced when plant material becomes damp because of a rain event or morning dew. Negative effects on combine performance are more prevalent in grass crops and soybeans which traditionally harvest the entire plant. Tough conditions start when the stem of the plant absorbs moisture and becomes less fragile. This made it harder for the combine to cut and break apart the plant. It was hypothesized that the combine would slow in tough conditions because the upper stalk and leaves versus the cobs and husks will cause a greater influence on machine performance. Tough crop conditions were tested in two different methods, the first was harvesting after dark when the dew was present and the second method was to wait until a rain. Each of these conditions allowed the plant residue to be tougher than normal. A total summary of passes completed has been detailed in Table 14.

Type of Harvest	Rows of Collection	Conditions	Number of Passes	Total Passes per Configuration	
Baling	0	Tough	4	10	
		Normal	6		
	50	Tough	2	8	
		Hill	2		
		Normal	4		
	100	Tough	4	12	
		Hill	2		
		Normal	6		
	Bulk	0	Tough	4	11
Normal			7		
50		Tough	2	8	
		Normal	6		
100		Tough	4	10	
		Normal	6		
Conventional		0	Tough	4	15
			High Moisture	5	
			Hill	2	
	Normal		4		
	50	Tough	4	13	
		High Moisture	5		
		Hill	2		
		Normal	2		
	100	Tough	4	12	
		High Moisture	4		
		Hill	1		
		Normal	3		

**Table 14: Final summary of the total test passes harvested by the harvest configuration and amount of stover collected based upon header setting.**

#### 5.2.5.2 IN-FIELD TEST PROCEDURE

Once the test passes were determined and crop conditions were fit, harvesting began. Fields were prepped prior to testing by removing all headlands. After an initial assessment of the crop conditions had taken place with the headlands removed. The additional headlands were added according to the field layout maps shown in Figure 5-17 and Figure 5-18. This increased the amount of test passes available in the field. Once this was completed test passes started to be harvested. As shown in Figure 5-17 and Figure 5-18 most passes were coupled with another pass of the same condition and configuration. This was done to help improve the logistics of the testing by minimizing equipment travel across the field and provide data points with similar crop characteristics. To begin a test pass, equipment was prepped for the chosen configuration of the harvest day. To speed up testing configurations were not changed often and most testing of a configuration was completed in one to two days. The turnaround time needed to be minimized in order to maintain a reasonable pace of harvest in order to complete harvest with good weather conditions and deliver harvest grain to nearby elevators which stayed open only on a seasonal basis.

Prior to starting into a test pass, the yield monitor was set to record and log the correct information for the dataset through the GreenStar 2 display. In the display the user input for corn variety was altered to read in the pass number, pass conditions, and configuration. This allowed for the data to be labeled as it was brought into the SMS Advanced software discussed earlier in the chapter. The next step was to plug in the data loggers wait for the LED diagnostic lights to start steadily blinking and start the test pass.

The combine separator and header were started along with the baler if it was being used. Once the machines were at high idle, 2300 rpm for the combine and 2500 rpm for the baler, the test began. The combine's forward speed was varied according to its engine rpm to maintain an engine rpm between 2200 rpm and 2250 rpm. This engine rpm range was selected to maximize the engine loading of the combine and to minimize variation amongst the data from factors other than the increased corn stover processed by the combine. For most configurations the engine would be loaded to the rpm range listed above, however for

the 0 row collection this scenario was not achievable and speed was adjusted to minimize header loss.

Upon completion of the pass the separator and the header of the combine along with the baler were turned off and the data loggers unplugged. The data file was then moved from the data logger and processed using a laptop computer. After processing the data was analyzed to ensure the data was properly logged and then sorted according to the pass for further processing discuss earlier in the chapter.

#### 5.2.5.3 YIELD MONITOR CALIBRATION

Prior to initial harvest testing a small area of the high moisture corn Bass Farm was selected to calibrate the mass flow and moisture sensors on the combine. For the mass flow sensor to be calibrated, the running counter for the sensor was reset to zero. Then a stretch of crop was selected and harvested at a speed of about 8-9.6 kph (5-6 mph) in order to calibrate based on a mass flow that was representative of the experimental treatments. Once this section of corn was tested it was then off loaded onto a weigh wagon and weighed. This was compared to the weight calculated by the combine mass flow sensor. The difference in weight was then recorded and the calibration was completed for the mass flow. The John Deere mass flow sensing system uses a single point calibration system; when crop flow was near the calibration point it was accurate but as crop flow moved away from this curve there was some error in the predicted mass flow values. Two calibrations were performed during the testing season once beginning of the harvest to setup the machine with the correct values for higher moisture grain and then once again in the middle of season when drier crop conditions were experienced. Calibrations were not performed daily due to varying configurations that were used in the testing, limited crop area for testing, and in the interest of time during harvesting

### 5.2.6 PRODUCTIVITY STATISTICAL ANALYSIS

The data which was averaged and recorded from the SMS Advanced program was scaled to adjust for the varying yields throughout the fields and compensate for different engine loading conditions which were due to the unique operation configurations and conditions.

**Equation 2: Productivity Index Equation.**

$$Productivity\ Index = \frac{CF}{Y_{norm} \times E}$$

Where as

CF = Crop Flow (Grain) (kg/sec)

$Y_{norm}$  = Yield of Pass as a percentage (%) of max yield of the testing areas.

E = Percent of engine load (out of 100%) at current speed

Since no prior method to quantify this data was in place, a new formula was developed that factored variables such as grain yield, crop flow, and engine loading. These were selected as the main variables due to the requirements of the testing to remain at an engine loading of 100% or near that level without stalling the engine and the need to factor out variations in the yield across the field. The formula displayed Equation 2 a productivity index was determined by compensating for the three major factors affecting combine productivity. These factors were crop flow, percent of maximum yield, and percent of load on the engine. Crop flow was determined from the amount of grain hitting the impact sensor at the top of the clean grain elevator in the combine before entering the grain tank. The percent of maximum yield is determined after harvest in the SMS Advanced software program, the highest yield is benchmarked at 100% and subsequent yields determine as a percent of the maximum yield. Percent engine load is the ratio of actual engine percent torque to maximum indicated torque available at the current engine speed (SAE, 1998).

To determine the productivity index, overall crop flow was used. However, since crop flow was inconsistent due to varying crop conditions across the field it had to be scaled by the percent of maximum yield and the percent engine load used in the field section. This formula was determined by looking at a comparison of the raw crop flow data recorded from the actual test runs and the speed of the combine. Results of the raw data are shown in Figure 5-20 and Figure 5-21.

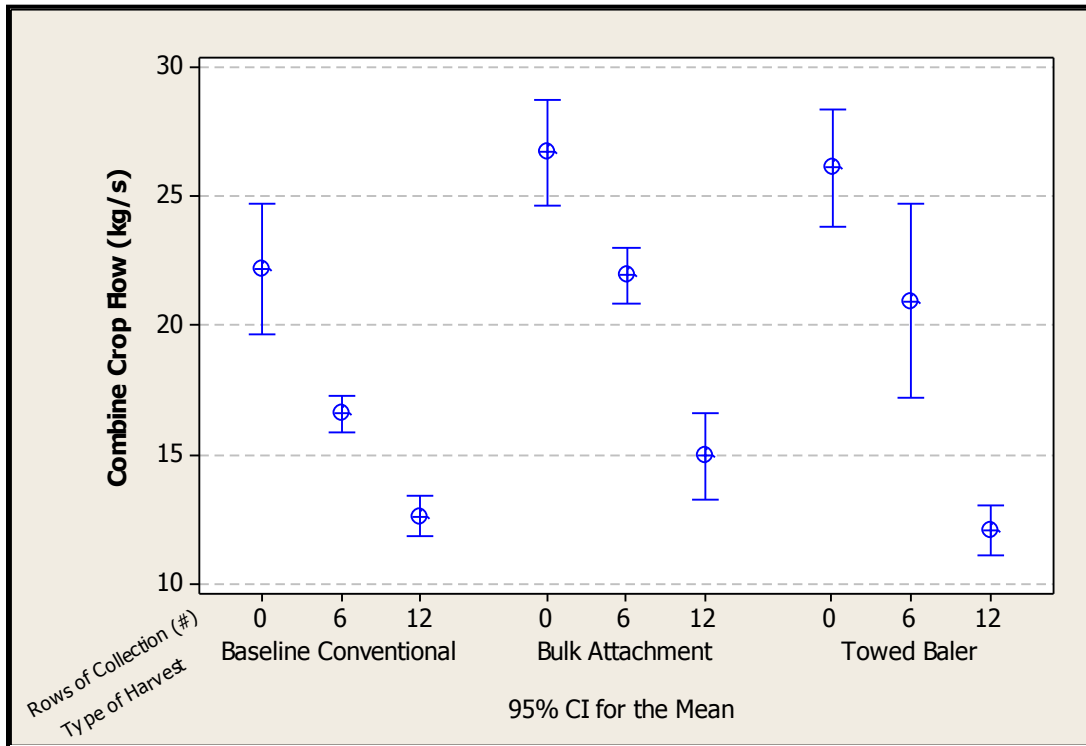

**Figure 5-20: Average crop flow data recorded by the combine's yield monitoring system during testing. The conventional test shows a decreased crop flow compared to the bulk and baling configurations which was not a predicted outcome.**

In Figure 5-20 the crop flow for the conventional harvest system was lower in all cases. If solely determining productivity from the crop flow, then the baseline conventional configuration had the lowest productivity. However, looking at the overall speed of the combine in Figure 5-21 the conventional configuration speed was greater than each of the corn stover harvest systems.



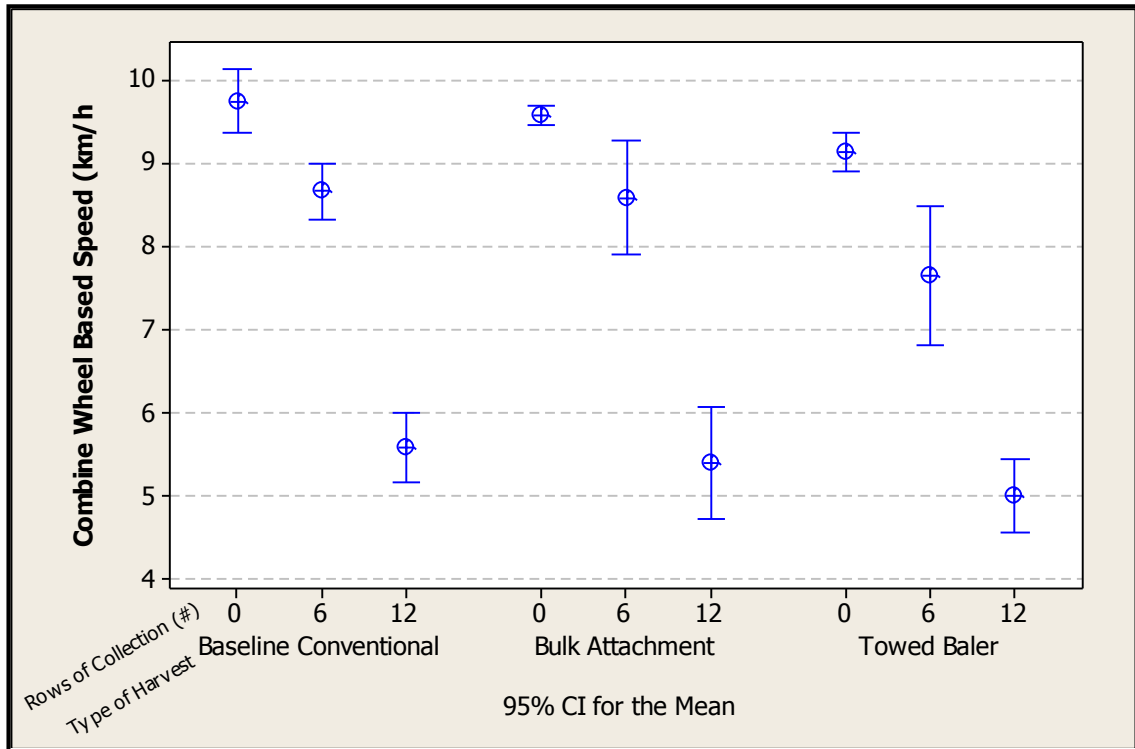

**Figure 5-21: Average speed of the combine during the test from the combine. Speed is more consistent across the configurations and show's a predicted drop off as more stover is harvested. .**

Yield was also determined to be a factor in the low crop flow values in the conventional harvest system due to the highly variable yield experienced in the test fields. Low yielding test passes also had low crop flow values and showed less productivity. By determining the highest yield in the test passes and normalizing the rest of the yields to that value a scalable number was created that would eliminate the variation in the yield. The raw yield data is shown in Figure 5-22.

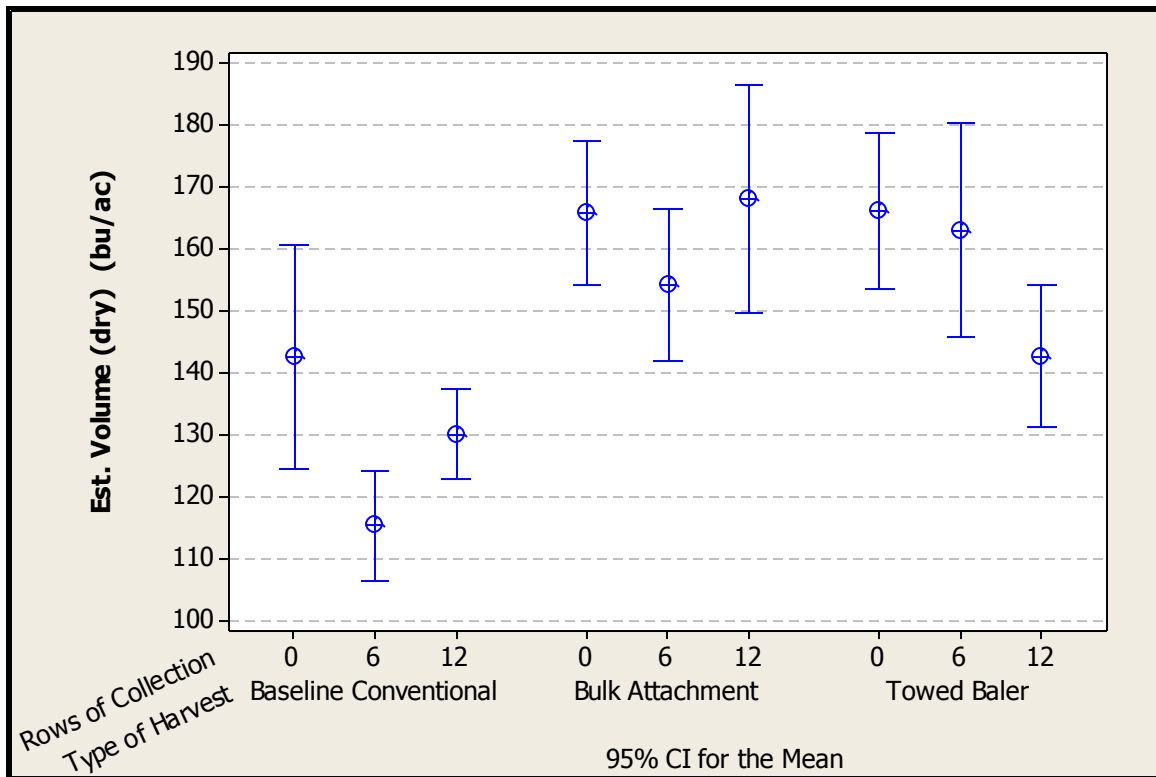
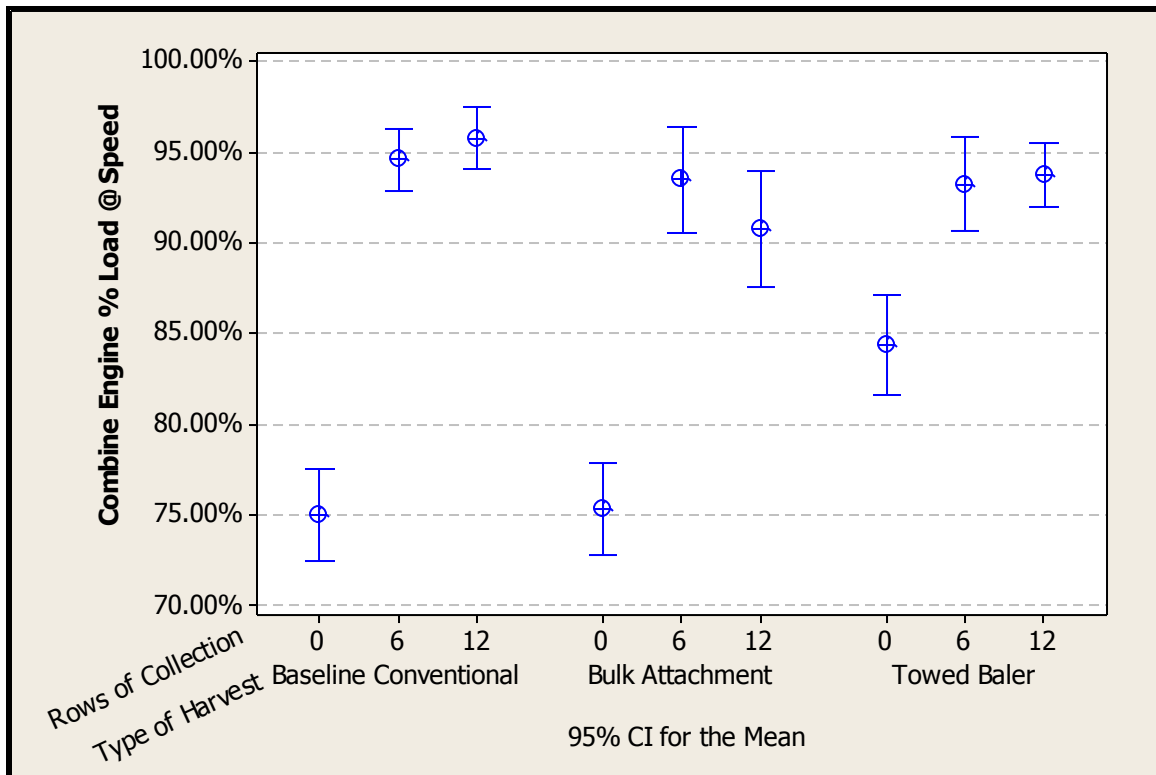

Figure 5-22: Estimated average yield of the test passes from the combine's yield monitoring system. The conventionally harvested passes are lower than the bulk and baling configurations.

Finally, the percent of load applied to the engine was also used to scale the crop flow data. It was determined that this was needed in order to compensate for test cases in which the engine was not required to be fully loaded, 100%. As shown in Figure 5-23, the raw engine percent loading data showed that in zero row collection the engine for the combine still had available power, but it was variable amongst the configurations. By eliminating this variation in the data all test configurations had the same engine power output.



**Figure 5-23: Combine engine loading % @ speed (engine rpm), for the test passes the lower harvest rates show that the engine is not loaded fully until more stover is introduced. The engine loading also increases when the baler is being towed by the combine.**

By dividing the crop flow by the percent of maximum yield and percent of load applied to the engine the reductions in these two factors were eliminated from biasing the data. This potential maximum productivity was expressed by each configuration with the assumption that the yield and the engine load were both maximized. The final adjustment to the productivity index was to normalize the output of the equation on a scale of 1-100%.

## 5.3 RESULTS

### 5.3.1 PRODUCTIVITY ANALYSIS RESULTS

#### 5.3.1.1 SYSTEM PRODUCTIVITY ANALYSIS

During the tests there were two treatment factors that provided significant shifts in overall productivity loss. The effects that each type of harvest system, bulk attachment or towed baler, had on the combine's productivity will be discussed first.

Entering the testing phase it was known that because of the differences in harvest system equipment configuration there was an inherent drag on the productivity for some systems. It was also known that the single-pass baler had an overall mass of 10,000 kg (22,000 lbs) and had a disadvantage in productivity versus single-pass bulk attachment due to the large draft load the single-pass baler induced on the combine. It was also assumed that the single-pass bulk attachment would have some effect on overall productivity. What was not known was the magnitude of the impact on productivity that each system would have on the combine.

Figure 5-24 shows the overall effect of both the collection systems and rates collected. Concentrating on the overall system effect first and comparing this to the baseline conventional data indicates that the single-pass bulk harvest has little effect on the overall productivity of the combine. As seen in Figure 5-24 there was no statistical difference in the overall confidence interval of the data under these conditions. The predicted means also were within 1-2% of each other and most variation can be accounted for by the overall variation in speed throughout the trials. Overall, the single-pass bulk harvest attachment had no statistical effect on the combine's productivity.

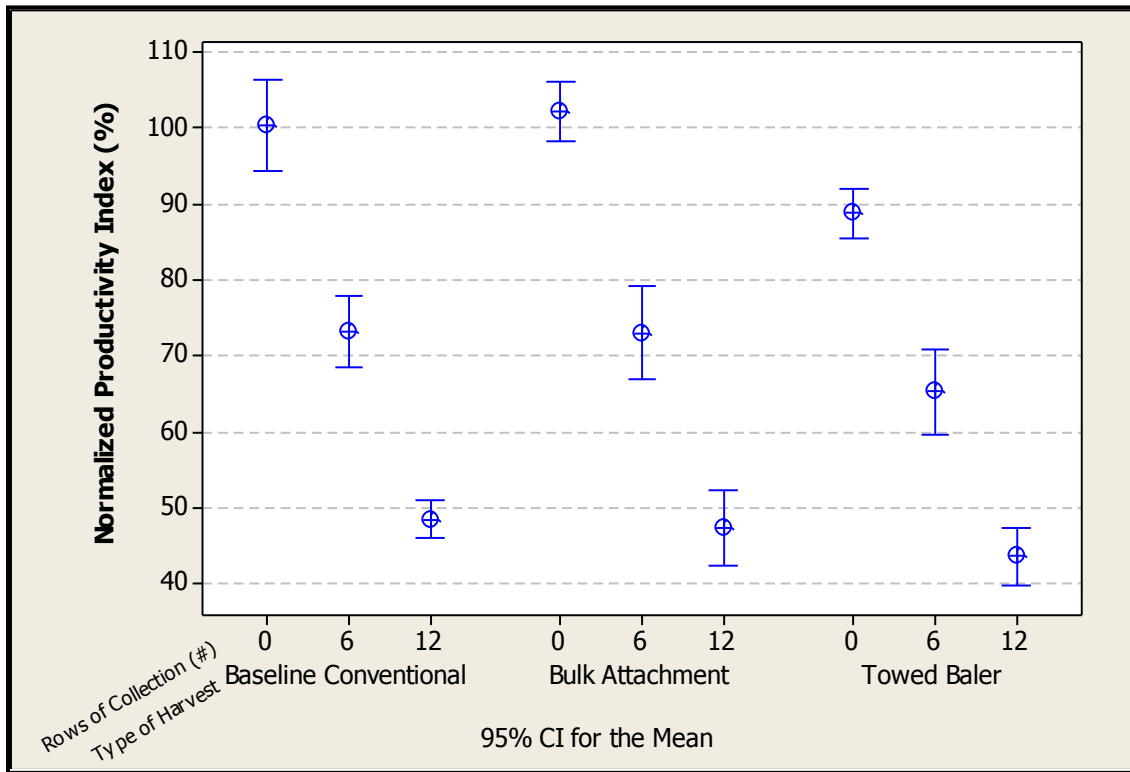

**Figure 5-24: Plot of normalized productivity of the combine in each harvest system over 3 different harvest rates. This shows the combine's productivity is reduced as the amount of corn stover is increased and when the baler is towed behind the combine.**

The single-pass baling harvest system showed more productivity loss than the baseline or bulk collection system. Only one interval was statistically different, which will be discussed later in the section. The predicted means as shown in Figure 5-24 tend to trend lower than either the baseline conventional harvest system or single-pass bulk harvest system. Analysis of the predicted means of the data shows an average loss in productivity of 10-12% for the single-pass baling harvest system.

### 5.3.1.2 AMOUNT HARVESTED ANALYSIS

What had more effect on productivity was the total amount of material that was harvested and processed through the combine. Figure 5-24 shows the overall effects of increased rates of corn stover that was collected and processed by the combine in an interval plot. In the plot there was a statistical difference in the loss of productivity between the different rates of stover harvested in each stover harvest system. The rates of stover

harvested were the main drivers for the productivity loss. This was shown by concentrating on the baseline conventional data which shows about a 27% loss in productivity seen in each increase in the rate of stover collected determined by the amount of harvested rows of corn stover. Collecting all twelve rows of stover will yield about a 52% drop in overall productivity to just the combine.

Further analysis of Figure 5-24 showed a rather large interval in the zero collection row units between the towed baling system versus the baseline conventional harvest system and the single-pass bulk harvest system. This was explained by two different factors.

The first factor was that towing the single-pass baler, the overall speed of the combine was slower, especially the top end speeds of the zero row collection setting. As the amount of rows that were set to collect stover increased, the rate of the corn stover increased, the combine speed was slowed to process the extra corn stover being harvested. The affect that the 11% productivity loss from the single-pass baling system was minor when compared to this major productivity loss associated with increasing stover collection rates. This was why in Figure 5-24 the intervals for the six row collection and six row conventional and twelve row collection harvest rates, begin to group together and become statistically indifferent.

The second factor was that the engine of the combine was also loaded more as it towed the baler. In the productivity index, Equation 2, the influence of varying engine loading was minimized by using the loading percent as a scaling factor for the crop flow. The engine loading percent for all cases was factored out by doing this. The potential productivity was factored into the data instead of expressing the actual productivity calculated during testing. The single-pass baler harvest system had less potential productivity because the engine of the combine was already loaded more and it maximized the use of its power production quicker than either the conventional harvest system or the single-pass bulk harvest system.

Additionally, this data indicates that at the zero row collection configuration the combine was not limited by power or speed. When analyzing the speeds, none were statistically different from each other and all were within one kph. This was due primarily to the intake limitation in the header. At forward speeds higher than 11 kph (6.8 mph) the header started to ‘push’ the stalks over prior to fully stripping the ear away from the plant. This was caused by the head not being able to pull the stalk through the stripper plates prior to reaching the back end of the row units as shown in Figure 5-28. When this happened the ear was still pulled off the stalk, but the stalk was not fully processed as it would be in normal operation. This also caused ear shatter which was when the ear of corn broke apart in the header leaving corn in the field instead of the ear reaching the combine separator. Ear shatter was determined through visual inspection during and after the test pass. Adjustments to the speed and stripper plate width were made to combat this problem.

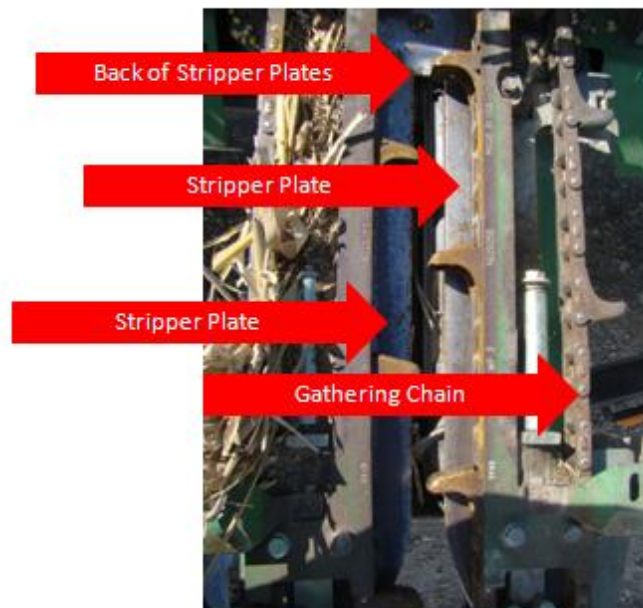

**Figure 5-25: Diagram of header row unit the stalk will reach the back of the stripper plates before it is completely pulled down by the stalk roll. When this happens the entire stalk will push over instead of straight down.**

### 5.3.2 PRODUCTIVITY PREDICTION EQUATION

A regression curve was formulated from the harvest data to further analyze the productivity index data. Not all factors tested were chosen to be included in the equation. The high moisture grain and terrain factors each had p-values that were out of range of the acceptable limit which was  $\alpha = .05$ . After removing these two factors the regression analysis produced Equation 3.

**Equation 3: Regression equation for predicted Productivity Index**

$$PI = 99.4 - 4.23 HR - 7.99 Ba + .29 Bu$$

Where as

PI = Percent of productivity based on the maximum productivity of a conventional harvest system

HR = Header rows set to collect stover. (# Header Rows)

Ba = If using the single-pass baling harvest system use (1) if not use (0).

Bu = If using the single-pass bulk harvest system use (1) if not use (0).

The regression equation produced an  $r^2$  value of 90.9%.

The productivity index regression equation showed a reasonably placed average could be determined for how much the combine productivity would be impacted depending on the system chosen to collect stover with and the amount of stover collected. In the equation 99.4% was the highest confidence interval mean percentage of machine productivity. The stover rate factor was scalable based upon the amount of rows of stover collected. This would help predict productivity for a header up to 12 rows wide because it was indifferent to the amount of conventional rows was used. The only requirement in this calculation was that it was assumed that the combine size was the same. Additional reductions were seen for each stover collection system. Only an 8% reduction was seen when baling according to the



regression equation, this was shown in the corresponding coefficient listed in the equation, however in the raw data analysis a larger reduction of 11% was seen. The difference here can be attributed to two factors; the first being that the  $r^2$  value for the curve is only 90% so there was some variation from the curve that could account for this, also the wide variation of crop conditions were not all accounted for in the treatment factors or by the productivity equation. This was only a predictive equation and will not fully fit the curve. The final term in the equation showed less than .3% reduction in productivity for bulk harvest. This value was representative of the values seen from the bulk productivity analysis.

#### 5.4 CONCLUSIONS

Data that was collected from the in-field testing that occurred in the fall of 2010 tested five different factors. The factors: collection system and collection rate were tested, collected data, and produced statistically significant results. The data collected was processed and combined with yield monitoring files in the Ag Leader SMS Advanced software, then was averaged for each trial pass, and then analyzed in Minitab. Little statistical difference was seen between a conventional harvest system and single-pass bulk harvest system. Between the conventional harvest system and single-pass baling harvest system there were statistical differences at the lower rates of collection in the 0 row collection header configuration. The difference seen between the two systems was 11%. Other statistically different data was seen in the different harvest collection rates of 0, 6, and 12 rows. The increased stover rates lowered combine productivity by about 27% for each increase in the rate of collection. The lower productivity was a result of slower forward travel speed in the combine as well. The slower forward travel speed of the combine, removed the statistical significance from the differences in the harvest systems but there was still about a 10-11% difference between single-pass baling harvest systems and the conventional system.

## Chapter 6.0 Single-Pass Harvest System Performance

### 6.1 INTRODUCTION

Actual single-pass harvest system performance was recorded for realistic production data for analysis. Data was analyzed to provide specific performance values for modeling single-pass harvest systems. The objectives of this analysis were to provide the following using the CyCAN data loggers as described in Chapter 4 and processed according defined procedures in Chapter 5:

- Power consumption data
- In-field speed of the combine
- Fuel consumption of the combine and support equipment

### 6.2 MATERIALS AND METHODS

#### 6.2.1 FIELD SPEED AND FUEL CONSUMPTION

Fuel and speed measurements were taken directly from the data logged with the CyCAN logger. Raw performance data from each test pass, listed in section 5.2.5, was averaged in the Ag Leader SMS Advanced Software package and then statistically analyzed. Test passes were replicated and thus the average results from a single test pass yield a single set of statistics for that replicate. Fuel consumption was analyzed for each machine (combine, tractor, baler) and system (conventional, single-pass baling, single-pass bulk). The metric for comparison was on a liter per dry ton of stover removed basis. To calculate the liter per ton fuel consumption three factors were used; acres per hour productivity from the combine's yield monitor, collection rate in tons per acre of stover, and the fuel consumption on a L/h basis which was taken from the raw CAN data.

By subtracting the average fuel consumption for the combine to harvest grain at the baseline level (conventional configuration, 0 collection rows), a fuel consumption value for the stover harvest equipment was determined. The average fuel consumption value for the

John Deere 9860 to harvest grain was 61.5 L/h (16.25 gph). The equipment analyzed for stover harvest fuel consumption was the combine, tractor, and baler.

## 6.2.2 POWER ANALYSIS

Horsepower required for each system was calculated based upon test data from in-field productivity testing. The basis of this calculation was determined from the fuel consumption of the combine and the stover collection systems. The raw horsepower was determined from Equation 4.

**Equation 4: Determination of the Fuel Equivalent Power. (Goering & Hansen, 2004)**

$$P_{fe} = \frac{HV \times M_f}{K_{fe}}$$

Where as

$P_{fe}$  = fuel equivalent power (kW)

HV = Higher Heating value of fuel (kJ per kg)

$M_f$  = Fuel consumption rate (kg per hour)

$K_{fe}$  = Constant (3600)

The raw horsepower generated was calculated according to how much fuel was consumed. However, this was not the actual mechanical power that was being output from the combine, baler, or tractor in this case, it was the power output of the fuel itself. To calculate the actual power being output from each piece of machinery the efficiency of each engine was determined. Test data from the University of Nebraska Lincoln Tractor Test lab and the Organization for Economic Cooperation and Development (OECD) provided fuel efficiency data for a tractor with the same engine used in the harvesting and stover collection equipment. Due to the developmental nature of the engine power systems of the combine and baler it was assumed that engines used in the equipment were similar to the engines used in the Test Lab tractors.

It was determined that the John Deere 9620 had the most similar engine configuration in comparison to the engine in the combine. The engine in this tractor was 12.5 L which was the same used in the combine. The 4.4 L baler engine was determined to be similar to the engine used in the AGCO Challenger 465B tractor. Power efficiency was determined from the OECD test of the 12.5 L engine in the combine, the 8.9 L engine in the 8230 tractor, and the 4.4 L engine in the baler. It was determined that the combine engine was 30% efficient, the tractor engine was 30% efficient, and the baler engine was 31% efficient.

**Equation 5: Calculation for determining the actual mechanical power used by the stover harvest machines in the analysis.**

$$P_{kW} = P_{fe} \times e$$

Where as

$P_{kW}$  = Actual mechanical power (kW)

$P_{fe}$  = Fuel equivalent power (kW)

$e$  = Engine efficiency (%)

## 6.3 RESULTS

### 6.3.1 FUEL CONSUMPTION ANALYSIS

The initial fuel consumption data recorded from the CAN bus system contained the total fuel consumption values for the combine to harvest grain and corn stover. In Figure 6-1, the fuel consumption for the combine to harvest grain was 61.5 L/h (16.25 gph). Harvesting additional stover increased the fuel consumption of the combine to 80 L/h (21.1 gph). At the 0 row harvest rate the fuel consumption for the single-pass bulk combine was not statistically different from the baseline conventional harvest system fuel consumption. However, the single-pass baling combine had a statistically different fuel consumption rate of 70 L/h (18.5 gph). The fuel consumption was similar for the baseline conventional system, bulk attachment system, and the towed baler at the stover harvest rates of 6 and 12 row. The combine in each system had fuel consumption rates within a range of 78- 80 L/h (20.5 – 21.1 gph). The fuel consumption stabilized at this rate because the combine's engine load

capacity was close to being maximized. When the engine load was near its limit the amount of fuel consumed was also maximized.

The tractor's fuel consumption was initially high but as the amount of stover harvested increased the fuel consumption trended lower. This was primarily because the combine was moving slower through the field due to increased stover harvest rates. Detailed further in Figure 6-4, the combine speed slowed as more stover was harvested and the tractor doesn't need as much fuel to produce the power needed to keep it at speed with the combine, so the fuel consumption rate decreased.

The baler's fuel consumption was similar to the combine's fuel consumption. At the lowest harvest rate, 0 rows, the fuel consumption was statistically lower than the consumption rates at the 6 – 12 row harvest rates. At the higher rates the consumption stabilized.

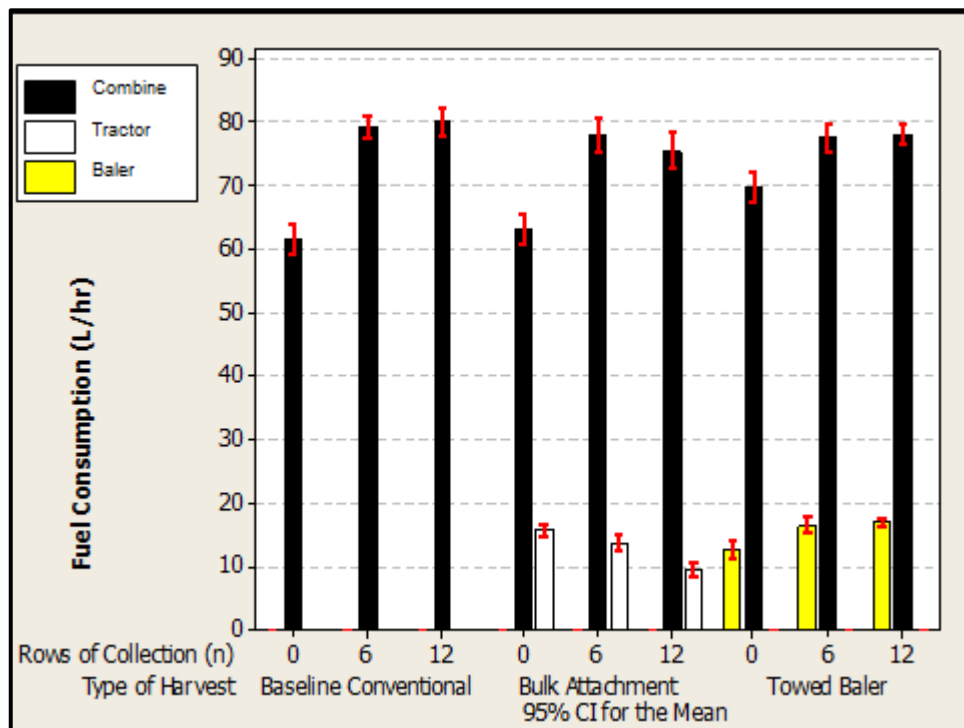
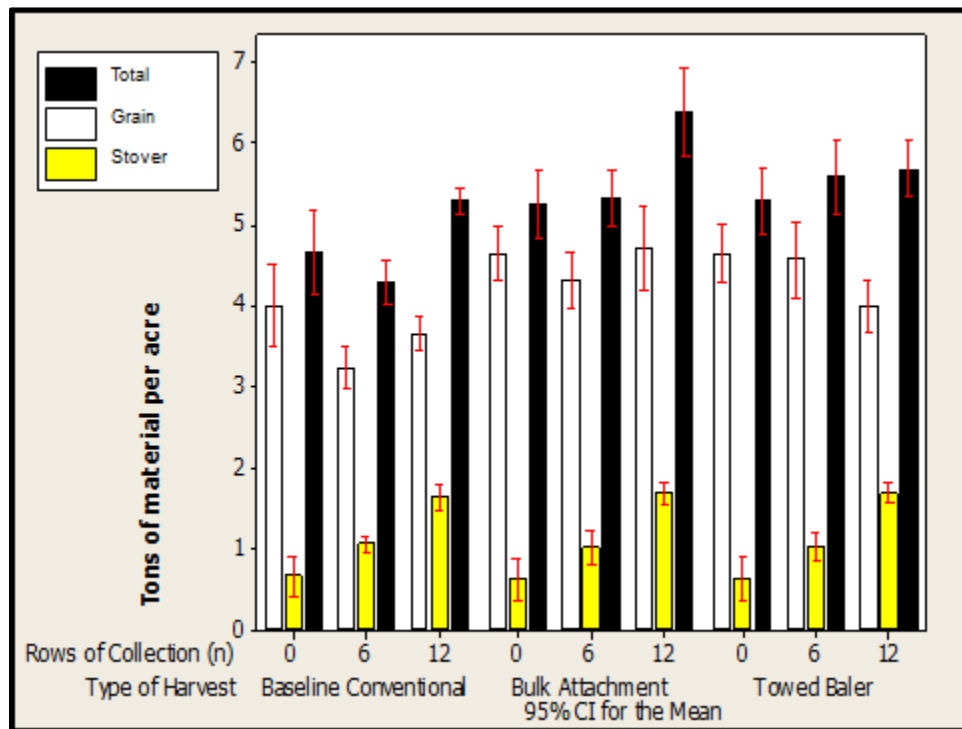

Figure 6-1: Fuel consumption of the combine, tractor, and baler in liters per hour based on harvest system configuration and stover collection rate. The fuel consumption reflects the loading of the engine loading; when the loading is higher the fuel consumption will reach close to the maximum fuel consumption for the machine.

Another fuel consumption metric was based upon how much crop material the combine processed in each scenario as seen in Figure 6-2. The stover and grain was used in order to compensate for all material being processed through the combine. In the figure it was shown that the grain was a large component of the material harvested per acre. This makes the total amount of material harvested by the combine tied closely to the amount of grain harvested while the stover plays a small part in this.



**Figure 6-2: The typical breakdown of grain and stover harvested per acre by collection configuration and header rows. The total yield reflects the maximum capacity of the combine.**

Analysis of the fuel consumption based upon how much fuel was consumed per unit ton of material harvested shows a steady increase in the consumption for the combine as more corn stover was processed by the combine. The range for consumption was .65 – 1.5 liters per ton of fuel consumed with statistically significant difference between each harvest rate. This consumption pattern was replicated across each system. The consumption amounts were different in each system because of the differences in the crop flow and then difference in the productivity of the baler. Bulk fuel consumption was influenced by the increased amount of material harvested especially at the 12 row rate.

The tractor's fuel consumption does trend lower as the harvest rate increases because the tractor slows as the combine was slowed and inherently uses less fuel. The baler's fuel consumption initially starts high as there was less stover to process for the power required to operate the functions of the baler. The fuel consumption stabilizes as the amount of total stover harvested reaches a maximum level per hour.

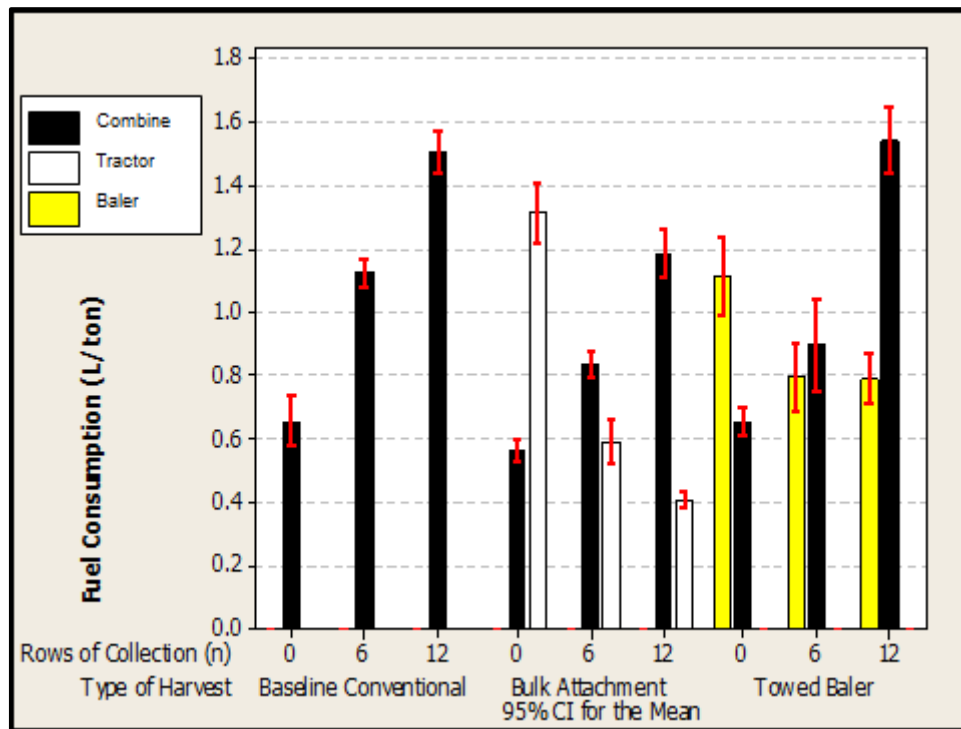
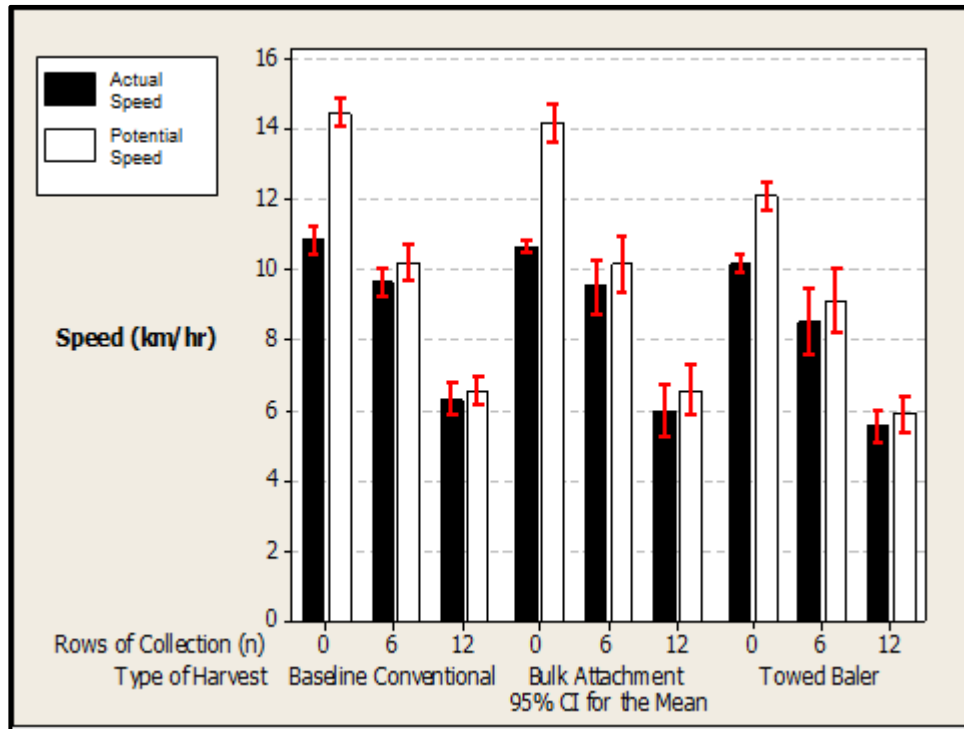

Figure 6-3: Fuel consumption of the combine, baler, and tractor based upon total tons of material harvested. The combine- grain and stover; tractor and baler- stover. As the combine is slowed by collecting a higher concentration of corn stover the fuel consumption is increased.

### 6.3.2 SPEED ANALYSIS

The combine's speed recorded from the CyCAN logger indicated a maximum harvest speed of 11 kph (6.8 mph). The speed however, was not limited by the power output of the machine in some cases. In the 0 row collection scenarios in which the combine was harvesting no extra stover it would become header limited rather than engine power limited. There was still combine engine power available to increase harvest speeds, however, the capability of the header to harvest the corn plant without damaging the ear or pushing the entire stalk over before harvesting the ear limited the speed of the combine. In Figure 6-4,

the potential speed of the combine was predicted by scaling the speed by the remaining engine power available.



**Figure 6-4: Actual combine speed from in-field testing versus predicted speed if combine was not head limited. This shows that the header is a larger limiting factor in productivity than the baler.**

Analysis of the figure shows that at the 0 row harvest rates of stover there was a statistically significant potential speed increase of 3 kph (1.9 mph). At the higher stover collection rate, the forward travel speed became limited by the power of the engine in the combine. This was reflected by the statistically significant difference in the data points among the speed values in the higher collection rates of the dataset.



### 6.3.3 POWER ANALYSIS

The power required in each test follows the same pattern as the fuel consumption. This was due to the fuel consumption being a function of the power as shown in the earlier calculation in Equation 4. As expected the lowest consumption of horsepower was the conventional grain harvest which accounts for about 186 kW (250 hp) of the combine's power. This was the minimum required power for the combine to operate and harvest. It was assumed that this minimum was constant power requirement for grain harvest and any additional power was a requirement of a machine to harvest and collect corn stover in one of the systems.

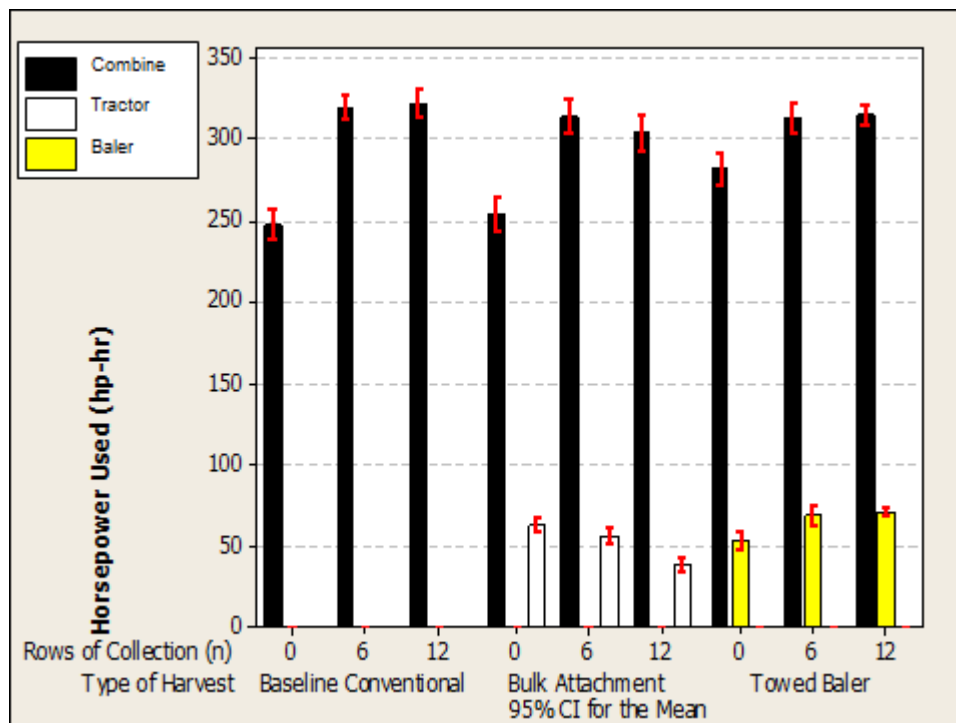

**Figure 6-5: Total horsepower used by the combine, tractor, and baler in grain harvest and corn stover collection. This reflects a similar trend to fuel consumption because horsepower is a direct calculation from fuel consumption.**

Dividing the total horsepower of the combine and support machines shows the power requirement of the higher harvest rates. The combine horsepower consumption was divided amongst two different material streams, the stover and the grain. Its total power consumption used was significantly higher because of this. Comparing the power used on a per unit ton basis the power required to harvest more stover as the harvest rates increase also increases.

The power required to operate or pull the bulk attachment and baler though was relatively unchanged and any difference was not statistically significant. The power for the combine to process the extra grain and stover remained relatively the same across all test scenarios. Two scenarios used statistically different power consumption which could be attributed to a higher overall productivity than the baler. Then the difference in the conventional combine versus the bulk combine could be explained by the difference in the crop flow of the two tests.

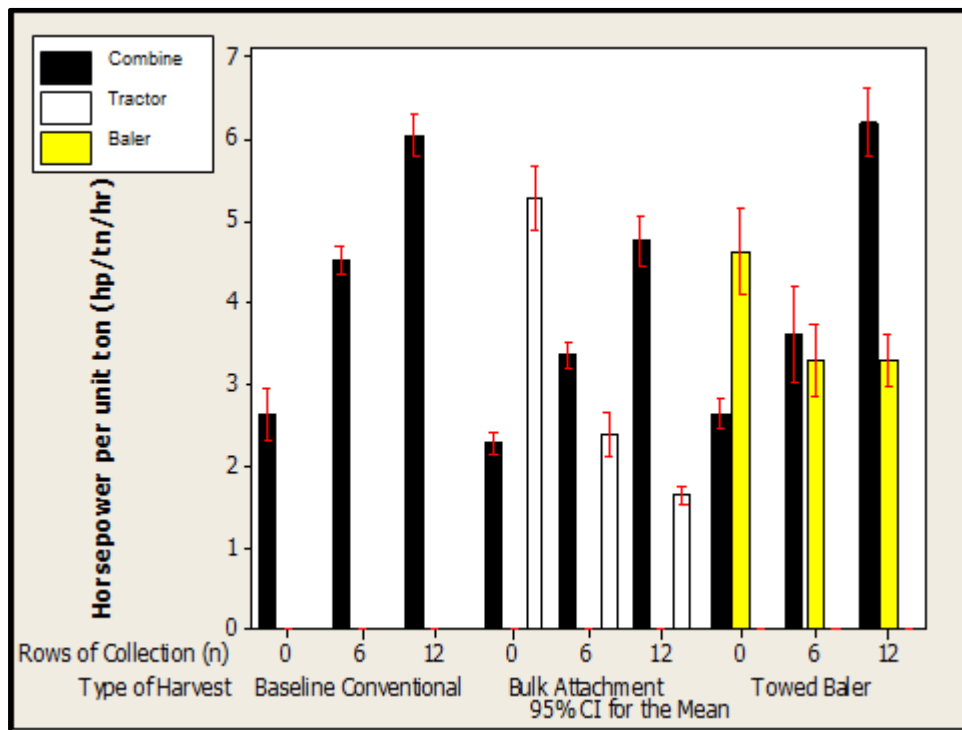
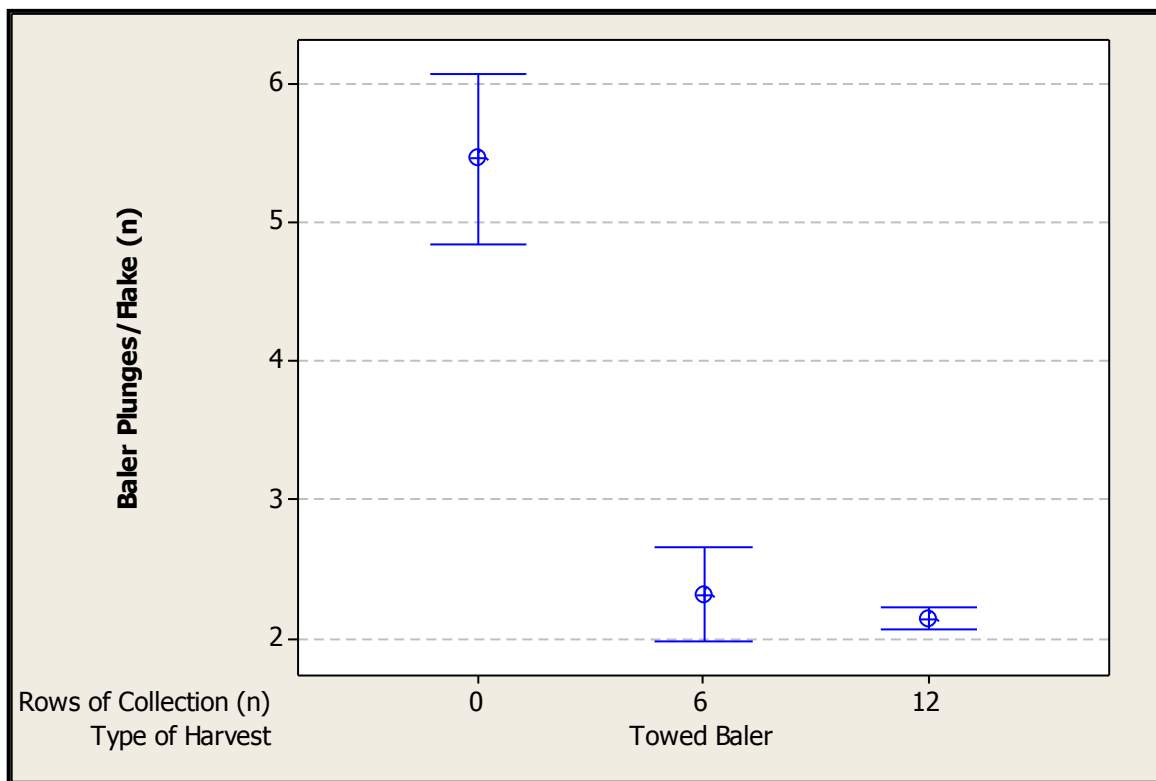

**Figure 6-6: Horsepower used to by the combine, tractor, and baler just to collect corn stover. The horsepower requirements increase as more rows of stover are harvested and the amount of material passing through the combine increases.**

Looking at power requirements for the bulk system, the tractor consistently used less power as the harvest rate increased. This was due to the reduced combine speed at higher collection rates. This trend was similar to the fuel consumption data since the fuel consumption values were used as a factor of power.

### 6.3.4 BALER POWER ANALYSIS

The analysis of the baler engine and performance data showed a correlation to the power requirements and the throughput of the baler by the amount of plunges per flake required to produce a viable bale. Looking at Figure 6-7 the lower rates of stover collection caused the plunger to plunge more times per flake. When the collection rate increased the plunges per flake ratio decreased and correlated to an increase in power consumption on the engine itself.



**Figure 6-7: Number of plunges the plunger of the baler made each new flake. As the collection rate increases the number of plunges per flake decrease as more the stuffer conveys more material into the baler. The ideal plunges per flake number for a baler was near 1 plunge per flake.**

The main power consumption point in the baler was the plunger. The plunger caused the power consumption in the baler to be very cyclic. This was most readily apparent when analyzing the data in a time-series plot. In each of the three time-series plots for the different stover collection rates the plots show a high and a low distribution of points that are grouped together forming the two operating conditions the baler was under, no flake being stuffed and flake being stuffed.

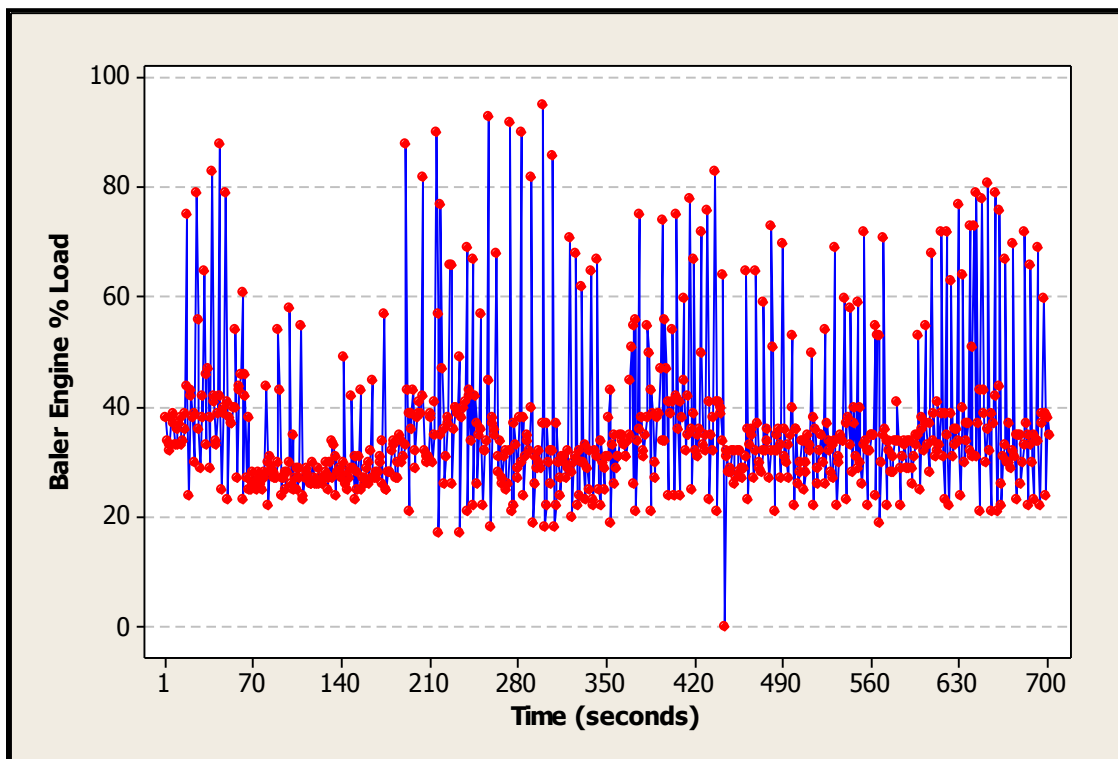

**Figure 6-8:** Time-series plot for 0 row collection stover collection for the towed baler. The plot show the variability in power output of the engine as the baler was in operation due to varying rates stover being fed into the baler and different plunger loads based on those rates.

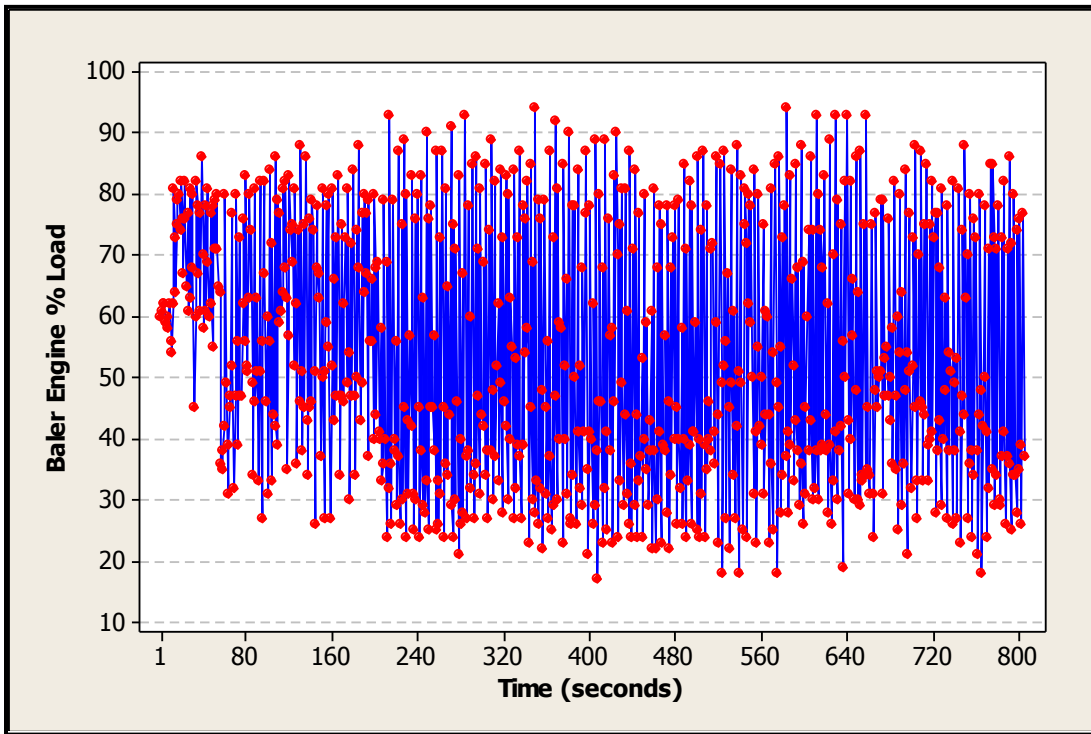

Figure 6-10: Time-series plot for 6 row collection stover collection for the towed baler. As the harvest rate increases the power consumption of the baler will become raise and also grow closer together due to plunges being closer together.

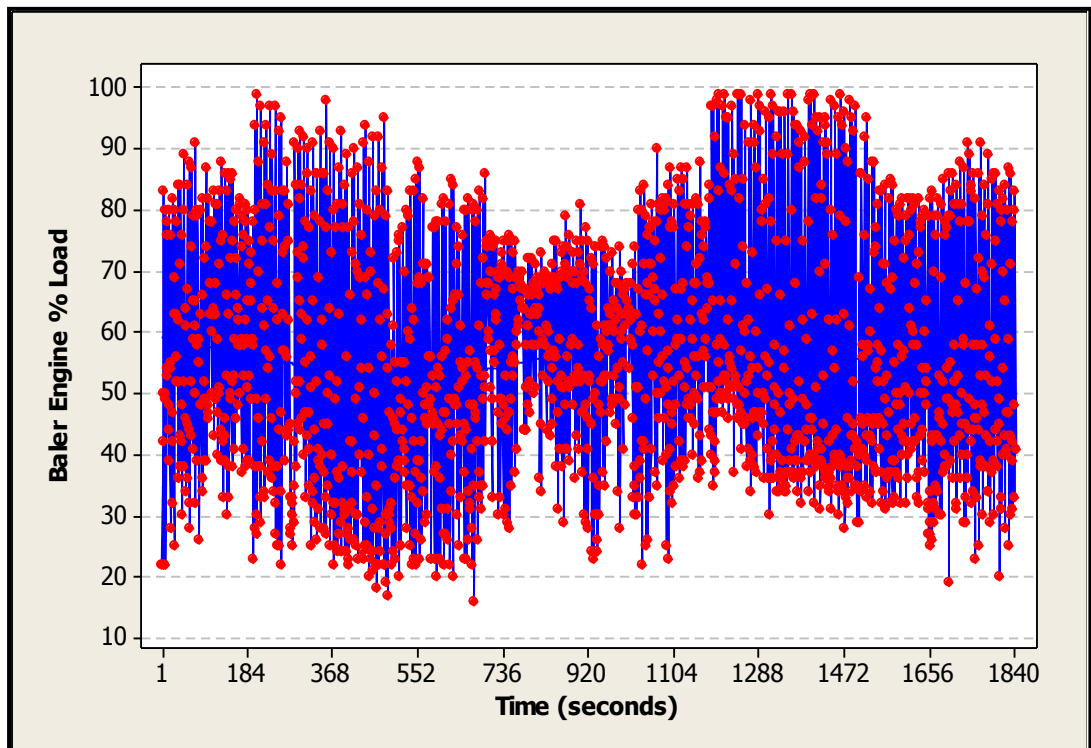
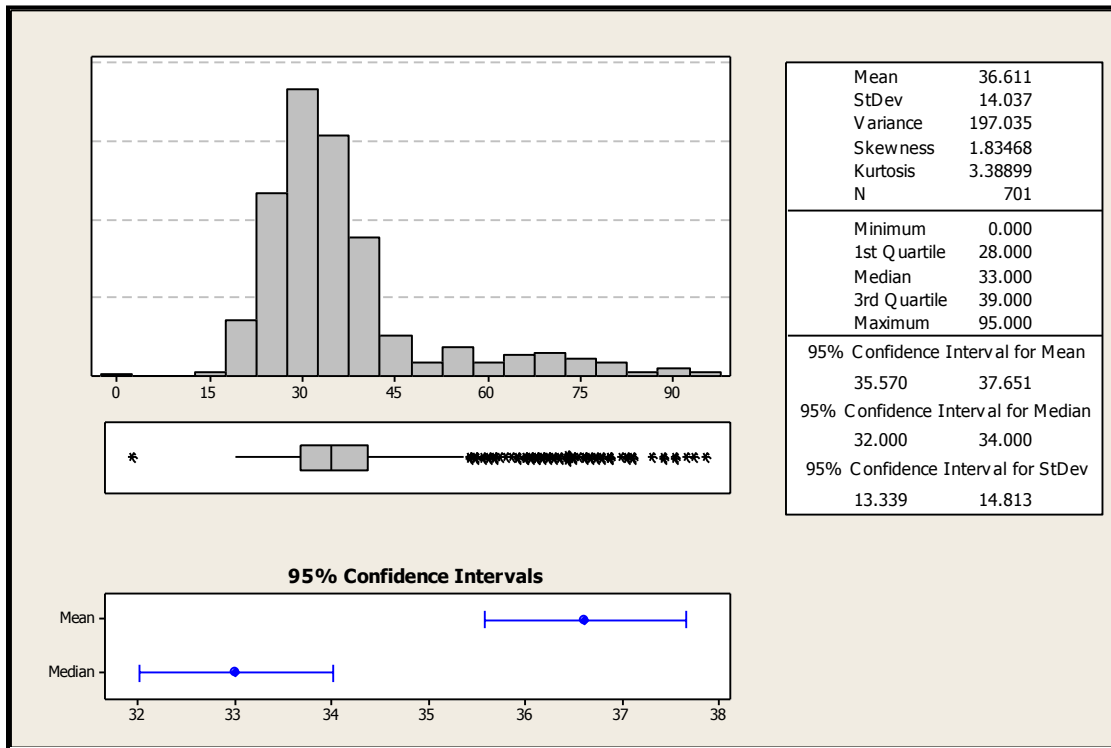
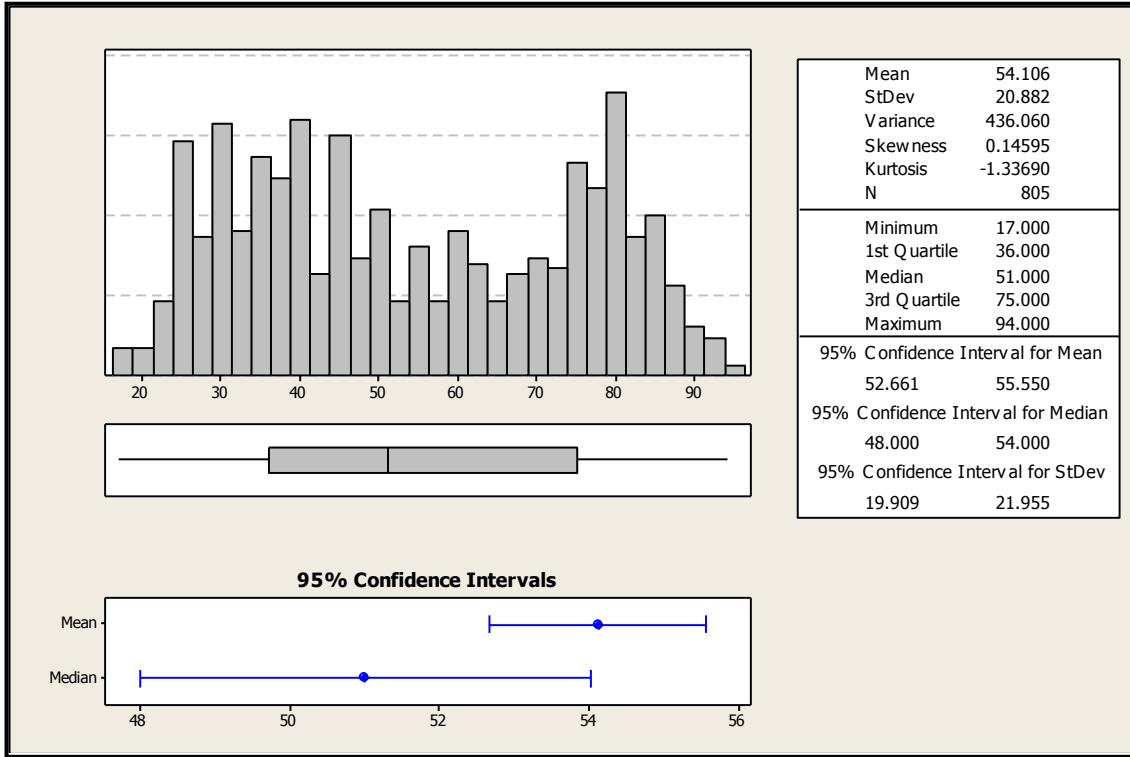

Figure 6-9: Time-series plot for 12 row collection stover collection for the towed baler. As the baler requires more power to operate from the higher rates of stover being collected the engine load will approach 100% but also consistently stay higher on the cyclical load because of the higher loads on the baler.

Histograms of engine loading at the higher collection rates showed a bimodal response. The portion of the dataset that falls in between the 30-50% engine loading area is indicative of the no load condition while the 70-90% range represents the power spike required to make a new bale flake.



**Figure 6-11: Normal distribution curve for the 0 row collection rate of the baler engine power load. At lower collection rates the baler power required was lower to operate the baler as shown in the curve.**



**Figure 6-12: Normal distribution curve for the 6 row collection rate of the baler engine power load. As the power requirement of the baler increased due to the higher rates of stover collection the curve became better distributed.**

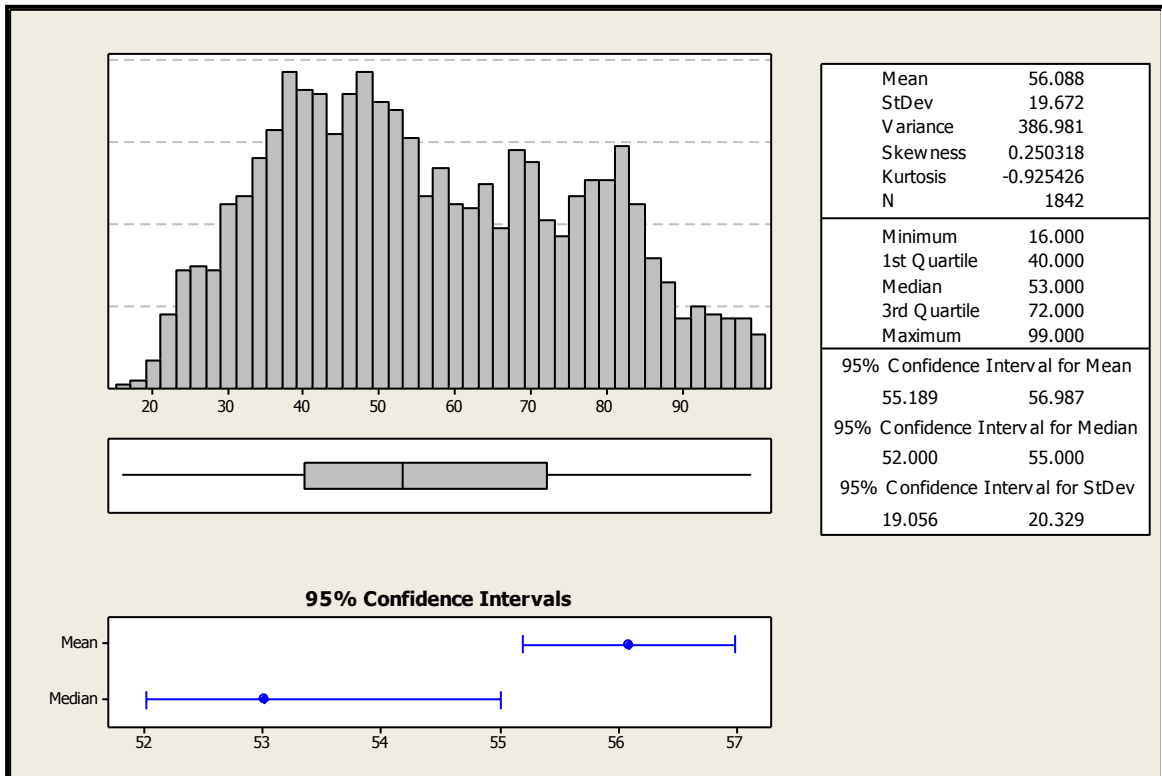

**Figure 6-13: Normal distribution curve for the 12 row collection rate of the baler engine power load. As the higher rates of stover intake were experienced the baler required more power, this power requirement was cyclical based upon the plunger position and stuffer actuation.**

## 6.4 CONCLUSIONS

The baseline combine operated at about 186 kW (250 hp) and consumed about 61.5 L/h (16.25 gph) of fuel. At the higher harvest rates the consumption ramps up to between 75 – 80 L/h (19.8 – 21.1 gph) of fuel while power consumption was maximized at about 246 kW (330 hp). Analyzing the amount of material harvested the combine still consumes less fuel and requires less horsepower per ton and as harvest rates increase the fuel and power rates. Combine fuel and power consumption remain relatively stable across each system.

Harvest speed varied depending on the system and collection rate. Maximum speed for the combine was reached when harvesting at a rate of 0 rows was 11 kph (6.8 mph). At this collection rate the combine was head limited and had the largest potential speed available at 12-14 kph (7.5-8.7 mph). As the harvest rates increased speed decreased to between 8-10 kph (5 – 6.2 mph) at the 6 row harvest rate and at the 12 row rate the maximum speed was about 6 kph (3.7 mph) across all systems. As the harvest rates increased the potential speed was reduced since nearly all power that was available at the lower harvest rates went to processing the additional stover.

The baler operated at two power levels while baling, not making a flake and making a flake. There was a bimodal distribution of power with peaks at 30% and 80% of maximum engine loading. Redistributing the power so that the bimodal curves become one normally distributed curve closer to the maximum engine load capacity could possibly allow for a smaller engine to be used. However it would require the development of a method to accumulate more power for plunge cycles on the baler in addition to what is already provided by the baler flywheel.



## Chapter 7.0 Single-Pass Baling Economics

### 7.1 INTRODUCTION

A key application of the single-pass collection system productivity data was to develop reasonable economic conclusions for potential adopters. The conclusions could be used to assess the value of corn stover when selling it by quantifying the cost to harvest the corn stover with a single-pass system. An economic model was developed for this research that specifically used the data collected during in-field testing. The model was used to determine the cost of the single-pass baling system with the goal of developing a cost database for various system parameters. Cost was developed in units of dollars per acre, dollars per ton, and dollars per hour basis. The model had the capability to create databases for the conventional, single-pass bulk, and single-pass baling systems. The conventional system was used to create a baseline cost for grain harvest.

Only the single-pass baling system was analyzed for this analysis. This was chosen over the single-pass bulk harvest system because the industry trend was moving towards a baling solution for stover harvesting and transportation logistics. The two cellulosic ethanol plants that are being constructed in Iowa will be using round and square bales. One plant will exclusively use 3 ft x 4 ft square bales. The single-pass bulk harvest system provides challenges in the movement of material from the field and in storing the material in a protected environment. The baling solution has more efficient solutions in both of these situations that make it the more preferred method of harvest.

### 7.2 MATERIAL AND METHODS

The economic model was developed using a Microsoft Excel workbook and an Excel based macro. The Excel workbook contained worksheets for inputs, combine performance, grain cart and tractor performance, single-pass baler performance, cumulative cost and the net cost. Within each worksheet calculations were placed in the cells that determined a certain value or factor of data that was pertinent to either a performance characteristic of a machine or an economic factor. The calculations and cells were then integrated with the

Excel macro to allow rapid calculations of the effects of multiple changing factors to be easily and quickly analyzed.

### 7.2.1 INPUT PAGE

The input section of the workbook contained the variables that allowed the user to adjust the operating parameters of selected variables. The variables that were given operational ranges were selected due to the highly variable nature of the crop, the need to model improved machine performance, and to account for various machine system configurations. The user input variables and the operating ranges are listed in Table 15. Calculations were logged in the output section of the Excel workbook for analysis at a later time.

There were also some constant inputs that were not given operational ranges. The inputs listed in Table 16 were selected to be constant through the analysis. Some of the constant variables dealt with an economic aspect of the data which required the use of a long term average for prices of corn and fuel. Another constant was the rental rates of machinery which had set prices that came from outside vendors who supplied equipment for the harvest tests. Fuel consumption was also a constant during each run of the model. Values for consumption for the model were taken straight from the harvest testing dataset and statistical analysis discussed earlier. There were three different fuel consumption levels used, a rate in the conventional configuration, a consumption rate at 0 row collection baling, and a consumption rate at the higher stover harvest level 12 row collection baling.

Variable Inputs				
Variable Name	Units	Minimum	Maximum	Interval
Stover Yield	Tons/Acre	0.5	4	0.5
Single-Pass Baling Productivity	%	5	100	5

**Table 15: Variables into the economic model used to analyze single-pass baling. Data from the 2010 harvest was used to set the boundaries of this model but not tied directly to the output of the model.**

Constant Inputs		
Variable	Units	Value
Machine operating hours per day	Hours	11
Machine operating days in season	Days	27
Fuel Price	\$/Gal	3.04
Labor Cost	\$/hour	13.45
Self Propelled Bale Collector Rental Cost	\$/hour	45
Tractor Rental Cost	\$/hour	72
Corn Price (5-year average)	\$/bushel	3.8
Unloading while harvesting	%	75
Crop Flow	lbs/sec	60

**Table 16: Inputs factored into the economic model for the determination of the single-pass baling system harvest cost. These inputs were based off of typical machines industry today or in field data from the 2010 harvest.**

Constant Inputs		
Variable	Units	Value
Grain Yield	Bushels	173
Grain Unload Rate	Bushels/Second	3.3
Grain Cart Capacity	Bushels	1000
Grain Cart Unload Rate	Bushels/Minute	500
Grain Cart Tractor Speed(estimated)	mph	7.5
Average Grain Cart Travel Distance	Feet	1300
Bale Density	lbs/cubic feet	10
Bale Length	Feet	8
Bale Width	Feet	4
Bale Height	Feet	3

**Table 17: Inputs factored into the economic model for the determination of the single-pass baling system harvest cost. These inputs were based off of typical machines industry today or in field data from the 2010 harvest.**

Constant Inputs		
Variable	Units	Value
Baler Average Fuel Consumption	gal/hr	4
Combine Conventional Configuration Fuel	gal/hr	16.25
Combine Single-pass baling Configuration	gal/hr	18.5
Combine Single-pass baling Configuration Fuel Consumption - 1.5 and 2.5 ton per acre	gal/hr	20.5
Bale Collection Vehicle average fuel consumption	gal/hr	8.24
Grain Cart Tractor Average Fuel Consumption Waiting	gal/hr	3
Grain Cart Tractor Average Fuel Consumption Loaded	gal/hr	11.7
Grain Cart Tractor Average Fuel Consumption Unloaded	gal/hr	11.7

**Table 18: List of fuel consumption inputs into the economic model for analysis.**

The fuel consumption and speed values were taken directly from field data. The grain cart and tractor were not instrumented to log data during harvest. It was assumed that fuel consumption from the tractor with the stover carts had similar fuel consumption. The speed of the cart traveling by itself in the field was estimated from previous experience of in-field operation of machinery. The knowledge base from operation of the machines in field provide a reasonable basis for any assumptions made and provide many statistically analyzed data values for input into the model. Fuel consumption data for the bale collection machine was taken from the Nebraska OECD tests. The tractor used for the bale collector was the Case IH MX 240 with a Cummins 8.2 L engine. Productivity was also provided from bale collection data collected from other 2010 corn stover harvest research activities.

Operational time was also a constant that was factored into the analysis. The operational time had two factors, operational days in season and operational hours per day. The operational days per year was determined from data that was extracted from the United States Department of Agriculture National Agricultural Statistics Service (USDA-NASS) weekly reports of working days and percent of corn harvested in the United States. Data for the State of Iowa was extracted for the entire harvest window for the years 1999 – 2010 (USDA - National Agriculture Statistics Service). The window of analysis spanned from the middle of August to the end of the reporting period which was when the corn harvest reached 95% complete for the United States. The completion percentage was chosen for the entire United States instead of just Iowa because it intended to cover the entire Midwest harvest timeline. In Figure 7-1, the last eleven years of harvest progress was calculated in order to determine the average time span for harvesting 80% of the crop with the 10% fringe areas of the dataset being disregarded. This data suggests that the typical harvest window in Iowa for a harvest is around 27 days.

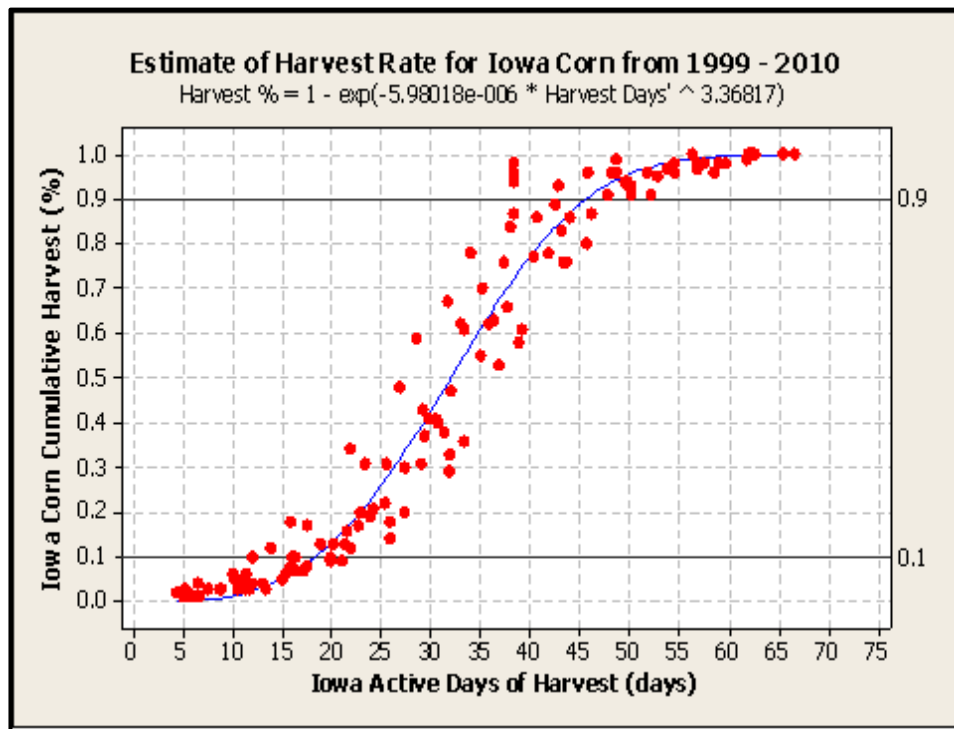

**Figure 7-1: The average trend in harvest progress for Iowa for the last 11 years based upon cumulative progress of the corn harvest. Markers are placed 10% for early harvest progress and 90% for late harvest progress. 80% of the crop is removed in under 30 days.**

The number of operational hours was determined to be 11 hours according to research conducted by Edwards (1979). This determination came from participants in the CROP-OPT program. The initial assumption for hours worked was 11 hours with a low assumption of 6.5 hours per day and high assumption of hours worked per day of 15.5 hours per day.

Another factor in the input page was the salvage value for each machine. The salvage value for a particular piece of equipment was determined from the formula from the ASABE standard D497.7 (ASABE, 2011). Further detailed in Equation 6, the salvage value was factored from the capital cost for the equipment listed in Table 21 and given coefficients for various types of machines from the ASABE standard listed in Table 19. Capital costs were acquired from industry contacts, equipment sales literature, and equipment dealers.

**Equation 6: Salvage Value Equation based upon ASABE factors salvage values (ASABE, 2011)**

$$RV_n = 100(C_1 - C_2n^{.5} - C_3h_a^{.5})^2$$

Where as

$RV_n$  = Remaining percent of list value of a machine after n years and h hours of use per year (%)

$C_1, C_2, C_3$  = Coefficient for various equipment types, Table 19

$h_a$  = Average annual usage (hours/year)

n = Years of usage (years)

Salvage Value Coefficients			
Equipment	C1	C2	C3
Combine & Header	1.13	0.17	0.01
Baler	0.85	0.10	-
Grain Cart	0.79	0.09	-

**Table 19: Coefficients for determine machine salvage value from the ASABE Standard 497.7. (ASABE, 2011)**

The ASABE D497.7 also provided an estimated life for the equipment which was further detailed in Table 20. An estimation of the yearly usage of a machine was determined to get the total number of years of use. This number was dependent upon the window for harvest and the hours worked per day for the stover harvest machines and average yearly use for the tractors.

Estimated Lifespan	
Equipment	Hours
Combine & Header	3000
Baler	3000
Grain Cart	2000

**Table 20: Estimated lifespan of purchased equipment for harvest. Based upon the average lifespan of equipment from the ASABE Standard D497.7. (ASABE, 2011)**

**Equation 7: Calculation for determining the salvage value price for a machine based upon the ASABE Salvage Value Equation and capital value of a machine for the 2010 harvest.**

$$RV_p = RV_n \times P_c$$

Where as

$RV_p$  = Remaining value (\$, dollars)

$P_c$  = Capital Cost of Machine (\$, dollars)

$RV_n$  = Remaining percent of list value of a machine at a certain level of use (\$, dollars)

Machine Capital Cost	
Equipment	Cost
Combine & 12 Row Header	\$466,800
Baler	\$140,000
Grain Cart	\$39,750

**Table 21: Capital prices for machinery for determining capital costs based upon the 2010 harvest.**



Depreciation and interest were factored into the cost by using the straight line depreciation and interest calculations. These produced hourly depreciation and interest costs for the machine which could be converted to a yearly basis. The equations are further detailed in Equation 8 and Equation 9.

**Equation 8: Calculation for determining the depreciation for a machine Turhollow et al (2009).**

$$Cap_d = \left( \frac{PP - SV}{h_1} \right)$$

Where as

$Cap_d$  = Capital Cost (depreciation), Table 21, (\$ per hour)

PP = Purchase price, (\$, dollars)

SV = Salvage value ( $RV_p$ ), (\$, dollars)

$h_1$  = Lifetime usage, Table 20 (hours)

**Equation 9: Calculation for determining interest for a machine Turhollow et al (2009).**

$$Cap_i = \frac{i(PP + SV)}{(2)(h_a)}$$

Where as

$Cap_i$  = Capital Cost (interest) (\$/h)

PP= Purchase price, (\$, dollars)

SV = Salvage value ( $RV_p$ ), (\$, dollars)

$h_a$  = Annual usage, (hours)

$i$  = Operating rate interest rate (6.64%; (Mellert, 2011))

To account for the diversity of machines like the tractor, which can be used year round, a rental rate was used. The rental rate that was charged for the fall 2010 harvest was 27 cents per horsepower hour (Hawbaker, 2010). For this analysis it was assumed that tractors of similar size to the ones used in the fall 2010 testing would be used. The John

Deere 8230 was used for to pull the grain cart in the field tests. The tractor was 265 horsepower which equated to \$71.55 per hour of operation. The self-propelled bale collector rental rate was determined to be \$45 per hour (Matlack, 2010). The rental cost was used because of the unknown maintenance and repair factors along with the unknown salvage value factors for the bale collector and other use of the tractor. The rental cost covered all ownership costs besides the fuel and labor in the rental price. Overall cost was divided into the cost per acre, cost per hour, and cost per ton. The rental cost was derived to determine the total cost per acre, total cost per hour, and total cost per ton of stover harvested.

Machine Rental Cost	
Equipment	Cost per Hour
Tractor	\$72
Self Propelled Bale Collector	\$45

**Table 22: Rental cost for tractors which were considered a multi-use machine over the year besides harvesting and the self-propelled bale collector which was could be used to move bales at different times of the year.**

By incrementally adjusting the stover harvest rate and single-pass baler productivity the effect of productivity reduction on the combine and cost was determined. This demonstrated either an improvement or drop in the productivity of the combine. When compared to the conventional combine system, an economic conclusion was developed. The conventional combine system in theory harvested a minimal rate of stover between 1.12-1.6 Mg/ha (.5-.7 tn/ac).

The lack of a test dataset using a header besides the 12 row or 30 ft header to validate the model at other header widths led to restricting the operational range of the header to 30 ft. Additional data collection at a later time with a smaller header should provide a broader set of data with which to compare the combine performance curves. A smaller header should produce a lower crop flow.

Operational times of the grain cart and tractor in field were also factored into the cost of harvesting stover. The longer operational times required to harvest grain at a slower rate meant that there were additional costs associated with paying the cart operator as well as additional hours on the cart and tractor. All of this was applied to the cost of stover harvest because of the reduction in grain harvesting capacity.

Some baler operational characteristics were assumed to be constant. The fuel consumption was considered to be constant and from the previous data it was determined to be 4 gph. Bale length, width, and height were 2.4, 1.2 and .9 m (8, 4, and 3 ft) which were considered maximized for current over the road transport logistics and remained constant throughout the model. String to tie the bales off was priced at \$20 per roll of 4000 ft. Bale density was consistent in this year's dataset and represented in the model as .13 kg per cu meter (10 lbs per cu ft).

As mentioned earlier a self-propelled multi-bale collector which carried twelve bales in a cycle was included within the cost model. This allowed the cost data to represent the total production cost associated with producing and stacking corn stover bales at the end of the field. In the model, the same collection unit was used throughout the analysis. Machine productivity was determined from the analysis of the 2010 fall harvest using a Stinger LTD 6500 Stacker. This machine collected and transported up to 12 bales per time to the field edge at a collection rate of 55.4 bales per hour.

#### 7.2.2 OUTPUT: COMBINE

The values inserted into the model were used in a series of calculations that predicted productivity and performance of the combine and support machines involved in stover harvest. These values were also used in the model for predicting the economic costs of harvesting. There were six data types that were analyzed for the combine that provided a basis for economic and performance calculations in other tabs of the workbook. These data types were area covered, grain and material throughput, fuel consumption, repair and maintenance cost, and event timing for the combine.

The model for the combine distinguished between the active time harvesting versus non-active harvesting events. For this model it was assumed that there were three major non harvesting events: turning on headlands, unloading grain while not harvesting, and miscellaneous delays. These were used to predict the maximum theoretical area covered by a combine conventionally harvesting corn or single-pass harvesting. In order to predict the amount of time spent harvesting on a per hour basis Equation 10 was developed.

**Equation 10: Time per hour spent harvesting based upon time for turning machine, unloading grain while harvesting, and miscellaneous stops.**

$$T_t = (1 - P_h - P_{ug} - P_m) * 60$$

Where as

$T_t$  = Total time per hour spent harvesting (minutes per hour)

$P_h$  = Percent of hour spent turning around on headlands (%)

$P_{ug}$  = Percent of hour spent unloading grain while not harvesting calculated in Equation 11 (%)

$P_m$  = Percent of hour stop for miscellaneous reasons (%)

This equation factored in the various non-harvesting time that a combine would experience during the day: unloading while stopped, turn time, and miscellaneous stoppages. In this the miscellaneous stoppages and turned times were assumed to be zero and the productivity reduction would account for these. It also factored the percent of the hour used for unloading grain while the combine was stopped was also determined as shown in Equation 11. This used a ratio that factored the amount of grain unloaded while harvesting versus the amount of grain being harvested by the combine.

**Equation 11: Calculation for determining the percent of the hour used for grain unloading based upon the ratio of grain entering the combine and the amount of grain being unloaded and percent of time the combine is stopped to unload.**

$$P_{ug} = 100 * \left( \frac{\frac{U}{1-G}}{\frac{C_f}{56} + \frac{U}{1-G}} \right)$$

Where as

$P_{ug}$  = Percent of hour spent unloading grain (%)

U = Unload rate (bushels per second)

G = Percent of unloading while harvesting (%)

C = Crop flow (lbs per second)

The total time spent harvesting value allowed for the total bushels per hour to be calculated as shown in Equation 12.

**Equation 12: Calculation for determining bushels per hour harvested by the combine based upon the total time per hour spent harvesting and crop flow into the combine.**

$$B_h = T_t \times \frac{C_f}{56}$$

Where as

$B_h$  = Bushels of grain harvested per hour (bushels per hour)

$T_t$  = Time per hour spent harvesting (minutes per hour)

$C_f$  = Maximum crop flow (lbs per second)

The bushels per hour harvested and the average yield of the field produced the total acres per hour as shown in Equation 13. By using the acres per hour and the average working hours per day from the input page, the total acres per day was determined as shown in Equation 14. An average harvest window of 27 days to remove 80% of the crop was determined for Iowa. Using this average the acres per year per combine was determined in Equation 15.

**Equation 13: Calculation for determination of acres per hour harvested by the combine based upon the total bushels per hour harvested and the average yield inputted into the model.**

$$A_h = \frac{B_h}{Y_a}$$

Where as

$A_h$  = Acres per hour harvested by the combine (ac/h)

$B_h$  = Bushels of grain harvested per hour (bushels per hour)

$Y_a$  = Average yield of the field (bushels per acre)

**Equation 14: Calculation for the determination of acres per day harvested by the combine based upon the average working hours per day and the acres per hour harvested.**

$$A_d = A_h \times H_d$$

Where as

$A_d$  = Acres per day harvested by the combine (acres per day)

$A_h$  = Acres per hour harvested by the combine (ac/h)

$H_d$  = Hours per day working (hours)

**Equation 15: Calculation for the determination of acres per year harvested by the combine based upon the average working days in Iowa for corn harvest and the average acres per day harvested.**

$$A_y = A_d \times D_y$$

Where as

$A_y$  = Acres per year harvested by the combine (acres per year)

$A_d$  = Acres per day harvested by the combine (acres per day)

$D_y$  = Average working days in harvest per year (days per year)

Fuel consumption was determined by taking the known consumption from previous analysis in chapter 6. The gallons per acre consumption were determined as further detailed in Equation 16.

**Equation 16: Calculation for the determination of fuel consumption on a per acre basis based upon the estimated fuel per hour consumed and the acres per hour harvested.**

$$F_a = \frac{F_h}{A_h}$$

Where as

$F_a$  = Fuel consumption (gallons per acre)

$F_h$  = Fuel consumption (gph)

$A_h$  = Acres per hour covered by a machine (ac/h)

The predicted repair and maintenance costs were determined by ASABE standard D496.3 (ASABE, 2006) for the combine and are listed in Equation 17. The repair and maintenance costs were derived to reflect a cost per hour basis which was found by calculating the total cost of repairs over the lifetime of the machine and then breaking that cost down by the number of hours in the life of the machine as shown in Equation 17.

**Equation 17: Repair and maintenance cost equation from the ASABE standard D496.3. (ASABE, 2006)**

$$C_{rm} = (RF_1)P x \left[\frac{h}{1000}\right]^{(RF_2)}$$

Where as

$C_{rm}$  = Accumulated repair and maintenance cost (dollars)

RF1, RF2 = Repair and maintenance factors, Table 23 (from ASABE 497)

P = Machine list price, Table 21 (current dollars)

H = Accumulated use of machine, Table 23 (hours)

Repair Factors				
	RF1	RF2	Total RM %	Est Life (h)
Small Tractor	0.007	2	100	12000
Large Tractor	0.003	2	80	16000
Combine	0.04	2.1	40	3000
Large Square baler	0.1	1.8	75	3000

**Table 23: Repair factors and estimated life expectancy of machine for calculating machine repair cost based upon ASABE standard D496.3 (ASABE, 2006). Repair factors were used with no adjustment for corn stover harvest.**

### 7.2.3 OUTPUT: GRAIN CART AND TRACTOR

Not having data for comparison of the activity of the grain cart during a conventional harvest versus a single-pass baling harvest led to the development of equations to determine travel time between the combine and field edge, unload time, fill time, and waiting time for the grain cart and tractor. This provided a comparison of the activity of the grain cart during in-field operation. To calculate the time spent per hour filling the grain cart from the combine, Equation 18 was used.

**Equation 18: Calculation for the amount of time spent filling the grain cart based upon the unload capacity of the combine and the total bushels per hour harvested by the combine.**

$$T_f = \frac{B_h}{U} \times \frac{1}{60}$$

Where as

$T_f$  = Amount of time per hour spent filling grain cart (minutes per hour)

$B_h$  = Bushels per hour harvested (bushels per hour)

$U$  = Unloading rate for the combine (bushels per second)

Equation 19 determined the total cycles per hour that the cart would have to make in order to carry away the predicted bushels per hour from the combine. The values produced from this equation were rounded up and assumed that there could not be a partial cycle of travel for a round trip in the field to the combine and back.



**Equation 19: Calculation for the determination of the number of cycles the grain cart would make in one hour based upon the amount of grain harvested and the grain cart capacity.**

$$N_c = \frac{B_h}{C_c}$$

Where as

$N_c$  = Number of cycles per hour needed (cycle per hour)

$B_h$  = Bushels per hour harvested (bushels per hour)

$C_c$  = Grain Cart Capacity (bushels)

Field travel time was calculated by using taking the average distance traveled in the field and dividing by the average speed of the tractor while at field speed was determined in Equation 20.

**Equation 20: Calculation for the determination of travel time in-field for the grain cart and tractor based upon in-field travel speed of the grain cart and tractor to and from the combine and the dump site.**

$$T_{gc} = \frac{D_a}{S_a} \times N_c \times 2$$

Where as

$T_{gc}$  = Travel time for the grain cart in-field (minutes per hour)

$D_a$  = Average field distance traveled to or from the combine (ft)

$S_a$  = Average in-field speed (mph)

$N_c$  = Number of cycles per hour needed (cycle per hour)

To determine the unloading time for the cart the total bushels harvested per hour was determined by using Equation 21.

**Equation 21: Calculation for the determination of time to unload the grain cart based upon the grain cart's capacity, unload rate and the number of time per hour it will need to unload.**

$$T_u = \frac{C_c}{C_u} \times N_c$$

Where as

$T_u$  = Grain cart unload time (minutes/hour)

$C_c$  = Grain cart capacity (bushels)

$C_u$  = Grain cart unload rate (bushels per minute)

$N_c$  = Number of cycles per hour needed (cycle per hour)

Total wait time was determined by calculating the total operational time of the tractor and grain cart which used the number of cycles, the time for the trips to and from the combine, the total time being loaded, and the total time unloading. The remaining time left in the hour was the predicted waiting time further detailed in Equation 22.

**Equation 22: Calculation for determining the total amount of time spent waiting by the grain cart and tractor per hour for the combine to be ready to unload based upon the grain cart unload time, time for the combine to fill the cart, and the travel time of the grain cart.**

$$T_w = 60 - (T_u + T_f + T_t)$$

Where as

$T_w$  = Time waiting per hour (minutes per hour)

$T_u$  = Grain cart unload time (minutes per hour)

$T_f$  = Time to fill grain cart (minutes per hour)

$T_t$  = Time traveling to and from combine (minutes per hour)

#### 7.2.4 OUTPUTS: BALER AND COLLECTION

The baler fuel consumption was determined by using Equation 16. This equation used the average fuel consumption determined earlier and then the predicted acres per hour harvested by the combine. The bale collection machine's fuel consumption was determined

by using the estimated consumption and the predicted acres per hour covered by the collector.

**Equation 23: Calculation for determining the number of bales per acre made by the baler based upon the density, size, and tons per acre of stover harvested.**

$$B_a = \frac{T_a}{B_{de}} \times \frac{K}{l \times w \times h}$$

Where as

$B_a$  = Bales per acre made by the baler (bales per acre)

$B_{de}$  = Bale density (lbs per cu ft)

$T_a$  = Tons per acre harvested by the combine (tn/ac)

$l$  = Length of bale (ft)

$w$  = Width of bale (ft)

$h$  = height of bale (ft)

$K$  = constant (2000 lbs/ton)

**Equation 24: Calculation for determining the number of bales per hour being produced based upon the average bales per acre produced and the acres per hour harvested.**

$$B_h = B_a \times A_h$$

Where as

$B_h$  = Bales per hour made by the baler during harvest (bales per hour)

$B_a$  = Bales per acre produced while harvesting (bales per acre)

$A_h$  = Acres per hour harvested

The final baler data value calculated was the cost of the string. This was calculated at on a cost per bale and cost per acre value. It was assumed that it was a normal baler and it used six strings. The length and height of the bale were used to determine its circumference. It was also assumed that the rolls of string that were placed in the baler were 4000 ft in length. To determine the cost per bale the cost per foot of string was determined by using

Equation 25. The cost per acre value was then extrapolated from the cost per bale by simply multiplying by the bales per acre value.

**Equation 25: Calculation for determining the cost of the string per bale based upon the string cost, length of string used on the bale and in the roll, and bale size.**

$$C_{bs} = \frac{C_r}{D_r} \times B_c \times N_s$$

Where as

$C_{bs}$  = Cost of string per bale (\$ per ft)

$C_r$  = Cost of roll of string (\$)

$D_r$  = Length of string on roll (ft)

$B_c$  = Bale circumference (ft)

$N_s$  = Number of strings per bale

To determine the cost and some performance metrics of a bale collection machine using data from the 2010 harvest, bales per hour collected was determined. The collection rate was then transformed to the number of acres per hour collected. This was determined in Equation 26.

**Equation 26: Calculation for the determination of acres per hour covered by the bale collector based upon the average amount of bales per hour collected and the bales per acre produced by the baler.**

$$A_h = \frac{BC_h}{B_a}$$

Where as

$A_h$  = Acres per hour by the bale collector (ac/h)

$BC_h$  = Bales per hour collected by the collection machine (bales per hour)

$B_a$  = Bales per acre produced by the baler (bales per acre)

### 7.2.5 OUTPUT: CUMULATIVE COSTS

Total costs were broken down in each system to differentiate the cost of harvesting the grain versus harvesting the stover. Within each system seven different cost categories were present: fuel, labor, maintenance, depreciation, rental cost, interest, and taxes, insurance, and housing (TIH). Depending upon how the system was configured or how costs were treated for certain machines these categories had varying amounts of machinery assigned to them as shown in Table 24.

Machine Cost Breakdown	
Cost Category	Equipment
Fuel	Combine Grain Cart Tractor Baler Bale Pickup Machine
Labor	Combine Grain Cart Tractor Bale Pickup Machine
Maintenance	Combine Baler Grain Cart String
Depreciation	Combine Baler Grain Cart
Interest	Combine Baler Grain Cart
Rental Cost	Grain Cart Tractor Bale Pickup Machine
Taxes Interest Housing	Combine Baler Grain Cart

**Table 24: The assigned cost categories that each machine was analyzed for based upon how they were factored for cost either rental cost or capital purchase cost.**

Assessing the fuel cost for each machine was done by calculating the cost per hour of the fuel use which was calculated by Equation 27.

**Equation 27: Calculation for determining the cost per hour of fuel consumption based upon the average fuel consumption per hour, fuel cost, and the surcharge for lubrication based upon ASABE standards.**

$$C_h = F_c \times P \times (1 + L)$$

Where as

$C_h$  = Cost of fuel per hour for each machine (dollars per hour)

$F_c$  = Fuel Consumption (gph)

$P$  = Price of fuel per gallon (over a 5 year average) (\$, dollars)

$L$  = Lubrication charge (15%) (ASABE, 2006)

This was then broken down further into calculations for cost per acre and cost per ton basis by using Equation 28 and Equation 29.

**Equation 28: Calculation for determining cost per acre of the stover harvest machines for fuel as based in Equation 27 and for other hourly costs as well.**

$$C_a = \frac{C_h}{A_h}$$

Where as

$C_a$  = Cost per acre (\$/ac)

$C_h$  = Cost per hour from Equation 27 (\$/h)

$A_h$  = Acres per hour covered by a machine (acres per hour)

**Equation 29: Calculation for determining cost per ton of the stover harvest machines based off of the cost per hour in Equation 27 and the tons per hour of stover harvested.**

$$C_t = \frac{C_h}{T_a \times A_h}$$

Where as

$C_t$  = Cost per ton (dollars per ton)

$C_h$  = Cost per hour from Equation 27 (\$/h)

$T_a$  = Harvest rate (tn/ac)

$A_h$  = Acres per hour covered by the machine (acres per hour)

The labor cost was figured to be at \$13.45 per hour. To determine the amount of hours worked a factor of 1.2 labor hours for every 1 machine hour was used to determine the labor cost as recommended by Turhollow et al. (2009). From this the cost per ton and cost per acre were derived by again using Equation 28 and Equation 29. The cost was only assigned to the machines with operators in them and again the cost per acre and cost per ton were based off of the combine and bale collector acres per hour as in the fuel consumption.

The final cost characteristic analyzed was the ownership cost of the machine. This was partially covered by the use of depreciation and interest calculations. The second part of the ownership cost was the expense associated with taxes, insurance and housing. ASABE standard EP 496.3 stated that the method for determining the estimated cost of these was at 2% of the total capital cost of the machines.

#### 7.2.6 OUTPUT: TOTAL GROSS LOSS

To determine the total cost to harvest the corn stover in the single-pass baling system the cost to harvest the grain was subtracted. Equation 30 and Equation 31 determined the cost of harvesting the grain included the combine and grain cart. To determine the cost of

stover harvest in the model, the analysis was operated concurrently with the single-pass baling system to determine the cost of the baseline grain harvest. The seven cost characteristics for the conventional harvest were then subtracted from the single-pass baling system. The difference between these two values was determined to be from the influence of the single-pass baling system on the combine or the extra capital equipment needed to operate a successful harvest as shown in Equation 32.

**Equation 30: Calculation for determining the stover harvest cost of the combine found by taking the cost to operate a normal harvest from the additional cost to harvest stover.**

$$D_c = C_{stover} - C_{conv}$$

Where as

$D_c$  = Combine cost difference (\$/ac or \$/ton)

$C_{stover}$  = Single-pass Baling Combine Cost (\$/ac or \$/ton)

$C_{conv}$  = Conventional Combine Cost (\$/ac or \$/ton)

**Equation 31: Calculation for determining the stover harvest cost of the grain cart and tractor which was found by taking the cost to operate a grain cart under normal harvested condition and subtracting it from the cost to operate when harvesting stover.**

$$D_{gc} = GC_{stover} - GC_{conv}$$

Where as

$D_{gc}$  = Grain cart and tractor cost difference (\$/ac or \$/ton)

$GC_{stover}$  = Single-pass Baling Combine Cost (\$/ac or \$/ton)

$GC_{conv}$  = Conventional Combine Cost (\$/ac or \$/ton)



**Equation 32: Calculation for determining the stover harvest cost of the grain cart and tractor which was found by adding the cost difference of the operation of the combine, baler, bale collection machine, and grain cart.**

$$SHC = D_{gc} + D_c + B_c + BC_c$$

Where as

$D_{gc}$  = Grain cart and tractor cost difference (\$/ac or \$/ton)

$D_c$  = Combine cost difference (\$/ac or \$/ton)

$BC_c$  = Bale Collection Cost (\$/ac or \$/ton)

$B_c$  = Baler Cost (\$/ac or \$/ton)

$SHC$  = Stover Harvest Cost (\$/ac or \$/ton)

## 7.3 RESULTS

### 7.3.1 CUMULATIVE COSTS

The model was configured to the aforementioned settings and operated. The output produced results that were analyzed further in Excel. The first analysis investigated was the cumulative cost to harvest the grain and stover. The initial outcome from the data was that the cost to harvest corn was the same throughout all the scenarios as shown in Figure 7-2 and Figure 7-3. The cost associated with harvesting the grain was determined to be \$45 per ton and \$22.52 per acre for the combine and grain cart and tractor systems. The cost of stover harvest varied depending on other factors that will be discussed later on in the section. The total cumulative cost to harvest stover and grain averages between \$50 - \$60 per ton of stover harvested and \$30 - \$60 per acre. This was dependent on the productivity level of the combine and the harvest rate both of which were affected by the configuration for stover collection and the amount of stover being harvested.

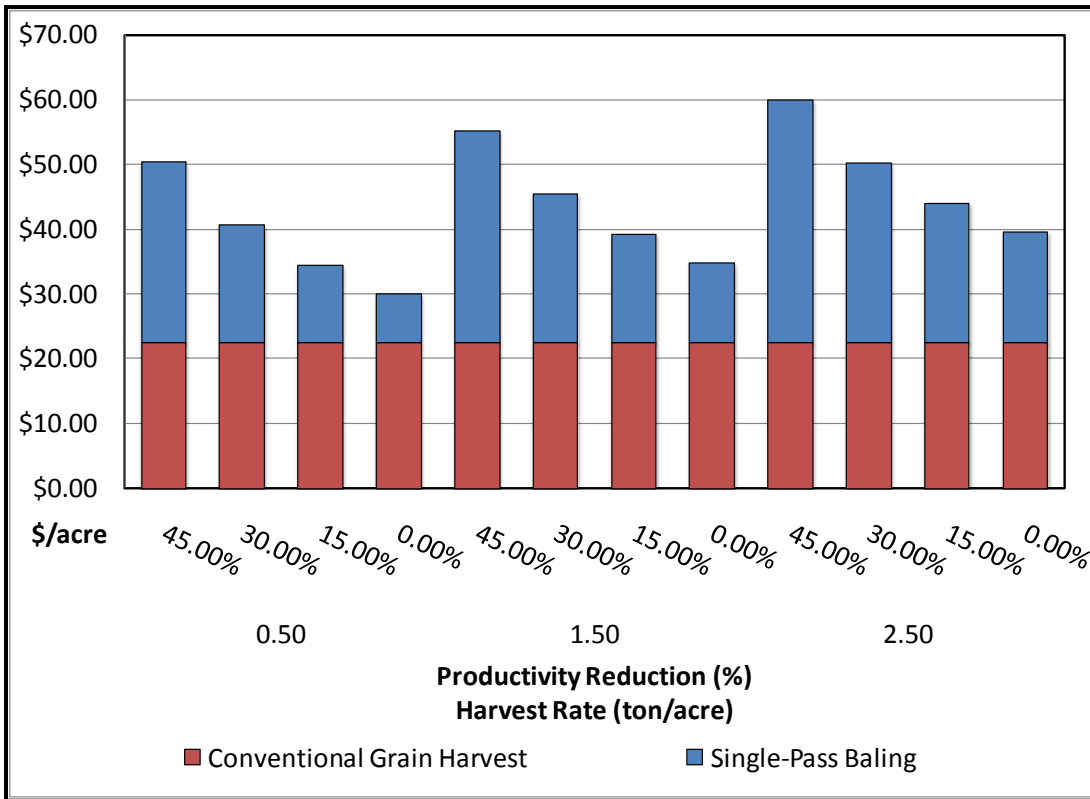

Figure 7-3: Total cumulative cost per acre for grain and stover harvest in the conventional configuration. The cost to normally harvest corn remains steady while the cost to harvest the stover varies according to the productivity of the combine.

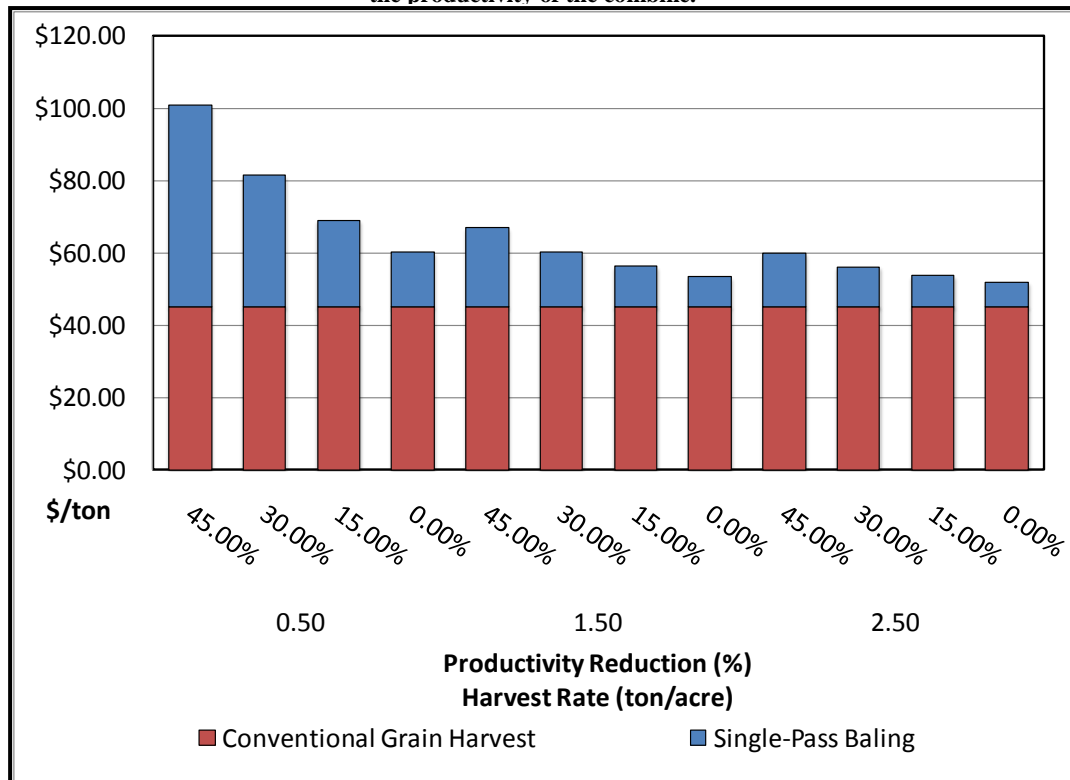

Figure 7-2: Total cumulative cost per ton for grain and stover harvest in the conventional configuration. As the harvest rate increases (ton/acre) the cost to harvest decreases as more cost was distributed amongst the higher rates of stover.

The model was used to figure the cost from the 2010 fall harvest. The fall stover harvest rates were .5, 1.1, and 1.75 tons per acre and the productivity reduction intervals of the three harvest rates were 11%, 45%, and 56.5% which were taken from the analysis completed in chapter 5. At these rates and percentages the cumulative cost for single-pass harvesting was \$65.62, \$52.73, and \$43.33 per ton and \$32.81, \$52.73, and \$65 per acre for the respective harvest rate and productivity reduction percentage respectively.

### 7.3.2 STOVER REMOVAL SYSTEM COSTS

Removing the cost to harvest the grain provides a direct assessment of the total cost of removing the stover and what expenses an end user will have to pay a producer to cover harvest costs. Figure 7-4 and Figure 7-5 show the general trend of the cost across four of the most likely harvest rates; .5, 1.5 and 2.5 tons per acre along with varying productivity responses. The two figures show that as the productivity of a machine was decreased the cost to operate the machine increased. Additionally, as the rate of harvest increased the cost per ton decreased but the overall cost per acre was higher. When using the harvest data from 2010 as a baseline for cost, the stover harvest which had harvest rates of .5, 1.1, and 1.75 tons per acre and productivity intervals at 11%, 45%, and 56.5% had a cost per acre of \$10.29, \$30.22, and \$42.48 per acre and \$20.06, \$30.39, and \$28.46 per ton respectively.

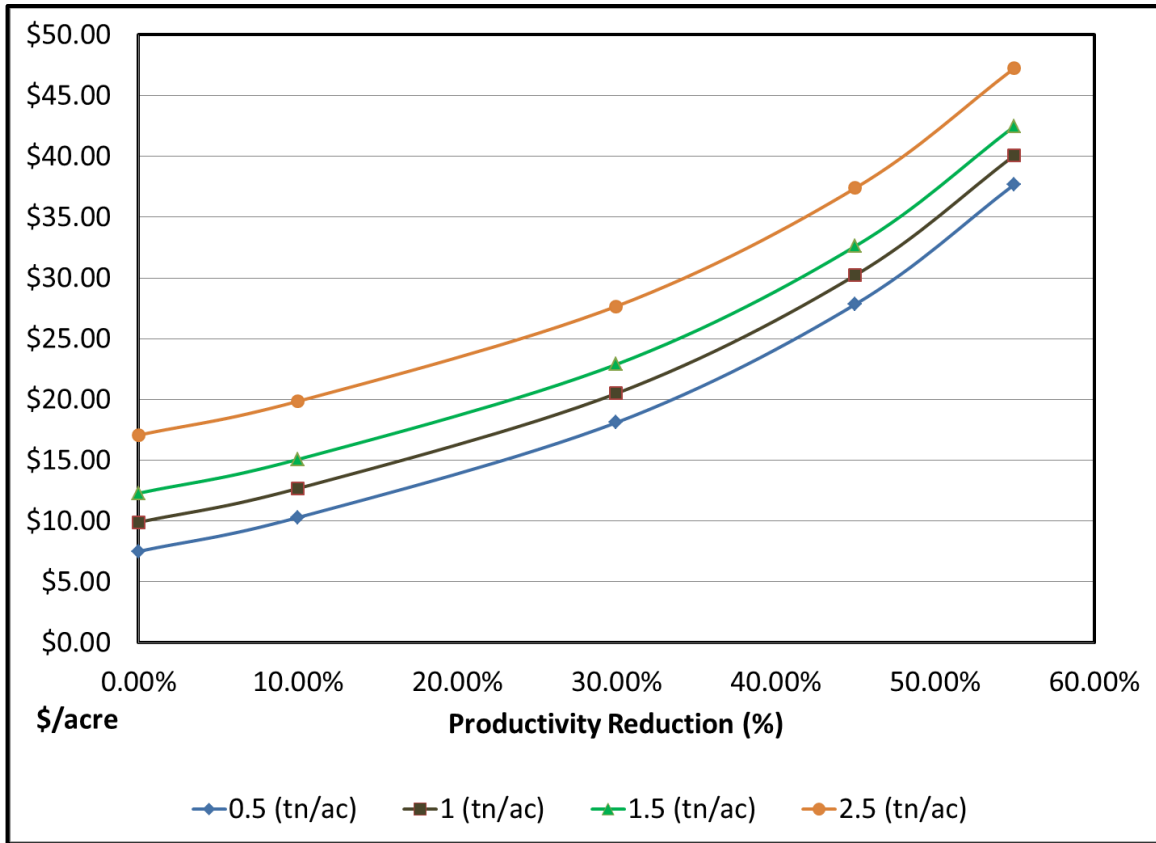

Figure 7-5: Cost per acre for harvesting stover at harvest rates between .5 tn/ac and 2.5 tn/ac with the factor of productivity reduction on the combine. Productivity reductions are not tied to a specific combine.

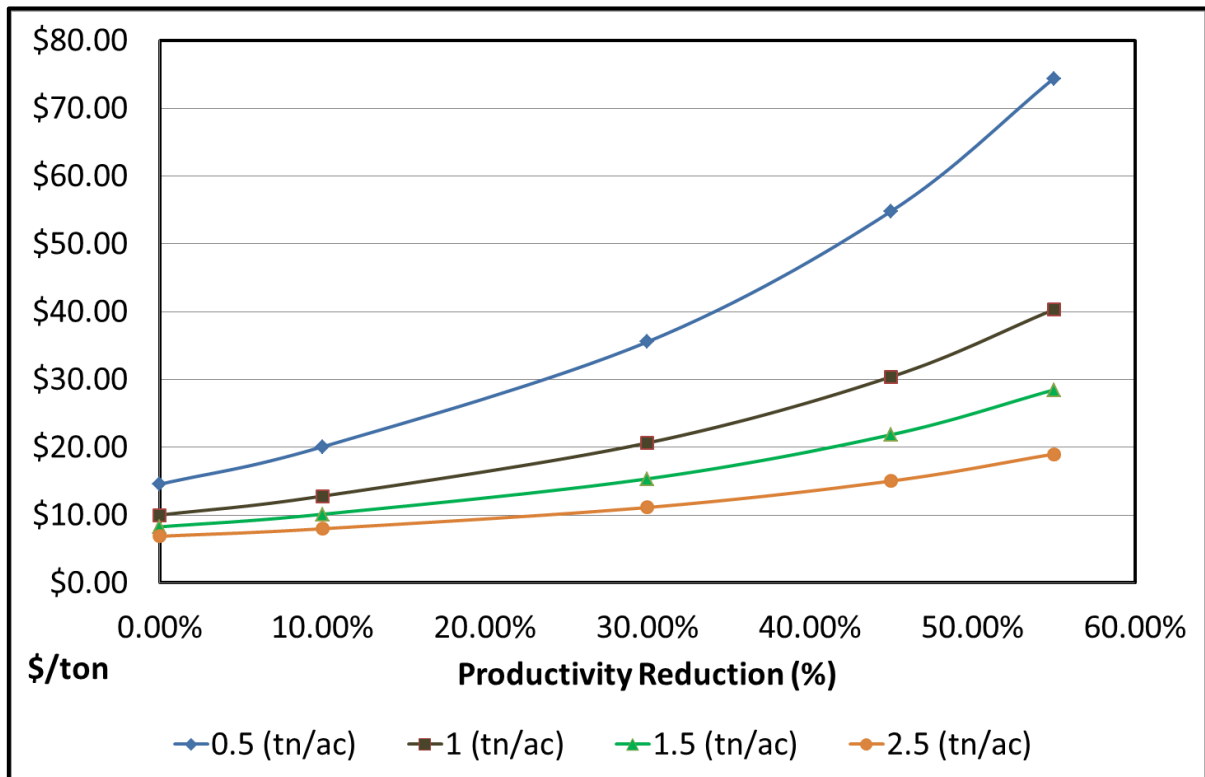

Figure 7-4: Cost per ton for harvesting stover at harvest rates between .5 tn/ac and 2.5 tn/ac with the factor of productivity reduction on the combine. Productivity reductions are not tied to a specific combine.

There are a couple of outcomes that can be drawn from these results. The first was that the reduction in the productivity loss in the system will reduce cost both in cost per ton and cost per acre. The other outcome was the cost per ton of stover decreases at the higher harvest rates but the cost per acre to harvest increases which was a tradeoff.

The next step in the analysis was to break the overall cost of the stover harvest into the cost applied to the harvest from each machine in the system. The five machines analyzed in this system were the combine, baler, bale collection machine, and the grain cart and tractor system. Figure 7-6 and Figure 7-7 show that the productivity reduction affects the cost of each machine differently. For example on a per ton basis the baler and the bale collection machine costs which were solely applied to the corn stover harvest cost remained level or relatively stagnant over the different productivity reduction levels. Through each increase in the harvest rate the cost per ton decreased. Meanwhile, the combine and grain cart had different responses. Through the increases in the harvest rates the cost remained stable at the same productivity reduction rates. However, when the productivity reduction was improved the cost for these was driven lower for both the cost per ton and cost per acre. The main driver for this was the area harvested by the combine.

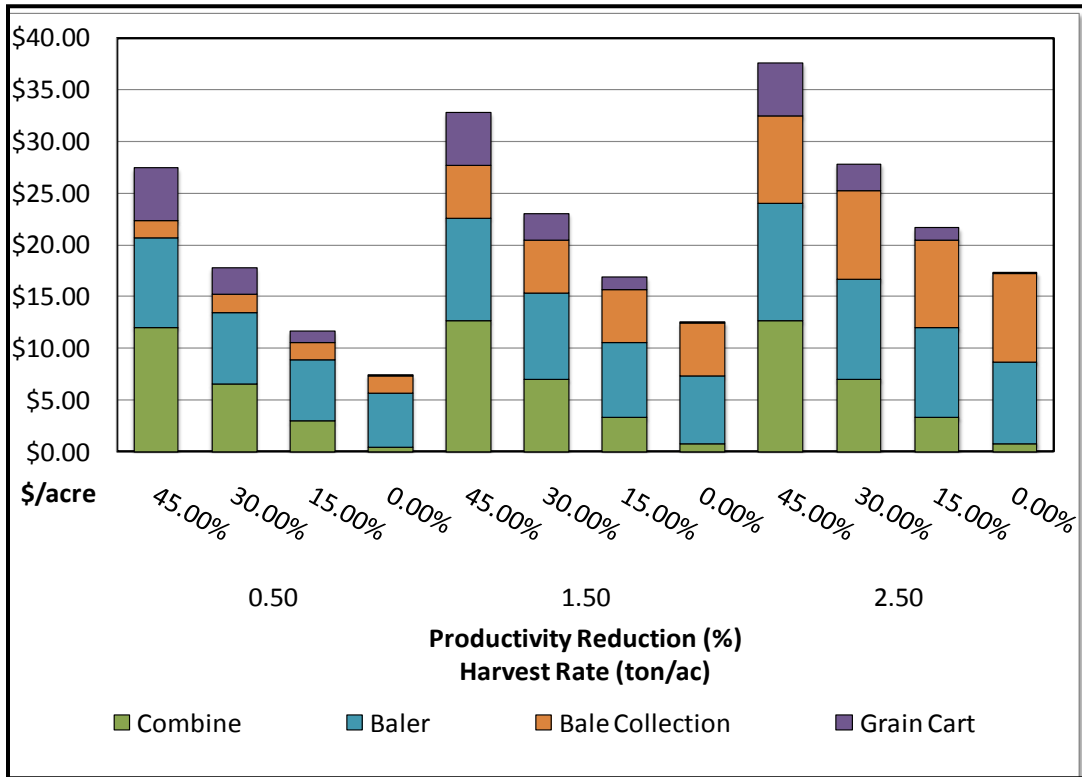

Figure 7-6: Total cost per acre for each machine system based upon the amount of stover harvested (tn/ac) and the reduction in productivity (%) for a combine harvesting stover.

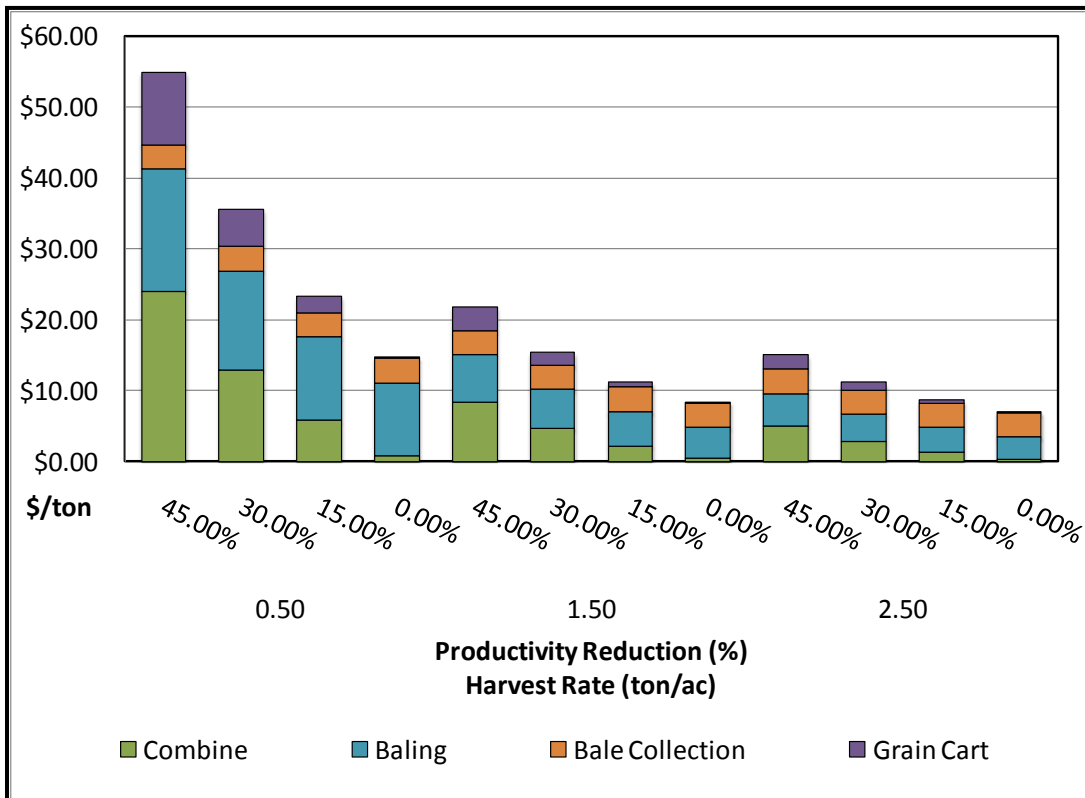

Figure 7-7: Total cost per ton for each machine system based upon the amount of stover harvested (tn/ac) and the reduction in productivity (%) for a combine harvesting stover.

7.3.3 MACHINE COST BREAKDOWN

As mentioned earlier, for most machines there are seven major cost categories that were used for this analysis. Further detailed in Figure 7-8, the seven major cost categories are distributed differently across each system and scenario. The breakdown of the combine cost the dominate cost category was the depreciation cost that was applied to the stover. As more acres are harvested per hour the productivity improved the added depreciation cost applied to stover became less because it was applied back to the cost of the grain harvest. As the productivity reduction got to 0% reduction the cost applied to the stover harvest was removed. This was the same case for the TIH, interest, maintenance, and labor costs.

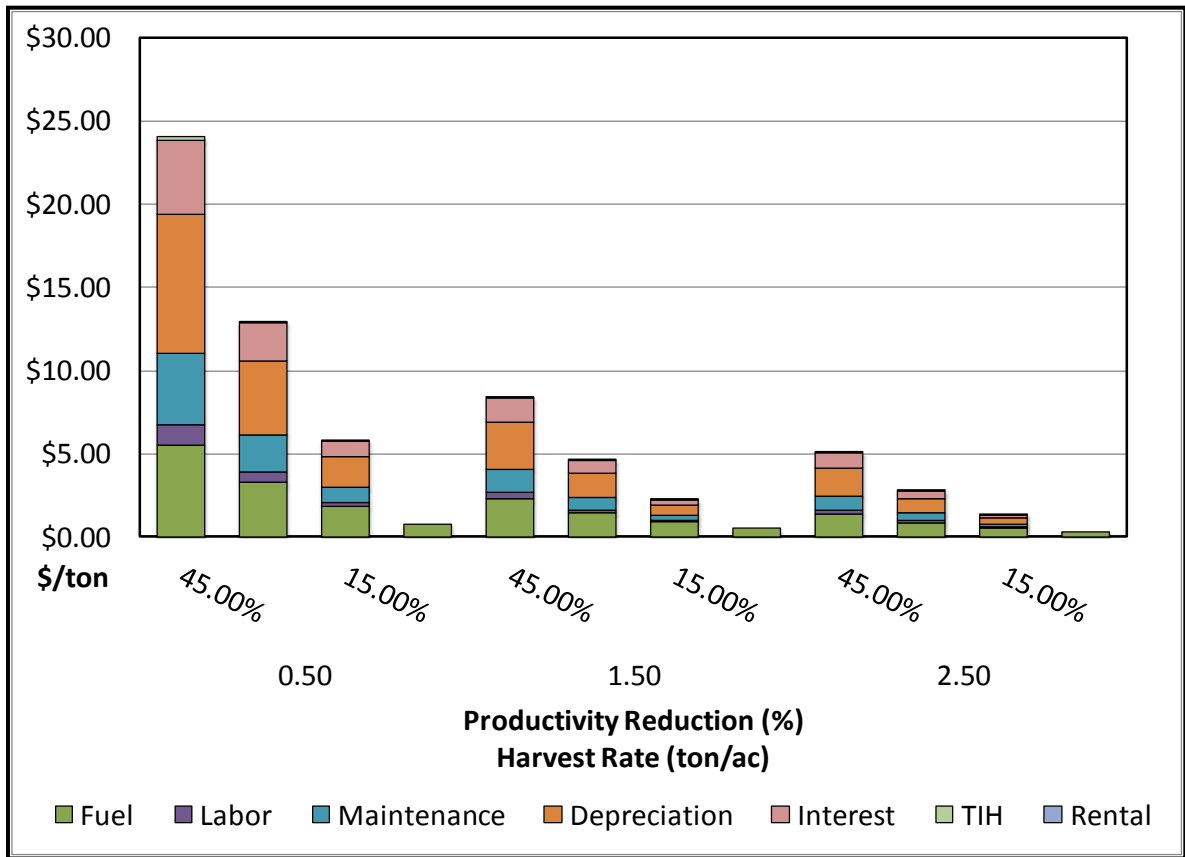

Figure 7-8: Total cost per ton for the combine to harvest stover broken down into seven cost categories for analysis based upon cost data from the ASABE D497 standard and current machine prices.

A main driver behind the large depreciation, interest, TIH, and maintenance cost for the combine was the high initial capital cost of the combine and header. As the price for a

combine and header ranged from \$300,000 - \$500,000 and typical salvage value for a system like this was around \$100,000. Which means \$200,000 - \$400,000 of the capital cost must be distributed between the grain and stover harvest. Each of the cost categories was determined from a total cost. For the combine used in 2010 the total maintenance cost was \$176,820, interest costs were \$180,390, depreciation costs were \$342,270, and TIH costs were \$8,790 over the life of the machine, which was 3000 hours.

Fuel cost was different from the ownership costs because there was an additional fuel cost penalty for pulling the baler through the field at all productivity reduction rates. The fuel cost from the combine was fairly moderate with the largest cost coming at the 45% reduction rate. While most of the fuel cost could be placed back onto the grain harvest at the 0% reduction rate there was still a fuel cost that ranged from \$.29 to \$.76 per ton.

The other machine system that had cost applied to both the grain harvest and stover harvest was the grain cart and tractor. The costs for the two tractors and grain cart were split evenly. As the productivity reduction improved the rental cost of the tractor also became slightly lower. Costs for the grain cart and tractor system were just as responsive to productivity as the combine cost. One difference between the grain cart and tractor system and the combine was that at the 0% reduction rate all costs were shifted to the grain harvest because there was no slowdown in harvest. Having no slowdown in the harvest meant that the grain cart and tractor system became a non-factor in the total cost for harvesting corn stover.



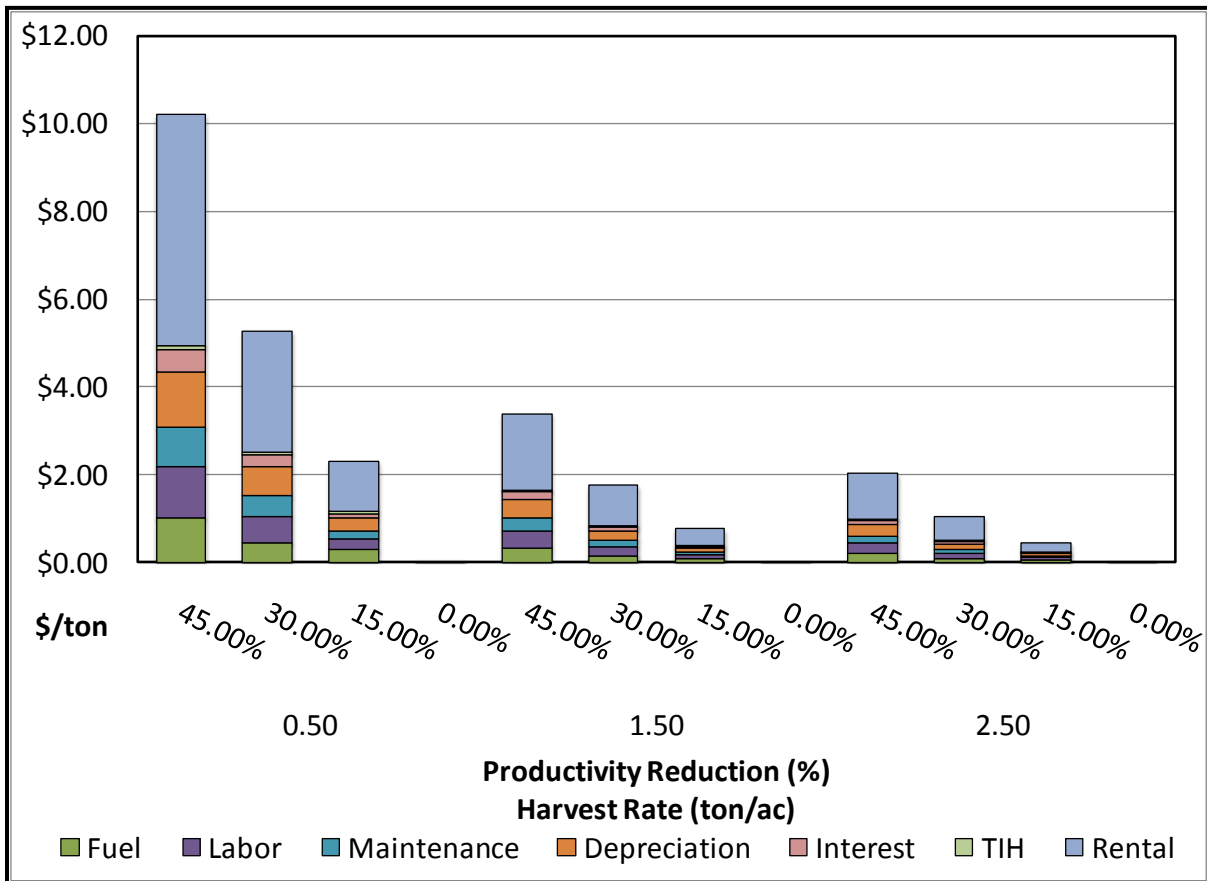

**Figure 7-9: Total cost per ton for the grain cart and tractor to harvest stover broken down into seven cost categories for analysis based upon cost data from the ASABE D497 standard and current machine prices.**

The lower capital cost of the grain cart in this system was the main reason that most costs were lower for the system. Another reason was that the tractor was treated as a multi-use machine and used the hourly rental rate which meant that not all of the total ownership costs were applied to harvesting grain or stover. This inherently drove down the cost of the tractor.

The grain cart and tractor system and the combine each had costs for stover harvest and grain harvest, the baler and bale collection machine did not. The costs associated with the baler and bale collection machine were strictly for the harvest of the corn stover.

The cost breakdown for the baler shown in Figure 7-10 had an eighth category, which was the cost of string for the baler. The baler had similar cost trends to that of the combine.

It had relatively high capital cost with limited usage outside of fall harvest. This drove costs for interest, depreciation, maintenance, and TIH higher. In each scenario the costs associated with these four costs categories were roughly 60% -80% of the total cost of operation. String cost also was a large cost of harvest. It cost \$1.38 per ton of the total cost to supply the string for the bales.

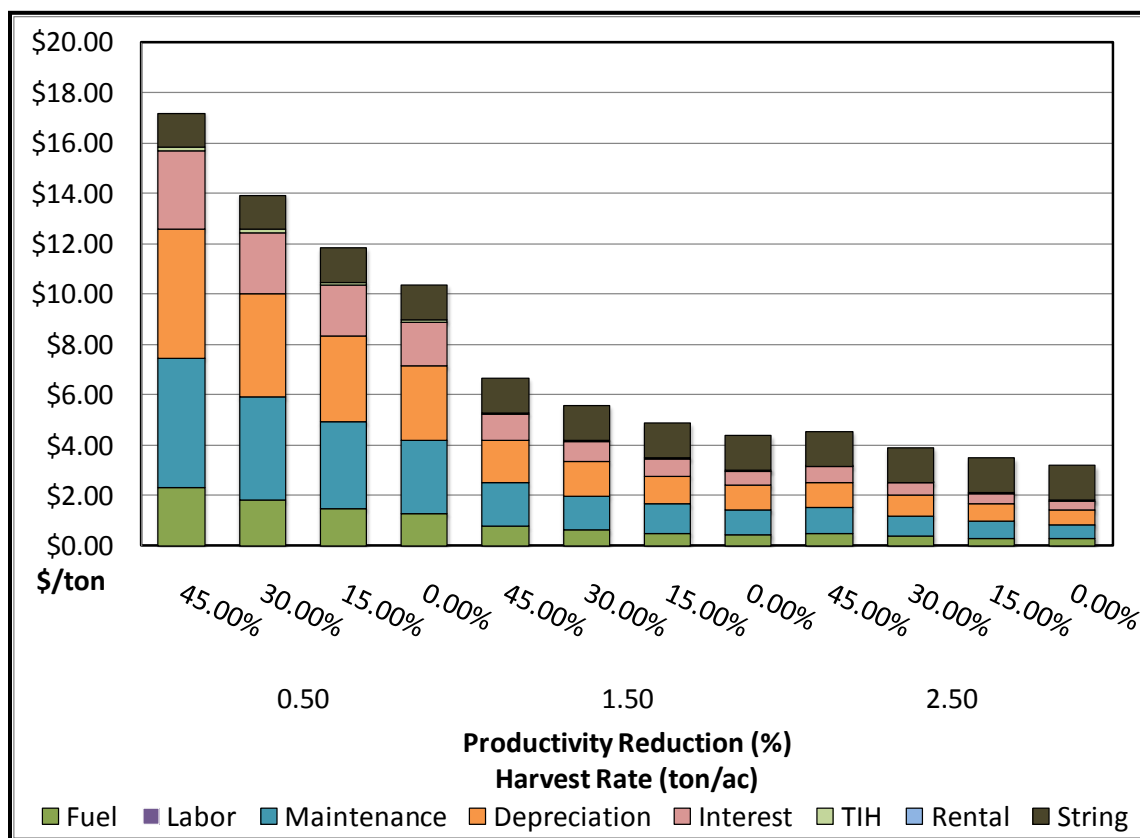

Figure 7-10: Total cost per ton for the single-pass baler to harvest stover broken down into eight cost categories for analysis based upon cost data from the ASABE D497 standard and current machine prices.

Fuel costs improved as the collection rates were increased and the productivity improved. At any rate of collection the extra fuel to operate the baler in the field behind the combine was about 10% or less of the total cost per ton of stover depending upon the productivity reduction interval.

Labor cost was completely removed from the baler. Since the combine operator could monitor and control the functions of the baler as well as the combine there was no additional labor cost associated with the baler.

The final machine system to break down in cost was the bale collection machine. Looking at the cost per ton of the machine it was similar across all scenarios. The reason behind this was that the bale collection machine was not tied to the productivity of the single-pass baler and could freely pick up bales as necessary which meant that it could pick the bales up after harvest of the field was complete. There were three major costs that were associated to the bale collection machine. These were the rental cost, labor cost, and fuel cost. The total cost for operation of the bale collector was \$3.41 per ton. Of the three costs the highest cost was the rental cost. The rental cost was 50% of the total cost. The rental cost was used because it was assumed that the bale collection machine would get some use away from the fall harvest season and that cost would lower the capital cost assigned to the collection machine. Also, this analysis only determined the cost to the field edge for bale hauling. The next step in the transport logistics cycle would be moving bales from the field to the next point in the bale supply chain. Potentially this machine could be used to move bales to that next step in the supply chain. Additional use would distribute the capital cost of the machine which would result in lower costs.

One other outcome to analyze for the bale collection vehicle to discuss was the cost per acre increase as the harvest rate increases. As the harvest rate increased, more bales were going to be produced per acre. Having more bales per acre caused the bale collection machine to stay within an acre longer in order to collect all of the bales present. This drove cost per acre higher, as shown in Figure 7-12.

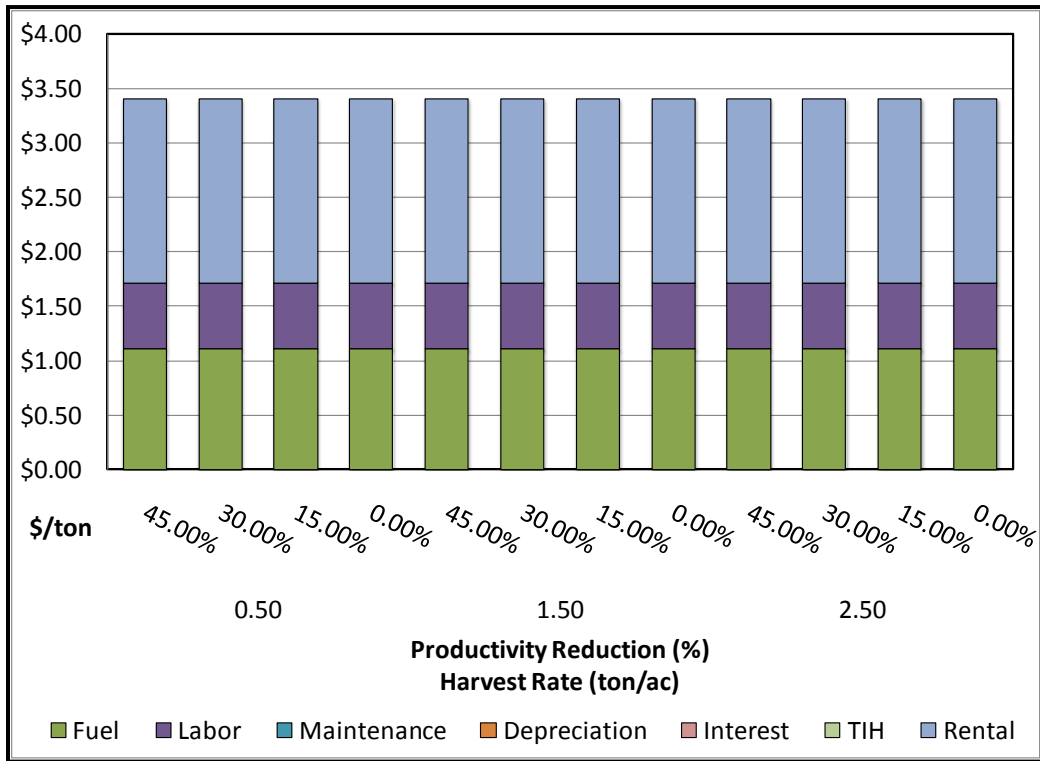

Figure 7-12: Total cost per ton for the single-pass baler to harvest stover broken down into eight cost categories for analysis based upon cost data from the ASABE D497 standard and current machine prices.

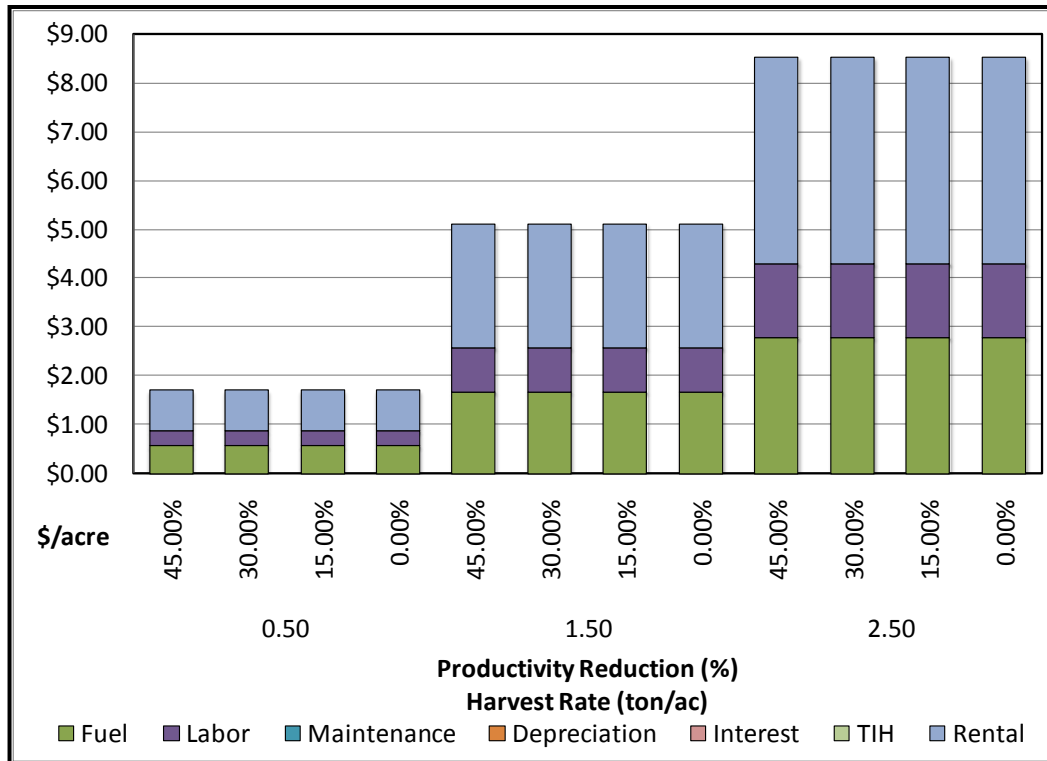

Figure 7-11: Total cost per acre for the single-pass baler to harvest stover broken down into eight cost categories for analysis based upon cost data from the ASABE D497 standard and current machine prices.

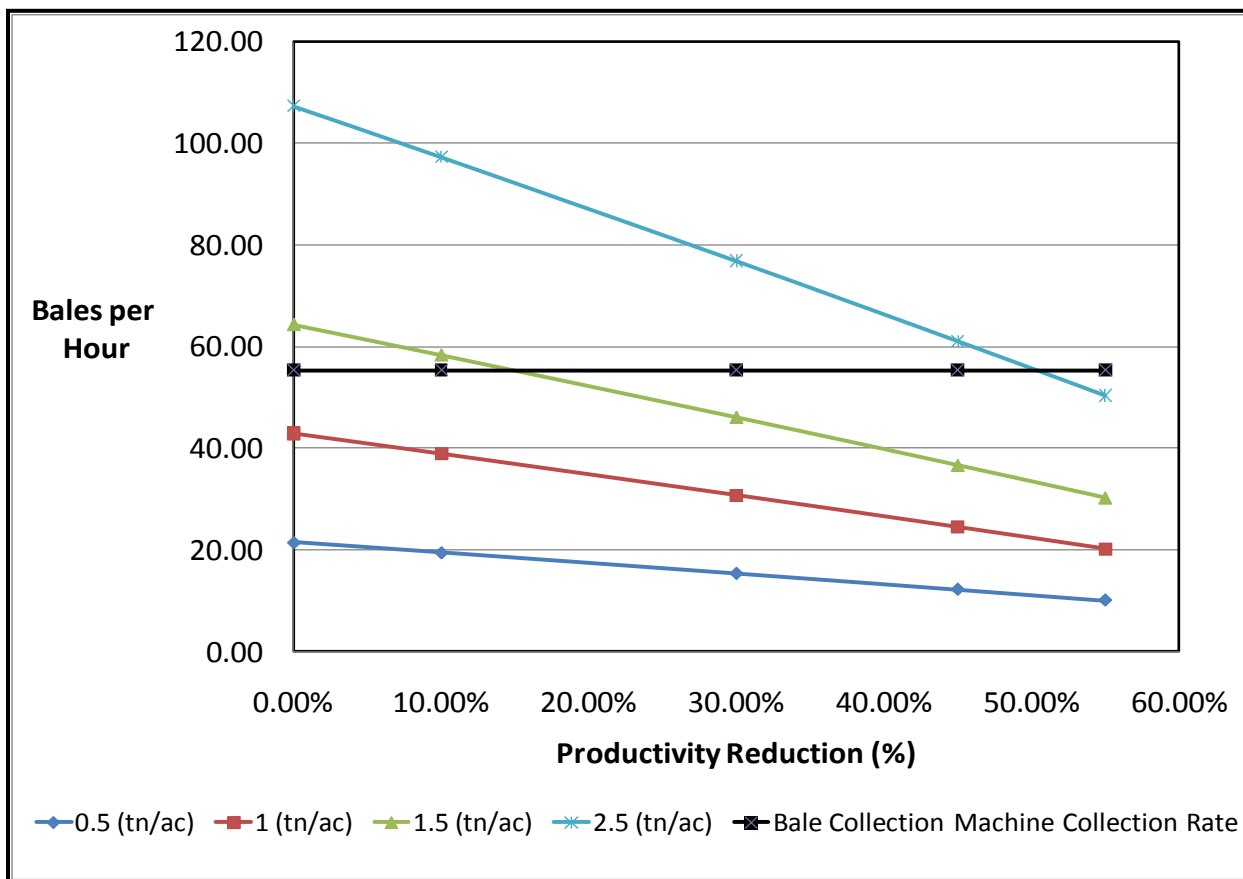

Figure 7-13: Comparison of the average amount of bales per hour collected versus the average amount of bales per hour produced by the baler by harvest rate and productivity reduction interval.

Comparing the capacity of the bale collection vehicle to the output of the baler, as shown in Figure 7-13, showed that the bale collection vehicle should be able to keep up with one single-pass baler bale output up to 1.5 tons per acre and 10% productivity reduction. What this meant was that at current harvest rates and productivity reduction levels one collection machine should be able to collect all of the daily output of the single-pass baler.

#### 7.4 CONCLUSIONS

A model was developed and implemented that calculated the cost for single-pass baling of corn stover with delivery of the grain and stover to the field edge. The corresponding harvest rates for 2010 for the 0, 6, and 12 row collections were .5, 1.1, and 1.75 tons per acre with productivity reduction levels of 11%, 45%, and 56.5% respectively

that were from the fall 2010 harvest. At these harvest rates and productivity reductions the total cost for stover harvest was determined to be \$20.06, \$30.39, and \$28.46 per ton and \$10.29, \$30.22, and \$42.48 per acre for each scenario respectively.

The model accounted for a variety of fixed and variable inputs such as fuel consumption, speed, crop flow, fuel cost, labor cost, and machinery cost. It also accounted for machine logistical variables like the unloading time, baled stover output, and time to collect the bales from the field.

The cost of single-pass baling harvest was broken into seven general cost categories: Fuel costs, labor costs, maintenance costs, depreciation costs, interest costs, taxes, insurance, and housing costs, and rental costs. An additional cost that was added for the baler was the cost of the string for the baler. Many of these cost categories were derived from ASABE machinery management standards and adapted for use in this model.

In addition to modeling the actual costs of the fall 2010 harvest the model was also used to predict costs for varying harvest and productivity rates of the harvest systems. Three harvest rates (.5, 1.5, 2.5 tn/ac) and four productivity reduction rates (0%, 15%, 30%, and 45%) were selected to determine cost to harvest grain and stover. Costs were also determined on machine system level, and individual cost categories level within each machine system. Outputs of the model were cost per ton of stover harvested and cost per acre of corn harvested.

The outcomes from the analysis of the modeled data were that the baseline total cost for the grain harvesting system (combine and grain cart) was \$45 per ton and \$22.52 per acre. The cumulative total cost for harvesting corn stover and grain was between \$50-\$60 per ton and \$30-\$60 per acre (combine, baler, bale collector, grain cart). The cost to harvest the stover was determined to be between \$7.50 - \$35 per acre and about \$10-\$35 per ton for the harvest scenarios most likely to be met in the analysis. The combine and grain cart costs diminished as the productivity of the single-pass baling system was improved. At the lowest

productivity reduction (0%) the grain cart and combine costs were minimized. The cost per acre indicated that as more stover was harvested the cost increased. The cost per ton to harvest more stover decreased because as more stover was harvested the cost was distributed further by more stover. Dividing the cost into the seven cost categories illustrated that the major costs of the machinery for stover harvest was the ownership cost, mainly depreciation and maintenance cost for the combine, grain cart, and baler. Rental cost for machines was also a significant influence for the bale collection machine and the tractors.

## Chapter 8.0 Conclusions

Quantification of the productivity loss and the cost to harvest the corn stover will provide information to farmers and end users to set a fair price for the stover to be removed from the field. It also provides a baseline for equipment manufacturers to determine future design goals for improving the system performance.

### 8.1 RESULTS

The CyCAN data logger provided an efficient platform for recording data from the CAN Bus systems of multiple ISO 11783 compatible machines. Data such as fuel consumption, engine load, and speed were captured using the logger. The loggers proved to be very robust in capturing 97 of 98 test passes with full sets of data collected. The loggers also proved to be a very efficient method for logging data by minimizing the instrumentation of the machine and the processing power required to log data.

The data provided by the CyCAN logger allowed for the analysis of combine performance of different single-pass harvest configurations and at different stover harvest rates. The combine performance was measured as a factor of crop flow through the combine, the engine load of the combine, and the percent of maximum yield seen during testing. Combine productivity was determined to be affected the greatest by the stover harvest rate. At the 0 row collection rate which took in the minimal amount of material that is normally seen by the combine no productivity was lost. At the 6 row collection the productivity was cut by 25% roughly. At the 12 row collection with stover yields of around 1.75 tons per acre the productivity loss was over 50%.

Depending upon the configuration of the harvest system productivity was also affected. The single-pass bulk harvest system had little to no effect on productivity. The single-pass baling harvest system lost about 11% of its productivity compared to the baseline system at the 0 row collection rate. As the combine slowed from the higher power requirement of the stover collection and separation the loss due to the bale shrunk to 8% for



the 6 row collection and 5% for the 12 row collection. A summary of the combine productivity is listed in Table 25.

Combine Productivity Analysis (Based from 2010 Fall Harvest)		
System	Harvest Rate (Rows of collection)	Productivity (of 100%)
Baseline	0	100%
	6	73%
	12	48%
Bulk	0	100%
	6	73%
	12	47%
Baling	0	89%
	6	65%
	12	44%

**Table 25: Summary of combine productivity analysis of the different harvest systems at harvest rates from 0-12 rows of collection. As harvest rates increase the productivity is reduced and productivity is reduced when the baler is pulled behind the combine.**

Data that was captured from the harvested machines by the CyCAN logger was used to develop a model for determining the cost to single-pass baling corn stover in comparison to a conventional combine. The analysis of modeled data showed that decreasing the productivity reduction rate will reduce cost to harvest stover by transferring cost from the corn stover to the grain harvest from the combine and grain cart. Most of the cost of the combine and grain cart can be removed from the corn stover harvest which will leave only the cost of the baler and bale collection equipment. Depreciation and maintenance costs of the machines make up the highest costs associated with owning the equipment. Other cost such as fuel, labor, and interest on machinery are also a portion of the cost. Improving the performance of the single-pass baling system and harvesting higher rates of corn stover will drive down the cost per ton for stover. Higher rates of collection will increase the cost per

acre because equipment must operate longer to collect more bales and cover the acre, but improved performance in the machine productivity will lower the cost. A case study of the 2010 fall harvest cost is summarized in Table 26.

Fall 2010 Harvest Cost				
Productivity Reduction %	Harvest Rate (ton per acre)	Fuel Consumption		
		Dollars per Acre	Dollars per Ton	
11%	0.5	\$10.29	\$20.06	
45%	1.1	\$30.22	\$30.39	
56.5%	1.75	\$42.48	\$28.46	

**Table 26: Summary of cost based on the 2010 harvest documented harvest and productivity reduction rates. Lower productivity reduction rates will have less cost but less stover will also be collected to offset these cost.**

## 8.2 RECOMMENDATIONS

The recommended collection system and harvest rate moving forward based off the data collected from this testing would be to move forward with the single-pass baling system due to its acceptance in the first cellulosic ethanol plants as the primary way of handling biomass. This method also reduces the need for additional cart operators and reduces the transportation logistics issues that might be seen with the bulk material. Not letting the material hit the ground and being able to handle a large amount of material at one time makes the single-pass baling a highly desirable method for collecting corn stover.

The collection rate to target based upon the 2010 fall harvest data would be to harvest with the 6 row collection rate. That equals between 1 -1.5 tons of material collected. This differs from the cost analysis which recommends that either the highest collection rate or the lowest collection rate would be the best cost scenario. Mainly this is due to the severe reduction in productivity at the 12 row collection rate and the lack of material collected when harvesting at the 0 row collection harvest rate. The 0 row harvest rate would not produce enough stover to sustain an ethanol plants supply requirements. The 12 row collection productivity penalty would not allow the combine to cover enough acres to supply any more

material than a combine collecting 6 rows of material which could cover more acres during a harvest period.

### 8.3 FUTURE WORK

Expansion of the data logging equipment onto the grain handling equipment would capture the whole grain harvest system to the field edge and help determine if the productivity reduction experienced by the combine with corn stover harvest is actual harvest productivity reduction. Determination of the bottleneck in a harvest system should shift the harvest productivity curve and reduce the effects that slowing the combine that is harvesting stover would have on the harvest productivity. If it is determined that another bottleneck is present in the grain handling side of harvest then the effects of the corn stover harvest on the entire harvest system should be minimized.

Other analysis could be done across different equipment manufacturers to determine differences in combine performance. This may key in on specific differences in designs that allow for more throughput and less penalty for harvesting stover. Also looking at the performance of the combine with different header widths the capture the full spectrum of crop flow rates though the combine should provide a more thorough performance dataset for future analysis.

## Chapter 9.0 Bibliography

- Mud Hog*. (2011). Retrieved June 21, 2011, from Tuthill Drive Systems: [www.mudhog.com](http://www.mudhog.com)
- AGCO Corporation. (2010). *Challenger Biomass Baler*. Retrieved February 15, 2011, from Challenger-Ag/AGCO: <http://www.challenger-ag.com/NA/EN/products/harvesting/1379.htm>
- ASABE. (2006, February). *Agricultural Machinery Management*, ASAE EP496.3. St. Joseph, Michigan: ASABE.
- ASABE. (2011, Mar). 497.7. St. Joseph, Mi, United States: ASABE.
- California Energy Commission. (2004, January). Retrieved June 20, 2011, from [http://www.energy.ca.gov/reports/2004-02-03\\_600-04-001.PDF](http://www.energy.ca.gov/reports/2004-02-03_600-04-001.PDF)
- CLAAS. (2011). *CLAAS Jaguar*. Retrieved February 16, 2011, from CLAAS: [http://www.claas.com/countries/generator/clpw/en/products/forage\\_harvester/jaguar\\_980-930/tech-data/start,lang=en\\_UK.html](http://www.claas.com/countries/generator/clpw/en/products/forage_harvester/jaguar_980-930/tech-data/start,lang=en_UK.html)
- Dupont Danisco Cellulosic Ethanol LLC. (2011, June 27). DDCE enters agreement to purchase land in Iowa for commercial biorefinery to make fuel from corn stover. Itasca, IL, United States of America: DDCE.
- Edwards, W. M. (1979). *Farm Machinery Selection Under Conditions of Uncertainty. Dissertation*. Ames, Iowa, United States of America: Iowa State University.
- EISA. (2007, January 4). Energy Independence and Security Act of 2007. (110 Congress). United States: United States Senate. Retrieved February 12, 2011, from [http://energy.senate.gov/public/\\_files/getdoc1.pdf](http://energy.senate.gov/public/_files/getdoc1.pdf)
- Glenvar Bale Direct. (2007). Retrieved February 16, 2011, from ASABE: <http://www.asabe.org/standards/ICCHP2007DirectBaler.pdf>
- Goering, C. E., & Hansen, A. C. (2004). *Engine and Tractor Power*. St Joseph: ASABE.
- Gray, W. H. (1898). *Corn Harvester and Binder*. U.S. Patent No. 602659.
- Hanna, M., & Al-Kaisi, M. (2008, 4 9). *Managing Residue for a Good Stand*. Retrieved June 20, 2011, from Integrated Crop Management News: <http://www.extension.iastate.edu/CropNews/2008/0402AlKaisiHanna.htm>
- Hawbaker, R. (2010). *Store Manager*. (M. Darr, Interviewer)
- Hettenhaus, J. R., & Wooley, R. (2000, October). Biomass commercialization prospects in the next two to five years. *BIOMASS COLLOQUIES 2000*. National Renewable Energy Laboratory.

- Hillco Technologies. (2010). *Cob Collection Attachment*. Retrieved February 15, 2011, from Hillco Technologies:  
<http://www.hillcotechnologies.com/cob-collection-attachment.html>
- Johnson, J. M., Wilhelm, W. W., Karlen, D. L., Archer, D. W., Wienhold, B., Lightle, D. T., et al. (2010). Nutrient Removal as a Function of Corn Stover Cutting Height and Cob Harvest. *Bioenergy Resources*, 342-352.
- Karlen, D. (2008, October). Cellulosic Ethanol From Corn Stover: Calculating—and Improving—the Bottom Line. *Agricultural Research*.
- Matlack, J. (2010, August). (K. Webster, Interviewer)
- Mellert, K. (2011, 6 27). Edwards, II.
- National Oceanic and Atmospheric Administration's. (2011). Retrieved April 10, 2011, from National Weather Service: [www.weather.gov](http://www.weather.gov)
- Perlack, R. D., & Turhollow, A. F. (2002, September). *Assessment of Options for the Collection, Handling, and Transport of Corn Stover*. Environment Sciences Division. Oak Ridge : Oak Ridge National Laboratory.
- POET Biorefining. (2011). *Project Liberty*. Retrieved February 16, 2011, from POET Biorefining:  
<http://poet.com/innovation/cellulosic/projectliberty/index.asp>
- Rosenthal, H. (1950). Corn harvester. *U.S. Patent No. 2524603*.
- SAE. (1998, October). J1939-71 Rev Oct 1998. Pennsylvania, United States: SAE.
- Schlesser, B. (2007). *Development and evaluation of a single pass, dual stream corn stover harvester*. Retrieved June 20, 2011
- Shinners, K. J., Binversie, B. N., & Phillippe, S. (2003, July 27-30). WHOLE-PLANT CORN HARVESTING FOR BIOMASS: COMPARISON OF SINGLE-PASS AND MULTIPLE-PASS HARVEST SYSTEMS. Las Vegas, Nevada, United States: ASABE.
- Shinners, K. J., Binversie, B. N., Digman, M. F., Muck, R. E., & Weimer, P. J. (2005, January). SINGLE-PASS, SPLIT-STREAM HARVEST OF CORN GRAIN AND STOVER. ASABE.
- Shinners, K. J., Boettcher, G. C., Hoffman, D. S., Munk, J. T., Muck, R. E., & Weimer, P. J. (2009). Single-Pass Harvest of Corn Grain and Stover: Performance of Three Harvester Configurations. *ASABE*. ASABE.
- Sokhansanj, S., & Turhollow, A. F. (2002). Baseline Cost for Corn Stover Collection. *Applied Engineering in Agriculture*, 525-530.
- Turhollow, A. F., Wilkerson, E. G., & Sokhansanj, S. (2008, November). Cost Methodology for Biomass Feedstocks: Herbaceous Crops and Agricultural Residues. Oak Ridge, Tennessee, United States: Oak Ridge National Laboratory.

- Turhollow, A., Wilkerson, E., & Sokhansanj, S. (2009, December). *Cost Methodology for Biomass Feedstocks: Herbaceous Crops and Agricultural Residues*. Oak Ridge National Laboratory.
- USDA - National Agriculture Statistics Service. (n.d.). Weekly Weather-State Stories & Crop Progress Report. United States: USDA.
- Vermeer Manufacturing. (2009). *Vermeer CCX770 Cob Harvester*. Retrieved February 15, 2011, from Vermeer Manufacturing:  
[http://www2.vermeer.com/vermeer/NA/en/N/equipment/cob\\_harvester/cx770](http://www2.vermeer.com/vermeer/NA/en/N/equipment/cob_harvester/cx770)
- Webster, K. E., Darr, M. D., Thoreson, C. P., & Zuchelli, M. (2010). *Productivity and Logistical Analysis of Single-Pass Stover Collection Systems*. ASABE. Pittsburgh: ASABE.