

2012

# Pretreatment and fractionation of lignocellulosic biomass for production of biofuel and value-added products

Chang Geun Yoo  
*Iowa State University*

Follow this and additional works at: <http://lib.dr.iastate.edu/etd>

 Part of the [Agriculture Commons](#), [Bioresource and Agricultural Engineering Commons](#), and the [Chemical Engineering Commons](#)

---

## Recommended Citation

Yoo, Chang Geun, "Pretreatment and fractionation of lignocellulosic biomass for production of biofuel and value-added products" (2012). *Graduate Theses and Dissertations*. 12700.  
<http://lib.dr.iastate.edu/etd/12700>

This Dissertation is brought to you for free and open access by the Graduate College at Iowa State University Digital Repository. It has been accepted for inclusion in Graduate Theses and Dissertations by an authorized administrator of Iowa State University Digital Repository. For more information, please contact [digirep@iastate.edu](mailto:digirep@iastate.edu).

**Pretreatment and fractionation of lignocellulosic biomass for production of biofuel and value-added products**

by

**Chang Geun Yoo**

A dissertation submitted to the graduate faculty  
in partial fulfillment of the requirements for the degree of

**DOCTOR OF PHILOSOPHY**

Major: Agricultural Engineering

Program of Study Committee:  
Tae Hyun Kim, Co-major Professor  
D. Raj Raman, Co-major Professor  
J (Hans) van Leeuwen  
Robert P. Anex  
Monlin Kuo

Iowa State University

Ames, Iowa

2012

Copyright © Chang Geun Yoo, 2012. All rights reserved.

## TABLE OF CONTENTS

ABSTRACT	iv
 CHAPTER 1: GENERAL INTRODUCTION	
Objectives	1
Thesis Organization	2
Authors' Role	3
Literature Review	5
References	17
 CHAPTER 2: TWO-STAGE FRACTIONATION OF CORN STOVER USING AQUEOUS AMMONIA AND HOT-WATER	
Abstract	25
Introduction	26
Materials and Methods	27
Results and Discussion	34
Conclusion	45
Acknowledgements	45
References	45
 CHAPTER 3: OPTIMIZATION OF TWO-STAGE FRACTIONATION PROCESS FOR LIGNOCELLULOSIC BIOMASS USING RESPONSE SURFACE METHODOLOGY (RSM)	
Abstract	47
Introduction	48
Methods	50
Results and Discussion	57
Conclusions	68
Acknowledgements	69
References	69
 CHAPTER 4: ETHANOL AND FURFURAL PRODUCTION FROM CORN STOVER USING A HYBRID FRACTIONATION PROCESS WITH ZINC CHLORIDE AND SIMULTANEOUS SACCHARIFICATION AND FERMENTATION (SSF)	
Abstract	73
Introduction	74
Materials and Methods	76
Results and Discussion	85
Conclusions	97
Acknowledgements	97

References	97
CHAPTER 5: PRETREATMENT OF CORN STOVER USING LOW-MOISTURE ANHYDROUS AMMONIA (LMAA) PROCESS	
Abstract	101
Introduction	102
Methods	105
Results and Discussion	113
Conclusion	121
Acknowledgements	121
References	123
CHAPTER 6: ENHANCEMENT OF ENZYMATIC HYDROLYSIS AND LIGNIN REMOVAL OF CORN STOVER USING PHOTOCATALYST-ASSISTED AMMONIA PRETREATMENT	
Abstract	126
Introduction	127
Materials and Methods	130
Results and Discussion	133
Conclusion	143
Acknowledgements	144
References	146
CHAPTER 7: GENERAL CONCLUSION	
Conclusions	149
Future Work	151
ACKNOWLEDGEMENTS	153

## ABSTRACT

Biorefineries are sustainable biomass conversion processes to make bio-based fuels and chemical products. In this thesis, several different lignocellulosic biomass pretreatment and fractionation processes are developed and described with possible biorefinery applications. Fractionation using aqueous ammonia and hot-water, hybrid fractionation using zinc chloride ( $\text{ZnCl}_2$ ) and simultaneous saccharification and fermentation (SSF), low-moisture anhydrous ammonia pretreatment, and photocatalyst-assisted ammonia pretreatment are investigated to improve the utilization of lignocellulosic biomass.

The two-stage fractionation process using aqueous ammonia and hot-water separated three main components with relatively high purity of each component. Ammonia treatment selectively removed lignin from biomass, while hot-water treatment separately hydrolyzed hemicellulose in the following stage. Under the optimal reaction conditions using RSM, relatively high purity of hemicellulose and lignin were recovered. High enzymatic digestibility and fermentability were also resulted with cellulose fraction.

A hybrid fractionation process using  $\text{ZnCl}_2$  and SSF was also investigated to improve the utilization of lignocellulosic biomass. The  $\text{ZnCl}_2$  showed high swelling effect and selectivity for hemicellulose; hence most of the hemicellulose was released into the liquid hydrolysate by  $\text{ZnCl}_2$  treatment. The fractionated hemicellulose in the liquid hydrolysates was converted into furfural by thermal reaction, while the residual solids which have high cellulose and lignin contents were converted into ethanol by SSF. Up to 98% of theoretical maximum ethanol yield was obtained; therefore, the residual solids could be high purity lignin.

Low-moisture anhydrous ammonia pretreatment was studied in an effort to minimize ammonia and water input and to obtain high enzymatic digestibilities and ethanol yield. Gaseous ammonia treatment significantly reduced ammonia input (0.1 g ammonia/g biomass) and water input (1.0 g water/g biomass). In addition, there was no washing step which required significant washing water. Even though water and ammonia inputs were significantly reduced compared to previous ammonia pretreatment methods, the maximum theoretical ethanol yield (based on glucan and xylan in the biomass) reached 90% by simultaneous saccharification and cofermentation (SSCF).

A photocatalyst-assisted ammonia pretreatment method was developed to enhance the effects of liquid ammonia pretreatment by oxidation reaction with photocatalysts. Higher delignification and enzymatic hydrolysis yield of treated solids resulted from photocatalyst-assisted ammonia pretreatment compared to ammonia pretreatment itself. Moreover, photocatalysts shortened the pretreatment time. Improving the pretreatment effects and shortening the pretreatment time by UV treatment using photocatalysts show a potential of photocatalytic treatment as a useful technology for lignocellulosic biomass utilization.

These studies show that the development of biomass conversion process can contribute to the utilization of lignocellulosic biomass. Each approach has its own particular solution to the problems of biomass conversion processes. Fractionation processes propose ways to produce valuable building blocks, and pretreatment processes suggest efficient methods by enhancing conversion yields and reducing production costs. Although there are still many obstacles to overcome, these studies are believed to help commercialize lignocellulosic biomass products.

## CHAPTER 1. GENERAL INTRODUCTION

### Objectives

The overall aim of this study was to improve the potential of economically using lignocellulosic biomasses by developing efficient fractionation and pretreatment process and by optimizing the operating parameters of these novel processes. This research explored multiple biomass treatments (hot-water, liquid ammonia, gaseous ammonia and zinc chloride treatments) and also explored the biological and thermo-chemical processing of the treated biomass. The detailed objectives of the dissertation were as follow:

- To investigate the effects of a two-stage ammonia and hot-water treatment on hemicellulose and lignin fractionation from corn stover. The enzymatic hydrolysis of the resulting fractionated biomass was also investigated.
- To determine the effects of reaction operating parameters such as retention time, flow rate, and temperature, on the performance of the two-stage fractionation process. Also to optimize the reaction conditions of the two-stage fractionation process to maximize the purity and yield of cellulose, hemicellulose, and lignin.
- To investigate the efficacy of zinc chloride for fractionation of lignocellulosic biomass. This study also examined the impact of ZnCl treatment on subsequent ethanol yield via biological conversion, and a furfural yield via thermal conversion.
- To explore the potential of gaseous ammonia pretreatment to minimize water and ammonia inputs. The gaseous ammonia pretreatment process was optimized so that downstream ethanol production was maximized.

- To investigate the possibility of using photocatalysts for the pretreatment of lignocellulosic biomass. Specifically, the impact of photocatalysts alone, and photocatalysts used in conjunction with ammonia, was explored. The changes of biomass composition were also investigated by comparing the Raman spectra of treated and untreated biomass.

### **Thesis Organization**

This thesis includes a general introduction, five research articles, a general conclusion as well as cited references and acknowledgements. The first chapter is a general introduction that includes the thesis objectives, a description of the thesis organization, an explanation of the authors' role in each of the articles, and a general literature review. The articles in chapters 2-6 have been published, or are in review, in peer-review journals. Chapter 2 is an article entitled "Two-stage fractionation of corn stover using aqueous ammonia and hot-water" published in the journal of *Applied Biochemistry and Biotechnology* (Yoo et al., 2011). This article demonstrates the effects of sequential ammonia and hot-water treatment for fractionating three main components of lignocellulosic biomass (cellulose, hemicellulose and lignin). The compositions of liquid and solid residues in each stage are presented, and enzymatic digestibilities of the resulting residues under different reaction conditions are also included. Chapter 3 is an article entitled "Optimization of two-stage fractionation process for lignocellulosic biomass using response surface methodology (RSM)" published in the journal of *Biomass and Bioenergy* (Yoo et al., 2011). The article describes the optimization of the two-stage reaction conditions to maximize hemicelluloses recovery and purity in the liquid hydrolysate. The ethanol production after optimized two-stage fractionation is also reported.



Chapter 4 contains an article titled “Ethanol and furfural production from corn stover using hybrid fractionation process with zinc chloride and simultaneous saccharification and fermentation (SSF)” published in the journal of *Process Biochemistry* (Yoo et al., 2012). It reports the effect of zinc chloride on the selective fractionation of lignocellulosic biomass. This article demonstrates furfural production with fractionated hemicellulose hydrolysate and ethanol production with residual solid by thermal and biological conversion process, respectively. Chapter 5, “Pretreatment of corn stover by low moisture anhydrous ammonia (LMAA) process,” is published in the journal of *Bioresource Technology* (Yoo et al., 2011). This article introduces an alkali pretreatment method using gaseous ammonia to reduce ammonia, water and energy inputs. The optimization of reaction conditions for ethanol production is also included. Chapter 6 is manuscript entitled “Enhancement of enzymatic hydrolysis and lignin removal of corn stover using photocatalyst-assisted ammonia pretreatment.” The manuscript explores the effects of photocatalysts on biomass compositional changes and enzymatic hydrolysis yields. This manuscript was submitted to the journal of *Bioresource Technology*. The general conclusion follows the five articles with discussion of future work for improving the lignocellulosic biomass utilization methods. Introduction and article references are included at the end of each chapter.

### **Authors' Role**

The authors have made a substantial contribution to each article in this thesis. All of the articles in this thesis are written by the primary author with co-authors' assistance and guidance. The primary author, Chang Geun Yoo, conducted experiments, collected data, analyzed and interpreted results. In the first and second articles (Chapters 2 and 3), the

primary author designed and conducted a flow-through reactor system with ammonia and hot-water. He also tested several different reaction conditions to explore the effects of operating factors and optimized these parameters by a statistical tool. Dr. Chi-Woo Lee (Associate Professor, Department of Automotive Engineering, Gyeongnam National University of Science and Technology) helped design reactor systems. Dr. Tae Hyun Kim (Major Professor, Department of Agricultural and Biosystems Engineering, Iowa State University) provided ideas and guidance. In the third article (Chapter 4), the primary author suggested the thermal conversion method for furfural production and selected fractionation conditions from the experiment results. Dr. Monlin Kuo (Associate Professor, Department of Natural Resource Ecology and Management, Iowa State University) provided ideas about the effect of zinc chloride and characteristics of lignocellulosic biomass structures. Dr. Tae Hyun Kim helped to find applications of furfural as a product. In the fourth article (Chapter 5), the primary author developed the ammoniation stage and the ammonia evaporation stage instead of the water washing step. Dr. Nhuan P. Nghiem (Chemical Engineer, Sustainable Biofuels and Co-Products Research Unit, Eastern Regional Research Center, Agricultural Research Service, USDA) and Dr. Kevin B. Hicks (Research Leader, Sustainable Biofuels and Co-Products Research Unit, Eastern Regional Research Center, Agricultural Research Service, USDA) provided an ammonia analyzer, ammoniation reactors, and knowledge of gaseous ammonia reaction. Dr. Tae Hyun Kim pointed out the importance of water, chemical and energy inputs in the pretreatment process. In the fifth article (Chapter 6), the primary author set up a technically viable photocatalyst-assisted ammonia pretreatment system and interpreted the results from enzymatic hydrolysis and Raman spectra analysis. Dr. Chenxu Yu (Assistant Professor, Department of Agricultural and Biosystems Engineering, Iowa State

University) provided the idea of photocatalyst utilization. The Raman spectra analysis was conducted with Dr. Chenxu Yu's equipment. Chao Wang (Master candidate, Department of Agricultural and Biosystems Engineering, Iowa State University) helped analyze Raman spectra and experiments using photocatalyst. Dr. Tae Hyun Kim suggested the idea of aqueous ammonia use with photocatalysts and suggested a shortcut to developing the method. In the overall dissertation, the primary author wrote a dissertation under the supervision of Dr. D. Raj Raman (Co-major Professor, Department of Agricultural and Biosystems Engineering, Iowa State University).

## **Literature Review**

### *Biorenewable Energy*

On the world markets, the cost of fossil fuel has increased as the demand for energy and petrochemical products increases. According to the Energy Information Administration 2011 Report (Energy Information Administration, 2011), world energy consumption will increase by 53 percent (from 505 quadrillion Btu in 2008 to 770 quadrillion Btu in 2035). However, our society heavily relies on fossil resources. About 82% of the world's energy needs are currently covered by fossil resources (Soetaert and Vandamme, 2009). Severe economic problem can occur as a consequence of unexpected disruption in oil supply. In addition, environmental problems such as greenhouse gas emissions, air pollution and acid rain by using fossil energy are still at issue. People have investigated several alternative energy resources such as wind, solar, geothermal, hydropower and biomass. Among the alternative energy, biorenewable energy is one of the fastest growing forms of energy in the world, and the ratio of biofuel keeps increasing (Energy Information Administration, 2011).

Biorenewable fuel, referred to as biofuel, is solid, liquid or gaseous fuels that are predominantly produced from biomass (Berkay and Nas, 2008; Chhetri and Islam, 2008; Demirbas, 2009; Konwer et al., 2007). In particular, liquid biofuels such as bioethanol, biodiesel, and biobutanol have the potential to replace petroleum with cheap and renewable materials; therefore, the interest in liquid biofuels has increased.

Bioethanol is one of the most used biofuels by now. Bioethanol is an important product of biotechnology because of the potential to replace some of the liquid fossil fuels in the transportation, to enhance the security of supply and to reduce greenhouse gas emissions (Gray et al., 2006). Ethanol can be blended with gasoline and used as a fuel without engine modification. It can also contribute to rural development and economic opportunities for developing countries (Demirbas, 2009; Steenblik, 2007). Current bioethanol is mostly produced from energy crops such as sugarcane and corn; however, these crops are also major food sources. For this reason, interest in fuel ethanol from lignocellulosic biomass continues to grow (Aristidou and Penttila, 2000; Jeffries and Jin, 2000; Wheals et al., 1999).

### *Lignocellulosic biomass*

Lignocellulosic biomass is biomass which is principally composed of cellulose, hemicellulose and lignin. The cell wall of lignocellulosic biomass is a composite material of crystalline cellulose fibrils bound by non-crystalline hemicellulose and surrounded by a matrix of hemicellulose and lignin (Ramos, 2003; Wyman, 1994). The composition of biomass is different depending on the species and environmental conditions (Cen et al., 2001). The compositions of biomass and interaction of these components in the cell wall

affect the hydrolysis of carbohydrates; therefore, understanding each component is important to efficiently utilize lignocellulosic biomass.

Cellulose, polymer of glucose, is the main component of lignocellulosic biomass and can be hydrolyzed to monomeric glucose for biofuels conversion. Cellulose is a linear polymer of glucose units linked with  $\beta$ -(1,4)-glycosidic bonds, and the degree of polymerization (DP) of this component is up to 15,000 (Bodîrlău et al., 2007). Intra- and inter-molecular hydrogen bonding in the cellulose structure forms the crystalline regions which hinder enzymes access during hydrolysis (Moore and Hatfield, 1991). Cellulose I which is the natural form of cellulose has parallel glucan chains and strong hydrogen bonds. Cellulose I $_{\alpha}$  and cellulose I $_{\beta}$  are predominant allomorphs of cellulose (Chundawat et al., 2011; Hayashi et al., 1997). The amount of cellulose I $_{\alpha}$  and I $_{\beta}$  varies depending on the species. These two native celluloses can be converted into cellulose II which is not reversible by mercerization or regeneration and into cellulose III by ammonia and other amines (Chundawat et al., 2011; Wada et al., 2004, 2006). Cellulose III and IV are formed by chemical treatment and heating (Sjöström, 1993).

Hemicellulose is the second largest polysaccharides in the lignocellulosic biomass. It supports cellulose microfibrils by hydrogen bonding and also binds to lignin by covalent bonds. Unlike cellulose which is homogeneous polysaccharide, hemicellulose is heterogeneous polysaccharides composed of polymer of pentoses (xylose and arabinose), hexoses (glucose, galactose and mannose) and sugar acids such as D-glucuronic acid, 4-O-methyl-D-glucuronic acid and D-galacturonic acid, and its DP is generally around 200 (Saha, 2003; Sjöström, 1993). The composition and structure of hemicellulose vary depending on the species. Moreover, considerable differences of hemicellulose composition exist between

the stem, branches, roots and barks (Sjöström, 1993). Xylan is the main component of hemicellulose in grasses and hardwood, while glucomannan is the dominant hemicellulose component in softwood (McMillan, 1993). Hemicellulose is amorphous and hydrophilic; therefore, it can be easily hydrolyzed by chemical treatments and enzymatic hydrolysis (Moore and Hatfield, 1994).

Lignins are polymers of phenylpropane units like guaiacyl, syringyl and p-hydroxyphenyl units. These precursors are derived from three aromatic alcohols (coniferyl, sinapyl and p-coumaryl alcohols) and form three dimensional phenolic polymers by cross-linkage. In general, softwood lignin is mainly composed of guaiacyl with small quantity of p-hydroxyphenyl units, and hardwood lignin consists of guaiacyl and syringyl units with a small amount of p-hydroxyphenyl units (Ramos, 2003; Whetten et al., 1998). Grass lignin is composed of all three types of units (p-hydroxyphenyl, guaiacyl and syringyl units) interconnected by aryl ether bonds ( $\beta$ -O-4 linkages) and/or resistant C-C bonds (Zhang et al., 2011). Lignin is hydrophobic and highly branched polymer by the oxidative polymerization (Higuchi, 1985). It fills the space between the cellulose, hemicellulose and pectin in the cell wall (Medie et al., 2012). Chemical bonds have been reported between lignin and carbohydrates (hemicellulose and cellulose). Lignin-carbohydrate complex (LCC) is the covalently bonded aggregates. The linkages are formed by ester, ether and glycosidic types of bonds (Sjöström, 1993). This structure gives physical strength or rigidity to plant tissue and prevents the collapse of the water-conducting elements (Ramos, 2003). It also protects plants from attack by microorganisms (Moore and Hatfield, 1994; Sarkanen and Ludwig, 1971).

Although the aforementioned three components are the main components of lignocellulosic biomass, a minor fraction of various components which are soluble in neutral organic solvents or water exists in the biomass. These components are called extractives. Extractives include chlorophyll, waxes, fats, resin acids, terpenoids, phenolic substances and gums (NREL, 2008a; Sjöström, 1993). In addition, biomass also includes structural or extractable inorganic materials which are called ash. Extractable ash can be removed by washing or extracting, while structural ash is bound in the physical structure of the biomass. In general, extractable ash is considered as soil remaining in biomass (NREL, 2008b).

### *Lignocellulosic Biorefinery*

Since lignocellulosic biomass conversion has been studied, many research and development efforts for the commercialization of biomass conversion technology have been made. The concept of biorefinery has been introduced as one of the utilization methods for the biomass. According to the definition of biorefinery by the American National Renewable Energy Laboratory (NREL), “a biorefinery is a facility that integrates biomass conversion processes and equipment to produce fuels, power and chemicals from biomass” (NREL, 2009). This concept is developed from the petroleum refinery which produces multiple products from petroleum (Kamm et al., 2006). As shown in Fig. 1, the objective of biorefinery is to produce multiple products from biomass feedstocks by a technology-mix (Kamm and Kamm, 2004; Van Dyne et al., 1999).

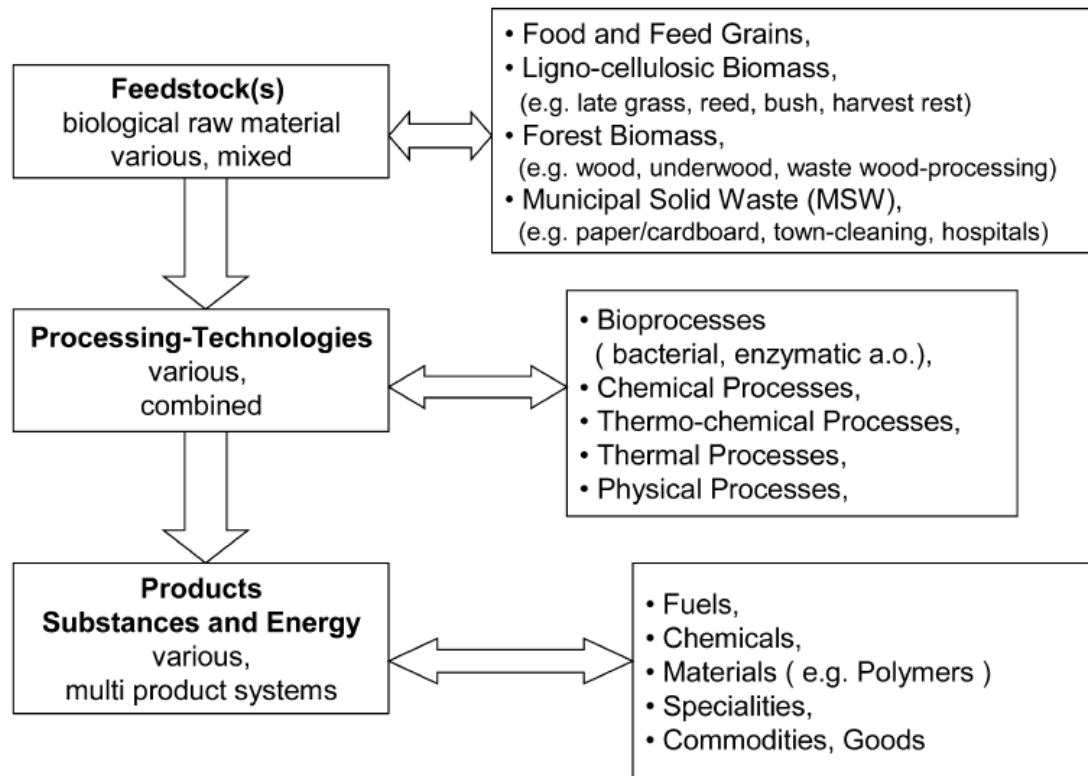
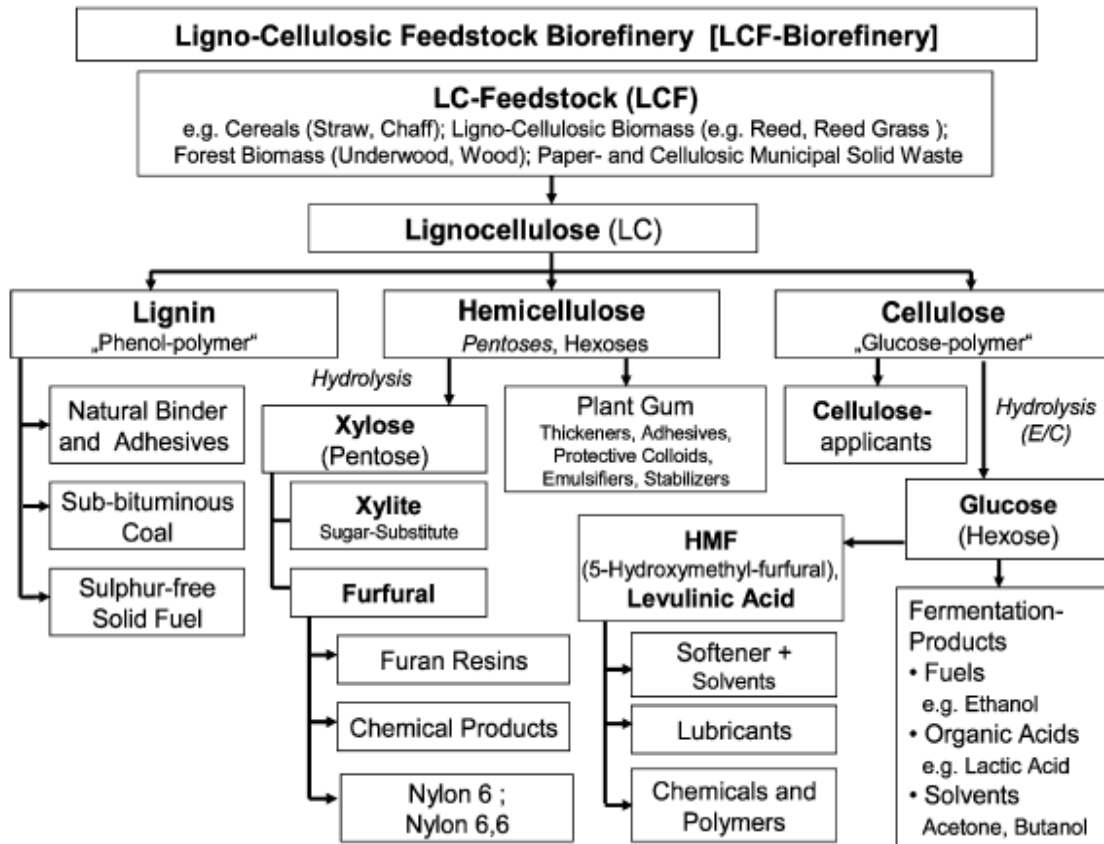

**Fig. 1.** Basic principles of a biorefinery (Kamm and Kamm, 2004)

Lignocellulosic feedstocks consist of three main chemical components: cellulose, hemicellulose and lignin. Fig. 2 shows an overview of lignocellulosic feedstock biorefinery. Cellulose is mainly hydrolyzed to glucose and converted into fermentation products such as ethanol, lactic acid, propanol, acetone, succinic acid, butandiol and butanol, while hemicellulose can be hydrolyzed to xylose and converted into xylite which is sugar-substitute (Vorlop et al., 2006; Zeikus et al., 1999). Interestingly, hydroxymethylfurfural (HMF) and furfural can be also produced from cellulose and hemicellulose through further conversion process. Furfural is a starting material for Nylon 6,6 and Nylon 6, and HMF is used for lubricants, softener and other chemicals. Although lignin can be utilized as fuel, adhesive and



binder, it is better suited to produce high value products because of its substantial amount of mono-aromatic hydrocarbons (Kamm et al., 2006).



**Fig. 2.** Lignocellulosic feedstock biorefinery (Kamm and Kamm, 2004; Van Dyne et al, 1999)

Glucose, the main component of cellulose, can be used as a substrate for bio-based products such as fuel, food and pharmaceutical components. Glucose is currently being produced from sugarcane and corn; however, these crops cannot meet the overall demand for both food and fuels. For this reason, interest in glucose produced from relatively cheap

substrate like lignocellulosic biomass has increased for the future biotechnology and food industry.

Hemicelluloses can also be converted into fuels, chemicals and food applications. Xylose which is the main component of hemicellulose has the potential to be converted into fuels (ethanol and hydrogen (Langvad, 2007)), chemicals (furfural (Binder et al., 2010), succinic acid (Nghiem et al., 2005)), food applications (xylitol (Sanchez et al., 1998), xylo-oligosaccharides) and others. Arabinose, another pentose sugar in hemicellulose, can also be used for the production of value-added chemicals such as furfural (Yoo et al., 2012) and astaxanthin (Montanti et al., 2010).

Lignin has been considered as a physical barrier to prevent enzyme access to cellulose structure. However, lignin is one of the most abundant components in the lignocellulosic biomass besides polysaccharides, so improving the utilization of lignin can enhance the overall lignocellulosic biorefinery. Current uses of lignin are concrete admixture, animal feed pellets, road binder, pesticide dispersant, oil well drilling mud, dye dispersant, vanillin production and solid fuel for combustions (Bozell et al., 2007). In addition, many studies have been investigated to convert the lignin into more valuable and usable products such as fuel additives.

#### *Biological conversion of lignocellulosic biomass*

A schematic of lignocellulosic biomass conversion process is shown in Fig. 3. The conversion process includes feedstock handling, pretreatment, hydrolysis, fermentation and purification. At the beginning, feedstock handling stage includes size reduction and washing. This lignocellulosic biomass is treated by chemical/mechanical/biological pretreatment to

open the bundles of lignocelluloses. The released cellulose and hemicellulose chains are hydrolyzed to monomeric sugars through chemical or biological methods. After the pretreatment stage, these hydrolyzed sugar solution can be converted into the products such as ethanol and lactic acid by fermentation. Recently, hydrolysis and fermentation stages can be integrated to save capital and operating costs and to reduce the product inhibition. After the conversion stages, fermented products are purified by distillation, dehydration or other separation process. Other residual components may be recovered as solid fuel or converted to value-added co-products (Wyman, 2008; Zheng et al., 2009).

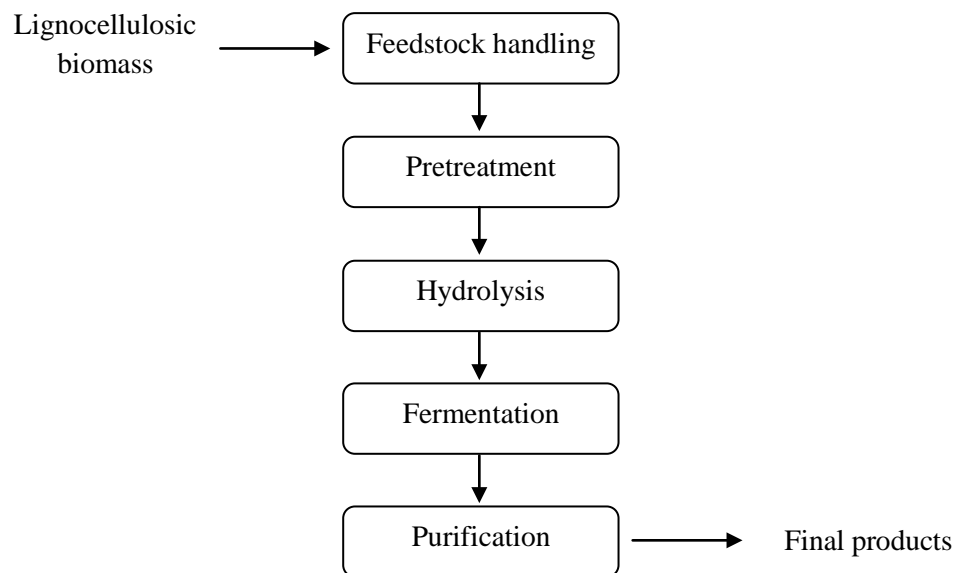

**Fig. 3.** Schematic of lignocellulosic biomass conversion process

### *Pretreatment*

Lignocellulosic biomass is attractive feedstock because of affordable price and high polysaccharide content; however, it is not easy to use lignocellulosic resources for ethanol and other chemicals production (Fujii et al., 2009). In particular, several factors including

lignin, hemicellulose, crystallinity of cellulose, lignin-carbohydrate complex, degree of polymerization, ash content, pore size and surface area are the native recalcitrance of lignocellulosic biomass to hinder biological conversion. The native form of lignocellulosic biomass can be partially digestible by enzymatic hydrolysis (Lee et al., 1999). For this reason, pretreatment is necessary to overcome the recalcitrance and convert biomass more efficiently. Various pretreatment methods have been developed to change the physical and chemical structures and break down the hemicellulose and lignin shield efficiently. However, pretreatment is still one of the most expensive stages within lignocellulosic biomass conversion process. Developing effective pretreatment methods and finding optimal operating conditions can contribute to overcoming the cost barriers of biomass utilization. Minimizing energy, chemical and water inputs, preserving cellulose and hemicellulose fractions, avoiding size reduction and limiting formation of inhibitors are key issues to develop cost-effective pretreatment methods (National Research Council, 1999; Zheng et al., 2009).

In general, pretreatment technologies enhance the enzymatic hydrolysis by removing lignin and hemicellulose, swelling pores in the biomass structure, increasing surface area, breaking and regenerating cellulose structure. These pretreatment methods including dilute acid pretreatment (Jacobsen and Wyman, 2000; Kim et al., 2001; Schell et al., 2003), hydrothermal pretreatment (Garrote et al., 2002; Petchpradab et al., 2009), ammonia pretreatment (Kim and Lee, 2007; Li and Kim, 2011; Murnen et al., 2007), lime pretreatment (Kim and Holtzapple, 2005), microwave pretreatment (Hu and Wen, 2008), ionic liquid pretreatment (Zhu, 2008), ultrasonic pretreatment (Montalbo-Lomboy et al., 2010) and

microbial pretreatment (Wan and Li, 2011) have been suggested, and each pretreatment has different impacts on compositional and structural features of biomass.

Acid pretreatments hydrolyze the hemicellulose fraction and the accessibility of cellulose is improved (Grohmann et al., 1985; Torget et al., 1990, 1992). In addition, it is a relatively inexpensive method. However, this process produces a large amount of by-products which can be inhibitors for biological conversion. Hydrothermal pretreatment releases acidic components such as acetic acid and formic acid in hemicellulose with high temperature water. The acetyl group works as a catalyst to break down hemicellulose (Fernandez-Bolanos et al., 1999). Ammonia pretreatments mainly break down the lignin structure with some of hemicellulose and change the crystalline structure of cellulose (Dale et al., 1996; Yoon et al., 1995; Kim and Lee, 1996; Kim et al., 2002). It is a strong swelling reagent and easy to recover because of its high volatility. Lime pretreatment removes lignin, acetyl group and uronic acid (Chang and Holtzapfle, 2000). Ionic liquid pretreatment also targets lignin removal by ionic liquid; however, ionic liquid recovery is still at issue (Shill et al., 2010). Microwave pretreatment and ultrasonic pretreatment contribute to improving the enzymatic hydrolysis with ammonia or acids. However, input energy for these pretreatments is relatively large. Biological pretreatment breaks lignin by fungi with low energy and no chemical inputs; however, this pretreatment is slow, and controlling the treatment conditions is difficult (Chandra et al., 2007; Zheng et al., 2009).

### *Fractionation process*

Another approach to overcoming the cost barrier of lignocellulosic biomass utilization is production of high value-added co-products (Zheng et al., 2009). Prior to

producing valuable co-products, separation of each component in lignocellulosic biomass is required. Fractionation of biomass has been proposed as the first step of biomass refining (Koukios and Valkanas, 1982). Each component in lignocellulosic biomass can be utilized by itself or converted into the intermediates of various products. Fractionation processes with various thermo-chemical treatments not only pretreat biomass for the conversion of main product but also separate other components for other value-added co-products. The combination of aforementioned pretreatment methods can separately hydrolyze target component in each stage for different following conversion process. Moreover, fractionation process can also contribute to reducing the cost in the downstream process, because a significant amount of energy, chemical and water are consumed in the downstream process. Therefore, higher purity and recovery yield of each component after upstream process are preferred to enhance the utilization of lignocellulosic biomass. Through the fractionation process, higher purity and recovery of each component and less downstream costs for these intermediates or products are expected. However, significant contamination of product streams was found from the previous studies (Kim and Lee, 2006; Martinez et al., 1995; Papatheofanous et al., 1995; Rubio et al., 1998; Torget et al., 1996; Torget et al., 2000). For the development of economically feasible fractionation process with lignocellulosic biomass, understanding the structure of biomass, selecting a proper treatment method for target components, designing the efficient process and operating under optimal conditions are necessary.

*Effects of ammonia on biomass structure*

Among various pretreatment and fractionation reagents, ammonia has been reported as one of the most promising biomass treatment reagents. It is highly selective in delignification and effective swelling reagent for lignocellulosic biomass (Kim et al., 2002; Wyman et al., 2005). It is also easy to recover because of high volatility and widely used commodity chemicals with relative cheap price (Kim and Lee, 2007; Wyman et al., 2005).

The high hydrogen bonding capacity of ammonia and its small molecular size effectively swell and soften biomass. Ammonia interacts with the cellulose hydroxyl group. It forms an intracrystalline swelling complex by replacing OH...O hydrogen bonds with OH...NH<sub>3</sub> bonds. In addition, hydrogen bonding between the biomass molecules is re-established by the high thermodynamic activity and high rate of diffusion of ammonia. It causes modification of the crystalline of cellulose structure (Owen and Pawlak, 1989). The hemicellulose is also degraded to oligomeric sugars and deacetylated, but only small amount of hemicellulose is solubilized (Gollapalli et al., 2002). Ammonia reacts primarily with lignin and causes depolymerization of lignin. The cleavages of the C-O-C bonds in lignin and the ether and ester bonds in the LCC are also observed by ammonia treatments (Kim et al., 2011).

**References**

- Aristidou A., Penttila M., 2000, Metabolic engineering applications to renewable resource utilization. *Current Opinion Chemical Biology*, 11, 187-198.
- Berkday A., Nas B., 2008, Biogas production and utilization potential of wastewater treatment sludge. *Energy sources Part A*, 30, 179-188.
- Binder J.B., Blank J.J., Cefali A.V., Raines R.T., 2010, Synthesis of furfural from xylose and xylan. *ChemSusChem*, 3, 1268-1272.

- Bodîrlău, R., Spiridon, I., Teacă, C.A., 2007, Chemical investigation of wood tree species in temperate forest in east-northern Romania. *BioResources*, 2(1), 41-57.
- Bozell J.J., Holladay J.E., Johnson D., White F., 2007, Top value added chemicals from biomass Volume II-Results of screening for potential candidates from biorefinery lignin, PNNL-16983.
- Cen Y.P., Turpin D.H., Layzell D.B., 2001, Whole-plant gas exchange and reductive biosynthesis in white Lupin. *Plant Physiology*, 126, 1555-1565.
- Chandra R.P., Bura R., Mabee W.E., Berlin A., Pan X., Saddler J.N., 2007, Substrate pretreatment: the key to effective enzymatic hydrolysis of lignocellulosics? *Advances in Biochemical Engineering/Biotechnology*, 108, 67-93.
- Chang V.S., Holtzaple M.T., 2000, Fundamental factors affecting biomass enzymatic reactivity. *Applied Biochemistry and Biotechnology*, 84, 5-37.
- Chhetri A.B., Islam M.R., 2008, Towards producing a truly green biodiesel. *Energy sources Part A*, 30, 754-764.
- Chundawat, S.P.S., Bellesia G., Uppugundla N., Sousa L., Gao D., Cheh A.M., Agarwal U.P., Bianchetti C.M., Phillips G.N., Langan P., Balan V., Gnanakaran S., Dale, B.E., 2011, Restructuring the crystalline cellulose hydrogen bond network enhances its depolymerization rate. *Journal of the American Chemistry Society*, 133, 11163-11174.
- Dale B.E., Leong C.K., Pham T.K., Esquivel V.M., Rios I., Latimer V.M., 1996, Hydrolysis of lignocellulosics at low enzyme levels: application of the AFEX process. *Bioresource Technology*, 56(1), 111-116.
- Demirbas A., 2009, Biofuels securing the planet's future energy needs. *Energy conversion and management*, 50, 2239-2249.
- Fernandez-Bolanos J., Felizon B., Heredia A., Jimenez A., 1999, Characterization of the lignin obtained by alkaline delignification and of the cellulose residue from steam-exploded olive stones. *Bioresource Technology*, 68, 121-132.
- Fujii T., Fang X., Inoue H., Murakami K., Sawayama S., 2009, Enzymatic hydrolyzing performance of *Acremonium cellulolyticus* and *Trichoderma reesei* against three lignocellulosic materials. *Biotechnology and Biofuels*, 2, 24.



- Garrote G., Dominguez H., Parajó J.C., 2002, Autohydrolysis of corncob: study of nonisothermal operation for xylooligosaccharide production. *Journal of Food Engineering*, 52, 211-218.
- Gollapalli L.E., Dale B.E., Rivers D.M., 2002, Predicting digestibility of ammonia fiber explosion (AFEX)-treated rice straw. *Applied Biochemistry and Biotechnology*, 98, 23-35.
- Gray K.A., Zhao L., Emptage M., 2006, Bioethanol. *Current Opinion Chemical Biology*, 10 (2), 141-146.
- Grohmann K., Torget R., Himmel M., 1985, Dilute acid pretreatment of biomass at high solids concentrations. *Biotechnology and Bioengineering Symposium*, 15, 59-80.
- Hayashi N., Sugiyama J., Okano T., Ishihara M., 1997, The enzymatic susceptibility of cellulose microfibrils of the algal-bacterial type and the cotton-ramie type. *Carbohydrate Research*, 305, 109-116.
- Higuchi, T., 1985. Biosynthesis of lignin. In: *Biosynthesis and Biodegradation of wood Components*. Higuchi T. Ed., Academic Press, New York, pp. 141-160.
- Hu Z., Wen Z., 2008, Enhancing enzymatic digestibility of switchgrass by microwave-assisted alkali pretreatment. *Biochemical Engineering Journal*, 369-378.
- Jacobsen S., Wyman C.E., 2000, Cellulose and hemicellulose hydrolysis models for application to current and novel pretreatment process. *Applied Biochemistry and Biotechnology*, 84-86, 81-96.
- Jeffries T.W., Jin Y.S., 2000, Ethanol and thermotolerance in the bioconversion of xylose by yeast. *Advances in Applied Microbiology*, 47, 221-268.
- Kamm B., Kamm M., 2004, Principles of biorefineries. *Applied Microbiology and Biotechnology*, 64, 137-145.
- Kamm B., Kamm M., Gruber P.R., Kromu S., 2006, Biorefinery systems – An overview, *Biorefineries-Industrial process and products*. Vol. 1, Kamm B., Gruber P.R., Kamm M., Eds., Wiley-VCH Verlag GmbH & Co. KGaA, Weinheim, pp.3-40.
- Kim J.S., Lee Y.Y., Torget R.W., 2001, Cellulose hydrolysis under extremely low sulfuric acid and high-temperature conditions. *Applied Biochemistry and Biotechnology*, 91-93, 331-340.

- Kim J.W., Kim K.S., Lee J.S., Park S.M., Cho H.Y., Park J.C., Kim J.S., 2011. Two-stage pretreatment of rice straw using aqueous ammonia and dilute acid. *Bioresour. Technol.* 102, 8992-8999.
- Kim S., Holtzaple M.T., 2005, Lime pretreatment and enzymatic hydrolysis of corn stover. *Bioresource Technology*, 96(18), 1994-2006.
- Kim S.B., Lee Y.Y., 1996, Fractionation of herbaceous biomass by ammonia-hydrogen peroxide percolation treatment. *Applied Biochemistry and Biotechnology*, 57/58, 147-156.
- Kim T.H., Kim J.S., Sunwoo C., Lee Y.Y., 2002, Delignification aspect of enzymatic hydrolysis in the ARP process. In: 24th Symposium on Biotechnology for Fuels and Chemicals.
- Kim T.H., Lee Y.Y., 2006. Fractionation of corn stover by hot-water and aqueous ammonia treatment. *Bioresource Technology*. 97(2), 224-232.
- Kim T.H., Lee Y.Y., 2007, Pretreatment of corn stover by soaking in aqueous ammonia at moderate temperature. *Applied biochemistry and biotechnology*, 136-140, 81-92.
- Konwer D., Kataki R., Saikia P., 2007, Pyrolysis of some indigenous tree species of northeast India: effect of pyrolysis temperature and heating rate on the products yield and char quality. *Energy sources Part A*, 29, 1433-1442.
- Koukios E. G., Valkanas, G. N., 1982, Process for chemical separation of the three main components of lignocellulosic biomass. *Industrial & Engineering Chemistry Product Research and Development*, 21, 309-314.
- Langvad N., 2007, BioGasol-biofuels for the future. California-Denmark Workshop on Clean Technology, San Francisco, California.
- Lee Y.Y., Lyer P., Torget R.W., 1999, Dilute acid hydrolysis of lignocellulosic biomass. *Advances in Biochemical Engineering /Biotechnology*, 65, 93-115.
- Li X., Kim T.H., 2011, Low-liquid pretreatment of corn stover with aqueous ammonia. *Bioresource Technology*. 102(7), 4779-4786.
- Martinez J.M., Granado J.M., Montance D., Salvado J., Farriol X., 1995, Fractionation of residual lignocellulosics by dilute-acid prehydrolysis and alkaline extraction: application to almond shells. *Bioresource Technology*, 52(1), 59-67.

- McMillan J.D., 1993, Pretreatment of lignocellulosic biomass. In: Enzymatic conversion of biomass for fuel production. Himmel M.E., Baker J.O., Overend R.P., Eds., American Chemical Society, Washington, D.C., pp 292-323.
- Medie F.M., Davies G.J., Drancourt M., Henrissat B., 2012, Genome analyses highlight the different biological roles of cellulases. *Nature reviews Microbiology*, 10, 227-234.
- Montalbo-Lomboy M., Khanal S.K., van Leeuwen J., Raman D.R., Dunn Jr. L., Grewell D., 2010, Ultrasonic pretreatment of corn slurry for saccharification: A comparison of batch and continuous systems. *Ultrasonics Sonochemistry*, 17(5), 939-946.
- Montanti J., Nghiem N.P., Johnston D.B., 2011, Production of Astaxanthin from Cellulosic Biomass Sugars by Mutants of the Yeast *Phaffia rhodozyma*. *Applied Biochemistry and Biotechnology*, 164, 655-665.
- Moore K.J., Hatfield R.D., 1994, Carbohydrates and forage quality. In: Forage quality, evaluation, and utilization. Fahey G.C., Collins M.C., Mertens D.R., Moser L.E., Eds., ASA-CSSA-SSSA, Madison, Wisconsin, pp. 229-280.
- Murnen H.K., Balan V., Chundawat S.H.S., Bals B., Sousa L.D.C., Dale B.E., 2007, Optimization of ammonia fiber expansion (AFEX) pretreatment and enzymatic hydrolysis of *Miscanthus x giganteus* to fermentable sugars, *Biotechnology Process*, 23(4), 846-850.
- National Renewable Energy Laboratory (NREL), 2009, <http://www.nrel.gov/biomass/biorefinery.html>
- National Research Council, Committee on Biobased Industrial Products, 1999, *Biobased Industrial Products-Priorities for Research and Commercialization*. National Academy Press.
- Nghiem N.P., Donnelly M., Sanville-Millard C.Y., 2005, A method to produce succinic acid from raw hydrolysates. WO 2005/116227.
- Owen N.L., Pawlak Z., 1989, An infrared study of the effect of liquid ammonia on wood surfaces. *Journal of molecular structure*, 198, 435-449.
- Papatheofanous M.G., Billa E., Koullas D.P., Monties B., Koukios E.G., 1995, Two-stage acid-catalyzed fractionation of lignocellulosic biomass in aqueous ethanol systems at low temperatures. *Bioresource Technology*, 54, 305-310.

- Petchpradab P., Yoshida T., Charinpanitkul T., Matsumura Y., 2009, Hydrothermal pretreatment of rubber wood for the saccharification process. *Industrial & Engineering Chemistry Research*, 48(9), 4587–4591.
- Ramos L.P., 2003, The chemistry involved in the steam treatment of lignocellulosic materials. *Química Nova*, 26, 863-871.
- Rubio M., Tortosa J.F., Quesada J., Gomez D., 1998, Fractionation of lignocellulosics solubilization of corn stalk hemicelluloses by autohydrolysis in aqueous medium. *Biomass and Bioenergy*, 15(6), 483-491.
- Saha B.C., 2003, Bioconversion of hemicellulose. *Journal of Industrial Microbiology and Biotechnology*, 30(5):279-291.
- Sanchez S., Bravo V., Castro E.A., Moya J., Camacho F., 1998, The production of xylitol from D-xylose by fermentation with *Hansenula polymorpha*, *Applied Microbiology and Biotechnology*, 50, 608-611.
- Sarkanen, K.V., Ludwig, C.H., 1971, *Lignins: Occurrence, Formation, Structure, and Reactions*. John Wiley & Sons Inc., New York.
- Schell D.J., Farmer J., Newman M., Mcmillan J.D., 2003, Dilute-sulfuric acid pretreatment of corn stover in pilot-scale reactor. *Applied biochemistry and biotechnology*, 105, 69-85.
- Shill K., Padmanabhan S., Xin Q., Prausnitz J.M., Clark D.S., Blanch H.W., 2010, Ionic liquid pretreatment of cellulosic biomass: enzymatic hydrolysis and ionic liquid recycle. *Biotechnology and Bioengineering*, 108(3), 511-520.
- Sjöström, E., 1993. *Wood Chemistry: Fundamentals and Applications*, second ed. Academic Press, Orlando.
- Sluiter A., Hames B., Ruiz R., Scarlata C., Sluiter J., Templeton D., 2008, Determination of Ash in biomass, NREL/TP-510-42622.
- Sluiter A., Ruiz R., Scarlata C., Sluiter J., Templeton D., 2008, Determination of Extractives in Biomass, NREL/TP-510-42619.
- Soetaert W., Vandamme E.J., 2009, *Biofuels*. John Wiley & Sons, Ltd, p.1.
- Steenblik R., 2007, *Biofuels – At what cost? The Global Subsidies Initiative of the International Institute for Sustainable Development*, Geneva, Switzerland.

- Torget R., Himmel M., Grohmann K., 1992, Dilute-acid pretreatment of two short-rotation herbaceous crops. *Applied Biochemistry and Biotechnology*, 34/35, 115-123.
- Torget R., Werdene P., Himmel M., Grohmann K., 1990, Dilute acid pretreatment of short rotation woody and herbaceous crops. *Applied Biochemistry and Biotechnology*, 24/25, 115-126.
- Torget R.W., Kim J.S., Lee Y.Y., 2000, Fundamental aspects of dilute acid hydrolysis/fractionation kinetics of hardwood carbohydrates. 1. Cellulose hydrolysis. *Industrial & Engineering Chemistry Research*, 39(8), 2817-2825.
- Torget R.W., Padukone N., Hatzis C., Wyman C.E., 1996, US Patent 6022419 – Hydrolysis and fractionation of lignocellulosic biomass. No 723399 filed on 09/30/1996.
- U.S. Energy Information Administration, 2011, International Energy Outlook 2011. DOE/EIA-0484.
- Van Dyne D.L., Blasé M.G., Clements L.D., 1999, A strategy for returning agriculture and rural America to long-term full employment using biomass refineries. In: *Perspectives on new crops and new uses*. Janeck J Ed., ASHS Press, Alexandria, Va., pp 114-123.
- Vorlop K.D., Wilke, Th., Prüße, U., 2006, Biocatalytic and catalytic routes for the production of bulk and fine chemicals from renewable resources, *Biorefineries-Industrial process and products*. Vol. 1, Kamm B., Gruber P.R., Kamm M., Eds., Wiley-VCH Verlag GmbH & Co. KGaA, Weinheim, pp.385-405.
- Wada, M., Chanzy, H., Nishiyama, Y., Langan P., 2004, Cellulose III<sub>I</sub> crystal structure and hydrogen bonding by synchrotron X-ray and neutron fiber diffraction. *Macromolecules*, 37, 8548-8555.
- Wada, M., Nishiyama, Y., Langan P., 2006, X-ray structure of ammonia-cellulose I: New insights into the conversion of cellulose I to cellulose III. *Macromolecules*, 39, 2947-2952.
- Wan C., Li Y., 2011, Effectiveness of microbial pretreatment by *Ceriporiopsis subvermispora* on different biomass feedstocks. *Bioresource Technology*, 102, 7507-7512.
- Wheals A.E., Basso L.C., Alves D.M.G., Amorim H.V., 1999, Fuel ethanol after 25 years. *Trends in Biotechnology*, 17, 482-486.

- Whetten R.W., MacKey J.J., Sederoff R.R., 1998, Recent advances in understanding lignin biosynthesis. *Annual Review of Plant Physiology*, 49, 585-609.
- Wyman C.E., 1994, Alternative Fuels from biomass and their impact on carbon dioxide accumulation. *Applied Biochemistry and Biotechnology*, 45/46, 897-915.
- Wyman C.E., Dale B.E., Elander R.T., Holtzapple M., Ladisch M.R., Lee Y.Y., 2005, Coordinated development of leading biomass pretreatment technologies. *Bioresource Technology*, 96, 1959-1966.
- Wyman C.E., 2008, Cellulosic ethanol: A unique sustainable liquid transportation fuel. *MRS Bulletin*, 33, 381-383.
- Yoon H.H., Wu Z.W., Lee Y.Y., 1995, Ammonia-recycled percolation process for pretreatment of biomass feedstock. *Applied Biochemistry and Biotechnology*, 51/52, 5-19.
- Zeikus J.G., Jain M.K., Elankovan P., 1999, Biotechnology of succinic acid production and markets for derived industrial products. *Applied Microbiology and Biotechnology*, 51, 545-55251.
- Zhang Y., Culhaoglu T., Pollet B., Melin C., Denoue D., Barriere Y., Baumberger S., Mechin V., 2011, Impact of lignin structure and cell wall reticulation on maize cell wall degradability, *Journal of Agricultural and Food Chemistry*, 59, 10129-10135.
- Zheng Y., Pan Z., Zhang R., 2009, Overview of biomass pretreatment for cellulosic ethanol production. *Int. Journal of Molecular Sciences*, 2(3), 51-68.
- Zhu S., 2008, Perspective use of ionic liquids for the efficient utilization of lignocellulosic materials. *Journal of chemical technology and biotechnology*, 83, 777-779.

## CHAPTER 2. TWO-STAGE FRACTIONATION OF CORN STOVER USING AQUEOUS AMMONIA AND HOT WATER

A paper published in the *Journal of Applied Biochemistry and Biotechnology*

Chang Geun Yoo, Chi-Woo Lee, Tae Hyun Kim

### **Abstract**

Hot-water and aqueous ammonia fractionation of corn stover was used to separate hemicellulose and lignin and improve enzymatic digestibility of cellulose. A two-stage approach was used: The first stage was designed to recover soluble lignin using aqueous ammonia at low temperature while the second stage was designed to recover xylan using hot-water at high temperature. Specifically, the first stage employed a batch reaction using 15 wt% ammonia at 60°C, in a 1:10 solid:liquid ratio for 8 hours, while the second stage employed a percolation reaction using hot-water, 190-210°C, at a 20 ml/min flow rate for 10 min. After fractionation, the remaining solids were nearly pure cellulose.

The two-stage fractionation process achieved 68% lignin purity with 47% lignin recovery in the first stage, and 78% xylan purity, with 65% xylan recovery in the second stage. Two-stage treatment enhanced the enzymatic hydrolysis of remaining cellulose to 96% with 15 FPU/g of glucan using commercial cellulase enzymes. Enzyme hydrolyses were nearly completed within 12-24 hours with the remaining solids fraction.

**Index Entries:** SAA (soaking in aqueous ammonia); Biorefinery; Lignocellulosic biomass; Lignin; Xylan

## **Introduction**

Corn stover, lignocellulosic biomass, is considered one of the most promising feedstocks for the production of bio- fuels and chemicals, since it is the biomass by-product of the single largest quantity in the USA [1]. Corn stover is a heterogeneous material consisting mainly of cellulose, hemicelluloses, and lignin which can be converted to compounds that either have direct applications or can serve as precursors for important industrial chemicals currently produced from oil refinery. Fractionation of lignocellulosic biomass into cellulose, hemicelluloses and lignin components has been proposed as the first step of biomass refining to high value-added products [2].

Glucose, which is the main component of cellulose (C6 stream), can be used as a feedstock for bio-based industry such as cellulosic ethanol, food and pharmaceutical companies. Glucose is currently being produced from sugar cane and corn for ~ 16 cents/kg (April, 2010), [3] but these feedstocks cannot meet the high demand for sugars in the future. C6 (mainly glucose) sugar produced from relatively cheap substrates like lignocellulosic biomass, has potential to be a valuable feedstock in the future biotechnology and food industry. Xylose, which is the main component of hemicellulose (mainly C5 sugars) stream, can also be converted to other products besides ethanol. These products include fuels such as hydrogen [4], and chemicals such as succinic acid [5], xylitol [6], xylo-oligosaccharides [7], and others. Xylo-oligosaccharides (XO) are of particular interest since they have high values and can potentially be used in a wide range of applications, including food additives, nutraceuticals, and pharmaceuticals [7-12]. Lignin, a complex compound that is comprised of aromatic rings that are linked by C-O-C and C-C, can be broken into smaller segments using existing facilities in oil refinery plants while maintaining the aromatic ring structures.



In order to realize the effective utilization of lignocellulosic material and to develop an economically viable biorefinery process, separation of each component with high purity is essential. Production of high value products from each component will have strong impacts on the future economics of the biofuel and biobased industry. This study is important since it demonstrates one possible upstream biorefinery concept utilizing biorenewable materials effectively.

Two-stage fractionation process using aqueous ammonia and hot-water was developed in this study. This fractionation process consists of low-molecular weight of lignin separation using aqueous ammonia at low temperature, and hemicelluloses separation with hot-water (Fig. 1). Kim and Lee have reported aqueous ammonia pretreatment at low temperature (60-80°C) retained most of carbohydrates (cellulose + hemicellulose) with solids, while it removed lignin significantly [13-15]. It was also reported that autohydrolysis using hot-water treatment (190-210°C) was effective for hemicellulose hydrolysis [14, 16-18].

Here the effects of various reaction conditions such as reaction time, flow rate and reaction temperature in each stage, are discussed to determine the proper range of the process conditions. Composition analysis and enzymatic digestibility tests after fractionation process were conducted to evaluate the efficacy of fractionation conditions.

## **Materials and Methods**

### *Materials*

Air-dried ground corn stover was supplied by the National Renewable Energy Laboratory (NREL, Golden, CO). The corn stover was screened to a nominal size of 9-35 mesh. The composition of corn stover was determined by our lab following the chemical

analysis and testing standard method developed by NREL [19]. The initial composition of the corn stover was 34.2 wt% glucan, 22.3 wt% xylan, 1.6 wt% galactan, 3.1 wt% arabinan, 12.2 wt% lignin (acid insoluble + acid soluble), 3.9 wt% acetate, 2.2 wt% sucrose, 1.6 wt% protein, 4.0 wt% uronic acid, 1.2 wt% ash, and 10.7wt% other extractives.

Cellulase enzyme, GC 220 (Genencor International Inc., Lot No #301-04232-162) was provided by Genencor International Inc. The average activity of the enzyme was 45 filter paper unit (FPU)/ml and the protein was 184 mg/ml. The  $\beta$ -glucosidase enzyme, Novozyme 188 (Novo Inc., lot no. 11K1088), was purchased from Sigma-Aldrich (St. Louis, MO). Activity of  $\beta$ -glucosidase (Novozyme 188 from Novo Inc., Lot No. 11K1088) was 750 cellobiase unit (CBU)/ml.

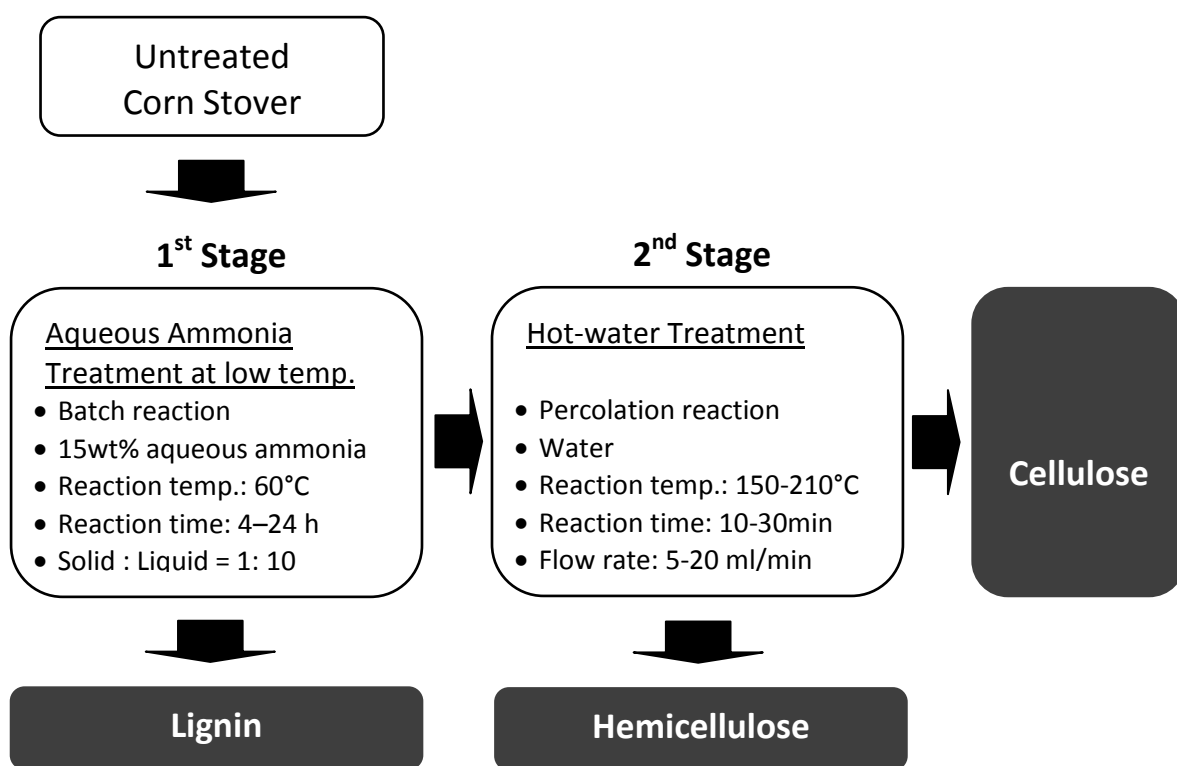

**Fig. 1.** Flow diagram of multi-stage fractionation process.

### *Experimental Setup and Operation*

Reaction conditions explored and process scheme are summarized in Fig. 1.

#### *First stage (aqueous ammonia treatment at low temperature)*

Corn stover was treated with 15 wt% of aqueous ammonia in glass media bottles (Fisher Cat No. 06-141-1C) at 60°C for 4-24 hours. Solid:liquid ratio was kept at 1:10. After completion of treatment, the solids and liquids were separated by fluted filter paper (Fisher Cat No. 09-790-14F) and solids were washed with de-ionized (DI) water using vacuum filter until the wash water had a neutral pH. Solid cakes were dried in the air in our lab until the moisture content of samples reached approximately 10% (drying conditions: ambient temperature and 48-72 hours of drying time) and stored in the refrigerator for the second-stage hot-water treatment.

#### *Second stage (hot-water treatment)*

The reactor system for the second stage treatment consists of flow-through column reactor with preheating coil, high performance liquid chromatography (HPLC) pump (Series II pump, Chrom Tech, Inc., MN), temperature-programmable gas chromatography (GC) oven (Hewlett Packard 5890, HP Inc., Ontario, Canada), solution reservoir and sample cylinder tanks #1 and #2. A schematic diagram of the laboratory reactor set-up is shown in Fig. 2. The reactor (70 cm<sup>3</sup> of internal volume) was constructed out of 6.5 inches of SS-316 tubing with an internal diameter of 0.9 inches. Two 1000 ml SS 304 cylinder were used as receiver tanks for collecting the liquid products.

Corn stover was treated using aqueous ammonia in the first stage and dried in the air as described above. Ten dry-gram of ammonia-treated sample was packed into the flow-

through type reactor. The packed bed reactor with preheating coil was placed in a temperature programmable GC oven for temperature control. The packed bed reactor with preheating coil was preheated to a desired temperature, at which point the water was pumped into the reactor through a preheating coil by a HPLC pump. After the GC oven was brought up to temperature, the HPLC pump supplied water to fill the preheating coil (not the reactor). The pump was then turned off, while the reactor set and the water in the coil preheated until it reached the target temperature (~15 min). The pump was then turned on again, while 300 psi of N<sub>2</sub> backpressure was applied to the reactor system to maintain the system pressure above the saturated pressure of water. Preheating time was not included in the reaction time. The second stage fractionations were tested under following reaction conditions: 170-210°C of reaction temperature and 5.0-15.0 ml/min of flow rate.

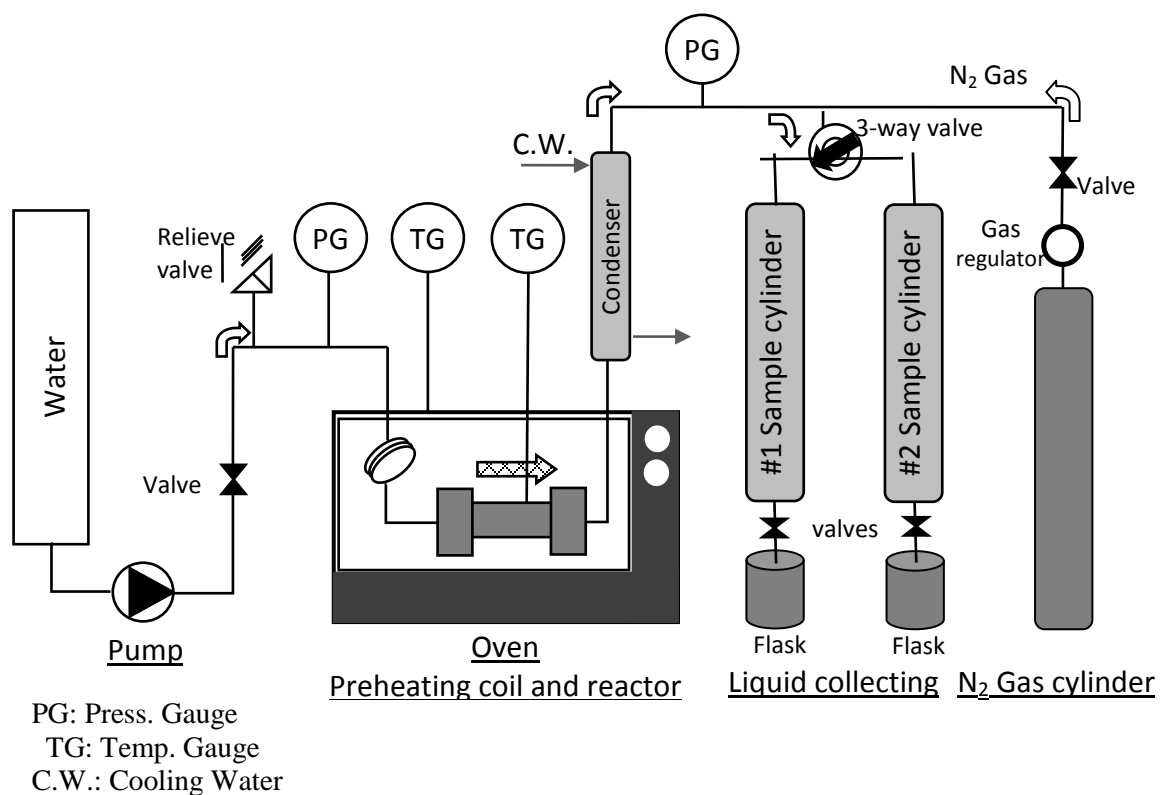

**Fig. 2.** Laboratory reactor set-up.

### *Enzymatic Digestibility Test*

The enzymatic digestibilities of solid samples obtained from two-stage fractionation were determined in duplicate according to the NREL Chemical Analysis and Testing Standard Procedure [20]. Treatment conditions used for sample preparations were as follows: two-stage treatment: 24 hours, 60°C, 15 wt% aqueous ammonia, 1:10 of solid:liquid in the first stage treatment and two different temperatures covering 170 and 210°C with the flow rates of 10 and 20 ml/min of hot-water in the second stage. The conditions of the enzymatic digestibility test were pH 4.8 (0.05 M sodium citrate buffer) on a shaker bath agitated at 150 rpm at 50°C. Enzyme loadings were 15 FPU of GC-220/g of glucan supplemented with 30 CBU of  $\beta$ -glucosidase (Novozyme 188)/g-glucan. The initial glucan concentration was 1% (w/v) based on 100 ml of total liquid and solid [20]. All the samples used in the digestibility tests were wet solid samples as collected from various pretreatments. The 250 ml screw-capped Erlenmeyer flasks containing the enzyme hydrolysis preparations were placed in an incubator shaker (New Brunswick Scientific, Edison, NJ). Samples were taken periodically (6, 12, 24, 48, 72 and 96 h) and analyzed for sugar contents using HPLC.

### *Solid and Liquid Sample Analyses*

Solid samples were analyzed for carbohydrates (sugars) and lignin following the two-stage acid-hydrolysis procedures given in NREL Chemical Analysis and Testing (CAT) Standard Procedures [19]. Each sample was analyzed in duplicate. The conditions of the first hydrolysis were 72 wt% sulfuric acid, 1:10 of solid-to-liquid ratio, and 30°C for one hour. The conditions for the secondary hydrolysis were 4 wt% sulfuric acid and 121°C for one hour. Sugars in the hydrolyzates were determined by HPLC using a Bio-Rad Aminex HPX-87P

column coupled with a refractive index detector (Varian 356-LC, Varian, Inc., Palo Alto, CA, USA). For the acid insoluble lignin analysis, the autoclaved hydrolysis solution was vacuum filtered, and the filtered hydrolyzed solid sample was dried and weighed. The dried samples were then combusted in a furnace at  $575 \pm 25^\circ\text{C}$  for 3 h to determine the ash content. The difference of the two weights was taken as the acid insoluble lignin. The absorbance of the hydrolysis liquor in the aliquot obtained from the vacuum filter sample at 320 nm on a UV–Visible spectrophotometer measured the acid soluble lignin.

Carbohydrates in the liquid samples were determined by secondary acid hydrolysis (conditions: 4%  $\text{H}_2\text{SO}_4$ ,  $121^\circ\text{C}$ , 1 h) following the NREL Standard Analytical Procedure [21].

*Recovery yield, Purity and Fractionation Factor (k)*

In order to quantitatively evaluate the fractionation effects of various reaction conditions on each component (glucan, xylan and lignin), recovery ratio (or yield) and purity of each component were defined as follow:

Xylan ( $R_X$ ) or lignin recovery ( $R_L$ ) [%]

$$= \frac{\text{Xylan or Lignin [wt. \%] in liquid}}{\text{Xylan or Lignin [wt. \%] in untreated corn stover}} \times 100$$

Xylan (Xylooligomer)( $P_X$ ) or Lignin purity (in liquid) ( $P_L$ ) [%]

$$= \frac{\text{Xylan or Lignin [wt. \%] in liquid}}{(\text{Glucan} + \text{Xylan} + \text{Lignin})[\text{wt. \%}] \text{ in liquid (hydrolysate)}} \times 100$$

In the liquid hydrolysates, other sugar components such as galactan and arabinan

were also released with water or ammonia, but the amounts of these sugars were relatively small compared to glucan, xylan and lignin components. Therefore, these other sugars were not considered in the calculation of xylan and lignin purities to simplify this study.

In order to combine above terms, we also introduced a new term, fractionation factor  $k$ , which combined purity and recovery in one variable and was defined as follow.

$$k_x = \left[ \frac{(R_x \times \eta_1) + (P_x \times \eta_2)}{\eta_1 + \eta_2} \right] / 100$$

$$k_L = \left[ \frac{(R_L \times \eta_1) + (P_L \times \eta_2)}{\eta_1 + \eta_2} \right] / 100$$

Where,  $\eta_1$  and  $\eta_2$  are weighting factor of purity and recovery, respectively.

Comparison of recovery yields and purities obtained from various fractionation conditions were simplified with the used of fractionation factor  $k_x$  and  $k_L$ .

In general, trade-off between purity and recovery yield were observed in our study. Although both purities and recovery yields are considered to be important, further study is needed to determine the range of each weighting factor (e.g. techno-economic analysis). It was unclear how each factor affects the overall fractionation economics. In this study these weighting factors were assumed to be equally important ( $\eta_1 = \eta_2 = 1$ ). The compositions of solid and liquid samples were analyzed to calculate the purity, recovery and  $k$  factor.

## Results and Discussion

### *Effects of the First stage Reaction Time*

The compositional changes in solids after first-stage fractionation are summarized in Table 1. In the series of experiments, four different reaction times (4, 8, 12 and 24 hours) were attempted at 60°C to find the lignin recovery keeping solid to liquid ratio at 1:10 and ammonia concentration of 15 wt%. Solubilization of xylan was only 6%-15% within 4-24 hours of reaction time. Nearly 100% of glucan was retained at all reaction times. Approximately 25% of the lignin was recovered within 4 hours of treatment and the lignin recovery ( $R_L$ ) (47%-62%) increased as reaction time (8-24 hours) increased but effect of reaction time had no significant effect on recovered lignin purity ( $P_L$ ) (67%-70). When  $\eta_1=\eta_2=1$  was assumed,  $k_L$  increased as reaction time increased and 24 hours treatment resulted in the highest  $k_L$  (=0.65). These first-stage fractionation results, support the previous reports [15] that the first stage treatment using aqueous ammonia remove lignins, while hemicellulose, mainly xylan, hydrolysis was not substantial. Data in Table 1 also indicated that 24 hours of reaction time in the first stage can be selected as the best reaction times in terms of lignin recovery ( $R_L$ ).

Although 24 hours of reaction time in the first stage was the optimum reaction condition for the lignin fractionation, overall performance of the fractionation process must be determined by considering other factors such as xylan recovery ( $R_X$ ) and purity ( $P_X$ ) in the second stage and cellulose recovery, yield, and digestibility after fractionation. To test effects of first stage reaction times on xylan fractionation in the second stage, the hot-water treatment was then conducted keeping reaction conditions at 210°C, 20.0 ml/min, and 10 min.  $R_X$  and  $P_X$  data are summarized in Fig. 3.  $P_X$  increased (63→79%) as the reaction time of the



first stage, while the  $R_X$  decreased (67→51%) and 8-h treatment in the first stage resulted in the highest  $k_X$  value (0.72) in the second stage. This result indicated that 8 hours of reaction time in the first stage was the best reaction time in terms of the xylan recovery ( $R_X$ ) in the second stage.

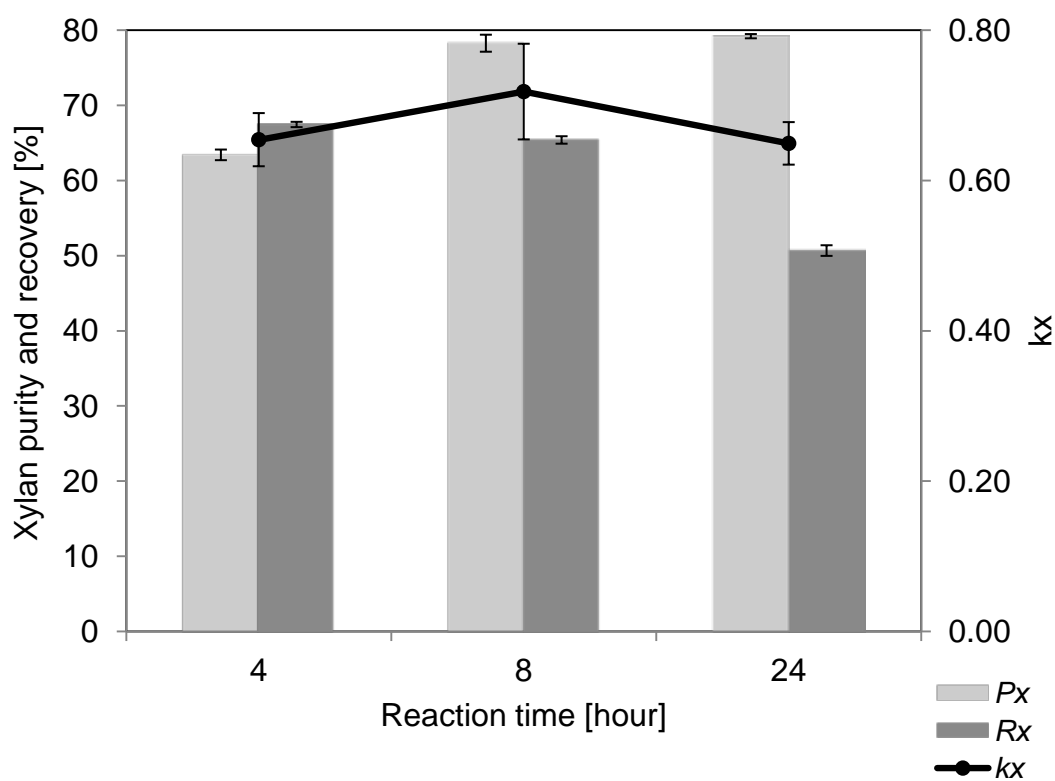

**Fig. 3.** Effects of first stage reaction time on xylan fractionation in the second stage. Note. treatment conditions: 15 wt% of ammonia, 60°C, solid:liquid=1:10, 4–24 h; hot-water, 20.0 ml/min, 210°C, 10 min; the data points and bars in the graph show the mean value (n=2); data are based on the oven-dried untreated corn stover.

**Table 1**Effects of reaction times on the compositions in the first stage <sup>a</sup>

Reaction Time	Solid				Yield in liquid		
	SR <sup>b</sup>	Glucan	Xylan	Lignin <sup>c</sup>	Lignin purity	Lignin recovery	$k_L$
[h]	[%]	[%]	[%]	[%]	[%]	[%]	[-]
Untreated	100.0	34.2	22.3	12.2	-	-	-
4	71.7	34.1	20.9	9.1	67.4	25.4	0.46
8	69.6	34.0	19.8	6.5	67.9	46.7	0.57
12	68.0	34.4	19.5	6.1	70.1	50.0	0.60
24	65.2	34.0	19.0	4.7	68.2	61.5	0.65

The data in the table show the mean value (n=2, SD < 0.3 for glucan, xylan, and lignin in solid, SD < 1.8 for Lignin purity, SD < 2.3 for Lignin recovery, SD < 0.1 for  $k_L$ , SD: standard deviation).

<sup>a</sup> Data in the table are based on the oven-dried untreated corn stover. Fractionation conditions: 15 wt% of ammonia concentration, 60°C of reaction temperature, solid : liquid ratio=1:10 (based on wt).

<sup>b</sup> SR stands for solid remaining after reaction.

<sup>c</sup> Acid insoluble lignin + Acid soluble lignin.

#### *Effects of Flow Rate in the Second stage on Xylan Fractionation*

The two-stage fractionation experiments of corn stover were conducted; the reaction conditions of the first stage treatment were 4 and 8 hours, 60°C, 15 wt% aqueous ammonia, 1:10 of solid:liquid. To evaluate the effects of various flow rates in the second stage, three to four different flow rates – (1) 1<sup>st</sup> series of run: 7.5, 10, 15 and 20 ml/min for the 4 h-treated corn stover in the 1<sup>st</sup> stage, and (2) 2<sup>nd</sup> series of run: 10, 15 and 20 ml/min for the 8 h-treated corn stover in the 1<sup>st</sup> stage - were applied at 210°C, maintaining reaction time at 10 min.

The  $P_X$ ,  $R_X$  and  $k_X$  values in the first series of run are presented in Fig. 4-a. Low  $R_X$  (51%) at 7.5 ml/min was observed with significant amounts of released xylose

decomposition. As the flow rate increase from 7.5 ml/min to 15 ml/min,  $R_X$  increased and reached maximum (72 %) with 15 ml/min of flow rate, while  $P_X$  (70%-71%) was not changed much with different flow rate. However, purity, recovery and  $k_X$  of xylan decreased when the flow rate was 20 ml/min. Therefore, 15 ml/min was preferred so as to obtain high  $R_X$  and  $k_X$  in this study. We assumed that low flow rate (<15 ml/min) resulted in longer residence time for xylan decompositions (43%) in the flow-through reactor. It was also speculated that the excessively higher flow rate reduced the residence time of hot-water in the percolation reactor, and thus xylan was not sufficiently hydrolyzed (67 %) from corn stover than 15 ml/min case (72 %). It was also able to explain as following results: At 7.5 ml/min, 80% of xylan was hydrolyzed from solid while 74% was hydrolyzed by hot-water at 20 ml/min.

The  $P_X$ ,  $R_X$  and  $k_X$  values in the second series of run are presented in Fig. 4-b. In this experiment,  $P_X$  and  $R_X$  increased (78% and 65% respectively) as the flow rate increased over all attempted flow rate range from 10 to 20 ml/min, which was different from those observed in the earlier experiments. Increased  $R_X$  with 20 ml/min may correlate with the reaction severity in the first-stage treatment; 8-hour treatment may result in more open structure than 4-hour treatment, and then the residence time with 20 ml/min was still sufficient enough to hydrolyze the xylan in the corn stover structure.

In the earlier series of run using 4-h-first-stage treated sample, the degradation of xylan at low flow rate was observed. To compare the decompositions of xylan at different flow rate more clearly, another set of experiments were conducted keeping the amount of hot-water throughput constant at 150 ml (Fig. 4-c). Two different flow rates were tested and conditions were: 5 ml/min for 30 min and 15 ml/min for 10 min. Fig. 4-c shows the effects of

flow rate of hot-water on the amounts of decomposed xylan during the hot-water fractionation stage using same amount of liquid throughput. At these conditions, the residence time with 5 ml/min using flow-through column reactor was longer than the time with 15 ml/min. Therefore, released sugar with 5 ml/min more easily underwent decomposition than with 15 ml/min at the same reaction temperature. At 5 ml/min, 52% of xylan (based on total xylan in untreated corn stover) was degraded to furfural, formic acid and other decomposed products, while only 15% of xylan was decomposed in 15 ml/min case. Therefore,  $R_x$  with 15 ml/min was 59%, which was higher than 35% with 5 ml/min-30 min.

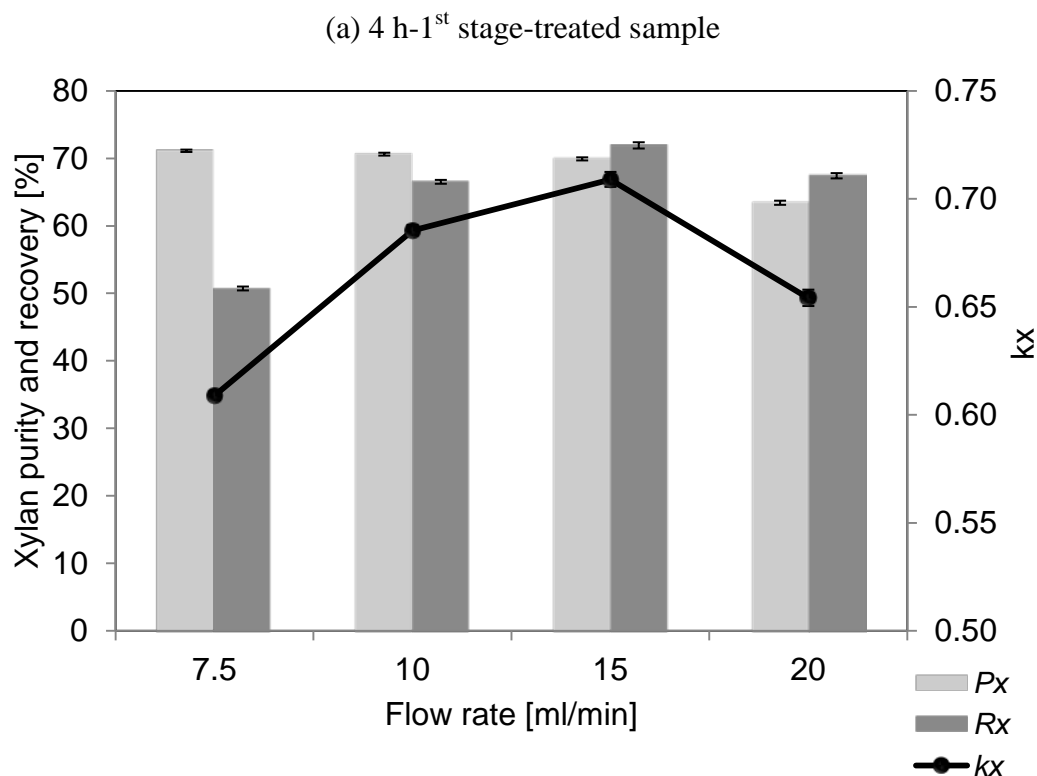

(b) 8 h-1<sup>st</sup> stage-treated sample

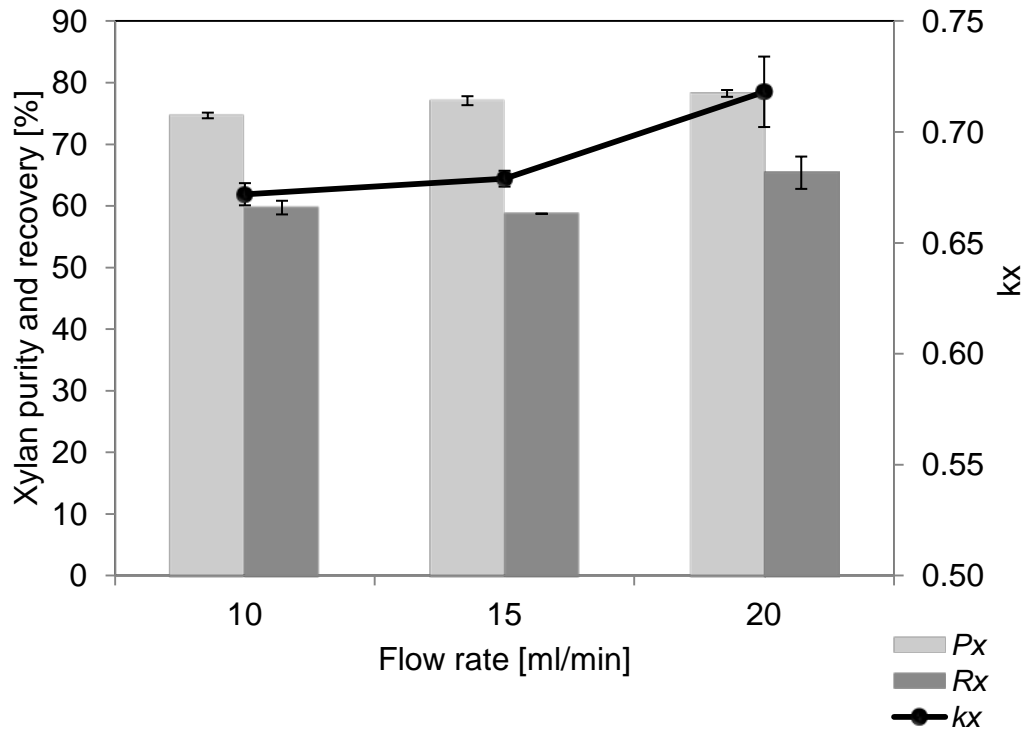

(c) Flow rate effects with constant liquid throughput on xylan mass balance

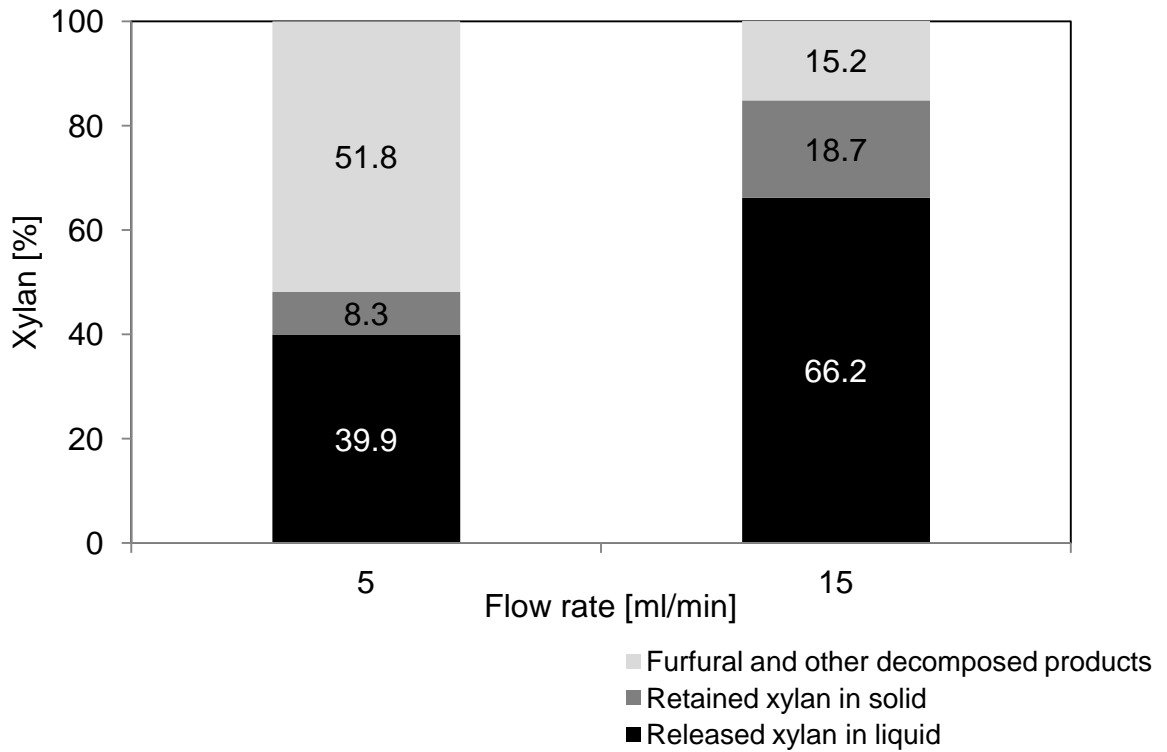

**Fig. 4.** Effects of flow rate of hot-water on xylan fractionation in the second stage.

Note: The data points and bars in the graph show the mean value (n=2); (a) and (b) reaction conditions: 15 wt% of ammonia, 60°C, solid:liquid=1:10, 4-8 h; hot-water, 210°C, 10 min; (c) reaction conditions: 15 wt% of ammonia, 60°C, solid : liquid ratio=1:10, 8 h; hot-water, 210°C, 10-30 min; total amount of water throughput: 150ml.

#### *Effects of Reaction Temperature in the Second stage on Xylan Fractionation*

The effects of reaction temperature of hot-water treatment on  $P_X$  and  $R_X$  were tested using two different sets of reaction conditions: (1) 1<sup>st</sup> stage: 4 hours, 15 wt% aqueous ammonia 60°C, 1:10 of solid:liquid; 2<sup>nd</sup> stage: three different temperatures covering 170-210°C with the flow rates of 15.0 ml/min; (2) 1<sup>st</sup> stage: 12 hours, 15 wt% aqueous ammonia 60°C, 1:10 of solid:liquid; 2<sup>nd</sup> stage: four different temperatures covering 150- 210°C with the flow rates of 5.0 ml/min. The  $P_X$ ,  $R_X$  and  $k_X$  are presented in Fig. 5.

In the first set of runs (Fig. 5-a) with 15 ml/min of hot-water flow rate, the maximum  $P_X$  (74%) and  $R_X$  (72%) were obtained under conditions of hot-water fractionation at 190°C and 210°C, respectively. On the other hand, in the second set of runs (Fig. 5-b) with 5 ml/min of hot-water flow rate,  $R_X$  increased as temperature increased, on the contrary decrease of  $P_X$  was observed as temperature increased; this explains that remaining lignin in corn stover also underwent the solubilization reaction. Fractionation factor,  $k_X$  increased with reaction temperature up to 190°C ( $k_X=0.62$ ), then decreased at 210°C. Overall, 5.0 ml/min of hot-water fractionation recovered xylan at low yields, which were only in the range of 12.5%-43.9%.

(a) 1<sup>st</sup> stage: 4 h ammonia treatment - 2<sup>nd</sup> stage: hot-water 15.0 ml/min, 10 min

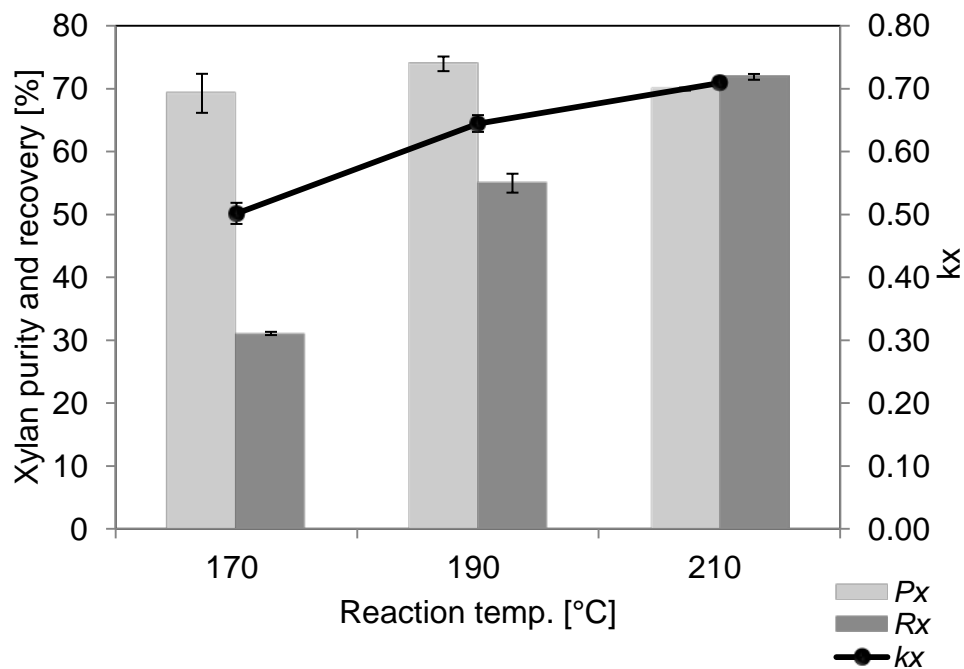

(b) 1<sup>st</sup> stage: 12 h ammonia treatment. - 2<sup>nd</sup> stage: hot-water 5.0 ml/min, 30 min

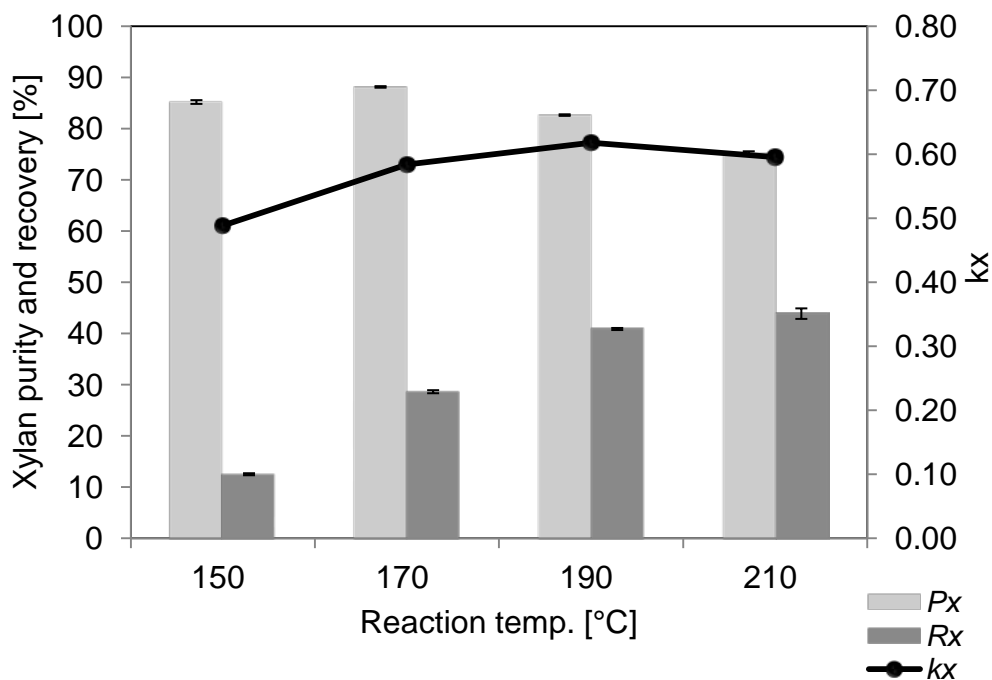

**Fig. 5.** Effects of reaction temperature of hot-water on xylan fractionation in the second stage. Note. treatment conditions: 15 wt% of ammonia, 60°C, solid:liquid=1:10, 4-12 h; hot-water, 5.0-15.0 ml/min, 10-30 min: the data points and bars in the graph show the mean value (n=2).

*Enzymatic Digestibility of Fractionated Corn Stover*

With the remaining solid samples after two-stage treatment, enzymatic digestibility tests were conducted using GC-220 cellulase supplemented with Novozyme 188  $\beta$ -glucosidase enzymes. Enzymatic digestibility test results are presented in Fig. 6. Enzyme digestibilities of two-stage treated corn stover were 91%-97% with 15 FPU/g of glucan. Digestibility (at 72 h) of 210°C-treated corn stover were substantially higher than 170°C-treated samples and glucan hydrolysis of 210°C-treated samples were nearly completed only within 24 hours. It should be noted that shorter enzyme hydrolysis time is considered to be important from the economic point of view because enzyme hydrolysis is the limiting step due to the slower reaction rate than that of microbial reaction in bioconversion of cellulosic using simultaneous saccharification and fermentation (SSF).

The impacts of treatment conditions on the composition of solids and liquids, and on the enzymatic digestibility of solids, are summarized in Table 2. Increasing temperature of the second stage from 170 to 210 °C reduced the xylan and lignin contents of the treated solids, regardless of flow rate, with the most significant composition change in the xylan: At 10 ml/min, xylan and lignin removals were increased 42% to 80%, and 72% to 80%, respectively; while at 20 ml/min, xylan and lignin removals were increased 51% to 85%, and 73% to 93%, respectively. These results probably reflect that the xylan was more labile in this temperature range. In contrast, glucan content remained relatively constant.

The glucan and xylan digestibilities of the untreated corn stover were 19% and 13% at 15 FPU/g of glucan, respectively. At both flow rates, the glucan and xylan digestibilities of the 170 °C-treated samples were all above 73%, while those of the 210 °C-treated samples



were all above 97%. Second-stage temperature appears far more important than flow rate, in determining the enzymatic digestibility of treated solids. It appears that the reduced xylan and lignin contents in the treated solid samples contributed to the improved enzyme digestibility of the remaining solids, but there is no clear evidence regarding which of these components contributes most significantly to the enhanced digestibility.

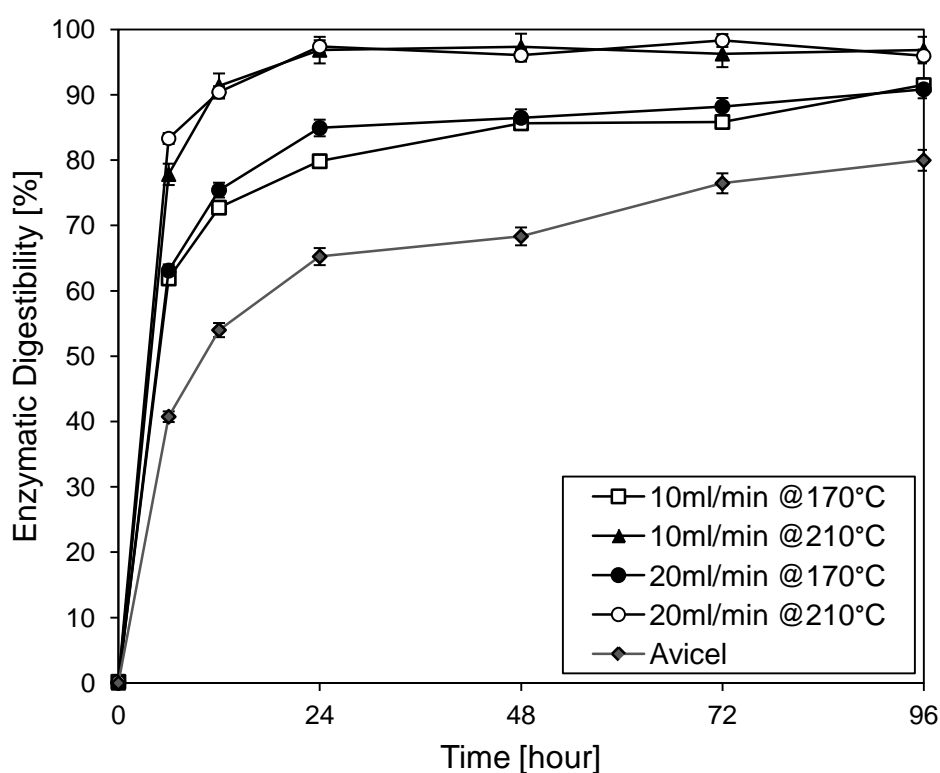

**Fig. 6.** Enzymatic digestibility of two-stage treated corn stover.

Note. treatment conditions: 15 wt% of ammonia, 60°C, solid:liquid=1:10, 24h; hot-water 20.0 ml/min, 10min, 170-210°C; enzymatic hydrolysis conditions: 15 FPU of GC 220 / g-glucan and 30 CBU of Novozyme 188 / g-glucan, pH 4.8, 50°C, 150 rpm; the data points in the graph show the mean value (n=2).

**Table 2**

Effects of flow rate and temperature on the solid- liquid compositions and enzymatic digestibility after the two stage fractionation <sup>a</sup>

Flow rate	Temp	SR <sup>b</sup>	Solid			Liquid			Enzymatic Digestibility <sup>c</sup>	
			Glucan	Xylan	Lignin <sup>c</sup>	Glucan	Xylan	Lignin <sup>d</sup>	Glucan	Xylan
[ml/min]	[°C]	[%]	[%]	[%]	[%]	[%]	[%]	[%]	[%]	
Untreated		100	34.2	22.3	12.2	-	-	-	19.0	12.5
10	170	54.4	34.2	13.0	3.4	0.9	6.1	0.6	79.8	73.1
	210	50.9	33.0	4.4	2.5	1.9	10.7	1.0	96.8	97.4
20	170	40.3	33.6	10.9	3.3	0.8	7.8	0.7	84.9	78.4
	210	38.7	32.2	3.4	0.8	1.8	11.3	1.2	97.4	100.0

The data in the table show the mean value (n=2, SD<0.5 for glucan, xylan, and lignin in solid, SD: standard deviation).

<sup>a</sup> Data in the table are based on the oven-dried untreated corn stover. Fractionation conditions: 1<sup>st</sup> stage- 15 wt% of ammonia concentration, 60°C of reaction temperature, 24 h or reaction time, and solid : liquid ratio=1:10 (based on wt); 2<sup>nd</sup> stage- hot-water, 5.0-15.0 ml/min, 10 min, 170-210°C.

<sup>b</sup> SR stands for solid remaining after reaction.

<sup>c</sup> Acid insoluble lignin + Acid soluble lignin.

<sup>d</sup> Digestibility at 72 h, enzymatic hydrolysis conditions: 15 FPU of GC 220 / g-glucan and 30 CBU of Novozyme 188 / g-glucan, pH 4.8, 50°C, 150 rpm.

## Conclusion

Three main components of corn stover: glucan, xylan, and lignin were effectively fractionated by fractionation processes using aqueous ammonia and hot-water. The best two-stage treatment conditions were observed as follows: first stage-15 wt% aqueous ammonia for 8 h at 60°C and solid:liquid ratio of 1:10, second stage- 20 ml/min hot-water at 190-210°C for 10 min. Under these conditions, (1) 78% of  $P_X$ , 65% of  $R_X$  and 0.72 of  $k_X$  and (2) 68% of  $P_L$ , 47% of  $R_L$  and 0.57 of  $k_L$  were obtained. The remaining solid contains mostly cellulose (> 86%) after fractionation process and it enhanced enzymatic digestibility of treated solid sample (97%).

## Acknowledgements

We are grateful to Genencor International Inc. for providing cellulase enzymes. We would also like to thank the National Renewable Energy Laboratory (NREL) for supplying the corn stover. This work was supported by Iowa State University and by a grant from Jinju National University Industry Academic Cooperation Foundation.

## References

1. Glassner, D. A., Hettenhaus, J. R., Schechinger, T. M. (1998), *BioEnergy '98: Expanding BioEnergy Partnerships*
2. Koukios, E. G., Valkanas, G. N. (1982), *Ind. Eng. Chem. Prod. Res. Dev.* **21**, 309-314.
3. Henschen, H. (2010), *Wall Street Journal. (Eastern edition). New York, N.Y.:* Apr 24, 2010. B.11.
4. Langvad, N. (2007), *California-Denmark Workshop on Clean Technology*, San Francisco, California.
5. Nghiem, N. P., Donnelly, M., Sanville-Millard, C. Y. (2005), *A method to produce*

- succinic acid from raw hydrolysates*, WO 2005/116227.
6. Sanchez, S., Bravo, V., Castro, E. A., Moya, J., Camacho, F. (1998), *Applied Microbiology and Biotechnology*, **50**, 608-611.
  7. Vazquez, M. J., Alonso, J. L., Dominguez, H., Parajo, J. C. (2001), *Trends in Food Science and Technology*, **11**, 387-393.
  8. Izumi, Y., Azumi, N., Kido, Y., Nakabo, Y. (2004), *Japan Patent*, JP 2,004,210,666.
  9. Katapodis, P., Kavarnou, A., Kintzios, S., Pistola, E., Kekos, D., Macris, B. J. (2002), *Biotechnol Lett.* **24**, 1413–1416.
  10. Katapodis, P. and Christakopoulos, P. (2005), *NutraCos.* **4**, 17-21.
  11. Moure, A., Gullon, P., Dominguez, H., Parajo, J. C. (2006), *Process Biochemistry* **41**, 1913-1923.
  12. Yukawa, M., Okuda, S., Ozeki, K. (2005), *Japan Patent*, JP 2,005,263,722.
  13. Kim, T. H., Lee, Y. Y. (2005), *Appl. Biochem. Biotechnol.* **121-124**, 1119-1132.
  14. Kim, T. H., Lee, Y. Y. (2006), *Biores. Technol.* **97** (2), 224-232.
  15. Kim, T. H., Lee, Y. Y. (2007), *Appl. Biochem. Biotechnol.* **136-140**, 81-92.
  16. Liu, C., Wyman, C. E. (2005), *Biores. Technol.* **96** (18), 1978-1985.
  17. Makishima, S., Mizuno, M., Sato, N., Shinji, K., Suzuki, M., Nozaki, K., Takahashi, F., Kanda, T., Amano, Y. (2009), *Biores. Technol.* **100** (11), 2842-2848.
  18. Sreenath, H. K., Koegel, R. G., Moldes, A. B., Jeffries, T. W., Straub, R. J. (1999), *Process Biochemistry.* **35**, 1-2, 33-41.
  19. NREL (2008), *Determination of Structural Carbohydrates and Lignin in Biomass*. NREL/TP-510-42618, 2008. National Renewable Energy Laboratory, NREL, Golden, CO.
  20. NREL (2008), *Enzymatic Saccharification of Lignocellulosic Biomass*. NREL/TP-510-42629, 2008. National Renewable Energy Laboratory, NREL, Golden, CO.
  21. NREL (2008), *Determination of Sugars, Byproducts, and Degradation Products in Liquid Fractionation Process Samples*. NREL/TP-510-42623, 2008. National Renewable Energy Laboratory, NREL, Golden, CO.

**CHAPTER 3. OPTIMIZATION OF TWO-STAGE FRACTIONATION PROCESS FOR  
LIGNOCELLULOSIC BIOMASS USING RESPONSE SURFACE METHODOLOGY  
(RSM)**

Modified<sup>1</sup> from a paper published in the Journal of *Biomass & Bioenergy*

Chang Geun Yoo, Chi Woo Lee, Tae Hyun Kim

**Abstract**

A two-stage process using aqueous ammonia and hot-water has been investigated to fractionate corn stover. To optimize the fractionation process so that hemicellulose recovery and purity in the liquid hydrolysate were maximized, the experiments were carried out employing response surface methodology (RSM). A central composite design (CCD) was used to evaluate and confirm the effectiveness and interactions of factors. The optimal fractionation conditions were determined to be as follow: (1) First-stage reactor operated in batch mode using a 15% NH<sub>4</sub>OH solution ( $W_{\text{NH}_3} = 15\%$ ) at 1:10 solid:liquid ratio, 60 °C and 24 h; (2) second stage percolation reactor operated using hot-water at 20 ml/min, 200 °C, and 10 min. The model predicted 51.5% xylan recovery yield and 82.4% xylan purity under these conditions. Experiments confirmed the maximum xylan recovery yield and purity were 54.7% and 83.9% respectively under the optimal reaction conditions.

---

<sup>1</sup> Some of the units in this article are modified for consistency throughout this thesis.

With the solids resulting from the two-stage treatment, 87-98% glucan digestibilities were obtained with 15 FPU of GC 220 per g-glucan and 30 CBU of Novo 188 per g-glucan enzyme loadings. Xylan digestibility of xylooligomer hydrolysates reached 76% with 8,000 GXU per g-xylan of Multifect-Xylanase loading. In the simultaneous saccharification and fermentation (SSF) test using treated solids and *Saccharomyces cerevisiae* (D<sub>5</sub>A), 86 - 98% of ethanol yield was obtained on the basis of the glucan content in the treated solids.

*Key words:* Corn stover; Biorefinery; Value-added co-products; Simultaneous Saccharification and Fermentation (SSF); Xylooligomer; Ethanol; *Zea mays*

## **1. Introduction**

Exploiting efficient processes for improving the processing of lignocellulosic materials has been an issue of great interest in biotechnology area during the last few decades. Recently, interest has been focused on the production of intermediates using fractionation processes [1-6].

Fractionation of lignocellulosic materials can be one method to improve overall biomass utilization. When separated, the three main components in biomass: cellulose, hemicelluloses, and lignin, can be utilized in direct applications or precursors for industrial chemicals; for example, (1) fractionated lignin can be directly combusted as a fuel [7], converted to gasoline blending stock [8], used as resources for many value-added products including as activated carbon, binder, dispersant, emulsifier, and sequestrant [9-16]; (2) cellulose can be converted to cellulosic ethanol, or used in food and pharmaceutical

applications; and (3) hemicellulose, mainly composed of xylose, can be converted to furfural [17, 18], hydrogen [19], succinic acid [20], xylitol [21], and xylo-oligosaccharides [22].

In our laboratory, two-stage fractionation process using aqueous ammonia and hot-water has been developed to fractionate corn stover effectively into cellulose, hemicelluloses and lignin with high purity [23]. Ammonium hydroxide was used to separate lignin from lignocellulosic biomass in the first stage. We have reported elsewhere that this process effectively removed the lignin without significant loss of cellulose and hemicelluloses, and increase the enzymatic digestibility of the remaining solids [23-25]. The remaining solids after first stage treatment, which contained most of cellulose and hemicellulose, were treated using hot-water in the second stage [23].

In this study, response surface methodology (RSM) was applied to optimize the second stage reaction of the two-stage fractionation process hot-water to maximize xylan recovery yield and hydrolysate purity. RSM is a statistical tool for designing experiments, building empirical models, and evaluating the effects of factors [26, 27]. RSM can reduce the number of experimental trials needed to evaluate multiple parameters and their interactions [28-30]. Several variables of the fractionation process, including reaction temperature of hot-water treatment and flow rate of hot-water treatment, were selected as factors of experimental design by preliminary tests. Optimal reaction conditions of these two factors for maximal xylan recovery yield and purity were determined by central composite design (CCD). For further evaluation of the effectiveness of the optimized reaction conditions, enzymatic digestibility tests for glucan in residual solids and for xylan in xylooligomer hydrolysates were conducted. In addition, the production of ethanol from residual solid after fractionation was tested by simultaneous saccharification and fermentation (SSF) reactions.

## 2. Methods

### 2.1. Materials

Air-dried ground corn stover was supplied by the National Renewable Energy Laboratory (NREL, Golden, CO). The corn stover (*Zea mays*) which includes stalks, leaves, tassel, husks, and cobs from Pioneer 34M95 was harvested in Wray, northeastern Colorado in 2002. The harvested corn stover was washed by distilled water and air-dried at ambient temperature, and then screened to a nominal size of 9-35 mesh. The prepared corn stover was stored in the refrigerator at 4°C. The composition of corn stover was determined by our lab following the chemical analysis and testing standard method developed by NREL [31]. The mass fraction of each component in the untreated corn stover was 34.2 % glucan, 22.3 % xylan, 1.6 % galactan, 3.1 % arabinan, 12.2 % lignin (acid insoluble + acid soluble), 3.9 % acetate, 6.2 % sucrose, 1.6 % protein, 4.0 % uronic acid, 1.2 % ash, and 10.7 % other extractives.

Cellulase enzyme, GC 220 (Genencor International Inc., Lot No #301-04232-162) and Multifect-Xylanase (Genencor International Inc., Lot. #301-04021-015) were provided by Genencor International. The average activities of cellulase (GC-220) and xylanase (Multifect) were 45 FPU/ml and 8000 GXU/ml, respectively. The  $\beta$ -glucosidase enzyme, Novozyme 188 (Novo Inc., lot no. 11K1088), was purchased from Sigma-Aldrich (St. Louis, MO). Activity of Novozyme 188 was 750 cellobiase unit (CBU)/ml.

The microorganism used for SSF was *Saccharomyces cerevisiae* ATCC<sup>®</sup> 200062 (NREL-D<sub>5</sub>A), which is a SERI strain genetically improved from Red Star baker's yeast. The growth media was YP medium. The mass fractions of yeast extract (Sigma cat. No. Y-0500) and peptone (Sigma cat. No. P-6588) in YP medium were 10 and 20 g/l respectively.



## 2.2. Experimental setup and Operation

The reaction and operating conditions are summarized in Fig. 1.

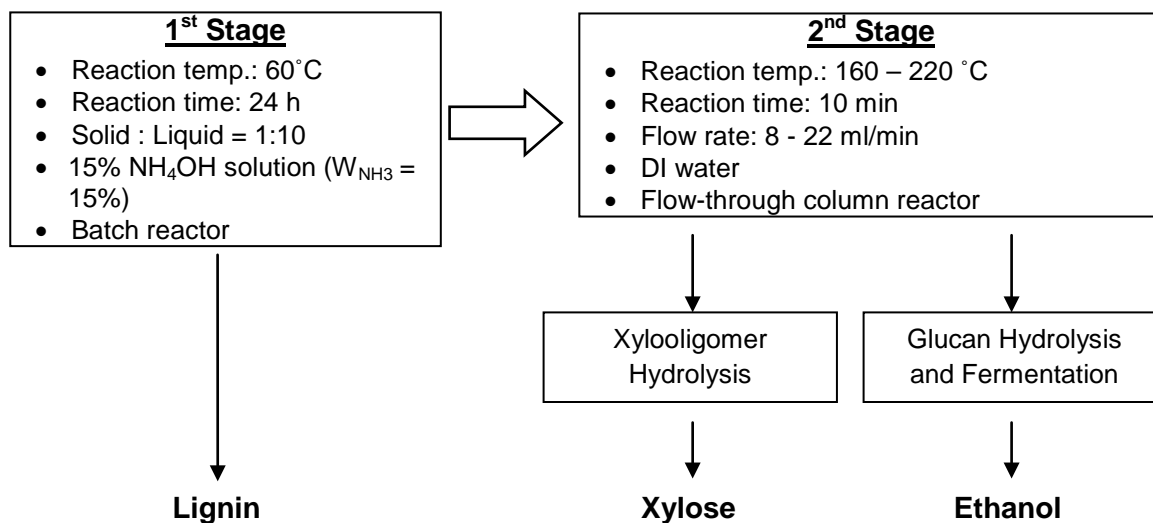

Fig. 1. Experimental conditions

### 2.2.1. First stage: aqueous ammonia treatment at low temperature

Corn stover was treated with 15%  $\text{NH}_4\text{OH}$  solution ( $W_{\text{NH}_3} = 15\%$ ) in glass media bottles (Fischer Cat# 06-414-1C) at 60 °C for 24 h. Solid-to-liquid ratio was kept at 1:10. The source of ammonia was 29.5% of ammonium hydroxide (Fisher Cat# A669C). This was diluted to 15%  $\text{NH}_4\text{OH}$  solution ( $W_{\text{NH}_3} = 15\%$ ) with deionized (DI) water and used for the treatment. After the completion of treatment, the solids and liquids were separated by fluted filter paper (Fisher Cat# 09-790-14F), and solids were washed with DI water using vacuum filter until the wash water had a neutral pH. Solid cakes were dried in the air until the moisture content of samples reached approximately 10% (drying conditions: ambient

temperature and 48-72 h of drying time) and stored in the refrigerator for the second-stage hot water treatment.

### 2.2.2. Second stage: hot-water treatments

The reactor system for the second stage treatment consists of a flow-through column reactor with preheating coil, an HPLC (high performance liquid chromatography) pump (Series II pump, Chrom Tech, Inc., MN), a temperature-programmable GC (gas chromatography) oven (Hewlett Packard 5890, HP Inc., Ontario, Canada), solution reservoirs and a sample cylinder tank. The reactor (70 ml of internal volume) was constructed from a 16.5 cm length of 2.3 cm I.D. SS-316 tubing. Two 1000 ml SS 304 cylinder were used as receiver tanks for collecting the liquid products.

Corn stover was treated using aqueous ammonia in the first stage and dried in the air as described above. After drying, 10 g of dry ammonia-treated stover was packed into the flow-through reactor. The oven was preheated for 15 minutes, and 2.1 MPa of N<sub>2</sub> backpressure was applied to the reactor system before reactor startup. Water was pumped by HPLC pump to the reactor in the second stage. At the completion of the run, the reactor was flushed with water to remove the residual sugar in the treated biomass. The wet solids obtained from the reactor were separated into three portions: One was dried for measurement of weight loss and subjected to composition analysis, while the others were subjected to the enzymatic digestibility test and fermentation tests.

### 2.3. Enzymatic digestibility test

The enzymatic digestibilities of solid samples obtained from two-stage fractionation were determined in duplicate according to the NREL Chemical Analysis and Testing Standard Procedure [32].

The reaction conditions used for two-stage treated solid sample preparation were as follows: (1) S:L = 1:10 using 15%  $\text{NH}_4\text{OH}$  solution ( $W_{\text{NH}_3} = 15\%$ ), at 60 °C for 24 h in the first-stage treatment using batch reactor and (2) 10 min, 160-220 °C with the flow rates of 8-22 ml/min of hot water in the second stage. In addition, xylooligomer hydrolysates were prepared under the following conditions: (1) S:L = 1:10 using 15%  $\text{NH}_4\text{OH}$  solution ( $W_{\text{NH}_3} = 15\%$ ) at 60 °C for 24 h in the first-stage treatment using batch reactor and (2) 210 °C, 20 ml/min, and 10 min using percolation reactor.

The conditions of the enzymatic digestibility test were pH 4.8 (0.05 mol/l sodium citrate buffer) on a shaker bath agitated at 2.5 Hz at 50 °C. Two different enzymatic digestibility tests were conducted with solid residue after two-stage fractionation and xylooligomer hydrolysate which was collected in the second stage.

For the enzymatic digestibility tests of the fractionated solid residue, 15 FPU of GC-220 per g of glucan supplemented and 30 CBU of  $\beta$ -glucosidase (Novozyme 188) per g-glucan were loaded. The initial glucan concentration was 1% of total liquid and solid. The solid residue samples used in the digestibility tests were wet samples as collected after two-stage fractionation. Avicel was put through the same procedure as a reference. For the enzymatic digestibility tests of xylooligomer hydrolysates, 8,000 GXU of Multifect-Xylanase were loaded. The initial xylan concentration was 1% of total liquid.

The 250 ml screw-capped Erlenmeyer flasks containing the enzyme hydrolysis preparations were placed in an incubator shaker (New Brunswick Scientific, Edison, NJ). Samples were taken periodically (6, 12, 24, 48, 72 and 96 h) and analyzed for glucose and xylose content using HPLC.

The glucan and xylan digestibilities were calculated as follows:

$$\text{Glucan digestibility} = \frac{\text{Total released glucose (g)} \times 0.9}{\text{Initial glucan loading (g)}} \times 100 \quad (1)$$

0.9 is the conversion factors of glucose to equivalent glucan.

$$\text{Xylan digestibility} = \frac{\text{Total released xylose (g)} \times 0.88}{\text{Initial xylan loading (g)}} \times 100 \quad (2)$$

0.88 is the conversion factors of xylose to equivalent xylan.

#### 2.4. Simultaneous saccharification and fermentation (SSF)

Fractionation conditions used for solid sample preparations were as follows: (1) 24 h, 60 °C, S:L = 1:10 using a 15% NH<sub>4</sub>OH solution (W<sub>NH<sub>3</sub></sub> =15%) in the first-stage treatment and (2) 10 min, 170 and 210 °C with the flow rates of 10, and 20 ml/min of hot water in the second stage.

For SSF test, a 250 ml Erlenmeyer flask was used as a bioreactor. It was shaken in the incubator shaker (New Brunswick Scientific, Edison, NJ) at 37 °C and 2.5 Hz. Into a 100 ml working volume of liquid, treated corn stover sample was introduced to reach 3g glucan content in the reactor. The SSF run was performed with buffer but without external pH control, starting at pH 5.0 at the beginning of the fermentation and gradually decreasing to pH 4.5 at the end. The loading of cellulase enzyme (GC-220) was 15 FPU per g-glucan, and

that of  $\beta$ -glucosidase (Novozyme 188) was 30 CBU per g-glucan. Samples were taken routinely until fermentation process ended.

The ethanol yield in SSF test was calculated as follows:

$$\text{Ethanol yield related to the maximum yield based on initial mass of glucose (\%)} \\ = \frac{\text{Ethanol produced (g) in reactor}}{\text{Initial glucose (g) in reactor} \times 0.511} \times 100 \quad (3)$$

### 2.5. Analytical methods

Solid samples were analyzed for carbohydrates (sugars) and lignin following the two-stage acid-hydrolysis procedures given in NREL Chemical Analysis and Testing (CAT) Standard Procedures [31]. Each sample was analyzed in duplicate. The conditions of the first hydrolysis were: 1:10 of solid-to-liquid ratio using a 72% sulfuric acid ( $W_{\text{H}_2\text{SO}_4} = 72\%$ ), and 30 °C for one hour. The conditions for the secondary hydrolysis were 4% sulfuric acid ( $W_{\text{H}_2\text{SO}_4} = 4\%$ ) and 121 °C for one hour. Sugars in the hydrolysates were determined by HPLC using a Bio-Rad Aminex HPX-87P column coupled with a refractive index detector. (Varian 356-LC, Varian, Inc., CA). For the acid insoluble lignin analysis, the autoclaved hydrolysis solution was vacuum filtered, and the filtered hydrolyzed solid sample was dried and weighed. The dried samples were then combusted in a furnace at  $575 \pm 25$  °C for 16 h to determine the ash content. The difference of the two weights was taken as the acid insoluble lignin. The absorbance of the hydrolysis liquor in the aliquot obtained from the vacuum filter sample at 320 nm on a UV-Visible spectrophotometer measured the acid soluble lignin [31].

Carbohydrates in the liquid samples were determined by secondary acid hydrolysis (conditions: 4% sulfuric acid ( $W_{H_2SO_4} = 4\%$ ), 121 °C, 1 h) following the NREL Standard Analytical Procedure [33].

### 2.6. Recovery yield and purity

In order to quantitatively evaluate the fractionation effects of various reaction conditions on each component (glucan, xylan and lignin), purity and recovery ratio (or yield) of each component were defined in the previous study [23]:

$$\text{Xylan recovery yield}(R_x) = \frac{\text{Xylose} \times 0.88 + \text{Xylan [g] in liquid}}{\text{Xylan [g] in untreated corn stover}} \times 100 \quad (4)$$

$$\text{Xylan purity}(P_x) = \frac{\text{Xylan [g] in liquid}}{(\text{Glucan} + \text{Xylan} + \text{Lignin})[\text{g}] \text{ in liquid hydrolysate}} \times 100 \quad (5)$$

### 2.7. Response surface methodology (RSM)

The series of experiments designed and conducted are shown in Table 1. To achieve high xylan recovery yield from corn stover, hot water fractionation conditions were optimized by RSM based on the  $2^2$  factorial central composite designs. The matrix corresponding to the CCD is presented in Table 2. Twelve experiments were carried out with two variables, and each variable varied at three levels ( $\alpha = 1.41$ ) for xylan recovery yield. Xylan recovery yield was the response (dependent) variables. The quadratic polynomial model was fitted for the xylan recovery yield ( $Y_1$ ), and xylan purity ( $Y_2$ ) giving the following Eq.(6):

$$Y = \alpha_0 + \alpha_1 A + \alpha_2 B + \alpha_{11} A^2 + \alpha_{22} B^2 + \alpha_{12} A B \quad (6)$$

Where  $A$ , and  $B$  represent coded levels of the independent variables;  $\alpha_0$  is intercept terms;  $\alpha_1$ , and  $\alpha_2$  are linear terms;  $\alpha_{11}$ , and  $\alpha_{22}$  are quadric terms;  $\alpha_{12}$  is interaction terms. The statistical analysis of the data was performed using "Design Expert" software (version 7.1.1, Stat-Ease, Inc., Minneapolis, USA).

**Table 1**

Independent variables and their levels in the experimental design

Independent variable	Symbols	Unit	Code Levels		
			-1	0	1
Flow rate	A	ml/min	10	15	20
Reaction temperature	B	°C	170	190	210

### 3. Results and discussion

#### 3.1. RSM

The optimal reaction conditions of the first stage treatment using 15%  $\text{NH}_4\text{OH}$  solution ( $W_{\text{NH}_3} = 15\%$ ) were chosen on the basis of the previous study as follows: 1:10 solid:liquid ratio using a 15%  $\text{NH}_4\text{OH}$  solution ( $W_{\text{NH}_3} = 15\%$ ) and 60 °C for 24 h [23]. In this condition, the maximum lignin recovery was obtained, which was approximately 62% based on lignin in the oven dry untreated corn stover. To simplify the experiment in this study, two variables such as reaction temperature and flow rate in the second stage only were identified as the most significant variables with a range of 160-220 °C, 8-22 ml/min, respectively.

A CCD with the Design-Expert (Stat-Ease, Inc., Minneapolis, USA) software was employed to investigate the simultaneous effect of reaction temperature and flow rate of hot-

water treatment on xylan recovery yield and purity. The performances of various combinations of fractionation conditions are summarized in Table 2. The polynomial equation, describing the xylan recovery yield ( $Y_I$ ) as a simultaneous function of reaction temperature and flow rate of hot-water treatment, is shown in Eq. (7)

$$Y_I = 45.45 + 3.77 A + 8.63 B - 5.58 B^2 \quad (7)$$

In addition to the data in Table 2, the detail compositional changes of treated solids and liquids in two-stage fractionation and enzymatic digestibilities of treated solids are summarized in Table 3. One negative phenomenon was observed in the 2<sup>nd</sup> stage treatment; as reaction temperature increased in the second stage, more xylan was solubilized into liquid (lower part of Table 3); however, the accountability of xylan (xylan content in the solid plus that in liquid) above 200 °C was 70-80% for at all tested flow rates, indicating substantial amount of xylan was decomposed under those conditions. On the other hand, the accountability of glucan was nearly 100% and the glucan content was well preserved.



**Table 2**

Experimental design and results of the central composite design

Run	Variables		Response	
	(A) Flow rate [ml/min]	(B) Reaction temp. [°C]	$Y_1$ xylan recovery [%]	$Y_2$ xylan purity [%]
1	-1	-1	27.6	80.6
2	-1	1	48.1	78.8
3	1	-1	34.8	83.9
4	1	1	50.7	79.2
5	0	0	50.4	82.1
6	0	0	42.7	80.9
7	0	0	50.1	82.3
8	0	0	41.6	79.8
9	-1.41	0	36.3	81.3
10	0	-1.41	22.3	82
11	0	1.41	76.6	45.4
12	1.41	0	50.7	79.2

**Table 3**

Effects of reaction conditions on the composition of liquid hydrolysates and residual solids in two-stage fractionation <sup>a</sup>

Single-stage treatment (after 1<sup>st</sup> stage – SAA)

Reaction Conditions		Liquid			Solids			Enzymatic Digestibility <sup>b</sup>	
Time [hour]	Temperature [°C]	Glucan [wt.%]	Xylan [wt.%]	Lignin [wt.%]	Glucan [wt.%]	Xylan [wt.%]	Lignin [wt.%]	Glucan [%]	Xylan [%]
Untreated		-	-	-	34.2	22.3	12.2	19.0	12.5
24	60	0.5	3.6	7.5	33.7	18.7	4.7	-	-

Two-stage treatment (1<sup>st</sup> stage-SAA and 2<sup>nd</sup> stage –hot water)

Temperature [°C]	Liquid			Solids			Total (liquid + solid)			Enzymatic Digestibility <sup>b</sup>	
	Glucan [wt.%]	Xylan [wt.%]	Lignin [wt.%]	Glucan [wt.%]	Xylan [wt.%]	Lignin [wt.%]	Glucan [wt.%]	Xylan [wt.%]	Lignin [wt.%]	Glucan [%]	Xylan [%]
SAA-treated solid	-	-	-	33.7	18.7	4.7	33.7	18.7	4.7	-	-
<u>8 ml/min</u>											
190	1.2	8.1	0.7	33.8	8.8	2.3	35.0	16.9	3.0	92.7	77.7
<u>10 ml/min</u>											
170	0.9	6.1	0.6	34.2	13.0	3.4	35.1	19.1	4.0	85.8	70.1
210	1.9	10.7	1.0	33.0	4.4	2.5	34.9	15.1	3.5	96.3	97.4
<u>15 ml/min</u>											
160	0.6	5.0	0.5	34.9	13.1	2.6	35.5	18.1	3.1	81.3	66.7
190	1.4	10.3	0.9	32.9	6.8	2.0	34.3	17.1	2.9	91.9	83.6
220	1.9	10.0	1.2	32.0	3.0	1.6	33.9	13.0	2.8	91.6	100
<u>20 ml/min</u>											
170	0.8	7.8	0.7	33.6	10.9	3.3	34.4	18.7	4.0	88.2	74.9
210	1.8	11.3	1.2	32.2	3.4	0.8	34.0	14.7	2.0	98.3	100
<u>22 ml/min</u>											
190	1.8	11.3	1.2	32.3	5.8	1.6	34.1	17.1	2.8	93.3	86.4

<sup>a</sup> All sugar and lignin content based on the oven-dry untreated biomass. Values are expressed as mean.

<sup>b</sup> Enzymatic digestibilities with the residual solids after two-stage fractionation.

The summary of the analysis of variance (ANOVA) is also presented in Table 4. Less than 0.05 of ' $Prob>F$ ' for coefficient of  $A$ ,  $B$ , and  $B^2$  imply that these coefficients in the model in Eq. (7) significantly affect xylan recovery yield, while coefficient of  $AB$  and  $B^2$  do not influence xylan recovery yield in the range of this study. The model  $F$ -value of 24.91 for  $Y_1$  (xylan recovery) and the value of ' $Prob>F$ ' (0.0002) for the overall model show that the overall model is also significant.

**Table 4**

ANOVA Analysis for Responses  $Y_1$  [xylan recovery (%)] and  $Y_2$  [xylan purity (%)]

Source	Sum of squares	Degree of freedom	Mean squares	$F$ -values	$Prob^{a>F}$
For $Y_1$					
Model	917.62	3	305.87	24.91	0.0002
A	113.74	1	113.74	9.26	0.0160
B	596.30	1	596.30	48.57	0.0001
$B^2$	207.58	1	207.58	16.91	0.0034
Residual	98.22	8	12.28		
Lack of Fit	31.96	5	6.39	0.29	0.8923
Pure Error	66.26	3	22.09		
For $Y_2$					
Model	24.98	1	24.98	14.38	0.0035
B	24.98	1	24.98	14.38	0.0035
Residual	17.37	10	1.74		
Lack of Fit	13.32	7	1.90	1.41	0.4234
Pure Error	4.05	3	1.35		

<sup>a</sup> Probability values ( $P$ -values).

The regression model for xylan purity is presented in Eq. (8). ANOVA test showed the predicted model well matched the observed values, and the values of ' $Prob>F$ ' suggest that the independent values B (reaction temperature) only had significant effects on the xylan purity in the range of this study (Table 4).

$$Y_2 = 80.56 - 1.77 B \quad (8)$$

The 3-D response surfaces using Eq. (7) for xylan recovery yield and Eq. (8) for xylan purity are respectively shown in Fig 2. The optimization of reaction temperature and flow rate of hot-water treatments for the maximum xylan recovery yield was carried out in the range of experimental runs using the Design Expert software. The maximum xylan recovery yield and optimal conditions were also determined as 51.5% at 200 °C and 20 ml/min by the Design Expert software. At the same reaction conditions, the confirmation experiments were conducted and xylose recovery yield of 54.7% was obtained with 84.3% xylan purity. For the xylose purity, 82.4% was predicted at 170 °C and 20 ml/min using the software, and 83.9% was obtained at the same reaction conditions in the confirmation experiments. These showed that these experimental results were in agreement with the model predictions. The model equations are reliable with the same substrate in a range of experimental conditions.

In our previous study without RSM-based optimization, poor lignin recovery yield (47%) and relatively low xylan purity (78%) were obtained even though high xylan recovery yield (65%) was obtained [23], whereas this study using RSM optimization resulted in increases of both lignin recovery yield (62%) and xylan purity (84.3%), but xylan recovery

yield (54.7%) was slightly sacrificed. Higher purity may be preferred, because if the xylooligomer hydrolysates resulting from the second stage are significantly contaminated by soluble lignin, in other word the xylan purity is low and they must be cleaned and detoxified before they are subjected to bioconversion, which makes the whole process complicated. This is an untested troublesome unit process and undoubtedly a significant cost factor [34].

(a)

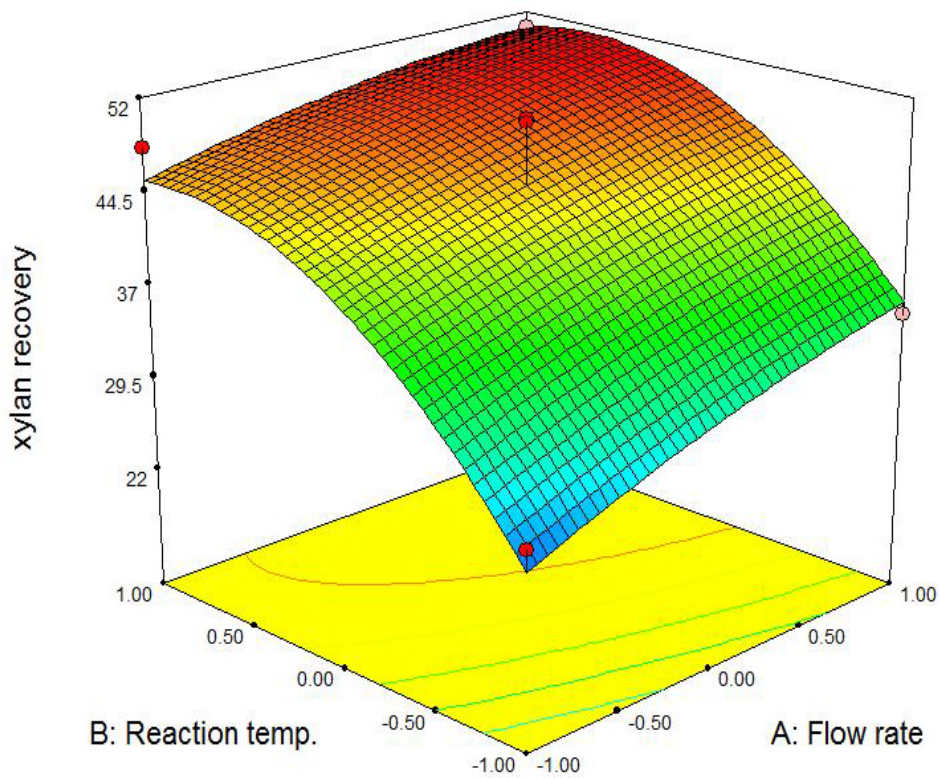

(b)

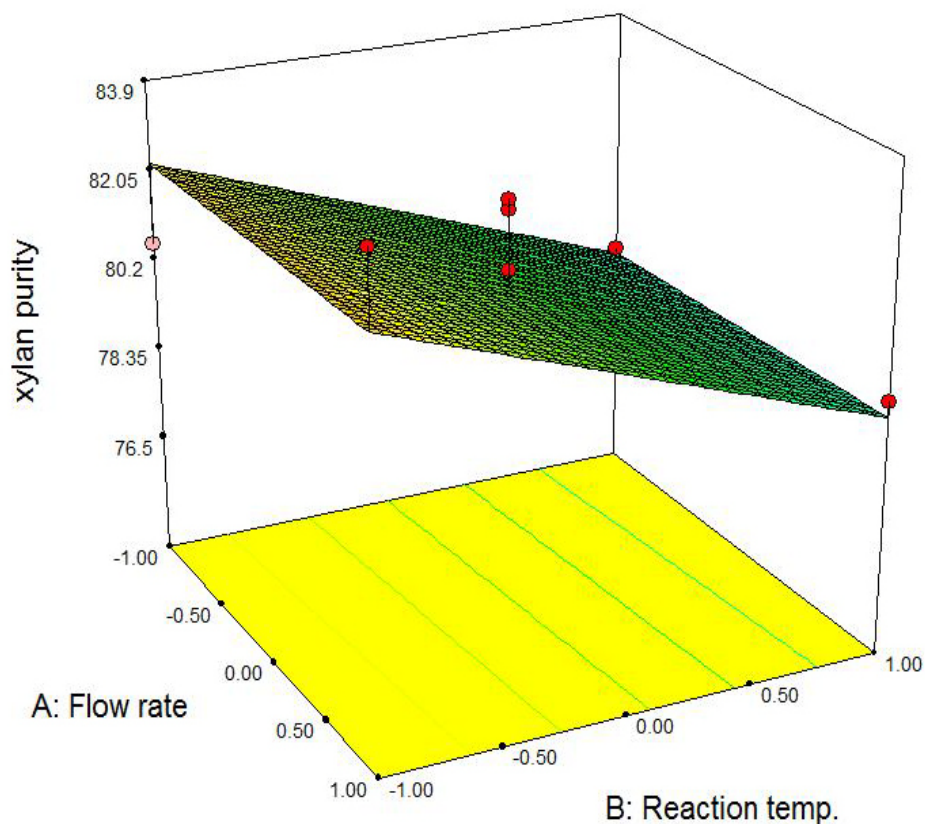

Fig. 2 Response surface curve showing combined effect of flow-rate and reaction temperature on xylan recovery and purity by hot-water pretreatment in the second stage

### 3.2. Enzymatic digestibility tests

Although the recovery yields and purities of each component in the two-stage fractionation process are important, the viability of downstream bioconversion should be considered. Therefore, enzymatic digestibility tests were conducted with remaining solids after two-stage fractionation using GC-220 cellulase enzyme and Novozyme 188  $\beta$ -glucosidase enzymes. Enzymatic digestibility test results of remaining treated-solids after

two-stage fractionation and Avicel are shown in Fig. 3 and Table 3. The data indicate that 72 h-glucan digestibilities of two-stage treated solids with 10-20 ml/min increased from 88% - 89% to 96% - 98% as the reaction temperature in the second stage increases from 170 °C to 210 °C, while the effect of flow rate was not significant. As shown in Table 3, 210°C-treated solids contained lower lignin mass fraction (0.8-2.5%) than 170 °C-treated solids (2.3-3.4%), which seemed to be related with improved digestibilities of 210 °C-treated solids. With all treated solids, the glucan digestibilities reached 80% - 97% within 24 h and initial hydrolysis rates were even much higher than that of Avicel which is typically considered as pure cellulose with no other chemical inhibitors. Avicel was subjected to the same procedure as a control.

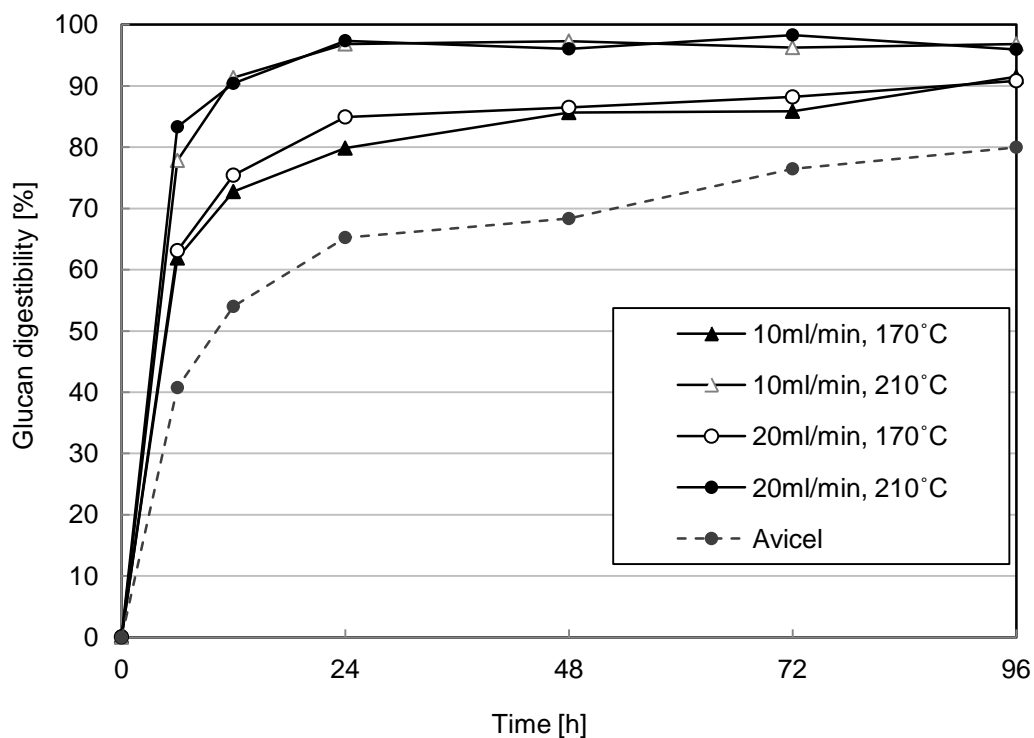

Fig. 3. Enzymatic digestibility of two-stage treated samples

Note: (1) Fractionation conditions: 1st stage - 15%  $\text{NH}_4\text{OH}$  solution ( $W_{\text{NH}_3} = 15\%$ ), 60 °C, solid : liquid ratio = 1:10, 24 h; 2nd stage - hot-water, 170 - 210 °C, 10 - 20 ml/min, 10 min. (2) Enzymatic hydrolysis: 15 FPU of GC 220 per g-glucan, 30 CBU of Novozyme 188 per g-glucan, 37°C, pH 4.8 maintained by 0.05 mol/l citrate buffer, 2.5 Hz. (3) The data points and bars in the graph show the mean value.

In addition, the enzymatic digestibility test for xylooligomer hydrolysates was also conducted (Fig. 4.). The xylan digestibility tests with enzyme loadings resulted in 69% and 76% with 8,000 GXU of Multi-fect Xylanase per g-xylan in 72 h and 96 h of hydrolysis times.

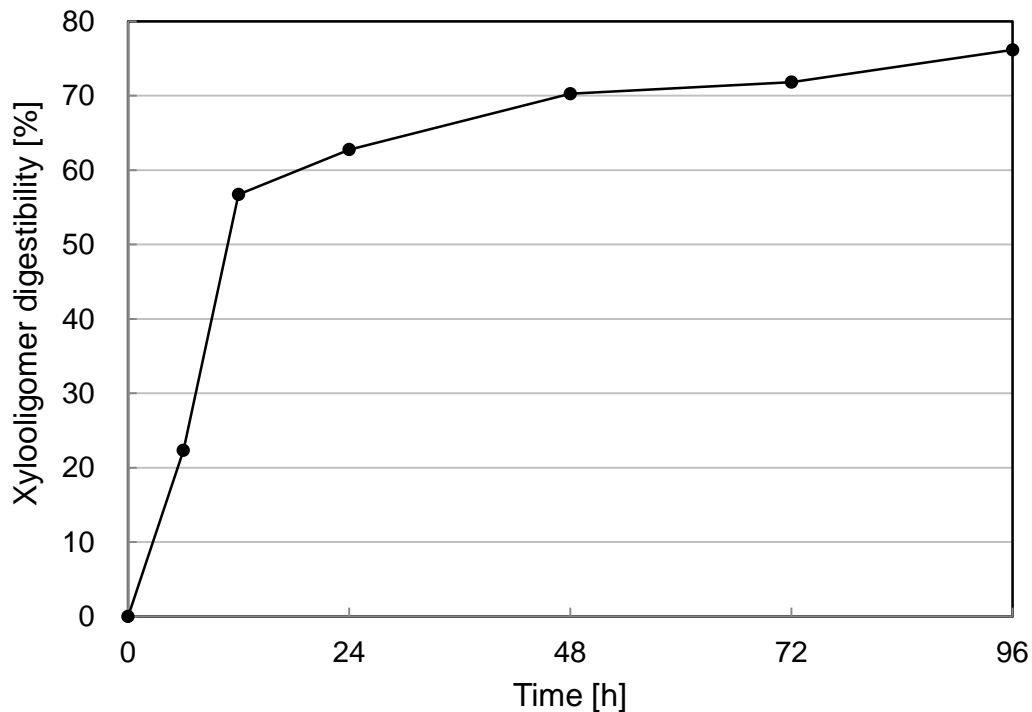

Fig. 4. Xylan digestibility of fractionated xylooligomer

Note: (1) Fractionation conditions: 1<sup>st</sup> stage - 15%  $\text{NH}_4\text{OH}$  solution ( $W_{\text{NH}_3} = 15\%$ ), 60 °C, solid : liquid ratio = 1:10, 24 h; 2<sup>nd</sup> stage - hot-water, 210 °C, 20 ml/min, 10 min. (2) Enzymatic hydrolysis: xylanase 8,000 GXU per g-glucan, 40°C, pH 4.8 maintained by 0.05 mol/l citrate buffer, 2.5 Hz. (3) The data points and bars in the graph show the mean value.



### 3.3. SSF

With two-stage treated solid samples at various reaction conditions, SSF of treated solids was also performed using *S. cerevisiae* D<sub>5</sub>A, GC-220 cellulase, and Novozyme 188  $\beta$ -glucosidase. Fig. 5 presents ethanol and glucose concentration profiles in the SSF reaction. In these experiments with 3g glucan loadings on 100 ml of total liquid, the theoretical maximum ethanol yield based on initial glucose loading (100%) corresponded to 17.0 g/l in the SSF reactor. Second stage treatment with hot water at 210 °C and 20 ml/min for 10 min removed more lignin and xylan than the treatment with hot water at 170 °C and 10 ml/min for 10 min (Table 3), which seemed to be related with enhanced ethanol yield. The ethanol yields of the treated solids at all fractionation conditions reached 87-98% of the ethanol yield based on initial glucose loading (14.8-16.7 g/l) within 72 h. In the early phase of the SSF reactions, 83-97% of ethanol yields were achieved within 24 h, which is much faster than the 48 - 96 h fermentation time typical of the current US corn-grain ethanol industry.

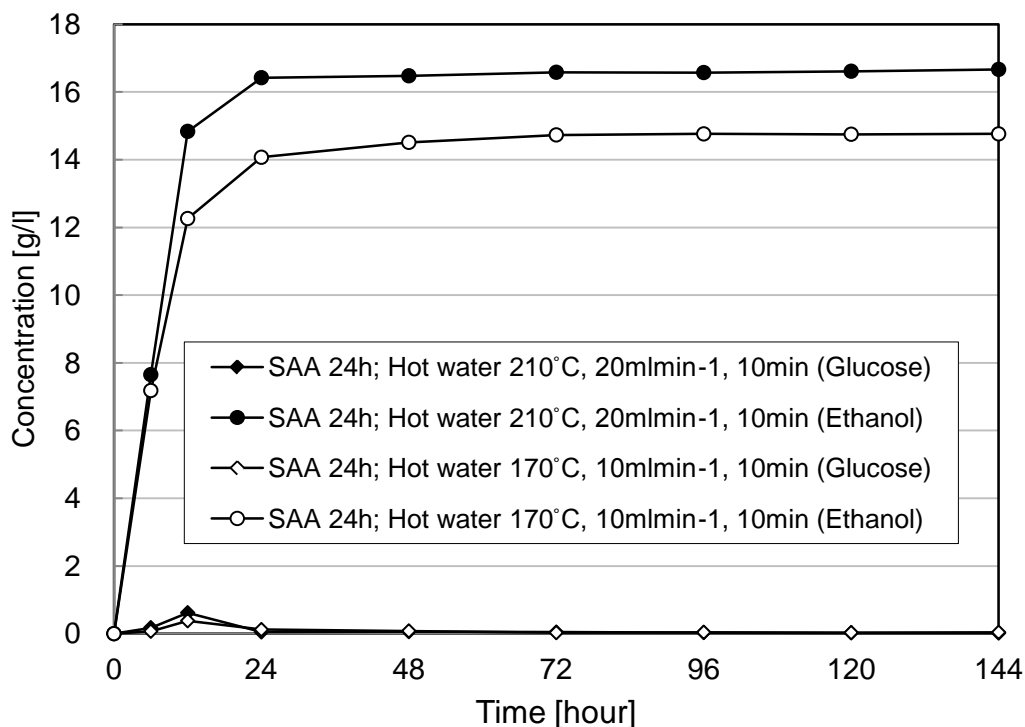

Fig. 5. SSF of two-stage fractionated corn stover

Note. Fractionation conditions: 1<sup>st</sup> stage -15%  $\text{NH}_4\text{OH}$  solution ( $W_{\text{NH}_3} = 15\%$ ), 60 °C, solid: liquid ratio = 1:10, 24 h; 2<sup>nd</sup> stage - hot-water, 170 - 210 °C, 10 - 20 ml/min, 10 min.

#### 4. Conclusions

The model equations predicted by RSM indicated that both reaction temperature and flow rate were significant factors for xylan recovery, while only reaction temperature was significant factor for xylan purity in the second stage. The predicted value of xylose recovery yield using RSM was 52%, and the value of purity was 82% under the optimal reaction conditions respectively. From the statistical results, the model equations for xylose recovery yield and purity were significant. Experimental verification of the optimal reaction conditions showed similar values of xylose recovery yield and purity: 55% and 84% respectively.

Cellulase enzymes hydrolyzed two-stage treated solids into fermentable sugars effectively. Accordingly, high yields of ethanol fermentation were obtained using stable *S. cerevisiae* yeast (D<sub>5</sub>A). Xylooligomer hydrolysate obtained from two-stage fractionation was effectively hydrolyzed by xylanase enzyme.

This study demonstrates optimization of a lignocellulosic biomass processing method that allows the production of ethanol from cellulose and the production of other value-added co-products from hemicelluloses sugars and lignin.

### **Acknowledgements**

We are grateful to Genencor International Inc. for providing cellulase enzymes. We would also like to thank the National Renewable Energy Laboratory (NREL) for supplying the corn stover. This work was supported by Iowa State University and by a grant from Gyeongnam National University of Science and Technology, Industry Academic Cooperation Foundation (2008). We also very sincerely thank Professor D. Raj Raman at Iowa State University for his critical reading of this manuscript.

### **References**

- [1] Kim TH, Lee YY. Fractionation of corn stover by hot-water and aqueous ammonia treatment. *Bioresource Technol* 2006;97(2):224-232.
- [2] Martinez JM, Granado JM, Montané D, Salvadó J, Farriol X. Fractionation of residual lignocellulosics by dilute-acid prehydrolysis and alkaline extraction: application to almond shells. *Bioresource Technol* 1995;52(1):59-67.

- [3] Papatheofanous MG, Billa E, Koullas DP, Monties B, Koukios EG. Two-stage acid-catalyzed fractionation of lignocellulosic biomass in aqueous ethanol systems at low temperatures. *Bioresource Technol* 1995;54(3):305-310.
- [4] Rubio M, Tortosa JF, Quesada J, Gomez D. Fractionation of lignocellulosics solubilization of corn stalk hemicelluloses by autohydrolysis in aqueous medium. *Biomass Bioenerg* 1998;15(6):483-491.
- [5] Torget RW, Padukone N, Hatzis C, Wyman CE, inventors; Midwest Research Institute, assignee. Hydrolysis and fractionation of lignocellulosic biomass. United States patent 6022419. 1996 Sep 30.
- [6] Torget RW, Kim JS, Lee YY. Fundamental aspects of dilute acid hydrolysis/Fractionation Kinetics of Hardwood Carbohydrates. 1. Cellulose Hydrolysis. *Ind Eng Chem Res* 2000;39(8):2817-2825.
- [7] Saddler JN, editor. Bioconversion of forest and agricultural plant residues. *Biotechnology in agriculture Series 9*, Wallingford: CAB international, 1993, p. 1-11.
- [8] Shabtai JS, Zmierzak WW, Chornet E, inventors; The university of Utah research foundation, assignee. Process for conversion of lignin to reformulated hydrocarbon gasoline, United States patent 5959167. 1999 Sep 28.
- [9] Demirbas A. Adsorption of lead and cadmium ions in aqueous solutions onto modified lignin from alkali glycerol delignification. *J Hazard Mater* 2004;109(1-3):221-226.
- [10] Dizhbite T, Zakis G, Kizima A, Lazareva E, Rossinskaya G, Jurkane V, Telysheva G, Viesturs U. Lignin – a useful bioresource for the production of sorption-active materials. *Bioresource Technol* 1999;67(3):221-228.
- [11] Srivastava SK, Singh AK, Sharma A. Studies on the uptake of lead and zinc by lignin obtained from black liquor - a paper-industry waste material. *Environ Technol* 1994;15(4):353-361.
- [12] Suhas Carrott PJM, Ribeiro Carrott MML. Lignin – from natural adsorbent to activated carbon: A review. *Bioresource Technol* 2007;98(12):2301-2312.
- [13] Adler E. Lignin chemistry – Past, present and future, *Wood Sci Technol* 1997;11(3):169–218.

- [14] Lin SY, Lebo SE Jr. Kirk-othmer encyclopedia of chemical technology. 4th ed. New Jersey: Wiley-Interscience; 1995, p. 268-289.
- [15] Rowell RM, Schultz TP, Narayan R, editors. Emerging technology for materials and chemicals from biomass. ACS Symposium Series 476. Washington, DC: American Chemical Society; 1992.
- [16] Sarkanen KV, Ludwig CH. Lignins: Occurrence, Formation, Structure and Reactions. New York: Wiley-Interscience; 1971.
- [17] Montané D, Salvadó J, Torras C, Farriol X. High-temperature dilute-acid hydrolysis of olive stones for furfural production. *Biomass Bioenerg* 2002;22(4):295-304.
- [18] Moreau C, Durand R, Peyron D, Duhamet J, Rivalier P. Selective preparation of furfural from xylose over microporous solid acid catalysts. *Ind Crop Prod* 1998;7(2-3):95-98.
- [19] Caye DC, Nghiem NP, Terry WH. *Biofuels Engineering Process Technology*. New York, Chicago, San Francisco: McGraw Hill companies; 2008.
- [20] Nghiem NP, Donnelly M, Sanville-Millard CY, inventors; UT-BATTELLE, LLC., University of Chicago, assignees. A method to produce succinic acid from raw hydrolysates, World Intellectual Property Organization patent WO 2005/116227. 2005 Dec 8.
- [21] Sharma S, Malik A, Satya S. Application of response surface methodology (RSM) for optimization of nutrient supplementation for Cr (VI) removal by *Aspergillus lentulus* AML05. *J. Hazard Mater* 2009;164(2-3):1198-1204.
- [22] Vazquez MJ, Alonso JL, Dominguez H, Parajo JC. Xylooligosaccharides: manufacture and applications. *Trends Food Sci Tech* 2000;11(11):387-393.
- [23] Yoo CG, Lee CW, Kim TH. Two-stage fractionation of corn stover using aqueous ammonia and hot-water. *Appl Biochem Biotech* 2011;164(6):729-740.
- [24] Kim TH, Kim JS, Sunwoo C, Lee YY. Pretreatment of corn stover by aqueous ammonia. *Bioresour Technol* 2003;90(1):39-47.
- [25] Kim TH, Lee YY. Pretreatment of corn stover by soaking in aqueous ammonia at moderate temperature. *Appl Biochem Biotech* 2007;137-140(1-12):81-92.
- [26] Ma H, Liu WW, Chen X, Wu YJ, Yu ZL. Enhanced enzymatic saccharification of rice straw by microwave pretreatment. *Bioresour Technol* 2009;100(3):1279-1284.

- [27] Yue ZB, Yu HQ, Hu ZH, Harada H, Li YY. Surfactant-enhanced anaerobic acidogenesis of *Canna indica* L. by rumen cultures. *Bioresource Technol* 2008;99(9):3418-3423.
- [28] Chen MJ, Chen KN, Lin CW. Optimization on response surface models for the optimal manufacturing conditions of dairy tofu. *J Food Eng* 2005;68(4):471-480.
- [29] Karacan F, Ozden U, Karacan S. Optimization of manufacturing conditions for activated carbon from Turkish lignite by chemical activation using response surface methodology. *Appl Therm Eng* 2007;27(7):1212-1218.
- [30] Sánchez S, Bravo V, Castro E, Moya AJ, Camacho F. The production of xylitol from D-xylose by fermentation with *Hansenula polymorpha*. *Appl Microbiol Biot* 1998;50(5):608-611.
- [31] Sluiter A, Hames B, Ruiz R, Scarlata C, Sluiter J, Templeton D, Crocker D. Determination of Structural Carbohydrates and Lignin in Biomass. National Renewable Energy Laboratory 1617 Cole Boulevard, Golden, Colorado: National Renewable Energy Laboratory; 2008, April, 16p, Report No. TP-510-42618.
- [32] Selig M, Weiss N, Ji Y. Enzymatic Saccharification of Lignocellulosic Biomass. National Renewable Energy Laboratory 1617 Cole Boulevard, Golden, Colorado: National Renewable Energy Laboratory; 2008, March, 8p, Report No. TP-510-42629.
- [33] Sluiter A, Hames B, Ruiz R, Scarlata C, Sluiter J, Templeton D. Determination of Sugars, Byproducts, and Degradation Products in Liquid Fractionation Process Samples. National Renewable Energy Laboratory 1617 Cole Boulevard, Golden, Colorado: National Renewable Energy Laboratory; 2006, December, 14p, Report No. TP-510-42623.
- [34] Kim TH, Lee YY. Pretreatment of Corn Stover by Soaking in Aqueous Ammonia. *Appl Biochem Biotech* 2005;124(1-3):1119-1132.

**CHAPTER 4. ETHANOL AND FURFURAL PRODUCTION FROM CORN STOVER USING  
HYBRID FRACTIONATION PROCESS WITH ZINC CHLORIDE AND SIMULTANEOUS  
SACCHARIFICATION AND FERMENTATION (SSF)**

A paper published in the Journal of *Process Biochemistry*

Chang Geun Yoo, Monlin Kuo, Tae Hyun Kim

**Abstract**

Two-stage hybrid fractionation process was investigated to produce cellulosic ethanol and furfural from corn stover. Zinc chloride ( $\text{ZnCl}_2$ ) was used to selectively solubilize hemicellulose in the first stage. During the second stage, the remaining treated solids were converted into ethanol using commercial cellulase and *Saccharomyces cerevisiae* or recombinant *Escherichia coli*, KO11. Hybrid fractionation process recovered 93.8% of glucan, 89.7% of xylan, 71.1% of arabinan, and 74.9% of lignin at optimal reaction conditions: 1<sup>st</sup> stage: 5% acidified  $\text{ZnCl}_2$ , 7.5 ml/min, 150 °C (10 min) and 170 °C (10 min); 2<sup>nd</sup> stage: Simultaneous saccharification and fermentation (SSF) using *Saccharomyces cerevisiae*. Furfural yield from hemicellulose hydrolysates was 58 %. The SSF of the treated solids resulted in 69-98 % of theoretical maximum ethanol yields based on glucan in the treated solids. After fermentation, the solid residues contained primarily lignin. Based on total lignin in untreated corn stover, the lignin recovery yield was 74.9%.

*Key words:* biofuel; lignocellulose; thermal conversion; lignin; xylooligomer; furfural

## 1. Introduction

Interest in lignocellulosic biomass as a resource of fuel ethanol has grown as conventional fuel prices rise [1, 2]. Ethanol production from lignocellulosic materials requires hydrolysis of carbohydrate polymers into monomeric sugars, which is typically performed with enzymes. In this bioconversion process the enzyme hydrolysis is one of the most costly unit operations [3]. Numerous efforts have been made to reduce the enzyme dosage and improve the fermentability of biomass. Pretreatments of lignocellulose using various alkaline or acidic reagents have been evaluated to improve accessibility of enzymes to the fiber [4]. Recently, fermentation of both cellulose and hemicellulose using recombinant strains has been introduced to produce ethanol effectively [5, 6]. However, the cost for production of ethanol from biomass is still economically unfavorable because simultaneous conversion of both cellulose and hemicellulose using simultaneous saccharification and co-fermentation (SSCF) has turned out to be problematic. The challenges in SSCF include the costs of enzymes need for hemicellulose hydrolysis, glucose inhibition of xylose uptake, and the low ethanol tolerance and poor stability of recombinant strains [7-11]. Therefore, independent utilization of these two carbohydrates may be more desirable. If lignocellulosic biomass can be effectively fractionated into cellulose, hemicellulose and lignin, it may be advantageous to improve overall efficiency of biomass utilization; for example, (1) cellulose-rich stream can easily be fermented, which can result in high ethanol concentration, and (2) hemicellulose and lignin can be used to produce value-added co-products. In addition, lignin can be burned as a power plant fuel or boiler fuel, a feedstock for activated carbon [12], hydrocarbon fuel additive to gasoline [13], and other



applications such as binder, or emulsifier [14–16]. Cellulose and hemicellulose can be converted into ethanol, food, pharmaceutical products, and other chemicals [17-20].

In this study, hybrid fractionation process using acidified  $\text{ZnCl}_2$ , followed by simultaneous saccharification and fermentation (SSF), was used to achieve the fractionation of corn stover into cellulose, hemicellulose and lignin. Zinc chloride ( $\text{ZnCl}_2$ ) has many advantages for biomass fractionation and pretreatment; it is the most effective swelling inorganic chemical reagent for biomass [21]. Although it is not highly toxic to living cells, it is highly selective for hemicellulose hydrolysis [22]. Zinc ions can react with carbohydrates to form zinc-cellulose complexes, which are reactive to acid hydrolysis, and hydrolyze cellulose to low-degree of polymerization (DP) compounds such as cellodextrin, and hydrolyzes hemicellulose to monosaccharides [23, 24]. Zinc chloride can expose the crystalline cellulose core by separating hemicellulose from biomass [22, 23]. After  $\text{ZnCl}_2$  treatment, most cellulose and lignin is retained in the solids and the cellulose can be then converted to ethanol by fermentation. Solubilized hemicellulose in the first stage can be converted to furfural at a high temperature.

Furfural, which is an acid degradation product of xylose, has many applications; it can be used as a chemical intermediate in herbicides, solvent in the refining of lubricating oil and synthesis of pharmaceuticals, nylon, vegetable oil, plastic and rubber products [25-27]. It can be produced from hemicellulose-rich agricultural materials [26]. Hemicellulose can be hydrolyzed into monomeric C5 sugars and successively formed furfural by dehydration. These reactions are catalyzed by acid [28]. In this study, significant amounts of hemicellulose were hydrolyzed with acidified  $\text{ZnCl}_2$  solution. After this first fractionation

stage, the acidified hemicellulose hydrolysates can easily be converted into furfural without additional catalysts. After furfural recovery by distillation, the remaining acidified  $\text{ZnCl}_2$  solution can be reused in the pretreatment step.

In this article, the process conditions for effective fractionation and pretreatment are explored. Various effects on the compositional changes, enzyme digestibility, fermentability, recovery/utilization of each component, and other technical aspects related to development of process were reported.

## **2. Materials and Methods**

### *2.1. Materials*

Corn stover was harvested from central Iowa in 2009 and air-dried at ambient temperature. The corn stover was ground and screened to a nominal size of 9-35 mesh. The initial composition of the corn stover, as determined by the NREL (National Renewable Energy Laboratory, Golden, CO) LAP (laboratory analytical procedure [29]), was 38.7 wt.% glucan, 23.3 wt.% xylan, 2.1 wt.% galactan, 4.5 wt.% arabinan, 17.1 wt.% lignin (acid insoluble + acid soluble), 1.5 wt.% sucrose, 1.2 wt.% ash, and 11.6 wt.% other extractives.

Cellulase enzyme, GC 220 (Genencor International Inc., Lot No #301-04232-162) was provided by Genencor International. The average activity of cellulase (GC-220) provided by the manufacture was 45 filter paper unit (FPU)/ml and the protein content was 184 mg/ml. GC-220 is also known to contain  $\beta$ -glucosidase activity (196 cellobiase unit (CBU)/ml) and xylanase activity (1526 unit/ml) [30]. Novozyme 188 ( $\beta$ -glucosidase) was

purchased from Sigma-Aldrich (Sigma Cat. #C-6150). Activity of  $\beta$ -glucosidase (Novozyme 188) was measured [31], which was 750 CBU/ml and the protein content was 152 mg/ml.

The microorganism used for simultaneous saccharification and fermentation (SSF) was *Saccharomyces cerevisiae* ATCC<sup>®</sup> 200062 (NREL-D<sub>5</sub>A). The growth media was YP medium, which contained 10 g/l yeast extract (Sigma cat. No. Y-0500) and 20 g/l peptone (Sigma cat. No. P-6588). For SSCF, recombinant *Escherichia coli* (KO11) ATCC<sup>®</sup> 55124 was purchased from the American Type Culture Collection (ATCC). The *E. coli* KO11 is recombinant cells that highly express chromosomally-integrated heterologous genes enabling it to metabolize both 5 and 6 carbon sugars. LB medium (Sigma, Cat. # L-3152) which consisted of 10 g/l tryptone, 5 g/l yeast extract, and 10 g/l NaCl, supplemented with 40 mg/l chloramphenicol (Sigma, Cat. #C-0378) was used for the growth of *E. coli* KO11. The fluted filter paper (medium pore) used for filtration was purchased from Fisher Scientific (Cat. #09-790-14F).

## 2.2. Experimental setup and Operation

The reaction and operating conditions are summarized in Fig. 1.

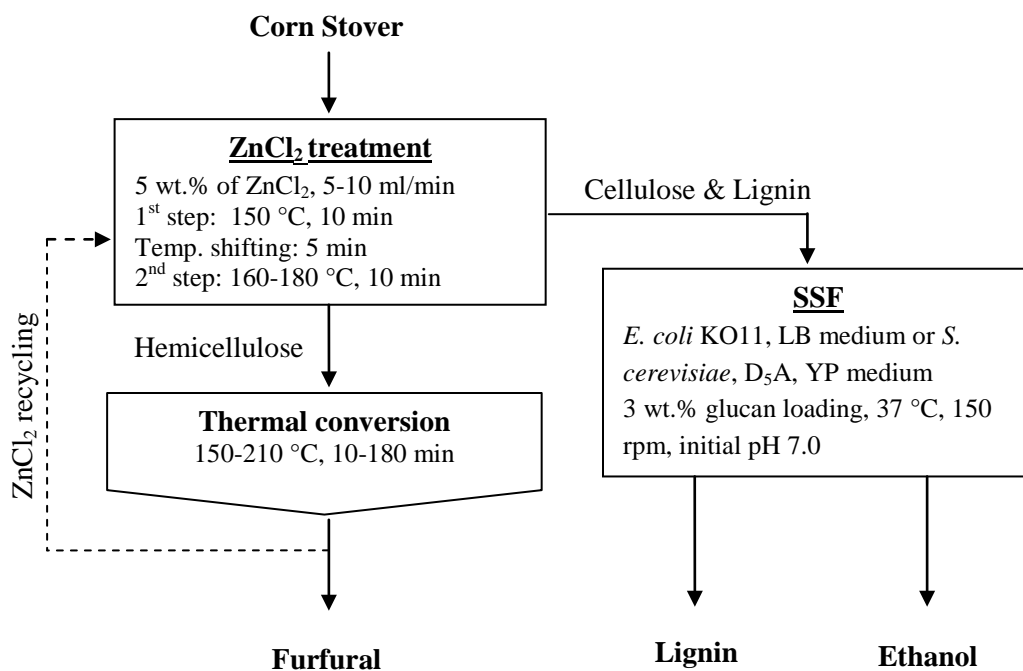

Fig. 1. Flow diagram of two-stage hybrid fractionation process.

### 2.2.1. First stage: ZnCl<sub>2</sub> treatment

Flow-through reactor system for ZnCl<sub>2</sub> treatment consists of SS-316 column reactor (2.3 cm internal diameter (ID) × 25.4 cm length (L), 104.3 cm<sup>3</sup> of internal volume), a high performance liquid chromatography (HPLC) pump (Series II pump, Chrom Tech, Inc., MN), temperature-programmable GC (gas chromatography) oven (Hewlett Packard 5890, HP Inc., Ontario, Canada), solution reservoirs, and sample receiver tank (SS 304 cylinder, 1,000 ml of internal volume). A schematic diagram of the laboratory reactor set-up is shown in Fig. 2. For the ZnCl<sub>2</sub> treatment, 5.0% ZnCl<sub>2</sub> with 0.03% of HCl solution was used. Ten gram (oven-dry basis) of air-dried corn stover was packed into the flow-through type reactor. The

preheating coil was filled with ZnCl<sub>2</sub> solution by the HPLC pump with no heating, and the pump was turned off. To maintain the system pressure above the saturated pressure of the ZnCl<sub>2</sub> solution, 300 psi of nitrogen backpressure was set to the reactor system. The reactor and preheating coil were preheated to a desired temperature by temperature-programmable GC oven for 15 min, and the acidified ZnCl<sub>2</sub> solution was pumped into the reactor when it reached the target temperature. In this study, preheating time was not included in the reaction time. Zinc chloride fractionation was done in two-step: 5% acidified zinc chloride at various flow rate (5.0, 7.5, and 10.0 ml/min) was heated to 150 °C for 10 min in the first stage, followed by heating at 160-180 °C for 10 min in the second stage maintaining the same flow rate. After completion of the first step, temperature shifting was done within a 5 min period keeping the pump running. At the end of the run, the biomass in the flow-through reactor was washed with DI water to remove the residual sugars and ZnCl<sub>2</sub>. After completion of treatment, both remaining solid and liquid hydrolysates were subjected to composition analysis. Based on the results of the analysis, furfural production tests were conducted with fractionated liquid hydrolysates, and the enzymatic digestibility and fermentability were also tested with residual solids.

### 2.2.2. Second stage: SSF/SSCF

Simultaneous saccharification and fermentation (SSF) were conducted by using *Saccharomyces cerevisiae* ATCC<sup>®</sup> 200062 (NREL-D<sub>5</sub>A) and simultaneous saccharification and co-fermentation were performed by using recombinant *Escherichia coli* ATCC<sup>®</sup> 55124 (KO11), with GC-220 cellulase enzyme and Novo 188 β-glucosidase enzyme with ZnCl<sub>2</sub>

treated corn stover. A 250 ml Erlenmeyer flask capped with rubber stoppers perforated with a syringe needle for CO<sub>2</sub> venting was used as a bioreactor. It was shaken in the incubator shaker (Model E24, New Brunswick Scientific, Edison, NJ) at 37 °C and 150 rpm. Into a 100 ml working volume of liquid, treated corn stover sample was introduced to reach 3% (w/v) glucan content in the reactor. The SSF/SSCF runs were performed with a buffer without external pH control, starting at pH 5.0/7.0 at the beginning of the fermentation and gradually decreasing to pH 4.5/6.0 at the end. The loading of cellulase enzyme (GC-220) was 15 FPU/g-glucan and that of β-glucosidase (Novozyme 188) was 30 CBU/g-glucan. At the end of fermentation, liquid products and residual solids were separated by vacuum filtration. The filtered solids were collected for lignin balance tests. Liquid samples were taken and analyzed routinely until the fermentation process ended. The theoretical maximum ethanol concentrations for SSF were calculated on the basis of total glucan in treated solids. It was also calculated on the basis of total carbohydrates (glucan + xylan) in treated solids for SSCF. SSF and SSCF tests were performed based on 3.0 g-glucan/ 100 ml working volume in the flask.

The ethanol yields in SSF/SSCF tests were calculated as follows:

$$\text{Theoretical maximum ethanol yield [\%]} = \frac{\text{Ethanol produced [g] in reactor}}{\text{Initial sugar [g] in reactor} \times 0.511} \times 100$$

Note. Sugar is interpreted as glucose in the SSF results or glucose and xylose in the SSCF work.

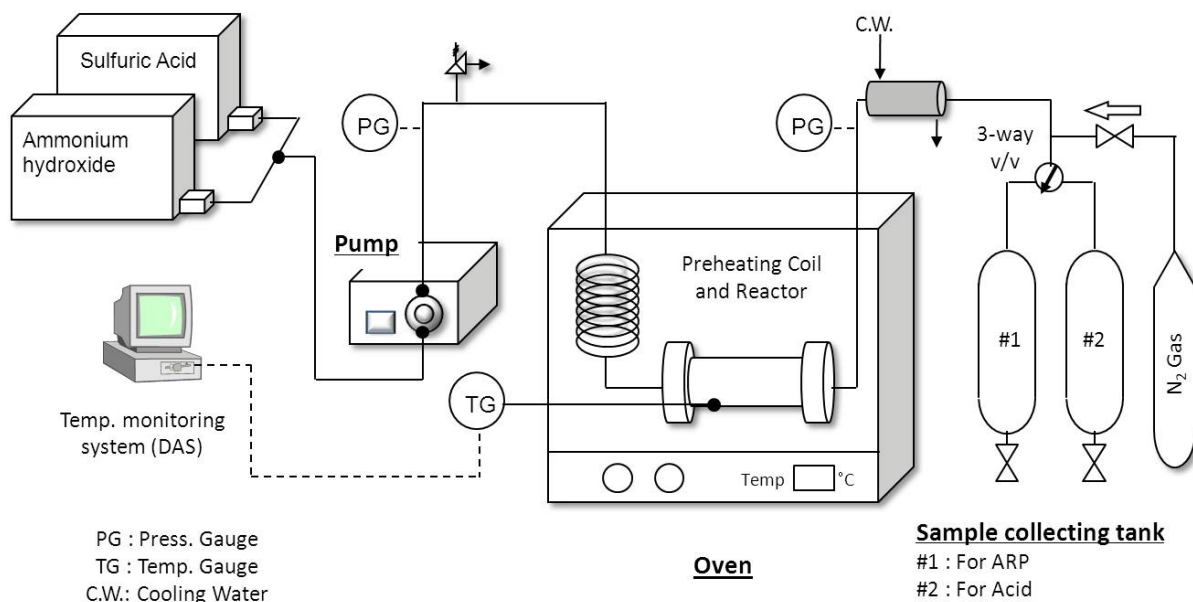

Fig. 2.  $\text{ZnCl}_2$  treatment laboratory reactor set-up.

### 2.3. Furfural Production

Hemicellulose hydrolysate was prepared in the  $\text{ZnCl}_2$  treatment, which was used for furfural production test. The treatment conditions were as follows: a 7.5 ml/min and two-step reaction (150 and 170 °C for 10 min at each step) with 5% acidified zinc chloride. The production of furfural was carried out in a batch reactor. The reactor (14.3 cm<sup>3</sup> of internal volume) was constructed out of 16.5 cm (6.5 inch) of SS-316 tubing with an internal diameter of 1.1 cm (0.43 inch) ID. The tubes were sealed with 316 stainless steel caps (Swagelok, Cat. # SS-810-C). A temperature-programmable GC oven (Hewlett Packard 5890, HP Inc., Ontario, Canada) controlled the reaction temperature and high temperature molded transition junction style thermocouple probes (Omega.com®, Cat. # HJMTSS-125-6) was installed inside the reactor to monitor the reaction temperature.

The furfural production tests and furfural production experiments were conducted at three different reaction temperatures (150, 180, and 210 °C) for 10 to 180 min. In each experiment, 5.0 ml of hemicellulose hydrolysates (1.3 g/l glucan, 10.1 g/l xylan, and 1.4 g/l arabinan) were loaded in the batch reactor. The reactor was placed in a GC oven for preheating to the desired reaction temperature and kept with constant reaction temperature. The preheating step took 5 min and was not counted toward reaction time. After the reaction, the reactor was immediately submerged in the cold water to stop the reaction. The reacted liquid products were analyzed by HPLC to quantify sugars and furfural in the product.

#### *2.4. Enzymatic digestibility test*

The enzymatic digestibility of corn stover was determined in duplicate according to the NREL LAP [32]. The reaction conditions used for sample preparation were a 5% acidified ZnCl<sub>2</sub> solvent with a 7.5 ml/min flow rate at 150 °C for 10 min and then 160-180 °C for 10 min. The enzymatic digestibility test were conducted with a solid residue after ZnCl<sub>2</sub> treatment at pH 4.8 (0.05 M sodium citrate buffer) in a 50 °C shaker bath agitated at 150 rpm. For the enzymatic digestibility tests of the ZnCl<sub>2</sub>-treated corn stover, 15 FPU of GC-220/g of glucan supplemented and 30 CBU of β-glucosidase (Novozyme 188)/g-glucan were loaded. The initial glucan concentration was 1% (w/v) based on 100 ml of total liquid and solid.

The 250 ml screw-capped Erlenmeyer flasks containing the enzyme hydrolysis preparations were placed in an incubator shaker (New Brunswick Scientific, Edison, NJ).



Samples were taken periodically (6, 12, 24, 48, 72 and 96 h) and analyzed for glucose and xylose content using HPLC.

The glucan and xylan digestibilities were calculated as follows:

$$\text{Glucan digestibility} = \frac{\text{Total released glucose} \times 0.9}{\text{Initial glucan loading}} \times 100$$

where 0.9 is the conversion factors of glucose to equivalent glucan.

$$\text{Xylan digestibility} = \frac{\text{Total released xylose} \times 0.88}{\text{Initial xylan loading}} \times 100$$

where 0.88 is the conversion factors of xylose to equivalent xylan.

### *2.5. Recovery yields of hemicellulose, lignin, and furfural*

To quantitatively evaluate the fractionation effects of various reaction conditions on each component (xylan and lignin), the recovery yield of each component were defined as follows:

$$\text{Xylan recovery yield (R}_x\text{)} = \frac{\text{Xylose} \times 0.88 + \text{Xylan [g] in liquid hydrolysate}}{\text{Xylan [g] in dry untreated corn stover}} \times 100$$

$$\text{Lignin recovery yield (R}_L\text{)} = \frac{\text{Lignin [g] in residual solid after SSF}}{\text{Lignin [g] in dry untreated corn stover}} \times 100$$

Two different samples were prepared to check the mass balance of lignin. The sample preparation conditions for lignin recovery tests were as follows: (1) 5% acidified ZnCl<sub>2</sub>, 7.5 ml/min, 150 °C (10 min) and 160 °C (10 min) in the first stage; SSCF with *E. coli* KO11 in the second stage, (2) 5% acidified ZnCl<sub>2</sub>, 7.5 ml/min, 150 °C (10 min) and 170 °C (10 min) in the first stage; SSCF with *E. coli* KO11 in the second stage.

The furfural production yield was defined as the ratio of the weight of furfural to the theoretical furfural yield that comes from the conversion of xylan and arabinan in hemicellulose hydrolysate. In this equation, the stoichiometric yield of furfural is 72.7% [33, 34].

$$\text{Furfural recovery yield (R}_F\text{)} = \frac{\text{Furfural [g] produced from sugars in hemicellulose hydrolysate}}{[(\text{Xylan} + \text{Arabinan}) \times 0.7272 + \text{Furfural}] \text{ [g] in hemicellulose hydrolysate}} \times 100$$

## 2.6. Analytical methods

The solid samples, such as treated/ untreated corn stover, and residual solids after SSCF were analyzed for carbohydrates (sugars) and lignin following NREL LAP [29]. Each sample was analyzed in duplicate. Carbohydrates were determined by HPLC with a Bio-Rad Aminex HPX-87P column and a refractive index detector (Varian 356-LC, Varian, Inc., CA). The carbohydrates in the liquid samples were determined by secondary acid hydrolysis (conditions: 4% H<sub>2</sub>SO<sub>4</sub>, 121 °C, 1 h. For the fermentation and furfural tests, an HPX-87H column was used to measure the sugar, furfural and ethanol.

### 3. Results and discussion

#### 3.1. $ZnCl_2$ treatment

A lower temperature was applied to hydrolyze the majority of xylan and higher temperature was applied to hydrolyze the remaining xylan. The sugar yield with two-step temperature process was higher than that with uniform temperature process (data not shown). In the first series of experiments (Table 1), three different flow rates (5.0, 7.5, and 10.0 ml/min) (0.25, 0.38, and 0.50 g- $ZnCl_2$ /g-biomass, respectively) were tested at 170 °C for 10 min to see the effects of flow rates on the compositions of solid and liquid. Table 1 shows that xylan and arabinan recovery yields in liquid generally increased, as flow rate increased, with the highest xylan and arabinan recovery yields (66.1% and 51.1% respectively) at 10.0 ml/min. In addition to the treatment using 5.0 wt.% acidified  $ZnCl_2$ , reaction using 0.03% HCl without  $ZnCl_2$  was initially tested at 150°C as a control (data not shown), which solubilized only 15% of xylan in corn stover.

Although the highest yields were observed with 10.0 ml/min, xylan yield at 7.5 ml/min gave almost same as the yield with 10.0 ml/min. The data also indicated that the first stage treatment at 10.0 ml/min also solubilized greater than 20% of lignin to liquid hydrolysates. This flow rate also hydrolyzed hemicellulose, which was present in higher amounts than in the reaction at 7.5 ml/min. Therefore, the 7.5 ml/min flow rate was selected for subsequent experiments because it can maximize xylan and arabinan recovery with minimal contaminations of lignin.

In the second series (Table 2), the  $ZnCl_2$  treatments were tested with three different second step reaction times (5, 10, and 15 min) at a 7.5 ml/min flow rate at 170 °C, while keeping the reaction conditions of the first step at 150 °C and 7.5 ml/min for 10 min. Overall,

the hemicellulose recovery yields increased as the reaction time increased from 5 min to 15 min. The highest hemicellulose recovery was achieved with a 10-15 min of reaction time in the second step. The xylan and arabinan recovery yields for 10 min and 15 min treatments were approximately the same, and the difference between the two reaction times was only < 2%. However, the total liquid throughput of the 15 min treatment was 1.5 times higher than that of the 10 min treatment in the second step. Moreover, more lignin (>7.0%) was solubilized during the longer treatment. It was anticipated that two factors, liquid throughput and lignin contamination, would significantly affect on the overall process cost. Consequently, 10 min was selected as the best reaction time in the second step of ZnCl<sub>2</sub> treatments.

Table 1. Effect of flow rate on the compositions in the single stage ZnCl<sub>2</sub> treatment <sup>a</sup>

Flow rate [ml/min]	Solid					Liquid		
	SR <sup>b</sup> [wt.%]	Glucan [wt.%]	Xylan [wt.%]	Lignin <sup>c</sup> [wt.%]	Arabinan [wt.%]	Glucan [wt.%]	Xylan [wt.%]	Arabinan [wt.%]
Untreated	100.0	38.7	23.3	17.1	4.5	-	-	-
5.0	56.7	36.7	11.0	15.4	2.3	2.4	12.1	1.5
7.5	55.4	36.1	7.7	14.5	1.9	2.5	15.2	1.7
10.0	52.9	35.5	7.4	13.6	1.3	2.8	15.4	2.3

*Note:* The data in the table show the mean value (n=2, SD < 0.3, glucan, xylan, arabinan, and lignin in solid and liquid, SD: standard deviation).

<sup>a</sup> Data in the table are based on the oven-dry untreated biomass. Fractionation conditions: 5 wt.% of ZnCl<sub>2</sub>, 170 °C, 5.0-10.0 ml/min, 10 min

<sup>b</sup> SR stands for solid remaining after reaction

<sup>c</sup> Acid insoluble lignin + Acid soluble lignin

Table 2. Effect of reaction time in the second stage on the compositions in the ZnCl<sub>2</sub> treatment <sup>a</sup>

Reaction time [min]	Solid					Liquid		
	SR <sup>b</sup> [wt.%]	Glucan [wt.%]	Xylan [wt.%]	Lignin <sup>c</sup> [wt.%]	Arabinan [wt.%]	Glucan [wt.%]	Xylan [wt.%]	Arabinan [wt.%]
Untreated	100.0	38.7	23.3	17.1	4.5	-	-	-
5	52.2	36.7	2.4	12.9	0.2	2.7	18.5	2.7
10	51.5	36.3	2.9	12.8	0.2	3.2	20.9	3.2
15	47.6	35.2	1.7	11.7	0.0	3.3	20.8	3.3

*Note:* The data in the table show the mean value (n=2, SD < 0.2, glucan, xylan, arabinan, and lignin in solid and liquid, SD: standard deviation).

<sup>a</sup> Data in the table are based on the oven-dry untreated biomass. Fractionation conditions: 5 wt.% of ZnCl<sub>2</sub>, 150 °C, 7.5 ml/min, 10 min in the first step; 5 wt.% of ZnCl<sub>2</sub>, 170 °C, 7.5 ml/min, 5-15 min in the second step

<sup>b</sup> See notes <sup>b</sup> in Table 1.

<sup>c</sup> See notes <sup>c</sup> in Table 1.

From the above results, 7.5 ml/min and 10 min reaction time were selected as flow rate and ZnCl<sub>2</sub> treatment time at the second step. To seek the best treatment temperature in the second step, four different reaction temperatures (150–180 °C) were applied in the second step of ZnCl<sub>2</sub> treatment while keeping the other reaction conditions constant (7.5 ml/min for 10 min) (Table 3). The reaction temperature in the first step of ZnCl<sub>2</sub> was maintained at 150 °C. Xylan and arabinan recovery yields in the liquid products by ZnCl<sub>2</sub> treatments increased as the reaction temperature increased between 150 °C and 170 °C. The xylan and arabinan recovery yields at 150 °C (1<sup>st</sup> step) and 170 °C (2<sup>nd</sup> step) were 89.7%, and 71.1%, respectively. This trend changed in 170-180 °C range (Table 3). As the temperature increased above 170 °C, the xylan and arabinan recovery in liquid decreased. This decreased recovery may be due to the degradation of hydrolyzed hemicellulose during treatment at higher temperature [22]. Therefore, 170 °C was selected as an optimum temperature. More glucan

and lignin were also released as reaction temperature increased, but >93% of glucan, and >75% of lignin were still retained in the solids at all tested temperatures. Our test results indicated that under the various treatment conditions, ZnCl<sub>2</sub> treatment were highly selective for hemicellulose solubilization, whereas other components, glucan and lignin were well preserved with solids.

Dilute sulfuric acid pretreatment was also reported to be effective method for hemicellulose recovery. When compared to dilute acid method [35, 36], ZnCl<sub>2</sub> treatment resulted in less contamination of hemicellulose hydrolysates by soluble lignin. The ZnCl<sub>2</sub> method and the dilute sulfuric acid method solubilized approximately 25% of lignin with 6% glucan contamination, and 29-45% of lignin with 10-15% of glucan contamination, respectively.

Table 3. Effect of second stage reaction temperature on the compositions in the ZnCl<sub>2</sub> treatment <sup>a</sup>

Reaction temp. [°C]	Solid					Liquid		
	SR <sup>b</sup>	Glucan	Xylan	Lignin <sup>c</sup>	Arabinan	Glucan	Xylan	Arabinan
	[wt.%]	[wt.%]	[wt.%]	[wt.%]	[wt.%]	[wt.%]	[wt.%]	[wt.%]
Untreated	100	38.7	23.3	17.1	4.5	-	-	-
150	58.7	36.0	6.5	15.0	1.4	2.3	16.6	2.8
160	56.6	36.4	3.8	12.9	0.3	2.9	20.1	3.0
170	51.5	36.3	2.9	12.8	0.2	3.2	20.9	3.2
180	52.7	36.0	1.8	12.9	0.0	3.4	18.5	3.1

*Note:* The data in the table show the mean value (n=2, SD < 0.3, glucan, xylan, arabinan, and lignin in solid and liquid, SD: standard deviation).

<sup>a</sup> Data in the table are based on the oven-dry untreated biomass. Fractionation conditions: 5 wt.% of ZnCl<sub>2</sub>, 150 °C, 7.5 ml/min, 10 min in the first step; 5 wt.% of ZnCl<sub>2</sub>, 150-180 °C, 7.5 ml/min, 10 min in the second step

<sup>b</sup> See notes <sup>b</sup> in Table 1.

<sup>c</sup> See notes <sup>c</sup> in Table 1.

### 3.2. Enzymatic hydrolysis and SSF/SSCF of ZnCl<sub>2</sub> treated solids

Enzymatic digestibility tests for both glucan and xylan were also conducted with the remaining solid after two-step ZnCl<sub>2</sub> fractionation using cellulase enzyme (GC-220) and  $\beta$ -glucosidase enzymes (Novozyme 188). The enzymatic digestibility of ZnCl<sub>2</sub> fractionated corn stover is shown in Fig. 3. Both glucan and xylan digestibility increased as the treatment temperature in the second step increased. The 72-h glucan digestibilities of ZnCl<sub>2</sub> treated solids reached 85-100%, and 72-h xylan digestibilities of 170-180 °C treated samples were in the range of 91-100%. Within 24-h, 97% of glucan and xylan digestibilities were achieved with 180 °C treated biomass.

SSF tests of ZnCl<sub>2</sub> treated solids were conducted using cellulase,  $\beta$ -glucosidase, and *S. cerevisiae* D<sub>5</sub>A strains. SSCF tests of ZnCl<sub>2</sub> treated solids were also conducted using same enzymes with *E. coli* KO11 strains. These ethanol concentration profiles of both SSF and SSCF reactors are shown in Fig. 4. The theoretical maximum ethanol yield (100%) corresponded to 17.0 g/l with 3% w/v glucan loading in the SSF tests. On the other hands, in the SSCF test with 3.0 g of glucan and 0.2-0.3 g of xylan loadings (see the Materials and Methods section), the theoretical maximum ethanol concentrations were 18.8 g/l and 18.2 g/l, respectively. Fig. 4 presents ethanol concentrations during the SSF and SSCF reaction time. The maximum ethanol concentrations in SSF process reached at 12.0, 14.5, and 16.8 g/l with different treated biomass (Fig.4a). In other words, 70% and 98% of theoretical maximum ethanol yield were obtained based on glucan in the treated corn stover. At 24-h, the ethanol yield of the treated samples reached 70 to 90%. The ZnCl<sub>2</sub> treatment typically produced glucan-rich solid cakes after 1<sup>st</sup> stage fractionation, which contained 65-75 wt.% of glucan in

the treated solids. This is desirable to implement high solid fermentation because higher ethanol concentration in the fermentor is possible.

(a) Glucan digestibilities of ZnCl<sub>2</sub> treated corn stover

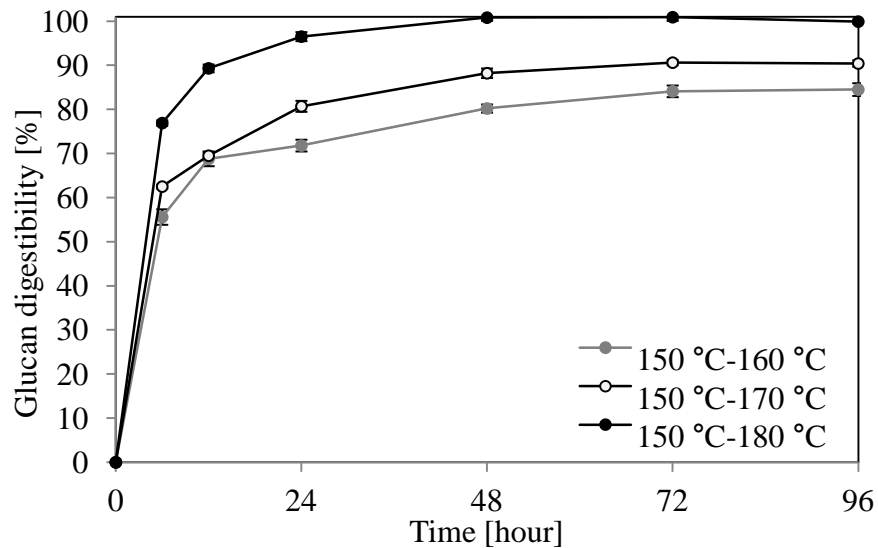

(b) Xylan digestibilities of ZnCl<sub>2</sub> treated corn stover

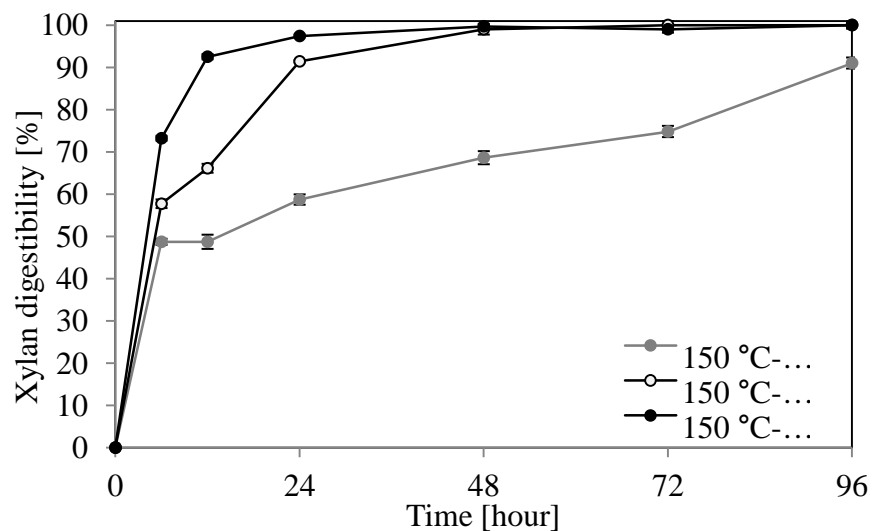

Fig. 3. Enzymatic digestibility of ZnCl<sub>2</sub> treated corn stover: (a) Glucan digestibility and (b) Xylan digestibility of ZnCl<sub>2</sub> treated corn stover

*Note:* treatment conditions: 5 wt.% of ZnCl<sub>2</sub>, 150 °C, 7.5ml/min, 10 min in the first step; 5 wt.% of ZnCl<sub>2</sub>, 160-180 °C, 7.5 ml/min, 10 min in the second step; enzymatic hydrolysis conditions: 15 FPU of GC 220 / g-glucan and 30 CBU of Novozyme 188 / g-glucan, pH 4.8, 50 °C, 150 rpm



In the SSCF test using *E. coli* KO11 and 3% glucan loading, 14.9 g/l and 15.6 g/l ethanol concentrations were obtained with 150 °C-160 °C-treated solid and 150 °C-170 °C-treated solid, respectively (Fig.4b). In other words, 79% and 86% of theoretical maximum ethanol yield were obtained based on glucan and xylan in the treated corn stover. With treated corn stover in the same treatment conditions (150 °C-170 °C), both SSF and SSCF process have similar ethanol yield (85% in SSF, and 86% in SSCF).

(a) SSF of  $ZnCl_2$  treated corn stover with *S. cerevisiae*

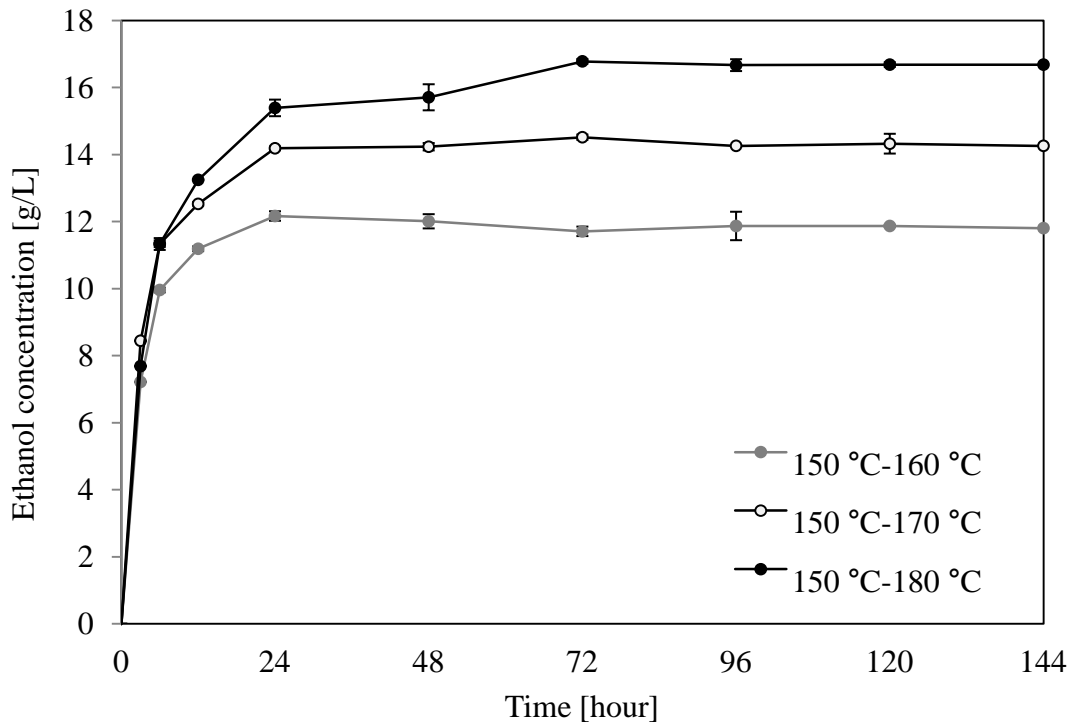

(b) SSCF of  $\text{ZnCl}_2$  treated corn stover with *E.coli* KO11

Fig. 4. SSF (a) and SSCF (b) of  $\text{ZnCl}_2$  treated corn stover with *S. cerevisiae* and *E.coli* KO11. Note: Microorganisms: *Saccharomyces cerevisiae* ATCC® 200062 for SSF, Recombinant *Escherichia. coli* KO11 (ATCC® 55124) for SSCF; substrate: 3% w/v glucan loading/100ml working volume;  $\text{ZnCl}_2$  treated corn stover (see the treatment conditions in Fig. 3); 15 FPU of GC 220 / g-glucan and 30 CBU of Novozyme 188 / g-glucan; YP medium for SSF, LB medium for SSCF; anaerobic condition; 37 °C, 150 rpm

### 3.3. Furfural production from hemicellulose hydrolysates

Most of the xylan and arabinan were solubilized into the hydrolysate during  $\text{ZnCl}_2$  treatment in the first stage. In this process, acidified  $\text{ZnCl}_2$  was used as the solvent and the hydrolysates already contained 0.03 % HCl; therefore, no additional catalyst was added.

Fig. 5 shows xylose and arabinose concentrations in the liquid products at various reaction temperatures. As shown in Fig. 5a, the xylan concentration increased between 10 min and 30 min of reaction, and then it decreased as the reaction time increased. It was speculated that between 10 min and 30 min, the reaction rate of xylose conversion from the

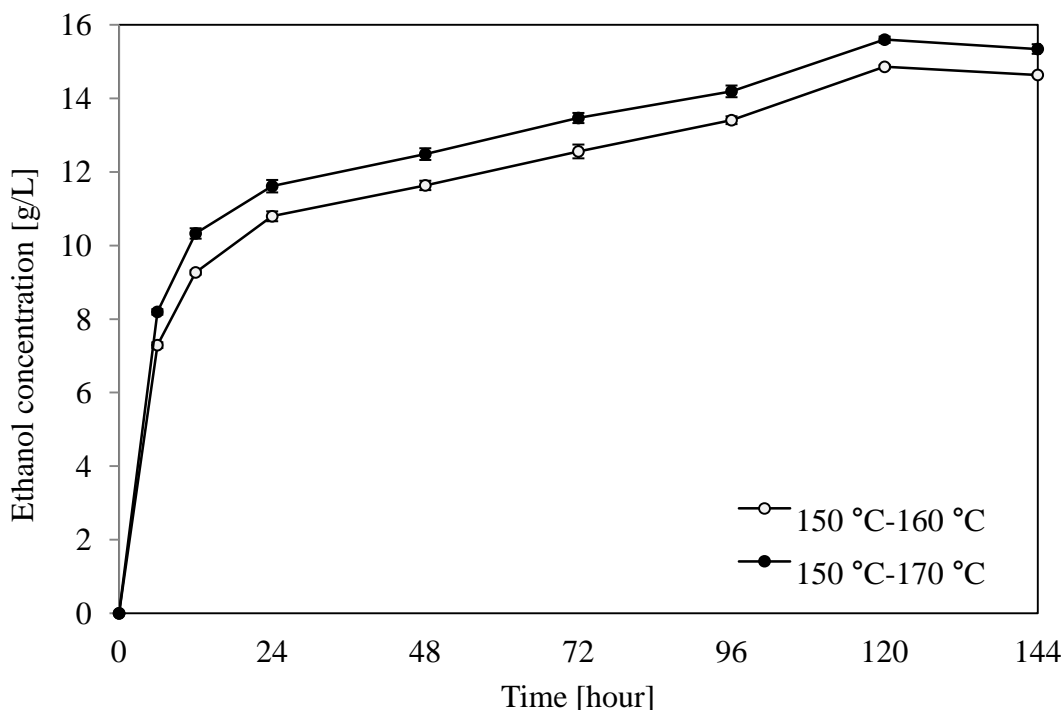
xylooligomer was faster than that of the furfural conversion from xylose. As the xylose and arabinose concentrations dropped, the furfural concentration increased and reached its highest concentration (4.2 g/l) at approximately 120 minutes (Fig. 5a). The highest furfural conversion yield at each reaction temperature was from 54 to 58%. At 180 °C and 210 °C, the furfural conversion occurred within 10 min of reaction, which was much faster than at 150 °C (Fig. 5b and c). However, the furfural concentration was observed to reach a maximum, and then the concentration gradually decreased. This decrease was because the monomeric C5 sugars were fully degraded to furfural, and if they were exposed to high temperature again, further degradation could lead to the formation of other products such as levulinic acid, formaldehydes, furan, and formic acids [25, 34]. Similar converting patterns were observed at all treatment temperatures, while the reaction time to obtain the highest furfural concentration was different at each reaction temperature (150, 180, and 210 °C). The highest furfural conversion yields at the three different temperatures were 71.4%, 71.6%, and 56.2%, respectively. According to the results, the furfural loss at 150 and 180 °C were almost the same, while more furfural loss was observed at 210 °C.

#### *3.4. Lignin mass balance*

The hybrid fractionation process produced a solid cake which contained glucan and lignin. Therefore, the remaining solid after fermentation was expected to be mostly lignin. Two different samples (150 °C-160 °C-treated biomass and 150 °C-170 °C-treated biomass) were used for lignin recovery tests. The residual solids of SSF tests were filtered by vacuum filtration, and analyzed for the amounts of lignin recovered in a solid form. In the first stage fractionation, 75.4% and 74.9% of lignin were retained in the prepared biomass, respectively

(Table 3). The analysis of the composition of the residual solids after fermentation shows that >99% of lignin in the  $\text{ZnCl}_2$ -treated solid samples was recovered. This recovery indicated that the lignin in this hybrid process could easily be recovered by simple filtration without a complicated separation method.

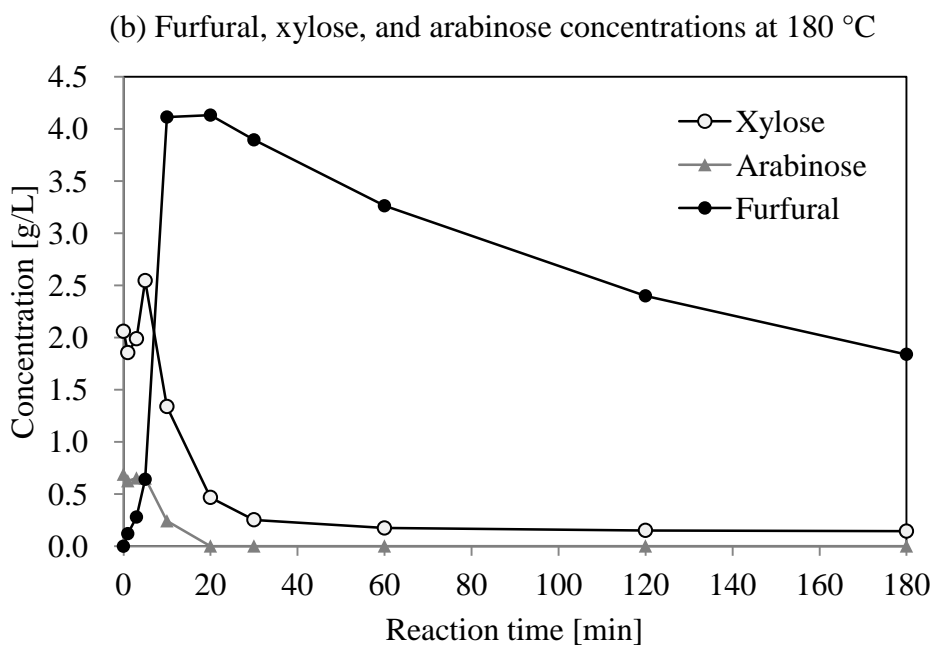
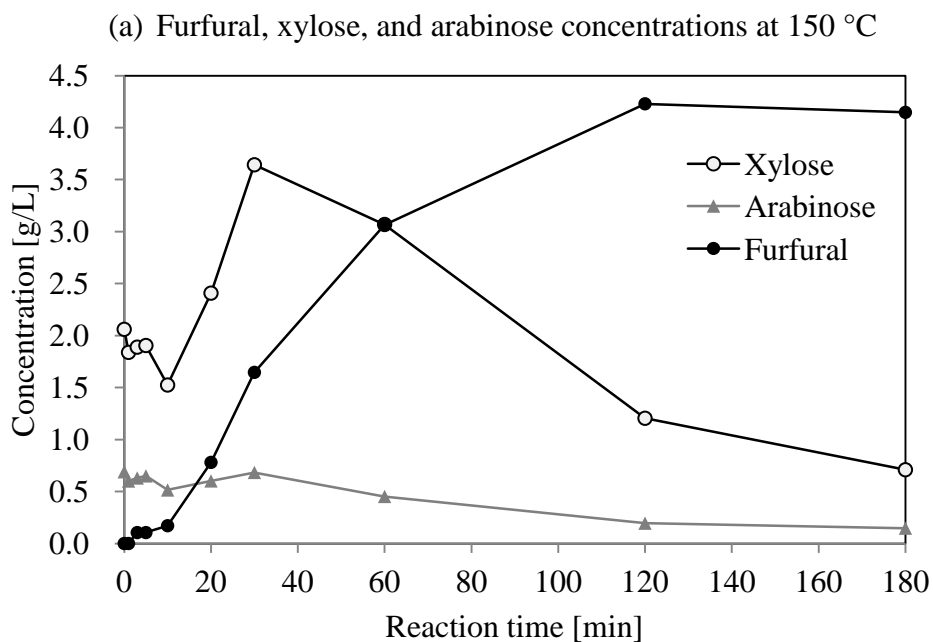

(c) Furfural, xylose, and arabinose concentrations at 210 °C

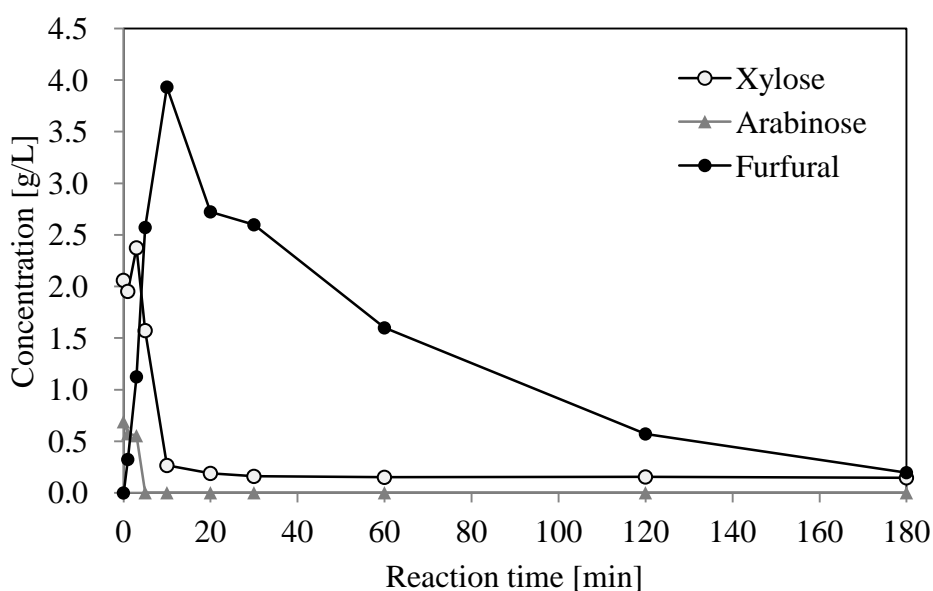

Fig. 5. Furfural production from hemicellulose hydrolysate at different reaction temperatures  
*Note:* sample preparation conditions: 5 wt.% of  $\text{ZnCl}_2$ , 150 °C, 7.5 ml/min, 10 min in the first step; 5 wt.% of  $\text{ZnCl}_2$ , 170 °C, 7.5 ml/min, 10 min in the second step; treatment conditions: (a) 150 °C, (b) 180 °C, and (c) 210 °C, 10-180 min; the data points in the graph show the mean value ( $\text{SD} < 0.3$ ,  $n=1$  for (a) and (c),  $n=2$  for (b)).

Fig. 6 represents the overall mass balance in the hybrid fractionation of corn stover using  $\text{ZnCl}_2$  followed by SSF under optimal fractionation conditions (shown in the figure). With 1.0 kg of corn stover, the hybrid fractionation process could produce 0.18 kg ethanol, 0.14 kg furfural, 0.13 kg lignin, and 0.17 kg carbon dioxide. Because most of the cellulose was retained in the solid and approximately 90% of the hemicellulose was removed after  $\text{ZnCl}_2$  treatment, cellulose-rich solid could be converted into ethanol by SSF with conventional yeast. This may be beneficial because of the simplicity of glucose fermentation with conventional yeast compared to the SSCF of C5 and C6 sugars with recombinant strains. Moreover, furfural and lignin can be produced as platform chemicals and potential high-

value co-products. Ethanol (\$0.60/kg) is a commodity chemical with small profit margin whereas furfural price is \$1.0/kg [37, 38]; therefore, the potential extra value-added chemicals can be produced by the utilization of hemicellulose and lignin in lignocellulosic biomass.

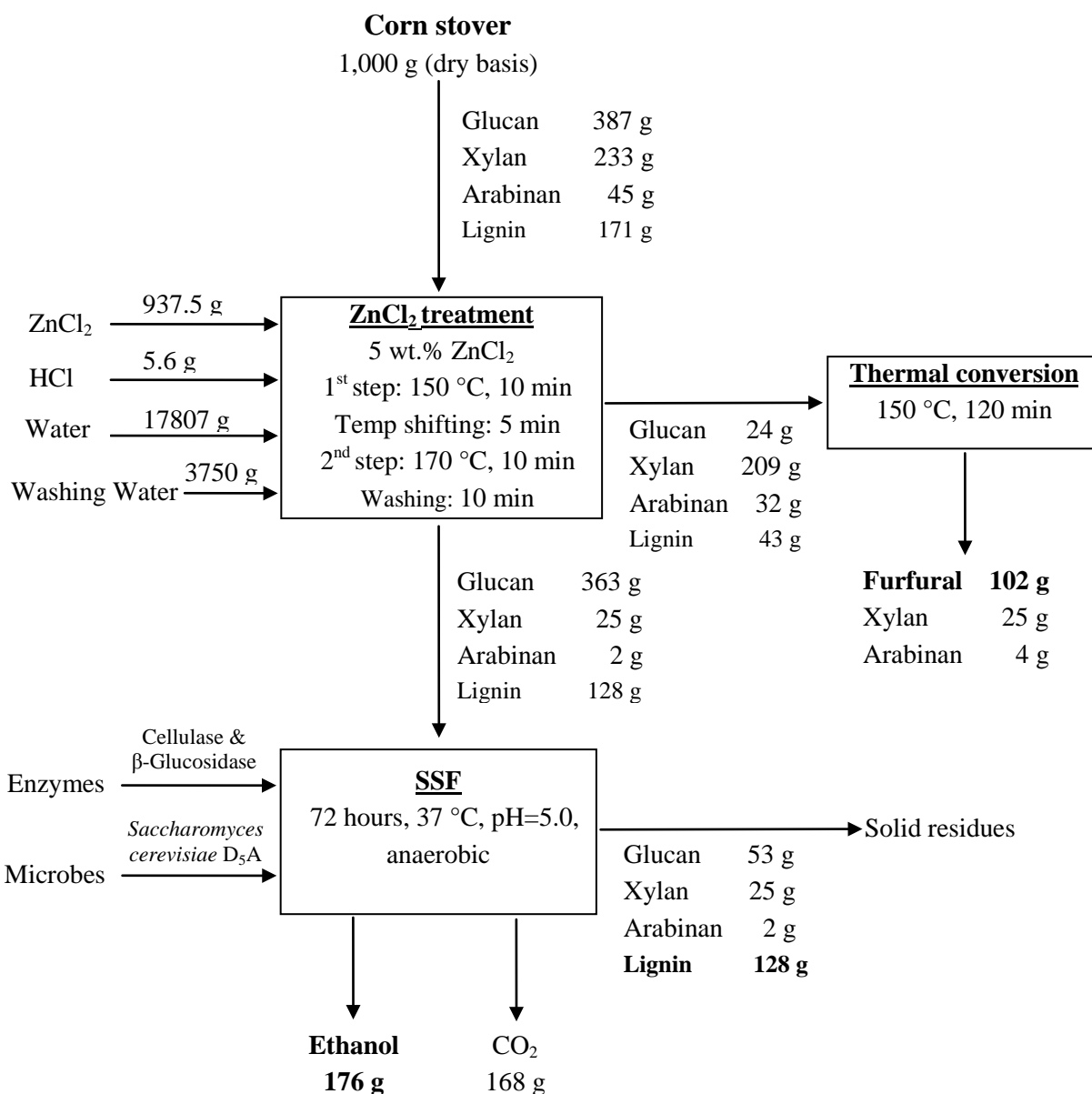

Fig. 6. Overall mass balance of hybrid fractionation of corn stover using ZnCl<sub>2</sub> and simultaneous saccharification and fermentation (SSF)

Note: treatment conditions; see Fig. 5. ; SSF conditions; see Fig. 4.

#### **4. Conclusions**

The Fractionation of corn stover using the hybrid process described here was highly effective in separating the three components of biomass (cellulose, hemicellulose, and lignin).  $ZnCl_2$  treatment enhanced the enzymatic digestibilities for both cellulose and hemicellulose in the treated solids. The celluloses in treated solids were effectively converted into ethanol with maximum 70-98% of theoretical maximum ethanol yield. The hemicellulose in the liquid hydrolysates was used as a source of furfural production with maximum 58% of furfural yield. This process is expected that this process can improve the utilization of biomass significantly due to the efficient recovery yield of each component and following simple process for hemicellulose application.

#### **Acknowledgements**

We are grateful to Genencor International Inc. for providing cellulase enzymes. We also would like to thank Dr. Raj Raman and Simone Soso at Iowa State University for their kind review of this article.

#### **References**

- [1] Jeffries TW, Jin YS. Ethanol and thermotolerance in the bioconversion of xylose by yeast. *Adv Appl Microbiol* 2000; 47: 221-268.
- [2] Yacobucci BD. Alternative fuels and advanced technology vehicles: Issues in congress. *Congressional research service* 2010; R40168
- [3] Aden A, Ruth M, Ibsen K, Jechura J, Neeves K, Sheehan J, Wallace B. Lignocellulosic

biomass to ethanol process design and economic utilizing co-current dilute acid prehydrolysis and enzymatic hydrolysis for corn stover. NREL technical report 2002; NREL/TP-510-32438.

- [4] Mosier N, Wyman C, Dale B, Elander R, Lee YY, Holtzapple M, Ladisch M. Features of promising technologies for pretreatment of lignocellulosic biomass. *Biores. Technol.* 2005; 96: 673-686.
- [5] Takahashi CM, de Carvalho Lima KG, Takahashi F, Alterthum F. Fermentation of sugar cane bagasse hemicellulosic hydrolysate and sugar mixture to ethanol by recombinant *Escherichia coli* KO11. *World J Microb Biot.* 2000; 16: 829-834.
- [6] de Carvalho Lima KG, Takahashi CM, Alterthum F. Ethanol production from corn cob hydrolysates by *Escherichia coli* KO11. *J Ind Microbiol Biotechnol.* 2002; 3: 124-128.
- [7] Kim TH, Taylor F, Hicks KB. Bioethanol production from barley hull using SAA (soaking in aqueous ammonia) pretreatment. *Biores Technol* 2008; 99: 5694-5702.
- [8] Laplace JM, Delgenes JP, Moletta R, Navarro JM. Effects of culture conditions on the co-fermentation of a glucose and xylose mixture to ethanol by a mutant of *Saccharomyces diastaticus* associated with *Pichia stipitis*. *Appl Microbiol Biotechnol* 1993; 39: 760-763.
- [9] Zhou B, Martin GJO, Pamment NB. Increased phenotypic stability and ethanol tolerance of recombinant *Escherichia coli* KO11 when immobilized in continuous fluidized bed culture. *Biotech Bioeng* 2008; 100 (4): 627-633.
- [10] Lynd LR, Weimer PJ, van Zyl WH, Pretorius IS. Microbial cellulose utilization: Fundamentals and biotechnology. *Microbiol Mol Biol Rev* 2002; 66 (3): 506-577.
- [11] Stambuk B, Franden MA, Singh A, Zhang M. D-xylose transport by *Candida succiphila* and *Kluyveromyces marxianus*. *Appl Biochem Biotech.* 2003; 106: 255-263.
- [12] Carrott SPJM, Carrott MMLR. Lignin-from natural adsorbent to activated carbon: A review. *Biores Technol.* 2007; 98: 2301-2312.
- [13] Shabtai JS, Zmierzak WW, Chornet E. US Patent 5959167 - Process for conversion of lignin to reformulated hydrocarbon gasoline, filed on 09/28/1999.
- [14] Lin SY, Lebo SE Jr. Lignin. *Kirk-Othmer encyclopedia of chemical technology*, fourth ed. 1995; 15: 268-289.



- [15] Northey RA. Low-cost uses of lignin; Emerging technology if materials and chemicals from biomass. ACS Symposium Series 476, Washington, DC. 1992.
- [16] Sarkanen KV, Ludwig CH, Editors. Lignins: Occurrence, Formation, Structure and Reactions. New York: Wiley-Interscience; 1971.
- [17] Langvad N. BioGasol – Biofuels for the future. California-Denmark Workshop on Clean Technology, San Francisco, California. 2007.
- [18] Montane D, Salvado J, Torras C, Farriol X. High-temperature dilute-acid hydrolysis of olive stones for furfural production. *Biomass Bioenergy* 2002; 22: 295-304.
- [19] Moreau C, Durand R, Peyron D, Duhamet J, Rivalier P. Selective preparation of furfural from xylose over microporous solid acid catalysts. *Industrial Crops and Products*. 1998; 7: 95-98.
- [20] Nghiem NP, Donnelly M, Sanville-Millard CY. A method to produce succinic acid from raw hydrolysates, WO 2005/116227.
- [21] Alfred JS. Wood and cellulose science. New York: The Ronald Press; 1964. 255-258.
- [22] Cao NJ, Xu Q, Chen LF. Xylan hydrolysis in zinc chloride solution. *Appl Biochem Biotechnol* 1995; 51/52: 97-104.
- [23] Cao NJ, Xu Q, Chen LF. Acid hydrolysis of cellulose in zinc chloride solution. *Appl Biochem Biotechnol* 1995; 51/52: 21-28.
- [24] Simkovic I, Antal M, Alfoldi J. Fractionation of wheat straw meal after pretreatment with acidified zinc chloride solutions. *Carbohydrate Polymers* 1994; 23: 111-114.
- [25] Zeitsch KJ. The chemistry and technology of furfural and its many by-products. Köln, Germany: Elsevier; 2000.
- [26] Al-Showiman SS. Furfural from some edible plants grown in Saudi Arabia. *J.King Saud Univ.*, vol.10, Science (3) 1998; 119-125.
- [27] Zhang J, Zhuang J, Lin L, Liu S, Zhang Z. Conversion of D-xylose into furfural with mesoporous molecular sieve MCM-41 as catalyst and butanol as the extraction phase. *Biomass and Bioenergy*. 2010; 1-5.
- [28] Dias AS, Pillinger M, Valente AV. Dehydration of xylose into furfural over micro-mesoporous sulfonic acid catalysts. *J. Catalysis*. 2005; 229: 414-423.
- [29] Sluiter A, Hames B, Ruiz R, Scarlata C, Sluiter J, Tmpleton D. Determination of

- structural carbohydrates and lignin in biomass. NREL/TP-510-42618, 2008, National Renewable Energy Laboratory. Golden, CO.
- [30] Berlin A, Balakshin M, Gilkes N, Kadla J, Maximenko V, Kubo S, Saddler JN. Inhibition of cellulase, xylanase and  $\beta$ -glucosidase activities by softwood lignin preparations. *J Biotech* 2006;125; 198-209.
- [31] Ghosh TK. Measurement of cellulase activities, *Pure Appl Chem* 1987; 59 (2): 257—268.
- [32] Selig M, Weiss N, Ji Y. Enzymatic saccharification of lignocellulosic biomass. NREL/TP-510-42629, 2008. National Renewable Energy Laboratory, Golden, CO.
- [33] Arnold DR, Buzzard JL. A novel process for furfural production. *Proceedings of South African Chemical Engineering Congress*. 2003.
- [34] Sangarunlert W, Piumsomboon P, Ngamprasertsith S. Furfural production by acid hydrolysis and supercritical carbon dioxide extraction from rice husk. *Korean J Chem Eng* 2007; 24(6): 936-941.
- [35] Lee YY, Chen RB, Wu Z, Hayes J. Kinetic and modeling investigation on dilute sulfuric acid and hot water fractionation of selected biomass plan. NREL/SR-510-36391, 2004. National Renewable Energy Laboratory, Golden, CO.
- [36] Kim TH, Sequential hydrolysis of hemicellulose and lignin in lignocellulosic biomass by two-stage percolation process using dilute sulfuric acid and ammonium hydroxide, *Korean J Chem Eng*, In-Printing, DOI: 10.1007/s11814-011-0093-6
- [37] Eric Linak, Hossein Janshekar and Yoshio Inoguchi, Report “Ethanol” in *Chemical Economics Handbook (CEH)*, SRI Consulting, 2011. Menlo Park, CA, USA. (Internet: <http://ceh.sric.sri.com>)
- [38] Ralf Gubler and Kazuteru Yokose, Report “Furfural” in *Chemical Economics Handbook (CEH)*, SRI Consulting, 2008. Menlo Park, CA, USA. (Internet: <http://ceh.sric.sri.com>)

## CHAPTER 5. PRETREATMENT OF CORN STOVER USING LOW-MOISTURE ANHYDROUS AMMONIA (LMAA) PROCESS

A paper published in the Journal of *Bioresource Technology*

Chang Geun Yoo, Nhuan P. Nghiem, Kevin, B. Hicks, Tae Hyun Kim

### Abstract

A simple pretreatment method using anhydrous ammonia was developed to minimize water and ammonia inputs for cellulosic ethanol production, termed the low moisture anhydrous ammonia (LMAA) pretreatment. In this method, corn stover with 30-70% moisture was contacted with anhydrous ammonia in a reactor under nearly ambient conditions. After the ammoniation step, biomass was subjected to a simple pretreatment step at moderate temperatures (40-120°C) for 48-144 h. Pretreated biomass was saccharified and fermented without an additional washing step. With 3% glucan loading of LMAA-treated corn stover under best treatment conditions (0.1 g-ammonia + 1.0 g-water per g biomass, 80 °C, and 84 h), simultaneous saccharification and cofermentation resulted in 24.9 g/l (89% of theoretical ethanol yield based on glucan + xylan in corn stover).

*Key words:* Ammoniation; Lignocellulosic Biomass; Xylanase; Ethanol; Simultaneous saccharification and cofermentation (SSCF); Pretreatment

## 1. Introduction

Lignocellulosic biomass is most available potential feedstocks for production of bioethanol, which is currently the most widely used liquid biofuel alternative to fossil fuels (Demirbas, 2004). Lignocellulosic biomass consists primarily of three different types of polymers, cellulose, hemicellulose and lignin, which are tightly associated with each other (Fengel and Wegener, 1984; Hendriks and Zeeman, 2009). The lignin-hemicellulose association shields the cell wall polysaccharides from enzyme hydrolysis, and thus a pretreatment process is required to permit saccharification. In the past several decades, various pretreatment methods have been suggested to enhance the enzymatic digestibility and fermentability of lignocellulosic biomass (Chang et al., 1998; Holtzapple, et al., 1992; Laser et al., 2002; Yang and Wyman, 2004; Kim and Lee, 2005; Mosier et al., 2005; Teixeira et al., 1999; Zhu et al., 2004). Although a few of them may be effective, several cost barriers which prohibit scale-up exist including high chemical input and excessive water use (Yang and Wyman, 2008; Zheng et al., 2009).

Ammonia is one of the most effective pretreatment reagents because of its many useful properties, which include delignification effect (Kim and Lee, 2005; Streeter and Horn, 1982), swelling effect (Bariska, 1975; Dale, 1986; Foster et al., 2001; Holtzapple et al., 1992; Mosier et al., 2005), and high preservation of cellulose and hemicellulose (Kim and Lee, 2007). From the previous studies, it was reported that ammonia caused swelling of cellulose structure and ammoniation prevents methoxyl groups on lignin from adsorbing cellulases, thus it enhanced the enzyme hydrolysis rates of lignocellulosic biomass and yields of fermentable sugars (Kawamoto et al., 1992; Sewalt et al., 1997). In addition, the antimicrobial effect of ammoniating allowed long-term storage of biomass with minimal

biodegradation of carbohydrates (Tajkarimi et al., 2008). In our group, various types of ammonia pretreatments have been investigated, which could achieve high enzymatic digestibility (Kim et al., 2003; Kim and Lee, 2005, 2007; Li and Kim, 2011).

Although ammonia pretreatments are effective in improving the applications of biomass, there are still some economical issues with high water and chemical consumption. Table 1 summarizes the chemical and water consumptions in various ammonia pretreatment methods and the maximum ethanol yield at optimal pretreatment conditions. Ammonia recycle percolation (ARP) needed relatively low amounts of liquids (0.5 g ammonia/g biomass and 2.8 g water/g biomass) (Table 1), and gave effective delignification (70-90 %). However, significant amounts of xylan (~50 %) were removed during the pretreatment. Moreover, the reaction temperature was relatively high (170-210°C) and additional energy was consumed to recover and reuse the ammonia and water in the process (Kim et al., 2006). Soaking in aqueous ammonia (SAA) was developed to alleviate these problems (Kim and Lee, 2005, 2007). It was tested at both ambient and moderate temperatures. The SAA was a low-severity process, so high ethanol yields (70-72 %) were achieved with lower energy consumption. However, ammonia and water consumptions were much larger than ARP (Table 1). Recently, Li and Kim (2011) developed low liquid ammonia (LLA) process to significantly reduce the liquid throughput. This process gave a similar ethanol yield (70 %) as that of SAA but using much less amounts of liquids (0.5 g ammonia/g biomass and 1.5 g water/g biomass). However, all of the aforementioned methods require an additional washing step to remove and recover the ammonia still associated with the biomass after pretreatment. From the previous study, the amounts of washing water required were 17.2 ml/g biomass for SAA-treated biomass and 20.9 ml/g biomass for LLA-treated biomass. For this reason, the

actual water consumptions of these processes are much higher than the numbers presented in Table 1.

**Table 1**

Chemical and water inputs in various ammonia pretreatment methods and their maximum ethanol yields.

Methods	Reaction conditions	Ammonia input [g/g-biomass]	Water input <sup>1</sup> [g/g-biomass]	Maximum ethanol yield & concentration <sup>2</sup> [%] ([g/l])
ARP <sup>3</sup>	170 °C, 10 min, 3.3 g-liquid/g-solid, 15 wt.% NH <sub>3</sub>	0.5	2.8	71 (19.4)
SAA <sup>4</sup> at room temp.	Ambient temp., 10 days, 8.0 g-liquid/g-solid, 29.5 wt.% NH <sub>3</sub>	2.4	5.6	72 (19.8)
SAA <sup>5</sup> at moderate temp.	60 °C, 12 h, 6.0 g-liquid/g-solid, 15 wt.% NH <sub>3</sub>	0.9	5.1	70 (19.2)
LLA <sup>6</sup>	30 °C, 4 week, 2.0 g-liquid/g-solid, 50 wt.% NH <sub>3</sub>	0.5	1.5	70 (19.2)
LMAA <sup>7</sup>	80 °C, 84-96 h, 50-70% MC	0.1	1.0 - 2.3	89-91 (24.9-25.1)

Note:

1. Water input does not include washing water.
2. Maximum ethanol yield and concentration are based on the optimal reaction conditions; ethanol yields are calculated based on total glucan and xylan in untreated corn stover.
3. ARP: Ammonia recycle percolation (Kim et al., 2006)
4. SAA: Soaking in aqueous ammonia (Kim and Lee, 2005)
5. SAA: Soaking in aqueous ammonia (Kim and Lee, 2007)
6. 6. LLA: Low liquid ammonia (Li and Kim, 2011)
7. 7. LMAA: Low moisture anhydrous ammonia

In order to eliminate the additional water washing step and to improve the cost-effectiveness of ammonia pretreatment processes, the low moisture anhydrous ammonia

pretreatment (LMAA) method was developed. The main objective of this study was to design an effective pretreatment process with anhydrous ammonia that can significantly reduce energy input and ammonia consumption. Pretreatment of biomass with low moisture using gaseous ammonia leads to short exposure time and can be carried out under ambient conditions, therefore, low capital costs are projected. In addition, it has been speculated that ammoniation can also supply assimilable nitrogen (up to 1.2 weight percent (wt.%) of dry biomass) for microbial growth in the fermentor using the treated biomass as substrate (Taylor et al., 2008).

In this study, various pretreatment conditions for the LMAA method were explored. Among the various reaction conditions, reaction time and temperature were optimized to maximize the ethanol yield in the subsequent fermentation. To establish the correlation between these factors and ethanol yield, response surface methodology was applied. The effects of xylanase and residual ammonia on the SSCF of LMAA-treated biomass were also investigated.

## **2. Methods**

### **2.1. Materials**

#### **2.1.1. Feedstock**

Corn stover was harvested from central Iowa in 2009 and air-dried at ambient temperature. The corn stover was ground and screened to a nominal size of 9-35 mesh. The composition of the corn stover was 38.7 wt.% glucan, 23.3 wt.% xylan, 2.1 wt.% galactan, 4.5 wt.% arabinan, 17.1 wt.% lignin (acid insoluble + acid soluble), 1.5 wt.% sucrose, 1.2 wt.%

ash, and 11.6 wt.% other extractives. The procedure for compositional analysis is described in the Analytical section.

### 2.1.2. Enzymes

Cellulase GC 220 (Lot #301-04232-162) and Multifect-xylanase (Lot #301-04021-015) were provided by Genencor, a Danisco Division. The average activities of cellulase (GC-220) and xylanase (Multifect) were 45 filter paper unit (FPU)/ml and 8000 Genencor xylanase unit (GXU)/ml, respectively. The  $\beta$ -glucosidase enzyme, Novozyme 188 (Novo Inc., Lot #11K1088), was purchased from Sigma-Aldrich (St. Louis, MO). Activity of Novozyme 188 was 750 cellobiase units (CBU)/ml.

### 2.1.3. Microorganism

Recombinant *E. coli* KO11 (ATCC\_55124) was purchased from the American Type Culture Collection (ATCC) and used for the simultaneous saccharification and cofermentation (SSCF) experiments. *E. coli* KO11 was maintained on LB (Luria–Bertani) solid medium (Sigma, Cat. #L-3152) which consisted of 5 g/l yeast extract, 10 g/l tryptone, and 5 g/l NaCl, supplemented with 15 g/l agar (Sigma Cat. #B0128234), 2 g/L dextrose (Fisher Cat. #D16), and 40 mg/l chloramphenicol (Sigma Cat. #C-0378). The culture was transferred monthly. To prepare the plates, the media were autoclaved at 121 °C for 15 min and allowed to cool to about 50 °C. Dextrose and chloramphenicol then were added and the media were poured onto the plates and allowed to solidify. The plates were kept refrigerated at 4 °C.



## 2.2. Experimental setup and Operation

### 2.2.1. Moisturization

The moisture content of air-dried corn stover was ~8%. In order to adjust the moisture content of corn stover to the various target levels (30, 50, and 70 wt.%), additional water was added and the corn stover was steeped for 24 h. Each sample was ammoniated, pretreated, and dried under same conditions. Residual ammonia content in each sample was measured and then the SSCF was conducted.

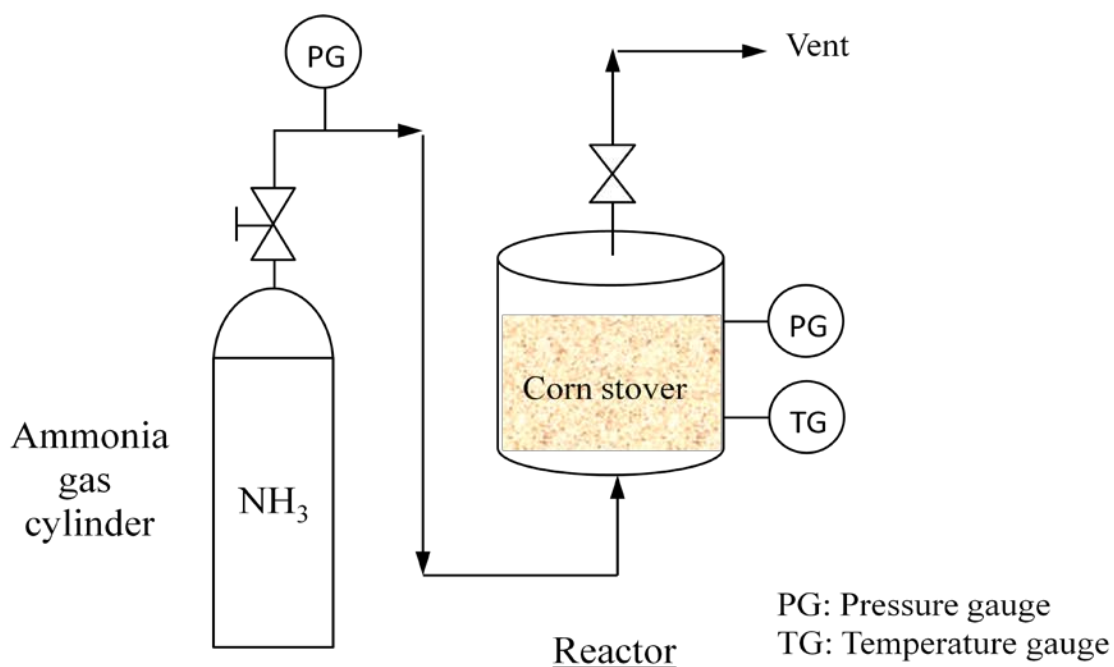

**Fig. 1.** Schematic of laboratory ammoniation system.

### 2.2.2. Ammoniation

Steeped corn stover was placed in the sealed batch reactor (2.9 inch (8.1 cm) internal diameter x 6.5 inch (18.5 cm) length, 690 ml internal volume). An ammonia gas cylinder

with single stage gas regulator was connected to the bottom of the reactor (Fig. 1). The top of the reactor was attached to a fume hood for ventilation of ammonia. The reactor top was equipped with a pressure gauge and temperature probe (Fig. 1). After packing the corn stover in the reactor, the reactor was purged with ammonia gas for 10 s. The connection to the vent was closed, and system pressure was monitored and maintained below 10 psig. Temperature was not controlled during ammoniation, but temperature increase ( $\sim 70^{\circ}\text{C}$ ) was observed due to the exothermic reaction. Then, 10 minutes later, the valve at the top of the reactor was opened to the atmosphere inside fume hood. After ammoniation, the corn stover was transferred to a plastic container, mixed, and weighed. One-two gram of biomass was used for residual ammonia analysis using an ammonia/nitrate analyzer and the remainder was subjected to the second next reaction (pretreatment). The procedure for ammonia analysis is described in the Analytical section.

### 2.2.3. Pretreatment

Ammoniated corn stover was packed into a smaller sealed batch reactor (0.93 inch (2.7 cm)  $\times$  6 inch (17.1 cm) length, 67 ml of internal volume). Then, the reactor was placed in the convection heating oven for 1 h-168 h. Various pretreatment temperatures ( $40\text{-}120^{\circ}\text{C}$ ) were tested. After the pretreatment was complete, the reactor was cooled down, opened, and then the treated corn stover was transferred into a plastic container with a tight lid. One-two gram sample of biomass was used for residual ammonia analysis and the rest was subjected to evaporation.

#### 2.2.4. Evaporation

Evaporation of excess ammonia was conducted in the fume hood. Treated corn stover was dried in the air for 12 h. The moisture level of the treated sample was carefully monitored and drying was stopped if it was less than 30% because over-drying can cause the collapse of the pretreated biomass structure, which may affect the enzyme hydrolysis of the biomass (Esteghlalian et al., 2001). One-two gram of biomass was used for residual ammonia analysis and the remainder was subjected to the SSCF test.

#### 2.3. Simultaneous saccharification and co-fermentation (SSCF)

Single colonies of *E. coli* KO11 on LB solid medium were used to inoculate 50 mL sterile LB medium supplemented with 20 g/l glucose in 250-mL flasks. The inoculated flasks were incubated at 37 °C and 150 rpm in the incubator shaker (Excella E24, New Brunswick Scientific, Edison, NJ) for 10–14 h (NREL, 2008). When the glucose concentration dropped below 2 g/L, the cells were harvested by centrifugation (IEC MODEL HN-S Centrifuge) at 2000 rpm (605g) for 5 min. The supernatant was removed, and the cell pellets were re-suspended in 5 mL of sterile DI water. The cells harvested from two flasks were combined (10 mL) and used as the inoculum for the experimental flasks.

Simultaneous saccharification and co-fermentation was performed using *E. coli* KO11 (ATCC® 55124) with GC-220 cellulase, Novo 188  $\beta$ -glucosidase, Multifect xylanase, and LMAA-treated corn stover. All SSCF experiments were performed in 250 ml Erlenmeyer flasks, which were placed in an incubator shaker (Model E24, New Brunswick Scientific, Edison, NJ) maintained at 37 °C and 150 rpm. Each flask contained 50 ml fermentation medium. The treated corn stover was added to the flasks to give 3% (w/v)

glucan content. The SSCF experiments were performed without external pH control, starting at pH 7.0 at the beginning of the fermentation and gradually decreasing to pH 6.0 at the end. The enzyme loadings were 15 FPU/g glucan of cellulase, 30 CBU/g glucan of  $\beta$ -glucosidase, and 1,000 GXU/g glucan of xylanase. At the end of the fermentation, liquid products and residual solids were separated by vacuum filtration. Liquid samples were taken and analyzed routinely until the fermentation process ended. The theoretical maximum ethanol concentrations for the SSCF were calculated on the basis of total carbohydrates (glucan + xylan) in the treated solids. The ethanol yields in the SSCF tests were calculated as follows:

$$\text{Theoretical maximum ethanol yield(\%)} = \frac{\text{Ethanol produced (g) in reactor}}{\text{Initial sugar (g) in reactor} \times 0.511} \times 100$$

The initial sugar in the above equation included glucose and xylose that would be produced by complete hydrolysis of glucan and xylan in the untreated corn stover used in each SSCF experiment.

## 2.4. Analytical methods

### 2.4.1. Compositional analysis

Untreated and pretreated corn stover was analyzed for carbohydrates (sugars) and lignin following the NREL LAP (NREL, 2008). Each sample was analyzed in duplicate. Carbohydrates were determined by HPLC with a Bio-Rad Aminex HPX-87P column and a refractive index detector (Varian 356-LC, Varian, Inc., CA). For the fermentation samples, an HPX-87H column was used to measure the sugars and ethanol.

#### 2.4.2. Ammonia analysis

To measure residual ammonia in the ammoniated solid samples, each ammoniated solid sample (0.3g) was placed in a screw-cap glass bottle (80 ml volume) with 30 g of 1.0 wt % boric acid solution. The glass bottles containing ammoniated biomass were capped and placed in an oven at 80°C for 24 h, where the biomass swelled and released the absorbed ammonia into the liquid phase. At the completion of this step, these bottles were cooled down, opened, and liquid samples were separated from the residual solids by filtration with fluted filter paper (Fisher, Cat. #09-790-2C). Ammonium ion concentration in the buffer solution in each bottle was then determined by an ammonia analyzer (TL-200, Timberline Instrument LLC., Boulder, CO). This instrument is based on the diffusion-conductivity method (Carlson, 1978). Ammonium ion in the liquid samples is first dissolved in a strong base solution (5% NaOH). This solution passes through a membrane which is permeable to gases but not to liquids, and ammonia passing through the membrane is dissolved in a buffer solution (200 ppm of boric acid). A temperature-controlled conductivity cell measures the change in electrical conductance of the absorbing solution, which is proportional to the concentration of ammonium ion in the sample.

Measurement of residual ammonia in each sample was performed in triplicate. The results of ammonia analysis were monitored, stored, and analyzed using PeakSimple Chromatography Data system (SRI 203, SRI instruments, Menlo Park, CA) with the associated software. To convert the measured conductivity into ammonium ion concentration, a calibration curve was established using four different standard solutions ranging from 20 to 200 ppm of ammonium ion. Samples containing ammonium ion concentrations outside the range of the standard curve were diluted as necessary before measurement.

**Table 2**  
Experimental design and results of the central composite design.

Run #	Variables		Response
	(A) Reaction Time [hour]	(B) Reaction Temp. [°C]	(Y) Ethanol production <sup>a</sup> [g/l]
1	-1.5	0	17.1
2	-1	1	24.3
3	-1	1	23.4
4	-1	-1	16.4
5	-1	-1	14.0
6	-1	1	24.5
7	0	-1.5	13.0
8	0	0	25.1
9	0	0	23.3
10	0	1.5	24.3
11	1	1	22.0
12	1	1	22.0
13	1	-1	16.9
14	1	-1	18.5
15	1.5	0	21.2

<sup>a</sup> Ethanol concentration measured at 120 h of fermentation

### 2.5. Response surface methodology (RSM)

Each independent variable was coded at three levels between -1, 0, and +1, where the reaction time and temperature were changed in the following ranges: 48, 96, and 144 hours; 40, 80, 120°C. The LMAA pretreatment conditions were optimized for maximum ethanol production by RSM based on the 2<sup>2</sup> factorial central composite design (CCD). The matrix corresponding to the CCD is presented in Table 2. Fifteen experiments were carried out with two variables, and each variable varied at three levels ( $\alpha = 1.5$ ). Ethanol concentration was the response (dependent variable). The quadratic polynomial model for the ethanol production ( $Y$ ) is given below:

$$Y = \hat{a}_0 + \hat{a}_1 A + \hat{a}_2 B + \hat{a}_{11} A^2 + \hat{a}_{22} B^2 + \hat{a}_{12} AB \quad (1)$$

Where  $A$  and  $B$  represent coded levels of the independent variables;  $\hat{a}_0$  is the intercept term;  $\hat{a}_1$  and  $\hat{a}_2$  are the linear terms;  $\hat{a}_{11}$  and  $\hat{a}_{22}$  are the quadric terms; and  $\hat{a}_{12}$  is the interaction term. To investigate the simultaneous effect of reaction time and temperature on ethanol production, the statistical analysis of the data was performed using "Design Expert" software (version 7.1.1, Stat-Ease, Inc., Minneapolis, USA).

### **3. Results and discussion**

#### *3.1. Effect of LMAA pretreatment on chemical composition of corn stover*

LMAA pretreatment did not result in any weight loss during ammoniation and pretreatment because there was no washing step. Ammoniated solid samples were subjected to the simple evaporation step in order to remove excess ammonia and approximately 90% of residual ammonia was removed. Chemical composition analysis also indicated that there was no noticeable change in either carbohydrates or lignin content in the LMAA-treated corn stover.

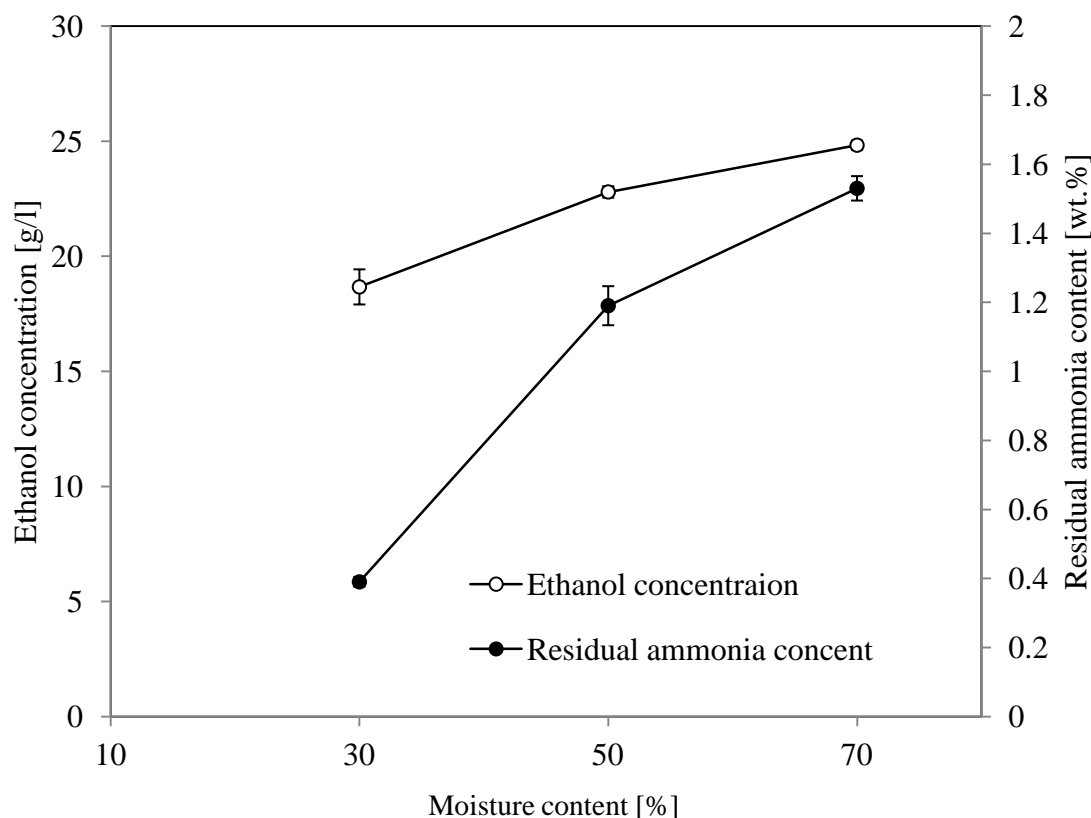

**Fig. 2.** Effect of moisture content on 120-h ethanol fermentation and residual ammonia content of LMAA-treated biomass

*Note:* Pretreatment condition: 30 - 70 % of MC, 110 °C, 92 h, SSCF condition: 3 % w/v glucan loading/50 ml working volume; recombinant *Escherichia. coli* KO11 (ATCC® 55124); 15 FPU of GC 220/g-glucan, 30 CBU of Novozyme 188/g-glucan, 1,000 GXU of Multifect xylanase /g-glucan; LB medium; anaerobic condition; 37°C, 150 rpm. Ammonia content is based on dry biomass weight.

### 3.2. Effect of moisture content of corn stover on ethanol production by SSCF

Fig. 2 shows the effects of moisture contents on ethanol fermentation and residual ammonia in the treated corn stover after evaporation step. It was observed that corn stover samples with higher moisture retained more ammonia. Residual ammonia after evaporation step increased from 0.39 wt.% to 1.53 wt.% as moisture content of corn stover increased from 30% to 70% (Fig. 2). Ethanol concentration in SSCF also increased as the moisture



content of corn stover increased. The SSCF of the 70%-moisture sample resulted in the highest ethanol concentration (24.9 g/l at 120-h fermentation). It is assumed that water molecule plays an important role in the pretreatment step; i.e. water molecules present in the biomass bind ammonium ion during the ammoniation and raising temperature may facilitates the pretreatment reaction. With the presence of bound water in biomass, ammonia molecule can form  $\text{NH}_3\text{-H}_2\text{O}$  and then ammonium ion ( $\text{NH}_4^+$ ) and hydroxyl ion ( $\text{OH}^-$ ), which is responsible for the reaction with lignin. Bound water also can form hydrogen bonds with cellulose, which causes swelling of crystalline cellulose structure and increases the accessibility to enzymes.

### 3.3. Ethanol production by SSCF with LMAA-treated solids

Among several important factors in pretreatment, two variables, pretreatment reaction time and temperature, were selected as the most significant variables. Ranges of two variables were decided as follows: 40-120 °C, and 48-144 h respectively.

The ethanol concentrations obtained with various combinations of reaction time and reaction temperature are shown in Table 2. The ethanol concentrations measured at 120 h-fermentation were 13.0 g/l to 25.1 g/l. The highest ethanol concentration was 25.1 g/l (91 % of theoretical maximum ethanol yield) on the pretreated by LMAA process at 80 °C for 96 h (Fig. 3). The polynomial equation, describing the ethanol production ( $Y$ ) as a function of reaction time and reaction temperature of pretreatment, is shown below (Eq. 2).

$$Y = 24.25 + 0.54A + 3.48B - 2.18A^2 - 2.40B^2 - 1.18AB \quad (2)$$

**Table 3**

Analysis of variance (ANOVA ) for ethanol production of LMAA treated corn stover (*Y*) by SSCF.

Source	Sum of squares	Degree of freedom	Mean squares	<i>F</i> -values	<i>Prob</i> <sup>a</sup> > <i>F</i>
Model	218.98	5	43.80	32.91	<0.0001
A	3.86	1	3.86	2.90	0.1227
B	161.27	1	161.27	121.20	<0.0001
AB	12.19	1	12.19	9.16	0.0143
A <sup>2</sup>	26.36	1	26.36	19.81	0.0016
B <sup>2</sup>	32.00	1	32.00	24.05	0.0008
Residual	11.98	9	1.33	1.33	
Lack of Fit	5.51	3	1.84	1.70	0.2647
Pure Error	6.47	6	1.08	1.08	
Total	230.96	14			

<sup>a</sup> Probability values (*P*-values).

The analysis of variance (ANOVA) results are summarized in Table 3. The model *F*-value of 32.9 for *Y* (ethanol production) and the value of '*Prob*>*F*' less than 0.05 for the model showed that the model is significant. There is only a 0.01% chance that a “model *F*-value” this large could occur due to noise. The determination coefficient ( $R^2 = 0.9481$ ) indicates that 94.81% of the variability in the response can be explained by the model. According to the statistical analysis results, B (reaction temperature), AB (interaction term), A<sup>2</sup>, and B<sup>2</sup> (quadratic terms) are significant model terms. Insignificant value of lack of fit for this model also indicates that the model satisfactorily fits the data.

The response surfaces were drawn as three-dimensional plots of two factors (reaction time and reaction temperature) while other reaction conditions were kept constant. The increases in reaction time with low reaction temperature (40 °C) significantly improved ethanol production. However, the effects of reaction time with higher reaction temperature (80-120 °C) on ethanol production were marginal, and even ethanol concentrations decreased

with over 96 h reaction time. When observed in terms of temperature, ethanol production increased as temperature was increased. The increase of ethanol production was marginal over 80 °C compared to the steep ethanol production increase at more moderate temperatures (40–80 °C). These are important observations, because longer reaction time or higher reaction temperature may significantly increase the ethanol production cost. The optimum reaction conditions predicted by the model were as follows: reaction time = 92.3 h; reaction temperature = 109.8 °C. The value of ethanol production estimated by Eq. (2) was 25.5 g/l.

Design-Expert?Software

Ethanol conc.

25.1

13

X1 = A: Treatment time

X2 = B: Treatment temp.

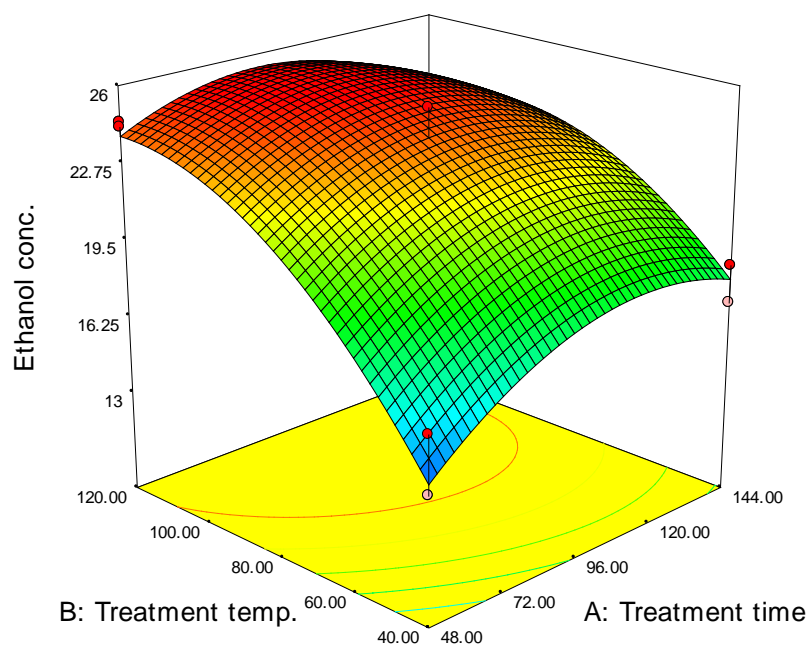

**Fig. 3.** Response surface curve showing combined effect of reaction time and temperature in the LMAA pretreatments on ethanol production by SSCF process

#### 3.4. Effects of xylanase addition on fermentation of LMAA-treated corn stover

Although most commercial “cellulase” enzyme products exhibit xylanase activity as well as glucanase activity, the xylanase activity normally present in these products may be insufficient to effectively hydrolyze large amount of xylan in the LMAA pretreated corn stover (23.3 wt.%). In fact, supplementation of cellulase with xylanase has been reported to enhance glucose release by xylose removal (Kim et al., 2008).

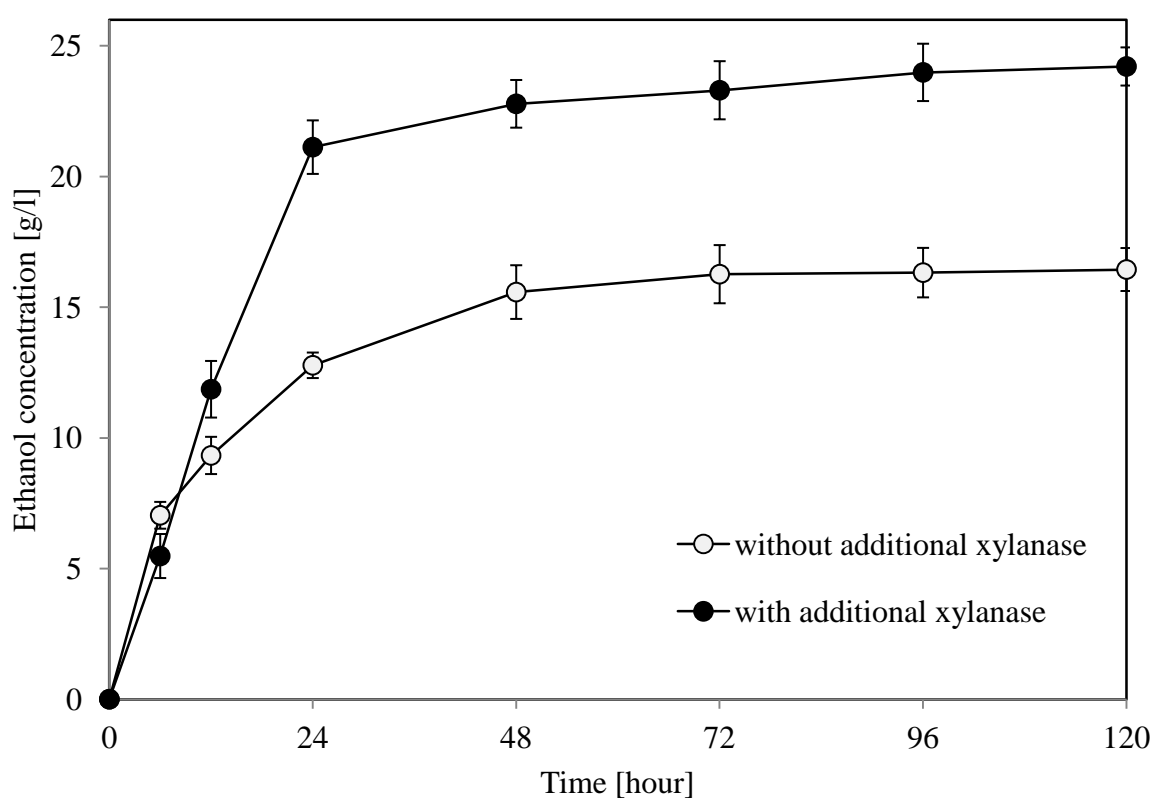

**Fig. 4.** Effect of xylanase addition on ethanol fermentation using LMAA-treated corn stover  
*Note:* Pretreatment condition: 70 % of MC, 80°C, 84 h, SSCF condition: 3 % w/v glucan loading/50 ml working volume; recombinant *Escherichia. coli* KO11 (ATCC® 55124); 15 FPU of GC 220/g-glucan, 30 CBU of Novozyme 188/g-glucan, (1) with 1,000 GXU of Multifect xylanase /g-glucan and (2) without xylanase; LB medium; anaerobic condition; 37°C, 150 rpm.

Addition of xylanase results in synergetic effect; i.e. it enhances cellulose accessibility to cellulase by xylose removal (Kumar and Wyman, 2009). Fig. 4 shows the ethanol productions in SSCF reactor by adding (1) cellulase only and (2) cellulase supplemented with xylanase. For the test, ammoniated corn stover was treated under the following pretreatment conditions: 70 % moisture, 80 °C, and 84 h, followed by 12 h air drying. It was observed that addition of xylanase enhanced both glucose and xylose hydrolyses, which resulted in more effective conversion of sugars into ethanol; ethanol production with 1,000 GXU/g glucan of xylanase addition was increased by 28 % (from 16.4 g/l to 24.2 g/l) (Fig. 4).

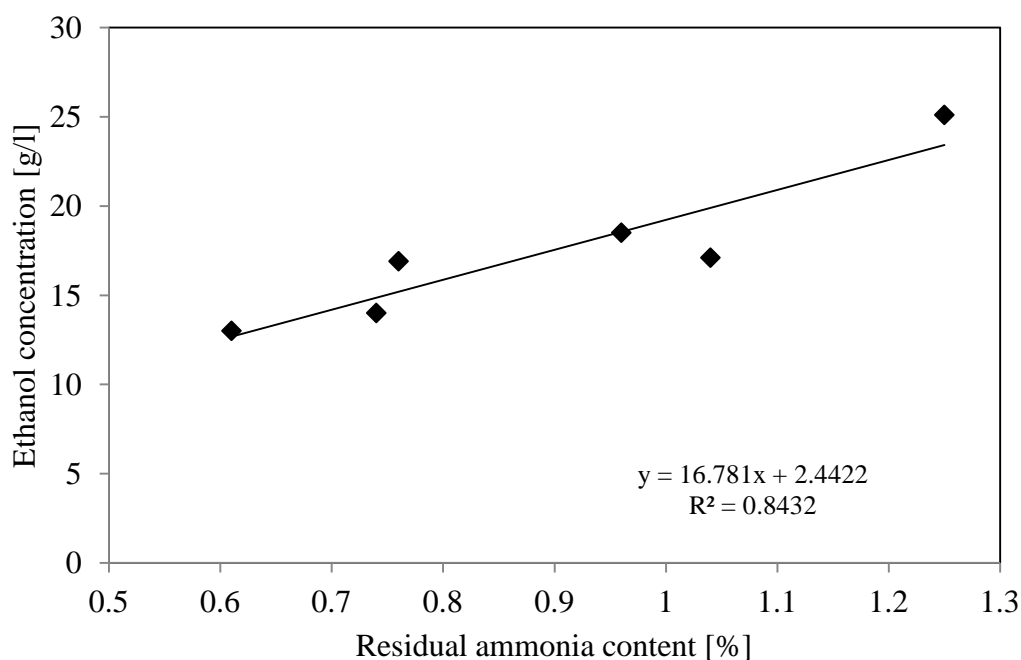

**Fig. 5.** Effect of residual ammonia on ethanol fermentation using LMAA-treated corn stover  
*Note:* Pretreatment condition: 70 % MC, 20-80°C, 24-144 h), SSCF condition: 3 % w/v glucan loading; recombinant *Escherichia. coli* KO11 (ATCC® 55124); 15 FPU of GC 220/g-glucan, 30 CBU of Novozyme 188/g-glucan, and 1,000 GXU of Multifect xylanase /g-glucan; LB medium; anaerobic condition; 37°C, 150 rpm.

### 3.5. Residual ammonia in LMAA-treated corn stover

Nitrogenous compounds are also critical components in fermentation. Ammonia is one of the most predominant nitrogen-containing compounds (Dharmadhikari, 2001) and is widely used as nitrogen source in industrial fermentations, either as a salt, e.g.  $(\text{NH}_4)_2\text{SO}_4$ , or as a base for pH control ( $\text{NH}_4\text{OH}$ ). If it is at an appropriate level, the residual ammonia in the LMAA-treated corn stover can serve as a nitrogen source for *E. coli* KO11 strain in the SSCF.

Fig. 5 shows the effect of residual ammonia contents on ethanol production. As shown in Fig. 5, different pretreatment conditions resulted in various residual ammonia contents (0.61-1.25 wt.% based on oven-dry treated corn stover) in the treated biomass even though the same evaporation condition (12 hours at ambient temperature) was applied to all treated corn stover samples. Evaporation of samples in the air for 12 hours removed 90% of ammonia in the corn stover, while most of the bound water (more than 50% of moisture content) remained. We observed a linear relationship between the ethanol concentration in SSCF reactor and the amounts of residual ammonia (Fig. 5). The determination coefficient ( $R^2$ ) of the trend line was 0.84; therefore, the model equation of the trend line was significant.

### 3.6. Mass balance of LMAA process

Fig. 6 summarizes the mass balance of the LMAA process. With 1,000 kg corn stover and LMAA pretreatment at the best conditions (50% moisture content, 80 °C, and 84 h), 320 kg ethanol, 306 kg carbon dioxide, and 171 kg lignin can be produced. Ammoniated corn stover contains 11.7 wt.% ammonia on the basis of treated corn stover. Evaporation removes around 90% of impregnated ammonia (11.7 wt.%), which results in 1.1 wt.% residual ammonia in the treated corn stover in the SSCF. Total chemical and water recycle from the

evaporation step is 613 kg, which is significantly reduced as compared to the other ammonia pretreatment methods. To pretreat the same amount of dry corn stover, 500-2400 kg of ammonia and 1500-8000 kg of water are required in other ammonia pretreatment processes (ARP, SAA, and LLA), whereas 117 kg of ammonia and 1000 kg of water are required with LMAA process. Therefore, this process reduced 80–95 % of ammonia input and 33 -82 % of water input compared to previous processes (Table 1). Moreover, this step reduces significant amounts of additional washing water (17,200-20,900 kg) from previous studies (SAA and LLA).

#### **4. Conclusion**

LMAA pretreatment has the potential to reduce ammonia and water inputs over other pretreatment technologies because it utilizes anhydrous ammonia gas with no washing step. Therefore, it is also anticipated that it requires low energy consumption for the pretreatment of biomass. With LMAA-treated corn stover under the best conditions (0.1 g ammonia/g biomass, 1.0 g water/g biomass, 80 °C, and 84 h), 90 % of the maximum theoretical ethanol yield (based on glucan and xylan of the untreated corn stover) was obtained by SSCF.

#### **Acknowledgements**

This work was supported by United States Department of Agriculture (USDA) Specific Cooperative Agreement #58-1935-9-976 (Project #1935-41000-072-04S) from the Agricultural Research Service (ARS), Eastern Regional Research Center (ERRC). We are grateful to Genencor International Inc. for providing cellulase and xylanase enzymes.

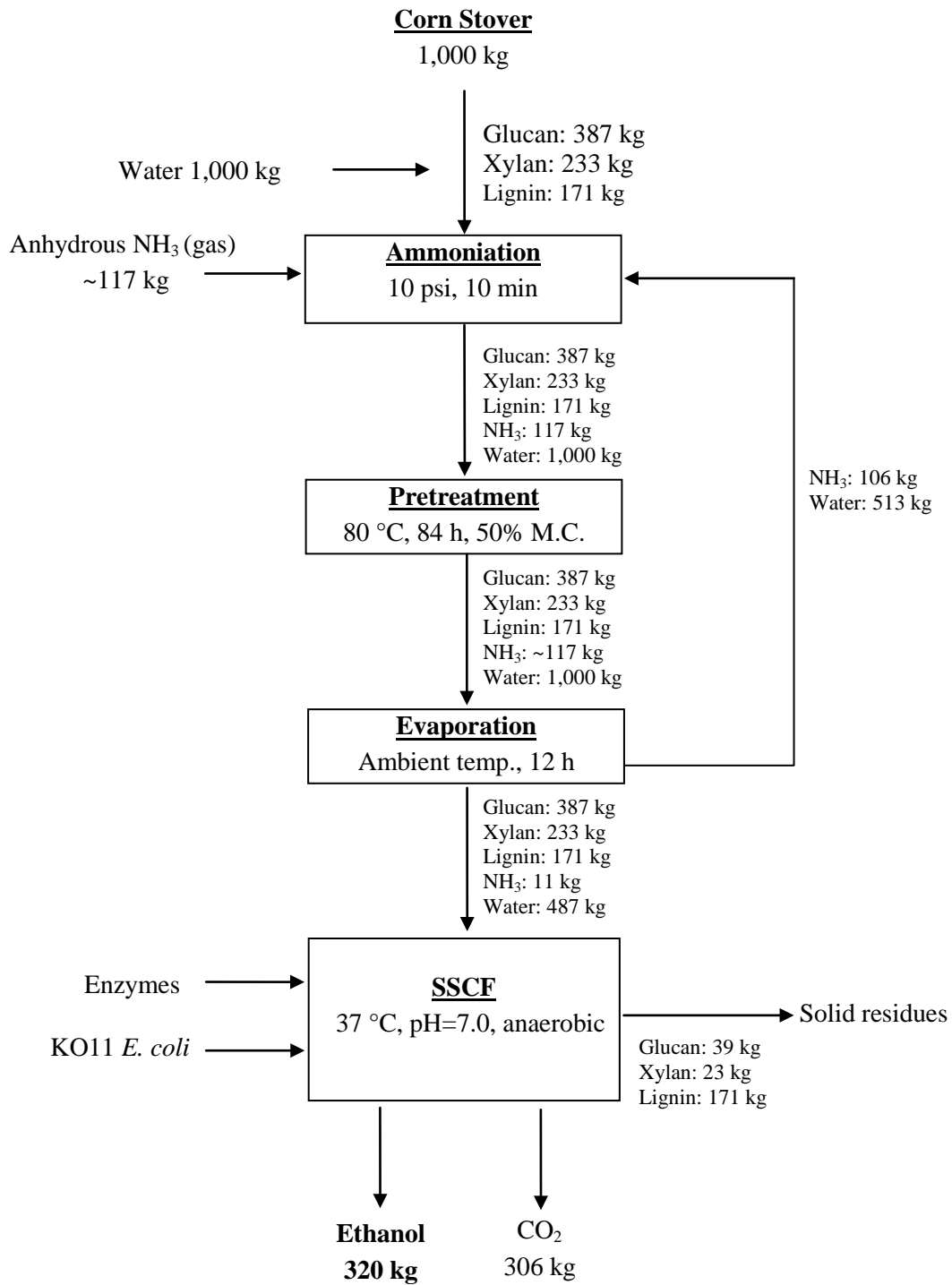

**Fig. 6.** Flow diagram and mass balance of LMAA ammonia pretreatment process  
*Note:* M.C.: Moisture content



**References**

- Bariska, M., 1975. Collapse phenomena in beechwood during and after NH<sub>3</sub>-impregnation. *Wood Sci. Technol.* 9, 293-306.
- Chang, V.S., Nagwani, M., Holtzapple, M.T., 1998. Lime pretreatment of crop residues bagasse and wheat straw. *Appl. Biochem. Biotechnol.* 74, 135-159.
- Dale, B.E., 1986. Method for increasing the reactivity and digestibility of cellulose with ammonia. US Patent 4.600.590.
- Demirbas A., 2004. Adsorption of lead and cadmium ions in aqueous solutions onto modified lignin from alkali glycerol delignification. *J. Hazard. Mater.* B109, 221-226.
- Dharmadhikari M., 2002. Nitrogen Metabolism during Fermentation, *Vineyard & Vintage View*. Vol. 17(2), 5-7.
- Esteghlalian, A.R., Bilodeau, M., Mansfield, S.D., Saddler, J.N. 2001. Do enzymatic hydrolyzability and Simons' stain reflect the changes in the accessibility of lignocellulosic substrates to cellulase enzymes? *Biotechnol Prog.* 17(6), 1049-1054.
- Fengel, D., Wegener, G., 1984. *Wood: Chemistry, Ultrastructure, Reactions*. De Gruyter, Berlin.
- Foster, B.L., Dale, B.E., Doran-Peterson, J.B., 2001. Enzymatic hydrolysis of ammonia-treated sugar beet pulp. *Appl. Biochem. Biotechnol.* 91 (3), 269-282.
- Hendriks, A.T.W.M., Zeeman, G., 2009. Pretreatments to enhance the digestibility of lignocellulosic biomass. *Biores. Technol.* 100, 10-18.
- Holtzapple, M.T., Lundeen, J.E., Sturgis, R., Lewis, J.E., Dale, B.E., 1992. Pretreatment of lignocellulosic municipal solid waste by ammonia fiber explosion (AFEX). *Appl. Biochem. Biotechnol.* 34-35(1), 5-21.
- Kawamoto, H.; Nakatsubo, F.; Murakami, K., 1992. Protein-adsorbing capacities of lignin samples. *Mokuzai Gakkaishi.* 38, 81-84.
- Kim, T.H., Kim, J.S., Sunwoo, C., Lee, Y.Y., 2003. Pretreatment of corn stover by aqueous ammonia. *Biores. Technol.* 90 (1), 39-47.
- Kim, T.H., Lee, Y.Y., 2005. Pretreatment of corn stover by soaking in aqueous ammonia. *Appl. Biochem. Biotechnol.* 121-124, 1119-1132.

- Kim, T.H., Lee, Y.Y., Sunwoo, C., Kim, J.S., 2006. Pretreatment of corn stover by low-liquid ammonia recycle percolation process. *Appl. Biochem. Biotechnol.* 133, 41-57.
- Kim, T.H., Lee, Y.Y., 2007. Pretreatment of corn stover by soaking in aqueous ammonia at moderate temperature. *Appl. Biochem. Biotechnol.* 136-140, 81-92.
- Kim, T.H., Taylor, F., Hicks, K.B., 2008. Bioethanol production from barley hull using SAA (Soaking in aqueous ammonia) pretreatment. *Biores. Technol.* 99, 5694-5702.
- Kumar, R., Wyman, C.E., 2009. Effects of cellulase and xylanase enzymes on the deconstruction of solids from pretreatment of poplar by leading technologies. *Biotechnol. Prog.* 25(2), 302-314.
- Laser, M., Schulman, D., Allen, S.G., Lichwa, J., Antal Jr, M.J., Lynd, L.R., 2002. A comparison of liquid hot water and steam pretreatments of sugar cane bagasse for bioconversion to ethanol. *Bioresour. Technol.* 81, 33-44.
- Li, X., Kim, T.H., 2011. Low-liquid pretreatment of corn stover with aqueous ammonia. *Bioresour. Technol.* 102 (7), 4779-4786.
- Mosier, N., Wyman, C., Dale, B.E., Elander, R., Lee, Y.Y., Holtzapfle, M.T., Ladisch, M., 2005. Features of promising technologies for pretreatment of lignocellulosic biomass. *Bioresour. Technol.* 96(6), 673-686.
- NREL (National Renewable Energy Laboratory) in Golden, CO. 2008. LAP (Laboratory Analytical Procedure), [http://www.nrel.gov/biomass/analytical\\_procedures.html](http://www.nrel.gov/biomass/analytical_procedures.html).
- Sewalt, V.J.H., Glassner, W.G., Beauchemin, K.A., 1997. Lignin impact on fiber degradation. 3. Reversal of inhibition of enzymatic hydrolysis by chemical modification of lignin and by additives. *J. Agric. Food Chem.* 45, 1823-1828.
- Streeter, C.L., Horn, G.W., 1982. Effect of treatment of wheat straw with ammonia and peracetic acid on digestibility in vitro and cell wall composition. *Anim. Feed Sci. Technol.* 7(4), 325-329.
- Tajkarimi, M., Riemann, H.P., Hajmeer, M.N., Gomez, E.L., Rzazvilar, V., Cliver, D.O., 2008. Ammonia disinfection of animal feeds – Laboratory study. *International Journal of Food Microbiology.* 122, 23-28.
- Taylor, F., Kim, T.H., Abbas, C.A., Hicks, K.B., 2008. Liquefaction, Saccharification, and Fermentation of Ammoniated Corn to Ethanol. *Biotechnol. Prog.*, 24, 1267-1271.

- Teixeira, L.C., Linden, J.C., Schroeder, H.A., 1999. Alkaline and peracetic acid pretreatments of biomass for ethanol production. *Appl. Biochem. Biotechnol.*, 19-34.
- Yang, B., Wyman, C.E., 2004. Effect of xylan and lignin removal by batch and flow through pretreatment on the enzymatic digestibility of corn stover cellulose. *Biotechnol. Bioeng.* 86 (1), 88-95.
- Yang, B., Wyman, C.E., 2008, Pretreatment: the key to unlocking low-cost cellulosic ethanol. *Biofuels Bioprod Bioref.* 2, 26 - 40
- Zheng, Y., Pan, Z., Zhang, R., 2009, Overview of biomass pretreatment for cellulosic ethanol production. *Int. J. Agric. Biol. Eng.* 2 (3) 51-68.
- Zhu, Y., Lee, Y.Y., Elander, R.T., 2004. Dilute-acid pretreatment of corn stover using a high-solids percolation reactor. *Appl. Biochem. Biotechnol.* 117, 103-114.

## CHAPTER 6. ENHANCEMENT OF ENZYMATIC HYDROLYSIS AND LIGNIN REMOVAL OF CORN STOVER USING PHOTOCATALYST-ASSISTED AMMONIA PRETREATMENT

A paper submitted to the Journal of *Bioresource Technology*

Chang Geun Yoo, Chao Wang, Chenxu Yu, Tae Hyun Kim

### Abstract

Photocatalyst-assisted ammonia pretreatment was explored to improve lignin removal of the lignocellulosic biomass for effective sugar conversion. Corn stover was treated with 5.0–12.5 wt.% ammonium hydroxide, two different photocatalysts ( $\text{TiO}_2$  and  $\text{ZnO}$ ) in the presence of oxygen in a batch reactor at 60 °C. Various solid-to-liquid ratios (1:20-1:50) were also tested. Ammonia pretreatment assisted by  $\text{TiO}_2$ -catalyzed photo-degradation removed 70 % of lignin under the optimum condition (12.5 % ammonium hydroxide, 60 °C, 24 h, solid:liquid=1:20, photocatalyst:biomass=1:10 with oxygen supply). The enzymatic digestibilities of pretreated corn stover were 85 % for glucan and 75 % for xylan with  $\text{NH}_3$ - $\text{TiO}_2$ -treated solid and 82 % for glucan and 77 % for xylan with  $\text{NH}_3$ - $\text{ZnO}$ -treated solid at 15 filter paper unit (FPU)/g-glucan of cellulase and 30 cellobiase unit (CBU)/g-glucan of  $\beta$ -glucosidase loadings, a 2-13 % improvement over ammonia pretreatment alone.

*Key words:* Lignocellulosic Biomass; Titanium dioxide ( $\text{TiO}_2$ ); Zinc oxide ( $\text{ZnO}$ ); Photo-degradation; Bioconversion

## 1. Introduction

Facing the global energy shortage, the efforts to find a feasible alternative from biomass based renewable energy (e.g., biofuels) have been intensified over the past decade. According to the US Energy Independence and Security Act (EISA), the consumption of biofuels, such as biomass-based diesel and advanced biofuels, needs to be increased by 100 times within the next 10 years (Fishman et al., 2010). Animal and human waste, trees, shrubs, yard waste, wood products and agricultural residues are all potential feedstock for production of biofuels. Among various biomass sources, lignocellulosic materials, in particular agricultural residues are among the most promising feedstock because of their relatively low cost (Zheng et al., 2009). Lignocellulosic biomass is mainly composed of cellulose, hemicellulose and lignin. Cellulose is encrusted with lignin and hemicellulose for protection. The molecular structure of Lignin is complex; it contains cross-linked polymers of phenolic monomers which are impermeable and chemically-resistant to enzyme. Therefore, lignin is considered as one of the primary reasons of recalcitrance in biomass structure (Kuhad and Singh, 2007, Sun et al., 2011). In order to convert lignocellulosic biomass into ethanol or other biofuels with high efficiency through biological/chemical processes, it is necessary to pretreat the biomass for lignin removal or alteration before the enzymatic hydrolysis and fermentation steps (Kumar et al., 2009).

It is known that lignin, as a major chemical oxygen demand (COD) component in pulp mill effluent, can be oxidatively decomposed by catalyzed photo-degradation. Photocatalytic degradation process is also effective in decoloration and bleaching of Kraft mill effluent (Tanaka et al. 1999). Semiconductor-photocatalyzed degradation processes have also been developed for the treatment of waste water and polluted air since 1980s

(Tantemsapya et al., 2004). In recent years, increasing efforts have been made to develop photocatalytic systems with the combination of photocatalysts and ultraviolet light for highly effective oxidation of aromatic compounds (Kansal et al., 2008), and TiO<sub>2</sub> and ZnO were shown to be among the most effective photocatalysts in various photo-degradation processes (Chakrabarti et al., 2008; Peralta and Peralta, 1998).

The photocatalytic reactions are initiated when holes (in valence band, VB) and electrons (in conducting band, CB) are photogenerated in the semiconductor particles such as TiO<sub>2</sub> and ZnO (Eq. 1) (Ohnishi et al., 1988; Pelizzetti and Serpone, 1986) by photons with equal or higher energy than the band gap of the semiconductors. For TiO<sub>2</sub> and ZnO, the band gaps are 3.23 eV and 3.17 eV, respectively

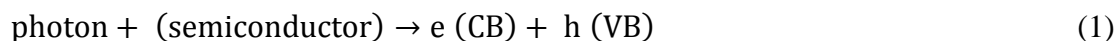

The holes (+) either oxidize the electron-donating substances (RX) directly (Eq. 2)

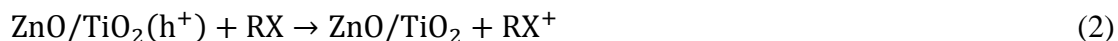

or react with surface hydroxyl groups (OH<sup>-</sup>) and/or adsorbed H<sub>2</sub>O to form hydroxyl radicals (Eq. 3 and 4).

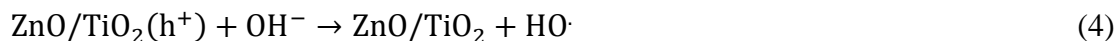
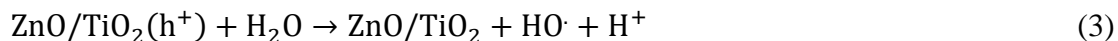

The hydroxyl radicals then decompose lignin into carbon dioxide and hydrocarbon gases (Kobayakawa et al., 1989). The electrons (-) in the CB (Eq. 1) can reduce oxygen and the superoxide anions formed are highly effective in various oxidative degradation processes (Eq. 5-7) (Ohnishi et al., 1989).

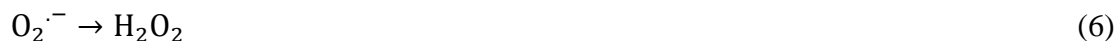
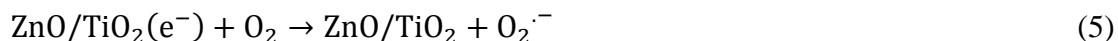



However, it has been shown that the photocatalyzed degradation methods alone were not capable of reducing lignin incorporated in biomass effectively (Niu et al., 2009).

Conventionally, lignin degradation is achieved through chemical pretreatment methods. Among these pretreatment methods, ammonia pretreatment shows excellent performance in sugar conversion with high selectivity for reaction with lignin over those with carbohydrates (Agbor et al., 2011). Ammonia is also easy to handle and recycle because of its high volatility and non-corrosive nature (Kim et al., 2003). Although ammonia pretreatment is considered as a promising method, excessive energy consumption and environmental pollution with ammonia use are still concerns need to be dealt with. It is desirable to find a way to improve the effectiveness of pretreatment without relying on increasing ammonia loading or reaction temperature. In this study, photocatalyst-assisted ammonia pretreatment was investigated to improve bioconversion of corn stover.

Herein, degradation or alteration of lignin using photocatalyst-assisted ammonia pretreatment to lower their affinity towards enzymes was the goal of this study. Two different photocatalysts, titanium dioxide ( $\text{TiO}_2$ ) and zinc oxide ( $\text{ZnO}$ ) were added into ammonia solution to pretreat corn stover. Ammonia concentration and solid-to-liquid loading were investigated as important control factors to optimize the subsequent sugar conversion yield by enzymatic hydrolysis of the pretreated biomass. The overall lignin mass balance throughout the pretreatment process was monitored by analyzing hydrolyzed lignin in the liquid pretreatment hydrolysate, and Raman spectroscopy was utilized to explore the structural changes in the biomass before/after the pretreatment.

## 2. Materials and Methods

### 2.1. Materials

Corn stover was collected from central Iowa in 2010, washed with deionized water and air-dried at ambient temperature. The corn stover was ground and screened to a nominal size of 9-35 mesh. The initial composition of the corn stover was 37.3 wt.% glucan, 22.5 wt.% xylan, 2.5 wt.% galactan, 3.3 wt.% arabinan, 17.2 wt.% lignin (acid insoluble + acid soluble), 4.8 wt.% protein, 1.5 wt.% sucrose, 4.6 wt.% ash, and 6.3 wt.% other extractives. Zinc oxide (Sigma-Aldrich, Cas #1314-13-2) and Titanium dioxide P25 (Evonik Degussa, Cas #13463-67-7) were used as photocatalysts.

Cellulase GC 220 (Lot #301-04232-162) was provided by Genencor, a Danisco Division. The average activity of cellulase (GC-220) was 45 filter paper unit (FPU)/ml. The  $\beta$ -glucosidase enzyme, Novozyme 188 (Novo Inc., Lot #11K1088), was purchased from Sigma-Aldrich (St. Louis, MO). Activity of Novozyme 188 was 750 cellobiase units (CBU)/ml.

### 2.2. Photocatalyst-assisted ammonia pretreatment

Corn stover was treated by aqueous ammonia solution with photodegradation under UV catalyzed by the photocatalysts. Each pretreatment condition was conducted in duplicate. Different ratios of biomass to solution were applied from 1:20 to 1:50 (g/ml). The amount of photocatalyst ( $\text{TiO}_2$  and  $\text{ZnO}$ ) was 10 wt.% of biomass loading. Biomass and photocatalysts were loaded in screw-capped 250 ml bottles with 5% to 12.5 % of ammonium hydroxide. The reaction temperature was maintained at 60 °C by isotemp basic ceramic stirring hotplate (Fisher, Cat. #11-100-100SH) and reaction time was 24 hours. The UV light source was 100



W UV lamps (American ultraviolet company, Lebanon, IN) with irradiation wavelength 380 nm for 24 h. During the first 6 hours, oxygen was supplied to enhance the photocatalytic reactions.

### 2.3. Enzymatic hydrolysis of pretreated biomass

The enzymatic digestibility of the corn stover samples was determined in duplicate according to the NREL Chemical Analysis and Testing Standard Procedure (NREL, 2008). For the enzymatic digestibility tests of pretreated solid residue, 15 FPU of GC 220 and 30 CBU of Novozyme 188 per gram of glucan supplemented were loaded in the 250 ml screw-capped Erlenmeyer flasks. The initial glucan concentration was 1 % (w/v) based on 100 ml of total liquid and solid, and pH was adjusted to 4.8 by 0.05 M sodium citrate buffer solution. Prepared flasks were placed in the incubator shaker (New Brunswick Scientific, Edison, NJ) and agitated at 150 rpm at 50 °C. Samples were taken periodically (6, 12, 24, 48, 72, 96, and 120 h) and analyzed by HPLC for calculating the glucose and xylose contents.

The glucan and xylan digestibilities were calculated as follows:

$$\text{Glucan digestibility} = \frac{\text{Total released glucose (g)} \times 0.9}{\text{Initial glucan loading (g)}} \times 100$$

0.9 is the conversion factors of glucose to equivalent glucan.

$$\text{Xylan digestibility} = \frac{\text{Total released xylose (g)} \times 0.88}{\text{Initial xylan loading (g)}} \times 100$$

0.88 is the conversion factors of xylose to equivalent xylan.

## 2.4. Analytical methods

### 2.4.1. Compositional analysis

Carbohydrates and lignin contents in the untreated and pretreated corn stover were analyzed following the NREL LAP (NREL, 2008). Each sample was analyzed in duplicate. Carbohydrates were determined by HPLC with a Bio-Rad Aminex HPX-87P column and a refractive index detector (Varian 356-LC, Varian, Inc., CA).

The compositional changes of each component (cellulose, hemicellulose and lignin) in the biomass by the pretreatment were calculated as follows:

Removed component from the biomass by the pretreatment (%)

$$= \frac{\text{Removed fraction of each component by the pretreatment}}{\text{Composition of each component in the untreated biomass}} \times 100$$

Dissolved lignin in the liquid hydrolysate was measured using LAMBDA™ 750 UV/Vis/NIR spectrophotometer (PerkinElmer, Shelton, CT). The absorption at 290 nm was used to characterize the soluble lignin. Alkali lignin (Sigma-Aldrich, St. Louis, MO) was dissolved in the water and the same concentration of ammonia (as used in the pretreatment) and used as standard for the generation of the calibration curve. During the pretreatment, 1 ml of liquid was periodically withdrawn from the bulk to monitor its soluble lignin content: after centrifugation, the supernatant was subjected to the UV-Vis measurement.

#### 2.4.2. Raman analysis

DXR Raman microscope (Thermo Scientific, Waltham, MA) was used for Raman spectra acquisition with 780 nm excitation at 14 mW, 20X objective and 50  $\mu\text{m}$  slit. The laser exposure time was 5 seconds and spectral resolution was  $2.5 \text{ cm}^{-1}$ - $4.6 \text{ cm}^{-1}$ . The OMNIC™ suite (Thermo Scientific, Waltham, MA) was used for data processing. The spectra were

baseline-corrected and smoothed. An iterative polynomial background removal algorithm was implemented to remove background fluorescence from the Raman spectral data (Zhang et al., 2009). 10 spectra were acquired from each sample and the average spectrum was calculated.

### **3. Results and discussion**

#### **3.1. Effects of photocatalytic UV treatments on composition of corn stover**

Corn stover was treated by aqueous ammonia and UV with two different photocatalysts ( $\text{TiO}_2$  and  $\text{ZnO}$ ) under various reaction conditions. Table 1 shows the effects of photocatalytic ammonia soaking/UV pretreatments on biomass compositional changes. The hydroxyl and superoxide radicals generated from the surface of  $\text{TiO}_2$  under UV irradiation caused oxidation or degradation of lignin in the biomass (Niu et al., 2009). Photocatalytic reaction by  $\text{TiO}_2$  removed 5 % of lignin, 4 % of glucan and 9 % of hemicelluloses (xylan, galactan, and arabinan) from the untreated biomass under the following conditions: no ammonia loading, 60 °C, 24 h, solid:liquid ratio=1:50, photocatalyst ( $\text{TiO}_2$ ):biomass=1:10, and oxygen supply. Delignification of biomass by  $\text{ZnO}$  (10 %) was slightly higher than by  $\text{TiO}_2$  under the same reaction conditions, but the photoreaction alone is not sufficient to cause significant compositional change that may affect the subsequent enzymatic hydrolysis or fermentation (Table 1).

Ammonia is an effective pretreatment reagent which has high reaction selectivity towards lignin over carbohydrates. It cleaves not only C-O-C bonds in lignin but also ether and ester bonds in the lignin-carbohydrates complex (LCC) (Kim et al., 2011). Aqueous ammonia treatment removed 55-65 % of lignin, while preserved over 93 % of glucan and 81 %

of xylan in the biomass under different solid-to-liquid ratios (1:20-1:50), without photocatalysts loading. With the addition of photocatalytic UV treatment to the ammonia pretreatment regime, lignin and xylan removal from the biomass is slightly increased in overall, as shown in the compositional changes of pretreated solid in Table 1. Delignification levels of photocatalyst-assisted ammonia treated corn stover were 60-70 % with both  $\text{TiO}_2$  and  $\text{ZnO}$ . The effect of each photocatalyst on lignin removal was similar; however, more carbohydrates were preserved in the treated solid in  $\text{TiO}_2$ -assisted pretreatment under the same reaction conditions besides type of photocatalyst.

Effects of various liquid loadings (gram liquid per gram biomass) were also investigated, as shown in Table 1. There was no substantial compositional change by adjusting the solid-to-liquid ratio without photocatalyst, while xylan and lignin contents decreased as the liquid loading was reduced with  $\text{TiO}_2$  (Table 1). In this study, highest lignin removal was obtained with 20 g of ammonia solution per gram corn stover under the following conditions: 5.0 wt.% ammonium hydroxide, 60°C, 24 h, and photocatalyst ( $\text{TiO}_2$ ):biomass=1:10, and oxygen supply. Another interesting observation was that different liquid loadings affected enzymatic digestibility of different carbohydrate components in the treated biomass differently in presence of  $\text{TiO}_2$ -assisted UV treatment with the same ammonia concentration (5.0 wt.%), reaction temperature (60°C), reaction time (24 h), and photocatalyst ( $\text{TiO}_2$ ) loading (photocatalyst:biomass=1:10) (Table 1): i.e., Glucan digestibility was not improved substantially at higher liquid loading; however, xylan digestibility was increased quite significantly by lowering liquid loading. When the ammonia liquid per gram biomass loading was decreased from 50 g to 20 g under the same conditions (5.0 wt.% ammonium hydroxide, 60°C, 24 h, and photocatalyst ( $\text{TiO}_2$ ):biomass=1:10, and

oxygen supply) except liquid/solid ratio, an 11 % xylan digestibility increase was observed, as shown in Table 1. A possible explanation is that lower liquid/solid ratio resulted in higher concentration of free radicals generated from the photoreaction, which led to more effective degradation or alteration to the biomass that favored subsequent enzymatic hydrolysis.

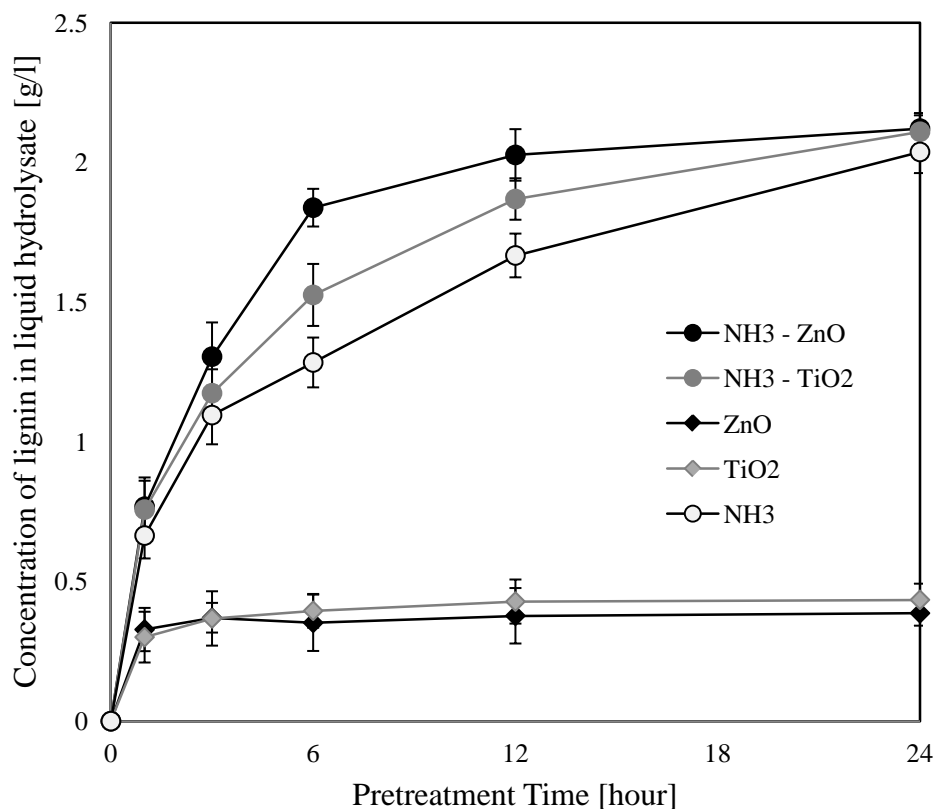

Fig. 1. Lignin concentration profile in the liquid hydrolysates during photocatalyst-assisted ammonia pretreatment

*Note:* Pretreatment condition: 5.0 wt. % ammonium hydroxide, 60 °C, 24 h, solid:liquid=1:50, photocatalyst (TiO<sub>2</sub> / ZnO):biomass=1:10, oxygen supply.

**Table 1**  
Effects of various treatment conditions on the composition and enzymatic digestibility in photocatalyst-assisted ammonia treated solids<sup>a</sup>

Treatment conditions		Composition					Enzymatic digestibility		
concentration	Photocatalyst	SR <sup>b</sup>	Glucan	Xylan	Galactan	Arabinan	Lignin <sup>c</sup>	Glucan	Xylan
[%]	[-]	[%]	[%]	[%]	[%]	[%]	[%]	[%]	[%]
Untreated		-	37.3	22.5	2.5	3.3	17.2	18.6	7.5
Solid : Liquid = 1 : 50									
0	TiO <sub>2</sub>	96.0	35.7	21.6	1.4	3	16.4	18.7	7.6
0	ZnO	91.5	35.4	20.8	1.3	3.1	15.5	22.1	7.9
5	No catalyst	67.4	35.1	19	1	2.8	7.3	74.6	56.8
5	TiO <sub>2</sub>	68.7	34.7	18.2	1	2.7	6.9	76.5	60.6
5	ZnO	66.5	34.3	17.7	0.7	2.4	6.8	80.7	63.9
Solid : Liquid = 1 : 30									
5	No catalyst	67.5	34.7	18.8	1.1	2.5	7	73.2	66.3
5	TiO <sub>2</sub>	66.1	35.6	17.4	1.4	2	6.5	75.5	67.4
Solid : Liquid = 1 : 20									
5	TiO <sub>2</sub>	64.8	35	16.3	1.1	1.9	6.5	77.4	71.3
12.5	No catalyst	67.3	35.3	18.3	1.4	2.3	5.9	80.8	63.6
12.5	TiO <sub>2</sub>	63.6	35.7	16.5	0.7	1.9	5.2	84.8	74.5
12.5	ZnO	62.1	32.9	15.2	1	1.6	5.2	82.4	76.9

The data in the table show the mean value (n=2, SD < 0.2 for glucan, xylan, and lignin in solid, SD < 0.3 for Lignin purity, SD < 2.8 for Enzymatic digestibility, SD: standard deviation).

<sup>a</sup>Data (lignin, glucan, xylan, galactan, and arabinan contents) in the table are based on the over dry untreated biomass. Pretreatment conditions: 5.0-12.5 wt.% ammonium hydroxide, 60 °C, 24 h, solid:liquid=1:20-50, photocatalyst:biomass=1:10, oxygen supply.

<sup>b</sup>Solid remaining after pretreatment

<sup>c</sup>Acid soluble lignin + Acid insoluble lignin

According to the solid composition changes, photocatalyst-assisted ammonia pretreatment removed significant amounts of lignin (60.0 % - 69.8 %) (Table 1). Figure 1 shows lignin concentration profile in the liquid hydrolysates during photocatalyst-assisted ammonia pretreatment. Significant lignin removal could be obtained with aqueous ammonia pretreatment alone, and it was further improved by the photocatalysts-assisted UV treatments. However, photocatalytic reactions alone, with both  $\text{TiO}_2$  and  $\text{ZnO}$ , could not solubilize lignin significantly. Compared to  $\text{TiO}_2$  in ammonia,  $\text{ZnO}$  in ammonia hydrolyzed more lignin from biomass from 6 hours to 24 hours; however, lignin recovery by each photocatalyst was almost identical after 24 hours (~2.1 g/l). It should be noticed that photocatalyst-assisted processes showed higher hydrolysis rates within the first 12 hours than that of ammonia-alone process, which could have major implication from energy consumption standpoint: an acceptable “pretreatment level” could be reached in shorter processing time with less energy needed.

It should be noticed that the presence of the  $\text{TiO}_2$  nanoparticles in the pretreated biomass may have negative impact on the fermentation of the saccharide solution into biofuels, although it seems their presence did not interfere with the enzymatic saccharification. They need to be removed in order to avoid any potential hindrance to subsequent fermentation. One strategy that is being explored is to incorporate  $\text{TiO}_2$  nanoparticles with magnetic nanoparticles in nanocomplexes, as shown in Figure 2. These nanocomplexes can be removed through magnetic separation after the pretreatment processes. Early results have confirmed the photocatalytic activities of these nanocomplexes, the effectiveness of the magnetic removal of the nanocomplexes from the process stream is being investigated.

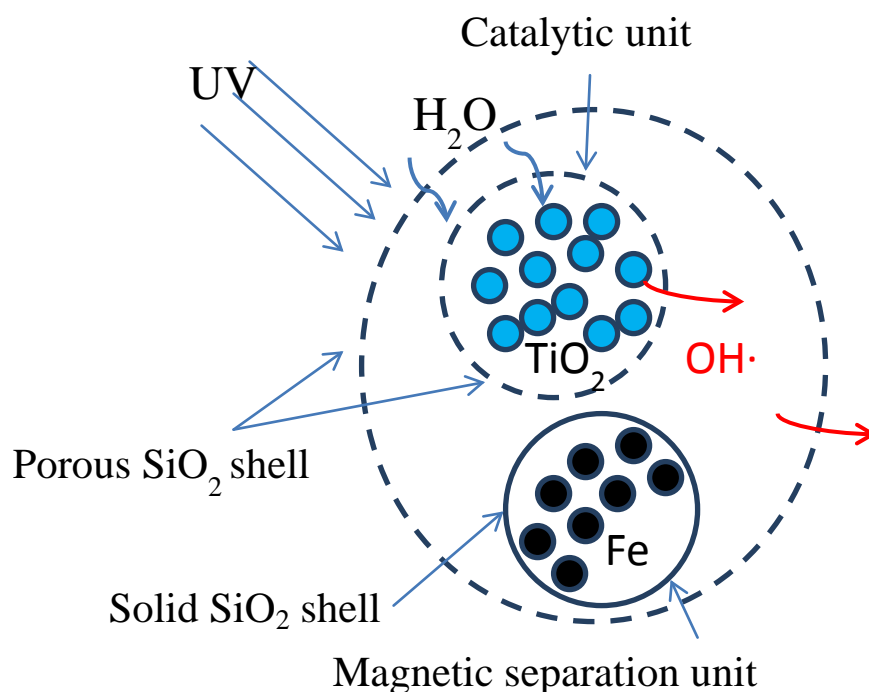

Fig. 2. Design of the nanocomplex containing a TiO<sub>2</sub>-based nanocatalyst catalytic unit and a magnetic separation unit

### 3.2. Effect of photocatalyst-assisted ammonia pretreatment on enzymatic digestibility of pretreated biomass

Subsequent enzymatic digestibility tests were conducted with ammonia-TiO<sub>2</sub> treated corn stover using 15 FPU/g-glucan of cellulase (GC-220) and 30 CBU/g-glucan of  $\beta$ -glucosidase enzymes (Novozyme 188). The pretreatment conditions were as follows: 12.5 % ammonia loading, solid:liquid=1:20, photocatalyst (TiO<sub>2</sub>):biomass (corn stover)=1:10, 60 °C, 24 h with oxygen supply and UV light irradiation. Glucan and xylan digestibilities of aforementioned TiO<sub>2</sub>-assisted ammonia treated biomass are summarized in Figure 3. TiO<sub>2</sub>-assisted UV treatment alone showed no improvement on enzymatic digestibility; while TiO<sub>2</sub>-assisted UV treatment in conjunction with ammonia (NH<sub>3</sub>-TiO<sub>2</sub> in Figure 3) improved the



digestibility (at 120 h) of the corn stove biomass from 18 % for glucan and 8 % for xylan to 85 % and 75 %, respectively. Compared to the treatment with same ammonia loading alone (NH<sub>3</sub> in Figure 3), an improvement of 5 % for glucan digestibility and 11 % for xylan digestibility were observed with the TiO<sub>2</sub>-assisted UV treatment (NH<sub>3</sub>-TiO<sub>2</sub> in Figure 3).

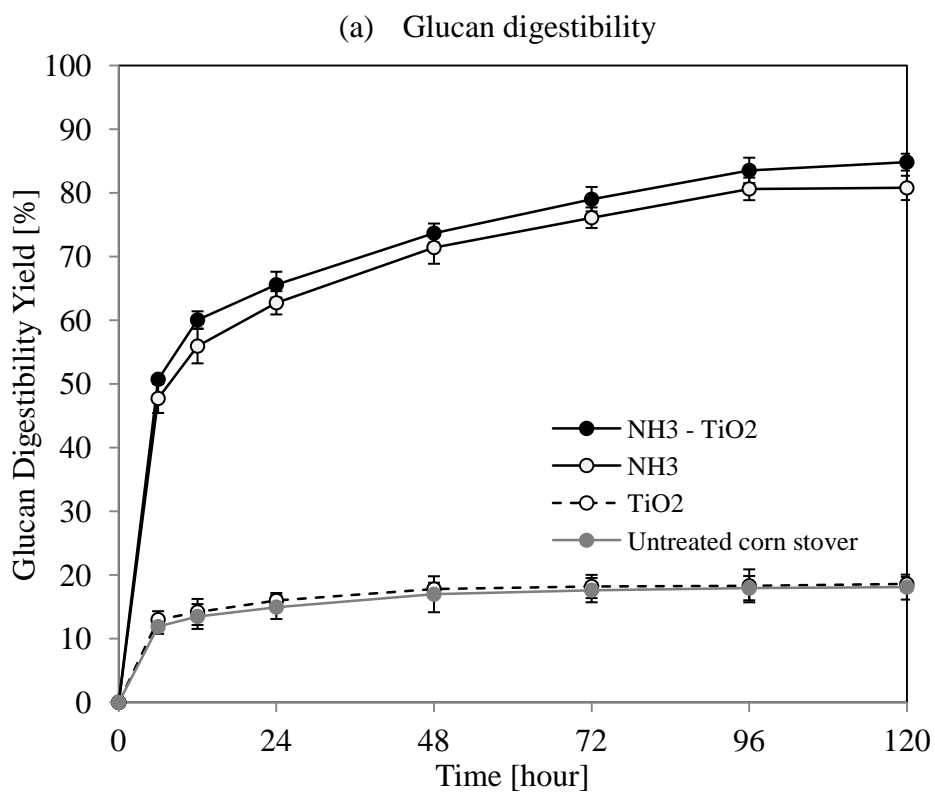

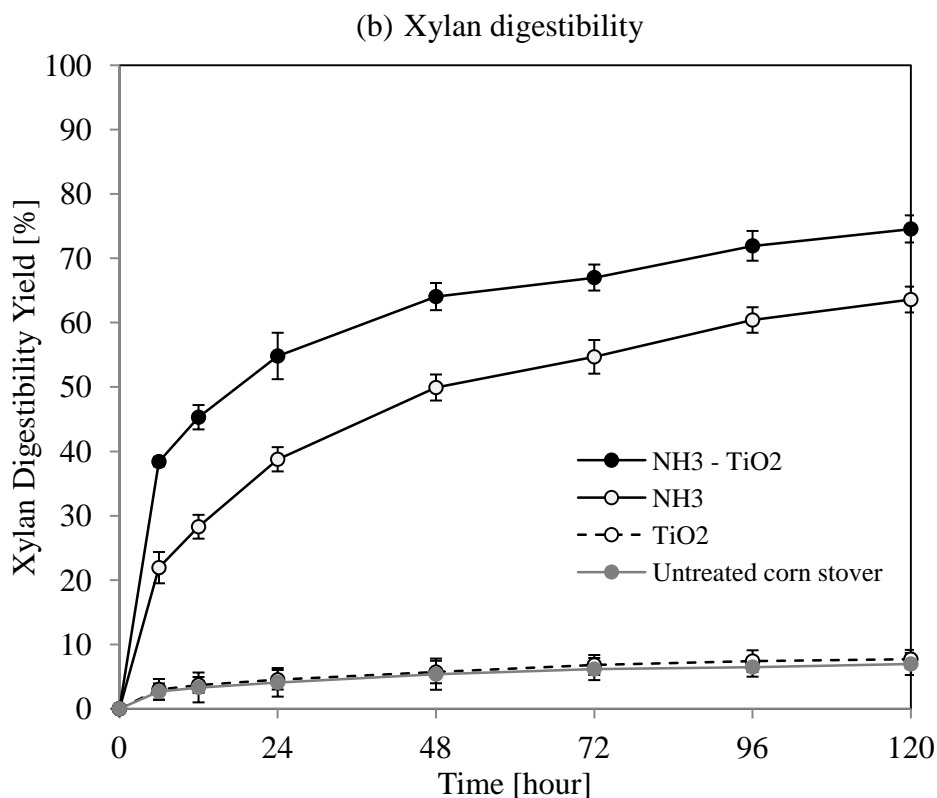

Fig. 3. Enzymatic digestibility of photocatalyst-assisted ammonia treated corn stover

*Note:* Pretreatment condition: 12.5 wt.% ammonium hydroxide, 60 °C, 24 h, solid:liquid=1:20, photocatalyst (TiO<sub>2</sub>):biomass=1:10, oxygen supply; Enzymatic hydrolysis condition: 1 % w/v glucan loading/100 ml working volume; 15 FPU of GC 220/g-glucan, 30 CBU of Novozyme 188/g-glucan, 50°C, 150 rpm.

### 3.3. Raman spectroscopic characterization of photocatalyst-assisted ammonia treated corn stover

Raman spectroscopy was used to characterize the structure constituents and chemical bonds in lignocellulosic biomass. Table 2 showed the relative intensities of characteristic Raman peaks of untreated corn stover, 5 % ammonia treated corn stover, and 5 % ammonia +TiO<sub>2</sub>-assisted UV treated corn stover with oxygen supply. The relative intensities were calculated against the Raman peak at 1,267 cm<sup>-1</sup>, which was identical for the treated and untreated biomass samples. Raman bands associated with cellulose, hemicellulose, and lignin

can be directly identified from the Raman spectra (see Figure S1 in the supplemental material). In addition, semi-quantification of lignin and cellulose components in corn stover samples before/after pretreatment could also be achieved by calculating spectral intensities of relevant Raman bands (Daferera et al., 2002).

**Table 2**

Raman characterization of ammonia-photocatalyst treated corn stover

*Note:* Pretreatment condition: 5 % ammonium hydroxide, 60 °C, 24 h, solid:liquid=1:50, Photocatalyst (TiO<sub>2</sub>):biomass=1:10, oxygen supply.

Wavenumber(cm <sup>-1</sup> ) and peak assignment	Relative Intensity	
	Untreated	Treated
<b>352</b> C-C skeletal bending	0.7353	4.0541
<b>421</b> -CH <sub>2</sub> OH methane bending	0.7059	1.4595
<b>800</b> skeletal deformation of aromatic ring	0.5882	0.1892
<b>897</b> H-C-C and CHO bending	0.1471	2.2702
<b>987</b> skeletal deformation of aromatic ring	0.5882	0.1351
<b>1096</b> COC,C-OH bending	1.0588	7.0270
<b>1266</b> Internal reference	1 <sup>a</sup>	1
<b>1334</b> Aliphatic O-H bending	0.7941	0.2702
<b>1380</b> HCC, HCO, HOC bending	0.0294	3.2432
<b>1456</b> O-CH <sub>3</sub> deformation or CH <sub>2</sub> scissoring	0.9412	0.3243
<b>1467</b> HCH and HCO bending	0.6471	1.6216
<b>1604</b> Symmetric stretching of aromatic ring	6.1764	0.4324
<b>1661</b> C=C or C=O stretching vibration	3.5294	0.2703
<b>2887</b> Aliphatic C-H stretching	0.8529	8.3783

<sup>a</sup> The intensities of Raman band for the untreated and treated biomass at 1,267 cm<sup>-1</sup> are identical and used as internal reference for the calculation of relevant intensities of different Raman bands.

In the untreated corn stover, two major lignin bands were identified at 1,604 and 1,661  $\text{cm}^{-1}$ . The most intense band at 1,604  $\text{cm}^{-1}$  can be attributed to symmetric stretching of aromatic ring, and the 1,661  $\text{cm}^{-1}$  band is attributed to the C=C stretching from coniferyl alcohol and the C=O stretching of coniferaldehyde (Adapa et al., 2009). Additionally, peak(s) at 1,456  $\text{cm}^{-1}$  from O-CH<sub>3</sub> deformation and CH<sub>2</sub> scissoring, at 785 and 897  $\text{cm}^{-1}$  due to the skeletal deformation of aromatic rings, and at 1,334  $\text{cm}^{-1}$  due to aliphatic O-H bending are also lignin signatures. These peaks were significantly reduced by ammonia treatment, and almost disappeared by photocatalyst-assisted ammonia pretreatment.

After pretreatments (5 % ammonia + TiO<sub>2</sub>), 60-70 % of the lignin components were removed or degraded/altered to various degrees; part of the hemicellulose components were decomposed as well. Investigation of the Raman spectra measured from the corn stover samples before and after the TiO<sub>2</sub>-assisted ammonia pretreatment indicated a clear switch from lignin dominated signatures to cellulose dominated signatures. The skeletal structures of cellulose molecules are mostly C-C bonds and C-O bonds which show relatively high polarizabilities and high Raman scattering coefficients (Agarwal, 2006; Atalla & Agarwal, 1985, Atalla and Isogai, 2010). In particular, cellulose bands at 1,059-1,148  $\text{cm}^{-1}$  due to the C-O-C and C-O-H bending vibrations, at 1,380  $\text{cm}^{-1}$  due to HCC, HCO and HOC bending, and at 2,887  $\text{cm}^{-1}$  due to aliphatic C-H stretch residual carbohydrates (methane C-H stretches of cellulose molecules) were remarkably improved after the pretreatments. This is because the relative content of cellulose in the biomass increased while the relative content of lignin decreased after the pretreatments. This trend was further confirmed by cellulose peaks between 350 to 550  $\text{cm}^{-1}$  of skeletal-bending modes (CCC, COC), methane bending (CCH, OCH) and skeletal stretching (CC, CO) and 897  $\text{cm}^{-1}$  (assigned to HCC and HCO bending at

C6), and 1,456-1,469  $\text{cm}^{-1}$  (due to HCH and HOC bending vibration) (Agarwal, 2006; Agarwal & Ralph, 1997; Atalla & Agarwal, 1985; Tanaka et al., 1999). Moreover, the peak between 1,163 to 1,181  $\text{cm}^{-1}$  is assigned to C-O structure, typical for p-hydroxyphenyl, guaiacyl and syringal lignins (Iskalieva et al., 2012; Sun, Simmons, & Singh, 2011). These peaks were significantly reduced by ammonia treatment, and almost disappeared by photocatalyst-assisted ammonia pretreatment, indicating the cleavage of the lignin-carbohydrate linkage. The cleavage of the lignin-carbohydrate bonds and the breaking-down of the long cellulose polymers into shortened fragments may lead to exposure of glucan- and/or xylan- residues for easier enzymatic access, and subsequent elevated hydrolysis efficiency.

The Raman spectroscopic investigation clearly revealed that lignin structure was significantly affected or decomposed, and the relative content of cellulose was increased by photocatalyst-assisted ammonia pretreatment, further verified the compositional analysis results. It should be noticed that most of Raman bands of hemicellulose overlap with those of cellulose; therefore, structure changes of hemicellulose caused by the pretreatment were not clearly shown in the Raman analysis.

#### **4. Conclusion**

Photocatalyst-assisted UV treatment could further improve the effectiveness of ammonia pretreatment to remove lignin from biomass. As a result, higher enzymatic digestibility and fermentability could be obtained. With ammonia-TiO<sub>2</sub>-treated corn stover

under the optimal conditions (12.5 % ammonium hydroxide, 60 °C, 24 h, solid:liquid=1:20, photocatalyst:biomass=1:10, oxygen supply), 85 % of glucan digestibility and 75 % of xylan digestibility were obtained using 15 FPU/g-glucan of cellulase and 30 CBU/g-glucan of  $\beta$ -glucosidase. The Photocatalyst-assisted UV treatment in conjunction with ammonia soaking can shorten the time needed for pretreatment, and potentially it can lead to significant reduction in energy consumption of pretreatment.

### **Acknowledgements**

This work was supported by Iowa state university. We are grateful to Genencor International Inc. for providing cellulase and xylanase enzymes.

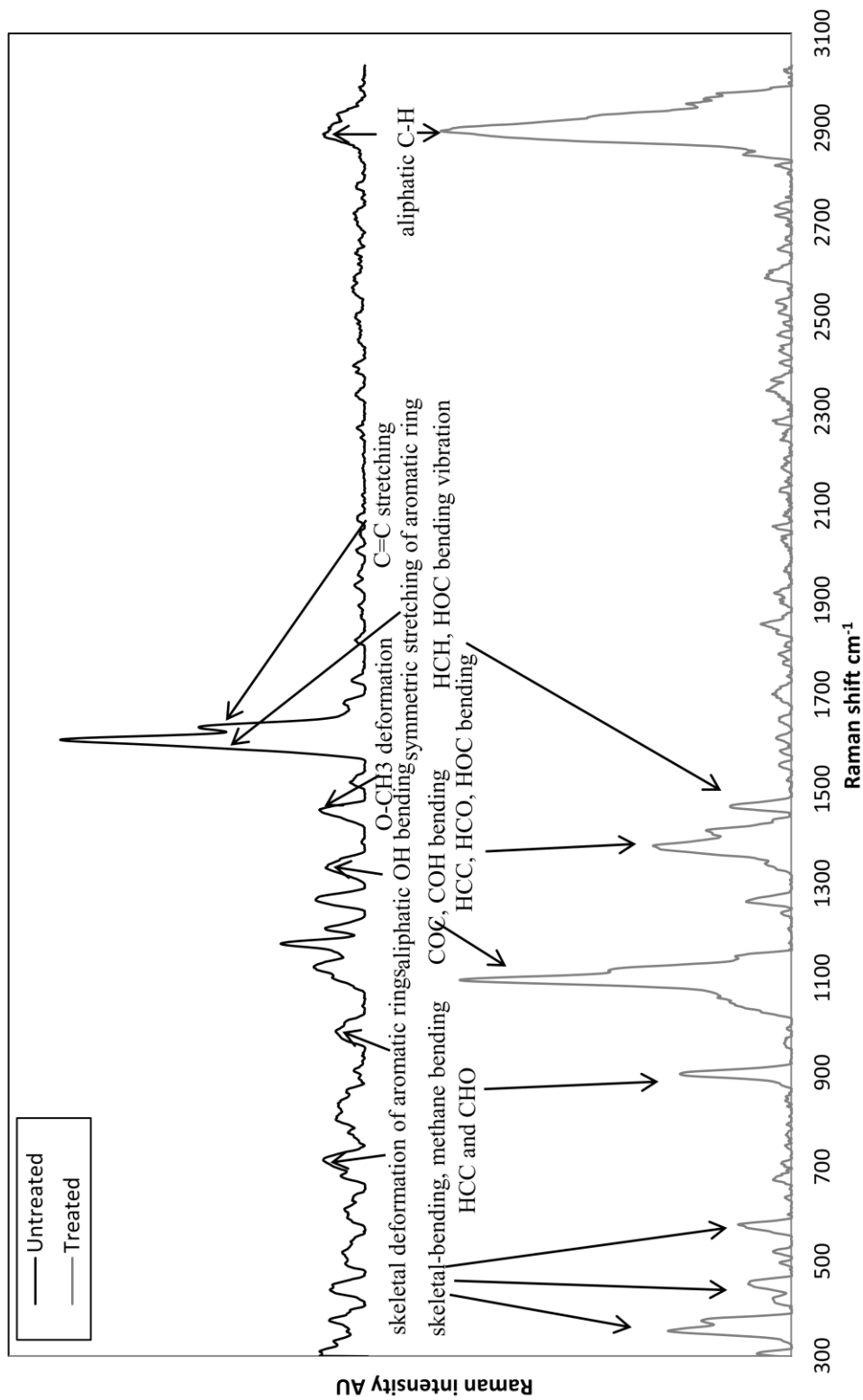

Fig. S1. Raman characterization of various treated solids

Note: Pretreatment condition: 5.0 wt.% ammonium hydroxide, 60 °C, 24 h, solid:liquid=1:50, Photocatalyst (TiO<sub>2</sub>):biomass=1:10, oxygen supply.

## References

- Adapa, P., Karunakaran, C., Tabil, L., Schoenau, G., 2009. Potential applications of infrared and Raman spectromicroscopy for agricultural biomass. *Agric Eng Int: CIGR journal*, 11, 1-25.
- Agarwal, U.P., Ralph, S.A., 1997. FT-Raman spectroscopy of wood: Identifying contributions of lignin and carbohydrate polymers in the spectrum of black spruce (*Picea mariana*). *Appl. Spectrosc.* 51, 1648-1655.
- Agarwal, U.P., 2006. Raman imaging to investigate ultrastructure and composition of plant cell walls: distribution of lignin and cellulose in black spruce wood (*Picea mariana*). *Planta*, 224, 1141-1153.
- Agbor, V.B., Cicek, N., Sparling, R., Berlin, A., Levin, D.B., 2011. Biomass pretreatment: Fundamentals toward application. *Biotechnol. Adv.* 29, 675-685.
- Atalla, R.H., Agarwal, U.P., 1985. Raman microprobe evidence for lignin orientation in the cell-walls of native woody tissue. *Science*, 227, 636-638.
- Atalla, R.H., Isogai, A., 2010. *Lignin and Lignans: Advances in Chemistry*, CRC Press, New York.
- Chakrabarti, S., Chaudhuri, B., Bhattacharjee, S., Das, P., Dutta, B.K., 2008. Degradation mechanism and kinetic model for photocatalytic oxidation of PVC–ZnO composite film in presence of a sensitizing dye and UV radiation. *J. Hazard. Mater.* 154, 230-236.
- Daferera, D., Pappas, C., Tarantilis, P.A., Polissiou, M., 2002. Quantitative analysis of  $\alpha$ -pinene and  $\beta$ -myrcene in mastic gum oil using FT-Raman spectroscopy. *Food Chem.* 77, 511-515.
- Fishman, D., Majumdar, R., Morello, J., Pate, R., Yang, J., 2010. *National Algal Biofuels Technology Roadmap*. U.S. Department of Energy, Office of Energy Efficiency and Renewable Energy, Biomass Program.
- Iskaleva, A., Yimmou, B. M., Gogate, P. R., Horvath, M., Horvath, P. G., & Csoka, L. (2012). Cavitation assisted delignification of wheat straw: A review. *Ultrasonics Sonochemistry*, 19(5), 984-993.
- Kansal, S.K., Singh, M., Sud, D., 2008. Studies on TiO<sub>2</sub>/ZnO photocatalysed degradation of lignin. *J. Hazard. Mater.* 153, 412-417.



- Kim, J.W., Kim, K.S., Lee, J.S., Park, S.M., Cho, H.Y., Park, J.C., Kim, J.S., 2011. Two-stage pretreatment of rice straw using aqueous ammonia and dilute acid. *Bioresour. Technol.* 102, 8992-8999.
- Kim, T.H., Kim, J.S., Sunwoo, C., Lee, Y.Y., 2003. Pretreatment of corn stover by aqueous ammonia. *Bioresour. Technol.* 90, 39-47.
- Kobayakawa, K., Sato, Y., Nakamura, S., Fujishima, A., 1989. Photodecomposition of kraft lignin catalyzed by titanium dioxide. *Bull. Chem. Soc. Jpn.* 62, 3433-3436.
- Kuhad, R.C., Singh, A., 2007. *Lignocellulosic Biotechnology: Future prospects*, I.K. International Publishing House Pvt. Ltd., New Delhi.
- Kumar, P., Barrett, D.M., Delwiche, M.J., Stroeve, P., 2009. Methods for Pretreatment of Lignocellulosic Biomass for Efficient Hydrolysis and Biofuel Production. *Ind. Eng. Chem. Res.* 48, 3713-3729.
- Niu, K., Chen, P., Zhang, X., Tan, W.-S., 2009. Enhanced enzymatic hydrolysis of rice straw pretreated by alkali assisted with photocatalysis technology. *J. Chem. Technol. Biotechnol.* 84, 1240-1245.
- NREL (National Renewable Energy Laboratory) in Golden, CO. 2008. LAP (Laboratory Analytical Procedure), [http://www.nrel.gov/biomass/analytical\\_procedures.html](http://www.nrel.gov/biomass/analytical_procedures.html).
- Ohnishi, H., Matsumura, M., Tsubomura, H., Iwasaki, M. 1989. Bleaching of lignin solution by a photocatalyzed reaction on semiconductor photocatalysts. *Ind. Eng. Chem. Res.* 28, 719-724.
- Pelizzetti, E., Serpone, N., 1986. *Homogeneous and heterogeneous photocatalysis*, Reidel, Dordrecht.
- Peralta, P., Peralta, Z., 1998. Evaluation of ZnO, TiO<sub>2</sub> and supported ZnO on the photoassisted remediation of black liquor, cellulose and textile mill effluents. *Chemosphere*, 36, 2119-2133.
- Sun, L., Simmons, B.A., Singh, S., 2011. Understanding Tissue Specific Compositions of Bioenergy Feedstocks Through Hyperspectral Raman Imaging. *Biotechnol. Bioeng.* 108, 286-295.
- Tanaka, K., Calanag, R.C.R., Hisanaga, T., 1999. Photocatalyzed degradation of lignin on TiO<sub>2</sub>. *J. Mol. Catal. a-Chem.* 138, 287-294.

- Tantemsapya, N., Wirojanagud, W., Sakolchai, S., 2004. Removal of color, COD and lignin of pulp and paper wastewater using wood ash. *J. Sci. Technol.* 26, 1-12.
- Zhang, Z.-M., Chen, S., Liang, Y.-Z., Liu, Z.-X., Zhang, Q.-M., Ding, L.-X., Ye, F., Zhou, H., 2010. An intelligent background-correction algorithm for highly fluorescent samples in Raman spectroscopy. *J. Raman Spectrosc.* 41, 659-669.
- Zheng, Y., Pan, Z., Zhang, R., 2009. Overview of biomass pretreatment for cellulosic ethanol production. *Int. J. Agric. & Biol. Eng.* 2, 51-68.

## CHAPTER 7. GENERAL CONCLUSIONS AND FUTURE WORK

### Conclusions

Lignocellulosic biomass is a biorenewable resource with the potential to serve a feedstock for liquid transportation fuels and chemicals. The recalcitrant nature of lignocellulosic biomass makes its utilization challenging. In this study, several pretreatment and fractionation technologies were developed and tested to improve subsequent enzymatic hydrolysis and ethanol fermentation yields, to separate hemicellulose and lignin with high purity for value-added co-products, and to reduce the required inputs of energy, chemicals, and water.

The fractionation processes described in Chapters 2 – 4 aimed to separate hemicellulose and lignin, and to provide high-purity streams of each, thereby producing readily-fermented carbohydrates and high value co-products. The production of co-products can contribute to increasing the overall economic viability of a process. Even though the fractionated hemicellulose was fermented to ethanol in this study, the hemicellulose could also have been fermented to higher value products such as xylitol and astaxanthin in a biorefinery. In Chapter 4, this approach of high-value compounds was examined by taking ZnCl<sub>2</sub>-fractionated hemicellulose into furfural by thermal reaction. Separated lignin fractions from these processes also have potential as feedstocks to make additional high-value products. In addition, the biological conversion yields of residual cellulose were improved with the fractionation of hemicellulose and lignin. Two stage fractionation using ammonia and hot-water produced high purity (over 80%) hemicellulose, and the ethanol yield of the cellulose fraction reached up to 98%. In Chapter 4, ZnCl<sub>2</sub> treatment removed over 90% of

hemicellulose. A furfural yield of 58% and an ethanol yield of 98% were obtained with the fractionated hemicellulose and residual solids respectively.

Pretreatment studies (Chapters 5 and 6) were conducted to efficiently utilize biomass from another viewpoint. Pretreatment is one of the most expensive and energy intensive processing steps in the biological conversion process using lignocellulosic biomass. In particular, chemicals, water, and energy inputs for the production and recovery have been at issue. Gaseous ammonia pretreatment and photocatalyst-assisted ammonia pretreatment aimed to reduce these inputs to save production costs. Minimizing the production costs can make the products more competitive in the marketplace. In Chapter 5, low-moisture anhydrous ammonia (LMAA) pretreatment resulted in high ethanol conversion yield (~90%) with significantly reduced ammonia (~10% of biomass weight) and water (~1:1 of biomass:water) inputs. In Chapter 6, photocatalyst-assisted ammonia pretreatment increased the delignification up to 70% within shorter period and enhanced the enzymatic digestibilities of the treated biomass compared to the other aqueous ammonia pretreatment with the same amounts of ammonium hydroxide loading.

The characteristics of lignocellulosic biomass vary depending on the species, environments and other factors, and the conversions methods can also be different with the characteristics and target products. Each method has its own pros and cons. The two-stage fractionation process with ammonia and hot-water can produce high purity of each component; however, the operating and capital costs of this process are relatively high because of the multiple stages. The hybrid fractionation with zinc chloride is a relatively simple process, but the zinc chloride recovery costs may be high. The LMAA pretreatment significantly reduced water and ammonia use compared to other liquid ammonia

pretreatment methods; however, economical viability of the LMAA still needs to be verified. Photocatalyst-assisted ammonia pretreatment can improve the enzymatic hydrolysis without increasing ammonia concentration. It also shortens the pretreatment time. However, the overall liquid loading is relatively high because of the photocatalyst distribution for efficient biomass pretreatment. The aforementioned approaches can be used by themselves or by combining with other methods depending on the biomass species and target products. Therefore, the studies in this thesis are worthwhile and contributable in lignocellulosic biomass utilization. Among these approaches, the LMAA process is the closest biomass conversion technology to a commercial process because of its simple process design and low operating costs for chemical, water, and energy inputs.

### **Future Work**

In the fractionation studies (Chapters 2 - 4), fractionation technologies of the three main components and conversion of ethanol and furfural were discussed. However, only one co-product (furfural) was investigated in this thesis. To maximize the advantage of these fractionation processes, further studies for conversion of various co-products are required. In particular, conversion of the lignin fraction has not yet been developed as much as that of carbohydrates in the biomass because of its structural variability and complexity. Lignin is an abundant component in lignocellulosic biomass and has high energy content. Therefore, the utilization of lignin will be an important key to the lignocellulosic feedstock biorefinery.

Secondly, even though several fractionation and pretreatment technologies are suggested, most of the results are limited to lab scale experiments. In the pilot scale process,

several unexpected problems can be encountered; therefore, studies with scale-up process are recommended to ensure the process is technically and economically viable in real industries.

In this study, some of the cost barriers such as chemical, water and energy inputs for lignocellulosic biomass utilization were discussed; however, the effects of these factors on the costs of final products were not studied. To understand the viability of the LMAA process, a techno-economic analysis on this process is required.

Moreover, many other obstacles such as transportation, storage, catalysts recovery and purification of products still exist to overcome for the commercialization of biorenewable products. Thus, further studies are necessary to commercialize the products from lignocellulosic biomass.

## ACKNOWLEDGEMENTS

I would like to express my sincerest gratitude to everyone who helped me accomplish my doctoral study. First, I would like to thank my advisor, Dr. Tae Hyun Kim, for his guidance, patience and support. It has been a great experience for me to work with him. I would like to thank Dr. Raj Raman, my co-advisor, for his interest, help and encouragement. He has always encouraged me to do my best at everything I do. I also thank Dr. Monlin Kuo, Dr. Hans van Leeuwen and Dr. Robert Anex, my POS committee members for their great instruction and valuable advice.

I want to give thanks to my colleagues, Xuan Li, Chao Wang, Simone Soso, Lam Nguyen, Weitao Zhang, Bo-ra Kim and Katrina Christiansen for their cooperation and help. I would also like to express my gratitude to Dr. Nhuan Nghiem in USDA-ARS-ERRC, for his advice and help.

I especially thank my wife, Jiyeon Hong, for her endless love, patience and support. I want to extend my appreciation to my parents and sister. It would not be possible to finish my graduate study without their help and support. I wish to dedicate this thesis to all of them.