

2010

Integration of a cob separation system into a biomass harvesting combine

Jeremiah Kingsley Johnson
Iowa State University

Follow this and additional works at: <http://lib.dr.iastate.edu/etd>

 Part of the [Bioresource and Agricultural Engineering Commons](#)

Recommended Citation

Johnson, Jeremiah Kingsley, "Integration of a cob separation system into a biomass harvesting combine" (2010). *Graduate Theses and Dissertations*. 11241.

<http://lib.dr.iastate.edu/etd/11241>

This Thesis is brought to you for free and open access by the Graduate College at Iowa State University Digital Repository. It has been accepted for inclusion in Graduate Theses and Dissertations by an authorized administrator of Iowa State University Digital Repository. For more information, please contact digirep@iastate.edu.

Integration of a cob separation system into a biomass harvesting combine

by

Jeremiah Kingsley Johnson

A thesis submitted to the graduate faculty
in partial fulfillment of the requirements for the degree of
MASTER OF SCIENCE

Major: Agricultural Engineering (Advanced Machinery Engineering)

Program of Study Committee:
Stuart J. Birrell, Major Professor
Matthew Darr
Brian Steward
Raj Raman

Iowa State University

Ames, Iowa

2010

Copyright © Jeremiah Kingsley Johnson, 2010. All rights reserved.

Table of Contents

Introduction	1
Literature Review	4
Corn cob Collection	4
Pneumatic Separation Properties	9
Objectives:	11
Machine Design and Development	13
Design Evaluation.....	13
Machine Development.....	16
Data Acquisition.....	24
Methods and Procedures.....	27
Preliminary Field Testing	27
Stationary Testing.....	30
Design of Experiment	31
Procedure	32
Material Characterization.....	36
Field Testing	38
Results and Discussion.....	40
Preliminary Testing.....	40
Stationary Testing.....	42
Field Testing	50
Conclusions and Recommendations.....	52
Conclusions	52
References	55
Acknowledgements.....	58
Appendix I. Raw data from stationary testing.....	59
Appendix II. Additional Pro/E figures of the cob separation system	61
Appendix III. Preliminary Testing Decision Matrix.....	63

Introduction

Before the invention of the combine harvester, corn was picked on the ear and threshed later. After threshing, farmers and coops were left with large piles of corn cobs (Dunning et al., 1948). With a seemingly abundant amount of corn cobs, innovative uses for corn cobs were found, including absorbents, animal bedding, chemical production, explosives, abrasives, and heat/energy production (Quaye and Schertz, 1983; Morey et al., 1984; Dominguez et al., 1997; Kaliyan and Morey, 2008).

Advancements in harvest technologies created harvesters that combined the collection of the ear corn and threshing of the grain. Material other than grain (MOG) that entered the combine is now discharged back to the ground, including the corn cobs. The combine harvester eliminated many of the large piles of corn cobs leaving seed companies as the primary supplier for the corn cob industry. Recently, a demand for energy independence and clean energy along with a concern for global warming has spawned a renewed interest in the collection of biomaterials for ethanol production.

Many look towards agricultural residues to lead the biorenewable fuel industry. Corn stover is one of the most readily available agricultural residues (Hahn-Hagerdal et al., 2006; Pordesimo et al., 2004; Shinnars et al., 2003) with nearly 35 million hectares of corn planted in the United States in 2008 (USDA, 2008). With so much infrastructure dedicated to the production of corn, the collection of stover requires few changes in farm management practices and no changes in land use. On the other hand, many environmental and economic

impacts must be considered when collecting stover. When returned to the ground, stover helps prevent soil erosion while returning nutrients to the soil and improving soil organic matter (Sheehan, 2004). To eliminate the disadvantages of collecting the whole plant and to keep the advantages of a widely available resource, one ethanol plant plans to convert corn cobs to ethanol (POET, 2008). Corn cobs account for approximately 8-15% of the above ground biomass (Pordesimo et al., 2004; Smith et al., 1984; Russel, 1986) and therefore have less impact on soil erosion and soil health. Another advantage includes the higher bulk density of corn cobs, $160\text{-}210\text{ kg/m}^3$ ($10\text{-}13\text{ lb/ft}^3$) (Dunning et al., 1948; Smith et al., 1984; Bargiel et al., 1982), compared to corn stover, 75 kg/m^3 (4 lb/ft^3) (Shinners et al., 2003). Therefore, corn cobs can be transported more economically than corn stover without further compaction. With the advantages of no land use changes, economical transport, increased uniformity of feedstock, and decreased environmental impacts, cobs provide a first step towards creating an alternative biofuel feedstock.

Before corn cobs become the feedstock of a bio energy industry, systems to efficiently and economically collect corn cobs from the field have to be available. The main focus of this project was the development of a cob separation system for a dual stream single pass combine harvester. Schlessner (2007) designed a system for collecting stover in a dual stream single pass combine including a modified chopper, a blower, and a spout mounted to the back of the combine. The harvester used in this study was based on the work of Schlessner (2007) with modifications provided by Deere and Company (Moline, IL). The combine was capable of harvesting grain and stover in separate material streams simultaneously, and can also easily switch

between conventional harvest and biomass harvest. The single pass system improves timeliness of harvest by eliminating extra field operations associated with conventional stover harvest systems (rake, shred, and bale) while also keeping the material off the ground and reducing soil contamination (Shinners et al., 2003). Furthermore, by maintaining the capacity for conventional harvest (grain only) the additional equipment requirements are minimized and provide the farmer with increased flexibility. This project improves the flexibility of the system by adding a corn cob collection system without negatively affecting the performance of conventional harvest or stover harvest.

A cob separation system was created with the addition of a pneumatic separation system after the blower. A strong blast of air across the material stream forced stalks, husks, and leaves out of the stream. Cobs, being the heaviest fraction, continue through the spout and into a wagon.

This paper discusses previous research as well as the design and development of the cob separation system created. Testing of the system was conducted under stationary conditions as well as in the field. The results of the tests were measured by cob purity, collection efficiency, and power consumption. Testing procedures and results are presented and followed by conclusions and recommendations.

Literature Review

Although corn cobs have several uses, the lack of economical corn cob harvest equipment has limited cobs to niche markets and impeded the adoption of new corn cob products, such as a biorenewable fuel source. Regardless of the end use, corn cobs provide an ingredient for environment friendly products but first they have to be collected.

Classification of previous corn cob recovery systems in the literature review uses the following three factors: separation method, separation location, and storage location. The corn cobs can be separated from the husk and leaves by mechanical methods, pneumatic methods, or a combination of these methods. Furthermore, separation can take place either on the combine or through the use of a towed wagon with separation capabilities. If separation occurs away from the combine, then storage also occurs away from the combine. On the other hand, combine-based methods of separation have been developed with and without on-board storage. The following literature review compares and discusses prior methods of harvesting corn cobs.

Corn cob Collection

Prior to the modern combine, corn was picked on the ear and shelled later (Stone, 1905; Snow, 1961). Therefore, all of the cobs in the field were collected but the grain still had to be threshed, and harvest was a labor intensive job. As harvesting grain became increasingly mechanized, the cobs were left on the field. Bargiel et al. (1982) developed one of the first systems to collect cobs, based on

pneumatic separation and a modified straw chopper to accelerate MOG through a spout. Initially, this was a purely ballistic separation method assuming that due to the different properties, cobs would exit the spout and land in a trailed wagon while the husks would fall between the combine and the wagon. However, results were not as successful as expected and a fan was mounted between the chopper and the spout. The fan directed air at an angle of 110 degrees from material flow to force lighter husk and leaf material back onto the ground while cobs kept traveling through the spout. With this design, 78% of the cobs were collected at a cob purity of 89%. Furthermore, of the husks collected with the cobs, 40% were attached to the cobs. This cob+husk fraction accounted for 34% of total material weight, with husks composing 5% of the cob+husk fraction. This study also reported a decrease in bulk density from 192 to 100 kg/m³ (12 to 6.25 lb/ft³) as the cob purity decreased from 100% to 85%.

Quaye and Schertz (1983) also developed a corn cob attachment for a combine, but this design incorporated the use of counter-rotating rollers to mechanically separate the cobs. This design used four pairs of counter-rotating rollers, one steel spiral wound roller and one belted roller, and was a pull behind attachment capable of recovering 96% of the cobs and achieving a maximum cob purity of 99%. These studies were conducted at flow rates ranging from 0.03-0.18 kg/sec. An analysis of the combine discharge showed that 37% of all the cobs had husks attached.

Chung (1980) provided a thorough examination of separation methods, which included laboratory tests on three different systems based on pneumatic, bounce

plate, and conveyor separation methods. The initial prototype harvester used a bounce plate at a forty five degree angle below the straw walkers and deflectors after the chaffer. The bounce plate allowed husk and stalk to slide to the ground while the cobs were bounced into a container and the deflectors after the chaffer allowed cob pieces to fall into a separate container. Due to the bounce plate becoming an unwanted collection area for husk and leaves it was replaced by a belt conveyor. The conveyor continued to move husks and stalks away while allowing cobs to bounce and fall into the collection container. Additionally, air from the chaffers also helped improve separation after the straw walkers. With the belt conveyor after the straw walkers and the deflectors on the chaffer, this system achieved collection efficiencies of 88% with a cob purity of 94%.

Smith et al. (1984) developed a pneumatic separating system utilizing a forage blower after the straw chopper. The fan was placed beneath the straw walkers of a John Deere 6600 (Deere and Company, Moline, IL), with air being directed against material flow to blow husks out while allowing cobs to continue to the straw chopper. Some of the air from the fan was deflected above a cross auger after the straw chopper to further separate husks. The auger fed the forage blower. For this design, collection efficiency and cob purity were 82% and 94% respectively. The blower required 0.3 kW, the chopper required 0.7 kW, and the fan required 2.3 – 9.8 kW for speed ranges of 1030-1726 rev/min (rpm). Smith and Stroshine (1985) found that 24% of this material was composed of the cob+husk fraction and husks accounted for 8% of the cob+husk fraction.

McBroom (1986) reported on methods to separate the husk and stalk material while collecting the grain and the cob in the combine grain hopper. This mixture, known as CCM (Corn and Cob Mix), not only provides an in-field storage solution that does not require a towed or tracked wagon, but also attempts to reduce the costs of transporting cobs. While this minor combine modification requires low capital investments, it provides no means of separating the grain from the cob. No separation at the combine adds another step later in the process, a step that the combine invention purposefully eliminated. Likely locations for separation would be at the field edge or at an intermediate storage and separation facility. In consideration of an additional separation step, it would require another piece of specialized equipment and another process that should not slow harvest down. Furthermore, if the cobs were to be stored with the grain, additional consideration would have to be given towards material handling, grain drying, methods of storage, and volume of storage required.

Stukenholz and Stukenholz (2002) developed an on board combine separation system to collect corn cobs which also provided on board combine storage. This system provides two methods of separation depending on customer input for both conventional and rotary combines. For conventional combines, the straw walker can be modified to larger openings to allow corn cobs to pass through to the sieve. If the customer does not want this to happen, a second sieve is added after the straw walkers which allow corn cobs to pass through to a cross auger. The cross auger then feeds them into a duct where they are pneumatically conveyed to a storage bin located on top of the grain storage bin. For a rotary combine, the

standard grain sieve can be used or a second sieve can be installed. If the second sieve is installed, for either combine styles, a method has been devised to recycle the material to improve collection efficiency. Unloading of the cob collection bin involves the bin extending laterally from the combine, a door opening, and a chain and slat floor discharging the material. This system also allows for unloading on the go.

Flamme (1999) developed a cob separation system utilizing a towed cart. This cart, commonly referred to as the “Cob Caddy”, collects the discharge from the combine on a conveyor. The conveyor moves the cobs, stalks, and husks upwards and towards the rear of the machine. As the material falls from the conveyor it passes through a stream of air. The lighter husk and stalk material are caused to exit the material stream and are discharged back to the ground. Cobs continue to another conveyor which moves them into a collection bin. While not capable of unloading on the go, it does remove material conveyance issues through use of a side dump unloading technique. This design receives power from an auxiliary engine mounted on the wagon frame. Vermeer (Vermeer Corporation, Pella, IA) now manufactures the CCX770 Cob Harvester after purchasing the patent rights. Also competing in the towed wagon market is Redekop Manufacturing (Saskatoon, SK, Canada). Redekop (2009) developed a similar system; however, the cobs are passed through two stages of cleaning. The first stage is designed to have lower air velocities than the second stage. Unlike the Cob Caddy, the Redekop H165 Cob Harvester receives power from the combine chopper drive and utilizes a conveyor on the side of the collection bin to unload the material. This also allows for the

combine/cart combination to unload without stopping. Table 1 provides a comparison of these cob collection systems.

Table 1. A description and comparison of cob harvest solutions.

Researcher	Description	Purity*	Coll. Eff.*
Bargiel et. al. (1982)	Modified straw chopper with fan on the spout	89%	78%
Quaye and Schertz (1983)	Counter-rotating roller attachent	99%	96%
Chung (1980)	Bounce plates and inclined conveyyor	94%	89%
Smith et al. (1984)	Pneumatic separation after straw walker with a blower and a spout	94%	82%
McBroom (1986)	Corn and Cob Mix (CCM)	NR**	NR
Stukenholz and Stukenholts (2002)	Cob sieve and fan with on-combine storage	NR	NR
Flamme (1999)	Towed cart with pneumatic cleaning	NR	NR
Redkop (2009)	Towed Cart with two stage pneumatic cleaning	NR	NR

*Max Reported

**Not Reported

Pneumatic Separation Properties

Several researchers have investigated the aerodynamic properties of corn grain and corn residues. Uhl and Lamp (1966) showed an air velocity of 13.6 m/s (45 ft/s) was required to separate cobs from grain and 15.4 m/s (50 ft/s) was required to completely separate stover from the grain. This study also found the suspension velocity of a corn cob taken from the straw walker to be 6.7-13.4 m/s (22.0-44.0 ft/s). Smith and Stroshine (1985) reported that separation of cobs and stalks required air velocities ranging from 6.5-10 m/s (21.3-32.8 ft/s). However, those values were reported for symmetrical cobs and stalks, and tested under highly controlled laboratory tests. Mean suspension velocities for straw walker fractions of cobs, stalks, cobs and husks, and husks and leaves were 11.51, 6.84, 7.66, and 2.66 m/s respectively.

The corn cob collection systems mentioned above show that there are many variations available to collect cobs. Despite the variations, none have stood out as

the best in terms of effectiveness (purity and collection efficiency) or flexibility. Furthermore, none have coexisted with a corn stover harvesting method. To improve flexibility in the field, this research project evaluated the strengths and weaknesses of previous corn cob collection systems for incorporation into a corn stover harvesting attachment.

Objectives:

Schlesser (2007) developed a biomass attachment for a John Deere 9750 STS (Deere and Company, Moline, IL) to harvest corn grain and corn stover in a single pass through the field. That attachment harvested corn stover only. The focus and goal of this research was the development of a corn cob separation system to coincide with the existing corn stover attachment. To achieve this goal, the following objectives were set forth:

- Design and develop a corn cob separation system compatible with the biomass attachment previously installed on a John Deere 9750 STS. The term compatible requires that the machine maintains stover harvesting capabilities and that the conversion between stover and cobs is fast and quick.
- Evaluate cob configurations in stationary and field tests to characterize the systems effectiveness. Evaluate stover configurations in the field to validate no adverse affects from the installation of the cob separation system
- Analyze each cob configuration for collection efficiency to quantify losses and determine optimum set points.
- Analyze each cob configuration for cob purity and determine optimum set points.
- Analyze additional power demands on the system due to the blower and the fans.
- Identify areas of limitations as related to collection efficiency, cob purity, and field capacity for improvement in future work.

Following the objectives, a cob separation system was developed and installed in conjunction with the stover attachment already in place. It was tested and analyzed in various configurations for both cob harvest and stover harvest. Areas of limitations were identified and conclusions were made.

Machine Design and Development

Harvesting biomass at Iowa State has been focused on the ideals of maximizing flexibility, minimizing risk, and increasing economical benefit to the farmer. With these goals, and in cooperation with Deere and Company (Moline, IL), an attachment was installed on a John Deere 9750 STS combine for harvesting corn stover. While considering a corn cob separation system, those same ideals were taken into consideration. This will allow producers to choose between collection of the whole plant or just cobs while minimizing additional equipment needs. This section will focus on the development of a corn cob separation system compatible with the existing corn stover attachment.

Design Evaluation

The driving factor for this design was a fully flexible single pass dual stream biomass harvester. The previous design included components to aid in the collection of corn stover while maintaining the flexibility of a conventional multi-crop harvester. This design and its flexibility are shown in Figure 1 with the combine harvesting soybeans in conventional mode and corn in collection mode. To accomplish the design objective, the design criteria dictated that the cob collection system would have no adverse affects on corn stover harvest. Furthermore, the design should limit weight, cost, complexity, and power (maintain field capacity).

The Pro/Engineer (Parametric Technology Corporation, Needham, MA) model of the stover attachment can be seen in Figure 2. The model shows the system beginning with the material conveyor, the chopper, the transition, the blower,

the blower/spout chute, and finally the spout. For visibility the drive system and structural frame have been hidden.



Figure 1. The stover attachment developed for a John Deere 9750 STS is shown in the spread mode while harvesting soybeans (left) and in collection mode while harvesting corn (right)

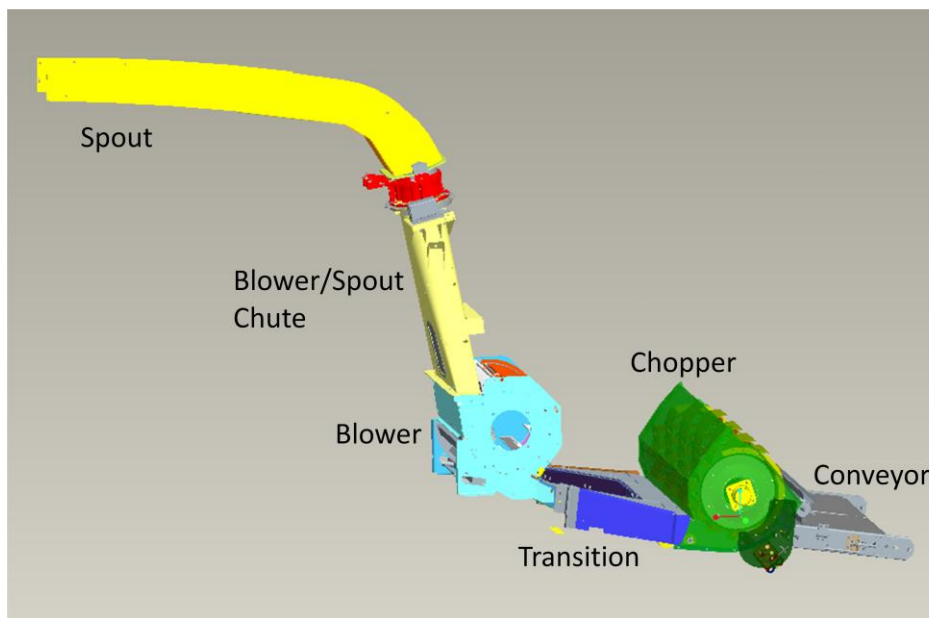

Figure 2. A Pro/E model of the corn stover attachment shows the material conveyor feeding the chopper, a transition to the blower, a blower/spout chute, and the spout.

For the increased flexibility of three harvest scenarios (grain only, grain and stover, and grain and cobs) the transition between any two scenarios should also be quick and uncomplicated. With the design goals and criteria in mind, this study focused on creating a pneumatic system. Pneumatics are attractive due to the

flexibility of controlling inlets and outlets to determine air flow. An air inlet is defined as the point where air enters the stover material stream and forms the separation zone and the discharge outlet is defined as an exit opening whereby stalks, husks, and leaves exit the material stream during cob collection. This flexibility allows a pneumatic system to be quickly shut down when transitioning to corn stover harvest through simply closing the inlets and outlets. Mechanical systems have shown the ability to produce a clean sample and minimize losses, but they can become cumbersome. A pneumatic system can utilize the existing attachment through the addition of a pneumatic inlet and a discharge outlet.

With the stover attachment already in place, the blower already provided conveyance of the material through the spout and a method was developed to pneumatically discharge the husk, leaf, and stalk fractions from the material stream. However, the cob design greatly relies on the location of the discharged materials. To prevent major modifications to the combine or disrupting flow of material, separation should occur after the chopper due to the conveyor belt that moves material from the sieves to the chopper. In addition, post-chopper separation offered a more consistent material stream due to the random orientation of the material entering the chopper. Therefore, these limitations forced the location of the cob separation system to either before or after the blower. Each location presented its own unique advantages and disadvantages. Since the blower accelerates material, separation before the blower is desirable to separate material with less energy. Conversely, inconsistent material flow and orientation into the chopper creates unpredictable trajectory of particles out of the chopper. Some of this unpredictability

stems from the shear chopper and the different reactions of the material to the shear knives and vertical knives. The problems of unpredictable trajectory are exaggerated for standard impact type choppers. The blower provided a more uniform and streamline particle trajectory. Therefore, based on the objectives and criteria for this work, it was decided to place the separation system after the blower.

For adjustment and flexibility during testing and development, a hydraulic system drove the separation system. An auxiliary hydraulic pump already driving the blower also provided hydraulic power for the additional separation fans. This was a Sauer-Danfoss Series 45 Model 4747-125 piston pump with a displacement of 90 cm^3 per revolution ($5.5 \text{ in}^3/\text{rev}$). The motor driving the blower was a Marzocchi motor (Marzocchi Pompe, Bologna, Italy) with a displacement of 52 cm^3 per revolution ($3.1 \text{ in}^3/\text{rev}$). The system utilizes two fans connected in series, powered by a Model WM09A1C190 motor from Haldex Hydraulic Corporation (Haldex, Stockholm, Sweden) with a displacement of 19 cm^3 per revolution ($1.16 \text{ in}^3/\text{rev}$). Using the hydraulic drive offered a way to control fan and blower speed independently, which was used to determine optimum set points. Both the fan and the blower were controlled by a 12 position switch to vary the position of the spool in a Sauer-Danfoss PVG 32 157B6530 electro-hydraulic proportional valve.

Machine Development

In order to separate husks from cobs pneumatically, the system needed an air inlet and a discharge outlet. To do this a new blower/spout chute was created. The lower half of the new blower/spout chute included an open front as well as an open

back. The opening in the front (vehicle front) allowed for an air plenum to be bolted on. A large air plenum, with a volume of 302 L (79.8 gal), was created to minimize pressure fluctuations and keep the airflow consistent. Figure 3 shows an exploded view of the basic components created to update the attachment to also collect cobs.

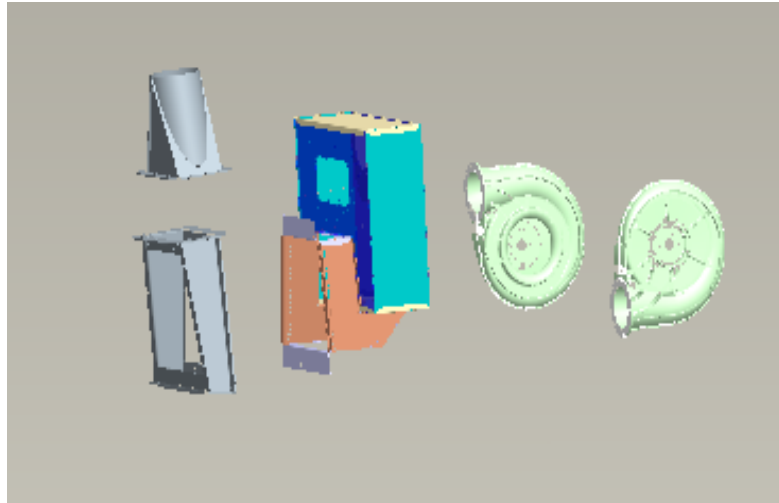

Figure 3. An exploded view of the cob separation system shows the two piece blower/spout chute, air plenum, and

Furthermore, a matrix of cover plates, Figure 4, provided a modifiable design to aid in determining correct location and size for the air inlet. The first two combinations shown, from left to right, include plates that are 50 mm in height. However, they are shifted 25 mm vertically from each other (due to the angle of the air plenum each plate can only have one position). The third set of plates has a height of 75 mm. Therefore, by selection of different plates, the air inlet to the separation zone could be located at any vertical location (to within 25 mm) with an air inlet height of 25, 50 or 75 mm.

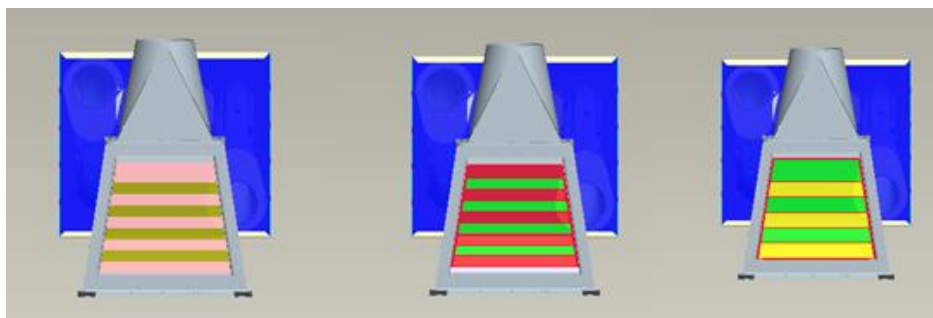

Figure 4. The cover plate matrix allows any height location for the separation zone to be selected within 25 mm. This also allows for a selectable inlet height

During the fall of 2007, an initial investigation revealed that the best air inlet location was 250 mm from the bottom of the air inlet plate with a height of 50 mm. This testing also concluded that separation worked best when air was directed at a downward angle of forty-five degrees from the material stream. To construct a permanent system, and a system that allowed for a quick conversion between cob collection and stover collection, the matrix of cover plates was discarded. In place of the matrix, the construction of two additional plates formed the air inlet and forced air at an angle of forty-five degrees to the material stream. Figure 5 shows the assembly of the two plates in Pro/E on the left and the right side shows a cross section view with system components identified. The top plate forms another air stream by bending into the material stream and directing air into the spout. The vertical gap between the two plates at the air inlet is 50 mm. The top plate allowed enough air to flow into the spout to keep material moving through the spout without causing the separation air velocity to decrease.

This setup operated on the theory of cobs achieving higher densities and therefore greater mass than other stover fractions. This mass gives the cobs more momentum moving through the separation zone leaving lighter materials to be

forced from the material stream. The cobs also have a higher terminal velocity than other fractions and therefore will not stall out as quickly as other fractions with the downward angle of the separation air. Figure 7 shows the theory of operation for the system. To determine the airflow of the system, the air velocities were measured at two points (once on each side) of both air streams. The velocities were averaged from side to side and then area at the point of measurement was calculated to determine airflow. Figure 6 shows the airflow provided by the fans at different speed ranges.

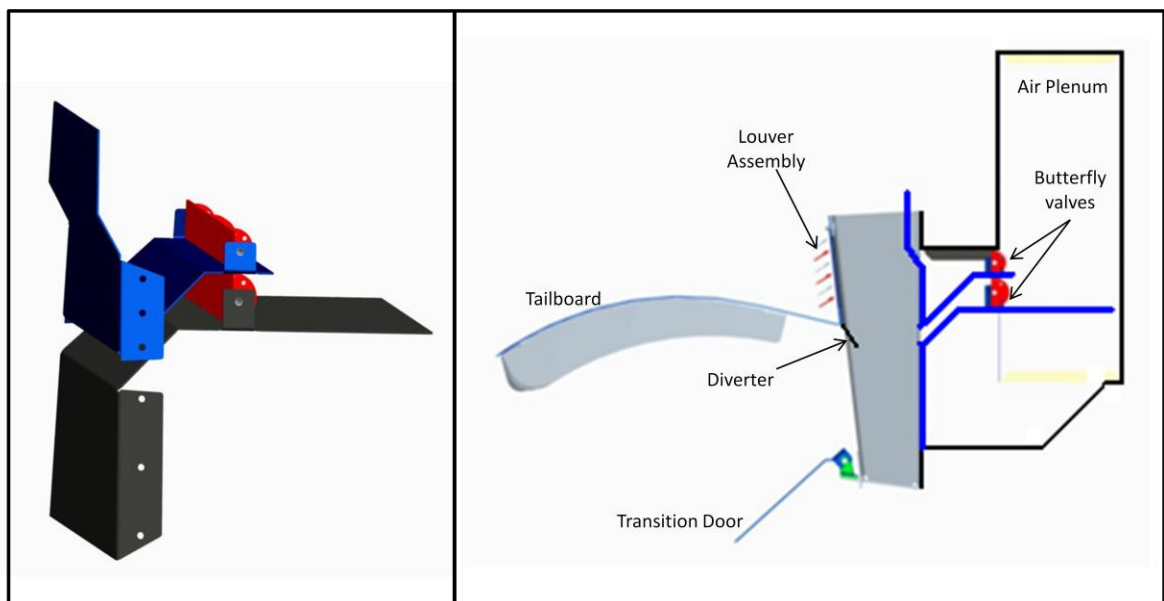

Figure 5. The Pro/E model of the top and bottom plates assembled is shown on the left. These plates direct air at an angle of forty five degrees across the material stream. A cross section view shows system components on the right.

Aside from hydraulic proportional control and controlling direction of the airflow, additional control devices were added into the design. With two different air streams, two butterfly valves were installed, one in each stream. The butterfly valves allowed the flow ratios to be changed. It was of interest to be able to control

the ratios to achieve an optimum point without requiring more airflow and therefore more power. These valves were controlled electronically through linear actuators with position feedback. An LED display was made to verify the position of the valves.

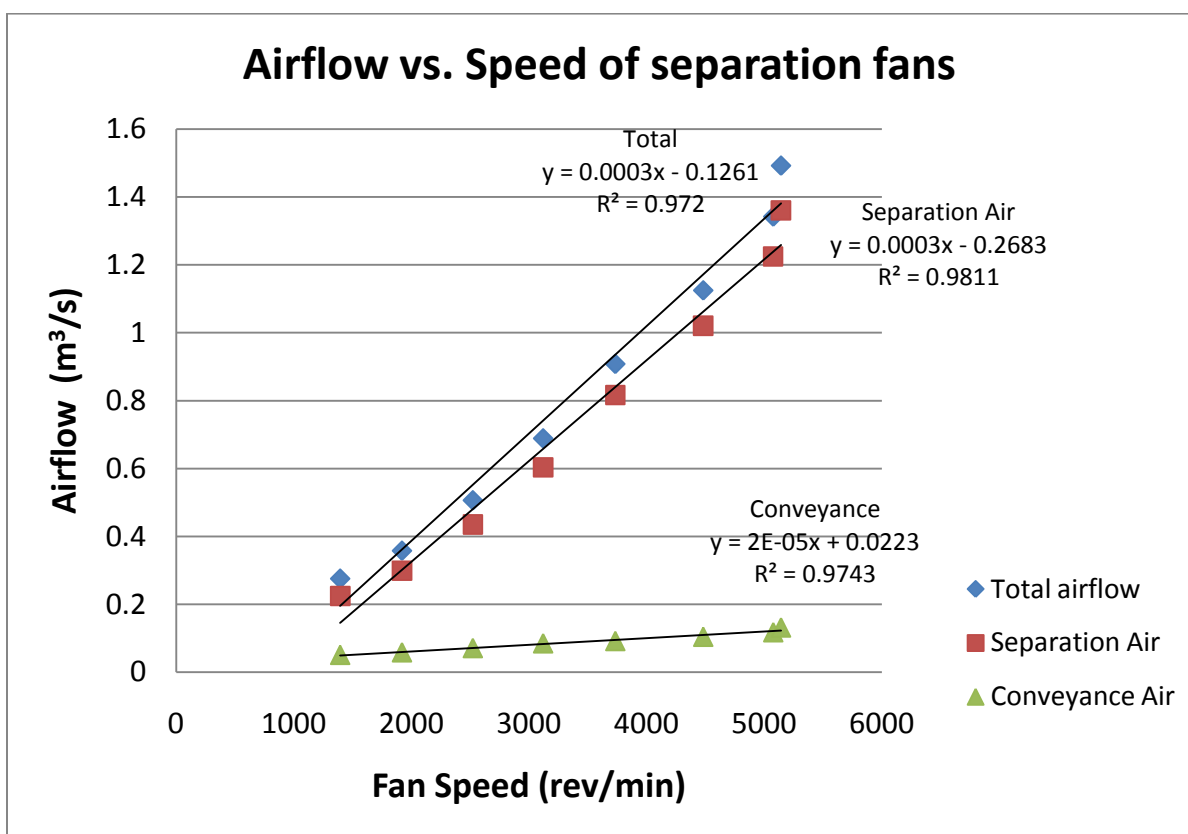

Figure 6. Airflow provided by the fans as determined from fan speed. Total airflow is displayed along with separation airflow and conveyance airflow.

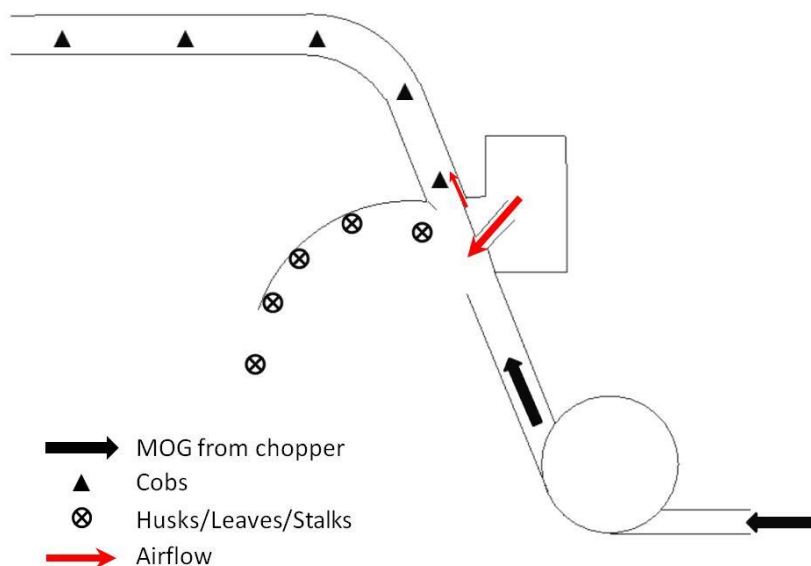

Figure 7. As material other than grain exits the blower, the husks, leaves, and stalks being lighter than the cobs are forced out of the material stream. The cobs continue through the spout.

As with any combine, the discharged residue needed to be spread. A tailboard was designed and manufactured to attach to the rear of the combine to spread discharged material. The tailboard helped return material to the ground with eight vanes added underneath to help spread the material. Additionally, fins were placed on the side as a support structure but also to hinder material from sweeping around the sides of the tailboard and recirculating into the material stream.

To help improve cleaning efficiency, a diverter was made that attached to the tailboard. The diverter, bent at a forty-five degree angle, attached to the tailboard and extended into the material stream. This diverter was built to catch husk material that otherwise would have exited through the spout and into the clean cob sample. Also attaching to the tailboard assembly was a louver assembly (Figure 8), whose purpose was to allow air to circulate into the spout when in cob separation mode and

keep loose husk material from recirculating into the spout. When not in cob separation mode, the louvers shut to keep the material stream enclosed. The louvers were also controlled electronically with their position displayed on the LED display in the cab. The tailboard assembly and louver assembly were built as modular assemblies and can be attached to the combine separately or as one large sub-assembly.

The transition elements between cob collection and stover collection include the door, cover plate, and louvers. To transition, the door and the louvers can be opened or closed by switch from the cab and the air inlet cover plate can be installed/removed by installing/removing four bolts. Additional Pro/E figures of the design are found in Appendix II.

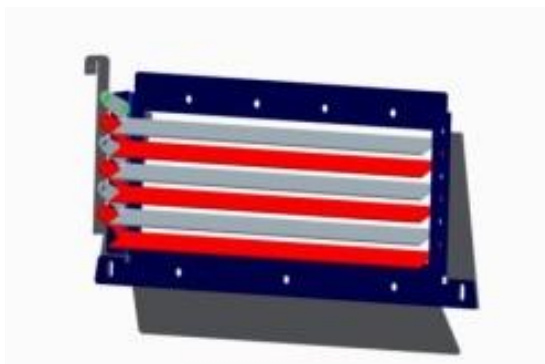

Figure 8. The louver assembly is composed of six louvers attached to one operating lever. The diverter attaches directly to this sub assembly.

It was noted that some cobs from the cleaning shoe and discharge beater would escape out of the cleaning shoe air vents. To combat excessive cob loss in the field, a guard was placed in front of air vents on the side of the combine (Figure 9). The guards were made of rubber reel fingers and placed in an orientation to

prevent whole cobs escaping out of the air vents. The machine operating in the field is seen in Figure 10.



Figure 9. Guards were installed over the air vents to prevent cobs from exiting the machine before the chopper.



Figure 10. The cob separation system is active during this field test.

Data Acquisition

Evaluation of the various configurations required data collection relating to power requirements of the blower and the fans and the air velocity in the air separation system. To assist collecting the necessary information a data acquisition computer was used. This data acquisition system was a PC-104 based computer from Diamond Systems (Mountain View, CA) and included the following:

- Athena II Single Board Computer with 800 MHz Processor and integrated data acquisition (16 analog inputs, 4 analog outputs, 24 digital I/O, and 2 counters/timers)
- GPIO-MM digital I/O board with 40 digital I/O, and 10 counters/timers
- HESC-104 (Tri-M Systems, Port Coquitlam, British Columbia) Power Supply
- Model 518 Smart Analog to Digital card (Sensoray, Tigard, OR) with 8 differential channels

This computer system operated on Microsoft Windows XP (Microsoft Corporation, Redmond, WA) and the data acquisition was controlled by a Microsoft Visual Basic program. The program commanded the data acquisition system to read values from the sensors and store those values on the hard drive. The sensors used included magnetic pickup sensors to record speed of the blower and fans, pressure transducers to record the pressure drop across the blower and the fans, and pressure sensors to read air pressure from pitot tubes. The pressure transducers were Model PX303-5KG5V from Omega Engineering (Stamford, CT). The air pressure sensors were Model PX137-005DV, also from Omega Engineering. These air pressure sensors were used to measure the pressure from Model 167

pitot tubes (Dwyer Instruments, Michigan City, IN) inserted into the air chamber to determine air velocity. Figure 11 shows a schematic of the data acquisition system.

The power consumed by the fan and blower were calculated using the pressure and speed of the motors. Through measurement of the pressure drop across the motors and given the displacement of the motors, the torque of the motor was calculated using equation (1). The speed of the motors was determined using the magnetic pickups and was then used to calculate power as shown in equation (2).

$$T = \frac{\Delta p d}{2\pi} \quad (1)$$

$$P = \frac{2\pi TN}{60000} \quad (2)$$

Where:

T is Torque (N-m)

p is pressure (MPa)

d is displacement of the motor (cm³)

P is Power (kW)

N is rotational speed (rev/min)

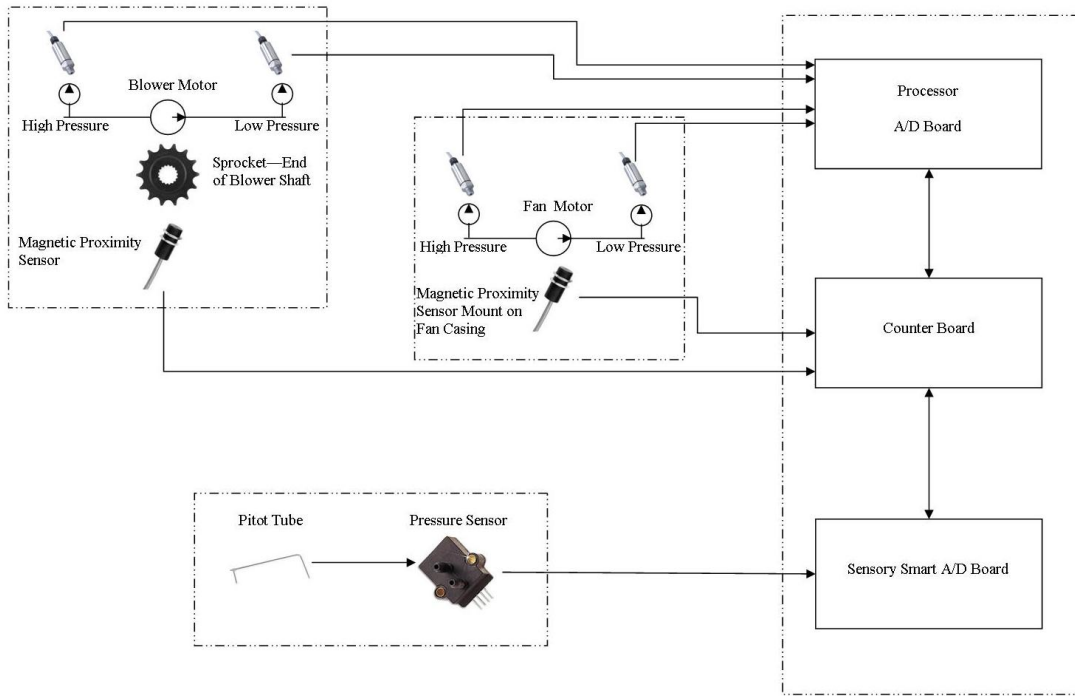

Figure 11. A data collection schematic representing the hardware used to collect data.

Methods and Procedures

The cob separation system was built to achieve the planned objectives and criteria. The next step was to test the system. Testing of the system included a preliminary analysis to determine appropriate test configurations, a series of stationary tests to characterize the system, and finally a set of field tests for comparison against the stationary tests. The design of experiments, data analysis, and equipment used is outlined in the following section.

Preliminary Field Testing

In preparation of system validation, a set of preliminary tests were performed. The objectives of the preliminary field tests were to characterize and learn about the system, determine final test parameters, and identify and correct any design flaws. These preliminary tests were conducted in Georgia during August 2008 and investigated the following parameters: chopper speed, fan speed, blower speed, and butterfly valve position. The chopper speed could be set to 900, 1100, 1400, and 1800 rev/min and was investigated as an independent variable. The blower speed range was 675-1900 rev/min and the fan speed range was 1400-5100 rev/min, and these were investigated to identify optimum ranges and explore the interaction between the two parameters. The butterfly valve position was also investigated as an independent variable while noting the effect it had on the interaction of the blower and fan speeds.

With the main objective of learning about the system, a complete design of experiment was not used and results were qualitative, based on visual observations.

For each chopper speed and butterfly valve position, the blower and fan speeds were set at their lowest settings and the combine would harvest a nominal distance of 91.4 meters. During this time, observations were made about the purity of material exiting the spout and collection efficiency observations were made through inspection of the ground behind the combine for lost cobs. Then the fan speed would be increased, observations made, and results for that configuration would be made on a worse, same, or better basis. This repeated for all fan speeds before the blower speed was increased.

From the results of the preliminary investigations (presented later), some conclusions and decisions were made. First, due to limited air flow to the spout, all remaining tests were conducted with the butterfly valve open. Secondly, for reliability and safety considerations the chopper speed remained at 1400 rev/min for all remaining testing. Furthermore, after preliminary testing, the decision was made to try a two stage cleaning technique with two separation zones. This was attempted to improve cob purity through incorporation of an initial separation zone. The initial separation zone was used to start moving material towards the back of the machine with a light blast of air so that the primary separation zone would not have to move material as far. This initial zone was perpendicular to the material stream and located immediately after the blower as indicated in Figure 12. Five different configurations were made for the initial zone and it was constructed using interchangeable plates at the base of the bottom plate described previously. The various configurations are seen in Figure 13. To create the different configurations, three geometry styles were created: solid, circular, and rectangular. The circular

and rectangular geometries were chosen because the circular hole will provide a stronger concentrated air blast while the slots allow for a more dispersed air curtain with a larger area covered.

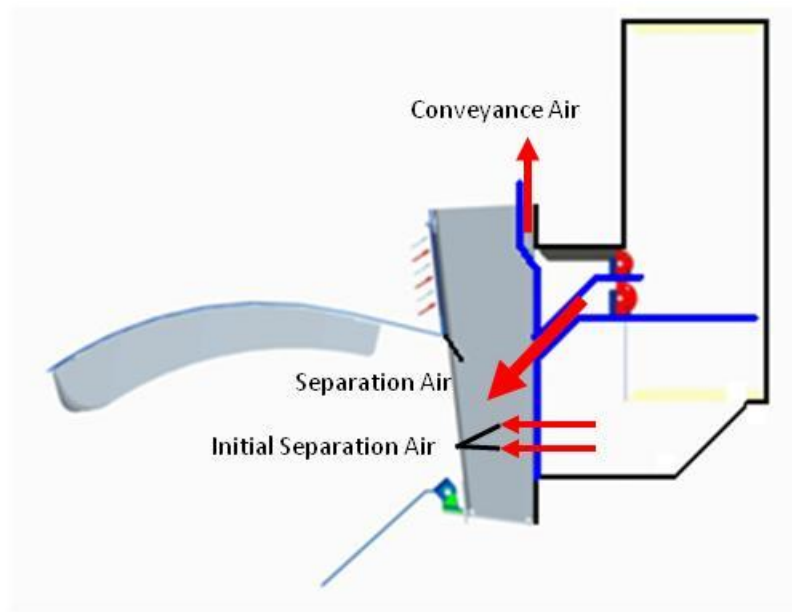

Figure 12. Airflow vectors including the initial separation zone.

The solid plate represents the baseline, or no change from the preliminary testing. Two plates were made for each remaining geometric configuration. Plate 2 contains two rows of 12 mm holes and the holes are on 60 mm centers horizontally (within the same row). Plate 4, similarly, contains the same pattern as Plate 2 but with an additional center row of holes on 30 mm centers. In the same way, Plates 3 and 5 are rectangular slots with widths of 6 mm. Plate 3 has two rows of slots with lengths of 70 mm on 128 mm centers while Plate 5 has three rows of 142 mm lengths on 212 mm centers.

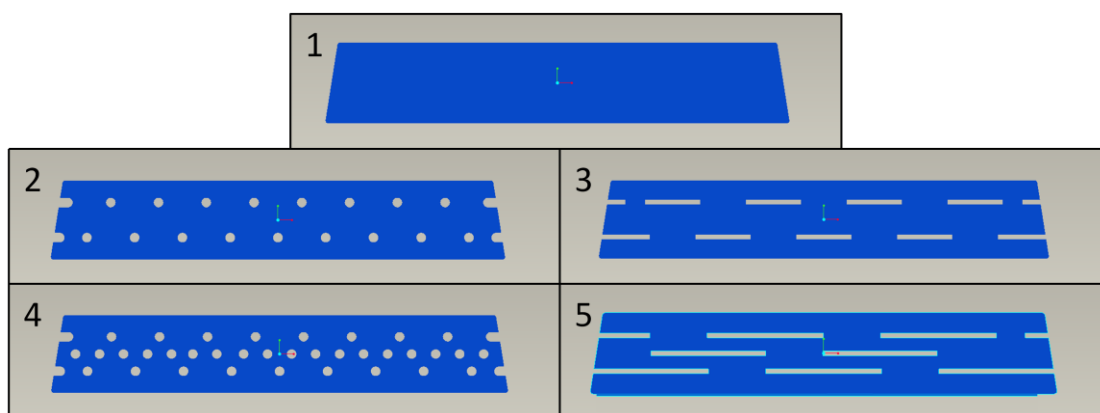

Figure 13. Five interchangeable plates were made to form an initial separation zone using three geometric designs; solid, hole, and slot.

Stationary Testing

To create a controlled testing environment, tests were conducted by feeding corn stover and ear corn into the combine. Field testing creates a challenge because of the variability in yield across the field for both grain and cobs. Controlling the amount of material entering the combine provides more favorable conditions to evaluate cob separation systems and reduces some of the uncertainty induced from variability of yield across the field. Furthermore, this method allowed the combine to go through all of its normal functions, just as it would in the field. To determine the amounts of material needed, some basic assumptions were made. The stationary tests were based on the assumption that each plot was 45.72 meters (150 feet) and would average 9.4 Mg per hectare (150 bu/ac) at 15.5% moisture content. Furthermore, an eight row corn head would be used. These estimates led to each run requiring 262 kg (10.33 bushels) of grain per test run.

Second, the amount of stover to add for each run was determined. According to Smith et al. (1985) and Quayle and Schertz (1983), cobs average 68% of the material exiting the combine. Considering the changes in equipment and crop

genetics in the last thirty years, these numbers may not hold true for current machinery and crops. A higher proportion than normal helps compensate for the high ratio of stalks contained in stover bales. The ratio of cobs to grain in the field is estimated between 8 and 20 percent (Pordesimo et al., 2004; Smith et al., 1984). Using the estimate of 68% of combine discharge being cobs and taking the median of the cob/grain ratio of 14%, it was determined to use 17.3 kg (32 lbs) of stover for each run.

To record the amount of material entering the combine and to transmit the material to the head of the combine, a barge box with hydraulic dump capabilities was used. The barge box was placed on top of platform scales (Schrran Engineering, Inc., Griswold, IA) to measure the mass of material.

Design of Experiment

In preparation of stationary testing, key configuration parameters were identified. Five separation plates, two fan speeds, and two blower speeds were included in the study (Table 2). The fan speeds and blower speeds were selected using results from the preliminary testing the merged decision matrix shown in Appendix III.

Each configuration was tested with three repetitions. The plates were ordered from smallest opening size to the largest opening size and the blower and the fan speeds were ordered from slowest to fastest. Due to the time involved with changing the initial separation plates, the experiment was designed as a randomized block diagram. The plates were assigned as the blocks and randomized for three

repetitions. Then the fan and blower combinations were randomized for each block and a total of twenty treatments were used.

Table 2. The parameters and values used for the stationary tests are shown in this table. The parameters include plate type, fan speed, and blower speed. The plate type is defined by geometry as well as the opening area.

Treatment	Plate Num [Geometry] (Area mm ²)	Fan	Blower
1	1 [Solid] (0)	3800	1250
2			1650
3		4650	1250
4			1650
5	2 [Circle] (2582)	3800	1250
6			1650
7		4650	1250
8			1650
9	3 [Rectangle] (3936)	3800	1250
10			1650
11		4650	1250
12			1650
13	4 [Circle] (4617)	3800	1250
14			1650
15		4650	1250
16			1650
17	5 [Rectangle] (6462)	3800	1250
18			1650
19		4650	1250
20			1650

Procedure

Setup for testing began with the barge box parked on top of the scales. Then the combine, with an attached John Deere (Deere and Co., Moline, IL) Model 613P belt pick up head, parked behind the barge box. The dumping capabilities of the barge box allowed material to transfer to the belt pickup head. A bag placed over the end of the spout collected all material exiting it and eliminated issues of sampling for cob purity levels. To collect the sample, a miniature bulk bag was attached to the forks of a forklift and then placed over the end of the spout.

For each run, corn stover was placed in the wagon with the ear corn added to the top. The mass of stover and ear corn added was recorded using platform scales resting beneath the barge box. Once the material was loaded, the combine operator turned the blower and fan switch to the appropriate position, and engaged the blower, fan, separator, and head. Then, the wagon began feeding material to the combine and the combine operator started the data acquisition system when material began feeding into the combine. When the last of the material exited the combine, the DAQ system was stopped. Figure 14 shows the test set up.



Figure 14. The stationary tests were conducted with combine and belt pick up head parked behind the barge box. A miniature bulk bag was located to collect all of the material exiting the spout.

After the tests were completed, the material was sorted into the appropriate fractions. This sorting took place on a shaker table (Figure 15). A sieve was made from 50 mm wire gate to separate the cobs. A portion of the sample was placed on the shaker table and large stalk and husk pieces were removed by hand. Smaller stalk and husk pieces were removed by the fan and the cobs were separated into a clean material collection bin. After the collection bin was emptied, the cleaned sample was sorted through by hand one more time to remove stalk and husk pieces that were missed. This process was repeated until the entire sample had been

sorted. While sorting, cobs with an attached husk were also separated out into another collection bin. After the sample had been sorted, the clean cobs were weighed, as were the cob+husk fraction. During the sorting process, fifteen cob+husk bins were randomly selected to remove the husk to determine the cob/cob+husk ratio and thus determine the total mass of cobs collected.



Figure 15. A shaker table was used to separate cobs from other material. A cob sieve was made with 50 mm openings which allowed cobs to pass through to the collection bin located underneath the table. A fan cleaned lighter material that fell through the sieve.

During the course of the study, several samples were taken to determine the Cob to Earcorn Ratio (CER), the Husk to Earcorn Ratio (HER), and the material moisture contents. It was desired to find these ratios to calculate the mass of cobs and husks that were inserted into the machine from the mass of earcorn that was recorded. CER and HER were calculated using equations (3) and (4).

$$CER = \frac{\text{Mass of cobs}}{\text{Mass of earcorn}} \quad (3)$$

$$HER = \frac{\text{Mass of husks}}{\text{Mass of earcorn}} \quad (4)$$

Using a hand thresher, each sample was sorted into three containers: grain, cob, and husk. After each portion had been weighed it was dried according to ASABE Standard S358.2 (2003b) for cob and husks and ASABE Standard S352.2 (2003a) for the grain. It was assumed that all mass lost during the drying process was the mass of water. The moisture content (MC) was determined using equation (5) and all masses were converted to dry masses using equation (6).

$$MC = \frac{m_w - m_d}{m_w} \quad (5)$$

$$m_d = M_w(1 - MC) \quad (6)$$

Where:

m_d is Dry Mass

m_w is Wet Mass

MC is moisture content on a wet basis (w.b.)

Due to the known ratios and weights of ear corn and stover entering the combine, it was not necessary to collect the material being blown back to the ground. Using the CER, the mass of cobs entering the combine was known and after separating the collected sample, the mass of cobs exiting the spout was known and collection efficiency was calculated using equation (7). Cob Purity was calculated using equation (8).

$$Collection\ efficiency = \frac{Mass\ of\ Cobs\ out\ (dry)}{Mass\ of\ Cobs\ in(dry)} \quad (7)$$

$$Cob\ Purity = \frac{Mass\ of\ Cobs\ Out\ (dry)}{Mass\ of\ Cobs+Stover\ Out\ (dry)} \quad (8)$$

Cobs out and *Cobs in* were calculated using equations (9) and (10).

$$Cobs\ Out = [m_{cc} + (m_{ch})CCHR] \times MC_{cobs} \quad (9)$$

$$Cobs\ in = Earcorn\ (kg\ dry) \times CER \quad (10)$$

Where:

m_{cc} : Cleaned Cobs from shaker table (dry kg)

m_{ch} : Cob+Husk fraction sorted off shaker table (dry kg)

CCHR: Cob/Cob+Husk Ratio (dry)

CER: Earcorn/Cob Ratio determined from hand sampling of earcorn

Material Characterization

The ear corn obtained for the testing was Pioneer 38B84, a 98 day corn that was planted on May 17, 2008 at a population of 82,780 seeds/hectare (33,500 seeds/acre). It was then harvested on October 16, 2008 with a John Deere 300 ear corn picker at 20% moisture, and stored in a corn crib until the ear corn was delivered to the Iowa State University Agricultural Engineering Research Farm on March 17th, 2009. The ear corn arrived at 17.1% moisture content but by the time the research was conducted, it had lost 7 percentage points. The amount of ear corn added for each sample was adjusted accordingly to ensure enough ear corn to complete the tests. Therefore, the amount of ear corn added to each run was 208.84 kg (460 lbs).

The average CER was 0.092 with an average cob moisture content of 14.81%. The husks account for 1.3% (HER) of the mass of earcorn with a moisture content of 11.66% (dry). These numbers add up to a cob/grain ratio of 10.3%, falling within the range discussed earlier. A sample of the corn stover was taken and the composition of stalks, husks, and cobs was 52, 45, and 3%, respectively. The

stover bale moisture content was 12.5%. Table 3 shows the results of the hand sampling of the earcorn. A representative sample of the ears can be seen in Figure 16.

Table 3. Earcorn ratios and moistures obtained from sampling during stationary tests to determine grain, cob, and husk input. These ratios were used to define the amount of cobs and husks entering the machine.

Sample	Percent of Earcorn (dry)		Moisture, %		
	Cob	Husk	Grain	Cob	Husk
1	8.85	1.12	15.69	18.51	17.57
2	10.08	1.20	8.39	12.64	7.54
3	10.24	0.90	14.16	15.20	13.42
4	9.10	1.84	10.75	15.43	9.84
5	7.90	1.11	8.84	14.82	9.94
6	10.79	1.16	13.26	13.40	12.35
7	9.06	1.53	10.61	14.27	11.72
8	9.13	1.22	7.34	16.10	13.91
9	7.31	1.29	9.74	17.59	14.53
Avg	9.16	1.26	10.34	14.81	11.66
Std Dev	1.11	0.27	2.82	1.88	2.98



Figure 16. A picture of representative earcorn samples. Some ears had no husks, some had partial husks, and some had full husks.

With the proposed input of ear corn at 208.84 kg per test, the grain input would be 167.7 kg of grain, 15.04 kg of stover (including the 14.53 kg of baled stover) and 17.16 kg of cob (dry weights).

Field Testing

As a collaborative effort with the United States Department of Agriculture, two field studies have been established to determine the effects of stover removal on soil health. The Boyd field was a corn-soybean rotation while Bruner was a continuous corn study. Within each study there were four levels of biomass removal: 100% removal, 50% removal, 0% removal, and cob removal with three replications of each treatment per field. Both fields are located in Boone County, Iowa.

Prior to harvest, each plot was hand sampled to determine the yield of the top 50%, bottom 50%, cobs, and grain. During harvest, the biomass was blown into a towed wagon (a John Deere Stacker 200) equipped with a Weigh Tronix (Avery Weigh Tronix, Fairmont, MN) three point scale system using 63.5 mm (2.5 inch) weigh bars to measure the collected biomass. The towed wagon was equipped with a sampling apparatus to sample the material directly out of the spout. For stover removal, one sample was taken to determine moisture content. For cob removal, two samples were taken: one to determine moisture content and one to determine cob purity. The samples were not large enough for the shaker table and they were hand sorted for purity, which was determined using equation (8) above. Once purity was known, collection efficiency was determined using equation (11). Using the obtained moisture contents and area of the plot, the collected material weight was

converted to a dry yield (w.b.) in terms of Mg/ha. The estimated cob yield was determined by averaging the cob yields from manual hand sample collected from each of the 24 plots within the field.

$$Coll. Eff._{field\ testing} = \frac{Collected\ Material\ x\ Cob\ Purity}{Estimated\ Cob\ Yield} \quad (11)$$

These limited field trials were used as a validation of the stationary testing. Results from the stationary testing were used to determine fan and blower speeds as well as initial separation plate configurations.

Results and Discussion

Evaluation of this system yielded good data as well as a number of observations. The following section will discuss the results of the tests based on the selected parameters and detail the observations. Conclusions and recommendations will be given afterwards.

Preliminary Testing

Preliminary testing took place August 4-11, 2008 in Colquit, Georgia. During the harvest period, the corn averaged 250 bu/ac at 20% grain moisture content. During combine setup, the chaffer was set to 19 mm, the sieve was set to 11 mm, rotor clearance was 35 mm, rotor speed was 400 rev/min, and the grain cleaning fan was set to 1000 rev/min. A John Deere 608 corn head was used. Initially, the chopper was set at 1800 rev/min with the top butterfly valve closed and the bottom butterfly valve fully open.

At 1800 rev/min, material exiting the spout was finely chopped with a chop length of approximately 50 mm and some cobs were found with husks still attached. Collection efficiency and cob purity samples looked acceptable. When the chopper speed was changed to 1400 rev/min, a noticeable difference was observed. Husks were not chopped as finely and more cobs were found with husks still attached. Cob purity decreased with the decreased chopper speed. The difference between 1400 and 1100 rev/min was minimal with differences hard to qualify. However, at 900 rev/min, chop size was relatively large and an increased number of cobs with attached husks were observed in the sample. Cob purity samples were poor.

At high fan speeds, cob purity increased while collection efficiency decreased and the opposite was true at low fan speeds. With fan speeds at maximum (5100 rev/min), an optimum blower speed was in the range of (900-1200) rev/min. Clean samples were observed at a fan speeds ranging from 2500-3700 rev/min and blower speeds ranging from 900-1500 rev/min. At blower speeds below 900, material did not have the momentum required for adequate conveyance through the spout. This led to poor collection efficiency as more cobs were separated out of the material stream and increased chances of material plugging in the spout. Above 1200 rev/min, material began to speed through the separation zone and increasing amounts of stalk and husks resulted in decreasing the cob purity.

In the next step of testing, the top butterfly valve was opened. This increased spout conveyance air and the minimum blower speed required dropped to 675 rev/min and the blower optimum point was in the 700-1500 rev/min range. While the blower speed dropped, the fan speed was able to increase to maximum (5100 rev/min) without a significant decrease in collection efficiency. However, cob purity started to decrease at speeds below 3100 rev/min. A decision matrix from these results (Appendix III) shows optimum ranges for collection efficiency, cob purity, and both of those matrixes merged. Samples were taken during the testing to quantify cob purity. With the top butterfly valve closed the optimum fan/blower combinations were 2500/900 and 3100/1200 rev/min and cob purity levels ranged between 75-80% on a wet mass basis. With the top butterfly valve opened, the optimum fan/blower set point became 5100/1800 rev/min with cob purity in the range of 80-85%, again on a wet mass basis.

For improved visibility during testing, the top residue spreader was removed. This revealed material being concentrated along the outside walls of the separation zone. To combat this, deflector plates were installed after the blower to force the material to spread towards the center of the separation zone (Figure 17). The deflectors were made at an angle of 14 degrees and provide 50 mm of separation from the wall at their highest point. The deflector plates improved separation with no visible changes in collection. An attempt was also made to change the geometry of the separation air outlet. A plate was made to decrease the vertical height of the outlet to 25 mm in an attempt to create a sharper knife edge with the air. The theory behind this was to create less area of separation but increase the air velocity. The plate was installed with no apparent changes and the idea was discarded.

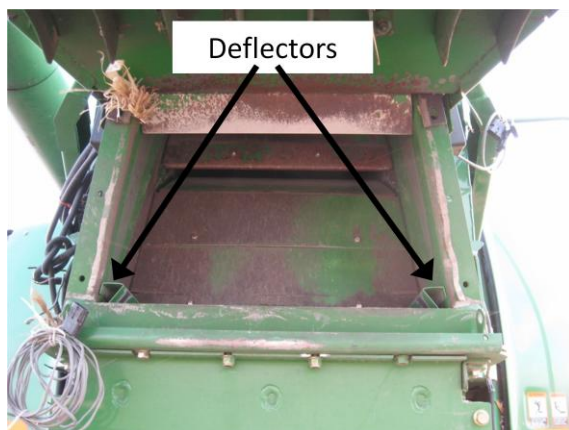

Figure 17. Deflectors were installed immediately after the blower to move material away from the

Stationary Testing

Evaluation of the cob separation system began on July 1 and lasted until July 13th. Important results of the study were cob purity and collection efficiency. The average mass of material exiting the spout was 22.53 kg at a nominal cob flow rate

of 1.4 dry Mg/hr (dry grain flow rate of 16.7 Mg/hr). The cob+husk fraction accounted for an average of 7% percent of the total amount of cobs collected (dry). Of the cob+husk fraction, 70% by dry weight was cob. Based on averages of the three replications for each treatment, cob purity levels ranged from 65.8 to 78.7% while collection efficiencies ranged from 65.4 to 95.4%. Table 4 shows the averages and standard deviations of all twenty treatments. The complete data set can be found in Appendix I. As a comparison to the cob purity range, the input purity was 53.5%. When compared to the overall purity average of 71.3%, it was observed that separation was taking place. In fact, over all the tests, an average of 62.5% of the stalk and husk material was separated out. Figure 18 compares treatment means for collection efficiency while Figure 19 compares treatment means for cob purity.

Table 4. Summary of test averages and standard deviations for each treatment in the static tests. These are the averages of three repetitions for each treatment and include collection efficiency, cob purity, blower and fan power, specific energy, and air velocity.

Control Variable			Results - Average (Std Dev)					
Plate	Fan Speed	Blower Speed	Collect Eff (%)	Cob Purity (%)	Blower Power (kW)	Fan Power (kW)	Spec. Energy	Air Vel. (m/s)
1	3800	1250	95.4 (5.3)	70.4 (2.8)	3.0 (0.3)	20.0 (0.3)	48.3	75.7
		1650	88.5 (5.3)	76.3 (9.1)	5.5 (0.5)	19.9 (1.0)	53.1	74.9
	4650	1250	86.0 (7.6)	72.3 (3.8)	2.8 (0.8)	37.8 (0.9)	85.3	93.3
		1650	87.2 (10.7)	70.7 (3.3)	4.7 (1.2)	36.8 (2.4)	87.1	91.2
2	3800	1250	75.0 (23.1)	68.2 (2.3)	2.5 (0.6)	20.3 (1.5)	48.0	68.3
		1650	90.4 (6.0)	72.4 (2.8)	4.5 (0.4)	19.5 (1.0)	50.4	68.3
	4650	1250	83.8 (10.0)	67.8 (7.5)	3.0 (0.3)	37.1 (0.8)	84.2	91.3
		1650	92.5 (12.1)	70.3 (2.8)	6.2 (0.9)	36.6 (0.9)	89.8	91.5
3	3800	1250	65.4 (5.2)	72.8 (6.3)	2.7 (0.5)	20.0 (1.0)	47.7	68.3
		1650	70.9 (13.7)	69.6 (5.4)	5.3 (0.8)	20.1 (1.1)	53.3	70.7
	4650	1250	81.9 (9.1)	70.8 (2.1)	3.0 (0.4)	37.5 (1.0)	85.0	93.9
		1650	87.8 (13.7)	78.7 (9.8)	5.7 (0.6)	37.2 (1.1)	90.0	96.0
4	3800	1250	82.2 (23.4)	74.1 (4.5)	3.1 (0.8)	20.4 (1.0)	49.3	67.3
		1650	84.0 (10.5)	65.8 (5.2)	5.5 (0.7)	21.1 (1.3)	55.8	73.8
	4650	1250	85.9 (5.5)	70.7 (1.4)	3.6 (0.7)	36.5 (1.9)	84.2	92.8
		1650	85.5 (8.8)	70.1 (5.1)	6.3 (0.3)	36.4 (1.1)	89.5	95.6
5	3800	1250	81.6 (13.6)	71.3 (6.2)	4.5 (1.9)	20.8 (2.4)	53.2	77.2
		1650	80.1 (9.9)	72.8 (1.3)	5.3 (0.1)	20.5 (2.3)	71.8	76.3
	4650	1250	82.0 (6.5)	70.2 (4.4)	3.7 (0.4)	37.2 (1.1)	87.0	92.8
		1650	87.1 (4.3)	71.5 (5.3)	5.3 (1.3)	36.8 (1.2)	88.1	92.8

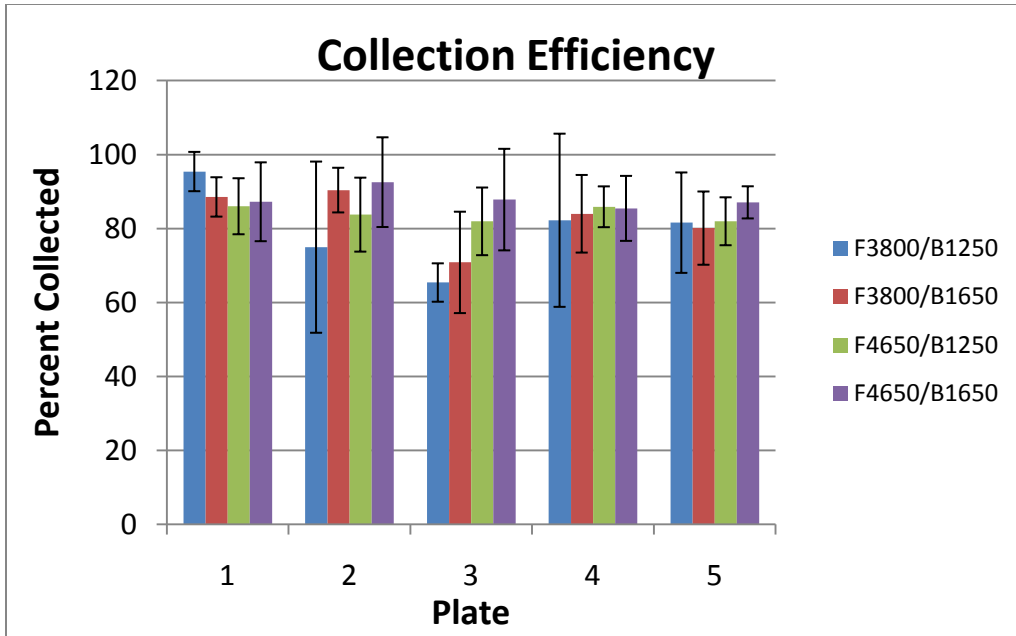

Figure 18. A comparison of treatment means on collection efficiency for two blower speeds (1250, 1650 rev/min) and for two fan speeds (3800, 4650 rev/min).

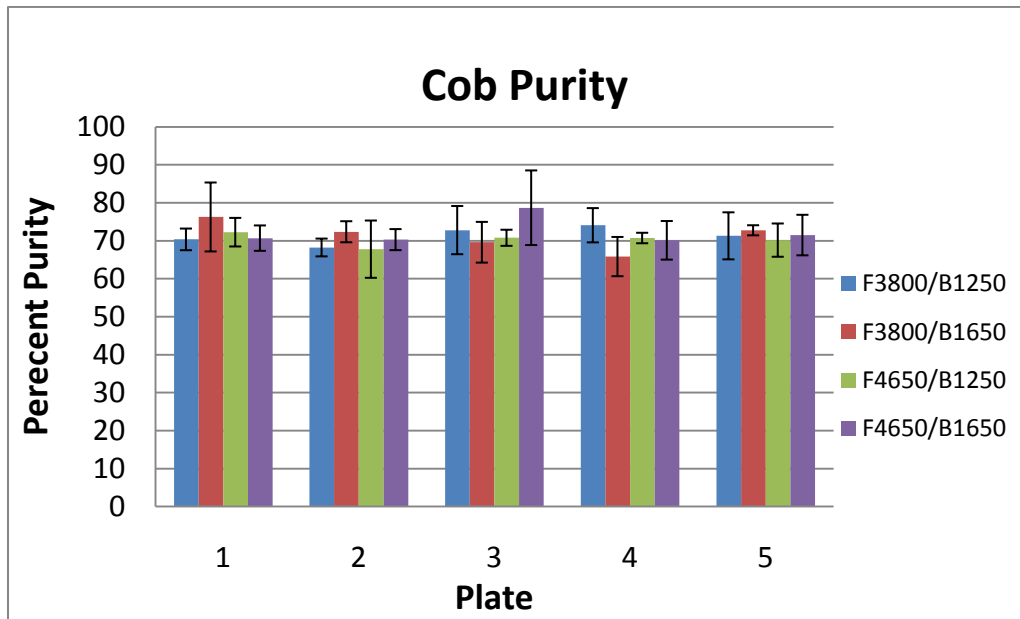

Figure 19. A comparison of treatment means on cob purity for two blower speeds (1250, 1650 rev/min) and for two fan speeds (3800, 4650 rev/min).

Observations during testing showed that corn cobs were still lost through the side air vents but Figure 20 shows after ten tests only a small amount of cobs are

seen on the ground. Other cob losses can be accounted for by losses through the separation process as well as losses including fines from the chopping and threshing processes.

An analysis of the data was conducted to ascertain any statistical significance among the configurations. The analysis was conducted utilizing JMP (SAS Institute Inc., Cary, NC). The fit model routine was used with the standard least squares personality selected. This combination provides a least square fit with an analysis of variance for the model. The experiment called for twenty treatments and three replications. The treatments consisted of each fan and blower setting for each plate configuration. A full factorial of the parameters was considered in determining the statistical effects of each parameter and every parameter interaction on both cob purity and collection efficiency. Two data points were not collected due to a failure of the machine and, therefore, only fifty-eight data points exist. The ANOVA results are shown in Table 5.

Figure 20. This figure shows that some cobs can still escape from the side air vents. This was taken after ten stationary tests.



A p-value $\leq .10$ would be considered statistically significant. In the initial analysis, no effects were statistically significant for the model of cob purity. Due to the high amount of stalks, no treatment means had an effect on cob purity. As discussed earlier, stalks have similar properties to cobs and being denser than husks and leaves, they were affected less by the separation air streams. This led to a greater percentage of material remaining in the clean material stream. Therefore, with less material exiting at the separation zone, greater changes in mass of the exit material were required to achieve statistical significance. A larger number of repetitions would have to be run or more stover would have to be added to see an effect from any of the treatments. More repetitions would enhance the difference among treatment means while adding additional stover would increase the differences through larger changes in the mass exiting the spout.

Table 5. Anova results for model response cob purity and collection efficiency from the stationary tests. The treatments were composed of 5 plate configurations, two fan speeds, and two blower speeds.

Response	Effect	DF	SS	F ratio	p > F
Cob Purity	Plate	4	60.91	0.57	0.68
	Fan	1	5.39	0.20	0.66
	Blower	1	52.26	1.96	0.17
	Fan*Plate	4	22.99	0.22	0.93
	Blower*Plate	4	197.55	1.85	0.14
	Fan*Blower	1	41.85	1.57	0.22
	Fan*Plate*Blower	4	166.02	1.56	0.21
Collection Efficiency	Plate	4	1447.46	2.75	0.04**
	Fan	1	132.06	1.00	0.32
	Blower	1	70.74	0.54	0.47
	Fan*Plate	4	554.87	1.05	0.39
	Blower*Plate	4	409.01	0.78	0.55
	Fan*Blower	1	48.92	0.37	0.55
	Fan*Plate*Blower	4	108.03	0.21	0.93

** Significant at 0.05 Level

However, the plate effect was significant to the model for collection efficiency. With plate as the only significant effect, all insignificant effects were removed. The model was then analyzed with plate type as the only effect, results shown in Table 6, and a t-test was utilized to determine plate differences. The t-test results shows Plate 1 and 3 are statistically different from each other while there is no difference among the other plates. The results of the t-test are likely explained by the geometric shapes and areas involved. Plates 2 and 4 possessed a circular geometric air zone. These zones were concentrated high velocity blasts and it would have been easy for cobs to pass by the initial zone without being adversely effected by the air. Plates 3 and 5 possessed the rectangular geometric air zone. These zones would have been less powerful but more widely distributed and by covering more area had a greater chance of negatively affecting the cobs. Plate 5 may not have had an effect due the area being so large as to decrease the air velocity in the initial zone.

Table 6. The model results using Plate Type as the only effect for the collection efficiency response (Top). A t-test shows the significant levels among the plates for that test (Bottom).

	DF	SS	MS	F	p>F
Model	4	1043.3	260.8	2.04	0.10*
Error	53	6761.7	127.6		
C. Total	57	7805.0			

* Significant at 0.10 Level

Level Effect Details

	Plate Type [Area mm ²]	Level	LSM
1	Solid [0]	A	89.31
2	Circular [2582]	A B	85.42
4	Circular [4617]	A B	84.40
5	Rectangular [6462]	A B	83.06
3	Rectangular [3936]	B	76.51

Plates not connected by same level are different

$\alpha = 0.05$

With no improvement on cob purity, and at least one initial separation plate with adverse effects on collection efficiency, there was no need to use any plate other than Plate 1. This also makes a simplified transition between cob and stover harvest because stover should only be harvested with Plate 1.

Also important to the study was power consumption of the fans and blower. The nominal speed settings for the fans were 3800 and 4650 rev/min while the blower was set to run at 1250 and 1650 rev/min. This correlated to an additional power requirement of 20.23 and 36.96 kW for the fan and 3.08 and 5.32 kW for the blower. These power numbers corresponded to average specific energy requirements of 49 kJ/kg and 89 kJ/kg for the low blower/low fan and high blower/high fan combinations, respectively. The specific energy numbers were found using the sum of fan and blower power and a nominal dry cob flow rate of 1.4

Mg/hr. The air velocity for the different fan speeds were on average 71.75 m/s and 93.13 m/s respectively. Even under worse case scenarios, no benefit was seen from the high fan speed and that the slower fan speed will provide the same results. Not only will the results be the same but the high power condition required the operator to slow harvest speed. Therefore, the slower speed provides the same results in terms of purity and collection efficiency, but also increases productivity and decreases fuel consumption verse the high power situation. From cob energy estimates of 19 MJ/kg (Clark and Lathrop, 1953) the specific energy used by the blower and fans to harvest the cobs represent less than one percent of the total cob energy for the highest fan/blower combination (89 kJ/kg). Therefore, the advantages of lower power consumption are primarily increased field capacities. The low blower speed was adequate to convey material to a towed wagon or even a wagon side tracking and so the high blower speed provides no benefit unless additional distances for conveyance are required.

Another area of interest was the effect of the plates on the air velocity at the separation zone. A statistical analysis was performed using air velocity as an independent variable with plate configuration and fan setting to determine changes in air velocity from different plates. Table 7 shows the results of the study and determined that the plates did not have a significant effect on the air velocity.

Table 7. A statistical analysis to determine if Plate Type affected the separation air velocity during stationary

Parameter	p-value
Plate	0.456
Fan Setting	<0.0001***

***Significant at 0.001 level

Field Testing

The Boyd plots were harvested on October 28, 2009 and the Bruner plots were harvested on October 31, 2009 with the same combine settings as the stationary testing. The Boyd plots averaged grain yields of 11.87 Mg/ha (15.5% M.C.) at 16.33% moisture content (w.b.). This corresponded to an average cob yield of 1.84 Mg/ha (dry mass), determined from hand sampling. The Bruner plots averaged grain yields of 9.62 Mg/ha at 18.31% moisture content and the average cob yields were 1.52 Mg/ha.

With the results of the stationary testing indicating no significant differences among blower and fan speeds, the field tests were conducted at a blower speed of 1250 rev/min and a fan speed of 4650 rev/min based on the results of the preliminary field testing. Plate 1 was used as a result of it having relatively less variance than the other plates and it was preferable to leave in for stover harvest. Table 8 shows the cob purity and collection efficiency results from six field trials.

While the stationary tests ranged in cob purity from 66 to 79%, the field tests showed an improvement with an average of 84%. These results validate the conclusions from the stationary tests that stalks are the most difficult to remove. The John Deere Model 693 corn head used in the field study did not allow as many stalks to enter the machine and the resulting purity levels were higher.

Table 8. Field test results for six plots harvested at a blower/fan combination of 1250/4650 rpm.

Field	Plot	% Purity	% Coll Eff
Bruner*	104	83	63
	202	76	78
	303	83	67
Boyd**	102	86	81
	201	89	85
	303	87	79
Bruner Avg (Std)		81 (3.8)	69 (7.6)
Boyd Avg (Std)		87 (1.5)	81 (3.0)
All Avg (Std)		84	76

* Grain Flowrate of 15.0 Mg/h

** Grain Flowrate of 18.5 Mg/h

The average collection efficiency for the field tests was 76% with a large difference between the two fields. Bruner averaged 69% while Boyd averaged 81%. Much of this difference was likely due to field conditions; the plots in Boyd contained a higher yielding and stronger standing crop than the plots in Bruner. The stationary test treatment means ranged from 65 to 95%, with a mean of 83.7% and a median of 84.7% showing the stationary tests and field tests were similar when comparing collection efficiency.

Conclusions and Recommendations

Conclusions

As a prime objective of this study to modify a combine capable of harvesting corn stover to also harvest cobs only, modifications were made to add a pneumatic separation system to the blower and chopper system already in place. To successfully complete the modifications, two fans were added to the system and an adequate path for the air to separate husks from the cobs was created. Completion of the study and analysis of the results resulted in the following conclusions:

1. Under high airflow, the fans alone place an additional power demand of 36 kW on the combine. During field testing, the combine operator was required to slow the ground speed of the combine compared to a conventional harvest for both cob and stover harvest. While this can be expected during stover harvest due to the increase in material throughput of the machine, cob harvest should have less of an impact because there is no increase in material flow.
2. On the other hand, high airflow is not needed. No additional gain in cob purity was extracted due to a higher fan speed in worst case scenario laboratory testing. A lower fan speed can be utilized to save power and maintain machine efficiencies.
3. In any system, stalks must be eliminated upfront as much as possible. The stationary tests show that removing stalk material from the material stream was problematic. An easy solution to elimination of stalk material was the selection of a proper corn head for the combine. The field tests were conducted using a modern

corn head and the collection efficiencies showed significant improvement over the lab tests.

4. The collection system had no adverse effects on stover collection and the transition between the two harvest scenarios was quick and easy. As one of the only single pass biomass harvesters, this combine has harvested 80 acres of corn stover plots with no effects from the addition of the cob separation system.
5. At low blower speeds, material conveyance through the spout was less than adequate and material was not exiting the blower at the blade tip resulting in apparent lower separation efficiencies and higher cob losses. At higher speeds, the material gained enough momentum to pass through the separation zone but with decreasing separation. An optimum point lies in between at the 1250 rev/min to 1650 rev/min range.
6. Due to the high velocities of the separation air and the pressure differentials, some air must be deflected into the spout beyond the separation zone to provide a venturi effect and maintain material conveyance through the spout.

Future Recommendations

The stationary test provided a means to accurately monitor the material input for each run. This situation allowed an accurate means of quantifying the collection efficiency for each test. However, the large fraction of stalks contained in the baled stover created difficulties in determining successes or failures of the separation system. A limited set of field trials suggests that the separation system works

adequately in a true field situation. With that in mind, future recommendations are as follows:

1. A full field test should be conducted to determine the effects of plate configurations, fan settings, and blower settings. The results provided here suggest that the increased power requirement of moving more air may not be required, but a field test could prove otherwise.
2. Furthermore, a field test could determine the effects of material flow rate on the separation system as well as determine machine capacities.

A driving objective of this study was a single pass combine capable of different harvest scenarios: grain only, grain and stover, and grain and cobs. In a parallel study, John Deere tested a design with similar principals but separation took place in front of the blower but after the chopper. The design in the parallel study produced similar results: fair separation but high power consumption. Keeping in mind the robustness of these designs to handle both biomass harvest scenarios, a future design consideration would be a system composed of two subsystems, with each subsystem dedicated to handling the unique challenges of each scenario.

References

- ASAE Standards. 2003a. S352.2: Moisture measurement – unground grain and sees. St. Joseph, Mich.: ASAE.
- ASAE Standards. 2003b. S358.2: Moisture measurement – forages. St. Joseph, Mich.: ASAE.
- Bargiel, D. A., B. Liljedahl, and C. B. Richey. A combine cob saver. 1982. *Trans. of the ASAE* 25(3): 544-548.
- Chung, Young G. 1980. Design of a corncob collector for a combine harvester. Unpublished MS thesis. Ames, Iowa: Iowa State University, Department of Agricultural Engineering.
- Clark, T.T. and Lathrop, E.C. 1953. Corncobs-Their Composition, Availability, Agricultural and Industrial Uses. USDA-ARS North Regional Research Lab., Peoria, IL. AIC-177.
- Dominguez, J.M., N. Cao, C.S. Gong, and G.T. Tsao. 1997. Dilute acid hemicelluloses hydrolysates from corn cobs for xylitol production by yeast. *Bioresource Technology* 61(1): 85-90.
- Dunning, J. W., P. Winter, and D. Dallas. 1948. The storage of corn cobs and other agricultural residues for industrial use. *Agricultural Engineering* 29: 11-13.
- Flamme, V. L. 1999. Corn cob collecting apparatus for use with a combine. U.S. Patent No. 5941768.
- Hahn-Hagerdal, B., M. Galbe, M. F. Gorwa-Grauslund, G. Liden, and G. Zacchi. 2006. Bio-ethanol – the fuel of tomorrow from the residues of today. *Trends in Biotechnology* 24(12): 549-556
- Kaliyan, N., and R.V. Morey. 2008. Densification characteristics of corn cobs. ASABE Paper No. 084267. St. Joseph, Mich.: ASABE.
- McBroom, C. L. 1986. Corn cob saver sieve for combines. U.S. Patent No. 4600019.
- Morey, R.V., D.P. Thimsen, J.P. Lang, and D.J. Hansen. 1984. A corncob-fueled drying system. *Transactions of the ASAE* 27(2): 556-560.
- POET. 2008. Overview. Project Liberty. Sioux Falls, SD.: Poet Energy. Available at : <http://www.projectliberty.com> . Accessed 03 Feb. 2009.

- Pordesimo, L. O., W. C. Edens, and S. Sokhansanj. 2004. Distribution of aboveground biomass in corn stover. *Biomass and Bioenergy* 26(4): 337-343.
- Quaye, S. A., and C. E. Schertz. 1983. Corn cob harvest with counter-rotating rollers. *Trans. of the ASAE* 26(5): 1303-1307, 1311.
- Redekop, L. 2009. Harvesting corn cobs. U.S. Patent Application No. 20090124309.
- Russell, J.R. 1986. Influence of harvest date on the nutritive value and ensiling characteristics of maize stover. *Animal Feed Science and Technology* 14 (1-2): 11-27.
- Schlesser, B. J. 2007. Development and evaluation of a single pass, dual stream corn stover harvester. Unpublished MS thesis. Ames, Iowa: Iowa State University, Department of Agricultural and Biosystems Engineering.
- Shinners, K. J., B. N. Binversie, and P. Savoie. 2003. Whole-plant corn harvesting for biomass: comparison of single-pass and multiple-pass harvest systems. ASABE Paper No. 036089. St. Joseph, Mich.: ASABE.
- Sheehan, J., A. Aden, K. Paustian, K. Killian, J. Brenner, M. Walsh, and R. Nelson. 2004. Energy and environmental aspects of using corn stover for fuel ethanol. *Journal of Industrial Ecology* 7: 117-146.
- Smith, R. D., J. B. Liljedahl, R. M. Peart, O. C. Doering, and W. C. Sahn. 1984. Development and evaluation of a cob salvaging system. *Trans. of the ASAE* 27(2): 590-596.
- Smith, R. D., and R. L. Stroshine. 1985. Aerodynamic separation of cobs from corn harvest residues. *Trans. of the ASAE* 28(3): 893-899.
- Snow, K. T. 1961. Corn picker. U. S. Patent No. 2974465
- Stone, J. A. 1905. Corn harvester and husker. U.S. Patent No. 786239
- Stukenholtz, T. E. and J. E. Stukenholtz. 2002. Combine system for harvesting, cleaning, and storing both corn kernels and whole cobs, and method of use. U.S. Patent No. 6358141.
- Uhl, J. B., and B. J. Lamp. 1966. Pneumatic separation of grain and straw mixtures. *Trans. of the ASAE* 9: 244-246.

USDA. 2008. Quick Stats – Crop and Plants. National Agricultural Statistics Database. Washington, D.C.: USDA National Agricultural Statistics Service. Available at: <http://www.nass.usda.gov/QuickStats/index2.jsp>. Accessed 2 February 2009.

Acknowledgements

Without the help of several individuals this research project would not have been possible. The author would like to acknowledge those who have helped along the way.

Dr. Stuart Birrell is acknowledged as the major professor on this project. He is appreciated for his patience and guidance during the course of the project.

Acknowledged for all of their hard work with fabrication and testing are Bret Hamilton and Wade Sohm.

Serving on the committee were Dr. Brian Steward, Dr. Matt Darr, and Dr. Raj Raman. Their contributions were appreciated.

Deere and Company are appreciated for the equipment and funds to support this project. Kevin Ehrecke and Mark Chaney of John Deere are also thanked for all of their support.

Additionally, the author would like to thank all of his family and friends for their support and understanding.

Appendix I. Raw data from stationary testing

Table AI-1. The collection efficiency, cob purity, power, specific energy and air velocity data collected during the stationary tests. The nominal grain flow rate was 16.7 Mg/hr and the nominal cob flow rate was 1.4 Mg/hr

Control Variable			Results							
Plate	Fan Speed	Blower Speed	Collect Eff (%)	Cob Purity (%)	Power (kW)		Specific Energy (kJ/kg)	Air Vel. (m/s)		
					Blower	Fan				
1	3800	1250	91.38	68.23	3.36	20.13	49.28	76.42		
		1250	101.44	73.60	2.80	19.64	47.10	77.62		
		1250	93.43	69.26	2.89	20.23	48.52	73.05		
		1650	87.67	86.58	4.91	18.73	49.53	73.09		
		1650	83.72	72.70	5.72	20.59	55.10	78.59		
		1650	94.25	69.52	5.82	20.25	54.59	72.88		
	4650	1250	79.88	75.79	2.48	38.02	85.11	94.45		
		1250	83.72	72.70	2.24	38.49	85.61	92.60		
		1250	94.49	68.30	3.78	36.77	85.15	92.92		
		1650	95.46	74.50	5.07	38.14	90.70	98.87		
		1650	75.19	69.35	3.35	38.28	87.45	87.77		
		1650	91.07	68.23	5.66	33.98	83.15	87.01		
		2	3800	1250	50.61	70.93	1.95	21.54	49.35	64.43
				1250	77.64	67.00	3.13	18.64	45.66	62.69
				1250	96.66	66.76	2.47	20.79	48.85	77.79
1650	83.73			74.75	5.00	20.02	52.42	62.08		
1650	95.49			69.33	4.32	18.41	47.64	67.98		
1650	91.98			73.05	4.22	20.14	51.06	74.71		
4650	1250	73.36	73.25	2.65	37.93	85.28	96.60			
	1250	93.30	70.92	3.05	36.70	83.52	84.65			
	1250	84.64	59.18	3.30	36.54	83.68	92.66			
	1650	79.44	67.11	5.69	37.64	90.92	96.67			
	1650	103.38	72.13	5.69	36.05	87.57	86.25			
	1650	94.82	71.66	7.30	36.06	90.90	91.58			
	3	3800	1250	59.69	78.82	2.23	19.52	45.66	52.80	
			1250	66.69	66.18	2.67	19.33	46.18	74.78	
			1250	69.83	73.41	3.28	21.15	51.24	77.45	
1650			57.37	66.90	5.27	21.23	55.52	69.21		
1650			70.41	66.13	4.60	18.98	49.41	67.39		
1650			84.77	75.78	6.16	20.11	54.99	75.64		
4650		1250	79.49	73.15	3.40	37.90	86.76	100.00		
		1250	92.07	69.06	2.73	38.30	86.20	91.95		
		1250	74.28	70.14	2.75	36.35	82.16	89.70		
		1650	102.03	89.54	5.15	37.71	89.95	101.29		
		1650	74.63	70.40	5.53	37.95	91.25	95.00		
		1650	86.83	76.15	6.36	35.93	88.71	91.69		

Table AI-1 (Continued).

Control Variable			Results							
Plate	Fan Speed	Blower Speed	Collect Eff (%)	Cob Purity (%)	Power (kW)		Specific Energy (kJ/kg)	Air Vel. (m/s)		
					Blower	Fan				
4	3800	1250	55.50	77.55	2.22	19.39	45.38	53.10		
		1250	99.04	68.99	3.67	20.49	50.67	66.27		
		1250	92.18	75.72	3.42	21.35	51.96	82.63		
		1650	72.06	59.89	4.80	20.64	53.30	59.71		
		1650	91.77	68.35	6.10	20.07	54.78	75.07		
		1650	88.17	69.26	5.74	22.58	59.32	86.65		
	4650	1250	80.47	69.62	2.89	38.36	86.68	-- ¹		
		1250	85.69	72.27	3.67	36.41	84.17	88.48		
		1250	91.51	70.27	4.30	34.62	81.69	97.07		
		1650	91.55	72.97	6.05	37.66	91.69	98.72		
		1650	89.43	73.13	6.59	35.73	88.75	92.87		
		1650	75.39	64.25	6.22	35.82	88.17	95.29		
		5	3800	1250	-- ²	--	--	--	--	--
				1250	91.19	75.68	5.89	19.11	52.33	72.34
1250	71.99			66.92	3.20	22.56	54.05	82.10		
1650	-- ²			--	--	--	--	--		
4650	1650		87.12	71.82	5.19	18.88	50.40	70.40		
	1650		73.12	73.69	5.38	22.08	57.52	82.16		
	1250		75.19	69.35	3.27	37.66	85.99	95.59		
	1250		88.10	66.26	3.73	37.91	87.46	91.63		
	1250	1250	82.62	74.90	3.98	35.96	83.86	91.23		
		1650	88.79	77.52	3.97	37.30	86.65	93.34		
		1650	82.15	67.33	5.38	37.72	90.43	91.02		
		1650	90.32	69.66	6.57	35.43	88.06	93.97		

¹ - Missing Data due to sensor malfunction

² - Missing Data due to combine malfunction

Appendix II. Additional Pro/E figures of the cob separation system

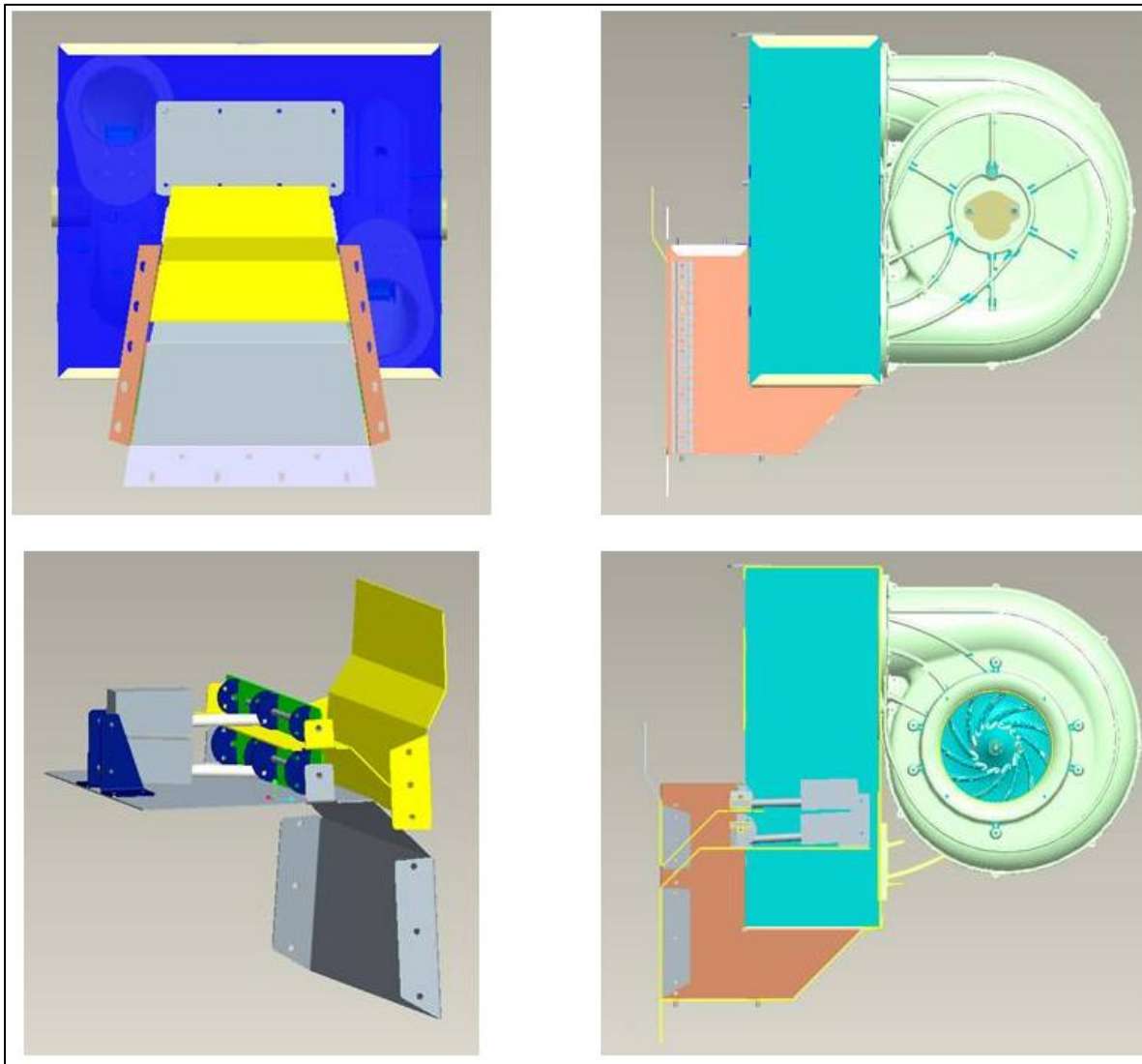

Figure AII - 1. Pro/E models showing the top and bottom plates inside of the air plenum. The top left shows a front view. The bottom left shows a three dimensional view with the butterfly valves and actuator assemblies. The top right shows the space available for the spout conveyance air and the bottom right shows a section view of the separation system.

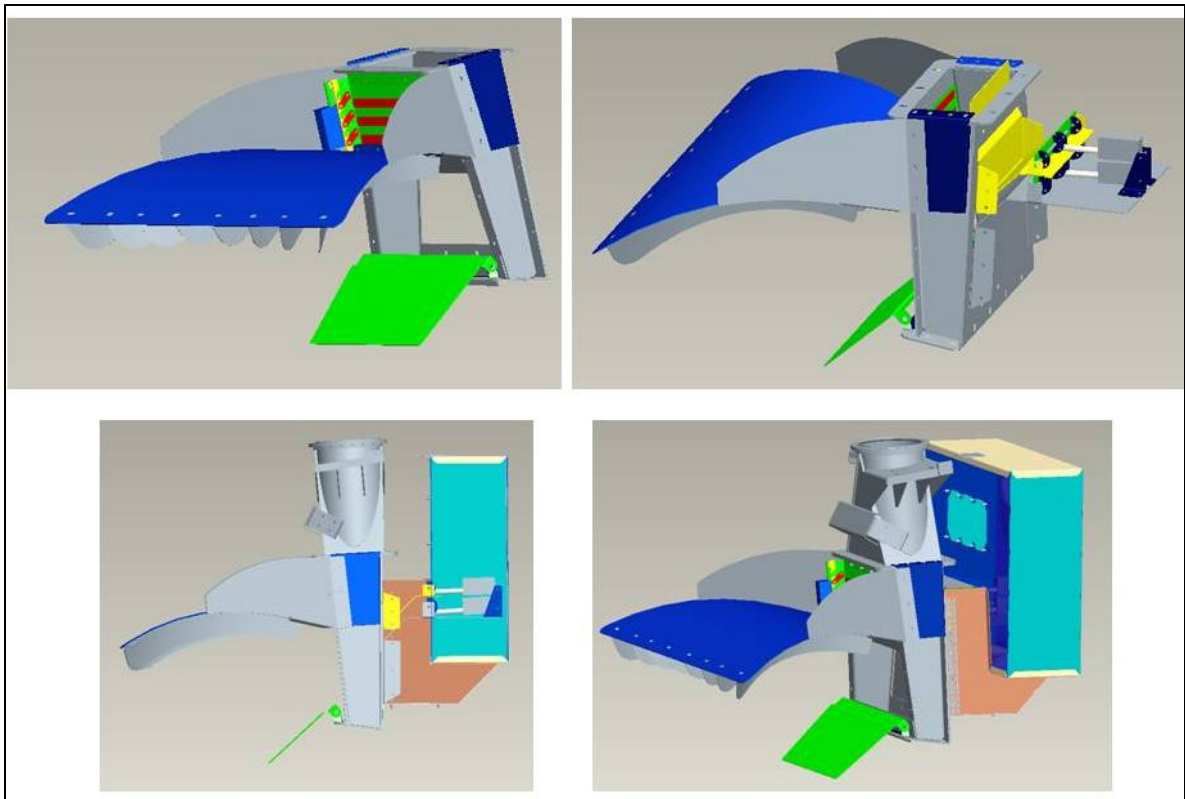

Figure AII - 2. Pro/E models showing the residue spreader, top and bottom plates, transition door, and the louver assembly.

Appendix III. Preliminary Testing Decision Matrix

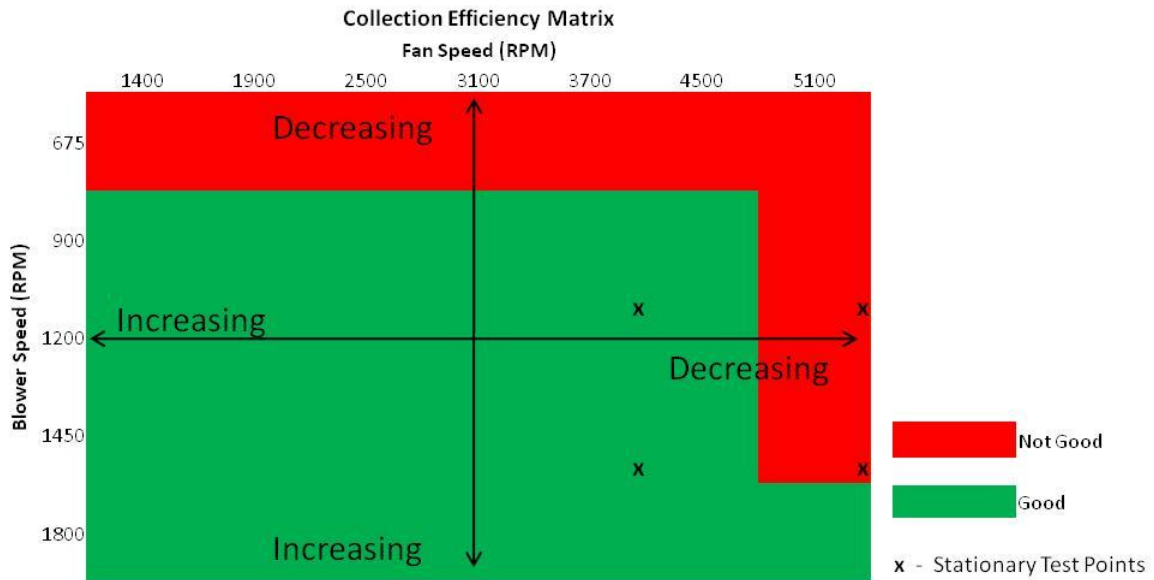

Figure AIII - 1. Matrix of results for collection efficiency obtained from preliminary testing.

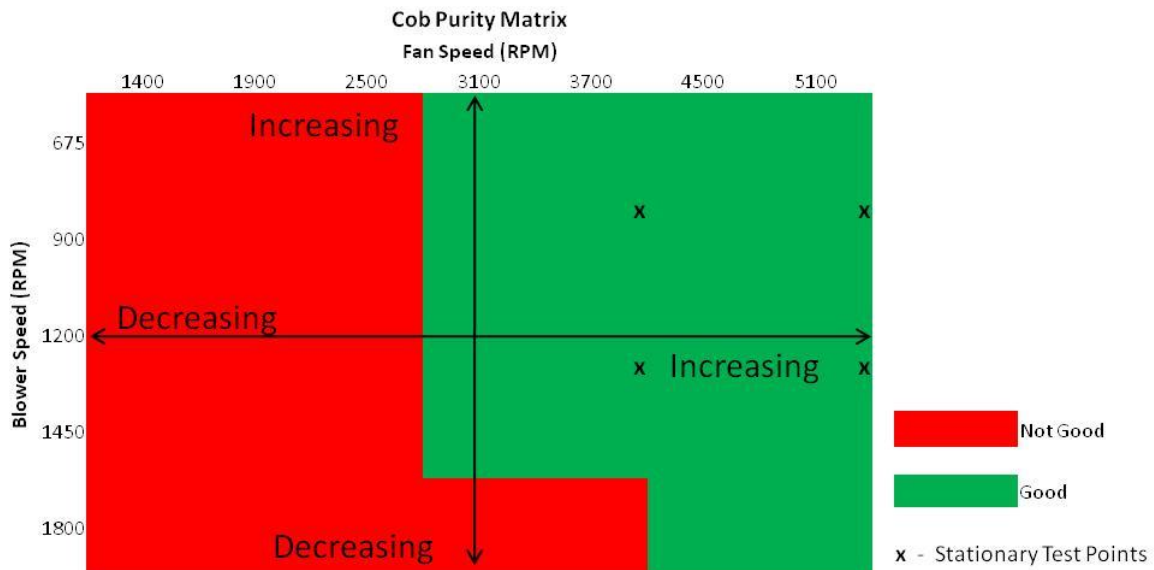

Figure AIII - 2. Matrix of results for cob purity obtained from preliminary testing.

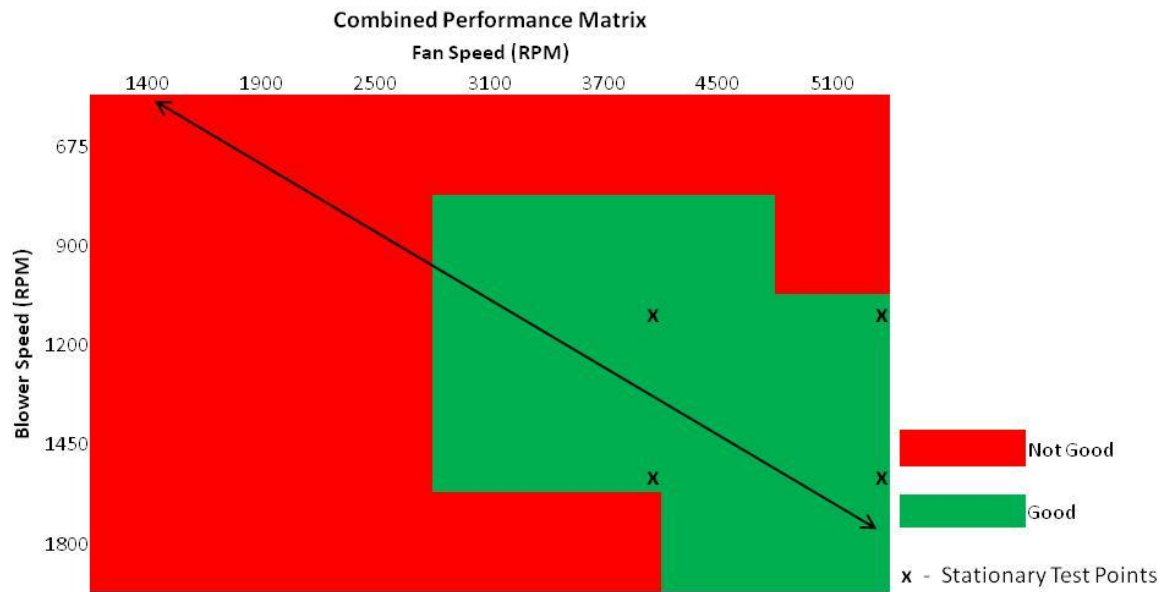

Figure AIII - 3. A combined matrix of cob purity and collection efficiency results from preliminary testing. From these results, fan and blower speeds were selected for testing under stationary conditions.