

4-29-2009

Exploring IT-Based Knowledge Sharing Practices: Representing Knowledge within and across Projects

Alina Maria Dulipovici

Follow this and additional works at: http://scholarworks.gsu.edu/cis_diss

Recommended Citation

Dulipovici, Alina Maria, "Exploring IT-Based Knowledge Sharing Practices: Representing Knowledge within and across Projects." Dissertation, Georgia State University, 2009.
http://scholarworks.gsu.edu/cis_diss/33

This Dissertation is brought to you for free and open access by the Department of Computer Information Systems at ScholarWorks @ Georgia State University. It has been accepted for inclusion in Computer Information Systems Dissertations by an authorized administrator of ScholarWorks @ Georgia State University. For more information, please contact scholarworks@gsu.edu.

Permission to Borrow

In presenting this dissertation as a partial fulfillment of the requirements for an advanced degree from Georgia State University, I agree that the Library of the University shall make it available for inspection and circulation in accordance with its regulations governing materials of this type. I agree that permission to quote from, or to publish this dissertation may be granted by the author or, in his/her absence, the professor under whose direction it was written or, in his absence, by the Dean of the Robinson College of Business. Such quoting, copying, or publishing must be solely for scholarly purposes and does not involve potential financial gain. It is understood that any copying from or publication of this dissertation which involves potential gain will not be allowed without written permission of the author.

signature of author

Notice to Borrowers

All dissertations deposited in the Georgia State University Library must be used only in accordance with the stipulations prescribed by the author in the preceding statement.

The author of this dissertation is:

Name: Alina M. Dulipovici
Address: HEC Montréal, Department of Information Technologies
3000 Côte-Sainte-Catherine Road
Montréal (QC) H3T 2A7 Canada

The director of this dissertation is:

Name: Daniel Robey, D.B.A.
Department: Department of Computer Information Systems
Department Address: 9th Floor, 35 Broad Street, Atlanta, GA 30302-4015, U.S.A.

Users of this dissertation not regularly enrolled as students at Georgia State University are required to attest acceptance of the preceding stipulations by signing below. Libraries borrowing this dissertation for the use of their patrons are required to see that each user records here the information requested.

Name of User

Address

Date

EXPLORING IT-BASED KNOWLEDGE SHARING PRACTICES:
REPRESENTING KNOWLEDGE WITHIN AND ACROSS PROJECTS

BY

ALINA M. DULIPOVICI

A Dissertation Submitted in Partial Fulfillment of the Requirements for the Degree

of

Doctor of Philosophy

in the Robinson College of Business

of

Georgia State University

GEORGIA STATE UNIVERSITY
ROBINSON COLLEGE OF BUSINESS

2009

Copyright by
Alina M. Dulipovici
2009

ACCEPTANCE

This dissertation was prepared under the direction of the candidate's Dissertation Committee. It has been approved and accepted by all members of that committee, and it has been accepted in partial fulfillment of the requirements for the degree of Doctor in Philosophy in Business Administration in the Robinson College of Business of Georgia State University.

Dean: H. Fenwick Huss
Robinson College of Business

Dissertation Committee:

Chair: Dr. Daniel Robey

Dr. Richard L. Baskerville

Dr. Balasubramaniam Ramesh

Dr. Marie-Claude Boudreau

Acknowledgements

*“A journey is best measured in friends rather than miles”
(Tim Cahill, traveler writer)*

Pursuing a doctoral degree was not about the destination but the journey that started in fall 2004 and ended four and a half years later. It may seem as a long period of time but the friends I made, the people I met, and my extended family made it seem short and sweet even when the road was sinuous and bumpy.

First and foremost, I wish to thank my adviser, Dr. Daniel Robey, for his guidance, advice, patience, and understanding. He was not only an amazing research mentor, but also an empathetic listener and friend. Dan shared his immeasurable expertise and showed me “*research in-practice*”: how it is done what should be done. He helped become a better researcher by letting me wander from time to time in unfamiliar theoretical realms and guiding me back toward my research goals. He has always encouraged and motivated me to come up with research ideas. Although I thought they were all interesting and important, he showed me how to polish my ideas to really become research questions, research projects, and eventually a dissertation. I feel so fortunate for having such an exceptional adviser.

I am sincerely grateful to my committee members, Dr. Richard Baskerville, Dr. Balasubramaniam Ramesh, and Dr. Marie-Claude Boudreau. Thank you for supporting my ideas, for providing valuable feedback, for the time spent reading various versions of the dissertation, and, last but not least, for encouraging me throughout the whole process. My research abilities have greatly benefited from your expertise.

During my PhD seminars, I have benefited from many GSU faculty members as well. To Dr. Richard Baskerville, thank you for the opportunity to work with and learn so much from you. When we met in 2004 I was already interested in knowledge management, but you helped me build a solid understanding of the knowledge management literature. The seeds of my dissertation emerged from our collaboration. To Dr. Detmar Straub, Dr. Veda Storey, Dr. Mark Keil, Dr. Lars Mathiassen, and Dr. Edward Rigdon, thank you for the opportunity to learn from some of the best in the field about the research and the writing processes.

My achievements would not have been possible without the unconditional love and support of my family. My husband, Patrick, has shown phenomenal understanding and helped me get through the difficult times in order to enjoy together the bright times. Thank you Patrick for your sacrifices so that I can pursue my dream in Atlanta. Thank you for using your professional contacts to help me find a research site and for letting me tag along at the PMI meetings. *Merci beaucoup mon amour pour tout ce que tu fais pour moi, pour nous et pour notre famille.* To my daughter, Melissa, thank you so much for your beautiful smile, contagious laugh, and energizing hug. I cannot imagine life without you. Some would consider this dissertation your twin sister. To Mom and Dad, *multumesc pentru tot ce ati facut pentru mine sa devin ceea ce sunt. Ca parinte, incep sa inteleg eforturile si sacrificiile care le-ati facut. Nu exista cuvinte pentru a va spune cat de mult apreciez. Multumesc din tot sufletul!* A special thought is for my sister Andreea. I could not have survived the maternity leave without you.

Finally, my gratitude goes to all those (family members, friends, and acquaintances) who contributed closely or from afar to this journey.

Table of contents

<u>ACKNOWLEDGEMENTS</u>	<u>IV</u>
<u>TABLE OF CONTENTS</u>	<u>VI</u>
<u>LIST OF FIGURES</u>	<u>IX</u>
<u>LIST OF TABLES</u>	<u>X</u>
<u>ABSTRACT</u>	<u>XI</u>
<u>1. INTRODUCTION</u>	<u>12</u>
1.1. MOTIVATION	12
1.2. RESEARCH QUESTIONS	17
1.3. DISSERTATION OVERVIEW	19
<u>2. SHARING ACROSS ORGANIZATIONAL BOUNDARIES</u>	<u>20</u>
2.1. BOUNDARY SPANNING AND KNOWLEDGE BOUNDARIES	21
2.2. BOUNDARY OBJECTS	24
2.3. BOUNDARY SPANNERS	27
<u>3. REVIEW OF THEORIES</u>	<u>29</u>
3.1. SOCIO-COGNITIVE THEORIES	31
3.2. THEORIES OF PRACTICE AND KNOWING	33
3.3. ORGANIZATIONAL LEARNING THEORIES	37
3.4. SOCIAL REPRESENTATION THEORY	41
3.4.1. THEORETICAL UNDERPINNINGS	41
3.4.2. STRENGTHS AND LIMITATIONS	44
3.4.3. SOCIAL REPRESENTATION THEORY IN THE IS LITERATURE	45
3.4.4. SOCIAL REPRESENTATION THEORY VS. OTHER THEORIES ON ORGANIZATIONAL CHANGE	47
<u>4. RESEARCH METHODOLOGY</u>	<u>53</u>

4.1. RESEARCH PARADIGM: EPISTEMOLOGICAL AND ONTOLOGICAL ASSUMPTIONS	53
4.2. RESEARCH DESIGN	56
4.2.1. CASE STUDY DESIGN	57
4.2.2. DATA COLLECTION PROCEDURES	59
4.2.3. DATA ANALYSIS PROCEDURES	64
<u>5. CASE DESCRIPTION</u>	<u>66</u>
5.1. TECHPROJECT	66
5.2. THE ENTERPRISE INTEGRATION (EI) PROGRAM	69
5.3. KNOWLEDGE-BASED ORGANIZATIONAL CHANGE AT TECHPROJECT	73
5.4. KNOWLEDGE-BASED SYSTEMS USED BY THE EI GROUPS	76
5.4.1. KNOWLEDGE SHARING PRACTICES: EI-EXTERNAL	80
5.4.2. KNOWLEDGE SHARING PRACTICES: EI-TECHNICAL	83
5.4.3. KNOWLEDGE SHARING PRACTICES: EI-SOLDEV	85
5.4.4. KNOWLEDGE SHARING PRACTICES: EI-INTERNAL	88
5.4.5. KNOWLEDGE SHARING PRACTICES ACROSS GROUPS	89
<u>6. CASE ANALYSIS</u>	<u>94</u>
6.1. UNDERSTANDING THE CONTEXT	94
6.2. SOCIAL REPRESENTATIONS OF KNOWLEDGE-SHARING PRACTICES VIA A KNOWLEDGE-BASED SYSTEM	99
6.3. EXAMINING THE SOCIAL REPRESENTATION FUNCTIONS	106
6.3.1. IDENTITY FUNCTION	106
6.3.2. JUSTIFICATION FUNCTION	107
6.3.3. KNOWING FUNCTION	109
6.3.4. ORIENTATION FUNCTION	110
6.4. ANALYSIS OF THE EI GROUPS' SOCIAL REPRESENTATIONS: KEY INSIGHTS	112
<u>7. DISCUSSION</u>	<u>115</u>
7.1. SHARING KNOWLEDGE PERTAINING TO INDIVIDUAL COGNITION AND TO SOCIAL KNOWING (RQ1)	115

7.1.1. DYNAMIC INTERPLAY BETWEEN PRACTICES AND REPRESENTATIONS	117
7.1.2. KNOWLEDGE SHARING REPRESENTATIONS AND ORGANIZATIONAL CHANGE	126
7.2. REPRESENTING KNOWLEDGE WITH IT-BASED BOUNDARY OBJECTS (RQ2)	133
<u>8. CONCLUSIONS</u>	<u>139</u>
8.1. SUMMARY OF FINDINGS	139
8.2. VALIDATION OF THE THEORETICAL ACCOUNT	139
8.3. IMPLICATIONS FOR RESEARCH	143
8.4. IMPLICATIONS FOR PRACTICE	146
8.5. RESEARCH LIMITATIONS	148
8.6. FUTURE RESEARCH	149
<u>APPENDIX A: INTERVIEW GUIDE</u>	<u>152</u>
<u>APPENDIX B: CONTACT FORM</u>	<u>156</u>
<u>APPENDIX C: DOCUMENT FORM</u>	<u>157</u>
<u>APPENDIX D: CODING SCHEME</u>	<u>158</u>
<u>REFERENCES</u>	<u>159</u>
<u>CURRICULUM VITAE</u>	<u>169</u>

List of Figures

FIGURE 1.1: PROJECT RESOLUTION (STANDISH GROUP, 2008).....	13
FIGURE 2.1: KNOWLEDGE BOUNDARY PROCESSES AND THE KNOWLEDGE SHARING CYCLE	23
FIGURE 3.1: A SIMPLIFIED VIEW OF SOCIAL REPRESENTATIONS (ADAPTED FROM BAUER & GASKELL, 1999)....	43
FIGURE 4.1: FRAMEWORK OF THE CASE STUDY RESEARCH DESIGN (ADAPTED FROM YIN, 2003, p.50)	59
FIGURE 5.1: TECHPROJECT - ORGANIZATIONAL CHART (BUSINESS PLAN UPDATE – MAY 2007, p.18)	67
FIGURE 5.2: ENTERPRISE INTEGRATION PROGRAM - ORGANIZATIONAL CHART	71
FIGURE 5.3: GROUP AFFILIATION OF THE EI MEMBERS (IN SHADED BOXES)	72
FIGURE 7.1: MAIN CHARACTERISTICS OF THE EI GROUPS' SOCIAL REPRESENTATIONS.....	116
FIGURE 7.2: DYNAMIC INTERPLAY BETWEEN 'SOCIAL REPRESENTATIONS (SR) AND WORK PRACTICES (WP)' (ADAPTED FROM FIGURE 3.1).....	119
FIGURE 7.3: POSSIBLE CHANGE PROCESS THEORY BASED ON THE EVOLUTIONARY MOTOR OF ORGANIZATIONAL CHANGE	132
FIGURE 7.4: THE ROLE OF OPPOSITIONS TO CREATE A PATTERN OF ACTIONS.....	133
FIGURE 7.5: DYNAMIC INTERPLAY AMONG THE SOCIAL REPRESENTATION (SR), WORK PRACTICES (WP), AND THE USE OF THE BOUNDARY OBJECT (BOBJ)	137

List of Tables

TABLE 3.1: OVERVIEW OF THE OTHER THEORIES ON ORGANIZATIONAL CHANGE.....	48
TABLE 4.1: LINKING RESEARCH QUESTIONS AND METHODS	62
TABLE 6.1: FRAMEWORK FOR THE MAIN KNOWLEDGE-SHARING MECHANISMS USED BY THE EI-MEMBERS (BOH, 2007).....	98
TABLE 6.2: SOCIAL REPRESENTATIONS OF KNOWLEDGE SHARING VIA KBS FOR THE EI PROGRAM.....	105
TABLE 7.1: KNOWLEDGE SHARING PATTERNS FOR THE EI GROUPS	120
TABLE 7.2: CONTRADICTION FORCES INFLUENCING IT-RELATED CHANGE AT TECHPROJECT	128
TABLE 8.1: SUMMARY OF FINDINGS	140
TABLE 8.2: EVALUATION OF THE RESEARCH DESIGN AND THE ANALYTIC STRATEGY (KLEIN & MYERS, 1999)..	141

ABSTRACT

EXPLORING IT-BASED KNOWLEDGE SHARING PRACTICES: REPRESENTING KNOWLEDGE WITHIN AND ACROSS PROJECTS

By

Alina M. Dulipovici

February 2009

Committee Chair: Dr. Daniel Robey

Major Department: Computer Information Systems

Drawing on the social representation literature combined with a need to better understand knowledge sharing across projects, this research lays the ground for the development of a theoretical account seeking to explain the relationship between project members' representations of knowledge sharing practices and the use of knowledge-based systems as boundary objects or shared systems. The concept of social representations is particularly appropriate for studying social issues in continuous evolution such as the adoption of a new information system. The research design is structured as an interpretive case study, focusing on the knowledge sharing practices within and across four project groups. The findings showed significant divergence among the groups' social representations. Sharing knowledge across projects was rather challenging, despite the potential advantages provided by the knowledge-based system. Therefore, technological change does not automatically trigger the intended changes in work practices and routines. The groups' social representations need to be aligned with the desired behaviour or patterns of actions.

1. Introduction

1.1. Motivation

“When a bridge falls down, it is investigated and a report is written on the cause of the failure. This is not so in the computer industry where failures are covered up, ignored, and/or rationalized. As a result, we keep making the same mistakes over and over again.” (The CHAOS Report 1994, p. 1)

Evidence from the venerable CHAOS Report by the Standish Group¹ (initially published in 1994 and regularly updated since) suggests that most IT projects do not meet schedule, budget, and functionality targets because of a number of reasons, including inadequate project management, lack of or bad planning, lost vision and support, and flawed contingency planning. Although the numbers have improved over the years (see Figure 1.1), the 2004 report still concluded that about 18 percent of the 9,236 IT projects surveyed were cancelled before completion, 53 percent run over budget, are seriously late, or lack the expected features, cost overruns average 56 percent, schedule overruns average 84 percent, and only 64 percent of originally planned functions make it to the end product (Beer, 2004). A more recent study (Tata Consultancy Services, 2007) of 800 middle and senior IT managers from US, UK, France, Germany, India, Japan, Singapore and Sweden found similar dire results to the CHAOS reports: schedule overruns (62% of IT managers interviewed), budget overruns (49% of IT managers), and failure to meet the expected business value and return on investment (41% of IT managers).

¹ http://www.standishgroup.com/sample_research/index.php

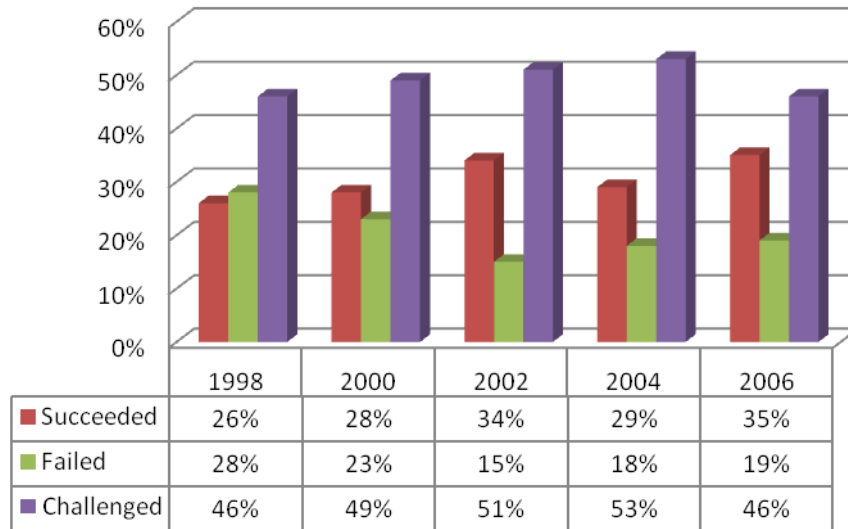

Figure 1.1: Project Resolution (Standish Group, 2008)

Note: The chart is based on data collected for the CHAOS Report, from more than 60 000 projects. The report for 2006 is yet to be released.

Through the execution of projects, organizations develop knowledge, core capabilities, and resources. The temporary nature of the projects (i.e. definite beginning and ending date) renders such organizations more flexible. However, projects (given their size, duration, and complexity) may negatively affect the organization's social structures and business processes (Hobday, 2000). If appropriate structures and incentives are not in place, the project may "go its own way" (Hobday, 2000). The more the organization tends towards a pure project-based form, the bigger the probability for the organization to lack the mechanisms for transferring knowledge among projects or creating organization-wide learning.

The dilemma of such organizations is the double-focus on the completion of each project, according to its quality, schedule, and budget objectives, and on the development of organizational knowledge over time. The former gives the company a short-term orientation where knowledge management activities may be neglected to cut costs in the short-run. The latter emphasizes a long-term orientation where costs in the short-run increase but

‘economies of repetition’ may be generated by accumulating knowledge. Organizations often choose short-term performance over long-term knowledge management (Grabher, 2002).

Knowledge management generally refers to "structured activities aimed at improving an organization’s capacity to acquire, share, and use knowledge in ways that enhance its survival and success” (Bock et al., 2006, p.357). Although knowledge creation is often viewed as more difficult to manage, knowledge sharing is usually the weakest link (O’Dell & Grayson, 1998; Brown et al., 2006). One of the reasons is that knowledge needs are seldom unique and individuals need to identify and use knowledge that is outside of their habitual areas of expertise. Sharing knowledge across organizational boundaries, between different functional departments, positions, or areas of expertise, raises several challenges: language, interpreter’s perspective, implicit assumptions, trust, and credibility. Individuals do not use the same language nor do they possess the same view of ‘what’ and ‘how’ needs to be shared. The specialization of each functional area renders organizational knowledge situational, cultural, and contextual (Boland Jr & Tenkasi, 1995; Orlikowski, 2002).

The ability to share and reuse existing knowledge is crucial as it decreases production time and time to market (Hansen et al., 1999). Hence, knowledge sharing is related to organizational effectiveness and performance (Markus, 2001; McKeen et al., 2006). With regard to sharing and reusing knowledge across projects, it can help project managers avoid making the same mistakes over and over again

The project management literature has suggested several strategies ranging from post-mortem reviews, use of standards and practices recommended by the Organizational Project Management Maturity Model (OPM3), to establishing a Project Management Office (PMO) (Project Management Institute, 2004). To improve long-term learning and knowledge

sharing, project managers need to conduct post-mortem reviews and to document the successes and failures of the project in a 'lessons learned' document at the end of each project. Yet, a survey of 63 large companies found that only 20 percent conducted post-mortem reviews and the reviews focused on technical aspects and bureaucratic measurements (Zedtwitz, 2002). These kinds of knowledge are easy to document but they may change quite often. The process-related tacit knowledge is seldom recorded because there are no structures or incentives to motivate or foster cross-project sharing of knowledge (Hobday, 2000).

Given the high internal turnover of project managers as key 'knowledge senders', knowledge usually becomes lost or distorted (Turner & Keegan, 2001). Often there is little reuse of existing knowledge unless those involved in their original production are also involved in their reuse (Gotel & Finkelstein, 1994). This is valid for both successful and less successful projects, especially in organizations where there is little time for formal training and staff development (Hobday, 2000). Hobday also notes that the 'learning closure' problem may affect long-term productivity and effectiveness, senior management coordination and control, and cross-project integration of knowledge.

Knowledge-based systems (or knowledge management systems), have been regarded by many researchers as possible IT solutions for codifying and sharing knowledge across domains (Alavi & Leidner, 2001; Markus, 2001). For instance, a central repository hosts an organizational knowledge base that is accessible to all employees for storage and retrieval. This approach seems intuitive and straightforward. Nevertheless, a number of organizations found that their employees avoided using such systems despite different incentives in place (Hansen & von Oetinger, 2001). Depending on the type of decision, experienced peers seem to be the most trusted source of information (Anonymous, 2006).

Previous research suggests that personal and institutional factors, characteristics of the knowledge-based systems, and the nature of knowledge can all foster and hinder knowledge sharing (Brown et al., 2006). Knowledge management activities cannot be performed in isolation of other organizational activities or by some employees only. From a system thinking viewpoint, “in order for [one activity] to succeed, others must succeed as well” (Senge, 1990, p.50).

Akin to ERP projects, benefits from sharing knowledge are not immediate; it is a long-term process involving people, technologies, organizational structures, organizational culture, and financial resources. For knowledge sharing to be valuable, it must enhance individual learning, team learning, and finally organizational learning. “Organizations learn only through individuals who learn” (Senge, 1990, p.139). To make it even more difficult, individual learning does not automatically imply organizational learning, but the latter cannot occur without the former. Knowledge management and knowledge sharing, in particular, are about the process and the means used to achieve organizational learning in the long-run. One should be committed to the whole process not just to the result itself (Senge, 1990).

In the end, knowledge sharing remains a difficult task because it is difficult to assess its outcome and to justify its costs. How can an organization evaluate the amount of new knowledge acquired by an employee as a result of the sharing process? The value of knowledge sharing can be subjectively assessed depending on its efficiency, its quality, its ability to enhance organizational learning, and its ability to reuse that learning (Brown et al., 2006). Knowledge creation, knowledge sharing, and knowledge integration need to continuously support each other so that the organization can reap the benefits of its efforts.

1.2. Research Questions

The focus of this research is the development of a theoretical account explaining knowledge sharing across organizational boundaries. Specifically, I focus on knowledge-based systems as boundary objects that can span across project boundaries and link organizational actors. In line with other studies documenting behavioural and organizational changes due to IT usage (Nonaka & Takeuchi, 1995; Orlikowski, 2002), I view organizations as knowledge-based rather than as information-processing structures. Knowledge is created via specific processes and then it is accumulated over time to generate organization-wide learning. Through specific processes of incorporating new ideas into work practices and everyday organizational life, new knowledge involves organizational change.

The topic of knowledge sharing across boundaries remains under-explored and previous research studies have identified three aspects that could bring more light:

- Adopting a micro-level, from the stakeholders' perspective, because social knowledge is held by actors and it cannot be detached from the knowledge of these actors and the actors' symbolic world (Vaast et al., 2006).
- Investigating the dynamic interaction between IT use and work practices in order to better capture the complexity of how IT usage impacts organizational change and collective sensemaking across boundaries (Baxter & Lyytinen, 2005)
- Investigating the IT artifact as embedded system or as structure (Orlikowski & Iacono, 2001).

Based on the above, one general research question (RQ) and two specific research questions are explored.

General RQ: How can the process of knowledge sharing across project boundaries be explained from the stakeholders' perspective?

This general question subsumes two more specific research questions. The first one pertains to the representation of knowledge sharing practices by various stakeholders. Using the social representation perspective, I examine how differences in the representations created by the various groups of stakeholders enable, constrain, or change the use of the IT artefact, namely the knowledge-based system. If the representations associated with the same knowledge-based system are conflicting or if the representations associated with different knowledge-based systems are incompatible, it is certainly a case worthy of further scrutiny in order to explain how coordination or conciliation mechanisms manage the symbolic conflicts. Thus,

RQ1: How do project team members create, maintain, and transform knowledge, which pertains both to individual cognition and to social knowing, using knowledge-based systems?

The second specific research question regards the knowledge-based system as an IT artifact common to several groups (i.e. boundary object). This is not a study on how people come to deal with the technology but rather on how IT-based boundary objects enable boundary spanning practices of knowledge sharing. Representation is the essence of information systems (Weber, 1997) and various knowledge elements need to be represented by the boundary objects. There is clearly a need to understand representations of knowledge-sharing practices at boundaries as embedded in the IT artifact. Thus,

RQ2: How do social representations of knowledge sharing practices affect the use of IT-based boundary objects?

To answer these questions, I adopt a multi-perspective approach because it has the ability to provide a richer explanation of the complex organizational environment. Stakeholders have different goals and perspectives and therefore, perceive the same event in different, sometimes contradictory, ways.

1.3. Dissertation Overview

Drawing on the knowledge-based literature in organizational theory, combined with a need to better understand knowledge sharing, the present research lays the ground for the development of a theoretical account seeking to explain knowledge sharing across project-boundaries. Chapter 2 of the current study presents background information on knowledge sharing across boundaries. Chapter 3 reviews the relevant literature on organizational change, such as sensemaking, storytelling, structuration-based theoretical approaches, and social representation theory. In chapter 4, I present the research methodology and the rationale for the case study, the data collection procedures, and the data analysis procedures. Chapter 5 describes TechProject, the organization chosen for this study, while Chapter 6 analyses the data collected at TechProject from the perspective of the social representation theory. Chapter 7 discusses how the results are used to answer the two research questions of this research study. Finally, Chapter 8 concludes by summarizing the findings and presenting the validation of the theoretical account, the contributions for research and practice, the research limitations, and potential avenues for future research.

2. Sharing across organizational boundaries

This study's research questions tackle two distinct aspects of the process of knowledge sharing across project boundaries. Therefore, this chapter presents the theoretical background by defining and describing the main concepts and implications of knowledge sharing practices across organizational boundaries. Both research questions allude to these practices because IT-based products and activities (e.g. design and implementation of new systems) are mostly project-based (Prencipe & Tell, 2001) and actors in different organizational groups provide their expertise about the technology itself and about the organizational context for which the IT-based product is intended. Naturally, IT-based products and activities imply sharing knowledge across organizational boundaries.

'Organizational boundary' is a concept with multiple meanings. It is the demarcation between the internal social structure of the organization and the external environment (organizational boundaries), the demarcation among organizational departments or groups of organizational members (intra-organizational boundaries), and even the demarcation of a sphere of influence (external or internal) (Santos & Eisenhardt, 2005). This study only looks at organizational boundaries as the demarcation among groups and divisions within an organization. Often these boundaries are relative, mostly conceptual rather than physical, and depend on the interpreter's point of view. They are socially constructed and, especially in times of crisis, they easily change and are dialogically reconstructed (Markova, 2000).

Working across organizational boundaries may create a competitive advantage, but it can also impede knowledge management activities (Carlile, 2002). To foster knowledge sharing

in cross-functional groups, four key concepts have emerged from previous studies: boundary spanning, knowledge boundary processes, boundary objects, and boundary spanners. These concepts are discussed in the following sub-sections because the research questions refer to them directly (e.g. boundary objects and boundary spanners) and indirectly (e.g. boundary spanning, knowledge boundaries, knowledge boundary processes).

2.1. Boundary Spanning and Knowledge Boundaries

Cross-boundary interactions between organizational members provide opportunities to integrate knowledge and “to develop collective, coherent, synergistic organizational learning” (Brown & Duguid, 1998). Boundary spanning implies formal and informal communication between an individual and an external source. As such, boundary spanning is an essential mechanism for cross-functional teams or any group that relies on external sources of knowledge.

As knowledge is localized, embedded, and invested in its context, knowledge boundaries inevitably appear when working across organizational boundaries. Knowledge boundaries are “cognitive borders around organizational units, such as communities of practice or functional areas, within which there are significant commonalities in tacit knowledge, and across which exist distinct cognitive differences” (Mitchell & Nicholas, 2006, p.310). In other words, knowledge borders form because ‘old’ (existing) knowledge is used under different constraints and the sender and the recipient need to adjust the intrinsic characteristics of knowledge to the new context (Carlile, 2002). For Carlile (2004) these intrinsic characteristics are: the degree of difference in localized knowledge, the degree of dependence, and the degree of novelty. Actors, on each side of the boundary, will perceive a

difference in the type or amount of specialized knowledge required to share knowledge. The greater the difference, the greater the effort required to assess each party's knowledge and to share it adequately. Second, the greater the interdependence of actors, the greater the effort to share as well. Third, novel knowledge creates unfamiliar circumstances and a lack of common meanings.

In a recent study, Faniel and Majchrzak (2007) found different characteristics of knowledge, such as associating knowledge with the expected source, presenting knowledge at different levels of detail, and presenting knowledge in a way that encourages adaptation. However, their meanings are not different from those mentioned by Carlile. For example, the necessity to associate the knowledge with an expert source is due to a high degree of difference in the localized knowledge and to a high degree of novelty. The receiver source in Faniel and Majchrzak's case study needed to find an expert source to help him assess the credibility and the usefulness of the knowledge content accessed from another domain. Similarly, the difference in localized knowledge and the degree of dependence are the root cause for the need to present knowledge at different levels of detail. Finally, the need to present the knowledge in a way that encourages easy adaptation draws on all three core characteristics. Thus, Faniel and Majchrzak's characteristics are just concrete examples in which combinations of Carlile's characteristics were found.

Furthermore, Carlile (2004) develops a framework composed of three main processes: sharing, translation, and transformation (see Figure 2.1). Knowledge *sharing* is the term used in the knowledge management literature to describe the movement of knowledge between the source (individuals who have it) and the recipient (individuals who don't have it). Knowledge sharing can be problematic because 1) knowledge means different things to

different people: what one group identifies as important knowledge to be transferred may not be identified as such by the other group; 2) the sharing of knowledge implies a certain degree of conversion into articulated and/or tacit knowledge (Nonaka & Takeuchi, 1995); and 3) knowledge sharing depends not only on actors, but also on the organization to provide

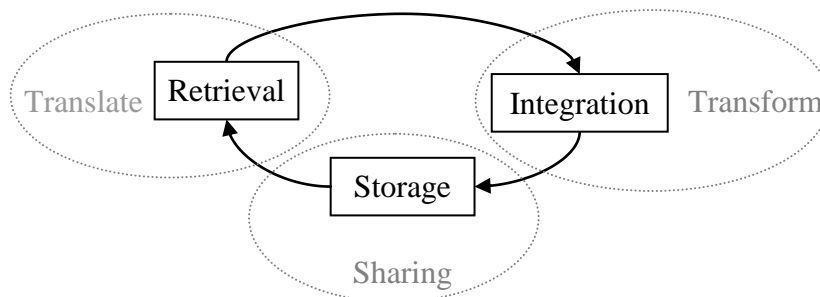

appropriate organizational structures, tools and technologies.

Figure 2.1: Knowledge boundary processes and the knowledge sharing cycle

For project-knowledge to become accessible to another project, its meaning must be *translated* into the receiving group's world view (Boland Jr & Tenkasi, 1995). Knowledge translation is difficult because knowledge is 'sticky' (i.e. situated knowledge) and 'leaky' (i.e. undesirable flow of knowledge) (Brown & Duguid, 2001). The *transformation* process requires a negotiation of practice and the communication tools common to the groups involved play an important role by providing the capacity to negotiate interests and thus, to transform knowledge (Carlile, 2004). Organizational members cannot simply transfer knowledge. Misunderstandings between groups can easily arise but can be overcome by jointly creating a common ground of understanding that facilitates reconciliation and visualization of knowledge application from one group to another (Bechky, 2003). Thus, boundary spanning can be viewed as influencing not only knowledge sharing but also knowledge creation, depending on how the transformation process is interpreted (Mitchell & Nicholas, 2006; Carlile, 2004). This dual role emphasizes the paradoxical nature of

boundaries: they isolate localized knowledge thereby nurturing its stickiness and preventing its leakage to other areas, while also exhibit plasticity to allow integration with external resources.

2.2. Boundary Objects

Boundary objects are generally seen as technological or non-technological objects relevant to multiple communities but used and viewed differently by each community (Star & Griesemer, 1989; Brown & Duguid, 1998). These communities need to represent current and new knowledge and to transform their knowledge to different views. “Boundary objects are both plastic enough to adapt to local needs and the constraints of several parties employing them, yet robust enough to maintain a common identity across sites” (Star & Griesemer, 1989, p.393). Researchers have established that effective boundary objects are tangible, concrete, accessible, and up-to-date (Bechky, 2003; Carlile, 2002), while also providing modularity, abstraction, accommodation, and standardization (Pawlowski & Robey, 2004; Star & Griesemer, 1989; Wenger, 1998).

Boundary objects may be shared information systems (Pawlowski & Robey, 2004; Sapsed & Salter, 2004) or artifacts, prototypes, and documents (Wenger, 1998; Sapsed & Salter, 2004). Star and Griesemer (1989) propose four types of boundary objects. *Repositories* are ordered ‘piles’ of objects accessed by different individuals with different goals. An *ideal type* boundary object is an abstraction, such as a diagram, that by excluding specific details is easily adaptable and easily shared by multiple communities. *Coincident boundaries* are common objects with the same boundaries but different content (e.g. political maps and

physical maps). *Standardized forms* as boundary objects are means of communication and knowledge sharing that use common methods of data collection.

In order to link multiple communities, all four types of boundary objects are inherently situated at the periphery of the communities. Nevertheless, this marginal nature is relative and some boundary objects may be more central to some communities than to others, thus creating political frictions. For instance, Sapsed and Salter (2004) examine project management tools (e.g. timelines, online status reporting tools, and modular roadmaps) as boundary objects in a geographically dispersed project-oriented organization. They found that these tools are a symbol of power and an asset for the negotiation of power relations between centralized and dispersed members. The authors conclude that “tools and objects may be useful as informational support for collaboration [among projects], and may symbolize and sustain agreement between communities. However, they are ‘high-maintenance’ items with a limited shelf life, [and] have no independent potency for alignment” (Sapsed & Salter, 2004, p.1531). Hence, boundary objects may be influenced by such factors as negotiation, interpretation, authority, control, and interdependence because, in spite of their plasticity, they cannot accommodate or standardize everybody’s needs.

Karsten et al. (2001) make an important distinction between boundary objects and conscription devices. A physical object, which facilitates knowledge sharing among projects or communities, may be a boundary object or conscription device depending on the interpreter’s point of view, as the conscription device also provides the means for participating in constructing the knowledge. For example, a map would be a boundary object for regular users, and a conscription device for the county’s surveying office. Ideally, boundary objects provide a basis for perspective-taking and conscription devices for

perspective-making (Boland Jr & Tenkasi, 1995). This distinction is, however, fuzzy in practice because boundary objects are sometimes constantly negotiated, while participation in the construction of conscription devices could be a punctuated or sporadic process. Nevertheless, the main advantage of a jointly created conscription device is that it is more easily accepted by the groups, more usable, more comprehensive, and more detailed (Karsten et al., 2001). Such a tool could prove to be extremely valuable for successful knowledge sharing across projects.

Levina and Vaast (2005) distinguish between designated boundary objects and boundary objects-in-use. The former refers to artifacts that were designated by the management team as valuable for boundary spanning. The latter refers to artifacts that, due to their characteristics, emerged in practice as the common identity of the joint groups. Boundary objects-in-use could be designated but often they are created by the activity of the joint groups, similarly to conscription devices (Levina & Vaast, 2005). Moreover, the same artifact could be a designated boundary object for some groups and a boundary object-in-use for other groups depending on their local usefulness and symbolic capital (Levina & Vaast, 2005). For example, a knowledge-based system could be designated as a boundary object but its usage may not necessarily be as intended. New functionalities could emerge in practice and thus, it is important to examine the social process surrounding the use of the knowledge-based system as a boundary object. Boundary spanners will negotiate and promote the boundary objects across contexts.

2.3. Boundary Spanners

Although boundary spanners may have their own agenda or be limited by temporal and physical constraints, they are considered vital individuals for facilitating the dissemination of ideas across boundaries (Cross & Parker, 2004). They also assume multiple roles to create and manage communication channels for knowledge sharing. They could act as scout, ambassador, sentry, and guard (Ancona & Caldwell, 1992). Other researchers distinguished between representative and gatekeeper, advice and trust broker (Friedman & Podolny, 1992). Pawlowski and Robey (2004) introduced the term 'knowledge brokers', which are external IT professionals positioned in the organization to encourage knowledge sharing across units, whereas boundary spanners are internal employees who create links for internal communication.

The task of boundary spanners is not easy as they need to be competent in multiple domains and are often marginalized within each domain. They do not belong to a particular group; they are on the borders between multiple groups and understand the vocabulary used by all these groups. Ideally they need to have some form of leadership and develop a certain symbolic capital and social network. These will prove to be valuable assets to negotiate the usefulness and use of boundary objects. Depending on the environment, some boundary spanners need to be more technical, while others need to have more people skills.

Similarly to boundary objects, boundary spanners could be nominated or emerge through their actions, with or without nomination (Levina & Vaast, 2005). The act of nomination is neither sufficient, nor necessary for efficient boundary spanning (Levina & Vaast, 2005). For example, in Bechky's (2003) study, the technicians, as a group of individuals, emerge as boundary spanners-in-practice because they were able to understand both the language and

artifacts used by engineers and by assemblers. Apparently the engineers and the assemblers would never have been able to communicate directly. Hence, boundary spanning is a necessary and important organizational competence.

3. Review of Theories

Sharing and integrating knowledge across boundaries can be studied from very different theoretical perspectives, such as the technology adoption models or the information processing theory. The knowledge management literature has mainly focused on the externalization of tacit or situated knowledge (Nonaka & Takeuchi, 1995), the use of boundary objects (Bechky, 2003; Sapsed & Salter, 2004), or the work of boundary spanners and knowledge brokers (Levina & Vaast, 2005; Pawlowski & Robey, 2004).

Drawing on these studies, several criteria emerge for selecting a theory to investigate how knowledge is shared across project boundaries and how the knowledge-based systems, as designated boundary objects, are used in practice.

1. *Knowledge-based organizational change*: The theoretical approach should view organizations as knowledge-based rather than as simple information processing systems. Knowledge is created via specific processes and then it is accumulated over time to generate organization-wide learning. As such, new knowledge may trigger organizational change. The theoretical approach of this research should encompass organizational change as “a process of incorporating new ideas or practices into everyday organizational life” (Hatch & Cunliffe, 2006, p.313).
2. *Social Process*: Use of knowledge-based systems may differ in practice from what was initially intended. The theoretical approach should allow the examination of the social process surrounding IT use. A practice lens that offers the dynamic view of how actors enact structures through IT use is considered necessary.

3. *Work-Practice focus*: As creation, accumulation, and sharing of knowledge may occur at different levels (e.g. individual, project, inter-project, and organizational level), the theory should capture this multi-level view. The unit of analysis should be the work practices, whereas the level of the theory should be the group or the organization.
4. *Socially constructed view of knowledge*: The ontological assumption of the theoretical approach views knowledge as socially constructed.
5. *Stakeholders' perspective*: The research objective needs to be approached from the stakeholders' perspective rather than from the perspective of the IS designers or the IT support team.
6. *Ensemble view of technology*: In line with the other criteria, the theory should allow the researcher to treat the IT artifact as only one element in a larger 'package'. Thus, an ensemble view of technology (Orlikowski & Iacono, 2001) will cast light on how new technologies come to be or on how technologies come to be used.

Several organizational theories satisfy more or less these criteria: socio-cognitive theories (sensemaking, technology frame of reference, narratives), theories of practice and knowing (knowledge-in-practice, collective reflection-in-action, temporal human agency), and organizational learning (routines, improvisations, situated learning). All these theoretical frameworks are social theories explaining organizational change as the human agency exercised in social contexts where 'structures' may either impede or foster change and knowledge sharing.

Rarely used in organizational studies, the social psychology theory of social representations also satisfies these criteria and, as shown later in this section, can be used as the analytical lens for organizational change. Thus, this section will provide a critical review of the other theories of organizational change previously mentioned and then, the social representation theory is elaborated upon given that it is largely unfamiliar in the IS field. The last subsection will compare all the theories and discuss how they satisfy the above criteria.

3.1. Socio-Cognitive Theories

Projects often pass through one or several rough periods when, despite good project management methods and techniques, nothing seems to work. Researchers found that the turning point is usually the development of a shared vision for the project's goals and its implementation process. For example, Engwall and Westling (2004) examine a complex R&D project that experienced a dramatic turnaround and subsequently became structured and effective. Before the sudden change, learning and knowledge sharing were mainly episodic and exploratory; after, the organization shifted toward exploitation of accumulated knowledge. According to the authors, the common search for answers and the collective problem-solving involving various groups (e.g. software and hardware engineers) were the main reason behind the shift. From this perspective, sensemaking appears more like a communication method than an organizational theory (Dervin, 1998). It provides guidance for thinking and talking about the actors involved, the barriers that separate them, and the systems that could serve as efficient boundary objects. As an organizational theory, sensemaking is much more than a communication method and examines how organizations deal with sudden changes in their environment (Weick, 1993). The collapse of role systems or formal structures creates situations that do not make sense anymore. Communication,

improvisation, respectful interaction, and past experience are all sources of collective sensemaking, which may ultimately affect the outcome of the crisis (Weick, 1993).

Drawing upon sensemaking processes, Orlikowski and Gash's technology frame of reference (1994) explains how social interaction affects the actors' decisions and actions. The technology frame represents assumptions, expectations, and knowledge used by organizational members to understand a particular technology and its role in the organization. Differences in the frames of key actors trigger a shift and influence how the actors make sense of the environmental information (Davidson, 2002). Hence, the focus of this theoretical lens is not only technology-related phenomena in organizational settings, but also the negotiation of meaning through social interaction and the sensemaking process that guides the group's behaviour.

At the individual level, we continuously create narratives with the unusual or unfamiliar experiences as we try to construct stories, which make more sense to us (Boland Jr & Tenkasi, 1995). This narrative capability is a cognitive process through which one's sense of self is constructed and maintained over time. Experiences that are not structured as stories are more easily forgotten (Nielsen & Madsen, 2006). Narratives show how stories and events fit within the cultural setting of each individual. In this context, the narrative mode of cognition makes sense of the environment through actual use, social interaction, storytelling, and conversation. The corresponding processes of 'perspective making' and 'perspective taking' develop and reinforce a group's knowledge of a particular domain (Boland Jr & Tenkasi, 1995). As actors continually construct and reconstruct the meaning of their experiences and of their environment, stories are not simple objects but the focus of the process of producing

the story. The quality of the storytelling has a major role in sharing an individual's knowledge and understanding of the events (Boje, 1991).

Storytelling is a powerful narrative mechanism for sharing knowledge as it can share norms and values (Denning, 2000), develop trust and commitment (Engwall & Westling, 2004), share tacit knowledge (Nonaka & Takeuchi, 1995), facilitate unlearning (Brown et al., 2004), increase morale, and create emotional connection (Engwall & Westling, 2004). Although the storyteller's view is limited and its interpretation is generally biased, storytelling is the preferred sensemaking approach among internal and external stakeholders (Brown et al., 2004; Boje, 1991). It follows that the community of knowing is the product of storytelling as well as its medium (Boland Jr & Tenkasi, 1995).

3.2. Theories of Practice and Knowing

Theories of practice are rooted in the works of Giddens and Bourdieu. Giddens' structuration theory (1984) puts forward the idea of *duality of structure and agency*: human action is both enabled and constrained by existing social structures while human action changes these social structures as well. Structures are both the medium and the outcome of action; they are systems of ongoing action that are continuously produced and reproduced over time (Poole & DeSanctis, 2004). Rules and resources provide a social system with meaning (structures of signification), power (structures of domination), and norms/routines (structures of legitimation) (Hatch & Cunliffe, 2006, ch.4). In practice, however, such structures are rather tacit as they are generally defined in cognitive terms such as "memory traces" (Giddens, 1984) and "schemas" (Sewell, 1992).

Given Giddens' emphasis on agency over structure, Bourdieu (1990) introduced the concepts of *field* and *habitus* to emphasize structure over agency. A field is constituted through the practices of its agents, whose actions may also transform it. The habitus allows the agents to know how to behave given the capital they control. Because the habitus operates as the internal logic of a field, it may exist as tacit knowledge among the agents of the field (Hatch & Cunliffe, 2006).

Human agency, defined as the capacity of agents to behave in ways not predetermined by structures (i.e. either by inertia or by transformation) (Sewell, 1992; Chu & Robey, 2008), is a core concept in theories of practice. Such theories attempt to explain why and how patterns of action develop in work practices. For example, studies on knowledge sharing across projects (e.g. Bresnen et al., 2004; Grabher, 2004) found that a high degree of embeddedness creates localized resistance to the introduction of new project practices, even when such practices are imposed by the central authority. Thus, the translation and the transformation of knowledge among projects are influenced by the interplay between organizational structures and existing project management practices (Bresnen et al., 2004).

The IS literature is particularly interested in understanding the impact of IT on work practices (e.g. Orlikowski, 2000; Pawlowski & Robey, 2004; Cousins & Robey, 2005; Baxter & Lyytinen, 2005; Robey & Sahay, 1996). Prior research has shown that the implementation of information technologies for shaping or controlling work practice may lead to a variety of outcomes as the effect is a function of use rather than of the technology per se.

Several variations of the agency-structure relation have been proposed. The adaptive structuration theory (DeSanctis & Poole, 1994) provides guidance on the interaction between social structures, human agency, and the IT artifact. Social structures are usually reproduced

within the information systems, such as group decision support systems or knowledge-based systems, to simulate the structures in actions. The recursive relation between technology and action continuously shapes both of them. The more restrictive the system is, the more limited the number of actions an agent can take to apply the structural features (i.e. Giddens' rules and resources) is. Therefore, information systems induce adaptive structurational processes that can modify over time the rules and resources of the social interaction. The focus should not tend to extreme views of either agency or structure. For example, studies on knowledge management systems that put too much emphasis on the technological structure are unable to explain the individual shifts in action (Saunders & Chiasson, 2004).

Orlikowski's (2000) practice lens highlights human agency in order to understand technology usage. By removing the assumption of stability in adaptive structuration theory, the practice lens offers a dynamic view of how people enact structures of technology use. Technology structures are not external or independent of human agency; they exist as rules and resources and emerge from people's use of the technology as *technologies-in-practice* (Orlikowski, 2000). Thus, agents enact both technologies and structures, reinventing and improvising the use of technologies (Chu & Robey, 2008). As usage is directly influenced by users' understanding of the technology, if work practices change, the technology-in-use changes as well. If technologies are used in new or different ways, which are socially shared and repeated, agents' recurrent and situated work practices also change (Orlikowski, 2002).

With respect to knowledge, work practices generate explicit knowledge, which is expressed in some written or spoken form, and more importantly they generate tacit knowledge, which is non-verbalized, intuitive, and unarticulated. Tacit knowledge is in fact a form of *knowing* whereas *knowledge-in-practice* is the situated knowing continuously enacted through people's

activities in a particular setting (Orlikowski, 2002). Hence, knowing is neither stable nor enduring; it is the result of the situated and ongoing interaction among context (time and place), human agency, and structure (Orlikowski, 2002).

Another structural, practice-based approach is the collective reflection-in-action (Levina, 2005), which argues that multiparty collaborative practice shapes and is shaped by agents producing, sharing, and reflecting on explicit objects (e.g. boundary objects). Depending on their levels of control and power over the various resources of the project and over those developed throughout the project, agents seemed to either ‘add to’, ‘ignore’, or ‘challenge’ others’ work. As such, some of the explicit objects may become efficient boundary objects, while others, less used by some of the agents, may simply become obsolete.

Another extension of the structuration and practice theories is the temporal theory of human agency (Emirbayer & Mische, 1998), which complements the practice lens by explaining how and why practices persist or change over time. Emirbayer and Mische (1998) analyze human agency from the perspective of three temporal elements as agents’ actions are simultaneously influenced by the past (as habits and routines), the future (as a capacity to imagine alternative possibilities), and the present (past habits and future projects constrain the actions at any given moment). Consequently agents’ behaviour and knowledge is continually reinterpreted in response to emergent events. As such, agency is not only social and relational, but also subjective and introspective (Cousins, 2004). Social interaction and communication are essential for exchanges with the social environment, while an interpretive process supports (re)assessment of one’s own meanings.

In sum, researchers have built upon Giddens' and Bourdieu's interpretations of the structuration theory to include other concepts such as technology and time. The adaptive structuration theory explains the emergence of social structures through interaction and use of technologies. Individuals shape technologies as they develop their own style of interacting with the technology; technologies shape the individuals' work practices based on how they are used for sensemaking and other decisional processes. Habits and routines constrain change, while changing practices and improvisations foster change.

Similarly to technologies-in-practice, knowledge-in-practice is the situated knowing continuously enacted through people's activities in a particular setting. It is the tacit knowledge that individuals develop 'by doing' their daily activities. Inherently, what individuals 'know' or 'reflect on' influences their actions and decisions, and the objects they produce and share. Orlikowski's (2000) observation that technology is enacted in practice also applies to IT artifacts and thus they can become boundary objects in-practice. .

Placing less emphasis on the structural properties of technologies, the temporal theory of human agency frames agency in temporal terms as the agents' behaviours and knowledge simultaneously reflect past practices, future possibilities, and present contingencies in order to make sense and act coherently when faced with novel events.

3.3. Organizational Learning Theories

Organizational learning is defined as "an organizational process, both intentional and unintentional, enabling the acquisition of, access to, and revision of organizational memory, thereby providing direction to organizational action" (Robey et al., 2000, p.130). It is an ongoing and pervasive process that may have spillovers at multiple levels (e.g. individual,

group, etc.). However, learning does not necessarily increase effectiveness as organizations may learn inappropriate, ineffective, inefficient, or erroneous behaviours.

One form of organizational learning is learning from experience or learning by-doing. Previous research has shown that while some organizations managed to learn from both successful and unsuccessful projects, others had repeated dysfunctional patterns for at least 15 years (Robey & Newman, 1996). Obviously the organizational and social context of learning have a significant impact (Robey et al., 2000), but the key point is that learning from experience is not easy and should not be taken for granted. The organizational context needs to provide the resources and the opportunities for the group to reflect on its work practices.

Organizational learning is not just the process of learning but also the management of organizational memory, which can be procedural (how things are done) (Cohen & Bacdayan, 1994) and declarative (facts) (Moorman & Miner, 1998). The former involves skills and routines and becomes automatic when individuals access this procedural memory unconsciously. As such, procedural memory often represents individual and organizational tacit knowledge (Moorman & Miner, 1998). Declarative memory includes memory of facts, events, or documents and, in contrast to procedural memory, has a more general use. It provides the basis for making sense out of novel situations or assisting with pattern recognition. Together, declarative and procedural memory, are complementary competencies that build on one another. During the enactment of a routine, their combined effect fosters improvisational learning (Moorman & Miner, 1998). “Improvisation is the deliberate and substantive fusion of the design and execution of a novel production” (Miner et al., 2001, p.314). It is also viewed as a special form of short-term learning in reaction to a change in the

parameters of the routine. In the long-term, improvisations have varied effects on organizational routines (Miner et al., 2001).

To examine whether a routine changes, one needs to link action (or improvisation) and long-term organizational learning. Routines are created and then continuously recreated but people do not reproduce actions and behaviours, each time, in the exact same way. Especially, when the routine is composed of tacit procedural memory, it is practically impossible to re-enact the routine in the exact same way. Therefore, the routine is continuously changing and adjusting to its social context. Learning generates permanent change in organizational routines when improvisations exist and are used for a longer time (Miner et al., 2001).

Some of the actors use the routine because it brings comfort, makes life predictable, and reduces uncertainty; they take advantage of organizational inertia and prefer ephemeral improvisations. In this case, the procedural memory brings organizational stability and changes slowly (Cyert & March, 1963). Other actors take advantage of the learning process and use improvisations to enhance the performance of the routine. Therefore, action generally leads to learning, but learning does not necessarily lead to action (Ford & Ogilvie, 1996). Through a process of selection and retention, the organization harvests the most valued improvisations, stores them as long-term learning, and institutionalizes them as part of the routine. The frequency and the importance of improvising determine in the end the effort to invest in organizational learning (Moorman & Miner, 1998). Additionally, in collaborative settings, a myriad of factors may influence learning such as team stability, authority structures, team leaders, and organizational factors (Edmondson et al., 2001).

Another theoretical approach for studying knowledge sharing is the situated learning theory in communities of practice (Lave & Wenger, 1991; Wenger, 1998). Situated learning is based

on the idea that knowledge is never absolute, but rather dependent on a specific social context. Within communities of practice, social interaction with the purpose of exchanging tacit and explicit knowledge generates learning at the individual level and at the group level (i.e. the community of practice). As novice learners get more involved within the community, they become experienced experts through what Lave and Wenger (1991) call the process of “legitimate peripheral participation”. The downside of this form of knowledge acquisition is that each community develops its own world view based on its values, meanings, assumptions, beliefs, and knowledge sharing practices (Brown & Duguid, 1991). If local knowledge is to be shared across communities, its meaning needs to be translated and transformed (Bechky, 2003). Albeit theoretically possible, Scarbrough et al. (2004) found no evidence of knowledge sharing from the projects to the organization. In this particular setting, project-based learning emerged within the communities of practice but their boundaries made the sharing of knowledge to and from other communities impossible. Thus, there was no effect on organizational learning.

In sum, organizational routines and improvisations as well as situated learning are forms of organizational learning that can generate organizational change through knowledge sharing. Organizational routines, as operating procedures, are “the memory of an organization” (Cyert & March, 1963). Each enactment of the routine contributes to both the procedural and the declarative memory, thus enabling organizational learning. The outcomes of learning from routines may very well range from positive to negative outcomes.

When combined with the tacit nature of a routine and the involvement of several actors, organizational learning fosters improvisation. Thus, using imagination, previous learning, and action, the actors involved with the routine create improvised routines, which may be

maintained and spread within the organization or may disappear through lack of re-enactment. If the improvisations become permanent learning, the corresponding routine changes. If the improvisations die out, they are considered short-term learning and the corresponding routine appears flexible yet persistent.

The situated learning perspective emphasizes the contextual and embedded nature of learning in a specific context. The key concepts of situated learning involve legitimate peripheral participation, contextual environment, and social group interaction. As such, the acquisition of knowledge creates both unintentional and deliberate learning, but it also assumes that local knowledge can be translated and transformed when shared across communities.

3.4. Social Representation Theory

3.4.1. Theoretical underpinnings

Social representation theory developed in Europe around the same time as social construction theory (Berger & Luckmann, 1967) in North America and the two theories possess several similarities. For example, social representations build on shared knowledge and understanding of common reality: the individual does not form his thoughts in isolation but based on collectively shared images of objects (Moscovici, 1984). This means that social representations are not *within* minds of co-acting individuals, but *across* minds; they are simultaneously individual and collective activities (Wagner et al., 1999). Social representations construct a framework of references useful for the interpretation of reality. The differences regard mostly how the social representation is formed.

Representation (or re-representation) of something or someone is the central element of social representation theory. Moscovici defines this act as “a means of transferring what disturbs us,

what threatens our universe [...] The transfer is effected by separating normally linked concepts and perceptions and setting them in a context where the unusual becomes usual, where the unknown can be included in an acknowledged category” (Moscovici, 1984, p.26).

Therefore, the concept of ‘social representation’ was initially defined as

“the elaborating of a social object by the community for the purpose of behaving and communicating” (Moscovici, 1963, p.251)

This definition was later refined as

“the ensemble of thoughts and feelings being expressed in verbal and overt behaviour of actors which constitutes an object for a social group” (Wagner et al., 1999, p.96).

The relation between the object that is represented, the subject that has the representation, and the social group in relation to which the subject is positioned characterizes any representation. If we assume a group of only two subjects (S_1 , S_2), the social representation concerning a particular object O (at that time) may be graphically depicted as a triangle S_1OS_2 (see Figure 3.1). However, no single social representation is stable and accepted by all the members of a group. The group’s pressure and opinions influence its form at any moment in time. Social negotiation, collective sensemaking, or changes in culture shape the representation and its evolution (Moscovici, 2001).

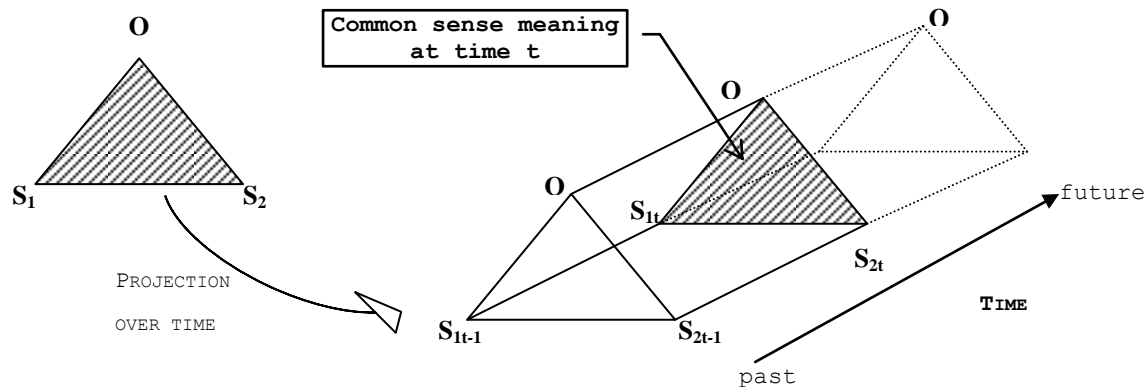

Figure 3.1: A simplified view of social representations (adapted from Bauer & Gaskell, 1999)

The evolution of a social representation can also be interpreted from the perspective of a double system (Abric, 1994b): the core system, which is directly linked to norms and values, and the peripheral system, which is linked to the context and the individual's characteristics. The core system promotes stability and persistence, while the peripheral elements are easily influenced and changed by the collective's opinion. Thus, a group is homogenous if the social representation is articulated around the same core system, even if there is no consensus for all the peripheral elements (Abric, 1994a). This idea is also explained by the process of anchoring and objectification (Moscovici, 1984). Anchoring is a form of 'symbolic coping' (Wagner et al., 1999) and involves naming and classifying novel objects according to an existing system of thought. Objectification strengthens the classification and makes the object tangible by associating it with images, material examples, models or verbal metaphors. In the case of a group, the anchoring system uses the same vocabulary for all members of the group, but the objectification represents the personal interpretation of each member and it may result in peripheral elements to the group's common sense. Furthermore, anchoring and objectification are complementary to one another: anchoring promotes stability or the status quo, while objectification promotes change (Markova, 2000).

In sum, social representations are cognitive structures that connect a subject to an object in a specific context. They are both the result of the socially constructed reality and the process through which this construction takes place in the individual's mind. Consequently, social representation theory is a social constructivist and discursively-oriented theoretical approach (Wagner et al., 1999).

3.4.2. Strengths and limitations

The primary strengths of the social representation theory lie in the functions that the social representations play in order to reduce the unfamiliarity, to provide guidance, to provide an identity, and to justify the actions. The *knowledge* function makes familiar the unfamiliar (Moscovici, 2001), plays a critical role in social communication (Abric, 1994a), and organizes and codifies the social world (Jaspars & Fraser, 1984). The *orientation* (or the guidance) function guides individuals' actions and behaviours (Moscovici, 1984). The *identity* function allows individuals to identify with the representations of their group, "what, if anything, binds people together in a group, society, and makes them act together" (Moscovici, 2001, p.21). The *justification* function provides a justification for specific attitudes and behaviours and explains differences between groups (Abric, 1994a).

Based on these functions, social representations present several advantages for knowledge sharing. First of all, as the sum of common beliefs and a shared vocabulary, social representations foster knowledge sharing by creating a common understanding within groups. The knowledge that is shared is not static (i.e. at a specific point in time), it continuously evolves over time according to the groups' updated representations. Additionally, the processes of anchoring and objectification allow individuals to collectively create tangible definitions grounded in a common understanding that could improve the

sharing of tacit knowledge within and across groups. Databases and project-related documents such as lessons-learned capture only a small part of the total knowledge created throughout the completion of a project. Socially representing project-knowledge moderates the sharing of knowledge across projects as individuals develop a common thinking or a system of classification. Finally, knowledge representation helps group members to handle novel knowledge by grounding it in an existing reference system. Generally, social representations manifest themselves in language but they can also be present in drawings, photographs, films, newspaper articles, etc. (Voelklein & Howarth, 2005).

The theory of social representation has its critics (Voelklein & Howarth, 2005; Potter & Edwards, 1999). Most often they argue that the theory is too broad and too vague and therefore, it is not clear how the concept of social representation differs from other theoretical concepts, such as attitude, norm, belief, stereotype, or social cognition. Moscovici's answer (1998) is that social representations are simultaneously individual (i.e. cognitive process) and collective (i.e. social process), while some of the previous concepts (e.g. attitudes, beliefs) are individual. Misunderstandings with respect to definitions have also resulted from a lack of English translations of social representation theory, which was predominately written in French (Voelklein & Howarth, 2005). Nevertheless Moscovici acknowledges that some overlap exists as social representation theory is not meant to replace existing theories, but to complement them (Moscovici & Markova, 1998). I discuss later how social representation theory is different from other theoretical approaches on organizational change.

3.4.3. Social representation theory in the IS literature

Moscovici's theory on social representations has slowly infiltrated the IS literature, although this theory is particularly suited for investigating research and practice. Researchers who

overtly used social representation theory as their theoretical framework examined the IT professionals' perceptions of job stress and burnout in the context of their work (Pawlowski et al., 2004), how work practices change with IT use (Vaast & Walsham, 2005), or the impact of IT capabilities on work practices (Baxter & Lyytinen, 2005). The advantage of using social representation theory is that it captures the micro level issues, using the work practice as the unit of analysis and the viewpoint of those directly involved. In this sense, it contributes to the emerging stream in the IS literature on the relation between action and cognition (e.g. Davidson, 2002; Bhattacharjee & Premkumar, 2004). By casting light on the different 'logics of action' (Bacharach et al., 1996) that guide the organizational members, the social representation theory may also explain how changes in knowledge management practices affect organizational change.

A recent panel at the International Conference on Information Systems (ICIS 2005) (e.g. Vaast et al., 2006) sought to introduce the concepts of social representation theory and show how it could stimulate research on knowledge sharing, on knowledge management systems, and on other topics in the knowledge management field. While such discussions are commendable, ultimately, more research is needed to further explore social representations. Given their novelty in the IS literature, there is a risk to mislabel them, either by using different names for the social representations or by using the label 'social representation' for concepts that are not in fact social representations. An example of the former may be Orlikowski's (2006) 'scaffolding of knowledgeability', which is defined with respect to the materiality of technological artifacts that structure human agency and knowledgeability over time. Orlikowski describes how knowing in practice is materially scaffolded with technological artifacts because knowing is not only emergent, embedded, and embodied, but

also materially intertwined. Certainly the material properties of any IT artifact are socially constructed. However, if Orlikowski also implies that, technologies-in-practice should be examined from the perspective of both the artifact (e.g. the representation) and its social construction (e.g. the representation process of the group), then the concepts of scaffolding of knowledgeability and social representation seem to have the same meaning.

Another example of a concept that closely resembles social representations is Wagner et al.'s (2002) collective symbolic coping. The authors state that collective symbolic coping is the process through which individuals “develop an understanding, make sense of, or come to terms with [an] innovation” (Wagner et al., 2002, p.324). It is unclear how collective symbolic coping differs from social representation and the authors’ argument that, contrary to social representations, collective symbolic coping applies only to “well-circumscribed technological innovations” seems insubstantial as it contradicts Moscovici’s interpretation of social representation theory.

3.4.4. Social representation theory vs. other theories on organizational change

Social representations address issues also tapped by other theoretical concepts such as culture, common sense, mediating structures, common knowledge, habitus, shared cognition, mental models, etc. (Lahlou, 2001). However, the theory of social representations is especially relevant for describing social issues in continuous evolution because it takes into account the relationship between social construction and individual thought and behaviour (Lahlou, 2001). This section will review differences and similarities between social representation theory and other theories on organizational change previously addressed (see

Table 3.1). The section concludes with a discussion on how well these theories satisfy the six criteria established for the theoretical lens of this study.

Table 3.1: Overview of the four theories examined

<i>Theories</i>	<i>Examples</i>	<i>Level</i>	<i>Focus</i>
Socio-Cognitive	Sensemaking	Individuals within groups (community of knowing)	Communication process
	Technology Frame of Reference	Group	Negotiation of meaning through social interaction and interpretation in sensemaking
	Narratives	Individual cognition and group communication	Communication process
Theories of practice and knowing	Knowledge-in-practice	Work practice or social practice	Enactment of knowing through everyday and ongoing activity in a particular setting
	Collective Reflection-in-Action	IT-use practice	Patterns of collaboration in multiparty IS projects
	Temporal Human Agency	Individual	Agents' behaviour concurrently influenced by past practices, future possibilities, present contingencies
Organizational Learning	Routines and Improvisations	Work practice	Impact of short-term changes in routines on long-term organizational learning
	Situated learning	Individual, Group (community-of-practice)	Learning within and across communities, as knowledge is situated in its context
Social Representation		Individual, Group, Work practice	Shared knowledge and understanding within a group, to interpret reality and guide behaviour

➤ **Compared with socio-cognitive theories**

With respect to sensemaking, 'communities of knowing' support integration of distributed cognition by emphasizing the communication process (Boland Jr & Tenkasi, 1995). In contrast, social representations focus on the actual representation and the process of

representing at the social level of the community rather than exclusively at the individual level (Vaast & Walsham, 2005). An example is Engwall and Westling's (2004) study of a poorly-performing project that had a sudden change. The authors draw on sensemaking and claim that the turnaround is due to the emergence of the participants' shared conceptualization of the project mission. A social representation interpretation argues that the turnaround is due to changes in the peripheral elements of the individual representations and to the subsequent emergence of a common core system at the group level. The group reached a homogenous representation of the unfamiliar events. Thus, in social representation theory, the 'peripety' (the moment of sudden change) is seen as a series of adjustments in the social representations of the group rather than the "converging moment of collective sensemaking where theory about future actions as well as experiences from present demonstrations were assembled at the right moment in time" (Engwall & Westling, 2004, p.1571).

Similarly to social representations, technology frames of reference (Orlikowski & Gash, 1994) focus on negotiation of meaning through social interaction and on interpretation in sensemaking with the purpose of guiding behaviour. Inconsistencies in the frames make it difficult for actors to understand each other and hence, it affects the use of the technology (Davidson, 2002). Thus, technology frames are used as an explanatory theory for technology phenomena in organizational settings. Social representation, on the other hand, is a broader concept that includes any 'unfamiliar' socio-cognitive phenomena. Social representations complement a technology frame of reference approach by allowing the researcher to examine at the micro-level how the frames emerge and evolve over time and how cultural values affect this evolution.

In narrative theory, individuals socially construct knowledge by hearing and telling stories. Organizational members continuously construct and reconstruct the meaning of their environment using divergent narrative accounts (Boland Jr & Tenkasi, 1995). This is similar to the social constructivist approach of social representation theory but the difference lies in the focus of storytelling, namely the communication process rather than the development of a common meaning (i.e. the social representation). Moreover, such narrative accounts may be efficient for sharing knowledge within groups but, according to Bechky (2003), they may also raise issues when sharing across boundaries.

➤ **Compared with theories of practice and knowing**

Structuration-based theories emphasize the reciprocal relationship between individual-level agency and group-level (or organizational-level) social structures. Therefore, similarly to the social representation theory, theories of practice and knowing view reality as an inter-subjective construction and provide interpretations that link individual action (e.g. adoption and use of a knowledge-based systems) to enabling social structures (e.g. decision to implement a knowledge-based systems, norms and guidelines for managing projects) and to group-level outcomes (e.g. common vision, specific patterns of collaboration). Additionally, such theories can provide insights into the interactions that take place at multiple levels: individual, group, and organization. Another common point is between social representation theory and the temporal theory of human agency, as both take into account the past to understand the actions and decisions in the present (Wagner et al., 1999).

In contrast to theories of practice and knowing, social representation theory is not only located between structures and individual, but also infuses both of them, regulating and organizing their functioning (Raudsepp, 2005). Through the process of representing, social

representations focus on the dialectics between representer and represented (Vaast et al., 2006). Thus, the practice lens can be enriched with more detailed insights provided by social representation theory. In other words, social representation theory complements the practice lens, without replacing it.

➤ **Compared with organizational learning theories**

With respect to organizational learning theories, the aim of social representations is not to create knowledge but to create a common understanding about the represented object. This implies that the two theoretical perspectives have different aspirations. For example, learning and knowledge creation from one level could not only be shared with other levels but also interfere with learning from other levels (Baxter & Lyytinen, 2005). The theory of social representations is more appropriate to capture this aspect.

Similarly to dualities found in organizational routines (Feldman & Pentland, 2003; Miner et al., 2001), social representations can be stable and changing, rigid and flexible, consensual and individualized (Abric, 1994a; Markova, 2000). They are formed and transformed in social practice, but their purpose is totally different from that of the routines. They provide a mental framework for the purpose of behaving and communicating.

The idea of negotiation and development of a shared meaning situated in a social context is common to both situated learning theory and social representation theory. Both theories view shared knowledge as dynamic and fluid (Vaast & Walsham, 2005). However, social representations focus on the common knowledge within a social group, whereas situated learning focuses on the work practice as an integrated process including discourse. Thus, social representations provide a more micro-level interpretation of boundary objects, translation processes, and transformation processes (Vaast & Walsham, 2005).

Knowledge sharing across project boundaries could thus be examined from all these perspectives. At the beginning of this section, six criteria were identified for the theoretical lens of this study: knowledge-based organizational change, social process, work-practice level, socially constructed view of knowledge, stakeholders' perspective, and ensemble view of technology. While all the theories discussed meet most of the criteria and are suitable for the purpose of this study, the main differences involve the level of analysis and the level of theory. As shown in Table 3.1, the differences in focus and level would provide different results and different interpretations of these results. Thus, social representation theory offers the best fit. Rather than replacing the other approaches, the social representations complement and enrich them with micro-level details.

4. Research Methodology

This section presents the research paradigm under which this research falls and the research design. With regard to the research design, I describe the case study design, the data collection procedures, and the data analysis procedures.

4.1. Research Paradigm: epistemological and ontological assumptions

Researchers should clarify the essence of their enquiry by explicitly stating their ontological and epistemological assumptions. In pre-paradigmatic or in multi-paradigmatic disciplines, such as IS, it is important to specify the assumptions under which the researcher operates (Vaishnavi & Kuechler, 2004). Ontology concerns assumptions about the reality of the phenomenon under study, while epistemology is concerned with ways of knowing the phenomenon under study (Mason, 2002). Depending upon the researcher's perspective, the reality may be perceived as either objective or subjective. In fact, the two concepts may also be seen as extremes on a reality continuum. Objectivists believe that reality is independent of their actions and they only react to emerging events. Subjectivists, on the other hand, believe that reality is constructed as a social collection of subjective interpretations.

In organization theory, the main epistemological perspectives are positivism, interpretivism, and postmodernism (Hatch & Cunliffe, 2006). Adopting one of the perspectives holds important implications about how the reality is created and described. In a positivist view of the world, truth can be objectively identified and measured in order to discover fixed

relationships (Orlikowski & Baroudi, 1991). Reason, truth, and validity are the fundamental values of a positivist epistemology. Researchers will develop theoretical propositions that are then measured as objectively as possible in order to provide an accurate explanation of the reality.

The interpretivist epistemology assumes that knowledge about the reality can only be constructed through the eyes of the social actors. Therefore, there will be multiple interpretations and understandings of the reality and they cannot be measured, nor used to make predictions. Researchers seek to separate their interpretations from those of their subjects through self-reflection but their bias is never completely eliminated (Hatch & Cunliffe, 2006).

Postmodernism is based on the rejection of ideas from both positivism and interpretivism. Knowledge is not an accurate description of 'Truth' and cannot be because the reality is not independent of the social actors. The development of knowledge is a 'power play' and researchers challenge the sources of power in order to expose such concepts as oppression, resistance, domination, marginalization, or destabilization (Hatch & Cunliffe, 2006).

According to these definitions, the current study of knowledge sharing practices across projects aligns with a subjective ontology and an interpretivist epistemology. Consistent with others' view of knowledge (Nonaka & Takeuchi, 1995), I view knowledge as subjective because knowledge does not exist independently of people's experiences and it develops through social interaction and social construction of meaning. The subjective and context-dependent nature of knowledge implies that interpretations of reality depend on individual perceptions and on a number of influences that may operate within the social context.

Moreover, I assume that the knowledge-based system is an artifact, with a specific purpose, and it remains open to interpretations during its usage.

Interpretive research plays an important role in the IS literature (Klein & Myers, 1999; Walsham, 1995) by emphasizing that meaning is embedded in social interactions, context, and artifacts. As individuals produce multiple interpretations and understandings, the organizational reality is the product of social interaction and collective negotiation. Interpretive research methods within the IS field seek to uncover the meanings people create by understanding the process through which the IT artifact influences and is influenced by that context (Klein & Myers, 1999). Studying social process within an interpretive paradigm is extremely useful because it can capture complex and dynamic social phenomena that are both context and time dependent (Orlikowski & Baroudi, 1991). Given this study's objective to examine knowledge sharing across projects, which could be either closed (completed projects) or active (ongoing projects), the selection of an interpretivist paradigm is an appropriate fit. Positivist methods would not have allowed the researcher to closely interact with the informants in their own environment or to get an intimate understanding of how the subjects socially constructed their reality. Additionally, the development of a theory regarding the knowledge-sharing representations through the use of IT artifacts requires a deeper understanding of the context than positivist methods can provide (Orlikowski & Baroudi, 1991).

The interpretive paradigm, however, is not perfectly homogenous. Orlikowski and Baroudi (1991) distinguish between 'weak' constructionist and 'strong' constructionist, depending on the role assumed by the researcher in his investigation. The weak constructionists see interpretive research as complementing positivist research, whereas strong constructionists

adopt a more extreme stance and claim that interpretive research should replace positivist research. My position, as a researcher, is to seek fit between the research questions and the research paradigm. While I see positivist and interpretive methods of equal status, I believe that the issues under study better fit an interpretive approach. Hence, my beliefs can be labeled as ‘moderate’ as I reject both stances and I position this research somewhere in between the two stances. The need to develop a more detailed view of knowledge sharing practices across boundaries can only be satisfied with a qualitative study because it allows the researcher to discover nuances (rather than general rules) in complex settings. Nevertheless, the findings of this study could be empirically tested and generalized to theoretical propositions by future research.

4.2. Research Design

The purpose of this study is to develop a theory that enhances our understanding about the use of knowledge-based systems to share knowledge across project boundaries. I seek to understand how mechanisms for knowledge representation form and change rather than test a particular theory. While the literature on knowledge sharing as well as the theories on organizational change provide a good foundation, I believe that project boundaries erect additional barriers to knowledge sharing that make this phenomenon less understood and the existing theories less appropriate. Hence, confirmatory research designs that focus on testing and prediction appear premature for the moment. In contrast, research designs aiming at building theory combine both deductive analysis, based on research and existing theories, and inductive analysis of empirical data (Miles & Huberman, 1994).

The choice of a research strategy is not independent of the elected research paradigm. According to my interpretive position, a naturalistic approach, rooted in a natural setting where the researcher attempts to “make sense of, or to interpret, phenomena in terms of the meanings people bring to them” (Denzin & Lincoln, 2000, p.3) is necessary. The desire to understand complex social phenomena renders laboratory or quasi-experimental designs less suitable to the task at hand. Moreover, a survey design would not allow the exploration of the intra-project dynamics and the role of representations in the project’s progress. Had my interest been to measure each group’s social representation, I could have also used quantitative research methods (Breakwell & Canter, 1993; Doise et al., 1993).

Given the nature of the research questions (i.e. ‘how’ questions), the lack of control of behavioural events, and the high degree of focus on a contemporary event (i.e. knowledge sharing practices and representations of the project team), an exploratory case study is the most appropriate research strategy (Yin, 2003).

4.2.1. Case study design

The case study is “an empirical inquiry that investigates a contemporary phenomenon within its real-life context, especially when the boundaries between phenomenon and context are not clearly evident” (Yin, 2003, p.13). This approach is extremely useful given that the research question requires an in-depth investigation and that the phenomenon can only be studied from inside the context in which it occurs (Dubé & Paré, 2003).

Miles and Huberman (1994) distinguish between tight and loose research design. Loose designs are preferred when the conceptual framework of the study emerges inductively from the field during the study. Thus, meaningful actors and settings cannot be selected before the

fieldwork, while instruments can only be developed based on the settings and actors selected. In contrast, tight designs are suitable for well-defined constructs in confirmatory studies. Most qualitative studies however, fall between these two extremes. At the outset, the researcher has some conceptual framework but not enough for a theory. Additionally, the researcher has a rather clear idea of which settings and which actors he needs to examine in order to clarify parts of a particular complex phenomenon. In line with Miles and Huberman's recommendations, this research design lies somewhere in the middle, maybe slightly toward the structured end. Therefore, the design is case-sensitive but can also yield comparable results.

Finally, this research is conducted as a single case study, which is consistent with the study's ontological and epistemological assumptions (Mason, 2002). A single case design is preferred when the aims are to extend emergent theory and to understand the dynamics more deeply (Eisenhardt, 1989). Although several natural groups are compared and contrasted as advocated by social representation research (Gal & Berente, 2008), this is not a multiple-case study because all the groups belong to the same context or case. The loose nature of the design will allow me to examine each group first and then to group them and to synthesize the results across groups. Consistent with the interpretive perspective adopted, no a priori framework is imposed upon the data. An inductive approach is used to examine each group, to write an individual group report, to look for supporting and contradictory evidence to the existing theory, to conduct the analysis across groups, and then to write the final report (see Figure 4.1). Similarly to a cross-case analysis in a multiple-case study, the analysis across groups deepens the understanding of the phenomenon and strengthens the theory being built (Miles & Huberman, 1994).

Next, the data collection and analysis procedures are explained, drawing heavily on guidelines and recommendations from Eisenhardt (1989), Miles and Huberman (1994), and Yin (2003).

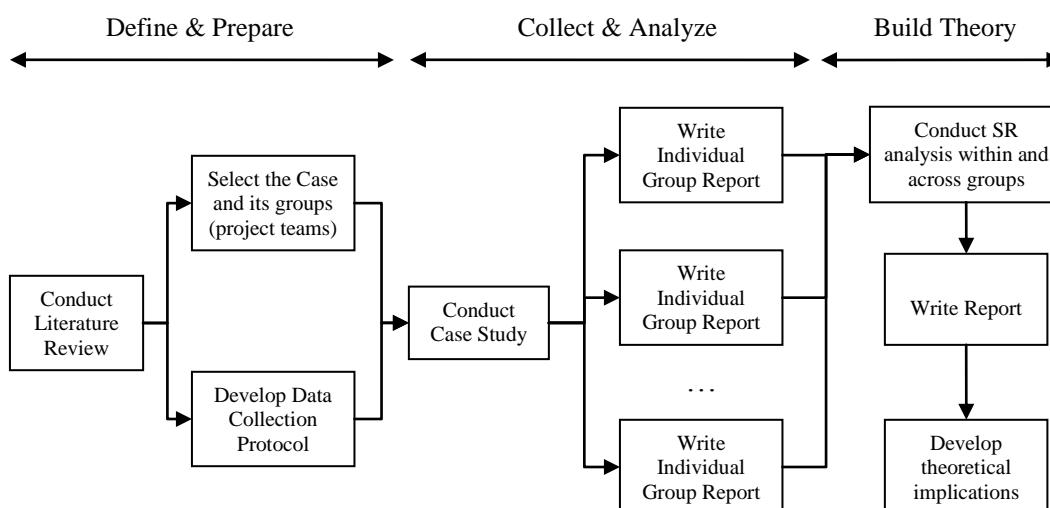

Figure 4.1: Framework of the case study research design (adapted from Yin, 2003, p.50)

4.2.2. Data collection procedures

➤ Unit of Analysis

Using social representations as the theoretical framework guiding the data generation process implies collecting data at the individual level and making inferences at multiple levels (e.g. individual, project team). Thus, the unit of analysis is the project team and its work practices for sharing knowledge. Work practices are defined as “the recurrent, materially bounded and situated action engaged in by members of the community” (Orlikowski, 2002, p.256). Focusing on work practices is a significant unit of analysis to investigate IT use (Orlikowski, 2002). Work practices pertaining to IT capabilities can be cognitive, representational, relational, and material (Baxter & Lyytinen, 2005). These dimensions are neither mutually exclusive nor independent of each other. For example, representational practices are interrelated with cognitive practices and they may refer to knowledge representation (e.g.

Boland Jr & Tenkasi, 1995) or to problem representation (e.g. Bolloju et al., 2002; Speier & Morris, 2003).

➤ **Case and group selection**

The selection of the case and the number of groups to examine within this case were made on conceptual grounds (Miles & Huberman, 1994), based on their theoretical usefulness rather than randomly or to ensure representativeness (Eisenhardt, 1989; Yin, 2003).

Medium or large organizations usually have more resources to implement formal knowledge sharing strategies. Thus, the case study focuses on one such organization and the reason is twofold. First, they usually have simultaneous, on-going projects and that may significantly reduce the duration of the data collection. Second, keeping constant the organizational environment, neither the governance model nor the cultural values are potential confounds in the analysis across groups.

The choice of projects was decided by the host organization and I had little input into it. Nevertheless, the projects had to respect certain characteristics:

- The project team involved more than three individuals;
- The project team used a knowledge-based system to share knowledge within the project or across projects;
- The project would benefit from applying knowledge shared by other projects;
- The project team saw benefits from sharing knowledge with others.

Similarly to an interpretive multiple-case study, it is generally difficult to determine, a priori, the number of groups (project teams) (Yin, 2003) to examine. Other issues such as sampling

logic and sample size are also irrelevant (Yin, 2003). Thus, the number of groups is a matter of judgement, closely related to achieving theoretical saturation.

In terms of knowledge-based systems, any IT system that stored knowledge and could span project-boundaries was suitable for this research. Such systems could have included knowledge discovery tools, collaboration tools, distributed learning tools, knowledge mapping, knowledge repositories, etc.

Finally, without claiming generalizability to any type of project or even to any project-based organization, the case selected had to be theoretically relevant but also fairly representative for the nature of this study. Although representativeness is usually associated with positivist theory testing, it also serves the purpose of interpretive researchers, especially for face validity.

➤ **Procedures and Data Sources**

“Social representation researchers *observe talk and action* which is related to a social phenomenon or object” (Wagner et al., 1999, p. 96) [italics added]. Thus, the rationale supporting the generation of data arises from the exploratory nature of the research questions as well as from the traditions associated with social representation theory. A mix of qualitative methods was used: interviewing, non-participant observation, and archival data. Table 4.1 is an overview of the methods and the data sources.

Table 4.1: Linking research questions and methods

<i>Research Questions</i>	<i>Data sources and methods</i>	<i>Justification</i>
<i>How do project team members create, maintain, and transform knowledge, which pertains both to individual cognition and to social knowing, using knowledge-based systems?</i>	<ul style="list-style-type: none"> • Project Managers, Team members: interviews • IT Support group: interviews • Project Managers and Team members: Non-participant observation • Organizational documents (paper-based and electronic files): discourse analysis 	<ul style="list-style-type: none"> • Interviews to identify the list of knowledge-based systems. • Interviews to identify the groups' representations • Observation of meetings and working sessions to reveal practices involving tacit knowledge • Documents might reveal rules and procedures justifying certain practices or the existence of 'tacit' practices.
<i>How is knowledge represented in the stakeholders' behaviour as well as in the boundary objects?</i>	<ul style="list-style-type: none"> • Organizational-level managers, Project Managers, Team members: interviews • Organizational-level managers, Project Managers, Team members: Non-participant observation • Organizational documents (paper-based and electronic files): discourse analysis 	<ul style="list-style-type: none"> • Interviews to identify the list of knowledge-based systems as boundary objects. Focus on history, emergence, content, and current usage. • Observation of meetings and working sessions to reveal opinions about specific boundary objects and practices involving their usage. • Documents might reveal additional uses of the knowledge-based systems (or its artifacts) as a boundary object.

The primary method was semi-structured personal interviews (structured interview items and unstructured response possibilities) with key informants such as project team members and organizational-level managers. Individual informants were chosen based on theoretical or purposive sampling and the sampling procedure evolved with the needs of the research. Additionally, a snowball sampling strategy was used as informants were asked at the end of the interview to identify other knowledgeable individuals. The snowball strategy is particularly beneficial to inductive, theory-building analysis (Miles & Huberman, 1994).

Ideally, all the members of the project team – although the unknown size of the project was sometimes an impediment – as well as key informants at the organizational level were interviewed. The generic interview guide is outlined in Appendix A. The questions were open-ended at the beginning and they focused on more specific issues as the data collection progressed.

Another method used was non-participant observation of regular activities, relevant meetings, working sessions, and training sessions. To get a deep understanding in the field, I was at the site for a sustained period of time (about 6 months).

Field notes and written documentation (project documentation, reports, newsletters, memos, PowerPoint handouts) related to the research questions were also examined using techniques similar to discourse analysis (Piette & Rouleau, 2008). The underlying logic is that the written text in various documents is not abstract, but purposeful and the words actually have a meaning in a particular historical, social or political context. For example, to validate the groups' social representations of knowledge sharing, I also looked at some of the documents created to see what was mentioned and what was omitted (on purpose or not); what images, expressions or terms were used to get the reader's attention; what concepts were emphasized or de-emphasized; and how the message was framed in terms of power relations. My intentions were not to conduct a discourse analysis of the examined groups' discourse but to use discourse analysis techniques to clarify aspects from interviews and observations.

The data collection stopped when theoretical saturation was reached. All three methods (interviews, observation, documents) initially focused on the themes emerging from the literature review (see Appendix A). The method triangulation not only cross-checked the validity of the findings, but also provided multiple perspectives of the same phenomenon so

that new concepts could emerge and strengthen the theory-building. Additionally, social representation researchers (Breakwell & Canter, 1993; Wagner et al., 1999) advocate the use of multiple methods for investigating social representations.

4.2.3. Data analysis procedures

The data generation and the data analysis were mainly done in parallel so that the two processes could inform each other (Mason, 2002). The analytic strategy was composed of four phases. The first phase was the pre-analysis. All interviews were transcribed as text for detailed analysis with the specialized software NVivo8². Field notes were also summarized in short write-ups and analyzed in NVivo8. Moreover, for each interview and document, I created a contact summary form (see Appendix B) and a document summary form (see Appendix C) respectively (Miles & Huberman, 1994). The purpose of these summary forms was to provide an early synthesis of newly discovered aspects, issues to clarify, forgotten issues, and other important issues to remember while collecting data.

In the second phase, a coding scheme from the transcripts and field notes was developed to analyze the data for valid inferences (Strauss & Corbin, 1998). This coding scheme reflected both new constructs and existing constructs identified in the literature (see the categories from axial coding in Appendix D). Thus, the coding scheme was finalized after the data collection so that I could remain open-minded and context-sensitive during the data collection.

In the third phase, axial coding was used to link subcategories to themes and make connections between categories (Strauss & Corbin, 1998). Finally, selective coding

² Available at: http://www.qsrinternational.com/products_nvivo.aspx

integrated all the analysis previously done to create the storyline (Strauss & Corbin, 1998). This was done by selecting each category and systematically verifying it against the other categories to validate their relationships and to identify categories that needed more refinement. The iterative process of literal, interpretive, and reflexive reading of the data transcripts also provided consistency for the coding (Mason, 2002). Additionally, a few key informants double-checked the descriptions from each group examined.

After the groups were individually analysed, the last phase of the analytic strategy was the analysis across groups. Specifically, based on theme codes identified in the data, I looked for similarities or contrasts between groups and I sought an alignment of themes with relevant social representations. The generation of data at the individual level is consistent with the theoretical lens of social representations in which knowledge-sharing representations are examined from the actors' viewpoint (Pawlowski & Robey, 2004).

5. Case Description

5.1. TechProject

The research site, given the pseudonym TechProject, was a state governmental agency in United States. Established by the state legislature in 2000, TechProject's role was to deliver secure, reliable technology services and solutions to 120 state agencies.

Specifically, TechProject's responsibilities were:

- to oversee governmental IT projects costing more than \$1 million;
- to establish the enterprise architecture for the state to support interoperability;
- to establish policies and standards for technology and security;
- to coordinate IT purchases consistent with established policies and standards;
- to facilitate a state wide strategic planning with regards to the state's information systems and telecommunication networks.

TechProject's organizational structure (see Figure 5.1) was composed of a 12-member board of directors, a chief information officer, four divisions (Human Resources, Finance, Operations, and Technology Planning) and several offices (Executive Director, Office of Communications, Chief Technology Officer, etc.). There were also three Project Management Offices that provided project management guidance and coordinated each group's projects. The three groups (see shaded boxes in Figure 5.1) were given the pseudonyms: *External* projects (responsible for projects with other state agencies, external to

TechProject), *Internal* projects (responsible for internal projects at TechProject), and *Technical* projects (responsible for any project, especially external, that had a major technical component). The Operations division also supervised the *Solution Development* group (see shaded boxes in Figure 5.1).

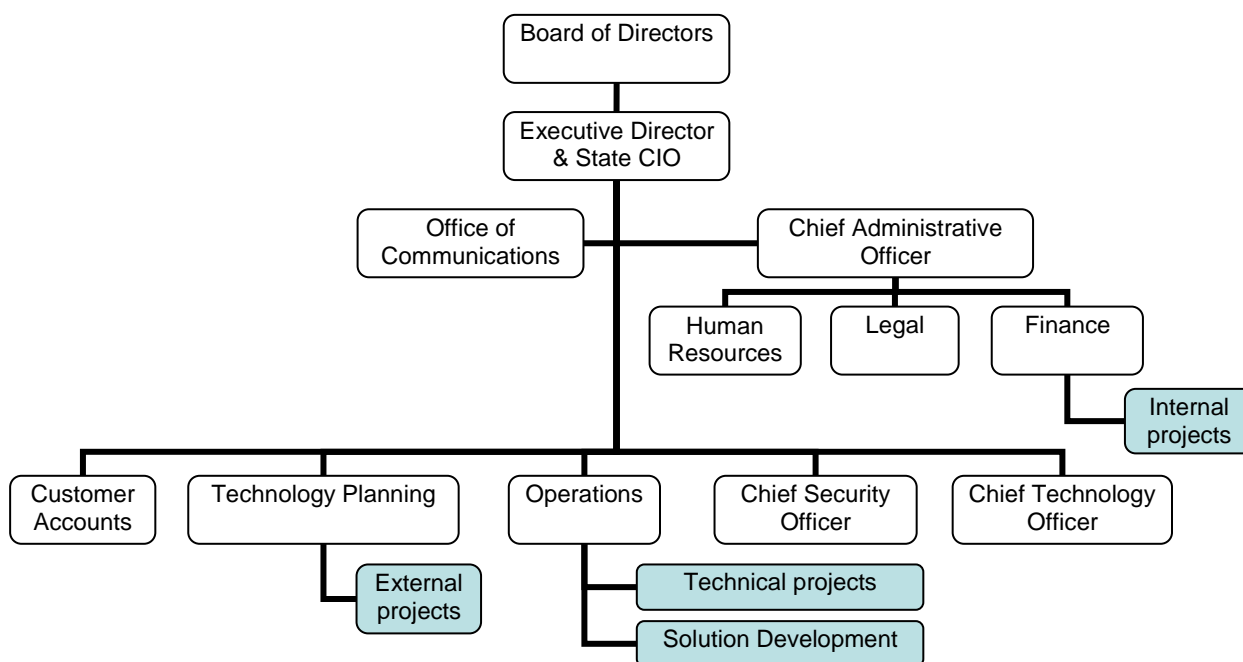

Figure 5.1: TechProject - Organizational chart (Business Plan Update – May 2007, p.18)

The primary criterion for selecting TechProject was its potential to support an investigation of knowledge sharing practices across boundaries and not because it was a representative or a typical case. In other words, several characteristics of this research site confirmed my criterion of theoretical sampling (see section “4.2.2 Data collection procedures”):

- TechProject oversaw various IT projects (including projects over \$1 million) involving collaboration and coordination among state agencies. Consequently, data and information needed to be shared among several individuals and across multiple boundaries.

- According to its IT Strategic Plan 2004-2006, TechProject's guiding principles included effective communication among internal groups to "succeed together". Hence, the agency did not perceive the integration of knowledge as being detrimental to its activities.
- TechProject intended to facilitate "cross-boundary information sharing" by leveraging IT within and across state agencies through shared applications, services, and processes.

"The need to share information and link various systems has been identified by agency staff at all levels: agency heads, program directors and IT directors. This includes efforts that connect programs within agencies, across agencies, and among local, state and federal governments." (IT Strategic Plan 2004, p.4)

- At TechProject, several knowledge-based systems were regularly used to support knowledge contribution and knowledge seeking, such as Microsoft SharePoint, Microsoft Project, shared drives, and emails.
- In line with its organizational principles to add value and to act as responsible stewards of public funds, TechProject's project managers sought to practice proper project management techniques to ensure that projects were completed on time and on budget. Project managers were encouraged to become certified Project Manager Professionals (PMP[®])³. Additionally, TechProject's top management audited the projects to make sure they followed the methodology recommended by the Project Management Institute (PMI). They even customized the PMI's Project Management

³ The [PMP[®] certification](http://www.pmi.org/prod/groups/public/documents/info/PDC_PMP.asp) (http://www.pmi.org/prod/groups/public/documents/info/PDC_PMP.asp) is offered by the Project Management Institute[®] (PMI). To be eligible, applicants with a baccalaureate degree must have 4,500 hours leading and directing project tasks and 36 months of project management experience. Afterwards, PMPs must comply with the Continuing Certification Requirements by developing their professional knowledge and participating in various professional activities every year.

Body of Knowledge (PMBOK®) Guide to present the methodology with specific examples from their own projects and with screen shots and guidelines for their own applications.

To obtain entry to this research site, I talked to directors and unit directors from the External projects group, within the Technology Planning division, and they authorized the interviews and non-participant observation of relevant meetings. In return, they asked for monthly status reports of the data collection and a final report synthesizing the results. They also recommended the ‘Enterprise Integration (EI) Program’ as the focus of the case study and introduced me to the Executive Project Director of the EI program and to other unit directors. Thus, I began the interviews at the highest level, allowing me to grasp the overall picture of the EI program before getting to the details.

5.2. The Enterprise Integration (EI) Program

Following the lead of the federal government, TechProject and other state agencies identified the need for an enterprise architecture framework, which was both a technology planning process and a blueprint to guide the design and implementation of future systems. The state’s computing environment was a complex mix of legacy, customized, third party, and standardized components and code. While developing a unified IT infrastructure was challenging, an enterprise approach presented opportunities to reduce redundant components, increase efficiency and make the infrastructure more robust and secure. Many other states (e.g. Missouri, Arizona, North Carolina) already had an enterprise architecture supporting across-agency collaboration but TechProject took it a step further. According to one of the Executive Project Directors, the state would be “*one of the very first states in the nation to*

[share data across agencies] once we get going full force". The big goal was to get the 120 agencies integrated one day. Sharing data among the agencies was essential in order to offer a seamless service to citizens. A few examples of such integrations included:

"...integrated child welfare information and case management activities among the Department of Human Resources, the courts, the Department of Juvenile Justice, schools and the Medicaid program in the Department of Community Health; or sharing of information in the criminal justice area among state law enforcement agencies, the courts, the Department of Corrections and the Board of Pardons and Paroles." (IT Strategic Plan 2004, p.6)

Despite some unique needs, the six communities of interest (education, health and social services, economic development, public safety, finance and administration, legal and regulatory) shared similar expectations: access to information, a balance between privacy and security, and a stable infrastructure. The barriers were funding, technology, and staffing. Hence, expertise acquired for a specific integration was helpful to the other integrations.

The EI effort was structured as a program, which meant managing multiple – albeit related – projects. In other words, each integration was viewed as a project, with a definite beginning and end, whereas the program was the collection of all projects and the end was less clear (e.g. when all agencies are integrated). The EI program was managed by the Program Manager, assisted by the Program Lead and the Program Coordinator. Project Managers were assigned to each project, while the development team was responsible for all the projects (see Figure 5.2).

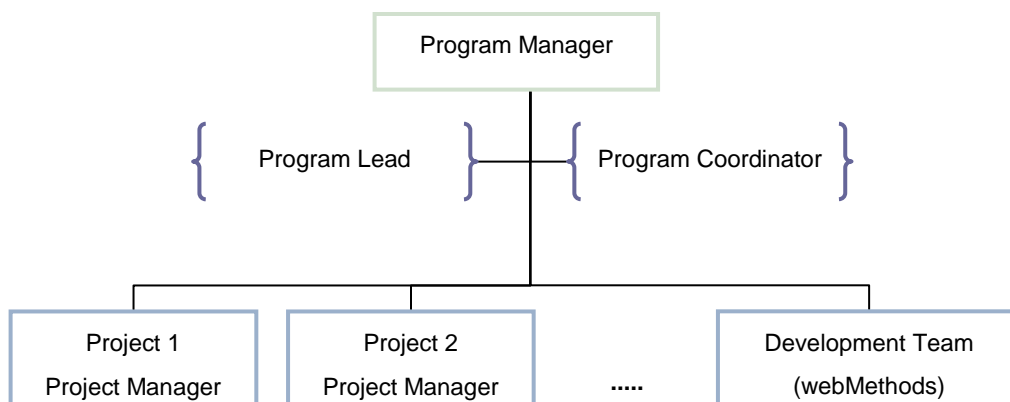

Figure 5.2: Enterprise Integration Program - organizational chart

The Program Manager's main responsibilities were to ensure that the program ran smoothly, to advise the project managers on the different projects within the program, and to report the project status to senior executive officers and managers. The project managers worked in close collaboration with the agencies, the development team, and the IT vendors. Generally, the project managers got the project initiated, defined the needs, and designed a solution. Then, they took care of the execution by controlling and monitoring the project.

The development team, common for all projects, was responsible for implementing and supporting the various solutions. For the technical integration, TechProject's management chose the webMethods Integration Platform (recently acquired by Software AG). Based on the hub-and-spoke model in which all applications are connected through a central server, agencies were able to integrate packaged applications, custom software, and legacy programs for use across agencies. Thus, the development team could incorporate or create applications as web services, build on the service-oriented architecture, and guarantee standardization across projects.

Although the EI program was chosen by TechProject's top management team, it satisfied the general criteria stated in section "5.2.1. Data collection procedures":

- The program was clearly challenging and required the project teams to collaborate with each other. Each project team was composed of more than three individuals.
- Being part of the same organization, all the teams were expected to conform to the same organizational standards, rules, and guidelines. They all benefited from the same technological infrastructure and support. The teams regularly used various tools (Microsoft SharePoint, Microsoft Project, shared drives, email, instant messaging, etc.) to exchange information and knowledge.

The EI program offers a good research setting for studying knowledge sharing across project teams but also across groups based on the divisional affiliation of the members (see Figure 5.3). Although my intention was to study knowledge sharing across project boundaries, the analysis of the data collected showed a much more interesting view of knowledge sharing across groups based on divisional affiliation.

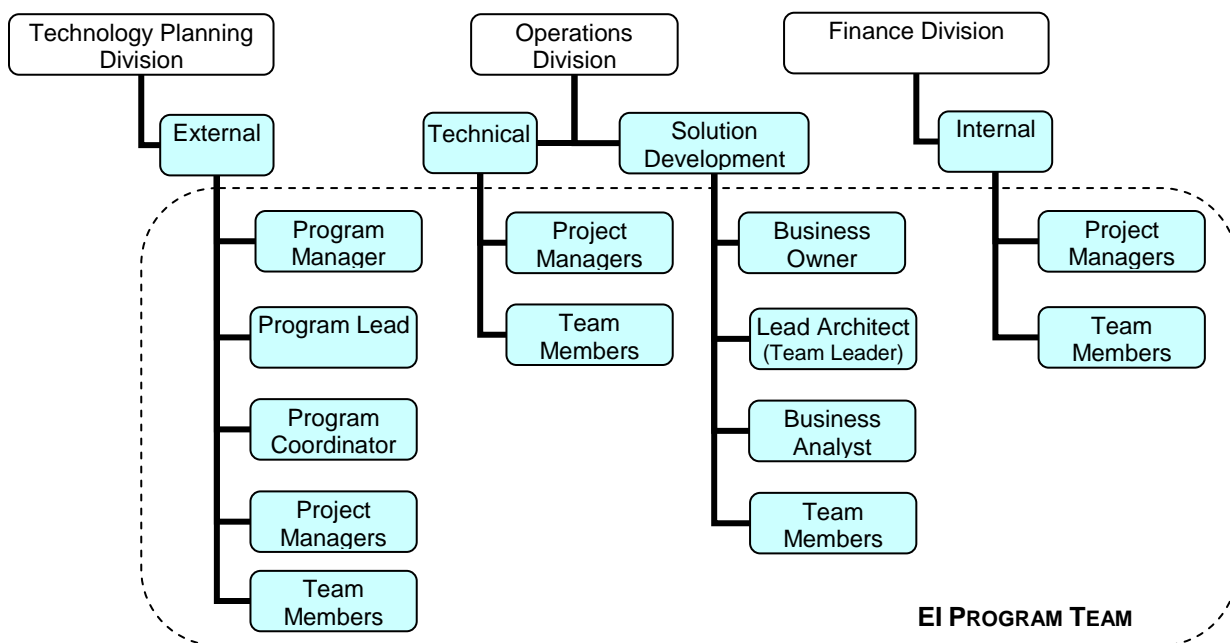

Figure 5.3: Group affiliation of the EI members (in shaded boxes)

First of all, a project manager could manage several EI projects, concurrently or consecutively. This characteristic of the EI program entailed that there were almost no differences in knowledge-sharing practices among project teams run by the same project manager. Second, given the matrix structure of the agency, EI members had to report to the program manager, who belonged to the External group, and also to their divisional reporting structure. The data analysis revealed that knowledge sharing practices conformed to rules and norms specific to each divisional group⁴. For these two reasons, the data analysis focused on four groups of members of the EI program (see Figure 5.3): EI-External (i.e., EI members of the External group); EI-Technical (i.e., EI members of the Technical group); EI-SolDev (i.e., EI members of the Solution Development group); and EI-Internal (i.e., EI members of the Internal group).

5.3. Knowledge-based Organizational Change at TechProject

Knowledge-based organizational change is defined as the process through which new ideas and practices are integrated into the organizational life to generate organization-wide learning and to potentially trigger organizational change (Hatch & Cunliffe, 2006). This section describes TechProject's plans and efforts to induce knowledge-based organizational change.

As part of a plan to improve processes and automation necessary to operate efficiently, TechProject decided to implement Microsoft Project Server integrated with Microsoft SharePoint Server (hereafter ProjectServer/SharePointServer). The new environment would allow project teams to record project details, to generate reports of aggregated data, and to

⁴ Three Project Management Offices provided project management guidance and coordinated each group's projects. However, the three Project Management Offices were not always 'in sync' and the project teams had to conform to the rules and norms specific to their group.

access the project documentation -- all in one place. The goal was to improve project transparency and allow project managers to run their projects more efficiently. Given the enthusiasm surrounding the EI program and its benefits “*for all citizens in this State*”, as mentioned by several EI members, new projects had to be on ProjectServer/SharePointServer from the beginning, while existing projects had to switch gradually to the new environment. Sharing knowledge has been part of the culture at TechProject since its foundation in 2000. Everybody had some formal or informal method for disseminating his expertise. Project teams usually used Microsoft Project and Microsoft SharePoint Services (hereafter SharePoint) as single-user standalone systems. However, the implementation of ProjectServer/SharePointServer as a multi-user networking system required that 1) everybody would use the same method to share knowledge, and 2) tacit knowledge was codified and stored in the web-based repository rather than transmitted orally in staff meetings or on a need-to-know basis.

At the beginning of the data collection, in November 2006, ProjectServer/SharePointServer was being implemented by the Internal group within its own division. In January 2007, the Internal group was excited to report that the implementation was complete in their division. According to an Internal group Director, most of the internal project managers were already using the new system:

“The implementation was tough. As you know, with any IT software tool, it is not about the tool. It is about the processes that you have in place to support the technology that you’re putting in. [...] After we passed that, the implementation went ok. The type of configuration that we did is really really good. We probably have all of the internal project managers currently using it.” (Internal group⁵ – Unit Director)

⁵ In the remainder of the analysis, the group affiliation is not mentioned for quotes or comments that are general and not specific to a particular group.

By March 2007, the ProjectServer/SharePointServer environment was also expected to be operational for the External group. Training sessions were offered for the Technology Planning division and “*as they are trained then that’s when the responsibility becomes that they manage the projects in Server*” (Internal group – Director). However, in May 2007, the ProjectServer/SharePointServer implementation was still ongoing and External members were still in training. Several training sessions had been cancelled (due to technical problems) and the ‘Go-live’ date had been changed several times.

ProjectServer/SharePointServer was expected to be implemented in the Operations division sometime in March or April 2007. Yet only a couple of pilot projects were under ProjectServer/SharePointServer in May 2007. As stated by a unit manager, lack of training sessions seemed to have played an important role:

“We are looking at any new projects going under Server. However, there are only so many training days. My project managers are so busy on critical projects, and the training is only sparse. So it’s very difficult to make an edict like that and not have training courses available for that.” (Operations – Unit Manager)

With regard to the Solution Development group, one of the directors showed excitement about the potential benefits provided by the new system, as well as concern because the transition was perceived to be too costly and time-consuming to be worthwhile:

“Will it better help us to get our work done and be able to cope with the stress and keep up with what’s going on and everything? No, it’s not going to help. [...] So to say ‘by the way I want you to open a different set of screens and I want you to go ahead and also go in and I want you to enter this information on SharePoint’. It’s not reasonable for us, but down the road...absolutely. When things slow down, absolutely, it can be very valuable. We’re just not ready for it.” (Solution Development – Director)

At the beginning of the data collection, this transitional period to a unique knowledge-based system for the whole organization seemed ideal for studying social representations and how they influence organizational change. In this sense, I managed to gain entry at TechProject in

November 2006, approximately six weeks before EI members started to be affected by the implementation of the new system. The system was supposed to be completed in March or April 2007 but, in May 2007, it was still an ongoing project.

Given “*unsustainable financial losses*” (Business Plan Update, June 2007), TechProject radically changed its strategy in May 2007 and decided to focus on investment management rather than on expense management. The EI program did not seem to be a priority anymore. Resources were allocated so that on-going projects were delivered to term, but no new projects were embarked on. Since then, several EI members left the agency.

As previously mentioned, my intention was to study social representations of knowledge sharing. During my time in the field, I found important discrepancies in the communication process that I considered problematic and that may have contributed to the ultimate disbanding of the program. A few days before the formal announcement of the organizational shift, I decided to leave the research field, believing that the change in the organizational environment was outside the scope of my study. Additionally, work on the EI projects was stalled and EI members were more concerned about their own jobs than about sharing project knowledge. The next section presents knowledge sharing practices of each of the four ‘natural’ groups observed during the six months I spent at TechProject, between November 2006 and May 2007.

5.4. Knowledge-based Systems Used by the EI Groups

One of the project managers referred to the panoply of technological and non-technological tools used at TechProject to share information by saying “*each of us has a tool bag*”. These tool bags included:

- *Microsoft SharePoint Services (SharePoint)*: a browser-based collaboration and document-management platform;
- *Microsoft SharePoint Server*: a server program to facilitate collaboration, provide content management features, implement business processes, and supply access to information. It integrates closely with Microsoft Office applications;
- *Microsoft Project*: a project management software program, which assists project managers in developing plans, assigning resources to tasks, tracking project progress, managing budgets and analyzing workloads;
- *Microsoft Project Server*: a project management server solution that leverages SharePoint Server as its foundation, and uses a web interface and Microsoft Project as the client application;
- *Email*: method of writing, sending, receiving and saving electronic messages;
- *Shared drive*: shared resource that can be remotely accessed from another computer, usually via a local area network, as if it were a resource on the local machine;
- *Instant Messaging*: real-time text-based communication between two or more people;
- *Intranet (website)*: TechProject's internal website;
- *Templates*: general templates developed by TechProject for the required project deliverables. They could represent 'standards' (that all the projects had to follow) or 'best practices' (modified versions of the standard templates, recommended for special cases);

- *Excel spreadsheets* such as checklists, audit lists, and the dashboard were used as communication and reporting tools;
- *One-on-one meetings*;
- *Face-to-face meetings* with conference call available for those not present in the room.

Due to this variety of methods, the implementation of ProjectServer/SharePointServer was planned to drive the organizational change toward a single platform for sharing knowledge. Before its implementation, three methods were widely used by all the groups: email, shared drives and meetings.

The email was perceived by several team members as the easiest and the most used tool because of its accessibility:

“We’ll exchange a lot via email. It’s easier when you have a problem to just send an email. So the sharing it’s not very formalized; it’s very ad-hoc. [...] We all have an email-client in front of us so we might as well send an email.” (Executive Project Manager)

However, process knowledge was often sent by email and the message was not regularly stored with the other project documents. Each individual had his own way of handling that issue but that knowledge was usually lost because, as noted by a project manager, there was no formal guideline for storing emails in a centralized or organized fashion:

“a lot of times the emails will contain a lot of good information and it gets lost in email. Everybody reads a newspaper, then you don’t want it and you throw it away. But there must be a specific person that watches what needs to be stored and a responsible person should transform it and store it.” (Project Manager)

The other tool to which everybody had access and used regularly was the shared drive. While some considered the shared drive as “*the wasteland in the desert*”, others found ways to deal

with version control, redundancy, notifications, or searching issues. Nevertheless, those solutions worked only within the group as they were known only by the group members. The other program members were frustrated because they couldn't find the documents:

“Somebody who developed the policy or procedure or process, they put it out on that shared drive, somewhere where they decide it should go, and basically only they know where it is.” (Unit Director)

In order to find a document, they had to figure out who could know about the existence of the document and direct them to its location. One of the Unit Managers didn't find that practice obvious or normal:

“You just try to figure out who may have access to it, or may know where it is, and you call them or you email them, and you say, ‘I’m looking for this. Do you happen to know where it is?’ That’s the way it’s done today, and it shouldn’t be done that way.” (Unit Manager)

The EI team members met bi-weekly to discuss the status of the projects but not all the members attended and the meeting minutes were not disseminated. One project manager thought meeting minutes might be somewhere on the shared drive but it would be too difficult to look for them. The exchange at the status meetings was formal but relaxed and those who could not be present could participate by phone. Some of the members found the meetings valuable because they heard about other teams' problems:

“The times that I did attend, actually I did find them valuable because I was hearing what other teams were dealing with. You know I was hearing what difficulties they had, even though they were not relevant at that time, you know as I touched those things in my project I thought, ‘Wait a minute, I remember hearing that that person has that same thing.’ And so if I needed to go to that person I could.” (Project Manager)

Others thought the meetings were too formal to be helpful. One of the Unit Managers revealed that there was a sense of fear and inability to act among team members. They heard

about other teams' issues, they shared their issues, but no constructive feedback was offered.

Hence, what was shared in meetings might not tell the whole story:

“They seem to formalize that communication in a way that we’re really not communicating. And providing information that you may or may not use, but I’m certainly not soliciting feedback during those meetings. And depending on who’s conducting those meetings and who’s sitting there, the communication is such that I don’t really want to tell you what I need to tell you, because of the setting that we’re in, so there again, we formalize too much with some of these meetings, and the real intimate conversations that need to take place don’t happen. And then people are afraid to act.” (Unit Manager)

Although they could, few people contacted the knowledge source for more details after a meeting. In general, asking for help from a colleague was common at the executive project manager level but it was a rather sensitive issue among the other project managers. One project manager said he preferred not to contact others because he didn’t like to justify his requests for help all the time:

“There are certain stumbling blocks for someone that is nosy like me. I am not going to call them and figure out who to call to get access to the data and provide a justification.” (Project Manager)

In addition to email, shared drives, and meetings, the four groups under study (EI-External, EI-Internal, EI-Technical, and EI-SolDev) used several other knowledge sharing tools consistent with their needs and motivations. The following sections present these tools along with explanations of the group’s needs and motivations.

5.4.1. Knowledge sharing practices: EI-External

For each EI project, the program coordinator created an electronic knowledge repository on SharePoint for content management, business process facilitation, and simplified information sharing. In order for these sites to have a coherent “look and feel”, the Internal group set out a default structure, which was supposed to be intuitive, simple, and broad enough to apply to

all projects at TechProject. However, due to the fact that the EI was a program and not a project, the program coordinator thought the structure didn't fit the team's needs well:

“A lot of times I feel that there are some things that fall off scope just because the structure is limited. Everybody can interpret differently.” (Program Coordinator)

Project deliverables, contact information, meeting minutes, lessons-learned databases and any other information pertaining to the projects were expected to be on the SharePoint site, organized by project phase. This requirement raised two important issues. First, some of the documents concerned several phases and the choice of a phase (where to store them) was open to interpretation. Second, members of the EI-External group interacted a lot with external agencies and other TechProject employees who, for security reasons, did not have access to SharePoint.

To deal with these issues, documents were put on both the SharePoint site and the shared drive. On the shared drive they could create their own structure and they could allow access to other TechProject employees. This solution also complied with the formal requirement of having all the documentation on SharePoint, although it was not always the most current version. Executive Project managers could nonetheless audit the project deliverables because they only checked the existence of the deliverables on the site, not their content. Hence, the SharePoint site was *“very useful primarily as a reporting tool”* (Program Coordinator), rather than as a sharing tool.

On the other hand, the shared drive did not have any mechanisms to deal with version control and redundancy. Project Managers were very upset with that situation as looking for documents on the shared drive became a real challenge: *“Just looking though and trying to retrieve documentation, it's been a hunt”* (Project Manager).

Frustration and confusion also rose from the use of the term “site”, which was employed to designate either the SharePoint site or the shared drive. For example, if someone was saying that the documents were on the site, it meant that the documents could be either on the SharePoint site or on the shared drive. Depending on their own usage of the term “site”, misunderstandings easily appeared.

“SharePoint is the magic word. They say SharePoint but in fact it is on the S-drive, which is not a SharePoint drive. [...] The thing about that is that in the old school, SharePoint was a drive that had to be shared. So that term was picked up by Microsoft and used in its software and that got us this miscommunication about what SharePoint is.” (Executive Project Manager)

The information on the SharePoint site was believed to be accurate because only one person, the program coordinator, was responsible to create or to update the documents. This practice was consistent with SharePoint’s usage as a reporting tool rather than as a sharing tool. If errors were noticed, the practice was to notify the program coordinator or the author of the document. Even those who had the right to make changes preferred to send a notification email, saying *“if I don’t author, I don’t change”* (Project Manager).

The main trade off of this ‘SharePoint – shared drive’ symbiosis was getting access to documents. EI members only got access to the projects they worked on and they didn’t know what was on the SharePoint sites from the other projects. Given this inability to access the other teams’ documents, one project manager expressed his discontentment: *“Those documents, who can view them? To me, it’s about faked know-how”* (Project Manager).

Access to the SharePoint sites could be requested from the IT department, but it took some time to get it and they had to know exactly for which projects they needed access. Therefore, the EI-External members thought neither SharePoint nor the shared drive was ideal for sharing knowledge but the shared drive was the least worst option:

“It makes it much worse if you put it on SharePoint. [...] Shared drive gives me a lot of crap, way too much, but I might be able to find a particular document on this project that I wouldn’t be able to find it on SharePoint.” (Project Manager)

Furthermore, since the transition to ProjectServer/SharePointServer, there was a moratorium on some of the SharePoint functionalities in order to facilitate the configuration and implementation of the new system. During the moratorium, the program coordinator felt the team had to use the shared drives to do the tasks that couldn’t be done on SharePoint anymore. The program coordinator asked the IT department for help on performing those tasks under the new restrictions on SharePoint but the answers received did not seem to be too helpful:

“I went to the training with all these 50 million questions from having used SharePoint before and shared databases and I was discouraged about the answers so I’ve sort of given up.” (Program Coordinator)

In sum, members of the EI-External group were fervent about the benefits of SharePoint to share knowledge within their group as well as across groups. However, their sharing practices revealed the limited use of SharePoint as a reporting tool. As no tool in the group’s tool bag met their needs perfectly, the group adjusted the usage of these tools to their work practices: SharePoint and staff meetings mainly as reporting tools; emails, documents on the shared drive and one-on-one meetings mainly to disseminate the lessons learned. Interestingly, their vocabulary did not convey that variety: the group used the term “site” to refer both to SharePoint and shared drive.

5.4.2. Knowledge sharing practices: EI-Technical

In the Operations division few people had access to SharePoint. Thus, the EI-Technical members used primarily the shared drive to share documents and information about their

projects. Only one Project Manager put the deliverables on the project's SharePoint site to comply with the External group's guidelines for the EI program.

“To make sure that we are following [TechProject's] methodology, the SharePoint is where all this information is available. So everybody can go out there and see if I had any change requests, what those impact are, if I went through the change control board, etc.” (Project Manager)

The EI-Technical members had the same difficulties with the shared drives as the EI-External members. According to one of the Directors, finding a document implied searching more than 900GB of data on almost everything:

“It's 900-plus gigabytes of information that revolves around almost everything and everybody. There's no index. There's no way to find what you're looking for.” (Director)

One project manager was also frustrated with the way the EI teams handled version control:

“The problem with [the shared drive] is that we don't have version control.” (Project Manager)

Hence, each project team developed its own way of working around those issues. Surprisingly, even for those that had access to a SharePoint site, the emphasis was put on face-to-face sharing:

“SharePoint is fairly new here. It hasn't been there that long, so I am still managing my resources on a more persona direct level, instead of relying on them to go to SharePoint to pull things down. So I know when working on multiple projects, with multiple resources, you know they sometimes do not always remember to go to SharePoint. So from a project management perspective, it's my job to make sure that tasks are being executed. So I send things directly to my resources [i.e. people], the resources that are assigned to those tasks, asking them what they do.” (Project Manager)

In line with this preference for face-to-face sharing, the weekly staff meetings were seen as *on-the-fly lessons learned* because writing the lessons learned during the project in a formal document was rarely done:

“In staff meetings, because we have a lot of projects running concurrently, there are things that are not documented yet as lessons learned. So, let’s call them on-the-fly lessons learned and that’s where the staff meetings come into play because we can talk about our issues and somebody says ‘oh, by the way, I had that and this is how we resolved it’.” (Project Manager)

Some frustration also emerged from the impossibility to benefit from the ProjectServer/SharePointServer platform. The Technical group was discontent because their division was always the last one to benefit from a new system or technology. Additionally, the Internal group kept delaying the phased rollout of the new system and the Technical members were anxious to see everyone from TechProject embarking on ProjectServer/SharePointServer:

“I think everyone is used to providing a lot of documentation, but everyone is doing it their own way. [...] We will have a SharePoint site, and be able to go, reach any document from the SharePoint. But that’s a paradigm shift for this organization, not only Operations. It’s going to take a while before people buy into it, but it is definitely a benefit. I definitely see it as a benefit.” (Project Manager)

In sum, as access to SharePoint was limited to only a few people, everyone was sending documents by email or putting them on the shared drive, not necessarily in an organized manner. Consequently, the shared drive became a huge wasteland of data about everything and everyone. There were no guidelines or group practices for versioning control and searching for documents was almost impossible. Hence, the EI-Technical group clearly preferred face-to-face exchanges to share their knowledge. Nonetheless, they were excited and anxious to get access to the ProjectServer/SharePointServer platform even if it required less oral sharing and more documenting.

5.4.3. Knowledge sharing practices: EI-SolDev

On a daily basis, members of the Solution Development group used several tools to share knowledge: shared drive, email, instant messaging, electronic repositories for technical documents, and meetings. The main tool however was the shared drive. A SharePoint site

had been set up for them but moving all the technical documents from the shared drive to SharePoint was considered so demanding that the site was not used at all. Hence, the team members did not even know they had access to such a site.

“Oh yeah. They don’t use it. We have [SharePoint], they have a site but they don’t use it. Because that is one of the jobs of our business analyst to move everything from the shared drives into SharePoint. He’s not done it yet.” (Section Director)

Compared to the other groups, working with the shared drives did not seem to be so problematic. Given their strong technical backgrounds, EI members of the Solution Development group created their own structure to store all the documents for each project, following a development methodology (the GEAR methodology⁶), rather than the project management methodology. They also had their own system of notifications and alerts for version control so redundancy, versioning, and inaccurate information were not an issue at all. The guidelines, although unwritten, were clear for everybody on the team:

“No one should be changing any documents without putting a note up in the front regarding the change and changing the version of the document.” (Team Leader)

The shared drive used by the Solution Development group was not the same as the one used by the EI-External or the EI-Technical members. When documents were sent from one group to another, they were usually sent by email and then saved on the shared drive. The EI-External group also put some of the documents directly on the EI-SolDev shared drive and alerted those concerned.

No one was formally assigned to promote, within this group, the knowledge-sharing guidelines. On the one hand, the group size was relatively small (around six people plus

⁶ The [GEAR](#) methodology (Gather requirements, Explore, Assemble, Roll out) is championed by WebMethods (recently acquired by the German company Software AG)

external consultants who temporally joined the team), while on the other hand they all knew how important it was to document and share technical documents:

“It is the whole culture from square one: whatever they have they share so that everyone can read and reach and get to it. So everything needs to be in one place. You want it to be in a place that everyone has access to it.” (Team Leader)

The Team Leader also joked about the importance of documenting adding:

“If you don’t want phone calls at 3 o’clock in the morning from someone working on it, you’d better document. So there is a bit of motivation.”

After participating at the training sessions for ProjectServer/SharePointServer, members of the Solution Development group saw a lot of benefits, but they also realized how painful the transition would be for them, as they were already swamped and understaffed.

“I’ve seen SharePoint and there are a lot of opportunities. However it’s going to take some time to maintain it. [...] If we had somebody who was an administrative and took care of that, that would be great. But we don’t have time to do it.” (Team Leader)

In sum, the EI-SolDev group was the only group that was effectively sharing knowledge on the shared drive without having any issues regarding version control, searching for documents, or sending alerts and notifications. They were also the only group to use instant messaging for real-time text-based communication. Documenting their work was such a big part of their culture and mentality that they didn’t need a formal promoter or a formal guide stating the guidelines for knowledge sharing. They all knew how important the traceability of their actions was for debugging and reuse. SharePoint was not an option for them yet because they were functioning so well with the current tools that the transition – from shared drive to SharePoint – was considered too difficult in terms of time and resources needed.

5.4.4. Knowledge sharing practices: EI-Internal

Only one of the projects was managed by a Project Manager from the Internal group. The Internal group was usually the first one to adopt new IT tools such as SharePoint or Project Server. However, the EI project run by the Internal project manager was too close to completion to make the transition to SharePoint worthwhile. The project team already had their documents on the shared drive and thus, no attempt was made to put them on SharePoint.

“Because the project started before SharePoint, we didn’t use SharePoint. The project had been going on for over a year. [...] Since everybody was used to the shared drive that worked fine, because we were on a tight schedule and that would not have added value at the time to add another level and move everything over and make sure everybody knew. It just didn’t make sense.” (Project Manager)

Furthermore, the size of the team was relatively small (around 10 people) so sharing documents on the shared drive was manageable. Everything was organized in folders and sub-folders and members of this group informed each other at meetings where things were. As the project moved on, the team also adjusted the structure of the drive in response to their changing needs.

“We knew after something got lost, ‘Okay we need a folder for this’ and we created a folder and everybody put all testing related stuff in this folder. So that evolved a little bit. I mean there weren’t so many documents that you could not find anything, it just made it cleaner as we went along.” (Project Manager)

As the project manager recalled, informal sharing of tacit knowledge took place regularly within the group at the weekly status meetings, at ad-hoc trouble-shooting meetings, or with other colleagues from the Internal group:

“I would have weekly conference calls with the team as needed. We got to a point where we didn’t need to have them every week. Then I had weekly meetings with the technical manager and with the business owner and just emails beyond that and

sometimes I would, if we were having a problem with a particular issue, I would call, just a conference call, for troubleshooting.” (Project Manager)

Collaboration with the other EI project managers had been relatively limited as the Internal project manager attended only one EI status meeting. However, status reports were sent weekly to the Program Manager to report on the project.

“I really did not talk to the other integration project managers, so I only participated in one meeting [...] But other than that, we really did not talk on a regular basis at all. I just gave them my status report.” (Project Manager)

In conclusion, the small EI-Internal group was sharing documents on the shared drive relatively effectively. Meetings and face-to-face exchanges also played an important part in their group. However, interactions with the other groups were limited to weekly status reports to the Program Manager.

5.4.5. Knowledge sharing practices across groups

A combination of methods was used to share knowledge across groups: *“presentations, word of mouth, people saying ‘we heard that this is going on’ [...] and it is also about documents and deliverables”* (EI Program Manager). According to several people, TechProject has done a good job at establishing an appropriate infrastructure in terms of hardware, software, and IT support to foster knowledge transfer: *“We have the best [infrastructure] for a State Agency; they’re ahead of the game”* (EI Program Lead). Throughout the organization, emphasis was also put on documenting and making deliverables available on SharePoint. However, time was limited and resources were scarce to always document the lessons learned during or at the end of a project. Meetings were often seen as ‘on-the-fly lessons learned’ where everyone had a chance to talk about their projects and their issues but not necessarily getting back

some feedback. Nevertheless, several project managers felt that knowledge sharing was most effective when occurring orally:

“There’s lots of information, and lots of communication that needs to occur, that really has no way to occur, unless we do this: we sit down and talk.” (Operations – Unit Director)

With the exception of the Solution Development group who used instant messaging, the other groups preferred ad-hoc meetings, one-on-one meetings and phone calls to troubleshoot critical or urgent issues.

“We have an ‘open door anytime’ policy around here. [...] I try to stay in touch with the project managers on the various projects, we get statuses every week from them, but if something is that critical, it is escalated, I am just a phone call away and vice-versa. If I hear something and I need to find something out I need to be able to call them.” (EI Program Manager)

The biggest issue, that neither SharePoint nor the shared drive addressed, was finding out what others (EI or non-EI members) were working on. As SharePoint sites were unavailable to external members (i.e., those not working on the same project) and the shared drives were not easily searchable, word of mouth was the least worst option:

“Basically, it will be nice for us to know what each other is doing because we may be able to help each other, they may have something that we need and vice-versa. But right now it’s not done. Basically, the environment is ‘This is your project. This is mine. I’m working on mine and I really don’t care what’s going on with yours’. If there is a defined need, yeah they may accommodate and inquire, but otherwise we don’t share knowledge.” (EI Program Lead)

The frustration was not only due to the lack of communication but also to the possible redundancy: *“Four weeks of wasted time before I found out [another group] already worked on this” (External – Executive Project Manager).*

Although meetings were highly necessary and convened regularly, some members believed they were not the most constructive way to share knowledge and that a more trustful environment would foster more knowledge sharing.

“I can tell you for a fact that there have been very limited constructive conversations about projects. I think a lot of them is politeness and ‘oh, I feel this way or this way’ and ‘oh, my users are the worst’.” (External – Executive Project Manager)

Documenting experiences in writing did not occur naturally either. As one project manager recalled, it was not obvious what to put in the document. The only reward possible was the feeling of having contributed to sharing knowledge, but the risk was to harm their image by showing their mistakes to the others:

“What is valuable to my eyes? I can’t predict that. So how do I know that is what I need to share? Otherwise said I will not have any return value for having made my contributions other than just the feeling that I contributed. So I’m reluctant to do it. [...] Personally, I don’t want to expose myself for everyone to read what I did [and think] ‘What an idiot!’.” (External – Executive Project Manager)

Therefore, documents tended to be very specific for two reasons. First, specificity protected the author from being judged by those unfamiliar with the project. Second, writing a document that described the issues ‘as is’ was easier than writing in a general form that could have been applied to other projects. As one project manager said:

“People’s documents have them in mind. They don’t have me in mind.” (EI-External – Project Manager)

Adopting a more proactive approach to documenting only meant justifying more one’s actions and decisions and not sharing knowledge beyond the project:

“Typically, I try to adopt a proactive approach to documenting but I’m not necessarily doing it for the organization at large, but for the organization’s ability to absorb the deliverable. So I’m still very project focused. I do it more because if I reach a point where the project’s going bad I need to know what we did, why and how we did it.” (External – Executive Project Manager)

For interactions across EI groups (EI-External, EI-Technical, EI-Internal, EI-SolDev), members of the EI team tried to comply with the guidelines set by the External group's executive management and they generally put the deliverables on the SharePoint site. When they did not have access to a SharePoint site, they sent the status report by email to the Program Manager. In fact, given the matrix structure of the organization, the status report was of interest to various stakeholders not only to the Program Manager. In this sense, the sender sought to present the information in the receiver's format. For example, the EI Program Manager – who was an Executive Project Manager in the External group – took the status reports received from the EI project managers and presented them in an aggregated form in the 'dashboard'. The dashboard was an Excel spreadsheet used among External Executive Project Managers to report on their projects to their superiors. The same project deliverable could also have different versions. For instance, there was usually a version for TechProject's managers that included more methodological details and one version for team members outside of TechProject. As one of the project managers stated, it was not easy complying with all these requirements:

“We have to find the best fit for our business owners, to which they have agreed and are willing to accept, but in the same time we have an obligation to our own department to produce the appropriate documentation.” (EI-External – Project Manager)

Thus, project managers and executive project managers were frustrated because they were spending too much time using too many tools to share the documents or creating several versions of the same document:

“I get to pick and choose: run over here and be compliant from an audit standpoint then I have to run and make sure that I execute from that standpoint.” (EI-External – Project Manager)

Sharing knowledge is not an innate characteristic but EI members had that desire. They wanted to share their experiences and have that feeling of having contributed to help others. Their frustrations and dissatisfaction were due to the challenges raised by having different expectations and different tools in the four groups.

“People have that desire to share and they feel frustrated because they could do it better. When they’re looking at a process, you know ‘why haven’t I done that better?’. They feel that there is no platform or opportunity or place for sharing knowledge and make a difference.” (External – Executive Project Manager)

EI members agreed that ProjectServer/SharePointServer offered several advantages that would make their group tasks easier but the transition to the new system seemed to have a laborious takeoff. As one of the Executive project managers observed, it seemed like the transition did not address enough the individual benefits of sharing: why individuals had to change their sharing habits and why they should conform to a common platform for the whole agency.

“It’s not natural for people to want to share it. It’s not consciously but it’s more like what’s in it for me. You know, there is that aspect of sharing that needs to be addressed.” (External – Executive Project Manager)

The next section discusses the challenges to share knowledge at TechProject from the perspective of the social representation theory.

6. Case Analysis

6.1. Understanding the Context

Knowledge-sharing practices were the medium through which the members of the EI program transformed their understanding of the knowledge-based system used. Thus, the knowledge-based system became a “social object by the community for the purpose of behaving and communicating” (Moscovici, 1963, p. 251). To properly understand the social representations of knowledge-sharing practices using knowledge-based system, it is important to examine the historical, cultural, and social context in which they were built (Wagner et al., 1999). Differences and similarities among the initial social representations of the four EI groups (EI-External, EI-Technical, EI-SolDev, EI-Internal) derived from past experiences and common background, cultural values and norms.

At TechProject everybody was familiar and experimented with either the shared drives or SharePoint. Some of the EI team members had used SharePoint in their previous positions and hence they had different expectations on how knowledge sharing should occur and how the knowledge-based system should support knowledge sharing at TechProject. For instance, those who had previously worked in the private sector found it hard to adjust to the hierarchical structure of the communication process as illustrated by the following quotation:

“The way that they communicate between teams, it is a little bit different than the commercials. [...] The environment was certainly very different than what we have here [in a government agency]. So, my expectation was completely different from what I found here. I found it hard getting [access to] the knowledge.” (Developer)

Expectations were also different for those who had used SharePoint at their previous employers. For example, at the onset of the EI program, the Program Coordinator was excited about having the opportunity to work again on SharePoint and she was already picturing in her mind the structure of the new SharePoint sites. She admitted later that those visualizations were very different from the current usage of SharePoint:

“Because of my background, I really got excited about the possibilities. So [I imagined] I would have this global entry point into the whole program, and then for each project I would have its own site with its own stuff. [...] It wouldn’t be this one mass of documents.” (Program Coordinator)

The results also showed that sharing practices had been emphasized at TechProject for several years in order to improve project outcomes. However, given their individual backgrounds, each EI team member had his tool bag for knowledge sharing: documents were generally used to share knowledge across projects or to report to the senior management, while oral sharing was still the dominant practice within each group. In regard to this last practice, it was something that had clearly worked out very well in previous projects for several key individuals of the EI team. The Program Manager confirmed by saying:

“In the past, I’ve never used a lot of documents. [...] Conversations and meetings...I mean we have meetings every other week and it is a collaborative effort. It is a matter of talking and communicating, making sure that we’ve done the right thing and staying on track.”(Program Manager)

Furthermore, the general opinion was that most of TechProject’s organizational knowledge was found in people’s heads and only a small part was in documents or in organizational processes. For example, in the EI-External group most of the members had management positions and therefore documenting projects and sharing project documents via a knowledge-based system were part of their formal responsibilities. Nevertheless, every time

someone left the agency made them realize how dependent they were on that person. The following quote from the Program Lead illustrated this issue:

“Everything is in the heads and that’s the problem. [...] The knowledge is gone but the project has to move on.” (Program Lead)

In the EI-Technical group, project managers believed that organizational knowledge “eventually gets into documents” (Project Manager). In one of the project manager’s words, there was no time, during the project, to look for project knowledge using the knowledge-based system:

“As projects are being planned and executed, I am not going out looking at another project SharePoint site. I don’t have time to look while they’re executing one and while I’m executing one. [...] I’ll go to that PM and ask him and then we share that information and what I have documented.” (Project Manager)

Good project management practices recommend a project close-out phase, which generally includes lessons learned, evaluations, and sponsor review activities (Project Management Institute, 2004). However, subsequent interviews with Executive Project Managers depicted a different reality in which the close-out phase was the ‘forgotten’ phase, due to time constraints. Time was also considered an impediment in the EI-Internal group where changes on the fly were not always documented or made available on the shared drives. The following quotation exemplified the frustration triggered by that situation:

“I discover things all the time and I’m like ‘Well, how was I supposed to know that?’... and it’s just a lot of it. It’s just because it’s in people’s heads.” (Project Manager)

The EI-SolDev group felt that they documented extensively but, for them, it was not enough and they still felt the need to meet and talk. Technical documents had a certain structure to respect depending on the methodology or programming language used and contextual

knowledge was generally added as comments. Inevitably that raised a need to also share contextual knowledge in group meetings or in one-on-one meetings.

This dominant preference for oral sharing was an important characteristic of the working style at TechProject. Although a significant number of employees were hired as contractors, the EI Business Owner believed it was not about withholding knowledge so that they hold on to their job. The project managers did not tolerate that attitude and the senior management was constantly reinforcing the need for documenting as well. Having most of the organizational knowledge in peoples' heads was simply a feature of the working environment, and TechProject's senior management tried to attenuate its downside by introducing tools such as shared drives, SharePoint, Project Server, or project deliverables.

In sum, the social context of the EI team was highly conducive to sharing tacit technical knowledge and tacit project-related knowledge through such activities as spending time together, working together, having formal and informal conversations, rather than through written documents. Along these lines, the term 'socialization' refers here to the activities and processes by which individuals acquire knowledge, attitudes, and behaviours necessary for their projects. This definition is more inclusive than Van Maanen and Schein's concept of organizational socialization⁷ because it includes technical, project-related, and socio-cultural knowledge. Knowledge sharing and learning occur informally by reflecting, thinking, discussing, doing, replicating, or adapting (Prencipe & Tell, 2001). Although the social activities sought to transfer knowledge from one individual to another, they did not necessarily correspond to Nonaka and Takeuchi's (1995) definitions of socialization and

⁷ Van Maanen and Schein defined organizational socialization as "the process by which an individual acquires the social knowledge and skills necessary to assume an organizational role" (1978, p. 84).

externalization as modes of knowledge conversion. Specifically, there was no cognitive transfer of knowledge (from tacit to tacit or from tacit to explicit) among EI members (Gourlay, 2006). Sometimes, interactions were simply used to develop cohesion and improve communication between team members. Thus, EI members used socialization tactics based mostly on individualized mechanisms oriented toward personalization and, to a lesser extent, toward codification (Boh, 2007) (see Table 6.1).

Table 6.1: Framework for the main knowledge-sharing mechanisms used by the EI-members (Boh, 2007)

	<i>Individualized</i>	<i>Institutionalized</i>
<i>Personalization</i>	EI-External EI-Technical	
<i>Codification</i>	EI-External (SharePoint, shared drive) EI-Technical (shared drive)	EI-Internal (shared drive) EI-SolDev (shared drive)

During the course of the project, the EI members realized that their work practices, predominantly based on socializing activities, could not be reproduced by knowledge-based systems such as SharePoint or even ProjectServer/SharePointServer. The main triggers of this perceived dissonance were: 1) loss of a team member; 2) lack of traceability for project decisions; and 3) lack of project close-out documents such as the ‘lessons learned’. In these respects, there was not much difference among the four EI groups. However, the EI members started questioning themselves about the way they represented their context, their knowledge-sharing work practices, and their knowledge-based systems. Each group’s opinions, needs and habits shaped differently the process of collective sensemaking (Moscovici, 2001), thus triggering a different evolution of the social representation of knowledge sharing using a knowledge-based system, as discussed in the following sections.

6.2. Social Representations of Knowledge-Sharing Practices via a Knowledge-based System

Despite the frustration that had built up over the use of shared drives and SharePoint, the main catalyst of change of the representation of knowledge sharing practices was the top management's decision to push even more for project transparency and traceability, by introducing ProjectServer/SharePointServer. Although all four groups were supposed to use ProjectServer/SharePointServer at some point in the future, the changes in the representations were different because the groups had, on one hand, different needs and aspirations (Wagner et al., 1999), and on the other hand, different levels of access to the main knowledge-based systems (shared drives, SharePoint, ProjectServer/SharePointServer). Everybody had access to the shared drives, but not everybody had access to SharePoint or ProjectServer/SharePointServer.

All four groups aspired to share knowledge and expertise efficiently and effectively, but they also had specific goals motivating their actions and behaviours. For example, given the EI-External group's role as an intermediary between TechProject and the other State agencies, the group wanted a knowledge-based system that allowed external stakeholders to track the program's progress and also to allow access to external documents in order to see how other departments and governmental agencies tackled similar issues. The EI-Technical and the EI-Internal groups wanted a viable solution to versioning, searching, and notifications problems regarding the group's documents on the shared drives. The EI-SolDev group's goal was to document more tacit knowledge because the opportunity for reuse was so evident that it was possible to measure it in dollars and time saved.

The dissonance between the groups' initial representation of knowledge sharing and their future goals created the need to adjust the social representation of knowledge sharing (Bauer & Gaskell, 1999) and in particular the social representation of knowledge sharing via a knowledge-based system. This gap, however, was less perceived by those whose needs required a basic usage of the knowledge-based system. For example, the Program Manager only needed to access documents previously put on the SharePoint site by the Program Coordinator. In this context, the SharePoint site was extremely useful and efficient, in contrast to having copies of all the documents on the hard drive, as noted by the program manager:

“SharePoint is very useful because it handles all that information. If [the program coordinator] is not there, or [the program lead] is not there, and I need something, I'll go to the SharePoint site. I depend on them to make sure the information is current and accurate. Instead of going through my hard drive looking for documents, I just go there and click.” (Program Manager)

Most of time, however, SharePoint and the shared drives were used for a variety of tasks thus creating opportunities for the groups to adjust their social representations. For instance, the program coordinator was disappointed with the way the SharePoint site had become “*a mass of documents*”. She knew the tool had the required functionalities to impose a structure that would fit the program's needs but the way in which the site was configured by the IT department pushed people to use other means (e.g. shared drive, email, phone) to disseminate documents to those who did not have access to a specific SharePoint site.

“I still think it's possible to use it differently than I'm using it. So I would have to say that my expectations about SharePoint have changed since I came on board [...] but, in reality, I don't blame the tool for that.” (Program Coordinator)

Frustration building from the drawbacks of the various knowledge-based systems together with the top management's decision to implement another knowledge-based system

(ProjectServer/SharePointServer), created the ‘unfamiliar phenomenon’ with which each group had to cope (Moscovici, 1984). It was this unfamiliarity that prompted each group to reassess its identity and understanding on how to share its knowledge and on how to use the knowledge-based system to share knowledge. Dealing with the unfamiliarity involves two kinds of responses: anchoring and objectification (Abric, 1994a). Anchoring allows the individual to name and classify novel objects according to an existing system of thought, while objectification associates an image with the classified object thus improving the classification. To each image there is a meaning and to each meaning there is an image (Doise & Palmonari, 1986, p.16). These two processes, anchoring and objectification, are different from one group to another depending on the group’s information filtering process and on the group’s previous experience with the knowledge-based system.

Members of the EI-External group regularly and extensively used SharePoint and Microsoft Project, so they anchored ProjectServer/SharePointServer to their experience with these two tools. Given that the EI-External team members had to conform to the External group’s rule to put all the project documents on SharePoint, the objectification process associated an image corresponding to the ineffective usage of SharePoint as a knowledge sharing tool:

“From all what I have seen I have to equate that SharePoint is not a disseminating knowledge tool and some of this knowledge is protected on purpose and this may or may not work with SharePoint and that’s why SharePoint may not be the best to use.”
(Project Manager)

For the EI-External members, SharePoint was represented as a reporting tool:

“From what I’ve seen, it’s very useful primarily as a reporting tool. You put anything in there and [senior management] can view it.” (Program Coordinator)

For the members from the EI-Technical and EI-SolDev groups, anchoring was completely different because most of them did not even have access to a SharePoint site and those who

had access were using it sparingly. Hence, they anchored their representations to their usage of another knowledge-based system (e.g. shared drives, email) and to their individual understanding – from training courses or colleagues – of what SharePoint could do. In view of that, the objectification strengthened the anchoring system with images and verbal metaphors that were ranging from optimistic to sceptical. For example, EI-Technical members believed that SharePoint would certainly improve knowledge sharing:

“We’re just getting to the point now where we’re starting to develop some of those real true SharePoint sites and SharePoint libraries. My vision is that we take those standards, policies, procedures, those things that everyone needs, we put them in a common library within SharePoint that certainly has some version control, certainly has access control, and has some approval process that we develop and build in. So, when I go look for a policy or standard, I know that the one I’m looking at is current, I know it’s approved, I know it’s the right version for me to see, and I have access to it. I know where to go look for it. So, it’s indexed in some way, or there’s metadata involved, so I can find it if I need to. Right now, on the [shared] drive, that’s not true. It’s out there, but it’s a waste-land.” (Unit Director)

By its nature, SharePoint is a more structured document repository than the shared drives are. Thus, the EI-Technical group anchored their social representation to their experience with the shared drives and they imagined it would be the solution to their problems.

The EI-SolDev group associated the use of SharePoint with a more organized and overt method to handle documents than their current method using the shared drive, as shown in the following quote:

“I think it’s a good opportunity for better documentation and more visibility into it because we already know where to find documents on the [shared] drive but, with SharePoint, we will force a methodology let’s say that will make it more visible to everybody else.” (EI-SolDev Team Leader)

In addition to this optimism, scepticism was present in the representations of both groups (EI-Technical, EI-SolDev) because the users seemed to lack motivation. Even if the technology is perceived to be useful, intrinsic motivation is also a key determinant

underlying short-term user acceptance (Davis et al., 1992; Venkatesh et al., 2002). For the EI-SolDev group, SharePoint could be a very valuable and helpful technology but the developers felt too swamped with their daily tasks to embark on a new project such as the transition to a SharePoint-based platform for knowledge sharing. For the EI-Technical group, the scepticism was due to previous less successful experiences with new applications and technologies, as a project manager remarked:

“I think SharePoint as a tool will help TechProject but TechProject a lot of times relies on tools to do the work for us and we don’t put enough energy and time into processes and into the behind the scenes stuff that allows tools to work for us.” (EI-Technical – Project Manager)

These social representations of sharing knowledge via SharePoint (based on their experience with SharePoint or their expectations from SharePoint) represented the groups’ common sense. Members, such as the Program Manager who used only the most basic functionalities of the knowledge-based system, were peripheral to their groups’ representations (Abric, 1994a) due to their limited needs to use the tool.

The introduction of ProjectServer/SharePointServer was another defining moment in the evolution of the social representation of knowledge sharing via the knowledge-based system. The initial decision to implement this integrated system created some sense of excitement and anxiety in the External and Internal groups, especially among Executive Project Managers who were the ones to benefit the most from the integration between Microsoft Project and SharePoint. After the training sessions, the External members sought to renegotiate their social representation, to articulate the social image around a core system that included Project Sever too. Similarly to SharePoint, elements of optimism and scepticism were both present in the description made by one of the External project managers:

“I went through the training [...] and Server it’s supposed to provide a lot of details about the project and therefore automatically or magically pull it out for you so that everything is consistent. That is what we want. [...] I’ve seen the details in the training about how it is supposed to work and how I am supposed to enter the details about the projects I’m managing but I haven’t seen the magical product yet.”
(Executive Project Manager)

The EI-Internal group was a unique case because the project was too close to completion and the project manager chose not to transition to the SharePoint platform. Thus, the social representation of the group’s main knowledge-based system (the shared drive) as a sharing tool was neither doubtful nor negative because the groups managed to create on the shared drive a structure similar to SharePoint. The small size of the group allowed them to adjust the structure as needed. As SharePoint was already implemented in their division, the EI-Internal members knew it was their last project without a SharePoint platform.

Table 6.2 summarizes this discussion by putting together the findings from this section as well as from the previous one. For each group, it presents the dominant characteristics of its background (2nd column), its future goals (3rd column) and its social representation of knowledge sharing via a knowledge-based system (KBS) (4th column).

The table emphasizes the similarities and the differences among the four groups, taking into account the past (common background and values) and the future (aspired goals) necessary to understand the present (social representations) (Wagner et al., 1999).

Table 6.2: Social representations of knowledge sharing via KBS for the EI program

Group	<i>Past:</i> Background	<i>Future:</i> Goals	<i>Present:</i> Social representation of Knowledge sharing via KBS
EI-External	<ul style="list-style-type: none"> - Focus on PM skills - Knowledge in people's heads - Individualized mechanisms 	<ul style="list-style-type: none"> - Access to and from external stakeholders - Institutionalized-codified (Project Server/ SharePoint Server) mechanisms 	<ul style="list-style-type: none"> - KBS adjusted to fit existing work practices - Use of SharePoint as reporting tool - Use of shared drives and email as sharing tool - Anxious about ProjectServer/ SharePointServer
EI-Technical	<ul style="list-style-type: none"> - Mix of PM and IT skills - Knowledge in people's heads - Individualized mechanisms 	<ul style="list-style-type: none"> - Efficient document collaboration - Institutionalized-codified (Project Server/ SharePoint Server) mechanisms 	<ul style="list-style-type: none"> - Knowledge sharing too time consuming via KBS (based on shared drive and email) - Imagine that SharePoint will solve their problems - Doubtful about the transition to SharePoint
EI-SolDev	<ul style="list-style-type: none"> - Focus on IT skills - Culture to document technical knowledge for reuse - Knowledge in people's heads - Institutionalized-codified mechanisms 	<ul style="list-style-type: none"> - Knowledge Reuse - Institutionalized-codified (Project Server/ SharePoint Server) mechanisms 	<ul style="list-style-type: none"> - Shared drive is great to exchange knowledge - Very satisfied with status quo - See the transition to SharePoint superfluous and too costly
EI-Internal	<ul style="list-style-type: none"> - Focus on PM skills - Knowledge in people's heads - Individualized-codified mechanisms 	<p><i>Not Applicable</i> (automatic switch to the new platform at the end of the project)</p>	<ul style="list-style-type: none"> - Shared drive can be used to exchange knowledge in a small group

In terms of knowledge-sharing practices, the findings are presented in Table 6.2 using Boh's (2007) framework (see Table 6.1). The key point at TechProject was that existing institutionalized-codification mechanisms, such as the shared drive or SharePoint, were not used to share knowledge in a systematic manner. The results showed that EI-External and EI-Technical members were discontent with such mechanisms and that they used these

mechanisms at the individual level – rather than at the collective level – in an ad hoc, unstructured or informal manner. Thus, in these two groups, experiences and project artifacts were mostly exchanged through individualized-codification mechanisms and, when these mechanisms failed to meet the members’ needs, individualized-personalized mechanisms were used. While such mechanisms might increase organizational flexibility and responsiveness, they relied on people to talk to the right person about their problems at the right time. Based on their systematic use of the shared drive, the EI-SolDev group and the EI-Internal group shared knowledge via institutionalized-codification mechanisms even though it was not the platform that TechProject’s executives were pushing.

The table clearly shows that the common values in the past and the future aspirations had an impact on the development of the social representation of each group. However, it is not obvious how these forces modelled the actions and decisions in the present. The next section addresses the social representation functions, which look at how the groups create their social identity, justify their actions, interpret new knowledge, and seek guidance.

6.3. Examining the Social Representation Functions

With the goal to “make the unfamiliar familiar”, social representations accomplish four functions: identity, justification, knowledge, and orientation (Abric, 1994a; Moscovici, 1984). This section discusses how these four functions operated within the four groups studied at TechProject.

6.3.1. Identity function

The identity function situates individuals and groups as social actors and facilitates the development of a social identity corresponding to the group’s norms and values. The EI-

External group associated itself with the norms and values of their division. SharePoint was the knowledge-based system promoted by the External group's senior management for sharing knowledge among projects. Thus, the members of the EI-External group praised the benefits of SharePoint for sharing knowledge among project teams, when in fact they used it as a reporting tool only. The identity function of the representation of the knowledge-based system gave the group an important advantage in the process of social comparison. Their representation not only defined the group's identity but also played a role in controlling the group's members: they ought to use SharePoint. Hence, in their social discourse, they used the term *site* to describe their method for sharing knowledge. This term would imply a 'SharePoint site' for an 'outsider' but, for EI-External members, it meant either a SharePoint site or a shared drive.

The identity function also played an important role in the EI-SolDev group, which was in charge of all the technical documents. Those documents were essential not only for the EI-SolDev group to evaluate opportunities for reuse, but also for the other groups in order to understand how the technical solution was deployed. Thus, EI-SolDev had a strong identity, backed by the culture to document and to share the technical knowledge of the projects. Their group was also proud to have created on the shared drive a working environment that offered the same advantages as SharePoint in terms of collaborative work.

6.3.2. Justification function

The justification function allows individuals and groups to explain and to justify normal or errant behaviour vis-à-vis their peers or the other groups. For example, the social representation of each group served as a justification to explain not only sharing via a knowledge-based system but also lack of sharing. Using the panoply of tools that were

associated with sharing knowledge across groups required time and effort. As one of the Executive Project Managers noted, people had the desire but didn't have the opportunity because everyone was too busy or unaware that their knowledge could be useful to others:

“I think there is a reasonable desire to share but I don't think that they have that opportunity. [...] One of [the reasons] is that they might not know that what they know needs to be shared. It's also about time. They'd be willing to share if they had the opportunity but they're always busy.” (Executive Project Manager)

From the non-executive employee's perspective, it was not easy to make time for an activity (i.e. sharing knowledge via a knowledge-based system) that was not formally recognized by senior management. Sharing knowledge was treated as a lone activity at TechProject and not as a part of a bigger organizational process, which drove the retention of organizational knowledge. In this sense, one of the project managers suggested that:

“Knowledge needs to be documented, disseminated and standardized. The process needs to drive the knowledge creation, like if somebody does something new, the process should augment the knowledge creation. If that is not part of their habit, some HR policies need to be in place to make sure that people think that the repository is part of their goals and their measures for their next appraisal.” (Project Manager)

The social representation justified why certain individuals and groups preferred sharing their knowledge orally rather than via a knowledge-based system. As there was no formal measure to evaluate knowledge shared via a knowledge-based system, the effort and time invested to share knowledge were not proportional to the rewards (Han & Anantatmula, 2006).

The justification function also played an important role in maintaining disparities among groups. For example, the parallel use of several knowledge-based systems (SharePoint, shared drive, email) allowed the groups to keep using their preferred knowledge-sharing method. Theoretically, all the EI members were required to exchange documents using the SharePoint sites. In practice, documents were sent by email or stored on the shared drives so

that non-EI-External members could access them. Additionally EI-SolDev members did not find it worthwhile to transition to SharePoint and most of the EI-Technical members did not even have access to the SharePoint sites. In this context, the EI Program Manager remarked that even ProjectServer/SharePointServer could become “*a fancy note-keeping program*” used in parallel with email and the shared drives, if a control board was not instituted to control and to manage data integration across groups.

6.3.3. Knowing function

The knowing function is the social representations’ *raison d’être* because it allows individuals to acquire knowledge and to integrate it in their own reference system. For the EI-External members, it was a given that SharePoint was a standard and that everybody would use SharePoint as a repository of information for that project. This social representation offers the common frame of understanding for all the individuals in the EI-External group. For them, SharePoint is the “*tool that’s out there to share information with*” (Program Manager).

For the other groups, the social representation facilitates knowledge creation and diffusion using shared drives, email and individualized-personalized mechanisms (Boh, 2007). These three groups inevitably compared the EI-External group’s usage of SharePoint to their own usage of the shared drive. For the EI-SolDev, SharePoint provided additional organization for the project but “*everything that SharePoint does we can do it on the shared drive*” (Business Analyst). Similarly, the EI-internal group also found ways to replicate SharePoint’s benefits on the shared drive. The EI-Technical group, however, perceived SharePoint as the solution to the inconveniences of the shared drives, especially if everybody embarked on the platform.

6.3.4. Orientation function

The orientation (or the guidance) function guides behaviour and practice in three ways. First, it defines a priori the relevant relations and guides the individuals about the cognitive steps to take to accomplish their tasks. Thus, the social representation of knowledge sharing via a knowledge-based system directly determines how the group is structured and how it communicates. Within the EI-External group, the rule was to put all the project documents on the SharePoint site. However, for interactions with the other groups – who didn't have regular access to SharePoint – project documents were put directly on the other groups' shared drives or sent by email. Additionally, given the restricted access to a specific SharePoint site, there was a general practice within the EI-External group to have the most up-to-date version of a document available on the shared drive and not on SharePoint. In this way, anybody in the group could access that knowledge, not just the project team.

Second, the social representation produces a system of anticipation and expectations that shapes the interpretation of the reality by selecting and filtering the information. In this sense, the representation precedes and determines the group's interactions. For example, in the EI-External group, documents were generally available on both the SharePoint site and the shared drive. Although each document should have been saved on the SharePoint site in the folder associated with a specific project phase, the team members anticipated that not everybody had the same interpretation about the right location of a document. Hence, they believed it was faster to search for a document directly on the shared drive, where there was no structure imposed. The quotation below illustrates how the representation preceded and determined the way knowledge was shared:

“I have different interpretations. People have slightly different ideas about what phase of the project we are in. It’s not consistent. So, as I said, it’s much faster and much more effective that I go to the shared drive and do a global search.” (Project Manager)

Third, the social representation is prescriptive and defines what behaviour is acceptable, unacceptable, lawful, or tolerable in a specific context. For example, all the project managers had to send their weekly status reports to the Program Manager. In the EI-External group, the status reports were posted on the SharePoint site as that was the ‘rule’ in the External group. Project managers from the EI-Technical and EI-Internal groups sent their status reports by email. Only one project manager from the EI-Technical group posted his status reports on the SharePoint site as well. Generally, project documents were sent by email or put on the shared drives. It was acceptable and tolerated to find alternative ways to perform project tasks by using a variety of knowledge-based systems. Even email was seen as a repository like SharePoint or the shared drive:

“When you’re using SharePoint, emails should be incorporated in your SharePoint site. Any pertinent emails to the project should be in SharePoint. But well...yes, email is another repository.” (Unit Manager)

To summarise, the four functions discussed in this section correspond to the properties of the social representations. They allow us to link the symbolic reality to the continuously changing reality of social groups (Moscovici, 1986). The role of the identity function, the justification function, the knowing function, and the orientation function is not to identify individual differences; by its nature, social representations analysis is about comparing and contrasting group differences.

6.4. Analysis of the EI Groups' Social Representations: key insights

Central to the theory of representations is that social representations mirror a common understanding for a particular group. At TechProject the work environment was highly conducive to individualized mechanisms (Boh, 2007). All four EI groups (EI-External, EI-Technical, EI-Internal, EI-SolDev) preferred methods that supported oral sharing of knowledge, such as group meetings, one-on-one meetings, phone calls, audio conferences, or informal conversations. Despite this communality, the groups developed different social representations because their filtering and interpretation systems were different. Each group's social representation provided a filtering frame and the group's members perceived only those aspects related to the goals and activities of their group (Dearborn & Simon, 1958; Hastorf & Cantril, 1954). Not only were the needs and habits of each group different, but also the access to the knowledge-based system available at TechProject varied across groups. That implied that all means were used to manipulate the situation and adjust its interpretation according to the group's beliefs (Moscovici, 1986). Thus, a key insight is that communalities among the social representations of the four groups were based on the preference for individualized mechanisms (Boh, 2007) and differences were triggered by the selection and interpretation processes, which were specific to each group.

Another aspect of the theory of social representations is the belief that representations are not individually, but socially produced. Based on social interactions within and across the groups, social representations of knowledge sharing via a knowledge-based system emerged. Each group's social representation evolved over time through action and communication. The implementations of SharePoint and ProjectServer/SharepointServer were important

points in that evolution. The EI-External group adjusted the knowledge-based system to fit their existing work practices and habits. Thus, SharePoint was used as a reporting tool and ProjectServer/SharepointServer was seen as a ‘magical’ tool that had the potential to integrate all the project data. For the EI-Technical group, the magical tool was SharePoint because the group imagined it would solve their problems with their existing knowledge-based system (i.e. primarily shared drive and email). Nevertheless, based on their previous experiences with IT implementations, the group was doubtful about the success of the transition process. The EI-SolDev group was also doubtful about the transition. While acknowledging the potential benefits provided by SharePoint, they were not at all anxious to change their methods for sharing knowledge. EI-SolDev and EI-Internal were the only groups that were content and satisfied with their work practices of knowledge sharing. Hence, we could see how social representations influenced the group’s behaviour, work practices, and even beliefs (Moscovici, 1986).

The analysis of the social representation functions shows how social representations are central to the understanding of the group dynamic. The social representation informs and explains the nature of the social ties within groups and among groups, based on the development of a social identity, on the elaboration of a common understanding, and on a system of expectations and anticipations. Project documents were expected to be made available to the other members of the EI team, but the expectations with respect to the knowledge-based system used for those documents varied across groups and even within groups: status reports for senior management had to be on SharePoint, weekly status reports from project managers were put on the shared drives or sent by email, and most of the other

documents were on the shared drive. Social representations created expectations and anticipations of how interactions among groups should occur (Moscovici, 1986).

The work practices for sharing, both explicit and tacit knowledge, provided advantages to each of the four groups studied. Thus, each group had its own social identity, which was essential in the process of exercising social control and establishing power relations.

Last, but not least, the justification function reveals how the social representation depends on the context and on the work practices. The same technology, for instance the shared drive, was socially represented by the EI-Technical group as inefficient and too time consuming for sharing knowledge, while for the EI-SolDev group, the shared drive was an extremely powerful tool, used to share knowledge in a similar way as SharePoint. Additionally, because the official discourse advocated institutionalized-codified mechanisms (Boh, 2007), social representations justified “errant” behaviour such as the dominant preference for individualized mechanisms (Boh, 2007). Project managers argued that this preference was due to a lack of opportunities to share, lack of organizational policies rewarding knowledge sharing, and a lack of methods to measure individual contributions to knowledge sharing. Therefore, divergence among the groups’ social representations inevitably created and maintained disparities among the groups’ work practices.

The next chapter will further discuss these results in order to show the mutual influence: how social representations are at the origin of social practices and how social practices determine the social representations.

7. Discussion

My inquiry into the knowledge sharing practices used in the EI program at TechProject resulted in a greater understanding of how the various groups created and maintained a social representation of their knowledge-based system. The social representations analysis revealed similarities and dissimilarities among the social representations of the four groups working on the EI program. Each group associated a particular image and meaning to their knowledge-based system. By so doing, they created a social representation that influenced how the members of the group talked, how they communicated with the other groups, how they behaved, and how they viewed and interpreted the reality. Thus, the analysis of a group's social representation of sharing knowledge via a knowledge-based system is a good indicator of the group's perception (see Figure 7.1). Drawing on the analysis presented in the previous chapter, the following two sections tackle this study's specific research questions.

7.1. Sharing Knowledge Pertaining to Individual Cognition and to Social Knowing (RQ1)

The first specific question seeks to explain how project teams create, maintain, and transform knowledge that pertains both to individual cognition and to social knowing, using knowledge-based systems. The advantage of the theoretical framework chosen is that it captures the complexity of the reality by exploring the group's holistic thinking about knowledge sharing practices as well as the individual members' practices that are embedded in the institutional, bureaucratic and cultural relationships of the organization (Walmsley, 2005). Representations are not individually produced; they are social creations formulated

through action and communication (Wagner et al., 1999). The result is a set of ideas that are socially shared among the individuals belonging to the same group in order to inform, identify, justify, and guide practice.

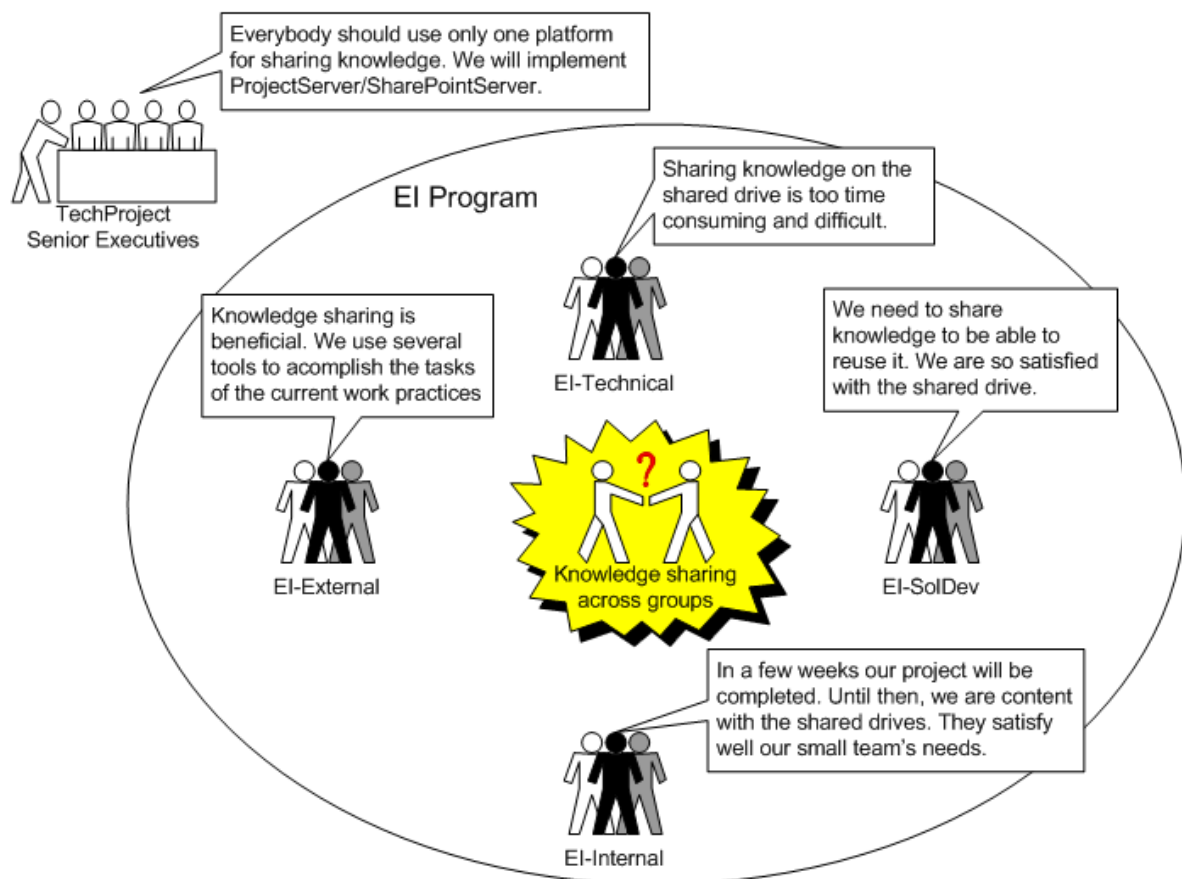

Figure 7.1: Main characteristics of the EI groups' social representations

Figure 7.1 summarizes this study's findings by illustrating the main characteristics of the EI groups' social representations with respect to knowledge sharing via a knowledge-based system. As presented in the previous chapters, I found that knowledge sharing was not considered an issue within each group. It was easier to find solutions to the various inconveniences of SharePoint or the shared drives within the group. For instance, multi-party work on the same document on the shared drive was regulated in the EI-SolDev group by a simple and effective system of notifications via emails. As for the EI-External group, they

put documents on both SharePoint and the shared drive to offer a more inclusive access to those documents. However, the differences across groups in terms of social representations and tools used (see Figure 7.1) inevitably raised challenges. Therefore, investigating how social representations influenced knowledge sharing practices across groups requires addressing issues such as the differences between individual and collective practices, the practices conducive to representations, the practices justifying or guiding behaviour through representations, the relationship between the daily experiences and routines, and the evolution of representations (Jodelet, 1986). Thus, this section is divided in two parts: first, I look at patterns of work practices and their mutual influence on social representations; second, I discuss the evolution of social representation and their influence on organizational routines and, eventually, on organizational change.

7.1.1. Dynamic interplay between practices and representations

Social representations play an essential role in describing and regulating the relations between the social actors (Doise, 1986, p.84). More precisely, they provide a common understanding within the group and a system of reference for interactions across the groups. The four groups under study had different needs, different levels of IT experience, and used different knowledge-based systems and, consequently, they created different social representations of knowledge sharing (see Figure 7.1).

These social representations acted as reference frames to create, maintain, and transform knowledge. Accordingly, each group developed individual and collective work practices. Not all individual practices became part of the collective stock. Individuals with limited or particular knowledge-sharing needs developed practices that remained peripheral to the group's collective practices (e.g. the Program Manager whose usage of the SharePoint site

concerned only a few basic functionalities). However, as the social representations of knowledge sharing practices depend on the knowledge-based system, changes in the knowledge-based system can lead to changes in the stock of collective practices. What previously was peripheral to the group's social representation may become part of the collective core. For example, the program manager's practices might be closer to the core once ProjectServer/SharePointServer is in place.

Another factor mediating the changes in the work practices and the groups' social representations is the temporal dimension. Social representations emerge based on shared values and norms, their most current form is reflected by the group's vocabulary and imagery, and they guide the groups to reach their future goals and aspirations. Therefore, social representations relate not only to the social context and background but also to the members' concerns about their future role at TechProject, for instance, how ProjectServer/SharePointServer might influence the group's status and identity. As a result, there is no single representation that is stable over time because social interactions continuously shape the evolution of the representation and the representation guides and justifies work practices (Moscovici, 2001). If one changes, the other one tends to adjust as well.

Although the data for this study was not collected to investigate the duality 'Work practices – Social Representations', this mutual influence surfaced over time as a dynamic interplay 'practices – representations' (Figure 7.2). For example, the introduction of SharePoint led to a change in the External group's knowledge-sharing work practices based on email and shared drive. Use of knowledge-sharing practices based on SharePoint led to further adjustments to the individual and, subsequently, to the group's social representation of

knowledge sharing via SharePoint. Each group continuously adjusted its social representation of the knowledge-based system used to its knowledge-sharing practices and vice-versa.

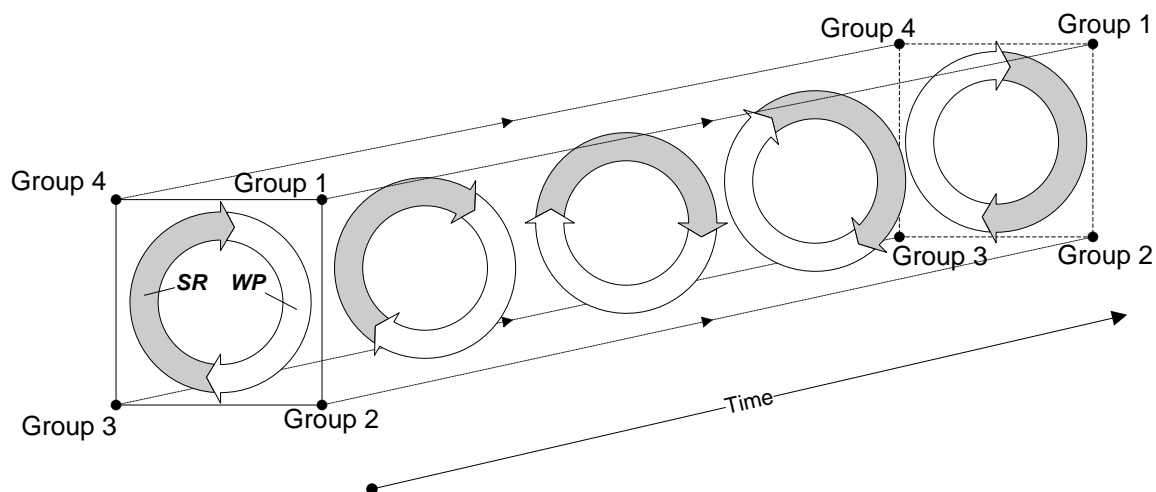

Figure 7.2: Dynamic interplay between 'social representations (SR) and work practices (WP)' (adapted from Figure 3.1)

This dynamic interplay created a series of knowledge-sharing patterns, some conducive to representations, some justifying or guiding behaviour through social representations. This idea of patterns has surfaced in other studies using the social representation theory (Vaast & Walsham, 2005; Walmsley, 2005) but the patterns differ from one study to another based on the research context. Given my interest in knowledge sharing, the patterns represented knowledge-sharing work practices that were regularly employed within and across groups.

As knowledge sharing was an activity widely encouraged at TechProject, some of the patterns initially emerged at the divisional level and were reproduced, with a few adjustments, within the EI groups, based on their divisional affiliation (see Figure 5.1). The main knowledge-sharing patterns for the EI groups are illustrated in Table 7.1. The patterns are not mutually exclusive and the table presents only the most dominant ones for each group. The remainder of this section describes and compares these patterns.

Table 7.1: Knowledge sharing patterns for the EI groups

EI-External	Contributing Transforming Disseminating			
EI-Technical ⁸	Imposing	Contributing Transforming Disseminating		
EI-SolDev ⁸	Disseminating	Contributing Transforming Disseminating	Contributing Transforming Disseminating	
EI-Internal	Ignoring	Ignoring	Disseminating	Contributing Transforming Disseminating
	EI-External	EI-Technical	EI-SolDev	EI-Internal

In Table 7.1 the diagonal shows the knowledge-sharing patterns used within the group, while the other cells indicate the knowledge-sharing patterns used between groups. The patterns identified are: 1) contributing – transforming – disseminating, 2) disseminating, 3) imposing, and 4) ignoring (see text boxes below for a detailed description of each pattern).

The first pattern (e.g. Contributing – Transforming – Disseminating) illustrates the case where knowledge is generally shared and, while a few bumps may exist in the process, the members of the group contribute to creating or updating the group’s knowledge, they transform it in order to apply it in different contexts, and they disseminate it within the group. Across groups, despite a few fruitful knowledge sharing cases especially at the senior-management level, problems generally appeared because everybody was too used to work in departmental silos. There was duplication of efforts and the wheel was often reinvented (simultaneously or successively) in different groups. For example, all three divisions

⁸ Group affiliated to the Operations division (see Figure 5.1)

(External, Operations, Internal) set standards and policies (which were not always specific to their group) and few knew what others were working on. The three remaining patterns (e.g. Imposing, Disseminating, and Ignoring) express this idea of different degrees of knowledge sharing: from barely any sharing at all (e.g. Ignoring) to simply disseminating the knowledge without contributing to it or transforming it (e.g. Disseminating).

PATTERN 1: CONTRIBUTING – TRANSFORMING – DISSEMINATING

Within each group, there were always “light-hearted people” (EI-External – Project Manager) who offered to share their knowledge either through emails or in informal conversations. They were overtly contributing to the group’s stock of knowledge, transforming old solutions to new problems, and disseminating within the group their knowledge. In short, sharing knowledge within the group didn’t raise major issues because everyone used the same vocabulary and conformed to the same rules and norms.

PATTERN 2: DISSEMINATING

This pattern characterized especially the interactions between the EI-SolDev group and the two groups from the other divisions (EI-External and EI-Internal). Given their technical expertise and their pivotal role in the structure of the EI program, the EI-SolDev group possessed a form of control (Hatch & Cunliffe, 2006, ch. 8) that they exerted by informing the members from the EI-External group and the EI-Internal group of their technical achievements. They were simply disseminating their knowledge and any other kinds of involvement (e.g. contributing to the other groups’ knowledge bases or transforming the knowledge shared by other groups) were rather limited.

PATTERN 3: IMPOSING

This pattern was characterized by the ongoing use in the day-to-day exchanges across groups of different forms of status and control. Status and control differences arose as the corresponding divisions did not share equal access to various types of capital (resources) and those differences reverberated at the EI groups level: project management skills and certifications (e.g. EI-External → EI-Technical), access to the technical knowledge (e.g. EI-SolDev → EI-External), control of technological infrastructure and IT resources (e.g. Internal Projects group → Technical Projects group), inability to measure and reward knowledge sharing, and opportunity or access to key-individuals in the organization (Levina & Vaast, 2008; Hatch & Cunliffe, 2006, ch. 8).

There was not a dominating EI group; each group played that role in different contexts. For instance, the EI-External group held the supremacy in project management expertise and most of the project managers in this group were certified by the Project Management Institute. The EI-SolDev group, composed mainly of technical experts, controlled access to technical knowledge necessary in almost all projects, independently of which group was formally responsible for the project. Finally, the Internal group owned all the internal IT implementation projects and controlled how, where, and when IT implementations were deployed at TechProject. As a result, Technical members were frustrated because the Internal group always implemented the technology in their own division, then in the External group's division, and lastly in the Operations division. It was also one of the reasons why SharePoint was a pilot project in the Operations division, while the Internal group was already implementing the next version, ProjectServer/SharePointServer.

Aside from the implementation of a common knowledge-sharing platform (ProjectServer/SharePointServer), there was little effort directed towards reducing these status differences or changing the cultural norms regulating knowledge sharing. There was no underlying fear (cf. Walmsley, 2005) of losing their job or losing the responsibility of a specific project. Given the governmental context, generally no one wanted to assume additional responsibilities and, instead, pushed decisions to a higher hierarchical level.

PATTERN 4: IGNORING

This pattern appeared at the group level in the interactions of the EI-Internal group with the EI-Technical group and the EI-External group. The EI-Internal group (composed of only one project team) kept the interactions at a minimum level, rarely participated in the status meetings, and never contacted the other project managers. Thus, this pattern is called ‘ignoring’ (Levina, 2005) because either the knowledge was not received or the group did not reflect upon it and, consequently, they did not apply it to their context. The data collected was insufficient to shed more light on the actual reason.

Moreover, given that Internal Projects group and the External Projects group were two titans at TechProject and both held significant access to four fundamental types of resources (economic, intellectual, social, and symbolic) (Bourdieu & Wacquant, 1992), knowledge sharing across the two groups was not always easy. For example, the templates created by the Internal group for all the TechProject project managers were often considered too vague and too general by External project managers and hence, they preferred to create their own templates.

The four patterns found were an important part of the working environment at TechProject. Not only were they influenced by the social representation of each group, but they also influenced the social representations of each group. Although all four patterns could be interpreted as conducive to representations, justifying or guiding behaviour through representations, they all had a dominant characteristic that can be directly linked to the social representations functions. For example, it was the knowing function that stood out in the first pattern (contributing – transforming - disseminating) and the third pattern (imposing), which were especially conducive to representations. The second pattern (disseminating) was predominantly guiding behaviour, while the fourth pattern (ignoring) was mainly justifying behaviour.

As the members of a group shared – to some extent – the same social representation, sharing knowledge within groups was more effective and unproblematic than sharing knowledge across groups. Differences in types of capital owned by each group, especially intellectual (project management certifications, ownership of information) and symbolic capital, created status differences, which inhibited collaboration and hence, the effectiveness of knowledge sharing (Levina & Vaast, 2008). The social representations of each group reflected these status differences and they were justified by the necessity to use several knowledge-based systems (SharePoint, shared drives, email) to access information across groups.

Some of the patterns were inherited as-is by the EI sub-groups from their divisional groups and they could be viewed as normal and logical practices in project management. For example, the EI-External group sought to impose its documents and rules for knowledge sharing to all the other EI groups. To some extent that practice was normal and logical given the fact that the EI-External group was in charge of the EI program. Differences in the

group's knowledge sharing practices arose because the two other groups did not have access to the same knowledge-based systems.

It is also interesting to note that EI-SolDev and EI-Technical used different patterns although they were both affiliated with the same division (Operations). EI-SolDev developed a different pattern than EI-Technical because they possessed all the technical deployment knowledge, which was needed by all the other groups. This is another example of differences in representations between 'individual elements'⁹ (here the EI-SolDev group) and the 'collective'¹⁰ (here, the Operations division), where the individual representation is peripheral to the core representation of the collective.

In sum, effective knowledge sharing and collaboration are not trivial to achieve. This finding explains in part why knowledge-based systems are not always used as intended and, consequently, the results are not as expected either. Effective knowledge sharing requires achieving synergistic solutions while balancing each party's concerns (Levina & Vaast, 2008). At TechProject, the top management team wanted to implement a synergistic solution, the ProjectServer/SharePointServer platform, but without balancing each group's concerns. The results showed that the challenge was to get all the EI groups to commit to the "one site" practice as required by the new platform. Hence, it was not only about technology or access to technology; it was also necessary to have a common representation of knowledge sharing that was harmonized across the organization (Fugate et al., 2008; Zahra & Nielsen, 2002).

⁹ The term 'individual' is used here very broadly to refer to any unit or individual element of higher level entities (Klein et al., 1994)

¹⁰ The term 'collective' describes "any interdependent and goal-directed combination of individuals" (Morgeson & Hofmann, 1999, p.251)

Since the implementation of SharePoint, new practices to share knowledge were created, while existing practices induced the preservation of the status quo. Next I explain whether knowledge shared by individuals within and across projects materialized as social knowing potentially leading to organizational change.

7.1.2. Knowledge sharing representations and organizational change

Given the mutual influence between changes in the work practices and the evolution of social representations, investigating social representations and social knowing also implies looking at the relationship between social (or collective) knowledge shared across the EI groups and organizational change. The choice of the theoretical framework of social representations was motivated, in part, by its ability to view the organisation as knowledge-based, meaning that knowledge is created and accumulated over time to generate organization-wide learning. Additionally, changes in the organizational environment offer an ideal setting for researching social representations because dealing with unfamiliar ideas and events triggers changes in the existing social representations (Bauer & Gaskell, 1999). Their potential influence on work practices may subsequently lead to organisational change. This section addresses the first research question by examining if and how changes in the EI groups' social representations of knowledge sharing led to social knowing and to organizational changes at TechProject.

As previously mentioned (see section 5.3), the initial plan at TechProject was to implement a single platform (i.e. ProjectServer/SharePointServer) for sharing knowledge within and across projects. The implementation was slated for March 2007 but, two months later, the EI groups were still using their own knowledge-based systems due to technical delays, insufficient training and, most importantly, significant differences among the social

representations of the groups involved (see Figure 7.1). During the six months I spent at TechProject, the only organizational attempt aiming to unify the groups' social representations was the training sessions for ProjectServer/SharePointServer. After these sessions, several External and Internal project managers could see the benefits of having all the data integrated and shared on a single platform. However, most of the attempts were individual ones that sought to lead-by-example or stimulate reflection:

- One project manager from the EI-Technical group put project deliverables on the shared drive for sharing within his group and he also put them on a SharePoint site to conform to the program manager's requests.
- Two External project managers did not agree with knowledge-sharing practices corresponding to the ignoring pattern. According to them, it was possible to reuse the knowledge shared by the Internal group (e.g. project deliverables templates).
- Four EI members suggested a system of rewards or formal recognition of knowledge-sharing activities.

Continuously seeking to adjust the social representation of knowledge sharing (beliefs and attitudes) to their work practices (actions and behaviours), EI members enacted incremental changes (Vaast & Walsham, 2005). The IS literature has examined such incremental changes triggered by the implementation of a new information system especially from the structural and practice perspectives (e.g. Orlikowski, 2000; DeSanctis & Poole, 1994; Chu & Robey, 2008). However, using the social representation framework, it is possible to look at a micro-level *how* these changes come about. Vaast and Walsham (2005) interpreted change as a dynamic process of consonance / dissonance between social representations and work practices. A more in-depth interpretation can be provided using a logic of opposition,

which “explains organizational change by focussing on opposing forces that respectively promote and oppose social change” (Robey & Boudreau, 1999, p. 168). Thus, incremental organizational changes at TechProject are seen as the result of three sets of opposing forces (see Table 7.2): 1) social representations of knowledge sharing using a knowledge based-system, 2) organizational routines pertaining to sharing knowledge, and 3) organizational learning.

Table 7.2: Contradictory forces influencing IT-related change at TechProject

<i>Forces influencing knowledge sharing</i>	<i>... promoting change through</i>	<i>... constraining change through</i>
Social Representations	Objectification mechanisms	Anchoring mechanisms
Organizational Routines and Organizational Learning	Improvisations and adaptations of existing routines based on new learning	Organizational Inertia and the existing Organizational Memory

A first explanation is advanced by the social representation theory through the mechanisms of objectification and anchoring: objectification promotes change while anchoring emphasizes stability. At the individual level, the reciprocal relation between change in work practices and the social representation is almost simultaneous: “By acting on the world, I not only change it, I also change myself, and I recognize this change in myself and in the world” (Markova, 2000, p.441).

At the group level, the process is more complex. For instance, the EI-Technical group and the EI-SolDev group both anchored the representation of their knowledge sharing practices based on the shared drive. Objectification processes differed significantly between the two groups and that triggered an efficient usage of the shared drive for the EI-SolDev group and a rather inefficient usage of the shared drive for the EI-Technical group. Hence, the group’s work practices had a major influence on the group’s social representation, which in turn led

to different knowledge sharing practices and routines using the knowledge-based system. Furthermore, the efficient and the inefficient usage of the shared drive respectively by the two groups further adjusted the social representation that the shared drive was an appropriate tool for sharing knowledge (EI-SolDev) or that the shared drive was the “*the wasteland in the desert*” (EI-Technical).

A second direction of reasoning is rooted in the knowledge-based perspective of the firm, where new knowledge is created and embedded over time in documents, systems, policies, routines, organizational learning and even in individuals (Alavi & Leidner, 2001). Thus, organizational routines and organizational learning become essential elements in the relationship between social representations and organizational change.

Organizational routines are generally seen as “repetitive, recognizable patterns of interdependent actions” (Feldman & Pentland, 2003, p.96) taking advantage of organizational inertia. However, organizational routines create a paradox because they can also bring change through improvisation, adaptations or mutations in the work practices (Feldman & Pentland, 2003). Routines are created and then continuously recreated with each enactment. When the routine is composed of tacit knowledge (or tacit procedural memory) as it was generally the case at TechProject, it is rather impossible to reproduce actions and behaviours, each time, in the exact same way. Therefore, the knowledge-sharing routines of each EI group were continuously changing and adjusting to their social context. For example, the EI-External group adjusted its “project status reporting” routine by making the deliverables available on both SharePoint and the shared drive. Furthermore, project managers who already attended the training on ProjectServer/SharePointServer envisioned further adjusting the routine by creating the deliverables on the new platform.

In the previous example, the first set of changes became permanent changes and triggered – unintended – organizational change through the usage of the combination of SharePoint and the shared drive to share knowledge within and across projects. In the second case, the training sessions opened the door to improvisations by trial-and-error, where learning does not necessarily lead to action, but action leads to learning (Ford & Ogilvie, 1996). In other words, it is possible for the changes to be ephemeral and to have no permanent effect on organizational routines (Miner et al., 2001).

With regard to organizational change, some of the actors used the routine because it brought comfort, made life predictable, and reduced uncertainty, thus slowly inducing change. Others took advantage of the learning process and used improvisations to enhance the performance of the routine. Through a process of selection and retention, the organization could harvest the most valued improvisations, store them as long-term learning, and institutionalize them as part of the routine.

Independently of the theoretical framework used (social representations or logic of opposition), the findings from the EI projects showed (yet again!) that technological change does not automatically trigger the intended changes in work practices and organizational routines. The groups' social representation needed to be aligned with the desired behaviour or patterns of action. Although the EI-External group was overtly advocating the benefits of SharePoint for sharing knowledge across projects, they were only using it as a reporting tool. The group justified its work practices as the knowledge-based system could not (and it was not intended to) reproduce most of the individualized-personalization mechanisms. Such behaviour could be interpreted as resistance to change. EI members could have asked the IT department to configure SharePoint in such a way that everyone working on an EI project

had access to a unified SharePoint site where they could share their project documents and their lessons learned. Instead, the EI-External members relied on their familiar routines with the shared drive. Pentland and Feldman (2008) recently noted that behaviour generally labelled as confrontation or resistance to change may in fact be directed toward the new work practice or routine that the technological artifact promotes. Hence, making live routines more efficient cannot be addressed solely by the implementation of a new technology. Even when the key actors are involved in the implementation process, as was the case for the ProjectServer/SharePointServer platform at TechProject, unintended patterns of use and unintended consequences can still arise (Pentland & Feldman, 2008). In addition to providing training and communicating the organizational vision with respect to the expected change, the anxiety generated by the new routine should be addressed through the evolution of the corresponding social representations.

Although I initially intended to study the social representations of the EI groups in a context that stretched from the past (i.e. a few weeks before the implementation of ProjectServer/SharePointServer) into the future (i.e. leave a few weeks after the implementation) as recommended by the literature (Bauer & Gaskell, 1999), the implementation delays as well as the disbandment of the EI program made it impossible to witness organizational changes due solely to the differences in social representations. As previously discussed, the interplay between practices and social representation had created small incremental changes to routines. These gradual and incremental changes could describe the organizational change as an evolutionary process where change proceeds through a continuous cycle of variation (among the groups' patterns of actions), selection, and retention (Van de Ven & Poole, 1995). However the data collected could only support the variation stage (see Figure 7.3).

For this reason, section 8.6 in the next chapter readdresses this point as an avenue for future research.

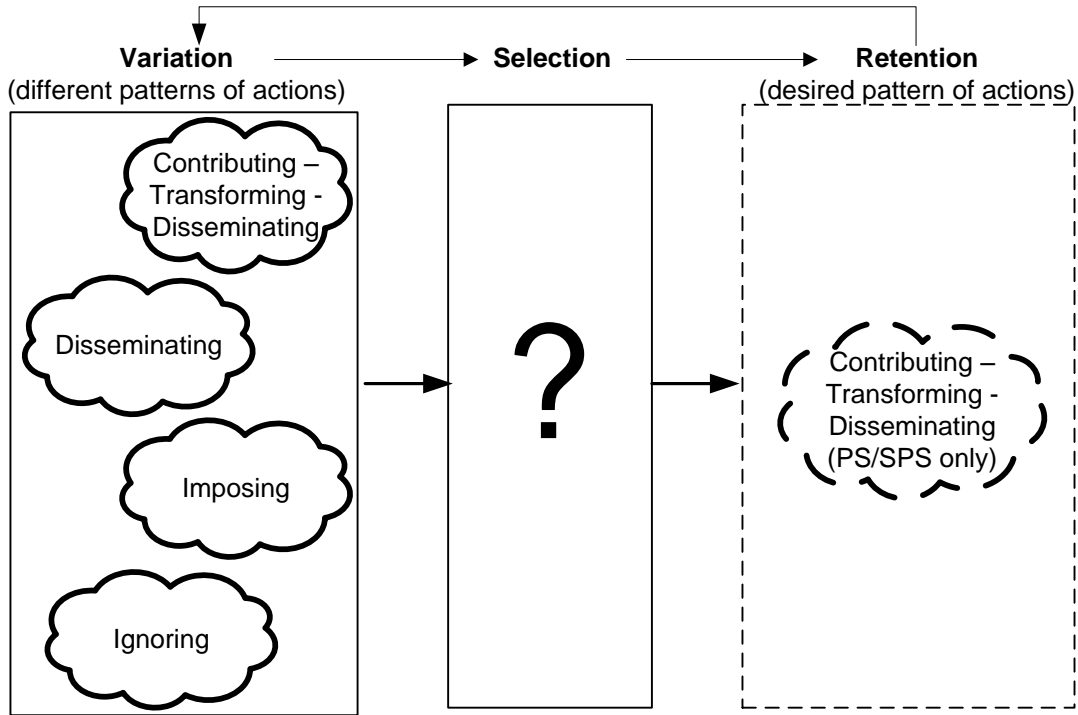

Figure 7.3: Possible change process theory based on the evolutionary motor of organizational change

Without doubt, organizational change is a complex phenomenon of interdependent actions and involving multiple actors. Inherently, these actors have various intentions and orientations and they are influenced in different degrees by existing artifacts and social expectations. As the actors interact to achieve their respective work practices, social representations change in response to the negotiation of opposing forces (e.g. anchoring and objectification mechanisms of the social representations, organizational routines and improvisations, organizational learning) (see Figure 7.4).

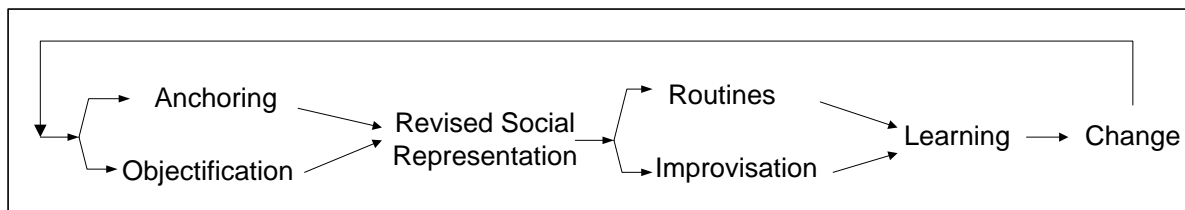

Figure 7.4: The role of oppositions to create a pattern of actions

However, these opposing forces did not create a dialectic motor of change as defined by Van de Ven and Poole (1995) because they didn't produce a revolutionary change (at least not yet!). Furthermore, the logic of thesis, antithesis, and synthesis operated only to create patterns of actions specific to each group. Thus, it is neither a dialectic motor nor an evolutionary motor of change (Van de Ven & Poole, 1995) but it is important to acknowledge the existence of a dialectic process that fosters the transformation of knowledge shared by individuals into social knowing as illustrated in Figure 7.4. An evolutionary process (see Figure 7.3) would push this transformation even further and would use the knowledge pertaining to social knowing to foster organizational change.

7.2. Representing Knowledge with IT-based Boundary Objects

(RQ2)

Consistent with the process view described in the previous section, the second specific research question asks how social representations of knowledge sharing practices affect the use of IT-based boundary objects. To address this question, I examine how the EI members used IT-based boundary objects and how these boundary objects were influenced by the EI groups' social representations.

Boundary objects are generally defined as technological or non-technological objects relevant to multiple groups but viewed differently by each group (Star & Griesemer, 1989;

Brown & Duguid, 1998). It follows that a boundary object could be anything that is used by two or more groups to share knowledge. In TechProject's case, the results showed that several knowledge-based systems had the potential to be used as IT-based boundary objects, to foster communication and collaboration across the four EI groups: SharePoint, Microsoft Project, emails, documents saved on the shared drives, templates for project deliverables, etc. (see section 5.4 for a detailed list). With such a panoply of IT boundary objects, the EI team members developed four patterns to share knowledge within and across the groups. Consequently, the IT-based boundary objects could not maintain a common identity across groups and they were far from being used effectively. A mix of reasons, emerging from existing research studies as well as from this study's data, explains this ineffectiveness: no boundary spanner, boundary objects not flexible enough to accommodate the groups' needs, and boundary objects not robust enough to maintain a common identity across groups.

First, previous studies (Levina & Vaast, 2005; Bechky, 2003) have identified boundary spanners as a necessary condition for efficient boundary spanning. At TechProject, there were neither nominated boundary spanners, nor in-practice boundary spanners (cf. Levina & Vaast, 2005). In addition to their project management responsibilities, project managers had to promote the use of the team's knowledge-based systems and to encourage their teams to share knowledge. However, the team's main knowledge-based system for sharing documents and information was not necessarily SharePoint as required by the EI program manager. Moreover, no special effort was made to converge toward a common IT-based boundary object across groups. A few senior project managers emerged in their respective groups as in-practice champions of knowledge sharing and of IT-based knowledge-sharing practices but, because their area of influence remained confined to their own group, they had not become

boundary spanners in practice. Hence, the top managers' formal discourse was the only sign promoting the importance and need for sharing knowledge across projects. Although several individuals understood the language and the artifacts of the four EI groups and could have exercised the role of a boundary spanner, top management relied on the knowledge-based systems to do the boundary spanners' work.

Second, boundary objects are said to be flexible enough to address individual needs as well as needs pertaining to a group of individuals. Indeed, each knowledge-based system satisfied individual needs well, but was not perceived by the group members as capable to support all the group's needs. For instance, all the members of the EI-External group found ways to work with SharePoint for their daily tasks. At the same time, they perceived it as an inefficient tool for sharing knowledge with the rest of the group and used it in combination with other boundary objects. Thus, the group's social representation of the knowledge-based system influenced the low degree of acceptance of the system as a boundary object.

Being flexible also implies that the boundary object has functionalities that are peripheral for a specific group but central for interactions across groups. This characteristic is essential so that the system can easily adjust to each group's needs and practices. In TechProject's case, the IT-based boundary objects were designed to allow sharing within and across groups. The impediments, however, came from the EI groups and from the technical constraints imposed by the work environment (e.g. access, training). The four EI groups did not adjust their usage of the knowledge-based systems for an efficient sharing across groups. For instance, they all used the shared drives to exchange documents and information, but each group had its own rules and habits that did not necessarily foster cross-sharing. In a way, each group expected

the other groups to adjust their practices. In this context, the IT-based boundary objects did not appear flexible enough to support knowledge sharing across groups.

Third, boundary objects should not only be flexible across groups but also robust to maintain a common identity across groups. Such a common identity did not emerge for any of the IT-based boundary objects used by the EI members. The groups' social representations were too divergent on certain points so that the knowledge-based systems acquire a common identity across groups without creating frictions. On the other hand, it was impossible to develop a common identity for SharePoint and ProjectServer given their limited accessibility.

The differences among the groups' social representations provide additional insights into why the IT-based boundary objects did not emerge in practice. Potential boundary objects become boundary objects when they are enacted as such in practice, through the corresponding social representations (see Figure 7.5). The use of a boundary object shapes its corresponding work practices as well as the groups' social representations of the boundary object. Over time, the social representation and the work practices shape the use of the boundary object. Work practices mediate the close connection between social representations and the use of boundary objects (Gal et al., 2008). The boundary objects are in fact dynamic and they should not be examined independently of the other elements (Gal et al., 2008).

Furthermore, boundary spanners are necessary to act on the social representation and position the boundary objects as peripheral elements with a common identity across groups. If these conditions are not satisfied, we can only talk about a nominated boundary object that has not been enacted in-practice and consequently, is ineffective.

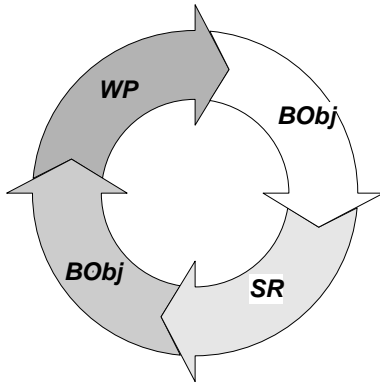

Figure 7.5: Dynamic interplay among the Social representation (SR), Work Practices (WP), and the use of the Boundary Object (BObj)

These results raise an important issue for the definition of a boundary object. How can we define a boundary object if the latter is not an independent entity? A boundary object can only be identified and defined once it is enacted in practice (Orlikowski, 2000; Levina & Vaast, 2005). For comparative purposes, it could be useful to identify a priori ‘potential’ or ‘designated’ boundary objects, but the *actual* boundary objects are those in-use.

When TechProject’s top management pushed for a change of the knowledge sharing practice, the new ProjectServer/SharePointServer platform was expected to standardize knowledge sharing practices and reconcile, at times, conflicting perspectives of the groups involved. This unique boundary object would have enhanced inter-project coordination and interaction. These objectives had a small chance to be attained as the EI groups’ social representations were clearly misaligned. The use of the existing boundary objects did enhance coordination and interaction but only within the groups. Across the groups, there was still reluctance to use the IT-based boundary object to share project knowledge for fear of public scrutiny. Additionally, there was the problem of access to a common boundary object across the groups and the differences in resources (economic, intellectual, social, and symbolic) among

the groups. Consequently the groups relied on the familiar IT artifacts (Pentland & Feldman, 2008) whose usage as boundary objects was rather ineffective.

Other studies (Gal et al., 2008; Levina & Vaast, 2008) found that the actors involved in boundary spanning attempt to renegotiate boundaries or boundary objects when inefficiencies surface. There was no clear evidence that such renegotiation took place (formally or informally) at TechProject. Possible reasons are the diversity of boundary objects and the limited role of knowledge-sharing champions who were only acting within their own groups.

Another implication of these results is that the way boundary objects are used cannot be mandated. The literature is full of examples of unsuccessful projects of technology-driven change. It appears that sharing across groups cannot work efficiently and effectively without boundary spanners (Bechky, 2003; Orlikowski, 2002; Friedman & Podolny, 1992). The boundary spanners' role is essential in creating differences of opinion at the periphery of a group's social representation. The boundary spanners do not only foster the transfer of knowledge, but also its transformation into the new context.

Lastly, the groups' social representations can lead to a renegotiation of the boundary objects in terms of their usage. If the boundary object is renegotiated and placed at the periphery of the groups involved in sharing knowledge, it has a greater chance to be enacted as such and to be used effectively. As the knowledge shared via the IT-based boundary object touches multiple organizational levels (individual, groups or project teams, organization), boundary objects in-use could change individual social representations as well as the social knowing.

8. Conclusions

The temporary nature of project structures and the strong focus on the completion of the project, according to its budget, schedule and objectives, render knowledge sharing activities rather challenging. In spite of several guidelines and tools recommended by the project management literature, sharing knowledge across projects, especially process-related knowledge, is still the weakest link in the chain of knowledge management activities. This study tackles this issue by building a theoretical account, which highlights the relationship between individuals' representations of the knowledge-based systems and their actions (i.e. how knowledge-based systems as shared systems or as boundary objects are used in order to link organizational members across projects).

8.1. Summary of Findings

The goal of this research was to explain, from the stakeholders' perspective, IT-based knowledge sharing practices across project boundaries. Thus, the theoretical framework of social representation was used to answer two specific research questions. Table 8.1 restates the research questions and highlights the main findings related to each question.

8.2. Validation of the Theoretical Account

When building theory, it is good practice to explicitly address the level of theory (Klein et al., 1994). In the current research, the level of theory is the project group as an aggregation of homogenous individuals with respect to the theoretical construct of knowledge sharing.

Table 8.1: Summary of findings

<i>Research Questions</i>	<i>Findings</i>
<p>RQ1: How do project team members create, maintain, and transform knowledge, which pertains both to individual cognition and to social knowing, using knowledge-based systems?</p>	<p>The four groups examined (EI-External, EI-Technical, EI-SolDev, EI-Internal) had different knowledge sharing practices, using various knowledge-based systems. Consequently, the groups' social representations varied greatly. In addition, TechProject senior executives pushed for the implementation of a common IT-platform for sharing knowledge.</p>
	<p>The differences across groups in terms of social representations of knowledge sharing practices using a knowledge-based system inevitably raised challenges. Within each group, sharing knowledge via a knowledge-based system was not as problematic as doing it across groups.</p>
	<p>The social representations acted as reference frame for creating, maintaining, and transforming knowledge.</p>
	<p>In close relation with its social representation, each group developed individual and collective work practices. Not all individual practices became part of the collective stock. Additionally, changes in the knowledge-based system used could lead to changes in the social representation and in the stock of collective practices.</p>
	<p>There was a dynamic interplay between social representations and work practices and consequently four knowledge-sharing patterns emerged: 1) contributing – transforming – disseminating, 2) disseminating, 3) imposing, 4) ignoring.</p>
	<p>Continuously seeking to adjust the social representation of knowledge sharing (beliefs and attitudes) to their work practices (actions and behaviours), EI members enacted incremental organizational changes. These incremental changes were the result of several opposing forces: social representations of knowledge sharing via a knowledge based-system, organizational routines pertaining to sharing knowledge and organizational learning. The dialectic process fostered the transformation of individual knowledge into social knowing.</p>
	<p>Technological change does not automatically trigger the intended changes in work practices and routines. The groups' social representation needs to be aligned with the desired behaviour or patterns of actions</p>
	<p>What is generally labelled as confrontation or resistance to change may be directed toward the new work practice or routine that the technological artifact would promote. The anxiety generated by the new routine should be addressed through the evolution of the corresponding social representations.</p>
<p>RQ2: How is knowledge represented in the IT-based boundary objects affected by the individuals' social representations?</p>	<p>There were neither nominated boundary spanners, nor in-practice boundary spanners. The knowledge-based systems were expected to do the boundary spanners' work.</p>
	<p>The knowledge-based systems, as IT-based boundary objects, were not robust enough and not flexible enough to maintain a common identity across groups and also to satisfy the groups' needs.</p>
	<p>Potential boundary objects become <i>real</i> boundary objects when they are enacted in practice through the corresponding social representations.</p>
	<p>The groups relied on the familiar routines of the knowledge-based system, whose usage as boundary objects was ineffective. Given the differences in social representations, the access to the knowledge-based systems, and the differences in resources, the groups did not attempt to renegotiate the boundary objects.</p>

Furthermore, the resulting theory is evaluated in terms of how well the researcher followed the principles of the research paradigm. For interpretive studies, it is typical in the IS literature to make this assessment using Klein and Myers' (1999) principles (e.g. Pawlowski & Robey, 2004; Vaast & Walsham, 2005). Table 8.2 summarizes these principles and explains how they were addressed by the study's research design.

Table 8.2: Evaluation of the research design and the analytic strategy (Klein & Myers, 1999)

<i>Principle</i>	<i>Justification</i>
<i>Hermeneutical process</i>	Analysis of individuals' responses represents the parts, while the storyline at the project level represents the whole.
<i>Contextualization</i>	Sustained involvement in the field allowed me to contextualize the observations
<i>Interaction between researcher and subjects</i>	I tried to question my own assumptions and also submitted narrations of the case-study to non-involved peers.
<i>Abstraction and generalization</i>	Although the findings were grounded in the context of the four groups examined, I tried to apply existing theories of knowledge sharing, organizational change, and social representations in order to build a more refined theory for knowledge sharing across project boundaries.
<i>Dialogical reasoning</i>	Prior research informed the initial constructs, but I was open-minded to other possible theoretical interpretations.
<i>Multiple interpretations</i>	I looked for multiple interpretations that indicated different social representations. However, I was also very sensitive to possible differences in the stakeholders' interpretation of the same events.
<i>Suspicion</i>	A good understanding of the context allowed me to identify possible biases in the subjects' answers. Discussions with peers about the case study also helped me identify possible biases.

The *principle of the hermeneutic circle* is fundamental to all interpretive studies and all the other principles draw from it. The hermeneutic circle suggests that the complexity of the 'whole' can be understood from the meanings of its parts and of their relationships. The circular process of interpretation begins from a simplistic understanding of the parts and

moves to the whole and then moves back to an improved understanding of the parts. This principle is incorporated in the research design by treating the individuals' responses as the parts and the description of work practices in the project as the whole. The analysis moved back and forth between the parts (the data from individuals) and the whole (the theory) to examine how individual representations affected work practices and vice-versa.

The *principle of contextualization* requires the researcher to critically reflect on the social and historical background of the research setting in order to set the subject in its context. This principle was fulfilled in this research by a sustained involvement in the field in order to provide a detailed account of the social, historical, and technical context of each group.

The *principle of interaction between the researcher and the subjects* requires the researcher to place himself and the subject in the historical context. Thus, the researcher needs to critically reflect on his interactions with the informants and on how the data was socially constructed. As a researcher, I conformed to this principle by critically reflecting on the informants' interpretive and analytical processes and by questioning my own assumptions. In addition, I asked non-involved peers to evaluate the narrations of the case study.

The *principle of abstraction and generalization* associates the particular subjects described according to the principles of contextualization to more abstract categories. This does not imply generalization of the findings in a positivist manner but rather that the findings are linked to theoretical and general concepts. This resulted in the construction of a logical chain of evidence showing the gradual passage from specific to general (Miles & Huberman, 1994). The goal of the case study design is analytic generalization, meaning that the researcher generalizes to theoretical propositions and not to populations or universes (Yin, 2003). Thus, the findings from the data analysis are related to the concepts of social

representation theory, boundary objects, knowledge sharing, and to various theoretical aspects of organizational change.

The *principle of dialogical reasoning* requires the researcher to question his preconceptions based on the emerging data. Although prior research informs the initial constructs and research themes, I was also sensitive to other possible theoretical interpretations.

The *principle of multiple interpretations* is different from the previous principles because it requires being sensitive to the informants' interpretations. Informants perceive the same event differently as they possess different assumptions, backgrounds, beliefs, or cultural values. To some extent, I expected and I even looked for multiple interpretations because they could indicate differences in the social representations of the individual or the group.

The *principle of suspicion* focuses on the discovery of 'false preconceptions' rather than on false interpretations of meanings. Consequently, as the researcher of this study, I was sensitive to potential biases and distortions in the informants' answers by systematically questioning the surface meaning of their answers.

8.3. Implications for Research

'When', 'how', or 'why' research questions are still essential to describe changes in work practices and how organizations adjust to environmental changes, despite the ubiquity of research on organizational change (Fox-Wolfgramm et al., 1998). Prior research has investigated the topic of knowledge sharing using a variety of theoretical angles but very few studies (in the management field) have used social representations to simultaneously examine the individual's and the group's practices. Thus, the first research implication is the provision of a theoretical account based on the social representation theory.

The social representation theory is particularly appropriate for investigating social issues in continuous evolution, from the stakeholders' perspective. This theoretical framework does not replace other theoretical frameworks (e.g. theories on practice and knowing, organizational learning, situated learning, sensemaking, etc.) but rather complements them by providing a micro-level view. The main premise of the social representation theory is that the socially produced representations determine our actions. Compared to the other theoretical angles, the social representations offered additional insights to better understand IT-based knowledge sharing across boundaries, more precisely:

- How changes in knowledge-sharing practices emerged and evolved to gradually influence organizational routines;
- How a link between the past (the groups' values, beliefs, symbols, and norms) and the future (the groups' goals and aspirations) was created through social exchange typical to each group;
- How each group understood and communicated the "substratum of images and meanings" (Farr & Moscovici, 1984, p.19) thus contributing to the collective memory and to social knowing;
- How reflection on the social context of IT-based knowledge-sharing practices in project management was fostered;
- And finally, why knowledge-based systems were not used as intended and did not provide the intended benefits.

A second research implication of the findings is the role of social representations in human agency. Social representations capture symbolic forms of individual and holistic thinking that

shape perception and guide behaviour. Under this light, IT-based knowledge sharing is not black or white anymore (e.g. to share or not to share). Project team members act as agents and make choices regarding their knowledge sharing practices that vary greatly between the two extremes. Thus, the social representation angle offers shades of grey between the black and white extremes. This is not a question whether the knowledge-based system is used, but rather “how” and “how much” the system is used. Some project teams will share more than others; some will use the systems to share knowledge better or more efficiently. By examining the social representations, it is possible to identify (even to measure, if a positivist stance is adopted) the degree of sharing.

A third implication is methodological and it regards the data collection and analysis procedures. In order to identify and analyze the groups’ social representations, I used not only data from the interviews and the non-participant observation, but also documents, reports, memos, charts, guides, etc. By coding and treating this data in the same manner as the ‘traditional’ data from interviews and observation, it was possible to distinguish differences in social representations, in interpretations, and in the meanings associates with the theoretical concepts.

Fourth, the findings in this research extend existing theoretical models of organizational change. For instance, in Robey and Boudreau’s (1999) logic of opposition of organizational consequences of information technologies, the social representation perspective fits as a fifth theory explaining IT’s role as an enabler and a constraint in IT-based organizational change.

A final implication is the contribution to the emerging IS literature on social action and cognition. This study’s findings imply that understanding the actors’ social representations is necessary to create organizational change. Especially in situations of crisis, the tension and

the time pressure within the project teams fosters the emergence of new social representations and the modification of existing social representations.

8.4. Implications for Practice

The main implication for organizations concerns the role of social representations in supporting organizational change. Opposing forces that act on individuals' representations and both 'stability' and 'change' elements influence how the individuals' representations form and change over time. Rather than push for a technology-driven change, organizations should tackle the groups' social representations, which guide behaviour and lead to action. Understanding these dynamics as well as the interplay between social representations and work practices is essential in order to foster organizational-wide learning and (indirectly) organizational change. Establishing strong knowledge sharing practices should not be an isolated activity but a part of a bigger organizational process, which drives the retention of organizational knowledge.

Social representations also become relevant in cases of conflicts or increased time pressure. Then, appropriate strategies for reconciling opposing social representations of the knowledge-based system used need to be developed. These findings reiterate and highlight the importance of the communicative processes within each group but also across groups.

Furthermore, in order to successfully introduce a common IT-based platform for sharing knowledge, TechProject (and any other organization in a similar case) should align the groups' social representations. This does not mean that peripheral representations will not exist; rather, it means that the top management's efforts should focus on aligning the groups'

core representations. By “manipulating” the social representations, the new system or technology has a better chance to get accepted by users.

Another important implication is the essential role of boundary spanners. TechProject’s case showed that, in the absence of boundary spanners, knowledge-sharing across groups did not occur effectively. These findings are consistent with those from other studies (Bechky, 2003; Orlikowski, 2002). Sharing knowledge is not an innate quality. The desire to share may be innate but *how* to share knowledge and *what* to share needs to be learned. The role of boundary spanners is to lead by example and to demystify the ‘unfamiliar phenomenon’.

Empirical studies have also shown that boundary objects are often marginalized by each group and under the influence of such factors as negotiation, interpretation, authority, organizational control, and inter-dependence. One study even concludes that project management tools (e.g. artifacts from Microsoft Project) as boundary objects are ‘high-maintenance items’, ‘with a limited shelf life’, and with ‘no independent potency for alignment’ (Sapsed & Salter, 2004). The theoretical lens used in the present research illuminates social representations as a key element in knowledge sharing practice. When representations differ among groups, IT-based systems may not become boundary objects in-use because they are likely to be understood differently. Therefore, the project management tools are not high-maintenance boundary objects but, in order to be efficient, they need to become boundary objects in-practice. These findings enrich our understanding of the types of IT artifacts, activities, and tools needed in organizations wishing to capitalize on knowledge acquired during each project.

8.5. Research Limitations

This study is not without some limitations. First, organizational change is viewed here as very gradual and the data collected did not show any radical changes. On one hand it could be the time period spent at TechProject and six months was maybe not enough, in this case, to see such changes. On the other hand, it might not be related to the length of the time period but to the time period itself. Social representations are best studied when ‘new’ issues emerge and the paths of different groups cross (Bauer & Gaskell, 1999). While that was the case at TechProject, a major organizational restructuring also occurred toward the end of the data collection phase. Thus, staying more than six months at TechProject would have introduced a significant level of noise in the findings.

Second, cultural values and symbols affect the evolution of a social representation (Markova, 2000) because social representations create a link between the past and the future. As a member of a particular group, one needs to conform to the social exchange typical to that group and to the groups’ values, beliefs, symbols, and norms (“the past”). Thus, an ethnography-based research would have provided more insights into the evolution process.

Third, it is important to note that there are always “power relations that underlie the construction of knowledge” (Gal & Berente, 2008, p.149). Any group has power relations and it is impossible to deny their existence especially in the context of a governmental agency. A political interpretation (as well as other theoretical interpretations of the data) could have been possible, but I chose an interpretation grounded on the data, based on the groups’ social representations.

Finally this study, like most of the studies on knowledge sharing across boundaries, assumes that knowledge integration is beneficial and that the advantages outweigh the costs. Nevertheless, when differences in knowledge at the boundaries do not converge, this assumption does not hold (Howard-Grenville & Carlile, 2006). To control for this potential risk, the teams examined had to already use a knowledge-based system for sharing knowledge within or across projects. However, no attempt was made to objectively assess knowledge convergence at the boundaries. In other words, this research assumed that, if an organization invested time and physical resources into a knowledge-based system, knowledge integration was beneficial.

8.6. Future Research

In addition to simply addressing the research limitations mentioned above, this first study on social representations of knowledge-sharing practices opens the door to several other research opportunities.

The results raised intriguing questions about the influence of social representations on organizational change. Thus, an important research opportunity, albeit rather challenging, is to focus on this relationship and on the motors generating the change (Van de Ven & Poole, 1995). Opposing forces in each EI group created social representations of the knowledge-based systems that were more or less similar across the groups. This variation engendered the adoption of four main patterns characterizing knowledge sharing within and across the groups. Based on these findings, the change process resembled Van de Ven and Poole's evolutionary model where some of the patterns are selected and others are eliminated through 'natural selection'. Through anchoring and objectification, the selected patterns shape the

form of the new social representation. Do social representations really influence organizational change following an evolutionary model? If so, how does the 'natural selection' occur? Do routines and improvisations really mediate the relationship between work practices and social representations? What are the conditions influencing the balance toward the forces promoting change or toward the forces promoting stability?

Furthermore, what is the relationship between the evolutionary change process and the opposing forces of the social representations? Do they support or constrain each other? A similar research avenue could also aim at refining Van de Ven and Poole's framework by examining how the two motors (evolutionary and dialectic) work together: as intertwined motors, in parallel, or consecutively.

Another research opportunity is to consider organizational culture, as an important dimension of the social context, exerting a powerful influence on the individuals' knowledge needs and their subsequent knowledge-sharing practices (Alavi et al., 2005). Previous research has already pointed out how an organization's cultural values influence its knowledge sharing practices (Alavi et al., 2005; Knapp & Yu, 1999; Davenport et al., 1998) as well as how they impact the way the knowledge-based systems are used (Alavi et al., 2005). Based on the TechProject case-study, I found that knowledge sharing across groups was ineffective and that the groups' social representations varied significantly. What is the role of the organizational culture when an organization aims to achieve a common social representation? Is the cultural transition the essential predecessor of a social representation harmonized across the organization? Is this cultural transition the key element to achieve an effective and efficient knowledge sharing process?

Finally, another research opportunity is to use the social representation theory to validate Nonaka and Takeuchi's (1995) concepts of socialization and externalization. Gourlay (2006) has recently remarked that Nonaka and Takeuchi's groundbreaking model does not have enough evidence supporting the socialization and the externalization of technical tacit knowledge. With respect to the former, Nonaka and Takeuchi seem to suggest that "when someone learns under the guidance of an expert that some indescribable kind of knowledge is 'transferred' by an *unknown* [emphasis added] process" (Gourlay, 2006, p.1420). As for externalization, Nonaka and Takeuchi based their reasoning on figures of speech suggesting "it is a linguistic process through which, *mysteriously* [emphasis added], tacit knowledge becomes explicit" (Gourlay, 2006, p.1420). While I agree in general with Gourlay's remarks I do not believe the two processes are unknown and mysterious. On the contrary, I think social representation theory is a very appropriate theory for demystifying this black box.

In conclusion, my dissertation examined IT-based knowledge sharing practices and gave an explanation of the social representations formed by each project team and how they affected the knowledge sharing practices within and across groups. Based on my findings, I also offered suggestions for management practices and future research opportunities by recognizing the critical role of social representations in introducing change and accepting the unfamiliar event. It is my hope that this research provided a different way to consider the socio-technical influences in IT change management, in both theoretical and practical terms.

Appendix A: Interview Guide

Note: This general protocol contains the universe of questions that may be sampled. Specific protocols will be tailored to the role of the informant as all informants may not necessarily be able to respond to all questions. Not all questions will be asked during an interview.

Research Objectives

- To understand how knowledge-based systems (KBS) act as boundary objects across projects
- To identify how knowledge is represented in the knowledge-based systems
- To understand, from the users' perspective, how knowledge-based systems are used to sharing, translate, and transform knowledge across project boundaries
- To identify similarities and differences in the groups' representations of the knowledge-based systems in terms of functionalities, access to knowledge, etc.
- To identify technological and organizational barriers to more effective and efficient use of the boundary objects
- To identify technological and organizational factors supporting the effective or efficient use of the boundary objects
- To identify formal and informal processes for creating and maintaining representations of the knowledge to be shared and of the boundary object

Interview Themes & Questions

<i>Themes</i>	<i>Questions</i>	<i>Informants</i>
Informant's role		
<ul style="list-style-type: none"> • General Info 	<ol style="list-style-type: none"> 1. What is your current position? 2. How long have you held this position? 3. What are your major responsibilities? What does that involve? 4. To whom do you report and on what basis? 	<ul style="list-style-type: none"> • All informants
Project		
<ul style="list-style-type: none"> • General info 	<ol style="list-style-type: none"> 5. Could you please describe the project, its objectives and main stakeholders? 	<ul style="list-style-type: none"> • Organizational-level managers • Project Managers
<ul style="list-style-type: none"> • Knowledge needs of the project 	<ol style="list-style-type: none"> 6. [current needs] Do you share knowledge from your project with other active projects? What are the relations between these projects and 	<ul style="list-style-type: none"> • Project Managers • Project team members

	your project? What kinds of knowledge do you share?	
	7. [future needs] Do you document knowledge from your project in case such knowledge might be needed in future projects? Any other methods besides documents?	
	8. [defined or undefined needs] In general, is the collaboration between projects mostly with active project (synchronous) or with closed projects (asynchronous)?	
	9. [explicit or tacit K needs] Have you felt the need to know more than what was written in a document? Have you tried to contact the PM for either closed or active projects?	
	10. [evolution] Overall, how has the collaboration among projects evolved over time?	
• Use of KBS	11. [kinds of K] What kinds of knowledge are generally shared via the KBS? How have they evolved over time?	• Project Managers • Project team members
	12. [use of KBS] What are the formal or informal rules for updating info stored in KBS?	
	13. [retrieve K] Who decides when and how to use the system to retrieve information?	
	14. [transform K] Who decides how to use the knowledge retrieved from the system?	
	15. [accuracy] If the information provided by the system proves to be inaccurate or incorrect, what do you do? How often has it happened?	
• Project Context	16. [context unique] How often or how fast does the context change (new requirements or new conditions) between when the knowledge is stored and when you retrieve it or when you store the K and others retrieve it?	• Project Managers • Project team members
	17. [K dependent on source] How dependent on the context is the knowledge you sharing to other projects? Or, how dependent on the context is the knowledge you retrieve from the KBS?	
	18. [K unique] How different or specialized is the knowledge transferred from your project? Or, how different or specialized is the knowledge transferred from other projects?	
<hr/>		
KBS usage by the project team		
• General use	19. [use] How is the KBS used by your project team? How much or how often are they used?	• Project Managers

	Is its usage mandatory or voluntary?	• Project team members
	20. [update] How much liberty do individual team members have in modifying knowledge in stored in the KBS?	
	21. [update] Can any team member modify the knowledge currently stored in the KBS?	
• Assessment of use	22. Do you have formal or informal processes for evaluating the knowledge in the KBS, its accuracy, its relevance, or its trustworthiness?	• Project Managers • Project team members
	23. How do you assess the current usage within your team? Across projects?	
KBS usage by individuals		
• List of KBS	24. Do you use any other system or informal “electronic notes” to share your experiences with members from other projects? And within the project?	• Project Managers • Project team members
• System functionalities (for the main KBS)	In your opinion, 25. What is the main purpose of using [specific KBS]? 26. Does [specific KBS] provide the features you need to carry out your task efficiently and effectively? 27. What are the advantages and disadvantages of using [specific KBS]? 28. How satisfied are you with [specific KBS]? 29. What are the most important areas/functionalities that you would improve based on your experiences and needs?	• Project Managers • Project team members
• Experience (for the main KBS)	30. How extensive is your personal experience with [specific KBS]? 31. Are they easy to use? Was it easy to learn to use them? Do you experience any difficulties in using them? 32. Have enough training sessions and support been offered? 33. Do you believe the information provided by [specific KBS] is relevant, accurate, or trustworthy for your professional work? 34. How has using [specific KBS] affected your work practices? 35. How have your expectations about [specific KBS] evolved over time? 36. [resistance] Do you have any “shortcut” methods to share your experiences your way,	• Project Managers • Project team members

	rather than via [specific KBS]?	
<ul style="list-style-type: none"> • Individual K needs (for main KBS) 	<p>37. What kinds of knowledge do you need to retrieve from [specific KBS]? Are these needs currently supported?</p> <p>38. What kinds of knowledge do you think you should store in the system for future use? Is this what you currently store?</p> <p>39. How have your knowledge needs evolved over time?</p>	<ul style="list-style-type: none"> • Project Managers • Project team members
Technological context		
<ul style="list-style-type: none"> • Infrastructure 	<p>40. Do you feel that TechProject has an appropriate IT infrastructure for the system, such as a proper communication network, IT support staff, hardware and software?</p> <p>41. Did you or someone from your group take part in the selection or implementation process?</p>	<ul style="list-style-type: none"> • Project Managers • Project team members • IT administrator
Organizational context		
<ul style="list-style-type: none"> • Organizational context 	<p>42. [K tacit or explicit] Do you feel that the kinds of knowledge you generally need is mostly captured by the KBS, embedded in organizational processes, or it resides in people?</p> <p>43. [use] What do you see as important organizational factors that need to be addressed for more efficient and effective systems use?</p>	<ul style="list-style-type: none"> • Organizational-level managers • Project Managers • Project team members • IT administrator
<ul style="list-style-type: none"> • Boundary Spanners 	<p>44. Has anyone been formally nominated to encourage usage of the KBS? Has anyone other than the nominated person encouraged project members to use the KBS to share their experience (i.e. spanner in practice)? Do they belong to particular projects or have a higher-level organizational role?</p> <p>45. What resources do these people employ to encourage KBS usage? (i.e. What forms of capital do they use: economic capital (e.g., money, time, technology), cultural capital (e.g., professional expertise, education, ownership of information), social capital (which social networks an agent can draw on), and symbolic capital (the ability to name any other resource as valuable, the power to name and classify things?))</p>	<ul style="list-style-type: none"> • Organizational-level managers • Project Managers • Project team members • IT administrator

Appendix B: Contact Form

Informant Description

Interview #:

Date & Time of Interview:

Name of Informant:

Title:

Phone:

Email:

Main Issues or Themes that were striking with this contact

Summary of information collected

Interview Question	Information

Other salient, interesting or important information

New questions or puzzling issues to resolve

- 1.
- 2.
- 3.

Appendix C: Document Form

Document Summary

Document #:

Document Title:

Date received:

Place received:

Event or contact with which document is associated:

Document Description

Significance or importance of document

Brief summary of contents

- 1.
- 2.
- 3.
- 4.
- 5.

New questions or puzzling issues to resolve

- 1.
- 2.
- 3.

Appendix D: Coding scheme

Code	# of text segments	Examples
Temporal dimension: future goals and aspirations	33	I just think we need to just start communicating more and making it more mandatory to put project information into SharePoint.
Temporal dimension: past (background)	76	From a project management perspective, in my group, we have sharing all the time, in our staff meetings. Are there things that have occurred that people haven't seen before?
Temporal dimension: present (anchoring and objectification)	65	You have your project site in SharePoint and you have the schedule and issues, and all that in Server. It's almost like you go in one place and you have everything you need to know about that project as opposed to looking on share drives and trying to figure out where the documents are.
Linking Social Representations to the Past	2	Everyone is used to providing a lot of documentation, but everyone is doing it their own way.
Linking Social Representations to the Future	1	This organization is really organized within individual groups, silos. We're trying to break down those walls when necessary, so that we're all on the same page.
Group dynamics: forms of collaboration	53	We have weekly status meetings where we share the issues and consent but not necessarily project documents.
Group dynamics: forms of imposing	30	They haven't even tried to circulate this thing. Saying "it's down on SharePoint, come look at it" is not the same as actively participating in a discussion about the templates.
Group dynamics: forms of ignoring	17	Look this is what I do; you can do whatever you want with it.
Social Representation: Identity function	9	In our team there is no need to reinforce sharing. We have that culture and we do it.
Social Representation: Justification function	24	The dashboard is driven by all the information on Project Server. So it almost forces people to comply because the dashboard is used in front of senior management. Obviously they want to look good.
Social Representation: Knowledge function	4	It's a standard here that we have and most projects are on [SharePoint]. That's a given. When a project is initiated we start a SharePoint site. We know that that's a repository of information for that project.
Social Representation: Orientation function	14	Everyone accepts [the use of shared drives] because the top management would be able to go look at the shared drives as well. It's not hiding anything. I can't think of any particular reason to hide anything.
Social Representation: Symbols	13	SharePoint is the magic word. They say SharePoint but in fact it is on the S-drive, which is not a SharePoint drive
Boundary Objects	231	We have our own SharePoint folder but half of the time it runs on email as much as anything.
Boundary Spanners	35	We formed an alliance and thus the Project Management leadership is comprised of [the Internal unit director], [the head of the knowledge center], [the External unit director], and [the Technical unit director]. We represented every aspect of TechProject. We would come together, get an agreement on getting forth with the tool, how it's going to be rolled out, and configurations and things like that. Then we disseminate that information down to our respective departments.

References

- Abric, J. C. (1994a). Les représentations sociales : aspects théoriques. In J. C. Abric (Ed.), *Pratiques sociales et représentations*. Paris: Presses Universitaires de France.
- Abric, J. C. (Ed.). (1994b). *Pratiques sociales et représentations*. Paris: Presses Universitaires de France.
- Alavi, M., Kayworth, T. R. & Leidner, D. E. (2005). An Empirical Examination of the Influence of Organizational Culture on Knowledge Management Practices. *Journal of Management Information Systems*, 22(3), 191-224.
- Alavi, M. & Leidner, D. E. (2001). Review: Knowledge management and knowledge management systems: Conceptual foundations and research issues. *MIS Quarterly*, 25(1), 107-136.
- Ancona, D. G. & Caldwell, D. F. (1992). Bridging the Boundary: External Activity and Performance in Organizational Teams. *Administrative Science Quarterly*, 37(4), 634.
- Anonymous. (2006). ITtoolbox Survey Shows Professionals Seek Advice on IT Purchasing Decisions from Experienced Peers. July 19, 2006. Retrieved January 5, 2007, from <http://www.ittoolbox.com/help/presscenter.asp?i=106>
- Bacharach, S. B., Bamberger, P. & Sonnenstuhl, W. J. (1996). The Organizational Transformation Process: The Micropolitics of Dissonance Reduction and the Alignment of Logics of Action. *Administrative Science Quarterly*, 41(3), 477-506.
- Bauer, M. W. & Gaskell, G. (1999). Towards a Paradigm for Research on Social Representations. *Journal for the Theory of Social Behaviour*, 29(2), 163-186.
- Baxter, R. & Lyytinen, K. (2005). Information Technology Impact on Work Practices: A Study of 3D CAD Capabilities in Architecture, Engineering, and Construction [Electronic Version]. *Sprouts: Working Papers on Information Environments, Systems and Organizations*, 5, 64-87 from <http://sprouts.case.edu/2005/050205.pdf>.
- Bechky, B. A. (2003). Sharing Meaning Across Occupational Communities: The Transformation of Understanding on a Production Floor. *Organization Science*, 14(3), 312-330.
- Beer, S. (2004). IT Wire: IT project failures up sharply according to US report. Retrieved Feb. 10, 2007, from <http://www.itwire.com.au/content/view/441/2/>
- Berger, P. L. & Luckmann, T. (1967). *The social Construction of reality: a treatise in the sociology of knowledge*. New York: Anchor Books, Doubleday.
- Bhattacharjee, A. & Premkumar, G. (2004). Understanding changes in belief and attitude toward information technology usage: a theoretical model and longitudinal test. *MIS Quarterly*, 28(2), 229-254.
- Bock, G.-W., Kankanhalli, A. & Sharma, S. (2006). Are norms enough? The role of collaborative norms in promoting organizational knowledge seeking. *European Journal of Information Systems*, 15(4), 357-367.

- Boh, W. F. (2007). Mechanisms for sharing knowledge in project-based organizations. *Information and Organization*, 17(1), 27-58.
- Boje, D. M. (1991). The storytelling organization: A study of story performance in an office-supply firm. *Administrative Science Quarterly*, 36, 106-126.
- Boland Jr, R. J. & Tenkasi, R. V. (1995). Perspective Making and Perspective Taking in Communities of Knowing. *Organization Science*, 6(4), 350-372.
- Bolloju, N., Khalifa, M. & Turban, E. (2002). Integrating knowledge management into enterprise environments for the next generation decision support. *Decision Support Systems*, 33(2), 163-176.
- Bourdieu, P. (1990). *The Logic of Practice*. Cambridge, MA: Polity Press.
- Bourdieu, P. & Wacquant, L. J. D. (1992). *An Invitation to Reflexive Sociology*. Chicago: University of Chicago Press.
- Breakwell, G. M. & Canter, D. V. (Eds.). (1993). *Empirical approaches to social representations*. Oxford, UK: Clarendon Press.
- Bresnen, M., Goussevskaia, A. & Swan, J. (2004). Embedding New Management Knowledge in Project-Based Organizations. *Organization Studies*, 25(9), 1535-1555.
- Brown, J. S., Denning, S., Groh, K., et al. (2004). *Storytelling in Organizations: How Narrative and Storytelling Are Transforming 21st Century Management*. Boston: Butterworth Heinemann.
- Brown, J. S. & Duguid, P. (1991). Organizational Learning and Communities-of-Practice: Toward a Unified View of Working, Learning, and Innovation. *Organization Science*, 2(1), 40-57.
- Brown, J. S. & Duguid, P. (1998). Organizing knowledge. *California Management Review*, 40(3), 90-111.
- Brown, J. S. & Duguid, P. (2001). Knowledge and Organization: A Social-Practice Perspective. *Organization Science*, 12(2), 198-213.
- Brown, S. A., Dennis, A. R. & Gant, D. B. (2006). Understanding the Factors Influencing the Value of Person-to-Person Knowledge Sharing. In *Proceedings of the 39th Hawaii International Conference on System Sciences (HICSS-39)* (pp. 10): CD-ROM, IEEE Computer Society, January 2006.
- Carlile, P. R. (2002). A Pragmatic View of Knowledge and Boundaries: Boundary Objects in New Product Development. *Organization Science*, 13(4), 442-455.
- Carlile, P. R. (2004). Transferring, Translating, and Transforming: An Integrative Framework for Managing Knowledge Across Boundaries. *Organization Science*, 15(5), 555-568.
- Chu, T.-H. & Robey, D. (2008). Explaining changes in learning and work practice following the adoption of online learning: a human agency perspective. *European Journal of Information Systems*, 17(1), 79.
- Cohen, M. D. & Bacdayan, P. (1994). Organizational Routines Are Stored As Procedural Memory: Evidence from a Laboratory Study. *Organization Science*, 5(4), 554-568.

- Cousins, K. C. (2004). *Access anytime, anyplace: an empirical investigation of patterns of technology use within nomadic computing environments*. Unpublished thesis for the Degree of Doctor of Philosophy, Georgia State University, Atlanta, GA.
- Cousins, K. C. & Robey, D. (2005). Human agency in a wireless world: Patterns of technology use in nomadic computing environments. *Information & Organization*, 15, 151-180.
- Cross, R. L. & Parker, A. (2004). *The Hidden Power of Social Networks: Understanding How Work Really Gets Done in Organizations*. Boston, MA: Harvard Business School Press.
- Cyert, R. M. & March, J. G. (1963). *A Behavioral Theory of the Firm*. Englewood Cliffs, NJ.: Prentice-Hall.
- Davenport, T. H., De Long, D. W. & Beers, M. C. (1998). Successful knowledge management projects. *Sloan Management Review*, 39(2), 43-57.
- Davidson, E. J. (2002). Technology Frames and Framing: A Socio-Cognitive Investigation of Requirements Determination. *MIS Quarterly*, 26(4), 329-358.
- Davis, F. D., Bagozzi, R. P. & Warshaw, P. R. (1992). Extrinsic and Intrinsic Motivation to Use Computers in the Workplace. *Journal of Applied Social Psychology*, 22(14), 1111-1132.
- Dearborn, D. C. & Simon, H. (1958). Selective Perception: a note on the departmental identification of executives. *Sociometry*, 21(2), 140-144.
- Denning, S. (2000). *The Springboard: How storytelling ignites action in Knowledge-era organizations*. Boston: Butterworth Heinemann.
- Denzin, N. K. & Lincoln, Y. S. (2000). Introduction: The Discipline and Practice of Qualitative Research. In N. K. Denzin & Y. S. Lincoln (Eds.), *Handbook of Qualitative Research* (pp. 1-29). Thousand Oaks, CA: Sage Publications.
- Dervin, B. (1998). Sense-making theory and practice: an overview of user interests in knowledge seeking and use *Journal of Knowledge Management*, 2(2), 36-48.
- DeSanctis, G. & Poole, M. S. (1994). Capturing the Complexity in Advanced Technology Use: Adaptive Structuration Theory. *Organization Science*, 5(2), 121-147.
- Doise, W. (1986). Les représentations sociales : définition d'un concept. In A. Palmonari & W. Doise (Eds.), *Textes de base en psychologie. L'étude des représentations sociales*. Neuchâtel: Delachaux et Niestlé.
- Doise, W., Clemence, A. & Lorenzi-Cioldi, F. (1993). *The quantitative analysis of social representations*. New York: Harvester Wheatshaf.
- Doise, W. & Palmonari, A. (Eds.). (1986). *Textes de base en psychologie: L'étude des représentations sociales*. Neuchâtel, Switzerland: Delachaux et Niestlé.
- Dubé, L. & Paré, G. (2003). Rigor in Information Systems Positivist Case Research: Current Practices, Trends, and Recommendations. *MIS Quarterly*, 27(4), 597-635.

- Edmondson, A. C., Bohmer, R. M. & Pisano, G. P. (2001). Disrupted Routines: Team Learning and New Technology Implementation in Hospitals. *Administrative Science Quarterly*, 46(4), 685.
- Eisenhardt, K. M. (1989). Building Theories From Case Study Research. *Academy of Management Review*, 14(4), 532-550.
- Emirbayer, M. & Mische, A. (1998). What is Agency? *American Journal of Sociology*, 103(4), 962-1023.
- Engwall, M. & Westling, G. (2004). Peripety in an R&D Drama: Capturing a Turnaround in Project Dynamics. *Organization Studies*, 25(9), 1557-1578.
- Faniel, I. M. & Majchrzak, A. (2007). Innovating by accessing knowledge across departments. *Decision Support Systems*, 43(4), 1684-1691.
- Farr, R. M. & Moscovici, S. (Eds.). (1984). *Social representations: European studies in social psychology*. Cambridge: Cambridge University Press
- Feldman, M. S. & Pentland, B. T. (2003). Reconceptualizing Organizational Routines as a Source of Flexibility and Change. *Administrative Science Quarterly*, 48(1), 94-118.
- Ford, C. M. & Ogilvie, D. (1996). The role of creative action in organizational learning and change. *Journal of Organizational Change Management*, 9(1), 54.
- Fox-Wolfgramm, S. J., Boal, K. B. & Hunt, J. G. (1998). Organizational Adaptation to Institutional Change: A Comparative Study of First-order Change in Prospector and Defender Banks. *Administrative Science Quarterly*, 43(1), 87-126.
- Friedman, R. A. & Podolny, J. (1992). Differentiation of Boundary Spanning Roles: Labor Negotiations and Implications for Role Conflict. *Administrative Science Quarterly*, 37(1), 28-47.
- Fugate, B., Stank, T. P. & Mentzer, J. T. (2008). Linking Knowledge Management To Operational And Organizational Performance. *Journal of Operations Management, In Press, Accepted Manuscript*.
- Gal, U. & Berente, N. (2008). A social representations perspective on information systems implementation: Rethinking the concept of "frames". *Information Technology & People*, 21(2), 133 - 154.
- Gal, U., Lyytinen, K. & Yoo, Y. (2008). The dynamics of IT boundary objects, information infrastructures, and organisational identities: the introduction of 3D modelling technologies into the architecture, engineering, and construction industry. *European Journal of Information Systems*, 17(3), 290-304.
- Giddens, A. (1984). *The constitution of society*. Cambridge, UK: Polity Press.
- Gotel, O. C. Z. & Finkelstein, C. W. (1994). *An analysis of the requirements traceability problem*. Paper presented at the Proceedings of the First International Conference on Requirements Engineering, Colorado Springs, CO.
- Gourlay, S. (2006). Conceptualizing Knowledge Creation: A Critique of Nonaka's Theory. *Journal of Management Studies*, 43(7), 1415-1436.

- Grabher, G. (2002). Cool projects, boring institutions: Temporary collaboration in social context. *Regional Studies*, 36(3), 205-214.
- Grabher, G. (2004). Temporary Architectures of Learning: Knowledge Governance in Project Ecologies. *Organization Studies*, 25(9), 1491-1514.
- Han, B. M. & Anantatmula, V. S. (2006). Knowledge Management in IT Organizations From Employee's Perspective. In *Proceedings of the 39th Hawaii International Conference on System Sciences (HICSS-39)* (pp. 9): CD-ROM, IEEE Computer Society, January 2006.
- Hansen, M. T., Nohria, N. & Tierney, T. (1999). What's Your Strategy for Managing Knowledge? *Harvard Business Review*, 77(2), 106-116.
- Hansen, M. T. & von Oetinger, B. (2001). Introducing T-shaped manager: Knowledge Management's Next Generation. *Harvard Business Review*, 79(3), 106-116.
- Hastorf, A. H. & Cantril, H. (1954). They saw a game: a case study. *Journal of Abnormal and Social Psychology*, 49, 129-134.
- Hatch, M. J. & Cunliffe, A. L. (2006). *Organization Theory: Modern, Symbolic, and Postmodern Perspectives* (2nd ed.). UK: Oxford University Press
- Hobday, M. (2000). The project-based organisation: an ideal form for managing complex products and systems? *Research Policy*, 29(7-8), 871-893.
- Howard-Grenville, J. A. & Carlile, P. R. (2006). The incompatibility of knowledge regimes: consequences of the material world for cross-domain work. *European Journal of Information Systems*, 15(5), 473-485.
- Jaspars, J. & Fraser, C. (1984). Attitudes and social representations. In R. M. Farr & S. Moscovici (Eds.), *Social representations: European studies in social psychology* (pp. 101-123). Cambridge: Cambridge University Press.
- Jodelet, D. (1986). Fou et folie dans un milieu rural français : une approche monographique. In W. Doise & A. Palmonari (Eds.), *Textes de base en psychologie: L'étude des représentations sociales* (pp. 171-192). Neuchâtel, Switzerland: Delachaux et Niestlé.
- Karsten, H., Lyytinen, K., Hurskainen, M., et al. (2001). Crossing boundaries and conscripting participation: representing and integrating knowledge in a paper machinery project. *European Journal of Information Systems*, 10(2), 89-98.
- Klein, H. K. & Myers, M. D. (1999). A Set of Principles for Conducting and Evaluating Interpretive Field Studies in Information Systems *Mis Quarterly*, 23(1), 67-93.
- Klein, K. J., Dansereau, F. & Hall, R. J. (1994). Levels issues in theory development, data collection, and analysis. *Academy of Management. The Academy of Management Review*, 19(2), 195.
- Knapp, E. & Yu, D. (1999). How culture helps or hinders the flow of knowledge *Knowledge Management Review*, 2(1), 16.
- Lahlou, S. (2001). Functional Aspects of Social Representation. In K. Deaux & G. Philogene (Eds.), *Representations of the Social: Bridging Theoretical perspectives* (pp. 131-146). New York: Basil Blackwell.

- Lave, J. & Wenger, E. (1991). *Situated Learning: Legitimate Peripheral Participation*. Cambridge, UK: Cambridge University Press.
- Levina, N. (2005). Collaborating on Multiparty Information Systems Development Projects: A Collective Reflection-in-Action View. *Information Systems Research*, 16(2), 109-130.
- Levina, N. & Vaast, E. (2005). The emergence of boundary spanning competence in practice: implications for implementation and use of information systems. *MIS Quarterly*, 29(2), 335-363.
- Levina, N. & Vaast, E. (2008). Innovating or doing as told? Status differences and overlapping boundaries in offshore collaboration. *MIS Quarterly*, 32(2), 307-332.
- Markova, I. (2000). Amedee or How to Get Rid of It: Social Representations from a Dialogical Perspective. *Culture Psychology*, 6(4), 419-460.
- Markus, M. L. (2001). Toward a theory of knowledge reuse: Types of knowledge reuse situations and factors in reuse success. *Journal of Management Information Systems*, 18(1), 57-93.
- Mason, J. (2002). *Qualitative Researching* (2nd ed.). London, UK: Sage Publications.
- McKeen, J. D., Zack, M. H. & Singh, S. (2006). Knowledge Management and Organizational Performance: An Exploratory Survey. In *Proceedings of the 39th Hawaii International Conference on System Sciences (HICSS-39)* (pp. 9): CD-ROM, IEEE Computer Society, January 2006.
- Miles, M. B. & Huberman, A. M. (1994). *Qualitative Data Analysis* (2nd ed.). Thousand Oaks, CA: Sage Publications.
- Miner, A. S., Bassoff, P. & Moorman, C. (2001). Organizational Improvisation and Learning: A Field Study. *Administrative Science Quarterly*, 46(2), 304-337.
- Mitchell, R. & Nicholas, S. (2006). Knowledge creation through boundary-spanning. *Knowledge Management Research & Practice*, 4(4), 310-318.
- Moorman, C. & Miner, A. S. (1998). Organizational Improvisation and Organizational Memory. *Academy of Management Review*, 23(4), 698-723.
- Morgeson, F. P. & Hofmann, D. A. (1999). The structure and function of collective constructs: Implications for multilevel research and theory development. *Academy of Management. The Academy of Management Review*, 24(2), 249.
- Moscovici, S. (1963). Attitudes and opinions. *Annual Review of Psychology*, 14, 231-260.
- Moscovici, S. (1984). The phenomenon of social representations. In R. M. Farr & S. Moscovici (Eds.), *Social representations: European studies in social psychology* (pp. 3-70). Cambridge: Cambridge University Press.
- Moscovici, S. (1986). L'ère des représentations sociales. In W. Doise & A. Palmonari (Eds.), *Textes de base en psychologie: L'étude des représentations sociales* (pp. 34-80). Neuchâtel, Switzerland: Delachaux et Niestlé.

- Moscovici, S. (2001). Why a Theory of Social Representations. In K. Deaux & G. Philogene (Eds.), *Representations of the Social: Bridging Theoretical perspectives* (pp. 8-35). New York: Basil Blackwell.
- Moscovici, S. & Markova, I. (1998). Presenting social representations: A conversation. *Culture and psychology*, 4(3), 371-410.
- Nielsen, L. & Madsen, S. (2006). Storytelling as Method for Sharing Knowledge across IT Projects. In *Proceedings of the 39th Hawaii International Conference on System Sciences (HICSS-39)* (pp. 9): CD-ROM, IEEE Computer Society, January 2006.
- Nonaka, I. & Takeuchi, H. (1995). *The knowledge-creating company: How Japanese companies create the dynamics of innovation*. New York: Oxford University Press.
- O'Dell, C. & Grayson, C. J. (1998). If only we knew what we know: identification and transfer of internal best practices. *California Management Review*, 40(3), 154-174.
- Orlikowski, W. (2000). Using Technology and Constituting Structures: A Practice Lens for Studying Technology in Organizations. *Organization Science*, 11(4), 404.
- Orlikowski, W. & Gash, D. C. (1994). Technological frames: making sense of information technology in organizations. *ACM Transactions on Information Systems (TOIS)*, 12(2), 174 - 207
- Orlikowski, W. J. (2002). Knowing in Practice: Enacting a Collective Capability in Distributed Organizing. *Organization Science*, 13(3), 249-273.
- Orlikowski, W. J. (2006). Material knowing: the scaffolding of human knowledgeability. *European Journal of Information Systems*, 15(5), 460-466.
- Orlikowski, W. J. & Baroudi, J. J. (1991). Studying Information Technology in Organizations: Research Approaches and Assumptions. *Information Systems Research*, 2(1), 1-28.
- Orlikowski, W. J. & Iacono, C. S. (2001). Research commentary: Desperately seeking "IT" in IT research - A call to theorizing the IT artifact. *Information Systems Research*, 12(2), 121.
- Pawlowski, S. D., Kaganer, E. A. & Cater, J. J. (2004). *Mapping perceptions of burnout in the Information Technology profession: A study using social representations theory*. Paper presented at the Twenty-fifth International Conference on Information Systems, Washington, D.C.
- Pawlowski, S. D. & Robey, D. (2004). Bridging User Organizations: Knowledge Brokering and the Work of IT Professionals. *MIS Quarterly*, 28(4), 645-672.
- Pentland, B. T. & Feldman, M. S. (2008). Designing routines: On the folly of designing artifacts, while hoping for patterns of action. *Information and Organization*, 18(4), 235-250.
- Piette, I. & Rouleau, L. (2008). Le courant discursif en théories des organisations : Un état des lieux [Electronic Version]. *Les cahiers de recherche du GÉPS*, 2, 1-64. Retrieved July 2008 from <http://web.hec.ca/geps/GePS-08-02.pdf>.

- Poole, M. S. & DeSanctis, G. (2004). Structuration theory in information systems research: methods and controversies. In M. E. Whitman & A. B. Wozzczynski (Eds.), *The Handbook for Information Systems Research* (pp. 206-249). Hershey, PA: Idea Group Publishing.
- Potter, J. & Edwards, D. (1999). Social Representations and Discursive Psychology: From Cognition to Action. *Culture Psychology*, 5(4), 447-458.
- Prencipe, A. & Tell, F. (2001). Inter-project learning: processes and outcomes of knowledge codification in project-based firms. *Research Policy*, 30(9), 1373-1394.
- Project Management Institute. (2004). *A Guide to the Project Management Body of Knowledge (PMBOK® Guide)* (3rd ed.). Newtown Square, PA: Project Management Institute.
- Raudsepp, M. (2005). Why Is It So Difficult to Understand the Theory of Social Representations? *Culture Psychology*, 11(4), 455-468.
- Robey, D. & Boudreau, M.-C. (1999). Accounting for the contradictory organizational consequences of information technology: Theoretical directions and methodological implications. *Information Systems Research*, 10(2), 167-185.
- Robey, D., Boudreau, M.-C. & Rose, G. M. (2000). Information technology and organizational learning: a review and assessment of research *Accounting, Management and Information Technologies*, 10(2), 125-155.
- Robey, D. & Newman, M. (1996). Sequential Patterns in Information Systems Development: An Application of a Social Process Model. *ACM Transactions on Information Systems Research*, 14(1), 30-63.
- Robey, D. & Sahay, S. (1996). Transforming Work through Information Technology: A Comparative Case Study of Geographic Information Systems in County Government. *Information Systems Research*, 7(1), 93-110.
- Santos, F. M. & Eisenhardt, K. M. (2005). Organizational Boundaries and Theories of Organization. *Organization Science*, 16(5), 491-508.
- Sapsed, J. & Salter, A. (2004). Postcards from the Edge: Local Communities, Global Programs and Boundary Objects. *Organization Studies*, 25(9), 1515-1534.
- Saunders, C. & Chiasson, M. (2004). *Employing the agency/structure debate as an integrative framework for knowledge management research*. Paper presented at the Administrative Sciences Association of Canada, Quebec, Canada.
- Scarborough, H., Swan, J., Laurent, S., et al. (2004). Project-Based Learning and the Role of Learning Boundaries. *Organization Studies*, 25(9), 1579-1600.
- Senge, P. M. (1990). *The Fifth Discipline: The Art and Practice of The Learning Organization*. New York: Currency Doubleday.
- Sewell, W. H. (1992). A Theory of Structure: Duality, Agency and Transformation. *American Journal of Sociology*, 98(1), 1-29.
- Speier, C. & Morris, M. G. (2003). The influence of query interface design on decision-making performance. *Mis Quarterly*, 27(3), 397-423.

- Standish Group. (2008). Trends in IT value. Retrieved December 23, 2008, from http://www.standishgroup.com/sample_research/trends_it_value.pdf
- Star, S. L. & Griesemer, J. R. (1989). Institutional Ecology, 'Translations' and Boundary Objects: Amateurs and Professionals in Berkeley's Museum of Vertebrate Zoology, 1907-39. *Social Studies of Science*, 19(3), 387-420.
- Strauss, A. & Corbin, J. (1998). *Basics of Qualitative Research: Techniques and Procedures for Developing Grounded Theory*. (2nd ed.) Beverly Hills, CA.: Sage Publications.
- Tata Consultancy Services. (2007). IT Projects: Experience Certainty. Retrieved January 26, 2009, from http://www.tcs.com/thought_leadership/Documents/independant_markets_research_report.pdf
- Turner, J. R. & Keegan, A. (2001). Mechanisms of governance in the project-based organization: Roles of the broker and steward. *European Management Journal*, 19(3), 254-267.
- Vaast, E., Boland, R. J., Davidson, E., et al. (2006). Investigating the "Knowledge" in Knowledge Management: A social representations perspective. *Communications of the Association for the Information Systems*, 17(article 15), 314-340.
- Vaast, E. & Walsham, G. (2005). Representations and actions: the transformation of work practices with IT use. *Information and Organization*, 15(1), 65-89.
- Vaishnavi, V. & Kuechler, W. (2004). Design Research in Information Systems. Retrieved February 1, 2005, from <http://www.isworld.org/Researchdesign/drisISworld.htm>
- Van de Ven, A. H. & Poole, M. S. (1995). Explaining development and change in organizations. *Academy of Management. The Academy of Management Review*, 20(3), 510-540.
- Van Maanen, J. E. & Schein, E. H. (1978). Toward a theory of organizational socialization. In B. Staw (Ed.), *Annual review of research in organizational behavior* (Vol. 1, pp. 84-89). New York: JIP Press.
- Venkatesh, V., Speier, C. & Morris, M. G. (2002). User Acceptance Enablers in Individual Decision Making About Technology: Toward an Integrated Model. *Decision Sciences*, 33(2), 297-316.
- Voelklein, C. & Howarth, C. (2005). A Review of Controversies about Social Representations Theory: A British Debate. *Culture Psychology*, 11(4), 431-454.
- Wagner, W., Duveen, G., Farr, R., et al. (1999). Theory and Method of Social Representations. *Asian Journal of Social Psychology*, 2(1), 95-125.
- Wagner, W., Kronberger, N. & Seifert, F. (2002). Collective symbolic coping with new technology: Knowledge, images and public discourse. *British Journal of Social Psychology*, 41(3), 323-344
- Walmsley, C. (2005). *Protecting Aboriginal Children*. Vancouver: UBC Press.
- Walsham, G. (1995). The emergence of Interpretivism in IS research. *Information Systems Research*, 6(4), 376-392.

- Weber, R. (1997). *Ontological Foundations of Information Systems*. Melbourne, Australia: Coopers and Lybrand.
- Weick, K. E. (1993). The Collapse of Sensemaking in Organizations: The Mann Gulch Disaster. *Administrative Science Quarterly*, 38(4), 628.
- Wenger, E. (1998). *Communities of practice: learning, meaning, and identity*. New York, N.Y.: Cambridge University Press.
- Yin, R. K. (2003). *Case study research: Design and methods* (3rd ed.). Thousand Oaks, CA: Sage Publications.
- Zahra, S. A. & Nielsen, A. P. (2002). Sources of capabilities, integration and technology commercialization. *Strategic Management Journal*, 23(5), 377-398.
- Zedtwitz, M. (2002). Organizational learning through post-project reviews in R&D. *R&D Management*, 32(3), 255-268.

Curriculum Vitae

Biographical Details

Name: Alina M. Dulipovici

Birthplace: Bucharest, Romania, January 1st, 1978

Address: 3000 Côte-Sainte-Catherine Road, Montréal (QC) H3T 2A7 Canada

Education

2009 Doctor of Philosophy (Business Administration – CIS), Georgia State University

2002 Masters of Science, (Major – Information Systems), HEC Montreal, Canada

2000 Bachelor of Business Administration (Major – Information Technologies), HEC Montreal, Canada

Work Experience

2007 – ... Assistant Professor, HEC Montreal, Canada

2004 – 2007 Graduate Research Assistant to Richard Baskerville and Dan Robey, Georgia State University, Atlanta, GA

2002 – 2004 Lecturer, HEC Montreal, Canada

2000 – 2004 Research Assistant, HEC Montreal, Canada

2001 Project Manager, Gestion, Canada

2000 – 2002 Teaching Assistant, HEC Montreal, Canada

Journal Publications & Refereed Book Chapters

1. Baskerville, R., & Dulipovici, A. (2006). The Theoretical Foundations of Knowledge Management. *Knowledge Management Research and Practice* 4(2), 83-105.
2. Dulipovici, A., & Baskerville, R. (2007). Conflicts between privacy and property: The discourse in personal and organizational knowledge. *Journal of Strategic Information Systems*, 16(2), 187-213.
3. Dulipovici, A., & Baskerville, R. (in press). “Privacy, Property and Ethics -- Conflicts between privacy and property: The discourse in personal and organizational knowledge” In R. D. Galliers & D. E. Leidner (Eds.), *Strategic Information Management: Challenges and Strategies in Managing Information Systems*: Routledge.

Refereed Conference Proceedings

1. Baskerville, R. & Dulipovici, A. (2006). "The ethics of knowledge transfers and conversions: property or privacy rights?", *Proceedings of the 39th Hawaii International Conference on System Sciences (HICSS-39)* (pp. 9): CD-ROM, IEEE Computer Society, January 2006.
2. Sneha, S. & Dulipovici, A. (2006). "Strategies for Working with Digital Medical Images", *Proceedings of the 39th Hawaii International Conference on System Sciences (HICSS-39)* (pp. 11): CD-ROM, IEEE Computer Society, January 2006.

Awards & Honours

- International Conference on Information Systems Doctoral Consortium, 2007
- Award from Quebec Ministry of Education for the academic performance in a master program, 2002
- Winner – Best Application Award from the refereed journal *Gestion*, Canada, 2001

Service

- Reviewer at journals: *Journal of Information and Organization*, *Journal of the Association for Information Systems (JAIS)*
- Reviewer at conferences: *International Conference on Information Systems (ICIS)*, *Administrative Sciences Association of Canada (ASAC)*
- Work for the IS Academic Heads group
- Organisational committee member for IFIP WG 8.6 – Atlanta 2005 : "Business Agility and IT Diffusion"