

7-11-2015

An Optimal Formulation for Handling SLD in Impairment Aware WDM Optical Networks

Aditi Bhardwaj
University of Windsor

Follow this and additional works at: <https://scholar.uwindsor.ca/etd>

Recommended Citation

Bhardwaj, Aditi, "An Optimal Formulation for Handling SLD in Impairment Aware WDM Optical Networks" (2015). *Electronic Theses and Dissertations*. 5300.

<https://scholar.uwindsor.ca/etd/5300>

This online database contains the full-text of PhD dissertations and Masters' theses of University of Windsor students from 1954 forward. These documents are made available for personal study and research purposes only, in accordance with the Canadian Copyright Act and the Creative Commons license—CC BY-NC-ND (Attribution, Non-Commercial, No Derivative Works). Under this license, works must always be attributed to the copyright holder (original author), cannot be used for any commercial purposes, and may not be altered. Any other use would require the permission of the copyright holder. Students may inquire about withdrawing their dissertation and/or thesis from this database. For additional inquiries, please contact the repository administrator via email (scholarship@uwindsor.ca) or by telephone at 519-253-3000ext. 3208.

An Optimal Formulation for Handling SLD in impairment aware
WDM optical networks

By

Aditi Bhardwaj

A Thesis

Submitted to the Faculty of Graduate Studies
through the School of Computer Science
in Partial Fulfillment of the Requirements for
the Degree of Master of Science at the
University of Windsor

Windsor, Ontario, Canada

2015

© 2015 Aditi Bhardwaj

An Optimal Formulation for Handling SLD in impairment aware

WDM optical networks

by

Aditi Bhardwaj

APPROVED BY:

S. Pandey
Department of Chemistry

D. Wu
School of Computer Science

S. Bandyopadhyay, Advisor
School of Computer Science

A. Jaekel, Advisor
School of Computer Science

May 4, 2015

DECLARATION OF ORIGINALITY

I hereby certify that I am the sole author of this thesis and that no part of this thesis has been published or submitted for publication.

I certify that, to the best of my knowledge, my thesis does not infringe upon anyone's copyright nor violate any proprietary rights and that any ideas, techniques, quotations, or any other material from the work of other people included in my thesis, published or otherwise, are fully acknowledged in accordance with the standard referencing practices. Furthermore, to the extent that I have included copyrighted material that surpasses the bounds of fair dealing within the meaning of the Canada Copyright Act, I certify that I have obtained a written permission from the copyright owner(s) to include such material(s) in my thesis and have included copies of such copyright clearances to my appendix.

I declare that this is a true copy of my thesis, including any final revisions, as approved by my thesis committee and the Graduate Studies office, and that this thesis has not been submitted for a higher degree to any other University or Institution.

ABSTRACT

The effect of physical layer impairments in route and wavelength assignment in Wavelength Division Multiplexed optical networks has become an important research area. When the quality of an optical signal degrades to an unacceptable level, a regenerator must be used to recover the quality of the signal. Most research has focused on reducing the number of regenerators when handling static and adhoc lightpath demands in such networks. In networks handling scheduled lightpath demands (SLD), each request for communication has a known duration and start time. Handling SLD in impairment aware networks has not been investigated in depth yet. We propose to study the development of an optimal formulation for SLD, using a minimum number of regenerators. We will compare our optimal formulation with another formulation which has been proposed recently.

DEDICATION

To my Loving Family:

Father: Lt. Vinay Bhardwaj

Mother: Suman Lata Rawat

Uncle: Ashok Kumar Bhardwaj

Aunt: Preeti Bhardwaj

Elder Brother: Rohatash Kumar Bhardwaj

Sister-in-Law: Shivani Mishra Bhardwaj

Younger Brother: Ankit Bhardwaj

Nephew: Aadrik Bhardwaj

ACKNOWLEDGEMENTS

I would like to express my deepest gratitude to my master thesis advisors, Dr. Subir Bandyopadhyay and Dr. Arunita Jaekel, for their guidance and support all throughout my graduate studies. I have learned many things since I became their student. They have spent varied amount of time instructing me how to write a thesis and how to collect data. This work could not have been achieved without their advice, suggestions and cooperation.

I would like to thank members of my M.Sc. thesis committee, Dr. Siyaram Pandey, Dr. Dan Wu and Dr. Imran Ahmad for their valuable time, suggestions and constructive comments.

I would also like to thank Dr. Quazi R. Rahman for his cordial support and help for providing his regenerator placement software and helping me in understanding it's working.

I would also like to express gratitude to the entire Department faculty and staff members for their help and support. I would also like to thank my friend Yaman for his continuous support as well as everybody else who has offered any help, during my graduate study at the University of Windsor.

My mother has been an inspiration throughout my life. She has always supported my dreams and aspirations. I'd like to thank her for all she is, and all she has done for me.

Aditi Bhardwaj

TABLE OF CONTENTS

DECLARATION OF ORIGINALITY	iii
ABSTRACT	iv
DEDICATION	v
ACKNOWLEDGEMENTS	vi
LIST OF TABLES	x
LIST OF FIGURES	xi
LIST OF ACRONYMS	xii
1 INTRODUCTION	1
1.1 Overview	1
1.1.1 Wavelength Division Multiplexing (WDM) Networks	2
1.1.2 Lightpath	2
1.1.3 Routing and Wavelength Assignment (RWA)	3
1.1.4 Impairments	4
1.1.5 3R-Regeneration	4
1.2 Motivation	5
1.3 Solution Outline	5
1.4 Organization of Thesis	6

2 REVIEW	7
2.1 Optical Networks	7
2.1.1 Data Transmission	10
2.2 Wavelength Division Multiplexing (WDM)	10
2.2.1 Different Lightpath-allocation Schemes	12
2.2.2 Scheduled Traffic Model	13
2.3 Physical Layer Impairments (PLI)	15
2.3.1 Linear Impairments	16
2.3.2 Nonlinear Impairments	17
2.4 3R-Regeneration	18
2.4.1 Regenerator-capable node	18
2.5 Optical Reach	19
2.6 Regenerator Placement and Usage	20
2.7 Transparent and Translucent Lightpaths	24
2.8 Literature Review.....	24
2.8.1 Regenerator allocation for SLD in translucent optical networks	24
2.8.2 An Exact (ILP) formulations, for translucent network design	24
2.8.3 Routing and spare capacity assignment for SLD and RLD in all-optical Networks	25
2.8.4 Routing and Wavelength Assignment of SLDs	26
2.8.5 Summary of related work	28
3 PROPOSED FORMULATION	29
3.1 Notation Used for Routing and Regenerator Placement RRP	29
3.1.1 Explanations of the RRP ILP1	34
3.2 Routing and Regenerator Assignment (RRA) ILP2	37
3.1.2 Explanation of the RRA ILP.....	39
4 EXPERIMENTAL RESULTS	42

4.1 Results of Execution Time	44
4.2 Results for Number of Requests	46
4.3 Number of Regenerators needed by ILP1 and ILP2.	46
5 CONCLUSION AND FUTURE WORK	51
5.1 Conclusion.	51
5.2 Future Work	51
REFERENCES	53
APPENDIX	58
VITA AUCTORIS.	59

LIST OF TABLES

2.8.5	Summary of Related Work	28
4.3	Average runtime for optimal formulation and Heuristic	45
4.4	Average number of successful calls for optimal formulation and heuristic	46
4.5	Average number of regenerator usage for optimal formulation and heuristic	47
4.6	Analysis of requests with and without regenerators for 10-node network	48
4.7	Analysis of requests with and without regenerators for 8-node network	49
4.8	Analysis of requests with and without regenerators for 12-node network	50

LIST OF FIGURES

1.1: A concept of Lightpath	3
2.1: Optical Cable	7
2.2: Cross section of an Optical Fibre	8
2.3: Refraction and Total Internal Reflection	9
2.4: Total internal reflection inside the core	9
2.5 [3]: Signal bandwidth and Channel spacing	11
2.6: Wavelength Division Multiplexing System	11
2.7: Different Lightpath Allocation Schemes	13
2.8: Division of scheduled demands over an entire time period [23]	14
2.9: Wavelength convertible 3R O-E-O Conversion	18
2.10: Network showing Regenerator Placement	21
2.11: Types of Optical Networks	22
2.12: Translucent Lightpath	23
4.1: Module 1: .lp File Generator for ILP1	43
4.2: Module 2: Invoking CPLEX Solver	44

LIST OF ACRONYMS

ILP – Integer Linear Program

RWA – Routing and Wavelength Assignment

WDM – Wavelength Division Multiplexing

ITU – International Telecommunication Union

WAN – Wide Area Network

PLI – Physical Layer Impairment

QoT – Quality of Transmission

OEO – Optical-to Electrical to Optical

RRP – Routing with Regenerator Placement

RRA – Routing With Regenerator Assignment

LED –Light Emitting Diode

LSD- Laser Diode

OOK- On-Off Keying

SLD – Scheduled Lightpath Demand

ALD – Adhoc Lightpath Demand

BER – Bit Error Rate

OSNR – Optical Signal to Noise Ratio

CD - Chromatic Dispersion

ASE - Amplified Spontaneous Emission

PMD - Polarization Mode Dispersion

PDL - Polarization Dependent Losses

XT - Crosstalk

FC - Filter Concatenation

SPM - Self Phase Modulation

FWM - Four Wave Mixing

XPM - Cross Phase Modulation

SBS - Stimulated Brillouin Scattering

SRS - Stimulated Raman Scattering

LD – Lightpath Demand

RLD – Random Lightpath Demand

RSCA – Routing and Spare Capacity Assignment

IA-RWA – Impairment Aware – Routing and Wavelength Assignment

LIST OF APPENDICES

Appendix A

Chapter 1

INTRODUCTION

1.1 Overview

Today the Internet is growing at very fast rate, as large amount of data is being utilized by cloud computing, e-commerce, social networking and other applications [en.wikipedia.org]. According to ITU 2014 report [33] almost 3 billion people, which accounts for 40% of the world population, are using Internet. These developments have led to the need for transmission of large amount of data at high speed, which require a transport network with high bandwidth and reliable data transfer capabilities.

The needs of data communication can be met by using different transmission media, such as optical fibre or copper cable. An optical network facilitates data communication by sending light signals (instead of electronic signals) along a glass or plastic fibre, to transfer the information between two or more nodes. These nodes can be computers in an office or large global telecommunication systems. An optical network consists of optical transmitters and receivers, optical switches, fibre optic-cables and various other optical components [3]. (A detailed discussion on various optical network components and optical network is presented in section 2.1).

Optical networks are one of the fastest communication networks, using light as the transmission medium. It can carry much more information than the traditional copper wire and it is not subjected to electromagnetic interference; also it is less susceptible to attenuation and external interference. It can provide high speed capability of up to 50 Tera bits per second and can span over countries or continents; hence optical networks are considered ideal candidates for backbone wide-area networks (WANs).

Optical systems are utilized to exchange a lot of information, at a very high rate, over a wide geographical area. As the signal travels over long distances, the signal quality falls below the acceptable level. This limits the transmission distance for consistent quality of signal. There are various techniques that are used to handle this limitation. One of them is placement of regenerators, at certain nodes, so that a signal travelling longer distances can be regenerated at certain intervals. Since large volumes (Terabytes) of data

is transferred, it is very important to take care of any distortion or any degradation of signal caused by physical layer impairments (PLIs).

1.1.1 Wavelength Division Multiplexing: (WDM) Networks

The technology of using multiple optical signals on the same fibre is called *wavelength division multiplexing* (WDM) [3]. In general, in WDM network a fibre transmits a number of optical signals in the band that has been utilized. Each of these optical signals is at different *carrier wavelength* [3]. The WDM provides a very efficient way to exploit the vast bandwidth of an optical fibre. The entire bandwidth (i.e. range of available frequencies in optical network) is envisioned as set of *channels* (or wavelengths). Every optical signal is assigned a different channel, so as to provide ample bandwidth to the signal. Every channel is separated by a minimum bandwidth or spacing known as *channel spacing*, to inhibit any interference between the adjacent channels carrying optical signals. In other words, WDM technology allows transmission of multiple optical signals using distinct channels (different carrier wavelengths) simultaneously over a single optic-fibre.

1.1.2 Lightpath:

An optical fibre carries an optical signal in form of light. A signals travels from the source node to the destination node, through the optical fibre network. An end-to-end optical connection from a source node to a destination node is called a *lightpath*. A lightpath is characterized by two things:

- A route from source node to destination node over the physical topology.
- A carrier wavelength assigned to the lightpath, on each edge in its route.

Figure 1.1 shows two lightpaths L1 and L2, established over a physical topology. Each bi-directional) physical link actually consists of two unidirectional optical fibres, one in each one direction. Suppose lightpath L1 uses path $1 \rightarrow 3 \rightarrow 4$, and is assigned wavelength λ_1 on both links. Lightpath L2 travels uses route $1 \rightarrow 3 \rightarrow 2$, using wavelength λ_2 . It is necessary to assign two different wavelengths to these to lightpaths, since they both use a common fibre on link $1 \rightarrow 3$.

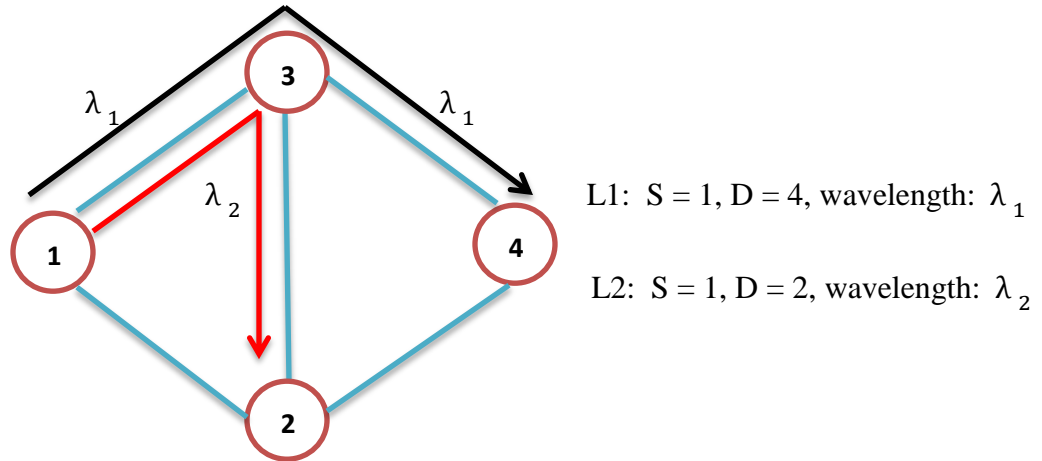

Figure 1.1: A concept of Lightpath

1.1.3 Routing and Wavelength Assignment: (RWA)

The *Routing and wavelength assignment* (RWA) problem deals with the establishment of the lightpath(s) in a WDM optical network. The RWA problem has been widely studied in the literature and optimal *Integer Linear Programming* (ILP) based solutions [34], as well as heuristic solutions [15] have been proposed. ILP based approaches quickly become computationally intractable, so heuristics are typically used for larger networks. RWA consists of two sub problems: i) assigning a route to each lightpath through physical topology and ii) finding a carrier wavelength (channel number) for every link of the physical path. RWA problems considered to be NP-complete problems [3]. In general, there are two constraints that must be satisfied while performing a RWA:

- **Wavelength Continuity Constraint:** The channel number (wavelength) allotted to a lightpath must be the same for all the optical fibres that lies in its route. (In certain cases, this constraint can be relaxed. This will be discussed later in the thesis.)
- **Wavelength Clash Constraint:** Any two lightpath sharing a same fibre link should not be assigned same channel numbers (wavelengths).

RWA can be performed for different traffic models, such as static traffic, ad-hoc traffic and scheduled traffic. A detailed discussion on various traffic requests is presented in section 2.2.1. In this thesis, we focus on the *scheduled traffic model*. Even though, we know the start and end time, but these requests arrive dynamically, hence the pattern is not predictable. As a result, it is not possible to determine, in advance, which nodes may need 3R regeneration capability [15].

1.1.4 Impairments:

In optical communication, data is converted from electronic form to optical form, transmitted over the network, and then converted back to electronic form at the destination. At the destination the quality of signal is measured, to determine whether it falls below the acceptable level of QoT (quality of transmission). As the signal propagates through the optical fibre, its QoT is degraded due to several physical phenomena termed as Physical Layer Impairments (PLI) [4]. The PLI is of two types linear and non-linear. The impact of PLI is more noticeable, as the distance of travel increases and signal becomes more deteriorated. As a result, a distance covered by a signal is limited.

The maximum distance a signal can travel before losing its quality is called an *optical reach*. Any optical signal that travels beyond the optical reach loses its quality and hence becomes unreliable for any communications. Optical reach is a widely used metric that is calculated based on linear impairments [15]. However it does not consider non-linear impairments because they cannot be estimated before the lightpath is actually established [15]. A lightpath whose total distance exceeds the optical reach must have its signal regenerated at one or more points along its route.

1.1.5 3-R Regeneration:

Regenerators are used to re-shape, re-amplify, and re-time the signal, to maintain the strength of the optical signal beyond the optical reach. This process is known as 3R regeneration. The 3R regeneration helps to reinstate the quality of signal to its original strength, hence enabling the signal to travel again until the optical reach. 3R regenerators typically use Optical-to-Electronic-to-Optical (OEO) conversion [17]. A network in

which the optical signal may undergo regeneration at certain intermediate nodes (but not necessarily at every intermediate node) is called a *translucent* optical network. In this thesis we consider the RWA problem for scheduled traffic in translucent optical networks.

1.2 Motivation

There are two main design problems that need to be addressed in translucent optical networks, they are *routing with regenerator placement* (RRP) and *routing and regenerator assignment* (RRA). In RRP [11], the objective is to optimize number of regenerators and their locations (or the number of regeneration sites [29]), in order to establish a given set of lightpath demands with guaranteed QoT [23]. A subset of this problem is to determine for each lightpath i) a feasible route, the node(s) (if any) along this route, where the lightpath will be regenerated and iii) a wavelength (channel) for each segment of the lightpath. For the RRA problem [11], the locations and number of regenerators are known in advance, and the objective is to efficiently use available regenerators during the RWA process under some design criteria [11]. There has been significant research focus on both the RRP and RRA problems for standard static and dynamic traffic, in recent years [11]. However, design strategies for *scheduled* traffic (discussed in detail in Sec. 2) have not been as well studied. So that's why the focus of this thesis is on the scheduled requests. It is important to develop comprehensive strategies for solving the RRP and RRA problems under the scheduled traffic models. This will lead to more effective resource sharing, which in turn will reduce the overall cost of the network.

1.3 Solution Outline

In this thesis, we have presented optimal integer linear program (ILP) formulations for solving the RRP and the RRA problem. The primary objective of both formulations is to minimize the number of regenerators needed to establish a given set of scheduled lightpath demands. The formulations were solved using the CPLEX [34] software and

solutions were generated for different traffic demand sets for network of different sizes, topologies and with a range of resource constraints.

The main contributions of this thesis are:

1. An optimal ILP formulation for the complete regenerator placement and RWA problem in translucent WDM networks, under the scheduled traffic model.
2. A modification of the ILP presented in [34] for solving RRA problem.
3. Extensive simulation results comparing the performance of the two approaches in terms of the quality of the solutions as well as the time taken to generate a solution.

1.4 Organization of Thesis

The rest of the thesis is organized as follows: Chapter 2 delivers the detailed review of fundamental concepts of fibre-optics, models and terminologies associated with this work and analysis of this thesis and research. A literature review of previous works on scheduled lightpath demands is also included in Chapter 2. Chapter 3 presents the proposed ILP formulation for RRP (ILP1) and the modified RRA formulation (ILP2), based on Chen [23]. Chapter 4 presents the simulations results for experiments that we carried out and related analysis. Finally, Chapter 5 contains the concluding comments and analysis with some directions for possible future work.

Chapter 2

REVIEW

2.1 Optical Networks

An optical network connects computers (or any other device which can generate or store data in electronic form) using optical fibers [3]. Here each node can be the source or the destination of data communication. It sends data in the form of light pulses through optical fibres between sender and receiver. Optical fibres are very long and thin strands of pure glass having a diameter of a human hair [32]. They are generally arranged in bundles and hence known as optical cables. The figure 2.1 shows the optical cable with the bundle of several optical fibres. [Image taken from <http://fibresale.com.au>]

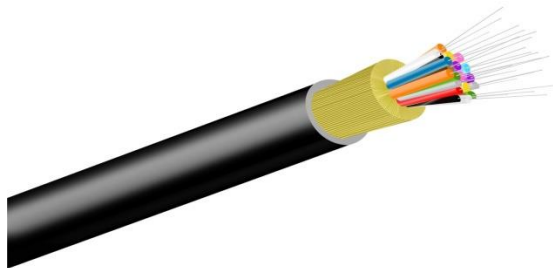

Figure 2.1: Optical Cable

Optical fibre can be of two types namely single mode and multi-mode fibres. A single-mode fibre has smaller core and transmits infrared laser lights; on the other hand multi-mode fibres have larger core and transmits infrared lights from LEDs (light emitting diodes).

A typical optical fibre is made up of three layers. The innermost layer is cylindrical core made up of very high quality glass (silica) or plastic. The outer optical material that surrounds the core is called cladding, and is also made up of glass. The third layer is known as buffer which protects the core and cladding from any physical damage and is made up of plastic such as nylon or acrylic. The most important part is core and

cladding. An optical signal travels through core in the form of light pulses and cladding reflects the light back into the core, which results in very low attenuation and less energy loss.

Fig. 2.2 shows the cross-section a typical optical fibre. [Image taken from <http://www.ustudy.in>]

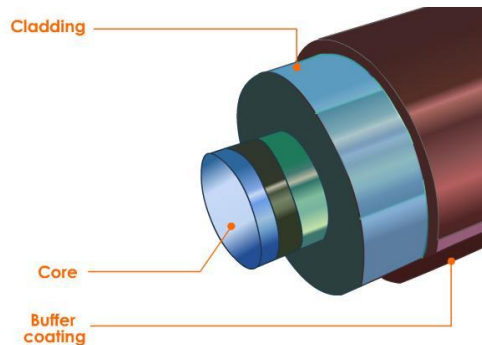

Figure 2.2: Cross section of an Optical Fibre

The general concept behind the optical communication is concept of refraction and total internal reflection. Any change that occurs in the speed when a light passes from one medium to another is accounts for bending of the light, or refraction, that takes place at an interface. When a light travels or crosses an interface into a medium of higher refracted index, the light bends towards the normal i.e., the perpendicular line to the surface which lies in the plane of incident and refracted ray. On the contrary, the light which is travelling across an interface from higher refractive index (n_1) to lower refractive index (n_2) will bend away from the normal. The angle of incidence for which the light, travelling from a medium of higher refractive index to lower refractive index, is refracted at 90° is known as critical angle (θ_c). If the light crosses the interface at any angle larger than the critical angle θ_c , it will not be permitted through the second medium at all. Alternatively, it will be reflected back into the first medium, and this process is called total internal reflection. The critical angle is that angle of incidence beyond which the total internal reflection occurs.

Figure 2.3 describes the concept of refraction and total internal reflection. [Image taken from <http://www.boundless.com>]

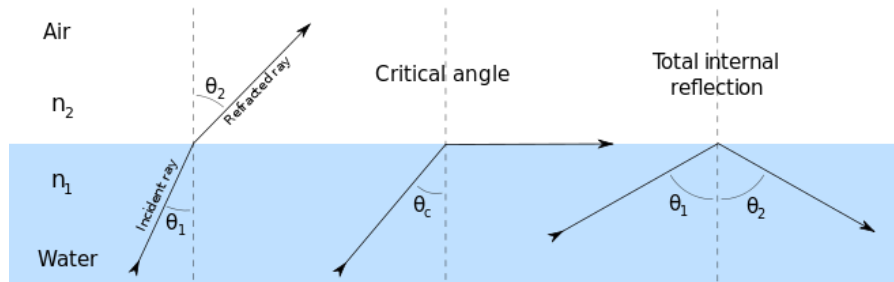

Figure 2.3: Refraction and Total Internal Reflection

Both inner core and cladding are made up of either glass or silica, but they both possess different optical densities. When a light travels through the core to the cladding at an angle that is greater than the critical angle then all the light is reflected back in to the inner core by the cladding causing the total internal reflection. This causes the signal to remain inside the core, and a little portion is absorbed during the transmission. Optical signals propagate through the core using a series of total internal reflections [3] as shown in Fig: 2.4 and, hence facilitates the data transmission between the sender and receiver.

[Image taken from <http://www.askmichellephysics.blogspot.com>]

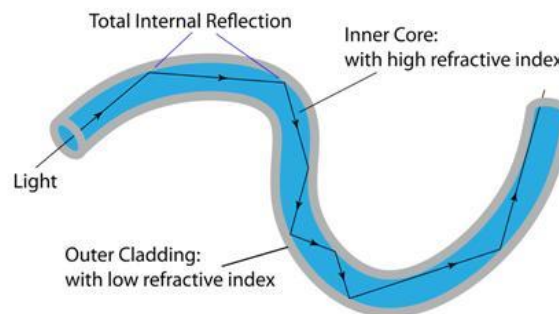

Figure 2.4: Total internal reflection inside the core

2.1.1 Data Transmission

To facilitate data communication, an optical network includes other optical devices to generate optical (electrical) signals from electrical (respectively optical) data, to restore optical signals after it propagates through fibers, and to route optical signals through the network [3]. The main component of transmitter is light source. The major work of the light source is to convert electrical signal to optical signal with the help of LEDs (light emitting diodes) or LSD (laser diodes) with a particular carrier wavelength. The data that is transmitted between the source and destination is received by the receiver via physical medium known as channel. The transmitter decodes the input data and also provides coding for error protection [29]. Modulation is a procedure of converting data in electronic form to encode an optical signal [3]. One very popular scheme is known as on-off keying (OOK), which transfers bits in the form of 1 (0) by switching light on (off). The heart of the receiver is photodetectors or photodiodes which convert the optical signal into electrical domain at the destination at some particular carrier wavelength. It restores or extracts the data into the original form i.e. is electrical form. However, there may be some distortion in signal due to the presence of physical layer impairments. Every channel owns a corresponding transmitter and receiver pair.

2.2 Wavelength Division Multiplexing (WDM)

The technology of allowing the multiple data streams to be transferred along the same fiber at the same time is called *wavelength division multiplexing* (WDM). Generally, in WDM networks various numbers of optical signals in the band that is being used are carried by a fiber. It is to be noted that each of these optical signals is travelling with a different carrier wavelength. The WDM technique partitions the available optical bandwidth into a large number of channels or set of channels.

Every optical signal is assigned a distinct channel so that every channel has adequate bandwidth to accommodate the modulated signal [3]. To eradicate the interference that exists between the various optical signals, every channel is disjointed from the adjacent channels by certain minimum bandwidth known as channel spacing, which is shown in fig 2.5. It is typical to have a channel bandwidth of 10 GHz and a channel spacing of 100 GHz in current networks [3]. The WDM technology employs the

several wavelengths to carry multiple signal channels and hence increases the capacity of the optical networks.

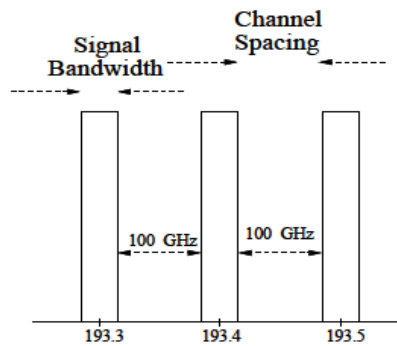

Figure 2.5 [3]: Signal bandwidth and Channel spacing

The WDM networks can transfer data on multiple channels by using a single fibre. In WDM networks light from different lasers, each one having a different wavelength is joined into single beam with the help of a multiplexer. At the receiving end a demultiplexer is placed that separates the different wavelengths from the beam into the independent optical signals. [Image taken from <http://www.newport.com>]

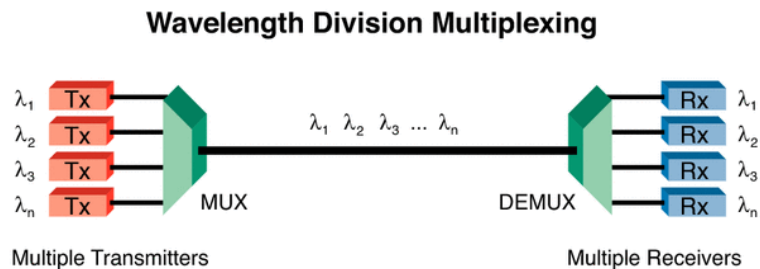

Figure 2.6: Wavelength Division Multiplexing System

Figure 2.6 shows the WDM system with n channels or n wavelengths. At the sender side there are n transmitters, each tuned to different wavelength from λ_1 to λ_n corresponding to a different channel number. The input data to be communicated is converted from

electrical to optical form and multiplexer combines the signals together into one composite signal to be transmitted through the fiber. Similarly, at the receiver side there are n receivers, each tuned to a different wavelength from λ_1 to λ_n . So, the signal is demultiplexed or separated and tuned into the corresponding wavelength and converted from optical to electrical to retrieve the original signal. An important element of high speed data transmission in optical networks is that a single fibre can accommodate hundreds of channels.

2.2.1 Different Lightpath Allocation Schemes

Network traffic or lightpath demands can be broadly divided into two categories: static lightpath demands and dynamic lightpath demands. The major difference between them is the lifetime of these requests. In *static lightpath allocation* all the requests are known in advance. This is also referred to as permanent (or semi-permanent) lightpath allocation; because once the request is set up that lightpath is expected to continue for a relatively long time - weeks, months or years. After some time, if the traffic pattern changes, a new set of lightpaths can be established. The RWA corresponding to a set of static lightpath requests is typically computed offline.

On the other hand in *dynamic lightpath allocation* the requests are not known in advance they are handled as and when they occur. These requests have a specified lifetime i.e., a start time when the lightpath is set up and an end time when the lightpath is taken down [1, 4], which is typically of much shorter duration compared to static lightpaths. These requests are taken down when communication is over, and the resources allocated to the lightpath can be reused. The dynamic lightpath allocation is further divided into *scheduled lightpath demands* and *ad-hoc lightpath demands*. The requests for which the start time and end time are known in advance (and are often periodic) are called scheduled lightpath demands (SLD). The demands, for which we neither know the start time nor the duration of such request in advance, are known as ad-hoc lightpath demands (ALD) [4, 5]. In this thesis we focus on scheduled lightpath demands. Figure 2.7 shows the various lightpath allocation schemes.

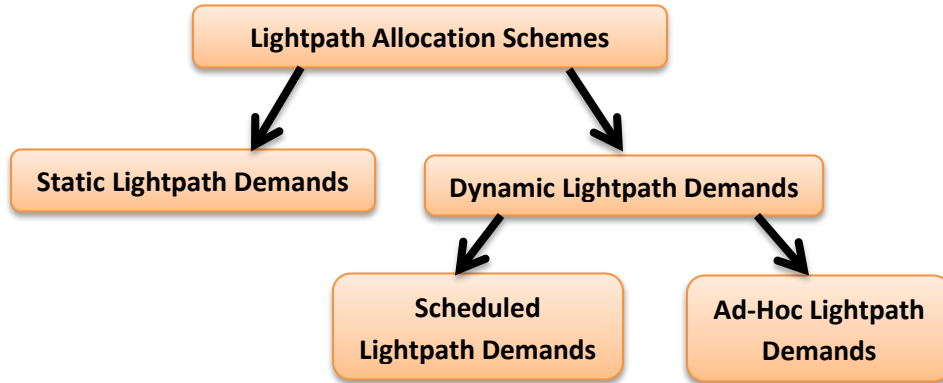

Figure 2.7: Different Lightpath Allocation Schemes

2.2.2 Scheduled Traffic Model

In scheduled traffic model demands are not permanent; they are predictable and periodic and have specific durations. The scheduled traffic model is ideal for applications that require scheduled, dedicated connections at predefined times [28]. It has been shown that such a model can lead to better resource utilization compared to approaches that are unaware of holding time [28].

The scheduled traffic model is of two types namely: *fixed window scheduled traffic model* and *sliding window scheduled traffic model*.

Fixed Window Scheduled Traffic Model

In *fixed window scheduled traffic model* the start time of and end time a demand are known in advance and are fixed. Each scheduled lightpath demands (SLDs) is represented by a tuple (s, d, n, t_s, t_e) , s and d are the source and destination, n is the number of requested lightpaths for the demand and t_s, t_e , are the setup and teardown times of the demand.

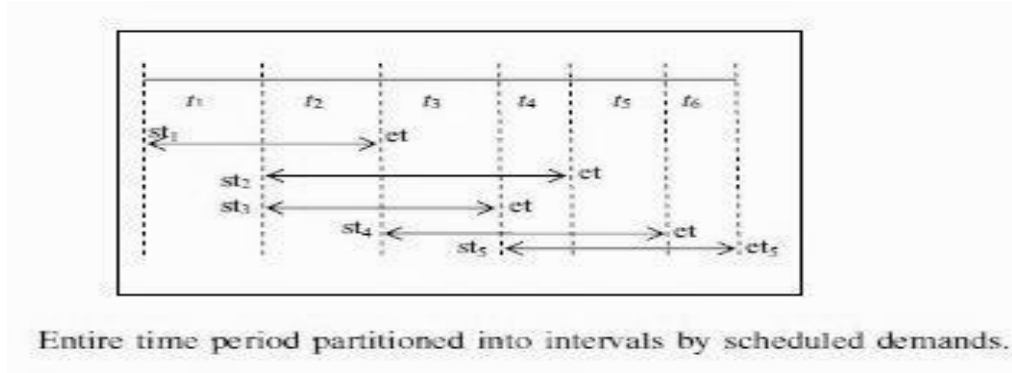

Figure 2.8: Division of scheduled demands over an entire time period [23].

The entire time period can be divided into a disjoint time intervals, by positioning demands according to ascending order of their start time, as shown in figure 2.8. Figure 2.8 shows five demands, with start times $st_1, st_2, st_3, st_4, st_5$ and end times' $et_1, et_2, et_3, et_4, et_5$ respectively. These demands have partitioned the whole time period into six intervals. The set of active intervals for each demand can be calculated, based on the start and end times of the demand, and given as input to the ILP [23]. We have considered fixed window model in our thesis.

Sliding Window Scheduled Traffic Model

In this model each demand is represented by a tuple $(s, d, n, \alpha, \omega)$, where s and d are source and destination, n represents the bandwidth requirement for the demand, α and ω are the start and end times of the larger window during which the demand is to be scheduled and τ is the demand holding time [26]. The demand setup and teardown times are not known beforehand. Instead a larger window of time as well as a demand holding time τ is specified for each demand, i.e. a demand can be scheduled any time within the specified window and the actual start and end times of the demand are determined by an appropriate resource allocation scheme [27].

2.3 Physical Layer Impairments (PLI)

Whenever an optical signal is propagated over a network, physical layer impairments (PLIs) in the components and links of the optical network lead to degradation of a signal. As the distance of travel increases, the effect of the PLIs becomes more significant. At some point, the quality of the signal falls below the acceptable level, which leads to error in transmission. The overall effects of PLI determine the feasibility of an optical path [4]. To verify the feasibility of a lightpath *quality of transmission* (QoT) is measured. QoT is evaluated at the destination node of a lightpath by computing the Q-factor, which is directly linked to the bit error rate (BER) and optical signal-to-noise ratio (OSNR) [7]. The bit error rate is defined as the rate at which errors occur in a transmission system [31]. This can be directly translated into the number of errors that occur in a string of a stated number of bits [31]. It is the error that is generated in the transmission system. For each lightpath, one verifies whether the signal quality at destination is acceptable or not with respect to the admissible BER threshold [11]. In some cases the BER is so high that we cannot adequately recover from the errors, we say that the QoT is unacceptable and that the lightpath is not feasible for data communication [8].

OSNR:

Optical signal to noise ratio (OSNR) is the ratio of optical signal power to noise power at any particular node in the network. The value of OSNR is evaluated by various analytical models.

The BER can also be calculated using OSNR. An improved OSNR is achieved with low noise and high signal power, which leads to higher OSNR. The OSNR is a significant factor for the quality of optical systems and OSNR monitoring is essential for optical performance monitoring [9].

Q Factor:

The Q-factor is a parameter that directly reflects the quality of a digital optical communications signal [10]. The higher the Q-factor better the quality of the optical signal [10]. The BER can also be calculated using Q factor. The impairments such as

noise, dispersion, and nonlinear effects accumulate along the signal route resulting in considerable deterioration of the signal quality [11].

The physical layer impairments are divided into two categories linear and non-linear.

2.3.1 Linear Impairments

Linear impairments are independent of the signal power and affect each of the wavelengths (optical channels) individually [4, 14]. They are static in nature. These impairments are caused by Chromatic Dispersion (CD), Amplified Spontaneous Emission (ASE), Polarization Mode Dispersion (PMD), Attenuation, Polarization Dependent Losses (PDL), Crosstalk (XT) and Filter Concatenation (FC). Some of the important ones are discussed below.

Chromatic Dispersion: (CD)

The velocity of propagation of light in the core of an optical fiber depends on its wavelength [12]. The degradation of light waves is caused by the various spectral components present within the wave, each traveling at its own velocity. This phenomenon is called dispersion [12]. *Chromatic dispersion* is due to the fact the various spectral components of optical signal and different wavelengths of light do not propagate with the same speed in the fiber. As a consequence, some components arrive late at the destination. CD depends on wavelength and increases with distance and is considered as one of the most penalizing linear impairments on QoT [7].

Amplified Spontaneous Emission: (ASE)

Amplified spontaneous emission is caused when spontaneous emission is amplified by an optical amplifier as a separate signal in the fiber. The primary source of additive noise in optically amplified systems is due to the ASE produced by the optical amplifiers [6]. The impact of amplified spontaneous emission (ASE) is expressed in terms of OSNR [7]. It affects the OSNR negatively. As a result QoT is degraded, when noise generated from ASE deteriorates the signal quality from laser amplifiers.

Polarization Mode Dispersion: (PMD)

A fiber can contain imperfections along the fiber span; it may be non-circular, susceptible to environmental factors such as local heating or movement [6]. These imperfections cause different polarizations of the optical signal to travel with different group velocities [6]. *Polarization mode dispersion* is caused due to the non-circular nature of the optical fiber. Consequently, the different polarizations of an optical signal travel with different velocities and arrive at the destination nodes at different times [13].

2.3.2 Non- Linear Impairments

Nonlinear impairments affect not only each optical channel individually but they also cause disturbance and interference between them [4, 14]. They are more complex and dynamic in nature. These impairments are caused by Self Phase Modulation (SPM), Four Wave Mixing (FWM), Cross Phase Modulation (XPM), Stimulated Brillouin Scattering (SBS) and Stimulated Raman Scattering (SRS). The most important non-linear impairments are discussed below.

Self-Phase Modulation: (SPM)

Self-phase modulation comes under Kerr effect which refers to the influence of optical power on a fibre's refractive index. SPM induces a phase shift of the optical pulses [7]. An ultra-short optical pulse, when traveling in a medium, will induce a time varying refractive index of the medium, i.e., the higher intensity portions of an optical pulse encounter a higher refractive index of the fiber compared with the lower intensity portions [6].

Cross Phase Modulation: (XPM)

Cross phase modulation is the non-linear phase modulation of an optical pulse caused by fluctuations in intensity of other optical pulses [6]. In other words this impairment is instigated by the existence of other lightpath on neighboring channels of an optical fiber link. The influence of XPM on system performance is more severe on multi-channel transmission. On the other hand SPM is more influenced on single channel transmission.

The effects of XPM can be reduced by increasing the wavelength spacing between individual channels [6].

2.4 3R Regeneration

The transmission reach of signals in optical transmission systems is limited [16]. When the quality of an optical signal becomes unacceptable i.e. when QoT falls below the acceptable level, it is necessary to re-amplify, reshape and retime the optical signal. These three processes clean-up and rectify the optical signals, and are often jointly called 3R regeneration [4, 16]. The 3R regeneration is performed by the regenerators at an optical node when signal quality falls below a specified threshold. It restores the signal to original form. The figure 2.9 [17] depicts a 3R regeneration process, including optical-electronic-optical (OEO) conversion at both ends. As shown in figure 10, at the receiver the incoming signal is converted from optical to electrical domain. Then signal undergoes 3R regeneration that is re-amplification, retiming and reshaping, and is finally converted back into optical form. When the signal is converting back from electrical to optical domain at the transmitter, there is a flexibility to choose the outgoing wavelength to be same as the incoming carrier wavelength or use a different carrier wavelength. Due to this feature 3R regeneration can facilitate wavelength conversion at no added cost.

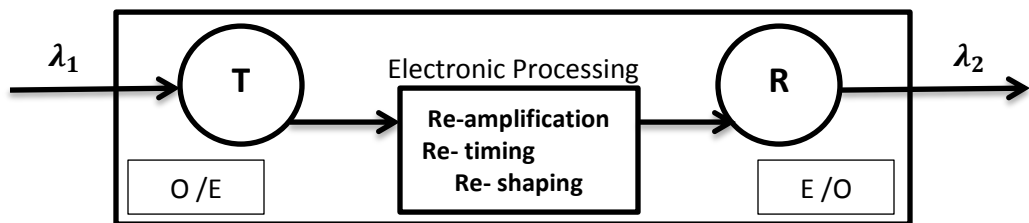

Figure 2.9: Wavelength convertible 3R O-E-O Conversion

2.4.1 Regeneration Capable Node:

A *Regenerator node* is a node which carries out 3R regeneration. Even though regeneration can be accomplished completely in the optical domain, regeneration in the

electronic domain (i.e., using OEO conversion) is still the most economical and reliable technique [18]. When OEO conversion takes place, carrier wavelength conversion is available for free [4, 6]. This means that if a lightpath from *source* to *destination* undergoes OEO conversion at some node P , the carrier wavelength of the incoming lightpath to P may be different from the carrier wavelength of the outgoing lightpath from P [1]. There are two things that need to be determined whenever a lightpath is traversing through the regenerator capable node. First, we need to identify if the traversing signal needs regeneration or not. Second, if the lightpath requires regeneration, we need to determine if there are any regenerators available at that node. Each regeneration site or regenerator capable node has a limited number of regenerators. If the number of incoming signals requiring 3R regeneration surpasses the number of regenerators available at that node, then some of the demands will be blocked due to unavailability of the regenerators.

2.5 Optical Reach

Optical reach (also called *transparent reach* [4] and *transmission reach* [18]) is the maximum distance an optical signal can travel before 3R-regeneration is needed and usually ranges from 2000 to 4000 km [19]. Generally, if the optical reach is longer, less the regeneration will take place. Many factors affect the optical reach; for example, the type of amplification, the launched power of the signal, and the modulation format of the signal [19].

The optical signal suffers from physical layer impairments such as noise, dispersion and nonlinear effects that are induced by long-haul and ultra-long-haul optical equipment [11]. As a result of this deterioration a high bit error rate is induced at destination of a lightpath. Due to PLI the QoT of the signal is also deteriorated, as the distance increases. Generally, in WDM networks as the gaps between the channels decreases or number of channels grow, it results in very poor quality of signal and high degree of interference. Due to all, these factors it is very important to minimize the impact of PLIs. We can tackle this problem, using a well-known technique called maximum distance constraint [20].

The impact of linear impairments can be measured analytically by measuring the value of ratio of optical signal to noise (OSNR) for a given bit error rate. Nevertheless, there is a more intuitive way in which QoT of a signal is calculated based on the distance travelled by the signal into the fiber. It can be observed that the quality of signal falls as the distance increases, and the impact on QoT becomes more visible [19]. As soon as it reaches certain distance, the configuration of signal drops resulting in unacceptable value of bit error rate, making the signal useless for communication further than that distance. This progression is known as the maximum distance constraint, which is defined as the maximum distance a signal can traverse that, can enable a proper communication.

On the other hand, as we know that non-linear impairments/constraints are dynamic in nature, and hence difficult to identify and calculate. In addition, the intensity and quantity of an interference and disruption may fluctuate substantially. To reduce the impact of various impairments/constraints a bound is put on the maximum transmission distance, which is known as optical reach. An *optical reach* is thus defined as the maximum distance an optical signal can travel before the signal quality degrades to a level that necessitates regeneration [19].

2.6 Regenerator Placement and Usage

The regenerator placement problem (RPP) is to determine the placement of regenerators all over the network, ensuring that quality of an optical signal of a lightpath does not fall below an acceptable level due to the presence of impairments. This problem has been studied in a number of works and has been proved to be NP-complete [1, 21]. The process of regeneration is very helpful in recovering and improving the signal. Regeneration can, in principle, be accomplished purely in the optical domain; however, regeneration in the electronic domain, which converts an optical signal into electronic format and then uses the electronic signal to modulate an optical laser, is currently the most economic and reliable technique [16]. The problem we consider in this thesis is to select the regeneration capable nodes so that there is a feasible communication path between the source and destination node for each lightpath request.

Sometimes, a lightpath may traverse a regenerator equipped node, but does not actually require 3R regeneration at that node. Therefore, in addition to RPP, it is important to determine when and how the available regenerators should be utilized. Let's take an example of a network, with 6 nodes A, B, C, D, E and F, with a regenerator at node D and distances in kilometers, as shown in figure 2.10.

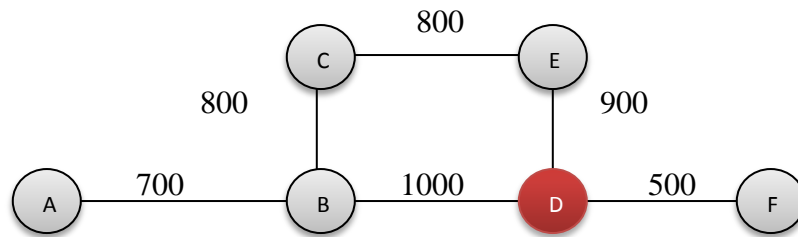

Figure 2.10: Network showing Regenerator Placement

Let's assume that the optical reach is 2000 km. Now, suppose a user wants to establish a connection for data transmission between nodes A to F, by following a path as A-B-D-F. We can see that the distance from A to F via A-B-D-F is greater than the optical reach, so the signal must be regenerated at node D before it is communicated to F. On the other hand, suppose we want to establish a lightpath between node B and node F, along the path B-D-F. Since the total distance from B to F along this path does not exceed the optical reach, no regeneration is required at node D. Therefore, this lightpath will not use a regenerator at node D, even if one is available. Generally, we try to eliminate the need of regeneration whenever possible, as regenerators are expensive and regeneration of a signal induces substantial delay as well due to OEO conversions. However, if we want to establish connections that are longer than the maximum optical reach, regenerators are necessary to maintain an acceptable QoT [22].

2.7 Types of Network

An optical network can be classified into three categories, based on the presence and usage of regenerators. Figure 2.11 shows the three different types of networks, namely (a) Transparent Network, (b) Opaque Network and (c) Translucent Network.

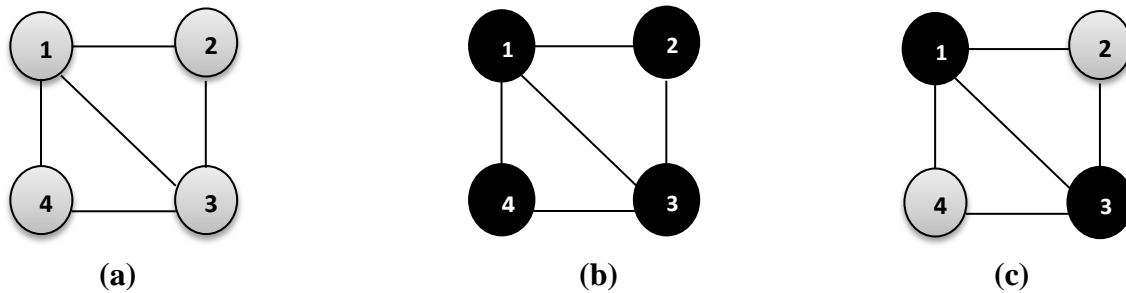

Figure 2.11: Types of Optical Networks

In *transparent* optical networks there is no OEO conversion at intermediate nodes, and the signal always stays in the optical domain between the source and the destination. In other words, there is no regeneration at any node as shown in Figure 2.11 (a). One important constraint for transparent lightpath is the total length of the lightpath should not exceed the optical reach. In the absence of wavelength converters, a transparent lightpath follows *wavelength continuity constraint* [30], which states that a lightpath should use the same wavelength on each link in its path.

Opaque Network

In *opaque* networks every node performs 3R regeneration as shown figure 2.11 (b). A regenerator is placed at each node so a signal undergoes O-E-O conversion and reamplified, reshaped and retimed at every intermediate node along its path. The advantage of opaque networks is that it minimizes blocking probability and hence increases network performance. On the other hand, the cost of performing regeneration at every node is very high.

Translucent network

Translucent network architectures have been proposed as a compromise between opaque and all-optical (transparent) networks [4]. In this type of network, 3R regenerators are placed sparsely and strategically to uphold the adequate signal quality from source node to destination. This is depicted in figure 2.11 (c), where regenerators are placed only nodes 1 and 3. In translucent networks a signal can travel as long as the signal quality does not falls below a threshold value. This approach also eliminates much of the electronic processing required in opaque networks, and allows a signal to remain in the optical domain for much of its path [4].

In translucent wavelength division multiplexing (WDM) networks, sparsely located regenerators at certain nodes can be used to offset the impact of physical layer impairments [23]. A translucent lightpath is made up of one or more transparent lightpath *segments*. A segment can range i) from the source node to a regenerator node, ii) from a regenerator node to the destination node, or iii) from one regenerator to another regenerator node. Typically, each segment in a translucent lightpath follows the wavelength continuity constraint, but different segments may be assigned different wavelengths. Figure 2.12 depicts a translucent lightpath made up of two transparent segments one is from node 1 to 3 and other is from 3 to 5 and a regenerator is placed at node 3.

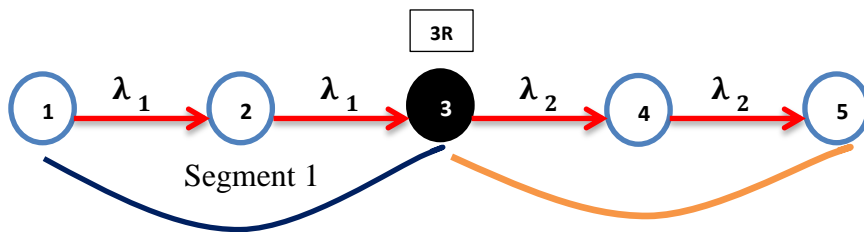

Figure 2.12: Translucent Lightpath

2.8 Literature Review

In the previous sections, we have explained some fundamental concepts and basic terminology related to translucent WDM optical networks. In this section, we review in detail some current literature dealing with RWA for scheduled demands, which are directly relevant to this thesis.

2.8.1 Regenerator allocation for SLD in translucent optical networks

The problem addressed

In [23], the authors address the problem of proper utilization of resource sharing capabilities for scheduled traffic model in translucent networks.

The new algorithm

The authors have developed a new Integer Linear Programming formulation, by using an expanded node representation scheme for those nodes that are equipped with regenerators, that basically optimally allocates resources for example wavelength–links and regenerators for scheduling the demands. In the expanded node representation each node ‘i’ with regenerator is represented by a group of three virtual nodes such as i_a , i_b and i_c . So, in this expanded node, virtual node i_c is where the regenerators are actually placed. So any lightpath using regeneration will go through edges of i_c . Hence, this representation enables the ILP to handle regenerator assignment by using only routing variables, which are required to perform the RWA.

2.8.2 An Exact (ILP) formulations, for translucent network design

The problem addressed

Deployment of large-scale transparent networks is a critical issue since transmission impairments arising from long-haul optical equipment may significantly limit the optical reach. [11]. On the other hand, opaque networks are very costly because at every node electrical regeneration is performed. In [11], the authors point out that fully opaque

networks provide quality of transmission, and translucent networks can provide a good trade-off between acceptable QoT and lowering the cost of transmission networks.

The new algorithm

The authors have devised a new and original approach that is based on ILP formulation which will handle the problem of translucent network design. They have made use of a realistic estimate of the signal quality, taking into account the simultaneous effect of four well-known transmission impairments. They have taken into account the problem of translucent network design that comes under dynamic but deterministic traffic pattern; that is scheduled lightpath demands (SLDs), since it deterministically controls the time and space distribution of the traffic demands in the network. The authors have decomposed the problem to improve the scalability of their approach into routing and regenerator placement (RRP), and the wavelength assignment and regenerator placement (WARP) sub-problems. For RRP, they have assumed that the quality of transmission is not dependent on wavelength value while placing the regenerators and route demands. In WARP phase, extra regenerators might be required for overcoming the dependency for the quality of transmission on the wavelength value. According to [11] the deployed regenerators may be shared among multiple non-concurrent SLDs. The author states that the solution they obtained at the end of RRP sub-problem, have accepted some SLD requests while rejected the others. The rejected SLDs are not considered in this sub-problem, while the accepted demands where the regeneration is required are divided into path segments at the regeneration sites.

2.8.3 Routing and spare capacity assignment for scheduled and random lightpath demands in all-optical networks

The problem addressed

In [24], the authors address the problem of protecting, routing and wavelength assignment for random and scheduled lightpath demands that occur in WDM all optical transport networks. In general terms the problem is that: if a network is provided with a limited amount of resources, and for every Lightpath Demand (LD) that can be scheduled or random (SLD or RLD) a pair of span disjoint paths is needed that will be used as working and protection paths, in such a way that the rejection ratio is minimized.

The new algorithm

The researchers have considered working and protected paths for SLD and RLD in optical transport networks, without the wavelength conversion functionality. Since the network resources are limited, the main aim is to minimize the rejection ratio. For this purpose they have used backup multiplexing techniques that will allow various lightpath demands to share the same resources, so that they can restore more WDM channels to service more lightpath requests. The authors have proposed and implemented two algorithms to handle routing and spare capacity assignment for RLDs and SLDs in WDM optical networks. The first algorithm calculates the *routing and spare capacity assignment* (RSCA) for the SLDs and the RLDs in two different and separate phases. The first routing algorithm called RSCASPPRA for *RSCA for the SLDs prior to RLDs*, requires two separate phases to calculate the routing solution. The first phase calculates the RSCA for SLDs and focuses on minimizing the number of blocked SLDs. Then taking into account assigning of SLDs, the second phase calculates on the fly the RSCA for SLDs and RLDs simultaneously, that is demand by demand. Both primary and backup paths are computed at the arrival time of each lightpath demand. The second routing algorithm called sRSCAA for *sequential RSCA* computes the routing solution for the SLDs and the RLDs on the fly at the arrival date of each LD [24].

2.8.4 Routing and Wavelength Assignment of SLDs

The problem addressed

In [25], the authors address the problem of RWA for scheduled lightpaths. They have found the routing for the network for those scheduled lightpaths which meets the

optimality criterion. Then for this routing solution, they have found the assignment of wavelengths to lightpaths that minimizes the number of required wavelengths, while satisfying the wavelength continuity constraint (no wavelength conversion exists in the optical switches). Here, the researchers have considered the optimality criteria of minimization of number of WDM channels and minimization of congestion (the number of lightpaths in the most loaded link) in the routing sub problem.

The new algorithm

The authors implemented the algorithm for computing the routing and wavelength assignment (RWA) for scheduled lightpath demands that are present in wavelength switching mesh network without the wavelength conversion functionality. They have separately developed the routing problem and the wavelength assignment problem as spatio temporal combinatorial optimization problems. They have formulated an alternative tabu search algorithm for approximate resolution for the latter and branch and bound algorithm for exact resolution for the former. Also, a generalized graph coloring approach is used to solve the wavelength assignment problem.

2.8.5 Summary of related work

A table below summarizes the four papers that are closely related to this work

Year	Title	Authors	Major Contribution
2012	Regenerator allocation for scheduled lightpath demands in translucent optical networks	Chen, Y., Jaekel, A.	An ILP formulation for resource allocation of scheduled lightpath demands in translucent optical networks.
2011	An exact approach for translucent WDM network design considering scheduled lightpath demands	Al Zahr, S., Doumith, E. A., Gagnaire, M.	An ILP based formulation solves the problem of translucent network design.
2005	Routing and spare capacity assignment for scheduled and random lightpath demands in all-optical networks	Gagnaire, M. Koubaa, M., Puech, N.,	Minimization of rejection ratio as network resources is not abundant.
2003	Routing and wavelength assignment of scheduled lightpath demands	Dotaro, E., Douville, R., Gagnaire, M., Kuri, J., Puech, N.	Presented algorithms for the RWA of SLDs without wavelength conversion functionality.

Chapter 3

Proposed Formulation

This section presents the proposed *integer linear programming* formulations to solve the routing and regenerator placement problem (RRP). The ILP performs IA-RWA for scheduled lightpath demands (SLD). The objective is to determine the minimum number regenerator sites and their locations to enable a maximum number of requests for SLD. For each request for SLD that may be handled, our objective is to set up a new lightpath from the source, specified by the request, to the destination, using available resources [23], and to choose the regenerator nodes, if the distance between the source and the destination node exceeds the optical reach. This section also presents a slight modification to the ILP proposed in [23] (ILP2). It proposes few more ILP formulations to solve the routing and regenerator assignment (RRA) and to make it comparable with our RRP scheduled lightpath demands formulations. In the RRA approach, the number of regenerators and their locations are known in advance. The goal is to use the available regenerators and other resources as efficiently as possible, when performing the RWA for each lightpath [23]. Most researchers have worked on RRA, as reported in Chapter 2.

3.1 Notation used for Routing and Regenerator Placement (RRP) ILP1

N : the set of nodes in the network

E : each set of edges connecting node i to node j representing a fiber from i to j .

G : the network, defined by a set of nodes N and a set of edges E .

(i, j) : an edge in the network, representing a fiber from node i to node j .

d_{ij} : the length of edge (i, j) .

K : the set of channels on each fiber.

T : the set of all time slots.

$s_q(d_q)$: the source (destination) node of the q^{th} request for communication.

d_{max} : the optical reach of the network.

y_q : a binary variable, where

$$y_q = \begin{cases} 1 & \text{if request } q \text{ could be handled} \\ 0, & \text{otherwise.} \end{cases}$$

r_j^q : a binary variable, where

$$r_j^q = \begin{cases} 1 & \text{if node } j \text{ is used to regenerate commodity } q, \\ 0, & \text{otherwise.} \end{cases}$$

$x_{ij}^{k,q}$: a binary variable, where

$$x_{ij}^{k,q} = \begin{cases} 1 & \text{if edge } (i,j) \text{ uses channel } k \text{ for routing commodity } q, \\ 0 & \text{otherwise.} \end{cases}$$

P_i^q : a continuous variable for node $i \in N$, and for commodity $q \in Q$, where

$$P_i^q = \text{distance of node } i, \text{ for commodity } q, \text{ from } \begin{cases} \text{a) source } s_q, \text{ if node } i \\ \text{lies on the first segment} \\ \text{b) last regenerator} \\ \text{before node } i, \text{ otherwise.} \end{cases}$$

a_t^q : a constant for all time $t \in T$ and all commodity $q \in Q$, where

$$a_t^q = \begin{cases} 1, & \text{if commodity } q \text{ is active at time } t \\ 0, & \text{otherwise.} \end{cases}$$

N_i : Number of regenerator used at node i .

IP_j^{kq} : a continuous variable $\forall j \in N, k \in K$, and all commodity, $q \in Q$, which will be constrained to have a value of 0 or 1, where

$$IP_j^{kq} = \begin{cases} 1 & \text{if } r_j^q = 0, \text{ and channel } k \text{ on edge } (i, j) \text{ is used in the lightpath for commodity } q \\ 0, & \text{otherwise;} \end{cases}$$

OP_j^{kq} : a continuous variable $\forall j \in N, k \in K$ and all commodity $q \in Q$, which will be constrained to have a value of 0 or 1, where

$$OP_j^{kq} = \begin{cases} 1 & \text{if } r_j^q = 0, \text{ and channel } k \text{ on edge } (i, j) \text{ is used in the lightpath for commodity } q \\ 0, & \text{otherwise;} \end{cases}$$

ILP Formulations for Scheduled Demands:

Objective Function:

The goal of the objective function is to maximize the number of requests that may be handled and minimize the number of regenerators used in the design. It is defined as follows:

$$\text{Maximize } \sum_{q:q \in Q} M.p^q. y^q - \sum_{i:i \in N} N_i$$

Subject to:

(a) Flow constraints must be satisfied:

$$\sum_{j:(i,j) \in E} \sum_{k:k \in K} x_{ij}^{kq} - \sum_{j:(j,i) \in E} \sum_{k:k \in K} x_{ji}^{kq} = \begin{cases} y^q & \text{if } i = s^q, \\ -y^q & \text{if } i = d^q, \\ 0 & \text{otherwise} \end{cases} \quad Q \in q \quad (1)$$

(b) At any time interval, only one lightpath can use channel k on edge $(i, j) \in E$.

$$\sum_{q:q \in Q} a_t^q \cdot x_{ij}^{kq} \leq 1 \quad \forall k \in K, \forall t \in T, \forall (i, j) \in E \quad (2)$$

(c) Each transparent segment must satisfy the wavelength continuity constraint¹.

$$(1 - r_j^q) \cdot \left(\sum_{i:(i,j) \in E} x_{ij}^{kq} - \sum_{i:(j,i) \in E} x_{ji}^{kq} \right) = 0 \quad \forall k \in K, \forall q \in Q, \forall j \in N - \{s_q, d_q\} \quad (3)$$

(d) Each segment of the path must obey the optical reach requirement.

$$P_i^q + d_{ij} \cdot \sum_{k:k \in K} x_{ij}^{kq} - d_{max} \left(1 - \sum_{k:k \in K} x_{ij}^{kq} + r_j^q \right) \leq P_j^q \quad \forall (i, j) \in E, j \neq d_q, \forall Q \in q \quad (4)$$

$$P_i^q + d_{ij} \cdot \sum_{k:k \in K} x_{ij}^{kq} \leq d_{max} \quad \forall (i, j) \in E, \forall Q \in q \quad (5)$$

$$P_i^q \leq d_{max} (1 - r_i^q) \quad \forall i \in N - \{d_q\}, \forall Q \in q \quad (6)$$

$$P_{s_q}^q = 0 \quad \forall Q \in q \quad (7)$$

(e) The number of regenerators used in node i must be N_i .

$$\sum_{q:q \in Q} a_i^q \cdot r_i^q \leq N_i \quad \forall i \in N, \forall t \in T \quad (8)$$

A Method to handle the nonlinear constraints for the RRP formulation for ILP1

CPLEX does not handle non-linear constraints. Since constraint (3) is not linear, the constraint has to be replaced by the constraints (9) to (15) given below.

We will prove later that constraint (3) is equivalent to constraints (9) to (15).

$$IP_j^{kq} \leq (1 - r_j^q) \quad \forall k \in K, \forall j \in N, \forall q \in Q \quad (9)$$

$$IP_j^{kq} \leq \sum_{i:(i,j) \in E} x_{ij}^{kq} \quad \forall k \in K, \forall q \in Q \quad (10)$$

$$IP_j^{kq} \geq \sum_{i:i,j \in E} x_{ij}^{kq} - r_j^q \quad \forall k \in K, \forall q \in Q \quad (11)$$

$$OP_j^{kq} \leq (1 - r_j^q) \quad \forall k \in K, \forall j \in N, \forall q \in Q \quad (12)$$

$$OP_j^{kq} \leq \sum_{i:(j,i) \in E} x_{ji}^{kq} \quad \forall k \in K, \forall q \in Q \quad (13)$$

$$OP_j^{kq} \geq \sum_{i:i,j \in E} x_{ji}^{kq} - r_j^q \quad \forall k \in K, \forall q \in Q \quad (14)$$

$$IP_j^{kq} - OP_j^{kq} = 0 \quad \forall k \in K, \forall j \in N - \{s^q, d^q\}, \forall q \in Q \quad (15)$$

To establish our claims, we note that constraint (3) is equivalent to the following nonlinear constraint,

$$(1 - r_j^q) \cdot \sum_{i:j \in E} x_{ij}^{kq} = (1 - r_j^q) \cdot \sum_{i:j,i \in E} x_{ji}^{kq} \quad (16)$$

3.1.1 Explanations of the RRP ILP for ILP1

The goal of the objective function is to maximize the number of requests for communications. The first part of the objective function maximizes the weighted sum of all the requests that are handled by the network. The first term also involves a priority p^q . If request q needs a higher priority compared to others, a higher value of p^q has to be used for that request. The second part minimizes the number of regenerator capable nodes.

Constraint (1):

Constraint (1) is a *standard flow balance equation* [30]. The objective of this constraint is to search for a valid route over the physical topology for each request.

Constraint (2):

Constraint (2) makes sure that, during any time interval $t \in T$, channel k on edge $(i, j) \in E$ is not allotted to more than one active request.

Constraint (3):

Constraint (3) takes care of the *wavelength continuity constraint*, which states that every segment must use the same channel throughout the segment. As pointed out in chapter 2, a transparent lightpath is always allocated the same channel on the outgoing and incoming fibers of all intermediate nodes in a lightpath, and can be changed only at regenerator nodes.

Here we have two cases to consider. In the first case $r_j^q = 0$. This means that $\sum_{i:(i,j) \in E} x_{ij}^{kq} = \sum_{i:(j,i) \in E} x_{ji}^{kq}$ for all k . It implies that channel k on some edge $i_1 \rightarrow j$ and

the same channel k on some link $j \rightarrow i_2$ from j to some node i_2 is used to allow commodity q to pass through node j . In other words, the wavelength continuity constraint must be satisfied if $r_j^q = 0$. In the second case, $r_j^q = 1$. This means that the LHS is 0, implying that this is a trivial constraint. In other words, there need not be any relation between the value of k used in the incoming link, say $i_1 \rightarrow j$, and the outgoing link, say $j \rightarrow i_2$.

Constraint (4) to (7):

Constraint (4) to (7) takes care of the optical reach constraint for every segment of each lightpath. We recall that the optical reach is the maximum distance a signal can travel before losing its signal quality. In other words, a valid translucent path for any commodity must ensure that the length of every segment is less than or equal to d_{max} .

Constraints (4) to (7) define P_i^q to be the distance of any node i in a network from the beginning of the segment that includes that node i such that a segment starts either from the source node of commodity q or from a regenerator node used by the lightpath for commodity q . The main goals of these constraints are as follows:

1. Constraint (5) confirms that the length of the segment that includes edge $i \rightarrow j$ should never surpass d_{max} .
2. Constraint (6) ensures that, if node i is used for regeneration (that is $r_j^q = 1$) P_i^q is forced to be 0, so that the length of a segment at starting node i is zero.
3. Constraint (7) confirms that if any node is the source node s_q for query q , then the distance of that node from s_q is 0.
4. For constraints (4) to (7) we have four cases to consider:
 - i). In this case, both $\sum_{k:k \in K} x_{ij}^{kq}$ and r_j^q are zero, this implies that no link from i is used to route request q . We get $P_i^q - d_{max} \leq P_j^q$ from equation (4). Now from equations (5) and (6) $P_i^q \leq d_{max}$, so $P_i^q - d_{max}$ is negative. Hence equations (5) and (6) do not impose any restriction on P_j^q . In other words, if a particular edge $i \rightarrow j$ is not used, then there is no

restriction on P_j^q , which is trivial, because we are only interested in the path that is actually followed.

- ii). In this case, $\sum_{k:k \in K} x_{ij}^{kq} = 0$ and $r_j^q = 1$ so that we are not using any edge from $i \rightarrow j$, so we get $P_i^q - 2d_{max} \leq P_j^q$, which is trivial.
- iii). In this case, $\sum_{k:k \in K} x_{ij}^{kq} = 1$ (which means that some channel k is used to travel from i to j) and $r_j^q = 0$. From equation (4), we get $P_i^q + d_{ij} \leq P_j^q$. Because of equation (5) we have $P_i^q + d_{ij} \leq d_{max}$ and from equation (6), we get $P_i^q \leq d_{max}$. Since the objective is to minimize the number of regenerators and we force, using equation (6) that P_i^q (or P_j^q) to be less than d_{max} , the net effect is that P_j^q has the minimum value. In other words, $P_j^q = P_i^q + d_{ij}$.
- iv). In this case, $\sum_{k:k \in K} x_{ij}^{kq} = 1$ and $r_j^q = 1$, so that channel k on edge $i \rightarrow j$ is used and j is a regenerator node. We get $P_i^q + d_{ij} - d_{max} \leq P_j^q$. Because of equation (5) $P_i^q + d_{ij} \leq d_{max}$, which means that $P_i^q + d_{ij}$ in equation (4) becomes negative and in equation (6) $P_i^q \leq 0$, because no variable can become negative, it forces $P_j^q = 0$.

Constraint (8):

Constraint (8) ensures that number of regenerators utilized by node i at a particular time instant t should not exceed the number of regenerators N_i at node i .

Constraint (9) to (15):

We now show that linear constraints (9) - (15) is equivalent to nonlinear constraint (16). This constraint is true for intermediate nodes only and is not applicable to the source node s_q and the destination node d_q . There are three cases to consider:

- i). Node j is not used by the lightpath. In this case, both $\sum_{i:i,j \in E} x_{ij}^{kq}$ and $\sum_{i:j,i \in E} x_{ji}^{kq}$ are 0.

- ii). Node j is used by the lightpath, for regeneration. In this case, both $\sum_{i:i,j \in E} x_{ij}^{kq}$ and $\sum_{i:j,i \in E} x_{ji}^{kq}$ are 1 and $r_j^q = 1$.
- iii). Node j is used by the lightpath, but is not used for regeneration. In this case, both $\sum_{i:i,j \in E} x_{ij}^{kq}$ and $\sum_{i:j,i \in E} x_{ji}^{kq}$ are 1 and $r_j^q = 0$.

In each case, the left hand side of constraint (16) becomes 1 (0) when the value of IP_j^{kq} is (1) 0. Similarly the RHS of constraint (16) becomes 1 (0) when the value of OP_j^{kq} is 1 (0). In other words, the constraints (9) - (15) is equivalent to nonlinear constraint (16).

3.2 Routing and Regenerator Assignment (RRA) ILP2

In [23] authors implemented the routing and regenerator assignment problem. In RRA we know the number of regenerators and their locations in advance, and the aim here is to use these resources effectively, while performing the RWA for each lightpath. We have included some additional constraints to the ILP proposed in [23], to make ILP2 formulation compatible with our formulation above.

Notations:

y_q : a binary variable, where

$$y_q = \begin{cases} 1 & \text{if demand } q \text{ can be accommodated using available resources,} \\ 0 & \text{otherwise.} \end{cases}$$

x_{ij}^q : a binary variable, where

$$x_{ij}^q = \begin{cases} 1 & \text{if demand } q \text{ is routed over edge } (i,j), \\ 0 & \text{otherwise.} \end{cases}$$

$$a_t^q = \begin{cases} 1 & \text{if commodity } q \text{ is active at time } t \\ 0 & \text{otherwise.} \end{cases}$$

N_i : Number of regenerators used at node i .

p_q : The priority assigned to demand q .

R_i : Maximum number of regenerators available at node i .

Objective Function:

Maximize

$$\sum_{q \in Q} p^q \cdot y^q - \sum_{i \rightarrow j \in E_R, i \in N_R} n_q \cdot x_{i,j}^q - \sum_{i: i \in N_R} N_i$$

Subject to:

(a) RWA Constraints

$$\sum_{j:(i,j) \in E} x_{i,j}^q - \sum_{j:(j,i) \in E} x_{j,i}^q = \begin{cases} y^q & \text{if } i = s^q, \\ -y^q & \text{if } i = d^q, \\ 0 & \text{otherwise} \end{cases} \quad (2)$$

$$\sum_{j:(i \rightarrow j) \in E} x_{ij}^q \leq y_q \quad (3)$$

Constraints (2) and (3) have to be repeated for all $q \in Q$ and for all $i \in N$.

$$\sum_{k=1}^{n_{ch}} w_{i,j}^{k,q} = n_q \cdot x_{i,j}^q \quad \forall (i \rightarrow j) \in E, \forall Q \in q \quad (4)$$

$$\sum_{q \in Q} a_{t,q} \cdot w_{i,j}^{k,q} \leq 1 \quad \forall (i \rightarrow j) \in E_p, \forall k \in K, \forall t \in T \quad (5)$$

$$\sum_{i:(i \rightarrow j) \in E} w_{i,j}^{k,q} = \sum_{j1:(j \rightarrow j1) \in E} w_{j,j1}^{k,q} \quad \forall q \in Q, \forall k \in K, \forall j \in N \setminus N_R, j \neq s_q, j \neq d_q \quad (6)$$

b) Segment length cannot exceed the optical reach

$$\delta_{i,j}^q \leq M \cdot x_{i,j}^q \quad \forall q \in Q, \forall (i \rightarrow j) \in E \quad (7)$$

$$\delta_{i,j}^q = 0 \quad \forall i \in N_R, \forall i \in s_q, \forall q \in Q, \forall (i \rightarrow j) \in E \quad (8)$$

$$\sum_{j1:(j \rightarrow j1) \in E} \delta_{j,j1}^q = \sum_{i:(i \rightarrow j) \in E} (\delta_{i,j}^q + l_{i,j} \cdot x_{i,j}^q) \quad \forall q \in Q, \forall j \in N \setminus N_R, j \neq s_q, j \neq d_q \quad (9)$$

$$\sum_{i:(i \rightarrow j) \in E} (\delta_{i,j}^q + l_{i,j} \cdot x_{i,j}^q) \leq d_{max} \quad \forall q \in Q, \forall j \in N \quad (10)$$

c) *Regenerator Availability Constraint:*

$$\sum_{q:q \in Q} \sum_{j:(i \rightarrow j) \in E_R} a_{t,q} \cdot n_q \cdot x_{ij}^{kq} \leq N_i \quad \forall i \in N_R, \forall t \in T \quad (11)$$

$$d) N_i \leq R_i \quad \forall i \in N_R \quad (12)$$

We note that constraints (11) and (12) replace constraint (11) in Chen's [23] formulation.

3.2.1 Explanation of the RRA ILP for ILP2

Objective Function:

The first term is the objective function that maximizes the weighted sum of requests can be handled by the network [23]. The second term minimizes the number of regenerators used, for each successfully routed request [23]. The third term tries to minimize the number of regenerators used by any regenerator node.

Constraint (2):

Constraint (2) is the *standard flow balance* [30] equation. The objective is to find a route over the physical topology for every request that is successfully handled.

Constraint (3):

Constraint (3) makes sure that there are no cycles in the physical route of a request. It also ensures that no resources will be allocated for the request if the request is not accommodated.

Constraint (4):

Constraint (4) ensures that n_q channels must be assigned to the request q using physical link $i \rightarrow j$ to route that request. If that route is not used, then no channel is assigned to request q on that link.

Constraint (5):

Constraint (5) makes sure that during a particular time interval $t \in T$, a channel k on a physical link $i \rightarrow j$ cannot be assigned to more than one active request, during that interval. Together with (4), which states that a request q must be allocated n_q channels, this ensures that only at most one active lightpath is assigned to a channel k on link $i \rightarrow j$ [23].

Constraint (6):

Constraint (6) implements the *wavelength continuity constraint*, which ensures that a particular lightpath is always allocated the same channel on the outgoing fiber and the incoming fiber of any intermediate node j , except when node j is a regenerator node or is the source or the destination node for the lightpath.

Constraint (7) – (9):

Constraint (7) – (9) ensures that segment length should not exceed the optical reach. All these constraints are used to calculate the value of $\delta_{i,j}^q$. If node i is a source node, intermediate regenerator node or any other node that does not exist in the route of source and destination nodes, then $\delta_{i,j}^q = 0$. Otherwise, (9) sets the value of $\delta_{i,j}^q$ to the distance from the beginning of the current segment to node i [23].

Constraint (10):

Constraint (10) ensures the distance of a segment does not exceed the maximum distance i.e. optical reach d_{max} .

Constraint (11): Regenerator availability constraint

Constraint (11) ensures that any lightpath requiring regeneration at node i , at time interval $t \in T$, should not surpass the maximum number of regenerators N_i presented at that node. Constraint (11), together with objective function ensure that N_i is the actual number of regenerators used.

Constraint (12): Regenerator availability constraint

Constraint (12) ensures that maximum number of regenerators N_i used at node i , should not exceed the number of regenerators R_i available at each node i .

Chapter 4

Experimental Results

In this chapter, we will describe our experiments to study the characteristics of the ILP formulation outlined in Chapter 3. Since our formulation considers all possible paths from the source to the destination of each request for communication, our ILP gives an optimal solution. However the search space for our formulation can become very large. In contrast, the formulation proposed by ILP2 fixes the positions of the regenerators. This can significantly reduce the search space and allow us to solve problems which are larger, in terms of the size of the networks and/or the number of requests to be handled. Since formulation ILP2 fixes the position of the regenerators, the quality of the solutions is likely to be compromised – either requiring more regenerators or rejecting more requests for communication. In this chapter, we will investigate the merits of the two approaches, in terms of execution times, quality of solutions and the numbers of regenerators used. The objectives of our experiments are as follows:

1. To study the sizes of the networks that can be handled by ILP1 and by ILP2.
2. To compare the times needed to handle networks of different sizes, using ILP1 and using ILP2.
3. To compare the numbers of regenerators needed by ILP1 formulation to those needed by ILP2, for problems of varying complexities.
4. To compare the number of requests that can be handled by networks of a given size.

We carried out all the experiments on the virtual server at the University of Windsor, using the commercial solver CPLEX. Since the resources on the virtual server were shared by other users, the computation time varied, according to the number of processes that are running at that time. We have outlined in Chapter 3 that, in order to make two formulations comparable, we have to slightly modify formulation ILP2. For each of the approaches, we developed two software modules outlined in Figure 4.1 and 4.2.

In the first module (Figure 4.1), corresponding to our ILP formulation (ILP1), our program (written in C), and reads in the following:

- The description of the network, including the topology of the network, the locations of the regenerators, the value of the optical reach, the number of channels per fiber and the distances between neighboring nodes, measured by the actual lengths of the fiber connecting each node to its neighbors.
- The set of requests for data communication. Each request is specified by the source node, the destination node, the start time, and the duration of the request for communication.

The program generates the description of a file, using the .lp format, corresponding to the problem specified by the input. The .lp file contains the mathematical formulation of the problem using the format required by CPLEX, corresponding to our ILP approach (ILP1) described in Section 3.1.1. In the second module (Figure 4.2), corresponding to formulation ILP1, our program (written in C),

- reads in the file created by the first module,
- invokes CPLEX to solve the formulation,
- generates an output corresponding to the solution.

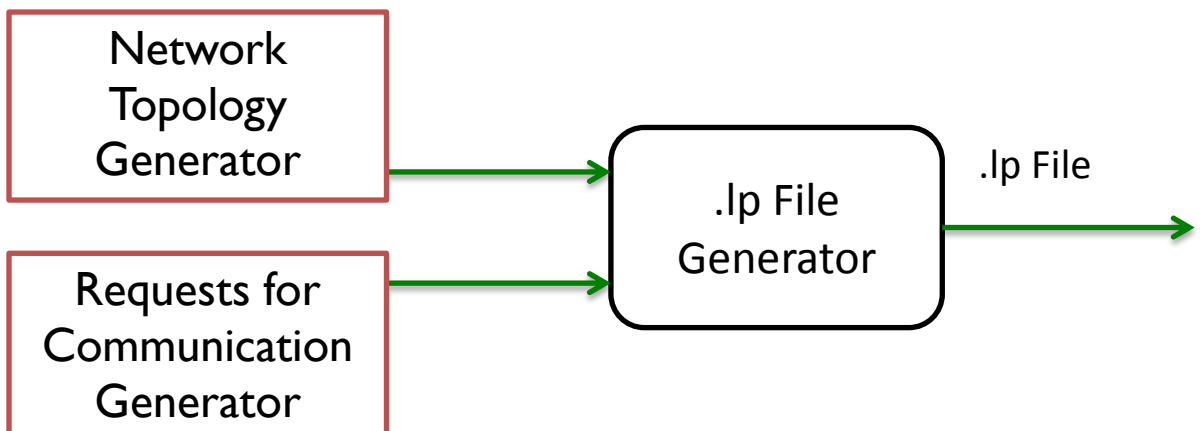

Figure 4.1: Module 1 : .lp File Generator for ILP1

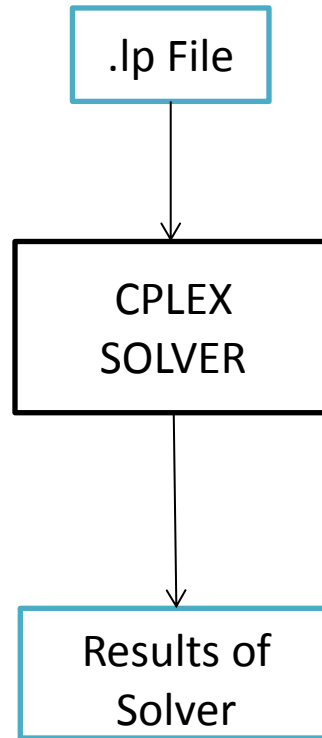

Figure 4.2: Module 2: Invoking CPLEX Solver

We have not shown how we handled formulation ILP2, since the approach is identical to that we used for ILP1. The only difference is that, in this case, the first module generates a .lp file corresponding to ILP2 described in Section 3.2.1.

For the experiments, we have generated five different sets of network topologies for every network size. We have considered five sets of requests for communication, for each network size (i.e. five sets of 15 requests for communication, five set of 20 requests for communication and five set of 30 requests for communication) to explore various scenarios.

4.1 Results of Execution time

The execution time is basically the total CPU time taken to successfully handle the demands to find the routes and associated wavelength. This time is calculated from the beginning of the ILP until every lightpath demands are successfully handled or there exists no routes to be explored for any other unsuccessful or unhandled demands. For a given network size and number of requests for communication, we have given the average of 25 runs corresponding to five topologies, each handling 5 sets of requests.

Table 4.3 shows the execution times for different network sizes and numbers of requests for communication.

# of Requests	#of nodes	Average execution time of ILP1 (Seconds)	Average execution time of ILP2 (Seconds)
15	8	232.86	0.12
	10	533.28	0.15
	12	521.53	0.16
20	8	363.44	0.17
	10	480.17	0.21
	12	1461.67	0.22
30	8	2374.30	0.30
	10	3024.10	0.35

4.3: Average run time for optimal formulation and heuristic

Table 4.3 describes the execution times of 8-node, 10-node and 12-node network respectively. It also shows the effect of varying the size of the set of requests. Furthermore, as mentioned above, the values presented in this table represent the average value from 25 runs of every set. We note that the time for formulation ILP1 to converge varies widely and therefore the average shown in the table is not very meaningful. In the Appendix A we have included the raw data for 12-node network with 20 requests showing how widely the solution times for individual data varied.

However we find that ILP1 often does not converge within a reasonable time (3600 seconds) if the number of requests exceeds 30. The time required for ILP2 is much shorter. This is to be expected, since we have determined the positions of the regenerators and hence have restricted the search space.

4.2 Results for Number of Requests

Any request for data communication from source node s to destination node d is deemed to be successful, if the formulation we use can assign a path and a channel for a lightpath to handle the request. If a call cannot be handled, the request has to be blocked, possibly to be attempted at some later time. Table 4.4 shows the average number of successfully handled requests for various scenarios. We note that generally ILP1 is able to satisfy more demands in comparison to ILP2. For 8-node networks and 10-node network mostly all the requests were handled. Even for 12-node networks with request sets with fewer demands were handled successfully. The fractional values in the table are as a result of averages taken for 25 different runs.

# of Requests	#of nodes	# of successful calls in ILP1	# of successful calls in ILP2
15	8	15	14.04
	10	14.96	11.76
	12	14.96	14.68
20	8	20	17.92
	10	19.88	15.2
	12	19.56	18.96
30	8	29.72	25.84
	10	29.16	22.32

4.4: Average number of successful calls for optimal formulation and heuristic

4.3 Number of Regenerators needed by ILP1 and ILP2

While performing RWA, the placement of regenerators to enable the establishment of some of the lightpaths is an important operation. Whenever the signal quality at any node in the path of an optical signal falls below the specified threshold (i.e. the length of the path exceeds the optical reach), a regenerator has to be placed at the preceding node. We have used 1000 km as the optical reach for our simulations. Table 4.5 shows the average

number of regenerators used by networks of different sizes when handling sets of requests for communication.

# of Requests	#of nodes	#of Regenerators in ILP1	#of Regenerator in ILP2
15	8	8.12	8.72
	10	10.88	8.00
	12	14.48	14.4
20	8	11.84	9.64
	10	16.32	9.52
	12	19.84	15.56
30	8	16.2	11.24
	10	18.16	11.16

4.5: Average number of regenerator usage for optimal formulation and heuristic

Some of the above results seem to indicate that ILP2 works better than ILP1. This, however, is not necessarily true and, with a few examples, we will discuss why the number of regenerators used by ILP1 is not worse than that used by ILP2. Table 4.4 shows that ILP1 was able to handle more requests. Therefore, when we used ILP1, the total number of channels needed to handle the requests was generally higher than that required by ILP2. Since the number of channels/fiber is fixed, this means that, when we used ILP1, a number of requests for communication required a relatively longer path. Further, the fact that more channels are busy means that it is harder to satisfy the wavelength continuity constraint and sometimes additional regenerators were needed to allow wavelength conversion in order to handle channel allocation. We will pick a few sample runs and analyze the results in more detail.

We recall that we generated 5 topologies for each size of the network (we considered size of network = 8, 10 and 12) and 5 sets of requests for communication for each value of the cardinality of the set of requests (we considered cardinality values 15, 20 and 30). To denote a specific case, our naming convention was to use the string “*topology_n_m_p*” to denote a situation where the size of the network was n , the topology number was m and p was the index associated with the set of requests. Table 4.6 below shows the results for topology_10_0_2 with 20 requests.

ILP1			ILP2		
#of calls with no regenerator	#of calls with 1 regenerator	#of calls with 2 regenerator	#of calls with no regenerator	#of calls with 1 regenerator	#of calls with 2 regenerator
0	5	2	0	8	
1	7	6	1	12	
3	8	11	3	14	
4	12	18	4	15	
9	13		9	16	
10	14		10		
19	15		19		
	16				
	17				

4.6: Analysis of requests with and without regenerators for 10-node network

After analyzing Table 4.6 we can say that that ILP1 required more regenerators, but was able to handle the entire set of request while ILP2 was not able to handle 8 requests (request numbers 2, 5, 6, 7, 11, 13, 17, 18). When using ILP1, request number 5, 7, 13, 17 required 1 regenerator, while request number 11 and 18 required 2 regenerators. We conclude that, in this case, ILP1 is a better formulation able to handle more requests.

Table 4.7 below shows the result for topology 8_2_4 with 30 requests.

#of calls with no regenerator	ILP1				ILP2		
	#of calls using number of regenerators				#of calls with no regenerator	#of calls with 1 regenerator	#of calls with 2 regenerator
	<u>1</u>	<u>2</u>	<u>3</u>	<u>4</u>			
0	1	5	7	13	0	2	6
3	2	18	9		1	7	8
4	8	22			3	9	
6	14	27			4	18	
10	16				10	20	
11	17				11	21	
12	19				24	22	
15	20				26	25	
24	21				28	27	
26	23					29	
28	25						
	29						

4.7: Analysis of requests with and without regenerators for 8-node network

Table 4.7 describes the number of requests handled and number of regenerators used by 8-node network topology with 30 requests. From Table 4.7 we see that, although ILP1 was using more regenerators but it was able to satisfy all requests. While in the case of ILP2 there were 9 requests (5, 12, 13, 14, 15, 16, 17, 19, and 23) that were not satisfied. When using ILP1, request number 12 and 15 does not require any regenerator. The request number 14, 16, 17, 19, 23 required 1 regenerator. The request number 5 required 2 regenerators, while request number 13 required 4 regenerators. We again conclude that ILP1 is better in terms of handling more requests.

Table 4.8 below shows the result for topology 12_4_2 with 20 requests.

#of calls with no regenerator	ILP1					ILP2					
	#of calls using number of regenerators					#of calls with no regenerator	#of calls using number of regenerators				
	<u>1</u>	<u>2</u>	<u>3</u>	<u>4</u>	<u>5</u>		<u>1</u>	<u>2</u>	<u>3</u>	<u>4</u>	<u>5</u>
2	6	3	0	13	19	2	1	4	13	0	3
5	8	4	1			5	6	9		12	
7	10	15	9			7	15	18		17	
		18	11			10					
			12								
			14								
			16								
			17								

4.8: Analysis of requests with and without regenerators for 12-node network

Table 4.8 shows an interesting case in which both the ILPs have used as many as 5 regenerators. In this case also ILP1 was successfully able to handle all the requests. On the other hand, in the case of ILP2 there were 5 demands (8, 11, 14, 16 and 19) that could not be accommodated. When using ILP1 the request number 8 required 1 regenerator. The request number 11, 14 and 16 required 3 regenerators, while the request number 19 required 5 regenerators.

Chapter 5

Conclusion and Future Work

5.1 Conclusion

In this thesis, we proposed a new ILP formulation to obtain an optimal solution for optimal formulation for handling SLD in impairment aware WDM optical networks. To the best of my knowledge no optical formulation for scheduled lightpath demands in translucent optical network exists, so we believe that this is the first proposal for an optimal solution to the problem This ILP formulation can be used to obtain an optimal solution for small networks (with size of 12 nodes or less). The objective is to handle as many requests as possible. We have tested our methodology with different network topologies and various set of scheduled requests. We have evaluated the performance of our approach with respect to execution time, regenerator count, successful calls or blocking probability and failed calls. We have also implemented a heuristic available in literature that uses RRA method for SLD [23]. We have made some changes in this approach to make it comparable to our method. The blocking probability is somewhat lower than the heuristic approach that was recently proposed. It is little overwhelming that the number of regenerators used is not uniformly less compared to the heuristic solution. However, we have analyzed many cases and we have find that the low blocking probability is responsible for this. With the increasing availability of the channels perhaps this high requirement of the regenerators will be avoided.

5.2 Future Work

Our experiments show that our optimal solution is expensive in terms of time. Therefore this optimal solution is useful only as a benchmark for heuristic solution. We need to explore this with faster heuristic. We feel that use of meta-heuristics such as tabu search, and other optimization techniques such as genetic algorithms or simulated annealing may give us better solutions and so this should be explored. Our experiments only considered

single-line rate WDM networks. This technique can also be explore with mixed line rate WDM networks where different channels have different data communication rates are becoming very popular. To the best of our knowledge the scheduled lightpath demands for mixed line rate networks have not been investigated. And so this can also serve as good area for future work.

REFERENCES

- [1] Aneja Yash, Bandyopadhyay Subir, Rahman Quazi: Optimal Regenerator Placement in Translucent Optical Networks. *Elsevier (2014)*
- [2] Bandyopadhyay, S., Rahman, Q., Banergee, S., Murthy, S., and Sen, A. 2009. Dynamic Lightpath Allocation in Translucent WDM Optical Networks. *Communications, 2009, ICC09. IEEE International Conference, 1 - 6.*
- [3] Bandyopadhyay, S.: Dissemination of Information in Optical Networks: From Technology to Algorithms. *Springer (2008)*
- [4] Azodolmolky, S., Klinkowski, M., Marin, E., Careglio, D., Sol- Pareta, J., and Tomkos, I. 2009. A Survey on Physical Layer Impairments Aware Routing and Wavelength Assignment Algorithms in Optical Networks. *Elsevier Computer. Network., vol. 53, no. 7, pp. 926944, May 2009.*
- [5] Bandyopadhyay, S., Rahman, Q., Banergee, S., Murthy, S., and Sen, A. 2009. Dynamic Lightpath Allocation in Translucent WDM Optical Networks. *Communications, 2009, ICC09. IEEE International Conference, 1 - 6.*
- [6] Saradhi, C., and Subramaniam, S. 2009. Physical layer impairment aware routing (PLIAR) in WDM optical networks: issues and challenges. *Communications Surveys and Tutorials, IEEE 11, 4, 109-130.*
- [7] Gagnaire, M, Zahr, S., Impairment-aware routing and wavelength assignment in translucent networks: state of the art- *Communications Magazine, IEEE, 2009 - ieeexplore.ieee.org*

- [8] Georgakilas, K., Katrinis, K., Tzanakaki, A., and Madsen, O. 2010. Performance evaluation of impairment-aware routing under single- and double- link failures. *Optical Communications and Networking, IEEE/OSA Journal* 2,8, 633-641.
- [9] Chen, W., Evans, J. S., Shieh, W., and Tucker, R. S. Optical Signal-to-Noise Ratio Monitoring Using Uncorrelated Signal-Spontaneous Beat Noise. *ATNAC 2004 (2004): 150-155*.
- [10] Ali, K. S., Rasheed, I., Sial, M. F. A., & Mehboob, T. (2012, May). Evaluation of optical receiver sensitivity–bit error rate (BER)/Q factor. *In International conference on computer and communication technologies (ICCCCT '2012) (pp. 26-27)*.
- [11] Al Zahr, S., Doumith, E. A., & Gagnaire, M. (2011, May). An exact approach for translucent WDM network design considering scheduled lightpath demands. *In Telecommunications (ICT), 2011 18th International Conference on (pp. 450-457). IEEE*.
- [12] Al Zahr, S., Gagnaire, M., Puech, N., & Koubaa, M. (2005, October). Physical layer impairments in WDM core networks: a comparison between a north-American backbone and a pan-European backbone. *In Broadband Networks, 2005. BroadNets 2005. 2nd International Conference on (pp. 1258-1263). IEEE*.
- [13] Ramaswami, R., Sivarajan, K., Sasaki, G.: Optical Networks: A Practical Perspective. 3rd edn. Morgan Kaufmann Publishers Inc., San Francisco, CA, USA (2009)
- [14] Datta, D., Feng, H., Heritage, J. P., Mukherjee, B. & Ramamurthy, B., (1999). Impact of transmission impairments on the teletraffic performance of wavelength-routed optical networks. *Journal of Lightwave Technology*, 17(10), 1713.

- [15] Bandyopadhyay, S., Jaekel, A. & Varanasi, S., (2014). Impairment-Aware Dynamic Routing and Wavelength Assignment in Translucent Optical WDM Networks. In *Distributed Computing and Networking* (pp. 363-377). Springer Berlin Heidelberg.
- [16] G. Shen, R. S. Tucker, Translucent optical networks: the way forward, *IEEE Communications Magazine* 45 (2) (2007) 48–54.
- [17] Yang, X., Ramamurthy, B.: Sparse regeneration in translucent wavelength- routed optical networks: Architecture, network design and wavelength routing. *Photonic Network Communications* 10(1) (2005) 39-53.
- [18] S. Azodolmolky, M. Angelou, I. Tomkos, T. Panayiotou, G. Ellinas, N. Antoniadis, Impairment-aware optical networking: A survey, *WDM Systems and Networks, Optical Networks* (2012) 443 – 479.
- [19] Simmons, J. M. (2006). Network design in realistic" all-optical" backbone networks. *Communications Magazine, IEEE*, 44(11), 88-94.
- [20] Simmons, J. M. (2005). On determining the optimal optical reach for a long-haul network. *Journal of Lightwave Technology*, 23(3), 1039.
- [21] Patel, A., Gao, C., Jue, J., Wang, X., Zhang, Q., Palacharla, P., and Naito, T. 2010. Traffic grooming and regenerator placement in impairment-aware optical WDM networks. *Optical Network Design and Modeling (ONDM), 2010 14th Conference*, 1-6.
- [22] Angelou, M., Azodolmolky, S., & Tomkos, I. (2013). Dynamic Impairment-Aware Routing and Wavelength Assignment. In *Cross-Layer Design in Optical Networks* (pp. 31-51). Springer US.

- [23] Chen, Y., & Jaekel, A. (2012, January). Regenerator allocation for scheduled lightpath demands in translucent optical networks. *In Computing, Networking and Communications (ICNC), 2012 International Conference on* (pp. 292-296). IEEE.
- [24] Gagnaire, M., Kubaa, M., & Puech, N., (2005, April). Routing and spare capacity assignment for scheduled and random lightpath demands in all-optical networks. In *Next Generation Internet Networks Conference, 2005* (pp. 39-46). IEEE.
- [25] Dotaro, E., Douville, R., Gagnaire, M., Kuri, J., & Puech, N., (2003). Routing and wavelength assignment of scheduled lightpath demands. *Selected Areas in Communications, IEEE Journal on*, 21(8), 1231-1240.
- [26] Chen, Y., Phibbs, S., & Jaekel, A. (2013). Joint scheduling and virtual topology design for sliding periodic traffic. *Optical Switching and Network Volume 10, Issue 3, July 2013, Pages 186–194*
- [27] Bari, A Chen, Y., & Jaekel, A., (2011). A new model for allocating resources to scheduled lightpath demands. *Computer Networks*, 55(13), 2821-2837.
- [28] Chen, Y., & Jaekel, A., (2007). Quality of service based resource allocation for scheduled lightpath demands. *Computer Communications*, 30(18), 3550-3558.
- [29] Farrell G., (2002). *Optical Communication Systems, presentation. Dublin Institute of Technology, School of Electronic and Communications Engineering*
- [30] Ahuja, R. K., Magnanti, T. L., & Orlin, J. B. (1993). *Network Flows: Theory, Algorithms, and Applications*
- [31] <http://www.radio-electronics.com/>
- [32] <http://computer.howstuffworks.com>

[33] International Telecommunications Union: The world in 2014: ICT facts and figures.

[34] Atasu, K., Dündar, G., & Özturan, C. (2005, September). An integer linear programming approach for identifying instruction-set extensions. In Proceedings of the *3rd IEEE/ACM/IFIP international conference on Hardware/software codesign and system synthesis* (pp. 172-177). ACM

APPENDICES

APPENDIX A

Topology for 12-node with 20 requests	Execution time
12_0_0	3835.83
12_0_1	2328.41
12_0_2	2073.12
12_0_3	1893.3
12_0_4	1793.49
12_1_0	1046.94
12_1_1	1021.89
12_1_2	1092.89
12_1_3	974.33
12_1_4	955.92
12_2_0	1010.12
12_2_1	982.33
12_2_2	983.54
12_2_3	931.84
12_2_4	836.15
12_3_0	833.29
12_3_1	785.88
12_3_2	1007.00
12_3_3	797.36
12_3_4	918.93
12_4_0	1038.41
12_4_1	1107.30
12_4_2	2462.89
12_4_3	2353.82
12_4_4	2454.35

VITA AUCTORIS

NAME: Aditi Bhardwaj
PLACE OF BIRTH: Pantnagar, India
YEAR OF BIRTH: 1988
EDUCATION: Uttarakhand Technical University, Dehradun,
India
Bachelor of Technology, Computer Science and
Engineering, 2010
University of Windsor, Windsor, ON, Canada
Master of Science, Computer Science, 2015