

2017

# A study of consistency in design selection and the rank ordering of alternatives using a value driven design approach

Tenkasi R. Subramanian  
*Iowa State University*

Follow this and additional works at: <http://lib.dr.iastate.edu/etd>

 Part of the [Aerospace Engineering Commons](#)

---

## Recommended Citation

Subramanian, Tenkasi R., "A study of consistency in design selection and the rank ordering of alternatives using a value driven design approach" (2017). *Graduate Theses and Dissertations*. 15623.  
<http://lib.dr.iastate.edu/etd/15623>

This Thesis is brought to you for free and open access by the Iowa State University Capstones, Theses and Dissertations at Iowa State University Digital Repository. It has been accepted for inclusion in Graduate Theses and Dissertations by an authorized administrator of Iowa State University Digital Repository. For more information, please contact [digirep@iastate.edu](mailto:digirep@iastate.edu).

**A study of consistency in design selection and the rank ordering of alternatives using a  
value driven design approach**

by

**Tenkasi R Subramanian**

A thesis submitted to the graduate faculty  
in partial fulfillment of the requirements for the degree of

**MASTER OF SCIENCE**

Major: Aerospace Engineering

Program of Study Committee:

Christina Bloebaum, Major Professor

Eliot Winer

Leifur Leifsson

David Sly

Iowa State University

Ames, Iowa

2017

Copyright © Tenkasi R Subramanian, 2017. All rights reserved.

## TABLE OF CONTENTS

	Page
LIST OF FIGURES	iv
LIST OF TABLES	vii
NOMENCLATURE	ix
ACKNOWLEDGMENTS	x
ABSTRACT	xi
CHAPTER 1 INTRODUCTION	1
CHAPTER 2 RESEARCH QUESTIONS	3
CHAPTER 3 BACKGROUND	5
Systems Engineering	5
Multidisciplinary Design Optimization	6
Value Driven Design	7
Trade Space Exploration	8
Decision Theory	9
Rank Correlation Metrics	12
CHAPTER 4 SATELLITE SYSTEM	18
CHAPTER 5 TESTING THE IMPACT OF FIDELITY OF THE VALUE FUNCTION	21
Comparison of Value Function Rank Ordering to Traditional Objective Function Rank Ordering	21
Determining Value Function Fidelity	29
Impact of Couplings on the Rank Ordering of Alternatives	32
CHAPTER 6 UNCERTAINTY ANALYSIS	37
CHAPTER 7 UTILITY THEORY	41
CHAPTER 8 CONCLUSION	52
REFERENCES	55

APPENDIX: SATELLITE DESIGN VARIABLES AND ATTRIBUTES	58
APPENDIX: TESTING THE FIDELITY OF VALUE FUNCTION	59
APPENDIX: UNCERTAINTY ANALYSIS	64
APPENDIX: IMPACT OF RISK ON VALUE FUNCTION RANK ORDERING	66

## LIST OF FIGURES

		Page
Figure 1	Systems Engineering V-model	5
Figure 2	Value Driven Design Process	7
Figure 3	Utility curve with risk preferences	11
Figure 4	Verbal description of the intensity of correlation of the metrics	14
Figure 5	Design Structure Matrix of the Satellite System	18
Figure 6	Comparison of the Rank Ordering Based Value Function vs Traditional Objective Function	24
Figure 7	Comparison of the Rank Ordering using Value function to the Multi Objective Function with Varying Weights	27
Figure 8	NPV vs High level attributes	29
Figure 9	Comparison of the Base Rank Ordering to NPP to the Rank Ordering obtained when High level attributes are fixed	30
Figure 10	Comparison of NPV obtained with and without the attributes being set as constant	31
Figure 11	Difference in NPV when a computational cost is added	31
Figure 12	(Top) global derivatives Value with respect to the SSL1 attributes (Bottom) Parallel coordinate plot of SSL1 Attributes	32
Figure 13	Sample System	33
Figure 14	Effect of coupling suspension on rank ordering of alternatives	35
Figure 15	Skewing the probability distributions to understand impact on ranking of alternatives	38
Figure 16	Effect of skewing the distributions (left) on the rank ordering of alternatives – Data Set 1	39

Figure 17	Effect of skewing the distributions (right) on the rank ordering of alternatives – Data Set 1	40
Figure 18	PDF plots of 6 designs with uncertainty	41
Figure 19	Utility Curves with varying degrees of risk aversion	43
Figure 20	Probability distributions for alternatives in Data Set 1	46
Figure 21	Comparison of the Rank Ordering of alternatives with mean of the NPV and their certainty equivalence Data Set 1 – Utility Function 1	47
Figure 22	Comparison of the Rank Ordering of alternatives with mean of the NPV and their certainty equivalence Data Set 1 – Utility Function 2	49
Figure 23	Comparison of the Rank Ordering Based Value Function vs Traditional Objective Function Data Set 2	59
Figure 24	Comparison of the Rank Ordering Based Value Function vs Traditional Objective Function Data Set 3	59
Figure 25	Comparison of the Rank Ordering using Value function to the Multi Objective Function with varying weights Data Set 2	60
Figure 26	Comparison of the Rank Ordering using Value function to the Multi Objective Function with varying weights Data Set 3	61
Figure 27	Comparison of the Base Rank Ordering to the Rank Ordering obtained when High level attributes are set as constant for Data Set 3	62
Figure 28	Comparison of NPV obtained with and without the attributes being set as constant for Data Set 3	62
Figure 29	Comparison of the Base Rank Ordering to the Rank Ordering obtained when High level attributes are set as constant for Data Set 3	63

Figure 30	Comparison of NPV obtained with and without the attributes being set as constant for Data Set 3	63
Figure 31	Effect of skewing the distributions (to the left) on the rank ordering of alternatives – Data Set 2	64
Figure 32	Effect of skewing the distributions (to the right) on the rank ordering of alternatives – Data Set 2	64
Figure 33	Effect of skewing the distributions (to the left) on the rank ordering of alternatives – Data Set 3	65
Figure 34	Effect of skewing the distributions (to the right) on the rank ordering of alternatives – Data Set 3	65
Figure 35	Comparing the Rank Ordering of alternatives with mean of the NPV and their certainty equivalence Data Set 2 – Utility Function 1	66
Figure 36	Comparing the Rank Ordering of alternatives with mean of the NPV and their certainty equivalence Data Set 2 – Utility Function 2	67

## LIST OF TABLES

		Page
Table 1	Example calculation of Kendall's tau and Spearman's Correlate on metrics	15
Table 2	Kendall's tau and Spearman rho for the Case 1 and Case 2	24
Table 3	Kendall's tau and Spearman rho when Value function rank ordering is compared to the Multi Objective function rank ordering with varying weights	27
Table 4	List of design variables through which uncertainty is propagated	37
Table 5	Rank ordering of 6 designs based on mean and certainty equivalent (with varying risk coefficients) –Utility function 1	43
Table 6	Rank ordering of 6 designs based on mean and certainty equivalent (with varying risk coefficients) –Utility function 2	45
Table 7	Kendall's tau and Spearman rho when comparing ranking based on mean to ranking based on certainty equivalence for Data Set 1 – Utility Function 1	47
Table 8	Kendall's tau and Spearman rho when comparing ranking based on mean to ranking based on certainty equivalence for Data Set 1 – Utility Function 1	49
Table 9	Satellite Design Variables and Attributes	58
Table 10	Kendall's tau and Spearman rho for the Case 1 and Case 2 (Data Set - 2)	59



Table 11	Kendall's tau and Spearman rho for the Case 1 and Case 2 (Data Set - 2)	60
Table 12	Kendall's tau and Spearman rho for the three design sets when Value function rank ordering is compared to the Multi Objective function rank ordering Data Set 2	60
Table 13	Kendall's tau and Spearman rho for the three design sets when Value function rank ordering is compared to the Multi Objective function rank ordering Data Set 3	61
Table 14	Kendall's tau and Spearman rho when comparing ranking based on mean to ranking based on certainty equivalence for Data Set 2 – Utility Function 1	66
Table 15	Kendall's tau and Spearman rho when comparing ranking based on mean to ranking based on certainty equivalence for Data Set 2 – Utility Function 2	67

## NOMENCLATURE

VDD	Value-Driven Design
MDO	Multidisciplinary Design Optimization
TSE	Trade Space Exploration
DM	Decision Maker
NPV	Net Present Value
GSE	Global Sensitivity Method
PDF	Probability Density Function
CE	Certainty Equivalence

## ACKNOWLEDGMENTS

First and foremost, I would like to thank my committee chair, Dr. Christina Bloebaum, for her guidance and support throughout the course of this research. I could not have imagined a better advisor for my Master's program.

I would also like to thank the rest of my committee members, Dr. Elliot Winer and Dr. Leifur Leifsson, and Dr. David Sly for their encouragement and constructive criticism. My sincere gratitude also goes to Dr. Hanumanthrao Kannan, who closely mentored, and helped me immensely throughout the course of my research.

I wish to thank my colleagues Ben, Garima, David, Chris, Suresh, Nazareen, Syed, Robert and Akash for making my time at Iowa State University a wonderful experience.

## ABSTRACT

In the current day, with the rapid advancement in technology, engineering design is growing in complexity. Nowadays, engineers have to deal with design problems that are large, complex and involving multi-level decision analyses. With the increase in complexity and size of systems, the production and development cost tend to overshoot the allocated budget and resources. This often results in project delays and project cancellation. This is particularly true for aerospace systems. Value Driven Design proves to be means to strengthen the design process and help counter such trends. Value Driven is a novel framework for optimization which puts stakeholder preferences at the forefront of the design process to capture their true preferences to present system alternatives that are consistent the stakeholder's expectations.

Traditional systems engineering techniques promote communication of stakeholder preferences in the form of requirements which confines the design space by imposing additional constraints on it. This results in a design that does not capture the true preferences of the stakeholder. Value Driven Design provides an alternate approach to design wherein a value function is created that corresponds to the true preferences of the stakeholder. The applicability of VDD broad, but it is imperative to first explore its feasibility to ensure the development of an efficient, robust and elegant system design. The key to understanding the usability of VDD is to investigate the formation, propagation and use of a value function.

This research investigates the use of rank correlation metrics to ensure consistent rank ordering of design alternatives, while investigating the fidelity of the value function. The impact of design uncertainties on rank ordering. A satellite design system consisting of a satellite, ground station and launch vehicle is used to demonstrate the use of the metrics to aid in decision support during the design process.

## CHAPTER 1

### INTRODUCTION

The Engineering design process has become ever more challenging with the increase in complexity of systems. Nowadays we see complex engineered systems are present in energy, maritime, automobile, aerospace and other industries. With the increase in complex nature of systems, the cost of development and production of such systems are exorbitant, and literature also shows that organizations face losses due to cost overruns, time overruns and even project cancellation [1]. There also exists enormous risk as testing these systems is impossible until completion. The challenge lies in effectively communicating the stakeholder preferences down each level of the organization's hierarchy as well as between different systems. Traditional systems engineering concepts promoted the communication of preferences in the form of requirements. These requirements limit the design space by creating additional constraints [2], and as a result each discipline has to identify their individual objectives which could result in inconsistencies in achieving the system objective or stakeholder preferences. With a meaningful representation, Systems Engineers can make decisions that are consistent with those of the stakeholder. Value driven design aids decision making process by primarily considering the desires of the stakeholder and capturing their true preferences.

Value driven design is not a method, but rather a philosophy of optimization that seeks to improve the design process by using an objective function that can be easily broken down and communicated through the design hierarchy [3]. VDD is generally implemented in the conceptual design phase where the designers have an idea of what to build. However, its usefulness extends beyond just the preliminary design phase. VDD takes in any design alternative and through its critical attributes, determines a single criterion as value that can be easily rank ordered. The single

value determined is the preference of the stakeholder. The most straight forward way of capturing the preference/ value is monetary. Soban, Price and Hollingsworth [3] laid out a research agenda which sheds light on fundamental questions regarding value-centric design that needed to be answered. One amongst them was on formulation, propagation and use of value functions. The research objective of this thesis is to investigate the use of statistical rank correlation metrics namely Kendall's tau and Spearman's rho metric, as a measure of consistency in value function rank ordering of design alternatives to aid decision making under uncertainty along with the support of visualization. These rank correlation metrics are non-parametric in nature and can be used only with ordinal data sets.

Chapter 2 describes the research questions that will be addressed in the thesis. Chapter 3 provides background on the relevant fundamentals to have a good understanding of the work being presented in this thesis. The chapter includes information on Multidisciplinary Design Optimization, VDD, Decision Analysis and the rank correlation metrics. Chapter 4 provides a description of the geo-stationary satellite system used as the test system for investigating the use of the rank correlation metrics. Chapter 5 explores the use of Kendall's tau and Spearman's foot rule metrics to determine the degree of fidelity required by the value function to enable consistent rank ordering of design alternatives. Chapter 6 investigates the use of the rank correlation metrics to understand the impact of the inherent system uncertainties on the rank ordering of alternatives. Chapter 7 investigates the impact of incorporation of risk preferences on the rank ordering of design alternatives. When considering risk preferences utility theory provided by von Neumann and Morgenstern, is used to as method of incorporating risk preferences into the analysis. Finally, Chapter 8 will provide the conclusions inferred from the thesis.

## CHAPTER 2

## RESEARCH QUESTIONS

This chapter describes the research questions formulated to investigate the use of rank correlation metrics in the VDD approach.

*Research Question 1:*

“Can the rank correlation metrics aid in determining the degree of fidelity required by the value function to enable consistent rank ordering of alternatives?”

A deterministic model will be used to tackle the tasks for the question. When considering a deterministic design, an outcome can be directly linked to an attribute and can be quantified to a point in the design space and the best choice is to select an action that yields the highest value. The following tasks will be conducted to address the research question.

**Task 1:** Comparison of value function rank ordering to tradition objective function rank ordering

This task deals with understanding how the value function rank orders the design alternatives when compared to the rank ordering obtained when tradition objectives are used. The metrics will be used to understand the degree of rank order change observed.

**Task 2:** Determining value function fidelity

This task involves fixing the high-level attributes as a constant. These attributes make up the value function being used. The metrics will be used to understand the change in rank ordering of alternatives.

**Task 3:** Impact of couplings on the rank ordering of alternatives

This task involves studying the impact of the system interaction on the value function rank ordering of alternatives. Global Sensitivity Equation is used to

*Research Question 2:*

Can the rank correlation metrics aid in understanding the effects of design uncertainty on the rank ordering of design alternatives?

This research question will be addressed by propagating the uncertainties in the system through design variables and determining its effect on the rank ordering of alternatives. The metrics will be used to determine the impact of design uncertainties on rank ordering.

*Research Question 3:*

Can the rank correlation metrics aid in understanding the effect of risk preferences on the rank ordering of design alternatives?

This question will be addressed by incorporating risk into the analysis. When considering risk preferences utility theory provided by von Neumann and Morgenstern, is used to as method of incorporating risk preferences into the analysis. The impact of the designer's risk preferences on the rank ordering of alternatives will be determined using the rank correlation metrics.

The following chapter provides background on the relevant fundamentals to have a good understanding of the work being presented in this thesis. The chapter includes information on Multi-objective optimization, VDD, Decision analysis and the rank correlation metrics. A sample calculation of the metrics is also demonstrated in the next chapter.

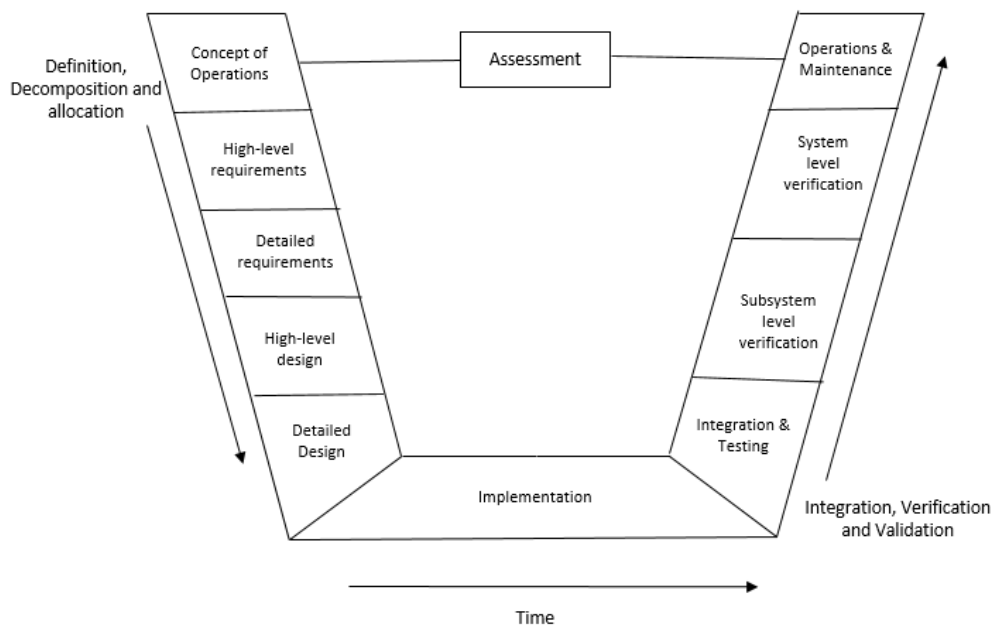


## CHAPTER 3

## BACKGROUND

Systems Engineering

In recent years, there has been unprecedented progress in the field of technology that fundamentally changed the nature of the systems we engineer [4]. Systems engineering is defined as a methodical, disciplined approach for the design, realization, technical management, operations, and retirement of a system [5]. It is an approach to develop an operable system that meets requirements within imposed constraints. The SE process can be explained using a V-model as shown in Figure 1. The V-model depicts the steps involved in a system development lifecycle.



**Figure 1:** Systems Engineering V-model

The process starts with the left side of the V-model which represents the ‘Definition, Decomposition and Allocation’ phase where the requirements are first formulated at the top level and generally decomposed and communicated through the design hierarchy. These requirements

limit the design space by creating additional constraints [2], and as a result each discipline must identify their individual objectives which could result in inconsistencies in achieving the system objective or stakeholder preferences. Once the design team has the detail design, 'Integration, Verification and Validation' phase occurs which is represented on the right side of the V model. This phase involves system integration where iterations are performed to validate the consistency of the system with the stakeholder requirements

### Multidisciplinary Design Optimization

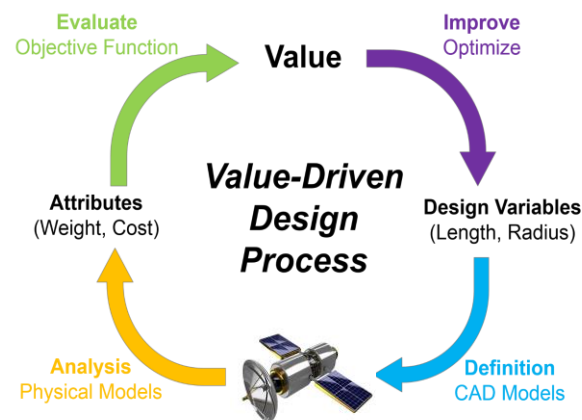
Optimization is the process of obtaining best design. The process of optimization involves the use of an objective function, formed from multiple attributes, that represents the preferences of a decision maker and then uses computational methods to generate alternatives [6, 7]. The objective function is designed to specify the preferred direction for performance improvement [ref]. The process of optimization also involves the use of constraints, which limit the feasible design space. These constraints are typically imposed on the performance attributes of the system. Optimization constraints are usually derived from design requirements which is a method of communicating preferences in a requirement-based design that is the foundation of the current system engineering practices [6].

The design of complex systems typically consists of the integrating numerous subsystems. Each subsystem has designers working closely to achieve their respective objective. Some Multidisciplinary design optimization (MDO) is field of engineering that focuses on the use of numerical optimization for the design of systems that involve a number of disciplines or subsystems. MDO is based on the idea that performance of complex systems is not only based on the performance of individual subsystems but also by the interactions between each of the subsystem. The presence of several such independent subsystems gives rise to a competition

between groups of designers because preferences of one subsystem will likely hinder the optimum of another [8, 9, 10]. MDO provides for the capturing of couplings or behavior variables during both analysis and optimization through frameworks such as the Multidisciplinary Design Feasible (MDF) shown [11].

### Value Driven Design

Value-Driven Design (VDD) [12] is not a specific method or process, but rather a novel framework for optimization in which critical attributes, including those from competing disciplines, combine to form the value function that best captures the true preferences of the stakeholder. Figure 2 shows a modified form of the graph from the Collopy paper, Value-Driven Design.



**Figure 2.** Value Driven Design Process

The first phase in the VDD process is the definition phase where the system configuration is formed from the design variables that are chosen. This is analogous to traditional optimization techniques. The analysis of physical models in the analysis phase will determine the attributes that are to be measured. The top half of the cycle is where the difference between traditional optimization techniques and VDD lies. VDD is a natural progression of Decision- Based Design [13, 14], which advocates the use of a single criterion objective function also known as a value function. The concept behind the value function is that it has only one single unit, with all the

contributing attributes related to the value function based on the same unit. This allows for an effective means to communicate the preferences through the design hierarchy. The designers at the subsystem level use this value function to evaluate the status of the component attribute and the system as whole to take the required steps to sustain the design goal [15]. The top half of the cycle uses the system value for optimization instead of evaluating the requirements like in traditional systems engineering methods. VDD focuses on capturing the true preferences of the stakeholder (decision maker), diverting the focus from requirements, thereby increasing the scope of exploration through the design space [16, 17].

When considering an organization, maximizing organizational profit is generally the primary preference. In the case of Value-Driven Design, the value is an intrinsic property of the engineering system and the set of system attributes used in the formulation of the value function can have a large impact on the outcome of the design process. VDD allows for a more meaningful means of comparison since the value function converts everything to a measure of a single unit (such as Net Present Profit). This enables the designer to rank order the alternatives based on a single measure to compare several viable options.

### Trade Space Exploration

Trade space is defined as the space spanned by the completely enumerated design variables, which means given a set of design variables, the trade space is the space of possible design options [18, 19]. TSE provides for data visualization of tradeoff behaviors and combines it with the designer's intuition to search and find the best design in the design space. Simpson et al. [20] characterize the trade space exploration process as a design by 'shopping' process, as visualization can aid the designer to steer through design space in search of a feasible design solution. Multidimensional visualization tools such as those found in the Applied Research Laboratory(ARL) Trade Space

Visualizer (ATSV) aid decision making by including “human-in-the-loop” interaction [21]. ATSV can be used for visualizing multi-dimensional data using 3D glyph plots, 2D scatter matrices, parallel coordinate plots and histograms. This helps designers to explore and interrogate the space

### Decision Theory

Decision theory is a framework for thinking logically about choices in the presence of uncertainty of outcome [22]. Previous research has shown methods of quantifying uncertainty [23, 24]. The methods to propagate these uncertainties have been addressed in [25, 26] and modelling the uncertainties have been shown in [27]. For the purpose of this thesis the Mean of the value function is used as a measure for comparison. The mean and standard deviations can be used to make decisions only when the distributions are normal. When the distributions are skewed, there is a need for a better means of facilitating choice.

Utility theory is a part of decision theory that was first suggested by Bernoulli in 1738 but the axiomatization of utility theory is attributed to von Neumann and Morgenstern. Utility theory is a mathematical model used to collapse probability distributions of outcome uncertainty into a single value. Utility theory also enables decision making under uncertainty. Von Neumann and Morgenstern also put forth a normative theory of decision by showing that under uncertainty the rational choice would be to take an action for which the probability distribution of the outcome has the highest expected utility [28]. Collopy [29] shows that for decision making, the expected utility and the expected value are equivalent, and the action that yields the highest expected utility is the most preferred in terms of value as well. Equation 1 is a sample utility function that has been used for the purpose of research. The function relates the outcome (V) to the value (U) that a person would receive and (a) is the risk preference of the stakeholder

$$U = -\frac{1}{a} * e^{-a*V} \quad (1)$$

Utility functions that are used for the investigations follow the von Neumann and Morgenstern axioms [28]. Utility theory can be used to incorporate the risk preferences of the designer, but before talking about the utility curve and risk preferences, it is imperative to understand the following terminology:

- Expected Outcome is the anticipated measure of a lottery. Equation 2 represents the expected outcome.

$$\text{Expected Outcome} = \sum_i V_i * P(V_i) \quad (2)$$

$V_i$  is the measure of alternative I and  $P(V_i)$  is the probability of occurrence of that measure.

- Utility of Expected Outcome is the player's value of the expected outcome. Equation 3 represents the utility of expected outcome.

$$\text{Utility of Expected Outcome} = U(\text{Expected Outcome}) \quad (3)$$

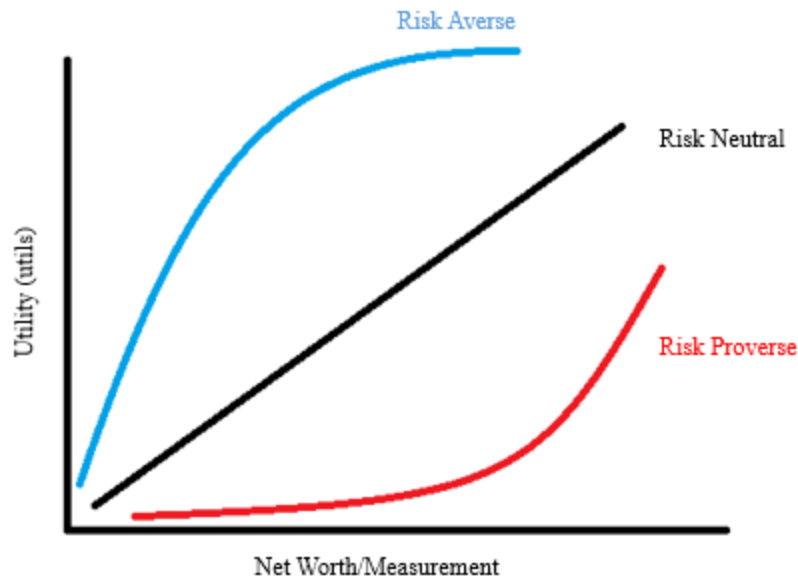
- Expected Utility is player's anticipated value of the lottery. Equation 4 represents the expected utility.

$$\text{Expected Utility} = \sum_i U(V_i) * P(V_i) \quad (4)$$

- Certainty Equivalent is minimum measure that the player would accept in lieu of playing the game. Equation 5 represents the certainty equivalent.

$$\text{Certainty Equivalent} = U^{-1}(\text{Expected Utility}) \quad (5)$$

The risk preferences can be categorized into three types i.e. risk averse, risk loving and risk neutral.



**Figure 3.** Utility curve with risk preferences

Figure 3 shows the utility curve with the risk preferences. If an individual's utility of expected outcome is greater than the expected utility, then the person is said to have a risk-averse preference. The concave-down curve in blue, in Figure 3, represents the utility function associated with a risk-averse nature. A risk-loving individual would always choose an alternative that has an expected outcome lesser than the expected utility from the game. The concave-up curve in red, in Figure 3, shows the utility function with a risk-loving nature. A risk-neutral individual would choose an alternative that has a utility of expected outcome equal to their expected utility from the lottery. The line in black in Figure 3 represents the utility function associated with a risk-neutral preference.

### Rank Correlation Metrics

Rank correlation statistics is useful for determining whether there is a corresponding between two measurements, particularly when the measure themselves are of less of interest than their relative ordering [30]. A cardinal number, for example 5, is a one that indicates a quantity or a size but does not indicate any order except when compared to another cardinal number. An ordinal number is one that indicates order or position in a list or series, i.e. first, fifth, etc. When objects are arranged in an order according to some quality which they all possess to a varying degree, they are said to be rank ordered with respect to that quality [31]. The position an object takes when ordered with respect to some quality is called the rank of that object. The arrangement/ order to its entirety is called a rank ordering [31]. For using the metrics, the ordinal numbers are treated as if they are cardinal numbers, carrying out basic arithmetic operations such as addition, subtraction, etc. The numerical processes associated with ranking are essentially those of counting, not of measurement. Dependency of the ordinal variables is denoted as rank correlation and their intensity is expressed by correlation coefficients [32]. To compare two ranked data sets, there has to be a base measure or in this case, a base set of rank ordering. The base rank ordering is the natural order of rank 1 to 15 with 1 being the first rank and 15 being the last rank. Two rank correlation metrics have been used to for the investigations in the thesis. They are as follows:

1. Kendall's Tau:

Kendall's tau is a coefficient that represents the degree of correspondence between two ranked ordinal data sets [31]. It is a non-parametric measure of association of ranks. The coefficient follows three basic properties:

- a) If the agreement between ranks is perfect, i.e. every individual has the same rank in both the data sets,  $\tau = +1$ , indicating perfect positive correlation



b) If the disagreement between ranks is perfect, i.e. one ranking is the inverse of the other,  $\tau = -1$ , indicating perfect negative correlation

c) For the arrangement  $\tau$  should lie between the limiting values, i.e. -1 and +1

When  $\tau = 0$  means that 50% of the pairs are concordant and the other half are discordant.

Kendall's tau can also be a measure of concordance between two ranked ordinal data sets.

Suppose two observations  $(X_i, Y_i)$  and  $(X_j, Y_j)$  are concordant if they are in the same order with respect to each variable. That is, if

1.  $X_i < X_j$  and  $Y_i < Y_j$  or if

2.  $X_i > X_j$  and  $Y_i > Y_j$

They are discordant if they are in the reverse ordering for X and Y, or the values are arranged in opposite directions. That is, if

1.  $X_i < X_j$  and  $Y_i > Y_j$  or if

2.  $X_i > X_j$  and  $Y_i < Y_j$

Every  $\tau$  maps directly to a percentage of concordant pairs (assuming there are no tied ranks) [30].

If C is the number of concordant pairs and D is the number of discordant pairs then  $\tau$  can be calculated using Equation 6.

$$\tau = \frac{C-D}{C+D} \quad (6)$$

Given two distinct rankings of the same  $n$  items, count the number of pairs that are concordant, in the same order in both sets and discordant, in the reverse order. One of the few downfalls of Kendall's  $\tau$  is that treats all swaps that occur in the rank ordering, as equal. An example calculation of Kendall's  $\tau$  is given along with the same for the Spearman's rank correlation.

## 2. Spearman's Rho:

Spearman's rho named after C. Spearman [27], is used to detect change in the distance of an object by comparing two sets of ranked data in which the object is a part. Spearman's rho calculates the differences between the pair of ranks to see the deviation in the ranks

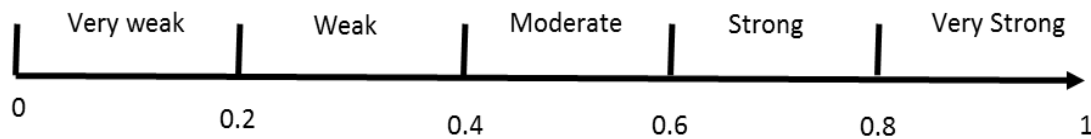
$$r_s = 1 - \frac{6 \sum(d^2)}{n(n^2-1)} \quad (7)$$

Where:

d – Difference  
n – Sample size

When two rankings are identical, all the differences are zero and from the equation given above,  $r_s = 1$ . On perfect disagreement  $r_s = -1$ .

Correlation is a measure of dependency and so we can verbally describe the metrics as:



**Figure 4.** Verbal description of the intensity of correlation of the metrics

Figure 4 shows the intensity of the correlation of the metrics in the form of a modified version the scale found in [32]. This scale shows the intensity for the absolute value of the metric. As mentioned above, both the metrics can vary between -1 and 1. The scale does not change when the metric values are negative. Once the metrics are calculated, it can be compared to the verbal scale in Figure 4 understand the impact on the rank ordering.

Example calculation of Kendall's Tau and Spearman's Rho:

**Table 1.** Example calculation of Kendall's tau and Spearman's correlation metrics

Ranks of 10 objects		Calculation of Kendall's Tau		Calculations for Spearman's rho	
Base Ranking by Designer A	Ranks of the Designs by Designer B	No of Concordant pairs (C)	Number of Discordant pairs (D)	Deviation (d)	d <sup>2</sup>
1	3	7	2	-2	4
2	1	8	0	1	1
3	4	6	1	-1	1
4	2	6	0	2	4
5	6	4	1	-1	1
6	5	4	0	-1	1
7	8	2	1	-1	1
8	7	2	0	1	1
9	9	1	0	0	0
10	10	-		0	0
		$\Sigma C = 40$	$\Sigma D = 5$		$\Sigma d^2 = 14$

Table 1 given above shows two arbitrary rank ordering of 10 objects. The first column in the table represents the base ranking for comparison. The first step in calculating Kendall's tau is to obtain the sum of the concordant and discordant pairs in the rank ordering that is being compared to the base ranking. Concordant pairs are calculated by adding the number of positions below the current rank that are greater than the current rank. Discordant pairs are calculated by adding the number of ranks that are less than the current rank. From the table above, Designer A has ranked object 1 and Designer B has ranked object 1 as third. There are seven ranks below 3 in Designer B's list that are greater than 3. Hence the number of concordant pairs for the object in the first position in the table is 7. For the same object, there are only two ranks that are lower than 3 in the list below, hence the number discordant pairs for the object at the first position on the list given by Designer B is 2. As we move down the table, the ranks which are above a particular rank are ignored when

calculating the concordance and discordance. The summation of the both the concordant and discordant pairs are calculated to obtain the Kendall's tau.

$$\tau = \frac{C-D}{C+D}$$

$$\tau = \frac{40 - 5}{40 + 5} = 0.7778$$

To calculate the Spearman's rho for the same ranked data, we find the deviation between two sets of ranked data, which is the row wise difference between the ranks in the same position in the two lists. For the case of shown in Table 1, the deviation for the object in the first position is calculated by subtracting the rank on the first position of the Designer B's list to the one at the first position Designer A's list, which is  $3 - 1 = 2$ . Similarly, the deviations for the rest of the objects in Designer B's list are calculated. The sum of the square of the total deviation is calculated and input into the Spearman's Rank Correlation. The sample size is 10.

$$n = 10$$

$$\sum (d^2) = 14$$

$$r_s = 1 - \frac{6 \sum (d^2)}{n(n^2-1)} = 1 - \frac{6*14}{10*(10^2-1)} = 0.9152$$

The tau value corresponds to a strong correlation according figure 3, whereas, the rho value shows a very strong correlation according to figure 3. The reason for the Spearman's coefficient giving such a high value is because rho is calculated based on the distances between each object. As seen in the table, the deviation between the ranks of the two tables is less because the  $d$  varies between -2 and -1, which means that the distance moved by each object in Designer B's list is also less, hence the coefficient shows a strong correlation. Spearman's correlation has the ability to detect

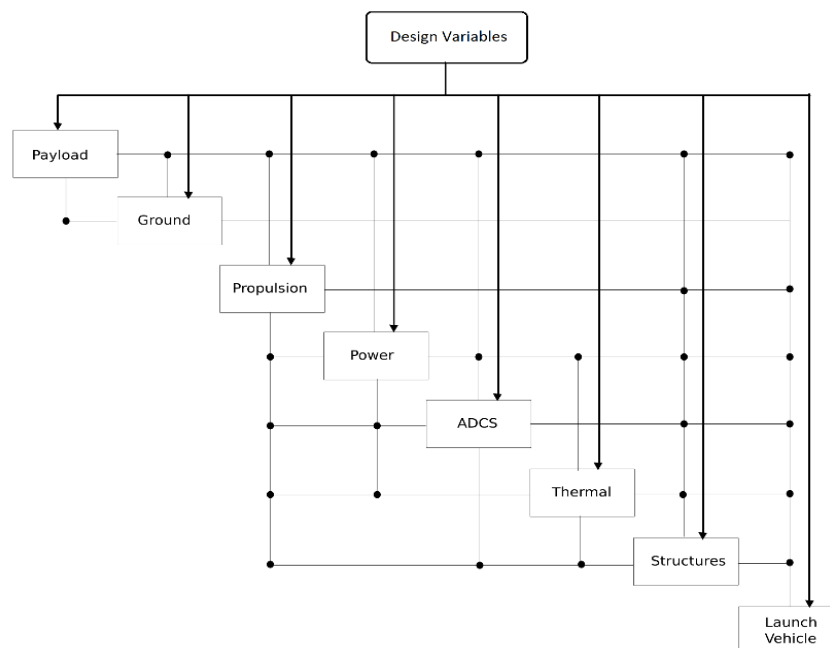
minor sensitivities in the rank ordering that yield very different rho values because of calculating pairwise deviations.

Chapter 3 talks briefly about the fundamental concepts of Systems Engineer, MDO, VDD and the rank correlation metrics required to understand the investigations presented in this thesis. Chapter 4 gives a detailed description of a geo-stationary satellite system which is used as the test system for addressing the research questions discussed.

## CHAPTER 4

## SATELLITE SYSTEM

A previously developed geo-stationary commercial communication satellite [33] will be used as test case to address the focal points of the thesis. The satellite system includes a geo-stationary communication satellite for TV broadcasting, ground station for signal transmission and a launch vehicle for the satellite to get into the orbit. The system being used for the purpose of addressing the research questions is a conceptual model and the design is simplified for the purpose of optimization. The mission objective of this satellite system to receive the signal from one ground station, amplify and process it and retransmit it to another receiving station. The conceptual model being used has eight broader subsystems compared to the several hundred subsystems present in a real case scenario. The subsystems in the test case are: Attitude Determination and Control, Ground, Launch Vehicle, Propulsion, Payload, Structures and Thermal [34].



**Figure 5.** Design Structure Matrix of the Satellite System

Figure 5 shows a design structure matrix that depicts the various subsystem interactions. In the figure, the arrows depict the input design variables to each subsystem. Thirty-six design variables define the satellite system. The solid dots that connect the lines between the subsystems are couplings between the subsystems that are basically the behavior variables that are the output of one subsystem that is necessary to design another. Couplings represent the interactions between the various subsystems. The couplings exist even at the lower level of the decomposed system. It is imperative to understand the interactions between the attributes across various subsystem and their impact on the system as whole as VDD advocates the formulation of a value function that is a function of various attributes. Despite proven to be applicable to a variety of systems, little research has been conducted to explore the feasibility and applicability of VDD to complex engineered systems which is discussed in [3]. For the satellite example, it is assumed a commercial organization is designing the system, which means the company is trying to maximize profit. The profit will be a recurring amount depending on the performance of the system. The impact of time is taken into account because the value function is formed on the profit of the system. The implemented value function captures both the true preference of the designer (the profit of the product over its operational lifetime), as well as the designer's time preference on when the product's profits are received, through a discount rate [33]. The total yearly revenues and cost, while complex to determine, enable an optimization process involving a meaningful objective function (profit) based on the true preference of the system designer [33].

$$\begin{aligned}
 \text{Profit} &= \sum_{y=1}^{OL} \text{Revenue}_y - \text{Total Cost} \\
 \text{Net present value (NPV)} &= -\text{Total Cost} + \sum_{y=1}^{OL} \frac{\text{Revenue}_y}{(1 + r_d)^y}
 \end{aligned}$$

where:

$r_d$ : discount factor = 10%

$OL$ : Operational Lifetime = 10 years

$y$ : year

(8)

A system decomposition chart for the satellite is provided in Appendix I.

To investigate the use of rank ordering metrics, three data sets of design alternatives are chosen. Each data set comprises of 15 design alternatives that will be used for investigating the impact on their rank ordering. The selection process for the design alternatives is as follows: At first, a single set of 10,000 design alternatives were generated using a randomize function. From the pool of 10,000 designs, three data sets, each consisting of 15 design alternatives were handpicked. The first design set, which will be called Data Set 1 for the rest of the thesis consists of design alternatives that yield profits in the range of \$314 million to \$290 million. The Data Set 2 comprises of design alternatives that yield profits in the range of \$314 million to \$200 million. The Data Set 3 consists of design alternatives that yield profits in the range of \$314 million to \$100 million. The design alternatives used for the investigations in this thesis are given in Appendix. The next chapter addresses research question 1 and its tasks. A deterministic model of the satellite system is used to investigate the tasks in research question 1.



## CHAPTER 5

## TESTING THE IMPACT OF FIDELITY OF THE VALUE FUNCTION

The focus of this chapter is to investigate the use of metrics in determining the degree of fidelity required by the value function to enable a consistent rank ordering of alternatives for the satellite system. The metrics are calculated in the same manner as shown in Chapter 2, subtopic Rank Correlation Metrics. A deterministic model is used for addressing the tasks in research question 1. In this chapter no uncertainties are considered, thereby making it straightforward to rank order the alternatives. The base measure for ranking is Net Present Profit of each alternative being ranked from the highest to lowest where rank 1 is given to the design alternative that yields the highest NPV and rank 15 is given to the alternative with the lowest NPV in the design data set. Since the primary goal of the research is understanding the use of the metrics to help arrive at a good value function, the chapter starts with a comparison of the current value function rank ordering of alternatives to traditional objective functions rank ordering of alternatives. This task is carried out to demonstrate the use of metrics to understand the changes in rank ordering of alternatives for a satellite system to enable consistency in design selection

**Task 1:** Comparison of value function rank ordering to traditional objective function rank ordering. In this task, the rank ordering obtained using a value function is compared to the rank ordering obtained when traditional objective functions are used. The first objective function being compared to the value function is a single objective cost formulation for the satellite system. Equation 9 shows the cost formulation.

$$\begin{aligned}
 & \text{find } \mathbf{X} \\
 & = [f_{down}, f_{up}, P_t, P_{gt}, D_{sat,trans}, D_{sat,rec}, D_{ground,rec}, D_{ground,trans}, \epsilon]^T \\
 & \text{Min } f(\mathbf{X}, \mathbf{y}) = \text{Total Cost} \\
 & \text{s. t. } g_1: 10\text{dB} - SNR_{composite} \leq 0 \\
 & \quad g_2: M_{total} - 1000 \leq 0 \\
 & \quad g_3: \text{ArraySize} - 40m^2 \leq 0 \\
 & \quad g_4: L_{structures} - 5m \leq 0
 \end{aligned} \tag{9}$$

$$\begin{aligned}
& g_5: r_{structures} - 2.5m \leq 0 \\
& 1 \text{ GHz} \leq f_{down} \leq 100 \text{ GHz} \\
& 1 \text{ GHz} \leq f_{up} \leq 100 \text{ GHz} \\
& 300 \text{ W} \leq P_t \leq 3000 \text{ W} \\
& 300 \text{ W} \leq P_{gt} \leq 30000 \text{ W} \\
& 0.5m \leq D_{sat,trans} \leq 2.5m \\
& 0.5m \leq D_{sat,rec} \leq 2.5m \\
& 2 \text{ m} \leq D_{ground,rec} \leq 20m \\
& 2 \text{ m} \leq D_{ground,trans} \leq 20 \text{ m} \\
& 35 \frac{W-hr}{kg} \leq \varepsilon \leq 200 \frac{W-hr}{kg}
\end{aligned}$$

The objective here, is to reduce the amount of money spent on production of the system. To limit the optimization process from reaching the natural optimum i.e. 0 (no mass and no cost), constraints have been imposed. Constraints are imposed on the signal to noise ratio, total mass and array size.

The second objective function used is a minimization of mass function. Minimization of mass is a common objective function for the design of an aerospace system, as cost will substantially increase with an increase in spacecraft mass that has to be launched into space. The mass function is often used as a surrogate to the cost model. The objective function is given below in Equation 10 along with its constraints.

$$\begin{aligned}
& \text{find } \mathbf{X} \\
& = [f_{down}, f_{up}, P_t, P_{gt}, D_{sat,trans}, D_{sat,rec}, D_{ground,rec}, D_{ground,trans}, \varepsilon]^T \\
& \text{Min } f(\mathbf{X}, \mathbf{y}) = M_{total} \\
& \text{s. t. } g_1: 10dB - SNR_{composite} \leq 0 \\
& \quad g_2: M_{total} - 1000 \leq 0 \\
& \quad g_3: ArraySize - 40m^2 \leq 0 \\
& \quad g_4: L_{structures} - 5m \leq 0 \\
& \quad g_5: r_{structures} - 2.5m \leq 0 \\
& 1 \text{ GHz} \leq f_{down} \leq 100 \text{ GHz} \\
& 1 \text{ GHz} \leq f_{up} \leq 100 \text{ GHz} \\
& 300 \text{ W} \leq P_t \leq 3000 \text{ W} \\
& 300 \text{ W} \leq P_{gt} \leq 30000 \text{ W} \\
& 0.5m \leq D_{sat,trans} \leq 2.5m \\
& 0.5m \leq D_{sat,rec} \leq 2.5m \\
& 2 \text{ m} \leq D_{ground,rec} \leq 20m \\
& 2 \text{ m} \leq D_{ground,trans} \leq 20 \text{ m} \\
& 35 \frac{W-hr}{kg} \leq \varepsilon \leq 200 \frac{W-hr}{kg}
\end{aligned} \tag{10}$$

Finally, the value function will be compared to a Multi-objective function. Multi-objective functions are generally used for the design of complex engineered systems as they allow the designer to explore the tradeoffs between surrogate objectives, there by further enabling the incorporation of preferences of the decision maker. A multi-objective function with two objectives namely total space craft mass and number of transponders is given below in Equation 11.

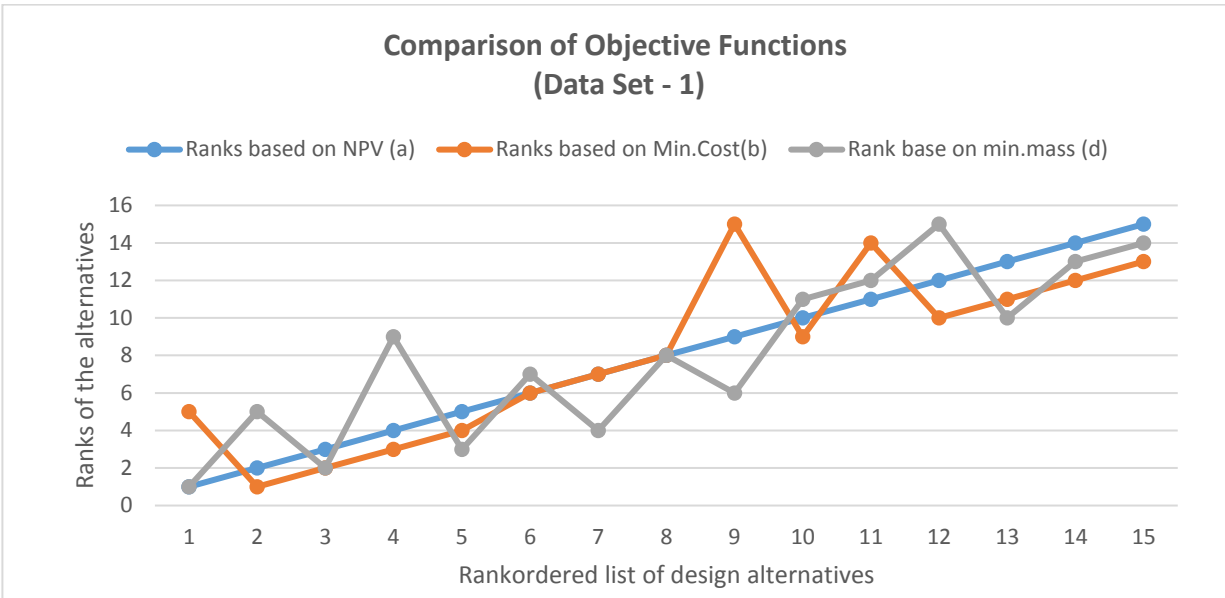
$$\begin{aligned}
 & \text{find } \mathbf{X} \\
 & = [f_{down}, f_{up}, P_t, P_{gt}, D_{sat,trans}, D_{sat,rec}, D_{ground,rec}, D_{ground,trans}, \varepsilon]^T \\
 & \text{Min } f(\mathbf{X}, \mathbf{y}) = w_1 \times M_{total} - w_2 \times N \\
 & \text{s. t. } g_1: 10dB - SNR_{composite} \leq 0 \\
 & \quad g_2: M_{total} - 1000 \leq 0 \\
 & \quad g_3: ArraySize - 40m^2 \leq 0 \\
 & \quad g_4: L_{structures} - 5m \leq 0 \\
 & \quad g_5: r_{structures} - 2.5m \leq 0 \\
 & \quad 1 \text{ GHz} \leq f_{down} \leq 100 \text{ GHz} \\
 & \quad 1 \text{ GHz} \leq f_{up} \leq 100 \text{ GHz} \\
 & \quad 300 \text{ W} \leq P_t \leq 3000 \text{ W} \\
 & \quad 300 \text{ W} \leq P_{gt} \leq 30000 \text{ W} \quad (11) \\
 & \quad 0.5m \leq D_{sat,trans} \leq 2.5m \\
 & \quad 0.5m \leq D_{sat,rec} \leq 2.5m \\
 & \quad 2 \text{ m} \leq D_{ground,rec} \leq 20m \\
 & \quad 2 \text{ m} \leq D_{ground,trans} \leq 20 \text{ m} \\
 & \quad 35 \frac{W-hr}{kg} \leq \varepsilon \leq 200 \frac{W-hr}{kg}
 \end{aligned}$$

For this task, three cases will be investigated:

**Case 1:** Comparison of value function rank ordering to minimization of cost function.

**Case 2:** Comparison of value function rank ordering to minimization of mass function.

**Case 3:** Comparison of value function rank ordering to multi-objective function with varying weights.



**Figure 6.** Comparison of the Rank Ordering Based Value Function vs Traditional Objective Functions

**Table 2:** Kendall's tau and Spearman rho for the Case 1 and Case 2

	Tau ( $\tau$ )	Rho ( $r_s$ )
<b>Case 1</b>	0.73	0.85
<b>Case 2</b>	0.69	0.85

Figure 6, shows the rank ordering of alternatives based on minimize cost function, minimize mass and the value function for the test system used. The y axis represents the ranks of alternatives in Data Set 1. The x axis represents the list of the design alternatives. The figure shows that the VDD formulation enables an easy method of ranking. It also is a meaningful means of representation of alternatives that a designer would be easily able to understand. Ranking the alternatives based on value facilitates choice as the ranking is based on a single dimensional function. It is also seen that the rank ordering of alternatives is greatly impacted when minimization of mass or cost are used.

Table 2, gives the value of Kendall's tau and Spearman's coefficient for Case 1 and Case 2 which was investigated above.

**Case 1 Discussion:** On comparing the metrics for Case 1 in Table 2 to the scale in Figure 4, it can be said that the metrics show that there exists a very strong correlation in the rank ordering in both cases albeit the graph showing that there exist many swaps in the rank ordering of alternatives. The plot for min. cost function represented by the orange line, shows a few alternatives have moved a large distance in the rank order. For example, when minimizing cost is the objective, alternative 5 is most preferred. As said before Spearman's rho is a measure of the distance moved by an object in the ranked list. It is observed that for Data Set 1, the Spearman's rho value shows a strong correlation, i.e. the two rank orderings are similar. The reason behind this case is that only 4 alternatives have moved by a large distance and the rest of the alternatives have moved a smaller distance. This can be observed in Figure 6. The sample size of the design alternatives also plays a key role when calculating Spearman's rho. In this case, the sample size averages out the large deviations in ranking observed in Figure 6. The reason Kendall's tau shows a slightly lower value is because Kendall's tau treats all swaps equally. Hence despite a high concordance, the presence of discordant pairs results in a lower tau value.

**Case 2 Discussion:** The rank correlation metric values obtained in Case 2 are quite similar to Case 1 despite having a very different rank ordering as observed in Figure 6. From Figure 4, it can be said the Spearman's rho shows a very strong correlation and Kendall's tau shows a strong correlation. The plot for min. mass function represented by the grey line, shows that there exist many swaps in the rank ordering. It is observed that the rho values are the same in both cases despite having different rank ordering. This is because, in Case 2, as in seen in Figure 6, almost every alternative has a significant deviation when compared to the few alternatives moving a large

distance as seen in Case 1. This results in a total deviation similar to the total deviation obtained in Case 1 and hence a similar rho value to Case 1. Due to the numerous swaps observed in the Case 2 rank ordering, the total number of discordant pairs are relatively higher than in Case 1. This attributes to tau giving a lower value when compared to Case 1. From this test, it can be inferred that Spearman's rho is sensitive to the distance moved by an alternative from its original position on the ranked list.

A very similar trend is observed when the same test is carried out using Data Set 2 and 3. The results for Data Set 2 and 3 are given in Appendix II.

It is also interesting to see that the rank ordering obtained when using a multi-objective function does not change when the weights on the sub objectives are varied. This is shown in Case 3. Case 3 is divided in two 4 subcases as follows:

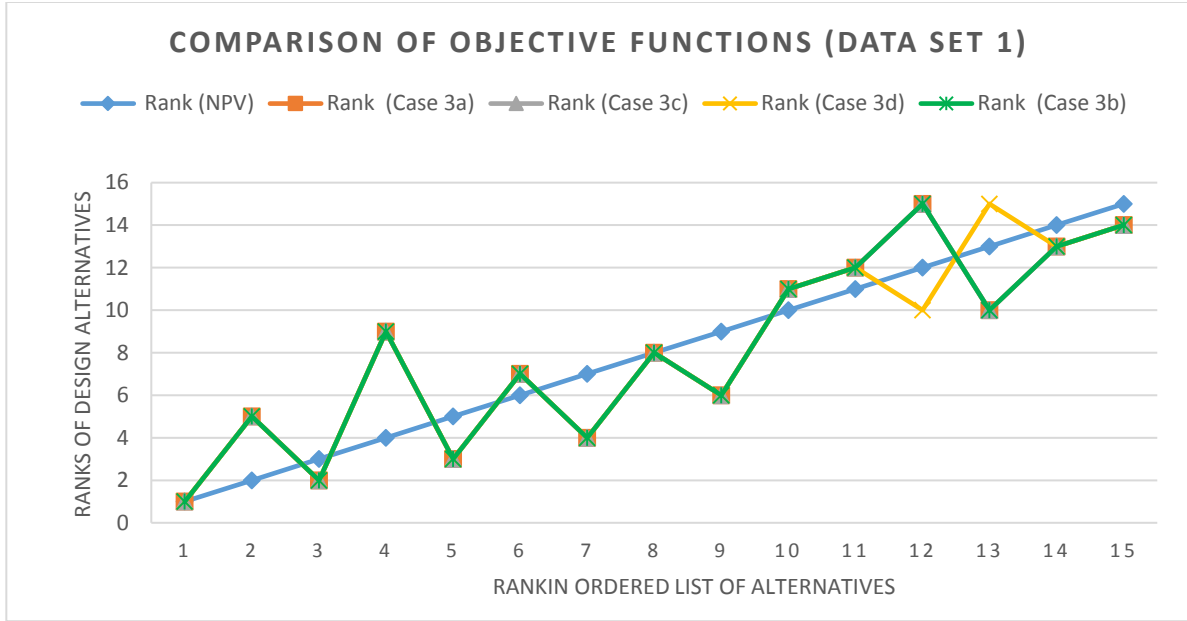
**Case 3:** Comparison of value function rank ordering to multi-objective function with varying weights.

**Case 3a.** Comparison of value function rank ordering to multi-objective function with weights ( $w_1 = 0.8$ ,  $w_2 = 0.2$ ).

**Case 3b.** Comparison of value function rank ordering to multi-objective function with weights ( $w_1 = 0.6$ ,  $w_2 = 0.4$ ).

**Case 3c.** Comparison of value function rank ordering to multi-objective function with weights ( $w_1 = 0.4$ ,  $w_2 = 0.6$ ).

**Case 3d.** Comparison of value function rank ordering to multi-objective function with weights ( $w_1 = 0.2$ ,  $w_2 = 0.8$ ).



**Figure 7.** Comparison of the Rank Ordering using Value function to the Multi Objective Function with Varying Weights

**Table 3.** Kendall's tau and Spearman rho when Value function rank ordering is compared to the Multi Objective function rank ordering with varying weights

	Tau ( $\tau$ )	Rho ( $r_s$ )
<b>Case 3a</b>	0.69	0.85
<b>Case 3b</b>	0.69	0.85
<b>Case 3c</b>	0.69	0.85
<b>Case 3d</b>	0.71	0.87

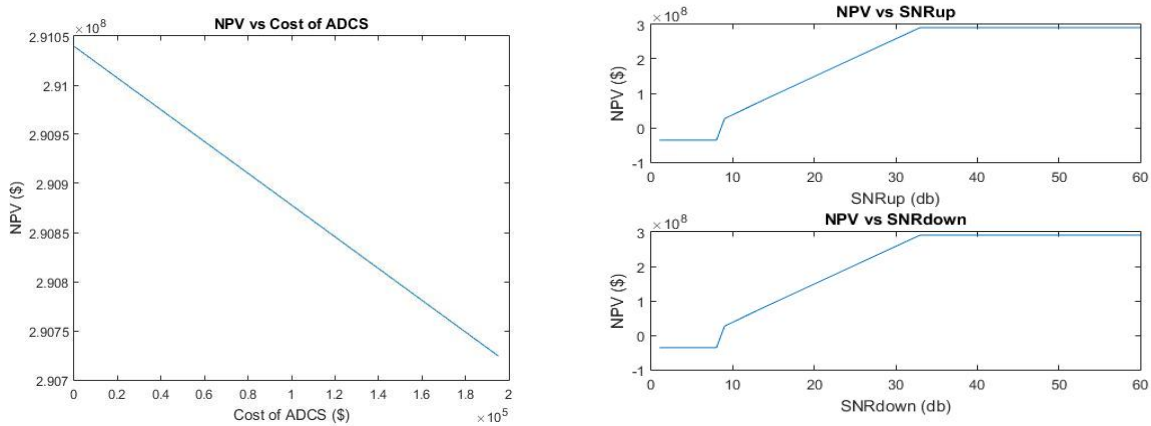
**Case 3 Discussion:** Figure 7 shows the rank ordering of alternatives based on value function and multi-objective function with varying weights. It is observed that upon using a multi-objective function, there is exists a several changes in ranking of alternatives compared to the ranking observed when a value function is used. It is also seen that, varying the weight of the multi-objective function does not affect the rank ordering. The rank ordering observed in Case 3 is similar to Case 2. Table 3 gives the metric values for the 4 subcases of Case 3. From Figure 4, it

can be said the Spearman's rho shows a very strong correlation and Kendall's tau shows a strong correlation. As observed in Figure 7, in all subcases, there exists significant deviations in ranking when compared to the base value function rank ordering. The maximum deviation observed is 5. The presence of a large sample size deems the swaps insignificant. Hence, a high rho value is obtained. The reason for the tau value being large is that, Kendall's tau does not account for the distances moved by an object in a ranked list. In this case the maximum discordance observed is 5 which is found in position 4 on the list. Due to the presence of discordance in the rank ordering results in a  $\tau = 0.69$ . A similar trend is observed when Data Set 2 and 3 are considered for the investigations. From these tests, we can infer that rank ordering based on a value function is more meaningful form of representing the feasible alternatives. It is also an easy means to rank ordering alternatives as the value function is of a single unit. It is observed for the cases above that, Spearman's rho shows a strong correlation when traditional objective function ranking is compared to the value function ranking. Despite the significant swaps observed in the rank ordering produced by the traditional objective functions, the deviations observed are not significant for the number of design alternatives used in the analysis, for rho to show a lower intensity in correlation. As observed in the cases above, Kendall's tau shows a lower strength in correlation of the rankings. This is because, Kendall's tau treats all swaps equally. The in reversal of the rank ordering leads to increase in the number of discordant pairs. This results in a Kendall's tau value showing a low intensity in the correlation of rank. The next task addresses the impact of the fidelity of the value function on the rank ordering of alternatives.



### Task 2: Determining value function fidelity

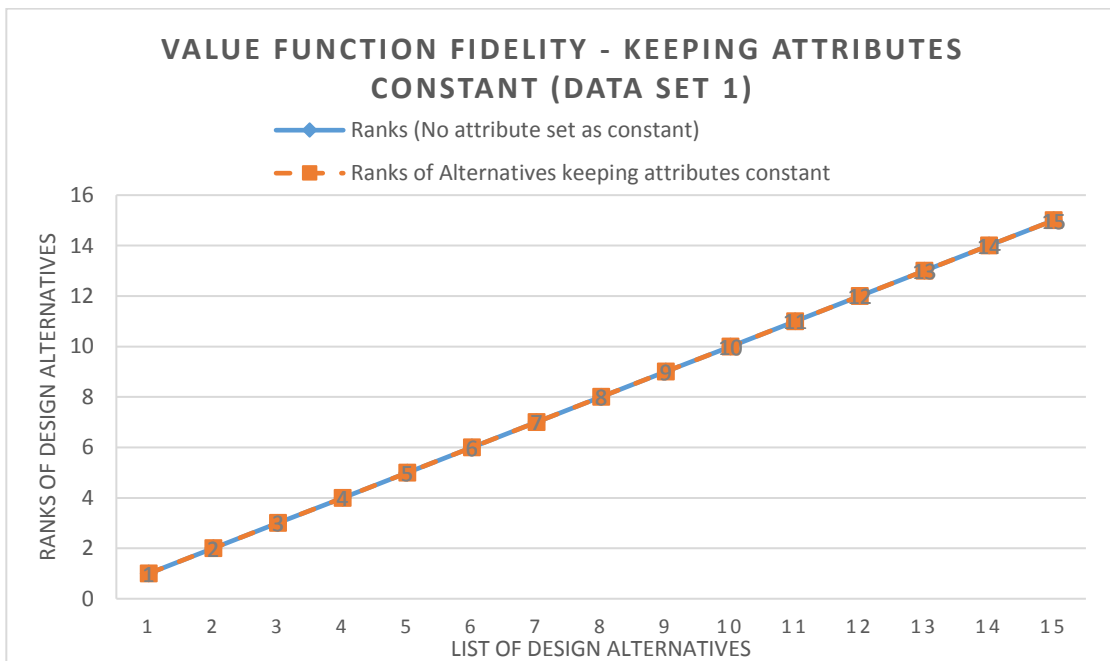
A key goal in VDD is to have the least complicated value function that would provide the desired value accuracy and an acceptable variation in rank ordering of alternatives [12]. The tau and rho metrics are being investigated to determine whether they can be useful together with visualization to help decision making with regards to what attributes are critical for the value function and which might be less so, as well as the hierarchical relationship across higher and lower level attributes.



**Figure 8.** NPV vs High level attributes

Figure 8 shows the variability of the Net Present Profit to changes in the attributes. The plot to the left represents the drop in NPV as the Cost of the ADCS subsystem increases. The plot to the right shows the variability of NPV to signal to noise ratio. This task investigates the impact of the fidelity of the value function on the rank ordering of alternatives when the attributes that form the value function are set as constants. Seven high-level attributes namely, the signal to noise ratio uplink and downlink, cost of structures, cost of thermal, cost of ADCS, cost of propulsion and cost of payload, are set as constant for the analysis in order to see the effects on the value function rank ordering. The attribute values are recorded for each data set. Then for each data set of alternatives, the attributes are fixed at the mean of the recorded attribute values for the data set. Once the

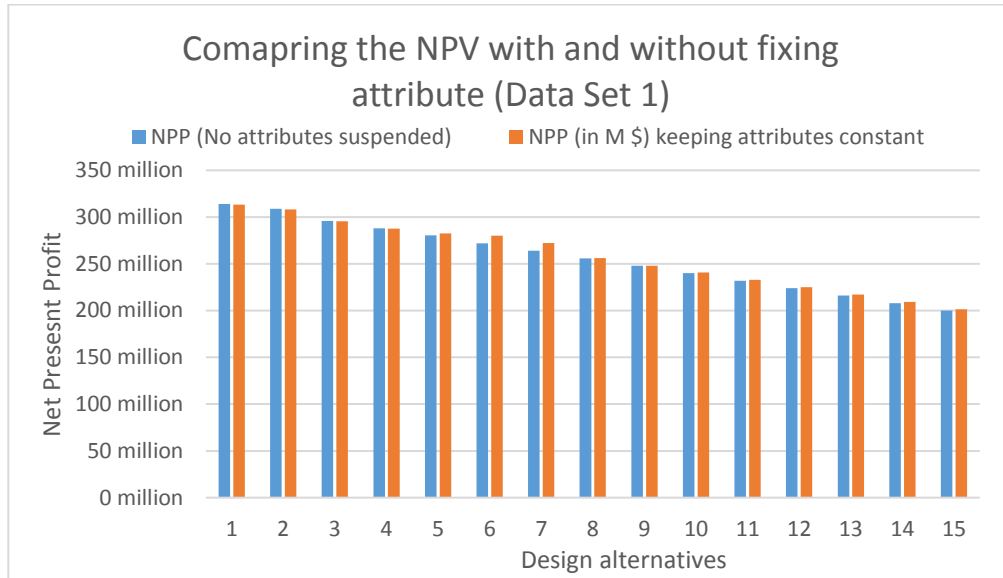
attribute is set as constant at the mean, the alternatives are rank ordered and the metrics are used to understand the variation. Figure 9 below shows the rank ordering of alternatives for Data Set 1 when the seven attributes mentioned above are set as constant. It is observed from the graph below that there exists no change in the rank ordering of alternatives. The tau and rho values hence is 1 which shows a perfect positive correlation meaning, the two rank orderings are exactly the same. The same trend is observed when Data Set 2 or 3 is used. The plot for Data Set 2 and 3 are given in Appendix II.



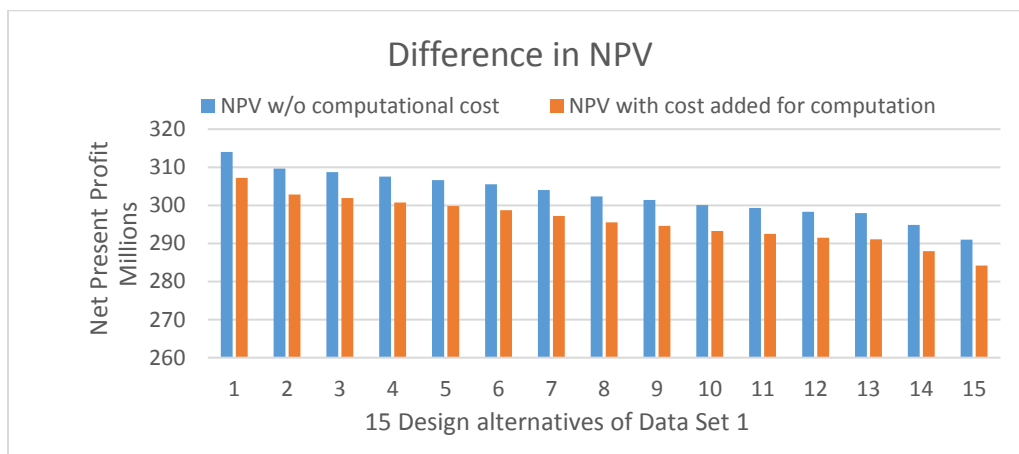
**Figure 9.** Comparison of the Base Rank Ordering to the Rank Ordering obtained when High level attributes are fixed

The perfect correlation in ranking allows for an informed decision making on design alternative selection for the system. Figure 9 shows the comparison of NPV observed when the top-level attributes are set as constant to the NPV obtained when all the attributes are obtained from the analysis. The x-axis represents the design alternatives, and the y-axis represents the profit. From

Figure 10, the NPV for each alternative remains almost the same despite the high-level attributes being set as constant.



**Figure 10.** Comparison of NPV obtained with and without the attributes being set as constant. Figure 11 below shows the difference in NPV when a computational cost is added for obtaining the attribute values through analyses. The analysis cost is calculated by the product of the number of lines to an arbitrary cost (in this case \$1000). The figure below shows the drop in NPV of the system when there is a cost for calculating the attributes, included in the total cost function.

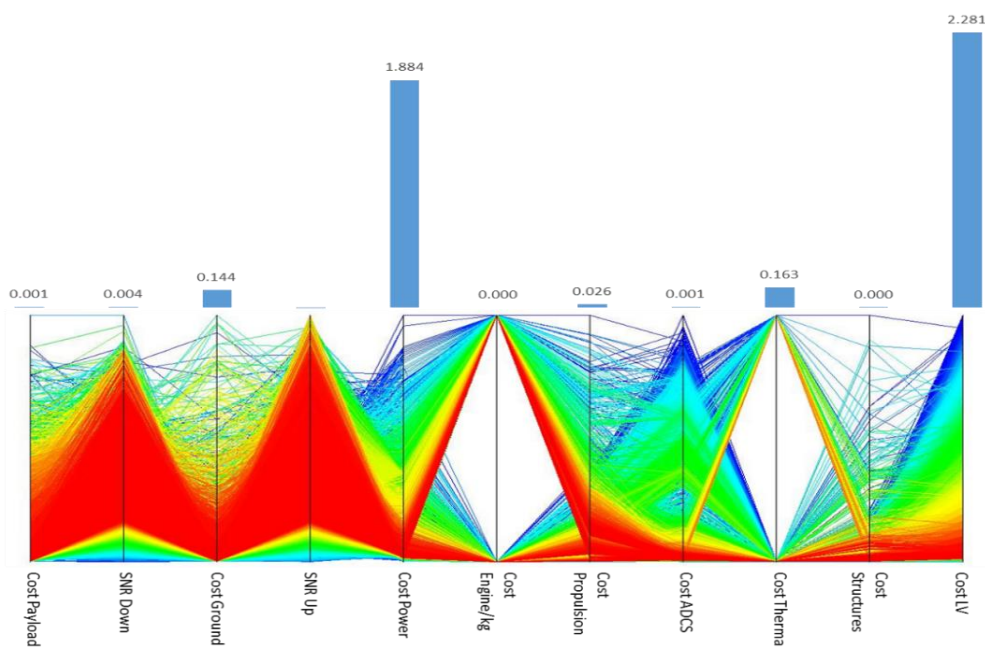


**Figure 11.** Difference in NPV when a computational cost is added

This task investigated the impact of high level attributes on the value function rank ordering. As show above the metrics shows that upon fixing the attributes as constants, there exist no changes in the rank ordering. The above analysis shows the need for understanding the impact of attributes even at lower levels so that it is possible to arrive at a meaningful value function fidelity such that the rank ordering is not affected. The next task examines about the derivative based coupling between the subsystems for the test case used in this thesis.

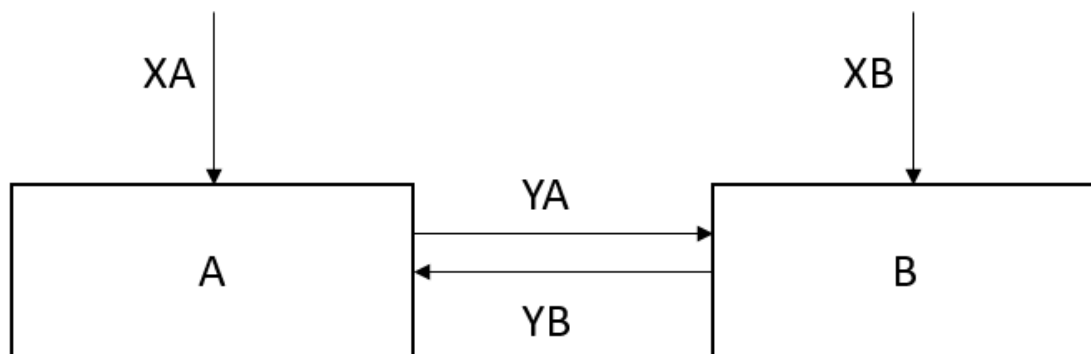
### Task 3: Impact of couplings on the rank ordering of alternatives

The design of large-scale complex systems includes interactions between multiple components and subsystems at various levels in the hierarchy. The previous task shows the need to analyze the impact of subsystem attributes on the value function. For the satellite system example used, the couplings are defined by derivatives. This involves the application of the Global Sensitivity Equation (GSE) method to obtain the total derivatives of the coupled subsystem [35,36]. The GSE method is an efficient approach for decoupling a large system into smaller subsystems in order to obtain the sensitivities between subsystems, and the sensitivity of one subsystem to the value function as a whole [36].



**Figure12.** (Top) global derivatives Value with respect to the SSL1 attributes  
(Bottom) Parallel coordinate plot of SSL1 Attributes

Previous researchers have shown methods of representing couplings. Figure 12 is a combination bar graph and parallel coordinate plot. The bar graph on top represents the global derivative of the total value of the system with respect to each attribute in the subsystem level 1. The parallel coordinate plot shows how the variability in these attributes affects the value function. Both plots describe the sensitivity of the value function. With the aid of the visualization it can be seen that Cost of Power and Launch Vehicle have a high global derivative, which means that a small change in the attributes can drastically affect the value, whereas signal to noise ratio down and up have very low sensitivities, which means the value remains almost unaffected with substantial changes in SNR. The figure below above an idea as to which attribute can be selected for setting as a constant such that value function still rank order the alternatives with acceptable variation.



**Figure 13.** Sample System

The GSE approach requires determining the derivatives with respect to the design variables. The derivative is found during the sensitivity analysis in the MDO process by determining the total system derivatives based on the local subsystem derivatives [37]. Consider a two sample subsystem as shown in Figure 13. Each subsystem has its own input design variables and subsystem outputs which feed into the other subsystems called behavior variables. The two

subsystems are said to be coupled since subsystem B requires the output from subsystem A before its output can be found and vice versa.  $X_A$  and  $X_B$  are the design variable vectors.  $Y_A$  and  $Y_B$  are the behavior variables.

$$\begin{bmatrix} 1 & -\frac{\partial Y_A}{\partial Y_B} \\ -\frac{\partial Y_B}{\partial Y_A} & 1 \end{bmatrix} \begin{bmatrix} \frac{dY_A}{dX_A} & \frac{dY_A}{dX_B} \\ \frac{dY_B}{dX_A} & \frac{dY_B}{dX_B} \end{bmatrix} = \begin{bmatrix} \frac{\partial Y_A}{\partial X_A} & 0 \\ 0 & \frac{\partial Y_B}{\partial X_B} \end{bmatrix} \quad (11)$$

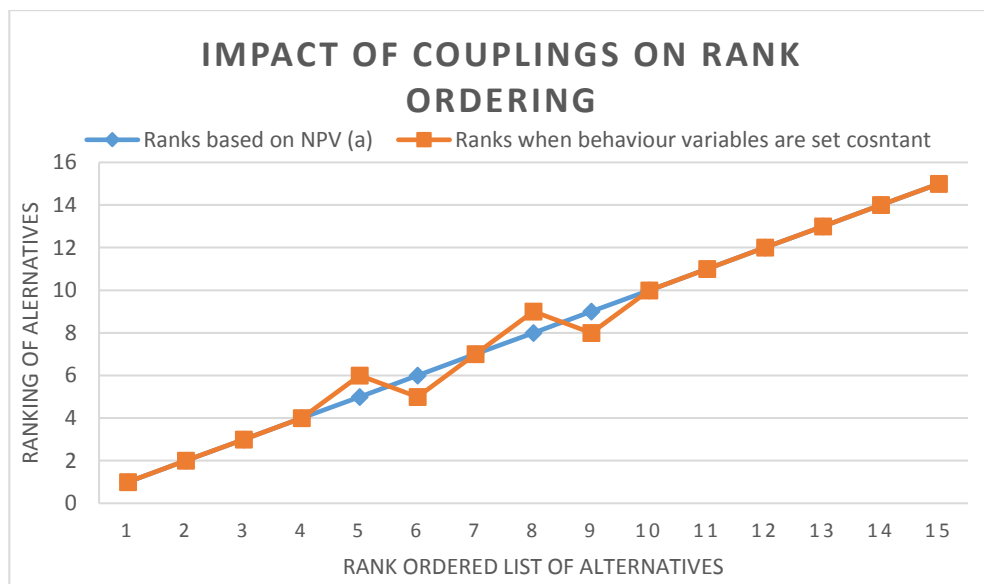
The left-hand side matrix is composed of the sensitivities of the subsystem outputs with respect to changes in other subsystem outputs. The matrix adjacent to the previous one is the sensitivity of the subsystem outputs to changes in that subsystem's inputs. The matrix equation is solved for the total derivatives of the subsystem outputs to subsystem inputs. These values obtained represents how the subsystem outputs change when design variables from other subsystems are perturbed. The local sensitivities are solved using finite difference methods. Usually, subsystem outputs and design variables vary widely in magnitude. To avoid error due to such variations, the derivatives have to be normalized [36]. The normalized derivative is given in Equation 12 below.

$$\frac{\partial Y'_A}{\partial Y'_B} = \frac{\partial Y_A}{\partial Y_B} \cdot \frac{Y_A}{Y_B} \quad (12)$$

The normalized local derivative can be used in solving for the total derivatives, thereby avoiding a chance for error. After solving the normalization is reversed to recover the true total derivative information.

$$\frac{dY_A}{dX_B} = \frac{dY'_A}{dX'_B} \cdot \frac{Y_A}{X_B} \quad (13)$$

This task investigates the sensitivity of the value function rank ordering to changes in the behavior variables. The GSE approach provides an insight in to which coupling are strong and which of them are weak. Once the weak couplings are identified, those behavior variables are set as constant and their impact on the value function rank ordering is observed. Figure 14 shows the rank ordering of the value function when subsystem level behavior variables are set constant. This test is represented by the orange line.



**Figure 14.** Effect of Coupling suspension on rank ordering of alternatives.

Tau ( $\tau$ ) = 0.96	Rho ( $r_s$ ) = 0.99
-----------------------	----------------------

As seen for the example system used when behavior variables at the subsystem level are kept constant, the rank ordering observed has a couple of swaps. This can be inferred from the rank correlation metrics used. Both Kendall's tau and Spearman's rho show a very strong correlation for the two ranks being compared. It can be seen in Figure 14, the maximum deviation observed is 1. Since the deviation is low, a  $r_s = 0.99$  is obtained. Due since the distance moved by the alternatives is less, the discordance is also less. Hence a  $\tau = 0.99$  is obtained.

This chapter investigates the changes in the value function rank ordering when the fidelity of the value function is reduced for the satellite system. The chapter began with a demonstration of how the rank correlation metrics are used in to determine the intensity of the correlation. This test was shown in Task 1. As seen in Task 1, the use of value function makes it easy to rank order the alternatives. Different traditional objective functions were also used to rank order the same set of alternatives. It was shown that the rank ordering of alternatives based traditional objective gave a very different rank ordering. The metrics were used to show that there exists no change in rank ordering when the weights in the multi-objective function were varied. From Task 2, we can infer than the there is no change in the rank ordering of alternatives when the attributes that form the value function are set as constant. The rank correlation metrics support the inference as both the metrics shows a perfect agreement in the two ranked lists compared. Task 3 talks about the impact on the rank ordering when the subsystem behavior variables are set as constant. In this case a few minor changes in rank ordering was observed. The rank correlation metrics show the same. Both the metrics showed a strong correlation when the two ranked lists were compared.

The next chapter discusses the impact on design uncertainty on the value function rank ordering of alternatives.



## CHAPTER 6

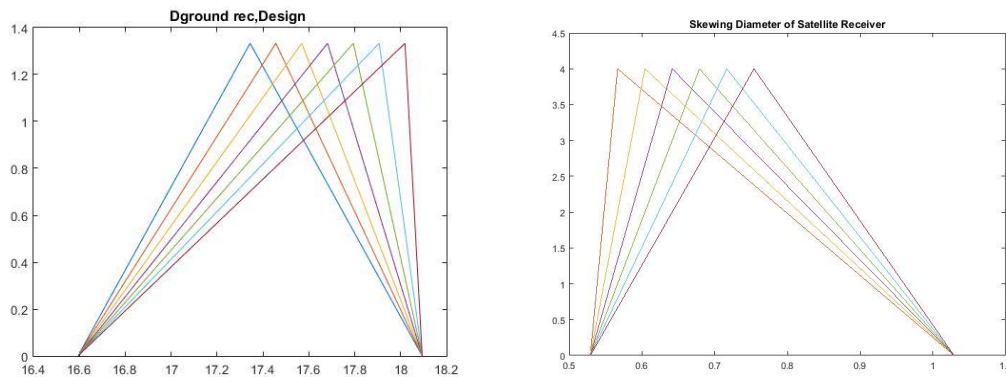
## UNCERTAINTY ANALYSIS

This chapter deals with investigating the use of the metric in understanding the effect of design uncertainty on the rank ordering of design alternatives. Uncertainties exist in all aspects of a complex engineered system (e.g. design variables, attributes, models etc.). Oberkampf et al. [38] categorized uncertainties in to three distinct classes. Variability refers to the inherent variation associated with the physical system and/ or the environment surrounding it. Uncertainty is defined as a potential deficiency in any phase of the design process that arises due to lack of knowledge/ information. Error is defined as the understandable deficiency in any phase in the design process that arises not due to lack of information. The two types of error are as acknowledged error or unacknowledged error. In this thesis uncertainty is used in a more general sense. The uncertainties in the value function are represented by propagating them through a probability distribution. The uncertainties were propagated through 13 design variables as shown in the Table 4

**Table 4.** List of design variables through which uncertainty is propagated.

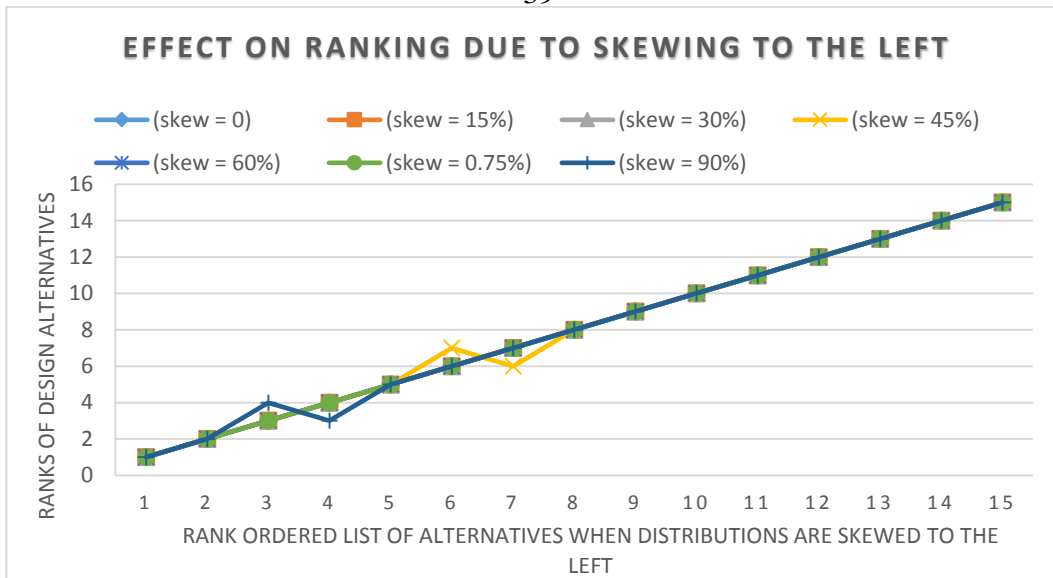
Design Variables	
$D_{sr}$	Diameter of Satellite receiving antenna
$D_{st}$	Diameter of Satellite transmitting antenna
$D_{gt}$	Diameter of ground transmitting antenna
$D_{gr}$	Diameter of ground receiving antenna
$P_{st}$	Satellite transmitter power
$P_{gt}$	Ground transmitter power
$f$	Downlink frequency
$f_{up}$	Uplink frequency
Ground longitude <sub>trans</sub> ,	Longitude of ground transmitter
Ground latitude <sub>trans</sub>	Latitude of ground transmitter
Ground longitude <sub>rec</sub>	Longitude of ground receiver
Ground latitude <sub>rec</sub>	Longitude of ground receiver
Satellite longitude	Longitude of satellite

Each design variable was assigned a triangular distribution with some tolerances to incorporate the variability in design rank ordering. A Monte Carlo simulation was carried out using random design variables within their respective distribution and the NPV was calculated. For this chapter, the rank ordering was based on the mean of NPV for each alternative that was obtained from the distributions. This study is strictly based on mean values. Incorporation of risk preferences in the analysis will be discussed in the next chapter. This chapter investigates the impact on rank ordering of design alternatives, when the distributions assigned to each variable is skewed both ways.



**Figure 15.** Skewing the probability distributions to understand impact on ranking of alternatives

Figure 15 shows two design variables skewed. The distributions are skewed uniformly at a rate of 15 % i.e. the design variable distributions are offset by 15% to the left-hand side and the right-hand side. The trend in rank ordering of alternatives when the probability distributions are skewed is shown in the Figure 15 below. Rank 1 in the ordered sets represent the design alternative with the highest mean value, and Rank 10 represent the design alternative with the least mean value.

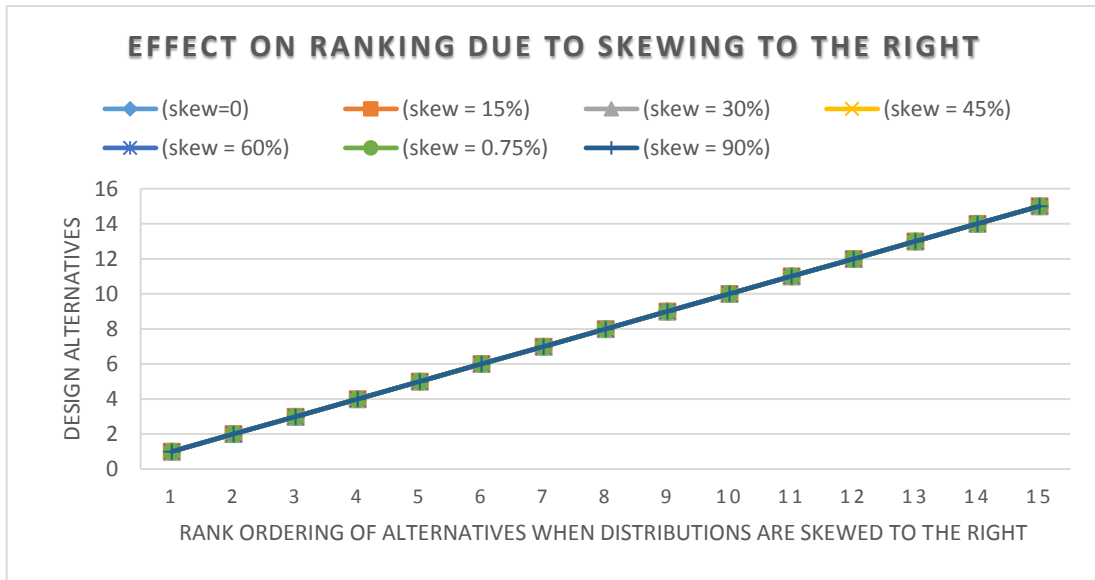


**Figure 16.** Effect of skewing the distributions (left) on the rank ordering of alternatives – Data Set 1

Tau ( $\tau$ ) = 0.96	Rho ( $r_s$ ) = 0.99
-----------------------	----------------------

Figure 16 represents the rank ordering of alternatives when the design variable distributions are skewed to the left. As observed, the skewing does not seem to affect the ranking significantly. The tau and rho in this case is varies between 0.95 to 1 which shows positive correlation meaning that the rank ordering of the different instances of skew remain the same despite the distributions being skewed to right. Such a case is observed in design Data Sets 2 and 3 as shown Appendix 3.

When the distributions are skewed to the right it is observed that there exist no changes in the rank ordering of alternatives. Kendall's tau and Spearman's rho both give a value of 1 which shows perfect correlation or no change in rank ordering. The base of comparison for this analysis is mean NPV. This trend in rank ordering is observed when Data Set 2 and 3 are used. Figure 17 shows the effect of skewing on ranking of alternatives.



**Figure 17.** Effect of skewing the distributions (right) on the rank ordering of alternatives – Data Set 1

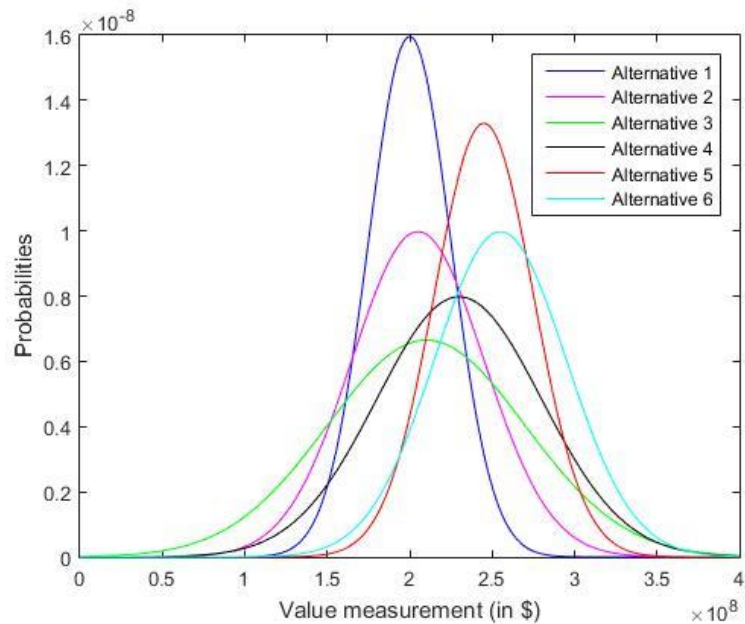
Tau ( $\tau$ ) = 1	Rho ( $r_s$ ) = 01
--------------------	--------------------

This chapter dealt with representing the uncertainties in the system. These uncertainties exist from lower to higher levels in the system. The uncertainties were propagated from the design variables and the rank ordering of alternatives did not show a notable change. The rank correlation metrics values obtained supports the trend observed in the graph. The metrics thus helps the designer to understand the changes in rank ordering, if any and then accordingly select a design with captures their preferences. Chapter 7 discusses the need to communicate risk preference using utility function so as to have consistency with decisions made by the stakeholder, even under uncertainty.

## CHAPTER 7

## IMPACT OF RISK ON VALUE FUNCTION RANK ORDERING

From the previous chapters it is observed that, since the value function is itself uncertain, due to the uncertainty in design variables and models, it becomes difficult to rank order them unless the probability distributions overlap. Utility theory will be used to collapse the distributions to a single value to facilitate rank ordering. Utility theory can be used to incorporate the risk preferences of the designer [39]. The utility function assigns a rank to each design alternative on the basis of the designer's preferences. Cases will be investigated to determine the impact of risk preferences on the rank ordering of alternatives. A risk averse designer would be less inclined to choose a design alternative that has a wide range of probability or high amount of uncertainty. A risk proverse or risk loving person would be more willing to take the risk if there is a chance of yielding higher value design alternative. The chapter investigates the use of metrics to understand the impact of the designer's risk preferences on the rank ordering of alternatives.



**Figure 18.** PDF plots of 6 designs with uncertainty

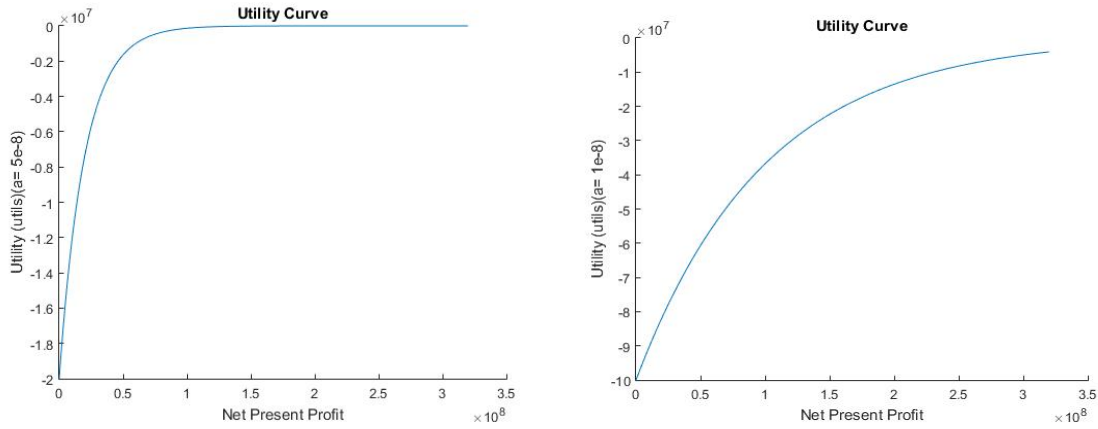
An arbitrary test case is first shown to demonstrate the use of utility functions. Figure 18 above shows the six designs with varying degrees of uncertainties which are considered to demonstrate the use of metrics to investigate the impact of risk preferences on design with uncertainties. As seen, Design Alternative 1 is less uncertain compared to rest of the alternatives, however, alternatives 2-6 have a broader range which may yield higher valued outcomes. The background on utility theory has been discussed in chapter 2. It can be inferred from Figure 18 that alternative 1 is less risky compared to the rest of the alternatives. For demonstration purposes, existing utility functions and the corresponding risk parameters were used. The first utility function is Equation 1 described in chapter 3. The second utility function used relates the outcome value (V) and the risk coefficient (a). The Utility function is given in Equation 12 below.

$$U2 = \frac{1}{a} * V^a \quad (14)$$

The risk coefficients were found by plotting the utility vs value to ensure that the risk coefficients do not result in a risk neutral analysis. The two risk coefficients used were as follows:

$$a = 5e-8 \text{ and } a = 1e-8$$

The two coefficients represent a higher and lower degree of risk aversion respectively. Figure 19 shows the utility curve when the two coefficients are used. The higher the risk aversion, the steeper the curve. The utility curve will be a straight line if the preference is risk neutral. In Figure 19 the plot to the left represent the utility curve for a designer with higher risk aversion. The plot to the right represent the utility of a designer with lower risk aversion.



**Figure 19.** Utility Curves with varying degrees of risk aversion

Three cases will be investigated wherein the risk preferences (coefficient of risk) are varied for the two utility functions mentioned in the thesis. The three cases are as follows:

**Case 1:** Utility function with a higher degree of risk aversion

**Case 2:** Utility function with a lower degree of risk aversion

**Case 3:** Utility function with a risk loving preferences

**Table 5.** Rank ordering of 6 designs based on mean and certainty equivalent (with varying risk coefficients) –Utility function 1

U1 Case 1 ( $a=5e^{-8}$ )			
Mean of Profit (\$)	Ranks	CE (\$)	Ranks
255 x10 <sup>6</sup>	1	255 x10 <sup>6</sup>	2
245 x10 <sup>6</sup>	2	248 x10 <sup>6</sup>	1
230 x10 <sup>6</sup>	3	240 x10 <sup>6</sup>	3
210 x10 <sup>6</sup>	4	228 x10 <sup>6</sup>	4
205 x10 <sup>6</sup>	5	220 x10 <sup>6</sup>	5
200 x10 <sup>6</sup>	6	215 x10 <sup>6</sup>	6
$\tau = 0.86$		$r_s = 0.94$	

U1 Case 2 ( $a=3e^{-8}$ )			
Mean of Profit (\$)	Ranks	CE (\$)	Ranks
255 x10 <sup>6</sup>	1	255 x10 <sup>6</sup>	1
245 x10 <sup>6</sup>	2	249 x10 <sup>6</sup>	2
230 x10 <sup>6</sup>	3	241 x10 <sup>6</sup>	4
210 x10 <sup>6</sup>	4	230 x10 <sup>6</sup>	3
205 x10 <sup>6</sup>	5	223 x10 <sup>6</sup>	5
200 x10 <sup>6</sup>	6	218 x10 <sup>6</sup>	6
$\tau = 0.86$		$r_s = 0.94$	

<b>U1 Case 3 (<math>a = -3e^{-8}</math>)</b>			
<b>Mean of Profit (\$)</b>	<b>Ranks</b>	<b>CE (\$)</b>	<b>Ranks</b>
255 x10 <sup>6</sup>	1	255 x10 <sup>6</sup>	1
245 x10 <sup>6</sup>	2	250 x10 <sup>6</sup>	2
230 x10 <sup>6</sup>	3	244 x10 <sup>6</sup>	3
210 x10 <sup>6</sup>	4	238 x10 <sup>6</sup>	4
205 x10 <sup>6</sup>	5	234 x10 <sup>6</sup>	5
200 x10 <sup>6</sup>	6	230 x10 <sup>6</sup>	6
$\tau = 1$		$r_s = 1$	

The base measure for ranking in this chapter is the mean of the profit. Table 5 shows a comparison of the rank ordering of 6 alternatives based on mean NPP to the rank ordering based on the utility functions. This table represents the ranking obtained when the first utility function is used. When we look at Case 1, for a higher degree of risk aversion, it is seen that the second alternative becomes the preferred choice. The Spearman's rho shows that only a few alternatives have moved in the list as the deviation of objects in the rank is less. The Kendall's tau value tells us that there is high concordance in the rank ordering, which is the reason for tau having a high value. Case 2 shows a similar value of tau and rho for the utility function with lower degree of risk aversion. In Case 2, although there are changes in the rank ordering, alternative 1 is still the preferred choice. When we consider using a utility function with a risk loving coefficient as in Case 3, no changes in rank ordering is observed. The metrics support the case as both tau and rho give a value of 1. This analysis shows the necessity to incorporate the risk preference of the designer when uncertainties are present.

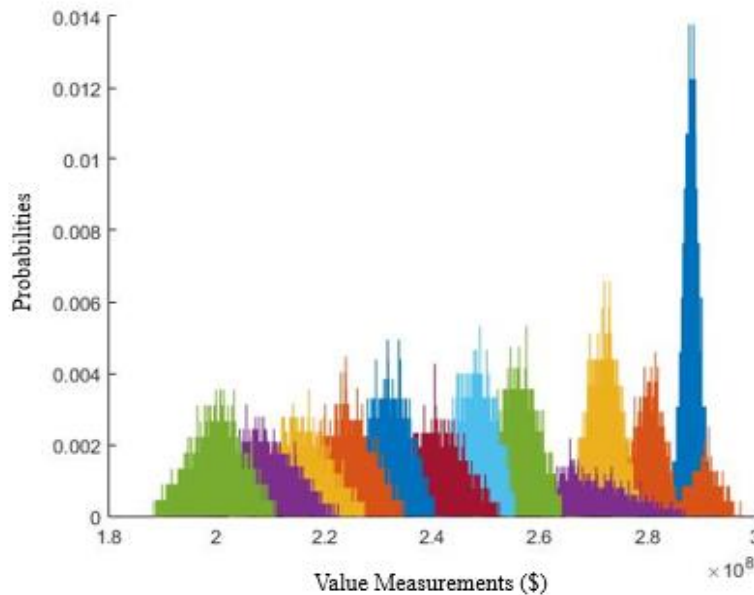


**Table 6.** Rank ordering of 6 designs based on mean and certainty equivalent (with varying risk coefficients) –Utility function 2

U2 Case 1 (a=0.12)				U2 Case 2 (a=0.25)			
Mean of Profit (\$)	Ranks	CE (\$)	Ranks	Mean of Profit (\$)	Ranks	CE (\$)	Ranks
255 x10 <sup>6</sup>	1	255 x10 <sup>6</sup>	1	255 x10 <sup>6</sup>	1	255 x10 <sup>6</sup>	1
245 x10 <sup>6</sup>	2	249x10 <sup>6</sup>	3	245 x10 <sup>6</sup>	2	249 x10 <sup>6</sup>	2
230 x10 <sup>6</sup>	3	243 x10 <sup>6</sup>	4	230 x10 <sup>6</sup>	3	243 x10 <sup>6</sup>	3
210 x10 <sup>6</sup>	4	238 x10 <sup>6</sup>	2	210 x10 <sup>6</sup>	4	246 x10 <sup>6</sup>	6
205 x10 <sup>6</sup>	5	229 x10 <sup>6</sup>	5	205 x10 <sup>6</sup>	5	228 x10 <sup>6</sup>	5
200 x10 <sup>6</sup>	6	233 x10 <sup>6</sup>	6	200 x10 <sup>6</sup>	6	223 x10 <sup>6</sup>	4
$\tau = 0.73$		$r_s = 0.82$		$\tau = 0.6$		$r_s = 0.77$	

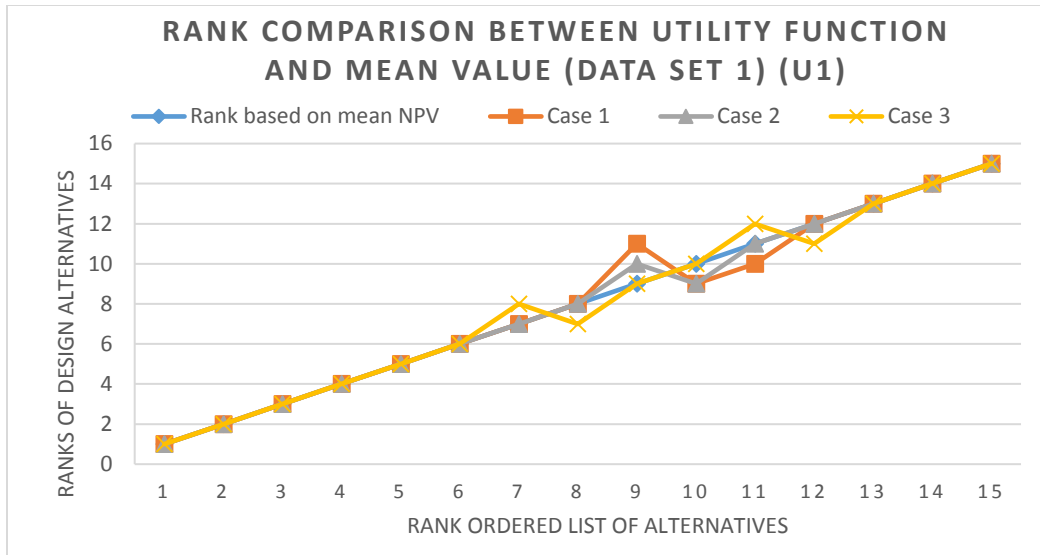
U2 Case 3 (a=0.25)			
Mean of Profit (\$)	Ranks	CE (\$)	Ranks
255 x10 <sup>6</sup>	1	255 x10 <sup>6</sup>	1
245 x10 <sup>6</sup>	2	248 x10 <sup>6</sup>	2
230 x10 <sup>6</sup>	3	243 x10 <sup>6</sup>	3
210 x10 <sup>6</sup>	4	234 x10 <sup>6</sup>	5
205 x10 <sup>6</sup>	5	228 x10 <sup>6</sup>	4
200 x10 <sup>6</sup>	6	222 x10 <sup>6</sup>	6
$\tau = 0.86$		$r_s = 0.94$	

Table 6 shows a comparison of the rank ordering of 6 alternatives based on mean NPP to the rank ordering based on the utility function given in equation 14. The rank correlation metrics for Case 1 shows that there is a strong correlation between the rank orderings. In Case 1, we observe that alternative 2 has a deviation of 2. The presence of such deviations results in  $r_s = 0.86$ . In Case 2, as seen in Table 6, the swaps occur in the bottom half of the rank ordered list. Due to larger deviations observed i.e. the distance moved by alternative 6, we observe a lower rho value. This same can be said for tau. When compared to Case 1, Case 2 has a higher number of discordant pairs which results in a lower tau value compared to Case1. When we consider using a utility function with a risk loving coefficient as in Case 3, no changes in rank ordering is observed. The metrics support the case as both tau and rho give a value of 1.



**Figure 20.** Probability distributions for alternatives in Data Set 1

Figure 20 shows the probability distributions for the rank ordered design alternatives in Data Set 1. It can be observed that thin and tall distribution in blue to right has a very high probability.



**Figure 21.** Comparison of the Rank Ordering of alternatives with mean of the NPV and their certainty equivalence Data Set 1 – Utility Function 1

**Table 7.** Kendall's tau and Spearman rho when comparing ranking based on mean to ranking based on certainty equivalence for Data Set 1 – Utility Function 1

	Tau ( $\tau$ )	Rho ( $r_s$ )
<b>Case 1</b>	0.96	0.98
<b>Case2</b>	0.98	0.99
<b>Case 3</b>	0.96	0.99

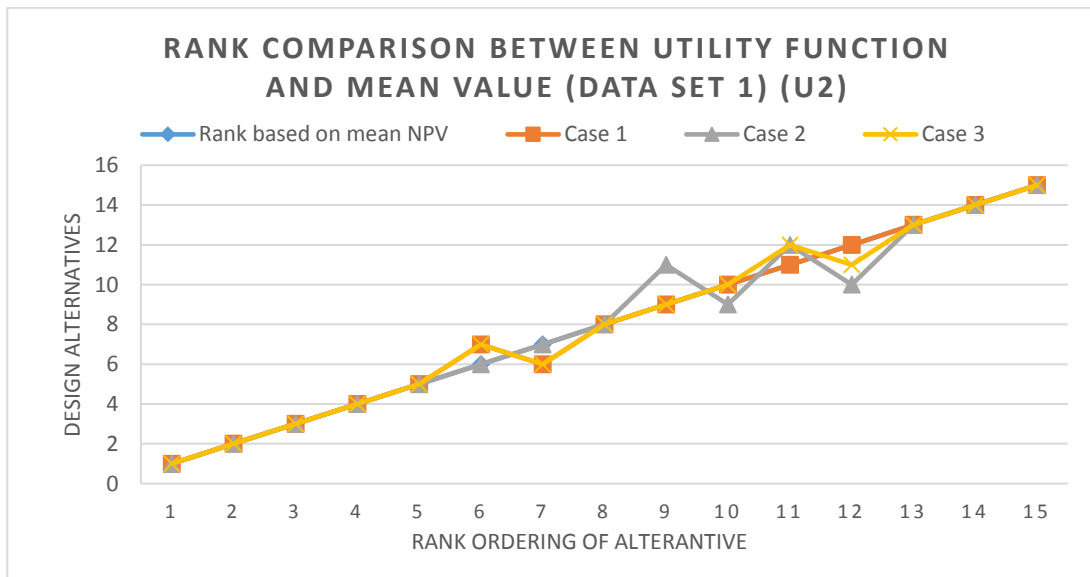
Figure 21 shows the rank ordering of alternatives based on the certainty equivalence with varying risk preferences. Three cases are shown wherein the utility function remained the same but the risk coefficients were varied to represent different risk attitudes. The utility function used in this test case is given in equation 1. The Kendall's tau and the Spearman coefficient values are given in Table 7. The values correspond with the graph above. With varying risk, the top 6 alternatives remained in the same order.

**Case 1 Discussion:** Case 1 investigates the comparison of rank ordering based on mean profit to the rank ordering obtained when a utility function with a higher degree of risk aversion is used. In Figure 21, Case 1 is represented by the orange line. Both the metrics show a strong correlation between the ranks. In this case, the maximum distance moved by an alternative is 2. Since the deviations in ranking are less, the rho value shows a strong correlation. As mentioned before, the sample size plays a key role in the calculation of Spearman's rho. The sensitivity to the deviations in ranking will be better observed if a smaller sample size is chosen. Kendall's tau value obtained is also high. This is because the number of discordant pairs are less. The visual aid provided in Figure 21, along with the metric values show that, for Data Set 1, a high degree of risk aversion does not affect the rank ordering of alternatives much.

**Case 2 Discussion:** Case 2 investigates the comparison rank ordering based on mean profit to the rank ordering obtained when a utility function with a lower degree of risk aversion is used. In Figure 21, Case 2 is represented by the grey line. Both the metrics show a very strong correlation between the ranks. In this case, the deviations in ranking is in rank ordering is observed in the bottom half of the Data Set 1 because the swaps occur in the bottom half of the data set. The maximum deviation observed is 2. Since most of the rank ordering remains unchanged, the presence of a deviation equal to 2 does not affect the metric values greatly. This gives a rho value showing that the rank ordering obtained using the utility function is very similar to the rank ordering based on mean. Kendall's tau value obtained is also high. This is because the number of discordant pairs are less. The visual aid provided in Figure 21, along with the metric values show that for Data Set 1, a high degree of risk aversion does not affect the rank ordering of alternatives.

**Case 3 Discussion:** Case 3 investigates the comparison rank ordering based on mean profit to the rank ordering obtained when a utility function with a risk loving preference is used. In Figure 21,

Case 3 is represented by the yellow line. The metrics show that upon using utility function as a measure of ranking, there is exist very few changes in rank ordering of alternatives when compared to the base ranking. In this case, the distance moved by an alternative in the ranked list is less. Hence the deviations are also less. Hence the rho value obtained shows a strong correlation. Kendall's tau value obtained is also high. This is because the number of discordant pairs are less. The visual aid provided in Figure 21, along with the metric values show that, for Data Set 1, a high degree of risk aversion does not affect the rank ordering of alternatives.



**Figure 22.** Comparison of the Rank Ordering of alternatives with mean of the NPV and their certainty equivalence Data Set 1 – Utility Function 2

**Table 8.** Kendall's tau and Spearman rho when comparing ranking based on mean to ranking based on certainty equivalence for Data Set 1 – Utility Function 2

	Tau ( $\tau$ )	Rho ( $r_s$ )
<b>Case 1</b>	0.82	0.89
<b>Case2</b>	0.94	0.92
<b>Case 3</b>	0.92	0.94

Figure 22 shows the rank ordering of alternatives when the alternatives are ranked based on the certainty equivalence with varying risk preferences. Three cases are shown wherein the utility function remained the same but the risk coefficients were varied to represent different risk attitudes. The Kendall's tau and the Spearman coefficient values are given in Table 8. It can be observed that the top 5 alternatives haven't been affected by different risk attitudes. The rank correlation shows that there is a strong correlation between the ranks, i.e. there are very swaps in ranking observed upon varying the risk preferences.

**Case 1 Discussion:** Case 1 investigates the comparison of rank ordering based on mean profit to the rank ordering obtained when a utility function with a higher degree of risk aversion is used. In Figure 22, Case 1 is represented by the orange line. Both the metrics show a strong correlation between the ranks. In this case, the deviations in ranking is less (-1). This gives a rho value showing that the rank ordering obtained using the utility function is similar to the rank ordering based on mean. Kendall's tau value obtained is also high. This is because the number of discordant pairs are less. The visual aid provided in Figure 22, along with the metric values show that, for Data Set 1, a high degree of risk aversion does not affect the rank ordering of alternatives much.

**Case 2 Discussion:** Case 2 investigates the comparison rank ordering based on mean profit to the rank ordering obtained when a utility function with a lower degree of risk aversion is used. In Figure 22, Case 2 is represented by the grey line. Both the metrics show a very strong correlation between the ranks. In this case, the deviations in ranking is in rank ordering is observed in the bottom half of the Data Set 1 because the swaps occur in the bottom half of the data set. The maximum deviation observed is 2. Since most of the rank ordering remains unchanged, the present of a deviation equal to 2 does not affect the metric values greatly. This gives a rho value showing that the rank ordering obtained using the utility function is very similar to the rank ordering based

on mean. Kendall's tau value obtained is also high. This is because the number of discordant pairs are less. The visual aid provided in Figure 22, along with the metric values show that, for Data Set 1, a high degree of risk aversion does not affect the rank ordering of alternatives.

**Case 3 Discussion:** Case 3 investigates the comparison rank ordering based on mean profit to the rank ordering obtained when a utility function with a risk loving preference is used. In Figure 22, Case 3 is represented by the yellow line. The metrics show that upon using utility function as a measure of ranking, there is exist very few changes in rank ordering of alternatives when compared to the base ranking. In this case, the distance moved by an alternative in the ranked list is less. Hence the deviations are also less. Hence the rho value obtained shows a strong correlation. Kendall's tau value obtained is also high. This is because the number of discordant pairs are less. The visual aid provided in Figure 22, along with the metric values show that for Data Set 1, a high degree of risk aversion does not affect the rank ordering of alternatives

This chapter talks about the importance of representing the uncertainties in this aspect of work. Uncertainties are present in every system and decisions. It can occur at the lowest levels of the design hierarchy and it compounds as probabilities that should be addressed in the higher levels of the design process. Utility theory was used to collapse the probability distributions and to also incorporate the risk preferences of the designer into the analysis. Two utility functions were used to demonstrate the need for incorporating risk into the assessment. The risk parameters were varied to understand its impact on the rank ordering of alternatives. As seen in the analysis above, the rank ordering is not greatly affected by the incorporation of risk. This metrics also show that change in rank ordering is less. The next chapter gives the conclusions derived from this thesis.

## CHAPTER 8

## CONCLUSION

Value-Driven Design was developed as a means to improve the design process by shifting the focus away from requirements, more accurately representing stakeholder preference, and expanding the feasible design space [40]. The use of a value function enables a means to rank order alternatives. The application of a value driven approach to design necessitates a need to determine the fidelity of the value function to enable consistent rank ordering. To understand the changes in rank ordering, two rank correlation metrics namely, Kendall's tau and Spearman's rho were used. The metrics used are non-parametric. Three data sets of design alternatives for the satellite system were handpicked to test the use of metrics to determine the consistencies in rank ordering when the value function is subject to several investigations. Investigations are conducted to understand the use of metrics to determine the rank ordering consistency.

The initial investigations were to determine the impact of varying the complexity of the value function on the rank ordering of alternatives. Chapter 5 presented the investigations pertaining to value function fidelity. An initial comparison is done to understand how the value function rank orders when compared to traditional objective functions. The task shows that value function provides an easy means of ranking alternatives as the measure of ranking is of a single unit. It is also observed that the rank correlation metrics provides an insight into the intensity of change in rank ordering observed. This helps the designer to make rational decisions for design selection of a satellite. The visualizations provided gives the designer an understanding of the swaps that occurred during the investigations and the distance moved by the alternatives in the rank ordered list. From the visualizations provided, the alternatives that are sensitive to the investigations can also be identified. Furthermore, the attributes that form the value function were



set as constant to determine any changes in rank ordering. The investigations showed no changes in rank ordering and the metrics support the results as it shows perfect correlation. To understand impact of the subsystem level attributes on the value function rank ordering, a derivative based coupling analysis was conducted. From this test it was observed that the rank correlation metrics showed a strong correlation in rank ordering when the subsystem level behavior variables were set as constant. The metrics in this case can be used to analyze which attributes and behavior variables can set as a constant in the system so as to reduce the computational expenses.

Chapter 6 focused on the propagation of uncertainties. The application of uncertainty in design variables and the way this uncertainty propagates through the system to impact the value function rank ordering is addressed in this chapter. It is important to include uncertainties for the value functions to be representative of real world systems. Probability density functions were used to visualize uncertainties. This allows the designer to better understand value rankings and also the robustness of the designs. The distributions assigned to the design variables were skewed and the observed rank ordering showed strong correlation to the base rank ordering. Skewing the distributions does not have a significant impact on the rank ordering for all data sets. The metrics along with the visualization supports the trend observed.

Chapter 7 addresses the impact on rank ordering of alternatives due to the incorporation of risk. Utility functions are used to incorporate the risk preferences into the analysis. An arbitrary example given in this chapter shows the need for investigating the effects of varying risk preference on the rank ordering. As seen in the chapter, varying risk preferences has not affected the rank ordering significantly in this test system used. The metric values in the three cases investigated support the visualization obtained. The representations in Chapter 7 demonstrated clearly how and risk preferences can significantly change alternative selection.

This research focused on the impact of value function fidelity on design selection for the satellite design. The thesis also investigates the usability of rank correlation metrics to understand the intensity of rank correlation. The metric along with the visualization helped to understand the impact on rank ordering when determining the fidelity of the value function. Effects of uncertainty propagation on the rank ordering was also studied. Future work on this project will expand on all investigating the use of the metrics in a number of different example systems, including aerospace and transportation. Other non-parametric tests can be conducted to compare the results to the metrics used in the thesis. Uncertainty will be a key focus moving forward. Different distributions can be used to represent the uncertainties and their effects on the value function rank ordering can be studied. This research forms a base for future work that enables the advancement of Value Driven Design as a powerful framework for design of large scale complex systems and systems engineering.

## REFERENCE

1. Maddox, I.D., Collopy, P.D., and Farrington, P.A., *Value-Based Assessment of DoD Acquisition Programs*. forthcoming in *Procedia Computer Science*, 2013.
2. Collopy, P., *Adverse impact of extensive attribute requirements on the design of complex systems*. AIAA Paper, 2007. **7820**: p. 2007.
3. Soban, D.S., Price, M.A., and Hollingsworth, P., *Defining a research agenda in Value Driven Design: Questions that need to be asked*. *Journal of Aerospace Operations*, 2012. 1(4): p. 329-342.
4. NASA, *NASA Systems Engineering Handbook*. Vol. NASA/SP-2007-6105 Rev1. 2007, Washington, D.C.
5. Calvano, C. N., & John, P. (2004). *Systems engineering in an age of complexity*. *Systems Engineering*, 7(1), 25-34.
6. Marler, R.T. and Arora, J.S., *Survey of Multi-Objective Optimization Methods for Engineering*. *Structural and Multidisciplinary Optimization*, 2004. 26(6): p. 369-395.
7. Coello Coello, C., Lamont, G.B., and Van Veldhuizen, D.A., *Evolutionary Algorithms for Solving Multi-Objective Problems*. 2nd Edition ed. 2007, New York, NY: Springer.
8. Bloebaum, C. L. (1992). "Non-hierarchic system decomposition in structural optimization." *Engineering optimization* 19(3): 171-186.
9. Deshmukh, A. and Collopy, P. *Fundamental Research into the Design of Large-Scale Complex Systems*. in 13th AIAA/ISSMO Multidisciplinary Analysis & Optimization Conference. 2010. Fort Worth, TX: AIAA.
10. Hazelrigg, G. A. (2012). *Fundamentals of Decision Making for Engineering Design and Systems Engineering*.
11. Keeney, R. L. 1992. *Value-Focused Thinking: A Path to Creative Decision Making*. Harvard University Press, Cambridge, MA
12. Collopy, P. D. and P. M. Hollingsworth (2011). "Value-driven design." *Journal of Aircraft* 48(3): 749-759.
13. Wassenaar, H.J. and Chen, W., *An approach to decision-based design with discrete choice analysis for demand modeling*. *Journal of Mechanical Design*, 2003. **125**(3): p. 490-497.
14. Lewis, K., Chen, W., and Schmidt, L., eds. *Decision Making in Engineering Design*. 2006, ASME: New York.
15. Collopy, P. *Economic-Based Distributed Optimal Design*. in *AIAA Space 2001-Conference and Exposition*. 2001. Albuquerque, NM.
16. Collopy, P., Bloebaum, C.L., and Mesmer, B.L., *The Distinct and Interrelated Roles of Value-Driven Design, Multidisciplinary Design Optimization and Decision Analysis*, in 14th AIAA/ISSMO Multidisciplinary Analysis and Optimization Conference. 2012: Indianapolis, Indiana.
17. INCOSE, *INCOSE Systems Engineering Handbook v3.2*. 2010, www.icose.org: International Council on Systems Engineering.
18. Ross, A.M. and D. E. Hastings. 2005. "The Tradespace Exploration Paradigm," INCOSE International Symposium, Rochester, NY, 15 (1): 1706-18.

19. Ng, W.Y. 1991. "Generalized Computer-Aided Design System: A Multiobjective Approach." *Computer-Aided Design* 23 (8): 548–53.
20. Simpson, T. W., D. B. Spencer, M. A. Yukish, G. Stump. 2008. "Visual Steering Commands and Test Problems to Support Research in Trade Space Exploration," 12th AIAA/ISSMO Multidisciplinary Analysis and Optimization Conference, Victoria, British Columbia, Canada, AIAA-2008-6085.
21. Stump, G.M., Sara E. Lego, Mike A. Yukish, Timothy W. Simpson, and Joseph A. Donndelinger, *Visual Steering Commands for Trade Space Exploration: User-Guided Sampling with Example*. *Journal of Computing and Information Science in Engineering*, 2009.
22. Berger, J. O. (2013). *Statistical decision theory and Bayesian analysis*, Springer Science & Business Media.
23. Thunnissen, D.P. *Uncertainty classification for the design and development of complex systems*. in 3rd annual predictive methods conference. 2003.
24. Smith, N. and S. Mahadevan, *Probabilistic methods for aerospace system conceptual design*. *Journal of spacecraft and rockets*, 2003. 40(3): p. 411-418.
25. Cao, H. and B. Duan. *Uncertainty analysis for multidisciplinary systems based on convex models*. in 10th AIAA/ISSMO multidisciplinary analysis and optimization conference. 2004.
26. Chen, W., Allen, J.K., Tsui, K.-L., and Mistree, F., *A procedure for robust design: minimizing variations caused by noise factors and control factors*. *Journal of Mechanical Design*, 1996. 118(4): p. 478-485.
27. Yao, W., Chen, X., Luo, W., van Tooren, M., and Guo, J., *Review of uncertainty-based multidisciplinary design optimization methods for aerospace vehicles*. *Progress in Aerospace Sciences*, 2011. 47(6): p. 450-479.
28. Von Neumann, J. and O. Morgenstern (2007). *Theory of games and economic behavior*, Princeton university press.
29. Collopy, P. D. (2009). "Aerospace system value models: A survey and observations." AIAA Paper 6560: 2009.
30. Carterette, Ben. "On rank correlation and the distance between rankings." *Proceedings of the 32nd international ACM SIGIR conference on Research and development in information retrieval*. ACM, 2009.
31. Kendall, Maurice George. "Rank correlation methods." (1948).
32. Göktas, Atila, and Öznur Isçi. "A comparison of the most commonly used measures of association for doubly ordered square contingency tables via simulation." *Metodoloski zvezki* 8.1 (2011): 17.
33. Mesmer, B.L., Bloebaum, C.L., and Kannan, H., *Incorporation of Value-Driven Design in Multidisciplinary Design Optimization*, in 10th World Congress on Structural and Multidisciplinary Optimization. 2013: Orlando, FL.
34. Richardson, Trevor, et al. "Incorporating Value-Driven Design into the Visualization of Design Spaces Using Contextual Self-Organizing Maps: A Case Study of Satellite Design."

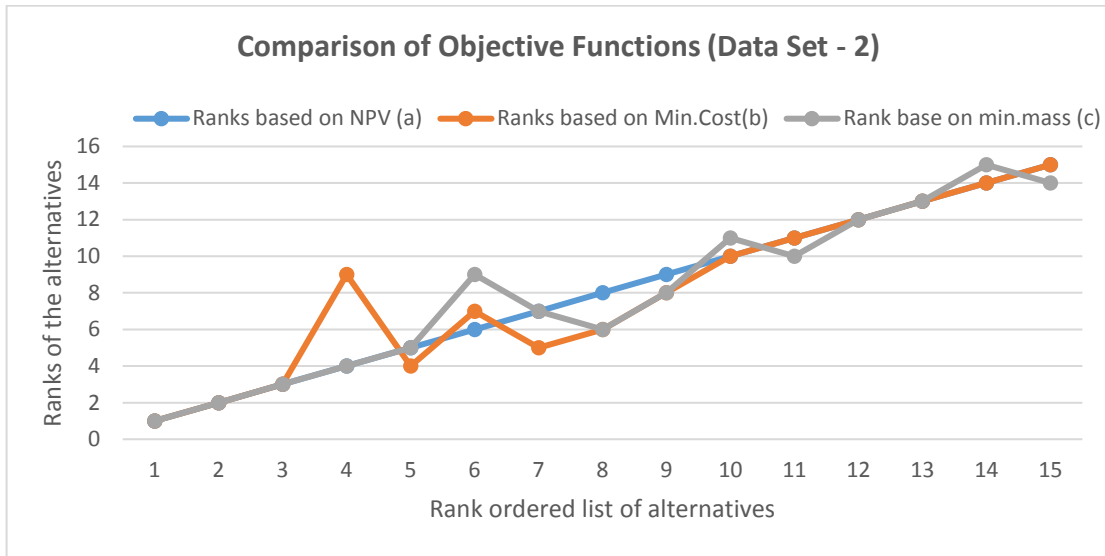
35. Sobieszczanski-Sobieski, J., Bloebaum, C.L., and Hajela, P., *Sensitivity of control-augmented structure obtained by a system decomposition method*. AIAA Journal, 1991. 29(2): p. 264-270.
36. Hajela, P., Bloebaum, C.L., and Sobieszczanski-Sobieski, J., *Application of global sensitivity equations in multidisciplinary aircraft synthesis*. *Journal of Aircraft*, 1990. 27(12): p. 1002-1010.
37. Sobieszczanski-Sobieski, Jaroslaw. "High order sensitivity analysis of complex, coupled systems." AIAA journal 28.4 (1990): 756-758.
38. Oberkampf, W. L. 1998: *Bibliography for Verification and Validation in Computational Simulation*, SAND98-2041, Sandia Natl. Lab.
39. Kenneth, J., Arrow. *Essays in the Theory of Risk-Bearing*. Markham, Chicago, IL, 1971
40. Tibor, Elliott. "Visualization-based decision support for value-driven system design." (2014).

## APPENDIX: SATELLITE DESIGN VARIABLES AND ATTRIBUTES

**Table 9:** Satellite Design Variables and Attributes

Tiers		Attributes	Design variables		
SYSTEM (Geo Communication Satellite)		Total cost, Revenue	Single satellite or satellite constellation?		
Subsystem level 1	(SS1) Payload	$C_{\text{payload}}, \text{SNR}_d$	N, Type of HPA, Satellite longitude		
	(SS2) Ground Station	$C_{\text{ground}}, \text{SNR}_{\text{up}}$	Ground longitude <sub>rec</sub> , Ground latitude <sub>rec</sub> Ground longitude <sub>trans</sub> , Ground latitude <sub>trans</sub>		
	(SS3) Power	$C_{\text{power}}$	Type of power source		
	(SS4) Propulsion	$C_{\text{Engine/kg}}, C_{\text{propulsion}}$	Type of liquid propulsion system(mono/bi)		
	(SS5) ADCS	$C_{\text{ADCS}}$	Type of controller		
	(SS6) Thermal	$C_{\text{thermal}}$	Type of passive thermal control		
	(SS7) Structures	$C_{\text{structures}}$	Configuration of bus		
	(SS8) Launch vehicle	$C_{\text{LV}}$	Launch site/Type of vehicle		
Subsystem level 2	Payload	(SS1) Satellite Transponders	$M_{\text{trans}}, P_{\text{payload}}, V_{\text{trans}}$	$P_{\text{st}}$	
		(SS2) Satellite antennae	$C_{\text{sat,ant}}, M_{\text{sat ant}}$	Antenna type (Parabolic/Helical antenna)	
	Ground station	(SS1) Ground transponder	$C_{\text{g,transmitter}}$	$P_{\text{gt}}$	
		(SS2) Ground antennae	$C_{\text{g,antennae}}$	Antenna type (Parabolic/Helical antenna)	
	Power	(SS1) Solar Array	$C_{\text{SA}}, \text{Array size}, M_{\text{SA}}$	SA_material	
		(SS2) Battery	$C_{\text{Batt}}, \text{Battery mass}, \text{Battery capacity}, V_{\text{batt}}$	Battery type	
	Propulsion	(SS1) Propellant	$M_{\text{propellant}}, V_{\text{propellant}}, C_{\text{Engine}}, C_{\text{propellant}}$	Propellant	
	Thermal	(SS1) Surface Finish	$C_{\text{thermalfinish}}$	$\left(\frac{\alpha}{\epsilon}\right)_{\text{SA}}, \left(\frac{\alpha}{\epsilon}\right)_{\text{sat,trans}}, \left(\frac{\alpha}{\epsilon}\right)_{\text{sat,rec}}$	
		(SS2) Radiator and Heater	$P_{\text{thermal}}, C_{\text{radiator}}, C_{\text{heater}}, M_{\text{radiator}}$	$\epsilon_{\text{radbattery}}, \epsilon_{\text{radRW}}, \epsilon_{\text{radproptank}}$	
	Structures	(SS1) Bus	$C_{\text{bus/kg}}$	Bus material	
Subsystem level 3	Satellite antennae	(SS1) Satellite transmitting antenna	$G_{\text{st}}, M_{\text{st}}$	$f_{\text{down}}, D_{\text{st}}$	
		(SS2) Satellite receiving antenna	$G_{\text{sr}}, M_{\text{sr}}$	$D_{\text{sr}}$	
	Ground antennae	(SS1) Ground transmitting antenna	$M_{\text{gt}}, G_{\text{gt}}$	$D_{\text{gt}}, f_{\text{up}}$	
		(SS2) Ground receiving antenna	$M_{\text{gr}}, G_{\text{gr}}$	$D_{\text{gr}}$	
	Propulsion	Propellant	(SS1) Propellant tank	$M_{\text{proptank}}, V_{\text{proptank}}, C_{\text{proptank}}$	Propellant tank material

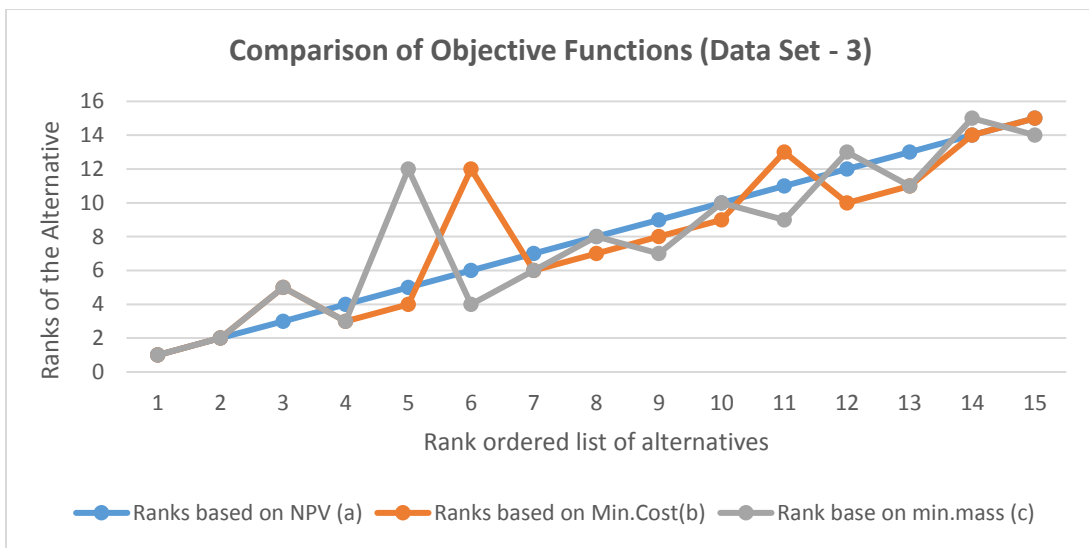
APPENDIX: TESTING THE FIDELITY OF VALUE FUNCTION



**Figure 23.** Comparison of the Rank Ordering Based Value Function vs Traditional Objective Function- Data Set 2

**Table 10:** Kendall’s tau and Spearman rho for the Case 1 and Case 2 (Data Set - 2)

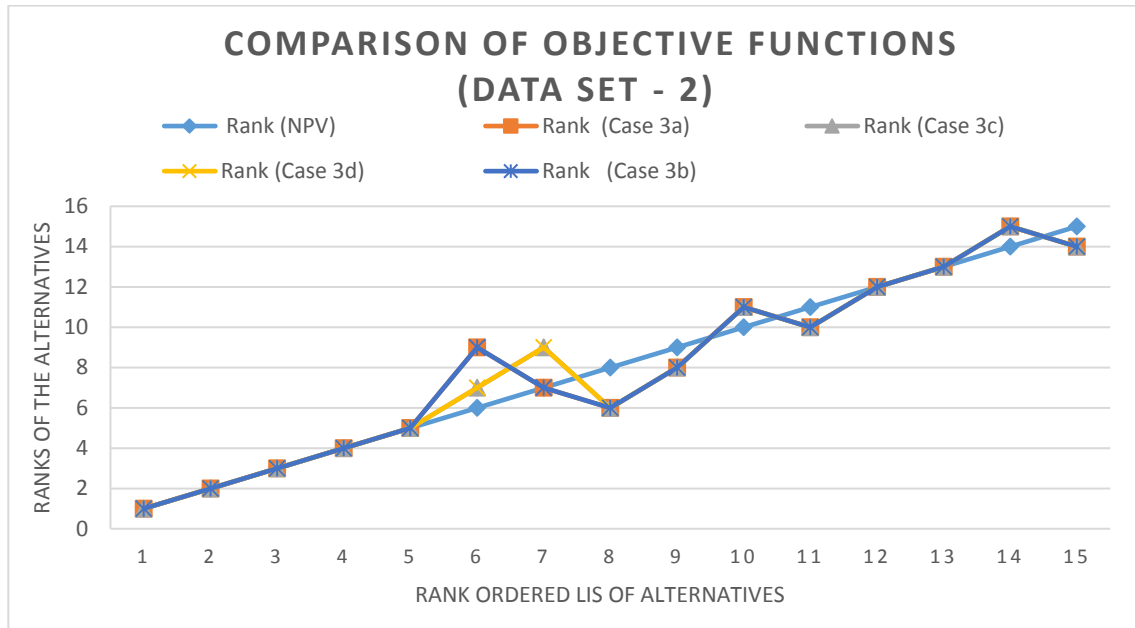
	Tau ( $\tau$ )	Rho ( $r_s$ )
<b>Case 1</b>	0.86	0.93
<b>Case 2</b>	0.88	0.96



**Figure 24** Comparison of the Rank Ordering Based Value Function vs Traditional Objective Function- Data Set 3

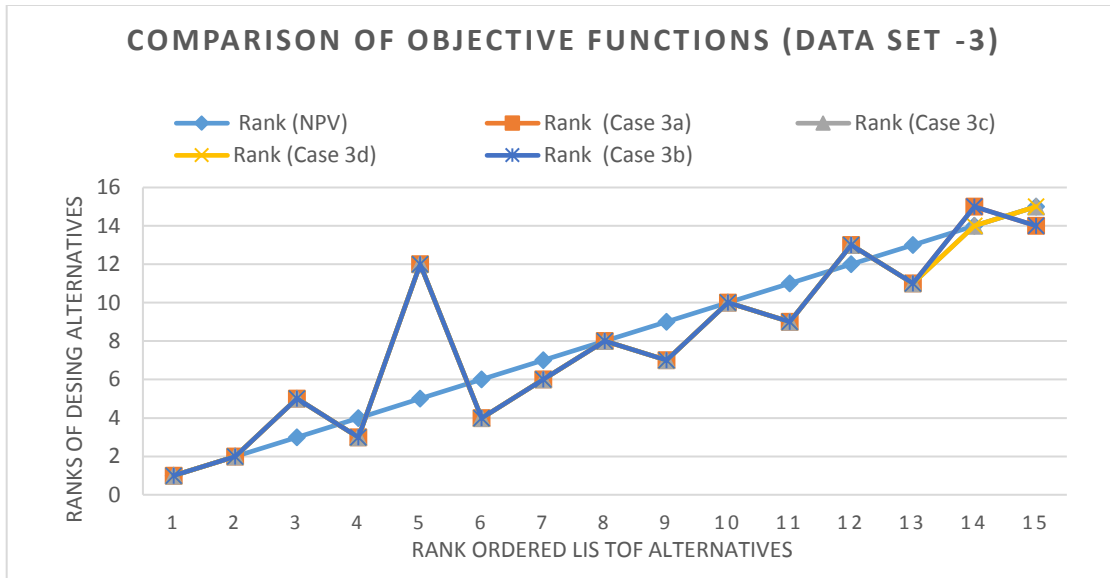
**Table 11:** Kendall's tau and Spearman rho for the Case 1 and Case 2 (Data Set - 3)

	Tau ( $\tau$ )	Rho ( $r_s$ )
<b>Case 1</b>	0.80	0.89
<b>Case 2</b>	0.75	0.86

**Figure 25.** Comparison of the Rank Ordering using Value function to the Multi Objective Function with varying weights -Data Set 2**Table 12.** Kendall's tau and Spearman rho for the three design sets when Value function rank ordering is compared to the Multi Objective function rank ordering- Data Set 2

	Tau ( $\tau$ )	Rho ( $r_s$ )
<b>Case 3a</b>	0.85	0.96
<b>Case 3b</b>	0.85	0.96
<b>Case 3c</b>	0.85	0.96
<b>Case 3d</b>	0.9	0.97

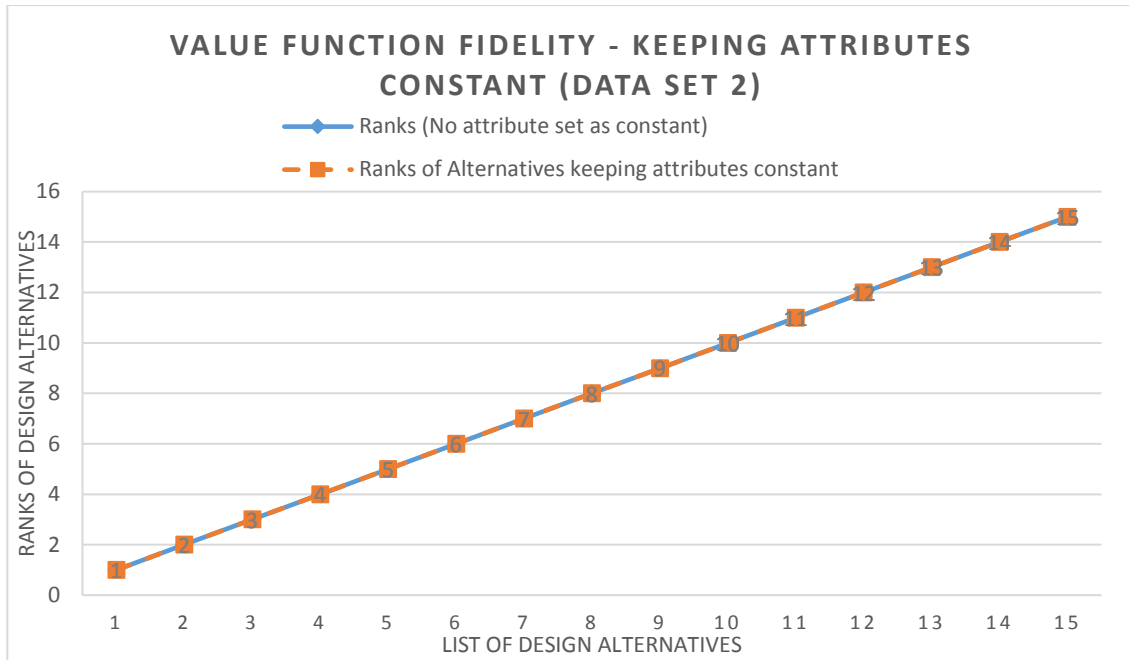




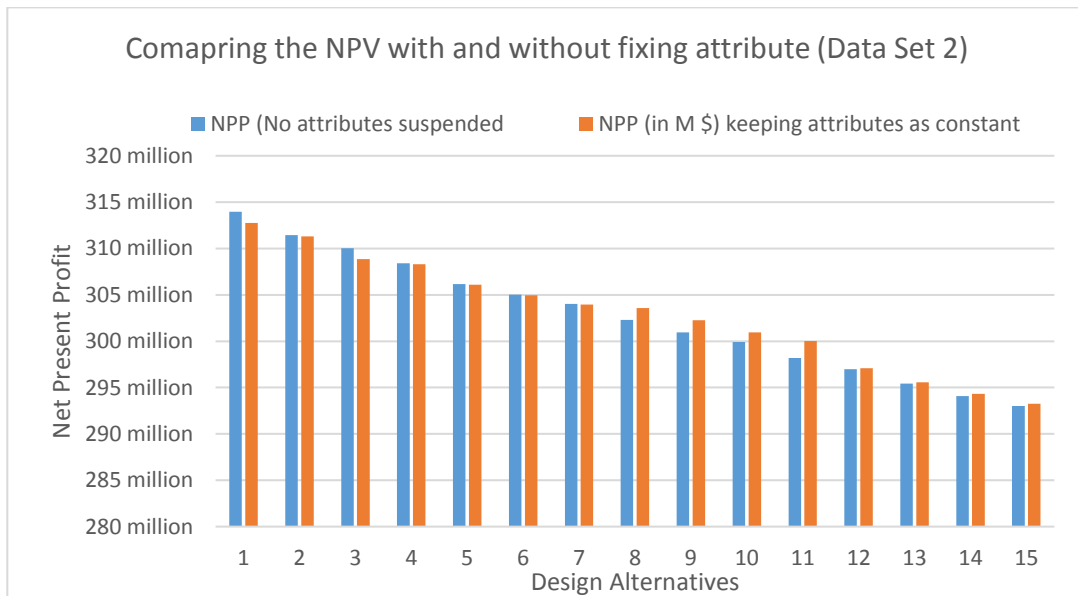
**Figure 26.** Comparison of the Rank Ordering using Value function to the Multi Objective Function with varying weights

**Table 13.** Kendall's tau and Spearman rho for the three design sets when Value function rank ordering is compared to the Multi Objective function rank ordering- Data Set 3

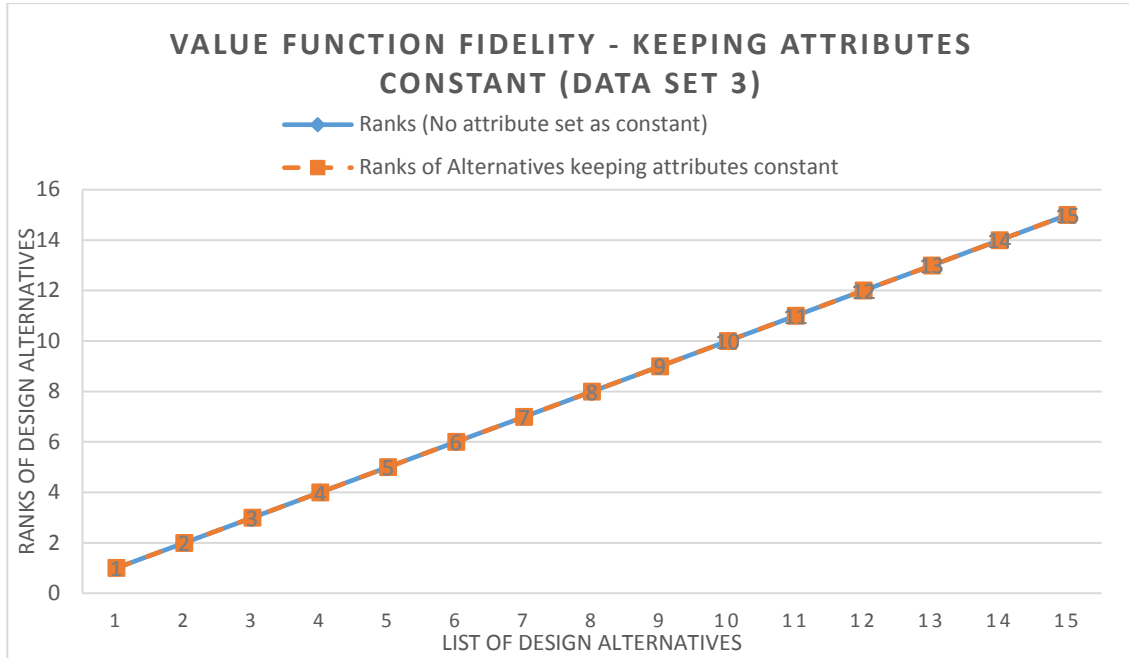
	Tau ( $\tau$ )	Rho ( $r_s$ )
<b>Case 3a</b>	0.75	0.86
<b>Case 3b</b>	0.75	0.86
<b>Case 3c</b>	0.75	0.86
<b>Case 3d</b>	0.77	0.87



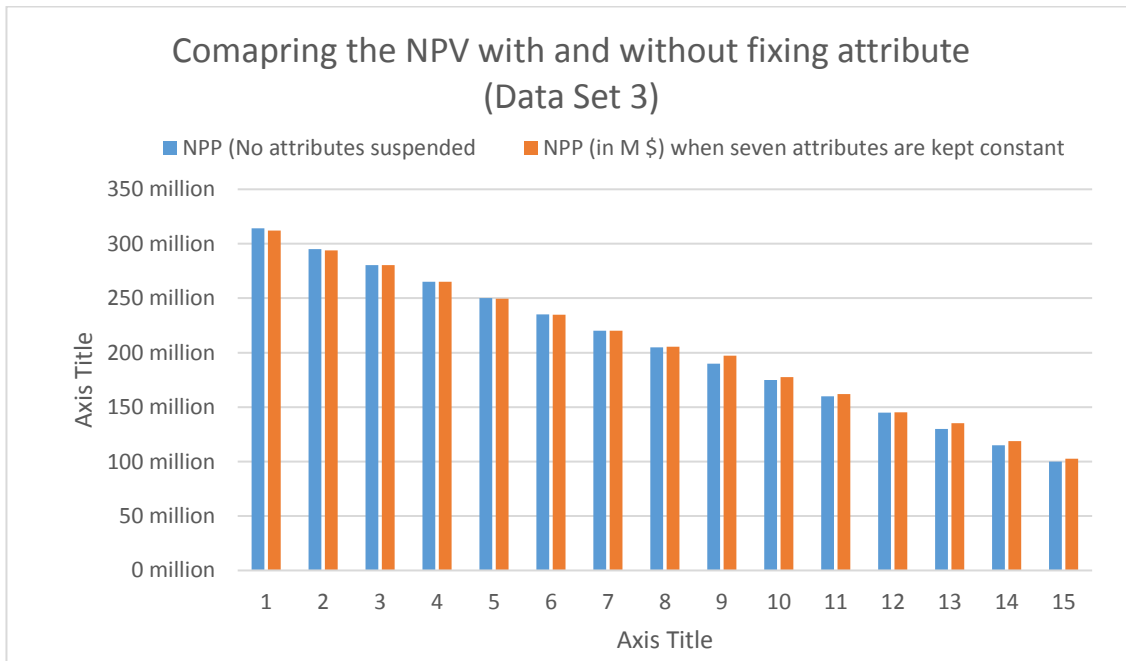
**Figure 27.** Comparison of the Base Rank Ordering to the Rank Ordering obtained when High level attributes are set as constant for Data Set 2



**Figure 28.** Comparison of NPV obtained with and without the attributes being set as constant for Data Set 2

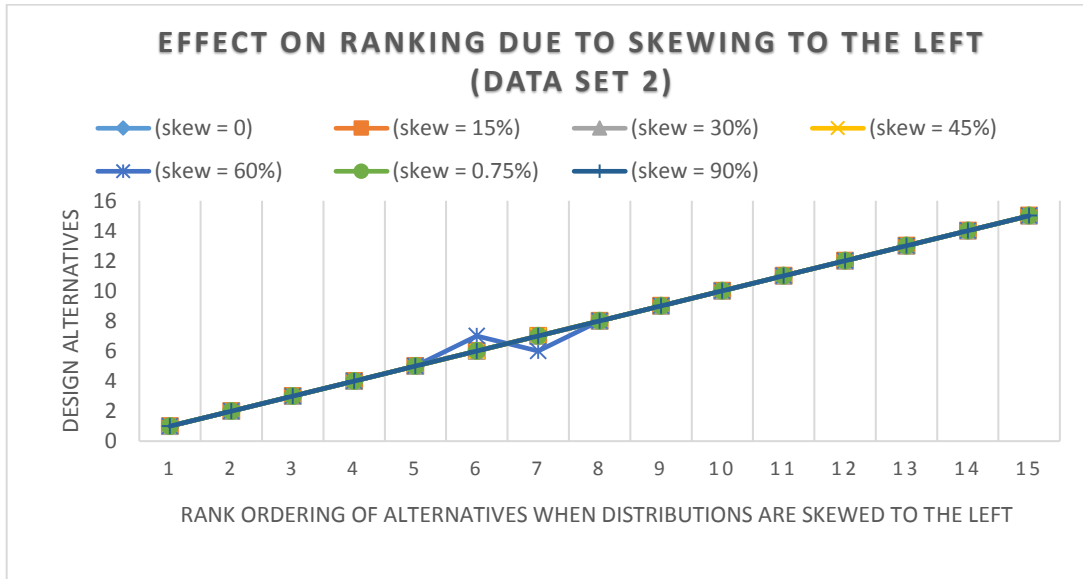


**Figure 29.** Comparison of the Base Rank Ordering to the Rank Ordering obtained when High level attributes are set as constant for Data Set 3



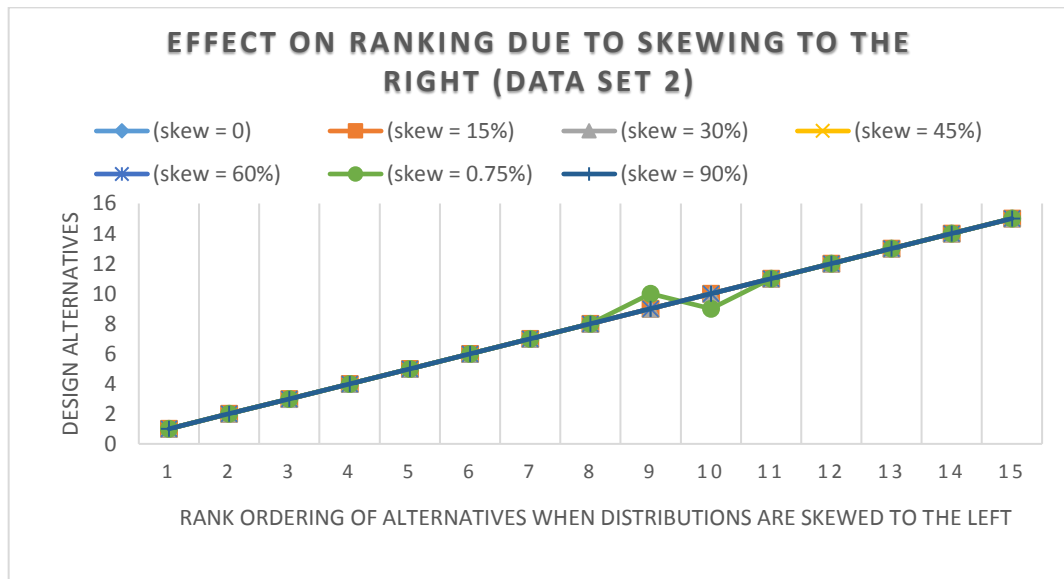
**Figure 30.** Comparison of NPV obtained with and without the attributes being set as constant for Data Set 3

APPENDIX: UNCERTAINTY ANALYSIS



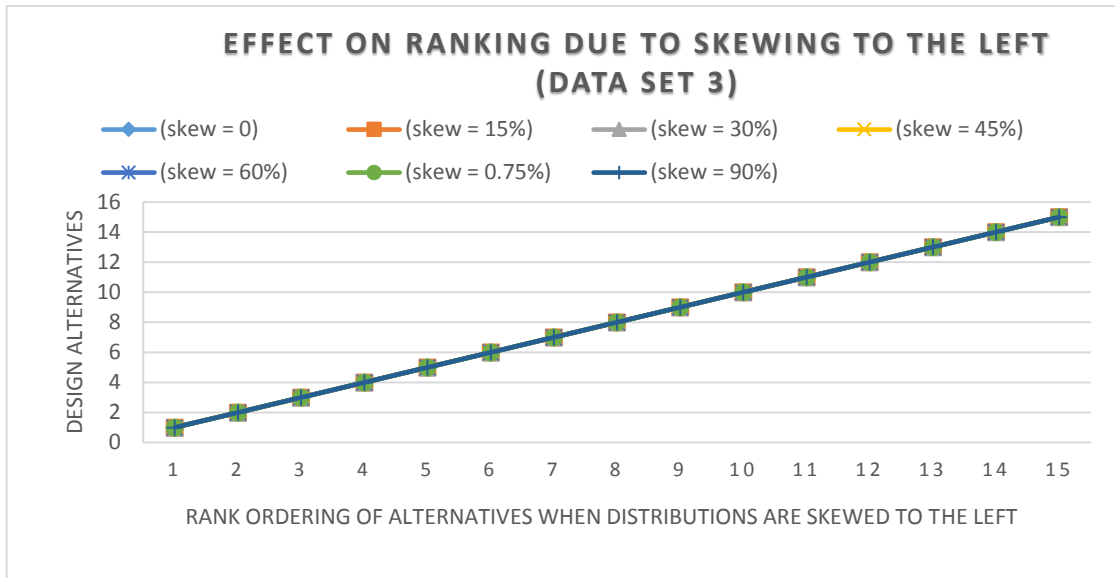
**Figure 31.** Effect of skewing the distributions (to the left) on the rank ordering of alternatives – Data Set 2

Tau ( $\tau$ ) = 0.98	Rho ( $r_s$ ) = 0.99
-----------------------	----------------------



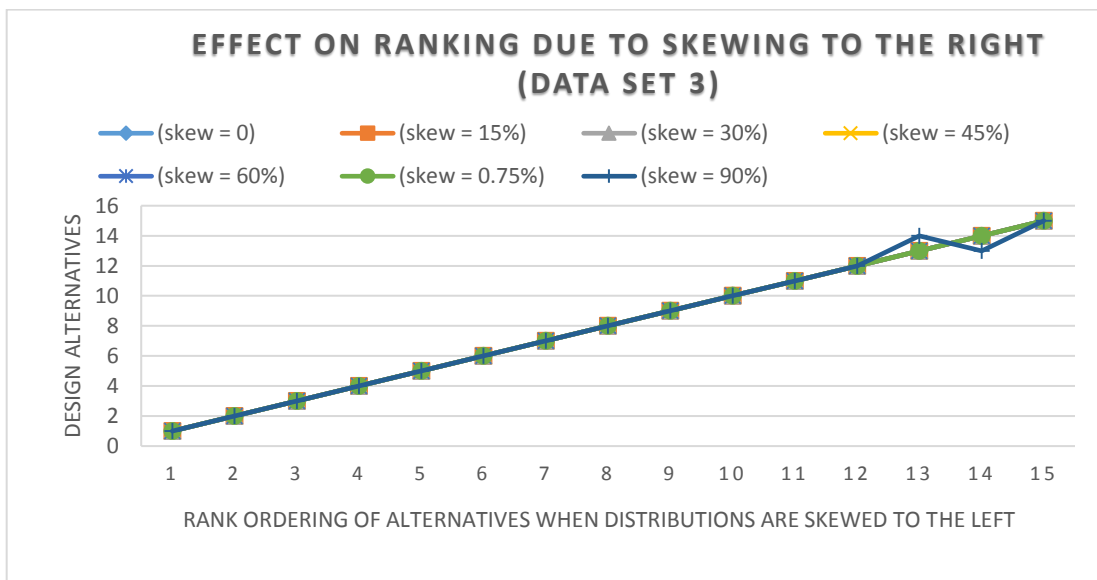
**Figure 32.** Effect of skewing the distributions (to the right) on the rank ordering of alternatives – Data Set 2

Tau ( $\tau$ ) = 0.98	Rho ( $r_s$ ) = 0.99
-----------------------	----------------------



**Figure 33.** Effect of skewing the distributions (to the left) on the rank ordering of alternatives – Data Set 3

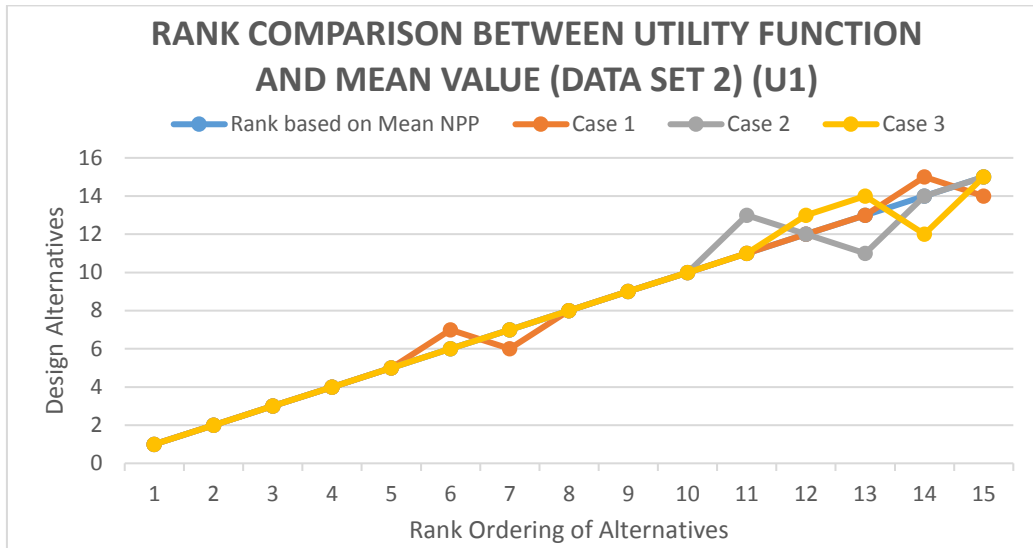
Tau ( $\tau$ ) = 1	Rho ( $r_s$ ) = 1
--------------------	-------------------



**Figure 34.** Effect of skewing the distributions (to the right) on the rank ordering of alternatives – Data Set 3

Tau ( $\tau$ ) = 0.98	Rho ( $r_s$ ) = 0.99
-----------------------	----------------------

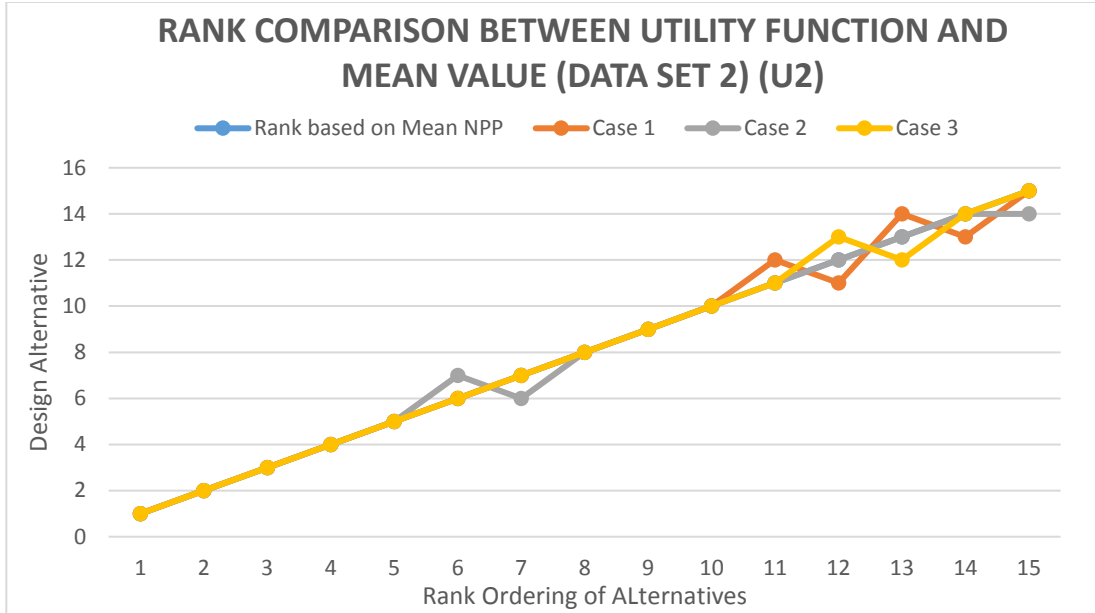
## APPENDIX: IMPACT OF RISK ON VALUE FUNCTION RANK ORDERING



**Figure 35.** Comparison of the Rank Ordering of alternatives with mean of the NPV and their certainty equivalence Data Set 2 – Utility Function 1

**Table 14.** Kendall's tau and Spearman rho when comparing ranking based on mean to ranking based on certainty equivalence for Data Set 2 – Utility Function 1

	Tau ( $\tau$ )	Rho ( $r_s$ )
<b>Case 1</b>	0.96	0.98
<b>Case2</b>	0.98	0.99
<b>Case 3</b>	0.96	0.99



**Figure 36.** Comparison of the Rank Ordering of alternatives with mean of the NPV and their certainty equivalence Data Set 2 – Utility Function 2

**Table 15.** Kendall's tau and Spearman rho when comparing ranking based on mean to ranking based on certainty equivalence for Data Set 2 – Utility Function 2

	Tau ( $\tau$ )	Rho ( $r_s$ )
<b>Case 1</b>	0.96	0.98
<b>Case2</b>	0.98	0.99
<b>Case 3</b>	0.96	0.99