

2015

Bonded Anchors in Concrete Under Sustained Loading

Douglas Droesch
ddroesch@engin.umass.edu

Follow this and additional works at: http://scholarworks.umass.edu/masters_theses_2



Part of the [Structural Engineering Commons](#)

Recommended Citation

Droesch, Douglas, "Bonded Anchors in Concrete Under Sustained Loading" (2015). *Masters Theses May 2014 - current*. 193.
http://scholarworks.umass.edu/masters_theses_2/193

This Open Access Thesis is brought to you for free and open access by the Dissertations and Theses at ScholarWorks@UMass Amherst. It has been accepted for inclusion in Masters Theses May 2014 - current by an authorized administrator of ScholarWorks@UMass Amherst. For more information, please contact scholarworks@library.umass.edu.

BONDED ANCHORS IN CONCRETE UNDER SUSTAINED LOADING

A Thesis Presented

by

DOUGLAS D. DROESCH

Submitted to the Graduate School of the
University of Massachusetts Amherst in partial fulfillment
of the requirements for the degree of

MASTER OF SCIENCE IN CIVIL ENGINEERING

May 2015

Civil and Environmental Engineering

BONDED ANCHORS IN CONCRETE UNDER SUSTAINED LOADING

A Thesis Presented

by

DOUGLAS D. DROESCH

Approved as to style and content by:

Scott A. Civjan, Chair

Sergio F. Breña, Member

Richard N. Palmer, Department Head
Civil and Environmental Engineering

DEDICATION

To my loving Wife, Alison. Without your support and love this project would never have happened. Thank you.

ACKNOWLEDGMENTS

I would like to thank my advisor, Dr. Scott Civjan, for his guidance and mentorship throughout this project. I have learned much more than I ever expected, not just about the specifics of the project, but the overall process of research and academics. I am not doubt a better researcher now, than I was when I started this project, but I also feel I have a better understanding of the world around me and way in which research is turned into codes and regulations. I would also like to thank Dr. Sergio Brena for his assistance with this project. He was able to help guide me through some of the difficulties that come with testing specimens in the real world. Lastly, I would like to acknowledge the Civil Engineering Department as UMass, specifically the Structures Group. I took classes and received guidance from all the members of this group and am indebted to them all.

ABSTRACT

BONDED ANCHORS IN CONCRETE UNDER SUSTAINED LOADING

MAY 2015

DOUGLAS D. DROESCH, B.S., WORCESTER POLYTECHNIC INSTITUTE

M.S., MISSOURI UNIVERSITY OF SCIENCE AND TECHNOLOGY

M.S., UNIVERSITY OF MASSACHUSETTS AMHERST

Directed by: Scott A Civjan

Post installed anchors come in either mechanical anchors that develop their strength purely through mechanical interlock with the base concrete, or bonded anchors that develop their strength by bonding anchor rod to the base concrete. Bonded anchors are either grouted, typically cementitious material, or adhesive, typically a chemical material. This thesis presents a current literature review of post-installed bonded anchors, preliminary testing of adhesive bonded anchors, and details of short term and long term test setups for future testing. The purpose of this thesis was to develop the test setups that will be used for future testing on anchors.

TABLE OF CONTENTS

	Page
ACKNOWLEDGMENTS.....	iv
ABSTRACT.....	v
LIST OF TABLES.....	viii
LIST OF FIGURES.....	ix
CHAPTER	
1. INTRODUCTION.....	1
1.1 Motivation for the Study	4
2. BEHAVIOR MODELS AND FAILURE MODES.....	7
2.1 Failure Modes	7
2.2 Concrete Capacity Design (CCD)	8
2.3 Uniform Bond Stress.....	10
3. ADHESIVE ANCHOR SYSTEMS LITERATURE REVIEW	15
4. GROUTED ANCHOR SYSTEMS LITERATURE REVIEW	27
5. PARAMETERS THAT AFFECT ANCHOR CAPACITY	37
6. TESTING STANDARDS FOR BONDED ANCHORS	51
7. TEST METHODS AND PROCEDURES	59
7.1 Research Plan.....	59
7.2 Short Term Tests.....	59
7.3 Long-Term Tests.....	64
7.4 Test Set Up Components	71
7.4.1 Steel anchor rod, bonding materials and concrete specimens	71
7.4.2 Instrumentation and Data Acquisition	77

7.5	Environmental Chamber	79
8.	PRELIMINARY TEST SPECIMENS AND RESULTS	83
8.1	Test Series	83
8.1.1	Test Series 0a	83
8.1.2	Test Series 0b	90
8.1.3	Test Series 0c	94
8.2	Test Series Results	97
8.2.1	Test Series Results Test Series 0a	97
8.2.2	Test Series Results Test Series 0b	106
8.2.3	Test Series Results Test Series 0c	107
8.3	Conclusions	108
9.	RECOMMENDED FUTURE WORK	109
9.1	Tasks required to complete MassDOT Project Phase I	110
9.2	Step by step procedure for each adhesive tested	111
	REFERENCES	114

LIST OF TABLES

Table	Page
3.1 Proposed Test Matrix (Cook et al. 2013)	19
3.2 Test Matrix (El Menoufy et al. 2014).	21
4.1 Test Matrix for Non-Headed Grouted Anchors (Zamora et al. 2003 p. 225).....	33
4.2 Test Matrix for Headed Grouted Anchors (Zamora et al. 2003 p. 225).....	33
4.3 Summary of Testing Program (Cook and Burtz. 2003).....	36
7.1 Bonding Materials Used per Test Series	75
8.1 Test Series Matrix.....	83
8.2 Test Series 0a Matrix.....	84
8.3 Proposed Test Series 0b Matrix of Experiments.....	94
9.1 Proposed Test Matrix for Follow On Testing	110

LIST OF FIGURES

Figure	Page
1.1 Anchor Systems (Cook and Burtz, 2003).....	3
1.2 Adhesive Anchor Failure in I-90 Tunnel Failure. Figure 1 (NTSB 2007 p. 1).....	5
2.1 Bonded Anchor Failure Modes (Zamora et al. 2003).....	8
2.2 Full Concrete Cone Break Out as Predicted by CCD (Fuchs et al. 1995).....	10
2.3 Hyperbolic Tangent Stress (Left) and Uniform Bond Stress (Right) (Cook, et al., 2013)	11
2.4 Stress Distribution Along Length of Adhesive Anchor for $h_{ef}/d_0=8.00$ (Cook, et al., 2013).....	13
3.1 Tertiary Creep (ASTM D2990, 2009).	17
3.2 Creep Tests for Dry Installation (McDonald 1998)	24
3.3 Creep Test Submerged Anchor Installation (McDonald 1998)	25
3.4 Average load at 0.2in (5mm) displacement static tests for Adhesives A (top), B (middle), and C (Bottom) (McDonald 1998).....	26
4.1 Examples of Headed and Non-headed Anchors (Cook et al. 2003)	28
4.2 Splitting Tube for Concrete Cracking (Rodriquez et al. 2001) Authorized Reprint from Jul.-Aug. 2001 ACI Structural Journal Vol. 98 No. 4.....	31
6.1 Example Stress Vs Time-To-Failure Graph (Cook et al. 2013).....	57
7.1 Short Term Setup Section A-A	61
7.2 Short Term Setup Section B-B.....	62
7.3 Coupler Details.....	63
7.4 Example Spring Stiffness Calibration.	66
7.5 Spring Photos	66
7.6 Long Term Test Setup Section A-A.....	69

7.7 Long Term Test Setup Section B-B.....	70
7.8 Anchor Rod.....	72
7.9 Concrete Samples	74
7.10 SPX Power Team RH202 Jack (Left) and SPX Power Team P460d Pump(Right)	77
7.11 Environmental Chamber Plan	81
7.12 Environmental Chamber	82
8.1 Non-Rigid Coupler of Experiments 0a-1 through 0a-3.....	85
8.2 Hole Drilling Series 0a	86
8.3 Hole Cleaning with Compressed Air.....	87
8.4 Mixed Epoxy (Left) and Installed Anchor (Right)	88
8.5 Two Non-Rigid Coupler Design	89
8.6 Brush Cleaning Hole (Left) and Alignment guide for Test Series 0b an 0c (Right)	91
8.7 Cleaned Hole with Tape (Left) Cleaning Subsequent Hole (Right).....	91
8.8 Test Series 0b depth gauge	92
8.9 Adhesive Application.....	93
8.10 Concrete Specimens for Test Series 0c	96
8.11 Test Series 0c Installation Photos.	96
8.12 Experiment 0a-1 failure photos	98
8.13 Experiment 0a-2 plot	98
8.14 Test 0a-2 Anchor Rod Elastic Displacements and Adhesive Displacements.....	100
8.15 Test 0a-2 Individual LVDT displacements and Average displacement.....	101
8.16 Experiment 0a-4 Creep Displacement	102
8.17 Test 0a-4 Force vs Displacement LVDT-1, LVDT-2, Average	103
8.18 Test 0a-4 LVDT 1, LVDT 2, and Average Displacements vs. Time	104

8.19 String Potentiometer Placement	105
8.20 Test 0a-4 Measured Spring Displacements.....	106
8.21 Test Series 0b anchor failure and washer deformation.....	107

CHAPTER 1

INTRODUCTION

Concrete is a material used extensively in structural applications across the world, creating a need to anchor other materials. Anchorage to concrete can be accomplished through a piece of steel, such as a threaded rod, bolt, or proprietary anchor, partially embedded in the base concrete and used to connect additional members. Anchorage of this type can be categorized as either cast in place or post installed. Cast in place anchors are embedded in the concrete before it hardens. Advantages of cast in place anchors are their predictable and more reliable behavior and failure modes, but require a high level of accuracy in their placement to ensure proper alignment as they cannot be moved after the concrete hardens. Post installed anchors typically use proprietary methods to attach to hardened concrete. This allows for freedom in placement to ensure proper alignment, but can be subject to much more variability in performance and capacity of the anchor. Post installed anchors can be categorized as either mechanical or bonded anchors as seen in Figure 0.1. Mechanical post installed anchors use friction and mechanical interlock to transfer their load from the anchor rod to the concrete. ACI 318-02 Appendix D was the first edition of anchor design standards in the ACI Building Code Requirements for Structural Concrete. It covered cast in place anchors and post installed mechanical anchors and gave design standards for both. Bonded anchorage systems generally comprise of a steel anchor rod, either threaded or dowel (rebar), and a bonding material. Bonding materials are loosely defined as either adhesive or grouted depending on hole diameter (Zamora et al. 2003 p. 222). Grouted anchors have a hole diameter greater than 1.5 times the anchor diameter where adhesive anchors are less, but there is no published standard by a governing body, such as ASTM, to define a grouted anchor vs an adhesive anchor (Cook et al. 2013 p. 5). Defining anchor systems strictly by their hole diameter allows for the same material

to be used as a grouted anchor system and as an adhesive anchor system. One example is a polymer grouted anchor system that uses the same bonding material as a polymer adhesive anchor system. The difference is the polymer grout uses a fine aggregate to fill the larger hole. Generally, grouted anchors can include either polymer or cementitious materials while bonded rely on polymer materials. Due to the larger diameter hole, grouted anchor systems can be installed with either headed or non-headed rod. The headed anchor rod changes the possible failure modes and can reach capacity at a lower embedment depth. More on anchor system failure modes is available in Chapter 2. ACI 355.4 (2011) provides the most comprehensive standard definition for adhesives used in adhesive anchor systems:

Any adhesive comprised of chemical components that cure when blended together.

Adhesives are formulated from organic polymers, or a combination of organic polymers and inorganic materials. Organic polymers used in adhesives can include, but are not limited to, epoxies, polyurethanes, polyesters, methyl methacrylates and vinyl esters.

(ACI 355.4 2011)

Bonded anchors, both adhesive and grouted, are generally installed the same way. A hole is drilled in base concrete using a rotary impact hammer or a diamond bit core drill. The hole is then cleaned with a brush, compressed air, and/or water jet. The bonding material then fills the hole and the anchor rod is inserted to the bottom of the hole. This process varies greatly by manufacturer. Adhesive anchors are generally installed with a caulking type gun or by a glass capsule that mixes the components in the hole, while cementitious anchors are mixed like concrete in the field or come ready to use from the manufacturer. The bonding material is then allowed to cure based a manufactures' recommendations, generally between 24 hours and 28 days, and load can then be applied.

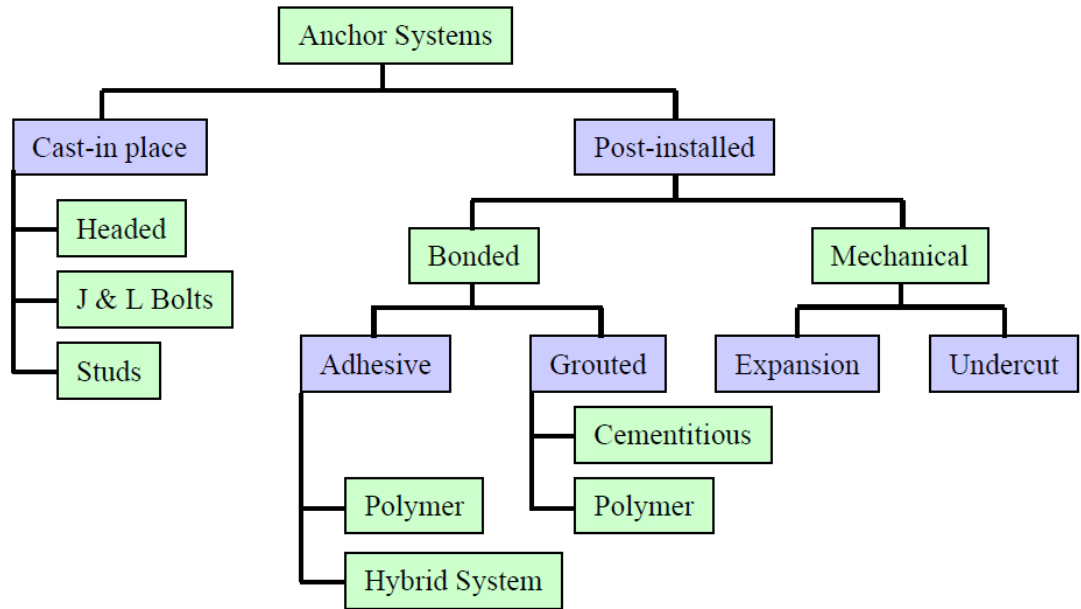

Figure 1.1 Anchor Systems (Cook and Burtz, 2003)

Post installed anchors allow contractors the freedom to put anchors in the proper position after the concrete base member is cast, but their behavior is less predictable and more susceptible to changes in environmental conditions. Both adhesive and grouted anchors can creep, deform or displace over time due to sustained stress. Creep over a period of sustained load can cause failure in adhesive anchors at loads lower than their short term static capacity.

Adhesive anchor research has recently been summarized in two National Cooperative Highway Research Program (NCHRP) reports, Cook et al. (2009) and Cook et al. (2013). These reports differed from Cook and Burtz (2003) and Zamora et al. (2003) by focusing only on adhesive anchors and specifically creep characteristics of adhesive anchors. Adhesive anchors are known to creep, but their specific capacity under sustained tensile loads is not clearly understood. Cook et al. (2009) proposed a new American Association of State Highway Transportation Officials (AASHTO) Provisional Standard AASHTO TP-84 (AASHTO TP-84 2010) which provides a stress versus time-to-failure test for adhesive anchors. This test provides a

guide criterion for designers showing maximum load of an adhesive anchor system when subjected to sustained tensile load under varying environmental conditions such as elevated temperature and humidity. The tests are conducted to failure at three separate sustained load levels. The guide uses the maximum load found from a static pull out test, known as the mean static load (MSL) or static capacity, as a reference for applying sustained tensile loads (Cook et al. 2009). Cook et al. (2013) expanded upon Cook et al. (2009) by investigating additional environmental parameters that can affect bond strength, eventually leading to additional recommended changes, such as using three sustained load levels instead of two for developing a stress vs. time to failure plot. ACI 355.4 (2011) presents pass/fail standards for adhesive anchors based on displacement after 42 days at 55% of MSL. More information on AASHTO TP-84 (2010) and ACI 355.4 (2011) is available in Chapter 6.

1.1 Motivation for the Study

The Massachusetts Department of Transportation (MassDOT) has used post installed anchors in a variety of projects, such as connecting new construction to existing structures, fitting two hardened pieces of concrete after forms are removed, and hanging structural or architectural features from concrete. The latter led to a catastrophic failure of adhesive anchors in the I-90 connector tunnel of Boston on July 10, 2006 shown in Figure 0.2. The anchor failure caused precast ceiling units to drop into the roadway causing one fatality, one person with minor injuries, and additional financial damage. This failure led to a permanent change in the allowance of post installed anchors by MassDOT, precluding all applications subject to creep load. Anchor creep was a major factor in the I-90 tunnel failure:

Contributing to the accident was the failure of Powers Fasteners, Inc., to determine that the anchor displacement that was found in the high-occupancy vehicle tunnel in 1999

was a result of anchor creep due to the use of the company's Power-Fast Fast Set epoxy, which was known by the company to have poor long-term load characteristics (NTSB 2007 p. 1)

After the accident, inspections were conducted on the remaining anchors and 78 of 198 in the westbound tunnel, 57 of 248 in eastbound tunnel, and 26 of 188 in the high occupancy vehicle (HOV) tunnel displaced. Displacement ranges were from less than 0.1 in (0.25 cm) to more than 1.0 in (2.54 cm). State and local authorities chose to close the tunnel while inspections and corrective actions occurred (NTSB 2007).

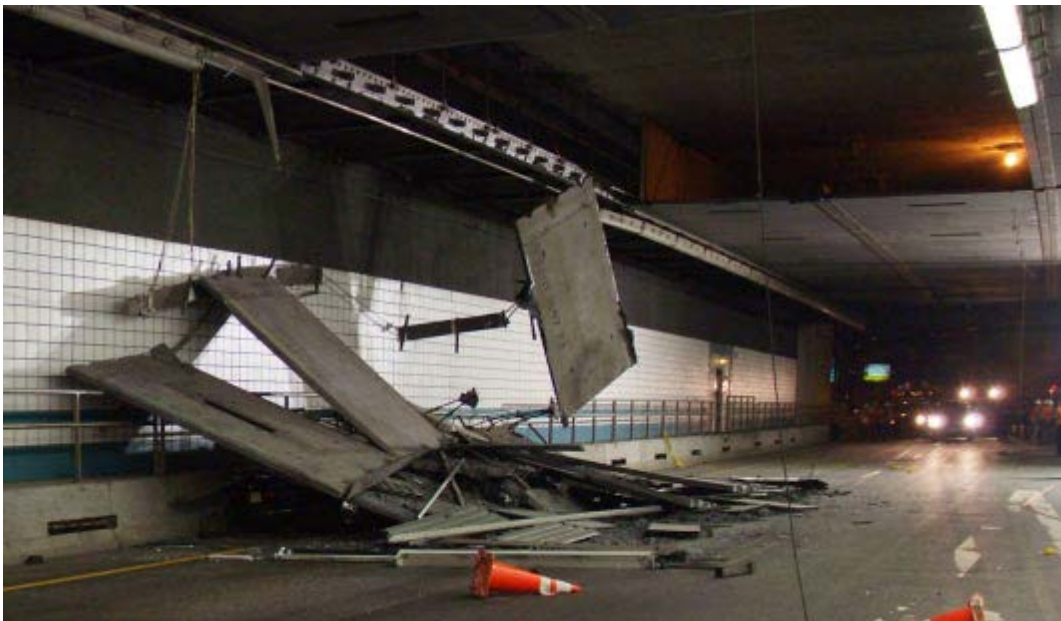

Figure 1.2 Adhesive Anchor Failure in I-90 Tunnel Failure. Figure 1 (NTSB 2007 p. 1)

The creep characteristic of adhesive anchors and bonded anchors in general requires further understanding and acceptance criteria for use of anchors to avoid such failures in the future.

MassDOT has funded this project to determine acceptance criteria for anchorage systems to be listed as a "Qualified Construction Material" on MassDOT projects. The purpose of this thesis is to develop the test capabilities to meet AASHTO TP-84 (2010) criterion at UMass

Amherst and provide initial test results for the project. This project will expand on Cook et al. (2013), research conducted at the University of Florida and the University of Stuttgart, and investigate if these newly developed standards, AASHTO(2010) and ACI 355.4 (2011), have merit in determining if materials are acceptable for use in MassDOT projects. The MassDOT project will be conducted in two phases. Phase I consists of 15 static tests and 30 creep tests in accordance with AASHTO TP-84 to evaluate comparatively a series of different anchor material types. This phase will include an in depth literature review, purchase of materials, construction of environmental chambers, construction of test samples, and calibration of laboratory equipment. This phase will end with a stress versus time-to-failure graph for each selected adhesive anchor system on the MassDOT Qualified Materials Construction List and preliminary conclusions for the sensitivity of grouted anchors to sustained loads. Additional environmental factors may be considered during Phase I and additional testing will be implemented in Phase II based on the outcomes from Phase I. Phase I will end with recommendations for further testing of Phase II. Phase II will consist of additional static and long-term tests based on the outcome of Phase I. This thesis covers the initial tasks of Phase I.

CHAPTER 2

BEHAVIOR MODELS AND FAILURE MODES

This chapter discusses five potential failure modes of bonded anchors and the stress behavior of a bonded anchor. This information comes from a literature review of published articles on the subject.

2.1 Failure Modes

Several studies on bonded anchors have been undertaken in the past fifteen years. Cook and Burtz (2003) provide a model for predicting bond strength under static load and validated pull-out capacities under varying conditions. While focusing mainly on grouted anchors, this project provides information that is valid for all bonded anchors. Additionally, this research defined four types of bonded anchor failure modes, as shown in Figure 2.1. Failure of the anchor rod is a fifth failure mode, but is not included because this failure mode is precluded in the research by the use of high strength steel and failure was defined as not reaching the capacity of the anchor rod. The four failure modes investigated in this project and most literature are concrete breakout failure, adhesive (or grout)/concrete interface bond failure, steel/adhesive (or grout) interface bond failure, and partial adhesive (or grout)/concrete and partial steel/adhesive (or grout) interface bond failure. The latter three failure modes are accompanied by a secondary shallow concrete cone failure plane for both adhesive and grouted anchors. Use of a headed anchor rod in grouted anchors precludes the grout/steel interface bond failure allowing for only three possible failure modes of headed grouted anchor systems (Cook et al. 2003).

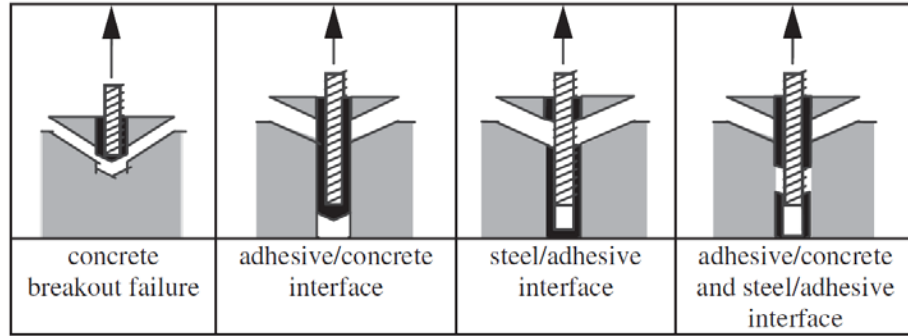

Figure 2.1 Bonded Anchor Failure Modes (Zamora et al. 2003) Authorized Reprint from Mar-Apr 2003 ACI Structural Journal Vol. 100 No. 2

Concrete breakout failure is predicted using the Concrete Capacity Design (CCD). The three bond failure modes are predicted using a uniform bond stress model. The CCD model was developed for cast in place and mechanical anchors, but is applicable to grouted anchors that fail with a full concrete breakout cone. The three bond failure modes are exclusive to bonded anchors.

2.2 Concrete Capacity Design (CCD)

Failure with a full concrete breakout cone is predicted using the CCD model. The CCD model was first incorporated in ACI 318-02 (ACI Committee 318, 2002 p. 409). This model was developed for cast in place and mechanical anchors that fail with a full concrete breakout cone. CCD was developed by Eligenhausen et al. (1987) and was first compared with existing ACI standards by Fuchs et al. (1995). It assumes that the base concrete fails in tension and a 35° full cone is formed from the end of the embedded head to the concrete surface, Figure 2.2. This design method was validated for headed cast in-place anchors and post-installed mechanical anchors and has been the model used by ACI for headed anchors that fail in tension or shear (cast in place or mechanical), but is applicable to post installed anchors that preclude bond

failure modes. Equation 1 shows the design equation from ACI (ACI Committee 318, 2002).

$$N_b = k\sqrt{f'_c}h_{ef}^{1.5} \quad \text{Equation 1}$$

N_b = Basic concrete breakout strength in tension of a single anchor in cracked concrete (lbs)

k = Coefficient for basic concrete breakout strength in tension

(24 for Cast in Place Anchors, 16 for Mechanical Post-Installed Anchors)

f'_c = Specified Compressive Strength of Concrete (psi)

h_{ef} = Effective anchor embedment depth (in)

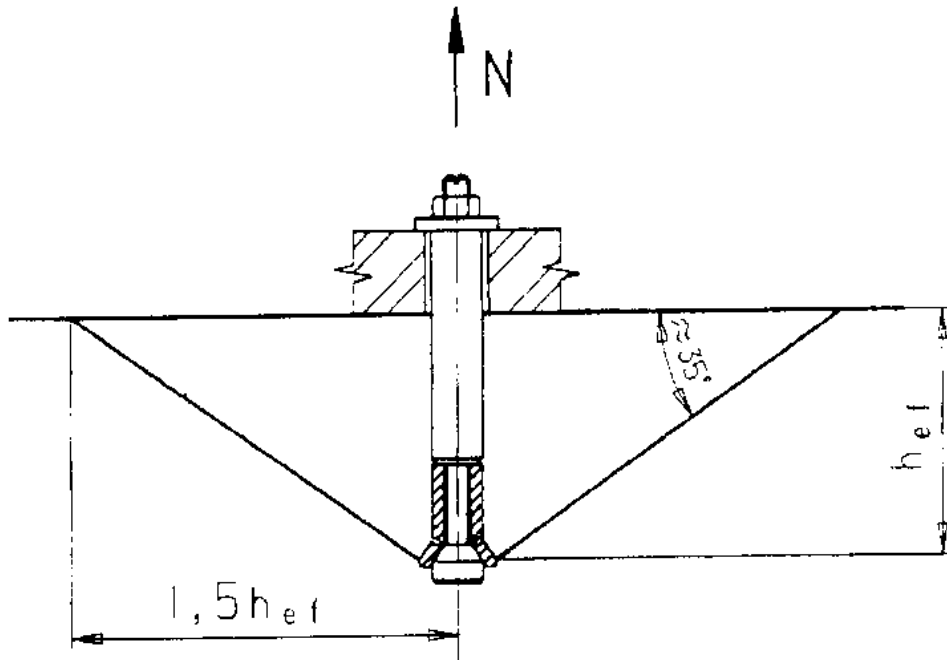

Figure 2.2 Full Concrete Cone Break Out as Predicted by CCD (Fuchs et al. 1995) Authorized reprint from Jan.-Feb. 1995 ACI Structural Journal Vol. 92 No. 1

2.3 Uniform Bond Stress

The uniform bond stress model was first recommended as the standard design model by Cook et al. (1998) and is summarized in Zamora et al. (2003) and Cook et al. (2013). Adhesive anchors experience a hyperbolic tangent stress distribution at low load levels with stresses being smallest at the end of the anchor in the concrete and highest where the anchor rod exits the concrete, left picture in Figure 2.3. Above 30% of mean static load (MSL), the higher stress portions experience plastic behavior and load begins redistributing across the adhesive. At approximately 70% MSL, the entire adhesive is in the plastic range and a uniform stress is achieved throughout, right picture in Figure 2.3. This later stress distribution is the basis for

using the uniform bond stress model to predict the capacity of an anchor at failure. Figure 2.4 shows the stress distribution along the length of an adhesive anchor at different percentages of MSL. It can be seen that stress at the bottom of the anchor varies from the middle and top of the anchor for all load levels, showing that the uniform bond stress model is only an approximation. This model is valid with the following assumptions:

“For adhesive-bonded anchors where the hole diameter does not exceed 1.5 times the anchor diameter and with an embedment depth to anchor diameter ratio not exceeding 20, the uniform bond stress model shown in Figure 8 [Figure 2.3] and given by Equation 1 [Equation 2] has been shown to be a valid behavioral model both experimentally and numerically” (Cook et al. 2013 p. 4)

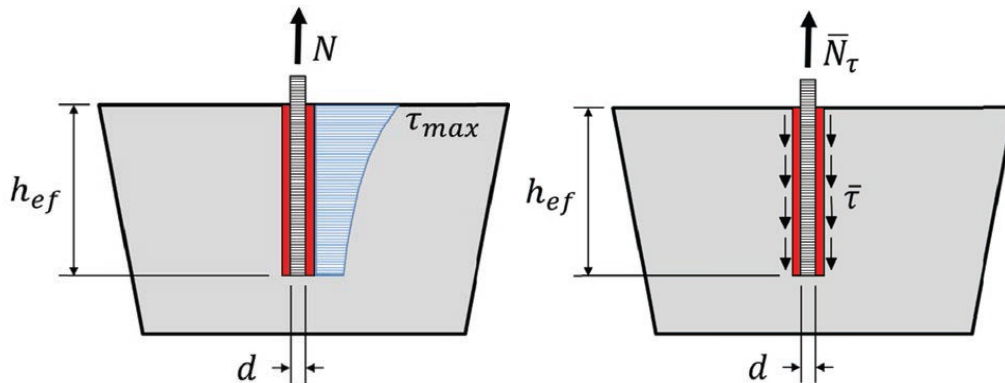

Figure 2.3 Hyperbolic Tangent Stress (Left) and Uniform Bond Stress (Right) (Cook, et al., 2013)

The Uniform Bond Stress Model is defined as:

$$\bar{N}_\tau = \bar{\tau}\pi d h_{ef} \quad \text{Equation 2}$$

\bar{N}_τ = mean failure load, lb

$\bar{\tau}$ = mean bond strength, psi

d = anchor diameter, in

h_{ef} = embedment depth, in

For Load and Resistance Factor Design (LRFD), $\bar{\tau} = \tau' \alpha_1 \alpha_2 \alpha_3$ where τ' is the 5% lower fractile of mean bond strengths and $\alpha_1, \alpha_2, \alpha_3$ are reduction factors determined by comparing bond strength of different conditions to baseline bond strengths. The 5% lower fractile is generally determined through confined laboratory tests. These tests force bond failure. While this gives a valid value of bond stress of the bonding material, it does not give an accurate description of anchor strength because of capacity lost to shallow concrete breakout cone (Cook, et al., 2013). ACI 355.4 (2011) uses a reduction ratio of 0.75 when bond shear stress is determined through confined testing. Cook et al. (2013) found the reduction value to be between 0.37 and 0.53. Detailed information on Cook et al. (2013) can be found in Chapter 3.

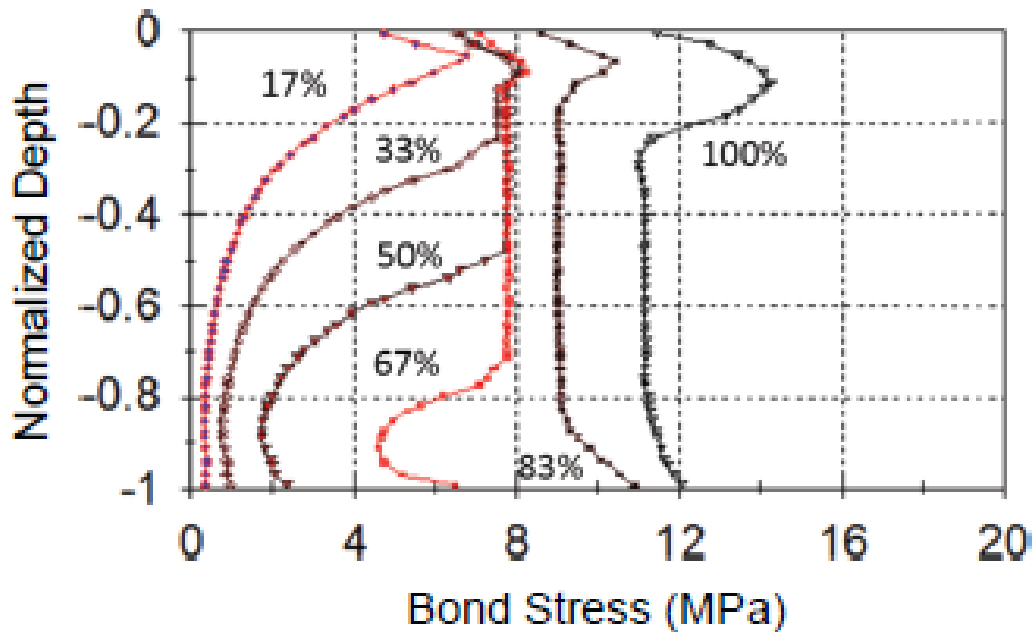

Figure 2.4 Stress Distribution Along Length of Adhesive Anchor for $h_{ef}/d_0=8.00$ (Cook, et al., 2013) With permission from ASCE. This material may be downloaded for personal use only. Any other use requires prior permission of the American Society of Civil Engineers.

Zamora et al. (2003) presents validated models of grouted anchor behavior in tension. Non-headed grouted anchors generally exhibit the same failure modes as adhesive anchors. That is, full concrete cone break out, failure of the grout/concrete interface bond, failure of the grout/steel interface bond, and partial failure of grout/concrete bond with partial failure of the grout/steel bond. The uniform bond stress model for adhesive anchors applies to grouted anchors with one exception. Grouted anchors have a bond stress for the grout/steel interface (τ) and a bond stress for the grout/concrete interface (τ_0). Equation 2 is modified and the lower of Equation 2 or Equation 3 is used to predict the mean failure load or mean static load of non-headed grouted anchors for the two different bond failures.

$$\bar{N}_\tau = \bar{\tau}_0 \pi d_0 h_{ef}$$

Equation 3

\bar{N}_τ = mean failure load, lb

$\bar{\tau}_0$ = mean bond strength, psi

d_0 = anchor diameter, in

h_{ef} = embedment depth, in

Headed grouted anchors will not experience a grout/steel bond failure due to the presence of the head, but can experience a bond failure at the grout/concrete interface or a full concrete breakout cone. Failure of the bond at the grout/concrete interface can be predicted by Equation 3. (Zamora et al. 2003) Failure of the grout is not mentioned in the literature, but is a possible failure mode that should be investigated.

CHAPTER 3

ADHESIVE ANCHOR SYSTEMS LITERATURE REVIEW

An adhesive anchor system has a hole less than 50% of the anchor rod diameter as defined by Zamora et al. (2003) and adopted by Cook and Burtz (2003), Cook et al. (2009), Cook et al. (2013), and El Menoufy et al. (2014). The material used in these anchors is defined by ACI 355.4 (2011) as “Organic polymers used in adhesives can include, but are not limited to, epoxies, polyurethanes, polyesters, methyl methacrylates and vinyl esters; or inorganic polymers.” Most of the organic polymer adhesives are contain two parts that require mixing just prior to application. This is typically done with a caulking type gun that mixes the two components as they are installed into the hole. Inorganic adhesive anchors allows for the use of cementitious products, typically reserved for grouted anchor applications with a hole diameter of greater than 1.5 times the anchor diameter. Adhesive anchor manufacturers provide a table listing allowable load and ultimate load for their anchor system based on anchor rod diameter, embedment depth, and concrete compressive capacity. Separately they provide a list of hole diameters to use with each acceptable anchor rod diameter.

Creep of adhesive anchors has been a known problem, but the long term capacity of the anchors under different conditions has only been heavily researched within the past ten years following the 2006 I-90 tunnel failure. Published research at the time of the accident showed the poor creep performance of adhesive anchors including a warning from James et al. (1989) “It should be emphasized that resins used in structural applications can exhibit significant viscoelastic response to long-term loadings, especially at elevated temperatures.” As with most engineering failures, additional guidelines were published in response to the failure. An NTSB report on the accident recommended to the Federal Highway Administration to prohibit the use of adhesive anchors under sustained load conditions until test standards were established (NTSB

2007). Additionally, MassDOT introduced Engineering Directive E-10-001 on April 20th, 2010 providing guidance to designers to always specify non-adhesive anchors unless the designer provides necessary dimensions for coring or drilling holes, including hole diameter and depth, spacing between dowels or anchors and edge distance; or when used in crash tested anchor bolt applications (MassDOT 2010). Since the publishing of the MassDOT directive, ACI and AASHTO have both developed standard tests for use of adhesive anchors under a variety of conditions, including sustained tensile loading. Cook et al. (2013) include an extensive review of standards of testing, behavior models, and parameters that affect capacity of adhesive anchors. A brief synopsis of this material is presented in the rest of this chapter.

Cook et al. (2009) discuss the creep resistance of adhesive anchors and provide a basis for AASHTO TP-84 (2010) and Cook et al. (2013). The main purpose of this research program was to develop a standard test procedure for AASHTO to qualify adhesive anchor systems for use in Federal Highway Projects. Stress vs. time to failure was compared with a pass/fail method from the existing ICC-ES AC308 (2008). This project tested three adhesives for short term capacity and only two of those for long term capacity due to budget and time constraints. 6 short term tests were conducted per adhesive to determine a mean static load, MSL. Three long term tests each were conducted per adhesive per load level for a total of 12 long term tests. Loads for long-term sustained loads in this test were 75% and 62% of MSL. Failure in creep was defined as the onset of tertiary creep per ASTM D299 (2009), Figure 3.1.

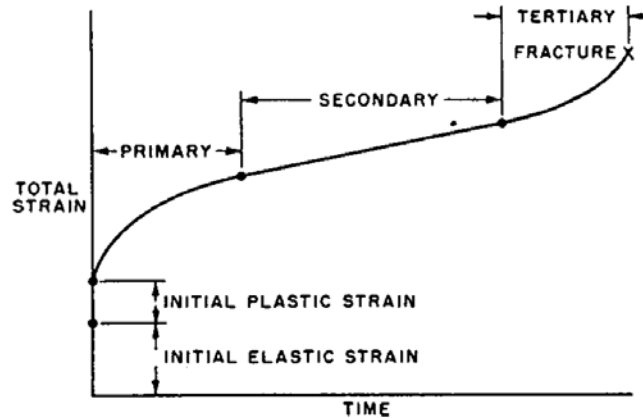

Figure 3.1 Tertiary Creep (ASTM D2990, 2009). Reprinted, with permission, from D2990-09 Standard Test Methods for Tensile, Compressive, and Flexural Creep and Creep-Rupture of Plastics, copyright ASTM International, 100 Barr Harbor Drive, West Conshohocken, PA 19428. A copy of the complete standard may be obtained from ASTM International, www.astm.org.

These loads generally cause failures within four months of application. The project concluded with a draft AASHTO test method, now AASHTO TP-84 (2010), and a recommendation that a stress vs time to failure approach is superior to the pass/fail method of ICC-ES AC308 (2008). (Cook et al. 2009)

The literature review of Cook et al. (2013) provides a thorough understanding of adhesive anchor research as of its publishing in 2013. This report had two goals:

- Investigate the influence of various parameters (e.g., type of adhesive, installation conditions, and in-service conditions) on the sustained-load performance of adhesive anchors
- Develop recommended test methods, material specifications, design guidelines, design specifications, quality assurance guidelines, and construction specifications for AASHTO for the use of adhesive anchors in transportation structures. (Cook et al. 2013 p. 3)

The report includes a research program of 17 test series with each series investigating the sensitivity of an adhesive anchor's creep capacity to a specified parameter, Table 3.1. Series 1-16 all started with five short term tests to establish a parameter mean static load (MSL). Each test series then ran a number of sustained load tests on the adhesive that showed the most sensitivity to a given parameter in the short term test in accordance with AASHTO TP-84 (2010), specifics can be seen in Table 3.1, to develop a stress vs time to failure plot of each parameter. Further information about AASHTO TP-84 (2010) and the stress vs time to failure plot can be found in Chapter 6. These tests were compared against the baseline tests, series 1 and 2, to develop an alpha reduction ratio (parameter MSL/baseline MSL). The alpha reduction ratios for the short term and the long term tests were then compared with each other to determine if a given parameter had more of an impact on long-term performance than short term performance. The alpha short term was divided by the alpha long term to determine an influence ratio. If this influence ratio was greater than 1 then the parameter had a negative effect on creep. Adhesive only tests were conducted to determine validity in their use to predicted anchor pullout strength. An adhesive only test was also conducted to determine an adhesive's sensitivity to loading before manufacturers recommended cure time. Alpha reductions were taken at a minimum of 1 because it is not recommended to increase design capacity above a baseline level. For example, the baseline mean static load (MSL) for adhesive B (an epoxy system) was 22.9 kips. The MSL for elevated service temperature (>120°F) was 23.1 kips. This correlates to an alpha reduction factor of 1.01, signifying that there is no statistical difference between the baseline MSL and the elevated temperature MSL. Cook et al. (2013) conclude that the elevated temperature does not affect the short term capacity of adhesive B. Similarly, the alpha reduction factor calculated between baseline and elevated temperature long term tests was 0.83. The calculated influence ratio was then $1.01/0.83=1.22$ showing that

elevated temperature had more of an effect on long-term performance than could be predicted by a short term test for the epoxy adhesive anchor system tested. (Cook et al. 2013)

Table 3.1 Proposed Test Matrix (Cook et al. 2013)

Test Series	Test Description (Influencing parameter)	Installation Temperature	Orientation during installation	Moisture of concrete during installation/service	Cleaning	Anchor Size x h _a	Concrete Composition	Product Type A	Product Type B	Product Type C	Test Temperature	Type of support	Number of sustained load steps	Number of sustained load tests	Number of reference tests	Test Location							
1	Baseline tests UF	75°F	downward	dry/dry	full	5/8x3	Standard	X	X	X	110°F	confined	4	36	15	UF							
2	Baseline tests US					M12x80	Standard	X	X	X			4	36	15	US							
3	Service temperature	75°F	downward	dry/dry	full	M12/80	Standard	X (2)	X (2)	X (3)	>120°F	confined	3	9	5 (11)	US							
4																	70°F	3	9	5 (11)	US		
5	Installation direction	75°F	horizontal overhead	dry/dry	full	M12/80	Standard	X (3)	X (3)	X (3)	110°F	confined	3	18	10 (11)	US							
6																	110°F	3	18	10 (11)	US		
7	Moisture during installation or service	75°F	downward	damp/dry	full	M12/80	Standard	X (4)	X (4a)	X (4)	110°F	confined	3	9	5 (11)	UF							
8																	70°F	3	9	5 (11)	US		
9	Hole cleaning	75°F	downward	dry/dry	reduced	5/8x3	Standard			X (5)	110°F	confined	3	9	5 (11)	UF							
10	Installation temperature	MFR min (6) & (6a)	downward	dry/dry	full	M12x80	Standard	X (7)	X (7)	X (8)	MFR min (6)	confined	3	9	5 (11)	US							
11																	110°F	3	9	5 (11)	US		
12	DOT Concrete mix	75°F	downward	dry/dry	full	5/8x3	DOT	X			110°F	confined	3	9	5 (11)	UF							
13	Type of drilling	75°F	downward	dry/dry	full	5/8x3	Standard		X		110°F	confined	3	9	5 (11)	UF							
14	Concrete composition	75°F	downward	dry/dry	full	5/8x3	with FA with BFS	X (9)	X (8)	X (9)	110°F	confined	3	9	5 (11)	UF							
15																	110°F	3	9	5 (11)	UF		
16	Test setup (wide support)	75°F	downward	dry/dry	full	5/8x3	Standard			X	110°F	un-confined	3	9	5 (11)	UF							
17	Concrete Age (tested at 3 days)	75°F	downward	dry/dry	full	M12x80	Standard	X	X	X	75°F	confined	0	0	15 (11)	US							
	Concrete Age (tested at 7 days)																X	X	X	0	0	15 (11)	US
	Concrete Age (tested at 14 days)																X	X	X	0	0	15 (11)	US
	Concrete Age (tested at 21 days)																X	X	X	0	0	15 (11)	US
	Concrete Age (tested at 28 days)																X	X	X	0	0	15 (11)	US
													Sum	216	185								

- Notes:
- (0) Type A = vinyl ester system, type B = epoxy system, type C = epoxy system.
 - (1) 4 sustained loads $N_p / N_{u,m}$ (reference) 0.75/0.85/0.55/0.45. Creep tests with $N_p = 0.55 N_{u,m}$ will be used to compare with current approach of AC308 3 sustained loads $N_p / N_{u,m}$ (reference) 0.70/0.55/0.40.
 - (2) Only the product that is most sensitive to increased temperature (high ratio glass transition temperature to service temperature) will be tested.
 - (3) Only the top two products that are most sensitive to installation direction (occurrence of voids) in static tests will be tested.
 - (4) Only the product that is most sensitive to wet concrete in static tests will be tested.
 - (4a) Product that is sensitive to high alkalinity will be tested. The tests are performed at normal ambient temperature because under increased temperature the concrete will dry out.
 - (5) Only the product that is most sensitive to hole cleaning (no brushing) will be tested.
 - (6) Concrete at manufacturer's lowest permissible concrete temperature.
 - (6a) Mortar at manufacturer's lowest permissible mortar preheating temperature.
 - (7) Only the product that is most sensitive to low installation temperature (low degree of cross linking) will be tested.
 - (8) Only the product that is most sensitive to fly ash concrete will be tested.
 - (9) Only the product that is most sensitive to blast furnace slag concrete will be tested.

Cook et al. (2013) found that, of the tested parameters, only two adversely affected the sustained loading capacity. Those parameters were in service temperatures above 120°F and manufacturers' cure time. ACI 355.4 (2011) mandates long term tests at category A temperatures of 110°F and an optional category B test above 110°F. Detailed information about ACI 355.4 (2011) can be found in Chapter 6. Designers can select a product that passes ACI 355.4 (2011) temperature category B temperature rated tests. The other major factor found by Cook et al. (2013) to significantly reduce the creep resistance of the tested adhesives was loading before manufacturers' minimum cure times. Manufacturers' recommendations should be followed closely for all adhesive anchor products and additional curing time is recommended.

The second goal of Cook et al. (2013) was to recommend changes to AASHTO TP-84 (2010). Those recommendations are to include at least three sustained load levels (instead of two), and to not include the short term test when constructing the stress versus time-to-failure graph. Separately, the report made an observation on design values from ACI 355.4 (2011) which uses a reduction factor of 0.75 to relate unconfined tests to confined tests. Cook et al. (2013) found that their unconfined tests compared to confined tests resulted in a reduction factor between 0.37 and 0.53 (Cook et al. 2013).

El Menoufy et al. (2014) investigated the effects of standard temperatures, moisture, and freeze/thaw on adhesive anchors. This research tested three types of adhesives, a fast setting acrylic based (Named Type A), fast setting epoxy based (Named Type B), and a standard setting epoxy based (Named Type C). The anchors used in this test were 15M deformed steel bars with 0.63 in diameter (16 mm) installed at 4.9 in (125mm). Static tests were conducted in accordance with ASTM E488 (2010). Detailed information on ASTM E488 (2010) can be found in Chapter 6. 72 total pull out tests were conducted (27 Static and 45 Sustained). Static failure was defined as yielding of the 15M bar. This yielding caused a decrease in cross section that caused the adhesive to expand and bond failure began to occur. Table 3.2 shows the four testing phases and the three environmental parameters considered (normal conditions $73^{\circ}\text{F} \pm 7^{\circ}\text{F}$ ($23^{\circ}\text{C} \pm 4^{\circ}\text{C}$), in-service moisture, and freeze/thaw). Test procedures were conducted in accordance with ICC-ES AC308 (2009) for in-service moisture and freeze/thaw. For freeze/thaw and moisture tests, the test specimens' top surfaces were covered with 0.47 in (12mm) deep 2.99 in (76mm) radius volume of water. For freeze/thaw, the sustained load was applied and 50 cycles were conducted by thawing for eight hours at $+68^{\circ}\text{F} \pm 3.6^{\circ}\text{F}$ ($+20^{\circ}\text{C} \pm 2^{\circ}\text{C}$) and freezing for 16 hours at $4^{\circ}\text{F} \pm 3.6^{\circ}\text{F}$ ($-20^{\circ}\text{C} \pm 2^{\circ}\text{C}$). Most specimens in this research failed after the anchor bar began yielding and results were normalized against the known yield strength of the anchor bar.

Type A adhesives experienced a decrease in tensile capacity under sustained loading. When compared to the room temperature results of a sustained load at 40% of anchor yield, both moisture and freeze/thaw almost doubled the creep displacement at 90 days. Type B adhesives did not experience a significant difference in creep behavior when compared to normal condition tests due to freeze/thaw. Variable results were achieved under moisture conditions tests with Type B adhesives. Type C experienced little to no creep at room temperature with only slight increase in long term displacements due to moisture. The displacements from the long term freeze/thaw tests on Type C adhesives were variable, but overall, greater than both room temperature and moisture creep test displacements. The project concluded that epoxy type adhesives exhibited higher ultimate capacities than the acrylic based and that moisture and freeze/thaw has some negative effect on creep capacity. (El Menoufy et al. 2014)

Table 3.2 Test Matrix (El Menoufy et al. 2014) With permission from ASCE. This material may be downloaded for personal use only. Any other use requires prior permission of the American Society of Civil Engineers.

Phase/conditions		Type-A	Type-B	Type-C
Phase I: static testing	Room temperature (Series I-1)	3	3	3
	Moisture exposure (Series I-2)	3	3	3
	Freeze-thaw cycles (Series I-3)	3	3	3
Phase II: creep testing under normal conditions	Sustained load = 40% ultimate (Series II-1)	3	3	3
	Sustained load = 60% ultimate (Series II-2)	3	3	3
Phase III: creep testing under moisture exposure	Sustained load = 40% ultimate (Series III-1)	3	3	3
	Sustained load = 60% ultimate (Series III-2)	3	3	3
Phase IV: creep testing under freeze-thaw cycles	Sustained load = 40% ultimate	3	3	3
		24	24	24

Note: Numbers denote number of specimens tested.

McDonald (1998) reported pull out capacities of three anchor systems: a polyester resin, an epoxy resin, and a cementitious grout under dry and submerged conditions with both short term and long term (creep) loads applied. This project was specifically concerned with submerged application of anchor systems for use below water level in dams. Submerged tests were conducted by ponding water for 2 weeks then installing the anchors into a completely

submerged hole. 144 anchor systems were tested in static pull out tests and 24 were tested in creep tests. Each anchor system was static tested 18 times dry and 18 times submerged except for adhesive D which was tested 18 times dry and adhesive E which was tested 18 times submerged. Three dry and three submerged creep tests were conducted for each anchor system except for D that was only tested three time dry and E that was only tested three times submerged. No. 6 A36 reinforcement steel bars were used for anchor rods. Five types of bonding materials were tested (A, B, C, D, and E) and the nomenclature is independent for this research. The research reported them all as adhesives even though one of them was a cementitious material. All hole sizes were less than 1.5 times the anchor rod diameter, which equates to adhesive anchors by the most current definitions available. Adhesive A, Epcon manufactured by ITW, was a two part ceramic filled epoxy adhesive. Adhesive B, Anchor-It manufactured by Adhesive Technology Incorporated, was “a light paste epoxy adhesive filled with superfine aggregates and hardener component” (McDonald 1998 p. 8). Adhesive C, HEA capsule/C100 manufactured by Hilti Corporation, was a combined application of two vinylester resins mixed together with a caulking type gun. Adhesive D was a two-component vinylester resin packed in a two-chambered plastic cartridge and was also the C100 portion from Adhesive C. Adhesive D was only used for dry testing due to a strong recommendation from the manufacturer to avoid submerged applications with the product. Adhesive E, Lokset manufactured by Forsoc International Unlimited, was a cementitious compound in a plastic wrapping that, when submerged, allowed a controlled wetting to cure the grout. The hole size for this grouted anchor was 1in (25mm) and the anchor was No. 6 rebar with 0.75in (19mm) diameter. Details about adhesive E can be found in Chapter 4. Static tests were conducted after cure times of 1 day, 3 days, 7 days, 28 day, and 365 days for both dry and submerged conditions. Average tensile capacity of adhesives A, B, and C at 0.2in (5mm) displacement can be seen in

Figure 3.4 for the different anchor cure times. Creep tests were conducted at 60% of the anchor rod's yield strength for 6 months. Results can be seen in Figure 3.2 and Figure 3.3. Adhesive B experienced a pullout failure before the end of the creep test of the submerged installation and its results were not included in the plot. The project concluded that Adhesives C and E showed the best performance in submerged applications in static tests and creep tests. (McDonald 1998)

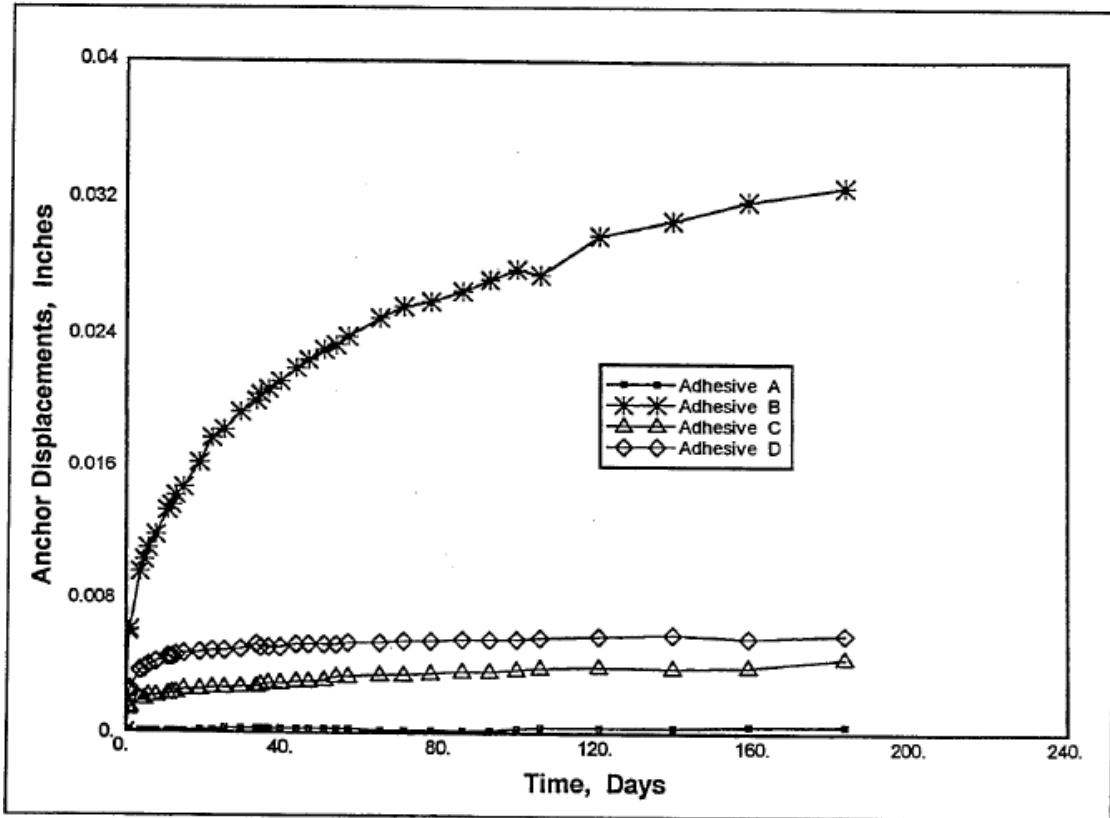

Figure 3.2 Creep Tests for Dry Installation (McDonald 1998)

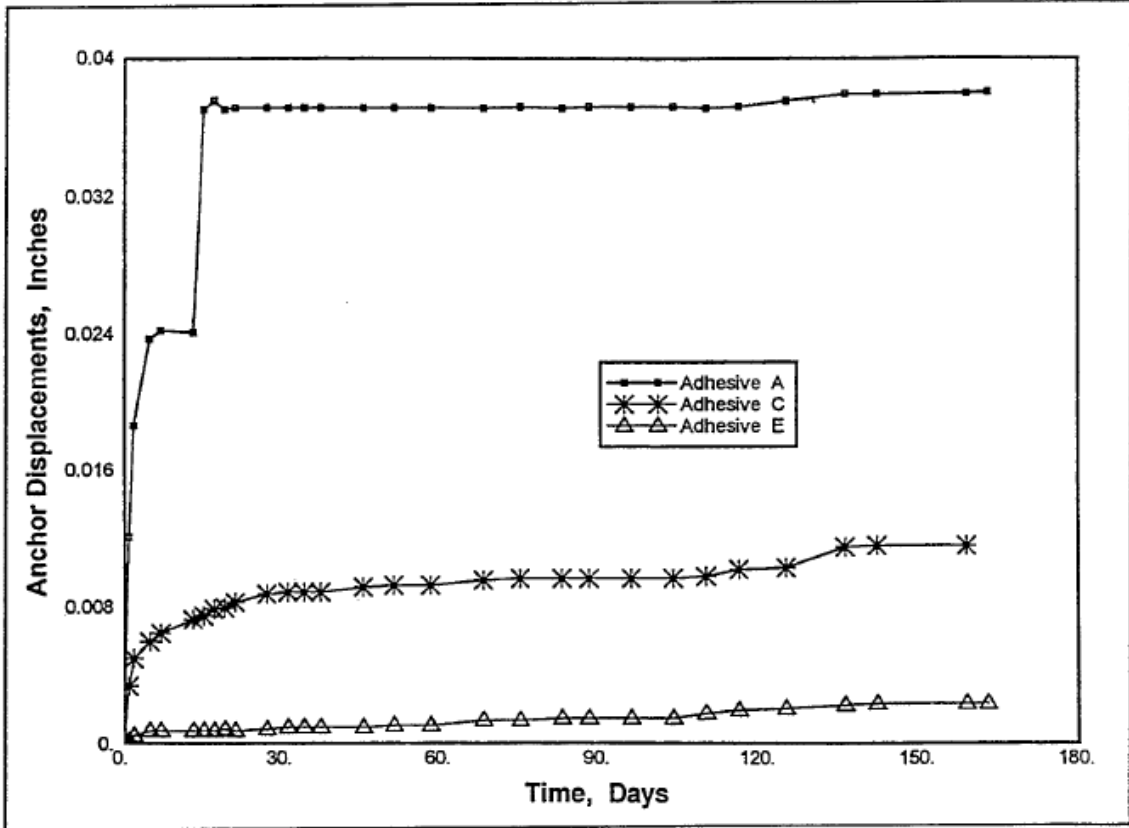

Figure 3.3 Creep Test Submerged Anchor Installation (McDonald 1998)

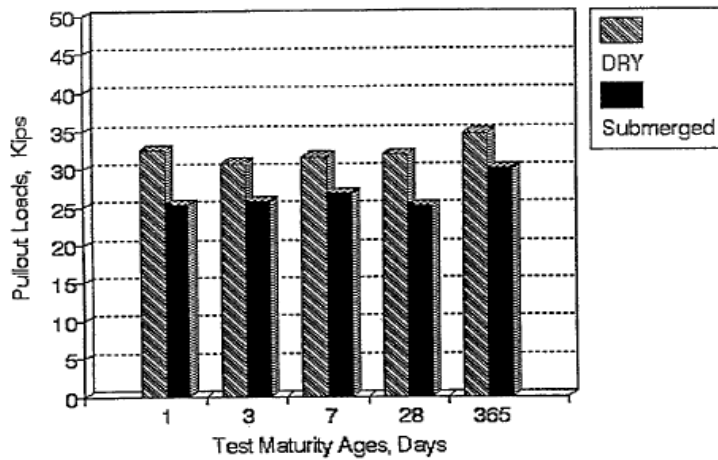
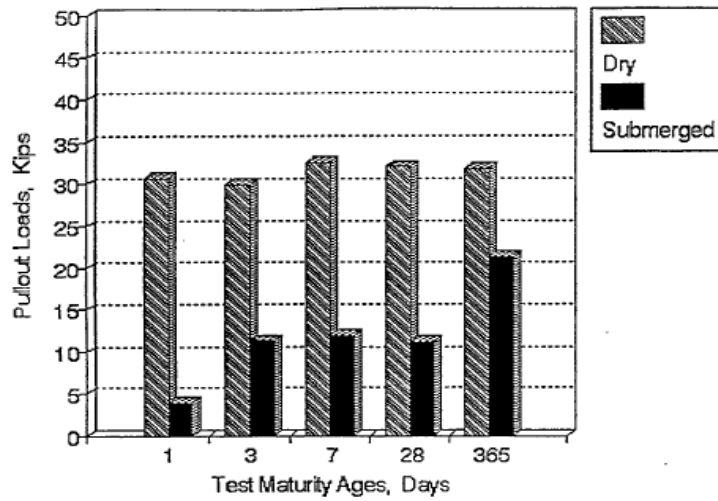
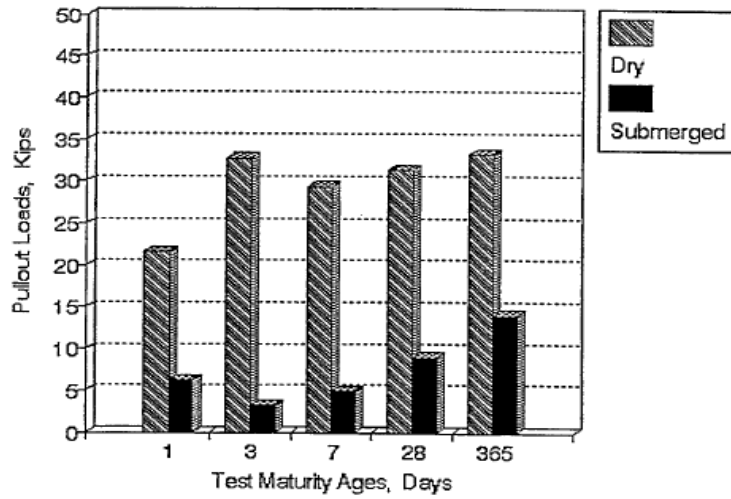

Figure 3.4 Average load at 0.2in (5mm) displacement static tests for Adhesives A (top), B (middle), and C (Bottom) (McDonald 1998)

CHAPTER 4

GROUTED ANCHOR SYSTEMS LITERATURE REVIEW

The second type of bonded anchor is grouted. A grouted anchor system has a hole larger than 50% of the anchor rod diameter as defined by Zamora et al. (2003) and adopted by Cook and Burtz (2003), Cook et al. (2009), Cook et al. (2013), and El Menoufy et al. (2014). These anchors can be classified as either cementitious or polymer based. Cementitious anchors are a mixture of sand, cement, water, and other additives. Most structural applications of cementitious anchors use non-shrink grout products that conform to ASTM C1107 which tests for compressive strength and shrinkage over time. Polymer grouts consist of small aggregates (i.e. sand), a resin, and a curing agent. The inclusion of small aggregates allows polymer grouts to fill larger holes, differentiate polymer grouted anchors from polymer adhesive anchors. Anchor manufacturers provide a table listing allowable load and ultimate load for their anchor system based on anchor rod diameter, embedment depth, and concrete compressive capacity. Separately they provide a list of hole diameters to use with each acceptable anchor rod diameter. Grouted anchor manufacturers generally provide a minimum oversize dimension for the hole based on anchor diameter. For example, Sakrete, 2014 recommends a hole 1 in (25 mm) diameter larger than the anchor being used and lists pull out data for a 1 in (25 mm) bolt at 14,000 lbs (62.3 kN). Anchor rods used in grouted anchors can be either headed or non-headed, Figure 4.1. Headed anchor rods include either an integrated head or a nut threaded on the end of the rod. All grouted anchors can experience the same failure modes as adhesive anchors, Figure 2.1, except headed anchors eliminate a grout/steel interface failure (Zamora et al. 2003). Grouted anchors can be more difficult to use as they are typically, but not always, more fluid, making overhead and horizontal applications very difficult due to possible sagging of grout material prior to curing.

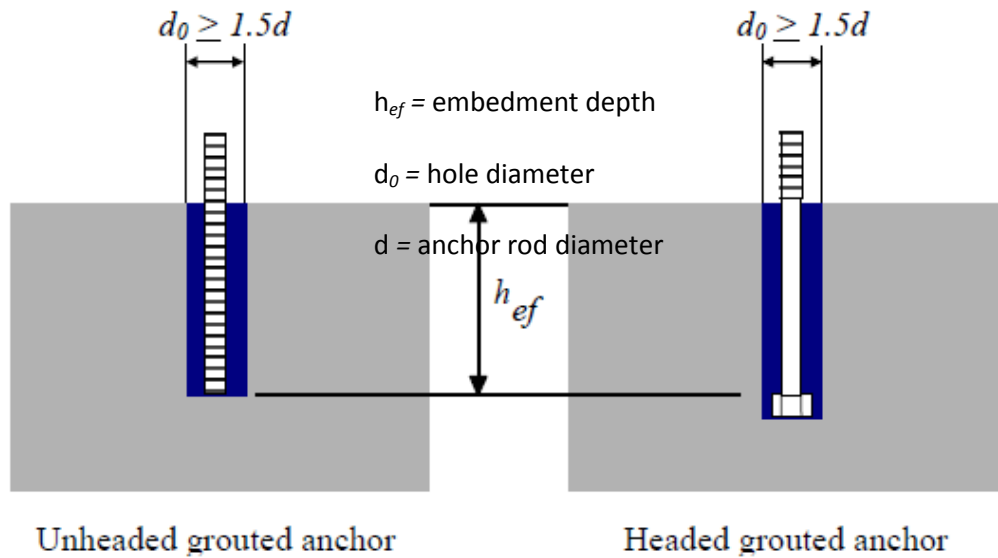

Figure 4.1 Examples of Headed and Non-headed Anchors (Cook et al. 2003)

Grouted anchor systems were used in design prior to the development of polymers for adhesive anchor systems and continue to be used today although a greater variety of grout materials have been developed. Conard (1969) reported results from 24 static pull out tests of three types of grout. The anchors were 0.5 in (12.7 mm) and 0.75 in (19.8 mm) diameter unfinished hex head bolts installed at an embedment depth of 3 in (7.6mm) Each test was conducted on one test slab. Dimensions for the slabs were not reported, but some of them failed in flexure before the anchor failed in tension. The author concludes this does not invalidate the results because the deformation of the anchor was large at failure or the tension load on the bolt was greater than the indicated maximum load. Failure was arbitrarily chosen as 0.05 in (1.27 mm) for the sake of comparison to mechanical anchors and cast-in-place anchors. Each type of grout was tested four times in tension and four times in shear. The grouts are:

- Type I – one part Type I portland cement and three parts fine sand by volume mixed with water.

- Type II – one part Type I portland cement and three parts fine sand by volume mixed with polymer resins as liquid.
- Type III – A premixed, nonshrink grout mixed with water.

Type I grouts failed at the grout/concrete interface with an average maximum load of 3,250 lbs (14.46 kN) for the 0.5 in (12.7 mm) diameter bolts and only 825 lbs (3.67kN) for the 0.75 in (19.8 mm) diameter bolts. The lower pullout for the larger bolt is due to an earlier bond failure of the Type I grout. Type II grouts experienced grout/concrete interface failure in half of the specimens and the other half failed in flexure of the test slab. Type III was the most had the highest capacity with only one bond failure of the tested specimens while the rest failed in flexure of the slab (Conard 1969). This experiment was conducted prior to standard pull out tests by ASTM so the results are not easily compared with more current research. Today, non-shrink grout is almost exclusively used in structural applications.

James et al. (1987) used finite element modeling to develop an approximate mathematical model to predict grouted anchor behavior. The Concrete Capacity Design, CCD, Method defined in Chapter 2 and uniform bond stress models are now the accepted design models for grouted anchors in recent literature (Cook et al. 2003 and Zamora et al. 2003). ACI Committee 318 (2002) defined a cone angle of 35° while a cone angle of 45° was predicted by James et al. (1987). The majority of the load transferred from the anchor rod to the concrete occurred within one or two anchor diameters from the top surface of the concrete, suggesting that a partial concrete cone will accompany any bond failure at embedment depth to anchor diameter ratios of greater than 3 to 4. This is confirmed for adhesive anchors in Cook et al. (1998).

Four of five anchor systems tested by McDonald (1998) are summarized in Chapter 3. Adhesive E, Lokset manufactured by Forsoc International Unlimited, was the only cementitious

anchor tested. It was only tested in submerged conditions because it requires the water from a submerged installation to hydrate the cement. Figure 3.4 shows adhesive E performed better than the other adhesives in the static tests. Figure 3.3 shows adhesive E's performance in the creep test, which is better than the other adhesives tested. (McDonald 1998)

Rodriguez et al. (2001) investigated the dynamic behavior of tensile anchors in concrete. Most of the testing was conducted on cast-in-place and mechanical post-installed anchors which are outside the scope of this project. Specifically of interest to this report are the effects of cracks on grouted anchors. Static tests were conducted in cracked and un-cracked concrete. The cracks were formed with hammer driven wedges and split-bearing tubes of high-strength steel, Figure 4.2. Tested anchor rods were A325 hex-head bolts, 0.75 in (19 mm) diameter by 6 in (152 mm) long. Cracks propagated along the grout/concrete interface for all but one test in cracked concrete and reduced the grouted anchor capacity by 41% when compared to the un-cracked tests. (Rodriguez et al, 2001)

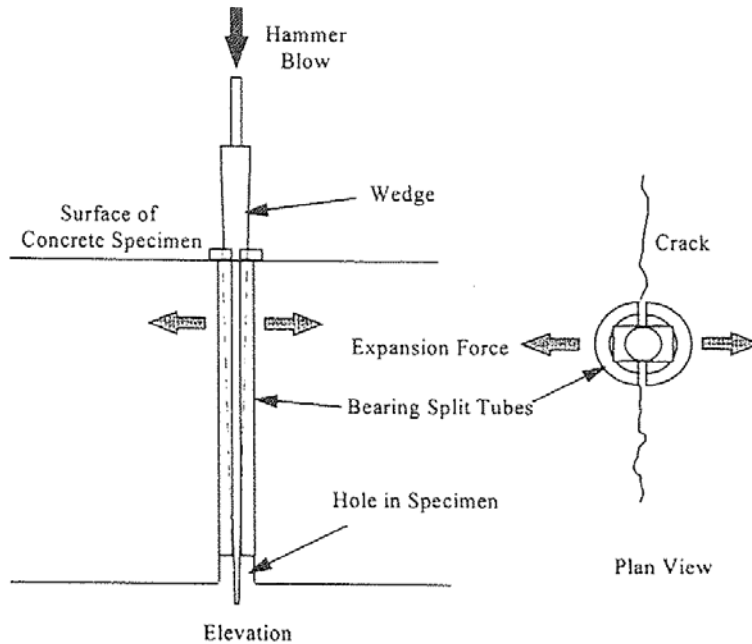

Figure 4.2 Splitting Tube for Concrete Cracking (Rodriquez et al. 2001) Authorized Reprint from Jul.-Aug. 2001 ACI Structural Journal Vol. 98 No. 4

Zamora et al. (2003) conducted 237 unconfined short term static tests on grouted anchors in tension in order to determine behavior of grouted anchors loaded in tension and to develop rational design procedures. Testing procedures of ASTM E 488-96 and ASTM E 1512-93 were followed. Six cementitious and three polymer grouts were tested with both headed and non-headed anchors. This study varied the following parameters: bonding agent (cementitious or polymer), anchor configuration (headed or non-headed), anchor and hole diameter, embedment depth, and concrete strength, Table 4.1 and Table 4.2 show the testing matrices. The main failure mode of non-headed anchors was failure at the steel/grout interface bond. Of 129 non-headed anchor tests only ten (7.8%) experienced a failure mode other than steel/grout interface bond failure. Five of these ten experienced failure at the grout/concrete interface. The failures at the grout/concrete interface occurred in test series with larger diameter anchor rods in the same sized hole. The author explains that the larger anchor rods allowed for a larger

steel/grout bond area and shifted the failure to the grout/concrete interface bond. The conclusion of the non-headed grouted anchors validates the uniform bond stress model for use in design procedures. The tested headed grouted anchors showed two main failure modes as predicted; failure at the grout/concrete interface bond and failure of the concrete with a full concrete breakout cone. Of the 113 headed anchor tests using cementitious and polymer grouts, 65 (57.5%) experienced failure at the grout/concrete interface bond and 48 (42.5%) experienced a full concrete breakout cone. Five tests were disregarded because they developed an exceptionally low bond stress at failure due to improperly mixed grout. There was no correlation found between type of grout (polymer or cementitious), failure mode, and capacity. Headed anchor behavior can be predicted by the lower value of the CCD or uniform bond stress model at the grout/concrete interface, Equation 1 and Equation 3 respectively (Zamora et al. 2003). This article represents in-depth research on the static pull out capacity of grouted anchors, but did not present a proposed test standard, nor did it investigate environmental parameters or creep. Further research is needed in developing a test standard for grouted anchors as is now available for adhesive anchors. "New research has led to the development of design recommendations for adhesive bonded anchors. With design standards for adhesive anchors, grouted anchors are left as the only bonded fastening system without recommended design procedures" (Zamora et al. 2003 p. 224).

Table 4.1 Test Matrix for Non-Headed Grouted Anchors (Zamora et al. 2003 p. 225) Authorized
 Reprint from Mar-Apr 2003 ACI Structural Journal Vol. 100 No. 2

Product	Total Number of Tests	d, mm				hef, mm				d0, mm				f'c at test, Mpa			
		Series				Series				Series				Series			
		1	2	3	4	1	2	3	4	1	2	3	4	1	2	3	4
CA	25	15.9	19.1	25.4	-	102	127	172	-	50.8	50.8	50.8	-	35.6	35.6	50.8	-
CB	15	15.9	19.1	25.4	-	102	127	178	-	50.8	50.8	50.8	-	35.6	33.4	31.0	-
CC	20	15.9	19.1	25.4	12.7	102	127	178	76	50.8	50.8	50.8	50.8	34.0	34.1	34.1	33.4
CD	15	15.9	19.1	25.4	-	102	127	178	-	50.8	50.8	50.8	-	39.9	39.9	35.8	-
CE	14	15.9	19.1	25.4	-	102	127	178	-	50.8	50.8	50.8	-	34.4	34.4	33.6	-
CF	5	19.1	-	-	-	127	-	-	-	50.8	-	-	-	38.0	-	-	-
PA	12	15.9	19.1	25.4	-	102	152	178	-	50.8	50.8	50.8	-	33.8	34.5	34.4	-
PB	12	15.9	19.1	25.4	-	102	152	178	-	50.8	50.8	50.8	-	33.9	33.9	34.4	-
PC	5	19.1	-	-	-	127	-	-	-	50.8	-	-	-	37.8	-	-	-

Note: Products starting with letter C are cementitious grouts; and products starting with the letter P are polymer grouts

Table 4.2 Test Matrix for Headed Grouted Anchors (Zamora et al. 2003 p. 225) Authorized
 Reprint from Mar-Apr 2003 ACI Structural Journal Vol. 100 No. 2

Product	Total Number of Tests	d, mm				hef, mm				d0, mm				f'c at test, Mpa			
		Series				Series				Series				Series			
		1	2	3	4	1	2	3	4	1	2	3	4	1	2	3	4
CA	25	19.1	19.1	25.4	19.1	127	127	178	127 152	50.8	50.8	50.8	38.1	35.7	32.7	32.6	49.9
CB	15	19.1	19.1	25.4	-	127	127	178	-	50.8	50.8	50.8	-	34.5	34.5	32.2	-
CC	15	19.1	19.1	25.4	-	127	127	178	-	50.8	50.8	50.8	-	31.1	31.1	31.0	-
CD	15	19.1	19.1	19.1	-	114	137	127	-	38.1	38.1	38.1	-	59.2	59.2	35.8	-
CF	13	19.1	19.1	19.1	-	102	114	127	-	50.8	38.1	38.1	-	30.9	30.9	35.9	-
PA	10	19.1	19.1	-	-	127	127	-	-	50.8	50.8	-	-	37.6	27.6	-	-
PB	5	19.1	19.1	-	-	127	127	-	-	50.8	38.1	-	-	37.6	27.6	-	-
PC	10	19.1	19.1	-	-	127	127	-	-	38.1	38.1	-	-	63.7	63.7	-	-

Note: Products starting with letter C are cementitious grouts; and products starting with the letter P are polymer grouts

Cook and Burtz (2003) proposed changes to FDOT (2000) anchor testing titled "Florida Method of Test for Anchor System Tests for Adhesive Anchors and Dowels". This project tested the effects of hole drilling (either diamond or carbide tip), edge distance effects, and group spacing effects on the capacity of grouted anchors under static tensile load. The main focus was investigating behavior of the grout/concrete failure mode. For this reason, high strength

concrete, headed anchors, and small diameter holes were used to promote failure at the grout/concrete interface. Anchor rods were 0.625 in (15.9 mm) diameter steel rods with threaded ends. A heavy hex nut was used to head the steel rod. The rod was installed in a 1.5 in (38.1 mm) diameter hole, just large enough to fit the head, at an embedment depth of 5 in (127 mm). 40 total tests were conducted and the test matrix can be seen in Table 4.3. Additionally, conclusions were made based on previously conducted research at the University of Florida including Zamora et al. (2003). Hole drilling tests consisted of six specimens installed in holes drilled with a diamond core drill, and six specimens installed in holes drilled with a hammer drill. One test series resulted in the hammer drilled holes have 3% more capacity than the diamond core drilled holes with a coefficient of variation of 0.012. The next test series resulted in the hammer drilled holes have 17% less capacity than the diamond core drilled holes with a coefficient of variation of 0.017. A reported explanation for the varied results is the possible presence of dust in the rougher surface of the hammer drilled hole, even after following the manufacturer's recommended cleaning procedure.

Cook and Burtz (2003) included results from other testing programs conducted at the University of Florida to make observations about behavior of grouted anchors with respect to strength vs curing time, threaded rod vs deformed reinforcing bar anchor rods, threaded anchor rods vs smooth anchor rods, regular hex nut head vs heavy hex nut head, damp hole installation, and elevated temperature effects on polymer grouted anchors. These observations are summarized below. Strength vs curing time was investigated by testing three different grouted products, one polymer grout and two cementitious grouts. Full strengths were obtained at different times with the polymer grout only taking 24 hours and the cementitious grouts taking seven days and 14 days respectively. Four different grouted anchor products were used to test bond strength to non-headed threaded rod in comparison to bond strength to deformed

reinforcing bar. Three of the four grouts showed a decrease in bond strength of 9%, 4%, and 27% when a deformed reinforcing bar was used in place of threaded rod. The fourth showed an increase of 104%, but is no longer marketed for this application. Three products, one polymer grout and two cementitious grouts, were used to compare bond strengths of non-headed threaded rod to bond strengths of non-head smooth rods. The smooth anchor rod caused an decrease in capacity for all three grouts. The two cementitious grouts experienced 91% and 81% reductions in bond strength while the polymer grout experienced a 53% reduction in bond strength with the smooth rod compared to the pullout capacity of the threaded rod. Three cementitious grouts and one polymer grout were used to compare regular vs heavy hex nut in headed anchors. The heavy hex nut caused reductions of 15%, 19%, and 8% in the cementitious grout and an increase of 10% in the polymer grout when compared to the static pullout capacity of the headed bolt used as an anchor rod. The report shows the coefficients of variation for each product are less than 20% and concludes it is not necessary to test products for use with different headed anchor types. Three polymer grouts were installed in damp holes and compared to dry hole installations as recommended by the manufacturer. Two of the polymer grouts experienced strength decreases of 17% and 27% in the wet hole compared to the dry hole with the third product increasing capacity 11%. Two polymer grouts were tested at elevated temperatures. Both products experienced a strength reduction of 6% when compared to ambient temperature tests. These were not significant decreases, but show there could be a correlation between elevated temperature and capacity for polymer grouted anchor systems. (Cook and Burtz 2003)

Sustained load tests were not conducted by Cook and Burtz (2003), but creep was addressed as a potential issue for grouted anchors and recommended a creep test at 40% MSL with procedures similar to ACI 355.4, including elevated temperature (Cook and Burtz 2003).

According to their website (FDOT) accessed on December 30th, 2014, no updates to the test method, FDOT (2000), were published.

Table 4.3 Summary of Testing Program (Cook and Burtz. 2003)

Installation #	Tested Effect	Hole Type	Anchor Diameter d , in (mm)	Hole Diameter d_0 , in (mm)	Embedment Depth h_{ef} , in (mm)	Edge Distance c , in (mm) ^a	Spacing s , in (mm) ^b	# of Tests n
1	Baseline	Core	0.625 (15.9)	1.5 (38.1)	5.0 (127.0)	N/A	N/A	5
1	Hammer	Hammer	0.625 (15.9)	1.5 (38.1)	5.0 (127.0)	N/A	N/A	5
1	Group	Core	0.625 (15.9)	1.5 (38.1)	5.0 (127.0)	N/A	5.0 (127.0)	3
2	Baseline	Core	0.750 (19.1)	1.5 (38.1)	5.0 (127.0)	N/A	N/A	3
2	Hammer	Hammer	0.750 (19.1)	1.5 (38.1)	5.0 (127.0)	N/A	N/A	3
2	Edge	Core	0.750 (19.1)	1.5 (38.1)	5.0 (127.0)	7.5 (190.5)	N/A	5
3	Baseline	Core	0.750 (19.1)	1.5 (38.1)	5.0 (127.0)	N/A	N/A	3
3	Edge	Core	0.750 (19.1)	1.5 (38.1)	5. (127.0)	4.5 (114.3)	N/A	5
3	Edge	Core	0.750 (19.1)	1.5 (38.1)	5.0 (127.0)	6.0 (152.4)	N/A	5
3	Group	Core	0.750 (19.1)	1.5 (38.1)	5.0 (127.0)	N/A	9.0 (128.6)	3

^a Edge distances designated as N/A refer to anchors installed at $\geq 8d_0$.

^b Spacing between anchors designated as N/A refers to anchors installed at $\geq 16d_0$.

Subramanian et al. (2004) use data from Zamora et al. (2003) and Rodriguez et al. (2001) to make independent conclusions and recommendations. There were no contradictory conclusions made, but additional information about the behaviour of grouted anchors is observed. Polymer grouted anchors, for example, experience larger deformations throughout a loading period with larger hole diameter. This research also proposes a capacity reduction factor (ϕ) of 0.85 based on the 5% fractile observed in Zamora et al. (2003).

CHAPTER 5

PARAMETERS THAT AFFECT ANCHOR CAPACITY

Cook et al. (2013) pp. 6-10 provides an extensive review of parameters that can affect adhesive anchor system capacities. This list is compiled from an extensive literature review on the subject. In this chapter, all effects for adhesive anchors are consolidated and cited directly from Cook et al. (2013). Grouted anchor effects are listed directly after the adhesive anchor effects and are compiled from various sources. Cook et al. (2013) only addressed a few of the parameters discussed in this chapter (those tested in the study are shown Table 3.1). Two ratios were used to compare the effect of a parameter on bond strength. The first is an alpha reduction ratio. This value is a ratio between a baseline test and a test at a specific parameter. For example, an adhesive with a baseline static capacity of 20 kips (89 kN) that has an elevated temperature static capacity of 18 kips (80 kN) would have an alpha reduction ratio of 0.9 for the elevated temperature parameter. A similar alpha reduction ratio can be found for long term performance by comparing a baseline creep test and a creep test subjected to a specific parameter. The other ratio is the influence ratio. This is the comparison of alpha reduction ratios for long term and short term tests of a specific parameter. For example, if the short term alpha reduction ratio is 0.9 and the long term alpha reduction ratio is 0.75, the influence ratio is 1.2. Influence ratios greater than 1 show a parameter has more of an effect on creep capacity than it does on short term capacity and short term tests will not accurately predict long term performance under the conditions of a specific parameter. An explanation of those testing procedures and results will be addressed in this section for comparison to current research on grouted anchors. Parameters that were not tested were expected to be less critical by the authors of Cook et al. (2013). Additionally, polymer grouted anchors may have different

performance from cementitious grouted anchors for certain parameters. Those cases will be addressed in this chapter as well.

PARAMETER: *Elevated In-Service Temperature - sustained elevated temperatures during a structure's life.* (Cook et al. 2013)

Adhesive: Elevated temperatures are shown to greatly reduce the creep capacity of adhesive anchors as tested by Cook et al. (2013). Of all the parameters tested, elevated temperature had the greatest effect on creep capacity of adhesive anchors, specifically, at temperatures over 120°F. For example, baseline MSL of adhesive B in Cook et al. (2013) was 22.9 kips (101.7 kN) when tested at 110°F. The MSL when tested at 70°F was 27.2 kips. A similar comparison can be made with the creep tests conducted at 110°F and 70°F. Three creep tests greater than 75% MSL at 110°F were run at 20.9 kips (93 kN) (81% MSL), 20.7 kips (92 kN) (81% MSL), and 19.2 kips (85.4 kN) (75% MSL). The respective failure times were 0.11 hours, 0.02 hours (failed before reaching 20.7 kips (92 kN)), and 0.04 (failed before reaching 19.2 kips (85.4 kN)). Compare that to three creep tests run at 70 °F at 20.4 kips (90.7 kN) (75% of 70°F MSL and 89% of 110°F MSL) that failed at 0.8 hours, 1.2 hours, and 2118 hours. (Cook et al. 2013)

Grouted: Cementitious grouts are believed to be less sensitive to temperature than polymer grouts and adhesive anchors (Cook et al. 2013). Polymer grouts would most likely be affected similarly to polymer adhesive anchor systems, but there is no research to validate this.

PARAMETER: *Reduced In-Service Temperature – sustained reduced temperatures during a structure's life* (Cook et al. 2013)

Adhesive: Reduced Temperatures make adhesives more brittle, but no standard exists for testing adhesives at reduced in-service temperature, though ACI 355.4 (2011) provides a standard test for reduced installation temperature (Cook et al. 2013). This parameter was not

tested in Cook et al. (2013) because reduced temperatures are believed to improve adhesive anchors creep resistance.

Grouted: Differences in coefficients of thermal expansion between grout and concrete could cause thermal induced stresses with potential tensile cracking at the interface of the materials and potentially reduce the bond strength, but this parameter has also not been researched.

PARAMETER: *Moisture-in-Service – presence of moisture for sustained periods of time* (Cook et al. 2013)

Adhesive: Moisture in service has been shown to affect the creep characteristics of adhesives to almost the same level as elevated temperature. This parameter was tested and found to affect bond strength, but did not affect creep capacity any more than it affected short term capacity. The influence ratio was calculated at 1.02 indicating some influence on long term performance by moisture in service, but the researchers believe this is due to the scatter of the data and not by the anchors reaction to the parameter. Short term capacity was not affected in comparison to the baseline tests with an alpha reduction ratio of 1.07. Moisture was held high by wrapping the concrete specimen in plastic and periodically re-wetting it. The anchors were installed dry. (Cook et al. 2013)

Grouted: Submerged conditions did not dramatically affect pull out strengths of a cementitious adhesive, when compared to the other adhesives (McDonald 1998). Cementitious grouted anchors would likely not be as affected by moisture in service as polymer grouted anchors or adhesive anchors, but research results are not available.

PARAMETER: *Freeze-Thaw – temperatures and durations of freeze/thaw cycles* (Cook et al. 2013)

Adhesive: El Menoufy et al. (2014) tested three types of adhesive anchors under freeze/thaw conditions and two of the three were negatively effected by freeze/thaw in creep tests. Only 9

total tests were conducted in El Menoufy et al. (2014). ACI 355.4 (2011) outlines test procedures for testing an adhesive anchor under sustained loading through 50 freeze/thaw cycles. Cook et al. (2013) placed this parameter as a low priority and did not explicitly test it based on recommendations from the NCHRP Panel.

Grouted: Freeze-thaw cycles could cause a crack to form and propagate along the grout/concrete interface causing failure, but there is no research available on these effects.

PARAMETER: *Type of Adhesive – epoxy, vinylester, polyester, etc. (Cook et al. 2013); Type of Grout – Cementitious or Polymer*

Adhesive: ACI 355.4 (2011) defines adhesive as any adhesive of chemical components that cure when blended together and contain organic polymers or a combination of organic polymers and inorganic materials. The organic polymers can be epoxies, polyurethanes, polyesters, methyl methacrylates, and vinyl esters. Research has shown that different chemical groups can have a wide array of bond strengths. This topic is investigated in Cook et al. (2013). Three types of adhesive anchor systems were tested. One vinylester (adhesive A for this report) and Two epoxy type (adhesives B and C for this report). The MSL for adhesive A was 19.8kips (88kN), adhesive B was 25.7kips (114kN), and adhesive C was 26.3kips (117kN). This is inline with other research that shows ester type adhesives generally have lower bond strengths than epoxy type adhesives. The vinylester adhesive (adhesive A) tested in Cook et al. (2013) had worse creep performance than the two epoxy adhesives (adhesives B and C). The % of MSL at 10,000 hours for Adhesive A was 40.66% and was 47.18% and 46.50% for Adhesives B and C respectively. (Cook et al. 2013)

Grouted: Nine different grouted anchor systems were tested and manufacturer was a larger contributing factor to short term strength than type (polymer or cementitious) (Zamora et al. 2003). There is no available literature on creep characteristics of grouted anchors.

PARAMETER: *Mixing Effort – properly combining all ingredients for bonding materials (Cook et al. 2013)*

Adhesive: Proper composition of the adhesive through mixing is required for proper bond strength. This job is typically done on site by the installer and is subject to variability due to field conditions (Cook et al. 2013). Cook et al. (2013) identified this as a low priority parameter for testing because proper mixing of adhesive materials is easily achieved if proper hardware is used and manufacturers' instructions are followed.

Grouted: Grouts can be mixed to different consistencies based on application and manufacturer recommendations. Cementitious grouts are mixed on site prior to installation. Installers make the final decision on viscosity prior to installation, leading to significant variability of in-situ material properties of cementitious anchors (Zamora et al. 2003). Polymer grouts typically come pre-mixed and are less variable.

PARAMETER: *Adhesive Curing Time When First Loaded – time between installation and when first load is applied; generally between 24 hours and 28 days. (Cook et al. 2013)*

Adhesive: Previous research has shown that average bond strengths of a 24 hour cure were only 88% of a seven day cure. This parameter was tested using adhesive only dogbone tests on specimens cured for 24 hours compared to specimens cured for seven days. While the influence ratio was 0.95 showing no overall influence to the parameter, the alpha reduction ratio for Adhesive B (epoxy) was 0.54, Adhesive A (vinyl ester) was 1.05, and Adhesive C (epoxy) could not be tested. The authors recommend an additional 24hour cure time over manufacturers' recommendation for structural applications of adhesive anchors. (Cook et al. 2013)

Grouted: Polymer grouted anchors were cured for 7 days and cementitious grouted anchors were cured for 28 days in Zamora et al. (2003). Cook and Burtz (2003) conducted short term pullout tests on one polymer grouted anchor and two cementitious grouted anchors at different

cure times. The polymer grout developed full strength after 24 hours while the two cementitious grouts developed full strength at 7 days and 14 days respectively. Loading a grouted anchor prior to full cure time could cause failure at a lower than expected load.

PARAMETER: *Bond Line Thickness – distance between the drilled hole and the anchor* (Cook et al. 2013)

Adhesive: Cook et al. (2013) references two reports with conflicted results. Decreased bond line thickness of adhesive has been shown to increase creep resistance for a study with tests in the 1.2 to 1.8 diameter range, but additional tests in the larger range of 1.2 to 4.1 times the anchor diameter have shown bond line does not affect resistance (Cook et al. 2013).

Grouted: Bond line thickness affects the grout/concrete interface failure mode for both headed and non-headed anchors (Zamora et al. 2003). Headed polymer grouted anchors experience larger displacements within the grout with larger hole diameters (Subramanian et al. 2004). For headed and non-headed anchors that experience grout/concrete bond failure mode, increasing the bond line thickness increases the surface area of the grout/concrete interface and increases capacity until another failure mode governs. Increase bond line thickness could also cause failure within the grout to occur. Creep resistance of grouted anchors may be affected by bond line thickness just as the adhesives might. (Cook, et al., 2013)

PARAMETER: *Fiber Content of Adhesive – type and amount of fillers in adhesive/grout* (Cook et al. 2013)

Adhesive: Fiber content is shown to increase creep resistance (Cook et al. 2013). Fiber content is used in bulk adhesive materials and was not explicitly tested in Cook et al. (2013) because it was outside the scope of the report.

Grouted: Fiber content of grouted anchors has not been studied. Fiber concrete materials show improved resistance to cracking compared to normal concrete, but the presence of fibers on bond strengths at the steel/grout and the grout/concrete interface are unknown.

PARAMETER: *Hole Orientation – downward, upward, horizontal, or in between* (Cook et al. 2013)

Adhesive: Upward holes are difficult to fill with adhesive as most adhesives want to flow out of the hole and sag downward. Horizontal holes are less susceptible but also have the potential for voids to develop between the adhesive and concrete or anchor rod. These voids significantly decrease anchor capacity. This is such a critical parameter that ACI 355.4 (2011) requires installation of adhesive anchors in horizontal to upward applications to be conducted by ACI certified personnel. This parameter was tested in Cook et al. (2013) and horizontal installation had an influence ratio of 0.93 and vertical installation had an influence ratio of 0.86. Hole orientation did not negatively affect long term performance and short term tests produced alpha reduction ratios greater than 1 showing no adverse affects. Also, ACI 355.4 (2011) includes qualification tests for adhesive anchors to be used between horizontal and vertical installations. If the product passes this test and is installed by a qualified installer, the parameter should not affect anchor performance. (Cook et al. 2013)

Grouted: Cementitious grouts are especially difficult to install in overhead applications due to sag of the grout material. It is recommended that both cementitious and polymer grouted anchors not be used in overhead applications (Cook and Burtz 2003).

PARAMETER: *Hole Drilling – rotary drill, core drill, or other drilling in accordance with manufacturers' recommendations* (Cook et al. 2013)

Adhesive: Different drill bits cause different surface roughnesses on the concrete. In general, a carbide tipped drill bit leaves a rougher surface and improves capacity when compared to a

diamond tipped core drill bit. This parameter was tested by Cook et al. (2013) and found to not adversely affect long term performance more than short term performance; influence ratio of 0.63. Though, the diamond core drilled holes only had 73% of the hammer drilled holes' capacity in short term testing. (Cook et al. 2013)

Grouted: Cementitious grouts transfer the load from the anchor rod to the base concrete through mechanical interlock and friction (Zamora et al. 2003). Cook and Burtz (2003) had a small (3%) increase in capacity of hammer drilled holes vs diamond core drilled holes for one test series, and a larger (17%) decrease in capacity of the hammer drilled holes compared to the core drilled holes for another test series.

PARAMETER: *Hole Cleaning – un-cleaned, partially cleaned, or fully cleaned in accordance with manufacturers' recommendations* (Cook et al. 2013)

Adhesive: Dust left behind from drilling can affect the bond strength. This parameter was tested using procedures from ACI 355.4 (2011), which calls for 50% of the manufacturers recommended cleaning effort to be used. This is clarified to include all types of cleaning (i.e. blowing, and brushing), but only done to 50% of the recommended time. For example, if the manufacture calls for six blowing and six brushing operations, three blowing and brushing operations are used to test for sensitivity to hole cleaning. If no cleaning instructions are provided, or instructions cannot be numerically reduced by 50% then no hole cleaning operations are used. Hole cleaning was found to not adversely affect long term performance more than short term performance; influence ratio of 0.84. Though, the half cleaned holes only had 81% of the fully cleaned holes' capacity in short term testing. (Cook et al. 2013)

Grouted: Hole cleaning is a parameter that could adversely affect bond strength of both cementitious and polymer grouted anchors. Test data on the influence of hole cleaning is lacking. (Zamora et al. 2003)

PARAMETER: *Moisture at Installation – dry, damp, submerged or other moisture conditions specified by the manufacturer (Cook et al. 2013)*

Adhesive: Moisture can form a physical barrier between the adhesive and the concrete and can affect the chemical interaction of the adhesive. This parameter was tested and found to not adversely affect long term performance more than short term performance; influence ratio of 0.61. Moist holes, however, only had 82% of the dry holes' capacity in short term testing. Moisture was introduced by ponding three inches of water for eight days on top of the specimens (Cook et al. 2013)

Grouted: Cementitious grouted anchors are generally installed in damp holes, while polymer grouted anchors are generally installed in dry holes. The presence of moisture has been shown to negatively affect polymer anchors' capacities (Cook and Burtz 2003). Damp hole installation is recommended for cementitious grouts to allow for proper hydration of the cement during curing (Cook et al. 2003). Installing cementitious grouted anchors in a dry hole could lead to lower bond strength because dry hardened concrete would wick moisture away and not allow for full hydration of the grout. Similarly, installing a cementitious grout in too moist of a hole could increase the water/cement ratio and decrease the strength of the grout.

PARAMETER: *Installation Temperature – concrete below freezing, adhesive below freezing, either material pre-heated. (Cook et al. 2013)*

Adhesive: Reduced temperatures affect curing time and final hardness. There is no mention of installation at elevated temperature in the literature, but it is assumed to speed the curing process and not adversely affect the anchor unless curing time was insufficient to allow for complete anchor installations prior to first set. Tests were conducted in Cook et al. (2013) on anchor systems installed and tested at manufacturer's minimum temperature, and anchor systems installed at minimum temperature and tested at elevated (110°F; 43.3°C) temperature.

The researchers conjectured that an adhesive anchor installed and tested at low temperatures could have an increase in bond strength. The test installed at low temperature and tested at high temperature did not negatively affect long term capacity with an influence ratio of 0.71, but short term performance was 86% of the standard installation capacity. (Cook et al. 2013)

Grouted: Cementitious grouts are believed to be less sensitive to temperature than polymer grouts and adhesive anchors (Cook and Burtz 2003). ASTM C1107 (2013) is the test standard for packaged dry hydraulic cement non-shrink grouts and it requires manufacturers to state a maximum and minimum usable temperature for their product. The grout must meet minimum standards for compressive strength and shrinkage at maximum temperatures and maximum workable times, but there are no minimum temperature requirements (ASTM C1107 2013). The requirement from ASTM to test non-shrink cementitious grouts at maximum temperatures shows a possible sensitivity to installation temperature.

PARAMETER: *Depth of Hole (Embedment Depth) – embedment depth can affect bond strength and failure mode* (Cook et al. 2013)

Adhesive: Longer embedment depth increases capacity until the assumptions of the uniform bond stress model are violated, beyond which embedment depth does not increase capacity. Cook et al. (2013) reports previous literature where this occurs at approximately 25 times the anchor diameter. This is valid as long as the concrete cone failure does not occur. The stress at the concrete/adhesive interface is approximately constant at failure to embedment depths of 25 times the anchor diameter at which point load does not transfer deeper into the adhesive until the upper part of the anchor is failing. This is true for adhesive/concrete interface bond failures and steel/adhesive interface bond failures (Cook et al. 2013).

Grouted: A longer embedment depth should increase the capacity of grouted anchors that experience grout/concrete and grout/steel interface bond failures according to the uniform bond stress models (Conard 1969).

PARAMETER: *Anchor Diameter – can affect bond strength* (Cook et al. 2013)

Adhesive: Bond stress is assumed independent of anchor diameter within manufacturers' recommendations of hole diameter, but increased anchor diameter is shown to potentially decrease bond stress (Cook et al. 2013). This parameter was not tested in Cook et al. (2013).

Grouted: Large anchor diameters have more area at the steel/grout interface, requiring greater force to achieve that failure mode per unit length of anchor, but also require more force to cause a steel only failure. For grouted anchors that experience steel/grout interface bond failure, increasing the anchor diameter without changing the hole diameter can shift the failure mode from the grout/steel interface bond to the grout/concrete interface bond; increasing the force required to cause failure up to grout/concrete interface failure. (Zamora et al. 2003)

PARAMETER: *Type of Base Concrete – inclusion of blast furnace slag, fly ash, or other additives* (Cook et al. 2013)

Adhesive: Fly ash and blast furnace slag have been shown to decrease bond strength of the base concrete. This parameter was tested in Cook et al. (2013) and found to not adversely affect long term performance more than short term performance; influence ratio of 0.69 for fly ash and 0.60 for blast furnace slag. Fly ash base concrete had a short term alpha reduction ratio of 0.93 and blast furnace slag had a short term alpha reduction ratio of 0.88. The fly ash base concrete replaced 20% of the cement with fly ash and the blast furnace slag base concrete replaced 50% of the cement with blast furnace slag. (Cook et al. 2013)

Grouted: Additives to base concrete, including fly ash and blast furnace slag, could affect the bond strength of grouted anchors, but further research is needed.

PARAMETER: *Concrete Strength of Base Concrete – low or high concrete compressive strength*
(Cook et al. 2013)

Adhesive: There is no correlation between bond strength and concrete compressive strength when bond failure occurs (Cook and Konz, 2001 p. 81). If bond failure can be eliminated and concrete cone breakout failure occurs, anchor capacity would increase in accordance with the concrete capacity design (CCD) model, Equation 1. In of previous research, a doubling of concrete strength caused changes in bond strength by as much as increasing 125% and decreasing 35%. (Cook et al. 2013)

Grouted: The dependency of bond strength to concrete compressive capacity has not been researched. This is different than overall anchor capacity which may be governed by failure of the concrete, which is directly related to compressive strength.

PARAMETER: *Type of Course Aggregate in Base Concrete – hole roughness due to mineralogy, absorption, and hardness* (Cook et al. 2013)

Adhesive: Results from previous tests show that harder course aggregates can produce higher bond strengths, and aggregates high in calcium, such as limestone, exhibit lower bond strengths. This parameter was not tested directly in Cook et al. (2013), but one test series used a standard DOT mix with granite aggregate (instead of river stone), fly ash, water reducer, and air entrainment. The results of using a different mix design are not applicable specifically to this parameter, but the concrete mix did not affect long term performance more than short term performance with an influence ratio of 0.53 and a short term alpha reduction ratio of 0.84. (Cook et al. 2013)

Grouted: Bond strength of grouted anchors depends on surface roughness (Zamora et al. 2003). Grouted anchors could show sensitivity to this parameter, but further research is needed.

PARAMETER: *Cracked or Un-cracked Base Concrete – cracks in base concrete can significantly reduce bond strength (Cook et al. 2013)*

Adhesive: Previous research has shown that cracked concrete can reduce bond strengths from 33% to 70% of bond strength in un-cracked concrete (Cook et al. 2013). This parameter was not tested in Cook et al. (2013).

Grouted: A 41% reduction in strength of grouted anchors was experienced in cracked concrete tests. Crack propagation occurred along the grout/concrete interface leading to a grout/concrete interface bond failure. (Rodriguez et al. 2001)

PARAMETER: *Age of Base Concrete – anchors installed and/or loaded in early age base concretes (Cook et al. 2013)*

Adhesive: High moisture content in young concrete could cause a decrease in bond failure. ICC-ES AC308 (2011) requires anchors to be installed in concrete after 21 days of curing. One test series with concrete younger than 21 days was performed. Bond strengths were generally similar beyond concrete age of 7 days. (Cook et al. 2013)

Grouted: Properly cured grouted anchors are not likely to be loaded in early age concrete because they require longer cure times than adhesive anchors. General manufacturers' recommendations are polymer grouted anchors to cure for seven days and cementitious grouted anchors to cure for 28 days prior to application of load compare this to adhesive cure times of 24 hours to seven days. Properly cured grout will be in concrete that is at least 7 days old for polymer grout and at least 28 days old for cementitious grout. The bond between grout and early age concrete has not been tested.

PARAMETER: *Type of Anchor Rod – threaded, smooth, heavy hex nut head, normal hex nut head, headed stud. (Cook and Burtz, 2001)*

Adhesive: Manufacturers' generally include both threaded rod and deformed reinforcing bar in their recommendations. There is no research to compare the use of threaded rod and deformed reinforcing bar in adhesive anchors. El Menoufy et al. (2014) used 15M deformed reinforcing bar in testing and found that yielding of the anchor rod led to onset of bond failure.

Grouted: Headed anchor rods eliminate failure at the grout/concrete interface bond and generally increase overall capacity. The use of deformed reinforcing bar in three different grouted materials showed a reduction in strength when compared to threaded rod of 9%, 4% and 27%. (Cook and Burtz 2003)

CHAPTER 6

TESTING STANDARDS FOR BONDED ANCHORS

This chapter discusses current test standards and methods for bonded anchors. Test standards for bonded anchors are published by multiple agencies. American Society of Testing and Materials (ASTM), American Concrete Institute (ACI), International Code Council – Evaluation Services (ICC-ES), and American Association of State Highway Transportation Offices (AASHTO) provide the most current and widely accepted testing standards for bonded anchors in the U.S.A. Most of the test standards are intended to apply only to adhesive anchors. This chapter specifically outlines four test methods: ASTM E488 (2010) “Test Methods for Strength of Anchors in Concrete Elements”, ASTM E1512 (2007) “Test Methods for Testing Bond Performance of Bonded Anchors”, ACI 355.4 (2011) “Qualification of Post-Installed Adhesive Anchors in Concrete,” and AASHTO TP-84 (2010) “Evaluation of Adhesive Anchors in Concrete under Sustained Loading.”

ASTM E488 (2010) Standard “Test Methods for Strength of Anchors in Concrete Elements” provides a procedure for static testing all types of concrete anchor systems (cast-in-place, mechanical post-installed, and bonded post-installed). This test “provides the fundamental test procedures to determine the static, seismic, fatigue, and shock, tensile, and shear strengths of concrete and masonry anchors” (Cook et al. 2013 p. 10). The test gives standards for seismic, fatigue, shock, freezing and thawing, moisture, decreased and elevated temperatures, and corrosion. 1996 was the first year this test was published and was reapproved in 2003. The test only provides standards for calculating mean static loads (MSL). It is also the only standard that is universal to bonded anchor systems. ASTM E1512 (2007), ACI 355.4 (2011), and AASHTO TP-84 (2010) all directly reference the static pullout test procedures from ASTM E488 (2010) to calculate MSL.

ASTM E1512 (2007) Standard “Test Methods for Testing Bond Performance of Bonded Anchors” is similar to E488 but is specifically for bonded anchors. ASTM E1512 (2007) defines bonded anchor in Chapter 3: Terminology as “a fastener placed in hardened concrete or masonry that derives its holding strength from a chemical compound placed between the wall of the hole and the embedded portion of the anchor.” (ASTM E1512 2007), but clarifies this in the scope:

The adhesive-bonded anchor system refers to a smooth or deformed steel bar or threaded rod, set in a predrilled hole containing chemical bonding compounds. Loads are transferred mainly by the bond of the adhesive both to the anchor and the surrounding elements along the sides of the hole. For anchoring systems made of significantly different materials, these tests methods shall be taken as a guideline.

(ASTM E1512 2007 p. 1)

ASTM E1512 (2007) provides testing procedures for the following environmental conditions: fire, radiation, freeze/thaw, dampness, elevated temperature on cured samples, reduced temperature on curing, and creep test. A major difference between ASTM E1512 (2007) and ASTM E488 (2010) (beyond the parameter testing noted) is the inclusion of creep load testing. This test qualifies adhesive anchors by testing an anchor at 40% of MSL for 42 days at 110°F (43.3°C). The criterion of 40% MSL was chosen based on ASD factor of safety of 4 and a 1.6 multiplier for maximum expected sustained load. The 42 day requirement comes from a database study that showed most anchor failures occurred within 21 days and those that did not fail were ended at 120 days. That number was doubled to be conservative. The 110°F (43.3°C) was chosen from the study of a bridge in the California desert showing the average maximum peak temperature of the bridge to be 110°F (43.3°C). The last 20 days (20 data points) from the test are used to construct a logarithmic trend line using a least square’s fit, Equation 4. This

trend line is extrapolated out to 600 days and the 600 day displacement is compared with static test displacement. The 600 day requirement is based on a bridge in California that experienced temperatures between 110°F (43.3°C) and 115°F (46.1°C) during 10% of a typical summer day. Summer is assumed to last four months long meaning a 50 year bridge would experience 600 days at or near 110°F (43.3°C). ASTM E1512 (2007) does not provide acceptance criterion for anchor systems to pass the test. It only provides standard testing procedures. ICC-ES AC308 (2013) and ACI 355.4 (2011) both use methods similar to ASTM E1512 for calculated displacement of an adhesive anchor system at the life span of a 50 year structure. (Cook et al. 2013)

$$\Delta = a \ln t + b \qquad \text{Equation 4 (Cook, et al., 2013)}$$

Δ = projected displacement

t = time

a, b = constants evaluated by regression analysis

ACI 355.4 (2011) Qualification of Post-Installed Adhesive Anchors in Concrete is the most comprehensive qualification test available. This test was developed directly from ICC-ES AC308 (2009), and the two tests can be explained as one. ACI 355.4 underwent an extensive research and review process prior to publication leading to the below statement from Cook et al. (2013):

“Due to the tremendous research and development invested into ICC-ES AC308, and the consensus review process conducted by ACI, it is suggested that ACI 355.4 serve as the basis for the testing program and specifications for AASHTO.”
(Cook et al. 2013 p. 15)

ACI 355.4 (2011) has four types of tests: identification, reference, reliability, and service conditions. For an anchor to be ACI 355.4 approved it must be tested for identification by three of the following methods:

- Infrared absorption spectroscopy per ASTM E1252;
- Bond strength per ASTM C882 or equivalent;
- Specific gravity per ASTM D1875;
- Gel time per ASTM C881;
- Viscosity per ASTM D2556, ASTM F1080, or equivalent; and
- Other appropriate tests to positively identify the material.

After the adhesive is identified, reference tests are conducted in accordance with ASTM E488 (2010) in dry concrete at standard temperature. Reliability tests determine an adhesive anchor's sensitivity to adverse installation conditions:

- Hole Cleaning Procedures – manufacturers' instructions provide number of times for standard procedures of vacuuming, blowing, or brushing.
- Drilling Methods – default test is rotary hammer drill with carbide tip with options for core drill or rock drill
- Hole Orientation – downward, horizontal, or overhead
- Installation Temperature – default temperatures are 50°F to 80°F (10°C to 27°C) with an option for lower tests
- Embedment Depth and Anchor Diameter – Specified by manufacturer within limits ACI 355.4 (2011) (embedment depths must be less than 20 times the anchor diameter)
- Type of Anchor – carbon or stainless steel, various strengths and geometries (threaded rod, deformed bar)

- Environmental Conditions of Use – dry and wet environment and temperatures ranging from 32°F to 104°F (0°C to 40°C). Optional tests for freeze/thaw and elevated temperature are provided.
- Chemical Exposure – Default condition of high alkaline moist condition with an optional test for sulfur dioxide condition.
- Concrete Condition – non-cracked or both cracked and non-cracked
- Load – static or sustained load with an optional test for seismic load
- Member Thickness – minimum member thickness to avoid spalling on opposite side of the anchor

All conditions are tested as short term tests and used to determine an alpha reduction ratio (α).

The reduction ratio is used by designers to calculate a design capacity.

Sustained tension (creep) tests are only conducted for nominal conditions (no reliability test parameters included) under standard temperature and elevated temperature. This test differs from ASTM E1512 by changing sustained load from 40% to 55% of MSL, testing sustained loads at both room and elevated temperatures, and by conducting a static test at the end of the 42 day long-term test. A trend line is constructed with the last 20 data points using the Findley Power Law, Equation 5. The Findley Power Law provides a more conservative estimate of long term creep displacement. Static failure is defined as either pullout of the rod, rupture of the rod, or concrete breakout cone. Acceptance by ACI 355.4 for long term testing is defined as:

- The projected displacement at ten years is less than the mean displacement at failure of the reference (MSL) elevated temperature tests.
- The projected displacement at 50 years is less than the mean displacement of the reference (MSL) standard temperature tests.
- The residual capacity from the static test is greater than 90% of the MSL.

$$\Delta(t) = \Delta_{t=0} + ab^t$$

Equation 5

$\Delta(t)$ = total displacement at time t

$\Delta_{t=0}$ = initial displacement under sustained load

t = time corresponding to recorded displacement

a, b = constants evaluated from regression analysis

AASHTO TP-84 (2010) "Evaluation of Adhesive Anchors in Concrete under Sustained Loading" defines a specific test to evaluate anchors under sustained load. This test is a provisional standard in the process of becoming a permanent standard. AASHTO standards are only applicable to transportation structures. This test method differs from the sustained load procedures in ACI 355.4 (2011) and ASTM E1512 (2007) in that it develops a stress versus time to failure graph for tested adhesive anchor systems based on sustained load (creep) failures at different percentages of MSL (five tests at 60%-70% MSL and five tests at 70%-80% MSL). Cook et al. (2013) recommended dividing these specimens into a third test series at a different percentage of MSL (between 60% and 80%) to better refine the data, but this has not been incorporated into AASHTO TP-84 (2010). The stress versus time to failure graph can then be used by designers to determine the life of an adhesive anchor system under a specified sustained load. For each long term anchor test the onset of tertiary creep, Figure 3.1, defines failure of adhesive anchors by AASHTO TP-84. Onset of tertiary creep is determined by analyzing the graph of displacement vs. time between 80% and 100% of the time to rupture. The slope of the line fluctuates slightly between negative and positive. Onset of tertiary creep is the last point at which the slope of the line becomes positive before rupture. For each test specimen, the load at on-set of tertiary creep is normalized against the mean static load and plotted on a stress versus log of time-to-failure graph. A linear trend line is then drawn through the data points plotted and that line is used as the stress versus time-to-failure graph (Cook et

al. 2013). An example of this graph can be seen in Figure 6.1. The advantage of this criteria is that rather than providing a pass/fail result that is meant to apply to any design life and load up to the ACI 355.4 (2011) test criteria, AASHTO TP-84 (2010) results in a plot that allows for a designer or agency to specify an allowable load factor and design life and directly relate this to the test results. Therefore a design life of 50 years versus 100 years explicitly requires a different anchor capacity due to creep effects over the additional time of load.

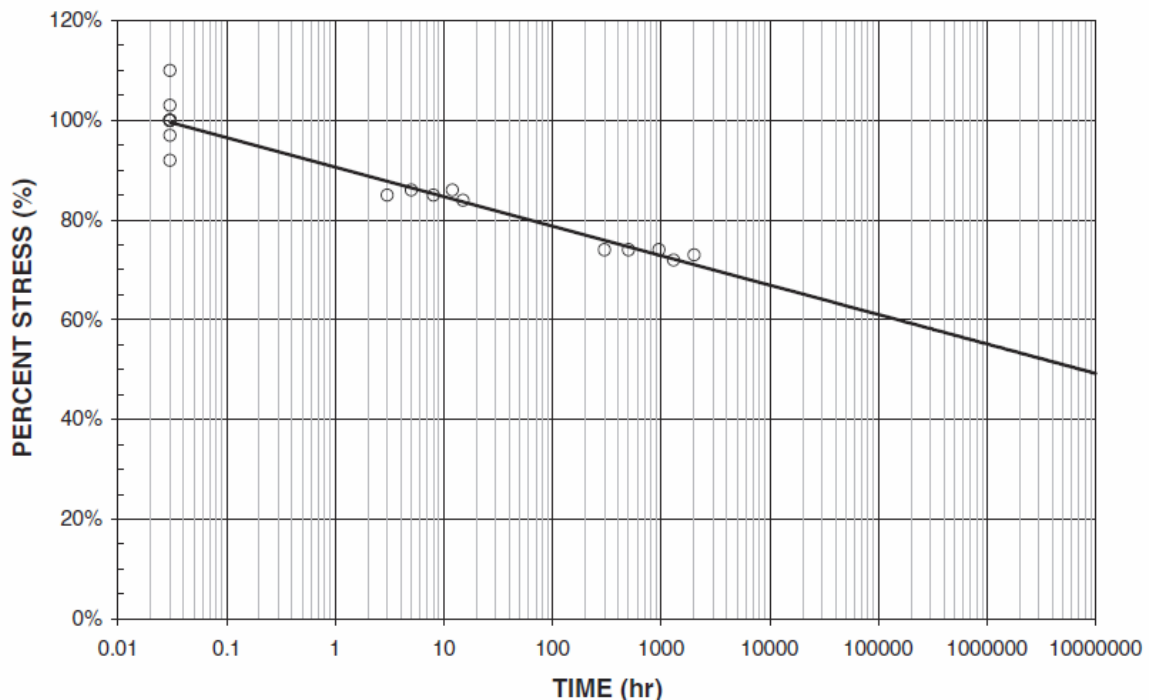

Figure 6.1 Example Stress Vs Time-To-Failure Graph (Cook et al. 2013)

ACI 355.4 (2011) and AASHTO TP-84 (2010) provide two methods of determining creep resistance of adhesive anchors. ACI 355.4 (2011) provides the most comprehensive testing program that is used to provide designers with reduction factors for varying conditions. AASHTO TP-84 (2010) provides a long term capacity graph for adhesive anchors based on known failures, as opposed to the pass/fail requirements of ACI 355.4 (2011) based on extrapolating displacement data. Cook et al. (2013) and Cook et al. (2009) argue that the stress versus time to

failure method of AASTHO TP-84 is a better method for calculated long term resistance to sustained load. Cook et al. (2013) also recommend that ACI 355.4 (2011) be used as the basis for testing programs and specifications for AASHTO. Grouted anchors are not covered by ACI 355.4 (2011), but AASHTO TP-84 (2010) explicitly allows cementitious materials and hole diameters over 1.5 times the anchor diameters.

CHAPTER 7

TEST METHODS AND PROCEDURES

7.1 Research Plan

The experimental plan for this project is to develop test capabilities at UMass Amherst and conduct tests on bonded anchors. This thesis will provide initial test results and a validate test setup. Three trial test series were run for this MS research project to provide troubleshooting for the overall test program and initial data at room temperatures. A test matrix can be found in Table 8.1. Details of each test series setup and results can be found in Chapter 8. The environmentally controlled chamber was not built for these tests, and they were run at unregulated ambient air temperature and humidity. Aside from these modifications, AASHTO TP-84 was followed for the testing. Initial experiments were designed to replicate results from tests in Cook et al. (2009) and Cook et al. (2013) conducted at the University of Florida. Test apparatus for both short term and long term tests were designed and fabricated for this project and final test setups are detailed in this chapter. The short term set ups conformed to ASTM E488 (2010), and, by definition, to AASHTO TP-84 (2009) and ACI 355.4 (2011). The long term set ups conformed to ASTM E1512 (2007), AASHTO TP-84 (2009), and ACI 355.4 (2011). Detailed description of components common to both short term and long term tests can be found in Section 7.4. The test set ups detailed in this chapter are the final designs to be used for future testing.

7.2 Short Term Tests

Short term test apparatus conforms with ASTM E488 (2010) standard and is replicated from Cook et al. (2013). A maximum load of 40 kips (178 kN) was assumed when designing the

test apparatus. Plans can be seen in Figure 7.1 and Figure 7.2 and the coupler details are in Figure 7.3. The 5/8 in (16mm) anchor rod being tested passes through the confining sheet, the steel confining plate, and through an 11/16 in (17.5 mm) diameter hole at the bottom of the non-rigid coupler where it is secured with a ASTM A194 2H heavy hex nut. Two ASTM A500 grade B HSS8x3x1/4 x 8 in (203mm) long are placed on either side of the non-rigid coupler parallel to each other. The loading rod is secured to the top of the non-rigid coupler with a ASTM A194 2H heavy hex nut, passing between the HSS sections, through a 10 in x10 in x1 in thick (254 mm x 254 mm x 25 mm thick) steel plate with a 2-3/4in (70mm) diameter hole, through the center hole hydraulic jack, and through the center hole load cell and secured with an ASTM A194 2H heavy hex nut. A tensile load of 5% of the estimated anchor strength is initially applied in order to bring all members into full bearing. The load is then increased at a rate that causes failure after one minute, but before three minutes. A constant load rate is applied within the limits of the hydraulic pump. Data (load, line pressure and displacement readings) is collected at a sampling rate of one sample every 0.5 seconds, exceeding ASTM E488 (2010) section 7.7. Load and displacement are measured for all short term tests. Variations for Test Series 0a, 0b, and 0c are described in Chapter 8.

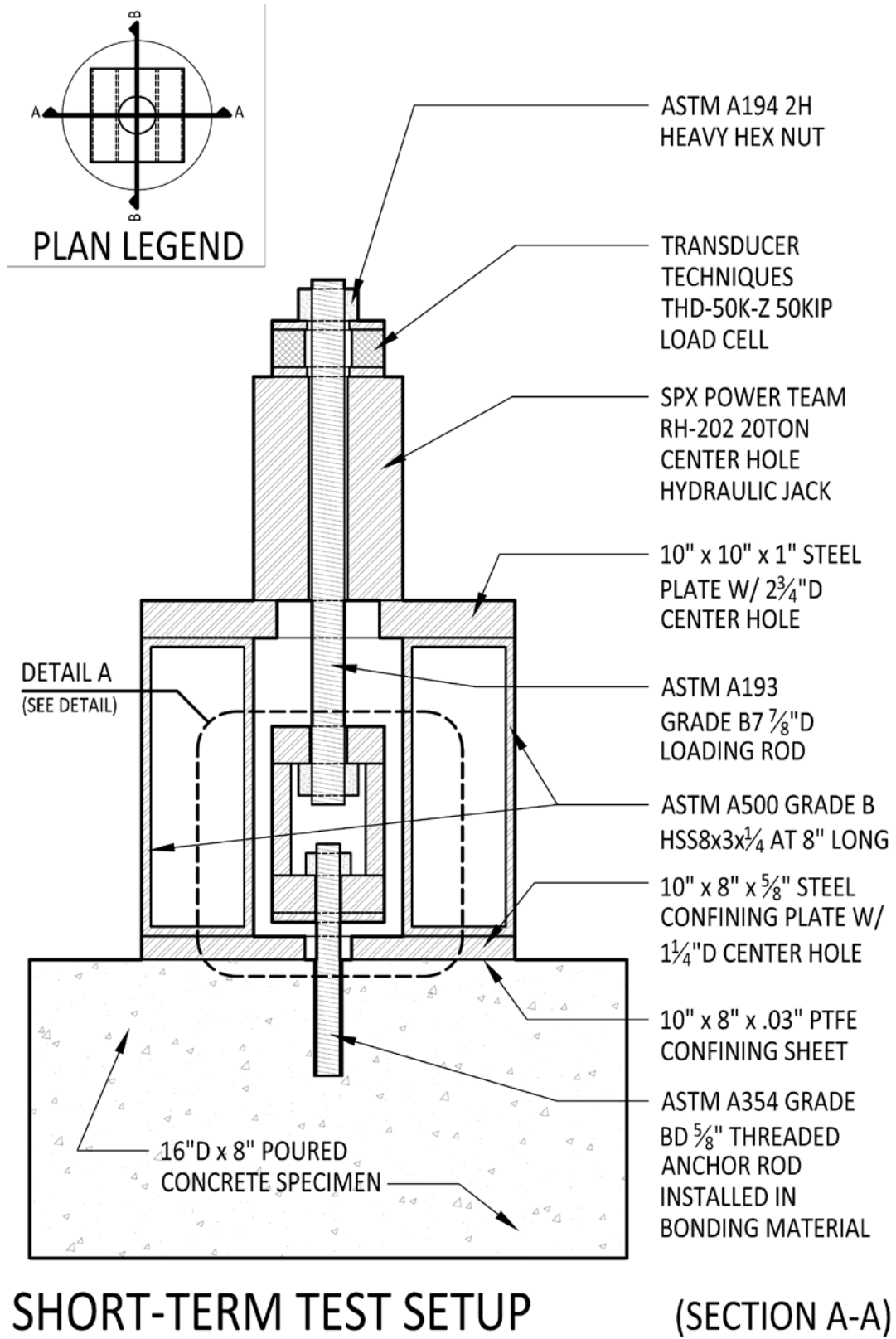
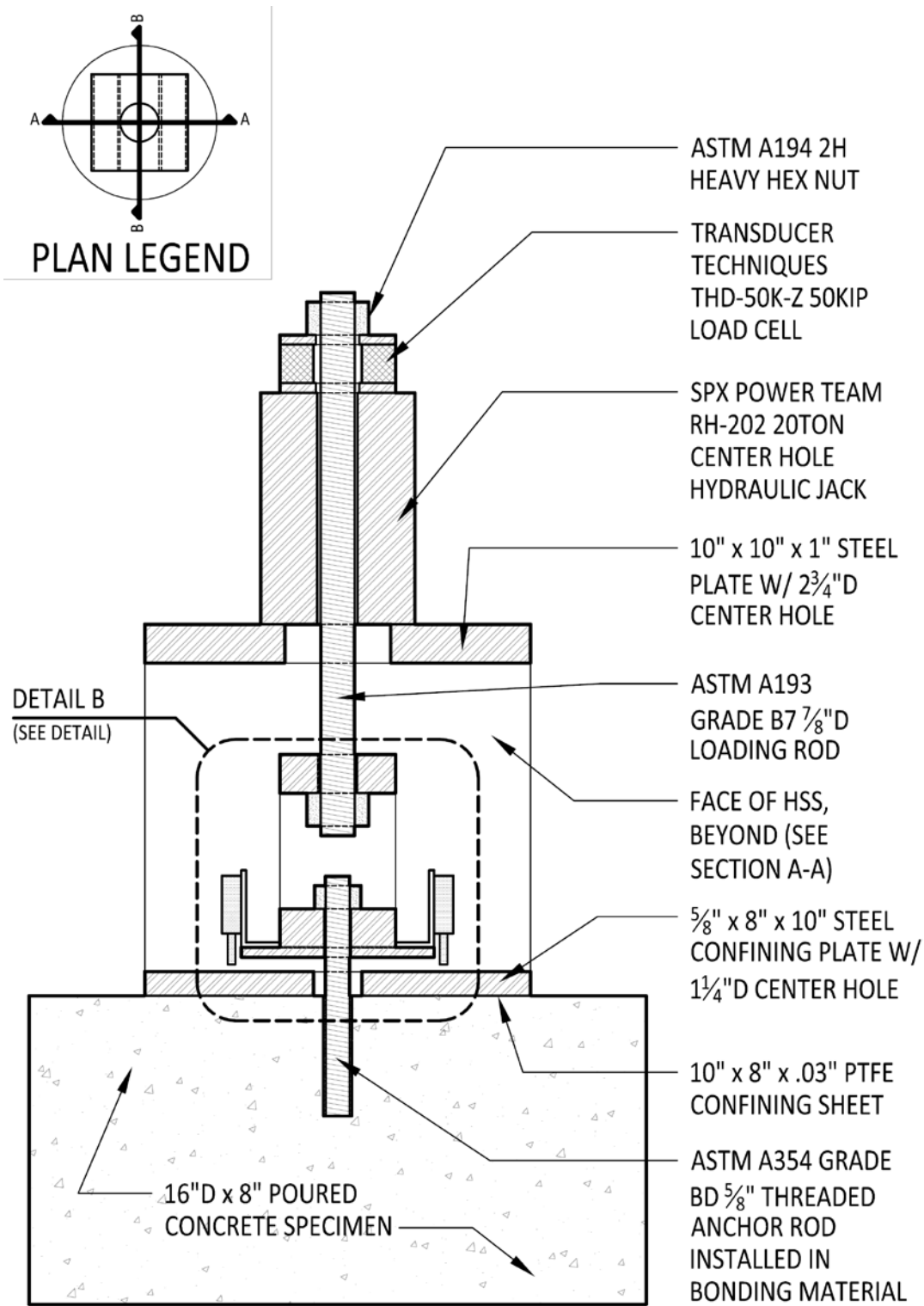

Figure 7.1 Short Term Setup Section A-A



SHORT-TERM TEST SETUP

(SECTION B-B)

Figure 7.2 Short Term Setup Section B-B

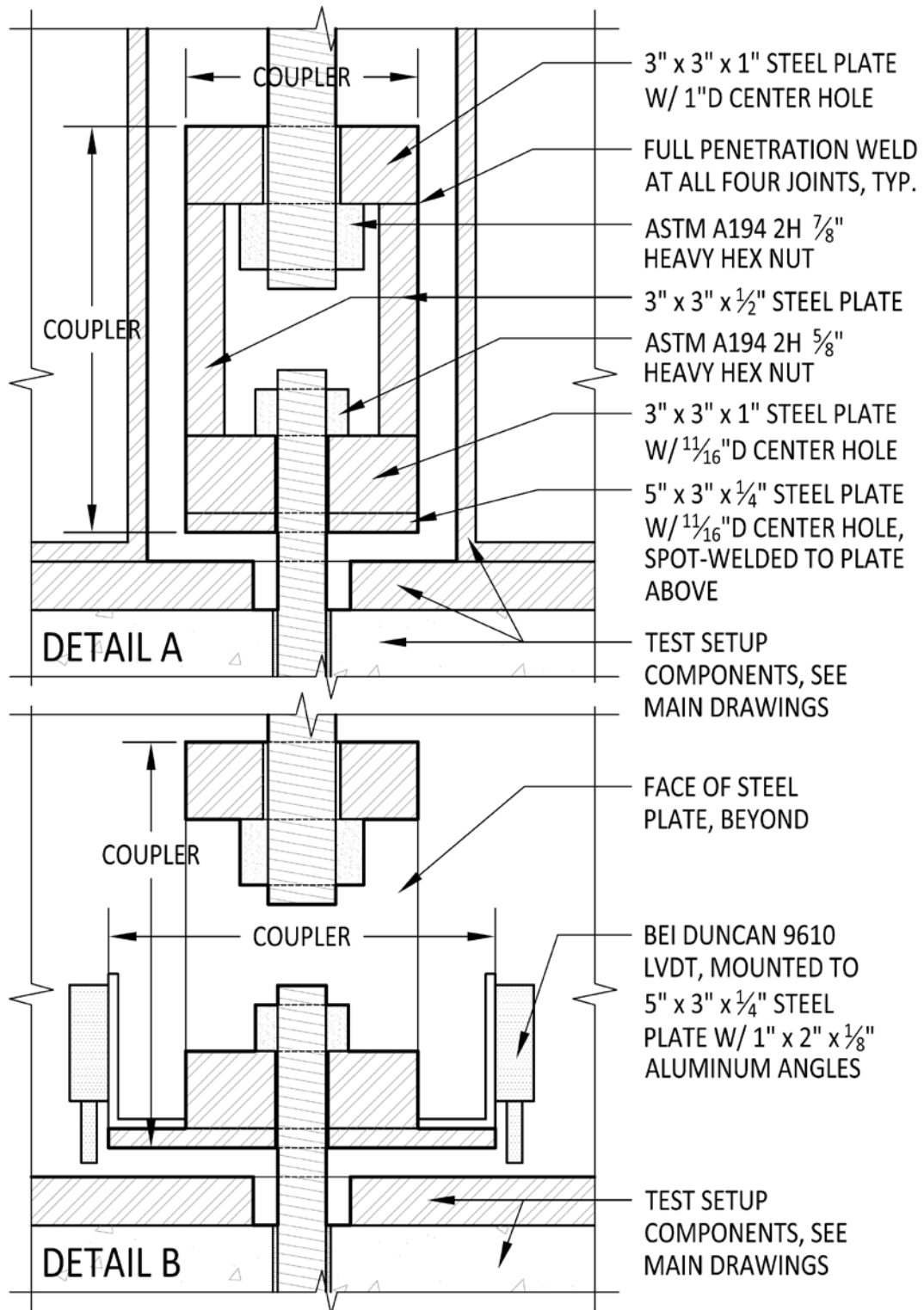

TYPICAL NON-RIGID COUPLER DETAILS

Figure 7.3 Coupler Details

7.3 Long-Term Tests

Long-term tests conform to AASHTO TP-84 (2010) and are replicated from Cook et al. (2013). Three long-term test setups are on loan from the University of Florida and were used to start this project. An additional 20 long term test set ups were ordered for the remainder of the project. Plans can be seen in Figure 7.6 and Figure 7.7 and the non-rigid coupler details in Figure 7.3. The anchor rod passes through the confining sheet and confining plate the same as the short term tests. On top of the confining plate is a steel frame that contains a set of Standard Car Truck Company D2 inner and D2 outer springs used to maintain load. Initial testing was conducted on springs on loan from University of Florida. The two railroad car suspension wire steel springs (large and small) seat within each other and are wound opposite to avoid torsion during loading. The small spring (D2 inner) fits inside the large spring (D2 Outer) when used in parallel, Figure 7.5. The large springs are approximately 5.5 in (140 mm) in diameter by 8.25 in (209 mm) in uncompressed length with a 1-7/32 in (40 mm) wire diameter, maximum load of 15.959 kips (70.99 kN) at 6-5/8 in (168 mm) height, and 9.8 kips/in (17.2 kN/cm) stiffness. The small springs are approximately 3 in (76mm) in diameter by 8.25 in (209 mm) in uncompressed length with an 11/16 in (17.5mm) wire diameter, maximum load of 5.386 kips (23.96 kN) at 6-5/8 in (168 mm) height, and 3.3 kips/in (5.8 kN/cm) . When used in parallel the maximum load is 21.345 kips (94.95kN) and stiffness is 13.1 kips/in (22.9 kN/cm). The stiffness of each spring individually and both in parallel will be measured as part of future testing prior to using in a sustained load test. An example spring calibration is shown in Figure 7.4. This spring has a stiffness of 12.56 kips/in (22kN/cm); lower than the listed spring stiffness of 13.1 kips/in (22.9 kN/cm). The springs are housed in a two piece spring retainer unit, Figure 7.3. The top piece is a 1/2 in x 10 in x 10 in (12.7 mm x 254 mm x 254 mm) plate with 1.5 in (31.8 mm) center hole and four 1 in (25.4 mm) corner holes spaced 7 in (177.8 mm) center to center welded to a 2.5 in

(63.5 mm) tall section of round HSS 6.625x0.25. The bottom is the same as the top with two C7x12.25 channels welded to the plate on a 45 degree angle.

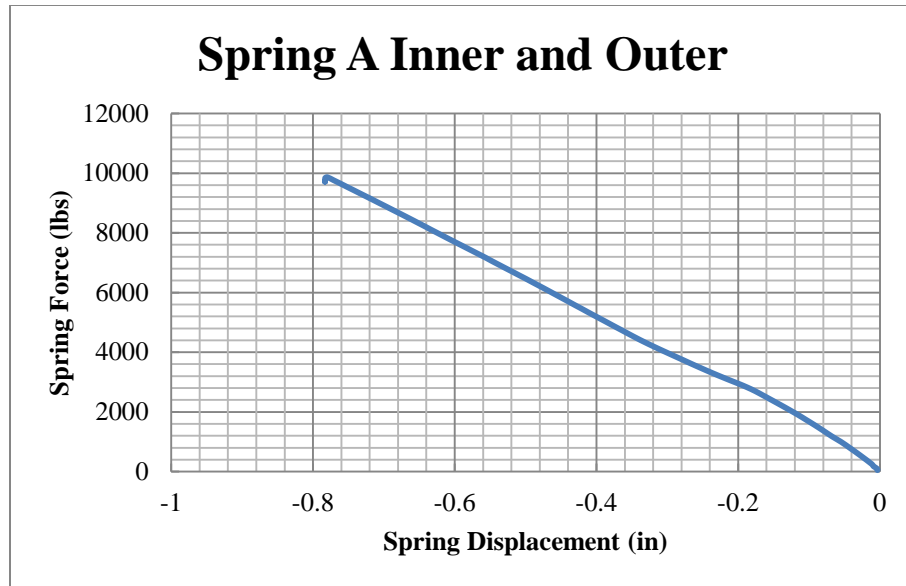

Figure 7.4 Example Spring Stiffness Calibration.

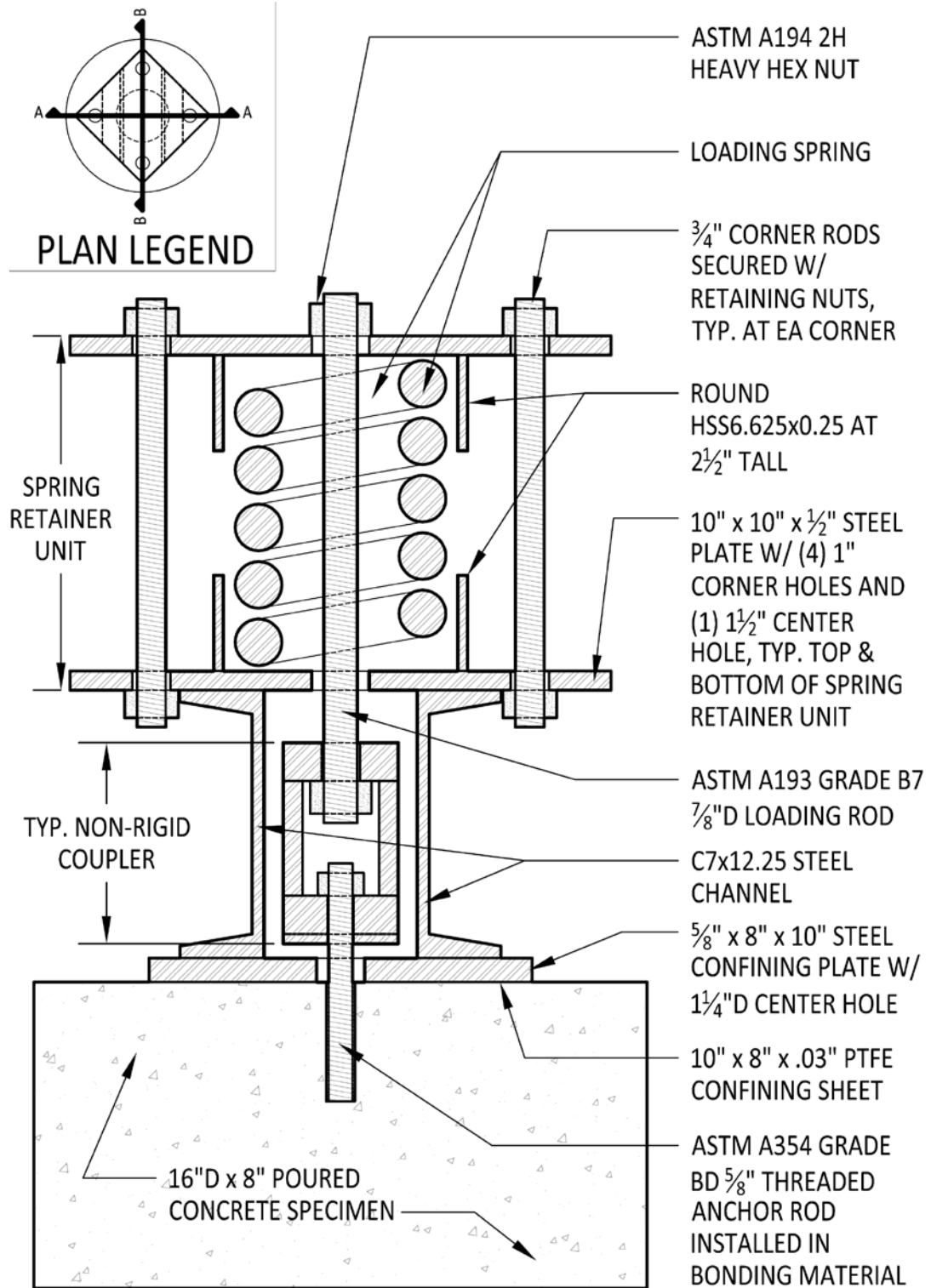

Figure 7.5 Spring Photos

The 5/8 in (16mm) anchor rod being tested passes through the confining sheet, the steel confining plate, and through an 11/16 in (17.5 mm) diameter hole at the bottom of the non-rigid

coupler where it is secured with a ASTM A194 2H heavy hex nut. The loading rod is secured to the top of the non-rigid coupler with a ASTM A194 2H heavy hex nut, passes through the springs in a steel frame, through the center hole hydraulic jack, through the center hole load cell and secured with an ASTM A194 2H heavy hex nut on top. A tensile load of 5% of the creep load is initially applied in order to bring all members into full bearing. The load is then increased at a rate that reaches the creep load after one minute, but before three minutes. A constant load rate is applied within the limits of the hydraulic pump. Data (load, line pressure and displacement readings) is collected at a sampling rate of one sample every 0.5 seconds during loading, exceeding ASTM E488 (2010) section 7.7. Load is measured during compression of the spring and displacement is measured at rate that starts at 0.5 seconds per sample during loading, then every one minute for the next 24 hours, then every hour until failure. Variations for Test Series 0a, 0b, and 0c are described in Chapter 8. In order to pre-load the springs and bring them up to the calibrated tension for the long term applied load, a load system is placed above the top plate of the spring retainer unit. A jack chair, center hole hydraulic jack and load cell are stacked to allow for tensioning of the springs. The springs are compressed with the hydraulic jack to the desired force measured by the load cell (and cross referenced to hydraulic pressure and load cell calibration factor). An ASTM A194 2H heavy hex nut within the jack chair secures the springs at the compressed distance and the hydraulic jack and load cell are removed for pre-loading the other long-term specimens. Sustained load is maintained through the compression of the spring. The sustained load does not need to be monitored if the load lost at maximum anchor creep displacement is less than one percent of the sustained load according to AASHTO TP-84. For example, a maximum creep displacement of 0.1 in (2.54 mm) causes a loss of 1.15 kips (5.11 kN) in a spring with stiffness of 11.5 kips/in (14 kN/m). This is a loss of 5% if the sustained load was 23 kips (28 kN); requiring the spring to be recompressed every .02 in (.25

mm) during the test. The compression of the spring would be measured by the displacement of the anchor system (displacement of the anchor-strain of the anchor rod = change in spring compression) daily.



LONG-TERM TEST SETUP

(SECTION A-A)

Figure 7.6 Long Term Test Setup Section A-A

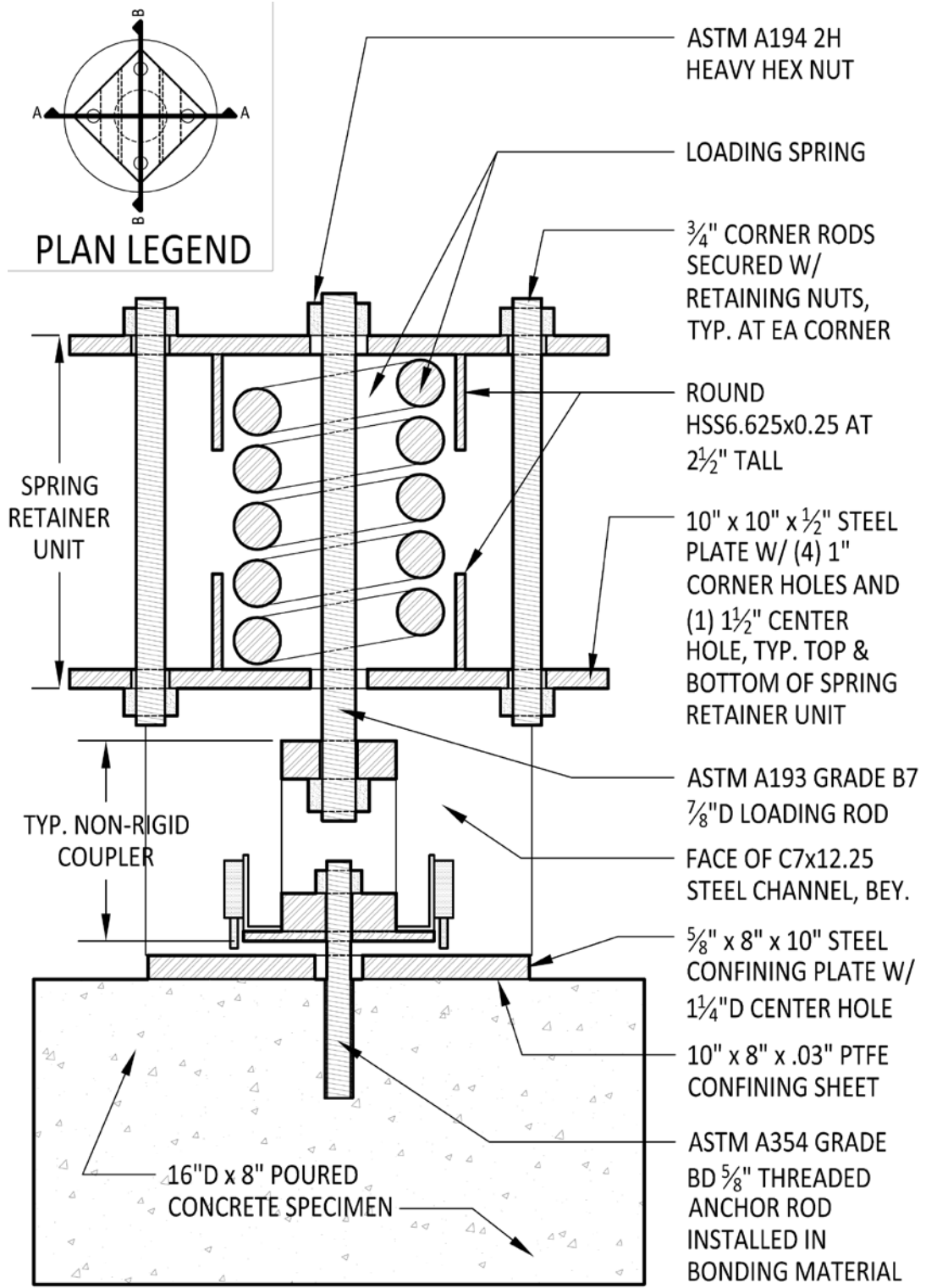

LONG-TERM TEST SETUP

(SECTION B-B)

Figure 7.7 Long Term Test Setup Section B-B

7.4 Test Set Up Components

Some components are used both in the long and short term test and are described in this sections. This section gives descriptions of components that are consistent in both sets of tests and can be used as a reference for understanding both the short term and long term test set apparatus which are discussed in Sections 0 and 7.3 respectively.

7.4.1 Steel anchor rod, bonding materials and concrete specimens

Anchor Rods

ASTM A354 Grade BD 11 threads per in threaded rod (yield stress of 130 ksi (896 MPa), ultimate tensile stress of 150 ksi (1034 MPa), yield strength of 29.4 kips (130.7 kN), and ultimate strength of 33.9 kips (150.8 kN)) was chosen to preclude steel failure. Anchor rod diameter of 5/8 in (15.875 mm) is recommended by AASHTO TP-84 (2009) and was chosen to match research conducted in Cook, et al. (2009), and Cook, et al. (2013) to allow for direct comparison of data. Minimum embedment depth allowed by AASTHO TP-84 (2009) is 3-1/8 in (79 mm). Initial testing at this embedment depth produced a strong enough bond to cause failure in a ASTM A 193 Gr B7 threaded rod. This minimum embedment depth was chosen for this project to allow ensure bond failure. ASTM A 193 Gr B7 threaded rod (ultimate tensile stress of 125 ksi (862 MPa) and ultimate strength of 28.25 kips (125.6 kN)) is the minimum strength anchor allowed by AASHTO TP-84 (2009), but initial testing induced failure of the B7 threaded rod and the ASTM A354 Grade BD was chosen. Anchor rods for testing were cut to 6 in (152 mm) lengths from 24 in (609 mm) stock and were stored in a plastic bucket filled with oil soaked paper to prevent corrosion. Immediately prior to installation, rods were cleaned with acetone and allowed to dry. Test series 0c used anchor rods cut to 9 in (229 mm) to allow for a deeper

embedment depth at the recommendation of the manufacturer to get less variation in pullout capacity. B7 threaded rod was not available for Test Series 0a and available 5/8 in (15.875mm) diameter threaded rod with a yield stress of 36 ksi (248 MPa) was used as the anchor rod.



Figure 7.8 Anchor Rod

Concrete Specimens

AASHTO TP-84 (2009) requires that the specimen edge be at least two times the embedment depth from the center of the anchor in order to avoid edge effects. This project uses a 5/8 in (15.875 mm) diameter anchor rod at an embedment depth of 3-1/8 in (79 mm), the minimum depth recommended by AASHTO TP-84 (2009). In order to account for possible variation in specimen preparation, it was decided that 16 in (406 mm) should be the minimum width of the specimen. AASHTO TP-84 (2009) requires the depth of the specimen to be 1.5 times the embedment depth. Due to concerns about cracking during drilling, the minimum specimen depth was chosen to be 8 in (203 mm), over two times the embedment depth. Preliminary specimens matching Cook et al. (2013) were cast and used in Test Series 0c. These specimens were difficult to handle due to their weight and size. In order to make casting easier and improve handling, 16 in (406 mm) diameter cylinders with 8 in (203 mm) depth were chosen for final specimens. These specimens weigh approximately 140lbs (0.6 kN) and can be handled without casting any additional supports into the block. These blocks are similar in size to tests conducted at the University of Stuttgart in Cook et al. (2013). The forms were 16 in (406 mm)

diameter 12 ft (3.66 m) Sonotube round concrete cardboard form tubes cut to 8 in (203 mm) height on a table saw. The forms were sealed to a standard 4 ft x 8 ft (1219 mm x 2438 mm) sheet of plywood with Sikaflex Construction Sealant along the inside of the tube. One sheet of plywood can fit 15 specimens and 30 specimens were cast at one time with 15 test cylinders made from the same batch out of a 1.5 yd³ (1.14 m³) concrete delivery. These specimens were cast as part of this Thesis as a proof of concept for the smaller specimens, but testing will be future work. Thirty specimens were cast from concrete provided by a local ready mix company. The concrete mix is a standard 4000 psi (27.6 MPa) MassDOT mix design and was allowed to cure for at least 28 days prior to testing. The thirty day compressive strength was 5190 psi (35.78 MPa). It was found that due to the material properties these forms were disposable and could not be re-used. However, they were easier to assemble, used much less space and are recommended for the future testing.



Figure 7.9 Concrete Samples

Bonding Materials

Final tests will be conducted on three adhesives. All three adhesives meet ICC-ES 308 standards.

Adhesive A – Adhesive A is the same adhesive used in test series 0b. This adhesive is a combination of Bisphenol A and Bisphenol F epoxy resins with fillers and m-xylene diamine and aliphatic polyamine hardeners.

Adhesive B – Adhesive B is a Bisphenol A/Epichlorohydrin (Epoxy Resin) with a Dimethaneamine hardener.

Adhesive C – Bisphenol A and Bisphenol F epoxy resins with amine hardeners. The listed uncracked bond stress is 2,148 psi (14.7MPa) and should have a static capacity of 13 kips (58 kN) for this research.

Table 7.1 Bonding Materials Used per Test Series

Test Series	Bonding Material	Description
0a	Adhesive	Two Part FRP Epoxy, 2 years past expiration date
0b	Adhesive	Bishphenol A and Bisphenol F Epoxy Resin with Amine Hardeners
0c	Grouted	Calcium Aluminate Cement, Aggregates, Fillers and Additives in a permeable capsule (cartridge) sock

Loading Rod

Capacity of the loading rod needs to be greater than the capacity of the anchor. The loading rod used for initial testing was #6 DYWIDAG THREADBAR® Reinforcing Steel ASTM A615 (Grade 75). Yield strength of these bars is 33 kips (147 kN) before application of a reduction factor. Maximum anticipated failure loads is 30 kips (133 kN) and close to the elastic limit of the loading rod used. Future testing will use 7/8 in (22.2 mm) diameter ASTM A193 Grade B7 Threaded Rod (yield strength of 48.5 kips (215.7 kN) without a reduction factor) to ensure no yielding of the loading rod.

Non-Rigid Coupler

A steel non-rigid coupler is used to connect the anchor rod to the loading rod. Details of this coupler can be seen Figure 7.3. This coupler has a 11/16 in (17.5 mm) diameter hole at the bottom that the anchor rod passes through and a 1 in (25.4mm) diameter hole at the top where the loading rod passes through. Both the anchor rod and the loading rod are secured with a A194 2H heavy hex nut. The use of the coupler is to reduce bending moments being applied to the anchor by allowing rotation at the connection points. The coupler is two 1 in (25.4mm) thick plates with an 11/16 in (17.5 mm) diameter center hole at the bottom and 1 in (25.4 mm) diameter center hole on top held apart by 0.5 in (12.7 mm) thick plate sides. The full capacity of

all the plates is required to carry loads of up to 40 kips (178 kN), so full penetration welds were used to connect the top and bottom plates to the side plates. A 0.25 in (6.35 mm) thick plate is tack welded to the bottom of the coupler for mounting the LVDT's that measure the anchor displacement.

Confining Plate

A 5/8 in (15.875 mm) thick 8 in x 10 in (203mm x 254mm) steel plate with a 1.25 in (31.75 mm) diameter center hole was used to confine the tests. AASHTO TP-84 requires the confining plate to be greater than or equal to the nominal anchor diameter $\pm 1/16$ in (± 1.5 mm). Confining the tests prevents concrete failure. This is done to allow for a more consistent measurement of bond failure.

Confining Sheet

A confining sheet was used between the concrete sample and the confining plate. This sheet is required by AASHTO TP-84 (2009). A 0.03 in (0.76mm) thick sheet of polytetrafluoroethylene (PTFE) the same dimensions as the confining plate, 8 in x 10 in (203mm x 254mm) with a 1.25 in (31.75 mm) diameter center hole, was placed between the concrete and the steel confining plate to account for surface irregularities. This sheet was not available for Test Series 0a.

Hydraulic Jack/Pump

The load is applied to the loading rod with an SPX Power Team RH-202 20 ton (178 kN) center hole hydraulic jack, Figure 7.10 (Left). The pressure is applied to the jack with an SPX Power Team P460d Hydraulic Hand Jack, Figure 7.10 (Right). Future purchase of an SPX Power Team E173-PC pump with a 9609 pressure compensated valve will allow for an electronically controlled application of the load; allowing for less variability in load rates and failure times of short term tests.

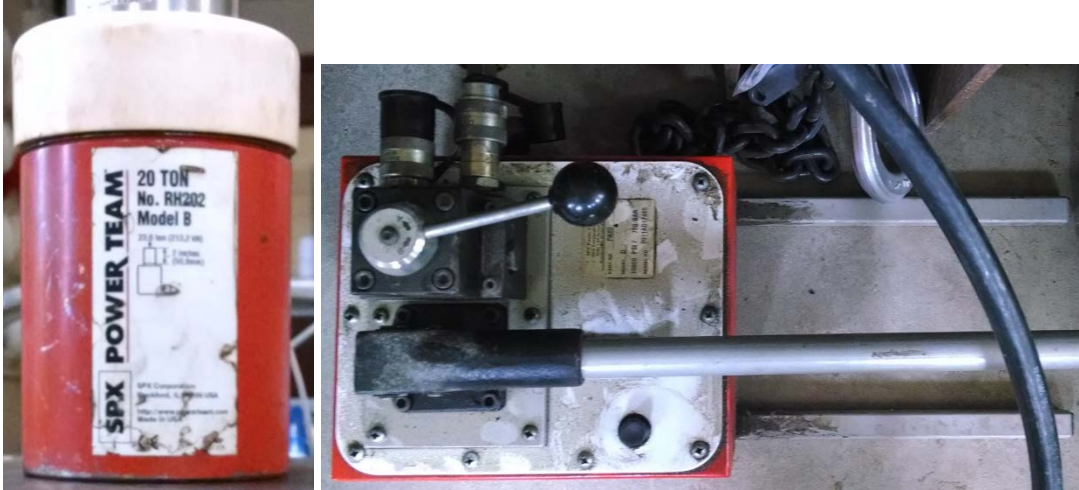

Figure 7.10 SPX Power Team RH202 Jack (Left) and SPX Power Team P460d Pump(Right)

7.4.2 Instrumentation and Data Acquisition

Load Cell/Strain Gauges

Load is measured at the top of the jack with a Transducer Techniques THD-50K-Z through hole donut 50kip (222.4kN) load cell with a through hole diameter of 1.281 in (32.53 mm). The loading rod passes through the load cell that sits on top of the jack. Test Series 0a was run with an Interface Force LW 2594-20K-327 20 kip (89 kN) load cell with a through hole diameter of 0.983 in (24.96 mm). Load for the long term tests is measured indirectly as displacement of the anchor equal to extension of the spring equal to change of applied load. Reloading of the spring is allowed to keep the force within 1% of desired load.

LVDT Linear Potentiometers

BEI Duncan 9610 Linear Variable Differential Transformer (LVDT) linear potentiometers are used to measure anchor displacement. These LVDTs are secured to the bottom of the non-rigid coupler using small bolts, washers, nuts, and aluminum angles. Future researchers are investigating ways to measure displacement from the top of the anchor rod instead of at the

non-rigid coupler. Final testing will be conducted with two LVDTs per specimen and the average will be used as the final displacement. Both potentiometers will measure the distance between the bottom of the non-rigid coupler and the top of concrete specimen. The distance between the top of concrete and top of the anchor is minimized to avoid the strain of the anchor affecting displacement readings.

Temperature Sensors

QTI Sensing Solutions QTSSP-14F-48 Thermistors were purchased to monitor the internal temperature of concrete specimens. These thermistors will be installed in a dry hole 1/2 the embedment depth and held in place with a rubber stopper. Thermistors will also monitor temperature of the environmental chamber through the data acquisition system.

Spring Displacement Sensors

The stiffness of each spring will be calibrated using four string potentiometers and the load cell and loading rod described above. The string potentiometers were used in some of the tests to determine how uniformly the spring compressed during loading of a creep test.

Data Acquisition

Data for Test Series 0a and 0b was collected using an HP 3852 data acquisition system. AASHTO TP-84 (2009) recommends sampling every 3 seconds during loading, every minute for the first hour following loading, every 10 minutes for the next 9 hours, then every hour until the test is complete. Load sampling will be every 0.5 seconds to give instant feedback to the operator of the hydraulic pump during loading. Then AASHTO recommended sampling is followed.

Future testing will be complete using a National Instruments' data acquisition system. This system consists of an NI 3100 Industrial Controller connected to an NI cDAQ 9188 chassis

with NI 9206 modules to measure voltage. This system will be programmed and calibrated by future researchers.

Data Interpretation

Displacement measurement will be a combination of bonding material displacement and anchor rod displacement. Cook, et al. (2013) uses a correction factor to subtract out the displacement of the anchor rod, Equation 6 and Equation 7.

$$\mathbf{disp}_{adj} = \mathbf{disp} - \mathbf{N} \times \delta_{cor} \quad \text{Equation 6 (Cook, et al., 2013)}$$

Where,

\mathbf{disp}_{adj} = displacement adjusted for strain in anchor,

\mathbf{disp} = unadjusted displacement, and

\mathbf{N} = load.

$$\delta_{cor} = \frac{1}{A_e E} \quad \text{Equation 7 (Cook, et al., 2013)}$$

Where,

\mathbf{l} = distance between top of concrete and coupler,

\mathbf{A}_e = effective area of anchor, and

\mathbf{E} = modulus of elasticity of anchor steel.

7.5 Environmental Chamber

A temperature and humidity controlled chamber is required to conduct controlled elevated temperature tests in accordance with AASHTO TP-84, between 110°F and 120°F (43°C to 48°C,) and humidity, less than 40%, tests. An 8ft tall x 5.5ft wide x 17ft long (2.44m tall x 1.68m wide x 5.18m long) box made of 2x4 dimensional lumber, 3/4 in (19mm) plywood, and 2 in (50.8 mm) rigid foam insulation houses up to twenty five 16 in diameter x 4ft-6in tall (0.406m

diameter x 1.372m tall) long term test specimens and ten 16 in diameter x 2 ft tall (406 mm diameter x 610 mm tall) short term specimens, Figure 7.11 and Figure 7.7. Two Dimplex CUH05B31T heaters will provide heat. Internal air temperature will be monitored and the heaters will be automatically switched on/off when the internal air temperature reaches a minimum/maximum temperature. Humidity will be controlled with a dehumidifier set to keep the relative humidity below 40%. Specimens tested at elevated temperature will be conditioned for at least 24 hours at the test temperature prior to applying load. Additional thermistors will be placed around the chamber to evaluate consistency of temperature. Baffles and heaters will be adjusted to ensure uniformity of temperature throughout the room.

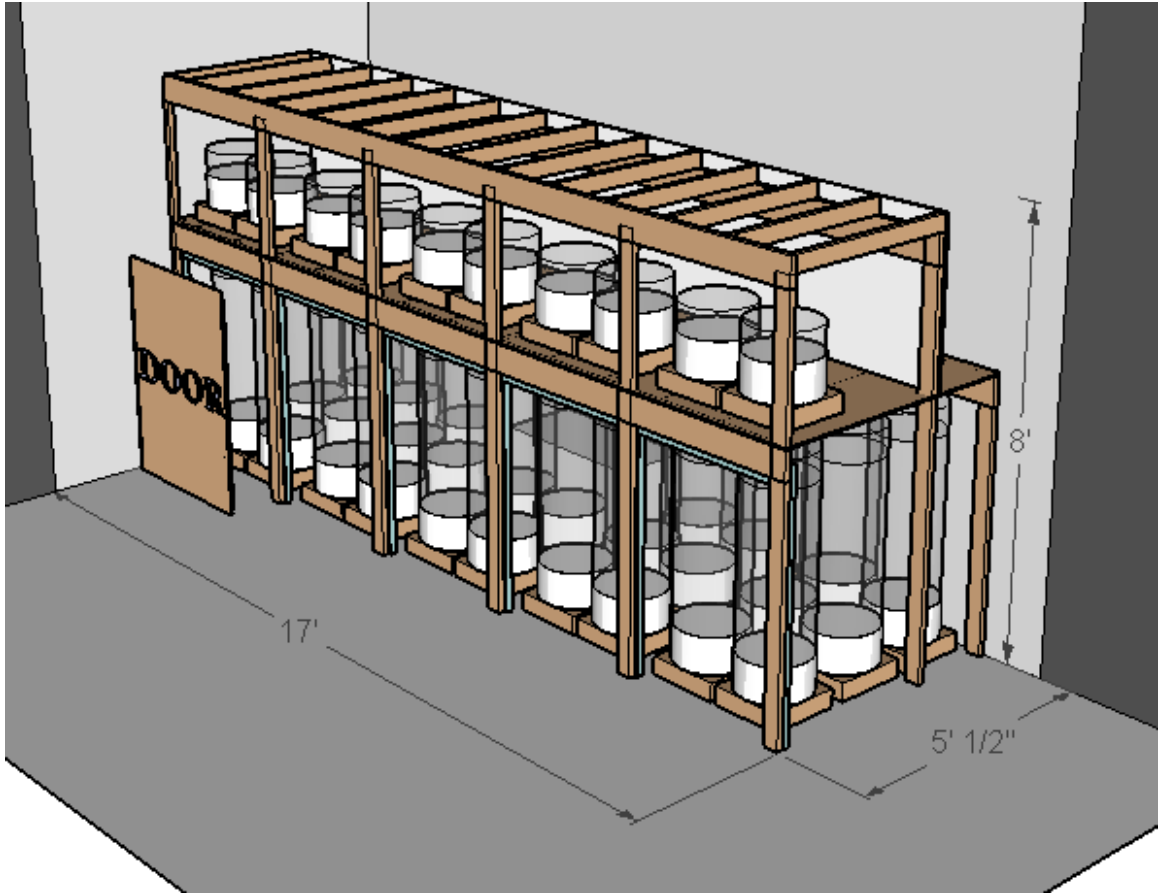

Figure 7.11 Environmental Chamber Plan



Figure 7.12 Environmental Chamber

CHAPTER 8

PRELIMINARY TEST SPECIMENS AND RESULTS

8.1 Test Series

Test Series 0a, 0b, and 0c were preliminary tests and did not necessarily follow the procedures or use materials listed in Chapter 7. These tests lead to the development of materials and procedures listed in the rest of this chapter. Test Series 0b was conducted on 10 anchors installed in one concrete block and was used to validate procedures and methods detailed in this chapter. Test Series 0c was a cementitious bonding material to compare with the epoxy bonding material of Test Series 0b. These tests are not to be considered valid test series, but provide insight into changes made to the test specimens or setups based on initial testing. A summary of these test series is presented in Table 8.1. Due to issues with data acquisition and anchor rods, test series 0b and 0c were incomplete.

Table 8.1 Test Series Matrix

Test Series	Test Description	Installation Conditions	Anchor Rod Type	Bonding Material	Hole Size	Embedment Depth	Static Tests	Sustained Load Tests
0a	Preliminary Testing	Summer Time Outdoor	F1554 Grade 36	Expired Two part Epoxy	3/4 in (19mm)	3.125 in (79mm)	2	2
0b	Validation Tests	Indoor	B7 Threaded Rod	Two Part Anchoring Epoxy	3/4 in (19mm)	3.125 in (79mm)	2	0
0c	Cementitious	Indoor	B7 Threaded Rod	Cementitious	1 in (25.4mm)	6in (152mm)	0	0

8.1.1 Test Series 0a

Test series 0a was the first test series conducted for this research. A summary of experiments from this test series is found in Table 8.2. The purpose of this test series was to gain experience with anchor installation and test capability of existing equipment at UMass. The

anchors used for this test series were 5/8 in (15.9mm) nominal diameter, 6 in (152mm) long threaded rod with a yield stress of 36 ksi (248 MPa) cut from 96 in (2438mm) stock.

Table 8.2 Test Series 0a Matrix

Experiment	Description	Conditions	Anchor cure time	Load	Failure
0a-1	Static Test	Summer time Outdoor	24hr	8 kips (35.6 kN)	Bond
0a-2	Static Test	Summer time Outdoor	7 days	12 kips (53.4 kN)	Steel
0a-3	Creep Test	Summer time Outdoor	11 days	11.5kips (51 kN)	None
0a-4	Creep Test	Indoor	78 days	8 kips (35.5 kN)	None

Experiments 0a-2 and 0a-3 used the same type of steel for the loading rod as the anchor rod. The non-rigid coupler for experiments 0a-1 through 0a-3 was on loan from the University of Florida and was the design listed in Cook, et al. (2009) and Cook, et al. (2013). This non-rigid coupler required the use of a 1 in (25.4mm) loading rod. The loading rod had to be threaded directly into the coupler and the anchor rod was secured to the coupler with a nut, Figure 8.1. This coupler was not compatible with the Interface Force LW 2594-20K-327 20 kip (89 kN) load cell with a through hole diameter of 0.983 in (24.9mm). Initially, two non-rigid couplers were combined to reduce the loading rod from the 1 in (25.4mm) diameter threaded rod to 5/8 in (15.9mm) diameter threaded rod, Figure 8.5. After experiment 0a-3, the non-rigid coupler described in Chapter 7.2 was designed and used for future testing.

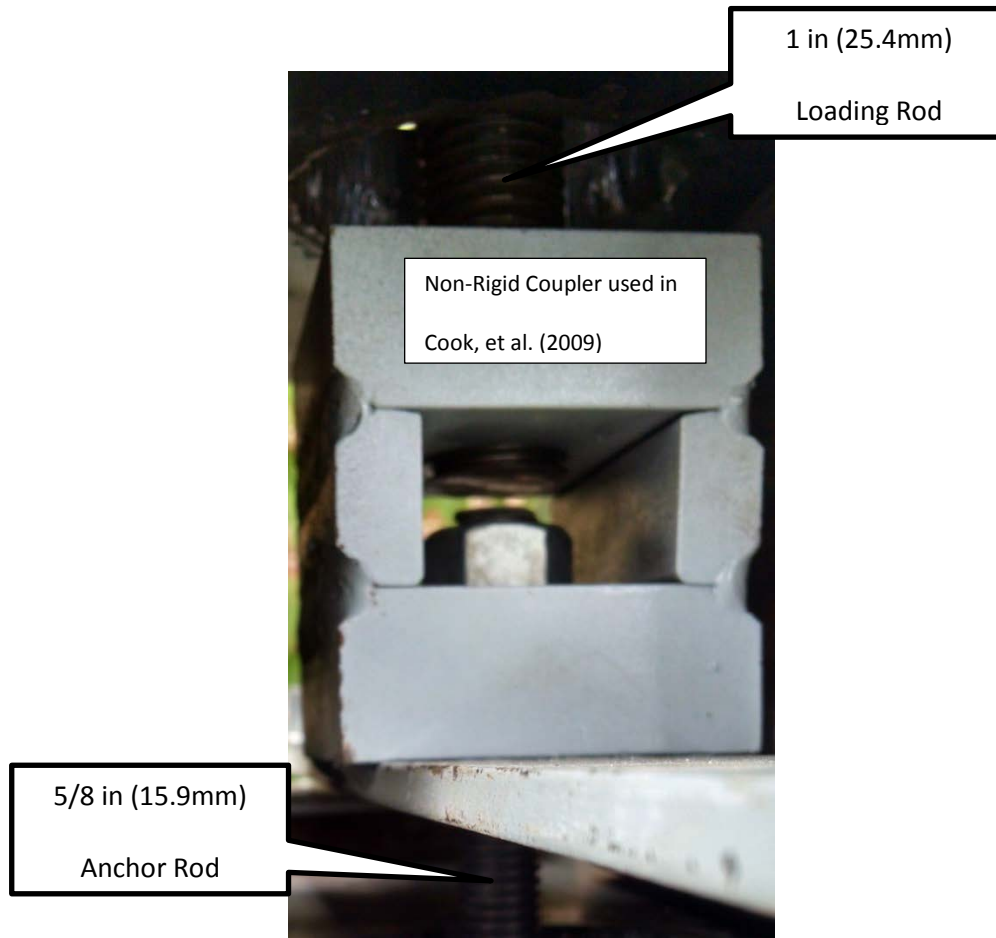

Figure 8.1 Non-Rigid Coupler of Experiments 0a-1 through 0a-3

Installation of these anchors was accomplished by assuming a generalized procedure from other adhesive anchors. First a 3/4 in (19mm) diameter hole was drilled to a 3-1/8 in (9.5mm) depth using a Hilti TE72 rotary impact hammer with a 3/4in (19mm) drill bit. A vertical hole was achieved by aligning the drill bit with two vertical reference lines created by placing two pieces of rectangular HSS on their ends and attaching a magnetic level to one piece for reference, Figure 8.2. Issues with keeping the drill vertically aligned with the HSS lead to the development of the steel section used to install Test Series 0b and 0c.



Figure 8.2 Hole Drilling Series 0a

The holes were cleaned using compressed air. A stiff bristled plastic brush combined with the use of compressed air is the preferred method for hole cleaning, but a brush was not available for series 0a and only compressed air was used to clean the hole. Compressed air was blown into the hole to remove the majority of dust, and then the nozzle was sprayed directly against the sides of the hole to remove as much dust as possible. A brush was purchased for Test Series 0b and 0c installations.



Figure 8.3 Hole Cleaning with Compressed Air

After the hole was cleaned, the two part epoxy was mixed. This epoxy was not designed for use in anchoring steel rods to concrete. It is a two part epoxy for use in attaching FRP sheet to concrete and was 2 years past its expiration date. The two parts were in separate buckets and were mixed manually in accordance with the manufacturer's recommendations and poured into the cleaned hole. The holes were filled 67% full with adhesive and the anchor rod was placed in the hole. Excess epoxy flowed out of the hole and created a thin puddle on the surface of the concrete around the anchor and can be seen in Figure 8.4. Duct tape was used to mark the 3-1/8 in (9.5 mm) embedment depth. The adhesive cured for 24 hours before the first test, 0a-1, was run. Subsequent tests were run after longer adhesive cure times.



Figure 8.4 Mixed Epoxy (Left) and Installed Anchor (Right)

Experiment 0a-1 was the first experiment conducted for this research. It was conducted on adhesive that only cured for 24 hours was no measurements were taken. The purpose of this first experiment was to determine if a valid static test could be conducted with the designed test setup. Pressure of the hydraulic pump was manually monitored with an analog gauge for this test and that was correlated to an applied force. The 24 hour cure time on this test was also less than the manufacturer's recommended 7 day cure time.

Experiment 0a-2 was the first experiment where force and displacement were digitally recorded for anchor pull out. It was a static test to further verify the test setup and tested short term bond stress of the FRP epoxy. This experiment used two non-rigid couplers coupled together and a 5/8 in (15.9mm) diameter loading rod. Measurements were taken with an HP 3852a data acquisition system.

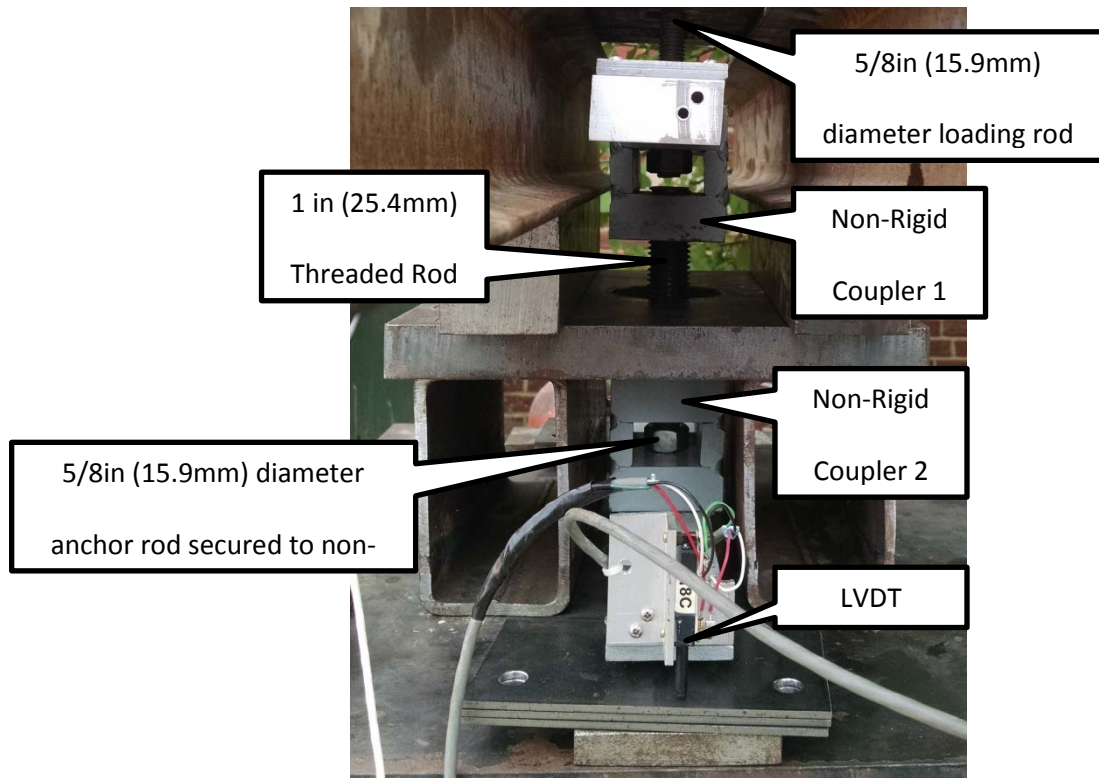

Figure 8.5 Two Non-Rigid Coupler Design

Experiment 0a-3 was the first creep test and run in order to verify the spring loading and application of load to an anchor. The concrete specimen was outdoors and the experiment could only be run during business hours of one day. In order to achieve a possible creep failure, a load close to the ultimate load of the anchor rod was chosen, 11.5 kips (51kN). Available steel pieces were stacked to achieve proper standoff between the two coupler design. This stacking caused the spring to bend during loading. The loading rod was bent by the spring, and the experiment was allowed to run for a few hours before it was terminated. The 5/8in (15.9mm) diameter loading rod was replaced with a #6 DYWIDAG THREADBAR® for subsequent experiments and a new non-rigid coupler was built.

Experiment 0a-4 was the longest running test for series 0a. This experiment used a #6 DYWIDAG THREADBAR® Reinforcing Steel ASTM A615 (Grade 75) loading rod and the short term

set up described in Section 7.2. An Interface Force LW 2594-20K-327 20 kip (89 kN) load cell was below the jack chair to monitor the force applied by the spring over time. An initial long term load of 7.6 kips (33.8 kN) was applied. After 7 days, minimal displacement had occurred. To further evaluate the test system the load was increased to 9.8 kips (43.6 kN) and after ten days total, the load was increased again to 10.2 kips (45.3 kN) where it was held for the remainder of the 25 day test. The test was ended to allow installation of test series 0b.

8.1.2 Test Series 0b

Test Series 0b consisted of ten experiments. A matrix of these experiments can be found in Table 8.3. Short term apparatus as described in Section 7.2 was used. An initial load of 1.2 kips (5.34 kN) was applied to bring the system into bearing for each test. Adhesive A detailed in section 7.4.1 was used in this test series. The epoxy was installed in accordance with the manufacturer's recommendations. First, a 3/4 in (19 mm) diameter hole was drilled to a 3-1/8 in (95.3 mm) depth using a Hilti TE72 rotary impact hammer with a 3/4 in (19 mm) drill bit. A steel section with two vertically aligned holes was used to drill a hole perpendicular to the concrete surface and a piece of tape was placed on the drill bit to mark 3-1/8 in (95.3 mm), Figure 8.6. The holes were then initially cleaned with compressed air. After initial cleaning, the hole was brushed, Figure 8.6, and cleaned with air again. The process was repeated three more times in conformance with manufacturer recommendations. Each hole was cleaned individually and covered with tape while the next holes were cleaned, Figure 8.7.



Figure 8.6 Brush Cleaning Hole (Left) and Alignment guide for Test Series 0b an 0c (Right)

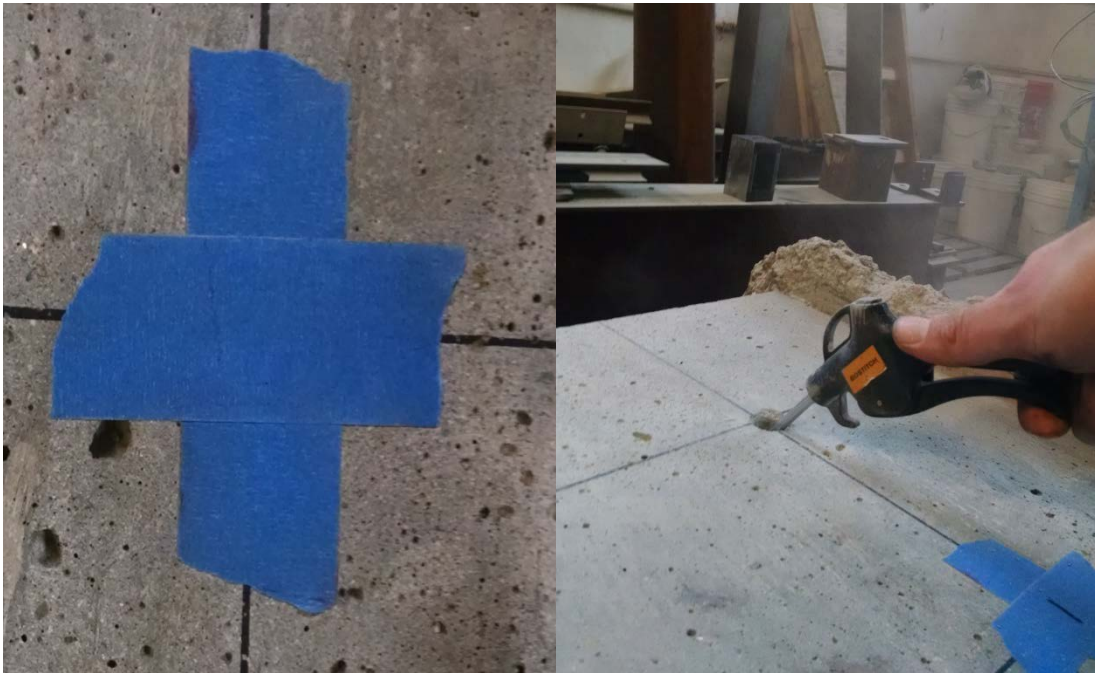

Figure 8.7 Cleaned Hole with Tape (Left) Cleaning Subsequent Hole (Right)

After the holes were cleaned, a depth gauge was used to ensure proper embedment depth of the anchor. The depth gauge was created from plastic cylinder molds cut into shorter sections. These provided standoff from the excess adhesive that flowed from the hole during installation and ensured the proper embedment depth was reached. A nut was placed on top of the anchor where the bottom of the anchor was 3-1/8 in (15.9mm) below the bottom of the depth gauge, Figure 8.8.

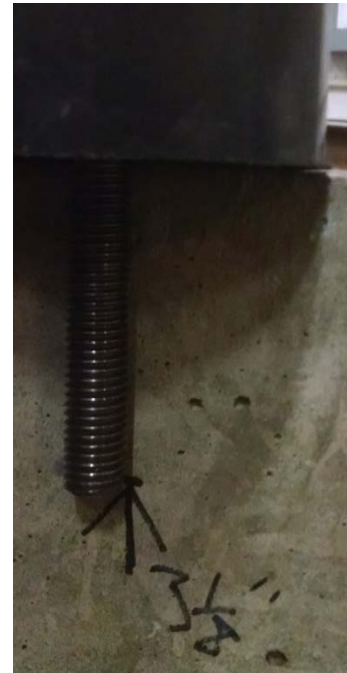

Figure 8.8 Test Series 0b depth gauge

Once the anchors were prepared with depth gauges, the adhesive was prepared. The two part adhesive required use of a special applicator that mixed the parts. This applicator was similar to a standard caulking gun with two compartments, one for each part of the adhesive. This applicator was specifically designed for use with this adhesive product, Figure 8.9 (far left). Three beads of adhesive were dispensed onto cardboard for immediate disposal to ensure proper mixing for the first anchor, Figure 8.9 (middle left). The anchor hole was then filled to approximately 50% to 70% full, Figure 8.9 (middle right), and the anchor rod was placed directly

in with the depth gauge for proper alignment. Excess adhesive was allowed to cure and hardened adhesive was left around the anchor rod, Figure 8.9 (far right). This adhesive was later chipped away using a hammer and putty knife, but future installations will not use a depth gauge and excess adhesive will be wiped away.



Figure 8.9 Adhesive Application

Table 8.3 Proposed Test Series 0b Matrix of Experiments

Experiment	Description	Conditions	Anchor Cure Time	Load	% Static Load	Failure
0b-1	Static Test	Indoor	7 days	25.5 kips		Steel
0b-2	Static Test	Indoor	7 days	28.5 kips		Steel
0b-3	Static Test	Indoor				
0b-4	Static Test	Indoor				
0b-5	Creep Test	Indoor			90%	
0b-6	Creep Test	Indoor			90%	
0b-7	Creep Test	Indoor			80%	
0b-8	Creep Test	Indoor			80%	
0b-9	Creep Test	Indoor			70%	
0b-10	Creep Test	Indoor			70%	

8.1.3 Test Series 0c

Test series 0c was a grouted anchor with a cementitious bonding material. This test series was installed into preliminary concrete specimens chosen that were rectangular prisms 16 in x 16 in x 12 in deep (406 mm x 406 mm x 305 mm deep) created with fabricated wood removable forms, Figure 8.10. This specimen size was used in Cook, et al. (2013) and Cook, et al. (2009) and was chosen as the starting point for this research. These specimens weighed approximately 270lbs (1.2 kN). For transport, 1/2 in (12.7 mm) inner diameter PVC pipe was cast 4 in (102 mm) from the bottom of the specimens. This allowed for handling using #3 reinforcing

bars. Three of these blocks were cast for initial testing and used in test series 0c using Sakrete High Strength Concrete Mix, a ready mix product, and each 80 lb bag (0.355 kN) was mixed with 3.5 quarts (3.3 L) of water. Two 4 in (101 mm) diameter cylinders were tested and the average 28 day compressive strength was 4,561 psi (31.44 MPa). Five anchors were installed into one of the blocks for use in determining static capacity. The other two blocks had only one anchor each for creep tests. The 5/8 in (15.9 mm) diameter B7 threaded anchor rod was used for this test series. The embedment depth was 6 in (152.4 mm) by suggestion of the manufacturer because previous testing with this product has yielded high variation at embedment depths less than 6 in (152.4 mm). The hole diameter for this test series was 1 in (25.4 mm) because 1 in (25.4 mm) samples were donated and require installation in a hole with at least 1 in (25.4 mm) diameter hole. Hole drilling methods described in test series 0b were followed. Hole cleaning for this product required initially removing most of the dust with compressed air. After the dust was removed, the holes were filled with water and allowed to sit for 10 minutes, Figure 8.11 (far left). After 10 minutes, the water was removed with compressed air, Figure 8.11 (middle left). The compressed air was sprayed along the sides of the hole for the entire depth to remove as much excess water as possible. The cementitious bonding material is contained in a permeable capsule (cartridge) sock. The sock was soaked in water for 1.5 minutes, and then placed into the hole with excess material to the side. The anchor rod was pushed through the sock, Figure 8.11 (middle right), to the bottom of the hole and excess cementitious bonding material was wiped away, Figure 8.11 far right photo.



Figure 8.10 Concrete Specimens for Test Series 0c



Figure 8.11 Test Series 0c Installation Photos.

The anchors were allowed to cure for a minimum of 28 days before testing. The results from the five static tests were averaged and creep tests were conducted at 90% of the static capacity.

8.2 Test Series Results

Three preliminary test series were run as part of this thesis. The purpose of these test series was to validate equipment and procedures for future testing. Test Series 0a resulted in a final design for the non-rigid coupler and the height of the short term and long term tests to account for the non-rigid coupler. Test series 0b resulted in improved installation techniques and higher capacity threaded rod. Test series 0c resulted in experience with cementitious anchor. Chapter 9 has recommended future work based on results from these three test series.

8.2.1 Test Series Results Test Series 0a

Experiment 0a-1 was the first experiment run in the series and for this project. This experiment resulted in a bond failure at the concrete/adhesive bond line with a shallow concrete cone. These results were exactly what was expected and were promising for future testing. The load for this test was not measured directly, but an analog pressure gauge was monitored during loading. The pressure reached approximately 2,000psi (13.8MPa) before failure. This equates to 8 kips (35.6 kN) of force. This test series showed that the FRP epoxy was capable of developing high enough bond stresses for testing and that the short term test apparatus could apply loads properly. Figure 8.12 shows the bond failure. This failure only occurred because the adhesive was tested prior to fully curing. Test 0a-2 was a static test on fully cured adhesive and resulted in steel failure of the anchor rod, Figure 8.13.



Figure 8.12 Experiment 0a-1 failure photos

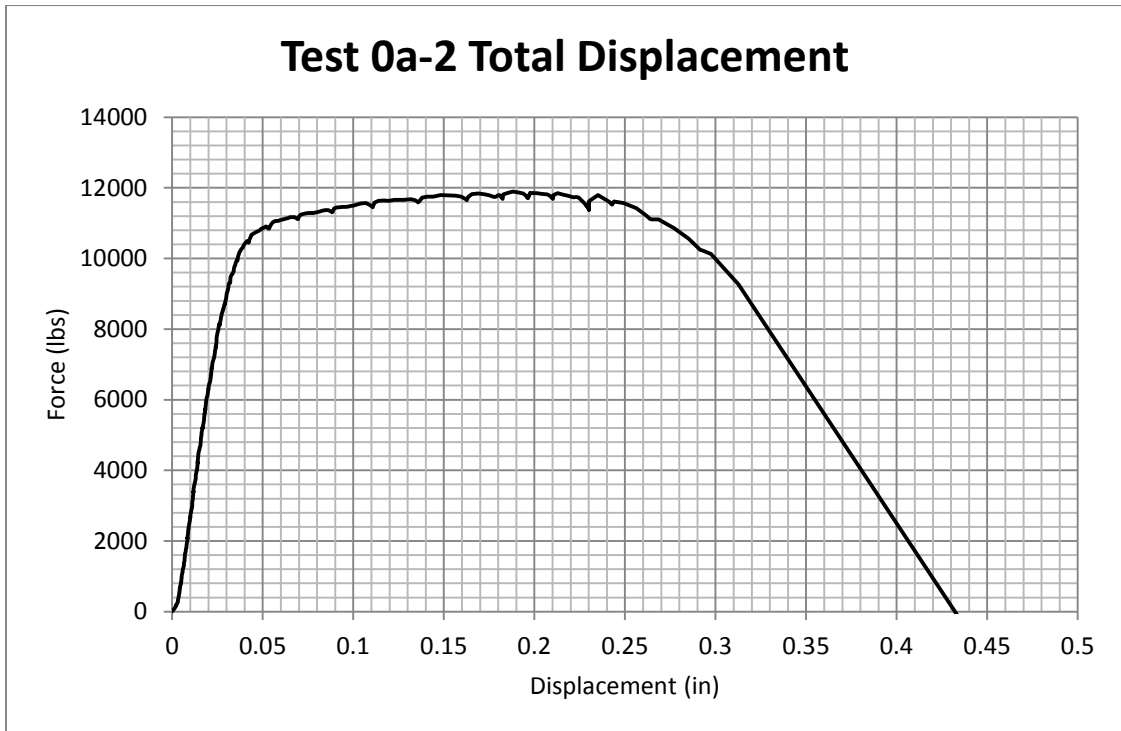

Figure 8.13 Experiment 0a-2 plot

Figure 8.13 shows the total displacement (average of two LVDTs) which is the combined displacement of the anchor rod and the displacement of the adhesive. A correction factor from Equation 6 (Cook, et al., 2013) and Equation 7 (Cook, et al., 2013) was determined. This correction factor was applied to data from elastic portion of experiment 0a-2 to determine how much of the displacement was from the adhesive.

For experiment 0a-2:

$l = 3 \text{ in (50.8mm)}$,

$A_e = 0.307 \text{ in (7.8mm)}$

$E = 29,000 \text{ ksi (199,947MPa)}$

$\delta_{cor} = 0.0003369 \text{ in/kip (0.0001924 cm/kN)}$

For experiment 0a-2, the adjusted displacement, the averaged measured displacement, and the calculated steel displacement are shown in Figure 8.14 only for the elastic range of the anchor rod. The horizontal distance between the corrected displacement and the total displacement is the calculated elastic deformation of the anchor rod. Yield of the exposed anchor occurred at 0.0036 in (0.0914 mm) and 10.4 kips (46.3 kN) from Figure 8.15. It is unclear from Figure 8.14 if the adhesive began failing before the steel yielded, or if the steel yielded prior to any bond failure. It is clear, however, measured displacement is a combination of elastic anchor rod displacement and adhesive displacement. This test showed the need for high strength steel to properly determine static capacity. Total averaged displacement was calculated from two LVDTs attached to the bottom of the non-rigid coupler. One of the LVDTs recorded positive displacements while the other recorded negative displacements. For this test, positive displacement is an increase in distance between the bottom of the non-rigid coupler and the top of the confining sheet. One negative displacement and one positive displacement shows the non-rigid coupler was rotating as well as moving vertically. Data from the two LVDTs and the

average of the two are shown in Figure 8.15. This same phenomenon was experienced in test 0a-3 and 0a-4. This rotation is attributed to improper alignment and will be corrected in future testing by ensuring proper alignment of test apparatus.

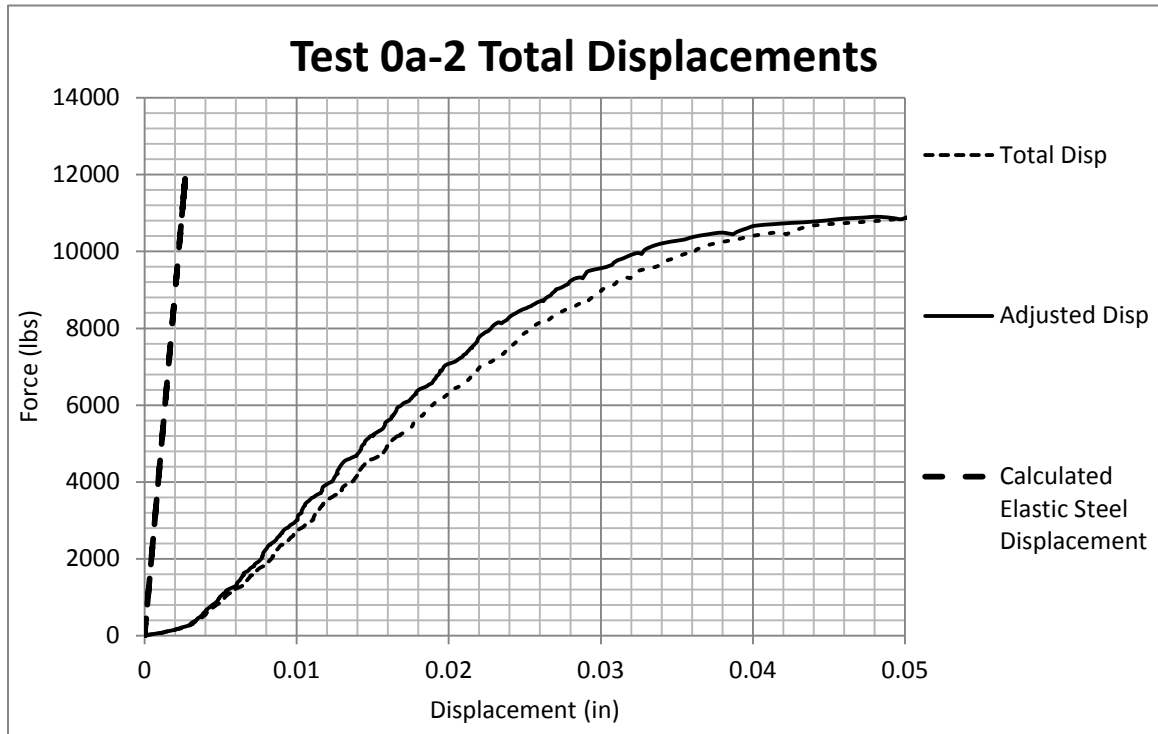

Figure 8.14 Test 0a-2 Anchor Rod Elastic Displacements and Adhesive Displacements

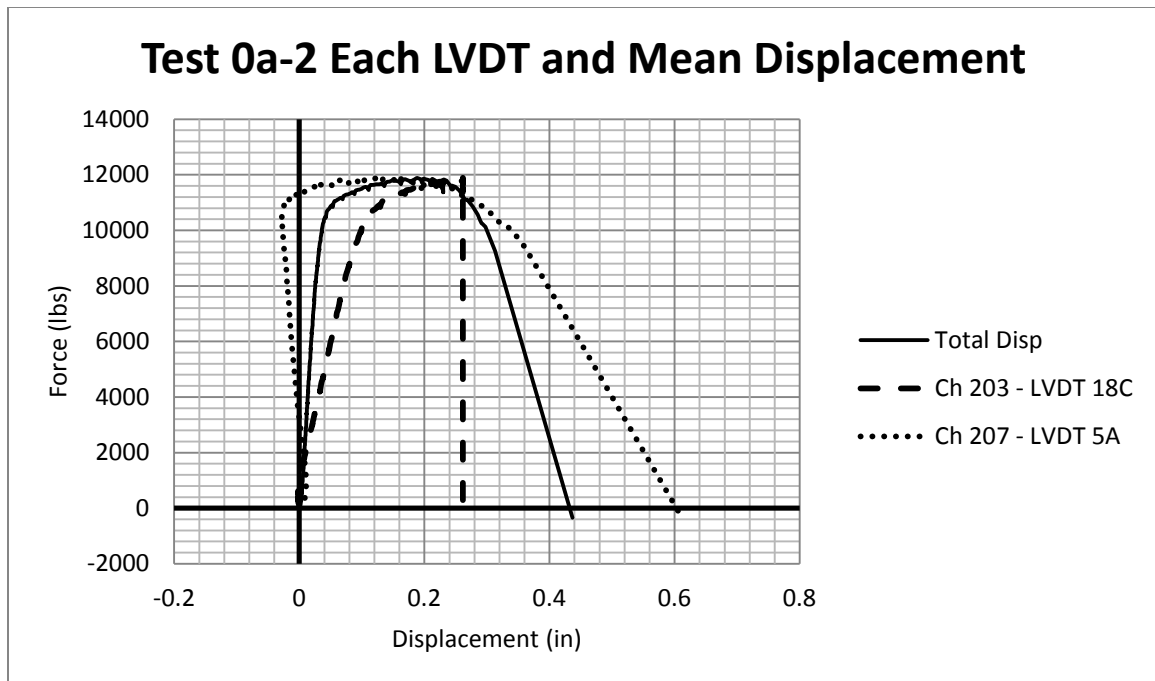

Figure 8.15 Test 0a-2 Individual LVDT displacements and Average displacement

In order to continue testing the adhesive in test series 0a, creep tests were conducted at loads close to the yield strength of the anchor rod. Test 0a-3 was conducted over a short period of time due to the specimens being outdoors and data is not presented because of the short experiment time. Figure 8.16 shows displacement vs time from after loading to 9.8 kips (43.6 kN). A small increase in displacement at 862,000 seconds is elastic deformation from increasing the load from 9.8 kips (43.6 kN) to 10.2 kips (45.3kN). This displacement was averaged from two LVDTs attached to the bottom of the non-rigid coupler. Total creep displacement from day 7 to termination of the experiment on day 25 was 0.0056 in (0.142 mm). This includes subtracting the elastic deformation from the load increase at 862,000 seconds. Figure 8.17 shows the total force vs average displacement as measured by the load cell and the two LVDTs for test 0a-4. Horizontal lines on the plot show displacement under sustained load. All three lines show creep at the three sustained load rates. The large decreases in load with no change in displacement

are from releasing the jack and the loading nut coming into bearing on top of the spring. Figure 8.18 shows the two LVDTs and their average plotted against time. Periods of loading are vertical lines on this plot and creep is the increase in displacement over time. Both Figure 8.17 and Figure 8.18 show the rotation of the non-rigid coupler, causing one of the LVDTs to measure negative displacement and the other to measure positive displacement. The creep displacements from both LVDTs are increasing positive with time.

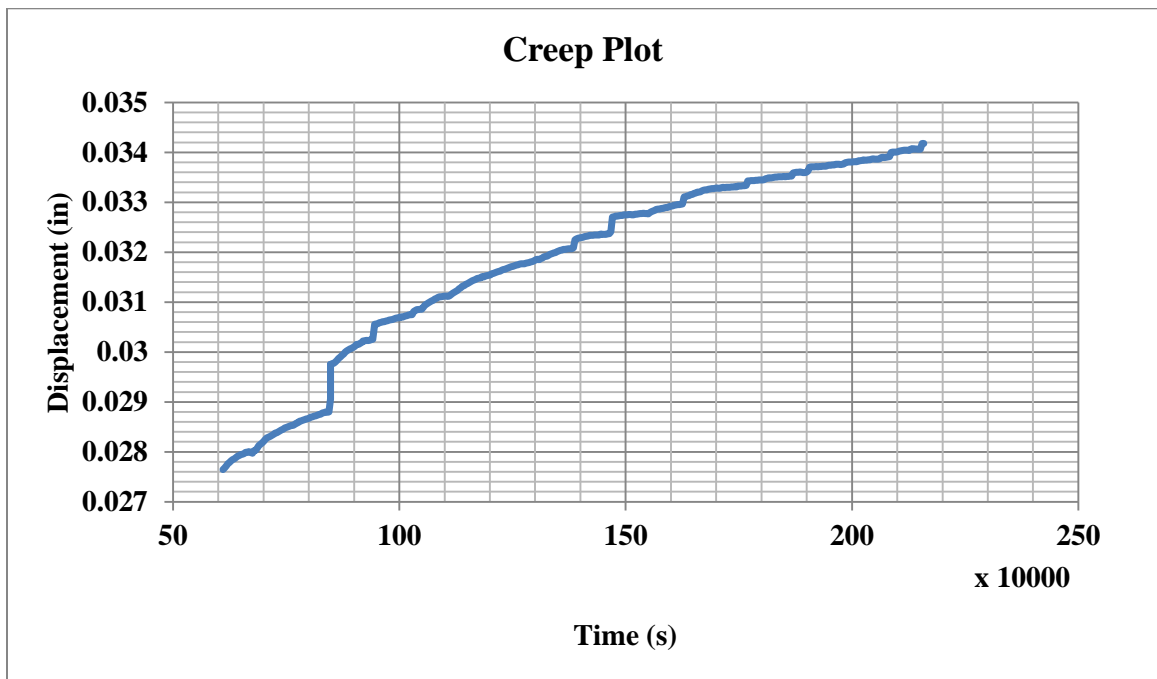

Figure 8.16 Experiment 0a-4 Creep Displacement

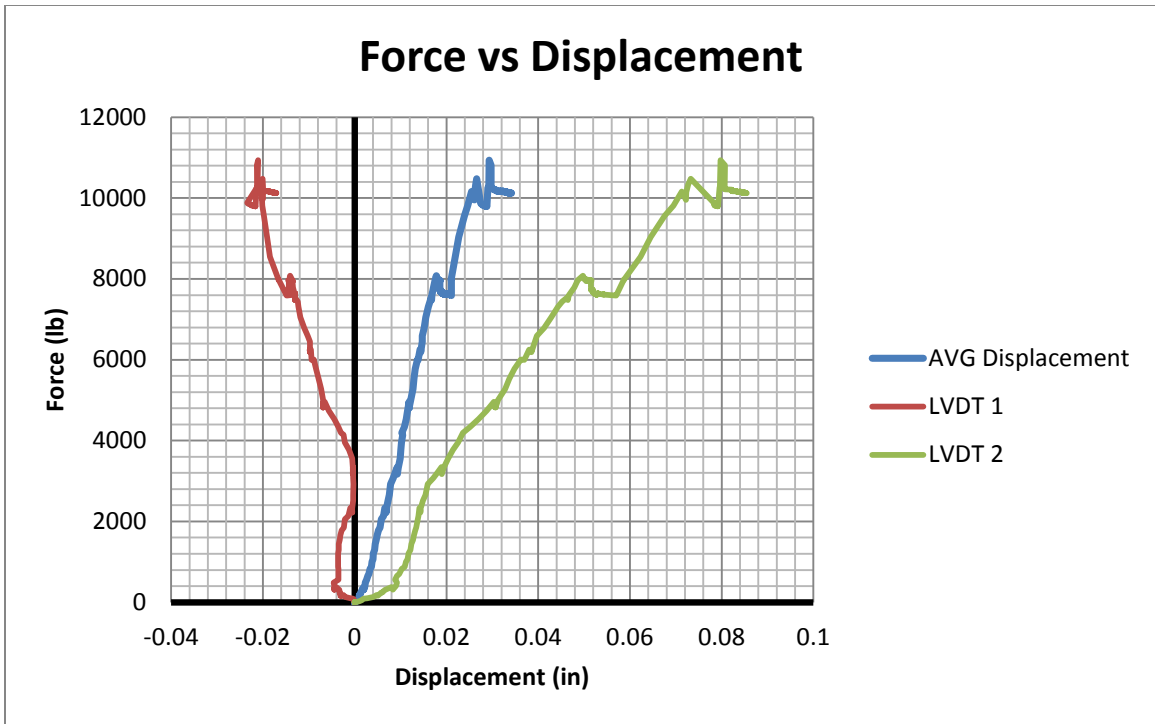

Figure 8.17 Test 0a-4 Force vs Displacement LVDT-1, LVDT-2, Average

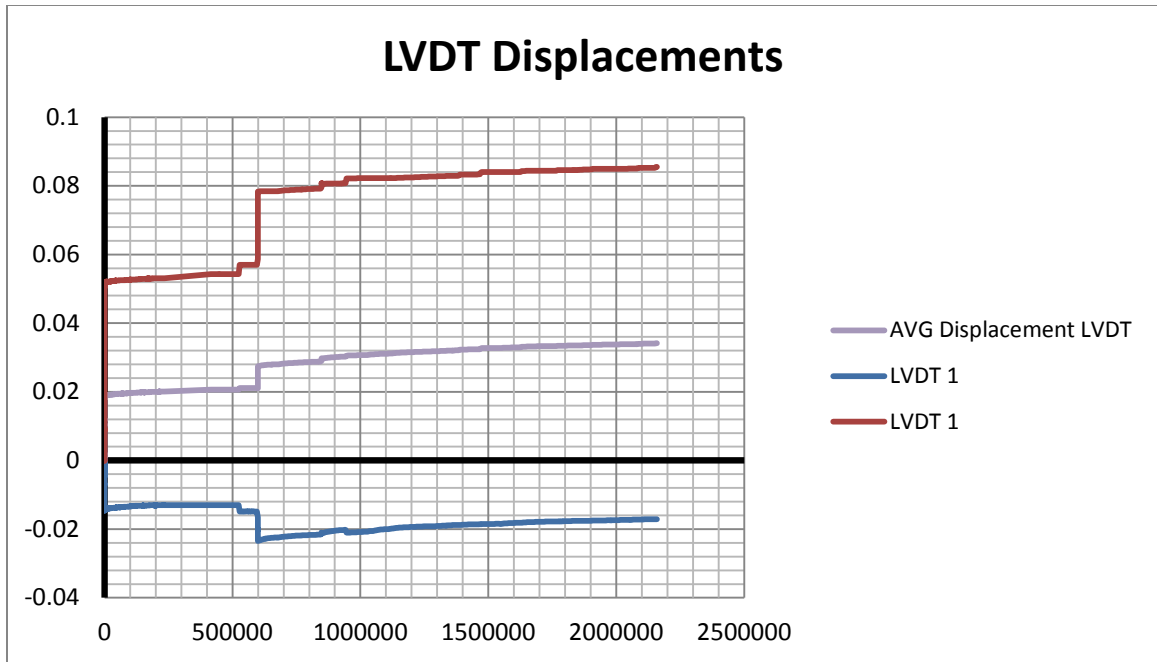

Figure 8.18 Test 0a-4 LVDT 1, LVDT 2, and Average Displacements vs. Time

The final results to show from test 0a-4 are from the spring displacements, Figure 8.20.

Four string potentiometers were used to measure the spring displacement in four corners, Figure 8.19. This gives a representation of the deformation of the spring in three planes. These results show the spring is bending as in test 0a-3. It is believed putting the load cell on the spring caused some of this rotation, as well as possible misalignment of the entire set up. This test shows that care must be taken when aligning the test set up.

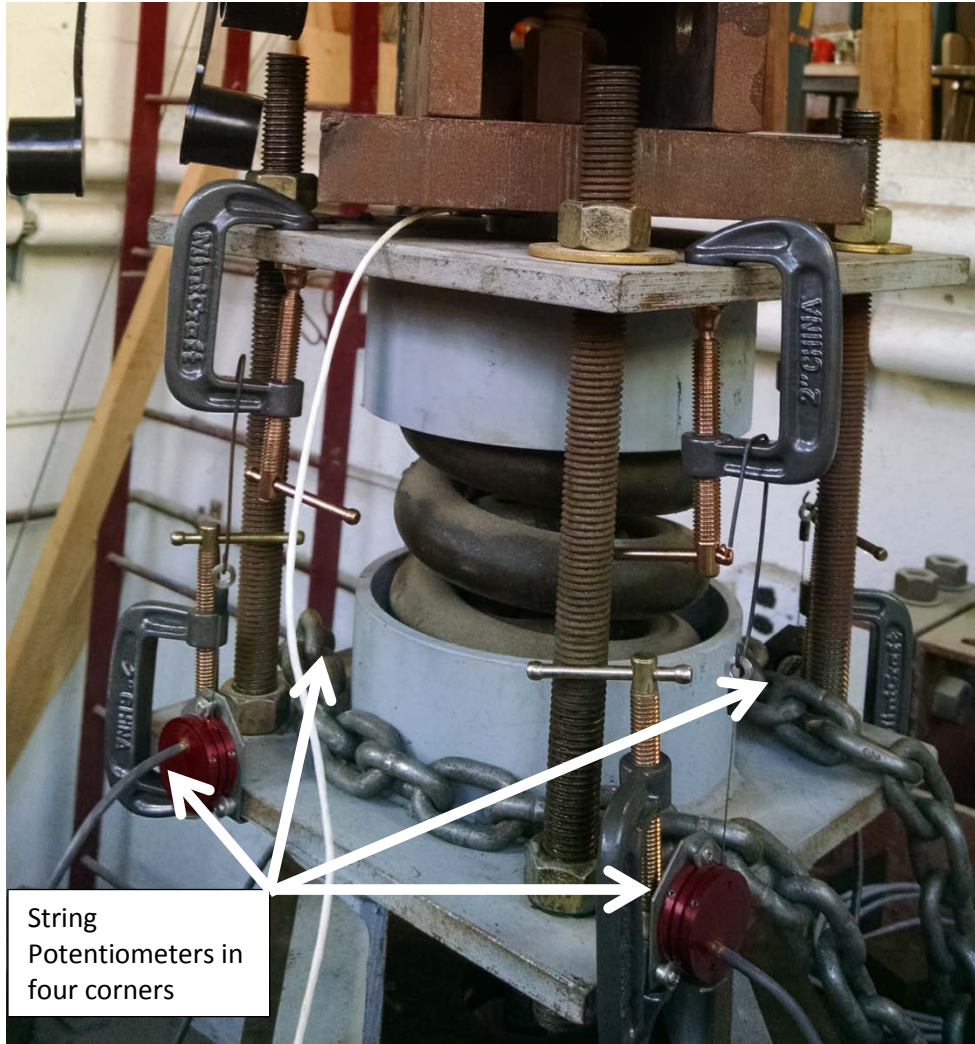

Figure 8.19 String Potentiometer Placement

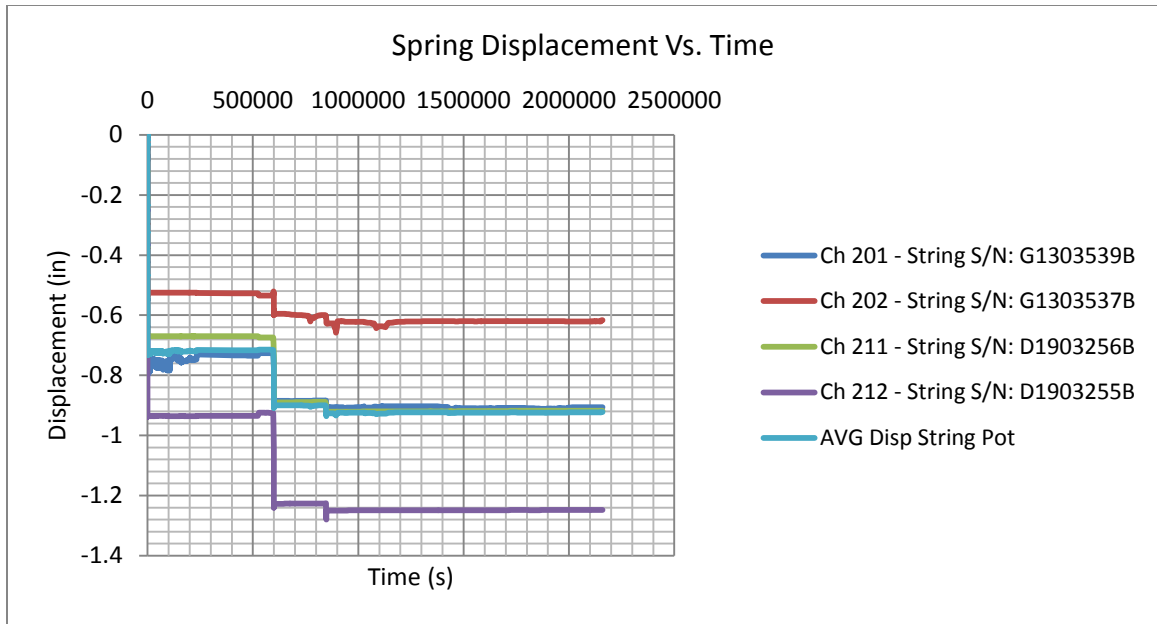

Figure 8.20 Test 0a-4 Measured Spring Displacements

8.2.2 Test Series Results Test Series 0b

Two static tests were conducted in this test series. Both of these tests resulted in tensile failure of the steel, one at 27 kips (120 kN) and one at 29 kips (129 kN), Figure 8.21. The non-rigid coupler used for these tests had an hole diameter of 15/16 in. (23.81 mm) for the 5/8 in (15.88 mm) diameter anchor rod. This hole diameter was to accommodate potential future testing of larger diameter anchor rods, but did not work with this diameter anchor rod. Steel washers were used to step down the hole size for the 5/8 in (15.88 mm) diameter anchor rod. These washers deformed significantly at the failure load, Figure 8.21. The washer deformation caused displacement of the non-rigid coupler that was measured by the LVDTs. This additional displacement from the washers made the displacement data from these tests invalid. This steel failure was an unexpected result based on previous results from Cook et. al (2013). Originally, five static tests were planned for this test series, but after two steel failures, the rest of the

static tests were cancelled. The bond strength of this adhesive is greater than the tensile capacity of the threaded rod. Future testing will use ASTM A354 GR BD threaded rod with a capacity of 33.9 kips (150.8 kN) compared to the ASTM A 193 GR B7 threaded rod with a capacity of 28.25 kips (125.7 kN) used in this test.



Figure 8.21 Test Series 0b anchor failure and washer deformation

One long term test was conducted as part of test series 0b. This test was loaded to the maximum capacity of the springs, 21 kips (93.4 kN) on December 13th, 2014. As of February 16th, 2015 this test was still running. The data acquisition system used for this experiment stopped working shortly after this test was loaded, so no displacement data is available.

8.2.3 Test Series Results Test Series 0c

Tests on the cementitious anchors were planned, but not conducted as part of this MS Research Project. Testing of this series will be conducted as future work.

8.3 Conclusions

Many lessons were learned from Test Series 0a. The data from this test series is not valid for comparing performance of adhesive anchor systems, but it is valid to show the functionality of the designed test apparatus. It also led to changes in testing procedures for Test Series 0b and 0c. Test 0a-1 shows that the short term test set up is capable of applying a failure load to an anchor. Tests 0a-2 and 0a-3 led to a new design for the non-rigid coupler. Test 0a-4 shows that a sustained load can be applied to an anchor and that the load and displacement can be measured. Test 0a-4 also shows the need to take care when aligning a long-term test set up to avoid non-vertical displacements of the spring. Overall, Test series 0a shows that sustained load experiments produce expected results. Lessons from this test series were applied to Test Series 0b and 0c.

Test Series 0b lead to a re-design of the non-rigid coupler with a hole 1/16 in (1.59 mm) larger than nominal anchor diameter used in testing. The failure of the B7 threaded rod lead to future research using the higher capacity ASTM A354 GR BD threaded rod. This test series also showed a potential need to measure displacement of the anchor from a different point than the non-rigid coupler. Future researches will investigate methods of measuring displacement from the top of the anchor rod instead of at the non-rigid coupler.

Test set ups discussed in Chapter 7 are a result of a thorough literature review and preliminary experiments and represent the main conclusion of this MS research project.

CHAPTER 9

RECOMMENDED FUTURE WORK

Future work on this project is already scheduled. Table 9.1 provides a matrix of future testing for the next phase of this project. These tests will be conducted on three adhesives. All three adhesives have been tested to ICC-ES 308 standards.

Adhesive A

Adhesive A is the same adhesive used in test series 0b. This adhesive is a combination of Bisphenol A and Bisphenol F epoxy resins with fillers and m-xylene diamine and aliphatic polyamine hardeners. The manufacturer lists an uncracked bond stress of 2,140 psi (14.75 MPa) for 5/8 in (15.9 mm) diameter threaded rod. This would equate to a static capacity of 13.1 kips (58.2kN).

Adhesive B

Adhesive B is a BisphenolA/Epichlorohydrin (Epoxy Resin) with a Dimethaneamine hardener. It lists an uncracked bond stress of 2,075 psi (14.3 MPa) which should cause bond failure at 12.7 kips (56.5 kN) for these tests.

Adhesive C

Adhesive C is Bisphenol A and Bisphenol F epoxy resins with amine hardeners. The listed uncracked bond stress is 2,148 psi (14.7MPa) and should have a static capacity of 13 kips (58 kN) for this research.

Table 9.1 Proposed Test Matrix for Follow On Testing

Test Series	Test Procedure	Installation Conditions	Anchor Rod Type	Adhesive	Hole Size	Embedment Depth	Static Tests	85% MSL	80% MSL	75% MSL	70% MSL	65% MSL	60% MSL
1a	AASHTO TP-84	Indoor	A354 BD Threaded Rod	Adhesive A	3/4 in 19mm	3.125 in (79mm)	5	1	2	2	2	2	1
1b	AASHTO TP-84	Indoor	A354 BD Threaded Rod	Adhesive B	3/4 in 19mm	3.125 in (79mm)	5	1	2	2	2	2	1
1c	AASHTO TP-84	Indoor	A354 BD Threaded Rod	Adhesive C	3/4 in 19mm	3.125 in (79mm)	5	1	2	2	2	2	1

Future work beyond Table 9.1 would be to continue exploring the creep characteristics of cementitious anchors. Other future testing should look at the combined effects of parameters. Currently, tests of just one parameter are used to find a reduction factor and individual reduction factors are applied. Testing an anchor under multiple parameters to determine if effects are additive would be worthwhile. For example, an anchor could be installed in moistened concrete, cured in a moist environment for the minimum manufacturer’s recommendation, and then tested under sustained load at high heat. This final sustained load test could be compared to individual tests of moisture during installation, moisture during curing, minimum cure time of adhesive, and sustained loading to determine if testing one parameter at a time is a valid way to predict performance under combined conditions.

9.1 Tasks required to complete MassDOT Project Phase I

Future researchers will be completing all work required for the larger MassDOT project. This section represents a checklist for future researchers to complete tasks required prior to initiating the first formal test series.

- Cut and fit confining sheets

- Label each set of springs and determine spring stiffness for each set of springs both individual and in parallel.
- Design and install heat and humidity control system for the environmental chamber.
- Calibrate environmental chamber by installing thermistors on a three dimensional grid to determine heat distribution within the chamber. Adjust heater location and control system until all thermistors are within the specified temperature range.
- Drill holes and install anchor rods for first two test series.
- Program and calibrate data acquisition system.

9.2 Step by Step procedure for each adhesive tested

The remainder of this chapter is devoted to a generalized step by step procedure to follow for each test from casting of the concrete through data analysis.

Step 1: Cast concrete samples in at least one batch per test series. Each test series should consist of at least 18 specimens to allow for at least 5 static tests and at least 10 creep tests and up to three extras in case of cracking during curing. After specimens are cast, they should be kept moist to allow for proper hydration of the cement and allowed to cure for 28 days before holes are drilled.

Step 2: Test specimen should be $75 \pm 10^{\circ}\text{F}$ ($24 \pm 5^{\circ}\text{C}$) and $50 \pm 10\%$ relative humidity prior to anchor installation. Holes should be drilled in accordance with manufacturer recommendations. Holes should be perpendicular to the surface of the concrete. Holes should be drilled to the desired embedment depth. Insert a rod marked at the embedment depth periodically while drilling to ensure proper depth.

Step 3: Clean holes in accordance with manufacturer's recommendations. All anchors of a test series should be installed on the same day. All holes should be drilled and cleaned prior to the first hole being filled with bonding material.

Step 4: Fill one hole with bonding material, then place the anchor rod, then remove excess adhesive before moving onto the next anchor hole. Cleaned holes should be kept covered until adhesive is ready to be placed.

Step 5: Cure bonding material according to the manufacturer recommendations, and then place the specimens into the environmental chamber until they reach proper temperature. Creep tests should be placed in the chamber with the steel apparatus attached, but no load applied. Ensure apparatus is centered around anchor rod at this point. Tighten a nut on the loading rod over the spring housing frame to keep everything aligned while moving into the chamber. Measure the exposed anchor rod length from the top of the concrete to the center of the nut holding the anchor rod to the non-rigid coupler. Record this number for use in calculating elastic displacement of the exposed anchor rod.

Step 6: Once specimens have reached proper temperature and maintained this condition for a minimum of 24 hours, conduct five static tests. Average the static capacity from these tests to get the MSL as a basis for creep test load.

Step 7: Systematically load all sustained load anchor setups to the predetermined percent of MSL, keeping them in the environmental chamber. Specimens with the lower percentage of MSL should be placed toward the back of the chamber, while higher percentage of MSL are placed near the front of the chamber.

Step 8: Monitor the displacement of the anchor rods during the creep tests. Only remove specimens from the environmental chamber if additional space in the chamber is needed. Keep doors of the chamber closed when possible.

Step 9: Record final displacement, initial applied load, final applied load (based on displacement and spring stiffness), and time at rupture for each specimen. Build a stress vs. time to failure for each adhesive.

REFERENCES

- AASHTO TP-84. (2010). *Standard Method of Test for Evaluation of Adhesive Anchors in Concrete under Sustained Loading Conditions*. Washington D.C.: American Association of State Highway and Transportation Officials.
- ACI 355.4. (2011). *Qualification of Post-Installed Adhesive Anchors in Concrete*. Farmington Hills, MI: American Concrete Institute.
- ACI Committee 318. (2002). *Building Code Requirements for Structural Concrete (ACI 318-02) and Commentary (318R-02)*. Farmington Hills: American Concrete Institute.
- ASTM C1107. (2013). *Standard Specification for Packaged Dry, Hydraulic-Cement Grout (Nonshrink)*. West Conshohocken, PA: ASTM International.
- ASTM D2990. (2009). *Standard Test Method for Tensile, Compressive, and Flexural Creep and Creep-Rupture of Plastics*. West Conshohocken, PA: ASTM International.
- ASTM E1512. (2007). *Standard Test Method for Testing Bond Performance of Bonded Anchors*. West Conshohocken, PA: ASTM International.
- ASTM E488. (2010). *Standard Test Methods for Strength of Anchors in Concrete Elements*. West Conshohocken, PA: ASTM International.
- Conard, R. F. (1969). Tests of Grouted Anchor Bolts in Tension and Shear. *ACI Journal*, 725-728.
- Cook, R. A., & Burtz, J. L. (2003). *Design Guidelines and Specifications for Engineered Grouts*. Tallahassee, FL: Florida Department of Transportation.
- Cook, R. A., Douglas, E. P., & Davis, T. M. (2009). *NCHRP Report 639 Adhesive Anchors in Concrete Under*. Washington D.C.: Transportation Research Board.
- Cook, R. A., Douglas, E. P., Davis, T. M., & Liu, C. (2013). *NCHRP Report 757: Long-Term Performance of*. Washington D.C.: Transportation Research Board.

- Cook, R. A., Kunz, J., Fuchs, W., & Konz, R. C. (1998). Behavior and Design of Single Adhesive Anchors under Tensile Loading in Uncracked Concrete. *ACI Structural Journal*, 95(1), 9-26.
- El Menoufy, A., & Soudki, K. (2014). Effects of Various Environmental Exposures and Sustained Load Levels on the Service Life of Postinstalled Adhesive Anchors. *Journal of Materials in Civil Engineering*, 26(5), pp. 863-871.
- Eligenhausen, R., Fuchs, W., & Mayer, B. (1987). Loadbearing Behaviour of Anchor Fastendings in Tension. *Betonwerk & Fertigteil-Technik (Wiesbaden)*(12), pp. 826-832.
- FDOT. (2000). *Florida Method of Test for Anchor System Tests for Adhesive Bonded Anchors and Dowels*. Tallahassee, FL: Florida Department of Transportation.
- FDOT. (n.d.). *FM 5-565 to FM 8-RP13B-4*. Retrieved July 15, 2014, from Florida Department of Transportation State Materials Office:
<http://www.dot.state.fl.us/statematerialsoffice/administration/resources/library/publications/fstm/fstmpage6.shtm>
- Fuchs, W., Eligenhausen, R., & Breen, J. (1995). Concrete Capacity Design (CCD) Approach for Fastening to Concrete. *ACI Structural Journal*, 92(1), 73-94.
- ICC-ES AC308. (2009). *Acceptance Criteria for Post-Installed Adhesive Anchors in Concrete Elements*. Whittier, CA: ICC Evaluation Services Incorporated.
- ICC-ES AC308. (2013). *Acceptance Criteria for Post-Installed Adhesive Anchors in Concrete Elements*. Whittier, CA: ICC Evaluation Services Incorporated.
- James, R. W., De la Guardia, C., & McCreary, C. R. (1987). Strength of Epoxy-Grouted Anchor Bolts in Concrete. *Journal of Structural Engineering*, 113(12).
- MassDOT. (2010, April 20). Engineering Directive E-10-001. Boston, Massachusetts: MassDOT.

- McDonald, W. E. (1998). *Evaluation of Grouting Materials for Anchor*. US Army Corp of Engineers.
- NTSB. (2007). *Highway Accident Report: Ceiling Collapse in the Interstate 90 Connector Tunnel Boston, Massachusetts, July 10, 2006*. Washington, D.C.: National Transportation Safety Board.
- Rodriquez, M., Lotze, D., Gross, J. H., Zhang, Y. G., Klingner, R. E., & Graves, H. L. (2001, July-August). Dynamic Behavior of Tensile Anchors to Concrete. *ACI Structural Journal*, 98(4), 511-524.
- Sakrete. (2014). Anchor Cement Technical Data. b: Sakrete.
- Subramanian, N., & Cook, R. A. (2004). Behaviour of Grouted Anchors. *Indian Concrete Journal*, 14-21.
- Zamora, N. A., Cook, R. A., Konz, R. C., & Consolazio, G. R. (2003, March-April). Behavior and Design of Single, Headed and Unheaded, Grouted Anchors under Tensile Load. *ACI Structural Journal*, pp. 222-230.