

2011

# Mobile personal health care system for patients with diabetes

Fuchao Zhou  
*Iowa State University*

Follow this and additional works at: <https://lib.dr.iastate.edu/etd>

 Part of the [Computer Sciences Commons](#)

---

## Recommended Citation

Zhou, Fuchao, "Mobile personal health care system for patients with diabetes" (2011). *Graduate Theses and Dissertations*. 10332.  
<https://lib.dr.iastate.edu/etd/10332>

This Thesis is brought to you for free and open access by the Iowa State University Capstones, Theses and Dissertations at Iowa State University Digital Repository. It has been accepted for inclusion in Graduate Theses and Dissertations by an authorized administrator of Iowa State University Digital Repository. For more information, please contact [digirep@iastate.edu](mailto:digirep@iastate.edu).

Mobile personal health care system for patients with diabetes

by

Fuchao Zhou

A thesis submitted to the graduate faculty  
in partial fulfillment of the requirements for the degree of  
MASTER OF SCIENCE

Major: Computer Science

Program of Study Committee:  
Johnny S. Wong, Major Professor  
Carl K. Chang  
Simanta Mitra

Iowa State University

Ames, Iowa

2011

Copyright © Fuchao Zhou, 2011. All rights reserved.

## TABLE OF CONTENTS

LIST OF FIGURES	iv
LIST OF TABLES	v
ACKNOWLEDGEMENTS	vi
ABSTRACT	vii
CHAPTER 1. OVERVIEW	1
1.1 Introduction	1
1.2 Motivation	2
1.3 Contributions	3
1.4 Road map	3
CHAPTER 2. LITERATURE REVIEW	5
2.1 Health monitoring system	5
2.1.1 Common architectures for health monitoring system	5
2.1.2 A mobile architecture for diabetes management	7
2.2 Health support system	8
2.2.1 On-line personal health records management platform	8
2.2.2 Existing systems in the smart home lab at Iowa State University	9
CHAPTER 3. SYSTEM DESIGN AND SOFTWARE IMPLEMENTATION	10
3.1 System Design	10
3.1.1 Wearable sensors	11
3.1.2 3G smart phone	11
3.1.3 Web services	12
3.1.4 Google sheet	12
3.2 Software framework and implementation	12
3.2.1 Introduction to Android development	12
3.2.2 Introduction to KSOAP2	14
3.2.3 Introduction to AChartEngine	15
3.2.4 Software framework	15
3.2.4.1 GUI module	16
3.2.4.2 Interface module	17
3.2.4.3 Inference module	17
3.2.4.4 Notification module	18
3.2.5 Class diagrams for Android application	18
3.2.5.1 Common database interface	20
3.2.5.2 MyHealthSys	21
3.2.5.3 HealthGoal	22
3.2.5.4 HealthTeam	24
3.2.5.5 TestResult	26
3.2.5.6 Medications	28
3.2.5.7 Exercise	29
3.2.5.8 SysSetting	31
3.2.6 Integration with GPS, Google search and Google Map	33

CHAPTER 4 BEHAVIORAL MODIFICATIONS FLOWCHARTS AND CASE STUDY	37
4.1 Behavioral modifications flowcharts	37
4.1.1 Medications	39
4.1.2 Diet	39
4.1.3 Exercise	40
4.2 Case study	40
4.2.1 BioHarness™ BT and Bluetooth communications	41
4.2.2 Communication module in Android	43
4.2.2 Analysis for the case study	44
CHAPTER 5 CONCLUSION AND FUTURE WORK	47
5.1 Conclusion	47
5.2 Future work	47
BIBLIOGRAPHY	49

## LIST OF FIGURES

Figure 1 CodeBlue communication substrate [5]	6
Figure 2 AlarmNet architecture [9]	7
Figure 3 A mobile architecture for diabetes management	8
Figure 4 System architecture of mobile personal health care system	10
Figure 5 Android architecture [24]	13
Figure 6 Software framework of mobile personal health care system	16
Figure 7 Class overview of personal health system	19
Figure 8 Class diagram of common database interface	20
Figure 9 Class diagram of MyHealthSys	21
Figure 10 GUI of the main menu	22
Figure 11 Class diagram of HealthGoal	22
Figure 12 GUI of health care goal	24
Figure 13 Class diagram of HealthGoal	25
Figure 14 GUI of health care team	25
Figure 15 Class diagram of TestResult	26
Figure 16 GUI of blood glucose level test result	27
Figure 17 Class diagram for Medications	28
Figure 18 GUI of Medications	29
Figure 19 Class diagram of Exercise	30
Figure 20 Class diagram of SysSetting	31
Figure 21 GUI of SysSetting	32
Figure 22 Class diagram for the integration of GPS, Google search and Google Map	34
Figure 23 Hospitals near to you	35
Figure 24 Direction to the selected hospital and Street view	36
Figure 25 Behavioral flow chart	38
Figure 26 The work flow of case study	41
Figure 27 Basic Message Format	42
Figure 28 Breathing rate message	43
Figure 29 Class diagram for ExerciseMonitorService	44
Figure 30 The real-time and history data in the system	45

**LIST OF TABLES**

Table 1. Health goal table .....	23
Table 2. Test result table .....	27
Table 3. Exercise table .....	30

## **ACKNOWLEDGEMENTS**

I would like to take this opportunity to express my thanks to those who helped me with various aspects of conducting research and the writing of this thesis.

First and foremost, I would like to thank my major professor Prof. Johnny .S Wong for providing me an opportunity for working on this research topic, and his guidance and support throughout the initial stages of my graduate career, this research, the writing of this thesis. His invaluable insights and words of encouragement have often inspired to complete my graduate study.

I would also like to thank Prof. Carl K. Chang and Dr. Simanta Mitra for serving on my thesis committee. Thank you for your support and guides at the smart home lab.

Lastly, I would like to thank Dr. Hen-I Yang for his guidance.

## **ABSTRACT**

In this thesis, we propose a personal diabetes monitoring system which integrates wearable sensors, 3G mobile phone, smart home technologies and Google sheet to facilitate the management of chronic disease - diabetes. The system utilizes wearable sensors and 3G cellular phone to automatically collect physical signs, such as blood glucose level, blood pressure and exercise data like heart rate, breathing rate and skin temperature. It allows users, especially seniors with diabetes, to conveniently record daily test results and track long term health condition changes regardless of their locations. It does so without having to ask users to manually input them into the system. The system also utilizes Google sheet to manage Personal Health Records (PHRs), which not only bridges the gaps between patients and different health care providers but enabling accesses to patients' PHRs anywhere and anytime by taking advantage of the universal accessibility of Google sheet. The system further integrates with GPS, Google Search and Google Map functionalities to facilitate the user to find all hospitals near to his/her current location including address, phone number, directions to the selected hospital and street view of the selected hospital.



## **CHAPTER 1. OVERVIEW**

### **1.1 Introduction**

There is no doubt that healthcare is a social-scale problem. Especially with the elderly populations increasing, the burden of healthcare is steadily increasing. Also, health care providers are faced with a shrinking professional care giving force, which means there is a need for the patients' family members, friends and communities to involve in the care activities. Thus, there is an urgent need for building collaborative care environment to maximize caregivers' efficacy, to improve the safety and quality of care by providing timely health information to professional health care providers, patients and patients' family members or friends.

In recent years, small and wearable sensors have become widely available, which allows convenient and non-intrusive monitoring of patients' blood glucose, medicine intake and life styles, e.g., daily diet and exercise. In addition, contemporary 3G smart phones incorporate unforeseen computational powers which include internal database, voice recognition, GPS position and continuous access to local wireless networks and the Internet. The latest International Telecommunication Union (ITU) statistics reveals that there were about 4.6 billion mobile-phone users by the end of the year 2009 as compared to the total number of the Internet users was just above 1.5 billion [1]. This makes newer cellular phones a very promising mobile platform for advanced applications. To complete the picture, we observe that the growing popularity in the third-party online data storage platform with security and privacy features, such as Google sheet. The advantages of Google sheet includes: (1) facilitates information sharing between patients and multiple health care

providers; (2) maintains comprehensive PHRs and provide easy access to the patient's own PHRs from any location at any time; (3) exports the PHRs into a trusted third-part health-care system for analysis purpose. Thus, it is possible to bring wearable sensors with Bluetooth, 3G smart phone and Google sheet together to create a personalized, integrated, and collaborative care system for real-time, long-term and remote self-monitoring the physical signs of patients like blood glucose, electrocardiogram (ECG) and blood pressure on a daily basis, which would improve people's long-term health, especially for chronic patients.

## **1.2 Motivation**

Diabetes is one of the most widely spread chronic diseases. In the United States, nearly 13 percent of adults aged 20 and older have diabetes. Diabetes is especially common in the elderly: nearly one-third of those aged 65 and older have the disease. It is suggested in a publication of the Department of Health and Human Services that in order to keep glucose at a healthy level, people with diabetes need to keep a balance between three important aspects: diet, exercise and diabetes medicine in daily routine [2, 3, 4]. Therefore, continuous self-monitoring of the blood glucose (blood sugar), daily diet, physical activity and medicine intake are crucial for the management of diabetes.

In this thesis, we design a personalized, integrated, and collaborative care system for self-monitoring and managing diabetes. The system monitors the blood glucose levels, collects information about the daily diet, medicine taken and exercise done. It is important for patients to monitor their own health conditions, to receive warning and guidance to adjust their behavior during their daily routine, and to be able to navigate intricate interaction

among diet, exercise and medications. Also, the system is to integrate mobile-based and smart home-based health monitoring systems with Google sheet, breaking down the wall between the patient, patient's family members and different health care providers such that they can now provide collaborative care for the patient.

### **1.3 Contributions**

The major contribution of this paper is that we build a personal diabetes monitoring system which integrates wearable sensors, 3G mobile phones, smart home technologies and Google sheet to facilitate the management of diabetes conditions. The system further integrates with GPS, Google search and Google map functionalities to facilitate the user to find all hospitals near to his/her current location including address, phone number, direction to the selected hospital and street view of any of the selected hospital. This diabetes monitoring system not only assist with the tasks of diabetes management, but also improves the medicine and food safety by taking full advantage of features in existing subsystems in smart home and related cutting edge technologies.

### **1.4 Road map**

This thesis is organized as follows. In Chapter 2, we summarize some related work to wearable and pervasive health monitoring systems. Chapter 3 describes the integrated architecture design including software, hardware and communication interfaces among different components of the system, and gives the software architecture design in mobile phone and its implementation. More detail explanation is given to outline the implementation of web services in smart home and the integration of GPS, Google search and Google map.

In Chapter 4, we describe the behavioral modification flowchart and the case study. Finally, conclusion and future work are presented in Chapter 5.

## **CHAPTER 2. LITERATURE REVIEW**

We summarize the healthcare system as two categories: 1) health mentoring system which is designed for monitoring physical vital signs of patients like blood glucose level, ECG and blood pressure; 2) health support system which is designed to facilitate the people's daily activities like taking medicine timely and completely, exercise and taking healthy food.

### **2.1 Health monitoring system**

#### **2.1.1 Common architectures for health monitoring system**

Wireless sensor networks (WSNs) and smart phone technology have opened up new opportunities in health monitoring system. The integration of the existing specialized medical technologies with cell phone and wireless sensor networks is a very promising application in home monitoring, medical care, emergency care and disaster response.

In the emergency situations, the most important thing is to determine the rapid and accuracy triage of the patients with limited resource. And the real-time and continuous triage information must be distributed to health care providers. Light weight and no-intrusive biomedical sensors like pulse oximeter and electrocardiogram are easy to be deployed for continuously monitoring the vital signs of a patient and deliver the data to the first responders[5][6][7]. For example, a wireless infrastructure for emergency response, CodeBlue is proposed and implemented as shown in Figure 1.

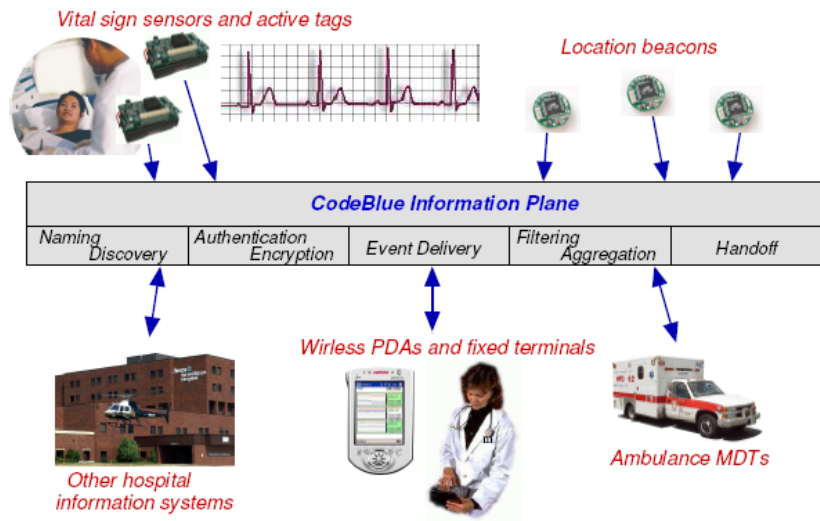

Figure 1 CodeBlue communication substrate [5]

CodeBlue is an efficient wireless communication substrate for medical devices used in an emergency care setting. It addresses ad hoc network formation, naming and discovery, security and authentication, as well as filtration and aggregation of vital sign data. CodeBlue is based on a publish/subscribe model for data delivery, which allows sensing node to publish streams of vital signs, locations, and identities to PDAs or PCs used by caregivers.

The AlarmNet architecture proposed in [8] [9] (Figure 2) is a common architecture which integrates body sensor networks, environment sensors, back-end data management and analysis system, and local or remote user interface.

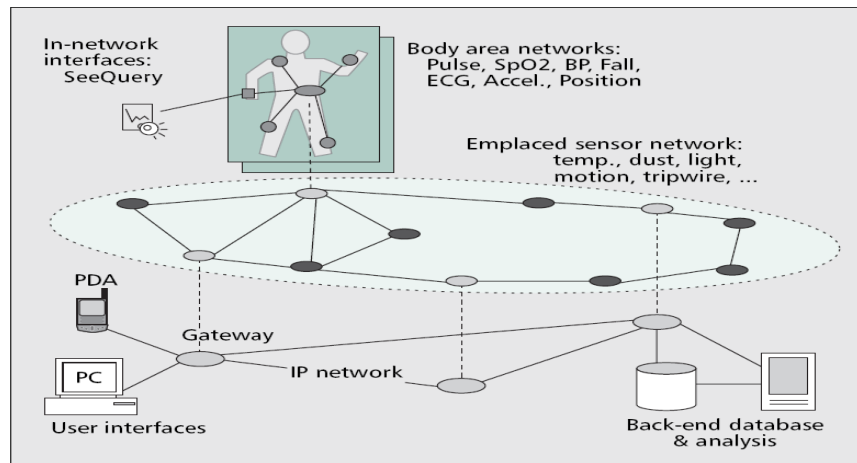

Figure 2 AlarmNet architecture [9]

In [10] [11] [12] [13], the authors proposed a similar architecture as AlarmNet. Body sensor networks are composed of wearable and wireless sensing and monitoring devices. These wearable devices are used to monitor the person's blood glucose level, blood pressure, ECG or to detect fall. Environmental sensors are used to monitor temperatures, humidity, light and motions at home. Also, RFID is widely used to identify items at home. Through the back-bone network, the data collected is transferred to a specific and professional medical management center, which equipped with large storage capability and computing resources to analyze and present the result. Further, the data and result may be distributed to remote PCs, handheld PDA and smart phones by using Wi-Fi, Bluetooth and 3G mobile networks.

### 2.1.2 A mobile architecture for diabetes management

Using mobiles with a multi-access service for the management of diabetic patients was proposed in [14] and shown in Figure 3, which was designed to collect data, either manually or automatically from the blood glucose meter; to monitor blood glucose levels; to

suggest insulin dose adjustment when needed; to deliver monitoring data to a health care center.



Figure 3 A mobile architecture for diabetes management

In [15] [16] [17] [29] [30], they proposed similar architectures as the one shown in Figure 3 for monitoring heart disease. In those systems, the cell phone acts as the controller and gateway. The cell phone collects data from wearable biosensors or independent meters like glucometer and insulin pump through Bluetooth. Also, the cell phone could access Internet delivering collected data to a specific data center through Wi-Fi wireless network or CDMA/3G mobile network.

## 2.2 Health support system

### 2.2.1 On-line personal health records management platform

There are three major on-line Personal Health Records (PHRs) management platform in the market: Dossia [31], Microsoft HealthVault [32] and Google Health [33]. These systems allow users to store and manage the health information in one central place. But the



disadvantage is that they provide a limited health records formats. For example, only the test results like Glucose levels and blood pressures could be stored into them and the exercise data like heart rate, breathing rate, skin temperature could not be stored into them. By using Google sheet, the user could store any data with various data formats. And it is easier to export the data into a trusted third-party health care system for analysis purpose. Also, user could make a decision to share the profile with other family members or health care providers. It also provides Google sheet APIs for the developer so that it can integrate with the applications with Google sheet.

### **2.2.2 Existing systems in the smart home lab at Iowa State University**

In the smart home lab at Iowa State University, several subsystems have already been developed to facilitate the people's daily activities, especially with respect to seniors' healthcare. For example, Smart Microwave and Smart Fridge can identify food and nutrition facts by scanning Universal Product Code (UPC) barcode with the help of U.S. Department of Agriculture (USDA) National Nutrition Database (USDA-NND) downloaded from USDA website, record the person's dietary history, and check conflicts with medicines taken. Watchdog is built not only for house safety but for reminder, like reminding the diabetic patient to carry the medicines and snack when leaving the house. The Medicine Information Support System (MISS) is designed for checking medicine conflicts and facilitating the person to take medicine in compliance for completeness and timeliness, with the support of a Global Medication Conflict Database (MCD) [18] [19].

## CHAPTER 3. SYSTEM DESIGN AND SOFTWARE IMPLEMENTATION

### 3.1 System Design

In this section, we introduce service-orientated system architecture, the software design and implementation of each component including the sensors used in the system and communication technologies among different components. Figure 4 shows the overall picture of the system architecture of our proposed mobile personal health care system for patients with diabetes [20].

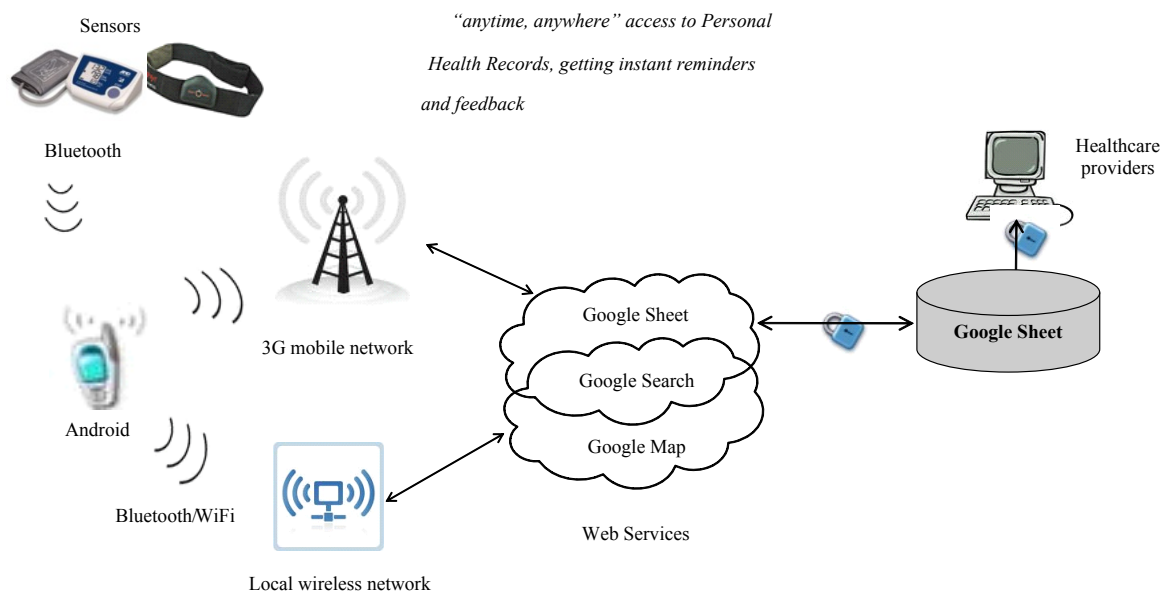

Figure 4 System architecture of mobile personal health care system

The system architecture includes four components: wearable sensors, 3G smart phone, web services and on-line data storage platform – Google sheet. For example, when the patient takes a blood glucose test result, the blood glucose meter will get the blood glucose level, then it will transfer the test result to the smart phone. The cell phone will store this test result into the internal database – Sqlite, and it will further push the test result to Google sheet through the web service. The patient's doctor will get a notification to look at the test result and give the immediate feedback to the patient.

### **3.1.1 Wearable sensors**

Wearable sensors allow convenient, continuous and non-intrusive monitoring of people with diabetes for their test results, medicines, daily diet and exercise. In our prototype, BioHarness™ BT [21] with fabric sensors is used as an exercise tracker measuring the heart rate, breathing rate and skin temperature. Also, we are studying the Bluetooth Blood Pressure device-Withings [22], to trace the person's blood pressure and the Bluetooth-enabled blood glucose meter, MyGlucoHealth® Meter [23], to trace patients' blood glucose level. In our prototype, we simulated the blood glucose data.

### **3.1.2 3G smart phone**

3G smart phone will gather, store and display statistical data from wearable sensors, update daily test results, diet and medicine taken, and get feedback and notification from caregivers. Also, the GPS embedded in the 3G smart phone will keep tracking the user's location which will be used to find all hospitals near to the user through Google Search service. There are two ways for smart phone to interact with Google sheet. In local area,

smart phone detects existing wireless Access Point (AP) and accesses Internet via Wi-Fi wireless networks. Otherwise it resorts to 3G mobile network.

### **3.1.3 Web services**

Web services enable the interaction among the 3G smart phone, existing systems at smart home and Google sheet, Google Map and Google search. They interact with smart home systems like Smart Microwave and Smart Fridge for diet tracking. Google search service provides location based searching for the user to get hospitals near to him/her and shows all of the hospitals in the Google Map. From Google search, the user also could get the name, address and phone number of the hospital. Further, through Google map service, the user could get the direction to the selected hospital and get the street view of any target displayed in the map.

### **3.1.4 Google sheet**

Google sheet is a free online service for patients to maintain their personal data like test results and exercise data. It also allows appropriate access as needed with the permission of the patient to different health care providers. In this system, it is used to manage PHRs and facilitates information sharing between patients and multiple providers.

## **3.2 Software framework and implementation**

### **3.2.1 Introduction to Android development**

Android is a software development platform for mobile devices built upon a foundation of the Linux kernel. It includes library, virtual machine, application framework

and key applications. The Android SDK provides the tools and APIs necessary for developing applications on the Android platform using the Java programming language.

Figure 5 shows an overview of the Android software architecture [24].

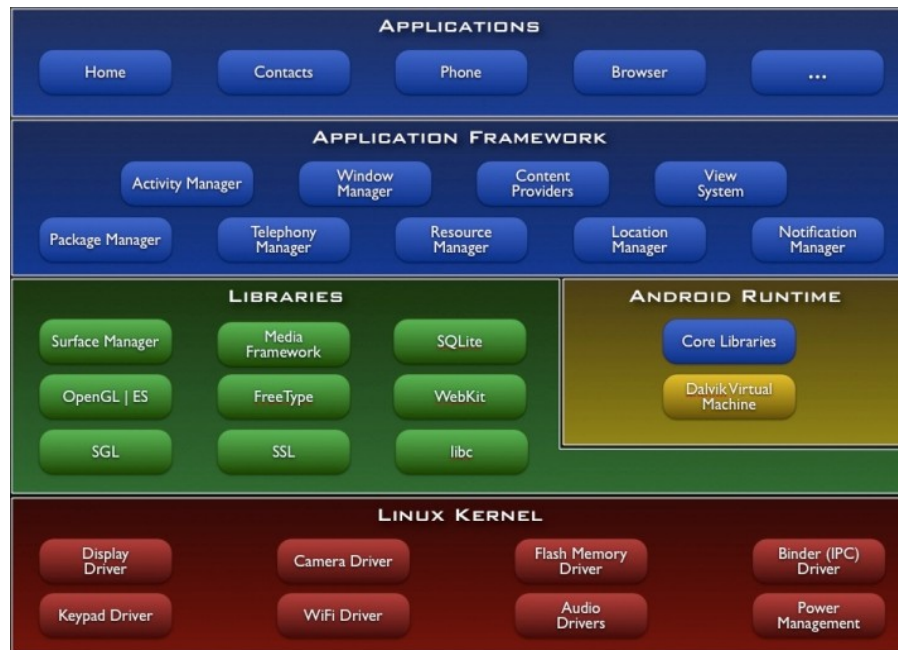

Figure 5 Android architecture [24]

There are many features provided by Android platform for the Android application developer. The UI subsystem includes windows, views lists and edit boxes, widgets, and an integrated browser built upon WebKit. The connectivity options include wireless networks like Bluetooth and Wi-Fi and mobile networks like GPRS, EDGE and 3G. It provides a 2D and 3D graphics library and an embedded Sqlite database. The camera, Google Maps, GPS and accelerometers are also available in the Android. The rich development environment includes a device emulator, memory and performance profiling, tools for debugging, and a plug-in for the Eclipse IDE.

Android applications do not have a single entry point for everything in the application (no `main()` function). An Android application consists of one or more of the four types of components:

**Activities:** An *activity* has a visible user interface. For example, a text messaging application might have one activity that shows a list of contacts to send messages to, a second activity to write the message to the chosen contact, and other activities to review old messages or change settings.

**Services:** A *service* does not have a visual user interface which runs in the background for a period of time. For example, in order to collect the data from wearable sensors, a Bluetooth connection should be setup by using a service running in the background in the application.

**Content providers:** A *content provider* is to manage access to persisted data which is stored in the file system or in a SQLite database. For example, a content provider will be used if you want to make contact list available to multiple activities in your application.

**Broadcast receivers:** A *broadcast receiver* is a component that does nothing but receives and reacts to broadcast announcements. For example, a broadcast receiver is used to receive or send or reply a text message.

### 3.2.2 Introduction to KSOAP2

KSOAP is a light weight SOAP web service client library for J2ME applications, which reduces the overhead for SOAP web services that may be problematic for mobile devices. In the Android application, we use a third-part open source web service framework called KSOAP2-ANDROID which is built upon Ksoap2 library. KSOAP2-ANDROID is a

light weight and efficient SOAP library for the Android platform which is held by Google Code project [25] [26].

### **3.2.3 Introduction to AChartEngine**

AChartEngine is a charting library for Android applications. It currently supports the following chart types: line chart, area chart, scatter chart, time chart, bar chart, pie chart, bubble chart, doughnut chart and range (high-low) bar chart. All of the above supported chart types could contain multiple series, could be displayed with the X axis horizontally (default) or vertically and support many other custom features. The charts can be built as a view that can be added to a view group or as an intent that can be used to start an activity [27].

### **3.2.4 Software framework**

Multi-module software architecture is developed in Android mobile platform and integrates software components with web service technologies. Every module in the architecture is loosely coupled and is implemented by using Activities, Intents and Services in the Android platform. Software architecture of mobile personal health care system for diabetes is illustrated in Figure 6, which include GUI (Graphical User Interface) module, interface module, inference module, and notification module, common database operation interface with internal database Sqlite and KSOAP2 interface with web services.

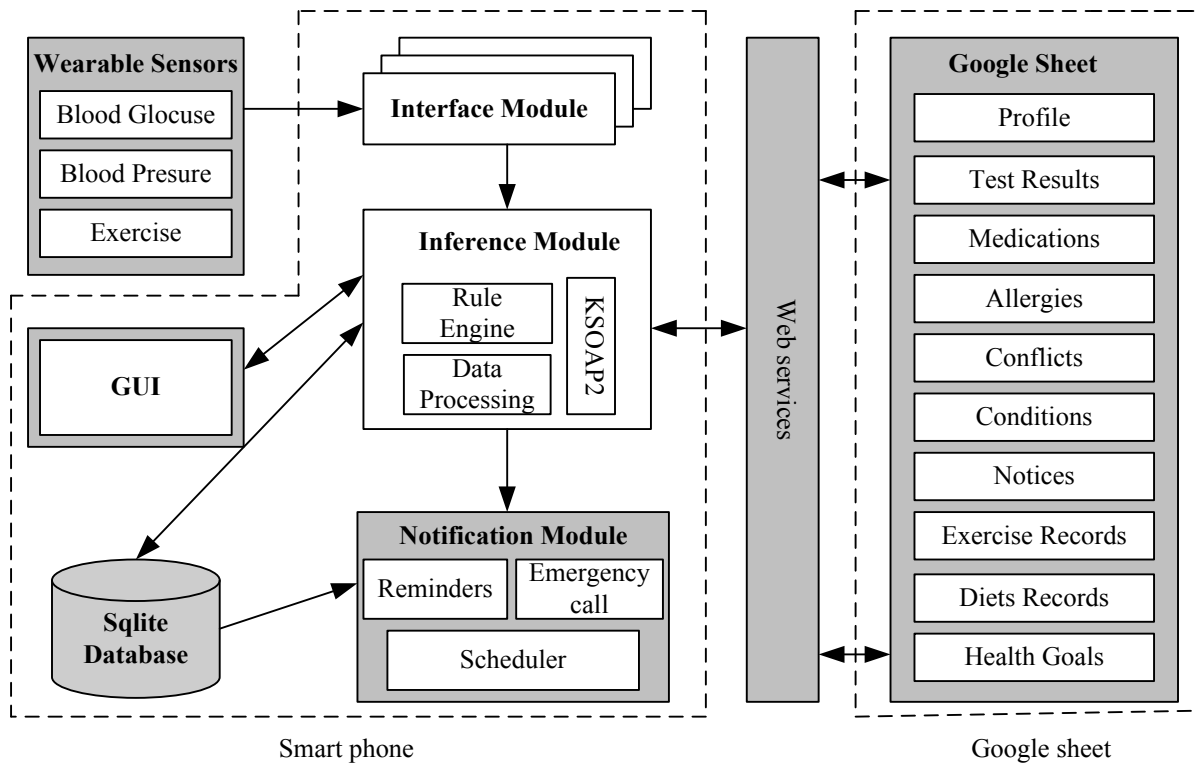

Figure 6 Software framework of mobile personal health care system

### 3.2.4.1 GUI module

The patient can retrieve or input data by interacting with GUI. The specific applications that could be operated through GUI include: 1) Health Care Team which contains the contact information of the person's health care team. 2) Health Care Goals includes the blood glucose, blood pressure, exercise and weight targets which are strictly set by the health care team. For example, the blood glucose target is 100mg/dL before a meal and is 140mg/dL after a meal. 3) Test Result Tracker displays daily, weekly or a custom time interval blood glucose test results in a graph that indicates whether the blood glucose is high, healthy or low. 4) Medicine Tracker, Exercise Tracker and Diets Tracker will track the



information about medicine taken, exercise and diet. 5) Notification is for patient to check feedback from his or her health care team or family members and to read the reminders and suggestion from the scheduler in the smart phone. 6) Setting application makes user to be able to turn on/off the blood glucose monitoring service, blood pressure monitoring service, exercise service and scheduler service which will run in the background to get data from monitors and send voice or text notification to remind the user to take medicine or take a test result.

### **3.2.4.2 Interface module**

Interface Module is responsible for gathering raw sensing data and transferring it into internal message format, which is implemented by using an experimental unofficial Bluetooth API for Android [28].

### **3.2.4.3 Inference module**

Inference Module is responsible for processing raw data from sensors. After receiving the sensor data from the interface module, the inference module will store it into a database by calling the common database operation interface. It will also perform inference tasks based on pre-defined rules which are described in CHAPTER 4. The outcomes of the inference procedure are transformed into corresponding notification messages and then sent to the notification module. Inference module will periodically query if there are any notices updated from the health care team. If there are notifications, it will trigger the corresponding action commands or notification messages. For example, when medications are updated in the Google sheet by personal health care team, inference module will get a notice whose message type is *MSG\_MEDICATIONS\_UPDATED*, and then it will release a command called

*CMD\_DOWNLOAD\_MEDICATIONS*. After getting the updated medications, it will notify the scheduler in the notification module to update the medicine taking schedule.

#### **3.2.4.4 Notification module**

Based on the outputs from inference module, notification module will post reminders to the person or notices to health care team. In emergency situations like when blood glucose is very high or the user has not taken medicine or blood glucose test for several days, notification module will make an emergency call to the person's health care team. The scheduler in the notification module will post a text or voice reminder to remind the user to take medicine or anything scheduled.

#### **3.2.5 Class diagrams for Android application**

In this section, we will briefly describe the class diagrams overview of the software implementation in Android. The attributes and operations in each class are not included in the class diagram.

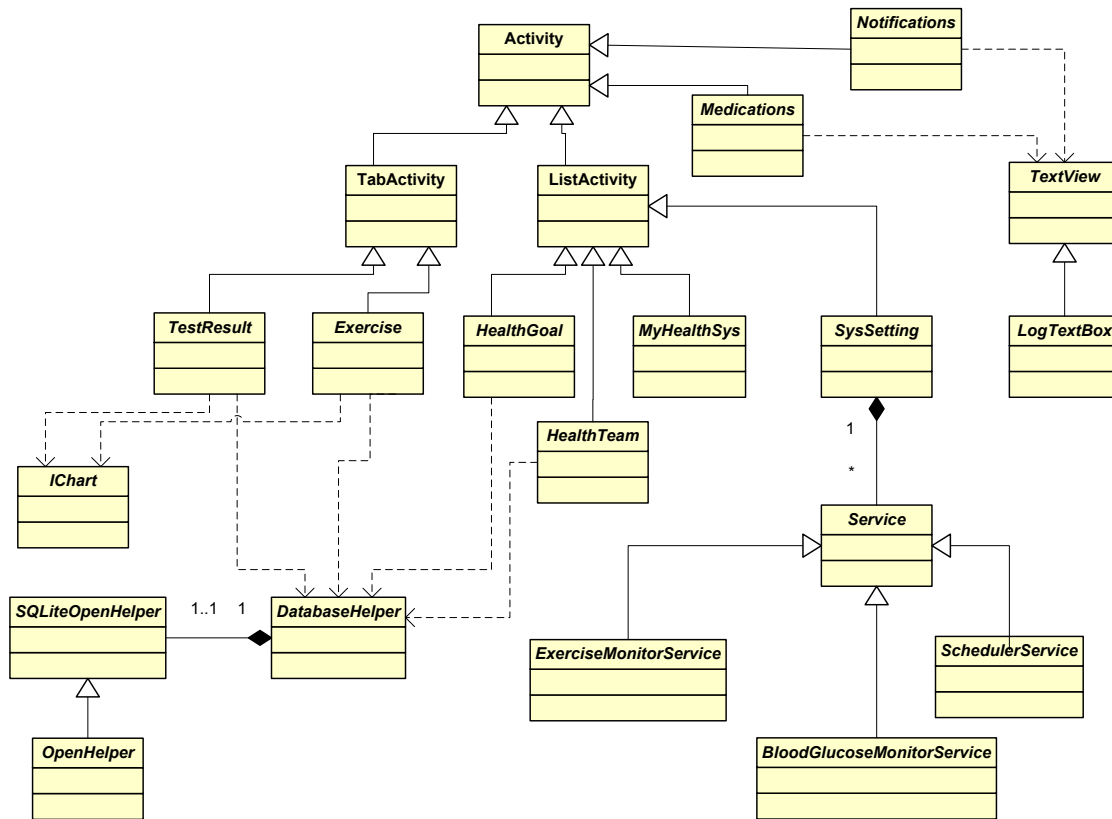

Figure 7 Class overview of personal health system

Figure 7 shows the relationships among different classes designed for the mobile application in the Android. We use four base classes provided by Android APIs: Activity, Service, TextView and SQLiteOpenHelper. All of the classes are inherited from at least one of these four base classes. The class Medications is designed to get medications stored in the Google sheet and display them in the Android. The class Notifications is used to get notices from Google sheet such that the doctors know his/her patient's test results and could give the feedback immediately based on the test results. The classes TestResult and Exercise implement TabActivity extended from the Activity base class. The TestResult class is designed to retrieve and display daily, weekly and monthly test results in the SQLite

database. The class Exercise is designed to retrieve and display exercise information like heart rate, speed and distance during the exercise. The classes HealthGoal, HealthTeam, MyHealthSys and SysSetting implement the base class ListActivity extended from Activity class. They will be described in detail in the following sections.

### 3.2.5.1 Common database interface

We design a common database interface to interact with Sqlite database in Android.

The class diagram of the common database interface is shown in Figure 8.

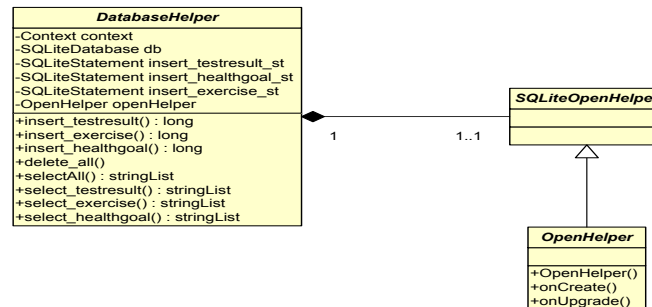

Figure 8 Class diagram of common database interface

In order to store data, delete data or retrieve data from Sqlite database, we design a common database interface such that it is flexible and easy to be further extended. The class DatabaseHelper provides the specific methods to operate database like insertion data to test result table and retrieve data from health goal table. It includes an OpenHelper class which creates database or data tables if they do not exist. Also, it will update the database or data tables if the database version is updated.

### 3.2.5.2 MyHealthSys

Figure 9 shows the MyHealthSys class diagram. ListActivity class is the base class of MyHealthSys which composes of EfficientAdapter class to draw the graphic user interface and to start the corresponding activities: HealthGoal, HealthTeam, TestReult, Medications, Diets and SysSetting activities.

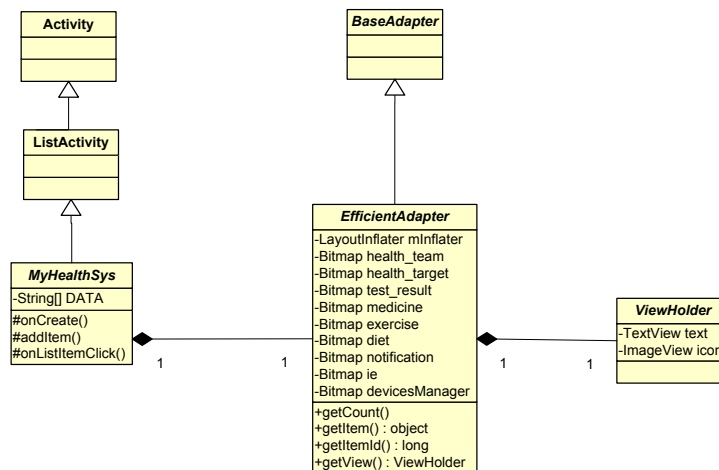

Figure 9 Class diagram of MyHealthSys

The class MyHealthSys uses EfficientAdapter to create a list of Activities including their names and icons displayed in GUI. It has an onListItemClick method to accept the click events from GUI starting the corresponding Activity (see Figure 10). ViewHolder is data class presenting the activities' names and icons.

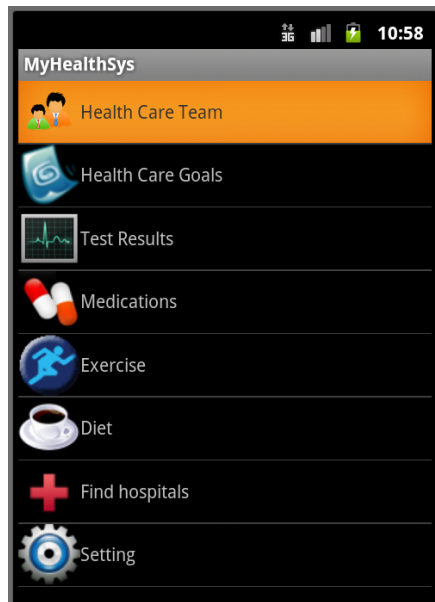

Figure 10 GUI of the main menu

### 3.2.5.3 HealthGoal

The class is designed to retrieve data from the database to get the pre-defined health goals like the blood glucose level, blood pressure, weight and exercise goal. The class diagram is shown in Figure 11.

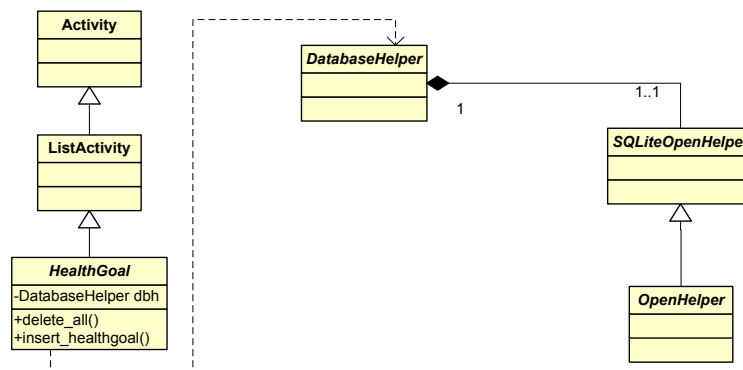

Figure 11 Class diagram of HealthGoal

The class HealthGoal includes two methods to operate the database through the common database interface – DatabaseHelper. The method delete\_all is used to clear the data in the Health goal table which is described in the Table 1. The method insert\_healthgoal is designed to insert or update records in the health goal table.

Table 1. Health goal table

healthgoal	
id	INTEGER PRIMARY KEY AUTOINCREMENT
glucoselevel	INTEGER
bloodpressure	INTEGER
weight	INTEGER
exercise	TEXT

Health goal table includes five fields: primary key id, target glucose level, target blood pressure, target weight and target exercise. These goals are pre-defined by the user's health care team based on the users' current health conditions and stored in the SQLite Database. They are used in the RuleEngine module to verify if the current data is in the range of the goal. For example, by comparing the current blood glucose test results with blood glucose goals, we know if the current test results are in the range of the normal level. If it is dangerously high or dangerously low, the system will give the user immediate suggestion or make an emergency call. The GUI of the health goal application is shown in Figure 12.

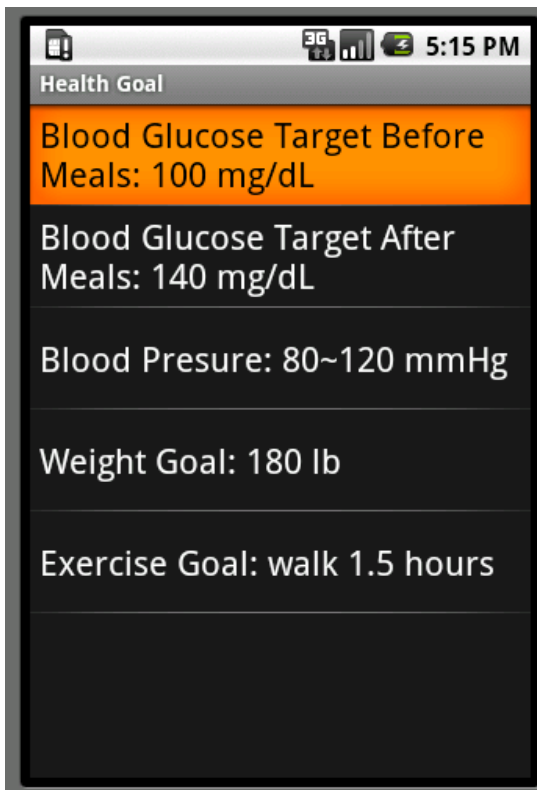

Figure 12 GUI of health care goal

#### 3.2.5.4 HealthTeam

Figure 13 shows the class diagram of HealthTeam. The HealthTeam class is inherited from ListActivity which is extended from the Activity base class. The implementation of HealthTeam depends on the API Contacts.People. This API is used to get the contacts list stored in the cell phone. We could use different retrieving conditions to get a subset of the contacts list that we need including contact name, phone number and email address such that the user could quickly make a phone call or send an email to the members of his/her health care team. The GUI of health care team is shown in Figure 14.



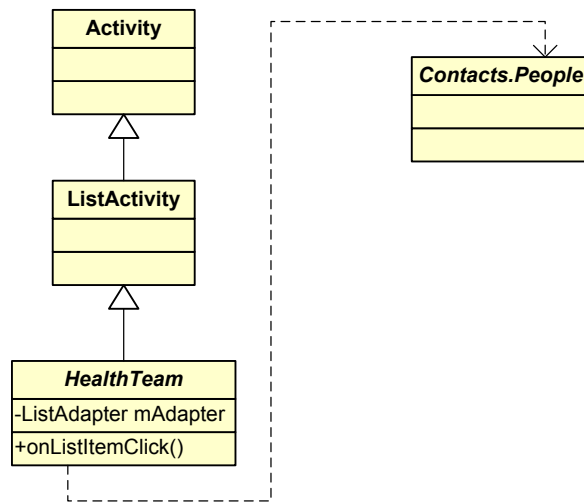

Figure 13 Class diagram of HealthGoal

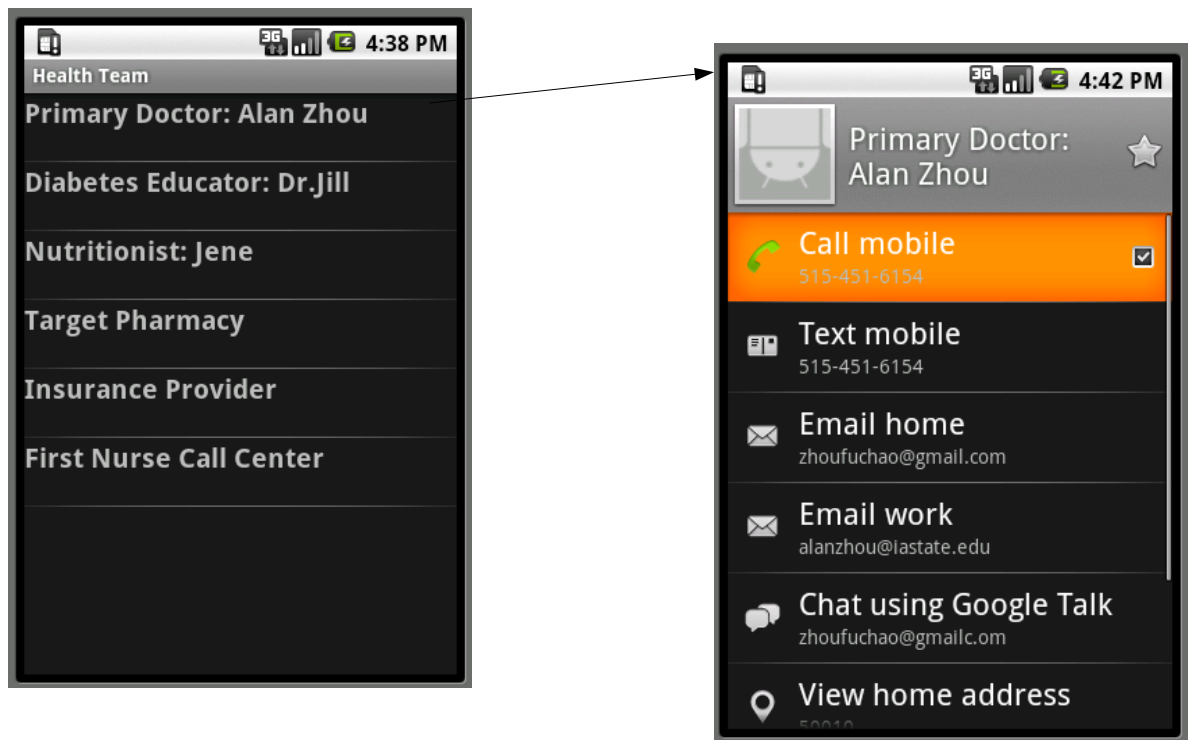

Figure 14 GUI of health care team

### 3.2.5.5 TestResult

Figure 15 shows the class diagram of TestResult which is inherited from TabActivity. The implementation of TestResult class depends on different packages. The org.achartengine.chart, org.achartengine.model and org.achartengine.renderer packages are used for drawing the different test results. Figure 16 is an example of the test results. There are three lines in the graph: the green one represents the current test results; there are two red lines representing the dangerously low or high limitations of the test results. If the test results cross one of the red lines, the system will send a notification reminding the user the current test result is not good and suggest the user to consult with his/her doctor.

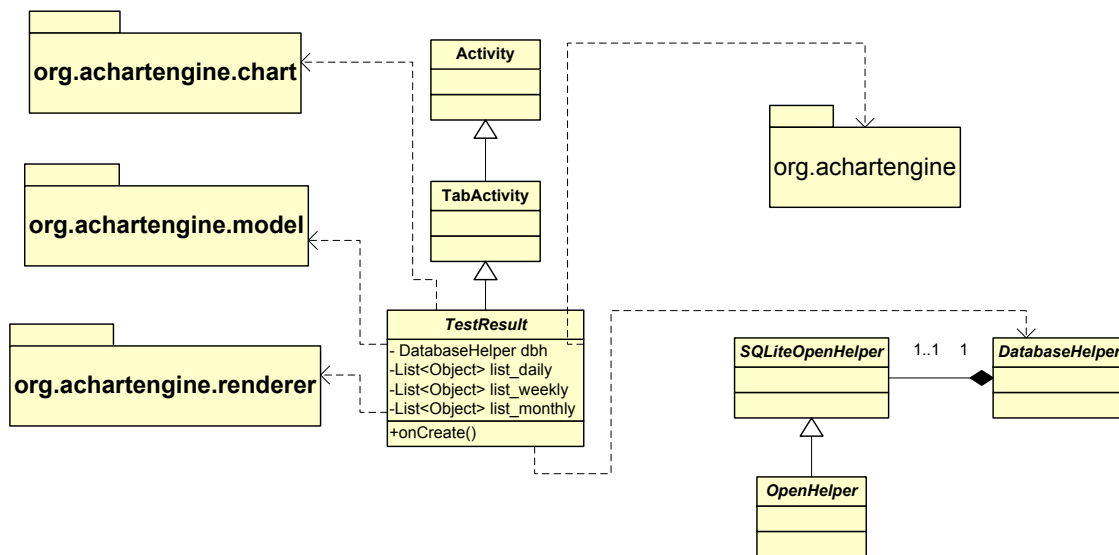

Figure 15 Class diagram of TestResult



Figure 16 GUI of blood glucose level test result

The last 30 days test results will be stored in the Sqlite database such that the user could retrieve the data very quickly without accessing the Google sheet. In this way, it will reduce the workload of the system. We design a testresult data table to store the test results. The table is shown in the Table 2. The testresult table includes four fields: the primary id, test type like blood glucose test or blood pressure test, test value and the time on which the test result is taken.

**Table 2. Test result table**

testresult	
id	INTEGER PRIMARY KEY AUTOINCREMENT
typeName	TEXT
value	INTEGER
datetime	LONG

### 3.2.5.6 Medications

Medications class is designed to get the medications from Google sheet and display the medications. The class diagram is shown in Figure 17. Its implementation depends on the `org.ksoap2`, `org.ksoap2.servlet`, `org.ksoap2.serialization` and `org.ksoap2.transport` packages from the open source project [25] [26].

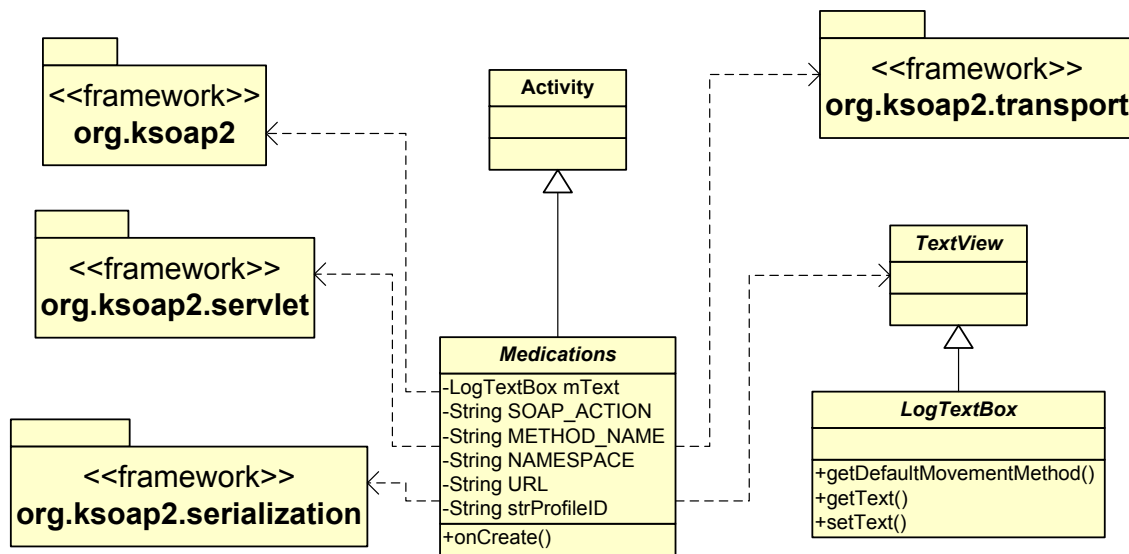

Figure 17 Class diagram for Medications

The Medications class defines the specific actions and URLs that could be used to access Google sheet. The Medications obtained from Google sheet is then displayed which are shown in Figure 18. It includes the name, dosage, unit and form of the medication. And it indicates the route and frequency of taking this medication, including the start date and end date. The id in the medication is RFID tag identification which is used to identify the specific medicine such that the user or his/her health care team could retrieve the medicine easily by scanning the RFID tag on the RFID reader.

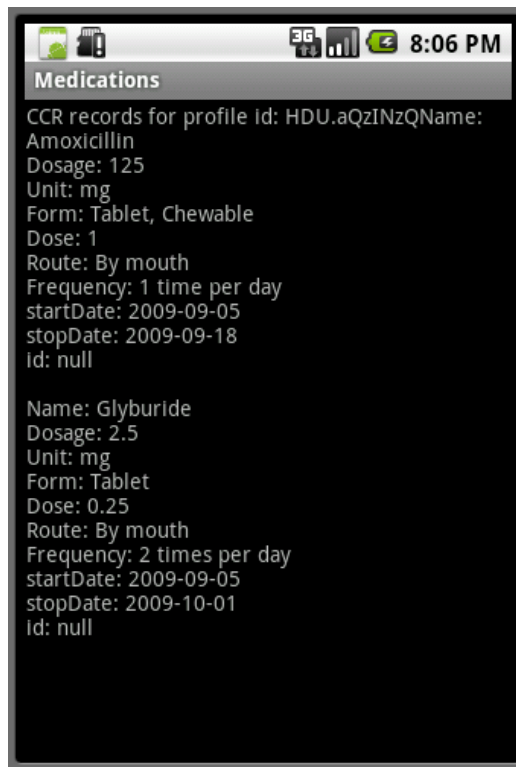

Figure 18 GUI of Medications

### 3.2.5.7 Exercise

The Exercise class is designed to retrieve the exercise information from database using the common database interface. It also draws the exercise information as the series lines on the GUI through the related org.achartengine packages.

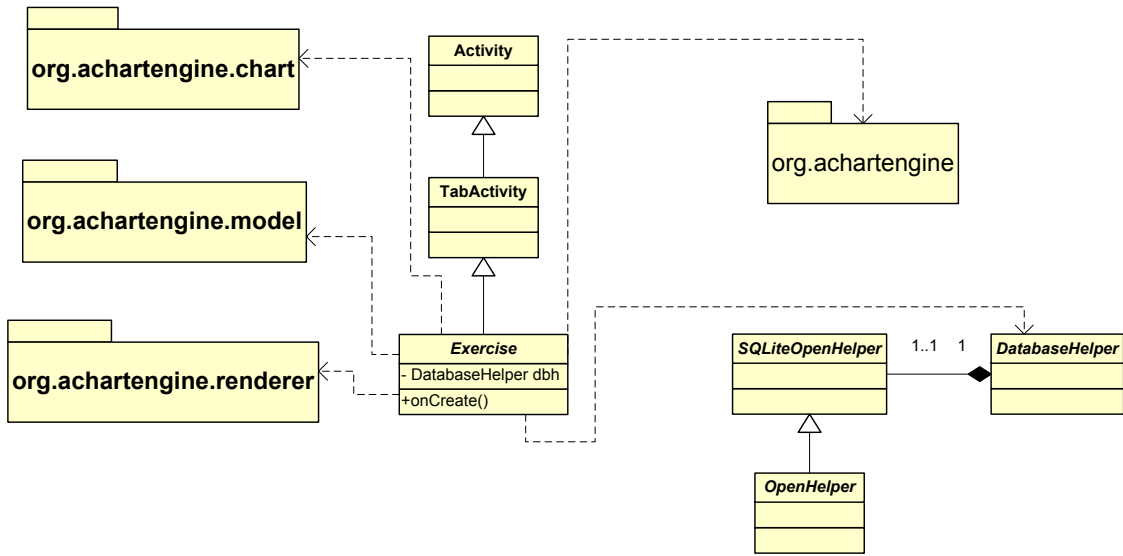

Figure 19 Class diagram of Exercise

The exercise data will be stored in the exercise data table in the database which is shown in Table 3. The exercise data table includes six fields: the primary id, exercise type name, heart rate, breathing rate, skin temperature and the date on which the exercise is done.

Table 3. Exercise table

exercise	
id	INTEGER PRIMARY KEY
typeName	TEXT
heartRate	INTEGER
breathingRate	INTEGER
skinTemperature	INTEGER
datetime	LONG

The user can retrieve the exercise data like the heart rate, breathing rate and the skin temperature during the exercise. And the doctors also could give the person a target heart rate

based on the duration of the exercise amount and his/her current health condition. If the person's heart rate is much higher than the target heart rate during the exercise, the system will send a notification message to the user to remind the user to slow down or take a break. The part is addressed in detailed in case studies of Chapter 4.2.

### 3.2.5.8 SysSetting

The SysSetting class is designed to stop/start the different monitors with Bluetooth which is shown in Figure 20. The SysSetting class is inherited from base class ListActivity and composes three services: BloodGlucoseMonitorService, SchedulerService and ExerciseMonitorService (See Figure 29).

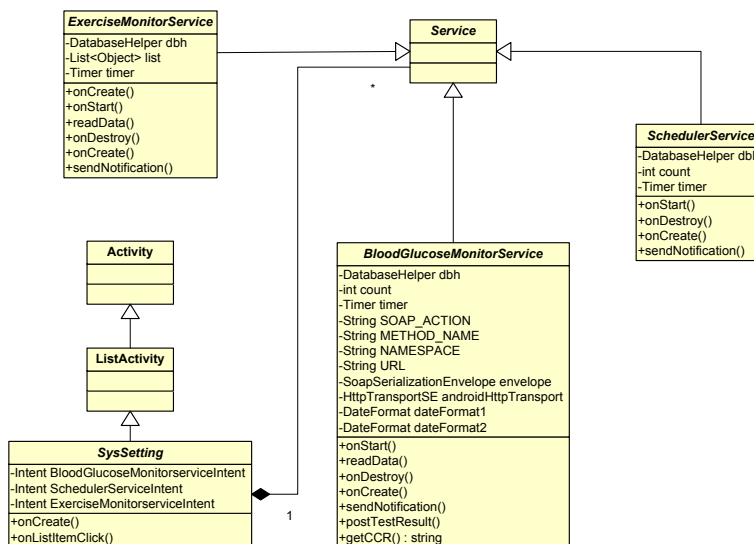

Figure 20 Class diagram of SysSetting

These services run in the background to collect data from monitors through Bluetooth. When the user wants to take blood glucose test, he/she needs to start the blood glucose monitor first. The service will listen to the incoming of the Bluetooth serial port.

After it gets the data through Bluetooth, it will store the data into the database in the Android phone and it will further push the data to the Google sheet through the web service interface. Also it will send a notification message to the user's doctor such that the doctor could check the test result to know his/her health condition immediately. Also because the long-term personal health records (PHRs) stored in the Google sheet, the doctor could make a comprehensive analysis based on his/her patients' test result, medications taken and exercise data.

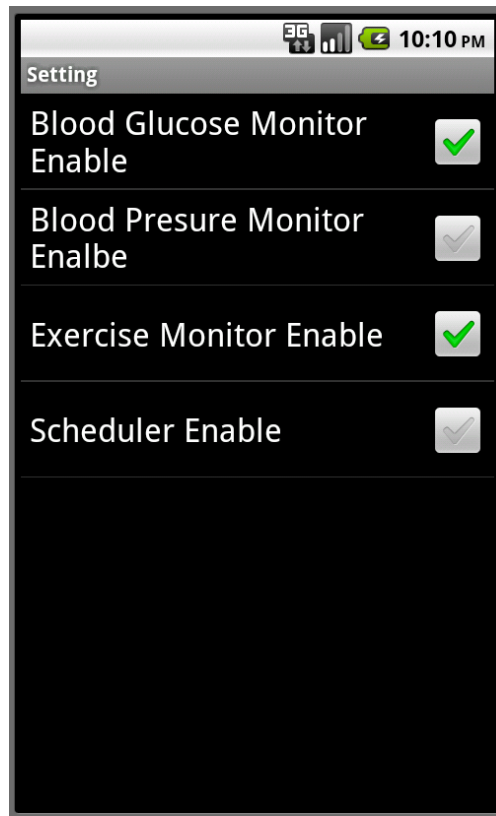

Figure 21 GUI of SysSetting

Exercise monitor service will collect data from BioHarness™ BT exercise monitor. The data includes heart rate, breathing rate and the user's skin temperature during the



exercise. The data will be stored into the database in the Android phone. Scheduler service should always run in the background because it reminds the user to take medicine, take the test result etc.

### **3.2.6 Integration with GPS, Google search and Google Map**

Google provides the Google search service and Google Map service to the user as web service which allows the user to integrate them to his or her applications. In our system, we integrate Google search and Google map with GPS embedded in the smart phone which could help the user to find all hospitals near to him/her and display all of them in the Google map with hospital name, address and phone numbers. Furthermore, it provides the direction to the selected hospital and street view which will help the user easily finding the right hospital. All of these features are done by one button click. This simplification is very important to the elderly patient, especially in the emergency situation. Figure 22 shows the class diagram of the integration of GPS and Google search and Google Map.

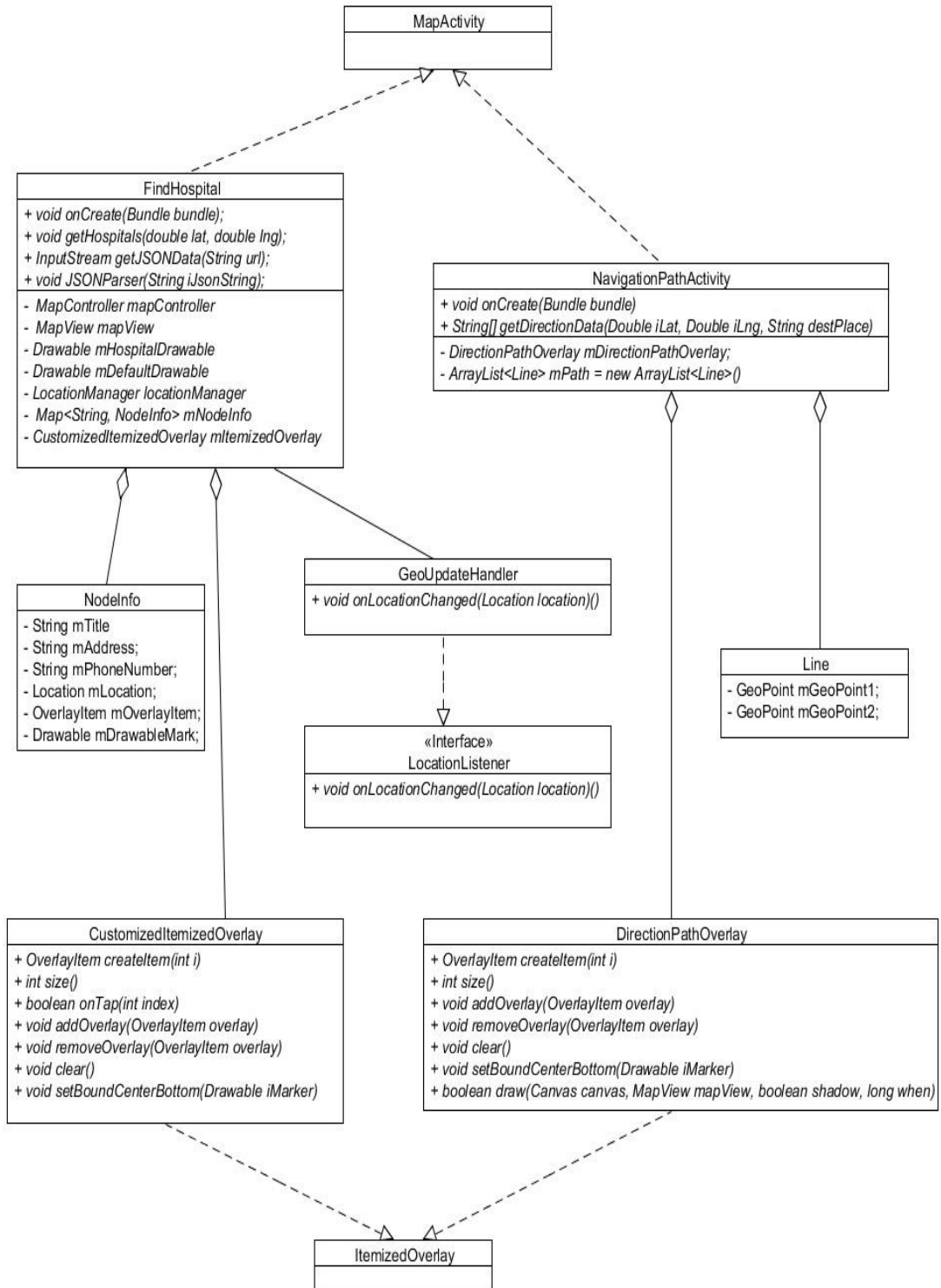

Figure 22 Class diagram for the integration of GPS, Google search and Google Map

The two major classes are extended from the base class MapActivity which provides the features of Google map. When the FindHospital activity is triggered, it will get the user's current location through reading the location info from GPS which is done by LocationListener class. Then it will submit an Ajax request with the location info to the Google search service and get the search results back as JSON object. After parsing the JSON object, we could get the name, address, phone number and the latitude and longitude position of all hospitals near to the user. For example, when the user is in the computer science department at Iowa State University, the system can find 4 hospitals near to him/her and display the hospitals and the user's current location at Google map which is shown in Figure 23.

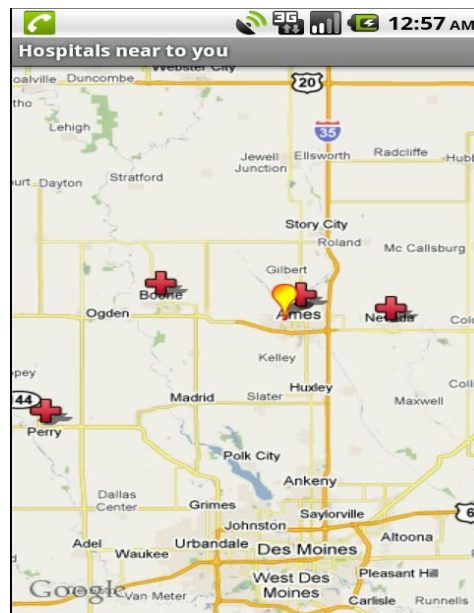

Figure 23 Hospitals near to you

When the user clicks any of them, it will show the name, address and phone number of the hospital. If the user clicks phone number in the dialog, a phone call will be made to the

hospital. If the user clicks the hospital address in the dialog, a navigation path will display in the map. For example, like what Figure 24 shows, when the user clicks the address of Mary Greeley hospital, the NavigationPath activity shown in Figure 24 will setup a URLHTTP connection with Google map server and send an http request with the user's current location and the hospital location to the server. Google map server will return the whole map info as KML file which is a kind of XML file for Google map. After parsing the KML file by using the DOM parser, we could get a collection of latitude and longitude pairs from user's current location to the hospital. Drawing a segment line between the adjective pairs, a path from user's current location and the hospital will be drawn. Also, the user could click street view but to get the street of the hospital which will further help the user to locate the hospital.

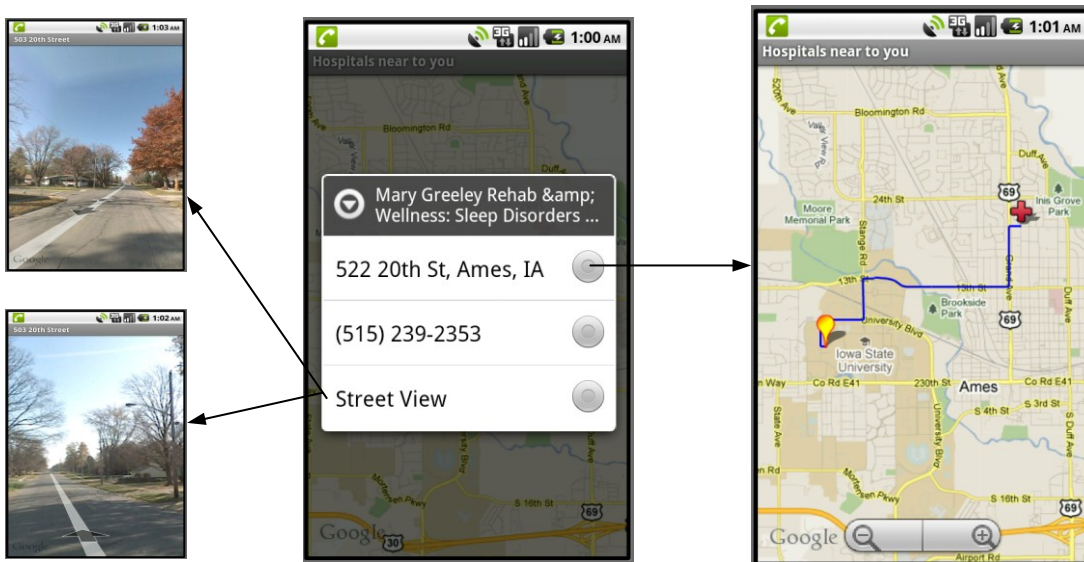

Figure 24 Direction to the selected hospital and Street view

## **CHAPTER 4 BEHAVIORAL MODIFICATIONS FLOWCHARTS AND CASE STUDY**

### **4.1 Behavioral modifications flowcharts**

Through web service, we integrate smart phone, smart home and external systems like Google sheet, Global Medication Conflict Database (MCD) and Weather web service. With the help of these subsystems and wearable sensors, the mobile health care system traces the person's activities in exercise, diet and medications taken, and gives warnings and suggestions for preventing accidents and improving the person's behaviors during his or her daily routine. The behavioral modifications flowchart is illustrated in Figure 25. In our design, we use Google sheet as PHR management system which breaks down the wall between the patients, patient's family members and different health care providers such that they can work together to continuously refine targets for blood glucose levels control, exercise and nutrition intake and issue a prescription to the patient.

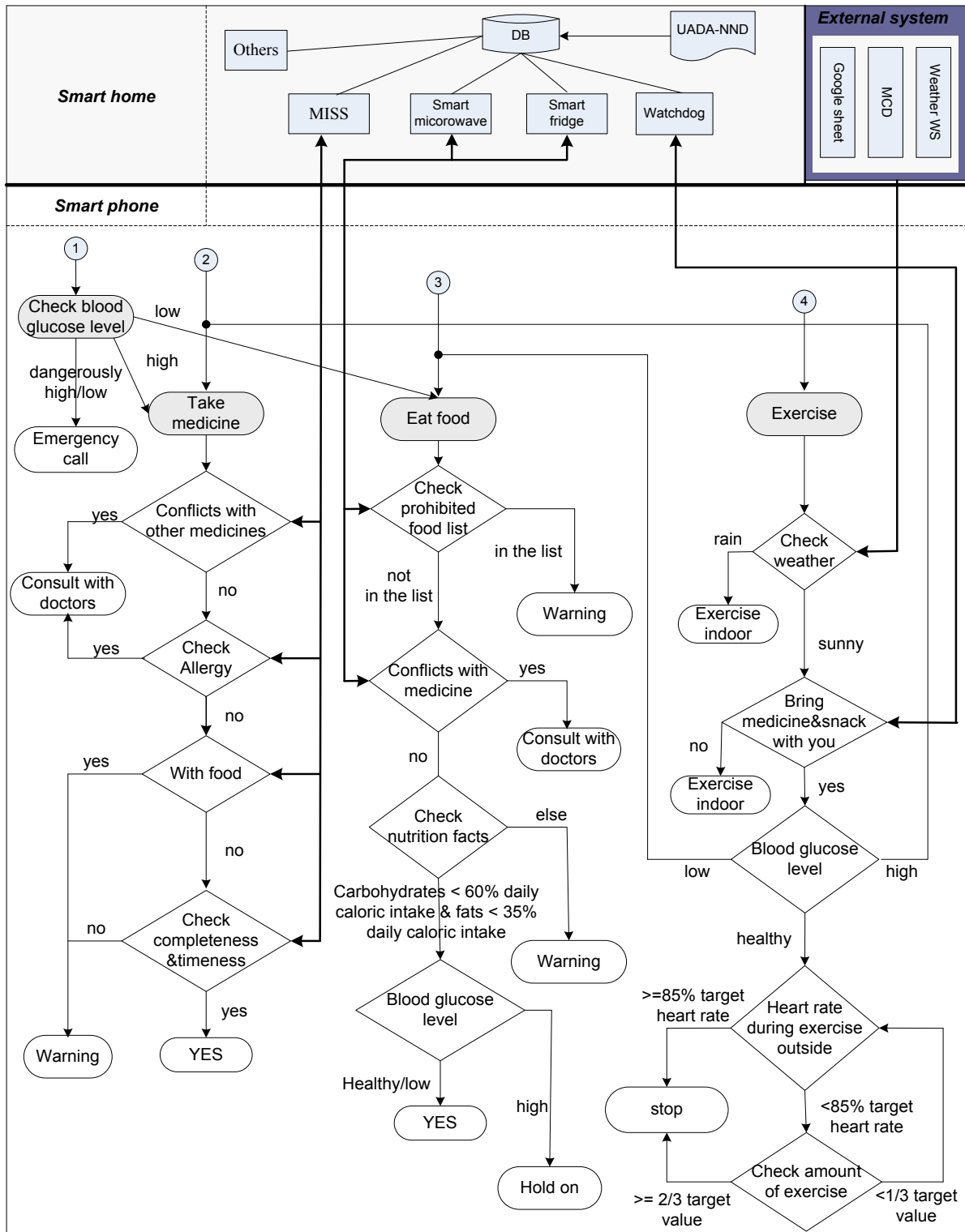

Figure 25 Behavioral flow chart

### **4.1.1 Medications**

When the person takes a blood glucose test, the system will automatically make an emergency call to prevent potential accidents if the blood glucose level is dangerously high or low. If it is relatively low or high, the person is suggested to eat food or take medicine under the guidance of the system. The system will remind the person to take medicines based on the prescription or whenever needed. With the helps from MISS and Google sheet, the system will check whether there are conflicts or allergies among medications the person is taking. If there are any medicine conflicts or allergies, the system will suggest the person to consult with his or her doctors. The system can also indicate whether the person needs to take medicine with food and whether he or she is complying with completeness (right dose) and timeliness (right time) [19].

### **4.1.2 Diet**

Diet is an extremely important factor affecting a patient's diabetes. Based on the personal health situations, food allergies and other dietary restrictions, the health care providers make a list of prohibited foods. With the support of Smart Microwave and Smart Fridge Subsystems at smart home and barcode reader embedded in cell phone, the health care system can check whether the food is in the prohibited food list. If it is not in the list, then the system further identifies nutrition facts of the food, checks the person's daily consumption history and then takes different actions based on the percentages of carbohydrates and fats accounting for the person's daily caloric intake respectively. Also, by checking the person's medicine intake history, it can check whether there are conflicts with medicines taken.

### **4.1.3 Exercise**

The system can suggest the person to exercise either indoor or outside based on weather information from the weather web service. When the person goes outside, he or she will lock the door by scanning a RFID tag identification. The Watchdog then will learn the fact that the owner will go outside and thus remind him or her to scan the RFID tag attached to the medicine bottle and the barcode on the snack packets to make sure the person brings the right medicine and snack. During exercise, the exercise tracker sensor will monitor the person's heart rate. If the heart rate is more than 85% (or any limit suggested by the health care team) target heart rate, the system will give an alert and may suggest the person to slow down or even stop exercising.

## **4.2 Case study**

In our case study, we use BioHarness™ BT to monitor physiological signs during the exercise and use Nexus One smart phone with Android platform to collect live streaming data packages from the BT monitor. The communications between a BT monitor and Nexus One smart phone is request/response based. After the wireless links are setup between the BT monitor and the cell phone, the BT monitor will transmit messages to the cell phone periodically. The real time data will be displayed in the cell phone and stored into the embedded SQLite database. Furthermore the data will be pushed into the Google sheet as long-term records. The user can share the data in the Google sheet with his/her family members or caregivers. The work flow is illustrated in Figure 26.



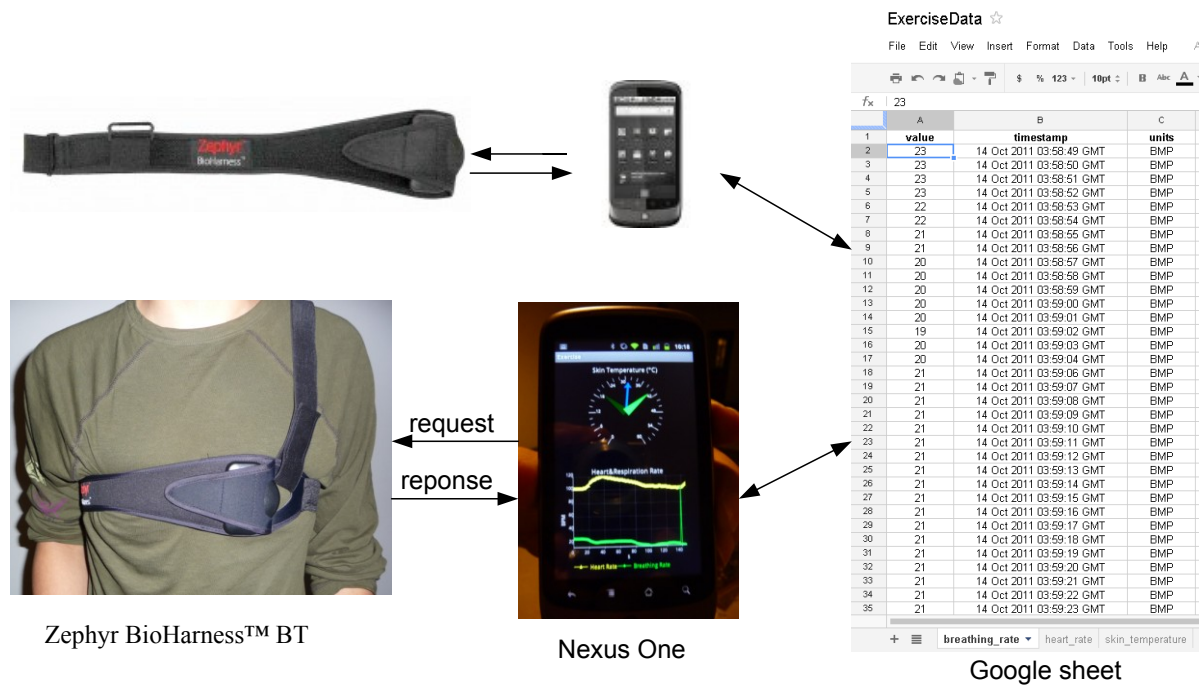

Figure 26 The work flow of case study

#### 4.2.1 BioHarness™ BT and Bluetooth communications

The Zephyr BioHarness™ BT [21] is a physiological monitoring system. During the exercise, the person wears a Smart Fabric chest strap which contains sensors for monitoring heart rate, breathing rate and skin temperature. BioHarness Module is attached to the strap in which raw sensor data is processed, analyzed and transferred into packages. The packages are transmitted by Class II Bluetooth over a 10 meter range to a corresponding Bluetooth receiver device. This will allow physiological data to be monitored using any suitably-configured Bluetooth mobile device, such as a laptop, phone or PDA.

The communications between a Zephyr Bluetooth BioHarness and Nexus One smart phone is request/response based. The delay between the request and response messages is

dependent on the message type. The protocol is defined together with the specification of each message which only accommodates a point-to-point communications transfer, with no addressing used. The BioHarness Module replies to the request message with one of two basic message types which are illustrated in Figure 27. If the request message is found to be valid, the response is in the form of an ACK with required data included; if found to be invalid, the response is in the form of a NAK message and no data is inserted into the message.

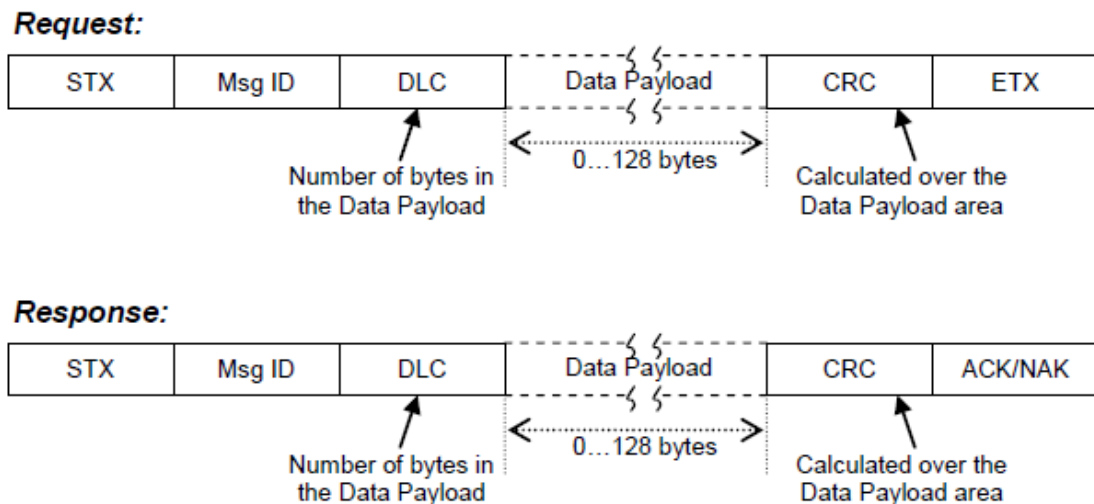

Figure 27 Basic Message Format

Once the wireless link between Zephyr Bluetooth BioHarness and Nexus One smart phone is setup, the heart rate, breathing rate and skin temperature packages will be encapsulated in the messages. The messages will be sent over the link to the cell phone from the monitor periodically (every 1.008 seconds) without requiring acknowledgement. Figure 28 illustrates a message format which contains the breathing rate data transmitted by the Zephyr Bluetooth BioHarness monitor.

Byte/Bit	7	6	5	4	3	2	1	0	Field
0	STX								STX
1	0x21								Msg ID
2	32								DLC
3	Sequence Number (0...255)								Payload
4	Timestamp – Year (LS Byte)								
5	Timestamp – Year (MS Byte)								
6	Timestamp – Month								
7	Timestamp – Day								
8	Timestamp – Milliseconds of day (LS Byte)								
9	:								
10	:								
11	Timestamp – Milliseconds of day (MS Byte)								
12	Breathing Waveform Data (18 Samples) – see “Packing Format”								
35	CRC								CRC
36	ETX								ETX

Figure 28 Breathing rate message

#### 4.2.2 Communication module in Android

The communication module is responsible for connecting/disconnecting with the Zephyr Bluetooth BioHarness monitor and receiving the messages from the meter. After getting the messages from the monitor, the communication module will parse the heart rate, breathing rate and skin temperature packages based on the corresponding package types from the payload of the messages. It will also put the data into the database in the cell phone. The exercise monitor service is the main class of the communication module. Figure 39 is the class diagram for ExerciseMonitorService.

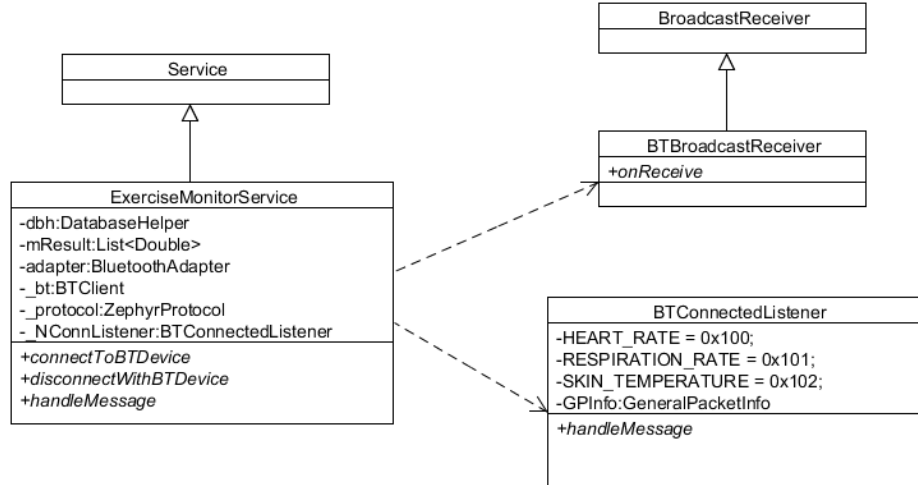

Figure 29 Class diagram for ExerciseMonitorService

#### 4.2.2 Analysis for the case study

The major purpose of the case study is to validate the whole system and to make sure it is simple enough for the end users, especially for the elderly users to use in their daily exercise. In the study, we let the whole system run for more than 2 hours, collecting the heart rate, breathing rate and skin temperature. The system works properly without throwing any exceptions. After the sampling data is collected into the database of the cell phone, we start the scheduler to push the data from the database into the Google sheet. And all of the data obtained from the monitor are pushed into the Google sheet consistently. From this experiment, we find that the whole system is robust. Now the question is whether it is simple enough for the end user, especially for the elderly users to use? The answer is YES because the user only needs to start the exercise service during their exercise. Then everything is done automatically. The exercise service running in the background will collect the data from the

monitor and the scheduler will automatically push the data into the Google sheet. The notification module of the system will remind the user to slow down or take a break if there is any sign that is much higher than the target. The real-time data is displayed in the charts in the cell phone and history data is stored into the Google sheet. The user could review the real-time data and history data very easily from the cell phone. The view of the data is shown in Figure 30.

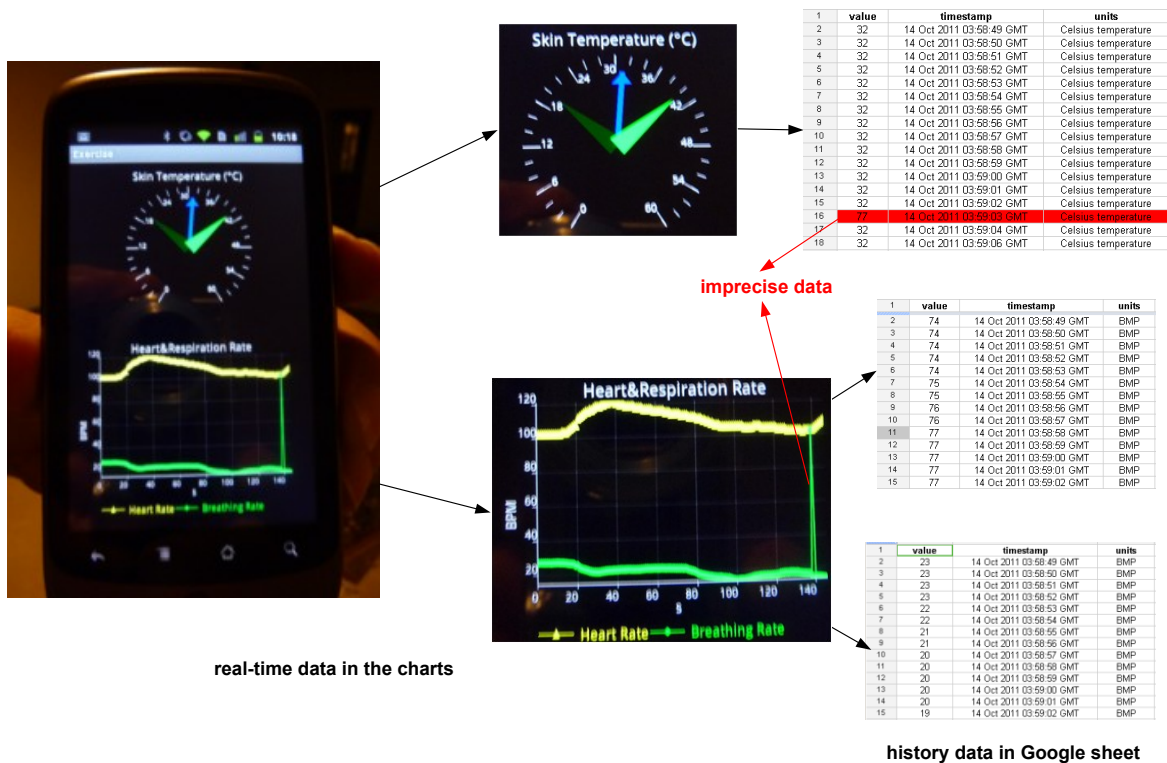

Figure 30 The real-time and history data in the system

From Figure 31, the skin temperature is shown in a dial chart. The range in the skin temperature is from 0~60 Celsius. The green hands in the dial chart indicate the desired skin

temperature range for the person during his/her exercise. And the blue hand in the dial chart indicates the current skin temperature of the person. In the Heart&Respiration Rate chart, the yellow line indicates the heart rates of the person and the blue line indicates the breathing rates of the person. The unit of the heart rate and breathing rate is BMP (beats per minute). Usually, the person will keep his/her heart rate a little bit lower than his/her target heart rate which is suggested by his/her health care team. The history data in the Google sheet include value, timestamp and unit. These data can be exported into a trusted third-part health care system for further analysis. Also the user can share his/her exercise data with her family members and health care givers.

From this case study, we find there is some imprecise data coming from the monitor which is shown in Figure 30. There is a skin temperature sample which is equal to 70 Celsius and a breathing rate sample of 100 BMP. These samplings are imprecise obviously. The imprecise samplings may be caused by noise of the environment that the monitor is running. From our observations, the imprecise data occurs very rarely in the samplings, it will not affect the precision of the system.

## **CHAPTER 5 CONCLUSION AND FUTURE WORK**

### **5.1 Conclusion**

This paper presents a personal diabetes monitoring system which integrates wearable sensors, 3G mobile phones, smart home technologies and Google sheet to facilitate the management of diabetes conditions. The system further integrates with GPS, Google search and Google map functionalities to facilitate the user to find all hospitals near to his/her current location including address, phone number, directions to the selected hospital and street view of any of the selected hospital. In the case study, we use BioHarness™ BT to monitor physiological signs during the exercise and use Nexus One smart phone with Android platform to collect live streaming data packages from the BT monitor. The whole system runs more than 2 hours collecting heart rate, breathing rate and skin temperature from BioHarness™ BT monitor. From the experiment, we find the system is robust. And collecting data, displaying data on the cell phone and pushing data into Google sheet are all done by one button click. It is simple enough for the end users, especially for the elderly users to use in their daily exercise. This diabetes monitoring system not only assist with the tasks of diabetes management, but also improves the medicine and food safety by taking full advantage of features in existing subsystems in smart home and related cutting edge technologies.

### **5.2 Future work**

We are currently working on 1) getting data from glucose and blood pressure sensors by using Bluetooth API for Android phone. The glucose and blood pressure sensors have

some challenges working with Android smart phone; 2) improving the accuracy of automatically collected exercise information; 3) getting feedbacks from real users. The system is developed and tested in the smart home lab. We are planning to get a number of users with diabetes to use the system and get the users' family members and health caregivers involved. We are expecting tons of feedbacks from the users which will help us to improve the system further; 4) integrating with diet system developed at the smart home lab to check food allergies, daily consumption history and conflicts between food and medicine.



## BIBLIOGRAPHY

- [1]. [http://www.itu.int/newsroom/press\\_releases/2009/39.html](http://www.itu.int/newsroom/press_releases/2009/39.html). Accessed January 26, 2009.
- [2]. New Survey Results Show Huge Burden of Diabetes, U.S. Department of Health and Human Services NIHNews National Institutes of Health. Accessed January 26, 2009.
- [3]. Centers for Disease Control and Prevention.  
<http://www.cdc.gov/diabetes/pubs/pdf/tctd.pdf>. Accessed January 20, 2009.
- [4]. National Institutes of Health National Diabetes Education Program. <http://ndep.nih.gov/>. Accessed January 20, 2009.
- [5]. David Malan, Thaddeus FulfordJones, Matt Welsh, and Steve Moulton, CodeBlue: An Ad Hoc Sensor Network Infrastructure Emergency for Medical Care, MobiSys 2004 Workshop on Applications of Mobile Embedded Systems (WAMES 2004) (2004).
- [6]. Victor Shnayder, Borrong Chen, Konrad Lorincz, Thaddeus R. F. FulfordJones, and Matt Welsh, Sensor Networks for Medical Care, Technical Report TR-08-05, Division of Engineering and Applied Sciences, Harvard University, 2005.
- [7]. Georgios Kambourakis, Eleni Klaoudatou and Stefanos Gritzalis, Securing Medical Sensor Environments: The CodeBlue Framework Case, Second International Conference on Availability, Reliability and Security, pp 637-643 (ARES'07).
- [8]. Anthony D. Wood, John A. Stankovic, Gilles Virone, Leo Selavo, Zhimin He, Qiuhua Cao, Thao Doan, Yafeng Wu, Lei Fang, and Radu Stoleru, Context-Aware Wireless Sensor Networks for Assisted Living and Residential Monitoring, IEEE Network, issue 4, pp 26-33, July-August 2008.
- [9]. G. Virone, A. Wood, L. Selavo, Q. Cao, L. Fang, T. Doan, Z. He, R. Stoleru, S. Lin, and J.A. Stankovic, An Advanced Wireless Sensor Network for Health Monitoring, Distributed

Diagnosis and Home Healthcare, 2006. D2H2. 1st Transdisciplinary, pp 2-5, Conference on 2-4 April 2006.

[10]. Hsu-Yang Kung, Chi-Yu Hsub and Mei-Hsien Lin, Sensor-based Pervasive Healthcare System: Design and implementation, Journal of High Speed Networks 16, pp 35–49 35 IOS Press, 2007.

[11]. Shanshan Jiang, Yanchuan Cao, Sameer Iyengar, Philip Kuryloski, Roozbeh Jafari Yuan Xue, Ruzena Bajcsy, Stephen Wicker, CareNet: An Integrated Wireless Sensor Networking Environment for Remote Healthcare, TRUST Autumn 2007, pp 9:1-9:3 Conference on October 10-11, 2007.

[12]. Tia Gao, Dan Greenspan, Matt Welsh, Radford R. Juang and Alex Alm, Vital Signs Monitoring and Patient Tracking Over a Wireless Network, In Proceedings of the 27th Annual International Conference of the IEEE EMBS, pp 102-105, Conference on September 2005.

[13]. Subhas C. Mukhopadhyay\*, Anuroop Gaddam and Gourab S. Gupta, Wireless Sensors for Home Monitoring - A Review, 2008 Bentham Science Publishers Ltd and Recent Patents on Electrical Engineering, pp 32-39, 2008.

[14]. Going Mobile with a Multiaccess Service for the Management of Diabetic Patients, Giordano Lanzola, Davide Capozzi, Giuseppe D'Annunzio, Pietro Ferrari, Riccardo Bellazzi and Cristiana Larizza, Journal of Diabetes Science and Technology, Volume 1, Issue 5, September 2007.

[15]. Valérie Gay, Peter Leijdekkers, Edward Barin, A Mobile Rehabilitation Application for the Remote Monitoring of Cardiac Patients after a Heart Attack or a Coronary Bypass Surgery (PETRA'09), Article No. 21, Corfu, Greece, June 09–13, 2009.

- [16]. Wan-Young Chung, Chiew-Lian Yau, Kwang-Sig Shin, and ksto Myllyla, A Cell Phone Based Health Monitoring System with Self Analysis Processor using Wireless Sensor Network Technology, Proceedings of the 29th Annual International Conference of the IEEE EMBS Cite Internationale, pp 3705-3708, Lyon, France August 23-26, 2007.
- [17]. Benny P.L.Lo, Surapa Thiemjarus, Rachel King, Guang-zhong Yang, Body Sensor Network - A Wireless Sensor Platform for Pervasive Healthcare Monitoring, Adjunct Proceedings of the 3rd International conference on Pervasive Computing (PERVASIVE'05), pp 77-88, May 2005.
- [18]. José M. Reyes Álamo, Johnny Wong, Ryan Babbitt, Carl Chang. MISS: Medicine Information Support System in Smart Home Environments. pp 185-199, ICOST 2008.
- [19]. José M. Reyes Álamo, Hen-I Yang, Ryan Babbitt, Johnny Wong and Carl Chang, Support for Medication Safety and Compliance in Smart Home Environments. International journal of advanced pervasive and ubiquitous computing, Volume 1, Issue 3, IGI Global, 2009.
- [20]. Fuchao Zhou, Hen-I Yang, José M. Reyes Álamo, Johnny S. Wong, Carl K. Chang, Mobile Personal Health Care, System for Patients with Diabetes, Volume 6159/2010, pp 94-101, ICOST 2010.
- [21]. BioHarness™ BT, <http://www.zephyr-technology.com/resources/case-studies>, Accessed October 01, 2011.
- [22]. Withings, <http://www.withings.com/en/bloodpressuremonitor>, Accessed October 05, 2011.
- [23]. MyGlucoHealth® Meter, <http://www.myglucohealth.net/myglucohealth-wireless.html>, Accessed October 03, 2010.

- [24]. Android developer, <http://developer.android.com/intl/es/sdk/index.html>, Accessed May 26, 2009.
- [25]. KSOPA2-ANDROID, <http://code.google.com/p/ksoap2-android/>, Accessed July 20, 2010.
- [26]. KSOPA2-ANDROID, <http://ksoap2.sourceforge.net/http://ksoap2.sourceforge.net/>, Accessed July 20, 2010.
- [27]. Achartengine, <http://code.google.com/p/achartengine/>, Accessed January 20, 2010.
- [28]. android-bluetooth, <http://code.google.com/p/android-bluetooth/>, Accessed January 25, 2010.
- [29]. Peter Leijdekkers, Valerie Gay and Edward Barin, Trial Results of a Novel Cardiac Rhythm Management System Using Smart Phones and Wireless ECG Sensors. ICOST 2009, LNCS 5597, pp. 32–39, 2009.
- [30]. W. Chung, et al., A Cell Phone Based Health Monitoring System with Self Analysis Processor using Wireless Sensor Network Technology (29th EMBC), pp 3705-3708, 2007.
- [31]. Dossia, <http://www.dossia.org/>, Accessed January 21, 2010.
- [32]. Microsoft Health Vault, <http://www.microsoft.com/en-us/healthvault/>, Accessed January 25, 2011.
- [33]. Google Helath, <http://www.google.com/intl/en-US/health/about/>, Accessed Nov 15, 2011.