



THE UNIVERSITY *of* EDINBURGH

This thesis has been submitted in fulfilment of the requirements for a postgraduate degree (e.g. PhD, MPhil, DClinPsychol) at the University of Edinburgh. Please note the following terms and conditions of use:

This work is protected by copyright and other intellectual property rights, which are retained by the thesis author, unless otherwise stated.

A copy can be downloaded for personal non-commercial research or study, without prior permission or charge.

This thesis cannot be reproduced or quoted extensively from without first obtaining permission in writing from the author.

The content must not be changed in any way or sold commercially in any format or medium without the formal permission of the author.

When referring to this work, full bibliographic details including the author, title, awarding institution and date of the thesis must be given.

**Why Not a Scots Hollywood?
Fiction film production in Scotland, 1911-1928**

Caroline Merz

Doctor of Philosophy

The University of Edinburgh
2016

Declaration

I declare that this thesis has been composed solely by me and that it has not been submitted, in whole or in part, for any other degree or professional qualification, nor has it been published in any form. Except where explicitly stated otherwise by reference or acknowledgement, the work presented is entirely my own.

Signature

Abstract

This thesis addresses a neglected area of British national cinema history, presenting the first comprehensive study of Scotland's incursions into narrative film production before the coming of sound. It explores both the specificity of Scottish production and its place within the broader cultural, political and economic contexts of the British film industry at key periods in the 'silent' era before and after the Great War. Early film production in Scotland has been characterised as a story of isolated and short-lived enterprises whose failure was inevitable. The work problematises this view, focusing instead on the potential for success of the various production strategies employed by Scottish film-makers. It demonstrates that producers were both ambitious and resourceful in the manner in which they sought to bring their films to local, national and international screens. Previously unknown markets for these films are also identified. In 1911 the first British three-reel film, *Rob Roy*, made in Scotland by a Glasgow production company, reached audiences as far away as Australia and New Zealand. Scottish efforts in film production, including the development of synchronised sound systems, were not haphazard but mirrored trends in the British and worldwide film industries until the late 1920s. With the coming of sound, the costs of commercial film production represented too great a challenge for the limited resources of Scottish producers. The study encompasses a detailed exploration of efforts in feature film production; how far these productions travelled and for whom they were made; the presentation and treatment of Scottish-made films by the trade press and local newspapers and their critical reception both at home and overseas. The majority of these films are lost, but close scrutiny of contemporary publicity and archival documents including business records has enabled a detailed picture to emerge of their content, nature and production background. Scottish stories and the Scottish landscape were important to the British film industry from its earliest days, and feature films shot on Scottish locations by outside producers are also discussed. Were these the films Scots would have made, if they could?

Acknowledgements

Special thanks go to my supervisor, Trevor Griffiths, for his encouragement, wisdom and good humour during the process of researching and writing this thesis - and for making it a more enjoyable experience than it might otherwise have been. Thanks are also due to my co-supervisor Ewen Cameron and to Annette Davison for their helpful comments and insights, which helped to stimulate new lines of enquiry. The Glasgow-based members of the Early Cinema in Scotland research team - Julia Bohlmann, John Caughie and Maria Velez-Serna - have been friendly and supportive colleagues from whom I have learned much. Their presence and the existence of the project, enabled by funding from the AHRC, has given a context for the work and a sense of purpose that I have valued. I am also particularly grateful to Janet McBain, whose extensive archival knowledge, combined with enthusiasm for this research, has been of great benefit. For similar reasons my thanks are due to Kay Foubister and Ruth Washbrook of the National Library of Scotland Moving Image Archive. Others who have helped me on my way include Charles Barr; Gordon Barr; John Burnett; Christine Gledhill; Janice Healey; Barry Robertson of the Aberdeen City Archives; Ronald Grant and staff of the Cinema Museum in Lambeth, and Catherine Koppe, Chris Otte and Belinda Washington, all of whom gave up their time to help me with formatting issues. Thank you, also, to Lindsay Scott for being a friendly face and a helpful presence in the School of History.

I would also like to thank Stella and Theo Merz for their support and interest. Finally, I owe a debt of gratitude to John Hoare for many things which include bearing with me during the time I have spent working on this thesis.

Contents

Abstract	1
Acknowledgements	2
List of Figures	4
Introduction	5
Chapter 1: Rob Roy.....	20
Chapter 2: To the Great War and beyond	62
Chapter 3: Cinema colleges and Football Daft	95
Chapter 4: Made in Scotland.....	140
Chapter 5: Glimpses from the Life of Maurice Sandground.....	198
Chapter 6: Scotland, Empire and the transition to sound.....	237
Conclusion.....	274
BIBLIOGRAPHY	282

List of Figures

1	Copyright registration form for <i>Rob Roy</i> (1911)	34
2	Six frames from the original film of <i>Rob Roy</i> (1911)	36
3	Advertisement for <i>Rob Roy</i> (1911)	44
4	Image from <i>Whisper and I Shall Hear</i> (1914)	90
5	Diagram of the Vocal Cinema operating system (1915)	92
6	Brochure for the Victoria Cinema College, London (1916)	102
7	Thornliebank film studio: set for <i>The Harp King</i> (1919)	112
8	Newspaper advertisement for <i>Football Daft</i> (1922)	128
9	Scene from <i>The Stolen Document</i> (1921)	133
10	Autographed postcard of Florence Turner (nd)	151
11	The Bailie Nicol Jarvie Hotel, Aberfoyle (nd)	164
12	Advertisement for <i>Christie Johnstone</i> (1921)	179
13	Poster for Gaiety Productions' <i>Kilties Three</i> (1918)	203
14	'Why Not a Scots Hollywood?' (1927)	222
15	Walter H B Sully, cinematographer (1926)	244
16	Lobby card for <i>Huntingtower</i> (1927)	262

Introduction

‘Everybody in the Trade knows, or can easily find out, the “history” of film production in Scotland. To hear some people talk one would imagine that you would need to be almost a centenarian to know the Trade’s “history.” Strictly speaking, it has no history. History can be made in a day, just as wine can, but before either history or wine can claim to be history or wine it must lie in bond for years and years.

Renfrew, for instance, has a history. Clydebank hasn’t. The oldest native of Renfrew might be any age. The oldest native of Clydebank is not long out of his teens. What, then, is the use of discussing the history of the youngest Trade in existence? A hundred years hence it might be interesting, or worth discussing. To-day it isn’t.’¹

It is now almost a hundred years since the editor of *The Scottish Cinema* expressed his views on the making of history, and the story of film production in Scotland has ‘lain in bond’, largely undisturbed, for most of the intervening period. The editorial was written in 1919: an optimistic time for those in Scotland wishing to begin, or resume, activities in film production after the hiatus caused by war. At various periods in the ten years that followed, Scottish companies were formed for the production of feature films and the manufacture of synchronised sound systems, and it is the story of these enterprises and their pre-war predecessors that is told in the following pages. The thesis examines recurrent attempts to develop a Scottish film industry in the period between 1911, when Britain’s first three-reel narrative film was produced in Scotland, and the advent of sound in 1929. Very few physical traces are left of the films that were made, but documentary evidence gathered from Scottish and British cinema trade journals, the British and overseas press, company records and other archival sources can be pieced together with the aim of giving an inclusive picture of fiction film production in Scotland in the silent era.

The decision to centre analysis on the form of film production in which the prevailing view of Scotland’s under-achievement is most apparent goes beyond the desire to address a neglected area of study. Scotland had far greater success in the

¹ *The Scottish Cinema*, 29 December 1919, p9

production of newsreels and documentary films both before and after the coming of sound, but these were not forms of mass entertainment. It was the medium's potential for storytelling on which film industries were based. Concentrating on fiction film production allows a closer focus on the way that themes of Scottish identity, articulated through selected and constructed narratives, played out in the context of an industry that was increasingly subject to global influences.

Scotland's relationship with film has been the subject of a growing body of work since the early 1980s, when the film theorists and historians represented in the *Scotch Reels* collection initiated a debate about the way Scotland was depicted on screen. None of this work, however, has fully engaged with indigenous production. The *Scotch Reels* writers' chief aim was to scrutinise filmic representations of Scotland for what were seen as the regressive discourses of tartanry and kailyard. In order for Scottish film to progress, they argued, such narratives of fantasy should be replaced by films representing the material realities of Scotland and Scottish life. This collection, and the other works that followed, notably *From Limelight to Satellite* (1990) edited by Eddie Dick, and Duncan Petrie's *Screening Scotland* (2000), were primarily concerned with film texts and textual analysis, and thus had little to say about lost films of the silent era.² In addition, such work tended to focus on representations of Scotland projected from outside, rather than the way Scotland presented itself to the world. Although the uncompromising views expressed in *Scotch Reels* were somewhat modified in the later works, until very recently most studies of Scottish film continued to approach the subject from a perspective of whether fictional representations of Scotland celebrated or deconstructed Scottish myths.

From this perspective the story of early film production in Scotland appeared to be one that was hardly worth telling: those films that were readily available to view in film archives reinforced a picture of feeble efforts to enter the production arena that were destined to fail. In the introduction to *From Limelight to Satellite*, Eddie Dick

² C McArthur (ed), *Scotch Reels: Scotland in Cinema and Television* (London, 1982); E Dick (ed), *From Limelight to Satellite: A Scottish Film Book* (London, 1990); D Petrie, *Screening Scotland* (London, 2000)

explained that ‘the limited number of [Scottish] silent films still available and the large number which are lost forever mean that no general light can be shed on the area’.³ Individual films, considered as texts, were used as primary evidence: thus it was possible for the film historian David Hutchison to base his somewhat scathing comments on the evidence offered by the very small number of Scottish films - a lone, amateur, Scottish production called *Mairi, The Romance of a Highland Maiden* (1912) and a few British feature films on Scottish subjects - of which viewing prints were available in the Scottish Screen and British National film archives. A lost, but well-documented Scottish film, *The Harp King*, (1919) was seen as representative of the best that Scotland could hope to produce at the time. As this discussion was so brief it could not fill a chapter, and was supplemented by a consideration of some documentary films.⁴ A more productive overview of Scottish film production in the silent period, based on documents held by the National Library of Scotland Moving Image Archive, was provided by Janet McBain and David Cloy in the catalogue produced to accompany a programme of Scottish films at the Pordenone Silent Film Festival in 1998. This short text was, until recently, the only attempt to ‘shed general light’ on the nature of early Scottish production, and included material on various forms of non-fiction as well as fiction films.⁵

Lamenting the fact that Scotland has no film industry has been commonplace for many decades. Writing in 2009, David Stenhouse remarked that Scotland’s ‘missing film industry’ had been seen for much of the twentieth century as ‘an embarrassment to Scottish culture’. But despite the apparent absence of a Scottish film-making tradition, other Scottish-themed films had not been welcomed but were censured for being what he called the Wrong Type of Scottish Film:

Early representations of Scots and Scottishness have tended to be stigmatised and dismissed by Scottish critics rather than being closely read: too often there has been a core assumption that the image presented is banal and kitsch, and therefore

³ E Dick, *From Limelight to Satellite*, p11

⁴ Dick, *From Limelight to Satellite*, p11; D Hutchison, ‘A Flickering Light’, *ibid*, pp31-40

⁵ D Cloy and J McBain, *Scotland in Silent Cinema: A commemorative catalogue to accompany the Scottish Reels programme at the Pordenone Silent Film Festival, Italy, 1998* (Glasgow, 1998)

unworthy of close study. The films have been quickly labelled a product of Tartanry or Kailyard or both.⁶

Stenhouse argued that representations of Scotland made largely outwith the country, particularly those enjoyed by the Scottish diaspora, should be engaged with rather than dismissed. He proposed an alternative way of viewing Scottish film, challenging the distinctions between ‘authentic’ and ‘inauthentic’ versions of the Scottish nation, history and iconography. Nevertheless, while usefully explaining the reasons for an early cinematic fascination with Scottish themes, his study did not engage in any detail with pre-sound films. Echoing Colin McArthur in 1982, he noted that ‘the history of these representations remains to be written’.⁷

In the apparent absence of an early Scottish film-making tradition and the paucity of home-produced feature films, lists and catalogues of early ‘Scottish films’ have combined indigenous productions with films set in Scotland or those on Scottish themes. The film historian and curator Janet McBain, who compiled the first Scottish silent filmography in 1998, used criteria based broadly on setting, backdrop, characters and the film’s reflection of some aspect of ‘Scottishness’. McBain’s work, later drawn on and extended by John Caughie, included just seven that were produced in Scotland.⁸ In these filmographies attention was drawn to the *lack* of Scottish production, presenting what did emanate from within the country as a handful of isolated attempts at film-making in a mass of other ‘Scottish films’ on apparently similar themes and subjects.⁹ As a category usually described in negative terms such as absence and failure, it is hardly surprising that there has been little scholarly interest in carrying out further investigation into early Scottish film production. The fact that in 1911 the first feature film to be produced in Britain was made in Scotland, by a Scottish company, has been noted as a matter of interest but

⁶ D Stenhouse, ‘Not Made in Scotland’ in J Murray et al (eds), *Scottish Cinema Now* (Newcastle upon Tyne 2009), p174

⁷ Ibid, quoting C McArthur, ‘Scotland and Cinema: The Iniquity of the Fathers’ in McArthur (ed), *Scotch Reels*, p42

⁸ Cloy and McBain, *Scotland in Silent Cinema*, pp14-18

⁹ J Caughie, Filmography, *Early Cinema in Scotland*, <http://earlycinema.gla.ac.uk/films-list/> (accessed January 2016)

seemed to excite no further curiosity.¹⁰ *Rob Roy* was a film known to be ‘lost’ made by a company known to have failed. Yet the circumstances surrounding its production invite a set of questions that surely demand to be answered. What was this film about, and who were the people that made it? Why did they decide to embark on such an ambitious production, and what were their resources? How, where and by whom was *Rob Roy* made, distributed and seen? These and other questions, applied to the various Scottish production initiatives, provide the central framework for this research.

Trevor Griffiths’ *The Cinema and Cinema-going in Scotland, 1896-1950*, published in 2012, has added considerably to the story of early Scottish production, although the wide-ranging scope of his survey did not allow detailed examination of individual productions or companies. An example of a growing scholarly interest in non-metropolitan and ‘regional’ British cinema history, this study placed greater emphasis on cinema-going culture and the exhibition and reception of films, regardless of their place of origin, than on production.¹¹ A final chapter chronicled the various forms of indigenous production from Scottish cinema’s earliest days: fiction film, local topicals, newsreels, scenics, documentaries and amateur film, identifying in the process a number of previously unknown productions.¹² Even Griffiths, however, approached the subject of Scotland’s efforts at feature film production as a story of assumed failure, commenting that ‘often... an authentic and distinctly Scottish perspective appeared to be lacking, as Scots seemed slow to embrace the potential of celluloid to present themselves to each other or to the citizens of other nations’. The inability of a nation of ‘inveterate cinema-goers’ to generate a film industry was again presented as a paradox, and emphasis was - as in Cloy and McBain’s earlier work - placed on Scotland’s greater success in the field of

¹⁰ D Gifford, *The British Film Catalogue: The Fiction Film, 1895-1994*, 3rd edn, (London, 2001); J McBain, ‘Scotland in Feature Film, A Filmography’ in E Dick (ed), *From Limelight to Satellite*, p235

¹¹ See, for example, D Berry, *Wales and Cinema: The First Hundred Years* (Cardiff, 1994); V Toulmin, S Popple and P Russell (eds), *The Lost World of Mitchell and Kenyon* (London, 2004); P Miskell, *A Social History of the Cinema in Wales, 1918-1951: Pulpits, Coal Pits and Fleapits* (Cardiff, 2006); J Hill, *Cinema and Northern Ireland: Film, Culture and Politics* (London, 2006)

¹² T Griffiths, *The Cinema and Cinema-going in Scotland, 1896-1950* (Edinburgh, 2012), pp2; 279-307

non-fiction production in order that the book did not end ‘on an extended note of diminuendo’.¹³

This thesis picks up threads of Griffiths’ survey but takes a different perspective, focusing on presence rather than absence. Instead of seeking to explain Scotland’s failure to develop a film industry in a context of enthusiastic investment in the exhibition sector or to compare it with the country’s greater success in the field of documentary production, this work argues that early Scottish feature film production is a neglected subject that deserves to be investigated both in its own terms and within the wider context of the British film industry. It considers the potential for success of commercial film production in Scotland in the years between 1911, when longer, feature-length films were becoming standard, and the coming of sound to cinema in the late 1920s. This is not a revisionist history in the sense that lost films have been discovered, or that the Scottish production story is presented as one of success. It does, however, offer a revised, substantially extended and non-judgmental account of early production initiatives, and a socio-historical framework within which these can be understood. In particular, it challenges the dismissal of Scotland’s efforts in commercial film production as the story of a few small companies that came and went in an apparently random fashion, their output having little if anything to do with the British or worldwide film industries. For Griffiths, if any pattern does emerge, it is the ‘substantial gap between aspiration and achievement’.¹⁴ While this gap undoubtedly existed, there are other more interesting patterns that can be detected from a detailed examination of each film’s production background, its distribution and (where possible) its popular and critical reception. Close viewing of film texts is obviously not an option, but those resources that are available - business and institutional records, the contemporary press, and archival documents, some previously unexamined - have been carefully cross-referenced in order to understand how these films were conceived and the visual and auditory experiences they presented to audiences. No single source (including British national trade journals *The Bioscope*, *Kinematograph Weekly* and *The Cinema*) can be relied

¹³ Ibid, p279

¹⁴ Griffiths, *The Cinema and Cinema-going in Scotland*, p280

on for its accuracy: indeed, accounts of a film's story or the activities of its producers were often at variance. Some material used in Cloy and McBain's account of early Scottish production that has been picked up by subsequent writers came from articles written in hindsight by members of the Scottish cinema trade whose memories appear, on closer inspection, to be faulty. One such example is the assertion that in 1911 *Rob Roy* was made in a rudimentary studio near Glasgow formerly used as a tram depot. This myth, whose origins appear to lie in an article written in 1946, has been passed down and embellished in subsequent accounts of early production.¹⁵

In 2009, Duncan Petrie, returning to his earlier work on contemporary Scottish cinema, remarked that it had become clear to him that, despite its legitimacy as a category, 'Scottish cinema, like the Scottish nation, remains a devolved rather than independent entity, embedded within the larger overarching British context and therefore subject to the same economic, political and ideological forces shaping the latter'.¹⁶ A similar perspective underpins this research, which seeks to re-present Scotland's forays in film production as part of the wider story of British cinema in the early twentieth century at a time when the Anglo-Scottish Union appeared impregnable. Despite the catastrophe of the First World War, the collapse of markets for Scottish heavy industry in the 1920s and the subsequent high level of emigration from Scotland, the Union remained secure. The British national press sometimes referred to Scotland simply as 'North Britain', and indeed a Scottish production company formed in 1928 chose to call itself North British Films, Ltd.¹⁷ As Tom Devine has noted, this relationship did not come at the expense of either cultural dependency or loss of identity.¹⁸ At the same time, Scotland's ties to the Empire were particularly strong:

So intense was the Scottish engagement with Empire that almost every nook and cranny of national life from economy to

¹⁵ Cloy and McBain, *Scotland in Silent Cinema*, p7

¹⁶ D Petrie, 'Screening Scotland: A Reassessment' in Murray et al (eds), *Scottish Cinema Now*, p154

¹⁷ National Records of Scotland (hereafter NRS), BT2/15183, North British Films Ltd. This company is discussed in Chapter 6

¹⁸ T M Devine, *Scotland and the Union, 1707-2007* (Edinburgh, 2008), p14

identity, religion to politics and consumerism to demography were affected by this powerful force.¹⁹

The traditional industries of the Scottish nation in the nineteenth and early twentieth centuries were believed to depend for their success on imperial markets. In similar fashion, those hopeful of creating a Scottish film industry sought out Empire markets for their productions. The Scottish audience was conceptualised not just as those living within Scotland's borders, but as the wider diaspora communities of Canada, New Zealand and Australia. In some cases, such as that of a production company formed in 1927 by the Scottish-Australian adventurer Alexander Macdonald, the connection with trade and Empire was more explicit. The new light industry of film production was of course very different from traditional industries such as jute or shipbuilding, in which Britain as a whole was dependent on Scottish output. Britain did not need Scotland to produce films, but it did depend on aspects of Scottishness to represent Britain on screen. The exploitation of authentic Scottish scenery was an important element in the development of early British cinema - a resource that was available not only to Scots but to anyone who chose to travel north with a camera and crew. The London-centric British film industry could, and did, manage quite well without direct Scottish input, making it all the more important for those under-capitalised companies that did emerge in Scotland to seek overseas, and particularly Empire and Dominions, markets for their productions.

Thanks to the advent of digital newspaper archives such as those created by the national libraries of Australia and New Zealand, it is now possible to discover how far some of these early Scottish films actually travelled, and the ways in which they were presented to Scottish audiences overseas.²⁰ Such internationally-available resources, together with archival documents such as company records, are used to ask not just how, but *why* these Scottish films were produced at certain moments. This evidence reveals that all the production strategies adopted within Scotland mirrored trends in the wider industry, adapted to fit a particular set of economic and cultural circumstances. In order to look at the Scottish story more closely, then, it is

¹⁹ Devine, *Scotland and the Union*, p109

²⁰ Trove, Australia, <http://trove.nla.gov.au/>; Papers Past, New Zealand, <http://paperspast.natlib.govt.nz/>

necessary to look at the way the film industry developed across Britain at certain key periods before the Great War, immediately after it, and in the period leading up to the introduction of the Cinematograph Films Act (generally known as the Quota Act) in 1927. Seen in this context it is possible to understand the Scottish story as one that was simultaneously unique and part of a much bigger picture in which British cinema struggled to assert itself in the face of growing Hollywood dominance.

It is also important to consider how representations of the nation on screen produced in Scotland differed from those imposed from outside. This involves a study not only of the actual achievements of Scottish producers and sound technicians, but of their plans and ambitions. Companies were not formed in order to make one film and then go into liquidation: they had a purpose, strategy for development and sometimes a production schedule. What versions of Scotland would they have presented, had these plans come to fruition? Externally-constructed representations of Scotland, as noted above, have been characterised as essentially backward-looking and defiantly anti-modern. As Griffiths has remarked:

Harnessing the elemental forces of nature and romance, the Scotland of the silver screen is often seen to embody the anti-modern ‘other’, which, when confronted by the values and expectations of the contemporary world, operates to challenge and subvert them.²¹

Scotland’s early efforts in fiction film production were not numerous enough for any conclusions to be drawn about the dominance of certain recurring filmic representations. ‘Scottish national cinema’ cannot be discussed in the way that British cinema and national identity has been conceptualised and debated. Nevertheless, its small output showed greater diversity and readiness to engage with aspects of modernity than might be assumed. Had a Scottish film industry developed, the signs are that it would have drawn on what Sarah Street calls ‘traditions, sensibilities and experiences’ other than those ascribed to the nation from outside.²² Scotland’s first real cinematic success was *Football Daft* (1922), an urban comedy about a day in the life of a hard-drinking Rangers fan. A series of sequels was

²¹ Griffiths, *The Cinema and Cinema-going in Scotland*, p7

²² S Street, *British National Cinema* (London and New York, 1997), p4

planned whose narratives revolved around other popular leisure pursuits of working-class Scots, including racing and cinema-going. Although these could not be made, they exemplify the way that some Scottish producers recognised the demand for stories reflecting, and parodying, the everyday lives of their compatriots.

One aim of this research has been to reconstruct the narratives and modes of presentation of each completed Scottish production. The process has been similar to doing a jigsaw puzzle, involving the assembly of many misshapen pieces in order to form a complete picture. Such activity is rewarding but - unlike completing a jigsaw - not an end in itself. The stories behind these images have much to tell us about the Scotland in which these films were made. The United Films' *Rob Roy*, produced in 1911, turns out to have been a cinematic version of an enormously popular stage adaptation of Scott's novel that was produced hundreds of times throughout Britain, especially in Scottish theatres, from the early nineteenth century until after the First World War. In Edinburgh, where it was staged at the King's Theatre every Christmas, it was presented as a kind of extravagantly-staged pantomime with songs and special effects that evolved over the years to suit changing popular tastes. *The Harp King*, made in 1919, was set in contemporary rural Scotland and combined romance and melodrama with elements of popular kailyard fiction. In contrast, *Football Daft* was set and filmed in Glasgow's streets and football grounds. The productions created by Maurice Sandground in the mid-1920s - *Bonnie Scotland Calls You*, *The Life of Robert Burns* and *Glimpses from the Life of Sir Walter Scott* - presented a nostalgic vision of Scotland 'in film and song' considered to hold particular appeal for the Scottish diaspora, while Scotland's ties with Empire were represented by the formation of the Seven Seas Screen Productions in 1927. Its films, *The Unsleeping Eye* and *The Kingdom of Twilight*, directed by Alexander Macdonald, were based on his own adventure stories and filmed in New Guinea and Australia respectively. Other films made or planned by Scottish companies fell within the popular genres of crime, comedy and stunt films. Together they represent a broad spectrum of products designed to appeal to the tastes and preferences of contemporary audiences.

The chapters that follow offer both a broadly chronological and thematic approach in seeking to explain not only how, but why, Scotland's continued endeavours in film production appeared at certain points in cinema history. Each chapter explores a film, or group of films, situated in the context of developments in the British and worldwide film industries and of conditions peculiar to Scotland. The themes are the different initiatives taken by Scottish producers, and each chapter explores a particular production strategy employed in attempting to generate a Scottish film industry.

The first chapter considers the frame of reference for the production of *Rob Roy* in 1911, when single-reel films still dominated exhibition and production practices. Drawing on previously unexplored archival evidence, including a single strip of film from this long-lost production, it reveals that the ambitions of its producers were rooted in an understanding of the maturing industry and extended to the production of a series of films based on Scottish literature. Formed by members of the Glasgow film trade, United Films employed a professional director and cameraman for the shooting of *Rob Roy*, a story with proven success. A key question centres on the intermedial relationship between theatre and cinema in this period and whether the novelty of this feature film was counterbalanced by more lavish live theatrical productions. An examination of promotional materials shows that this film, like many of its successors, was aimed at a worldwide Scottish audience.

Chapter two, which takes in the period from 1912 to 1918, considers moves made by two successful Glasgow exhibition and rental companies - The BB Pictures and Green's - to enter fiction film production against a background of growth in vertical integration combining all three operations, in France and the USA. The optimism of the years leading up to the war are contrasted with the challenges faced by British producers and exhibitors during the Great War, and the mystery of a series of slapstick comedies said to have been made by Green's, the company with the greatest potential to extend production activity, is investigated. It explores the connections between these Glasgow companies and personnel involved in the production of *Rob Roy*, and reveals a willingness to engage with a popular genre that would appeal to non-Scottish, as well as Scottish, audiences. The chapter's second

section discusses the Vocal Cinema, a production company formed in 1914 in order to produce synchronised sound films, using a system devised and patented by a Glasgow naval mechanic. The ambitions of the company, which extended to the building of its own studio, are situated within an early worldwide trend for similar sound systems used to present ‘singing and talking pictures’ and an existing film held by the NLS Moving Image Archive is identified as having been produced by this company.²³

Whereas the first two chapters present a picture of Scottish endeavours that clearly reflect aspects of the maturing worldwide film industry, the third shows that although the post-war boom in British film production was to some extent mirrored in Scotland between 1919 and 1922, the route towards the hoped-for development of a Scottish film industry was more circuitous. The central question here is how, with minimal resources and facilities, Scottish film production could be revived after the war. One solution was the attempt to build an industry on the foundations of a cinema college. Many such early British film schools were money-making enterprises set up to exploit would-be film stars, but in Glasgow the goal was to fund and develop feature film production. Although the first production of the A1 Cinema College, *The Harp King*, was an over-ambitious flop, it enabled the building of Scotland’s first film studio. This was later used in the production of the more successful *Football Daft* by another company which also employed the cinema college model as a means of funding production. The chapter highlights a theme running through this work of ongoing concern to those in the Scottish film trade and press: the issue of what constituted a truly ‘Scottish film’, in which story and genre was of less importance than production personnel.

The next chapter focuses on films shot in Scotland, both before and after the war, by English production companies seeking to exploit Scotland’s scenery and enhance the international marketability of their Scottish stories. It offers a more complete overview of film production in Scotland until the coming of sound, and to some extent fills the gap identified by McArthur and later by Stenhouse, noted above, in

²³ National Library of Scotland, Moving Image Archive (hereafter NLS/MIA) 2803: *Whisper and I Shall Hear*

the history of early filmic representations of the nation. It considers the importance of Scotland to Britain's national identity and the reasons why English producers went to the expense of mounting large-scale productions on Scottish soil during a period in which only one American - and no European - company felt a similar need for authentic Scottish settings. The content and nature of these films is explored rather than their production backgrounds, and for the first time all the feature films that were actually (rather than thought to have been) shot in Scotland between 1914 and 1923 are identified. Of equal importance is the Scottish perspective on these productions both in terms of their contemporary reception and in the ways they benefited the local economy, particularly through the engagement of armies of Scottish film extras at a time when unemployment had become a serious problem.²⁴ British films such as *Bonnie Prince Charlie* (1922) were not primarily made for Scottish audiences. A key question running through the research is whether these were the kind of films that Scots would have made if they had been able to command similar resources. The answer seems likely to have been in the negative.

An exception was Maurice Sandground, whose filmic output is described in Chapter Five. A Londoner who moved to Scotland in 1924 in the hope of reviving a stalled career as a film producer, Sandground can only be described as a maverick. At a time when the British film industry was ailing, he arrived in Glasgow and proclaimed himself the champion of Scottish film. Although Sandground's talents lay in the field of publicity and (self) promotion rather than in film-making, he was canny and knowledgeable about actual and potential developments in the British film industry. In 1924, when the British industry mounted a series of British Film Weeks in an attempt to promote the domestic industry, Sandground invented a Scottish Film Week which involved the presentation of just one film: his own *Bonnie Scotland Calls You*. The companies he formed between 1924 and his departure from Scotland in 1928 turned out a series of filmic entertainments that were extremely cheap to produce and put a large burden of the cost on the exhibitors' shoulders. His films were packed with traditional Scottish tropes of tartanry and kailyard, sometimes directly addressing the Scottish audience overseas and a longing for their Scottish

²⁴ E A Cameron, *Impaled Upon a Thistle: Scotland since 1880* (Edinburgh, 2010) p132

homeland. It is easy to ridicule Sandground and his oeuvre, yet he was a lone voice in the mid-1920s campaigning for Scottish production. Indeed, the title of this thesis is taken from the headline of a newspaper article in which Sandground maintained that there was no reason why Scotland should not be at the centre of the British film industry.²⁵ In this narrative of early film production in Scotland, some strands can be explained by what was going on in the wider British industry, while others were unique to Scotland - the result of the actions of individuals such as Sandground.

A final chapter looks at the films and the sound systems created by those from Scotland in the period leading up to the passing of the Cinematograph Films Act (generally known as the Quota Act) in 1927 and the advent of the 'talkies' in the following two years. Both factors had a significant impact on the activities of those within Scotland and their potential futures in the film industry. A spirit of optimism and entrepreneurship prevailed, and between 1926 and 1928 there were renewed attempts to form a commercially viable production company in Scotland as well as a revival of activity in Scotland by English producers. For the first, and only, time in the silent period, a Scottish company made films that were not concerned with any aspect of Scottish identity. These productions have never been included in any overview of early Scottish production, and indeed have only been briefly remarked upon in the history of Australian cinema. Attention is also given to the development by Scottish engineers - one of whom was also a film producer - of two different sound systems, intended for use in Scotland's cinemas. The recurring theme of a close engagement with, and understanding of, developments in the international film industry runs through this chapter. Although the coming of sound, accompanied by a huge rise in the cost of feature film production, marked the death knell for Scottish feature film production, even at this late stage the story is more complex and diverse than has been assumed.

²⁵ 'Why Not a Scots Hollywood?' *Evening Telegraph*, Dundee, 16 February 1927, p2

The American inventor Thomas Edison is supposed to have said ‘I have not failed. I just found 10,000 ways that won’t work’.²⁶ A similar perspective is taken on the efforts of Scottish producers described in the following pages.

²⁶ The source of this quotation is unknown; various possibilities are offered by <http://quoteinvestigator.com/> (accessed February 2016)

Chapter 1: Rob Roy

'At the King's Theatre, Mr John Clyde's special production of the Scottish national drama, "Rob Roy", has been attracting big audiences. There is no doubt that the "Rob Roy" of John Clyde is the greatest living impersonation of the character. He has made the part specially his own, and when one speaks of "Rob Roy" one mentally thinks of John Clyde'.¹

Introduction

It is no surprise that the first excursion the Scots made into fiction feature production was a version of the Rob Roy story. The outlawed clan chief Rob Roy Macgregor (1671-1734) was already a legendary figure when Walter Scott wrote *Rob Roy* in 1817.² Scott's novel added to Rob Roy's fame, presenting him as a romantic folk hero whose career was caught up in both Jacobite rebellion and modern economic life. *Rob Roy's* representation of commercial life in Glasgow was instantly recognisable to a middle-class public, while at the same time it engaged with an interest in Rob Roy and in other legendary outlaw figures - most notably Robin Hood - in the popular culture of the time. Rob Roy was destined to become one of the most popular figures of the Scottish imagination long after Scott's literary works had fallen out of favour with the reading public. There were many hundreds of adaptations of Scott's novels performed on the British stage from the mid-1810s onwards, of which *Rob Roy* was by far the most popular with theatregoers.³ As Ann Rigney puts it, 'The intensity with which it [*Rob Roy*] was produced over and over again up to the First World War, especially in the Scottish theatres, offers a unique perspective on the cultural resonance of Walter Scott'.⁴

Scott's vision of Scotland, where historical romances were played out in dramatic landscapes, was all-pervasive by the time the cinema was born, and it was almost

¹ *Entertainer*, 11 July 1914, p3

² A fictionalised account of Rob Roy's life possibly written by Daniel Defoe, *The Highland Rogue or the Memorable Actions of the Celebrated Robert Macgregor, Commonly Called Rob-Roy* (1723), was published during his lifetime

³ H P Bolton, *Scott Dramatized* (London, 1992) p67

⁴ A Rigney, *The Afterlives of Walter Scott: memory on the move* (Edinburgh, 2013), p50

inevitable that film-makers both at home and abroad would draw on this vision when choosing and creating ‘Scottish’ subjects for films. The potential of the fiction film as a medium for historical romance was quickly recognised, and in the early silent cinema (1909-1914) fourteen Scott films were made in Britain, France, USA and Italy. These were *The Bride of Lammermoor* (USA, 1909); *The Bride of Lammermoor* (Italy, 1910); *Kenilworth* (USA, 1909); *Lochinvar* (based on *Marmion*, USA, 1909); *Quentin Durward* (France, 1911); *Rob Roy* (Scotland, 1911); *The Lady of the Lake* (USA, 1912); *Guy Mannering* (USA, 1913); *Ivanhoe* (Britain, 1913); *Ivanhoe* (Leedham Bantock, Britain, 1913); *Rebecca the Jewess* (based on *Ivanhoe*, Britain, 1913); *Rob Roy* (USA 1913); *A Woman’s Triumph* (based on *The Heart of Midlothian*, USA, 1914); *The Heart of Midlothian* (Britain, 1914).⁵ One of them, a film version of a theatrical adaptation of *Rob Roy*, was the product of a newly-established Scottish film company, United Films, Limited.

This production, made in 1911 and featuring the well-known Scottish actor John Clyde in the title role, is usually mentioned only as an interesting footnote to the history of British cinema. Its fame rests on the fact that it was thought to be the first three-reel feature to be produced in Britain.⁶ Why and how an all-Scottish production should have come to occupy this place is not considered. The implication is that this was somehow an accidental occurrence; an aberration in the wider story of British film production. While Scottish film historians such as Duncan Petrie, Janet McBain and Trevor Griffiths acknowledge the film’s significance in terms of indigenous production, they have little (particularly in Petrie’s case) to say about it. This is understandable, given that until recently all traces of *Rob Roy* appeared to be lost. Griffiths’ research revealed evidence of a few screenings of the film confined to the Glasgow area, leading to the conclusion that it simply promised more than it delivered.⁷

⁵ T Dolin, ‘The Great Uncredited: Sir Walter Scott and Cinema’, www.screeningthepast.com (accessed November 2013)

⁶ D Cloy, ‘Scottish Film Production in the Silent Period’ in J McBain (ed), *Scotland in Silent Cinema: A Commemorative Catalogue to Accompany the Scottish Reels Programme at the Pordenone Silent film Festival, Italy, 1998*, p7

⁷ Griffiths, *The Cinema and Cinema-going in Scotland*, p282

This chapter demonstrates how a production that apparently came from nowhere and then sank without trace was far from incidental. Indeed, it is probably the most significant narrative film of the silent period to be made in Scotland, representing a deliberate and carefully calculated attempt to create an entertainment with the widest possible popular appeal. This was a project with real ambition; contrary to previous assumptions, there were several prints of this film, which also travelled much further than Glasgow. Discovery of the existence of some frames from the original film of *Rob Roy* and accompanying documentation has proved surprisingly revelatory about the company and its ambitions. The film itself is lost, but by tracing its genesis and its antecedents - particularly a popular stage adaptation of Scott's *Rob Roy* - it is possible to get some idea of how this film might have played, and why it was, and remains, so central to the chequered story of film production in Scotland. The history of the company behind the production is also outlined. United Films, Ltd was set up in 1911 in order to create Scottish narrative films at a time when few had dared to embark on the perilous journey of feature-length production, and when audiences' and cinema managers' attitudes towards longer films were still equivocal. Throughout, reasons are offered for why this project - despite all its potential for success - failed to live up to the hopes of its producers.

The United Films Limited, with offices at 4 Union Street, Glasgow, was incorporated on 18 November 1910. It had three directors; Thomas McKinnon and James Bowie, both listed as merchants, and Robert Neilson, a draper. A private company, its nominal capital was £5000, divided into 20,000 shares of five shillings each. By the end of December the three initial subscribers had been joined by two more merchants, two manufacturers, a 'merchant manufacturer', an engineer, a curator, a manufacturer's agent, two travellers (presumably salesmen rather than gypsies), a commission agent, and an umbrella manufacturer. All of them were local, with addresses in Glasgow. The only new shareholder with experience of the cinema industry was Arthur Vivian, the manager of St George's Picture Theatre, Paisley. The sole female shareholder was Anna McKinnon, presumably the wife or a relative of Thomas McKinnon. The range of occupations appears representative of those who

chose to invest in film production in this period: that is, men whose social background was middle class or lower-middle class and unconnected, with the exception of Vivian (who was to play an active role in the production of *Rob Roy*) with the film or entertainment business. Six weeks after the company's incorporation, 3,930 shares had been allotted with a nominal value of £982.10s.⁸

The first Ordinary General Meeting of United Films, Ltd was held in January 1911, and by 8 February the total number of shares taken up had risen to 4260. New subscribers included a dentist, an engineer, a tailor, and the wife (Mrs Jessie Faulds) of one of the existing shareholders. A further 8000 shares were allotted on 12 January 1911 to some of the existing shareholders, together with two other Glasgow men. For the first time a non-Scottish investor was listed, Alexander Roberts of Newcastle upon Tyne. The final list of share allotments was in September 1911 (following *Rob Roy*'s release) with subscribers including a wine merchant and a 'Gentleman', William Semple of Glasgow.

Arthur Vivian was an entrepreneurial cinema manager who appears to have had an eye for any opportunity to be involved in the cinema business at a time when the first dedicated cinemas were being established. In June 1910 he had formed his own company, the Scottish Moving Pictures Company, and taken over the lease of premises formerly known as St George's United Free Church in Kerr Street, Paisley. From this point on, it would become the St George's Picture Palace. Vivian, who was 48, was the manager while his wife Emily (some 20 years younger than him) worked as a cashier.⁹ A short biography of Vivian in the *Bioscope* reveals that before moving into cinema management and then (briefly) production he had been a travelling exhibitor with a Wrench projector, and then worked as an electrician with the Benson Shakespearean Company in the West Indies. After this he worked for A D Thomas and Ralph Pringle, both of whom are significant figures in the story of early cinema in Britain.¹⁰ Pringle and Thomas were itinerant exhibitors based in the north of

⁸ NRS, BT2/7704/1 and BT2/7704/3: The United Films Limited, Memorandum of Association, 17 November 1910; Return of Allotments, 28 December 1910

⁹ In 1915 Emily was listed as the tenant of the St George's Picture Theatre in Paisley, with the proprietor given as Scottish Moving Picture Co Ltd (in liquidation)

¹⁰ *Bioscope*, 8 January 1912, p363

England and closely associated with Mitchell and Kenyon. Originally an agent for Thomas (who presented films under the banner of Edison-Thomas Pictures), Pringle set up his own travelling exhibition company, North American Animated Photo, which presented moving picture shows in town halls and theatres throughout Britain and Ireland. Between 1901 and 1907, he commissioned Mitchell and Kenyon to make non-fiction films of local scenes that were shown in the same evening. His circuit included Edinburgh and Glasgow as well as Sunderland, Newcastle, Bristol, Huddersfield, Birmingham, Liverpool and Dublin. From 1908 onwards, Pringle opened permanent cinemas in Glasgow and Edinburgh as well as Bristol and Leyland.¹¹ Vivian's association with these showmen/exhibitors demonstrates that he was certainly no novice, and would have had a thorough grounding in the film business.

Many cinemas were, like the St George's Picture Palace, converted from existing buildings, but changes initiated by the 1909 Cinematograph Act also resulted in a boom in the building of purpose-built cinemas across Scotland and throughout Britain from that year onwards. With the increased investment that bricks and mortar could attract, the cinema business began to evolve. A regular audience meant that the supply and marketing of films throughout Britain could become more efficient, with far-reaching implications for the industry. Within a few years it would become clear that, as Griffiths puts it, [in Scotland] 'the expectation of profit that motivated many to acquire shares in cinemas was, for the most part, realised'.¹² Hindsight would also prove that those who invested in feature (fiction) film production were most unlikely to receive any kind of profit. In 1910, however, this would have not been so obvious. Feature films, like purpose-built cinemas, were a new concept. While the launch of newsreels in British cinemas from June 1910 proved almost immediately successful, fiction films were evolving only slowly, and in Britain the one-reel drama was still the norm.¹³

¹¹ R Abel (ed), *Encyclopedia of Early Cinema* (5th edn) (London, 2013), p532

¹² Griffiths, *The Cinema and Cinema-going in Scotland*, pp38-42

¹³ Continental productions led the way with longer films, the first of which was *The White Slave Trade*, a 1910 Danish multi-reel drama of sensational and salacious content leading to the development of the longer feature and the crime serial (www.screenonline.org.uk)

Trevor Griffiths has demonstrated, through an analysis of sources of funding of 46 cinema companies established across Scotland between 1910 and 1914, that the capital which funded the first wave of cinema building across Scotland came from outside the moving picture business itself, and that the majority of investors were middle class.¹⁴ Griffiths goes on to compare this with the profile of investors in the other great Scottish entertainment business of the time, football. While it is not possible to carry out a similar analysis of Scottish film production companies, the case of United Films, Ltd suggests that film production, as opposed to exhibition, may have been considered too risky a business for it to guarantee a good rate of return. There were few investors from outside Glasgow (and indeed Scotland) in the case of most Scottish production companies. Those that were willing to invest appear to have been relatively prosperous, in steady employment in the manufacturing and sales sectors, and perhaps able to take a chance on a new form of industry. In comparison with the 11 per cent of women designated as married, spinsters, or widows, identified by Griffiths as perhaps the largest single group to hold stock in local picture houses before 1914, less than one per cent of investors in United Films were women.¹⁵ On 29 January 1912 at an Extraordinary General Meeting of United Films, Ltd held at 145 Saint Vincent Street, Glasgow, the Members agreed to wind up the company as it could not, ‘by reason of its Liabilities, continue its business’.

Arthur Vivian and Vivian’s Pictures

Equally telling is a comparison with the company Arthur Vivian founded after the Scottish Moving Picture Co, Vivian’s Pictures Ltd, which was established in November 1911. While the articles of association state that this company’s business included the production, as well as the representation and performance of ‘Cinematograph Films, Operas, Operettas, Plays of any description, Vaudevilles, Pantomimes, Promenades or any other Musical or Dramatic Performances or Entertainments’, it is evident that the focus was on exhibition rather than production, and on the acquisition of land and property for cinema building. The company appears to have traded successfully between 1911 and 1936, when it was wound up. Not only were the shareholders far more numerous (running into the hundreds over

¹⁴ Griffiths, *The Cinema and Cinema-going in Scotland*, pp38-39

¹⁵ *Ibid*, p40

the period) than those who chose to invest in the United Films Ltd, but their profile was much more varied - ranging from bankers, surgeons and solicitors to clerks, picture theatre proprietors, brewers, wine and spirit merchants, provision dealers and a mineral water manufacturer. The interests of many of these individuals were, of course, represented by the various aspects of Vivian's Pictures Ltd, in direct comparison with investors in United Films, who were gambling on a highly speculative enterprise. The coming of war dealt a fatal blow to most film production in Britain, but the exhibition business thrived: there is a long list of new shareholders in Vivian's Pictures in 1913 and 1914, some but fewer in 1915, more again in 1916 and 1917, and a very long list in 1920.¹⁶

Arthur Vivian himself, however, appears not to have benefited personally from the longevity of the company that bore his name. Contemporary accounts in the trade press of Vivian's career show that while in 1912 his career was flourishing with the opening of a cinema in Rosyth naval base and the building of the Majestic in Govanhill, Glasgow (two enterprises of Vivian's Pictures), as well as being appointed sole agent for the New Century Film Service, by 1914 he was seeking employment again, eventually finding a position as the manager of the Pavilion in Coatbridge.¹⁷ In 1915 he had moved down a notch and was the manager of a shooting saloon at 31 Argyle Street, Glasgow. According to the *Entertainer*, Vivian was out of work again in 1916 and looking for a position that would give him a free hand, although the writer of the article noted with caution: 'Methods which would have carried one through yesterday cannot apply today'.¹⁸

Investment into film production as opposed to exhibition may have been seen as a riskier proposition, but for those like Arthur Vivian who were fascinated by the business of film and the potential for return on speculative investment, the idea of backing a new Scottish film industry must have seemed an exciting prospect. Vivian's ambition, however, went beyond the role of financial backer when it came to his involvement in United Films, Ltd. He was closely involved in the production

¹⁶ NRS, BT2/8039/2, Vivian's Pictures Limited, Memorandum of Association, 14 November, 1911

¹⁷ *Bioscope*, 4 April 1912, p45

¹⁸ *Entertainer and SKR*, 6 October 1916, p141

of *Rob Roy*, and certainly he and the other investors would have good reason to believe that this film had every chance of success.

Cast and crew

The United Films, Ltd was formed for the purpose of making *Rob Roy*, which was to be followed by a series of other Scottish dramas adapted for the screen. Only six months after the company's formal inception in November 1910 *Rob Roy* was already in production.¹⁹ While publicity for the film prominently featured the actors (all of whom were associated with the theatrical drama on which the film was based), no mention was made of the production team. The *Bioscope*'s Scottish correspondent, 'Scotty', reported in June 1911:

United Films Ltd, 4 Howard Street, Glasgow have very enterprisingly arranged for the taking of films representing the famous play of 'Rob Roy' and other historic Scottish dramas. A company of leading actors and actresses has been engaged to produce the entire dramas on our native heath - right in the heart of the Highlands - and the resulting pictures ought undoubtedly to stir many audiences everywhere to the highest pitch of enthusiasm... The films will be produced under the personal supervision of Mr Arthur Vivian, and this expert cinematographist will take charge of the company during the sojourn up North... Produced before our own Scottish audiences they are bound to create the greatest enthusiasm. Undoubtedly this is the most ambitious venture of the kind, so far promoted hereabouts, and I congratulate Mr James Bowie on his up-to-dateness and energy'.²⁰

Scotty's comments have led to the inference that Arthur Vivian was the film's director and/or cameraman, but it is unlikely that he held either of these roles.²¹ The term 'cinematographist' is perhaps misleading; today it would generally be understood as referring a camera operator or director of photography. In the early days of cinema, however - when the language of cinema was still being established - it could also mean someone who projected or exhibited films or magic lantern shows. The words 'personal supervision' are also vague and suggest a role as production

¹⁹ Griffiths, *The Cinema and cinema-going in Scotland*, p282

²⁰ *Bioscope*, June 8 1911, p467

²¹ See, for example, Janet McBain, 'A Scottish Filmography' in E Dick (ed), *From Limelight to Satellite*, p235

manager rather than director. The energetic James Bowie was the managing director of United Films; evidently he was also involved in the film's production and one of the driving forces behind it. His brother (or another relative) also had a key role in company, although he was not a shareholder: the Post Office directory listing for the United Films names Hugh Bowie of 83 High Street, Glasgow as the company manager.²²

Research has revealed some clues which suggest there was a higher degree of professional expertise among those involved in the filming of *Rob Roy* than was previously supposed. In 1946 a Scottish cinema trade veteran called Jack Kissell wrote an article for a special edition of the *Educational Film Bulletin* in which he reminisced about the early days of cinema in Glasgow:

Mention of this film [*The Lady of the Lake*] reminds me that Danvers Yates of Barker's was director and camera man of a film of Rob Roy with John Clyde in the title role; there were no interior scenes. It had only a moderate success but it was probably the first Scottish produced film.²³

Kissell went on to describe how Yates then joined JJ Bennell of the BB Pictures 'who had a laboratory', and helped him make two films, *The Land of Burns* and *Tam o' Shanter*, which are discussed in the following chapter.²⁴ While Kissell's account was written 35 years after *Rob Roy's* appearance and cannot be verified (although Danvers Yates' name is sufficiently memorable for this to be plausible), it seems quite probable that Vivian and Bowie would have sought the assistance of people who had greater experience in film production than they had themselves. *Rob Roy* - and the series of productions of 'great Scottish dramas' that United Films were planning to make - was a serious enterprise. At 2,500 feet and three reels its running time would have been around 45 minutes. This is not a long film by later standards, but in its day would have been considered feature length.²⁵

²² *Scottish Post Office Annual Glasgow Directory 1911-12*, p112 <http://digital.nls.uk/directories>

²³ *Kinematograph Weekly* (hereafter *KW*), 7 February 1946, p30. In an article called 'Trade Makes Merry at Cinema Ball', Jack Kissell is described as the employee with the longest service, suggesting he was working in the cinema trade as early as 1908

²⁴ J Kissell, 'Cinema in the By-ways', *Educational Film Bulletin* 1946 no. 33, p27

²⁵ *Bioscope*, 8 June 1911, p467

Frank Danvers Yates was also linked with another cameraman, Walter Buckstone, who appears from recently-discovered documentary evidence to have worked on *Rob Roy*. Yates began his career as an actor and then moved into directing short sound films in 1909 for the Warwick Trading Company, who had adopted the Cinephone sound system.²⁶ He then joined Barker Motion Photography, listed as a ‘technician’ in the darkrooms, although he also acted as a cameraman. In January 1911 (six months before filming began on *Rob Roy*) Yates was credited as one of the cameramen on Will Barker’s documentary *Fox Hunting*, along with Walter Buckstone and another cameraman, Frank Bassill. Yates was also cameraman for Barker’s on at least one of several films made by British production companies taken to mark the most newsworthy event of 1911, the Delhi Durbar. The world’s press covered this event, and film footage was extremely popular at cinemas in India and throughout the Empire.²⁷ This elaborate series of events and pageants surrounding the Durbar ceremony, which took place over ten days in December 1911, celebrated King George V’s coronation and his status as the new Emperor of India. Barker’s film was entitled *King Emperor and Queen Empress Hold a Durbar in Delhi*.²⁸

After Barker’s, for whom he developed, edited and printed the footage he took while filming in Delhi, Yates joined Cherry Kearton’s company who had taken over the Warwick Trading Company in 1912 along with the company’s interests in the lightweight Aeroscope camera.²⁹ Walter Buckstone’s career trajectory seems to have been equally successful. His first job in the film industry appears to have been as another technician/cameraman on *Fox Hunting* for Barker’s. He later joined the British branch of Pathé and also worked on fiction films for G B Samuelson, becoming George Pearson’s main cameraman on such films as *A Study in Scarlet* (1914). Buckstone worked as a British official cameraman on the Western Front

²⁶ These included *Apache Dance*, *The Taximeter Cab*, *Sneezing* and *Land of Hope and Glory*
<http://bufvc.ac.uk/newsonscreen/search/index.php/person/1022>

²⁷ The most famous of these is a set of films produced by Charles Urban, who took four or five cameramen with him to film the entire royal visit to India in the Kinemacolor process. *With Our King and Queen Through India* ran for two and a half hours

²⁸ A print of this film is held by Screen Archive South East

²⁹ Aeroscope is said to have been the first successful hand-held film camera. It was patented in England in 1910

during the First World War, and his career as a cameraman on news and documentaries continued well beyond the coming of sound.³⁰

Barkers' and *Henry VIII*

It is significant that both Yates and Buckstone worked for Barker's: in 1911, this company under its founder Will Barker - whose trademark logo was a British bulldog - was credited with leading, along with Cecil Hepworth, a revival in British cinema. This was the year that producers of films in Britain made a concerted effort to improve the standing of their product within the industry, both in Britain and the rest of the world. Barker produced a film adaptation of Shakespeare's *Henry VIII*, famously paying the actor Sir Beerbohm Tree £1000 for a day's work. Barker hired the celebrated composer Edward German to write music especially for the film - the first time this had been done.³¹ He also paid for the stage sets at Her Majesty's Theatre to be transported to his studios and rebuilt there.³² The film received huge publicity in the trade press. In November 1910, for example, the *Bioscope* announced that 'Barker tops the world', while in February 1911 the *Kinematograph and Lantern Weekly* ran an article headlined 'Henry VIII Successfully Filmed. Barker's Fine Picture of Sir Herbert Tree in His Greatest Production', which described the production and its extraordinary success.³³ *Henry VIII* was also, highly unusually, being released 'for hire only' at a time when most films were still bought outright by renters. Barker announced in the trade press that after 28 days all copies of the film would be burned, so the film would never be seen except in pristine condition. This publicity stunt appears to have been successful in terms of bookings, although how popular the film actually was with audiences is unclear.³⁴ The film itself consisted of five scenes from *Henry VIII*. There is no evidence of how long it was, but it may (like *Rob Roy*) count as a feature rather than short film.

³⁰ <http://bufvc.ac.uk/newsonscreen/search/index.php/person/124> (accessed November 2013)

³¹ Sir Edward German (1862-1936) was one of the most popular English composers of the early twentieth century: a successor to Arthur Sullivan in the field of comic opera, and the composer of light classical music and incidental music for stage productions

³² <http://www.screenonline.org.uk/people/id/519480/> (accessed January 2014)

³³ *Bioscope*, 17 November 1910, p47; *KW*, 16 February 1911, p63

³⁴ *Bioscope*, 13 April 1911, p61; cartoon depicting the film being burned; *Bioscope*, 20 April 1911, p85, article about its burning

The above is more than a digression. Arthur Vivian and James Bowie would certainly have heard of and probably have seen (or in Vivian's case shown) *Henry VIII*, which was released in British cinemas in February 1911. Indeed, their decision to make a film of a theatrical version of *Rob Roy* featuring the actor John Clyde - closely associated with the title role in 1911 - may well have been influenced by the grandiose aspirations and enormous publicity surrounding *Henry VIII*. This production had an ecstatic reception in the trade press: 'Words fail one to adequately describe this great triumph of the cinematographer's art... This picture is without doubt the greatest that has been attempted in this country' gushed A E Taylor in *Moving Picture World*.³⁵ Cinema managers were equally enthusiastic, but the film's reception by audiences appears to have been mixed. Robert Hamilton Ball, for example, speculates that 'the typical motion picture spectator accustomed to different fare must have been somewhat baffled [by an] 'incomplete reproduction of a stage play he had never read'.³⁶ More sophisticated spectators, on the other hand, felt that much had been left out.

At this time in cinema's development, film adaptations of plays were becoming common, not just in Britain but worldwide. In Ireland the intermedial relationship between theatre and cinema was particularly important. In the early 1910s Irish film productions of the Kalem Company of New York such as *The Colleen Bawn* and *Arrah-na-Pogue* were popular worldwide, particularly in places with large Irish immigrant communities. Both productions were adapted from mid-nineteenth century stage plays by Dion Boucicault which had been among the most successful of their time, performed in almost every city in Britain and the United States.³⁷ Arthur Vivian, in particular, would have recognised the enormous appeal of these, and numerous other, Irish films to Irish/Scottish audiences and their commercial potential.

³⁵ A E Taylor, 'London Letter', *The Moving Picture World*, Jan-July 1911, p705

³⁶ R Hamilton Ball, *Shakespeare on Silent Film* (London, 1968), p82

³⁷ For discussion of those forms of theatre that were most influential on early film entertainments in Ireland see D Condon, *Early Irish Cinema 1895-1921* (Dublin, 2008) and K Rockett, L Gibbons and J Hill (eds), *Cinema and Ireland* (London, 2013)

If this new breed of film appeared to guarantee popular appeal and commercial success, it made sense for the first Scottish production company to adopt a similar approach. The United Films' ambition was to create a truly Scottish narrative film with national and international appeal, and in this context it would seem natural to turn to Walter Scott, and a popular contemporary stage version of one of his best-loved works. It is evident from contemporary accounts [see below] that *Rob Roy* was intended to be 'the film of the play' featuring the well-known and enduringly popular cast of a production that had been performed in theatres in Edinburgh and Glasgow for more than a decade. The name of Scottish actor John Clyde had become synonymous with the title role of Rob Roy, while his fellow actor/singer Durward Lely was almost equally associated with the play's romantic lead, Francis Osbaldistone. During filming in July 1913 Scotty wrote of 'the performances in the open air for cinematographic purposes of "Rob Roy"', adding that he was 'greatly charmed with the realism of the acting, the company, headed by Mr John Clyde and Mr Durward Lely, enacting their respective *roles* admirably'.³⁸ The comparisons with *Henry VIII* are numerous: Scott for Shakespeare; Clyde for Beerbohm Tree, and a ready-made and very popular theatrical drama with proven power to draw in big audiences. Will Barker, of course, had two things that Bowie and McKinnon of United Films lacked: professional expertise and respectability within the emerging film industry. If United Films were to take the audacious step of producing Scotland's first feature film, they would need to employ a professional crew; and who better to draw on than men who had a proven track record with Barker himself?³⁹

Copyright registration

Two documents reveal Walter Buckstone's involvement with United Films, Ltd and the production of *Rob Roy*. These relate to the registration of the film for copyright purposes with the Stationers' Company in August 1911, and the re-assignment of

³⁸ *Bioscope*, 13 July 1911, p75

³⁹ Hamilton Ball, *Shakespeare on Silent Film*, p84. The author suggests that, despite the publicity, the film of *Henry VIII* was by no means a popular success

copyright in April 1912.⁴⁰ The significance of both these documents is discussed in more detail below. In both documents, Walter Buckstone is named as the ‘author’ of ‘photograph films’ of *Rob Roy*. His address is given as 4 Howard Street, Glasgow - the office of United Films, Ltd. In this context, the word ‘author’ would have meant the person who created the ‘photograph films’; that is, the cameraman. It would therefore appear that Frank Danvers Yates was *Rob Roy*’s director and Walter Buckstone its cameraman. Production of this film began only a few months after the filming of *Fox Hunting* for Barker’s. While Yates’ and Buckstone’s experience in the respective roles of director and cameraman was limited, they would have brought ambition and the cachet of working for a famous London firm to this new Scottish enterprise.

The fact that Scotty of the *Bioscope* failed to acknowledge their involvement is significant only for what it tells us about his (and his readers in the Scottish cinema trade) interest and pride in the ‘Scottishness’ of the production. Arthur Vivian in particular was already well known to those in the Scottish cinema trade. The remark that he was to ‘take charge of the company during the sojourn up North’ would more likely have referred to a role as production manager during filming of *Rob Roy* on locations in and around Aberfoyle in Stirling, some 35 miles north of Glasgow.⁴¹ While Vivian, with his local knowledge, may well have overseen the company, evidence points to Buckstone being behind the camera. The first copyright registration document referred to above had a section of the film of *Rob Roy* attached to it. This portion of the original nitrate film, a strip of six frames, survives and is held in the National Archives in Kew. A print of it which is now attached to the document shows a scene in which John Clyde as Rob Roy and another (unidentifiable) character are seen sitting outside a thatched cottage (the ‘rude inn’ of

⁴⁰ TNA, COPY 1/559/172, Photograph film (for cinematographs) of the play of ‘Rob Roy’ as actually produced at Aberfoyle, originally registered on 31st August 1911; COPY 1/565/150, Photographs registered at the Stationer’s Company. Bundle of forms applying for copyright

⁴¹ Cloy and McBain, ‘Scotland in Silent Cinema’, p7. Although it is claimed that parts of the film were shot in a rudimentary studio in a disused tram shed at Rouken Glen on the outskirts of Glasgow, documentary evidence strongly suggests that the film was made entirely on location. Post-war films that were made in a studio converted from the old Queen Mary Tearoom in Rouken Glen/Thornliebank (*The Harp King*, (Ace Film Company, 1919) and *Football Daft*, (Broadway Cinema Productions, 1921)) are discussed in Chapter 3

Frank Bassill of Walcot Square, Kensington, along with William Barker.⁴³ At this time (and until as late as 1957) films were not protected as a single entity, but as sequences of photographs.

It was normal practice to attach a portion of the particular scene of the film to the registration form. The Scott polar expedition film, for example, has so many copyright registration forms with so many portions of film attached that together they may constitute the entire film. In the case of *Rob Roy*, however, just one scene is attached. If registration was not mandatory and involved paying a considerable fee, why did the producers of *Rob Roy* decide to register their film with the Stationers' Company in August 1911? It is interesting that the only other non-factual film to be registered in the same year - and indeed in the entire period between 1910 and 1920 - appears to be the film adaptation of the stage production of *Henry VIII* starring Beerbohm Tree, mentioned above.⁴⁴

This film was registered in May 1911, just three months before *Rob Roy*, which also suggests that McKinnon, Bowie *et al* may have been attempting to emulate Will Barker in creating a Scottish production of equal standing to *Henry VIII*. But there was another, more specific, intention behind the copyright registration of *Rob Roy* and a reason for attaching to the document the strip of film showing Clyde as Rob Roy and another character outside a row of cottages at the Clachan of Aberfoyle. The Clachan (meaning settlement or hamlet) was one of the main settings of Walter Scott's *Rob Roy* and theatrical adaptations of the novel. It was originally a collection of houses around an inn, about a mile from the modern centre of the village. In Scott's novel and in the theatrical version discussed below, it was in Jean McAlpine's hut or 'rude inn' there that Frank Osbaldistone received an important note from the outlaw Rob Roy, and Bailie Nicol Jarvie fought off an attacker using a red-hot poker. Until recently the Bailie Nicol Jarvie Inn stood on the site of the inn, but little of the original clachan remains.⁴⁵ Scott describes the Clachan thus:

⁴³ TNA, COPY 1/562/45A; COPY 1/553/240; COPY 1/553/217

⁴⁴ TNA, COPY 1/556/340: Photograph (cinematograph) of Henry VIII as played by Sir Herbert Tree and Company. Portion of print attached depicting Wolsey in Cloisters

⁴⁵ The building remains, but has been converted into private housing

The miserable little bourocks, as the Bailie termed them, of which about a dozen formed the village called the Clachan of Aberfoil, were composed of loose stones, cemented by clay instead of mortar, and thatched by turfs, laid rudely upon rafters formed of native and unhewn birches and oaks from the woods around.⁴⁶



Figure 2: The only surviving fragment of United Films' 1911 *Rob Roy*, showing John Clyde (left) as the eponymous hero, outside the inn at the Clachan of Aberfoyle. TNA, COPY 1/565/150

⁴⁶ Sir W Scott, *Rob Roy*, (London, 1995), p273. The novel was originally published in 1817

The registration of *Rob Roy* for copyright and the significance of this portion of film is related to an issue relevant not only to this production, but to most films made in Scotland in the period before the coming of sound. This is the notion of authenticity. Long before writers such as Forsyth Hardy and the *Scotch Reels* critics called for efforts to achieve an authentic and credible portrayal of Scotland, Scottish film-makers were competing over whose film was the most authentic, albeit in terms of location rather than documentary-style or social realism.⁴⁷ Nowhere is this more evident than in the publicity for two versions of *Rob Roy* that appeared in 1911; the United Films' production under discussion, and another film called *Rob Roy* (later renamed *An Adventure of Rob Roy*) produced in Scotland by the French company Gaumont, which was to be released almost simultaneously. The Gaumont film was much shorter at a mere 995 feet and was based (as was the 1922 version of *Rob Roy* discussed later) on escapades of the outlaw Rob Roy. But the very fact that two films concerned with Rob Roy had been produced at the same time led to an extraordinary occurrence; a public battle played out in the trade press over which production was more authentic, and (literally) on what grounds it was said to be so.

Advertising and authenticity

On 15 June 1911 a full-page advertisement in the *Bioscope* for the United Films' *Rob Roy* announced 'A Great and Popular Entertainment' with the 'The coming Pioneers of the Picture World of Scottish Drama' in the shape of John Clyde and 'all the best Actors in the various principal parts'. The advertisement also noted that 'Special scripts have been written, and already for weeks the plays have been under rehearsal'. But most of the page is given to the announcement that United Films, Limited 'are taking these remarkable films on the actual World Renowned historic ground at the CLACHAN OF ABERFOYLE, PERTHSHIRE, SCOTLAND'.⁴⁸ It appears from this advertisement that another of the popular plays apparently set to go into production was *Jeanie Deans*, written by Dion Boucicault in 1860 and named after the heroine of another of Scott's Waverley novels, *The Heart of Midlothian*.

⁴⁷ McArthur (ed) *Scotch Reels*; F Hardy, *Scotland in Film* (Edinburgh, 1990), p221

⁴⁸ *Bioscope*, 15 June 1911, p566

Over the next few weeks the wording of advertisements for the rival films became increasingly combative, making claims for the superiority of their acting talent as well as the greater ‘authenticity’ of their respective locations. In August 1911, for example, another full-page advertisement entreated cinema managers to WAIT FOR GAUMONT’S WONDERFUL FILM OF ROB ROY which was performed by a ‘First Class company of Star Artistes thoroughly experienced in picture work’ and taken ‘in the Macgregors Country, the actual spots in Perthshire and Argyllshire, by kind permission of His Grace the Duke of Argyll’.⁴⁹ The oblique reference to the ‘actual spots’ became slightly clearer in a subsequent advertisement, stating that ‘For some time the Gaumont Company have been preparing a series of Scottish historical dramas, which are being filmed on the actual ground which the original incidents occurred’.⁵⁰

Both production companies appeared to believe that the key to attracting bookings was the authenticity of the Scottish location(s), as if this would add authority and a sense of historical accuracy to the fictional narrative. In August 1911 United Films played its trump card by registering the scene at the Clachan of Aberfoyle for copyright and providing the visual evidence to prove that this was, indeed, the World Renowned historic ground. From now on, advertisements for United’s version of *Rob Roy* bore the words ‘As actually filmed at the Clachan of Aberfoyle (Registered)’.⁵¹ Interestingly, neither of the promotional campaigns made any reference to the narrative. In the case of the United Film’s treatment this is perhaps understandable: renters and audiences were assumed to be familiar with the play of *Rob Roy* and its various roles, but the *Bioscope* advertisements offer no hints about Gaumont’s story. By November 1911 their film had been renamed *An Adventure of Rob Roy* (to distinguish it from the United production released in August) and a short promotional summary described it as ‘a magnificent drama, dealing with the famous Scottish outlaw, enacted in the wild and romantic country of the MacGregors’.⁵² A newspaper

⁴⁹ *Bioscope*, 31 August 1911, p454

⁵⁰ *Ibid*, 14 September 1911, p579

⁵¹ *Ibid*, 14 September 1911, p535

⁵² *Ibid*, 16 November 1911, Supplement p ix

description of this film promoting a screening in Gisborne, New Zealand in February 1912 offered more detail and is also interesting for the mild critique at the end:

The wild life of the outlaw has produced many notable characters in the past, and perhaps the most respected of all who have departed from the avowed customs of their countries is Rob Roy, whose story is familiar to all Scots ... The story was re-enacted in the actual spots in Perthshire and Argyllshire associated with Rob Roy's escapades, and for this reason the film is extremely useful from an historical point of view. The events of the tale are so numerous that any attempt to enumerate them would be almost futile, but a brief resume of the play will indicate its character to those who are not already familiar with it. In the first scene Rob Roy rescues a peasant from the redcoats, who are preparing to hang him by the wayside for some trivial offence, and earns his undying gratitude. Rob Roy himself is later caught asleep by the soldiery, and during his brief term of captivity the redcoats devastate his home. When he is released by the grateful peasant, Rob swears vengeance on the soldiery, and it is to do with the carrying into effect of this curse that the film has most to do with. Teeming with dramatic incidents the latter stages of the picture-story must command the interest and attention of all who witness its production.⁵³

All this action seems a lot to pack into a single reel, but it was characteristic of the short narrative films of the time that would have constituted part of a programme. There is also more than a hint that this *Rob Roy* was a kind of Scottish Western - a genre that was already hugely popular with audiences.⁵⁴ Precisely why filming in the actual spots associated with Rob Roy's escapades should be considered 'extremely useful from an historical point of view' was not explained, but the fact that this French company chose to travel to Scotland to film the story does indicate how much importance was attached to authenticity of location. It is easy to see how galling it must have been for the Scottish production company with its local knowledge and Scottish actors to discover that another film sharing the same title - if not the same story - was making an equal claim to authenticity and thus appealing in the same way to Scottish national sentiment. Would audiences care whether the film they saw was financed from within, or outwith, Scotland as long as they enjoyed the story and

⁵³ *Poverty Bay Herald*, 21 February 1912, p9

⁵⁴ The first film Western is generally considered to be *The Great Train Robbery*, directed by Edwin S Porter in 1903

appreciated the genuinely Scottish settings? United Films must have thought so, going to the lengths of paying for copyright registration and making sure that everyone knew about it. It is also clear from ensuing publicity that Gaumont was trying to undermine United's confidence by referring to the superior acting talent employed in their *Rob Roy*, implicitly contrasted with the stage actors of United's film.

That there were two film versions produced in the same year of a Rob Roy story - whether based on the Scott play or on the folkloric outlaw/hero - is also telling. As Griffiths has noted, a 'vogue' for Scottish stories was emerging on both sides of the Atlantic, including a third version of *Rob Roy*, produced in the USA by the Eclair company in 1914. These competing 'Scottish' films, he suggests, were one reason why a modestly-budgeted version made on home soil had little chance of success.⁵⁵ United Films, Ltd, of course did not have the benefit of hindsight and the fact that even before 1911 there was a trend for films on Scottish themes would have encouraged them to believe that a genuinely Scottish film, 'made on Scottish ground', of a popular and well-known Scottish story, had all the ingredients for solid commercial success.⁵⁶

It seems curious that when United Films discovered the existence of the rival film, they chose not to promote the single feature which made their production stand out: its running time. At 2,500 feet this would have been around 45 minutes. The decision to make a feature-length film showed its modernity; the 'up-to-dateness' for which Scotty of the *Bioscope* praised the company's manager, James Bowie. It was also a considerable risk, and not just in financial terms. This was the period (lasting roughly from 1908 to 1917) referred to as cinema's transitional era, in which the film industry saw a series of dramatic changes leading to standardised practices. As well as the transition from single-reel to multiple-reel films these changes included an increasing complexity in representational practices and formal techniques, and a shift in exhibition from a variety format in theatres to feature programmes in cinemas. One of the most important changes that took place around 1908-9 was the adoption

⁵⁵ Griffiths, *The Cinema and Cinema-going in Scotland*, p283

⁵⁶ A later British version of *Rob Roy*, filmed in Scotland in 1922, is discussed in Chapter 4

of a 1,000-foot reel of 35mm film as the industry standard. A single, interchangeable film length meant that print delivery and rental charges to distributors became more straightforward.⁵⁷ This in turn allowed exhibition programmes to become more predictable, and audiences came to expect films to last a certain amount of time. But in 1911, when *Rob Roy* went into production, the idea of a multiple-reel film constituting an entire programme, rather than a number of short films, was still quite new. Cinema managers were unsure how audiences would respond to this kind of innovation, evidenced by a debate in the *Bioscope*. In September 1911, for example, an exhibitor from Newcastle complained in a letter to the editor:

Northern picture houses are mostly run on the lines of a programme consisting of about seven subjects (about 4000 feet), interspersed with two variety turns, and this entertainment is given twice nightly. I find that my patrons are fully appreciative of their evening's entertainment ... What should I do if ever the 2,000 feet subject became popular? ⁵⁸

The following month the *Bioscope* ran a long feature called 'A Plea for the Long Film', commenting:

This is a period of transition [which is] almost invariably a painful thing ... Now, however, that the cinematograph theatre is by way of being no longer a novelty, the public is critical and quite ready to cavil at the *potpourri* of dramas, comics, comedies and travel films thrust upon it for an hour or two's entertainment.

If managers maintained this kind of exhibition practice, the writer concluded, there was a danger of the public becoming bored and the very future of the cinema being put into jeopardy.⁵⁹

Instead of focusing its promotional campaign on the modernity of its film, United Films chose to highlight other aspects: its status as a version of the 'world renowned and dearly loved Scottish drama' and the national character of the production. The latter was heavily emphasised in the course of United's publicity battle with Gaumont. In September 1911, for example, a full page advertisement asked: 'Have

⁵⁷ T Balio, *The American Film Industry* (Wisconsin, 1985), p175

⁵⁸ *Bioscope*, 28 September 1911, p667

⁵⁹ *Bioscope*, 12 October 1911, p698

you booked this magnificent production? The Scottish Drama, produced by Scottish Actors on Scottish ground by the Scottish firm'.⁶⁰ In retrospect it is possible to see that the assumption that renters and audiences would care about film's Scottishness was faulty. This may have served only to emphasise its insularity and even discourage non-Scottish renters. United Films was a new company with (unlike Gaumont) no track record in the industry, and the fact that comments on its activities were confined to the Scottish section of the trade press may not have helped to establish it as a presence on the world stage. In July 1911, shortly before *Rob Roy*'s release, Scotty wrote again about the 'enterprising firm's' production:

I have just returned from Aberfoyle in connection with the performances in the open air for cinematographic purposes of "Rob Roy" and other famous Scottish dramas... I had the pleasure of witnessing a performance, and I was greatly charmed with the realism of the acting, the company, headed by Mr John Clyde and Mr Durward Lely... There is no doubt that the resulting series of films will be much sought after.⁶¹

What happened to the 'series of films', and particularly *Jeanie Deans*, is unknown. There is no evidence of their production, although it appears from the above comment that some scenes were shot, or that this was the intention. An advertisement for *Rob Roy* in June 1911 announced that United films would also 'produce two pictures of Royal Scottish Drama' indicating the scale of the company's ambition.⁶² Perhaps coincidentally, Gaumont was also preparing a series of Scottish dramas which were advertised alongside their *Rob Roy*. A news item in the *Bioscope* entitled 'Scottish Historical Dramas' noted that the Gaumont Company had 'for some time been preparing a series of Scottish historical dramas, [which] are being filmed on the actual ground on which the original incidents occurred'. It continued:

These films should go towards popularising what may be termed native picture plays in this country, and give to the Southron an opportunity of witnessing some of the famous Scottish dramas enacted in the locality in which they were first written.⁶³

⁶⁰ *Bioscope*, 21 September 1911, supplement p xxii

⁶¹ *Ibid*, 13 July 1911, p75

⁶² *Ibid*, 15 June 1911, p566

⁶³ *Ibid*, 14 September 1911, p579

While Gaumont's claims to authenticity of location seem vague or even contradictory, their series of Scottish productions did get made and were widely distributed. A film called *Gems of Scottish Scenery* was released in the same month as *An Adventure of Rob Roy*, while their 'Grand Coloured Historical Drama' *Mary, Queen of Scots*, (another one-reel production) 'dealing with Mary Queen of Scots and Rizzio, and the incidents which led to the assassination of the latter in 1566' appeared early in 1912.⁶⁴ Gaumont made it clear that their Scottish films were intended for audiences beyond Scotland, whereas United's advertising strategy suggested their film(s) would be of interest mainly to Scottish audiences; those who might have heard of the Scottish actors, and care about the existence of the Scottish company. National pride may have stood in the way of success in the rest of Britain. In taking the high ground about the greater authenticity of their proposed productions, they were unknowingly restricting their potential - even before *Rob Roy* had been seen.⁶⁵

As noted above, promotion for United's *Rob Roy* focused on the stage play on which it was based. The company was trading on the appeal of this much-performed musical drama, employing a similar strategy to Barker's with *Henry VIII* and Kalem with their Irish dramas.

⁶⁴ *Bioscope*, 23 November 1911, p75

⁶⁵ This paradox lies behind much of Scottish production in the silent era and is discussed in other chapters

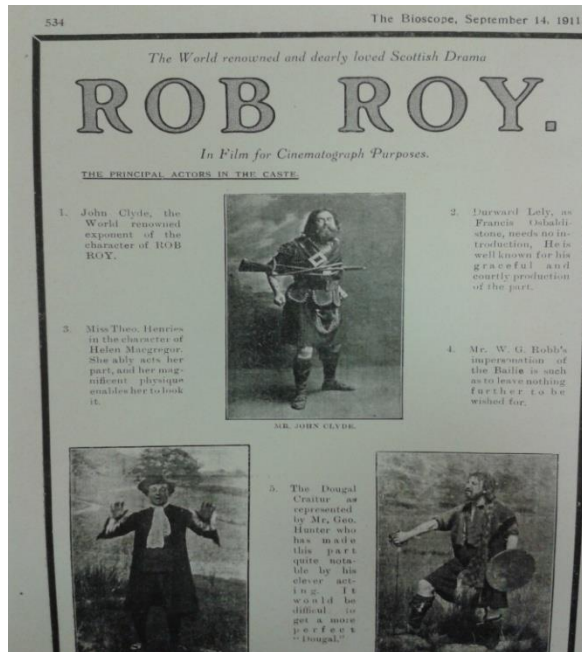

Figure 3: Full-page advertisement for *Rob Roy*, the 'World renowned and dearly loved Scottish Drama'. *Bioscope*, 14 September 1911

An item on the 'Scottish Film Talk' page of *To-Day's Cinema* published in 1953, shortly before shooting began in the Highlands for Disney's version of *Rob Roy*, offered an intriguing insight into the techniques behind the 1911 production.⁶⁶ Noting that this 'Scottish film' has been made in the Highlands before, the writer continued:

Records are still intact of the shooting of the story at Aberfoyle, in the Trossachs, in 1912 [sic]. The prints which remain show up clearly the very simple techniques of those early film-makers. Amid the natural wooded setting at Aberfoyle, scenes of various episodes in the book were enacted against a screen painted to represent each different locale. In two of the photographs one can quite plainly distinguish actor Durward Lely. Another Scots actor who took part was John Clyde.⁶⁷

Unfortunately these records and photographs have disappeared since 1953. But this short paragraph in itself reveals much: not just the way that a fundamentally theatrical technique was deployed in an outdoor setting, but also that the entire film was made on locations around Aberfoyle. No studio filming would have been

⁶⁶ *Rob Roy, the Highland Rogue* (dir Harold French), 1953

⁶⁷ *To-Day's Cinema*, 21 October 1953, p10

involved, cutting down considerably on cost but creating other (weather-related) difficulties.

Aside from this, there is little evidence of how *Rob Roy* was presented on screen or of how the original story and the theatrical version were adapted. Scotty's remarks were vague but positive, offering no detail about the narrative; his purpose was to help publicise and recommend this uniquely Scottish production to all. In August 1911, for example, he wrote:

I have had the great pleasure of witnessing "Rob Roy" projected on the screen, and I can safely assure all interested that the film bristles with excitement and thrills everyone... I have no doubt that this film will meet with the approval of every Scotsman, both at home and abroad, and of many more besides Scots.⁶⁸

The trade press did not feature United's *Rob Roy* in their (paid-for) listings of new films, although the Gaumont production was listed on its release. This is understandable given the size of that company, whose offerings regularly occupied two pages. In order to understand United's *Rob Roy* better, it is therefore necessary to look at its back story; the popular theatrical production on which it was based. Looking at the play in detail, the way it was performed, how it was reviewed around the time the film appeared and how it may have been understood by audiences at this time, also helps to cast some light on why the film failed to live up to its ambitions.

John Clyde and stage adaptations of *Rob Roy*

As Ann Rigney has noted, there is no doubt that *Rob Roy* dominated the nineteenth century stage, especially in Scotland.⁶⁹ The story was first produced in 1818, in Scott's lifetime. While there are hundreds of existing programme bills advertising stage productions, many of them invoking the 'popular novel' on which the play was based, the name of the dramatist is seldom mentioned. It seems probable, however, that the vast majority of these anonymous stage versions of *Rob Roy* were based on the version dramatised by Isaac Pocock: *Rob Roy MacGregor; or, Auld Lang Syne! A musical drama, in three acts, founded on the popular novel of Rob Roy, first*

⁶⁸ *Bioscope*, 24 August 1911, p 397

⁶⁹ Rigney, *The Afterlives of Walter Scott*, p6

performed at the Theatre-Royal Covent-Garden, Thursday March 12, 1818. The play is set at the time of the first Jacobite uprising in 1715 and features many of the characters from the novel; in addition to the outlaw Rob Roy and his wife Helen, these include the romantic hero, Francis Osbaldistone; his sweetheart Diana Vernon, daughter of the attainted and exiled Jacobite Lord Beauchamp; Dougal (often referred to as the ‘Dougal Craitur’), the wild-looking turnkey at the Glasgow tollbooth; Bailie Nicol Jarvie of Glasgow and his housekeeper, Mattie; Jean MacAlpine, innkeeper at the Clachan of Aberfoyle, and Captain Thornton, a Redcoat. In later versions it is referred to as ‘A national operatic drama’.⁷⁰ In a rare appearance, Pocock’s name featured in an 1879 advertisement for a Rob Roy ‘dramatized by Isaac Pocock with the consent and approval of SIR WALTER SCOTT’:

There is no evidence that this version had been officially endorsed by Scott, as the playbill claimed, but the invocation of the Great Man’s authority implies that Pocock’s version was seen as somehow the ‘official’ or canonical one... The most important indication of Pocock’s influence is in the titles given to the many productions which, by and large, carry a variation on his subtitles with the tell-tale inclusion of *Auld Lang Syne*.⁷¹

By 1911, the best-known and most frequently staged professional production of this play both within and outwith Scotland was that of a company managed by William Mollison (also an actor), featuring John Clyde as Rob Roy and Durward Lely as Francis Osbaldistone. Neither of these actors were young men when they performed their roles for the camera: Clyde was 50 and Lely (playing the youthful romantic lead) was 58. Lely was best known as an operatic tenor who had been one of the original Savoyards, the company who introduced Gilbert and Sullivan to the public. Lely grew up in highland Perthshire and worked in a solicitor’s office before training as a singer, first in Dundee and then in Italy. He toured the world as an operatic

⁷⁰ For example *Rob Roy Macgregor, or Auld Lang Syne, a national operatic drama extended with an intr. & c. by a Glasgow playgoer* (Glasgow, 1868)

⁷¹ Rigney, *The Afterlives of Walter Scott*, p68

singer before returning to Britain in 1878.⁷² An obituary in the *Scotsman* paid particular attention to his performance in stage productions of *Rob Roy*:

Many today will recall with pleasure his Francis Osbaldistone in “Rob Roy” and perhaps in particular his singing of “My Love is Like a Red, Red Rose.” It was a delightful production of “Rob Roy” which embraced two such sterling Scots artists as the late William Mollison as the Bailie and Durward Lely as Francis.⁷³

The obituary, which appeared in 1944, invoked memories of Lely’s performance in *Rob Roy* many years before, and it is clear from the following account that he had been appearing in the drama alongside John Clyde as early as 1892, almost 20 years before the film went into production. A newspaper review of a production of the play in 1894 remarked:

It was with feelings of the liveliest anticipation that we wended our way one night last week towards the Princess Theatre, Glasgow South Side. We may at once confess that the primary object of our visit was to see and hear Durward Lely as Francis Osbaldistone in “Rob Roy”. We had a vivid recollection of his visit to Motherwell some two years ago, and we wanted to hear him again... Arrived at the theatre, we found the ‘early door’ besieged... “Rob Roy” as presented now in Glasgow is the most powerful production of the popular play... The principal actors are exceptionally strong... [and] the stage effects and scenery are magnificent.⁷⁴

The review went on to praise William Mollison in his role as Bailie Nicol Jarvie and ‘the Rob Roy of Mr John Clyde, powerful in conception and splendid in delineation. The daring figure of the outlaw stands out clearly defined’. Significantly, it noted that ‘the part of Francis Osbaldistone is primarily a singing one’, heaping praise on Lely for his ability to act as well as sing. The bulk of the lengthy review was devoted to performances of songs by the main characters and the chorus (‘The singing of the chorus ‘Now Tramp’ was very fine’.) There were also some acerbic comments ‘contra’, particularly on ‘a cockney travesty on the Highlands and Highlanders’

⁷² Lely, like Clyde, appeared at times with his own acting company; in 1919 it performed *The Bonnie Brier Bush* at Her Majesty’s Theatre in Glasgow. A filmic version of this popular kailyard story is discussed in Chapter 4

⁷³ *Scotsman*, 2 March 1944, p4

⁷⁴ *Motherwell Times*, 29 September 1894, p6

which the reporter was greatly surprised ‘to see perpetuated before a Scotch audience’.⁷⁵

John Clyde was also so closely associated with the stage production of ‘the national drama’ that he needed no introduction to the theatrically-aware Scottish public. He seems to have enjoyed a modest celebrity status in his native country. The reviewer quoted at the top of this chapter remarked that ‘he has made the part specially his own, and when one speaks of “Rob Roy” one mentally thinks of John Clyde’. Aside from the obvious tautology (perhaps aimed at those who tended to think with their feet) this would not have been overstating the case. By 1911 Clyde must have performed the role on stage hundreds of times throughout Scotland as well as in London. In the 1890s he was already receiving star billing in productions mounted first by his own company, then that of Captain W Vernon and later of William Mollison, who took over the management of Vernon’s company. After Mollison’s death in 1916 Clyde, in turn, became the manager of this company while continuing to perform the title role.⁷⁶ By 1905 Clyde was often the only named actor as well as commanding top billing.

In 1897, for example, he was billed as ‘Scotland’s Premier Actor’ for performances of *Rob Roy or Auld Lang Syne* and *Lady of the Lake* at the New Public Hall, Arbroath. The production is said to have ‘played to crowded houses at the Royal and Lyceum Theatres, Edinburgh and the Theatre Royal, Glasgow’. The advertisement announced ‘new and magnificent scenery specially painted by that Eminent Artist, Wm. Glover, Esq’ and an ‘Elaborate Wardrobe as used in the Edinburgh and Glasgow productions,’ while the ‘beautiful incidental music, songs, chorus and overture are arranged and composed by E. T. De Banzie, Esq’.⁷⁷

No lover of the beautiful and romantic scenery of the Trossachs
should miss seeing these, the most Complete, Expensive and
Gigantic Productions ever staged and toured throughout
Scotland. Both are produced under the personal

⁷⁵ *Motherwell Times*, 29 September 1894, p6

⁷⁶ Captain W Vernon’s company, for example, performed *Rob Roy* at the Theatre Royal, Edinburgh in June 1898

⁷⁷ The light opera composer and conductor Edward De Banzie was, at various times, musical director of the Empire and Gaiety theatres in Glasgow

superintendence of Mr John Clyde, who will sustain his favourite parts of Roderick Dhu and Rob Roy... acknowledged By Press and Public to be the Greatest Living Representation of these parts.⁷⁸

In February 1897 Clyde and his company performed the play to a ‘literally packed’ house at the Town Hall, Falkirk. Clyde, with his ‘commanding appearance’ and ‘strong, resonant voice’ was commended for his portrayal of Rob Roy, said to be ‘as near Sir Walter Scott’s ideal of the “bold outlaw” as one could imagine’.⁷⁹ For the next twenty years Clyde reprised the role several times a year in theatres throughout Scotland. A report on his own production at the Gaiety Theatre in Dundee in March 1909 notes that in this ‘splendid production’ the adventures of the bold outlaw were ‘faithfully depicted by John Clyde. His capture and escape are particularly exciting’. In this production, the part of Francis Osbaldistone was played by Mr J W Bowie (probably James Bowie, soon to become the manager of United Films Ltd), who was congratulated on his performance of the songs *Soon the Sun, Though You Leave Me Now in Sorrow* and *Old Langsyne*. The dresses and scenic effects were said to be ‘appropriate’, showing that ‘no expense has been spared to make the play a success’.⁸⁰ A review of the show performed at the Empire, Dundee in 1908 remarked upon a thrilling effect:

It is seldom we have the opportunity of seeing realism on stage, but at the Empire Theatre last night the swish of water rolling over the rock in the clachan of Aberfoyle sent a thrill through the audience.⁸¹

There are numerous similar reviews and advertisements spanning a 20-year period before and after the United Films’ production. These are significant not only for what they say about John Clyde’s fame, but also for what they tell us about the nature of the various theatrical productions; their lavishness, spectacular scenery and stage effects, the many songs which were evidently popular and well-known, and the style of performance expected of, and delivered by, Clyde. Whether a rudimentary film production could hope to satisfy an audience accustomed to this kind of spectacle,

⁷⁸ *Arbroath Herald*, 23 September 1897, p4

⁷⁹ *Falkirk Herald and Midland Counties Journal*, 13 February 1897, p7

⁸⁰ *Evening Telegraph*, Dundee, 9 March 1909, p6

⁸¹ *Evening Telegraph*, Dundee, 5 May 1908, p5

without the benefit of speech or music, is questionable. Substituting natural settings for theatrical ones, but maintaining the pantomimic acting style with which Clyde presumably delivered his performance, may have resulted in the worst of all possible worlds.

Clyde died in 1920 at the age of 59. While obituaries remarked on his versatility as an actor who had performed roles in popular Scottish plays such as *Jeanie Deans*, *Cramond Brig*, *The Bonnie Brier Bush* and *The Lady of the Lake*, it was *Rob Roy* that took centre stage. The *Scotsman* described Clyde as ‘prominently associated with the exposition of essentially Scottish drama’, noting his ‘striking and commanding appearance,’ continuing:

He furnished a magnificent impersonation of Scotland’s famous hero, Rob Roy... His recurrent seasons in the leading Scottish cities were looked forward to by many, and his popularity wore remarkably well... In maturing his conception of the part [of Rob Roy] he studied local colour to an extent seldom attempted, studying the action and movement of the play in the country in which it is located so as to saturate himself with the spirit of the Highlands. The result of his careful study was that on the boards Clyde always seemed to be the perfect embodiment of the MacGregor chief.⁸²

No mention was made of his temporary film stardom. Interestingly, three of Clyde’s six children became screen actors, one in Britain and two in Hollywood.⁸³ Clyde himself came from a relatively humble background, which may have added to his appeal in Scotland as a ‘man of the people’. Born in 1860 in Blairgowrie, Perthshire, he later moved to Glasgow where his first job was as an assistant in a draper’s shop. His transition to professional acting was gradual; he joined a stock company which had a regular summer season at a small Glasgow theatre and was noticed by the manager of Her Majesty’s Theatre in Dundee, who engaged him to take on a small part in *Rob Roy*. Through a chain of accidents he was suddenly promoted to the title role. The *Scotsman* obituary notes that ‘his success in the part of the famous outlaw

⁸² *Scotsman*, 3 November 1920, p8

⁸³ The most successful of these was Andy Clyde (1892-1967) who broke into films in 1922 as a Mack Sennett comic, later becoming well known on television as the farmer Cully Wilson in *Lassie*

was immediate and emphatic' and from then on his full time professional career was on the stage.

It is clear from the above that by 1911 John Clyde and *Rob Roy* were very familiar to the theatre-going public. By this time a production was mounted annually around Christmas time in Glasgow, Edinburgh and Dundee theatres, as well as at other times during the year. Late in December 1909, for example, *Rob Roy* was entering its second week at Her Majesty's Theatre in Dundee, where it was said to form 'a suitably varied entertainment for this time of year'. The scenery was both 'highly ornate' and 'very realistic', the *Dundee Courier* review also commenting that 'scenes like the clachan of Aberfoyle and the Pass of Lochard are veritable feasts for the eye'.⁸⁴ The review is also informative about some of the songs that constituted such an important part of the production: these included *Annie Laurie* and *Within a mile o' Edinburgh town* sung by Joan Keddie as Diana Vernon and *Macgregor's Gathering*, sung by Mr Wilson Pembroke. John Clyde's 'sonorous voice and stately presence' were said to be 'excellent'.

Rob Roy had evolved into a form of family entertainment similar to pantomime: endlessly repeated, with well-known songs, a series of familiar scenes rather than a flowing narrative, and featuring popular performers with strong local credentials. Audiences knew what to expect, but could look forward to the surprise of new and ever more elaborate staging, scenery and costumes. The songs must have changed over the decades, as the many airs and choruses written into the original Pocock adaptation (including a rendering by Frank of *Auld Lang Syne* at the end of Act Two, scene two) are not mentioned in any review of the drama in the late nineteenth and early twentieth centuries. This adds to the suggestion that *Rob Roy* was a populist form of entertainment similar to pantomime rather than a staid adaptation of Scott's novel. A 1909 review of the show at Her Majesty's Theatre in Dundee, which focused almost entirely on musical performances, remarked:

Certainly as the years go on "Rob Roy" undergoes certain changes which may not appeal to all as improvements, and the range of the music is widened with a heroic disregard for the

⁸⁴ *Courier*, Dundee, 26 December 1909, p7

perfect fitness of things when Diana Vernon sings “The Jewel Song” from “Faust.” But one can overlook such daring anachronisms in view of the all round excellence of the production.⁸⁵

Although Clyde carried on staging *Rob Roy* until two years before his death, by the time the film went into production the drama was already considered a little tired and worn. This is amply illustrated by a review in the *Scotsman* of June 1911, just two months before the film’s release, of an Edinburgh production that was to run for two weeks:

If only for its memories, “Rob Roy” must afford pleasure to a Scottish audience. Its sentimental picture of a romantic past has become familiar by frequent repetition, and the flaws in its dramatic construction have long been obvious. But presented so efficiently as it was last night in the King’s Theatre, the play has still much to commend it. The production is superintended by Mr John Clyde, who has succeeded in making it quite satisfying.⁸⁶

Durward Lely did not appear in this production (‘It was unfortunate that Mr E. C. Hedmond, the well-known operatic tenor, who is undertaking the role of Francis Osbaldistone, should be suffering from a severe attack of bronchial catarrh’), but the other main roles were performed by actors who also appeared in the film, including Theo Henries as Helen MacGregor, George Hunter as ‘the faithful Dougal Craitur’ and William Robb as Bailie Nicol Jarvie. John Clyde’s gifts were ‘never better displayed than in portraying the adventures of the bold outlaw’, and ‘one of the most striking *tableaux* of the evening was afforded at the Clachan of Aberfoyle, when Rob Roy falls a prey to the Sassenach troops through the treachery of Rashleigh Osbaldistone’. This scene was also central to the film. It is likely that the film would have followed a similar format of a series of tableaux, some (like the Clachan of Aberfoyle and the ‘romantic pass, bordering a loch’ of Act 3, scene 1) performed out of doors rather than in front of staged scenery. The clash between the naturalism of the setting and the style of performance must have been considerable, a disjuncture that would have been apparent to cinema audiences. Many of the scenes in the play

⁸⁵ *Evening Telegraph*, Dundee, 18 May 1909, p6

⁸⁶ *Scotsman*, 6 June 1911, p10

are set indoors: in the library in Osbaldistone Hall, inside the tollbooth (jail) in Glasgow, inside Jean McAlpine's hut, and indeed in Rob Roy's Highland cave. Where - or whether - these scenes were actually filmed is unknown. The character of Rob Roy McGregor barely features in the first act of the play (he is disguised as a character called Campbell); the 'adventurous' part featuring him in Highland dress is mainly played out in the third act.

The above and many other reviews emphasise the importance of song to the stage production, with detailed attention being paid to the quality of singing and the familiarity of the songs. There is no evidence as to how music was performed to accompany the film of *Rob Roy*, but it is certain that Clyde, Lely *et al* would not have been present in person. A musical score was evidently written to accompany the film, although what it consisted of is unknown. An advertisement in the *Bioscope* simply says: 'Please note: The MUSIC for the production, specially written, can be had on application'.⁸⁷ The substitution of this for live singing by the performers whose stage presence was so inextricably linked with their voice (particularly in Lely's case) may well have proved disappointing to the cinema audience. One of the few clues as to how music accompanied the film was provided by Scotty in his enthusiastic report on its debut performance at the St George's Picture Theatre in October 1911. He commented that 'Mr Vivian had all his staff dressed in full Highland costume, and at special parts of the production pipers played well-known airs pertaining to the drama'.⁸⁸

This was, surely, a poor musical substitute for a show full of songs performed by acclaimed opera singers. The dramatic action would have had to be very exciting and very *cinematic* in order to compensate. As far as we can tell, this was not the case. The film strived to live up to the reputation of the stage production, transferring the action to natural settings which may have been less spectacular and exciting from the audience's point of view than the stage show. At the same time, the action of the

⁸⁷ *Bioscope*, 28 September 1911, p698

⁸⁸ *Bioscope*, 19 October 1911, p157

film would have been more difficult to follow, possibly depending on lengthy intertitles and certainly on previous knowledge of the story.

At the time, however, United Films had good reason to expect that a version of the most successful theatrical drama to have come out of Scotland would be a hit with cinema audiences. It was known as the ‘national drama’, and perhaps they hoped that theirs would be the ‘national film’.⁸⁹ As a popular drama *Rob Roy* would have had a wider appeal than, for example, *Henry VIII* - whose target audience was the respectable middle-class public, more used to visiting the theatre than the cinema. As Jon Burrows points out in his discussion of the ‘pantomimic’ acting style deployed in some film adaptations of stage plays, the transitional era ‘witnessed the greatest concentrated profusion of Shakespeare adaptations in film history, as production companies around the world strove to rebrand the cinema as a respectable and sophisticated storytelling medium capable of appealing to an acculturated audience by appropriating the work of the international figurehead for artistic genius and achievement’.⁹⁰ The film of *Rob Roy*, by contrast, had the potential to be both respectable and populist. But the very fact that the musical drama was so frequently performed (and, as noted above, was already considered old-fashioned) may well have worked against its success.

Between 1910 and 1912 alone there were many amateur as well as professional theatrical productions of *Rob Roy* drama, most (but not all) in Scotland. In March 1910, for example, the recently-formed Alyth Amateur Dramatic Society gave an ‘interesting and successful representation’ of ‘Pocock’s dramatised version of *Rob Roy*’. This followed the previous season’s productions of popular Irish plays, *The Colleen Bawn* and *The Shaughraun*.⁹¹ The following year the (also newly-formed) Kinross Amateur Dramatic Society gave a production of *Rob Roy* ‘in a hall packed with appreciative audiences, many of them unable to gain admission’.⁹² The same month the *Times* reported that ‘The London Scottish [regiment] is to begin a week’s

⁸⁹ In the event this title was not claimed until as late as 1924, by Maurice Sandground’s *Bonnie Scotland Calls You*. See Chapter 5

⁹⁰ J Burrows, *Legitimate Cinema, Theatre Stars in Silent British Films 1908-1918* (Exeter, 2003) p46

⁹¹ *Courier*, Dundee, 26 March 1910, p4

⁹² *Courier*, Dundee, 18 March 1911, p4

run of *Rob Roy* at the King's Theatre, Hammersmith,' assuring the audience that 'the male parts will all be acted by members of the regiment'.⁹³ In February 1912 the Cluny Dramatic Club staged the drama 'to crowded audiences ... Professionals would have found it a difficult task to surpass the local artistes'.⁹⁴ The same Aberdeen paper reported that another crowded house was present for a staging of the play at Stewart's Hall, Huntly, in December 1912, in aid of the local cricket club.⁹⁵ Put simply, audiences might have had enough of *Rob Roy*, and if not there was ample opportunity to see a staged version that might compare favourably with the film. On the other hand, those filmgoers unfamiliar with Scott or stage productions might not have appreciated the significance of 'Actually produced on the original historic ground, the Clachan of Aberfoyle, Perthshire' and the famous theatrical performers, preferring to see a film that promised action and adventure.

Presentation and distribution

There is little evidence as to how the film was received by the viewing public; most reports were filtered through Scotty's admiring gaze. In October 1911, he described an invitation performance at the Picture House in Sauchiehall Street, Glasgow in the presence of the Lord Provost and the magistrates of the City of Glasgow and other specially invited guests. The film produced 'great enthusiasm' and 'universal admiration' among the 400 guests, and 'Mr Bowie was the recipient of many hearty congratulations on the success of the film to the public'. He added: 'since the release to the public on Monday of this week, large and enthusiastic audiences have crowded the Picture House in order to witness it'.⁹⁶ The following week *Rob Roy* was shown at the St George's Picture Theatre in Paisley, where Arthur Vivian was the manager. Scotty described the film's 'overwhelming success' with 'overflowing audiences at every performance'. This was the occasion on which, with characteristic showmanship, Vivian had all his staff dressed in full Highland costume. Later in October, Scotty mentioned that *Rob Roy* was the 'leading film' at the Burgh Hall in

⁹³ *Times*, 11 March 1912, p12

⁹⁴ *Aberdeen Journal*, 12 February 1912, p3

⁹⁵ *Aberdeen Journal*, 21 December 1912, p3

⁹⁶ *Bioscope*, 19 October 1911, p155

Pollokshaws, observing that ‘there is no doubt that this film has proved an enormous success wherever it has been shown’.⁹⁷

Riding on the success of these first performances, an advertisement in the same month claimed that ‘Rob Roy is the greatest money magnet on the market’ and included testimonials from cinema managers to this effect. In addition to the cinemas mentioned above, these included the managers of the Gaiety Theatre in Ayr and the Town Hall, Clydebank - where ‘hundreds [were] turned away’.⁹⁸ Currently available evidence suggests that Ayr was the furthest this film travelled within Britain, although it is possible it was seen in England. United Films’ connection with the Barker Motion Photography company of Soho, mentioned above, was not just informal. They had arranged a distribution deal with Barker’s, who were to distribute *Rob Roy* in Leeds and the south of England, while United itself was responsible for the film’s distribution in the north and in Scotland.⁹⁹ This arrangement also suggests a more ambitious exhibition strategy than was previously supposed.

Advertisements for *Rob Roy* that appeared in Dundee and Aberdeen newspapers the following month are likely to refer to the Gaumont production. A report on a screening at the Palace Theatre in Dundee, for example, says that ‘thrilling scenes from the life of that noted Scottish outlaw left great impression on last night’s large audience’.¹⁰⁰ By now, perhaps with the disappearance of United’s *Rob Roy* from the scene, Gaumont (and the BB Pictures who presented the film as part of their programme) may have felt free to drop the ‘Adventure of’ from the title of their film. The final advertisement for United’s *Rob Roy* appeared on 28 September 1911, when it was announced that ‘We only have a few vacant weeks, so if you wish it HURRY UP or you will be TOO LATE!’¹⁰¹

Aside from Scotty’s partisan reports and publicity in the trade press, the only other mentions of United’s *Rob Roy* from within Britain are found in retrospectively-written accounts of Scottish film production. As well as Jack Kissell’s remarks

⁹⁷ *Bioscope*, 26 October 1911, p233

⁹⁸ *Bioscope*, 26 October 1911, p272

⁹⁹ *Bioscope*, 14 September 1911, p535

¹⁰⁰ *Courier*, Dundee, 14 November 1911, p6

¹⁰¹ *Bioscope*, 28 September 1911, p698

(noted above), in 1918 a Scottish cinema manager called Matt Cullen wrote an article in a new film magazine about ‘early’ film production in Scotland. One of his three memorable productions was *Rob Roy*.

The first really Scottish picture I remember seeing was a production by a Glasgow company having premises down about Howard Street. That was a screen version of the national drama, “Rob Roy”. The producers had the right idea when they decided to take every scene directly on the spot, and, for a time the MacGregor country was photographed as it had never been before. Comparing it with what we see now, the production was not great by any means, but it may be judged better by its success. Few pictures enjoy such a successful run as this one had, and if it had only been possible to continue the series what a following this company would have obtained!¹⁰²

Cullen’s comments are noteworthy for several reasons. While it is impossible to guess what his view of a ‘successful run’ might be, it does suggest that the film succeeded in attracting the interest of local cinemagoers. Seven years after *Rob Roy*’s appearance films may have moved on in terms of sophistication, but Cullen remained impressed by the photography and choice of locations. It also stood out in his memory as a ‘really Scottish picture’ and there was no mention of the rival *Rob Roy*. This is interesting given that the other two films of which he wrote, *The Shepherd Lassie of Argyle* (1914) and *The Call of the Pipes* (1917) although filmed in Scotland were both produced by non-Scottish companies.¹⁰³ His enthusiasm for the production (despite its deficiencies) and the regret he expressed that the company was unable to make the proposed series of Scottish dramas suggests that *Rob Roy* was by no means an embarrassing failure.

Overseas distribution

Trevor Griffiths rightly suggests that this modestly-budgeted production may have struggled for attention in the wealth of ‘Scottish’ films that surrounded it, but *Rob Roy* fared better than he supposes. Rather than disappearing from the scene ‘soon after its much trumpeted debut’, prints of the film travelled across the world.¹⁰⁴ In November 1911 it was shown at the King’s Theatre in Wellington, New Zealand

¹⁰² M Cullen, ‘Film Production in Scotland’, *The Cinema*, Scottish Section, 3 January 1918, p67

¹⁰³ These films are discussed in Chapter 4

¹⁰⁴ Griffiths, *The Cinema and Cinema-going in Scotland*, p283

(‘exclusive to West’s Pictures’), billed as the ‘World-renowned and dearly loved Scottish drama’. As in Scotland, the advertisement noted that it was taken on the actual ground where the historic events occurred, adding ‘by kind permission of Their Graces the Duke and Duchess of Montrose’.¹⁰⁵ The following month the film made its way down south to Dunedin, where it was described by the Otago Daily Times as ‘the illustration of Sir Walter Scott’s historical drama’. The review continued:

It can safely be said that a more realistic picture drama has never been witnessed in Burns Hall, and the bagpipe music supplied assisted very materially to make lifelike the various incidents in this piece. Those who have read this work will appreciate the significance of these remarks, and those who have not would do well to spend an evening with the Haywards this week in order to see the genuine and entertaining pictures screened in connection with this work. The programme was repeated on Saturday evening, when there was a good attendance of the public.¹⁰⁶

In January 1912 it was similarly promoted at Hayward’s Pictures in Wanganui (in New Zealand’s North Island), where the film was to be accompanied by the in-house Lyceum Orchestra. New Zealand exhibitors - in contrast to their Scottish counterparts - chose to remark upon and even exaggerate the film’s length: ‘3000 feet of a picture story to be appreciated by everybody’.¹⁰⁷ This aspect was also highlighted in a promotional article for *Rob Roy* at West’s Pictures in Adelaide, Australia, in late November 1911.

The growing demand for a lengthy star film on each programme was quickly recognised by West’s, and steps were at once taken to secure the exclusive rights to a large number of the very latest and best photo-plays. That their enterprise has been recognised is fully evidenced by the increasing attendances at each entertainment. For this week West’s have secured “Rob Roy”, which re-enacts many actual incidents in the life of the famous outlaw.¹⁰⁸

¹⁰⁵ *Dominion*, 20 November 1911, p1

¹⁰⁶ *Otago Daily Times*, 26 December 1911, p6

¹⁰⁷ *Wanganui Chronicle*, 15 January 1912, p7

¹⁰⁸ *The Advertiser*, Adelaide, 27 November 1911, p11

The notice concluded by highlighting performances by John Clyde and Durward Lely ('who visited Australia a few years ago'). It can be inferred from this advertisement that at least two prints of *Rob Roy* were in circulation at the same time, since the film was being screened in Australia almost simultaneously with an appearance in New Zealand. By May 1912 *Rob Roy* had travelled to Auckland, New Zealand, where it enjoyed four screenings at the Windsor Theatre in Ponsonby. Here it was billed as 'A Scotch Film, A Great Subject' produced by United Films Ltd, Glasgow. An advertisement in the *Auckland Star* described *Rob Roy* as 'Dealing with one of the most exciting adventures in the career of Scotland's most adventurous outlaw, "Rob Roy". The many scenes are magnificently staged, and the drama is admirably played in Scotland by famous Scottish actors and actresses'.¹⁰⁹

The wide distribution of *Rob Roy* in the Antipodes may be partly explained by the fact that Clyde/Lely stage production on which it was based had not been seen in either Australia or New Zealand. The film was therefore promoted as a substitute for the 'real thing'. The promotion of the film's national character would have appealed to national sentiment in the many Scottish communities of New Zealand and Australia, whose appetite for Scott and for filmic representations of Scotland in general was probably greater than it was in Britain. As Tanja Buelmann has noted in her discussion of Scottish associational culture, the Scottish diaspora in New Zealand was primarily cultural rather than (as with the Irish Diaspora) political.¹¹⁰ Scott himself was regularly celebrated by Scottish societies well into the twentieth century, usually for the purpose of maintaining a connection with the homeland. It is, of course, also possible that cinema managers and audiences in Australia and New Zealand were ahead of Britain in their acceptance of longer films.

The Wanganui advertisement stated that *Rob Roy* was 'produced by the Barker Co., of London', suggesting that it was Barker's who had been successful in recognising the film's potential to reach out to 'Scotchmen throughout the world' and attracting overseas bookings.¹¹¹ By this time United Films was in severe difficulties, pursued by

¹⁰⁹ *Auckland Star*, 23 May 1912, p2

¹¹⁰ T Buelmann, *Scottish Ethnicity and the Making of New Zealand Society*, (Edinburgh, 2011) p16

¹¹¹ *Bioscope*, 14 September 1911, p535

creditors and unable to pay even for the film stock it had purchased. In December 1911 a writ was issued on behalf of the Cinés Company of Charing Cross Road, London, whose account for ‘cinematograph films to the value of £53.9s.10d.’ supplied between 7 October and 2 December had not been paid.¹¹² The Cinés Company operated as a film distribution business, but is referred to in the writ as a ‘manufacturer of cinematograph films’ from which it can be inferred that it also supplied film stock. The fact that by October 1911 United was unable to pay this relatively modest sum shows how dire its financial situation was. In January 1912 the company went into voluntary liquidation due to the weight of liabilities incurred.¹¹³ Three months later, copyright in *Rob Roy*, together with the company’s assets, was reassigned to Alexander Hendry Turnbull of Dalveen, Cardonald.¹¹⁴ Turnbull does not appear in any other documentation related to the United Films, Ltd, although he may have been a creditor.¹¹⁵

Conclusion

Rob Roy was in many ways a very modern production as an early example of a ‘long’ film. The United Films, Ltd was a short-lived company whose plans for a series of Scottish dramas may have come to nothing, but it should not be written off as an enterprise that was destined to fail. As they claimed in advertisements for *Rob Roy*, United Films were indeed ‘pioneers of the picture world of Scottish drama’. Their intention to make a ‘great and ambitious work that will stir the heart of every Scotchman throughout the world’ may not have been realised but, as outlined above, the rationale behind the production of *Rob Roy* was sound.¹¹⁶ The reasons for its (heroic) failure are evident today; under-capitalisation of the company, a film that was too hidebound by the stage version from which it was drawn, and a lack of

¹¹² NRS, CS46/1912/1/85, Decree for payment, Cinés Co, otherwise called Società Italiana “Cinés” Rome against The United Films Limited

¹¹³ NRS, BT2/7704/15, The United Films, Ltd, Extraordinary General Meeting of Members, 29 January 1912

¹¹⁴ TNA COPY 1/565/150

¹¹⁵ *The Scottish Post Office directory 1911-12* lists an A Turnbull of Robert Johnstone & Sons, 27 to 41 Anderson Street, Paisley, whose home address corresponds with that on the copyright re-assignment document. <http://digital.nls.uk/directories/> (accessed December 2013)

¹¹⁶ *Bioscope*, 14 September 1911, p535

experience in feature film production. Many other production companies made the same mistakes, but for this Scottish company there was no second chance.

Chapter 2: To the Great War and beyond

*‘In an interesting statistical article in the Edinburgh Evening News, Mr Langford Reed puts the total amount of capital invested in cinematograph finance of every kind (in England) as, approximately, £17,126,533, of which the theatres take £13,911,758, and film production, etc, £3,214,775. Mr Reed is one of the most authoritative writers contributing to the lay Press on the subject of cinematography’.*¹

Introduction

In this chapter attempts at narrative and non-topical film production in Scotland between the demise of United Films, Ltd and the end of the First World War are considered within the context of the broader British film industry, and their potential for success is discussed. The focus remains on professional productions intended for national or international audiences, rather than amateur productions with their narrower, more local appeal. One amateur film, which is discussed briefly, still exists and is held in the National Library of Scotland Moving Image Archive. This accident of history has distorted the general view of the development of Scottish cinema during a period in which much larger enterprises were going into professional production. In attempting to redress the balance, close attention is given to the productions of the BB Pictures and Green’s Film Service, the largest of the Scottish film exhibitors and renters at the time of the first cinema boom. Both companies played an important part in the remarkable development of the film trade in Scotland in the years leading up to, and during, the First World War. This development encompassed technological change, in particular the production of a new synchronised sound system and accompanying films by a Glasgow company, The Vocal Cinema Ltd, the efforts of which are also discussed.

The best-known and best-documented narrative film to have been made in this period was a one-off amateur production with limited aspirations. *Mairi, The Romance of a*

¹ *Bioscope*, 2 July 1914, p9. Herbert Langford Reed (1889-1945) was a screenwriter and film editor, film critic and journalist, author of limericks and short stories, and biographer of Lewis Carroll

Highland Maiden, a drama with a running time of 18 minutes, was written, produced and filmed by an Inverness portrait photographer, Andrew Paterson. Shot around North Kessock on the Moray Firth in the summer of 1912, it tells the story of a young Highland girl in love with an excise officer who gets caught up in a fight to catch whisky smugglers. Paterson was heavily involved with amateur theatricals and the film's cast consisted of local amateur actors. The film was privately shown in May 1913 and then to the public at the Central Hall, Inverness, where there were continuous screenings for one week in June 1913. It seems to have had no further outings until it was re-edited by James Nairn in 1953. He added a written introduction, intertitles and credits. This is the version that has been transferred to video and is held by the NLS Moving Image Archive.²

While *Mairi* was undoubtedly a valiant effort at narrative film production which proved popular with a local audience, it was not intended for wider distribution. Paterson did not pursue a career in the film industry and made two short films of Scottish scenery on behalf of the Highland Railway Company before returning his camera to Gaumont.³ Thanks to the accident of history that has seen *Mairi* preserved while other films discussed in this thesis are lost, this film has come to be regarded as representative of the apparently amateurish nature of Scottish production in the early silent era.

From contemporary newspaper and trade journal accounts it is not always easy to distinguish films that were produced in Scotland and other Scottish-themed films shot in Scotland, by producers from elsewhere. These other Scottish films are discussed in Chapter 4: the intention of this chapter is to look at what was happening in Scotland in the period between 1912 and 1918 in terms of the development of indigenous narrative film production. In doing so, a somewhat more 'joined-up' and purposeful strategy is revealed than has previously been assumed. While it is true to say that attempts to create a Scottish film industry were unsuccessful, there is

²'Silent film 'Mairi'', www.patersoncollection.co.uk (accessed October 2014)

³ *Bioscope*, 2 July 1913, p33; NLS/MIA 1131, *Mairi: The Romance of a Highland Maiden*, NLS/MIA 4/3/1, Booklet for show at Central Hall Picture House

certainly evidence in the initiatives that can be documented of ambition, innovation and understanding of the way the international film industry was progressing.⁴

As the economic historian Tracy Davis has noted, by 1909 film exhibition in Britain was already dependent on foreign producers, with 85 per cent of the films shown in Britain being made abroad - although British-made films were exported to Europe and the Dominions. American films made inroads into British markets extremely rapidly. By 1914, the USA's share of the British market was 60 per cent, with American films accounting for 70 per cent of the London market. By the outbreak of war, British films may have comprised only two per cent of the domestic market. Box office profits were used to hire American films rather than finance British production.⁵ Among distributors, too, the market was foreign-dominated. The French firm Gaumont had an agency in London by 1898. By 1909, only half of the 46 distributing firms in Britain were British, and of the six largest (accounting for 60 per cent of releases) only one, Hepworth Manufacturing Company, was indigenous. The British-made films were all handled by small firms. 'By 1910, the large companies were handling 85 per cent of releases, concentrating more control of the English [sic] market in foreign hands and still ignoring British products'.⁶

It would be easy to assume that, in the context of all the above, attempts at Scottish film production would inevitably be doomed to failure. The short-lived United Films was not, however, the only Scottish producer of fiction films in the period from 1911 to the end of the Great War. Indeed, many years before the practice of vertical integration (that is, ownership of the means of production, distribution and exhibition by the same company) is considered by film historians to have been fully established in Britain by the Associated British Picture Corporation⁷ and the British arm of

⁴ Griffiths, *The Cinema and Cinema-going in Scotland*, pp279-285

⁵ T C Davis, *The Economics of the British Stage 1800-1914* (Cambridge, 2007), p358; S Street, *British National Cinema* (London and New York, 1997), p5

⁶ Davis, *The Economics of the British Stage 1800-1914*, p358

⁷ ABPC was created in 1927 and incorporated the ABC cinema chain

Gaumont⁸, two Scottish companies - already well-known, successful film exhibitors and renters - had diversified into film production.

These companies, the BB Pictures and Green's Film Service, were perhaps emulating the pioneering spirit of the French in attempting to create an integrated industry within Scotland. By 1907 Pathé and Gaumont had already established themselves as the leading production and distribution companies in the world, and by 1910 both had opened their own exhibition venues in Paris, meaning that they became the first vertically integrated companies in the film industry.⁹ By contrast, the American production company Vitagraph did not open its own cinemas until 1914, followed by the Fox Film Company in 1915. These companies were of course primarily producers of fiction films, whereas both the BB Pictures and Green's (the more successful of the two in achieving integration, albeit concentrated in Glasgow and the surrounding area rather than across Scotland) were primarily associated with the production of local topicals and newsreels.¹⁰ However, both companies did enter the arena of fiction film production before and during the Great War, and it is these efforts - largely overlooked until now - that are focused on below.

Economic activity in the British film industry had already begun to separate into distinct production, exhibition and distribution sectors by the early 1910s but, as Andrew Higson has noted, 'where the latter two sectors were relatively well organised and adequately financed, production remained piecemeal and underfunded'.¹¹ The state of Scottish film production in this period must be contextualised within British production as a whole, and the quotation at the top of this chapter is intended to demonstrate what a small proportion of the total capital invested into the British cinema business went into production. Langford Reed's newspaper article containing many 'amazing facts and figures' (although largely a discussion of the number of picture halls opening, leading to his conclusion that the

⁸ The formation of Gaumont British Picture Corporation in 1926 was an attempt at vertical integration, resulting from the amalgamation of Gaumont as producers with three other companies with distribution, production and exhibition interests

⁹ S Hayward, 'France', in G Kindem (ed), *The International Movie Industry* (Carbondale and Edwardsville, 2000), pp 195-196

¹⁰ See J McBain, 'Green's of Glasgow: 'We Want "U" In'', *Film Studies* Issue 10, Spring 2007, p57

¹¹ A Higson, 'Great Britain', in G Kindem (ed), *The International Movie Industry*, pp 234-246

kinema boom was ‘emphatically not a “craze”’) was based on data from the Board of Trade from 1908 onwards when the first three picture theatre companies were registered. After various adjustments had been made, the estimated total of all non-exhibition activity (which included not just film production companies but also renters and ‘the apparatus makers, etc’) from 1909, when seven companies ‘of this nature’ were registered to the end of March 1914, came to £3,214,775. This figure represented around 23 per cent of the total capital invested in ‘kinematograph finance of every kind’, of which investment into production could well have constituted less than a third.¹² Scotty of the *Bioscope* noted in December 1910 that, according to his calculations, 16 new Scottish companies were ‘established in the interests of cinematography’ during that year with a combined share capital of £71,000, concluding ‘That isn’t at all bad, is it, for puir auld Scotia?’¹³

That film production in Scotland (as well as Wales and Ireland) was generally overlooked is evident from a section in the introduction to the 1914 *Kinematograph Year Book*, which was simply called ‘Film Production in England’. Referring to the previous year’s production activity, the writer remarked:

As we have already pointed out English film production is rapidly advancing both in quantity and quality as compared with America and the rest of the Continent. True, the smaller concerns are in some cases going to the wall...¹⁴

Charles Barr has characterised this period of transition as one in which ‘all the obvious rival countries to Britain managed to produce at least one set or strain of films whose national character was distinctive and attractive enough to make a strong, lasting impact, abroad as well as at home’. He notes that when the United States came to dominate the world market, it continued to import films from Europe and to learn lessons from European countries, often signing up their directors, like Lubitsch and Murnau from Germany and Sjöström from Sweden.

¹² L Reed, ‘7000 Picture Houses - Will the Kinema “Boom” Last?’, *Evening News*, Edinburgh, 27 June 1914, p7

¹³ *Bioscope*, 29 December 1910, p57

¹⁴ *KYB* 1914, p26

No British film of this time made any significant impact, nor was any British film-maker head-hunted by Hollywood. If Britons worked and prospered there - Chaplin for instance - it was not because of any experience in their native film industry.¹⁵

Barr is of course describing *English* films. Scottish films, by contrast, offered several strains of a distinctly ‘national character’ with narratives almost exclusively based on Scottish romantic literature, myths, heroes and Highland scenery that were highly distinctive and exportable. But while Scotland had its own stories and a national ‘brand’ with huge appeal to overseas audiences, it lacked the professional expertise and the financial backing to make any significant impact on domestic, never mind overseas, markets. So while there was an clear appetite for filmic narratives that told Scottish stories, most ‘Scottish’ films made before and during the First World War were actually produced, and most of them filmed, far away from what the *Bioscope’s* Scottish correspondent all too often referred to as the ‘Land o’ Cakes’.¹⁶

While America needed to import films and directors from European countries such as Sweden and Germany and, as Barr puts it, to learn lessons from them, it seemed to have little need of authentic Scottish narratives. It is hard to imagine that the Americans would have considered producing ‘German’ or ‘Swedish’ films on their home ground, but Scotland was another matter. ‘Scottish’ films were already being produced in quantity not just by English and European companies but also in America, considerably diminishing the impact of indigenous production. Scottish film-makers were in a difficult position, expected to make films with a distinct national character but already in competition with overseas producers with greater expertise and bigger budgets. Although by 1911 Scotland was, as Ewen Cameron has described, one of the most urbanised societies in Europe, with almost half the population living in large towns and cities of overcrowded tenements, there was an almost inevitable expectation that any Scottish film would represent the old, mythical

¹⁵ C Barr, ‘Before *Blackmail*: Silent British Cinema’, in R Murphy (ed) *The British Cinema Book*, 3rd edn (London, 2009), pp145-153

¹⁶ An expression referring to Scots oatcakes. It was used by Robert Fergusson in his poem ‘The King’s Birthday in Edinburgh’ (1772)

and romanticised Scotland rather than contemporary reality.¹⁷ It has become commonplace to assume that ‘Scottishness’ in film was an outside construct created by the Americans or the British which projected a national identity based on an essentially touristic view of the country. However, it appears that from the earliest days of cinema, Scottish producers were happy to reinforce this construction themselves, rather than attempting to engage with modernity in the way that cinema helped construct an American national identity for the machine age. But from the war years onwards there were also certain attempts by Scottish producers to break out of this mould.

In the pre-war and war years there were three influential Scottish film renters whose activities eventually extended into production. The first of these was William ‘Prince’ Bendon, from whom both the BB Pictures and Green’s hired films before setting up their own renting services. Bendon’s business is not discussed in this chapter, as his apparent foray into fiction film production (including setting up the first studio at Rouken Glen) is based on anecdotal and unverifiable evidence.¹⁸

The BB Pictures

The BB Pictures was the creation of JJ (James Joseph) Bennell, who started out in the film business as a travelling salesman for Sidney Carter’s Pictures in Manchester and moved to Scotland in 1907 to establish himself as an exhibitor.¹⁹ The company, whose headquarters were at the Wellington Palace in Commercial Road, Glasgow, was established in October 1910 with capital of £30,000 in £1 shares. An abridged prospectus published in Scottish newspapers on 10 October inviting the public to subscribe to the BB Pictures stated that:

The Company has been formed for the purpose of acquiring as a going concern certain businesses of cinematograph entertainments presently carried on by Mr J.J. Bennell in Glasgow, Dundee, Greenock, Coatbridge, Perth and Airdrie, and the Film Hiring business carried on by him from

¹⁷ E A Cameron, *Impaled Upon a Thistle*, p18

¹⁸ T A Blake, ‘Prince Bendon’, *Educational Film Bulletin* 1946, pp31-32. Blake tells of Bendon’s hope of setting up a Scottish production company with £100,000 of American capital in order to make a film of *Bonnie Prince Charlie*, with a script by J J Bell and crew who worked for D W Griffith. This ‘fell through for lack of financial support’

¹⁹ NLS/MIA, 5/7/135, *The Story of the BB Pictures*, brochure

Wellington Palace, Glasgow, with a branch at the Free Trade Hall Buildings, Manchester. It is also intended to lease buildings, and open other premises as opportunity offers.²⁰

There was no mention either in this prospectus or in the Memorandum of Association of any plans for film production. Instead, the wording of the advertisement was designed to encourage subscribers by drawing attention to the growing success of the permanent, purpose-built picture theatre which, ‘although only recently introduced into this country, is already taking a firm and rapid hold on the public’, adding that ‘there is every reason to believe that it will continue to be attractive and remunerative’:

There are no heavy expenses for artistes’ salaries such as are necessary at theatres and music halls. The management can charge low prices for admission, and thus bring the entertainment within the reach of all classes... The whole of the Picture Halls are established in public favour, and are yielding substantial profits’.²¹

Not only was Bennell a successful businessman, entrepreneur and founder (later president) of the Scottish Cinema Exhibitors Association (CEA), he was also a member of the Independent Labour Party and an enthusiastic supporter of the temperance movement. A 1919 profile of Bennell - the first in a series on ‘cinema trade celebrities’ published in the trade journal *Scottish Cinema* - commented:

In addition to being interested very deeply in the cinema industry, Mr Bennell has had a lifelong association with temperance reform. Pictures and temperance may seem a strange combination, but in Mr Bennell’s mind they are very closely and strongly bound together. In his comparatively early days Mr Bennell was actively engaged in the promotion of public entertainments as counter-attractions to the public-house, and it was while acting in this capacity that he made his first acquaintance with Glasgow.²²

The first of Bennell’s cinemas, the Wellington Palace, was in the Gorbals, an inner-city area of Glasgow on the banks of the Clyde. By the late nineteenth century the

²⁰ NLS/MIA, 5/8/24, printed prospectus, The BB Pictures, Ltd

²¹ *Courier*, Dundee, 10 October 1910, p1; NRS BT2/7670/3, The BB Pictures Limited, Memorandum of Association, 3 October 1910

²² *Scottish Cinema*, 22 September 1919, p14

area had become overpopulated and adversely affected by industrialisation, and was widely known as a dangerous slum associated with the problems of drunkenness and crime. The Wellington Palace was already associated with the temperance movement, having been owned by the Good Templars and used by them for temperance concerts before 1907.²³ Providing local people with a place for respectable recreation was part of Bennell's mission, and in this he seems to have succeeded. A description of the programme at the BB Pictures' Electric Hall in Lochee in April 1911, for example, remarked that it was 'entertaining, and very educative, and had a most beneficial effect upon the conduct of certain sections of the community'.²⁴ The programmes at Bennell's cinemas, which he chose himself, were associated with variety and quality and attracted huge audiences. Children's matinee performances began with the singing of the bright and wholesome BB Pictures Song. This, together with Bennell's involvement in the ILP, suggests that the company, as Griffiths puts it, 'may have been expected to generate support from like-minded elements within the working class' - although this proved not to be the case, and only a small proportion of shares were allocated to those whose occupations ascribed them working-class status.²⁵

A week after the company's incorporation 20,262 shares had been allotted, and in November 1910 the name of the Independent Labour Party founder, James Keir Hardie MP, was added to the list of new subscribers. He, together with his wife and son, acquired 200 shares.²⁶ New exhibition venues were purchased during the following year, including the Corn Exchange in Kirkcaldy, and by December 1911 the company's accounts show that 24,212 shares had been taken up. Along with Bennell as managing director, the company directors were Robert Wilson, a printer; Peter Spencer, a brassfounder; Alexander Williamson, an accountant, and John Lawton, general manager of the BB Pictures.²⁷ By this time the BB Pictures was the

²³ The Independent Order of Good Templars was a fraternal society for total abstinence founded in the USA in 1867. By the late nineteenth century there were hundreds of branches across Scotland

²⁴ *Evening Telegraph*, Dundee, 11 April 1911 p6

²⁵ Griffiths, *The Cinema and Cinema-going in Scotland*, p39

²⁶ James Keir Hardie (1856-1915) was born in Lanarkshire and rose from very humble beginnings to become one of Britain's most notable politicians and the first chairman of the Labour Party

²⁷ NRS, BT2/7670/20, summary of share capital and list of subscribers, 11 December 1911

largest-scale film exhibitor in Scotland, and became the first company in the country to extend its activities into both film hire and production. Its first productions were of local events, designed to enhance the attractiveness of a programme of films to the local audience. In July 1911, for example, the *Dundee Courier* reported that

Those who witnessed the procession on Saturday had the opportunity of seeing their happy, smiling faces as they appeared to others at the BB Picture Theatre this week. The Palace Theatre had an excellent picture taken on Saturday, and it is reproduced this week.²⁸

The company began producing its own newsreel, the *BB Budget of Scottish News*, with topical subjects including football matches, the aftermath of the fire at the Empire Theatre in Edinburgh and the funeral of its famous victim, the Great Lafayette, and the dousing of another fire, at Aberdeen's Broadford Works. This pattern of production activity was later to be adopted by Green's and there was much continuity between the two businesses. Local cameramen were engaged, including Alexander Gray who had already made a name for himself as cameraman with the Aberdeen showman/exhibitor William Walker. When Walker went out of business and the BB Pictures took over the lease of the Aberdeen Coliseum, Gray carried on his career making films for Bennell, including matches at Aberdeen Football Club's Pittodrie ground where Bennell had secured the rights to film. In turn, when the BB Pictures ceased production Gray went to work for Green's, becoming one of the staff cameramen for the *Scottish Moving Picture News*.²⁹ In May 1911 the *Bioscope* reported that the BB Company was 'having a busy time just now with special film production' and the company's activity in news and topicals was certainly more than merely 'the fitful recording of local events,' given the regularity with which the *BB Budget of Scottish News* was presented at its own cinemas in Dundee, Aberdeen and possibly elsewhere between 1911 and 1912.³⁰ By now the company was confident

²⁸ *Courier*, Dundee, 11 July 1911, p7

²⁹ NLS/MIA, 'Biography of Alexander Joe Gray', <http://ssa.nls.uk/biography/10015>. The National Library of Scotland Moving Image Archive also holds a number of films with which Gray was associated, although none made for the BB Pictures.

³⁰ *Bioscope*, 18 May 1911, p305; Griffiths, *The Cinema and Cinema-going in Scotland*, p281; *Evening Telegraph*, Dundee, 7 November 1911, p5; *Aberdeen Journal*, 2 January 1912, p6

enough to decide to develop its activities into the filming of specially composed subjects, including fictional narratives as well as scenics.

The first mention of the company expanding into fiction film production was in the *Bioscope* in August 1912, where Scotty told readers that Bert Foulger, the company's 'enterprising manager', had sent him a booklet giving 'particulars regarding four new exclusive films which have been issued by the same Service', including *Tam O'Shanter's Ride* and *Land of Burns*. The former was to be presented at the Ayr Picture Palace on 5 August 1912, and the latter at the same venue a week later. The titles of the other two 'exclusive films' were not mentioned, and it is not known whether these were fiction films. Scotty was, as ever, enthusiastic at a new Scottish foray into production:

This is quite a new line for the B.B. Service - the production, photographing, and printing of their own special films - and I am sure that Mr Foulger with his accustomed business ability, will make this scheme a great success.³¹

Filth in the Film

Given Bennell's association with the temperance movement it is understandable that the BB's first fiction film production was a popular Scottish narrative about the nightmarish outcome of lingering in the pub. In Burns' famous narrative poem *Tam o'Shanter* (1780), the ne'er-do-well Carrick farmer Tam has spent a long day at market in Ayr. Instead of heeding his wife's advice he stays out drinking - as is his habit - with his pal Souter Johnnie, until near the witching hour. Riding home on his gallant horse, Maggie, he has to flee for his life from witches, gathered to dance to the devil's bagpipes, at the old Kirk in Alloway. In their flight Maggie's tail is pulled off by a witch and never grows back. The elements of humour, horror and social comment and a vivid narrative already familiar to audiences must have appeared an ideal film project for Bennell, particularly at a time when 'filth in the film' was becoming a major issue for the film trade.³²

³¹ *Bioscope*, 8 August 1912, p413

³² See, for example, an editorial under this title in the *Bioscope*, 9 May 1912, p389, which rebutted accusations that the Trade 'deliberately panders to the lowest taste'

Sadly, Scotty's prediction that the special productions would become 'a great success' was inaccurate. *Land of Burns* and *Tam O'Shanter's Ride* were indeed advertised as showing at Ayr, but afterwards disappeared. Griffiths suggests that the Ayr Picture Palace may have commissioned BB to make these pictures, leading to the inference that (as the company had no direct interest in the venue) it was producing pictures for others outside its own chain of cinemas. 'In many respects, this represented BB at its peak'.³³ Newspaper advertisements for the screening of these two films, however, offer a different explanation. The fact that a significant part of the narrative of *Tam O'Shanter's Ride* is set in 'Old Ayr, which never a town surpasses/For honest men and bonny lasses' and was partly filmed in the town, was the real reason.³⁴ As with United Films' *Rob Roy* and so many subsequent Scottish productions, authenticity of location was of great importance. On 1 August 1912 the front page of the *Ayr Advertiser* trumpeted the forthcoming film, which was to be shown all week at the Picture Palace, as an 'important local attraction'. *Tam O'Shanter's Ride* was described as 'the specially taken and latest cinematograph triumph' and a 'magnificent film introducing Burns' most popular work': a picture that 'all lovers of Burns should not fail to see'. An advertisement on the Entertainments page of the same newspaper addressed the local audience:

Next week's fare should be of extraordinary interest, especially to Ayr people. The principal attraction during the week will be a film dealing with Tam O'Shanter's famous ride on the grey mare. This film was partly taken in Ayr, so as to incorporate all the local landmarks which we read of in the poem. Ayr people will be the first to see this fine film.³⁵

The following week BB's other film, a scenic called *Land of Burns*, was showing at the same venue, probably using film shot in Ayr as one of its constituent parts. This was described again as 'a picture of great local interest' as well as being 'the most comprehensive and complete scenic picture of the choice districts associated with the Poet's life'.³⁶ Like *Tam O'Shanter's Ride*, this film seems to have had few if any further outings. Confusingly, there were occasions on which scenic films were

³³ Griffiths, *The Cinema and Cinema-Going in Scotland*, p281

³⁴ From *Tam O'Shanter* (1791) by Robert Burns

³⁵ *Ayr Advertiser*, 1 August 1912, pp 1 and 4

³⁶ *Ayr Advertiser*, 8 August 1912, p1

grouped together under the generic title of ‘The Land of Burns’, such as a programme shown by Aberdeen cinema proprietor Dove Paterson to a social meeting of the Stonehaven branch of the Northern Co-operative Society in 1912.³⁷

In 1915, however, a Glasgow newspaper announced that there would be a ‘special display of animated pictures’ at the City Hall including films ‘representing “The Land of Burns,” “Auld Lang Syne” and “The Pipes and their Players”, giving a pictorial view of the homes and haunts of Scotland’s immortal bard from the “auld cley biggin” at Alloway to the mausoleum at Dumfries, depicting the beauty spots of Scotland of which Rabbie Burns wrote and sang; also the meeting of Tam O’Shanter and Souter Johnnie and Tam’s encounter with the witches’.³⁸ On this occasion it seems likely that this was indeed the BB’s *Land of Burns* which had been spliced together with *Tam O’Shanter’s Ride*. The notice suggests that the latter consisted of just two basic scenes and locations. What had happened to the films in the preceding three years is unknown. Evidence is very limited about the form these two films took, but it is reasonable to assume that they were one-reel (1000 foot) productions and did not attempt to approach the scale or ambition of United Films’ *Rob Roy*, released only months before. The lack of fanfare or publicity suggests that BB was testing the water and starting out with productions of modest ambition, which - in the light of United Films’ collapse - was understandable.

In 1946 the Scottish cinema trade veteran Jack Kissell wrote an article looking back at early film production in Scotland. He described how, after directing *Rob Roy*, ‘[Frank Danvers] Yates joined Bennell, who had a laboratory, and two films were produced, *The Land of Burns* and *Tam O’Shanter*’.³⁹

The former was purely scenic; the latter had an amateur cast (staff and friends), and the interiors were painted by the Theatre Royal scene-painters. None of the actors were paid except the

³⁷ *Aberdeen Daily Journal*, 1 February 1912, p7

³⁸ *Daily Record and Mail*, 22 January 1915, p4

³⁹ Kissell, ‘Cinema in the By-ways’, p27. Kissell, a Scottish cinema trade veteran, addressed a group in the Masonic Hall, Glasgow, on the subject of JJ Bennell in 1946 (see *KW*, 31 October 1946, p 33). He was a prominent member of the Lodge Anima, a British freemason’s lodge for those in the film business, established in 1912. Frank Danvers Yates’ career is discussed in Chapter 1

witches, who were given half-a-crown, and allowed to keep their costumes (sarks).⁴⁰

The Glasgow-based author and historian Charles Oakley, writing in the 1950s, stated of *Tam O'Shanter's Ride* that 'some of the photography was done in Ayr but most of the filming took place in the Premier Cinema in Kirkpatrick Street [Glasgow] and the editing was carried out in the Wellington Palace'.⁴¹ This suggests that only exteriors were shot in Ayr, while scenes depicting Tam and Souter Johnny at the inn and Tam's encounter with the witches were set up in a makeshift studio. The production was a mixture of the professional (in the form of Frank Danvers Yates and the scene painters) and the amateur (the actors). It is possible that Yates approached Bennell with a view to directing *Tam O'Shanter* rather than vice-versa, knowing that the BB Pictures had embarked on production and had its own facilities for editing and printing films, and recognising the potential for narrative film production in Scotland - despite the lack of success at home of *Rob Roy*.

It would appear that although Ayr people were the first to see both this film and *Land of Burns*, they were also, apart from the occasion in 1915, the last. There is no evidence of either film touring BB's own cinemas in Glasgow, Airdrie, Dundee or Aberdeen in the summer or autumn of 1912, suggesting that the Ayr experiment did not produce a favourable audience response. Bennell may have been trying to avoid the mistakes made by United Films and produce two short films back-to-back (using the same crew for both), but they could not compete with the flow of other 'Scottish' films coming from elsewhere. By 1912 the resources of the company were already squeezed and production activity ceased. It seems unlikely, however, that efforts in film production (topicals as well as features) were entirely responsible for the BB Pictures' marked financial decline in the two years leading up to the war, which resulted in a serious scaling back of activity including shedding the film hire part of the business.

⁴⁰ The sark (or cutty-sark) was the Scots name given to a short, shift-like undergarment worn by women in the seventeenth and eighteenth centuries

⁴¹ NLS/MIA, 5/7/22, cutting from the *Glasgow Evening Citizen*, nd (marked as '1950s'). A prominent Glasgow citizen, Charles Oakley (1900-1993) was Chairman of the Film Society and of the Scottish Film Council

No evidence of production activity can be gleaned from the BB Pictures' memorandum of association, accounts or financial statements, although these are quite detailed in respect of other activities and assets.⁴² The various pieces of equipment and machinery listed in the BB's annual accounts relate to cinema apparatus and furnishing rather than film production. The evidence that the company was in serious financial difficulties only a year after its incorporation is, however, unmistakable. The business continued to attract new subscribers from a wide cross-section of the public during 1912, but accounts made up to the end of September that year show that although profits were just over £1,000, there were significant liabilities, unpaid dividends and a bank overdraft of £350.⁴³ The following year's accounts show that 25,292 shares had been issued, but profit for the year was now less than £65.⁴⁴ The company had been making alterations to the property it had inherited and these, along with the new businesses purchased, had cost well over £10,000. By the last year before the war, no further shares had been allotted, the bank overdraft had grown and the BB Pictures' recorded loss was almost £7,000.⁴⁵ New directors came and went, by 1914 leaving only Bennell, Wilson and Lawton. The company's troubles were described in detail in the 'Kinematograph Finance' pages of *Kinematograph Weekly* in 1915.

Through the courtesy of a correspondent, I have received a copy of the report and balance sheet of the above-named company. This document was presented to the general meeting of shareholders held in Glasgow on Nov 30th... Having perused the report and balance sheet, I can well understand the disinclination of the officials of the company to have such a document made public to an unsympathetic world. The report possesses one merit, that of extreme brevity. It merely states that the loss on trading for the year amounted to the very substantial sum of £7,337,3s.9d., that two directors retire from the board, and that the auditors likewise retire, but are eligible for re-election.⁴⁶

⁴² NLS/MIA, 5/8/24, Prospectus, the BB Pictures Limited; NRS BT2/7670, The BB Pictures Limited

⁴³ NRS, BT2/7670/28, Balance Sheet made up to 30 September 1912. Subscribers included a railway clerk, a publisher and a marble cutter

⁴⁴ NRS, BT2/7670/30, Balance Sheet made up to 30 September 1913

⁴⁵ NRS, BT2/7670/31, Balance Sheet at 26 September 1914

⁴⁶ *KW*, 7 January 1915, p40

By September 1917 the firm had ceased distribution activity, selling the film hire part of the business to the Argosy Film Co Ltd. Bennell's son, Ritson Bennell, who had joined the company as a department manager and director, wrote later about the 'revolution in the cinema trade' between 1912 and 1914 and how this impacted on small local firms 'of which Prince Bendon and The BB Pictures were the most important in the Glasgow district'. He explained how with the advent of the 'exclusive' film, most major production companies opened their own distributing offices in London or released their films through agents appointed to cover the whole of the UK.

Gradually... the supply of independent product died out and one after another the independent renters who had been the backbone of the business were forced to shut up shop... The great change-over from open-market to exclusive which was virtually completed by about 1914, resulted in the elimination of the independent renter, and by the end of the 1918 war, the business had assumed pretty much the form which it has retained ever since.⁴⁷

The Scottish cinema trade paper the *Entertainer* published an 'obituary' entitled 'The passing of B.B. as Film Renters' which offered another reason for the company's decline:

The severing of old associations is always painful. "B.B.'s" have dropped from the ranks of Film Hirers, in which they have always stood for that which is highest and best, and the place which knew them, now knows them no more. The exciting cause is, of course, the War and its drainage in the ranks of young men available for the carrying on of the business. Those who have had the pleasure and the privilege of doing business with the old firm will, we are sure, sympathise with the reason, and be filled with regrets at the result. B.B.'s for many years have been in the forefront of the Renting business, and throughout Scotland have been held in the highest esteem. Mr J J Bennell, the head of the firm, is regarded, and rightly so, as the champion of everything that is best in the picture world.⁴⁸

⁴⁷ R Bennell, 'The Film Industry Settles Down', *Educational Film Bulletin*, September 1946, pp38-39

⁴⁸ *Entertainer*, 15 September 1917, p12

What is interesting is that none of these accounts mentioned the company's activity in film production, suggesting that money spent on this was not the primary reason for the company's failure to thrive in the pre-war years; the cost of converting theatres to cinemas was probably responsible. Along with the withdrawal from distribution, the BB production plant at the Wellington Palace was acquired by Green's, which by then was well launched on similar career as a vertically-integrated concern covering production and distribution as well as the exhibition of moving pictures.

In February 1920 the original BB Pictures (which by the end of the war was once again making a profit) went into voluntary liquidation 'for the purpose of reconstituting and increasing its capital', and a new company called The BB Pictures (1920) Limited was formed.⁴⁹ JJ Bennell died in 1922, and his popularity and importance in the cinema trade was reflected in many pages of press tributes. One of these commented that he was 'blessed with a noble self-sacrificing wife, who gave herself wholly to him as he gave himself wholly to us'.⁵⁰ But once again none of the writers who described Bennell's career made any reference to his company's incursion into film production.

Green's

Along with JJ Bennell, the biggest name in the early Scottish film business was that of George Green. They were both collaborators - for example co-founding the CEA in Scotland - and rivals. George Green established Green's Film Service in 1914 as an adjunct to his cinema-owning business, which was already thriving. As the number of cinemas in his circuit increased, Green's volume of film hires also grew and he decided that it would be more cost-effective to buy films outright. This strategy, an unusual one for the time, proved so successful that Green began selecting and supplying programmes to other exhibitors, and the professional renting service took off. By the time of George Green's death in 1915 the circuit that bore his name consisted of ten cinemas, making it one of the largest in Britain.⁵¹ Very few circuits

⁴⁹ *Edinburgh Gazette*, 27 February 1920, p537

⁵⁰ *Scottish Kinema Record*, 23 December 1922, pp1-5

⁵¹ McBain, 'Greens of Glasgow: 'We Want "U"ln'', p55

had emerged at this time: by far the largest was Albany Ward's with 29 screens, followed by Provincial Cinematograph Theatres with 18 screens.⁵² Green's Film Service, which was taken over by his two sons, had offices in both London and Glasgow. By 1917 Green's had expanded further into other areas of the film business. As well as a distribution department renting comedies, serials and dramas, it had a mechanical department which sold projectors, a music department renting sheet music and its own printing facilities for programmes, tickets and posters. The same year the company launched its own magazine, *Green's Kinema Tatler*.

As early as December 1914 the 'Cinema Chit-Chat' page of the *Entertainer* announced that Green's, in addition to opening two new cinemas in Glasgow, was building 'a studio for the production of films under their own management'. The company was said to have 'already turned out some very creditable pictures'.⁵³ This in-house production facility may have been located within the Whitevale Theatre in Gallowgate. In October 1915 the *Bioscope* reported that Green's were considering making a series of comedy films as well as a version of *Annie Laurie*.⁵⁴ It was not until November 1917, a month after Green's introduced a regular topical called the Scottish Moving Picture News, that the company announced their buy-out of rival JJ Bennell's producing plant, 'including cameras used by BB Film Service at Wellington Palace'.⁵⁵ By this time it would appear that Green's had already gone into production with a series of films called Club Comedies. None of these survive and there is only one reference to the series' existence, a long piece in the *Bioscope* in February 1916 entitled 'Producing in Scotland':

Some time ago, while visiting a cinema in the suburbs of Glasgow, I witnessed a comedy on the screen with a new brand. The name was "Club Comedies", and never having heard of them, I inquired as to who were the producers. Imagine my surprise when I was told they were produced in dear, dirty old Glasgow! I immediately determined to hunt down the

⁵² P Cook, 'Albany Ward and the development of cinema exhibition in England', *Film History* vol 20 no. 3, 2008, pp294-307; Film Distributors' Association, 'The origins of UK film distribution', www.launchingfilms.com, (accessed October 2014)

⁵³ *Entertainer*, 12 December 1914, p8

⁵⁴ *Bioscope*, 21 October 1915, p325

⁵⁵ *Entertainer*, 24 November 1917, quoted by J McBain; 'Mitchell and Kenyon's Legacy in Scotland' in V Toulmin, S Popple and P Russell (eds), *The Lost World of Mitchell and Kenyon* (London 2004), p115

producer... Perseverance was rewarded, and having caught my man, I was invited to attend at the studio and see the whole outfit. I expected to find an amateurish concern, but was pleasantly surprised, for where the "Clubs" come from everything is as perfectly fitted up as though for the production of big things. "Universal City" had better look to its laurels.⁵⁶

Frustratingly, Scotty was 'not at liberty' to reveal the exact location of the studio, but from the description below it can be assumed that (wherever it was) the studio was already being used by Green's for the production of their topical and news films. He continued with a lengthy description of its excellent facilities and the comedy film currently in production:

I first visited the studio, where, at the moment, rehearsals were being held for a comedy which will shortly be released under the name of "His Highness". The studio is a large glass-roofed building, with excellent natural light, and, by an arrangement of rails near the roof, powerful arc lamps can supply sufficient light when the natural supply gives out... The director of productions is Mr Foote, an American with experience in several of the best-known picture producing companies in the States, and having seen him at work - and heard him - I am more than ever convinced that the cinema artist deserves all the nice things said about him or her. The producer is a hard taskmaster, or seems so, but in reality he is only doing his best to get the correct effect, and he usually succeeds. From the studio I was conducted to the dark rooms. I have been in several similar rooms previously, but must say that those in which "Club Comedies" are finished are about perfection.

The studio was also described as having six or seven dark rooms, drying rooms, an electrical air shaft and a projection room 'where the finished production is viewed before being sent on its errand to amuse the masses'. Most intriguing was Scotty's assertion that *His Highness* was just one in a series of (non-Scottish-themed) comedies apparently designed to appeal to an urban audience. There was a full, professional crew and a studio equipped to deal with large-scale production. The article concluded:

"Club Comedies" are yet in their infancy, but already the number produced reaches a dozen, all of which have been successful. While at the studio I was shown where extensive

⁵⁶ *Bioscope*, 10 February 1916, p645

additions are to be made. Space has been marked off for outside studios, where at least six scenes can be set, and films taken out of doors when the light permits. The staff at present numbers about twenty, all told, with Mr Foote as director and Mr Verne as camera man.

Who, then, were Mr Foote and Mr Verne? The latter would have been Alf Avern (also sometimes referred to as Le Verne and Vern), a cameraman with Green's Film Service. An obituary in *Kinematograph Weekly* stated that he 'was originally with Charles Urban, taking the first Kinemacolour pictures, and had also been with Scottish Movietone'.⁵⁷ In 1915, Avern was said to have been the first cameraman to film the visit of the Fleet to the Forth, dodging security guards and going out onto the Forth Bridge where he strapped himself to one of the girders to film the Fleet. He was the staff cameraman for Green's *Scottish/British Moving Picture News*⁵⁸ from its launch in 1917 and stayed with the company until about 1922.⁵⁹ Avern's impressive professional credentials would have made him Green's natural choice as cameraman for *His Highness*, although his previous experience was entirely in non-fiction film.

Mr Foote is more difficult to identify. There is no record of any American film director or producer of that name during this period. He may have been Courtenay Foote (1879-1925), a Yorkshire-born actor who became a successful Hollywood film actor. From 1912 he worked with the Vitagraph Company, appearing in many productions and film serials alongside Florence Turner and Larry Trimble - who in 1916 were still producing and directing films in Britain.⁶⁰ There is also a (potential) connection between Foote, the Vitagraph Company and another of the earliest production companies to move to Hollywood in 1912, the Nestor Film Company headed by David Horsley. At the time studios were just becoming established in Hollywood, and the community there was relatively small and closely knit - meaning

⁵⁷ Charles Urban was the most significant figure in the early British film industry, founding the Warwick Trading Company and producing his own films, as well as developing his own projector, the Bioscope; *KW*, 7 January 1946. I am grateful to Janet McBain for information about Alf Avern

⁵⁸ The name of the newsreel changed from Scottish to British Moving Picture News in May 1919 in order to compete with its bigger rivals, Pathe and Gaumont, but changed back again in 1921.

⁵⁹ 'Alf Le Verne', www.bufvc.ac.uk (accessed September 2014). Two of the films in the Scottish Moving Picture News series on which Le Verne/Avern worked, *Glasgow Riots* and *Military Called Out* (both 1919) are held by the NLS Moving Image Archive

⁶⁰ See Chapter 4

that Foote would almost certainly have known Horsley. In 1915 Horsley, now working for Mutual Films, became the producer of a very popular series of short, slapstick comedy films known as the Cub [sic] Comedies, starring the actor/comedian George Ovey.⁶¹ Within a prolific career, Ovey (1870-1951) was best known for his role as 'Merry Jerry' in this series.⁶² From 1915 until 1920 he starred as Jerry in over 100 Cub Comedies.⁶³

Given that Cub Comedies were being produced a year before the Club Comedies discussed by Scotty, there are various possibilities. One is that Green's - noting the success of the American series in 1915 - had decided to make its own version and went into production the following year. There is no evidence of these films' existence. Another is that the 'dozen or so' existing Club Comedies mentioned by Scotty were actually Cub Comedies produced in Hollywood, and that *His Highness* was the first in a series planned by Green's for production in their Glasgow studio. Foote may have been approached by Green's to direct the film(s) thanks to his connection with Florence Turner, (with whom Green's had a professional connection) or he may have approached them himself.⁶⁴ It is interesting to see that although he appeared in several Hollywood films in most years between 1913 and 1917, he has only one film credit as actor in 1916 and could have been in Britain for most of that year.

The most interesting aspect of *His Highness* and the actual or intended series of Club Comedies is their difference from other Scottish film productions to that date. Green's had identified a popular genre - the slapstick comedy - that would be both relatively cheap to produce and appealing to both Scottish and non-Scottish audiences. There was no mention of 'Bonnie Scotland', scenery or authenticity of location in Scotty's description. This in turn indicates that Green's, along with being a renter, exhibitor and news magazine producer already successful at both local and national levels, 'had all the appearance of ambitions to become players on a national

⁶¹ *Mutual News*, Chapter 8, 1915 <http://www.thanouser.org/> (accessed October 2014)

⁶² These include *Merry Jerry Holds His Own*, (1916?), www.youtube.com (accessed September 2014)

⁶³ See www.imdb.com for George Ovey's filmography

⁶⁴ See Chapter 4

(and perhaps international) stage'.⁶⁵ Janet McBain has suggested that Green's Film Service may have been following in the footsteps of another one-time British renter, G B Samuelson. Unlike the United Films or the BB Pictures, Green's had its own studio, plans to extend it to make it suitable for the production of feature films and the means, it would appear, with which to do so.

Green's company accounts and records are not available for scrutiny so there is no way of drawing any inference from its entry into non-factual production and its financial situation, or determine why it may have decided to retreat from larger-scale production activity. It was a bold move to aim for this level of production during the war, at a time when it was difficult to get the manpower and even established English companies were rapidly going to the wall. The period of optimistic activity in British film production early in the war, described by Rachael Low as a time of 'high hopes and great expectations', had already passed.⁶⁶ *His Highness* and the Club Comedies appear to have left no trace. Ironically, because of their non-Scottishness they would be very difficult to identify, even if they did exist. Scotty's article was accompanied by a production still from *His Highness*, although this of course does not prove that the finished film ever appeared. The fact that Green's had made only one low-key announcement of its new venture into comedy film production - and that Scotty had heard nothing of the Club Comedies before seeing one by chance at a Glasgow cinema, leading to his visit to the mystery studio - is curious. It was extremely unusual for any Scottish production activity to go without mention in the press, yet research into Glasgow newspapers around this time has revealed nothing. What was the film that Scotty saw in the cinema? Were there really 'a dozen or so' already in the can that audiences had seen? If so, why was the trade press unaware that these had been produced in Glasgow?

The other fiction film that Green's announced was under consideration in 1915 was *Annie Laurie*. The company may have been unaware at the time that the Hepworth Manufacturing Company intended to produce a version of the same story. In June

⁶⁵ McBain, 'Greens of Glasgow' p54

⁶⁶ R Low, *History of the British Film, 1914-1918*, p48. Low discusses the larger companies that failed, including the London Film Company, British Empire Films, the Neptune Film Company and the Windsor Film Company

1916 Hepworth's version, with a cast including Alma Taylor and Stuart Rome (two of the first British film stars) was released, billed as 'a picturised version of the world's most-loved song in four charming parts'.⁶⁷ With this kind of competition it is understandable that Green's production did not go forward. Cecil Hepworth's company was established as a major force in British film production, and he was better placed to produce and direct the first British version of this popular romantic Scottish story. *Annie Laurie* had already been filmed at least once in the USA, and stage adaptations were also regularly mounted throughout Britain.⁶⁸ On the other hand, the intention to produce *Annie Laurie* may have been abandoned simply because it was over-ambitious.

Green's made no further announcement about an alternative to *Annie Laurie*; possibly the experience of making the Club Comedies proved too much of a practical and financial burden in wartime conditions. Instead, the company continued to play to its strengths in the production of news and topicals. This activity was further developed with the announcement in October 1917 that it was to handle production in Scotland for the Topical Budget, one of the three major newsreels of the silent era, although by the end of 1922 newsreel making had ceased. Green's Topical Productions continued in business until about 1925.⁶⁹

Of the few film companies in Scotland in this period, Green's was the best-placed to become an established presence in the British film industry. In its bid to do so, the company recognised that in order to speak to the widest possible audience it should produce fiction films in a genre with universal, contemporary and populist appeal, as well as looking to 'Scottish audiences everywhere'. The Club Comedies were evidently a well-considered attempt to do so in a way that no other Scottish company was to approach until several years later.⁷⁰

⁶⁷ *Surrey Mirror*, 24 November 1916, p1

⁶⁸ *Annie Laurie*, Reliance Film Company (USA, 1913)

⁶⁹ McBain, 'Green's of Glasgow', p57. See also L McKernan, *Topical Budget: The Great British News Film* (London, 1991)

⁷⁰ *Football Daft* (1922), discussed in Chapter 3

The Vocal Cinema Company

Despite the wartime conditions which were to severely hamper the advancement of film production in Scotland, there were other significant attempts to set up film studios and to establish Scotland as a home of modern and technologically-advanced film making. As early as 1900 there were many efforts at synchronising films with sound disc recordings. The American film historian Rick Altman has described the large-scale introduction of synchronised film sound projection systems in the period between 1907 and 1909 as one of cinema's 'best-kept secrets'. As he notes, from the autumn of 1907 the trade papers were for years 'full of details of the newest sync-sound system, the latest theatre to convert and the most recent films released'.⁷¹ These widely-adopted systems, the most successful of which included the (French) Gaumont Chronophone and the (American) Cameraphone, were used for both song and speech. A short film of Sir Harry Lauder was used to demonstrate the Chronophone and had a successful 16-week run at the London Hippodrome in 1907.⁷² One of Gaumont's Chronophone films produced by the company's British facility in Camberwell, South-East London, *It Was a Nice Quiet Morning* (1907), is the only British-made sound film from the pre-war years known to survive.⁷³

Equally successful was the Cinephone, patented in England by film producers William Jeapes and Will Barker (of the Barker Motion Picture Company). By 1909 their system is said to have been installed in more than 1,000 venues in Britain.⁷⁴ Its chief advantage was an exclusive relationship with the Victor Talking Machine Company, which supplied Cinephone with audio recordings made in its own studios by its stable of British music hall artistes, and exhibitors with state-of-the-art sound producing equipment. The system was so successful that in 1910 it was imported into the USA, and Cinephone films were made geared specifically to the American market. In Scotland, the Cinephone was widely used within film programmes, where

⁷¹ R Altman, *Silent Film Sound* (Columbia, 2007), pp158-161

⁷² D Gomery, *The Coming of Sound* (Abingdon and New York, 2005), p25

⁷³ T Fletcher, 'Alf Collins and Gaumont: South-East London's cinematic past', www.silentlondon.co.uk (accessed October 2014)

⁷⁴ Altman, *Silent Film Sound*, p164

one or two 'cinephone pictures' or 'cinephone songs' were a regular feature in 1909 and 1910. The Aberdeen exhibitor Dove Paterson, for example, included Cinephone features in his programmes in venues including church halls, Craiginches Prison and the Aberdeen Swimming Club.⁷⁵ In Dundee, 'singing pictures' in programmes at the BB Pictures included popular and sentimental songs such as *Tomorrow Will Be Friday*, *The Bellman* and *The Anchor's Weigh'd*.⁷⁶

Despite this, by 1912 the Cinephone, along with the Chronophone and Cameraphone, had gone out of business. There were several reasons, including a lack of controllable synchronisation and inadequate amplification. As Altman notes, early sync-sound films were also hampered by the way they were conceived as a substitute for song and dance acts and by insufficient film production. 'Never able to provide the entire evening's entertainment, as would their late-twenties descendants, early sync-sound technology remained no more than a novelty because of its inability to achieve any significant economy of scale'.⁷⁷

Efforts to create a synchronised sound system for singing and talking pictures continued, however, until the outbreak of war. The best known of these is Thomas Edison's Kinetophone, which had been in development since 1911 and was made commercially available in 1913. In Britain, the Vivaphone - the creation of Cecil Hepworth - proved very popular and was employed in many cinemas to provide 'singing pictures' between 1912 and 1915. In January 1914, Vivaphone pictures constituted part of the programme at the Electric Theatre, Aberdeen, and the system was still in operation in Bedford in October 1915, although by this time it had disappeared elsewhere.⁷⁸ It was possibly the apparent success of the Vivaphone that encouraged a group of Scottish entrepreneurs to form a company and patent the invention of a new synchronised sound system in 1914. Its name made it stand out: rather than sounding like yet another complicated device with a name ending in

⁷⁵ Shows included those at the Aberdeen Swimming Club in November 1909 (*Aberdeen Journal*, 27 November 1909, p3; John Knox Parish Church, Aberdeen, (*Aberdeen Journal*, 27 February 1909, p3) and Craiginches Prison (*Aberdeen Journal*, 11 November 1909, p7)

⁷⁶ *Evening Telegraph*, Dundee, 30 August 1910, p4

⁷⁷ Altman, p163

⁷⁸ Vivaphone pictures were being shown in a Bedford cinema until as late as October 1915

‘phone’, the system was simply known as Vocal Cinema. It was invented by George W Ford from Gourock, who worked as a mechanic at the Royal Naval Torpedo Works in Greenock.

A feature in the *Entertainer* heralding the ‘latest form of talking pictures’ offered a description of how Ford’s invention worked:

The idea consists of a new form of electric motor controlled to within 1-16th of a second and a device attached to the sound producing machine, which, placed behind the projected picture upon the screen is connected to the cinematograph motor by ordinary telephone wires. Immediately the sound record begins to revolve the patent controller attached thereto transmits impulses of electric current to the cinematograph motor, and operates and controls it throughout the whole run of the record and film. It is claimed by the inventor that the apparatus can be simply adapted to any existing cinematograph, and may be utilised for producing appropriate incidental automatic music to suit any film manufactured, the method of obtaining synchronism being so simple. The new patent apparatus is being demonstrated at the premises of Campbell McLean & Co, 67 West Regent Street, Glasgow.⁷⁹

The Vocal Cinema Company was registered on 21 January 1914. The memorandum of association showed the new company’s level of ambition, not only in manufacturing and supplying synchronising devices and accessories ‘whereby cinema cameras or projectors may be used in conjunction with a gramophone or other sound producing or recording machine’ [such as an automatic piano] and to apply for patent rights, but also to ‘carry on the businesses of entertainment and amusement proprietors and managers to provide for the production, representation and performance of cinematograph films’ and all the other activities carried out by film exhibitors and producers such as acquiring the rights to operas, plays, burlesques, pantomimes, musical performances and ‘cinematograph displays’. The document also covered the rebuilding or building of picture houses, indicating that the Vocal Cinema may have hoped to extend activities into exhibition.⁸⁰ While all

⁷⁹ *Entertainer*, 20 December 1913, p16. A full description of the operating system can be found with the US patent application at www.google.com/patents/US1153210

⁸⁰ NRS, BT2/8946/2, The Vocal Cinema Company Limited, Memorandum of Association, 21 January 1914

these ambitions may not have been achieved, there is evidence to show that the company did succeed in some of its aims, including manufacturing the machine, producing some films which were seen and heard in British cinemas, and patenting the apparatus in the USA. Unlike Cecil Hepworth, who was already a well-established film producer and director with his own film studios by the time he went into the sync-sound business, the Vocal Cinema was starting from scratch. They would have had to build their own studio, however simple, in order to make the films to go with the music or sound recordings.

The company, whose registered office was at 170 Hope Street, Glasgow, had four directors: John Chrystie of Aberdeen, a dental surgeon; John Hawthorne, an insurance manager; James McLean, a solicitor, and Thomas Calderhead, a merchant, all of Glasgow - none of them appearing to have a connection with the cinema or entertainment business.⁸¹ The capital was £10,000 in shares of £1 each. A month after the company's registration in January 1914 the Vocal Cinema Company demonstrated its new apparatus at the International Kinematograph Exhibition in Glasgow. The *Entertainer's* response was highly enthusiastic, remarking that 'at an early date the patrons of the picture palaces will have the pleasure of hearing animated pictures which are remarkable if not almost uncanny,' and noting that the invention was the outcome of 'many years' experimenting by a cinematograph expert'.

A new era seems to have dawned for the pictures, for now they talk and sing quite naturally, and the illusion is at once fascinating and bewildering. The experts who have been fortunate enough to be present at the numerous demonstrations of the apparatus, predict that it will undoubtedly be universally adopted. The clear enunciation of the talking apparatus and the marvellous synchronisation of the pictures are the outstanding features of the "Vocal Cinema." The fact that it can be used in conjunction with any existing projector should appeal strongly to the cinematograph section of the entertainment world.

⁸¹ In 1915 the company's address was listed as 102 Bath Street, Glasgow

We understand that the inventor of the “Vocal Cinema” is perfecting an entirely new colour cinematograph film, and future developments are being eagerly awaited.⁸²

Other reporters were equally enchanted by the revolutionary device which apparently created the perfect ‘illusion of the singing and talking picture’ where ‘every movement of the lips in the pictures synchronise[d] with the sound’.⁸³ By April 1914 the system had been launched. A full-page advertisement in the *Entertainer* drew attention to the ‘perfect automatic synchronism to 1/16th of a second’ and the fact that ‘no indicator [was] necessary - the human element eliminated’. These must have been the features that distinguished the Vocal Cinema from previous sync-sound devices. The advertisement stated that songs, recitals, operas and sketches were available.⁸⁴

The following month the *Entertainer* reported that applications for installations had been received from many parts of the United Kingdom and that a representative had been invited to America ‘with a complete outfit of apparatus and films’. A London office was about to be opened and, more intriguingly, an outdoor film studio was in the course of being built at the coast for production purposes, ‘the private theatre and works of the company being at Anderston’.

The latest development of “vocal cinema” is now in its final stage, and is no less than the production of a complete vaudeville programme upon the screen, the various gestures of the artistes being accompanied by appropriate words, music and general sound production. Of the vocal cinema subjects at present being circulated, it is passing strange in these days of “ragtime” that the old favourite songs as displayed by Vocal Cinema are meeting with universal approbation.⁸⁵

This is another indication of the Vocal Cinema’s difference from its predecessors. Attempting to film and produce sound for a complete vaudeville programme was something that had never been done before, particularly in an open-air studio. It appears that this was not achieved, although the outdoor studio in the unknown

⁸² *Entertainer*, 28 February 1914, p10

⁸³ *Saturday Post*, Glasgow; *Evening Post*, Glasgow, quoted in advertisement for the Vocal Cinema

⁸⁴ *Entertainer*, 25 April 1914, p10

⁸⁵ *Entertainer* 16 May 1914, p9

coastal location may have been built. While the *Entertainer* was wrong in its prediction that the Vocal Cinema would become ‘a permanent feature in the programme of up-to-date picture houses’, some productions were certainly made and shown in British cinemas. In October 1914, for example, ‘Vocal Cinema Singing and Talking Pictures’ were included in a programme also featuring a ‘dramatic film play’, *To Love an Actress*, and a military picture called *The Making of a Soldier* at the Grand Theatre in Hull.⁸⁶

One product of the Vocal Cinema Company is held by the NLS Moving Image Archive, a two-and-a-half-minute film called *Whisper and I Shall Hear*. It is a version of a very popular song of the Victorian era, which begins ‘If, in the summer morn, dear, you wander amid the flowers/If you feel sad and lone, dear, thinking of past glad hours/Just breathe my name to the woodlands...’ The film shows a couple dressed in elaborate Regency costume walking in a garden, which looks very much as if it were part of a public park. In this rendering the song (written for soprano voice) appears to have been adapted for the male voice, as the woman’s mouth remains closed.⁸⁷ The sound recording that would have accompanied the film is missing.⁸⁸



Figure 4: The Vocal Cinema’s short ‘singing picture’ *Whisper and I Shall Hear* (1914). NLS/MIA, 2803

⁸⁶ *Hull Daily Mail*, 21 October 1914, p4

⁸⁷ *Whisper and I Shall Hear* (c1891), lyrics by Georgeanne Hubi-Newcome (1843-1936), music by Marietta Piccolimini (1834-1899)

⁸⁸ NLS/MIA, 2803, *Whisper and I Shall Hear*

Despite initial interest, the Vocal Cinema Company did not thrive. On its formation in January 1914 George Ford had sold the patent for his invention to the company and was partly paid for this in shares.⁸⁹ Together with shares bought by the other directors and a consulting engineer, Henry Hewat, this accounted for £4,000 of the £10,000 capital to be raised. By April 1914 only 350 further shares had been allotted to just three other people: an electrical manufacturer, another dental surgeon and a chartered accountant, all of Glasgow. There was no activity in 1915, but in 1916 two women, one from Glasgow and one from Gorebridge, were allotted 70 shares between them. This brought the total of shares issued to 5,470, which is where the figure stayed. Having struggled through four years of wartime to survive, the company evidently gave up in 1918, when the last set of accounts was recorded.⁹⁰ As a private company no invitation to the public to subscribe had been issued, but it seems that hopes to raise capital privately were dashed.

⁸⁹ NRS, BT2/8946/10, Minute of Agreement between George W Ford and The Vocal Cinema Company Ltd, 2 March 1914

⁹⁰ NRS, BT2/8946/18, summary of share capital, 31 December 1918

G. W. FORD.
APPARATUS FOR OPERATING TWO MECHANISMS IN SYNCHRONISM.
APPLICATION FILED JAN. 6, 1914.

1,153,210.

Patented Sept. 14, 1915.

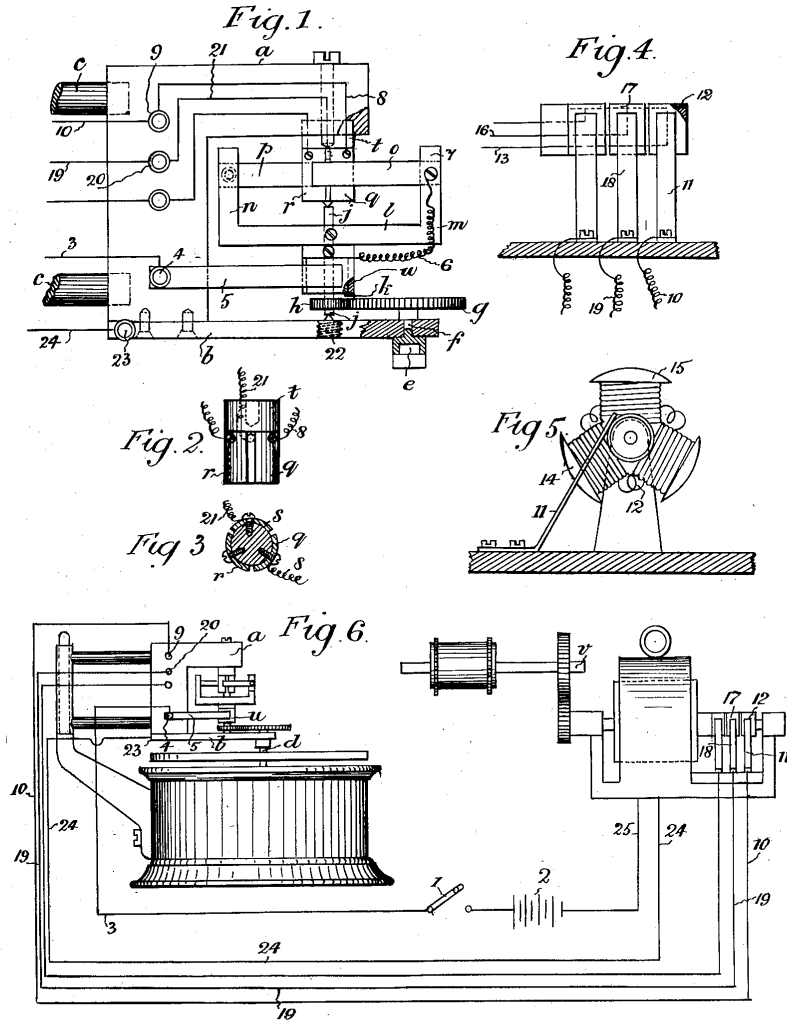

Witnesses:
M. A. Kelling
Ben R. Hancock.

Inventor:
George W. Ford
by B. Singer Atty.

Figure 5: Illustration of George Ford's Vocal Cinema apparatus, presented as part of the US patent application. www.google.com/patents/US1153210

In February 1921 a letter was sent by a Glasgow solicitor on the company's behalf to the Registrar of Joint Stock Companies. Headed 'The Vocal Cinema Co, Ltd', it read:

Dear Sir

Your circular addressed to the above company has been handed to us. The Directors have explained to us that this Company was formed to develop and put on the market a patent for speaking pictures. A great deal of money has been spent on it and the directors themselves presently [sic] out of pocket on the patent. An attempt before the War and since has been made either to sell the patent or put it on the market. Unfortunately no buyers can be got. The Directors have for a number of years paid the patent fees and Annual Charges for lodging the Annual Return. They do not feel inclined to continue making any further payment nor do they feel inclined to put up the necessary funds to carry out a formal liquidation. The Company's whole assets are a Gramophone [sic] with electric appliance attached thereto and few old records and films and also a patent rights the dues of which have not been paid. The Creditors are chiefly the Directors. We shall be pleased to know therefore if you will have the company written off the Register in terms of Section 242 of the Companies Act.⁹¹

The technology may have been modern, but evidently its appeal was not wide enough to make the business viable. Live acts continued to be a part of film programmes in many theatres until the coming of sound, when cine-variety took over. The Vocal Cinema Company had been confident and ambitious enough to enter the international market, rather than seeking to stay local. None of its advertisements mention any aspect of 'Scottishness', and it would appear that the subject matter of its films were songs and acts with general popular appeal.

Conclusion

Other production companies were established in Scotland before and during wartime, including Scotia Films and the Scottish Artistic Film Producing Company. Both of these produced (or in the former's case, intended to produce) Scottish scenics, rather

⁹¹ NRS, BT2/8946, letter from Strang & Weir to the Registrar of Joint Stock Companies, 9 February 1921

than narrative films.⁹² It is unlikely that any other professional efforts in Scottish fiction film production in this period remain to be discovered. For all that, as can be seen from the above, there was far more happening in the pre-war and even wartime years in terms of production activity than has previously been imagined. Artistic and technological initiatives within Scotland were in line with, and sometimes in advance of, those seen elsewhere in Britain. While Green's and the BB Pictures, both well-established businesses, decided that fiction film production was too risky a proposition to pursue, the entrepreneurs behind the Vocal Cinema had ambitions to create a foothold for Scotland in the wider British film industry.

⁹² Griffiths, *The Cinema and Cinema-going in Scotland*, p283

Chapter 3: Cinema colleges and Football Daft

‘What is meant by production is thoroughly understood by every intelligent member of the Trade in Scotland to-day. It necessarily does not mean half-boiled comedies made for exhibition in a purely local and restricted circuit, nor a Scottish drama promoted by an English company - photographed in Scotland, and developed in England; but a drama written, produced, photographed, developed, and distributed in Scotland, for the universal market, without any restriction or qualification.’¹

Introduction

By the end of the war the gap between British film productions and Hollywood’s expensive and heavily marketed feature films had widened. An article in the *Bioscope* published in January 1918 entitled ‘Shall Britain Lag Behind?’ discussed the British producer’s opportunity to capture trade after the war:

It cannot be gainsaid that the labours of the British film-producing firms have in the past been hampered by the fact that, unlike their [foreign] competitors, they have not had unlimited capital at their disposal, given which we firmly believe they could hold their own against all comers.²

It was no longer possible to argue that the ‘failure of British films to win appreciation’ could reasonably be ascribed to climatic conditions or to a lack of cinema acting talent, the article concluded: the problem was purely financial. ‘Given the opportunity, the producing end of the business in the homeland is capable of rendering a good account of itself and of earning substantial dividends for those with sufficient confidence to put up the necessary capital’.³

Film production in Britain suffered during the war, and so, for a time, did the exhibition sector. A rise in the cost of attending the cinema was brought about by Government policies concerned to help raise taxes to finance the war effort, particularly the introduction of the Entertainments Tax in 1916. This tax on

¹ *The Scottish Cinema*, 29 December 1919, p 17

² *Bioscope*, 19 January 1918, p 4

³ *Ibid*

amusements including music hall, theatre and sporting events as well as cinema was initially set at the rate of between 25 and 50 per cent of the price of tickets. It had unintended consequences not just for exhibitors but also for domestic film production, as cinema-goers began to reduce the number of times they visited the cinema per week and became more selective about what they chose to see.

Audiences were increasingly drawn to films featuring Hollywood stars such as Mary Pickford and Charlie Chaplin: by contrast, British offerings starring Violet Hopson or Stewart Rome proved somewhat less attractive. As Rachael Low puts it, 'It is fair to say that hardly any of the English [sic] film players were film stars on the American scale'.⁴ Trevor Griffiths' detailed analysis of statistics relating to the cinema-going habits of the Scottish public shows there were peaks and troughs in cinema-going and that the years of war to 1917 were 'a time of mounting challenges for the trade as it sought to operate in an often unfavourable economic and political climate'. Nevertheless, the Scottish habit of cinema-going continued to grow in the later stages of the war as incomes caught up with the rise in prices.⁵ During the war cinema-going had become part of the fabric of Britain's cultural life, and by 1918 it had emerged as a dominant leisure activity.

The year the Entertainments Tax was introduced marked a low point for the development of feature film production in Scotland. Green's (presumably one of the purveyors of 'half-boiled comedies' denounced by the *Scottish Cinema*) had ceased any attempt at fiction film production, and between 1916 and 1918 there were no further attempts to establish a studio within Scotland for the production of fiction films. With minimal resources and facilities, how could Scottish film production be revived once the war was over? One answer was to attempt to rebuild it on the shaky foundations of a cinema college, where aspiring film stars paid to learn their craft. The first result of this process was *The Harp King* (1919), produced by the A1 Cinema College in Glasgow. Today this (lost) film, a romantic tale set in the Highlands, is dismissed as sadly representative of all that Scotland could hope to produce. At the time, however, local hopes rode high on this production, not least

⁴ Low, *History of the British Film, 1914-1918*, p59

⁵ Griffiths, *The Cinema and Cinema-going in Scotland*, pp99-109

because it was the first to meet all the criteria (set out by the *Scottish Cinema* writer quoted at the top of this page) for being a ‘truly Scottish film’ and particularly because it was made in a newly-established film studio at Thornliebank, Glasgow.

While *The Harp King* itself has not survived, existing documentation offers a fuller account of this production than of any other Scottish film of the period.⁶ This fact, together with its producers’ skills as publicists, have led to a distorted view of the film’s importance in Scottish cinema history both at the time of its production in 1919 and now. But there is no doubt that the years between 1919 and 1922 represented a kind of boom in Scottish film production which paralleled that in the rest of Britain. In Scotland, these were years which saw the formation of a series of companies whose hopes rested on building a new industry beginning with film acting schools and ending with fully-fledged feature films.

After considering the context in which *The Harp King* was produced and the film’s reception, this chapter considers other paths taken by film producers in Scotland in the four years immediately following the war. While some cinema colleges may have exploited naïve cinema aspirants, the output of another such enterprise proved to be a popular, well-received and widely-seen ‘all-Scottish’ film. *Football Daft*, an urban comedy produced in 1921 by the Broadway Stage and Cinema Company, presented a very different set of Scottish tropes from those of *The Harp King*: contemporary city life, football and drunkenness. With scenes filmed at Ibrox Park and on the streets of Glasgow, *Football Daft* (also known as *Fitba’ Daft*) was the first Scottish film aimed specifically at a working class audience. The story of *Football Daft* and other productions discussed below illustrate not just the renewed hopes for the development of a Scottish film industry in the optimistic period following the war, but also the variety of strategies and approaches employed by writers and producers.

In Scotland, the flurry of production activity in the immediate post-war period can be understood in the context of the unexpected boom in the British economy which

⁶ NLS/MIA, 4/5/101, Film Productions, Miscellaneous, 15 November 1919, Nan Wilkie, certificate of proficiency; cutting from *Sunday Mail*, 26 October, 1919

lasted until 1920 or 1921. Its origins lay in the sudden release of pent-up demand from industry together with consumption deferred during wartime. Credit was readily available, interest rates were low, and the anticipated problem of mass unemployment did not become an immediate reality. The boom contributed to a mood of optimism which affected the British film industry as much as any other, although it was the exhibition sector that saw most benefit. There was a wave of investment in cinema building throughout Britain, including Scotland; in the absence of housing to invest in, cinemas were an attractive alternative. Although film production was unable to command similar confidence, the optimistic mood prevailed. The result was a surge of activity between the end of the war and the onset of slump two years later. Many new English production companies were set up and studios built, while established producers such as Cecil Hepworth expanded their studios and operations.⁷

The number of British-produced feature films spiked, with around 160 new films made between 1919 and 1920.⁸ Even so, film production was not an attractive investment and, as Rachael Low has described, there was still a chronic shortage of capital:

Much British production was conducted on a hand-to-mouth basis with an advance here and an advance there until the film was completed somehow. Capital increased gradually but it was argued that production companies in this country got, and indeed asked for, too little capital in the first place.⁹

Even if the necessary capital was found to complete production, a return on production costs would not be seen until the film was exhibited. Aspiring Scottish film producers were in an even more difficult situation, with no existing studios and no real history of production on which to build. Nevertheless, optimism extended

⁷ Low, *History of the British Film, 1918-1929*, pp 107-109. The most ambitious of the new studios was in fact built in 1919 by the American company Famous Players-Lasky, better known as Paramount, but its production programme failed and the studio was taken over in 1923 by the British company Gainsborough Pictures, headed by Michael Balcon. C Barr and A Kerzonkuf, *Hitchcock Lost and Found* (Lexington, 2015)

⁸ House of Lords Select Committee on Communications, 2010: *The British Film and Television Industries - decline or opportunity?* Fig 1: number of feature films produced in the UK, 1912-2008. www.publications.parliament.uk (accessed April 2015)

⁹ Low, *History of the British Film, 1918-1929*, p278

north of the border and a creative solution to lack of investment was found. The result was a two-year period which marked an unusual concentration of new production initiatives in Scotland.

Cinema Colleges

Establishments offering special training for cinema acting emerged during the war. The economically advantageous position of Hollywood films in the British market had continued to grow, creating an impact on the styles and genres of film-making that British audiences expected to see. British producers were coming to recognise that stage and screen acting were different disciplines, and that the wider audience was attracted by film stars rather than thespians. If Britain was to compete with Hollywood (or Europe), then it must have its own screen stars, and a cinema college was a low-risk and potentially profitable way of attracting raw talent. There was certainly no shortage of would-be film actors hoping for fame and fortune. Like cinema itself, cinema colleges attracted women and men from across the social divide; the most important criterion was the ability to pay. An article in the *Scottish Cinema* of December 1919 entitled 'The Lure of the Cinema' maintained that 'the waiting rooms of the cinema-training schools' were daily filled with film-struck people from high social circles who aspired to fame on the screen. One such upper-class cinema school recruit (described as 'big pots who want to act') was 17-year-old Flavia Forbes, daughter of Lady Angela Forbes and niece of the Duchess of Sutherland, who earned 15 shillings a day as 'one of the crowd'. Another, Miss Gwen Williams ('daughter of the late Surgeon-General Sir William Williams') had begun on the bottom of the ladder with pay of eight shillings and sixpence a day but was now playing leading parts.

'Well-known people invading the Cinema?' [said] Miss Leila Lewis, the vice-president of the Stoll Picture Theatre Club, 'The number of aspirants who call to see me averages from ten to fifteen a week. Many titled people are doing really good work on the films, but curiously enough producers rarely cast them for characters of similar social position. They play more humble parts in film productions'.¹⁰

¹⁰ *Scottish Cinema*, 29 December 1919, p8. The article was first published in the *Daily Mail*

One of the first enterprises to offer specialised courses of training for cinema acting was advertised in March 1915 by the London Film Company, which had been founded in 1913 and quickly became one of the most important British production companies.¹¹ Despite the company's success in the pre-war years, by 1915 it was experiencing sharp losses. The tutor was to be an experienced and respected director, Harold Shaw, an American who had begun his career in film as an actor with Edison in 1908 before graduating to directing and eventually moving to London, where he made several films for the London Film Company.¹² Shaw, described as the company's chief producer, would take 12 pupils for a course of 12 lessons for individual and group training at its Twickenham studios for the not inconsiderable fee of 50 guineas each.¹³ Pupils would be given 'every opportunity to witness, and to appear in, actual picture productions of the London Film Company' and after graduating would be given 'special consideration' (presumably for film roles) by Mr Shaw and the other producers. The advertisement made clear that Shaw would reject any applicants who seemed to him unsuited to cinema acting, and that he reserved the right to 'dismiss, after two or three lessons, any accepted member of the class if, in his opinion, it is not worth the pupil's while to go on with the work'. In this eventuality the pupil's tuition fees would be refunded.¹⁴ There is no evidence about the success or otherwise of this venture; what is certain is that Shaw's example was followed by many other film acting schools, some less principled and most less well-connected.

There do not appear to have been any other professional production companies offering comparable training opportunities. The film colleges that emerged during and soon after the war had a more tenuous connection with the industry, creating a model in which a production company was developed from the screen acting school,

¹¹ KW, 25 March 1915, p50; Low, *History of the British Film, 1906-1914*, p112

¹² Shaw's American films as director include a fantasy called *The Land Beyond the Sunset* (USA 1912). His British films include *The House of Temperley* (1913), adapted from the novel *Rodney Stone* by Arthur Conan Doyle, *Trilby* (1914) and *You* (1916), a propaganda film encouraging civilians to join the war effort. IMDB

¹³ The equivalent of around £5,300 in 2015. Historic inflation calculator, www.thisismoney.co.uk (accessed February 2015)

¹⁴ KW, 25 March 1915, p50

rather than vice versa. The Victoria Cinema College in London, also established in 1915, was one such venture. An early advertisement read:

CINEMA ACTING. All desiring to become cinema artistes should immediately write for free guide to the Victoria Cinema College, which discovers, trains, and uses talent in its own and other productions. Lessons in well-equipped studio. Correspondence courses for provincial students. Always vacancies. Write V.C.C., 47 Bedford Street, Strand, W.C.¹⁵

Despite its catch-all strategy, this college was a genuine enterprise that took pride in being the only respectable cinema school in London. Its manager was Edward Godal, whose background included writing sketches for the variety theatre. After the war Godal became head of the British & Colonial Kinematograph Company, and had a successful career in independent film production until the coming of sound.¹⁶

In 1916 the Victoria Cinema College moved to new premises in Rathbone Place off Oxford Street. A brochure dating from this period offers a more detailed description of its activities, which included group classes at different levels of advancement, private lessons and special tuition for children, as well as training in scenario writing and film projection. All these classes involved practical experience in the College's 'well equipped' studio'. Other sections covered 'The Art that Pays'; 'How to Become a Film Artist'; 'What the Press Advises'; 'How the Victoria Cinema College can Help You' and 'Pit-falls for Cinema Aspirants'. The list of companies which, according to the prospectus, students 'have been employed by, and are now on the books of' included Hepworth, Turner, Samuelsons, Ideal, Barkers, Neptune, B&C, Clarendon and Cricks - indeed, all the major producers of the time. Presumably the trainees were a ready source of film extras, although whether any of them went on to have a career in the film industry is unknown. One of the many glowing testimonials from film producers and former students reproduced in the brochure came from a retired Major, who wrote that since graduating he had been engaged by the Windsor Film Co and Samuelson's, adding that 'the Gaumont Film Co have kept a part for me

¹⁵ *Whitstable Times*, 1 May 1915, p5

¹⁶ See C O'Rourke, *London Filmland*, www.londonfilmland.wordpress.com, November 15, 2012 for an account of the formation of the Victoria Film College, Godal's career and the low status of so-called film schools (accessed February 2015); Low, *History of the British Film, 1918-1929*, pp198-199

in their forthcoming production'. The fact that a copy of the brochure is held by the NLS Moving Image Archive suggests that someone - possibly those who established the first cinema college in Scotland, discussed below, had sent for it when making their own plans for a similar establishment.¹⁷

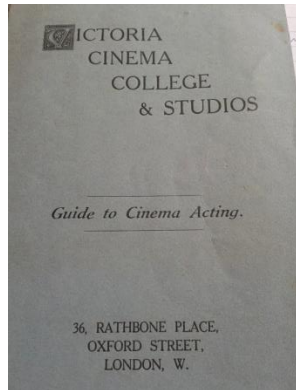

Figure 6: Brochure for the Victoria Cinema College, London. NLS/MIA, 4/5/52

This well-known and evidently successful business set the standard for the cinema colleges which sprang up in Britain's major cities.¹⁸ One of these, the A1 Cinema College in Birmingham, began inviting anyone wishing to 'become a cinema star' to send for a prospectus in October 1917 and opened for business two months later. Although it styled itself as a 'cinema college and studio' along the lines of the Victoria Cinema College, the A1 was in reality a part-time operation and lacked a dedicated film studio; classes took place on Friday afternoons at the Arcadia Hall in White Street, while the company's office was in Broad Street in the city centre. Its main selling point, like other such outfits, was the high pay that screen actors could enjoy when trained.¹⁹

¹⁷ NLS/MIA, 4/5/52, *The Victoria Cinema College and Studios, London, Guide to Cinema Acting*. A compliments slip inside the brochure is dated 24 November 1916; it may have been the property of Max Leder, the future founder of the A1 Cinema College in Glasgow

¹⁸ The Victoria Cinema College was formally dissolved in 1931 but appears to have ceased operations in the late 1920s after Edward Godal left to form his own production company

¹⁹ *Birmingham Daily Mail*, 27 October 1917, p5; *Birmingham Daily Post*, 12 February 1918, p5

The A1 was the brainchild of a Swiss national, Eugene Max Leder.²⁰ Trying to emulate the evident success of the Victoria Cinema College, he also established a production company alongside the college in order to make films featuring its students, who were promised the chance of being ‘filmed when proficient’.²¹ The Midland Actors’ Film Producing Company was incorporated in 1918 but although ‘a drama, including local talent’ was announced as forthcoming in July 1918, it has not proved possible to discover any details of this production.²² By December the company had abandoned immediate film-making plans, with ‘successful’ students (those who passed an exam) instead being offered a recommendation to ‘other first-class picture producers’. The screen acting exam was conducted by Leder’s business partner Mr Ingram, the secretary of the Midland Actors’ Film Producing Company. A *Coventry Standard* journalist, invited to view the proceedings, described it as ‘inclined to severity’, but not beyond the limits of the actors who ‘were quite prepared and took their respective parts with complete confidence... Great credit is due to Mr Seder, [sic] the principal trainer, for the able way in which he handles his students, quickly discovering the latent possibilities of each one, and in a very short time turning them from amateur actors to proficient cinema artistes’.²³

Whether any A1/Midland Actors’ production made it to the big screen is unknown.²⁴ What is known, however, is that Leder had a talent for publicity, and that the fame of at least one of the Birmingham college’s students extended well beyond the West Midlands. In March 1919 a Fife newspaper ran a story about a 15-year-old ‘runaway girl’ called Janet Fowler who had made her way (unknown to her parents) all the way from her home in Kelty, Fife, to Birmingham in an attempt to follow in the footsteps of ‘the Birmingham girl Vera Barnes who, after a course of instruction at a cinema school in that city, secured a position as a screen star at a salary of over £1000 a year’. On reaching Birmingham, Janet spent the night in a hotel and the next day travelled by bus to the Barnes family home in Cradley Heath, where she met Vera Barnes and got a letter of introduction from her mother to ‘Mr E M Leder, the

²⁰ Usually referred to as Max Leder or E M Leder

²¹ *Birmingham Daily Mail*, 3 June 1918, p1

²² *Coventry Evening Telegraph*, 16 July 1918, p4

²³ *Coventry Standard*, 13 December 1918, p6

²⁴ TNA, BT 31/24187/151490, Midland Actors Film Producing Company Ltd

manager of the A1 Cinema College, where Vera was trained'. The report suggests that Vera Barnes was a child or teenage actor, and although there are no available records of any films in which she appeared, her name and impending stardom were evidently well-publicised at the time. Janet did get to meet Leder, who according to the report 'was very sympathetic, but realising the position of a young girl alone in a strange city, and far away from home, deemed it advisable to telephone to the detective office and wire her parents'. According to Janet herself, 'Mr Leder asked me if I had had any previous stage or cinema experience. I said no. He then took two photographs of me and telegraphed home to my parents. Later the women police took me to a Ladies Home, where I remained until father arrived'.²⁵

The A1 Cinema College in Glasgow

Publicity from the runaway girl story helped to promote Leder's enterprise beyond the West Midlands.²⁶ It may also have influenced his decision to relocate the A1 Cinema College to Glasgow later that year: if one young Scottish girl was so desperate to train for screen stardom that she was prepared to travel hundreds of miles to England to pursue her dream, this surely indicated the lack of (and a demand for) a cinema college closer to home. On the other hand, the reason for the move to Scotland may simply have resulted from the failure of the Birmingham business and the lack of funding behind the Midland Actors' Film Producing Company. Max Leder, like Maurice Sandground - another itinerant and opportunistic 'outsider' who followed him - recognised the potential for film production in Scotland's largest city and a gap in the market apparently waiting to be filled.²⁷ The widespread popularity of Scottish stories on screen, together with the Scots' love of cinema-going would also have made Scotland, and Glasgow in particular, appear an ideal location from which to operate. Neither man was deterred by a lack of capital: what they both, in their different ways, identified was a strategy for producing such films cheaply and at relatively low risk to themselves, while gaining credit for re-stimulating the Scottish film industry.

²⁵ *Sunday Post*, 13 March 1919, p5

²⁶ The story might well have been exaggerated or even involve an element of hoax, with the 'runaway girl' being assisted in her mission to gain an introduction to Vera Barnes' tutor

²⁷ See chapter 5 for an account of Maurice Sandground's career

Leder must have been aware of earlier attempts by Scottish companies such as Green's to develop a permanent base for the production of feature films, and the reasons for their failure. While he appears to have been over-optimistic about his chance of success, his strategy was significantly different from those of his predecessors: the cinema college would provide a source of income and, when money was found for production, a pool of unpaid talent. He had no competition either in terms of Glasgow production companies or of a similar cinema college attempting feature film production. Besides this, he was young, ambitious and an incomer who had no connection with the close-knit world of the Scottish cinema trade. He, and others, believed that the cinema college/production company model which led from amateur to low-budget professional production was a viable one. There was a series of such ventures in the period between 1919 and 1922, and Leder was involved in most of them.

What brought Leder to Britain from Switzerland is unclear. He is sometimes referred to as 'Mr E M Leder', and it is likely that he was person of that name whose naturalisation documents are held by the National Archives. This E M Leder was born in 1894, making him 25 in 1919.²⁸ By the time he arrived in Glasgow and began advertising for students, at least one other Scottish cinema college was already up and running. In September 1917 the Dunedin Film Company of 8 North Bridge, Edinburgh, was seeking 'cinema authors' via a classified advertisement in the *Scotsman*, and a month later, now calling itself the Dunedin Film Agency, announced that classes in cinema acting for ladies and gents would begin the following week.²⁹ The college must have thrived, or at least survived until well after the war ended: in April 1919 the *Entertainer and Scottish Kinema Record* reported that 'good business' was being done by the (re-named) Edinburgh Cinema College and that its proprietors Mr Lea and Mr Dudley had produced a film in which Portobello promenade was

²⁸ TNA, HO 405/34027: *Nationality and Naturalisation: Leder, E M. Date of birth 15/10/1894.* (Record closed until 1 January 2055)

²⁹ *Scotsman*, 8 September 1917 p3; 20 October 1917, p3

featured.³⁰ Their publicity typically appealed to ordinary working people with dreams of a more glamorous life. One such advertisement read:

CINEMA ACTING - WANTED BEGINNERS. Mary Pickford earns £4000 per week, Charlie Chaplin earns £250,000 per year. What do you earn? We want British talent for our new production. Have you got it? If you think so, let us train you. If proficient we put our students in a film.³¹

While actually promising nothing, the advertisement implied that the college had all the resources and facilities for star-making. This was of course far from the truth: the Edinburgh Cinema College had no studio, and the Portobello film (if it was completed) was never exhibited in public. Its purpose was supposedly to enable students to evaluate their own screen acting performances. But at least students were given the opportunity of performing for the camera and there was some connection, however tenuous, with film production. This was not the case with another Edinburgh establishment. The Cinema Artistes' Academy opened at 24 Shandwick Place in the West End of the city in November 1919, apparently offering training solely in screen acting methods. An article in the *Scottish Cinema* by 'Young Reekie' revealed that this business was backed by a syndicate of Edinburgh businessmen who recognised a growing demand from the 'many people who wish to be initiated into the art of the screen'. Noting that this idea had 'distinctly caught on,' he continued:

A public performance by first term pupils which was given at the studio the other evening disclosed some excellent amateur film talent and reflected great credit on the instructor Mr A B Harley, who has got the scheme into such strong stride in such a short time. The studies in expression by the ladies and gentlemen who are taking the tuition were remarkably good.³²

The 'striking little wordless scenes' performed by the student actors were written by Gordon Comrie, a former Edinburgh journalist recently returned from the war, 'who was in East Africa in khaki'. In another issue, the *Scottish Cinema* described the Cinema Artistes' Academy as a 'fully-fledged Cinema star factory', optimistically

³⁰ *Entertainer*, 19 April 1919, p9. This trade paper changed its name to *The Scottish Kinema Record* (hereafter *SKR*) in May 1920

³¹ *Scotsman*, 4 October 1919, p5

³² *Scottish Cinema*, 15 December 1919, p8

suggesting that its presence could mark the beginning of feature film production in Edinburgh:

From these small beginnings one never knows what may spring.
Look at the A1 Cinema College, Glasgow, for instance.
Founded in June, I think, and on the screen with a five-reel
drama in November! When may we expect Edinburgh's
"Waverley" or "Heart of Midlothian?"³³

The idea of getting students to pay for tuition in cinema acting skills was a simple and cheap way of buying in to the cinema boom without involving any investment in production. In this instance, cinema acting appears to have been interpreted as mime, although in many silent films the actors spoke lines.³⁴ Another cinema college that opened in Edinburgh the following year may have adopted a similar approach. The Competent Film Company and Cinema College at 15 Stafford Street ('open six days a week') simply advertised itself by saying 'Shall Us? Let's become a cinema actor' and despite its name did not publicise any production activity.³⁵ It seems that Edinburgh was fated, despite the *Scottish Cinema's* hopes, to remain on the margins of the film industry. Training actors was one thing; finding the resources, facilities and technical expertise to make a film with these actors quite another.

Max Leder was more ambitious than those behind the Edinburgh cinema colleges; his aspirations in Glasgow, as they had been in Birmingham, were not just to open a 'respectable' cinema college with a studio, but also to produce commercial films that would be seen in cinemas. He acquired a new business partner, Thomas Keir Murray, and in April 1919 an advertisement in the *Scotsman* announced that 'Gentlemen with sound knowledge of film production and financial backing would like to invest additional Scottish capital in a proposed Scottish Film Producing Co'.³⁶ Assuming that these gentlemen were Leder and Murray, the intention seems to have been to form a production company alongside the cinema college from the outset, but the need for financial backing delayed the process for several months. In the meantime,

³³ *Scottish Cinema*, 24 November 1919, p4

³⁴ See, for example, the actor James Beirne's testimony in the James Howie Milligan v The Broadway Cinema Productions court case (NRS, CS/1923/7/28), discussed in more detail below

³⁵ *Scotsman*, 19 February 1920, p1

³⁶ *Scotsman*, 2 April 1919, p8

Leder set up the new A1 Cinema College in temporary premises at St Andrew's Hall in the Charing Cross area of Glasgow, which opened on 21 June 1919. It was a part-time venture, with classes taking place on Tuesdays and Thursdays and, according to his own later account, there were just four pupils.

A few days later Mr Murray joined in. Their total equipment at the time consisted of two small lamps, a table, and two chairs.³⁷

Within weeks the pair had found new full-time premises for the college at 171 Renfield Street and set about the business of producing a feature film in which their local 'discoveries' could display their talent. By this time advertising was so successful that the college had managed to attract almost 200 pupils. The college's letterhead described Murray and Leder as cinema film producers rather than film acting tutors, and the college itself, whose slogan was 'To discover talent and use it', as 'the only institute and producing firm of its kind in Scotland'.³⁸ Throughout August a series of advertisements and notices for the A1 Cinema College appeared in the *Entertainer*; most made reference to plans for forthcoming productions including a stunt film as its 'first outdoor picture'. By the end of the month the college was advertising for leads for the 'second all-Scottish production' - that is, *The Harp King*.³⁹

In September 1919 the *Scottish Cinema* promised that, 'when circumstances were more favourable' it would have something interesting to say 'regarding the ramifications' of the A1 Cinema College and Studio. Meanwhile it provided readers with some information about the two principals of the college. Leder was described as the 'former managing director of the Midland Actors' Film Producing Company', who enjoyed a 'high reputation as a teacher of cinema acting and discoveries of talent'. His co-principal Mr T K Murray, the 'son of the founder of the indispensable Murray's Time Tables'⁴⁰ was said to have had 'a quite remarkable experience of cinema acting out West, having been associated for some time with the famous G M

³⁷ *Scottish Cinema*, 20 October 1919, p23

³⁸ NLS/MIA 4/5/101, contract between the A1 Cinema College and Miss E A Wilkie, 9 September 1919

³⁹ *SKR*, 1919: 9 August, p11; 16 August, p3; 23 August, p5; 30 August, p9

⁴⁰ *Murray's timetable for trains, steamers and coaches throughout Scotland, Ireland and the North of England* was published annually between 1843 and 1966

Anderson, better known as Broncho Billy'. The writer went on to note that Broncho Billy's 'stunts in Glasgow have already caused a sensation and there are more to follow'.⁴¹

Murray, whose stunt acting experiences in the USA had taken place before the war, liked to describe himself as an old hand in the cinema business. During the war he was a captain in the Machine Gun Cavalry Corps who 'took part in General Allenby's historic march to Damascus in the course of the Palestine campaign'.⁴² There are no records of films in which he appeared, with or without Broncho Billy Anderson, but there is no reason to suppose that he was inventing this story; he could well have been a film extra. By 1919 Broncho Billy Anderson's film acting career was over and he was working, briefly, as a producer of short films with Stan Laurel. It was during this period that he evidently performed his sensational stunts in Glasgow, possibly thanks to his connection with Murray.

The Harp King

The 'ramifications' mentioned above by the *Scottish Cinema* were concerned with *The Harp King*, (and the opening of the film studio at Thornliebank) which received its trade show in November 1919 - just five months after the college opened. The publicity campaign surrounding the film was as skilful and professional as if it were a major Hollywood production. In September it was reported that 'Mr Leader [sic] informs us that he has taken nearly 2000 feet of film during the past three days... The fact that the Company have procured a fine open-air location has greatly facilitated the work'.⁴³ Leder let it be known that he had made a new acting 'discovery' in Glasgow - 'a young lady without means or education, but possessing much natural talent who promises to become a Scottish Mary Pickford'.⁴⁴ This was Elizabeth (known as Nan) Wilkie of Pollokshields, who played the part of Cynthia, the film's heroine. Described as a native of Perth who had worked at the Erskine Hospital for the Limbless during the war, Wilkie had been a keen amateur actor as a child and, 'when the cinema came into being... resolved to go into film acting'. The

⁴¹ *Scottish Cinema*, 22 September 1919, p8

⁴² 'Scottish Film Thrills', *The People's Journal*, 20 March 1920 [page number obscured]

⁴³ NLS/MIA/4/5/101, cutting from *Daily Record and Mail*, 24 September 1919

⁴⁴ *Scottish Cinema*, 22 September 1919, p8

A1 Cinema College presented her with this opportunity but, after making the film and marrying her co-star David Watt, a former Royal Flying Corps officer, she seems to have lost her aspiration to film stardom. She was paid £10 for her role in *The Harp King* and, it would appear, this was the only money she would earn from cinema acting.⁴⁵

The ‘Scottish romance’ *The Harp King* was written by a well-known member of the Glasgow film trade, the renter and distributor Jack Baker, also known as J C Baker. Set in the Highlands of Scotland, it was a rambling romantic tale of a farmer (played by David Watt) in love with the laird’s daughter (Nan Wilkie) who uncovers a plot by an impostor (J C Baker) to cheat her father (W R Bell) out of his estate. The farmer saves the laird’s life and wins the hand of the daughter through his skill in playing the harp. At 5000 feet it had a running time of around one hour and fifteen minutes; a full-length feature advertised as being ‘in five parts’.⁴⁶ It was ambitious and also foolhardy for Leder and Murray to produce a first film of such length, and to allow one person to have so much control over it. Perhaps they believed that Baker’s influence in the Glasgow trade was sufficient to ensure the film’s success, and they may well have secured his services as distributor free of charge.

As early as 1914 Baker was described as a ‘film expert’ while a member of the judging panel for a film acting competition mounted at the Kinematograph Exhibition in Glasgow; fellow judges included J J Bennell and John Clyde.⁴⁷ He appears to have been associated with a producer of non-fiction films, the Scottish Artistic Film Producing Company, which made four Scottish scenics in 1915 but was dissolved a year later.⁴⁸ By the time the A1 Cinema College opened its doors in 1919 he was running a cinema supplies business known as The House of Baker at 130 Renfield Street which offered a complete service to exhibitors, including slides, projector repairs, tip-up chairs and even floral decorations. But Baker’s ambitions

⁴⁵ NLS/MIA 4/5/101: contract between the A1 Cinema College and Studio and Miss E A Wilkie, 9 September 1919

⁴⁶ A ‘part’ meant a single 1000’ reel of film

⁴⁷ SKR, 17 January 1914, p11

⁴⁸ KYB 1917, p356: the address for the Scottish Artistic Film Producing Company of 95 Renfield Street, Glasgow, is the same as that given for Jack Baker, listed as a ‘Scottish renter’

extended beyond the more workaday aspects of the film trade, as not only did he write the screenplay for *The Harp King*, edit it and subsequently distribute the film, but he also played one of the leading roles. This appears to be the only time his creative talents were given an outlet: when Leder and Murray formed the Ace Film Producing Co they were joined by a screenwriter called James Husband Smith. This is hardly surprising, as reviewers criticised Baker's story as 'lacking cohesion and with a thin plot' and his acting as the impostor Stephen Graham as 'just a little stiff in certain scenes'.⁴⁹ It seems likely that the prominent part Baker was allowed to play in the creation of *The Harp King* was in return for his many connections within the trade.

The Harp King was eagerly awaited by the Scottish cinema trade and the press, whose hopes for a real Scottish success were fuelled by the regular titbits of information they were fed by the producers. The fact that it was the product of a cinema college did not dampen enthusiasm for the new venture, even when a scandal broke surrounding other film training establishments. In November 1919 the *Scottish Cinema* reported that 'action is likely to be taken in London to protect silly young girls - and others - against the allurements of certain alleged bogus Cinema schools which are springing up on the other side of the border', the writer adding that 'I am happy to state that there is nothing bogus about Glasgow's enterprise in this direction, as "The Harp King" will prove. It (the College) is A1. As in name, so in nature'.⁵⁰ At the beginning of October Leder and Murray announced that their new company, the Ace Film Producing Co, had secured its own studio and was completing filming of *The Harp King* there. As the production company was not registered until 28 February 1920, this was an informal title and statement of intent.⁵¹ The studio, located in the disused Queen Mary Tea Gardens at Thornliebank, to the west of Glasgow, was set in grounds leased to the new company by the Paisley and

⁴⁹ *SKR*, 22 November 1919, p9; NLS/MIA, 4/5/33, cutting from *KW*, 25 November 1919

⁵⁰ *Scottish Cinema*, 15 November 1919, p4

⁵¹ NRS, BT2/11004/2, Memorandum of Association, Ace Film Producing Co Ltd

District Tramways Company.⁵² Despite being called an ‘open air studio’, certain parts of it must have been covered.

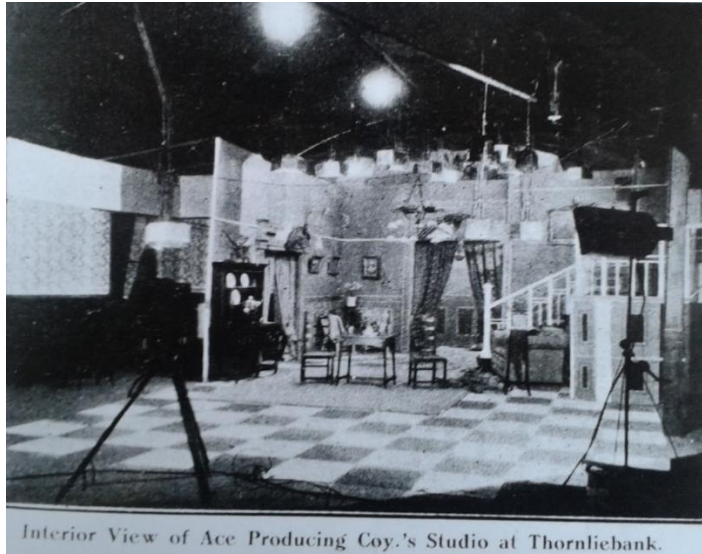

Figure 7: Studio set for *The Harp King*. NLS/MIA, 4/5/48, copy of illustration taken from the *Entertainer*, 22 November 1919

There has been some confusion in previous accounts of Scottish film production about the presence of a film studio at Thornliebank/Rouken Glen, including the suggestion that that *Rob Roy* was filmed there in 1911 and/or a film of the same title in 1922.⁵³ Although this was not the case, it is possible that some kind of basic studio was constructed there before the war by the Glasgow film distributor and would-be producer Prince Bendon. According to an article looking back on Bendon’s career some thirty years later:

[Bendon] was accustomed to taking news reels and later tried an industrial film for Peacemaker Whisky. But he wanted something more ambitious, so he took over a tea-room at Rouken Glen, converting it into a studio. Two films were

⁵² Thornliebank was part of the privately owned Rouken Glen estate, which had opened to the public in 1906 and became a popular destination for day-trippers from Glasgow. Before the war the Queen Mary Tea Garden had its own bandstand, nursery and a large pond exhibiting model historic ships. ‘Rouken Glen: a history in pictures’, <https://personal.cis.strath.ac.uk/d.mcmenemy/website/history01.htm> (accessed February 2014)

⁵³ See Chapter 1

produced but they were not a success. Inferior premises, equipment and lighting cannot produce first-class films.⁵⁴

An October 1919 report on the Ace Film Company's new studio was entitled 'Scotland's first cinema studio' and made no reference to Bendon's previous tenure. It did state, however, that except for the lighting in the studio 'all the work of *reconstructing* [emphasis added] and fitting the studio was accomplished by the principals and students of the A1 Cinema College without any professional assistance whatever'. This 'workmanlike' set-up in the old tea-room had 'all the necessary adjuncts, such as dressing-rooms for ladies and gentlemen, special rooms for the "stars", store-room, carpenters' shop, joining-up room, fire-proof chambers for storing films, private and general offices, electricity control chamber, etc'.⁵⁵ The students must have been extremely hard workers as all this was accomplished in just 12 days. The article did not mention Green's production facilities in Glasgow, perhaps because they were now used only for the production of topicals.

By the time the studio was ready most of *The Harp King* had already been filmed in a 'fine open-air location' somewhere in the west of Scotland. Although a more remote setting was implied, it transpired that shooting took place in the Rouken Glen area which offered 'excellent views of Bearsden'.⁵⁶ The film was produced on the lowest possible budget: this extended to the camera work, which Leder carried out himself. The final reel of *The Harp King* was shot in the studio, which was 'fitted up as an entrance hall'. Far from being charlatans who sat back and took money from gullible students, Leder and Murray were dedicated and hardworking: throughout production of *The Harp King* and construction of the studio new students were still being taken on at the A1 Cinema College. The problem was their inclination to run before they could walk, behaving as if they were experienced professionals ready to compete in the national market. No expense was spared when it came to publicising the production, including a press and cinema trade junket which began with a high tea at the Carlton Restaurant in Glasgow and proceeded to Thornliebank to view the

⁵⁴ Cloy and McBain, 'Scotland in Silent Cinema', p8; T A Blake, 'Prince Bendon', *Educational Film Bulletin*, September 1946, pp31-32

⁵⁵ *Scottish Cinema*, 20 October 1919, p23

⁵⁶ NLS/MIA, 4/5/33, cuttings from *Daily Record and Mail*, 24 September 1919; *Weekly News*, 11 October 1919. See also *Scottish Cinema*, 24 November 1919, p9; *ibid*, p24

new studio. After the tour the visitors were treated to ‘an enjoyable social evening’ with speeches, toasts and dancing ‘on the excellent floor of the studio’ which went on until 10.30pm.⁵⁷

The much-anticipated trade show took place on 17 November; with 500 people present, it was said to be one of the best-attended trade shows Glasgow had ever known. *The Harp King* was now announced as ‘The First All Scottish Production’, having been ‘Written in Scotland, Played in Scotland and Filmed in Scotland’. Memories were short as *Rob Roy* had been made only eight years earlier with an almost identical set of selling points but not, of course, in a studio. It is more likely that the implied comparison was with the popular 1914 film *The Shepherd Lassie of Argyle*, filmed in Scotland but whose other credentials were essentially non-Scottish. Advertisements exhorted exhibitors to book the film and ‘adorn his screen with the “kilts”’.⁵⁸

When, inevitably, *The Harp King* failed to live up to hopes, reviews were charitable - even in the non-Scottish *Kinematograph Weekly*. While the screenplay was roundly criticised the actors were praised for making the most of their parts, ‘some of which are difficult’. Leder’s camerawork got mixed reviews: *Kinematograph Weekly* thought the interior photography was ‘disappointing’ but that ‘photographs of some of the exteriors are exceptionally well done’.⁵⁹ Reviewers focused on two aspects of the production: the fact that it was played entirely by amateurs, and that it was ‘the first all-Scottish film’. This was of course inaccurate, but it demonstrates the producers’ powers of persuasion and the eagerness with which the trade greeted any film that appealed to local patriotism. Given the reviews, it is hardly surprising that an anticipated ‘scramble for the first all-Scottish film’ did not take place.

Not everyone was happy, however: there was some debate in the *Scottish Cinema* about what qualities could be said to constitute an all-Scottish production. It was a matter of national pride that Scotland should have its own film studio, but how was this to be defined? An editorial in the *Scottish Cinema* remarking on the ‘exception

⁵⁷ *Scottish Cinema*, 30 October 1919, p23

⁵⁸ *Scottish Cinema*, 30 October 1919, p23

⁵⁹ NLS/MIA, 4/5/33, cutting from *KW*, 25 December 1919

that had been taken' to the cinema [sic] studio at Thornliebank being described as the first in Scotland took the view that the term was synonymous with feature-film production:

I have no desire whatever to belittle the efforts of others, both past and present, all of which are well known to me; but I do not think that those interested in these efforts, or any other intelligent member of the Trade, will seriously contest the claim - the very obvious claim - made on behalf of the Thornliebank Studio. It may be unfortunate that there is not yet a word, unless one introduce the adjectival "dramatic", to distinguish between one kind of studio and another; but when one knows that a Scottish drama is being produced in Scotland by an all-Scottish company, I think it is quite unnecessary to say more to justify the claim that, in the true broad sense of the word, the studio at Thornliebank is the first in Scotland.⁶⁰

Together with the quotation at the top of this chapter, which is taken from the same editorial, this comment demonstrates how strongly some in the trade felt about the significance of *The Harp King* to Scotland, despite its deficiencies. It fulfilled all the criteria for a completely and unarguably Scottish film; 'a drama written, produced, photographed, developed and distributed in Scotland, for the universal market, without any restriction or qualification'.⁶¹ The few previous Scottish fiction film productions had each lacked some of these qualities; *Rob Roy* was 'promoted by an English company'; *The Shepherd Lassie of Argyle* (received by many as a truly Scottish film) fulfilled hardly any of the criteria, and the 'half-boiled comedies' were never intended for a universal market. The Thornliebank studio was significant because it enabled the production of dramas as opposed to news films and documentaries - already catered for by the well-equipped studios of Greens - and symbolised Scotland's potential to develop its own film industry.

After playing at the Cinema House in Renfield Street for just three days (rather than the previously announced six) in December 1919, *The Harp King* had no further outings in Glasgow. Early the next month it was said to be doing good business at small houses including the Electric Theatre at Dalmellington, near Ayr, where large

⁶⁰ *Scottish Cinema*, 3 November 1919, p4

⁶¹ *Ibid*

attendances were reported. The furthest the film travelled was Dundee, where advance publicity for two days of screenings at the Victoria Theatre noted that ‘the fact that the story was written and played in Scotland ensures its success’. As was often the case, this was a wild exaggeration - but there was little else to say about a film that lacked any of the usual selling points such as stars, an identifiable genre or a well-known story. At the Victoria Theatre *The Harp King* was screened in a programme that included the first episode of a new Vitagraph serial called *The Iron Test* and was followed later in the week by *Heading South* starring Douglas Fairbanks, both American productions with more obvious audience appeal than this ill-defined ‘Scottish romance’.⁶² After the trade show one reviewer had judged that *The Harp King* was ‘not exactly a typically Scotch story’ despite the scenery, Highland dances and harvest scenes, all of which imparted ‘a real Scottish atmosphere’, and this may also have blighted its chances with exhibitors.⁶³ If for no other reason, the story behind *The Harp King* is important for the way it illustrates the cinema trade’s struggle to associate the concept of ‘Scottishness’ with a film’s provenance.

The week before *The Harp King*’s trade show Leder was said to be in London ‘making certain arrangements with Gaumont’s in connection with the first all-Scottish production’.⁶⁴ He and Murray must surely have realised by this time that their first production was an over-ambitious flop, but with a studio built and a production company established they were not giving up. The Ace Film Producing Co was registered on 28 February 1920, by which time they had been joined by another business partner, Frederick Amacher. Articles of association described Leder as a film producer, Murray as a film actor and Amacher as an assistant film producer. There were four other shareholders: Allan Cooper, the company secretary; James Husband Smith, scenario writer; Andrew Goudie Murray, publisher, and Arnold Thompson, property manager. All were residents of Glasgow. The company’s capital was £10,000 divided into 8000 £1 shares and 8000 deferred shares of five shillings each. It would appear that this company represented an amalgamation of the Cinema

⁶² *Evening Telegraph*, Dundee, 6 January 1920, p6

⁶³ *Scottish Cinema*, 24 November 1919, p24

⁶⁴ *Scottish Cinema*, 10 November 1919, p31

College with the producing business, as Leder was named as the ‘former proprietor of the A1 Cinema College’ and one of the purposes of the company (also registered at 171 Renfield Street, Glasgow) was ‘to carry on business as instructors in cinema acting, photographers and producers of cinematograph plays’.⁶⁵

Always in Trouble

Production was resumed on the previously-announced stunt film, a two-reel comedy called *Always in Trouble*. In March 1920 the Aberdeen edition of the *People’s Journal* published an interview with Murray in which he stated that the film was almost complete and would be ‘on the market in a very short time’, adding that ‘it will, I believe, be an instant success’. It was very different in terms of genre and length from *The Harp King* and perhaps more in tune with audience taste, although the actors were again local amateurs trained at the Cinema College. Murray starred in it himself alongside novice actress Jean MacDonald of Glasgow, whose role seems to have involved considerable personal danger. In one scene described by Murray she was flung from the sidecar of a motorcycle and fell over a precipice:

From her perilous position she is rescued by your humble [sic]. I hang on a ledge of a cliff, 20 feet from the surface, and 25 feet from the bottom, in order to effect the rescue. During this episode Miss MacDonald was actually rendered unconscious. There was no make believe about it.

Another scene involved Murray jumping from Jamaica Bridge into the River Clyde and rescuing her from drowning:

I take the dive, swim to the drowning maiden, [and] lift her into a boat, which, happily, arrives on the scene. Then we row to the bank, where the end of the steam crane chain is seized, and the girl and I are hauled up, swung around, and dumped down on terra firma.

Always in Trouble was a vehicle for Murray’s stunt acting skills. While there is no record of the film being completed or exhibited, it is evident from the interview that the company had made some not unrealistic short and longer-term plans. If this film was a success, they intended to produce a ‘serial stunt film picture’. Murray also

⁶⁵ NRS, BT2/11004/2, Ace Film Producing Co, Ltd, Memorandum and Articles of Association

claimed that an order for a series of comedy films had just been received from an English firm, 'who export these productions'.

We propose filming Scottish subjects and scenes as far as possible. In America and Canada there is a great demand for these at the moment. Scottish themes, like 'Bonnie Mary o' Argyll' and 'Annie Laurie' are being produced by artistes who have never set foot in Scotland, so you can judge how hard-up they are. One of our projects is to produce a Robert Burns drama, the scenes of which we propose to lay in the poet's own country.⁶⁶

These plans never came to fruition; *Always in Trouble* could not have been cheap to make and funding may have run out before its completion. By June the Ace Film Producing Co was in trouble. Leder and Murray resigned from the board and control passed to Arthur Reid, a Glasgow property agent. No further production activity was attempted, and the company was liquidated on 30 December 1921. After *Always in Trouble* it appears that Leder and Murray parted company, with Leder still convinced that the cinema college/production company model was viable. Meanwhile, Arthur Reid negotiated the rental of the Thornliebank studio to a new company which also developed from a film acting school, the Broadway Stage and Cinema Company, and later became chairman of that company.⁶⁷

There was undoubtedly a demand for 'real Scottish stories': the problem was that nobody seemed to know precisely what these were. What did Scottish cinemagoers actually want to see, and what kind of Scotland should be represented on screen? The writer of a satirical article in the *Scottish Cinema* described what a 'Glasgow life film' might look like. It would be a novelty, he argued, for cinema-goers satiated with 'plots in which the characters appeared in patrician surroundings of vast wealth and swooped around in motor-cars' to see a film representing real Glasgow life, in which 'the action represented Glasgow life as flat-dwellers are compelled to live it, a nice suburban film, having for its scene say Dennistoun, Mount Florida, or Ibrox'. The heroine would be 'a dutiful daughter, going round to the butcher's for the day's

⁶⁶ *The People's Journal*, Aberdeen, 20 March 1920, p6

⁶⁷ NRS, CS46/1923/7/28, Proof, evidence of R D Laurie, p65

dinner with her hair in curlers under a dust cap’ and the hero ‘would appear running for a tramcar, just as you or I might’. The article concluded:

The question is, would a Glasgow audience, after all, like to see a film displaying romance in a tenement? Or do we prefer when we go to the pictures to see romance in the Cannibal Islands, High Society, or some region equally remote?⁶⁸

Unknowingly, the writer had his finger on the pulse: local audiences were indeed ready for films that represented aspects of their own lives on screen. Although Leder’s subsequent productions were far from successful, he had learned from the mistakes of *The Harp King*. There were no more lengthy, serious ‘Scottish romances’; instead, he recognised a market for short comedy films that would appeal to an urban audience. In November 1920 the *Scottish Kinema Record* published a large advertisement for his new production, *The Referee’s Eye*, billed as a ‘Glasgow’ comedy and described as ‘a most laughable story of a football, a pudding, and an amateur detective’. Production was ‘by Max Leder with an “All Glasgow” cast’, suggesting that the actors were former cinema college students; there is no mention of any production company. This low-budget production was advertised throughout Glasgow ‘by the distribution of 10,000 small tickets’. Its distributor was J C Baker who, despite his contribution to the failure of *The Harp King*, had evidently maintained good relations with Leder. The following week’s *SKR* claimed that Baker had received ‘numerous enquiries regarding *The Referee’s Eye*’ but despite this there is no evidence of any screenings. It may have been shown in some houses as part of a programme without receiving individual billing.⁶⁹ A (possible) later reference to *The Referee’s Eye* described it as a football film ‘of a very poor kind’ which compared most unfavourably with *Football Daft*.⁷⁰

The Broadway Stage and Cinema Co

Leder was not alone in believing that there was a future in such productions using local, trainee actors, and that the way forward lay in shorter, more entertaining films

⁶⁸ *Scottish Cinema*, 29 December 1919, p18

⁶⁹ *SKR*, 13 November 1920 p; 20 November 1920, p5

⁷⁰ NRS CS46/1923/7/28: James H Milligan v The Broadway Cinema Productions, Ltd, evidence of J M Kissett, p80

of 'Glasgow life'. The important difference between these Glasgow (and later Dundee) enterprises and their English counterparts was that the acting school or cinema college was seen as a launching pad and source of revenue for film production, rather than as an end in itself. When the production side of the business was underway, classes could cease. This strategy is particularly well demonstrated by another enterprise, the Broadway Stage and Cinema Company, incorporated the same week that *The Harp King* received its much-trumpeted trade show. Leder also worked for a time for this company as a film acting instructor. Thanks to a legal case involving a dispute over copyright in the screenplay of its first film, *Football Daft*, which went before the courts in December 1922, more extensive and revealing documentary evidence is available for the Broadway Company than any other Scottish production company in this period.

The Broadway Stage and Cinema Co Ltd was incorporated in November 1919 with a modest nominal capital of £4000 divided into 4000 shares of £1 each. Its headquarters were in West Nile Street, Glasgow.⁷¹ Whereas Leder and Murray had plunged head first into film production at the same time as opening the A1 Cinema College, relying on amateur talent for acting and technical roles alike, the strategy adopted by the founders of the Broadway Company was more measured. Although it is clear from the company name and articles of association that film production was intended, for the first year it operated purely as an actors' training school. Professional staff were engaged at every stage: there would be no *Harp King*-like disaster resulting from amateur efforts in scriptwriting and camera work.

The first person to be engaged was a Glasgow journalist and writer of popular songs, James Howie Milligan. He was not only offered an exclusive five-year contract to write plays, revues, sketches and such like 'suitable for stage or screen production' but also the position of chairman and managing director of the new company. Milligan's name was associated with that of Harry Lauder, for whom he had written several songs, and the Glasgow men behind the new enterprise - Alexander Martin, a

⁷¹ NRS, BT2/10774/2, The Broadway Stage and Cinema Company, Memorandum of Association, 26 November 1919

‘decorative artist’ (painter and decorator) and Alexander Clapperton⁷², a trade paper journalist - evidently believed he was the right person for the job: a Scot who wrote in the vernacular, but whose work had proven appeal to a wider audience.⁷³ Milligan, who was aged around 30 when he joined the Broadway Stage and Cinema Co, had been under contract with Lauder before being called up to the merchant service in 1916. When he left in 1919 he had no savings or employment, and the prospect of a lucrative position which offered an up-front payment of £1000 and a salary of £500 a year must have been extremely attractive. He and his wife put £50 into the new company, and work began. Unfortunately for Milligan the prospect of success and financial security was not to be fulfilled. His association with Broadway was to end in an acrimonious court battle over copyright with his employers, an accusation of fraud by a former acting student and, in 1924, bankruptcy.⁷⁴

In contrast to the high-profile promotional activities of the A1 Cinema College and the Ace Film Producing Co, the new company kept its plans away from the public gaze. Until August 1921 its main business was tuition, and no films were produced. Newspaper advertisements for the Broadway Stage and Cinema Co simply offered ladies, gentlemen and children training ‘for either profession’ and a part in (unspecified) ‘forthcoming productions’.⁷⁵ Courses of training by Milligan and Max Leder, who was employed part-time as a tutor and potential producer, cost ten guineas as part of a class and 50 guineas for private tuition.⁷⁶ During this period Milligan wrote a comedy sketch about football called ‘Two-Nothing’ which toured Scottish music halls early in 1921 and proved successful enough to make a profit for the company.⁷⁷

⁷² Clapperton’s career included editorship of the *Building Trades Journal*, staff writer with the *Bo’ness Journal*, *Greenock Telegraph* and *Glasgow Herald*, and culminated with editorship of the *National Guardian* - the organ of the Scottish wine and spirit trade. Obituary: *Glasgow Herald*, 19 December 1944, p4

⁷³ These include *The Kilty Lads* (1913); *It’s Nicer to be in Bed* (1913); *Nanny (I never loved another lass but you)* (1916) and *The Message Boy* (1920). Milligan resumed writing songs for Lauder in the 1930s, including *Pin Your Faith on the Motherland* (1931); *It’s A’roon th’ Toon* (1932) and *Always Take Care of your Pennies* (1933)

⁷⁴ *Scotsman*, 28 February 1924, p5; NRS CS46/1923/7/28; *Aberdeen Journal*, 22 March 1923, p2

⁷⁵ *Sunday Post*, Glasgow, 25 July 1920, p11

⁷⁶ *Evening Telegraph*, Dundee, 21 March 1923, p6

⁷⁷ *Aberdeen Journal*, 24 March 1921, p1

Football Daft

In August, a point at which some directors had resigned and others had been appointed, it was decided that the Broadway was ready to embark on film production. A screen adaptation of ‘Two-Nothing’ was decided upon and Milligan was asked to write the scenario. Auditions and film trials for the production took place and Milligan and Leder cast the three star roles, supporting parts and some extras from the ranks of former film acting students. Other extras who took part in crowd scenes were unemployed people recruited from the Labour Exchange, so that the eventual cast totalled about 60. This was to be a true ‘Glasgow life’ film: the action of ‘Two-Nothing’ took place in the kitchen of a Glasgow tenement, but the screen version, later renamed *Football Daft*, expanded into the city’s streets and football grounds. As the film was extensively reviewed, and also as a result of a subsequent dispute over copyright in the scenario between Milligan and the Broadway Company, it is possible to reconstruct in some detail not just the narrative of the film but also the story behind its production.⁷⁸

Much of the praise for the two-reel *Football Daft* concerned its freshness and novelty: it did not attempt to imitate American slapstick productions, instead presenting a more naturalistic form of comedy depicting ‘the Saturday happenings in a typical Scottish working-class household’. The three main characters were Jock McPhail, a football-obsessed Rangers supporter, his young wife who ‘has to pass the time as best she can while “hubby” goes footballing’, and a bewhiskered temperance advocate nicknamed ‘Pussyfoot’. Jock was played by Jimmy Brough, a former postman from Glasgow’s East End, his wife by Catherine Jarvis and Pussyfoot by Bulmer Mewless, real name James Beirne, who had performed the same role in ‘Two-Nothing’. The newly-married couple live in a Glasgow tenement, whose interiors are ‘reproduced with absolute fidelity. The Scotch kitchen, with its familiar kitchen-bed, “jaw-box” [kitchen sink] and other equipment is pictured...’ On this typical Saturday afternoon Jock goes to Ibrox Park to see his team play and is ‘worked up to a fury of intensity, shouting exhortations to the players - “Shoot,

⁷⁸ NRS, CS46/1923/7/28: James H Milligan v The Broadway Cinema Productions Ltd

shoot, ye gomeril!”⁷⁹ After ‘destroying a fellow spectator’s bowler hat and administering sundry kicks to others in his keenness to see his team win, he arrives home in a “happy” condition and proceeds, in the absence of his wife, to change the vinegar bottle into a whisky receptacle’. His wife returns followed by an unexpected visitor in the form of ‘Pussyfoot’, the secretary of a temperance organisation, who is invited to stay to supper - with ‘diverting’ consequences.

As well as the domestic interiors which were shot in the Thornliebank studio, scenes included an ‘important football match in progress’, a group of excited spectators, and brake-clubs⁸⁰ returning from the football ground through Glasgow streets, in which the Rangers group ‘spills itself into a Paisley Road hostelry’. The match Jock attends is Rangers playing Motherwell at Ibrox Park, ‘although that is left for the audience to find out’ - but was made explicit in advertisements for the film inviting the audience to ‘see the Rangers v Motherwell match’, while one review mentions that ‘some remarkably clear views are shown of Ibrox and Cathkin Parks’.⁸¹ This suggests that some scenes (possibly newsreel footage) of the 26 August 1921 match between Rangers and Motherwell may have been intercut with those featuring Jock shot at a different match at Cathkin Park, the home at the time of Third Lanark football club.⁸² A scene shot in Sauchiehall Street notoriously ‘made a great disturbance and held up the traffic,’ and another street scene was filmed outside the company’s headquarters in West Nile Street. The settings and language of *Football Daft* would have been very familiar to Scottish audiences: the ‘smart and pawky’ subtitles throughout the film were written in Scots vernacular.⁸³

The circumstances that were to lead to the dispute over copyright between Milligan and the Broadway Company came about through their decision to employ a

⁷⁹ ‘Fool’

⁸⁰ Organised groups of football supporters who travelled to matches in horse-drawn wagons. Brake clubs emerged in Glasgow in the 1880s from the temperance movement, but by the 1920s were associated with rowdy and drunken behaviour. See B Murray, *The Old Firm: Sectarianism, Sport and Society in Scotland* (Edinburgh, 1984)

⁸¹ *Evening Telegraph*, Dundee, 5 April 1922, p4

⁸² The final score was Rangers 2, Motherwell 1

⁸³ NLS/MIA 4/5/33, SKR advertisement for *Football Daft* with reviews from the *Times*, 2 December 1921; *Glasgow Herald*, 2 December 1921; *Bioscope*, 8 December 1921; *Glasgow Citizen*, 1 December 1921; *Glasgow Observer*, 3 December 1921; *Glasgow Evening News*, 2 and 7 December 1921.

professional producer as well as a camera operator for *Football Daft*. The latter role was fulfilled by the Glasgow cameraman Alf Avern, formerly of Green's, who in 1921 was employed by the Bendon Trading Company and 'loaned' to the Broadway for the duration of filming. Finding a local producer with any solid professional experience of feature film making was more of a challenge. Max Leder had proved a disappointment: one of the company directors, Robert Lawrie, later said they had 'employed a man Leader [sic] as prospective producer, but from what we had seen of his results he was useless to us'.⁸⁴ Accordingly, Milligan was sent to Clapham, South London, to discuss the position with a former music hall artiste and sometime film producer, Victor Weston Rowe, who had responded to an advertisement.⁸⁵

I explained to Mr Rowe in London the position of the Company, that this production was going to be done on the narrowest possible margin of staff and money, and he... had not been producing for ten years and was keen to get back to it.⁸⁶

Although Rowe had his doubts about the story which he thought was 'not very strong' and lacking appeal, he agreed to be the producer for a fee of £50 - the same sum paid to Alf Avern for camera work. The dispute leading to the court case was over whether Rowe, in addition to his role as producer, wrote the finished screenplay of *Football Daft*. He and Milligan had conflicting versions of events following their first meeting, after which Milligan had dental surgery and fell ill. During the following week a bedridden Milligan claimed that he dictated the full script based on his original scenario 'with the entire sequence of action' to Rowe, who 'merely transferred [it] onto paper'. Rowe, on the other hand, stated that Milligan's original scenario had proved completely unsuitable, and that he was the true author of the work. Milligan counter-claimed that he had been substantially involved in production activities which should have been carried out by Rowe, such as location-finding. As a Londoner, Rowe 'knew absolutely nothing about the city of Glasgow' and 'had to continually refer to me in the studio and on the street to keep guided [about] the

⁸⁴ NRS, CS46/1923/7/28, evidence of R D Laurie, p65

⁸⁵ A database entry for Weston Rowe's daughter, a nun and religious artist, describes him as a 'music hall artiste'. www.findagrave.com, 'Sr Mary of the Compassion (Constance Mary) Rowe' (accessed April 2015)

⁸⁶ NRS, CS46/1923/7/28, Complainer's Proof, p19

atmosphere in the picture. An atmosphere is one of the biggest assets in any production'. One claim that was not disputed was over the writing of intertitles. Milligan had written these in Scots vernacular: Rowe tried to change them to standard English but was overruled, the originals being reinstated before *Football Daft's* trade show. Rowe, in turn, undoubtedly improved the quality of the production in other ways. After being shown Broadway's existing studio in West Nile Street he had pronounced it 'absolutely impossible to produce there' and negotiated with Arthur Reid to take over the tenancy of the Ace Company's Thornliebank studio for the filming of interior scenes. Even then Rowe was not satisfied, later telling a newspaper reporter that 'he was handicapped through not having sufficiently powerful arc lamps at the Thornliebank studio'.⁸⁷

To produce *Football Daft* as professionally but on as low a budget as possible involved a good deal of multi-tasking. The electrician, paid £20 for his services, helped Rowe (who had never been inside a Glasgow tenement) to construct the kitchen set, as well as assisting with art direction. The only crew member with a single role appears to have been cameraman Alf Avern. His description of filming in the rain is evidence of the film-makers' technical skills:

It began to rain one day during the process of photographing, and I was of the opinion that the rain would not affect the technical quality of the picture, therefore I carried on during the rain. We had other scenes to put in between, and we had to manufacture rain for the rest of the time.⁸⁸

The film had its first screening at Cranston's Picture House in Glasgow on 1 December 1921, a 'private view' rather than a publicly-advertised trade show, to which the press and the trade were invited. Many invitees, anticipating an experience as depressing as the trade show of *The Harp King*, were pleasantly surprised. 'It is quite probable that some among the audience expected to witness a failure, but any who came in doubt departed more hopefully,' said the *Evening News*.⁸⁹ As the *Times'* Scottish correspondent put it:

⁸⁷ NLS/MIA, 4/5/33, cutting from *Glasgow Evening News*, 7 December 1921

⁸⁸ NRS, CS46/1923/7/28, evidence of Alfred Avern, p36

⁸⁹ *Evening News*, 2 December 1921

Almost every cinema man of note attended the screening... most out of curiosity and some sceptical. I was one of the latter. There was greater unanimity of opinion after the "show." Mr J H Milligan, the producer [sic] ... has constructed a two-reel film as good as anything of its kind done in this country, and better - "more entertaining" might be a happier expression - than the bulk of films of the slapstick comedy variety from America. It depends on natural situations for its humour, and technically it reaches a high standard.⁹⁰

Reviewers were taken with the film's humour, its lack of pretension and the realism of its contemporary Glasgow settings. The appeal of *Football Daft* lay in the way it presented 'a slice of life from any Scottish working man's home'; a refreshing alternative to 'those American travesties of Scottish life and customs which have hitherto been the only thing Scotch (!) obtainable in the pictures'.⁹¹ The novice actors were praised for their 'natural' performances and the overall look for its 'vraisemblance', with the exception of Pussyfoot's overdone make-up and costume. The *Bioscope* echoed many reviewers' comments:

The artists are all new to the work, but it must be said they have done splendidly. The whole comedy is good, and many a worse picture has been hailed as a big success... The Broadway Cinema Productions, Limited, must be heartily congratulated on their first attempt. We hope they will keep on, and keenly anticipate their next venture.⁹²

For the first time in the short history of Scottish film production there was no need to qualify criticism and make allowances for the film-makers' lack of experience, or to claim success based purely on 'all-Scottish' credentials. *Kinematograph Weekly* believed that *Football Daft* would be 'well received by most publics'. Its recommendations were that 'Scottish exhibitors can book and boost this, Northern exhibitors in general will find it a good booking, while Southern audiences, even if they do not derive any amusement from the Northern style of humour, should find it interesting'.⁹³ This evidently came as a surprise to certain among the company, particularly Victor Weston Rowe, who stated that when he had finished editing the

⁹⁰ *Times*, 2 December 1921

⁹¹ *Bulletin*, 2 December 1921, quoted in advertisement published in *SKR*

⁹² *Bioscope*, 8 December 1921, p43

⁹³ *KW*, 15 December 1921, p45

film he ‘did not like it at all... Everything was wrong with it’. As a Southerner he may have failed to understand the humour, although his view was shared by Alf Avern who later admitted that ‘We [he and Rowe] were wrong; either that or the people in the theatre were’.⁹⁴ Even Milligan, with his uncompromising stance on the Scots subtitles, may have believed his comic story of Glasgow life would only appeal to local audiences.

Football Daft did indeed prove to be a popular success which toured cinemas the length and breadth of Scotland in the six months following the private trade show. Starting in Glasgow in January 1922, where it was shown at the Cinema House, Louvre Theatre and Grand Central Picture House, it moved on in February to Motherwell, where it was billed as *Fitba’ Daft*. In late March and April it could be seen at all the main cinemas in Dundee: the Electric Theatre, Kinnaird Picture House, Caird Hall and Kings Theatre, where it proved so popular that ‘hundreds [were] turned away’.⁹⁵ A typical advertisement described the film as ‘Glasgow’s own comedy’ and ‘almost the first attempt to put Scottish humour on screen’.⁹⁶ In the first three weeks of May alone, *Football Daft* was shown in at least 18 Scottish towns and cities.⁹⁷ The film had done such good business in Motherwell (whose football team it had of course featured) that it was re-booked, returning to the Pavilion in August 1922.⁹⁸ Later in the year it made its way south to England, where a newspaper advertisement for screenings at the King’s Hall in Dover described *Football Daft* - shown alongside *The Avenging Arrow*, episode 8, as the supporting programme to main feature *East Lynne* - as ‘A Scotchman’s idea of the National Game’.⁹⁹ Although there is no other currently available evidence of screenings in England, it is unlikely that Dover was the only town where it played. The difference was that outwith Scotland it did not receive prominent billing. The distributor, Waverley Films, re-

⁹⁴ NRS, CS46/1923/7/28, evidence of Alfred Avern, p37

⁹⁵ *Evening Telegraph*, Dundee, 31 March 1922, p2

⁹⁶ *Motherwell Times*, 17 February 1922, p3

⁹⁷ NRS, CS46/1923/7/28, Complainers’ Proof, p7; *Hawick News and Border Chronicle*, 12 May 1922, p2. *Football Daft* was shown between 1 and 22 May 1922 in Kirkcaldy, Kilsyth, Kilbirnie, Inverness, Inverurie, Helensburgh, Campbeltown, Shotts, Edinburgh, Crieff, Stirling, Old Cumnock, Darvel, Renfrew, Burntisland, Cardenden, Troon and Hawick

⁹⁸ *Motherwell Times*, 11 August 1922, p1

⁹⁹ *Dover Express*, 17 November 1922, p6

released *Football Daft* in August 1923, describing it as ‘The Scottish comedy that topped the league last season, and will again gain all the points next season’.¹⁰⁰



Figure 8: Advertisement for *Football Daft* at the Pavilion Theatre, Hawick. *Hawick News and Border Chronicle*, 19 May 1922, p6

Soon after *Football Daft*'s trade show the Broadway directors decided they were in a position to drop the actors' training side of the business and concentrate on film production. In February 1922 the company changed its name to The Broadway Cinema Productions, Ltd, and the nominal capital was increased to £6000.¹⁰¹ A series of six films capitalising on *Football Daft*'s success was planned and Milligan began writing synopses and scenarios. Two of these, *Racing Daft* and *Picture Daft*, were announced in the *Scottish Kinema Record* in May 1922 under the auspices of a new local company, Balmoral Productions, associated with cameraman Alf Avern.¹⁰² No records exist for this company, which was not officially registered. By this time Milligan had left Broadway and he and Avern were evidently trying to go it alone, as Milligan owned the rights to these new, post-*Football Daft*, scenarios. The screenplay for *Racing Daft* does appear to have been completed as it was named as one of Milligan's assets during his bankruptcy hearing at Glasgow sheriff court in February 1924.¹⁰³

¹⁰⁰ *Bioscope*, 24 May 1923, p48

¹⁰¹ NRS, BT2/10774/6, The Broadway (Stage and) Cinema Productions, Ltd

¹⁰² *SKR*, 13 May 1922, p7

¹⁰³ *Scotsman*, 28 February 1924, p5

The reason for Milligan's departure from Broadway Cinema Productions was not just the argument over his right to claim authorship of *Football Daft*, which he lost, but also a result of the company's shortage of funds. Milligan was owed money and some of his promised £500 per annum salary was unpaid, so in February 1922 he entered into a new agreement under which he would be the company's scenario writer and producer until November of that year and have 'sole charge of the studio and staff' for a salary of £10 a week and a bonus of 20 per cent on all profits. By this time Rowe had gone back to London, and the financial situation was so precarious that other staff were dismissed. Under the new agreement, however, Milligan's position did not improve and although he had begun writing the scenarios and synopses for the 'Daft' sequels, 'owing to a lack of capital they were not proceeded with'. One of the reasons for shortage of capital was, Milligan claimed, the fact that the directors' fees had been increased. Arthur Reid, formerly of the Ace Film Production Co, had been made chairman, but only brought £50 to the company. When the Broadway Cinema Productions ceased trading two years later, however, it was claimed by the company secretary Robert Muirhead that 'the whole of the capital was lost and the directors were left with a bank overdraft... The directors never received any payment for their services, and my position as Secretary was for years unpaid'.¹⁰⁴

The total cost of producing *Football Daft* was £1,001,15s 2d. One of the most expensive items apart from salaries was the film stock, which cost £75. Rental of the Thornliebank studio was £100, and paying the Williamson Film Co to print the first copy from the negative cost £63. There are no records of box office returns, but it is clear that even a successful and widely-booked film made on a low budget could not generate sufficient profit to keep the company afloat. No further films were made at the Thornliebank Studio, which, with a 'position and atmospheric conditions splendid for camera work' was advertised as being for sale or to let in June 1923, a reflection of the changed economic conditions resulting from the major downturn of 1921. The company's city centre studio in Nile Street had already been vacated.¹⁰⁵

¹⁰⁴ NRS, BT2/10774/15, letter from Robert W Muirhead, chartered accountant, to the Registrar of Joint Stock Companies, Edinburgh, 16 February 1927

¹⁰⁵ SKR, 3 June 1923, p3

The Broadway Cinema Co ceased trading in 1924, by which time according to Muirhead ‘the whole of the capital was lost and the directors were left with a bank overdraft of over £1,100 for which they were personally liable’. Three years later - following a plea from Muirhead that the directors could not afford the expense of appointing a liquidator - it was struck off the Register of Joint Stock Companies.¹⁰⁶

Football Daft is now lost, although according to Charles Oakley a print still existed in the 1930s:

Twenty years ago a copy of this film was found in a city office and the scene in which a Rangers brake club spills itself into a Paisley Road hostelry was found as uproariously funny as ever, but the film has disappeared and two requests made in the Press to bring its whereabouts to light have brought no response.¹⁰⁷

After 1922 it would seem that Milligan made no further attempts at screenwriting or producing. An unsuccessful attempt to sue him for fraud by a former acting trainee, Mrs Baxter - who had paid the Broadway Company more than £50 and wanted it back after failing to be given contacts with Hollywood film studios - was widely reported. Although Milligan was cleared of any wrongdoing, with the judge calling it a ‘fishy, stupid business,’ it must have brought him unwanted notoriety and added to the poor reputation of cinema colleges in general.¹⁰⁸ Following his departure from the Broadway Company he wrote a book about horse racing called *Betting with Safety*, which was published by his wife’s company, the Northern Press. The first print run of 5,000 copies sold out and was followed by another run of the same number. Within the next two years he had also written a series of ‘character sketches’ about a Scotsman called McAlister and two books, *The Heckler* and *Twenty Tales of the Sea*. Despite this activity, in 1924 Milligan applied to be declared bankrupt.¹⁰⁹ He left Glasgow and moved to Blackpool, where he returned to his previous occupations of journalism and song writing, the latter under the name of J Howie-Milligan. One song, published in 1938, rejoiced in the title of ‘How Would You Put a Poultice on a

¹⁰⁶ *Edinburgh Gazette*, 18 November 1927, p959

¹⁰⁷ NLS/MIA, 5/7/22, photocopy of cutting from *Evening Citizen*, Glasgow, nd, thought to be 1950s

¹⁰⁸ *Scotsman*, 22 March 1923, p8; *Dundee Courier*, 22 March 1923, p7; *Aberdeen Journal*, 22 March 1923, p2

¹⁰⁹ *Scotsman*, ‘Glasgow Cinema Play Writer examination in bankruptcy’, 28 February 1924, p5

Fly?’¹¹⁰ The same year he wrote and presented a talk for BBC Northern Radio called ‘Football pools and how to win’ and a 10-minute programme, ‘Autumn Assizes’, in a series called ‘Brief Chronicle’.¹¹¹

James Howie Milligan died in 1940, aged only 51. A locally-published obituary did not mention his Scottish roots, referring to him only as a ‘Blackpool man who had composed famous songs’ and as ‘well known among journalists in the North West’. Another obituary, in the *Aberdeen Journal*, focused on Milligan’s association with Harry Lauder, erroneously stating that he had written the words and music of ‘Sir Harry’s most famous song, “Roamin’ in th’ Gloamin’”’, and more accurately that he had written the words for the comedian’s patriotic song of 1931, ‘Pin Your Faith on the Motherland’.¹¹² It is difficult to trust the accuracy of what appears to be a slapdash account of Milligan’s achievements: the obituary added that he was ‘one of Fleet Street’s greatest characters’ [although the term ‘Fleet Street’ may have been used as a synonym for ‘journalist’] popularly known as “Milly”’, and that two days before he died Milligan had signed the contract for the publication of ‘yet another of his songs, “Let the Old Love Game Roll On”’.¹¹³ The only mention of Milligan’s work in Glasgow was a revue he was said to have written in 1921 called ‘Mum’s the Word’, which ‘met with instantaneous success’. A search for other references to this revue has revealed nothing, and it is likely (although curious) that this was a misremembering of ‘Two-Nothing’. Milligan was under contract to the Broadway Company in 1921, and anything he had written would almost certainly have been mentioned in the documentation discussed above. The obituary writers seem to have been unaware of Milligan’s brief film career in Scotland or of *Football Daft*.¹¹⁴ His son, James Mason Milligan, was born in Glasgow in 1918 and, as a child, aspired to follow his father into the journalistic profession.¹¹⁵ He served as a lance-corporal in

¹¹⁰ J Howie-Milligan, ‘How Would You Put a Poultice on a Fly?’ Mills Music, Inc/Lennox Publishing, New York 1938

¹¹¹ <http://genome.ch.bbc.co.uk/schedules/regional/northern/1938-03-13> (accessed April 2015); *Yorkshire Post*, 8 March 1938, p3; *Sunderland Echo*, 20 November 1938, p6

¹¹² Lauder wrote the words and music of ‘Roamin’ in the Gloamin’ (first recorded in 1911) himself

¹¹³ *Aberdeen Journal*, 28 March 1940, p3

¹¹⁴ *Lancashire Evening Post*, 18 March 1940, p5

¹¹⁵ At the age of 12 James Mason Milligan sent a short story to George Bernard Shaw, asking his advice on becoming a journalist. In a handwritten reply, Shaw suggested that he should put the story

the infantry in the Second World War, but there is no evidence that he subsequently fulfilled his childhood ambition.

The revival of Milligan's song-writing career in the 1930s did not bring him financial security. In September 1935 he made another court appearance, this time accused by his Manchester tailor of having worn a dress suit that he had ordered but then returned, claiming that it did not fit and that it had been delivered too late for him to wear at Christmas. The tailor, however, noticed that there were fragments of tobacco in the pockets - suggesting that it had indeed been worn. In court, Milligan was asked to try on the suit and the judge agreed that the trousers were too long. The outcome was that Milligan was ordered to pay for the suit but was also awarded damages for the cost of putting it right, and for his wife's travel expenses from Blackpool to Manchester to collect it.¹¹⁶

The Arc Film Producing Co

The demise of the company behind Scotland's most successful film to date and the departure of the first screenwriter to demonstrate real understanding of Scottish contemporary popular culture did not, however, signal the end of film production as the output of an acting school. Max Leder's belief in this concept had not wavered, and although his new film acting school/production company was not formally registered until June 1922, he had been operating under the name of the Arc Film Producing Company in both Glasgow and Dundee since the autumn of 1921. In October that year the *Dundee Courier* printed a story about the Arc Company's visit to the city:

A few Dundee citizens were regaled with entertainment of a novel nature yesterday when a small party of real, live film-artistes came to the city to make some scenes. Laden with luggage and wearing their make-up, which in the light of day looked rather bizarre, the film people naturally attracted considerable attention, and when the first scene was being pictured at West Station a large crowd of sightseers gathered to see a film in the making.

in the fire and wait seven years, as 'your judgment is not yet critical enough to qualify you for what is a man's job'. *Sunday Post*, Newcastle, 5 November 1950, p3

¹¹⁶ *Nottingham Evening Post*, 18 September 1935, p9



Figure 9: *The Stolen Document*: a 'real Dundee newsboy' directs Aberdeen fisher-girls played by Daisy Cree and Winifred Vynne to the harbour. The lurking man is not identified. *Courier*, Dundee, 15 October 1921, p7

The article described *The Stolen Document* as ‘among the first pictures to be produced by the Arc Film Company, Glasgow, a comparatively new firm whose aim is to portray Scottish life and characters... Within two months [the company] has almost completed two pictures’. The plot of this film, which the paper described as ‘rather sensational, with more than enough incident’, included a chase scene down by the docks and the attempted abduction of the heroine named Louis Stevenson (played by Mabel Dunbar of Glasgow) by the villain. This role was played by John F McEwan of Glasgow; a replacement figure for Thomas Keir Murray as Leder’s new business partner.¹¹⁷ Despite its reservations, the paper added with a marked lack of conviction that ‘the local interest being introduced should make the film a success’.¹¹⁸ Whether the film was ever completed or screened is unknown.

Perhaps as a result of the local interest generated by the filming of scenes for *The Stolen Document*, Leder decided to extend activities to Dundee. This was a city with a large concentration of cinemas, a sizeable working-class population and large

¹¹⁷ McEwan was the only other director of the Arc Film Producing Company

¹¹⁸ *Courier*, Dundee, 15 October 1921, p7

numbers of young women in paid work, making it an attractive centre for such an enterprise. His new business was not promoted as a cinema college offering students the prospect of film stardom in the wider world, but focused specifically on local production. From November 1921 advertisements appeared in the local press for ‘refined ladies, gentlemen and juveniles to commence training at once for inclusion in a local trial production’.¹¹⁹ Dundee had the ambition to become a film-producing city, if not the centre of a Scottish film industry, and hopes were immediately raised. Noting that Arc’s advertisement for local film talent had resulted in almost 100 applications and a queue from which ‘many had to be turned away’ outside the Masonic Temple where auditions were taking place, the *Dundee Courier* argued that ‘This fact raises a hope that Dundee may yet play a part in the development of an industry new to this country,’ continuing:

It is felt, even in film-making circles, that Dundee would be an admirable centre for the industry in Scotland, owing to the remarkable clearness of the atmosphere in the district and the convenience of the city... The cinema company which has taken such an interest in Dundee, the Arc Film Company, Glasgow, has mapped out a scheme for developing the industry in this part of the country which, if it materialises, should do much to bring the city into the limelight in a new connection. If sufficient talent and support is forthcoming it is intended to erect a studio in the neighbourhood of Dundee for the employment solely of Dundee and district artistes. It is expected that the scheme will mature in the spring.¹²⁰

The plan did not materialise, but the article shows that Leder still aspired to develop a self-financing model of Scottish film production on a limited and local scale. The trial production went ahead, although male cinema aspirants were evidently in short supply in Dundee: ‘gents’ were still being urgently sought almost three months later.¹²¹ The resulting film was advertised in May 1922, one of three ‘delightful, refined, all-Scottish comedies’ produced by the Arc Company. These were *His Last Bachelor Night* and *Blasted Ambitions* (both two-reel films), and a one-reel short called *Keep to the Left*. Another film, *Blinds and Blushes*, was advertised as ‘coming

¹¹⁹ *Courier*, Dundee, 16 November 1921, p1

¹²⁰ *Courier*, Dundee, 8 November 1921, p4

¹²¹ *Ibid*, 27 January 1922, p4

shortly'. Trade shows were announced on 8 June at Cranston's Picture House in Glasgow and the following day at La Scala in Dundee.¹²² The *Bioscope* reported that two of these comedies had been made in Glasgow and one in Dundee, and as *His Last Bachelor Night* was evidently made in Glasgow, the Dundee production must have been one of the other two.¹²³ Before having seen *His Last Bachelor Night*, (referred to as *A Bachelor's Night Out* - indicating either a last-minute change of title, or simply a mistake) one Glasgow newspaper described it as 'promising to have a successful run'. The article was based on an interview with one of the film's stars, a 13-year-old Glasgow schoolgirl called Winnifred Adam, who played the Queen of the Fairies. Winnifred told of her ambition to become a real cinema star like Lillian Gish, whom she particularly admired. She was said to be 'recognised as a promising film star' and her work as 'exceptional for one so young'. All that can be inferred from this piece is that the bachelor of the film's title had an interesting, and possibly inebriated, night out.¹²⁴

The *Bioscope*'s chief reviewer was in London during the week of the trade shows and deputed the duty of viewing the Arc Company's comedies to an assistant, 'a gentleman who has been viewing since the old open market days', remarking:

I thought I had sometimes used vitriol instead of ink myself, but my assistant must have secured an even more biting fluid, for his opinions of the pictures are unprintable. I had better leave it at that.¹²⁵

Although the local trade did not have high expectations of these examples of the 'home-made article,' prior to their first show, this response must have been a crushing blow to Leder and McEwan, particularly as the Arc Film Producing Company was formally registered only a week before the *Bioscope*'s verdict appeared. Based at 5 Renfrew Lane in Glasgow, its objects were similar to those of the A1 Cinema College: 'to carry on business as instructors in cinema acting, photographers, and producers of cinematograph plays'. Capital was £2000 divided into 1000 shares of £1 each and 4000 deferred shares each of five shillings: half that

¹²² *SKR*, 13 May 1922, p4; 3 June 1922, p11

¹²³ *Bioscope*, 8 June 1922, p65

¹²⁴ *Weekly News*, Dundee, 3 June 1922, p2

¹²⁵ *Bioscope*, 29 June 1922, p79

of the Broadway Stage and Cinema Company's initial capital at flotation, and only a fifth of the nominal capital of the A1 Cinema College.¹²⁶ There is no evidence of the Arc Company making any further films, or of the 'delightful, refined, all-Scottish comedies' playing in any cinemas. Clearly their vision of Glasgow (and Dundee) life was very different from that of *Football Daft*, which was still enjoying a successful run. At an Extraordinary General Meeting of the Arc Film Production Co in May 1923, the resolution was passed that, 'as the company cannot by reason of its liabilities continue its business, it be wound up voluntarily'. A liquidator was appointed and the company was wound up in October 1923.¹²⁷

In 1922 British film production in general was in a state of crisis, a result of the adverse effects of a lack of capital, rising costs, and a shortage of original screenplays and stars that could compete with American output. Cinema colleges continued to operate in Britain until the coming of sound, although not in Scotland. By 1928 the once admired Victoria Cinema College in London had lost its reputation and an application to renew its licence was opposed not just by disappointed would-be film stars but also by the editor of *Picturegoer* magazine, who argued that the college 'held out prospects of employment which it could not fulfil, owing to the fact that it was unqualified to give instruction and was entirely discredited by the cinema industry'.¹²⁸

Other productions

The interconnected stories of the cinema colleges, the Thornliebank studio, James Howie Milligan, Max Leder and the Broadway Stage and Cinema Company demonstrate the progression (and regression) of Scottish film production in the years immediately following the war. There were, however, some other isolated attempts at feature film production in this period. Scotland's 'greatest ambassador', Harry Lauder, set up his own production company in 1920. He was said to have employed C H Williams of the Dunoon Picture House to produce his first film, *I Love a Lassie*,

¹²⁶ NRS, BT2/12268/2, Arc Film Producing Company Limited, Memorandum of Association, 31 May 1922

¹²⁷ NRS, BT2/12268/15, Arc Film Producing Company, Extraordinary General Meeting of members, 8 May 1923

¹²⁸ *Yorkshire Post*, 28 January 1928, p12

inspired by his popular song of the same title.¹²⁹ The result - ironically the only Scottish fiction film of the period to survive - is a slow-paced and clumsily-edited story of country folk, in which Lauder fails to get his girl after allowing her to be chased by a bull while saving himself. Made on his estate at Glenbranter, Argyll, the film featured Lauder as a lovesick shepherd called Mack and his sister-in-law Effie Vallance as his true love, Mary. The intertitles written in Scots are verses from 'I Love a Lassie' and other Lauder songs, and would have been instantly recognisable to audiences. It seems, however, that the film was never released, and only came to light in the early 1970s as part of Lauder's estate. At the end of the one-reel film (also a component of a longer, expanded feature film) held by the NLS Moving Image Archive, Mack resolves to win back Mary's love and respect, and prepares to set sail for Africa to become a gold miner.¹³⁰ The feature-length version held by the BFI National Archive includes scenes set in South Africa which must have been filmed during one of Lauder's tours to that country.¹³¹ It is impossible to say whether Lauder ever intended the film to be publicly released or if he had made further plans for feature film production, but certainly this film made no impact on the Scottish film trade.

In August 1920 the *Bioscope* included a feature on a forthcoming film called *The Greater Riches*. This was the production of Mr C E Partoon, a well-known Dundee photographer and topical film-maker, who was said to be in the process of building a large film studio on the site of a smaller studio that he had bought in Montrose. Outdoor scenes had already been filmed 'in lovely settings around Dundee,' and interior scenes were to be shot as soon as the studio was completed. *The Greater Riches* employed local talent: the screenplay was written by Gordon Crystal, described as 'a discovery' who also played the leading role, while the leading lady was played by Betty Willocks, 'for whom there is a very bright future in screen

¹²⁹ SKR, 30 October 1920, p1; 13 November 1920, p14

¹³⁰ NLS/MIA, 4431, *I Love a Lassie*, alternative title *All for the Sake of Mary*, credited to the Page Film Company, 143 St Vincent Street, Glasgow

¹³¹ BFI, 3791: *All for the Sake of Mary*, alternative titles *Mack's First Love* and *I Love a Lassie: a Simple Story of Scots Folks*. This version is credited to Harry Lauder Productions

work'. The writer of the article was impressed by the script and by the section of the film he had viewed:

The theme of the story I will not disclose, although I have read the scenario. It is original, not 'stunty', and just what is wanted for a Scottish production... the Trade may look with confidence to his first work, which will only lack one thing, and that is the stamp of amateurism.¹³²

The final remark was surely directed at *The Harp King* and other efforts of the Ace Film Producing Company the previous year. There were no further announcements in the trade press about *The Greater Riches* or the Montrose studio, and it would appear that neither were completed. Partoon continued to make local topicals, including films of the British star Violet Hopson's visit to Dundee in September 1920.¹³³

Conclusion

The period between 1918 and 1922 saw a remarkable resurgence of activity in Scottish fiction film production, albeit on a limited and local scale. Uniquely in Britain there was a genuine attempt to create a local film industry on the basis of cinema colleges, with one of the resulting productions becoming Scotland's first cinematic hit. The unassuming, low-budget *Football Daft* indicated the potential for a cultural shift in the representation of Scotland on screen, at the same time demonstrating the impossibility of sustaining production on the basis of box office returns alone.

There is no evidence to show why, or whether, *Football Daft* failed to recoup its production costs, but there are a number of possible explanations for the obstacles that stood in the way of the Broadway Company remaining in business after its release. One was the competition: as a two-reel film, *Football Daft* was shown in a programme of films selected by the exhibitor. Prices were driven down as exhibitors sought to support an expensive main feature with a selection of supporting 'shorts' rented as cheaply as possible from distributors. By 1920 the overall cost of running a

¹³² *Bioscope*, 12 August 1920, pp78-79

¹³³ *Bioscope*, 12 August 1920, p75. Films of Violet Hopson's visit to Dundee shot by Partoon include NLS/MIA 0833, *Miss Violet Hopson visits Dundee Fire Station*

cinema amounted to around 150 per cent of pre-war levels, the largest single expense of which, after labour costs, was film hire.¹³⁴ Exhibitors attempted to address this problem in different ways, some choosing to show old and substandard prints of popular films which were made available by small Scottish distributors such as Tom Gilbert who operated in Fife. In 1921 and 1922, for example, pre-war Charlie Chaplin comedies produced by the Keystone Company were still in circulation, and *Football Daft* may well have suffered as a result of having to compete with such cheaply-available product.¹³⁵ Although the Broadway Company was set up in 1919, *Football Daft* did not appear in cinemas until early 1922, by which time the economic boom had proved unsustainable. In the period of slump that followed, the problem of raising capital or attempting to borrow money to sustain further production activity must have been insurmountable. None of those involved in the production of *Football Daft* continued to work in the film industry apart from Alf Avern, who resumed his work as a newsreel cameraman with the Bendon Trading Company and subsequently with Green's in Glasgow.

Other Glasgow-based producers may have been less successful, but attempts to present contemporary stories with urban settings appeared for a while to signal a new direction for film production in Scotland. Economic circumstances meant that these new possibilities were to be left largely unexplored, and the few Scottish feature films made in the following years showed a return to more traditional representations of Scotland on screen.

¹³⁴ See Griffiths, *The Cinema and Cinema-going in Scotland*, pp 112-122 for a detailed account of cinema running costs and the fortunes of the trade in this period

¹³⁵ NRS, SC36/79/18, Letter Book of Thomas Gilbert 1916-21

Chapter 4: Made in Scotland

'There are a great many firms operating in England, but very few have tried their luck north of the Tweed, though Scotland presents a splendid opening for men of enterprise. The immortal works of Scott, Stevenson, Barrie, and many other writers, would make admirable picture plays. The stories could be staged in their actual settings amidst our beautiful and romantic scenery. Anything Scottish makes a universal appeal, as the tremendous success of Scottish plays on the legitimate stage everywhere proves'.¹

Introduction

The appeal of the authentic extended beyond producers active within Scotland.

Throughout the period, Scotland was the focus for initiatives emanating from outwith its borders, which would also colour the prospects for success of native film-makers.

By the time this Dundee newspaper article calling for more British films to be made in Scotland appeared in 1919, some 150 Scottish 'picture plays' had already been seen by cinema audiences throughout the world. Most of these were produced by companies from far beyond Scotland's borders, in Europe and North America.

Scottish subjects did indeed have universal appeal; not only because of the popularity of writers such as Scott and Stevenson, but because of a historic fascination with Scottish landscape, dress and customs. Pre-existing visual iconography established in the eighteenth century easily translated, as David Stenhouse has noted, to the moving image.² Such imagery was influenced by the Ossian cycle of epic poems published by the Scottish poet James Macpherson from 1760, which contributed to the perception of Scotland as a remote and beautiful land populated by heroes. The Clearances of the eighteenth and nineteenth centuries transformed the cultural landscape of Scotland, and in the Victorian period the Highlands began to be represented by artists as a romantic wilderness instead of a populated space. The art historian Murdo Macdonald has described the way in which, by the 1860s, 'the main elements of the tartan, heather and hills stereotype of modern Scotland' were already in place.³ Such visions of Scotland were maintained and reinforced through the

¹Film Scotland Here! *Courier*, Dundee, 18 June 1919, p8

² D Stenhouse, 'Not Made in Scotland' in Murray et al (eds), *Scottish Cinema Now*, p194

³ M Macdonald, *Scottish Art*, (London 2000), pp104-105

development of tourism in the nineteenth century. Early cinema audiences knew what to expect of a Scottish film, which, as Stenhouse puts it, promised romance, exoticism and a certain set of narrative conventions. ‘Even if you missed the film’s title, it was clear that you were looking at a work about “Scotland”, if not Scotland’.⁴

As this chapter shows, while American-made Scottish films may have been popular with audiences, they were usually poorly received by the British press for their lack of authenticity and realism. But both before and after the Great War films were also produced in Scotland which did indeed stage the stories written by Scott and other Scottish writers, set in ‘beautiful and romantic’ Scottish scenery. The pages that follow consider a strand of narrative film production in Scotland between 1914 and 1924 running in parallel with the films discussed in other chapters: Scottish stories filmed in Scottish locations, but with all the studio and post-production activity taking place elsewhere. Locally-produced representations of Scottish life such as *Football Daft* were not always universally marketable, but these other ‘Scottish’ films recognised the worldwide appeal of Scottish stories. All but one of these 15 films were produced by English companies, the exception being an American serial filmed in several countries, including Scotland. These productions are included in catalogues of the many other early ‘Scottish films’ identified originally by Janet McBain and more recently by John Caughie and based on broad criteria including subject matter, writer, original story or setting.⁵ In identifying for the first time a separate category of films which were at least partly made in Scotland, my aim is to contextualise and extend the consideration of film production in a ten-year period within which hopes for the emergence of a Scottish film industry were still alive. What is perhaps surprising is that, of some 95 Scottish or Scottish-related dramas identified by Caughie made between 1914 and 1924, so few prove to have been filmed on Scottish soil.

Research based on advertisements and reviews in local newspapers and the Scottish sections of trade journals has helped to identify, in most cases, those productions that

⁴ Stenhouse, p174

⁵ J McBain, ‘Scotland in Feature Film: a Filmography’ in E Dick (ed), *From Limelight to Satellite*, pp233-255; J Caughie, *Filmography, Early Cinema in Scotland*, <http://earlycinema.gla.ac.uk/films-list/> (accessed January 2016)

were actually made in Scottish locations and those which, despite their producers' original intentions or vague or misleading publicity, were not. Particular attention is paid to their reception by the Scottish trade and press and their acceptance as 'Scottish films,' contrasting this with the way they were received by the British trade journal *The Bioscope*. The extent to which these productions generated some form of inward investment into the Scottish economy in terms of the use of local labour, hospitality or other less tangible but culturally significant forms of investment is also considered, along with the kind of subjects, stories and genres chosen; the importance of authentic settings, locations and 'atmosphere'; their popularity (where documented) with Scottish audiences both at home and abroad; the manner in which they were presented to these audiences and the period in which they were made.

The most obvious point of comparison between this group of films and those discussed in other chapters is the difference in their production values. They were intended for the national (UK) or international market, and commanded resources unavailable to Scottish producers. None of them could meet the criteria set out by the Scottish trade press for an 'all-Scottish production', since much of the filming and all the post-production work took place in studios far from Scotland, in the south of England or, in one case, in the USA. What is interesting is that some were promoted and received within Scotland as 'Scottish films' with considerable national pride, while others were promoted only on the basis of their stars or genre - much as they were throughout the rest of Britain. The reasons for these differing levels of acceptance are not always immediately obvious, but are all connected in some way with the extent to which producers made an effort to engage with the 'real' Scotland.

The productions discussed in this chapter are: *Black Roderick, the Poacher* (1914); *The Shepherd Lassie of Argyle* (1914); *At the Torrent's Mercy* (1915); *On the Banks of Allan Water* (1916); *The Call of the Pipes* (1917); *Bonnie Mary* (1918); *The Vanishing Dagger* (serial, 1920-21); *In His Grip* (1921); *Christie Johnstone* (1921); *The Wee Macgregor's Sweetheart* (1922); *Rob Roy* (1922); *The Romany* (1923); *Young Lochinvar* (1923) and *Bonnie Prince Charlie* (1923). All are lost films apart

from *Rob Roy*, a viewing print of which is held by the BFI National Archive.⁶ Rather than investigating the background to each production in detail, as in other chapters, these films are considered within a contextual framework which identifies certain patterns in the way Scotland was presented to the viewing public immediately before, during and after the war. Certain other films pertinent to a discussion of production in Scotland in this period, *Beside the Bonnie Brier Bush* (1921), *The Lilac Sunbonnet* (1922) and *The Fair Maid of Perth*, (1924) are also briefly discussed.

The Highland

There is insufficient evidence to reveal the popular response to these productions within Scotland, although in his survey of box-office returns from several cinemas across Scotland in the 1930s, Trevor Griffiths suggests that audiences had no particular predisposition to Scottish subjects on screen, exercising the same discretion over these as they applied to films more generally:

Evidence for a national audience for cinema, predisposed to favour Scottish subjects is less than compelling. Rather, this survey confirms that cinema-goers remained sharply divided, box-office returns exposing fractures along the lines of class, region and, if children's tastes are also considered, age.⁷

It seems likely that Scottish audiences one or two decades earlier would have used similar discretion, with the appeal of a film residing in its genre, mode of presentation (including music) or stars, rather than its Scottish setting or subject matter. The local audience may, however, have discriminated between those films made close to home and those that were not. In such cases, discussed in more detail below, the appeal would be similar to that of the local topical, offering the excitement of seeing familiar people (sometimes used as extras) and places on screen. Many of the films also served the dual purpose of being both fictional narratives and 'scenics', which were popular throughout the period and beyond.⁸

⁶ *Rob Roy* (1922), BFI/43196

⁷ Griffiths, *The Cinema and Cinema-going in Scotland*, pp 207-208

⁸ 'Everyone Loves Scottish Scenery' was the slogan used to promote a full-length scenic, *The Clyde, from its Source to the Sea*, produced in 1921 by the Square Film Co of Glasgow. See Griffiths pp289-290 for a discussion of this and other scenic films

This type of Scottish film - which could perhaps be known as the Highland - is comparable with the American Western, defined from its earliest days by background scenery of the open spaces of the West as represented by its plains, mountains and harsh desert landscapes. One reason American film-makers flocked to the West from 1909 onwards was to create 'sensational films with the unique and authentic scenery of real locations,' and their British counterparts recognised the advantages of filming narratives in some of Scotland's most spectacular and recognisable mountains, glens and lochs.⁹

Florence Turner and The Shepherd Lassie of Argyle

There is no doubt that when a non-Scottish producer had a serious commitment to Scotland that went beyond the exploitation of scenery, their film received the highest level of approval and acceptance by both the local film trade and audiences. This is particularly evident in the case of the American star and producer Florence Turner, whose three-reel romantic drama *The Shepherd Lassie of Argyle* was listed in *Kinematograph Year Book* as one of the 'big films' of 1914, despite having been released only in November that year.¹⁰ Its standing in Scotland was so high that it was later remembered as one of the few genuinely Scottish productions of the pre-war years, and uniquely in the story of early cinema in Scotland, produced not by a 'man of enterprise', but by a woman. In 1918 an article on film production in Scotland described Turner Films' *The Shepherd Lassie of Argyle* as 'the next picture [after *Rob Roy*] actually taken in Scotland,' continuing:

This was taken under the shadow of Ben Nevis, and was really first-class. It had a long and very successful run ... Mr Dick Lever (now of Oak Films) was, in part, responsible for the excellence of the film, by obtaining the correct atmosphere and detail in dealing with Scottish life and character. The story is told that, in order to obtain the tartan skirt worn by Miss Turner, Mr Trimble followed a Highland girl in and around Fort William for a whole day, finally following her home and, at long last, purchased the skirt for two guineas.¹¹

⁹ J Agnew, *The Creation of the Cowboy Hero: Fiction, Film and Fact* (Jefferson, N Carolina, 2015), p98

¹⁰ *KYB* 1915, p30

¹¹ NLS/MIA, 4/5/137, Film Production, Miscellaneous, cutting from *The Cinema* Scottish section, 3 January 1918; 'Film Production in Scotland' by Matt Cullen

Leaving aside Trimble's dubious behaviour, the article highlights the main credentials necessary for a production to qualify as Scottish: place (of filming), 'atmosphere' and attention to detail.¹² In 1919 the Dundee *Courier's* campaign to 'film Scotland here' (quoted above) compared *The Shepherd Lassie* favourably with United Films' *Rob Roy* of 1911:

Many years ago a picture version of "Rob Roy" was made here. Though the whole production was rather crude, and would not compare with present-day pictures, it put a lot of money into the pockets of the exhibitors. The most popular production was "The Shepherd Lassie of Argyle", produced by the Turner Film company, New York and London. This picture proved such a draw that repeat exhibitions of it had to be given in several towns.¹³

But Florence Turner brought other qualities to the film which added to its exceptional level of popular and critical acceptance. In June 1914, a few months before *The Shepherd Lassie of Argyle* went into production, she had been voted Britain's favourite female film star by readers of *Pictures and Picturegoer* magazine.¹⁴ In 1910 she was the first actress to be put under contract by a film company and became known as 'the Vitagraph Girl'. But at the height of her fame, in 1913 she abandoned a successful career with Vitagraph and travelled to Britain in order to establish her own film company along with her long-time director Larry Trimble and his collie dog, Jean - who became Turner Films' mascot as well as appearing in many of its productions. Turner's explanation for this move was that she wanted to take control of her own career and establish herself as an independent producer, seeing an opportunity in the British industry which, unlike that in the USA, was not dominated by trade factions. She and Trimble recognised that her enormous popularity in Britain could compensate for a lack of financial assets and generate the greatest returns.¹⁵ During her three-year stay in Britain Turner produced, acted in and

¹² Laurence/Larry Trimble directed the majority of Florence Turner's films both for Vitagraph in the USA and for Turner Films in Britain, including *The Shepherd Lassie of Argyle*

¹³ *Courier*, Dundee, 13 June 1919, p8

¹⁴ *Pictures and Picturegoer*, June 1914, pp358-359

¹⁵ J Burrows, 'Florence Turner: her British career' in J Gaines et al (eds), *Women Film Pioneers Project* (New York, 2013), <https://wfpp.cdrs.columbia.edu> (accessed January 2014); A-M Cook, 'The Adventures of the Vitagraph Girl in England' in A Burton and L Porter (eds), *Pimple, Pranks &*

wrote some of the screenplays for 30 films including one-reel shorts, comedies and full-length features, beginning with *The Harper Mystery* in 1913 and ending with *Sally in Our Alley* in 1916. She also directed herself in at least one film, *Daisy Doodad's Dial* (1914).¹⁶

Turner arranged to rent the Hepworth Manufacturing Company's studio in Walton on Thames along with many of its stock company players, with Hepworth as Turner Films' distributor. While these arrangements were taking shape, she began a tour of British music halls with an act consisting of comic character impersonations - similar to her recent vaudeville tour of the USA. The tour was interspersed with personal appearances in England, Scotland and Wales. As James Anderson, a journalist and contemporary of Florence Turner's remarked, such visits by screen idols were very unusual at the time. 'In Florence Turner's case she usually told a few jokes against herself, "pulled a few dials" [made faces] and gave a sort of entertainment... It was this party spirit which made her so loved'.¹⁷

One such appearance, made after the Turner company had begun production, took place at a week-long Glasgow cinema trade exhibition in February 1914, opened by J J Bennell. On the 'people's day' the public was reported to have turned out in their hundreds to see their screen idol, who was accompanied by Trimble and Jean the dog.

In the afternoon a reception was held, when Mr Trimble and Miss Turner delivered addresses of thanks, and "Jean" was put through a demonstration of how she "acts" for the pictures. The function was repeated in the evening, when the crowd was even more dense, and Miss Turner's fingers must have ached with signing souvenir postcards and autograph books... Hundreds waited outside the building and gave Miss Turner a real Scotch send off as she drove away in her car.¹⁸

Pratfalls: British Film Comedy before 1930 (Trowbridge, 2000). I am also grateful to Christine Gledhill for sharing with me references from her own research on Florence Turner's career

¹⁶ See L McKernan, 'Women Silent Film-makers in Britain,' version 2 (2007) for a complete list of Turner's British productions. <http://lukemckernan.com/> (accessed January 2014)

¹⁷ BFI, ITM-125, James Anderson Special Collection: manuscript notes by Anderson on 'The Screen's First Real Star' (nd). Turner's aptitude for 'pulling dials' was the subject of a short comedy, *Daisy Doodad's Dial* (1914)

¹⁸ *Bioscope*, 5 March 1914, p106

Later in the week Turner presented the awards at a cinema actors' competition, the efforts of the 150 Glasgow contestants described by *The Entertainer* as 'a scream'. The real success of the exhibition was not the trade stands - where stallholders were said to be mostly 'marking time' - but Turner's receptions. 'She's a peach!' ¹⁹

The purpose of Turner's presence at the Glasgow exhibition was not just to interact with her fans (to whom she referred as 'my friends,') but also to promote Turner Films' recent productions to the trade and the public. A typical advertisement in the *Bioscope* for two early 1914 films, *The Murdock Trial* and *Flotilla the Flirt*, emphasised her new roles as both star and producer. 'Barring reissues, the only pictures on the market featuring Miss Florence Turner are those produced by The Turner Films, Ltd'. ²⁰ Publicity also sought to promote her as a British personality, deliberately downplaying her American-ness. The country she was identified with varied; at times she was said to be partly of English stock, with a claim to have been 'related to Turner, the great painter'; ²¹ but more frequently the emphasis was placed on her Scottish ancestry. Even Jean the canine actress was said to be 'of Scottish descent, her parents having emigrated to America from Ayrshire... she seemed quite at home in Glasgow'. ²² The company's slogan was 'Pictures made for *You*,' and during their tour of Britain Turner and Trimble came to recognise the potential appeal to audiences of pictures made in the localities they visited, in Scotland and Wales as well as in England. ²³ In an interview given during her first visit to Glasgow, Turner announced her plans for Scottish production:

While I am in Scotland just now I am looking around me, and am preparing for a series of Scottish photoplays which I hope to produce - plays depicting the Scottish and Celtic spirit, where the artists will wear accurate costumes, and where they will perform their part in their natural romantic surroundings. There are many Prince Charlie and other chivalrous episodes that could be beautifully depicted. You see, although I am American, I have a warm side to your country, for my

¹⁹ *Entertainer*, 28 February 1914, p10

²⁰ *Entertainer*, 21 February 1914, p10; *Bioscope*, 26 March 1914

²¹ 'Picture Personalities,' *Pictures and the Picturegoer*, 28 February 1914, p1

²² 'Miss Florence Turner,' *Illustrated Films Monthly*, April 1914, p95

²³ In 1915 Turner produced and starred in *The Welsh Singer*, based on a best-selling novel by Allen Raine

grandparents were born in Scotland and came from Scottish stock.²⁴

Although the outbreak of war was to thwart these plans, *The Shepherd Lassie of Argyle* - a three-reel drama based not on a 'chivalrous episode' but an original screenplay by an American, Hector Dion, who also played one of the main roles - went into production soon afterwards. The film, whose narrative told of a shepherd's daughter who is struck dumb when her dog frustrates an attack on her by the local laird's mad brother, was shot in various Highland mountain and forest settings.²⁵ Evidence is scarce about precisely where these were, although the anecdote quoted above suggests that Fort William was used as a base. A full description of the narrative is also unavailable, but as the other characters included a 'modern Scotch laird,' a romantic hero described as 'a young man of pleasant but indecisive personality' and his 'rather colourless' fiancée, a romantic entanglement between the shepherd lassie and the hero (or possibly the laird) might be inferred. The real star of the film, however - particularly in the *Bioscope*'s estimation - was the Scottish scenery. In the opinion of that journal's reviewer, 'the opportunities offered by such a magnificent background might have suggested, one would have thought, a theme more closely connected and more strictly in keeping with the setting - a typical Scotch peasant story, that is to say'.²⁶

The Shepherd Lassie of Argyle received star billing in Scottish cinemas on its release in January 1915, and returned to many Scottish towns later in the year, with further repeat visits taking place in 1916. Advertisements in the Scottish press focused on the 'histrionic power' of its star and the authenticity of the 'remote Highland' settings - much as they did throughout Britain.²⁷ Turner and Trimble made good use of their time in Scotland, filming not only *The Shepherd Lassie* but also a short (390 foot) scenic, *Scenes in Highlands of Scotland*, described in the *Bioscope* as 'of splendid quality' [which] includes many of the most famous beauty spots, views of

²⁴ Ion, 'Interview with the Vitagraph Girl', *Scots Pictorial*, 21 February 1914, p583

²⁵ IMDB

²⁶ *Bioscope*, 29 October 1914, p471

²⁷ *Courier*, Dundee, 19 January 1915, p4; *Hamilton Advertiser*, 30 January 1915, p5

the native cattle “at home,” and concludes with moonlight effects on famed Loch Lomond’.²⁸

Highland landscapes and romanticised stories of Scottish history and myth were so closely connected in the popular and critical imagination that few film-makers attempted (or perhaps considered) anything else. Turner was an exception: following her visit to Scotland, her film-making plans had evidently changed. Although it featured some traditional character types such as the shepherd lassie’s ‘stern Highlander’ father, *The Shepherd Lassie of Argyle* had an original screenplay and was set in the present day. At the same time, Turner kept her promise to have players wear ‘accurate costumes’ and to film in ‘natural, romantic surroundings’ - in contrast to most American-produced ‘Scottish’ films. Turner Films already enjoyed a very high reputation among its British peers, and its first Scottish film did not disappoint: Turner’s own performance as the shepherd lassie was considered ‘as admirable as always,’ and the technical quality of the film-making similarly excellent, despite ‘evident climatic difficulties’.²⁹

Scottish trade shows took place on three consecutive days in January 1915 at the De Luxe in Glasgow, where, as expected, the ‘great Turner drama’ proved a huge draw. The *Bioscope*’s Scottish section review did not specify the selection of Scottish music played by Mr Meaton’s orchestra or the precise locations of the ‘lovely Scottish scenery’, but on this occasion the attractions of the film may have appeared so obvious as to be taken for granted.³⁰ Not exactly a kailyard story, it nevertheless celebrated a traditional, rural life and evidently explored class differences, with the working class girl as the heroine and the aristocrats at the castle both good (the modern laird) and bad (his mad brother). The scenery and Turner’s and Jean’s star presence were so dominating that Scottish newspapers had little to say about it other than remarking on its remote Highland settings, the ‘intense interest’ of the ‘exciting’ and ‘enchanted’ tale of a Scottish castle, Turner’s finely conceived performance in the role of shepherd lassie, and Jean’s performance as the shepherd’s dog, hailed as

²⁸ *Bioscope*, 10 September 1914, supplement pviii

²⁹ *Bioscope*, 29 October 1914, p471

³⁰ *Bioscope*, ‘Scottish News and Notes’, 31 January 1915, p236. *The Shepherd Lassie of Argyle* opened in England in December 1914, a month earlier than in Scotland

‘almost human’. Most found it, in the words of the *Hamilton Advertiser*, ‘equally attractive as a story and an exhibition of histrionic power’.³¹

Despite the outbreak of war, Turner stayed in Britain for another two years and the company remained buoyant, with many of its British films also released in the USA. In this respect, as Jon Burrows puts it, Turner Films ‘boasted an unusually strong transatlantic export record among British producers’.³² In March 1916 Turner made another visit to Glasgow. Announcing that ‘Miss Florence Turner would just love to shake hands with you at the Grand Theatre next week,’ the *Entertainer* described arrangements which included removing the fixed screen at the Grand and substituting it with a temporary one, ‘in order to allow of a full drawing-room set being erected on the stage for Miss Turner’s character sketches’.³³ In a week packed with activities she also held receptions for the public and exhibitors, visited trade houses and appeared at cinemas where repeat screenings of *The Shepherd Lassie of Argyle* were held, and spent a day visiting military hospitals. Autographed postcards were available at the Grand for 6d each, the proceeds going to provide cigarettes for wounded soldiers.³⁴ Another purpose of her visit was to promote Turner Films’ new (decidedly non-Scottish) production, *The Welsh Singer*.

³¹ *Courier*, Dundee, 19 January 1915, p4; *Newcastle Journal*, 14 January 1915, p1; *Evening Telegraph*, Dundee, 18 January 1915, p2; *Evening News*, Edinburgh, 17 February 1915, p1; *Hamilton Advertiser*, 30 January 1915, p5

³² Burrows, ‘Her British Career’

³³ *Entertainer*, 11 March 1916, p14

³⁴ *Entertainer*, 18 March 1916, p8



Figure 10: 'Miss Florence Turner of the Turner Films Ltd.' Autographed postcard, date unknown.
<http://www.ebay.co.uk/>

Turner's place as an honorary Scottish producer was enhanced by her association with Green's Film Service, the largest of the Scottish film exhibitors, renters and producers of local topicals at the time of the pre-war cinema boom.³⁵ The company, 'under the personal supervision of Mr Bert Green,' made a topical film of Turner's arrival in Glasgow, while arrangements for a tour of 'various towns in the East of Scotland' following her Glasgow visit were handled by Bert's brother and fellow company director Fred Green. This tour included appearances and receptions at the Empire in Edinburgh sponsored by the Anglo-American Film Company.³⁶ In the spring of 1916 Turner and Trimble's plans to extend production activities in Scotland were evidently still very much alive. It was announced that they intended to make one or more films in Scotland in the summer of 1916; one of these was to be a version of 'a very celebrated novel by one of our best-known authors,' for which 'elaborate arrangements' were made.³⁷ But in the event the only film to get made was a Green's topical called *A Cinema Star's Holiday with Florence Turner*, shot during her tour of Scotland and shown to an enthusiastic trade audience (many of whom

³⁵ See Chapter 2 for a detailed account of Green's activities

³⁶ *Bioscope*, 30 April 1914, p531

³⁷ NLS/MIA, 4/5/137, cutting from *The Cinema*, Scottish section, 3 January 1918: 'Film Production in Scotland' by Matt Cullen; *Entertainer*, 18 March 1916, pp8-9

appeared in the picture) at the Grand Theatre in early April.³⁸ In November 1916 Turner and Trimble returned to the USA, explaining the move as the result of difficulties involved in hiring technicians and actors and in securing permits for location shooting in Britain, as wartime privations started seriously to affect the business of film production. The plans for further Scottish productions were shelved, although in 1918 it was believed that, if Turner returned to Britain, these might still be made.³⁹

At a time when America's cultural and industrial dominance had already become a major concern of the British film industry, Turner's willingness to champion that industry and make films that appealed specifically to British audiences played an essential role in her success.⁴⁰ If circumstances had been different, her contribution to film production in Scotland would have been even more significant. As it was, *The Shepherd Lassie of Argyle* was to set a benchmark for Scottish film production until well after 1918; its themes, settings and technical qualities being admired and apparently emulated by both Scottish and non-Scottish producers. None of them, however, had the attraction of a producer/star of equivalent status to Florence Turner.

None of the other four productions shot, at least partly, in Scotland up to and during the Great War made a similar impact on the Scottish trade or press, and only *The Call of the Pipes* (1917) was recalled by Matt Cullen as having been 'taken in Scotland'. What they have in common with *The Shepherd Lassie of Argyle* and with each other - apart from Highland settings - are their stories: dramas featuring lairds, gamekeepers, poachers, family feuds and romances across the class divide. These three or four-reel narratives – full-length features for the time - exemplify genres that were particularly popular in Britain immediately before and during the war years: crime melodramas, war dramas and literary adaptations.⁴¹ In many ways their themes

³⁸ *Bioscope*, 8 April 1916, p13

³⁹ NLS/MIA, 4/4/137, 'Film Production in Scotland' by Matt Cullen

⁴⁰ A M Cook, 'From 'Vitagraph Girl' to British Star: Florence Turner as a Transnational Celebrity', unpublished paper delivered at the Women and Silent Screen conference, Guadalajara, Mexico, 2006

⁴¹ S Street, *British National Cinema*, pp44-45. Other popular genres were comedies, spy/espionage thrillers and sporting dramas about boxing or horse racing

fit with the list of recurring topics of British films of the period summarised by Rachael Low:

Inheritance and fallen women; the underworld of London with its night clubs and gambling halls; the superiority of honest poverty, with class acting as a one-way barrier to marriage; the regenerating effects of war, the worthlessness of shirkers, and the savage and drunken stupidity of the 'Hun', and death-defying feats by which people won their spurs.⁴²

As Sarah Street puts it, 'from this list it can be seen that film drama drew heavily on the obsessions of late Victorian dominant ideology: virtue, thrift, temperance, class society, nationalism, xenophobia, heroism'.⁴³ What separates the films discussed below is their distinctive Scottish perspective on these themes and the use of Scottish landscapes to enhance their authenticity, both at home and abroad. The timeless nature of these stories (even when apparently set in the present day) and their 'natural' settings suggest - and at times are directly concerned with - a contrast with the shallow sophistication of urban life.

Pre-war and wartime productions

Described by the *Bioscope* as a 'well written, domestic and sporting drama, with an interesting plot, and the beauties of the Scottish Highlands as a setting', *Black Roderick, the Poacher* was released in April 1914, seven months before *The Shepherd Lassie of Argyle*'s English release.⁴⁴ Like that film it had an original screenplay and was the product of a well-regarded British company, Union Films, which had been established in 1913 by Pathé and was released as one of its series of 'Big Ben' productions.⁴⁵ It was one of two Scottish films written and directed by H O Martinek in which he also starred opposite his sister, Ivy Martinek (now calling herself Ivy Montford, possibly to suggest that she was British): the other was *At the Torrent's Mercy*, which appeared a year later.⁴⁶ *Black Roderick*'s plot was summarised thus:

⁴² Low, *History of the British Film, 1914-1918*, p201

⁴³ Street, *British National Cinema*, p44

⁴⁴ *Bioscope*, 23 April 1914, p393

⁴⁵ Low, *History of the British Film, 1914-18*, p96

⁴⁶ Oceano Henry Oscar Martinek was born into a circus family in 1876, 'at sea, between St Petersburg and Stockholm' (IMDB)

Lord Dane, who is engaged to the daughter of Sir Ronald Cameron, and who spends a lot of his time in making love to Mary, the daughter of Donald, the gamekeeper. This latter fact is discovered by Roderick, the poacher, who when accused of poaching by Donald, betrays Dane to him with the consequence that there is a violent quarrel between the keeper and the lord. Coming suddenly upon Roderick shooting deer, Donald tries to arrest him but is badly wounded by the poacher, who throws the suspicion upon Dane. As the gamekeeper is unconscious and not expected to recover, the poacher believes himself safe, but Donald's almost miraculous revival saves the innocent and brings the guilty one to justice.⁴⁷

The *Scotsman* thought that, as a drama of Highland life, *Black Roderick, the Poacher* 'should appeal to Scottish people' not only for its 'intense interest', but also for the 'charming scenery amidst which the pictures have been taken'.⁴⁸ These sentiments were echoed by other newspapers, although none appeared to know, or specify, where the film was actually shot. While the 'striking beauty' of the scenery was noted, most Scottish papers preferred to describe it simply as 'a fine Scottish film' or a 'Highland drama, amid Scottish scenery'. The *Hamilton Advertiser*, however, while describing the characters in the film as reminiscent of those in *Rob Roy*, suggested that it may not have been filmed in the Highlands (or indeed in Scotland) after all: 'The scenery reminded one of the rugged Highlands, and was realistic in almost every detail'.⁴⁹ Perhaps by the time *Black Roderick* had reached Hamilton, three months after its release, word had got out that the Highland setting was not as authentic as the initial publicity suggested, but this did not appear to be of concern to Scottish exhibitors. In contrast, an advertisement for a New Zealand screening in July 1914 exaggerated its supposed authenticity in a poetic description of the 'stirring Scottish drama' as 'The real Mackay/ 'twill make your blood tingle/ a company of Kilties/A breath o' Scotland's heather/Ah, mon, but it's gran'/Scotland's mountains, moors and glens/ the genuine article/ come and see for yourselves/3000 feet of Scottish romance/Scottish scenic grandeur/all the elements of Roderick Dhu...'⁵⁰ The purpose of this hyperbole was of course, to emphasise *Black*

⁴⁷ *Walsall Advertiser*, 27 June 1914, p3

⁴⁸ *Scotsman*, 12 May 1914, p9

⁴⁹ *Aberdeen Evening Express*, 14 May 1914, p6; *Stirling Observer*, 9 June 1914, p5; *Hamilton Advertiser*, 18 July 1914, p6

⁵⁰ *Otago Daily Times*, 27 July 1914, p1

Roderick's appeal to a Scottish audience far from home. A Singapore newspaper, however, merely informed readers that the film featured Ben Webster 'of House of Temperley fame'.⁵¹

Martinek's second Scottish production, *At the Torrent's Mercy*, was treated in a very similar manner, but with greater conviction that 'all the scenes were laid in Scotland'. A laird in his baronial hall, gamekeepers in their cottages and poachers featured once again, 'and amid it all a beautiful young lady artist and a love story in which jealousy plays a part'.⁵² The story was said to conclude with a scene in which the laird presided over an 'old Scottish wedding breakfast'.⁵³ After its Scottish trade show at the Theatre de Luxe in Glasgow in early January 1916, the *Bioscope* predicted that this 'exceptionally well done' drama would go well with hard-to-please local audiences, as the mountain scenery was beautiful and 'the dresses are correct'. This was a covert reference to American-made Scottish films, whose fantasy versions of Scotland and Scottish attire were often criticised by the local trade press.⁵⁴ Like *Black Roderick*, *At the Torrent's Mercy* was commended for the technical quality of filming and its sensational and thrilling plot. 'Last night crowded audiences testified by hearty applause their appreciation of the fine picture,' remarked one Glasgow newspaper, which also asserted that this was 'a Scottish film in every respect. It was taken amidst Scottish scenery, and produced and enacted by Scots'. This was of course inaccurate: neither Martinek nor any of his cast were remotely Scottish, but at the same time indicates that when film-makers paid sufficient attention to detail in terms of costume and setting, their production was received as enthusiastically as if it had, indeed, been Scottish all respects. For exhibitors and audiences, the quality of the film and its gripping story was what mattered, rather than the producers' local credentials - or even the exact locations on which the film was made. If it looked Scottish, it was Scottish.

⁵¹ *Straits Times*, 19 June 1914, p11. *The House of Temperley* was a successful British drama of 1913, based on *Rodney Stone* by Arthur Conan Doyle and directed by Harold Shaw

⁵² *Perthshire Advertiser*, 3 June 1916, p2

⁵³ *Folkestone, Hythe, Sandgate & Cheriton Herald*, 1 April 1916, p6

⁵⁴ *Bioscope*, 13 January 1916, p219

Another wartime production of a well-established London production company, Clarendon, was the four-reel *On the Banks of Allan Water* (1916). Directed by Wilfred Noy, it was an adaptation of a famous ballad of the same name, in which a lovely miller's daughter is wooed in springtime by a soldier with a 'winning tongue'.⁵⁵ By the autumn the false soldier - the son of a baronet - has abandoned her, and on a winter's day her frozen corpse is discovered by the banks of Allan Water. The song's tragic ending was changed in the cinematic version: the soldier returns as a hero who 'arrives in the nick of time to rescue the miller's daughter, and the audience is left to decide for themselves whether the false soldier and his lovely bride find the happiness the song-writer denied them'.⁵⁶ As the ballad has only three short verses and the film was a full-length feature said to present 'an appealing story of Scottish life,' the filmic narrative must have had considerably more substance.⁵⁷ Newspaper reviews and advertisements highlighted three elements: the film's 'close adherence to the old Scotch ballad,' its revised (happy) ending and the authentic Scottish settings. The stars, Violet Leicester and Basil Gill, were sometimes mentioned, but generally in a secondary position.

Information about precise locations was once again lacking: the *Bioscope* told readers that many of the scenes were 'enacted on the banks of Allan Water,' while an advertisement for the film in the same paper announced that it was 'photographed on the famous beauty spots with which its name is associated'.⁵⁸ The Scottish press was unable to supply any more information, referring to the film as 'a delightful drama partly set in the romantic district of the Allan', featuring 'beautiful scenes of 'mountains, glens and rushing water'.⁵⁹ One English newspaper commented that as the film was 'delightfully set amid the natural romantic scenery of Bonnie Scotland, it is sure to make a great appeal to the country,' but it is unclear whether this was a reference to Britain as a whole or to Scotland.⁶⁰ There is no doubt that this was

⁵⁵ *On the Banks of Allan Water* is believed to have been written by the English author, socialite and MP Matthew Lewis (1775-1818)

⁵⁶ *Bioscope*, 15 February 1917, p741

⁵⁷ *Aberdeen Evening Express*, 22 January 1918, p4

⁵⁸ The Allan Water or River Allan in central Scotland rises in the Ochil hills and runs through Strathallan to Dunblane and Bridge of Allan before joining the River Forth

⁵⁹ *Sunday Post*, 15 April 1917, p9; *Aberdeen Evening Express*, 22 January 1918, p4

⁶⁰ *Derby Daily Telegraph*, 8 September 1917, p2

another example of a production filmed in Scotland whose main purpose was to look outwards rather than inwards. The producers took the trouble of travelling to Scotland during wartime not so much in order to please local audiences but to enhance the film's international appeal: as one (English) review noted, 'the beautiful views of the Scotch scenery make it as good as a travel picture'.⁶¹

The influence of Florence Turner is apparent, and not only in terms of a narrative in which the carefree young daughter of a Scottish rural worker is damaged by a man from outside her own social class, as in *The Shepherd Lassie of Argyle*. Turner Films' greatest British success, made a year before *On the Banks of Allan Water*, was an adaptation of Thomas Hardy's novel *Far From the Madding Crowd*. In this story the heroine, Bathsheba Everdine, also falls for a dashing young soldier who is not what he seems. At a sheep-shearing supper, Bathsheba sings 'On the Banks of Allan Water' - a narrative device used to prefigure her disastrous marriage to Sergeant Troy. Together with the popular success of *The Shepherd Lassie of Argyle*, these factors may well have helped to guide Clarendon's choice of subject. In addition, a romantic story in which a young soldier leaves his fiancée and returns just as she has given up hope of ever seeing him again would have had a distinct contemporary resonance for audiences in 1917.

Apart from Florence Turner's films, the only wartime production shot in Scotland to attract the interest of the Scottish trade press was *The Call of the Pipes*, (also known as *The Bonnie Banks of Loch Lomond* and as *Hear the Pipers Calling*)⁶² a five-reel war drama produced by Regal Films in 1917. Despite the fact that the film was 'rich with picturesque scenes' shot in the Loch Lomond area, *The Entertainer* considered it 'not a treatment expected of a Scottish story'.⁶³ Its atypical narrative was rooted firmly in the present day, with much of the action taking place in London. In some ways it appears to have been a corollary to *On the Banks of Allan Water*, told from the errant soldier's perspective and with a similar redemptive element. The story, written by H Grenville-Taylor, tells of a young man who is tired of 'peaceful'

⁶¹ *Nottingham Evening Post*, 29 May 1917, p3

⁶² *The Call of the Pipes* and *Hear the Pipers Calling* are incorrectly listed as separate films by IMDb and the BFI database

⁶³ *Entertainer*, 20 October 1917, p14

Highland life and evidently of his sweetheart, Mary, and goes to London. There he is dogged by misfortune, falls for an uncaring actress and 'reaches the border of criminality'. While lying ill in bed he hears the pipes of the London Scottish regiment as it passes his window. The pipes 'urge him to noble deeds'; he enlists in the Army and ultimately wins the Victoria Cross for saving the life of his colonel. He returns to Scotland a hero and reclaims his Mary, who has 'remained faithful throughout'.⁶⁴

Advertisements stressed that it had been filmed 'on Scottish soil' and, most emphatically, that it was 'not an American production'.⁶⁵ The *Bioscope*'s review was slightly disdainful in tone, admiring the beautifully photographed scenery, but dismissing the story of the 'Highland laddie, who has some small love affair in the Highlands'. Although the military scenes were thought unconvincing, it was believed that the film would probably be popular in the North.⁶⁶ The prediction proved accurate: Scottish exhibitors were enthusiastic and *The Call of the Pipes* was widely booked after its trade show in late October 1917, making its Glasgow debut at the Playhouse in Glasgow in early January 1918. In June 1918 the 'enormously successful Scotch film' was chosen for the gala re-opening of the Denny Cinema in Falkirk, and in 1921 it was re-released by the Glasgow renter George W Baker.⁶⁷ *The Call of the Pipes* may have been so well-received in Scotland because of its contemporary theme, in which the corrupting effect of London life was contrasted with the soldier's Highland home. It spoke directly to national pride, and Scottish viewers were probably less concerned about the representation of London than their southern British counterparts. The *Bioscope* praised the Scottish exteriors filmed around Loch Lomond, but poured scorn on the studio-made London scenes for lacking similar realism and attention to detail, complaining that 'no trouble has been taken to match studio "sets" with genuine exteriors... It is an astonishment to see an

⁶⁴ *Rochdale Observer*, 17 April 1918, p4; *Aberdeen Evening Express*, 17 May 1918, p1; *Gloucestershire Chronicle*, 19 April 1918, p8

⁶⁵ *Bioscope*, 5 October 1917, p51

⁶⁶ *Ibid*

⁶⁷ *KW*, 14 July 1921, p63

elegant and spacious apartment which is utterly incongruous with its plebeian outside'.⁶⁸

In addition to scenery, Scottish films were defined in part by their musical accompaniment. Music was used not only to enhance the emotional impact of the moving image, but also to reinforce its authenticity and to exploit the production's earning power.⁶⁹ Although it is beyond the scope of this chapter to go into detail about the musical accompaniment of each individual film, it is clear that the promotion of local performers playing appropriate music was regarded as an essential element of any advertising campaign, particularly in helping to identify the social class to whom the film might appeal. Advertisements did not always specify the pieces to be performed, but attention was generally drawn to the special selection of Scottish airs that would be played during (and sometimes before and after) the screening. Depending on the size of the cinema, the resources of the exhibitor and the anticipated popular appeal of the film, the musicians varied from a lone pianist to a vocal quartet, a full orchestra or a band of pipers. In Motherwell (and doubtless elsewhere), pipers were engaged to play during the screening of *The Call of the Pipes*, while in Perth Miss Dolly Rogers - said to be 'equal to the occasion' - played a 'specially appropriate "Scotch Selection"' for *At The Torrent's Mercy* on the piano. In Aberdeen the West End Cinema engaged the Scottish Quartette for (unspecified) 'renderings' to accompany a special Burns' Night screening of *On the Banks of Allan Water*.⁷⁰

Even in wartime, some London-based companies were prepared to travel to Scotland in order to shoot scenes on location. Unlike Florence Turner, however, these producers had no particular commitment to Scotland or to local audiences, but were attempting to capitalise on the international appeal both of Scottish stories and of the Scottish scenic film. At a time when American productions were threatening to overwhelm the British market, they must have believed that making the effort to film

⁶⁸ 'London as She Is Produced,' review of Glenville-Taylor Scottish Production, *Bioscope*, 5 October 1917, p52

⁶⁹ See Griffiths, *The Cinema and Cinema-going in Scotland*, p121

⁷⁰ *Motherwell Times*, 12 August 1921, p1; *Aberdeen Evening Express*, 22 January 1918, p4; *Perthshire Advertiser*, 3 June 1916, p4

in an authentic setting, dress the characters correctly and have them ‘speak’ in genuine Scottish vernacular (as written in intertitles) would give them the edge over their American rivals. It was not until after the war had ended that much larger-scale ‘Highlands’ filmed on Scottish soil would make any significant impact on either the Scottish press or on the local economy.

It was reported in 1916 that the internationally successful Scottish playwright Graham Moffat, author of *Buntly Pulls the Strings*, had visited some American film studios ‘with a view to studying methods at first hand’. *Kinematograph Weekly*’s Scottish reporter, noting that Moffat was a ‘shrewd Scot’, wondered what might be in the wind, but in the event Moffat must have decided that it was best to leave production to large, well-established companies.⁷¹ In 1923 Moffat addressed the Glasgow Rotary Club on the subject of ‘The Cinema and Melodrama’, expressing the opinion that ‘Scottish individuality was fast being lost’ as national differences between Scotland, England and even America were gradually eroded. In his view, it was only ‘the Scotland of the past’ that was capable of presenting an authentic vision of the country.⁷²

Post-war productions

Held back by the war, the main problem confronting the British film industry was the ever-increasing dominance of American companies and, as a result, British audiences’ growing taste for American films featuring stars such as Mary Pickford and Charlie Chaplin and the expensive and technically sophisticated epics of D W Griffith and Cecil B de Mille. Despite this (as discussed in the previous chapter), the post-war economic boom saw a resurgence of British feature production. Of a total of 881 feature films trade-shown in 1920, 147 were made in British studios. The renowned producer Sir Michael Balcon, who entered the industry in 1919, co-founded Gainsborough Pictures in 1924 and subsequently became head of production at Ealing Studios, later recalled that many of these films were ‘considered to be quite

⁷¹ *KW*, 9 March 1916, p90. Some ten years later Moffat produced his first (and only) film, *Till the Bells Ring*, using an experimental sound system. See Chapter 6

⁷² ‘Mr Graham Moffat on Play Writing’, *Scotsman*, 1 August 1923, p5

good', despite having been turned out in small studios which had scarcely changed since before the war:

The British feature film of 1920 averaged 5,500ft in length, took about four weeks to shoot, and cost less than £1 per foot. If a film was reasonably good it might obtain 500 bookings and the renters' receipts might touch £12,000... One of the biggest successes of that year was George Pearson's "Nothing Else Matters," which took four weeks to shoot, cost £7,000 to make and grossed about £30,000 in the domestic market and abroad. Other producers were less fortunate. It was a constant source of amazement to me how the British producers of the time managed to carry on.⁷³

Scotland and Britain

The early 1920s was a period in which British producers set out in earnest to find ways in which to emulate the success of American productions. The British National Film League, founded in 1921 to protect and develop the domestic industry, attempted to redress a situation in which younger cinema-goers were becoming increasingly attuned to American films. Leading players such as Ivor Novello, Betty Balfour, Stewart Rome and Alma Taylor were cultivated and promoted as home-grown stars in vehicles which sought to associate them with a particular kind of role. While the films in which they appeared could not emulate American production values, British producers attempted both to satisfy the domestic audience's taste for large-scale dramas and to create an identifiably British, quality product with export potential. In this context, it is not surprising that a number of Scottish subjects were chosen during the short-lived post-war boom in British film production. In contrast with, for example, typically unadventurous and middle-class English adaptations of stage productions, Scotland and Scottish stories, myths and legends offered the opportunity to create narratives with appeal to audiences across the class divide, at the same time representing a unique and recognisable aspect of Britishness. The productions filmed in Scotland between 1919 and 1923, when the decline in the domestic industry accelerated, represent a variety of ways in which Scottish stories and Scottish landscapes could be exploited and exported. Only in one production - an

⁷³ M Balcon, 'Thirty Years of British Film Production', *British Kinematography*, Vol 15 issue 4 (1949), pp 105-115 <http://the.hitchcock.zone/> (accessed August 2015)

episode of *The Vanishing Dagger*, made in 1920 - were images of modern, industrialised Scotland presented on screen.

The backgrounds to these films were largely rooted in Scottish nineteenth-century fiction, described by Andrew Noble as examples of ‘fictional impotence’ through which Scottish novelists failed to make any contribution to the great realist tradition. The city, and Glasgow in particular, made no appearance in ‘the literary imagination of educated Scotland’ for almost a century after the publication of Scott’s *Rob Roy*. Rather than depicting the ‘harsh reality of its grinding slum poverty, factories and its ostentatious wealth... the Scottish imagination retreated into the safe pseudo-pastoral; into a world of pietistic peasants of no radical aspiration or revolutionary protest and potential whatever’.⁷⁴

The first of the post-war productions in many ways fits the profile of the earlier group. *Bonnie Mary o’Argyle* (often referred to simply as *Bonnie Mary*), released in April 1919, was an adaptation of a popular Scots ballad filmed partly in the western Highlands, and generally agreed to be ‘so far easily the best example’ of this genre.⁷⁵ It was received within Scotland both as an ‘all-British production’ and as a ‘purely Scottish drama’, and received high praise from all quarters for its artistic and technical excellence and the ‘atmosphere’ captured by location filming.⁷⁶

One realises on seeing it how a splendid story and splendid acting would have been wasted had the picture been produced elsewhere than “on the spot.” It is all British, but its quality is so far ahead of many American productions, and so near the best of them that comparison is a waste of paper.⁷⁷

For once, the *Bioscope* concurred, applauding the admirable technical skill and artistic perception of the camerawork, and pronouncing that this was a film ‘which cannot fail to please the popular taste, on account of its homely, simple sentiment and the extreme beauty of its settings’.⁷⁸ A more detailed review called it a

⁷⁴ A Noble, ‘Urbane Silence: Scottish writing and the nineteenth century city’ in G Gordon (ed), *Perspectives of the Scottish City*, (Aberdeen 1985) p79

⁷⁵ *Scottish Cinema*, 29 September 1919, p16

⁷⁶ *Courier*, Dundee, 26 August 1919, p4

⁷⁷ *Hawick News and Border Chronicle*, 2 January 1920, p2

⁷⁸ *Bioscope*, 27 March 1919, p70

‘masterpiece’ and a ‘credit to British-made films’.⁷⁹ The Master Films production was written by Herbert Pemberton, adapted by Eliot Stannard and produced by A V Bramble, all three of whom already had film industry pedigrees.⁸⁰ The story once again featured lovers of different social classes; Rob, the son of a laird, and Mary, the daughter of a farmer. Faced with parental disapproval resulting from an ancient clan feud, they marry in secret, are disowned by their families, and flee first to Edinburgh - where Mary gives birth to a son - and eventually to London where Rob, an orchestral musician, hopes to find more lucrative work. But - as in *The Call of the Pipes* - London instead turns out to be the site of poverty, illness and despair. With Rob apparently on his deathbed, the laird and the farmer are sent for, resolve their differences, and all return happily and in good health to the Highlands. Music was an essential feature of the production; in an early scene, Rob is seen singing the title song, accompanying himself on the piano.⁸¹

Bonnie Mary set the stage for the larger-scale and higher-quality films that characterised Scottish-made films in the following four years. The film industry had matured, and after the Armistice the potential economic benefits of making Scottish stories on location - or, as the Dundee *Courier* put it, ‘in nature settings’ - became increasingly evident.⁸² The writer of this article, whose main purpose was to promote the idea of Scotland (and Dundee in particular) having its own film studio, noted that ‘any town where a studio was situated would benefit greatly, as large numbers of electricians, carpenters, and other workers are constantly employed by film companies,’ continuing:

A single picture may take six months to make, and two or three hundred persons may be engaged on it. When scenes are photographed in the country the company has usually to reside

⁷⁹ *Bioscope*, 12 December 1918, p27

⁸⁰ The playwright Herbert Pemberton’s first screenplay was *Nearer My God to Thee* (1917), directed by Cecil Hepworth. Eliot Stannard wrote scripts for at least 150 silent films, including eight of Alfred Hitchcock’s early films. A V Bramble began as an actor in films which included *At the Torrent’s Mercy*, and went on to direct some 30 films. In 1927 he co-directed *Shooting Stars* with Anthony Asquith

⁸¹ BFI, N-36685, Herbert Pemberton Collection, handwritten script for *Bonnie Mary*

⁸² *Courier*, Dundee, 18 June 1919, p8

on the spot for a time, so hotel-keepers and others would reap a rich harvest.⁸³

While the dream of a permanent Scottish studio that would benefit local workers was to remain unfulfilled, this period saw the incursion of film companies who made Scottish towns and villages their temporary home while on location, undoubtedly boosting the profits of hotel and other local businesses during a stay of several weeks. The first of the big post-war productions was *Christie Johnstone*: during filming in the village of Auchmithie in late April and early May of 1921, the Broadwest company took over the White Hart Hotel in the nearest town, Arbroath.⁸⁴ Its charm for the visitors would have been enhanced by the knowledge that both Robert Burns and Walter Scott had stayed there, and out of the usual tourist season the presence of a sizeable film company would have been particularly beneficial. The Bailie Nicol Jarvie Hotel in Aberfoyle - used by United Films during filming of *Rob Roy* in 1911 - hosted companies from Gaumont's film of the same title in 1922 and from the Stoll Film Company's *Young Lochinvar* in 1924. Accommodation during filming of *Bonnie Prince Charlie* on Arran in July 1923 was hard to find, as the *Bioscope*'s Scottish reporter noted: 'Even Gladys Cooper's name did not lighten the labours of those who had the arranging of rooms for the company in Arran... and [an account of it] would provide a good comedy film plot'.⁸⁵

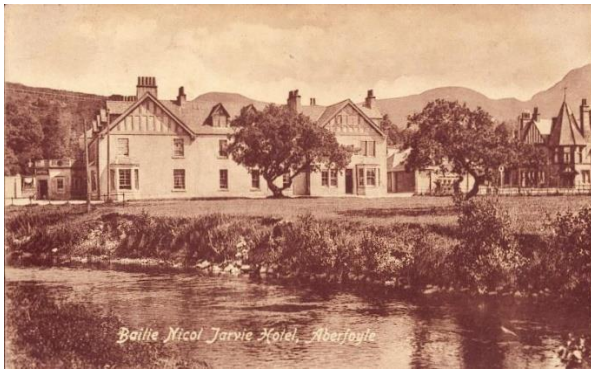

Figure 11: The Bailie Nicol Jarvie Hotel, Aberfoyle, a popular base for visiting film companies. Paris-Roubaix, nd. <https://www.flickr.com/>

⁸³ *Courier*, Dundee, 18 June 1919, p8

⁸⁴ *Bioscope*, 25 May 1921, p27; *ibid*, supp p xix; *Dundee Courier*, 22 April 1921, p5

⁸⁵ *Bioscope*, 12 July 1923, p49

Hoteliers lost out with the filming of *The Romany* (Welsh Pearson) in Perthshire in August 1922: no accommodation could be found during the holiday season, and Victor McLaglen and the cast and crew ended up living ‘under canvas’ alongside gipsy caravans on the Duke of Atholl’s estate at Blair Atholl, Perthshire, for two weeks.⁸⁶ But even without hotel rooms, the presence of several hundred incomers would have benefited local businesses.⁸⁷ The numbers of personnel involved varied according to the nature of the production, but even films that did not require a large cast and elaborate historical reconstructions necessitated the presence of a sizeable location company. In September 1921, for example, the *Bioscope* reported that producer Donald Crisp of Famous Players-Lasky British had been searching for suitable locations for a forthcoming adaptation of Ian Maclaren’s *Beside the Bonnie Brier Bush*.⁸⁸

After motoring hundreds of miles, Crisp at last found the Drumtochty of his dreams, thatched roofs, brier bushes and all, near Killen [sic] on Loch Tay.⁸⁹ Arrangements have been made for the "shooting" of the exteriors in that locality, and also for the accommodation of the two hundred people who will assist in the making of the picture.⁹⁰

As it turned out, the *Bioscope*’s information was incorrect: the two hundred people were destined for Somerset rather than Scotland. A rival trade journal reported that the producers had been disappointed with the ‘natural environment’ of Maclaren’s famous book and stage play:

It was found that the cottages which should have provided the picturesque setting had lost their thatch, and had been roofed with corrugated iron! A wig could never be as good or look as well as natural hair, and Scotch cottages with corrugated iron roofs were unthinkable. So hoping to find the right article, Donald Crisp resorted to the West Country, and discovered in the pretty little village of Selworthy, which has been described

⁸⁶ *SKR*, 5 August 1922, p1

⁸⁷ *Bioscope*, 9 November 1922, p44

⁸⁸ Ian Maclaren was the pen name of John Watson

⁸⁹ Killin, sometimes referred to as the ‘gateway to the Highlands’, is a village at the western head of Loch Tay in Perthshire

⁹⁰ *Bioscope*, 9 June 1921, p45

as the most beautiful village in the kingdom, the ideal setting for his picture.⁹¹

As the article concluded, ‘what is one country’s loss is another’s gain’, and not just in terms of the potential economic benefits. In the case of *The Bonnie Brier Bush* (and later films, notoriously *Brigadoon* in 1954) the real Scotland was simply not ‘Scottish’ enough, failing to live up to the romanticised image created for it in the art and literature of the eighteenth and nineteenth centuries.

The critically-despised traditions of tartanry and kailyard emerged, as Jeffrey Richards has noted, in order to give Scotland a distinctive cultural identity that was not English.⁹² It is all the more ironic that a film emanating from a prime example of kailyard literature - a volume of nostalgic tales of Scottish life based on the author’s experiences as a Free Church minister in rural Perthshire, first published in 1894 - should end up being filmed in England. Despite this, *The Bonnie Brier Bush* was received with enthusiasm by the Scottish trade on its release in December 1921, and reviews demonstrate that if a production was well-made and entertaining enough its lack of authenticity could be indulged or simply overlooked. The *Scotsman* predicted correctly that, ‘with its mixture of pathos, humour and quaintness’ *The Bonnie Brier Bush* would have universal appeal: four months after its release it was being promoted as ‘the story that has won the world’. The *Dundee Evening Telegraph* claimed that the company had spent five weeks in the Highlands filming ‘beautiful Scottish exteriors’, also praising the ‘quaint costumes of 1870’ and the magnificent ball scene in the banqueting hall of Drumtochty Castle, which presented ‘an interior typical of a Scottish nobleman’s ancestral home’. It is possible that general views of Highland scenery were indeed filmed, as the *Edinburgh Evening News* also asserted that ‘the scenes were taken amid some of the most picturesque scenes [sic] in the Scottish glens’, but equally possible that exhibitors and advertisers had a careless lack of regard for the facts.⁹³ It was left to the *Bioscope* to point out that the ‘verdant, rose-laden villages of Devonshire’ [sic] made an unconvincing Scottish background

⁹¹ *KW*, 14 July 1921

⁹² J Richards, *Films and British National Identity: from Dickens to Dad’s Army* (Manchester, 1997), pp175-176

⁹³ *Scotsman*, 2 January 1923, p7; *Hawick News and Border Chronicle*, 9 March 1923, p2; *Evening Telegraph*, Dundee, 28 November 1922, p9; *Evening News*, Edinburgh, 10 May 1923, p7

despite a profusion of sheep and tam o'shanter, and that the film was 'no more convincing as a picture of North British life than if it had been produced in America'. This lack of realism was of no great concern; provided that the 'subterfuge' was accepted, *The Bonnie Brier Bush* was declared to be a very good picture.⁹⁴ The *Bioscope*'s Scottish reviewer was more critical. While agreeing the film was a masterpiece in terms of its production and that it was certain, 'even in Scotland', to be a winner at the box-office, 'from the Scottish historical and characteristic standpoint' it was said to resemble a curate's egg.

It has many faults observable to those who know Scottish country character, but most audiences are blind to these. The kirk scenes bristle with inaccuracies. The elders' "lum hats" are too, too, modern, while in the kirk itself we missed the pulpit, the precentor, and the beadle - without which a country kirk of the Drumtochty type - even today - would be incomplete. Donald Crisp is evidently not acquainted with the kirks of the land of his nativity.⁹⁵

In the years before, during and after the film's appearance, a stage adaptation of *The Bonnie Brier Bush* could be seen in theatres throughout Britain. Favoured by amateur dramatic societies, the play was also performed by professional companies with a cast that regularly included John Clyde and Durward Lely of the United Films' *Rob Roy*.

The reception of *The Bonnie Brier Bush* in Scotland illustrates a flexible attitude towards productions that failed to meet certain standards of authenticity. English-made versions of Scottish stories were generally regarded as far superior to those made in America, but quality and box-office potential were the overriding factors. When the famous French director Maurice Tourneur's entirely American-made production of *The White Heather* was showing at the St Enoch in Glasgow in May 1920, for example, the *Entertainer and Scottish Kinema Record* had nothing but praise for the 'unique and thrilling spectacle' offered by this masterpiece, commenting that 'Scottish people will find the picture a true to life portrayal of the

⁹⁴ *Bioscope*, 1 December 1921, p57

⁹⁵ *Bioscope*, 8 December 1921, p53

Highlands - not an American travesty'.⁹⁶ It was unusual for any American Scottish film to be praised in this way, but the comment demonstrates that each film was assessed on its own merits. There was no guarantee that shooting a film in its 'natural setting' would make it a success with Scottish audiences.

The post-war films made in Scotland by non-native producers can be divided into two main categories: those based on adaptations of kailyard stories and newly-written but thematically similar scenarios, and those (such as *Bonnie Prince Charlie* and *Rob Roy*, discussed below) based on history and legend, 'enshrining the myths and images of tartanry, the clans, the national struggle and heroic defeat'.⁹⁷ Both groups, and indeed all the films made in Scotland in this period - apart from a single Glasgow-set episode of the 1920 film serial *The Vanishing Dagger*- fall within the Highland genre as anti-modern and anti-city narratives. As well as *The Bonnie Brier Bush* - whose title alludes to the first line from a traditional Jacobite song, 'There grows a bonnie brier bush in our kailyard'⁹⁸ - the first group includes *Christie Johnstone* (1921, from the novel by Charles Reade), *The Lilac Sunbonnet* (1922, novel by S R Crockett) and *The Wee Macgregor's Sweetheart* (1922, stories by J J Bell). The leading writers of the kailyard group, with the exception of J M Barrie, were all represented. Many versions of Barrie's plays were filmed, but none in Scotland.⁹⁹

Kailyard stories

Kailyard writers relied, as Richard Cook has noted, on 'imaginary versions of the Scottish Highlands as original Scottishness that distinguish them from England or the industrial lowlands of Scotland'. The Highlands were not only geographically isolated from the rest of Britain, but also morally and culturally separate.¹⁰⁰ The

⁹⁶ *ESKR*, 15 May 1920, p11. *The White Heather* was an adaptation of a Drury Lane drama, noted for scenes in which Tourneur filmed under the sea

⁹⁷ J Richards, *British Films: from Dickens to Dad's Army*, p190

⁹⁸ The Scots term 'kailyard' means a small cabbage patch or kitchen garden. The song is called 'The Cuckoo's Nest'

⁹⁹ Early filmic adaptations of J M Barrie's stage plays include four versions of *The Little Minister* and three versions of *The Admirable Crichton*. For a complete filmography see <http://thebioscope.net> (accessed July 2015)

¹⁰⁰ R Cook, 'The Home-ly Kailyard Nation: Nineteenth Century Narratives of the Highland and the Myths of Merrie Auld Scotland', *English Literary History* vol 66 no 4 (1999), pp1053-1073

novels, often written in episodic form, were love stories celebrating the values of a simple, rural existence: humility, modesty, community, piety and poverty. In these narratives the amusing local peasant characters spoke in Scots dialect, while the professionals - typically a doctor, minister, lawyer or dominie (teacher) - used standard English, and this was evidently also the case with filmic versions.

Although 'kailyard' later became a derogatory term, associated with writing that presented a sentimental, backward-looking and sanitised version of rural and small-town Scottish life, the novels and stories were extremely popular with the reading public. The first printing of 10,000 copies of Crockett's *The Lilac Sunbonnet*, for instance, sold out on the day of publication in October 1894. *Beside the Bonnie Brier Bush*, published in 1896, attracted such a wide readership (said to include Queen Victoria and W E Gladstone) that by 1908 it had sold 256,000 copies in Britain and 485,000 in North America.¹⁰¹ Kailyard novels were best-sellers in Britain, the USA and in Canada until around 1900, and indeed it has been argued by scholars such as William Donaldson that the writers of these stories - most of whom no longer lived in Scotland - tailored them predominantly to an Anglo-American readership.¹⁰² Not only was such fiction popular, but it also 'gained the reputation of representing the real Scotland - authentic literature peering into the heart of Scottish nation, culture, and life'.¹⁰³

It is hardly surprising that kailyard or quasi-kailyard stories were chosen by English film-makers striving to make identifiably British, exportable, products. The popularity of the original fiction with audiences in the countries they wished to reach, with the added dimensions of authentic scenery, the on-screen presence of real Scottish 'characters' and the accompanying traditional Scottish music must have been thought to guarantee such films' success. These were well-made, entertaining and uncontroversial features directed at an international audience, including those of

¹⁰¹ R Zumkhawala-Cook, *Scotland As We Know It: representations of national identity in literature, film and popular culture* (Jefferson, NC, and London (2008), p29

¹⁰² A Nash, 'Literary Publishing, 1880 to 1914' in D Finkelstein and A McCleery (eds) *The Edinburgh History of the Book in Scotland*, vol 4 (Edinburgh, 2007) p216, referring to W Donaldson, *Popular Literature in Victorian Scotland*, (Aberdeen, 1986) p145

¹⁰³ Zumkhawala-Cook, p29

Scottish ancestry. Just as the original stories were aimed at audiences far beyond Scotland, so were the films.

As these productions grew in size and scale, so did the interest of the Scottish press. This was partly the result of the use of local people as ‘supers’ (extras) and partly the presence of some of the most popular new British stars: Stewart Rome in *Christie Johnstone*, Betty Balfour in *The Wee Macgregor’s Sweetheart*, Victor McLaglen in *The Romany*. Lengthy accounts in the Scottish trade and local press of production activity and interviews with members of the visiting company help to identify precise filming locations. Even so, there were occasions on which exhibitors appeared unclear about whether a film had actually been shot in Scotland.

As in the case of *The Bonnie Brier Bush*, the original intention of producers to film in authentic locations was sometimes thwarted, leading to ambiguous accounts in the trade and local press. *The Lilac Sunbonnet* is another such example: while the *Entertainer and Scottish Kinema Record* noted that ‘pleasing scenes [had been] taken in the Trossachs’ and the *Bioscope* thought the ‘Scottish settings’ were very beautiful, Scottish newspapers advertised it simply as ‘S R Crockett’s famous novel of the Scottish Highlands’ without mentioning any locations. A film gossip column in one northern newspaper noted that the English actress Pauline Peters, after finishing work on *The Missioner*, had ‘gone off to Scotland to play in the Sidney Morgan production, “A Lilac Sunbonnet”’ [sic], suggesting that some scenes were indeed shot in the Highlands.¹⁰⁴ Other accounts, however, state that the film was shot in and around Shoreham-by-Sea and Brighton, Sussex. The writer and director Sidney Morgan’s Progress Film Studios were certainly in Shoreham: known as the Shoreham Beach Studio, *The Lilac Sunbonnet*, which starred the director’s daughter, Joan Morgan, was the last film to be made there before part of the facilities burned down.¹⁰⁵ An adaptation of Walter Scott’s *The Fair Maid of Perth* (1924) was another such example: although the *Dundee Courier* stated before filming began that the services of local supers would be required as ‘it is probable that a considerable part,

¹⁰⁴ SKR, 1 July 1922, p2; *Bioscope*, 20 July 1922, p52; *Evening Telegraph*, Dundee, 5 April 1923, p2; *Hull Daily Mail*, 12 October 1921, p2

¹⁰⁵ www.brightonfilm.com/films_made_in_shoreham.htmThe Lilac Sunbonnet (accessed June 2015)

if not the whole, of the story will be filmed within the Fair City [Perth] and its environs' and, in a subsequent review, that 'all the scenes were taken in Scotland', it was also announced in the *Bioscope* that 'The many friends of Mr Russell Thorndyke ... will learn with regret that, as the result of an accident whilst taking part in the film production of "The Fair Maid of Perth" in Ashdown Forest [Sussex], he will be incapacitated for some time'.¹⁰⁶

The Lilac Sunbonnet was warmly received both within and outwith Scotland. Apparently faithful to Crockett's novel and described by the *Bioscope* as 'a pretty love story', the narrative told of young lovers confronted by religious bigotry and social convention. Ralph Peden, son of a minister of a strict Kirk of Scotland sect, goes to the Highland village of Dullarg to study divinity with the Reverend Allan Walsh. There he meets and falls in love with Winsome Charteris, who has been brought up by her grandfather, an elder of the Kirk. Unknown to Winsome, she is actually Allan Walsh's daughter. Walsh had eloped to Gretna Green with Ralph's father's betrothed, 'an action which constituted so grave a scandal that to expiate its offence and still remain in his position, it was decreed by the elders that he should renounce all claim to his child'.¹⁰⁷ Ralph is told that for this reason it is impossible for him and Winsome to marry. All ends well: a meeting between the two old men settles their differences and the marriage is sanctioned.

The *Scottish Kinema Record* noted that the *The Lilac Sunbonnet* presented many typical 'scenes of Scottish life', including one of blanket washing by a stream.¹⁰⁸ From the eighteenth century such images of everyday life were, in the art historian Anne McLeod's words, 'absorbed into the romantic iconography of Highland life' as a form of primitivism. These images, which included household customs such as washing out of doors, subsistence fishing and the living conditions of the poor, were seen by 'improvers' as hallmarks of backwardness, but 'to the romantic, it was their status of emblems of an earlier age which gave them value'.¹⁰⁹ In the twentieth

¹⁰⁶ *Courier*, Dundee, 16 October 1923, p6; 8 December 1925, p8; *Bioscope*, 29 November 1923, p57

¹⁰⁷ *Bioscope*, 20 July 1922, p52

¹⁰⁸ *SKR*, 1 July 1922, p2

¹⁰⁹ A MacLeod, *From an Antique Land: visual representations of the Highlands and Islands 1700-1880*, (Edinburgh, 2012), p175

century the cinematic exploitation of this repertoire of images helped to preserve and perpetuate what was already believed to be the essence of Highland life. After the trade show, the SKR praised *The Lilac Sunbonnet* for its pleasing scenes in the Highlands, remarking that it was a ‘British production well done, that should go particularly well in any house in Scotland’. Music to accompany the film included ‘Annie Laurie’ and ‘Blue Bells of Scotland’ as well as some of Harry Lauder’s songs.¹¹⁰

Not all kailyard fiction was set in the Highlands, however. *The Wee Macgreegor’s Sweetheart* (1922), based on popular stories by J J Bell, was ‘a story of Glasgow life’ - but a very different Glasgow from that of *Football Daft*, made in the same year. Bell’s career began in journalism and his (self-published) first novel, *Wee MacGreegor*, was based on a series of sketches about the comical adventures of a young Glasgow boy which appeared in the *Evening Times* between 1901 and 1902. The novel, written in Glasgow dialect, presented a sentimental and stylised picture of working-class life and was an instant success: it sold over a quarter of a million copies and was quickly ‘pirated’ in North America.¹¹¹ In 1904 a sequel called *Wee MacGreegor Again* was published, and more than ten years later Bell returned to the successful formula with *Wee MacGreegor Enlists* (1915).¹¹² In the meantime Bell created another Glasgow ‘incorrigible’, a female counterpart to the Wee MacGreegor, who first appeared in *Oh! Christina!* (1909) and subsequently in *Courtin’ Christina* (1913). Christina also appeared as MacGreegor’s sweetheart in *Wee MacGreegor Enlists*, and it was a blend of stories about these two characters on which *The Wee Macgreegor’s Sweetheart* was based, with the British star Betty Balfour playing the title role. Balfour was already an extremely popular actress

¹¹⁰ SKR, 22 July 1922, p2

¹¹¹ Bell had not considered taking out copyright, as he recounted in the introduction to *Wee MacGreegor*. ‘Introduction: the Story of the Book’, <http://gutenberg.net.au/ebooks11/1100201h.html> (accessed September 2015)

¹¹² T Royle, *The Mainstream Companion to Scottish Literature*, entry on J J Bell (Edinburgh, 1993) (ebook, no page numbers)

sometimes referred to as ‘our own Mary Pickford’, and her starring role in *Squibs* (1921) had confirmed her talent for comedy.¹¹³

The Welsh-Pearson production appeared in 1922, only seven years after the last Wee MacGregor novel was published. According to the director George Pearson, J J Bell himself proposed putting the character on screen:

Bell had been very successful with a series of short stories built around a little Glasgow laddie... He had also written a joky tale of a young harum-scarum lassie, “Oh! Christina!” Perfect material for Betty. He agreed that we might combine both under the title of “The Wee Macgregor’s Sweetheart”. Merged together, they made a merry tale of two young lovers always in trouble, due to the guileless Macgregor and the fiery, irrepressible Christina.¹¹⁴

The film was made in its ‘correct Scottish locations’: Glasgow, Edinburgh and the Isle of Bute. This was thought important, as ‘the environment would give true colour to the story’. Pearson’s autobiography recounts amusing incidents in the pursuit of authenticity, including one occasion when Bell himself had to intervene after the cast and crew - despite having a filming permit - were frogmarched from Kelvingrove Park in Glasgow by two ‘burly constables’ who claimed that the permit was a forgery.¹¹⁵

The finished film was a triumphant success for Pearson and for Bell. Often advertised as *The Wee Macgregor’s Sweetheart*, it was top of the bill on its release throughout Britain. After a private screening in Glasgow prior to its release, the *Sunday Post* pronounced that the Glasgow and Clyde scenes were ‘capital,’ the musical accompaniments ‘stirring and appropriate’ and that the film would be ‘appreciated from Land’s End to John O’Groats’.¹¹⁶ Scotland was happy to receive the film as a ‘story of Glasgow life’, as envisioned by J J Bell. ‘The picture had caught all the quaintness and humour, the truly Glasgow humour, which abounds in J

¹¹³ Betty Balfour was to become best known for her starring roles in the series of *Squibs* comedies, comprising *Squibs Wins the Calcutta Sweep* (1922), *Squibs M.P.* (1923) and *Squibs’ Honeymoon* (1923)

¹¹⁴ G Pearson, *Flashback*, (London, 1957) p99

¹¹⁵ *Ibid*

¹¹⁶ *Sunday Post*, 13 August 1922, p11

J Bell's books, and no wonder patrons were enthusiastic over it,' said the *Motherwell Times*' reviewer. The comforting nature of the story was also appreciated: 'As one lady was overheard to say on the street, "It really does you good to be there."' ¹¹⁷ In Dundee, the film was received as a 'brilliant example of how to screen the spirit of a book as well as its action' - the writer observing that this was an art in which American productions, as well as British, often failed. The *SKR* called *Wee Macgreegor* a 'right good Scottish story', adding that '[it] is going particularly well up here, which is just as it should do'. ¹¹⁸ The production and reception of this film serve as a reminder that in the early 1920s kailyard fiction was by no means outmoded, and that such stories could have a contemporary setting. In the case of *The Wee Macgreegor's Sweetheart*, the writer adapted his own work for the screen: a particularly clear example of the way in which 'Scottish films' and kailyard were bound together almost from the start.

There are no press accounts of the filming of *The Wee Macgreegor's Sweetheart*: the cast and crew were not resident in one area for long, and the production did not call for crowds of local extras. It was very different when the Welsh-Pearson company returned to Scotland the following year to film *The Romany*, written by Eliot Stannard and directed by F Martin Thornton. Once again, real Scotland proved disappointing: on a scouting trip in Perthshire, the producers failed to find any 'picturesque caravan gipsies' in the neighbourhood and filming was postponed. ¹¹⁹ Authentic gipsies were later tracked down at Buckie Fair in north-east Scotland. They 'gladly and enthusiastically joined forces' under the leadership of king and queen Samson and Wilhelmina Young (from Epping Forest) and with their 16 caravans, 50 horses and 195 caravan and tent dwellers, their presence was said to have 'attracted great attention from the many holiday makers in the district'. ¹²⁰ The romantic story had some similarities with *The Wee Macgreegor's Sweetheart*, notably a snobbish aunt whose disapproval of her niece precipitates the narrative. In *The Romany* the niece is a Scottish maid, Flora, who runs away from the suitor

¹¹⁷ *Motherwell Times*, 28 September 1923, p6; 21 December 1923, p1

¹¹⁸ *Courier*, Dundee, 1 May 1923, p8; *SKR*, 26 August 1922, p3

¹¹⁹ *SKR*, 5 August 1922, p1

¹²⁰ *Bioscope*, 9 November 1922, p44; *SKR*, 26 August 1922, p1

picked out by her wealthy aunt, and is sheltered by a chivalrous Romany chief. His action 'incurs the superstitious wrath of his followers and the jealousy of his gipsy sweetheart'. The unwanted suitor is killed in a thunder storm, leaving Flora free to marry her real sweetheart Robbie, and in doing so allows the gipsy couple to be happy again.¹²¹ George Pearson, recalling how he had travelled to Blair Atholl to help sort out Thornton's problems with finding facilities, summarised *The Romany's* plot as 'a tale of colourful adventures with a Gipsy Band in the Scottish Highlands'.¹²²

Filming took place in Perthshire at Dalnaspidal - amid the 'frowning Grampian mountains' - and Glen Tilt, close to Blair Atholl.¹²³ *The Romany's* star was Victor McLaglen, a former boxer who appeared in several British films in the early 1920s before moving to Hollywood. His presence was well publicised, and regular bulletins concerning his close involvement with gipsy life during several weeks of camping out on the Duke of Atholl's estate surrounding Blair Castle helped to enhance the film's Scottish credentials - in England, if not in Scotland. On his return to London, McLaglen was quoted as saying that he did not know how he would ever settle down to city life again, having learned to do the eightsome reel and the sword dance and claiming to 'wear a kilt all the time'.¹²⁴ His character acting as the Romany chief and that of the gipsy heroine - played, it was revealed after the London trade show by the Marchioness of Queensberry, making her screen debut under the name of Ida Fane - was applauded by the *Bioscope*, but most praise was reserved for the Scottish exteriors:

Scenically and photographically the film is an outstanding piece of work, enormously to the credit of Mr Thornton and Percy Strong, his cameraman. Rarely, if ever, has the characteristic atmosphere of Scotland been so faithfully interpreted in screen pictures.¹²⁵

¹²¹ *Bioscope*, 18 January 1923, p66

¹²² Pearson, *Flashback*, p100

¹²³ *Bioscope*, 9 November 1922, p44

¹²⁴ *Bioscope*, 5 October 1922, p54

¹²⁵ *Bioscope*, 18 January 1923, p66

The Dundee *Courier*, however, was at pains to disagree. In a lengthy and excoriating review it described the Scottish characters as ‘on lines from American-made films’, which it found particularly disappointing of a film made in Glen Tilt:

One expected something better than a caricature of Scottish characterisation. The film idea of a Scot seems to be: Take a man, put a tam o’ shanter on him, a gravat¹²⁶ even on a summer’s day round his neck or a plaid over his shoulder, and make him produce - at least once - a gill bottle. The herdsman in “The Romany” fits this bill. He produces a bottle, takes a sup, and talks about “ma maister’s lands.” Other characters have their gravats, though every other person in the film is clad for summer.¹²⁷

The Scottish subtitles were also considered a weak point (‘no-one in Scotland says “weel” when they mean “will”’) although the reviewer conceded that there were ‘difficulties in producing satisfactory realistic Scots on the screen’; indeed, it was ‘difficult to recall a film where the detail in this respect is without blemish’.¹²⁸ Eliot Stannard was an accomplished screenwriter, but he was careless in his rendering of the Scots vernacular. The *Bioscope*, however, was unaware that anything was amiss, describing the subtitling and dialogue as good but occasionally ‘a little stilted’, while remarking condescendingly that ‘such a phrase as “this mad philandering” does not sit well on the lips of a Scottish countrywoman’.¹²⁹

Even the disgruntled Dundee reviewer, however, found something positive to say about the film’s scenic attractions, particularly the magnificent views of Glen Tilt. If *The Romany* could not present credible Scottish characters to the world, at least it provided an opportunity to appreciate real Scottish scenery. Despite all the carping, the story itself was thought to be ‘quite good’, with a boldly depicted ‘gipsy element’, and there was no implication that local audiences would be put off by the unsatisfactory representation of Scots or the Scottish vernacular. This was another high-quality and technically sophisticated production, and its presentation was accompanied by a ‘remarkable’ musical accompaniment said to include ingenious

¹²⁶ Woollen scarf

¹²⁷ *Bioscope*, 18 January 1923, p66

¹²⁸ *Courier*, Dundee, 25 September 1923, p7

¹²⁹ *Ibid*

atmospheric effects - presumably including those representing the dramatic thunder storm towards the end of the film. The *Bioscope* noted that the score had been arranged by Louis Levy, musical director of the New Gallery Kinema, whose picture settings had made him 'justly famous'.¹³⁰ Band parts for a large or small orchestra, with an explanatory score of the effects to be used, were made available to exhibitors.

The gap between the actuality of Scottish life and outsiders' view of it was reinforced away from the screen. Publicity surrounding the Scottish-made films tended to emphasise quaintness and difference, as if the London-based visitors had travelled through time as well as distance on their journey to a location shoot. Newspaper and magazine reports often focused on the sophisticated southern screen actors' first impressions of the Scottish locality and its inhabitants. 'Oh, do look at a real fisher girl in a real costume!' exclaimed one of the members of the cast of *Christie Johnstone*, as the train bearing members of the Broadwest Film Company arrived in Arbroath in April 1921.¹³¹ Actors frequently revealed (or discovered) a Scottish heritage: the film's female star, Gertrude McCoy, told the same reporter that although this was her first visit to Scotland, her father was 'Scotch-American. Scotch, that is'. Despite this connection, most anecdotes highlighted the gulf separating visitors and natives. The English actress Mercy Hutton complained that, during filming of *Christie Johnstone*, her greatest trouble was trying to understand the children. 'I don't think I should ever talk Scotch... it's worse than American!'¹³² Even the horses behaved differently: the only 'smart-looking' horses to found in Auchmithie (the main location for *Christie Johnstone*) were those normally used to pull a funeral hearse, and insisted on walking one behind the other rather than side by side as the scene required.¹³³ A bulletin sent after the company's return to London served to reinforce the notion of Scotland as a quaint, faraway holiday destination, reporting that they had arrived back with 'tanned faces and full of enthusiasm about

¹³⁰ *Bioscope*, 18 January 1923, p47. The New Gallery Kinema was in Regent Street, London. As its resident musical director and band leader, Louis Levy was a star in his own right

¹³¹ *Courier*, Dundee, 20 April 1921, p5

¹³² *Sunday Post*, 15 May 1921, p9

¹³³ *Courier*, Dundee, 13 May 1921, p4

the beauty of the Scottish scenery and the big welcome accorded them in the “Land o’cakes”.¹³⁴

Local colour

Christie Johnstone was the first post-war production to employ significant numbers of local people. Most of the 60 locals were ‘supers’ in crowd scenes, but individual villagers were also used to add authentic local colour to this ‘close study of Scottish fisher folk’ during location filming in late April and early May 1921.¹³⁵ The original novel of 1853 by the English writer Charles Reade was set in the fishing village of Newhaven, near Edinburgh, but ‘on account of unromantic modern amenities that [had] changed Newhaven during the past fifty years from the original charm of the period of the story’, the better-preserved village of Auchmithie, near Arbroath, was chosen as a substitute.¹³⁶ Locations included the harbour, village and Arbroath Abbey. Excited by this turn of events, the local paper claimed that the Arbroath area could equal Cornwall for filming purposes.¹³⁷ The production, directed by Norman McDonald and starring Stewart Rome alongside Gertude McCoy, attracted much Scottish press interest, particularly that of a reporter from nearby Dundee who - having observed proceedings alongside a crowd of curious locals - reported that 38 scenes were shot from the beach in the course of a single day.¹³⁸

¹³⁴ *Courier*, Dundee, 13 May 1921, p4

¹³⁵ *Evening Telegraph*, Dundee, 28 April 1921, p5; *SKR*, 30 April 1921, p6

¹³⁶ NLS/MIA, 4/4/118, ‘Edina Notes’: cutting from the *Kilmarnock Standard*, nd

¹³⁷ *Arbroath Herald*, 25 March 1921, p4

¹³⁸ *Courier*, Dundee, 22 April 1921, p5



Figure 12: Advertisement for *Christie Johnstone*, *Kinematograph Weekly*, 8 September 1921

The story followed the adventures of wealthy, bored Viscount Ipsden (Stewart Rome) who is sent to the Scottish fishing village for the sake of his health. There he falls for Christie Johnstone, a beautiful fisher-girl, but she has lost her heart to a visiting artist. Ipsden decides to help ‘smooth her difficulties’ which include the opposition of the artist’s dotting mother. But when Christie and Ipsden save the artist from drowning, problems dissolve and ‘everyone becomes engaged to the right person in the beautiful glow of a summer evening on the Auchmithie beach’.¹³⁹

The presence of the locally-recruited extras and the naturalness with which they played their parts helped to add authenticity. Their behaviour was observed with a kind of ethnographical interest:

When the viscount lands at Auchmithie he converses with several of the natives, who, seated on the doorsteps of their little whitewashed cottages, appear to enjoy being filmed. One old fisherwife seated between two brawny fishermen carries on an intermittent conversation with the cinema star between puffs at a clay pipe, while later a bearded native seated on a boulder

¹³⁹ *Arbroath Herald*, 6 October 1922, p3

offers one of the actors a pinch of snuff, which is declined with disdain.¹⁴⁰

Many of the Scottish-made feature films served as scenics as well as narratives, but *Christie Johnstone* incorporated a third function, that of the local topical. Such films - taken of local people at work and play, visits by dignitaries, marches, parades and so on - continued to flourish in the 1920s. Added to the programme of films at the nearest cinema or town hall, they encouraged people to come along and see themselves on screen. A newspaper article of October 1922 reported that the previous evening 'many of the fisher-folk of Auchmithie travelled to Arbroath in order to see themselves and their village on the screen' where *Christie Johnstone* was playing to crowded houses at the Palace Picture Theatre. It noted that as numerous scenes had been taken at Auchmithie in the spring, 'many local personalities found themselves very much in the picture'.¹⁴¹ The screen presence of these characters undoubtedly boosted box office returns in the Arbroath area, but perhaps more significantly added authenticity, at the same time reinforcing an image of Scotland as a timeless land inhabited by 'primitive' people. The cinematic representation of 'simple Scottish fisher-folk' has been heavily criticised (in relation to much later films such as *Whisky Galore* (1949) and *The Maggie* (1954)) and it is interesting to see how a film made some 30 years earlier included such characters in the pursuit of documentary-style realism within a fictional narrative.¹⁴²

The *Bioscope*'s review described *Christie Johnstone* as a simple story of 'pleasant sentiment', although lacking dramatic intensity. The main points of appeal were felt to be the beautiful settings, the 'fine types of Scots fisherfolk' portrayed in the film, and the extraordinary care that had been taken to reproduce the period faithfully, down to the most minute details. The local press agreed, remarking that although *Christie Johnstone* was one of the first 'big pictures' to be filmed in Scotland it should not be the last, as 'the exterior scenery is undoubtedly superior to what is seen in most English and American dramas'. Another important feature was the subtitles

¹⁴⁰ *Courier*, Dundee, 19 September 1922, p2

¹⁴¹ *Courier*, Dundee, 10 October 1922, p5. On the popularity of local topicals, see J McBain, 'The world of local topicals', <http://thebioscope.net/> (accessed June 2015)

¹⁴² C McArthur, *Whisky Galore! & The Maggie: A British Film Guide* (London & New York, 2003), p94

written in ‘broad Scottish dialect’ - evidently accurately transcribed on this occasion.¹⁴³ The pleasant and undemanding story was also warmly received as being ‘freed entirely from the “problem” business, which almost entirely dominates the present film world’.¹⁴⁴ While it is impossible to know exactly which films the writer had in mind, there were certainly many Hollywood melodramas of the silent era whose narratives revolved around contemporary issues of poverty, crime and social injustice. In this typical Scottish drama, by contrast, inequality and class difference were used simply as devices through which the narrative was propelled towards a satisfactorily romantic ending.

Glasgow life

Not all Scottish-set productions of this period were adaptations of kailyard fiction or backward-looking romances. By 1920 the film serial - the cinematic descendant of sensational fiction published in popular magazines - had become a regular feature of most cinema programmes.¹⁴⁵ Each episode ended with a cliffhanger to encourage return visits: as the *Entertainer and Scottish Kinema Record* remarked in April 1920, ‘as an attention compeller and an audience attracter there is no doubt that the serial story holds a big place in the hearts of many of our cinema-goers’. *The Vanishing Dagger*, released in May 1920, was made by Universal, one of the major Hollywood studios. Exteriors for all 18 episodes were filmed in English and Scottish locations which served chiefly as backgrounds, but the *Bioscope* noted wryly that ‘all the studio work appears to have been done at Universal City’.¹⁴⁶

The name of Eddie Polo may be forgotten today, but in 1920 he had devoted fans throughout the world.¹⁴⁷ A former trapeze artist, he starred in and co-directed a series of loosely autobiographical serials about life in the circus. One of these, *King of the Circus*, toured Scottish picture houses early in 1920, accompanied by Polo himself. The ‘tremendous ovation’ he was given by Scottish audiences wherever he appeared evidently encouraged him to return to Scotland to film episodes of *The Vanishing*

¹⁴³ *Courier*, Dundee, 19 September 1922, p2

¹⁴⁴ *Arbroath Herald*, 6 October 1922, p3

¹⁴⁵ R Abel, *Silent Film* (London, 1996) p63; *ESKR*, 10 April 1920, p1

¹⁴⁶ *Bioscope*, 2 December 1920, p63

¹⁴⁷ S Putnam Hughes, ‘Silent film genre, exhibition and audiences in South India’ in R Maltby, D Biltereyst and P Meers (eds), *Explorations in New Cinema History* (Chichester, 2011), pp298-309

Dagger, along with his co-directors John P McGowan and Edward Kull, who also served as cameraman.¹⁴⁸ After the *King of the Circus* tour Polo had told the American press that ‘never in the whole course of his career as a cinematographer [had] he been so deeply touched by any reception than that accorded him by the average Scottish audience’, confessing that he was ‘lionised in the most kindly and delightful manner both by the young and old’.¹⁴⁹ This must have provided a good reason to set several episodes of *The Vanishing Dagger* - whose story involved the international pursuit of a stolen bejewelled dagger, originally the property of the wicked hypnotist Prince Narr - in Scottish, as well as English, cities. Episode 11 is entitled ‘A Race to Scotland’ and exterior scenes were said to have been filmed in Edinburgh and Glasgow, at ‘Glasgow Shipyard’ and the Port Dundas canal. Other British scenes were filmed at London Euston and Liverpool Lime Street railway stations, and Liverpool docks.¹⁵⁰ Port Dundas (the terminus of a branch of the Forth and Clyde canal in the centre of Glasgow) had been a centre of heavy industry since the nineteenth century, and was the site of the giant Pinkston power station. The Glasgow shipyard, probably at Port Glasgow, would also have presented a very different aspect of the city to that of *The Wee Macgregor’s Sweetheart*.

This ‘whirling melodrama’ with its ‘wonderful drawing powers in the matter of stars, thrills and story’ was designed to appeal to a working-class audience, presenting its sensational narrative against a backdrop of some of Britain’s most authentically urban and industrial locations.¹⁵¹ Although much was written about Eddie Polo and the fact that he performed all his death-defying stunts himself, the Scottish press carried no reports of location shooting, perhaps because it was so speedily done. The *Bioscope* found the ‘real British exteriors’ an ‘effective and welcome novelty’ in a story that involved various groups of villains drifting about and fighting furiously whenever they met. The disorderly narrative was of no great importance, however, as ‘one does not expect a very highly organised plot in a tale of this class’.¹⁵²

¹⁴⁸ J J McGowan, *J P McGowan: Biography of a Hollywood Pioneer* (Jefferson, N Carolina, 2005), p92

¹⁴⁹ *ESKR*, 10 April 1920, p1

¹⁵⁰ *Bioscope*, 2 December 1920, p63

¹⁵¹ *Motherwell Times*, 2 September 1921, p2

¹⁵² *Bioscope*, 2 December 1920, p63

In contrast to the lurid melodrama of *The Vanishing Dagger, In His Grip* (1921) an adaptation of the English writer David Christie Murray's novel of the same name - was a middle-class, restrained and very British affair. Filmed partly around Loch Lomond and in St Vincent Street, Glasgow, it had two things in common with *The Vanishing Dagger*: a story involving jewel theft and an urban setting. In every other way it was the complete opposite, presenting a 'character study' of a wealthy railway contractor, Sir Donald MacVeigh, a pillar of the church whose austere and highly principled life in Glasgow is disrupted when he is tempted to sell some priceless diamonds intended to go to his young ward, Jessie. Although Sir Donald thwarts an attempt to steal the diamonds, he hides them and pretends they have been stolen. When his deception is accidentally discovered, he is overcome with shame but is forgiven by Jessie.¹⁵³

David Christie Murray (1847-1907) was a successful journalist, playwright and novelist who travelled widely and made extensive lecture tours of Australia and North America. *In His Grip*, published posthumously, was one of Murray's last works. As Andrew Nash has noted, Murray was one of the most vehement critics of the success of writers of the kailyard school, singling out the work of J R Crockett (author of *The Lilac Sunbonnet*) for particular contempt and deploring 'the unblushing affrontery of those gentlemen of the press who have set him on a level with Sir Walter Scott'.¹⁵⁴ Murray's novel represented the antithesis of kailyard fiction: serious, naturalistic (in the manner of Émile Zola, whom Murray much admired) and concerned with an individual's interior world.

The film adaptation of *In His Grip* was directed by Charles Calvert, an English former army captain who continued to use his rank in civilian life. It was received as a quality British production, containing a remarkable performance by Cecil Morton York as a 'strong and upright man' struggling with his conscience, and it was left to the *Bioscope's* Scottish section to remark on its national character.¹⁵⁵ In May 1921 it reported that the Gaumont company had attracted a great deal of attention while

¹⁵³ *Bioscope*, 30 June 1921, p54

¹⁵⁴ Nash, *Kailyard and Scottish Literature*, pp195-196, quoting from Murray's critical book *My Contemporaries in Fiction* (1897)

¹⁵⁵ *Bioscope*, 30 June 1921, p4

filming near Loch Lomond and in two different locations on St Vincent Street, Glasgow, and because of its authentic settings it was thought that the film, ‘when it comes North, will receive a double welcome’. Following the trade show two months later this additional interest for Scottish audiences was again noted, but the film’s main strength was said to be its presentation of ‘one of Scotland’s dour, straight characters’: the type of old Scotsman who ‘would rather “do his duty” as a member of the Hospital Committee than go to see his dying friend’.¹⁵⁶

In His Grip presented an authentic portrait of a certain kind of repressed, middle-class life in Edwardian Glasgow, and yet was never referred to as a ‘Glasgow life’ film: this description was reserved for light-hearted films of working-class life such as *The Wee Macgregor’s Sweetheart* or *Football Daft*. Perhaps this is why the Scottish press made so little mention of its Scottishness, with promotion of the film focusing on Murray’s novel, Cecil Morton York’s starring role and the philosophical question posed by the narrative, ‘Is conscience more influential than man-made laws?’¹⁵⁷ Local and national reviews praised the film for its technical and artistic excellence, but as *In His Grip* was not easily allocated to a specific genre it was described simply as ‘an unusual type of photo-play’ or a ‘picture worth seeing’. Whatever the (unpublicised) musical accompaniment may have been, it seems unlikely this would have consisted of traditional Scottish airs, despite one of its settings being in the Highlands.¹⁵⁸

Tartanry

In His Grip was director Charles Calvert’s first Scottish venture: the second, *Bonnie Prince Charlie*, was shot in Arran and Inverness two years later. His reputation for a workmanlike approach to film-making was gained in a career which had begun well before the war. Calvert was particularly keen on getting the right ‘atmosphere’, a term often used in reviews of Scottish films. This elusive quality was not necessarily associated with authenticity of location (as evidenced by *The Romany*) and it was perfectly acceptable for atmosphere to be created in a studio far from Scotland, as

¹⁵⁶ *Bioscope*, 5 May 1921, sup p xix; 7 July 1921, p53

¹⁵⁷ *Arbroath Herald*, 3 November 1922, p1

¹⁵⁸ *Ibid*

long as it was convincing. In an interview given at Gaumont's West London studios, Calvert explained how he had gone about building the atmosphere for *In His Grip*:

"Here you see", he said, pointing across the studio, "a general stores such as would have existed in the Scotch country forty or fifty years ago. It would have been possible to have made this quite a good-looking scene even if we had used properties, but to get "atmosphere" everything in this shop - and as you can see for yourself, there are hundreds of different articles - is absolutely the real thing."¹⁵⁹

He added that reproduction of a genuine atmosphere, which in this case meant the contents of the shop not only looked but also smelled right, 'helped the imagination of the actors'. While the *Bioscope*'s review observed that *In His Grip* was 'notable for that elaborate attention to detail which is characteristic of Captain Calvert' it did not comment on the overall 'atmosphere' - possibly because this was not regarded as a typical 'Scottish film', and its Scottish reviewer had nothing to say on the subject.

The same could not be said of another Gaumont British production filmed in Scotland. *Rob Roy*, directed by W P Kellino, attracted enormous interest in the Scottish trade, national and local press from the moment it was announced early in 1922 that the story was to go into production. By the time *Rob Roy* received its trade show in October that year the film, released simultaneously in England and Scotland, had been the subject of dozens of column inches and thousands of words on its cast, locations, storyline, and production details. This was a very different version of *Rob Roy* from the United Films' 1911 adaptation of a stage play, and was the first real British cinematic example of 'tartanry', a term which Jeffrey Richards summarises as '[placing] emphasis on the clans, the wild Highlands and Jacobitism ... tribal, neo-feudal and atavistic, defiantly pre- and anti-modern'.¹⁶⁰ Tartanry's great celebrant was Sir Walter Scott, whose Waverley novels helped to popularise these aspects of Scottish life and history. Along with kailyard, tartanry was the mode of representation most reviled by the *Scotch Reels* critics of the 1980s, who regarded it as a fantasy depiction of Scotland usually projected from outside the country.¹⁶¹

¹⁵⁹ *Bioscope*, 26 May 1941, p5

¹⁶⁰ Richards, *Films and British National Identity*, p191

¹⁶¹ McArthur (ed), *Scotch Reels*

The producers were keen to emphasise that this *Rob Roy* was no highbrow literary adaptation, letting it be known that Scott's novel had been little drawn upon, 'save for details and "atmosphere" - it being found difficult to do justice to Sir Walter's hero and at the same time provide the "thrills"'.¹⁶² It was noted that although the real Rob Roy, 'with his short body and long arms which reached below his knees' was 'not at all attractive', the Gaumont company was determined to make the character as heroic and physically attractive as possible in selecting David Hawthorne for the role.¹⁶³ The original screenplay by Alicia Ramsay was based on the Highland outlaw 'whose deeds inspired Sir Walter Scott', rather than by the novel. She 'deftly adjusted historical facts' to present a story with Rob Roy McGregor's romance with Helen Campbell at its centre.¹⁶⁴ The narrative, set some time in the early eighteenth century, follows events in the outlaw hero's life from his early days in Inversnaid. His marriage to Helen causes the Duke of Montrose (formerly an ally) to declare Rob Roy his enemy, and the Macgregor homestead is burned down. After ten years as an outlaw Rob Roy is captured, but escapes and is supposedly drowned. The Duke allows Helen to take her husband's body to be buried at Inversnaid, but after the funeral a very much alive Rob Roy leaps from the coffin, and at the head of his clan, he captures Montrose's castle and regains his own estate.

Great emphasis was placed on period detail - paradoxically, given the story's basis in legend rather than fact. W P Kellino explained that he was hampered in trying to present Rob Roy as a real historical figure, as there were no records of his birth, marriage or death, but there was 'some compensation in the great fascination and interest of the research work associated with the production of an historical film'.¹⁶⁵ Various Scottish authorities were engaged to help ensure a sense of authenticity: these included the Dukes of Argyll, Atholl and Montrose (on whose estate filming took place); Charles Whitelaw, an expert on armoury and Highland costume; Mr Curle, director of the National Scottish Museum; Mr Callendar of the Antiquities Museum and Mr Caw, director of the National Portrait Gallery. Francis Ells of the

¹⁶² *SKR*, 19 August 1922, p1

¹⁶³ *SKR*, 27 May 1922, p10

¹⁶⁴ *Bioscope*, 5 October 1922, p86

¹⁶⁵ *Weekly Scotsman*, 23 September 1923, p2

Victoria and Albert Museum, the ‘greatest living authority on the history of ecclesiastical ceremonies’, was consulted about how the wedding ceremony of Rob Roy and Helen Campbell should be presented.¹⁶⁶

Curiously, getting the atmosphere right also involved a connection with John Clyde’s *Rob Roy*, although the stage version rather than the 1911 film. In March 1922 Kellino and two assistants visited Montrose ‘with a view to accruing “colour”’. There they were received by Mrs John Clyde, widow of the late actor, and carried out a kind of screen test, although it appears there was no expectation that she would actually take part in the new film:

Mr Kellino did not make a vain quest, as Mrs Clyde, having all the necessary costumes & c. to hand, played before the camera her old stage part of Helen McGregor, in which she made a great hit while playing “opposite” her husband, Mr John Clyde, as Rob Roy.

The visit ended with Kellino asking other members of the family to dress up in other costumes from the stage play, and he took away with him ‘a plaid which belonged to the late Mr Clyde as a pattern for copying the necessary tartan required by him for his production’.¹⁶⁷

Rob Roy was a direct attempt to demonstrate that British-made films of Scottish stories were far superior to American efforts. Ensuring the film was historically correct would ‘show the American producer that we know how to produce the best of films on this side’, after the ‘futile attempts of the American producers to film Sir Walter Scott’.¹⁶⁸ The British National Film League had been formed in December 1921 with a mandate to counteract Hollywood dominance by protecting and developing the British film industry, and *Rob Roy* was one of the first productions to be promoted under its auspices. The producers spared no efforts to make the film as exportable as possible, with extensive filming in the Highlands an essential element

¹⁶⁶ *Scotsman*, 19 September 1922, p10

¹⁶⁷ *Courier*, Dundee, 29 March 1922, p5

¹⁶⁸ *Sunday Post*, 1 October 1922, p8

of this enterprise. The production was said to have cost £80,000, and with a budget of this size was clearly expected to be an international success.¹⁶⁹

Multiple press accounts of the company's activities during filming provide evidence about which Scottish locations were used and the extent of local involvement in the making of *Rob Roy*. As with the pre-war *Rob Roy*, the Bailie Nicol Jarvie Hotel in Aberfoyle operated as the company's headquarters. A train was commissioned to convey actors and crew to the Stirlingshire village in early June 1922, and from then on a regular flow of publicity ensured that the Scottish press was kept informed about their every move. Filming of the outdoor scenes took almost six weeks, the most dramatic of which was a huge battle scene shot near Aberfoyle. To add realism to the fight Kellino came up with the idea of 'giving local rivalry full play', with the main armies of 'supers' coming from Stirling and Glasgow. One account, by a Glasgow music hall manager who acted as a local 'fixer', stated that the some of the 'Stirling' soldiers were actually cockneys: they played the Lowlanders while the Glasgow men were the Highlanders. Armed with broadswords and carried away by the excitement of the fight, 15 men were said to have been injured: 'a Celtic and Rangers Cup tie wasn't in it'. Four companies of Argyll and Sutherland Highlanders took part (and were later treated to a private screening of the finished film), alongside 'practically every able-bodied man for miles around Aberfoyle'.¹⁷⁰ This was a huge operation: as noted by the *Bioscope*'s Scottish reviewer, in terms of logistics it was the biggest thing ever attempted in Britain, and Scots, it was argued, should feel honoured that it was being done 'on Scottish soil and for a Scottish play'.¹⁷¹ Trains were commissioned to convey players and props from Glasgow to Aberfoyle, and the number of extras, which also included local women and children, was said to total 1,000.¹⁷² Proceedings were so well organised that all the battle scenes were shot in under seven hours, and afterwards Kellino announced that he had 'never seen

¹⁶⁹ "'Rob Roy" Revived', *Weekly Scotsman*, 15 July 1922, p3

¹⁷⁰ T J Colquhoun, 'My memories of Glasgow music halls', *Thomson's Weekly News*, 23 June 1928, p18

¹⁷¹ *Bioscope*, 4 May 1922, p57

¹⁷² *SKR*, 20 July 1922, p4; *Weekly Scotsman*, 15 July 1922, p3

experienced players give greater realism than many local people did in the fire and fight scenes'.¹⁷³

Many other scenes involved local extras and even local cattle: Kellino's pursuit of realism went as far as negotiating the loan of several herds of Highland cows to add 'colour'.¹⁷⁴ Similarly well-publicised was the filming of a ball scene, for which an eighteenth century Scottish version of the pavane was unearthed and revived.¹⁷⁵ But the exteriors of Stirling Castle and the chapel where Rob Roy is supposedly laid to rest - both locally constructed - were less authentic: these were flimsy sets made of plaster and cardboard, a fact that did not go unnoticed in reviews.

There was a marked difference between the English and Scottish reception of this historical drama which involved the participation of so many Scots, both as advisers and extras. The first Scottish public screening which took place on 23 October 1922 at the Salon, Glasgow, was 'attended by extraordinary scenes' both inside and outside the theatre. The Salon's manager, Mr Watson, was said to have paid a record figure for Scotland to secure the rights to an exclusive first run.¹⁷⁶ Officers and men of the Royal Scots Fusiliers marched with their pipe band, and police held up traffic in Sauchiehall Street while convoys of ambulances brought 250 wounded soldiers from the Erskine, Bellahouston and Ralston military hospitals to the show, which was also attended by David Hawthorne, Will Kellino and the managing director of the Gaumont company.¹⁷⁷

Kinematograph Weekly felt the film 'lacked altogether a real Scottish atmosphere', but in Scotland - where *Rob Roy* was promoted very much in the manner of its 1911 predecessor, with bagpipe music preceding and accompanying screenings - it was applauded for its 'realistic atmosphere' achieved through careful attention to detail. The film was received almost as if it were an indigenous production, with particular attention being paid to the extensive use of natural locations in Aberfoyle and

¹⁷³ *SKR*, 20 July 1922, p4

¹⁷⁴ Film of Kellino at a cattle fair in Oban was included in an 'Around the Town' newsreel released on 1 June 1922, held by the BFI national archive. See also *KW*, 1 June 1922, p60

¹⁷⁵ *Aberdeen Daily Journal*, 5 August 1922, p7

¹⁷⁶ *KW*, 5 October 1922, p87

¹⁷⁷ *Bioscope*, 26 October 1922, p38

Stirling, and the story's Scottish status.¹⁷⁸ One Scottish newspaper described it as 'one of the most realistic Scottish reproductions that we have ever been given'.¹⁷⁹ After showing at the Salon in Glasgow it moved on to La Scala for a second run, and bookings all over Scotland were said to be 'enormous'.¹⁸⁰

Although the British trade press believed that this offering from the British National Film League was entertaining enough to do well at the box office if properly exploited, it was regarded as uninspired but workmanlike, a 'tale of missed opportunities' in terms of direction and storytelling.

"Rob Roy" shows that British producers have still much to learn from Griffin¹⁸¹ [sic] and his like in the handling of crowds, particularly in the battle scenes ... and is a long way from being the historical spectacle which might have been founded on the title, good popular material as it is as action drama.¹⁸²

Photography of the beautiful Scottish scenery, however, was thought to be excellent, and despite its deficiencies it was believed that the film would pack houses as Rob Roy was 'a romantic figure that appeals to the imagination of everybody'.¹⁸³ Gaumont recognised that stories based on Scottish history and legends, filmed in Scotland itself, had the potential for great international appeal: after *Rob Roy* the company announced it had commissioned Alicia Ramsay to write the screenplay for a further Scottish film 'dealing with [the] lives of Robert Burns and Highland Mary'.¹⁸⁴ This film was not made, but Ramsay did write the screenplays for Gaumont's *Bonnie Prince Charlie*, and for *Young Lochinvar* (Stoll), both produced the following year. These two major British productions represented the increasingly desperate efforts of the British film industry to save itself from complete Hollywood domination, exploiting Highland landscapes as a means through which Britain could present its most romantic side to the world. Noting that the Stoll company were

¹⁷⁸ *Courier*, Dundee, 2 January 1923, p3

¹⁷⁹ *Sunday Post*, 1 October 1922, p8

¹⁸⁰ *Bioscope*, 26 October 1922, p38

¹⁸¹ A reference to the American director D W Griffith

¹⁸² *KW*, 5 October 1922, p65

¹⁸³ *KW*, 5 October 1922, p68

¹⁸⁴ *New Zealand Herald*, 25 November 1922, p8

going to Aberfoyle to shoot parts of *Young Lochinvar*, the *Bioscope* recommended that more producers should be using Highland locations.¹⁸⁵

Another Scott adaptation, *The Fair Maid of Perth*, was produced by the London-based Anglia Productions in 1924. Although some scenes may have been shot in Scotland it was a relatively small-scale production and poorly received by the trade. The *Bioscope* advised exhibitors that it was ‘purely a title booking that may get over with suitable music and effects’, and not even the optimistic Scottish press, while applauding the film’s ‘proper medieval atmosphere’ considered it worthy of much attention.¹⁸⁶

Like *Rob Roy*, *Young Lochinvar* was based on a character from a work by Sir Walter Scott and directed by W P Kellino. It was regarded as a worthy successor to the former, with its ‘picturesque romance and action, stirring fight episodes and cattle-storming scenes’.¹⁸⁷ In this case the original source was Scott’s epic poem *Marmion*, (1808) of which the most famous verses concern the gallant knight Lochinvar and tribal rivalry in the Border country between England and Scotland. The ballad of Young Lochinvar still ‘[held] a popular place in the school curriculum’ - and perhaps for this reason the film was promoted less on its literary credentials than for its thrills, romance and magnificent scenery.¹⁸⁸ Although set in the sixteenth rather than eighteenth century, the narrative had remarkable similarities to that of *Rob Roy*: a visit to a castle where the hero falls in love with a woman called Helen, resulting in a feud and battles between clans. Like the former, the narrative had elements of the Western, however poorly executed: one review remarked that ‘the hero’s flight with Helen, though on the best steed of the Border, seems a gentle amble when compared with what we are accustomed to in the cowboy drama’.¹⁸⁹ The *Bioscope* stated that the screenplay had been written by J Preston Muddock, a well-known author of mystery stories featuring Glasgow detective Dick Donovan.¹⁹⁰ It appears to have

¹⁸⁵ *Bioscope*, 27 September 1923, p62

¹⁸⁶ *Bioscope*, 15 October 1925, p37; *Courier*, Dundee, 8 December 1925, p8

¹⁸⁷ *Hawick News and Border Chronicle*, 29 February 1924, p2

¹⁸⁸ *Courier*, Dundee, 19 April 1924, p4

¹⁸⁹ *Bioscope*, 11 October 1923, p62

¹⁹⁰ *Ibid*

been confusing this writer with J E Muddock, who adapted his own novel *Young Lochinvar, A Tale of the Border Country* (1896) for the screen. Muddock brought a popular touch to the story, adding comedy to the romance and a partial 'Highland' (Trossachs) setting.

Armies of extras

While the Scottish locations were less authentic than those used for *Rob Roy*, the filming of *Young Lochinvar* and of *Bonnie Prince Charlie* was of great interest to local people. Not only were over 1,000 Scots involved as extras in both productions, but filming also provided free entertainment for similar numbers of locals and holidaymakers. This local involvement served as advance publicity for the films in Scotland, and encouraged a sense of pride and ownership in the finished product. Reporters from Scotland's regional and national newspapers were also invited to witness events. Nelson Ramsay, one of *Young Lochinvar*'s stars, remarked on the difference in behaviour of the locally-recruited extras and the sightseers who were conveyed to the Aberfoyle location by 'special charabancs':

Sight-seers came from miles and miles around to watch us at work, but they behaved in a wonderful manner. There was no pushing or shouting; instead the onlookers sat upon the sides of the hills, turning the whole place into a sort of amphitheatre. When any of them were asked to move out of range of the camera they did so like a flock of sheep - all together. They were absolutely obedient, better, in fact, in this respect than most of our local supers.¹⁹¹

During filming of *Bonnie Prince Charlie* the same year, a gathering of 1,000 spectators was said to have witnessed a reconstruction of the battle of Culloden 'on the actual ground on which the battle was fought' while a similar number of Scottish extras took part as the opposing armies.¹⁹² Most of the other exterior scenes were shot on the island of Arran, a fact remarked upon by both national and local press. An Aberdeen reporter noted caustically that 'Some might think that if a proper "atmosphere" were desirable for such a production, Moidart, Skye or South Uist should have been selected' but the 'tremendous amount of research work' done by

¹⁹¹ *Bioscope*, 11 October 1923, p62

¹⁹² *Aberdeen Journal*, 6 October 1923, p8

director Charles Calvert and his associates was still appreciated and the battle scene, in particular, wholeheartedly commended for its verisimilitude. In similar fashion to the reporting of the battle scene in *Rob Roy*, much was made of the over-excitement of parts of the armies of extras, resulting in real war wounds. In Inverness, another crowd looked on while ‘cinema operators busily worked their machines and took what they say will be a realistic re-enactment of an incident’: this involved extras in Hanoverian uniforms marching up the hill to the Castle, where the Young Pretender was proclaimed a rebel.¹⁹³

On its release in October 1923 *Young Lochinvar* was well received by the British trade press as a crowd pleaser which, on account of its stirring tale and magnificent scenery ‘should equal the success of any of its Scottish predecessors’.¹⁹⁴ *Bonnie Prince Charlie*, released the following month, got a slightly cooler reception as a ‘fairly entertaining costume drama, built on conventional lines, but endowed with some individuality by the many delightful period features’. Among its special features were the lovely Scottish mountain and coast exteriors and the ‘acting and personality’ of Gladys Cooper, who played Flora McDonald opposite Ivor Novello’s Prince Charles Edward Stuart.¹⁹⁵ At least one Scottish newspaper, however, strongly disagreed: in the *Aberdeen Journal*’s assessment Gladys Cooper’s performance was disappointing and showed a distinct lack of Highland spirit, particularly in the first part of the film. ‘She was not a merry, winsome, Heilan’ lass, but rather a pale and somewhat listless one’ it opined, adding that even her hairstyle seemed to accentuate this. The second part was ‘less tedious’ than the first, but even though Ivor Novello made a reasonable Prince Charlie, the musical and other effects were also ‘distinctly disappointing’ and it was thought that on the whole the film would ‘please English picture-goers better than Scottish ones’.¹⁹⁶ The same newspaper had published enthusiastic accounts of the filming process, and this review demonstrates that Scottish critics were ready to use their powers of discrimination even when discussing a production with strong Scottish connections.

¹⁹³ *Aberdeen Journal*, 9 October 1923, p6

¹⁹⁴ *Bioscope*, 11 October 1923, p62

¹⁹⁵ *Bioscope*, 22 November 1923, p64

¹⁹⁶ *Aberdeen Journal*, 12 January 1924, p6

In 1924 both *Young Lochinvar* and *Bonnie Prince Charlie* were selected for British Film Weeks, sponsored by the British National Film League.¹⁹⁷ In advising exhibitors on exploitation ideas, the *Bioscope* yoked the two films together as ‘Highland pictures’ which could be advertised not only as British productions but also as ‘essentially British’ stories. For promotional purposes it suggested that ‘some such phrases as, “British story from British studios for the British screen lover”’ could be used, continuing (of *Young Lochinvar*):

You will probably be able to dig up the famous poem which bears the same title as the film, and which we believe is being made into a song. Have a chat with your musical director regarding this, and, if possible, arrange for a number of Scottish melodies to be played, giving your patrons a small multigraphed slip on which they should enter the names of the various selections played.¹⁹⁸

There was no reason, of course, why American-made Scottish films could not be marketed in the same way. In Scotland, *Young Lochinvar* was promoted simply as a ‘Scottish film’ and *Bonnie Prince Charlie* as a ‘splendid Scottish picture’: although one Scottish newspaper noted that the former was being shown as part of a British Film Week, it focused on the story (‘a worthy successor to “Rob Roy” with picturesque romance and action’) and the characteristic Scottish music accompanying screenings.¹⁹⁹

The patriotic British Film Weeks scheme was ineffectual: not enough good quality films were available for it to succeed, and in November 1924 the domestic industry reached its lowest point with not a single film in production. The British cinema could not match the dynamism of American production or find an alternative style - such as that of German cinema - that could give it a distinctive niche in the world market.²⁰⁰ The Highland film with its authentic Scottish settings was uniquely British, but despite all the effort that went into making them, films such as *Young*

¹⁹⁷ C A Oakley, *Where we came in: 70 years of the British Film Industry* (Abingdon, 1964), p76

¹⁹⁸ *Bioscope*, 3 January 1924, ‘Exploitation Ideas for British Film Weeks’ supplement, pxii

¹⁹⁹ *Courier*, Dundee, 19 April 1924, p4; *Evening News*, Edinburgh, 10 May 1924, p1; *Hawick News and Border Chronicle*, 29 February 1924, p2

²⁰⁰ A Burton and S Chibnall, *Historical Dictionary of British Cinema*, p5

Lochinvar and *Bonnie Prince Charlie* lacked the energy and excitement that audiences had come to expect. After 1925 and the release of *The Fair Maid of Perth*, there were no further big-budget British ‘Highlands’. It was left to Maurice Sandground, discussed in the following chapter, to reinvent the ‘Scottish film’ in an entirely different form. A revival of interest in Scottish settings for British film-makers would only become apparent in the altered circumstances produced by the transition to sound at the end of the decade.

Conclusion

It may seem surprising that London-based companies were prepared to spend so much time and money on location shooting in Scotland at a time of economic slump. The evidence above, however, shows that Scotland and Scottish stories were regarded as vital to the British industry’s drive to produce internationally-marketable films. Scotland, with its instantly recognisable scenery and iconography, represented Britain more readily than England or Wales, and Scottish legends had greater potential to be transformed into exciting, populist screen stories than the middle-class romantic comedies and literary adaptations that characterised much of British production. Scotland was not the only exotic location used by London-based producers in this period, although it was the most important: in September 1922, for example, the English director Graham Cutts travelled to the West of Ireland to film scenes for *Paddy the Next Best Thing* and in 1923 Stoll’s *The Prodigal Son*, directed by A E Coleby, was filmed in Iceland.²⁰¹ Both were adaptations of novels set, or partly set, in those countries.

Most of the advantages of Scottish location filming were associated with authenticity, but there were also practical considerations particularly relevant to the large-scale productions such as *Rob Roy* and *Bonnie Prince Charlie*. The armies of extras (many of them recruited via the Labour Exchange) would have cost little to employ, and the majority of the filming locations were on land owned and made available by members of the Scottish aristocracy, keen to associate themselves with the production of high-quality historical dramas. Shooting took place in the summer

²⁰¹ C Barr and A Kerzoncuf, *Hitchcock Lost and Found*, pp 37-38

months, when daylight hours were long and (weather permitting) outdoor filming could continue longer than would have been possible further south.

It is clear that the Scots made no sweeping judgement of productions filmed in their country by those from far away: each film was judged on its own merits. If there was an overriding factor, this was how well - or badly - a real Scottish 'atmosphere' was captured. As far as the trade and local press were concerned, the most important comparison was between American-made Scottish 'travesties' and British-made films, although it is impossible to say whether audiences had similar views. Until the arrival of 'Kinoman' of the Glasgow *Evening Times* in the late 1920s and of Forsyth Hardy, who became the *Scotsman's* film correspondent in 1932, there were no named Scottish film critics. It could therefore be assumed that there was little real written criticism of Scottish films before the coming of sound. Close scrutiny of the Scottish press, however, overturns this assumption: the un-named film reviewers of certain Scottish newspapers, particularly those of Aberdeen and Dundee, had many complaints about the presentation of Scottish character, dress and traditions, in a very similar manner to Kinoman and Hardy. Even the dialogue, in the form of 'subtitles' or inter-titles, was scrutinised, as it would be in later films with synchronised sound.²⁰² These unknown critics and the Scottish film trade reviewers welcomed the presence of film-makers in Scotland, but were sometimes disappointed by the results. The only point at which British and Scottish trade and local press were in complete accord was over the filming and presentation of Scottish scenery. It was this element that united most of the films discussed above, and helped to differentiate the 'Scottish film' from those films made in less scenic parts of Scotland.

The representations of Scotland discussed in this chapter played a wider role within British film production at a time when the American market was buoyant, but the domestic market was in increasing difficulty. In this climate it proved impossible for Scotland to sustain its own production activity, and in the virtual absence of any Scottish feature film production, considerable national pride could be taken in Scottish stories, filmed in Scotland, being brought to the international market.

²⁰² Griffiths, *The Cinema and Cinema-going in Scotland*, pp206-207

Production of *Rob Roy* in 1922 claimed the attention of the Scottish trade press at the same moment that the Thornliebank studios near Glasgow were advertised as for sale or let.²⁰³ When Kinoman (looking back on earlier productions) poured scorn on the distorted version of Scottish history presented in the British company Ideal's *The Loves of Mary Queen of Scots* (1923), he was writing of a film made in an English studio. It would be interesting to have had his views on the Scottish stories that also served as 'scenics'.

²⁰³ *SKR*, 3 June 1922, p3

Chapter 5: Glimpses from the Life of Maurice Sandground

'The scenery in Scotland is the finest in the world, and once the British film industry gets into swing, as it should very shortly, there seems to be no reason why Scotland should not become the centre of film production in Britain ... For exterior work Scotland is unrivalled, and the acting talent which very few people had believed to exist in the country has been brought out by the mere existence of the opportunity'.¹

Introduction

In 1927 the film producer and director Maurice Sandground expressed a 'bright view' of the future of the British film industry, and especially of the prospects of its development in Scotland. In an interview published in the Dundee *Evening Telegraph* he declared that, although British cinemas were swamped with American product, 'a small band of British producers have kept hard at work': these special few, among whom he included himself, were now 'very gradually beginning to break down the foreign monopoly in the industry'. Claiming that no Scottish or English person liked to sit through films whose 'sole aim [was] to extol the virtues of the American citizen', he continued:

One can easily imagine the effect of such a film when it reaches the British colonies... The propagandist potentialities of the film are enormous, and it is only right that the opinions and sentiments of each country should have a chance of finding expression in them.²

Maurice Sandground may be disregarded today by scholars of British film history, but he is an important figure in the story of film production in Scotland. Although a Londoner, Sandground's career is relevant to this research for a number of reasons. He set up a series of production companies in Glasgow between 1923 and 1927 in order to produce films on Scottish subjects for Scottish audiences throughout the world. Whether he was simply an opportunist or a genuine enthusiast for Scotland and Scottish themes, Sandground's input into the film industry in Scotland should not be ignored. Indeed, his greatest success was a production called *Bonnie Scotland*

¹ 'Why Not a Scots Hollywood?', *Evening Telegraph*, Dundee, 16 February 1927, p2

² *Ibid*

Calls You, (1924) which was hailed at home as ‘the national film’ and became his calling card for future productions.

The first of Sandground’s ‘Scottish’ films, *Kilties Three*, (1918) was a product of his London-based company, Gaiety Films. It may have been the modest success of this film, and the failure of subsequent English productions, that led to his arrival in Glasgow five years later with the intention of reviving Scotland’s dormant film industry. Like Max Leder who founded the A1 Cinema College in Glasgow in 1919, Sandground was an ‘outsider’ who recognised an opportunity for a certain kind of inexpensive Scottish film production, and was similarly undaunted by the fate of those who had gone before.³ His Glasgow-produced films - *Bonnie Scotland Calls You* (1924); *The Life of Robert Burns* (1926); *Glimpses from the Life of Sir Walter Scott* (1926) and *Immortals of Bonnie Scotland* (1927, a repackaging of the Burns and Scott films) - illustrate the key issues for Scottish film production in the late silent era, and the reasons for its failure to make its mark in the wider world. By the mid-1920s he had become a self-appointed ambassador for the Scottish film industry both at home and abroad. Dismissed in a sentence by Rachael Low (who described his Gaiety productions as films that ‘nobody would book’), Sandground was later recognised as a potentially key figure in the story of early Scottish film production.⁴ The films he produced during his four-year sojourn in Scotland have not, however, been fully explored.

Maurice was born Moses Sandground in 1874 in Shoreditch, east London, the son of Polish immigrants from Warsaw. He married Harriet Salmon in 1908 and the following year their first child, Barnet Abraham, was born. Barnet was followed by a daughter, Doris, in 1911 and another son, John, in 1915.⁵ By this time the family appear to have moved from the East End to Willesden in North West London, and

³ See Chapter 3

⁴ Cloy and McBain, *Scotland in Silent Cinema*, p9; Griffiths, *The Cinema and Cinema-going in Scotland*, pp291-295

⁵ I am indebted to Janice Healey for providing some of this biographical information, which is derived from www.freebmd.org.uk, www.findmypast.co.uk and www.ancestry.co.uk

Maurice's career in the emerging British film industry had begun. Dogged with bad luck and, it seems from the few reviews of his films that are available, a conspicuous lack of talent for telling a story, Sandground nevertheless showed remarkable persistence and tenacity born of an apparent desire to play a part in the emerging British film industry. His original career may have been as a cabinet maker, but by the time his first child was born he was already working in the film business, soon to become a producer and director.

Sandground was listed as one of six directors of the Bonanza Cinema Co Ltd, Exhibitors (theatre owners), of 83 St Paul's Churchyard in the City of London. This company traded from March 1913 until it was dissolved in October 1916.⁶ He was simultaneously (between February 1914 and March 1917, when the company was dissolved) active in the distribution side of the industry as a director of the London and Provincial Film Renting Co Ltd, with offices at 120 Wardour Street.⁷ Although declared bankrupt in 1915, by 1916 Sandground had moved into production.⁸ Under the banner of the Gaiety Film Company and using studios formerly occupied by the well-known film producers Cricks and Martin in Norwood, South London, he and his co-director John William Hinks released a large number of comedies, features and 'shorts', some produced by Dave Aylott and some by Sandground himself.⁹ By this time Cricks and Martin had parted company and Cricks had ceased production.

While it is difficult to know precisely which films were directed by Sandground and which by Aylott, the company's major films (*Kilties Three*, 1918 and *Russia - Land of Tomorrow*, 1919) were certainly Sandground's.¹⁰ Significantly in terms of his future career, *Kilties Three* was a Scottish film, or at least a film on a Scottish theme. Promotional material for this seven-reel 'Scottish romance of the Great War' suggested that some scenes were shot in Edinburgh and (possibly) Argyllshire,

6 BT 31/14074/127506, Bonanza Cinema Co Ltd; *KYB* 1914, p58 (as cited by The London Project), <http://londonfilm.bbk.ac.uk/view/business/?id=106> (accessed June 2013)

7 BT 31/14225/134245, London and Provincial Film Renting Co Ltd; *KYB* 1915, pp88 and 432, *ibid*

8 *The Edinburgh Gazette*, 23 February 1915, p331: List of bankrupts from the *London Gazette*

9 *The Girls of the Village*; *Cast Adrift*; *When the Heart Is Young*; *The Walrus Gang*; *Splash Me Nicely*; *His Uncle's Heir* (all 1917) *The Magistrate's Daughter*; *The Base Deceivers*; *Living by Their Wits*; *How Could You, Uncle*; *Kilties Three* (all 1918); *Russia - Land of Tomorrow* (1919)

10 Low, *History of the British Film, 1914-1918*, p 97

although given the hybrid nature of the production, footage of these locations was probably used to provide background to the action. A promotional article published in *The Era* revealed that *Kilties Three* was a ‘skilful admixture of illusion and reality’ concocted of pre-existing documentary film of the wartime activities of the Red Cross and the Women’s Army Auxiliary Corps (WAAC), shots of camouflaged ships, views of Scottish scenery and a fictional narrative concerning the serious and comic adventures of the three Kilties.¹¹ Also included was a ‘unique introduction of episodes in the life of Bobby [sic] Burns’ - pointing ahead to Sandground’s subsequent Scottish films. As the advertisement made clear, ‘many of the scenes and personages depicted in this film have been taken from actual life’, setting this production apart from other war dramas.¹² Sandground’s films were certainly unconventional in their construction, employing a kind of magpie approach in which pieces of film of different styles, ages and genres were collected and displayed.

The story of *Kilties Three*, written by Sandground and ‘Captain B Merivale’ concerned three ‘rather indolent’ Edinburgh factory hands who decide to join up in 1914.¹³ After some initial awkwardness the three ‘give very excellent accounts of themselves’ in France. Here they are not only ‘the life of the canteen’, but when necessary ‘show of what real grit they are made’. After being wounded in combat they are sent to work on a government farm, where humorous scenes include the Kilties trying to clean a piglet’s teeth and being upstaged in their cow-milking efforts by a ‘wee Scotch lassie’. The narrative also involved a German spy who ‘meets with a thrilling end’, and (in Sandground’s own description) ‘scenes of German cruelty are wonderfully shown’. The spy’s widow marries the father of one of the Kilties, a wealthy Edinburgh foundry owner, who is profiting from the war. Events lead him to realise the true meaning of patriotism and he sells his property for the benefit of the Red Cross, while his ‘frivolous’ wife becomes a nurse.¹⁴

¹¹ Members of a Highland regiment of the British Army

¹² *The Era*, 18 September 1918, p25

¹³ The playwright Bernard Merivale (1882-1939) had an intermittent career as a screenwriter which began with *Kilties Three*. His best-known play was *The Wrecker* (1924), co-authored with Arnold Ridley, which was adapted for the screen in 1929

¹⁴ *The Era*, 18 September 1918, p5; *Bioscope*, 7 November 1918, p28; *Times of India*, 24 January 1920, p5

Kilties Three was shown to the trade in late October 1918, two weeks before the Armistice, and the film's patriotic nature rather than its technical or artistic merits may have helped its success at the box office. Newspaper advertisements described it as a Scottish version of *The Better 'Ole* - a popular British film directed by George Pearson, released some six months earlier - and this, too, would have contributed to its appeal.¹⁵ Pearson's film was an adaptation of a 1917 hit musical comedy produced by C B Cochran, itself a theatrical version of the adventures of the cartoon infantryman Old Bill, drawn by Bruce Bairnsfather. Bill and his pals Bert and Alf featured in Bairnsfather's weekly 'Fragments from France' cartoons published in *The Bystander* during the war.¹⁶ The *Bioscope* did not feel *Kilties Three*'s resemblance to the earlier film presented a problem, remarking that the ambitious Gaiety production had 'a little of everything to appeal to the popular taste', its only caveat being that 'maybe too much has been attempted'. The 'Scotch scenery associated with the poet Burns', however, was thought to be exceptionally good.¹⁷

A connection between this film and Sandground's later, more thoroughly, Scottish productions was their target market of Scottish audiences worldwide. *Kinematograph Weekly* commented that *Kilties Three* would 'have a good reception in Scotland and the Colonies, where it will give many an opportunity of revisiting the scenes of their youth', and soon afterwards a display advertisement in *The Era* showed that Sandground was seeking offers from overseas buyers for the territorial, colonial and foreign rights to the film.¹⁸ This advertisement appears to have represented Sandground's first attempt to exploit his own productions as expressions of Scottish 'opinions and sentiments'.

¹⁵ *Falkirk Herald*, 21 May 1919, p3

¹⁶ M Bryant, 'Bairnsfather, (Charles) Bruce (1887-1959)', *Oxford Dictionary of National Biography*, www.oxforddnb.com (accessed October 2015)

¹⁷ *Bioscope*, 7 November 1918, p28

¹⁸ *KW*, 26 September 1918, quoted in advertisement in *The Era*, 2 October 1918, p18

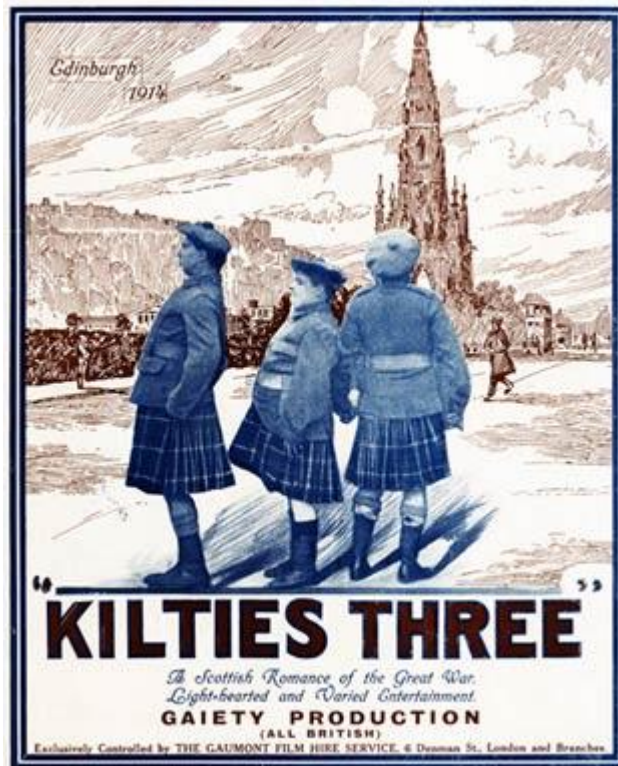

Figure 13: 1918 poster for *Kilties Three*, 'A Scottish Romance of the Great War'. Copyright ©: Lordprice Collection/Alamy Stock Photo

Kilties Three was shown in Scottish picture houses from December 1918, usually advertised as six or seven part [reel] 'Scottish romance of the Great War' and once - causing possible confusion to Perthshire cinemagoers - as a 'five-part drama of the American Civil War'.¹⁹ It could be seen in Dundee in April 1919, returning to the city's screens in both May and June, and for the remainder of the year it travelled widely in Scotland as well as England. In 1920 *Kilties Three* could be seen at the Excelsior cinema in Delhi, where it was advertised as 'light-hearted and varied entertainment'.²⁰ The film was re-released in 1921, distributed, as before, by Gaumont.²¹

After *Kilties Three*, Sandground's attention turned from Scotland. It appears that the promising-sounding *Russia - Land of Tomorrow* (1919) was never actually seen in public, for a variety of reasons. One, put forward by film historian Tony Shaw, is that

¹⁹ *Perthshire Advertiser*, 28 December 1918, p1

²⁰ *Times of India*, 24 January 1920, p5

²¹ *Courier*, Dundee, 22 April 1919, p2; *Evening Telegraph*, Dundee, 26 May 1919, p4 and 26 June 1919, p4; *Hastings and St Leonards Observer*, 5 March 1921, p1

after a private performance attended by government ministers, MPs and representatives from the press, *The Times* condemned the film as a ‘scurrilous attack on Tsarism’. The film, also co-written by Bernard Merivale, told of a doomed love affair between a Russian radical, played by Eve Balfour, and her jilted German boyfriend Carl, embedded in an ambitious survey of Russian events between 1905 and 1917. Balfour’s character is recalled to Russia during the revolutionary upheaval associated with the Great War, after several happy years of marriage to an English lord, in order to save a former comrade. Once there, however, she becomes a tool of the unscrupulous Carl and dies a gruesome death on a revolutionary mission ordered by him. Shaw argues that the film’s apparently anti-Bolshevik message was misunderstood, ‘such was the sensitivity that surrounded cinematic depictions of the USSR in this period’, noting that the last thing the Government wanted was anything that brought undue attention to events in the Soviet Union.²²

An equally likely reason for *Russia - Land of Tomorrow*’s failure to get a theatrical release is that it was, to put it simply, a terrible film. With characteristic over-ambition, Sandground had attempted to combine a complex narrative with a survey of turbulent years of Russian history. This was, in the *Bioscope*’s view, ‘almost impossible’: even D W Griffith, with all the resources at his command, ‘might have hesitated before so colossal a task’. In an uncharacteristically savage review of a British film, the *Bioscope* described the unconvincing, rambling and incoherent plot of this ‘melodramatic Russian melange’ as ‘likely to try the patience of an audience by its length and lack of continuity’.²³

Undeterred by the debacle of *Russia - Land of Tomorrow*, Sandground continued film production from the Croydon studio and even found new investors, William Herbert Manning and George Victor Smith. Gaiety Films Productions, Ltd, of London and Croydon was formally incorporated as a private company in 1919, with a nominal capital of £5250. Manning and Smith were the directors, and Sandground was appointed as general manager at a salary of £8 a week, plus expenses. In May of

²² T Shaw, ‘Early Warnings of the Red Peril: a Pre-History of Cold War British cinema, 1917-1939’, *Film History*, 14 (2002), pp354-368

²³ *Bioscope*, 18 February 1919, p25

that year the new company acquired the Croydon premises from Sandground and Hinks together with the use of scenery, fittings and ‘studio effects’. The following month a further agreement was drawn up in which Sandground’s trustee assigned to the company ‘all his interest in an agreement for the exclusive service of a comedian and feature artistes in film production’.²⁴ After taking over the Croydon premises, several more comedies were produced.²⁵ As the *Kinematograph Year Book* later reported, ‘what was reckoned to be the best production was exhibited at an evening performance at a London kinema theatre, but it was not a success’. The group of comedies was then shown to the trade at the company’s Wardour Street premises, but received no offers. In September 1919 Sandground, who ‘did not appear to have worked harmoniously with the directors’, resigned, and it was decided that owing to the lack of success in marketing its existing films, the company would cease production. It went into receivership with debts of £2,635 18s.4d. At a meeting of shareholders, one gentleman was reported as saying that the company ‘had every element of success but was not given a fair run’, adding that there were ‘many pitfalls in the kinematograph trade, and outsiders such as himself should not embark in it’.²⁶

Despite having parted company with his benefactors, Sandground was clearly determined to continue his career in film production. In 1920 he took back the lease of the Croydon facilities and established another new production company, Empire Comedies. All six films that are listed as productions of this business give Sandground the director’s credit, suggesting that this was his own company.²⁷ A print of one of these films, *The Lambs of Dove Court*, survives and is held in the BFI National Archives. It is a badly-made slapstick comedy in which a misunderstanding leads to the Lambs, a poor but cheerful family from the East End of London, believing they have inherited a grand country estate and temporarily living (and behaving) like ‘toffs’. This chapter in Sandground’s story was soon to come to an

²⁴ KYB, 1924, p194

²⁵ *Griff’s Lost Love, Griff Swims the Channel, Ne’er Do Well, Slocum Harriers and Pussyfoot*

²⁶ KYB, 1924, p194

²⁷ *Down on the Farm; In Borrowed Plumes; The Lambs of Dove Court; The Boy Messenger; The Little Poacher; Truants* (all 1920)

end. On 16 August 1920 a huge fire destroyed the studios in Waddon New Road, Norwood, next door to Cricks and Martin's former studio and laboratory.²⁸

According to a local history magazine, 'Operations ceased immediately; the lessee (Maurice Sandground), left the area, and the building was never again used for cinematograph purposes'.²⁹

Sandground's occupation in the following three years is unknown: there is no evidence of his involvement in film production. By the time he re-emerged in Scotland, the post-war economic boom was over, the British film industry was in decline, and no Scottish feature production had been attempted for well over a year.³⁰ Although Sandground was an incompetent film-maker, he was knowledgeable about the industry in which he so desired to play a prominent role and would have been aware of the difficulties facing British producers. Nevertheless, in 1923 he set up the first of a series of production companies in Glasgow, and turned his attention to a peculiar and very inexpensive style of film-making that was, briefly, to bring him some fame as a cultural ambassador for his adopted country. The seeds of his iconoclastic style had been sown in *Kilties Three*, and it may have been the modest success of this production that gave Sandground the idea of establishing himself as a Scottish film producer. If he read the trade papers he would also have known of the fate of previous Scottish production companies and - other than the United Films' *Rob Roy*, made before the war - their failure to reach an international market. The more recent big-budget British dramas such as Gaumont's *Rob Roy*, *Young Lochinvar* and *Bonnie Prince Charlie*, however, had considerable success with overseas audiences, but were enormously expensive to produce. Sandground could not (and apparently did not wish to) emulate these narratives based on Scottish legends, whose creation involved a huge cast, crew and production team.³¹ Evidence about his previous efforts in the mainstream British industry suggests that he was not a natural collaborator and had few resources at his disposal other than a talent for

²⁸ West Norwood and nearby Croydon are used interchangeably in references to Cricks and Martin's production base

²⁹ A Falks, 'Henderson's Laboratories', *The Norwood Review*, summer 2011. www.norwoodsociety.co.uk/pdf/review193.pdf (accessed June 2013)

³⁰ See chapter 3

³¹ See Chapter 4

self-promotion. But he was adept at spotting an opportunity, and early in his film-making career had identified the potential of cheaply-made films aimed at the Scottish diaspora of North America and the Antipodes as well as Scottish audiences in Britain. By 1920 he appears to have become *persona non grata* in the London-based film community, but Glasgow in 1923 represented a fresh start. Sandground's efforts from this time onwards would be put into productions made by his own companies, over which he had complete control as producer/director. Scotland was a country in need of its own film industry, and Sandground evidently believed he could provide it.

There was certainly no competition at the time for the production of films that were 'written in Scotland, played in Scotland [and] filmed in Scotland', as publicity for *The Harp King* had so proudly announced in 1919. It was this appeal to national pride that Sandground was to play on so skilfully in the creation and marketing of his next four films.³² Scottish scenery had played a relatively minor role in *Kilties Three*, but was one of its most-praised elements and, as Griffiths has noted, the Scottish scenic film 'built on the appeal of the landscape' continued to flourish in the immediate post-war years. The full-length Scottish-produced scenic film, *The Clyde, from its Source to the Sea* (1921) had been predicted to 'gladden the hearts of all true Scots at home and abroad', and it was precisely this market that Sandground hoped to capture.³³

The Scottish Films Limited, a private company, was incorporated on 8 May 1923, with an office registered at 156 Vincent Street, Glasgow. The studio itself was at 47 Jamaica Street. The initial subscribers with one share each were two typists, Agnes Robertson and Lilian Naismith. In July, allottees with 100 shares each were listed as William Stewart of Perthshire, Maurice Sandground, and the company accountant Harold Riley. In October 1923 a further 150 shares were allotted to John Oliphant, an insurance official of Glasgow, and James Compton, a retired cotton broker, of Manchester. The following month, Sandground's wife Harriet and Harold Riley were allotted 600 and 400 shares respectively. It is possible that the ever-ambitious

³² *Scottish Cinema*, 30 October 1919, p23

³³ Griffiths, *The Cinema and Cinema-going in Scotland*, p289; *SKR*, 26 November 1921, p5

Sandground may have hoped to extend activities into film exhibition, as the objects for which The Scottish Films Limited was established included '[carrying on] the business of teashop, restaurant and refreshment room-keepers, tobacconists, theatrical agents, box-office keepers, concert-room proprietors', and so on.³⁴

With *Bonnie Scotland Calls You*, Sandground hit on a format that would appeal to Scottish sentimentality and national pride, based on a notion of authenticity and a construction of Scottish national identity that is still debated today in discussion of films such as *Braveheart*.³⁵ He and his contemporaries were continuing to shape this identity as they went along, contributing to 'Scotland the brand' that permeates today's tourist marketing strategies. In one sense he was ahead of his time, recognising the marketing potential of such films to Scottish audiences overseas and to the developing tourist industry. If only his vision and ambition had been matched by a talent for film-making, Sandground's name might be as synonymous with Scottish film as that of John Grierson. As it was, his fame was temporary and largely self-generated.

Like Sandground himself, *Bonnie Scotland Calls You* seems to have gone through a series of metamorphoses, depending on where it was presented. Although of feature length, with a running time of two and a half hours, whether it can be classified as a narrative film is debatable. Contemporary advertisements and reviews in the local press offer some clues as to how this composite film/live drama/musical entertainment was presented to audiences. They also reveal Sandground's other talent, that of a tireless self-publicist.

The film opened in Glasgow in January 1924 and was immediately well received, running for three weeks at the Lyric Theatre. According to its own publicity, the film's reception was 'a revelation - packed houses and queues for a picture made in Scotland'.³⁶ An advertisement for its subsequent run at the Synod Hall, Edinburgh

³⁴ NRS, BT2/12681, The Scottish Films Limited, Memorandum and Articles of Association, 8 May 1923; Return of Allotments, 27 July 1923; 26 October 1923; 30 November 1923

³⁵ T Edensor, 'Reading Braveheart: representing and contesting Scottish identity', *Scottish Affairs* 21 (1997), pp135-158, www.scottishaffairs.org/backiss/pdfs/sa21/sa21_Edensor.pdf (accessed August 2013)

³⁶ *Aberdeen Press and Journal*, 14 February 1924, p2

called *Bonnie Scotland Calls You* (incorrectly, but characteristically) ‘the first All-Scottish film’ and quoted extensively from the Glasgow press. These snippets help to identify the nature of the production and its various constituent elements. The *Weekly Record*, for example, described it as ‘charged with sentiment and dramatic appeal’, while the *Daily Record* believed it struck ‘a fresh note in cinema production’, and deserved attention from a wide public. The *Glasgow Herald* commented that ‘the numerous dramatic episodes interspersed in the film are full of interest’, and the *Glasgow Citizen* that ‘the spirit which it suggests is that Scotsmen should know Scotland’. The *Evening News* stated that ‘Macpherson’s story of love and romance compels attention, and as the picture proceeds Scotland’s scenery from Dumfries to the distant isles is unfolded in all its grandeur’. Describing the presentation as ‘a pictorial record of Scottish beauty spots’, the *Bulletin*’s opinion was that ‘Scots folks at home should find a great deal to interest them in “Bonnie Scotland Calls You”’.³⁷

From the above comments, it becomes clear that *Bonnie Scotland Calls You* had several elements, chiefly scenery and dramatic episodes, held together by a character called Macpherson who - significantly, given Sandground’s intended audience - ‘comes home to the country he left as a youth and makes a grand tour of the beauty spots in the West, North, East and South’. It began with a (filmed) dramatised prologue: a ‘celebration of a “Burns night” at a land beyond the seas’ at which Macpherson, who has recently been home on a visit, ‘describes to his “brither Scots” a tour through Bonnie Scotland’.³⁸ Macpherson’s travels began near Glasgow and took in the Firth of Clyde, the Crinian Canal, ‘picturesque corners’ of the West Coast, the Isle of Skye, Inverness, Strathpeffer, Aberdeen, Dundee, Perth, Dunkeld, Blair Atholl, Edinburgh, Dumfries and the ‘famed Burns country’.³⁹ The *Bulletin*’s assumption that *Bonnie Scotland*’s audience would be ‘Scots folks at home’ is also worth noting. For Sandground, whose ambitious plans extended well beyond the Borders, this meant Scots folks at home wherever they were in the world. Late in 1924 *Bonnie Scotland Calls You* was made ready for a tour of North America, although there is no evidence that this took place. He did, however, achieve this

³⁷ *Scotsman*, 14 January 1924, p8

³⁸ *Aberdeen Journal*, 19 February 1924, p4

³⁹ *Evening Telegraph*, Dundee, 13 March 1924, p4

ambition with a subsequent production, *Immortals of Bonnie Scotland*, which had a short run in Toronto in 1927.

Short 'feature films' were interpolated in their appropriate settings: Edinburgh 'recalled the story of Jeanie Deans' and the story of Tam O' Shanter was presented in 'striking and realistic fashion' in the Ayrshire section, as was the 'meeting of Robert Burns and Highland Mary and their romantic parting'. A fourth dramatic episode was the story of Auld Robin Gray, which was said to 'add variety and interest to the film'.⁴⁰ These dramatised segments, extracted from well-known Scottish ballads and poems, were shot in the studio (later described by Kinoman of the Glasgow *Evening Times* as 'a poky little attic') at Jamaica Street rather than in their natural settings.⁴¹ Advertisements for the film suggest that local, topical segments were also added as it made its way through Scotland, which would have added to its appeal to local audiences. Far from being a novel concept, as Griffiths comments, this was 'a well-established exhibition tradition, with scenic attractions allied to items of immediate appeal'.⁴² The advertisement for *Bonnie Scotland's* first appearance in Edinburgh, at the Synod Hall (where it was to be shown for a week from 28 January) invited local people to 'see your own beautiful city inter-woven in this picture depicting its historical and romantic traditions'.⁴³ Attention was drawn to the prologue called 'A Nicht Wi' Burns' and to the well-known songs 'Caller Herrin'', 'Annie Laurie' and 'Bonnie Banks of Loch Lomond', performed by a chorus of local singers.⁴⁴

February 1924 saw the film's arrival at the Music Hall, Aberdeen. The 'On the Screen' column of the *Aberdeen Press and Journal* proudly announced that the film was 'entirely of Scots origin', and had been 'acted by native artists', adding that 'only a few tentative efforts' had been made previously at turning out a purely Scottish film, and this [was] the most ambitious so far'.⁴⁵ Sandground was later to be

⁴⁰ *Evening Telegraph*, Dundee, 13 March 1924, p4

⁴¹ *Evening Times*, Glasgow, 2 August 1933, p7

⁴² Griffiths, *The Cinema and Cinema-going in Scotland*, p291

⁴³ *Scotsman*, 14 January 1924, p8

⁴⁴ 'Caller Herrin'' was an eighteenth century song written by Lady Nairn with a tune by Nathaniel Gow; 'Annie Laurie' was based on a poem by William Douglas (1672-1748), with a tune added by Alicia Scott around 1834; 'Bonnie Banks of Loch Lomond', by an unknown composer, was first published in 1848

⁴⁵ *Aberdeen Journal*, 13 February 1924, p5

criticised for his use of inexperienced screen actors, but here the fact that they were ‘native artists’ predominates. In Aberdeen, the vocalists were Miss Gertrude Simpson, soprano; Miss Crue Davidson, contralto; Mr Neil MacLean, tenor and Mr Alex Macgregor, bass, ‘assisted by a Highly Trained Choir’.⁴⁶ Some of these performers would have been well-known locally, adding to the film’s appeal to Aberdeen audiences while keeping production costs down. The fact that the ‘feature films’ were largely made in a studio seems to have escaped the notice of the Aberdeen reviewer who remarked (no doubt prompted by a press release written by Sandground) that ‘to travel the length and breadth of Scotland with a company of players, meeting and overcoming the climatic conditions, must have been a gigantic task’. None of these difficulties, however, were apparent on the screen: what the spectator saw was ‘Scotland - beautiful, romantic, interesting’. The scenic elements were not ‘thrown at him like a lesson in geography’, but ‘skilfully woven into a narrative’. Scenes from ‘The Lady of the Lake’ were said to have been ‘reproduced by Scottish actors and actresses in the Scott country’.⁴⁷ The review went on to describe scenes that were shot in Aberdeen - the River Don, Marischal College and the Duthie Park.⁴⁸ It is interesting to note that no mention of these locally-filmed sequences was made in the advertisement for *Bonnie Scotland* published in the same newspaper a few days earlier, suggesting that they were added after Sandground and his crew had arrived in the city. Publicity for the Aberdeen screenings also revealed that there was only one print of the film: with characteristic Sandground bravado, this was claimed to add to its appeal. *Bonnie Scotland* was not a picture released in the same way as others ‘in several copies’, but was ‘shown exclusively wherever it goes’.⁴⁹

Bonnie Scotland Calls You was, in some respects, an old-fashioned form of travelling entertainment that combined live music and drama with film of Scottish scenery. For its Dundee and Aberdeen performances the musical accompaniment was provided by an orchestra under the ‘able leadership’ of Mr Tom B Shaw, the Glasgow violinist.

⁴⁶ *Aberdeen Journal*, 14 February 1924, p2

⁴⁷ The Trossachs

⁴⁸ *Aberdeen Journal*, 19 February 1924, p3

⁴⁹ *Ibid*, 26 February 1924, p4

His conducting was said to be so skilful that ‘every air was timed to the second as every air [sic] with which it was associated appeared on the screen’.⁵⁰ As Griffiths has noted in his discussion of early sound practices in Scottish cinemas, the approach to a film’s musical accompaniment - an integral part of the production - differed according to the size of the population centre in which it was presented.⁵¹ This could mean that in a big cinema in a major city a full orchestra might be employed, while in a small-town hall the same film would be accompanied by a lone pianist. Griffiths’ research into the business records of Aberdeen picture houses reveals the crucial role played by sound, particularly music, not just to a show’s commercial success but also to the reputation of the cinema in which it was presented. At the larger, better-appointed houses, ‘much was made of music’s capacity to secure the reputation of the business as a source of respectable, high-quality entertainment’. The director of music was an important figure, and their prominence in publicity highlighted the importance of music in establishing the relative standing of venues.⁵²

‘Yes, Scotland can make films!’ was the triumphant advertising slogan for *Bonnie Scotland Calls You*. After a successful three weeks in Aberdeen (where it was held over for an extra week at the Music Hall, although continuous performances were suspended ‘owing to the severe strain upon the Artistes’) the film made its way to Dundee in March 1924. From then on, it was referred to as the ‘National Film’. At the Caird Hall the music was provided by a ‘splendid orchestra’ and local scenes of Dundee were included. The production’s nationalistic and touristic appeal was noted by the *Courier*’s ‘review’, which addressed a local audience presumed not to stray far from their home city:

To know Scotland well is to be proud of the fact that one is a Scot. There are a number of people living in the East who have never penetrated into Scotland’s distant isles and the Lowlands, and this picture will be an introduction to scenes which they may have attempted to picture but never quite adequately realised.

⁵⁰ Ibid, 12 February 1924, p2

⁵¹ T Griffiths, ‘Sounding Scottish - Sound Practices and Silent Cinema in Scotland’ in J Brown and A C Davison (eds), *The Sounds of the Silents in Britain* (Oxford and New York 2013), p73

⁵² Griffiths, ‘Sounding Scottish’, p75

But even those Dundonians who had ‘tramped over mountains and moors, and knowing these love them’ would find the film held a powerful appeal. As in Aberdeen, the publicity noted that the ‘numerous romantic episodes’ were acted by Scottish film players, while a quartet of vocalists sang ‘Gaelic and Scottish songs’.⁵³

Bonnie Scotland Calls You appeared during one of the most turbulent periods for the British film industry. As noted in the previous chapter, cinemas were swamped by Hollywood productions. Huge American distribution chains operated what was widely seen as an unfair and anti-competitive block-booking system which resulted in British productions being sidelined, and by 1923 only 10 per cent of the films shown in Britain were made in Britain.⁵⁴ Britain’s response in the form of the British National Film League, which attempted to encourage exhibitors to keep a regular slot open in their schedule for British productions, was not a success. In November 1923 the first of several British Film Weeks was launched in the trade and national press under the banner of ‘British films for British people’. As Kenton Bamford puts it, this movement gave British producers ‘the opportunity to display their product within a nationalistic context while risking a further erosion of their already tenuous hold on the hearts and purses of British audiences’.⁵⁵

There has been some scholarly interest in the reasons for the failure of British Film Weeks and the subsequent crisis point in November 1924 when, for the first time since the British film industry had begun, not a single film was produced. However, the situation in Scotland (still regarded by the industry as a ‘region’) has not been considered. One of the few successes of the British Film Weeks was Gaumont’s *Bonnie Prince Charlie*, which figured prominently in Glasgow’s all-British film week in March 1924. The *Bioscope*’s Scottish correspondent noted glumly that ‘a greater measure of success could have been achieved by more active co-operation of both exhibitors and renters’, but ventured the opinion that ‘when the final survey of the whole campaign is made, Scotland will be found to be in the forefront,’ despite

⁵³ ‘National film to be shown in Dundee’, *Courier*, Dundee, 1 March 1924, p3

⁵⁴ J Richards, *The Age of the Dream Palace: Cinema and Society in 1930s Britain* (London and New York, 2009), p35

⁵⁵ K Bamford: *Distorted Images: British National Identity and Film in the 1920s* (London, 1999), p93

the ‘detrimental effect of the advent of Lent in the middle of the Scottish week’.⁵⁶ The fact that *Bonnie Prince Charlie* was an outstanding success of a British Film Week in Scotland was noted with pride as far away as New Zealand, where Scots communities had a keen interest in representations of Scotland on screen.⁵⁷

Another event of March 1924 was the Scottish Film Week in Dundee. This was almost certainly Sandground’s own invention, as *Bonnie Scotland Calls You* was its sole constituent. The banner heading BONNIE SCOTLAND CALLS YOU (without any explanatory text) could be seen at the top of the *Telegraph*’s pages for several successive days from late February, and on 7 March the paper announced that ‘Dundee will have a Scottish Film Week under the title of “Bonnie Scotland Calls You” on show in the Caird Hall next week’. This was followed by a ‘review’ or description of the film almost identical to that of the Aberdeen paper quoted above. Another advertisement made a direct appeal to national sentiment and the national economy, in the manner of the British National Film League. Describing *Bonnie Scotland* as ‘the picture that has won its way to the hearts of the people’, the notice asked readers to ‘Remember Scotland pays 1 ¼ million [sic] annually for foreign film hire. Should some of this be retained for home productions?’⁵⁸

Although in December 1924 a chorus was being sought for *Bonnie Scotland Calls You* in Motherwell and the film was said to be being prepared for its tour of Canada and the USA, The Scottish Films Limited went into liquidation on 18 August 1925.⁵⁹ Its fortunes were not helped by having to pay a large sum in compensation for loss of earnings to one of the company’s regular singers, Gertrude Simpson, after she fell down some unlit stairs and broke several bones during a performance of *Bonnie Scotland* at the Perth City Hall. A court heard that the electric light had been ‘extinguished by order of the defenders’, and the Scottish Films Ltd were ordered to pay £750 for their negligence.⁶⁰ More significantly, it seems that despite the

⁵⁶ *Bioscope*, 13 March 1924, p 72

⁵⁷ *Evening Post*, Wellington, 31 May 1924, p20

⁵⁸ *Courier*, Dundee, 7 March 1924, p8

⁵⁹ *Edinburgh Gazette*, 21 August 1925, p956

⁶⁰ NRS, CS46/1925/1/54, Closed Record in the action at the instance of Mrs Gertrude Simpson against The Scottish Films Limited

‘outstanding merits of [the] National Film’, which demonstrated that ‘a purely Scottish film can make an irresistible appeal to a Scottish audience’, this audience was simply not large or enthusiastic enough to sustain Sandground’s career. The competition was fierce, even in terms of appeal to Scottish sentiment: *Bonnie Prince Charlie*, for example, was seen by the British trade press as an opportunity for exhibitors to ‘appeal to [their] Scottish patrons’. Cinema exhibitors were encouraged to make its screening experience as ‘Scottish’ as possible: suggestions included employing a piper ‘attired in full Highland dress wearing a Stuart tartan parading the streets with his instrument a week or so prior to your screening’, as bagpipes, ‘even in an English town’, always attracted considerable attention. The piper could be accompanied by a boy, also in Highland costume, who could distribute handbills. Exhibitors were further encouraged to ‘try to get as much co-operation from dealers in Scottish goods, such as tweeds, Scotch shortbread, Scotch whiskey [sic], etc’. Small sprigs of heather could be distributed to cinema patrons before the screening, and the Scottish experience would be further enhanced if the orchestra played Scottish melodies, ‘such as “Scots Wha Hae”, “Annie Laurie”, “Bonnie Dundee”, etc’.⁶¹

While *Bonnie Scotland Calls You* had found a niche, it was a limited one. It was an expensive production for exhibitors to mount as the musical elements required a large number of performers, which would have been a deterrent for all but the larger houses. At the same time, did audiences care that this unsophisticated, cheaply-made filmic entertainment was produced by a Scottish company? For the same ticket price, *Bonnie Prince Charlie* could offer them an equally ‘Scottish experience’, a star-studded cast in the place of local amateurs and an exciting, coherent, full-length narrative.⁶² Other major British releases of 1924 included a remake of Cecil Hepworth’s *Comin’ Through the Rye*, while sophisticated and technically advanced European films included *He Who Gets Slapped* (Victor Sjöström, Sweden) and *The Last Laugh* (F W Murnau, Germany). Among the many American releases of 1924

⁶¹ *Bioscope*, 3 January 1924, supplement p vi

⁶² See Chapter 4

were Buster Keaton's *Sherlock, Jr*, *The Thief of Baghdad* directed by Raoul Walsh and John Ford's *The Iron Horse*.⁶³

A petition for the winding up of The Scottish Films Limited was presented to the court on May 1925. The petitioner was a junior scenery contractor from Kelvinside, William Glover, who was presumably a creditor.⁶⁴ On 18 August 1925 a liquidation notice was served on John Fraser Horn, Maurice Sandground, Harold Riley, Frederick A Downes and Thomas Armstrong.⁶⁵ No stranger to failed film businesses, Sandground by this time had already set up a new company, The Glasgow Film Studios Limited, which was registered in January 1925. The sole director of this company (whose objects were identical to those of The Scottish Films), with 100 shares of £1, was Maurice Sandground.⁶⁶ There are no records of any film being produced by The Glasgow Film Studios; an appeal for investors early the following year must have been unsuccessful. An advertisement that appeared in the *Scotsman* under the headline of 'A New Industry for Scotland' described Sandground as the 'producer of the successful Scottish film, "Bonnie Scotland Calls You"'. Claiming that he was 'engaged in the creation of a new Scottish film' with the title of *Scotland Yet*, he invited the 'co-operation of a few investors'. Those interested could send for particulars from John S Gavin, an accountant of 58 West Regent Street, Glasgow. The advertisement ended with the appeal to 'Support Home Productions'.⁶⁷

Having failed to find any patriotic investors, Sandground took a different tack. Now settled in Scotland, and living at 42 Carnarvon Street in the West End of Glasgow, his subsequent productions were made under the auspices of The Burns-Scott Films Limited, a company incorporated in September 1926 with studios at 26 India Street, Glasgow.⁶⁸ His co-director in this new enterprise was a Glasgow businessman and

⁶³ Even the popularity of *Comin' Thro the Rye* could not save Hepworth's company from going into receivership

⁶⁴ NRS, BT2/12681/10, Petition of William Glover for winding up The Scottish Films Limited, 27 May 1925

⁶⁵ *Scotsman*, 22 August 1925 p1

⁶⁶ NRS, BT2/13492/2, The Glasgow Film Studios Limited, Memorandum of Association, 20 January 1925

⁶⁷ *Scotsman*, 27 February 1926 p2

⁶⁸ NRS, BT2/14314/2, The Burns-Scott Films Limited, Memorandum of Association, 14 September 1926

entrepreneur, Malcolm A Irvine, whom Sandground approached with a proposition to make a film about the life of Robert Burns.⁶⁹ Irvine was an interesting figure in his own right: as well as being a qualified pharmacist and botanist, during the First World War he had devised a method of electric welding and set up the Double Arc Electric Welders, Ltd and Phoenix Electrical Co, Ltd, for the production of electric welding rods. It was the success of these businesses that allowed him to invest in film production, and it was he, rather than Sandground, who would carry on producing Scottish films from the India Street studios after the coming of sound.⁷⁰

Evidence suggests that The Burns-Scott Films, Ltd was to be run along the lines of the cinema colleges discussed in chapter 3, an inexpensive way of producing films compared with the cost of engaging professional actors and singers. One of the objects stated in the articles of association was ‘To carry on, present, conduct and manage school training in painting, drawing, acting, photography, singing, dancing, elocution and all kindred arts’.⁷¹ The first two films to be released by Burns-Scott Films, *The Life of Robert Burns* and *Glimpses from the Life of Sir Walter Scott* (both released in 1926) were sometimes credited to the Scottish Film Academy, another hint that the company intended to offer training in return for a part in its productions. Whether this intention was carried out is not known, but it is certainly the case that these films were made using local talent (referred to in publicity as ‘well-known artistes’) and that they were cheaply produced.⁷² Indeed, Malcolm Irvine later recalled that *The Life of Robert Burns* cost under £600 to produce, a sum that was recouped by the first week’s showings at the Coliseum in Glasgow in October 1926.⁷³ This was an extraordinarily low budget for any production of the period, and a comparison with the £80,000 spent on the production of *Bonnie Prince Charlie* in

⁶⁹Cloy and McBain, *Scotland in Silent Cinema*, p29, extract from transcript of a lecture given in 1945 by Malcolm Irvine on film production in Scotland

⁷⁰ See chapter 6. 26 India Street was also the headquarters of Irvine’s engineering business, the Double Arc Electric Welders, Ltd

⁷¹ NRS, BT2/14314/3, The Burns-Scott Films Limited, Articles of Association, 20 September, 1926

⁷² *Sunday Post*, 19 September 1926, p4

⁷³ Cloy and McBain, *Scotland in Silent Cinema*, p29

1922 makes the fact that some audiences were willing to part with money to see it all the more startling.⁷⁴

The model for both the Burns and Scott films directed by Sandground appears to have been *Bonnie Scotland Calls You*, and it is not inconceivable that he decided to recycle some of the filmed scenes of beauty spots made for that film. They were both, ostensibly, biographical films that used filmed episodes from the authors' works backed by appropriate music; early examples of a genre that came to be known as the biopic. However, the *Bioscope's* review of *The Life of Robert Burns* suggests that while the film was suitable 'for Scottish audiences anywhere where Scottish music and vocalists are employed', its narrative construction lacked clarity and purpose. With echoes of its criticism of *Russia - Land of Tomorrow*, the story was summarised as 'a jumbled-up concoction of incidents in the life of Scotland's national bard, interspersed with some splendid examples of Scotland's beauty spots, and insets illustrating some of the poet's well-known poems and songs'. The rest of the review noted some features characteristic of Sandground's *oeuvre*:

It is full of glaring mistakes, which will appear farcical and disappoint those who know their "Burns." Many of the subtitles are unnecessary, and the portrayal of Burns himself leaves much to be desired. The same careless methods which are so obvious in the historical parts are repeated in the dresses and some of the settings.⁷⁵

The actors, 'most of whom have local reputations as actors in Scottish dramas on the legitimate stage' were said to have 'still a long way to go' as screen actors, despite having faithfully carried out the producer's instructions. Noting that the film was 'built on the lines of a previous box-office winner by the same producer', the review concluded that as the photography was mostly excellent and there was scope for exploitation with Scottish music and songs, it would be a 'popular offering despite its obvious drawbacks'. This view was echoed by the *Bioscope's* Scottish correspondent, who - while acknowledging the film's 'inaccuracies' - thought that the outdoor scenes '[rivalled] the brilliance of Hollywood' while its scope for

⁷⁴ See Chapter 4

⁷⁵ *Bioscope*, 7 October 1926, p48

Scottish music and vocalists was sufficient to make *The Life of Robert Burns* a money maker ‘in Scotland, at least’.⁷⁶ It was left to a one-time president of the Burns Federation, John S Clarke, to lambast the production in its entirety, describing the photography of the Scottish scenery as ‘an act of vandalism one cannot forgive’ and concluding that ‘the picture would be considerably improved by cutting out fully fifty per cent of the celluloid and then setting fire to the other fifty’.⁷⁷

These reviews are interesting for what they reveal about Sandground’s seemingly slapdash and even arrogant approach to his subject matter, given that he was making a film for a home audience likely to be reasonably well-informed about its own history and ‘national bard’, and accustomed to the meticulously-researched Scottish productions of Will Kellino and Charles Calvert.⁷⁸ Not only had he failed to master the art of storytelling, but even the scenic elements (at least in Clarke’s opinion) left much to be desired. Nevertheless, the *Bioscope*’s prediction that *The Life of Robert Burns* would be a ‘popular offering’ for Scottish audiences proved correct.

It was unusual for newspaper advertisements at this time to mention a film’s director or producer: if names were published, they were those of the star(s). Sandground’s Scottish films were a notable exception, with advertisements prominently featuring his own name. The names of the musicians were sometimes included, but in an inferior position and smaller typeface. In the absence of any evidence about audience reception, it must be assumed that the Scottish cinema-going public of the time were sufficiently convinced by the publicity and by the lure of local musicians to want to experience *The Life of Robert Burns*. After a successful run in Glasgow it moved on to the Synod Hall in Edinburgh. Here it was an even greater success, generating one of the highest returns of any film in the first half of 1927. In Edinburgh the musicians included four soloists, a choir of twelve, a piper, and an augmented orchestra.⁷⁹

⁷⁶ *Bioscope*, 7 October 1926, p57

⁷⁷ Ibid. John S Clarke was also the Labour MP for Maryhill, Glasgow

⁷⁸ *In His Grip* (1921); *Rob Roy* (1922); *Bonnie Prince Charlie* (1923); *Young Lochinvar* (1923). See chapter 4

⁷⁹ NLS/MIA, 5/4/15, Poole Family, Diary of Attendances, Synod Hall, 31 January 1927, quoted in Griffiths, *The Cinema and Cinema-going in Scotland*, p291

The *Scotsman*'s reviewer was more generous towards Sandground than the trade press, commenting that 'no happier choice of producer of a film outlining the life story of Robert Burns could have been made than Maurice Sandground, who was responsible for the highly successful picture "Bonnie Scotland Calls You."' The reviewer applauded the way in which the outstanding events of the 'bard's chequered career' were illustrated 'in a manner which is nearly as true to life as could be wished... the effect being heightened by the inclusion of picture of the actual scenes from which he drew his inspiration'. Some of these scenes may have included recycled images from the 'Bobby Burns' section of *Kilties Three*, made seven years earlier.

The *Scotsman* review also helps to identify more precisely the dramatised components of *The Life of Robert Burns*. These 'pictorial representations' of Burns' work included *The Cottar's Saturday Night* and *Tam O'Shanter* (probably the same scene used in *Bonnie Scotland Calls You*).⁸⁰ Burns songs, 'adding greatly to the enjoyment of the film' were performed by the All-Scottish Picture Quartette and Choir. The review was more equivocal about the actors' performances, noting that while the actor playing the part of the poet 'deserves the highest commendation,' to some, 'the studious and sterner side of Burns' character may seem somewhat over accentuated'.⁸¹ Advertisements for the film in Dundee, where it was shown for a week at the Kinnaird in February 1927, stated that the story of Burns' career was adapted from biographies by Professor Wilson and Mr J G Lockhart.⁸² The latter volume was reviewed at the time of its publication in 1828 by Thomas Carlyle, who praised the way in which Lockhart 'avoided the method of separate generalities, and rather sought for characteristic incidents, actions, habits, sayings; in a word, for aspects which exhibit the whole man, as he looked and lived among his fellows'. Carlyle went on to remark that 'The book... with all its deficiencies, gives more

⁸⁰ An epigram written by Burns in 1785-6 included in the *Kilmarnock Edition of Poems, Chiefly in the Scottish Dialect* (1786). Contemporary critics of the poem enthused over its rustic simplicity and sentimental, moral tone

⁸¹ *Scotsman*, 1 February 1927 p9

⁸² *The Works of Robert Burns; with a Complete Life of the Poet and an Essay on his Genius and Character* (1859) by Professor Wilson, and *Life of Robert Burns* (1828) by J G Lockhart. The Kinnaird was Dundee's largest picture house, with seating for 1500 people

insight into the true character of Burns, than any prior biography'.⁸³ As Sandground had no screenwriter he did the 'adapting' himself, and the pretentious assertion that he took his researches into Scottish history seriously (in the manner of Charles Calvert) was not borne out on the screen.

For its screenings in Dundee, where it was shown in continuous performance at two-hour intervals from 2.30 to 8.30pm, *The Life of Robert Burns* was given a 'fitting accompaniment' in the form of The Kinnaird Orchestra and 'a number of talented vocalists' singing Burns songs, including Letty Linburne and Rene Ellison (sopranos), Lilian Hamer (contralto), Taggart Whyte (tenor), and William Cruikshank and Robert Stewart (baritones). Mr Joe Barker gave Longfellow's 'Ode to Robert Burns'. This was another showcase for local talent and publicity also emphasised the picture's national character:

The film version of "The Life of Robert Burns" which is showing at the Kinnaird during the whole of this week, has the advantage of being produced by a Scottish film company, and adapted from the biographies of two such eminent Scotsmen as Professor Wilson and J G Lockhart.⁸⁴

In a possible riposte to the *Bioscope's* remarks, a review in the same newspaper (again likely to have been based on Sandground's own publicity) noted that 'it is not surprising that the film, besides being accurate, achieves the true spirit of the poet's life and circumstances'. The unspecified 'Highland settings of unparalleled beauty and grandeur' were warmly recommended, while there was said to be 'real emotion and romance in [this] portrayal of the poet's parting with his beloved Highland Mary'.⁸⁵

A feature article in the Dundee *Evening Telegraph* accompanied the film's presentation at the Kinnaird Picture House in February 1927. The article, under the headline 'Why Not a Scots Hollywood?' took the form of an interview (or statement)

⁸³ T Carlyle, 'The Life of Robert Burns by J G Lockhart' (1828), *The Edinburgh Review* no. 36, <http://www.ntsyrshire.org.uk/Burns-CarlyleEssayMain1.html> (accessed August 2013)

⁸⁴ *Courier*, Dundee, 12 February 1927 p8

⁸⁵ *Courier*, Dundee, 15 February 1927, p7

by Sandground, who argued that there was no reason why Scotland should not become a centre for British film production.



Figure 14: Sandground expresses a 'bright view of the future of the British film industry'. *Evening Telegraph*, Dundee, 16 February 1927, p2

Leading off with an out-of-date remark about the effect of British climatic conditions on film production - which he had 'met and overcome' - and an equally superfluous protest that British film stars (none of whom ever featured in his films) were 'as good as those in America', Sandground argued that once the British film industry got 'into swing' again, there seemed to be no reason why Scotland should not become the centre of film producing in Britain. It offered not only superb scenery, but 'scenery of every kind', and he was convinced that within 60 miles of Glasgow it was possible to find a 'scenic background for any sort of film one cares to produce'. Not only was Scotland unrivalled for exterior work, but the 'acting talent which very few people had believed to exist in the country has been brought out by the mere existence of the opportunity'. This last remark reveals not just Sandground's self-importance but his ignorance of Scotland's cultural history. In the remainder of the article (an extract from which is quoted at the beginning of this chapter) he discussed the 'over production in the American industry' and the practice of block booking, with its detrimental effects on the British industry. The feature concluded with a mention of

Sandground's Scottish films, noting that he had 'been doing film work for the last ten years'.⁸⁶ It was remarkable not only as a demonstration of his considerable powers of rhetoric but also for his appraisal of the state of the British film industry. The connection he made between Scottish scenery and its relevance to (British) national film production was curious, overlooking the need for purpose-built studios if Scotland was indeed to become the centre of the industry. More interesting, however, is the appeal he made to nationalist, and explicitly anti-American, sentiment.

At the time the article was published, the British film industry had been struggling against the tide of American imports for more than a decade. In the period leading up to the passing of the Cinematograph Films Act (1927) there were moves to counter American dominance and to promote Britain and its empire through the medium of film. In 1926 the Imperial Conference called for an increase in British film production, and the Empire Marketing Board was established to encourage inter-Empire trade and cultural bonds, leading to the foundation of John Grierson's documentary film unit.⁸⁷ In December that year the Federation of British Industries formed a film producers' group to lobby for greater support for domestic production, of which it appears the Burns-Scott Films, along with major British companies such as Welsh-Pearson and Stoll, was a member.⁸⁸ Sandground evidently had sufficient confidence to include his small Scottish enterprise in a group representing the cream of British film-making, in anticipation of legislation designed to boost domestic film production. Generally known as the Quota Act, the Cinematograph Films Act went before parliament in 1927 and received the Royal Assent in December that year. It introduced a requirement for British cinemas to show a quota of British films, with the aim of promoting a vertically integrated British industry on similar lines to the American industry. By creating an artificial market for British films, it was hoped

⁸⁶ *Evening Telegraph*, Dundee, 16 February 1927, p2

⁸⁷ See L Grieveson 'The Cinema and the (Common) Wealth of Nations' in L Grieveson and C McCabe (eds), *Empire and Film* (London, 2011), pp73-100. These issues are discussed more fully in Chapter 6

⁸⁸ P Jumar, *Cinema at the End of Empire*, p254, citing PRO [sic], CO323/974/1, Colonial Office Conference, 1927: Cinematograph Films: Memorandum on British Films, prepared by the Federation of British Industries. The other group members were Archibald Nettlefold Productions, Astra National Productions, Britannia Films, British Instructional Pictures, British Projects, New Era Productions and the Topical Film Company

that increased economic activity in the production sector would eventually lead to the growth of a self-sustaining industry.⁸⁹

The Life of Robert Burns began its run in grand style at the Synod Hall in Edinburgh in January 1927, moving briefly to the Hamilton Hippodrome before commencing its two-week run at the Kinnaird in Dundee. These seem to have been the film's only outings immediately after its release, but it appeared again, around the time of Burns Night, in 1928 and 1929, at the smaller population centres of Hawick, Falkirk, Montrose and Arbroath, and in September 1928 at Motherwell.⁹⁰ Its connection to one of Scotland's most important annual celebrations explained *The Life of Robert Burns*' modest success, but the film that immediately followed did not share this advantage. *Glimpses from the Life of Sir Walter Scott* was shown to the trade at the Coliseum, Glasgow, on 15 December 1926. The *Scotsman*'s review the following day offered a comprehensive description:

Sir Walter's wanderings over his beloved Trossachs district is shown. He is seen in deeply thoughtful mood, pausing at various places, leaning on his staff, and recalling the days that are gone. Loch Lomond and the adjacent district, so fertile of romance, comes into the picture. Here Scott collected much of the material for the exploits of the immortal freebooter, Rob Roy. A considerable portion of Rob Roy is given in dramatic form, and the incident in which harsh treatment is meted out to Rob's wife and children, who are turned adrift from their home while he is absent on a visit to Ballie Nicol Jarvie in Glasgow, is finely treated. Much is made of the famous story of "The Lady of the Lake," which is also treated dramatically, and the combat scene between Fitzjames and Roderick Dhu is made a living thing. A feature is the excellent selection of songs which are used to give point and character to the film, such as the "Macgregor's Gathering," &c. The figure of Sir Walter Scott is

⁸⁹ The Act specified that in order to qualify for quota a film must be made by a British or British-controlled company; studio scenes must be photographed within the British Empire or Commonwealth; the author of the scenario or original work on which the screenplay was based must be British, and at least 75 per cent of the salaries must be paid to British subjects. Under the 1927 Act the quota was set at 5 per cent for exhibitors and 7.5 per cent for distributors: this was to be raised to 20 per cent by 1935. See L Napper, *British Cinema and Middlebrow Culture in the Interwar Years* (Exeter, 2015) pp25-28. See also Chapter 6

⁹⁰ *Scotsman*, 1 February 1927, p9; *Motherwell Times*, 28 January 1927, p1; *Courier*, Dundee, 8 February 1927, p4; *Hawick News & Border Chronicle*, 13 January 1928, p2; *Falkirk Herald*, 21 January 1928, p8; *Motherwell Times*, 7 September 1928, p8; *Courier*, Dundee, 22 January 1929, p8; *Arbroath Herald*, 25 January 1929, p7

fairly well represented, and throughout the film his many appearances are always welcome and refreshing. The film is an excellent and educative production, and a suitable companion work to “The Life of Robert Burns”.⁹¹

Despite its ‘excellent and educative’ nature, this film seems to have fared less well at the box office than *The Life of Robert Burns*. There is no evidence of it being screened anywhere between the trade show in December 1926 and its ‘premier world presentation’ at Poole’s Synod Hall in Edinburgh in the first week of April 1927, which was followed by a short run at the Playhouse, Selkirk.⁹² A live prologue was given by the actor playing Sir Walter Scott in the film, George Hunter, and musical accompaniment was provided by a ‘double quartette of Scottish vocalists’.⁹³ Once again, the production was promoted as an ‘All Scottish Film’, and Sandground’s name featured prominently in advertisements as the producer of *Bonnie Scotland Calls You* and *The Life of Robert Burns*. There was no mention of any literary source material, although it seems likely that Sandground would have attempted to draw on J G Lockhart’s definitive, ten-volume biography, *The Life of Sir Walter Scott*, published between 1837 and 1839. In an attempt to exploit the educational angle, newspaper advertisements included a coupon allowing schoolchildren tickets at less than half price for performances before 4.30 pm, Saturdays excepted.⁹⁴ Even at these prices, the strategy must have failed: *Glimpses from the Life of Sir Walter Scott* produced the Synod Hall’s lowest earnings of 1927.⁹⁵ Never one to waste valuable film stock, Sandground later extracted the Rob Roy sequences from the film and presented them as a new production called *Scotland Yet*. This film was shown in at least two Scottish cinemas in late December 1928. Advertisements revealed that it centred on scenes from the stage version of Rob Roy, featuring the Scottish stage actors Walter Roy as Rob Roy and Robert Wallcroft as Baillie Nicol Jarvie, while the

⁹¹ *Scotsman*, 16 December 1926 p7

⁹² *Scotsman*, 5 April 1927, p1; *Southern Reporter*, Selkirk, 21 April 1927, p5

⁹³ *Scotsman*, 5 April 1927 p1

⁹⁴ Ninepenny seats were fourpence; one shilling and threepenny seats were sixpence, and the most expensive, two shilling, seats were ninepence.

⁹⁵ NLS/MIA, 5/4/14, quoted in Griffiths, *The Cinema and Cinema-going in Scotland*, p291

‘eminent Scottish tenor’ Robert Davidson sang ‘The Banks o’ Loch Lomond, ‘The Braes o’ Balquhiddy’, ‘The Piper o’ Dundee’ and ‘MacGregors’ Gathering’.⁹⁶

Sandground’s intended audience was, as evidenced by the above, the educated middle class. Whether he was lagging behind the times in terms of contemporary British film production, as Trevor Griffiths has suggested, is less clear.⁹⁷ Research into modes of presentation in the mid to late silent era has shown that the 1920s saw a return of ‘mixed media’ (film and live theatre) productions aimed at the intelligentsia. Commenting on an exhibition practice inaugurated by D W Griffith for *Broken Blossoms* in 1919, Christine Gledhill describes how this special presentation involved ‘not only dressing the theatre and usherettes in Chinese fashion (including hanging up cages of canaries that sang throughout the film) but beginning the performance with an elaborate prologue in which Mabel Poulton made her first appearance, miming Gish dying in a Buddhist temple’.⁹⁸

The success of *Broken Blossoms* was of great interest to the British trade press, which thereafter included regular columns on the promotion of special presentation (in the manner of *Bonnie Prince Charlie*, discussed above), the creation of overall atmosphere - including appropriate music - and the production of live stage prologues which were presented immediately before the feature film. Prologues consisted of a dramatic or musical performance which had a direct relationship to the film, and were promoted as a device fully to immerse the audience in its fictional world. Their nature varied according to the size and budget of the venue, with the most elaborate reserved for enormously expensive one-off presentations for the trade and invited guests. For its trade show screening at the Royal Albert Hall in 1924, for example, the American film *The Sea Hawk* was preceded by an extravagant prologue involving a huge ship from which the film’s theme song was sung by a chorus of sailors. Less lavish but equally notable was the West End run of Cecil Hepworth’s *Comin’ Thro’ the Rye* (1923), whose prologue consisted of a synopsis of the film’s

⁹⁶ *Motherwell Times*, 2 November 1928, p8; *Falkirk Herald*, 29 December 1928, p9

⁹⁷ Griffiths, *The Cinema and Cinema-going in Scotland*, p291

⁹⁸ C Gledhill, *Reframing British Cinema* (London, 2003) p 12

plot enacted in pantomime behind screens, to the accompaniment of harp music.⁹⁹ Sandground would have been well aware of these events, attempting to emulate the style displayed by Hepworth and *The Sea Hawk's* director, Glasgow-born Frank Lloyd, without the accompanying expense. He would also have known of the fate of the Hepworth Manufacturing Company: *Comin' Thro the Rye* had failed to improve its fortunes, and the company was declared bankrupt in 1924.

In smaller cinemas, prologues were either created by the exhibitor or provided as a package. As Julie Brown has noted, the inclusion of live performance alongside the feature film was 'only the latest turn in a long history of the appearance of moving pictures in mixed programmes', and until the 1930s and beyond moving pictures were routinely screened alongside live musical, dramatic, and variety performances. Although in Britain the popularity of the prologue began to wane as early as 1923, it survived until the end of the 1920s, evidenced by continued coverage in the trade papers. The *Kinematograph Weekly* columnist E Fletcher-Clayton criticised the way prologues were used, particularly those 'cheap local productions' that drew on local talent and were promoted in positive terms as helping to localise the show, as 'simply poor, even laughable'.¹⁰⁰ Although these comments were made four years before the appearance of Sandground's Scottish films, Fletcher-Clayton's remarks could have been directed at them, so prescient was his description.

Cinema's association with established art forms such as music and theatre lent it cultural prestige and respectability that would attract a better, higher-paying class of clientele. As Gledhill argues, this strategy also opened up an 'interface between live and screen performance' that British entertainment culture was quick to exploit. Throughout the 1920s exhibitors experimented with different forms - including 'revuettes', variety turns, musical interludes, spoken dialogue and dancing as well as prologues - which were interpolated into cinematic entertainment. Such practices met with varying approval from different audience groups: while 'complaints about musical interludes and interminable prologues' were made with increasing regularity

⁹⁹ J Brown, 'Framing the Atmospheric Film Prologue in Britain, 1919-1926' in Brown and Davison (eds), *The Sounds of the Silents in Britain*, pp200-221

¹⁰⁰ E Fletcher-Clayton, 'Film Prologues - 1', *KW Supplement*, 2 August 1923, vi, quoted in Brown, 'Framing the Atmospheric Film Prologue in Britain, 1919-1926', p211

in the second half of the 1920s, the prologue or variety interlude at the very least ‘contributed a community function to the cinema, showcasing the “splendid talents of our children” and of local dancing, dramatic or elocution schools’.¹⁰¹

Seen in this context, Maurice Sandground was keeping up with the times rather than attempting to revive a moribund form of entertainment. The success and popularity of his Scottish films can therefore be seen as resting on how good (or bad) they were, rather than on their mixed-media presentation. In the case of *Glimpses from the Life of Sir Walter Scott*, it appears that the audience voted with their feet. This setback did not deter Sandground, who proceeded to splice the film together with *The Life of Robert Burns* and re-present it as *Immortals of Bonnie Scotland* in 1927. This ‘new’ production, said to comprise ‘selected portions of the [Burns and Scott] films carefully fitted together and orchestrated with music of an entirely Scottish character’ was to be pitched firmly at the Scottish market in Canada and the USA.¹⁰² The Burns and Scott films were each listed in the British Board of Film Censors’ Register for 1927 as being 7,600 feet long (an approximate running time of an hour and 25 minutes), and although *Immortals of Bonnie Scotland* was subsequently added to the Register as an amalgamation of the two films, there was no indication of its running time.¹⁰³

On 4 June 1927 Sandground sailed from Greenock on the S.S. Montclare bound for Quebec, where he arrived on 11 June. His forwarding address was given as c/o C.P.R. Publicity Department, Windsor Street Station, Montreal.¹⁰⁴ The reason for this journey was to accompany *Immortals of Bonnie Scotland* on its proposed grand tour of Canada. How far he travelled is uncertain, but there is documentary evidence that *Immortals of Bonnie Scotland* was seen in Toronto. Once again, Sandground’s talent for publicity came to the fore. Under the heading ‘First Scottish Film Here’ the *Toronto Star* announced:

¹⁰¹ Gledhill, *Reframing British Cinema*, p13

¹⁰² NLS/MIA 4/1/29: Proposal for The Empire Films Limited

¹⁰³ British Board of Film Censors, Register of Films Passed, 1927. Sandground’s films were given ‘U’ (universal exhibition) certificates

¹⁰⁴ Canadian Pacific Railway

The first “made in Scotland” motion picture to be seen in Canada has been brought here by Maurice Sandground of Glasgow and will soon be exhibited here. The picture combines episodes from the poems Tam O’Shanter, Rob Roy and The Lady of the Lake. It is said to blend the natural scenic beauties of Scotland with an unusual degree of technical skill.¹⁰⁵

It took Sandground almost five months to get his production shown in Canada. In *Variety*’s words, it was ‘a feminine press agent’ who ‘ballyhooded’ *Immortals of Bonnie Scotland* throughout Canada by addressing service clubs, urging their members to demand British pictures, and ‘putting in a plug for her own bosses’. Eventually an Englishman called Jimmy Travers agreed to exhibit the film. Travers rented the Regent in Toronto - a small, failing, cinema - for two weeks, paying its owners a ‘tidy sum’ for the privilege of presenting two British films: *Immortals of Bonnie Scotland* and *Roses of Picardy*, a 1927 war film directed by Maurice Elvey. While the latter did well, the Sandground production ‘looked like a dud on the preview’, but thanks to the efforts of his press agent and her relentless ‘society plugging on patriotic stuff’, advance ticket sales were promising. Further efforts to increase its attractiveness were made by the musical director, Lloyd Collins, who interspersed the various episodes with songs. Nevertheless, it ‘started off like a flop’, shown daily at 2.30 and 5.30pm for a week and accompanied by a stage cast of 25 people - making it an expensive production to mount.¹⁰⁶ Advertisements appealing to the local Scots audience to ‘Dinna Forget! Scotland’s First Motion Picture’ may have fallen on indifferent ears. There is no doubt that such an audience existed: indeed, an adjacent advertisement on the entertainment page of the *Toronto Globe* promoted a ‘Sons of Scotland’ Scottish Concert, featuring the ‘Famous Scottish Tenor, Templeton Moore’.¹⁰⁷

On 9 November, however, it was announced that while on a visit to Toronto, the Governor General of Canada and his wife, the Viscountess Willingdon, would ‘extend their patronage to the first Scottish picture to be shown in Canada’. A week later, in between dinner and a military ball, they attended a screening accompanied

¹⁰⁵ *Toronto Daily Star*, 6 July 1927, p3

¹⁰⁶ *Variety*, 2 November 1927, p8; 16 November 1927, p6

¹⁰⁷ *Toronto Globe*, 16 November 1927, p2

by the Governor of Ontario and a 'large party from Government House'. Despite their approval the film only took \$5,000 at the box office, representing 'little, if any, profit'. After *Immortals of Bonnie Scotland* ended its run the Regent Theatre was sold and demolished to make way for an office building, and although *Variety* reported that the film was to be 'roadshowed across Canada', Toronto was its only outing.¹⁰⁸

'Dennysonian', a Scottish expatriate who had seen the film in Toronto, was so incensed by its representation of his fellow countrymen that he was driven to write a letter of protest to the *Falkirk Herald*.¹⁰⁹ He had found some of the film's scenic elements 'beautiful beyond description', but felt that on the whole the film was of an 'inferior quality, and finished with a long-drawn-out picture of drunken men', continuing:

The picture was advertised as "Bonnie Scotland", and, while the songs, costumes dancing and scenery did much to cheer many a lonely exile, surely it is not true that drunkenness is such a national characteristic as to be pictured in such detail. It was quite disgusting in the extreme, and if future films do not cease bringing disgrace to Scotland and making her sons hang their heads in shame, then better far, for Scotland's reputation, that the Yankees make our Scottish films.¹¹⁰

On Sandground's return from Canada it was announced that *Immortals of Bonnie Scotland* was to be tried out on a wider audience. In January 1928 the *Bioscope* notified readers that it was to start a run at the Polytechnic Theatre in Regent Street, an announcement confirmed by the *Glasgow Herald*, which explained that the proposed six-week run was 'by way of testing the English taste for Scottish pictures'.¹¹¹ If this proved successful, it would be the 'forerunner of several films to be produced in Scotland'. The notice mendaciously stated that the Scott and Burns films had been 'a triumphant success for the producer in Scotland and Canada during the past two years', implying that their combination as 'one serial picture' under the title of *The Immortals of Bonnie Scotland* was a new development. Sandground made

¹⁰⁸ *Toronto Daily Star*, 17 November 1927, p2

¹⁰⁹ A native of Denny, a small town west of Falkirk

¹¹⁰ *Falkirk Herald*, 7 January 1928, p8

¹¹¹ *Bioscope*, 12 January 1928, p55

it clear that, although the Council of the Scottish Clans Association and other Scottish societies were ‘taking a strong interest’ in the exhibition of this film, his target market was not Scots in London - among whom its popularity was assured - but ‘general cinema-goers in the Metropolis’.¹¹²

The improbability of a Sandground production being booked by a premier London cinema was borne out in the last paragraph of this notice, indicating that the ‘newly renovated 610-seat cinema in the West End’ was merely the *proposed* [my italics] venue for *The Immortals of Bonnie Scotland*’s London showing. In Sandground’s dream, the six-week run was to be followed by a tour ‘covering all the important towns of GB and Ireland’, while overseas tours would ‘carry on through the principal towns of Canada and the USA for the next two or three years’.¹¹³ Needless to say, these ambitious plans came to nothing. Even in the unlikely event that *Immortals of Bonnie Scotland* would find favour with a mainstream audience, it was an expensive production from the point of view of the exhibitor. Synchronised sound films were on their way, and Sandground’s hopes for a series of Scottish films along the lines of *Immortals of Bonnie Scotland* were unlikely to be realised.¹¹⁴

This is not quite the end of Sandground’s story. In 1927, before sailing for Canada, he had put together a proposal to establish a new company, The Empire Films Limited. This company would combine the assets of Scottish Film Productions and Burns-Scott Films, including prints of *The Life of Robert Burns*, *Scotland Yet* and *Immortals of Bonnie Scotland*, together with all music and other materials. The principal directors were to be Malcolm Irvine and Sandground himself, and capital of £50,000 was to be made up of 50,000 £1 ordinary shares: a much larger capitalisation than his previous companies.¹¹⁵ The proposal makes fascinating reading, not only for its hyperbole about Sandground’s previous productions, but for the way he was now presenting his films as a ‘subtle form of film publicity’ designed to attract overseas tourists:

¹¹² *Glasgow Herald*, 11 January 1928, p11

¹¹³ NLS/MIA 4/1/29, Proposal for The Empire Films Limited

¹¹⁴ See Chapter 6

¹¹⁵ NLS/MIA, 4/1/29, Typescript of proposal regarding The Empire Films Limited

While in America, Mr Sandground observed the enormous development which had taken place in this application of films for the purposes of advertisement and propaganda. Nothing has yet been done in the subtle form exemplified in the productions of the Burns-Scott Films, Limited. As a means of advertising Britain therefore, the exhibition of “Immortals of Bonnie Scotland” in America will create amongst Americans a strong desire to see for themselves the scenes portrayed. Glimpses of Scotland’s beauty... cannot but create in the mind of the viewer a desire to travel.¹¹⁶

This was crucially different from the previous pitch to ‘Scottish audiences everywhere’. Here, the medium of film was distinguished from art, literature, and ‘all [other] methods of advertising a country’ as ‘capable of inducing in the viewer all the pleasurable emotions for a prolonged period’. Once again, it is possible to see Sandground as a contemporary - or even visionary - thinker: it would be decades before the formation of local tourist boards (whom he would undoubtedly have sought as sponsors), and before official recognition that feature films set in Scotland could provide a huge economic boost from tourism.¹¹⁷

The proposal also indicates that Sandground had not given up hope that his existing films would remain in circulation. It claimed that ‘a substantial income’ to fund the new venture would be available from the ‘large number of contracts’ to show *The Life of Robert Burns*, while *Scotland Yet* was also expected to generate a ‘substantial return’. These productions still existed as separate entities, with the former, as noted above, remaining in circulation until at least 1929. As for *Immortals of Bonnie Scotland*: ‘A fifty-fifty contract’ was said to have been made for its exhibition in Canada and the USA and ‘substantial patronage’ had been secured. Letters proving this were said to be attached to the document.

¹¹⁶ The Empire Marketing Board had been established in 1926 in order to promote imperial products, but it was not until 1928 that its film unit, headed by John Grierson, was formed

¹¹⁷ See, for example, Alex Salmond’s remark after the premiere of *Brave* in 2012: ‘I know how impressed people are with Scotland after seeing *Brave*, and we have the chance to reap some of the benefits of that after people see this beautiful film’. *Evening Standard*, 19 June 2012, www.standard.co.uk

The name for the proposed new company, Empire Films, was carefully chosen.¹¹⁸ Under the heading ‘Pioneer Efforts’, the document stated: ‘It has been the privilege of a small number of Film Producers in this country to prove that Empire films can be made equally if not more attractive than foreign films’. The company’s first production for 1928 was to be a film called *Come Back to Erin*, whose scenario included ‘a group of romances with settings in the better known beauty spots of Ireland’: a subject with potentially large appeal in the USA - although he had overlooked the fact that a film of the same title had already been made. The romantic drama *Come Back to Erin* (1914) was a production of the well-known (American) Kalem company, whose producer Sidney Olcott made a series of films in Ireland between 1910 and 1915.¹¹⁹

Despite Sandground’s persuasive efforts, The Empire Films Limited did not become a reality. The putative company’s head office was given as 26 India Street, Glasgow, ‘pro tem’ and its London office as 89 and 91 Wardour Street, suggesting that he was already in the process of a permanent move from Scotland. Records show that Sandground and his family lived at 27 Birchington Road in West Hampstead in the 1930s, but there is no evidence that he was still active in the film industry. After the failure of The Empire Films to be realised, the assets of the Burns-Scott Films, Ltd were transferred to a new company headed by Malcolm Irvine, Scottish Films Productions (1928), Ltd, which continued to operate from the India Street studios in Glasgow, and whose work is discussed in the following chapter.¹²⁰ In the autumn of 1939 Maurice Sandground died, aged 64, in Hove, Sussex.¹²¹ Whether he and Harriet had moved to Hove for health or financial reasons, or whether they were visiting Harriet’s sister Julia Salmon, who lived there, is unknown.¹²²

¹¹⁸ The name also recalled Sandground’s early career as the producer of the unsuccessful Empire Comedies

¹¹⁹ D Condon, *Early Irish Cinema, 1895-1921* (Dublin, 2008), p125

¹²⁰ Irvine developed his own sound system, the Albion Truphonic, and went into the production of ‘talkies’. See Chapter 6

¹²¹ Deaths Registered in July, August and September 1939: <http://www2.freebmd.org.uk> (accessed August 2013)

¹²² *The London Gazette*, 29 September 1944, p4516. Recently deceased spinster Julia Salmon’s addresses were listed as 34 Brunswick Square, Hove, Sussex, and 50 Queensway, Bayswater, London.

The success of *Bonnie Scotland Calls You* is not in question. It was probably the most successful feature film to have been produced in Scotland in the silent era, and its legacy lived on. In 1938 a British sound film of the same title was released which featured Scottish scenery and song, but had no fictional element. Its method of storytelling, however - a travelogue following the journey of two hikers through the Highlands and Islands - was similar to that of the original.¹²³ The genre that Sandground invented and the kind of representation of Scotland that his films traded in became the target of critical derision but continued to be successful with audiences.¹²⁴ In Scottish cinemas the most successful 'Scottish' film of the 1930s was a Laurel and Hardy comedy called *Bonnie Scotland*, in which MacLaurel and MacHardy travel to Scotland to inherit a legacy which turns out to be a set of bagpipes and a snuff container. The only indigenously-produced film to have come close to rivalling *Bonnie Scotland Calls You* in popularity was *Football Daft* (1922), discussed in Chapter 3.

Sandground's work was, in the word's most literal sense, unrivalled, although he had one local competitor for the Scottish market overseas. The apparent success of *Bonnie Scotland Calls You* early in 1924 may have prompted an Edinburgh city councillor called J Wilson McLaren to produce a film later that year called *The Home and Haunts of Robert Louis Stevenson* which was also intended for Scots not just at home, but 'to their kith and kin across the seas'. Despite its literary connection, this was essentially another documentary: a 'screen impression of the romance of Edinburgh' which took viewers on a tour of places associated with the famous Scottish author starting in the city's New Town (where Stevenson was born), out to Dean Village, the Pentland Hills and Colinton, and ending in the Old Town. The filmic presentation of Edinburgh's most-visited tourist spots was intended to 'kindle memories' in those far from Scotland, while a citizen 'might be excused a

Her beneficiaries were (Sandground's widow) Harriet, (son) Jack Sandground and (daughter) Dorothy Sandground. Their first son, Barnet, may have died in childhood

¹²³ *Bonnie Scotland Calls You* (1938), Dir Howard Gaye, Associated British Picture Corporation

¹²⁴ The 1982 film *Scotch Myths* (dir Murray Grigor), for example, which could be seen as parodic of Sandground's work, although it is unlikely that the film-makers were aware of the existence of his films

feeling of surprise as he obtains glimpses of the beauty of the valley of the Water of Leith'.¹²⁵

McLaren had literary credentials as the author of several books and was a 'noted authority' on old Edinburgh.¹²⁶ Although he must have been several years younger than Robert Louis Stevenson, the two had attended the same school for a time and later corresponded, and advance publicity for the film suggested that Stevenson's son would appear in several scenes. Production of *The Home and Haunts of Robert Louis Stevenson* was publicised as far away as New Zealand, but despite having been made 'as true to nature and life as far as up-to-date cinematography can make it', the film was only briefly presented at one Edinburgh cinema. For two days in November 1924 it could be seen at the Princes Cinema as a 'special added attraction' to the programme of films, presented by Councillor McLaren himself. Its subsequent outings were in the form of an illustrated lecture, including one given at the Markinch Institute, Fife, in January 1928.¹²⁷

Conclusion

Maurice Sandground was the only Scottish-based producer to succeed in the ambition of having a film seen by Scottish audiences overseas in the 1920s, albeit in one Canadian city. A single physical trace of his Scottish-made films remains today: a tattered poster for *The Life of Robert Burns* held by the NLS Moving Image Archive.¹²⁸ When this research began, it appeared that a DVD copy of *Glimpses From the Life of Sir Walter Scott* might be held in the library of the Near East University in Northern Cyprus. A visit to Cyprus in March 2015 proved (disappointingly, but not unexpectedly) that this was not the case. But Sandground deserves a more prominent place in the history of Scottish cinema than he has previously enjoyed. In the 1920s he was a lone voice campaigning in a sustained way

¹²⁵ *Courier*, Dundee, 16 June 1924, p8; *Scotsman*, 11 November 1924, p8

¹²⁶ McLaren's published work included *Scots Poems and Ballants* (1892); *Tibbie and Tam* (1894); *A Canny Scot* (1926) and *Edinburgh Memories and Some Worthies* (1926). He was also the co-author of a dramatic version of R L Stevenson's *The Weir of Hermiston*

¹²⁷ W McLaren, 'Memories' in R Masson (ed), 'I can remember Robert Louis Stevenson' (Edinburgh, 1922), p32, <https://archive.org/details/icanrememberrobe00massrich> (accessed October 2015); *New Zealand Herald*, 6 September 1924, p8; *Evening News*, Edinburgh, 10 November 1924, p1

¹²⁸ NLS/MIA, 5/7/395, Poster, *The Life of Robert Burns* (incomplete, in three sections)

for a Scottish film industry, and was prepared to put his efforts and resources into film production in Scotland. Even if his productions had been more proficient and popular, economic and cultural forces meant his chance of success would have been minimal.

Chapter 6: Scotland, Empire and the transition to sound

'Sir Harry Lauder has one of the best recording voices in the world, and he is wasted in a silent film when one considers how effective he might be as a British Al Jolson'.¹

Introduction

This chapter is concerned with Scotland's response to the two factors dominating the British film industry in the last years of the 1920s: the Cinematograph Films Act of 1927 (generally known as the Quota Act) and the arrival of 'the talkies' in 1929.

Until the coming of sound the efforts of Scottish producers stayed close to those of the English industry in terms of trends and production strategies, but 1929 witnessed a parting of the ways. Between 1926 and 1929 there were several new attempts to form a commercially viable production company in Scotland as well as a revival of activity in Scotland by English producers, although on less grand scale than some of the productions discussed above.² Uniquely in the story of Scottish film production to this point, the last two non-sound films to be produced by a Scottish company were in no sense 'Scottish stories' and were filmed thousands of miles from its Glasgow headquarters. In the same period, there were attempts by Scottish producers and exhibitors to develop their own sound systems, and even renewed hope in some quarters that commercial production could be sustained through the building of a new Scottish film studio. This carried faint echoes of hopes raised elsewhere. British producers were optimistic of their chances of developing a large and prosperous industry arising from opportunities offered by the Quota and the coming of sound. The final failure of Scottish feature film production should not be seen as inevitable, but requires an explanation which this chapter provides.

The Quota Act and British Empire films

In 1927 British film production was in danger of dying out. The introduction of quota legislation which came into force the following April - in response to pressures that

¹ *Aberdeen Journal*, 3 April 1929, p7

² For example, *Rob Roy* (1922), *Bonnie Prince Charlie* and *Young Lochinvar* (both 1923). See Chapter 4

had been building for several years - was designed to revive the film industry by guaranteeing an outlet for British films. This resulted in a period of intense activity in production: new companies were launched, funded on a wave of City and public enthusiasm, and, after April, new studios were built and existing facilities extended in order to meet the demands of the quota.³ The most controversial aspect of the Cinematograph Films Act (1927) was that distributors were required to acquire, and exhibitors to screen, a certain percentage of British films. This was on a sliding scale, initially set at 5 per cent for exhibitors and 7.5 per cent for distributors: by 1936, when the act was to be reviewed, the legislation stated that 20 per cent of all films rented and exhibited in Britain were to be British. The definition of a 'British film' was not straightforward: among other factors, the Act allowed a film to be registered as British if it were directed by a British subject or made by a British company, if its studio scenes were shot in a studio in the British Empire, if the author of the original scenario was a British subject, or if 75 per cent of salaries were paid to British subjects or those domiciled in the British Empire. Films made anywhere within the British Empire, dominions and colonies could be categorised as 'British', and were therefore eligible for a quota in Britain.⁴ Indeed the original pressure for a quota came from the Dominions, seeking for a way to counter American domination of their own film industries.⁵

Film historians have tended to focus on the aspects of the Act which enabled American film companies (with British citizens on their board of directors) to set up British subsidiary companies to make films for quota purposes and the resulting production of 'quota quickies': cheap, poor quality films financed by distributors in order to fulfil their obligations.⁶ An equally important aspect of the legislation was the effect it had in promoting the 'British Empire film'. This term referred both to films made with British or empire resources and to those originating from British colonies or dominions. As Priya Jaikumar has noted, the trade press helped to

³ The Cinematograph Films Act (1927) received Royal Assent in December 1927 and became law on 1 April 1928

⁴ L Wood, *British Films 1927-1939* (1986), www.bfi.org.uk (accessed November 2015)

⁵ L Grieveson, 'The Cinema and the (Common) Wealth of Nations', p73

⁶ See, for example, M Glancy, 'Hollywood and Britain: MGM and the British 'Quota' Legislation' in J Richards (ed) *The Unknown 1930s: An Alternative History of the British Cinema, 1929-1939* (London, 1998) pp60-62

promulgate the notion of ‘Empire film’ as a cover-all term: The *Bioscope*, for example, described 1927 as an opportune time for the ‘big-boosting of every Empire-made film’, as there was a ‘rich fund of literature from which to make our own - speaking imperially - epics of colonisation, our own “Birth of a Nation” and “Covered Wagon”’. In this way ‘Empire-made films’ were equated with British ‘epics of colonisation’ at a time when imperial markets provided the most reliable outlet for British exports, and the Empire was seen as crucial to economic recovery.⁷

In August 1926 the *Bioscope* had published a series of articles and editorials stressing the importance of presenting British films throughout the Empire as part of a wider attempt to revive the film industry. One such article, entitled ‘British Industry in Hopeless Position’, was followed by a separate article announcing that three British feature films ‘which will convey the best of British ideals and sentiments’ were to be trade-shown on consecutive days in September. One of these was *Palaver*, a ‘marvellous story of Empire conquest in Northern Nigeria’, whose ‘inspiring’ narrative revolved around the efforts of two Britons, a brave civil servant and an unprincipled adventurer, to make their mark on the untamed African country. The two fought for the love of the same woman and for control of a people and their land.⁸ Shown in cinemas throughout Britain from March 1927, *Palaver* proved to have greater audience appeal than the Empire Series of documentaries (such as *Blazing the Trail*, about the building of railways on the Gold Coast) produced by the same company, British Instructional Films.⁹

Public and press enthusiasm for colonial adventure films such as *Palaver*, together with the much-publicised arrival of the Quota Act and its aim of promoting film production throughout the British Empire, set the scene for the formation of a new Scottish production company in 1927. Seven Seas Screen Productions Ltd was registered in Glasgow on 18 January 1927 with a nominal capital of £10,000. This was a modest sum for a company with ambitions to produce mainstream adventure

⁷ P Jaikumar, *Cinema at the End of Empire: A Politics of Transition in Britain and India*, (Durham and London, 2006) p45

⁸ BFI screenonline: <http://www.screenonline.org.uk/film/id/570373/> (accessed November 2015)

⁹ *Bioscope*, 23 September 1926, p37. The other two films were *Nelson* and *Mons*, also products of British Instructional Films. See <http://www.colonialfilm.org.uk/> (accessed November 2015)

films overseas - indeed, it was £10,000 less than another new Scottish company registered the same week, the ham and bacon curers R and H Turnbull of Strathallan.¹⁰ A private company with the number of potential subscribers limited to 50, the sole purpose of the Seven Seas Productions was to enable one of its three directors, the well-known Scottish explorer and writer Alexander Macdonald (1878-1939), to make Empire-themed films based on his own adventures. Macdonald, a Fellow of the Royal Geographical Society and friend of the American author Jack London, had worked as a mining engineer and gold prospector and had spent much of his life in Australia. He wrote several accounts of his adventures including *In Search of El Dorado* (1905) and *Through the Heart of Tibet* (1910), as well as adventure stories for boys, many of which drew upon his experiences in Australia.¹¹

In 1927 Macdonald was almost 50 and had returned to live in Perthshire in his native Scotland. Although he had no experience in film-making, he was evidently confident that he possessed the skills necessary to write and direct productions that would recreate in fictional form his past experiences as an 'Empire pioneer'.¹² He flagged up his intentions in an article he wrote for the *Bioscope* called 'Trade will follow the Film', in which he discussed the importance of film to the Empire.¹³ Macdonald enjoyed celebrity as an explorer in Britain and Australia, and was socially well-connected in both countries. One of his two fellow directors on the original board of Seven Seas Screen Productions was Sir Bruce Seton of Edinburgh, the ninth Baronet of Abercorn, who took the role of company secretary.¹⁴ Seton was himself the author of several books and military manuals, including *The Pipes of War: a Record of the Achievements of Pipers of Scottish and Overseas Regiments during the War, 1914-1918* (1920). The other director was a solicitor, Harold John Black of Glasgow. The arrangement between Seven Seas and Macdonald, described in the Articles of

¹⁰ *Aberdeen Journal*, 22 January 1927, p10

¹¹ 'Macdonald, Alexander', in *Oxford Companion to Australian Literature* (2005), 2nd edn (Oxford, 2005), www.oxfordreference.com (accessed December 2015)

¹² *Evening Telegraph*, Dundee, 19 November 1926, p3

¹³ *Bioscope*, 12 September 1926, p35. This idea was the prime justification of the Quota Act

¹⁴ Sir Bruce Gordon Seton (1868-1932) was the father of the film and television actor Bruce Seton, best known for his role as the eponymous detective in the 1950s BBC police drama series *Fabian of the Yard*

Association as ‘traveller and author’, was that the latter would receive shares in return for his services in making films for the company.¹⁵

Unlike any of its predecessors, this Glasgow-based production company had no intention of making films on Scottish subjects - although Macdonald’s first film was to be shot in Scotland, with Glenshee in the Highlands standing in for the Chilkoot Pass between Alaska and north-west Canada. This treacherous mountain pass became known as the ‘Golden Staircase’ during the Klondike gold rush of 1896 to 1899, as prospectors had to climb its slopes to reach the gold fields. The Dundee *Evening Telegraph*, reporting in November 1926 on Macdonald’s plans to film an adventure story based on his book *In Search of El Dorado* described how, as a young engineer, Macdonald had ‘led the first rush to the gold-fields beyond the Chilcoot [sic], an undertaking which was fraught with great danger’. He now proposed to show the public what was entailed in this feat ‘which held breathless the world of about thirty years ago’. The snow-covered Grampians near the Devil’s Elbow in Glenshee were considered very suitable, as not only did they resemble the notorious Pass, but the road between Blairgowrie and Braemar was usually impassable in mid-winter, allowing the film-makers greater freedom. It was considered natural that Macdonald would choose to shoot the film near his Scottish birthplace, and a ‘sign of the times’ that Glenshee was to be used for this essentially British (rather than Scottish) enterprise, as British films for British people had been ‘the subject of discussion recently in many influential circles’. Macdonald’s lack of directorial experience was not mentioned, the article focusing instead on the way he was uniquely positioned to ‘present just that exactness of detail which gives immense value to a film of this nature’.¹⁶

If Macdonald had a calling card as a feature film-maker, it was his insistence on the advantages of outdoor filming. No studio seems to have been used for any of his productions, and there was certainly no suggestion that the Seven Seas company would benefit the Glasgow economy through the building or renting of film studios, or the employment of local people. Like Maurice Sandground, Macdonald was an

¹⁵ NRS, BT2/14453, Seven Seas Screen Productions Limited, Return of Allotments, 13 July 1927

¹⁶ *Evening Telegraph*, Dundee, 19 November 1926, p3

excellent self-publicist and had a similar knack of making a virtue out of necessity. Both men attempted to make commercial feature films on extremely low budgets, using non- or semi-professional actors and exploiting those resources that were freely available to them. But when Macdonald told a newspaper reporter that he was ‘anxious to break away from the orthodox screen work and give a glimpse of the great out-of-door romance which had made our country famous’ he was probably sincere, although naïve about the realities of attempting to make feature films entirely in the open. He expressed himself perfectly confident that ‘if there was thrown on the screen a true tale of Empire pioneer work, both young and old would appreciate it’. Macdonald saw the cinema as another medium through which his ideas on the benefits of overcoming adversity in the wild as a way of building physical and mental strength could be presented: the best way of preserving the Empire’s ‘vast heritage’, he announced, was to ‘live up to it unafraid’. Following the Klondike story he intended to make more films ‘of British significance’ in other parts of the world.¹⁷

The entire film was to be shot in Perthshire: the River Tay was to represent a mountain stream in Skagway; the cast and crew was to stay at the Spittal of Glenshee during the anticipated two-month filming period, and a large number of local men would be engaged to represent the crowd of adventurers who ‘rushed from Dawson City over the mountains in search of fabulous wealth’. An unknown Australian was to be the only woman in the film (‘something novel in the picture world’): this was Wendy Osborne, Macdonald’s wife, who had no previous acting experience.¹⁸ Despite these well-laid plans no film was produced, and by the time the Seven Seas Screen Productions Limited was officially incorporated in January 1927 thoughts of film-making in Glenshee seem to have been forgotten. The only reference to this film was in an Australian newspaper article publicising Macdonald’s plans for his next film, *The Unsleeping Eye*, which stated that ‘part of a story set in the Klondyke [sic] has already been photographed’.¹⁹

¹⁷ *Evening Telegraph*, Dundee, 19 November 1926, p3

¹⁸ *Ibid*

¹⁹ *Kalgoorlie Miner*, 1 August 1927, p4

The two Seven Seas productions that were made and exhibited were filmed in New Guinea and Australia, and although they employed large numbers of local men these were not Scots but indigenous Papuans and Aboriginal Australians. In August 1927 Macdonald, accompanied by his wife, arrived in Melbourne, Australia, en route to New Guinea, where *The Unsleeping Eye* was to be filmed. It was announced in the Australian press that Macdonald and the Glasgow production company were ‘interested in the production of British films’, and that *The Unsleeping Eye* would be the first of an Empire series: a demonstration of the unproblematic conflation of British-made Empire films and films made in the Empire. Macdonald must have recognised that Australia and his Australian connections could prove more useful than Scotland, as he also announced that in 1928 the company hoped to establish a branch in Australia, and Australian writers would be encouraged to submit stories ‘of a national character’.²⁰ His personal connections and newly-acquired professional credentials served him well: on arrival at Port Moresby in Papua he was entertained by the Governor, Sir Hubert Murray, while on his return home via Sydney he was called before a Royal Commission which was ‘enquiring into the conditions regarding British film production’. To this enquiry Macdonald ‘expressed the view that the American cowboy was always cameod [sic] in the pictures, while, in his opinion, the most romantic figure in the world was the Australian bushman, to whom he thought British films should pay more attention’.²¹ With greater sophistication (but far less film-making experience) than Maurice Sandground, Macdonald recognised the potential to exploit the opportunities offered by the Quota Act, together with Australia’s desire to develop an ‘inter-imperial’ film market as part of an effort to halt the serious decline in its own film industry.²²

The film-making party in New Guinea consisted of Macdonald as director and screenwriter, his Sydney-born wife Wendy Osborne who again played the only (adult) female role, their infant daughter ‘Baby Laurel’,²³ an unknown actor called

²⁰ *Kalgoorlie Miner*, 1 August 1927, p4

²¹ *Courier*, Dundee, 24 December 1927, p6

²² The Royal Commission on the Moving Picture Industry in Australia began in 1926 and ended in 1928. It explored a series of issues concerned with the serious decline of the film industry

²³ Possibly styled after Baby Peggy (Peggy-Jean Montgomery), one of the most prolific and popular Hollywood child actors of the early to mid-1920s

Len Norman, and a journalist from Dundee, David Givin Smith, who played a starring role in *The Unsleeping Eye* under the screen name of David Wallace.²⁴ Givin Smith had been badly wounded in 1918 in the Second Battle of the Marne, and had a wooden arm. The only member of the cast or crew with professional film-making experience was the Australian cameraman Walter H B Sully, whose career as a cinematographer had begun in 1918.²⁵ It appears that none of the cast or crew were paid, with the likely exception of Sully: the Seven Seas company's accounts for 1928 show that Givin Smith was given shares in return for 'personal services rendered as an actor in the production in Australia of the film "The Unsleeping Eye"', along with a Melbourne journalist called Mr C Lincham. Another Australian, Scott Norman of Sydney - who may have been the actor Len Norman - appeared on the new list of subscribers.²⁶



Figure 15: Cinematographer Walter H B Sully on an expedition in Western Australia in 1926, a year before filming *The Unsleeping Eye*. National Library of Australia, NLA pic-vn4549564

Filming in Papua took about three months, and subsequent publicity mentioned that although the film party had encountered a number of 'cannibal tribes of the hills', these had caused 'little or no trouble', the greatest challenge having been the penetration of the wildest part of the island. The *Scotsman* published an article (probably penned by Macdonald) focusing on the more gruesome aspects of life in New Guinea, 'the most savage island in the world, where women are kept in their

²⁴ *Advertiser*, Adelaide, 4 November 1927, p14

²⁵ IMDB

²⁶ NRS, BT2/14453: Seven Seas Screen Productions, Return of Allotments 22 March 1928

place, wives have been murdered for “talking too much”, daughters are given in marriage in exchange for a wild pig [and] human bodies are eaten daily’. Macdonald himself believed in keeping women in their place: his travel books and adventure stories were firmly in a tradition of an Empire shaped by daring male pioneers, and his approach to screenwriting showed little regard for the female audience. His three-year-old daughter Laurel was said to have been ‘almost worshipped’ by the Papuan tribes, who had never seen a white child before, while David Givin Smith’s artificial arm also ‘raised him to divine heights’ in local estimation. In the tribal culture anyone who lost a limb had to die, because they had ceased to be perfect. When Smith took his arm off, held it over a fire and then put it on again ‘without injury or inconvenience’ this was regarded as magic, and ‘gave the party valuable status among the natives’.²⁷

Macdonald’s screenplay told the story of John ‘Mad’ Challoner (Norman) who has been driven to drink after years of rough living among the indigenous tribes of New Guinea. When news spreads that Challoner has struck gold in a remote gully he is tracked down by a mining engineer, Dick Holloway (Givin Smith) - a war veteran with a wooden arm - and despite many challenges they make their fortune. Challoner departs for a holiday in Sydney, leaving Holloway in charge of his workers who are protected from vengeful spirits by totems painted with the ‘unsleeping eye’. A group of white men looking for gold attempt to mine in the gully and are murdered by warriors of the Papangi tribe. When Challoner returns with his new wife, Marjorie (Osborne) he finds his workers have fled and his home is threatened. Unafraid of the ‘unsleeping eye’ the Papangi attack again: Challoner orders his wife and Holloway to run, and distracts attention by challenging their chief to a duel. Years later Marjorie and Holloway - now engaged to be married, as they believe Challoner to be dead - return to New Guinea. At the gully they encounter the Papangi again, but the Chief gives them Challoner’s belongings and gold, and guarantees them safe passage to

²⁷ *Scotsman*, 25 March 1929, p7

Port Moresby. Before they leave a rival tribe shoots the Chief with a poisoned arrow. As he lies dying, the Chief reveals himself to be 'Mad' Challoner.²⁸

The Unsleeping Eye was advertised in May 1928 - six months after Macdonald's return to Scotland - as a unique production that would 'appeal to the love of adventure and pride in Empire of every Britisher'.²⁹ At the trade show the music chosen to accompany the film was by the Russian composer Ippolitov-Ivanov, as no authentic Papuan music could be found, although the *Bioscope* remarked 'I do not think it matters a tinker's cuss that the Caucasus is a long way from Papua'.³⁰ Its review of the film itself was much more critical: the story was said to be unreal and poorly constructed, and the attempt to mix drama with travel interest 'ill-advised'. The only acting honours belonged to the 'savages', whose performances were 'noteworthy for spontaneity'. Despite these drawbacks it was felt that, in slightly condensed form (the original version was 6450 feet), *The Unsleeping Eye* 'might please at minor halls'.³¹ The film was to be distributed by British Screen Productions, who produced a booklet to publicise it: this, at least, was considered to be of good quality.³² BSP decided to hold the release of *The Unsleeping Eye*, now advertised as a 'British production for the Quota' until April 1929, by which time Macdonald had already completed work on the next film in his proposed Empire series, *The Kingdom of Twilight*. Macdonald later claimed that the former had enjoyed 'tremendous success' during an initial six-week run in the West End of London, and it was undeniably screened at a few British cinemas in May and June.³³ In Hartlepool it was described as 'a remarkable production, showing wild forests, jungle ghost men and tribal fights among the real savage cannibals of New Guinea', with a 'star cast' including the previously unheard-of Wendy Osborne, Len Norman and Baby

²⁸ BFI 59176, *The Unsleeping Eye* (Original), *The Unsleeping Eye: A Pioneering Tale of New Guinea, the Last Stronghold of the Savage* (Alternative)

²⁹ *Bioscope*, 24 May 1928, p2

³⁰ *Bioscope*, 24 May 1928, p51

³¹ *Bioscope*, 24 May 1928, p51

³² *Bioscope*, 20 June 1928, piii

³³ *Cairns Post*, 29 May 1937, p6

Laurel.³⁴ The fate of *The Unsleeping Eye* seems to have been that of many previous Scottish productions, as it soon disappeared from view.

By this time the Seven Seas company had raised its share capital from £10,000 to £12,000, but in April 1928 only 3375 shares of £1 each had been paid for in cash. The remaining shares had been given to those such as David Givin Smith and Macdonald himself in return for services rendered.³⁵ The original board of directors had now been joined by James Dick, an iron merchant of Glasgow, and the shareholders included several army officers as well as members of Sir Bruce Seton's family, stockbrokers, merchants, an optician and a doctor - and, intriguingly, three Roman Catholic priests of St Benedict's Abbey in Fort Augustus. The Quota Act had come into force, and from now on publicity could state that Seven Seas' productions were being made 'for the Quota'.

Between April and August 1928 much publicity surrounded the production of *The Kingdom of Twilight* although, as with *The Unsleeping Eye*, this was mainly focused on Macdonald - who was variously claimed to have travelled round the world either 28 or 31 times.³⁶ His productions were seen as personal films trading on his celebrity as a British explorer, and the Scottish press took little interest in the fact that Seven Seas was a Glasgow company whose board and investors consisted largely of Scots. The *Aberdeen Journal*, for example, referred simply to 'an adventurous British party going off to the Queensland Bush in order to take advantage of the romance of the land', noting that the group would travel by car and camel through the Australian desert.³⁷ Only the *Bioscope* described Seven Seas as 'the Scottish production company', in a report on a distribution agreement with British Screen Productions which noted that the company's productions were entirely self-funded.³⁸ Conversely, the Australian press usually remarked on the presence of a production company from Glasgow.³⁹ Two women were to take part: one was Wendy Osborne and the other

³⁴ *Hartlepool Mail*, 1 June 1929, p7

³⁵ NRS, BT2/14453, Return of Allotments, 5 April 1928

³⁶ *Evening Telegraph*, Dundee, 19 November 1926, p3; *Nottingham Evening Post*, 5 July 1929, p4

³⁷ *Aberdeen Journal*, 14 April 1928, p7

³⁸ *Bioscope*, 19 April 1928, p6

³⁹ *Sydney Morning Herald*, 25 May 1928, p17; *Daily Mercury (Mackay, Qld)*, 22 August 1927, p2; *The Mercury (Hobart)*, 25 May 1928, p4

was Jean Seton, daughter of Sir Bruce Gordon Seton and ‘a direct descendant of one of Mary Queen of Scots’ ‘Four Marys’’.⁴⁰ Another member of the party was named by the *Scotsman* as Lieutenant-Commander Arnot, RN, who appeared in *The Kingdom of Twilight* under the screen name of Rex Arnot. Lieutenant Reginald Arnot was one of the directors of Seven Seas Screen Productions and was married to Jean Seton: the couple lived with her parents at 12 Grosvenor Crescent in the West End of Edinburgh. In the company records for 1928 Arnot’s name was accompanied by his naval rank, but in 1929 his status had changed to that of coal merchant.⁴¹ David Givin Smith was again present in the dual role of journalist and actor, and the fifth ‘leading member’ of the Scottish party was Baby Laurel, who also had a role in the film.⁴² This, then, was even more of a family affair than *The Unsleping Eye*, and it may have been that Macdonald saw feature film production as a kind of adventure holiday with family and friends as much as a serious attempt to break into the Empire market. He certainly had little respect for screen acting as a profession that required talent or training.

Once again, publicity about the making of the film created more interest than the finished product, which had cost ‘at least’ £5,000 to produce and involved the exposure of five miles of film.⁴³ The narrative had many similarities with *The Unsleping Eye*. It told of an Englishman, Jim Carrington (played by the only professional actor in the film, John Faulkner) who leaves England with his daughter Dorothy (Osborne) after a scandal and seeks his fortune as a gold prospector in northern Australia.⁴⁴ There he learns of a mysterious tribe of Aborigines, but is wounded and captured. He is given up for dead by everyone except for Dorothy, who continues to search for him. When she, too, is captured by the tribe she discovers her

⁴⁰ *The West Australian* (Perth), 12 May 1928, p7

⁴¹ NRS, BT2/14453, Return of Allotments, 28 August 1929

⁴² *Scotsman*, 14 April 1928, p16; NRS, BT2/14453, Return of Allotments 22 March 1928 and 28 August 1929

⁴³ *Telegraph*, Brisbane, 1 September 1928, p2

⁴⁴ John Faulkner (1872-1934) was a British-born actor who appeared in nine Australian films between 1918 and 1930

father is alive, and they return together to white civilisation where Dorothy is reunited with her admirer, a young gold miner.⁴⁵

Like *The Unsleeping Eye*, *The Kingdom of Twilight* (which Macdonald had originally proposed calling *Tanami*, meaning ‘white father’) attempted to blend drama with travelogue, and camerawork was again carried out by Walter Sully. After completing this film he was the official Commonwealth Government cameraman for the Prince of Wales’ tour of New South Wales.⁴⁶ The Australian gold miners who appeared in *The Kingdom of Twilight* offered their services in portraying ‘actual everyday scenes’ in return for Macdonald’s advice as a former mining engineer about whether their small claim was worthy of expansion. These bushmen were said to be ‘overjoyed’ that Macdonald had ‘come from the Old Country to take notice of them, and to tell on the screen a true story of their adventurous life’. Twenty five ‘full-blooded aboriginals’ were also engaged, and ‘practically all the white population’ of the town of Chillagoe in northern Queensland took part in many scenes, some of which were shot inside the nearby Mungana Caves. There were no interior scenes: Macdonald, while ‘by no means underestimating the value of the studio in the production of films’ was reported to hold that indoor work was frequently overdone: a very important part of the Empire, it was necessary that the real Australia be shown on the screen in Britain, since ‘good films of the Commonwealth would do more to draw industrial and economic attention to Australia than any Government propaganda’.⁴⁷ Despite Macdonald’s admirable intentions, *The Kingdom of Twilight* was not one such film and failed to serve its purpose.

Although it was announced in December 1928 that *The Kingdom of Twilight* would be the first Australian film to be guaranteed a release in London and that it had been acquired by British Screen Productions for release on 1 April 1929, it had very few outings in England and the absence of any advertisements or reviews suggests it was

⁴⁵ IMDB; A Pike and R Cooper, *Australian Film 1900–1977: A Guide to Feature Film Production* (Melbourne, 1998), p148

⁴⁶ *Bioscope*, 12 December 1928, p6

⁴⁷ *Falkirk Herald*, 1 December 1928, p14; *Telegraph*, Brisbane, 1 September 1928, p2

never shown in Scotland.⁴⁸ In July the so-called 'Great British Quota Picture' acquired a new distributor, European, but this did not improve its fortunes.⁴⁹ It appears to have been exhibited on only two occasions in Australia: in Chillagoe in January 1931 - where the audience consisted mainly of those who had taken part - and three years later at a private screening in Cairns, in support of Macdonald's plan to add sound to this film and to *The Unsleeping Eye*.⁵⁰

In the face of this lack of success it would not have been surprising if the Seven Seas Screen Productions had decided to shelve further plans for a third Empire film, but this was not the case. Company records show that both Alexander Macdonald and Bruce Seton had resigned from the board by March 1929, but in August the former had returned. Seton, however, remained absent and died in 1932. The anticipated success of the two films made 'for the quota' must have encouraged new shareholders, as in August 1929 almost 9000 shares had been paid for in cash, bringing the total number of shares issued to 11,080.⁵¹ This figure remained the same throughout the 1930s and indeed until 1949, when the company was finally dissolved.⁵²

Macdonald, like Maurice Sandground before him, was tenacious and reluctant to abandon his film-making aspirations after the coming of sound. In 1933 he set sail for Australia once again, bringing with him the 'plant to produce a talking picture of native life in the Pacific Islands north-east of Australia'. This film was to be called *Ni-Noa* and concerned a young white girl (a role probably intended for his daughter Laurel) who had lived as a member of a native tribe ever since the aeroplane she was travelling in had crashed 'outside the reach of civilisation'. The pilot had died, leaving her in the care of the native tribe who 'regarded her as something of a goddess'.⁵³ Macdonald also announced plans for adding sound to *The Unsleeping*

⁴⁸ *Courier*, Dundee, 28 November 1928, p8; *Bioscope*, 'British Films for the World' Special Number 1928, p40

⁴⁹ *Nottingham Evening Post*, 5 July 1929, p4

⁵⁰ *Courier*, Dundee, 28 November 1928, p8. In 1931 *The Kingdom of Twilight* played at the Empire Cinema, Derby: *Derby Daily Telegraph*, 7 January 1931, p3

⁵¹ NRS, BT2/14453, Register of Directors, 9 March 1929; Return of Allotments and Register of Directors, 29 August 1929

⁵² *Edinburgh Gazette*, 1 February 1949, p45

⁵³ *Sunday Mail*, Brisbane, 10 September 1933, p23

Eye and *The Kingdom of Twilight*, although it would take four years for this to be achieved - and then only to the former film: meanwhile, he repositioned himself as an Australian producer. In 1934 an Australian newspaper announced that Macdonald, 'a one-time owner of one of Sydney's most popular suburban theatres at Croydon', was to head a new production unit called Epic Films, associated with the National Studios Ltd of Sydney.⁵⁴ Three years later a talkie version of *The Unsleeping Eye* was shown for the first (and possibly last) time at the Tropical Theatre in Sydney. The Seven Seas Screen Productions of Glasgow was conveniently forgotten, and production of the original film was said to be entirely 'the work of Australians' with the exception of David Givin Smith, a 'London journalist'.⁵⁵ Macdonald died in Sydney in 1939, and after his death the Seven Seas Screen Productions remained dormant for ten years.⁵⁶ A letter from the company secretary to the Registrar of Companies dated 30 July 1948 stated that 'no operations' had taken place since November 1938 and that as none were 'at all likely to take place', no purpose would be served in keeping the company alive any longer.⁵⁷

The transition to sound

The story of the Seven Seas Screen productions fits the pattern of previous years, in which Scottish producers sought to exploit the opportunities provided by broader trends within the industry. The coming of sound, however, while seen to offer favourable circumstances for growth for British producers more generally, did not do so for those operating in Scotland.

One other new Scottish production company was launched in the late 1920s, by Maurice Sandground's former business partner Malcolm Irvine. After Sandground's departure the assets of the Burns-Scott company were transferred to the Scottish Films Productions (1928) Ltd, which was launched in August 1928 with capital of £10,000 in shares of £1 each. The new company remained in existing studios at 26

⁵⁴ *Sunday Times*, Perth, 10 June 1934, p17. The National Studio, part of Australia's plan to revive film production, was established in collaboration with Gaumont British and local independent producers

⁵⁵ *Cairns Post*, 29 May 1937, p6

⁵⁶ *Sydney Morning Herald*, 28 March 1939, p16

⁵⁷ NRS, BT2/14453, Letter from R W Reid, Secretary, to the Registrar of Companies, Edinburgh, 30 July 1948. Seven Seas Screen Productions was removed from the register of Scottish companies on 3 May 1949

India Street, Glasgow, also the headquarters of Irvine's other business, the Double Arc Electric Welders, Ltd.⁵⁸ This enterprise was more firmly rooted in Scotland than Seven Seas Screen Productions, and the *Bioscope's* Scottish correspondent remarked optimistically that 'a Carl Laemmle or Jesse Lasky may yet arise in Caledonia'.⁵⁹ Whether Irvine shared this aspiration is unknown: he was a less enthusiastic self-publicist than Sandground and made no grand pronouncements on the state of the British film industry - which, at the time of the Scottish Film Productions' formation, was buoyant. The company's plans to make a series of silent films, however, were soon thrown into disarray with the advent of the synchronised sound film (discussed in more detail below) and in a small way illustrate the quandary faced by other British producers at the time.⁶⁰ Even if a company had the resources to produce its own sound films, in 1928 and through 1929 many cinemas were not capable of showing them. At the end of 1929, for example, only 56 of Scotland's 605 cinemas were wired for sound.⁶¹ Exhibitors still wanted silent films, which were soon in short supply, and this 'extraordinary state of affairs' for the British industry was much discussed in the press.⁶²

Malcolm Irvine was ambitious, albeit in a different way from his former business partner. He drew on his engineering background to develop his own sound system, the Albion Truphonic, in order to record the company's own talking pictures, which he also attempted to market to local cinemas.⁶³ Unwilling to waste the existing Sandground-made films at their disposal, in February 1929 Scottish Films advertised the release of a 'talkie or silent version' of *Rob Roy* and a silent version of *The Lady of the Lake*, with the talkie version to follow.⁶⁴ These short features had both been included in *Glimpses from the Life of Sir Walter Scott*, with the Rob Roy film being subsequently repackaged by Sandground as *Scotland Yet*, and were evidently

⁵⁸ NRS/MIA, 4/1/1, Scottish Film Productions (1928) Ltd, Memorandum and Articles of Association, 13 August 1928. The Double Arc Electrical Welders, Ltd was not dissolved until 1949. *Edinburgh Gazette*, 1 November 1949, p510

⁵⁹ *Bioscope*, 22 August 1928, p48

⁶⁰ NRS/MIA, 4/1/8, Scottish Films Productions (1928), Ltd, cutting from Glasgow Herald, 1936

⁶¹ KYB 1930, quoted in Griffiths, *The Cinema and Cinema-going in Scotland*, p180

⁶² *Aberdeen Journal*, 9 April 1920, p7

⁶³ Griffiths, *The Cinema and Cinema-going in Scotland*, p293

⁶⁴ *Bioscope*, 6 February 1929, p8

considered the most attractive elements of the unwieldy original.⁶⁵ There is no evidence, however, that Scottish exhibitors booked either film as part of a programme. They may have preferred to show Gainsborough's more lavish feature-length version of *The Lady of the Lake*, the exterior scenes of which had been shot on location around Loch Lomond, Loch Katrine and at Stirling Castle in September 1928. The *Bioscope* reported that 50 unemployed local people had been recruited to act as Highlanders and paid nine shillings a day (plus refreshments) for their services, despite which they refused to work after 5pm unless they were paid overtime.⁶⁶ This film had its British release in December 1928, and a sound version appeared in 1931. Nevertheless, the Scottish Films' ambition to produce its own talkies remained in place until the mid-1930s, when a change of direction towards documentary production brought it greater success and recognition.⁶⁷ Trevor Griffiths has charted the company's wide-ranging plans for fiction film production in the early 1930s, which included a series of twelve short comedies beginning with a farce called *The Scottish Italians*, and an adaptation of a Glasgow-set play by T M Watson, *Diplomacy and the Draughtsman*. In 1931 the studios were said to be undergoing expansion to allow for the production of feature-length talkies such as an eight-reel version of *Jeannie Deans*.⁶⁸ If any of these films were completed, however, they do not seem to have found a distributor.

The Albion Truphonic sound system in itself fared rather better. It was used to record the company's documentaries and 'cinemagazines' until the end of the 1930s, although Irvine's hopes that it would also provide the sound system for local cinemas were not realised. As a Scottish film producer with experience of sound he was consulted by the directors of the Glasgow Picture House Company, who in the autumn of 1929 were considering which system to use. They decided on the Powers Cinephone and appointed Irvine as its agent for Glasgow. Over the course of the next six months this system, installed at the company's Regent Picture House in Renfield

⁶⁵ *Motherwell Times*, 26 October 1928, p8.

⁶⁶ *Bioscope*, 19 September 1928, p63

⁶⁷ One of the company's best-remembered short films, included in the news magazine 'Things That Happen no. 1', was taken at Loch Ness in 1934 and purported to include authentic shots of the monster. NRS/MIA 0373

⁶⁸ T Griffiths, *The Cinema and Cinema-going in Scotland*, p292

Street, proved to be extremely unreliable and caused great embarrassment to the proprietors. In April 1930 Irvine's offer to make the Truphonic system available as standby equipment was accepted although whether it was ever used is unknown: the following month the Powers Cinephone was finally abandoned in favour of the more efficient Western Electric sound technology system, which had already been installed in many British cinemas and occupied a large share of the market.⁶⁹ Irvine himself (or one of his colleagues) may have been partly responsible for the poor performance of the Cinephone at the Regent: in September 1930 the Powers company rejected an account of maintenance costs incurred by Double Arc Electric Welders, stating that its representative had found the equipment in a neglected state.⁷⁰

Malcolm Irvine was not the only Scottish engineer to apply his technical knowledge to the development of a sound system. In May 1929 J Stephen Souter, an Elgin town councillor and proprietor of a local engineering firm, demonstrated his own system to an invited audience of press representatives at the Elgin Picture House, of which he was a director.⁷¹ Souter had presided over the opening ceremony of the 900-seater Picture House in December 1926, and his enthusiasm for the 'talkies' was such that he produced his own film to show how well his invention worked.⁷² For this purpose he enlisted the help of the veteran Glasgow-based cameraman and producer, Paul Robello, who had worked for Green's Film Service after the war and in the early 1920s established a new company called Topical Productions with another local film-maker, Bobbie Mann. Their company specialised in topical, industrial and educational films: one of its productions, completed around 1928, was *St Kilda - Britain's Loneliest Isle*.⁷³

The film directed by Souter and shot by Robello showed the Scottish entertainer Dufton Scott (1880-1944) performing two of his most popular sketches, 'Geordie

⁶⁹ By the end of 1930 there were 1,134 Western Electric installations across Britain, with 38 in Glasgow alone. *Bioscope*, 17 December 1930, p20

⁷⁰ NRS/MIA, 5/22/4, Glasgow Picture House Co Ltd, minute book 17 March 1924-7 January 1930: Meetings of Directors, 10 October 1929-24 September 1930 inclusive

⁷¹ George Souter & Son, Greyfriars Foundry, Elgin

⁷² *Aberdeen Journal*, 21 December 1926, p5

⁷³ NRS/MIA, 0418. The film shows the final period of St Kilda's habitation and was added to the Unesco Memory of the World register in 2010

Broon on Fairmers' and 'Selling Sewing Machines'. Scott was well-known for his writing and performance of humorous songs and sketches spoken in 'Braid [broad] Scots'. The demonstration of Souter's sound system impressed those present, the *Aberdeen Journal's* reporter stating that 'perfect synchronism and reproduction was obtained', along with 'ample volume and clarity of speech'. The equipment - said to 'compare most favourably with the most expensive installations' - was to be fitted in the Elgin Picture House the week after the demonstration, making it the first cinema in the north of Scotland to be wired for sound.⁷⁴ Later reports, however, state that the Picture House was equipped with the British Acoustic sound system and its first 'talkie', *Black Waters*, was not screened until 16 September 1929.⁷⁵ The experimental Dufton Scott film appears to have been Souter's only foray into film production, and nothing more was heard of his sound system.

The failure of Irvine's or Souter's individual sound systems to be taken up by Scottish cinemas does not necessarily imply that they were of inferior quality, however. The introduction of sound in both the United States and Britain was a complicated process which involved not only technological issues but also patent wars, different delivery systems (sound on disc or sound on film) and the large financial outlay necessary to convert film studios and cinemas to sound. Although a number of British manufacturers of sound systems (including De Forest Phonofilm, British Acoustic and British-Thompson-Houston) had emerged as early as 1923, two American companies - Western Electric and RCA - occupied most of the British market in 1929. Some film historians have argued that this was not because of the American systems' innate superiority, but a result of the power of the giant US corporations. It would take three years for the British companies to recover some ground.⁷⁶ The De Forest Phonofilm system, an American invention, had been

⁷⁴ *Aberdeen Journal*, 24 May 1929, p9; *Courier*, Dundee, 24 May 1929, p11; *Bioscope*, 5 June 1929, p52

⁷⁵ <http://cinematreasures.org/theaters/44691>, (accessed January 2016). British Acoustic was formed in 1926: its system was being used by Gaumont in 1929. *Black Waters* was a 'British' horror film, filmed in America after producer Herbert Wilcox moved some of his production team there to make use of sound recording equipment not available in Britain

⁷⁶ T Ryall, 'Blackmail', in E Buscombe and R White (eds), *BFI Film Classics Vol 1* (London, 2003) pp96-97; M Dickinson and S Street, *Cinema and State: Film Industry and the British Government, 1927-1984* (London, 1985), p42

acquired by British Talking Pictures in 1923 and the company began releasing short sound films, produced at a small studio in Clapham, at the end of 1926.⁷⁷ One of these experimental films was an adaptation of a Scottish drama written and directed by the successful Glasgow-born playwright and actor Graham Moffat (1866-1951).⁷⁸

In 1908 Moffat had been inspired by a tour of the Irish Abbey Theatre company to Glasgow to form his own company, the Scottish National Players, for which he wrote plays on Scottish themes in which the characters spoke ‘Braid Scots’.⁷⁹ The company, whose core players were Moffat himself, his wife Margaret and their daughter Winifred, was launched at the Athenaeum Hall in Glasgow in March 1908 with the performance of two one-act plays: *Annie Laurie* and *Till the Bells Ring*. The latter was a ‘sketch of Victorian Scottish life’; a comedy in which a widower courts a poor spinster in the belief that she is wealthy.⁸⁰ The play proved to be an enduring popular success throughout Britain and its colonies and had the distinction of being the first drama used to test the De Forest Phonofilm system. Moffat directed the film himself, in which he also acted alongside his wife, Winifred and the Scottish actor David Clyde, who played the leading male role.⁸¹

Moffat had a long-standing interest in film production: in 1916 he had visited some American film studios on his way back from an overseas theatre tour ‘with a view to studying methods at first hand’. At the time *Kinematograph Weekly*’s Scottish reporter noted that Moffat was a ‘shrewd Scot’ and wondered what this visit might lead to.⁸² Ten years later, in an interview in which he deplored the exorbitant cost of mounting live theatrical productions, Moffat predicted that talking films (and the Phonofilm in particular) would ‘restore prosperity to the English studios’, as well as creating more work for English [sic] actors and actresses, ‘for the demands upon the

⁷⁷ L Wood, *British Films 1927-1939*

⁷⁸ See also Chapter 2

⁷⁹ C Morash, *A History of Irish Theatre, 1601-2000* (Cambridge, 2002), p154; I Brown, ‘Scots Language in Theory and Practice in Graham Moffat’s Playwriting’, *Scottish Language* vol 33, (2014) p65

⁸⁰ *Scotsman*, 9 October 1926, p2

⁸¹ David Clyde was a brother of the actor John Clyde, star of *Rob Roy* in 1911 (see Chapter 1). In 1926 he was an actor on the London stage, and later moved to Hollywood where he appeared in many films

⁸² NRS/MIA, 5/7/338: cutting from *KW*, 9 March 1916, p90

speaking voice will cut out the Yankee altogether... Once the speaking film is in, Hollywood will be out so far as England is concerned'. This was a reasonable, if over-optimistic, assumption - and it seems curious that a prominent advocate for Scottish writing should choose to focus his remarks on English, rather than British (or even Scottish) production. Before this revolution could take place the Phonofilm system would be further developed, as there were still 'many difficulties to be faced'.⁸³ This remark seems to have been an acknowledgement of its unsatisfactory performance with *Till the Bells Ring*, which was included in a private demonstration of De Forest Phonofilms at the Holborn Empire in January 1926. While the non-fiction films - including one of farm life, 'in which the bleating of a sheep and the furious barking of a chained terrier provided really true to life impressions' - were well-received, the spoken parts of *Till the Bells Ring* were said to be 'unintelligible to most'. This was considered to be a gramophone fault which would 'no doubt speedily be remedied', and the film itself was praised as a 'perfect example of film production'.⁸⁴

Improvements may have been effected by the time *Till the Bells Ring* was shown at Poole's Synod Hall, Edinburgh, in October. After a private screening the *Scotsman* noted that 'the range of [the Phonofilm's] possibilities is at the moment only being guessed at', but its demonstration was held to show that the screen was no longer limited to the silent drama. The novelty of sustained dialogue replacing intertitles and 'narrative tags' was remarked upon, as was the perfect synchronisation offered by the Phonofilm equipment. 'For just a minute or so at the start the words were a little indistinct, due perhaps to the players not having straightaway got the right pitch or to the listener's ear not being quite tuned, but after that the amusing dialogue, assisted no doubt by its deliberate Scottish character, was clearly heard and followed to the end.'⁸⁵ The production was considered to be of good enough quality to merit a public premiere at the Synod Hall the following week, where the audience was said to have thoroughly enjoyed Moffat's film and its 'true vein of Scottish humour'.⁸⁶

⁸³ *Hull Daily Mail*, 16 June 1926, p7

⁸⁴ *Gloucester Citizen*, 29 January 1926, p4

⁸⁵ *Scotsman*, 9 October 1926, p7

⁸⁶ *Scotsman*, 12 October 1926, p9

Nevertheless, this was the only film Moffat directed and the only British screen adaptation of any of his plays.⁸⁷ Experimental screenings of films with synchronised sound, using various systems in development, took place in the following two years, although none were Scottish in theme or origin.

Another Scottish production company, North British Films, Ltd was registered in Glasgow in July 1928 with a nominal capital of £7,000. This company, whose headquarters were at 127 Queen Street in Govan, was formed in order to take over as a going concern a Newcastle-based business called The “A” Production Company. Its board of directors was constituted of two cinema managers, a coalmaster, three merchants and a manufacturing chemist. Of these, three had served on the board of The “A” Production Company: Thomas Winning and James Lyle of Newcastle, and George Lyle of Hawick, the last two being the cinema managers. The takeover cost North British Films £1,400 which it paid for mostly in shares. For this it acquired the “A” Production Company’s assets and debts and the ‘full benefit of all contracts and agreements’, along with films in production and all the equipment apparatus necessary for feature film production.⁸⁸ A detailed inventory shows that this included a camera, lamps, film stock, titling apparatus, printing and developing equipment, two projectors, assorted electrical equipment and motors, a gramophone and records, studio flats (scenery) and studio furniture, greasepaints and make up as well as all the office furniture, typewriters and even carpets and curtains. While all these items were individually priced, some (un-named) scenarios were thrown in for nothing, as was a film called *Bang Went Sixpence*, said to be ‘in process’. This was a separate entity from a ‘film in making’ valued at £53. The saying ‘bang went sixpence’ originated in a *Punch* cartoon of 1878 concerning two ‘thrifty’ Scotsmen, and the expression ‘bang went saxpence!’ was later popularised by Harry Lauder.⁸⁹ There are no other clues as to the film’s nature other than the likelihood that it was a comedy.

⁸⁷ A film of Moffat’s most successful play, *Bunty Pulls the Strings*, (1910) was produced in Hollywood in 1921

⁸⁸ NRS, BT2/15183, North British Films Limited: Minute of Agreement 6 October 1928, Inventory, p4

⁸⁹ E Partridge, *A Dictionary of Catch Phrases American & British: from the sixteenth century to the present day* (Lanham, Maryland 1992), p27

Despite the acquisition of films and equipment, the North British Film Company did not thrive and it would appear that no production activity took place. Its fate may have been sealed by the arrival of sound soon after its formation, although the fact that it had acquired a gramophone and records from the “A” Company suggests that the original intention may have been to attempt to synchronise sound or music with *Bang Went Sixpence* and the other uncompleted film. A few new subscribers were found - mostly members of the directors’ families - but by the end of October 1928 only 2000 shares had been issued.⁹⁰ It is unclear whether the “A” Production Company’s studio was relocated to Glasgow or remained in the Newcastle area. In June 1929 it was reported that a joiner engaged in demolishing a building (which may have housed a studio) owned by the North British Film Company in Back Station Lane, Birtley, Gateshead, had fallen from the roof to the concrete floor, receiving severe injuries from which he later died.⁹¹ Six months later the North British Films was sued by its own solicitor for non-payment of fees incurred in setting up the company, and went into liquidation.⁹²

Harry Lauder, Huntingtower and Auld Lang Syne

The well-documented upheaval caused by the transition to sound in the late 1920s and its consequences for British film producers is perhaps best exemplified by two feature films shot partly in Scotland, both of which starred Sir Harry Lauder: *Huntingtower*, made in 1927 and released in February 1928, and *Auld Lang Syne*, made later that year and released in 1929-30. In June 1926 the Dundee *Courier* had announced that Alfred Hitchcock (then working for Gainsborough) intended to film an adaptation of John Buchan’s 1922 novel *Huntingtower* and had been searching for a suitable Scottish castle by the sea, but this plan went no further and it was George Pearson of the Welsh-Pearson Company who directed both *Huntingtower* and *Auld Lang Syne*.⁹³ Pearson had made two films in Scotland a few years earlier: *The Wee Macgreegor’s Sweetheart* (1922) and *The Romany* (1923), and the approaching quota

⁹⁰ NRS, BT2/15183, Summary of Share Capital and Shares, 9 November 1928

⁹¹ *Hartlepool Mail*, 18 June 1929, p3

⁹² NRS, BT2/15183, Deliverance appointing Harold Walker, Chartered Accountant, Glasgow, as official liquidator on the estates of North British Films Limited, 30 December 1929

⁹³ *Courier*, Dundee, 8 June 1926, p10. Hitchcock had just completed work on *The Lodger*, and despite his enthusiasm for Buchan’s work it was not until 1935 that he directed an adaptation of one of his novels, *The 39 Steps*

legislation represented a new opportunity for his company to renew activity in the production of contemporary Scottish stories with broad popular appeal.⁹⁴

Buchan's tale revolves around the imprisonment of an exiled Russian princess by Bolshevik agents. Its reluctant hero is Dickson McCunn, an affluent and respectable retired Glasgow grocer, and the story of espionage and covert violence set against an apparently tranquil Scottish background also features the Gorbals Diehards, an unofficial scout group from the Glasgow slums who first discover the goings-on at Huntingtower, a deserted manor near Carrick on the coast of south west Scotland.⁹⁵ The Diehards have been sent to the seaside by a well-wisher, while McCunn (a romantic at heart) is on a walking holiday in the course of which he meets a communist poet, John Heritage. Between them they rescue Princess Saskia and she is reunited with her lover, another Russian of noble birth.

This was Lauder's first feature film, and it is an indication not only of its anticipated success but of the resources of the Welsh-Pearson company that he was widely reported to have been paid £10,000 for his role.⁹⁶ The film had a tie-up with Paramount-Famous Lasky, a distribution deal under whose terms Pearson had to use an American co-star (Vera Voronina, who played the Russian princess), scriptwriter and cameraman.⁹⁷ Although Kiev-born Voronina's authentic Russian accent was not heard in this film, it was to be responsible for ending her brief Hollywood career after the coming of sound.⁹⁸ As a newcomer both to screen acting and to Britain, she had nervously anticipated her first meeting in Glasgow with Harry Lauder. 'He took me by the hand and said "My, you are a bonnie lass!" I almost gasped with astonishment. I thought he was telling me that I was a 'bony' lass, and I felt very disappointed to think that the great actor with whom I was to play was far from pleased with me'. The misunderstanding was soon resolved, and Voronina's eagerness to please was underlined by her assertion that 'after the sun and heat of

⁹⁴ See chapter 4

⁹⁵ As distinct from the (real) fifteenth century Huntingtower Castle in Perthshire

⁹⁶ *Sunday Post*, 30 January 1927, p3; *Portsmouth Evening News*, 27 January 1927, p5

⁹⁷ Low, *History of the British Film 1918-1929*, p163

⁹⁸ Vera Voronina appeared in several German silent films before moving to Hollywood, where she made only three films

Hollywood, she was greatly pleased to see the rain of Glasgow'. Almost as newsworthy was the departure for London of nine local boys who were to play the Gorbals Diehards. At Glasgow's Central Station many of their mothers were said to be weeping, but the boys themselves 'laughed to scorn the idea that they would feel a bit "wannert" in London'. 'Diminutive' Robert Mackie, who was to play the part of Wee Jackie, insisted that he was 'no' the least feart'.⁹⁹

The boys returned unscathed, and the following month filming in Glasgow for sequences that were to come in the early part of the film generated enormous local interest. The first scene was filmed 'in bright sunshine' in mid-morning at the corner of Sauchiehall and Dalhousie Streets in the city centre. It showed the Gorbals Diehards watching from a window above Dickson McCunn's shop a parade of genuine Boy Scouts marching past, headed by pipers. The crowd who had gathered on the street to 'help create the correct setting for the episode' were far more interested in watching the Diehards' antics than the parade, and the scene had to be re-shot. A second sequence, which showed McCunn locking up the shop and walking up the hill in Dalhousie Street until he disappeared over the horizon, was filmed later in the day when the crowd had dispersed.¹⁰⁰ The remainder of the film had been shot in England: Bamburgh Castle in Northumberland was used to represent Huntingtower, and interiors were filmed at the Stoll studio in Cricklewood. According to the *Picturegoer*, the baronial castle designed by art director Walter Murton was 'the largest set ever seen inside a British studio' at 8,000 square feet.¹⁰¹

⁹⁹ *Sunday Post*, 5 June 1927, p5

¹⁰⁰ *Evening Telegraph*, Dundee, 4 July 1927, p6

¹⁰¹ P L Mannoock, 'Screening Sir Harry', *Picturegoer*, August 1927, p12; L N Eade, *British Film Design: A History* (London and New York 2010), p24



Figure 16: Cinema lobby card for *Huntingtower*, showing Dickson McCunn and the Gorbals Diehards. www.sirharrylauder.com

With the Gorbals Diehards in attendance, *Huntingtower* was trade shown at the Scala Theatre in Glasgow in early March 1928 and went on to have a ‘successful short season’.¹⁰² A month earlier, anticipating the imminent arrival of quota legislation, its production company had been reorganised as Welsh-Pearson-Elder. T C Elder, formerly a director of Stoll Picture Productions, became joint managing director with George Pearson and R C Buchanan, an Edinburgh film exhibitor and city councillor who had a financial interest in *Huntingtower*, was chairman. The new company was floated with capital of £200,000. Invitations to subscribers issued by the Scottish Finance Company stated that it would have a ‘substantial working capital’ of over £100,000 and estimated annual profits of £42,000. Uniquely, the company had a major production running at a London cinema at the time of flotation.¹⁰³ The wave of enthusiastic investment in film production had begun to subside, however, and it was not fully subscribed: nevertheless, the anticipated box-office success of *Huntingtower* persuaded Welsh-Pearson-Elder to put Harry Lauder under contract until the end of 1930 for the exclusive right to his film services, and by the summer of 1928 the production of his next vehicle was already well under way.¹⁰⁴ Lauder was said to be ‘anxious to continue screen work’, which gave him ‘unlimited scope for characterisation’.¹⁰⁵

¹⁰² *Bioscope*, 15 March 1928, p61

¹⁰³ *Scotsman*, 23 February 1928, p4

¹⁰⁴ Low, *History of the British Film 1918-1929*, p163; *Falkirk Herald*, 22 February 1928, p2; ‘Sir Harry Lauder’s “Talkie”’, *Nottingham Evening Post*, 8 April 1929, p4

¹⁰⁵ *Bioscope*, 30 June 1928, p56

Auld Lang Syne had an original screenplay written by Patrick L Mannoek, a prolific film journalist: ironically, given the argument between Pearson and his co-directors over its production, the film's storyline revolved around a clash between outdated and modern ideas. Lauder played the part of a Scottish farmer, Sandy McTavish, whose son and daughter are living in London, the former supposedly studying chemistry and the other also supposedly training to be a nurse. In reality the son is a professional boxer and the daughter a cabaret dancer. When McTavish visits London he is deeply shocked and disappointed, but eventually accepts his children's choices. In common with many of the Scottish films discussed in Chapter 4, *Auld Lang Syne* contrasted the peaceful, old-fashioned life of rural Scotland with the fast-paced modernity of London - giving an 'excuse', as the *New York Times*' review put it, to 'drag the inevitable prize ring and cabaret scenes into the up-to-date film'.¹⁰⁶ Like *Huntingtower* it was intended to be a silent comedy-drama, although this production incorporated several of Lauder's best-known songs, presented in the traditional manner: words written as subtitles and music performed by the cinema's orchestra or pianist.¹⁰⁷

In August 1928 Lauder, Pearson and a crew of around a dozen arrived in Perth (where they stayed at the Royal British Hotel) to look for suitable locations, including a farmhouse and a fishing river, for the exterior scenes. Although poor weather conditions delayed the start of filming, these were soon found and work was completed within a week. A day was spent shooting scenes involving McTavish and his friend Wullie McNab the 'postie' at the salmon leap on the River Garry at Struan, and at the Bridge of Tilt, near Blair Atholl, where Lauder was again filmed fishing for salmon. Other 'purely scenic views' were shot, as well as passing trains. A reporter from the Dundee *Courier* who accompanied the crew for the day observed that the River Garry was unusually high for the time of year: after filming was completed one salmon leapt about five feet clear of the water, and Lauder - a keen fisherman - 'could not resist having a "cast" in the stream'. A small crowd of onlookers gathered at both locations, taking 'much interest' in the presence of Sir

¹⁰⁶ *New York Times*, 6 October 1929: www.nytimes.com, (accessed January 2016)

¹⁰⁷ *Aberdeen Journal*, 3 April 1929, p7

Harry and in the work of film production.¹⁰⁸ Two days later several scenes featuring Lauder and Hugh E Wright, who played the postman, were shot in the grounds of Dupplin Castle near Perth with the River Earn in the background. These were ‘mainly for the sake of the Highland scenery’ and were ‘of a minor nature’. The production manager, Denis Shipwright, told a reporter that filming was now complete, as all the studio work had already been done. The producers believed that *Auld Lang Syne* would ‘go through the world as a masterpiece representing Scottish life and scenery’. He added that a trade show would probably take place in September, and the film was expected to be released in about three months’ time.¹⁰⁹

By the time *Auld Lang Syne* was eventually trade-shown in April 1929 audience expectations had changed, and the Welsh-Pearson-Elder company found itself caught up in the confusion of the transition to sound. At this stage many British producers were uncertain whether the vogue for ‘talkies’ was simply a passing phase, and it was not until mid-1929 that British sound films began to appear in any number. Famously, Alfred Hitchcock’s *Blackmail* (often cited as the first British all-talking feature film) was begun as a silent film and then re-made in a sound version, released in August 1929. The silent version was also released and actually proved more popular, largely because most British cinemas were not yet equipped for sound.¹¹⁰ By the end of 1929 only 22 per cent of British cinemas had been wired for sound, a figure that rose to 63 per cent by the end of 1930.¹¹¹ But after the release in England (almost a year after of its American release) of the first Hollywood ‘talkie’, *The Jazz Singer*, in September 1928, British audiences had quickly developed a taste for talking pictures. The first American sound film to be shown in Scotland, *The Singing Fool* - also starring Al Jolson - had received a spontaneous round of applause on its debut at the Coliseum in Glasgow in January 1929.¹¹² In this context it was understandable that the response to *Auld Lang Syne* as a silent (part) ‘musical’ was less than enthusiastic. Under the headline of ‘Not a Movietone’ the *Aberdeen Journal* commented that ‘Sir Harry has one of the best recording voices in the world, and he

¹⁰⁸ *Courier*, Dundee, 18 August 1928, p3

¹⁰⁹ *Courier*, Dundee, 20 August 1928, p3

¹¹⁰ Ryall, ‘Blackmail’, p94

¹¹¹ *Ibid*, p97

¹¹² Griffiths, *The Cinema and Cinema-going in Scotland*, p181

is wasted in a silent film when one considers how effective he might be as a British Al Jolson'.¹¹³

It would soon become clear that Welsh-Pearson-Elder had made a serious error of judgement in planning a series of silent films, but they were not alone.¹¹⁴ In April 1929 the press reported a state of chaos in the film industry, with the production activities of British companies being 'practically brought to a standstill owing to the "talkies" situation'. Producers were faced with a dilemma, some finishing up their schedule of silent films and others 'making half-hearted plans to synchronise with speech and sound effects existing silent films'. This inaction was said to be creating severe hardship among film extras, many of whom had been waiting for work for months, and were now 'in a state of starvation'. Adding to the chaos was the fact that many British sound pictures were having to be set to music abroad, as British studios did not possess the necessary equipment. Exhibitors were waiting until the last minute before booking silent films because they thought these pictures might represent a 'dead loss to them in nine months' time', but they were unwilling to book the same films with synchronised sound, as they were not certain whether 'talkies' would last.¹¹⁵

George Pearson's disagreement with his co-directors over their commitment to ongoing silent film production and his 'vigorous support for the sound film' has been documented elsewhere, but in April 1929 even he was quoted as saying that 'personally, I do not think the vogue [for talking pictures] will last'.¹¹⁶ Five months later he succeeded in his aim of making *Auld Lang Syne* a (part) sound film, through the addition of synchronised sound to Lauder's songs. For this Lauder recorded four songs from the film on disc: 'The End of the Road', 'It's a Fine Thing to Sing', 'I

¹¹³ *Aberdeen Journal*, 3 April 1929, p7. Movietone was an American sound system, essentially a development of the Phonofilm

¹¹⁴ Low, *History of the British Film 1918-1924*, p164

¹¹⁵ *Aberdeen Journal*, 9 April 1929, p7

¹¹⁶ Low, *History of the British Film 1918-1929*, p164; *Aberdeen Journal*, 9 April 1929, p7

Love a Lassie’ and ‘Just a Wee Deoch an Doris’, which were synchronised to the image using the RCA sound system, with great technical difficulty.¹¹⁷

Meanwhile, the Welsh-Pearson-Elder company had run into difficulties. The ‘talkies’ were, as one newspaper put it, ‘taking a firmer grip in Britain every day’, with ninety more (American) sound films appearing every month.¹¹⁸ At the company’s annual general meeting in July, R C Buchanan in his role as chairman reported that plans for expansion including a new studio at Wembley had been abandoned, and it was impossible to place any financial value on the company’s completed films as this would be ‘merely speculative’. In his report, T A Welsh said that the passing of the Quota Act had resulted in over-production of British films and rental values had dropped by at least 50 per cent. As a result of this slump the British bookings of *Huntingtower* had fallen ‘far below their justifiable expectations’, and in the USA its release had clashed with the first big ‘talkies’ which had ‘practically swept the silent film off American screens’.¹¹⁹

The sound version of *Auld Lang Syne* was released in Britain in December 1929 as a ‘Synchronised Sound Picture’ although in reality most of it was still silent. Advertisements presented it as a kind of novelty item: an ‘enormous Christmas attraction’ in which the audience could ‘hear Sir Harry sing four of his popular songs’ as part of a mixed programme. In Tunbridge Wells, for example, *Auld Lang Syne* was shown alongside a new Mickey Mouse sound film and a popular silent of 1923, Harold Lloyd in *Safety Last*. The original, silent, *Auld Lang Syne* was also released the same month; interestingly, sometimes shown alongside a ‘talkie’.¹²⁰ The run continued into the following year: in March *Auld Lang Syne* ran for three days at the Olympia, Arbroath, where it was promoted as a ‘brilliantly directed and flawlessly acted comedy-drama, packed with fun and incident, beautiful Scottish scenery, and of course, Sir Harry himself, one of Arbroath’s most illustrious sons’.

¹¹⁷ Pearson, *Flashback*, pp156-157; *Glasgow Herald*, 22 July 1929, p7. The British director Thorold Dickinson, whose early career was as an editor, assisted Pearson in editing *Auld Lang Syne*. See G Brown, ‘Dickinson, Thorold’, www.screenonline.org.uk (accessed January 2016)

¹¹⁸ *Evening Telegraph*, Dundee, 1 May 1929, p6

¹¹⁹ *Glasgow Herald*, 22 July 1929, p15

¹²⁰ *Kent & Sussex Courier*, 20 December 1929, p10; *Courier*, Dundee, 24 December 1929, p1; *Gloucester Citizen*, 18 December 1929, p11

As this advertisement made no reference to synchronised sound, it must have been shown on the silent screen.¹²¹ From the summer of 1929 and through 1930 the permanent installation of sound equipment into cinemas throughout Scotland remained newsworthy, as did the resulting redundancy of the many orchestral musicians who had been employed by exhibitors. One of the first Edinburgh cinemas to install sound equipment was Poole's Synod Hall: in July 1929 an advertisement announced that 'we can no longer keep "silent"' and talkies would begin the following week presented on the RCA Photophone, 'the £6000 supreme sound system'.¹²² In deference to the 'expressed desire of the vast majority of his patrons', however, Mr Poole intended to retain the orchestra: with a full sound programme there would be 15 minutes of 'harmony' twice nightly, and silent pictures would be 'presented with orchestral accompaniment as heretofore'.¹²³ But despite these intentions, a year later between 480 and 500 cinema musicians were recorded as unemployed in Scotland and only 27 cinemas remained to be wired.¹²⁴

Although *Auld Lang Syne* with its 'abundance of dry Scottish humour' appears to have been moderately well-received, it did not improve the fortunes of the Welsh-Pearson-Elder company.¹²⁵ In an article headed "'Talkies" hit Lauder film', the *Scotsman* described the heckling that took place at the annual general meeting in July 1930, at which shareholders were told that the company had - as predicted the previous year - made a loss. By the time additional work on *Auld Lang Syne* had been completed and the film was ready for the market, 'many all-talking films, made in Hollywood, were available for showing in this country', so that the 'once apparently high value of the synchronised "Auld Lang Syne" diminished so rapidly that it was doubtful whether the additional cost had been covered by increased bookings'.¹²⁶

¹²¹ *Arbroath Herald*, 21 March 1930, p1

¹²² In mid-June 1929 the New Picture House in Princes Street was the first Edinburgh cinema to be wired for sound

¹²³ *Scotsman*, 22 July 1929, p1

¹²⁴ J Izod, 'Screen Tests: a historical snapshot of the Musicians' Union and technological change', <http://livemusicexchange.org/blog> (accessed January 2016)

¹²⁵ *Hartlepool Northern Daily Mail*, 11 February 1930, p3

¹²⁶ *Scotsman*, 30 August 1930, p14

Harry Lauder did not go on to enjoy, as some had predicted, a glittering career on the big screen.¹²⁷ Pearson directed him again in *Sir Harry Lauder in a Series of his World Famous Songs* (1931), produced by Michael Balcon at Gainsborough. His only other feature film was *The End of the Road* (1936), a musical comedy drama produced by at Wembley Studios, in which his co-star was Bruce Seton, son of Sir Bruce of the Seven Seas Screen Productions.¹²⁸

After *Auld Lang Syne* George Pearson went to Hollywood where he supervised production of his first all-sound film, an adaptation of R C Sherriff's *Journey's End*. This was the English director James Whale's first big film, and after its production he stayed on in Hollywood where he had a successful career.¹²⁹ On Pearson's return to England he discovered the company he had founded with Welsh was in serious financial difficulty, and would soon be forced into voluntary liquidation.¹³⁰ He continued directing films for other producers, including many 'quota quickies', and during the Second World War became head of production at the Colonial Film Unit.¹³¹

The story of Welsh-Pearson-Elder and the production of *Huntingtower* and *Auld Lang Syne* amply illustrates the difficulties faced by British producers in the transitional period. The production of synchronised sound feature films involved a far heavier financial outlay than that of silent pictures; more than half the smaller production companies that had been set up in 1928 in an attempt to capitalise on the introduction of the quota did not survive past 1931. In the period leading up to the Quota Act two vertically-integrated companies, Gaumont-British and the Associated British Picture Corporation, had been formed and it was these much larger concerns

¹²⁷ See, for example, P Mannock, 'Screening Sir Harry', p12

¹²⁸ *The End of the Road* was not released in the USA until 1940, under the new title of *Song of the Road*

¹²⁹ James Whale is best remembered today as the director of four horror films: *Frankenstein* (1931), *The Old Dark House* (1932), *The Invisible Man* (1933) and *The Bride of Frankenstein* (1935)

¹³⁰ Welsh-Pearson-Elder and Gainsborough had jointly secured the film rights to *Journey's End* in 1929. Under a deal with Tiffany Pictures in Hollywood, Gainsborough retained overall control and Pearson (as associate producer) was sent to Hollywood to choose the cast and supervise production. Welsh-Pearson-Elder was liquidated in 1932

¹³¹ Pearson, *Flashback*, pp170-202

that had the resources to withstand the transition to sound.¹³² In this context, the implications for the feasibility of Scotland developing a facility for the production of sound films are clear.

During the silent era the production of prints of films for release in non-English-speaking countries had simply involved the insertion of appropriate intertitles in other languages, meaning that a British film could be marketed worldwide. Producers' plans to continue doing so after the advent of sound were soon abandoned: not only did scripts have to be rewritten, but sometimes different stars had to be used because of the difficulties in coping with a foreign language. As a result, British productions for the next few years were aimed primarily at the home market and were made on the kind of budgets that could be recouped from domestic release. In the summer of 1929 the major English film studios (Gainsborough, Shepherd's Bush, Elstree, Isleworth and Twickenham) were all in the process of being converted to sound. Welsh-Pearson-Elder's ambition to build studios at Wembley was not achieved, but under the ownership of British Talking Pictures, Wembley Studios - Britain's first purpose-built sound studios - were opened in September 1929.¹³³

Proposal for a new Scottish film studio

In this period of intense activity following the introduction of the quota and the transition to sound, Aberdeen Town [sic] Council seriously considered building a 'film colony' along the lines of John Maxwell's Elstree Studios in the south of England. The only Scottish production facility to date had been the short-lived and basic studio at Thornliebank near Glasgow, unused after the production of *Football Daft* in 1921.¹³⁴ Eight years later Aberdeen was searching for a new light industry that would help to offset the effects of industrial depression and bring back some prosperity to the city. One hope was that a film studio would generate a range of highly-skilled trades to sustain it. To this end, it was announced in June 1929 that a

¹³² Associated British Picture Corporation, an amalgamation of a distribution company and the ABC cinema chain with a newly-formed production company, British International Pictures, was founded in 1927 by Scottish solicitor John Maxwell

¹³³ Wood, *British Films 1927-1939*; P Warren, *British Film Studios: an illustrated history* (London, 2001)

¹³⁴ See Chapter 3

consultation would take place between representatives of the council and important London-based Scottish businessmen, followed by a conference. The leaders of industry to be consulted were Sir Eric Geddes, his brother Sir Auckland Geddes, Lord Meston, Sir John Ferguson, Sir Alexander Roger and Sir Robert Horne - collectively representing a vast experience of trade, industry, finance and politics.¹³⁵ The film studio idea was one of several said to be under consideration by the council, but was the only one to receive any publicity.

Before going any further the council sought the advice of the new manager of the Aberdeen's La Scala cinema, William Muir, who was also an experienced cameraman.¹³⁶ Muir took the brief seriously and offered a realistic appraisal of the chances of success of a new Scottish film studio, which would actually be located at Stonehaven, a harbour town 15 miles south of Aberdeen. He considered that for the project to succeed it would have to receive significant financial backing by (unspecified) production companies and local businesses. Muir estimated that it would cost about half a million pounds to build the studios, and a further million to carry on production until a profit was made. If this capital could be raised, in his judgment Aberdeen would undoubtedly benefit from the employment of local people, increased trade and the spending brought about by an influx of technicians, actors and other production personnel. The only real drawback was the erratic climate. A few consecutive sunny days or 'even one whole day of sunshine' were 'often looked for in vain... A film being produced with stars and staff at immense cost might be held up for a week after inside scenes had been taken waiting for good weather. Imagine the loss!' But as Muir went on to point out, this made no difference to studio work, while the natural surroundings of sea and mountains offered huge scope to film-makers. 'Cowboy films' could be made, 'with all the adjuncts of rocky gorges, rushing torrents, landslides, and so on'. The magnificent stretch of railway to Stonehaven with its embankments and bridges was perfect for stunts, and along the rocky coast there were fishing villages 'ready for a film of homely seafaring life'. Aberdeen itself, with its white, clean buildings, would offer a perfect background for

¹³⁵ 'Film-Making in Aberdeen', *People's Journal* Aberdeen city edition, 15 June 1929, pp1,6. There is no evidence that the proposed conference took place

¹³⁶ M Thomson, *Silver Screen in the Silver City* (Aberdeen, 1988), p157

street scenes, while rival Dundee ‘with its brown buildings and smoky atmosphere’ would be impossible. Muir’s wide-ranging appraisal took into account considerations such as transport from Aberdeen to London and onwards to Southampton ‘for shipping abroad’, which he deemed a ‘short journey from one end of Britain to the other [that] should not trouble us at all’. He concluded that the question of whether the film colony could succeed centred on the ‘points of light’ and photographic conditions.¹³⁷

The *Bioscope* published a patronising ‘open letter’ addressed to the leaders of Aberdeen Town Council, in which it suggested that there was little hope of the project succeeding - at the same time professing admiration for the council’s ‘true Scottish grit’ in seeking a new industry. There was ‘not much to look for this (especially in Aberdeen!)’ but if the council was prepared to subsidise the building of a local film-making enterprise, ‘by no means let us discourage you’. The writer’s only helpful suggestion was that ‘the canny Scot of Elstree’ [John Maxwell] should be called to the proposed conference. ‘He knows Scotland and he knows film finance!’¹³⁸

The notion of a new film studio for Aberdeen was not as preposterous as the *Bioscope* (or hindsight) might suggest. For years English production companies had gone to the effort and expense of bringing casts and crews to Scotland in the knowledge that authentic Scottish scenery and settings added value to their productions. In 1921 *Christie Johnstone* had memorably been filmed in the fishing village of Auchmithie, some 30 miles south of Stonehaven, and both before and since many other British feature films had exploited the Scottish landscape.¹³⁹ In June 1929 the game was not quite over for smaller British producers, but the amount of capital required to set up studios capable of sound film production must have been the main deterrent to the Aberdeen scheme - of which nothing was heard after Muir’s report.

¹³⁷ ‘Film-Making in Aberdeen’, pp 1 and 6. Hollywood was sometimes referred to as a ‘film colony’ as was Elstree Studios, which aspired to be Britain’s Hollywood

¹³⁸ *Bioscope*, 19 June 1929, p17

¹³⁹ See Chapter 4

Conclusion

There was no lack of ambition in Scotland to seize the opportunities brought about by the Quota Act and the onset of synchronised sound. But even if the entrepreneurial efforts of Scottish film producers and skilled engineers had been less fragmented, their chances of success were receding. In the silent era the main problem for aspiring Scottish producers had been a lack of investment, together with the absence of a national strategy for film production: the main competition came from English companies, who had the resources to make relatively big-budget 'Scottish' feature films on location. But in the late 1920s the business of film became not only bigger but much more complex, and the cost of producing sound films on any scale effectively precluded Scottish efforts at feature film production from 1929. Alternatives were also rendered unattractive: short films did not qualify for the quota, and were therefore unlikely to be screened in mainstream cinemas.¹⁴⁰

The example of Welsh-Pearson-Elder, a well-established and respected production company that had attempted to re-capitalise on the back of the quota, shows how precarious the situation of British producers was in the transitional period. 'Talkies' were far more expensive to make than silent films: the average cost of a sound film was between £12,000 and £20,000 compared with £5,000-£12,000 for a silent production. Sound recording equipment was also costly and, faced with these overheads, many of the smaller companies did not survive.¹⁴¹ The Quota Act was the catalyst for the creation of large British corporations that were vertically integrated along the lines of Hollywood studios. In 1929 the majority of the British studios that converted to sound used the American RCA recording system, and although particularly in smaller cinemas some British-made sound systems had some initial success in competition with the more expensive American technology, American dominance grew in other areas, including international copyright agreements which controlled the use of music in synchronised sound films.¹⁴²

¹⁴⁰ Gomery, *The Coming of Sound*, pp54-67

¹⁴¹ Dickinson and Street, *Cinema and State*, p42

¹⁴² J Mundy, *The British Musical Film* (Manchester, 2007), pp29-30; L Wood, *British Films 1927-1939*

After 1929 there were no further attempts at Scottish feature film production. Alexander Macdonald, determined to continue in the production of sound films, repositioned himself as an Australian producer but his ambition and high-ranking connections proved to be no substitute for film-making experience, skill, and financial backing. The most successful of the Scottish production companies to be formed during the silent era was the Scottish Films Productions (1928) Ltd, which proved itself adaptable enough to survive in the sound era. In the mid-1930s the company, in response to the ever-decreasing opportunities for the exhibition of short films in commercial cinemas, chose to produce films only in response to specific commissions.¹⁴³ This successful strategy enabled the company founded by Malcolm Irvine and later run by Stanley L Russell to maintain a steady output of documentaries until after the Second World War, using Irvine's Albion Truphonic sound system. In 1938 the Scottish Films Productions' *Sport in Scotland* was the only one of the group of seven British documentaries produced (under the supervision of John Grierson) for the Empire Exhibition in Glasgow to be made by a Scottish company.¹⁴⁴

With the advent of sound, Britain's film studios became even more firmly rooted in London and south east England, and almost 90 years later Scotland still has no permanent facility for the production of feature films.

¹⁴³ Griffiths, *The Cinema and Cinema-going in Scotland*, p293

¹⁴⁴ NRS/MIA, 0314, *Sport in Scotland* (1938, Dir Stanley L Russell). The other films made under the direction of John Grierson to spotlight Scotland were *Face of Scotland*, *Wealth of a Nation*, *Scotland for Fitness*, *They Made the Land*, *Sea Food* and *The Children's Story*

Conclusion

This thesis has explored the productions, ambitions and plans of Scottish film-makers in the period between the emergence of the feature film as a standardised form and the coming of sound to cinema. It has filled the gap left by other film historians in bringing fiction film production to the foreground and in going beyond previous selective and distorted views of Scotland's output. Setting each production initiative against its cultural and socio-economic background has allowed a narrative to emerge in which, rather than being a random collection of 'flickering images', the Scottish production story makes sense within its own terms. At the same time, it has charted and sought to explain aspects of Scotland's engagement with film production within the context of particular stages in the evolution of the British and worldwide film industries. The dismissal of Scottish production as a story of weakness and shortcomings, presented in comparison with its strength in film exhibition and cinema-building, has been challenged. A surprising variety of production strategies and a number of forgotten production companies have been identified, showing that the story of early Scottish film-making is broader and more complex than was previously acknowledged. At the same time, reflections on what constituted a 'Scottish' film have run throughout this work, showing up the inadequacy of many existing definitions which focus exclusively on films with 'Scottish' subjects.

Throughout the period the union with the United Kingdom remained strong, and as a small country Scotland's chances of developing an autonomous film industry were minimal. There was no national strategy for production, and the challenges faced by aspiring Scottish producers were greater than those faced by those in southern England. Britain as a whole did not have a large enough domestic audience to underwrite the risk of investing in film production, a problem that affected Scotland even more sharply. While the British film industry struggled to compete with Hollywood, Scotland's attempts to create an industry or a sustainable studio infrastructure were hampered not only by a lack of investment from within the

country but also by the ease with which Scottish stories, characters and history could be appropriated and presented on screen by those from outwith Scotland.

In one sense the reason for Scottish producers' inability to found an industry was straightforward: the economics of film production and national aspiration did not add up. Nonetheless, there was no lack of ambition and innovation, and evidence shows that the recurrent attempts to launch a programme of Scottish-produced films were made at certain periods in which their producers had reason to be optimistic about their chance of success. A variety of production strategies were adopted, each one responding to a particular set of circumstances. Such strategies echoed trends within the British and worldwide industries, and showed a readiness to engage with modernity both in terms of the kinds of stories chosen and in technological developments. Consideration of the aims and production schedules of Scottish companies alongside films that were completed reveals that the aspects of national identity Scots wished to present to each other frequently differed from those projected from outside. Genres and modes of presentation were selected to chime with the tastes and preferences of Scottish audiences both at home and overseas, and few Scottish producers sought to emulate the kinds of narratives imbued with tartanry that were filmed in Scotland by English production companies. The production that was most popular with Scottish audiences was an urban comedy of working-class life, representing aspects of Scottishness that were to be drawn on many years later by film-makers such as Bill Forsyth, Danny Boyle and Ken Loach.

The work has separated amateur from professional and semi-professional film-making, and clarified the extent to which the existing Scottish film trade was involved in attempts at commercial production. In the pre-war period, most production initiatives emanated from members of the Glasgow film trade eager to embrace the medium in order to present Scottish stories in their 'authentic' settings - which they believed was the key to commercial success. Rather than going it alone, as was previously supposed, these novice producers engaged professional directors and cameramen in order to enhance their films' marketability. After the war, members of the trade played a less prominent role in the formation of Scottish companies. The aspirations of Scotland's producers varied: not all sought to play on

the world stage, or shared the overblown ambitions of mavericks such as Maurice Sandground and Alexander Macdonald. At the same time, it was these ‘outsiders’ who recognised and responded to specific opportunities that arose from attempts to foster British production in the 1920s.

The achievements of Scottish entrepreneurs in the development of synchronised sound systems, both before and after the Great War, have also been identified and foregrounded. One new discovery of this research was the existence of the Vocal Cinema as the developer of an early sound system which was patented and used in the company’s own productions. Other discoveries include the plans and hopes throughout the period for the building of film studios, and an accurate account is finally given of the history of the Thornliebank studio. There was a desire to build studios outside Glasgow, and Dundee and Aberdeen were particularly vocal at different times in their calls to ‘Film Scotland Here’.¹ Both cities had a large concentration of cinemas and sizeable working-class populations, and both suffered badly as a result of the post-war decline in their traditional industries. Shifting attention to these other urban centres also uncovers a deeper critical engagement with cinema. An unexpected by-product of this research has been the discovery of the existence of Scottish film correspondents long before the arrival of ‘Kinoman’ at the Glasgow *Evening Times* and Forsyth Hardy at the *Scotsman*. The journalists of the Aberdeen and Dundee newspapers quoted throughout this thesis may not have had a byline, but their role certainly included film criticism as well as the detailed reporting of production activity.

In order to understand fully the development of production, it has been important to reconstruct the content of each film as precisely as possible. This exercise is also of value to film archivists, as copies of these lost films are still being sought. One possible lead was followed to its source, and the film held by the Near East University in Cyprus catalogued as *Glimpses from the Life of Sir Walter Scott* was identified as actually being a recording of a television programme about the great Scottish author.

¹ *Courier*, Dundee, 13 June 1919, p8

The study also offers new information about the distribution and reception of Scottish-made films as well as those films shot in Scotland by English companies, and shows that the opinions of the British national trade journals the *Bioscope* and *Kinematograph Weekly* were often at variance with those within Scotland, particularly over the issue of the way the Scots language was presented. The extent to which outside productions of Scottish stories were received and accepted as 'Scottish films' depended on the producers' commitment to Scotland and the involvement of local people, rather than simply on the exploitation of Scottish landscapes or subject matter. While Scottish trade papers welcomed any sign of local production activity, a film's local credentials did not affect its appeal to audiences. The 1911 *Rob Roy* was filmed and produced entirely in Scotland, but these factors appear to have generated only limited interest. The most popular and widely-distributed film within Scotland was *Football Daft*, but box office success did not generate sufficient income for production costs to be recouped.

Throughout the period the chief difficulty faced by producers in Scotland was a lack of stability or infrastructure on which to build up a body of experience. Despite intentions, most productions were one-off enterprises. This study has demonstrated, however, that Scottish producers were purposeful and strategic in their attempts to develop the foundations of a Scottish film industry, and were well aware of developments within the wider industry. The silent era represented a particular phase in Scottish cinema history where production strategies parallel to those in the UK and the USA could be contemplated. That possibility was effectively closed off from 1929 and the triumph of sound.

The particular focus of this thesis means that it has not been possible to answer all the new questions that have arisen in the course of research, and certain key areas have emerged that deserve further exploration.

As a small country, Scotland's output of films in the silent era compared favourably with Wales, but unfavourably with Ireland. Over 60 fiction films have been identified as being made in Ireland between 1896 and 1923, although many of these were not genuinely indigenous productions but were made by American companies headed by the Irish-American producer Sidney Olcott. In 1910, the Kalem company

was said to be the first American film studio to travel outside the USA to film on location in Ireland, where a team of three made *The Lad From Old Ireland*, a story of Irish migration. A larger crew led by Olcott returned to Ireland to make films in the summers of 1911 to 1914, even after he and the leading actress Gene Gauntier, who wrote most of the screenplays, had parted company with Kalem. The output of the 'O'Kalems', as Olcott's unit in Ireland came to be called, represent the largest body of films produced by a foreign film company in the country. Between June and September of 1911, for example, they produced 12 fiction and two non-fiction films in Ireland.² Ireland did, however, gain its own film production company in 1916. The Film Company of Ireland was founded by a lawyer, James Mark Sullivan, whose family had emigrated to the USA from Killarney when he was a child. He returned to Ireland in order to make feature films presenting the Irish nationalist cause. This company made a series of highly successful feature films in Ireland between 1916 and 1920.³ A comparison with the situation in Scotland in this period - either politically or culturally - and its impact on film production is not straightforward, and merits attention that is beyond the scope of this thesis. Similarly, the reasons why Scotland had greater relative success than Wales in attempting to develop a film industry deserve further exploration.

Another potential area for further study generated by this research concerns the circulation, presentation and reception of Scottish films overseas, particularly in the Scottish diaspora. Overseas markets were included in the plans of Scottish filmmakers from the earliest days, and the Scottish audience was conceived of, more often than not, as a worldwide community. Although there were Scottish associations around the world, the traditional emigrant destinations of Canada, the USA and the Antipodes were where Scottish associational culture was liveliest. By the early twentieth century Australia and New Zealand were each home to around 100 Caledonian Societies alone, and in the same period Toronto in Canada was home to ten separate Scottish clubs and societies. Many of these associations, which from the

² D Condon, 'Rebels and Redcoats: Political Melodrama in the Kalem Company's Irish Films', <http://www.academia.edu/> (accessed February 2016)

³ K Rockett, 'The Silent Period' in K Rockett, L Gibbons and J Hill (eds), *Cinema and Ireland* (Syracuse, 1988), pp7-15

late nineteenth century focused on socialising and promoting Scottish culture through music, poetry and literature, limited membership to those who could prove their Scottish ethnicity.⁴ The place of film within associational culture has not been considered, yet from the 1910s onwards such societies regularly screened programmes of ‘Scottish films’ which may have emanated from Britain, the USA or Europe. Investigation of the records of some of these associations would help to identify which films were screened and potentially shed some light on the way they were received. The discovery that United Films’ 1911 *Rob Roy* was seen in New Zealand and Australia, and Maurice Sandground’s films were targeted specifically at Scots in Canada and England as well as those at home, indicates the importance of pursuing this line of enquiry. It is, of course, also possible that a print of one of these well-travelled films may yet be discovered somewhere far from Britain.

A third area for further research concerns the cinema colleges and film acting academies that sprang up throughout Britain from around 1915. There has been little scholarly interest in the history of such enterprises other than Chris O’Rourke’s account of the history of the Victoria Cinema College in London.⁵ Research into Scottish cinema colleges, presented here in order to understand and contextualise production of *The Harp King* in 1919, has revealed that not all of these colleges were established purely to exploit gullible would-be film stars, and that (at least in Scotland) some had a more serious purpose.⁶ Some of the early colleges offered training in technical and other aspects of film production, as well as in acting for the camera. The low esteem in which cinema colleges and actors’ training schools were held by the late 1920s is evident from contemporary newspaper reports, yet it seems unlikely that all were fraudulent enterprises. It would be useful to discover if it was only in Scotland that cinema colleges were established in order to fund commercial film production. Whether anyone who graduated from such a college became a successful screen actor is unknown, and this line of enquiry, together with a comparison of the popularity and longevity of the acting academies in Britain’s

⁴ T Bueltmann, A Hinson and G Morton, *The Scottish Diaspora* (Edinburgh, 2013), p118-120

⁵ C O’Rourke, ‘The Victoria Cinema College and Studios, c. 1917’, londonfilm.land.wordpress.com

⁶ See Chapter 3

towns and cities, the fees they charged, the training they offered and the kind of clientele they attracted, are questions that could usefully be asked.

Original contribution

This study contributes to the realisation of the research aims of the AHRC-funded project ‘Early Cinema in Scotland, 1897-1927’, whose central purpose was to produce a comprehensive account of the early development of cinema in Scotland.⁷ The thesis makes an original contribution to the understanding of Scottish cinema history in several areas, presenting a more multi-faceted and coherent picture of Scotland’s efforts to develop its own film industry than that drawn in previous studies such as Griffiths’ *The Cinema and Cinema-going in Scotland*. It transforms assumptions about early Scottish fiction film production, showing that producers operating within Scotland were highly attuned to developments within the wider industry, and desired to create a foothold for Scottish production within it.

The work fills the gap in the history of filmic representations of Scotland identified in 1982 by Colin McArthur, and noted again by David Stenhouse in 2009.⁸ Situating non-Scottish productions alongside those made within the country, the research has revealed significant formal and thematic differences which challenge assumptions passed down through the decades from the *Scotch Reels* critics of the early 1980s, and will inform future debates around cinema’s relationship with Scottish national identity. The research also contributes to a growing body of work on the history of film in small countries, and provides background and context to studies of ‘new Scottish cinema’, concerned with the emergence and expansion of a culturally distinctive Scottish cinema in the late twentieth and early twenty-first centuries.⁹

The research findings are also important to scholarship in the wider history of British film, particularly as they demonstrate that non-metropolitan, ‘regional’ production continued to develop after the First World War and indeed until the end

⁷ <http://earlycinema.gla.ac.uk/>

⁸ Stenhouse, ‘Not Made in Scotland’, p174; McArthur, ‘Scotland and Cinema: The Iniquity of the Fathers’, p42

⁹ J Murray, *The New Scottish Cinema* (London and New York, 2015); Murray et al (eds): *Scottish Cinema Now*

of the silent era. Current understanding of this subject is based largely on the output of the Lancashire producers Mitchell and Kenyon and the Welsh film-maker William Haggart, who had ceased production activity by 1914. In showing that non-metropolitan film production extended well beyond early cinema's first phase, this research therefore points to the importance of including Scottish production in general histories of British film.

The thesis is also of value to the fields of twentieth century Scottish historical and cultural studies, particularly in its contribution to the understanding of the relationship between film production, technical entrepreneurship and contemporary society, and in using empirical evidence to reveal the connections between individual films and art, literature, theatre and music throughout the period. There has been a tendency to discuss film as a discrete cultural product, and this work begins the process of integrating it more firmly in wider Scottish form.

BIBLIOGRAPHY

Primary sources - printed and manuscript

National Records of Scotland, Edinburgh

Register of Dissolved Companies:

BT2/7704, The United Films Limited

BT2/8039, Vivian's Pictures Limited

BT2/11004, Ace Film Producing Co Ltd

BT2/10774, The Broadway Stage and Cinema Company/The Broadway Cinema Productions, Ltd

BT2/12268, Arc Film Producing Limited

BT2/12681, The Scottish Films Limited

BT2/13492, The Glasgow Film Studios Limited

BT2/14314, The Burns-Scott Films Limited

BT2/14453, Seven Seas Screen Productions Limited

BT2/15183, North British Films Limited

Court of Sessions: Warrants of the Register of Acts and Decrees, 5th Series:

CS46/1912/1/85, Decree for payment, Cinés Co, otherwise called Società Italiana "Cinés" Rome against The United Films Limited

CS46/1923/7/28, James H Milligan v The Broadway Cinema Productions, Ltd

CS46/1925/1/54, Closed Record in the action at the instance of Mrs Gertrude Simpson against The Scottish Films Limited

SC36/79/18, Letter Book of Thomas Gilbert, 1916-1921

National Library of Scotland Moving Image Archive, Glasgow

Andrew Paterson, Inverness (4/3)

Film Productions, Miscellaneous (4/5)

Film Stills, Posters, Publicity (4/8)

George Green, Ltd (5/8)

Green's Film Service file

Miscellaneous Film Material (5/7)

Proposal for The Empire Films Limited (4/1)

Scottish Films Productions (1928), Ltd (4/1)

Whisper and I Shall Hear (2803)

I Love a Lassie (4431)

Miss Violet Hopson visits Dundee Fire Station (0833)

Things that Happen, No. 1 (0373)

St Kilda - Britain's Loneliest Isle (0418)

Sport in Scotland (0314)

Scotch Myths (6382)

The National Archives, Kew

BT 31/24187/151490, Midland Actors Film Producing Company Ltd

COPY 1/553/217, Photograph of cinematograph film 'Fox Hunting'

COPY 1/553/240, Photograph of cinematograph view of Central Railway of Peru Limited

COPY 1/556/340, Photograph (cinematograph) of 'Henry VIII' as played by Sir Herbert Tree and Company

COPY 1/559/172, Photograph films (for cinematographs) of the play of 'Rob Roy' as actually produced at Aberfoyle

British Film Institute (BFI)

N-36685, Herbert Pemberton Collection; handwritten script for *Bonnie Mary*

ITM-125, Personalities, Florence Turner and James Anderson:

correspondence from Florence Turner; cuttings relating to Florence

Turner's career; manuscript notes by Anderson on 'The Screen's First Real Star'

Official publications

HL Communications Committee, *The British Film and Television Industries*, 2010: <http://www.publications.parliament.uk/>

Newspapers and Periodicals

Aberdeen Evening Express

Aberdeen Journal

Advertiser, Adelaide

Arbroath Herald

Auckland Star

Bioscope

Birmingham Daily Mail

Birmingham Daily Post

Cairns Post

Coventry Evening Telegraph

Coventry Standard

The Cinema/To-day's Cinema

Courier, Dundee

Daily Mercury (Mackay, Queensland)

Derby Daily Telegraph

Dominion (New Zealand)

Dover Express

The Edinburgh Gazette

The Edinburgh Review

Entertainer/Entertainer & Scottish Kinema Record/Scottish Kinema Record
The Era
Evening News, Edinburgh
Evening Post, Glasgow
Evening Post, Wellington (New Zealand)
Evening Telegraph, Dundee
Falkirk Herald
Folkestone, Hythe, Sandgate & Cheriton Herald
Glasgow Herald
Gloucestershire Chronicle
Hamilton Advertiser
Hartlepool Mail
Hawick News & Border Chronicle
Hull Daily Mail
Kalgoorlie Miner
Kent & Sussex Courier
Kinematograph and Lantern Weekly/Kinematograph Weekly
Lancashire Evening Post
The London Gazette
Mercury (Hobart)
Motherwell Times
The Moving Picture World
New York Times
New Zealand Herald
Nottingham Evening Post
Otago Daily Times (New Zealand)
People's Journal (Aberdeen edition)
Pictures and the Picturegoer
Portsmouth Evening News
Poverty Bay Herald (New Zealand)
Rochdale Observer
Saturday Post, Glasgow
The Scotsman
Scots Pictorial
Scottish Cinema
Stirling Observer
Straits Times
Sunday Mail, Brisbane
Sunday Post, Glasgow
Sunday Post, Newcastle
Sunday Times, Perth (Australia)
Sydney Morning Herald
The Times
Times of India
Toronto Daily Star

Toronto Globe
Variety
Walsall Advertiser
Wanganui Chronicle
Weekly News, Dundee
Weekly Scotsman
West Australian, Perth
Whitstable Times
Yorkshire Post

Annual publications and works of reference

Kinematograph Year Book
Scottish Post Office Annual Glasgow Directory
British Board of Film Censors, Register of Films Passed
 Denis Gifford, *The British Film Catalogue: The Fiction Film, 1895-1994*, 3rd edn, (London, 2001)

Contemporary works

J J Bell, 'Introduction by the author, telling the story of the book' in *Wee MacGregor* (1902) <http://gutenberg.net.au/ebooks11/1100201h.html>
 R Bennell, 'The Film Industry Settles Down', *Educational Film Bulletin* 33, September 1946
 T A Blake, 'Prince Bendon', *Educational Film Bulletin* 33, September 1946
 Q D Bowers, '1915 Mutual News' in *Thanouser Films: An Encyclopedia and History*, vol 1, <http://www.thanouser.org>
 T J Colquhoun, 'My memories of Glasgow music halls', *Thomson's Weekly News*, 23 June 1928, p18
 J Kissell, 'Cinema in the By-ways', *Educational Film Bulletin* 33, 1946, pp22-23
 W McLaren, 'Memories' in R Masson (ed), *I can remember Robert Louis Stevenson* (Edinburgh 1922), p32
 I Pocock, *Rob Roy Macgregor: or, "Auld Lang Syne", an operatic play, in three acts extended with an intr. & c. by a Glasgow playgoer* (Glasgow, 1868)
 W Scott, *Rob Roy* (London, 1995) [first published 1817]

Secondary sources - books

Richard Abel, *Encyclopedia of Early Cinema* (Abingdon, 2005)
 Richard Abel, *Silent film* (London, 1996)
 Jeremy Agnew, *The Creation of the Cowboy Hero: Fiction, Film and Fact* (Jefferson, N Carolina, 2015)
 Robert C Allen, *Vaudeville and Film, 1895-1915: A Study in Media Interaction* (New York, 1980)
 Rick Altman, *Silent Film Sound* (Columbia, 2004)
 Tino Balio, *The American film industry* (Madison, Wisconsin, 1985)

- Robert Hamilton Ball, *Shakespeare on Silent Film: A Strange Eventful History* (Abingdon, 1968)
- Kenton Bamford, *Distorted Images: British National Identity and Film in the 1920s* (London, 1999)
- Charles Barr (ed), *All Our Yesterdays: 90 years of British cinema* (London, 1986)
- Charles Barr, *English Hitchcock* (Moffat, 1999)
- Charles Barr and Alain Kerzoncuf, *Hitchcock Lost and Found: The forgotten films* (Lexington, 2015)
- Richard Meran Barsam, *Nonfiction Film: A Critical History* (London, 1974)
- David Berry, *Wales and Cinema: The First Hundred Years* (Cardiff, 1994)
- Neil Blain and David Hutchison (eds), *The Media in Scotland* (Edinburgh, 2008)
- H Philip Bolton, *Scott Dramatized* (London, 1992)
- Ian Brown (ed), *The Edinburgh History of Scottish Literature, vol 2: Enlightenment, Britain and Empire (1707-1918)* (Edinburgh, 2007)
- I Brown (ed), *The Edinburgh History of Scottish Literature, vol 3: Modern transformations: New Identities (from 1918)* (Edinburgh, 2008)
- Julie Brown and Annette Davison (eds), *The Sounds of the Silents in Britain* (Oxford, 2014)
- David Bruce, *Scotland the Movie* (Edinburgh, 1996)
- Judith Buchanan, *Shakespeare on Silent Film: An Excellent Dumb Discourse* (Cambridge, 2009)
- Tanja Bueltmann, *Scottish Ethnicity and the Making of New Zealand Society, 1850-1930* (Edinburgh, 2011)
- Tanja Bueltmann, Andrew Hinson and Graeme Morton (eds), *Ties of Blood, Kin and Countrie: Scottish Associational Culture in the Diaspora* (Guelph, 2009)
- James McDonald Burns, *Cinema and Society in the British Empire, 1895-1940* (Basingstoke, 2013)
- Jon Burrows, *Legitimate Cinema: theatre stars in silent British films, 1908-1919* (Exeter, 2003)
- Alan Burton and Steve Chibnall, *Historical Dictionary of British Cinema* (Plymouth, 2013)
- Ewen A Cameron, *Impaled upon a Thistle: Scotland since 1880* (Edinburgh, 2010)
- Francesca Carnevali and Julie Marie Strange (eds), *Twentieth-Century Britain: Economic, Cultural and Social Change* (Harlow, 2007)
- Catherine MacFarlane Carswell, *The Life of Robert Burns* (London, 1951)
- Steve Chibnall, *Quota Quickies: The Birth of the British 'B' film* (London, 2007)
- David Cloy and Janet McBain, *Scotland in Silent Cinema: A Commemorative Catalogue to Accompany the Scottish Reels Programme at the Pordenone Silent Film Festival, Italy, 1998* (Glasgow, 1998)
- Denis Condon, *Early Irish Cinema 1895-1921* (Dublin and Oregon, 2008)
- Stuart Cunningham, *In the Vernacular: a generation of Australian culture and controversy* (St Lucia, Queensland, 2008)
- Tracy C Davis, *The Economics of the British Stage 1800-1914* (Cambridge, 2007)
- T M Devine (ed), *Scotland and the Union 1707-2007* (Edinburgh, 2008)

- T M Devine, *To the Ends of the Earth: Scotland's global diaspora 1750-2010* (London, 2011)
- Eddie Dick, *From Limelight to Satellite: a Scottish film book* (London, 1990)
- Margaret Dickinson and Sarah Street, *Cinema and State: the film industry and the government 1927-84* (London, 1985)
- Bryony Dixon, *100 Silent Films* (London, 2011)
- William Donaldson, *Popular literature in Victorian Scotland: Language, fiction and the press* (Aberdeen, 1986)
- Laurie N Ede, *British Film Design: A History* (London and New York, 2010).
- Ray Edmondson and Andrew Pike, *Australia's Lost Films: The loss and rescue of Australia's silent cinema* (Canberra, 1982)
- Thomas Elsaesser and Adam Barker (eds), *Early Cinema: Space, Frame, Narrative* (London, 1990)
- Christine Gledhill, *Reframing British Cinema, 1918-1928* (London, 2003)
- Douglas Gomery, *The Coming of Sound* (New York and London, 2005)
- Lee Grieveson and Colin MacCabe (eds), *Empire and Film* (London, 2011)
- Trevor Griffiths, *The Cinema and Cinema-going in Scotland, 1896-1950* (Edinburgh, 2012)
- Michael Hammond, *The Big Show: British Cinema Culture in the Great War 1914-1918* (Exeter, 2005)
- Stuart Hanson, *From Silent Screen to Multi-Screen: A history of cinema exhibition in Britain since 1896* (Manchester, 2007)
- Forsyth Hardy, *Grierson on Documentary* (London, 1979)
- Forsyth Hardy, *Scotland in Film* (Edinburgh, 1990)
- Christopher Harvie, *Scotland & Nationalism: Scottish Society and Politics 1707-1994* (London, 1994)
- Andrew Higson, *Waving the Flag: Constructing a National Cinema in Britain* (Oxford, 1995)
- John Hill, *Cinema and Northern Ireland: Film, Culture and Politics* (London, 2006)
- Priya Jaikumar, *Cinema at the End of Empire: A Politics of Transition in Britain and India* (Durham and London, 2006)
- Paul Johnson (ed), *Twentieth Century Britain* (London and New York, 1994)
- Will Kaufman and Heidi Slettedahl Macpherson (eds), *Britain and the Americas: Culture, Politics and History* (Santa Barbara, Denver and Oxford, 2005)
- Robert Kemp and Walter Scott, *Rob Roy: a play in three acts based on the novel by Sir Walter Scott* (Glasgow, 1983)
- Gorham Kindem (ed), *The International Movie Industry* (Carbondale and Edwardsville, 2000)
- Murray Stewart Leith and Duncan Sim (eds), *The Modern Scottish Diaspora: Contemporary Debates and Perspectives* (Edinburgh, 2014)
- Rachael Low, *The History of the British Film, 1906-1914* (London, 1949)
- Rachael Low, *The History of the British Film, 1914-1918* (London, 1950)
- Rachael Low, *The History of the British Film, 1918-1929* (London, 1971)
- Murdo Macdonald, *Scottish Art* (London, 2000)

- Anne MacLeod, *From an Antique Land: Visual Representations of the Highlands and Islands 1700-1880* (Edinburgh, 2012)
- Geoffrey Macnab, *Searching for Stars: Stardom and screen acting in British cinema* (London and New York, 2000)
- Richard Maltby, Daniel Biltereyst and Philippe Meers (eds), *Explorations in New Cinema History: approaches and case studies* (Malden, Mass and Oxford, 2011)
- Richard Maltby and Melvyn Stokes (eds), *Identifying Hollywood's Audiences: Culture, Identity and the Movies* (London, 1999)
- Andrew Martin, *Going to the Pictures: Scottish memories of cinema* (Edinburgh, 2000)
- David Martin-Jones, *Scotland: Global Cinema: genres, modes and identities* (Edinburgh, 2009)
- Paul Matthew St Pierre, *Music Hall Mimesis in British Film, 1895-1960* (Cranbury, New Jersey, 2009)
- Colin McArthur (ed), *Scotch Reels: Scotland in Cinema and Television* (London, 1982)
- Colin McArthur, *Whisky Galore! and The Maggie* (London, 2003)
- Colin McArthur, *Brigadoon, Braveheart and the Scots: Distortions of Scotland in Hollywood Cinema* (London, 2003)
- Janet McBain, *Pictures Past: Recollections of Scottish cinemas and cinema-going* (Edinburgh, 1985)
- Angela McCarthy (ed), *A Global Clan: Scottish Migrant Networks and Identities since the eighteenth century* (New York, 2006)
- Angela McCarthy, *Scottishness and Irishness in New Zealand since 1840* (Manchester, 2011)
- David McCrone, *Understanding Scotland: the Sociology of a Nation* (London, 2001)
- Brian McFarlane, *The Encyclopedia of British film* (London, 2005)
- J J McGowan, *J P McGowan, Biography of a Hollywood Pioneer* (Jefferson, North Carolina, 2005)
- Luke McKernan, *Charles Urban: Pioneering the non-fiction film in Britain and America, 1897-1925* (Exeter, 2013)
- Luke McKernan, *Topical Budget: The Great British News Film* (London, 1991)
- Peter Miskell, *A social history of the cinema in Wales, 1918-1951: pulpits, coal pits and fleapits* (Cardiff, 2006)
- Claire Monk and Amy Sargeant (eds), *British Historical Cinema: the history, heritage and costume film* (London and New York, 2002)
- Christopher Morash, *A History of Irish Theatre, 1601-2000* (Cambridge, 2002)
- Sheridan Morley, *The Brits in Hollywood: Tales from the Hollywood Raj* (London, 2006)
- Robert F Moss, *The Films of Carol Reed* (New York, 1987)
- John Mundy, *The British Musical Film* (Manchester, 2007)
- Robert Murphy (ed), *The British Cinema Book*, 3rd edn (London, 2008)
- Bill Murray, *The Old Firm: Sectarianism, Sport and Society in Scotland* (Edinburgh, 1984)
- Jonathan Murray, *The New Scottish Cinema* (London and New York, 2015)

- Jonathan Murray, Fidelma Farley and Rod Stoneman (eds), *Scottish Cinema Now* (Newcastle upon Tyne, 2009)
- Tom Nairn, *The Break-up of Britain: Crisis and neo-nationalism* (Altona, 2003)
- Lawrence Napper, *British Cinema and Middlebrow Culture in the Interwar Years* (Exeter, 2009)
- Andrew Nash, *Kailyard and Scottish Literature* (Amsterdam and New York, 2007)
- Charles Allen Oakley, *Where We Came In: Seventy Years of the British Film Industry* (London, 1964)
- Eric Partridge and Paul Beale, *A Dictionary of catch phrases British and American, from the sixteenth century to the present day* (London, 1985)
- George Pearson, *Flashback: The Autobiography of a British Film-maker* (London, 1957)
- Duncan Petrie, *Screening Scotland* (London, 2000)
- Jock Phillips and Terry Hearn, *Settlers: New Zealand Immigrants from England, Ireland and Scotland 1800-1945* (Auckland, 2008)
- Andrew Pike and Ross Cooper, *Australian Film, 1900-1977: A guide to feature film production* (Melbourne and Oxford, 1998)
- Buck Rainey, *Serials and Series: A World Filmography, 1912-1956* (Jefferson, N Carolina, 1999)
- Jeffrey Richards, *The Age of the Dream Palace: cinema and society in 1930s Britain* (London, 2010)
- Jeffrey Richards, *Films and British National Identity: from Dickens to Dad's Army* (Manchester, 1997)
- Ann Rigney, *The Afterlives of Walter Scott: memory on the move* (Oxford, 2012)
- Kevin Rockett and Emer Rockett, *Film exhibition and distribution in Ireland, 1909-2010* (Dublin, 2011)
- Trevor Royle, *The Mainstream Companion to Scottish Literature*, (Edinburgh, 1993)
- Tom Ryall, *Alfred Hitchcock and the British Cinema* (London, 1996)
- Walter Scott, *Rob Roy* (London, 1995)
- Jamie Sexton, *Alternative Film Culture in Interwar Britain* (Exeter, 2008)
- Anthony Slide, *Early American Cinema* (Metuchen, NJ and London, 1994)
- Janet Staiger, *Interpreting Films: Studies in the historical reception of American cinema* (Princeton, 1992)
- Melvyn Stokes and Richard Maltby, *Hollywood Spectatorship: changing perceptions of cinema audiences* (London, 2001)
- Sarah Street, *British National Cinema* (London, 1997)
- Paul Swann, *The British Documentary Film Movement, 1926-1946* (Cambridge, 1989)
- F M L Thompson (ed), *The Cambridge Social History of Britain, 1750-1950*, 3 vols (Cambridge, 1990)
- Michael Thomson, *Silver Screen in the Silver City: A history of cinemas in Aberdeen, 1896-1987* (Aberdeen, 1988)
- Patricia Warren, *British Film Studios: An illustrated history* (London, 2001)
- James Wierzbick, *Film Music: A History* (London, 2008)

William H Wilde, Joy Hooton and Barry Andrews (eds), *Oxford Companion to Australian Literature*, 2nd edn (Oxford, 2005)

Gregory Paul Williams, *The Story of Hollywood: An Illustrated History* (Los Angeles, 2011)

Richard Zumkhawala-Cook, *Scotland As We Know It: Representations of National Identity in Literature, Film and Popular Culture* (Jefferson, NC, 2008)

Secondary sources - articles and essays in books and journals

G Bakker, 'The Economic History of the International Film Industry', in Robert Whaples (ed), *EH.net Encyclopedia* (2008) <http://eh.net/encyclopedia/the-economic-history-of-the-international-film-industry/>

M Balcon, 'Thirty Years of British Film Production', *British Kinematography*, vol 15 issue 4 (1949), pp 105-115 <http://the.hitchcock.zone/>

C Barr, 'Before *Blackmail*: Silent British Cinema', in R Murphy (ed) *The British Cinema Book*, 2nd edn (London, 2002), pp11-19

I Brown, 'Scots Language in Theory and Practice in Graham Moffat's Playwriting', *Scottish Language* vol 33 (2014), p65-81

J Brown, 'Framing the Atmospheric Film Prologue in Britain, 1919-1926' in J Brown and A C Davidson (eds), *The Sounds of the Silents in Britain* (Oxford and New York, 2013), pp200-221

J Burrows, 'Florence Turner: her British career' in J Gaines et al (eds), *Women Film Pioneers Project* (New York, 2013), <https://wfpp.cdrs.columbia.edu>

D Cloy, 'Scottish Film Production in the Silent Period', in J McBain (ed), *Scotland in Silent Cinema: A Commemorative Catalogue to Accompany the Scottish Reels Programme at the Pordenone Silent film Festival, Italy, 1998* (Glasgow, 1998), pp5-13

D Condon, 'Rebels and Redcoats: Political Melodrama in the Kalem Company's Irish Films', <http://www.academia.edu/>

A M Cook, 'Adventures of the Vitagraph Girl in England,' in A Burton, and L Porter (eds) *Pimple, Pranks & Pratfalls: British Film Comedy before 1930* (Trowbridge, 2000), pp 34-35

A M Cook, 'From 'Vitagraph Girl' to British Star: Florence Turner as a Transnational Celebrity', unpublished paper delivered at the Women and Silent Screen conference, Guadalajara, Mexico, 2006

P Cook, 'Albany Ward and the development of cinema exhibition in England', *Film History* vol 20 no 3 (2008), pp294-307

R Cook, 'The Home-ly Kailyard Nation: Nineteenth century narratives of the Highland and the myths of Merrie Auld Scotland', *English Literary History* vol 66 no 4 (1999), pp1053-1073

S Curtis, "'If It's Not Scottish, It's Crap!' Harry Lauder Sings for Selig", *Film History*, 11 (1999), pp 418-425

T Dolin, 'The Great Uncredited: Sir Walter Scott and Cinema', *Screening the Past* (2012). <http://www.screeningthepast.com/2012/08/the-great-uncredited-sir-walter-scott-and-cinema/>

- T Edensor, 'Reading Braveheart: representing and contesting Scottish identity', *Scottish Affairs* 21 (1997), pp135-158,
www.scottishaffairs.org/backiss/pdfs/sa21/sa21_Edensor.pdf
- A Falks, 'Henderson's Laboratories', *The Norwood Review*, summer 2011, pp21-23
www.norwoodsociety.co.uk/pdf/review193.pdf
- T Fletcher, 'Alf Collins and Gaumont: South-East London's cinematic past',
<http://silentlondon.co.uk/2014/08/09/alf-collins-and-gaumont-south-east-londons-cinematic-past-tony-fletcher/>
- M Glancy, 'Hollywood and Britain: MGM and the British 'Quota' Legislation' in J Richards (ed) *The Unknown 1930s: An Alternative History of the British Cinema, 1929-1939* (London, 1998) pp60-62
- L Grieveson 'The Cinema and the (Common) Wealth of Nations' in L Grieveson and C McCabe (eds), *Empire and Film* (London, 2011), pp73-100
- T Griffiths, 'Sounding Scottish - Sound Practices and Silent Cinema in Scotland' in J Brown and A C Davison (eds), *The Sounds of the Silents in Britain* (Oxford and New York, 2013), pp72-94
- S Hayward, 'France', in G Kindem (ed), *The International Movie Industry* (Carbondale and Edwardsville, 2000), pp195-205
- A Higson, 'Great Britain', in G Kindem (ed), *The International Movie Industry*, pp234-245
- J Izod, 'Screen Tests: a historical snapshot of the Musicians' Union and technological change', <http://livemusicexchange.org/blog>
- E Lebas, 'Sadness and Gladness: the films of Glasgow Corporation, 1922-1938', *Film Studies*, 6 (2005), pp27-45
- J McBain, 'Green's of Glasgow: 'We Want "U" In'', *Film Studies*, 10 (2007), pp54-57
- J McBain, 'Mitchell and Kenyon's Legacy in Scotland - the inspiration for a forgotten film-making genre' in V Toulmin, S Popple and P Russell (eds), *The Lost World of Mitchell and Kenyon* (London 2004), pp113-121
- R Murphy, 'Coming of Sound to the Cinema in Britain', *Historical Journal of Film, Radio and Television*, 4 (1984), pp143-60
- A Nash, 'Literary Publishing, 1880 to 1914' in D Finkelstein and A McCleery (eds) *The Edinburgh History of the Book in Scotland*, vol 4 (Edinburgh, 2007) pp203-222
- A Noble, 'Urbane Silence: Scottish writing and the nineteenth century city' in G Gordon (ed), *Perspectives of the Scottish City* (Aberdeen, 1985), pp 64-90
- T Ryall, 'Blackmail', in E Buscombe and R White (eds), *BFI Film Classics Vol 1* (London, 2003) pp94-112
- T Shaw, 'Early Warnings of the Red Peril: a Pre-History of Cold War British cinema, 1917-1939', *Film History*, 14 (2002), pp 354-368
- D Stenhouse, 'Not Made in Scotland' in J Murray, F Farley and R Stoneman (eds), *Scottish Cinema Now*, (Newcastle upon Tyne, 2009) pp171-186

Web resources and databases

- BBC Genome Project, <http://genome.ch.bbc.co.uk/>
- The Bioscope (blog), <http://thebioscope.net/>
- British Film Institute, www.screenonline.org.uk

British Newspaper Archive, <http://www.britishnewspaperarchive.co.uk/>
British Universities Film Council, <http://bufvc.ac.uk/newsonscreen>
Cinema Treasures, <http://cinematreasures.org/theaters/>
Colonial Film Database, <http://www.colonialfilm.org.uk/>
Early Cinema in Scotland, <http://earlycinema.gla.ac.uk/>
Elstree Studios, <http://www.elstreestudios.co.uk/>
Evening Standard, London, www.standard.co.uk
Film Distributors' Association, www.launchingfilms.com
Find a Grave, <http://www.findagrave.com>
Free BMD, <http://www2.freebmd.org.uk/>
The Hitchcock Zone, <http://the.hitchcock.zone>
Internet Archive, <https://archive.org/>
Internet Movie Database (IMDB), <http://www.imdb.com/>
London Filmland, <https://londonfilmland.wordpress.com>
The London Project, <http://londonfilm.bbk.ac.uk/>
Luke McKernan, <http://lukemckernan.com/>
The National Archives, www.nationalarchives.gov.uk/records/research-guides/copyright.htm
National Library of Scotland Moving Image Archive,
<http://movingimage.nls.uk/>
Papers Past, paperspast.natlib.govt.nz/
Newspaper SG, Singapore, <http://eresources.nlb.gov.sg/newspapers/>
New York Times, www.nytimes.com
Oxford Reference, www.oxfordreference.com
Paterson Collection, www.patersoncollection.co.uk
Portal to the Past, <http://www.portaltothepast.co.uk/>
Project Gutenberg, <https://www.gutenberg.org/>
Screening the Past, <http://www.screeningthepast.com>
Silent London, www.silentlondon.co.uk
Sir Harry Lauder, <http://www.sirharrylauder.com/>
This is Money, www.thisismoney.co.uk
Trove, <http://trove.nla.gov.au/>
YouTube, www.youtube.com

