

2010

# Food Traceability Information Modeling and Data Exchange and GIS Based Farm Traceability Model Design and Application

Hafize Gunsu Gemesi  
*Iowa State University*

Follow this and additional works at: <http://lib.dr.iastate.edu/etd>

 Part of the [Bioresource and Agricultural Engineering Commons](#)

---

## Recommended Citation

Gemesi, Hafize Gunsu, "Food Traceability Information Modeling and Data Exchange and GIS Based Farm Traceability Model Design and Application" (2010). *Graduate Theses and Dissertations*. 11597.  
<http://lib.dr.iastate.edu/etd/11597>

This Thesis is brought to you for free and open access by the Graduate College at Iowa State University Digital Repository. It has been accepted for inclusion in Graduate Theses and Dissertations by an authorized administrator of Iowa State University Digital Repository. For more information, please contact [digirep@iastate.edu](mailto:digirep@iastate.edu).

**Food traceability information modeling and data exchange and GIS based  
farm traceability model design and application**

by

**Hafize Gunsu Gemesi**

A thesis submitted to the graduate faculty  
in partial fulfillment of the requirements for the degree of  
MASTER OF SCIENCE

Major: Sustainable Agriculture

Program of Study Committee:

Charles R. Hurburgh, Major Professor

Paul F. Anderson

John D. Lawrence

David Sly

Iowa State University

Ames, Iowa

2010

Copyright © Hafize Gunsu Gemesi, 2010. All rights reserved.

## TABLE OF CONTENTS

LIST OF FIGURES	v
LIST OF TABLES	viii
ABSTRACT	ix
CHAPTER 1: INTRODUCTION	1
Introduction	1
Thesis Outline	1
Research Objectives	2
CHAPTER 2: GENERAL LITERATURE REVIEW	4
Traceability	4
TRU (Traceable Resource Unit) Concept	6
Traceability Data Modeling	8
Product Centric Data Modeling	10
PDM Standardization Initiatives	12
Product Life Cycle Management (PLM)	17
Traceability Information Integration and Exchange	18
XML as a Global Traceability Language	18
XML Schema	18
TraceCore XML Standards	19
Use of GIS Technology for Geo-Traceability	20
GIS Based Traceability Studies	21
References	23
CHAPTER 3: FOOD TRACEABILITY SYSTEM MODELING AND DATA EXCHANGE	26
Introduction	26
Traceability System Analysis	27
Defining the Traceability System	30
Track and Trace Concept	30

Process Characteristics	32
Mapping Organizational Data Structure: <i>Where Is the Data?</i>	32
Defining Material and Information Flow, Identification and Linkage	32
Defining and Identifying Traceable Resource Unit (TRU)	34
Traceability Information Interoperability and Exchange	37
Product Centric Information Modeling	39
Implementation of the Proposed Model	42
Developing XML Document from Product Centric UML Data Model	43
Conclusions	54
References	56
CHAPTER 4: GIS BASED TRACEABILITY SPATIAL DATABASE	58
MODEL FOR IP GRAIN	
Introduction	58
Statement of the Problem	59
Grain Supply Chain Trends in United States	60
Identity Preserved (IP) Grain	62
Grainsafe Program	64
Research Objectives	68
Model Development	70
Reference Data Model for Grain Tracing and Tracking	72
Tools Used In GIS Based Farm Traceability Project	76
ArcSDE	76
SQL Server	78
Project Process Steps	79
Identification of the Information Required for Project Design	80
SQL Server& ArcSDE Installation and Coordination	81
ArcSDE Data Access	82
Attribute Data Input and Management	85
Creating Spatial and Non-Spatial Attribute Data	85
Creating Domains in a Geodatabase	87

Relational Database Design	89
Creating Relationships within ArcSDE Geodatabase	92
Testing Functionality of the Farm Traceability Geodatabase	96
Conclusions	99
References	100
GENERAL CONCLUSION AND FUTURE RESEARCH	102
APPENDIX: SCOR MODEL DAIRY SUPPLY CHAIN APPLICATION	103
SCOR Model Overview	103
SCOR Thread Diagram Modeling	105
References	109
AKNOWLEDGEMENTS	110

## LIST OF FIGURES

Figure 1. Product Centric Paradigm (Baina et al., 2005)	10
Figure 2. Enterprise applications Reference Information Model (RIM) and product-driven point of view (Tursi, et al., 2007)	12
Figure 3. The IEC Model Hierarchy (IEC 62264, 2002)	14
Figure 4. Correspondence between Holonic and IEC/ISO 62264 concepts (Baina, 2007).	15
Figure 5. Defining Holon (Gouyon, 2004)	16
Figure 6. IDEF0 Model is used to demonstrate Whole Supply Chain Traceability Transformation.	28
Figure 7. Decision Support Tool for Electronic Traceability System Implementation	31
Figure 8. TRU related traceability information	34
Figure 9. GS1 Numbering Schema Implementation	36
Figure 10. Different types of Traceability Data Integration and Exchange Requirements	38
Figure 11. UML Product Centric Data Modeling	40
Figure 12. Declaring TRU_Types in XML Schema	44
Figure 13. Declaring TRU_Batch in XML Schema	45
Figure 14. Type of Trade Units Declaration in XML Schema	45
Figure 15. Assigning Global Unique Identification Schemas to Trade Units	46
Figure 16. Defining the TRU Transformations	47
Figure 17. Corn Supplier Data Model Diagram	49
Figure 18. Grain Supplier XML File	51
Figure 19. Flour Company Data Diagram	51
Figure 20. Flour Company XML File	54
Figure 21. Grain differentiation trends and grain market characteristics in US (The Changing Face of the U.S. Grain System / ERR-35 Economic	63

Research Service/USDA)	
Figure 22. Identification of each step during HACCP implementation process	68
Figure 23. Process flow diagram used in the project for non_GMO grain production and handling at the farm level	71
Figure 24. Harvesting Procedure and Data Collection	73
Figure 25. Analysis of the crop movement throughout harvesting, inbound and outbound transportation; lot dynamic changes in several points	75
Figure 26. ArcSDE can be used to manage geographic information to make geo- data available to all ArcGIS applications	77
Figure 27. Granting permissions to ArcSDE database users in SQL Server	79
Figure 28. Hierarchical Representation of Process Design	80
Figure 29. Highlighted area shows the Farm that was selected for this project	81
Figure 30. The ArcSDE service can be started by clicking Computer Management/ under Services and Application Window	82
Figure 31. Example of how to register tables as versioned in ArcSDE	83
Figure 32. Database Connection Properties Window	84
Figure 33. How to give privileges for database users in ArcSDE geodatabase	84
Figure 34. Creating tables in ArcSDE	86
Figure 35. Domains used in Farm Traceability Geodatabase	88
Figure 36. Representation of domain values in database table	88
Figure 37. Logical Data Model was created by using RDBMS model	91
Figure 38. Conceptual representation of FIELD and LOT entities and cardinality between both entities	92
Figure 39. Creating new relationship class by right clicking the FIELD Feature Dataset	93
Figure 40. Defining the origin-destination direction of a relationship	93
Figure 41. Choosing the relationship class type and the message direction	94
Figure 42. Defining the cardinality between entities	94
Figure 43. Defining the primary and foreign key values and the summary of the relationship class properties	95

Figure 44. Relationship class properties between two entity; feature class and non-spatial table	95
Figure 45. Geodatabase representation on the ArcGIS map	97
Figure 46. The Parcel (green selected area) and its neighboring field information can be viewed by using identify window in ArcGIS	98
Figure 47. SCOR Model (Supply Chain Council, 2008)	103
Figure 48. SCOR Hierarchy (Supply Chain Council, 2008)	104
Figure 49. Thread Diagram for Milk Supply Chain	106



**LIST OF TABLES**

Table 1. Associated Codes with Activities	105
Table 2. SCOR Modeling Table	106
Table 3. Traceability Critical Activities within the Milk Supply Chain	107

## **ABSTRACT**

This thesis investigates the concept of electronic food traceability throughout the supply chain, with an emphasis on Traceable Resource Unit (TRU) identification, data management, and information exchange technologies from farm to fork. To accomplish these tasks, a UML (Unified Modeling Language) was used to create a product centric data model for managing TRU traceability data throughout the chain. After this step XML (Extensible Markup Language) schema was created using the UML model as a model foundation. The schema was used for the validation of XML files, which was written as an example of traceability information exchange and record keeping within and between supply chain parties. The model was able to represent production lots/batches and their sub components. The composition of a certain end product is then represented through modeling all its previous materials along with their intermediate relations. By registering all relations between each TRU, a method of tracking the composition of the end product was achieved. The second part of the thesis investigates the use of GIS (Geographic Information Systems) for creating a farm based traceability system. The system was able to visually identify and record each activity at the farm level, therefore enhancing upstream supply chain traceability.

## **CHAPTER 1: INTRODUCTION**

### **Introduction**

Due to the dramatic increase in food borne illnesses over the past decade, consumers become more and more concerned about the safety of the food they consume. Food has to travel much further than in previous decades, changing several hands before it reaches its final consumers. In an event of an outbreak these complex food production and distribution structure makes tracing and tracking of food a challenging task and has caused severe financial losses. This has lead food industry and regulatory bodies to take action on enhancing food safety by introducing new food safety and traceability standards. For example, since 2002 the European Union now requires food business operators to have traceability systems based on the ‘one-up, one-down’ principle (the 178/2002 Common Food Law). Essentially, this means that besides keeping records of current process, food industry participants are required to keep track of all products delivered to their customers and of all ingredients and raw materials received from their suppliers. In the USA, the Bioterrorism Act 2002 requires for food industry participants to keep record of each product they receive and a record of to where each product was sent; which is referred to as one-up/one-down traceability.

### **Thesis Outline**

The thesis consists of two parts; the first part of the thesis investigates the concept of establishing whole chain electronic traceability throughout a grain supply chain, with an emphasis on determining the best practices for the development and implementation of such systems. Analysis of the Traceable Resource Unit (TRU) dynamics, design of an information

model that integrate traceability within the concept of product centric data modeling, as well as the analysis of common information exchange methods for establishing electronic whole chain traceability

The second part the thesis explores how GIS can be used for tracing/tracking grain at farm level. GIS provides tools for linking traceability data with a geographical location. To be able accomplish this goal a GIS based geo-database was developed to provide an efficient and effective way to trace and track the IP production at farm level. This proposes a reference data model for farm base traceability to eliminate GMO contamination and comply with current grain production regulation by using GIS (Geographic Information Technology) and the integration of GrainSafe Program for crop production as the foundation for system implementation.

### **Research Objectives**

The main research objective of the thesis is to define a reference data model that will enable continuity of product information chain of custody throughout the value chain. Determining the necessary data elements and their transformation within the concept of Product Lifecycle Management (PLM) enables the products' information to be linked in the chain to the next to expand traceability for any product throughout all stages of production, processing and distribution. Track and trace requires that all parts of the supply chain invest in compatible technology and agree upon capturing and sharing information about product movement. For example, the time that a TRU has moved from the primary producer to the retail store, we will find it may have gone through a number of steps. These steps are named

as transformations, such as mixing, merging, pooling (clustering), splitting, joins, convert, etc. Therefore, this research proposes a model for registering and maintaining the TRU information chain of custody throughout the supply chain by using a products centric data modeling based on PLM, ISO/TC 10303 - IEC 62264 standards. In the second part of the thesis, I propose a design methodology for an internal/external traceability system implementation. The next part of the thesis will cover XML and its use in traceability as a common language for data exchange between food chain participants.

The final part of the thesis proposes a tool for monitoring and recording traceability data at farm level by using GIS. In general, traceability at farm level usually is neglected due to the high cost of system implementation and maintenance. In the past the cause of several food borne illnesses were traced back to farm level. These outbreaks surely brought the importance of traceability at farm level under the radar.

## CHAPTER 2: GENERAL LITERATURE REVIEW

### Traceability

Many definitions of traceability exist, which are defined and interpreted by using many standards, stemming from a variety of regulatory bodies, and experts. Standard ISO 8402 defines traceability as the “ability to trace the history, application or location of an entity, by means of recorded identifications”. Moe (1998) defines traceability as “an ability by which one may track a product batch and its history through the whole, or part, of a production chain from harvest through transport, storage, processing, distribution and sales, or internally in one of the steps in the chain, for example the production step”. According to the European Community Food Law, article 11 and 16-20 (EU General Food Law, 2004) each food business owner is expected to provide relevant information in regards to the nature of the products and their production practices to their trading partners. In the US, food safety is already a major priority however, there is currently only one single legal requirement for producers—the US Bio-Terrorism and Response Act of 2002, which obligates any entity that chooses to sell or market food products to provide all requested records to the FDA including one up/one down product traceability. These records are due to the FDA within 24 hours from the time of receipt of the official request. The Public Health Security and Bioterrorism Preparedness and Response Act of 2002 require the registration of all food facilities, domestic and foreign, supplying food to the U.S.; it has a direct impact on the whole US Food Supply Chain, especially regarding the imported segment (Sporeleder and Moss 2002). Fully integrated traceability systems have ability to record, capture and handle data on site, and can provide sufficient documentation to meet traceability requirements (Opara, 2004). Information collected by a traceability system can also be utilized by food industry to

improve product quality, streamline recall procedures, enhance supply-side management, and capture desirable product attributes. Furthermore, all these elements of traceability mentioned can be used for marketing and creating a recognizable product brand (Gledhill et al.2002). A recent study by Dickinson and (Gledhill et al.2002) found that U.S. consumers would be willing to pay more for products that provide traceability, transparency and enhanced quality assurances.

Traceability can be identified two ways according to the information recalled in the supply chain (Dupuy et al., 2005). *Backward traceability* or *tracing* is the ability to determine from where the product originated and its characteristics at any given point in the chain. *Forward traceability*, or *tracking*, is the ability to find the location of products and desired characteristics at any given time in the chain (Jansen-Vullers et al., 2003). Successful traceability system implementation allows only defected products to be identified and recalled, therefore confining potential hazard and reducing the recovery cost (Bechini et al., 2008)

Accuracy of the tracing information is also implied to be an essential requirement for the traceability system in order to realize the practical benefits of traceability. Also other factors such as customer values and the legal environment can affect the desired level of traceability. For example Hobbs (1996, p. 509) suggests that increased customer concerns about farm animal welfare may have increased the need for traceability as there is a need to trace cattle to the farm of origin. Similar consumer pressures have been caused by genetically engineered food.

It is important to have information system infrastructure that will support both type of traceability, also the accuracy of the data collected from chain participants. In general, the information accuracy increases when the product moves towards its final destination. This problem was defined by Bechini et al. (2008) as the “first mile” problem, which can decrease the effectiveness of the traceability system. Therefore, assuring the accuracy of the data captured in upstream of the supply chain carries a crucial role for effective system functioning. It is also important to automate the data capturing process to eliminate the data error due to the manual data registration (Bechini et al., 2008).

The new merging technologies in regards to data collection, which enable upstream supply chain partners—specifically the producers—to collect traceability data during every stage of farming operations are getting more attention. These new advancements allow producers to automate and streamline the data during the farming operations. This will minimize data collection and registration inaccuracy allowing for the efficient use of multiple types of information to be captured throughout every stage of farming, transportation and receiving by creating a single point of access to this information (Pape, et al., 2004).

### **TRU (Traceable Resource Unit) Concept**

According to GS1 Standards, “Traceable Resource Unit” is defined as “any item upon which there is a need to retrieve predefined information and that may be priced, or ordered, or invoiced at any point in any supply chain” (GS1, 2005). In practice it often refers to lot, batch, which is the smallest uniquely identified entity that is created during the internal production process. According to Kim et al.(1995), unique identification and the size of the TRU is to key to the successful traceability system implementation. Dupuy et al. (2005)



defines TRU as “The resource representation that must be traceable, since a TRU is neither an abstracted nor aggregated entity.” TRU can be a batch, a trade unit, or a variation of these two main types.

As mentioned earlier, traceable resource units are the smallest uniquely identified entities corresponding to physical objects of the value chain, and the success of the traceability system relies on tracing and tracking these core entities throughout the value chain. Determining what the Traceable Entities are is a major part of creating a dynamic traceability model for a particular value chain. For example if the production batches are too big or there is too much mixing occurs during production, the precision of the traceability system will be compromised (Dupuy et al., 2005). Therefore it is important to analyze the current production practice within the organization as well as how TRUs are defined. If it is needed, necessary adjustments have to be made to implement an effective traceability system. According to Moe et al. (1998), defining the TRU for continuous processing can be challenging. It may depend on how the raw material TRU was received and or on a change in processing conditions such as the clean out process for production equipment.

One of the major challenges in regards to establishing whole chain traceability is the transformations that TRU goes through throughout its life cycle (Schwagele, 2005). Transformation can be described as an operation, which happens between different traceable resource units. Transformations occur when products move from upstream to downstream through the supply chain. TRU transformations can occur when products mix, join, split-up, are added, or converted into another TRU (Derrick and Dillon, 2004) within the company or between companies in a value chain (Olsen et al., 2008).

According to Steel (1995) physical lot-integrity, which can be defined as TRU integrity, is one of the most important elements for designing a traceability system. Since its determination is highly correlated with the precision of the traceability system, physical lot integrity provides the maximal resolution of a traceability system. There are three factors that affect the physical lot integrity during the production process: lot-mismatching, lot end-mixing and lot-sequence mixing (Steele, 1995). Lot-mismatching refers to how a new created batch size does not match with the original batch. Lot-end-mixing occurs if production is based on continual processing practices and the enterprise fails to create uniquely identified batches (Fransoo & Rutten, 1994). Lot sequence mixing occurs when organizations fail to maintain sequential processing of job lots at shop floor.

In summary, physical lot-integrity is determined by the preserving the identity of the lot throughout its production process. How well the integrity of the batch is preserved will determine the precision of the traceability system (Kim et al. 1995). Therefore, it is important to take necessary adjustments to ensure the integrity of the TRU and its information goes along with it.

### **Traceability Data Modeling**

Modeling traceability data that effectively optimizes the use of data and creates information transparency throughout the supply chain is the most important element of a whole chain electronic traceability concept. There are two aspects of traceability information modeling that need to be developed for effective traceability information management. First, the model needs to be established for each enterprise, which can be defined as internal traceability. Internal Traceability allows data about incoming materials and processes to be

linked to the final product separately in each stage of production, processing or distribution. Establishment of well structured and timely recording of the input/output properties (raw materials, semi-finished and finished products) enables dynamic control of the production process and subsequent processes in the value chain (Chaco'n et al., 2002). This provides most sufficient and accurate representation of the internal traceability data. Second, the traceability data model needs to be established for the entire supply chain, which is defined through modeling of retrieved data in regards to the elements and requirements of a traceability system. This level of data modeling will allow us to achieve a TRU based traceability level from the source of the product through to its final destination (Khabbazi et al., 2009). Moe et al (1998) defines the management of whole chain traceability information in two ways;

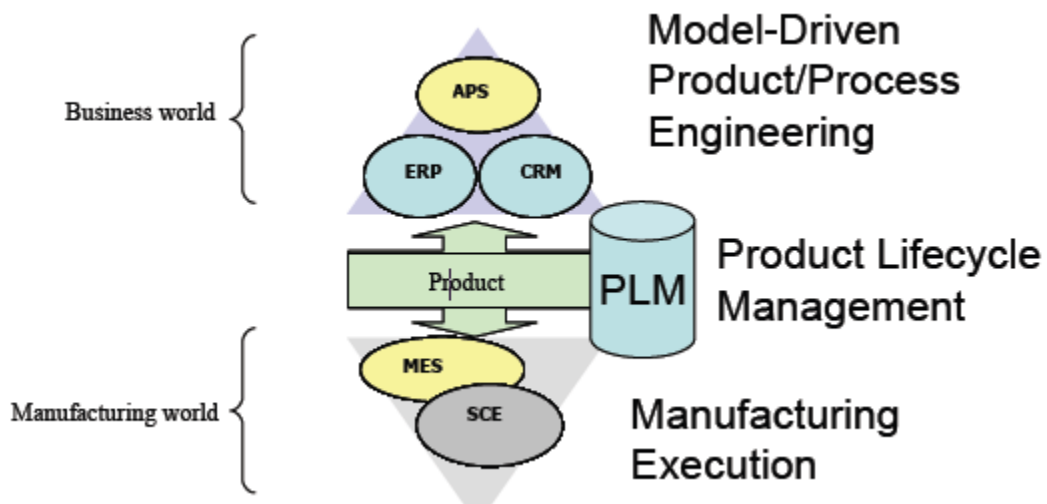
- 1) Information is stored locally and only the product identification is shared with value chain partners. This only allows the product and its sub-types to be traceable one step at a time.
- 2) Information follows the product all the way through the chain. This approach is especially important if there is a demand for traceability information at the early stages of a product's lifecycle.

According to Khabbazi et al. (2009), to be able to establish effective TRU level traceability is only possible by using an appropriate information system with an efficient approach of resource management. Most of the company's product traceability data is stored in different systems and in highly heterogeneous sources, such as electronic documents, ERP systems, legacy systems and databases. Thus, traceability data modeling should provide a comprehensive representation of the contents of these sources, thereby correlating the

scattered traceability data by providing a single point of access to product information throughout its lifecycle. To achieve this, information about the data sources (e.g., type, structure, version history, storage location) combined with information about their contents should be mapped. After this step, the new data model should be integrated with existing tools and data stores to promote easy access to the original sources (Jarke et al., 2004).

### Product Centric Data Modeling

Product centric data modeling has been addressed by several researchers as a solution to tackle with challenges in regards to whole chain traceability implementation within the food industry (Morel et al., 2004). The product centric model entails to trace and track relevant information related to the product lifecycle.



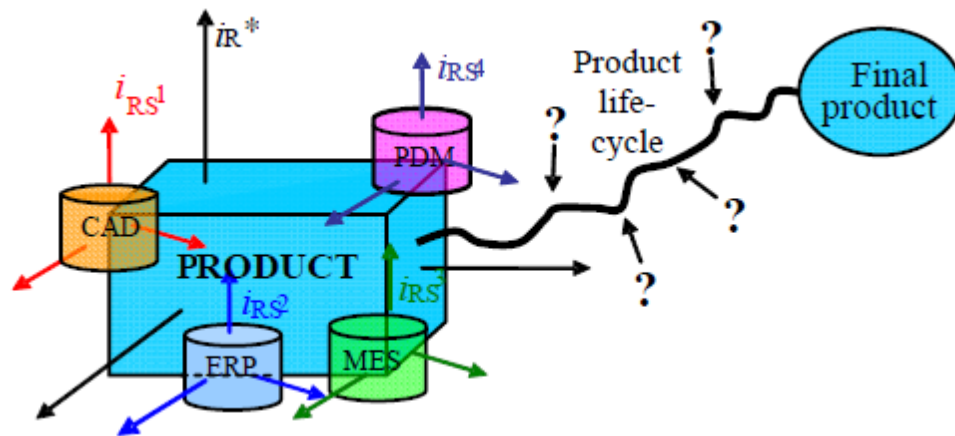
**Figure 1.** Product Centric Paradigm (Baina et al., 2005)

According to Bechini et al. (2008), traceability models must be general enough to be applicable to any kind of product and also allow for the unique identification of TRUs and its activities within the enterprise and value chain. His proposed model was designed by using

static UML (Unified Modeling Language) notation. The model contains two UML packages, all classes were grouped within these two packages; Traceability and Quality. The first package contains entities that enable tracing and tracking the product through its lifecycle. The second package contains entities that represent the quality features of the product. Further, the SuperClass was identified in the traceability package as *TraceableEntity* and has two derived classes which were defined as *Lot* and *Activity*. The associations were established with two object classes respectively, *Site* and *ResponsibleActor*. The model imposes a constraint to enforce a *TraceableEntity.Id* to always be associated with a *ResponsibleActor* and a specific *Site* where the activity takes place. Therefore, it enables users to retrieve the information about each site where traceability activity takes place within its value chain.

Secondary reference data modeling was proposed by Tursi et al. (2007) to solve the interoperability problem in manufacturing systems. He indicated that many problems in regards to product traceability information management stems from the heterogeneity of applications used to manage data within the enterprise. Different application usage for product data management leads to an interoperability problem especially when there is a need for information exchange. Usually interoperability problems occur due to the differences between the representations of the data structure within the different application protocols. Therefore, there is a need for information modeling that will be centered on the “product-driven point of view” (Tursi et al., 2007), which will enable each information system to perceive the product related to the data in same way.

The product-driven data modeling will allow the administration and exchange of semantically enhanced and precise product information. This can improve the quality of a traceability system and offer a high level of interoperability with other systems. His proposed model was based on development of product ontology which plays an important role in the formalization of product data. Ontology can be defined as a “formal representation of a set of concepts within a domain and the relationships between those concepts. It is used to reason about the properties of that domain, and may be used to define the domain” (Ontology-information science, 2009). Product ontology modeling will permit to capture all the relevant traceability information by providing structured standard data modeling and mapping each products centric data from different applications such as PDM, MES and ERP, throughout its life cycle (Tursi et al., 2007)



**Figure 2.** Enterprise applications Reference Information Model (RIM) and product-driven point of view (Tursi, et al., 2007)

### **PDM Standardization Initiatives**

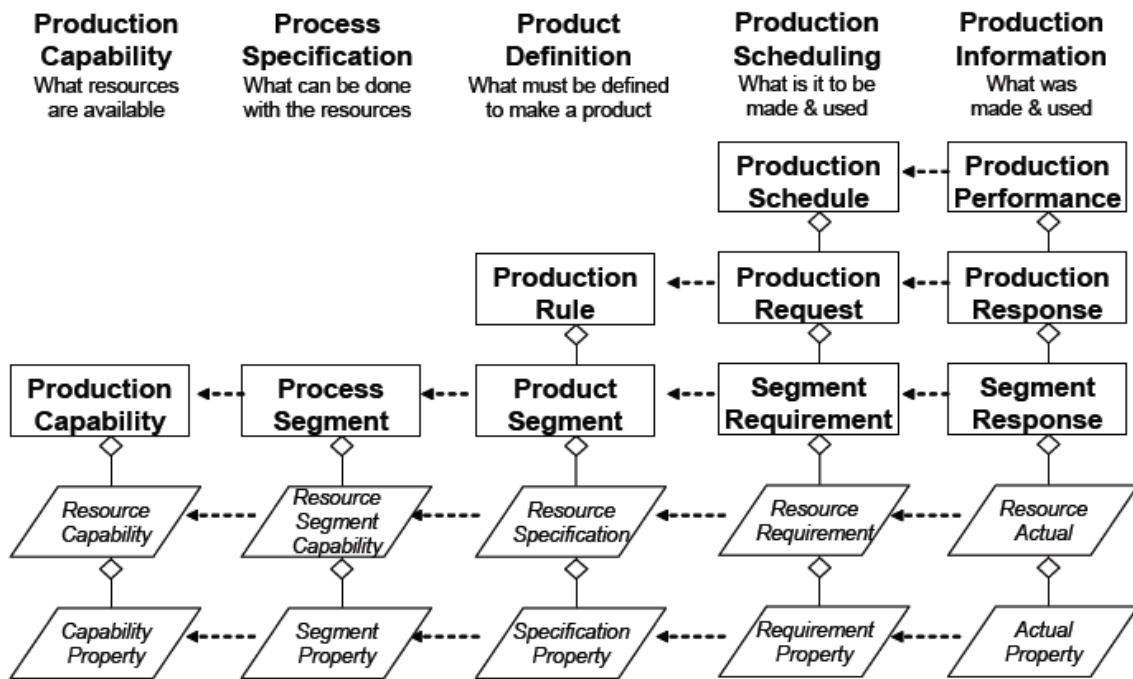
Currently there are two major initiatives, ISO/TC 10303 and IEC 62264, which were established to solve the information system interoperability problem by introducing standards

for computer-interpretable representation of product data management, and its exchange. These two standards aim to provide a tool for describing product data throughout the lifecycle of a product, independent from any particular system. The purpose of ISO 10303-Standard for the Exchange of Product model data, commonly known as STEP is to provide a standard information model for describing product data throughout the life cycle regardless of the computer system used for storing product information (ISO TC184/SC4, 2009). STEP can mitigate the interoperability problem by providing a single product data storage standard that integrates the product's centric data within the enterprise.

STEP enables PDM (Product Data Management) data to exchange by using unified PDM schemas. The PDM systems provide necessary tools to control data accessibility and manage all product-related data using common standard data formats. It does this by maintaining information (meta-data) about product information. Unified PDM Schema, which is a basic specification for the exchange of product centric definition data known as STEP-XML was designed to handle XML-based STEP product data schemas. It is used to manage process integration, supply chain management, collaborative engineering, process control analysis, manufacturing, and customer support in industry since 2001 (Cover, 2001). It has been created to associate all PDM data between all existing STEP application protocols, and permits the exchange of product information that is stored in PDM applications.

The IEC 62264 standard was developed to define the data exchange interface between Manufacturing Control Systems and other Enterprise Management Systems. The different models were linked and represented together to define a hierarchy of models within the enterprise (Figure 3). The production information segment represents what was produced and

the materials used in production. It contains information about production scheduling and the description of the final product and the materials used to finalize the product. Product scheduling segment contains information about the timing of the activities that initiates the production. The production segment contains elements that identified resources which are needed to initiate the production activity such as equipment, personnel, raw material(s), etc. The product definition element defines the information about inputs that is used to make the product. Process specification defines the way how the resources should be used to make the product. And finally, production capability information provides the terminology for capacity scheduling and equipment maintenance information (Panetto et al., 2007).



**Figure 3.** The IEC Model Hierarchy (IEC 62264, 2002)

The IEC 62264 based data model represents each segment of product data within the enterprise, combined together with real-time information coming from these different



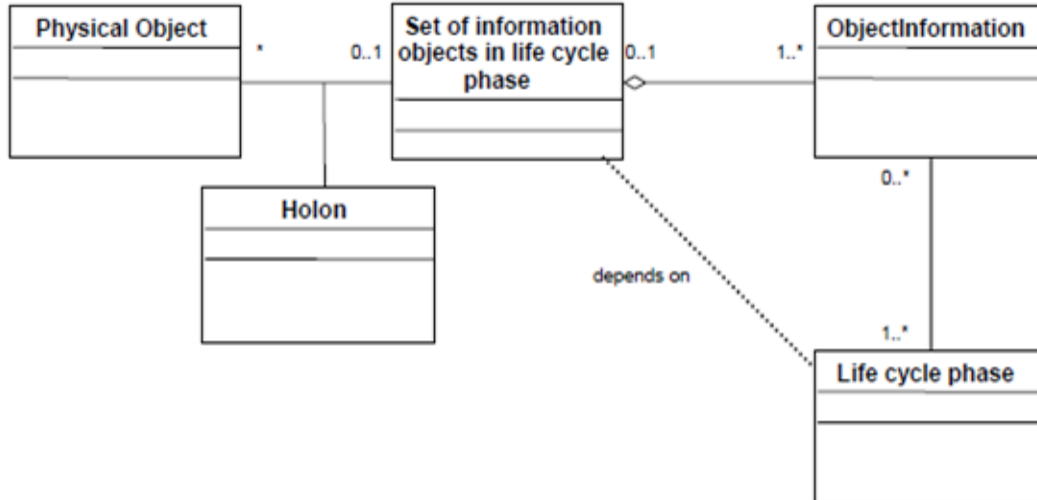
compartments of the enterprise. This approach helps to cover every aspect of product data throughout its lifecycle and supports the different parts in the product and process modeling by using the model hierarchy elements as a reference (Panetto et al., 2006).

Another approach studied to develop product centric traceability information modeling in manufacturing is the paradigm of “product+information” defined as Holonic worldview (Bařna et al., 2005). Seidel (1994) defined Product Holon as an “autonomous and co-operative building block of a system transforming, transporting, storing and/or validating information and physical objects.”

	Holonic Process Model	IEC/ISO 62264
Material Model mapping	Holon	Material subplot
	Holon Flow	Material lot
	Informational Part	Material definition
	Properties	Material lot property and Material lot property definition
Product Definition Model mapping	Process Instance	Product segment
	Equipment	Equipment specification

**Figure 4.** Correspondence between Holonic and IEC/ISO 62264 concepts (Baina, 2007)

The Holon consists of an information processing part and often a physical processing part (Seidel 1994). Together with previously presented product centric data models, the Holon concept was defined in figure below by Gouyon (2004). The model was developed using the object-oriented notation of UML (Unified Modelling Language).



**Figure 5.** Defining Holon (Gouyon, 2004)

In this approach, the Holon represents the connection between the product and its information. If the link between the product and its information is not established, the Holon concept cannot be realized, this results with non-functioning traceability system (Terzi et al., 2005). The connection can be established by using technologies that can collect, store and provide a transparent view of the product centric data throughout its lifecycle, such as barcodes, RFID (radio frequency identification devices) and third party web-based traceability solution providers. According to Baina et al. (2005), to be able to integrate the Holon concept into IEC/ISO 62264, product information will be categorized into two views:

- Genealogical view: this view includes the genealogy of the Holon, which means the product Holon and its stages throughout its life cycle. The object classes defining this view are product definition and product information as defined in the IEC 62264 model hierarchy concept.

- Process view: this view includes the lifecycle stages of the Holon, from the beginning to final stage within the enterprise. This view is covered under the “Product production rules” concept of the IEC/ISO 62264 model hierarchy, particularly the “Product segment” concept, which governs the information in regards to process steps that product, goes through during its lifecycle.

### **Product Life Cycle Management (PLM)**

To be able to create a product centric data model that will carry the product information with the physical product throughout its lifecycle we should be able to define the product lifecycle concept within the frame of product traceability. According to Terzi et al. (2007), the “lifecycle” term includes several phases that product may follows (Terzi et al., 2007).

These are;

1. Product development, which includes designing the product and together with its production environment
2. Product production ; is an complex stage, which includes several sub stages such material requirement planning, production process, quality and safety testing, etc.
3. Product distribution, deals with storage and delivery of the finished product
4. Product use includes all the activities that takes place during the usage of the product, which includes support and maintenance
5. Product dismissing and recycling represents the stage which product is no longer in use, which includes the destroying the product and recycling of the product.

In this paper to enable traceability of the product through its lifecycle, product centric data model will mainly focus on the product production, product distribution and product use

phases of the PLM concept. The proposed model will facilitate the collection of product data through its lifecycle by enabling data retrieval from different and heterogeneous enterprise systems.

## **Traceability Information Integration and Exchange**

### **XML as a Global Traceability Language**

In recent years, XML (Extensible Markup Language) is becoming an increasingly important tool in the exchange of a wide variety of data on the Web and within commerce channels. XML provides a common format for data representation and exchange in Internet-enabled B2B e-commerce. Therefore XML needs no special handling when used with the most widely employed protocols of the Internet. Because of the technical advantages, XML tools are readily available in most platforms and for most programming languages.

The next section will focus on XML's ability to facilitate the sharing of structured data across different information systems. In recent years, many industry groups are using XML to suit their needs, creating industry-specific extensions, namely XML vocabularies and formats to create common platform for data exchange (Gould et al., 2008).

### **XML Schema**

XML Schema is becoming more and more popular in terms of its extensive capability for representing the structure and typing constraints for data embedded in XML documents. According to Kiritsis et al. (2007), XML Schema allows a higher level of expressiveness than the earlier DTD (Document Type Definition) descriptions. A schema is an XML specification that specifies the data structure and its types of the allowable elements of an XML document and the relationships between those elements (W3C, 2009). XML schema

identifies not only the elements and their data types, but also the order they must appear and their attributes. XML schemas allow the information to be broken up and represented as smaller components. Therefore, their usage makes sense in supply chain traceability because all participants in the chain can maintain common glossaries and concepts that can be written once and reused across the whole domain.

As mentioned earlier, XML schemas are being developed to exchange business related data between the value chain partners. For example EDI (Electronic Data Interchange) and SOAP (Simple Object Access Protocol) were developed as an information exchange standard (W3C, 2005).

### **TraceCore XML Standards**

TraceCore XML is developed as part of TraceFood framework. TraceFood is a European Commission funded project which was developed under the fifth and sixth framework programs. TraceCore XML (eXtensible Markup Language) has become a standardized language for the food industry supply chain participants to exchange traceability information electronically using predefined names and references. This includes but is not limited to parameters, standard measurements and values, such as data on identifying numbers, origin, methods and dates of processing, transport and reception, joining and splitting of units, and more. (TraceCore XML Standards Guidelines, 2007)

Basic Principles of TraceCore XML is can be identified as follows;

- To uniquely identify the trade units (TRU, Traceable Resource Units) by creating standardized schemas, that uses standard numbering schemes (GTIN, SSCC, etc.)

- To link all the traceability information keyed to a unique identifier that defines single TRU and its components.
- To identify each steps that TRU goes through, that includes transformations from the origin to final destination of the product.

TraceCore XML ensures that relevant information can be gathered and shared in a standard way through a supply chain for food products. In the near future information about the food we buy will not only be available on the packages, but also on terminals in the shops and via the Internet.

### **Use of GIS Technology for Geo-Traceability**

In recent years technological advancement in the area of geomatics, which can be defined as a discipline of gathering, storing, processing, and delivering geographic information, or spatially referenced information has enabled the acquisition, processing and presentation of the agricultural related geospatial data (GeoTraceAgri (GTA) Final Report, 2005). Specifically, the use of geographic information system (GIS), for spatial information management, allow users to manage, analyze and present spatial information in terms of integrating geographical locations with other spatial entities and other related attributes (ESRI, 2010).

In the context of geographical traceability coupled with GIS, enables assigning unique identification and a geo-identifier to a spatial object (production parcel). This allows to relate and retrieve geo-identifiers with site specific information such as traceability related data (Setten et al., 2006).

### **GIS Based Traceability Studies**

In recent years, there were projects designed and implemented by the European Union for establishing geo-traceability at the farm level. For example, GTIS-CAP (Geo-Traceability Integrated System for Common Agricultural Policy) The purpose of GTIS CAP is to create and implement an integrated information system at farm level that will provide CAP regulatory bodies and primary producers an effective tool for managing and monitoring CAP practices. It can also be used together with other integrated agricultural management systems. The most important aspect of GTIN-CAP project is the aim to define the reference model for geographical traceability based on the Integrated Administrative and Control Systems (IACS) used for managing subsidies allocated to producers as part of the CAP (Setten et al., 2006). The GTIS-CAP project provided a valuable contribution and foundation for the implementation of the GeoTraceAgri project.

The GeoTraceAgri project has enabled the concept of geo traceability to be applied and used by several European countries. Beginning January 1, 2005 the EU commission adopted a new Common Agricultural Policy (CAP). This policy imposes a regulation upon EU Member States to use a single system for registering all agricultural parcels into a GIS based database for geographical references (GeoTraceAgri, Final Report, 2005). The GeoTraceAgri project provided the ground work for the development of indicators and tools for gathering and storing agronomic and geographical data. The following are just a few of the benefits stemming from this geographical traceability project:

- To increase consumers confidence in food supply chain protection

- To provide an effective tool for farmers to document their sustainability claims and increase their market share and profitability
- To Ensure improved risk management at farm level (Oger, 2005)



## References

- Alessio Bechini , Mario G. C. A. Cimino , Francesco Marcelloni , Andrea Tomasi,(2008). “Patterns and technologies for enabling supply chain traceability through collaborative e-business, Information and Software Technology”, v.50 n.4, p.342-359, March, 2008 [doi>10.1016/j.infsof.2007.02.017]
- Art. 3. Regulation (EU) No 178/ 2002 of the European Parliament and the Council of 28 January 2002.
- Bañna.S, H. Panetto and G. Morel, 2005. “A holonic approach for application interoperability in manufacturing systems environment.” In Proc of the 16th IFAC World Congress, Prague, July 4-8, 2005.
- D. Van Setten, R. Oger and M. Debord (2006). “GeoTraceAgri and GTIS-CAP projects: Definition of the geotraceability concept” . Peter Project, York wokshop 2006.
- Derrick, S., & Dillon, M. (2004). A guide to traceability within the fish industry. Copenhagen, Denmark: SIPPO, Eurofish, Humber Institute of Food and Fisheries.
- Dimitris Kiritsis, Van Khai Nguyen, John Stark, (2008). “How closed-loop PLM improves Knowledge Management over the complete product lifecycle and enables the factory of the future”. International Journal of Product Lifecycle Management. Volume 3, Number 1 / 2008. Pages: 54 – 77.
- Dupuy et al. (2005). “Batch dispersion model to optimize traceability in food industry”. Journal of Food Engineering, Special Issue: Operational Research and Food Logistics. v70 i3. 333-339.
- Edgar Chaco´n, Isabel Besembel, Flor Narciso, Jona´s Montilva, Eliezer Colinac (2002). “An integration architecture for the automation of a continuous production complex.” ISA Transactions 41 ~2002! 95–113
- Fransoo, J.C., Rutten, W.G.M.M., 1994. A typology of production control situations in process industries. International Journal of Operations and Production Management 14 (12), 57–72.
- GeoTraceAgri Final Report (2005). “Geotraceabiity: an innovative concept for the qualification of crop production”. Information Society Technologies, <http://www.cordis.lu/ist/>, IST- 2001 – 34281, March 2005.
- Gledhill, J. (2002). “Tracing the line: Using information technology to reduce costs while meeting industry requirements”. Food Processing (March Issue), pp. 48-57.
- Gouyon D., Simão J. M., Alkasssem K., Morel G., 2004, Work in progress for product driven manufacturing automation, 2004, Proceedings of IFAC INCOM Symposium, April 7th-9th, Salvador de Bahia, Brasil.
- GS1 (2009). <http://www.gs1.org/traceability>
- IEC 62264, 2002. IEC FDIS 62264-1:2002. “Enterprisecontrol system integration”, Part 1. Models and terminology, IEC, Geneva.
- ISO/TS 10303: (2004). “STEP modules related to Product Data Management”. Industrial automation systems and integration — Product data representation and exchange, 2004 Geneva.

Jansen-Vullers, M.H., van Dorp, C.A. and Beulens, A.J.M. (2003), "Managing traceability information in manufacture", *International Journal of Information Management*, Vol. 23

Jarke, M., Miatidis, M., Schluter, M., Brandt, S., 2004. "Media-assisted product and process traceability in supply chain engineering". In: *Proceedings of the 37<sup>th</sup> Annual Hawaii International Conference on System Sciences*. 30088.1.

Jill E. Hobbs, (2003). "TRACEABILITY AND COUNTRY OF ORIGIN LABELLING". Presented at the Policy Dispute Information Consortium 9th Agricultural and Food Policy Information Workshop, Montreal, April 25 2003.

Kim, H.M., Fox, M.S. and Gruninger, M. (1995), *Ontology of Quality for Enterprise Modeling*, WET-ICE, Los-Albarnos, CA. Mary, J. and Meixell, M.J. (2006), "Quantifying the value of web services in supplier networks", *Industrial Management & Data Systems*, Vol. 106 No. 3.

M.R. Khabbazi\*, N. Ismail, Md. Yusof Ismail (2009), "Data Modeling of Traceability Information for Manufacturing Control System". 2009 International Conference on Information Management and Engineering

Michael Gould, Laura Diaz, Arturo Beltran, Alejandro Llaves, Carlos Granell (2008). "Multipurpose Metadata Management in gvSIG". *Proceedings of academic track of the 2008 Free and Open Source Software of Geospatial (FOSS4G) Conference incorporating the GISSA*. 29 September – 3 October 2008, Cape Town, South Africa.

Moe, T. (1998), "Perspectives on traceability in food manufacture", *Trends in Food Science and Technology*, Vol. 9, pp. 211-4.

Morel G., H. Panetto, A. Zaremba, G. Mayer, 2004, *Manufacturing enterprise control and management system engineering rationales and open issues*, IFAC Annual Reviews in Control, 27 : 199-209.

Opara, Linus U. 2003. *Traceability in agriculture and food supply chain: a review of basic*  
Panetto H. and Pétin, J.F., 2005. "Metamodelling of production systems process models using UML stereotypes", *International Journal of Internet and Enterprise Management*, 3/2, 155-169 – Inderscience Publisher, ISSN: 1476-1300, 2005.

Panetto H., Baïna, S., Morel G. (2007). Mapping the IEC 62264 models onto the Zachman framework for analysing products information traceability: a case study. *Journal of Intelligent Manufacturing*, Springer Verlag, ISSN 0956-5515, à paraître.

Pape, W.R., B. Jorgenson, D. Larson, and R. Boyle "Is Traceability Too Expensive?" *Food Traceability Report* January 02 (2003): 16-7.

Petter Olsen, Kathryn Anne-Marie Donnelly, Kine Mari Karlsen (2008). "The importance of transformations for traceability – A case study of lamb and lamb products". *Norwegian Institute of Food, Fisheries and Aquaculture Research (Nofima)*, Muninbakken 9-13, Breivika, 9291 Tromsø, Norway.

Public Health Security and Bioterrorism Preparedness and Response Act of 2002.

Regulation (EC) n. 178/2002 of the European Parliament and of the Council of 28 January 2002, ch. Robert Oger, (2005). “The GTIS-CAP Project, geographical origin of food crops and corresponding quality indicators”. *US-EC Workshop on Innovative Technologies for Increasing Food Safety in the Fork-to-Farm Chain Brussels, 24-25 January 2005*

Robin Cover, Editor URI: <http://xml.coverpages.org/stepml.html> ; [robin@oasis-open.org](mailto:robin@oasis-open.org)

Salah Baïna, Hervé Panetto, Khalid Benali (2006). “A PRODUCT ORIENTED MODELLING CONCEPT Holons for systems synchronization and interoperability”. CRAN-UMR 7039, Nancy-University, CNRS

Schwägele, F. (2005). Traceability from a European perspective. *Meat Science*, 71, 164–173.

Seidel D., Mey M. (1994), *IMS – Holonic Manufacturing Systems: systems components of autonomous models and their distributed control – Vol 0*. Also known as *The Book of HMS, TC5 project*

Seidel, D. and Mey, M. 1994, *IMS. “Holonic Manufacturing Systems: Glossary of Terms”*, In Seidel D. and Mey M. (eds), *IMS – Holonic Manufacturing Systems: Strategies Vol. 1*, March, IFW, University of Hannover, Germany.

Sergio Terzi, Jacopo Cassina, Hervé Panetto (2007). “Development of a metamodel to foster interoperability along the product lifecycle traceability.” Politecnico di Milano, Department of Economics, Management and Industrial Engineering, Piazza Leonardo da Vinci, 32, 20133, Milano, Italy.

Sporleder, T.L., & Moss, L.E. (2002). Knowledge management in the global food system: Network embeddedness and social capital. *American Journal of Agricultural Economics*, 84(5), 1345-1352.

Steele, D.C., 1995. A structure for lot-tracing design. *Production and Inventory Management Journal* 36 (2), 53–59.

TRACE. (2007). The EU project “Tracing the origin of food” <[http:// www.trace.eu.org/](http://www.trace.eu.org/)> downloaded 16.10.08 8.59CET. Retrieved 10.20CET 26.10.07. Available from <<http://www.trace.eu.org/>>.

Tracecore (2009). “XML: The Language of Traceability”. [www.tracefood.org](http://www.tracefood.org)

Tursi A., Dassisti M., Panetto H., (2007). “Products information interoperability in manufacturing systems.”. Centre de Recherche en Automatique de Nancy, Nancy-University, CNRS, Nancy

W.R. Pape, B. Jorgenson, R.D. Boyle, J. Pauwels, (2004). “Let’s get animal traceback right the first time”, *Food Traceability Report*, Feb 2004, pp. 14-15.

W3C – (2009) World Wide Web Consortium, <http://www.w3.org/>.

W3C –(2005) World Wide Web Consortium, <http://www.w3.org/>.

## **CHAPTER 2: FOOD TRACEABILITY SYSTEM MODELING AND DATA EXCHANGE**

### **Introduction**

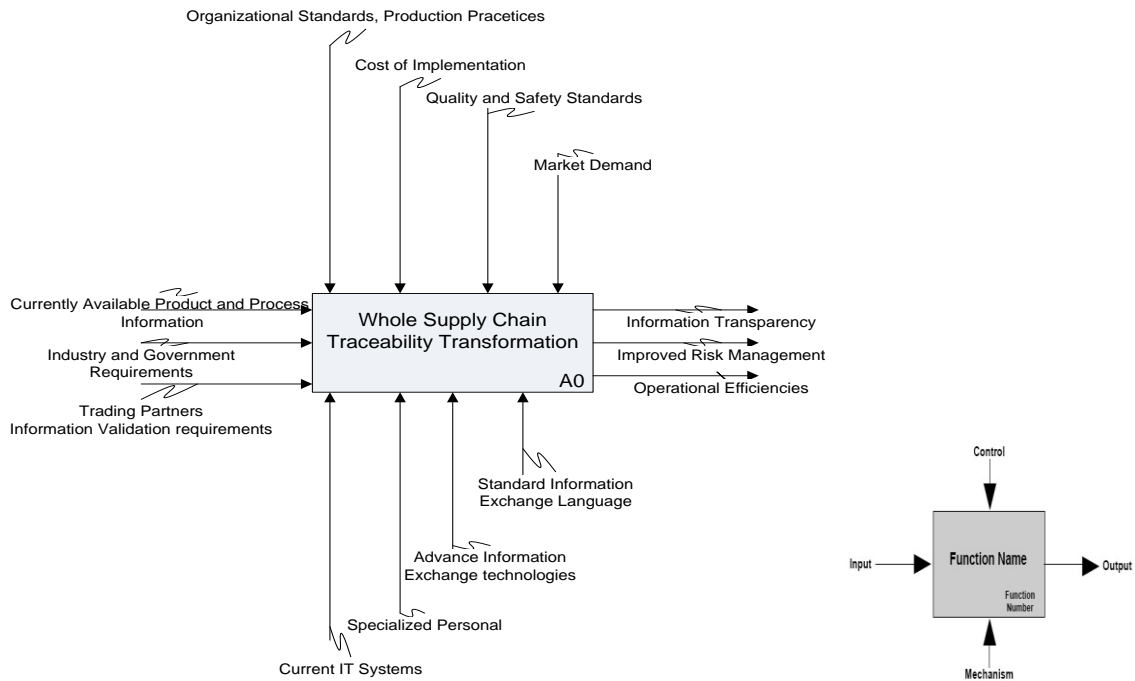
The Traceability Resource Unit (TRU) based production flow control enables the concept of traceability by uniquely identifying the location and the stage of the production process, keeping the record of each stage of the product from farm to its final destination. Therefore, this thesis will outline the tools and methodologies for assessing the TRU identification and transformation. The product centric data model proposes a reference model for collecting and communicating traceability related product data internally and externally (internal/external traceability). Together with relevant technological advancements such as XML (Extensible Markup Language and GIS (Geographic Information System), enable information exchange and traceability system establishment at the farm level is the major focus of this paper. The objective of this paper is to analyze the concept of whole chain electronic traceability from three perspectives

1. Determining the necessary steps for establishing electronic traceability within the enterprise and for the whole chain
2. Determining the appropriate information model for designing electronic chain traceability; a proposed generic information model will be based on defining TRU and its data elements, which will be evaluated within the product centric data modeling concept
3. Current technological advancement such as XML technologies that enables the use of common data exchange platform for whole chain electronic traceability

### **Traceability System Analysis**

From an information management perspective, adaptation of the whole chain electronic traceability system within a supply chain requires all parties involved to consistently engage in the physical flow of materials, which includes the intermediate and finished products and the relative information about them. For every participant has a responsibility to gather, keep and share information in order to enable one up/one down traceability (GS1, 2007). Effective traceability system adaptation requires a holistic supply chain approach, which at best, can be achieved by creating an information chain and easy access to this information by using appropriate technologies. Today there are sophisticated traceability software systems that can enable producers to track a product from the field to the food store, and every step along the way to the end user.

Adaptation to a whole chain traceability concept is a complex issue, which depends on several factors. An IDEF0 model was created to indentify the dynamics of whole chain traceability transformation. The IDEF0 Functional Modeling is a modeling methodology used to model the decisions, actions, and activities of an organization or system (Grover et al., 2000). In this example IDEF0 is used to show the variables' role in whole chain traceability transition.



**Figure 6.** IDEF0 Model is used to demonstrate Whole Supply Chain Traceability Transformation

The input function indicates the existing sources that will be used to transform food industry towards whole chain traceability. As indicated in the model, companies are already using the principles outlined in the current food safety and traceability standards. For example the Bio-Terrorism Act requires for each supply chain participant to keep record of incoming and outgoing shipments of product. Due to the increased demand for production process information—originating mostly from recent food borne outbreaks— food producers and processors need to document and validate they are utilizing safe production practices of the highest quality.

The mechanism defines the variables that are necessary for a successful system transformation such as appropriate technology, qualified personnel, etc. Without those

variables the whole chain electronic traceability concept cannot be realized. For example without an effective traceability software that can create instant access to traceability information, participants must rely on their own information system to record traceability data about each TRU as well as establish links between them. This information is generally kept in different systems, and in the event of a recall this information needs to be retrieved from a variety of systems. This is a time consuming method and has a high susceptibility for data errors. Many recent outbreaks prove that the FDA's ability to fulfill its responsibilities highly depends upon whether it can trace a food product's movement throughout each stage of the food supply chain instantly. Therefore mechanism variables defined in the IDEF0 diagram demonstrates the crucial elements for a successful system transformation.

The control identifies variables, such as standards, regulations, cost or other factors that constrain the activity of a WCET (Whole Chain Electronic Traceability) system transformation throughout the food industry. Finally, output defines the outcome of the successful WCET transformation.

Overall, the objective of establishing whole chain electronic traceability is to provide a platform for ensuring and improving the interoperability between different enterprise systems by:

- Storing all technical product data in-line with product traceability throughout the product's lifecycle (from farm-to-plate)
- Accessing product information for all users independently from the heterogeneous sources and manufacturing operations (e.g. customers, manufacturers, suppliers, retailers, etc)

- Creating an effective lot tracing/tracking system, which identifies the source materials or processes associated with defective lots as well as identifying other lots that may be similarly contaminated by the same processes or materials
- Associating each trade unit with quality/safety assurance systems' control data (e.g. third party audit results, certifications, laboratory test analysis)
- Providing data structure necessary for forward traceability, and also guarantee recording of the product's history for backward traceability

## **Defining the Traceability System**

### **Track and Trace Concept**

For tracing and tracking the material flow process in a manufacturing environment, following data needs to be captured and linked.

- Recording the source of incoming material (*supplier information*)
- Inventory of raw material (*storage location records*)
- Work-In-Process (WIP) tracking (*which machinery is used for processing, and its function*)
- Finished goods (*Storage information, quality control records*)
- Shipment confirmation (*who received the products*)

The first step to successful traceability system implementation is to make a system analysis on the production chain (Figure 8), from the origin of the raw material, through the processing of the product and all the way to the consumers. The Traceability system design will identify three important components:



1. Analyses of current system and production process flow characteristics, such as: data capture of both product and process (lot/batch identification, transformations)
2. System integration: integration with administrative systems, floor systems, and quality assurance systems
3. Analyses of the current information system: what data is already electronically available?  
And, is the equipment for automatic identification and data capturing in place?

Decision Support Tool for Electronic Traceability System Implementation			
	Information Analysis	Traceability GAP Analysis	Implementation Phase
<b>Process Characteristics</b>	<ul style="list-style-type: none"> <li>• Process description and production methodology:               <ul style="list-style-type: none"> <li>-Account base/ item centric production or</li> <li>-Discrete/ continues flow production processing</li> </ul> </li> </ul>	<ul style="list-style-type: none"> <li>• Realise a GAP analysis with regard to process characteristics</li> <li>• Highlight the required changes by using conducted GAP analysis between current production practices to establish optimum processes for traceability</li> </ul>	<ul style="list-style-type: none"> <li>• Apply the necessary changes into current production process, which was identified by GAP analysis</li> <li>• Determine the scope of a pilot project to test the proposed traceability system performance</li> </ul>
<b>Information Infrastructure characteristics</b>	<ul style="list-style-type: none"> <li>• Appropriate information record keeping methods and procedures</li> <li>• Defining an application-independent view of data, which can be validated by users and transformed into a physical database design;</li> </ul>	<ul style="list-style-type: none"> <li>• Analyze existing Production and process traceability data inconsistencies and missing link to fill the identified traceability gaps with collaboration of the current Information system</li> <li>• Determine the amount of information to be transferred</li> <li>• The nature of information to be transferred</li> </ul>	<ul style="list-style-type: none"> <li>• Identify the primary keys for each traceable entity (Trade Units, Batches) that will <b>enable the tracking and tracing</b> along the value chain.</li> <li>• Determine the property information link to each entity that can be added incrementally to allow for a phased implementation of traceability / business objectives and associated applications.</li> </ul>
<b>Analysis of Demand Characteristics</b>	<ul style="list-style-type: none"> <li>• Compliance with Regulations and standards</li> <li>• Compliance with supply chain partners</li> <li>• Customer demand</li> <li>• Increasing Operational efficiencies and transparency</li> <li>• Brand Protection</li> </ul>	<ul style="list-style-type: none"> <li>• Realize a gap analysis of minimum requirements to comply with legislation on traceability and the recall of products</li> <li>• Conduct a gap analysis to determine minimum information required to exchange between parties for effective recall management</li> </ul>	<ul style="list-style-type: none"> <li>• Determine if current setting of the system is matching with your organization's traceability system expectations</li> <li>• Make necessary modifications to obtain maximum results</li> <li>• Test the system effectiveness by conducting mock recalls.</li> </ul>

**Figure 7.** Decision Support Tool for Electronic Traceability System Implementation

### **Process characteristics**

Process characteristics should include machinery and equipment, shop-floor environment, and production process methodologies (figure 8).

- Current documentation that is electronically available such as BOL (Bill Of Lading), BOM (Bill Of Material) invoice, Purchase Order and other forms
- Current Information systems in place, which identifies performance and system information to be recorded

### **Mapping Organizational Data Structure: *where is the data?***

In general, product data and information are dispersed along a variety of information systems. Product data is generated and used in diverse phases of the product's lifecycle, and by many different actors within the supply chain and/or within the same enterprise. Therefore at the planning phase it is important to identify applications used for data management within each enterprise. In most cases, during the manufacturing process traceability information is collected, stored in different ways in different systems. The problem arises when the information needs to be exchanged, or information chain of custody needs to be established that will allow the tracing and tracking of the product through its life cycle phases.

### **Defining Material and Information Flow: identification and linkage**

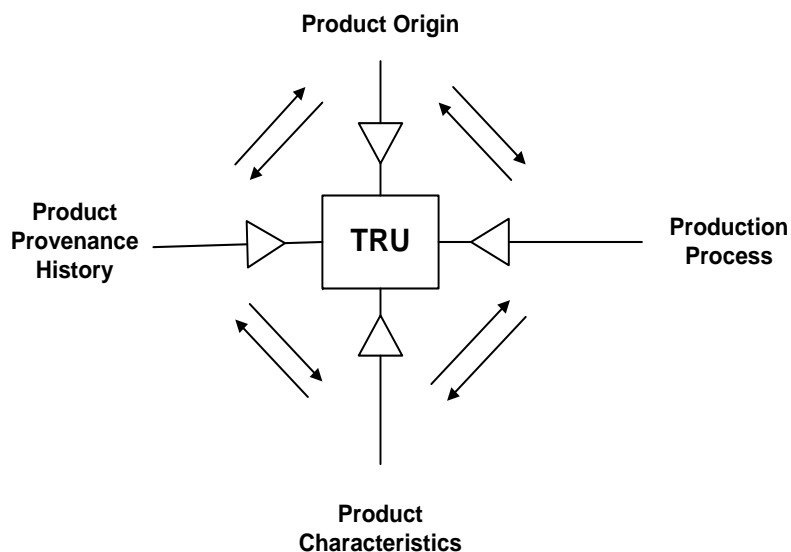
Before implementing any traceability system it is important to identify the characteristics of the each business unit within the enterprise and its supply chain. Using an illustration of the production process flow and the information captured during the process would be a useful reference tool for the next steps. Data captured during each step of production/process flow, which includes the incoming/production/packing/storage and outgoing shipment, needs

to be located and include product source information. Identification of the links between each process step is achieved by using information captured electronically; Identifying primary keys (Unique Ids) for each traceable resource unit (Trade Unit, Batches) that will enable the tracking and tracing along the value chain needs to be established. The following points should be analyze and documented before any new traceability technology adaptation is undertaken.

- Mapping the material/flow throughout its lifecycle (production, process, packaging, distribution)
- Defining traceable units and rules for assigning unique IDs to all traceable entities
- Analyzing current method of batch transformation management
- Identifying the link between traceable units within each stage of the production process
- Identifying the link between the raw materials traceable unit and its supplier (one step back) and between the product's traceable unit and its buyer (one step forward)
- Information handling, the creation and storage of unique IDs and other relevant attributes, such as quality and safety information about the traceable entities (batch, trade units, etc.)
- Determining the methodology for assigning unique IDs to each traceable entity (i.e. label, barcodes, RFID tag etc.)

## Defining and Identifying Traceable Resource Unit (TRU)

TRUs are the uniquely identifiable physical items that are produced and exchanged by the chain members. There are two types of TRU; production batch and trade unit. TraceFood Framework (TraceFood Wiki, 2008) defines a *production batch* as “the traceable unit that raw materials and ingredients go into before they are transformed into products placed in new Trade Units and Logistic Units.” TraceFood defines a *trade unit* as “an item ready for transport and/or storage that needs to be managed through the supply chain, such as incoming shipment/received product or finished product/outgoing shipment, etc.” In practice, a trade unit consists of one or more separate TRUs such as boxed items placed on the pallets.



**Figure 8.** TRU related traceability information

**TRU:** Traceable Resource Unit: Two types of TRU; Batch and Trade Unit

**Product Origin:** It is the location where a product originated

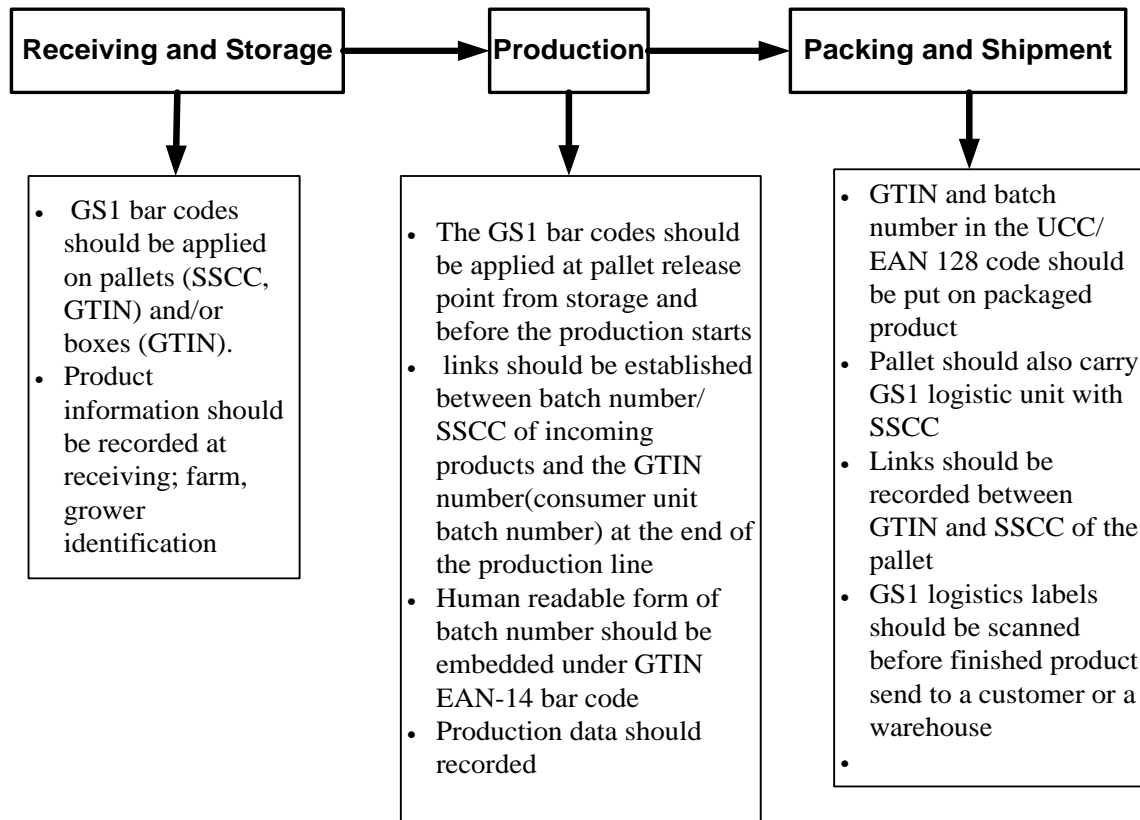
**Product Provenance History:** Process or steps that a product has passed through, from its point of origin

**Product Characteristics:** Product properties, process specifications, quality requirements

**Production Process:** Characteristics of production process, TRU transformation, alteration, mixing or segregation through all stages of production process; includes raw materials, semi-finished and finished TRU

Unique identification of TRUs on a global scale is an important aspect of a successful traceability system implementation. For example, use of the GS1 standards provides more effective supply chain management by providing standardized tools that enables each actor within the chain to communicate in one global language (GS1, 2007). The GS1 numbering system can be used as the primary identification system for Trade Units by creating unique identifications and using these Ids according to GS1 guidelines.

Realization of the effective traceability (as well as the accountability, security and data integrity) requires a common language of information, chain-wide, and even world-wide. Therefore, global standards such as GS1 provide unique, global, generic, and voluntary standards for each participant in the supply chain to alleviate the identification pressures of companies and their products, while enabling information exchange between trading partners (GS1, 2008).



**Figure 9.** GS1 Numbering Schema Implementation

Figure 9 depicts the implementation steps for GS1 standards for a typical food manufacturing process.

- GLN (Global Location Number: identifies all supply chain partners through unique coding
- GTIN (Global Trade Identification Number): allows for the identification of all unique products during the physical product flow throughout the supply chain
- Identification of logistic units using the Serial Shipping Container Code (SSCC)

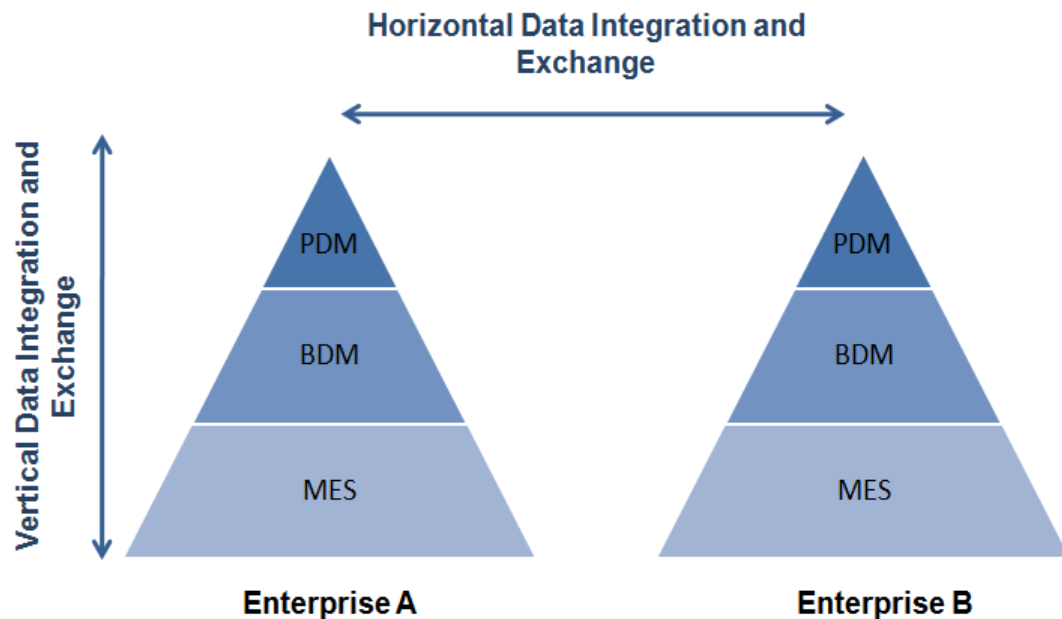
Therefore, the use of GS1's Globally Unique Product Identifier (GUPI) can be a good option to consider as a unique ID schema for product lifecycle data when globally identifying

product information (Yang et al., 2009). Throughout this process collaboration is very important, which includes dialogue between all supply chain participants. Encouraging communication between players and users by enabling standardized electronic interchange of information will lead to a fully integrated information system and harmonization of practices throughout the supply chain.

### **Traceability Information Interoperability and Exchange**

One of the major obstacle facing companies today is the integration of product centric information models across multiple systems to create a single transparent view of the data. This will provide a unified and consistent view of traceability data for the entire enterprise including its value chain partners by enabling solidarity between the physical product flow and its information flow (Baïna et al., 2008). Baina et al. (2008), describes two levels of data interoperability for information exchange;

1. Horizontal Data Integration and Exchange aims to synchronize traceability data that were used in different enterprises, even those managed by different application protocols
2. Vertical Data Integration and Exchange aims to create interoperability between different information systems within a single enterprise. This category of interoperability is to maintain common data integration modeling between the systems



**Figure 10.** Different types of Traceability Data Integration and Exchange Requirements

- (PDM) Product Data Management systems (sales order management, purchasing, logistics, etc.)
- (BDMA) Business data management applications (Enterprise Resource Planning (ERP), Legacy systems, etc.)
- (MES) Manufacturing Execution Systems (Control system for managing and monitoring work-in-process on a factory floor, etc.)

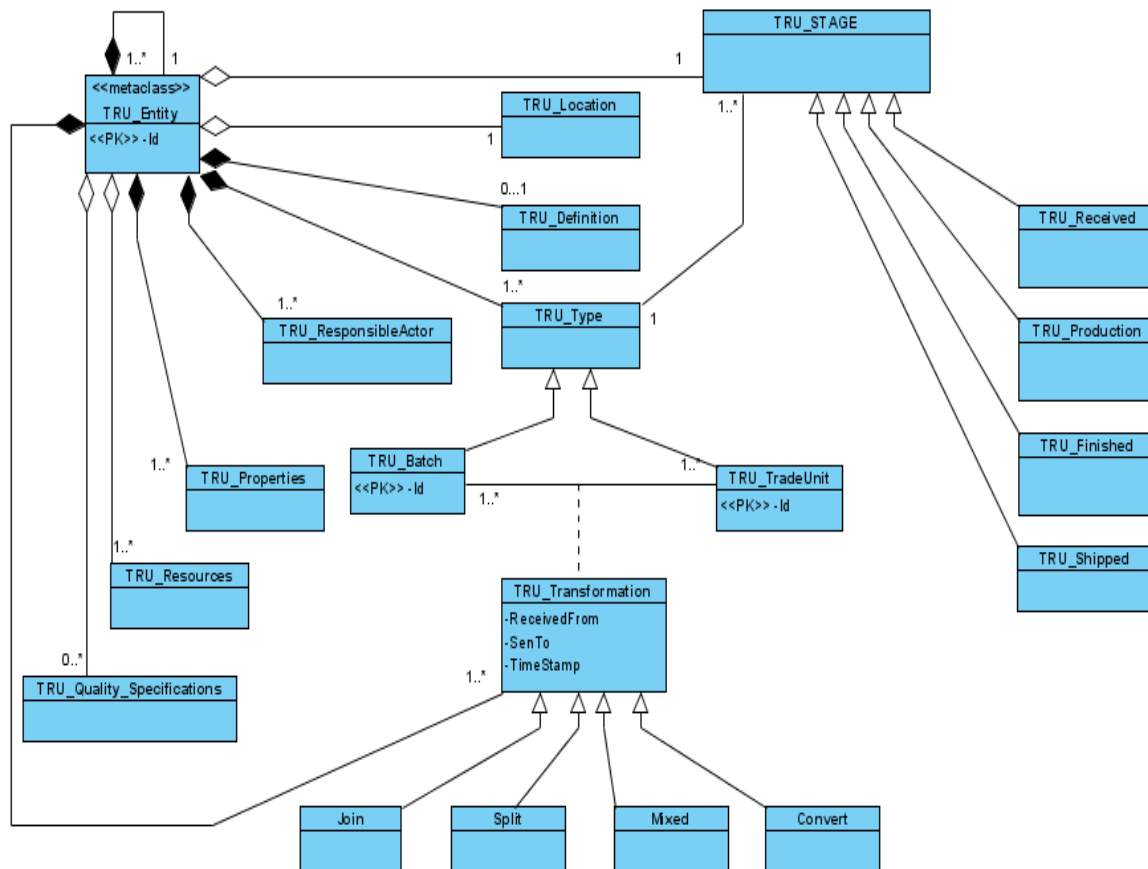
To be able to manage both vertical and horizontal traceability data, there are a few necessary points to consider: the integration and exchange within the enterprise, its value chain and between different information systems are located in a heterogeneous environment, and the use of an appropriate technology and common information exchange language are necessary. It is also important to have the component for effective management of



traceability data within or between enterprises. In order to solve the interoperability problem, each information system based on different application protocols should be able to communicate effectively, which means they must be able to interpret the same data in the same way. To represent product life cycle information such that semantics originating from various life-cycle disciplines can be represented in one information system will be the right approach for solving the traceability information interoperability problem (Rosén, 2006).

### **Product Centric Information Modeling**

The purpose of the proposed solution is to define the product centric information model needed to ensure traceability of the TRU throughout its lifecycle. TRU entity represents the group of information that can summarize all the life of the product; it can follow the product during its lifecycle phases, for example, during its production, or use. The TRU\_Entity class contains general information of the product, such as the identification, class and batch information, a description of the product, its characteristics and the results of possible tests performed. The model principles were derived from the main IT enterprise standards (in particular, ISA/ANSI 95, ISO 10303-STEP, ISO 10303-239- PLCS, PLM XML) (Terzi et al., 2005). From a Traceability point of view, the development of a “product centric” information model will help an enterprise to overcome both vertical and horizontal interoperability problems between different information systems. It will also help to establish a relationship between process, resources and the product itself by cohering information from different Holon to a “product” lifecycle direction. The TRU information modeling describes how to structure traceability information and is the initial abstraction that hides the complexity of the system (Kanellopoulos et al., 2005).



**Figure 11.** UML Product Centric Data Modeling

TRU Information Model for an enterprise can be described as a meta-model, which mainly focuses on defining the information involved for ensuring product traceability, as defined by **TRU\_Entity**. **TRU\_Entity** class is composed of many sub-classes that are needed to achieve information about the product during its lifecycle. Sub-classes of the **TRU\_Entity** are the following:

- **TRU\_Type** describes the “type” of the TRU at its current stage such as **TRU\_Batch** and **TRU\_TradeUnit**
- **TRU\_Properties** class describes the attributes of the product such as description of the product, weight, dimensions, grades, etc.

- TRU\_Quality\_Specifications class represents any quality and safety tests that have been conducted on the product
- Location class identifies TRU by using location and time parameters
- TRU\_Stage is used to identify the phases TRU goes through during its lifecycle. In this case it identifies the internal process of manufacturing. (This class includes Received\_TRU, Process\_TRU, Finished\_TRU and Shipped\_TRU sub classes)
- TRU\_ResponsibleActor always represents the party that is responsible of managing and sharing traceability data
- TRU\_Transformation class defines the stages and the relationship between each TRU. It is the most important class in terms of establishing links between each step through products lifecycle. The model covers four different transformations sub classes; join, split, mix, convert

The proposed model was generic enough to be used for different products. If there is a need for a more specific data model, then the model can be modified to fit a different context. For this to occur an extra XML file needs to be constructed that will describe the additional data elements and their structure, so the valid XML data exchange files can be created. It covers different stages of the lifecycle phases in a way that allows for both vertical and horizontal product data interoperability by only mapping the traceability related product data. The transformation class is specifically included to handle and keep track of previous and further steps of the TRU information. Therefore, it establishes an information chain of custody throughout its lifecycle.

### **Implementation of the Proposed Model**

The proposed UML case diagram can be used as a reference data model for implementing a product centric traceability information system for vertical and horizontal data integration and exchange systems within and between enterprises. To serve this purpose, the model was translated into XML schema to describe the data structure and format for creating interoperability of traceability information between different information systems.

The XML schema, which is a formalization of the constraints expressed as rules or a model of the structure applied to an XML document has been designed to convert the product centric UML data model into XML schema document. Based on this, the specific dynamic data structure can then be defined, and XML files, which will carry the data, can be validated against the schema. For XML to describe and carry the information with the object (product), the TRU\_Entity (Product needs to be traced) needed to be given a unique identification. Unique identification of TRU\_Entity enables responsible actor to retrieve traceability-related information from different remote databases (Karkkainen 2003).

Prior to implementation, several points need to be determined:

- Is the proposed traceability information system to be only used for vertical integration and data exchange, or it will also enable horizontal data integration?
- Does the traceability data need to be delivered frequently (e.g., real time or near real time) or infrequently (e.g., daily, weekly production)?
- Does new traceability information system require any data collection tools or is it capable of utilizing the data which has already kept it in different application protocols within the enterprise?

- Does new system implementation require point-of-entry data cleansing and/or data reformatting to ensure quality and avoid data redundancy?
- Does the system require access to a variety of data sources and transformations to ensure completeness?
- Does the new system require movement of large data volumes or small datasets between applications?

### **Developing XML Document from Product Centric UML Data Model**

The following XML schema was created using AltovaSpy XML Schema Editor. Model elements contain classes that have been described in the UML model above. The TRU is the root element of the schema and the rest of the “child elements” are nested under TRU-root element. The XML schema allows users to create models, which are similar to Object Oriented modeling principles. The schema shown below can be used to exchange information between different application protocols within and between any enterprises. It allows defining the structure and the content of the traceability data needed to be carried along with the physical product, while also allowing the retrieved traceability-related product centric data into traceability databases. This will help to view and access traceability-related information from one single location.

Our TRU\_Entity class was the metaclass for the UML model, here it is represented as a TRU root element. Every time a new TRU was created, the TRU entity needed to be associated with Unique identifier (Id) and the datetime stamp.

#### XML Schema Components:

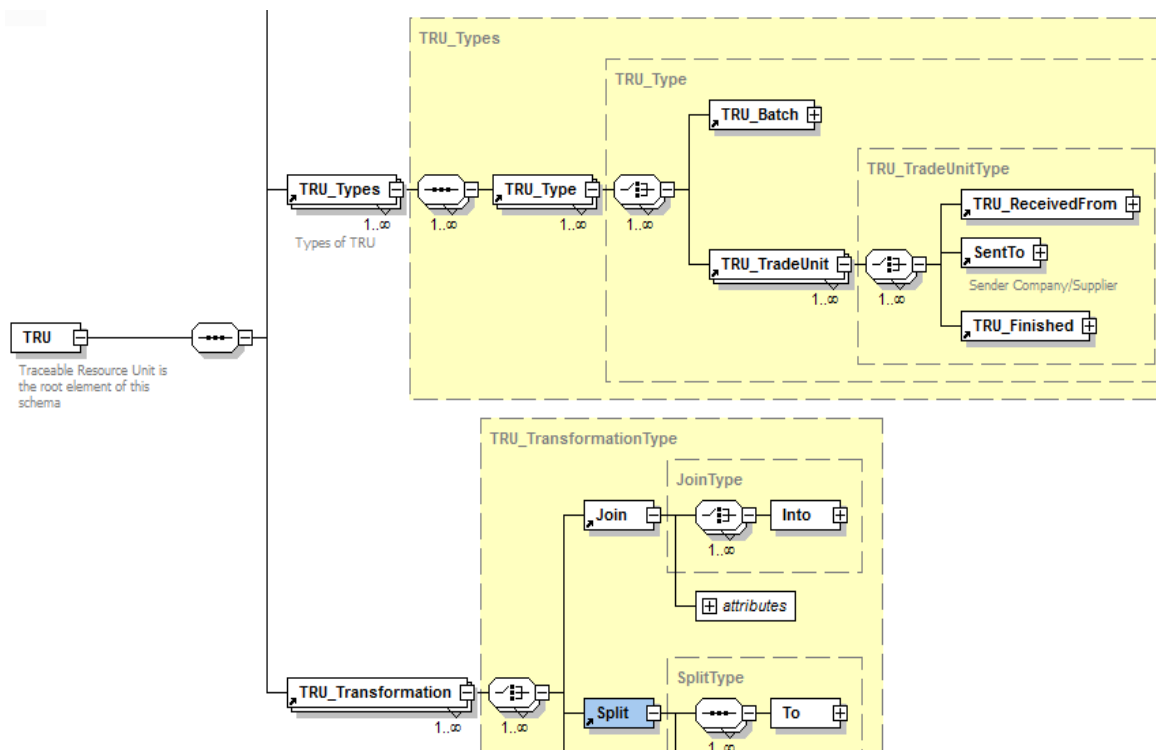
Root Element: TRU (Traceable Resource Unit)

TRU Attributes: Id, Date; Every time new TRU is created, transferred, or transformed Unique Id and the datetime stamp needed to attach to the message that is needed to be exchanged between responsible parties.

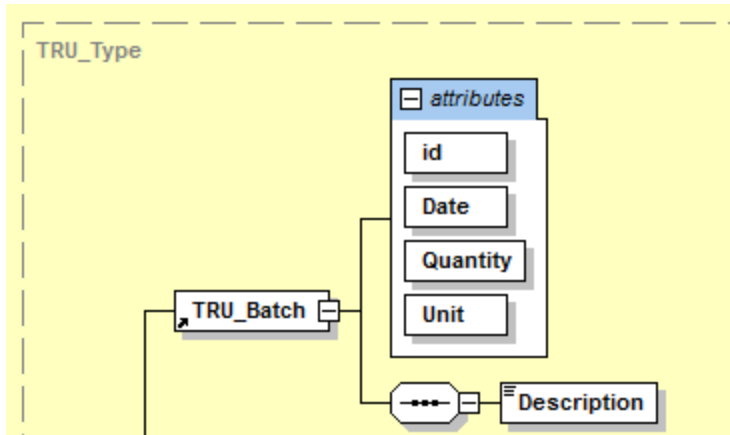
TRU Child Elements: TRU\_Definition, , TRU\_Types, TRU\_Transformations

TRU\_Definition: defines the nature of the TRU

TRU\_Types; Define the type of TRU that are TRU\_Batch and TRU\_TradeUnit, TRU\_Type also contains following child elements:

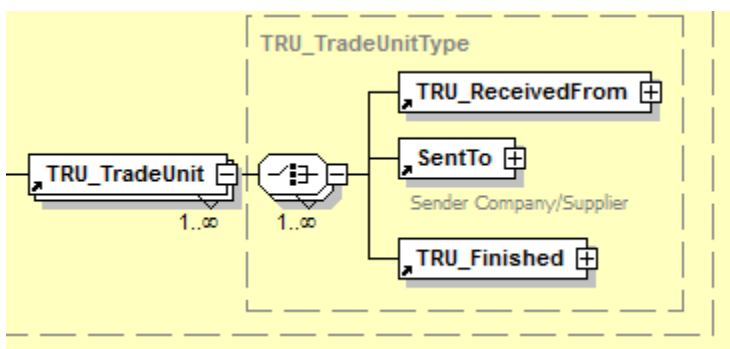


**Figure 12.** Declaring TRU\_Types in XML Schema



**Figure 13.** Declaring TRU\_Batch in XML Schema

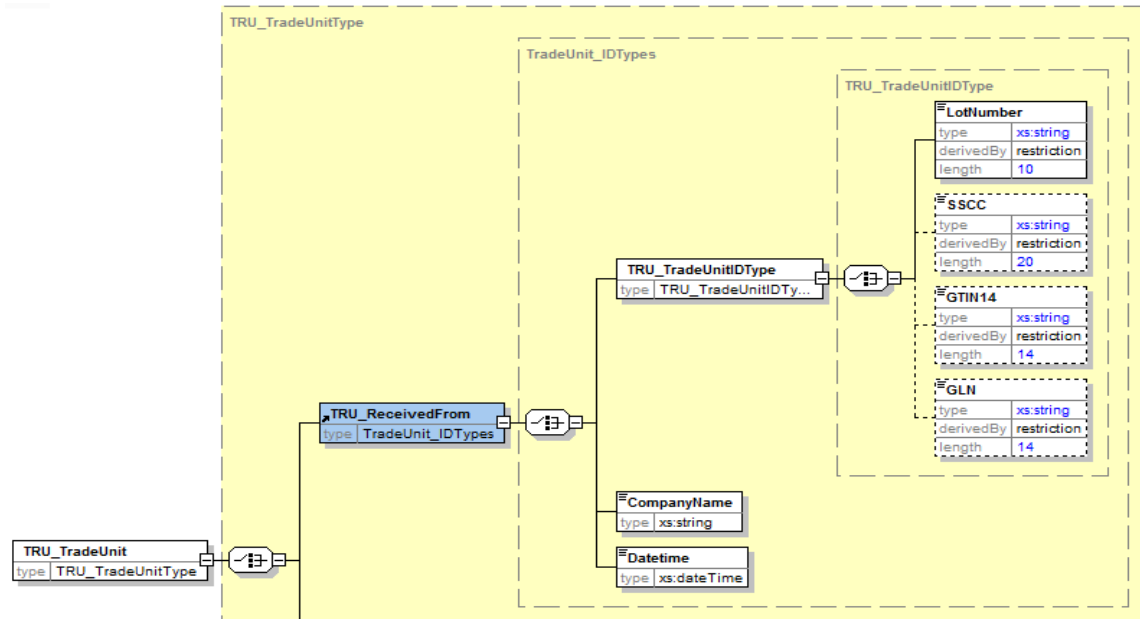
TRU\_Batch was identified by four attributes, which are Id, Date, Quantity and Unit. Description was added as a child element to define the batch activity. These four attributes will allow us to carry the information with the physical product whenever the new production batch is created. Therefore, the uses of these four attributes are required. TRU\_TradeUnitType has three child elements, which means TradeUnit can be in three different forms; these are TRU\_ReceivedFrom, TRU\_Finished and TRU\_SentTo.



**Figure 14.** Type of Trade Units Declaration in XML Schema

Identification schemas for the TradeUnitTypes were also declared under each TradeUnitType in the schema, which contains three child elements, TRU\_TradeUnitIDType,

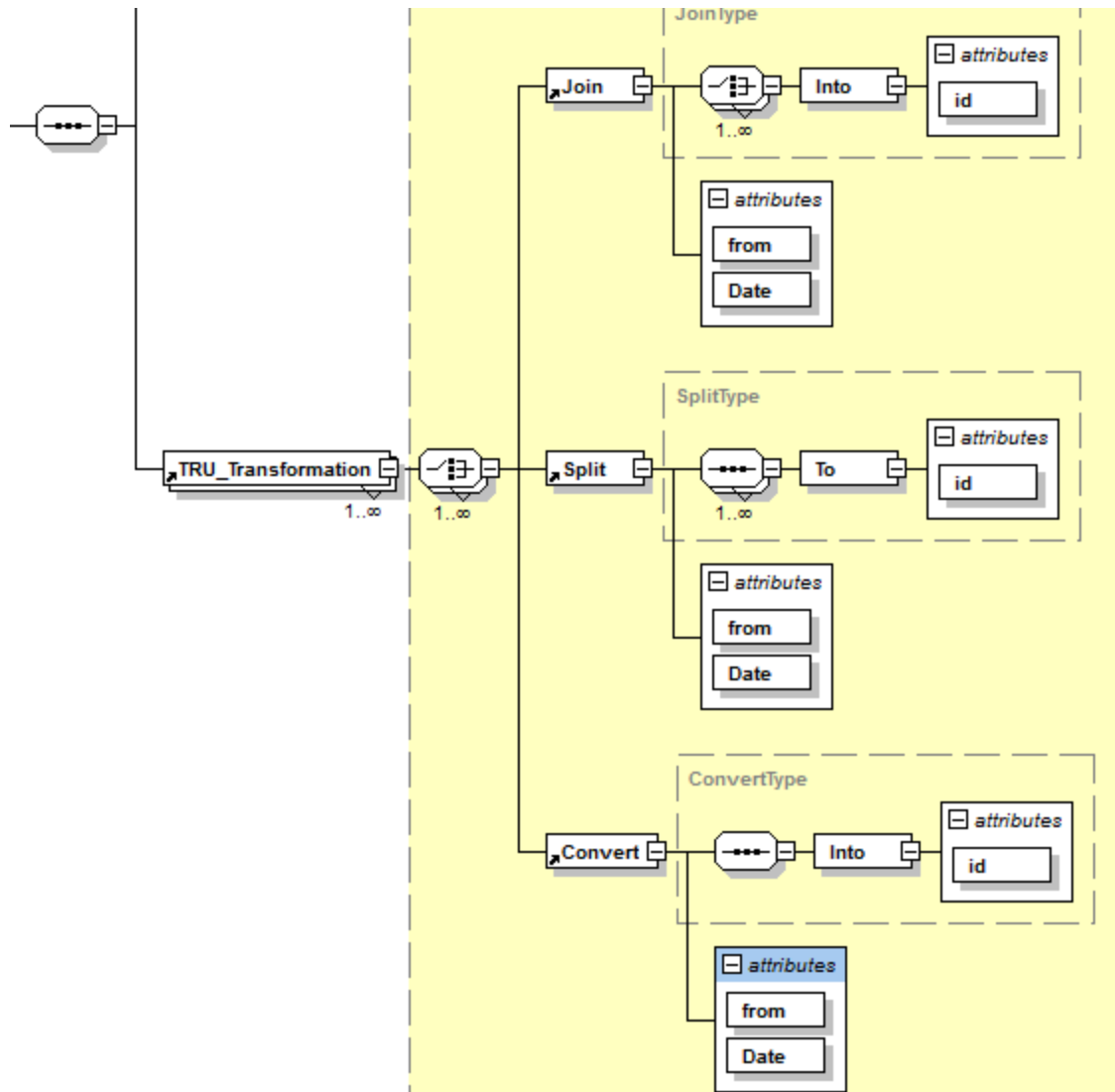
CompanyName and Datetime elements. The most significant part of this declaration is that it allows a trade unit to carry GS1 global identifiers such as GLN, GTIN and SSCC.



**Figure 15.** Assigning Global Unique Identification Schemas to Trade Units

`TradeUnitIDType` global declaration is applicable to other two trade unit types as well. Altova XMLSpy Schema Editor allows us to predefine a type to be used in other common elements such as `TRU_Finished` and `TRU_SentTo` trade unit types. Another child element of `TRU` was described as `TRU_Transformation`. This is the same class which was also described in the UML model as a `TRU_Transformation`.





**Figure 16.** Defining the TRU Transformations

The TRU\_Transformation has its own child element of four types, Join, Mixed, Split and Convert. Transformation is an important class in both UML model and the XML Schema for accomplishing whole chain traceability. In the life of a TRU, it goes through several transformations. When the TRU is created, it can join the other TRU, or mixed with different TRUs. This class enables for the registration of the sub lots/batches, or trade units, which enables to track and trace each TRU from upstream to downstream or vice a versa.

When the product moves and the new TRU is created, movement direction can be indicated in the XML file by using appropriate child elements of TRU\_Transformation\_Types. Next step includes a scenario to demonstrate the use of XML as a data exchange tool between trading partners, which involves three growers and a flour company.

### Scenario

This XML document instance was created to demonstrate how the use of XML enables product traceability information to be exchanged between trade partners while creating links between batches and trade units, so information chain of custody can be maintained throughout the product lifecycle.

First, corn was chosen as a raw material for simplified flour production process to demonstrate internal and external traceability data capturing and linking between chain partners. First party was identified as a Corn Supplier involving three different growers. XML file is created to demonstrate the corn harvesting-transportation to packing station at the farm- mixing the grain which is provided from 3 different Lot at Grower B's farm.

Second, flour company XML file created from the assumption that the raw material was received from three different growers. The file contains operational data that includes single WIP (Work In Progress) line which is run through the day and produce flour for three different customers. Steps include Receiving-Production-Shipment.

### Corn Supplier

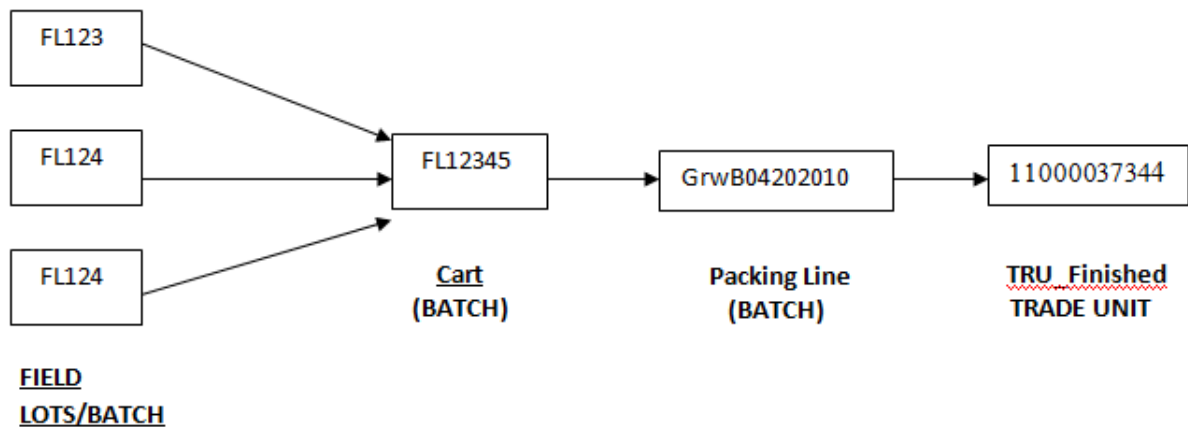
XML file was created to demonstrate the harvest-storage-packing activities on specific date, 11-19-2010. Grower B harvests the corn from three different Lots at the farm on 2010-11-19

Field Lot 1:FL123

Field Lot 2:FL124

Field Lot 3:FL125

Aggregated Order is assigned with new internal “Lot Number: 12345”, which indicates the cart used for carrying the harvested corn to the packing line location. After this step, corn is packed into sacks for final delivery. During this final process, new batch number was assigned as a “Production Batch Number: GrwB04202010” to uniquely identify this step. Before Order leaves the premises, system assigns an external Unique ID, GLN of the farm location to the finished “Trade Unit Number:1100003734465”. This number was included into Bill of Lading along with the DateTime and internal Lot number for traceability purpose. The GTIN also can be used to identify trade units encoded into GS1 128 barcode together with internal Lot number, packing date and commodity description. Barcode can be placed on to each unit for unique identification of TRUs.



**Figure 17.** Corn Supplier Data Model Diagram

<?xml version="1.0" encoding="UTF-8"?>

<!-- edited with XMLSpy v2005 rel. 3 U (<http://www.altova.com>) by Gunsu Altindag -->

```

<TRU xmlns:xsi="http://www.w3.org/2001/XMLSchema-instance"
xsi:noNamespaceSchemaLocation="C:\Users\owner\Desktop\Gunsu_TRU_Schema.xsd">
  <TRU_Definition>Grower B Shipment File for 60 lb Grain to Company
X</TRU_Definition>
  <TRU_Types>
    <TRU_Type>
      <TRU_Batch id="FL123" Date="2010-11-19T00:00:00.00000"
Quantity="10" Unit="">
        <Description>Number 2 Yellow Dent Corn</Description>
      </TRU_Batch>
      <TRU_Batch id="FL124" Date="2010-11-19T00:00:00.00000"
Quantity="20" Unit="lb">
        <Description>Number 2 Yellow Dent Corn</Description>
      </TRU_Batch>
      <TRU_Batch id="FL125" Date="2010-11-19T00:00:00.00000"
Quantity="30" Unit="lb">
        <Description>Number 2 Yellow Dent Corn</Description>
      </TRU_Batch>
      <TRU_Batch id="FL12345" Date="2010-11-19T00:00:00.00000"
Quantity="60" Unit="lb">
        <Description>Number 2 Yellow Dent Corn</Description>
      </TRU_Batch>
      <TRU_TradeUnit>
        <TRU_Finished id="GrwB04202010" Date="2010-11-
19T00:00:00.00000" Description="60lb 3 sack of Number 2 Yellow Dent Corn"
Location="Grower B packing line 1" Quantity="60" Unit="lb"/>
        <SentTo id="1100003734465" Date="2010-11-
19T00:00:00.00000" OrgName="Company X" Quantity="60" Unit="lb"
CustomerAccountNo="ComX20100008" LotNumber="GrwB04202010">
          <Description>60lb 3 sack of Number 2 Yellow Dent
Corn</Description>
          <Address>
            <StreetAddress>220 Old Quarry Rd.
N.</StreetAddress>
            <City>Larkspur</City>
            <State>CA</State>
            <Country>USA</Country>
            <ZipCode>94939</ZipCode>
          </Address>
        </SentTo>
      </TRU_TradeUnit>
    </TRU_Type>
  </TRU_Types>
  <TRU_Transformation>
    <Join from="FL123" Date="2010-11-19T00:00:00.00000">

```

```

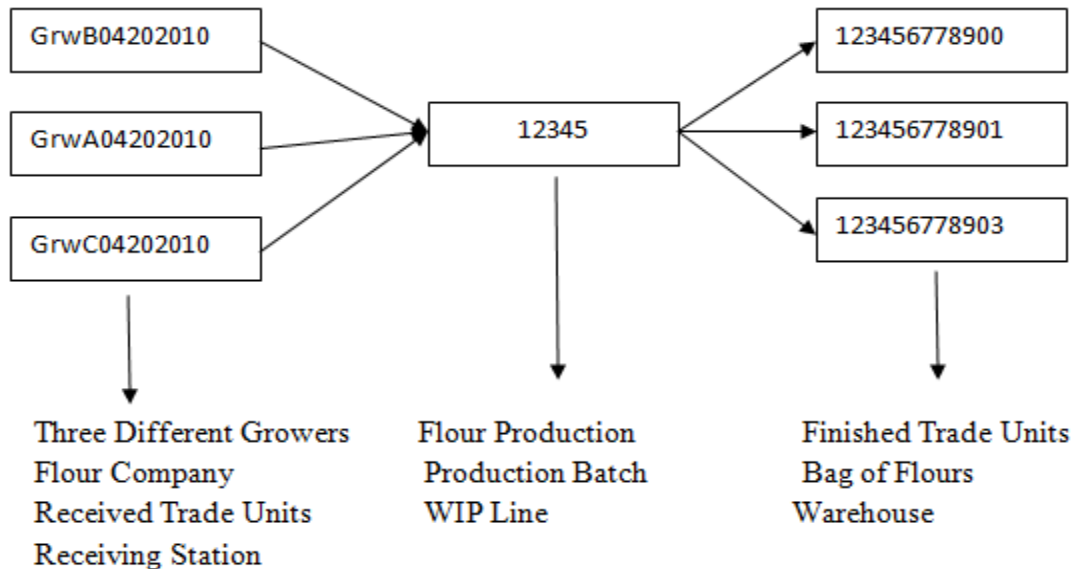
        <Into id="FL12345"/>
    </Join>
    <Join from="FL124" Date="2010-11-19T00:00:00.00000">
        <Into id="FL12345"/>
    </Join>
    <Join from="FL125" Date="2010-11-19T00:00:00.00000">
        <Into id="FL12345"/>
    </Join>
    <Convert from="FL12345" Date="2010-11-19T00:00:00.00000">
        <Into id="GrwB04202010"/>
    </Convert>
    <Convert from="GrwB04202010" Date="2010-11-19T00:00:00.00000">
        <Into id="1100003734465"/>
    </Convert>
</TRU_Transformation>
</TRU>

```

**Figure 18.** Grain Supplier XML File

### Flour Company

XML files was created to demonstrate the Company X's 1 day of process activity, which includes received raw material-processing flour in a WIP (Work In Process) line and shipment of produced trade units to the customers.



**Figure 19.** Flour Company Data Diagram

```

<?xml version="1.0" encoding="UTF-8"?>
<!-- edited with XMLSpy v2005 rel. 3 U (http://www.altova.com) by Gunsu Altindag -->
<TRU xmlns:xsi="http://www.w3.org/2001/XMLSchema-instance"
xsi:noNamespaceSchemaLocation="C:\Users\owner\Desktop\Gunsu_TRU_Schema.xsd">
  <TRU_Definition>Flour Company X's Daily Operational Data Traceability
File</TRU_Definition>
  <TRU_Types>
    <TRU_Type>
      <TRU_TradeUnit>
        <TRU_ReceivedFrom id="1100003734465" Date="2010-11-
19T00:00:00.000000" OrgName="Grower B" Quantity="60" LotNumber="GrwB04202010"
Unit="lb">
          <Description>bag of corn</Description>
        </TRU_ReceivedFrom>
        <TRU_ReceivedFrom id="1100003857466" Date="2010-11-
19T00:00:00.000000" OrgName="Grower A" Quantity="40" LotNumber="GrwA04202010"
Unit="lb">
          <Description>bag of corn</Description>
        </TRU_ReceivedFrom>
        <TRU_ReceivedFrom id="1100003955467" Date="2010-11-
19T00:00:00.000000" OrgName="Grower C" Quantity="100" LotNumber="GrwC04202010"
Unit="lb">
          <Description>pack of corn</Description>
        </TRU_ReceivedFrom>
        <SentTo id="123456778900" Date="2010-11-
19T00:00:00.000000" OrgName="Company A" Quantity="30" Unit="lb"
CustomerAccountNo="ComA20100009" LotNumber="Ln12345">
          <Description>sack of corn</Description>
          <Address>
            <StreetAddress>12 Melody
Dr.</StreetAddress>
            <City>Mill Valley</City>
            <State>CA</State>
            <Country>USA</Country>
            <ZipCode>94941</ZipCode>
          </Address>
        </SentTo>
        <SentTo id="123456778901" Date="2010-11-
19T00:00:00.000000" OrgName="Company B" Quantity="60" Unit="lb"
CustomerAccountNo="ComB20100007" LotNumber="Ln12345">
          <Description>sack of corn</Description>
          <Address>
            <StreetAddress>345 Lincoln
Way</StreetAddress>
            <City>San Francisco</City>

```

```

        <State>CA</State>
        <Country>USA</Country>
        <ZipCode>94108</ZipCode>
    </Address>
</SentTo>
    <SentTo id="123456778903" Date="2010-11-
19T00:00:00.000000" OrgName="Company C" Quantity="110" Unit="lb"
CustomerAccountNo="ComC20100006" LotNumber="Ln12345">
    <Description>sack of corn</Description>
    <Address>
        <StreetAddress>234 Addison
Rd.</StreetAddress>
        <City>Salinas</City>
        <State>CA</State>
        <Country>USA</Country>
        <ZipCode>93912</ZipCode>
    </Address>
    </SentTo>
</TRU_TradeUnit>
    <TRU_Batch id="Ln12345" Date="2010-11-19T00:00:00.000000"
Quantity="200" Unit="lb">
        <Description>Corn Flour Production</Description>
    </TRU_Batch>
</TRU_Type>
</TRU_Types>
<TRU_Transformation>
    <Join from="1100003734465" Date="2010-11-19T00:00:00.000000">
        <Into id="Ln12345"/>
    </Join>
    <Join from="1100003857466" Date="2010-11-19T00:00:00.000000">
        <Into id="Ln12345"/>
    </Join>
    <Join from="1100003955467" Date="2010-11-19T00:00:00.000000">
        <Into id="Ln12345"/>
    </Join>
    <Split from="Ln12345" Date="2010-11-19T00:00:00.000000">
        <To id="123456778900"/>
    </Split>
    <Split from="Ln12345" Date="2010-11-19T00:00:00.000000">
        <To id="123456778901"/>
    </Split>
    <Split from="Ln12345" Date="2010-11-19T00:00:00.000000">
        <To id="123456778903"/>
    </Split>
</TRU_Transformation>

```

</TRU>

**Figure 20.** Flour Company XML File

As indicated earlier the purpose of this model is to demonstrate the use of XML to enable traceability information exchange between supply chain parties. Therefore additional desired elements and attributes can be included in the XML files such as quality, commodity specifications, grade, etc.

To be able to effectively use the XML, appropriate solution architecture needed to be implemented. One of the most recognized and accepted solution architecture, which is achieving widespread acceptance within the food industry, is the use of distributed solution architecture. This enables traceability information to be exchanged between different databases and establish links between these databases along the supply chain. It will also enable chain participants to keep the integrity of their data by allowing them ownership of their traceability data. Further discussion about distributed system architectures is not covered by this paper.

**Conclusions**

In this paper, I have proposed a generic product centric data model for food industry that will enable traceability information to be exchanged, shared along the value chain. I have identified the basic classes of the model and the relationships used to represent the dynamic behavior of product as a Traceable Resource Unit (TRU) along the food supply chain. The traceability Information that is carried along with the product with respect to its lifecycle, has to be structured and exchanged in a common formal model and language such



as XML. The proposed model was developed using several product centric data modeling concept and standards such as Holon, PLM, IEC 62264 and ISO/TS 10303.

The future research will continue improving the concepts coming from existing product centric data modeling standards in order to insure the full traceability of product lifecycle.

## References

- C.A. van Dorp, [Kees-Jan.vanDorp@wur.nl](mailto:Kees-Jan.vanDorp@wur.nl), Traceability application based on Gozinto graphs, Information Technology Group, Universiteit Wageningen (NL) Institute for Knowledge and Agent Technology (IKAT), Universiteit Maastricht (NL), 5-9 July 2003, Efita Conference, technological implications, and future prospects. *Food, Agriculture & Environment* Vol. 1(1):101-106.
- Dorp, C.A. van (2002a). "Induction of a reference data model for tracking and tracing". Proceedings of the 8<sup>th</sup> Americas Conference on Information Systems (AMCIS 2002), (Ed.) R. Ramsower, J. Windsor and J.I. DeGross, Association for Information Systems, August 9-11, Dallas, Texas, USA.
- E Vlist. (2002). "XML Schema". O'Reilly & Associates, Inc.
- ebXML official website – <http://www.ebxml.org>.
- F 54506 Vandoeuvre les Nancy, France, [salah.baina@cran.uhp-nancy.fr](mailto:salah.baina@cran.uhp-nancy.fr), [herve.panetto@cran.uhp-nancy.fr](mailto:herve.panetto@cran.uhp-nancy.fr), [benali@loria.fr](mailto:benali@loria.fr). For product data exchange and integration". *Computer-Aided Design* 33 (2001)
- ISO/TS 10303: (2004). "STEP modules related to Product Data Management". Industrial automation systems and integration — Product data representation and exchange, 2004 Geneva.
- Jonas Rosén (2006). "Federated Through-Life Support, Enabling Online Integration of Systems within the PLM Domain." 1st Nordic Conference on Product Lifecycle Management - NordPLM'06, Göteborg, January 25-26 2006.
- M. Cimino, B. Lazzerini, F. Marcelloni, A. Tomasi, "Cerere: an information system supporting traceability in the food supply chain", *Seventh IEEE International Conference on Vol. , Issue , 19 July 2005* Page(s): 90 - 98
- Mc Farlane, D and Bussmann, S. (2000.) "Developments in holonic production planning and control", *International Journal of Production Planning and Control*, Vol. 11, N° 6, pp. 522-536.
- Pramatari, K.C., Doukidis, G.I. and Kourouthanassis, P. (2005), "Towards 'smarter' supply and demand-chain collaboration practices enabled by RFID technology", in Vervest, P.,
- Salah Baïna , Hervé Panetto , Khalid Benali , Gérard Morel (2005). "Adapting HPM to B2M interoperability issues: Towards Interoperability between Business Management
- Sebastian C. Brandt, Jan Morbach, Michalis Miatidis , Manfred Theißen , Matthias Jarke , Wolfgang Marquardt (2007). "An ontology-based approach to knowledge management in design processes". *Computers and Chemical Engineering* 32 (2008) 320–342
- .SOAP Specifications, <http://www.w3.org/TR/soap/>; 2005.
- STEPml—STEP markup Language, <http://www.stepml.org/>; 2005
- UML. 2005. "Unified Modeling Language, UML2 OCL specification", document ptc/05-06-06, OMG.V.

Varun Grover, William J. Kettinger (2000). "*Process Think: Winning Perspectives for Business Change in the Information Age*".

W.C. Burkett, (2001). "Product data markup language: a new paradigm"

Xiaoyu Yang, Philip Moore, Seng Kwong Chong (2009). "Intelligent products: From lifecycle data acquisition to enabling product-related services." *Computers in Industry* 60 (2009) 184–194

## **CHAPTER 4: GIS BASED FARM TRACEABILITY SPATIAL DATABASE MODEL FOR IP GRAIN**

### **Introduction**

Drastic increase of food –borne diseases in the past decade such as mad cow disease, E. coli, Salmonella, etc and the current fear over the possible epidemic of avian flu, and bioterrorism is created public demand for tighter security measures on the entire food production chain. Therefore, the determination of the origin of food products is a vital for successful food traceability systems. The effective traceability requires a close documentation of all activities beginning with farm to final consumers. So far, there is no well established field based Management Information System (MIS) for monitoring the agricultural practices, which includes the production processes, visualization of the field activities, transportation; both inbound and outbound, storage activities, etc.

To be able to achieve this goal, it is important to determine appropriate indicators for each farmland that is necessary for capturing minimum amount of information necessary to establish effective geo-traceability systems that enable users to locate, obtain, and evaluate precisely the origin and other qualities of agricultural products. The biggest advantage of this kind of system is that the geographical location is objective and verifiable, and can be linked to geographical co-ordinates to all pertinent traceability information. It is also possible to view the information on the Internet using secure geo-portals that can be developed for specifically for this purpose.

## **Statement of the Problem**

Discussions revolving around U.S. industrial agriculture are often concerned with farming methods and technologies, which include but are not limited to chemical inputs and subsequent environmental degradation, as well as the larger socio-environmental factors of how industrial agriculture has impact on global populations (Lyson 2004; Frewer et al. 2004). Industrial agriculture and its technologies have expanded since the end of the Second World War. As farm technologies' reach and support increased over time so too have complementary technologies for farm accountability and efficiency such as precision farming technologies, i.e., Geographic Positioning System (GPS) (Wolf and Buttel 1998). These technologies have been able to reduce the amount of input applications for farmers, which help to save time and money. Likewise, precision farming has been able to decrease the amount of waste flowing into ground and surface water systems, therefore reducing external negative impacts of industrial agriculture. However, what precision farming is unable to account for thus far is the tracing of agricultural products, specifically grain along the food chain. If we consider the grains harvested in the Midwest, they are shipped to local grain elevators, mixed with other farmers' grains and then shipped and processed at other locations. Oftentimes the final destinations for grains are foreign markets where grains are used for food supplies, for both animal and human consumption as well as for seed.

In recent years food security has become an issue here in the states (Golan et al. 2004). For much of the rest of the world food security is of high concern, especially in regard to genetically engineered foods grown and entering their borders (Frewer et al. 2004; Pyle 2005). GMOs, E. coli, BSE ("mad cow" disease), petro-chemicals, and a plethora of other

possibilities for food contamination are increasing the likelihood of trade barriers to go up around the world. Countries of Africa, China, and a number in the E.U. have already denied entry of many U.S. commodities, including grains and meat (Pyle 2005).

GIS is a technology able to complement and enhance not only farmers wishing to increase accountability for their products, but has the potential to increase marketability as well for U.S. and other global commodities in the world market. For consumers, the ability for GIS traceability to account for the food chain they utilize offers a piece of mind, much like label of origin; an understanding from whom or where their food was sourced, and what factors influenced the integrity of their food (Thorpe and Robinson 2004). The main problem and pertinent question at this point is how can GMO crops be traced in order that the industrial food chain can become more transparent for reflexive consumerism and activism, while allowing farmers to be more accountable in their operations?

Today extensive research is underway to establish farm traceability utilizing GIS, which includes the option for tracing GMO crops. Based on the rising popularity of GIS technology (Steinberg and Steinberg 2006; Chang 2006), it can be safely assumed GIS will further benefit the traceability and therefore the social empowerment of both farmer and consumer in the future.

### **Grain Supply Chain Trends in United States**

The grain supply chain in the United States is established to handle large flows of products that are identified in a limited variety or attributes and then commingled or processed to meet the quality and safety requirements of the current market. Most of the time blending starts as soon as farmers deliver their crops to the elevator and it continues until the

product is packaged; this may include processing and manufacturing of the product. This transformation of the grain throughout the chain requires redefining the quality and safety standards at each step until it reaches the consumers. To achieve this goal, appropriate traceability system establishment starting from farm level must be accomplished.

In recent years Identity Preservation (IP) has gained substantial market share. As IP markets expand and their production practices become more widespread, it is likely that the grain commodity system itself would be altered by placing greater emphasis on quality (facilitated by better measurement technologies). The current grading system, which relies primarily on tests for visual traits such as cleanliness or damage, may be expanded to recognize intrinsic quality of grains and oilseeds. There are several occasions that testing is not feasible (as for credence attributes), therefore auditing, certification, and traceability systems may be needed (Dunahay, 1999). For example, organic crops rely exclusively on certification for ensuring product integrity. Organic producers are certified for observing production protocols that cover pesticides, fertilizers, cropping histories, and biotechnology. Their farms and fields are subject to inspection by certifying agencies, which are private businesses and government agencies accredited by the USDA National Organic Program (Greene and Kremen, 2003).

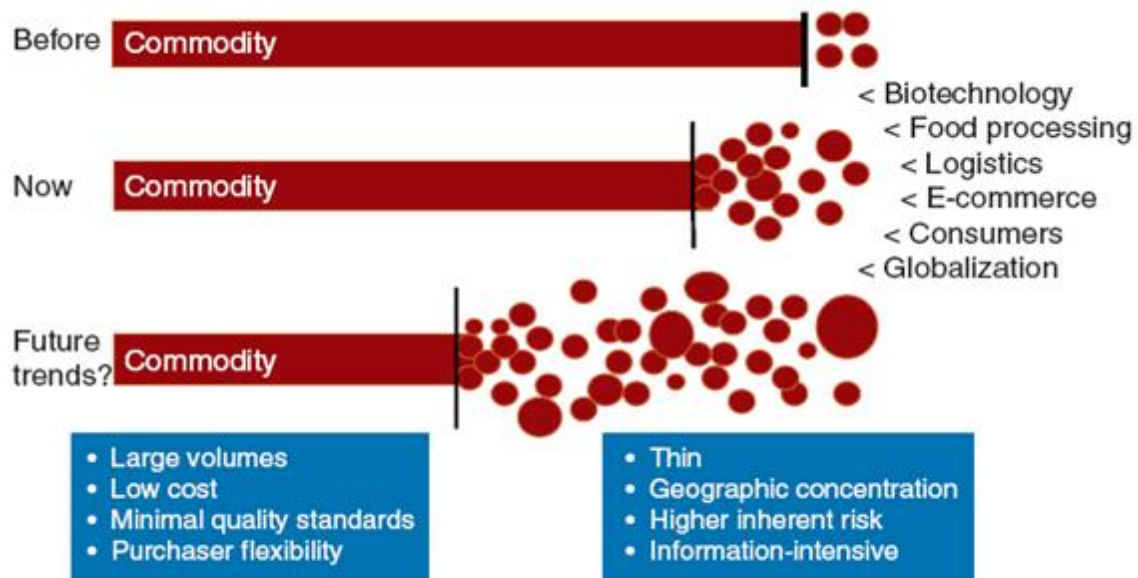
Recently, consumer and processor demand for specialty grains, including products not genetically engineered, has introduced the need to differentiate product over a new set of quality characteristics. In a few cases, these new quality demands are accompanied by demands for traceability systems to track back to the farm. The elevator also plays an important role in quality control point for the grain supply chain. Current elevator quality and

safety control systems don't have certain procedures to address the issue of preserving the identity of the grain and any methodology to enable one step up and one step down traceability. But they control and monitor grain quality and maintain records about the product from farms to the elevators. Depending upon the intent of the system, labeling may or may not be included. For value-added products, such as certified seeds, labeling may be advantageous. In other cases, labeling is not desired or necessary, as when undesired components are maintained below established threshold levels via the certification or traceability system.

### **Identity Preserved (IP) Grain**

Identity Preserved (IP) a grain crop means that crop is grown and handled under controlled conditions and delivered for specific use. Producers who have IP grain must follow strict handling and production practices required for quantity and uniformity. IP grain in general refers to specialty production, segregation, and identification of food grade crop varieties through specialty marketing channels so the end user of the product is assured that the specific variety is pure and meets minimum quality standards.





**Figure 21.** Grain differentiation trends and grain market characteristics in US  
(The Changing Face of the U.S. Grain System / ERR-35 Economic Research Service/USDA)

In recent years, U.S. grain system is undergoing increased product differentiation and market segmentation. Figure above shows underlying factors and number of forces including biotechnology, industrial processing innovations, logistical advances, information and measurement technologies, and consumer preferences that have created more opportunities for IP products and for the development of products with specific traits as farmers sought to diversify outside the commodity system.

IP grains require more coordination and communication between growers and handlers or processors and more sharing of information. This stems from the trait specific quality attributes of IP grains. Throughout the supply chain, information must be shared about raw materials, key ingredients, and production/manufacturing processes. Assurance of product quality and authentication of process/product claims is often required. Farm product suppliers

(for example, seed producers) must demonstrate that product attributes are verifiable and show supporting documentation (Good et al. 2001)

Production requirements for IP crops differs from simply using a specific variety to specialized production methods such as organic crops, from preventing against GM contamination (non-GM crop) to crops that require an elaborate set of safeguards and confinement practices (pharmaceutical and industrial crops). Therefore, farms and fields are subject to inspection by certifying agencies, which are private businesses and government agencies accredited by the USDA National Organic Program (Greene and Kremen et al., 2003). For identity verification, it is important to include process steps to review and record details of delivered loads and supporting certification, and costs to validate claims about IP (Maltsbarger and Kalaitzandonakes, 2000). IP costs are also affected by whether verification claims are required. Testing or documentation requirements are particularly important for crops marketed as non-GM, which require additional steps to avoid accidental commingling on the farm. In practice, this means growing border fields and staggering harvests to avoid pollen drift and contamination from non-GM fields (Elbehri, 2007)

### **Grainsafe Program**

Grainsafe is a quality assurance program at farm level that was mainly developed to assist value-added grain producers, handlers and processors to provide assurance about the quality of the grain to buyers and end users. (Kaynak) The principle of the program is based on HACCP and ISO 9000:2001 quality/safety management and traceability systems to provide required documentation, monitoring and improvement for the current production practices. It

also aims to help primary producers to comply with national and international regulations with respect to food safety and traceability.

The Grainsafe program is heavily rely on detailed record keeping about the grain production handling practices, focusing on production of non-GMO (non-genetically modified food corn. However, it can be modified any IP grain or oilseed crop that has to carry certain characteristic such as sugar or protein content from seed to delivery. Its scope starts from field selection and goes to the first point of sale. It is strict record keeping requirements allow third party or customer audits regards to quality or safety.

As it is mentioned above Grainsafe Program was established according to HACCP (Hazard Analysis and Critical Control Points) principles described by the Codex Alimentarius Commission (CAC).CAC was created in 1963 by FAO and WHO to develop food standards, guidelines and related texts such as codes of practice under the Joint FAO/WHO Food Standards Program. The main objective of the CAC is to protect health of the consumers by enhancing safety, ensuring fair trade practices in the food trade, and promoting coordination of all food standards work undertaken by international governmental and non-governmental organizations (Codex Alimentarius, 2008).

HACCP is a food safety management program that is scientifically design to identify the hazards that are likely to occur during production process and prevent them from happening (Mortimore and Wallace, 2001). Prior to adopting any HACCP systems, organizations should already have prerequisite programs (PRP) in place. The PRP are not part of the HACCP system, but are necessary for any effective HACCP system implementation (Surak, 2002).

For the food industry there are two PRP have been established; Good Hygiene Practices (GHP) and Good Manufacturing Practices (GMP).

The Good Agricultural Practices (GAP) have also been established as the complementary PRP for HACCP systems (Maier, 2003). The Food and Agriculture Organization (FAO) of the United Nations (UN) defines GAP as the “recommendations and available knowledge to addressing environmental, economic and social sustainability for in-farm production and post-production processes resulting in safe and healthy food and non-food agricultural products” (FAO, 2005).

For the Successful implementation of a HACCP plan relies on completing several preliminary steps. These steps involve establishment of a HACCP team, clear description of a product and its use and constructing process flow diagram of the production process (CAC, 2001). According to Grainsafe Programs Hazards that are likely to occur during production process were identified as follows;

#### 1. Field Selection

If any Neighboring field contains GMO corn, through pollen drift that result with genetic contamination in the selected field. Also previous crop residues on the field may cause same type of contamination.

#### 2. Seed Selection

Seed that are carries genetic impurities may result with contamination of corn seeds.

#### 3. Planting

Residues of other crops or foreign material in the planter may cause contamination

#### 4. Harvest

Residues of other crops in the combine hopper and other internal parts of the combine may result with GMO contamination of harvested crop.

#### 5. Inbound Transfer

Residues of other crops or foreign material in the cart, truck, wagons etc. which used to transfer grain from the field may result with GMO contamination.

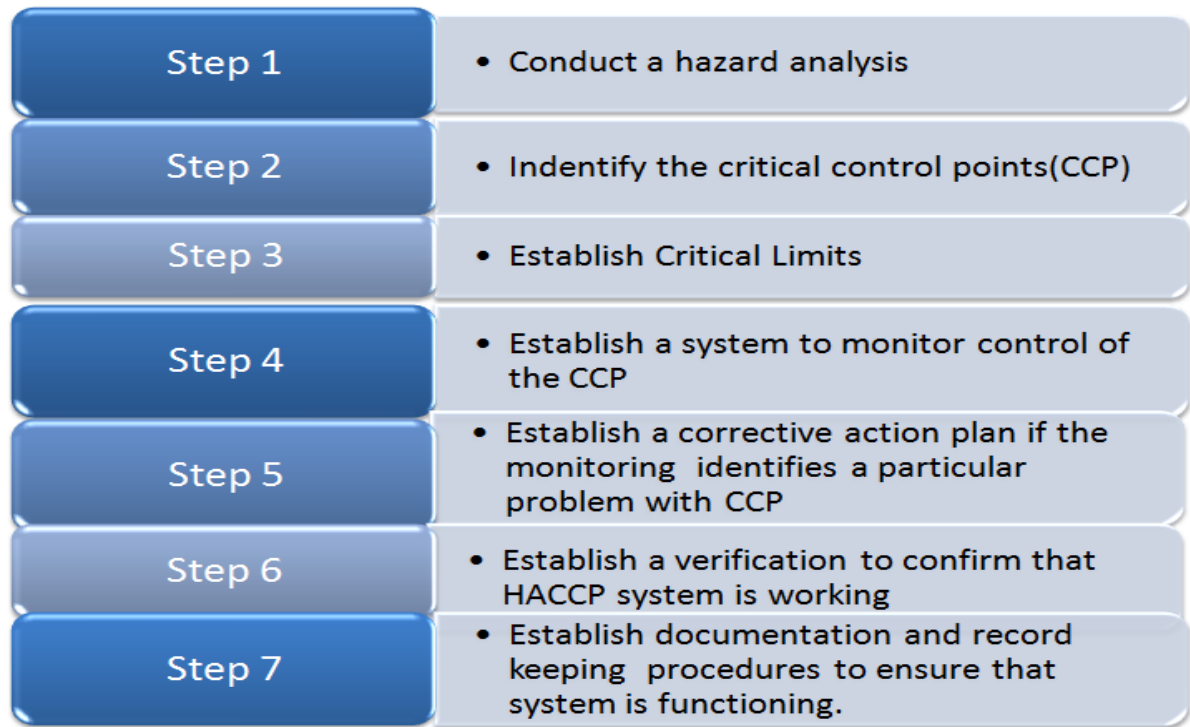
#### 6. Storage

Residues of other crops or foreign material in the storage areas such as bins or other storage structures may result with GMO contamination.

#### 7. Outbound Transportation

Residues of other crops or foreign material in the vehicle, which is used for shipping grain from farm to next point may caused GMO contamination. Therefore, it is critical to obtain information about each production steps to prevent any contamination from happening.

The figure below identifies the HACCP principles described by CAC which was taken as foundation principles in development of Grainsafe program as follows (CAC, 2001)



**Figure 22.** Identification of each step during HACCP implementation process

### Research Objectives

The main objective of this project is to development of crop management monitoring system that will help farm land to as part of the Traceability Information System required for ensuring agronomic and ethical standards in crop production and supply to the markets. It is becoming increasingly important in ‘geo-tracking’ food and feed production chains, especially for sensitive cases such as non-GMO crop, organic farming and /or where the certification of foods from designated geographical origin of produce is in question. Other issues such as food born diseases and bioterrorism treat are also the main factors that traceability becomes a viable issue in food sector. To be able to improve the traceability of food products, it is inevitable to establish corresponding traceability systems to monitor the IP (Identity Preserved) crop products in US.

The Geo- traceability Information System requires digital mapping and GIS-driven database development, which requires aggregated digital plot maps of the farms, agronomic and observation of GAP (Good Agricultural Practices) for food safety monitoring (Faalong et al., 2006). It also allows monitoring according to the recently developed food safety standards such as Grainsafe Program, or complying with insurance claims, contracting requirements, private sector, and consumer associations' demands. The project objective can be summarized as follows;

- Provide information about specific production practices (IP, non-GMO, organic, etc.)
- Visualize traceability data and make use of GIS to study the relationships between environment and the production parcels
- Reduce costs of risk management and restore consumer confidence in production practices
- Provide detailed documentation for insurance companies and contractors
- Reduction of liability and recall cost
- Creation of an information system that is compliant with legal requirements (FDA Bioterrorism Act, Grainsafe Programs, etc.)

To serve the purpose SQL Server database administrators is use to manage ArcSDE databases and clients. ArcSDE technology combines ArcGIS application logic with information management in an RDBMS. It is utilized to enhance data management performance, extend the range of data types that can be stored in an RDBMS, and facilitate a multi-user-editing environment. (ESRI, ArcSDE)

The next step is to develop a reference system for geographical traceability for selected agricultural areas and developing IT infrastructure to ensure the appropriate data management tools are used for geographical traceability of the agricultural products by means of gathering and managing real-time data. It is possible to obtain the data by using real-time information platform such as GPS, yield sensors, etc. that collects geotrace data and enables the record of the lifecycle of the product. These data can be managed to create individual and aggregated geo-identifier by GIS that will be assigned into predetermined field plots in ArcMap.

According to ISO 9001:2000 and Grainsafe Program all the farm activities should be documented. Documentation should indicate, who does it, what is being done, and should include appropriate answers to; where, when, why and how. The GIS Based Farm Geotraceability Modeling project will bring new solutions to find the relevant answer to these questions, especially it will simplified and create appropriate platform for implementation of quality management systems. Major innovation of the project is the use of Geographic Information System (GIS) ArcSDE Enterprise geodatabase solution for traceability as means of production history.

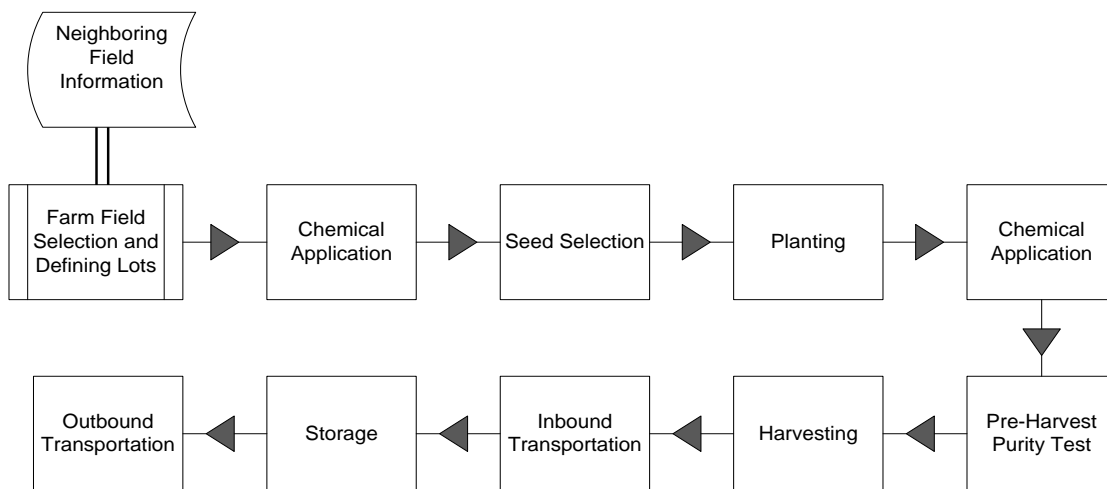
### **Model Development**

To use of GIS in creating farm base traceability system for IP grain, several key techniques is implemented including the design of conceptual and logical design of traceability geodatabase, the construction of traceability data requirement, and mapping of production process flow. Both tracking and tracing information have spatial data elements



that can be tied to non-spatial data, which provides great convenience for accessing and managing these data geographically.

Secondly, usage of Grainsafe Program for determining critical data elements for non-GMO and IP crops traceability provided strong foundation for effective traceability system development at farm level. For the purpose of this thesis, the product description was based on non-GMO food corn. The intended end use of this product was domestic processors, or international markets that have strict standards to prevent entering GMO corn into their market. The process flow diagram below was design to outline each step for production of non-GMO corn according to HACCP principles. The diagram includes every steps beginning from fields selection, assessment of the neighboring fields and ends with shipment of the grain off the farm. These processes were taken as a critical data capturing point for this project.



**Figure 23.** Process flow diagram used in the project for non\_GMO grain production and handling at the farm level

Grainsafe Program has very strict requirements in terms of records keeping for each steps of production. For example, during field selection for non-GMO crop planting; selected field should not be planted with GMO crop at least one growing season. There should be 60 feet buffer between selected field and the neighboring fields, which a GMO crop maybe or will be planted. Also there should be at least 7 days between the planting dates of selected field and the planting dates of the neighboring fields on which GMO corn will be or may be planted during the same growing season (Grainsafe Program, 2005).

In this study GIS based geodatabase was created to develop a system that will provide visualization tool for record keeping, documentation procedures. The system will provide assurance for consumers and customers regards to safety of the product and also ease the auditing process by third parties.

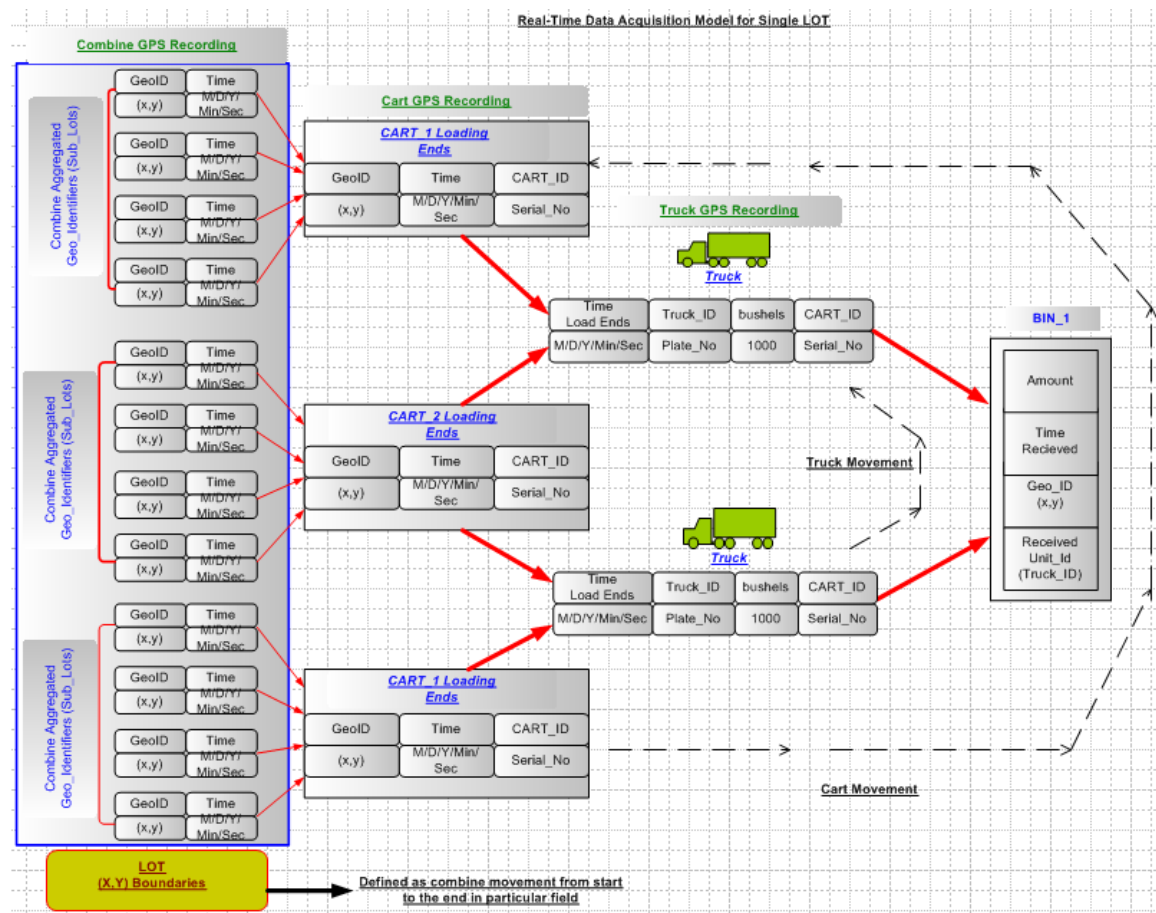
### **Reference Data Model for Grain Tracing and Tracking**

The facilitating a GIS solution for geo-traceability from the farm field to the grocery store is complex, but the usage of ArcGIS geodatabase model can be ideally designed to be used in the creation of an interactive polygonal object (lot/parcel) that can provide history of production process at farm level. For example, the result of such systems can be used to comply with market requirements for non GMO agricultural IP production. This type of GIS implementation is able to maintain every transaction on each parcel, warehousing metadata, and other critical data needs required for future certification of GMO compliance regulations. The core requirements for building this model were to:

1. Identifying historic relations between lots/ batches

2. Analyzing available technologies for recoding operations on lots and/or batches in production
3. Identifying related variables and ends values on operation such as depth of the data requirements, and what level of information is required to create efficient tracing and tracking systems?

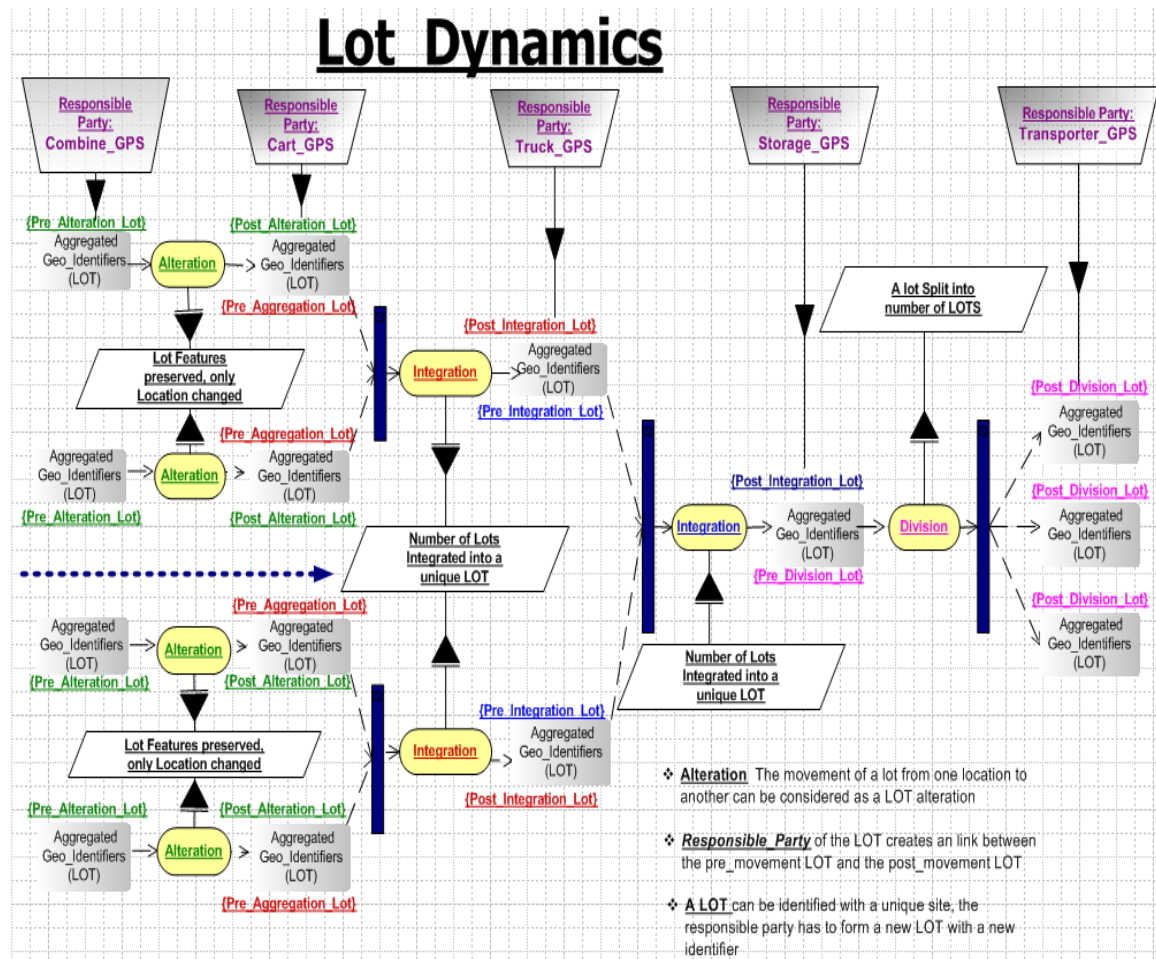
Before the implementation of a GIS base farm traceability system, the organization should plan each step carefully.



**Figure 24.** Harvesting Procedure and Data Collection

Tracking the movement of grain requires electronic data collection tools such as GPS, PDA or mobile phones. Today many of the farm equipment have built in GPS units that collect data automatically such as sprayers, planters, combines. Extra data regarding to other production practices or products attributes such as type of pesticides, seeds or machinery used during the production can also be gathered by using PDAs or other hand held devices. For example, usage of advance technology during harvesting, the coordinates taken from an integrated GPS and the weight taken from a machine interface can be transmitted to the central GIS with using mobile technology by sending SMS to driver. Then, diver can send the SMS back to system indicating the loading is done (PROGIS, 2006). This way the optimization of the trucks for the removal and transport to the next destination can start as the operator knows at exactly where how much grain is waiting for transport.

It is very important to determine when and where to collect data; and to track the changes of lot dynamics. By means of lot dynamics is that the harvested grain goes through several transformation from point of harvest to storage. During the harvesting process several changes occurs related to lot size and integrity. When the product is harvested by combine, it directly goes in to a cart that follows the combine movements throughout the harvesting. Filled cart leaves the combine and dumps the grain into trucks, then trucks take the grain to its next location. In this case assumption is that the grain is delivered to on farm storage units.



**Figure 25.** Analysis of the crop movement throughout harvesting, inbound and outbound transportation; lot dynamic changes in several points

Therefore, when and where to collect data to keep track on this process becomes a crucial part of the traceability system construction. Geo-ID (identifier) is the element that should allow not only to trace but also to track a lot. A geo-identifier can be characterized an individual or aggregated geographic objects, always includes information on the (x,y) coordinates of the point characterizing the object.

At the upstream of the agro-food chain, the geographic information provided by the (composite) geo-identifier that can be obtained by GPS or other data collection tools. It is

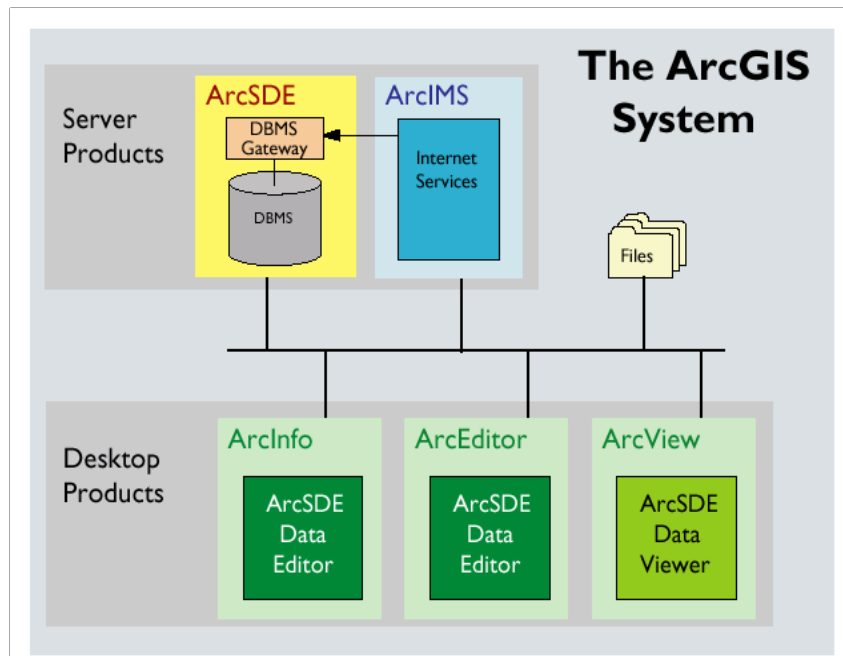
possible to disaggregate an aggregated geo-identifier into the different geo-identifiers (possibly also aggregated) composing it, in this case it will be possible to track back the history up to the initial objects such as the individual land parcels or product lots (LAPIS, 2007). The collected data from a field machine could comprise GPS data creating a time and geo-stamp for every set of data acquired (Figure 6). Another benefit of the system is the possibility to document the activities of the machines at given times. This could be used as documentation and traceability measures to comply with increasing legislative regulations in this area. (Jensen et al., 2007). If all machines and implements involved in the production process can be electronically identified the automation of the data acquisition can be realized.

### **Tools Used In GIS Based Farm Traceability Project**

#### **ArcSDE**

ArcSDE is the major element of ArcGIS Server. It serves as a data access technology to spatial data within a relational database management system (ESRI, 2008). It can be used for reach, store and process large multiuser geographic databases which is stored in relational database management systems (RDBMs). It provides a suite of services, which helps to increase database performance, extend data types and also allow schema transfers between different RDBMs. It is an important element for integrating GIS into any organization's IT system.

ArcSDE also allows organizations to keep their data integrity regardless of the underlying RDBMS system. With ArcSDE, data is stored in central database and also can be utilized by different server platforms such as Windows, UNIX, Linux, etc



Source: DWAF, 2007

**Figure 26.** ArcSDE can be used to manage geographic information to make geo- data available to all ArcGIS applications

ArcSDE is developed to provide enterprise GIS database management solution. Its main role is to provide database access engine to spatial data, its associated attributes, and metadata stored within a relational database management system (RDBMS) (ESRI, 2008). There are many advantages for using ArcSDE over ArcGIS Personal Database solution. ArcSDE has the capacity to enhance database management performance, It is utilized to enhance data management performance, provides more compressive range of data types that can be stored in an RDBMS, and allows a multiuser editing environment. ArcSDE allows you to manage spatial data in one of four commercial databases such as DB2, Microsoft SQL Server, Oracle and Informix. While the traditional RDBMS software is used to keep track of the tables and records contained in the database, ArcSDE enhances the relational model in a way that geographic data - which contains several tables, can be handled by client software

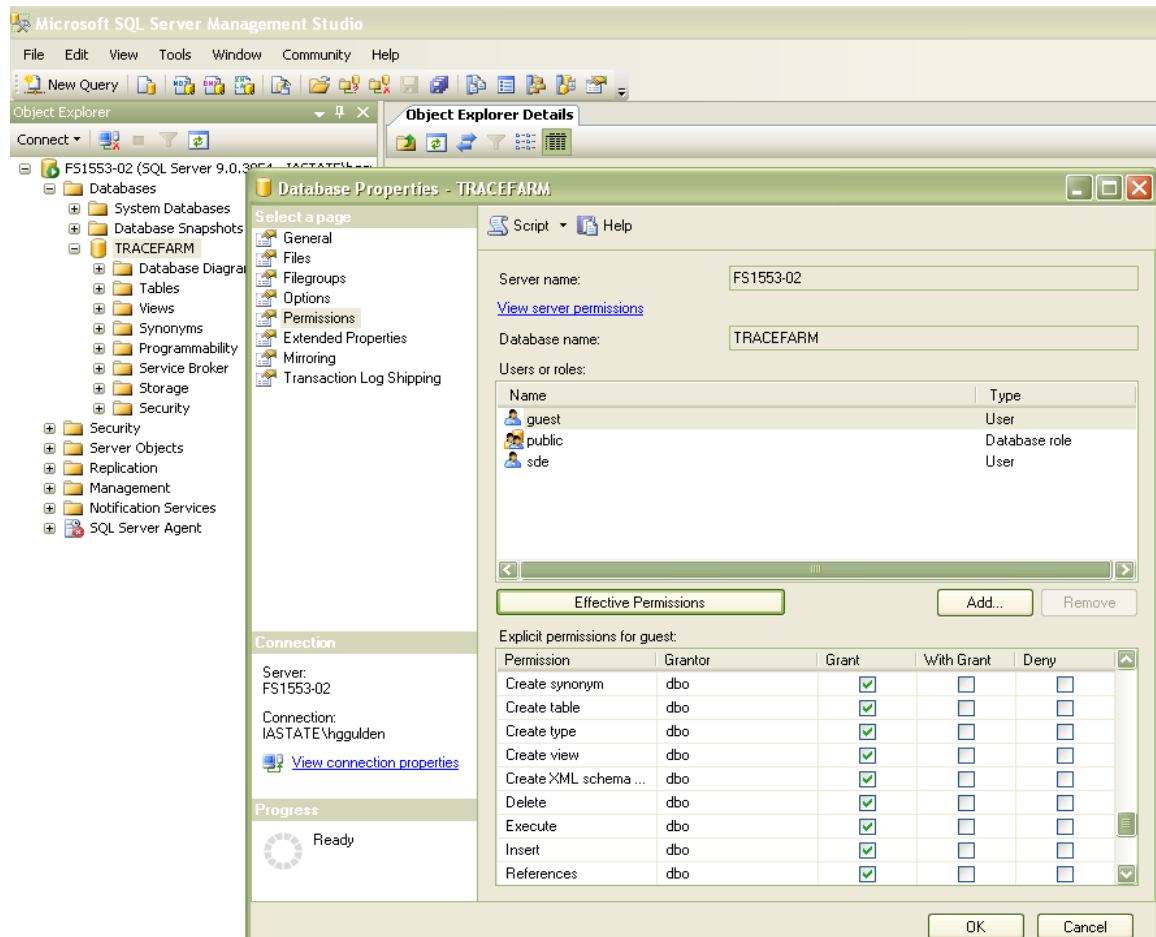
seamlessly (ESRI, 2007). The user is not aware of, nor do they have to deal with, the particulars of the RDBMS. Connections to the database are all routed through the ArcSDE middleware, which performs the storing, and retrieval of data. There are many benefits when using ArcSDE;

- It provides multi user environment
- It is built on sophisticated object model that support representation of many advance features, rules, and relationships—the geo-database
- It provides data integrity for all forms of data within geodatabase will not allow ill-formed feature geometry to be inserted
- It enables use of Enterprise GIS
- It also reduces data management responsibilities (Esri, 2007)

### **SQL Server**

The main advantage of using SQL server is that it is very simple to manage and anybody who has knowledge of SQL Server can access and manage the server. There are other advantages using SQL Server with ArcSDE; It increases the database performance drastically and it does not create any versioning problems on SQL Server. At last, use of SQL Server allows integration with ArcIMS Web services seamlessly; this will allow developing subscription base Web services for farmers to upload their data directly on the GIS server cost effectively.

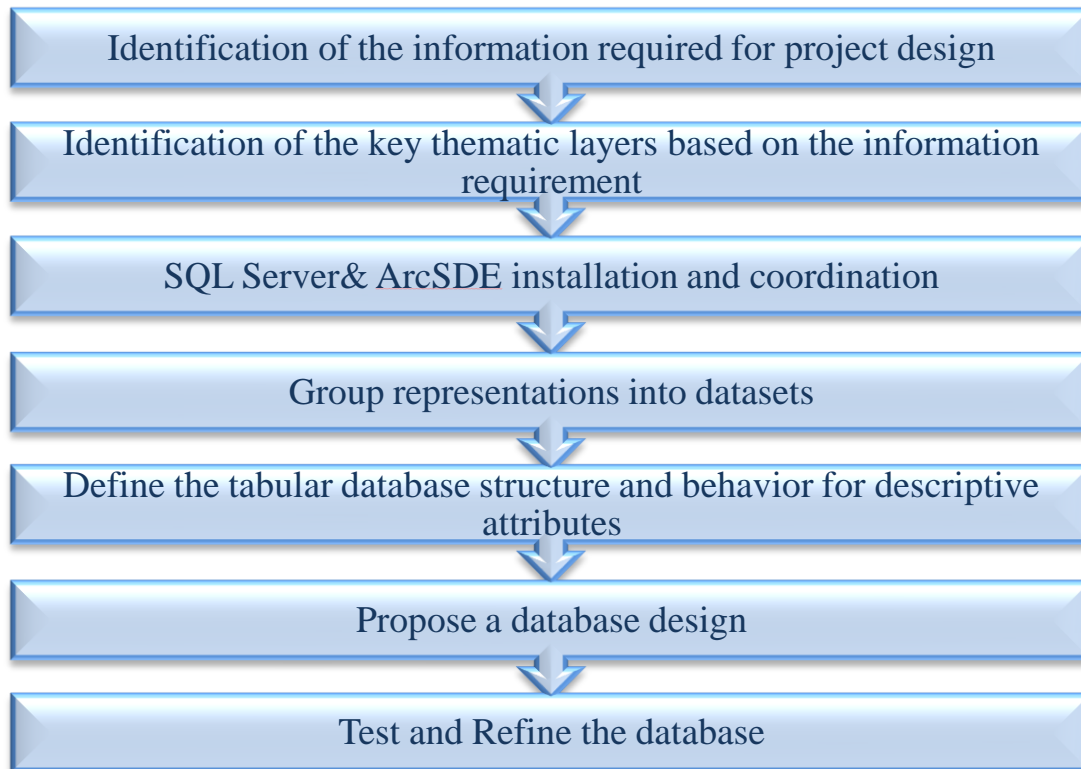




**Figure 27.** Granting permissions to ArcSDE database users in SQL Server

## Project Process Steps

First the necessary data layers for the project and information requirements were determined. Predetermination of each data layer enabled the specification of standard geodatabase elements such as feature classes, tables, relationships, subtypes, topologies and domains. After identifying data layers, next step was to develop specifications for representing the contents of each layer in the physical database. This process includes, how geographic features will be presented, for example as polygons, lines, tabular attributes, etc. It also includes how the data is organized into feature classes, tables and relationships.



**Figure 28.** Hierarchical Representation of Process Design

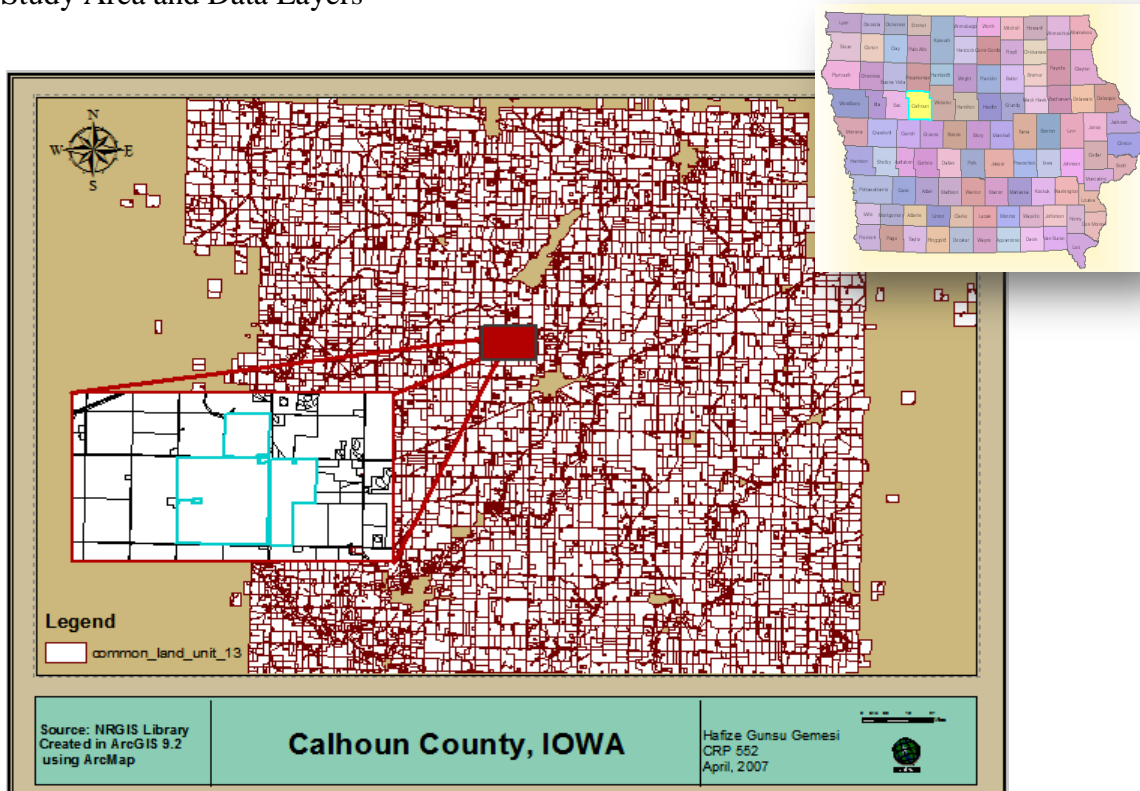
Above figure identifies the process steps, which was taken while successful GIS Based Farm Traceability System creation.

### **Identification of the Information Required for Project Design**

Data was obtained from NRGIS Library. Data layer(s) that is used in the study was; 2007 National Agriculture Imagery Program (NAIP) Aerial Photography of Calhoun County. Rest of the data layers was digitized. ArcGIS Desktop Editing function was used to create farm parcels for the selected farm and each parcel was divided into lots to increase the precision of the traceability system.

## Study Area and Data Layers

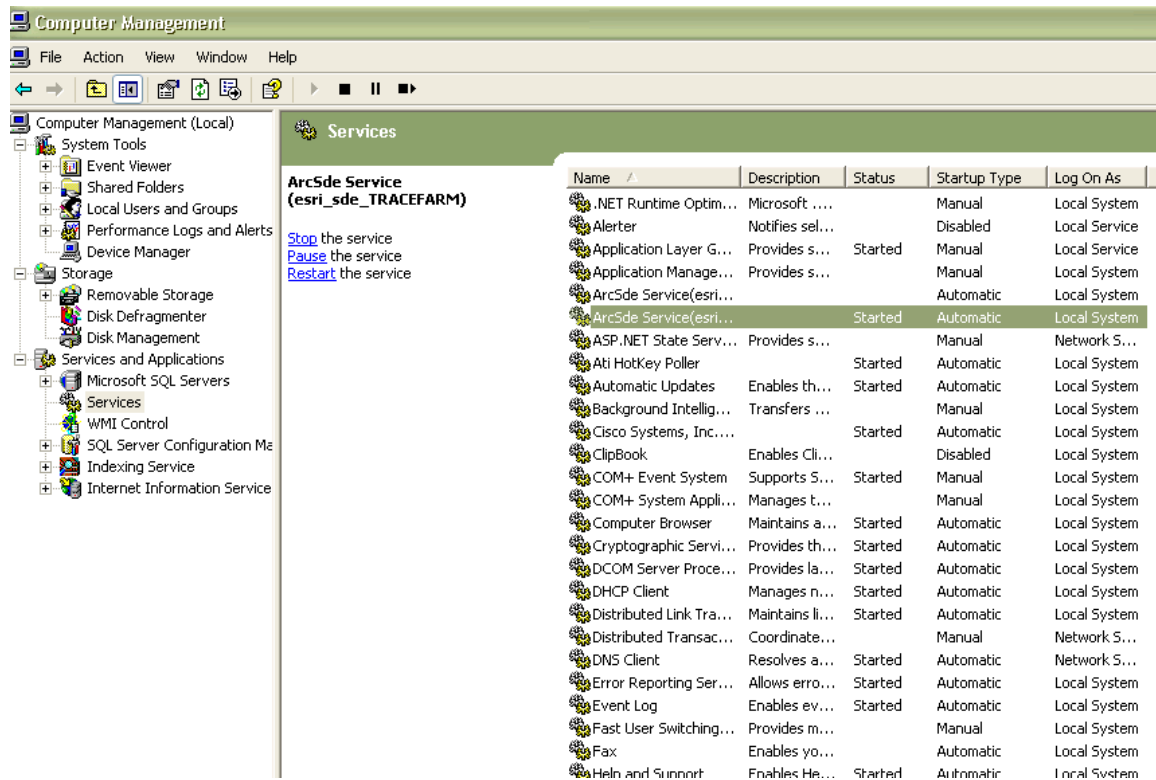
## IOWA, Calhoun County



**Figure 29.** Highlighted area shows the Farm that was selected for this project

### SQL Server & ArcSDE Installation and Coordination

To be able to access the ArcSDE server from remote locations, server should be started on the machine that carries the ArcSDE server. Otherwise, the connection to SDE database cannot be achieved.



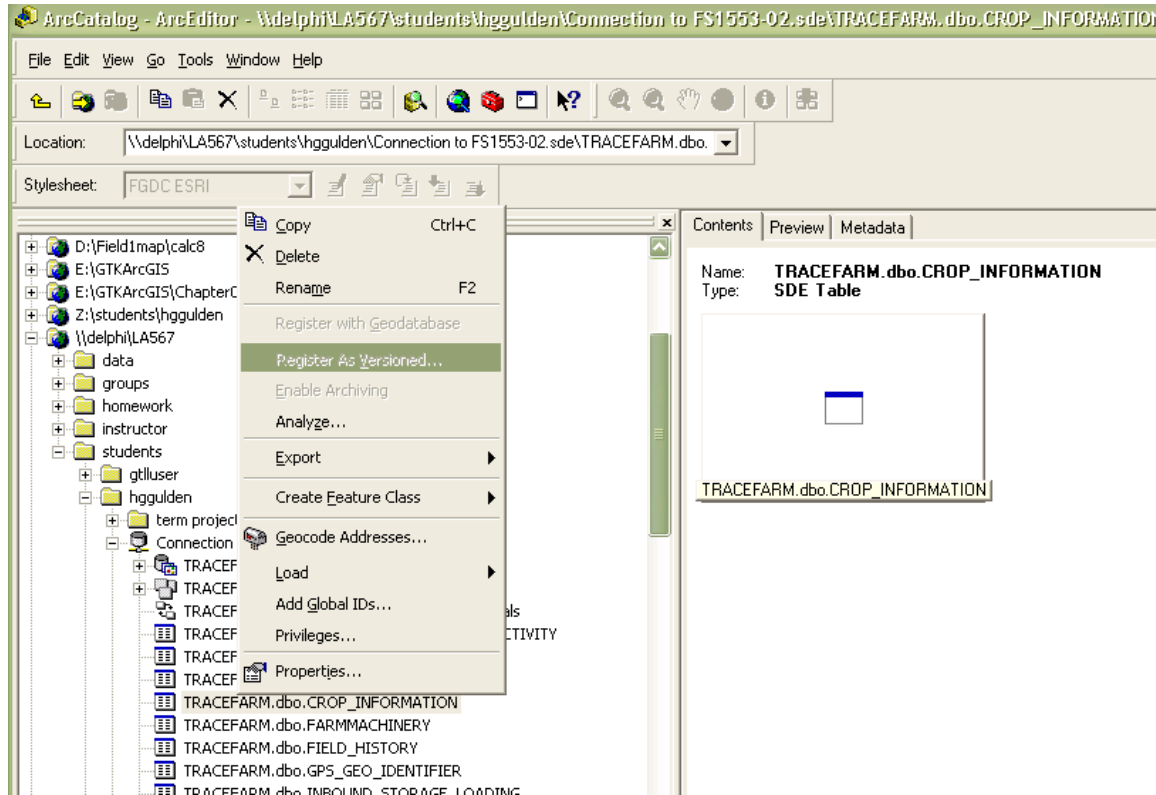
**Figure 30.** The ArcSDE service can be started by clicking Computer Management/ under Services and Application Window

### ArcSDE Data Access

To be able to access the spatial data, each table should be registered with ArcSDE as a feature class, this will allow user to view the data in ArcGIS Desktop and register the feature class as versioned. It also permits to perform nonversioned edits, and register the table as versioned.

Once the dataset is registered with the geodatabase, it is possible to use functions such as relationship class, creating subtypes or domains with it. In addition, it is possible to move feature classes into feature datasets so functions like topologies, networking, or other dataset

constructs can be used. To register a nonspatial table with ArcSDE, the sdetable command with the register operation.



**Figure 31.** Example of how to register tables as versioned in ArcSDE

To be able to connect to dbo-schema geodatabase from ArcCatalog, it is important to change the version, which connection will be established. In general the default version is set to sde.DEFAULT, but when you using dbo schema, the version should change to dbo-schema geodatabase.

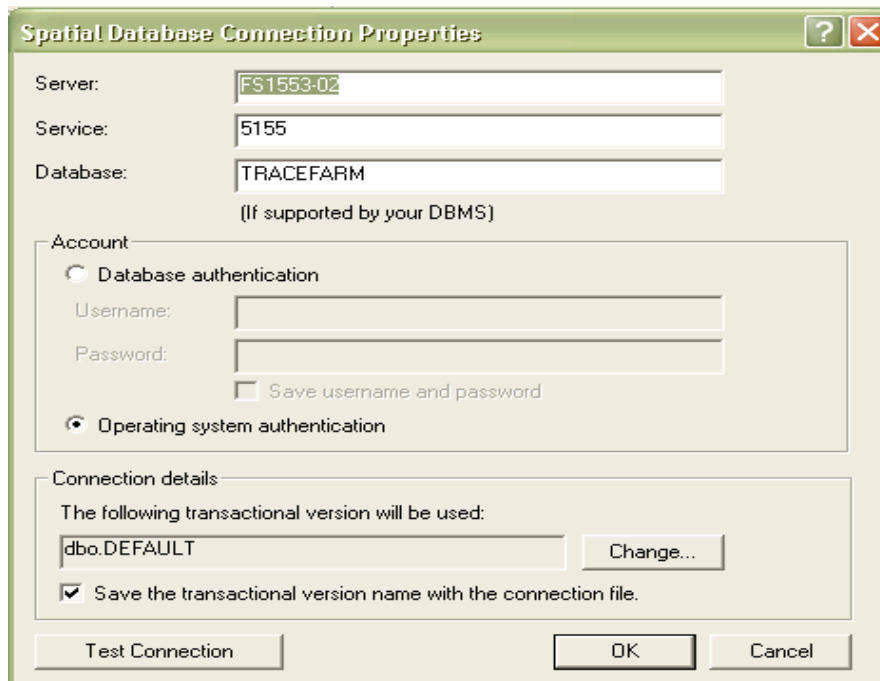


Figure 32. Database Connection Properties Window

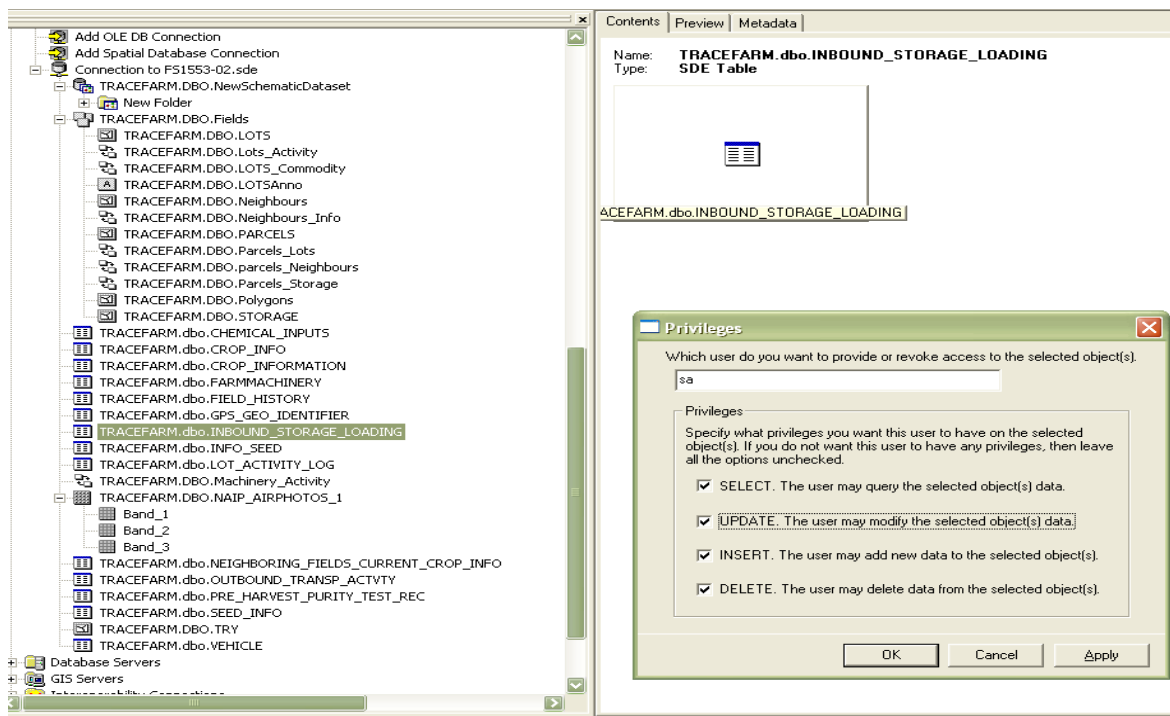


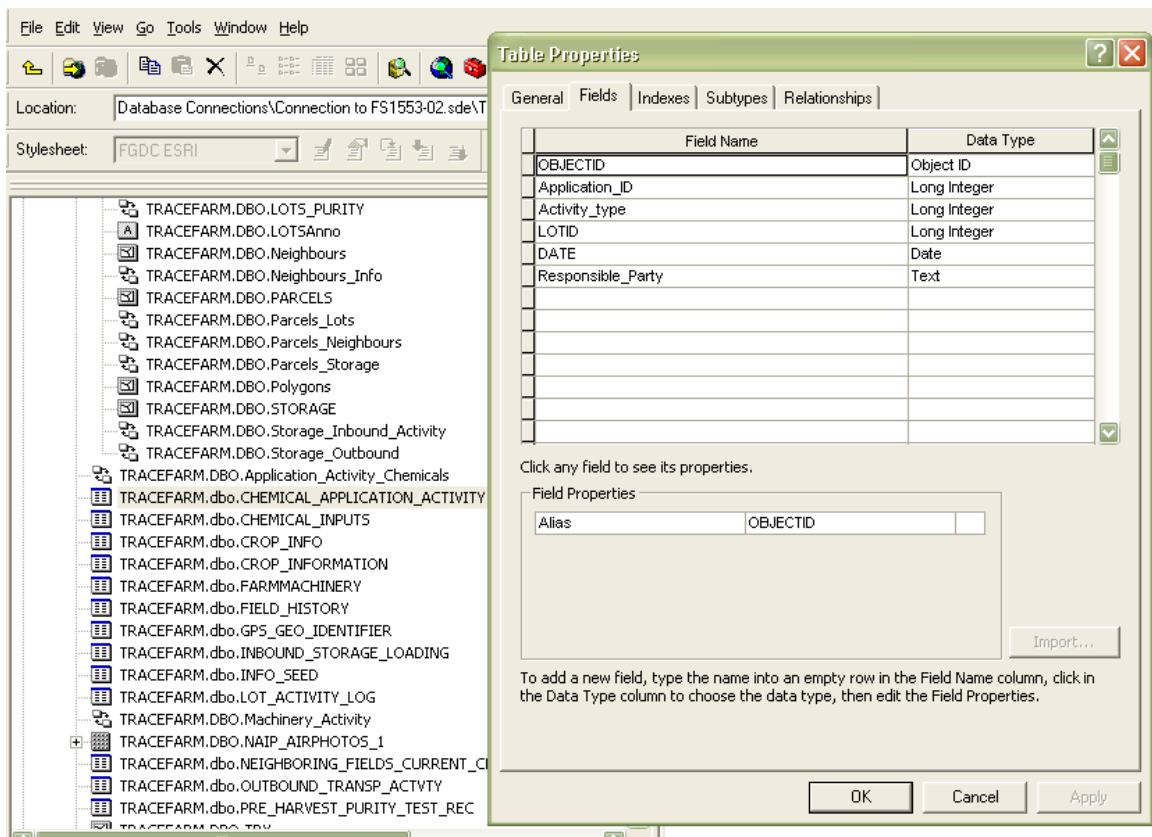
Figure 33. How to give privileges for database users in ArcSDE geodatabase

It is also important to understand how to give privileges to users while accessing the ArcSDE geodatabase. For the study there were several privileges were granted to enable other database users to view modify the data in the geodatabase. When accessing the ArcSDE geodatabase through database server connection there are three type of permission you can grant the database users; Read Only, Read/Write or None (Esri, 2007).

### **Attribute Data Input and Management**

#### **Creating Spatial and Non-Spatial Attribute Data**

In GIS there are two types of attribute data can be stored: first is the spatial data, which represents the geometry of spatial features. And second, attribute data define the characteristics of the spatial features (Chang, 2005). It means attribute table is not represent any spatial features but it can be linked to geometry of feature by relate, join function or creating relationship classes within geodatabase. Both data type can be synchronized so that they can be displayed and analyzed accordingly. For example above, the farm database model has several spatial feature data table, which is linked to tabular data tables. Non-spatial data tables may import to geodatabase in several forms such as text files, excel files, dBASE files, etc.



**Figure 34.** Creating tables in ArcSDE

Above figure is a screenshot from ArcCatalog, which shows how Chemical-Application-Activity table was created in ArcSDE. To be able to track the crop from seed to harvest and harvest to transportation to next destination; several data about the activities at farm level should be recorded. Therefore, use of GIS technology plays a crucial role to link the geographical coordinate information with other attribute information about crop product and other interrelated entities as a spatial infrastructure (Xiao-hui et al., 2007). As mentioned earlier, GIS can provide functions to integrate data collection technologies such as GPS, GSM, or PDAs to develop the optimum functionalities for tracing and tracking.

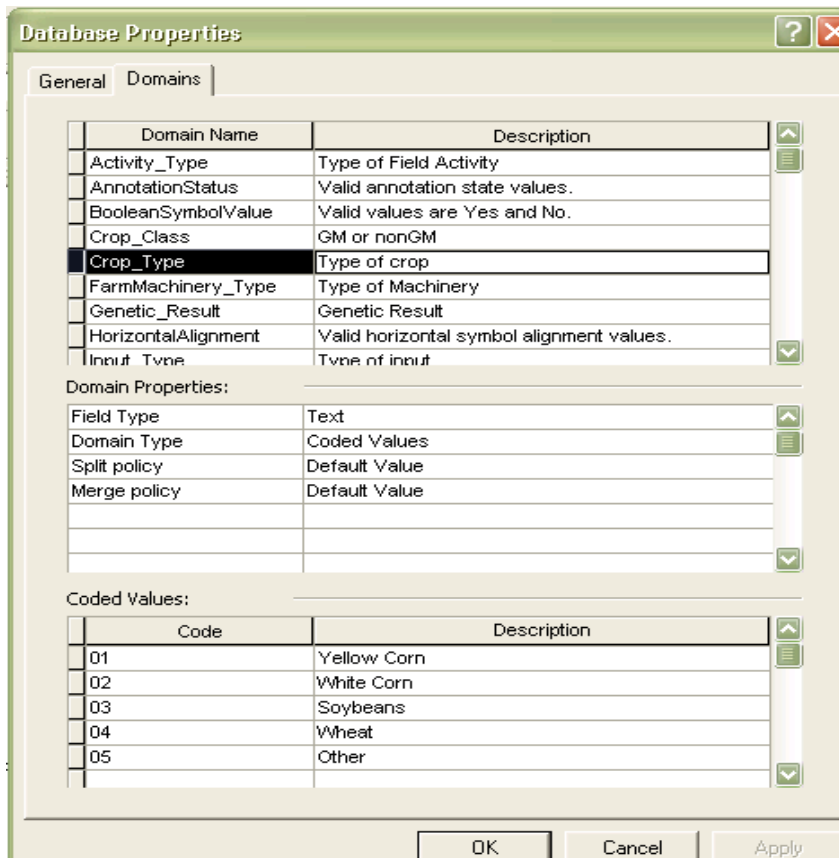


Above facts were taken under consideration while creating the Farm Traceability geodatabase model. The information requirements for the model were determined in line with Grainsafe Programs. This approach allowed focusing on production of non-GMO (non-genetically modified crop) to comply with international trade requirements. Therefore, tables such as Neighboring\_field\_crop\_info, seed info, or Pre\_Harvest Purity\_Test tables and many more were created to provide critical information about assurance of non-GMO crop production.

### **Creating Domains in a Geodatabase**

Domains are rules that are created to enforce data integrity. The use of domains allows only specified values to be entered into the data field. Domain rules can be applied to feature classes, tables and subtypes. There are two types of domains can be defined; coded value domain and range domain. Range domain can only contain numeric values while coded domain can contain any type of value such as text, numeric, date, etc.

Within the study, there were several domain rules were created to minimize the data error and geodatabase data integrity. Below is the screenshot of domain window that was created in ArcSDE geodatabase.



**Figure 35.** Domains used in Farm Traceability Geodatabase

The screenshot shows a table view of 'Attributes of TRACEFARM.DBO.Chemical\_Inputs'. The table data is as follows:

OBJECTID *	Input_Name	Application_Rate	Restrictions	Activity_Type	Application_ID
1	C-Anhydrous	144	Max 150 per min	Fertilizer Application	10
2	C_NitrogenNitrate	134	Max 155 per min	Fertilizer Application	11
3	C-Surpass	165	Not apply	Pesticide Application	12
4	C-MarksMan	120	Max 130 per min	Fertilizer Application	13
5	S-Tri4	125	Max 130 per min	Pesticide Application	14
6	S-Tri4 Round up 1	160	Max 170 per min	Pesticide Application	15

At the bottom of the table view, there are navigation controls: Record: 1, Show: All Selected, Records (0 out of 6 Selected), and an Options button.

**Figure 36.** Representation of domain values in database table

Above screen shots shows how domain values can be selected during editing information into data table. The Activity type can be only contains two values. It does not allow any other value entry in Activity\_Type field.

## **Relational Database Design**

Relational database is a collection of tables (relations) that are related to each other by creating unique keys such as primary and foreign keys (Chang, 2005). Primary key is a data which is created from combining one or more attributes in a table. Its value should uniquely identify a record in a table. When primary key is used in another table to link it's called foreign key. When primary key is represented in another table it enables to create relationship between two tables. Using relational database model allows each table in the database to be prepared, maintained and edited separately from other tables.

In ArcSDE , the links between the various datasets in a geodatabase are managed as relationships. There are three ways to support relationships in a geodatabase

- Spatial relationships— creates relation between two feature classes
- Non-spatial relationships—creates row to row relationships between two non-spatial tables
- Spatial to non-spatial relationships—creates relationship between spatial feature and the non-spatial table (feature to row)

In ArcGIS geodatabase, the spatial features are stored in a feature class and non-spatial rows are stored in tables, relationships are stored and managed in a relationship class (Esri, 2007). When creating a relationship class; type of relationship between origin and the destination table was defined; origin and the destination classes, cardinality between entities, primary and foreign keys, simple or composite relationship, message notification direction should be determined in advance. ArcSDE relationship class can handle three types of

cardinality; one-to-one, one-to-many, or many-to-many. Once the relationship class is created, it is possible to specify rules to refine the cardinality.

Another important factor needs to be specified before creating a relationship class is whether it is simple or composite relationship. In a simple relationship, related objects can exist independently of each other. When the origin entity is deleted, foreign key value in destination is appear as null value. If the origin feature is deleted, there won't be any foreign key value that relates both entities with each other, the value appear as null in destination table. This feature helps to maintain referential integrity when there is an update or change occurs within the database entity. The composite relationships also maintain referential integrity when there is any changes occurs within objects, the difference is the destination entity cannot exist without origin entity, when the origin is deleted related destination objects are also deleted.

Below figure is the representation of the farm traceability relational database model. As shown in the figure, there are several relationship were created to link the spatial data with spatial data and tabular data.

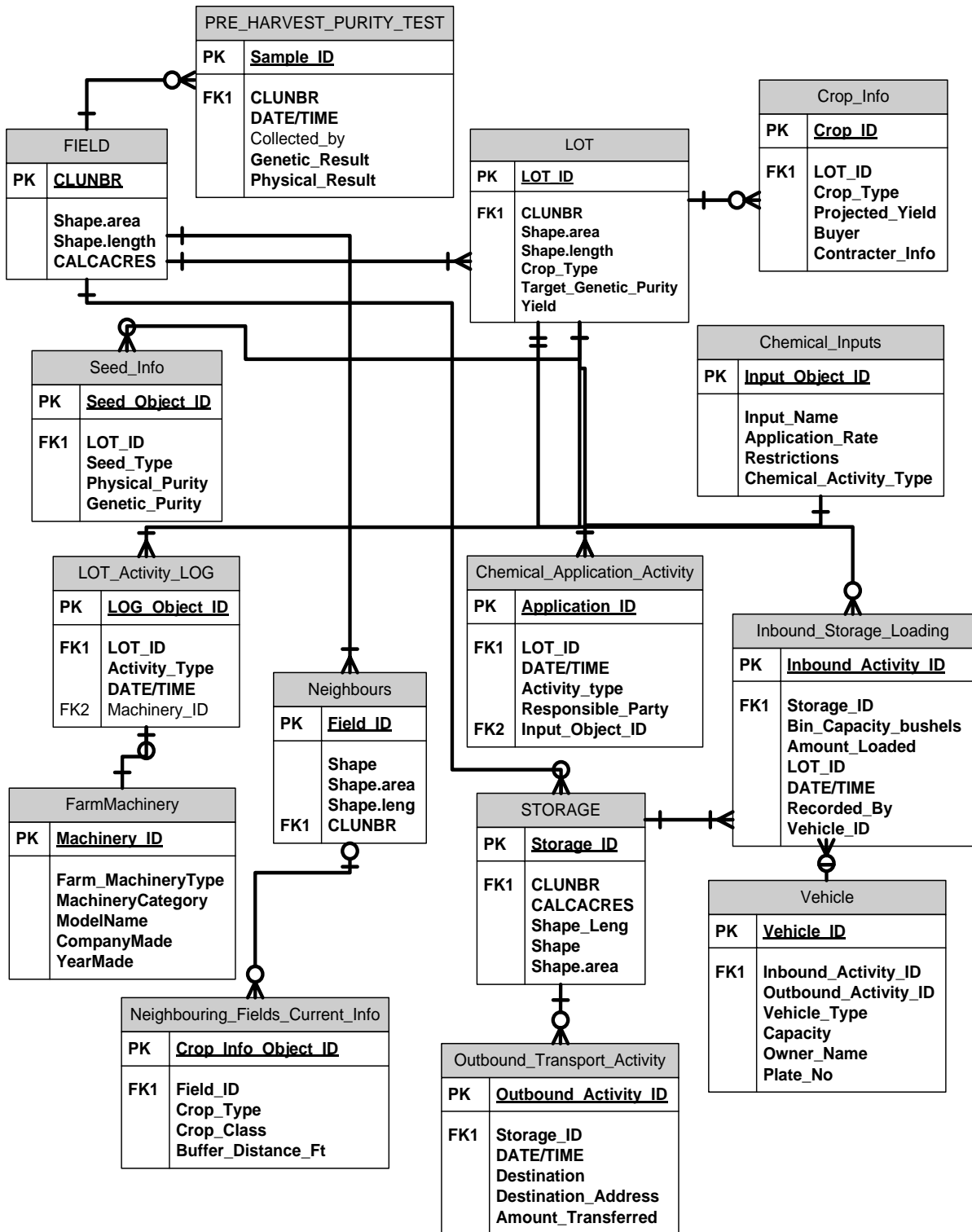
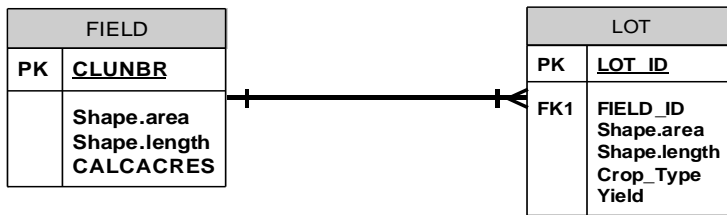


Figure 37. Logical Data Model was created by using RDBMS model

When designed with RDBMS the conceptual model becomes a beginning point from which other implementations can be derived (forward engineering). The first step is to define the entities by means of identifying basic concepts of application field. This concept was represented as ‘spatial entities’ or ‘features’ in the model. The three spatial entities were identified in the conceptual model; these were Fields, LOTS and Storage. When the actual data is used during implementation phase, the GPS readings from Vehicle entity and Chemical Application should be accounted as spatial entity. For this project, these entities were identified as non-spatial entities.

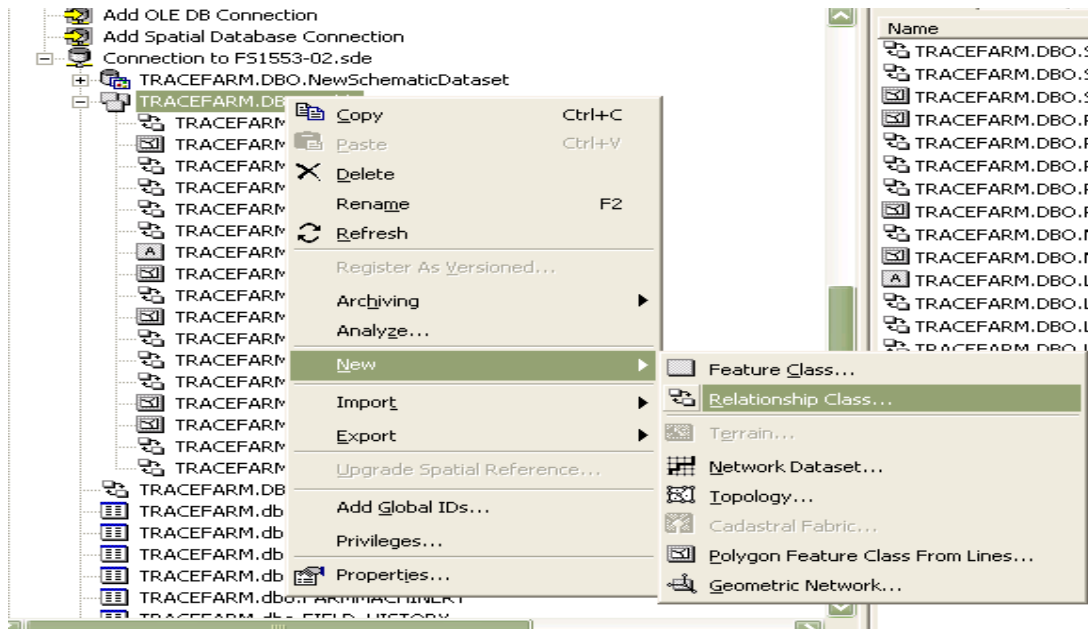
### Creating Relationships within ArcSDE Geodatabase

After the design of logical data model and creation of feature class and tabular tables, relationship classes were created to link the both data types. Below is a step by step representation of how the relationship class was created between FIELD (PARCEL) and LOT entity.

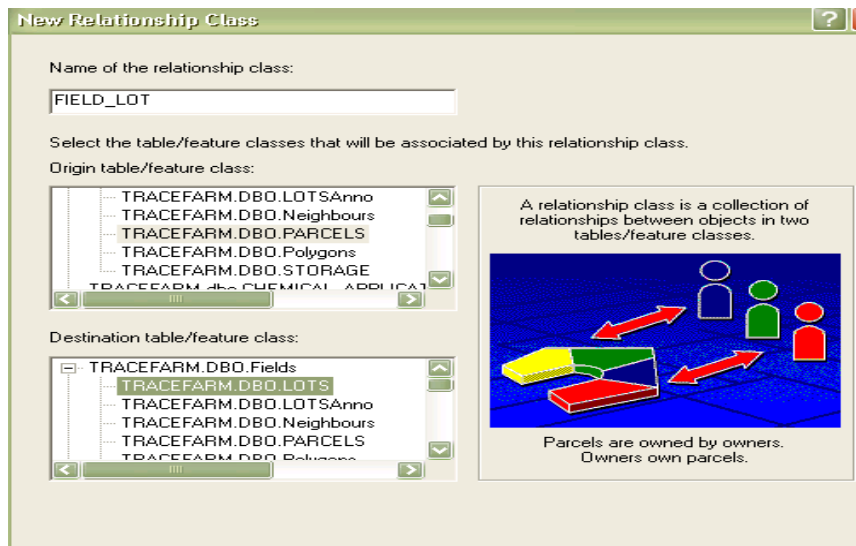


**Figure 38.** Conceptual representation of FIELD and LOT entities and cardinality between both entities

Above entities and their properties were used to create relationship class in the ArcSDE Farm Traceability Geodatabase. This relationship is identified as one-to-many cardinality rules.

**Step 1**

**Figure 39.** Creating new relationship class by right clicking the FIELD Feature Dataset

**Step 2**

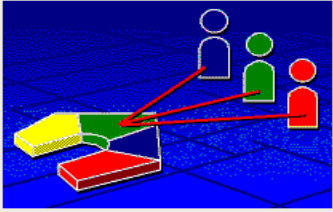
**Figure 40.** Defining the origin-destination direction of a relationship

### Step 3

New Relationship Class	New Relationship Class
<p>Select the type of relationship that this relationship class will store.</p> <p><input checked="" type="radio"/> Simple (peer to peer) relationship</p> <p>Simple or peer-to-peer relationships are relationships that exist between two or more objects in the database that can exist independent of each other. In this kind of relationship, when the object(s) in the origin table/feature class are deleted, the related object(s) in the destination table/feature class are not by default.</p> <p><input type="radio"/> Composite relationship</p> <p>Composite relationships are relationships where the lifetime of the object(s) in the destination table/feature class are controlled by the lifetime of their related object in the origin table/feature class. When the object in the origin table/feature class is deleted, the related object(s) in the destination table/feature class are also deleted.</p>	<p>Specify a label for the relationship as it is traversed from the origin table/feature class to the destination table/feature class.</p> <p><input type="text" value="have"/></p> <p>Specify a label for the relationship as it is traversed from the destination table/feature class to the origin table/feature class.</p> <p><input type="text" value="contained within"/></p> <p>Which direction will messages be propagated between the objects related by this relationship class?</p> <p><input checked="" type="radio"/> Forward (origin to destination)</p> <p><input type="radio"/> Backward (destination to origin)</p> <p><input type="radio"/> Both</p> <p><input type="radio"/> None (no messages propagated)</p>

**Figure 41.** Choosing the relationship class type and the message direction

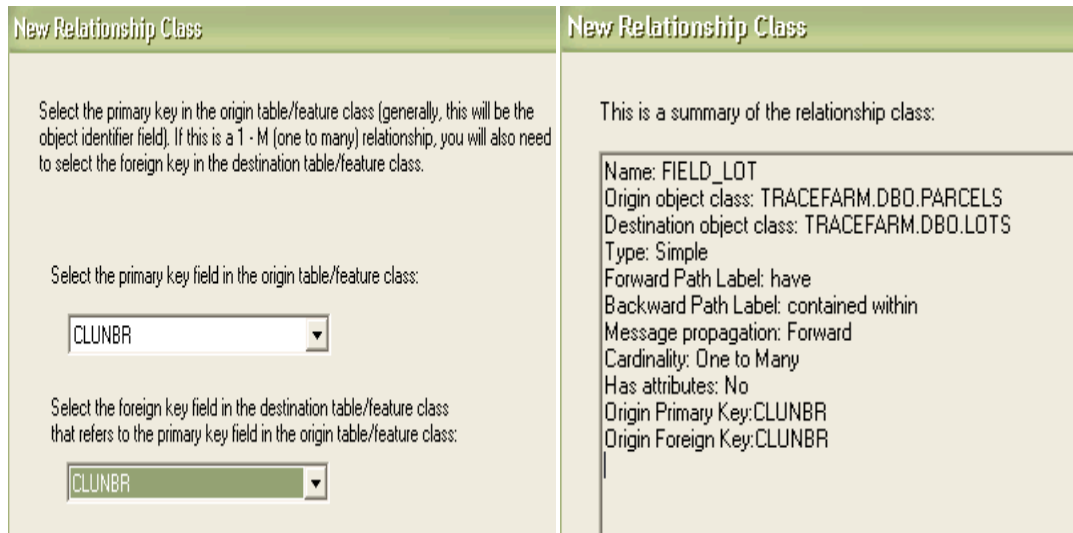
### Step 4

New Relationship Class <span style="float: right;">?</span>			
<p>Select the cardinality for this relationship class (origin - destination).</p> <p><input type="radio"/> 1 - 1 (one to one)</p> <p><input checked="" type="radio"/> 1 - M (one to many)</p> <p><input type="radio"/> M - N (many to many)</p> <p>Note: If this is a composite relationship class, then the cardinality must be 1-1 (one-to-one) or 1-M (one-to-many)</p> <div style="border: 1px solid gray; padding: 5px; margin-top: 10px;"> <p>In a 1-M (one to many) relationship, each object in the origin table/feature class can be related to multiple objects in the destination table/feature class.</p> <table style="width: 100%; text-align: center;"> <tr> <td style="width: 50%;">Parcels Table/Feature Class</td> <td style="width: 50%;">Owners Table/Feature Class</td> </tr> </table>  </div>		Parcels Table/Feature Class	Owners Table/Feature Class
Parcels Table/Feature Class	Owners Table/Feature Class		

**Figure 42.** Defining the cardinality between entities

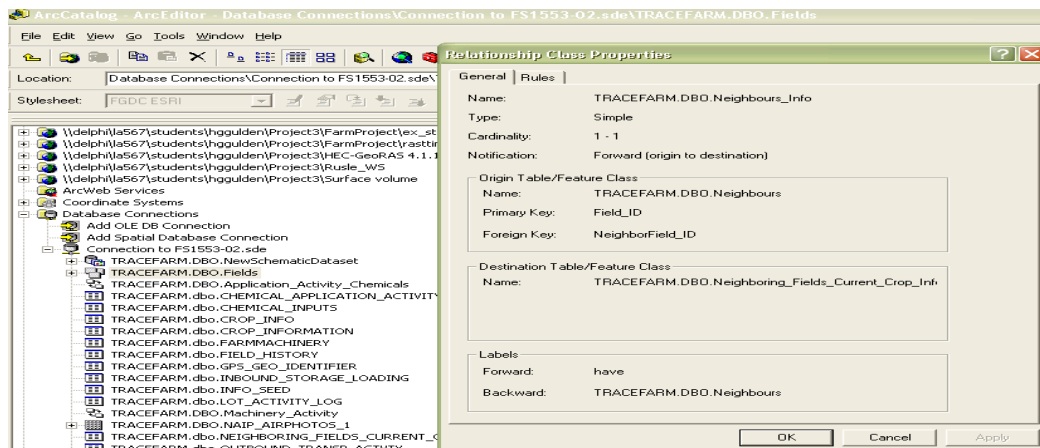


### Step 5



**Figure 43.** Defining the primary and foreign key values and the summary of the relationship class properties

The result from new relationship class can be seen in summary window at right hand side. It is also possible to view each relationship class properties from ArcCatalog



**Figure 44.** Relationship class properties between two entity; feature class and non-spatial table

Above figure is an example of how the neighbor fields feature class was related to crop information table. It is possible to view information about each relationship classes by right-

clicking the relationship class and clicking Properties to open the Relationship Class Properties dialog box in ArcCatalog.

### **Testing Functionality of the Farm Traceability Geodatabase**

After creation of relationship classes between entities within the ArcSDE geodatabase, the final ArcGIS map was created to test the database functionality. Below the map shows how entities, which are defined in conceptual database model and created in ArcSDE database can be visualize on ArcGIS map. Each parcel were divided in lots, each lot, parcel, neighboring fields and storage can be selected by using interactive selection tool in ArcGIS. The data regards to selected area can be reached by using information or attribute window under the editing tool (to be able to view data attribute window, Editing function should be started). Below, figure is the attribute window for LOT 21, which is also highlighted on the map. The attribute information of each entity regards to LOT 21 can be view by clicking on the desired activity ID such as seed information (supplier, physical purity, genetic purity, type of seed, seed certifying firm and company); commodity properties (crop type, projected yield, buyer contract info); lot activity during production year (machinery use—application use and date, tillage, cultivation, year, make and model of machinery as well).

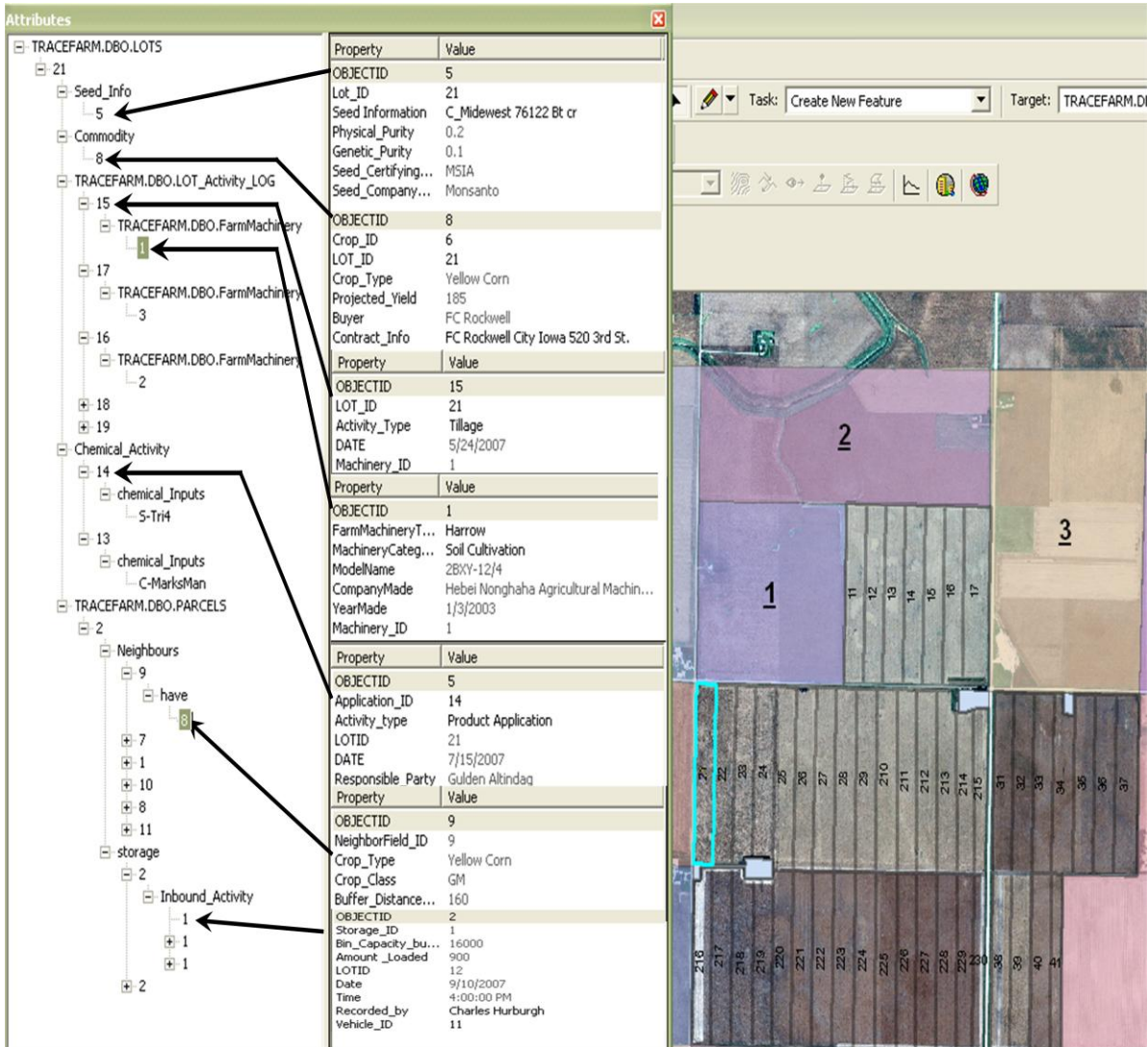
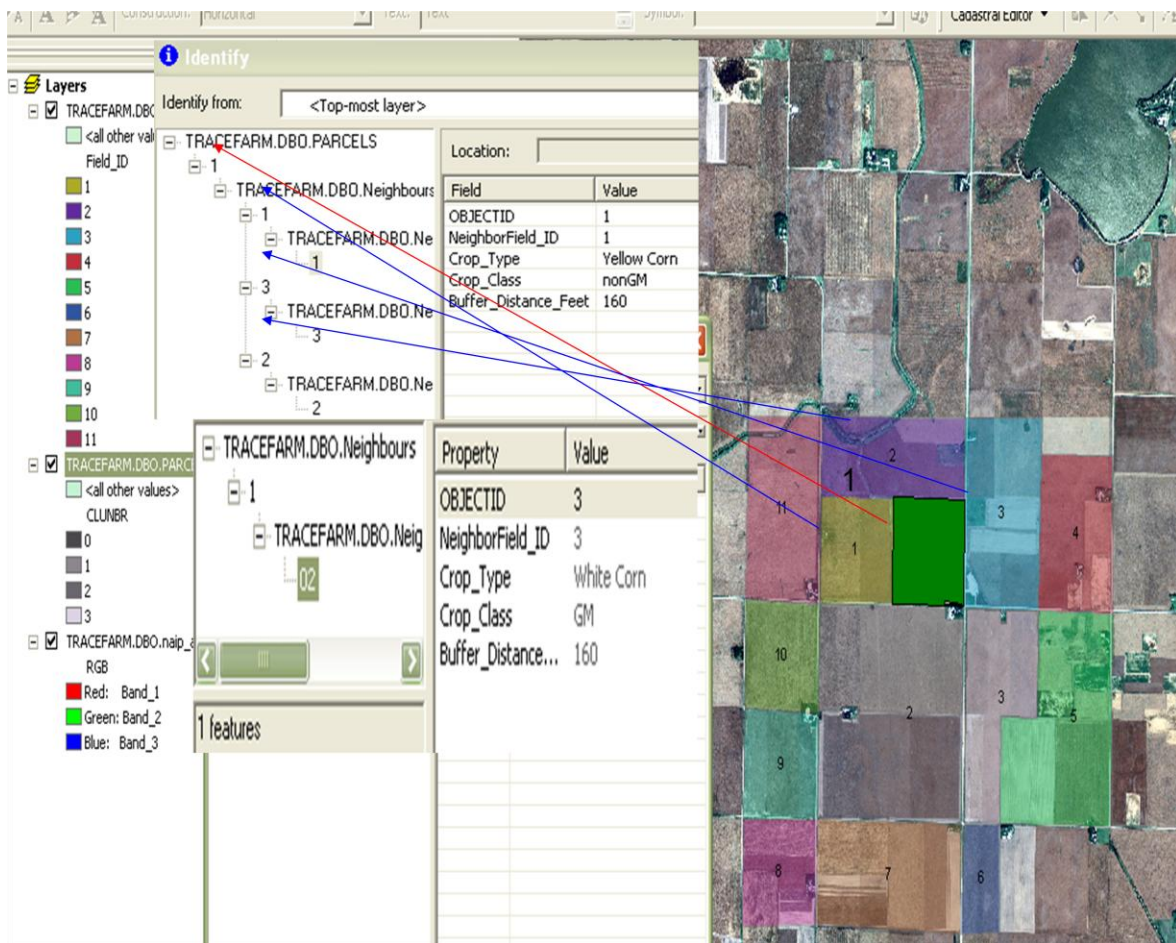


Figure 45. Geodatabase representation on the ArcGIS map



**Figure 46.** The Parcel (green selected area) and its neighboring field information can be viewed by using identify window in ArcGIS

Above map shows how ArcGIS technology can be used among farmers and their neighbors to map out potential cross-pollination/contamination areas, such as adjacent fields. Using GIS for mapping of neighboring farm information is also one of the requirements of Grainsafe Program. This will prevent potential risk for pollen drift that may lead to contamination of non-GMO crop at selected farm level.

Based on the complex information ArcSDE GIS is able to manipulate, farm traceability data flow management is dissected down to every last stage involved in the production and

movement of a commodity. For the farmer, this offers transparency and accountability in their production. Most importantly, this same model can be used for all types of farming methods with diverse crop rotations and

## **Conclusions**

With a technology integration of GIS will enable many activities on the farm to be measured or done at once with one single click “where is growing what”, attributive database with lots of farm applications, time and workflow management, etc. These capabilities will provide great convenience for reaching farm production process data for government organization, third party certification bodies, and insurance or contractor companies.

GIS mapping shows promise for bringing traceability and food safety standards at farm level. Tracing non-GMO crop production and the data collected for increasing marketability of IP products can be combined to help reduce consumer anxiety domestic and international scale. Research in food safety has already confirmed consumers are wary of the current food system’s standards; pesticides, food borne illnesses, and the uncertainty of GMO crop side effects have become increasingly hot topics of debate (Pyle 2005; Burton et al. 2001). Considering GIS technology has only recently been utilized for food traceability, the deterministic nature of the users and developers for this technology will continue to improve upon its current capabilities.

## References

“Capacity Building in Digital Mapping and GIS for Boosting the Agricultural Sector: Development of GIS-driven Horticulture Produce Information System for Managing the Export Sector”. *Promoting Land Administration and Good Governance 5th FIG Regional Conference Accra, Ghana, March 8-11, 2006*

Brookes, G. (2002). “Identity preservation of genetically modified organisms in the food chain: requirements, methods, and costs.” *Journal of AOAC International*. Vol.85(3), P. 762-767.

CAC. 2001. *Codex Alimentarius: Food Hygiene Basic Texts*. Joint FAO/WHO Food Standards Programme. Rome, Italy

Cellini, F., A. Chesson, I. Colquhoun, A. Constable, H.V. Davies, K.H. Engel, A.M.R. Gatehouse, S. Kärenlampi, E.J. Kok, J.-J. Leguay, S. Lehesranta, H.P.J.M. Noteborn, J. Pedersen, and M. Smith. (2004). “Unintended Effects and Their Detection in Genetically Modified Crops.” *Food and Chemical Toxicology* 42:1089-1125.

Chang, Kang-tsung. (2006). “*Introduction to Geographic Information Systems*”. 3d ed. New Delhi: Tata McGraw-Hill Publishing Company Limited.

D. Van Setten<sup>1</sup>, R. Oger<sup>2</sup> and M. Debord<sup>1</sup>. (2005). “GeoTraceAgri and GTIS-CAP projects Definition of the geotraceability concept”. *EU 6 Frame Program: York Workshop, October 2006*

ESRI, (2003). Agriculture Data Model.

ESRI, 2007. [www.esri.com/library/brochures/pdfs/arcsde-server.pdf](http://www.esri.com/library/brochures/pdfs/arcsde-server.pdf)

GeoTraceAgri (2005). “Geotraceability: an innovative concept for the qualification of crop production. Final Project Report (GTA).

Golan, E., B. Krissoff, F. Kuchler, L. Calvin, K. Nelson, and G. Price. (2004). “Traceability in the U.S. food supply: Economic theory and industry studies.” Agricultural economic report, Golan, Elise, Barry Krissoff, and Fred Kuchler. 2004. “Food Traceability: One Ingredient in a Safe and Efficient Food Supply.” *Amber Waves* 2 (2):14-21.

<http://support.esri.com/index.cfm?fa=downloads.dataModels.filteredGateway&dmid=35>

Joseph Yeng Faalong, Mawuli Agboka, E. Amamoo-Otchere, B. Akuetteh, Ghana. (2006). König, A., A. Cockburn, R.W.R. Crevel, E. Debruyne, R. Grafstroem, U. Hammerling, I. Kimber, I. Knudsen, H.A. Kuiper, A.A.C.M. Peijnenburg, A.H. Penninks, M. Poulsen, M. Schauzu, J.M. Wal. (2004). “Assessment of the Safety of Foods Derived from Genetically Modified (GM) Crops.” *Food and Chemical Toxicology* 42:1047-1088

L. A. Jensen, C. G. Sørensen and R. N. Jørgensen. December, 2007. "Real-time Internet-based Traceability Unit for Mobile Payload Vehicles". *Agricultural Engineering International: The CIGR Ejournal*. Manuscript CIOSTA 07 003. Vol. IX.

Neményi, M. P.Á. Mesterházi, Zs. Pecze, Zs. Stépán. (2003). "The Role of GIS and GPS in Precision Farming." *Computers and Electronics in Agriculture* 40:45-55.

Opara, December, 2002L. "Engineering and Technical Outlook on Traceability of Agricultural Production and Products". *Agricultural Engineering International: the CIGR Journal of Scientific Research and Development*. Invited Overview Paper. Vol. IV.

Robert Oger, (2005). "The GTIS-CAP Project, geographical origin of food crops and corresponding quality indicators". US-EC Workshop on Innovative Technologies for Increasing Food Safety in the Fork-to-Farm Chain Brussels, 24-25 January 2005

Suomi P.; T. Oksanen; L. Pesonen; J. Kaivosoja; H. Haapala; A. Visala, (2006). " Intelligent functions for crop production automation". *Proc. Of XVI CIGR World Congress 2006, Bonn*

## **GENERAL CONCLUSION AND FUTURE OBJECTIVES**

Well-established data acquisition and sharing in regards to food products along with its process history is the core of the successful traceability system functioning. Today new advancements in data collection technology enables us to collect, store and use the data to supplement supply chain activities such as logistics of product movement, managing production environment, or complying with data keeping requirements, etc.

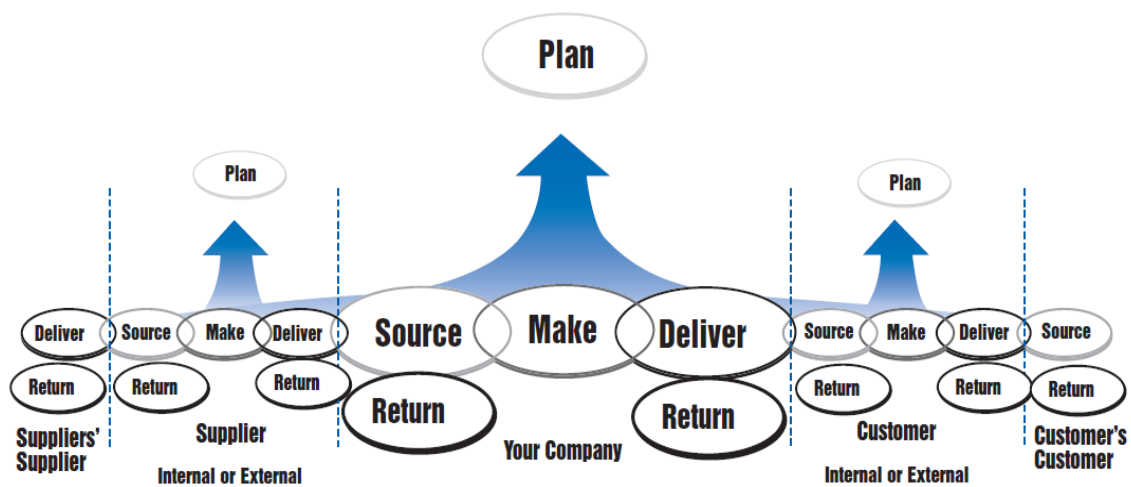
Therefore, with the adaptation of these advancements, such as barcoding, RFID, XML, GIS, etc. enables electronic communication and traceability information exchange among supply chain participants. More pilot studies need to be conducted testing the effectiveness of these technologies and determining the benefits of whole chain traceability not only as a tool for enhancing food safety but also as a differentiator at the market place.



## APPENDIX: SCOR MODEL DAIRY SUPPLY CHAIN APPLICATION

### SCOR Model Overview

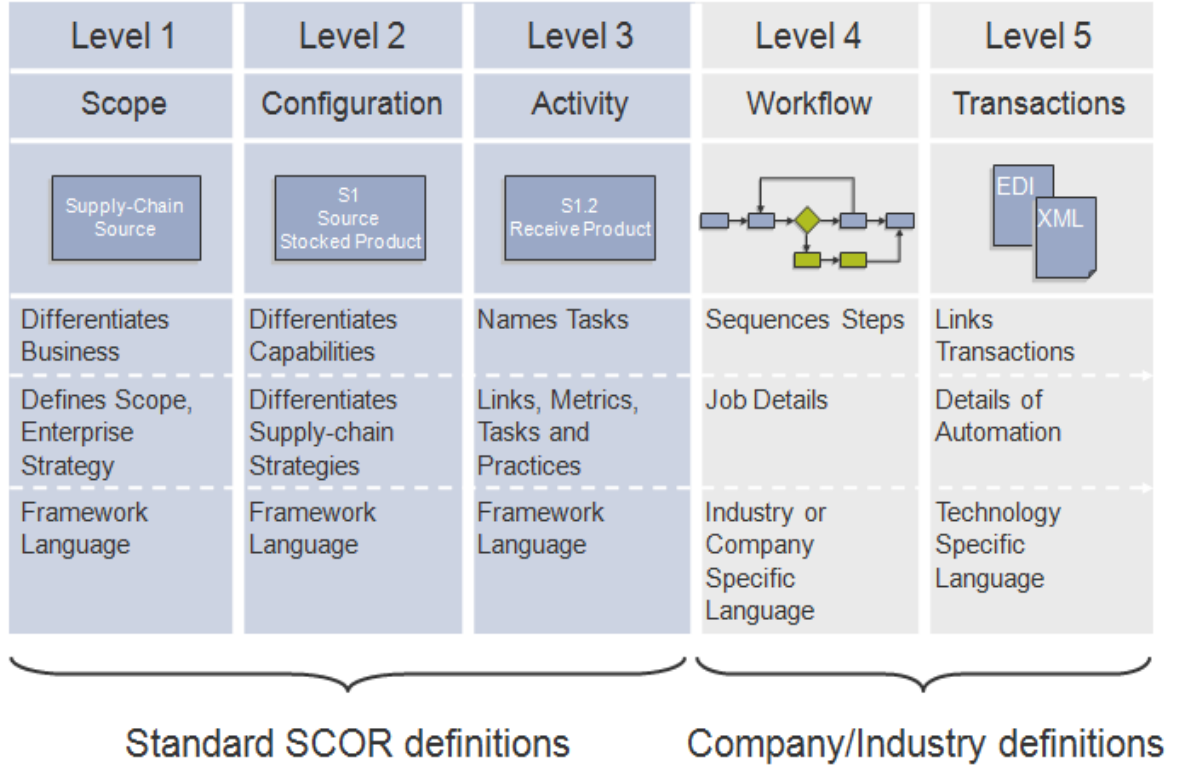
Score model is an effective tool to link and manage every aspect of supply chain segments by using business process, metrics, technology, best practices. This enables better communication between supply chain parties and more effective supply chain management (Supply Chain Council, 2008).



**Figure 47.** SCOR Model (Supply Chain Council, 2008)

SCOR is a supply chain management tool, which includes supplier's supplier to the customer's customer. It compasses following areas;

- Customer relations and correspondence from order to delivery
- Product related transactions such as equipment, supplies, raw material, etc.
- Demand forecasting and other marketing aspects of operations



**Figure 48.** SCOR Hierarchy (Supply Chain Council, 2008)

The basic structure of the reference-model focuses on the four key Supply Chain processes: plan, source, make, and deliver. In our model we included only three of the component, source –make-deliver (Dutta, 2003).

The purpose of the SCOR Thread Diagram is to determine the critical data elements and their location in regards to enabling whole chain traceability between different supply chain partners.

### SCOR Thread Diagram Modeling

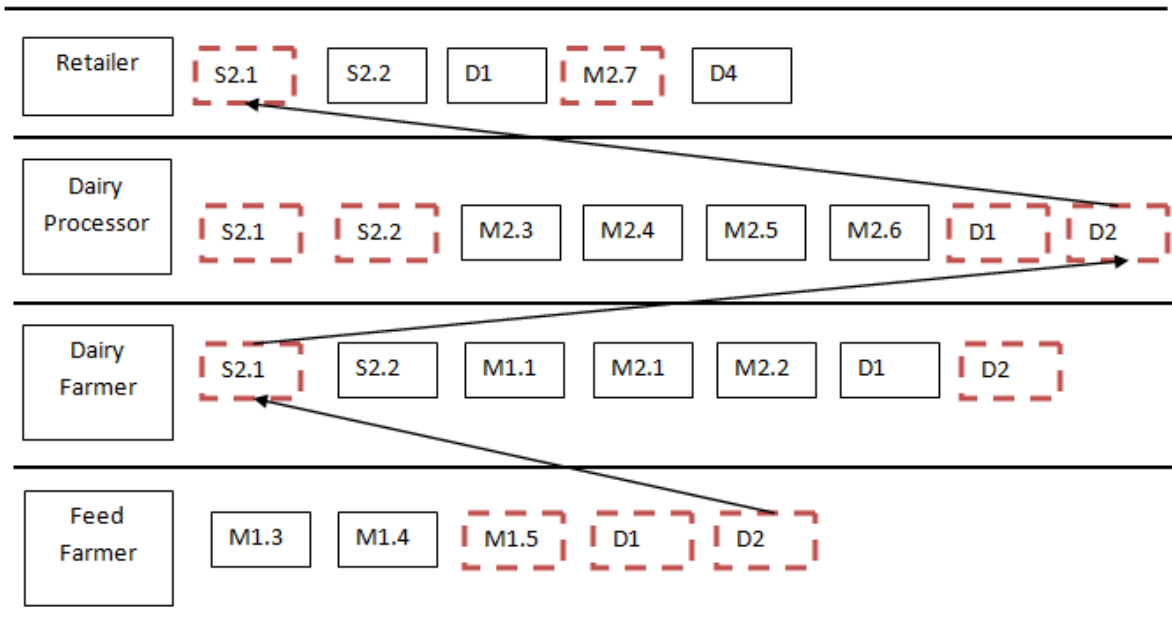
Thread diagram is used for configuration of a supply chain is driven by plan levels of aggregation, information sources, source location, methods for make production sites, delivery channels, products inventory deployments. In this model we use simple milk processing supply chain to identify the data critical location(s) for purpose of whole chain traceability system implementation. Below table defines the activity codes, which will be used as a reference codes in SCOR modeling table and thread diagram.

**Table 1.** Associated Codes with Activities

Source	S1	Make to Stock
	S2	Make to Order
	S3	Engineer to Order
Make	M1	Make to Stock
	M2	Make to Order
	M3	Engineer to Order
Deliver	D1	Deliver to Stock
	D2	Deliver to Order
	D2	Deliver to Engineer
	D4	Deliver Retail Product

**Table 2.** SCOR Modeling Table

SCOR Process Numbers	Type of SCOR Process	SCOR Process Description
S2.1	Source Make to Order	Schedule Product Deliveries
S2.2	Source Make to Order	Product Receiving and Verification
M1.1	Make to Stock	Feed Storing
M1.2	Make To Stock	Feeding Operation
M1.3	Make to Stock	Planting Operation
M1.4	Make to Stock	Seed Treatment
M1.5	Make to Stock	Harvesting
M2.1	Make to Order	Animal Feeding
M2.2	Make to Order	Milk the Animals
M2.3	Make to Order	Filtration
M2.4	Make to Order	Homogenization
M2.5	Make to Order	Pasteurization
M2.6	Make to Order	Bottling
M2.7	Make to Order	Product Staging
D1	Make to Stock	Product Storing
D2	Make to Order	Product Shipment/Delivery and Delivery Confirmation
D4	Deliver Retail Product	Shipment to Final Destination



**Figure .** Thread Diagram for Milk Supply Chain

Highlighted boxes indicate the critical activities that need to be examined carefully prior to any traceability system implementation. Below table was created to define the traceability critical activities and its properties needs to be captured, recorded and link with previous and next activity in the chain.

**Table 3.** Traceability Critical Activities within the Milk Supply Chain

Process Elements	Activities	Data Elements	Traceability
S2.1	Scheduling product deliveries: Sending purchase order	P.O number Quantity Unit Product Spec.	Storing P. O Details Electronically
S2.2	Received product and verification	Q.A test results Lot# GTIN, GLN, SSCC (if applicable) Supplier Name Date Quantity Unit	Storing and syncing the Q.A data with TRU ID Recording TRU related product attributes electronically
M1.5	Harvesting of feed	Crop type Date of harvest Lot# Quantity Unit Location Farm ID	Recording and syncing Harvest operation data electronically. Creating link between Harvest data and distribution/Storage process
M2.7	Product Staging at retail level	Product Lot number Expiration date Brand Name	Record item level information with previous TRU (case level)
D1	Product Storing	Lot Number/TRU Unique ID Product Description Quantity Unit Product Specs	TRU Id should be link to previous step and other TRU information should be capture and store electronically
D2	Product	EDI msg/Shipment	Use of EDI/or

	Shipment/Delivery and Delivery Notification/Confirmation	Manifest ID TRU IDs Product Specs Quantity Unit	advance delivery message should be communicated with the customer/ Information should be stored internally
--	--	---	---

### References

Danish Irfan, Xu Xiaofei, and Deng Sheng Chun “SCOR Reference Model of the Supply Chain Management System in an Enterprise”. 2008. School of Computer Science and Engineering, Harbin Institute of Technology, China. Department of Computer Science, COMSATS Institute of Information Technology, Pakistan,” A 2008

Devangshu Dutta, 2003, “Measure your supply chain performance”, ICFAI University Press

Supply Chain Council, 2004 “SCOR version 6.1 Overview”

### **ACKNOWLEDGEMENTS**

This thesis partially fulfills the degree requirements for Master of Science at Iowa State University. The assignment is done in collaboration with my supervisors and my major professor Dr. Charles R. Hurburgh, to whom I am very grateful for comments, suggestions, and valuable insight along the way.