

2011

# Cap-and-Trade Modeling and Analysis for Electric Power Generation Systems

Patricio Rocha

*University of South Florida*, [patricio.andres.rocha@gmail.com](mailto:patricio.andres.rocha@gmail.com)

Follow this and additional works at: <http://scholarcommons.usf.edu/etd>

 Part of the [American Studies Commons](#), [Economics Commons](#), [Industrial Engineering Commons](#), and the [Operational Research Commons](#)

---

## Scholar Commons Citation

Rocha, Patricio, "Cap-and-Trade Modeling and Analysis for Electric Power Generation Systems" (2011). *Graduate Theses and Dissertations*.

<http://scholarcommons.usf.edu/etd/3316>

This Dissertation is brought to you for free and open access by the Graduate School at Scholar Commons. It has been accepted for inclusion in Graduate Theses and Dissertations by an authorized administrator of Scholar Commons. For more information, please contact [scholarcommons@usf.edu](mailto:scholarcommons@usf.edu).

Cap-and-Trade Modeling and Analysis for Electric Power Generation Systems

by

Patricio Rocha

A dissertation submitted in partial fulfillment  
of the requirements for the degree of  
Doctor of Philosophy  
Department of Industrial and Management Systems Engineering  
College of Engineering  
University of South Florida

Major Professor: Tapas K. Das, Ph.D.  
Ralph E. Fehr, Ph.D.  
José L. Zayas-Castro, Ph.D.  
Susana K. Lai-Yuen, Ph.D.  
Kandethody M. Ramachandran, Ph.D.  
Audun Botterud, Ph.D.

Date of Approval:  
June 23, 2011

Keywords: Carbon Trading, Emissions, Electricity Markets, Revenue Recycling,  
Environmental Policy

Copyright © 2011, Patricio Rocha

## **Dedication**

To those who at some points in their lives have lost hope.

## **Acknowledgements**

I want to thank my mother Maria, father Nelson, and brother Marco for their unrelenting support and infinite love. Also, my infinite gratitude goes to my advisor, Dr. Tapas K. Das, for his support, academic and personal. An advisor that caring makes a tremendous difference. I also thank Dr. José L. Zayas-Castro, for his constant support and attention, Dr. Jaime Bustos, for giving me the opportunity to pursue this Ph. D., and my friends in Tampa, Diana, Ana, Mariah, Joe, Wilkistar, Vishnu, Chaitra, Diego, and Felipe. They are and, since different times during the past 6 years, have always been there for me. Last but not least, I acknowledge my relatives and friends who have been part of my life in Chile and in the U.S. You all have helped me get here.

## Table of Contents

List of Tables	iv
List of Figures	v
Abstract	vii
Chapter 1 Introduction	1
1.1 Cap-and-Trade Overview and History	2
1.2 Cap-and-Trade Design Features	4
1.2.1 Point of Regulation	4
1.2.2 Auction vs Free Distribution of Allowances	4
1.2.3 Gradual Stringency of Cap	5
1.2.4 Banking	5
1.2.5 Safety Valve	6
1.2.6 Revenue Recycling	6
1.3 Features of Implemented $CO_2$ Cap-and-Trade Programs	6
1.4 Research Contributions	8
1.5 Research Objectives	10
1.6 Dissertation Outline	11
Chapter 2 $CO_2$ Cap-and-Trade - Joint Electricity and Allowance Markets	12
2.1 Electricity Markets	12
2.2 Allowance Market	16
2.2.1 Allowance Allocation	16
2.2.2 Relationship Between Electricity and Allowance Markets	17
Chapter 3 Impact of $CO_2$ Cap-and-Trade on Investment Decisions of Power Generators	19
3.1 Literature Review	21
3.1.1 Capacity Expansion in Regulated Markets	21
3.1.2 Game Theoretic Models for Capacity Expansion	22
3.1.3 Real Options Models for Capacity Expansion	24
3.1.4 Chapter Outline	25
3.2 Game Theoretic Model	26

3.2.1	Schematic Representation of the Game Theoretic Modeling Framework	26
3.2.2	Expansion-Allowance-Electricity Games	28
3.2.2.1	Electricity Market Payoff	31
3.2.2.2	Allowance Market Payoff	32
3.3	Solution Procedure	32
3.3.1	Reinforcement Learning Algorithm	34
3.3.2	Computational Issues	36
3.4	A Case Study from Illinois Electricity Market	37
3.4.1	Background	37
3.4.2	Capacity Expansion Scenario	38
3.4.3	Allowance Market Scenario	40
3.4.4	Electricity Market Scenario	42
3.4.5	Results	43
3.5	Concluding Remarks	48
Chapter 4	Optimal Policies for $CO_2$ Cap-and-Trade Revenue Redistribution	52
4.1	Relevance	52
4.2	Revenue Recipients	53
4.3	Chapter Outline	53
4.4	Background	54
4.4.1	Literature Review	54
4.5	Types of Subsidies	57
4.6	Mathematical Models	58
4.6.1	Subsidy Modeling	58
4.6.2	Mathematical Formulations	60
4.6.2.1	Mathematical Formulation to Allocate Bid Subsidies	61
4.6.2.2	Mathematical Formulation to Allocate R & D Subsidies	63
4.6.3	Solution Methodology	66
4.7	Application	67
4.7.1	Allocation of Bid Subsidies	68
4.7.2	Allocation of R & D Subsidies	70
4.8	Feasibility of Implementation	73
4.9	Concluding Remarks	74
Chapter 5	Future Work	76
5.1	Analysis of Generation Investment Decisions Including Revenue Recycling Policies	77
5.2	Penalties for Violation of Cap	77
5.3	Demand Side Management Concepts: Consumers as Electricity 'Producers'	78

5.4	Integration of Different Cap-and-Trade Schemes	79
	List of References	80
	Appendices	88
	Appendix A: Approximation Using Least-Squares Method	89
	Appendix B: Least-Squares Approximation for Example Problem in 4.7	91

## List of Tables

Table 1.1	Attributes of Some Implemented and Proposed Cap-and-Trade Designs	7
Table 3.1	Installed Capacity in the Model Network	39
Table 3.2	Sample Expansion Plan Choices in Northern Illinois Electricity Market	39
Table 3.3	Capital Cost of Each Technology	40
Table 3.4	Lead Times for Each Considered Power Plant	40
Table 3.5	Selected Expansion Plans of the Generators for Each Scenario	45
Table 4.1	Supply/Demand Curve Parameters for Generators and Load in SC1 and SC2	68
Table 4.2	Quantity Supplied, Total Demand, Bid Subsidies, and LMP at Load Node for Scenarios SC10, SC1, SC20, and SC2	69
Table 4.3	Supply/Demand Curve Parameters for Generators and Load at $t = 1$	70



## List of Figures

Figure 1.1	Framework for Reducing $CO_2$ Emissions from the Power Electricity Sector	2
Figure 2.1	Effect of Allowance Cost on Supply Bids	18
Figure 3.1	A Schematic for the Game Theoretic Framework	27
Figure 3.2	Solution Algorithm Flow Diagram	33
Figure 3.3	Nine-Node Model for Illinois Network	38
Figure 3.4	A Schematic Representation of Yearly Demand Increase	43
Figure 3.5	Model Results for the Sample Network Under Three Cap-and-Trade Scenarios	46
Figure 3.6	Aggregated Cap and Emissions for the Planning Horizon (2007-2030) (Left) - $CO_2$ Emissions per MWh (Right)	47
Figure 4.1	Supply Curve Before and After Subsidy $\alpha$ s	59
Figure 4.2	Four-Node Sample Network	68
Figure 4.3	Supply Curves of G2 and G3 in Scenarios SC10 and SC20	70
Figure 4.4	Stock of R & D Throughout the Planning Horizon for Each Low-Emission Generator	71
Figure 4.5	Demand and Load LMP in the Scenario Post R & D Subsidies Implementation and the Scenario with No R & D Subsidies	72
Figure 4.6	Market Share of the Generators in the Scenario Post R & D Subsidies Implementation and the Scenario with No R & D Subsidies	73

Figure B.1 Reduction of Production Cost Function and Least-Squares Approximation for G2 and G3 in Example Problem in 4.7.2

91

## **Abstract**

Cap-and-trade is the most discussed  $CO_2$  emissions control scheme in the U.S. It is a market-based mechanism that has been used previously to successfully reduce the levels of  $SO_2$  and  $NO_x$  emitted by power generators. Since electricity generators are responsible for about 40% of the  $CO_2$  emissions in the U.S., the implementation of  $CO_2$  cap-and-trade will have a significant impact on electric power generation systems. In particular, cap-and-trade will influence the investment decisions made by power generators. These decisions in turn, will affect electricity prices and demand. If the allowances (or emission permits) created by a cap-and-trade program are auctioned, the government will collect a significant amount of money that can be redistributed back to the electricity market participants to mitigate increases on electricity prices due to cap-and-trade and also, to increase the market share of low-emission generators.

In this dissertation, we develop two models to analyze the impact of  $CO_2$  cap-and-trade on electric power generation systems. The first model is intended to be used by power generators in a restructured market to evaluate investment decisions under different  $CO_2$  cap-and-trade programs for a given time horizon and a given forecast in demand growth. The second model is intended to aid policymakers in developing optimal  $CO_2$  revenue redistribution policies via subsidies for low-emission generators.

Through the development of these two models, our underlying objective is to provide analysis tools for policymakers and market participants so that they can make informed

decisions about the design of cap-and-trade programs and about the market actions they can take if such programs are implemented.

## Chapter 1: Introduction

In the last ten years, serious concerns regarding the climate change phenomenon have spurred the implementation of emissions control schemes, particularly for  $CO_2$ , in the U.S. and countries around the world. A  $CO_2$  emissions control scheme will significantly impact the future power generation landscape in the U.S. since the power sector is responsible for a sizable share (about 40%) of the  $CO_2$  emissions [1].

The two most commonly debated  $CO_2$  emissions control schemes are a cap-and-trade program and a carbon tax. In the past, cap-and-trade programs have been used effectively in the U.S. to limit  $NO_X$  and  $SO_2$  emissions [2]. More recently, the European Union, New Zealand, and Australia, have implemented or considered the implementation of  $CO_2$  cap-and-trade programs [3–5]. In the U.S., several states in the Northeast have signed on to the Regional Greenhouse Gas Initiative (RGGI), a cap-and-trade program for  $CO_2$  emissions. California is also about to implement a cap-and-trade program [6]. A  $CO_2$  cap-and-trade program, in its most general form, will establish a *cap* for the total quantity of  $CO_2$  emitted in a geographic region. A certain number of pollution permits or *allowances*, consistent with the cap, will then be issued. Individuals and companies will need to procure allowances in order to emit  $CO_2$  and avoid fines. If allowances are auctioned, part of the revenue raised can be recycled to households and/or used to subsidize green generation technologies. Allowances can be *traded* among individuals and companies. In contrast, a carbon tax scheme levies a tax on the production, distribution, and use of fossil fuels. The government sets a price per ton of carbon emitted, and the tax is expected to encourage

the utilities, businesses, and individuals to reduce the use of carbon-intensive energy. The revenue raised from the tax can also be recycled. In this dissertation, we focus on cap-and-trade programs though this should not be interpreted as an endorsement of cap-and-trade programs over carbon tax programs.

In Figure 1.1, the relationship between a cap-and-trade program and carbon revenue redistribution (recycling) can be observed in the context of reducing  $CO_2$  emissions in the power electricity sector.

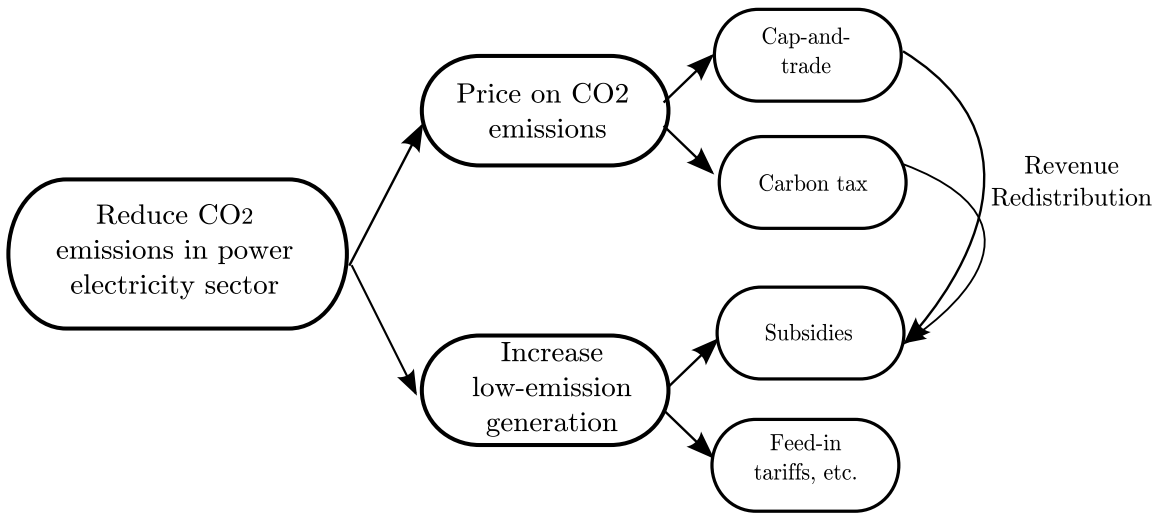

Figure 1.1: Framework for Reducing  $CO_2$  Emissions from the Power Electricity Sector

## 1.1 Cap-and-Trade Overview and History

Cap-and-trade is a market-based tool designed to control and reduce externalities, such as greenhouse gas emissions, at a reduced cost. It is an approach that has been long favored by economists as an alternative to command-and-control government regulation. Due to its market-based nature, it allows polluting companies to choose: a) if they will reduce greenhouse gas emissions (or pay penalties for failing to do so) and b) how emissions reductions will be achieved (as opposed to the government telling the companies how).

As noted earlier, there are three key elements in a cap-and-trade program: cap, allowances, and trade. Successful companies under a cap-and-trade regime will either restrict output or switch to a cleaner fuel, thus reducing the number of allowances they need. This reduction will allow these successful companies to sell allowances to less efficient companies, obtaining additional profits. Since the number of allowances issued is commensurate with the size of the cap and the penalties for failing to surrender enough allowances can be hefty, it is expected that the total number of emissions will fall below the cap.

The theoretical work that serves as basis for cap-and-trade was developed by the British economist Arthur Cecil Pigou (1877 - 1959), who introduced the concept of externalities i.e., costs that are not included in the price of a product. Pigou proposed that companies should be responsible for these costs. It was not until the 1980s that cap-and-trade was seriously considered as a practical means for controlling externalities. Under President George H. W. Bush, a group of conservative economists and environmentalists, proposed a cap-and-trade program to reduce the emissions of pollutants responsible for *acid rain*,  $NO_X$  and  $SO_2$ . The program was implemented as part of the Clean Air Act of 1990. After 20 years of its implementation, the program had reduced emissions of  $NO_X$  and  $SO_2$  by half, at a reduced cost for utilities, and also has generated health benefits for the population.

Despite this success story, the current economic and political situations in the U.S. and several countries have proven to be formidable obstacles for the implementation of a similar program to reduce greenhouse gas emissions,  $CO_2$  chiefly among them.

It may be noted that in the rest of this document we will focus only on power generators as the entities potentially subjected to a  $CO_2$  cap-and-trade program, despite the fact that other economic sectors, such as transportation, could also be regulated by the program.

## **1.2 Cap-and-Trade Design Features**

In addition to the concepts of cap, allowance, and trade, cap-and-trade is a framework comprising multiple features. These features are an important source of debate among policymakers that are involved in the design of cap-and-trade programs. The choices made on each of these features are likely to play a significant role in the environmental effectiveness of the program as well as on the economic consequences of the program's implementation.

### **1.2.1 Point of Regulation**

The debate about the point of regulation in a cap-and-trade program is mainly centered on upstream and downstream approaches. In the upstream approach, a cap is placed on primary fuel distributors, whereas in the downstream approach a cap is placed on fuel users, particularly large-point sources such as electricity generators. If an upstream approach is considered, electricity generators do not need to procure allowances to produce electricity. However, they will face higher production costs since the primary fuel distributors will pass the allowance cost on to them. On the other hand, in a downstream approach, the generators will have to procure allowances in order to produce electricity. In [7], a comparison between the upstream and downstream approaches in the electricity markets context can be found.

### **1.2.2 Auction vs Free Distribution of Allowances**

In a downstream approach, a free distribution of allowances can result in large generator profits since generators will pass on to the consumer the market price of the allowances. For example, under the European Union Emissions Trading Scheme, the UK



electric sector received free allowances based on historic emissions and enjoyed wind-fall profits of £500 million in the first year of the program [8]. On the other hand, if all allowances are auctioned right from the beginning of the program, generators can be negatively impacted due to new financial and administrative burdens. Most of the cap-and-trade programs implemented or under consideration in the U.S. include the adoption of a hybrid approach with a gradual increase in the proportion of allowances auctioned. For instance, the Regional Greenhouse Gas Initiative (RGGI) mandates the auction of at least 25% of the allowances using a uniform price auction mechanism [9]. If all or a portion of the allowances are auctioned, generators will have to develop allowance bid strategies for the auction. A study comparing the above allowance allocation approaches in the electricity markets context is presented in [10].

### **1.2.3 Gradual Stringency of Cap**

All  $CO_2$  cap-and-trade plans include this feature, yet there is no agreement as to how stringent the cap reduction should be. For instance, the EU ETS has reduced the cap for the 2008-2012 period by 7% [3]. RGGI is considering a fixed cap for the period 2009-2014 before initiating an emissions decline of 2.5% per year for the years 2015 through 2018 [9]. This is a key feature since inadequate cap stringency levels can lead to over-compliance but failure to achieve environmental goals [11].

### **1.2.4 Banking**

If banking of allowances is permitted, generators will be able to use allowances for later periods. Thus, generators with excess allowances at the end of a period will have two alternatives: sell them in a secondary market or keep them for the later periods. Banking offers interesting possibilities to generators, particularly in stringent programs, since the

value of banked allowances increases with the stringency of the cap (this also stimulates early emissions reductions) [12].

### **1.2.5 Safety Valve**

A safety valve has been proposed by economists with the objective of limiting the potential volatility in the price of allowances. In this way, the cost of meeting the cap can be limited [13]. Critics of including safety valves in cap-and-trade programs argue that they are intended to relax emission target reductions by limiting the cost of emissions.

### **1.2.6 Revenue Recycling**

If all (or, a portion) of the allowances are auctioned, the collected revenue may be redistributed by the government back to consumers, low-emission generators, and other market participants. Several economists have argued in favor of this redistribution. We formulate a mathematical model to obtain carbon revenue redistribution strategies in Chapter 4.

## **1.3 Features of Implemented $CO_2$ Cap-and-Trade Programs**

Table 1.1 presents a compilation of the significant attributes of some proposed and implemented cap-and-trade programs in the U.S. and abroad. The columns titled “2020 Reduction Target” and “2050 Reduction Target” are included to illustrate the level of stringency of each cap-and-trade design. From the table, it can be clearly seen that there is no standard cap-and-trade design i.e., the setting of each cap-and-trade attribute varies from design to design.

Table 1.1: Attributes of Some Implemented and Proposed Cap-and-Trade Designs

Design	Point of Regulation	Allowances Auctioned	2020 Reduction Target	2050 Reduction Target	Banking Allowances	Revenue Recycling	Safety Valve
Waxman - Markey	Downstream/Upstream	15%	Cut 17% using 2005 baseline	Cut 83%	Unlimited	Yes. No details	\$10 floor
Boxer - Kerry	Downstream/Upstream	25%	Cut 20% using 2005 baseline	Cut 83%	Unlimited	15% of revenue	\$11 floor
Cantwell - Collins	Upstream	100%	Cut 20% using 2005 baseline	Cut 83%	Limited	75% back to consumers	\$7 floor \$21 ceiling
Kerry - Lieberman Graham	Downstream	15%	Cut 17% using 2005 baseline	Cut 80%	No info	Yes. Up to each state	Yes. No details
EU ETS	Downstream	0%	Cut 21% using 2005 baseline	Cut 80%	Unlimited	No revenue	No
CPRS	Upstream	Majority	Cut 5% using 2000 baseline	Cut 60%	Unlimited	Yes. No details	A\$40 ceiling
RGGI	Downstream	25% or more	Up to each State e.g., MD cuts 50% (2006 baseline)	Up to each State e.g., MD cuts 90%	Unlimited	Yes. Up to each state	\$7 or \$10 ceiling

EU ETS: European Union Emissions Trading Scheme, CPRS: Carbon Pollution Reduction Scheme (Australia), RGGI: Regional Greenhouse Gas Initiative

The existence of multiple cap-and-trade designs (or, in other words, the lack of a standard design) is one of the main motivations for the models presented later in this dissertation.

## 1.4 Research Contributions

The notion of using a cap-and-trade program to control the amount of greenhouse gases in the atmosphere is relatively recent. As such, there are several open research questions about the design of these programs and the resulting impact of their implementation. This dissertation presents models that can be used to obtain answers to two of these questions. These models can be identified as the main contributions of the dissertation. The two questions that we address with our models are:

- What would be the impact of a  $CO_2$  cap-and-trade program (with a particular design) on the capacity expansion decisions of electricity generators in a restructured power market?
- How should the revenue collected through selling allowances in a cap-and-trade program (or via a carbon tax) be redistributed back to market participants to mitigate electricity price hikes and to increase low-emission generation?

The game theoretic model we present in Chapter 3 addresses the first question. The model considers multiple electricity generators, closed-loop information structures, and a planning horizon. Each generator considers a set of multiple expansion plans with multiple features, namely technology, location, and construction lead-times. This is in contrast to previous models in the literature that only include technology and location. The expansion plans are evaluated based on the profit they accrue to the generators in the electricity and allowance markets. We model the allowance market considering players that submit strategic bids to an auction whose settlement provides the allowance allocation. Previous

capacity expansion models in the literature have assumed the allowance market as perfectly competitive. We model the electricity spot market considering the strategic bids of players and the network transmission constraints. The consideration of transmission constraints is absent in previous capacity expansion models (in both, those that do not consider the impact of cap-and-trade and in those that do consider it) with the exception of [14]. We acknowledge that there is a trade-off in considering all of the above features: the state-space of the variables in our model is discrete and thus, our solutions are local equilibria (with respect to the other elements in the state-space).

The nonlinear nonconvex optimization model we present in Chapter 4 addresses the second question. This model is new since most of the literature on carbon revenue redistribution is addressed from a micro-economics perspective, without specific consideration of power generators and the power network. We believe it is important to consider the generators and the network since the expected electricity price increases due to cap-and-trade will depend on the location of generators and consumers in the network (i.e., consumers located in regions that depend more on coal-based generators will experience higher average electricity prices). In addition, we believe that cap-and-trade alone will not be sufficient to reduce emissions from the electricity sector; to achieve emissions reductions at a reduced cost for the economy, an increase in market share of low-emission generators will also be required. The novel carbon revenue redistribution model we develop, thus, has a twofold objective, mitigating electricity price increases due to cap-and-trade and increasing the market-share of low-emission generators. The revenue redistribution in our model is achieved via subsidies that are allocated to low-emission generators taking into consideration their R & D learning curves. To our knowledge, a model with these characteristics has not been developed before in the literature.

## 1.5 Research Objectives

The overall objective of this dissertation is:

- Provide analysis tools for policymakers and market participants so that they can make informed decisions about the design of cap-and-trade programs and about the market actions they can take if such programs are implemented.

The specific objectives of this dissertation are:

- Develop a framework to evaluate multi-year capacity expansion plan alternatives for power generators in restructured markets under different cap-and-trade designs.
- Formulate and implement a solution algorithm for the above framework to derive equilibrium expansion plan strategies for the generators.
- Develop a welfare maximization mathematical model to obtain optimal redistribution policies for the revenue collected through a cap-and-trade program or a carbon tax via subsidies.
- Incorporate the impact of R & D subsidies on reduction of production cost for low-emission generators in the carbon revenue redistribution mathematical model.
- Find a solution for the nonlinear nonconvex revenue redistribution mathematical model by using piece-wise linear approximations.
- Demonstrate the use of the capacity expansion framework and the revenue redistribution model on sample problems and draw potentially generalizable insights from the results in each case.

## 1.6 Dissertation Outline

In the next chapter, we present an overview of spot (or day-ahead) electricity and allowance markets, their settlements, and the relationship between both markets. We note that the market settlements presented in Chapter 2 are used throughout the remaining chapters of the dissertation. In Chapter 3, we present a game theoretic model to analyze the impact of  $CO_2$  cap-and-trade on capacity expansion decisions of power generators in restructured markets. This chapter also includes a review of the capacity expansion literature, a solution methodology for the game theoretic model, a case study from the Illinois electricity market, and conclusions and findings from the case study. In Chapter 4, a mathematical model for developing optimal redistribution policies for the revenue collected by a  $CO_2$  cap and trade or a carbon tax program is presented. A review of the literature, a solution methodology, an example application, and conclusion/findings are also presented. Finally, in Chapter 5, future work and research opportunities are discussed.

## **Chapter 2: $CO_2$ Cap-and-Trade - Joint Electricity and Allowance Markets**

In this chapter we first describe how the generators bid in spot electricity markets and how the system operator dispatches power in a network and obtains the locational marginal prices. Later in the chapter, we describe the  $CO_2$  allowance market and show how it is connected to the electricity market. The description and settlement of these markets are used in the models presented in Chapters 3 and 4.

### **2.1 Electricity Markets**

Participants of an electricity market maximize their benefits by seeking optimal bidding strategies. Strategic bidding behavior of the participants results in different market outcomes (e.g., nodal electricity prices and generation quantity allocations) under different auction mechanisms used by the system operator [15]. Two forms of auctions commonly used in deregulated electricity markets are uniform price auction and discriminatory auction [16].

- In a uniform price auction, all selected suppliers are paid a uniform price, equal to the market clearing price. The selection process starts by distributing the requested electricity generation units to the highest bidder, then to the second highest bidder, and so forth until all generation needs (in MWh) are allocated. The market clearing price corresponds to the bid offered by the last selected bidder.



- In a discriminatory auction, the suppliers are selected in a manner similar to the uniform auction, but are paid according to their own bids instead of the market clearing price.

A game theoretic model in [17] compares uniform-price and discriminatory auction. It is shown that the equilibrium revenues of the generators under uniform price auction and discriminatory auction are different, in particular, that the expected total auction revenue of a network with *market power* is higher under uniform price auction when compared to discriminatory auction (pay-as-bid type). Market power is defined in the microeconomics literature as the ability of a seller to maintain prices above competitive levels for a sustained period of time. Commonly used market power indices are Herfindahl-Hirschmann index, Lerner index, quantity modulated price index (QPMI), and revenue-based market power index (RPMI) [15].

In the process of developing bids for the day-ahead and real-time electricity markets, generators and loads consider market forecasts for the power network. The forecasts provide information regarding expected prices, transmission network conditions, demand, among other parameters. Generators and loads then submit their bids to the system operator which in turn solves an optimal power flow (OPF) problem to determine the quantity allocations and the prices in the network. The solution of the OPF, thus, serves as the basis to compute the profits that generators and loads make in the day-ahead and real-time markets. Since all market participants develop bids with the objective of maximizing their respective profits, the competition in a deregulated electricity market can be modeled as a multi-player matrix game.

Let  $z_i = (z_{i_1}, z_{i_2}, \dots, z_{i_{N_i}})$  denote a supply bid vector submitted by generator  $i$ . Each element of the vector represents the supply bid for each of the  $N_i$  power plants generator  $i$  owns in the network. Each individual supply bid  $z_{i_k}$  is defined by the pair  $(a_{i_k}, b_{i_k})$ , where the first element is the intercept and the second is the slope of the supply curve. Hence, each supply bid curve is characterized by  $p = a_{i_k} + b_{i_k}q$ , where  $p$  and  $q$  denote the price

and quantity, respectively. Let  $z_{-i}$  denote the supply bids of the rest of the generators in the network. When the range of values of the supply bid vector elements are suitably discretized, the total number of action choices for each bidder is finite. Then the cardinality of the supply bid vector of bidder  $i$  for each power plant  $k$  is given as follows,

$$|z_{i_k}| = |a_{i_k}| \times |b_{i_k}|. \quad (2.1)$$

The cardinality of the total action space for generator  $i$  in the electricity market can be written as

$$|z_i| = \prod_{k=1}^{N_i} |z_{i_k}|. \quad (2.2)$$

It is assumed that the loads submit linear demand bids. The payoff for generator  $i$  in a single instance of the electricity day-ahead or spot market can be written as follows,

$$r_i[z_i] = \sum_{k=1}^{N_i} q_{i_k} p_h - \sum_{k=1}^{N_i} (a_{i_k}^0 q_{i_k} + \frac{1}{2} b_{i_k}^0 q_{i_k}^2), \quad (2.3)$$

where  $q_{i_k}$  is the quantity of electricity produced by plant  $k$  of generator  $i$ ,  $p_h$  is the locational marginal price (LMP) at node  $h$  where plant  $k$  is located, and  $\sum_{k=1}^{N_i} (a_{i_k}^0 q_{i_k} + \frac{1}{2} b_{i_k}^0 q_{i_k}^2)$  is the total cost for each generator  $i$  (thus,  $a_{i_k}^0, b_{i_k}^0$  are the true marginal cost parameters). The values for  $q_{i_k}$  and  $p_h$  in (2.3) are obtained by solving the following Optimal Power

Flow (OPF) problem as presented in [18],

$$\max \sum_h B_h[p_h] - \sum_h C_h[p_h], \quad (2.4)$$

subject to:

$$\sum_{i \in i(h)} q_i[p_h] - \sum_{\theta \in \theta(h)} d_\theta[p_h] - \sum_{l \in l(h)} (m_{hl} - m_{lh}) = 0 \quad \forall \text{ node } h,$$

$$\sum_{hl \in V(\rho)} R_{hl}(m_{hl} - m_{lh}) = 0 \quad \forall \text{ voltage loop } \rho,$$

$$m_{hl} \leq M_{hl} \quad \forall \text{ arc } hl,$$

$$m_{hl} \geq 0 \quad \forall \text{ arc } hl,$$

where  $B_h[p_h]$  is the total benefit to consumers at node  $h$ ,  $C_h[p_h]$  is the total cost to producers at node  $h$ . If consumers and producers are assumed to submit linear demand bids and linear supply bids, respectively, the benefit/cost for a single consumer/producer can be computed by integrating its linear demand/supply with respect to  $d/q$ . For instance, if a consumer  $\theta$  submits a demand bid  $p = e_\theta - f_\theta d$ , then the benefit function is  $B = e_\theta d - \frac{f_\theta}{2} d^2$ .

The rest of the notation in (2.4) is as follows:  $i(h)$  is the set of generators at node  $h$ ,  $\theta(h)$  is the set of consumers at node  $h$ ,  $q_i[p_h]$  is the quantity supplied by generator  $i$  located at node  $h$ ,  $d_\theta[p_h]$  is the quantity demanded by consumer  $\theta$  at node  $h$ ,  $l(h)$  is the set of nodes directly connected through a transmission line with node  $h$ ,  $m_{hl}$  is the power flow between nodes  $h$  and  $l$ ,  $V(\rho)$  is the set of arcs that define loop  $\rho$ ,  $R_{hl}$  is the reactance of arc  $hl$ , and  $M_{hl}$  is the fixed capacity of arc  $hl$ . The formulation is a quadratic convex problem whose solution provides the quantities supplied, quantities demanded, and power flows in the network. The locational marginal prices (LMPs) at each node in the network are obtained from the shadow prices of the first set of constraints in the above formulation.

## 2.2 Allowance Market

Under a  $CO_2$  cap-and-trade program, fossil fuel generators need to procure a sufficient number of allowances to compensate for the emissions caused by electricity generation and thus avoid costly penalties. We note that the procurement of allowances is not restricted to fossil fuel generators only. Excess allowances procured by the generators can be traded in secondary markets.

### 2.2.1 Allowance Allocation

Allowances are distributed among generators and other entities either via auction, or for free based on historic emissions (grandfathering), or by using a hybrid approach. Per the auction or the hybrid approaches, generators submit strategic allowance bids. For example, in the Regional Greenhouse Gas Initiative (RGGI), a cap-and-trade program implemented in the Northeast U.S., generators submit bids indicating price and quantity of allowances required. The auction is cleared using a uniform price scheme [9].

Generators bid in the allowance market considering their strategies in the electricity market for an allowance bidding period (e.g. six months). Generators determine the number of allowances to procure based on the fossil fuel-driven capacity that they offer to the market. The price that the generators pay for the allowances impact their supply bids in the electricity market. When generators are not able to surrender allowances commensurate with the emissions resulting from their electricity production, they are subjected to hefty fines.

In this dissertation, it is assumed that allowances are distributed via auction to which each generator  $i$  submits bids  $y_i$  indicating price ( $\omega_i$ ) and quantity ( $\zeta_i$ ). Similar to the situation described earlier for the spot electricity market, generators can develop multiple bids by varying discretized parameters for price and quantity.

If the entity in charge of the allowance auction has the objective of maximizing the allowance auction revenue, then allowance allocations can be developed by solving the following linear optimization problem,

$$\max \sum_i \omega_i o_i, \quad (2.5)$$

subject to:

$$\sum_i o_i \leq A \quad (2.6)$$

$$o_i \leq \zeta_i \quad \forall \text{ generator } i$$

$$o_i \geq 0 \quad \forall \text{ generator } i$$

where  $o_i$  is the number of allowances allocated to generator  $i$ ,  $A$  is the total amount of allowances available in the auction,  $\omega_i$  and  $\zeta_i$  are the price and quantity elements of the allowance bid submitted by generator  $i$ , respectively. We consider a uniform market clearing price auction where the auction price  $P$  is obtained from the shadow price of constraint 2.6. If the sum of the quantity bid elements of the generators ( $\sum_i \zeta_i$ ) is less than  $A$ , the allowance is cleared at a reserve price.

## 2.2.2 Relationship Between Electricity and Allowance Markets

We assume that the allowance cost is incorporated into the supply bids of the generators as presented in [19] by increasing the intercept term  $a_{i_k}$ ,

$$\hat{a}_{i_k} = a_{i_k} + \delta P, \quad (2.7)$$

where  $\delta$  is the emissions factor (which indicates the amount of  $CO_2$  (in tons) generated per MWh of electricity production, depending on the technology) and  $P$  is the allowance price obtained from the allowance auction settlement. This is equivalent to shift a supply

curve to the left (similar to the effect of a tax) as shown in Figure 2.1. Let  $P'$  be the price

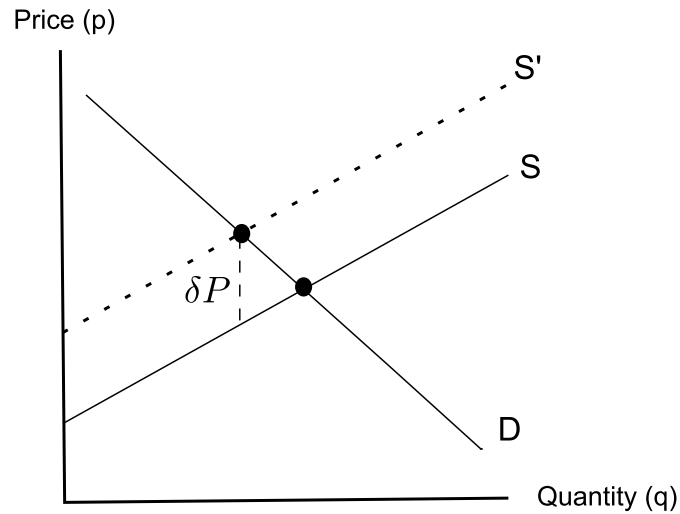

Figure 2.1: Effect of Allowance Cost on Supply Bids

at which a generator trades unused allowances in the secondary market. Assuming there is sufficient supply and demand in the secondary market, the allowance revenue/loss  $S_i$  for generator  $i$  during an entire allowance bid period can be obtained as

$$S_i = P'(o_i - o_i^c), \quad (2.8)$$

where  $o_i^c$  is the number of allowances consumed. It may be noted that  $o_i^c$  is a function of the supply bids submitted by generator  $i$  for each instance of the day-ahead (or spot) electricity market during the allowance bidding period. This relationship is explained in detail in the next chapter.

### **Chapter 3: Impact of $CO_2$ Cap-and-Trade on Investment Decisions of Power Generators**

According to the U.S. Department of Energy's Annual Energy Outlook [20], electricity demand in the U.S. is expected to increase at an average rate of 1.1 % per year from 3,659 billion KWh in 2006 to 4,705 billion in 2030. In regulated markets, system operators coordinate generation expansion decisions among the generators. In restructured markets, competition among generators guides the expansion decisions of when, where, and what type of capacity to add that maximize the profits. Our focus in this chapter is on the restructured markets. In recent years, the process of making capacity expansion decisions has become more challenging due to the implementation/consideration of  $CO_2$  emissions control policies such as cap-and-trade. In this chapter we present a game theoretic model that the generators can use to develop their long term capacity expansion plans in restructured electricity markets subjected to  $CO_2$  cap-and-trade.

Capacity expansion investments made by generators impact their strategic trading behavior in the electricity markets (forward, day-ahead, and spot), and also in other related markets including trading for  $CO_2$  allowances, financial transmission rights, generation capacity, and ancillary services. For instance, adding a large nuclear generator (with lower marginal cost) to a network will likely lower the current locational marginal prices and reduce the present demand and price for  $CO_2$  allowances. Clearly, the profitability of an expansion plan is impacted by the changes the plan itself imparts on the trading conditions in the electricity and related markets. Hence, these changes must be accounted for in the economic assessment of a capacity expansion investment plan.

In the last decades the real options theory [21] has been applied to assess capacity expansion investments in electricity markets [22–27]. Real options theory gives the opportunity to analyze the effect of delaying an irreversible investment (as opposed to considering the case where the only option for making an investment is now or never) or abandon an investment plan. This is of particular importance in capacity expansion since, in the presence of uncertainty introduced by the competing interests of the generators, the ability to delay an irreversible capacity expansion investment or abandon an investment plan can profoundly affect the generators' profit. Most of the real options literature on generation expansion considers the uncertainty in electricity price and demand as known stochastic processes. These studies do not explicitly model the interactions of the generators' strategies in electricity and related markets that are at the root of the above uncertainties. In this chapter, we present a model that explicitly considers the competition in the allowance and electricity markets, interaction between these markets, and how they impact the capacity expansion decisions.

As noted earlier in this dissertation, in recent years power markets have been subjected to new environmental regulations. The current climate change legislation debate is centered around the implementation of a cap-and-trade program to reduce the  $CO_2$  levels in the atmosphere and encourage greener electricity generation. Since electricity generators are responsible for about 40% of the  $CO_2$  emissions in the U.S. [1], any program aimed at reducing  $CO_2$  emissions will have a significant impact on the power generation sector. In fact, if an emissions control program is to achieve its goals, there will have to be a shift from the current fossil-fuel technologies to nuclear power and renewable sources. Thus, power generators need to assess the potential implications of a  $CO_2$  emissions control plan when making generation expansion decisions. Thus far, the only  $CO_2$  emissions control program implemented in the U.S. is the Regional Greenhouse Gas Initiative (RGGI), which is a regional cap-and-trade program. In this research, we develop a game



theoretic model to obtain capacity expansion plans for generators in a restructured market under a  $CO_2$  cap-and-trade program.

In general, the implemented and proposed cap-and-trade programs have common elements such as the cap, a limited number of allowances (commensurate with the size of the cap), and the possibility of trading allowances. Albeit this common framework, the programs may differ as to how they treat various of the design attributes presented in Section 1.2 including stringency of the cap, upstream or downstream point of regulation, method of allowance distribution (sold via auction, free grandfathering, or a combination of both), and banking of allowances. The choice of these attributes continues to be a source of debate among the policymakers. The capacity expansion model presented in this chapter provides an effective instrument for policymakers to assess various alternatives. This is exemplified in the case study presented in Section 3.4.

### **3.1 Literature Review**

We first offer a short overview of the literature on capacity expansion in regulated electricity markets. Later in the section, we discuss capacity expansion models for restructured electricity markets focusing on those developed using game theory and real options theory.

#### **3.1.1 Capacity Expansion in Regulated Markets**

Restructuring of electricity markets began in the early 1990s. All the capacity expansion literature during most of that decade and prior to it addressed the expansion problem in regulated markets. These papers [28–30], to cite a few, present optimization models where a central planning authority solves a cost minimization problem subject to transmission constraints. In restructured electricity markets, capacity expansion decisions are

not coordinated by a central authority, but instead made independently and non-cooperatively by competing generators in a network. Consequently, the expansion models developed for regulated markets are not applicable in the restructured settings. The dynamic noncooperative interactions of the generators, retailers, and investors in restructured electricity market are best represented by game-theoretic models.

### **3.1.2 Game Theoretic Models for Capacity Expansion**

One of the first game-theoretic models for capacity expansion in restructured power markets is presented in [31]. The competition is modeled using Cournot theory of oligopoly. Generators decide on how much capacity to expand, new entries are not allowed, and the expansion decisions are made simultaneously by all competitors. Each player seeks to maximize its profit subject to operational and physical constraints. The Cournot equilibria is obtained using an iterative search procedure that maximizes the profit of each player, one at a time, while keeping all other players' actions fixed. The state spaces of the expansion quantity variables are considered to be continuous for each generator. In [32], two imperfect competition models for capacity expansion are presented: 1) an open-loop Cournot model similar to the model in [31], in which each generator selects its capacity and generation plans at the same time assuming the generation levels of its competitors are known; 2) a closed-loop Cournot model where capacity decisions are made in the first stage and operation decisions are made in the second stage. Equilibrium conditions in both of these models are established resulting in a quadratic programming and an MPEC model, respectively.

A different approach to model the capacity expansion problem was taken in [14] where a two-tier matrix game model is presented. The upper tier game models the competition in generation investment, while the lower tier is a supply function game that captures the competition at the power network operational level. Each matrix game is solved using

a reinforcement learning algorithm. Risk due to volatilities in profits is incorporated in the payoffs via a *conditional value at risk* (CVaR) measure. A game theoretic model that incorporates  $CO_2$  emissions in the expansion problem is presented in [33]. Their model is similar to the open-loop Cournot in [32] but the operational decision variables are not only restricted to the electricity market but also to the allowance and green certificate markets. Competition in the electricity market is modeled using the conjectural variations approach and the allowances and green certificate markets are assumed to be perfectly competitive. Prices of allowances and green certificates are obtained endogenously.

Our approach is different from those presented in [31], [32], and [33] in that we consider a discrete set of feasible expansion plans for each generator, for a time horizon and a forecasted growth in demand. The expansion plans take into account the constraints of capital availability, network location, lead time, and technology. We assess the financial performance of these plans by assuming that all generators implement their plans simultaneously at the beginning of the time horizon (i.e., no leader-follower dynamics are present). This performance assessment is based on the outcome of the competition between the generators in both the electricity market and the  $CO_2$  allowance market during each period of a planning horizon. The competition in the electricity market is modeled assuming that each generator has a discrete set of supply function bids that is consistent with its mix of available capacity and technology. We consider transmission constraints and resulting congestion to accurately assess the performance of each of the expansion plans (these features are not considered in [31], [32], and [33]). The  $CO_2$  allowance market is also modeled assuming that generators have a discrete set of allowance bids comprising price and quantity. As in [33], equilibrium allowance prices are determined endogenously by our model. Our approach considers discrete sets of expansion plans and supply function bids as in [14]. However, we also model the competition among the generators in the allowance market. Additionally, we consider a multi-year time horizon with construction lead times for new plants.

Papers that discuss the implications of a  $CO_2$  cap-and-trade program, but that are not particularly focused on capacity expansion, are [34, 35]. In [34], an economy-wide analysis of different cap-and-trade proposals considered by the U.S. Congress in spring 2007 is presented. The analysis is performed using the MIT Emissions Prediction and Policy Analysis (EPPA) model. EPPA simulates the world economy through time with special emphasis on creating scenarios of greenhouse gas emissions [36]. Allowance prices and expected emissions reductions are presented for each cap-and-trade proposal. In [35], the energy and economic implications of the State of Maryland joining RGGI are presented. The analysis is performed by integrating three components: a simulation model for interregional trade among regional electricity markets, a market equilibrium model that incorporates market power in regional electricity markets, and a software system to assess economic impacts by industrial sector. Some of the findings of the study include distinct but modest emissions reductions, and reduced profits for coal generator, though coal plants are not retired. Other studies analyzing the implications of cap-and-trade programs can be found in [37, 38].

### **3.1.3 Real Options Models for Capacity Expansion**

As alluded to earlier, real options theory has been applied to evaluate generation expansion plans in electricity markets. In [22], a set of investment alternatives are evaluated using real options analysis taking into consideration the learning curve information of renewable power generation technologies. Uncertainties in the price of fossil fuels and the price of electricity are modeled via geometric Brownian motion (GBM) processes. The stochastic investment model presented in [24] addresses the problem of power generation capacity adequacy in restructured markets. An explicit model of the power market is included to obtain the future electricity spot prices. Demand is modeled through a stochastic process. The impact of two potential regulatory mechanisms on the expansion

investments are analyzed with the model. Real options theory is also used in [23] to examine the effect that lower electricity prices in a network, caused by increased capacity due to generation investments, has on the timing of the investments themselves. Electricity prices are modeled via geometric Brownian motion (GBM) processes. In [26], an expansion investment model under uncertainty is presented. The future price of electricity is obtained by considering a supply curve modeled as an exponential function and an equilibrium quantity that follows a geometric mean-reverting process. A model that uses real options to analyze the effect of an allowance market on generation investments is presented in [27]. Uncertainty in the allowance and electricity prices is modeled through discrete-time continuous-state processes. The model is applied to the Finnish power market.

#### **3.1.4 Chapter Outline**

In summary, this chapter presents a game theoretic model for capacity expansion in restructured electricity markets that incorporates  $CO_2$  emissions trading. We consider transmission constraints and the effect of congestion in the electricity market. The model allows for the consideration of different design attributes of a  $CO_2$  cap-and-trade program. The expansion plans derived from our model provide information regarding capacity, location, technology, and the time of expansion. The model is intended to be used by the generators to evaluate expansion plans under different  $CO_2$  cap-and-trade programs for a given time horizon and a given forecast in demand growth. The expansion plan options of the generators can be adapted to include the possibilities of postponement and abandonment of specific investments. The rest of the chapter is organized as follows. Section 3.2 presents the components of the game theoretic model: expansion game, allowance game, and electricity game, and how the markets they represent interact with each other. In Section 3.3 we present an algorithm to solve the model and discuss its computational

implementation. An application of the model to a sample network representing the northern Illinois power market is presented in Section 3.4. Section 3.5 presents the concluding remarks.

## 3.2 Game Theoretic Model

We consider a planning horizon  $T$  and a network with  $H$  nodes,  $L$  transmission lines, and  $n$  generators. Each generator owns an array of plants based on different technologies at one or more nodes in the network. We assume that the region served by the power network operates under a  $CO_2$  cap-and-trade program, where the generators are required to obtain allowances allocated via auction. The generators bid for allowances with price and quantity, and surrender the acquired allowances at the end of the production period commensurate with their emissions. It is assumed that the generators pass the cost of the allowances on to the consumers in the electricity market.

### 3.2.1 Schematic Representation of the Game Theoretic Modeling Framework

A schematic of the game theoretic modeling framework (for a hypothetical scenario with 3 players) is presented in Figure 3.1. The *expansion game* represents all possible combinations of the multi-year expansion plans of the generators. An expansion plan comprises a set of yearly actions to add generation capacity (or to do nothing) over the planning horizon. The attributes of an action include location of the new capacity and its size, technology, construction lead times, and cost. Each of the combinations in the expansion game (e.g., the shaded section) represents a specific network generation portfolio (in terms of nodal capacities and technology mix), which evolves as new capacities are added over the planning horizon  $T$ . With the change in the network generation portfolio, the need for allowances change, and hence the *allowance game* is solved each year of

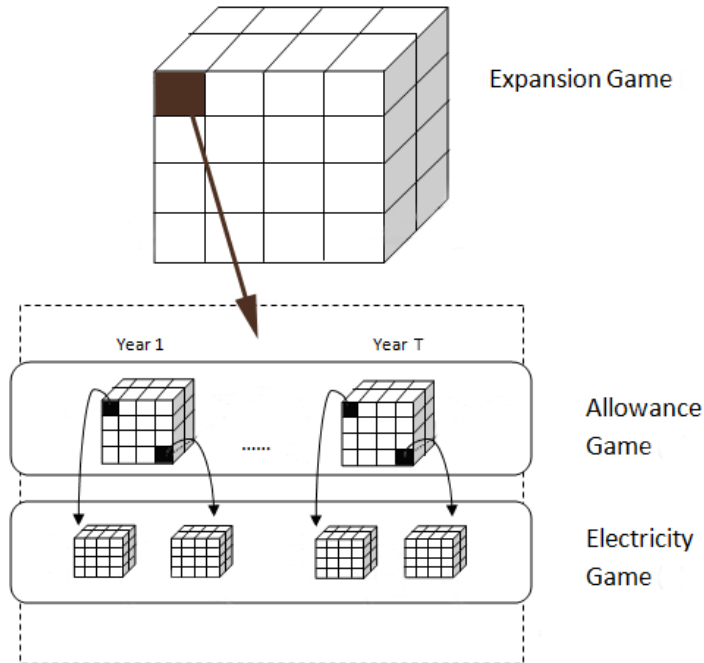

Figure 3.1: A Schematic for the Game Theoretic Framework

the planning horizon  $T$  with new allowance bids by the generators. Each of the yearly allowance games consider multiple bidding strategies for each generator (represented by the cubes in the middle tier of Figure 3.1). Each combination of the allowance bids (e.g., the shaded section), when settled, results in a specific allowance allocation and clearing price. These parameters influence the generators' supply function bids in the *electricity game* as presented in Figure 2.1, since the generators attempt to maximize their revenue while recovering the costs of allowances and potential penalty for emissions violation. Hence, for each bid strategy combination of the yearly allowance game, we solve an electricity game. Though electricity games are played in day-ahead and spot markets over the whole year, for computational simplicity, we assume a single game representing the whole year. Clearly, the action choices of the generators in the expansion, allowance, and electricity games, collectively determine the profit from the electricity market. The equilibrium payoff from the electricity game is used to construct the payoff matrix of the

allowance game, and the equilibrium payoff of the allowance game is used to construct the payoff matrix of the expansion game. The solution of the expansion game provides the equilibrium expansion plan combination. Consequently, the solution methodology for the game theoretic framework must begin by solving the electricity game, followed by the allowance and expansion games. Note that the inherent chronological order for selecting actions in the expansion, allowance, and electricity markets requires a tiered modeling framework and a solution methodology based on the method of backward induction that we present later.

### 3.2.2 Expansion-Allowance-Electricity Games

Let  $x_i = (x_i^1, \dots, x_i^T)$  denote an expansion plan for the entire planning horizon for the  $i^{\text{th}}$  generator, of which each element  $x_i^t$  is also a vector comprising expansion capacity and technology for each node location of the network. Let  $y_i^t$  and  $z_i^t$  denote the allowance bid and the supply function bid, respectively, where, for any period (stage)  $t$ ,  $y_i^t$  is a 2-tuple comprising allowance price and quantity, and  $z_i^t$  is also a 2-tuple comprising the intercept and the slope of the supply function. Similarly, let  $x_{-i}$  denote the expansion plans of the rest of the generators for the entire planning horizon and let  $y_{-i}^t$ , and  $z_{-i}^t$  denote the allowance bids, and supply function bid vectors, respectively, of the rest of the generators for each period (stage)  $t$ . Each generator,  $i = 1, \dots, n$ , selects an equilibrium expansion plan  $x_i^*$  for the planning horizon, and equilibrium strategies  $y_i^{*t}$ ,  $z_i^{*t}$  for each period  $t$  via the following discrete maximization problem,

$$\begin{aligned} \max_{x_i} F(x_i, x_{-i}) - \sum_{t=1}^T \frac{\sigma(x_i^t)}{(1+\pi)^t} + \frac{\zeta(x_i)}{(1+\pi)^T}, \quad (3.1) \\ \text{s.t. } \max_{y_i^t, z_i^t} G(y_i^t, z_i^t, y_{-i}^t, z_{-i}^t), \quad \forall t \\ x_i \in \mathbb{E}_i, \quad y_i^t \in \Upsilon_i^t, \quad z_i^t \in \Psi_i^t \end{aligned}$$



where  $F(x_i, x_{-i}) = \sum_{t=1}^T \frac{G(y_i^{*t}, z_i^{*t}, y_{-i}^{*t}, z_{-i}^{*t})}{(1+\pi)^t}$  is the present value of the total joint profit from the allowance and electricity markets for generator  $i$  from year 1 to  $T$  if expansion plans  $x_i$  and  $x_{-i}$  are implemented. The discount rate is denoted by  $\pi$ ,  $\sum_{t=1}^T \frac{\sigma(x_i^t)}{(1+\pi)^t}$  is the cost of investment of plan  $x_i$ , and  $\frac{\zeta(x_i)}{(1+\pi)^T}$  is the residual value of the installed capacity at the end of year  $T$ .  $\Xi_i = \{x_{i1}, x_{i2}, \dots, x_{i\hat{x}_i}\}$  denotes a set of  $\hat{x}_i$  feasible alternative expansion plans for each generator  $i$ .  $\Upsilon_i^t$  denotes a finite discrete set of  $CO_2$  allowance bid strategies and  $\Psi_i^t$  denotes a finite discrete set of supply function bid strategies, respectively, for each generator  $i$  for period  $t$ . The sets  $\Upsilon_i^t$  and  $\Psi_i^t$  depend both on the expansion plan  $x_i$  (which determines the generation portfolio of each generator for each period  $t$ ) and the equilibrium bidding strategies of the previous period,  $y_i^{*t-1}$  and  $z_i^{*t-1}$ . The initial equilibrium bidding strategies  $y_i^{*0}$ ,  $z_i^{*0}$  are assumed to be known. Hence, the information structure used by the players at each stage (period) of the game theoretic modeling framework can be called a *memoryless perfect state for all the players* [39] i.e., the bidding strategies are a function of the initial state and the current state of the system only. This is in contrast to use constant bidding strategies at each stage, as in the open-loop information structure pattern, and to use bidding strategies that are a function of the entire history of the system, as in the closed-loop information structure pattern. The equilibrium expansion plan combination resulting from our model, thus, can be referred to as a *closed-loop no memory Nash equilibrium solution*.

We assume that each generator develops a finite number of expansion plans in  $\Xi_i$  considering an installed capacity target for year  $T$  based on the network demand growth forecast and other real life constraints on location, timing, and budget. This bounds the state-space of the game. Each expansion plan  $x_i \in \Xi_i$  explicitly describes type of technology, capacity, location, the year in which construction of the new capacity begins, and the construction lead time. An expansion plan is composed of one or more expansion actions e.g., expansion plan 1 = (nuclear plant with capacity 1,221 MW, located in node A, beginning of construction on 2009, lead time 5 years; coal plant with capacity 320

MW, located in node B, beginning of construction on 2014, lead time 2 years). By characterizing an expansion plan in these terms we are able to incorporate the postponement option (e.g., by having an alternate expansion plan that delays the year of beginning of construction of a plant) or the abandonment option (e.g., by having an alternate expansion plan with only the nuclear plant and not the coal plant). Note that, since an expansion plan is composed of expansion actions throughout the planning horizon, the solution of the expansion game accounts for the entire planning horizon as opposed to finding expansion plans for one year at a time, see [14]. A limitation of the year-by-year approach is that it fails to account for the impact of any future capacity additions to the network on the current action.

A unique feature of modeling the competition in the allowance and the electricity markets is that same payoffs are used in solving the corresponding games, though the settlement of electricity markets occur after the settlement of the allowance markets. In this regard, without loss of generalization, we assume that allowances are auctioned once a year followed by the electricity auction in the day-ahead and spot markets throughout the year. For each bid combination  $(y_i^t \in \Upsilon_i^t, \forall i)$  that is considered in the allowance market, the corresponding electricity market bids choices  $(z_i^t \in \Psi_i^t, \forall i)$  are formulated. Then for each allowance and electricity bid combination, a joint payoff  $G(y_i^t, \dots, y_n^t; z_i^t, \dots, z_n^t)$  is formulated. This joint payoff is used to first solve the electricity game (i.e., to find  $z_i^{*t}, \forall i$ ) whose equilibrium joint payoff  $G(y_i^t, \dots, y_n^t; z_i^{*t}, \dots, z_n^{*t})$  is then used to solve the allowance game (i.e., to find  $y_i^{*t}, \forall i$ ).

Following the formulation presented in (3.1), the allowance and the electricity games can be jointly presented as follows. For each generator  $i$  and period  $t$ ,

$$\begin{aligned} \max_{y_i, z_i} G(y_i^t, z_i^t, y_{-i}^t, z_{-i}^t) & \quad (3.2) \\ \text{s.t. } y_i^t \in \Upsilon_i^t, z_i^t \in \Psi_i^t, & \end{aligned}$$

where  $g(y_i^t, z_i^t, y_{-i}^t, z_{-i}^t)$  is the joint payoff from the allowance and electricity games, given as

$$G(y_i^t, z_i^t, y_{-i}^t, z_{-i}^t) = R(y_i^t, z_i^t, y_{-i}^t, z_{-i}^t) + S(y_i^t, z_i^t, y_{-i}^t, z_{-i}^t), \quad (3.3)$$

where  $R(\cdot)$  and  $S(\cdot)$  represent the payoffs from the electricity and the allowance markets, respectively. We explain how to compute the payoffs next.

### 3.2.2.1 Electricity Market Payoff

Generators are assumed to compete in the electricity market by submitting a supply bid vector  $z_i^t = (z_{i_1}^t, z_{i_2}^t, \dots, z_{i_{N_i}}^t) \in \Psi_i^t$ . Each element of the vector represents the supply bid for each of the  $N_i$  power plants generator  $i$  owns in the network. Each individual supply bid  $z_{i_k}^t$  is defined by the pair  $(a_{i_k}^t, b_{i_k}^t)$ , where the first element is the intercept and the second is the slope of the supply curve, given as  $p = a_{i_k} + b_{i_k}q$ , where  $p$  and  $q$  are price and quantity, respectively. The payoff for generator  $i$  in the electricity market in year  $t$  is computed as follows,

$$R(y_i^t, z_i^t, y_{-i}^t, z_{-i}^t) = \sum_{k=1}^{N_i} q_{i_k} LMP_{i_k} - \sum_{k=1}^{N_i} (a_{i_k}^0 q_{i_k} + \frac{1}{2} b_{i_k}^0 q_{i_k}^2), \quad (3.4)$$

where  $q_{i_k}$  is the quantity of electricity produced by plant  $k$ ,  $LMP_{i_k}$  is the locational marginal price at the node where plant  $k$  is located, and  $\sum_{k=1}^{N_i} (a_{i_k}^0 q_{i_k} + \frac{1}{2} b_{i_k}^0 q_{i_k}^2)$  is the total cost for each generator  $i$  (thus,  $a_{i_k}^0, b_{i_k}^0$  are the true marginal cost parameters). The values for  $q_{i_k}$  and  $LMP_{i_k}$  in (3.4) are obtained by solving the Optimal Power Flow (OPF) formulation (2.4) presented in Section 2.1,

### 3.2.2.2 Allowance Market Payoff

Let  $Y_i^t$  the set of allowance bids that generator  $i$  chooses from on year  $t$ , where each bid consists of unit price and desired number of allowances. Though the type of auction used to allocate the allowances depends on the design of the  $CO_2$  cap-and-trade program, without loss of generality, we adopt a uniform-price sealed-bid auction (as in RGGI [9]). Uniform-price sealed-bid auction is modeled as in the formulation (2.5). The market clearing price of the allowance auction,  $P^t$ , corresponds to the price of the last accepted bid. Let  $o_i^t$  denote the number of allowances allocated to generator  $i$  in year  $t$  as a function of the allowance bid  $y_i$ ,  $o_{i_c}^t$  is the number of allowances *consumed* by generator  $i$  during year  $t$  as a function of the electricity bid  $z_i$ , and  $P^t$  is the price at which allowances are traded in the secondary market (an exogenous quantity). The profit (loss) from the allowance market is computed as in (2.8)

$$S(y_i^t, z_i^t, y_{-i}^t, z_{-i}^t) = P^t (o_i^t - o_{i_c}^t). \quad (3.5)$$

We have assumed that the auction allocates allowances for the current vintage year only (not for future years). Thus, if the generators do not have enough allowances to surrender at the end of each electricity production period (i.e., to compensate for the emissions) they are subjected to penalties. Such a situation arises when a generator fails to procure sufficient number of allowances from the auction and the secondary market. RGGI, for instance, considers a penalty of 3 times the outstanding balance of allowances.

### 3.3 Solution Procedure

A schematic of the solution algorithm is presented in Figure 3.2. In step 1, the following indices are initialized:  $t = \{1, 2, \dots, T\}$  for years in the planning horizon  $T$ ,  $j_1 = \{1, 2, \dots, |\Xi|\}$  for set of expansion plan combination  $\Xi = \Xi_1 \times \dots \times \Xi_n$ ,  $j_2 = \{1, \dots, |\Upsilon|\}$

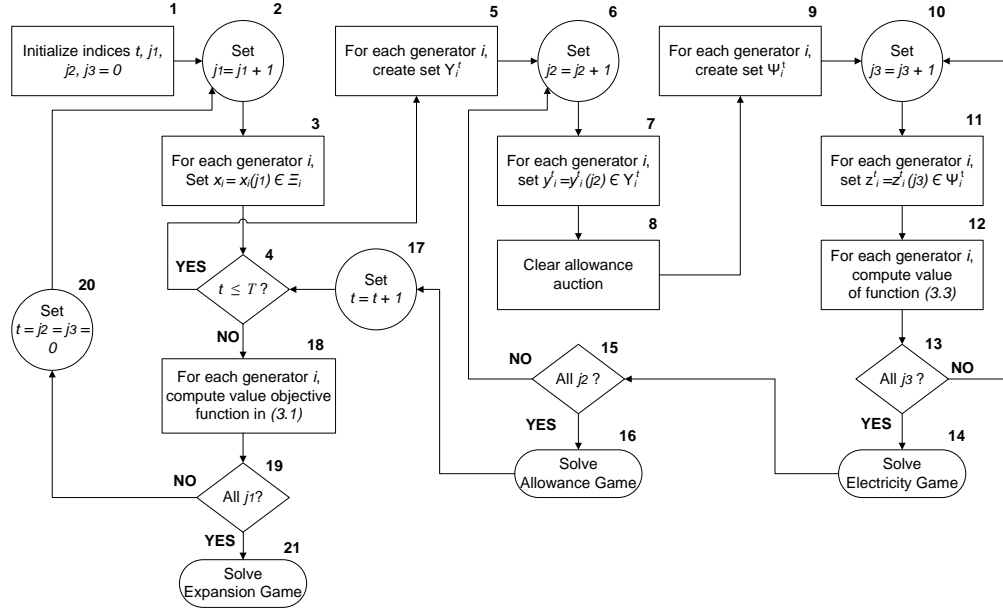

Figure 3.2: Solution Algorithm Flow Diagram

for set of allowance bid combination on any given period  $\Upsilon = \Upsilon_1 \times \Upsilon_2 \times \dots \times \Upsilon_n$ , and  $j_3 = \{1, 2, \dots, |\Psi|\}$  for set of supply bid combination on any given period  $\Psi = \Psi_1 \times \Psi_2 \times \dots \times \Psi_n$ . Steps 2 and 3 ensure that each expansion plan combination is evaluated, while step 4 ensures that this evaluation is made for each year of the planning horizon. In step 5, the set of allowances bid strategies  $\Upsilon_i^t$  is developed for each generator  $i$  with an expansion plan  $x_i$  for year  $t$ . Steps 6 and 7 ensure that each allowance bid combination is evaluated. In step 8, the allowance auction is cleared, which gives the allowance market clearing price and allowance quantities. In step 9, the set of supply function bid strategies  $\Psi_i^t$  is developed for each generator  $i$ . Steps 10 and 11 ensure that each supply function bid combination of the generators is evaluated. The profit from the allowance and the electricity markets for year  $t$ , as given in (3.3), is computed in step 12. These profits are used to form the electricity game payoff matrix. In step 13, we check if all the supply bid function combinations have been evaluated. If so, the electricity game is solved in step 14, using the reinforcement learning (RL) algorithm (explained below). The solution of

the game provides the equilibrium supply function bid combination. Step 15 checks if all the allowance bid combinations have been evaluated. Note that, the payoff matrix for the allowance game is constituted by the equilibrium profits from the electricity games. The allowance game is solved in step 16, which yields the equilibrium allowance bid combination. Steps 17 and 4 together ensures that the loop comprising steps 5 through 16 is repeated for each year of the planning horizon. The value of the objective function (given by the present value of profit from the years in planning horizon, minus the overnight cost, plus the residual value of the installed capacity), as defined in (3.1), is computed in step 18. This completes the evaluation of an expansion plan combination. Steps 19 and 20 ensure that all expansion plan combinations are evaluated. Finally, in step 21 the expansion game is solved using the RL algorithm and the equilibrium expansion plan combination is obtained.

### 3.3.1 Reinforcement Learning Algorithm

We use the reinforcement learning (RL) algorithm developed in [40] in steps 14, 16, and 21. The following are the main steps of the RL algorithm, presented in the context of the expansion game.

- Step 1: Let iteration count  $\hat{p} = 0$ . Initialize r-values for each generator  $i$  with  $\hat{x}_i$  expansion plan choices  $(r_0(i, 1), \dots, r_0(i, \hat{x}_i))$  to an identical small positive number. Also initialize the learning parameter  $\epsilon_0$ , exploration parameter  $\phi_0$ , and parameters  $\epsilon_\tau$  and  $\phi_\tau$  needed to obtain suitable decay rates of learning and exploration. Let *Maxsteps* denote the maximum iteration count.
- Step 2: If  $\hat{p} < \text{Maxsteps}$ , continue learning of the r-values through the following steps:
  - Action Selection:

Greedy action selection:

Each generator  $i$ , with probability  $(1 - \phi_{\hat{p}})$ , chooses an action  $x_i$  for which  $r_{\hat{p}}(i, x_i) \geq r_{\hat{p}}(i, \bar{x}_i)$  where  $\bar{x}_i$  stands for all the other expansion actions excepting  $x_i$ . A tie is broken arbitrarily.

Exploratory action selection:

With probability  $\phi_{\hat{p}}$ , a generator chooses an action  $x_i$  from the possible expansion actions choices (excluding the greedy action), where each action can be chosen with equal probability.

– r-value Updating:

Update the specific r-values for each generator  $i$  corresponding to the chosen action  $x_i$  using the learning scheme given below.

$$r_{\hat{p}+1}(i, x_i) \leftarrow (1 - \varepsilon_{\hat{p}})r_{\hat{p}}(i, x_i) + \varepsilon_{\hat{p}}(\kappa_i(x_i, x_{-i})), \quad (3.6)$$

where  $\kappa_i(x_i, x_{-i})$  is the payoff of generator  $i$  for choosing expansion plan combination  $x_i$  when the other generators choose actions  $x_{-i}$ . Note that  $\kappa_i(x_i, x_{-i}) = F(x_i, x_{-i}) - \sum_{t=1}^T \frac{\sigma(x_i^t)}{(1+\pi)^t} + \frac{\zeta(x_i)}{(1+\pi)^T}$  (see the objective function in (3.1)).

– Set  $\hat{p} \leftarrow \hat{p} + 1$ .

– Update the learning parameter  $\varepsilon_{\hat{p}}$  and exploration parameter  $\phi_{\hat{p}}$  as in [40].

– If  $\hat{p} < MaxSteps$ , go back to beginning of Step 2, else go to Step 3.

- Step 3: From the set of r-values, select the expansion action  $x_i^*$  for each generator  $i$  as follows.

$$x_i^* = \arg \max_{x_i} r_{\hat{p}}(i, x_i) \quad (3.7)$$

The RL algorithm is applied in a similar way to solve the allowance and electricity games.

It is well known that matrix games, with or without pure strategy Nash equilibrium, always have one or more mixed strategy Nash equilibria. However, in energy markets, it is practically impossible to implement mixed strategies. Hence, while solving matrix game models, the RL algorithm considers only pure strategy solutions. As shown in [40], the *value* based reinforcement learning (RL) algorithm, that we have used in our methodology, finds a pure strategy solution which almost always coincides with a Nash equilibrium, when one exists. When multiple pure strategy NE exist, the RL algorithm finds the one with the highest values (as computed in equation (3.6)) for the players. For games without a pure strategy NE, an out-of-equilibrium solution [41] provides a practical alternative. For such games, the greedy action selection approach of the RL algorithm (that prevails after the exploration ends) drives each player to choose the highest-value action. The resulting action combination of the players and the corresponding payoffs constitute the out-of-equilibrium solution for the game. It may be noted that the RL algorithm is not equipped to determine the uniqueness of a NE solution. However, the nature of the solution (NE or out-of-equilibrium) can be easily determined.

### 3.3.2 Computational Issues

The computational challenges of the solution procedure stem from the large number of OPFs that need to be solved when the sets  $\Xi$ ,  $\Upsilon$ , and  $\Psi$  have large cardinalities. Since an OPF problem is solved each time the step 12 of the procedure is visited (see Figure 3.2), the total number times an OPF solution is invoked is given by the product  $|\Xi| \times |\Upsilon| \times |\Psi|$ . However, since the payoffs of the expansion plan combinations (of the expansion game) can be evaluated independently, the loop comprising steps 2 through 20 can be run in parallel using a distributed computing framework. Moreover, this model is intended to support the long term strategic planning process of the generators and regulators, and, hence, it is not a real time tool.



### **3.4 A Case Study from Illinois Electricity Market**

In this section we demonstrate the use of our model on a 9-node network representing the northern region of the Illinois power network. We assume a RGGI type cap-and-trade program in operation for the network. The planning horizon considered is from 2007 through 2030, which is supported by a complete set of market data (demand, installed capacity, transmission capacity, generation allocation, and LMPs) for the year 2007. We obtain equilibrium expansion plans for the generators and the resulting mix of generation technology (between coal, gas, and nuclear), nodal electricity prices, generator profits, emissions, and allowance prices, for each year of the planning horizon. We contrast these outcomes for three cap-and-trade scenarios with different allowance prices.

#### **3.4.1 Background**

Market data was simulated by the Argonne National Laboratory (ANL) for a report submitted to the Illinois Commerce Commission, [42]. According to the report, the Illinois electricity market, in 2007, had 4 main producers of electricity (henceforth referred to as Generators 1 through 4), whose combined market share was approximately 90%. The capacity of Generator 1 was predominantly nuclear, whereas the other 3 generators owned mostly coal and natural gas-fueled power plants. The report also indicated that most of the electricity consumed in the state was produced by nuclear and coal plants, with natural gas plants producing only a marginal quantity. More details about the network, as reported in [42], are presented in Table 3.1. We constructed a 9-node model network (see Figure 3.3) replicating the electricity market conditions reported in [42]. Seven of the nine nodes represent different zones of the power network (each node being an aggregation of the actual nodes). One of the two remaining nodes aggregates the rest

of the nodes in the Illinois network, while the other aggregates the nodes outside of the state that interact with the Illinois network.

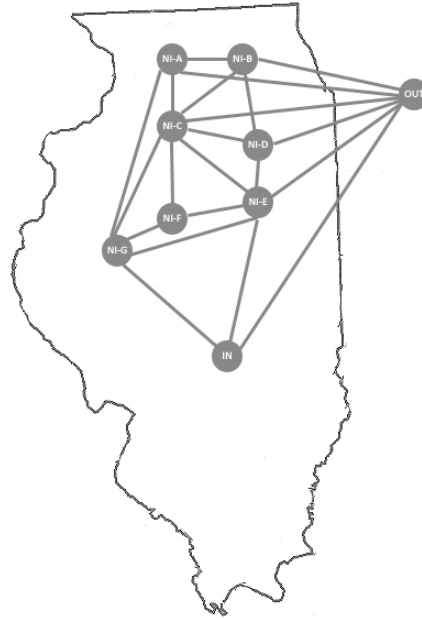

Figure 3.3: Nine-Node Model for Illinois Network

### 3.4.2 Capacity Expansion Scenario

We consider four choices of expansion plans for each of the four generators (see Table 3.2). Consideration of a small number of alternative plans for the generators was made to limit the size of the case study. The plant capacities in the expansion plans were chosen in line with the current plant capacities of the generators. Options for new nuclear plants were considered only in those nodes that currently host nuclear plants to account for environmental and other restrictions. Construction lead times were obtained from a study presented in [43]. The costs of adding capacity with different generation technologies are assumed as given in Table 3.3. It is considered that generators make the capacity available in the electricity market after the construction lead time has lapsed (lead times for each

Table 3.1: Installed Capacity in the Model Network

Company	Node	Type	Cap. (MW)	Company	Node	Type	Cap. (MW)
Gen 1	NI-B	Gas	540	Gen 3	IN	Coal	3,160
Gen 1	IN	Gas	1,455	Gen 4	NI-C	Gas	212
Gen 1	IN	Coal	4,711	Gen 4	NI-D	Gas	414
Gen 2	NI-A	Nuclear	4,154	Gen 4	NI-E	Gas	141
Gen 2	NI-F	Nuclear	4,156	Gen 4	NI-F	Gas	1,638
Gen 2	NI-G	Nuclear	2,305	Gen 4	NI-B	Coal	789
Gen 2	IN	Nuclear	944	Gen 4	NI-D	Coal	868
Gen 2	NI-D	Gas	328	Gen 4	NI-E	Coal	2,140
Gen 3	NI-B	Gas	398	Gen 4	NI-G	Coal	1,538
Gen 3	IN	Gas	484				

plant are presented in Table 3.4). The time required to obtain permits for new plants was not considered.

Table 3.2: Sample Expansion Plan Choices in Northern Illinois Electricity Market

	Plan	Type	Cap. (MW)	Node	Construction Begins		Plan	Type	Cap. (MW)	Node	Construction Begins
Gen 1	Plan 1	Nuclear	1,221	NI-A	2007	Gen 3	Plan 1	Nuclear	1,221	NI-A	2007
		Nuclear	867	NI-A	2013			Plan 2	Nuclear	1,221	NI-A
	Plan 2	Nuclear	1,221	NI-A	2018		Plan 3		Gas	67	NI-B
		Nuclear	867	NI-A	2024			Gas	67	NI-B	2009
	Plan 3	Nuclear	1,221	NI-A	2007			Gas	67	NI-B	2011
		Coal	320	IN	2013			Coal	320	IN	2013
	Plan 4	Nuclear	1,221	NI-A	2024		Plan 4	Gas	67	NI-B	2024
		Coal	320	IN	2021			Gas	67	NI-B	2026
Gen 2	Plan 1	Nuclear	1,221	NI-A	2007	Gas		67	NI-B	2028	
		Nuclear	1,221	NI-A	2013	Coal		320	IN	2021	
...	Plan 1	Gas	554	NI-D	2019	Gen 4	Plan 1	Nuclear	1,221	NI-A	2007
		Nuclear	1,221	NI-A	2018			Nuclear	867	NI-A	2013
	Plan 2	Nuclear	1,221	NI-A	2024		Plan 2	Nuclear	1,221	NI-A	2018
		Gas	554	NI-D	2015			Nuclear	867	NI-A	2024
	Plan 3	Nuclear	1,221	NI-A	2007		Plan 3	Coal	769	NI-B	2007
		Nuclear	867	NI-A	2013			Coal	769	NI-B	2011
	Nuclear	867	NI-A	2019	Coal			320	NI-B	2015	
	Nuclear	867	NI-A	2012	Plan 4			Coal	769	NI-B	2022
	Plan 4	Nuclear	1,221	NI-A		2024	Coal	769	NI-B	2026	
		Nuclear	867	NI-A	2012	Coal	320	NI-B	2019		
	Nuclear	867	NI-A	2018							

Table 3.3: Capital Cost of Each Technology

Technology	Overnight Cost (\$/KWh)
Nuclear	1,975
Coal	1,213
Gas	558

Table 3.4: Lead Times for Each Considered Power Plant

Technology	Capacity (MW)	Lead Time (years)
Nuclear	1,221	6
Nuclear	867	6
Gas	554	3
Gas	67	2
Coal	769	4
Coal	320	3

### 3.4.3 Allowance Market Scenario

We consider a cap that is held constant for the period 2007-2015, which is then reduced on a yearly basis by 2.5 % until 2030. We assume that 100% of the allowances are auctioned. Each generator bids for allowances indicating price and quantity. The auction is assumed to be sealed-bid uniform-price with a reserve price (the minimum acceptable bid in the allowance auction) and a restriction on the maximum number of allowances (40%) that a single generator can receive. We formulated the case study to examine the impact of allowance reserve prices on the equilibrium expansion plans. Therefore, we considered three different scenarios for reserve prices: \$ 3.38 based on the clearing prices obtained in the first RGGI auctions [44] (SC1), and two other scenarios (SC2 and SC3) with higher reserve prices of \$5 and \$6, respectively. We consider that the reserve price acts as a base price for allowance bids for the generators, and hence, the minimum auction clearing price. In order to limit the computation required for the case study, we assumed

each generator to have a single allowance bid derived based on generation portfolio of the year, reserve price, and any penalty incurred from emissions violation in the previous year. These bids were incorporated into a linear program (2.5) with an objective function of maximizing the auction revenue subject to the constraints of availability of allowances, reserve price, and maximum allocation to a single generator. The market clearing price corresponds to the shadow price of the constraint for availability of allowances.

It was considered that Generators 1, 3, and 4, which own only coal and natural gas plants at the beginning of the planning horizon (see Table 3.1), bid 1.5 times the reserve price, while generator 2 with no coal capacity and small natural gas plants bids the reserve price. When a generator incurs emissions penalty, it is considered that the generator increases its original bid price for the next period by 1.2 times. The quantity component of a generator's allowance bid is guided by the likely total amount of fossil-fuel based power supply to the network. This amount is obtained by summing the products of the fossil-fuel based plant capacities available to each generator and the respective plant capacity factors from the previous year. The capacity factors for the first year of the planning horizon are obtained from [42] while the capacity factors for the first year of operation of new plants is considered to be equal to the capacity factor of similar plants (in technology and capacity) for the previous year. When emissions penalty is incurred by a generator due to a negative allowance balance at the end of a period, it is considered that the generator increases its quantity bid by the outstanding allowance balance (as explained below) in the next period.

We also consider that generators trade any unused allowances at the end of each period in the secondary market. However, the majority of the allowance procurement is assumed to occur through the primary auction. Our assumption here is different from what has been seen in the EU ETS, where the allowances are distributed for free (not auctioned), and hence, allowance trading occurs only in the secondary market. The trading price of the allowances in the secondary market is considered to be 1.2 times the

auction clearing price of the period. This consideration is based on the fact that secondary trading occurs only when allowances are scarce during a period and consequently trade at a higher price. We also assume that the generators bank any surplus allowance, remaining after the end-of-period secondary trading, for the next period. If the overall balance of allowances at the end of a secondary trading is negative, a 150% penalty is applied to the generator with negative balance. For example, if a generator falls short of 100 allowances for a period, then the outstanding balance for the generator at the beginning of the next period is considered to be 150. The generators pass on the additional cost of penalty to the consumers through an increase in their electricity supply bids. It is considered that at the end of the planning horizon the generators pay off any outstanding allowance balance. An allowance surplus at the end of a planning horizon is considered to have a positive cash value.

#### **3.4.4 Electricity Market Scenario**

The 9-node network is depicted in Figure 3.3. We focus on the northern region of the state since most of the generation and peak loads are located in this area. Seven nodes that represent the electricity production and consumption in this area are named: NI-A, NI-B, NI-C, NI-D, NI-E, NI-F, and NI-G. Two other nodes are named: IN (which is a super node representing all the remaining nodes in the state) and OUT (which is a super node representing the out of state nodes that trade electricity with Illinois). Demand bid curves were constructed for each node for year zero of the planning horizon based on the results in [42]. Subsequently, to represent a demand increase for each year of the planning horizon, the demand bid curves were shifted to the right as shown in Figure 3.4. The nodal capacities of each generator, by fuel type, in year zero are presented in Table 3.1. Note from table that, 4154 MW in nuclear-based generation for generator 2 in node NI-A is obtained by adding the capacities of four different nuclear plants (1221 MW,

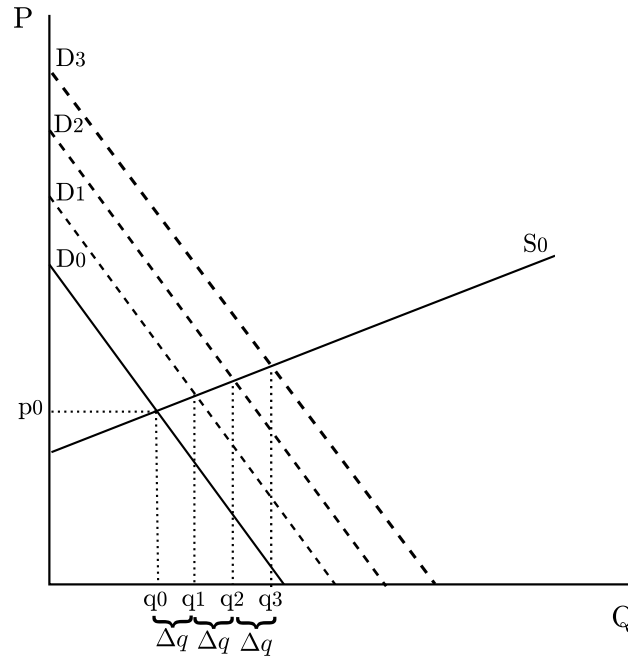

Figure 3.4: A Schematic Representation of Yearly Demand Increase

1199 MW, 867 MW, 867 MW) in the NI-A zone. Supply bid curves for year zero were constructed for each combination of the generator, node, and fuel type using the results in [42]. Throughout the planning horizon the supply bid curves are adjusted endogenously on a yearly basis to accommodate the total cost of allowances (including penalty) incurred by the generators. Fuel costs are assumed to remain same as year zero throughout the planning horizon.

### 3.4.5 Results

We coded our capacity expansion model for the 9-node network in C, which was implemented using an Intel Core Duo 2.20 GHz processor. The embedded optimization problems (OPFs and allowance auctions) were modeled in C through a callable CPLEX library and solved using ILOG CPLEX version 10.1.

The equilibrium expansion plans selected by the generators in scenarios SC1, SC2, and SC3 discussed earlier in this section, are presented in Table 3.5. It can be observed

that, for the three scenarios considered, the equilibrium expansion plans chosen by the generators are similar. This similarity is in part due to the limited number of action choices that were considered for the generators. However, as we discuss below, the chosen plans have different impacts on the market prices, demand for electricity, emissions reductions, and market share of generation technologies.

For the average weighted LMP, in Figure 3.5, we observe an upward trend. Though an increase in LMPs is expected from the implementation of an emissions control scheme, we note that it is also a result of the expected increase in demand over the planning horizon, which we have modeled as shown in Figure 3.4. It can also be seen that there are three distinct segments in the weighted LMP plot. In the first segment, between years 2007 and approximately 2012, the weighted LMPs increases steadily (the increase of the LMPs at each node is at the same rate, not shown in the figure) as the new generation capacities of the chosen expansion plans are still in construction, the  $CO_2$  cap has not yet been lowered, and the allowance price is at its lowest level (see the allowance curve on the same figure). The second segment, between 2012 and 2020 (in SC1), 2024 (in SC2) and 2026 (in SC3), exhibits a fluctuating weighted LMP (that are somewhat identical across the network nodes, not shown in figure). We note that the identical nature of the LMPs is caused by the excess capacity in the network brought about by the new nuclear plants that start operating in 2013. The LMP fluctuation, on the other hand, is triggered by both the excess capacity and the cap reduction, which can be further elaborated as follows. As the cap reduction begins and less allowances are made available, the generators find themselves in emissions violation and subjected to penalty. In the following year, the generators try to pass on the cost of penalty by increasing the supply bid prices, which causes the coal generation to be less competitive, supplying less power to the network, and producing less emissions.



Table 3.5: Selected Expansion Plans of the Generators for Each Scenario

SC1						SC2					SC3				
	Plan	Type	Cap.	Node	Const. Begins	Plan	Type	Cap.	Node	Const. Begins	Plan	Type	Cap.	Node	Const. Begins
Gen 1	Plan 3	Nuclear	1,221	NI-A	2007	Plan 3	Nuclear	1,221	NI-A	2007	Plan 3	Nuclear	1,221	NI-A	2007
		Coal	320	IN	2013		Coal	320	IN	2013		Coal	320	IN	2013
Gen 2	Plan 1	Nuclear	1,221	NI-A	2007	Plan 1	Nuclear	1,221	NI-A	2007	Plan 1	Nuclear	1,221	NI-A	2007
		Nuclear	1,221	NI-A	2013		Nuclear	1,221	NI-A	2013		Nuclear	1,221	NI-A	2013
		Gas	554	NI-D	2019		Gas	554	NI-D	2019		Gas	554	NI-D	2019
Gen 3	Plan 3	Gas	67	NI-B	2007	Plan 4	Gas	67	NI-B	2024	Plan 3	Gas	67	NI-B	2007
		Gas	67	NI-B	2009		Gas	67	NI-B	2026		Gas	67	NI-B	2009
		Gas	67	NI-B	2011		Gas	67	NI-B	2028		Gas	67	NI-B	2011
		Coal	320	IN	2013		Coal	320	IN	2021		Coal	320	IN	2013
Gen 4	Plan 1	Nuclear	1,221	NI-A	2007	Plan 1	Nuclear	1,221	NI-A	2007	Plan 1	Nuclear	1,221	NI-A	2007
		Nuclear	867	NI-A	2013		Nuclear	867	NI-A	2013		Nuclear	867	NI-A	2013

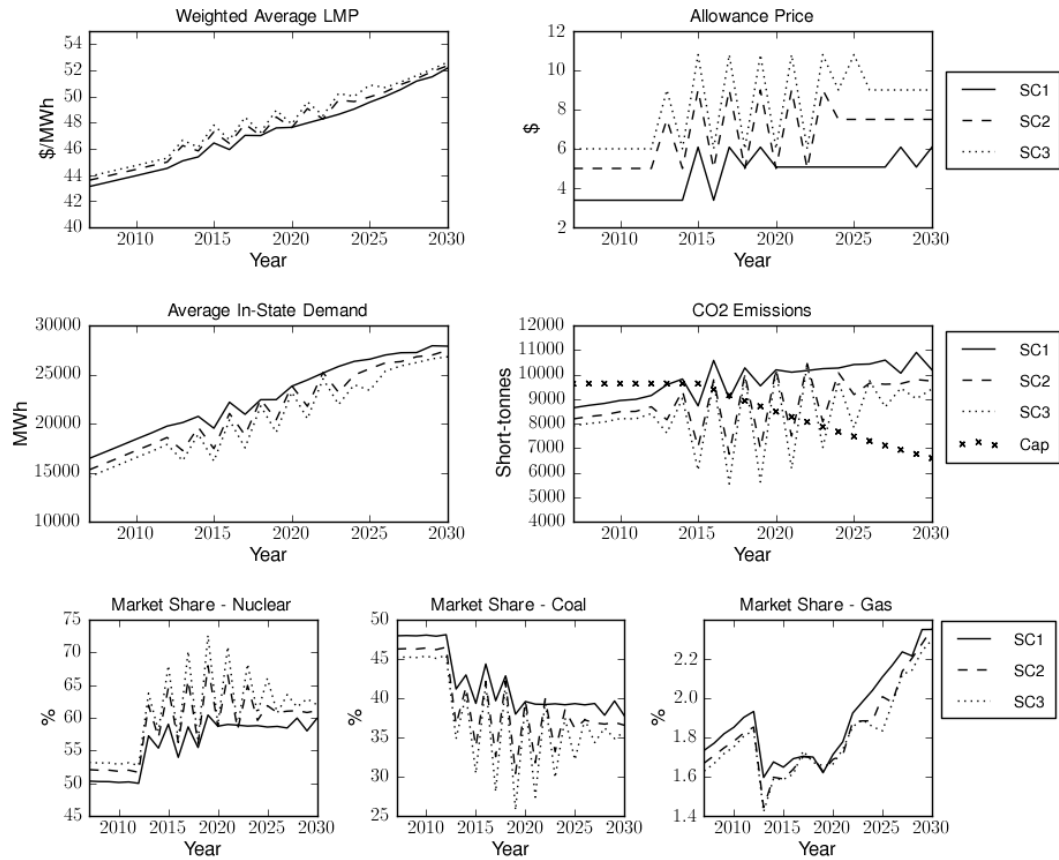

Figure 3.5: Model Results for the Sample Network Under Three Cap-and-Trade Scenarios

This, in the subsequent year, reduces the cap violation penalty and the generator supply bid prices, which results in coal generators supplying more power and violating the cap again. This cycle repeats until demand grows to a point where excess generation capacity is reduced and so is the fluctuation in coal generation from year to year, thereby reducing the fluctuations in the LMPs (as observed in the third segment of the LMP plots).

A similar but complimentary fluctuation can be seen in the demand and emissions values, where both demand and emissions are lower in years when the LMPs are higher and vice versa. It may be noted, as evident from the last segment of the emissions and market share plots, that the capacity mix of the network and the increased demand result

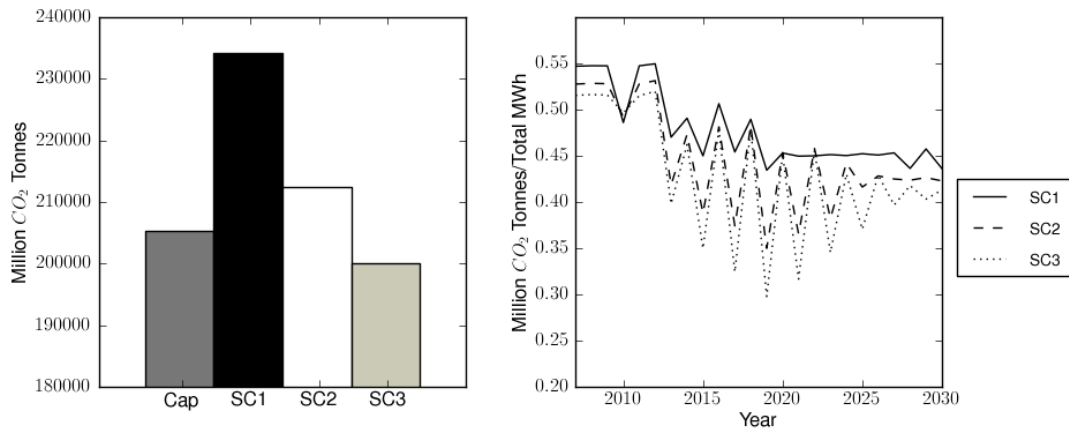

Figure 3.6: Aggregated Cap and Emissions for the Planning Horizon (2007-2030) (Left) -  $CO_2$  Emissions per MWh (Right)

in a steady selection of coal-based generation and increasing emissions cap violation under continuing cap reduction. As expected, the smallest violation of the cap is observed for SC3. It can also be seen from the demand plot that the demand elasticity (modeled via demand side bidding in the OPF) causes the network demand to be generally lower in SC3 than in SC2, and lower in SC2 than in SC1.

As to the market share by technology, Figure 3.5 shows that nuclear and coal generation undergo a similar fluctuation, whereby the nuclear generation peaks in years when supply bids for coal plants attempt to recover penalties due to cap violation in the previous year. Overall, for the period 2007-2030, the market share of nuclear generation exhibits a net increase of around 10%, natural gas-based generation exhibits a negligible net increase, while the coal generation decreases around 10%.

Figure 3.6 shows the overall effect of the cap-and-trade design on emissions reduction in each scenario. The line graph presents the emissions per MWh of electricity produced revealing the emissions reduction trend due to cap-and-trade in all three scenarios. Note that, this reduction trend is in contrast to the increasing trend for *total emissions* that we observe in Figure 3.5, which is caused in part by the increase in demand over the planning horizon. It can also be observed that emissions per MWh in SC3 are reduced

approximately 20 % over the period 2007-2030. The bar graph in Figure 3.6 depicts the aggregated cap (i.e., the total allowed emissions during 2007-2030) and the aggregated emissions in each of the scenarios. It can be seen that in SC3, contrary to the other scenarios, the aggregated emission is below the aggregated cap, which attests to the higher effectiveness of the pricing scheme in SC3.

### 3.5 Concluding Remarks

Cap-and-trade is the most discussed scheme to control  $CO_2$  emissions in the U.S. In recent years, the European Union and a group of Northeastern states in the U.S. have implemented such programs. Generation expansion decisions will need to be made taking into account any such regulation. In fact, if a cap-and-trade program is to succeed there will have to be a shift from dominant fossil-fuel technologies to low-emission technologies such as renewables or nuclear power.

In this chapter, we develop a game theoretic model for generation capacity expansion that is able to accommodate different designs of a cap-and-trade program to assess their impact on expansion decisions. The model incorporates the competition among the generators in the allowance and electricity markets. We develop a solution algorithm for the game theoretic model that provides the equilibrium expansion plans, allowance bid strategies, and supply function bid strategies of the generators for a specific planning horizon. The model can be used to assess the impact that different features of a cap-and-trade program can have on expansion decisions of the generators and their implications for total emissions, electricity prices, and electricity demand. For instance, besides assessing the impact of the allowance reserve price (as presented in the case study), we can use the model to analyze the impact of other cap-and-trade features including the maximum number of allowances that a generator can procure in the auction, not allowing

the banking of allowances, changing the type of auction used to distribute the allowance (such as using a pay-as-go scheme), considering different allowance penalties.

The chapter also presents a case-study based on the northern Illinois power network, which is subjected to a hypothetical cap-and-trade program (with features similar to those considered in RGGI). We can draw the following insights from the results.

- Allowance price is a key factor to achieve emissions reductions. As shown in the results from scenarios SC1, SC2, and SC3, the higher the allowance price, the lower the amount of emissions. An increase of \$2.02 in the average allowance price during the planning horizon triggers a 9.35% decrease in  $CO_2$  emissions. A further increase of \$1.41 in the average allowance price triggers a further 5.28% decrease in emissions.
- An increase of \$2.02 in the average allowance price during the planning horizon decreases demand by 5.4%. A further increase of \$1.41 in the average allowance price triggers a further 3.9% decrease in demand.
- Fossil-fuel based plans, coal in particular, preserve a sizable market share (not lower than 25%) throughout the planning horizon. In SC1, the average market share of coal-based plants is 41.9% whereas in SC3 is 37.47% (as noted above, demand is lower under SC3).
- The initial phase through which the cap gets tightened can cause instability in emissions, prices, and demand in the electricity market since generators will take time in settling their supply bid strategies. The variance of prices and demand tends to be similar across the 3 scenarios while the variance of emissions tends to be higher in SC3 than in the other two scenarios.
- Even if expansion plans that are 80% free of emissions are implemented, there are still issues of overall cap compliance when allowance prices are comparatively lower (as shown by the results from SC1 and SC2).

- Overall emissions reductions is a valid metric to assess the effectiveness of a cap-and-trade program as shown in Figure 3.6. This metric complements the year-by-year cap violation assessment.
- Generators integrating penalties for cap violations is a feasible scenario that occurs when there is neither enough low-emission generation nor network transmission capacity in the network.
- Allowance scarcity can become an issue if the penalties for cap violation are set at a high level of allowances.

We did not consider other elements of future electricity markets under emissions regulation, such as renewable power, offsets, recycling of  $CO_2$  revenue, and demand side efficiency incentives. With regards to these elements, we offer the following comments.

- We did not include renewables because we did not have any data for this type of generation for the Illinois network. From an emissions perspective, renewable power is comparable to nuclear power. However, other aspects are different such as construction lead times and the level of capacity offered to the market.
- Offset is another type of financial instrument within an emissions control scheme, which is used to compensate for emissions. Common offset mechanisms include supporting forestation, carbon sequestration, renewable energy and energy efficiency projects. As with allowances, the level of offsets in a cap-and-trade program is limited. In our model, consideration of offsets (which are generally cheaper than penalties) would have allowed generators a cheaper means to comply with the cap.
- Recycling the revenue, collected from allowance auctions, among the consumers could mitigate the effect of the observed increase in electricity prices due to the cap-and-trade implementation. On the other hand, part of the revenue could be

recycled to low-emission generators so that they can improve their competitiveness against fossil-fuel generators. One of the recent emissions control bills in the U.S. Congress ([45]) considers recycling 75% of the cap-and-trade revenue to consumers. We present a model to develop optimal carbon revenue recycling policies in the next chapter.

- Demand side management (DSM) strategies (e.g., smart meters, efficiency and consumption incentives) are intended to have an impact on the level and patterns of energy consumption, thereby, impacting total emissions. However, the inclusion of DSM strategies in our methodology would significantly increase the modeling challenge.

## Chapter 4: Optimal Policies for $CO_2$ Cap-and-Trade Revenue Redistribution

A design feature that is common to both market-based emissions control schemes, cap-and-trade and carbon tax, is the possibility of returning to the market participants the revenue raised by selling allowances (in the cap-and-trade case) or by collecting the tax (in the carbon tax case). This chapter is concerned with developing strategies to redistribute this carbon revenue.

### 4.1 Relevance

The amount of revenue collected by  $CO_2$  emissions control schemes can be significant. Metcalf et al. in [46] compile estimates of the potential revenue that could be collected through several carbon tax bills proposed in the U.S. Congress. The estimates range from \$69 billion to \$126 billion in the first period of a carbon tax program, gradually increasing throughout the years. Paltsev et al. in [34] estimates that the revenue collected by auctioning allowances in some cap-and-trade proposals for the U.S. range from \$130 to \$366 billion during the first period of implementation. It may be noted that the revenue collected in a cap-and-trade program depends on the number of allowances that are auctioned (in some designs, such as the initial stage of the European Union Emission Trading System, all allowances can be given away for free and no revenue is collected). The only  $CO_2$  cap-and-trade program currently functioning in the U.S., the Regional Greenhouse Gas Initiative (RGGI), has collected proceeds that range from \$38 million to \$117 million in the auctions run so far [44].



## 4.2 Revenue Recipients

Several economists [47–49] are in favor of redistributing (recycling) the carbon revenue, in other words, of developing emissions control schemes that are *revenue neutral*. The market participants that are most often mentioned as the potential recipients for the revenue are households and low-emission companies. Some of the means to achieve the redistribution of revenue include lump-sum distribution to households [47], reducing labor or capital taxes, and spending the funds for other purposes such as R & D in low-carbon technologies and energy efficiency [48]. The case for redistributing carbon revenue back to households is based on the assumption that electricity companies will pass on to the consumers the cost of allowances or carbon tax, therefore increasing the electricity prices. In [47], it is estimated that households will spend an additional \$1,158 to \$4,119 annually (in 1999 dollars) if a carbon tax is implemented. The case for redistributing part of the revenue to low-emission companies, on the other hand, is based on the need to increase the market share of low-emission generation. The European Union, for instance, have set targets for renewable-based generation (21 %) for the next decade [50]. This will demand a great deal of innovation from renewable-based generation companies which could potentially be achieved through R & D investment (according to [51], emissions pricing alone might not be enough to improve renewable technologies).

## 4.3 Chapter Outline

In this chapter, we present a mathematical model to develop revenue redistribution strategies for a cap-and-trade or a carbon tax program among market participants in a power market. The model is a multi-year version of the DC-based Optimal Power Flow (OPF) problem modified to accommodate carbon revenue constraints and subsidies. We focus on electricity markets that are subjected to emissions control schemes, similar to

the case of several existing markets under the Regional Greenhouse Gas Initiative (RGGI) [9].

In the next section we present a review of the current literature on the topic. We present the model and variations of it in Section 4.6. In Section 4.7 some numerical examples are presented. Section 4.9 deals with the conclusions and future work.

## **4.4 Background**

The implementation of a carbon tax or a cap-and-trade program that considers the auction of allowances will represent an important new source of revenue for the government. Economists have argued in favor of using this revenue to mitigate some of the distributional impacts of such programs, in particular, the fact that low-income households will be hit harder in terms of percentage of total expenditures by the new carbon charges. However, there are disagreements with regards to the best way of redistributing the revenue.

### **4.4.1 Literature Review**

Two are the most discussed approaches for redistributing the carbon revenue when considering an economy-wide emissions control scheme: lump-sum redistribution and reduction of distortionary taxes (in labor and capital markets). In a lump-sum redistribution scenario, the revenues will be directly redistributed to consumers via rebates. Barnes and Breslow [47] suggest a trust fund, the "Sky Trust", that would be in charge of collecting and administering the revenue for current and future citizens. Each individual would receive the same annual payout from the trust. Lump-sum redistribution to households was found to have the most progressive distributional effect in a study by the Congressional Budget Office [52] (the study considers a cap-and-trade program with all allowances auc-

tioned). Dinan and Rogers in [53] conclude that lump-sum redistribution would be more helpful for low-income households though the cost for the economy would be greater than if the government would use the revenue to reduce pre-existing distortionary taxes. Using carbon revenue to reduce pre-existing distortionary taxes is espoused by several authors in the literature due to the possibility of obtaining a *double dividend* i.e. achieving environmental benefits and at the same time reducing the economic costs of the tax system [49]. The double dividend hypothesis has been widely discussed in the literature. Goulder in [54] identifies different versions of the hypothesis (weak, intermediate, and strong) and concludes that the weak version (returning revenues through cuts in distortionary taxes leads to cost savings in comparison with lump sum redistribution) is easily defended on theoretical grounds whereas this is not the case for the strong version (returning tax revenues through cuts in distortionary taxes leads to negative gross costs). Parry et al. in [49] argue that a strong double dividend can be obtained for a scenario where part of consumer spending is deductible from labor taxes. Other papers that cover the double dividend hypothesis include [55–57]. The main argument against both, the lump-sum redistribution and the redistribution via reduction of distortionary taxes, is that the two approaches are likely to have little impact on environmental effectiveness of an emissions control scheme.

Other options through which revenue recycling can be achieved include output-based rebates to emitters, investments in energy efficiency, and investments in R & D [58]. In the case of investments in R & D, the redistribution can be implemented via subsidies. The use of subsidies to carry out revenue recycling has a precedent in transport networks where congestion revenue has been used to subsidize public transportation [59, 60] (as in the London's congestion charging scheme). The allocation of subsidies for low-emission technologies (biofuels, in particular) from revenue collected by a carbon tax is discussed in [61]: 'if the state (Washington) chooses to provide direct support for the biofuel industry based on carbon tax revenues, it can do so by providing tax credits (subsidies)

to low-carbon renewable fuels, and/or it can invest carbon tax revenues in research and development into advanced biofuels. The tax/subsidy combination will reduce the price increase of blended fuels due to the carbon tax and reduce the price of biofuels relative to all other goods in the economy.’ Subsidies for R & D are common in several parts of the world with major programs implemented in the United Kingdom, Denmark, Ireland, Germany, Japan, and The Netherlands [51]. Subsidies for R & D, as part of carbon revenue redistribution strategies, have been included in recent emission control bills introduced in the U.S. Congress. In [45], for example, a portion of the 25% of revenue collected in the allowance auction is targeted for investments in clean energy. The only implemented cap-and-trade program in the U.S., the Regional Greenhouse Gas Initiative, also includes provisions for investment of allowance auction proceeds in R & D. For instance, Connecticut, one of the states members of RGGI, assign 23 % of proceeds to support renewable energy programs administered by the Connecticut Clean Energy Fund (CCEF) [62]. In Europe, Denmark recycle part of the carbon revenue to industry through energy efficiency incentives [63]. There are criticisms to the use of subsidies, R & D subsidies in particular, to redistribute carbon revenue. It is argued that in some cases these subsidies often pay for technologies that would have been installed even without the subsidy [58]. Also, another criticism is that the government, by allocating subsidies, is picking winners and losers.

We develop our revenue redistribution models based on the allocation of subsidies for low-emission generators as discussed next. In considering this approach, we expect to:

- improve the environmental effectiveness of an emissions control scheme via improving the competitive position of low-emission generators against fossil-fuel generators and
- mitigate some of the distributional impacts of an emissions control scheme via lowering electricity prices.

## 4.5 Types of Subsidies

We focus on the revenue redistribution problem of a utilities-only cap-and-trade or carbon tax program. We analyze two types of subsidies through which the carbon revenue redistribution is accomplished: bid subsidies for low-emission generators and R & D subsidies for low-emission generators. The objective of the first type of subsidy (bid subsidies) is to increase the market share of low-emission generators during a particular electricity auction and, in some cases, lower LMPs in the network. This would allow customers to pay lower prices for electricity (in comparison with the case where no bid subsidies are allocated) and have more money at their disposal for other activities.

The second type of subsidy that we consider, R & D subsidies for low-emission generators, have a comparable objective (to the bid subsidies): to increase market share of low-emission generators and to lower LMPs in the network. However, the emphasis in the allocation of these subsidies is in the long run. There is empirical evidence that shows how new technologies are able to reduce their production costs based on their cumulative stock of R & D [51]. Thus, it can be expected that low-emission generators (based on new technologies such as solar, wind, biomass) will achieve desired reductions of production cost if they receive subsidies targeted for R & D during a planning horizon.

The optimization models that we propose in this chapter are built to allocate these two types of subsidies. In addition, by considering the OPF as the basis for our model formulations, we intend to address some of the regional (locational) equity concerns that may arise if an equal per capita revenue redistribution rule (as proposed in [45, 47]) is implemented. Such concerns are rooted in the fact that, due to different patterns of congestion and load, the electricity prices in some regions can be higher than in others.

## 4.6 Mathematical Models

The mathematical formulations that we present next are developed from the perspective of the government (or any other entity in charge of collecting and redistributing the revenue), which aims at distributing the revenue in order to maximize a social welfare function defined as the benefit to consumers minus the cost to producers.

We consider a  $CO_2$  cap-and-trade program (or a carbon tax program) implemented on a defined geographical region covering emissions from power companies during a planning horizon  $T$ . The government makes 100% of the carbon revenue available for redistribution via bid subsidies for low-emission generators and R & D subsidies. We assume that there is a forecast for the amount of revenue collected  $W^t$  for each period  $t$  of the planning horizon based on an expected allowance price  $P^t$  and a certain amount of allowances  $A^t$ .

Generators (high-emission and low-emission) are assumed to have a quadratic cost function based on which a linear supply bid can be derived. If the marginal cost for a generator  $j$  is given by  $C_j = (a_j^0 q + \frac{1}{2} b_j^0 q^2)$ , then a linear supply bid can be derived as  $p = a_j^0 + b_j^0 q$ . We model the effect of a subsidy on a supply bid of a generator as shown in Figure 4.1.

In Figure 4.1, the original equilibrium of the market occurs at the intersection of the supply (S) and demand (D) curves. A subsidy of size  $\alpha * s (\frac{1}{MWh} * \$)$  shifts the supply curve to the right (see curve S'). Now, the equilibrium occurs at a point where consumption is larger and consumer's price is lower than in the original equilibrium.

### 4.6.1 Subsidy Modeling

As mentioned earlier, we consider two types of subsidies for low-emission generators through which the revenue redistribution is carried out: bid subsidies and R & D subsi-

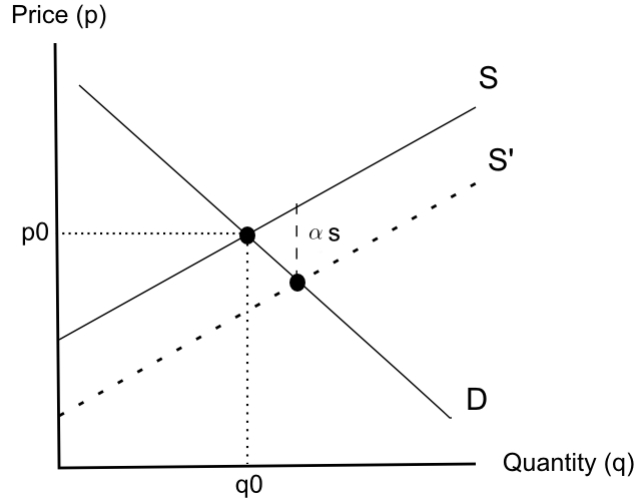

Figure 4.1: Supply Curve Before and After Subsidy  $\alpha s$

dies. The bid subsidies are allocated during an electricity auction and have the purpose of decreasing the supply bid intercept of a low-emission generator only during the auction. Thus, the bid subsidies are not modeled to have a long-term effect. For this type of subsidy, the subsidy coefficient  $\alpha$  of a low-emission generator  $j$  is computed as  $\alpha_j = 1/Q_j$ , where  $Q_j$  is the maximum amount of power that low-emission generator  $j$  can offer in the auction. This computation implies that the total subsidy quantity  $s$  (in \$) is prorated over the total amount of power offered to the market by the low-emission generator to obtain how much the supply curve of the generator is shifted.

The R & D subsidies are also allocated during an electricity auction, however, in contrast with the bid subsidies, the R & D subsidies are cumulative and thus, have a long-term effect on reduction of production costs. This long-term effect is modeled based on the cumulative *stock of R & D* ( $U^t$ ) concept that is presented in [51].

In [51],  $U^t$  is introduced as part of another expression called *knowledge stock* defined as  $K(\mathcal{W}, U) = (\frac{\mathcal{W}^{t-1}}{\mathcal{W}^0})^{v_1} (\frac{U^{t-1}}{U^0})^{v_2}$  with  $\mathcal{W}^t$  denoting the cumulative production of the generator up to year  $t$ , and  $v_1, v_2$  estimated learning elasticities. The impact of  $K$  on the production cost  $C$  of a generator is given by  $K^{-1}C$ .

In our model, we focus on the second part of the expression for  $K$ , thus we assume that the knowledge stock depends only on the cumulative stock of R & D at the beginning of year  $t$  i.e.,  $K(U) = (\frac{U^{t-1}}{U^0})^v$ . Such mathematical relationship has also been explored in [64, 65]. It may be noted that the impact of  $K$  on reducing production cost is realized in year  $t$  yet the value of  $K$  is a function of the cumulative stock of R & D at the end of year  $t - 1$ . For fixed values of elasticity ( $v$ ) and initial stock of R & D ( $U^0$ ), we define the reduction on unit production cost due to cumulative stock of R & D for a year  $t$  as  $\mathcal{R}^t = C^t - K^{-1}C^t$ . Using the least squares method (see Appendix A), we approximate  $\mathcal{R}^t$  to  $\hat{\mathcal{R}}^t = \gamma U^{t-1}$ , where  $\gamma$  is the regression coefficient. In economics, it has been established that R & D investment shifts supply curves to the right. Therefore, the equivalent effect of  $\alpha s$ , in the case of R & D subsidies (during a single electricity auction at time  $t$ ), is given by  $\gamma U^{t-1}$ .

#### 4.6.2 Mathematical Formulations

We present two mathematical formulations, one for each type of subsidy, based on the DC Optimal Power Flow (OPF) formulation published in [18]. We modify the formulation to accommodate the subsidies in the objective function and add a constraint for the amount of carbon revenue available for redistribution. For the R & D subsidy formulation, we also consider a multi-year planning horizon.

In both formulations, we consider that generators have supply curves  $p = a + bq$  where  $a$  and  $b$  are the intercept and slope, respectively and loads have demand curves  $p = e - fd$  where  $e$  and  $f$  are the intercept and slope, respectively.

The rationale for considering the OPF formulation as the basis for the allocation of subsidies is to ensure that the resulting revenue redistribution strategy is optimal with respect to the way power will be allocated in the actual market. This will also allow pol-



icymakers to assess the performance of the redistribution policy once is implemented against what was expected to occur.

#### 4.6.2.1 Mathematical Formulation to Allocate Bid Subsidies

The mathematical formulation to allocate the bid subsidies is as follows,

$$\begin{aligned} \max \sum_h \sum_{\theta} (e_{\theta_h} - \frac{f_{\theta_h}}{2} d_{\theta_h}) d_{\theta_h} - \sum_h \sum_i (a_{i_h} + \frac{b_{i_h}}{2} q_{i_h}) q_{i_h} \\ - \sum_h \sum_j (a_{j_h} - \alpha_{j_h} s_{j_h} + \frac{b_{j_h}}{2} q_{j_h}) q_{j_h}, \end{aligned} \quad (4.1)$$

subject to:

$$\sum_i q_{i_h} + \sum_j q_{j_h} - \sum_{\theta} d_{\theta_h} - \sum_{l \in l(h)} (m_{hl} - m_{lh}) = 0 \quad \forall \text{ node } h \quad (4.2)$$

$$\sum_{hl \in V(\rho)} R_{hl} (m_{hl} - m_{lh}) = 0 \quad \forall \text{ voltage loop } \rho \quad (4.3)$$

$$\sum_h \sum_j s_{j_h} \leq W \quad (4.4)$$

$$m_{hl} \leq M_{hl} \quad \forall \text{ arc } hl \quad (4.5)$$

$$m_{hl} \geq 0 \quad \forall \text{ arc } hl \quad (4.6)$$

$$q_{i_h} \leq Q_{i_h} \quad \forall i, h, \quad q_{j_h} \leq Q_{j_h} \quad \forall j, h \quad (4.7)$$

$$q_{i_h}, q_{j_h} \geq 0 \quad \forall i, j, h \quad (4.8)$$

where

$d_{\theta_h}$	quantity demanded by load $\theta$ at node $h$ (decision variable)
$q_{i_h}$	quantity of electricity (in MW) produced by fossil-fuel generator $i$ located at node $h$ (decision variable)
$s_{j_h}$	bid subsidy (per MW produced) for low-emission generator $j$ at node $h$ (decision variable)
$q_{j_h}$	quantity of electricity (in MW) produced by low-emission generator $j$ located at node $h$ (decision variable)
$e_{\theta_h}, f_{\theta_h}$	intercept and slope of demand bid curve submitted by load $\theta$ located at node $h$
$a_{i_h}, b_{i_h}$	intercept and slope of supply bid curve submitted by fossil fuel generator $i$ located at node $h$
$a_{j_h}, b_{j_h}$	intercept and slope of supply bid curve submitted by low-emission generator $j$ located at node $h$
$\alpha_{j_h}$	learning coefficient due to cumulative stock of R & D of low-emission generator $j$ located at node $h$
$m_{hl}$	power flow on arc $hl$ (decision variable)
$R_{hl}$	reactance of arc $hl$
$W$	available revenue for redistribution
$M_{hl}$	transmission limit of arc $hl$
$Q_{i_h}$	production limit of fossil-fuel generator $i$ located at node $h$
$Q_{j_h}$	production limit of low-emission generator $j$ located at node $h$ .

The first term in the objective function (4.1) corresponds to the total benefit to consumers, the second term stands for the total cost to the fossil-fuel generators, and the third term corresponds to the total post bid subsidy cost to the low-emission generators for a single electricity auction. Constraints (4.2) and (4.3) enforce Kirchhoff's laws in the DC linearized load flow model, constraint (4.4) ensures that the amount allocated to the participants via subsidies is not greater than the total revenue considered for redistribution

during the electricity auction, and constraints (4.5), (4.6), (4.7), (4.8) enforce transmission and generation limits. In the case of constraint (4.8), the RHS should reflect the actual deliverable production limit of low-emission generator  $j$ , i.e. the maximum amount of power generator  $j$  can supply given the transmission constraints in the network. This is of particular importance since the objective of the subsidy allocation is to increase the supply of low-emission generators in the network while social welfare, the function maximized in the mathematical formulation, can be increased via the allocation of subsidies even if generators cannot supply more power to the network (by making the third term in the objective function smaller).

In the absence of subsidy terms, the above is a regular DC OPF formulation. The inclusion of the bid subsidy terms modifies the original solution. If there is enough transmission capacity in the network, there are chances of an increase in overall demand in the network (with respect to the original solution) due to larger amounts of electricity supplied by the subsidy recipients. On the other hand, if the network is congested, subsidy allocations can cause disturbances to the original dispatch solution that might result in overall network demand reduction or unintended consequences such as increasing the market share of fossil-fuel generators. It may be noted though that even in these cases of high congestion the recipient of the bid subsidy will increase supply (provided constraint (4.8) is not tight).

#### **4.6.2.2 Mathematical Formulation to Allocate R & D Subsidies**

In the case of R & D subsidies, the above formulation has to be modified. First of all, a multiperiod horizon  $T$  is considered. Increasing amounts of R & D investment generate larger reductions in production cost [51] (this relationship is commonly represented via R & D learning curves), thus the stock of R & D of a generator at a certain point in time must be treated as a cumulative quantity that depends on the R & D stock at previous

points in time. In our model (presented below), the difference between the stock of R & D of a generator at times  $t + 1$  and  $t$ ,  $U^{t+1} - U^t$ , is represented by the amount of R & D subsidy allocated to a generator  $j$ ,  $u_j$ , at time  $t$ . Additionally, we also consider a stock of R & D target  $\beta_{j_h}$  for the final period of the horizon. The rationale for setting this target is that policymakers cannot allocate subsidies indefinitely and, based on the R & D learning curves of the generators  $t$ , they can estimate the projected stock of R & D that would leave the low-emission generators in a competitive position against the fossil fuel generators at the end of the planning horizon. We note that this target must also consider the network transmission constraints that limit the current and expected future delivery of power by the low-emission generators.

The mathematical formulation to allocate the R & D subsidies is as follows,

$$\begin{aligned} \max \sum_t \sum_h \sum_\theta (e_{\theta_h}^t - \frac{f_{\theta_h}^t}{2} d_{\theta_h}^t) d_{\theta_h}^t - \sum_t \sum_h \sum_i (a_{i_h}^t + \frac{b_{i_h}^t}{2} q_{i_h}^t) q_{i_h}^t \\ - \sum_t \sum_h \sum_j (a_{j_h}^t - \gamma_{j_h} U_{j_h}^{t-1} + \frac{b_{j_h}^t}{2} q_{j_h}^t) q_{j_h}^t, \end{aligned} \quad (4.9)$$

subject to:

$$\sum_i q_{i_h}^t + \sum_j q_{j_h}^t - \sum_\theta d_{\theta_h}^t - \sum_{l \in l(h)} (m_{hl}^t - m_{lh}^t) = 0 \quad \forall \text{ node } h, t \quad (4.10)$$

$$\sum_{hl \in V(\rho)} R_{hl}^t (m_{hl}^t - m_{lh}^t) = 0 \quad \forall \text{ voltage loop } \rho, t \quad (4.11)$$

$$U_{j_h}^t - U_{j_h}^{t-1} - u_{j_h}^t = 0 \quad \forall j, h, t \quad (4.12)$$

$$U_{j_h}^T = \beta_{j_h} \quad \forall j, h \quad (4.13)$$

$$\sum_h \sum_j u_{j_h}^t \leq W^t \quad \forall t \quad (4.14)$$

$$m_{hl}^t \leq M_{hl}^t \quad \forall \text{ arc } hl, t \quad (4.15)$$

$$m_{hl}^t \geq 0 \quad \forall \text{ arc } hl, t \quad (4.16)$$

$$q_{i_h}^t \leq Q_{i_h}^t \quad \forall i, h, \quad q_{j_h}^t \leq Q_{j_h}^t \quad \forall j, h \quad (4.17)$$

$$q_{i_h}^t, q_{j_h}^t \geq 0 \quad \forall i, j, h \quad (4.18)$$

where most of the terms are the same as in the formulation for bid subsidies but with a superscript indicating the time period. The new variables and parameters are:

$U_{jh}^{t-1}$	cumulative stock of R & D of low-emission generator $j$ located at node $h$ at the beginning of year $t$ (decision variable)
$u_{jh}^t$	R & D subsidy for low-emission generator $j$ located at node $h$ during year $t$ (decision variable)
$U_{jh}^0$	initial stock of R & D of low-emission generator $j$ located at node $h$ at the beginning of year $t$
$\gamma_{jh}$	regression coefficient for the reduction on unit production cost due to cumulative stock of R & D of low-emission generator $j$ located at node $h$
$\beta_{jh}$	minimum required amount of cumulative stock of R & D at end of planning horizon for low-emission generator $j$ located at node $h$
$W^t$	available revenue for redistribution during year $t$ .

The constraints are the same as in the bid subsidy formulation (though each one of the constraints is now a set of  $T$  elements) with the addition of constraint sets (4.12) and (4.13). The former constraint set establishes the relationship between the cumulative stocks of R & D and the yearly subsidies for R & D of each generator while the set (4.13) ensures that each generator achieves a target of cumulative R & D stock at the end of the planning horizon.

Note that in this formulation, the parameter  $a_{i_h}^t$  (intercept of supply curve of fossil fuel generator  $i$  at node  $h$ ), is modified throughout the planning horizon via the following expression,

$$a_{i_h}^t + \delta P^t, \quad (4.19)$$

where  $\delta$  is the emissions factor (which indicates the amount of  $CO_2$  (in tons) generated per MWh of electricity production, depending on the technology) and  $P^t$  is the expected allowance price during period  $t$ . The parameters  $e_{\theta_h}^t$  are also modified throughout the planning horizon to represent an increase in demand from a load  $\theta$  in node  $h$  of the network (this is equivalent to shift a linear demand curve to the right).

### 4.6.3 Solution Methodology

Both formulations are, in general, nonlinear nonconvex problems. The nonconvexity is due to the bilinear terms in the objective function:  $sq$  (in the bid subsidies formulation) and  $U^{t-1}q$  (in the R & D subsidies formulation). By using suitable transformations [66], we convert each formulation into a separable model. The resulting quadratic terms that still render each separable problem nonconvex are approximated using piecewise linear functions [66].

After implementing these approximations, the first formulation (for the allocation of bid subsidies) is solved in CPLEX obtaining a local optimum. In the case of the second formulation, we adopt a backward induction procedure to find the local optimum. The procedure is based on the fact that the target stocks of R & D for each low-emission generator, for the final period of the planning horizon  $U_{jh}^T$ , are known. If the elements of the objective function and constraints that correspond to the last period of the planning horizon are considered as a new problem and the following constraints are added,

$$U_{jh}^{T-1} \leq U_{jh}^T \quad \forall j, h \quad (4.20)$$

$$U_{jh}^{T-1} \geq U_{jh}^T - W^T \quad \forall j, h \quad (4.21)$$

$$\sum_h \sum_j U_{jh}^{T-1} \leq \sum_1^T W^t \quad (4.22)$$

then the resulting optimization problem is similar to the problem formulated to allocate the bid subsidies (4.1) - (4.8) with the addition of linear constraints (4.20), (4.21), and (4.22). The solution of this optimization problem provides the values for  $U_{j_h}^{T-1}$  ( $T - 1$  is the second to last period) of each low-emission generator which can then be used to iteratively solve the other optimization problems in a backward fashion. The constraints above can be generalized for each of the previous periods by substituting  $T$  for  $t$  and  $T - 1$  for  $t - 1$ . Constraint (4.20) ensures that the stock of R & D from the previous period is not higher than in the current period; constraint (4.21) ensures that the stock of R & D at the end of the current period is achievable with the revenue available from redistribution during the current period; and constraint (4.22) ensures that there is enough accumulated revenue available for redistribution up to period  $t$  to satisfy the total sum of the stock of R & D of the low-emission generators at the end of period  $t - 1$ . This last constraint has a *greedy* effect in that the sum of the cumulative values for the stock of R & D of the generators during a single period is reduced only if it is strictly necessary (otherwise the cumulative stock of R & D,  $U_{j_h}^t$ , would not be reduced since higher values increase the objective function).

The optimization problems were modeled in C through a callable CPLEX library and solved using ILOG CPLEX version 12.1. Descriptions and results for a sample application of the model are presented next.

## 4.7 Application

We demonstrate our proposed optimization model on a 4-node sample network (in Figure 4.2). We consider two different low-emissions generators G2 and G3 (one with a higher impact of cumulative stock of R & D on cost reductions, i.e. a higher regression coefficient  $\gamma_{j_h}$ ), a fossil fuel generator G1 that needs to procure allowances to produce electricity, and a load L1.

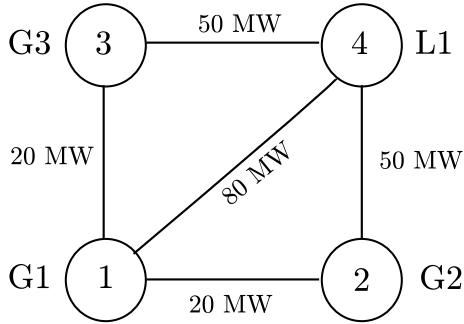

Figure 4.2: Four-Node Sample Network

#### 4.7.1 Allocation of Bid Subsidies

Initially, we use the first formulation to allocate bid subsidies to the low-emission generators in the network during a single electricity auction (period). We consider that the amount of revenue available for redistribution during the electricity auction is  $W = 50.0$ . We analyze two scenarios (SC10 and SC20) to show how the subsidy allocation varies with the parameters of the supply curve of the low-emission generators. Note that in scenario SC10 the network is not congested while in scenario SC20 the network is congested. The supply and demand curve parameters of the generators and load for both scenarios are presented in Table 4.1. The results of the OPF problem for the respective

Table 4.1: Supply/Demand Curve Parameters for Generators and Load in SC1 and SC2

	SC10 Supply/Demand Parameters	SC20 Supply/Demand Parameters
L1	$e_1 = 27.6; f_1 = 0.05$	$e_1 = 27.6; f_1 = 0.05$
G1	$a_1 = 17.0; b_1 = 0.05$	$a_1 = 17.0; b_1 = 0.05$
G2	$a_2 = 19.047; b_2 = 0.05$	$a_2 = 19.047; b_2 = 0.002$
G3	$a_3 = 18.48; b_3 = 0.05$	$a_3 = 18.48; b_3 = 0.05$

scenarios with no subsidy allocation (SC10 and SC20) are presented in the first and third rows, respectively, of Table 4.2. We solve the optimization model (4.1)-(4.8) and obtain that for a network with supply and demand curves as in SC10 the bid subsidy allocation



is  $s_{1_2} = 0$  and  $s_{1_3} = 50$  while for a network with supply and demand curves as in SC20 the bid subsidy allocation is  $s_{1_2} = 50$  and  $s_{1_3} = 0$ . The corresponding scenarios post allocation of bid subsidies are named SC1 and SC2 and their OPF results (that incorporate the effect of the bid subsidy allocation) are presented in the second and fourth row of Table 4.2, respectively. In SC1, the bid subsidy is allocated to G3 which as a result

Table 4.2: Quantity Supplied, Total Demand, Bid Subsidies, and LMP at Load Node for Scenarios SC10, SC1, SC20, and SC2

	$d_{1_4}$	$q_{1_1}$	$q_{1_2}$	$q_{1_3}$	$s_{1_2}$	$s_{1_3}$	LMP 4
SC10	141.365	70.635	29.695	41.035	0	0	20.532
SC1	142.988	68.135	27.634	47.219	0	50	20.451
SC20	142.745	58.723	49.633	34.389	0	0	20.463
SC2	140.755	55.937	50.827	33.991	50	0	20.562

supplies more power to the network than in SC10. Note also that overall generation from the low-emission generators (G2 and G3) is higher in SC1 than in SC10 (74.853 in SC1 vs 70.730 in SC10) and carbon emissions are reduced since G1 produces less power in SC1. Furthermore, the bid subsidy allocated to G3 causes a net increase in load demand (and consequently, LMP 4 to decrease). In SC2, the allocation of the bid subsidy to G2 increases G2's supply to the network, reduces emissions, and increases total generation from low-emission generators (84.818 in SC2 vs 84.022 in SC20). However, due to the congestion already existent in the network in SC20, the allocation of the bid subsidy to G2 results in a net reduction of load demand and thus, in an increase of LMP 4 in SC2.

The allocation of bid subsidies obtained from solving problem (4.1)-(4.8) in each case is dictated, to a large extent, by what is observed in Figure 4.3. In SC10, G3 always has a lower price per MWh than G2 (and thus, a lower cost). Therefore, the bid subsidies are allocated to G3 regardless of the quantities produced by G2 or G3. In SC20, on the other hand, the quantity that each generator produces is important to determine the allocation of bid subsidies since G3 is cheaper than G2 only within a small range of values for  $q$ .

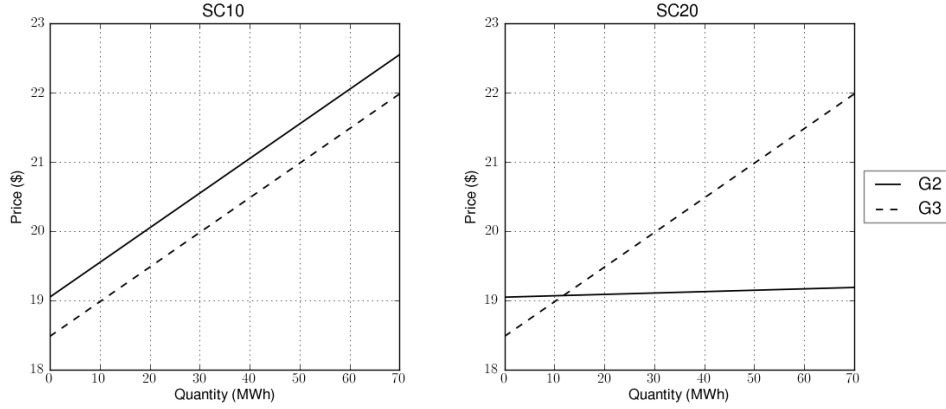

Figure 4.3: Supply Curves of G2 and G3 in Scenarios SC10 and SC20

#### 4.7.2 Allocation of R & D Subsidies

To develop the allocation of R & D subsidies, we consider the same 4-node sample network (in Figure 4.2). The supply and demand curves of the generators and load are different than in the previous example and are presented in Table 4.3. In addition, we

Table 4.3: Supply/Demand Curve Parameters for Generators and Load at  $t = 1$

	Supply/Demand parameters
L1	$e_1^1 = 27.0; e_1^1 = 0.05$
G1	$a_1^1 = 10.524; b_1^1 = 0.05$
G2	$a_2^1 = 22.0; b_2^1 = 0.05$
G3	$a_3^1 = 24.0; b_3^1 = 0.05$

consider a planning horizon comprising 5 periods ( $T = 5$ ) and an initial allowance price of  $P = \$3.38$  readjusted annually by 10 % (this is a simplification since, in practice, the price is obtained in the marketplace for allowances). We assume that the fossil fuel generator buys all the available allowances and passes the cost on to the consumers through the supply bids via expression (4.19). We also assume that the cap (in tonnes of  $CO_2$ ) for the first period of the horizon is set at the maximum level of production of the fossil

fuel generator ( $90.25 \text{ MW} \times 1.12 \text{ tonnes of } CO_2/MW$ ) and is reduced by 5 % for each subsequent period with respect to the previous year. We use the expected allowance price and the emissions cap to compute the amount of revenue available for redistribution for each period,  $W^t$ . Regarding demand, we increase the intercept value  $e^t_{\theta_h}$  of the load's linear demand curve (i.e., we shift the demand curve to the right) for each period of the horizon to represent an increase in network demand. Finally, the cumulative R & D stock regression coefficient for each low-emissions generator,  $\gamma_{j_h}$ , is computed using expression (A.5). Thus,  $\gamma_{1_2} = 0.0087$  (for G2) and  $\gamma_{1_3} = 0.0083$  (for G3). We also consider a target for the cumulative stock of R & D for each low-emission generator  $\beta_{1_2} = \beta_{1_3} = 800$  and an initial amount of stock of R & D for each low-emission generator  $U_{1_2}^0 = U_{1_3}^0 = 100$ . Note that, when  $t = 5$  (final period), the generators reach their expected target of R & D stock, the intercept of the fossil fuel generator's supply curve is  $a_{1_1}^5 = 29.85 \frac{\$}{MWh}$ , and the intercept of the load's demand curve is  $e_{1_4}^5 = 27.8 \frac{\$}{MWh}$ . For this set of supply and demand curves at  $t = 5$ , the low-emission generators are not expected to be generating at their maximum deliverable capacity (as mentioned earlier, this is a requirement of our model).

The resulting allocation of R & D subsidies for the 5-period planning horizon is presented in Figure 4.4. It can be seen that G2 reaches the target for stock of R & D earlier than G3. This is partly due to a higher regression coefficient ( $\gamma_{1_2} > \gamma_{1_3}$ ), which implies a faster translation of R & D stock into production cost reductions by G3. Figures 4.5

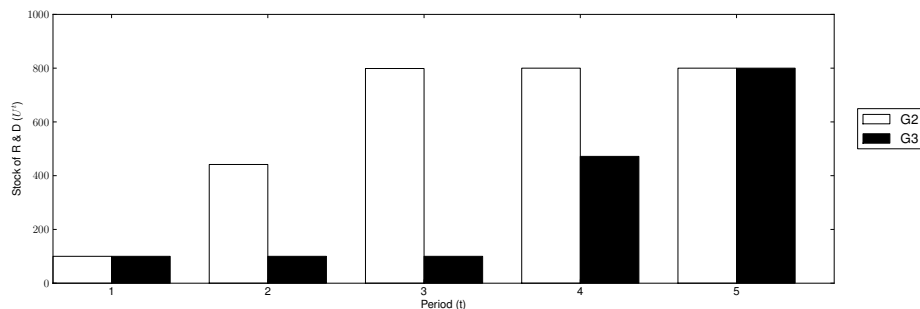

Figure 4.4: Stock of R & D Throughout the Planning Horizon for Each Low-Emission Generator

shows demand and load LMP for the scenario with R & D subsidies implemented and for the scenario in which subsidies are not considered (a scenario without revenue recycling). It can be observed that consumers at the load node are expected to greatly benefit via higher levels of demand and lower prices when R & D subsidies are considered. This is clearly manifested during the final two periods of the planning horizon where, in the absence of subsidies, the load would severely curtail demand. The expected market share

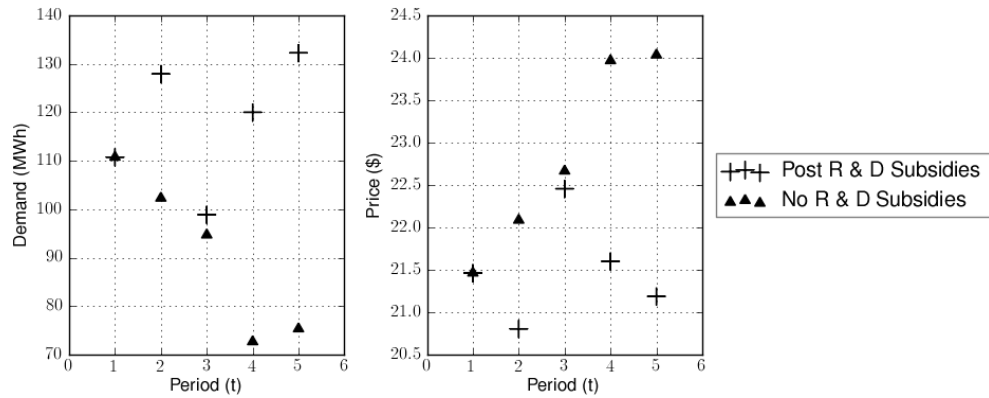

Figure 4.5: Demand and Load LMP in the Scenario Post R & D Subsidies Implementation and the Scenario with No R & D Subsidies

for the scenario post implementation of R & D subsidies and the scenario with no revenue recycling are presented in Figure 4.6. At  $t = 2$ , G2 starts increasing its market share as a consequence of the R & D subsidy received during the previous period. The most clear effect of the R & D subsidy is observed at  $t = 3$  when G1 loses a substantial portion of market share to G2. At  $t = 4$  and  $t = 5$ , due to the R & D subsidy received, G3 increases its generation and almost achieves the same market share as G2. It may also be noted that, for this particular example,

- An average increase in load electricity price of 6.4% due to a cap-and-trade program of the nature considered can be reduced to be less than 1% by redistributing the carbon revenue to low-emission generators via R & D subsidies.

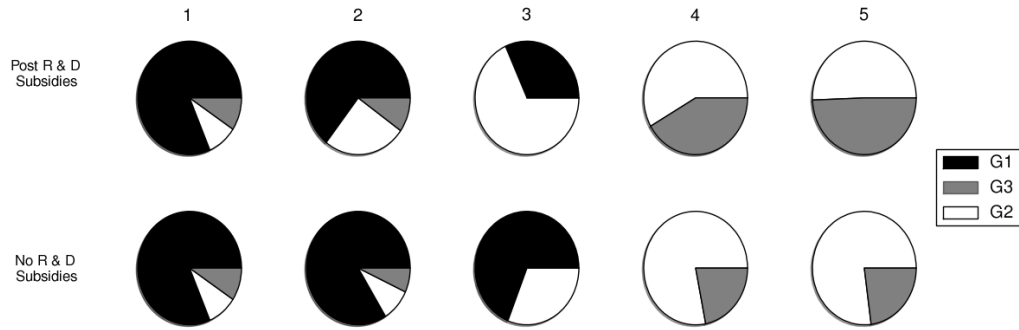

Figure 4.6: Market Share of the Generators in the Scenario Post R & D Subsidies Implementation and the Scenario with No R & D Subsidies

- Total low-emission generation is increased 80% by allocating R & D subsidies to low-emission generators with respect to the scenario without revenue recycling.
- An equitable redistribution of the revenue is not the optimal way of carrying out the redistribution during each period when social welfare is maximized.

#### 4.8 Feasibility of Implementation

In general, we consider that the revenue redistribution policies proposed in this chapter seem more applicable for a regulated electricity market setting. In the case of bid subsidies, their implementation is more straightforward than the R & D subsidies. The government entity in charge of collecting the carbon revenue could simply provide the bid subsidy to the low-emission generating companies as proposed herein, for each electricity dispatch. The effect of the subsidy would be perceived immediately (increased low-emission generation and potentially, lower prices). However, the main drawback of the bid subsidy is that it does not have a lasting effect on the offers submitted by the low-emission generators. In fact, the low-emission generators can become dependent on the bid subsidy, discouraging them to reduce costs on their own.

The procedure whereby the R & D subsidies could be implemented seems more complicated. In the first place, low-emission generation companies should be required to submit their historic R & D learning curves which the government entity should then compare with general empirical curves for the corresponding technologies (e.g., wind, solar, biomass). Since our model to allocate R & D subsidies is supposed to be used as a planning tool, the government entity in charge of distributing the carbon revenue should evaluate how well the scheme has worked after a defined period of time (e.g. a year). In particular, it should verify that the low-emission generators have been able to achieve the expected reduction in production cost that their R & D learning curves predicted. According to this verification, the R & D learning curves should be updated and the revenue redistribution model should be run again for the next planning period. The participation of companies owning the low-emission generation resources in the scheme should be voluntary and possibly, a premium for participation can be charged. Penalties for under-performance could be included so that R & D learning curves submitted reflect the real expected reduction on production costs.

#### **4.9 Concluding Remarks**

Redistributing the carbon revenue to market participants is one of the most important features in the design of an emissions control scheme. Among the potential recipients, households are the most commonly mentioned by economists due to the possibility of using the revenue to mitigate the likely increase of electricity prices after the implementation of an emissions control scheme. Other potential recipients are low-emission generators, especially renewable-based generators, since subsidies can be used to reduce their production costs and supply curves and thus, increase their competitiveness against fossil-fuel generators. In this chapter, we present nonlinear nonconvex optimization models to obtain carbon revenue redistribution strategies via two types of subsidies for low-emission

generators: bid subsidies and R & D subsidies. Through the bid subsidies, we aim at reducing electricity prices for households across the network and increase the market share of low-emission generators during a single electricity auction. The R & D subsidies are allocated with the same two objectives but their effect is expected to be realized during a planning horizon by leveraging the relationship between a generator's cumulative stock of R & D and reductions in production cost. From the examples presented we can draw the following conclusions:

- In uncongested networks the benefits of allocating bid subsidies to low-emission generators include increased power supply by the subsidy recipient, lower emissions, and increased benefit for consumers. In congested networks, not all these benefits can be reaped.
- R & D subsidies allocated to low-emission generators throughout a planning horizon also achieve the above benefits. The optimal timing to allocate these subsidies is partly determined by how fast each low-emission generator is able to translate increasing stocks of R & D into reductions of production cost (in our model, this is given by the regression coefficient  $\gamma_{j_h}$ ).
- The allocation of both types of subsidies also depends on the supply curve of each low-emission generator as shown in Figure 4.3.
- The maximum dispatchable capacity of each low-emission generators needs to be carefully considered when solving the subsidy allocation models since social welfare can be increased by cost reductions that do not result in increased production.

## Chapter 5: Future Work

The Great Recession wreaked havoc in the global economy and, at the same time, created a political scenario in the U.S. (and several other countries) where the passage of meaningful legislation to limit the amount of greenhouse gas emissions seems a very distant possibility. This is certainly bad news for those of us who believe that something needs to be done to cap emissions. If anything positive can be drawn from this situation, it is that we, researchers, have some additional time to study and perfect the design of emissions control schemes so that when policy-makers are finally ready to take action, they have all the analysis tools they need.

With the exception of the success story of the acid rain cap-and-trade, there is not much empirical evidence as to how a cap-and-trade (or carbon tax) program should be designed such that  $CO_2$  emissions are effectively decreased at a reduced cost for the world (or a country's) economy. Furthermore, the acid rain problem was significantly smaller in scale than the greenhouse gas emission problem and solutions that allowed utilities to comply with the program were readily available (e.g., scrubbers, catalytic converters). Thus, the same exact program design is probably not the best approach to cap greenhouse gas emissions.

As noted in previous chapters, there are some  $CO_2$  cap-and-trade programs fully functioning around the world. However, they are in their early stages and policy-makers are still learning from them. The implementation of emissions control schemes is, for the most part, a work-in-progress with several open questions/research opportunities, some of which I discuss next.



## **5.1 Analysis of Generation Investment Decisions Including Revenue Recycling Policies**

Considering the models that we have presented in this dissertation, this is the most immediate research question that we can tackle in the near future. It involves incorporating a revenue recycling module (similar to that presented in Chapter 4) into the investment decision framework of Chapter 3. This will entail computational difficulties though, since the revenue redistribution model assumes ex-ante allowance prices whereas the investment decision framework computes actual allowance prices. A more straightforward approach would be to include and analyze a particular revenue recycling policy, as opposed to computing optimal revenue recycling policies, within the investment decision framework.

## **5.2 Penalties for Violation of Cap**

In the event that market participants cannot surrender an amount of allowances commensurate with their emissions at the end of a determined period, they will be subjected to penalties. In the EU ETS cap-and-trade program, the penalty is calculated as the amount in tonnes of carbon dioxide equivalent by which the annual reportable emissions exceeded the number of allowances surrendered multiplied by 100 euros [67]. In the RGGI case, the penalty is in allowances using a ratio of 3 to 1 (i.e., the penalty is 3 times the amount of outstanding allowances) [9]. In the model presented in Chapter 3, we considered a penalty of 1.5 times the outstanding balance of allowances. Critics have argued that penalties in dollars (euros) basically give polluters the opportunity to 'pay their way out' without consideration of the emissions cap. On the other hand, if the penalties are set in allowances, the overall emissions cap will be respected, but there can be scarcity of allowances in the market, as polluting companies hoard allowances to pay penalties (this

is a phenomenon we observed in the Illinois case study). Some experts have pointed out that in the RGGI case, the penalty multiplier (3 to 1) is set too high, and will cause high allowance prices [68]. We believe that penalties should be set in allowances yet the multiplier is a key element that needs to be obtained based on considerations such as expected demand increase, gradual stringency of the cap, and expected growth of low-emission generation within a region. To find the optimal penalty multiplier, we envision a mathematical model that minimizes the expected number of allowances used to pay penalties and includes the above considerations as constraints.

### **5.3 Demand Side Management Concepts: Consumers as Electricity 'Producers'**

Even if revenue recycling strategies are implemented alongside a cap-and-trade or a carbon tax program, electricity prices will most certainly increase. This will demand more efficiency on the consumer's end. Several demand side management (DSM) concepts have started to be implemented by consumers, especially large electricity consumers, to shed load, become more energy efficient, and simultaneously, profit from this increased efficiency (by selling back to the network the energy not consumed). Examples of these DSM concepts are smart meters included in household appliances, power tools, photovoltaic systems, combined heat and power generators, space heating and cooling equipment, and electric vehicles chargers. As the practical use of these concepts becomes more profitable for consumers, they will need to consider investments in smart buildings and in comprehensive IT platforms that allow them to coordinate real-time (and possibly, ahead-of-time) responses to changes in electricity prices. These DSM concepts will also allow customers to compete strategically in allowance markets. We envision a game theoretic model along the lines of the investment decision model presented in Chapter 3 that can be used by large electricity consumers to analyze investment decisions and coordination strategies on DSM concepts. The model will be based on evaluating the profits that elec-

tricity customers can make in the allowance and electricity markets based on investment/-coordination on DSM concepts.

#### **5.4 Integration of Different Cap-and-Trade Schemes**

Ideally, an emissions control scheme should be implemented at a global level. This will prevent trade distortions among countries and foster the creation of a global marketplace for allowances (in the case a cap-and-trade program is the scheme chosen). However, due to varying levels of importance assigned to the emissions reduction problem and also, due to different financial and political scenarios, the implementation of emissions control is happening in some countries (or regions in a country) earlier than in others. Since the greenhouse gas emissions problem is not confined to a particular region, the different emissions control programs should, at some point, be integrated. This can be a difficult matter, especially if the design of the programs differ significantly. For instance, if two cap-and-trade programs start with different cap levels, work for some time separately allowing participants to bank allowances for future periods, and then, after a few years, are integrated: should the banked allowances (purchased when the programs were not integrated) be worth the same now in the integrated program? If there are goods and services exchanged between the two regions under the two different cap-and-trade program, should the products from the region with the previously less stringent cap be subject to tariffs in the region with the previously more stringent cap to compensate for the use of banked allowances in future periods in the integrated program? How would the two regions settle on the cap for the integrated program considering the different trajectories of the allowance market before integration? All these are questions for which the limited practical experience does not offer an answer.

## List of References

- [1] R. N. Stavins, “A U.S. cap-and-trade system to address global climate change,” The Hamilton Project - Discussion Paper 2007-13, Washington, DC, Tech. Rep., 2007.
- [2] A. D. Ellerman, “Are cap-and-trade programs more environmentally effective than conventional regulation,” in *Moving to markets in environmental regulation: Lessons from Twenty Years of Experience*, J. Freeman and C. D. Kolstad, Eds. Oxford University Press US, 2006, ch. 3, pp. 48–62.
- [3] European commission, “European Union emission trading scheme (EU ETS),” 2010, last accessed on 05/31/2011. [Online]. Available: [ec.europa.eu/clima/policies/ets/index\\_en.htm](http://ec.europa.eu/clima/policies/ets/index_en.htm)
- [4] Climate Change Information New Zealand, “New Zealand emission trading scheme,” 2010, last accessed on 05/31/2011. [Online]. Available: [www.climatechange.govt.nz/emissions-trading-scheme/](http://www.climatechange.govt.nz/emissions-trading-scheme/)
- [5] Australian Government. Department of climate change and energy efficiency, “Carbon pollution reduction scheme,” 2010, last accessed on 05/31/2011. [Online]. Available: [www.climatechange.gov.au/government/initiatives/cprs.aspx](http://www.climatechange.gov.au/government/initiatives/cprs.aspx)
- [6] California environmental protection agency, “Cap-and-trade,” 2011, last accessed on 05/31/2011. [Online]. Available: [www.arb.ca.gov/cc/capandtrade/capandtrade.htm](http://www.arb.ca.gov/cc/capandtrade/capandtrade.htm)
- [7] B. F. Hobbs, J. Bushnell, and F. A. Wolak, “Upstream vs. downstream CO<sub>2</sub> trading: A comparison for the electricity context,” *Energy Policy*, vol. 38, no. 7, pp. 3632–3643, 2010.

- [8] Market Advisory Committee to the California Air Resources Board, “Recommendations for designing a greenhouse gas cap-and-trade system for California,” 2007.
- [9] Regional greenhouse gas initiative, “Memorandum of understanding,” 2005, last accessed on 05/31/2011. [Online]. Available: [www.rggi.org/design/history/mou](http://www.rggi.org/design/history/mou)
- [10] J. Zhao, B. F. Hobbs, and J. S. Pang, “Long-run equilibrium modeling of emissions allowance allocation systems in electric power markets,” *Operations Research*, vol. 58, no. 3, pp. 529–548, 2010.
- [11] L. K. McAllister, “The overallocation problem in cap-and-trade: Moving toward stringency,” *Columbia Journal of Environmental Law*, vol. 34, no. 2, pp. 395–444, 2009.
- [12] D. Burtraw, “Cap and trade policy to achieve greenhouse gas emission targets,” Civil Society Institute, Newton, MA, Tech. Rep., 2007.
- [13] H. D. Jacoby and A. D. Ellerman, “The safety valve and climate policy,” *Energy Policy*, vol. 32, no. 4, pp. 481–491, 2004.
- [14] V. Nanduri, T. K. Das, and P. Rocha, “Generation capacity expansion in energy markets using a two-level game-theoretic model,” *IEEE Transactions on Power Systems*, vol. 24, no. 3, pp. 1165–1172, 2009.
- [15] V. Nanduri and T. K. Das, “A reinforcement learning model to assess market power under auction-based energy pricing,” *IEEE Transactions on Power Systems*, vol. 22, pp. 85–95, 2007.
- [16] V. Nanduri and T. Das, “A survey of critical research areas in the energy segment of restructured electricity markets,” *Electrical Power and Energy Systems*, vol. 31, pp. 181–191, 2009.
- [17] Y. Son, R. Baldick, K. Lee, and S. Siddiqi, “Short-term electricity market auction game analysis: uniform and pay-as-bid pricing,” *IEEE Transactions on Power Systems*, vol. 19, pp. 1990–1998, 2004.

- [18] C. A. Berry, B. F. Hobbs, W. A. Meroney, R. P. O'Neill, and W. R. Stewart, "Understanding how market power can arise in network competition: A game theoretic approach," *Utilities Policy*, vol. 8, pp. 139–158, 1999.
- [19] P. Rocha and T. K. Das, "A game theoretic framework to develop joint bidding strategies in electricity and electricity-related markets," in *Handbook of Networks in Power Systems*, ser. Energy Systems, S. Rebennack, P. M. Pardalos, M. V. F. Pereira, N. A. Iliadis, and O. P. Zheng, Eds. Springer Berlin Heidelberg, 2011, to appear.
- [20] Energy information administration, "Annual energy outlook," 2009, last accessed on 05/31/2011. [Online]. Available: [www.eia.doe.gov/oiaf/aeo/pdf/0383\(2009\).pdf](http://www.eia.doe.gov/oiaf/aeo/pdf/0383(2009).pdf)
- [21] A. K. Dixit and R. S. Pindyck, *Investment Under Uncertainty*. Princeton, NJ: Princeton University Press, 1994.
- [22] G. Kumbaroglu, R. Madlener, and M. Demirel, "A real options evaluation model for the diffusion prospects of new renewable power generation technologies," *Energy Economics*, vol. 30, pp. 1882–1908, 2008.
- [23] J. Keppo and H. Lu, "Real options and a large producer: the case of electricity markets," *Energy Economics*, vol. 25, pp. 459–472, 2003.
- [24] A. Botterud and M. Korpas, "Modelling of power generation investment incentives under uncertainty in liberalised electricity markets." Proceedings of the 6th IAEE European Conference, ETH Zurich, Switzerland, 1-3 Sep 2004, 2004.
- [25] J. Frayer and N. Z. Uludere, "What is it worth? Application of real options theory to the valuation of generation assets." *The Electricity Journal*, vol. 14, no. 8, pp. 40–51, 2001.
- [26] R. Takashima, Y. Naito, and H. Kimura, "Investment in electricity markets: equilibrium price and supply function." 11th Annual Real Options Conference, Berkeley, CA, USA, June 6-9, 2007, 2007.
- [27] H. Laurikka and T. Koljonen, "Emissions trading and investment decisions in the power sector - a case study in Finland," *Energy Policy*, vol. 34, no. 8, pp. 1063–1074, 2006.

- [28] J. A. Bloom, "Long-range generation planning using decomposition and probabilistic simulation," *IEEE Transactions on Power Systems*, vol. 101, no. 4, pp. 797–802, 1982.
- [29] B. Mo, J. Hegge, and I. Wangensteen, "Stochastic generation expansion planning by means of stochastic dynamic programming," *IEEE Transactions on Power Systems*, vol. 6, no. 2, pp. 662–668, 1991.
- [30] A. B. Borison, P. A. Morris, and S. Oren, "A state-of-the-world decomposition approach to dynamics and uncertainty in electric utility generation expansion planning," *Operations Research*, vol. 32, no. 5, pp. 1052–1068, 1984.
- [31] A. S. Chuang, F. Wu, and P. Varaiya, "A game-theoretic model for generation expansion planning: problem formulation and numerical comparisons," *IEEE Transactions on Power Systems*, vol. 16, no. 4, pp. 885–891, 2001.
- [32] F. Murphy and Y. Smeers, "Generation capacity expansion in imperfectly competitive restructured electricity markets," *Operations Research*, vol. 53, no. 4, pp. 646–661, 2005.
- [33] P. Linares, F. J. Santos, M. Ventosa, and L. Lapiedra, "Incorporating oligopoly,  $CO_2$  emissions trading and green certificates into a power generation expansion model," *Automatica*, vol. 44, pp. 1608–1620, 2008.
- [34] S. Paltsev, J. M. Reilly, H. D. Jacoby, A. C. Gurgel, G. E. Metcalf, A. P. Sokolov, and J. F. Holak, "Assessment of U.S. cap-and-trade proposals," National Bureau of Economic Research, No. 13176, Cambridge, MA, Tech. Rep., 2007.
- [35] M. Ruth, S. A. Gabriel, K. L. Palmer, D. Burtraw, A. Paul, Y. Chen, B. F. Hobbs, D. Irani, J. Michael, K. M. Ross, R. Conklin, and J. Miller, "Economic and energy impacts from participation in the regional greenhouse gas initiative: A case study of the state of Maryland," *Energy Policy*, vol. 36, no. 6, pp. 2279–2289, 2008.
- [36] M. H. Babiker, J. M. Reilly, M. Mayer, R. S. Eckaus, I. S. Wing, and R. C. Hyman, "The MIT emissions prediction and policy analysis (EPPA) model: revisions, sensitivities, and comparisons of results." MIT Joint Program on the Science and Policy of Global Change, No. 71, Cambridge, MA, Tech. Rep., 2001.

- [37] D. Burtraw, “CO<sub>2</sub> allowance allocation in the regional greenhouse gas initiative and the effect on electricity investors,” *The Electricity Journal*, vol. 19, no. 2, pp. 79–90, 2006.
- [38] D. Burtraw, R. Sweeney, and M. Walls, “The incidence of U.S. climate policy: where you stand depends on where you sit,” Resources for the Future, DP 08-28, Washington, DC, Tech. Rep., 2008.
- [39] T. Basar and G. J. Olsder, *Dynamic Noncooperative Games*, 2nd ed. New York, NY: Academic Press, 1995.
- [40] V. Nanduri and T. K. Das, “A reinforcement learning approach for obtaining the Nash equilibrium of multi-player matrix games,” *IIE Transactions in Operations Engineering*, vol. 41, no. 2, pp. 158–167, 2009.
- [41] W. B. Arthur, “Out-of-equilibrium economics and agent-based modeling,” in *Handbook of Computational Economics, Vol. 2: Agent-Based Computational Economics*, K. Judd and L. Tesfatsion, Eds. North Holland: Elsevier, 2005.
- [42] R. Cirillo, P. Thimmapuram, T. Veselka, V. Koritarov, G. Conzelmann, C. Macal, G. Boyd, M. North, T. Overbye, and X. Cheng, “Evaluating the potential impact of transmission constraints on the operation of a competitive electricity market in Illinois,” Argonne National Laboratory and University of Illinois at Urbana-Champaign, Tech. Rep., 2006.
- [43] A. Naini, T. Walden, K. Pinno, M. Stogran, and D. Mutysheva, “Electricity generation technologies: performance and cost characteristics,” Canadian Energy Research Institute, Prepared for the Ontario Power Authority, Tech. Rep., 2005.
- [44] Regional greenhouse gas initiative, “Auction result,” 2010, last accessed on 05/31/2011. [Online]. Available: [www.rggi.org/market/co2\\_auctions/results](http://www.rggi.org/market/co2_auctions/results)
- [45] M. Cantwell, “S.2877: Carbon limits and energy for America’s renewal (CLEAR act) (Introduced in U.S. Senate),” 2009. [Online]. Available: [thomas.loc.gov/cgi-bin/query/z?c111:S.2877](http://thomas.loc.gov/cgi-bin/query/z?c111:S.2877)
- [46] G. E. Metcalf, S. Paltsev, J. M. Reilly, H. D. Jacoby, and J. F. Holak, “Assessment of U.S. greenhouse gas tax proposals,” MIT Joint Program on the Science and Policy of Global Change, No. 160, Cambridge, MA, Tech. Rep., 2008.



- [47] P. Barnes and M. Breslow, "Pie in the sky? the battle for atmospheric scarcity rents," Political Economy Research Institute (PERI) University of Massachusetts Amherst, No. 13, Amherst, MA, Tech. Rep., 2001.
- [48] G. E. Metcalf and D. Weisbach, "The design of a carbon tax," Discussion Paper 0727, Department of Economics, Tufts University, Tech. Rep., 2008.
- [49] I. Parry and A. M. Bento, "Tax deductions, environmental policy, and the 'double dividend' hypothesis," *Journal of Environmental Economics and Management*, vol. 39, no. 1, pp. 67–96, 2000.
- [50] European parliament, "Directive 2001/77/EC," 2001. [Online]. Available: [eur-lex.europa.eu/LexUriServ/LexUriServ.do?uri=CELEX:32001L0077:EN:NOT](http://eur-lex.europa.eu/LexUriServ/LexUriServ.do?uri=CELEX:32001L0077:EN:NOT)
- [51] C. Fischer and R. G. Newell, "Environmental and technology policies for climate mitigation," *Journal of Environmental Economics and Management*, vol. 55, pp. 142–162, 2008.
- [52] The Congress of the United States congressional budget office, "Who gains and who pays under carbon-allowance trading? The distributional effects of alternative policy designs," Washington, DC, Tech. Rep., 2000.
- [53] T. Dinan and D. L. Rogers, "Distributional effects of carbon allowance trading: How government decisions determine winners and losers," *National Tax Journal*, no. 2, pp. 199–221, 2002.
- [54] L. H. Goulder, "Environmental taxation and the double dividend: A reader's guide," *International Tax and Public Finance*, vol. 2, pp. 157–183, 1995.
- [55] A. L. Bovenberg and R. A. de Mooij, "Environmental tax reforms and endogenous growth," Discussion Paper 1994-98, Center for Economic Research, Tilburg University, Tech. Rep., 1994.
- [56] D. Fullerton and G. E. Metcalf, "Environmental taxes and the double dividends hypothesis: Did you really expect something for nothing?" Discussion Paper 9706, Department of Economics, Tufts University, Tech. Rep., 1997.

- [57] C. Carraro, M. Galeotti, and M. Gallo, "Environmental taxation and unemployment: Some evidence on the 'double dividend hypothesis' in Europe," *Journal of Public Economics*, vol. 62, pp. 141–181, 1996.
- [58] "Achieving 2050: A carbon pricing policy for Canada," National Round Table on the Environment and the Economy, Tech. Rep., 2009.
- [59] Y. Kidokoro, "Revenue recycling within transport networks," *Journal of Urban Economics*, vol. 68, pp. 46–55, 2010.
- [60] I. W. Perry and A. M. Bento, "Revenue recycling and the welfare effects of road pricing," Resources for the Future, DP 99-45, Washington, DC, Tech. Rep., 1999.
- [61] J. Yoder and R. Stodick, "Market incentives for Washington biofuels and feedstocks," in *Biofuel Economics and Policy for Washington State*, J. Yoder, R. Shumway, P. Wandschneider, and D. Young, Eds. School of Economic Sciences - Washington State University, Pullman, WA, 2010.
- [62] RGGI Connecticut, "CO<sub>2</sub> budget trading program," 2008, last accessed on 05/31/2011. [Online]. Available: [www.rggi.org/rggi\\_benefits/program\\_investments/Connecticut](http://www.rggi.org/rggi_benefits/program_investments/Connecticut)
- [63] P. Ekins and T. Barker, "Carbon taxes and carbon emissions trading," in *Issues in Environmental Economics*, N. Hanley and C. J. Roberts, Eds. Oxford, UK: Blackwell, 2002.
- [64] M. I. Nadiri, "Innovations and technological spillovers," National Bureau of Economic Research, Working Paper No. 4423, Cambridge, MA, Tech. Rep., 1993.
- [65] M. E. Porter and S. Stern, "Measuring the 'ideas' production function: evidence from international patent output," National Bureau of Economic Research, Working Paper No. 7891, Cambridge, MA, Tech. Rep., 2000.
- [66] H. P. Williams, *Model Building in Mathematical Programming*. Chichester, UK: Wiley, 1999.

- [67] Scottish environmental protection agency, "Civil penalties," 2009, last accessed on 05/31/2011. [Online]. Available: [www.sepa.org.uk/climate\\_change/solutions/eu\\_emissions\\_trading\\_system.aspx](http://www.sepa.org.uk/climate_change/solutions/eu_emissions_trading_system.aspx)
- [68] Caiteur group climate change institute, "Comments on the RGGI draft model rule," 2006, last accessed on 05/31/2011. [Online]. Available: [www.rggi.org/docs/caiteur.pdf](http://www.rggi.org/docs/caiteur.pdf)

## **Appendices**

## Appendix A: Approximation Using Least-Squares Method

For any period  $t$ , let  $\mathcal{R}^t$  the reduction of production cost due to the effect of the cumulative stock of R & D of a given low-emission generator,

$$\mathcal{R}^t = C^t - K^{-1}C^t \quad (\text{A.1})$$

with  $C^t$ , the production cost, and  $K = (\frac{U^{t-1}}{U^0})^\nu$ , the knowledge stock, defined as a function of the cumulative stock of R & D at the beginning of period  $t$ ,  $U^{t-1}$ . Since  $U^0$  is a constant ( $\nu$  is the estimated learning elasticity), we rewrite  $\mathcal{R}$  as (from here on in we remove the superindex  $t$  since the results are independent of the time period)

$$\mathcal{R} = C - U^{-\nu} \mathcal{A} \quad (\text{A.2})$$

with  $\mathcal{A} = \frac{C}{U_0^{-\nu}}$ . We want to approximate  $\mathcal{R}$  to

$$\hat{\mathcal{R}} = \gamma U \quad (\text{A.3})$$

writing the least-square function  $L$  as,

$$L = \int_{U_{lb}}^{U_{ub}} \mathcal{R} - \gamma U \, dU \quad (\text{A.4})$$

with  $U_{lb}$  and  $U_{ub}$  the minimum and maximum values that  $U$  can take in the optimization problem (2.4), respectively. The minimum value  $U_{lb}$  is the stock of R & D a generator owns at the beginning of the horizon while the maximum value  $U_{ub}$  corresponds to the target of R & D stock  $\beta_{j_h}$  considered for each low-emission generator. After differentiating with respect to  $\gamma$ , making the resulting expression equal to 0, and substituting the

## Appendix A: (continued)

limits of the integral, we obtain the following expression for  $\gamma$ ,

$$\gamma = \frac{C\left(\frac{U_{ub}^2}{2} - \frac{U_{lb}^2}{2}\right) - \mathcal{A}\left(\frac{U_{ub}^{2-v}}{2-v} - \frac{U_{lb}^{2-v}}{2-v}\right)}{\frac{U_{ub}^3}{3} - \frac{U_{lb}^3}{3}} \quad (\text{A.5})$$

We compute a  $\gamma$  value for each of the low-emission generators and then we use these values in the objective function in (4.9).

## Appendix B: Least-Squares Approximation for Example Problem in 4.7

Figure B.1 shows the plots for the reduction of production cost function  $\mathcal{R} = C - U^{-\nu} \mathcal{A}$  and the least-squares approximation  $\hat{\mathcal{R}} = \gamma U$  (with  $\gamma$  computed as described in the previous section) for G2 and G3 in the example problem from Chapter 4. In the figure, the

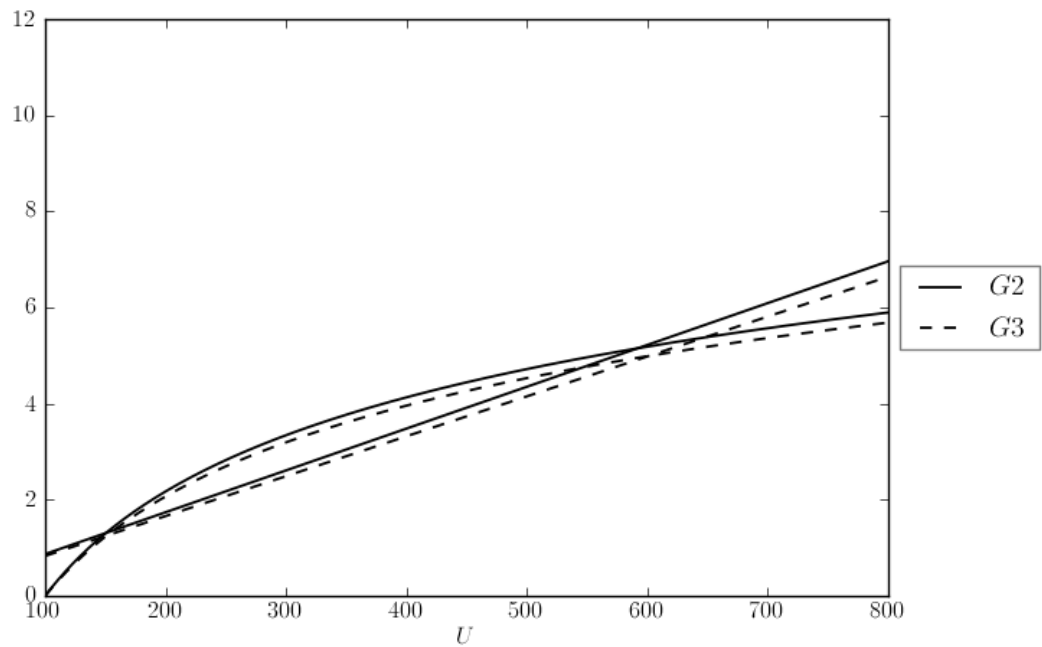

Figure B.1: Reduction of Production Cost Function and Least-Squares Approximation for G2 and G3 in Example Problem in 4.7.2

straight lines represent the least square approximation  $\hat{\mathcal{R}}$  while the curved lines represent the actual reduction of production cost function  $\mathcal{R}$ .