

The Islamic University – Gaza
Deanery of Higher Studies
Faculty of Engineering
Dept. of Electric Engineering



Fiber To The Home (FTTH) Networks based on OCDM Technique

شبكات الألياف الضوئية إلى المنازل المبنية على تقنية النفاذ الضوئي
بتقسيم الشفرة

Prepared By

Sulaiman Saber El Faleet

Supervised by

Dr. Fady El Nahal

A Thesis Submitted to IUG In Fulfillment of the Requirements for the Degree of Master
of Electric Engineering

1436 هـ – 2015م

DEDICATION

With all love in my heart I dedicate this theses:

To whom, who I held his name with all proud.

To whom I miss since I was a child.

To whom who, the heart is trembling to his memories

To my father

To the spring softness, patience and hope.

To whom, who is all in my life, after God and his passenger

To my mother

To my first and last resort

To whom, who teach me the science of life .my uncles

To the honest and soft hearts

To priceless brothers and sisters

To lovely friends

Acknowledgments

I express my special and deep sense gratitude to my advisor Dr. Fady El Nahal for his invaluable and unlimited support and constructive advices that inspired me the way to prepare the thesis.

I would like to acknowledge the inspirational instruction and guidance of Dr. Talal Skaik who was supportive and provided me with fruitful guidance. And special thanks for Dr. Yousef Hamouda for his support and his very useful comments and discussion at the start of this research.

I would like to acknowledge the discussion session manger Dr Amar Abo Hadrouss who help me a lot in my study.

I would also like to acknowledge the support and assistance give me by my friends and everyone who help me.

Abstract

Passive Optical Networks (PON) have garnered interest in recent years from network providers and researchers alike owing to their tremendous economic advantages for application in last mile services and optical sensing.

Optical code division multiple access (OCDMA) is a multiplexing technique that has a number of inherent advantages that make it suitable for use in passive optical networks. Such as large capacity, high security and excellent anti-interference ability, which make OCDMA a forefront topic of research in all-optic access networks.

To satisfy future bandwidth demands, existing Fiber To The Home (FTTH) access networks must be upgraded to guarantee at least a 100 Mb/s dedicated connection per subscriber. Fiber To The Home is one of the applications of the passive optical network.

In this thesis, we introduce passive optical network technology in detail, especially Fiber To The Home depended on optical code division multiple access structure. Then we use (Optisystem), software program to design and analyze the networks. Firstly, we design and analyze three users fiber-to-the-home network at 200Mbps for each user. Also we study the effect of increasing distance of fiber link and optimize data rate.

Secondly, we design and analyze seven users system network at 200Mbps for each user. Then we discuss the effect of increasing length of fiber cable, increasing number of users and input power. Thirdly, compares my design result with related work.

Finally, several measurements are found;, Bit Error Rate (BER), Maximum Quality Factor (Max Q). We found the BER increased exponentially with distance , bit rate, and number of users . Also we found the optimal minimum bit rate at 125 Mbps and maximum bit rate at 300 Mbps can be transmit

ملخص الرسالة

تتزايد أهمية الشبكات البصرية الغير نشطة PON بشكل ملحوظ في عالم الاتصالات نظرا لمزايا اقتصادية هائلة حيث تستخدم في العديد من تطبيقات الاتصالات الضوئية. حيث أن النفاذ الضوئي بتقسيم الشفرة تعتبر تقنية مضاعفة لها العديد من المزايا الكامنة التي تجعلها مناسبة للاستخدام في الشبكات البصرية الغير نشطة مثل سعة كبيرة ، درجة كبيرة من السرية ، القدرة العالية والمضادة للتشويش مما جعل (OCDMA) موضوع طليعة البحوث في شبكات النفاذ الضوئية. لتلبية متطلبات عرض النطاق الترددي في المستقبل يجب ترقية شبكات النفاذ الضوئي إلى المنازل لضمان الحصول على 100ميجا/ الثانية على الأقل حيث نحصل على اتصال سريع . الألياف إلى المنازل هو واحد من التطبيقات على الشبكات البصرية الغير نشطة . في هذه الأطروحة نقدم شبكات الألياف الضوئية الغير نشطة بالتفاصيل وخصوصا شبكات الألياف الضوئية إلى المنازل اعتمادا على تقنية النفاذ الضوئي بتقسيم الشفرة حيث تم استخدام برنامج حاسوبي لتصميم وتحليل الشبكات (Optisystem).

أولا : قمنا بتصميم وتحليل ثلاثة مستخدمين في شبكة (FTTH) حيث لكل مستخدم 200ميجا / الثانية، أيضا دراسة تأثير زيادة طول كابل الألياف الضوئية وتحسين سرعة نقل البيانات

ثانيا : قمنا بتصميم وتحليل سبع مستخدمين في الشبكة حيث لكل مستخدم 200ميجا/ الثانية، كذلك مناقشة تأثير زيادة طول كابل الألياف الضوئية وزيادة عدد المستخدمين ومدخلات الطاقة.

ثالثا : مقارنة نتائج تصميمنا بنتائج دراسات ذات صلة .

أخيرا : تم الحصول على عدة قياسات منها منحنيات نسبة الخطأ ومعامل الجودة .

TABLE OF CONTENTS

Dedications	I
Acknowledgments	II
ABSTRACT	III
ملخص الرسالة	IV
TABLE OF CONTENTS	V
LIST OF FIGURES	VII
LIST OF TABLES	IX
LIST OF ABBREVIATIONS	X
Chapter one: Introduction	1
1.1. Introduction.....	1
1.2. Related work.....	1
1.3. Research motivation.....	2
1.4. Thesis Objectives.....	4
1.5. Simulation using Optisystem.....	4
1.6. Thesis novelty.....	4
1.7. Thesis outline.....	5
Chapter Two: Passive Optical Network	6
2.1. Introduction.....	6
2.2. optical fiber in broadband access network.....	7
2.3. Advantages of optical fiber cables.....	8
2.4. Passive Optical network (PON).....	9
2.4.1 . PON architecture.....	9
2.4.1.1 Optical Line Terminal (OLT).....	10
2.4.1.2 Optical Network Unit (ON).....	11
2.4.1.3. optical splitter.....	12
2.4.2. PON Advantages.....	13
2.4.3. PON Topologies.....	14
2.4.3.1. Tree Topology.....	14
2.4.3.2. Ring Topology.....	14
2.4.3.3. Bus topology.....	15
Chapter Three: Fundamental concepts of FTTH,FBG and OCDMA	16
3.1. Introduction	16
3.2. FTTx Networks.....	17
3.3. FTTH networks.....	18
3.3.1 FTTH Architectures.....	18
3.3.1.1 Point to Point Architectures (P2P).....	18
3.3.1.2 Point to Multi Point architectures (P2MP)	18
3.3.2 FTTH advantages	19
3.4. Fiber Bragg Grating (FBG).....	20
3.4.1. The principle of fiber Bragg Grating (FBG).....	20
3.4.2. Fiber Bragg Grating Theory.....	21
3.4.3. Fiber Bragg Grating (FBG) Advantages.....	22

3.4.4. Characteristics of FBG.....	22
3.4.5 Current Applications of FBG.....	22
3.5. Optical Code Division Multiple Access(OCDMA)	23
3.5.1.OCDMA principle.....	23
3.5.2 . Block diagram of OCDMA.....	24
3.5.3. Classifications of OCDMA codes.....	25
3.5.4. OCDMA Encoding/Decoding.....	25
3.5.5. Incoherent and Coherent OCDMA Systems.....	25
3.5.6. Spectral amplitude coding (SAC) OCDMA	26
3.5.7 FBG Encoder/Decoder	27
3.5.8. SAC-OCDMA using FBGs.....	28
3.5.9. OCDMA Advantages.....	28
3.6 Summary.....	29
Chapter Four: System design and rustles.....	30
4.1.Introduction.....	30
4.2. System Architecture.....	30
4.2.1. Optical transmitter	30
4.2.2 .Fiber link.....	31
4.2.3.Optical receiver.....	32
4.3. System Design.....	33
4.3.1.Design and Analysis three user.....	33
4.3.2.Simulation Result for Design three users.....	34
4.3.2.1 .Performance Result for effect increasing length.....	34
4.3.2.1.1. Result Comparison.....	45
4.3.2.2 . Bit Rate Result.....	46
4.4 .Design and Analysis seven User.....	49
4.4.1. Simulation Result for seven users.....	50
4.4.1.1 .performance Result.....	50
4.4.1.2 . In put power Result.....	53
4.4.2 . Results Analysis.....	54
Chapter Five: Conclusion and Future work.....	55
5.1. Conclusion.....	55
5.2. Future work.....	56
6. References:.....	57

LIST OF FIGURES

Figure 1.1: User Data rate evolution.....	3
Figure 2.1: Generic structure of a modern telecommunication network.....	6
Figure 2.2: operating range of optical fiber.....	8
Figure 2.3: Active versus Passive Optical Network.....	9
Figure 2.4 : General structure of a PON.....	10
Figure 2.5: EPON OLT FD2000S.....	10
Figure 2.6: EPON ONU FD204HW.....	11
Figure 2.7: Schematic drawing for PLC Splitter.....	12
Figure 2.8: Tree with single splitting point.....	14
Figure 2.9: Ring topology.....	15
Figure 2.10: Bus topology.....	15
Figure 3.1: Some FTTx scenarios.....	17
Figure 3.2: FTTH solution.....	17
Figure 3.3: Point to point access topology.....	18
Figure 3.4: Point to Multipoint topology.....	19
Figure 3.5: Principle of a Fibre Bragg Grating.....	20
Figure 3.6: Uniform fiber Bragg grating.....	21
Figure 3.7: Typical OCMDA System Schematic.....	23
Figure 3.8: the block diagram of OCDMA.....	24
Figure 3.9 : block diagram of spectral amplitude coding for OCDMA.....	26
Figure 3.10 schematic diagram of spectral distribution function of FBGs.....	27
Figure 3.11: Encoder and decoder based on a linear array of FBGs.....	27
Figure 3.12: SAC-OCDMA using FBGs.....	28
Figure 4.1: system model description.....	30
Figure 4.2: Transmitter part.....	31
Figure 4.3: Optical link part.....	31
Figure 4.4: Receiver part.....	32
Figure 4.5: Block diagram of system design.....	33
Figure 4.6 :Block diagram of 3user design.....	33
Figure 4.7: BER Vs Length for user one.....	34
Figure 4.8: Diagram of BER for user one.....	35
Figure 4.9: Diagram Max Q for user one.....	36
Figure 4.10: BER Vs Length for user two.....	36
Figure 4.11: Diagram of BER for user two.....	37
Figure 4.12: Diagram Max Q for user two.....	38
Figure 4.13: BER Vs Length for user one when all users are on.....	39
Figure 4.14: Diagram of BER for user one when all users are on.....	40
Figure 4.15: Diagram Max Q for user one when all users are on.....	40
Figure 4.16: BER Vs Length for user two when all users are on.....	41
Figure 4.17: Diagram of BER for user two when all users are on.....	42
Figure 4.18: Diagram Max Q for user two when all users are on.....	42
Figure 4.19: BER Vs Length for user three when all users are on.....	43
Figure 4.20: Diagram of BER for user three when all users are on.....	44
Figure 4.21 :Diagram Max Q for user three when all users are on.....	44
Figure 4.22 : BER Vs Bit Rate for all three users.....	46

Figure 4.23 :BER Vs Signal Bite Rate For user one.....	47
Figure 4.24 :BER Vs Signal Bite Rate For user two.....	47
Figure 4.25 :BER Vs Signal Bite Rate For user three.....	48
Figure 4.26: Block diagram of seven User.....	49
Figure 4.27: BER Vs Length when all seven user are on.....	50
Figure 4.28:Input power Vs BER.....	53

LIST OF TABLES

Table (2.1) : DSL Technologies bandwidth versus distance capability.....	7
Table (2.2) : Typical losses for splitters.....	13
Table (4.1) : System design parameter.....	34
Table (4.2) : User one result.....	35
Table (4.3) : User two result	37
Table (4.4) : User one result when all users are on.....	39
Table (4.5) : User two result when all users are on.....	41
Table (4.6): User three result when all users are on.....	43
Table (4.7) : BER Comparison.....	45
Table (4.8) : User one comparison.....	45
Table (4.9) : BER comparison.....	45
Table (4.10): User one result for data rate	47
Table (4.11): User two result for data rate	48
Table (4.12): User three result for data rate.....	48
Table (4.13): System design parameter for seven users.....	49
Table (4.14): User one result when all seven users are on.....	50
Table (4.15) : User two result when all seven users are on.....	51
Table (4.16) : User three result when all seven users are on.....	51
Table (4.17) : User four result when all seven users are on.....	51
Table (4.18) : User five result when all seven users are on.....	52
Table (4.19) : User six result when all seven users are on.....	52
Table (4.20) : User seven result when all seven users are on.....	52

LIST OF ABBREVIATIONS

3DTV	Three Dimension TV
AON	Active Optical Network
ASE	Amplified Spontaneous Emission
APON	ATM over Passive Optical Network
ATM	Asynchronous Transfer Mode
BER	Bit Error Ratio
BPON	Broadband Passive Optical Network
BW	Bandwidth
CO	Central Office
CPE	Customer Premises Equipement
CW	Continous Wave
CWDM	Coarse Wavelength Division Multiplexing
DBA	Dynamic Bandwidth Assignment
DS	Down Stream
DSL	Digital Subscriber Line
DWDM	Dense Wavelength Division Multiplexing
ESON	Ethernet Switched Optical Network
EPON	Ethernet Passive Optical Network
FBG	Fiber Bragg Grating
FTTB	Fibre-to-the-Building
FTTC	Fibre-to-the-Curb
FTTCab	Fibre-to-the-Cabinet
FTTH	Fibre-to-the-Home

FTTN	Fibre-to-the-Node
FTTx	Fibre-to-the-x
FO-CDMA	Fiber Optical- Code Division
Gbps	Giga bit per second
G-EPON	Gigabit Ethernet Passive Optical Network
GPON	Gigabit Passive Optical Network
HDTV	High Definition TeleVision
HZ	Hertz (Cycle per second)
IEEE	Institute of Electrical and Electronics Engineers
IPTV	Internet Protocol TV
ISDN	Integrated Service Digital Network
ISP	Internet Service Provider
ITU-T	International Telecommunication Union/ Telecommunication Standardization Sector
Laser	Light Amplification by Stimulated Emission of Radiation
LANs	Local Area networks
LED	Light-Emitting Diodes
MAC	Media Access Control
Mbps	Miga bit pere second
MUX	Multiplexer
MZM	Mach-Zehnder Modulator
NGA	Next Generation Access
MQC	Modifed Quadratic Congrence Code
NRZ	Non-Return-to-Zero
OCDMA	Optical Code Division Multiplexing Access

ODN	Optical Distribution Network
ODSM-PON	Opportunistic and dynamic spectrum management PON
OSCDMA	Optical Spectrum Code Division Multiplexing Access
OFDM	Orthogonal frequency-division multiplexing
ONT	Optical Network Terminal
ONU	Optical Network Unit
OSNR	Optical Signal-to-Noise Ratio
PRBS	Pesudo Random Bit Sequence
P2MP	Point-To-Multi-Point
P2P	Point-To-Point
PLC	Planar Light Circuit
PON	Passive Optical Network
POTS	Plain Old Telephone Service
Q-Factor	Quality Factor
RZ	Return to Zero (line encoding)
SAC-OCDMA	Spectral Amplituede coding- OCDMA
SDH	Synchronous Digital Hierarchy
SMF	Single Mode Fiber
SNR	Signa-to-Noise Ratio
SONET	Synchronous Optical Networking
SPC-OCDMA	Spectral Phase Code- OCDMA
TDM	Time Division Multiplexing
TDMA	Time Division Multiple Access
TDM-PON	Time Division Multiplexing - Passive Optical Network
TWDM-PON	Time and Wavelength - Passive Optical Network

TPC-OCDMA	Temporal Phase Code- OCDMA
US	Upstream
VDSL	Very high speed Digital Subscriber Loop
VOD	Vedio-On-Demand
VOIP	Voice Over IP
WDM	Wavelength Division Multiplexing
XG-PON	10 Gigabit Passive Optical Network

Chapter 1: Introduction

1.1. Introduction

Optical network is the technology that uses fiber optics to connect two or more devices together. Optical networking supports much faster data transfer rates than other convention networks out there and can be stretched over an extremely large length. While optical networks are costly to install, they are more reliable and efficient than other modes of connectivity. Optical technology is a promising candidate in solving the bandwidth limitation in access networks due to its large bandwidth that is at least 10 to 100 times (50tera-bits per second) more than conventional communication over a large area. However, to realize the full potential of optical technology, it is necessary to build fully optical networks. The speed at which optical signals may be communicated is far greater than the speed at which data can be processed by electronic circuits. Optical networks now convert from optical to electronic form every time it needs to be routed or switched which bring down its full potential. It seems that there are more to explore of optical components in the electronic networking world. Currently there are two generations of optical networks. In first-generation optical network simply replaced the copper wires with optical fibers. The second-generation optical networks takes into account the differences and recent developments in optical device and network technologies. [1]

1.2. Related work

Many papers have been published aiming to use Optical Code Division Multiplexing Access technique (OCDMA). Some of these papers are :

Current research on OCDMA focuses on direct time spread OCDMA, spectral encoding-decoding, pulse-position modulation OCDMA, asynchronous phase encoding OCDMA and frequency hopping OCDMA [56]. However, in [56] chromatic dispersion of fiber is not considered. Chromatic dispersion can reduce system performance and occurs when increasing the inter-chip interference and decreasing the receiver optical power.

Intensity modulation with direct detection On-Off Keying (OOK) OCDMA and Pulse Position Modulation (PPM) OCDMA systems are analyzed in [57]. The capacity of these networks is limited because the number of signature sequences available with good correlation properties for a given sequence length is small [58].

Hiroyuki Yashima et.al.[59] proposed OCDMA for high-speed multimedia transmission and its performance is investigated. The proposed system introduces time hopping to vary transmission bit rate and power control to control performance of transmission signal, which allows various signals with different desired rate and performance. An expression for the Bit Error Rate (BER) of the proposed system is derived and the numerical results are shown. Optical Power Selector (OPS) coupled with hard limiter are also proposed to improve system performance.

Mohsen Razavi et.al.[60] present a thorough analysis based on photon-counting techniques on temporal/spatial fiber-optic code division multiple-access systems incorporating both post- and pre optical amplifiers. In this analysis, they consider the effect of shot noise, thermal noise, and source extinction on system bit-error rate. Their results can be used to estimate their maximum tolerable amount of quantum fluctuations in the received signal.

Swapni IAwasthi et. at. [2] simulated a three user Fiber Bragg Grating (FBG) placed OCDMA network at 200 Mbit/s. The signal generated using incoherent source modulated with energy Pseudo Random Bit Sequence (PRBS) data using mux and demodulator . When user 1 and 2 are on and user 3 is off. Optical fiber in single mode with length 10 km.

M. A. Othman et. at [3] designed and analysis of FTTH based on OCDMA structure. the design simulated a 3-user FBG based OCDMA network at 200 Mbit/s. Uniform FBGs are used to implement the codes by spectral amplitude encoding. The signal is generated using an incoherent source modulated with NON Return to Zero (NRZ) PRBS data using a Mach-Zehnder Modulator. The optical link is 10 km of single mode fiber. The receiver is comprised of a spectral filter and a photo detector connected in a balanced configuration which performs the decoding with a low-pass filter and a BER analyzer. The difference between this paper and my thesis , we found the optimal minimum bit rate (125 Mbps) and maximum bit rate (300 Mbps). Also we studied the effect of increasing the number of users .

Ranjan et. at [4] this paper investigates the performance improvement of OCDMA. To improve the bit error rate of the system uniform fibre bragg grating is used at transmitter and receiver end with same reflectivity. The simulation is done at 200 Mbps and varying cable length.

1.3. Research motivation

Today's communication network traffic is converged voice, video and data network . According to the developed applications and services previously described, user demand increases every year making it vital for telecommunication companies and carriers to increase their network capacity as a primary and most important characteristic of broadband access network.

High Bandwidth demand applications for home user and business applications [5].

- Video file transfer and Video on demand (VOD) like YouTube, Daily Motion
- Internet protocol TV (IPTV) applications with different resolutions such as Standard definition (SD) High Definition TV (HDTV), Ultrahigh Definition TV (UHDTV) known as 4k technology and Three Dimension TV (3DTV).
- Voice over IP (VOIP) like Skype and Video conference
- Online Games
- Telemedicine Services

Network companies can measure user requirements by counting the traffic passing through network nodes and using statistical data analysis they can predict the future traffic requirements which is vital for planning network upgrades smoothly to meet the everyday increase in traffic through the network.

The data rates passed many progress steps (see Figure 1.1) from the first days of copper cables to future expectation for mobile and fixed broadband FTTH utilizing fiber cables Telecommunication networks passed many upgrades from the first generation with very low data rates for sending text between remote network units to future prediction of data rate required for single user.

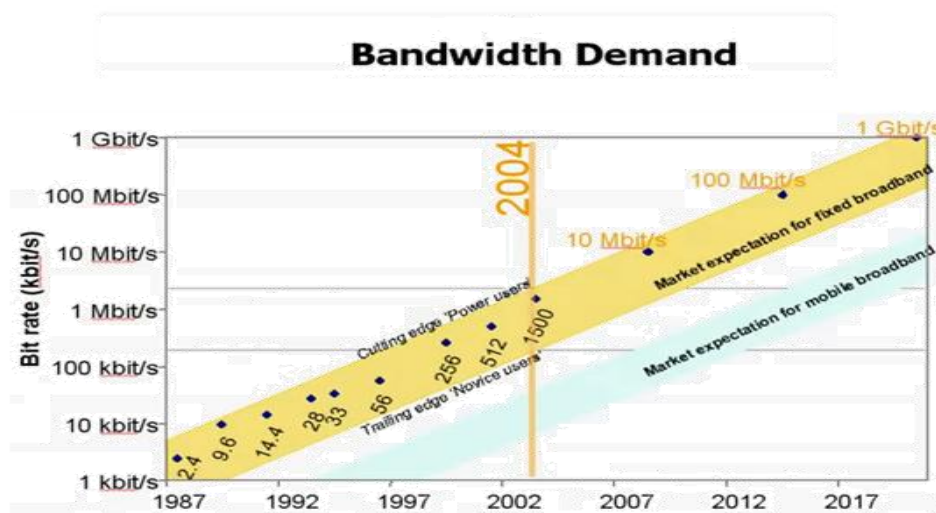

Figure 1.1 User Data rate evolution [6]

1.4 .Thesis Objectives

The main objectives of this thesis work are as follows:

- The first objective is to design a high performance Fiber to the home using Optical Code Division Multiple Access networks, by using OptiSystem simulation tool v.13.
- The second objective is to make comparison between my work and previes related work.
- Finally , analyze the effect of increasing the distance of fiber cable, optimize bit rate . Also discuss the change of input power and increasing number of users on system design.

1.5. Simulation using Optisystem

Since optical network device is very expensive, network designers cannot test network design with real network device as they can change the design many times to enhance and optimize the network. Computer aided design tools are common to be used in network [7] .

Optisystem is an innovative, rapidly evolving and a powerful optical network design tool that enables user to plan, test, optimize and simulate optical communication systems from components to system level. Users can change component parameters and connections to test endless scenarios in minimum time and decrease cost of design with high precision .

Optisystem can be used to design several applications such as PON, Wavelength Division Multiplexing/Time Division Multiplexing (WDM/TDM), OCDMA, Synchronous Optical Networking/Synchronous Digital Hierarchy (SONET/SDH), link budget calculations and transmitter, channel, amplifier, and receiver design.

Optisystem profiled some useful tools like parameter sweep and optimization. Parameter sweep lets users input range of values for one component parameter or more to test the output against that range and specify output peaks and values related to that input. Nested sweep enables designer to perform multidimensional analysis to get better values. While optimization is used to set any component parameter to value required to maximize, minimize or set output to target value.

1.6. Thesis Novelty

- Data rate increased from 200 to 300 Mbps in part one
- The number of users increased from 3 to 7

1.7.Thesis outline

This section gives a brief description of all the chapters constructing this thesis

Chapter one: is an introduction of this thesis providing a brief related work ,also defining the research problem and the objectives . Short introduction to optisystem software tool used for optical network design with scope and applications of that software , thesis novelty , and finally , the thesis structure.

Chapter two: presents the introduction to optical network communications. This chapter explains the optical access network , it also illustrates the passive optical network and its structure.

Chapter three: explains fiber to the home concepts, structures, and its advantages, and defining fiber Bragg grating principle, theory, advantages, characteristics , and its applications. Also, demonstrated optical code division multiple access fundamental concepts, principle, classifications, encoding and decoding, spectral amplitude coding, and advantages of OCDMA .

Chapter four: discusses the methodology of this thesis in two parts , first part is simulated a three user fiber Bragg grating, and second part is simulated a seven user, also, compares the work with related works, the networks is fully designed and simulated by using OptiSystem simulation software V.13

Chapter five: provides the conclusion of this thesis and the future work is described

Chapter 2: Passive Optical Network

2.1. Introduction

Telecommunications network consists of three parts backbone/core/long-haul network, metro/regional network and access network. In the Plain Old Telephone System(POTS) with only voice services utilized mainly two types of transmission media.

- 1- Twisted pairs of copper wires to carry analog voice signals and low data rate user data to central office.
- 2- Optical fibers in the long haul trunk links between central offices to carry multiplexed subscriber voice signals.

The last years witnessed a great development in the telecommunications network introducing the optical fiber into the access segment of the network.

Various implementations of Access networks[8]. (see Figure 2.1)

Its consist of three parts, first part contains the backbone network (WDM) ,second part contains the metro network (SONET) and third part contains the Access network.

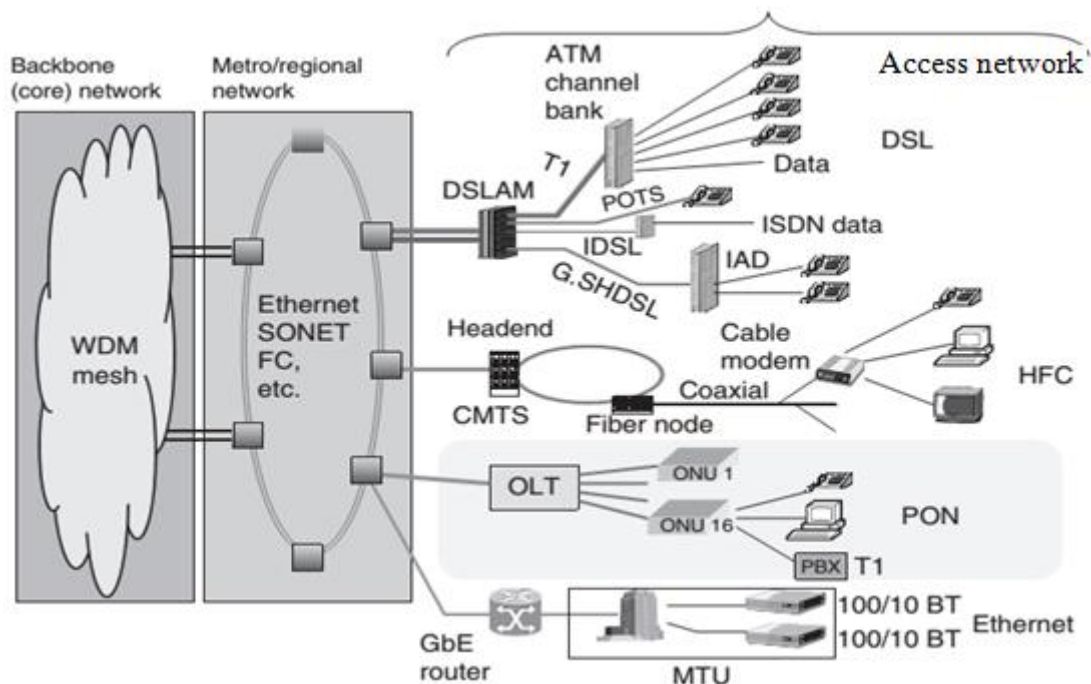

DSLAM	DSL Access Multiplexer	DSL	Digital subscriber line
CMTS	Cable Modem Termination System	HFC	hybrid fiber coaxial
OLT	Optical line terminal	ISDN	Integrated Services Digital Network
HDSL	High data rate DSL	POTS	plain old telephone service
GBE	Gigabit Ethernet	MTU	<i>maximum transmission unit</i>
SONET	Synchronous Optical Networking		

Figure 2.1: Generic structure of a modern telecommunication network [9]

2.2. Optical fiber in broadband access network

A broadband access network provides various high-speed services to the end user such as multimedia, telemedicine, internet distant learning.

The history of broadband access network points to copper wires (twisted-pair cables) made the local loop from telecommunications operator central office to the user device.

Copper media access technologies like Digital Subscriber Line (DSL) or cable-modem access suffers bottleneck in bandwidth-on-demand performance as they limit the bit rate to a maximum value that doesn't satisfy today and future user requirements. This limit is described by the Shannon-Hartly theorem [10].

$$C = BW \times \log_2(1 + SNR) \quad (2-1)$$

where C refers to the capacity measured bits per second (bps), BW is Bandwidth measure in Hz and SNR is the Signal to Noise Ratio of channel [11].

Table 2.1: DSL Technologies bandwidth versus distance capability

Technology	Max Upstream Capacity	Max Downstream Capacity	Max Distance	Downstream Capacity @ Max Distance	Frequency Range
ADSL	640 Kbps	12 Mbps (0.3km)	5.4 km	1.5 Mbps	Up to 1.1 MHz
SDSL	3 Mbps	3 Mbps	2.7 km	2 Mbps	Up to 1.1 MHz
ADSL 2+	1 Mbps	26 Mbps (0.3km)	3.6 km	4 Mbps	Up to 2.2 MHz
VDSL	16 Mbps	52 Mbps (0.3km)	1.3 km	13 Mbps	Up to 12 MHz

Table 2.1 shows various xDSL technologies with maximum theoretical downstream and upstream data rates and maximum distance with practical downstream and upstream rates at maximum distance. It is obvious that the maximum distance is limited to 5.4 km and the maximum downstream data rate is severely decreased due to low SNR caused by distance Shannon theory traced the base line for data communications system capacity limits over noisy channel of old telephone line cables. This problem arises the need for communications over optical fiber [11].

The optical fibers were used only for core network connections between central offices for the demand of high traffic. These days and in the future with the growth of competition between telecommunication companies to offer advanced service that need very high data rates – at least 50 Mbps Downstream and 10 Mbps Upstream per user at peak time - the service providers offers optical access networks. The telecommunication business seek the highest capacity with the lowest cost[12]. It is found that access network consists in active device in the distribution network that needs electric power and backup batteries in case of power failure. The solution for those problems leads to

green network technologies with no power requirements in the distribution network highlighted as passive optical network .

2.3. Advantages of optical fiber cables

- 1- High Bandwidth: optical fiber has a high bandwidth spectrum as shown in figure 2.2[13].
- 2- Data security, where it is no radiation of signals outside the core of the fiber cable so no one can sniff the optical light signals without interrupting the cable and it is easy to detect any interruption trial.
- 3- The optical fiber cable is easier than before to install where there are dedicated ships to lay the cables in the seas and oceans, there is also special vehicles to open slots beside or under the roads, others to lay the cable in the slots and close the slots again leaving manholes for cable test and repair. Moreover fiber cables termination tools are available and easy to use for cable connection.
- 4- Immunity to electromagnetic interference: in contrast with copper wires, fiber cables do not suffer from electromagnetic interference so optical signals can be sent reliably for long distances with acceptable bit error rate (BER).
- 5- Low attenuation: Figure 2.2 shows the attenuation versus wavelength for single mode fiber, it is clear that the fiber cable has two low attenuation windows at 1310 nm and 1550 nm (see Figure 2.2), and these windows are preferable for transmission over long distances. with minimum fiber attenuation where most optical networks device vendors and optical network designers specify upstream and downstream optical signals.[14].

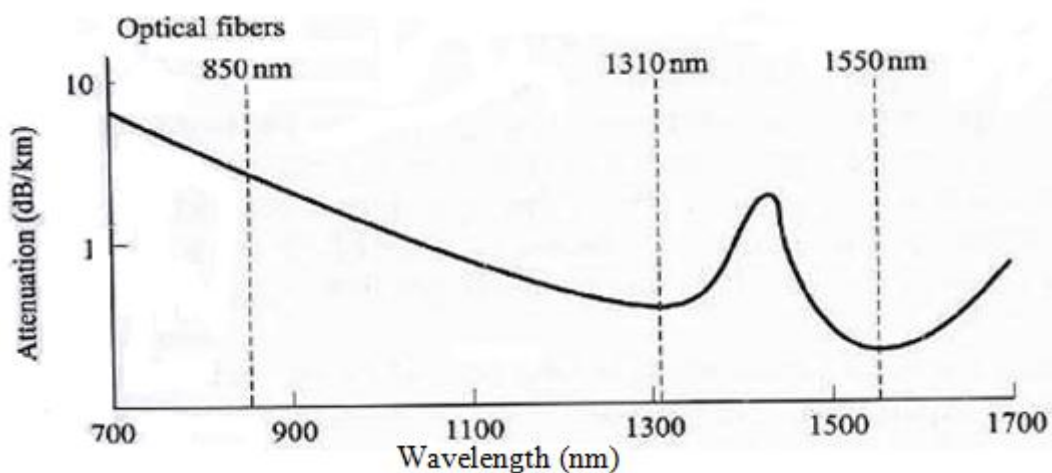

Figure 2.2: Operating range of optical fiber [14]

2.4. Passive Optical network (PON)

There are two important types of systems that make fiber-to-the home connections possible (see Figure 2.3). These are active optical networks and passive optical networks.

Unlike Active Optical Network (AON) [15, 16] which uses an active devices and network elements to connect operator to end user, A passive optical network is a network by which its nature provides a variety of broadband services to users through optical fiber access. PON allows removing all active components between the server and client introducing in place optical passive components to guide the traffic throughout the network. Its principal element is the optical splitter. The usage of passive architecture can reduce costs and are mainly used in FTTH networks. By contrast, the bandwidth is not dedicated, but rather multiplexed in a single fiber in the network access points. In short, this is a point-to-multipoint configuration network.

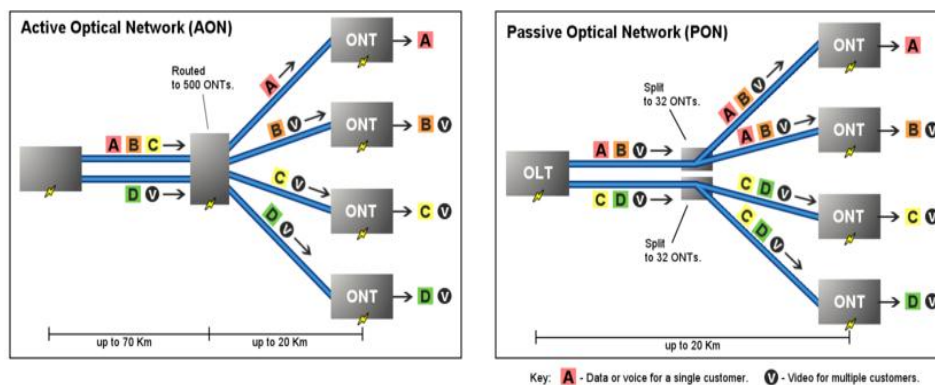

Figure 2.3: Active versus Passive Optical Network[17]

2.4.1. PON architecture

In general PON network consists of the following device as shown in Figure (2.4) : an Optical Line Terminal (OLT) at the service provider's central office , a number of Optical Network Units (ONUs) or Optical Network Terminals (ONTs) close to end users and The splitter also denoted as passive since finally Optical Distribution Network (ODN) that connects OLT and ONUs.

The difference between ONT and ONU can be described as ONU is a device that terminates distributed endpoints of ODN and ONT is subscriber device that terminates distributed endpoints of ODN and it is considered a special form of ONU

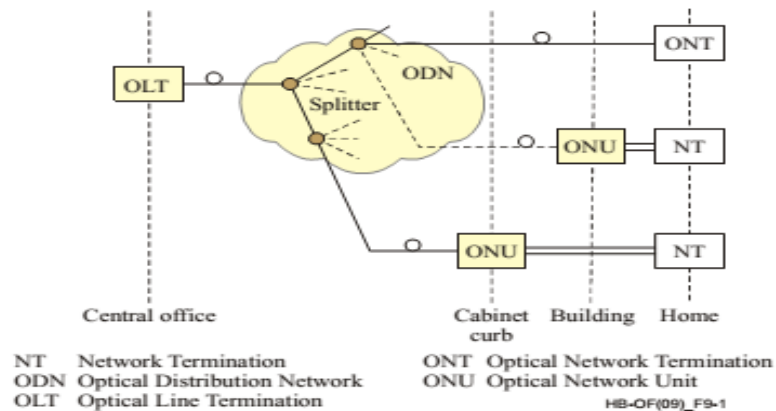

Figure 2.4 : General structure of a PON[18]

2.4.1.1 Optical Line Terminal (OLT)

Optical Line Terminal is a network element in PON network and it is usually placed in the central office. It works as interfaces the backbone network to access network. OLT consists of Media Access Control (MAC) layer protocol, optical transmitter and optical receiver [19]. OLT controls data flow across the ODN into two directions. In the downstream direction the function of an OLT is to take in voice, data, and video traffic from a long-haul network and broadcast it to all the ONT modules on the ODN. In the reverse direction (upstream), OLT accepts and distributes all the traffic from the network users [20]. Figure 2.5 shows EPON OLT FD2000S.



Figure 2.5: EPON OLT FD2000S[21].

EPON OLT is system terminal platform, it is combined with the advanced industrial design. Manufacturing technology by mini designing, which is highly reliable, flexible, and easy to maintain. It can support 8 GE PON ports and connect 512 remote ONU mostly (by 1:64 splitter), and provides 8 GE optical/electrical uplink interfaces. FD2000S can be applied to Fiber To The Building/Point/Home (FTTB/FTTP/FTTH) access solutions.[21].

2.4.1.2 Optical Network Unit (ONU)

ONU is an interface to the network at the customer/subscriber end. At one side, it connects to the OLT via Optical Splitter and on the other side to the subscriber directly, hence providing the subscriber a true triple play service of voice, video and data. [19]. ONU is available in many form factors for many services like EPON ONU (see Figure2.6) FTTH EPON ONU FD204HW terminal devices are designed for fulfilling FTTH and triple play demand of fixed network operators or cable operators[21].



Figure2.6: EPON ONU FD204HW[21]

2.4.1.3. Optical splitter

Splitter is the main element in PON since it is passive power divider that gives Passive Optical Network its name. It is known as splitter, but it is bidirectional device that divides the power downstream optical signal from OLT to all splitter outputs connected to ONUs. It also combines the incoming upstream signals from ONUs to one fiber connecting to OLT. The losses due to power division limits the number of outputs N connecting to ONTs or split ratio [22].

$$Attenuation_{Splitter} = 10 \log \frac{1}{N} \quad (3-1)$$

There are two types of splitters

- splitters based on planar technology for split ratio > 32
- splitters based on fused bi-conical couplers for split ratio < 32

Figure 2.7 shows the schematic [23] of Planar Light Circuit (PLC) splitter while Table 2-2 lists typical losses due to split ratio.

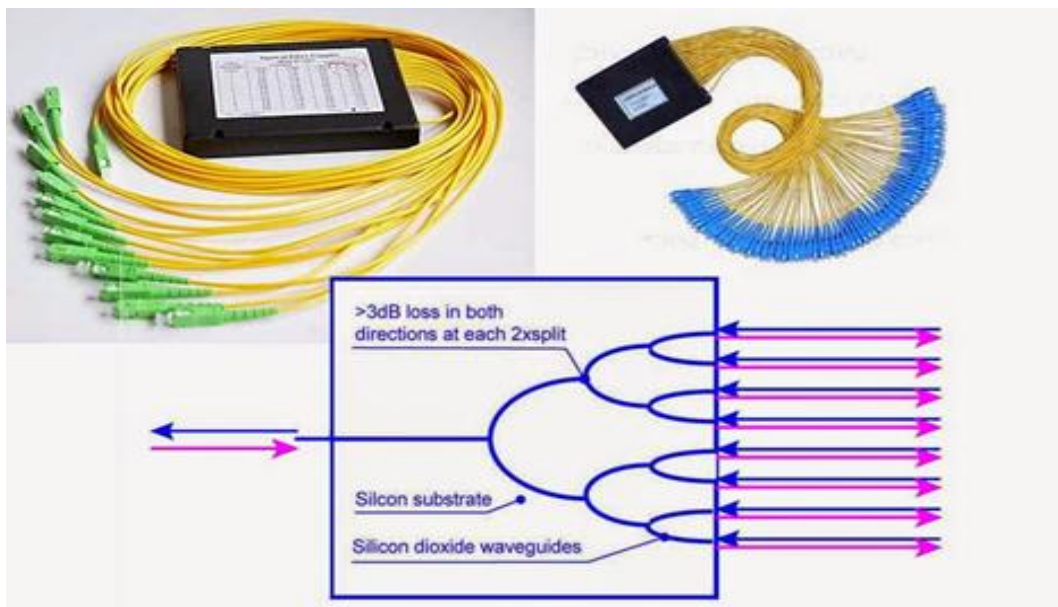

Figure 2.7: Schematic drawing for PLC Splitter[24]

Table 2.2: typical losses for splitters[25]

Splitter Ratio	1:2	1:4	1:8	1:16	1:32
Ideal Loss / Port (dB)	3	6	9	12	15
Excess Loss (dB, max)	1	1	2	3	4
Typical Loss (dB)	4	7	11	15	19

2.4.2.PON Advantages

There are a lot of benefits of using broadband PON local access networks such as:

- A PON allows for longer distances between central offices and customer premises. While with the Digital Subscriber Line (DSL) the maximum distance between the central office and the customer is only 18000 feet (approximately 5.5 km), a PON local loop can operate at distances of over 20 km [26].
- More signals in one fiber to cabinet allows for very dense CO equipment .
- Very low power consumption
- Much higher bandwidth per user
- As point to multi point allows for downstream video broadcasting.
- No need for multiplexing or demultiplexing components in cabinets [27].

2.4.3. PON Topologies

There are many basic PON topologies such as tree, bus and ring.

2.4.3.1. Tree Topology

Tree is the most commonly used topology in fiber access networks. Especially, tree with single splitting point (see Figure 2.8) is prevalent for PON. It uses a single fiber from the OLT to a remote node (RN), which is an intermediate splitting point. From this splitting point, there is a separate fiber allocated to each ONU connected to the network. The main advantage of this topology is that the splitting is only performed at a single point; thus it is simple to adopt all ONUs to have a similar power budget which means they all transmit or receive approximately the same optical signal power and quality.

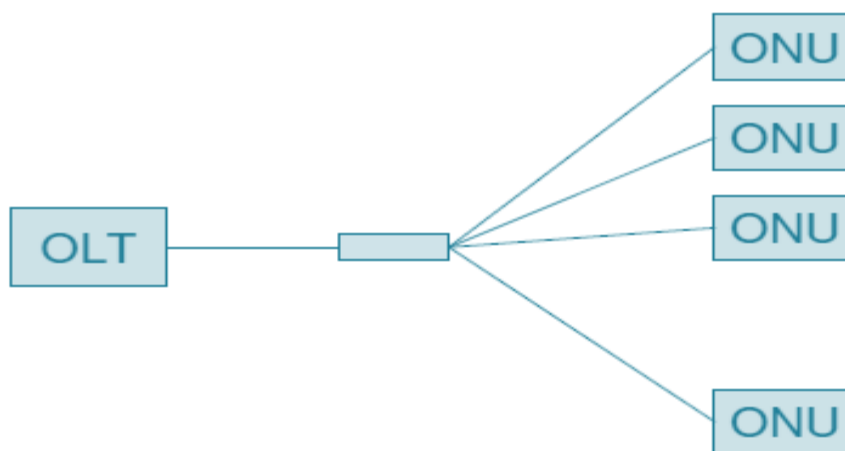

Figure 2.8: Tree with single splitting point[28]

2.4.3.2. Ring Topology

In ring topology there are two possible ways to reach the OLT from each ONU. (see Figure 2.9). Therefore, in case of a fiber cut, it is still possible to establish and maintain the connection. However, ring topology has the same drawback as the bus in terms of the power budget. When the optical signal passes through several couplers, it becomes degraded and attenuated. Thus, the total number of ONUs that can be connected to the ring PON is also limited.

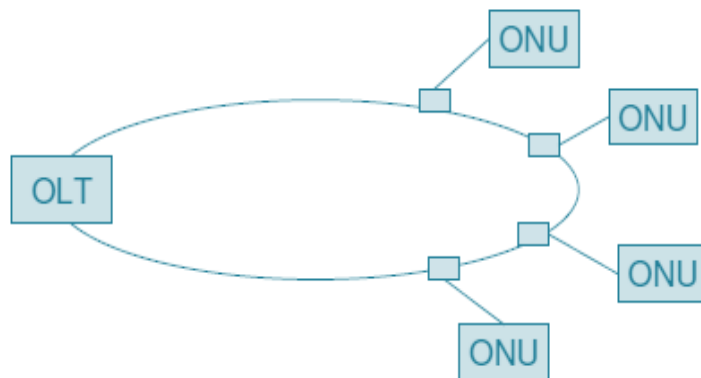

Figure2 9: Ring topology[28]

2.4.3.3. Bus topology

where each ONU is connected to a tap coupler that can extract a part of power sent by the OLT, it can be considered as a special case of tree topology (see Figure2.10). Its two main advantages are:

- 1- use of minimal amount of optical fiber
- 2- flexible deployments since new ONUs can be connected to the network by adding more taps.

However, the problem is that the signals of the ONUs, which have to pass several tap couplers, are degraded and weak. Thus, the number of ONUs that can be connected to the bus PON is limited. Furthermore, it's not easy to apply the cost-efficient protection scheme to the bus topology.

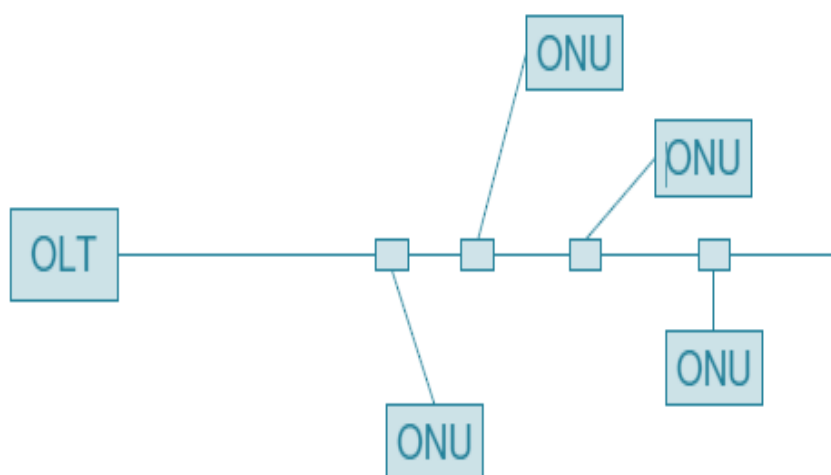

Figure 2.10: Bus topology[28]

Chapter 3: Fundamental Concepts of FTTH, FBG and OCDMA

3.1. Introduction

In this chapter, we review the basic concepts behind this thesis. In the beginning, we will discuss the concept of fiber to the home, architecture and its advantages

Next, we will demonstrate the principle of fiber bragg grating, theory, characteristics, advantages and its Current applications .

Finally , we will explain the fundamentals of optical code division multiple access, principle, classifications, OCDMA encoding/decoding, spectral amplitude coding and its advantages .

3.2.Fiber To The x (FTTx) Networks

PON technology has several applications for supporting broadband connectivity in the access network to homes, multiple-occupancy units, and small businesses commonly is called Fiber-to-the-x.

The FTTx group comprises a set of technologies depend on transport of digital signals optical fiber as transmission medium. Different levels of scope, based on the of optical fiber closer to the end user, which arise as a result of a greater or lesser price reduction of these systems. All FTTx networks support a logical network configuration of tree, star, bus and ring, all with the ever present possibility of using active components depending on the location of users or end customers [2]

FTTx networks can be classified into the following[20] :

FTTB (Fiber to the Building): the optical fiber is reaches the building of the business or enterprise.

FTTC (Fiber to the Curb): describe the shared of optical fiber cables run from central office equipment to a communication switch located within 300m from the home or the building (Curb), then a dedicated cable (twisted-pair, Coaxial cable) or other transmission medium is connected from the curbside to the device in the customer building.

FTTN (Fiber to the Node): shared optical fiber cable run from CO to distribution device located within 1000m from the home or the building (Curb).

FTTH (Fiber to the Home): the optical fiber cable run from central office to the home.

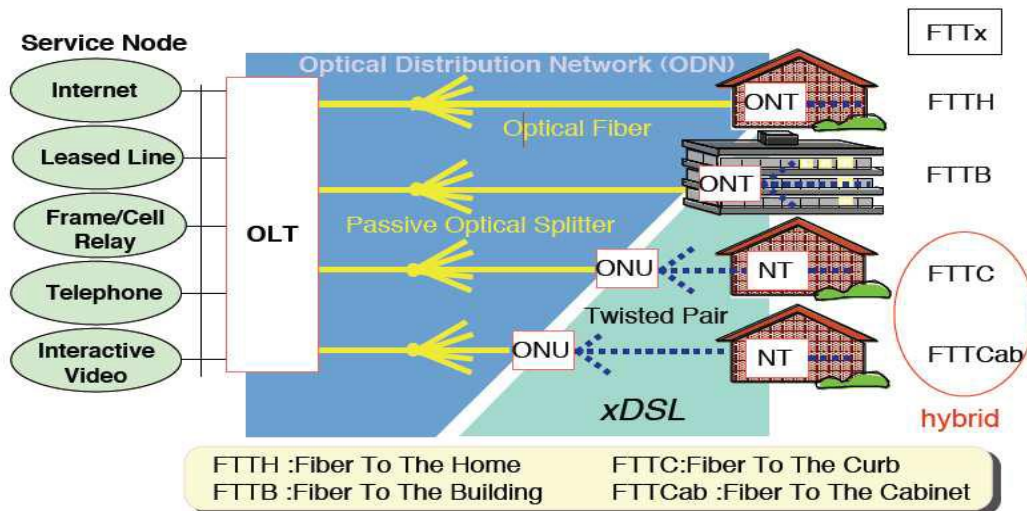

Figure 3.1: Some FTTx scenarios [29].

3.3.FTTH networks

FTTH networks belong to the family of FTTx transmission systems within the world of telecommunications. These networks, which are considered broadband, have the ability to transport large amounts of data and information at very high bit rates up to a point close to the end user [2]. Figure 3.2 explain these idea of FTTH solutions

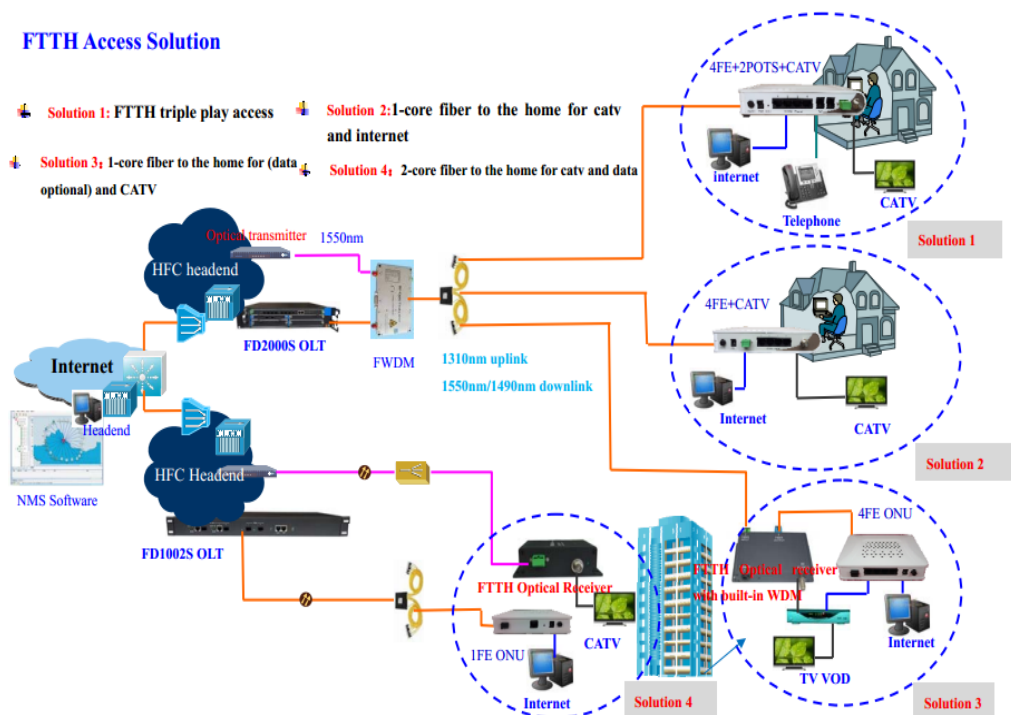

Figure 3.2: FTTH solution [21]

3.3.1 FTTH Architectures

Point to Point(P2P) and Point to Multi Point(P2M) are two commonly used FTTH architectures for FTTH deployment. Choice of Point to Point(P2P) or Point to Multi Point(P2M) architectures for deployment depends on the type of services to be delivered cost of the infrastructure, current infrastructure and future plans for migrating to the new technologies.

3.3.1.1 Point to Point Architectures (P2P)

Point to Point is called Ethernet Switched Optical Network (ESON). A P2P architecture is a very simple network design[10]. P2P is a direct dedicated link between central office (CO) and user equipment (UE) (see Figure 3.3). The user is mainly companies or business offices requiring huge data transfer with remote sites. In P2P topology the bandwidth is dedicated to user with very high cost[30].

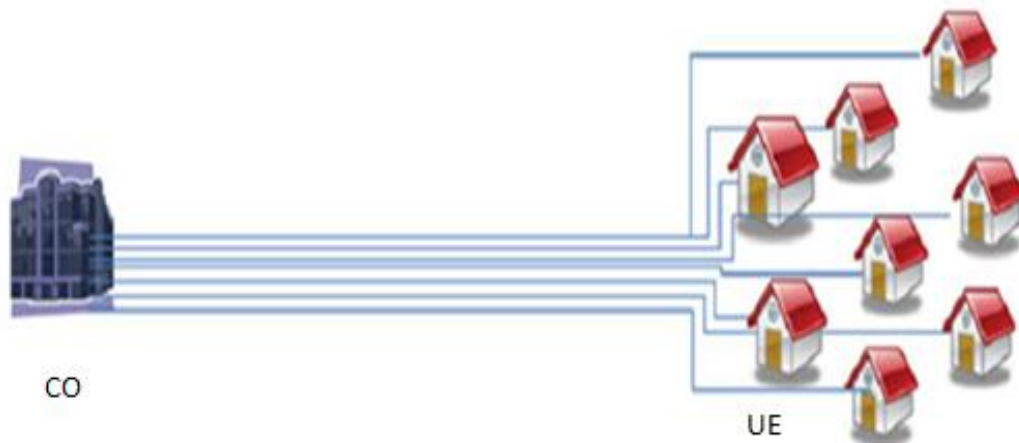

Fig 3.3: Point to point access topology [31]

3.3.1.2 Point to Multi Point architectures (P2MP)

Any network user does not use the network resources in the same manner (i.e. there will be peaks and valleys) the high speed link from CO can be shared between groups of users. This topology is suitable for home users and small offices [10]. Point-to-multipoint architectures (see Figure 3.4) have passive optical splitters in the field are deployed in conjunction with standardized PON technologies – GPON is today's frontrunner in Europe, while EPON has been massively deployed in Asia [31].

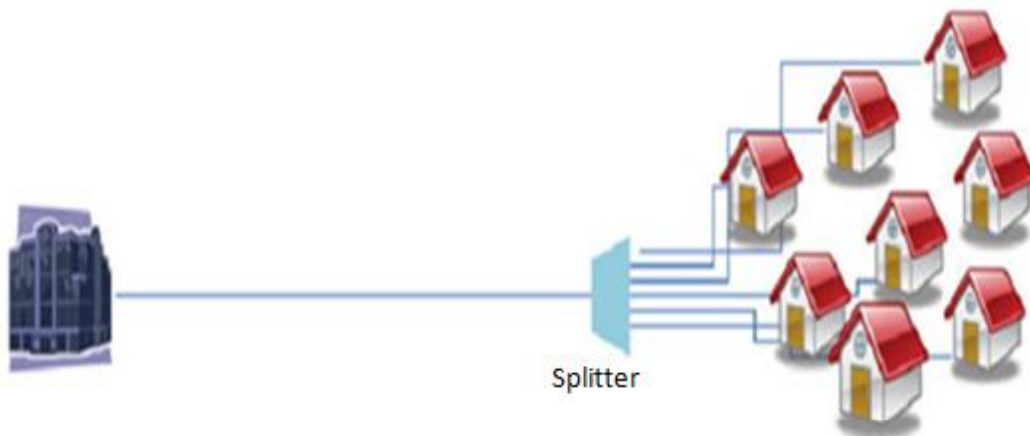

Fig 3.4: Point to Multipoint topology[31]

Point-to-multipoint cost of implementation and operation is less than Point-to-point because the shared portion cost will be shared between all the users served by the same fiber.

3.3.2 FTTH advantages

There are several advantages associated with FTTH including the following :

1. It is a passive network, so there are no active components from the CO to the end user. This dramatically minimizes the network maintenance cost and requirements, as well as eliminating the need for a DC power network.
2. It is a single fiber to the end user , providing revenue -generating services with industry standard user interfaces, including voice ,high-speed data, analog or digital CATV , and video on demand.
3. FTTH features local battery backup and low-power consumption .
4. FTTH is reliable, scalable, and secure.
5. The FTTH network is a future proof-architecture.

3.4. Fiber Bragg Grating (FBG)

Fiber Bragg Grating (FBG) had been discovered by Ken Hill and co-workers in Canada, nearly 1978 [32]. It is defined as a type of distributed Bragg reflector constructed in a short segment of optical fiber that reflects particular wavelengths of light and transmits all others. This is achieved by adding a periodic variation to the refractive index of the fiber core, which generates a wavelength specific dielectric mirror. A fiber Bragg grating can therefore be used as an inline optical filter to block certain wavelengths, or as a wavelength-specific reflector [33].

3.4.1. The principle of fiber Bragg Grating (FBG)

Fiber Bragg Gratings are made by laterally exposing the core of a single-mode fiber to a periodic pattern of intense ultraviolet light. The exposure produces a permanent increase in the refractive index of the fiber's core, creating a fixed index modulation according to the exposure pattern. This fixed index modulation is called a grating. At each periodic refraction change a small amount of light is reflected. All the reflected light signals combine coherently to one large reflection at a particular wavelength when the grating period is approximately half the input light's wavelength. This is referred to as the Bragg condition, and the wavelength at which this reflection occurs is called the Bragg wavelength. Light signals at wavelengths other than the Bragg wavelength, which are not phase matched, are essentially transparent[33].

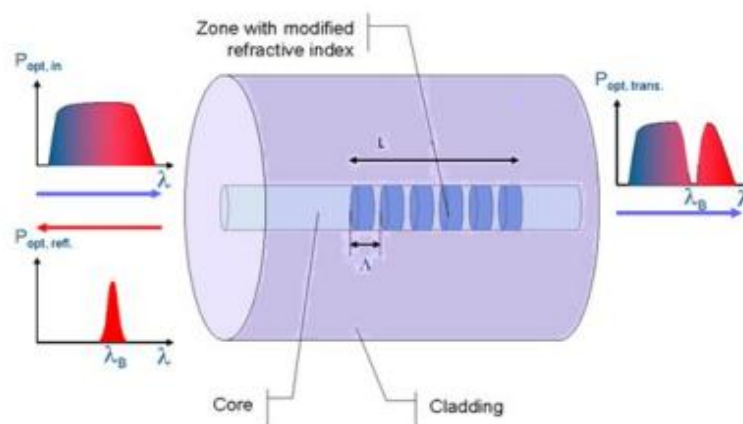

Figure 3.5: Principle of a Fiber Bragg Grating [34]

3.4.2. Fiber Bragg Grating Theory

It is important to know the term “uniform fiber Bragg grating”. A grating is a device that periodically modifies the phase or the intensity of a wave reflected on, or transmitted through, it [36]. The propagating wave is reflected, if its wavelength equals Bragg resonance wavelength, λ_{Bragg} , in the other case is transmitted. The uniform means that the grating period, Λ , and the refractive index change, δn , are constant over whole length of the grating. The equation relating the grating spatial periodicity and the Bragg resonance wavelength is given by [35, 36]. In the following equation, the centre wavelength is represented by the well-known Bragg condition:

$$\lambda_{Bragg} = 2n_{eff}\Lambda \quad (3.1)$$

Where λ_{Bragg} , is the centre wavelength, n_{eff} is the effective index of the guided mode and Λ is the period of the index modulation[37].

A typical layout of uniform fiber Bragg gratings with input and output signal indicated is shown on Figure. 3.6

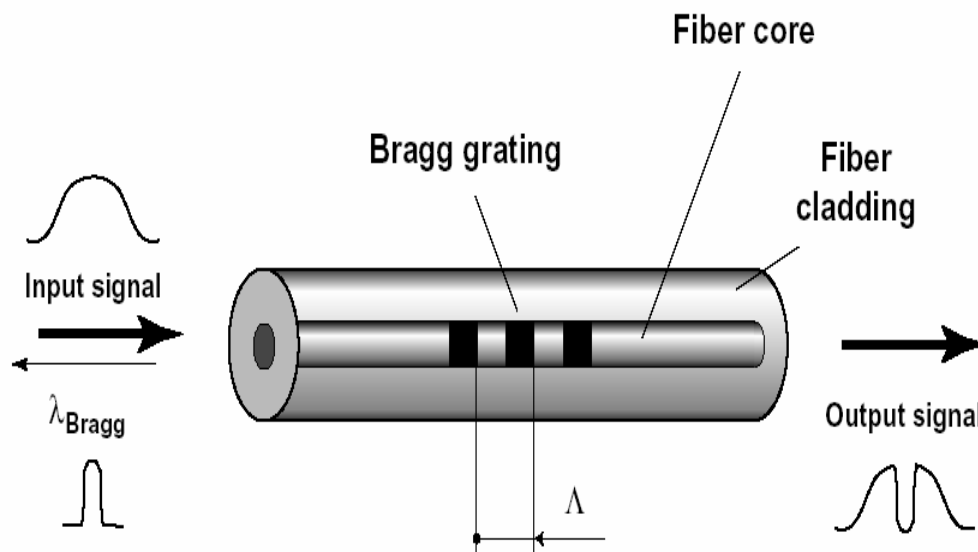

Figure 3.6: Uniform fiber Bragg grating [36]

3.4.3. Fiber Bragg Grating (FBG) Advantages

FBG has a lot of advantages like:

1. It is a simple structure.
2. low insertion loss.
3. high wavelength selectivity.
4. polarization insensitivity and full compatibility with general single mode communication optical fibers [38].
5. It is used in several applications like communication, sensors, civil engineering.

3.4.4. Characteristics of FBG

Fiber Bragg Grating has some of characteristic such as

- 1- It is a reflective type filter
 - Not like to other types of filters, the demanded wavelength is reflected instead of transmitted .
- 2- It is very stable after annealing
 - The gratings are permanent on the fiber after proper annealing process.
 - The reflective spectrum is very stable over the time.
- 3- It is transparent to through wavelength signals
 - The gratings are in fiber and do not degrade the through traffic wavelengths, very low loss.
- 4- It is an in-fiber component and easily integrates to other optical devices.

3.4.5 Current Applications of FBG

Fiber Bragg gratings have a lot of applications in fiber optical telecommunication systems likes dispersion compensation, gain flattening for Erbium-Doped Fiber Amplifier (EDFA) Raman amplifiers and add/drop multiplexers and in fiber grating sensors and pulse shaping in fiber lasers. Combining, controlling and routing light are three main uses of FBGs in the optical communications it can use as encoder and decoder [39].

They are also stimulating growth in fiber optic applications outside of telecommunications, such as nonlinear frequency conversion, spectroscopy, remote sensing [40].

3.5. Optical Code Division Multiple Access(OCDMA)

Multiple-Access techniques are proposed to meet the growing demand for high-speed optical broadband access. There are several techniques to provide multiple accesses and one of them is Fiber Optic Code Division Multiple Accesses (FO-CDMA) to allow several users to transmit simultaneously over the same optical fiber. OCDMA combines the large bandwidth of the fiber medium with the flexibility of the CDMA technique to achieve high speed connectivity. Recently, (OCDMA)method is getting more attractive due to its several features and its ability to support asynchronous access, bursty traffic, secure transmission and effective cost [41, 42].

3.5.1.OCDMA principle

The OCDMA principle depended on spread spectrum techniques, which have been widely used in mobile-satellite and digital cellular communication system [43]. The concept is to spread the energy of the optical signal over a frequency band that is much wider than the minimum bandwidth required to send the information . This spreading is done by a code, that is independent of the signal itself. Thus, an optical encoder is used to map each bit of information into a high rate optical sequence. Optical Spectrum Code Division Multiple Access (OSCDMA) is an excepted spread spectrum family transmission technique. In optical world, CDMA has been suggested as possible technology in two roles, which are optical shared medium LANs and local access networks [44]. In OSCDMA, each user is identified by a different code. An OCDMA user inserts its code in each data bit and asynchronously initiates transmission. Hence, this modifies its spectrum appearance, in way recognizable only by the intended receiver. Otherwise, only noises like bursts are observed [45]. Figure 3.7shows a typical OCDMA system in which each of these blocks represents a function unit in the system.

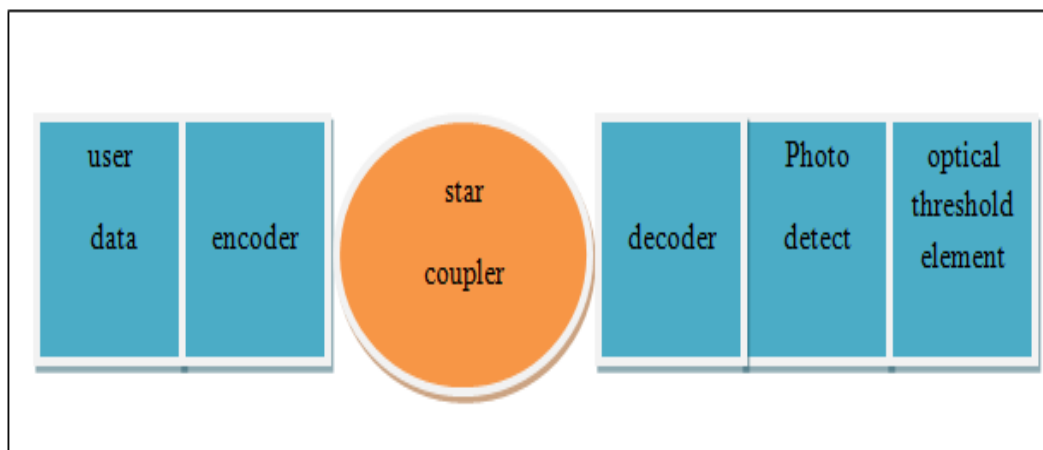

Figure 3.7: Typical OCDMA System Schematic

The process of multiplexing in OCDMA can be described by the following steps:

1. Every data stream is encoded by using a unique code sequence for time spreading of each data bit and/or by spectrally encoding of each data bit.
2. All the encoded signals are fed into a star coupler simultaneously and asynchronously.
3. The mixed signal goes through the star coupler for a distance which is not fixed.
4. Each of the encoded signals is decoded and de-spread at one of the receiving ends simultaneously with the help of a decoder whose function is basically the opposite of a corresponding encoder, thus the data signal is recovered from the encoded signal as detectable data bits [46].

A star coupler is a simple passive optical device with an equal number of input and output ports. The behavior of the star coupler is to broadcast any signal received at one of its inputs to all outputs, with a degree of attenuation. The number of ports on a star coupler is usually a power of two due to the structure of subcomponents required in construction.

3.5.2 . Block diagram of OCDMA

The aim of Optical Code Division Multiple Access is taking benefits of radio frequency communications. Figure 3.8 shows the block diagram of OCDMA

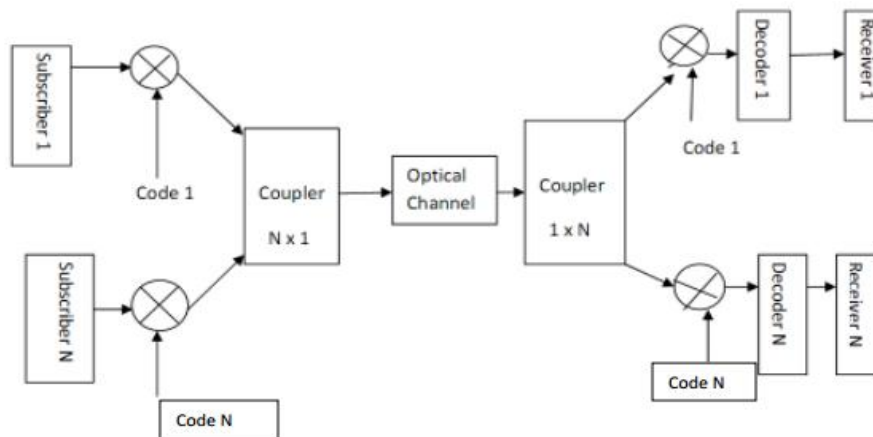

Figure 3.8: the block diagram of OCDMA[47]

3.5.3. Classifications of OCDMA codes

Several types of OCDMA have been proposed as the result of intensive research on OCDMA in the past 20 years. OCDMA depend on different choices if optical sources (e.g. coherent vs. incoherent narrowband vs. broadband), detection schemes (e.g. coherent vs. incoherent), and coding techniques (e.g. time vs. wavelength, amplitude vs. phase), coding schemes can be techniques (e.g. time vs. wavelength, amplitude vs. phase). Coding schemes can be classified into six main categories [48]:

1. Spectral amplitude coding .
2. Spectral phase coding .
3. Pulse-amplitude coding .
4. Pulse phase coding .
5. Spatial coding .
6. Wavelength hopping time spreading coding.

3.5.4. OCDMA Encoding/Decoding

In general, the encoder/decoder structures used in OCDMA system can also be generalized in common:

1. encoder/decoder based on optical delay line.
2. encoder/decoder based on diffraction gratings and spatially patterned mask
3. FBG or Fiber Bragg Grating encoder/decoder.
4. AWG or Arrayed Waveguide Grating encoder/decoder etc.

3.5.5. Incoherent and Coherent OCDMA Systems

Incoherent and Coherent OCDMA Systems, the optical signal is applied to a specific user's code sequence. These categories are coherent and incoherent OCDMA systems. In coherent OCMDA systems, a particular user's code sequence is usually applied through phase coding of optical signal field which is generally achieved with the use of a mode-locked laser ("a highly coherent wideband source"). At the receiving end of a coherent OCDMA system, the original data is retrieved by the signal field's coherent reconstruction. Coherent OCDMA systems are further classified into several types, there are Spectral Phase Coded OCDMA (SPC-OCDMA) and Temporal Phase Coded OCDMA (TPC-OCDMA). An incoherent OCDMA system depends on amplitude-modulated codes instead of direct optical phase manipulation. Here, the decoding process at the receiving end is done through an "incoherent decoding and recovery process". Some incoherent OCDMA systems employ wideband incoherent sources like broadband Amplified Spontaneous Emission (ASE), while other incoherent OCDMA systems employ laser sources which are coherent [48].

3.5.6. Spectral amplitude coding (SAC) OCDMA

Zacarrin and Kavehrad first illustrated and verified the idea of frequency encoding in OCDMA, in other words SAC-OCDMA [49], [50]. The block diagram of their proposed system is shown in Figure 3.9. At the transmitter side, a spectral amplitude encoder is used to selectively block or transmit certain frequency components according to the spreading code. At the receiver side, a balanced receiver filters the incoming signal with the same spectral amplitude filter used at the transmitter as well as its complementary filter. For an unmatched transmitter, half of the transmitted spectral components will match the direct filter and the other half will match the complementary filter (In the case of m-sequence or Hadamard codes). Since the output of the balanced receiver represents the difference between the two photo detector outputs, unmatched channels will be cancelled, while the matched channel is detected.

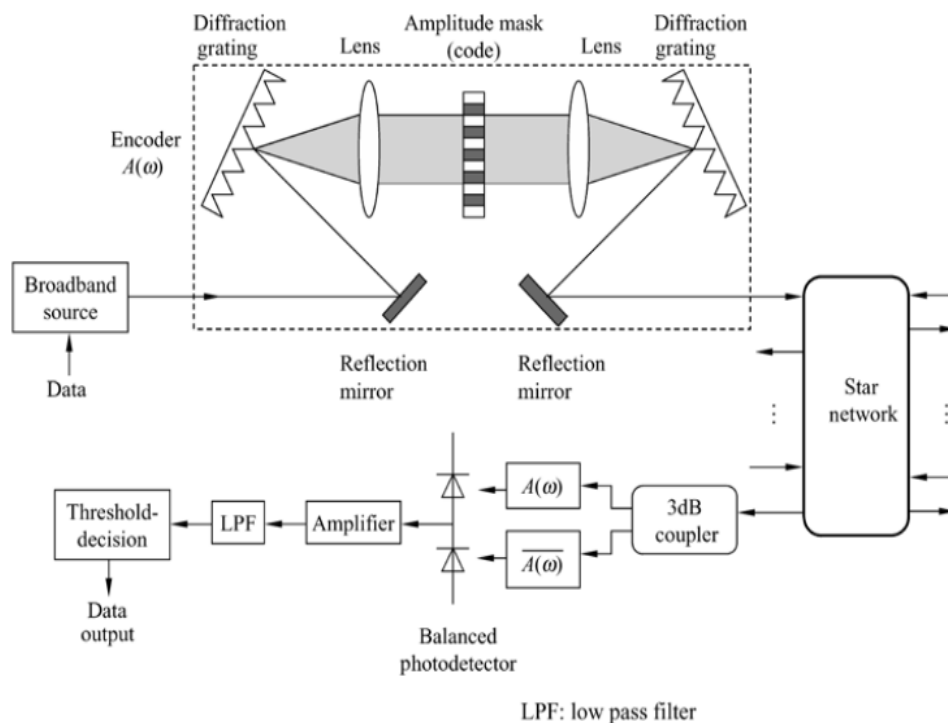

Figure 3.9 : block diagram of spectral amplitude coding for OCDMA [49]

To avoid the use of the bulk optics system proposed in [49], and to provide the advantage of a low cost reconfigurable all-optic encoder/decoder, fiber Bragg gratings (FBGs) have been proposed as encoders/decoders for SAC-OCDMA. The reflection and transmission responses (amplitude and phase) of the FBGs depend on their design [51].

3.5. 7.FBG Encoder/Decoder

FBG has a lot of applications and one of these applications can be used as encoder and decoder Figure 3.10 shown the spectral function of FBGs , where $A(\omega)$ represents the reflection spectrum of FBGs and $\overline{A(\omega)}$ is the transmission spectrum of FBGs.

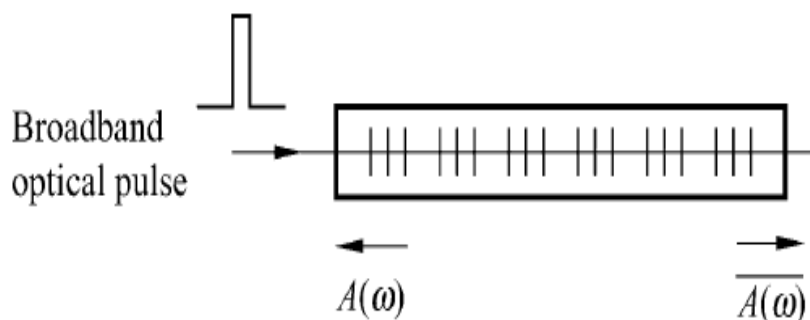

Figure 3.10: Schematic diagram of spectral distribution function of FBGs[52]

The spectral amplitude encoder and decoder based on the linear array of FBGs is shown in Figure 3.11

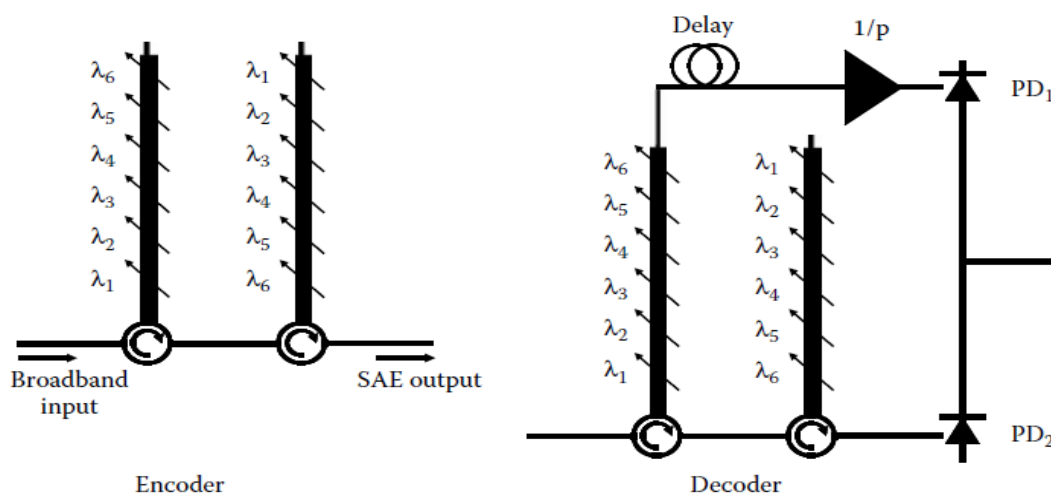

Figure 3.11:Encoder and decoder based on a linear array of FBGs [52]

A line array of FBGs is a concatenation of FBGs, each centered at a frequency (wavelength) defined by the code. In terms of spectral content, the reflection of a broadband pulse (signal) representing a “1” bit from the linear array will correspond directly to the desired code (the grating reflection response corresponds to the direct filter); on the other hand the transmission will correspond to the code complement (the grating transmission response corresponds to the complementary filter). The wavelengths of each FBG can be individually tuned (for example using localized thermal means or applied strain), which allows the encoder/decoder to be dynamically reconfigured.

When a broad-band pulse is input into a group of FBGs, the spectral components corresponding to $A(\nu)$ pulse is generated by the reflection of a fiber grating and, hence, at the receiver, the power of original data pulse will be completely reflected when the grating is sufficiently long. Due to the lower weight of MQC codes, we can construct a transmitter–receiver with only a few FBGs. Therefore, it is very easy to implement. However, if Hadamard codes are used for the same purpose, we may need too many FBGs.

3.5.8. SAC-OCDMA using FBGs

A broadband optical signal is first modulated by the data in the time domain and then fed to the spectral encoder. The spectral encoder consists of an optical circulator and a set of FBGs. When a broadband signal is passed through the set of FBGs certain frequency bands are reflected which form the chips of the spectral code. The spectrally coded data is then transmitted on a fiber along with other spectrally coded signals from other users. It is obvious that the quality of the coded spectrum is governed by the reflection characteristics of the FBGs. In the ideal case an optical filter (FBGs in this case) should reflect only certain band which we can call 'pass band'. However an FBG along with the pass band also reflects (passes) other frequencies (wavelengths) due to its non ideal band pass response. The spectral codes generated using FBGs then do not show orthogonality and the system performance deteriorate.[53] Figure 3.12 show the schematic of a SAC-OCDMA system using FBGs

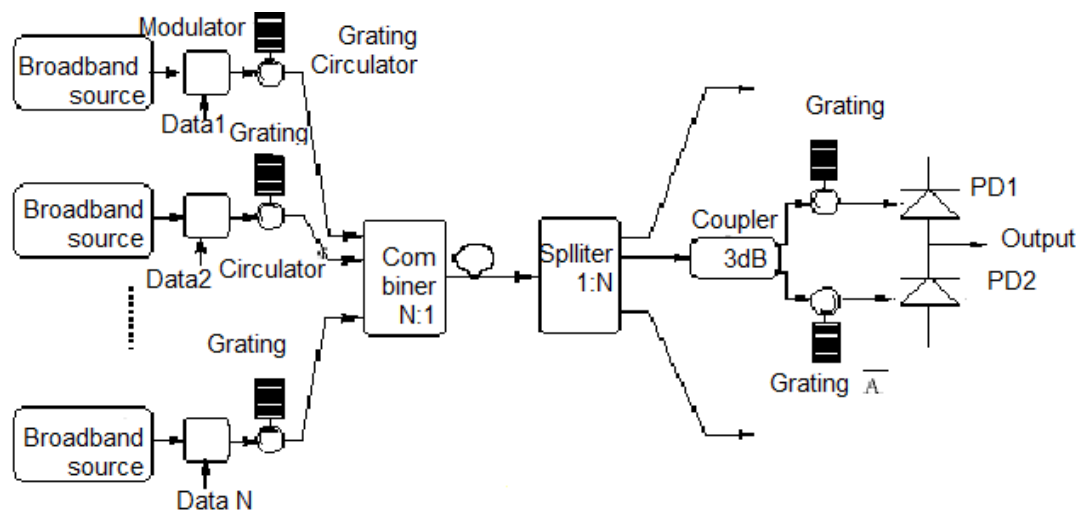

Figure 3.12: SAC-OCDMA using FBGs[53]

3.5.9. OCDMA Advantages

OCDMA has several advantages some of the main advantages of using OCDMA systems can be summarized as follows:

1. All optical communications : OCDMA system encodes and decodes signals (data) from different users optically, the messages are converted to optical signals at the source end and are retrieved as electronic signals after transmission has completed. The electronic bottlenecks in transmitting and receiving ends are conquered in comparison with OWDM. Realization of photon to photon transmission actually enables all-optical communications[54].

2. Band Width : In OCDMA, users can access equal portions of the available channel bandwidth. Here, the bandwidth is equally shared by all active users and can be divided into virtual channels. Consequently, the OCDMA system users can equally share access of the available resources of the network. Further, this is also the reason why, no single user one can block another from accessing the optical channel, one major advantage of OCDMA networks[55].

3. Security Performance : The signal transmitting in OCDMA networks is multiplexed signal of various users, the spread spectrum technology guarantees the received signal at any receiving end is multiplexed and can only be de-multiplexed when the address sequences are strictly matched [54].

4. Anti- interference Ability : The bandwidth of transmitting signal is increased with the use of spread spectrum technology at encoding. Therefore OCDMA is not sensitive to wavelength drifting and the anti-interference ability is enhanced [54].

5. Asynchronous Access : OCDMA system allows various users to access the same channel asynchronously. The signal of a new user adds directly onto the multiplexed signal vector, no synchronization between different users and wavelength adjustability needed. Moreover, the requirements of burst and high-rate transmissions in Local Area Networks (LANs) can be satisfied since the awaiting time before medium accessing is negligible [54].

6. Integrated Transmission Services: : OCDMA can actually support multi-rate transmissions and various transmission services such as IP transmission, ATM (Asynchronous Transfer Mode) and SONET (Synchronous Optical Network) transmissions simultaneously [54].

7. Network control: In OCDMA technology, the optical codes of optical are distributed in such a way that, the peak autocorrelation for the shifted and non shifted optical signals can be alternatively small or large. Consequently, the optical receivers can manipulate asynchronously these signals without the need of global clock synchronization between them. In this way, the OCDMA technology can properly manipulate and control the signal transmitted within the whole system[55].

3.6 Summary

The first section of this chapter discusses the concept FTTx and the second section is talked about the FTTH networks .The third section illustrates the Fiber Bragg Creating . The final section gives us details about the Optical Code Division Multiple Access.

Chapter 4: System Design and Results

4.1.Introduction

In this chapter FTTH network depending on OCDMA is designed at 200 Mbps, and it is applied in two parts, first part is simulating a three users fiber Bragg grating, and second part is simulating a seven users, system networks are fully designed and simulated by using OptiSystem simulation software V.13

4.2. System Architecture

The system model can be described by three parts transmitter part, optical fiber link and receiver part as shown in Figure 4.1.

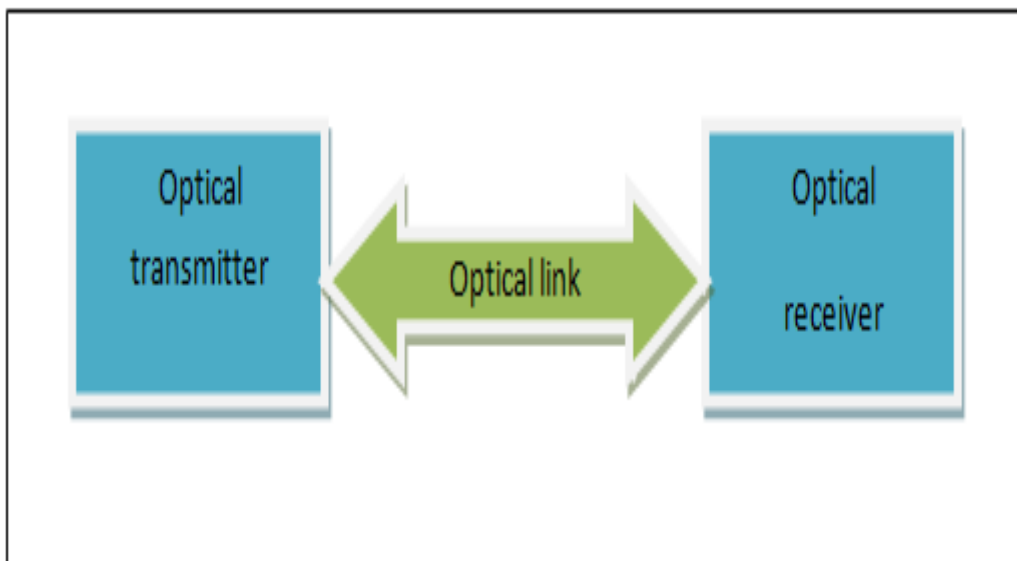

Figure 4.1: system model description

4.2.1. Optical transmitter

At the transmitter part, as shown in Figure 4.2 , each optical line terminal(OLT) includes five components: Pseudo Random Bit Sequence (PRBS) generators, Non-return-to-zero (NRZ) pulse generator, White Light Source, Fiber Bragg Grating and Modulators . pseudo random bit sequence (PRBS) generators are used to generate a PRBS depending on different operation modes. The bit sequence is designed to approximate the characteristics of random data. The function of NRZ pulse generator is to generate NRZ coded signal. The fiber Bragg grating works as a filter in encoder and decoder, The function of the encoder is to encode the source according to the specific code it uses. The modulators are Mach-Zehnder modulators, which are intensity modulator depending on an interferometer principle. The signal coming from the transmitter will be combined by power combiner and drive into a single fiber.

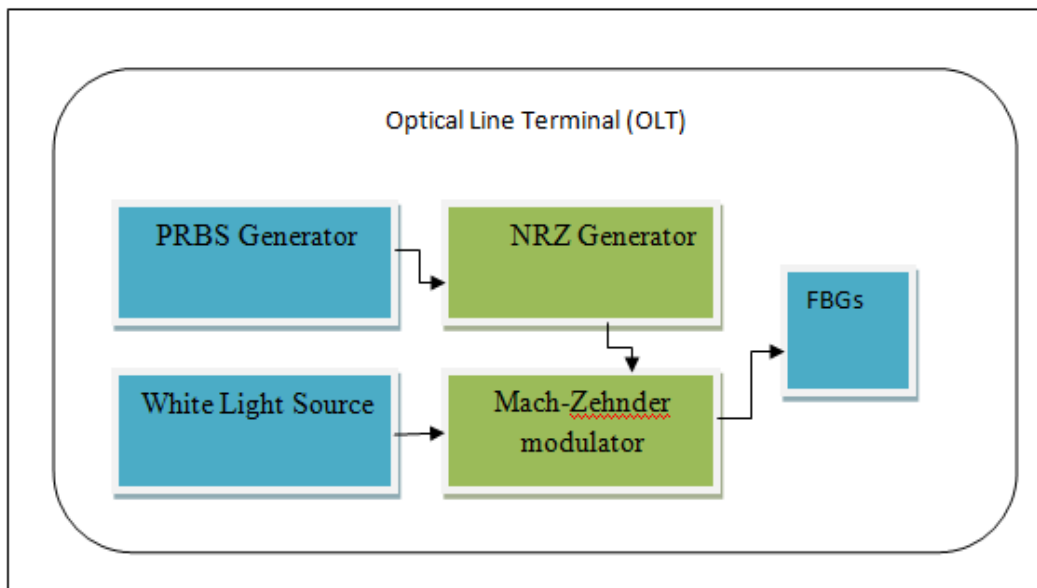

Figure 4.2: Transmitter part

4.2.2 .Fiber link

The fiber link part, as shown in Figure 4.3, contains the power combiner, optical fiber cable, and power splitter where the signals that coming from the transmitter will be combined by power combiner and drive into a single fiber. The fiber cables used for transmission at 1550 nm wavelength. In this system, the power splitters are used to represent the branches to the drop part on an optical network unit(ONU).

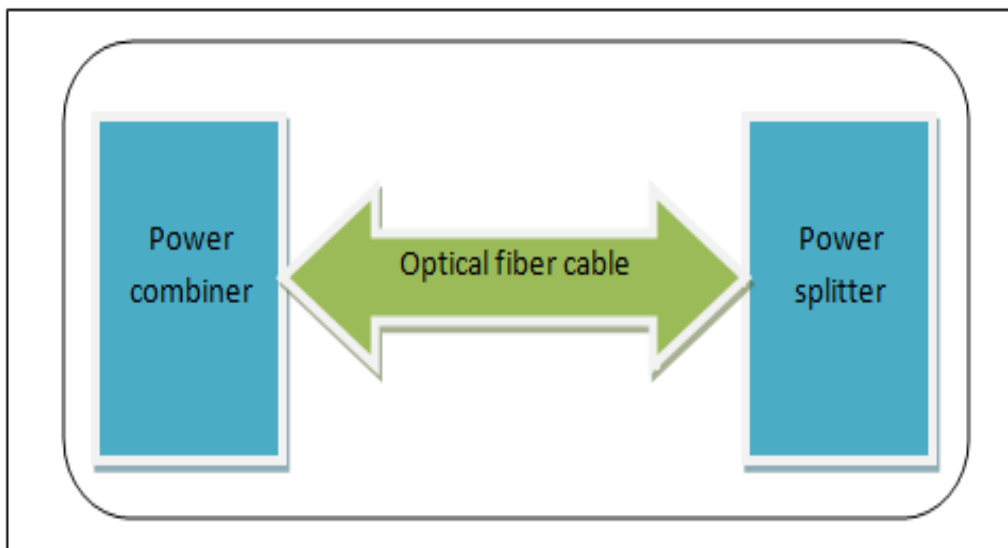

Figure 4.3: Optical link part

4.2.3. Optical receiver

In the receiver part, as shown in Figure 4.4. Receiver consists of 2 spectral filters and 2 photo detectors connected in a balance configuration which perform the decoding with low pass filter and BER analyzer . The incoming signal is split into two sections, one to the decoder that has an identical filter with the encoder and the other to the decoder that has the complementary filter . Photo detector Positive-Intrinsic-Negative (PIN) used to performs conversion from optical to electrical domain. An electrical subtracted is used to subtract the overlapping data from the wanted one. The performance of the system referring to the bit error rate (BER) at BER analyzer.

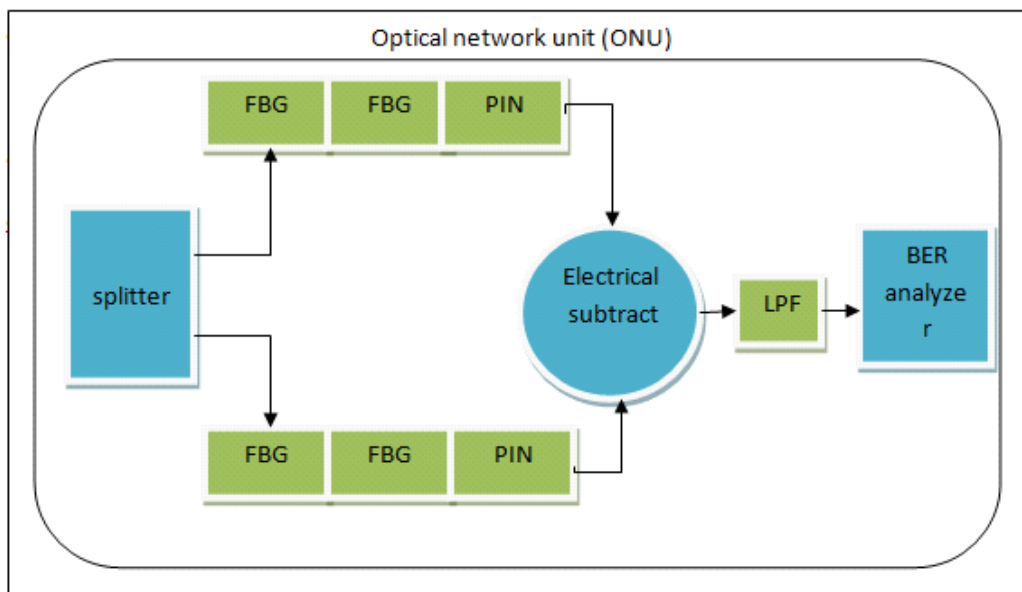

Figure 4.4: Receiver part

4.3. System Design

There are two parts in system design . Firstly, the design is done to investigate the FTTH with three users. Secondly, we simulated seven users FBG based OCDMA network. Figure 4.5 shows the block diagram of system design.

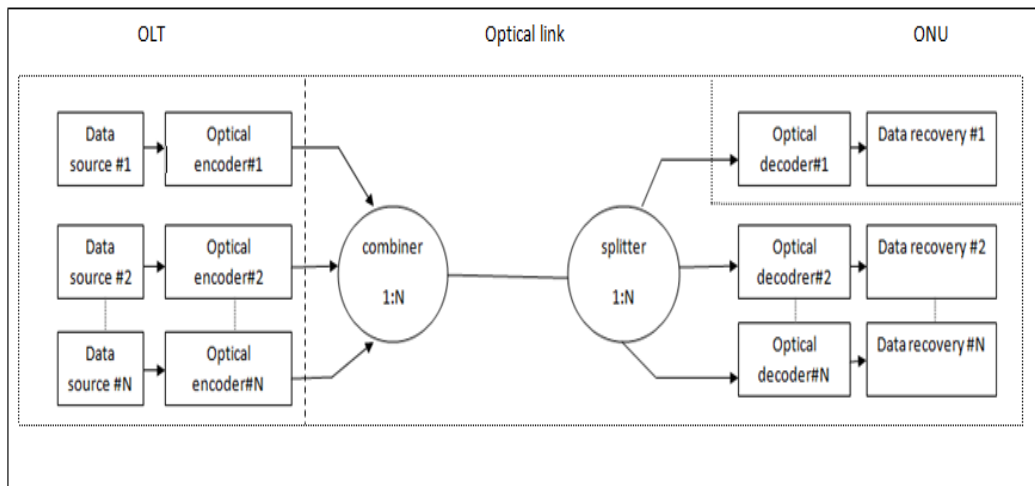

Figure 4.5: Block diagram of system design

4.3.1.Design and Analysis of three user

Here the design is divided in two sections, the first section presents design of three user FTTH network based on OCDMA at 200 Mbps for each user. Uniform FBGs are used to implement the Modified Quadratic Congruence(MQC) code by spectral amplitude encoding [52]. Also here study the effect of increasing the length of fiber, Firstly the user 1 and 2 are on and user 3 is off. Secondly all 3-users are on. Then in second section, we study the effect of the increases the signal data rate . The block diagram of the network is shown in Figure 4.6.

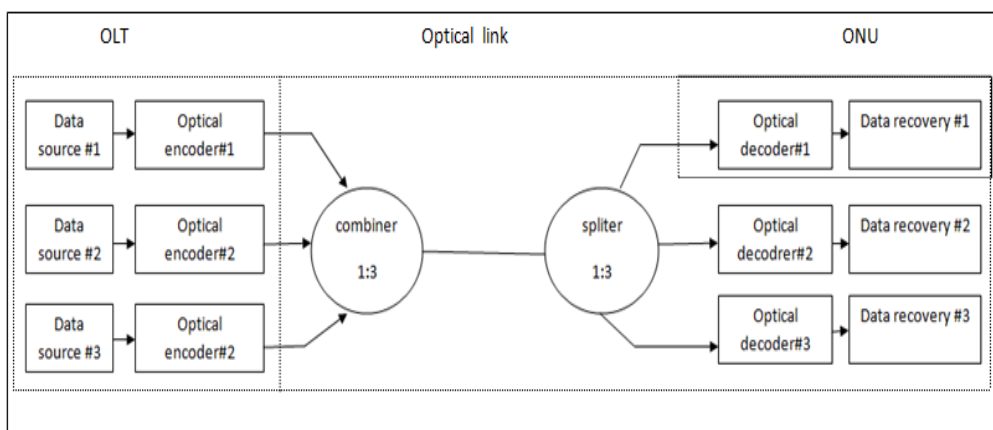

Fig4.6 :Block diagram of 3user design

The system design of 3-users, each of user can be simulated at signal bit rate of 200Mbps. The system design parameters are listed in table (4.1).

Table (4.1) : System design parameter

Parameter	Value
Signal bit rate	200Mbps
Distance	Sweep(10to50)Km
Frequency	1550.1nm
Band width	0.3 nm
Power	-115dbm
Reflectivity	0.9998
Attenuation	0.2db/km
Wave length of white light source	1550.5nm
PRBS	NRZ

4.3.2.Simulation Result for Design three users

The simulation results of 3-users FTTH using OCDMA networks for different transmission length starting from 10km to 50km are presented and discussed in the first. Then we demonstrate the effect of varying signal bit rate starting from (125 to 525) Mbps on the system.

4.3.2.1 .Performance Result for effect increasing length

The flowing figures and tables show the results when user one, user two are on, and user three is off. Figure 4.7 shows the result when user one is one, and the Figure 4.7 discusses the relation between Min. log .of BER, and the length of fiber link . As we can see from Figure 4.7 by increasing the length, the Min. log .of BER increases.

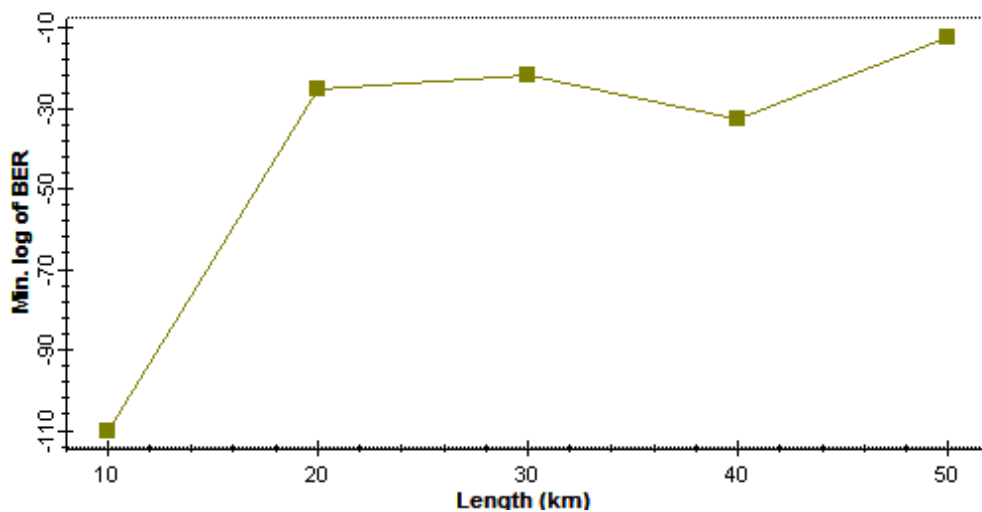

Figure 4.7: BER Vs Length for user one

Table(4.2) shows, the results when user one is on . As we can see the Bit Error Rate (BER) increases , and the Maximum Quality Factor (Max Q) decreases by increasing the distance of fiber cable. The best value of BER and Max Q is (9.27474e-111 and 22.3258) at distance of 10km.

Table (4.2) : User one result

Iteration	Length(Km)	Min.log of BER	Min BER	Max Q
1	10	-110.033	9.27474e-111	22.358
2	20	-25.053	8.85032e-026	10.4321
3	30	-21.6633	2.17102e-022	9.66289
4	40	-33.5045	3.12952e-033	11.9406
5	50	-12.5860	2.59045e-013	7.1876

We can find the Quality (Q) from this equation

$$Q = \frac{I_1 - I_0}{\sigma_1 + \sigma_0} \tag{4.1}$$

Where Q is the quality factor , Here $-I_0$ and $-I_1$ are the means of the low-pass filtered electrical current at the sampling time for the spaces and marks, respectively, and σ_0 and σ_1 are the corresponding standard deviations

Figure 4.8 shows the Diagram of BER after 5 iterations as we can see that with increasing the length. The figure of Eye Diagram of BER becomes worse. The best figure of BER at 10km, and the worst figure at 50km.

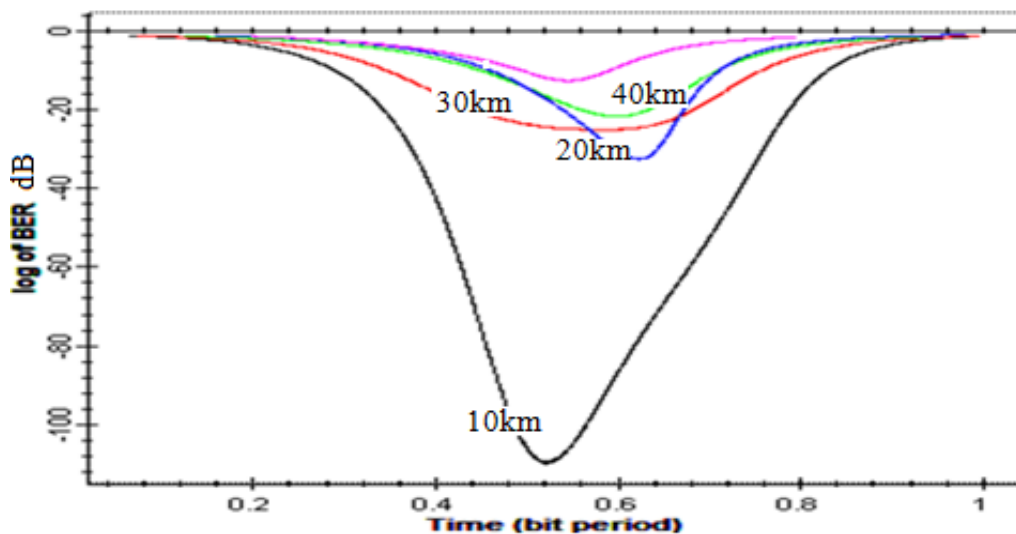

Figure 4.8: Diagram of BER for user one

Figure 4.9 shows the Diagram Max Q Factor after 5 iterations as we can see that with increasing the length. The figure of Eye diagram of Max Q factor becomes worse. The best figure of BER at 10km, and the worst fig at 50km.

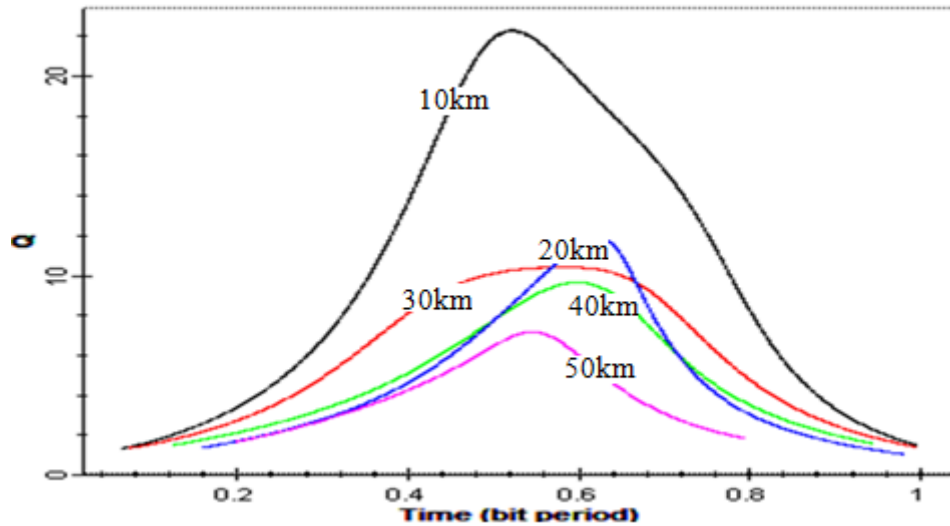

Figure 4.9: Diagram Max Q for user one

Figure 4.10 demonstrates the result when user two is on , and it explains the relation between Min. log .of BER, and the length of fiber link . As we can see from Figure 4.10 by increasing the distance the Min. log .of BER increases.

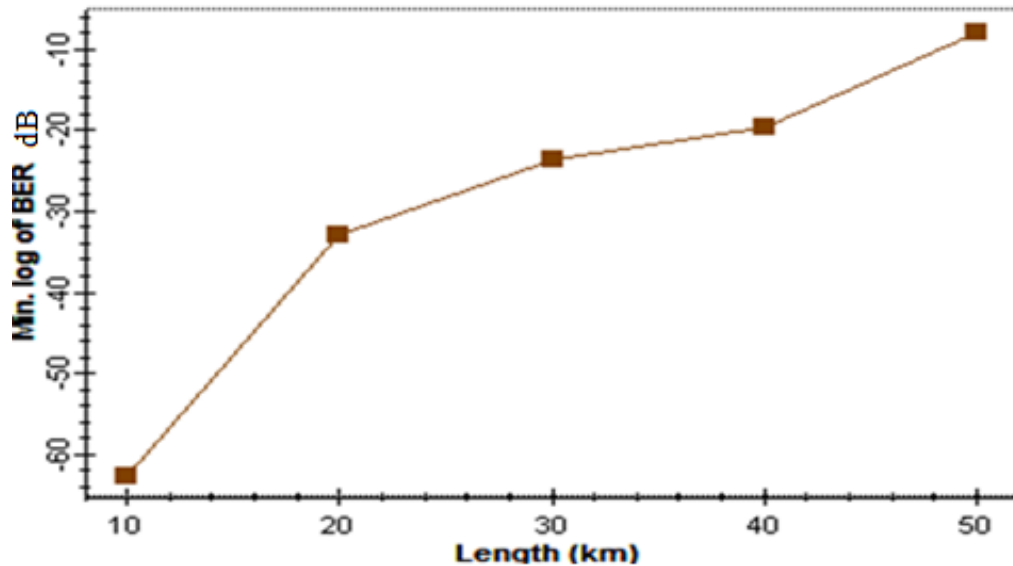

Figure 4.10: BER Vs Length for user two

Table (4.3) shows that the results when user two is on . As we can see Bit Error Rate (BER) increases , and Maximum Quality Factor (Max Q) decreases by increasing the distance of fiber cable. The best value of BER and Max Q is(1.55031e-063,and 16.7729) at distance of 10km.

Table (4.3) :User two result

Iteration	Length(Km)	Min.log of BER	Min BER	Max Q factor
1	10	-62.8096	1.55031e-063	16.7729
2	20	-32.9386	1.15178e-033	12.0341
3	30	-23.5486	2.82724e-024	10.90956
4	40	-19.643	2.27519e-20	9.16781
5	50	-7.86638	1.36025e-008	5.5583

Figure 4.11 shows the Diagram of BER after 5 iterations as we can see that with increasing the length. The figure of Diagram of BER becomes worse. The best BER at 10km, and the worst at 50km.

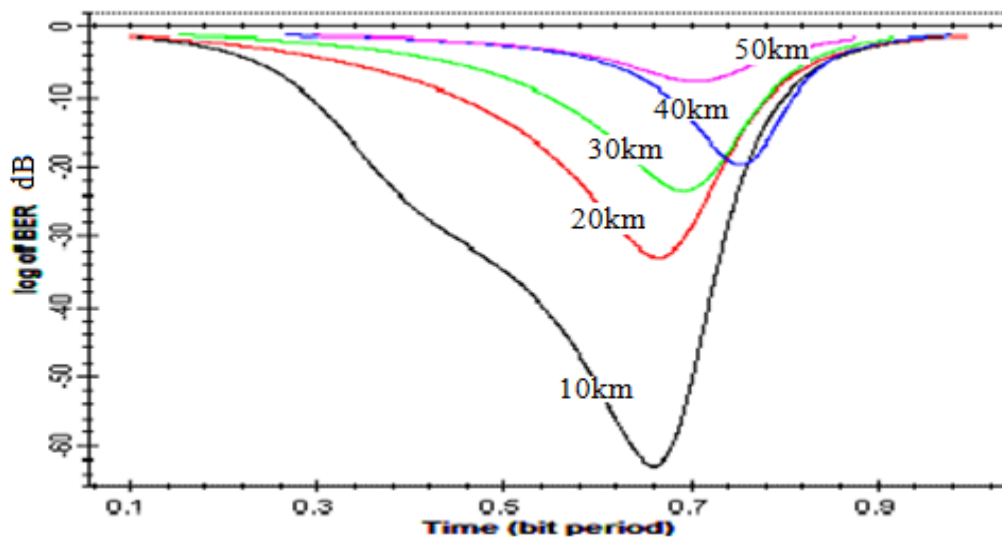

Figure 4.11: Diagram of BER for user two

Figure 4.12 shows the Diagram Max Q Factor for user 2 after 5 iterations as we can see that with increasing the length. The figure of diagram of Max Q factor becomes worse. The best Max Q factor at 10km, and the worst at 50km.

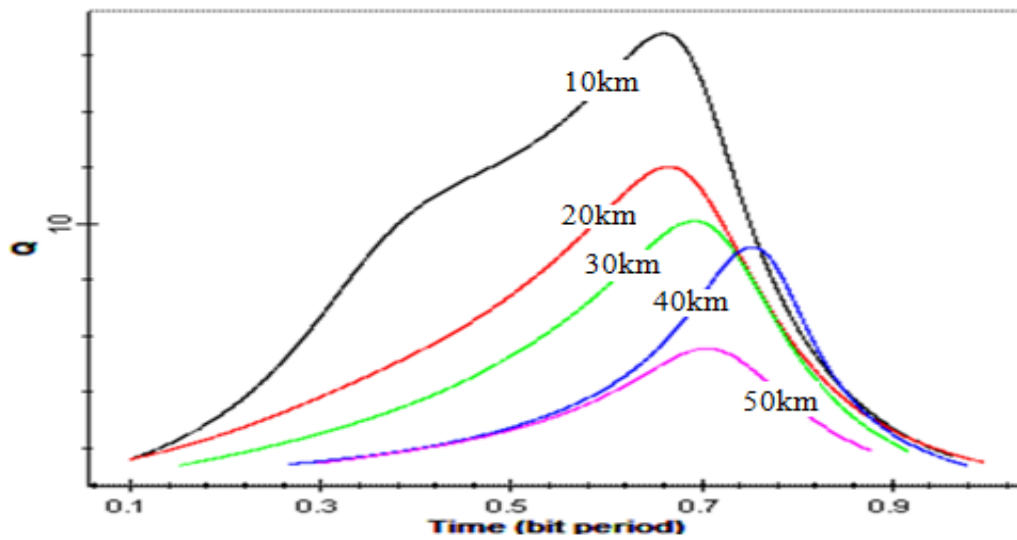

Figure 4.12: Diagram Max Q for user two

When all users are on the results are shown as in the following Figures and tables

Figure 4.13 shows the result of user one when all three users are on, and Figure 4.13 discusses the relation between Min. log .of BER, and the length of fiber link . As we can see from Figure 4.13 by increasing the length the Min. log .of BER is increase.

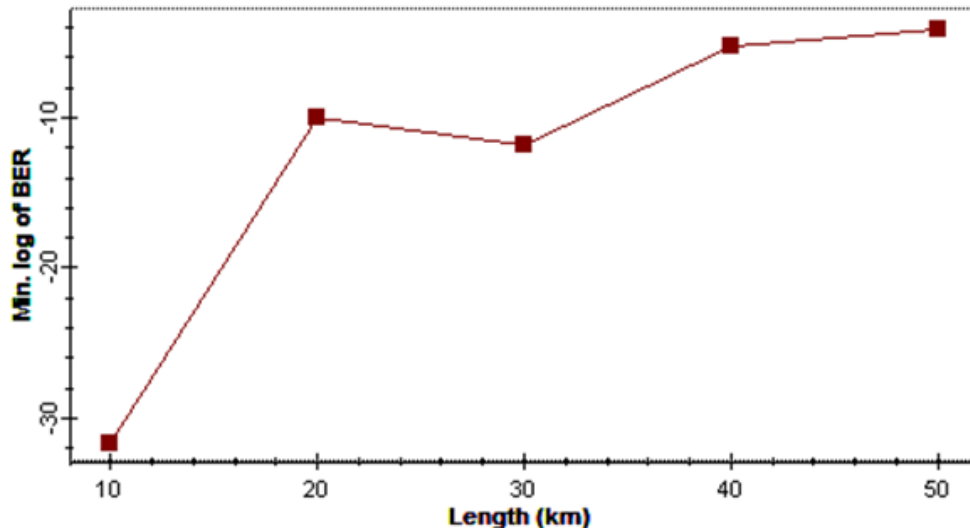

Figure 4.13: BER Vs Length for user one when all users are on

Table (4.4) demonstrates that the results of user one when all three users are on, and the results are listed as we can see the Bit Error Rate (BER) increases, and the Maximum Quality Factor (Max Q) decreases by increasing the distance of fiber cable. The best value of BER and Max Q is(2.33316e-032,and11.7832) at distance of 10km.

Table (4.4) : user one result when all users are on

Iteration	Length(Km)	Min.log of BER	Min BER	Max Q factor
1	10	-31.6321	2.33316e-032	11.7832
2	20	-10.0379	9.16487e-011	6.36596
3	30	-11.8476	1.42052e-012	6.98523
4	40	-5.18521	6.52822e-006	4.33373
5	50	-4.17813	6.63549e-005	3.81761

Figure 4.14 shows the Diagram of BER after 5 iterations as we can see that with increasing length. The Eye Diagram of BER becomes worse. The best BER at 10km, and the worst at 50km.

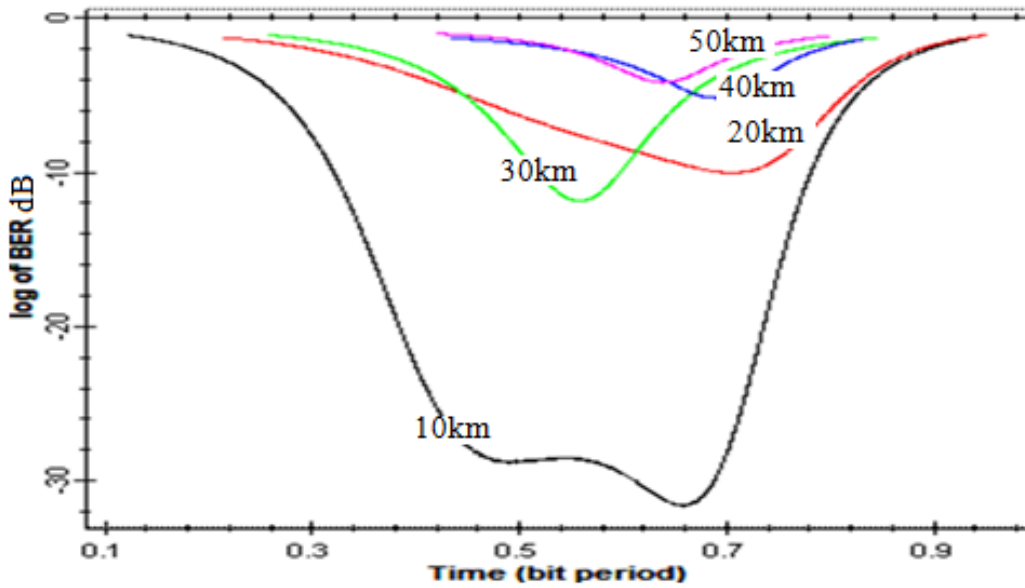

Figure 4.14: diagram of BER for user one when all users are on

Figure 4.15 shows the Diagram Max Q Factor after 5 iterations as we can see that with increasing the length. The Eye diagram of Max Q factor becomes worse. The best Max Q factor at 10km, and the worst at 50km.

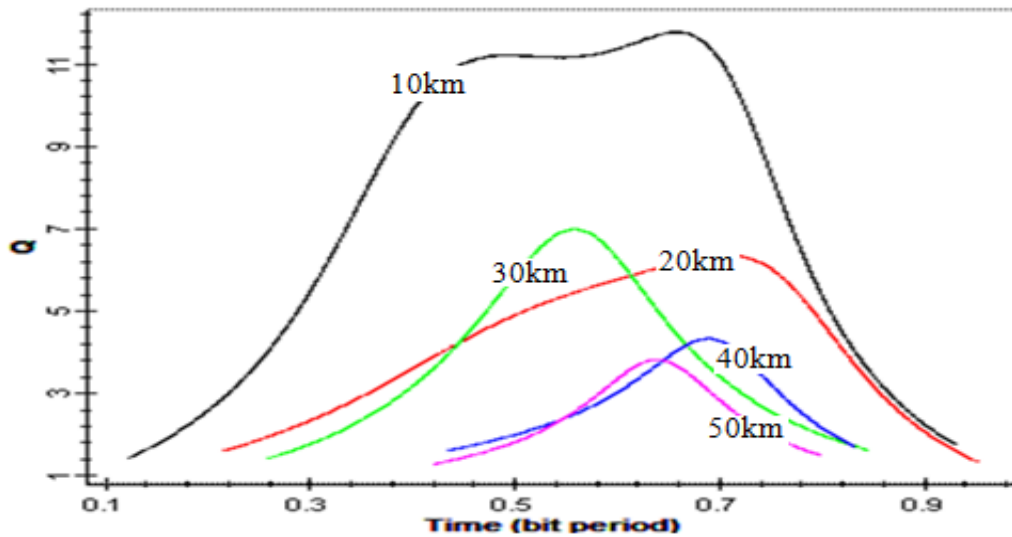

Figure4.15: Diagram Max Q for user one when all users are on

Figure 4.16 demonstrates the result of user two when all three users are on , and it describes the relation between Min. log .of BER, and the length of fiber link . As we can see from Figure 4.16 by increasing the distance the Min. log .of BER increases.

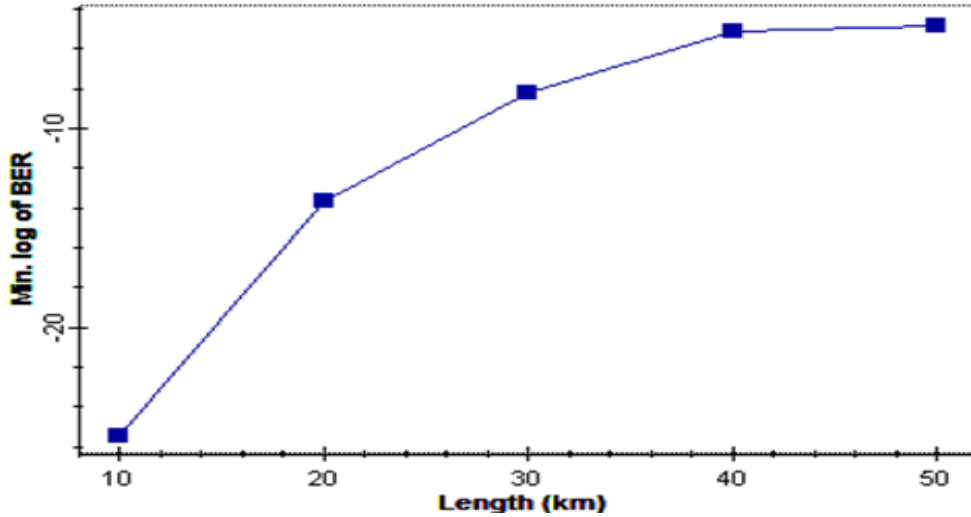

Figure 4.16: BER Vs Length for user two when all users are on

Table(4.5) describes that the results of user two when all three users are on. As we can see the Bit Error Rate (BER) increases, and the Maximum Quality Factor (Max Q) decreases by increasing the length of fiber link. The best value of BER and Max Q is(3.76291e-026,and10.4989) at distance of 10km.

Table (4.5) : user two result when all users on

Iteration	Length(Km)	Min.log of BER	Min BER	Max Q factor
1	10	-25.4245	3.76291e-026	10.4989
2	20	-13.6276	2.35741e-014	7.53935
3	30	-8.24146	5.73509e-009	5.70335
4	40	-5.17766	6.6426e-006	4.345
5	50	-4.9023	1.5228e-005	4.20102

Figure 4.17 describes the Diagram of BER after 5 iterations as we can see that with increasing the length. The Diagram of BER becomes worse. The best BER at 10km, and the worst at 50km.

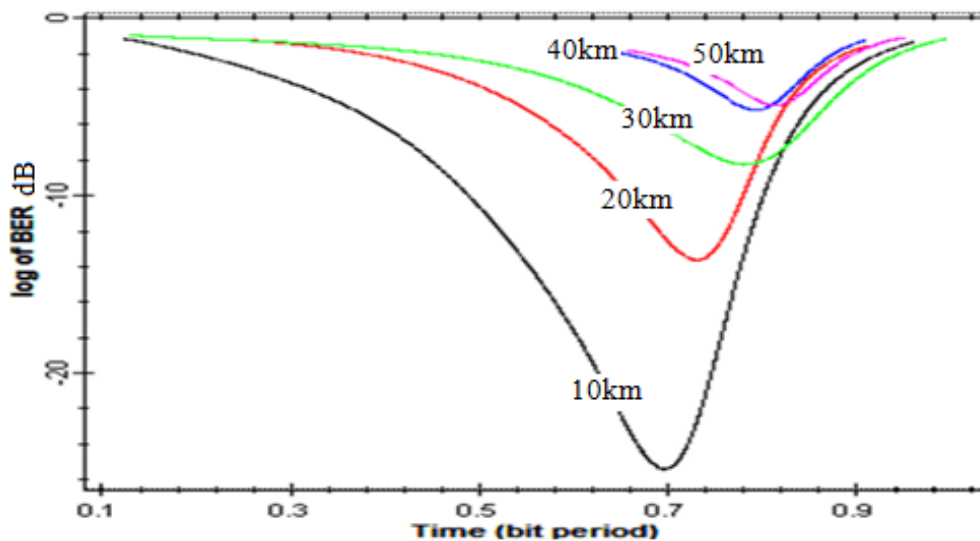

Figure 4.17:Diagram of BER for user two when all users are on

Figure 4.18 shows the Diagram Max Q Factor after 5 iterations as we can see that with increasing the length. the Eye diagram of Max Q factor becomes worse. The best Max Q factor at 10km, and the worst at 50km.

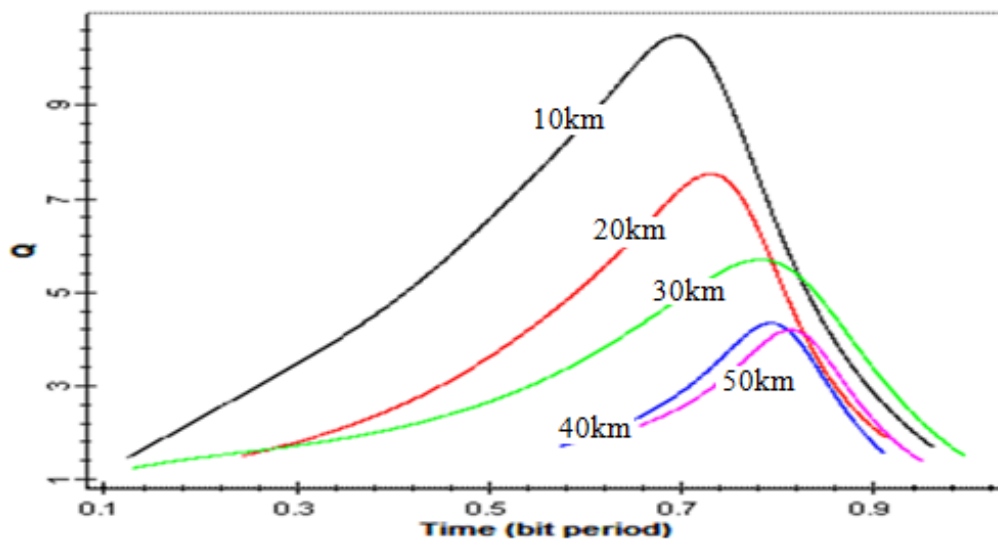

Figure 4.18:Diagram Max Q for user two when all users are on

Figure 4.19 describes the result of user three when all three users are on , and Figure 4.19 discusses the relation between Min. log .of BER, and the length of fiber link . As we can see from Figure 4.19 by increasing the length the Min. log .of BER increases.

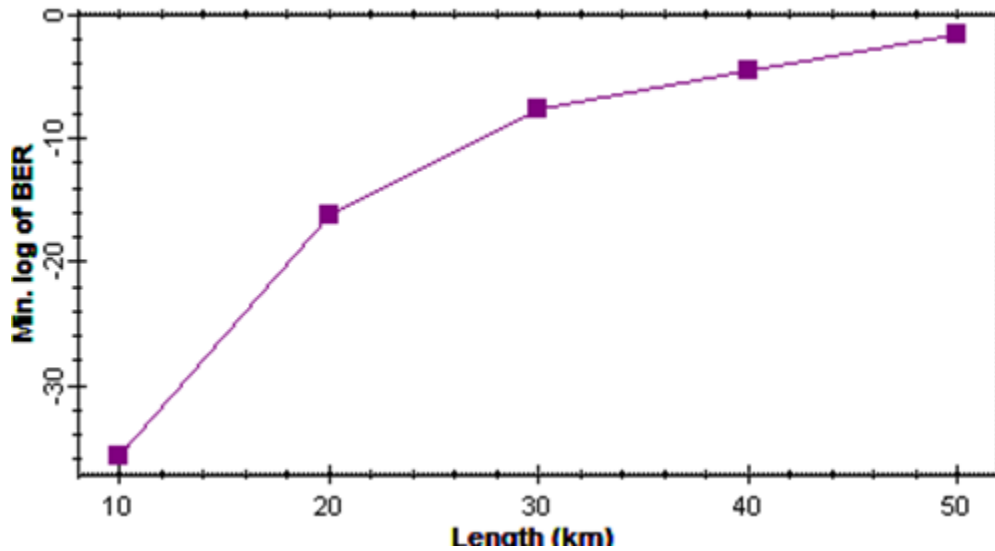

Figure 4.19: BER Vs Length for user three when all users are on

Table(4.6) describes that the results of user three when all three users are on . As we can see the Bit Error Rate (BER) increases, and the Maximum Quality Factor (Max Q) decreases by increasing the length of fiber link. The best value of BER and Max Q is(2.16886e-036,and12.5315) at distance of 10km.

Table (4.6): user three result when all users on

Iteration	Length(Km)	Min.log of BER	Min BER	Max Q factor
1	10	-35.6638	2.16886e-036	12.5315
2	20	-16.1442	7.17419e-017	8.26177
3	30	-7.65435	2.21639e-008	5.45393
4	40	-4.62333	2.38051e-005	4.06694
5	50	-1.6781	.0209598	2.02954

Figure 4.20 demonstrates the Diagram of BER after 5 iterations as we can see that with increasing the length. The Diagram of BER becomes worse. The best BER at 10km, and the worst at 50km.

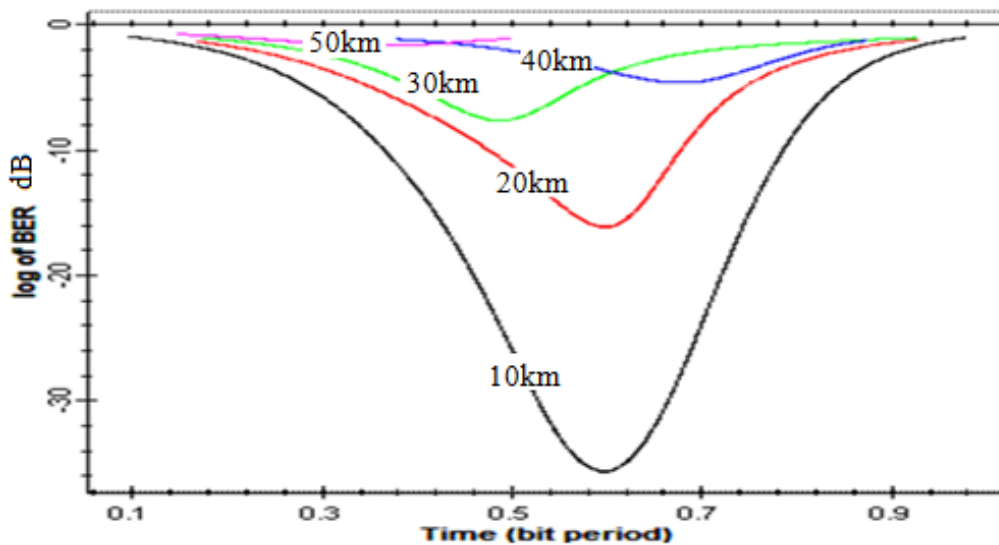

Figure 4.20: Diagram of BER for user three when all users are on

Figure 4.21 shows the Diagram Max Q Factor after 5 iterations as we can see that with increasing the length. The diagram of Max Q factor becomes worse. The best Max Q factor at 10km, and the worst at 50km.

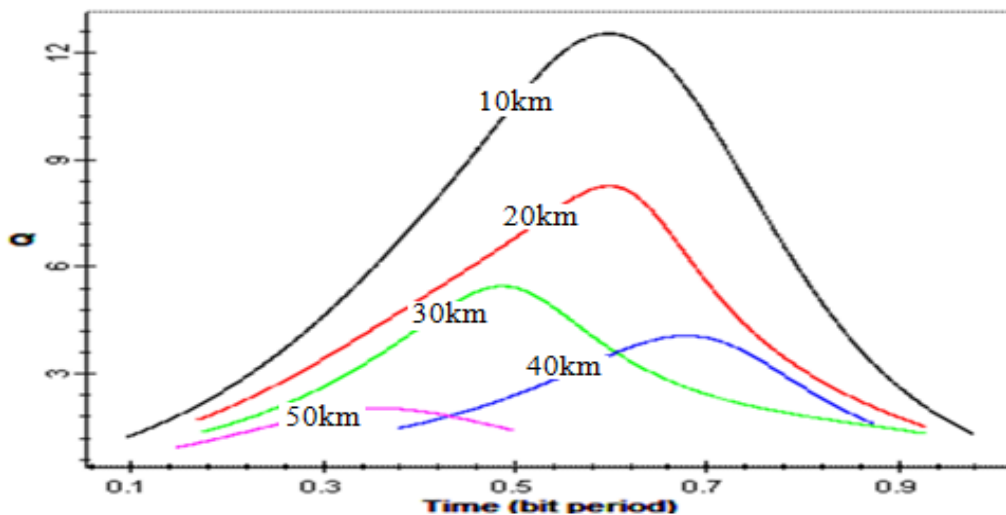

Figure 4.21 :Diagram Max Q for user three when all users are on

4.3.2.1.1. Result Comparison

Here we compare my design result with Fiber To The Home Design and Analysis using OCDMA Structure paper [3]. In this paper the author designed and analysis of FTTH based on OCDMA structure. the design simulated a 3-user FBG based OCDMA network at 200 Mbit/s. Uniform FBGs are used to impalement the codes by spectral amplitude encoding. The signal is generated using an incoherent source modulated with NON Return to Zero PRBS data using a Mach-Zehnder Modulator. The optical link is 10 km of single mode fiber. The receiver is comprised of a spectral filter and a photo detector connected in a balanced configuration which performs the decoding with a low-pass filter and a BER analyzer. The Comparison is shown in the next tables , when the three users are on and the length =10K .

Table(4.7) : BER Comparison when all users on

U ser	My design BER result	Paper design BER result
User 1	2.3316e-032	1.07097e-022
User 2	3.76291e-26	6.79957e-024
User 3	2.16886e-36	1.01435e-016

when the length of fiber cable is variable from (10 to 50)Km in user one

Table (4.8) : User one comparison

Length	User1 my design BER result	User1paper design BER result
10	2.3316e-032	1.07097e-022
20	9.16487e-011	8.73454e-015
30	1.42052e-012	3.64609e-009
40	6.52822e-006	1.45063e-005
50	6.563549e-005	0.00299773

When user1, user2 are on, and user3 is off

Table (4.9):BER comparison

U ser	My design BER result	Paper design BER result
User 1	9.2747e-110	1.52665e-018
User 2	1.55031e-063	2.65098e-023
User 3	1	1

As we see form above tables my results in general best than paper results because we used code different the code that used in paper in reference [3] .

4.3.2. 2. Bit Rate Result

The following figures and tables show the results. when all three users are on at length of 10km, with different signal bit rate . Figure 4.22 discuss the relation between Min. log .of BER, and the signal data rate . As we can see from Figure 4.22 by increasing the bit rate the Min. log .of BER increases

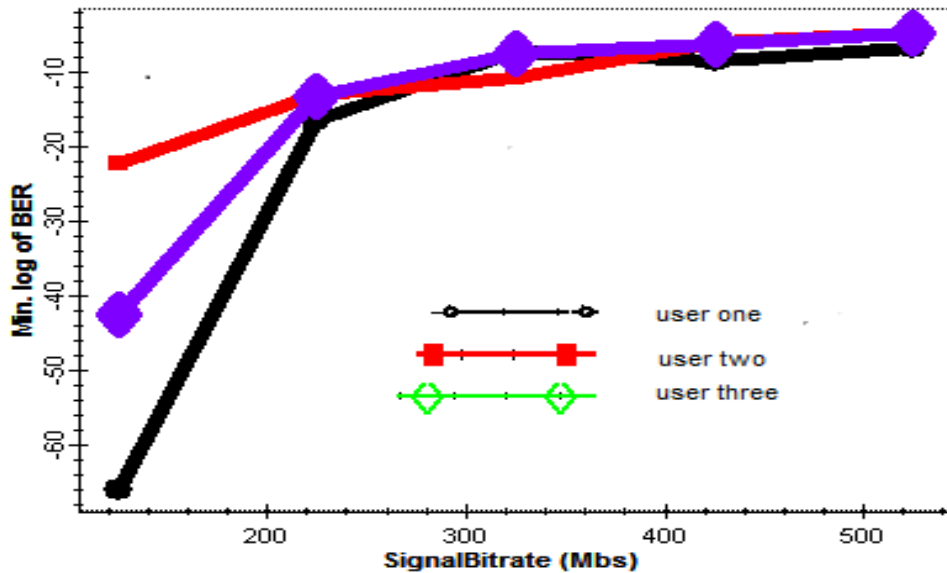

Figure 4.22 : BER Vs Bit Rate

Figure 4.22 shows the results when all three users are on, with different signal bit rate for each user starting from 125Mbps to 525Mbps . as we can see from figure 4.22 the best value for user one is $(8.37856e-067)$ at 125 Mbps and the worst value for user the same user is $(2.1822e-007)$ at 525 M bps. Also the best value of user two BER is $(6.67278e-023)$ at 125 Mbps and the worst case is $(2.58706e-005)$ at 525Mbps. Finally. the best value about user three BER is $(2.59567e-043)$ at 125 Mbps and the worst value is $(2.27522e-005)$ at 525 Mbps.

By using optimization methods in Optisystem software likes minimization method and maximization method. We find the minimum signal bit rate is 125 Mbps and the maximum signal bit rate is 300 Mbps.

Figure 4.23 explains the result of user one when all users are on , and Figure 4.23 discusses the relation between Min. log .of BER, and signal bit rate. As we can see from Figure 4.23 by increasing the signal bit rate , the Min. log .of BER increases.

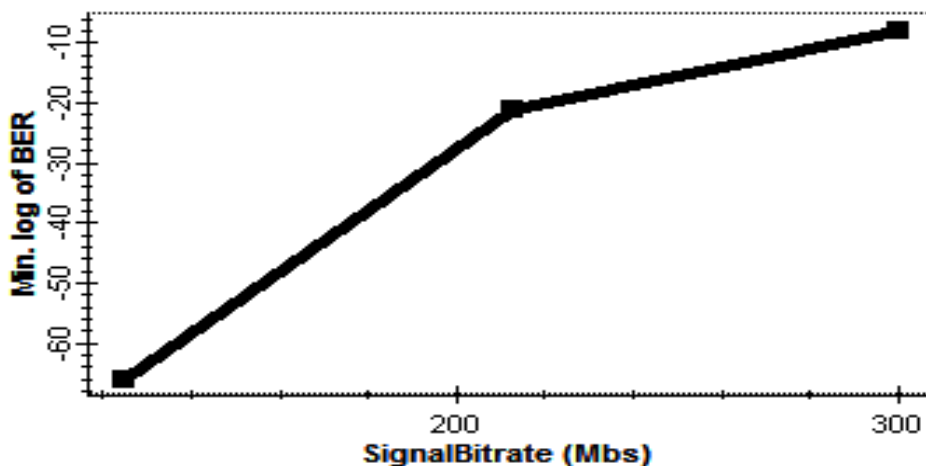

Figure 4.23 :BER Vs Signal Bite Rate For user one

Table(4.10) demonstrates the results of user one when all users are on , and the results are listed as we can see ,the Bit Error Rate (BER) increases , and the Maximum Quality Factor (Max Q) decreases by increasing the signal bit rate at distance of 10km.

Table(4.10) : user one result for data rate

Iteration	Bit Rate Mbps	Min.log of BER	Min BER	Max Q factor
1	125	-66.0768	8.37856e-067	17.223
2	212.5	-21.1952	6.38028e-022	9.5437
3	300	-8.06421	8.62552e-009	5.63646

Figure 4.24 demonstrates the result of user two when all users are on , and Figure 4.24 explains the relation between Min. log .of BER, and signal bit rate. As we can see from Figure 4.24 by increasing the signal bit rate , the Min. log .of BER increases.

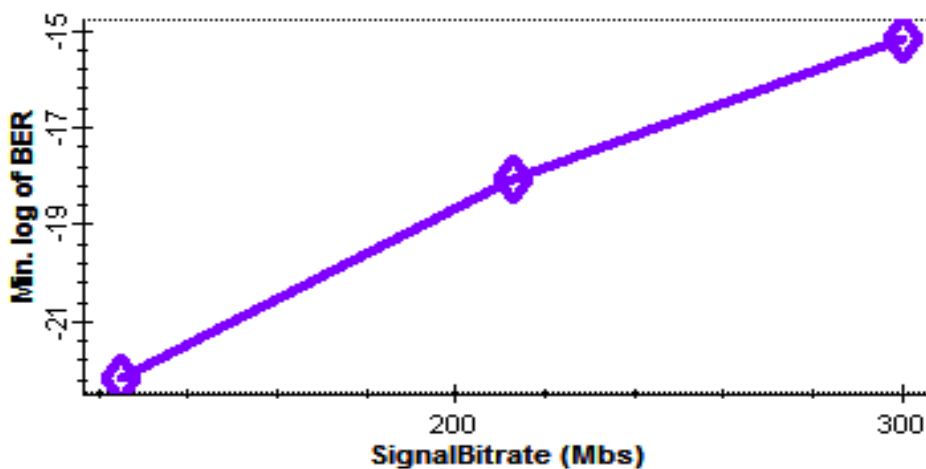

Figure 4.24 :BER Vs Signal Bite Rate For user two

Table (4.11) shows the results of user two when all users are on , and the results are listed as we can see ,the Bit Error Rate (BER) increases , and the Maximum Quality Factor (Max Q) decreases by increasing the signal bit rate at distance of 10km.

Table(4.11):user two result for data rate

Iteration	Bit Rate Mbps	Min.log of BER	Min BER	Max Q factor
1	125	-22.1757	6.67278e-023	9.78231
2	212.5	-18.0519	8.87359e-019	8.76752
3	300	-15.1533	7.02597e-016	7.98478

Figure 4.25 explains the result of user three when all users are on , and Figure 4.25 shows the relation between Min. log .of BER, and signal bit rate. As we can see from Figure 4.25 by increasing the signal bit rate , the Min. log .of BER increases.

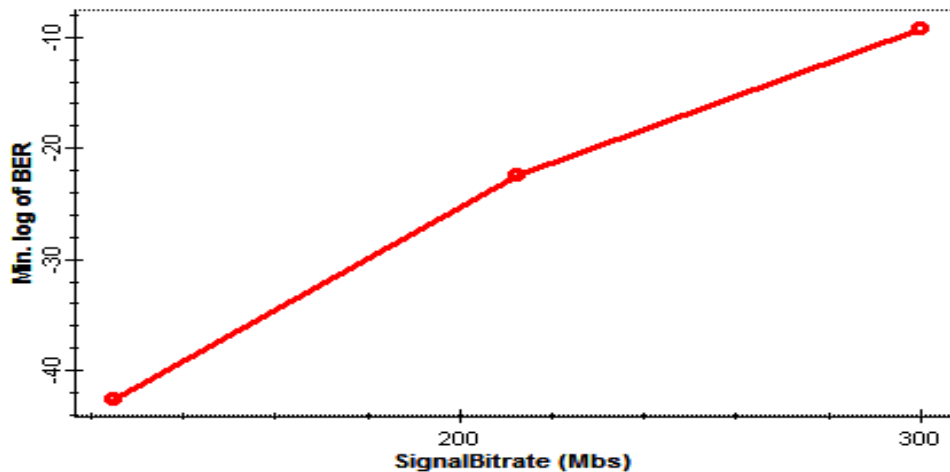

Figure 4.25 :BER Vs Signal Bite Rate For user three

Table(4.12) shows the results of user three when all users are on , and the results are listed as we can see ,the Bit Error Rate (BER) increases, and the Maximum Quality Factor (Max Q) decreases by increasing the signal bit rate at distance of 10km.

Table(4.12) : User three result section tow

Iteration	Bit Rate Mbps	Min.log of BER	Min BER	Max Q factor
1	125	-42.5858	2.59567e-043	13.7385
2	212.5	-22.4649	3.42869e-023	9.84618
3	300	-9.29585	5.06e-010	6.1015

4.4 .Design and Analysis seven User

In this part, the system is designed using a spectral - amplitude -encoding OCDMA. It has seven users , where each user is transmitting at 200Mbit/s. The FBGs in the system are working as encoder-decoder(hadamard code) [7]. Also in this part we study the effect of increasing number of users ,increasing the distance of fiber link and change of input power. The system is designed by using Optisystem software V.13. Figure 4.26 shows the block design of seven users.

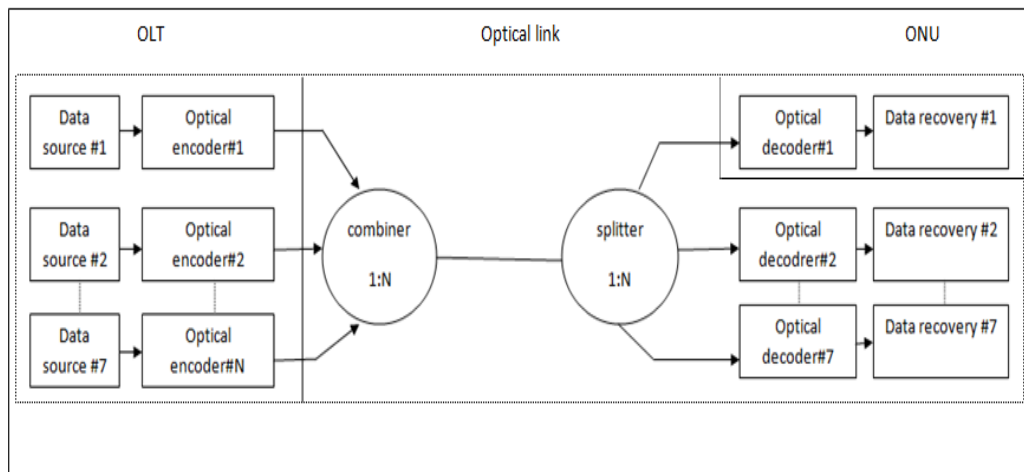

Figure 4.26: Block diagram of seven Users

The system design of seven-users, each user is simulated at signal bit rate of 200Mbps. The system design parameters are listed in table (4.13).

Table (4.13) : System design parameter for 7 user

Parameter	Value
Signal bit rate	200Mbps
Distance	Sweep(10to50)Km
Band width	0.3 nm
Power	-100dbm
Reflectivity	0.9998
Attenuation	0.2db/km
Wave length of white light source	1550.75nm
PRBS	NRZ

4.4.1. Simulation Result for seven users

The simulation results for 7-user FTTH system using OCDMA networks for different transmission distance starting from 10km to 50km are presented and discussed .

4.4.1.1 .performance Result

The following figures and tables show the results. Figure 4.27 shows the result when all seven users are on, and Figure 4.27 discusses the relation between Min. log .of BER, and the length of fiber link . As we can see from Figure 4.27 by increasing the length the Min. log .of BER increases.

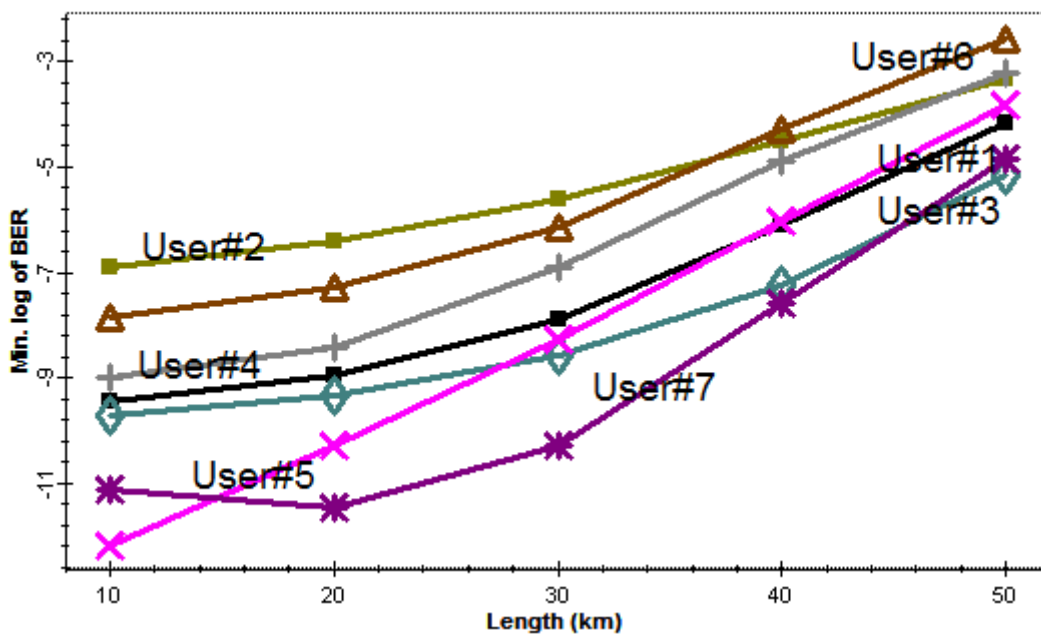

Figure 4.27: BER Vs Length when all seven users are on

Table(4.14) describes that the results of user one when all users are on , and as we can see the Bit Error Rate (BER) increases, and the Maximum Quality Factor (Max Q) decreases by increasing the length of fiber link. The best value of BER and Max Q is(3.64865e-10,6.15492) at distance of 10km.

Table (4.14) :user one result when all seven users are on

Iteration	Length(Km)	Min.log of BER	Min BER	Max Q
1	10	-9.34787	3.64865e-010	6.15492
2	20	-8.94828	1.12647e-009	5.97467
3	30	-7.89502	1.27343e-008	5.56733
4	40	-6.10593	7.83554e-007	4.80079
5	50	-4.14504	7.16079e-005	3.80145

Table(4.15) shows the results of user two when all users are on . As we can see the Bit Error Rate (BER) increases , and the Maximum Quality Factor (Max Q) decreases by increasing the distance of fiber cable. The best value of BER and Max Q is(1.28e-7,and 5.14) at distance of 10km.

Table (4.15) : user two result when all seven users are on

Iteration	Length(Km)	Min.log of BER	Min BER	Max Q
1	10	-6.89	1.28e-007	5.14
2	20	-6.4	0.399e-007	4.94
3	30	-5.6	2.49e-006	4.56
4	40	-4.51	3.07e-005	4
5	50	-3.23	0.000481	3.3

Table(4.16) describes the results of user three when all users are on. As we can see the Bit Error Rate (BER) increases , and the Maximum Quality Factor (Max Q) decreases by increasing the length of fiber link. The best value of BER and Max Q is (1.91e-10,and6.26315) at distance of 10km.

Table (4.16) : user three result when all users are on

Iteration	Length(Km)	Min.log of BER	Min BER	Max Q
1	10	-9.72	1.91e-010	6.26
2	20	-9.43	0.454e-010	6.12
3	30	-8.59	2.56e-009	5.84
4	40	-7.24	2.78e-008	5.3
5	50	-5.15	7.06e-006	4.34

Table(4.17) demonstrates the results of user four when all users are on . As we see the Bit Error Rate (BER) increases , and the Maximum Quality Factor (Max Q) decreases by increasing the distance of fiber cable. The best value of BER and Max Q is(9. 66e-010,and6) at distance of 10km.

Table (4.17): user four result when all seven users are on

Iteration	Length(Km)	Min.log of BER	Min BER	Max Q
1	10	-9.02	9.66e-010	6
2	20	-8.42	3.81e-009	5.77
3	30	-6.9	1.26e-007	5.15
4	40	-4.9	1.26e-006	4.21
5	50	-3.21	0.000616	3.23

Table(4.18) describes the results of user five when all users are on. As we can see the Bit Error Rate (BER) increases, and the Maximum Quality Factor (Max Q) decreases by increasing the length of fiber link. The best value of BER and Max Q is(6.49e-013,and7.09) at distance of 10km.

Table (4.18) : User five result when all seven users are on

Iteration	Length(Km)	Min.log of BER	Min BER	Max Q
1	10	-12.2	6.49e-013	7.09
2	20	-10.3	5.06e-011	6.46
3	30	-8.26	5.52e-009	5.71
4	40	-6.03	9.25e-007	4.76
5	50	-3.83	0.0000146	3.62

Table(4.19) describes that the results of user six when all users are on . As we can see the Bit Error Rate (BER) increases, and the Maximum Quality Factor (Max Q) decreases by increasing the length of fiber link. The best value of BER and Max Q is(1.44e-008,and5.54) at distance of 10km.

Table (4.19) : user six result when all seven users are on

Iteration	Length(Km)	Min.log of BER	Min BER	Max Q
1	10	-7.84	1.44e-008	5.54
2	20	-7.27	0.543e-008	5.51
3	30	-6.15	7.01e-007	4.82
4	40	-4.27	5.37e-005	3.87
5	50	-2.57	0.00265	2.78

Table(4.20) shows the results of user seven when all users are on. As we can see the Bit Error Rate (BER) a increases , and the Maximum Quality Factor (Max Q) decreases by increasing the distance of fiber cable. The best value of BER and Max Q is(3.29e-12 and6.7) at distance of 10km.

Table (4.20) : User seven result when all seven users are on

Iteration	Length(Km)	Min.log of BER	Min BER	Max Q
1	10	-11.1	3.29e-012	6.75
2	20	-11.5	7.14e-012	6.86
3	30	-10.3	5.23e011	6.45
4	40	-7.57	2.69e-008	5.43
5	50	-4.85	1.4e-005	4.19

4.4.2 . Input power Result

Here we study the effect of changes input power on the design seven users and Figure 4.34 shows the relation between the input power and Min log of BER.

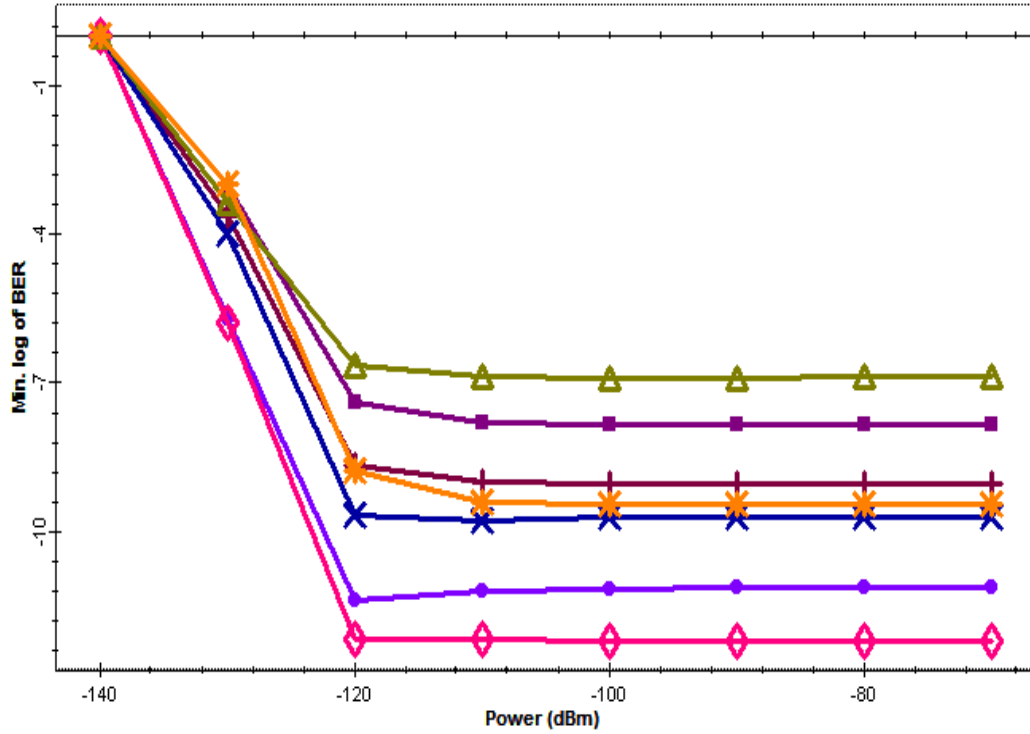

Figure 4.28:Input power Vs BER

As we can see from Figure 4.28 the Min log BER is constant with for input power each user until saturation point . From Figure 4.28 the input power is constant from (-120 to -70) dbm.

4.4.1.2 . Results Analysis

First, when optical source three is disabled, that means there is no signal received at User three, and user three become off. The results respecting are shown in the tables (4.2, and 4.3) , and figures (4.7,4.8,4. 9,4.10,4.11, and4.12).

Second, when the light source three is enabled, the signal is received at user three and it becomes on. The results shown in tables(4.4,4.5,and 4.6), and figures (4.13,4.14,4.15,4.16,4.17,4.18,4.19,4.20,and4.21) .

Third, when all seven users are on the results are shown in figures (4.27,4.28,) and tables in (4.14,4.15,4.16,4.17.4.18,4.19 and 4.20).

we can analyze the above mentioned results. we found from tables and figures . The BER is reduced exponentially when the distance of cable is decreased. and when the distance increases the Min Log of BER is increased. Also by increasing the distance, the Q factor decreases. Finally with increasing the number of users the Min log of BER increases.

Chapter 5: Conclusion and Future work

5.1. Conclusion

This Chapter Provides the summary of the research work done in this thesis. In this thesis work, the comparison of the different FTTH using OCDMA networks have been presented. Throughout this thesis, we have discussed the design, analyses, and deployment of FTTH Networks based on OCDMA .

In the beginning of this research, we introduced the outline of this work . Firstly, we presented a general overview of the PON . secondly, we demonstrate the basic concepts and fundamentals of this thesis, we explained the concepts and architecture of FTTH networks. Also we shown the principle and applications of FBG. Then we described the fundamentals and advantages of OCDMA .

Next, the system design is done in two parts . In the first part , we design a three users FTTH networks depended on OCDMA . Also we studied the effect of increasing the length of optical link and signal bit rate. The second part contains the design of seven users FTTH networks using OCDMA stricture. Then we described the effect of increasing distance of fiber distribution network and discuss the change of the input power.

After presenting the system, describing the different components composing the system, explaining the techniques and analyzing the system performance a final conclusion of results can be made. Comparing my work with related work is done .

Finally, we found The BER increased exponentially with distance , bit rate, and number of users . also we found the optimal minimum bit rate at 125 Mbps and maximum bit rate at 300 Mbps can be transmit

5.2.FutureWork

Although extensive research has been studied in this thesis , a number of issues related to FTTH networks may still be worth investigating in the future.

Next we using different simulation tools for the proposed FTTH architectures could help to estimate the performance for larger systems under different conditions and network parameters.

we hope to increases the number of users and make it in to k users .

we hope to generate a new code.

we hope to use different multiplexing techniques likes WDMA,TDMA and compares between them.

References

- [1] I. Mohammand, T.M.Hussein, "The Handbook of Optical Communication Network", CRC Pres, 2003.
- [2] S.Awasthi, D.Bhadauria, "Performance Analysis Of FTTH Network Using OCDMA Technique" AEICT-2014
- [3] M.A.Othman, "Fiber To The Home (FTTH) Design and Analysis using OCDMA Structure" IJEI - DES 2012
- [4] Ranjan, "Performance Improvement of OCDMA by FBG" ISSN Journal 2348-6988 - September 2014
- [5] P.T. Inovacoo, "Evolution of FTTH Networks for NG-PON2", White Paper 2013
- [6] website: www.ad-net.com.tw
- [7] website: <http://optiwave.com>
- [8] M. Johnson, "Optical Fibers Cables and Systems", ITU-T Manual 2009
- [9] L. Cedricf, Passive Optical Networks Principles and Practice, Elsevier 2007.
- [10] Lin. Chinlon, "Broadband Optical Access Networks and Fiber-to-the-Home", wiley, 2006.
- [11] Broadband Technology Overview, White Paper, WP6321, Issued: June 2005.
- [12] J. Prat "Next-Generation FTTH Passive Optical Networks" Springer. 2008.
- [13] G. P. Agrawal, Fiber-Optic Communication Systems, 3rd ed. New York: Wiley, 2002.
- [14] Y.Guo, C. K. Kao, and K. S. Chiang, "Nonlinear photonics: nonlinearities in optics, optoelectronics and fiber communications." Springer -Verlag, 2002. Berlin, Germany.
- [15] G. Keiser, "Optical Fiber Communications", 5th ed., McGraw-Hill, 2014.
- [16] D. K. Mynbaev, L. L. Scheiner, Fiber Optic Communications Technology. New Jersey: Prentice Hall. 2001
- [17] http://en.wikipedia.org/wiki/Passive_optical_network.
- [18] C. Decusatis, Handbook of Fiber Optics Data Communication, A Practical Guide to Optical Networking. 4TH ed. Academic Press, 2013.
- [19] website: <http://www.nationalfiberconnections.com/gpon-olt.html>
- [20] Keiser, FTTH concepts and applications. John Wiley & Sons, Inc. 2006

References

- [21] website : www.cdatatec.com
- [22] www.jdsu.com/fttx ,Understanding Passive Optical Network Testing
- [23] website: <http://online-telecom-exhibition.blogspot.com/>
- [24] website: <http://www.exfiber.com/tutorial/How-does-a-PLC-Splitter-work-13.html>
- [25] website: <http://www.thefoa.org/tech/ref/testing/test/couplers.html>
- [26] G.Kramer, "Ethernet Passive Optical Networks", 1st Edition, McGraw-Hill 2005
- [27] Kramer, Glen; Mukherjee, Biswanath; Pesavento, Gerry "Ethernet PON (EPON): Design and Analysis of an Optical Access Network. University of California. 2000.
- [28] J.CHEN, "Design, Analysis and Simulation of Optical Access and Wide-area Networks"
- [29] [<http://policom.dei.polimi.it/education/comunicazioni/lezione-PON.pdf>]
- [30] J. Zhang, "Media Access Control and Resource Allocation , For Next Generation Passive Optical Networks", springer 2013
- [31] J. Shaik, "FTTH Deployment Options for Telecom Operators, Sterlite Optical Technologies" Ltd
- [32] K.O. Hill, Y. Fujii, D. C. Johnson, B. S. Kawasaki, "Photosensitivity in optical fiber waveguides: application to reflection fiber fabrication". Appl. Phys. Lett. 1978
- [33] Low Cost Fiber Bragg Grating(FBG) Sensors for Structural Health Monitoring
- [34] J. Missinne and B. V. Hoe, "Artificial skin based on flexible optical tactile sensors," Spie International Society for Optic and Photonics Journal, pp. 10-12, Jan. 2010
- [35] R. Kashyap, "Fiber Bragg Gratings", San Diego, Academic Press, 1999, ISBN 0-12-400560-8
- [36] Iocco, A.: Tunable Fiber Bragg Grating Filters. Ecole Polytechnique Federale de Lausanne, 1999, Ph.D. Thesis
- [37] J. L. Pinto, I. Abe, and H. J. Kalinowski, "Fiber Bragg Grating for Telecommunications Applications..," Journal of Microwaves and Optoelectronics, vol. 2, no. July, pp. 32-45, 2001.

References

- [38] M.A. Othman¹, M.M. Ismail², H.A. Sulaiman³, M.H. Misran⁴, M.A. Meor Said⁵, Y.A. Rahim⁶, A.N. Che Pee⁷, M.R. Motsidi⁸, "An Analysis of 10 Gbits/s Optical Transmission System using Fiber Bragg Grating (FBG),"IOSR Journal
- [39] H. S. Phing, J.Ali, R. Rahman, B.A., Tahir. "Fiber Bragg grating modeling, simulation and characteristics with different gating length," Journal of Fundamental Sciences vol.3,pp 167-175. 2007
- [40] N. Aulakh, " Investigations on fiber bragg gratings for fiber optic communication systems, ", department of electronics & communication engineering thapar university 2010
- [41] N. Karafolas and D. Uttamchandani, Optical fiber code division multiple access network: A review, Optical Fiber Technology, vol.2, no.2, pp149-168, 1996.
- [42] H.W. Chen, G.C. Yang, C.Y. Chang, T.C. Lin and W. C. Kwong, Spectral efficiency study of two multirate schemes for asynchronous optical CDMA, Journal of Lightwave Technology, vol. 27, no.14,pp. 2771–2778, 2009.
- [43] J.G. Proakis, "Digital Communications" Third Edition, McGraw-Hill, New York, 1995
- [44] J.R. Harry Dutton, "Understanding Optical Communications", First Edition, Prentice Hall PTR, 1998.
- [45] M.B. Pearce, B. Aazhang, (1994) "Multiuser Detection for Optical Code Division Multiple Access Systems" , IEEE Transaction On Communication Vol.42, No.2-4, pp. 1801-1810, Feb, March, April 1994.
- [46] N. A. n. d. "Enhanced optical fast frequency hopping-CDMA by means of over-spreading and interleaving."
- [47] y. Rishi, "'Performance of Dispersion effects in OCDMA systems and Timing Jitter with Fiber Type" Thapar University, Patiala3147004 (INDIA) June 2010.
- [48] P. R. Prucnal. " Optical Code Division Multiple Access" CRC Press2006
- [49] D. Zaccarin, and M. Kavehrad, "An optical CDMA system based on spectral encoding of LED," IEEE Photonics , vol. 5, no. 4, pp. 479-482, Technology Letters April 1993
- [50] M. Kavehrad, and D. Zaccarin, "Optical code- on spectral encoding of noncoherent sources," division-multiplexed systems based IEEE J. Lightwave Technology vol. 13, no. 3, pp. 534-545, March 1995.

References

- [51] T. Erdogan, "Fiber grating spectra," *IEEE J. Lightwave Technology*, vol. 15, no. 8, pp. 1277-1294, August 1997
- [52] Zou Wei, H. M. H. Shalaby, and H. Ghafouri-Shiraz: Modified Quadratic Congruence Codes for Fiber Bragg-Grating-Based Spectral-Amplitude-Coding Optical CDMA Systems. *IEEE/OSA Journal of Lightwave Technology*, Vol. 19, No. 9, September 2001,
- [53] S. S. Pawar and R.K Shevgaonkar: Modelling of FBG for encoding/decoding in SAC-OCDMA System UMIT universitySantacruz(w), Mumbai 400049, India
- [54] M. Zhang," DESIGN AND PERFORMANCE ANALYSIS OF NOVEL SIGNATURE CODE IN TWO-DIMENSIONAL OPTICAL CDMA SYSTEMS' Birmingham University,2012
- [55] A. Gafur," Dispersion Effects on OCDMA System Performance" BTH University,2009
- [56] S. P. Majumder, Afreen Azhari, "Performance Limitations of an Optical CDMA System Impaired by Fiber Chromatic Dispersion", 0-7803-8783-X/O4/\$20.00 0 2004 IEEE.
- [57] S.P. Majumder and Md. Forkan Uddin, "The effect of four wave mixing on bit error rate performance of a direct sequence optical code division multiple access system", 2005 Asia-Pacific Conference on Communications, Perth, Western Australia, 3-5 October 2005.
- [58] T.O. Farrell and S. Lochmann, "Performance analysis of an optical correlator receiver for SIK DS-CDMA communications systems", *Electronics Lett.*, Vol.30, No.1, pp. 63-64, 6th January 1994.
- [59] Hiroyuki Yashima and Toshihiro Kobayashi, "Optical CDMA With Time Hopping and Power Control for Multimedia Networks", *Journal of lightwave technology*, vol. 21, no. 3, march 2003, pp. 695-702.
- [60] M. Razavi, and A. S. Jawad, "Temporal/Spatial Fiber-Optic CDMA Systems with Post- and Pre-Optical Amplification", *IEEE transaction on communications*, vol. 50, no. 10, october 2002, pp. 1688-1695.