

اقرار

أنا الموقع أدناه مقدم الرسالة التي تحمل العنوان:

تعظيم كفاءة نظام الطاقة الشمسية باستخدام المنطق الضبابي

أقر بأن ما اشتملت عليه هذه الرسالة إنما هي نتاج جهدي الخاص، باستثناء ما تمت الإشارة إليه حيثما ورد، وإن هذه الرسالة ككل، أو أي جزء منها لم يقدم من قبل لنيل درجة أو لقب علمي أو بحثي لدى أية مؤسسة تعليمية أو بحثية أخرى.

DECLARATION

The work provided in this thesis, unless otherwise referenced, is the researcher's own work, and has not been submitted elsewhere for any other degree or qualification.

Student's name:

اسم الطالب:

Signature:

التوقيع:

Date:

التاريخ:



The Islamic University of Gaza
Research and Graduate Affairs
Faculty of Engineering
Electrical Engineering

الجامعة الإسلامية بغزة
شئون البحث العلمي و الدراسات العليا
كلية الهندسة
الهندسة الكهربائية

Maximizing Solar Power System's Efficiency Using Fuzzy Logic

By
Ahmed A. Alhaddad

Supervisor
Dr. Hatem A. Elaydi

**This Thesis is submitted in Partial Fulfillment of the
Requirements for the Degree of Master of Science in
Electrical Engineering**



مكتب نائب الرئيس للبحث العلمي والدراسات العليا هاتف داخلي 1150

الرقم ج س ع / 735

التاريخ 2014/01/25

نتيجة الحكم على أطروحة ماجستير

بناءً على موافقة شئون البحث العلمي والدراسات العليا بالجامعة الإسلامية بغزة على تشكيل لجنة الحكم على أطروحة الباحث/ أحمد العبد رمضان الحداد لنيل درجة الماجستير في كلية الهندسة قسم الهندسة الكهربائية - أنظمة التحكم وموضوعها:

تعظيم كفاءة نظام الطاقة الشمسية باستخدام المنطق الضبابي

Maximizing Solar Power System's Efficiency Using Fuzzy Logic

وبعد المناقشة التي تمت اليوم السبت 24 ربيع الأول 1435هـ، الموافق 2014/01/25م الساعة التاسعة صباحاً بمبنى طيبة، اجتمعت لجنة الحكم على الأطروحة والمكونة من:

د. حاتم علي العايدي	مشرفاً ورئيساً
أ.د. محمد توفيق حسين	مناقشاً داخلياً
د. محمد حاتم مشتهي	مناقشاً خارجياً

وبعد المداولة أوصت اللجنة بمنح الباحث درجة الماجستير في كلية الهندسة / قسم الهندسة الكهربائية -

أنظمة التحكم

واللجنة إذ تمنحه هذه الدرجة فإنها توصيه بتقوى الله ولزوم طاعته وأن يسخر علمه في خدمة دينه ووطنه.

والله ولي التوفيق،،،

مساعد نائب الرئيس للبحث العلمي والدراسات العليا

أ.د. فؤاد علي العاجز

DEDICATION

*I dedicate this work to my parents, to my family, to my friends,
and to everyone who helped me in this work*

ACKNOWLEDGMENTS

First, our thanks are wholly devoted to **ALLAH** for blessings and for helping me all the way to conclude this work successfully.

I would like to thank my supervisor of thesis, *Dr. Hatem Elaydi*, for his support, outstanding, guidance and encouragement throughout my thesis, and special thanks go to my discussion committee, *Prof. Mohammed Hussein and Dr. Mohammed Mushtaha* for their acceptance to discuss my thesis.

Also, I would like to thank my family, especially my parents, for their encouragement, patience, and assistance over the years. I am forever indebted to my parents, who have always kept me in their prayers.

I would also like to express my gratitude and appreciation for everyone who help and guided me throughout this work.

ABSTRACT

Maximizing Solar Power System's Efficiency Using Fuzzy Logic

By:
Ahmed A. Alhaddad

Solar energy is one of renewable sources it is important in electric power generation. There are various renewable sources. Solar energy is a good choice for electric power generation, which is viewed as clean and renewable source of energy for the future since the solar energy is directly converted into electrical energy by solar photovoltaic modules which are suitable for obtaining higher power output.

This thesis proposes a solution for this problem by replacing diesel generator using solar PV as a backup system, and a battery-bank as a storage system. Such system is expected to: satisfy the load demands, minimize the cost, maximize the utilization of renewable sources, optimize the operation of battery-bank which is used as backup unit ensure efficient operation of the diesel generator, and reduce the environment pollution emissions from the diesel generator.

This thesis presents a maximum power using fuzzy logic for a PV stand-alone system. Since the PV array characteristic is hardly nonlinear, conventional control technique could be inefficient for an optimal use of these systems. We know that PV systems are still very expensive, therefore a fuzzy logic controller is proposed to ensure the transfer of the maximum power to the system. This controller is designed to regulate the current of the system to get the maximum power.

This thesis will focus on a small stand-alone solar power system. MATLAB software will be used to simulate the proposed solution. Results show that the current of PV after implementing fuzzy logic controller is more efficient, which means that more power transfer to the system.

ملخص

تعظيم كفاءة نظام الطاقة الشمسية باستخدام المنطق الضبابي

إعداد:

أحمد العبد الحداد

الطاقة الشمسية هي واحدة من مصادر الطاقة المتجددة وهي مهمة لتوليد الطاقة الكهربائية. هناك مصادر الطاقة المتجددة المختلفة. الطاقة الشمسية هو خيار جيد لتوليد الطاقة الكهربائية، والتي ينظر إليها على أنها مصدر نظيف ومتجدد للطاقة في المستقبل، حيث يتم تحويل الطاقة الشمسية مباشرة إلى طاقة كهربائية بواسطة اللوحات الشمسية الذي هو مناسب للحصول على أعلى إنتاج الطاقة.

وتقترح هذه الأطروحة حلا لهذه المشكلة عن طريق استبدال مولدات الديزل باستخدام الطاقة الشمسية كنظام النسخ الاحتياطي، وبطاريات كنظام التخزين. ومن المتوقع لهذا النظام: تلبية مطالب الحمل، وتقليل التكاليف، وتعظيم الاستفادة من مصادر الطاقة المتجددة، وتحسين تشغيل البطارية الذي يستخدم كوحدة احتياطية لضمان التشغيل الفعال لمولدات الديزل، والحد من انبعاثات تلوث البيئة الناتجة عن مولدات الديزل.

تقدم هذه الأطروحة الحصول على أقصى طاقة باستخدام المتحكم الضبابي لنظام الطاقة الشمسية القائم بذاته. وحيث أن نظام اللوحات الشمسية يكون غير خطية، لذلك تقنية التحكم التقليدية تكون غير فعالة لاستخدام الأمثل لهذه النظم. مع العلم أن الأنظمة اللوحات الشمسية لا تزال مكلفة للغاية، ولذلك يقترح وحدة تحكم المنطق الضبابي لضمان نقل الطاقة القصوى للنظام. وحدة التحكم هذه المصممة لتنظيم التيار للنظام المقترح للحصول على أقصى قدر من الطاقة.

وتركز هذه الأطروحة على شبكة نظام الطاقة الشمسية الصغيرة القائمة بذاتها. وتم استخدام برنامج (MATLAB) لمحاكاة هذا الحل المقترح. توضح النتائج أن تيار اللوحات الشمسية بعد تنفيذ المتحكم الضبابي أكثر كفاءة، والذي يعني المزيد من نقل الطاقة إلى النظام.

Table of Contents

<i>Dedication</i>		iv
<i>Acknowledgments</i>		v
<i>Abstract</i>		vi
<i>ملخص</i>		vii
<i>Table of Contents</i>		viii
<i>List of Figures</i>		x
<i>List of Tables</i>		xii
<i>List of Abbreviation</i>		xiii
CHAPTER 1	INTRODUCTION	1
	1.1 Background	1
	1.2 Motivation	2
	1.3 Statement of Problem	3
	1.4 Objectives	3
	1.5 Literature Review	4
	1.6 Contribution	6
	1.7 Thesis Organization	6
CHAPTER 2	INTRODUCTION TO RENEWABLE POWER	7
	2.1 Wind Energy	7
	2.2 Geothermal Energy	9
	2.3 Waves Energy	10
	2.4 Solar Energy	12
	2.4.1 Solar Radiation in Gaza	13
	2.4.2 Potential of Solar Energy in Gaza	13
CHAPTER 3	PV TECHNOLOGY AND SOLAR SYSTEM	17
	3.1 Solar Cells: Construction and Operation	17
	3.1.1 Photovoltaic construction	17
	3.1.2 Photovoltaic operation	18
	3.1.3 Photovoltaic mathematical modeling	19
	3.1.4 Temperature and solar radiation effects on PV performance	20
	3.2 Solar Radiation in Palestine	22
	3.3 Main PV Cell Types	22
	3.4 PV Solar Cell Technology	23
	3.4.1 Recent technology in manufacturing PV modules	24
	3.4.2 Energy payback of PV cells	25
	3.5 Solar power system	26

CHAPTER 4	SYSTEM DESIGN AND RESULTS	31
4.1	Introduction	31
4.2	Fuzzy Sets	31
4.3	Fuzzy Logic	35
4.3.1	Fuzzy Logic Controller Structure	35
4.3.2	Fuzzification	36
4.3.3	Fuzzy Interference	37
4.3.4	Defuzzification	37
4.4	Fuzzy Logic Control in Solar Power System	38
4.4.1	Fuzzy Logic Controller	38
4.4.2	FLC design	38
4.4.2.1	Fuzzification	40
4.4.2.2	Control rule base	41
4.4.2.3	Defuzzification	43
4.4.3	Results and Discussion	44
CHAPTER 5	CONCLUSION AND FUTURE WORK	47
5.1	Conclusion	47
5.2	Future Work	47
	<i>References</i>	48
	<i>Appendix</i>	51

List of Figures

CHAPTER 2

Figure 2.1	Offshore wind turbines	8
Figure 2.2	Geothermal energy process	10
Figure 2.3	Wave Energy Conversion Device - Gaza	11
Figure 2.4	Yearly sum of direct beam insolation in the world	12
Figure 2.5	Solar energy project in UCAS	14
Figure 2.6	Solar energy project in Al-Naser hospital	15
Figure 2.7	Solar energy project in Al-Shifa hospital	16

CHAPTER 3

Figure 3.1	Silicon PV cell construction	18
Figure 3.2	I-V characteristic curve of a typical Si cell	18
Figure 3.3	Equivalent circuit of an ideal solar cell	19
Figure 3.4	Variation in solar radiation in Gaza Strip	22
Figure 3.5	Monocrystalline Solar Panels	22
Figure 3.6	Polycrystalline Solar Panels	23
Figure 3.7	Amorphous Solar Panels	23
Figure 3.8	Typical PV power system	26
Figure 3.9	Boost Power Stage States	28
Figure 3.10	CCM Boost power stage waveforms	29

CHAPTER 4

Figure 4.1	Fuzzy and Classical sets	32
Figure 4.2	Different shapes of membership functions	33
Figure 4.3	Membership function example	34
Figure 4.4	Universe of discourse for linguistic variable	34

Figure 4.5	Basic parts of a Fuzzy Controller	35
Figure 4.6	Fuzzification	36
Figure 4.7	Center of gravity (COG)	38
Figure 4.8	The block diagram of PV control system	38
Figure 4.9	FLC controller	39
Figure 4.10	The block diagram of FLC for system	39
Figure 4.11	Input Membership function for given error	40
Figure 4.12	Input Membership function for change in error	40
Figure 4.13	Output Membership Function	41
Figure 4.14	General Rule Base	41
Figure 4.15	Surface shape	42
Figure 4.16	Input – error	43
Figure 4.17	Input - change in error	43
Figure 4.18	Output of the FLC	43
Figure 4.19	Values of reference and desired current	44
Figure 4.20	Generating the Error and Change in Error	45
Figure 4.21	Error and change of error model subsystem	46
Figure 4.22	Output of the solar system using FLC	46

LIST OF TABLES

CHAPTER 4

Table 1	Fuzzy Table	42
Table 2	Values of PV current	45

LIST OF ABBREVIATIONS

AC	Alternating Current
a-Si	amorphous silicon
COG	Center of Gravity
DC	Direct Current
FL	Fuzzy Logic
FLC	Fuzzy Logic Controller
MPP	Maximum Power Point
MPPT	Maximum Power Point Tracking
PV	Photovoltaic
TSK	Takagi-Sugeno-Kang
USD	United States Dollar
UCAS	University College of Applied Sciences

CHAPTER 1

INTRODUCTION

1.1 Background

Since the political situation in Gaza Strip and the unjust siege imposed since 2006 by the Israeli occupation just after Palestinian election, the Power Generation Sector faced several obstacles of Gaza Power Plant in June 2006 blocking fuel entry into Palestinian Territories in 2008 ending with unknown and horrible situation. Thus, there is a need for an alternative power sources for emergency cases as hospitals and medical centers. The shortage in electric power forced hospitals and medical centers to run their own generation units if fuel creating more pollution and noise.

Energy is central to many economic, social and environmental concerns facing the world today. Access to clean, affordable and sustainable energy services is essential to modern society. Developing countries need suitable access to modern energy if they are to achieve economic growth; investment in modern energy is indispensable for a prosper and sustainable future [1].

Over the last few years, photovoltaic (PV) technology has been developed and upgraded its role in renewable energy sources while producing the benefits for power production cannot be ignored and have to be considered. Nowadays, many applications in rural and urban areas use solar systems. Many isolated loads try to adopt this kind of technology because of the benefits which can be received in comparison with a single renewable system [2].

The energy sector in the Palestinian territory, a developing country, suffers from special circumstances due to unique political status of the occupied territories. According to Paris agreement signed by the Palestinian Authority and Israel, the Palestinian Authority was given little freedom in all aspects of energy sources including electricity and refined petroleum products. About 140 MW Palestinian power station was built in Gaza in 2002 and supposed to supply Gaza Strip with all of its electrical power needs. The power station can be run using industrial fossil fuel or

natural gas. Energy imports and fuel prices are completely controlled by Israel which resulted in discontinuous supply in most of fuels used in the Palestinian territories. In fact chosen renewable power sources will considerably reduce the need for fossil fuel leading to an increase in the sustainability of the power supply.

This thesis studies the energy sector in the Palestinian territories in terms of the quantity of energy consumption in all sectors and all types of available fuels and their outcomes. The solar energy and its potential in the Palestinian territories were studied in terms of the amount of incident radiation during the year and the various possible applications, and the projects that have been implemented in various regions.

Therefore, the increase of the intensity of radiation received from the sun is the most attainable method of improving the performance of solar power. There are many approaches to maximize power extraction in solar systems. These methods depend on controlling certain aspects; thus, using control methodology such as intelligent methods is justified. Fuzzy logic controller (FLC), as an intelligent control, will be used in this study.

The advantage of the FLC is that it does not strictly need any mathematical model of the plant. It is based on plant operator experience, and it is simple to apply. In addition, fuzzy logic simplifies dealing with nonlinearities in systems. A good point about fuzzy logic control is that the linguistic system definition becomes the control algorithm.

This thesis focuses on a small stand-alone solar power system in Gaza Strip with maximum possible usage of solar energy as an domestic, clean and cheap source of energy. The analysis will show that solar energy is capable of feeding the proposed system, while diesel generator will be a standby unit; if any problem happens in the system or in battery-bank source.

1.2 Motivation

Fuzzy logic controllers have an efficient performance over the traditional controller researches especially in complex model systems. This motivated me to implement FLC on the proposed system. Gaza Strip has a continuous electrical power supply

problem, since all supply sources do not cover the required demands; thus, Gaza Strip faces scheduled daily electrical power interruptions. This created a need to look for other electrical power generation sources. Clean renewable energy sources that do not depend on importing fuel are a priority. Big problem of electricity in Gaza has motivated to investigate solar power as an application to apply fuzzy control to increase the system efficiency

1.3 Statement of Problem

Gaza Strip is a small but one of the most density populated area in the world. About 360 square kilometers. Gaza Strip's population is expected to grow at a rate of 4.2% annually and reach a total of 2.13 million in 2020 [3].

Gaza Strip is supplied with electricity from three main sources: Israel Electricity Corporation provides 120 MW to the northern and central area of the Gaza Strip. Gaza Power Plant ("GPP") provides 70 MW to the northern and central area of the Gaza Strip; and Egypt provides 21 MW to the Rafah area [4].

In 2013, demands reached 400 MW while the supplies dropped to 147–173 MW. This deficit leads to extensive load shedding. Thus we can say that our society in Gaza Strip suffers from electricity shut down so diesel generators are the temporary solution, but not efficient because fuel is not available in all times.

One can say that the PV cells are a good solution to the electricity problem in Gaza. On the another scope we look for increase the efficiency of PV cells which is a another aim of this study

1.4 Objectives

We propose the use of solar power in Gaza in order to give a solution of the problem detailed in the problem description; one way to solve the problem in the electricity in Gaza and to provide a cost efficient system. The main objective in this study is building a FLC to maximize the power output of the solar power system by regulating the current supplied to the converter to get efficient output power. This increase the efficiency of PV cells by regulating the PV current supplied to the grid system by the line of inverter.

1.5 Literature Review

Ricalde, et.al. [5] proposed a smart grid integrating wind, photovoltaic and batteries into an AC bus. The solar and wind characterization taken from a meteorological station during 2010 was presented showing the vast wind and solar energy potential in the region. The second part was to scale the microgrid installing 20 kW in two Wind Turbines and 7 kW in Photovoltaic modules. It dealt with Microgrids, which mean small scale energy generation systems mainly from renewable energy. This researcher maintained the microgrid energy balance but did not minimize the total cost.

Mets, et.al. [6] presented a distributed algorithm for residential energy management in smart power grids. This algorithm consisted of a market-oriented multi-agent system using virtual energy prices, levels of renewable energy in the real-time production mix, and historical price information, to achieve a shifting of loads to periods with a high production of renewable energy. The researchers optimized for either the consumption of green energy or reduction of the average and peak loads for externally supplied power. The researchers scope only for residential and did not take into account different weather conditions.

Michiorri, et.al. [7] analyzed and tested the suitability of recent developments in distribution networks management for facilitating the connection of distributed renewable generators, improving the security of supply and letting customers and other actors to provide network services. Researchers presented also preliminary results on the works on the integration of PV production forecasts in the system. Result cleared that performance of the algorithm need to be developed to maximize the benefit of probabilistic forecasts in the network energy management. Researchers did not satisfy the exact performance and work is ongoing to improve it.

Kalpesh, et.al. [8] presented an update on a case study undertaken for the underground cable fed electrical power distribution network with two types of local grid-connected small solar photovoltaic (SPV) systems. The distribution network was situated in an institutional premise in Gujarat, India. Research analysis with actual load model and actual generation data can be useful for economic viability studies of the SPV plants for long run. On the other hand cable sections were overloaded during summer peak load profile. Separate parallel cable sections were required to diverse the overload.

Researchers need to install automatic switching device for capacitor bank to optimize the use of capacitor bank which it was not satisfy in this paper.

Muoka, et.al. [9] developed models for an integrated PV power plant which comprises PV array, SEPIC (single ended primary inductance converter) converter, bidirectional dc-dc converter, dc-ac converter, and battery energy storage system using Matlab/Simulink. Also, the integration of energy storage to PV system via bidirectional dc-dc converter was invaluable in the mitigation of the problems of intermittency and variability of a PV power generator. This study did not address how to improve PV system it's only presented a simulation and result to the model.

Chao-Shun Chen, et.al. [10] proposed an advanced distribution automation system (ADAS) of PV inverter control to reduce the system impact due to intermittent power generation by renewable energy such as wind and solar power. The researcher's aimed for system self-healing, effective utilization of renewable energy, more active participation of customers to improve operation efficiency of power systems. The paper improved a suitable system for network and data center which need low power. Researchers need to develop to achieve the desired time reduction of customer outage duration.

AlBarqouni [11] implemented of an experimental solar model for lighting an apartment to validate the proposed solar control system taking into account the IEEE Recommendations. The researcher re-designed and re-evaluated lighting and controlling projects in Gaza Strip and motivates providing solutions for the current situation. This study can be used as stand-alone system for any solar projects and related studies.

EL-Moghany [12] presented fuzzy logic controllers that were fabricated on modern FPGA card (Spartan-3AN, Xilinx Company, 2009) to increase the energy generation efficiency of solar cells. Maximum Power Point Tracking in Solar Array Systems is used in this study. The results showed that the proposed sun tracking solar array system and MPPT were feasible methods of maximizing the energy received from solar cells. This study used fuzzy control for tracking the sun and did not consider regulation the current.

1.6 Contribution

In this thesis, fuzzy logic control has been implemented to get maximum power by regulating the current of the system, which improves the efficiency of electrical power generated from photovoltaic module. These controllers have been tested using MATLAB program.

1.7 Thesis Organization

The thesis is organized into five chapters. Chapter 2 introduces introduction to the renewable power. Chapter 3 handles some basic principles of photovoltaic technology and description of solar system. Chapter 4 focuses on Fuzzy logic control, applying FLC in the proposed system, simulation and results. The last chapter concludes the thesis and proposes some future work.

CHAPTER 2

INTRODUCTION TO RENEWABLE POWER

Renewable energy sources have been important for humans since the beginning of civilization. For centuries, biomass has been used for heating, cooking, steam rising, and power generation; hydropower and wind energy are used for movement and later for electricity production. Renewable energy sources generally depend on energy flow through the Earth's ecosystem from the insolation of the sun and the geothermal energy of the Earth.

Furthermore, many renewable technologies are suited to small off-grid applications, good for rural, remote areas, where energy is often crucial in human development. At the same time, such small energy systems can contribute to the local economy and create local jobs.

The theoretical potential of what they can produce for human needs exceeds current energy consumption by many times. For example, solar power plants on one percent of the world's desert area would generate the world's entire electricity demand today [13]. The following sections introduces several renewable energy sources.

2.1 Wind Energy

Wind energy, in common with other renewable energy sources, is broadly available but diffuse. Wind energy was widely used as a source of power before the industrial revolution, but later displaced by fossil fuel use because of differences in costs and reliability. The oil crises of the 1970s, however, triggered renewed interest in wind energy technology for grid-connected electricity production, water pumping, and power supply in remote areas. In recent decades enormous progress has been made in the development of wind turbines for electricity production. Around 1980 the first modern grid-connected wind turbines were installed. In 1990 about 2,000 MW of grid-connected wind power was in operation world-wide at the beginning of 2000, about 13,500 MW. In addition, more than 1 million water-pumping wind turbines (wind pumps), manufactured in many developing countries, supply water for

livestock, mainly in remote areas. Tens of thousands of small battery-charging wind generators are operated in China, Mongolia, and Central Asia.

Because of the sensitivity to wind speed and altitude, determining the potential of wind energy at a specific site is not straightforward. More accurate meteorological measurements and wind energy maps and handbooks are being produced and mostly published; enabling wind project developers to better assess the long-term economic performance of their projects.

In densely populated countries the best sites on land are occupied, and public resistance makes it difficult to realize new projects at acceptable cost. That is why Denmark and the Netherlands are developing offshore projects as shown in Figure 2.1, despite less favorable economics. Sweden and the United Kingdom are developing offshore projects to preserve the landscape.



Figure 2.1: Offshore wind turbines

Based on available data and topographical features of Palestine, potential of wind energy seems to be limited to the mountains (elevation of about 1000m); regions of Nablus, Ramallah and Hebron where the speed surpass 5 m/s and the potential about 600 kWh/m². Initial studies shows that the wind regime is suitable for operating a wind turbine for wind power generation in city of Hebron in West Bank. Al-Ahli Hospital is located in the south-western part of Hebron at 1000m above sea level on a site of 27500 m². The average wind speed at 10 m high could be as high as 6.2m/s in this region according to detailed data supplied by the Weather Authority. The

proposed and the required wind turbine(s) to be installed at Al-Ahli Hospital are expected to be around ~700 kW total power production capacity [14].

Generally, the wind speed in Gaza Strip is considered very low during the year. Wind speed range between 1.9-2.5 m/sec and 2.5-3.9 m/sec in summer and winter time, respectively. Potential wind applications are restricted partially to mechanical water pumping [15].

Wind atlas is in the developing process for Palestinian Territories. Further researches and more field measurements for wind are required. Utilization of wind could be feasible in some locations for cut-off electricity production and water pumping [14].

2.2 Geothermal Energy

Geothermal energy has been used for bathing and washing for thousands of years, but it is only in the 20th century that it has been harnessed on a large scale for space heating, industrial energy use, and electricity production. Prince Piero Ginori Conti initiated electric power generation with geothermal steam at Larderello in Italy in 1904. The first large municipal district heating service started in Iceland in the 1930s.

Geothermal energy process that has been declared as shown in Figure 2.2 has been used commercially for some 70 years, and on the scale of hundreds of megawatts, 40 years, both for electricity generation and direct use. Its use has increased rapidly in the past three decades at about 9 percent a year in 1975-1995 for electricity and at about 6 percent a year for direct use. Geothermal resources have been identified in more than 80 countries, with quantified records of geothermal use in 46 countries.

The utilization of geothermal technology as a source of energy for heating and cooling has been started in Palestine during the MED-ENEC project in one of the ITEHAD subdivision villas in Ramallah city and through establishing the first company in the region utilize the geothermal energy in residential and commercial sectors called MENA Geothermal.

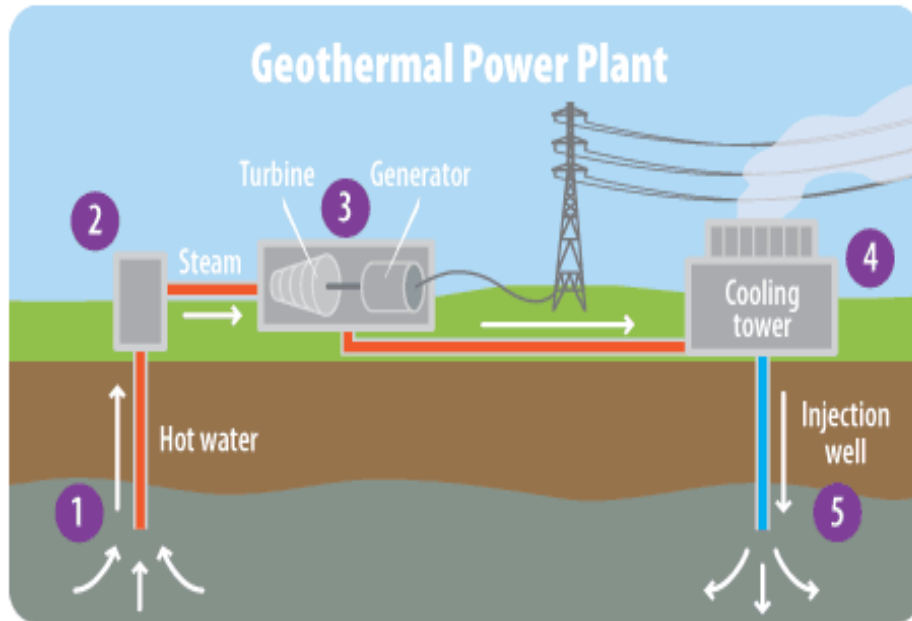

Figure 2.2: Geothermal energy process

2.3 Waves Energy

Wave power technology has been around for nearly thirty years and is considered as a serious competitor among the renewable energies. During this period, many wave energy devices have been invented and used, and some are only proposed as study.

This energy transfer provides a natural storage of wind energy in the water near the free surface. Once created, wind waves can travel thousands of kilometers with little energy losses, unless they encounter head winds. Near the coastline the wave energy intensity decreases due to interaction with the seabed. Energy dissipation near shore can be compensated by natural phenomena as refraction or reflection, leading to energy concentration.

There are many designs available to extract energy from waves. Deciding on a locally viable configuration would first involve the collection of wave height and wave period data over time. A statistical model could then be built up and theoretical values determined.

A viable offshoot of wind energy is wave energy. Waves occurring in ocean water can contain considerable power. For example a ~ 2m high ocean wave with a period of ~10sec has an energy flux of between 50 to 70 kW per meter of width. Actual efforts to harness this energy have been ongoing for many years. Records of successfully installed wave power generating systems include a system in California commissioned in 1909 (Twidell and Weir 2006) [16].

The present in Gaza Strip introduces one of such energy conversion devices. The main theme of the present prototype is based on converting the kinetic and potential energies, that exist in moving sea waves, into potential energy as the water is stored in an elevated reservoir. The stored water can then be fed through a turbine (and a generator) to generate electricity.



Figure 2.3: Wave Energy Conversion Device - Gaza

Based on assumed electrical-power requirement (1.5 kWh per day) and available conditions, the present model was designed, analyzed, fabricated, and finally tested on Gaza shoreline for few days see Figure 2.3. Several modifications were introduced whenever needed. These modifications were adopted according to results obtained during three different experimental phases. The present device produced average filling rates, at 15-m head, that would generate about 55% of the assumed power with a device efficiency of 85.7%. The preset study, also, indicated that short and wide

pistons should be used in similar applications. Results obtained are very satisfactory and encouraging to continue research in this field [17].

2.4 Solar Energy

Solar energy is the direct conversion of sunlight into electricity by using the Photovoltaic modules. This can be done by flat plate and concentrator systems. An essential component of these systems is the solar cell. The photovoltaic effect the generation of free electrons using the energy of light particles takes place. These electrons are used to generate electricity.

Solar radiation is available at any location on the surface of the Earth. The maximum irradiance of sunlight on Earth is about 1,000 watts on square meter, irrespective of location. It is common to describe the solar source in terms of insolation the energy available per unit of area and per unit of time (such as kilo-watt-hours per square meter a year). Measured in a horizontal plane, annual insolation varies over the Earth's surface by a factor of 3 from roughly 800 kilowatt-hours per square meter a year in northern Scandinavia and Canada to a maximum of 2,500 kilowatt-hours per square meter a year in some dry desert areas. The differences in average monthly insolation (June to December) can vary from 25 percent close to the equator to a factor of 10 in very northern and southern areas as shown in Figure 2.3, determining the annual production pattern of solar energy systems. The ratio of diffuse to total annual insolation can range from 10 percent for bright sunny areas to 60 percent or more for areas with a moderate climate, such as Western Europe. The actual ratio largely determines the type of solar energy technology that can be used.

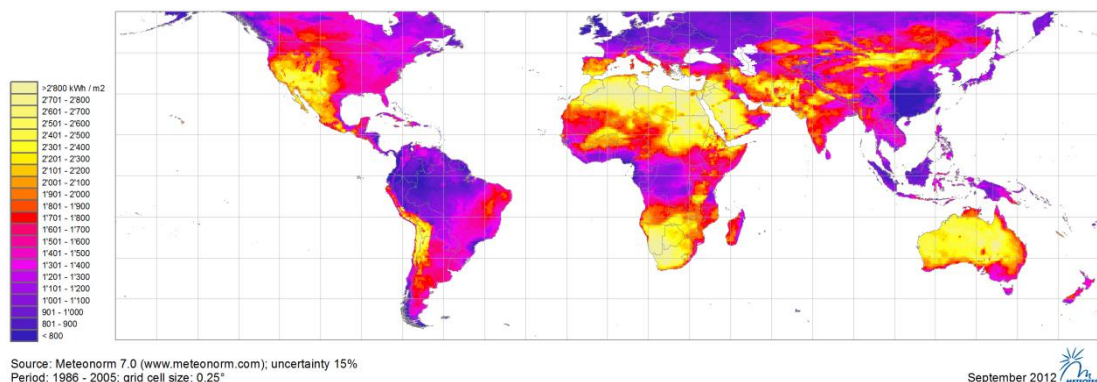

Figure 2.4: Yearly sum of direct beam insolation in the world

The average power density of solar radiation is 100-300 watts a square meter. The net conversion efficiency of solar electric power systems (sunlight to electricity) is typically 10-15 percent. So substantial areas are required to capture and convert significant amounts of solar energy to fulfill energy needs (especially in industrialized countries, relative to today's energy consumption). For instance, at a plant efficiency of 10 percent, an area of 3-10 square kilometers is required to generate an average of 100 megawatts of electricity-0.9 terawatt-hours of electricity or 3.2 pet joules of electricity a year using a photovoltaic system.

The PV electrification could be using the decentralized stand alone and centralized systems depending to the nature of the load and the distribution of houses. Photovoltaic electrification is limitedly used in different rural areas in Palestine mainly for schools, clinics, bedouins, communities, agricultural and animal farms, and private homes. The total installed capacity is about 50 kW [14].

2.4.1 Solar Radiation in Gaza

Solar insulation in Gaza Strip is relatively high. The daily average on horizontal surface is about 222 W/m², which is varying during the day and throughout the year (5.58 kWh/m² day) [15].

2.4.2 Potential of Solar Energy in Gaza

Flat plate solar collector is widely used in Gaza Strip since early seventies. More than 95% of houses use solar energy for domestic water heating according to 1996 statistics; however, the percentage has dropped due to the increasing number of apartment buildings that are not equipped with central solar water heating systems. The flat plate solar collector usually used as equipped with auxiliary 3.0 kW electric heaters that are mainly used in wintertime.

Photovoltaic systems in Gaza Strip are rarely used in very limited applications such as remote area housing and water pumping. This is due to the high cost of the system that gives electricity with estimated cost of 0.4 USD/kWh compared with cost to value of 0.14 USD/kWh for the electricity from the grid.

Solar energy is considered as potential resources in spite of the wide spread of usage of solar collectors. Potential applications include solar water desalination, solar pumping, solar crop drying and remote area electrification.

The policy of PV electrification focuses on settling the communities threatened from land confiscation and people eviction due to occupation practices especially after construction of the separation wall. It is urgently needed to enhance the living conditions of these communities by offering more and better quality services and implementing sustainable development plans. The policy contributes to development of renewable energy resources and reliance reduction on imported fuels, and eventually leads to environment protection and sustainable development [15].

The most recently PV electrification project was implemented by the energy research center at Al-Najah National University. It is about electrifying a Palestinian village Atouf by PV centralized power system. The village includes 25 houses, school, and clinic with power capacity about 24 kW. The project is considered a successful renewable energy application in Palestine. The project was financed by EU. This project is financed by UNDP/PAPP [14]. In Gaza many project were installed, one of these in University College for Applied Sciences which powered of 6 kW to feed last floor. Al-Naser hospital project which give 14 kW and feed intensive care unit, Al-Shefa hospital produces a solar system with 4.2 kW and specially feed intensive care unit. Solar panels for home usage are available in Gaza Strip. We focus in some project implemented in Gaza Strip:

- 1. University College of Applied Sciences (UCAS) is the first academic institution in the Gaza Strip to start a solar Energy project**



Figure 2.5: Solar energy project in UCAS

UCAS opening of the first solar energy project which aims at using clean renewable energy as an alternative to the non-renewable environment-unfriendly energy. UCAS has started the initiative of establishing the first clean alternative renewable energy which is used to feed the 8th floor of the Administration building which contains several study rooms and administrative ones as well as operating the fans.

On the other hand, the project is the first in its medium capacity which aims at generating 6 kW through the transformation of solar energy to electricity that fits with the local network of 220 V. The system consists of 32 optical cells of 320 W which have been set at the roof of the administration building of UCAS. Those cells feed the control unit which in turn feed the main network through the reflection and a battery charger that is used in the case of shortage in solar energy to work for around 4-5 hours.

2. Al-Naser Hospital Solar Energy project in the Gaza Strip



Figure 2.6: Solar energy project in Al-Naser hospital

Al-Naser hospital opened the largest solar power system in Gaza to feed the intensive care unit.

This new system will increase the production of electrical power of 20 kW, pointing out that the energy authority will oversee the project to measure its performance and take its advantage in the upcoming projects.

3. Al-Shifa Hospital solar Energy project in the Gaza Strip



Figure 2.7: Solar energy project in Al-Shifa hospital

Al-Shifa hospital produces solar energy to work for the replacement of the power supply which is currently missing from the sector by a large margin, due to the electricity black-out that affected the health facilities. The project installed consist of 18 panels scanned on the surface, this system feed intensive care unit.

The PV panels shipped 12 batteries, each one about 60 V. Direct Current (DC) is capable of producing 4 kW of electricity after conversion to Alternating Current (AC) unusable through an inverter. The current exponential surplus is converted to 5 beds in cardiac care department equipped with private after converting it to AC current.

Batteries store energy exotic light from the sun during the day while preventing current surplus to beds care , while taken advantage of these batteries with the sunset and nightfall in the supply of family sick installed on them Equipment private electricity , indicating that the dump 12 battery fully takes 6 hours.

For future the use of renewable energy in electricity generation, There is a serious thought to run sections sensitive within the hospital, such as processes, laboratories and incubation of premature infants by solar energy, but noted at the same time to the problem of providing places can accommodate large numbers of photovoltaic cells for power generation Electricity.

The data presented in this chapter show that there is a not good potential for solar energy applications such as solar water desalination, solar pumping, solar crop drying and remote area electrification. So we need encourages local authorities to spread of this technology and set rules and policies concerning the treatment of solar usage of renewable energy.

CHAPTER 3

PV TECHNOLOGY AND SOLAR SYSTEM

The sun is the largest energy source of life. It is the ultimate source of most of renewable energy sources. Solar energy can be used to generate electricity in a direct way with the use of photovoltaic modules. Photovoltaic is defined as the generation of electricity from light where the term photovoltaic is a compound word which comes from the Greek word for light "photo", with, volt, which is the unit of electromotive power. The technology of photovoltaic cells was developed rapidly over the past few decades. Nowadays the efficiency of the best crystalline silicon cells has reached 24% for photovoltaic cells under laboratory conditions and for that used in aerospace technology and about 14-17% overall efficiency for those available commercially [18].

3.1 Solar Cells: Construction and Operation

3.1.1 Photovoltaic construction

A solar cell is considered the basic part in the photovoltaic system. It is a device that converts light energy into electrical energy by the photovoltaic effect. Solar cells are often electrically connected and encapsulated as a module. PV modules often have a sheet of glass on the front (sun up) side, allowing light to pass while protecting the semiconductor wafers from the elements (rain, hail, etc.). Solar cells are also usually connected in series in modules, creating an additive voltage. Connecting cells in parallel will yield a higher current. Modules are then interconnected, in series or parallel, or both, to create an array with the desired peak DC voltage and current.

PV cells consist basically of a junction between two thin layers of semi conducting materials, known as p (positive) type semiconductors and n (negative) type semiconductors. The p-type semiconductor is created when some of the atoms of the crystalline silicon are replaced by atoms with lower valence like boron which causes the material to have a deficit of free electrons. The n-type semiconductor is created when some of their atoms of the crystalline silicon are replaced by atoms of another

material which has higher valence band like phosphorus in such a way that the material has a surplus of free electrons.

The photovoltaic cell consists of 6 different layers of materials as shown in figure 3.1.

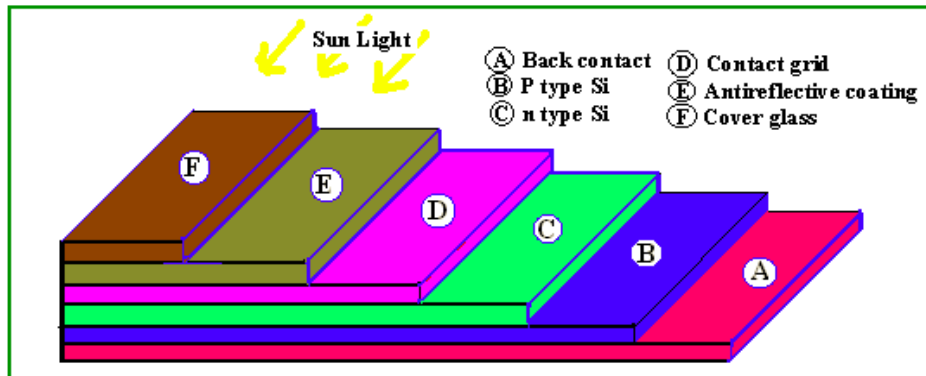

Figure 3.1: Silicon PV cell construction

3.1.2 Photovoltaic operation

When the photovoltaic cell becomes exposed to the light beam which consists of photons, the electrons are stimulated. The electrons start moving rapidly, jump into the conduction band and they leave holes in the valence band. Some of the electrons are attracted from n-side to combine with holes on the nearby p-side. Similarly, holes on the near p side are attracted to combine with the electrons on the nearby n-side. The flow of the electrons from one semiconductor to the other creates the electric current into the photovoltaic cell.

If a variable load is connected through the terminals of the PV cell, the current and the voltage will be found to vary. The relationship between the current and the voltage is known as the I-V characteristic curve of the PV cell. The I-V curve for a typical silicon PV cell under standard conditions is shown in figure 3.2.

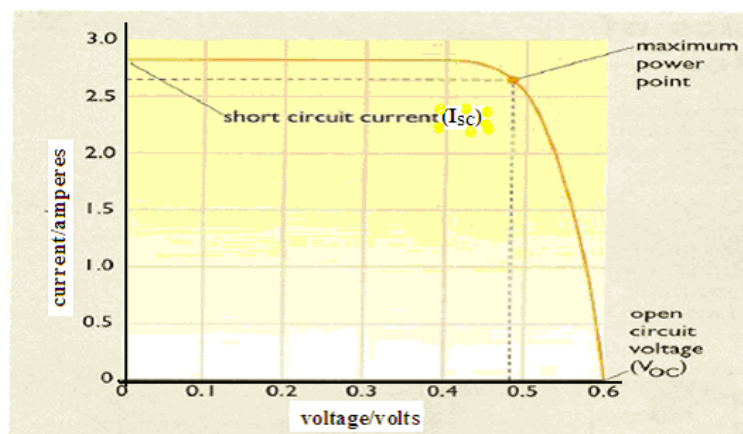

Figure 3.2: I-V characteristic curve of a typical Si cell

To measure the I-V characteristic of a PV cell and to find the maximum power point, an international standard conditions shall be fulfilled. These standard conditions are: irradiance level that shall be 1000 W/m^2 , the reference air mass that shall be 1.5 solar spectral irradiance distributions, and cell or module junction temperature that shall be of 25°C [18].

Open circuit voltage (V_{OC}) is the voltage appears across the terminals of the PV cell when it is open circuited, while short circuit current (I_{SC}) is the current passes through the short circuit when the terminals of the PV cell are short circuited. The term fill-factor is defined as the ratio between the maximum power delivered by the PV cell and the product of open circuit voltage and the short circuit current of the cell.

The cell will deliver maximum power at maximum power point (MPP) on the I-V characteristic curve which represents the largest area of the rectangular under the I-V characteristic. A technique to utilize effectively the photovoltaic is known as a maximum-power- point tracking (MPPT) method, which makes it possible to acquire as much power as possible from the photovoltaic, this is accomplished by a built in circuit in the charger controller or in the inverter circuit following the PV module.

The efficiency of a solar cell is defined as the power produced by the cell at MPP divided by the power of radiation incident upon it [19].

3.1.3 Photovoltaic mathematical modeling

The equivalent circuit diagram of an ideal solar cell is shown in Figure 3.3.

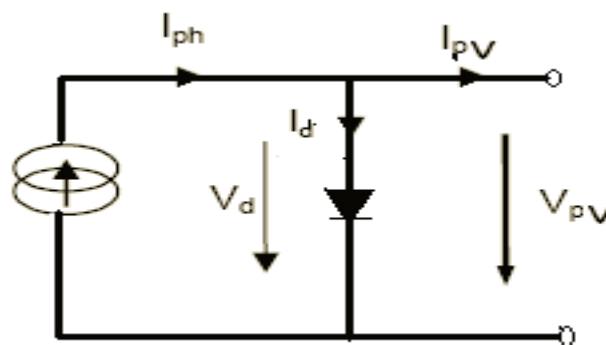

Figure 3.3: Equivalent circuit of an ideal solar cell

The mathematical function of an ideal illuminated solar cell is given in the following equation [20]:

$$I_{pv} = I_{ph} - I_d = I_{ph} - I_o * (e^{\frac{qV_d}{K_b T}} - 1) \quad (3.1)$$

Where:

I_{pv} : load current [A]

I_{ph} : photon current which represents the short circuit current I_{sc} [A]

I_o : saturation current [A]

q : electron charge [$e = 1.602 * 10^{-19}$ C]

V_d : which represents the PV voltage (VPV) [V]

K_b : Boltzmann constant [$1.38 * 10^{-23}$ J/K]

T : diode absolute temperature [°K]

3.1.4 Temperature and solar radiation effects on PV performance

The two most important effects that must be considered are due to the variable temperature and solar radiation. The effect of these two parameters must be taken into account when sizing the PV system.

Temperature effect: This has an important effect on the power output from the cell. The temperature effect appears on the output voltage of the cell, where the voltage decreases as temperature increases. This decrease for silicon cell is about 2.3 mV per 1°C increase in the solar cell temperature.

The solar cell temperature T_c can be found by the following equation [19]:

$$T_c = T_{amb} + \left(\frac{NOCT-1}{800} \right) * G \quad (3.2)$$

Where:

T_{amb} : ambient temperature in °C

G : solar radiation in W/m²

NOCT: Normal Operating Cell Temperature which is defined as the cell temperature when the module operates under the following conditions at open circuit:

Solar radiation :	800 W/m ²
Spectral distribution :	AM1.5
Ambient temperature :	20 °C
Wind speed :	> 1 m/s

Solar radiation effect: The solar cell characteristics are affected by the variation of illumination. Increasing the solar radiation increases in the same proportion the short circuit current. The following equation illustrates the effect of variation of radiation on the short circuit current:

$$I_{sc}(G) = I_{sc}(\text{at } 1000 \text{ W/m}^2) * (G \text{ (in W/ m}^2) / 1000) \quad (3.3)$$

The output power from the PV cell is affected by the variation of cell temperature and variation of incident solar radiation. The maximum power output from the PV cell can be calculated using the following equation [19]:

$$P_{\text{out-pv}} = P_{\text{r-pv}} * \left(\frac{G}{G_{\text{ref}}} \right) * [1 + K_T (T_c - T_{\text{ref}})] \quad (3.4)$$

Where:

$P_{\text{out-pv}}$: output power from the PV cell

$P_{\text{r-pv}}$: rated power at reference conditions

G : solar radiation in W/m²

G_{ref} : solar radiation at reference conditions (1000 W/ m²)

T_c : cell temperature.

T_{ref} : cell temperature at reference conditions (25 °C)

K_T : temperature coefficient of the maximum power (- 3.7 *10^{- 3} / 1°C)

The following equation can be used to calculate the cell temperature approximately if the NOCT is not given by the manufacturer [19]:

$$T_c = T_{\text{amb}} + (0.0256 * G) \quad (3.5)$$

Where, T_c , T_{amb} , and G are as defined before.

3.2 Solar Radiation in Palestine

Solar radiation data during a year are very important and essential for design and sizing of PV power systems. Solar radiation measurements in addition to temperature measurements are necessary to calculate the output power of the PV system. Solar radiation and temperature measurements shall be available on hourly basis to be used by the simulation program for the evaluation process [15].

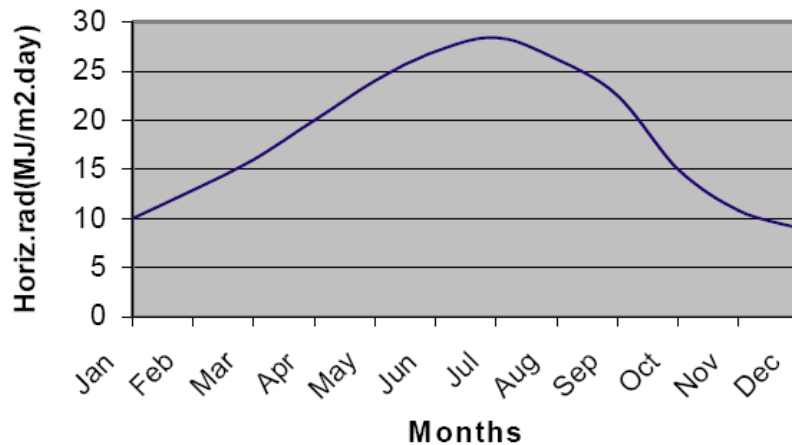

Figure 3.4: Variation in solar radiation in Gaza Strip

3.3 Main PV Cell Types

The material that is widely used in the industry of PV cells is silicon. Silicon can be found inside the sand in the form of silicon oxide (SiO_2). Depending on the structure of the basic material from which PV cells are made and the particular way of their preparation, PV cells can mainly be categorized as follows [21]:

1. Mono-crystalline: The efficiency of a single crystal silicon cell varies between 13-16% and it is characterized by a high cost for manufacture and has a dark blue color.

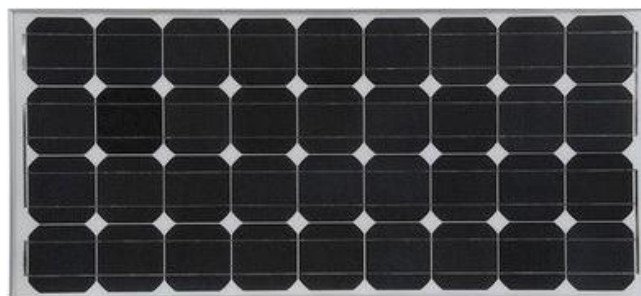

Figure 3.5: Monocrystalline Solar Panels

2. Poly-crystalline: Its efficiency varies between 10-14% and it is characterized by lower cost silicon which is used in manufacture and has light blue color.

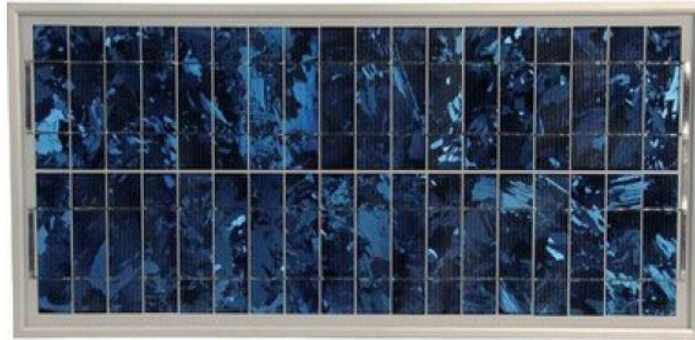

Figure 3.6: Polycrystalline Solar Panels

3. Amorphous (non crystalline) silicon: This type of photovoltaic cells achieves maximum efficiency not more than 10%. Production cost is much cheaper than what is for the previous two types. Its efficiency degrades with time.



Figure 3.7: Amorphous Solar Panels

Other types of PV cells use other materials or compounds rather than silicon. Other innovative PV technologies use multi-junction in manufacturing the PV cells which depend on wavelength of light and its efficiency reach 30% [18].

3.4 PV Solar Cell Technology

In contrast to widely-used electricity generation technologies, photovoltaic systems produce little environmental pollution. However, there are numerous materials and energy inputs that go into the fabrication of the components of PV systems that may carry significant environmental burdens.

3.4.1 Recent technology in manufacturing PV modules

Crystalline silicon was the original materials technology used by the PV industry to manufacture solar cells. First widely used in space satellites, conventional crystalline silicon solar cells are fabricated in a step-and repeat, batch process from small wafers of single crystal or polycrystalline silicon semiconductor materials. Although, substantial advances have been made in the development of this technology, the cost of crystalline PV modules is still high because of materials costs and numerous processing steps that are needed to manufacture the modules. Crystalline silicon solar modules are bulky, break easily, and consume more energy in manufacturing.

A major cost limitation of the current dominant silicon solar cell technologies, which are fabricated using traditional crystalline and polycrystalline silicon based processes, is with the large volume of material used and the associated expensive assembly and interconnection methods required to produce the large area products required for substantial power generation.

For the past 15 years a new kind of PV has emerged based on thin-film semiconductors deposited on a variety of substrates. The most common of these thin films currently in use is amorphous silicon (a-Si). The PV cells built from it are invariably less efficient than crystalline PV, but thin film PV counters this with a host of advantages including relatively low cost of manufacture, flexibility and savings on materials. The last of these factors has proved especially importance, since there has been an ongoing shortage of silicon that has plagued the industry [22].

Amorphous silicon PV modules were the first thin-film PV modules to be commercially produced and are presently the only thin-film technology that has had an impact on the overall PV markets. However, the efficiencies of these modules have not yet reached levels that were predicted in the 1980's. To a significant degree this is due to the intrinsic degradation of a-Si under illumination. The amount of light-induced degradation can be limited to 20% in modules operating under outdoor conditions. Both material processing schemes and device design schemes have been developed to improve the stabilized solar cell efficiency of a-Si solar cells. The use of multi-band gap multi junction devices (allowing the use of thinner absorber layers in

the component cells) and the use of light-trapping appear to be the most powerful device design techniques to improve stabilized device performance. Presently, champion cells have stabilized efficiencies of 12% and champion modules have stabilized efficiencies of over 10% [23].

3.4.2 Energy payback of PV cells

There is a significant energy input needed for manufacturing PV equipment. This manufacturing energy input has been reduced during the research and development efforts of the past decades, although there is still room for considerable improvements.

A common method used to express economic costs of electricity-generating systems is to calculate a price per delivered kilowatt-hour (kWh). The solar cell efficiency in combination with the available irradiation has a major influence on the costs, but generally, the overall system efficiency is important. Using the commercially available solar cells and system technology leads to system efficiencies between 5 and 19%. In 2005, photovoltaic electricity generation costs ranged from ~0.60 US\$/kWh (central Europe) down to ~0.30 US\$/kWh in regions of high solar irradiation. Recently in 2013 world record solar cell with 44.7% efficiency, made up of four solar sub cells based on compound semiconductors for use in concentrator photovoltaic [24]. This electricity is generally fed into the electrical grid on the customer's side of the meter.

Another approach to look on the energy cost production of PV modules, the environmental effects while manufacturing PV modules, the amount of energy required during manufacturing PV modules, and comparison between different technologies in manufacturing PV modules, is to calculate the energy payback time of a module. The energy payback time is one standard of measurement adopted by several analysts to look at the energy sustainability of various technologies. It is defined as the time necessary for a photovoltaic module to generate the amount of energy used to produce it.

The energy payback time of a photovoltaic cell is an indication about the energy required to make a cell compared to how much it could generate in its lifetime. The

energy payback time of a modern photovoltaic module is anywhere from 1 to 20 years (usually under five) depending on the type and where it is used. This means that they generate more energy over their lifetime than the energy expended in producing them [25].

Parameters determine the energy payback time for a PV module is: manufacturing technology used to produce PV panel, the amount of illumination that the system received, and the conversion efficiency of the PV system. The energy needed to produce a product includes both the energy consumed directly by the manufacturer during processing, and the energy embodied in the incoming raw materials.

How a PV module is used is primarily a question of location and module efficiency. By determines the solar radiation, and combined with efficiency, determines the electrical output of the PV module. But installation details are also important (fixed tilt or tracking, grid-connected or stand-alone, etc.), as are balance of system requirements such as mounting structure, inverter, and batteries [26].

Until now the silicon cells in the photovoltaic industry have mostly been made from material that has been rejected by the micro-electronics industry. This silicon is of unnecessarily high quality for PV and it is believed that to use lower-grade silicon would substantially reduce the energy input [27].

3.5 Solar power system

The main building constructions of the proposed solar power system are PV panels, Controller, DC-AC inverter, and also diesel generator.

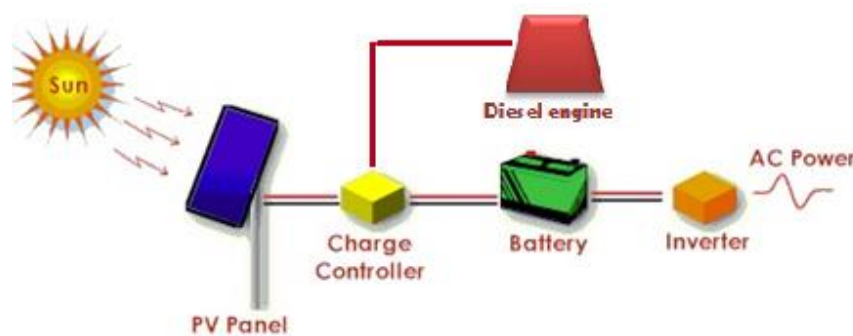

Figure 3.8: Typical PV power system

1. Solar PV

The word 'photovoltaic' consists of the two words, photo and Volta. Photo stands for light is the unit of the electrical voltage. In other words, photovoltaic means the direct conversion of sunlight to electricity [28]. Solar PV modules collect the solar energy and convert it into direct current (DC) electricity.

2. Battery-bank

Batteries in PV system are needed when sunlight is unavailable. So the longest period without sunlight is an important factor in sizing batteries with considering cost effect. In the previous designs, batteries were not selected carefully to overcome the absence of sunlight. Battery-bank can be connected to the system with a photovoltaic inverter. PV generators can be combined with a wind generator or diesel generator to create a hybrid system; thus reducing energy costs and increasing system reliability; however, operating complex systems needs a complex energy management system [28].

3. DC/DC converter

To connect a PV to an external system, it is necessary to boost its voltage or to increase its number. Therefore, a boost converter is used. A boost converter is a class of switching-mode power supply containing at least two semiconductor switches and at least one energy storage element. In addition, a capacitor is often added to the output of the converter to reduce the ripple of its output voltage [29]. There are three types of DC-DC converter:

- Buck converter (Step-down converter).
- Boost converter (Step-up converter) which is used in the research.
- Buck-Boost converter (Step-down/step-up converter).

Boost Steady-State Continuous Conduction Mode (CCM)

In continuous conduction mode, the boost power stage assumes two states per switching cycle. In the on state, Q1 is on and D1 is off. In the off state, Q1 is off and D1 is on. A simple linear circuit can represent each of the two states where the switches in the circuit are replaced by their equivalent circuit during each state. Figure 3.9 shows the linear circuit diagram for each of the two states.

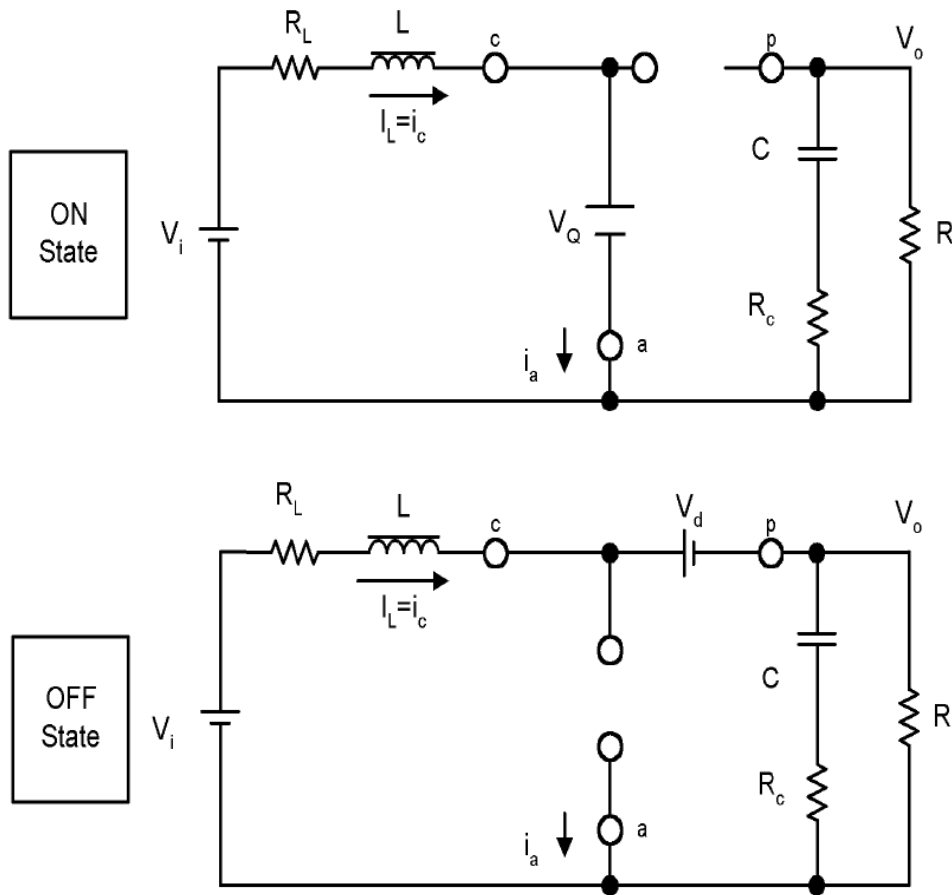

Figure 3.9: Boost Power Stage States

In the On-state, the switch is closed, resulting in an increase in the inductor current. In the Off-state, the switch is open and the only path offered to inductor current is through the fly back diode D , the capacitor C and the load R . This result in transferring the energy accumulated during the On-state into the capacitor.

The duration of the on state is $D \times T_s = T_{ON}$, where D is the duty cycle set by the control circuit, expressed as a ratio of the switch on time to the time of one complete switching cycle, T_s . The duration of the off state is T_{OFF} [30].

Figure 3.10 show the voltage and current waveforms for boost converter

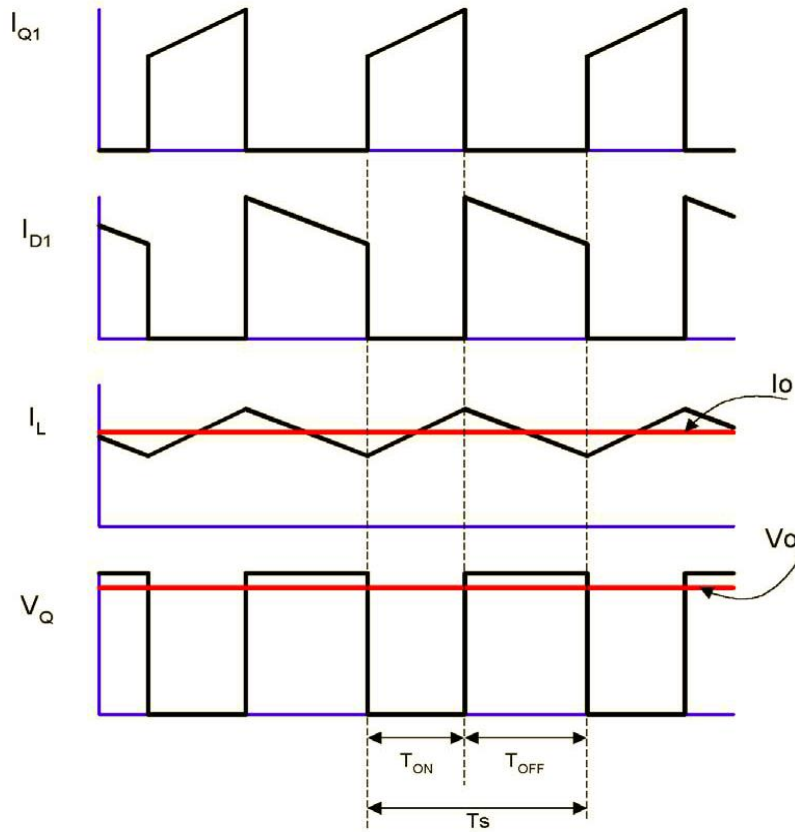

Figure 3.10: CCM Boost Power Stage Waveforms

Therefore, these two equations can be equated and solved for V_O to obtain the continuous conduction mode boost voltage conversion relationship:

$$V_O = (V_i - I_L * R_L) * \left(1 + \frac{T_{ON}}{T_{OFF}}\right) - V_d - V_Q * \left(\frac{T_{ON}}{T_{OFF}}\right) \quad (3.6)$$

And

$$D = \frac{T_{ON}}{T_{ON} + T_{OFF}} = \frac{T_{ON}}{T_s} \quad (3.7)$$

$$(1 - D) = \frac{T_{OFF}}{T_s} \quad (3.8)$$

The steady-state equation for V_O is:

$$V_O = \frac{V_i - V_L * R_L}{1 - D} - V_d - V_Q * \left(\frac{D}{1 - D}\right) \quad (3.9)$$

The above voltage conversion relationship for V_o illustrates that V_o can be adjusted by adjusting the duty cycle, D , and is always greater than the input because D is a number between 0 and 1. A common simplification is to assume V_Q , V_d , and R_L are small enough to ignore. The above equation simplifies considerably to:

$$V_o = \frac{V_i}{1-D} \quad (3.10)$$

4. Inverter

An AC averaged switched model inverter is implemented using to convert the direct current (DC) into alternating current (AC), at a switching frequency (f_s) greater than the AC line frequency (50Hz - 60Hz) and feeds it into an existing electrical grid. Equation (3.7) describes the relation between the input and the output voltage:

$$V_o = V_{in}(2D-1) \quad (3.11)$$

Where:

D: Duty cycle

Types of Solar Panel Power Inverters:

Stand Alone (Off-Grid) Inverters: They are the inverters that work separately from the grid. Electronic devices are connected to the inverter output directly. The main reason why they work separately from the grid is because there is no hardware that would enable them to work synchronously with the grid.

Stand-Alone inverters have DC input and AC output units. Output wave doesn't necessarily have to be full sine. They can have modified sine or true sine output structures. We will go into detail on those wave types shortly.

Grid Tie (Synchronous) Inverters: These are the inverters that are connected to the grid. The sine wave of the grid shows V-T (voltage-timing) compatibility. When the voltage of the grid has pick value, the inverter output voltage is also the same [29].

CHAPTER 4

SYSTEM DESIGN AND RESULTS

4.1 Introduction

Lotfi Zadeh conceived the concept of Fuzzy Logic (FL) in early 1960's [31]. Zadeh reasoned that people do not require precise, numerical information input, and yet they are capable of highly adaptive control [32]. This approach to set theory was not applied to control systems until the 70's. In 1974; Mamdani proposed to control a steam engine where the fuzzy inference system proposed by Mamdani is known as the Mamdani model in fuzzy system literature.

Benefits and Application of FL

- Fuzzy logic is used to control the complex and nonlinear systems without making analysis for these systems.
- Fuzzy control enables engineers to implement the control technique by human operators to make ease of describing the systems [33].
- Fuzzy logic is flexible with any given systems [34]. If any changes are happening in the system we do not need to start from the first step, but we can add some functions on top of it.
- Fuzzy logic can be blended with conventional technique to simplify their implementation.

There are many more applications of fuzzy logic.

- In washing machine, there is a soft and bad manner clothes, and there are different quantities of laundry. Control of washing cycle is based on these date.
- Robotics controls, Refrigerators for temperature control.
- Engine Control in the modern cars.

4.2 Fuzzy Sets

In crisp sets, an element in the universe has a well-defined membership or non-membership to a given set. Membership to a crisp set E can be defined through a membership function defined for every element x of the universe as:

$$\mu_{\mathbf{E}}(\mathbf{x}) = \begin{cases} \mathbf{1} \forall \mathbf{x} \in \mathbf{E} \\ \mathbf{0} \forall \mathbf{x} \notin \mathbf{E} \end{cases} \quad (4.1)$$

But for an element in a universe with fuzzy sets, the membership function can take any value between 0 and 1. This transition among various degrees of membership can be thought of as conforming to the fact that the boundaries of the fuzzy sets are vague and ambiguous. An example of a graphic for the membership function of a crisp set is illustrated in Figure 4.1.

Fuzzy membership of an element from the universe in this set is measured by a function that attempts to describe vagueness. In fuzzy logic, linguistic variables take on linguistic values which are words with associated degrees of membership in the set. Thus, instead of a variable temperature assuming a numerical value of 70 Co, it is treated as a linguistic variable that may assume, for example, linguistic values of "hot" with a degree of membership of 0.92, "very cool" with a degree of 0.06, or "very hot" with a degree of 0.7. Each linguistic term is associated with a fuzzy set, each of which has a defined membership function.

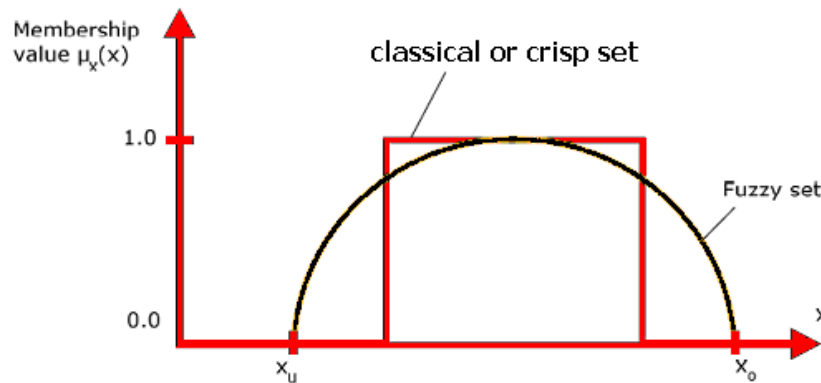

Figure 4.1: Fuzzy and Classical sets

Formally, a fuzzy set is defined as a set of pairs where each element in the universe F has a degree of membership associated with it:

$$\mathbf{E} = \{(\mathbf{x}, \mu_{\mathbf{E}}(\mathbf{x})) \mid \mathbf{x} \in \mathbf{F}, \mu_{\mathbf{E}}(\mathbf{x}) \in [0, 1]\} \quad (4.2)$$

The value $\mu_{\mathbf{E}}(\mathbf{x})$ is the degree of membership of object x to the fuzzy set E where $\mu_{\mathbf{E}}(\mathbf{x}) = 0$ means that x does not belong at all to the set, while $\mu_{\mathbf{E}}(\mathbf{x}) = 1$ means that the element is totally within the set [33].

Every fuzzy set can be represented by its membership function. The shape of membership function depends on the application and can be monotonic, triangular, trapezoidal or bell shaped as shown in Figure 4.2 [35].

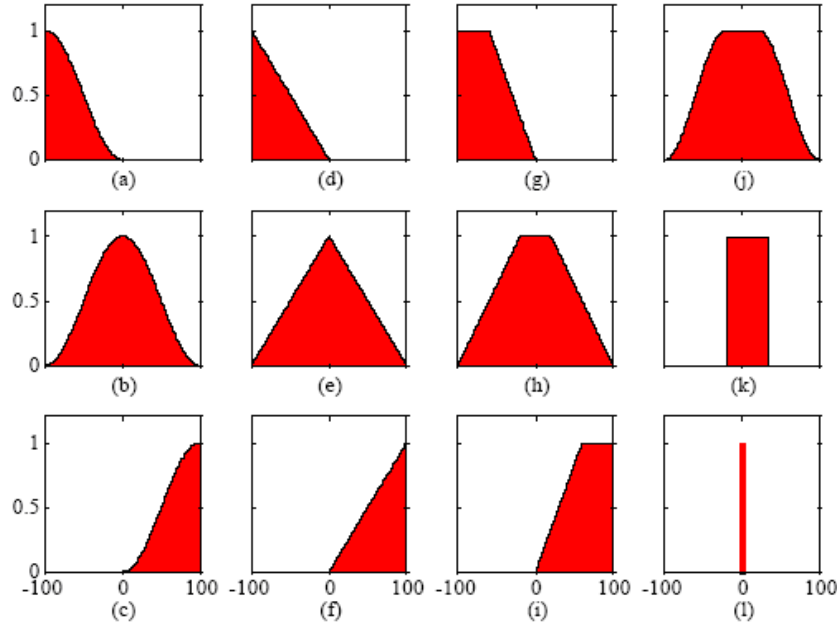

Figure 4.2: Different shapes of membership functions (a) s_function, (b) π _function, (c) z_function, (d-e-f) triangular versions, (g-i) trapezoidal versions, (j) flat π _function, (k) rectangle, (l) singleton.

The membership function could be defined as a graphical representation of the quantity of participation of the inputs. It links a value with each of the inputs parameters that are treated, defines functional overlap amongst inputs, and finally defines an output parameter. The rules usually take the input membership parameters as features to establish their weight over the "fuzzy output sets" of the final output response. Once the functions are deducted, scaled, and combined, they have to be defuzzified into a crisp output which leads the application. There are some different memberships functions linked to each input and output parameter [36].

As an example to represent the property: warm of the linguistic variable "temperature" shown in Figure 4.3. If the measured temperature in one system is x , then the level of membership of x in the fuzzy set positive small is given by $\mu(x)$ and it is 0.7. We can say that the level of truth for the proposition: "The temperature x is warm is 0.7 or 70%".

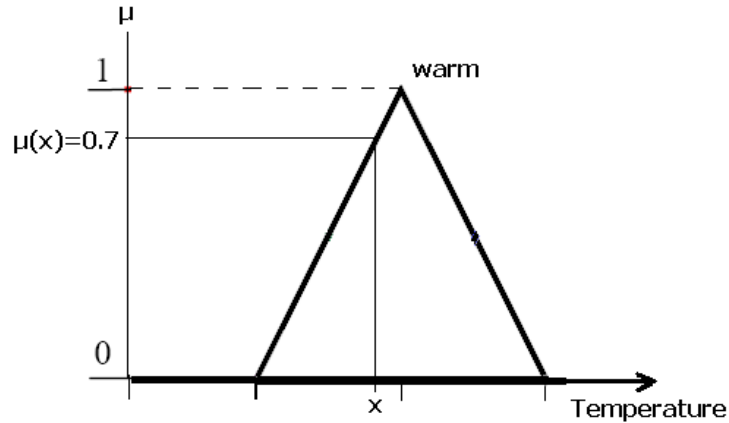

Figure 4.3: Membership function example (warm temperature)

One of the first steps in every fuzzy application is to define the universe of discourse (dynamic range) for every linguistic variable. The set of terms: T(temperature) can be characterized as fuzzy sets whose membership functions are shown in Figure 4.4. Every fuzzy set in a universe of discourse represents one linguistic value or label.

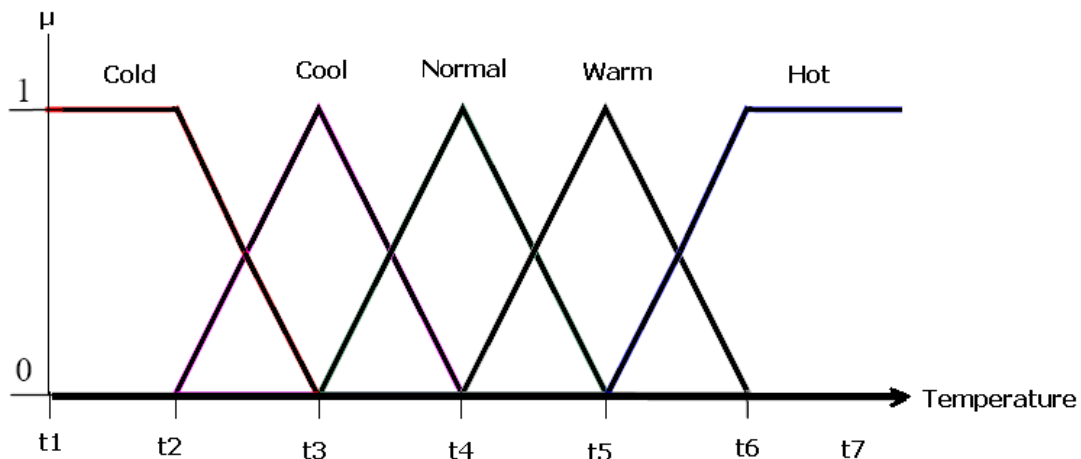

Figure 4.4: Universe of discourse for linguistic variable: temperature

Basic operations on sets in crisp set theory are the set complement, set intersection, and set union. Fuzzy set operations are very important because they can describe intersections between variables for a given element x of the universe, the following function theoretic operations for the set theoretic operations of complement, intersection, and union are defined in reference [37].

4.3 Fuzzy Logic

Fuzzy Logic is a control system methodology designed for solving problems implemented in a widely range of systems such as: simple and small devices, microcontrollers, large systems joined to networks, workstations or normal control systems. It may be developed in hardware, software, or both in combination [38].

Fuzzy logic extends conventional Boolean logic to handle the concept of the partial truth the values falling between “totally true” and “totally false”. These values are dealt with using degree of membership of an element to a set. The degree of membership can take any real value in the interval [0, 1]. Fuzzy logic makes it possible to imitate the behavior of human logic, which tends to work with “fuzzy” concepts of truth [34].

Fuzzy Logic shows a usual rule-based IF condition AND condition THEN action. It approaches to a solving control problem rather than intending to model a system based on math's. The Fuzzy Logic model is based on empiric experience, relying on a number of samples rather than some technical understanding of the problem to be solved [39].

4.3.1 Fuzzy Logic Controller Structure

The basic parts of every fuzzy controller are displayed in Figure 4.5 [32] .The fuzzy logic controller (FLC) is composed of a fuzzification interface, knowledge base, inference engine, and defuzzification interface.

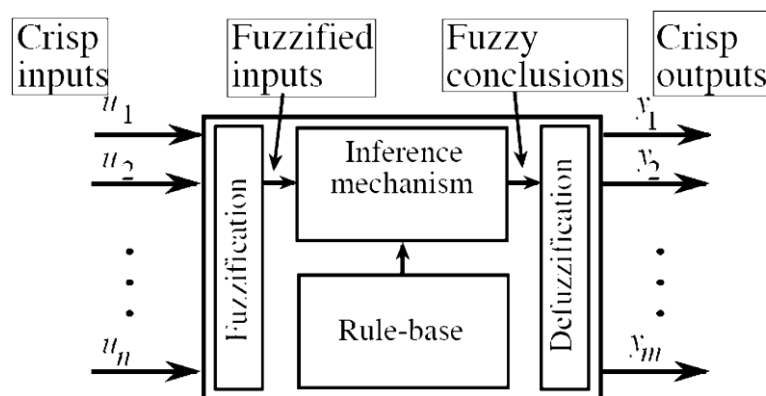

Figure 4.5: Basic parts of a Fuzzy Controller

The fuzzifier maps the input crisp numbers into the fuzzy sets to obtain degrees of membership. It is needed in order to activate rules, which are in terms of the linguistic variables. The inference engine of the FLC maps the antecedent fuzzy (IF part) sets into consequent fuzzy sets (THEN part). This engine handles the way in which the rules are combined. The defuzzifier maps output fuzzy sets into a crisp number, which becomes the output of the FLC [40].

4.3.2 Fuzzification

The first step in fuzzy logic processing the crisp inputs is transformed into fuzzy inputs (Figure 4.6). This transformation is called fuzzification. The system must turn numeric values into language and corresponding domains to allow the fuzzy inference engine to inference to transform crisp input into fuzzy input, membership functions must first be defined for each input. Once membership functions are defined, fuzzification takes a real time input value, such as temperature, and compares it with the stored membership function information to produce fuzzy input values. Fuzzification plays an important role in dealing with uncertain information which might be objective in nature.

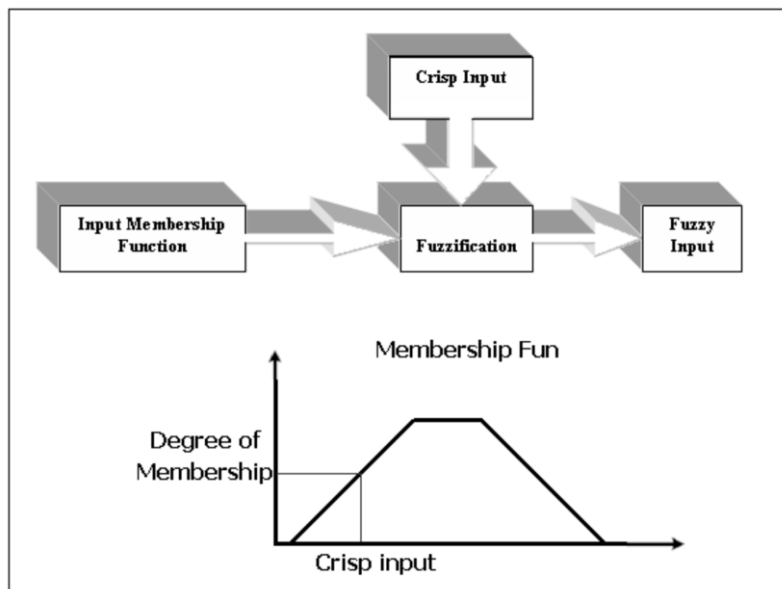

Figure 4.6: Fuzzification

4.3.3 Fuzzy Inference

Knowledge base is the inference basis for fuzzy control. It defines all relevant language control rules and parameters. The knowledge base is the core of a fuzzy control system.

Basically a linguistic controller contains rules in the (if-then) format [35]. The Rule base is the cornerstone of the fuzzy model. The expert knowledge, which is assumed to be given as a number of if-then rules, is stored in a fuzzy rule base [40]. The rules may use several variables both in the condition and the conclusion of the rules.

There are many inference methods, which deals with fuzzy inference like: Mamdani method, Larsen method, Tsukamoto method, and the Sugeno style inference, or Takagi-Sugeno-Kang (TSK) method. The most important and widely used in fuzzy controllers are the Mamdani and Takagi-Sugeno methods.

4.3.4 Defuzzification

The reverse of fuzzification, defuzzification [41] converts the resulted fuzzy sets defined by the inference engine to the output of the model to a standard crisp signal. This process gives output control signals to the controlled system [34]. There is no systematic procedure for choosing a good defuzzification strategy, but the selection of defuzzification procedure depends on the properties of the application [42].

There are several methods available for defuzzification of fuzzy control inference; these methods can be classified into different classes based on a common basis [43].

The most important one for control are described in the following:

Center of gravity (COG):

It is a basic general defuzzification method that determines the value of the abscissa of the center of gravity of the area below the membership function (Figure 4.7).

$$\text{COG} = \frac{\sum_{x_{\min}}^{x_{\max}} x * \mu(x)}{\sum_{x_{\min}}^{x_{\max}} \mu(x)} \quad (4.6)$$

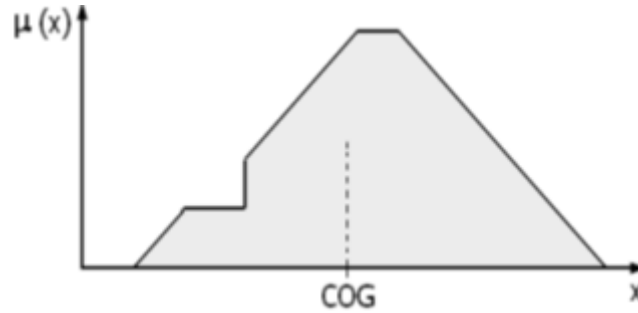

Figure 4.7: Center of gravity (COG) defuzzification method

For more details about other methods you can see reference [43].

4.4 Fuzzy Logic Control in Solar Power System

4.4.1 Fuzzy Logic Controller

In this study the proposed Fuzzy controller, as shown in Figure 4.8, has two inputs, i.e. error and change in error of the reference current with membership functions, the output is the desired current. Each input has seven linguistic variables. FLC has been constructed and the block diagram shows the FLC for the of proposed PV control system.

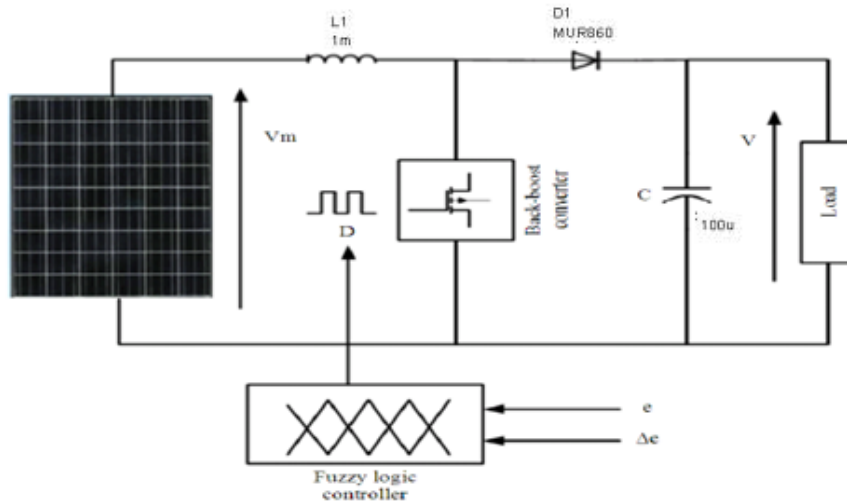

Figure 4.8: The block diagram of proposed PV control system

4.4.2 FLC design

FLC has two inputs which are: error and the change in error, and one output feed the charge controller. Input of the FLC will be current and the voltage constant as shown in Figure 4.9. Rules of controller depend on a relation of error and change of error for PV current. As an example if the error is positive (desired current –reference current)

and the change error (error – past error) is negative which means that the response is going in the increase; hence, the FLC will go forward in this direction.

Using the same criteria when the error is negative and change of error is bigger negative; hence, the response is going in decrease.

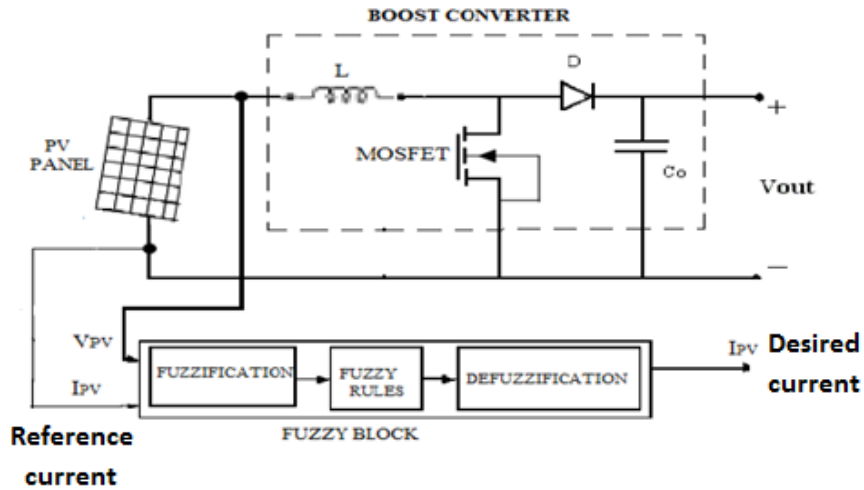

Figure 4.9: FLC controller

There are two widely used approaches in FLC implementation: Mamdani and Sugeno. In this thesis, Mamdani approach has been used to implement FLC for solar power system. FLC contains three basic parts: Fuzzification, Base rule, and Defuzzification. Figure 4.10 illustrates the fuzzy inputs and output of the FLC

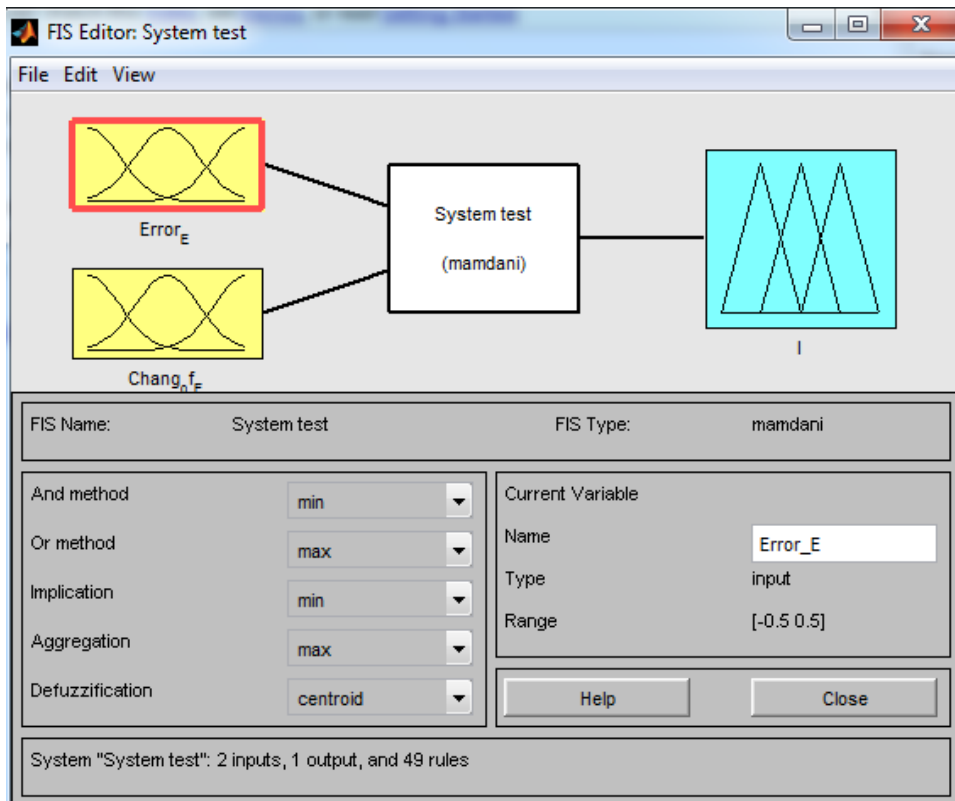

Figure 4.10: The interface of FLC for system

4.4.2.1 Fuzzification

Figure 4.11 illustrates the fuzzy set of the Error input which contains 7 Triangular memberships

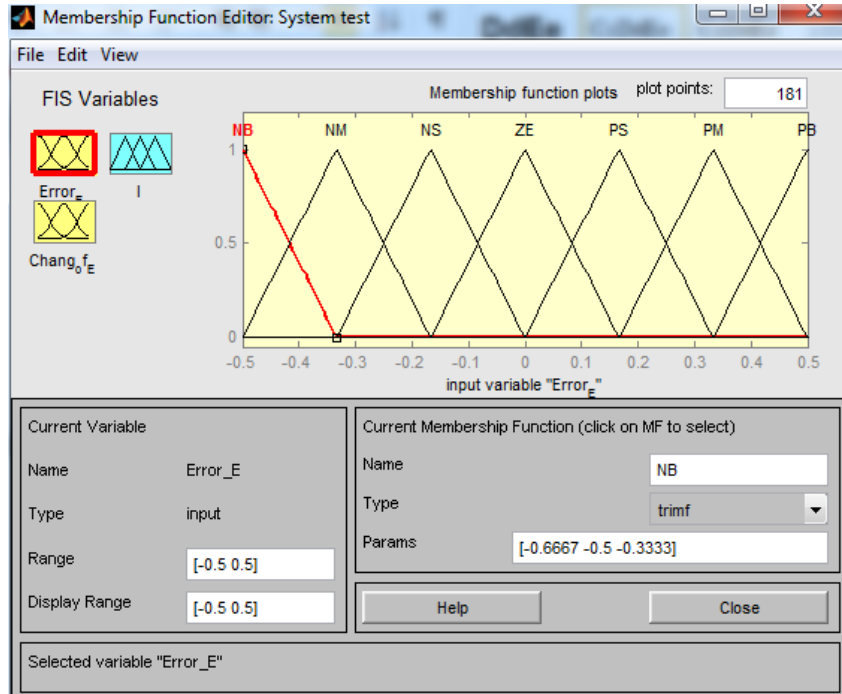

Figure 4.11: Input Membership function for given error

Figure 4.12 illustrates the fuzzy set of the Change of Error input which contains 7 Triangular memberships.

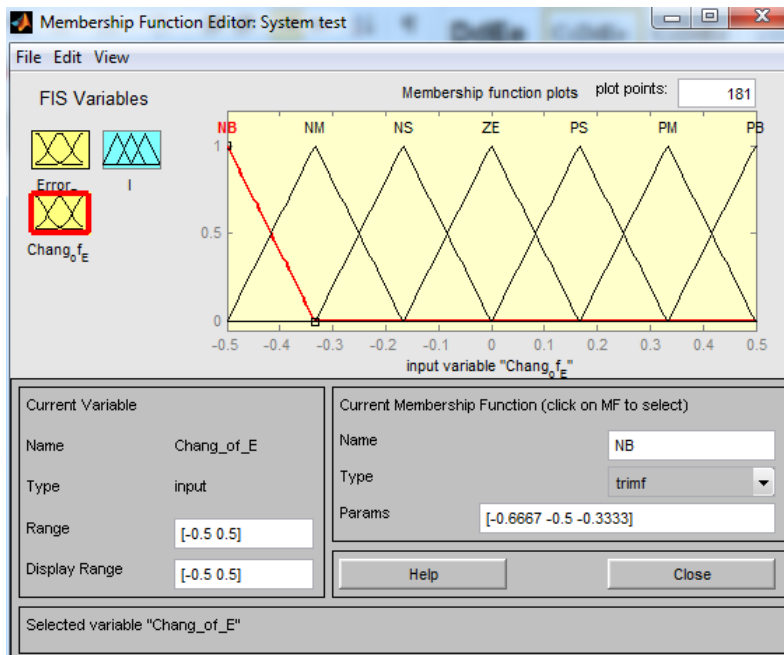

Figure 4.12: Input Membership function for change in error

Figure 4.13 illustrates the fuzzy set of the output which contains 7 Triangular memberships.

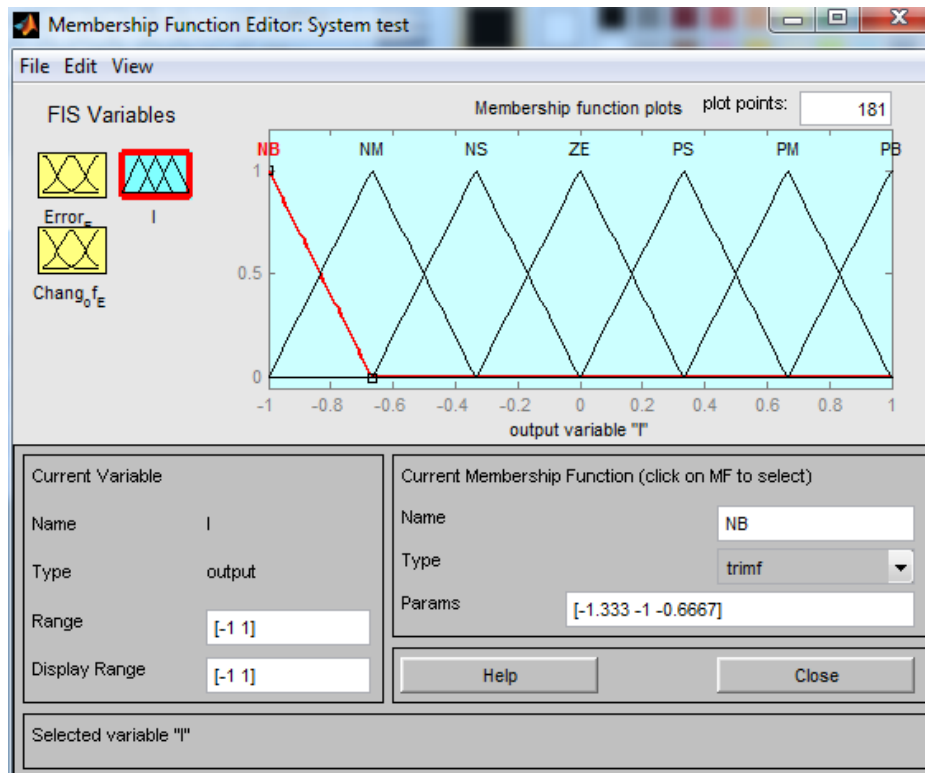

Figure 4.13: Output Membership Function

4.4.2.2 Control rule base

The knowledge base defined the rules for the desired relationship between the input and output variables in terms of the membership functions illustrated in (Table 1). The control rules are evaluated by an inference mechanism, and represented as a set of: IF Error is ... and Change of Error is ... THEN the output will ...

Figure 4.14 shows an example of a rule: IF Error is NS and Change of Error is ZE THEN the output is NS.



Figure 4.14: General Rule Base

Table 1: Fuzzy Table

Error	Chang of Error						
	NB	NM	NS	ZE	PS	PM	PB
NB	NB	NB	NB	NB	NM	NS	ZE
NM	NB	NB	NB	NM	NS	ZE	PS
NS	NB	NB	NM	NS	ZE	PS	PM
ZE	NB	NM	NS	ZE	PS	PM	PB
PS	NM	NS	ZE	PS	PM	PB	PB
PM	NS	ZE	PS	PM	PB	PB	PB
PB	ZE	PS	PM	PB	PB	PB	PB

The linguistic variables used are:

NB: Negative Big.

NM: Negative Medium.

NS: Negative Small.

ZE: Zero.

PS: Positive Small.

PM: Positive Medium.

PB: Positive Big.

Consider that the actual current is high compared with reference current, so the error obtained is negative. If the change in error is also negative then the fuzzy controller is made to operate in negative region. Now the duty cycle of the converter is reduced to minimize the error so that the battery tends to charge as in normal stats.

Figure 4.15 show the surface of the base rules using in FLC which is the representation for the inputs and output values of the controller in three dimensions.

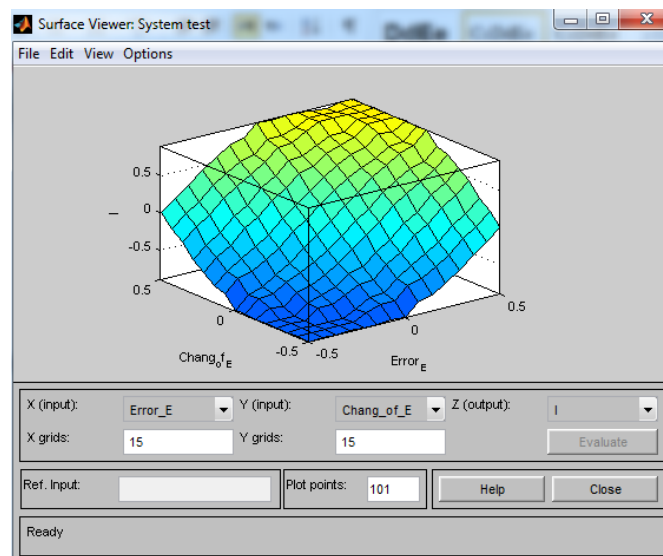

Figure 4.15: Surface shape (E, CE and output I)

Figures 4.16 and 4.17 show the error and change of error respectively the difference between them is so little and the percentage of error is about 0.013 which give high performance of the FLC output.

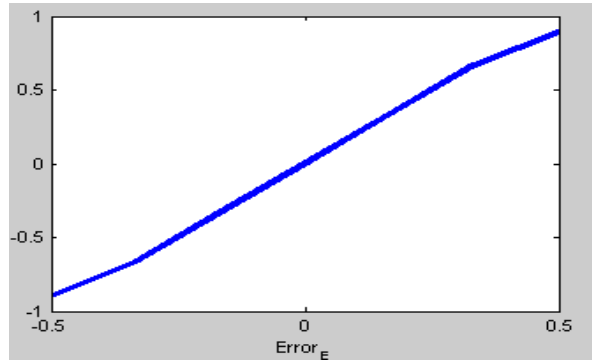

Figure 4.16: Input – error

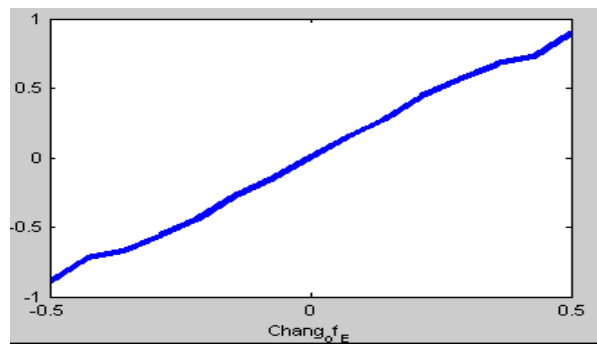

Figure 4.17: Input - change in error

4.4.2.3 Defuzzification

Similarly, since the energy system cannot respond directly to the fuzzy controls, the fuzzy control sets generated by the fuzzy algorithm have to be changed back by using the method of defuzzification. As illustrated in Chapter 3, the center of gravity (COG) method is widely used in Mamdani approach which has been selected in this thesis to compute the output of the FLC.

Figure (4.18) shows the output of the FLC which we can get it by applying equation (4.6)

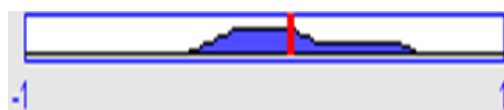

Figure 4.18: Output of the FLC

Simulation has been done on a simplified model of a grid connected photovoltaic array via a dc link line commutated inverter. The input of FLC controller is PV current and constant line voltage, the output is the desired current which gives the maximum power that can be generated under given conditions.

4.4.3 Results and Discussion

According to error and change in error, as shown in Figures 4.16 and 4.17, the fuzzy controller is made to select the appropriate duty cycle of the converter. So this intelligent controller will make the battery to charge immediately with the standard charging current. After making defuzzification step we will get crisp value of current, and as we know that the value of voltage is constant. The values of current before applying fuzzy control and after implementing fuzzy controller (Table 2). The data of the currents get from the solar system installed in UCAS.

Figure 4.19 illustrates the deference between the values before applying fuzzy controller (reference value of I) and after applying FLC (desired value of I). We can see that the desired value on the proposed system increases by decreasing the error which make the power increase as $P=I*V$, and V is constant.

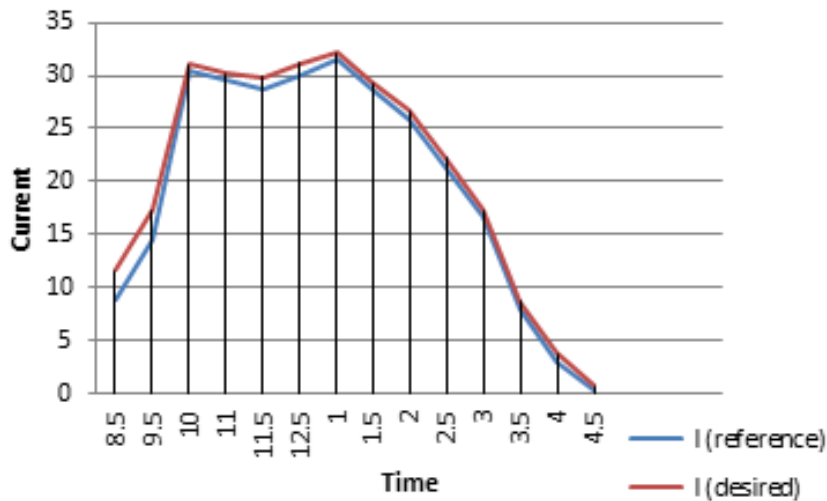

Figure 4.19: Values of reference and desired current

Table 2: Values of PV current

Time	I (reference)	I (desired)
8:30 AM	8.8	11.7
9:30 AM	14.5	17.3
10:00 AM	30.4	31
11:00 AM	29.6	30.2
11:30 AM	28.8	29.8
12:30 PM	30.1	31.2
13:00 PM	31.5	32.1
13:30 PM	28.6	29.3
14:00 PM	25.9	26.7
14:30 PM	21.3	22.2
15:00 PM	16.8	17.3
15:30 PM	8	8.7
16:00 PM	3.1	3.8
16:30 PM	0.4	0.8

For example at first row in (Table 2):

$$P_{\text{Before}} = I * V = 8.8 * 12 = 105.6W$$

$$P_{\text{After}} = I * V = 11.7 * 12 = 140.4W$$

This result conclude that when we apply FLC to the proposed solar power system we get more power depend on the output current which is controlled by the rules of FLC applied on the system.

In this section, we generate the error and change in error signals as inputs for the FLC as shown in Figure 4.20.

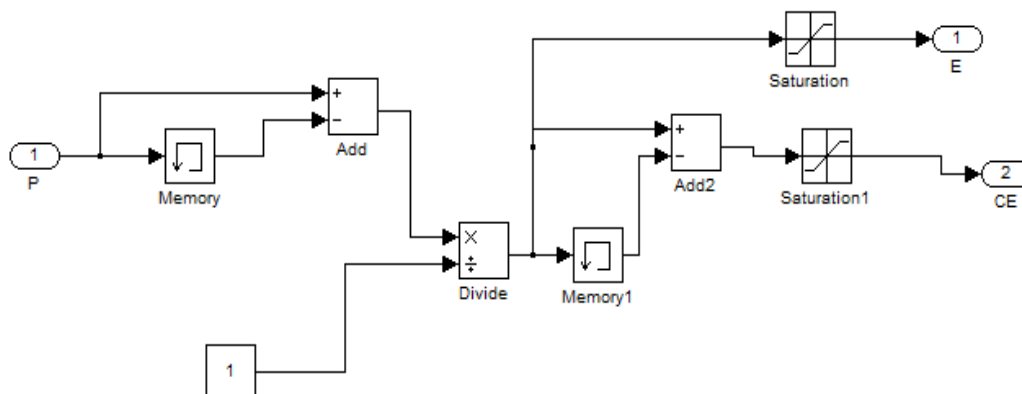

Figure 4.20: Generating the Error and Change in Error

After generating the error and change in error as shown, we converted to one subsystem block with input and outputs (E, ΔE) which collected in multiplexer to inter in FLC as shown in Figure 4.21.

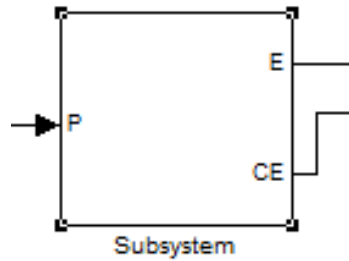

Figure 4.21: Error and change of error model subsystem

Now, we want to implement the FLC by using Simulink as shown in figure 4.22. The system's efficiency increased about 20% in average calculation, because the reference current is not the same.

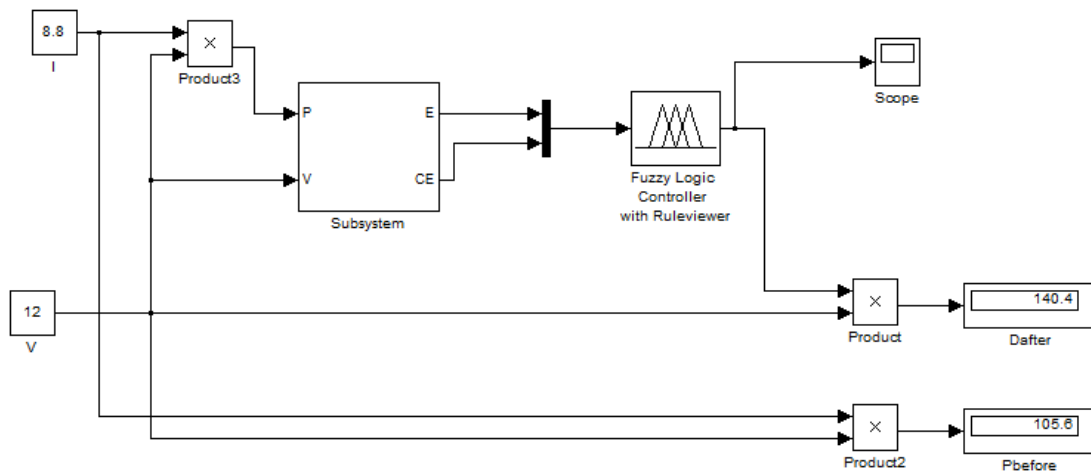

Figure 4.22: Output of the solar system using FLC

CHAPTER 5

CONCLUSION AND FUTURE WORK

5.1 Conclusion

In this thesis we understood a lot of information about solar power system which is a photovoltaic technology, Fuzzy Logic Control and how to implement it to increase the efficiency of the system.

In Gaza Strip we have big problem in electrical power generation, since the supplies does not cover the demand; thus renewable energy sources such as solar energy may play an important role in electric power generation, since it is clean and unlimited. One of the drawbacks on solar system is the high cost installation and its efficiency. To increase its efficiency regulating its output current is one way.

In this study, an interested to improve the power of a stand-alone solar power system. The proposed system was controlled using a fuzzy logic controller to get the maximum power available at the output of the PV array by making regulation of the PV current. PV current feeding the DC/ DC converter in order to get a regulated current by minimize the duty cycle of the converter, fuzzy logic controller regulates this current and get the desired current which is better response then feed it to the inverter. This controller was tested using MATLAB software program. The study showed that the fuzzy logic controller was better in response and it increased the system's efficiency.

5.2 Future work

Using Sugeno approach to implement the fuzzy control rules, and compared with Mamdani. Also a good area of research is using optimization method to reduce the rules of the controller. Another scope is hardware implementation for the system.

REFERENCES

- [1] UNDP, Sustainable Energy, http://www.undp.org/content/undp/en/home/ourwork/environmentandenergy/focus_areas/sustainable-energy.html [Access Date: 26/6/2013].
- [2] Mahmoud Ismail, "Simulation of a Hybrid Power System Consisting of Wind Turbine, PV, Storage Battery and Diesel Generator with Compensation Network: Design, Optimization and Economical Evaluation", Master Thesis, An-Najah National University, Nablus, Palestine, 2008.
- [3] BBC News Middle East, Life in the Gaza Strip, Available at: <http://www.bbc.co.uk>, Update at 22 November 2012, [Access Date: 20/11/2013].
- [4] Palestinian Energy & Natural Resources Authority (PENRA), available at, http://penra.gov.ps/index.php?option=com_content&view=article&id=590:2011-08-24-06-0943&catid=1:2009-12-29-11-09-44&Itemid=29, [Access on: 28/11/2013].
- [5] Luis J. Ricalde, Eduardo Ordoñez, Manuel Gamez and Edgar N. Sanchez, "Design of a Smart Grid Management System with Renewable Energy Generation", IEEE Computational Intelligence Applications In Smart Grid (CIASG), Paris, pages 1 – 4, 2011
- [6] Kevin Mets, Matthias Strobbe, Tom Verschueren, Thomas Roelens, Filip De Turck and Chris Develder, "Distributed Multi-Agent Algorithm for Residential Energy Management in Smart Grids", IEEE Network Operations and Management Symposium (NOMS), Netherlands , pages 435 – 443, 2012.
- [7] A. Michiorri, R. Girard, G. Kariniotakis, C. Lebossé and S. Albou, "A Local Energy Management System for Solar Integration and Improved Security of Supply: the Nice Grid Project", 3rd IEEE PES Innovative Smart Grid Technologies Europe (ISGT Europe), Berlin, pages 1 – 6, 2012.
- [8] Kalpesh A. Joshi and N. M. Pindoriya, "Impact Investigation of Rooftop Solar PV System: A Case Study in India," 3rd IEEE PES Innovative Smart Grid Technologies Europe (ISGT Europe), Berlin, pages 1 – 8, 2012.
- [9] P.I. Muoka, M.E. Haque, A. Gargoom, and M. Negnevitsky, "Modeling, Simulation and Hardware Implementation of a PV Power Plant in a Distributed Energy Generation System," University of Tasmania, Australia, pages 1 – 6, 2013.
- [10] Chao-Shun Chen, Chia-Hung Lin, Shih-Chieh Hsieh, Wei-Lin Hsieh, "Development of Smart Distribution Grid," IEEE 2nd International Symposium on Next-Generation Electronics (ISNE), February 25-26, Taiwan, pages 4 – 6, 2013.
- [11] Shadi N. AlBarqouni, "Re-Evaluation and Re-Design Stand-Alone PV Solar Lighting Projects in Gaza," Master Thesis, Electrical Engineering Department, Islamic University of Gaza, Gaza, Palestine, 2010.

- [12] Mohammed S. EL-Moghany, "Sun and Maximum Power Point Tracking in Solar Array Systems Using Fuzzy Controllers Via FPGA ," Master Thesis, Electrical Engineering Department, Islamic University of Gaza, Gaza, Palestine, 2011.
- [13] UNDP. "World Energy Assessment", United Nations Development Programme , NewYork , 2009.
- [14] Basel T. Q. Yaseen, "Renewable Energy Applications in Palestine", Palestinian Energy and Environment Research Center (PEC)- Energy Authority, Tehnical report, Palestine, 2007.
- [15] Mohamed Ouda. "Prospects of Renewable Energy in Gaza Strip", Energy Research and Development Center, Technical report, The Islamic University of Gaza, 2008.
- [16] L F Yeung, Paul Hodgson and Robin Bradbeer, "Generating Electricity Using Ocean", Technical report, City University of Hong Kong, July 2007.
- [17] Jamal M. Elzebda and Shokri Z. El-Zaza, "Development of Wave Energy Conversion Device - Gaza Shoreline", Master Thisis, Fuculty of Civil Engineering, The Islamic University of Gaza, 2007.
- [18] G. Boyle , Renewable Energy, OXFORD university press, 2004.
- [19] Marwan Mahmoud , Renewable Energy Technology 1 &2 *Lecture notes*, An-Najah National University. 2006-2007.
- [20] Roger A. Messenger and Jerry Ventre, *Photovoltaic Systems Engineering*, 2nd edition, CRC press, 2004.
- [21] Iakovos Tzanakis. "Combining Wind and Solar Energy to Meet Demands in the Built Environment", Master Thesis, Energy Systems Research Unit. University of Strathclyde, Glasgow, UK, 2005-2006.
- [22] Research and markets Brochure. Available at:
<http://www.researchandmarkets.com/reports/328418/> [Access Date: 4/12/2013]
- [23] Technical Status of Thin Film Solar Cells. Available at:
[http:// www . udel.edu/iec/status.html](http://www.udel.edu/iec/status.html) [Access on: 20 November 2013]
- [24] Solar cell-Wikipedia, the free encyclopedia. Available at:
[http:// en.wikipedia.org/wiki/Solar_cell](http://en.wikipedia.org/wiki/Solar_cell) [Access date 28/12/2013]
- [25] EV World Blogs: Personal Perspectives on the Future In Motion. Available at:
<http://www.evworld.com/blogs/index.cfm?page=blogentry&blogid=497&authorid=183&archive=0> [Access Date: 10/12/2013]
- [26] PV payback .Available at: <http://www.gosolarnow.com/pdf%20files/pvpaybackHP.pdf> [Access Date: 10/12/2013]

- [27] Environmental Impact of Photovoltaic. Electrification in Rural Areas. Available at: <http://www.tiedekirjasto.helsinki.fi:8080/bitstream/1975/295/1>, [Access Date: 12/12/2013]
- [28] V. Quaschnig, *Understanding Renewable Energy Systems*, London, 2005.
- [29] E. M. Natsheh, A. Albarbar and A.-R. Natsheh, "An Automated Tool for Smart Grid Solar Power Systems" *Power and Energy Magazine*, IEEE, 2010
- [30] Understanding Boost Power Stages in Switchmode Power Supplies, Application report TI Literature Number SLVA061, 1999.
- [31] L. A. Zadeh, "Fuzzy sets," *Information and control*, 8, 338-353, 1965.
- [32] K. M. Passino and S. Yurkovich, *Fuzzy Control*, Addison-Wesley, 1998.
- [33] B.Riza, Sheldon,T., *Fuzzy Systems Design Principles Building Fuzzy IF-THEN Rule Bases*, IEEE PRESS, 1997.
- [34] John Yen & Langari Reza, *Fuzzy Logic Intelligence Control and Information*, Prentice- Hall, Englewood Cliffs, 1999.
- [35] J. Jantzen, Design Of Fuzzy Controllers. Technical report no 98-E 864, University of Denmark, 1998.
- [36] P. Funk, Online fuzzy case-based individual stress diagnosing system, Master Thesis, Mälardalen University, Västerås, Sweden,2005.
- [37] M. Jamshidi, N. Vadiiee, and T. Ross, *Fuzzy Logic and Control Software and Hardware Applications*, Englewood Cliffs: Prentice Hall, Inc,1993.
- [38] S. Kaehler, "Fuzzy Logic Tutorial ,Published at Encoder, the newsletter of the Seattle Robotics Society", 2009, [URL:http://www.seattlerobotics.org/encoder/mar98/fuz/flindex.html](http://www.seattlerobotics.org/encoder/mar98/fuz/flindex.html).
- [39] S. Guo, L. Peter, A reconfigurable analog fuzzy logic controller, IEEE World congress on computational intelligence. Proceeding of the Third IEEE conference on, Vol. 1:pgs. 124-128, 1994.
- [40] D. Liu, J. Abonyi, *Software of Fuzzy Logic Control*, New York: Oxford,2005.
- [41] Z. Xinhong, W. Zongxian, and Y. Zhengda, Intelligent Solar Tracking Control System Implemented on an FPGA, Nios II Embedded Processor Design Contest Outstanding Designs,2007.
- [42] C.C. Lee, Fuzzy Logic in Control Systems: Fuzzy Logic Controller, Part II. *IEEE Transactions on Systems, Man and Cybernetics*, 20(2):419 – 435, 1990.
- [43] W. Leekwijck, and E. Kerre, Defuzzification: criteria and classification, *Fuzzy Sets and Systems* 108 159-178, 1999.

APPENDIX

The Rule Base of Mamdani Fuzzy Controller for solar power system:

- 1) If Error is NB and Change of Error is NB then Current is NB
- 2) If Error is NB and Change of Error is NM then Current is NB
- 3) If Error is NB and Change of Error is NS then Current is NB
- 4) If Error is NB and Change of Error is ZE then Current is NB
- 5) If Error is NB and Change of Error is PS then Current is NM
- 6) If Error is NB and Change of Error is PM then Current is NS
- 7) If Error is NB and Change of Error is PB then Current is ZE
- 8) If Error is NM and Change of Error is NB then Current is NB
- 9) If Error is NM and Change of Error is NM then Current is NB
- 10) If Error is NM and Change of Error is NS then Current is NB
- 11) If Error is NM and Change of Error is ZE then Current is NM
- 12) If Error is NM and Change of Error is PS then Current is NS
- 13) If Error is NM and Change of Error is PM then Current is ZE
- 14) If Error is NM and Change of Error is PB then Current is PS
- 15) If Error is NS and Change of Error is NB then Current is NB
- 16) If Error is NS and Change of Error is NM then Current is NB
- 17) If Error is NS and Change of Error is NS then Current is NM
- 18) If Error is NS and Change of Error is ZE then Current is NS
- 19) If Error is NS and Change of Error is PS then Current is ZE
- 20) If Error is NS and Change of Error is PM then Current is PS
- 21) If Error is ZE and Change of Error is PB then Current is PM
- 22) If Error is ZE and Change of Error is NB then Current is NB
- 23) If Error is ZE and Change of Error is NM then Current is NM
- 24) If Error is ZE and Change of Error is NS then Current is NS
- 25) If Error is ZE and Change of Error is ZE then Current is ZE
- 26) If Error is ZE and Change of Error is PS then Current is PS
- 27) If Error is ZE and Change of Error is PM then Current is PM
- 28) If Error is ZE and Change of Error is PB then Current is PB
- 29) If Error is PS and Change of Error is NB then Current is NM
- 30) If Error is PS and Change of Error is NM then Current is NS

- 31) If Error is PS and Change of Error is NS then Current is ZE
- 32) If Error is PS and Change of Error is ZE then Current is PS
- 33) If Error is PS and Change of Error is PS then Current is PM
- 34) If Error is PS and Change of Error is PM then Current is PB
- 35) If Error is PS and Change of Error is PB then Current is PB
- 36) If Error is PM and Change of Error is NB then Current is NS
- 37) If Error is PM and Change of Error is NM then Current is ZE
- 38) If Error is PM and Change of Error is NS then Current is PS
- 39) If Error is PM and Change of Error is ZE then Current is PM
- 40) If Error is PM and Change of Error is PS then Current is PB
- 41) If Error is PM and Change of Error is PM then Current is PB
- 42) If Error is PM and Change of Error is PB then Current is PB
- 43) If Error is PB and Change of Error is NB then Current is ZE
- 44) If Error is PB and Change of Error is NM then Current is PS
- 45) If Error is PB and Change of Error is NS then Current is PM
- 46) If Error is PB and Change of Error is ZE then Current is PB
- 47) If Error is PB and Change of Error is PS then Current is PB
- 48) If Error is PB and Change of Error is PM then Current is PB
- 49) If Error is PB and Change of Error is PB then Current is PB