

Electronic Thesis and Dissertation Repository

---

September 2015

# Understanding Nurses' Knowledge Work

Heidi M. Siu

*The University of Western Ontario*

Supervisor

Dr. Heather Laschinger

*The University of Western Ontario*

Graduate Program in Nursing

A thesis submitted in partial fulfillment of the requirements for the degree in Doctor of Philosophy

© Heidi M. Siu 2015

Follow this and additional works at: <https://ir.lib.uwo.ca/etd>

 Part of the [Nursing Administration Commons](#)

---

## Recommended Citation

Siu, Heidi M., "Understanding Nurses' Knowledge Work" (2015). *Electronic Thesis and Dissertation Repository*. 3222.  
<https://ir.lib.uwo.ca/etd/3222>

This Dissertation/Thesis is brought to you for free and open access by Scholarship@Western. It has been accepted for inclusion in Electronic Thesis and Dissertation Repository by an authorized administrator of Scholarship@Western. For more information, please contact [tadam@uwo.ca](mailto:tadam@uwo.ca).

UNDERSTANDING NURSES' KNOWLEDGE WORK

(Thesis format: Monograph)

by

Heidi M. Siu

Graduate Program in Nursing

A thesis submitted in partial fulfillment  
of the requirements for the degree of  
Doctor of Philosophy

The School of Graduate and Postdoctoral Studies  
The University of Western Ontario  
London, Ontario, Canada

© Heidi M. Siu 2015

## ABSTRACT

Hospitals are increasingly investing in technologies and electronic knowledge management systems to improve patient care outcomes. Yet, effective implementation of these initiatives has been difficult with questionable return on investment outcomes (Ontario Hospital Association [OHA], 2007, 2008). Paton (2009) argues that understanding how employees put their knowledge into action at work is essential to successful knowledge management for organizations. Thus, strategies that target nurses' knowledge work may be more effective for hospitals; particularly in times of mounting fiscal deficits and demands for health services.

This study examined the behaviors, influences, and outcomes of nurses' knowledge work. The hypothesized model was based on Kelloway & Barling's (2000) knowledge work theory; explaining the impact of empowering leadership on nurses' accountability, role-breadth self-efficacy, and control over practice to influence their knowledge work behaviours and ultimately, patient care delivery outcomes. The model was tested on a random sample of 318 registered nurses in Ontario, and initially demonstrated poor fit with the observed data; with further refinement to improve the overall model fit [ $\chi^2(df) = 512.66 (199), p < .001, SRMR = .064, CFI = .91, RMSEA = .071$ ].

Final model results suggest that empowering leadership practices increase nurses' knowledge work behaviors, which subsequently enhances their care coordination activities and patient care quality. Empowering leadership specifically increases nurses' knowledge work by positively influencing their accountability and role-breadth self-efficacy, but not control over practice. This study is among the first to identify the

behaviors by which nurses' demonstrate their knowledge work, and the process by which empowering leadership influences such work behaviors to improve patient care quality.

Keywords: nurses' knowledge work, knowledge work behaviors, empowering leadership, accountability, role-breadth self-efficacy, control over practice, care coordination, quality of patient care

## **ACKNOWLEDGEMENT**

Doctoral education has been one of the most challenging yet stimulating experiences I have ever pursued. I feel very fortunate to be guided by such an insightful supervisor, Dr. Heather Laschinger, who provided continuous support from beginning to end. While I am grateful for her persistence in keeping me focused, I especially appreciated the discussions we had over the years about nursing research, leadership and practice. I would also like to thank my supervisory committee, Dr. Mickey Kerr, Dr. Joan Finegan and Dr. Catherine Connelly, for providing thought-provoking insights and direction.

I am particularly thankful to Allison Patrick, Sara Lankshear, and Nancy Purdy for gently pulling me over the wall. Our meeting discussions, shared experiences, and visions for nursing have kept me inspired throughout this process, and will continue to do so for years to come.

Finally, I would like to thank my family and friends for keeping me sane with their constant support through all the ups and downs. I am awed by the many ways they have encouraged me during this challenging journey, including helping with stamping envelops, editing thesis drafts, cooking meals, or offering reassuring prayers. I dedicate this thesis to them as we share this success together.

## TABLE OF CONTENTS

ABSTRACT.....	ii
ACKNOWLEDGEMENT .....	iv
TABLE OF CONTENTS.....	v
LIST OF TABLES.....	viii
LIST OF FIGURES .....	ix
LIST OF APPENDICES.....	x
CHAPTER I: INTRODUCTION & STUDY OBJECTIVES.....	1
Background and Significance .....	1
Study Objectives .....	4
CHAPTER II: LITERATURE REVIEW AND THEORETICAL FRAMEWORK .....	8
Definition and Perspectives of Knowledge .....	8
Perspectives of Knowledge Work .....	9
Nurses’ Knowledge Work .....	12
Kelloway and Barling’s Theory of Knowledge Work in Organizations .....	18
Knowledge Work Behaviours.....	19
Predictors and Outcomes of Knowledge Work.....	25
<i>Related Research</i> .....	27
Empowering Leadership: An Organizational Predictor of Nurses’ Knowledge Work ....	32
Individual Predictors of Nurses’ Knowledge Work.....	38
<i>Accountability</i> .....	38
<i>Role-breadth Self-efficacy</i> .....	40
<i>Control Over Nursing Practice</i> .....	43
Outcomes of Nurses’ Knowledge Work .....	45
<i>Nursing Care Coordination</i> .....	45
<i>Quality of Patient Care</i> .....	50
Summary of Literature Review .....	53
Research Purpose, Objectives, and Hypotheses.....	55
CHAPTER III: RESEARCH METHODS .....	58
Research Design.....	58

Setting.....	58
Sample Description .....	58
Inclusion & Exclusion Criteria .....	59
Sample Size & Response .....	60
Data Collection Procedures .....	62
Study Survey .....	64
Concept Measures .....	64
<i>Leader Empowerment Behaviours Scale</i> .....	64
<i>Specht &amp; Ramler Accountability Index</i> .....	68
<i>Role-Breadth Self-Efficacy Scale</i> .....	69
<i>Control Over Nursing Practice Scale</i> .....	71
<i>Knowledge Work Behaviours Scale</i> .....	72
<i>Nurse Care Coordination Inventory Scale</i> .....	76
<i>Quality of Patient Care Measure</i> .....	77
Data Management Procedures .....	79
<i>Case Screening</i> .....	80
<i>Variable Item Screening</i> .....	81
<i>Missing Values &amp; Expectation Maximization Likelihood Imputation</i> .....	82
Data Analysis Procedures .....	83
<i>Structural Equation Modeling</i> .....	84
Ethical Considerations .....	88
<i>Risks &amp; Benefits</i> .....	89
CHAPTER IV: RESEARCH RESULTS.....	90
Demographic Results .....	90
<i>Sample Characteristics</i> .....	90
<i>Demographic Comparisons</i> .....	91
Descriptive & Psychometric Measurement Results .....	94
<i>Leader Empowerment Behaviours</i> .....	98
<i>Specht &amp; Ramler Accountability Index</i> .....	99
<i>Role-Breadth Self-Efficacy</i> .....	102
<i>Control Over Nursing Practice</i> .....	107

<i>Knowledge Work Behaviours</i> .....	108
<i>Nurse Care Coordination Inventory</i> .....	112
Hypothesis Testing Results.....	115
CHAPTER V: DISCUSSION & IMPLICATIONS .....	126
Key Research Findings .....	126
Outcomes of Nurses' Knowledge Work Behaviours.....	126
Impact of Empowering Leadership on Nurses' Knowledge Work Outcomes.....	128
Mediating Roles of Accountability & Role-breadth Self-efficacy .....	129
Study Limitations .....	131
Opportunities for Further Research .....	133
Implications for Nursing Leadership, Education, & Practice.....	135
Conclusion.....	137
REFERENCES .....	139
APPENDICES .....	162



## LIST OF TABLES

Table 1. Concept Measures.....	65
Table 2. Sample Demographics .....	92
Table 3. Mean Differences by Origin of Initial Nursing Education .....	93
Table 4. Descriptive Variable Results .....	95
Table 5. Final LEB Scale Item Definitions.....	101
Table 6. Final SRAI Scale Item Definitions .....	104
Table 7. Final RBSE Scale Item Definitions .....	106
Table 8. Final CONP Scale Item Definitions.....	110
Table 9. Final KWB Scale Item Definitions.....	114
Table 10. Final NCCI Scale Item Definitions.....	117
Table 11. Final Structural Model Parameter Estimate Results.....	122

## LIST OF FIGURES

Figure 1. Kelloway & Barling's (2000) Theory of Employee Knowledge Work .....	5
Figure 2. Theoretical Model of Nurses' Knowledge Work.....	7
Figure 3. Hypothesis Research Model .....	56
Figure 4. Structural Hypothesis Model.....	61
Figure 5. Final CFA Model for the Leader Empowering Behaviors (LEB) Scale .....	100
Figure 6. Final CFA Model for the Specht & Ramler Accountability Index (SRAI)...	103
Figure 7. Final CFA Model for the Role Breadth Self-Efficacy (RBSE) Scale .....	105
Figure 8. Final CFA Model for the Control Over Nursing Practice (CONP) Scale .....	109
Figure 9. Final CFA Model for the Knowledge Work Behaviours (KWB) Scale.....	113
Figure 10. Final CFA Model for the Nurse Care Coordination Inventory (NCCI) .....	116
Figure 11. Structural Model of Theoretical Model.....	118
Figure 12. Initial Structural Model Results.....	119
Figure 13. Final Structural Model Results .....	121

## LIST OF APPENDICES

Appendix A. Initial Introduction Letter of Study & Offer to Participate .....	163
Appendix B. Reminder Letter of Study & Offer to Participate .....	165
Appendix C. Final Letter of Study & Offer to Participate.....	166
Appendix D. Study Survey .....	1668
Appendix E. Ethics Approval .....	177

## **CHAPTER I: INTRODUCTION & STUDY OBJECTIVES**

### **Background and Significance**

According to Drucker (1991), knowledge is the key resource to any organization's competitive advantage in today's economy, thus it needs to be considered, managed and maximized for improved productivity. The stakes are higher for health care organizations to successfully manage and maximize use of knowledge given additional responsibilities for improving patient care and safety. Generating organizational strategies to optimize knowledge use is imperative when further viewed in context of large health care deficits, growing demands for health services, and an increasing patient population with multiple chronic illnesses (Health Council of Canada, 2009). Yet, developing these strategies requires an understanding of what type of knowledge is effective, the circumstances under which it is most effective, and the impact it has on patients' health. Indeed, this is no simple task.

Increasingly, health care organizations are turning towards knowledge management strategies to achieve organizational goals. Knowledge management centers on developing an organization's ability to acquire, organize, and disseminate knowledge throughout the organization for the purposes of improving effectiveness, efficiency, and competitiveness (Alavi & Leidner, 2001; Davenport & Glaser, 2002; Orzano, McInerney, Scharf, Tallia, & Crabree, 2008a). While knowledge management may encompass ways of improving knowledge use, decision-making, and/or employee commitment within an organization (Becerra-Fernandez & Sabherwal, 2005), many health organizations heavily investing in tools, protocols, and technologies in the form of electronic knowledge management systems (Alavi & Leidner, 2001; Bose, 2003; Canadian Nurses Association [CNA], 2006; Ontario Hospital Association [OHA], 2008; Snyder-Halpem, Corcoran-

Perry & Narayan, 2001). However, the benefits of these knowledge management initiatives have been questionable. On average, Ontario acute care hospitals report mediocre use of clinical information technology (58.7%), data for decision-making (59.0%), and standardized protocols to assist with care delivery (38.1%) (OHA, 2007). The high costs associated with these initiatives have also called into question their return on investment value for organizational outcomes, particularly for hospitals with mounting pressures to increase productivity and decrease cost (OHA, 2009). These limitations may be due to a focus on knowledge management initiatives targeted at improving storage, organization, access, or delivery systems of technical knowledge for wide distribution throughout hospitals (Nicolini, Powell, Conville, & Martinez-Solano, 2007), rather than initiatives concentrated on directly influencing the behaviours of human resources, such as nurses, to actively use their knowledge in practice.

Theorists have emphasized the role individuals play in the success of knowledge management. They note that while some knowledge may be readily translated into documents, manuals, or process maps, other types of knowledge such as tacit or embodied knowledge may not be as easily extracted for incorporation within an organization's knowledge management system (Blacklar, 1995; Davenport, 2005; Nonaka, 1994; Senge, 1990). This is certainly true in hospitals where the knowledge of health professionals, such as nurses, provide the foundation for daily decision-making in pursuit of quality patient care outcomes. Thus, strategies focused on influencing nurses who embody the knowledge to actively use it may be a more valuable knowledge management approach for health organizations (Paton, 2009).

There is opportunity for hospitals to leverage nurses' knowledge as a knowledge management strategy. With expenditures of approximately \$50 billion a year, Canadian

hospitals have one of the highest cost intensive labor operations as they employ nearly 46% of all health care workers (Canadian Institute for Health Information [CIHI], 2005, 2010a), of which nurses account for 50% (CIHI, 2010a, 2010b; Institute of Medicine [IOM], 2010). Additionally, the increased use of health care services by a progressively complex patient population, and the increased use of advanced technology to deliver care has necessitated the employment of more sophisticated and knowledgeable nurses. Given that nurses account for the majority of the health care industry's labor force and are key providers who mobilize health services at the point of care, understanding how nurses put their knowledge into action is essential to quality patient care outcomes (IOM, 2010). More importantly, it is the potential key to creating effective knowledge management strategies.

According to Kelloway and Barling (2000), knowledge work is discretionary behavior in that individuals choose, or choose not to find, share, develop or apply knowledge in their work role for the purposes of achieving work goals. Whether an individual decides to engage in knowledge work depends on one's ability, motivation, and opportunity to do so. Thus, organizations may only optimize their employees' knowledge work by creating structures, practices, or climates aimed at influencing employees' ability, motivation, and opportunity for knowledge work within the work setting. Estabrooks, Scott-Findley, & Winther (2004) also call for a research shift towards understanding the individual, social and organizational factors that contribute to nurses' knowledge utilization within health organizations. They argue that the predominant focus on demographic data such as age or years of work experience as determining proxies of nurses' knowledge utilization is insufficient, as most nurses work within complex organizational systems that structure and guide their practice. Given the purported

linkages between organizational predictors, individual determinants, and outcomes of knowledge work behaviors, Kelloway and Barling's (2000) theory offers a useful framework for guiding research aimed at understanding nurses' knowledge work (Figure 1).

Understanding how nurses' knowledge work contributes to positive outcomes within their work context is critical to identifying strategies for nursing resource optimization. If healthcare organizations can better understand the factors facilitating nurses' knowledge work, they will be able to more easily promote nurses' willingness to engage in knowledge work. Similarly, if health care organizations can identify factors that hinder nurses' knowledge work, they may be able to address these issues as well. Despite this proposition, research on the factors that influence nurses' knowledge work remains limited, still in its early stages with regards to identifying the determinants and outcomes of effective knowledge work in organizations. In order to address this research gap and evaluate the practical implications mentioned above, the aim of this study was to examine the organizational and individual predictors of staff nurses' knowledge work, and the effects of nurses' knowledge work on quality care outcomes in acute care hospitals.

### **Study Objectives**

In order to facilitate health care knowledge management strategies that optimize the knowledge of nurses to effect quality patient care delivery and outcomes, we need to first understand how nurses' use their knowledge in practice by means of identifying factors that influence or drive nurses' knowledge work behaviors. The aim of this study was to gain a comprehensive understanding of staff nurses' knowledge work in acute care

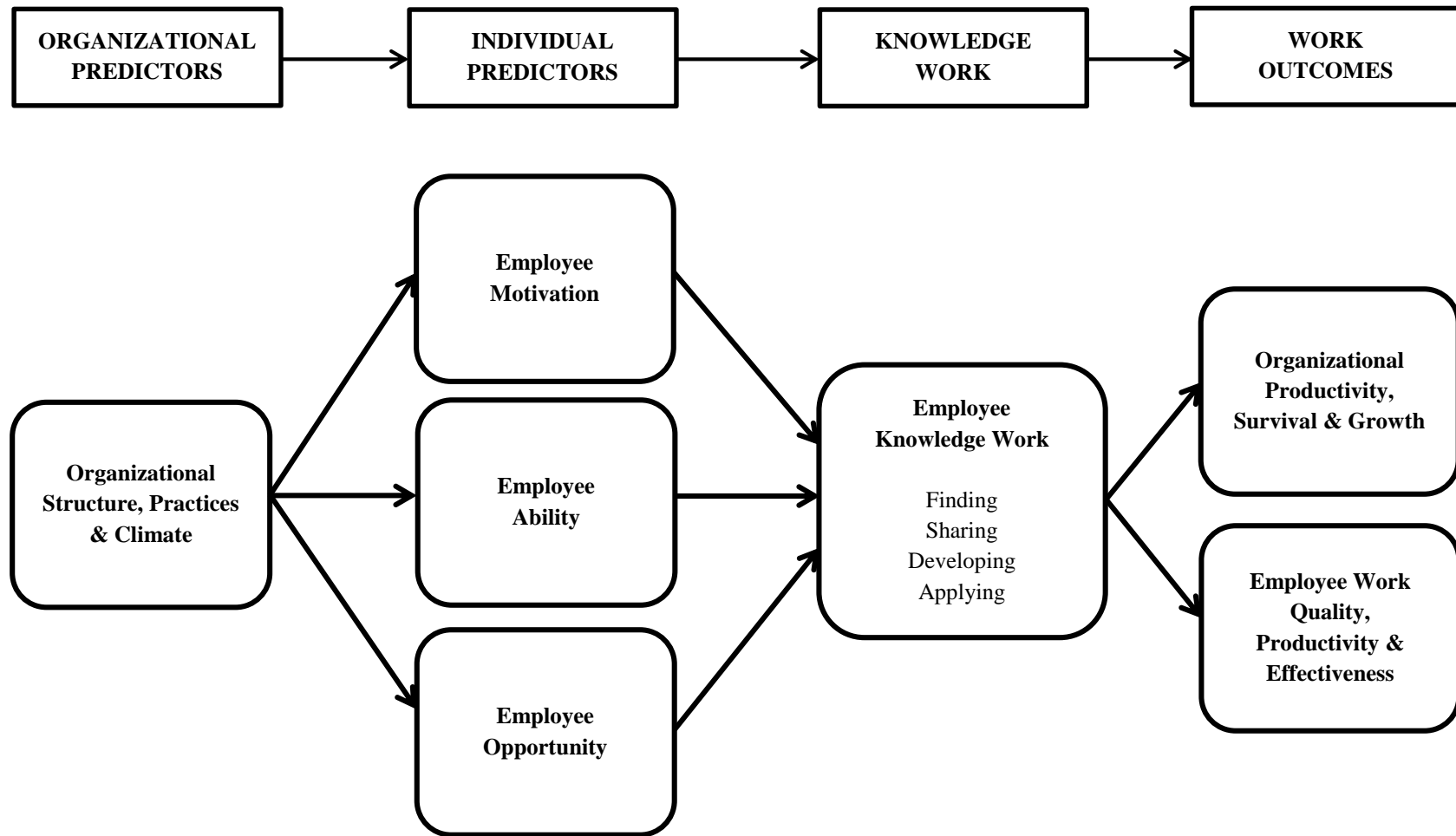

Figure 1. Kelloway & Barling's (2000) Theory of Employee Knowledge Work in Organizations



settings, and examine the relevant predictors and outcomes of their knowledge work. As such, the following research questions guided this study:

1. What are the behaviours that represent staff nurses' knowledge work in acute care settings?
2. What are the organizational and individual predictors of staff nurses' knowledge work in acute care settings?
3. What is the impact of staff nurses' knowledge work on patient care delivery outcomes?

To achieve the aims of this study, an explanatory model predicting individual differences in nurses' knowledge work was developed and tested (Figure 2). Specifically, based on Kelloway and Barling's (2000) theory of knowledge work, it is proposed in the model that organizational practices (empowering leadership) influences nurses' knowledge work behaviours (knowledge finding, seeking, development, and application) by means of facilitating nurses' motivation (nurse accountability), ability (role-breadth self-efficacy), and opportunity (control over nursing practice) to engage in knowledge work. In addition, this study tested a model in which nurses' discretion for engaging in knowledge work positively predicts patient care delivery outcomes including nursing care coordination and quality of patient care.

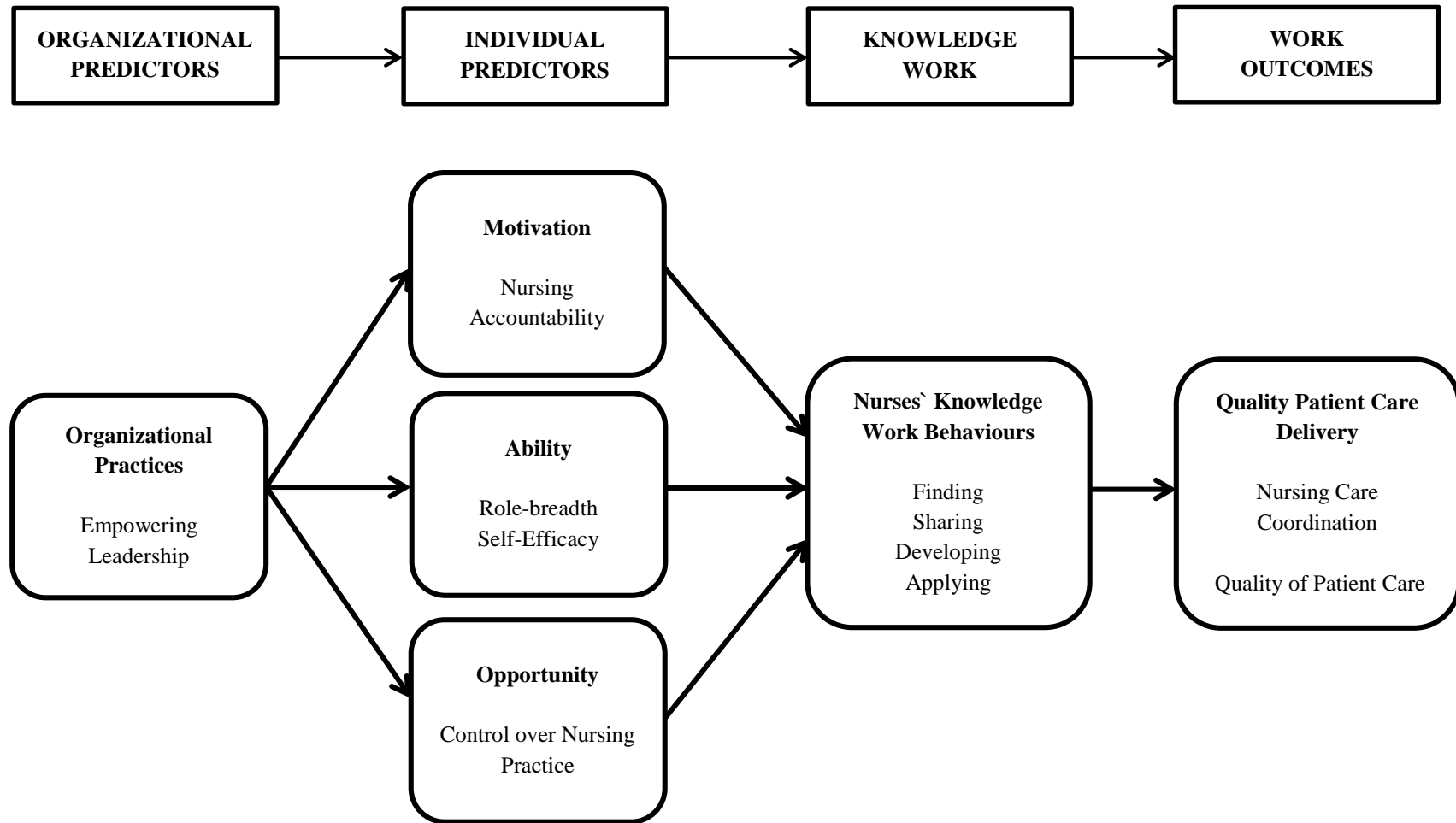

Figure 2. Theoretical Model of Nurses' Knowledge Work

## **CHAPTER II: LITERATURE REVIEW AND THEORETICAL FRAMEWORK**

### **Definition and Perspectives of Knowledge**

Knowledge is central to the work of nurses and their professional practice (College of Nurses of Ontario [CNO], 2002). However, clear understanding of the term is required for suitable examination of how nurses use their knowledge in practice, as well as the strategies for maximizing its use as a critical resource in health care. Thus, it is important to first define and distinguish knowledge from commonly associated terms such as information and evidence.

Information is an accumulation of data and facts that become knowledge only when it has relevance, is placed in context, and is analyzed by people for a particular purpose. Thus, knowledge is considered a higher structure of information that is ready to be used for decisions or actions when and if individuals choose to do so (Newell, Robertson, Scarborough, & Swan, 2009). Conversely, evidence is often referred to scientific evidence resulting from research, although Higgs and Jones (2000) have more broadly defined evidence as multiple types of knowledge that have been empirically tested and found credible.

Knowledge has been widely discussed in the literature as existing in two main forms: explicit and tacit (Nonaka, 1994; Polanyi, 1962; Spender 1996). Though a complete discussion of explicit and tacit knowledge is beyond the scope of this study, it is useful to briefly define these two knowledge forms so as to better understand how nurses' choose to use their knowledge in practice. Explicit knowledge is expressed, categorized, and communicated in some symbolic form or language. Tacit knowledge refers to an individual's cognitive mental mappings that are developed through their experience and within specific contexts. Thus, explicit knowledge may be commonly formalized and

communicated across various contexts, whereas tacit knowledge may not (Newell et al., 2009). Within the context of health care, explicit knowledge is often accessed through information in textbooks, journals, or clinical practice guidelines, written policies, and procedures. Tacit knowledge, on the other hand, resides in the cognitions of health professionals and is often gained by reflections on clinical experiences and facts (Benner, 1984; Benner, Tanner & Chesla, 1996; Chinn & Kramer, 2011; Mansingh, Osei-Bryson & Reichgelt, 2009).

In this study, knowledge was conceptualized to include both explicit and tacit forms which nurses draw upon to inform their practice. It is important to note that it was not in the interest of this study to identify what nurses know and the types of knowledge they use in practice; particularly since different knowledge forms are selected for use by nurses at highly varying times, depending on the issue at hand, and the personal experiences of the nurse. Rather, this study aimed to understand nurses' knowledge work by examining the differential behaviours that nurses' demonstrate to use their knowledge for providing quality patient care.

### **Perspectives of Knowledge Work**

Despite growing interest in employee knowledge work for the purposes of achieving organizational success (Davenport, Thomas & Cantrell, 2002; Drucker, 2009; Kerfoot, 2002), the concept remains poorly defined within the literature. Lack of conceptual clarity for knowledge work is mainly due to its interchangeable use with the term knowledge worker, and inconsistent frames of reference for identifying related attributes. In their review of the literature, Kelloway and Barling (2000) noted that knowledge work has been either defined as an individual's occupational category,

personal characteristic, or work activity. Each of these conceptual perspectives are discussed as follows.

Since Drucker (1969) first introduced the concept of knowledge-worker productivity where organizational success is dependent on optimizing the unique work contributions of employees, knowledge work has since been popularly defined as occupational categories differentiated by service versus manual work (Kelloway & Barling, 2000; Nomikos, 1989; Paton, 2009). This perspective assumes that knowledge work is associated with service work that emphasizes mental processing and customer interactions, as opposed to manual work that is viewed as monotonous with limited knowledge application (Frenkel, Korzynski, Donoghue, & Shire, 1995). As a result, this has led to further knowledge worker classifications based on professional group associations such as “scientists, engineers, professors, attorneys, physicians, and accountants” (Nomikos, 1989, p. 165). This conceptual perspective is problematic especially when organizational success requires active involvement of all employees within an organization. Defining knowledge work as an occupational characteristic places emphasis on occupational qualifications such as levels of education, expertise or job positions (Davenport, 2005; Janz, Colquitt & Noe, 1997), as opposed to how employees contribute to organizational goals. This perspective exclusively favors the knowledge work of a select few, and limits the opportunity and expectation that all employees contribute to organizational goals (Kelloway & Barling, 2000).

Knowledge work has also been defined as an individual trait such as being intelligent, creative, or innovative (Augier, Shariz & Vendelo, 2001). This perspective is rooted in the belief that knowledge work is a function of knowledge possession, in that one engages in knowledge work by means of attaining specialized knowledge through

greater education, creation or innovation. Although this perspective moves away from occupational membership towards focusing on an individual's contribution to organizational goals, the emphasis on what individuals know is also limiting. Paton (2009) argues that the possession of knowledge is not in itself the defining feature of knowledge work, nor would it advantage organizations when unused. This suggests that individual traits or possession of specialized knowledge are insufficient for defining individual contributions of knowledge work. More importantly, when viewed within work contexts that are often hierarchically designed, it is unclear as to whether individuals' knowledge work contributions are a function of what they know as opposed to the opportunity they are afforded to use their knowledge for organizational goals (Kelloway & Barling, 2000).

Lastly, knowledge work has been defined as a workplace activity associated with individuals who utilize their thought processing to analyze information, solve problems, or make decisions that benefit organizational goals (Wolf et al., 2006). In this case, knowledge work is exemplified by employees who utilize their body of knowledge in a specified way (Garrick & Clegg, 2000). This perspective emphasizes employee work performance based on the use of knowledge in the workplace rather than what individuals know (Blackler, 1995). Although this perspective has potential for understanding individual contributions of knowledge work, it also runs the risk of describing knowledge work as task categories associated with occupational membership, work roles, or work process pathways. This limits the opportunity for identifying behavioural elements that are unique to knowledge work and provide competitive advantage to organizations (Paton, 2009). As such, Kelloway and Barling (2000) extend this perspective to define knowledge work as behaviors representative of employees' choice to use knowledge for

work goals. This definition takes several things into account. First, despite the amount or type of knowledge that employees possess, whether they choose to use such knowledge within the workplace is the emphasis; and so knowledge work is expressed as an individual behavior rather than what one knows. Second, this perspective suggests that there are individual behaviors specific to the use of knowledge within the workplace, regardless of the work activities associated with employees' work role, responsibilities, or occupational membership. These behaviors determine how employees' choose to use their knowledge to meet work goals. Hence, the extent, nature, and subsequent effects of employees' knowledge work in an organization may vary considerably (Kelloway & Barling, 2000).

### **Nurses' Knowledge Work**

There have been many conceptual papers found within the nursing literature noting the importance of nurses' knowledge work, particularly in the provision of safe patient care and the interception of medical errors (Benner, 1984; Davenport & Prusak, 1998; Estabrooks et al., 2002; Hall, 2003; IOM, 2004; 2010; McCormack, Kitson, Harvey, Rycroft-Malone, Titchen, & Seers, 2002; Moody, 2004; Snyder-Halpern, Corcoran-Perry & Narayan, 2001; Sorrells-Jones & Weaver, 1999). However, empirical research to support conceptual clarity for nurses' knowledge work and an understanding of its outcomes is scarce. In fact, only two relevant nursing studies were identified (Ayers LaFave, 2008; Quinlan, 2009).

Ayers LaFave (2008) sought to describe nurses' knowledge work within the clinical microsystem by identifying the essential components of systems-based knowledge and information exchange from the perspective of 18 practicing nurses in various roles on an intensive care nursery unit. In her qualitative study, Ayers LaFave

discovered that participants' knowledge of their clinical microsystem included knowledge about the organizational goals and expectations, the coordinating operations, and the social relations among staff and patients within the microsystem. Ayers LaFave further noted that interpersonal communication served as the primary mechanism by which systems-based knowledge was exchanged among nurses. More specifically, the study participants exchanged their knowledge about practice-based patterns, staffing roles and patterns, tips and tricks about nursing related techniques, and general unit-based operations within the acute intensive care unit setting.

In order to investigate how primary health care teams collectively engaged in knowledge work, Quinlan (2009) conducted an institutional ethnographic study with three new graduate nurse practitioners and shadowed their coordination of clinical duties and interactions with colleagues across urban, rural, and remote health care settings. Quinlan viewed knowledge work as the exchange of knowledge claims in the context of clinical decision-making among members of the primary health care team. In analyzing the dialogue exchanges, text references, and the context in which collective clinical decision-making was achieved, two main study findings were revealed. First, Quinlan noted that the knowledge work of primary health care teams is organized around team members' shared tasks involving documentary forms of knowledge such as written work policies and regulations. Such organization of work roles and responsibilities offered opportunities for team members to exchange tacit knowledge that was practice-based, which the researcher concluded as being a crucial component to the teams' creation of new knowledge. Second, Quinlan found that collective decision-making involved negotiating knowledge claims within the context of social relationships. As such, Quinlan



further concluded that the knowledge work of the primary health care teams' is best understood by considering the social organization of power within the teams.

In addition to these empirical investigations, other related areas of research associated with knowledge work are worthy of discussion; namely evidence-based practice, knowledge exchange, knowledge utilization, and knowledge translation. Evidence-based practice emphasizes the integration of individual clinical expertise gained through clinical experience and practice, with the best available clinical evidence from systematic research (Sackett, Rosenberg, Gray, Haynes, & Richardson, 1996). Early proponents of evidence-based practice tended to rest on preferences of scientific evidence attained from applied health care research to guide best clinical practice (Haynes, 2004). However, critics have argued that this perspective is too narrow and linear in assuming that practitioners who base their decisions on scientific evidence will thus provide quality patient care (Tonelli, 2006). As such, in nursing, evidence-based practice has since been viewed as an approach to clinical problem solving that incorporates various forms of evidence such as patient values, experiential learning, and pathophysiologic knowledge (Melnyk & Fineout-Overholt, 2005). Additionally, Cochrane et al. (2007) identified in their literature review numerous factors that contribute to quality clinical practice beyond the type of evidence used. These include individual factors such as cognitive, behavioral, attitudinal, or personal characteristics, and health care system or clinical context factors including support, resources, and system processes.

To address the linear assumptions of evidence-based practice, the Promoting Action on Research Implementation in Health Services (PARIHS) framework was proposed specifically for health care environments by Kitson, Harvey & McCormack (1998). The PARIHS model is an organizational evidence-based practice implementation

model that is dependent on three interdependent factors for success. These factors include the type of evidence that is to be implemented, the context in which the evidence is to be implemented, and how the evidence-based practice implementation is facilitated. Each factor is positioned on a continuum from high to low, with high end scores representing the most successful implementation of evidence in practice (Rycroft-Malone, 2004). In this model, evidence is a broad concept that includes research, clinical experience, and local data or patient information; each requiring critical appraisal. Context represents the environment or setting where health care is delivered, and considers social, cultural, psychosocial, and political influences. Finally, facilitation refers to an individual who helps others implement evidence into their practice (Kitson, Harvey & McCormack, 1998; Rycroft-Malone, 2004). While the PARIHS model offers a systematic evidence-based practice approach for evaluating how well evidence is implemented into clinical practice, it assumes individuals' critical appraisal of all evidence prior to implementation in practice for success (Rycroft-Malone, 2004). Thus, despite the type of evidence selected for implementation, individuals continue to play an influential role in the success of evidence-based practice outcomes, by critically evaluating the evidence to be applied in practice.

Moving away from a focus on the type of evidence needed for decision-making towards an understanding of how knowledge is used for decision-making is the concept of knowledge utilization. In health care, knowledge utilization is often described as an activity process involving the use of research results for a particular purpose, such as policy making or clinical decision making (Denis, Lehoux & Champagne, 2004; Estabrooks, Scott-Findley & Winther, 2004). Again, the emphasis is on the use of knowledge, which has been generally reported as one of three types: instrumental use,

conceptual use, or symbolic use. Instrumental use refers to the direct application of evidence into materials or tools such as guidelines or clinical decision-making pathways for use in practice (Estabrooks, 1999). Conceptual use involves the use of research results for general enlightenment, whereas symbolic use represents the use of research results to support or legitimize a decision or position (Estabrooks, 1999). While the concept of knowledge utilization is helpful in clarifying the various purposes for why health care providers use research or knowledge, a gap remains in understanding how individual nurses demonstrate their knowledge use in practice. Such an understanding may lead to a clearer conceptual definition of knowledge work in nursing.

A relatively new yet related concept is knowledge exchange. Within the broader management and information science literature, knowledge exchange is synonymous with the concept of knowledge sharing. Knowledge exchange is understood to be the driver to successful decision making as the knowledge needed to solve problems or complete work tasks is often shared among a number of individuals (Mitton, Adair, McKenzie, Patten, & Perry, 2007). This is also demonstrated in Quinlan's (2009) study discussed above. In health care, knowledge exchange focuses primarily on the sharing of research knowledge between researchers and knowledge users such as clinicians and policy makers for collaborative decision-making (Mitton et al., 2007). Given this perspective, knowledge exchange is tightly connected with the research process. However, the research process represents only a portion of knowledge exchange activities in health care settings, considering that exchange between health professionals account for the majority of the information flow in practice settings (Parker & Coiera, 2000). Thus, understanding the knowledge exchange practices of nurses with their practice-based colleagues is one means of understanding their knowledge work. However, given that nurses may also

make clinical decisions that impact patient care independently suggests that knowledge work goes beyond knowledge sharing.

Knowledge translation is another related concept that incorporates knowledge exchange and utilization. Knowledge translation is defined according to the Canadian Institutes of Health Research as “a dynamic iterative process that includes synthesis, dissemination, exchange, and ethically sound application of knowledge to improve the health of Canadians, provide more effective health services and products and strengthen the health care system” (Straus, Tetroe & Graham, 2009, p.165). Within this broad-based view of knowledge translation, research is considered a subset of knowledge, and the focus is on changing health outcomes while using critically appraised clinical knowledge (Davis et al., 2003; Graham & Tetroe, 2007; Straus, Tetroe & Graham, 2011). Though the broad perspective of knowledge translation is beyond the scope of this study, understanding the elements of synthesizing, exchanging, and applying knowledge to improve patient care is important to understanding how knowledge work may be enacted by individual nurses within the clinical setting.

While the literature reviewed above provides some insight to nurses’ knowledge work, the conceptual definition of knowledge work remains elusive and unclear. This may be due to nurses’ knowledge work being primarily referenced as an individual’s possession of a specialized knowledge base (Ayers LaFave, 2008), or coordination of work activities including shared tasks with health care team members (Quinlan, 2009). Nevertheless, the identified literature gaps reviewed thus far offer some new direction for examining nurses’ knowledge work. First, a focus on work behaviors specific to knowledge work rather than nurses’ specialized knowledge possession, individual traits, or role specific activities may help unravel the concept of knowledge work from other

confounding concepts that was previously discussed. Examples of such behaviors specific to knowledge work include sharing, synthesizing and applying knowledge. Second, considering the individual influences of nurses when examining the concept of knowledge work may not only help specify how nurses' knowledge work contribute to organizational goals, but may also provide a foundation for future understandings of knowledge work such as that of health care teams. Finally, evaluating nurses' knowledge work within the context of the clinical work setting is necessary for identifying key factors that influence or inhibit such behaviors, given that the ultimate aim is to understand how nurses' knowledge work impact patient care delivery and outcomes. As a model that takes into account the considerations highlighted above, Kelloway and Barling's Theory of Knowledge Work in Organizations (2000) (Figure 1) was selected as the framework that guided the examination of nurses' knowledge work in this study.

### **Kelloway and Barling's Theory of Knowledge Work in Organizations**

According to Kelloway and Barling (2000), knowledge work is defined as "discretionary behavior focused on the use of knowledge" (p. 292). Central to this definition is the premise that employees have choice over when and how much knowledge they use within the organizations they work for. Employees may choose not to use their knowledge to achieve work goals as well. In this perspective, knowledge work is not represented as one's occupation, inherent traits, or specific work tasks. Rather, knowledge work is conceptualized as a dimension of work focused on how employees choose to behave when using knowledge in the workplace. The emphasis is on what employees are currently doing as opposed to what they know or have done in the past (Kelloway & Barling, 2000). Thus, knowledge work is not a function of one's

knowledge base or past work experiences, but the degree to which a person chooses to actively use knowledge effectively at work.

Unlike other knowledge work perspectives (Frenkel et al., 1995, Janz et al., 1997), Kelloway and Barling propose that employees and their knowledge are not tangible assets owned or controlled by their employing organizations. Instead, they suggest that employees are like investors who decide the extent with which to invest their knowledge in a given organization, so as to aid organizational goals and outcomes (Kelloway & Barling, 2000; Davenport, 1999). Thus, simply employing individuals does not guarantee that they will decide to actively use their knowledge. Rather, the decision to “invest” is highly dependent on employees’ perceived payoff for investing their knowledge use in the workplace. The greater the perceived payoff, the more likely employees’ will choose to invest. With this in mind, nurses’ knowledge work cannot be demanded. However, nurses’ knowledge work behaviors may be stimulated by organizational practices aimed at creating appropriate conditions where nurses are more amiable to use their knowledge at work (see Figure 1).

### **Knowledge Work Behaviours**

Kelloway and Barling (2000) describe four forms of knowledge work based on existing research of employee knowledge use in organizations (Davenport, Jarvenpaa, & Beers, 1996; Ruggles, 1999). These four forms include acquiring existing knowledge through research and learning, creating or innovating new knowledge, packaging knowledge for teaching and dissemination, and applying existing knowledge to current problems at work. However, these identified behaviors may not necessarily be applicable to nurses as they were derived from research with employees who worked in business

firms that hold different performance expectations and objectives when compared to health care organizations.

Similarly, Wright (2005) conducted a descriptive case study of workplace learning activities with experienced software developers employed in a small Canadian software firm. Based on the study results, Wright suggested that individuals manage their personal knowledge use to enhance work effectiveness by employing a combination of competencies related to cognitive processing, information seeking, facilitation of work relationships with colleagues, and continuous learning development. This competency-based approach offers some insight to how individuals process their knowledge within the workplace.

In their study of organizational knowledge management practices of high performing family care health centers, Oranzo, McInerney, Scharf, Tallia, and Crabree (2008a, 2008b) identified knowledge finding, sharing, and development processes as critical to making decisions that impact patient care. While these processes were examined at the organizational level, they highlighted the need for active engagement of individual employees in the facilitation of organizational knowledge finding, sharing, and development. By integrating the work of these researchers with Kelloway and Barling's (2000) perspectives of employee knowledge work, knowledge work behaviors may be expressed in at least one of the following dimensions: knowledge finding, knowledge sharing, knowledge development, and knowledge application. Accordingly, nurses' knowledge work was redefined in this study as discretionary behavior representing the degree to which an individual chooses to actively find, share, develop, and apply knowledge at work (Kelloway & Barling, 2000; Oranzo et al., 2008a)

Knowledge finding reflects a complex cognitive process that involves being aware of one's knowledge base needs, choosing means of addressing one's knowledge gaps by accessing assistive resources, and assessing the quality of acquired information to meet identified knowledge gaps (Case, 2007, Fourie, 2009). Based on the belief that individuals' knowledge finding behaviors are driven by the need to make sense of a situation, Dervin and Nilan (1986) suggest that individuals engage in finding knowledge so as to search for meaning and understanding. As for nurses who aim to provide therapeutic care to patients, finding knowledge not only reflects making sense of a clinical situation (Oranzo et al, 2008a, 2008b), but help with identifying knowledge that facilitates learning or problem-solving through the clinical situation (Dewey, 1997; Fourie, 2009; Squires, Estabrooks, Gustavsson, & Wallin, 2011). Thus, knowledge finding encompasses behaviors of both seeking and selective use. As such, knowledge finding behavior was defined in this study as the degree to which an individual finds knowledge in order to use it at work.

According to Oranzo et al. (2008a), knowledge sharing entails the willingness and ability of employees to share what they know to help others expand their own learning. Thus, knowledge sharing is a social process where individuals mutually exchange their knowledge and jointly create new knowledge (Rycroft-Malone, 2004). Van den Hooff & de Ridder (2004) further describe knowledge sharing as a process where one actively communicates to others what they know or actively consults with others to learn what they know. Within the context of health care, knowledge sharing between care providers accounts for the majority of information flow, especially when the knowledge needed to effectively deliver patient care is often distributed across a group of individuals (Curran, 2009; Parker & Coiera, 2000). As such, it is not surprising that nurses report social



interactions with other nurses, care providers and patients to be primary sources from which they draw their knowledge for practice (Estabrooks et al., 2005). This highlights the importance of knowledge sharing to the work of nurses. In this study, knowledge sharing behavior was accordingly defined as the degree to which individuals share what they know at work.

Drawing on cognitive learning theory, Flavell (1979) describes knowledge development as the process by which individuals select, evaluate, and review or abandon work tasks, goals and strategies. As part of the knowledge development process, individuals also consider how the work tasks, goals and strategies relate to each other; their abilities, and their work interests in a given context (Flavell, 1979). This suggests that nurses' knowledge development behaviors are closely tied to evaluating the need for new knowledge given the clinical context, setting learning goals for meeting identified learning needs, and creating strategies to actively address the learning need. In the case of knowledge work, the goal of knowledge development is to generate new knowledge for use and application to practice (Kelloway & Barling, 2000). Thus, in this study, knowledge development behavior was defined as the degree to which individuals develop knowledge that is new to them for use at work.

Perhaps the foundation of knowledge work is to apply the knowledge gained to solve clinical problems, change practice, or make decisions for patient care delivery. Based on interview data with employees working in a health care organization, Daigle-LeBlanc (2001) concluded that knowledge application precedes work performance, in that individuals who choose not to apply knowledge do so because they either do not possess the necessary knowledge, or they willingly withhold the knowledge that is essential to the performance of their work. Similar to clinical reasoning where individuals

use formal and informal strategies to assemble and analyze information which is then evaluated relative to its significance and contribution to patient care (Simmons, Lanuza, Fonteyn, Hicks, & Holm, 2003), knowledge application involves an individual's purposeful action to make use of the knowledge they have, while evaluating the impact and outcomes of such use. Given this, knowledge application behaviors reflect the degree to which individuals use their knowledge for action at work.

With the exception of Daigle-Le Blanc's (2001) study of individual knowledge work in organizations, there has not been any existing research to date evaluating nurses' knowledge finding, sharing, development, or application behaviors as a collective concept. Likewise, there is no research evaluating nurses' knowledge work from a behavior-based perspective that reflects discretionary use of knowledge in practice. Kelloway and Barling (2000) are the first to describe knowledge work as a multi-factorial structure of discretionary work behaviors. However, they did not specify the details of those behaviors and despite existing conceptual discussions about knowledge work within the literature (Blackler, 1994; Alvesson, 2001; Pyoria, 2005), there has been limited empirical research to evaluate its purported composition. To address this gap, Daigle-LeBlanc (2001) conducted a two-phased study that first explored the experience of individuals' use of knowledge in the workplace. These findings were subsequently used to derive a measure of knowledge work, as grounded in Kelloway & Barling's (2000) definition of the concept.

In phase 1 of her study, Daigle-LeBlanc (2001) conducted semi-structured interviews with full-time employees ( $N = 25$ ) of varying occupational groups and organizational levels that worked in a major tertiary care hospital. Study participants included managers (40%), health care professionals (36%), and personnel in non-

professional and non-management positions (24%). Using both theory and data-driven approaches to analyze the interview data, Daigle-LeBlanc found initial support for Kelloway & Barling's (2000) hypothesis that employee knowledge work is expressed by at least one of the following behaviours: acquiring knowledge, creating knowledge, consolidating knowledge, and applying knowledge.

In phase 2 of the study, Daigle-LeBlanc (2001) developed a measure of knowledge work based on the qualitative results from phase 1, which was subsequently tested among a sample of 208 individuals employed in varying industries including television networking, health care, education, sales, and administration. Daigle-LeBlanc conducted separate principal component analyses on each of the four knowledge work behaviour subscales, primarily to maintain adequate 'subjects-to-variables' ratio for the analyses. As a result, Daigle-LeBlanc found more discrete forms of knowledge work and reported that a ten-factor model with a 29.09% proportion of explained variance was more internally consistent (Cronbach's  $\alpha = .83$ ) than the four-factor model proposed by Kelloway and Barling (2000). However, these findings should be taken with caution. Since Daigle-LeBlanc conducted separate principal component analyses by knowledge work behavior groups with no comparison between first and second-order factor analyses of the measure as a whole, the dimensionality of knowledge work remains questionable. Additional psychometric testing of the measure is needed to confirm whether knowledge work may possibly be represented as a higher order factor structure. Furthermore, after conducting a second-order factor analysis using the ten scales measuring knowledge work, Daigle-LeBlanc found that there were a number of items that overlapped across the ten scales. This raises the question as to whether the forms of knowledge work as described by Kelloway and Barling (2000) are valid, or whether there is the possibility

that there are more discrete forms of knowledge work beyond Kelloway and Barling's propositions. Nevertheless, Daigle-LeBlanc's (2001) study offers initial support for Kelloway and Barling's (2000) notion of individual knowledge work as comprising varying groups of distinct discretionary behaviors of knowledge work. In light of these considerations, this study sought to build on Daigle-LeBlanc's research to better understand the construct of knowledge work and its corresponding dimensions as it relates to nursing practice.

### **Predictors and Outcomes of Knowledge Work**

Kelloway and Barling's model for knowledge work is primarily aimed at uncovering organizational factors that influence employees' knowledge work behaviors. In particular, they suggest that changes in organizational practices, structures or climates are likely to directly or indirectly affect an employee's knowledge work to the extent that they enhance the employee's ability, motivation, and opportunity to engage in knowledge work behaviors (see Figure 1). Hence, individual ability, motivation and opportunity are the three central requirements for employee knowledge work in organizations. It is important to note that Kelloway and Barling's (2000) argue that an employee's ability, motivation, and opportunity for knowledge work are non-compensatory in that none of these three requirements may be replaced by each other, and that all three need to be present in order for employees to engage in knowledge work. The importance of these requirements is further discussed as follows.

Organizations often offer educational training opportunities as strategies to increase their employees' knowledge within the workplace (Calarco, 2011). However, these strategies do not necessarily ensure that individuals will have the ability to apply knowledge in their practice. Thus, promoting employee knowledge work within the

workplace requires organizational strategies that extend beyond providing employees' educational training opportunities to enhancing employees' ability to use such knowledge (Kelloway & Barling, 2000) (see Figure 1). This ability includes judging what one may do with the skills and knowledge they have, otherwise known as self-efficacy (Bandura, 1989). More specifically, Kelloway and Barling (2000) suggest that employees who are self-efficacious with their interpersonal and problem-solving skills by being proactive and taking initiative are likely to choose to engage in knowledge work, and thus will more likely demonstrate knowledge work behaviors.

While necessary, employee ability is insufficient for knowledge work. Employees also need to be willing to use their knowledge, which highlights motivation as the second central requirement for employees' choice to engage in knowledge work (see Figure 1). Based on the notion that employees choose to invest their knowledge use in organizations, Kelloway and Barling (2000) suggest that employee motivation is a function of both their trust in their employing organization and their commitment to meeting their organization's goals. In other words, when employees trust their employer to be adequately skilled to lead them, to have good intentions for their work potential, and to not deliberately harm their work efforts, they are more likely to be motivated to actively use their knowledge for meeting work goals. Thus, motivated by their desire to contribute by means of effective work performance, employees who are committed to the success of their employing organization are more likely to engage in knowledge work (Kelloway & Barling, 2000).

Finally, even if employees are able and want to use their knowledge within their organizations, they need to be given the opportunity do so at work (see Figure 1). This includes opportunities for employees to take advantage of available experiences, support

resources, and latitude to express their knowledge use within the workplace. In this sense, employees who perceive their employing organizations as giving them opportunities to use their knowledge are more likely to engage in knowledge work for meeting work goals (Kelloway & Barling, 2000).

Kelloway and Barling (2000) imply that employees' active engagement in knowledge work contributes to positive outcomes at the individual and organizational levels; namely individual work productivity, growth and organizational survival (see Figure 1). However, the outcome of this relationship is dependent on the amount of knowledge work employees decide to engage in. Thus, identifying the determinants that drive employees' decisions to engage in knowledge work is fundamental to optimizing their beneficial effects.

### ***Related Research***

With the exception of research conducted by Daigle-LeBlanc (2001) and Lin (2007a), earlier empirical investigations using Kelloway and Barling's (2000) framework have focused on identifying organizational predictors of individual employees' knowledge work, namely individuals' knowledge sharing behaviours (Connelly & Kelloway, 2003; Lin, 2007b). Connelly & Kelloway (2003) surveyed 126 graduate business students across four Canadian universities in order to evaluate the effects of organizational and demographic factors on employees' perceptions of a knowledge sharing culture within their workplace. Their study results revealed that management support were significant positive predictors of respondents' perceived knowledge sharing culture ( $\beta = .47$  and  $\beta = .33$ , respectively) within their workplace. The only significant demographic variable was gender, which significantly moderated the effect of social interaction on respondents' perceived knowledge sharing culture by accounting for

32.4% of the criterion variance. In other words, while both men and women who perceived a positive social interaction culture in their workplace also perceived positive knowledge sharing cultures, the effect was more pronounced for female participants. Connelly & Kelloway suggested that this difference may be linked to women recognizing and taking greater advantage of the opportunity for sharing knowledge amidst a positive social interaction culture when they are typically in less advantaged positions within the organization. While this proposition requires further testing for validation, the study results provide initial insight to how organizational culture and practices may condition employees' attitudes to engage in knowledge work.

Similar insights were revealed in Lin's (2007b) survey study with 172 employees from 50 large organizations in Taiwan. Lin evaluated the effect of individual and organizational factors on employees' knowledge sharing behaviours and the organization's capability for innovation. The results demonstrated that employees' perceived pleasure and self-efficacy for knowledge sharing significantly predicted their knowledge sharing behaviors. Top management support and use of information technology were also significant predictors of employees' knowledge sharing. Together, these factors increased employees' knowledge sharing behaviors, which ultimately predicted their organization's increased propensity to adopt innovation. Although Lin's study compliments Connelly and Kelloway's (2003) research findings to lend support for Kelloway and Barling's (2000) model of knowledge work, it is the first to link knowledge sharing behaviors to an organizational outcome.

Using data from the same respondents, Lin (2007a) also sought to better understand the effects of intrinsic and extrinsic motivation on employees' knowledge sharing intentions. Results of the study showed that the intrinsic motivators of

knowledge self-efficacy and enjoyment in helping others predicted employees' attitudes toward ( $\beta = .27$  and  $\beta = .21$ ,  $p < .05$ ; respectively) and intentions for ( $\beta = .42$  and  $\beta = .24$ ,  $p < .01$ ; respectively) knowledge sharing. However, these intrinsic motivators demonstrated a stronger direct effect on employees' knowledge sharing intentions, rather than through the mediation of employees' positive attitudes for knowledge sharing. As for the extrinsic motivators of expected monetary organizational rewards and reciprocal benefits from other colleagues, only reciprocal benefits significantly predicted employees' knowledge sharing intentions ( $\beta = .25$ ,  $p < .001$ ). This effect was stronger when mediated by employees' attitudes for knowledge sharing ( $\beta = .35$ ,  $p < .05$ ). Interestingly, expectation for organizational rewards was not a significant motivator for employees to share knowledge, considering contrary findings within the management literature (Bartol & Srivastava, 2002; Cabrera, Collins & Salgado, 2006; Wang & Noe, 2010). Lin suggested that one possible reason for this unexpected finding is that many of the respondents were executives who may be extrinsically motivated by other non-monetary rewards. Regardless, these study findings validate Kelloway and Barling's (2000) theory that employee intent to engage in knowledge work is a direct function of their motivation to do so.

As related literature from information management sciences indicates, predictors of individual knowledge work behaviors may have psychosocial influences (Bock, Zmud, Kim, & Lee, 2005; Kuo & Young, 2008; Ryu, Ho & Han, 2003). Kuo and Young (2008) examined the motivational drivers of Taiwanese teachers' knowledge sharing behaviors across two separate research studies [Study 1 ( $N = 200$ ) and Study 2 ( $N = 260$ )]. Results of both studies indicate that individual's intent to share knowledge with colleagues is significantly predicated by their positive attitude towards ( $\beta = .50$ ,  $p < .05$ ), subjective



norms for ( $\beta = .14, p < .05$ ), perceived control over ( $\beta = .18, p < .05$ ), and perceived self-efficacy ( $\beta = .13, p < .05$ ) for knowledge sharing practices. Collectively, these predictors explained 49% of the variance found in individuals' reported knowledge sharing intentions. Of all the variables studied, perceived self-efficacy was the only variable to directly predict knowledge sharing behavior ( $\beta = .19, p < .05$ ). The influence of self-efficacy on knowledge sharing behavior is even more pronounced based on Kuo and Yong's finding that self-efficacy still predicted knowledge sharing behaviors ( $\beta = .21, p < .05, \Delta R^2 = .03$ ) even when respondents viewed their work environment for sharing knowledge was unfavorable as opposed to favorable. Ryu, Ho and Han's (2003) study results corroborate the variable linkages tested by Kuo and Yong (2008). Ryu et al. (2003) specifically examined the knowledge sharing intentions of 334 physicians working in tertiary hospitals in Korea, and found that physicians' perceived positive subjective norms for knowledge sharing had the strongest effect on their knowledge sharing intentions ( $R^2 = .48$ ).

In addition to self-efficacy and work norms, knowledge sharing has also been linked to work performance behaviours, attitudes, and outcomes. De Vries, van den Hooff and de Ridder (2006) surveyed 424 employees from various organizational sectors and work positions to examine the impact of team communication styles, job satisfaction and perceived performance beliefs on employees' knowledge sharing behaviors. Results of their survey indicated that constructive communication styles, job satisfaction and self-rated performance had direct and significant positive effects on individuals' knowledge sharing attitudes while respectively explaining 23% and 27% of the variance in individuals' willingness and eagerness to share knowledge.

Knowledge sharing behaviors have also been demonstrated to effect positive work outcomes among staff nurses. In their study of 919 Taiwanese nurses employed in a major medical center, Chang, Huang, Chiang, Hsu, and Chang (2012) found that those who trusted their colleagues and shared a vision for nursing practice were more likely to engage in knowledge sharing behaviors ( $\beta = .22, p < .01$  and  $\beta = .18, p < .05$ ; respectively). In turn, nurses' knowledge sharing behaviors significantly predicted the extent with which predetermined patient safety goals were achieved in their workplace ( $\beta = .19, p < .05$ ). These findings are important as they are among the first to show the process-outcome link between nurses' knowledge sharing behavior to a work outcome such as patient safety.

In summary, the research discussed thus far suggest that individuals' self-confidence in their abilities to meet job-related goals, attitudes for work efficiency, and control over work practices are critical in predicting their enactment of knowledge contribution behaviors. However, these behaviors are further facilitated within an environment of positive norms for knowledge work. As such, these studies provide a good start to understanding how organizational practices, climates, and individual attitudes or capabilities influence employees' knowledge work, as well as their work outcomes. However, there remain opportunities for further research and knowledge development in this field, to which this study aimed to expand by examining nurses' knowledge work in clinical care settings. In particular, the present study sought to understand the linkages by which organizational practices may influence nurses' knowledge work behaviours to achieve positive patient care outcomes.

Guided by the Kelloway and Barling's (2000) framework and evidence from the reviewed literature, the explanatory model presented in Figure 2 was tested in this study.

The specific variables of interest were selected according to their relevance to current nursing practice, as well as their purported influences on nurses' knowledge work and work outcomes. In applying Kelloway and Barling's (2000) theory, nurses' decisions to engage in knowledge work behaviors are dependent on their motivation, ability and opportunity to do so. Specifically, nurses' accountability, role-breadth self-efficacy, and control over nursing practice were hypothesized to have a direct effect on their knowledge work behaviors. Working within an empowering environment was also purported to have an effect on nurses' knowledge work. Such an environment may be facilitated by nurse managers' use of empowering leadership practices that are targeted at nurses' motivation, ability, and opportunity for engaging in knowledge work within the clinical setting. Ultimately, nurses' knowledge work efforts should encourage nurses' ability to effectively coordinate and deliver quality patient care. The following sections outline in greater detail the literature and hypothesized relationships between the variables researched in this study.

### **Empowering Leadership: An Organizational Predictor of Nurses' Knowledge Work**

Kelloway and Barling (2000) specify several organizational practices that may promote individual knowledge work within the workplace such as the influential practices of transformational leaders (Bass, 1990), the creation of autonomous job design features (Kulick, Oldham & Hackman, 1987), the opportunity for employees to interact with affinity groups for the purposes of knowledge sharing and development (Van Aken, Monetta, & Sink, 1994), and the establishment of an organizational climate that compensates employee knowledge work (Despres & Hiltrop, 1996). While the list of potential strategies is not limited to those previously outlined, Kelloway and Barling (2000) suggest that organizational practices may successfully influence individual

knowledge work so long as they are aimed at developing opportunities where employees may master their work abilities, giving employees control over their work practices, and creating a fair work environment where employees are committed to and are recognized for fulfilling work goals through their knowledge use. As such, empowering leadership is one approach to establishing these work conditions for nurses.

The literature on leadership and its related outcomes is vast and spans a variety of fields including psychology, education, business, and health care. In a systematic review of research examining the relationship between leadership and nurses' work performance, Germain & Cummings (2010) found 6,289 independent titles and abstracts from their initial search. In this vast field of research, Cummings et al. (2010) note four common elements in the definitions of leadership. In particular, leadership is a process that entails influence, occurs within a group setting or context, establishing a common vision for work goals, and the use of behaviours to influence employees' goal achievements. Germain & Cummings (2010) concluded that leadership behaviors focused on displaying confidence in employees' abilities, building trusting and supportive staff work relationships, and facilitating employee access to resources directly impact employees' motivation to effectively perform at work. These behaviors reflect what Conger and Kanungo (1988) describe as leader empowering behaviors.

Leaders can play an essential role in the empowerment process, particularly as it relates to employee work behaviours. Conger and Kanungo (1988) argue that empowering leadership involves the process of implementing conditions that heighten "motivation for task accomplishment through the development of a strong sense of personal-efficacy" (p.474), or removing conditions that foster a sense of powerlessness and enabling employees' the freedom to be flexible as circumstances warrant. As a result,

empowered employees are likely to work effectively by initiating and sustaining work behaviors that meet task accomplishment objectives despite difficulty. Within the health care context, where nurses work as key individual contributors, leader empowering behaviors should be powerful in facilitating nurses' ability to engage in knowledge work behaviors that support their quality patient care delivery.

There are five strategies by which leaders may affect nurses' empowerment experiences (Conger & Kanungo, 1988; Hui, 1994). First, leaders need to express confidence in their nursing employees' abilities to meet high performance expectations. This not only includes the belief that nurses are competent and able to expand their practice to benefit quality patient care, but the assurance that they will do so within their work role. Secondly, leaders need to foster opportunities for participation in decision-making by encouraging greater discretion to do so. These decision-making opportunities are not only limited to those that directly relate to patient care interventions such as providing patient education, but include key decisions that may have indirect impact such as the initiation of a unit-based practice improvement change. Although nurses are afforded professional decision-making discretion when providing patient care interventions, bureaucratic rules, processes, and systems may impede their ability to maximize their professional scope of practice (Laschinger & Wong, 1999). Thus, providing autonomy from bureaucratic constraints is the third strategy by which leaders may affect nurses' empowerment experience (Conger & Kanungo, 1988; Hui, 1994). The fourth strategy is to enhance the meaningfulness of nurses' work. Conger and Kanungo (1988) indicated that this strategy aims to arouse employees' intrinsic interest in the work that they do rather than to inspire or emotionally excite. Thus, empowering leaders who assist nurses with understanding how their work affects the overall effectiveness of the

nursing unit and patient outcomes not only validates nurses' positive work contributions, but encourages their work accountability as well. Finally, leaders may foster nurses' empowerment through behaviors that facilitate nurses' capacity development and means to accomplish their goals. Such efforts include the provision of educational resources, support structures, and opportunities for nurses to develop role expansion and decision-making capacities within their work environment (Hui, 1994).

Empowering leadership strategies have been linked to various positive employee work attitudes, behaviors, and outcomes in nursing, information technology, and business literature (Ahearne, Mathieu & Rapp, 2005; Laschinger, Wong, McMahon, & Kaufmann, 1999; Lee, Kim & Kim, 2006; Rapp, Ahearne, Mathieu, & Schillewaert, 2006). In order to better understand the empowerment process of nurses in acute care settings, Laschinger, Wong, McMahon, and Kaufman (1999) conducted a study that tested an empirical model linking leader empowering behaviors and acute care staff nurses' perceptions of empowerment, occupational stress and work effectiveness. The results indicated that leader empowering behaviors positively predicted nurses' empowerment experience within the workplace ( $\beta = .31, p < .01$ ), which subsequently decreased nurses' occupational stress ( $\beta = -.39, p < .01$ ) and increased their work effectiveness ( $\beta = .26, p < .01$ ). These findings specifically suggest that leader empowering behaviors decrease occupational stress and increase work effectiveness by enabling nurses' greater access to information, resources, support, and opportunity within the workplace. This study not only demonstrates the impact that leader empowering behaviors have on individual nurses' empowerment experience, but is also among the first to outline the particular process by which leader empowering behaviors influence nursing work attitudes and outcomes.

Although Lee, Kim and Kim (2006) did not examine the outcomes of leader empowering behaviors as conceptualized by Conger and Kanungo (1988), they did find support for similar empowering organizational strategies that enhanced employees' work attitudes and knowledge sharing behaviours. Specifically, organizational support strategies such as monetary rewards, promotion opportunities, education opportunities, and recognition positively predicted employees' commitment to knowledge management activities ( $\beta = .36, p < .05$ ). Employee commitment was measured by the degree of their interest in, recognition of, participation in, and willingness to sacrifice for knowledge management activities at work. Lee et al. also examined the impact of management support practices on employees' commitment to knowledge management activities. Management practices such as setting a clear vision, demonstrating understanding, providing mentorship, and actively engaging in knowledge management activities was found to positively predict employees' commitment to knowledge management activities ( $\beta = .30, p < .01$ ). Greater employee commitment for knowledge management subsequently increased the degree with which employees' shared and utilized their knowledge for work ( $\beta = .48, p < .01$ ). The results of Lee et al.'s study indicate that supportive organizational and leadership strategies may enhance employee commitment for knowledge management, which was found to be the most influential variable in employees' greater likelihood for using and sharing their knowledge. This finding supports Kelloway and Barling's (2000) tenet that employee knowledge work is discretionary, and that organizational strategies may influence employees' choice to engage in knowledge work behaviors as long as it encourages their motivation and opportunity to do so.

Finally, Rapp, Ahearne, Mathieu, and Schillewaert (2006) studied pharmaceutical sales employees and examined the impact that their knowledge and their managers' empowering leadership behaviors had on employees' ability to work smarter and harder. Working smarter was conceptualized as employees' sales planning abilities, their capacity to use a wide range of selling behaviors, and their ability to adapt their sales behaviors according to situational contexts. Working harder was conceptualized as the effort or amount of time employees' spent in trying to achieve sales goals. The study results indicated that empowering leader behaviors had a positive effect on sales employees' ability to work smarter ( $\beta = .21, p < .05$ ), which ultimately increased their sales performance ( $\beta = .23, p < .05$ ). However, empowering leader behaviours had no impact on employees' ability to work harder. Together, these findings suggest that managers who demonstrate leader empowering behaviors utilize strategies that are tailored to support individual employees' capabilities for working smarter.

Given the literature discussed above, empowering leadership should yield benefits in terms of not only influencing nurses to engage in knowledge work, but also in reducing work constraints so that nurses may use their knowledge to deliver quality patient care. By enabling nurses to make decisions through the provision of supportive resources and opportunities, expressing confidence in these decisions, and removing constraints or barriers that may impede a nurse to maximize their scope of practice, it is argued that leader empowering behaviors may encourage nurses' greater accountability for their practice, self-efficacy to maximize and expand their work role, and control over the decisions they make in their practice. This, in turn, would result in a greater likelihood that nurses would engage in knowledge work. Thus, the following hypotheses were tested in this study:



Hypothesis 1a: Nurses' perceptions of their manager's leader empowering positively predicts nurses' accountability.

Hypothesis 1b: Nurses' perceptions of their manager's leader empowering behaviors positively predict nurses' role-breadth self-efficacy.

Hypothesis 1c: Nurses' perceptions of their manager's leader empowering behaviors will positively predict nurses' control over their practice.

### **Individual Predictors of Nurses' Knowledge Work**

#### ***Accountability***

In keeping with Kelloway & Barling's (2000) theory of knowledge work, accountability was conceptualized in this study as an intrinsic motivator for nurses' engagement in knowledge work behaviors. Accountability is defined as the answerability of a nurse to patients, peers, and the organization for outcomes of his/her actions (Maas, 1989). This definition implies that nurses have both the authority and autonomy to perform the acts and standards for which they are responsible in their professional role. When nurses choose to exercise the authority and autonomy to fulfill the responsibilities of their profession, they are thereby accountable for the decisions and actions they make. As Snowdon and Rajacich (1993) outline, nurses are accountable for their own practice according to minimum professional standards. In order to achieve such answerability, nurses need to provide rationale for their actions based on knowledge as opposed to tradition and routine, which can only be achieved by developing a sound knowledge and theoretical basis for practice (Snowdon & Rajacich, 1993). Thus, nurses who choose to be accountable for their nursing responsibilities are in turn motivated to engage in knowledge work so as to build knowledge and rationale for their actions.

A few studies offer some insight into the impact of accountability on nurses' work attitudes and performance (Houk , 2011; Lashinger & Wong, 1999; Sorensen, Seebeck, Scherb, Specht, & Loes, 2009). In order to understand how nurses enacted their accountability obligations, Houk (2011) conducted a qualitative study with nurses working in various clinical settings. Houk discovered that nurses' accountability perceptions are not static and that decisions to enact accountability are influenced by one's social and contextual work environment. As Sorensen, Seebeck, Scherb, Specht, and Loes (2009) discovered in their descriptive correlational study, nurses' perceived accountability was significantly and positively related to their satisfaction with extrinsic rewards ( $r = .12, p < .01$ ), work scheduling ( $r = .24, p < .01$ ), coworkers ( $r = .19, p < .01$ ), work interactions ( $r = .24, p < .01$ ), professional development opportunities ( $r = .26, p < .01$ ), praise and recognition ( $r = .28, p < .01$ ), and level of control and responsibility at work ( $r = .30, p < .01$ ). These findings highlight the impact of work environments on nurses' individual accountability. Similar implications were discussed in Laschinger and Wong's (1999) cross-sectional survey study with acute care staff nurses. This study found that nurses' perceived structural empowerment positively impacted nurses' collective accountability ( $\beta = 0.19, p < .01$ ), which then enhanced their perceptions of work effectiveness ( $\beta = .26, p < .01$ ).

Individual accountability has also been found to impact the work performance of aviation pilots, whose work, like nurses, involves high-risk outcomes. Mosier, Skitka, Heers, & Burdick (1998) found that pilots who reported a greater internal sense of accountability had a greater tendency to verify correct automation functioning, and to commit fewer errors. Mosier et al. suggested that such perceptions of accountability encouraged the pilots' use of vigilance, proactive strategies, and all available information

to inform their interactions with the automation simulators. Similar findings were noted in Skitka, Mosier and Burdick's (2000) study in that pilots who were conditioned to be accountable for their performance were more likely to verify aid directives than pilots who were conditioned to not be accountable for their actions [ $F(1,176) = 4.12, p < .01$ ]. Together, these studies indicate that individual accountability for work effectiveness impacts one's behaviors for gathering information to support rationale for one's work actions.

Given the research above, it is argued that individual accountability serves as an intrinsic motivator for nurses' knowledge work. When nurses perceive themselves to be accountable for their decisions and actions, they may more likely enact their accountability by engaging in knowledge work behaviors that will support the development and gathering of rationale for their patient care decisions. As such, the following hypothesis was tested:

Hypothesis 2: Nurses' accountability will positively predict their knowledge work behaviors.

### ***Role-breadth Self-efficacy***

While nurses are taught strategies for knowledge work throughout their nursing education, the realities of practice and education are often not equated. As health care services become more specialized and patient populations become more complex, the practice of nursing has expanded to include greater demands for patient advocacy, management of interpersonal relationships, interdisciplinary approaches to health care, reasoned decision-making as informed by evidence, and continuing competence within a constantly changing work environment (CNA, 2006; CNO, 2002; IOM, 2010). Meeting these demands necessitates that nurses take the initiative to mobilize their knowledge in

practice by finding, sharing, developing, and applying existing or new knowledge. However, a nurse's decision to initiate these knowledge work behaviors may depend on their beliefs in their ability to do so (Kelloway & Barling, 2000), especially when engagement in such behaviors requires considerable self-direction and effort by the individual nurse.

Role breadth self-efficacy (RBSE) refers to the extent to which individuals feel confident in their ability to take on expanded integrative and interpersonal tasks beyond traditionally prescribed technical requirements (Parker, 1998). It differs from common conceptualizations of self-efficacy that focus on specific nursing task capabilities such as skills for health teaching, patient resuscitation, or medication dosage calculations (Goldenburg, Andrusyszyn & Iwasiw, 2005; van Schaik, Plan, Diane, Tsang, & O'Sullivan, 2011; McMullan, Jones & Lea, 2011). Rather, RBSE focuses on the perceptions that individuals have in their abilities to be proactive including taking on new roles, challenging prescribed technical tasks, creating new work processes, or making suggestions for improvement at work (Axtell & Parker, 2000; Parker 1998, 2007; Parker, Blindl & Strauss, 2010; Parker, Williams & Turner, 2006).

Having RBSE is essential for nurses to engage in knowledge work because such behaviors require nurses to assess the likely outcomes of their work actions. Examples include whether the risks of suggesting and implementing a nursing practice change outweigh the benefits, or if sharing knowledge with one's nursing peers will be perceived as mutually favorable (Rycroft-Malone, 2004; Simmons et al., 2003). Those who are more confident in their capabilities are more likely to judge that their actions will be successful, and therefore take the risk to be proactive in initiating and actively engaging in knowledge work behaviors (Morrison & Phelps, 1999; Parker, 1998). As such, when

nurses are confident in their abilities to expand their interpersonal skills and role beyond functional nursing tasks, they are likely to exercise such abilities to engage in knowledge work behaviors.

RBSE has been consistently linked to proactive work behaviors in various work sectors and occupations including management, human resources, and nursing (Burns, 2002; Griffin, Neal & Parker, 2007; Johnson, Hong, Groth, & Parker, 2010; Strauss, Griffin & Rafferty, 2009). For instance, Strauss, Griffin and Rafferty (2009) identified that the perceived RBSE of employees of an Australian public sector agency was significantly associated with self-starting and initiating tasks that were not specified in advance, and that supported the work team ( $\beta = .43$ ) and the organization ( $\beta = .45$ ). Griffin, Neal and Parker (2007) noted similar results in their study of employees in two different organizations. These researchers found that while RBSE was a significant predictor of employees' proficiency, adaptivity and proactivity, it was a stronger predictor of proactivity than either proficiency or adaptivity. These results were consistently found across three levels of analyses that included individual employees, teams of employees, and an organization of employees.

RBSE has also been found to impact work attitudes and performance among nurses. In a study aimed at understanding how nurses conceptualize their role and assess their competency for working with families in acute care settings, Burns (2002) identified that nurses' RBSE was significantly related to their delivery of family centered-care ( $r = .30, p < .001$ ). Likewise, Johnson, Hong, Groth, and Parker (2010) found that RBSE significantly predicted nurses' perceptions of their core performance ( $\beta = .20$ ), and delivery of quality ( $\beta = .30$ ) and proactive ( $\beta = .31$ ) patient care. Johnson et al. also found that nurses' RBSE mediated the relationship between nurses' learning development

activities and their patient care delivery performance. This suggests that RBSE influences the potential benefits of nurses' learning development activities (Johnson et al., 2010).

The research presented above highlights the role that RBSE may have over nurses' engagement in knowledge work behaviors and subsequent outcomes. Specifically, the research demonstrates that effective performance outcomes within changing work environments and organizations rely on employees' confidence in their ability to assume broader responsibilities (Parker, 1998). This is in line with Kelloway & Barling's (2000) notion that a nurse's decision to engage in knowledge work behaviors depends on their belief in their ability to do so. As such, it is argued that when nurses are confident in their abilities to be proactive and take on broader responsibilities within their work role, they are likely to choose to engage in knowledge work behaviors that will aid in their success in meeting such responsibilities. Thus, the following hypothesis was tested in this study:

**Hypothesis 3:** Nurses' role breadth self-efficacy will positively predict their knowledge work behaviors.

### ***Control Over Nursing Practice***

Kelloway and Barling (2000) contend that while employees may have the ability and motivation to engage in knowledge work, their efforts in doing so may be limited by their opportunity, which is the third necessary condition for knowledge work. In this study, nurses' control over their practice represented the opportunity for which nurses' are afforded to engage in knowledge work.

Control over nursing practice (CONP) is defined as the perceived freedom to evaluate and modify nursing practices, to make autonomous decisions related to patient's care, and to influence the work environment and staffing at the unit level of analysis

(Gerber, Murdaugh, Verran, & Milton, 1990). This definition implies that nurses may influence standards of nursing practice, be creative in the delivery of nursing care, introduce new nursing practices and procedures, and adjust plans of care to meet patient needs so long as they are given the opportunity, expectation and authority to do so (Weston, 2009). Should the opportunity exist, nurses are thereby free to engage in knowledge work behaviors that support their influential change in practice when they choose to. Thus, it is proposed that nurses' CONP affords them the opportunity to engage in knowledge work behaviors.

Aside from being identified as a key work attribute for ensuring patient safety (IOM, 2004), CONP has been found to be associated with several nursing work outcomes. CONP has been examined in research on Magnet hospitals as an intervening variable between positive organizational characteristics associated with magnet hospitals and quality patient outcomes (Lundmark, 2008; Scott, Sochalski & Aiken, 1999). However, because CONP is often measured together with autonomy and nurse-physician relationships, it is difficult to determine the specific influences of CONP on patient outcomes with the magnet hospital literature.

As a variable independent from other related concepts such as autonomy, Laschinger and Havens (1996) examined the effects of acute care nurses' perceived work empowerment and degree of CONP on their work attitudes and outcomes. The researchers found that both nurses' workplace empowerment and CONP significantly predicted their work satisfaction ( $R^2 = .52, p < .001$ ) and work effectiveness ( $R^2 = .58, p < .001$ ). However, CONP was found to be the stronger predictor ( $\beta = .63$ ) when compared with empowerment ( $\beta = .15$ ). As Laschinger and Havens (1996) note, these findings demonstrate that decisional control over practice can impact effective nursing outcomes.

Similar relationships between decisional control over work practices and performance outcomes have been found in other industries as well. In their research examining cooperative learning among business teams, Janz and Prasarnphanich (2003) found that teams with greater freedom over planning, people, and work process decisions reported more positive group interdependence, interaction, and process. More specifically, control over work related decisions was found to be a significant positive predictor of cooperative learning in teams ( $\beta = .43, p < .001$ ), which ultimately predicted the efficiency, effectiveness, and timeliness of the teams' work efforts ( $\beta = .41, p < 0.001$ ).

These studies support the notion that decisional control over one's practice and actions influence one's work behaviors and subsequent outcomes. Specifically, when nurses perceive themselves to have the freedom to make autonomous decisions and changes in their practice, they are more likely to engage in knowledge work behaviors that support their practice decisions. Given this, the following hypothesis was tested in this study:

Hypothesis 4: Nurses' control over practice will positively predict their knowledge work behaviors.

## **Outcomes of Nurses' Knowledge Work**

### ***Nursing Care Coordination***

Nurses' knowledge work is argued to be an important key to achieving quality patient care. Without its application to support decisions and processes of quality care delivery, nurses' knowledge work efforts are ineffective and futile (Moody, 2004; Moody & Pesut, 2006; Sorrells-Jones & Weaver, 1999). However, just as there is limited evidence in the literature examining nurses' engagement in knowledge work, so too is the



research examining the impact of nurses' knowledge work on their work outcomes limited. To address this gap, this study examined the hypothesis that nurses who choose to engage in knowledge work behaviors are better able to mobilize their knowledge for action when providing care to patients. Specifically, it is argued that engagement in knowledge work behaviors enhances nurses' ability to make informed decisions that support their coordination and delivery of quality patient care.

The role that nurses play in coordinating patient care has been identified as a key factor to patient safety (IOM, 2004, 2010; Robinson, 2010). As primary providers at the point of care, nurses are well positioned to provide patient surveillance, implement therapeutic interventions, and coordinate interdisciplinary services that support patients' transitional care and quality outcomes. According to the Institute of Medicine (2004), these include direct and indirect care activities such as implementing and explaining physician treatment orders to patients; facilitating patients' discharge plans from health care facilities to community settings; providing education about the patients' disease, course of therapy, medications, and self-care activities; and collaborating with other care providers to integrate patient care services. While it is evident that nursing care coordination activities are diverse and contextually dependent, it is the nurses' ability to integrate different aspects of care to meet patients' needs that results in improved patient outcomes (Beringer & Fletcher, 2008; Beringer, Fletcher & Tacket, 2006; IOM, 2004; Robinson, 2010). Nurses' knowledge work may be the vehicle that enables nurses to integrate such aspects of care for improving patient outcomes.

For the purposes of this study, Lamb, Schmitt, Sainfort, Edwards and Duva's (2007) concept of nurse care coordination was examined as an outcome of nurses' knowledge work behaviours. Nurse care coordination is defined as a mechanism that

nurses facilitate in acute care settings to keep patients' seamless care trajectory throughout their hospital stay and following discharge (Duva, 2010). It consists of "actions initiated by nurses with patients, families, and/or members of their health care team to manage and correct the sequence, timing, and /or effectiveness of patient care from hospital admission to hospital discharge" (Lamb, et al., 2007; Duva, 2010, p. 23). There are six activity domains in which nurse care coordination is enacted. These activity domains include providing or seeking assistance to carry out care coordination activities that a nurse would normally facilitate independently; checking the accuracy, timeliness, sequence, and completion of steps necessary to carry out care coordination activities; mobilizing others to take actions for which they are accountable in order to proceed with care coordination processes; exchanging or managing necessary information for care coordination activities; organizing an infrastructure that allows for care coordination processes to be safely and timely carried out; and completing the work of other care providers for which they are responsible but did not do (Lamb et al., 2007; Duva, 2010).

Nursing care coordination has been linked to positive patient outcomes and satisfaction with care (Kruse et al., 2010; Lee et al., 2011; Marek et al., 2005). In their study examining the impact of a nurse care coordinator within a family medical clinic, Kruse et al. (2010) collected longitudinal health care utilization data among two groups of patients over five years. The first group consisted of patients who utilized the family medical clinic that included a nurse-care coordinator; whereas the second group received no additional care coordination by a nurse. Results from Kruse et al.'s study indicated significant differences between the two groups. Specifically, patients who received the care of a nurse care coordinator in addition to the usual medical services demonstrated

significantly fewer emergency department and urgent care visits to the hospital when compared to patients who only received usual medical services.

Lee et al. (2011) conducted a similar study to examine the beneficial health outcomes of nurse navigators in assisting outpatients with cancer. The role of the nurse navigator was to serve as the primary care provider for patients. That is, they were responsible for facilitating a continuum of care from initial assessment on admission to follow-up care; arrange all diagnostic tests and explain treatment plans; educate patients and provide caregiver support to family members; coordinate multidisciplinary services within the hospital; provide assistance with arranging medical or related appointments; and continuously monitor patient progress and care (Lee et al., 2011). When compared to patients who received routine care through their oncologists and medical staff, Lee et al. found that patients who received care coordination from a nurse navigator demonstrated significantly greater social functioning ( $F = 3.68, p < .005$ ), physical functioning ( $F = 4.33, p < .002$ ), and satisfaction with care ( $F = 4.62, p < .001$ ). Likewise, patients who received nursing care coordination demonstrated less financial burden ( $F = 6.43, p < .005$ ), incidences of constipation ( $F = 3.34, p < .009$ ), and shortened length of stay in hospital ( $M_{\text{diff}} = 9.11$  days;  $F = 14.52, p < .001$ ) than patients who did not have a nurse navigator to coordinate their care.

Finally, Marek et al. (2005) compared clinical outcomes between older adults who lived in nursing homes and a group of similar older adults who were enrolled in a government funded program where a nurse care coordinator was assigned to each participant longitudinally across three time points (i.e., at 6, 12 and 18 months). The nurse care coordinator was primarily responsible for completing a comprehensive admission assessment, creating a care plan that coordinated interventions across a variety

of health services, monitoring the clinical conditions of patients with early detection of concerns, communicating with other care providers, and providing home health care services as needed (Marek et al., 2005). Results from the study revealed that patients who received care from a nurse care coordinator had significantly better clinical outcomes in activities of daily living, cognition, depression, and incontinence in at least one of the data collection time periods.

When considering the antecedents of nursing care coordination, professional practice environments have an important role to play. Specifically, Duva (2010) identified that strong nursing leadership and a governance structure that supports nurses to function at the highest scope of their clinical practice was related to nurses' less frequency ( $r = -.51, p < .05$ ) and time spent ( $r = -.41, p < .05$ ) on care coordination activities. These results provide some insight into the supportive structure that professional practice environments offer for streamlining nurses' care coordination processes and greater patient care delivery efficiency (Duva, 2010).

Results from research on relational coordination among health care providers also emphasize the effect of coordination processes on patient care delivery outcomes (Gittell, Weinberg, Pfefferle, & Bishop, 2008; Gittell, Seidner & Wimbush, 2009; Havens, Vasey, Gittell, & Lin, 2010). The concept of relational coordination rests on the interpersonal dynamics among care providers as they coordinate patient care. Specifically, it is a mutually reinforcing process between communication and relationship interactions carried out for the purpose of task integration (Gittell et al., 2008). Havens, Vasey, Gittell, and Lin (2010) studied the relational coordination perceptions among 747 direct care nurses' and found that nurses' relational coordination with fellow nursing colleagues had the strongest associations with their perceived quality of care ( $r = .49, p < .01$ ).

Havens et al. also found that as nurses' relational coordination ratings increased, they were likely to report less occurrences in patient family complaints ( $r = -.16, p < .01$ ), medication errors ( $r = -.14, p < .01$ ], hospital-acquired patient infections ( $r = -.14, p < .01$ ), and patient falls resulting in injuries ( $r = -.08, p < .05$ ). Positive outcomes of relational coordination were also found in Gittell, Weinberg, Pfefferle, and Bishop's (2008) study with nursing aides, in that nursing aides' relational coordination significantly predicted the job satisfaction of nursing aides ( $\beta = .30, p < .001$ ), and nursing home residents' perceived quality of life ( $\beta = .37, p < .01$ ).

Gittell, Seidner and Wimbush's (2009) research examining relational coordination among 9 different hospitals adds to the growing empirical evidence supporting the positive effects of relational coordination on quality care outcomes. In particular, Gittell, et al.'s research results demonstrated that care providers perceived relational coordination positively predicted patient-ratings quality of care ( $\beta = 1.93, p < .05$ ) and negatively predicted patients' length of stay in hospital ( $\beta = -1.19, p < .01$ ). Though these study findings reveal the importance of coordination processes in effecting safe and quality patient care, they particularly emphasize components of effective communication and positive mutual relationships beyond task coordination activities.

### ***Quality of Patient Care***

In this study, nurse assessed-quality of patient care was examined as a desired outcome of nurses' knowledge work behaviors, as mediated by nurses' care coordination activities. Findings from numerous nursing studies have indicated the significant impact that nursing work environments and characteristics have on patient care quality. Drawing from the magnet hospital literature, hospitals with a flat organizational structure, nursing representation in top management decision-making, flexible nurse scheduling systems, a

self-governance model, and investment by management in nurses' continuing education have demonstrated success in attracting and retaining professional nurses. This is because these organizational attributes have proven to offer nurses greater job satisfaction, autonomy, control over their practice conditions, and better relationships with physicians (Aiken, Smith & Lake, 1994; Schmalenberg & Kramer, 2008; Sochalski, 2004). Over the years, the magnet hospital research has extended to empirical investigations of how such magnetizing work conditions influence nurses' ability to influence positive patient outcomes, particularly by means of delivering quality and safe patient care (Aiken, Clarke & Sloane, 2002; Needleman, Buerhaus, Mattke, Stewart, & Zelevinsky, 2002; Poghosyan, Clarke, Finlayson, & Aiken, 2010; Schmalenberg & Kramer, 2008; Shen, Chiu, Lee, Hu, & Chang, 2012). Such research has primarily linked increased hospital organizational support for nursing care and increased proportion of registered nurse staffing and skill mix on patient care units to greater nurse assessed quality of care and key patient outcomes (Aiken et al., 2002; Needleman et al., 2002; Shen et al., 2011). These patient outcomes include a decrease in patients' length of stay in hospital, urinary tract infection rates, upper gastrointestinal bleeding, hospital acquired pneumonia, patient shock/cardiac arrest, and failure to rescue incidences (Needleman et al., 2002). Despite these findings, there remains a significant gap in understanding the direct process by which nurses' contribute to quality patient care and positive patient outcomes. Sochalski (2004) sought to bridge this gap by examining the impact of patient care workload on nurses' assessed ability to deliver quality patient care.

Findings from Sochalski's (2004) research indicate that increased patient care workload was significantly related to nurses' increased reports of patient safety problems and increased reports of nursing tasks left undone, which subsequently relates to nurses'

lower assessments of quality of care. Though these findings demonstrate how the structural barrier of limited time affects nurses' inability to complete work responsibilities for providing quality patient care, understanding nurses' individual knowledge work contributions and abilities to mobilize strategies for quality care delivery may offer greater insight to how nurses may overcome the effects of such structural barriers to care. Thus, nurses' quality of patient care was examined in this study as an outcome of nurses' knowledge work behaviors and care coordination activities.

The collective studies discussed above lend support for nursing care coordination in sustaining and promoting patients' quality health. However, successful care coordination requires that nurses' have sufficient clinical knowledge and skills needed to carry out care coordination activities, as well as the abilities to effectively integrate nursing care with the interventions of other members of the health care team. More importantly, the knowledge and skill level of nurses and the extent to which they collaborate with others in sharing their knowledge and skills not only affect how well coordinated a patient's care is, but as the research above suggests, can ultimately impact patient safety outcomes and quality of care (IOM, 2004; Kruese et al., 2010; Lee et al., 2011; Marek et al., 2005). Likewise, engaging in knowledge work behaviors may be the necessary process by which nurses develop and maintain relevant clinical knowledge and skills that support their effective care coordination decisions and activities so as to deliver quality nursing care. Given this, the following study hypotheses were tested:

Hypothesis 5: Nurses' knowledge work behaviors will have a positive effect on their care coordination effectiveness.

Hypothesis 6: Nurses' care coordination effectiveness will have a positive effect on their perceived quality of patient care.

## **Summary of Literature Review**

To date, research examining nurses' knowledge work behaviors is limited, particularly as it relates to the factors that facilitate such knowledge work behaviors, as well as the work outcomes that knowledge work behaviors can lead to. An in depth literature review of the facilitating factors and outcomes of nurses' knowledge work within the workplace setting was examined. These include a review of theoretical papers and empirical studies on individual knowledge work behaviours, and empowering work climates (i.e., leader empowering behaviors) proposed to enhance work attitudes (i.e., role-breadth self-efficacy, accountability, and control over nursing practice) that influence nurses' knowledge work behaviours and related care delivery outcomes (i.e., care coordination and quality of care).

Results of the studies discussed in this literature review provide support for Kelloway & Barling's (2000) theory of knowledge work in organizations as a guiding framework for this study, in that individual abilities, motivation, and opportunity may facilitate nurses' knowledge work behaviors that ultimately support their positive work outcomes and effectiveness. Furthermore, organizational strategies may influence individual knowledge work insofar as the strategies support nurses' abilities, motivation, and opportunity to engage in knowledge work.

Self-efficacy research has suggested that role-breadth self-efficacy is a driving force for nurses' engagement in self-starting and future oriented behaviors, participation in knowledge development activities, and self-assessment of appropriate competencies for meeting role expectations and responsibilities (Burns, 2002; Griffin et al., 2007; Johnson et al., 2010; Strauss et al., 2009). As such, nurses' role-breadth self-efficacy demonstrates the confidence they have in their abilities to be proactive and take on



broader role responsibilities. This confidence encourages their ability to take the initiative and engage in knowledge work behaviors that will help meet their practice goals and accountabilities. Nursing accountability has also been supported in the literature as an intrinsic motivator for nurses' engagement in knowledge work behaviors. Specifically, it is argued that nurses who perceive a greater need to provide rationale for their decisions and actions will likely be motivated to develop and apply their knowledge by means of knowledge work behaviors. Indeed, individuals' internalized accountability has been found to encourage the use of greater vigilance, proactive work strategies, and use of multiple information sources to inform their decision-making (Mosier et al., 1998; Skitsa et al., 2000). Results from nursing studies have suggested that nurses' abilities to effectively meet their work accountabilities is also dependent on the opportunity and control they have in making decisions within their nursing scope (Laschinger & Wong, 1999; Sorensen et al., 2009). Thus, as nurses are afforded greater control over their practice decisions, they are more likely to take advantage of the decisional latitude and engage in knowledge work behaviors to inform their decisions.

Nurse leaders may further encourage their nursing staff's knowledge work behaviors by employing strategies that create an empowering work climate. Such strategies include expressing confidence in nurses' abilities to deliver quality patient care, fostering opportunities for nurses to partake in participative decision-making, providing autonomy from bureaucratic constraints, enhancing the meaningfulness of nurses' work contributions, and facilitating nurses' practice accomplishments (Conger & Kanungo, 1988; Hui, 1994). Research studies have demonstrated the positive effects of empowering leadership on employee attitudes and outcomes including individual employees' enhanced employee commitment to knowledge sharing (Lee et al., 2006), greater ability

to work smarter (Rapp et al., 2006), and increased work effectiveness (Laschinger et al., 1999). Together, these leader empowering strategies create an empowering work climate that enhances nurses' confidence in their abilities, motivational goals, as well as practice expansion and decision-making opportunities for engaging in knowledge work behaviors within the workplace. Ultimately, as the research of Kruese et al. (2010), Lee et al. (2011) and Marek et al. (2005) suggests, knowledge work behaviors serve to advance nurses' clinical knowledge base and skills to be able to competently deliver and integrate quality nursing care (IOM, 2004). Thus, when nurses engage in knowledge work behaviors, they are better able to effectively mobilize their knowledge to inform their decisions and actions when coordinating and delivering quality patient care.

In summary, this literature review provides theoretical and empirical support for the research propositions tested in this study. Guided by Kelloway and Barling's (2000) knowledge work framework, it is postulated that nurses' accountability, role-breadth self-efficacy, and control over practice positively affects their motivation, ability and opportunity to engage in knowledge work behaviors. Empowering leadership is also postulated to create an influential work climate that influences nurses' knowledge work behaviours by enhancing their accountability, role-breadth self-efficacy, and control over practice. This, in turn, encourages nurses' discretion to engage in knowledge work behaviors that ultimately has a positive effect on nurses' coordination and quality patient care.

### **Research Purpose, Objectives, and Hypotheses**

The aim of this study was to test an explanatory model of staff nurses' knowledge work in acute care settings, as presented in Figure 3 and guided by Kelloway and

Barling's (2000) theory of knowledge work. In doing so, the specific objectives of this study were to:

1. Examine the behaviors that represent nurses' knowledge work in acute care settings.
2. Examine how empowering leadership practices impact nurses' accountability, role-breadth self-efficacy, and control over practice to influence their knowledge work behaviours.
3. Evaluate the impact of nurses' knowledge work on their ability to coordinate and deliver quality patient care.

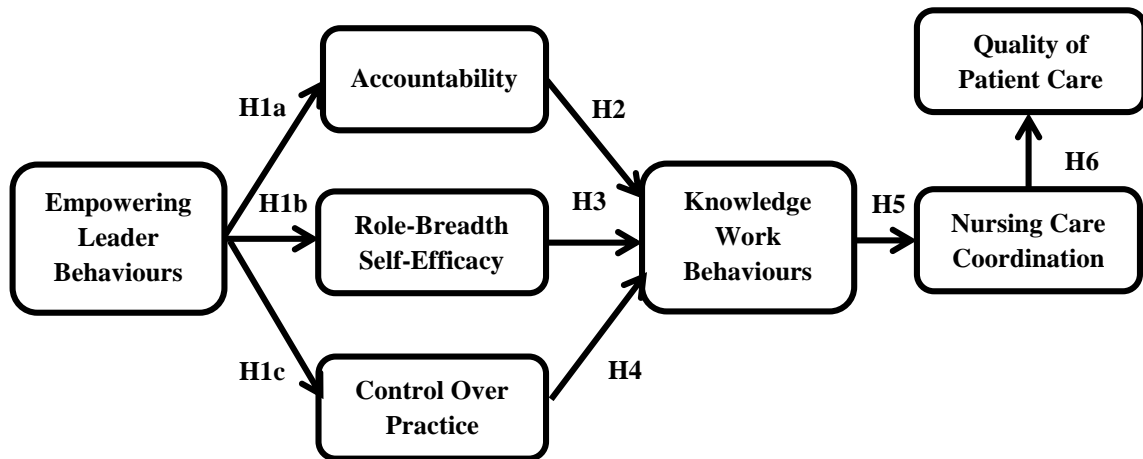

*Figure 3.* Hypothesis Research Model

Given the hypothesized explanatory model of this study, the following relationships in were tested:

Hypothesis 1a: Nurses' perceptions of their manager's leader empowering behaviors will positively predict nurses' accountability.

Hypothesis 1b: Nurses' perceptions of their manager's leader empowering behaviors will positively predict nurses' role-breadth self-efficacy.

Hypothesis 1c: Nurses' perceptions of their manager's leader empowering behaviors will positively predict nurses' control over their practice.

Hypothesis 2: Nurses' accountability will positively predict their knowledge work behaviors.

Hypothesis 3: Nurses' role breadth self-efficacy will positively predict their knowledge work behaviors.

Hypothesis 4: Nurses' control over their practice will positively predict their knowledge work behaviors.

Hypothesis 5: Nurses' knowledge work behaviors will have a positive effect on their care coordination effectiveness.

Hypothesis 6: Nurses' care coordination effectiveness will have a positive effect on their perceived quality of patient care.

## CHAPTER III: RESEARCH METHODS

### Research Design

A non-experimental, cross-sectional survey design was used in this study to test the hypothesized model explaining predictors and outcomes of nurses' knowledge work behaviours. Specifically, the influence of antecedent constructs including nurses' perceived work empowerment, accountability, role-breadth self-efficacy, and control over practice on nurses' knowledge work behaviours was examined. Effective nursing care coordination activities and perceived quality of care were also examined as work outcomes of nurses' knowledge work behaviours. The overall aim of this research was to provide empirical support for the nomological network and theoretical links among the constructs of the hypothesis model (see Figure 3).

### Setting

Cross-sectional survey data were collected by post mail from RNs who work in acute care hospitals within medical or surgical care settings. These clinical settings were of interest for this study as they represent areas where nursing surveillance and care coordination are key to preventing injuries associated with patient safety (IOM, 2004), thus, signify where nurses' knowledge work behaviours would presumably have impact.

### Sample Description

Given that RNs represent one of the largest professional groups with whom patients in acute care settings have contact with, they are often directly involved in decisions and activities that may impact patients' safety and transitional care out of hospital (IOM, 2004). As such, acute care RNs represented the target population in this study, whereby the accessible population was Ontario RNs working in acute medical or

surgical care areas. A random sample of acute care RNs was drawn from the College of Nurses of Ontario's (CNO) 2012 registration list. This sample provided the opportunity to survey a representative sample of the target population and to increase the possibility of generalizing the findings to RNs in similar clinical roles and settings.

### **Inclusion & Exclusion Criteria**

RNs who indicated their willingness to participate in research on their 2012 annual CNO registration were included in the randomization pool of nurses that were asked to participate in this study. Participant inclusion criteria for this study were as follows:

1. Currently practising as a RN;
2. Currently providing direct patient care;
3. Currently employed as a staff nurse in an Ontario acute care hospital;
4. Currently working in either medical or surgical care settings;
5. Has worked on their current nursing care unit for at least 6 months; and
6. Currently employed on either a full-time or part-time basis.

Casually employed RNs were excluded from this study because they may not have worked sufficient hours to develop a work relationship with their colleagues, nursing unit or manager. This may limit their ability, motivation or opportunity to engage in knowledge work behaviours within their work role on the nursing unit. RNs who worked in management, clinical education or advanced nursing practice positions were also excluded from participating in the study, as direct patient care activities including care coordination is often not a primary responsibility of their role. Similarly, given that nursing care coordination was conceptualized in this study as a mechanism that nurses

use to facilitate to keep patients' seamless care trajectory throughout their hospital stay leading up to and following discharge (Duva, 2010), such coordination activities are primarily performed by nurses in clinical settings where patients spend most of their length of hospital stay and just before discharge out of hospital, such as medical or surgical inpatient care units. Thus, RNs who did not work in an acute care hospital or in either a medical or surgical care setting were excluded as their care coordination activities may vary from that which was conceptualized in this study.

### **Sample Size & Response**

A medium to large sample size was required to ensure sufficient statistical power for hypothesis testing using structural equation modeling (SEM) techniques (Kline, 2005; Tabachnick & Fidell, 2007). Several factors affect sample size requirements in SEM, including the hypothesis model complexity and choice of estimation methods. For these reasons, there is no definitive formula for estimating sample size requirements in SEM (Kline, 2005), although Jackson (2003) recommended using a minimum ratio of 10:1 sample cases to the number of model parameters that require statistical estimates for SEM techniques using maximum likelihood estimation method. With some empirical support, Jackson further argues that ratio values less than 10:1 would limit the trustworthiness of study results. Given this recommendation and the study hypothesis model to be tested by means of partial latent SEM (see Figure 4), 32 parameters requiring statistical estimates were calculated as follows: 14 error variances, 1 latent variance, 9 factor loadings, and 8 structural paths. Thus, a minimum of 320 participants (i.e., 10 cases x 32 free parameters) was required in this study to ensure adequate power for testing the hypothesis model using SEM techniques.

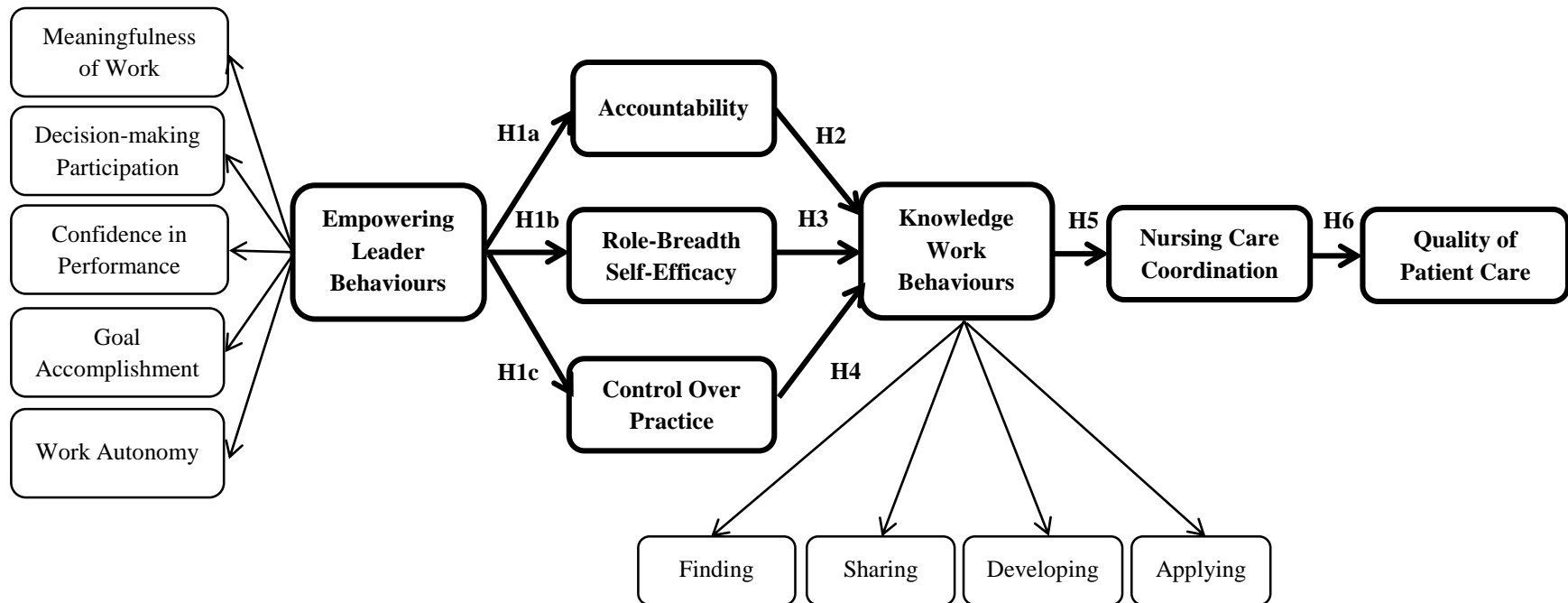

Figure 4. Structural Hypothesis Model



Recent nursing research using mail surveys to gather data from similar Ontario RN samples have reported response rates of appropriately 30% (Squires, Tourangeau, Laschinger, & Doran, 2010; Laschinger et al., 2013). An additional 10% was overestimated to accommodate for nurses who have changed their mailing address, made career changes, or chosen to no longer be registered with the CNO. Hence, a random sample of 1,600 acute care RN names and corresponding mailing addresses were selected from the CNO's 2012 registration database to ensure sufficient collection of useable data for analysis.

Of the randomly selected 1,600 RNs supplied by the CNO for this study, 80 RNs were eliminated from the survey distribution list due to incomplete or out of province mailing addresses. A subsequent total of 1,520 surveys were distributed to potential participants, of which 557 either declined to participate or had their mailed surveys post marked "return to sender". While 488 participants responded with completed surveys, 328 participants fulfilled the study inclusion criteria. Accordingly, the response rate for this study was 21.58% (i.e., 328 useable returned surveys out of 1,520 surveys distributed to potential participants). The data from 10 participants were deleted from further analysis because of identified anomalies such as univariate outliers, multivariate outliers or a high percentage of missing data. Thus, a sample of 318 participant responses was retained in the final dataset for analysis in this study.

### **Data Collection Procedures**

Mail surveys were selected as the data collection approach for this study. The use of mail surveys provides reasonably economic and timely access to samples and respondents across a large geographical region that might be difficult to reach by phone or have limited internet access (Dillman, Smyth & Christian, 2009). Furthermore, as

compared to telephone survey designs, mail surveys may be more feasibly distributed with minimal human resources and infrastructure. Finally, mail surveys allow participants to select a convenient time and location to reflect on their answers while completing the survey (Dillman et al., 2009).

A modification of Dillman et al.'s (2009) Tailored Design Method for mail surveys was employed to maximize response rates. Dillman et al.'s method involves the use of multiple successive communications throughout the data collection phase in conjunction with tokens of appreciation, which are believed to create greater participation and respondent trust in the research (Dillman et al., 2009). The methodology involves three rounds of communication and mailing distributions as follows:

- 1) An initial survey mailing to all potential participants (Appendix A);
- 2) A reminder/thank you letter mailing to non-respondents two weeks following the initial mailing (Appendix B); and
- 3) A final reminder letter with a replacement survey to non-respondents three weeks following the second mailing (Appendix C).

The initial survey mailing includes an introductory letter describing the study and assuring complete anonymity, the survey, a stamped and addressed return envelope, a contact number should participants have any questions, and a packaged tea beverage as a small token of appreciation. The survey itself takes approximately 40 minutes to complete in its entirety.

Dillman et al.'s methodology has demonstrated improvements in respondent rates, ranging from 58-92%. In this study, response rates of the final sample (N=318) were approximately evenly distributed across the initial mailing (34.9%), the second mailing (34.9%), and the final mailing rounds (30.5%). These findings lend further support for

the modified Tailored Design Method procedure as an effective methodology for maximizing survey response rates.

### **Study Survey**

The survey comprised seven instruments that each measured the concepts of interest in this study, and a demographic questionnaire (Appendix D). The concepts of interest stem from the nomological network of theoretical propositions examined in this study, and were as follows: Empowering leadership of nurses' direct managers, nurses' accountability for nursing practice, role-breadth self-efficacy within their work role, control over nursing practice at work, engagement in knowledge work behaviours, nursing care coordination activities that facilitate patients' care, and the overall quality of care provided to patients.

A demographic questionnaire was included in the survey. The variables of interest for this study included age, gender and nursing education, location of their initial nursing education, years of current unit and total nursing work experience, type of nursing unit that they work in, and employment status.

### **Concept Measures**

Table 1 is a summary of the instruments used in this study, six of which have demonstrated sound psychometric properties in previous research and one composite instrument newly compiled for this study to measure nurses' knowledge work. Scale development, scoring conventions, and psychometric properties for each measure are further detailed in the following sections.

#### ***Leader Empowerment Behaviours Scale***

Nurses' perceptions of their direct nurse manager or supervisor's empowering leadership behaviours was measured using Hui's (1994) Leadership Empowerment

Table 1

*Concept Measures*

<b>Study Concept</b>	<b>Definition</b>	<b>Instrument Measure</b>	<b># Item(s)</b>
<b>Empowering Leadership</b>	Leadership practices that facilitate staff empowerment experiences for task accomplishment (Conger & Kanungo, 1988).	Leader Empowerment Behaviors Scale (Hui, 1994)	16
<b>Nursing Accountability</b>	The answerability of an individual nurse to patients, peers, and the organization for outcomes of his/her actions (Maas, 1989).	Specht and Ramler Accountability Index (Specht & Ramler, 1994)	11
<b>Role-Breadth Self-Efficacy</b>	The extent to which individuals feel confident in their ability to take on expanded integrative and interpersonal tasks beyond traditionally prescribed technical requirements (Parker, 1998).	Role-Breadth Self-Efficacy Scale (Parker, 1998)	10
<b>Control Over Nursing Practice</b>	The perceived freedom to evaluate and modify nursing practices, to make autonomous decisions related to patients' care (Gerber et al., 1990).	Control Over Nursing Practice Scale (Gerber et al., 1990)	21
<b>Knowledge Work</b>	Discretionary behavior representing the degree to which an individual chooses to actively find, share, develop and apply knowledge at work (Kelloway & Barling, 2000; Oranzo et al., 2008).	Knowledge Work Behaviours Scale (newly developed)	26
<b>Nursing Care Coordination</b>	A mechanism that nurses facilitate, particularly in acute care settings, to keep patients' seamless care trajectory throughout their hospital stay and following discharge (Lamb et al., 2007).	Nurse Care Coordination Inventory (Duva, 2010; Lamb et al., 2007)	25
<b>Quality of Patient Care</b>	A nurse's assessment of the usual quality of care provided to patients on their unit (Schmalenberg & Kramer, 2008).	Quality of Patient Care Measure (Schmalenberg & Kramer, 2008)	1

Behaviours (LEB) scale. The LEB is a 16-item instrument structured on a 7-point Likert-type rating scale that ranges from 1 (*strongly disagree that manager demonstrates empowering leadership behaviour*) to 7 (*strongly agree that manager demonstrates empowering leadership behaviour*). It is composed of five subscales, each measuring a dimension of leadership practices that managers may use to facilitate staff empowerment experiences so as to improve work productivity (Conger & Kanungo, 1998). These five subscale dimensions are: enhancing the meaningfulness of employees' work (4 items), encouraging employees' decision-making participation (3 items), expressing confidence in employees' high performance (3 items), facilitating employees' work goal accomplishments (3 items), and fostering employees' work autonomy from bureaucratic constraints (3 items). The LEB was originally constructed from data based on employees who worked in either middle management, technical or professional roles ( $N = 315$ ), as well as their immediate supervisors. For the purposes of this study, the scale items were adapted for a nursing context by modifying the stem question to reference staff nurses' perceptions of their unit supervisor or manager's behaviour towards them.

The LEB was initially created by Hui (1994) with 27 items. After conducting an exploratory factor analysis of the instrument, Hui retained 16 items with the highest factor loadings and conceptual relevance to the five subcategories of empowering leadership practices. These 16 items were subsequently included in the confirmatory factor analysis (CFA) of the measure. The CFA results demonstrated good fit with the observed data, providing construct validity support for the LEB (Hui, 1994). The measure also demonstrated internal reliability consistency with high Cronbach alpha results ranging from .71 to .90 across the five LEB subcategories. Finally, Hui empirically tested a combined effects model of leader empowering behaviors and found predictive validity

support for the LEB subscales, in that LEB directly predicted employees' performance (as rated by the employees' immediate supervisors), and indirectly predicted employees' performance through the mediating effects of employees' perceived psychological empowerment (i.e., personal control, voice, and self-efficacy).

Comparable psychometric results for the LEB were demonstrated in studies with other sample populations (Laschinger et al., 1999; Ahearne et al., 2005). Laschinger et al. (1999) gathered data from 537 RNs in Ontario using the original 27-item LEB scale, which demonstrated high internal consistency reliability across all LEB subscales (Cronbach  $\alpha = .77 - .95$ ) and the scale as a whole (Cronbach  $\alpha = .96$ ). As demonstrated by good model fit results [ $\chi^2(df,6) = 37.934$ , GFI = .98, AGFI = .93], leader empowerment behaviours indirectly predicted nurses' work effectiveness ( $\beta = .26$ ,  $p < .05$ ) and job tension ( $\beta = -.39$ ,  $p < .05$ ) by means of nurses' perceived structural empowerment ( $\beta = .31$ ,  $p < .05$ ). These findings provide convergent and predictive validity for the LEB measure, particularly among a nursing sample.

Predictive validity for the LEB was similarly demonstrated in studies with sales employees (Ahearne et al., 2005; Rapp et al., 2006). Empowering leader behaviours significantly predicted employees' increased self-efficacy, selling adaptability, and ability to work smarter; which further predicted employees' increased overall work performance. These researchers conducted an unrestricted maximum-likelihood factor analysis of the LEB subscales that revealed a single underlying dimension of empowering behaviours, which the researchers further justified averaging the subscale scores to create a single composite score for empowering leadership (Cronbach  $\alpha = .88 - .93$  across two different studies). Thus, in this study, an overall measure of empowering leadership is calculated by sum averaging the five LEB subscale scores that yields a possible total

mean score ranging from 1 to 7, where low scores represent nurses' poor perceptions of their manager's empowering leadership and high scores represent nurses' greater perceptions of their managers' empowering leadership.

### ***Specht & Ramler Accountability Index***

Nurses' perceived accountability for outcomes of their nursing actions was measured using the Specht and Ramler Accountability Index (SRAI) (Specht & Ramler, 1994; Sorensen et al., 2009). Originally developed to evaluate the effects of a shared governance model for nursing within a health care organization, the SRAI is comprised of two related instruments: one that measures a nurse's perceptions of their own nursing accountability, and one that measures a nurse's perceptions of the collective nursing accountability of the nurses on their unit. Differences between the instruments are attributed to the referent in which respondents are asked to consider when answering questions. For example, note the referent difference for the following item within the SRAI (Individual Referent) scale, "*I am accountable to my peers for the nursing care I deliver*" as opposed to the corresponding item within the SRAI (Group Referent) scale, "*Nurses on this unit feel accountable to each other for the care they deliver*" (Specht & Ramler, 1994). Given that nursing accountability was conceptualized as an individual motivator of nurse's discretionary choice to engage in knowledge work behaviours in this study, only the SRAI (Individual Referent) instrument was administered for use.

The SRAI (Individual Referent) is a unidimensional instrument consisting of 11 items that asks respondents the extent with which they agree to each item statement of accountability as a nurse where they work. Responses to the 11 items are averaged for an overall perceived accountability score, with higher scores indicating higher levels of nursing accountability. Although the SRAI was initially structured on an increasing 4-

point rating scale (Specht & Ramler, 1994), the scoring template was modified in this study to reflect a 5-point Likert rating scale that ranges from 1 (*strongly disagree with statement*) to 5 (*strongly agree with statement*). This modification was made to allow for greater variability in responses, thereby allowing greater robustness to the SRAI measure.

Specht and Ramler (1994) demonstrated initial evidence for construct validity of the SRAI (Individual Referent) by means of known groups validation testing among a sample of nurses in a hospital, and a sample of nurses in a long-term care facility (Boni, 2001). While only 5 items of the SRAI tool were used in the study, exploratory factor analysis of the 5-item measure revealed a common single factor, with moderate internal consistency ( $\alpha = .40 - .74$ ) and only two correlations less than 0.50 among the items. More recent nursing studies demonstrated improved internal consistency reliability scores ( $\alpha = .82 - .87$ ) for the SRAI containing 11 items (Boni, 2001; Sorensen et al., 2009); thus, providing support for its use over the 5-item version of the measure.

While predictive validity testing of the SRAI (Individual Referent) is limited in the literature, Laschinger and Wong (1999) found some empirical support for the SRAI (Group Referent). In particular, the researchers demonstrated that structural empowerment had a positive effect on nurses' collective accountability ( $\beta = .19, p < .05$ ) which subsequently had an effect on nurses' work effectiveness ( $\beta = .26, p < .05$ ). These findings supplement those of previously discussed research to add empirical support for the SRAI as a valid measure of perceived nursing accountability.

### ***Role-Breadth Self-Efficacy Scale***

Nurses' perceptions of their ability to take on expanded integrative and interpersonal responsibilities beyond their prescribed nursing role requirements at work was measured by Parker's (1998) Role-Breadth Self-Efficacy (RBSE) scale. The RBSE is



a unidimensional scale consisting of 10 items that ask the respondent to rate their confidence in carrying out each of the tasks outlined in the scale items. Of interest to this study was the respondents' belief in their capability to perform such tasks if it were asked of them at work, rather than whether they had actually performed the task. The RBSE is structured on a 5-point Likert rating scale that ranges from 1 (*not at all confident in capability*) to 5 (*very confident in capability*), with an overall RBSE score calculated by averaging the score responses to each of the 10 items. Higher scores represent respondents' greater perceptions of their role-breadth self-efficacy (Parker, 1998).

Parker (1998) conducted a simultaneous CFA test for the RBSE scale with two related constructs: self-esteem and proactive personality. The CFA results yielded a good model fit in favour of a three-factor model, providing discriminant validity support for role-breadth self-efficacy as a distinct concept from self-esteem and proactive personality (Parker, 1998). Factor-loading estimates for all items tested in the CFA were reported to be significant ( $p < .001$ ) with standardized coefficients greater than .45, whereas standardized coefficients specific to RBSE ranged from .68 to .88 ( $p < .001$ ). Lower RBSE scores among non-professional employees as compared to professional employees was found ( $t = 7.21, p < .001$ ), providing evidence for the scale's construct validity (Parker, 1998).

Hornung and Rousseau (2007) also conducted a CFA to demonstrate further discriminant validity for the 10-itemed RBSE scale among a sample of health care professionals and technical staff. Specifically, the researchers compared CFA model results between a one-factor and two-factor model of RBSE and a related concept of personal initiative. The CFA results supported the two-factor model. This finding adds

validity to the RBSE construct as distinct and separate from the construct of personal initiative (Hornung & Rousseau, 2007).

Internal consistency reliability of the RBSE scale has been demonstrated among a variety of samples including manufacturing employees ( $\alpha = .96$ ), public human resources sector employees ( $\alpha = .86$ ), and health care personnel including nurses ( $\alpha = .91 - .92$ ); although several of these studies have modified Parker's (1998) original 10-item RBSE scale to 3-, 4-, or 6- itemed scales (Hornung & Rousseau, 2007; Johnson et al., 2010; Parker, 1998; Parker & Mason, 2010; Strauss, Giffen & Rafferty, 2009). Given the empirical support provided by previously discussed CFA results, the 10-itemed RBSE scale was used in this study and modified for a nursing context.

#### ***Control Over Nursing Practice Scale***

Nurses' perceived freedom to evaluate, modify and make autonomous practice decisions at work was measured by the Control Over Nursing Practice (CONP) scale instrument (Gerber et al., 1990; Weston, 2009). The CONP is a unidimensional instrument containing 21 items that respondents rate on a 7-point Likert type rating scale ranging from 1 (*strongly disagree with statement*) to 7 (*strongly agree with statement*). An overall CONP score is calculated by averaging the 21 item responses, with a higher score indicating a greater perception of control over practice at work.

Reliability coefficient alphas of the CONP are reported to range from .89 to .94 (Baernholdt & Mark, 2009; Lancerno & Gerber, 1995; Lynn & Kelly, 1995). Some evidence for the CONP's discriminant validity was also reported by Turnball (2001), who conducted a simultaneous confirmatory factor analysis (CFA) on the instrument with measures of organizational commitment and group cohesion. While specific details and statistical results of the CFA were not provided, Turnball reported that the CONP scale

items discretely loaded onto one latent variable, even when analyzed with items of the other two measures. Laschinger and Havens (1995) further demonstrated that CONP predicted acute care staff nurses' perceived work effectiveness ( $\beta = .65, p < .001$ ), over the effect of workplace empowerment structures ( $\beta = .16, p < .001$ ). Lynn and Kelly (1995) reported similar findings where nurses' perceived CONP and job stress both accounted for 53% of the variance in nurses' overall work satisfaction, with CONP demonstrating a stronger positive impact. Together, these results provide adequate psychometric evidence for the CONP instrument's reliability, validity, and selected use to measure nurses' work autonomy in this study.

### ***Knowledge Work Behaviours Scale***

Nurses' discretion to engage in knowledge work within their nursing role was measured by the Knowledge Work Behaviours (KWB) scale, a new multi-dimensional instrument developed specifically for this study. Based on knowledge work literature and the conceptual work of Kelloway and Barling (2000), the KWB scale is designed to measure four behavioural dimensions of nurses' knowledge work: finding, sharing, developing, and applying knowledge. Separate instruments were selected to measure each of the four behavioural dimensions; which were all founded on conceptual definition alignment, good instrument development techniques, and empirically tested psychometric properties. A composite score for each of the four instruments was to represent a nurses' overall knowledge work engagement within their workplace.

The information sensing and collecting dimensions of Hwang's (2003) Personal Information Capability scale were included in the KWB to measure nurses' knowledge finding behaviours in this study. The Personal Information Capability (information sensing) subscale consists of 5 items that ask respondents the extent to which they

actively scan their environment to detect and identify necessary information for their job. Whereas the Personal Information Capability (collecting) subscale comprises 3 items that ask respondents the extent to which they gather information that is relevant for their job. Using partial least squares techniques, Hwang (2003) conducted a CFA of the Personal Information Capability scale to demonstrate evidence for the instrument's internal consistency reliability and construct validity. CFA results also demonstrated that all scale items loaded on their respective subconstructs with no exceptions, item factor loadings greater than .75, and no first-order factors loading higher on unintended second-order variable constructs. This includes that of the sensing ( $\beta = .25, p < .001$ ) and collecting ( $\beta = .30, p < .001$ ) factor structures to respectively represent respondents' personal information management capability. The reliability of each subscale was .92 (Hwang, 2003; Hwang, Kittinger & Yi, 2014). These findings demonstrate that the sensing and collecting subscales of the Personal Information Capability instrument are reliable and valid behavioural measures of identifying and collecting relevant information for work within one's work role. Hence, these subscales were collectively selected as the conceptual measure of nurses' knowledge finding behaviours in this study.

Nurses' knowledge sharing behaviours were measured using 8 items from van den Hooff and de Ridder's (2004) Knowledge Sharing Scale. The items ask respondents the extent to which they actively use one of two processes to share knowledge: donating or communicating one's knowledge to others (4 items), and collecting from or consulting others for their knowledge (4 items). The knowledge sharing scale specifically measures behaviours of mutual knowledge exchange among individuals at work. The scale has been found to be reliable after empirical testing among general employees within various organizations ( $\alpha = .83 - .90$ ) (Chang et al., 2012; van den Hooff & Huysmann, 2009; van

den Hooff & de Leeuw van Weenen, 2004). The scale has also demonstrated validity by means of significant positive associations with individuals' departmental commitment ( $\beta = .45$ ) (van den Hooff & de Leeuw van Weenan, 2004), social capital within an organization ( $\beta = .29$ ) (van den Hooff & Huysman, 2008), patient safety ( $\beta = .16$ ) (Chang et al., 2012), and organizational innovation ( $\beta = .41$ ) (Lin, 2007b). While van den Hooff and de Ridder (2004) argue that the two processes of knowledge sharing (i.e., donating and collecting) are distinct, the processes are correlated ( $r = .69, p < .01$ ) (de Vries, van den Hooff & de Ridder, 2006). Thus, the sound psychometric properties of the Knowledge Sharing Scale lend support for its adapted use as a composite measure of nurses' knowledge sharing behaviour in this study.

The remaining behavioural dimensions of knowledge developing and knowledge applying were measured by adaptations of Daigle-LeBlanc's (2001) Knowledge Use in Organizations scale, which was developed based on Kelloway and Barling's theory of knowledge work (2000). Analysis of the instrument's development process was discussed in the previous chapter. Thus, the present discussion is limited to the psychometric properties of the knowledge creation and knowledge application subscales, as well as their modified use in this study.

Following separate principal components analysis with varimax rotation on each of the Knowledge Use in Organizations subscales (i.e., acquisition, packaging, creation, and application), Daigle-LeBlanc (2000) found evidence to support a single extracted factor for the knowledge creation subscale. Fifteen items had factor loadings ranging from .31 – .81, and together accounted for 41.86% of the variance in responses. Of these 15 items, 5 items were subsequently selected for use in the present study to measure nurses' knowledge developing behaviours at work. Selection decisions were based on

their higher factor loadings (i.e., greater than .75) (Daigle-LeBlanc, 2000), and whether the item conceptually reflected active behaviours of knowledge development.

Daigle-LeBlanc also discovered a two-factor solution explaining 30.33% of the variance in the knowledge application subscale. Internal consistency reliability was adequately demonstrated for each of the factors, which respectively reflected problem-solving behaviours ( $\alpha = .71$ ) and technical knowledge ( $\alpha = .78$ ) necessary for the application of knowledge at work. The subscale consists of 16 items (factor loadings range = .40 – .82), of which 5 items with factor loadings greater than .70 were selected to measure nurses' engagement in knowledge application behaviours.

In summary, the Knowledge Work Behaviours (KWB) scale developed for this study consisted of 26 items. While the KWB is comprised of a collection of previously tested and validated instruments, the items were accordingly modified with a 7-point Likert type rating scale ranging from 1 (*never engage in behaviour*) to 7 (*constantly engage in behaviour*). The items were also introduced with a common stem question that asks respondents to rate the extent with which they engaged in the itemized knowledge work behaviour while at work. Where necessary, items were also edited to reflect the nursing practice context.

Mean score responses for each KWB subscale (i.e., finding, sharing, developing, and applying) were summed and averaged to obtain an overall KWB score for respondents, with higher scores representing nurses' greater engagement in knowledge work behaviours while at work. It is important to emphasize that the KWB scale is a newly developed instrument, despite its inclusion of items from previously tested and validated measures. For this reason, psychometric testing of the multi-dimensional KWB scale was conducted by means of CFA, results of which are detailed in the next chapter.

### ***Nurse Care Coordination Inventory Scale***

The Nurse Care Coordination Inventory (NCCI) (Duva, 2010; Lamb et al., 2007) was adapted to measure nurses' estimated frequency with which they engage in care coordination activities at work. The original NCCI consists of 25 base questions, of which 10 were duplicated under three different stem questions, resulting in a total of 45 questions. The scale was designed to reflect eight different domains of nursing care coordination activities on medical and surgical care hospital units. These domains include getting or giving *assistance* with care coordination processes that a nurse would ordinarily do independently, *checking* the accuracy and timeliness of care coordination activities, *mobilizing* others to take action for which they are accountable in order to facilitate care coordination processes, *managing* information needed to facilitate coordination processes, *organizing* the safe and timely delivery of care coordination processes, and doing the work of other health care members for which they are responsible but did not do by *backfilling*.

Cronbach's alpha for the overall NCCI scale has been established at 0.86, with subscale alpha reliability scores ranging from .59 – .87 (Duva, 2010). While initial psychometric testing of the NCCI indicated an 8 factor solution (Duva, 2010; Lamb et al., 2007), Duva's (2010) exploratory factor analysis of the NCCI with a sample of 339 acute care registered nurses did not support an 8 factor solution. Rather, an 8 to 11 factor solution was found to explain between 61–68% of the variance in the NCCI. However, subsequent confirmatory principal components analysis revealed that only five iterations were needed to force an 8-factor solution, which explained 60.27% of the NCCI variance. Thus, initial reliability and validity for the NCCI at the individual level of analysis has been supported (Duva, 2010).

For the purposes of this study, the 25 base items from the NCCI were selected to measure nurses' care coordination using one stem question. Nurses were asked to rate the frequency they engaged in each itemized activity on a usual work shift, using a 5-point Likert scale ranging from 1 (*never*) to 5 (*always*). A total mean NCCI score was then calculated, with higher scores indicating greater care coordination.

### ***Quality of Patient Care Measure***

Nurses perceptions of the usual quality of care provided to patients on their unit was measured using the single-item Quality of Care (QOC) measure (Schmalenberg & Kramer, 2008). Respondents rated the quality of care on an 11-point Likert-type rating scale that ranges from 0 (*dangerously low quality of care*), to 5 (*it's safe but not much better*), and then to 10 (very high quality of care). While this particular version of the QOC measure has yet to be tested, considerable psychometric support has been demonstrated for Aiken et al.'s (2002) 4-point scaled QOC measure, from which Schmalenberg and Kramer (2008) modified to create their 11-point scaled measure.

Using multivariate linear regression analysis, Sochalski (2004) examined the influence of workload, patient care tasks left undone, and perceived patient problems (such as medication errors and patient falls), on nurses' assessed quality of patient care. Nurses' assessed quality of patient care was measured by means of Aiken et al.'s (2002) 4-point scaled QOC measure that asked respondents "*In general, how would you describe the quality of nursing care delivered to patients on your unit on your last shift?*", with response options ranging from 1 (*poor quality*) to 4 (*excellent quality*). Results of Sochalski's (2004) study indicated that nurses' assessed quality of care significantly decreased with increased ratings of added patient care workload ( $\beta = -.07, p < .001$ ),



patient safety problems ( $\beta = -.12, p < .001$ ) and patient care tasks left undone ( $\beta = -.24, p < .001$ ). Decreased QOC perceptions have also been consistently shown to associate significantly with increased reports of burnout by nurses across six different countries (Poghosyan et al., 2010). More recently, Shen et al. (2011) found empirical support for the positive impact of hospital environments and nurse-physician relationships as predictors of quality patient care, as assessed by nurses ( $\beta = .16, p < .05$  and  $\beta = .58, p < .05$ , respectively) and as assessed patients ( $\beta = .14, p < .05$  and  $\beta = .77, p < .05$ , respectively). While nurses' tended to assess all three variables lower than their patient counterparts, the trend results were consistent among both samples which provide some support for the QOC measure as a reliable and valid assessment of patient care quality.

Aiken et al.'s (2002) 4-point scaled QOC was not selected for use in this study due to several reasons. First, the 4-point scaled QOC measure asks nurses' to assess the patient care quality of their unit, based on their last work shift. This potentially limits nurses' rating responses to their most immediate work experiences rather than their global perception of patient care quality on their unit, which was the interest of this study. Second, Schmalenberg and Kramer's (2008) 11-point scaled QOC measure offers greater potential for increased sensitivity and variance in nurses' responses, thereby limiting the potential for skewed data (Leung, 2011). Thus, the 11-point scaled QOC single-item measure was selected in this study to measure nurses' global patient care quality perceptions on their unit, over the 4-point scaled QOC measure. Nevertheless, the demonstrated consistency in nurses' QOC response ratings and its empirically tested relationships with nursing work characteristics and work attitudes provided supporting evidence for its use in this study.

## **Data Management Procedures**

Each participant was provided a unique identification number that appeared on their survey packages. The identification numbers were secured within an electronic database and used for the sole purposes of tracking returned surveys, and to identify non-respondents who were mailed subsequent reminder letters. The master list connecting the identification numbers with the potential participants' names and addresses was kept in a secure, locked cabinet that was accessible only to the researcher in order to maintain confidentiality of the sample. Response data for each consenting participant was entered into the IBM SPSS Statistics 22.0 ® software program for data management, cleaning and analysis. Using various statistical procedures and techniques, data for all response cases and individual study variables were examined to detect missing data, outliers, and violations of normality assumptions.

Missing data has key implications for the validity, reliability, and generalizability of study results. Depending on the nature and pattern, missing data may lower the statistical power of inferential analysis results; but more importantly, if it occurs in a systematic pattern, missing data may yield biased parameter estimate results (Allison, 2003; Graham, 2009; Tabachnick & Fidell, 2007). Available data management techniques may range from case deletion to data augmentation and imputation procedures. Decisions for selecting the appropriate technique depend on the amount, pattern, and biasing effects of the missing data (McKnight, McKnight, Sidanai, & Figueredo, 2007).

The presence of univariate and multivariate outliers may also distort the validity and reliability of study results. There are four general reasons that contribute to the presence of outliers within a dataset: incorrect data entry; not assessing for missing data;

the outlier is not a member of the population intended for sampling; and finally, the outlier is from the intended population but has more extreme values than that of a normal distribution (Tabachnick & Fidell, 2007). Outliers caused by incorrect data entry were fixed. Statistical and graphical analysis techniques were also used to assess for violations of normality assumptions, which if violated, may greatly impact the statistical power of inferential analyses. These techniques include skewness, kurtosis and scatter plot matrix analyses (Tabachnick & Fidell, 2007).

### *Case Screening*

Missing values analyses by case identification for all study variables were conducted so as to identify cases with large missing values. Four cases had missing values greater than 25% of the total dataset. In each case, most of the missing data was found among the dependent variables, knowledge work behaviours and nursing care coordination. These four cases were subsequently deleted from the final dataset for analysis.

Anomaly index, boxplot graphs and standard deviation analyses were also conducted by case identification for all study variables to identify univariate case outliers. Six cases were assessed to have extreme response values for dependent study variables including control over nursing practice, knowledge work behaviours, and nursing care coordination. Specifically, these cases demonstrated anomaly indices or standard deviation scores greater than  $\pm 3$ , which were validated with boxplot graph results (Field, 2013). Five of these six cases were also identified to be multivariate outliers by means of a high and statistically significant Mahalanobis Distance value, which measures the extent of a case's distance from the means of predictor variables (Field, 2013). These cases were subsequently deleted from further analysis. In total, ten cases were deleted so

as to prevent their biasing effects on further inferential analyses; resulting in a final dataset of 318 cases.

### ***Variable Item Screening***

Missing values analyses by item for the entire dataset were conducted to identify variable items with large missing values. Most of the missing data found were related to items of the nursing care coordination measure. Four items of the nursing care coordination variable each demonstrated greater than 26% of missing data when compared to the entire dataset. Upon closer analysis, the items all pertain to care coordination activities involving personal support workers. Due to the unregulated roles of personal support workers in Ontario, the nature in which nurses' interact with personal support workers may greatly vary across work settings; thereby limiting the items' representativeness of nurses' care coordination activities. These items were subsequently deleted from the final dataset.

Missing values analyses by item for each study variable was also conducted so as to detect potential anomalies. Seven items of the nursing care coordination variable demonstrated more missing or extreme data responses than other items of the same measure. These items relate to activities that require nurses to monitor or follow-up on incomplete patient care provided by other care providers. Given the relative missing data, extreme responses and scoring format interpretation difficulties, these variable items were deleted from the dataset. Similar missing or extreme data response patterns were found for two items of the control over nursing practice measure, which asks nurses the freedom they have to "*negotiate time off duty*" and "*utilize research findings to improve nursing practice*". Given that most acute care nurses in Ontario work in unionized settings, opportunities to negotiate time off duty are often limited; suggesting this item is

not representative of the construct. The same reasoning exists for the item that asks nurses' their perceived ability for utilizing research findings to improve practice. This item may not be a true reflection of nurses' control over their practice given that the study concept reflects the degree of freedom to make decisions within existing boundaries and regulations for nursing practice (Weston, 2008), whereas the use of research findings to improve one's practice may be conceived as an activity that falls outside such boundaries. Thus, both these items were subsequently deleted from the dataset. In total, twelve variable items were deleted following missing values analyses, and precluded from further analysis based on grounds that include non-representative, double-barrelled, or negative response items that elicit potentially biasing responses (Field, 2013).

Descriptive and histogram graph analyses were conducted for each study variable to assess for violations of normality assumptions. Specifically, absolute skew and kurtosis values were evaluated for all variables to note for respective scores greater than 2 and 7, which would indicate significantly skewed data distributions (Field, 2013). All variable scales and subscales demonstrated relatively normal distributions, with absolute skew and kurtosis results values not exceeding 0.85 and 0.94, respectively. Multivariate normality was also assessed by means of scatter plot matrix analyses. Graphical results indicated normal and linear systematic relationships among all assessed variables; thus satisfying assumptions of linearity and homoscedasticity.

#### ***Missing Values & Expectation Maximization Likelihood Imputation***

Following the case and variable screening procedures described above, missing values analyses and Little's MCAR tests were conducted on the entire remaining dataset and each variable scale to assess the extent, nature and pattern of the missing data. Of all the variable items assessed, 53.5% were missing one or more responses; each with

missing values of less than 5% of the total sample. Visual review of the missing cases patterns and statistically significant Little's MCAR test results for all variable scales indicated that the missing data were missing completely at random, with no discernable or systematic pattern.

Expectation maximization (EM) likelihood imputation techniques were employed in order to generate a complete dataset with no missing information to inform structural equation model testing, by means of modification indices, within the IBM SPSS AMOS 22.0 ® software program. The EM likelihood method is a model-based data augmentation procedure that uses observed data to estimate parameters, which are then used to estimate the missing scores (McKnight et al., 2007). Unlike traditional techniques for managing missing data such as listwise deletion, nonstochastic imputation, and regression imputation methods, the EM likelihood method is a more robust approach that takes into account the observed data, the missing data, the relationships among the observed data, and some underlying statistical assumptions when estimating parameters (Schlomer, Bauman & Card, 2010). While it is noted that multiple imputation techniques are less sensitive to problematic effects of missing data patterns than EM likelihood methods, which may be employed only when missing data is ignorable, both techniques share principled methods for handling missing data. Furthermore, EM likelihood methods offer a more efficient approach to calculating parameters directly from incomplete data (Schlomer et al., 2010). For these reasons, EM likelihood was the method selected to address missing values within the final dataset used in this study.

### **Data Analysis Procedures**

All data were analyzed and interpreted at the individual level of analysis. Demographic data were examined using descriptive statistics including means, standard

deviations, and frequencies as appropriate. Correlation analyses and analyses of variances were also conducted between key demographic and dependent variables; so as to identify and control for potential extraneous effects, if necessary. Controlling extraneous variables is important because they may affect the hypothesized relationships under study and present a threat to the validity of the study findings (Pedhazur & Pedhazur Schmelkin, 1991). Descriptive analyses of each study variable were also conducted including means, standard deviations, and internal consistency reliabilities using the Cronbach's alpha coefficient. These results informed decisions for further data evaluation and inferential analyses.

### ***Structural Equation Modeling***

Structural Equation Modeling (SEM) was used to test the fit of the hypothesized model. Sample data were entered into to IBM SPSS AMOS 22.0 software program to facilitate the SEM data analysis. SEM is a collection of statistical techniques that examines the covariance structure and relationships between and among latent and observed variables at the same time. In doing so, it allows researchers to investigate relationships among multiple measures of theoretical constructs at various levels. SEM has the ability to incorporate latent variables analysis, which can significantly reduce the effects of measurement error; to interface analyses with graphical modeling; to include multiple outcome variables for testing; and to test coefficients across multiple groups (Tabachnick & Fidell, 2007). In effect, SEM simultaneously examines the effects of direct, indirect, reciprocal and spurious relationships among variables, making it a more robust and precise technique for testing a priori theoretical models (Kline, 2005).

Two models are concurrently tested in SEM: the measurement model that specifies how each study variable in the model is measured, and the structural model that

specifies the hypothesized relationships between the study variables. Such models that synthesize both measurement and path models are called structural regression models (Kline, 2005). Because valid tests of the structural model are dependent on the fit of the measurement model to the sampled data, initial evaluation of the measurement model is particularly important for strengthening subsequent testing of the structural model (Tabachnick & Fidell, 2007).

Kline (2005) recommends a two-step analysis process that starts with a CFA of the measurement model. Specifically, hierarchical CFAs including both first-order factors (i.e., indicators of latent subconstruct variables) and second-order factors (i.e., latent subconstructs corresponding with latent construct variables) were conducted on all measurement scales to respectively assess each instrument's construct validity and internal consistency prior to simultaneous testing with the hypothesized structural model (Kline, 2005). In this study, all scale instruments were tested by a CFA to ensure that the measurement model is valid and psychometrically sound. Once the measurement model was supported, the structural model was then tested using SEM to compare its fit with the sample data (Byrne, 2001).

Assessing the fit of the hypothesized model and observed data involves comparing the estimated population covariance matrix, as represented by the relationships between the study variables, against the observed covariance matrix generated from the sample data (Tabachnick & Fidell, 2007). Population parameters are also simultaneously estimated in SEM through the maximum likelihood estimation method, so as to minimize the difference between the estimated population and observed covariance matrices. When the difference is assessed to be minimal and non-significant, the hypothesized model is considered to be a good fit with the observed data (Kline,



2005). The Model Chi-Square ( $\chi^2$ ) relative to the degrees of freedom ( $df$ ) is the primary model fit statistic that tests for this difference. As  $\chi^2$  increases in size with a non-significant value, an inadequate fit of the observed data to the hypothesized model is suggested (Byrne, 2010). While, a small non-significant  $\chi^2$  value is desired, the  $\chi^2$  is very sensitive to large sample sizes and can easily result in a significant result should any non-zero residual be present in the data. This is a case that often happens with larger sample sizes. Thus, in addition to the  $\chi^2$ , descriptive statistic indices are also examined to assess the approximate model fit to the observed data (Tabachnick & Fidell, 2007; Kline, 2005).

Despite the variety of available descriptive model fit indices, there continues to be limited consensus as to which are the most appropriate for assessing model fit. Rather, Tabachnick and Fidell (2007) note that in many cases, good-fitting models produce consistent results on many different indices. Thus, if results of the fit indices are inconsistent, the model likely requires refinement. Given this, analysis of multiple model fit indices for consistency or inconsistency of the model fit results were conducted. In addition to the model chi-square ( $\chi^2$ ), Kline (2005) recommends the following set of fit indices for assessing the fit of a structural model: the standardized root mean square residual (SRMR), the comparative fit index (CFI), and the root mean square error of approximation (RMSEA).

The *Standardized Root Mean Square Residual (SRMR)* index indicates the average differences between the sample variances and covariances, and the estimated population (model) variances and covariances. In other words, the SRMR is based on transformations of the covariance matrices into correlation matrices, thereby resulting in a measure of the mean absolute correlation residual (i.e., the overall difference between

the observed and predicted correlations). Good-fitting models are supported by small SRMR values less than .08 (Tabachnick & Fidell, 2007).

The *Comparative Fit Index (CFI)* evaluates the fit of the estimated model relative to the fit of the independence model, which is the case where no relationships are estimated between the variables (Kline, 2005). A reasonably good fit is demonstrated by values greater than .90 (Kline, 2005).

Finally, the *Root Mean Square Error of Approximation (RMSEA)* index estimates the lack of fit in a model compared to a perfect or saturated model. The RMSEA is less affected by sample size and takes into account the error of approximation. Values of .06 or less indicate a good-fitting model relative to the model degrees of freedom, whereas values larger than .10 indicate a poor model fit (Tabachnick & Fidell, 2007). The RMSEA may also be calculated with an accompanying confidence interval reflecting the degree of uncertainty associated with the RMSEA as a point estimate at the 90% level of statistical confidence. Ideally, the lower and upper boundaries of the 90% confidence interval are not to exceed .05 and 1.0, respectively. If exceeded, sampling error may be a confounding factor (Kline, 2005). All RMSEA results reported for this study were within acceptable 90% confidence interval ranges.

In summary, model fit indices support inferences about the sample data fit with the hypothesized model. Such information also provides directions for model refinement, if necessary; although any model modifications should be based on relevant theoretical rationale. If model modifications are made, the next step to SEM is to examine the relative difference or improvement of fit among the two competing models so as to determine if one model fits the data significantly better than another.

When comparing alternative models based on the same variables that are hierarchically related, the *Chi-square Difference Statistic* ( $\chi^2_{\text{diff}}$ ) is used to test the hypothesis of equal-fit for the two models, with the null hypothesis suggesting equivalence (Kline, 2005). This test is analogous to a multivariate test of whether all added or deleted paths within a modified model significantly contribute to the fit of the model. The  $\chi^2_{\text{diff}}$  statistic is calculated by means of subtracting the chi-square value of the model with less degrees of freedom, from the model with more degrees of freedom. The calculated  $\chi^2_{\text{diff}}$  is then compared against a critical  $\chi^2$  value from a  $\chi^2$  distribution table. Ultimately, a statistically significant  $\chi^2_{\text{diff}}$  value indicates improvement in model fit.

While the model fit indices discussed above assist with interpreting whether the hypothesized model fits with the observed data, it does not establish whether the particular path relationships within the model are significant (Kline, 2005; Tabachnick & Fidell, 2007). Thus, once the model is accepted as a good fit with the sample data, the significance of the hypothesized parameters in the model are evaluated.

### **Ethical Considerations**

Prior to commencing this study, ethical approval was obtained from the Health Sciences Research Ethics Board at Western University (Appendix E). Participants' confidentiality was maintained by assigning an identification number to each participant survey and corresponding responses, with no direct linkage to identifiable names. Participants' anonymity and confidentiality were also maintained in all communications made by the researcher throughout the study.

A small token of appreciation was included in survey packages to all potential participants, regardless of their choice to participate in the study. Participants' choice to participate in this study was voluntary, with consent demonstrated by the return of their

completed survey to the researcher. All returned surveys were collected and securely stored throughout the study duration, and will be subsequently destroyed one year after.

### ***Risks & Benefits***

Given the voluntary nature of this study, no known risks were associated with participation. Participants were given the choice to skip any question on the survey, or to not participate in the study at any time with no consequence. Benefits of this study relate to an increased understanding of nurses' knowledge work, the influential factors within the work setting that encourage such behaviours, and its consequential outcomes on patient care. Such understanding will assist health care administrators, managers, and nurses alike to not only identify strategies that facilitate nurses' knowledge work, but gain a greater understanding of nurses' contribution to patient care delivery as well.

## CHAPTER IV: RESEARCH RESULTS

Presented in this chapter are the results of this research that includes demographic characteristics of the sample, descriptive and confirmatory factors analyses of each study construct, and final findings of the hypothesized model.

### **Demographic Results**

#### *Sample Characteristics*

In keeping with the study inclusion criteria, all respondents were RNs working on either an inpatient general medicine unit (56.6%) or inpatient general surgery unit (41.5%). Majority of the participants were female (96.2%), with the total sample averaging 48 years of age. These findings are similar to those of the wider population of RNs in Ontario when compared against the CNO's membership statistics (CNO, 2014), although the male representation in the sample for this study was lower. CNO reported that the RN membership consisted of 93.9% females and 6.1% males, with an average age of 45 years.

Most participants in this study completed their nursing education in Canada (84.6%), and more than half of the sample was prepared with a nursing diploma education (65.7%). Recent studies of acute care nurses in Ontario reported similar demographic findings in that approximately 72%–75% of the nurses sampled were diploma prepared (Laschinger, Read, Wilk & Finegan, 2014; Roche, Laschinger & Duffield, 2015).

While the average amount of nursing practice experience among the sample is 20 years, the range in nursing experience is between 2 and 45 years. Similar trends in respondents' work experience on their current nursing unit were noted. On average, respondents reported 12 years of work experience on their current nursing unit, with

individual responses ranging between 1 to 41 years. Study participants were commonly employed by urban teaching hospitals (43.1%), and had full-time nursing positions (67.9%). The majority were employed with just one nursing position (92.5%), although some reported maintaining up to five positions (5.6%). The CNO (2014) reported different employment position results with 84.8% of the RN membership employed by one employer, 13.3% employed by two employers, and 1.9% employed by more than three employers. Regardless, the trends are similar such that in both samples, the majority of RNs were employed with one nursing position. Comparable employment status findings were also found in the 2014 CNO RN membership, of which 66.5% and 26.2% reported full-time and part-time employment statuses, respectively. Roche et al. (2015) reported similar full-time and part-time employment trends in their study with 3156 acute care staff nurses in Ontario (68.51% and 30.13%, respectively). All sample demographic findings are summarized in Table 2.

### ***Demographic Comparisons***

Demographic comparisons were conducted using independent t-test and one-way ANOVA procedures. No significant differences in responses to the main study variables by gender, clinical specialty, highest level of education, or employment status were found. However, differences were found between respondents who were internationally educated ( $N=42$ ) and respondents who were educated in Canada ( $N = 269$ ). On average, internationally educated participants reported greater empowering leadership [ $t(309) = 3.36, p < .001, d = .56$ ], nursing accountability [ $t(309) = 3.28, p < .001, d = .06$ ], role-breadth self-efficacy [ $t(72) = 3.49, p < .001, d = .44$ ], control over their nursing practice [ $t(309) = 4.32, p < .001, d = .72$ ], and knowledge work behaviours [ $t(65) =$

Table 2

Sample Demographics (N=318)

Demographic Variable	<i>n</i>	Sample %
<b>Gender <sup>a</sup></b>		
Female	306	96.2%
Male	6	1.9%
<b>Highest Nursing Education <sup>a</sup></b>		
Diploma	209	65.7%
Baccalaureate Degree	90	28.3%
Master Degree	4	1.3%
Clinical Nurse Specialty Certificate	8	2.5%
Nurse Practitioner Certificate	1	0.3%
<b>Origin of Initial Nursing Education <sup>b</sup></b>		
Canada	269	84.6%
International	42	13.2%
<b>Clinical Specialty <sup>a</sup></b>		
Inpatient general medicine	180	56.6%
Inpatient general surgery	132	41.5%
<b>Current Employment Status <sup>a</sup></b>		
Full-time	216	67.3%
Part-time	96	30.2%
<b>Employment Hospital Type <sup>b</sup></b>		
Urban Teaching Hospital	137	43.1%
Urban Community Hospital	102	32.1%
Rural Community Hospital	72	22.6%
<b>Total Number of Current Nursing Jobs <sup>a</sup></b>		
1 Nursing Job	294	92.5%
2 Nursing Jobs	14	4.4%
3 Nursing Jobs	3	0.9%
5 Nursing Jobs	1	0.3%
<b>Number of Years</b>		
	<b><i>M (SD)</i></b>	<b><i>Range</i></b>
Age <sup>c</sup>	47.8 (10.4)	26.0-73.0
Nursing Work Experience (on current unit) <sup>a</sup>	11.7 (8.8)	1.0-41.0
Nursing Work Experience (overall) <sup>b</sup>	20.4 (10.9)	2.0-45.0

<sup>a</sup> Due to missing data for this variable, *n* = 312.<sup>b</sup> Due to missing data for this variable, *n* = 311.<sup>c</sup> Due to missing data for this variable, *n* = 302.

3.38,  $p < .001$ ,  $d = .47$ )] when compared to their counterparts who were educated in Canada. While these differences were statistically significant, most represented medium effect sizes, according to Cohen's (1992) established metrics:  $d = .20$  (small),  $d = .50$  (medium),  $d = .80$  (large). In addition, sample sizes between the two groups were substantially disproportionate and so further data analysis or transformations were not conducted. Descriptive results for these differences by origin of initial nursing education are summarized in Table 3.

Table 3

*Mean Differences by Origin of Initial Nursing Education*

Study Variable	Canada ( $n = 269$ )	International ( $n = 42$ )	95% CI <sub>diff</sub>
	$M (SD)$	$M (SD)$	
Empowering Leadership	4.52 (1.24)	5.21 (1.18)	(-1.09, -0.28)
Nursing Accountability	4.09 (0.51)	4.37 (0.49)	(-0.44, -0.11)
Role-breadth Self-Efficacy	3.52 (0.77)	3.85 (0.53)	(-0.52, -0.14)
Control Over Nursing Practice	5.08 (0.92)	5.74 (0.90)	(-0.96, -0.36)
Knowledge Work Behaviours	5.47 (0.81)	5.84 (0.62)	(-0.31, -0.01)

One-way ANOVA analysis results also indicated that there was a significant effect of hospital employer type on participants' empowering leadership responses [ $F(2,308) = 5.16$ ,  $p = .006$ ]. On average, respondents employed by urban teaching hospitals reported greater empowering leadership [ $M (SD) = 4.85 (1.17)$ ] than those employed by urban community hospitals [ $M (SD) = 4.47 (1.35)$ ] or rural community hospitals [ $M (SD) = 4.32 (1.20)$ ]. While the pairwise comparisons were statistically significant ( $p < .04$  and  $p < .01$ , respectively), the effect size was small ( $r = .18$ ) (Field,



2013). Thus, additional differential analyses or data transformation was not conducted. Interestingly, there were no statistically significant group differences in empowering leadership reports between participants in urban and rural community hospital employments.

The potential effects of age and work experience on responses for each main study variable were also assessed by means of Pearson correlation analysis. Participants' age was significantly related to their responses of role-breadth-self efficacy [ $r = .13$ , 95% BCa CI (-.001, .243),  $p < .05$ ] and knowledge work [ $r = .14$ , 95% BCa CI (.026, .244),  $p < .05$ ]. Likewise, participants' nursing work experience on a unit was significantly related to their reported role-breadth self-efficacy [ $r = .12$ , 95% BCa CI (.005, .238),  $p < .05$ ], control over their practice [ $r = .15$ , 95% BCa CI (.053, .254),  $p < .01$ ] and knowledge work behaviours [ $r = .16$ , 95% BCa CI (.018, .283),  $p < .01$ ]. Interestingly, overall nursing work experience was also significantly related to respondents' knowledge work behaviours [ $r = .14$ , 95% BCa CI (.021, .260),  $p < .05$ ]; in addition to respondents reported role-breadth self-efficacy [ $r = .11$ , 95% BCa CI (.002, .222),  $p < .05$ ] and quality of patient care [ $r = .12$ , 95% BCa CI (.003, .233),  $p < .05$ ]. However, all correlational findings demonstrated small effect sizes and so further demographic analyses were not necessary.

### **Descriptive & Psychometric Measurement Results**

Final descriptive results for all study variables are referenced in Table 4; including sample means, standard deviations, internal consistency reliabilities, and bivariate correlations. Exploratory factor analyses (EFA) and confirmatory factor analyses results (CFA) for each multi-item scale measure are also detailed in the following sections. These results formed the basis of the measurement model that was further used in the structural equation model for testing the study hypotheses.

Table 4

*Descriptive Variable Results*

	Variable	Correlations ( <i>r</i> ) <sup>a</sup>								
		$\alpha$	# Items	<i>M</i> ( <i>SD</i> )	Range	1	2	3	4	5
1	<b>Empowering Leadership</b>	<b>0.96</b>	<b>16</b>	<b>4.57 (1.26)</b>	<b>1.07-7.00</b>	<b>1.00</b>				
2	Meaning	0.95	4	4.53 (1.52)	1.00-7.00	.86	1.00			
3	Decision-making	0.89	3	4.00 (1.65)	1.00-7.00	.89	.69	1.00		
4	Confidence	0.88	3	5.34 (1.25)	1.00-7.00	.83	.66	.66	1.00	
5	Goals	0.90	3	4.58 (1.42)	1.00-7.00	.93	.79	.79	.72	1.00
6	Autonomy	0.83	3	4.47 (1.39)	1.00-7.00	.85	.61	.71	.66	.74
7	<b>Role-Breadth Self-Efficacy</b>	<b>0.90</b>	<b>8</b>	<b>3.56 (0.76)</b>	<b>1.13-5.00</b>	<b>.19</b>	<b>.15</b>	<b>.17</b>	<b>.16</b>	<b>.13*</b>
8	<b>Accountability</b>	<b>0.79</b>	<b>10</b>	<b>4.13 (0.51)</b>	<b>2.60-5.00</b>	<b>.24</b>	<b>.23</b>	<b>.23</b>	<b>.18</b>	<b>.22</b>
9	Peers	0.70	2	4.46 (0.61)	2.50-5.00	.06 <i>ns</i>	.06 <i>ns</i>	.06 <i>ns</i>	.11*	.05 <i>ns</i>
10	Unit standards	0.87	3	3.58 (0.95)	1.00-5.00	.25	.22	.26	.14*	.24
11	Individual practice	0.67	5	4.33 (0.50)	2.60-5.00	.19	.20	.14*	.17	.18
12	<b>Control Over Practice</b>	<b>0.91</b>	<b>14</b>	<b>5.16 (0.94)</b>	<b>2.06-7.00</b>	<b>.46</b>	<b>.34</b>	<b>.46</b>	<b>.31</b>	<b>.42</b>
13	Evaluate care	0.87	5	4.49 (1.27)	1.00-7.00	.45	.32	.47	.27	.42
14	Delivery of care	0.89	9	5.83 (0.85)	2.78-7.00	.35	.28	.31	.27	.32
15	<b>Knowledge Work Behaviours</b>	<b>0.94</b>	<b>19</b>	<b>5.53 (0.80)</b>	<b>3.25-7.00</b>	<b>.22</b>	<b>.20</b>	<b>.19</b>	<b>.17</b>	<b>.17</b>
16	Finding	0.88	6	5.36 (0.93)	2.67-7.00	.24	.21	.23	.21	.17
17	Sharing	0.87	4	5.64 (0.96)	1.50-7.00	.16	.16	.10 <i>ns</i>	.11*	.12*
18	Developing	0.93	3	5.13 (1.19)	1.33-7.00	.15	.14*	.16	.10 <i>ns</i>	.13*
19	Applying	0.91	6	6.01 (0.78)	3.50-7.00	.18	.17	.13*	.16	.17
20	<b>Care Coordination</b>	<b>0.84</b>	<b>14</b>	<b>4.10 (0.45)</b>	<b>2.54-5.00</b>	<b>.20</b>	<b>.18</b>	<b>.14*</b>	<b>.19</b>	<b>.20</b>
21	Team	0.74	3	4.07 (0.63)	1.33-5.00	.17	.14*	.17	.14*	.17
22	Patient care	0.72	4	4.61 (0.42)	3.00-5.00	.13*	.14*	.10 <i>ns</i>	.15	.13*
23	Changes	0.75	4	3.82 (0.68)	1.50-5.00	.18	.14*	.11*	.17	.20
24	Unit resources	0.66	3	3.90 (0.67)	2.00-5.00	.11 <i>ns</i>	.13*	.05 <i>ns</i>	.12*	.10 <i>ns</i>
25	<b>Quality of Patient Care</b>	-	<b>1</b>	<b>8.00 (1.34)</b>	<b>4.00-10.0</b>	<b>.28</b>	<b>.21</b>	<b>.28</b>	<b>.22</b>	<b>.23</b>

<sup>a</sup>All significant,  $p < .01$ , unless otherwise noted

\*Significant,  $p < .05$

*ns* Non-significant

Table 4 continued

Variable	Correlations ( $r$ ) <sup>a</sup>									
	6	7	8	9	10	11	12	13	14	15
1 <b>Empowering Leadership</b>										
2     Meaning										
3     Decision-making										
4     Confidence										
5     Goals										
6     Autonomy	1.00									
7 <b>Role-Breadth Self-Efficacy</b>	<b>.21</b>	<b>1.00</b>								
8 <b>Accountability</b>	<b>.22</b>	<b>.36</b>	<b>1.00</b>							
9     Peers	-.20 <i>ns</i>	.19	.63	1.00						
10    Unit Standards	.22	.28	.85	.23	1.00					
11    Individual Practice	.16	.35	.71	.29	.44	1.00				
12 <b>Control Over Practice</b>	<b>.46</b>	<b>.40</b>	<b>.49</b>	<b>.11*</b>	<b>.51</b>	<b>.40</b>	<b>1.00</b>			
13    Evaluate Care	.45	.35	.43	.04 <i>ns</i>	.52	.30	.93	1.00		
14    Delivery of Care	.35	.36	.45	.20	.36	.45	.84	.58	1.00	
15 <b>Knowledge Work Behaviours</b>	<b>.22</b>	<b>.51</b>	<b>.50</b>	<b>.20</b>	<b>.41</b>	<b>.52</b>	<b>.51</b>	<b>.44</b>	<b>.48</b>	<b>1.00</b>
16    Finding	.24	.44	.44	.20	.35	.45	.49	.42	.47	.86
17    Sharing	.16	.33	.36	.19	.25	.40	.36	.30	.34	.81
18    Developing	.15	.50	.36	.08 <i>ns</i>	.34	.36	.40	.37	.33	.85
19    Applying	.18	.40	.52	.21	.23	.55	.47	.37	.50	.80
20 <b>Care Coordination</b>	<b>.16</b>	<b>.29</b>	<b>.41</b>	<b>.19</b>	<b>.35</b>	<b>.37</b>	<b>.45</b>	<b>.38</b>	<b>.44</b>	<b>.55</b>
21    Team	.17	.22	.33	.20	.24	.30	.37	.33	.32	.47
22    Patient Care	.13*	.16	.38	.18	.30	.39	.33	.24	.39	.44
23    Changes	.18	.22	.27	.14*	.24	.21	.32	.26	.31	.36
24    Unit Resources	.09 <i>ns</i>	.26	.29	.08 <i>ns</i>	.28	.26	.34	.29	.32	.39
25 <b>Quality of Patient Care</b>	<b>.24</b>	<b>.10 <i>ns</i></b>	<b>.28</b>	<b>.14</b>	<b>.25</b>	<b>.22</b>	<b>.43</b>	<b>.40</b>	<b>.37</b>	<b>.15</b>

<sup>a</sup>All significant,  $p < .01$ , unless otherwise noted

\*Significant,  $p < .05$

*ns* Non-significant

Table 4 continued

Variable	Correlations ( $r$ ) <sup>a</sup>									
	16	17	18	19	20	21	22	23	24	25
1 <b>Empowering Leadership</b>										
2 Meaning										
3 Decision-making										
4 Confidence										
5 Goals										
6 Autonomy										
7 <b>Role-Breadth Self-Efficacy</b>										
8 <b>Accountability</b>										
9 Peers										
10 Unit Standards										
11 Individual Practice										
12 <b>Control Over Practice</b>										
13 Evaluate Care										
14 Delivery of Care										
15 <b>Knowledge Work Behaviours</b>										
16 Finding	1.00									
17 Sharing	.61	1.00								
18 Developing	.62	.53	1.00							
19 Applying	.63	.56	.55	1.00						
20 <b>Care Coordination</b>	<b>.51</b>	<b>.41</b>	<b>.40</b>	<b>.52</b>	<b>1.00</b>					
21 Team	.45	.35	.33	.44	.75	1.00				
22 Patient Care	.38	.29	.30	.52	.69	.46	1.00			
23 Changes	.35	.29	.26	.32	.78	.44	.36	1.00		
24 Unit Resources	.36	.31	.31	.34	.77	.37	.44	.45	1.00	
25 <b>Quality of Patient Care</b>	<b>.16</b>	<b>.10 ns</b>	<b>.05 ns</b>	<b>.22</b>	<b>.16</b>	<b>.15</b>	<b>.14*</b>	<b>.12*</b>	<b>.10 ns</b>	<b>1.00</b>

<sup>a</sup>All significant,  $p < .01$ ; unless otherwise noted

\*Significant,  $p < .05$

ns Non-significant

Overall, the study sample reported moderately high perceptions of their direct manager's empowering leadership ( $M = 4.59$ ). Similar levels were reported for respondents' perceptions of their nursing accountability ( $M = 4.13$ ), role-breadth self-efficacy ( $M = 3.56$ ), and control over their practice at work ( $M = 5.16$ ). Respondents also reported moderately high levels of engagement in knowledge work behaviours ( $M = 5.53$ ) and care coordination activities ( $M = 4.10$ ) while at work. Finally, the study sample reported their units to deliver relatively high levels of quality patient care ( $M = 8.00$ ).

Bivariate correlations among the study variables were in the positive direction and as theoretically expected, with the exception of one particular result. Respondents' perceptions of their managers' leadership behaviours that foster control over nursing practice was negatively related to their perceived nursing accountability with their peers ( $r = -.20$ , ns). However, the effect size of the coefficient was small and non-significant.

### ***Leader Empowerment Behaviours***

An initial first-order confirmatory factor analysis was conducted on the 16 items, which demonstrated a poor fitting model [ $\chi^2(df) = 1054.64 (104)$ ,  $p < .001$ , SRMR=0.07, CFI = .80, RMSEA = .170]. Based on Hui's (1994) theoretical proposition of empowering leadership, a second-order confirmatory factor analysis was conducted on the 16 items as a five factor latent measurement structure. Substantial improvement in good fit of the model was demonstrated [ $\chi^2_{diff} (df) = 255.08 (96)$ ,  $p < .001$ ]; thereby demonstrating construct validity for the LEB scale structure to be represented by five underlying factors and corresponding items as opposed to a unidimensional model [ $\chi^2(df) = 255.08 (96)$ ,  $p < .001$ , SRMR = .04, CFI = .97, RMSEA = .072]. The final LEB measurement model is presented in Figure 5, with a list of matching scale items defined in Table 5. This served as the blueprint on which sum mean items were computed for

corresponding second-order factor scores of the LEB latent variable, and for subsequent analysis of the hypothesized structural model.

### ***Specht & Ramler Accountability Index***

An initial unidimensional first-order CFA was conducted on the 11 SRAI scale items, which demonstrated poor model fit results [ $\chi^2(df) = 483.31 (44), p < .001, SRMR = .134, CFI = .62, RMSEA = .177$ ]. Among all the items, the item “*I am accountable to patients for the care I deliver*” had the lowest standardized regression path coefficients. For this reason, the item was subsequently deleted from further analysis, thereby reducing the SRAI scale to a total of 10 items.

In keeping with Mass’ (1990) conceptual definition for nursing accountability, which reflects a nurse’s answerability to patients, peers, and the organization for the outcomes of their actions, a revised CFA was conducted on the remaining 10 SRAI items as manifests of the following latent variables: accountability with peers (2 items), accountability for unit standards (3 items), and accountability for individual nursing practice (5 items) [ $\chi^2(df) = 74.85 (31), p < .001, SRMR = .047, CFI = .96, RMSEA = .067$ ]. While the general rule of thumb for latent variables is to have at least three indicators to ensure stability and accuracy in parameter estimates, Kline (2005) argues that two indicators is satisfactory as long as the latent variable is correlated with another variable in the model, which in this case, significant correlations were demonstrated among the three latent factor variables (see Table 4). Results for the revised CFA showed a substantial improvement in model fit above the initial model [ $\chi^2_{diff}(df) = 408.48 (13), p < .001$ ]. Thus, construct validity for the SRAI was supported.

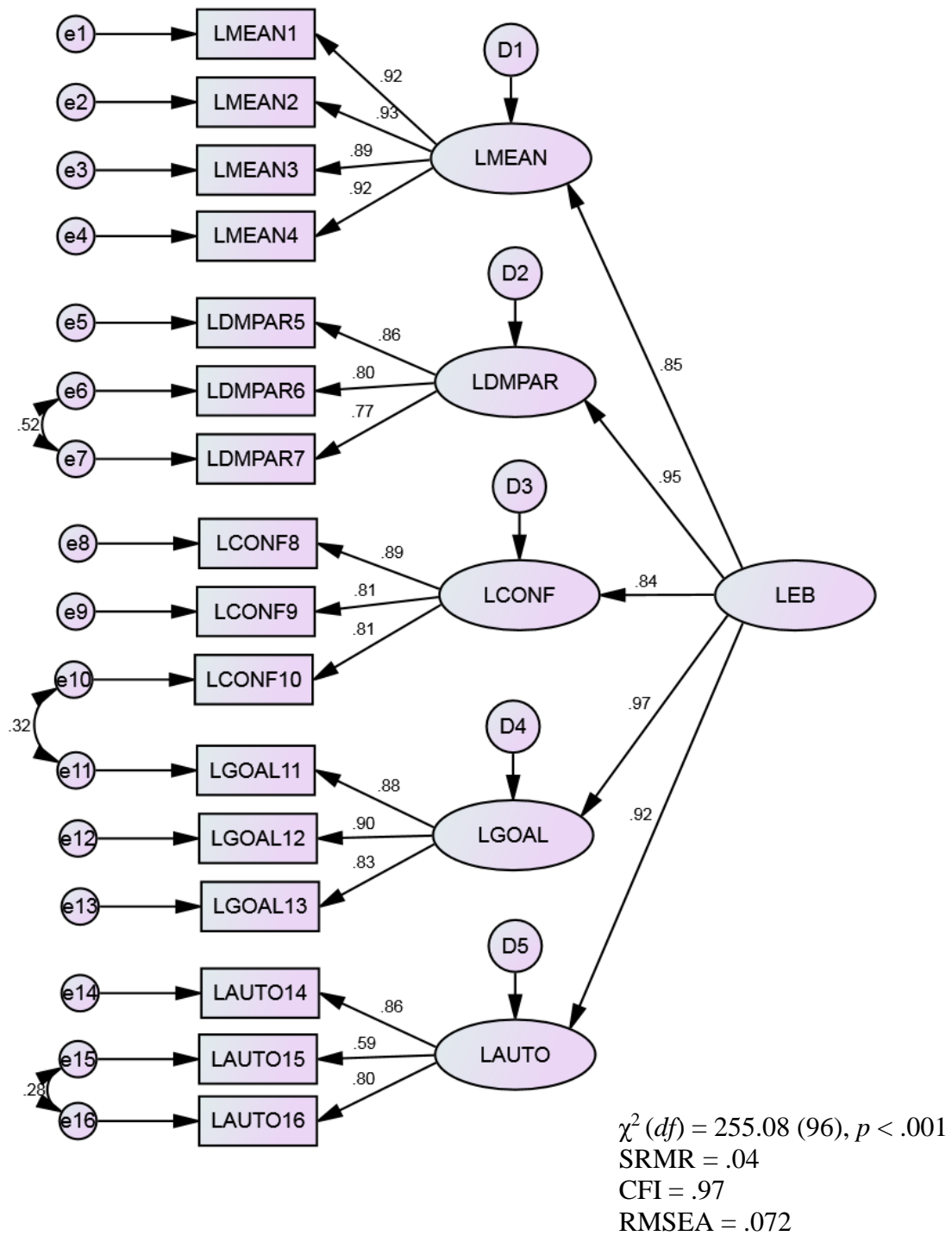

**Note:** All regression weights and covariances are significant,  $p < 0.01$

Figure 5. Final CFA Model for the Leader Empowering Behaviors (LEB) Scale

Table 5

*Final LEB Scale Item Definitions*

<b>LEADER EMPOWERING BEHAVIOURS (LEB)</b>		
<b># Items</b>	<b>Label</b>	<b>Definition</b>
<b>4</b>	<b>LMEAN Enhance Meaningfulness</b>	
	Lmean1	<i>My manager helps me understand the importance of my work.</i>
	Lmean2	<i>My manager helps me understand how my work fits into “the bigger picture”.</i>
	Lmean3	<i>My manager helps me understand how the objectives and goals of my nursing unit relate to that of the entire organization.</i>
	Lmean4	<i>My manager helps me understand the purpose of my work.</i>
<b>3</b>	<b>LDMPAR Encourage Decision-Making Participation</b>	
	Ldmpar5	<i>My manager provides many opportunities for me to express my opinions.</i>
	Ldmpar6	<i>My manager often consults me on work issues.</i>
	Ldmpar7	<i>My manager makes many decisions with me.</i>
<b>3</b>	<b>LCONF Express Confidence</b>	
	Lconf8	<i>My manager always shows confidence in my ability to do a good job.</i>
	Lconf9	<i>My manager believes that I can handle demanding tasks.</i>
	Lconf10	<i>My manager believes in my ability to improve even when I make mistakes.</i>
<b>3</b>	<b>LGOAL Facilitate Goal Accomplishments</b>	
	Lgoal11	<i>My manager helps me overcome obstacles to my performance</i>
	Lgoal12	<i>My manager helps me to identify what I need in order to achieve my performance goals</i>
	Lgoal13	<i>My manager always makes sure that I have the resources needed for effective performance</i>
<b>3</b>	<b>LAUTO Foster Work Autonomy</b>	
	Lauto14	<i>My manager makes it more efficient to do my job by keeping the rules and regulations simple.</i>
	Lauto15	<i>My manager allows me to do my job my way.</i>
	Lauto16	<i>My manager encourages me to make important decisions that are directly related to my job.</i>



Figure 6 and Table 6 summarize the revised CFA model results and items for the SRAI scale. This model was retained as the final model on which second-order factor scores for the nursing accountability latent variable was computed by means of sum mean item scores.

### ***Role-Breadth Self-Efficacy***

An initial first-order CFA was conducted on the 10 items, which demonstrated a poor fitting model [ $\chi^2(df) = 176.73 (35), p < .001, SRMR = .05, CFI = .91, RMSEA = .110$ ]. Upon review of the results, two items with the lowest standardized regression path coefficients asked respondents about their confidence in “*Writing a proposal to spend money in their nursing unit*” and “*Contacting people outside the hospital to discuss problems*”. Given that these items do not necessarily reflect expanded tasks reflective of nursing practice, they were deleted from a subsequent CFA of the RBSE, reducing the scale to a total of 8 items. Following deletion of the 2 items, construct validity for the RBSE was attained by means of improvements of the revised CFA model [ $\chi^2(df) = 42.96 (18), p < .001, SRMR = .03, CFI = .98, RMSEA = .066$ ] over the initial CFA model [ $\chi^2_{diff}(df) = 133.77(17), p < .001$ ]. Displayed in Figure 7 is the final CFA model of the RBSE with respective scale item definitions (see Table 7). Path estimate results for each scale item were used to inform parcelling decisions and second-order latent variable constructions for the RBSE in the structural model.

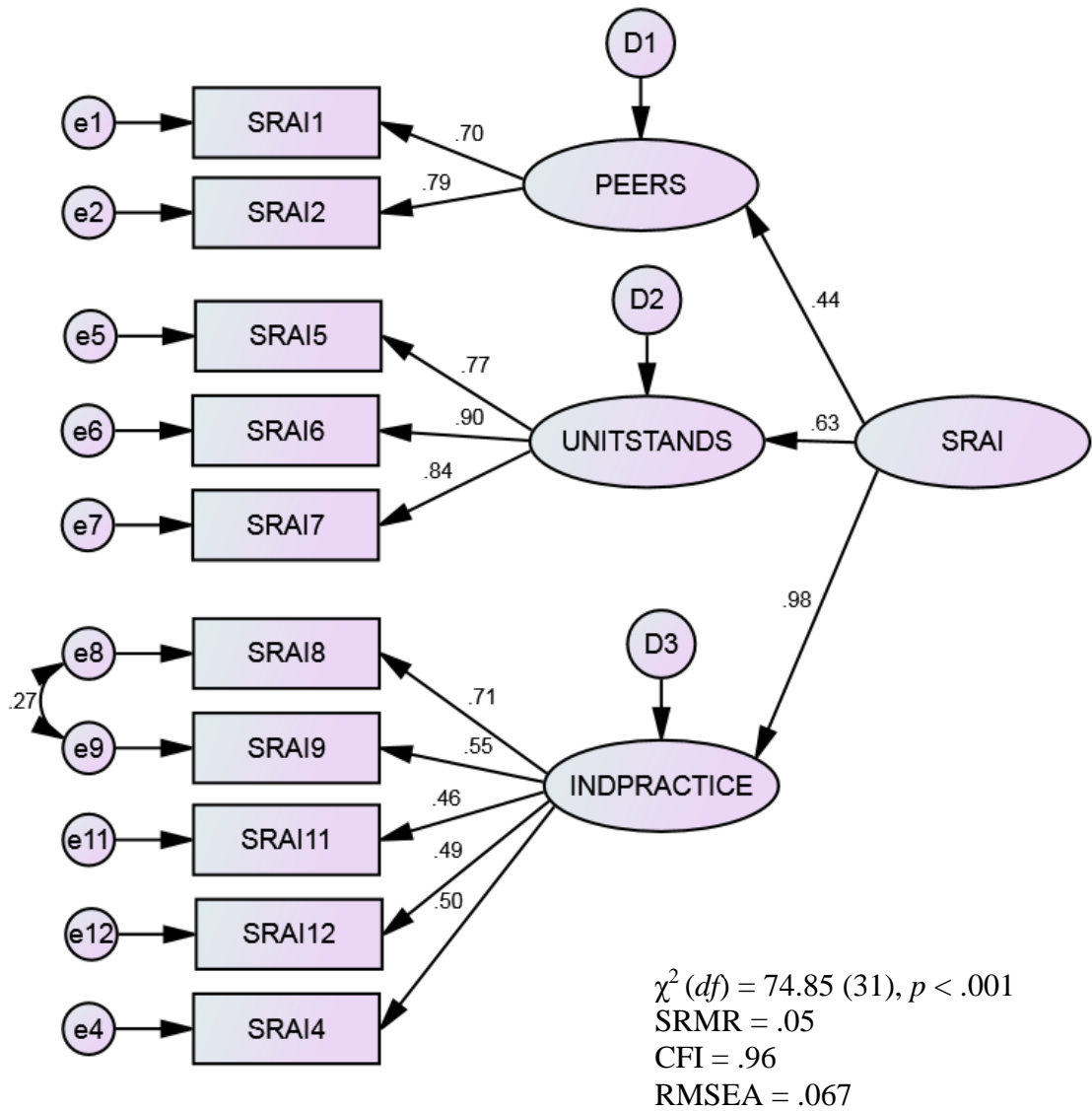

**Note:** All regression weights and covariances are significant,  $p < .01$

Figure 6. Final CFA Model for the Specht & Ramler Accountability Index (SRAI)

Table 6

*Final SRAI Scale Item Definitions*

<b>SPECHT &amp; RAMLER ACCOUNTABILITY INDEX (SRAI)</b>		
<b># Items</b>	<b>Label</b>	<b>Definition</b>
<b>2</b>	<b>PEERS</b>	<b>Accountability with Peers</b>
	Srai1	<i>I am accountable to my peers for the nursing care I deliver.</i>
	Srai2	<i>I hold my peers accountable for the nursing care they deliver.</i>
<b>3</b>	<b>UNITSTANDS</b>	<b>Accountability for Unit Standards</b>
	Srai5	<i>I am responsible for defining and monitoring standards of care for the patients on the unit.</i>
	Srai6	<i>I am actively involved in defining standards of care for the patients on the unit.</i>
	Srai7	<i>I am actively involved in monitoring standards of care for the patients on the unit.</i>
<b>5</b>	<b>INDPRACTICE</b>	<b>Accountability for Individual Practice</b>
	Srai8	<i>I am familiar with the standards of care pertaining to my patients and use the standards to guide my practice.</i>
	Srai9	<i>I am accountable for acquiring the knowledge and skill required to care for the patients on this unit.</i>
	Srai11	<i>If a patient or family member has a complaint about the care under my direction, their concerns should be referred to me and I should contact them with a response.</i>
	Srai12	<i>I regularly consult with nurse peers, read current nursing literature, attend professional conferences, and incorporate new knowledge into my practice.</i>
	Srai4	<i>I am accountable to have the patients I care for prepared for discharge.</i>

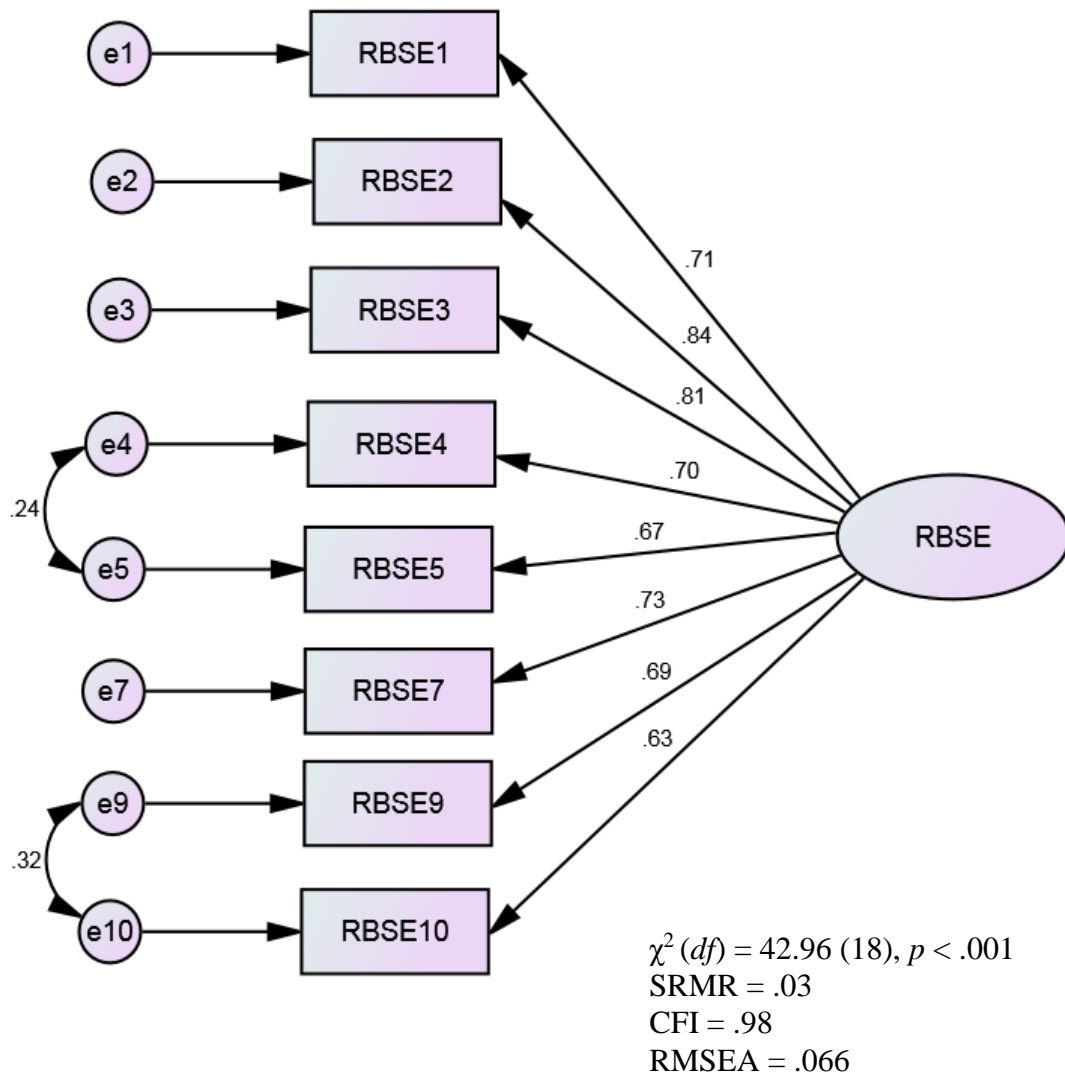

**Note:** All regression weights and covariances are significant,  $p < .01$

Figure 7. Final CFA Model for the Role Breadth Self-Efficacy

Table 7

*Final RBSE Scale Item Definitions*

<b>ROLE-BREADTH SELF-EFFICACY (RBSE)</b>		
<b># Items</b>	<b>Label</b>	<b>Definition</b>
8	Rbse1	<i>Analyzing a long-term problem in your nursing unit to find a solution.</i>
	Rbse2	<i>Representing your nursing unit in meetings with nursing management.</i>
	Rbse3	<i>Designing new policies and/or procedures for your nursing unit.</i>
	Rbse4	<i>Making suggestions to nursing management about ways to improve the nursing practice of your unit.</i>
	Rbse5	<i>Contributing to discussions about the hospital's strategy.</i>
	Rbse7	<i>Helping to set targets/goals in your nursing unit.</i>
	Rbse9	<i>Presenting information to a group of colleagues.</i>
	Rbse10	<i>Visiting people from other departments (e.g., lab, x-ray, dietary) to suggest doing things differently.</i>

In order to keep the number of manifest variables to latent constructs manageable for structural equation modelling, three parcels were created for the RBSE scale; among which items were then distributed. Item parcelling is a psychometric technique used to sum two or more items, responses or behaviours to an aggregate-level indicator for a particular construct of interest (Little et al., 2002). It differs from computing a set of subscale or scale scores in that the entire set of item parcels reflects a single primary latent construct, whereas a set of subscale or scale scores reflect several separable yet closely related latent constructs (Hall, Snell & Foust, 1999). Before considering the use

of item parcelling techniques, the normality and unidimensionality of the items intended for parcelling must first be satisfied (Rocha & Chelladuri, 2012). In this study, all items retained for the RBSE scale demonstrated acceptable absolute skew (0.18 – 0.79) and kurtosis (0.08 – 0.88) values, indicating that univariate assumptions of normality have been met. Final CFA model results for the RBSE also support the unidimensional structure of the construct. Thus, item parcelling for the RBSE was appropriate.

The item-to-construct balance approach was used to build three balanced parcels for the RBSE construct (Hall et al., 1999). Using the factor loading results from the final CFA model as a guide, the three items with the highest loadings were first anchored to the three parcels. Then, the next three items with the next highest item-to-construct loading was added to the anchors in an inverted order so that the highest loaded item from among the anchor item was matched with the lowest loaded item among the second round of item assignments. This balancing process continued until there were no more items left for assigning to a parcel. In summary, parcel 1 was assigned items RBSE1 ( $b = .71$ ), RBSE2 ( $b = .84$ ) and RBSE4 ( $b = .70$ ). Parcel 2 was assigned items RBSE3 ( $b = .81$ ), RBSE5 ( $b = .67$ ) and RBSE10 ( $b = .63$ ). Finally, Parcel 3 was assigned items RBSE7 ( $b = .73$ ) and RBSE9 ( $b = .69$ ). Item scores in these three parcels were subsequently aggregated to three respective indicators for the RBSE, which was then included for testing the structural hypothesis model.

### ***Control Over Nursing Practice***

While the CONP scale consists of 21 items, 2 items were previously deleted due to large missing values and theoretical grounds for item reduction. However, five of the 19 items revealed either low communality values less than .47, or cross-loading values on both factors within less than .20 of each other following an exploratory factor analysis.

Thus, these items were subsequently deleted from further analysis so as to attain a parsimonious measurement model for the CONP scale. The deleted items are listed in Table 8, along with the items that were retained in the final CFA model.

An initial first-order CFA was conducted on the remaining 14 scale items with poor model fit outcomes [ $\chi^2(df) = 702.59 (77)$ ,  $p < .001$ , SRMR = .101, CFI = .74, RMSEA = .160]. A second-order CFA was subsequently conducted as a 2-factor latent measurement structure given that control over nursing practice is conceptually defined as the freedom to evaluate nursing practice *and* make autonomous care delivery decisions. Evidence from relevant nursing literature also validated the CONP as a multidimensional rather than unidimensional structure (Williams, Goode, Krsek, Bednash, & Lynn, 2007). As such, the new latent factors conceptually represented nurses' opportunity to evaluate care, and to provide autonomous nursing care. Results for the revised second-order CFA model indicated a substantially improved model [ $\chi^2 \text{diff} (df) = 512.86 (5)$ ,  $p < .001$ ] to demonstrate good fit with the observed data and construct validity for the CONP measure [ $\chi^2(df) = 189.73 (72)$ ,  $p < .001$ , SRMR = .052, CFI = .95, RMSEA = .072]. This CFA model was reserved as the final model structure on which scores for each second-order factor were computed and subsequently analyzed in the structural model (see Figure 8 and Table 8).

### ***Knowledge Work Behaviours***

The new KWB scale was developed specifically for this study to measure nurses' knowledge work, the key variable of interest. The scale was designed according to knowledge work theory (Kelloway & Barling, 2000) and consists of 26 items distributed across 4 subscales, each representing a set of behaviours that facilitate use of knowledge for work goals.

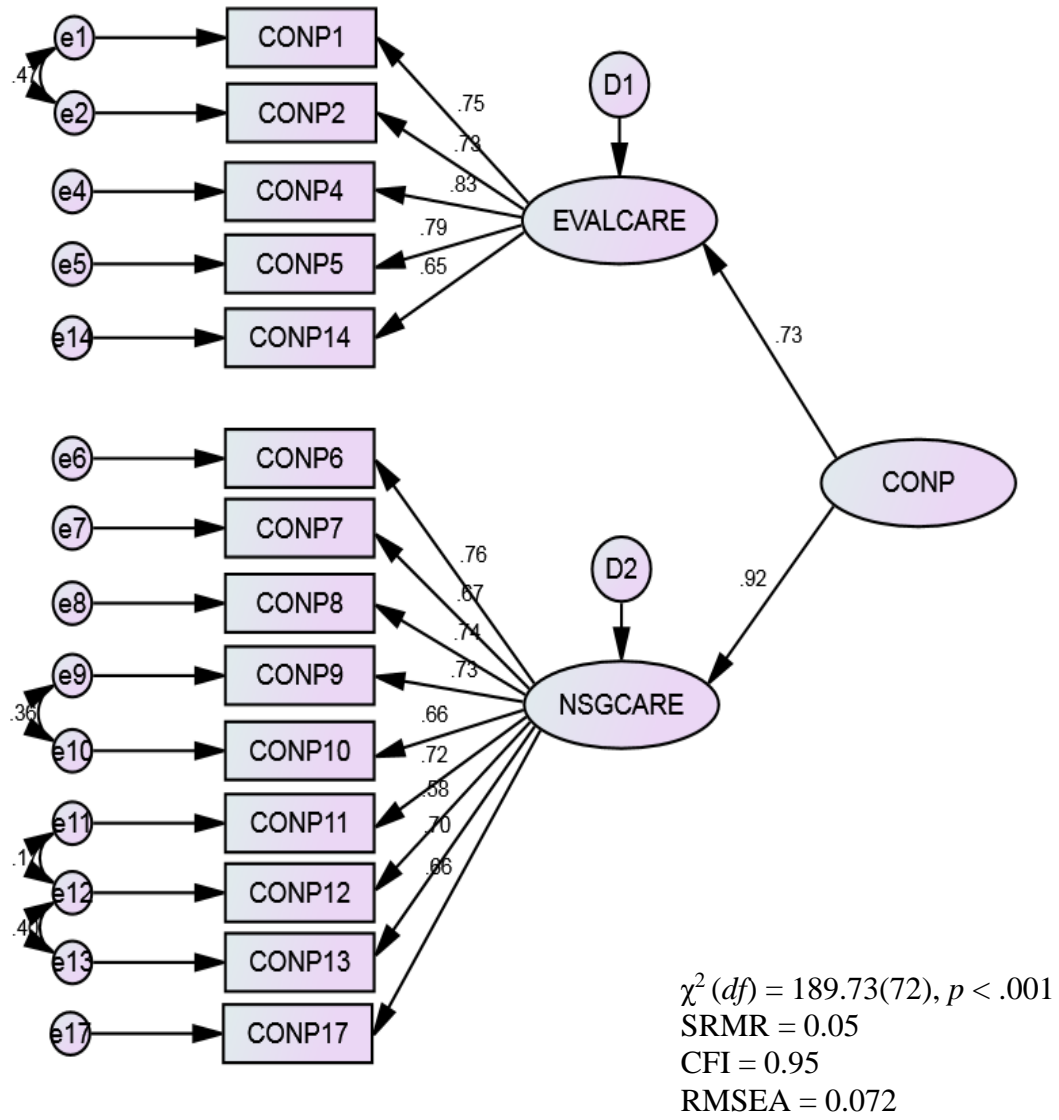

**Note:** All regression weights and covariances are significant,  $p < .01$

Figure 8. Final CFA Model for the Control Over Nursing Practice (CONP) Scale



Table 8

*Final CONP Scale Item Definitions*

<b>CONTROL OVER NURSING PRACTICE (CONP)</b>		
<b># Items*</b>	<b>Label</b>	<b>Definition</b>
<b>5</b>	<b>EVALCARE</b>	<b>Opportunity to Evaluate Nursing Care</b>
	Conp1	<i>Evaluate current nursing policies and procedures.</i>
	Conp2	<i>Evaluate the outcomes of nursing care.</i>
	Conp4	<i>Influence standards of nursing practice.</i>
	Conp5	<i>Modify or adapt patient care procedures and protocols.</i>
	Conp14	<i>Introduce new nursing practices and procedures.</i>
<b>9</b>	<b>NSGCARE</b>	<b>Opportunity to Provide Autonomous Nursing Care</b>
	Conp6	<i>Implement nursing care in an efficient manner.</i>
	Conp7	<i>Provide holistic, patient-centered care.</i>
	Conp8	<i>Plan strategies to meet my own developmental need.</i>
	Conp9	<i>Practice clinical skills to the best of my ability.</i>
	Conp10	<i>Analyze problems critically.</i>
	Conp11	<i>Plan care with other members of the health care team such as physician, dieticians, and therapists.</i>
	Conp12	<i>Act on my own decisions related to care giving.</i>
	Conp13	<i>Be creative in the delivery of care.</i>
	Conp17	<i>Adjust plans of care to meet patients' changing needs.</i>
<b>5</b>	<b>DELETED ITEMS</b>	
	Conp3	<i>Consult with others when solving complex care problems.</i>
	Conp15	<i>Identify problems in the delivery of nursing care.</i>
	Conp18	<i>Coordinate care activities among various health services.</i>
	Conp19	<i>Exert the authority needed to fulfill patient care responsibilities.</i>
	Conp20	<i>Obtain assistance from other staff members when needed.</i>

\*Total of 14 scale items retained.

A first-order CFA was initially conducted on the 26 items, which demonstrated a poor fitting model as expected [ $\chi^2(df) = 2654.41(299)$ ,  $p < .001$ , SRMR = .099, CFI = .62, RMSEA = .158]. Given the conceptual definition of knowledge work behaviours, a second-order CFA analysis was conducted on the 26 items as a 4-factor latent measurement structure. While results of the approximate model fit indices showed some improvement, the alternate model also demonstrated a poor fit with the observed data and so additional model modifications was required [ $\chi^2(df) = 1041.44(287)$ ,  $p < .001$ , SRMR = .077, CFI = .88, RMSEA = .091].

Closer analysis of the item statements, CFA model estimates and modification indices revealed that 7 items of the KWB showed either a similarly written statement with other items specified for the same latent factor variable, or a low standardized regression path to a latent factor as compared to other specified items. For these reasons, these 7 items were deleted from the KWB scale and further analysis (see Table 9).

CFA model modification indices also suggested specification changes for 2 items from the latent factor variable of developing knowledge, to applying knowledge. The content of both items were reviewed and conceptually represented application of knowledge more so than knowledge development, thus, was accordingly respecified to the applying knowledge factor in the revised second-order CFA model. Results for the revised CFA model showed substantial improvement over previous models [ $\chi^2_{diff}(df) = 737.99(145)$ ,  $p < .001$ ], and demonstrated construct validity by means of a good model fit with the observed data [ $\chi^2(df) = 303.45(142)$ ,  $p < .001$ , SRMR = .046, CFI = .96, RMSEA = .060]. This revised measurement model for the KWB was kept as the final model on which sum item mean scores for each second-order latent factor was computed,

in order to facilitate further structural analysis of the hypothesis model (see Figure 9 and Table 9).

### ***Nurse Care Coordination Inventory***

Eleven items from the original 25-itemed Nurse Care Coordination Inventory (NCCI) were previously deleted from further analysis, due to large missing value percentages and theoretical grounds for item reduction. Thus, only the remaining 14 scale items were evaluated in an initial CFA of the NCCI scale.

An initial first-order confirmatory factor analysis was subsequently conducted on the 14 NCCI scale items, which demonstrated a poor fitting model [ $\chi^2(df) = 543.43 (77)$ ,  $p < .001$ , SRMR = .098, CFI = .66, RMSEA = .138]. As per the original design structure of the NCCI, a second-order confirmatory factor analysis was also conducted on the 14 items as an alternate 2-factor latent measurement structure, which showed poor model fit results as well [ $\chi^2(df) = 244.21 (72)$ ,  $p < .001$ , SRMR = .074, CFI = .87, RMSEA = .087], albeit, better results than the first-order CFA model. A revised second-order CFA was conducted on the 14 scale items as a modified 4-factor latent measurement structure. The revised CFA model demonstrated an improved fit with the observed data [ $\chi^2_{diff}(df) = 377.06 (10)$ ,  $p < .001$ ], thereby confirming the scale's construct validity as a four-dimensional measure [ $\chi^2(df) = 166.37 (67)$ ,  $p < .001$ , SRMR = .064, CFI = .93, RMSEA = .068].

Following thematic content analysis of the item clusters for each latent factor, nurses in this study reported engaging in various coordination activities to facilitate patients' care that could be categorized as: 1) team coordination activities, 2) individual care delivery coordination activities, 3) coordination activities to manage unexpected changes in patient needs, and 4) unit resource and supplies coordination activities (Duva,

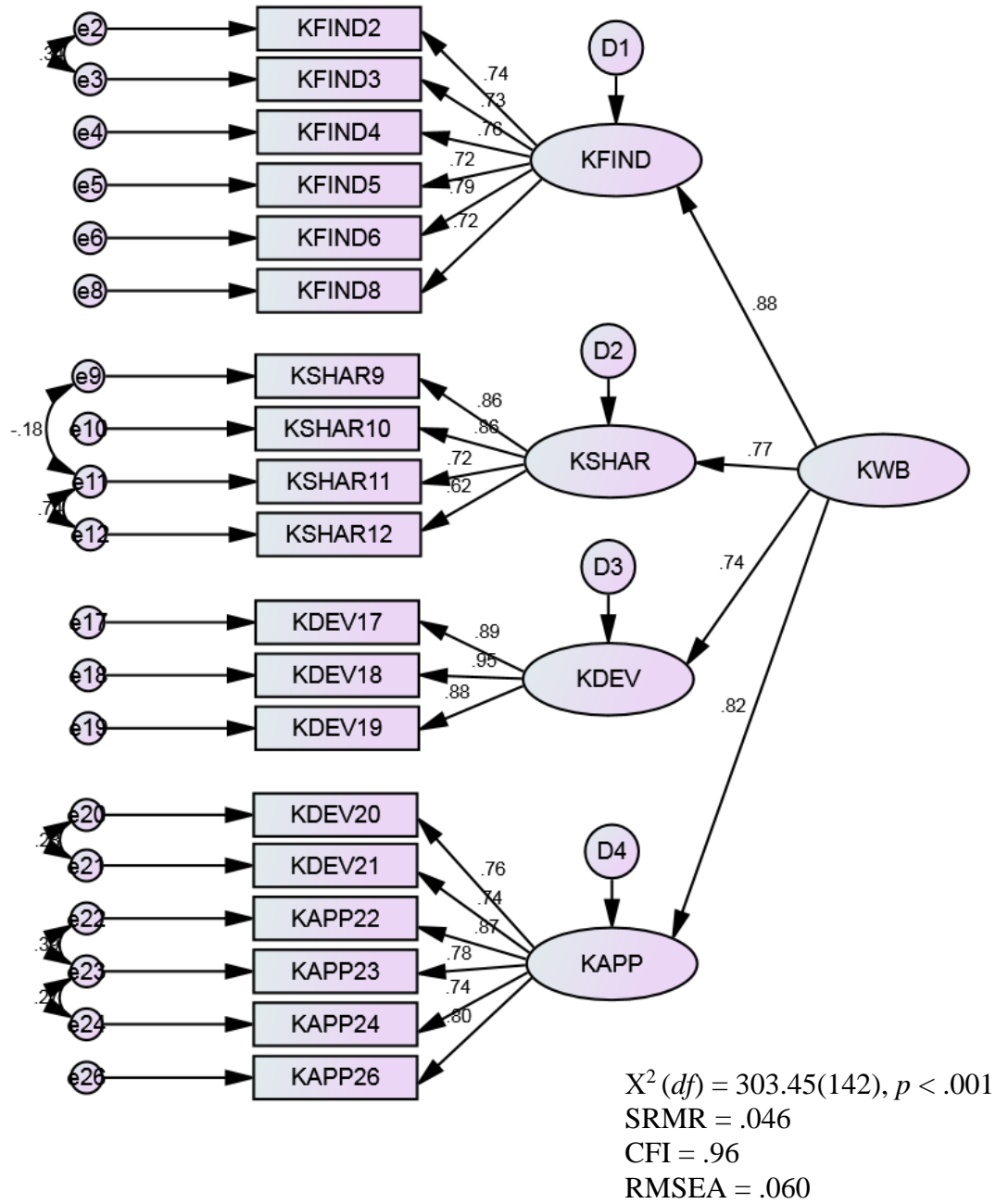

**Note:** All regression weights and covariances are significant,  $p < .01$

Figure 9. Final CFA Model for the Knowledge Work Behaviours Scale

Table 9

*Final KWB Scale Item Definitions*

<b>KNOWLEDGE WORK BEHAVIOURS (KWB)</b>		
<b># Items*</b>	<b>Label</b>	<b>Definition</b>
<b>6</b>	<b>KFIND</b>	<b>Knowledge Finding Behaviours</b>
	Kfind2	<i>I significantly contribute to collecting information other people need to do their work.</i>
	Kfind3	<i>I detect potential problems and find knowledge that will eliminate them.</i>
	Kfind4	<i>I evaluate changes in my environment and respond with the right knowledge.</i>
	Kfind5	<i>People seek my advice about defining new knowledge needs.</i>
	Kfind6	<i>I sense changes in my unit's practice that requires new knowledge.</i>
	Kfind8	<i>I gather the right information to prevent information overload.</i>
<b>4</b>	<b>KSHAR</b>	<b>Knowledge Sharing Behaviours</b>
	Kshar9	<i>When I've learned something new, I make sure my colleagues learn about it.</i>
	Kshar10	<i>I share information I have with my colleagues.</i>
	Kshar11	<i>I think it is important that my colleagues are aware of what I am doing.</i>
	Kshar12	<i>I regularly inform my colleagues of what I am doing.</i>
<b>3</b>	<b>KDEV</b>	<b>Knowledge Development Behaviours</b>
	Kdev17	<i>I come up with new ideas.</i>
	Kdev18	<i>I generate new ideas to solve problems at work.</i>
	Kdev19	<i>I generate new ideas to improve current practices at work.</i>
<b>6</b>	<b>KAPP</b>	<b>Knowledge Application Behaviours</b>
	Kdev20	<i>I evaluate the effectiveness of my actions at work.</i>
	Kdev21	<i>I use my knowledge to solve problems at work.</i>
	Kapp22	<i>I use my knowledge to make decisions at work.</i>
	Kapp23	<i>I use my knowledge to create plans of action at work.</i>
	Kapp24	<i>I evaluate what I need to know to perform my work.</i>
	Kapp26	<i>I reflect on my practice and act to address my knowledge gaps.</i>
<b>7</b>	<b>Deleted Items</b>	
	Kfind1	<i>I recognize potential problems and sense information to address them.</i>
	Kfind7	<i>I filter information for others to prevent information overload.</i>
	Kshar13	<i>When I need certain knowledge, I ask my colleagues about it.</i>
	Kshar14	<i>I like to be informed of what my colleagues know.</i>
	Kshar15	<i>I ask my colleagues about their abilities when I want to learn something.</i>
	Kshar16	<i>When a colleague is good at something, I ask them to teach me.</i>
	Kapp25	<i>I explain to my colleagues the rationale for my decisions at work.</i>

\*Total of 19 scale items retained.

2010; Lamb et al., 2007). The final CFA model for the NCCI is depicted in Figure 10 with a summary list of corresponding scale items listed in Table 10. This model was used to inform computation of sum mean scores for each NCCI latent factor, and for inclusion in subsequent analyses of the hypothesis model.

In summary, all multi-itemed scales that were used to measure the study constructs demonstrated sound psychometric properties. Internal consistency reliability was established for each measurement scale and corresponding subscales, with Cronbach alpha reliability results ranging from .66 – .96. Construct validity for each measure was also demonstrated by the second-order CFA results discussed previously. These findings provided support for appropriately proceeding with testing the structural hypothesis model.

### **Hypothesis Testing Results**

In review, this study examined the relationships among the following study constructs: empowering leadership, nursing accountability, role-breadth self-efficacy, control over nursing practice, knowledge work behaviours, care coordination, and quality of patient care (see Figure 11). Results for the initial SEM test of the theoretical model showed a poor model fit with the observed data [ $\chi^2(df) = 651.38 (202), p < .001, SRMR = .114, CFI = .88, RMSEA = .084$ ] (see Figure 12). Upon examination of the modification indices and regression weight parameter change statistics, three additional paths were suggested for a better model fit. Specifically, the additions of covariance paths between the three individual variable predictors of nurses' knowledge work behaviours were made. According to Kelloway and Barling (2000), individuals are more likely to engage in knowledge work only if they have the ability, motivation, and opportunity to do so.

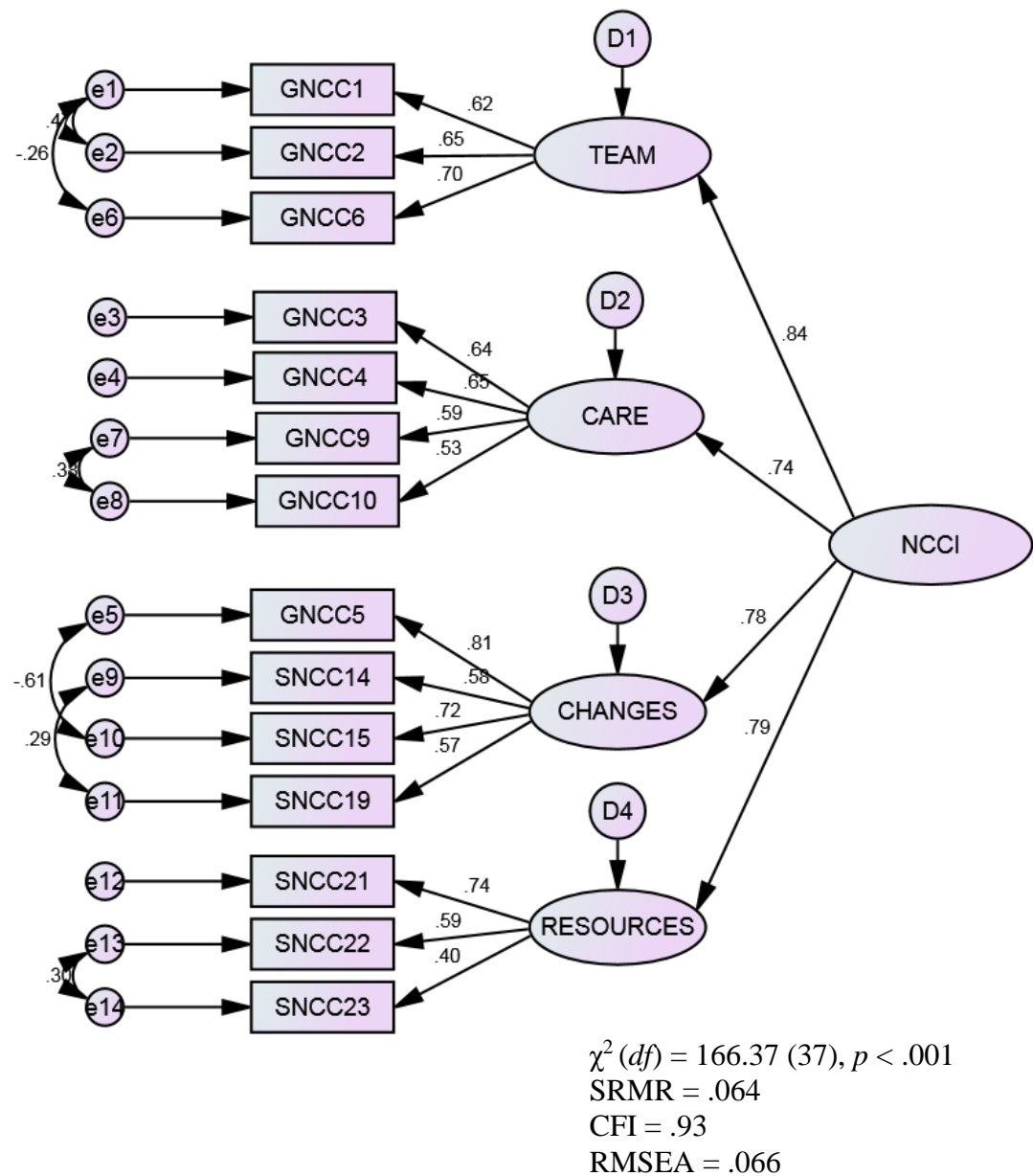

**Note:** All regression weights and covariances are significant,  $p < .01$

Figure 10. Final CFA Model for the Nurse Care Coordination Inventory (NCCI)

Table 10

## Final NCCI Scale Item Definitions

<b>NURSE CARE COORDINATION INVENTORY (NCCI)</b>		
<b># Items*</b>	<b>Label</b>	<b>Definition</b>
<b>3</b>	<b>TEAM</b>	<b>Team Coordination</b>
	Gncc1	<i>I communicate information to my interdisciplinary team members that they need to know to carry out their patient care activities or to make changes in the plan of care.</i>
	Gncc2	<i>I initiate actions to get my nursing team members to do what is needed to keep my patients on their plan of care.</i>
	Gncc6	<i>I initiate actions to get my interdisciplinary team members to do what is needed to keep my patients on their plan of care.</i>
<b>4</b>	<b>CARE</b>	<b>Individual Patient Care Activities Coordination</b>
	Gncc3	<i>I perform my patient assessments so that they will be useful to everyone on the team.</i>
	Gncc4	<i>I check that orders and procedures for my patients are carried out when they are scheduled.</i>
	Gncc9	<i>I organize my own activities to be able to keep the care of my patients on track.</i>
	Gncc10	<i>I organize the supplies that I need to be able to keep the care of my patients on track.</i>
<b>4</b>	<b>CHANGES</b>	<b>Unexpected Changes in Patient Needs Coordination</b>
	Gncc5	<i>I ask my nursing team members to assist me with my patient activities when I am tied up with one or more of my patients.</i>
	Sncc14	<i>When I need to spend more time with a patient than expected, I ask other staff on the unit to assist with my other patients.</i>
	Sncc15	<i>When I notify a team member that a patient is not progressing as expected, I recommend actions that I think will get the patient back on track.</i>
	Sncc19	<i>When I am unable to get my work done on time, I ask members of my nursing team to assist me.</i>
<b>3</b>	<b>RESOURCES</b>	<b>Unit Resources and Supplies Coordination</b>
	Sncc21	<i>I assist other nurses to get the information they need to care for their patients.</i>
	Sncc22	<i>When I start my shift, I make sure that the equipment my team and I need to get our work done is on the unit and accessible.</i>
	Sncc23	<i>When I go to get a supply, if I notice it is running low, I either restock it or ask someone else to do it.</i>

---

\*Total of 14 scale items



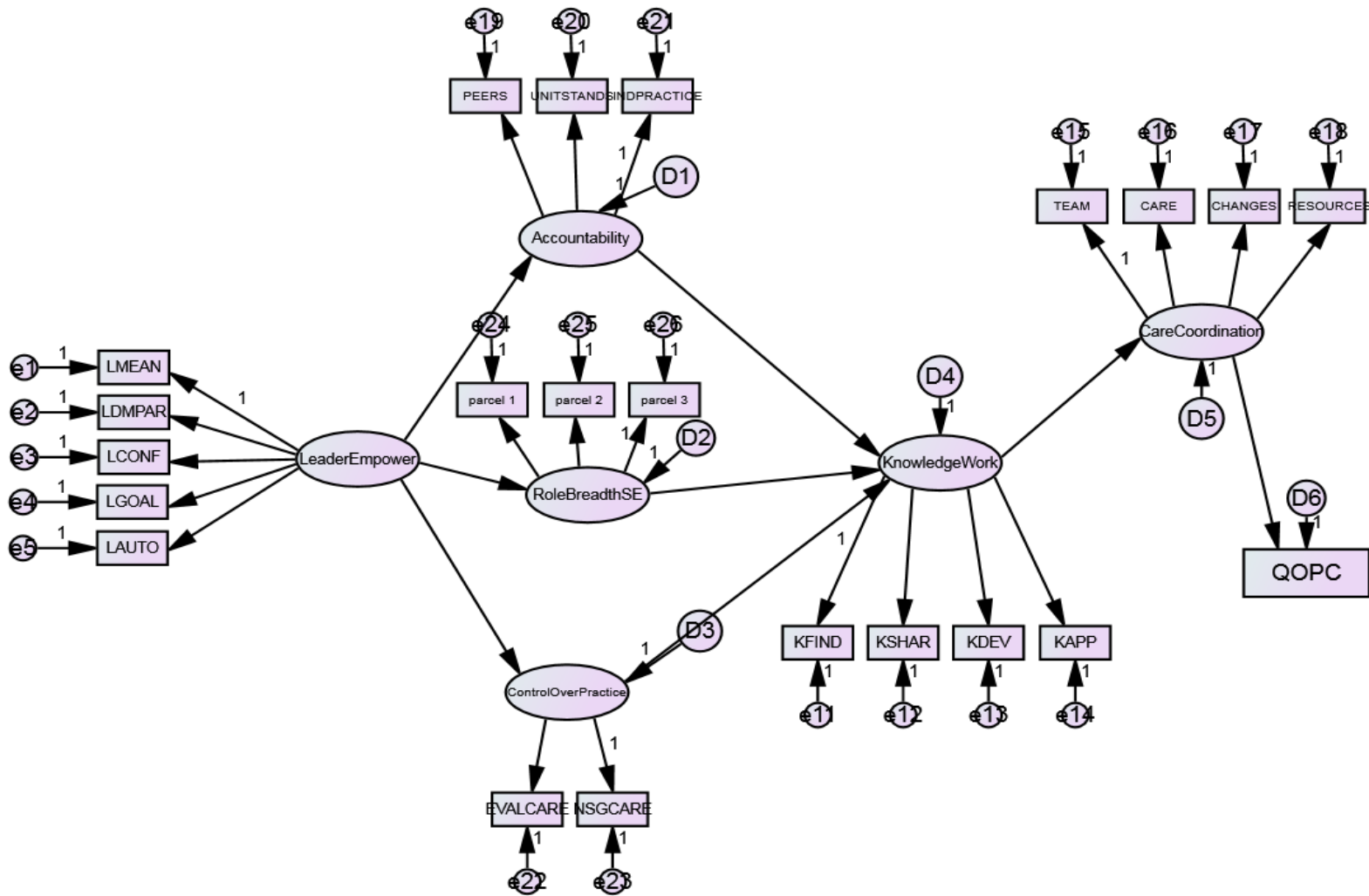

Figure 11. Structural Model of Theoretical Model

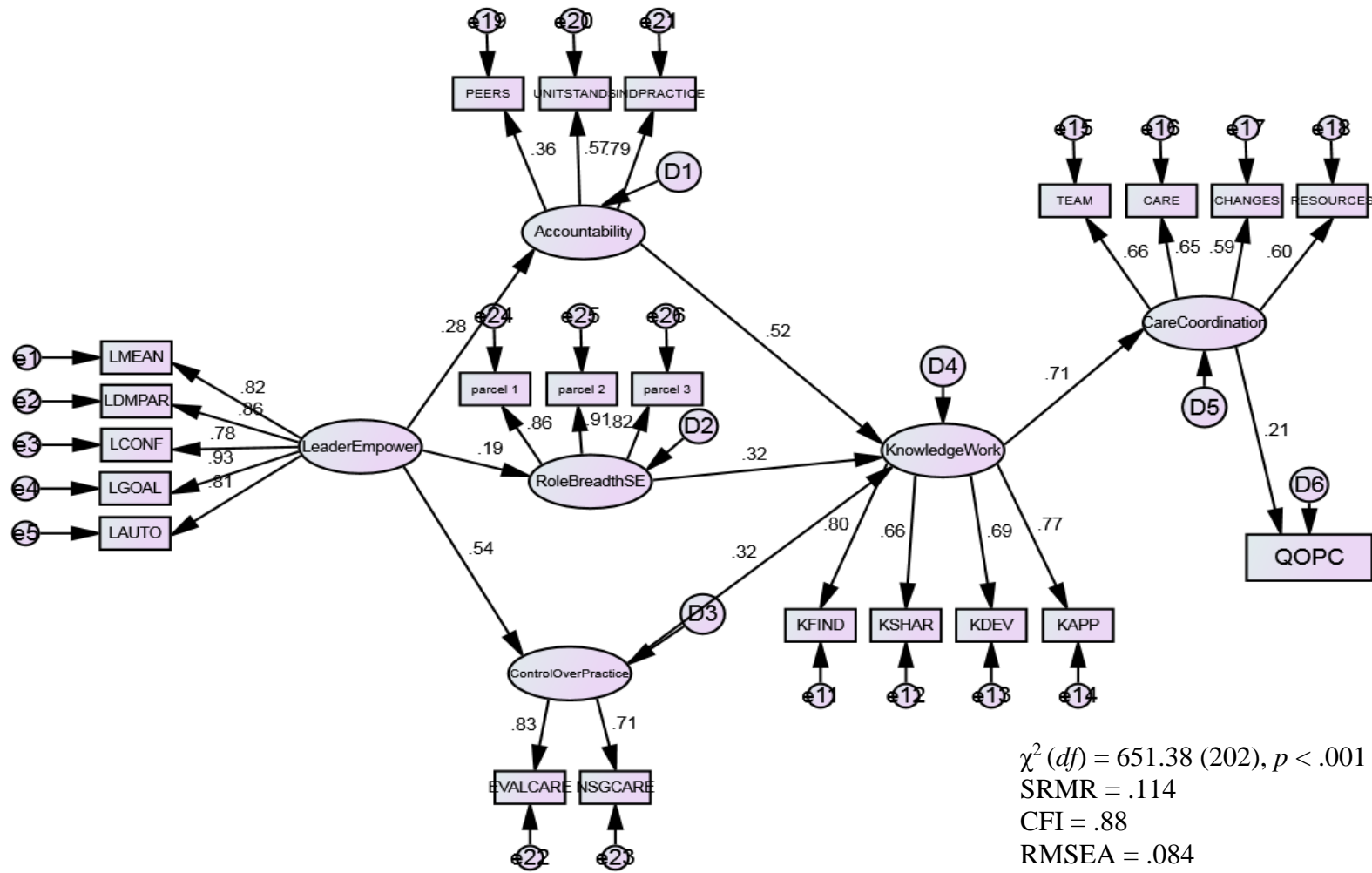

Figure 12. Initial Structural Model Results

They also argue that individual motivation, ability, and opportunity are non-compensatory necessities with shared influences on an individual's knowledge work behaviours. While model modifications based on post-hoc correlations or covariance analyses is cautioned against (Byrne, 2010; Kline, 2005), the suggested path additions were supported by Kelloway and Barling's (2000) theory of knowledge work as previously discussed. Thus, the structural model was modified with additional correlations among nurses' accountability, role-breadth self-efficacy, and control over nursing practice.

The revised structural model demonstrated significant improvement in model fit [ $\chi^2_{\text{diff}}(df) = 138.72(3), p < .001$ ], good model fit indices [ $\chi^2(df) = 512.66(199), p < .001$ , SRMR = .064, CFI = .91, RMSEA = .071], and was thus retained as the final model for analysis of parameter estimates among the study variables (see Figure 13). Parameter estimate results for all hypothesized pathways are presented in Table 11, including unstandardized estimates ( $b$ ), corresponding standard error values ( $SE$ ), and standardized estimates ( $\beta$ ). Cohen's (1988) criteria for small ( $d < .30$ ), medium ( $d = .30 - .50$ ) and large ( $d > .50$ ) effect sizes were used to interpret the magnitude and impact of the path estimates (Field, 2013). All unstandardized parameter estimates in the final model were statistically significant ( $p < .01$ ), except the path between control over nursing practice and nurses' knowledge work behaviours; although the corresponding standardized estimate indicated a small effect size for the non-significant relationship. For additional information, standardized indirect effects for key constructs and subconstructs are also presented in Table 11. Indirect effects include a mediator variable between independent and dependent variables. They are calculated by multiplying the relevant path coefficients among the independent, mediator, and dependent variables of interest (Kline, 2005).

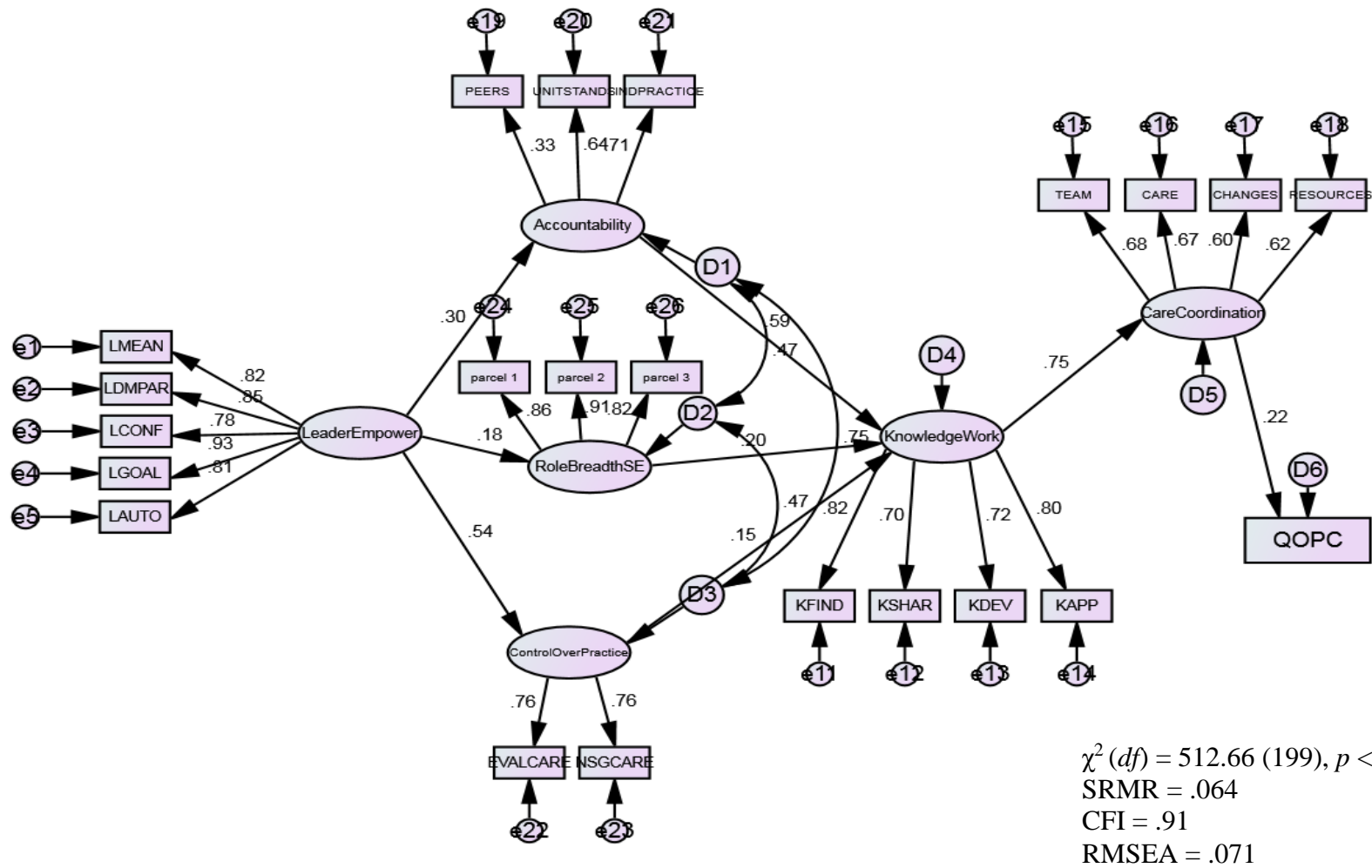

Figure 13. Final Structural Model Results

Table 11

*Final Structural Model Parameter Estimate Results*

<b>Path</b>	<b><i>b</i></b>	<b>SE</b>	<b><math>\beta</math></b>
<u>Direct Effects</u>			
Empowering leadership → Accountability	0.08	0.02	0.30
Empowering leadership → Role-breadth self-efficacy	0.10	0.04	0.18
Empowering leadership → Control over practice	0.28	0.04	0.54
Accountability → Knowledge work behaviours	1.27	0.31	0.59
Role-breadth self-efficacy → Knowledge work behaviours	0.21	0.07	0.20
Control over practice → Knowledge work behaviours	0.17*	0.14	0.15
Knowledge work behaviours → Care coordination	0.42	0.04	0.75
Care coordination → Quality of patient care	0.70	0.20	0.22
<u>Correlations</u>			
Accountability ↔ Role-breadth self-efficacy	0.11	0.02	0.47
Accountability ↔ Control over practice	0.14	0.02	0.75
Role-breadth self-efficacy ↔ Control over practice	0.18	0.03	0.47
<u>Indirect Effects</u>			
Empowering leadership → Knowledge Work	-	-	0.29
Empowering leadership → Knowledge finding	-	-	0.24
Empowering leadership → Knowledge sharing	-	-	0.20
Empowering leadership → Knowledge development	-	-	0.21
Empowering leadership → Knowledge application	-	-	0.23
Empowering leadership → Care coordination	-	-	0.21
Empowering leadership → Team coordination	-	-	0.15
Empowering leadership → Individual care coordination	-	-	0.13
Empowering leadership → Unexpected changes coordination	-	-	0.13
Empowering leadership → Unit resources coordination	-	-	0.14
Empowering leadership → Quality of patient care	-	-	0.05

**Note:** All significant,  $p < .001$ , unless otherwise noted

\*Non-significant estimate

Table 11 continued

Path	<i>b</i>	SE	$\beta$
<u>Indirect Effects</u>			
Accountability → Knowledge finding	-	-	0.48
Accountability → Knowledge sharing	-	-	0.41
Accountability → Knowledge development	-	-	0.42
Accountability → Knowledge application	-	-	0.47
Accountability → Care coordination	-	-	0.44
Accountability → Team coordination	-	-	0.30
Accountability → Individual care coordination	-	-	0.29
Accountability → Unexpected changes coordination	-	-	0.27
Accountability → Unit resources coordination	-	-	0.27
Accountability → Quality of patient care	-	-	0.10
Role-breadth self-efficacy → Knowledge finding	-	-	0.16
Role-breadth self-efficacy → Knowledge sharing	-	-	0.14
Role-breadth self-efficacy → Knowledge development	-	-	0.14
Role-breadth self-efficacy → Knowledge application	-	-	0.16
Role-breadth self-efficacy → Care coordination	-	-	0.15
Role-breadth self-efficacy → Team coordination	-	-	0.10
Role-breadth self-efficacy → Individual care coordination	-	-	0.10
Role-breadth self-efficacy → Unexpected changes coordination	-	-	0.09
Role-breadth self-efficacy → Unit resources coordination	-	-	0.09
Role-breadth self-efficacy → Quality of patient care	-	-	0.03
Knowledge work behaviours → Team coordination	-	-	0.51
Knowledge work behaviours → Individual care coordination	-	-	0.50
Knowledge work behaviours → Unexpected changes coordination	-	-	0.45
Knowledge work behaviours → Unit resources coordination	-	-	0.46
Knowledge work behaviours → Quality of patient care	-	-	0.17

**Note:** All significant,  $p < .001$ , unless otherwise noted

\*Non-significant estimate

Of the primary relationships examined in this study, three demonstrated large effect sizes. These include the impact of empowering leadership on nurses' control over practice ( $\beta = .54$ ), accountability on knowledge work behaviours ( $\beta = .59$ ), and knowledge work behaviours on care coordination ( $\beta = .75$ ). While the relationship between empowering leadership and accountability was moderate in size ( $\beta = .30$ ), all other relationships among the study variables had relatively small effect sizes ( $\beta < .22$ ).

The final structural model provided support for all study hypotheses, except for the relationship between nurses' control over practice and knowledge work behaviours. Specifically, empowering leadership positively influenced nurses' accountability ( $\beta = .30$ ), role-breadth self-efficacy ( $\beta = .18$ ), and control over practice ( $\beta = .54$ ). While nurses' accountability and role-breadth self-efficacy positively influenced their knowledge work behaviours ( $\beta = .59$  and  $\beta = .20$ , respectively), control over practice did not ( $b = 0.17$ , ns). However, control over nursing practice was strongly correlated with accountability ( $\beta = .75$ ) and moderately correlated with role-breadth self-efficacy ( $\beta = .47$ ), of which both correlations were statistically significant. The hypothesized outcomes of nurses' knowledge work behaviours were also supported in that knowledge work behaviours had a large positive effect on nurses' care coordination activities ( $\beta = .75$ ), which subsequently had a positive effect on nurses' perceived quality of patient care ( $\beta = .22$ ). In summary, the combined effects of accountability, role-breadth self-efficacy, and control over nursing practice accounted for 67.7% of the variance in nurses' knowledge work behaviours. Whereas nurses' knowledge work behaviours accounted for 55.8% of the variance in nurses' care coordination, which subsequently accounted for 5% of the variance in nurses' perceived quality of patient care.

As Figure 13 illustrates, the relationships between empowering leadership and quality of patient care were fully mediated by nurses' accountability, role-breadth self-efficacy, knowledge work behaviours, and care coordination. The standardized indirect effect of empowering leadership on quality of patient care was .047. The significance of this indirect effect was further tested using bootstrapping procedures. Bootstrapping methods allows for comparison of estimates over repeated samples drawn, with replacement, from the original sample (Byrne, 2010). Thus, the stability of model parameters and estimates can be evaluated (Kline, 2011). Unstandardized indirect effects were computed with 95% confidence intervals for each of 500 bootstrapped samples. The bootstrapped unstandardized indirect effect of empowering leadership on quality of patient care was 0.20 and the 95% confidence interval ranged from 0.020 – 0.118. Thus, the indirect effect of empowering leadership on the quality of patient care was statistically significant at  $p < .001$ .



## CHAPTER V: DISCUSSION & IMPLICATIONS

### Key Research Findings

The overall aim of this study was to examine the impact of organizational practices on nurses' knowledge work behaviours and patient care delivery outcomes, by testing an explanatory model of nurses' knowledge work in acute care settings. The study results confirmed that empowering leadership practices can impact the quality of patient care delivery by influencing nurses' engagement in knowledge work behaviours. Specifically, empowering leadership practices can enhance quality patient care and coordination by encouraging nurses' decisions to find, share, develop, and apply knowledge at work. The results also showed that empowering leadership practices mostly influence nurses' knowledge work behaviours by enhancing nurses' accountability and to a lesser extent, their role-breadth self-efficacy. While empowering leadership practices can also improve nurses' perceived control over their practice, such perceptions did not influence nurses' knowledge work behaviours.

The significance of these key research findings are discussed as follows according to three broad areas: 1) the outcomes of nurses' knowledge work behaviours, 2) the impact of empowering leadership practices on nurses' knowledge work outcomes, and 3) the mediating role of accountability and role-breadth self-efficacy.

### Outcomes of Nurses' Knowledge Work Behaviours

One of the objectives of this research was to identify the behaviours reflective of nurses' knowledge work in acute care settings. The study results provide empirical support for defining nurses' knowledge work as a collection of four broad behaviours that include finding, sharing, developing, and applying knowledge. These findings build on Daigle-Le Blanc's (2001) research that investigated the varying discretionary behaviours

of individuals' knowledge use at work, to validate the identification of four discrete behavioural forms of nurses' knowledge work. These four discretionary behaviours represent the degree to which nurses choose to find knowledge in order to use it at work; to share what they know at work; to develop knowledge that is new to them for use at work; and to apply knowledge for action at work. Unlike past research focused on the study of one behavioural form such as knowledge sharing (Connelley & Kelloway, 2002; Wang & Noe, 2010), this study contributes to an understanding of knowledge work as four discrete behavioural forms and of how these behaviours collectively influence nurses' work outcomes.

In this study, nurses' care coordination was a strong positive outcome of their engagement in knowledge work behaviours. Further analysis of the findings indicated that of the various types of care coordination activities, nurses' knowledge work behaviours had the greatest effect on team coordination ( $\beta = .51$ ) and individual nursing care delivery coordination activities ( $\beta = .50$ ). One possible reason for this finding may be that team coordination and individual nursing care delivery coordination activities occur more frequently during a nurse's daily practice, as compared to coordination activities involving managing unit resources and supplies, or situations with unexpected changes in patient needs.

While nurses' care coordination practices have been linked to several positive work attitudes and patient outcomes (Duva, 2010; Aiken et al., 1994; Sochalski, 2004; Aiken et al., 2002; Gittel et al., 2009; Havens et al., 2010; Needleman et al., 2002; Shen et al., 2011), evidence to identify the nursing work behaviours that directly contribute to quality patient care and positive patient outcomes is limited. The results of this study begin to fill this gap by confirming that when nurses choose to actively find, share,

develop, and use their knowledge at work, they are more able to coordinate their patients' seamless care trajectory throughout their hospital stay, which subsequently leads to improved patient care quality.

### **Impact of Empowering Leadership on Nurses' Knowledge Work Outcomes**

Empowering leadership is defined as leadership practices that facilitate staff empowerment experiences for task accomplishment (Conger & Kanungo, 1988). These practices or behaviours include enhancing nurses' work meaningfulness; encouraging nurses' decision-making participation, expressing confidence in nurses' high performance, facilitating nurses' goal accomplishments, and fostering nurses' work autonomy from bureaucratic constraints (Hui, 1994).

The positive influence of empowering leadership on nurses' knowledge work behaviours leading to improved patient care delivery outcomes is a significant finding in this study. This finding not only add to the literature linking empowering leadership to individual work attitudes and work effectiveness (Ahearne et al., 2005; Germain & Cummings, 2010; Laschinger et al., 1999; Lee et al., 2006; Rapp et al., 2006), but also specify nurses' knowledge work propensities as the mechanism through which empowering leadership practices enhance quality patient care delivery.

Similar influences of leadership practices on quality of patient care were reported in Laschinger, Wong, Grau, Read, and Stam's (2011) study with middle and front line nurse managers. These researchers found that transformational leadership practices enhanced managers' access to organizational opportunity, support, information and resources, which indirectly impacted their' assessed quality of care delivery on their respective units (front line managers:  $\beta = .05, p < .001$ ; middle managers:  $\beta = .04, p < .001$ ). Laschinger et al. noted that the outcome effects of transformational were similar

among nursing managers, regardless of the leadership level at which they operated within the organization. Despite the fact that Laschinger et al.'s study focused on transformational leadership practices that impact the quality of patient care as reported by nurse managers, their findings parallel the results noted in our study with staff nurses.

This study demonstrates that nursing leaders may empower their staff nurses to deliver quality care when they help nurses understand the importance of their work, provide decision-making participation opportunities, express confidence in their abilities, enable their goal accomplishments, and provide work autonomy from bureaucratic constraints (Hui, 1999). Together, these practices create an empowering work climate that enhances nurses' knowledge work behaviours, enabling them to better use knowledge in their practice for coordinating and delivering quality care (Kruese et al., 2010; Lee et al., 2011, Marek et al., 2005).

### **Mediating Roles of Accountability & Role-breadth Self-efficacy**

Nurses' accountability and role-breadth self-efficacy are important mediators by which empowering leadership behaviors influence nurses' knowledge work behaviours, although accountability was found to be the stronger mediator. These findings complement Boxall, Hutchlson & Wassenaar's (2014) study with general distribution centre employees, who found that intrinsic motivation and skill utilization were significant mediators of employees' access to empowering work conditions and its effects on employee's job satisfaction and affective commitment to work goals. However, the results of this study also extend Boxall et al.'s findings to show the extent with which accountability and role-breadth self-efficacy mediate the effects of empowerment on not only nurses' work attitudes, but behavioural work outcomes as well.

In this study, accountability was the strongest predictor of nurses' knowledge work behaviours. This significant finding supplements previous research that emphasize the importance of internalized accountability in initiating individuals' knowledge work behaviours such as use of greater vigilance, proactive work strategies, and multiple information sources to inform decision making (Mosier et al., 1998; Skitss et al., 2000). Thus, this study demonstrates that empowered nurses' are more likely to be motivated by their accountabilities for using knowledge work behaviours to achieve their patient care coordination responsibilities.

Despite having less effect when compared to accountability, the role of role-breadth self-efficacy in linking empowering leadership behaviours to nurses' knowledge work behaviour outcomes was a significant finding as well. The results of this study shows that empowering leadership behaviours may enhance nurses' confidence in their abilities to be proactive and take on broader role responsibilities within the clinical setting, which further encourages their engagement in knowledge work behaviors and care coordination activities. These findings supplement existing self-efficacy research and add to the list of behavioural outcomes empirically associated with role-breadth self-efficacy, among which include increased engagement in self-starting and future oriented behaviors, participation in knowledge development activities, and self-assessment of appropriate competencies for meeting role expectations and responsibilities (Burns, 2002; Griffin et al., 2007; Johnson et al., 2010; Strauss et al., 2009).

The findings discussed above support Kelloway and Barling's (2000) theory that organizational practices may influence individuals' knowledge work behaviours and outcomes insofar as it affords individuals motivation, ability, and opportunity to do so. This study demonstrates that empowering leadership practices are only able to influence

nurses' propensity for knowledge work behaviours by means of creating empowering work climates that facilitate nurses' accountability and role-breadth self-efficacy.

Empowering leadership practices was also found to directly enhance nurses' control over their practice. However, these enhanced perceptions did not further impact nurses' knowledge work behaviour propensities or care delivery outcomes. This finding was unexpected, particularly in light of past literature where control over practice was found to strongly predict employee work satisfaction, cooperative learning, and work effectiveness (Laschinger & Havens, 1996; Janz & Prasarnphanich, 2003). In a recent study, Havaei, Dahinten and MacPhee (2014) found that although psychological competence was found to be the strongest predictor of novice nurse managers' empowering behaviours, their perceptions of autonomy had no impact on their behavioural outcomes. Havaei et al. suggested that their study finding may be attributed to participants' limited leadership experience as novice nurse managers. Yet, in the present study, the finding that nurses' control over practice did not impact knowledge work behaviour outcomes may potentially be because of its influence may be mediated by the effects of accountability and role-breadth self-efficacy, particularly given that control over nursing practice was highly correlated with accountability and role-breadth self-efficacy. However, further research is needed to test this hypothesis.

### **Study Limitations**

There are several limitations to this study, starting with the use of a cross-sectional design method. Given that data for predictor and outcome variables were simultaneously collected from study respondents, causality for any relationships observed between the variables remains unclear (Pedhazur, Pedhazur & Schmelkin, 1991). Specifically, evidence for the temporal relationship between empowering leadership,

nurses' knowledge work behaviors, and their care coordination activity outcomes is limited. Thus, in light of the results for this study, interpretations of causality among study variables are cautioned. This presents opportunity for expanded research and design to address this limitation and better examine the sequential relationships between organizational practices, nurses' knowledge work behaviors, and patient care outcomes. Such opportunities include repeating this study with use of longitudinal or hierarchical design strategies to gather data for predictor and outcome variables at separate time points (Pedhazur et al., 1991). However, Podsakoff, MacKenzie and Podsakoff (2003) argue that the lag time between points of measure needs to be carefully considered according to the process under examination, so as to limit the introduction of contaminating factors that may intervene between the measurement of predictor and outcome variables. Thus, an interventional quasi-experimental design method may also offer meaningful insight to the cause and effect relationships between leader empowering behaviors, nurses' knowledge work behaviors, and patient care outcomes.

The use of self-report survey methods is another limitation in this study in that there is a potential for common method variance biases. Common method variance is measurement error ascribed to the measurement methods used to gather data, rather than to the constructs of interest (Podsakoff, MacKenzie, & Podsakoff, 2003). Such systematic error variance can confound and mislead conclusions about empirical results. Several procedural techniques were used in this study to control for potential biases of common method variance. These techniques include the use of different response formats, scale endpoints, and clear scale midpoint labels for measures to limit biases caused by commonalities in scale endpoints and anchoring effects. Attempts to control biases associated with item ambiguity was also addressed by means of eliminating double-

barreled or negatively worded items from scale measures and results. Finally, attempts to limit biases associated with social desirability or evaluation apprehension were made by allowing respondents' answers to be anonymous.

This study employed a voluntary approach for sampling by means of the CNO's registry list. While convenient, the approach increases the potential for non-response bias that can skew study results (Dillman et al., 2009). Unfortunately, there is no way to compare characteristic differences among nurses who did or did not consent to participate in the study. Likewise, there is no way of comparing results among nurses who were not randomly selected for participation.

The final sample size ( $N = 318$ ) for this study also presents limitations for generalizing results to the wider nursing population. In particular, selection bias may be of concern as indicated by the low response rate for this study (21.58%). Nonetheless, the study findings are generally representative of acute care nurses in Ontario given demographic commonalities between study respondents and Ontario registered nurses at large (CNO, 2013, 2014; Laschinger et al., 2014; Roche et al., 2015).

Finally, not all influencing variables were included for hypothesis testing in this specific study. Thus, there are likely other unknown and unmeasured variables that may influence nurses' knowledge work behaviours. Equally, other potential outcomes of nurses' knowledge work behaviours such as patient safety indicators or patient satisfaction are possible. Nevertheless, the results of this study offer support for the use of Kelloway & Barling's (2000) knowledge work theory as a framework for further research into the impact of these other variables.

### **Opportunities for Further Research**

Several gaps and findings in this study present opportunities for future research.



First, demographic group differences were noted among the sample including origin of nursing education, type of hospital employment, age, and length of nursing work experience. A systematic analysis of these demographic differences and their influences on nurses' knowledge work behaviour outcomes could provide new insights for knowledge work research, particularly if such demographic variables can influence the extent that nurses' knowledge work behaviours affect patient care delivery outcomes.

The unexpected finding that nurses' control over nursing practice did not impact their knowledge work behaviours also deserves further study, particularly in light of the finding that nurses' control over practice was strongly correlated with accountability ( $r = .75, p < .001$ ). This raises questions as to whether the relationship between control over nursing practice and nurses' knowledge work behaviours could potentially be mediated or moderated by nurses' accountability. Further research to test this hypothesis would be helpful to better identify the different mechanisms that organizational structures, practices and climates may influence nurses' knowledge work behaviours and outcomes.

While the primary focus of this study was to test a model linking nursing leadership to individual nurses' attitudes for knowledge work, the variables selected for study are by no means exhaustive. Other variables that could potentially influence nurses' motivation, ability and opportunity knowledge work behaviours are worth further investigation. Nurses' role clarity, competence for nursing practice, workload, and access to facilitative work resources are a few examples. Investigations of other potential knowledge work behaviour outcome variables that reflect health care productivity are also worthwhile to further understand and assess the significance of nurses' knowledge work. Such outcome variables may include patient care satisfaction, patient care complaints, near misses, and cost savings.

Kelloway and Barling also suggest that outcomes of individuals' knowledge work behaviours are influenced by organizational practices that shape individuals' motivation, ability and opportunity for knowledge work. This perspective creates the opportunity to use multi-level research model designs to better examine the linkages between organizational practices, work environments, nursing work behaviours, and patient care outcomes. Multi-level research designs are particularly appropriate for the study of nurses' knowledge work given that nurses generally work in set health care teams, under specific leaders, within patient care units that are within hospitals. Such research would allow for the simultaneous analysis of influences that different organizational practices or work environment variables may have on nurses' knowledge work behaviours, patient care processes, and outcomes.

### **Implications for Nursing Leadership, Education, & Practice**

Despite the study limitations and opportunities for future research, the results of this study provide preliminary support for Kelloway and Barling's theoretical framework by demonstrating that empowering leadership practices can influence nurses' to actively use their knowledge for providing quality patient care. These key findings offer some practical implications for nursing leadership, education and practice.

Beyond investments in knowledge management technologies, health organizations can leverage nurses' knowledge work and achieve quality patient care outcomes by implementing strategies that promote empowering leadership practices. The results of this study show that by using empowering leadership behaviours to target nurses' motivation, abilities, and opportunity for engaging in knowledge work behaviours, nursing leaders can set the stage for effective patient care delivery on their units. Thus, health organizations seeking to build a sustainable knowledge management

infrastructure may want to consider implementing empowering leadership practice development opportunities for their nursing leaders as a knowledge management strategy. Such opportunities include developing leadership practice capabilities for enhancing nurses' work meaningfulness, decision-making participation, confidence in their abilities, goal accomplishment, and work autonomy (Conger & Kanungo, 1999).

With roots in organizational behaviour perspectives, Kelloway and Barling's (2000) theoretical framework outlines the direct and indirect processes by which organizational strategies influence organizational productivity and employee work outcomes. In doing so, the framework offers a tangible blueprint for developing, implementing, and evaluating the effectiveness of organizational productivity strategies. More specifically, the framework provides a cohesive and systematic approach to evaluating the extent in which organizational strategies influence nurses' work behaviours to achieve patient care delivery goals. This may be of particular interest for nursing administrators seeking to monitor or evaluate the effectiveness of their organizational strategies, as well as the quality assurance and performance of their health care units and nursing staff.

As demonstrated in this study, nurses' knowledge work behaviour decisions are dependent on the extent of nurses' accountability and role-breadth self-efficacy. The results of this study also support the notion that nurses need to have the motivation and abilities to engage in knowledge work behaviours in order use their knowledge for providing patient care (Bandura, 1989). Effectively developing such abilities require nurses to understand what knowledge work behaviours are, to continuously engage in those behaviours across various clinical contexts, and to reflect on the evaluated goal outcomes of the behaviours at the onset and throughout their career. This brings to light

the foundational and ongoing educational needs that may be required in order for nurses to leverage outcomes of their knowledge work behaviours at work.

Motivational drivers such as accountability are often established over time, though initially developed in foundational nursing education programs. The results of this study emphasize the effect of accountability on nurses' knowledge work and consequential quality care delivery outcomes. This has significance for nursing leaders, educators, and practitioners alike, particularly in light of Berkow, Virkstis, Stewart, and Conway's (2009) descriptive study describing a lack of accountability in new graduate nurses. Berkow et al. reported that among a list of 36 new graduate nurse competencies, only 35% of nurse leaders were satisfied with new graduate nurses' ability to be accountable for their actions. The researchers further reported that while new graduate nurses ranked highest in their use of information technologies (58%), they ranked the lowest in delegation of tasks (10%). Hence, it is important that nurse educators build opportunities for students to develop professional accountability and life-long learning abilities early on and throughout the nursing educational curriculum, so as to establish students' nursing accountability foundations for knowledge work once they enter the practice setting.

## **Conclusion**

In summary, this study provides new insights for knowledge management in health care organizations by testing Kelloway and Barling's (2000) organizational behaviour theory of knowledge work. Linkages between empowering leadership practices and nurses' accountability, ability, and opportunity to enact knowledge work behaviours for coordinating quality patient care were demonstrated; thus, illuminating the potential value of empowering leadership for effecting positive care delivery outcomes. Of equal

note is the mediating role of nurses' knowledge work for achieving such positive care delivery outcomes.

The results of this study indicate that nurses' greater exposure to empowering leadership behaviours at work enhances their behaviours of finding, sharing, developing, and applying knowledge for patient care by means of positively influencing their work accountability, role-breadth self-efficacy, and control over practice. Nurses' enhanced knowledge work behaviours subsequently led to improved care coordination and quality patient care outcomes. Consistent with the underlying theory of knowledge work (Kelloway & Barling, 2000), nurses' work accountability, role-breadth self-efficacy, and control over practice were positively correlated to influence nurses' knowledge work behaviours. Although no significant relationship was found between nurses' control over practice and knowledge work behaviours, nurses' accountability and role-breadth self-efficacy positively affected their knowledge work behaviours; with accountability being the stronger of the two predictor variables.

The findings of this study offer some practical implications for nursing leadership, education, and practice. Recommendations for additional research are also provided for further investigation of nurses' knowledge work behaviours. In conclusion, this study is among the first to provide new understanding about the mechanisms by which organizational practices may influence nurses' knowledge work behaviours, and the benefits that these behaviours may have for health organizations and patients. These new insights support the use of empowering leadership practices as an alternative organizational knowledge management strategy for leveraging nurses' knowledge work to achieve quality patient care delivery outcomes.

## REFERENCES

- Ahearne, M., Mathieu, J. & Rapp, A. (2005). To empower or not to empower your sales force? An empirical examination of the influence of leadership empowerment behavior on customer satisfaction and performance. *Journal of Applied Psychology, 90*(5): 945-955.
- Aiken, L. H., Clarke, S. P. & Sloane, D. M. (2002). Hospital staffing, organization, and quality of care: Cross-national findings. *International Journal for Quality in Health Care, 14*(1): 5-13.
- Aiken, L. H., Smith, H.L. & Lake, E.T. (1994). Lower Medicare mortality among a set of hospitals known for good nursing care. *Medical Care, 32*(8):771-787
- Alavi, M. & Leidner, D. E. (2001). Review: Knowledge management and knowledge management systems: Conceptual foundations and research issues. *MIS Quarterly, 25*(1): 107-136.
- Allison, P. D. (2003). Missing data techniques for structural equation modeling. *Journal of Abnormal Psychology, 112*(4): 545-57.
- Alvesson, M. (2001). Knowledge work: Ambiguity, image and identity. *Human Relations, 54*(7): 863-86.
- Augier, M, Shariz, S. Z. & Vendelo, M. T. (2001). Understanding context: its emergence, transformation and role in tacit knowledge sharing. *Journal of Knowledge Management, 5*(2): 125-37.
- Axtell, C. M. & Parker, S. K. (2003). Promoting role breadth self-efficacy through involvement, work redesign, and training. *Human Relations, 56*(1): 113-31.

- Ayers LaFave, L. R. (2008). *Nursing practice as knowledge work within a clinical microsystem* (Doctoral dissertation). University of Massachusetts Worcester, Massachusetts, USA.
- Baernholdt, M. & Mark, B. A. (2009). The nurse work environment, job satisfaction and turnover rates in rural and urban nursing units. *Journal of Nursing Management, 17*(8): 994-1001.
- Bandura, A. (1989). Human agency in social cognitive theory. *American Psychologist, 44*(9): 1175-84.
- Bartol, K. M. & Srivastava, A. (2002). Encouraging knowledge sharing: The role of organizational reward systems. *Journal of Leadership and Organizational Studies, 9*(1): 64-73.
- Bass, B. H. (1990). From transactional to transformational leadership: Learning to share the vision. *Organizational Dynamics, 18*(3): 19-31.
- Becerra-Fernandez, I. & Sabherwal, R. (2005). Knowledge management at NASA-Kennedy Space Center. *International Journal of Knowledge and Learning, 1*: 159-170.
- Benner, P. (1984). *From novice to expert: Excellence and power in clinical nursing practice*. Menlo Park, CA: Addison-Wesley.
- Benner, P., Tanner, C. A. & Chesla, C. A. (1996). *Expertise in nursing practice: Caring, clinical judgement, and ethics*. New York, NY: Springer Publishing Company, Inc.
- Beringer, A. J. & Fletcher, M. E. (2008). Who does what? How staff in England and Denmark perceive roles in the coordination of children's inpatient care: A

- comparison of questionnaire survey data. *Journal of Clinical Nursing*, 17(23): 3217-3225.
- Beringer, A. J., Fletcher, M. E. & Taket, A. R. (2006). Rules and resources: A structuration approach to understanding the coordination of children's inpatient health care. *Journal of Advanced Nursing*, 56(3): 325-35.
- Berkow, S., Virkstis, K., Stewart, J., & Conway, L. (2009). Assessing new graduate nurse performance. *Journal of Nursing Administration*, 38(11): 468-474.
- Blackler, F. (1995). Knowledge, knowledge work and organizations: An overview and interpretation. *Organization Studies*, 16(6): 1021-46.
- Bock, G., Zmud, R. W., Kim, Y., & Lee, J. (2005). Behavioral intention formation in knowledge sharing: Examining the roles of extrinsic motivators, social-psychological forces, and organizational climate. *MIS Quarterly*, 29(1): 87-111.
- Bose, R. (2003). Knowledge management-enabled health care management systems: Capabilities, infrastructure, and decision-support. *Expert Systems with Applications*, 24(1): 59-71.
- Boni, C. E. (2001). *Accountability in nurses who practice in three different nursing care delivery models* (Doctoral dissertation). University of Massachusetts Worcester and Amherst, Massachusetts, USA.
- Boxall, P., Hutchison, A. & Wassenaar, B. (2014). How do high-involvement work processes influence employee outcomes? An examination of the mediating roles of skill utilisation and intrinsic motivation. *International Journal of Human Resource Management*. doi: 10.1080/09585192.2014.962070
- Burns, C. (2002). *Assessing staff nurses' styles of involvement with the families of their patients* (Doctoral dissertation). University of Florida, Florida, USA.



- Byrne, B. M. (2001). *Structural equation modeling with AMOS: Basic concepts, applications, and programming*. Mahwah, NJ: Lawrence Erlbaum Associates, Inc.
- Cabrera, A., Collins, W. C. & Salgado, J. F. (2006). Determinants of individual engagement in knowledge sharing. *International Journal of Human Resource Management*, 17(2): 245-64.
- Calarco, M. M. (2011). The impact of positive practices on nurse work environments: Emerging applications of positive organizational scholarship. *Western Journal of Nursing Research*, 33(3): 365-84.
- Cameron, S. & Armstrong-Stassen, M. (2007, November). *Factors influencing workplace choice: A cross border study*. Paper presented at the Sigma Theta Tau International 39<sup>th</sup> Biennial Convention, Baltimore, MD.
- Canadian Institute for Health Information (2005). *Canada's health care providers: 2005 Chartbook*. Ottawa, ON: Canadian Institute for Health Information. Retrieved from [www.cihi.ca](http://www.cihi.ca).
- Canadian Institute for Health Information (2010). *National health expenditure trends, 1975 to 2010*. Ottawa: ON: Canadian Institute for Health Information. Retrieved from [www.cihi.ca](http://www.cihi.ca).
- Canadian Institute for Health Information (2010). *Regulated nurses: Canadian trends, 2005 to 2009*. Ottawa: ON: Canadian Institute for Health Information. Retrieved from [www.cihi.ca](http://www.cihi.ca).
- Canadian Nurses Association (2006). *Position statement: Nursing information and knowledge management*. Ottawa, ON: Canadian Nurses Association. Retrieved from [www.cna-aicc.ca](http://www.cna-aicc.ca).

- Case, D. O. (2007). *Looking for information: A survey of Research on information seeking, needs, and behavior* (2<sup>nd</sup> ed). London: UK.
- Chang, C., Huang, H., Chiang, C., Hsu, C. & Chang, C. (2012). Social capital and knowledge sharing: Effects on patient safety. *Journal of Advanced Nursing*, 68(8): 1793-1803.
- Chinn, P. L. & Kramer, M. K. (2011). *Integrated theory and knowledge development in nursing* (8<sup>th</sup> ed.). St. Louis, MI: Mosby, Inc.
- Cochrane, L., Olson, C., Murray, S., Dupuis, M., Tooman, T., & Hayes, S. (2007). Gaps between knowing and doing: Understanding and assessing the barriers to optimal health care. *Journal of Continuing Education in the Health Professions*, 27(2): 94-102.
- Cohen, J. (1992). A power primer. *Psychological Bulletin*, 112(1): 155-159.
- College of Nurses of Ontario (2002). *Professional standards, Revised 2002*. Toronto, ON: College of Nurses of Ontario. Retrieved from [www.cno.org](http://www.cno.org).
- Conger, J. A. & Kanungo, R. N. (1988). The empowerment process: Integrating theory and practice. *The Academy of Management Review*, 13(3): 471-82.
- Connelly, C. E. & Kelloway, E. K. (2003). Predictors of employees' perceptions of knowledge sharing cultures. *Leadership & Organization Development Journal*, 24(5): 294-301.
- Costello, A. B. & Osborne, J. W. (2005). Best practices in exploratory factor analysis: Four recommendations for getting the most from your analysis. *Practical Assessment, Research & Evaluation*, 10(7): 1-9.
- Cummings, G. G., MacGregor, T., Davey, M., Lee, H., Wong, C. A., Lo, E., Muise, M., & Stafford, E. (2010). Leadership styles and outcome patterns for the nursing

- workforce and work environment: A systematic review. *International Journal of Nursing Studies*, 47(3): 363-85.
- Curran, J. A. (2009). *Development of a knowledge exchange and utilization model for emergency practice* (Doctoral dissertation). Dalhousie University, Nova Scotia, CA.
- Daigle-LeBlanc, M. (2001). *Measuring knowledge use in organizations* (Doctoral dissertation). St. Mary's University, Halifax, Nova Scotia, CA.
- Davenport, T. (1999). *Human capital: What is it and why people invest in it*. San Francisco, CA: Josey-Bass.
- Davenport, T. H. (2005). *Thinking for a living: How to get better performance and results from knowledge workers*. Boston, MA: Harvard Business School Press.
- Davenport, T. H., & Prusak, L. (1998). *Working knowledge: How organizations manage what they know*. Boston, MA: Harvard Business Press.
- Davenport, T. H., Jarvenpaa, S. L. & Beers, M. C. (1996). Improving knowledge work processes. *Sloan Management Review*, 37(4): 53-65.
- Davenport, T. H. & Glaser, J. (2002). Just-in-time delivery comes to knowledge management. *Harvard Business Review*, 80(7): 107-111.
- Davenport, T. H., Thomas, R. J. & Cantrell, S. (2002). The mysterious art and science of knowledge-worker performance. *MIT Sloan Management Review*, 44(1): 23-30.
- Davis, D., Evans, M., Jada, A., Perrier, L., Rath, D., Ryan, D., Sibbald, G., Straus, S., Rappolt, S., Wowk, M., & Zwarenstein, M. (2003). The case of knowledge translation: Shortening the journey of evidence to effect. *British Medical Journal*, 327(7405): 33-5.

- Denis, J. L., Lehoux, P. & Champagne, F. (2004). A knowledge utilization perspective on fine-tuning dissemination and contextualizing knowledge. In F. Champagne & L. Lemieux-Charles' (Eds.) *Using knowledge and evidence in health care: Multidisciplinary perspectives*. University of Toronto Press: Toronto, ON (pp. 18-40).
- Despres, C. & Hiltrop, J. (1996). Compensation for technical professionals in the knowledge age. *Research Technology Management*, 39(5): 48-56.
- Dervin, B. & Nilan, M. (1986). Information needs and uses: A conceptual and methodological review. *Annual Review of Information Science and Technology*, 21: 3-33.
- de Vries, R. E., van den Hooff, B. & de Ridder (2006). Explaining knowledge sharing: The role of team communication styles, job satisfaction, and performance beliefs. *Communication Research*, 33(2): 115-35.
- Dewey, J. (1997). *How we think*. Mineola, NY: Dover Publications.
- Dillman, D. A., Smyth, J. D. & Christian, L. M. (2009). *Internet, mail, and mixed-mode surveys: The tailored design method* (3<sup>rd</sup> ed). Hoboken, NJ: John Wiley & Sons, Inc.
- Drucker, P. (1969). *The age of discontinuity: Guidelines to our changing society*. New York, NY: Harper & Row.
- Drucker, P. (1991). The new productivity challenge. *Harvard Business Review*, 69(6): 69-79.
- Drucker, P. (2009). *Managing in a time of great change*. Boston, MA: Harvard Business Publishing Corporation.

- Duva, I. H. (2010). *Factors impacting staff nurse care coordination* (Doctoral dissertation). Emory University, Georgia, USA.
- Estabrooks, C. A. (1999). The conceptual structure of research utilization. *Research in Nursing & Health*, 22(3): 203-216.
- Estabrooks, C. A., Rutakumwa, W., O'Leary, K. A., Profetto-McGrath, J., Milner, M., Levers, M. J., & Scott-Findlay, S. (2005). Sources of practice knowledge among nurses. *Qualitative Health Research*, 15(4): 460-476.
- Estabrooks, C. A., Scott-Findley, S. & Winther, C. (2004). Knowledge utilization in nursing and the allied health sciences. In F. Champagne & L. Lemieux-Charles' (Eds.) *Using knowledge and evidence in health care: Multidisciplinary perspectives*. University of Toronto Press: Toronto, ON (p. 242-280).
- Estabrooks, C. A., Tourangeau, A. E., Humphrey, C. K., Hesketh, K. L., Giovannetti, P., Thomson, D., et al. (2002). Measuring the hospital practice environment: A Canadian context. *Research in Nursing and Health*, 25(5): 256-268.
- Field, A. (2013). *Discovering statistics using IBM SPSS statistics* (4<sup>th</sup> ed.). London, UK: Sage Publications, Ltd.
- Flavell, J. H. (1979). Metacognition and cognitive monitoring. A new area of cognitive-developmental inquiry. *American Psychologist*, 34(10): 906-11.
- Fourie, I. (2009). Learning from research on the information behaviour of healthcare professionals: A review of the literature 2004-2008 with a focus on emotion. *Health Information & Libraries Journal*, 26(3): 171-86.
- Frenkel, S. Korzynski, M., Donoghue, L., & Shire, K. (1995). Reconstituting work: Trends towards knowledge work and info-normative control. *Work, Employment & Society*, 9(4): 773-96.

- Garrick, J. & Clegg, S. (2000). Knowledge work and the new demands of learning. *Journal of Knowledge Management*, 4(4): 279-86.
- Gerber, R., Murdaugh, C., Verran, J., & Milton, D. (1990, September). *Control over nursing practice scale: Psychometric analysis*. Poster presentation at the National Conference on Instrumentation in Nursing, Chapel Hill, NC.
- Germain, P. B. & Cummings, G. G. (2010). The influence of nursing leadership on nurse performance: A systematic literature review. *Journal of Nursing Management*, 18(4): 425-39.
- Gittell, J. H., Weinberg, D., Pfefferle, S., & Bishop, C. (2008). Impact of relational coordination on job satisfaction and quality outcomes: A study of nursing homes. *Human Resource Management Journal*, 18(2): 154-170.
- Gittell, J. H., Seidner, R. & Wimbush, J. (2009). A relational model of how high-performance work systems work. *Organization Science*, 21(2): 490-506.
- Goldenberg, D., Andrusyszyn, M. & Iwasiw, C. (2005). The effect of classroom simulation on nursing students' self-efficacy related to health teaching. *Journal of Nursing Education*, 44(7): 310-14.
- Graham, I. D. & Tetroe, J. (2007). Some theoretical underpinnings of knowledge translation. *Academic Emergency Medicine*, 14(11): 936-41.
- Graham, J. W. (2009). Missing data analysis: Making it work in the real world. *Annual Review of Psychology*, 60: 549-76.
- Griffin, M. A., Neal, A. & Parker, S. K. (2007). A new model of work role performance: Positive behavior in uncertain and interdependent contexts. *Academy of Management Journal*, 50(2): 327-47.

- Hall, L. M. (2003). Nursing intellectual capital: A theoretical approach for analyzing nurse productivity. *Nursing Economics*, 21(1): 14-19.
- Hall, R. J., Snell, A., F. & Foust, M. S. (1999). Item parceling strategies in SEM: Investigating the subtle effects of unmodeled secondary constructs. *Organizational Research Methods*, 2(3): 233-256.
- Haynes, R. B. (2004). An evidence-based medicine perspective on the origins, objectives, limitations and future developments of the movement. In F. Champagne & L. Lemieux-Charles' (Eds.) *Using knowledge and evidence in health care: Multidisciplinary perspectives*. University of Toronto Press: Toronto, ON (p. 227-241).
- Havaei, F., Dahinten, V. S. & MacPhee, M. (2014). Psychological competence: The key to leader empowering behaviors. *Journal of Nursing Administration*, 44(5): 276-283.
- Havens, D. S., Vasey, J., Gittell, J. H., & Lin, W. (2010). Relational coordination among nurses and other providers: Impact on the quality of patient care. *Journal of Nursing Management*, 18(8): 926-37.
- Health Council of Canada (2009). *Value for money: Making Canadian health care stronger*. Toronto, ON: Health Council. Retrieved from [www.healthcouncilcanada.ca](http://www.healthcouncilcanada.ca).
- Higgs, J. & Jones, M. (2000). Will evidence-based practice the reasoning out of practice? In J. Higgs & M. Jones (Eds.), *Clinical reasoning in the Health Professionals* (pp.307-315). Oxford: Butterworth Heinemann.

- Hornung, S. & Rousseau, D. M. (2007). Active on the job proactive in change: How autonomy at work contributes to employee support for organizational change. *Journal of Applied Behavioral Science*, 43(4): 401-26.
- Houk, S. L. (2011). *Enacting and/or retreating: A theory of registered nurses' practice of accountability* (Doctoral dissertation). Dalhousie University, Nova Scotia, CA.
- Hui, C. (1994). *Effects of leader empowerment behaviors and followers' personal control, voice, and self-efficacy on in-role and extra-role performance: An extension and empirical test of conger and kanungo's empowerment process model* (Doctoral dissertation). Indiana University, Indiana, USA.
- Hwang, Y. (2003). *Personal information effectiveness: A scale development and empirical test of its relationship to performance* (Doctoral dissertation). University of South Carolina, South Carolina, USA.
- Hwang, Y., Kittinger, W. J., & Yi, M. Y. (2014). Personal information management effectiveness of knowledge workers: Conceptual development and empirical validation. *European Journal of Information Systems*, 26. doi: 10.1057/ejis.2014.24
- Institute of Medicine. (2004). *Keeping patients safe: Transforming the work environment of nurses*. Washington, DC: National Academy of Sciences. Retrieved from [www.iom.edu](http://www.iom.edu).
- Institute of Medicine (2010). *The future of nursing: Leading change, advancing health*. Washington, DC: National Academy of Sciences. Retrieved from [www.iom.edu](http://www.iom.edu).
- Jackson, D. L. (2003). Revisiting sample size and number of parameter estimates: Some support for the N:q hypothesis. *Structural Equation Modeling*, 10(1): 128-141.



- Janz, B. D., Colquitt, J. A. & Noe, R. A. (1997). Knowledge worker team effectiveness: The role of autonomy, interdependence, team development, and contextual support variables. *Personnel Psychology*, 50(4), 87-904.
- Janz, B. D. & Prasarnphanich, P. (2003). Understanding the antecedents of effective knowledge management: The importance of a knowledge-centred culture. *Decision Sciences*, 34(2): 351-84.
- Johnson, A., Hong, H., Groth, M., & Parker, S. K. (2010). Learning and development: Promoting nurses' performance and work attitudes. *Journal of Advanced Nursing*, 67(3): 609-620.
- Kelloway, K. E. & Barling, J. (2000). Knowledge work as organizational behavior. *International Journal of Management Reviews*, 2(3): 287-304.
- Kerfoot, K. (2002). On leadership: The leader as chief knowledge officer. *Nursing Economics*, 20(1): 40-43.
- Kitson, A. L., Harvey, G. & McCormack, B. (1998). Enabling the implementation of evidence based practice: A conceptual framework. *Quality in Health Care*, 7(3): 149-158.
- Kline, R. B. (2005). *Principles and practice of structural equation modeling* (2<sup>nd</sup> ed). New York, NY: The Guilford Press.
- Kruse, R. L., Zweig, S. C., Nikodim, B., LeMaster, J. W., Coberly, J. S., & Cowill, J. M. (2010). Nurse care coordination of older patients in an academic family medicine clinic: 5-year outcomes. *Journal of Clinical Outcomes Management*, 17(5): 209-215.
- Kulik, C. T., Oldham, G. R. & Hackman, J. R. (1987). Work design as an approach to person-environment fit. *Journal of Vocational Behavior*, 31(3): 278-96.

- Kuo, F. & Young, M. (2008). Predicting knowledge sharing practices through intention: A test of competing models. *Computers in Human Behavior, 24*(6): 2697-722.
- Lamb, G. S., Schmitt, M. H., Sainfort, F., Edwards, P. J., & Duva, I. H. (2007). *The development of the staff nurse care coordination instrument: An interdisciplinary approach to measuring nursing care* (Doctoral dissertation). Emory University, Georgia, CA.
- Lancero, A. W. & Gerber, R. M. (1995). Comparing work satisfaction in two case management models. *Nursing Management, 26*(11): 45-8.
- Laschinger, H. K. S. & Havens, D. S. (1996). Staff nurse work empowerment and perceived control over nursing practice: Conditions for work effectiveness. *Journal of Nursing Administration, 26*(9): 27-35.
- Laschinger, H. K. S., Read, E., Wilk, P., & Finegan, J. (2014). The influence of nursing unit empowerment and social capital on unit effectiveness and nurse perceptions of patient care quality. *Journal of Nursing Administration, 44*(6): 347-352.
- Laschinger, H. K. S. & Wong, C. (1999). Staff nurse empowerment and collective accountability: Effect on perceived productivity and self-rated work effectiveness. *Nursing Economics, 17*(6): 308-16, 351.
- Laschinger, H. K. S., Wong, C. A., Grau, A. L., Read, E. A., & Stam, L. M. P. (2011). The influence of leadership practices and empowerment on Canadian nurse manager outcomes. *Journal of Nursing Management, 20*(7): 877-888.
- Laschinger, H. K. S., Wong, C. A., Macdonald-Rencz, S., Burkoski, V., Cummings, G., D'amour, D., Grinspun, D., Gurnham, M. E., Huckstep, S., Leiter, M., Perkin, K., Macphee, M., Matthews, S., O'Brien-Pallas, L., Ritchie, J., Ruffalo, M., Vincent,

- L., Wilk, P., Almost, J., Purdy, N., Daniels, F., & Grau, A. (2013). Part 1: The influence of personal and situational predictors on nurses' aspirations to management roles: Preliminary findings of a national survey of Canadian nurses. *Journal of Nursing Management, 21*(2): 217-230.
- Laschinger, H. K. S., Wong, C., McMahon, L. & Kaufmann, C. M. (1999). Leader behavior impact on staff nurse empowerment, job tension, and work effectiveness. *The Journal of Nursing Administration, 29*(5): 28-39.
- Lee, J. H., Kim, Y. G. & Kim, M. Y. (2006). Effects of managerial drivers and climate maturity on knowledge management performance: Empirical validation. *Information Resources Management Journal, 19*(3): 48-60.
- Lee, T., Ko, I., Lee, I., Kim, E., Shin, M., Roh, S., Yoon, D., Choi, S., & Chang, H. (2011). Effects of nurse navigators on health outcomes of cancer patients. *Cancer Nursing, 34*(5): 376-84.
- Leung, S. (2011). A comparison of psychometric properties and normality in 4-, 5-, 6-, and 11-point likert scales. *Journal of Social Service Research, 37*(4): 412-21.
- Lin, H. (2007a). Effects of extrinsic and intrinsic motivation on employee knowledge sharing intentions. *Journal of Information Science, 33*(2): 135-49.
- Lin, H. (2007b). Knowledge sharing and firm innovation capability: An empirical study. *International Journal of Manpower, 28*(3/4): 315-32.
- Little, T. D., Cunningham, W. A., Shahar, G., & Widaman, K. F. (2002). To parcel or not to parcel: Exploring the question, weighing the merits. *Structural Equation Modeling, 9*(2): 151-173.

- Lundmark, V. A. (2008). Chapter 46: Magnet environments for professional nursing practice. In R. G. Hughes' (Ed) *An Evidence-Based Handbook for Nurses*. Rockville, MD: Agency for Healthcare Research and Quality.
- Lynn, M. R. & Kelley, B. (1995). Effects of case management on the nursing context: Perceived quality of care, work satisfaction, and control over practice. *Journal of Nursing Scholarship*, 29(3): 237-41.
- Maas, M. L. (1989). Professional practice for the extended care environment. *Journal of Professional Nursing*, 5(2): 66-76.
- Mansingh, G., Osei-Bryson, K. & Reichgelt (2009). Issues in knowledge access, retrieval and sharing – case studies in a Caribbean health sector. *Expert Systems with Applications*, 36(2): 2853-63.
- Marek, K. D., Popejoy, L., Petroski, G., Mehr, D., Rantz, M., & Lin, W. (2005). Clinical outcomes of aging in place. *Nursing Research*, 54(3); 202-11.
- McCormack, B., Kitson, A., Harvey, G., Rycroft-Malone, J., Titchen, A., & Seers, K. (2002). Getting evidence into practice: The meaning of 'context'. *Journal of Advanced Nursing*, 38(1), 94-104.
- McKnight, P. E., McKnight, K. M., Sidani, S., & Figueredo, A. J. (2007). *Missing data: A gentle introduction*. New York, NY: The Guilford Press.
- McMullan, M., Jones, R. & Lea, S. (2011). The effect of an interactive e-drug calculations package on nursing students' drug calculation ability and self-efficacy. *International Journal of Medical Informatics* 80(6): 421-30.
- Melnyk, B. M. & Fineout-Overholt, E. (2005). Making a case for evidence-based practice. In B. M. Melnyk & E. Fineout-Overholt (Eds.), *Evidence-based practice*

- in nursing and healthcare: A guide to best practice* (pp. 3-24). Philadelphia, PA: Lippincott, Williams & Wilkins.
- Mitton, C., Adair, C. E., McKenzie, E., Patten, S. B., & Perry, B. W. (2007). Knowledge transfer and exchange: Review and synthesis of the literature. *The Milbank Quarterly*, 85(4): 729-69.
- Moody, R. (2004). Nurse productivity measures for the 21st Century. *Health Care Management Review*, 29(2), 98-106.
- Moody, R. C. & Pesut, D. J. (2006). The motivation to care: Application and extension of motivation theory to professional nursing work. *Journal of Health Organization & Management*, 20(1): 15-48.
- Morrison, E. W. & Phelps, C. C. (1999). Taking charge at work: Extrarole efforts to initiate workplace change. *The Academy of Management Journal*, 42(4): 403-19.
- Mosier, K. L., Skitka, L. J., Heers, S., & Burdick, M. (1998). Automation bias: Decision making and performance in high-tech cockpits. *The International Journal of Aviation Psychology*, 8(1): 47-63.
- Needleman, J., Buerhaus, P., Mattke, S., Stewart, M., & Zelevinsky, K. (2002). Nurse-staffing levels and the quality of care in hospitals. *New England Journal of Medicine*, 346(22): 1715-22.
- Newell, S., Robertson, M., Scarborough, H., & Swan, J. (2009). *Managing knowledge work and innovation* (2<sup>nd</sup> ed). New York, NY: Palgrave Macmillan.
- Nicolini, D., Powell, J., Conville, P., & Martinez-Solano, L. (2007). Managing knowledge in the healthcare sector: A review. *International Journal of Management Review*, 10(3): 245-63.

- Nomikos, G. E. (1989). Managing knowledge workers for productivity. *National Productivity Review*, 8(2), 165-74.
- Nonaka, I. (1994). A dynamic theory of organizational knowledge creation. *Organization Science*, 5(1): 14-37.
- Ontario Hospital Association (2007). Hospital report 2007: Acute care. Toronto, ON: Ontario Hospital Association. Retrieved from [www.oha.org](http://www.oha.org).
- Ontario Hospital Association (2008). *Incentives for transformation: E-health as a strategic health system priority*. Toronto, ON: Ontario Hospital Association. Retrieved from [www.oha.org](http://www.oha.org).
- Ontario Hospital Association (2009). *Healthcare governance in volatile economic times: Don't waste a crisis*. Toronto, ON: Ontario Hospital Association. Retrieved from [www.oha.org](http://www.oha.org).
- Orzano, A. J., McInerney, C. R., Scharf, D., Tallia, A. F., & Crabree, B. F. (2008). A knowledge management model: Implications for enhancing quality in health care. *Journal of the American Society for Information Science and Technology*, 59(3): 489-505.
- Orzano, A. J., McInerney, C. R., Scharf, D., Tallia, A. F., & Crabree, B. F. (2008). Family medicine practice performance and knowledge management. *Health Care Management Review*, 33(1): 21-8.
- Parker, J. & Coiera, E. (2000). Improving clinical communication: A view from psychology. *Journal of the American Medical Informatics Association*, 7: 453-61.
- Parker, S. K. (1998). Enhancing role breadth self-efficacy: The roles of job enrichment and other organizational interventions. *Journal of Applied Psychology*, 83(6): 835-52.

- Parker, S. K. (2007). That is my job: How employees' role orientation affects their job performance. *Human Relations*, 60(3): 403-30.
- Parker, S. K., Bindl, U. K. & Strauss, K. (2010). Making things happen: A model of proactive motivation. *Journal of Management*, 36(4): 827-856.
- Parker, S. K. & Mason, C. M. (2010). Leader vision and the development of adaptive and proactive performance: A longitudinal study. *Journal of Applied Psychology*, 95(1): 174-82.
- Parker, S. K., Williams, H. M. & Turner, N. (2006). Modeling the antecedents of proactive behavior at work. *Journal of Applied Psychology*, 91(3): 636-52.
- Paton, S. (2009). Cutting through the confusion of contemporary work. *Journal of Knowledge Management*, 13(1): 88-97.
- Pedhazur, E. J. & Schmelkin, L. P. (1991). *Measurement, design, and analysis: An integrated approach*. Hillsdale, NJ: Lawrence Erlbaum Associates Inc., Publishers.
- Podsakoff, P. M., MacKenzie, S. B., & Podsakoff, N. P. (2012). Sources of method bias in social science research and recommendations on how to control it. *Annual Review of Psychology*, 63: 539-569.
- Poghosyan, L., Clarke, S. P., Finlayson, M., & Aiken, L. H. (2010). Nurse burnout and quality of care: Cross-national investigation in six countries. *Research in Nursing & Health*, 33(4): 288-98.
- Polanyi, M. (1962). *Personal knowledge*. Chicago, IL: University of Chicago Press.
- Pyoria, P. (2005). The concept of knowledge work revisited. *Journal of Knowledge Management*, 9(3): 116-27.

- Quinlan, E. (2009). The 'actualities' of knowledge work: An institutional ethnography of multi-disciplinary primary health care teams. *Sociology of Health & Illness*, 31(5): 625-641.
- Rapp, A., Ahearne, M., Mathieu, J., & Schillewaert, N. (2006). The impact of knowledge and empowerment on working smart and working hard: The moderating role of experience. *International Journal of Research in Marketing*, 23(3): 279-93.
- Rocha, C. M. & Chelladurai, P. (2012). Item parcels in structural equation modeling: An applied study in sport management. *International Journal of Psychology & Behavioral Sciences*, 2(1): 46-53.
- Roche, M. A., Laschinger, H. K. S. & Duffield, C. (2015). Testing the nursing worklife model in Canada and Australia: A multi-group comparison study. *International Journal of Nursing Studies*, 52(2): 525-534.
- Robinson, K. M. (2010). Care coordination: A priority for health reform. *Policy, Politics, & Nursing Practice*, 11(4): 266-74.
- Ruggles, R. (1999). The state of the notion: Knowledge management in practice. In J.W. Cortada and J. A. Wood's (Eds.) *The Knowledge Management Yearbook 1999-2000*. Butterworth-Heinemann: Boston, MA (pp. 295-305).
- Rycroft-Malone, J. (2004). The PARIHS Framework – A framework for guiding the implementation of evidence-based practice. *Journal of Nursing Care Quality*, 19(4): 297-304.
- Ryu, S., Ho, S. H. & Han, I. (2003). Knowledge sharing behavior of physicians in hospitals. *Expert Systems with Applications*, 25(1): 113-22.



- Sackett, D., Rosenberg, W., Gray, J. A., Haynes, R. B., & Richardson, W. S. (1996). Evidence based medicine: What it is and what it isn't. *British Medical Journal*, *312*(7023): 71-72.
- Schmalenberg, C. & Kramer, M. (2008). Essentials of a productive nurse work environment. *Nursing Research*, *57*(1): 2-13.
- Schlomer, G. L., Bauman, S. & Card, N. A. (2010). Best practices for missing data management in counseling psychology. *Journal of Counseling Psychology*, *57*(1): 1-10.
- Scott, J. G., Sochalski, J. & Aiken, L. (1999). Review of magnet hospital research: Findings and implications for professional nursing practice. *The Journal of Nursing Administration*, *29*(1): 9-19.
- Senge, P. M. (1990). *The fifth discipline: The art and practice of the learning organization*. New York, NY: Doubleday.
- Shen, H., Chiu, H., Lee, P., Hu, Y., & Chang, W. (2011). Hospital environment, nurse-physician relationships, and quality of care: questionnaire survey. *Journal of Advanced Nursing*, *67*(2): 349-58.
- Simmons, B., Lanuza, D., Fonteyn, M., Hicks, F., & Holm, K. (2003). Clinical reasoning in experienced nurses. *Western Journal of Nursing Research*, *25*(6): 701-19.
- Skitka, L. J., Mosier, K. & Burdick, M. D. (2000). Accountability and automation bias. *International Journal of Human-Computer Studies*, *52*(4): 701-17.
- Snowdon, A. W. & Rajacich, D. (1993). The challenge of accountability in nursing. *Nursing Forum*, *28*(1): 5-11.

- Snyder-Halpern, R., Corcoran-Perry, S. & Narayan, S. (2001). Developing clinical practice environments supporting the knowledge work of nurses. *Computers in Nursing, 19*(1), 17-26.
- Sochalski, J. (2004). Is more better? The relationship between nurse staffing and the quality of nursing care in hospitals. *Medical Care, 42*(2 Suppl): II-67-73.
- Sorensen, E. E., Seebeck, E. D., Scherb, C. A., Specht, J. P., & Loes, J. L. (2009). The relationship between RN job satisfaction and accountability. *Western Journal of Nursing Research, 31*(7): 872-88.
- Sorrells-Jones, J. & Weaver, D. (1999). Knowledge workers and knowledge-intense organizations, Part 3: Implications for preparing healthcare professionals. *Journal of Nursing Administration, 29*(10), 14-21.
- Specht, J. & Ramler, C. (1994). *Development of a nurse accountability instrument*. Milwaukee, WI: Author.
- Spender, J. C. (1996). Organisational knowledge, learning and memory: Three concepts in search of a theory. *Journal of Organisational Change and Management, 9*(1): 63-78.
- Squires, J. E., Estabrooks, C. A. , Gustavsson, P., & Wallin, L. (2011). Individual determinants of research utilization by nurses: A systematic review update. *Implementation Science, 6*(1). doi:10.1186/1748-5908-6-1
- Squires, M., Tourangeau, A., Laschinger, H. K. S., & Doran, D. (2010). The link between leadership and safety outcomes in hospitals. *Journal of Nursing Management, 18*(8): 914-25.
- Straus, S. E., Tetroe, J. & Graham, I. (2009). Defining knowledge translation. *Canadian Medical Association Journal, 181*(3/4): 165-8.

- Straus, S. E., Tetroe, J. & Graham, I. (2011). Knowledge translation is the use of knowledge in health care decision making. *Journal of Clinical Epidemiology*, 64(1): 6-10.
- Strauss, K., Griffin, M. A. & Rafferty, A. E. (2009). Proactivity directed toward the team and organization: The role of leadership, commitment and role-breadth self-efficacy. *British Journal of Management*, 20(3): 279-91.
- Tabachnick, B. G. & Fidell, L. S. (2007). *Using multivariate statistics* (5<sup>th</sup> ed). Boston, MA: Pearson Education, Inc.
- Tonelli, M. (2006). Integrating evidence into clinical practice: An alternate to evidence-based approaches. *Journal of Evaluation in Clinical Practice*, 12(3): 248-256.
- Turnball, A. (2001). *Empowerment and autonomy among continuing care nurses/residents* (Master's Thesis). University of Alberta, Alberta, CA.
- van Aken, E. M., Monetta, D. J. & Sink, D. S. (1994). Affinity groups: The missing link in employee involvement. *Organizational Dynamics*, 22(4): 38-54.
- van den Hooff, B. & de Ridder, J. A. (2004). Knowledge sharing in context: The influence of organizational commitment, communication climate and CMC use on knowledge sharing. *Journal of Knowledge Management*, 8(6): 117-30.
- van den Hooff, B. & de Leeuw van Weenen, F. (2004). Committed to share: Commitment and CMC use as antecedents of knowledge sharing. *Knowledge & Process Management*, 11(1): 13-24.
- van den Hooff, B. & Huysman, M. (2009). Managing knowledge sharing: Emergent and engineering approaches. *Information & Management*, 46(1): 1-8.
- van Schaik, S. M., Plant, J. L., Diane, S., Tsang, L., & O'Sullivan, P. (2011). Interprofessional team training in pediatric resuscitation: A low-cost, in situ

simulation program that enhances self-efficacy among participants. *Clinical Pediatrics*, 50(9): 807-815.

Wang, S. & Noe, R. A. (2010). Knowledge sharing: A review and directions for future research. *Human Resource Management Review*, 20(2): 115-31.

Weston, M. J. (2009). Validity of instruments for measuring autonomy and control over nursing practice. *Journal of Nursing Scholarship*, 41(1): 87-94.

Williams, C. A., Goode, C. J., Krsek, C., Bednash, G. D., & Lynn, M. R. (2007). Post-baccalaureate nurse residency 1-year outcomes. *Journal of Nursing Administration*, 37(7/8): 357-365.

Wolf, L. D., Potter, P., Sledge, J. A., Boxerman, S. B., Grayson, D., & Bradley, E. (2006). Describing nurses' work: Combining quantitative and qualitative analysis. *Human Factors: The Journal of Human Factors and Ergonomics*, 48(1): 5-14.

Wright, K. (2005). Personal knowledge management: Supporting individual knowledge worker performance. *Knowledge Management Research & Practice*, 3: 156-65.

**APPENDICES**

## Appendix A

### Initial Introduction Letter of Study & Offer to Participate



Arthur Labatt Family School of Nursing, Faculty of Health Sciences

#### Examining the Factors, Determinants & Outcomes of Nurses' Knowledge Work

October 2012

Dear Nursing Colleague,

My name is Heidi Siu, and I am a Registered Nurse completing graduate studies at Western University. I would like to invite you to participate in an important study investigating the influences and outcomes of nurses' knowledge work. Your name was randomly selected from the College of Nurses of Ontario's registry database. If you agree to participate, this survey will take approximately 40 minutes to complete at your convenience and contains questions that ask your perspectives about your current nursing role, work activities and relationships. Your answers to these questions are critical to highlight nurses' knowledge work and its impact on patient care. Your participation is entirely voluntary and you may refuse to participate, answer any question or withdraw from the study by contacting us at any time without negative consequences. Completion and return of your survey indicates your consent to participate in this study.

All individual responses will be kept confidential and securely locked in a filing cabinet accessible only to the study researchers, which will be shredded within one year of the study's completion. A study number will be pre-assigned to your survey in order to not invite your participation again once you have returned your survey to us. To ensure your anonymity, only grouped data will be reported in all study reports and communications.

There are no known risks to participate in this study. If you have any questions about the conduct of this study, please contact us directly using the email or phone numbers listed below. If you have any questions about your rights as a research participant, please contact The Office of Research Ethics at [REDACTED] or by email at [REDACTED].

Enclosed is some packaged tea as our way of saying thank you. The beverage and this letter of information are yours to keep regardless of your choice to participate in this study. If you choose to participate, please use the pre-addressed, stamped envelope to return your completed survey by post mail. If you are interested, please email us your full name, email address, and the title of this

study (i.e., “Nurses’ Knowledge Work”) at [REDACTED] to request for a certificate of study participation and summary of study results, which will be emailed to you at the conclusion of the study should you choose to participate.

Sincerely,

## Appendix B

### Reminder Letter of Study & Offer to Participate



Arthur Labatt Family School of Nursing, Faculty of Health Sciences

November 2012

Dear Nursing Colleague:

Approximately two weeks ago a survey was mailed to you with an invitation to participate in a study investigating the influences and outcomes of nurses' knowledge work. If you have already returned your completed survey to us, we sincerely thank you for your participation. If not, please consider doing so today as your answers are important for highlighting nurses' knowledge work and its impact on patient care.

If you did not receive a survey or if it was misplaced, please contact us via the contact information provided below and we will send you another copy in the mail as soon as possible. We would like to remind you that there are no known risks for participating in this study and all responses will be kept confidential. If you have any questions about your rights as a research participant, please contact The Office of Research Ethics at [REDACTED] or by email at [REDACTED].

Thank you for considering our request.

Sincerely,



## Appendix C

### Final Letter of Study & Offer to Participate



Arthur Labatt Family School of Nursing, Faculty of Health Sciences

January 2013

Dear Nursing Colleague,

About two months ago, we invited you to participate in a survey study investigating the influences and outcomes of nurses' knowledge work. If you have already returned your completed survey to us, we sincerely thank you for your participation. In the event that your survey has been misplaced, please find enclosed a replacement survey package and our final request for your participation. Based on the responses received to date, we believe the information is critical for highlighting the knowledge work of nurses. However, feedback from all invited participants is important in order to represent the perspectives of nurses in Ontario, such as yourself.

The enclosed survey contains questions about your perspectives of your work relationships, nursing role and work activities. Your answers to these questions are valuable for understanding factors that influence nurses' knowledge work and its impact on patient care. The survey takes approximately 40 minutes to complete at your convenience if you agree to participate. Your participation is entirely voluntary and you may refuse to participate, refuse to answer any question or withdraw from the study by contacting us at any time without negative consequences. Completion and return of your survey indicates your consent to participate in this study.

There are no known risks to participate in this study as all individual responses will be kept confidential and securely locked in a filing cabinet accessible only to the study researcher, which will be shredded within one year of the study's completion. To ensure your anonymity, only grouped data will be reported in all study reports and communications. If you have any questions about the conduct of this study, please contact us directly using the email or phone numbers listed below. If you have any questions about your rights as a research participant, please contact The Office of Research Ethics at [REDACTED] or by email at [REDACTED].

If you choose to participate, please use the pre-addressed, stamped envelope to return your completed survey. If you are interested, please email us your full name, email address, and the title of this study (i.e., "Nurses' Knowledge Work") at [REDACTED] to request for a certificate of study

participation and summary of study results, which will be emailed to you at the conclusion of the study should you choose to participate.

We thank you again for your time and consideration.

Sincerely,

## Appendix D

### Study Survey

#### Leader Empowerment Behaviors (LEB) scale (Hui, 1994)

The following questions contain items that ask you to describe your relationship with your direct nurse manager or supervisor of the clinical unit where you work the majority of your time. When you answer the following questions, please answer honestly and think of the current unit manager or supervisor you work with most frequently.

To what extent do you agree or disagree with the following about your current unit manager/supervisor?	Strongly Disagree				Neither Agree or Disagree		Strongly Agree
<b><i>Enhancing meaningfulness of work:</i></b>							
1. My manager helps me understand the importance of my work	1	2	3	4	5	6	7
2. My manager helps me understand how my work fits into "the bigger picture"	1	2	3	4	5	6	7
3. My manager helps me understand how the objectives and goals of my nursing unit relate to that of the entire organization	1	2	3	4	5	6	7
4. My manager helps me understand the purpose of my work	1	2	3	4	5	6	7
<b><i>Encouraging participation in decision-making:</i></b>							
5. My manager provides many opportunities for me to express my opinions	1	2	3	4	5	6	7
6. My manager often consults me on work issues	1	2	3	4	5	6	7
7. My manager makes many decisions with me	1	2	3	4	5	6	7
<b><i>Expressing confidence in high performance:</i></b>							
8. My manager always shows confidence in my ability to do a good job	1	2	3	4	5	6	7
9. My manager believes that I can handle demanding tasks	1	2	3	4	5	6	7
10. My manager believes in my ability to improve even when I make mistakes	1	2	3	4	5	6	7
<b><i>Facilitating goal accomplishment:</i></b>							
11. My manager helps me overcome obstacles to my performance	1	2	3	4	5	6	7
12. My manager helps me to identify what I need in order to achieve my performance goals	1	2	3	4	5	6	7

13. My manager always makes sure that I have the resources needed for effective performance	1	2	3	4	5	6	7
<b>Providing autonomy from bureaucratic constraints:</b>							
14. My manager makes it more efficient to do my job by keeping the rules and regulations simple	1	2	3	4	5	6	7
15. My manager allows me to do my job my way	1	2	3	4	5	6	7
16. My manager encourages me to make important decisions that are directly related to my job	1	2	3	4	5	6	7

### Role-Breadth Self-Efficacy (RBSE) scale (Parker, 1998)

The following questions contain items that ask you about your current nursing role where you work. Please read each statement carefully and indicate the best answer to the following questions as it relates to where you work the most frequently.

<b>In your nursing role where you work, how confident would you feel...</b>	Not At All Confident		Somewhat Confident		Very Confident
1. Analyzing a long-term problem in your nursing unit to find a solution?	1	2	3	4	5
2. Representing your nursing unit in meetings with nursing management?	1	2	3	4	5
3. Designing new policies and/or procedures for your nursing unit?	1	2	3	4	5
4. Making suggestions to nursing management about ways to improve the nursing practice of your unit?	1	2	3	4	5
5. Contributing to discussions about the hospital's strategy?	1	2	3	4	5
6. Writing a proposal to spend money in your nursing unit?	1	2	3	4	5
7. Helping to set targets/goals in your nursing unit?	1	2	3	4	5
8. Contacting people outside the hospital (e.g., home health care, support groups, volunteer groups) to discuss problems?	1	2	3	4	5
9. Presenting information to a group of colleagues?	1	2	3	4	5
10. Visiting people from other departments (e.g., lab, x-ray, dietary) to suggest doing things differently?	1	2	3	4	5

**Specht & Ramler Accountability Index (SRAI) – Individual Referent (Sorensen et al., 2009)**

<b>To what extent do you agree or disagree with the following statements about your nursing role where you work?</b>	Strongly Disagree		Neither Agree or Disagree		Strongly Agree
1. I am accountable to my peers for the nursing care I deliver.	1	2	3	4	5
2. I hold my peers accountable for the nursing care they deliver.	1	2	3	4	5
3. I am accountable to patients for the care I deliver.	1	2	3	4	5
4. I am accountable to have the patients I care for prepared for discharge.	1	2	3	4	5
5. I am responsible for defining and monitoring standards of care for the patients on the unit.	1	2	3	4	5
6. I am actively involved in defining standards of care for the patients on the unit.	1	2	3	4	5
7. I am actively involved in monitoring standards of care for the patients on the unit.	1	2	3	4	5
8. I am familiar with the standards of care pertaining to my patients and use the standards to guide my practice.	1	2	3	4	5
9. I am accountable for acquiring the knowledge and skill required to care for the patients on this unit.	1	2	3	4	5
11. If a patient or family member has a complaint about the care under my direction, their concerns should be referred to me and I should contact them with a response.	1	2	3	4	5
12. I regularly consult with nurse peers, read current nursing literature, attend professional conferences, and incorporate new knowledge into my practice.	1	2	3	4	5

**Control over Nursing Practice (CONP) scale** (Gerber et al., 1990)

<b>To what extent do you agree or disagree with how free you are to do the following as a nurse where you work?</b>	Strongly Disagree		Neither Agree or Disagree			Strongly Agree	
1. Evaluate current nursing policies and procedures.	1	2	3	4	5	6	7
2. Evaluate the outcomes of nursing care.	1	2	3	4	5	6	7
3. Consult with others when solving complex care problems.	1	2	3	4	5	6	7
4. Influence standards of nursing practice.	1	2	3	4	5	6	7
5. Modify or adapt patient care procedures and protocols.	1	2	3	4	5	6	7
6. Implement nursing care in an efficient manner.	1	2	3	4	5	6	7
7. Provide holistic, patient-centered care.	1	2	3	4	5	6	7
8. Plan strategies to meet my own developmental need.	1	2	3	4	5	6	7
9. Practice clinical skills to the best of my ability.	1	2	3	4	5	6	7
10. Analyze problems critically.	1	2	3	4	5	6	7
11. Plan care with other members of the health care team such as physician, dieticians, and therapists.	1	2	3	4	5	6	7
12. Act on my own decisions related to care giving.	1	2	3	4	5	6	7
13. Be creative in the delivery of care.	1	2	3	4	5	6	7
14. Introduce new nursing practices and procedures	1	2	3	4	5	6	7
15. Identify problems in the delivery of nursing care.	1	2	3	4	5	6	7
16. Coordinate care activities among various health services.	1	2	3	4	5	6	7
17. Adjust plans of care to meet patients' changing needs.	1	2	3	4	5	6	7
18. Negotiate my time off duty.	1	2	3	4	5	6	7
19. Exert the authority needed to fulfill patient care responsibilities.	1	2	3	4	5	6	7
20. Obtain assistance from other staff members when needed.	1	2	3	4	5	6	7
21. Utilize research findings to improve my nursing practice.	1	2	3	4	5	6	7

### Knowledge Work Behaviors (KWB) scale

In my current nursing role....	Never		Occasionally		Constantly		
<b>Knowledge Finding Behaviors (Hwang, 2003):</b>							
1. I recognize potential problems and sense information to address them.	1	2	3	4	5	6	7
2. I detect potential problems and find knowledge that will eliminate them.	1	2	3	4	5	6	7
3. I evaluate changes in my environment and respond with the right knowledge.	1	2	3	4	5	6	7
4. People seek my advice about defining new knowledge needs.	1	2	3	4	5	6	7
5. I sense changes in my unit's practice that requires new knowledge.	1	2	3	4	5	6	7
6. I gather the right information to prevent information overload.	1	2	3	4	5	6	7
7. I filter information for others to prevent information overload.	1	2	3	4	5	6	7
8. I significantly contribute to collecting information other people need to do their work.	1	2	3	4	5	6	7
<b>Knowledge Sharing Behaviors (van den Hooff &amp; de Ridder, 2006):</b>							
9. When I've learned something new, I make sure my colleagues learn about it.	1	2	3	4	5	6	7
10. I share information I have with my colleagues.	1	2	3	4	5	6	7
11. I think it is important that my colleagues are aware of what I am doing.	1	2	3	4	5	6	7
12. I regularly inform my colleagues of what I am doing.	1	2	3	4	5	6	7
13. When I need certain knowledge, I ask my colleagues about it.	1	2	3	4	5	6	7
14. I like to be informed of what my colleagues know.	1	2	3	4	5	6	7
15. I ask my colleagues about their abilities when I want to learn something.	1	2	3	4	5	6	7
16. When a colleague is good at something, I ask them to teach me.	1	2	3	4	5	6	7
<b>Knowledge Developing Behaviors (Daigle-LeBlanc, 2001):</b>							
17. I come up with new ideas.	1	2	3	4	5	6	7
18. I generate new ideas to solve problems at work.	1	2	3	4	5	6	7
19. I generate new ideas to improve current practices at work.	1	2	3	4	5	6	7

20. I evaluate what I need to know to perform my work.	1	2	3	4	5	6	7
21. I reflect on my practice and act to address my knowledge gaps.	1	2	3	4	5	6	7
<b>Knowledge Applying Behaviors (Daigle-LeBlanc, 2001):</b>							
22. I use my knowledge to solve problems at work.	1	2	3	4	5	6	7
23. I use my knowledge to make decisions at work.	1	2	3	4	5	6	7
24. I use my knowledge to create plans of action at work.	1	2	3	4	5	6	7
25. I explain to my colleagues the rationale for my decisions at work.	1	2	3	4	5	6	7
26. I evaluate the effectiveness of my actions at work.	1	2	3	4	5	6	7

#### **Nurse Care Coordination Inventory (Duva & Lamb, 2010)**

The following questions contain items that ask you about your nursing work activities. Please read each statement carefully and indicate to what extent you do the following in your current nursing role where you work the most frequently.

<b>In your current nursing role, how often do you do the following?</b>	Never	Occasionally	Constantly		
1. Initiate actions to get my nursing team members to do what is needed to keep my patients on their plan of care.	1	2	3	4	5
2. Initiate actions to get my interdisciplinary team members to do what is needed to keep my patients on their plan of care.	1	2	3	4	5
3. Perform my patient assessments so that they will be useful to everyone on the team.	1	2	3	4	5
4. Check that orders and procedures for my patients are carried out when they are scheduled.	1	2	3	4	5
5. Ask my nursing team members to assist me with my patient activities when I am tied up with one or more of my patients.	1	2	3	4	5
6. Communicate information to my interdisciplinary team members that they need to know to carry out their patient care activities or to make changes in the plan of care.	1	2	3	4	5
7. Step in and do the work other members of my nursing team are responsible for doing so I can get my own work done and keep patients on their plan of care.	1	2	3	4	5



8. Prompt my interdisciplinary team to do the work they are responsible for doing so I can get my own work done and keep patients on their plan of care.	1	2	3	4	5
9. Organize my own activities to be able to keep the care of my patients on track.	1	2	3	4	5
10. Organize the supplies that I need to be able to keep the care of my patients on track.	1	2	3	4	5
11. When the personal support worker on my team has not completed patient care tasks that I need to complete my work, I direct them to get their work done.	1	2	3	4	5
12. I have to contact the staff in the laboratory to get reports needed to carry out my patients' plan of care.	1	2	3	4	5
13. I remind physicians or nurse practitioners to document verbal changes in medication orders in the record.	1	2	3	4	5
14. When I need to spend more time with a patient than expected, I ask other staff on the unit to assist with my other patients.	1	2	3	4	5
15. When I notify a team member that a patient is not progressing as expected, I recommend actions that I think will get the patient back on track.	1	2	3	4	5
16. When I start my shift, I have to do things that should have been completed on the previous shift.	1	2	3	4	5
17. I delegate patient care activities that I need done to the personal support worker on my team to make sure that the patient is progressing as expected.	1	2	3	4	5
18. When my patient is off the unit I follow up with other departments to check that my patient is receiving the expected procedure or treatment at the expected time.	1	2	3	4	5
19. When I am unable to get my work done on time, I ask members of my nursing team to assist me.	1	2	3	4	5
20. I have to prompt the physician, or nurse practitioner to write orders so that my patient can be discharged as planned.	1	2	3	4	5
21. I assist other nurses to get the information they need to care for their patients.	1	2	3	4	5
22. When I start my shift, I make sure that the equipment my team and I need to get our work done is on the unit and accessible.	1	2	3	4	5
23. When I go to get a supply, if I notice it is running low, I either restock it or ask someone else to do it.	1	2	3	4	5
24. I wind up doing the work the personal support workers should be doing.	1	2	3	4	5
25. I check on the work of the personal support workers on my team for accuracy (i.e., completeness, timeliness).	1	2	3	4	5

### Quality of Patient Care (Schmalenburg & Kramer, 2008)

Please select the number that best indicates the usual quality of care provided to patients on your unit where you work the most frequently.

Dangerously Low Quality				It's Safe But Not Much Better				Very High Quality		
0	1	2	3	4	5	6	7	8	9	10

### Demographic Questionnaire

The following questions contain items that ask you to describe yourself, your nursing education, and work experience. Please read each statement carefully and indicate the best answer to the following questions.

#### Gender

1. Please indicate your gender:  Male  Female

#### Age

2. In what year were you born? 19 \_\_\_\_

#### Nursing Education

3. What is the highest nursing education level you have completed?  
(If you are currently enrolled as a student, please mark the previous highest level of nursing education you received)
- Diploma  
 Bachelor's Degree  
 Master's Degree  
 Doctorate Degree  
 Other

Please elaborate:

\_\_\_\_\_

4. Did you complete your initial nursing education in Canada?
- Yes  
 No
- If no, where did you complete your initial nursing education?  
 \_\_\_\_\_(Country)

#### Nursing Work Experience

5. What is your current nursing designation?  RN  
 RPN
6. How long (in years) have you worked as a nurse?  
 \_\_\_\_\_ Years

7. How long have you worked as a staff nurse on your current nursing unit where you work most frequently? \_\_\_\_\_ Years

### Nursing Employment

Please answer the following questions based on the nursing job where you work the most frequently.

8. What is your current nursing position where you are employed?  
(Please check all that apply)
- Staff Nurse  
 Team Leader  
 Nurse Educator  
 Manager  
 Other  
 Please elaborate:  
 \_\_\_\_\_
9. What is your employment status on your current nursing unit?
- Full-time  
 Part-time  
 Casual
10. What type of employer do you work for?
- Rural Community Hospital  
 Urban Community Hospital  
 Urban Teaching Hospital  
 Other  
 Please elaborate:  
 \_\_\_\_\_
11. What type of nursing care specialty do you work in?
- General Medicine  
 General Surgery  
 Critical Care  
 Intensive Care  
 Other  
 Please elaborate:  
 \_\_\_\_\_
12. Are you presently employed in more than one nursing job?
- Yes  
 If yes, how many nursing jobs do you have in total?  
 \_\_\_\_\_
- No

## Appendix E

### Ethics Approval



#### Use of Human Participants - Ethics Approval Notice

**Principal Investigator:** Dr. Heather Laschinger  
**File Number:**102524  
**Review Level:**Delegated  
**Approved Local Adult Participants:**0  
**Approved Local Minor Participants:**0  
**Protocol Title:**Examining the Contextual Factors, Individual Determinants, and Performance Outcomes of Nurses' Knowledge Work - 19006E  
**Department & Institution:**Health Sciences\Nursing,Western University  
**Sponsor:**  
**Ethics Approval Date:**May 16, 2012 **Expiry Date:**May 31, 2013  
**Documents Reviewed & Approved & Documents Received for Information:**

Document Name	Comments	Version Date
Western University Protocol		
Letter of Information		
Other	Reminder Letter	
Other	Final Invitation to Participate	

This is to notify you that The University of Western Ontario Research Ethics Board for Health Sciences Research Involving Human Subjects (HSREB) which is organized and operates according to the Tri-Council Policy Statement: Ethical Conduct of Research Involving Humans and the Health Canada/ICH Good Clinical Practice Practices: Consolidated Guidelines; and the applicable laws and regulations of Ontario has reviewed and granted approval to the above referenced revision(s) or amendment(s) on the approval date noted above. The membership of this REB also complies with the membership requirements for REB's as defined in Division 5 of the Food and Drug Regulations.

The ethics approval for this study shall remain valid until the expiry date noted above assuming timely and acceptable responses to the HSREB's periodic requests for surveillance and monitoring information. If you require an updated approval notice prior to that time you must request it using the University of Western Ontario Updated Approval Request Form.

Members of the HSREB who are named as investigators in research studies, or declare a conflict of interest, do not participate in discussion related to, nor vote on, such studies when they are presented to the HSREB.

## CURRICULUM VITAE

**Name:** Heidi M. Siu

**Post-secondary Education and Degrees:** McMaster University  
Hamilton, Ontario, Canada  
1997-2001, BScN

The University of Western Ontario  
London, Ontario, Canada  
2001-2003, MScN

Western University  
London, Ontario, Canada  
2006-2015, PhD

**Honours and Awards:** The University of Western Ontario Special University Scholarship  
2001-2003

Iota Omicron Chapter: Sigma Theta Tau Research Grant  
2002-2003

Nursing Research Interest Group Research Grant  
2002-2003

Provincial Nurse Educators Interest Group Scholarship  
2003

**Related Work Experience:** Teaching Assistant  
The University of Western Ontario  
2001-2003, 2008, 2010

Research Assistant  
The University of Western Ontario  
2002-2003, 2006-2008

Registered Nurse  
Sunnybrook Health Sciences Centre  
2003-2005

Nursing Clinical Instructor  
The University of Toronto  
2005

Workload Consultant  
Sunnybrook Health Sciences Centre  
2005-2010

Entry to Practice Assessor  
College of Nurses of Ontario  
2010-2013

Entry to Practice Consultant  
College of Nurses of Ontario  
2013-present

**Publications:**

- Siu, H. M., Laschinger, H. K. & Vingilis, E. (2005). The Effect of problem-based learning on nursing students' perceptions of empowerment. *Journal of Nursing Education, 44*(10): 459-469.
- Siu, H., Laschinger, H. K. S. & Finegan, J. (2008). Nursing professional practice environments: Setting the stage for constructive conflict resolution and work effectiveness. *Journal of Nursing Administration, 38*(5): 250-257.