

2018

# Tightening the large diameter anchor bolts of sign, signal, and luminaire structures

Connor Schaeffer  
*Iowa State University*

Follow this and additional works at: <https://lib.dr.iastate.edu/etd>

 Part of the [Civil Engineering Commons](#)

---

## Recommended Citation

Schaeffer, Connor, "Tightening the large diameter anchor bolts of sign, signal, and luminaire structures" (2018). *Graduate Theses and Dissertations*. 16456.  
<https://lib.dr.iastate.edu/etd/16456>

This Thesis is brought to you for free and open access by the Iowa State University Capstones, Theses and Dissertations at Iowa State University Digital Repository. It has been accepted for inclusion in Graduate Theses and Dissertations by an authorized administrator of Iowa State University Digital Repository. For more information, please contact [digirep@iastate.edu](mailto:digirep@iastate.edu).

**Tightening the large diameter anchor bolts of sign, signal, and luminaire structures**

by

**Connor Schaeffer**

A thesis submitted to the graduate faculty

in partial fulfillment of the requirements for the degree of

**MASTER OF SCIENCE**

Major: Civil Engineering

Program of Study Committee:

An Chen, Major Professor

Brent Phares

Jennifer Shane

The student author, whose presentation of the scholarship herein was approved by the program of study committee, is solely responsible for the content of this thesis. The Graduate College will ensure this thesis is globally accessible and will not permit alterations after a degree is conferred.

Iowa State University

Ames, Iowa

2018

Copyright © Connor Schaeffer, 2018. All rights reserved.

**DEDICATION**

To my wife, Jordynn. Your continued support made it all possible. Here's to many more late nights and pots of coffee. Thank you.

## TABLE OF CONTENTS

	Page
LIST OF FIGURES .....	vi
LIST OF TABLES .....	xiii
ACKNOWLEDGMENTS .....	xiv
ABSTRACT .....	xv
<b>CHAPTER 1. LITERATURE REVIEW, SURVEYS, AND SITE VISITS .....</b>	<b>1</b>
Introduction .....	1
Literature Review .....	1
Problems Associated with Loose Anchor Rods .....	1
Rod Tightening and Pretensioning.....	1
Relationships between Anchor Rod Stresses, Torque, and Structural Loading .....	6
Governing Loads and Load Types .....	11
Inspection .....	14
Summary of Nationwide DOT Practices .....	15
Summary of Possible Causes of Nut Loosening .....	16
Survey Procedure and Results .....	18
State, District, and Industry Survey Procedure .....	18
Survey Results .....	19
District Survey Results.....	19
State Survey Results.....	22
Industry Survey Results .....	25
Site Visits and Interviews .....	28
Minnesota Site Visit – Multiple Locations, Metro District, Near Minneapolis, MN.....	28
Minnesota Site Visit – District 6, Near Owatonna, MN .....	31
Interviews and Meeting with MnDOT Personnel .....	32
Iowa Site Visits – Interstate I-35 near 13th Street, Ames, IA .....	33
Iowa Site Visits – Interstate I-35 near University Avenue, Des Moines, IA .....	34
Meeting with IowaDOT Personnel.....	35
General Conclusions.....	48
<b>CHAPTER 2. TESTING BY SKIDMORE WILHELM MACHINE.....</b>	<b>50</b>
Introduction .....	50
Theoretical Background .....	50
Testing Using Skidmore Wilhelm Machine .....	53
Skidmore Wilhelm Testing Objectives .....	53
Testing Setup and Applicability .....	53
Testing Results .....	60



Limitations to Testing .....	60
Snug, Torque, and Rotation Results and Analysis .....	61
DTI Testing Results and Analysis .....	82
General Conclusions .....	86
CHAPTER 3.    FIELD MONITORING & LABORATORY TESTING .....	87
Introduction .....	87
Monitoring & Laboratory Testing Background .....	87
Field Monitoring of OH Sign Structure .....	88
Monitoring Objectives .....	88
Monitoring Plan .....	88
Monitoring Results .....	97
Monitoring Conclusions .....	103
Lab Testing of OH Sign Post .....	104
Testing Objectives .....	104
Testing Setup .....	104
Testing Results .....	116
Tightening Test .....	116
Static Test .....	120
Fatigue Test .....	123
General Conclusions .....	127
CHAPTER 4.    FINITE ELEMENT MODELING .....	129
Introduction .....	129
Modeling Objectives .....	129
Modeling of Field Structure .....	129
Results .....	129
Modeling of a Single Bolt .....	132
Results .....	132
Modeling of Lab Specimen .....	135
Results .....	135
General Conclusions .....	138
CHAPTER 5.    RECOMMENDATIONS FOR NEW SPECIFICATIONS .....	139
Specification Basis .....	139
Controlling Snug-tight .....	139
Methods of Controlling Snug-tight .....	139
Accounting for Grip Length .....	141
Recommendations for Verification .....	144
CHAPTER 6.    TESTING OF LOAD MEASURING SENSOR .....	146
Organic Sensor Design .....	146
Design of the Capacitor .....	146
Testing of Capacitor Design .....	148
Testing Using MTS Machine .....	148
Testing Using Skidmore-Wilhelm Tension Measurement Device .....	149
System Level Testing on Laboratory Specimen .....	151

CHAPTER 7. GENERAL CONCLUSIONS, LIMITATIONS, AND RECOMMENDATIONS FOR FUTURE TESTING.....	153
Conclusions .....	153
Limitations to Testing.....	154
Future Testing.....	155
REFERENCES .....	157
APPENDIX A. MNDOT OH SIGNS AND ANCHOR BOLT DETAILS.....	160
APPENDIX B. DISTRICT SURVEY .....	162
APPENDIX C. STATE SURVEY .....	165
APPENDIX D. INDUSTRY SURVEY .....	168
APPENDIX E. EXAMPLE CALCULATIONS.....	171
APPENDIX F. RECOMMENDATIONS FOR SPECIFICATION .....	173

## LIST OF FIGURES

	Page
Figure 1.1 - Current MnDOT Specification for Anchor Tightening .....	17
Figure 1.2 - Current MnDOT Standard Drawings .....	17
Figure 1.3 - Current IowaDOT Bridge Design Manual .....	18
Figure 1.4 - Number of HMLT, Overhead Sign Supports Per State Survey .....	26
Figure 1.5 - Preferred Anchor Tightening Procedure Per State Survey .....	26
Figure 1.6 - Lubrication Methods Per State Survey .....	27
Figure 1.7 - Verification Method Per State Survey .....	27
Figure 1.8 - Percentage of Structures with Loose Nuts Per State Survey.....	28
Figure 1.9 - Overhead Sign Truss on Interstate 494 Near Maple Grove .....	36
Figure 1.10 - Overhead Truss Baseplate and Anchor Bolts.....	36
Figure 1.11 - Cantilevered Sign Support on Interstate 494 Near Maple Grove .....	37
Figure 1.12 - Cantilevered Sign Support Baseplate and Anchor Bolts.....	37
Figure 1.13 - Leveling Nut Tightening in Minnesota .....	38
Figure 1.14 - Top Nut Tightening with Calibrated Wrench in Minnesota .....	38
Figure 1.15 - Puncturing of Threads after Tightening .....	39
Figure 1.16 - Distance from Foundation to Bottom Leveling Nut .....	39
Figure 1.17 - VMS Support on I-494 Near 1-35.....	40
Figure 1.18 - Washers Struck to Inspect Nut Tightness .....	40
Figure 1.19 - Reference Marks Used During Maintenance .....	41
Figure 1.20 - Hydraulic Wrench Used for Maintenance Retightening .....	41
Figure 1.21 - After Maintenance Retightening .....	42
Figure 1.22 - Tagging After Maintenance .....	42

Figure 1.23 - Leveling During Iowa Site Visit .....	43
Figure 1.24 - Preparing for Pole Installation .....	43
Figure 1.25 - Installation of Pole .....	44
Figure 1.26 - Hand Tightening of Bolts.....	44
Figure 1.27 – Snug-tightening of Bolts.....	45
Figure 1.28 - Final Tightening After Making Reference Marks.....	45
Figure 1.29 - Post Tightening with Reference Marks Shown.....	46
Figure 1.30 - Final Assembly with Jam Nuts .....	46
Figure 1.31 - Rusted Washers Found in District 6.....	47
Figure 1.32 - Undersized Washers Found in District 6 .....	47
Figure 2.1 - Hydraulic Wrench Tightening.....	56
Figure 2.2 - Operation of Hydraulic Wrench.....	57
Figure 2.3 - Skidmore Wilhelm Instrumentation.....	57
Figure 2.4 - Lubrication of Nut Bearing Surface .....	58
Figure 2.5 - Zeroing of Digital Level.....	58
Figure 2.6 - Digital Level Measurement after Tightening.....	59
Figure 2.7 - Double Nut to Prevent Bolt Rotation .....	59
Figure 2.8 – 0.75" Bolts Torque vs. Tension .....	67
Figure 2.9 - 1" Torque vs. Tension .....	67
Figure 2.10 – 1.25" Torque vs. Tension .....	68
Figure 2.11 – 1.5" Torque vs. Tension .....	68
Figure 2.12 – 1.75" Torque vs. Tension .....	69
Figure 2.13 - 2" Torque vs. Tension .....	69
Figure 2.14 – 2.25" Torque vs. Tension .....	70

Figure 2.15 - Pre-Snug & Rotation Beyond Snug Curve.....	70
Figure 2.16 - 0.75" A325 Rotation vs. Tension.....	71
Figure 2.17 - 1" Gr. 36 Rotation vs. Tension.....	71
Figure 2.18 - 1" Gr. 105 Rotation vs. Tension.....	72
Figure 2.19 - 1" Gr. 55 with 2" Grip Rotation vs. Tension.....	72
Figure 2.20 - 1" Gr. 55 with 3" Grip Rotation vs. Tension.....	73
Figure 2.21 - 1" 304 Stainless Steel Rotation vs. Tension.....	73
Figure 2.22 - 1" A325 Rotation vs. Tension.....	74
Figure 2.23 - 1.25" A325 Rotation vs. Tension.....	74
Figure 2.24 - 1.25" Gr. 55 Rotation vs. Tension.....	75
Figure 2.25 - 1.5" Gr. 105 with 2.5" Grip Rotation vs. Tension.....	75
Figure 2.26 - 1.5" Gr. 105 with 4.5" Grip Rotation vs. Tension.....	76
Figure 2.27 - 1.5" Gr. 105 with 5.5" Grip Rotation vs. Tension.....	76
Figure 2.28 - 1.5" Gr. 105 with 5.5" Grip (K-Series) Rotation vs. Tension.....	77
Figure 2.29 - 1.5" Gr. 105 with 5.5" Grip (K-Series & No Lubricant) Rotation vs. Tension.....	77
Figure 2.30 - 1.75" Gr. 105 with 5.75" Grip Rotation vs. Tension.....	78
Figure 2.31 - 2" Gr. 105 with 5.75" Grip Rotation vs. Tension.....	78
Figure 2.32 - 2" Gr. 105 with 7.75" Grip (No Lubricant) Rotation vs. Tension.....	79
Figure 2.33 - 2" Gr. 105 with 7.75" Grip Rotation vs. Tension.....	79
Figure 2.34 - 2.25" Gr. 105 with 6.25" Grip Rotation vs. Tension (No Lubricant).....	80
Figure 2.35 - 2.25" Gr. 105 with 6.25" Grip Rotation vs. Tension.....	80
Figure 2.36 - Bolt Stiffness vs. $k_s$ .....	81
Figure 2.37 - Bolt Diameter / Grip Length vs. $k_s$ .....	81
Figure 2.38 - 0.75" A325 DTL.....	82

Figure 2.39 - 1.0" Gr. 105 DTI .....	83
Figure 2.40 - 1.25" A325 DTI.....	83
Figure 2.41 - 1.5" Gr. 105 DTI .....	84
Figure 2.42 - 1.75" Gr. 105 DTI .....	84
Figure 2.43 - 2" Gr. 105 DTI .....	85
Figure 2.44 - 2.25" Gr. 105 DTI .....	85
Figure 3.1 – Aerial View of Site.....	89
Figure 3.2 - Strain Gage Layout .....	91
Figure 3.3 - Elevation View of Strain Gages.....	91
Figure 3.4 - Labeling for Strain Gages .....	92
Figure 3.5 - Predrilled Hole in 2-1/4" Anchors .....	92
Figure 3.6 - Anchor Bolts after Strain Gage Installation.....	93
Figure 3.7 - Calibration of Anchor Bolts .....	93
Figure 3.8 - Anchor Bolt and Post Strain Gages.....	94
Figure 3.9 - Conduit Leading to Data Logger.....	94
Figure 3.10 - Anemometer Placement .....	95
Figure 3.11 - View of Interior of Cabinet.....	95
Figure 3.12 - Camera Inside Enclosure.....	96
Figure 3.13 - Antenna for Wireless Connection .....	96
Figure 3.14 - Bolt 2 Stress Histogram .....	99
Figure 3.15 - Bolt 3 Stress Histogram .....	100
Figure 3.16 - Bolt 5 Stress Histogram .....	100
Figure 3.17 - Bolt 6 Stress Histogram .....	101
Figure 3.18 - Average Wind Speeds During Monitoring .....	102

Figure 3.19 - Maximum Wind Speeds During Monitoring .....	103
Figure 3.20 - Top View of Lab Specimen .....	107
Figure 3.21 - Cross Section of Concrete Block (A-A).....	107
Figure 3.22 - Top View of Concrete Block Reinforcement (C-C) .....	108
Figure 3.23 - Side View of Lab Specimen.....	108
Figure 3.24 - Strain Gage Numbering for Lab Specimen.....	109
Figure 3.25 - Concrete Block Formwork .....	109
Figure 3.26 - Rebar Cage .....	110
Figure 3.27 - Individual Calibration of Anchor Bolts.....	110
Figure 3.28 - Anchor Bolt Cage.....	111
Figure 3.29 - Rebar, Anchors, and PVC Placed in Formwork .....	111
Figure 3.30 - Anchor Bolts during Concrete Curing .....	112
Figure 3.31 - Shear Studs and Wood Form Inside Sign Post.....	112
Figure 3.32 - HP10x57 and Confinement Placed in Sign Post.....	113
Figure 3.33 - H-Pile Placed Inside Sign Post.....	113
Figure 3.34 - HP10x57 Curing in Concrete .....	114
Figure 3.35 - Top View HP10x57 Curing in Concrete.....	114
Figure 3.36 - Concrete Block Following Post-tensioning .....	115
Figure 3.37 - Test Frame Following Construction.....	115
Figure 3.38 - Torque vs. Tension for 2-1/2" Diameter Bolts.....	116
Figure 3.39 – Circle Pattern Data .....	119
Figure 3.40 – Star Pattern Data.....	119
Figure 3.41 - Deflection vs. Bolt Stress .....	120
Figure 3.42 - Base Moment vs. Bolt Stress .....	121

Figure 3.43 - Deflection vs. Stress in the Post.....	121
Figure 3.44 - Time vs. Bolt Stress .....	122
Figure 3.45 - Average Stresses vs. Time .....	122
Figure 3.46 - Post Stress vs. Deflection.....	124
Figure 3.47 - Bolt Stress vs. Deflection.....	124
Figure 3.48 - Bolt Stress vs. Base Moment .....	125
Figure 3.49 - Bolt 3 Stress vs. Deflection.....	125
Figure 3.50 - Bolt Stress vs. Time .....	126
Figure 4.1 - Mesh Generation for Sign Structure .....	130
Figure 4.2 - Stress in Bolts Under 20 PSF Wind.....	130
Figure 4.3 - Bolt Numbering Plan.....	131
Figure 4.4 - Reaction Force in 8 Anchors Using Predefined Prestress Option.....	131
Figure 4.5 - Reaction Force in Anchor Bolts Using Predefined Preload Step.....	132
Figure 4.6 - Single Bolt Model with Boundary Conditions.....	133
Figure 4.7 - Reaction Force on the Top Surface of Leveling Nut .....	134
Figure 4.8 - Comparison of Experiment and Modeling.....	134
Figure 4.9 – Deflection vs. Base Moment .....	135
Figure 4.10 - Base Moment vs. Stresses in the Pole.....	136
Figure 4.11 - Base Moment vs. Stress in Bolt 6 .....	136
Figure 4.12 - Anchor Bolt Stresses.....	137
Figure 4.13 - Stresses on Bottom Nuts .....	138
Figure 4.14 - Stresses on Top Nuts.....	138
Figure 5.1 - $k_s$ Value vs. Bolt Stiffness.....	143
Figure 5.2 - $k_s$ Values vs. Bolt Stiffness and Diameter .....	143



Figure 5.3 - $k_s$ Values vs. Ratio of Bolt Diameter to Grip Length .....	144
Figure 6.1 – Development of Prototype Capacitor Scheme .....	147
Figure 6.2 – MTS Test and Resulting Damage.....	148
Figure 6.3 – Testing using Skidmore-Wilhelm.....	150
Figure 6.4 – Load Application .....	150
Figure 6.5 - Memory Foam Capacitor during Loading.....	151
Figure 6.6 - Examining the Capacitor after Loading .....	152
Figure A.1 - Sign Post Dimensions.....	160
Figure A.2 - Type IV Baseplate Dimensions.....	160
Figure A.3 - Type V Baseplate Dimensions.....	161
Figure A.4 - Anchor Bolt Dimensions.....	161

## LIST OF TABLES

	Page
Table 1.1 – AASHTO LTS-1 (2015) Table of Top Nut Rotation for Turn-of-Nut Pretensioning of Double-Nut Moment Connections .....	5
Table 1.2 - Minimum Anchor Rod Pretension by Tensile Strength for Double-Nut Moment Connections per NHDOT Supplemental Specification (2012).....	7
Table 1.3 – NCHRP 469 Structural Susceptibility to Various Wind-Loading Phenomena .....	12
Table 1.4 - NCHRP 469 Fatigue Importance Factors.....	14
Table 1.5 – AASHTO LTS-1 (2015) Sign Structure Importance Factors .....	14
Table 1.6 – AASHTO LTS-1 (2015) Fatigue Limit State Pressure Range for HMLT ....	14
Table 1.7 - Summary of District Survey Results .....	21
Table 2.1 - Summary of Snug-tight Results.....	64
Table 2.2 - Torque Testing Results.....	65
Table 2.3 - Rotation Testing Results.....	66
Table 3.1 – Field Tightening Results .....	97
Table 3.2 - Monitoring Stress/Cycle Summary .....	101
Table 3.3 - Summary of Tightening Test Results .....	116
Table 3.4 – Comparison of Star & Circle per Bolt .....	118
Table 3.5 – Comparison of Star & Circle by Tightening Order .....	118
Table 5.1 - Calculated Wrench Lengths (inches) for F1554 Anchors .....	140
Table 5.2- Maximum Snugging Torque (ft-lbs) Values for F1554 Anchor Bolts .....	141
Table F.1- Wrench Lengths for Snugging.....	174
Table F.2- Torque and Turns for MnDOT Structures.....	175

## ACKNOWLEDGMENTS

I would like to thank my committee chair, An Chen, and my committee members, Brent Phares, and Jennifer Shane, for their guidance and support throughout the course of this research.

None of this would have been possible without the support of both sponsors, the Minnesota DOT and National Cooperative Highway Research Program.

In addition, I would also like to thank Jihshya Lin, without whose adamant support and encouragement this project may have never taken off. Other MnDOT personnel, including the TAP team, design engineers, and bridge maintenance staff were huge benefits. The collective investment simplified the entire research process, and helped create a specification that will lead to safer structures and simpler maintenance procedures.

I would like to thank my close friends, colleagues, the department faculty and staff for making my time at Iowa State University a wonderful experience. In particular, I would like to thank Doug Wood and Owen Steffens, whose expertise made most of this research possible. Thank you to Xiangchen Che, Clint Otto, Brandon Kuehl, Elizabeth Miller, David Morandeira, and Yinglong Zhang for their collective efforts on these projects. I want to also offer my appreciation to those who were willing to participate in my surveys and observations, without whom, this thesis would not have been possible.

I would like to thank my parents for a lifetime of help. I truly believe most of my success now is from all the flashcards and books as a kid. Thank you.

Finally, I would like to thank God. You are good, and I am needy.

## ABSTRACT

Many state Departments of Transportation (DOT) across the US, including MnDOT, are experiencing problems associated with loose anchor bolts used in support structures (e.g., overhead signs, high-mast light tower (HMLT), and tall traffic signals). Specifically, MnDOT inspection crews have found loose nuts at most anchor bolt locations, even at some newly installed signs. Many of these nuts became loose in less than two years, even after being tightened by the maintenance crew following current recommended procedures. This situation has placed tremendous strain on the resources from the districts' maintenance group and also causes concerns related to inspection frequency and public safety.

This project investigated causes of the loose anchor bolts and proposes solutions based on site surveying, field monitoring, laboratory study, and numerical analysis. In particular, in Chapter 1 it studied how these anchor bolts were initially tightened and whether they were adequately pretensioned. Chapter 2 contained Skidmore Wilhelm testing to determine relationships between torque, rotation, and tension for different bolt diameters and grades. In Chapter 3, field monitoring was completed to quantify the torque, rotation, and tension relationships of MnDOT structures. Chapter 3 also contained testing of a laboratory specimen of a MnDOT sign structure to determine how anchors loosen during service loading. In Chapter 4, finite element modeling was completed to develop models that could be used for future parametric and fatigue studies. In Chapter 5, recommendations are made for a new specification for MnDOT structures. The objective of this project was to develop the best practical procedures using available equipment to re-tighten the loose anchor bolts so as to develop required pretension. This project will ensure that the anchor bolts will perform as designed while minimizing required

inspection frequency. During testing, it became clear there was a need for cheap, digital measurements of bolt pretension. In Chapter 6, an organic sensor developed and tested for a National Cooperative Highway Research Program (NCHRP) funded project is described.

The project found that most states experience issues with loose nuts of sign and signal structures. The loose nuts are attributed to one of two reasons: inadequate tightening (under-tightened) or yielding leading to permanent deformation under service loads (over-tightened). In each case, the loose nuts can be due to an incorrect specification or contractor error. Typically, large diameter bolts are more susceptible to under-tightening, while small diameter bolts are more likely to yield and elongate under service loading. Fatigue testing of a MnDOT structure using MnDOT's previous specification for large diameter bolts resulted in loose anchor bolts due to under-tightening. The research team found that the tightening process proposed in AASHTO's specification is a sufficient alternative for MnDOT, though it requires modification in three key areas: defining snug-tight, accounting for grip length, and recommending verification procedures. Through laboratory testing and field monitoring, the research team found that there is an actual snug-tight value near 10% of yield stress. The relationship between nut rotation and bolt tension becomes linear beyond the actual snug-tight threshold. The team found that the relationships between torque, tension, and rotation beyond snug-tight for varying grip lengths can be estimated with empirical constants. Through literature review and surveying of state DOT's, the team examined verification procedures and recommends the use of a form similar to WisDOT's dt2321. The team began testing a prototype organic sensor for digital measurement.

## CHAPTER 1. LITERATURE REVIEW, SURVEYS, AND SITE VISITS

### Introduction

#### Literature Review

##### *Problems Associated with Loose Anchor Rods*

NCHRP 412 (Kaczinski et al. 1998) examines and presents findings on the issues that arise from loose anchor nuts in cantilevered overhead sign structures (COSS) and high-mast light towers (HMLT). The research found that pretensioned anchor bolts will decrease the possibility of nuts becoming loose under service-load conditions. Loose nuts will cause an inability in one of the bolts to carry necessary loads and will redistribute the stresses in the remaining anchor bolts. Loose nuts will likely lead to greater movement under the fatigue loads seen by sign structures and high-mast luminaires which will lead to greater chances of crack initiation in the weld and anchor rod details (Garlich & Koonce 2010). NCHRP 412 (Kaczinski et al. 1998) also found that crack initiation was a majority of the service life of the anchor rod. This means that once cracks are initiated in the anchor rod threads or unthreaded part, the crack will quickly propagate to a point of failure. Knowing that initiation of cracks in the anchor rod creates a significant chance of movement and structural failure, it is imperative for both the safety and serviceability of the structure that the anchor rods be adequately tightened and pretensioned.

##### *Rod Tightening and Pretensioning*

Development of proper pretension in the double-nut moment connection will usually shift the zone of failure from between the leveling and top nut to below the leveling nut (Kaczinski et al. 1998). This is desirable as it signifies smaller stress ranges in the clamping zone between the two nuts and thus greater fatigue strength for the anchor bolts. As stated in NCHRP Report 469 (Dexter & Ricker 2002), torque is an unreliable way to ensure pretension, though it is the sole way to check tension post-tightening. Due to the unreliability of torque, proper pretensioning of

anchor rods in double nut moment connections is often accomplished by Turn-of-Nut tightening. The Turn-of-Nut method for double nut moment connections is specified by AASHTO, and will be examined in detail later in this review. Turn-of-Nut tightening develops pretensioning in two stages: snug-tight and beyond snug-tight.

The definitions of snug-tight and beyond snug-tight have always been ambiguous and can easily be misconstrued. According to the Research Council on Structural Connections (RCSC) (2014), a joint in the snug-tightened condition shall have “the tightness that is attained with a few impacts of an impact wrench or the full effort of an ironworker using an ordinary spud wrench to bring the plies into firm contact.” Garlich & Thorkildsen (2005) define snug-tight as the torque between 20-30 percent of the verification torque. In the Michigan Field Manual for Structural Bolting (2014), snug-tight is specified to be at least 10% of the pretensioned load. All tightening beyond snug-tight is completed by torquing the nut for a specified number of turns. In Specifications for Structural Joints Using High-Strength Bolts (2009), the RCSC states that the minimum required bolt pretension is 70 percent of specified minimum tensile strength of the bolts. This pretension should provide sufficient clamping force and help mitigate the effects of fatigue. The RCSC comments that even when a bolt is fully pretensioned it may not be possible to reach continuous contact throughout the total faying surface area, but this will not be detrimental to the performance of the joint. The clamping force from the pretensions in the bolts will still be transferred to the locations in contact and the joint will be effective.

For Turn-of-Nut pretensioning, the nut is rotated a specified amount to develop the necessary elongation and thus pretension in the bolt. The exact pretension will be impacted by the amount of clamping force developed during snug-tightening and how far the nut is turned (Phares 2016). Rotations of the nut is specified based on fastener length and diameter, as well as

any misalignment of the plies. Pretensioning of double-nut moment connections by the Turn-of-Nut method should be completed according to the latest version of AASHTO's Standard Specifications for Structural Supports for Highway Signs, Luminaires, and Traffic Signals, also known as LTS-1. The current AASHTO procedure is adapted from Guidelines for the Installation, Inspection, Maintenance and Repair of Structural Supports for Highway Signs, Luminaires, and Traffic Signals by Garlich & Thorkildsen (2005). Garlich & Thorkildsen (2005) derived the method from a multitude of references, including Till & Lefke (1994), James et al. (1997), Johns & Dexter (1998), and Dexter & Ricker (2002). Noting that the AASHTO LTS-1 specification is widely available and used, the steps are briefly summarized below:

1. Verify that the assembly is adequate, properly lubricated, and prepared for installation.
2. Apply leveling nuts, structural washers, install base plate, top washers, and turn the top nuts onto the anchor rods.
3. Tighten the top nuts to the snug-tight position, followed by snug-tightening the leveling nuts.
4. Achieve the specified nut rotation for the final tightening of the top nuts. Specified rotations are presented in *Table 1.1*.
5. Torque wrench is used to verify that the verification torque is required to adequately tighten the leveling and top nuts.

After at least 48 hours, a torque wrench is used to verify that a torque of at least 110 percent of the verification torque is required to additionally tighten the leveling and top nuts.

One of the significant issues for anchor rod design is determining the relationship between applied torque and the tension in the anchor rod. In 1994, Till & Lefke performed



research on 8UN and UNC anchor rods to investigate possible relationships between the two factors, presented in *The Relationship Between Torque, Tension, and Nut Rotation of Large Diameter Anchor Bolts*. The research found that the verification torque, or the torque applied at least 48 hours after final tightening using the Turn-of-Nut method, can be defined by  $T = KPD$ .  $T$  is the verification torque,  $P$  is the clamp load in the rod, and  $D$  is the diameter of the rod.  $K$  is an empirical constant. Till & Lefke (1994) found 0.12 to be a good estimate to account for the effects of relaxation due to zinc flow in the rods. The  $T = KPD$  relationship was developed for the verification torque, but is the relationship used to determine the torque required for a desired rod pretension (Garlich & Koonce 2010).

Many states suggest that tightening of the top nuts be completed using a hydraulic torque wrench or a box end “slug” or “knocker” wrench with an extension or long pipe handle. Other states, including New Hampshire, specify that reinforcing bars not be used in place of anchor rods for fatigue-susceptible structures.

Garlich & Thorkildsen (2005) use the verification torque equation of  $T_v = 0.12d_bF_t$ . Where  $d_b$  is the nominal bolt diameter and  $F_t$  is the installation pretension, equal to 50 percent of the specified minimum tensile strength of F1554 Grade 36 rods, and 60 percent for all other threaded fasteners. AASHTO uses the same equation in the current LTS-1, but use 50-60% of the yield strength instead of tensile strength as proper pretensioning. This equation was developed during research performed by Till & Lefke (1994), the research will be addressed later in this review. NCHRP 412 (Kaczinski et al. 1998) recommends that base plates be at least as thick as the anchor bolt diameter to minimize prying force. The report also notes that tightening bolts with coarse thread pitches may cause yielding in the anchor bolt material. The research found that rolled threads exhibit greater fatigue strength at low max stresses, but that rolled and

cut threads performed similarly at high max stresses. In order to minimize bending effects on the anchor rods, the leveling nuts should leave one diameter or less of exposed length above the concrete.

Table 1.1 – AASHTO LTS-1 (2015) Table of Top Nut Rotation for Turn-of-Nut Pretensioning of Double-Nut Moment Connections

Anchor Bolt diameter, in. (mm)	Top Nut Rotation beyond Snug-Tight <sup>a,b,c</sup>	
	F1554 Grade 36	F1554 Grade 55 and 105
≤ 1.5 (≤ 38)	1/6 turn	1/3 turn
> 1.5 (> 38)	1/12 turn	1/6 turn

<sup>a</sup> Nut rotation is relative to anchor bolt. The tolerance is plus 20 degrees (1/18 turn)

<sup>b</sup> Applicable only to double-nut moment connections

<sup>c</sup> Use a beveled washer if the nut is not in firm contact with the base plate or the outer face of the base plate is sloped more than 1:40

In 1997, researchers at the Texas A&M University set to determine tightening procedures for large diameter anchor rods. James et al. (1997) completed field studies and lab studies on both COSS and HMLT structures, and presented the results in Tightening Procedures for Large Diameter Anchor Bolts. James et al. (1997) did not observe any nut loosening or observable nut rotation when the rods were tightened to 60 degrees past snug-tight. There was no significant creep or relaxation in the bolt, nut, or galvanizing. The rod details tested at 60 degrees past snug-tight could be classified as AASHTO Category D details. It was found that the required torque to tighten the nuts to the 60 degree rotation was not consistent from bolt to bolt and even varied when retesting the same bolt, which brings serious doubts to the reliability of a calibrated torque wrench to achieve a specified preload. It was determined that one person could use a 7 kg (16 lb) sledgehammer and knockerwrench to tighten the nuts to an effective preload of 400 to 450 MPa (60 to 65ksi). James et al. (1997) also tested to determine if striking the nut with a hammer was useful for nut tightness inspection. It was found that striking the nut with a hammer will not help

discern between snug-tight and beyond snug-tight, but any tightness below snug will omit a duller sound than snug-tight nuts. Based on field monitored behavior of an HMLT structure for 0.3 year, James et al. (1997) determined that anchor rods in the snug-tight position should have an infinite life. The research team observed higher stress ranges seen in misaligned snug-tightened anchor rods, and this lost some of the positive effects of preloading the rod. Due to this fact, the team concluded that alignment is more critical than preload when considering fatigue failure of large diameter rods in HMLT structures.

*Relationships between Anchor Rod Stresses, Torque, and Structural Loading*

One of the significant issues for anchor rod design is determining the relationship between applied torque and the tension in the anchor rod. In 1994, Till & Lefke performed research on 8UN and UNC anchor rods to investigate possible relationships between the two factors, presented in *The Relationship Between Torque, Tension, and Nut Rotation of Large Diameter Anchor Bolts*. The research found that the verification torque, or the torque applied at least 48 hours after final tightening using the Turn-of-Nut method, can be defined by  $T = KPD$ .  $T$  is the verification torque,  $P$  is the clamp load in the rod, and  $D$  is the diameter of the rod.  $K$  is an empirical constant. Till & Lefke (1994) found 0.12 to be a good estimate to account for the effects of relaxation due to zinc flow in the rods. The  $T = KPD$  relationship was developed for the verification torque, but is the relationship used to determine the torque required for a desired rod pretension (Garlich & Koonce 2010).

Table 1.2 - Minimum Anchor Rod Pretension by Tensile Strength for Double-Nut Moment Connections per NHDOT Supplemental Specification (2012)

Grade 36 Rods							
Nominal Diameter, d, (in)	Gross Area (sq in)	UNC Stress Area (sq in)	Pretension Stress (ksi)	Installation Pretension, Fi (kips) Pre-Stress * Area	Snug Tight Torque Check (ft-lb) 20-30% Tv	Verification Torque Check, Tv (ft-lb)	Relaxation Check (ft-lb) 110% Tv
1.00	0.79	0.61	29	18	35-53	177	195
1.25	1.23	0.97	29	28	70-105	351	387
1.50	1.77	1.41	29	41	123-184	613	674
1.75	2.41	1.9	29	55	193-289	964	1060
2.00	3.14	2.5	29	73	250-435	1449	1594
2.25	3.98	3.25	29	94	424-636	2120	2332
Grade 55 Rods							
Nominal Diameter, d, (in)	Gross Area (sq in)	UNC Stress Area (sq in)	Pretension Stress (ksi)	Installation Pretension, Fi (kips) Pre-Stress * Area	Snug Tight Torque Check (ft-lb) 20-30% Tv	Verification Torque Check, Tv (ft-lb)	Relaxation Check (ft-lb) 110% Tv
1.00	0.79	0.61	45	27	55-82	274	302
1.25	1.23	0.97	45	44	109-164	545	600
1.50	1.77	1.41	45	63	190-285	951	1047
1.75	2.41	1.9	45	86	299-449	1496	1645
2.00	3.14	2.5	45	113	450-675	2249	2474
2.25	3.98	3.25	45	146	658-987	3289	3618
Grade 105 Rods							
Nominal Diameter, d, (in)	Gross Area (sq in)	UNC Stress Area (sq in)	Pretension Stress (ksi)	Installation Pretension, Fi (kips) Pre-Stress * Area	Snug Tight Torque Check (ft-lb) 20-30% Tv	Verification Torque Check, Tv (ft-lb)	Relaxation Check (ft-lb) 110% Tv
1.00	0.79	0.61	75	46	91-137	457	503
1.25	1.23	0.97	75	73	182-273	909	1000
1.50	1.77	1.41	75	106	317-476	1586	1744
1.75	2.41	1.9	75	143	499-748	2493	2742
2.00	3.14	2.5	75	188	750-1125	3749	4123
2.25	3.98	3.25	75	244	1096-1645	5482	6030

Fatigue loading due to wind is going to have a significant effect on the service life of overhead, cantilever, and high-mast structures. In a 25 year life span, the structure is expected to experience over 100 million wind load cycles (AASHTO 2015). AASHTO specifies designing these structures for infinite life. In short, if stress ranges in the member are below the constant amplitude fatigue threshold (CAFT, previously constant amplitude fatigue limit CAFL), then the structural member will behave as if it had infinite life. NCHRP 412 (Kaczinski et al. 1998) found that the CAFT of AASHTO Stress Category D (48 MPa or 7 ksi) are conservative lower bound estimates for snug-tight and fully tightened axially loaded anchor bolts. AASHTO specifications

call for anchor rods with misalignments less than 1:40 with firm contact existing between anchor bolt nuts, washers and base plate to be designed with the CAFT for Category D.

NCHRP 412 (Kaczinski et al. 1998) found that when the above tightening method and specifications were followed, the simple flexure formula ( $f = Mc/I$ ) could be used to calculate axial stresses in the anchor bolts. Variance in the bolt stresses was determined to be ignorable, as the variance will have no effect on the ultimate strength. It was found that the higher stress bolts will be balanced by lower stress bolts. As previously stated, if the exposed length of the rod is less than one bolt diameter, bending effects can be ignored. The NCHRP 412 (Kaczinski et al. 1998) research team found that it was reasonable to conclude that results from individual bolt tests can accurately predict the behavior of bolts in a complete assembly. Kaczinski et al. (1998) also found that higher maximum stresses that would be found in high strength anchors are detrimental to fatigue performance. When selecting an anchor grade, there is a balance between the fatigue benefit of increased yield and the fatigue detriment of increased maximum stress (Kaczinski et al. 1998). For these purposes, the use of additional Grade 55 bolts with a lower maximum stress in each bolt would exhibit slightly greater fatigue strength than using fewer Grade 105 bolts with greater maximum stresses (Kaczinski et al. 1998).

In 2014, Hoisington conducted research for an AKDOT project to investigate anchor nut loosening in high-mast light poles and presented the research in Investigation of Anchor Nut Loosening in High-Mast Light Poles Using Field Monitoring and Finite Element Analysis. Over the course of 177 AKDOT inspections, 54 revealed loose nuts on the anchor rods. The nuts were loosening regardless of foundation type, pole height, lamp configuration, date of installation, number of rods, rod diameter, or temperature at time of installation. Hoisington (2014) also noted that AKDOT determined that rods were not misaligned beyond the limits specified by

earlier research, yet the rods still experienced anchor nut loosening. AKDOT also were not aware of any anchor rods that ruptured or large cracks that manifested by fatigue failure. This challenged the conclusions of the 1997 research completed by James et al. in *Tightening Procedures for Large Diameter Anchor Bolts*. Hoisington (2014) monitored an HMLT to measure the rod strains and thus the stresses moving through the rod during the tightening procedure. FHWA tightening procedures were followed properly, where snug-tightened is 20-30% of the final pretension, and the minimum pretension for high strength bolts be equal to 70% of their minimum tensile strength per RCSC specifications. For non high-strength rods, the recommended pretension of 50-60 percent minimum tensile strength was used. The study produced pretensions in the rods between 50-80% of their minimum tensile strength.

Hoisington (2014) completed another study with a modified tightening procedure that produced pretensions between 50-60% of their minimum tensile strength. While the modified procedure produced a smaller scatter of rod pretensions, neither procedure produced under-tightened rods. This led to the conclusion that inadequate pretensioning is likely not a factor behind the loose nuts AKDOT was finding. Hoisington (2014) did find that over the course of the specified tightening procedure, some of the rods experienced stresses that were greater than the nominal yield strength of 55 ksi. In conjunction with this fact, the average measured force in the rods after snug-tightening was over the target range of 20-30% of final pretension. If the rods yield during tightening or the verification torque tightening, the rod is liable to deform from external loads. If the rod deforms, then the clamp load between the rod and nut is lost, which would lead to nut loosening. Hoisington (2014) believes that current specifications for the degree of rotation in the Turn-of-Nut method should be adjusted for the grip length/rod diameter ratio to ensure that final bolt pretensions fall within the necessary ranges. Hoisington (2014) also

concluded that the verification torque for Grade 55 rods be reduced from 60% to 50% of the minimum tensile stress to make the rods less likely to yield.

Hoisington (2014) completed finite element analysis of the anchor rods in different connection models. Clamp load loss due to permanent deformation was captured in all 3 of the connection scenarios, and the clamp load loss was not affected by pretension magnitude in Grade 55 rods. Increasing the number of bolts, use of a double-nut moment connection, and use of high strength bolts increased the resistance to separation and resistance to significant clamp load loss. The use of high strength bolts over Grade 55 bolts contradicted the previous research in NCHRP 412. Hoisington (2014) found that the load necessary to separate one rod and several rods is very similar. Thicker flange and baseplates increased the resistance to clamp load loss. Hoisington (2014) concludes that it is important to prevent the pretension from causing yielding in the anchor rods, particularly in the clamp load zone, and that permanent deformation in the clamp load zone will cause nut loosening.

The clamping force will be equal to the compression applied to the joint, which will be equal and opposite to the tension load in the fastener group (Hoisington 2014). It is important to note that while the bolt and joint experience equal and opposite forces, they do not experience equal strain. The bolt will have a smaller stiffness than the joint, usually around the magnitude of  $1/3$  to  $1/5$ . This will correlate with a stretch 3-5 times more than the joint at a given pretension (Hoisington 2014). This could be the factor that led to the permanent deformation and loss of clamp load that Hoisington examined in his FE models. Nassar & Matin (2005) performed research to examine clamp load loss in high strength bolts. Their results showed that clamp load loss is caused by the permanent deformation from loading a bolt beyond yield. If the bolt experiences significant loading past yield, the clamping force can be entirely removed. As

Hoisington's research proved, loss of clamping force and separation of one bolt will quickly lead to separation in the other bolts.

### *Governing Loads and Load Types*

The four governing fatigue loading types that are applicable to COSS and HMLT structures are galloping, vortex shedding, truck gust, and natural wind loading. These load cases only apply to specific structures and are influenced by structure type, shape, size and attachments. *Table 1.3* excerpted from NCHRP 469 below summarizes what structure types are affected by the four loads. The table is also included in the current AASHTO specifications.

In 1998, Researchers at Lehigh University wanted to determine equivalent static pressures for the four main fatigue loads on cantilevered highway sign support structures with Variable Message Signs (VMS). In *Fatigue Related Wind Loads on Highway Support Structures*, Johns & Dexter (1998) monitored a VMS on Interstate 80 in northern New Jersey with strain gages, pressure transducers, and a wind sentry for 3 months. No galloping of the mast arm was observed during the three months' period, but prior research indicates an equivalent static loading of 21 psf (1000 Pa). This loading is applied vertically to the vertical projected area of signal or sign attachments mounted rigidly to the horizontal mast arm. Truck induced gusts are 36 psf (1760 Pa) multiplied by the AASHTO drag coefficient from 0 to 20 feet (0 to 6 meters) above the road way and linearly decrease to 0 psf when 32 feet (10 meters) above the roadway. The gust load is applied for the length of the sign or 12 feet, whichever length is greater. AASHTO LTS-1 (2015) specifies 18.8 psf multiplied by an importance factor and structural member's drag coefficient when calculating truck gust loads. The value of 18.8 psf was suggested in NCHRP 469 (Dexter & Ricker 2002). Natural wind gusts can be estimated with a static pressure of 5.2 psf (250 Pa) times the AASHTO drag coefficient. The drag coefficient can be found on Table 3.8.7-1 of AASHTO LTS-1 (2015). Natural wind gust pressures are applied



horizontally to the horizontally projected area of all exposed portions of the structure and its attachments. Vortex shedding is not a factor on VMS structures. The above loads modify the design loads from NCHRP 412 (Kaczinski et al. 1998), but Johns & Dexter (1998) concluded that it can be prudent to use the design loads from NCHRP 412 (1998). Researchers also determined that non high-strength bolts should have a preload equal to 60% of the ultimate strength instead of the 70% used for high strength bolts to avoid yielding. This correlates with the research that was completed by Hoisington (2014).

Table 1.3 – *NCHRP 469 Structural Susceptibility to Various Wind-Loading Phenomena*

Type of Structure	Galloping	Vortex Shedding	Natural Wind	Truck Gust
Cantilever Sign (one/two chord)	X		X	X
Cantilever Sign (four chord)			X	X
Bridge Support Sign or Signal		*	X	X
Cantilevered Sign	X		X	X
Luminaire		X	X	

\*Vortex shedding has occurred in a monotube bridge support (overhead sign) and can occur in cantilevered structures if the sign or signal attachment is not attached.

Design loads are often multiplied by importance factors which reflect the consequences of failure of the structure. For example, a cantilevered support structure on a major highway will result in a greater chance for loss of life than a support structure in an area with low traffic volume. AASHTO (2015) defines importance factors with three importance categories. Note that high-mast light towers are defined by only two importance categories. For high-mast light towers, the importance category is based on the comparison of HMLT height and distance to the roadway. In short, a HMLT that could fall into the roadway has a greater hazard level than one that could not fall into the roadway.

Category I – Critical cantilevered support structures installed on major highways

Category II – Other cantilevered support structures installed on major highways and all

cantilevered support structures installed on secondary highways

Category III – Cantilevered support structures installed at low-risk locations

Dexter & Ricker (2002) sought to quantify the requirements for each importance category. In NCHRP 469 (2002), Category I is quantified as “all structures without mitigation devices on roadways with a speed above 35 mph (60 km/h) and average daily traffic (ADT) exceeding 10,000 in one direction (regardless of number of lanes) or average daily truck traffic (ADTT) exceeding 1,000 in one direction...” At an ADT of 10,000, the structure has a new vehicle passing underneath it at an average of every 8.6 seconds. 1,000 trucks per day means that the structure will see more than 10 million truck-gust cycles in a 28-year lifetime. The cycles would be enough to initiate fatigue cracking if the stress ranges are right above the CAFL. A few supplemental Category I conditions include: cantilevered structures with a span greater than 55 ft (17 m) or high-mast towers in excess of 100 ft (30 m), the structure location is in an area known to have wind conditions with a mean annual wind speed above 11 mph (5 m/s), or if the structure is located near the foothills of mountain ranges. If a structure does not meet speed limit, ADT, or ADTT conditions but has supplemental conditions that apply, the structure should be included in Category I. Category III structures are those that are located on secondary roads with speed limits of 35 mph (60 km/h) or less. Structures on secondary streets in residential areas will also be Category III. Category II structures are all structures not explicitly meeting the criteria for Category I or III. *Table 1.4* is excerpted from NCHRP 469 (2002).

AASHTO has since added quantified importance factors to the AASHTO LTS-1 specification. The factors are similar to the ones presented above, but have separated COSS and HMLT structures. For HMLT, AASHTO (2015) simply has a table with design pressures to be used. The AASHTO (2015) importance factors are presented in *Table 1.5* and *Table 1.6*.

Table 1.4 - NCHRP 469 Fatigue Importance Factors

Category		Importance Factor			
		Galloping	Vortex Shedding	Natural Wind	Truck Gusts
I	Sign	1.0	X	1.0	1.0
	Signal	1.0	X	1.0	1.0
	Luminaire	X	1.0	1.0	X
II	Sign	0.72	X	0.85	0.90
	Signal	0.64	X	0.77	0.84
	Luminaire	X	0.66	0.74	X
III	Sign	0.43	X	0.69	0.79
	Signal	0.28	X	0.53	0.67
	Luminaire	X	0.31	0.48	x

Table 1.5 – AASHTO LTS-1 (2015) Sign Structure Importance Factors

Fatigue Category			Fatigue Importance Factor, $I_F$		
			Galloping	Natural Wind	Truck Gusts
Cantilever	I	Sign, Traffic Signal	1.0, 1.0	1.0, 1.0	1.0, 1.0
	II	Sign, Traffic Signal	0.7, 0.65	0.85, 0.80	0.9, 0.85
	III	Sign, Traffic Signal	0.40, 0.30	0.70, 0.55	0.80, 0.70
Non-cantilever	I	Sign, Traffic Signal	-	1.0, 1.0	1.0, 1.0
	II	Sign, Traffic Signal	-	0.85, 0.80	0.9, 0.85
	III	Sign, Traffic Signal	-	0.70, 0.55	0.80, 0.70

Table 1.6 – AASHTO LTS-1 (2015) Fatigue Limit State Pressure Range for HMLT

Fatigue Design Case	Importance Category	
	I	II
$V_{\text{mean}} \leq 9$ mph	6.5 psf	5.8 psf
$9 \text{ mph} < V_{\text{mean}} \leq 11$ mph	6.5 psf	6.5 psf
$V_{\text{mean}} > 11$ mph	7.2 psf	7.2 psf

### Inspection

In the Roads & Bridges article Sign Structures under Watch, Collins & Garlich (1997) give a brief overview of the necessary pieces for a strong sign-structure management program. The authors state that each program should include an inventory, inspection report and maintenance program, and that the three would be established in a comprehensive database. The

authors advise use of climbing or a bucket lift to gain access for visual examination of the structure. While propagation of weld details is a significant concern in these structures, the authors noted that cracked anchor bolts above and within the concrete, loose nuts and missing connectors of the anchor bolts, and structure overload due to the installation of signs greater than design square footage had been reported. A developed inspection program will identify the overarching needs of the maintenance program.

If one wishes to retighten an existing base, Garlich & Koonce (2010) recommend replacing the nuts on the rod. This allows for lubrication of the existing rod and for broken washers to be replaced. Prior to removing the old nuts, it is crucial that thread pitch and rod diameters be measured and new nuts be readily available. If the rod material and strength is unknown, it is recommended that field hardness testing be completed. Otherwise it is prudent to use rotations recommended for Grade 36 rods to avoid damaging the existing rods by overtightening. Garlich & Koonce (2010) stated that severely corroded or damaged threads may be reconditioned by “chasing.”

#### *Summary of Nationwide DOT Practices*

As part of the literature review, state DOT specifications and standard drawings from across the nation were examined. The specifications were found online from DOT websites. Eight states did not have an anchor bolt tightening procedure listed in their standard specifications. Thirty-seven of the remaining forty-two states specified some form of the Turn-of-Nut method. The level of clarity in the specifications ranged from state to state. Some states listed a twelve to sixteen step procedure mirroring the procedure outlined in AASHTO’s LTS-1. Other states specified a Turn-of-Nut rotation or lubrication, but not the procedure outlined as in the AASHTO specification. Three states specified that nuts be left snug-tight and that no pretensioning be accomplished. Two states quantified snug-tightening; Illinois specified 200 lb-ft

of torque and Wyoming called for 250 lb-ft of torque. Most other states defined snug-tight as “firm contact between nut, washer, and baseplate” or the maximum rotation achieved by one man with a 12” wrench with or without a cheater bar. Two states specified that Direct Tension Indicator (DTI) be used to verify proper pretensioning. Four states specifically stated that calibrated wrenches be used for pretensioning the bolts. Three states specified double top nuts and three states specified the use of lock nuts. Based on the limited number of states using double top nuts, lock nuts, and DTI’s, it is difficult to draw conclusions or correlations between these practices and nut loosening. MnDOT’s current specifications are shown in *Figure 1.1* and *Figure 1.2*. The current IowaDOT Bridge Design Manual, which calls for Turn-of-Nut pretensioning, is shown in *Figure 1.3*.

#### Summary of Possible Causes of Nut Loosening

1. All previous research points to the fact that the relationship between torque and tension of large diameter anchor bolts is hard to fully predict and can be affected by a variety of factors.
2. As NCHRP 412 (1998) demonstrated, lack of pretensioning will lead to a greater chance of nuts loosening as the bolts are loaded.
3. As Hoisington's (2004) research found, too great of pretensioning can lead to yielding and elongation of the anchor bolt.
4. Currently, the AASHTO specification does not take grip length of the fastener into account.

In short, an anchor bolt must be pretensioned to a point that is sufficient to prevent loosening but not beyond the limit that will lead to elongation. The zone between deficient torque and excessive torque can vary from bolt to bolt based on the factors above, and greater

quantification of the relationship between torque and tension will be key to creating specifications that are in this zone.

**E Structural Steel**  
 Manufacture and fabricate structural steel in accordance with 2471, "Structural Metals," and the additional requirements and limitations specified in this subsection (2564.3.E).

Provide shop drawings for overhead sign structures and for Type A sign structures in accordance with 2471.3.B, "Shop Detail Drawings."

Assemble the truss sections and posts in the shop before galvanizing. Check truss sections and posts for straightness, alignment and dimensions and correct any variations. Correct warpage from galvanizing before installing structural steel.

Ensure main chord angles for overhead sign structures that are at least 1/2 in [13 mm] thick, meet a Charpy V-notch impact strength requirement of 15 ft•lb [20 N•m] at 40 °F [5 °C].

Drill or mechanically cut overhead sign post base plate anchor rod holes.

Lubricate the threads of anchor rods and nuts with anti-seize material before installation. Use the following minimum torque values:

Anchor Rod Diameter	Torque
2 in [51 mm]	300 ft•lb [400 N•m]
2 1/4 in [57 mm]	375 ft•lb [500 N•m]
2 1/2 in [64 mm]	450 ft•lb [600 N•m]
2 3/4 in [70 mm]	550 ft•lb [750 N•m]
3 in [76 mm]	700 ft•lb [950 N•m]

Tighten all leveling nuts and top nuts against the post base plate so that no shifting of top or bottom washers occurs when they are struck with an inspection hammer. After this tightness has been achieved, additionally tighten the top nuts another 1/12" turn (one-half of a flat).

Mar the anchor rod threads directly above the top nuts after tightening is completed.

Mar the threads of the anchor bolts in accordance with 2402.3.H, "Setting Anchor Bolts."

Unless otherwise required by the contract, provide and install galvanized structural steel posts (H-Pile) as footings for Type A signs in accordance with 2452, "Piling," 2471, "Structural Metals," and the following:

- Construct footings as required by the contract;
- The Department will allow use of a 14 ft [4.3 m] H-Pile post instead of welding a 2 ft [0.6 m] stub post to the 12 ft [3.7 m] H-Pile;
- Obtain a bearing capacity from 12 ton [107 kN] to 14 ton [125 kN] for each H-Pile in accordance with 2452, "Piling;"

Minnesota 2016 Standard Specifications 445

Figure 1.1 - Current MnDOT Specification for Anchor Tightening

**B. THE FOLLOWING TORQUE VALUES SHALL BE USED WHEN INSTALLING ALL ANCHOR NUTS FOR OVERHEAD SIGN STRUCTURES:**

ANCHOR BOLT DIAMETER	TORQUE (FT./LBS.)
2/4"	375
2/2"	450

THE CONTRACTOR SHALL BURR THE THREADS OF THE ANCHOR BOLTS IN ACCORDANCE WITH MNDOT 2402.3H AFTER TORQUEING NUTS.

CRETE CY (2)	REIN. STEEL LBS. (2)	ANCH. ASSM. LBS	ST. EXC. C.Y. (2)
3 + 0.46 G	945 + 98G	781	7.4 R
+ 0.46 G	2333 + 133G	1320	12.1 R

M REIN. BARS		(6) N REIN. BARS		P REIN. BARS (1)	
REQ'D SIZE	LENGTH	NO.	REQ'D SIZE	LENGTH	NO.
*7	13'-6"	20	*9	H + 2'-6"	2G
*10	17'-6"	24	*10	H + 2'-9"	2G
					*5 14'-3"
					*5 14'-3"

STATE PROJ. NO. \_\_\_\_\_ SHEET NO. \_\_\_\_\_ OF \_\_\_\_\_ SHEETS

Figure 1.2 - Current MnDOT Standard Drawings

**C10.2.5 Detailing**

**Procedure for tightening anchor rod (bolt) nuts for overhead bridge truss**

- 1) This work shall be performed only on days with winds less than 15 mph. All tightening of the nuts is to be done in the presence of the inspector. Once the tightening procedure is started it must be completed on all of the base plate nuts without pause or delay.
- 2) Properly sized wrenches designed for tightening nuts and/or bolts shall be used to avoid rounding or other damage to the nuts. Adjustable end or pipe wrenches may not be used.
- 3) Base plate, anchor rods, and nuts are to be free of any dirt or debris.
- 4) Apply stick wax or bees wax to the threads and bearing surfaces of the anchor rod, nuts, and washers.
- 5) Tighten top nuts so they fully contact the base plate. Tighten leveling nuts to snug tight condition. Snug tight is defined as the full effort of one person on a wrench with a length equal to 14 times the bolt diameter but not less than 18 inches. Apply the full effort as close to the end of the wrench as possible. Pull firmly by leaning back and using the entire body weight on the end of the wrench until the nut stops rotating. Use a minimum of two separate passes of tightening. Sequence the tightening in each pass so that the nut on the opposite side, to the extent possible, will be subsequently tightened until all of the nuts in that pass have been tightened.
- 6) Tighten top nuts to snug tight as described for the leveling nuts.
- 7) Match-mark the top nuts and base plate using paint, crayon, or other approved means to provide a reference for determining the relative rotation of the nut and base plate during tightening. Using a striking or hydraulic wrench, further tighten the top nuts in two passes as listed in the following table. Use a sequence of tightening in each pass so that the nut on the opposite side, to the extent possible, will be subsequently tightened until all nuts in that pass have been turned. Do not rotate the leveling nut during the top nut tightening.

Anchor bolt size	First pass	Second pass	Total rotation
Less than or equal to 1½ inch diameter	1/6 turn	1/6 turn	1/3 turn
Greater than 1½ inch diameter	1/12 turn	1/12 turn	1/6 turn

- 8) Lubricate, place, and tighten the jam nuts to snug tight.

**Procedure for tightening anchor rod (bolt) nuts for overhead cantilever truss**  
Use the same notes as above, but delete the second line in the table because the typical cantilever truss has 2¼-inch diameter anchor rods.

**Erection tolerances for aluminum/steel overhead bridge truss**  
Foundations and anchor bolts

- 1) Each foundation shall be accurately located, with the center of the two anchor bolt groups not more than 1 inch from the plan location in the direction parallel with and perpendicular to the overhead truss.

---

1 July 2016

Figure 1.3 - Current IowaDOT Bridge Design Manual

## Survey Procedure and Results

### State, District, and Industry Survey Procedure

To further pursue the research topic, a survey was prepared and sent to the eight districts in Minnesota. The survey was sent through email by the technical liaison from MnDOT. The goal of the survey was to better understand the tightening techniques, materials specified, lubrication method, and extent of anchor bolt loosening in different MnDOT districts. A copy of the survey is in Appendix B. In conjunction with the district survey, a separate survey was sent to the 49 other state DOTs, as described previously. This survey aimed to determine what other DOTs specify for anchor bolt installation, if other DOTs have experienced anchor bolt loosening

on overhead sign, signal, and luminaire structures, and what corrective action was taken. A copy of the survey is in Appendix C. Lastly, a survey was sent to industry representatives at several companies. The survey was completed by structural engineers with experience in both transmission tower, substation design, and sign/signal structures. A copy of the survey is in Appendix D.

### Survey Results

After the state, district, and industry surveys were completed, results were compiled.

#### *District Survey Results*

Major findings from the District Survey:

1. Responses arrived from all 8 districts, as summarized in *Table 1.7*.
2. Tightening procedure, including lubrication, anchor grade, and equipment used, varied from district to district.
3. Districts have different inventories and inspection procedures.
4. Based on prior research of the torque-tension relationship, current tightening torques are not enough to develop sufficient pretension in the bolts.

The district survey revealed that each district can have a high level of variance in the amount of overhead sign structures (OSS), as well as the amount of loose nuts observed. For example, District 4 stated that they have twelve overhead structures under their jurisdiction, while the Metro District claimed nearly 2000. Some of the districts stated having fewer than 10% of OSS with loose nuts, while the Metro District claimed 30% and upwards of 45% in a smaller sample size. It was found that the Metro District had recently evaluated the specification for anchor bolt tightening, and had adopted the FHWA (2005) & AASHTO (2015) procedure for Turn-of-Nut pretensioning. In the words of a Metro District engineer, the new specifications "flesh out" the installation process. The previous specifications stated the turn value to be



reached and the torque to be used in four steps. The new specifications from the Metro District are seventeen steps in length and provide tables and diagrams to insure proper contractor usage in the field. Furthermore, the torque values used by other districts could vary significantly from what is necessary for proper pretensioning.

Many factors impact the required tightening torque, including material, grade, lubrication, and galvanization. The anchor rod grade used in practice may be differing from district to district and by type of structure. One MnDOT official stated that MnDOT specifies Grade 55 rods, while another shared standard drawings that specify anchors meet MnDOT 3385, which calls for a 105 ksi rod. As stated previously, the equation  $T_v = 0.12d_b F_t$  is specified by AASHTO for verification torques. The verification torque is greatly dependent on the anchor bolt grade, for example a 55 ksi bolt will require nearly double the torque of a 36 ksi bolt. Two districts called out the 2015 revision of MnDOT Drawing ST-3 Foundations and Anchor Rods, where it is specified that bolts of 2¼" and 2½" require torques of 375 ft-lbs and 450 ft-lbs respectively. While these values would be sufficient for Grade 36 bolts, they are far too low for Grade 55 or Grade 105. The Metro District's modified specification includes a table of verification torques for 105 ksi anchors, the values for 2¼" and 2½" bolts are 1400 ft-lbs and 1575 ft-lbs respectively.

Table 1.7 - Summary of District Survey Results

District	# of Structures <sup>b,c</sup>	Tightening Method	Lubrication	Verification	Loose Nuts	% Structures with Loose Nuts
1 <sup>a</sup>	128	-	No	Yes	No	0
2	15	Turn-of-Nut	Yes	No	Yes	"Seldom"
3	74	Calibrated Wrench	No	Yes	Yes	"Several"
4 <sup>a</sup>	12	-	No	-	Yes	-
Metro	1970	Turn-of-Nut	Yes	Yes	Yes	30% - 45%
6	203	Turn-of-Nut	Yes	Yes	Yes	-
7E <sup>a</sup>	156	Calibrated Wrench	Yes	No	Yes	-
7W <sup>a</sup>	131	Calibrated Wrench	Yes	No	Yes	10%
8 <sup>a</sup>	10	Wrench Tightened	No	No	Yes	"Sometimes"
Lighting and Signals	N/A	Turn-of-Nut	Yes	Yes	Yes	-
<sup>a</sup> Survey stated survey completion by maintenance personnel or survey is believed to have been completed by maintenance personnel						
<sup>b</sup> Only high-mast light tower and overhead sign structures included						
<sup>c</sup> Level of inventory varies from District to District, these numbers may not be the most accurate						

One MnDOT official shared in the survey that most signal and light pole bases are high bases or transformer bases which will cover the top nuts of the double nut connection. The covering of the top nut makes it difficult to pretension the top nut, so contractors use the bottom nuts for Turn-of-Nut pretensioning. The survey also revealed that the Turn-of-Nut pretensioning for high-mast lights had been modified from the Grade 55 and 105 rotations (1/3 turn, 1/6 turn for bolts  $\leq 1.5$ " diameter and  $> 1.5$ " diameter respectively) to the use of grade 36 rotations (1/6 turn, 1/12 turn for bolts  $\leq 1.5$ " diameter and  $> 1.5$ " diameter respectively) for HMLT anchor tightening.

District responses created doubt that the service life prior to nut loosening can be predicted. Multiple districts indicated that loose nuts had been found within 6 months of installation, while others lasted decades in the field. This highlights the need for both verification

during installation and regularly scheduled inspections. A strong inspection program requires a full inventory. Based on the district responses, it was clear that inventories were not standard across the districts. Some districts inventoried overhead signs only, overhead signs and high-mast lights, or overhead signs, high-mast poles, signal arms, and regular light poles.

Some MnDOT districts indicated that lubrication is not used during construction tightening or maintenance tightening. Survey responses also highlighted a differing level of tightness verification during new construction. Responses varied from visual inspection of Turn-of-Nut reference marks, employing a specified verification torque, visual inspection of nut-washer-plate connection, and no verification at all. While pipe wrenches and torque wrenches were the most common tool used by districts, slug wrenches, cheater bars, and open end wrenches were also mentioned.

#### *State Survey Results*

Major findings of the State Survey:

1. Responses from 29 of 49 available states (not including Minnesota).
2. 24 states indicated experiencing loose nuts, ranging from 1% to 90% of structures  
(*Figure 1.8*)
3. Multiple states believe contractor error during tightening or poor construction oversight are the cause of nut loosening.
4. State inventories on sign, signal, and lighting supports vary significantly.

Over 80% of responding states indicated that they had seen loose nuts in the past. Similar to the responses of MnDOT districts, nuts were found to be loose in a significant time range, spanning from 6 months to 20 years. State responses overwhelmingly agreed that a majority of loose nuts are found during routine inspections. It should be noted that some state responses indicated that anchor bolts were not a part of routine inspection or that no routine inspection was

completed. The lack of routine inspection or proper inventory may well skew the data that was compiled for this report. There was a significant variance in which types of structures are inventoried by states, as demonstrated in *Figure 1.4*. While most respondents had numbers on overhead signs and high-mast poles, fewer than half of the respondents had inventories on light poles and signal arm structures. The lack of consistent inventories and similar inspection approaches makes it very difficult to establish relationships between tightening techniques and percentages of loose nuts found in states using that technique. Furthermore, states that indicated experiencing no nut loosening did not have consistent practices. Of the four states indicating no nut loosening by using Turn-of-Nut pretensioning, none had the same lubrication method, equipment usage, or verification procedure. Data did not demonstrate that one specific lubrication method, set of equipment, or verification procedure led to better mitigation of loosening. In short, there was no one variable that seemed to govern or control nut loosening.

A majority of states preferred to use Turn-of-Nut pretensioning (*Figure 1.5*). The most common lubrication method is wax, but many states do not specify lubrication (*Figure 1.6*). A surprisingly high number of states responding do not have a specified verification technique, though most states use the reference marks from Turn-of-Nut pretensioning (*Figure 1.7*). Of those responding, few stated that they had taken corrective action in the past to mitigate nut loosening.

Some responses stated that the state had reviewed and revised their specifications to prevent confusion for contractors performing tightening. The standard specifications became longer, more detailed, and less ambiguous to avoid errors or shortcomings. One state DOT official summarized it by writing:

"It has been our experience over the past 20 years that most contractors do not know how to properly tighten large diameter bolts. Prior to our research and specifications, most nuts were only tightened to about snug-tight using improper equipment (such as pipe extensions and pipe wrenches). As a result, loose nuts develop during cyclical loading. It is mandatory that specifications require the contractor to use proper equipment, and have inspectors present during the tightening process to verify that proper procedures have been followed."

Another states' response stated that:

"Compliance by contractor with Turn-of-Nut is virtually non-existent. Instead, most contractors simply tighten anchor nuts by feel."

Both of these states' responses highlight the need to have a fully specified procedure that includes verification of proper pretensioning during initial construction. The state of Washington specifies that an engineer observe the entire erection process, but the survey stated this does not always happen in practice. At this time, MnDOT does not have a standard verification during or after installation.

Washington stated that nearly 90% of existing support structures in their state had at least one loose nut. They believe that these nuts are loose due to improper installation and not environmental or loading conditions. Washington also stated that tightening in the star pattern is necessary to ensure all of the bolts have the required tension, and that hydraulic tools are the only practical method to tighten bolts larger than 1-1/2" diameter.

In reference to tightening anchor bolts, a response from Kansas stated that a "...Contractor must use a hydraulic wrench for this operation or it does not work." Maryland is currently in the process of moving away from Turn-of-Nut pretensioning. The response stated that they were in the process of developing tightening torques for hydraulic wrench tightening.

The respondent stated that Maryland and the wrench manufacturer were developing standard torques to be used for various anchor bolt sizes.

Three states were able to provide a cost estimate for the time and labor necessary for maintenance retightening of bolts. Maryland believed that it cost nearly \$1500 per structure to retighten bolts. The engineer who responded stated that a majority of this cost would be due to controlling interstate traffic while maintenance was completed. The response from Kansas estimated a cost of \$450 per bolt with “all things considered.” Washington stated that correcting loose nuts accounted for half of the time spent on site when performing structural condition inspections. The engineer in Washington stated that two full time inspector positions focus 90% on sign structures and high mast luminaires.

#### *Industry Survey Results*

The results of the industry survey were unexpected. In both the substation and transmission tower response, no form of pretensioning was used. Both engineers stated that bolts were left snug-tight upon installation. The anchor systems would include a lock or jam nut. It should be noted that the anchor circles on these structures may include thirty-six to forty-eight anchors, much more than the eight to twelve anchor systems seen on MnDOTs structures. It should also be noted that these structures are similar in their susceptibility to wind fatigue, but not identical in their responses to wind loading. The engineers from HDR did state that transmission towers are designed for absolute strength and wind fatigue. Engineers at Valmont stated that AASHTO’s Turn-of-Nut Method was the recommended anchor tightening procedure. They also stated that most states simply retighten nuts and that grade 55 or 105 anchors are the most used anchors.

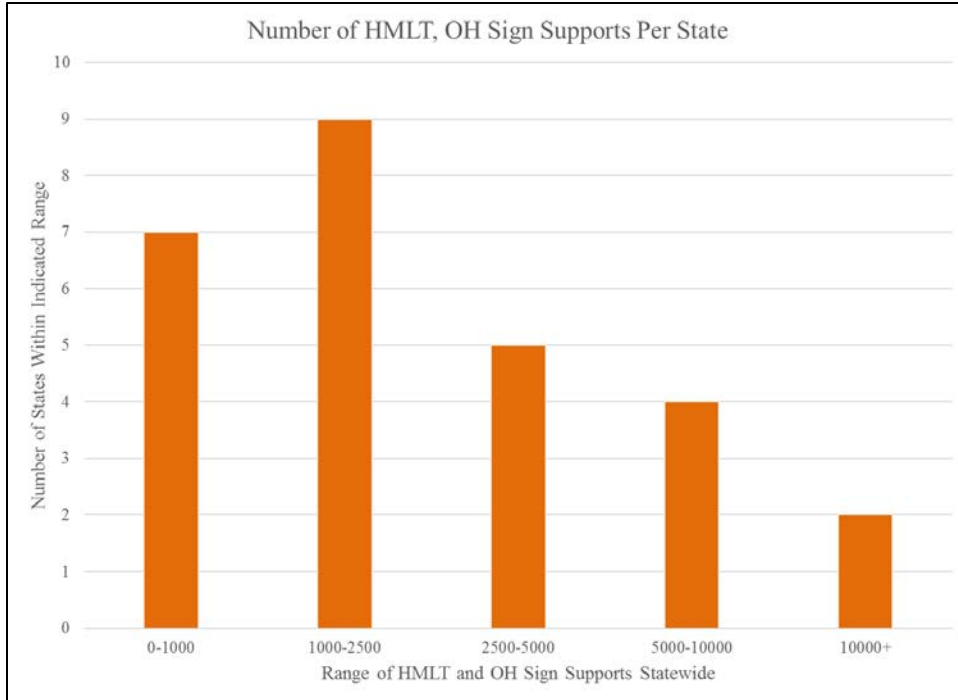

Figure 1.4 - Number of HMLT, Overhead Sign Supports Per State Survey

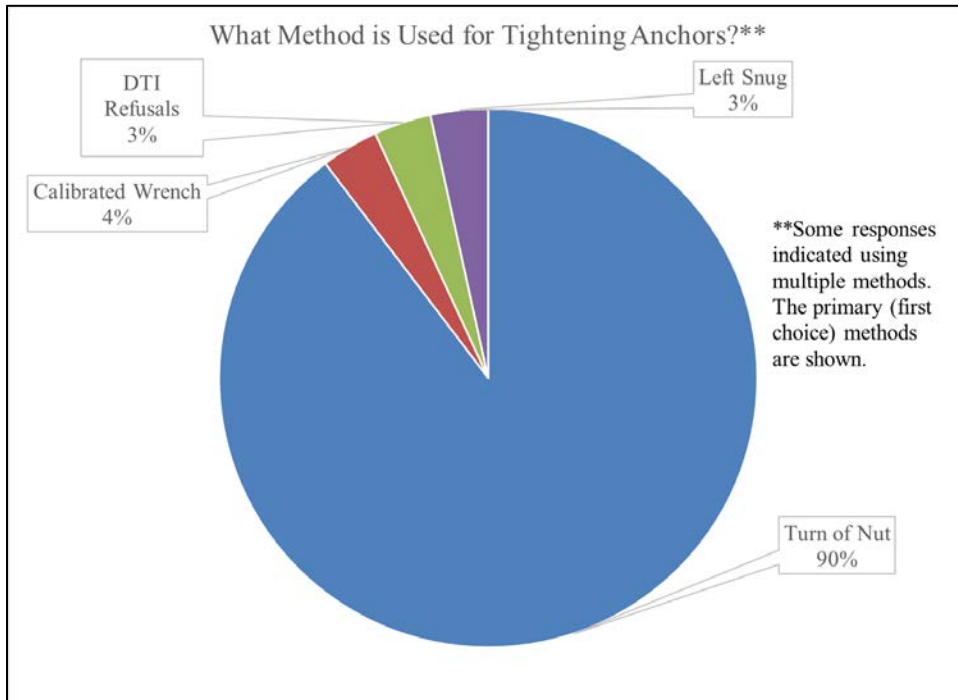

Figure 1.5 - Preferred Anchor Tightening Procedure Per State Survey

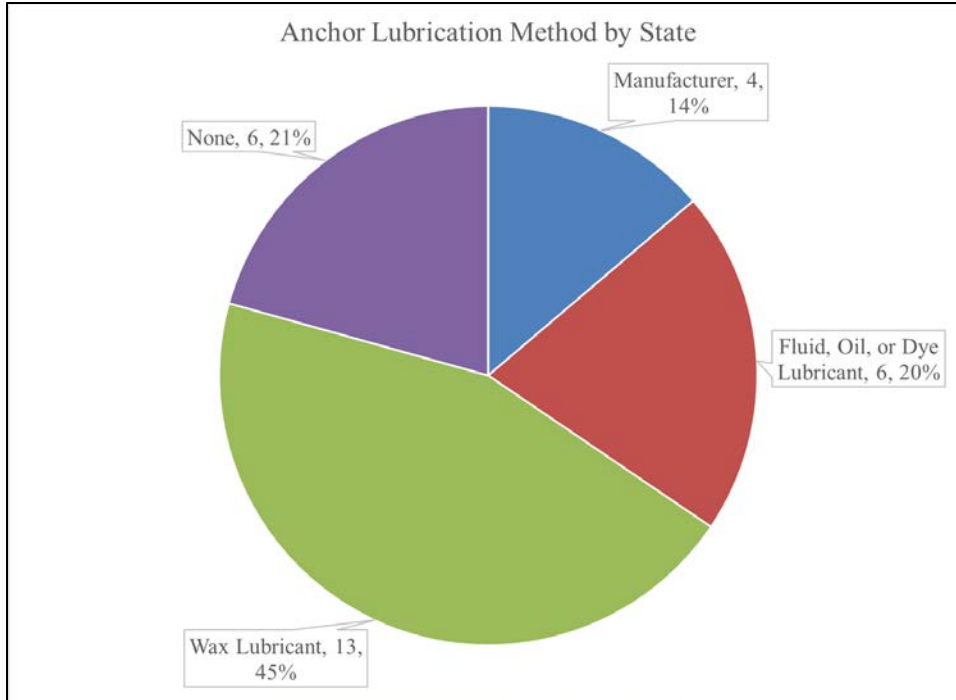

Figure 1.6 - *Lubrication Methods Per State Survey*

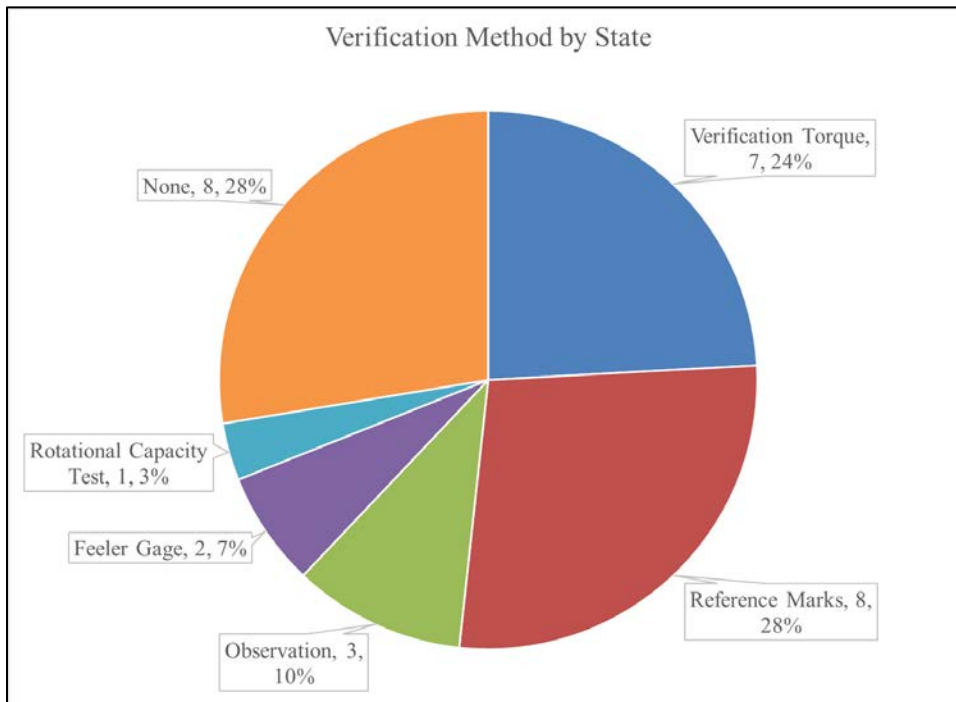

Figure 1.7 - *Verification Method Per State Survey*



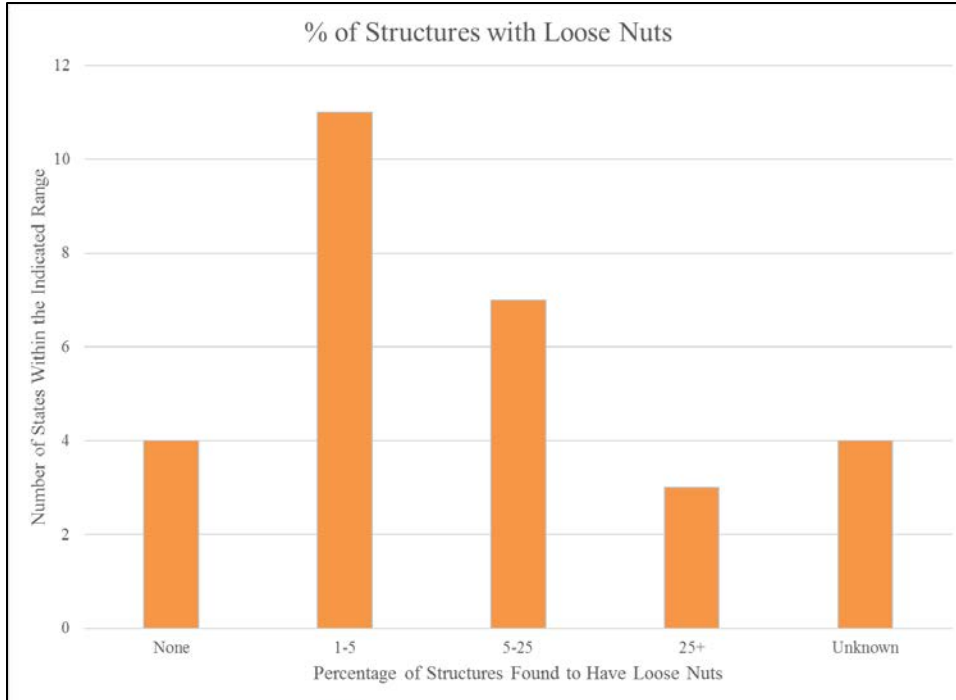

Figure 1.8 - *Percentage of Structures with Loose Nuts Per State Survey*

### Site Visits and Interviews

Multiple site visits and interviews conducted in Iowa and Minnesota yielded the following conclusions:

1. Installation practices in Minnesota vary by structure type and size.
2. Maintenance re-tightening is very time consuming and costly. Proper installation is necessary to ensure public safety and provide cost savings.
3. Contractor experience can have a significant effect on adherence to tightening procedures.
4. Snug-tight needs to be clearly defined in a specification.

#### Minnesota Site Visit – Multiple Locations, Metro District, Near Minneapolis, MN

To gain a greater understanding of the state of tightening practice in Minnesota and to view locations with loose anchor bolts, a site visit was conducted in September of 2016. During the site visit, the research team observed tightening of both an overhead sign truss (*Figure 1.9*,

*Figure 1.10*) and a cantilevered sign support (*Figure 1.11, Figure 1.12*) on Interstate 494 North near Maple Grove, Minnesota.

The overhead sign truss had been erected at 1 am that morning; tightening was scheduled for 8 am. The contractor stated that he had leveled and “hand tightened” the nuts the night before to keep the sign in place until that morning. The anchor bolts were 2½” bolts, and the distance from the foundation to the leveling nuts was greater than 1” but less than the bolt diameter. The contractor explained that before placing the baseplate, the four corner leveling nuts are leveled with each other using a hand level, and then the base is placed on top of them. No lubrication was used on the bolts, and the contractor stated lubrication was not specified. While this contract was created before the Metro District began specifying the Turn-of-Nut Method, a Metro engineer told the team that lubrication was specified in the overhead sign contract. The contractor used a 36” cheater bar and open end wrench to tighten the leveling nuts (*Figure 1.13*). Top nuts were tightened to the MnDOT specified torque using a 48” torque wrench (*Figure 1.14*). The research team did not witness the torque wrench being calibrated before tightening. The contractor stated that he preferred to supply a small amount of additional torque beyond what is specified. After tightening, the threads just above the top nut are punctured (*Figure 1.15*). During the tightening procedure, the star tightening method was not used; the contractor tightened bolts in a circle around the foundation. The contractor stated that there was no verification check for the bolts and that a leveling check was not completed either. The leveling nuts were approximately 1.75” above concrete (*Figure 1.16*).

The cantilevered sign support was tightened in the same fashion. It had been erected earlier that week and had been left “hand tightened” until that morning so the research team could view tightening. An inspection team came on site to check the cantilevered sign after

tightening. Minutes after tightening the team found one of the nuts were loose. The nut was one of the first to be tightened and could have come loose as the others were tightened. The contractor stated that he had completed tightening on nearly 65 supports in 2015 and had over 70 scheduled for 2016. He had never used the Turn-of-Nut Method and was not aware of the procedure. The specific contractor did not handle signal supports, light poles, or high-mast lighting. MnDOT had specified Turn-of-Nut on high-mast lighting for some time, but not on sign structures.

The research team was able to observe the inspection process of both the newly erected cantilevered sign support near Maple Grove and an existing VMS truss support (*Figure 1.17*) near the I-494 and I-35 interchange. The existing VMS support had been tagged in 2014, indicating the last time maintenance had been completed. The inspectors demonstrated how loosening of nuts was checked. First a brief visual inspection was completed, and then the inspector struck the washers with the pointed end of a hammer (*Figure 1.18*). If the washer moved or rotated, it indicated that the top nut was loose. Leveling nuts are only inspected visually due to space restrictions. When loose nuts are found, a hydraulic wrench is used to tighten them. The inspectors stated that older structures provide significant issues if the bolts have rusted or if additional friction has built up between the nut and bolt. Inspectors also described experiences tightening the nuts and seeing the entire bolt turn in the foundation because the stored friction was so significant. To mitigate this, the inspectors draw reference marks on the bolts, nuts, and baseplate before tightening (*Figure 1.19*). The top of the hydraulic wrench is open, so the reference marks can be seen during tightening (*Figure 1.20*). During the inspection of the VMS support, 6 of 8 nuts were found to be loose. 75% of the nuts had become loose in just two years. The current inspection tightening does not specify the star tightening

pattern, and some of the nuts became loose again as the others were tightened. Lastly, the support was tagged again and the inspection report was completed (*Figure 1.21, Figure 1.22*).

#### Minnesota Site Visit – District 6, Near Owatonna, MN

In order to understand inspection and maintenance procedures outside of the Metro District, a site visit to Owatonna, MN in District 6 was completed in November of 2016. The research team observed inspection of three structures and interviewed the inspector. The inspector took the team to locations that had been inspected within the previous 24 months. These locations all had loose nuts during their initial inspection, which took place within 24 months of installation. The inspector stated his belief that improper and inconsistent installation is leading to nut loosening. He described times when leveling nuts are entirely loose, and times when only the corner bolts are tightened. One of the structures had rusted washers, meaning that washers were not properly galvanized or the protective coating had been removed by the motion of the loose nut (*Figure 1.31*). Another structure had severely undersized washers that were barely visible under the nut (*Figure 1.32*). The inspector stated that some installations would include punctures to the threads above the top nut, but punctures were not visible on the structures observed during the site visit. He also stated that contractors did not consistently leave sufficient thread length above the top nut.

During the interview, it was discovered that District 6 did not have maintenance plans for many of these structures. The inspector was a member of the bridge inspection team, as is common for many MnDOT Districts. Based on provided inspection reports, the nuts on these structures had been loose for over 20 months. One structure was hand-tight to the point that the inspector could rotate the nut with almost no effort. These facts emphasize the importance of proper installation. Many districts do not have the adequate funding to purchase a hydraulic wrench and supply labor, especially not on an inspection cycle that would be necessary based on

the poor performance of multiple structures. This site visit provided a clear picture of the importance of proper installation to ensure public safety and reduce inspection efforts.

#### Interviews and Meeting with MnDOT Personnel

During the inspection procedure in September, 2016, an interview of the inspectors was conducted. The inspectors stated they had spent the previous five years building up an inventory by inspecting the sign supports in the Metro District. It was estimated that the crews had inspected and tightened 4-5 structures per day, 5 days a week for the last 5 years. The inspectors had seen loose nuts on cantilevered, overhead, and VMS supports, but stated that VMS bridges were usually the worst cases. They stated that the anchors on the side opposite the VMS were almost always loose during inspection. The inspectors discussed the difficulty of tightening leveling nuts with the current tools they have. Many times leveling nuts have to be left as is or top nuts need to be tightened until the leveling nuts are making contact with the baseplates. The inspectors also stated they had seen loose nuts immediately after installation, and they believed it was due to a contractor forgetting to perform tightening. Multiple times they've seen a contractor tighten the corner leveling nuts (that the plate is initially placed on), but forget to tighten the remaining leveling nuts. The inspectors also preferred structures with 8 anchors over 12 as it provided more space for them to perform the inspection and retightening. It should be noted that the inspectors interviewed deal strictly with overhead and cantilevered signs; they do not work with high-mast lights or smaller light poles.

While the research team was in Minnesota, a meeting was held at a MnDOT facility in September of 2016 to discuss the research and the issues MnDOT was experiencing. Representatives from state signing, maintenance, bridge division, lighting and signals, and the Metro District were all present. During the meeting, it was decided that a versatile specification that covered high-mast lighting, sign structures, and signal structures was needed.

Representatives from signals and lighting stated that iron spud wrenches should be specified, as aluminum pipe wrenches can break before a significant torque is achieved. The validity of calibrated torque wrenches was called in to question. Some personnel stated that if contractors are not calibrating the wrench properly, they could easily be providing too little or too great of torque. It was decided by all parties that lubrication would be included; multiple parties liked Bostik Mariner's Anti-Seize. The use of lock or jam nuts as top nuts was questioned, but some members of the meeting did not like that. From past experiences, lock nuts had performed inconsistently and typically marred the bolt. Once the threads of the bolt are marred maintenance becomes a greater issue, and many times the bolt is effectively ruined. The personnel all agreed that a new method of verification was necessary. Maintenance stated that it would be difficult to send inspectors to all installation and tightening, and they believed it would be best if the construction division handled initial verification. The Metro District was currently working on a contractor inspection form that would require contractors to indicate they performed every step of proper installation and then sign the form. The greatest concern of the meeting was the need for a more accurate measurement of pretension in MnDOTs anchor bolts. The understanding of how galvanizing, lubrication, grip length, and material grade affect the pretension were all brought up during the discussion. Quantifying this relationship and developing an effective and enforceable specification will be focuses of this research moving forward.

#### Iowa Site Visits – Interstate I-35 near 13th Street, Ames, IA

Two site visits were conducted in Iowa, near the 13<sup>th</sup> street exit on Interstate 35. Iowa DOT was placing light poles near the off ramp to illuminate the area at night. During the first site visit, the anchor bolts were set and the foundation was poured. The contractors used a template to keep the bolts plumb and within acceptable distances. During the concrete pour, the exposed threads of the anchor bolts were covered with duct tape to prevent concrete splatter hardening on

the threads. After pouring the concrete, the duct tape and anchor bolt template were removed so the concrete could harden around the bolts.

The structures being placed were typical 50' light poles. These structures are not tightened using the Turn-of-Nut method and contain breakaway bases. While the structures are atypical from a sign support, cantilevered signal, or high-mast light, the contractor has experience placing and tightening all of the aforementioned structures. From the site visit the research team gained a better understanding of the installation conditions in the field. During this specific visit, the contractor had been completing other work beforehand and did not have the usual tools to complete proper tightening. There was also confusion between a few members of the construction team as to how the base and pole were to be erected, and which anchors and washers went together. The research team learned that having a clear, specific, and verifiable specification will be critical to preventing nut loosening.

#### Iowa Site Visits – Interstate I-35 near University Avenue, Des Moines, IA

To provide a better comparison between tightening practices in Iowa and Minnesota, additional Iowa site visits were conducted. The structure being installed was a cantilever sign truss. Due to the size of the structure and the nature of heavy construction, a lane closure along I-35 North was required. To prevent traffic pile-up, the lane closure and construction took place at night.

Upon arriving at the site, the foundation had set. Anchors were in place and being prepared for pole installation. At first bottom nuts were leveled with each other and topped with a washer (*Figure 1.23, Figure 1.24*). Next the pole was lifted with a crane and set onto the leveling nuts (*Figure 1.25*). Washers were placed on top and then nuts were hand tightened (*Figure 1.26*). After hand tightening, a slug wrench was used for snug-tightening (*Figure 1.27*). Each top nut was then given two reference marks; one at 1/12 turn and another at 1/6 turn. The

initial location of the nut was marked on the nut and the baseplate. The first round of tightening will rotate the nut to the 1/12 mark and the second round will rotate the nut to the 1/6 mark (*Figure 1.29*). Nut tightening was completed in a circular pattern around the outside of the baseplate, not with the conventional star tightening pattern. Turn-of-Nut tightening was completed with a combination of wrenches (*Figure 1.28*). After tightening the nuts, lock nuts were placed on top and tightened with a wrench (*Figure 1.30*). No verification of nut tightness was completed. The bolts came factory lubricated; the contractor stated that factory lubricant was preferred. The bottom of the leveling nuts were less than 1" from the face of the foundation.

It was clear that contractor experience and compliance can have a significant effect on the quality of tightening. Even if the contractor is aware of the proper specifications and construction procedures, there can still be errors. During this site visit, one of the crew leaders had to stop improper tightening. Instead of completing 1/12 turn of all of the nuts and then completing a second pass to finish tightening, the crew began by tightening individual nuts the full 1/6 turn in one pass. It was also clear that the snug-tight condition had not been met. As Turn-of-Nut tightening began, a member of the crew was still able to rotate one of the nuts by hand. The crew then described the 1/6 rotation as snug-tightening of the nuts. Without reaching the snug-tight condition, additional rotation will not provide adequate pretension to resist loosening.

#### Meeting with IowaDOT Personnel

Following the meetings with MnDOT personnel, an additional meeting with IowaDOT personnel was completed. Iowa personnel had experienced loose nuts in the past and had adjusted their specifications. One of the engineers stated that many of the current AASHTO Turn-of-Nut specifications came out after Iowa began specifying Turn-of-Nut. The research team was also informed that much of the research that went into the current AASHTO specifications was completed in conjunction with IowaDOT. The engineer also stated that without lubrication



bolts cannot be properly pretensioned. He did state that lack of lubrication or overtightening would cause damage to threads.



Figure 1.9 - *Overhead Sign Truss on Interstate 494 Near Maple Grove*



Figure 1.10 - *Overhead Truss Baseplate and Anchor Bolts*



Figure 1.11 - *Cantilevered Sign Support on Interstate 494 Near Maple Grove*



Figure 1.12 - *Cantilevered Sign Support Baseplate and Anchor Bolts*





Figure 1.13 - *Leveling Nut Tightening in Minnesota*



Figure 1.14 - *Top Nut Tightening with Calibrated Wrench in Minnesota*



Figure 1.15 - *Puncturing of Threads after Tightening*



Figure 1.16 - *Distance from Foundation to Bottom Leveling Nut*





Figure 1.17 - VMS Support on I-494 Near I-35



Figure 1.18 - Washers Struck to Inspect Nut Tightness



Figure 1.19 - *Reference Marks Used During Maintenance*



Figure 1.20 - *Hydraulic Wrench Used for Maintenance Retightening*



Figure 1.21 - *After Maintenance Retightening*



Figure 1.22 - *Tagging After Maintenance*





Figure 1.23 - *Leveling During Iowa Site Visit*



Figure 1.24 - *Preparing for Pole Installation*





Figure 1.25 - *Installation of Pole*



Figure 1.26 - *Hand Tightening of Bolts*



Figure 1.27 – Snug-tightening of Bolts



Figure 1.28 - Final Tightening After Making Reference Marks





Figure 1.29 - *Post Tightening with Reference Marks Shown*



Figure 1.30 - *Final Assembly with Jam Nuts*





Figure 1.31 - *Rusted Washers Found in District 6*



Figure 1.32 - *Undersized Washers Found in District 6*

## General Conclusions

Based on the study in Chapter 1, the following conclusions can be drawn:

1. Minnesota is not the only state experiencing loose nuts on sign, signal, and luminaire support structures.
2. Maintenance of these structures is a time consuming and costly procedure that leads to varying levels of success.
3. Multiple states believe that improper installation by contractors is leading to poor performance by the structures.
4. It is very possible that contractors do not have the proper training or past experience to complete adequate Turn-of-Nut pretensioning.
5. It was clear that “snug-tight” takes different meaning depending on the source.
6. The literature review proved that bolts can be overtightened; leading to permanent elongation and loss of clamp force between the bolt and nut.
7. The literature review also proved that bolts can be under-tightened; causing loosening immediately after installation.
8. Research reports demonstrated that previous fatigue testing disagrees as to whether the use of Grade 55 or Grade 105 rods leads to greater fatigue strength.
9. Lubrication, bolt diameter, bolt grade, galvanization, and alignment have all been shown to affect the required torque for sufficient preload in the anchor bolts of COSS and HMLT structures.
10. MnDOT districts have a high level of variance in their tightening procedures, level of inventory, and maintenance procedures. Some districts have no current maintenance procedure beyond inspection, which places high importance on proper installation.

These conclusions lead to two very probable reasons for the nut loosening in Minnesota:

1. The current understanding of the relationship between torque and tension in double nut moment connections is incomplete. States using Turn-of-Nut, DTI's, and Calibrated wrench tightening all experienced nut loosening; none of the methods were consistently sufficient in double-nut moment connections.
2. It was clear that contractor error or negligence during initial tightening can play a significant role in nut loosening.

The research team aimed to establish a clear tightening specification that provides sufficient pretension without causing the bolt to elongate. The site visits and literature review proved that determining the torque-tension relationship through field monitoring of a MnDOT sign structure and lab studies of double-nut moment connections was necessary. This quantitative data was used to determine the most effective and applicable tightening procedure for Minnesota. Bearing in mind that proper installation is critical to preventing nut loosening, a portion of the proposed specification is focused on verification of contractor performance.

## CHAPTER 2. TESTING BY SKIDMORE WILHELM MACHINE

### Introduction

#### Theoretical Background

The double nut moment connections used for sign, signals, and luminaires have been tested in the past. Experimental results have led to the 2016 AASHTO Standard Specification for Sign, Signals, and Luminaires (LTS-1) specifications for nut rotation and verification torque. However, the AASHTO specification does not account for grip length of the anchor. Testing completed in Alaska determined that accounting for grip length would lead to a reduction in pretension scatter in the anchor rod groups (Hamel & Hoisington 2014). The traditional relationship between torque and pretension in structural fasteners is shown in Equation 2.1.

$$T = KFD$$

Equation 2.1

T is the applied torque, F is pretension in the fastener, D is the bolt diameter, and K is a nut factor. In smaller fasteners, the nut factor is affected by the finish, lubrication, and tightening method. In short, anything affecting the friction between the bolt, nuts, and joint will influence the nut factor. Based on Hamel & Hoisington's (2014) data and the mechanics of structural fasteners, grip length must also be affecting the nut factor. Classic mechanics states that axial deformation in the bolt is determined by Equation 2.2.

$$\Delta_{\text{bolt}} = \frac{FL}{AE}$$

Equation 2.2

where  $\Delta$  is the axial deformation, F is the axial force, L is the bolt length, A is the tensile stress area, and E is the modulus of elasticity. In a double nut moment connection, F is the

preload (pretension) and  $L$  is the length between the two nuts (grip length). The understanding of structural connections also relates nut rotation to total deformation in Equation 2.3.

$$\Delta_{\text{total}} = \frac{\alpha}{360} * P_i$$

Equation 2.3

where  $\Delta$  is again deformation,  $P_i$  is the pitch factor, and  $\alpha$  is the nut rotation in degrees.

One can relate Equation 2.2 and Equation 2.3 to determine how nut rotation affects the preload in a rod. This is an incomplete picture though. Bickford (1995) made note that the deformation in Equation 2.3 is the total deformation in the connection. This deformation will be distributed between the fastener and surrounding joint, and the distribution will be due to the stiffness ratio between the fastener and joint. This is shown in Equation 2.4.

$$\Delta_{\text{bolt}} = k_s \left( \frac{\alpha}{360} * P_i \right) = \frac{FL}{AE}$$

Equation 2.4

In Equation 2.4, the  $k_s$  value is the percentage of total deformation that is causing elongation in the bolt. The  $k_s$  value will vary based on the ratio between the bolt and the total stiffness of the connection. It is expected that the  $k_s$  value will change as the bolt stiffness changes. In smaller structural connections, data has shown that the bolt stiffness is one third to one fifth that of the joint (Bickford 1995). In that case, one would expect a majority (~75% to 85%) of the deformation to be experienced by the bolt. However, by examining data from Hamel & Hoisington's research and the extensive research that has altered the LTS-1 specification, it is clear that a much lower percentage of deformation is taking place in the bolt. Testing and numerical analysis are necessary to determine what portion of total deformation is taking place in



the bolt. Theoretically, if one were to treat a threaded fastener as a series of springs, then one can calculate bolt stiffness by Equation 2.5.

$$\frac{1}{k_b} = \frac{1}{k_t} + \frac{1}{k_d}$$

Equation 2.5

where  $k_b$  is the bolt stiffness within the grip length,  $k_t$  is the stiffness of the threaded portion within the grip length,  $k_d$  is the stiffness of the non-threaded portion within the grip length, and all units are measured in force per unit-length. The stiffness values for  $k_t$  and  $k_b$  can be found using Equation 2.6 and Equation 2.7.

$$k_t = \frac{A_t * E}{l_t}$$

Equation 2.6

$$k_d = \frac{A_d * E}{l_d}$$

Equation 2.7

where  $A_t$  is the bolt tensile area,  $E$  is the modulus of elasticity,  $l_t$  is threaded rod length within the grip,  $A_d$  is the bolt area based on diameter, and  $l_d$  is the non-threaded length of bolt within the grip length. If one examines Equation 2.8, a few relationships become clear. If the stiffness of the bolt and joint were equal, one would expect equal deformation. If there is an expectation that the baseplate joints of MnDOT's standard structures are all of equal stiffness, then one can see that decreasing bolt diameter (and therefore tensile area) will decrease the bolt stiffness and increase the deformation of the bolt. Increased deformation in the bolt will cause a greater value for  $k_s$ . To conclude, if baseplate thickness is constant, as bolt diameter increases for a given anchor bolt grade, one will expect the  $k_s$  value to decrease.

$$\Delta_{\text{total}} = \Delta_{\text{bolt}} + \Delta_{\text{joint}}$$

Equation 2.8

The relationships between torque, rotation, and bolt tension are all linear once beyond the snug-tight value. Before reaching snug-tight, any tightening will flatten the washers and clamped material until there is firm contact throughout the joint. In order to rely on the linear relationship between rotation and tension, achieving a proper snug-tight value is critical.

### **Testing Using Skidmore Wilhelm Machine**

#### Skidmore Wilhelm Testing Objectives

1. Determine nut constants,  $K$  of *Equation 2.1*, at various diameters and grip lengths for MnDOT standard structures.
2. Determine an approximate ratio of bolt elongation and total deformation,  $k_s$ , based on bolt diameter and grip length for MnDOT structures.
3. Determine how snug-tightening will affect final pretension values in bolts in the double-nut moment connection.
4. Determine typical snug-tight values achieved with a regular wrench.
5. Determine how lubricity affects torque tightening and Turn-of-Nut tightening.
6. Determine the effectiveness and usefulness of DTI's for double-nut moment connections.

#### Testing Setup and Applicability

To observe values for  $K$  in Equation 2.1 and  $k_s$  in Equation 2.4, extensive testing was completed with Skidmore Wilhelm tension measuring devices. A Skidmore Wilhelm is used to measure the axial tension of a fastener within the machine's grip length. Mechanically, a bolt is placed in the Skidmore Wilhelm, and then a tension output is observed as torque is applied. For

bolt diameters from 3/4" to 1-1/2", the HS unit was used. For 1-1/2" to 2-1/4" bolts, the K unit was used.

Skidmore Wilhelm testing provides greater benefits than simply examining the nut factor, K, for MnDOT's standard anchors. The relationship between nut rotation and axial tension can also be investigated. The clamped material used during testing with Skidmore Wilhelm machines is a 4140 steel. This material has similar modulus of elasticity, E, values as the steel baseplate material used by MnDOT. Since the modulus of elasticity, E, is the same, the results from Skidmore Wilhelm testing should have direct applicability to expected results in the field. Knowledge of the actual stiffness distribution will allow for adequate pretensioning of the bolt, while also preventing the yielding that Hamel & Hoisington (2014) examined in Alaska. At a minimum, the Skidmore Wilhelm testing data provides an empirical foundation for the basis of  $k_s$  in Equation 2.4 that can be compared with data from field monitoring and tightening tests of anchors in a MnDOT baseplate.

To accomplish these goals, over 120 bolt pieces and threaded rods were tested with the Skidmore Wilhelm devices. For low torque values (< 150 ft-lbs), a calibrated torque wrench was used to incrementally apply torque to each bolt. For larger torque values (> 150 ft-lbs), a hydraulic wrench was used, as shown in Figure 2.1 and Figure 2.2. Tightening was stopped once the LTS-1 recommended pretension had been met, the torque or hydraulic wrench limitations had been met, or the Skidmore Wilhelm load cell limitations had been met.

Before being placed in the Skidmore Wilhelm, the bolts were cleaned with a wire brush and lubricated with Bostik Never Seez Mariner's Choice as shown in *Figure 2.4*. The bolt threads, nut threads, and nut bearing surfaces were lubricated. These processes are specified by MnDOT for tightening of sign, signal, and luminaire structures. The F1554 bolt lengths did not

have an attached head, therefore one end of the threaded rod needed to be double-nutted to prevent the bolt from rotating as torque was applied. This process was suggested by the Skidmore Wilhelm manufacturer, and is shown in *Figure 2.7*. The prevention of rotation by the double-nutting is based on the friction built up between the two hex nuts. In order to maximize this friction and prevent rotation, no lubrication was provided to these nuts or that end of the thread length.

Once the bolt had been placed in the Skidmore Wilhelm, it was incrementally tightened. First, the bottom nuts were tightened to snug-tight to create the double-nut in *Figure 2.7*. For the double-nut, snug-tight was defined as firm contact. Next, the bolt length was placed in the Skidmore Wilhelm. The portion of the bolt protruding from the Skidmore Wilhelm was lubricated. Next a lubricated, hardened washer was applied, and then a lubricated nut was tightened to snug-tight. For the application of the lubricated nut, typical snug-tight values were defined by testing. A regular open end wrench was used to tighten the bolts with “full effort”. The lubricated nut was then incrementally tightened using predetermined torques. The torques used for incremental tightening were calculated using the nut factor,  $K$ , of 0.12 that was determined by Till & Lefke (1994). Data was logged using a pressure transducer attached to the Skidmore Wilhelm, as shown in *Figure 2.3*.

After an individual torque had been reached, the rotation achieved was measured. Rotation angles were measured using a digital level. Once a bolt had reached snug-tight, the digital level was zeroed along one edge of the nut, shown in *Figure 2.5*. As the nut was tightened, the digital level would measure the rotation from zero, and thus the corresponding rotation of the nut. Typical measurement is shown in *Figure 2.6*.

A small amount of bolts were randomly selected to be tested without any lubrication. This testing demonstrated the effect that contractor adherence has on the effectiveness of torque and rotation relationships. Finally, DTIs were placed between the lubricated nut and hardened washer to examine their effectiveness in measuring preload. DTI testing was accomplished by comparing the manufacturers provided gap-tension curve with measurements taken in the lab.

During testing, careful attention was paid to ensure that none of the bolts yielded. By keeping bolts in the elastic range, the behavior of each test specimen could be compared with that of others. Not only is the behavior of the bolt simpler to predict and understand before yielding, it also prevents the loss of clamp force phenomena found in research conducted by Hamel & Hoisington (2014).



Figure 2.1 - *Hydraulic Wrench Tightening*



Figure 2.2 - *Operation of Hydraulic Wrench*

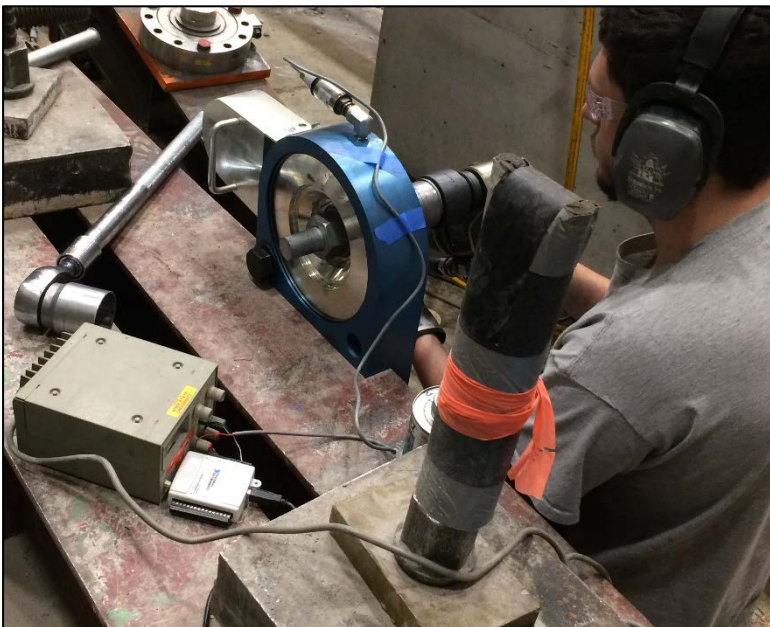

Figure 2.3 - *Skidmore Wilhelm Instrumentation*





Figure 2.4 - *Lubrication of Nut Bearing Surface*



Figure 2.5 - *Zeroing of Digital Level*



Figure 2.6 - *Digital Level Measurement after Tightening*



Figure 2.7 - *Double Nut to Prevent Bolt Rotation*



## Testing Results

### *Limitations to Testing*

Before analyzing the data, it is important to note the limitations to the results. Due to spatial requirements in the Skidmore Wilhelm and manufacturing error of some of the bolts, the exact grip lengths used by MnDOT could not be met. Data proved that the snug-tight tension had a strong impact on torque and rotation test outputs. Skidmore Wilhelm tension measuring devices are more precise when above minimum tension values. For example, the HS unit (for smaller diameters) is more accurate when the measured tension is  $\geq 20$  kips. Similar to structures in the field, taking precise angle measurements was difficult. For very small diameters (3/4" and 1"), it was very difficult.

Grip length is the major issue with using a Skidmore Wilhelm device to test large diameter bolts. In order to test large diameters ( $> 1.5$  inch), the Skidmore Wilhelm requires a significantly longer grip length than what would be seen in the field. Data was compared with the results of Hamels & Hoisington (2014) and Till & Lefke (1994) to extrapolate to smaller grip lengths. Though this provides some uncertainty to the effectiveness of using the Skidmore Wilhelm to model MnDOT's double-nut moment connections, it does provide a direct benefit on the understanding of the effect of grip length.

By using the relationship in Equation 2.1, the effect of grip length on the nut factor,  $K$ , can be examined. In particular, the 1-1/2" bolts were tested using a very small grip length in the HS unit and a much larger grip length in the K unit. This was the most dramatic change that could be modeled, but for other bolt sizes, spacers were used to increase the grip length. Whenever over 6 bolts of one diameter and grade were to be tested, spacers were used to vary the grip length. This was not the case with the 3/4" A325 bolts due to a manufacturing error that limited the available thread length.

Following preliminary analysis of test results, it was clear that the pretension established at snug-tight would affect all of the following pretension values. In order to reduce the effect of the snug-tight value, bolts were tightened or loosened to a consistent snug-tight level before torquing or rotation began. In the field, it is much more difficult to provide consistent snug-tight values, but for lab testing purposes it was relatively simple to control. Furthermore, the  $k_s$  value calculated is not dependent on the snug-tight value, just based on the linear portion beyond snug-tight. This can be seen in *Figure 2.15*.

It should be noted that a majority of the tension outputs for the  $\frac{3}{4}$ " and 1" bolts were below the 20-kip threshold of the HS unit. This should be considered as results are examined.

#### *Snug, Torque, and Rotation Results and Analysis*

Testing resulted in the following conclusions:

1. The snug-tight value has a direct impact on final pretensions when using Turn-of-Nut tightening.
2. There is typically a difference between 'actual' snug-tight and 'achieved' snug-tight, as demonstrated in *Table 2.1*. Using a snug-tightening torque of 20-30% of the verification torque (recommended by Garlich & Thorkildsen 2005) should push the 'achieved' snug-tight beyond the 'actual' snug-tight value.
3. The nut factor,  $K$ , of 0.12 proposed by Till and Lefke is accurate for new bolts. This is shown in *Table 2.2*.
4. Grip length demonstrated little impact on the  $K$  value of *Equation 2.1*. This is shown in *Table 2.2*.
5. The ratio of bolt elongation vs. total deformation,  $k_s$ , has an inverse relationship to bolt stiffness (i.e. diameter / grip length). This is shown in *Figure 2.36* and *Figure 2.37*.

6. Similar to Hamel & Hoisington's conclusions, it was found that a significant amount of total deformation was not flattening the clamped material nor elongating the bolt. For bolt diameters greater than 1.5" with a grip length less than 4 inches, one would expect 5-10% of the deformation due to nut rotation to cause bolt elongation. This can be extrapolated using *Figure 2.36* and *Figure 2.37*.
7. Lubrication has an effect on both the torque-tension and rotation-tension relationships for large diameter anchor bolts (> 1.5"). Proper lubrication reduces pretension scatter, increases achievable snug-tight, and lowers the torque required for tightening.
8. DTIs demonstrated usefulness as an approximate measurement of bolt tension at the AASHTO LTS-1 specified pretension values, but there was limited precision among the results. This is shown in DTI Testing Results and Analysis.

It was very apparent during all of the testing that the pretension value at the snug-tight condition would affect final pretensions. This is critical to take into account to avoid yielding, as Hamel & Hoisington (2014) concluded. Furthermore, it is important to define 'actual' snug-tight as the point where the washers have flattened and the clamped material and bolt will flatten or elongate linearly. For multiple tests, specifically with diameters greater than 1.5", the 'achieved' snug-tight pretension was not beyond the 'actual' snug-tight value. Failure to reach the 'actual' snug-tight value will impact final pretension values. It was determined that the Garlich & Thorkildsen (2005) definition of snug-tight of 20-30% of the verification torque was sufficient to reach the 'actual' snug-tight value, as seen in the comparison of columns 4 and 8 of *Table 2.1*.

The testing resulted in nut factors, K, of 0.09-0.16. These values are very similar to the value of 0.12 suggested by Till and Lefke (1994) for verification torques. It is important to note that a K factor of 0.12 combined with MnDOT's previous torque specification of 450 ft-lbs for

2.5" diameter bolts would result in a pretension of 18 kips. The recommended pretension of  $0.6F_y$  for 2.5" F1554 Gr. 105 bolts is 252 kips. The 450 ft-lb torque would result in a pretension stress that is less than 10% of the recommended stress. The torque vs. tension and rotation vs. tension data is shown in *Figure 2.8* through *Figure 2.35* for various bolt diameters, grades, grip lengths, and lubrication cases.

Till and Lefke (1994) completed similar testing using 1-1/2", 2", and 2-1/2" UNC bolts. 1-1/2" 6 UNC bolt data using the Skidmore Wilhelm was compared with the data for 1-1/2" 6 UNC bolts in Table 3 of Till and Lefke's report. Using the equations presented in Chapter 2.1, one can calculate an average K value of 0.17 for Till & Lefke's data. The  $k_s$  value for rotation based tightening was 0.06. The standard deviation of K and  $k_s$  values were 0.04 and 0.03 respectively. The K value found for 1-1/2" 6 UNC bolts found by Till & Lefke varied significantly from that found during the Skidmore Wilhelm testing. However, the  $k_s$  value calculated using Till & Lefke's data fits with the data collected during Skidmore Wilhelm testing. A  $k_s$  value of 0.06 for 1-1/2" grip length has a linear relationship with Skidmore Wilhelm testing  $k_s$  values of 0.09 for 2-1/2" grip and 0.15 for 4-1/2" grip. The 2" 4-1/2 UNC data collected by Till & Lefke (1994) also paired well with data from Skidmore Wilhelm testing. Till & Lefke nut constant, K, or 0.13 was very close to the 0.12 found with the Skidmore Wilhelm. Furthermore, the  $k_s$  value of 0.07 for a grip length of 1-5/8" matched the theoretical principals and was much smaller than the  $k_s$  value of 0.16 for 5-3/4" grip using the Skidmore Wilhelm.

Skidmore Wilhelm data was also compared to field data from Hamels & Hoisington in Alaska. The Alaska data was for 1.5" diameter F1554 Gr. 55 bolts, with a 4.5" grip length. The average  $k_s$  value for the Alaska data set was 0.179, with a standard deviation of 0.006. The  $k_s$  value from Skidmore Wilhelm testing for a 1.5" diameter bolt with a 4.5" grip was 0.15.

Considering the approximate nature of measuring turn angles in the field and other errors of measurement, the data is very similar. Noting the comparisons and that standard deviation values from Skidmore Wilhelm testing were significantly lower (by a factor of 2-3 on average) than that of data from Till & Lefke's and Hamels and Hoisington's reports, the research team was confident with the accuracy and applicability of the Skidmore Wilhelm testing results.

Table 2.1 - *Summary of Snug-tight Results*

Type	Diameter (in)	Yield (ksi)	Actual Range (kips)	Wrench Length (in)	Average Achieved (kips)	Snug Achieved / $F_y$ (%)	$0.3 * F_{Tv}$ (kips)
A325	0.75	92	4-6	24	28.8	94%	6
A325	1	92	5-10	24	29.5	53%	10
F1554	1	55	5-10	24	21.0	63%	6
F1554	1	105	5-10	24	21.5	34%	11
A325	1.25	81	7-15	20	18.2	23%	14
F1554	1.25	55	7-15	20	18.3	34%	10
F1554	1.5	105	17-25	24	16.3	11%	27
F1554 <sup>a</sup>	1.5	105	17-25	24	11.8	8%	27
F1554	1.75	105	20-30	22	9.3	5%	36
F1554	2	105	25-40	28	10.5	4%	47
F1554	2.25	105	30-40	36	15.5	5%	61
F1554 <sup>a</sup>	2.25	105	30-40	36	11.0	3%	61

<sup>a</sup> Non-lubricated Bolts

Table 2.2 - Torque Testing Results

Bolt Type	Bolt Diameter (in)	Yield Stress (ksi)	Number	Grip Length (in)	K	Standard Deviation
A325	0.75	92	24	3.75	0.13	0.0095
F1554	0.75	36	5	1.75	0.12	0.0051
304 SS	1.00	42	6	2.00	0.16	0.0068
A325	1.00	92	6	5.00	0.14	0.0170
F1554	1.00	36	4	2.00	0.15	0.0183
F1554	1.00	55	6	4.00	0.15	0.0072
F1554	1.00	55	6	2.00	0.14	0.0089
F1554	1.00	105	6	2.00	0.13	0.0189
A325	1.25	81	6	5.3	0.13	0.0019
F1554	1.25	55	5	4.25	0.12	0.0013
F1554	1.50	105	3 <sup>a</sup>	2.50	0.09	0.0094
F1554	1.50	105	3	2.50	0.10	0.0077
F1554	1.50	105	4	4.50	0.10	0.0034
F1554	1.50	105	8	5.50	0.11	0.0036
F1554	1.50	105	3 <sup>a</sup>	5.50	0.10	0.0061
F1554	1.75	105	6	5.75	0.13	0.0026
F1554	2.00	105	5	5.75	0.12	0.0075
F1554	2.00	105	6 <sup>a</sup>	7.75	0.21	0.0249
F1554	2.00	105	6	7.75	0.13	0.0100
F1554	2.25	105	4 <sup>a</sup>	6.25	0.23	0.0025
F1554	2.25	105	4	6.25	0.12	0.0043
LUBRICATED AVERAGE K					0.127	
LUBRICATED STANDARD DEVIATION					0.016	

<sup>a</sup>Non-lubricated bolts

Table 2.3 - *Rotation Testing Results*

Type	Diameter (in)	F <sub>y</sub> (ksi)	Number	Grip Length (in)	k <sub>b</sub> (kips/in)	k <sub>s</sub> Average (%)	Standard Deviation
A325	0.75	92	24	4.75	2701.75	34%	2%
F1554	0.75	36	5	1.75	5534.86	24%	4%
A325	1.00	92	6	5.00	4300.68	27%	1%
F1554	1.00	55	6	3.00	5858.00	12%	1%
304 SS	1.00	42	4	2.00	8787.00	8%	1%
F1554	1.00	36	4	2.00	8787.00	9%	1%
F1554	1.00	55	6	2.00	8787.00	8%	1%
F1554	1.00	105	6	2.00	8787.00	12%	1%
A325	1.25	81	6	5.25	6673.16	22%	4%
F1554	1.25	55	5	2.25	12489.33	17%	1%
F1554	1.50	105	3 <sup>a</sup>	2.50	16298.0	9%	1%
F1554	1.50	105	3	2.50	16298.0	9%	1%
F1554	1.50	105	4	4.50	9054.4	15%	1%
F1554	1.50	105	4	5.50	7408.2	15%	2%
F1554	1.50	105	3 <sup>a,b</sup>	5.50	7408.2	22%	4%
F1554	1.50	105	4 <sup>b</sup>	5.50	7408.2	25%	2%
F1554	1.75	105	6 <sup>b</sup>	5.75	9582.6	18%	4%
F1554	2.00	105	6 <sup>b</sup>	5.75	12608.7	16%	3%
F1554	2.00	105	6 <sup>b</sup>	7.75	9354.8	17%	3%
F1554	2.00	105	6 <sup>a,b</sup>	7.75	9354.8	23%	2%
F1554	2.25	105	4 <sup>a,b</sup>	6.25	15080.0	13%	5%
F1554	2.25	105	4 <sup>b</sup>	6.25	15080.0	14%	2%

<sup>a</sup> Non-lubricated bolts

<sup>b</sup> Tested with K-Series

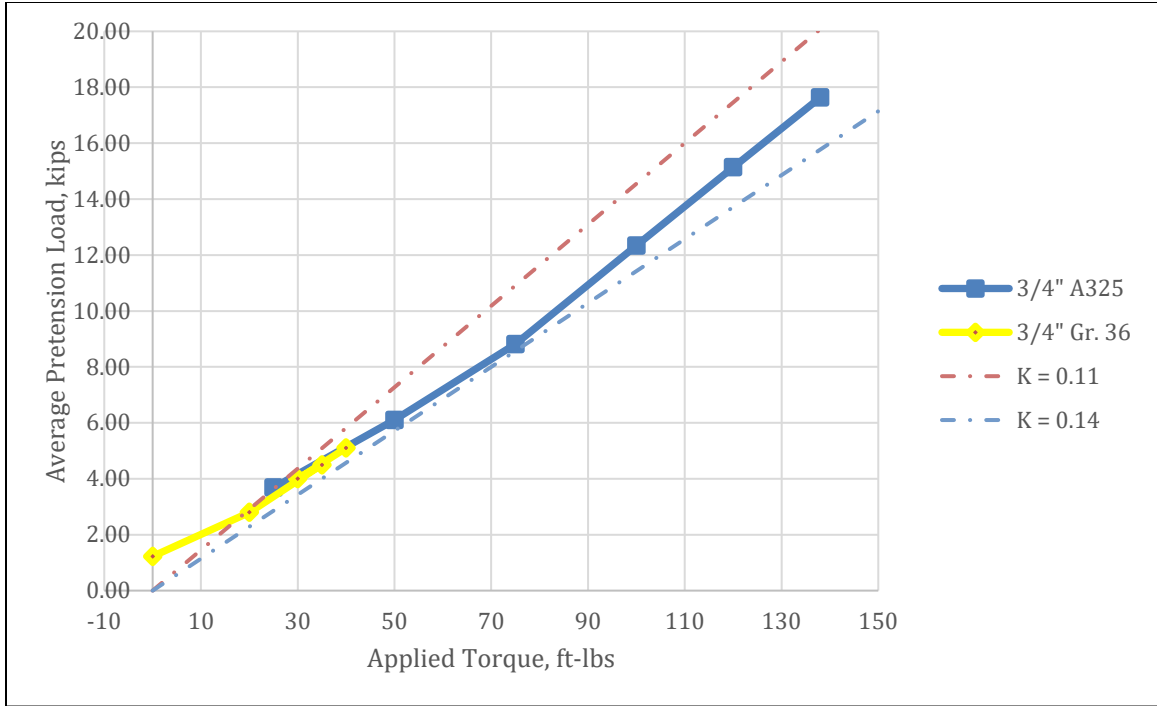

Figure 2.8 – 0.75" Bolts Torque vs. Tension

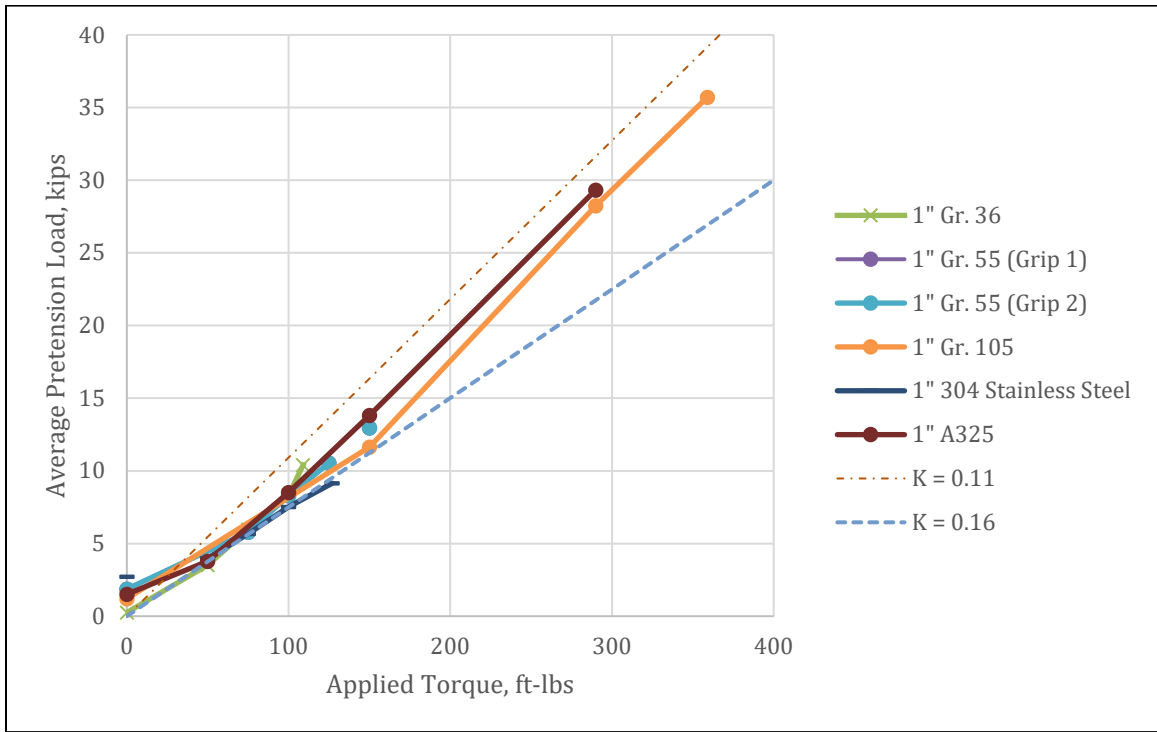

Figure 2.9 - 1" Torque vs. Tension



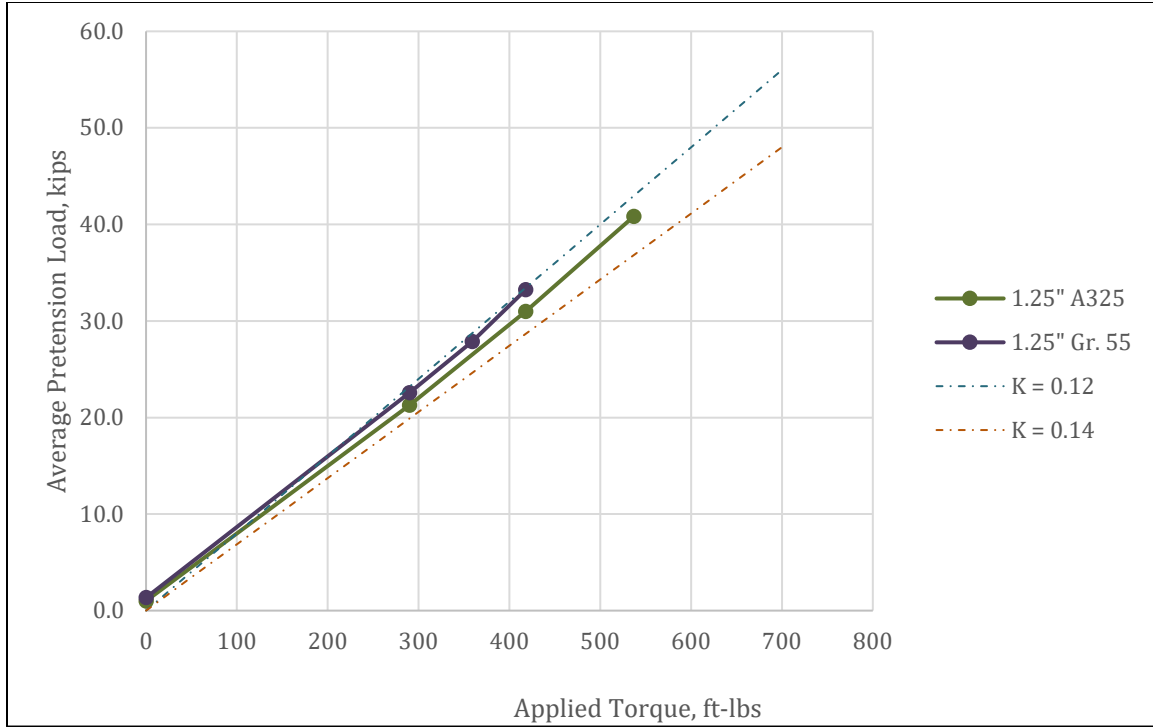

Figure 2.10 – 1.25" Torque vs. Tension

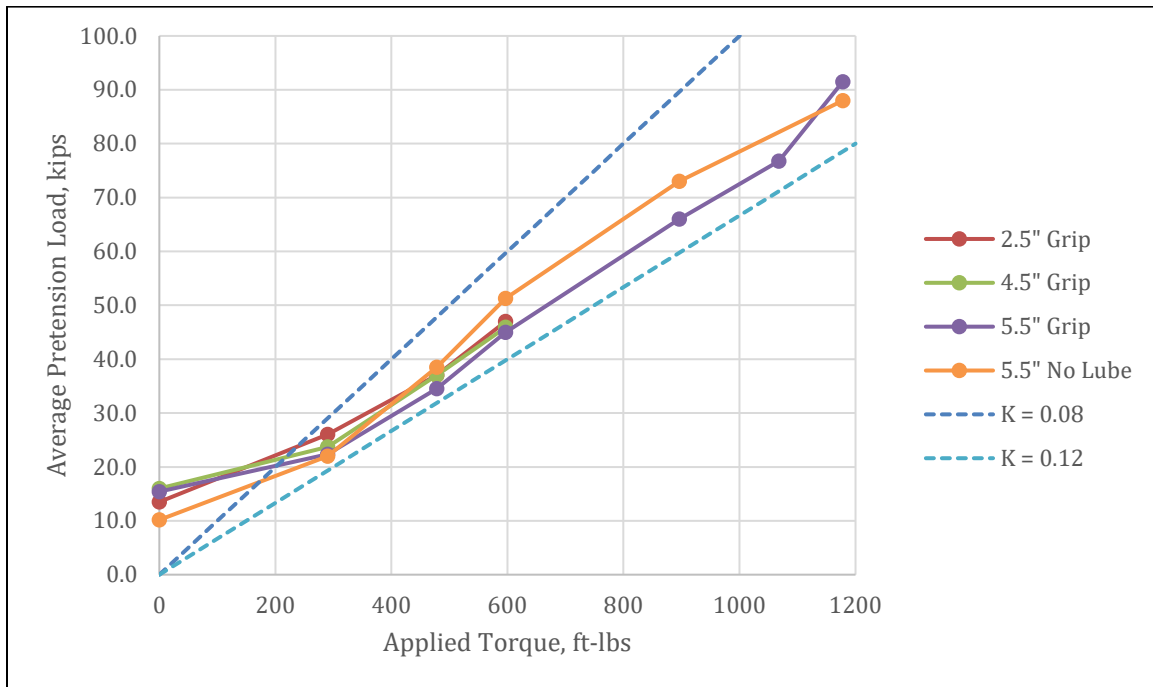

Figure 2.11 – 1.5" Torque vs. Tension

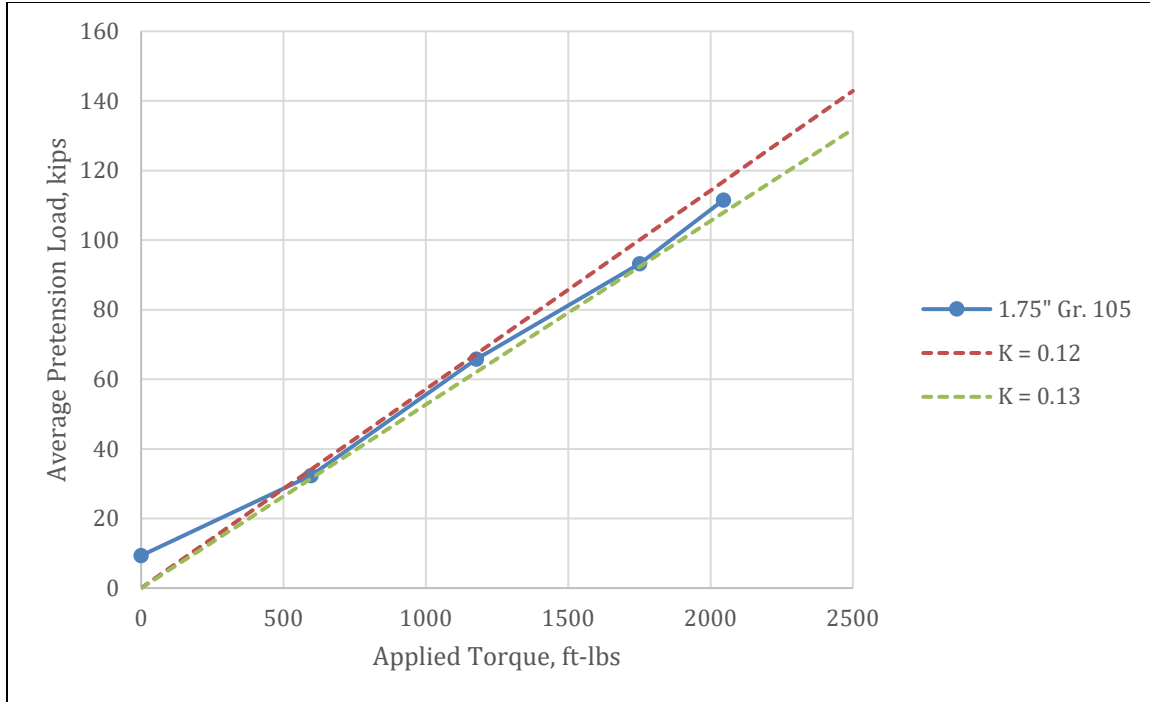

Figure 2.12 – 1.75" Torque vs. Tension

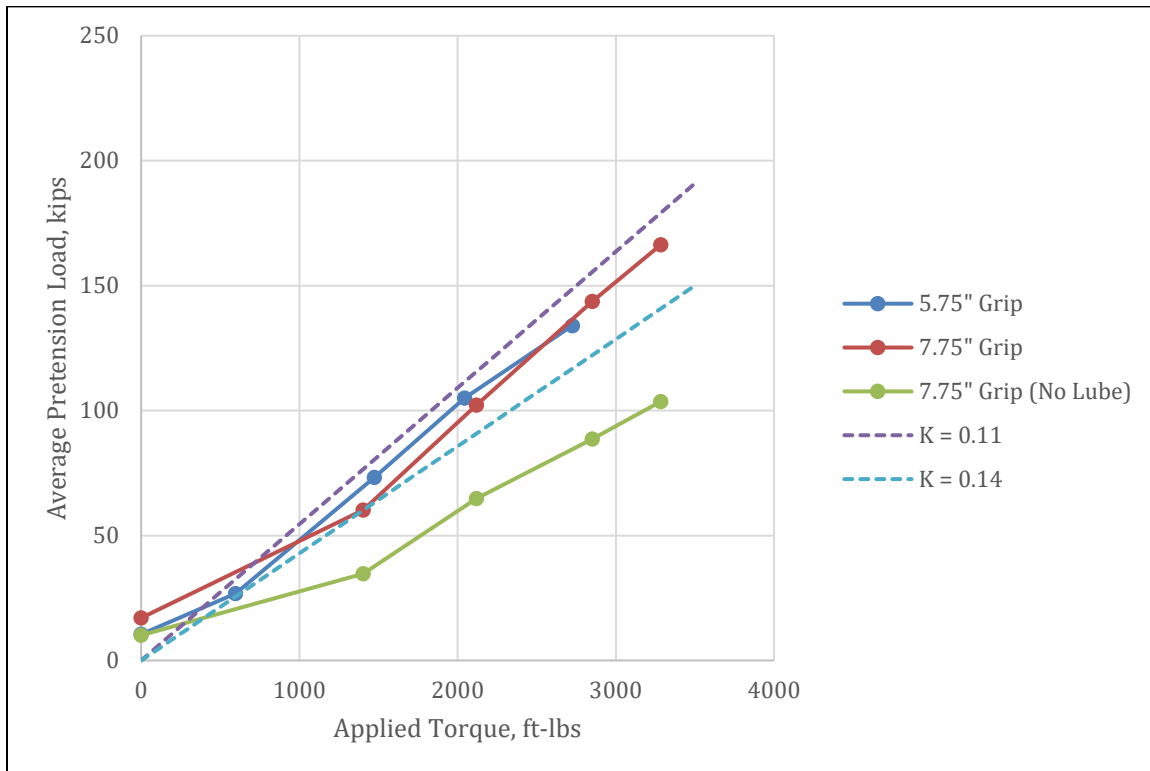

Figure 2.13 - 2" Torque vs. Tension

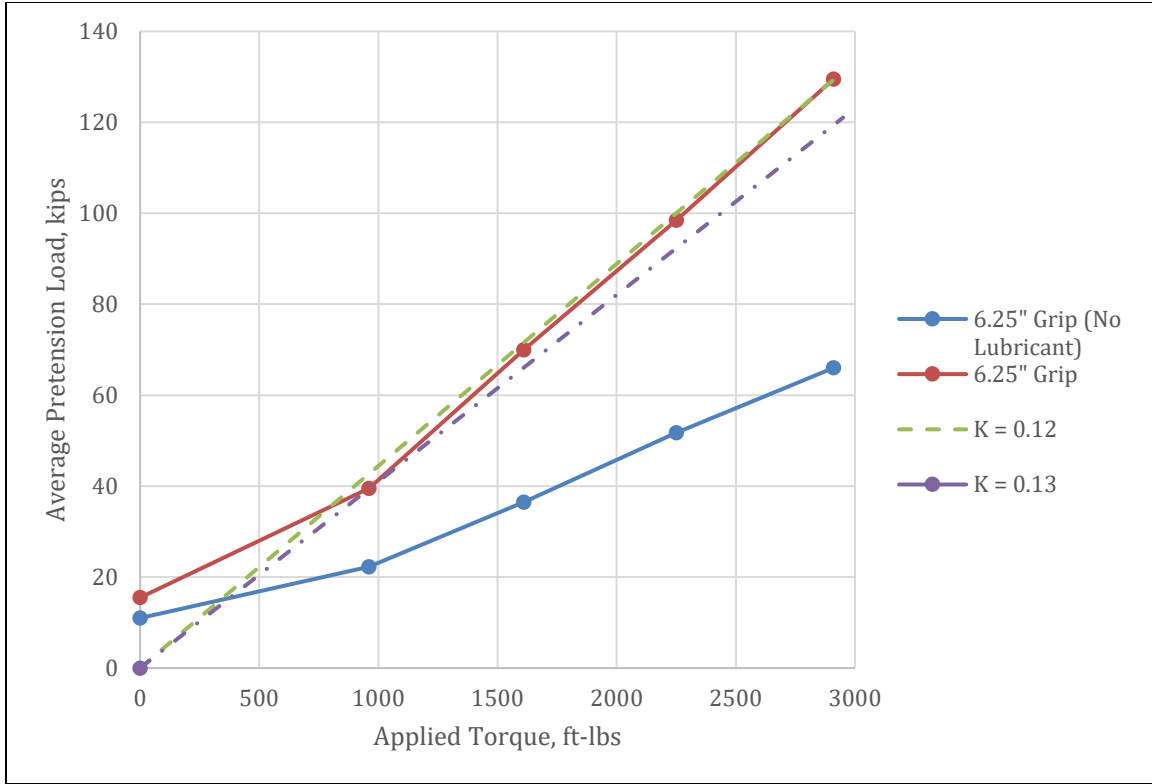

Figure 2.14 – 2.25” Torque vs. Tension

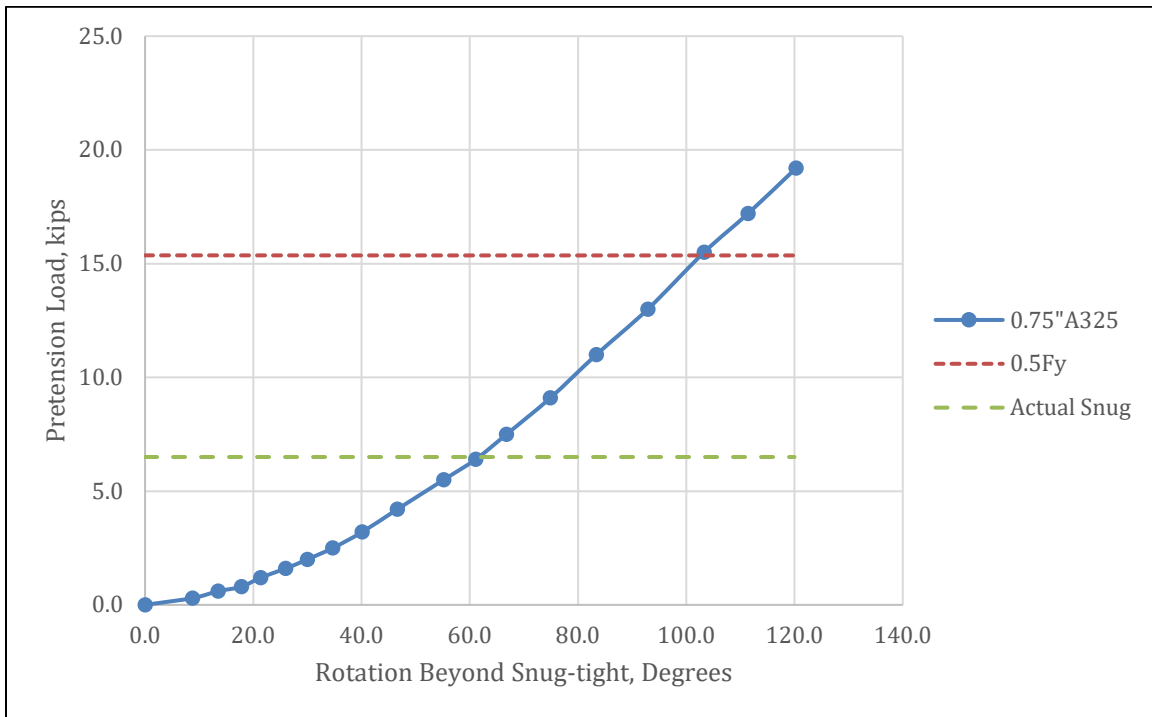

Figure 2.15 - Pre-Snug & Rotation Beyond Snug Curve

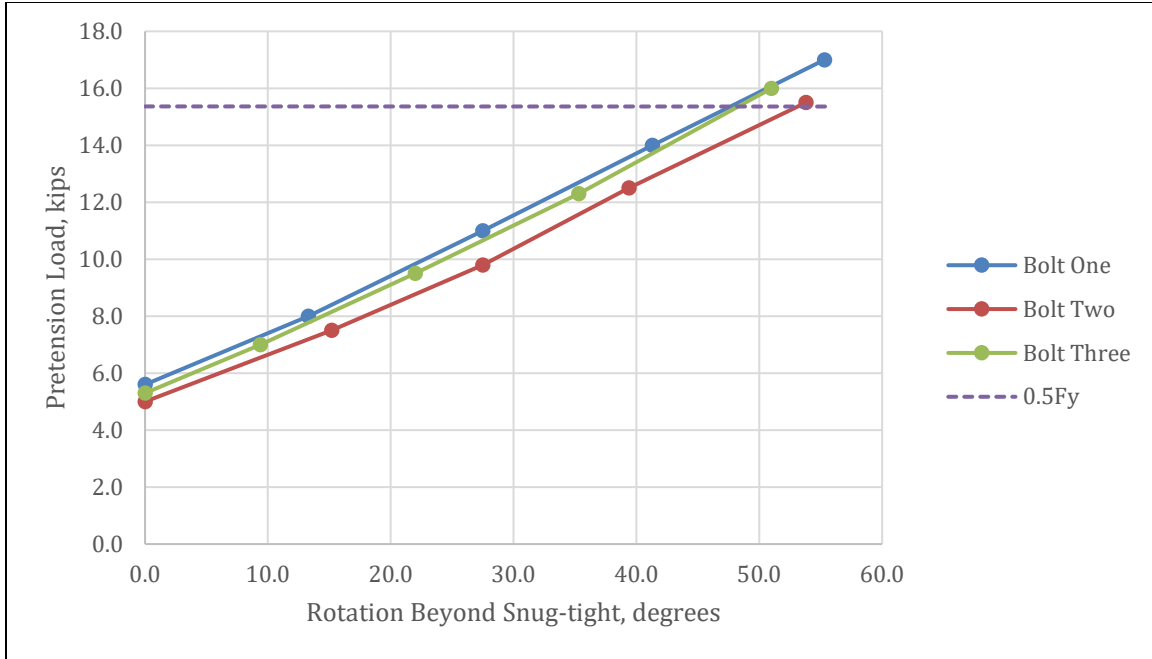

Figure 2.16 - 0.75" A325 Rotation vs. Tension

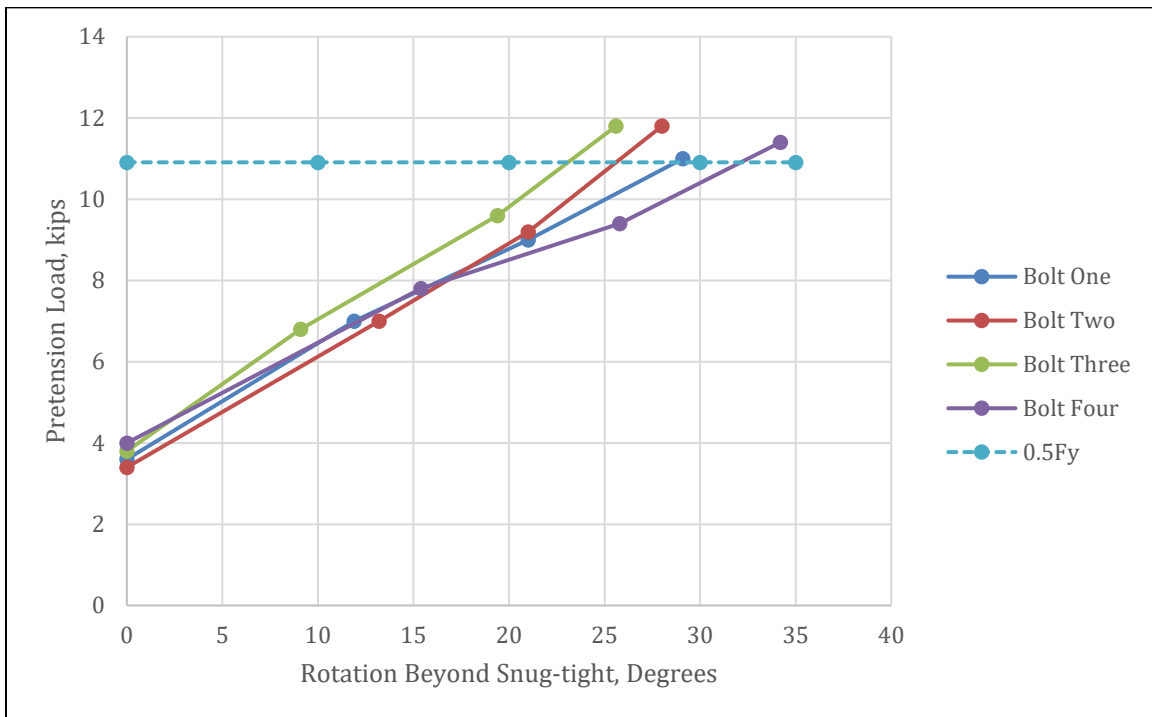

Figure 2.17 - 1" Gr. 36 Rotation vs. Tension

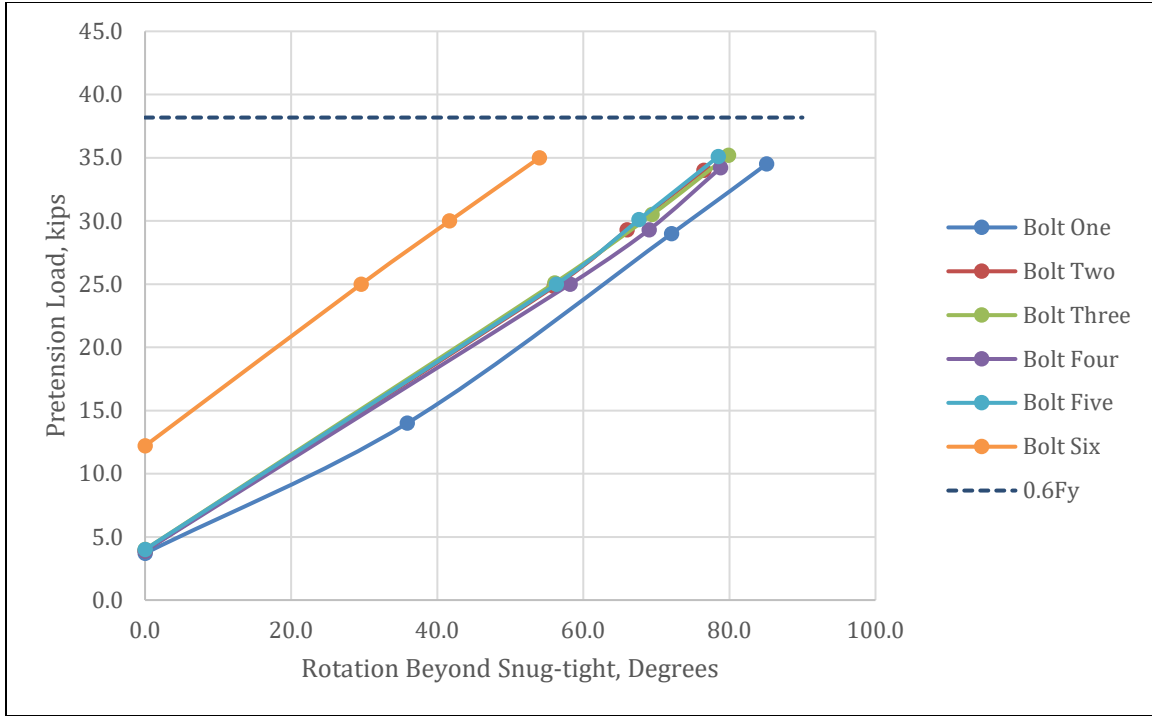

Figure 2.18 - 1" Gr. 105 Rotation vs. Tension

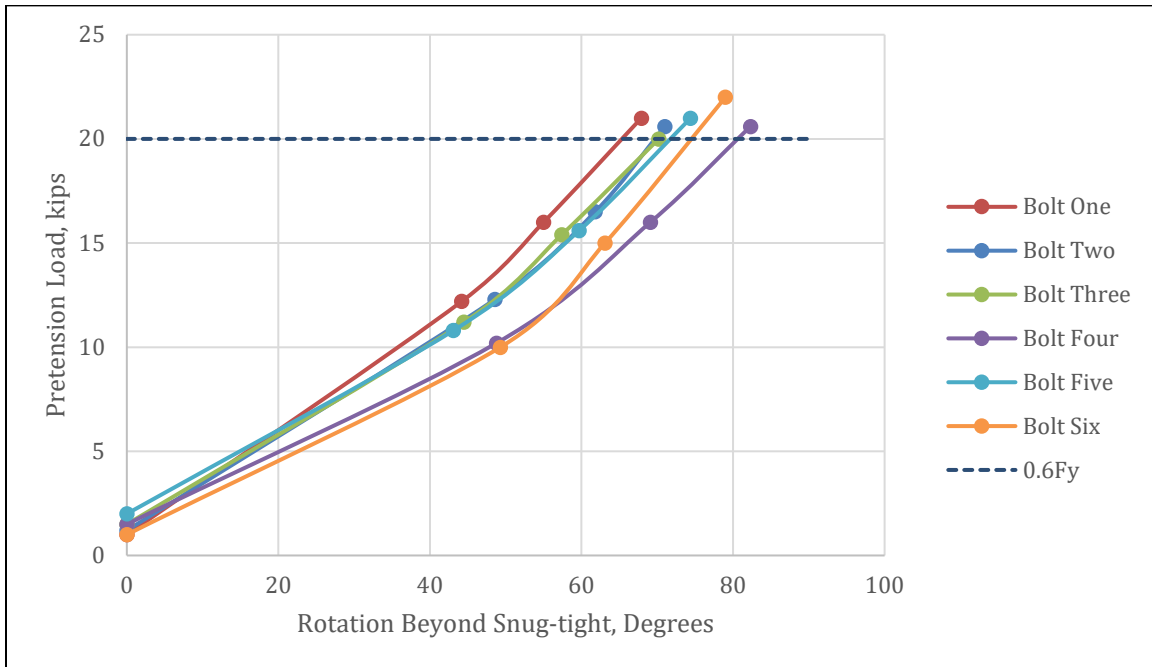

Figure 2.19 - 1" Gr. 55 with 2" Grip Rotation vs. Tension

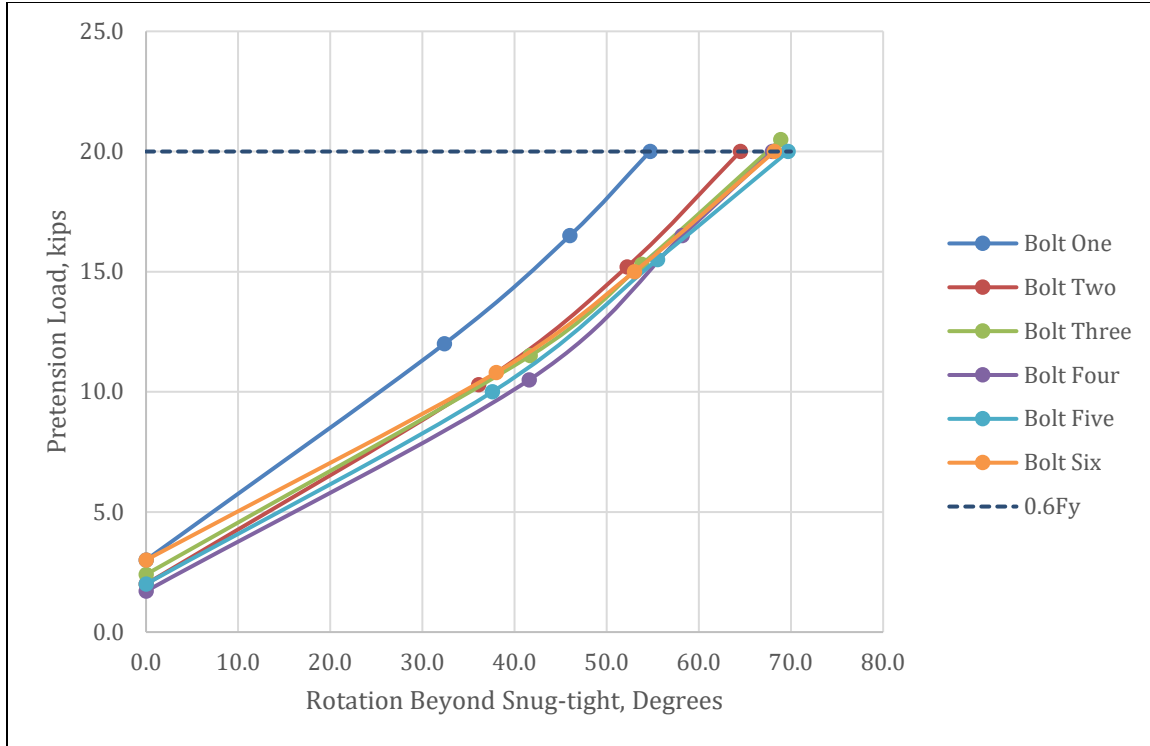

Figure 2.20 - 1" Gr. 55 with 3" Grip Rotation vs. Tension

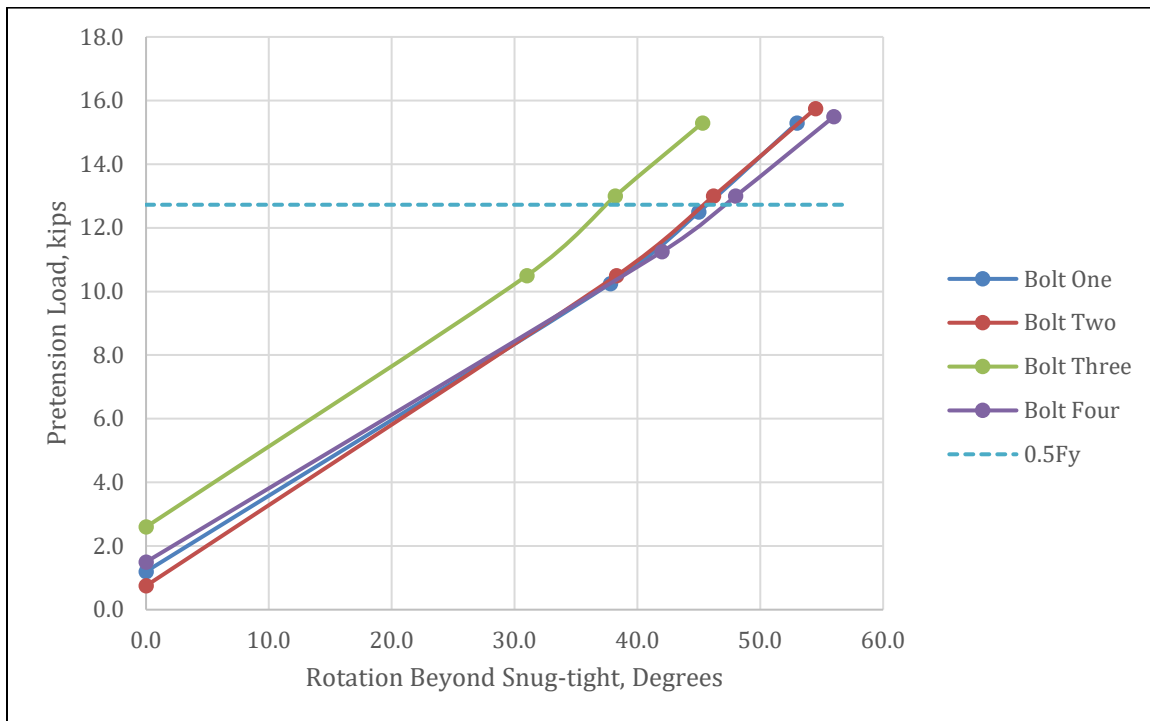

Figure 2.21 - 1" 304 Stainless Steel Rotation vs. Tension

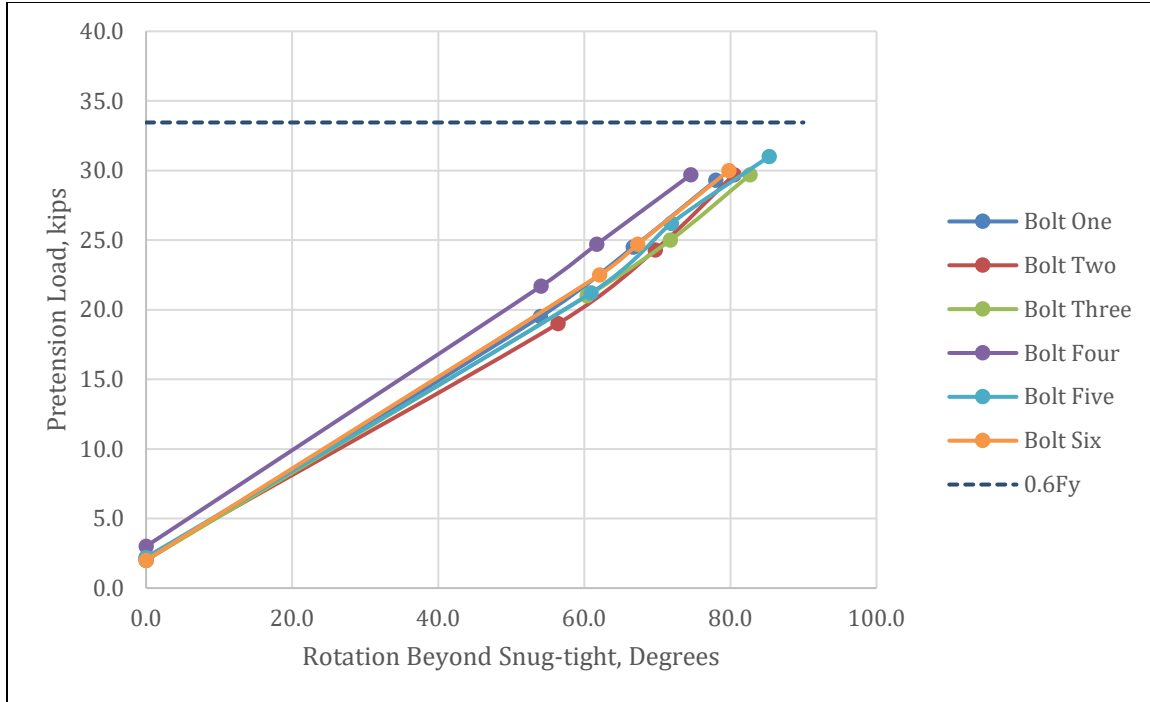

Figure 2.22 - 1" A325 Rotation vs. Tension

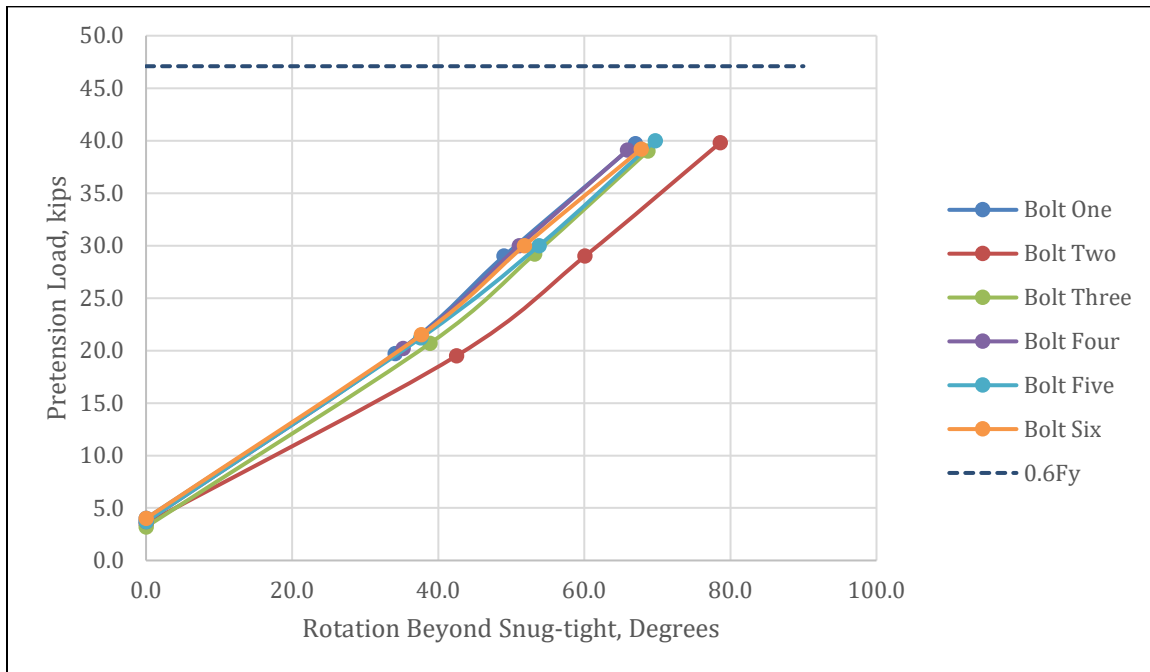

Figure 2.23 - 1.25" A325 Rotation vs. Tension

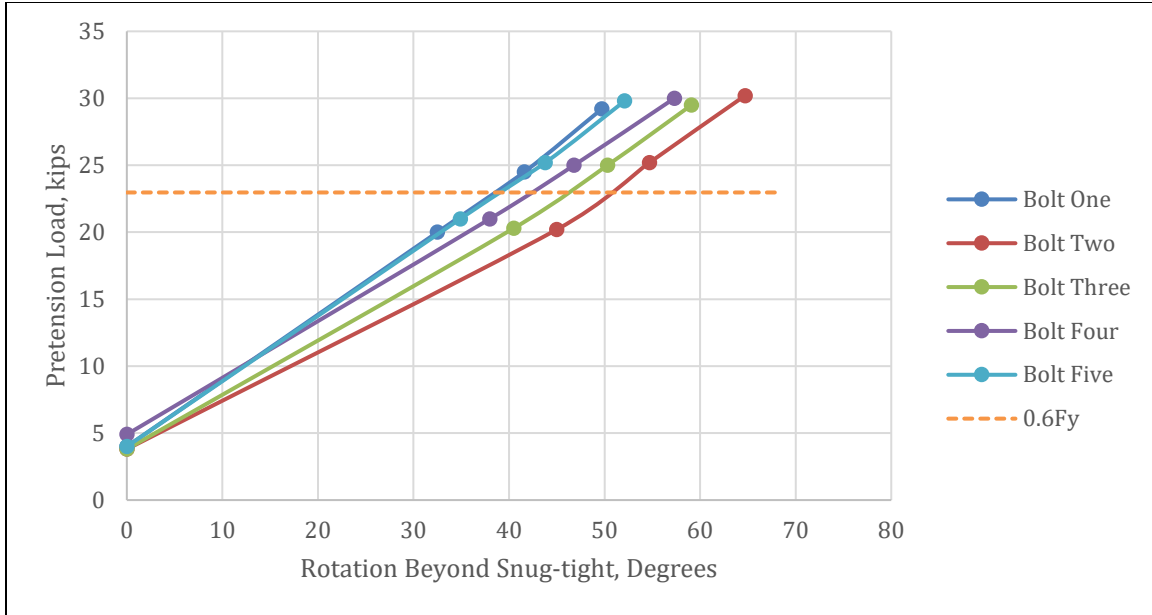

Figure 2.24 - 1.25" Gr. 55 Rotation vs. Tension

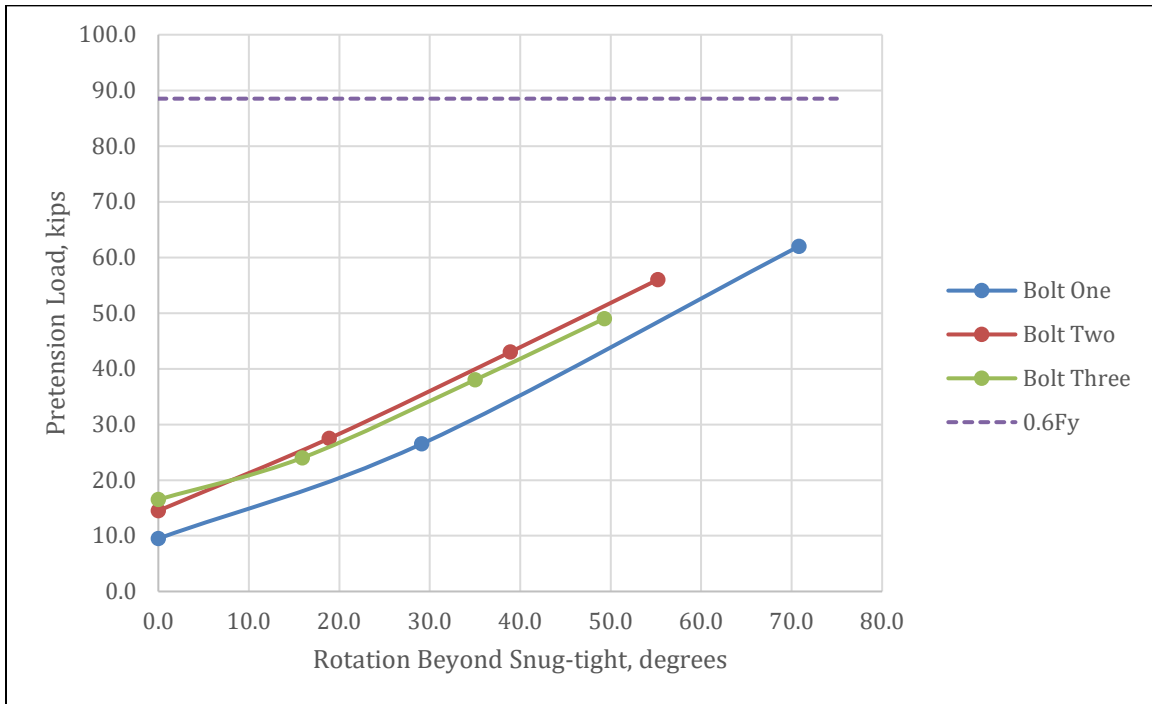

Figure 2.25 - 1.5" Gr. 105 with 2.5" Grip Rotation vs. Tension



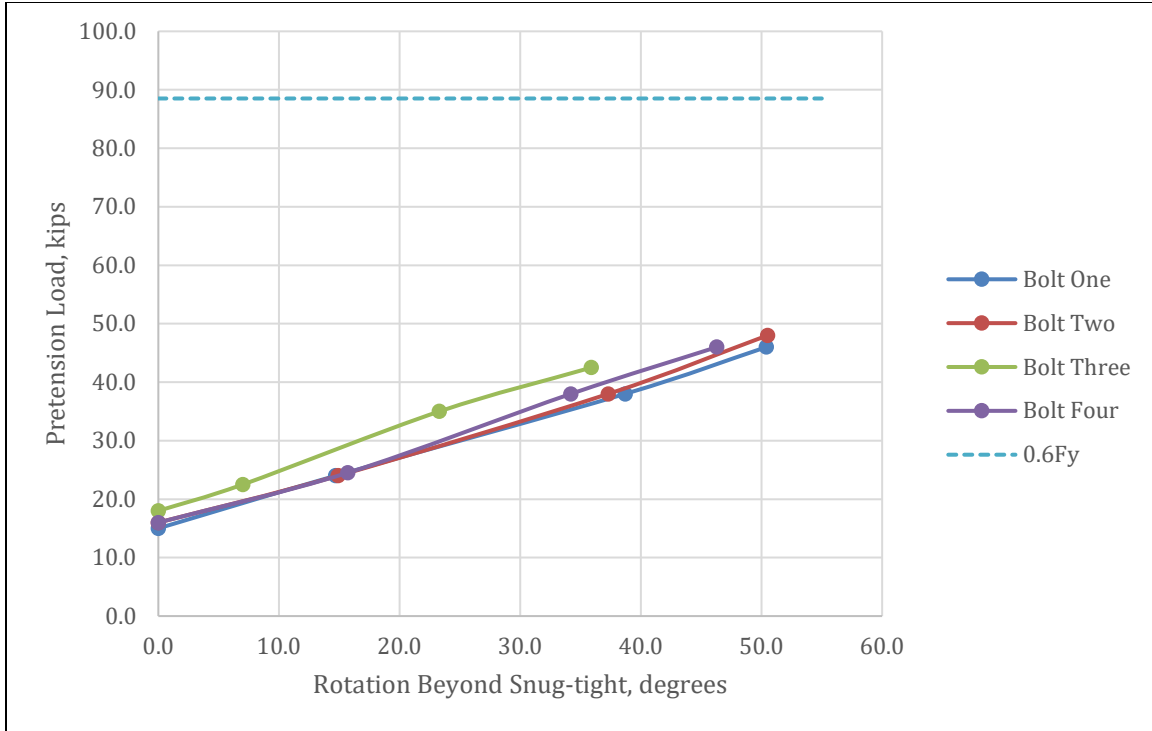

Figure 2.26 - 1.5" Gr. 105 with 4.5" Grip Rotation vs. Tension

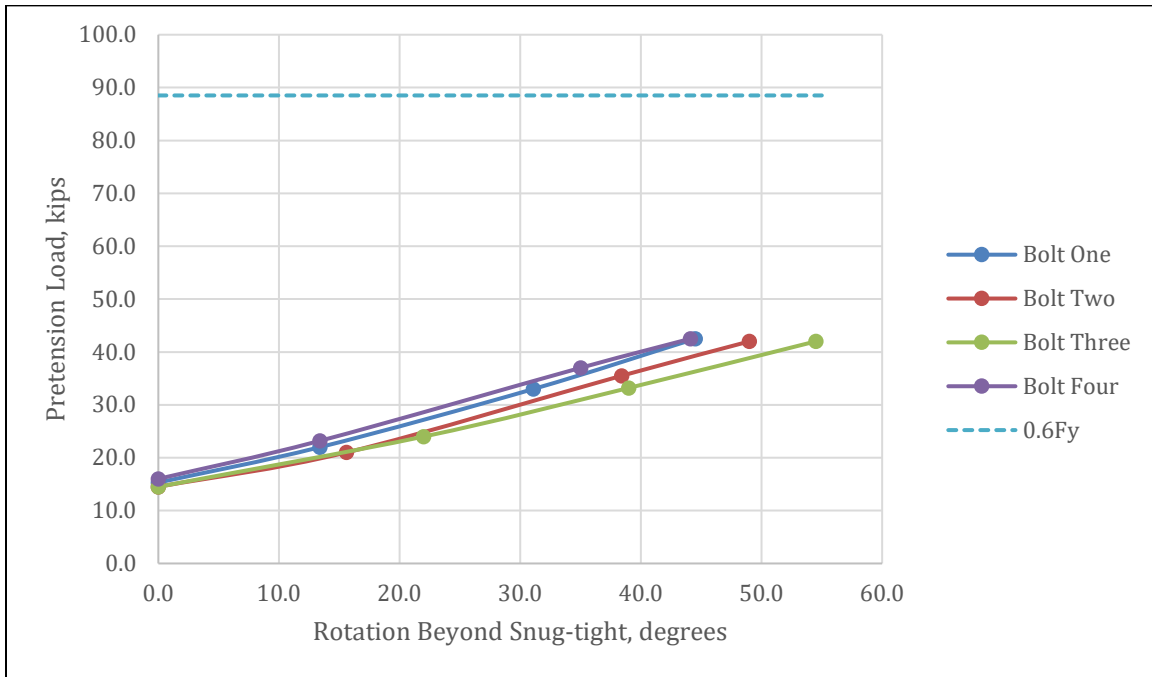

Figure 2.27 - 1.5" Gr. 105 with 5.5" Grip Rotation vs. Tension

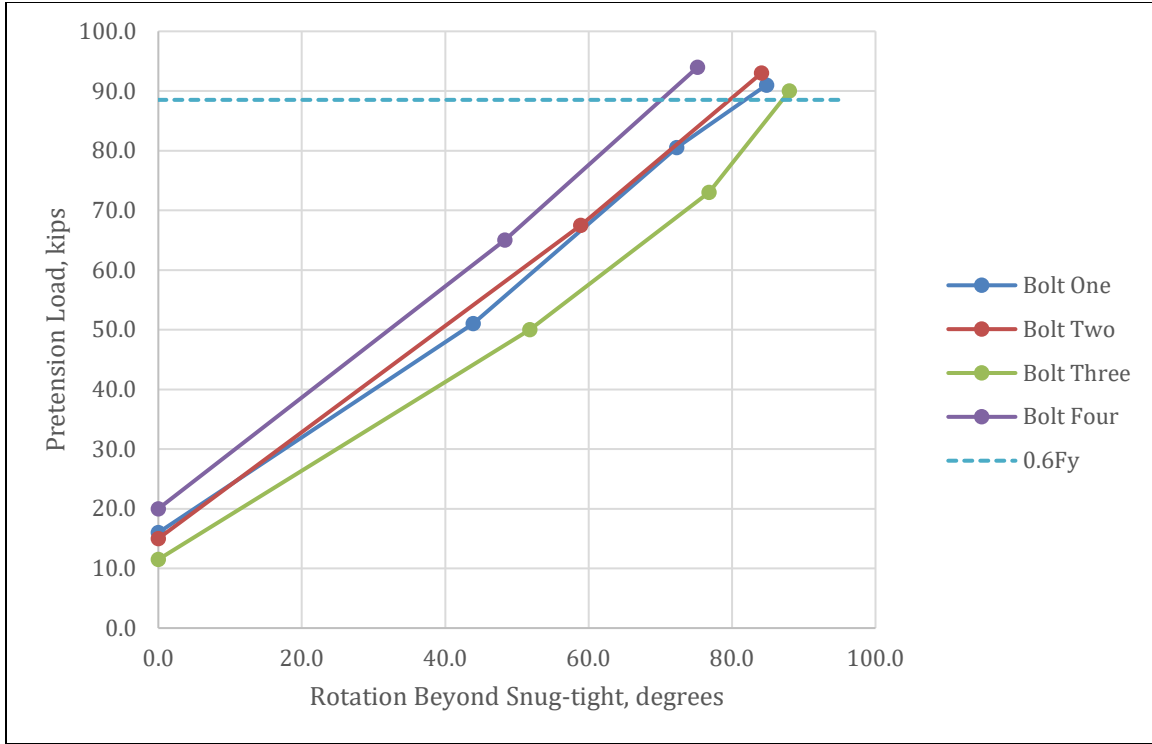

Figure 2.28 - 1.5" Gr. 105 with 5.5" Grip (K-Series) Rotation vs. Tension

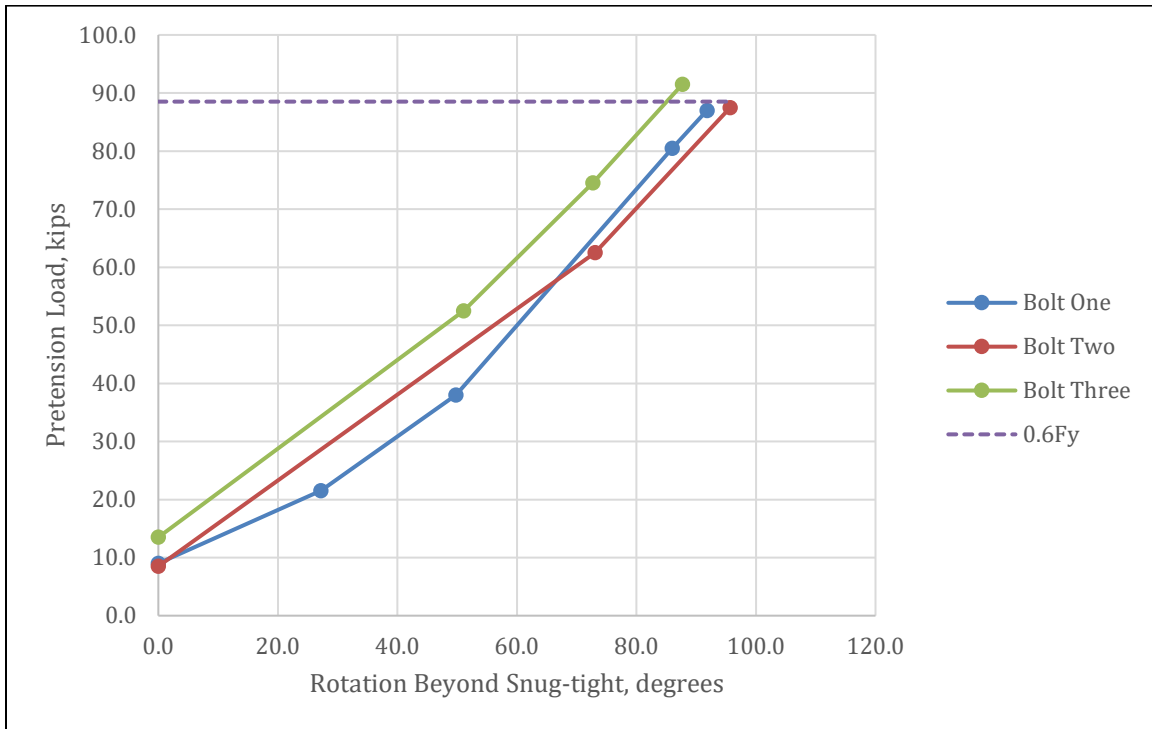

Figure 2.29 - 1.5" Gr. 105 with 5.5" Grip (K-Series & No Lubricant) Rotation vs. Tension

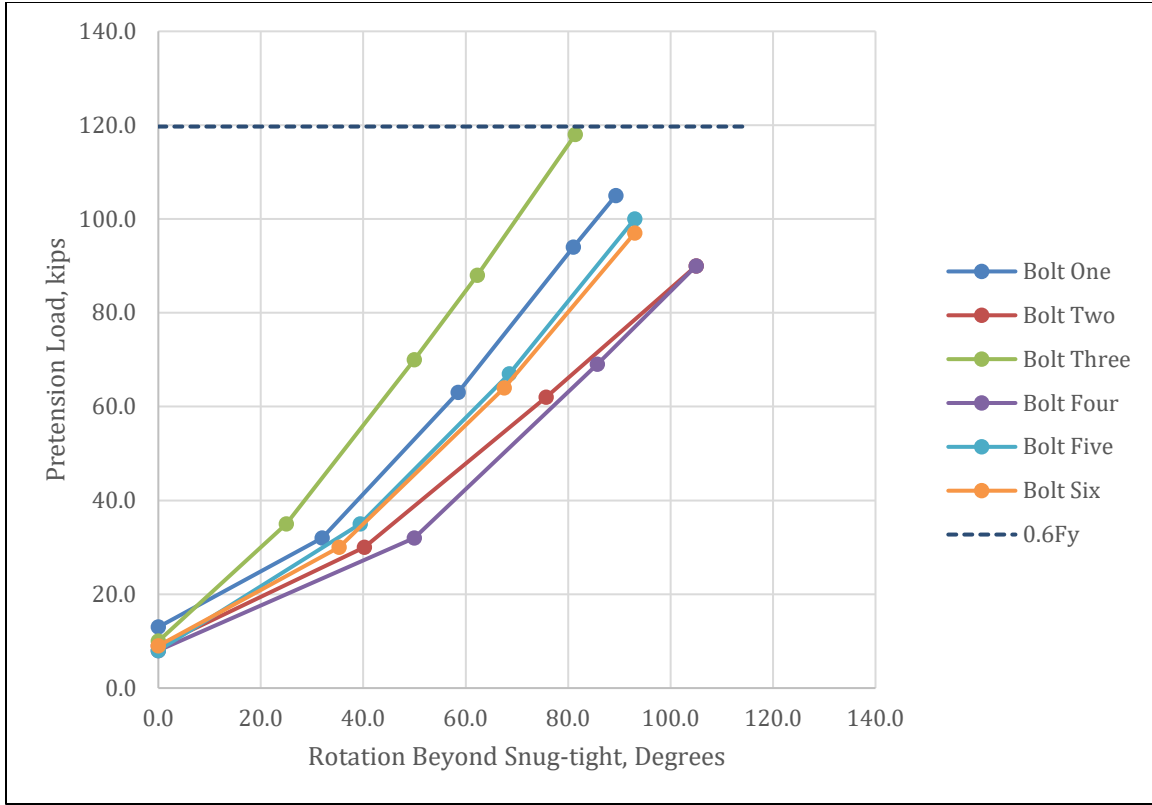

Figure 2.30 - 1.75" Gr. 105 with 5.75" Grip Rotation vs. Tension

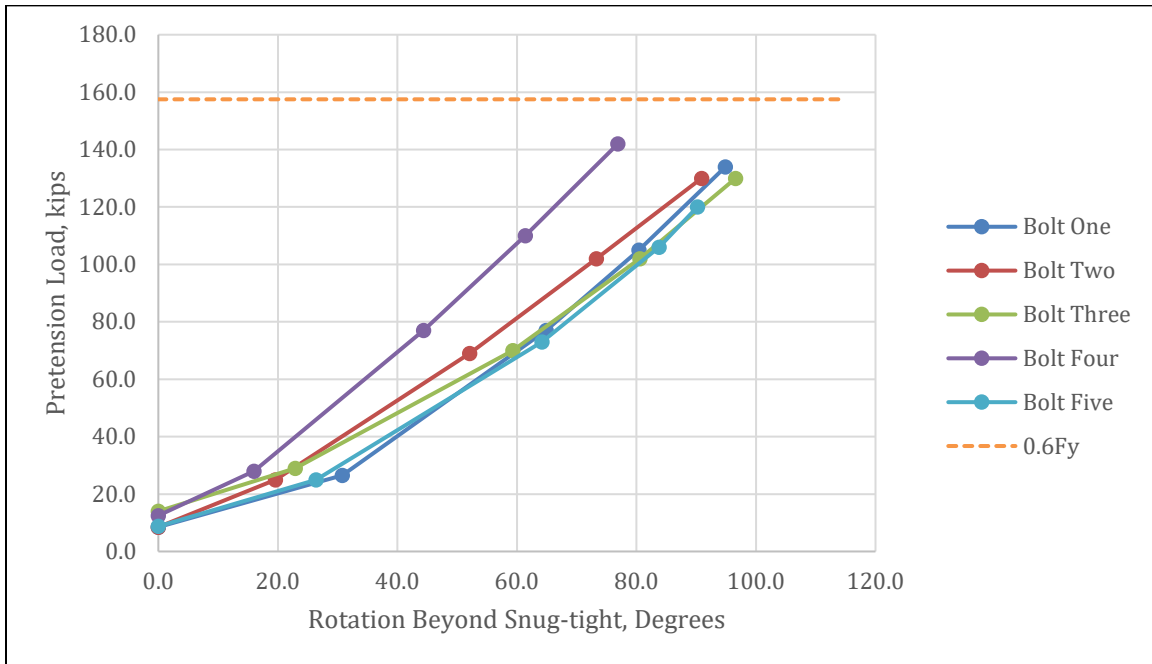

Figure 2.31 - 2" Gr. 105 with 5.75" Grip Rotation vs. Tension

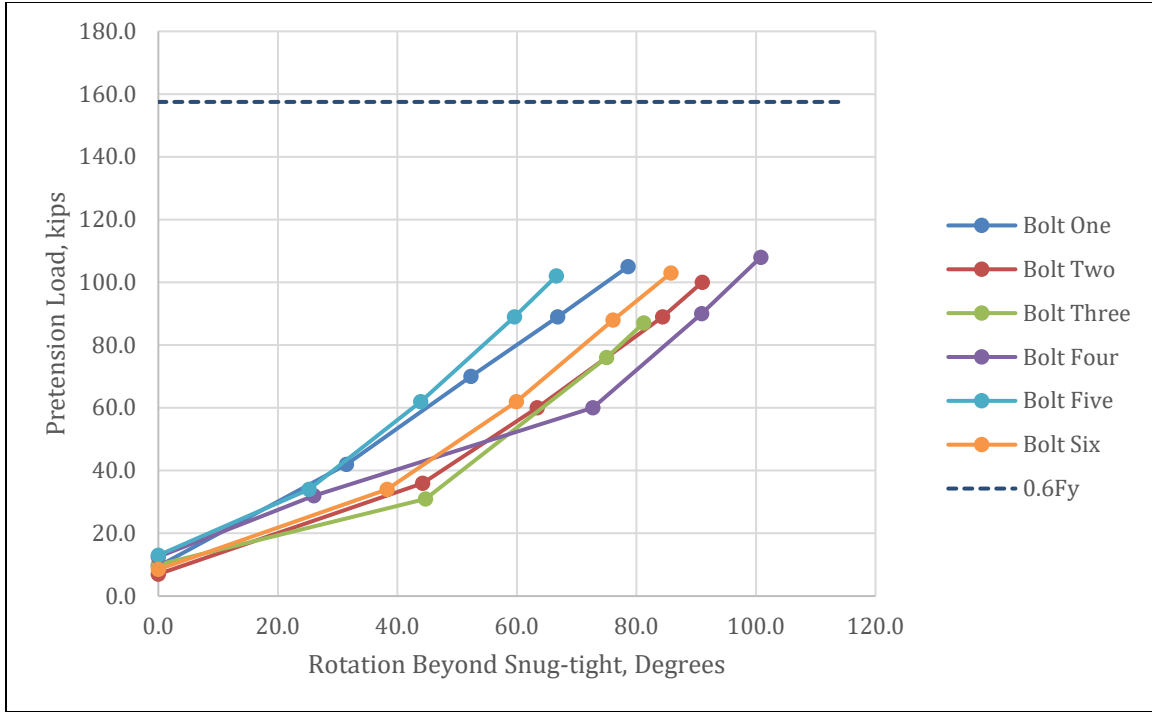

Figure 2.32 - 2" Gr. 105 with 7.75" Grip (No Lubricant) Rotation vs. Tension

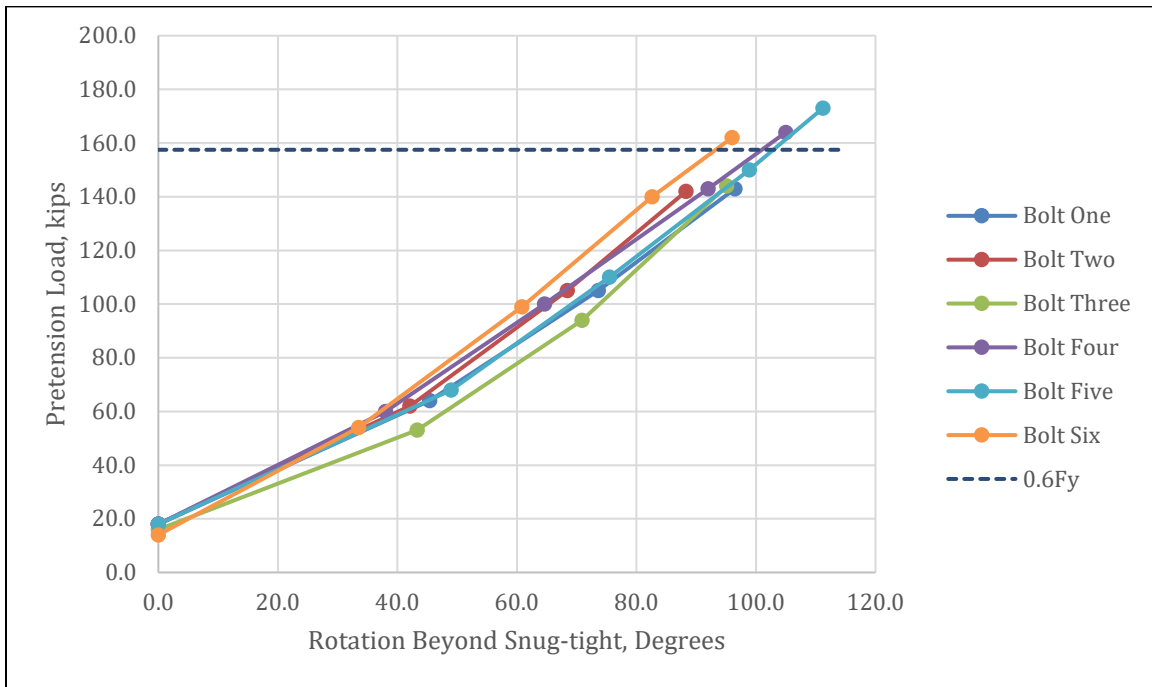

Figure 2.33 - 2" Gr. 105 with 7.75" Grip Rotation vs. Tension

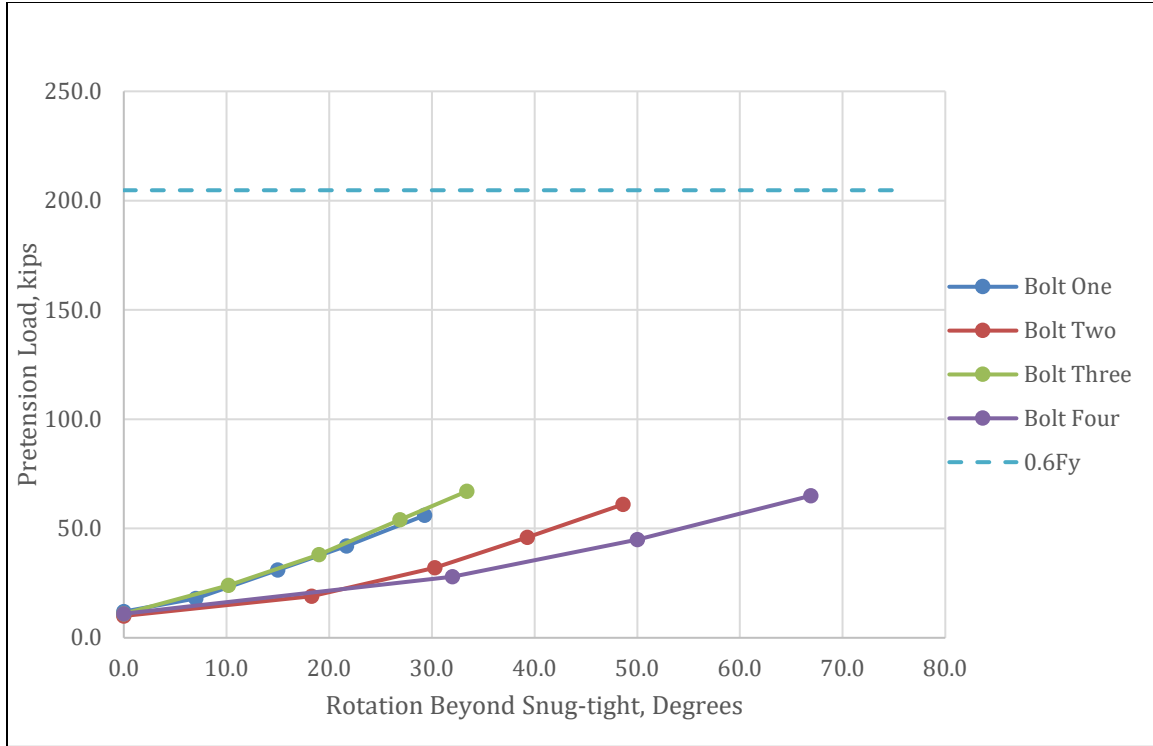

Figure 2.34 - 2.25" Gr. 105 with 6.25" Grip Rotation vs. Tension (No Lubricant)

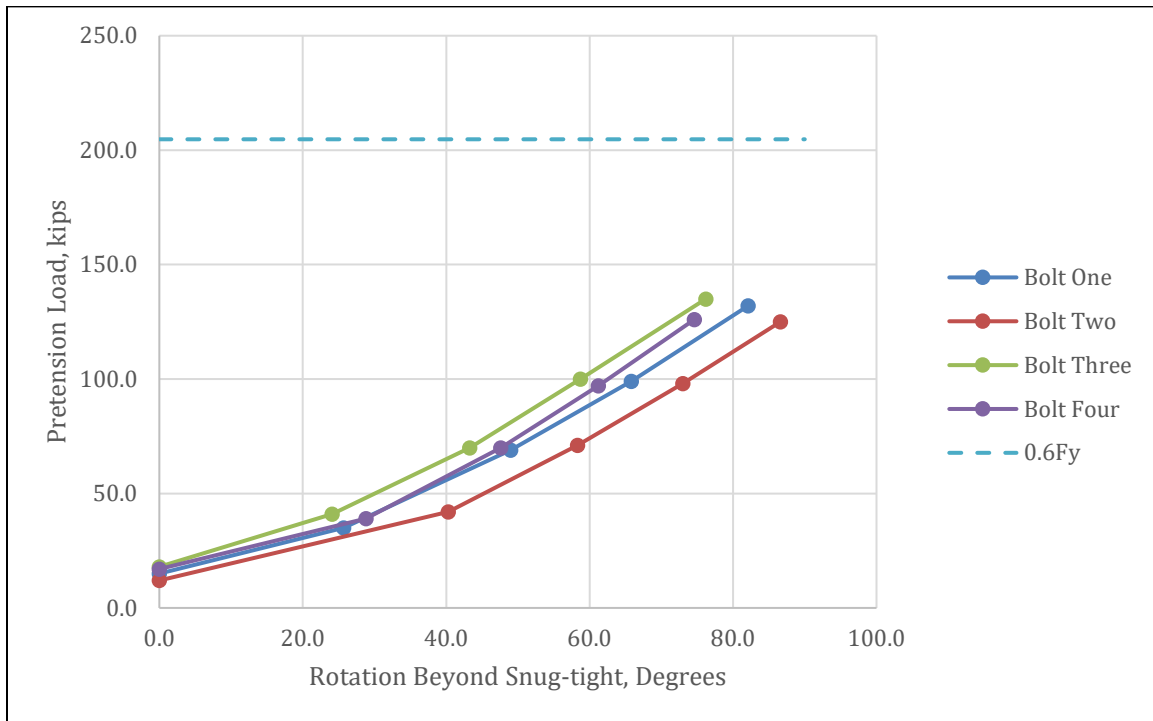

Figure 2.35 - 2.25" Gr. 105 with 6.25" Grip Rotation vs. Tension

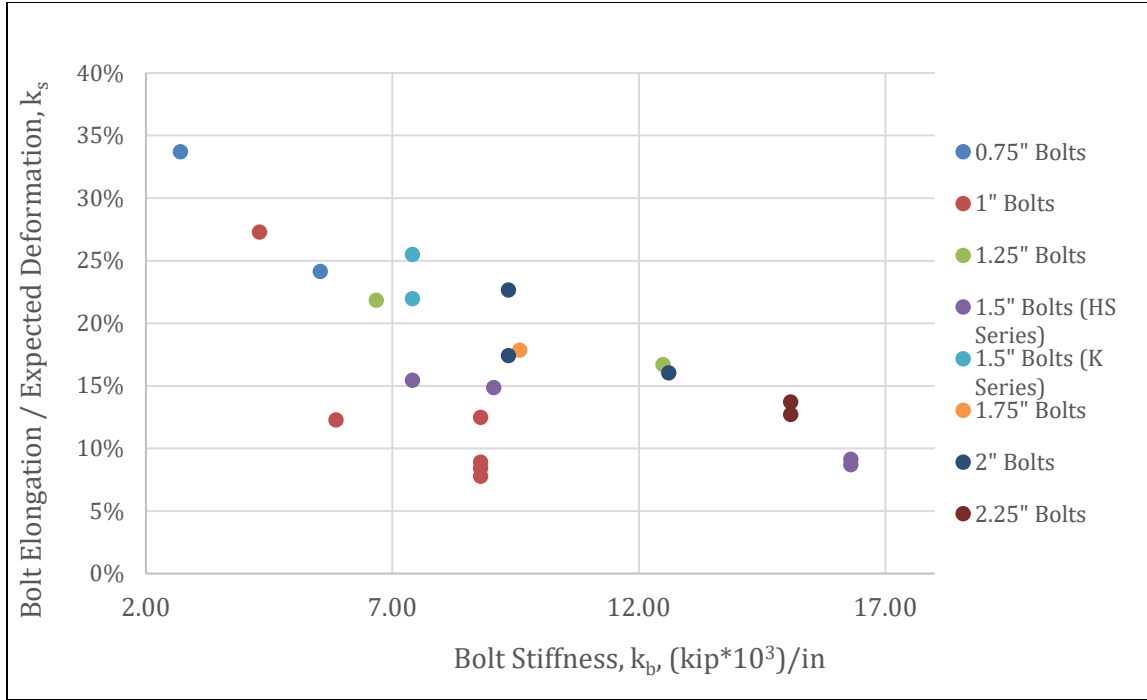

Figure 2.36 - Bolt Stiffness vs.  $k_s$

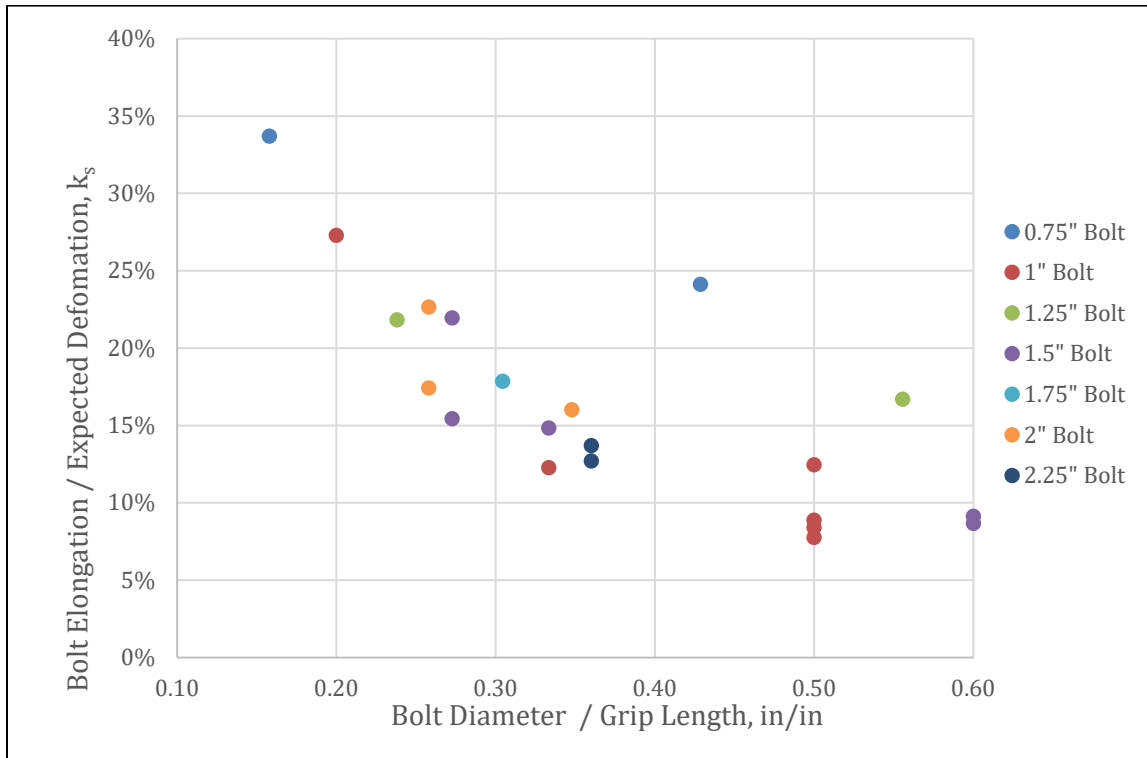

Figure 2.37 - Bolt Diameter / Grip Length vs.  $k_s$

### *DTI Testing Results and Analysis*

Traditional DTIs require feeler gages to measure the gap between the DTI and washer. The usage of a feeler gage as a measurement tool reduces the precision of determining pretension in the bolt. Furthermore, proper feeler gage usage requires a competent contractor or inspector. It was generally concluded that traditional DTI washers can be effectively used as a tool for determining an approximate pretension value. One major benefit of using a DTI, is that the achieved snug-tight value will not impact the gap of the final pretension value. *Figure 2.38* through *Figure 2.44* show the comparison of testing data vs. the manufacturer's calibration curve for various bolt diameters and grades. These tests were completed to determine the accuracy and ease of use for traditional DTI's. The variance in test results vs. the manufacturer's calibration demonstrate the approximate nature of DTI measurements. The protrusions rarely all flatten at the same rate, which can lead to confusion for the person measuring the feeler gage. In general, the testing data was within 10% of the manufacturer's curve. The issue with using DTI's is not the accuracy of the product, but ensuring proper use in the field.

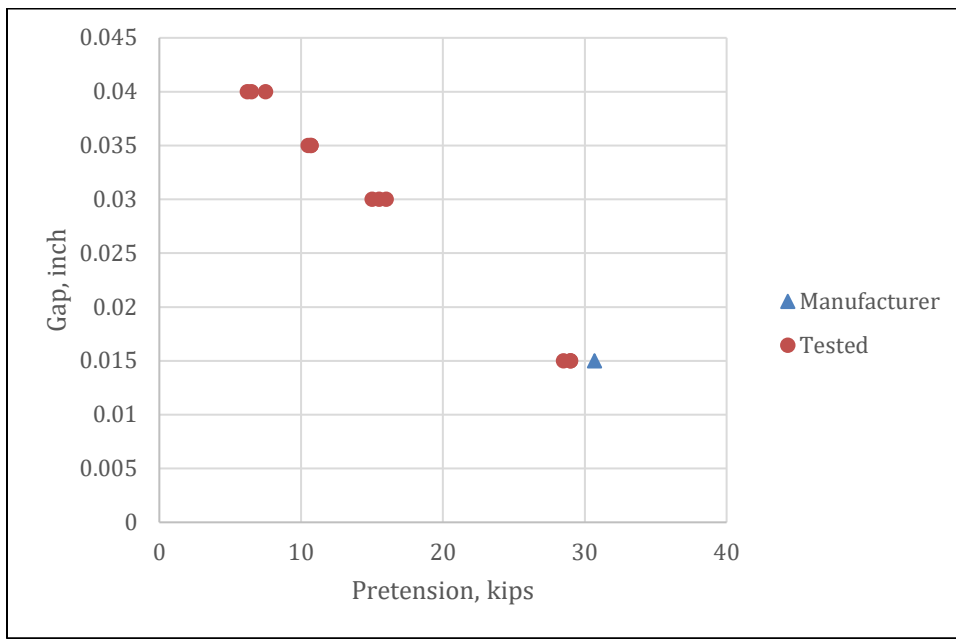

Figure 2.38 - 0.75" A325 DTI

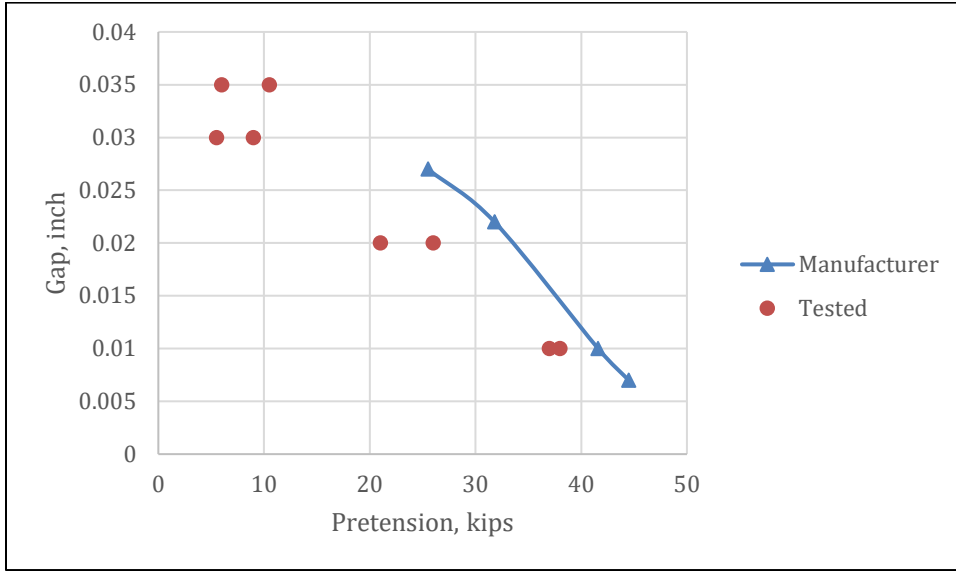

Figure 2.39 - 1.0" Gr. 105 DTI

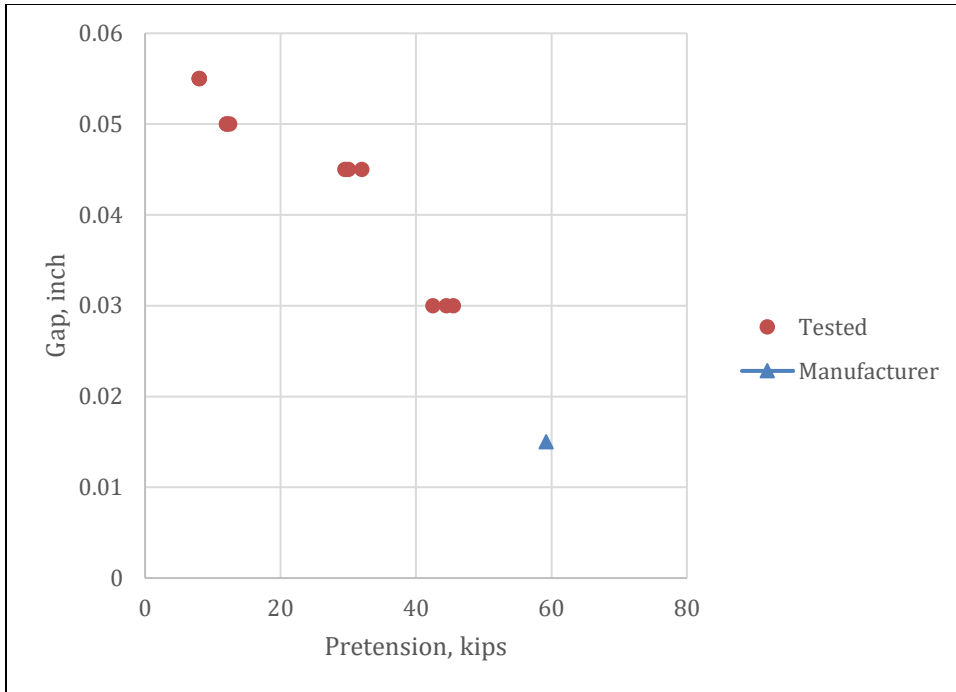

Figure 2.40 - 1.25" A325 DTI



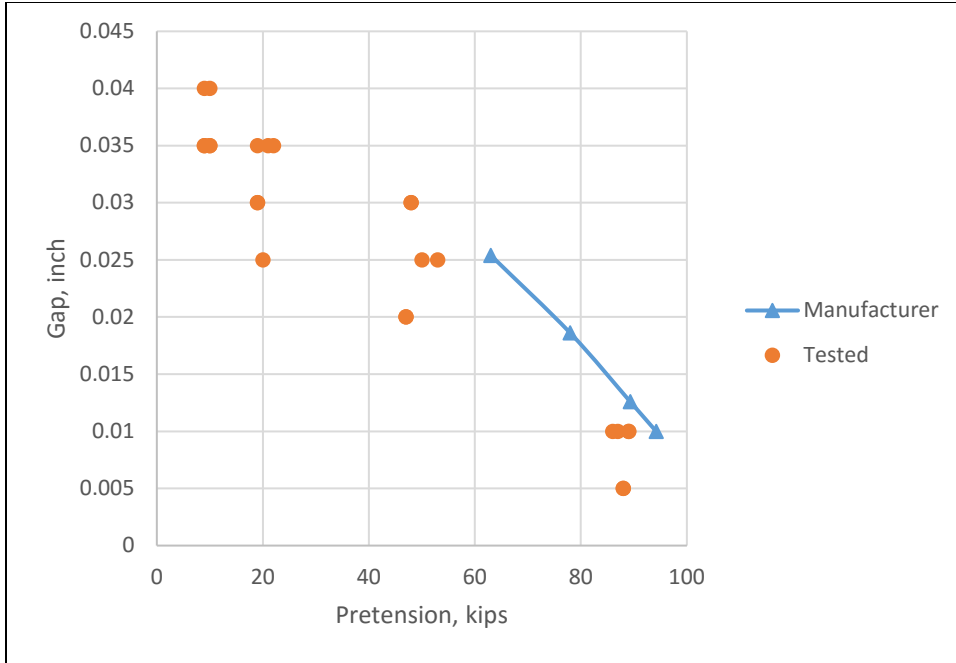

Figure 2.41 - 1.5" Gr. 105 DTI

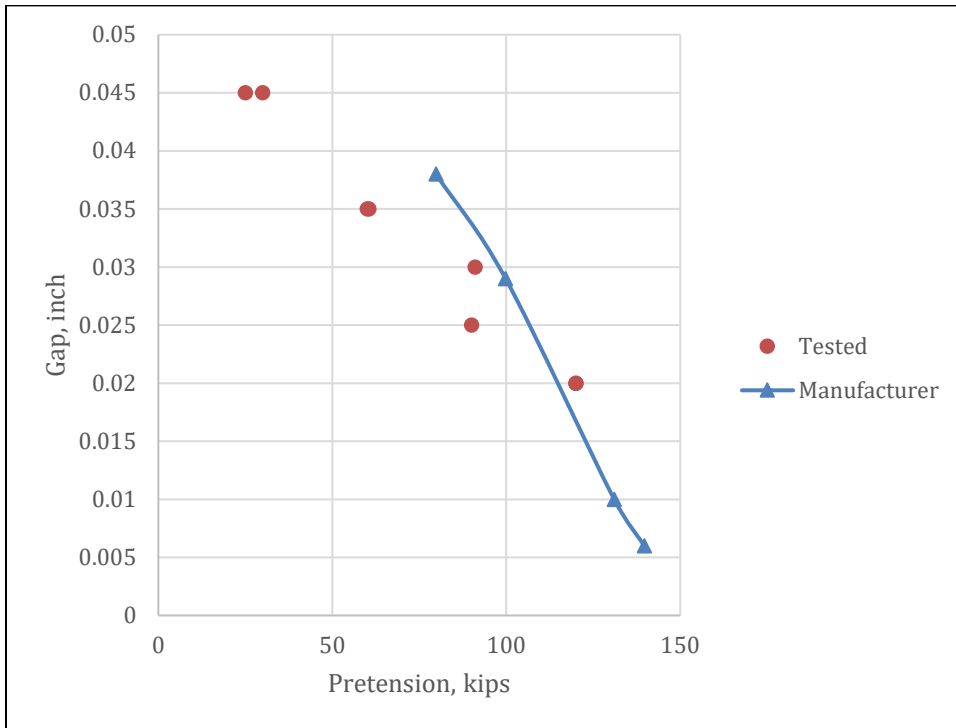

Figure 2.42 - 1.75" Gr. 105 DTI

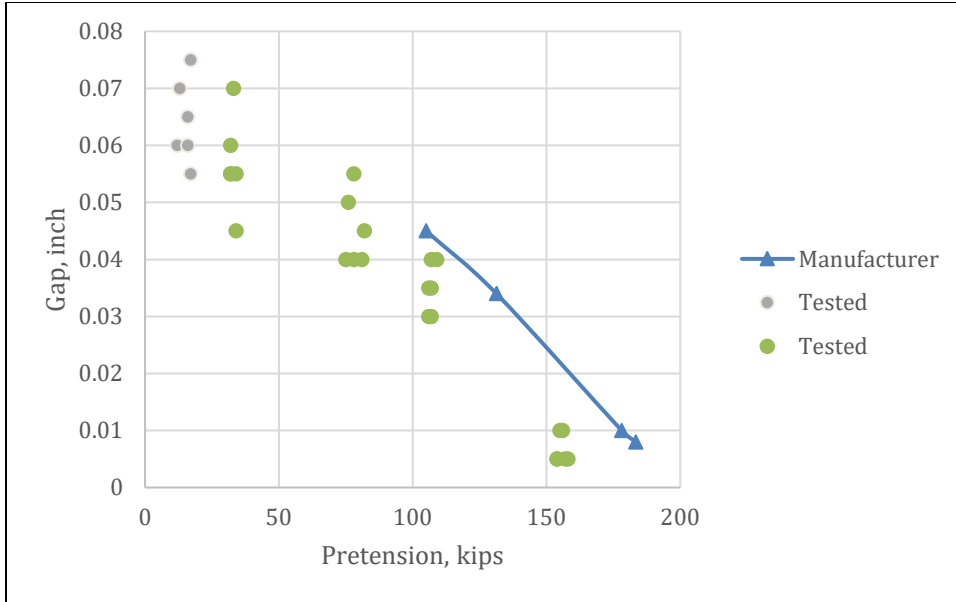

Figure 2.43 - 2" Gr. 105 DTI

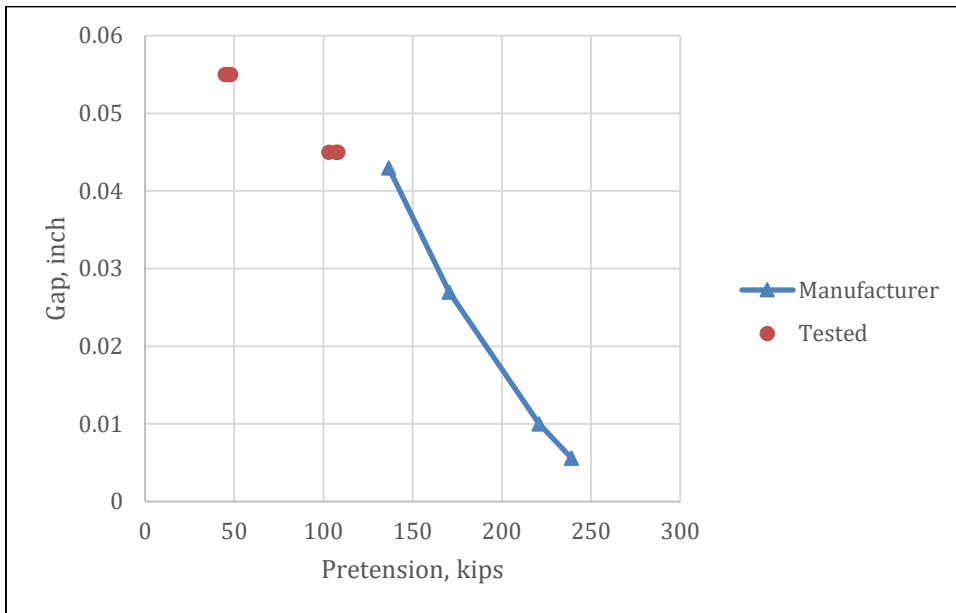

Figure 2.44 - 2.25" Gr. 105 DTI

## General Conclusions

In regards to developing a sufficient specification, the research team concluded:

1. Bolt stiffness (i.e. grip length effect) must be considered when developing a Turn-of-Nut specification. *Figure 2.36* can be used to determine a conservative  $k_s$  value beyond snug.
2. Grip length demonstrated minimal effect on the torque-tension relationship.
3. Results demonstrated that lubrication will impact the torque-tension relationship for larger diameter anchor bolts ( $> 1.5''$ ). As demonstrated in *Table 2.2*, failure to lubricate larger bolts will increase the nut constant,  $K$ , by a factor of 1.5 – 2.0. This will cut pretension in the bolt by a factor of 1.5 – 2.0.
4. The specification must control snug-tight and aim to get the achieved snug-tight beyond the actual snug-tight value.
5. Snug-tight can be controlled using a specified torque or DTI, though both are only approximate methods.
6. Anchor bolts should be properly lubricated to ensure adequate snug-tightening, minimal pretension scatter, thread protection, and achievable final pretensions.

Necessary torque values for snug-tight, final pretension, and the verification 48 hours after tightening for standard MnDOT structures are shown in Appendix F. An adequate specification will address all of the factors tested with the Skidmore-Wilhelm. Without reaching a sufficient snug-tight value, the bolts will not be properly tightened. If a bolt is over-snugged, it can very easily lead to yielding. It is very difficult to predict the bolt's conditions in the field if it is not properly lubricated; that is a basis for all of the tests results. Finally, if grip length is neglected, then a contractor may be able to perfectly follow the specification, and it will still lead to under or over-tightened bolts.

## CHAPTER 3. FIELD MONITORING & LABORATORY TESTING

### Introduction

#### Monitoring & Laboratory Testing Background

Testing in NCHRP 412 (Kaczinski et al., 1998) showed that snug-tight and pretensioned anchor bolts are designed in the same manner. The report found that the Constant Amplitude Fatigue Limit (CAFL) for snug-tight bolts and pretensioned bolts are nearly the same. The CAFL is simply a stress range limit, below which the fatigue life appears to be infinite. Kaczinski noted that if less than 0.01% of stress cycles are above the CAFL, infinite fatigue life can be assumed. AASHTO LTS-1 (2015) points out that while pretensioning will not benefit the design of the anchor bolts for infinite life, it will reduce the probability of the bolts becoming loose under service loads. Thus, the benefit of applying a pretension beyond snug-tight is to prevent loosening under service loads. As long as loosening is prevented, whether the anchor is in the snug-tight or pretensioned phase, the fatigue life of the bolt will be benefitted.

Noting that preventing loosening is the primary benefit of pretensioning anchor bolts, a fatigue test can be performed. The purpose of the fatigue test is to determine how loosening would occur in anchors tightened with MnDOT's previous specification. Before a fatigue test can be conducted, an effective stress range must to be determined. Over their lifetime, the anchors will experience various cycles at different stress ranges. An effective stress range can be determined by using a stress range histogram and one of various numerical methods. Long-term field monitoring on a MnDOT structure will provide data for a stress range histogram. By use of a rainflow algorithm, the monitoring data can be transformed into stress and cycle bins. These stress and cycle bins are used for calculating the effective stress that will be applied to the anchor bolts during the fatigue test. The effective stress range will be calculated as a root-mean-cube (RMS) stress range as shown in Equation 3.1.

$$S_{re3} = \left( \sum_i^v \left( \frac{n_i}{N} \right) S_i^3 \right)^{1/3}$$

Equation 3.1

where  $S_{re3}$  is the effective stress range,  $n_i$  is the number of cycles of stress  $S_i$ , and  $N$  is the total number of cycles. The stress and cycle data can also be compared to AASHTO's specified CAFL of 7 ksi.

### **Field Monitoring of OH Sign Structure**

#### Monitoring Objectives

Long-term monitoring of a MnDOT structure was conducted to determine the following:

1. Approximate achievable snug-tight by contractors in the field.
2. Stress range histogram of the anchor bolts.
3. Effective stress range for fatigue testing.
4. Design  $k_s$  value for future specifications.
5. Independent check of Skidmore Wilhelm testing results.

#### Monitoring Plan

To gather service loading data, long-term field monitoring of a standard MnDOT structure took place at OH MN51-013. The sign is south of County B2 on the southbound lane of TH 51 off of Snelling Ave in Roseville. The site is in the heart of the metro area, between St. Paul and Minneapolis, shown in *Figure 3.1*.



Figure 3.1 – Aerial View of Site

The site was chosen as new construction during MnDOT’s summer 2017 construction schedule. The structure was a MnDOT standard Type 4 post and Type A sign truss with eight 2-1/4” Gr. 55 anchor bolts. Five of the anchors were instrumented with BTM-6C-3LJRTA (Texas Measurements) strain gages to measure axial strain in the bolt. The BTM gage was placed into a predrilled hole in the anchor bolt (*Figure 3.5* and *Figure 3.6*), and then the hole was filled with M-Bond AE-10 epoxy (Micromeritics). Holes were predrilled to 4-1/2” deep (the approximate center of the grip length) at American Machine & Gundrilling in Maple Grove, Mn. In conjunction with the gages in the bolts, eight FLA-6-11-1LJC (Texas Measurements) strain gages were glued to the post at 4’ above the baseplate to measure post stresses (*Figure 3.8*). The strain gage layouts are shown in *Figure 3.2*, *Figure 3.3*, and *Figure 3.4*. Finally, a Young 05103V Wind Monitor was placed at 10’ above the pole (40’ above the baseplate) to measure wind speed and direction. The wind monitor is shown in *Figure 3.10*.

Each anchor was individually calibrated after the BTM gage was installed. Calibration was completed using a Satec universal testing machine, shown in *Figure 3.7*. On average, one microstrain correlated to 100 pounds of pretension force.

A Campbell Scientific CR9000 high speed data logger took measurements in the field. A sampling rate of 100 Hz was used for all thirteen strain gages and the anemometer. The data logger was stored in a protective cabinet, along with a computer for data storage, a cellular modem for remote access, and a Dropcam camera (*Figure 3.11* and *Figure 3.12*). All of the items were powered using direct line access. An IP power switch was used to control power to the equipment remotely and ensure reliable performance. Wires from strain gages were protected by buried conduit, shown in *Figure 3.9*. Wireless communication required the antenna shown in *Figure 3.13*.

In the field, the anchor bolts were snug-tightened using a 48" wrench. Following snug-tightening, the bolts were tightened using a hydraulic wrench. The tightening guidelines were set at 1/6 of turn or a 3,000 ft-lb torque. For each bolt, the 3,000 ft-lb torque was met before reaching a 1/6 turn. At the time of tightening, it was believed that the anchor bolts were F1554 Gr. 105 as ordered, but it was discovered during lab testing that the steel fabricator erroneously sent grade 55 bolts for both the field structure and lab specimen. The following results will all be for Gr. 55 bolts.

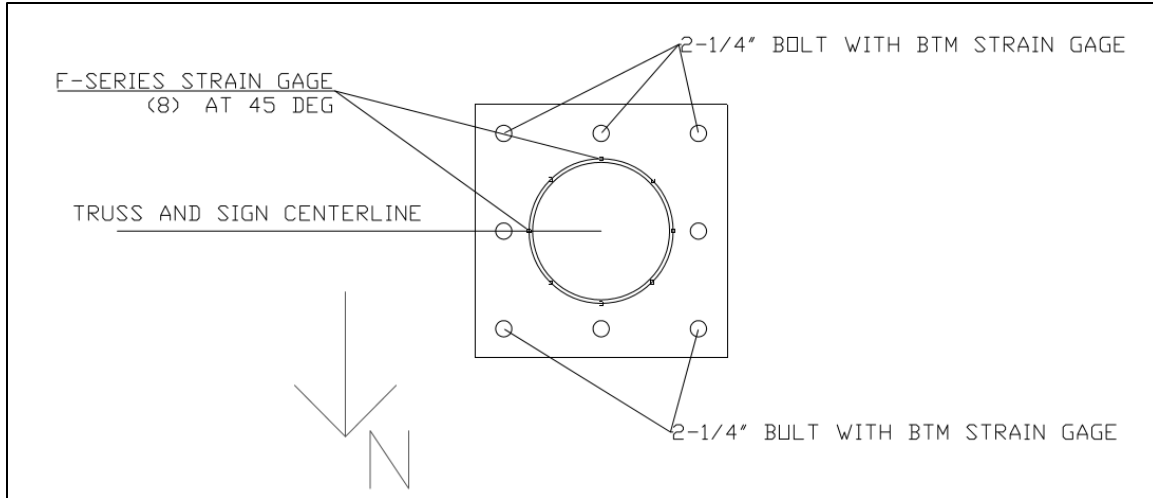

Figure 3.2 - *Strain Gage Layout*

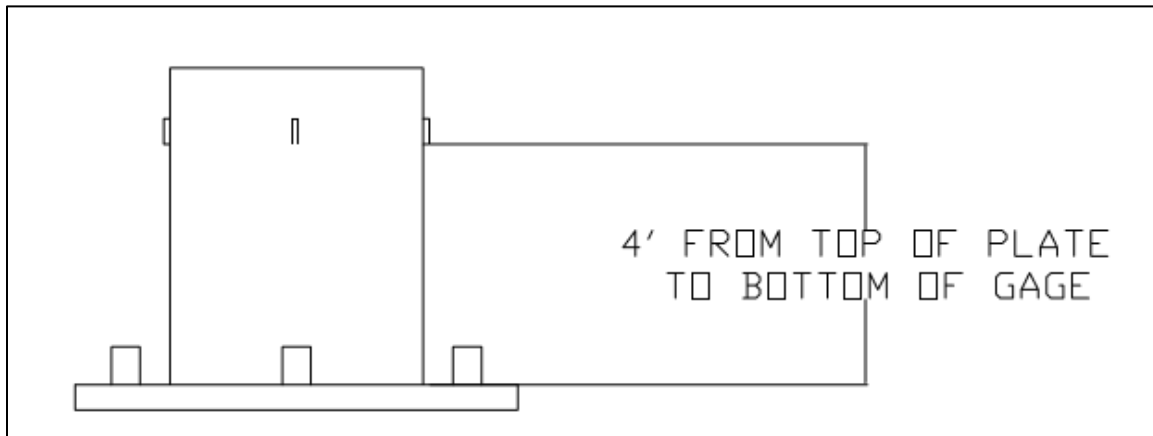

Figure 3.3 - *Elevation View of Strain Gages*



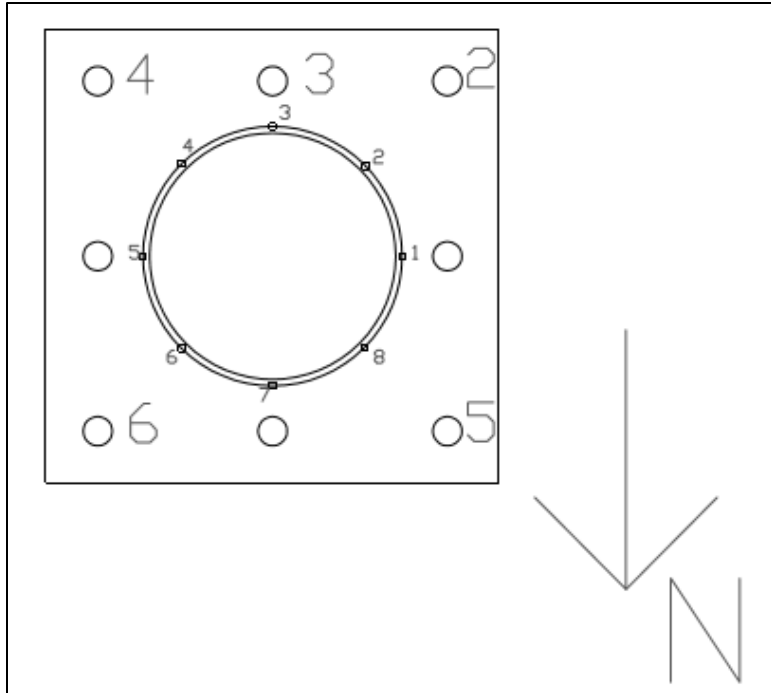

Figure 3.4 - *Labeling for Strain Gages*



Figure 3.5 - *Predrilled Hole in 2-1/4" Anchors*



Figure 3.6 - Anchor Bolts after Strain Gage Installation



Figure 3.7 - Calibration of Anchor Bolts





Figure 3.8 - Anchor Bolt and Post Strain Gages



Figure 3.9 - Conduit Leading to Data Logger



Figure 3.10 - *Anemometer Placement*



Figure 3.11 - *View of Interior of Cabinet*



Figure 3.12 - Camera Inside Enclosure



Figure 3.13 - Antenna for Wireless Connection



## Monitoring Results

The main results for the Gr. 55 bolts are summarized as:

1. Average  $k_s$  value of 0.09 as seen in *Table 3.1*.
2. Average nut factor,  $K$ , measured at 0.13 as seen in *Table 3.1*.
3. Achieved snug-tight force of 24.1 kips, or 13% of the yield stress, as seen in *Table 3.1*.
4. An effective stress range for the monitored bolts was 1.0 ksi.
5. An adjusted effective stress for the monitored bolts was 5.9 ksi.

Table 3.1 – *Field Tightening Results*

Average achieved snug-tight force (kips)	Average angle beyond snug (degree)	Average final pretension (kips)	$K$	$k_s$
24.1 (13% yield)	47.2	120.8 (68% yield)	0.13	0.09

Based on the results of the Skidmore Wilhelm testing, the actual snug-tight force is typically near 10% of the yield stress. The field observed result of 13% of yield means that these bolts likely reached the linear phase of the rotation-tension relationship. For reference, a Gr. 105 bolt would have reach 7% yield, and would likely be below the actual snug-tight value. A 48” wrench was used to complete snugging. Using the nut factor of 0.13 and traditional torque equation, the laborer tightening the bolts applied approximately 150 lbs of force on the end of the wrench.

AASHTO LTS-1 currently specifies 1/12 turn (30 degrees) beyond snug-tight for a 2-1/4” bolt. With a 47.2 degree turn beyond snug, the bolts are above but near 60% yield stress as specified within LTS-1. For reference, a Gr. 105 bolt would have reached 35% of yield, which is well below the 60% criteria per AASHTO. It should also be noted that MnDOT’s previous

specification of 450 ft-lbs would have caused a stress of 4.62 ksi, which is less than 10% yield for both Gr. 55 and Gr. 105 bolts.

The research team felt very confident about the Skidmore Wilhelm results after taking field measurements. The  $k_s$  value of 0.09 is within the expected range, but slightly greater than what the research team expected based on extrapolation of the Skidmore Wilhelm data. Due to geometric limitations during the Skidmore Wilhelm testing, the 2-1/4" bolts tested in the field were much stiffer than those tested in the lab. The average nut factor,  $K$ , found in the lab was 0.12. After observing a similar nut factor of 0.13 in the field, as well as  $k_s$  values within the expected range, the team was very confident in all of the Skidmore Wilhelm data.

For testing purposes, aggregate data was analyzed after a 4 month period from August 21<sup>st</sup>, 2017 to January 21<sup>st</sup>, 2017. During monitoring, one of the bolts (Bolt 5) experienced wire failure. That bolt provided a limited data set prior to wire failure, but could still be used for effective stress range calculation and checking the CAFL. After analyzing initial results, it became clear that the calibration for Bolt 4 was incorrect. Bolts 2, 3, 5, and 6 all gave viable data, and it was decided to not assume a scaling factor for the Bolt 4 data.

Prior to analyzing the data with a rainflow algorithm and RMS analysis, the signal had to be transformed into a collection of 'turning' points. A rainflow only requires the peaks and valleys of the stress range, and there is no need for intermediate points. In order to manage the size of the data set and eliminate unnecessary data points, the gross data was simplified into a signal of only peak and valley data. The final signals for each bolt are shown in *Figure 3.14*, *Figure 3.15*, *Figure 3.16*, and *Figure 3.17*. Note that a positive stress value is tension, while negative is compression. Also note that the stresses are induced stresses from the wind, and do not include the initial pretension.

After analyzing the long term data, it was found that the effective stress range was 1.0 ksi. The majority of stress ranges experienced were under 1.0 ksi. If the stresses under 1.0 ksi are ignored due to the minimal damage caused by each stress, the adjusted effective stress range is 5.9 ksi. Furthermore, no bolt exceeded the criteria for AASHTO's CAFL of 7 ksi. The stress range and cycle data is shown in Table 3.2. The maximum stress range was 73 ksi, which occurred for one cycle in Bolt 2. When looking at *Figure 3.14*, it is clear that the maximum induced compression was nearly 55 ksi, with a maximum induced tension of 18 ksi, totaling a stress range of 73 ksi.

The typical stress range was nearly 1 ksi, while some large stresses were caused by wind events. It is very difficult to correlate wind speed with bolt stress, as wind direction is just as important. A smaller wind gust acting perpendicular to the sign panel is going to create larger stresses than a high wind gust acting parallel to the sign panel.

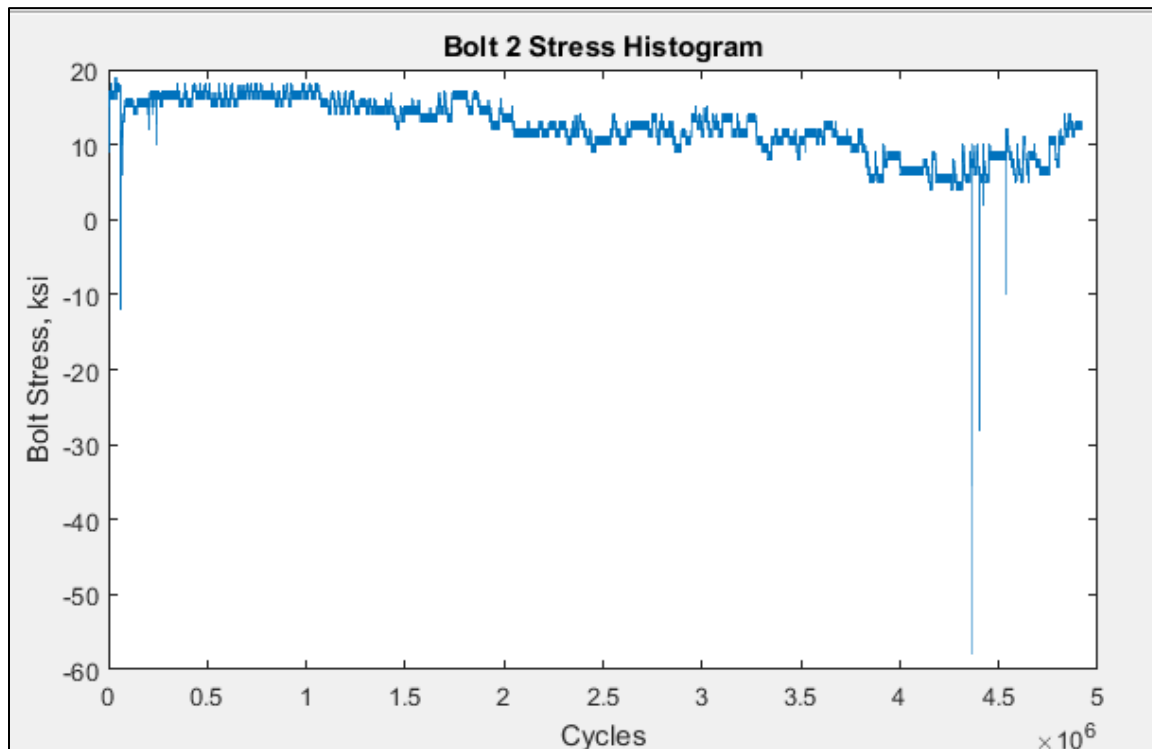

Figure 3.14 - Bolt 2 Stress Histogram



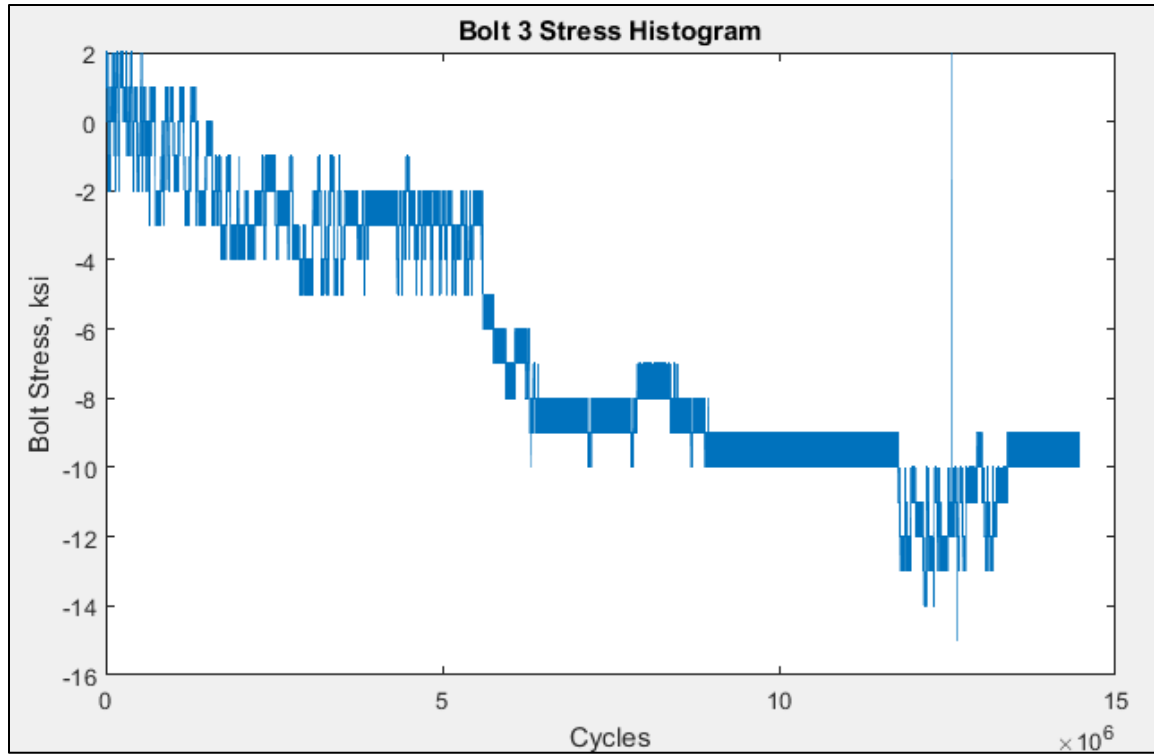

Figure 3.15 - Bolt 3 Stress Histogram

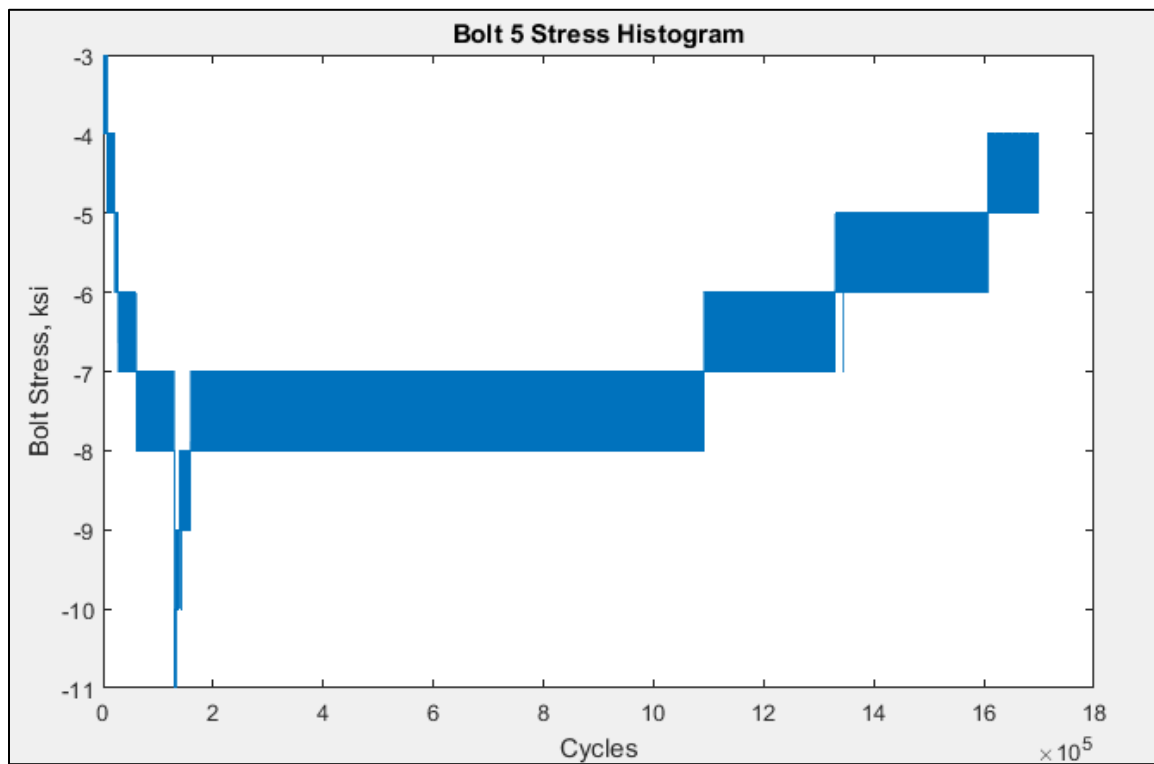

Figure 3.16 - Bolt 5 Stress Histogram

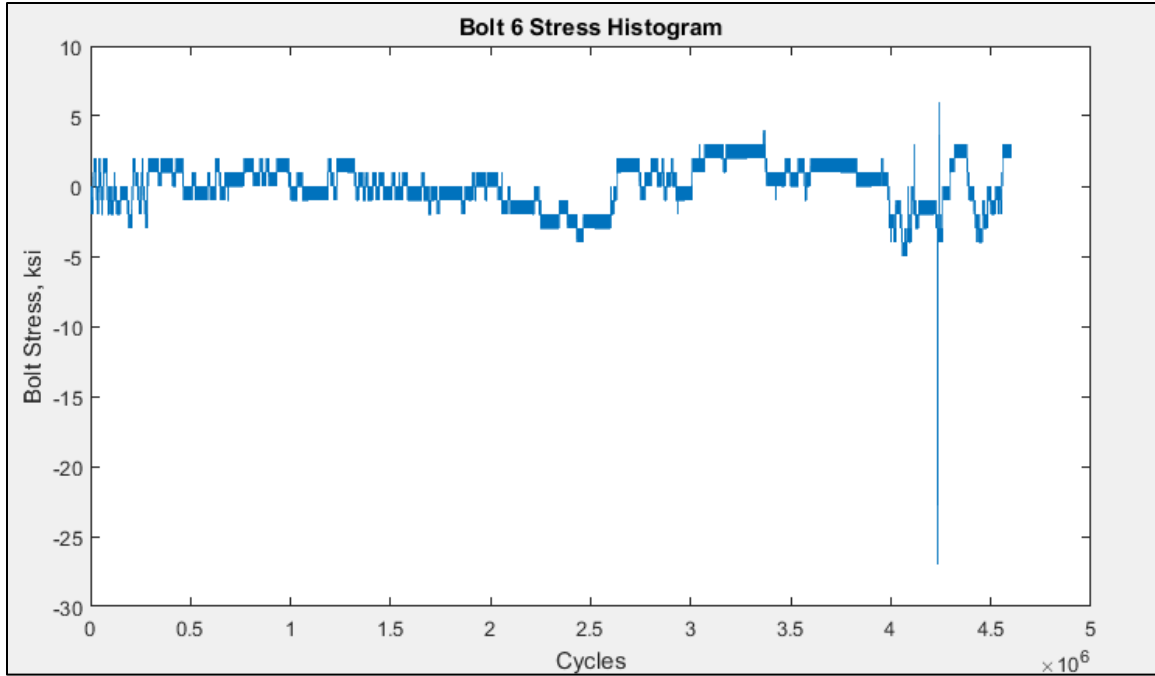

Figure 3.17 - Bolt 6 Stress Histogram

Table 3.2 - Monitoring Stress/Cycle Summary

Stress Range, ksi	Number of Cycles, N				Total
	Bolt 2	Bolt 3	Bolt 5	Bolt 6	
1	2458762	7233011	852807	2302523	12847103
2	260	173	10	127	570
3	45	37	-	20	102
4	24	18	-	9	51
5	10	-	-	4	14
6	4	1	-	1	6
7	2	-	1	2	5
8	1	-	1	2	4
10	1	1	-	1	3
11	1	1	-	-	2
16	-	1	-	-	1
18	1	-	-	-	1
31				1	1
33				1	1
38	1	-	-	-	1
72	1	-	-	-	1
73	1	-	-	-	1
<b>Total:</b>	<b>2459114</b>	<b>7233243</b>	<b>852819</b>	<b>2302691</b>	<b>12847867</b>

*Figure 3.18* and *Figure 3.19* show the average wind speed per day and maximum gust speed per day, respectively. One can see from *Figure 3.19* that the maximum gusts were typically below 50% of the design wind speed (115 mph). The average wind speed over the 4 month period was 10 mph. The maximum wind gust over the 4 month period was 47 mph. When correlating wind speed to bolt stresses, it is critical to note the importance of wind direction. A very high wind moving parallel to the sign panel will have a very small area to act upon in comparison to a wind moving perpendicular to the sign panel.

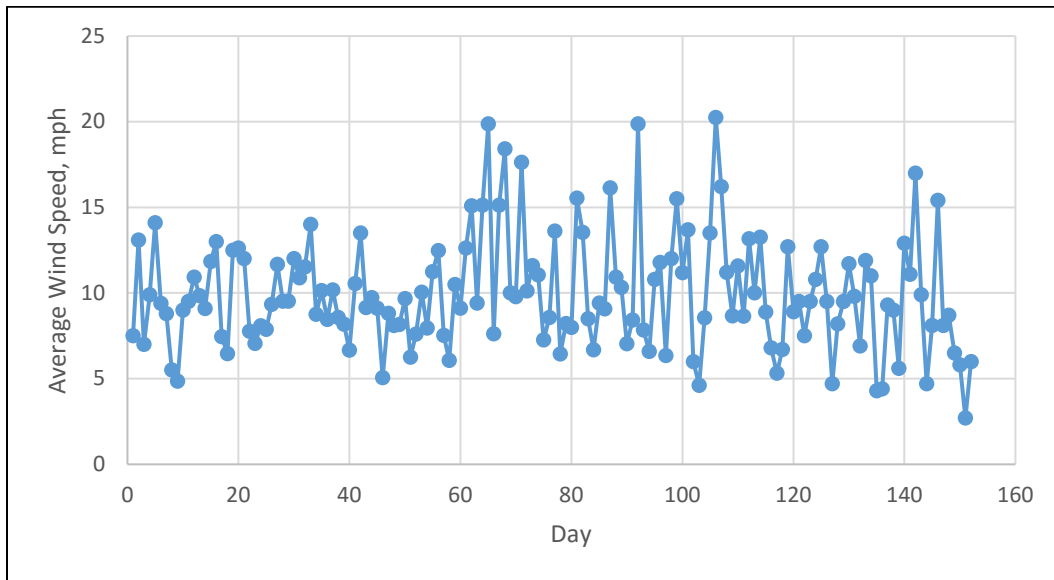

Figure 3.18 - Average Wind Speeds During Monitoring

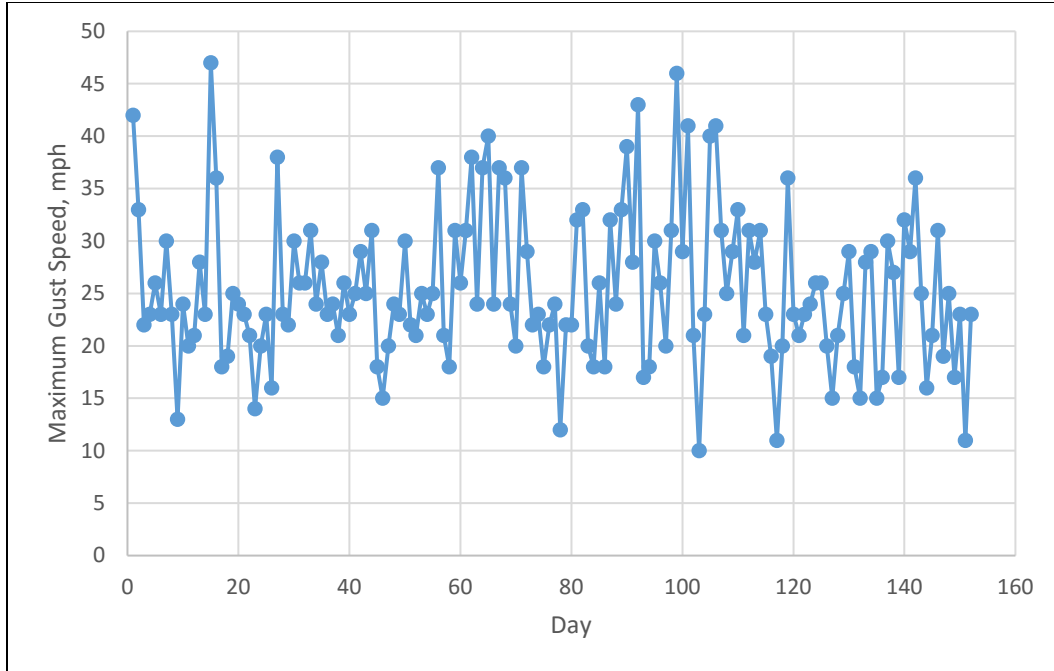

Figure 3.19 - Maximum Wind Speeds During Monitoring

#### Monitoring Conclusions

1. MnDOT's former tightening specification of 450 ft-lbs was rendering significantly under-tightened large diameter bolts (*Table 3.1*).
2. The CAFL of 7 ksi for anchor bolts is appropriate for MnDOT sign structures.
3. The Skidmore Wilhelm data was validated, and bolts with larger stiffness values were added to the data set.
4. The effective stress range for fatigue testing is 1 ksi. An adjusted stress range is 5.9 ksi.
5. The average nut factor of 0.12 from Skidmore Wilhelm testing is a viable and conservative design value for lubricated bolts of MnDOT's sign structures (*Table 3.1* and *Table 3.3*).

## Lab Testing of OH Sign Post

### Testing Objectives

1. Determine an approximate stiffness distribution factor,  $k_s$ , between the fastener and joint in the double-nut moment connections of sign, signal, and luminaire structures.
2. Determine the nut constant,  $K$ , for 2-1/2" diameter bolts in MnDOT sign structures.
3. Determine if the lack of sufficient tightening torque caused previous nut loosening in MnDOT structures.

### Testing Setup

In order to meet the testing objectives, a MnDOT Type 5 sign post was tested. The Type 5 post contains (12) 2-1/2" F1554 Gr. 55 anchor bolts. The sign post is 20" in diameter with 3/8" thick walls. The post is connected to a 2" thick base plate, and stiffened at the post to base weld with welded plates. In order to house the testing specimen in the lab, the sign post was cut to 12' length from the top of the baseplate (*Figure 3.20*). The anchor bolts were embedded in a 4'-0" X 4'-0" X 4'-0" reinforced concrete base. Prior to embedment, 9 of the 12 anchors were individually calibrated. An average calibration factor was used for the remaining 3 bolts. The calibrated bolts were put furthest from the neutral axis into positions where the maximum bolt stresses would occur. Strain gages were placed at 45 degrees around the post, at a height of 4'-0" from the top of the base plate (*Figure 3.24*). A string pot was attached to the end of the post to measure deflection. The base contained rebar details similar to MnDOT's standard pedestal (*Figure 3.21* and *Figure 3.22*). The reinforced concrete base was post-tensioned to the 2' thick laboratory strong floor (*Figure 3.23*).

Photos of various stages of the construction process are shown in *Figure 3.25* through *Figure 3.36*. After constructing the base and setting the post, the entire specimen was lifted and set onto its side. From this position, loading would be applied to the post to cause static and

fatigue loads. An HP10x57 was connected to the end of the post in order to efficiently apply the loads. By connecting the H-pile, there was no need to manufacture a yoke to fit the post (*Figure 3.37*). Loading was applied using a 55 kip hydraulic actuator with a +/- 3" stroke. By using the moment of inertia of the bolt group, initial calculations were made to determine approximate base moments. The calculations determined that a base moment of 380 kip-ft would cause 10 ksi stresses in the outer anchor bolts. The concrete base was designed for this moment, though final monitoring data concluded that stresses of 6 ksi would be applied to the bolts.

Prior to post-tensioning the concrete base to the lab floor, a tightening test was conducted. Anchor bolts were lubricated with Bostik Mariner's Choice Never Seez, and then tightened by hydraulic wrench. Tightening testing included snug-tightening of the bolts, followed by application of 4 torque values. As discussed with the tightening test results, a star pattern was attempted. It was believed that the required torque to reach the assumed actual snug-tight values would not be reached during snugging. A 2.5" diameter, grade 55 bolt would require approximately 550 ft-lbs of torque for snugging. The available wrench was 3 feet long, and thus the force at the end of the wrench would need to be 183 lbs. This is not a reasonable value for a single person to achieve. In order to get a correct  $k_s$  value, the rotation angle was measured between the first applied torque and the final torque. This range would be beyond the actual snug-tight value, and would yield an accurate  $k_s$  value. Following the tightening test, bolts were loosened for the static and fatigue test.

In order to confirm the base moment to bolt stress relationship, a static test was conducted. The results of the static test were used to determine the necessary base moment for the fatigue test. Following construction of the testing frame, the specimen was incrementally

loaded until a maximum induced bolt stress of +/- 6 ksi was observed. Maximum bolt stresses were expected in the interior anchors furthest from the neutral axis (2, 3, 6, 7).

Following the static test, bolts were tightened to 450 ft-lbs to match MnDOT's previous specification for 2-1/2" diameter anchors. Due to the strain gages in the bolts, an open end wrench was required for torque application. Due to the stiffener plates on the post, the bottom nuts (typically "leveling" nuts) were tightened with the 450 ft-lb torque, while top nuts were left snug-tight. A torque wrench was modified in order to fit a wrench with an open end, and then connected to a pipe wrench. This modified torque wrench was calibrated using a Skidmore Wilhelm and the known nut factor, K. After the bolts were tightened and the base moment required was identified, the specimen was loaded.

AASHTO LTS-1 requires a minimum loading frequency of 1 Hz. Simple calculations of the natural frequency while ignoring the stiffness of the concrete and HP10x57 segment result in a natural frequency of nearly 40 Hz. Research by Kaczinski et. al (1998) and James et. al (1996) demonstrate that a typical natural frequency for the structures is between 1 Hz and 10 Hz. A frequency of 1 Hz was selected due to the limitations of the actuator. Testing by James et. al (1996) experienced multiple failures of the welds between the base plate and post. This failure mode was watched closely during testing.

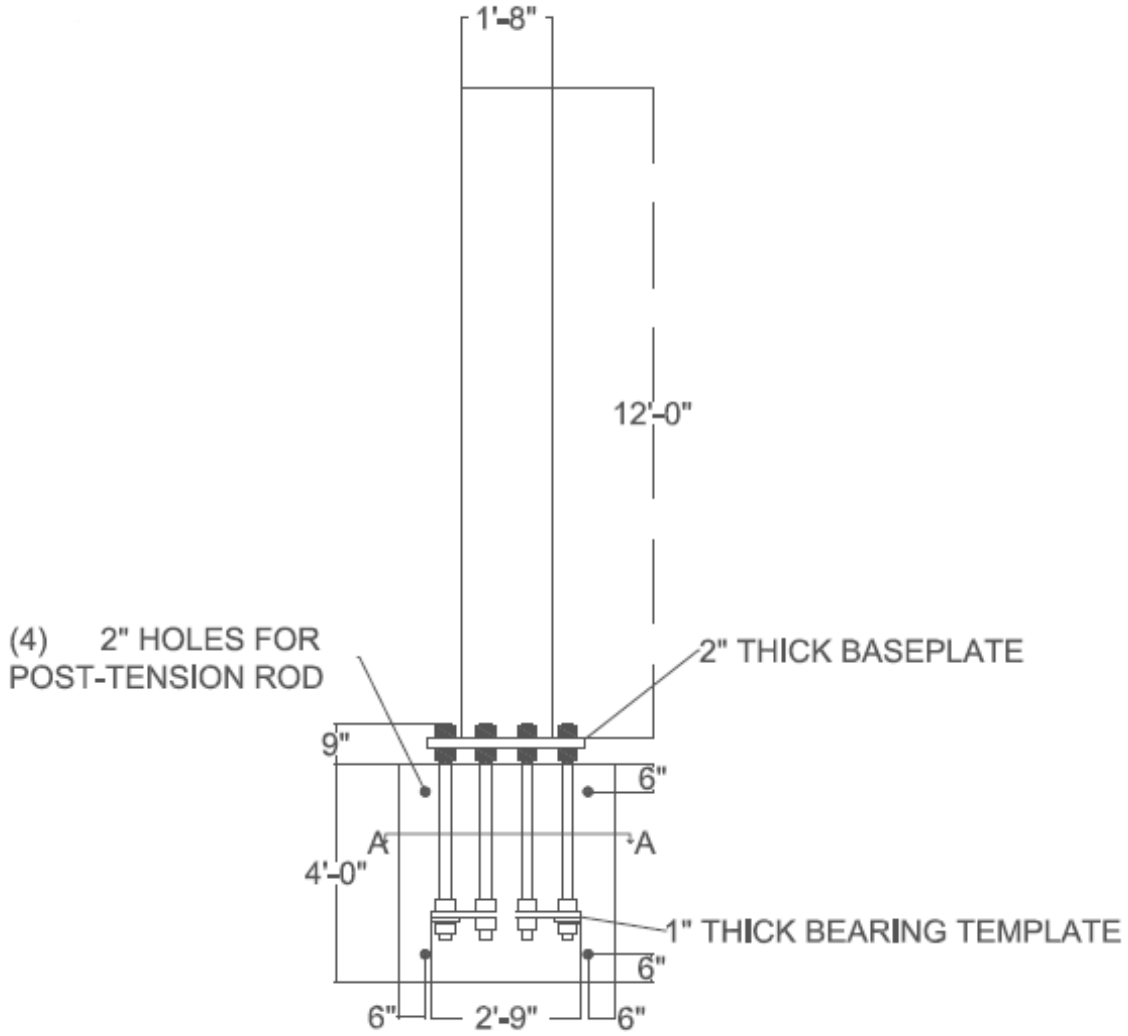

Figure 3.20 - Top View of Lab Specimen

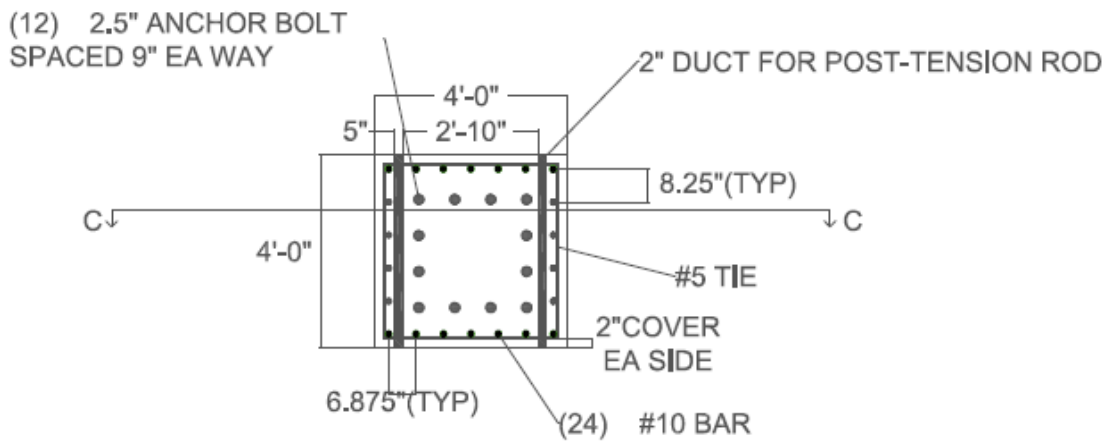

Figure 3.21 - Cross Section of Concrete Block (A-A)



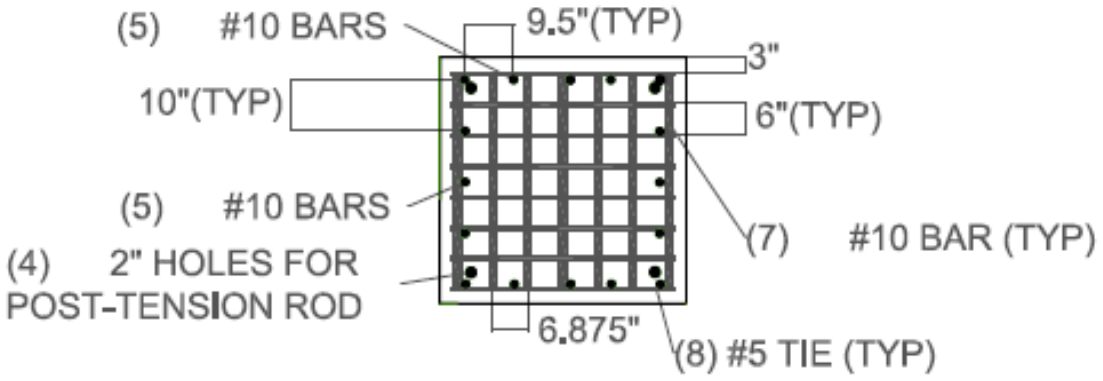

Figure 3.22 - Top View of Concrete Block Reinforcement (C-C)

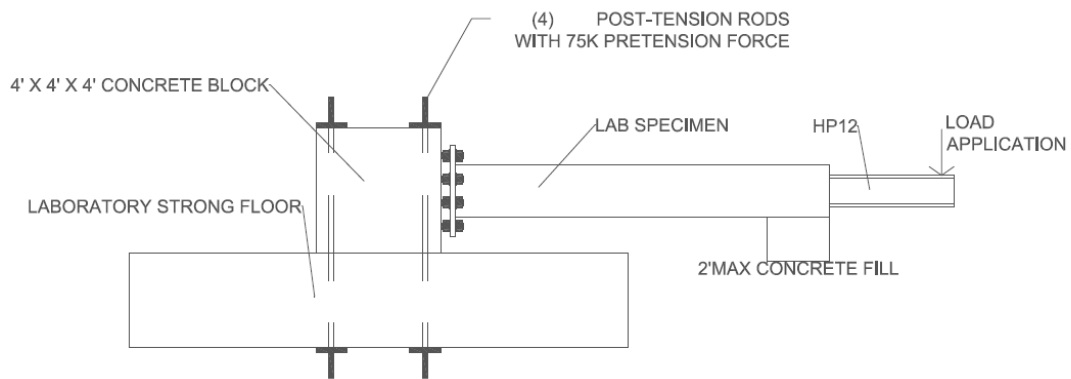

Figure 3.23 - Side View of Lab Specimen

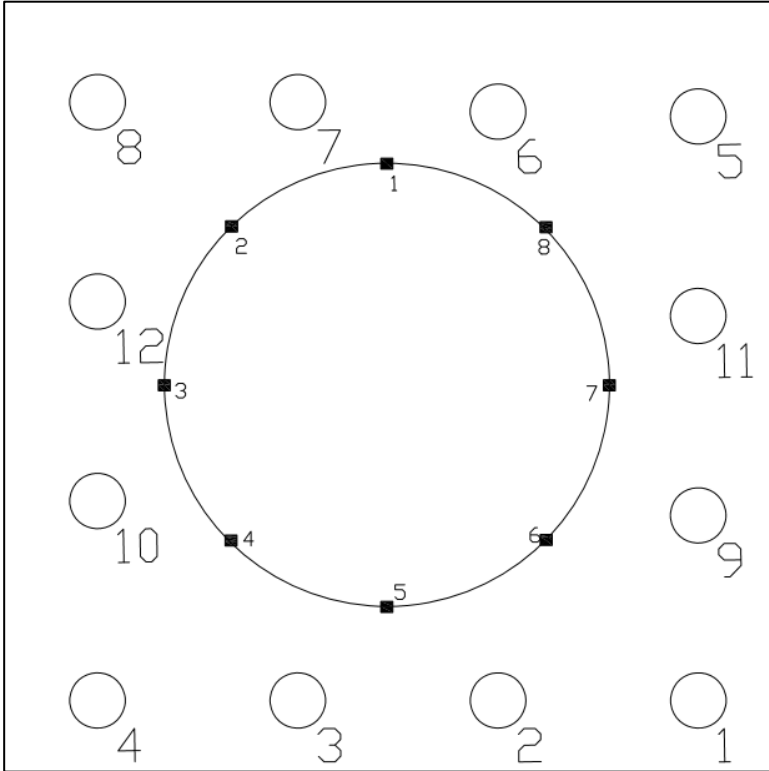

Figure 3.24 - *Strain Gage Numbering for Lab Specimen*



Figure 3.25 - *Concrete Block Formwork*



Figure 3.26 - *Rebar Cage*

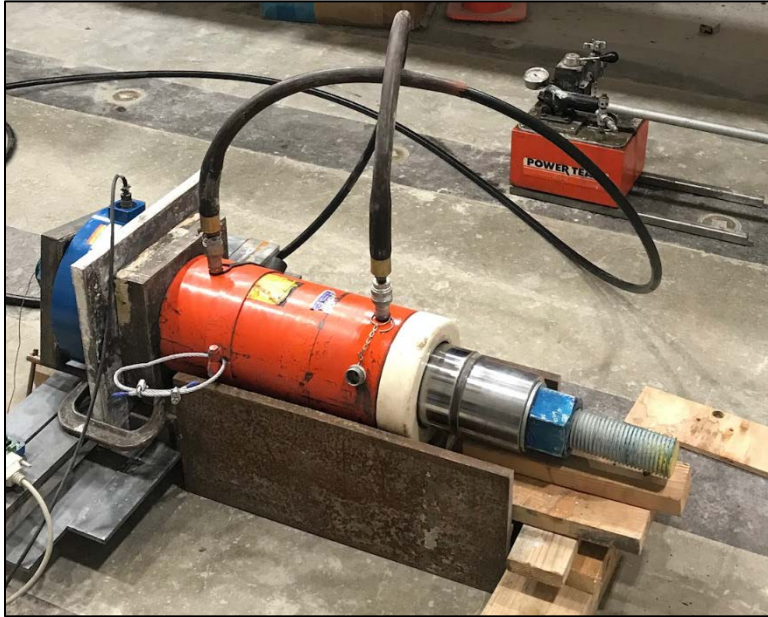

Figure 3.27 - *Individual Calibration of Anchor Bolts*





Figure 3.28 - Anchor Bolt Cage



Figure 3.29 - Rebar, Anchors, and PVC Placed in Formwork



Figure 3.30 - *Anchor Bolts during Concrete Curing*



Figure 3.31 - *Shear Studs and Wood Form Inside Sign Post*



Figure 3.32 - *HP10x57 and Confinement Placed in Sign Post*



Figure 3.33 - *H-Pile Placed Inside Sign Post*





Figure 3.34 - *HP10x57 Curing in Concrete*



Figure 3.35 - *Top View HP10x57 Curing in Concrete*



Figure 3.36 - *Concrete Block Following Post-tensioning*



Figure 3.37 - *Test Frame Following Construction*



Testing Results

*Tightening Test*

The tightening test provided the following results:

1. An average nut factor, K, of 0.12 as seen in *Table 3.3*.
2. An average  $k_s$  value of 6.4% as seen in *Table 3.3*.
3. An average snug-tight force of 8.82 kips as seen in *Table 3.3*.

Table 3.3 - *Summary of Tightening Test Results*

Average achieved snug-tight force (kips)	Average angle between torques (degree)	Average final pretension (kips)	K	$k_s$
8.8 (4% yield)	54.8	166.4 (75% yield)	0.12	0.064

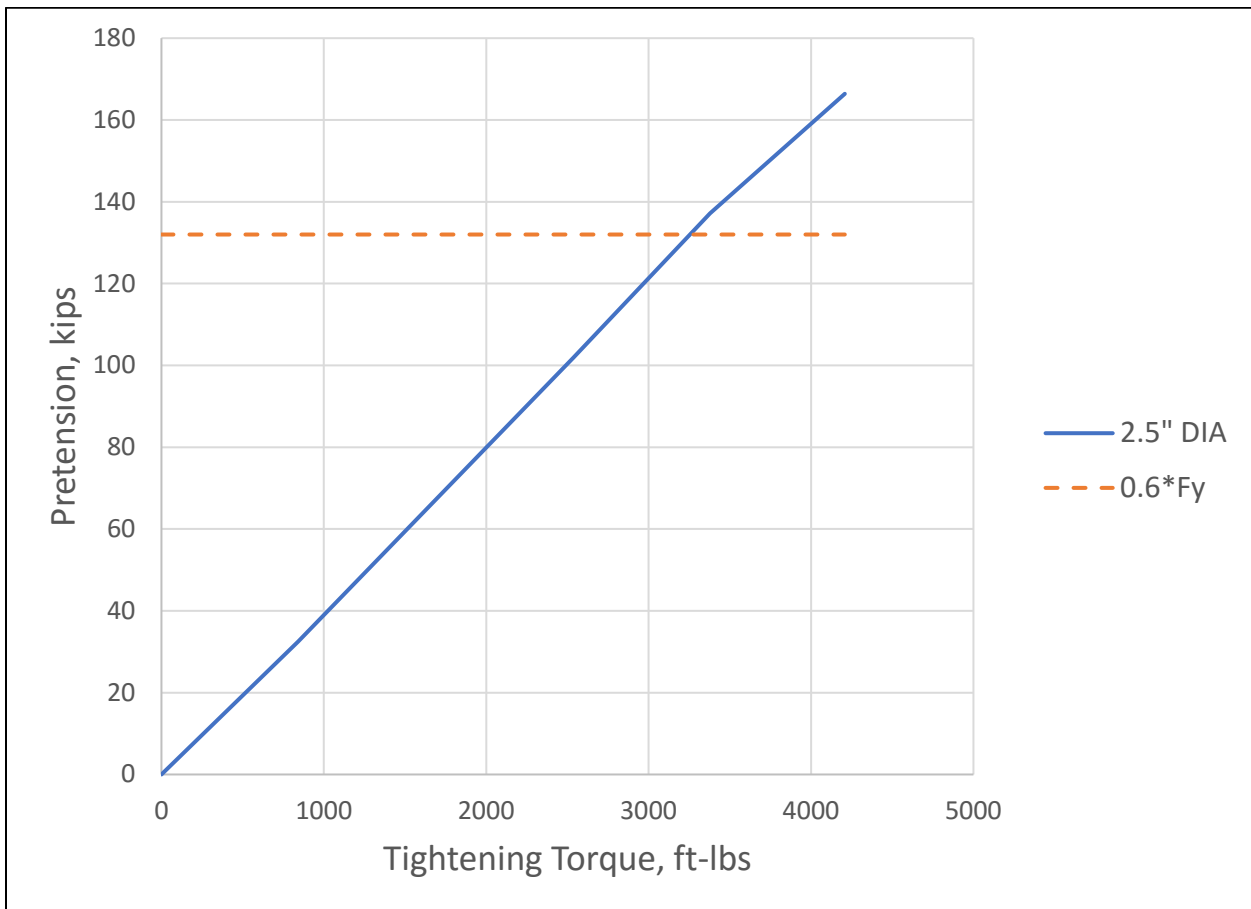

Figure 3.38 - *Torque vs. Tension for 2-1/2" Diameter Bolts*

After testing bolts 1, 5, and 8, the team observed unexpected results and realized that the steel fabricator had provided the wrong grade of bolts. The research team requested 105 ksi yield bolts, but were provided with 55 ksi bolts. This caused three of the bolts to yield during tightening, but none demonstrated necking or permanent elongation. It was decided that since no elongation occurred, the low stresses induced during static and fatigue testing would not be enough to damage the bolts, and that results of these tests would not be impacted by the yielding. Furthermore, corner bolts were expected to take a smaller portion of stresses due to bending than the inner bolts. However, due to the yielding, it was decided that loosening and then retightening the bolts at the same pretension would risk permanent damage to the bolt. The team decided to not risk damaging the bolts, and therefore could not compare final pretensions if tightened with a hydraulic wrench while using the star pattern or a circular pattern. In lieu of using the hydraulic wrench, the team later compared the star and circular pattern by using a regular, 3' long wrench. This test is described below.

The team continued tightening the remaining bolts. It was also discovered that some of the bolts could not be tightened due to the stiffener plates in MnDOT's designs. The plates prevent a hydraulic wrench from fully covering the hex nuts. Due to this prevention, four of the twelve bolts could not be tightened with the hydraulic wrench. The only way to tighten and loosen the bolts blocked by the stiffeners is to remove the reaction arm from the wrench. The wrench then bears against the stiffener while tightening. This can be an effective approach, but the risk of damaging the wrench is significantly higher. Considering the cost of these wrenches, it is unadvisable to use the wrench without the reaction arm. MnDOT should consider updating the geometry of the baseplate and stiffeners so that hydraulic wrenches can be used for tightening.

Follow the static and fatigue tests, the team completed another tightening test to compare the circular and star patterns. Tightening was completed using a regular wrench, and the data was examined by looking at the percentage change from when the individual bolt was tightened to when all bolts had been tightened. The circular pattern began at Bolt 1 and went counter-clockwise, finishing with Bolt 2. The star pattern was in the following order: 6, 3, 11, 10, 7, 2, 12, 9, 8, 1, 5, and 4. Note that the strain gage in Bolt 2 was damaged before the previous tightening test, and that the gage or wire in Bolt 8 failed during the fatigue test. *Table 3.4* shows the percent change comparison between star and circle for each individual bolt.

*Table 3.5* shows the same data, but the columns are arranged in the order of tightening. For reference, column 1 in *Table 3.5* shows Bolt 1 data for circle tightening, and Bolt 6 data for star tightening. From the tables, one can see that in general the star pattern yielded more consistency. Bolt 10 had a very large change in the star pattern. This is most likely due to the low amount of pretension achieved when tightening the bolt with a regular wrench.

Table 3.4 – *Comparison of Star & Circle per Bolt*

Bolt	1	3	4	5	6	7	9	10	11	12
Circle	17%	30%	0%	3%	4%	0%	10%	3%	5%	14%
Star	0%	0%	0%	0%	9%	0%	0%	55%	13%	11%

Table 3.5 – *Comparison of Star & Circle by Tightening Order*

Order	1	2	3	4	5	6	7	8	9	10	11	12
Circle	17%	10%	5%	3%	4%	0%	*	14%	3%	0%	30%	*
Star	9%	0%	13%	55%	0%	*	11%	0%	*	0%	0%	0%

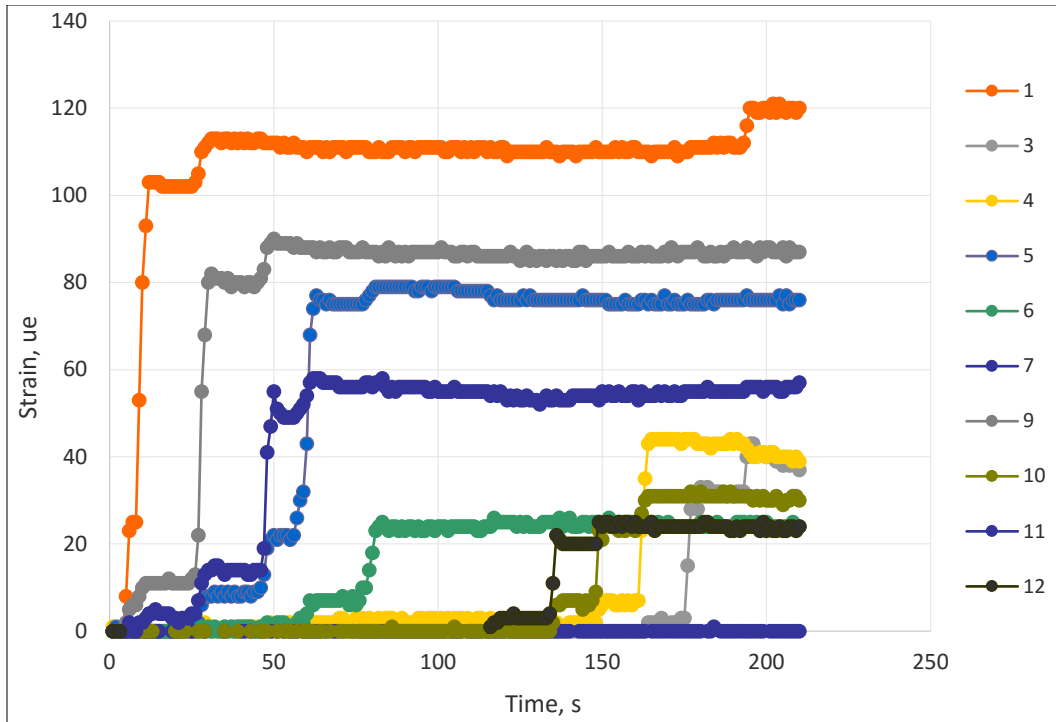

Figure 3.39 – Circle Pattern Data

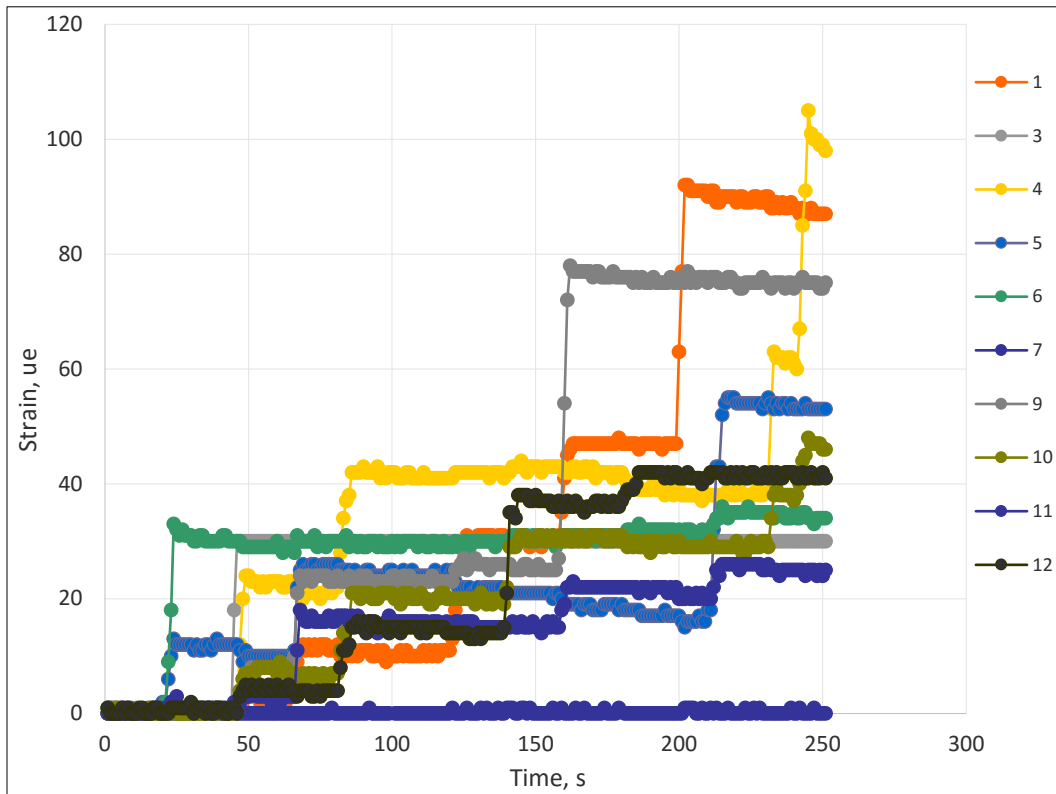

Figure 3.40 – Star Pattern Data

### Static Test

It was observed that bolts in tension displayed linear relationships between loading and bolt stress, as seen in *Figure 3.41*. However, when bolts transferred to compression, a non-linear relationship was seen. This was unexpected, but is believed to be due to the pretension from tightening. Note that positive deflection is upward, and positive stress is tensile stress.

The static test determined that 5.9 ksi (0 to 5.9) could be achieved by using a 0.56" stroke. This would cause Bolt 6 to undergo a stress range of 5.9 ksi. The relationship between base moment and stresses in the bolts are shown in *Figure 3.42*. The stresses in the post at a given deflection are shown in *Figure 3.43*. The figure clearly shows the linear relationship between applied loading and stresses in the post. Finally, a full cycle is shown in *Figure 3.44*. This shows the nonlinear compression zone clearly.

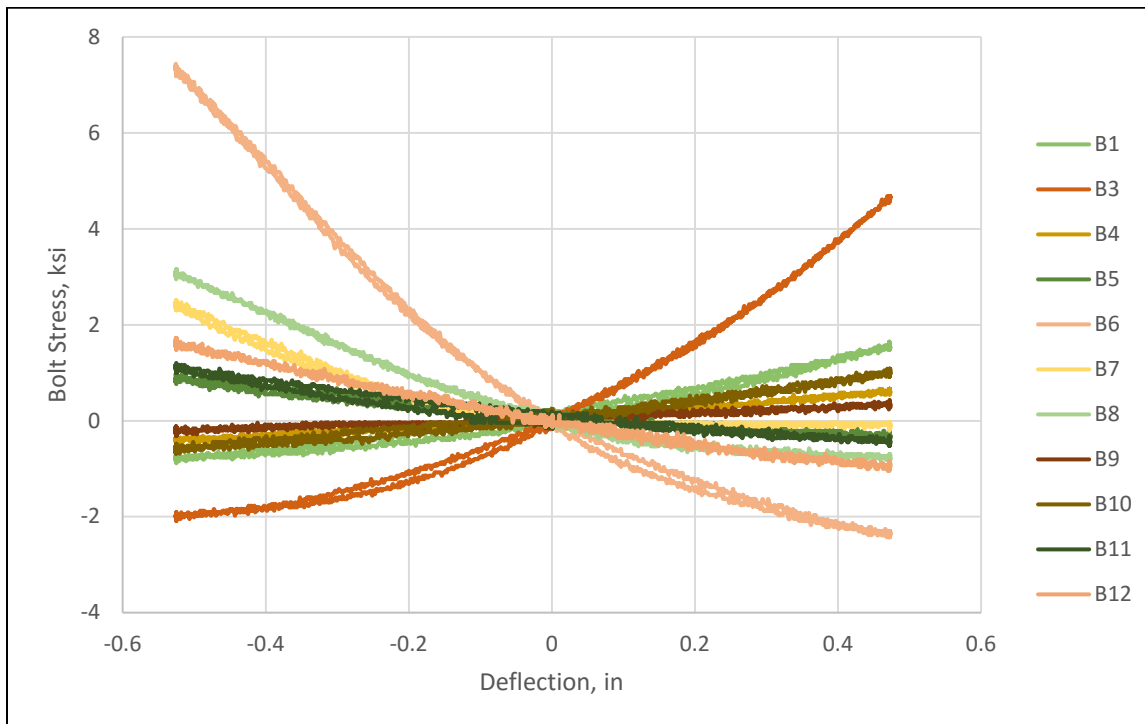

Figure 3.41 - Deflection vs. Bolt Stress

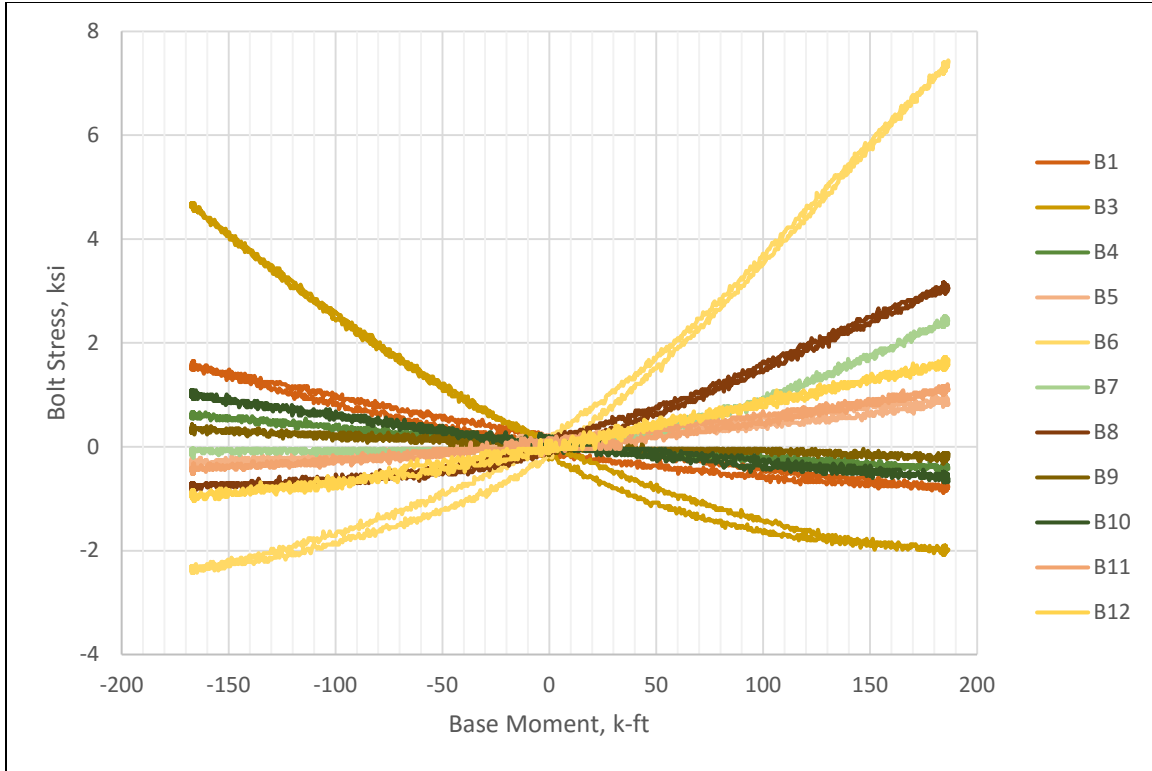

Figure 3.42 - Base Moment vs. Bolt Stress

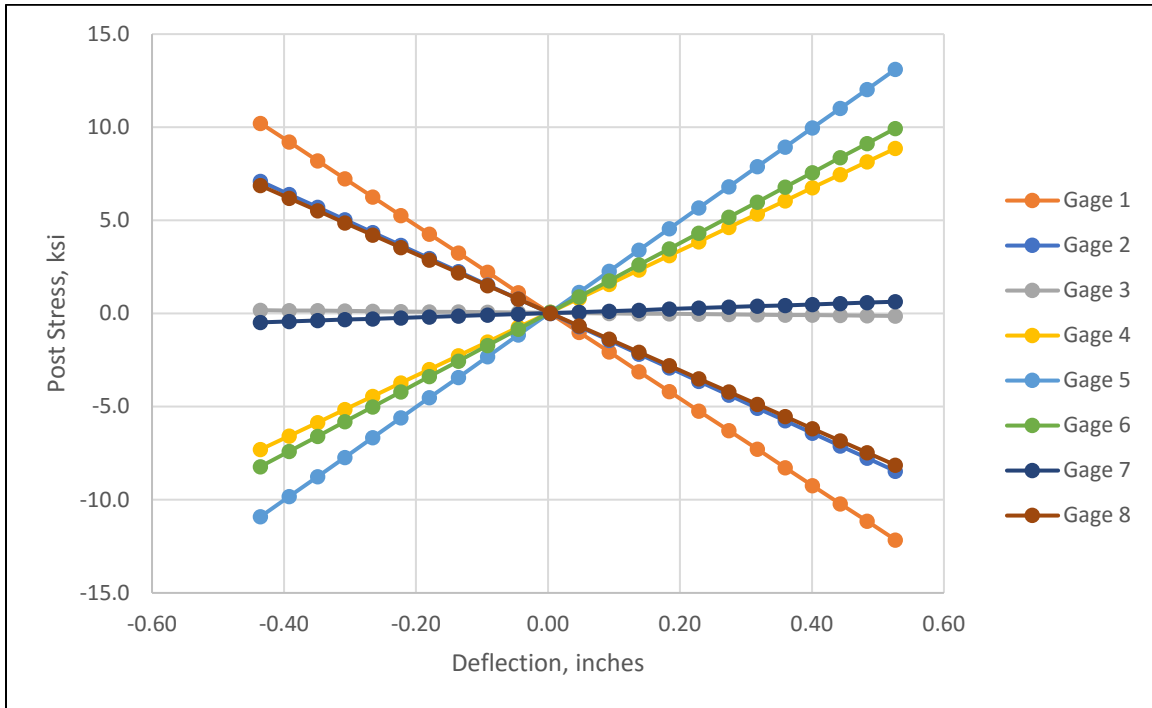

Figure 3.43 - Deflection vs. Stress in the Post

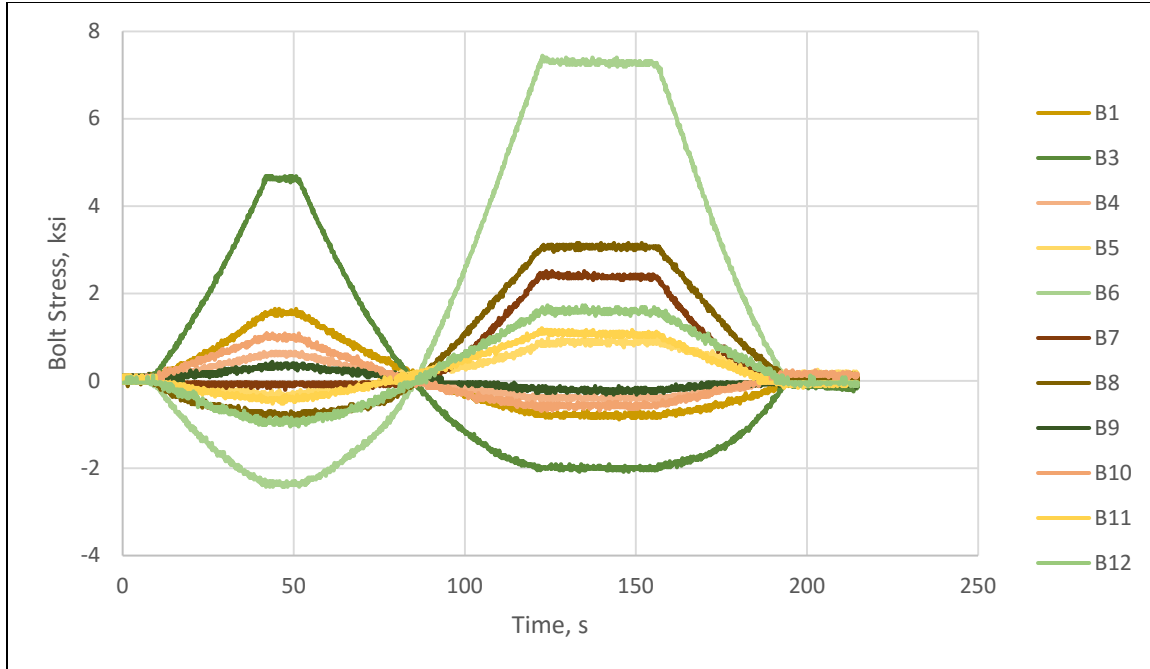

Figure 3.44 - *Time vs. Bolt Stress*

Figure 3.44 demonstrates that while in tension or compression, the innermost bolts carry a significantly higher percentage of the load than the other bolts. In reality, bending stress will not be the only stresses in the post. Wind will be hitting the sign, sign truss, and post from all angles; causing shear stresses as well as bending stresses.

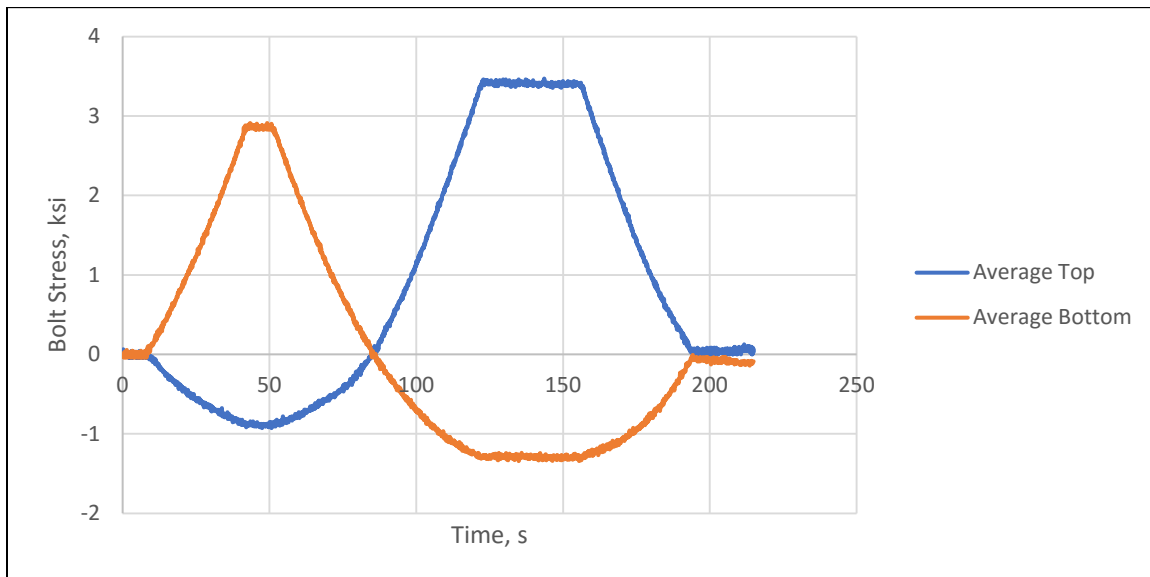

Figure 3.45 - *Average Stresses vs. Time*

*Fatigue Test*

Stresses in Bolt 6 were typically the maximum. Therefore, the test was arranged so that a 6 ksi stress range would act on Bolt 6. From *Figure 3.42*, the required base moment is nearly +/- 117 kip-ft, or a +/-9 kip load applied at the HP10x57. Data was captured on a timed schedule. Every 30 minutes, data would be collected at a speed of 10 Hz for 15 seconds. The wires in Bolt 2 and Bolt 7 failed before and during testing, respectively.

After 600 cycles, it was observed that some of the washers were becoming loose. After 2000 cycles of 6 ksi loading, testing was stopped so that 'tightness' could be checked. The 'tightness' was checked by striking washers with a hammer, similar to the procedure done by MnDOT maintenance personnel in the field. Through inspection, both Bolt 7 and Bolt 8 were loose.

The modified torque wrench was then used to check the 'tightness' of Bolt 7 and Bolt 8. The nut on Bolt 8 began to turn at a torque value of 180 ft-lbs. This indicates that Bolt 8 became loose at the tightened nut. Bolt 7 did not turn, even with 450 ft-lbs applied. This indicates that the leveling nut was loose, similar to the findings of MnDOT maintenance personnel. For the interior bolts, the baseplate is stiff enough that it will not move as the tightening nut is tightened, even when the leveling nut is loose. In a case where the leveling nut is loose, turning the tightening nut will not lead to added pretension.



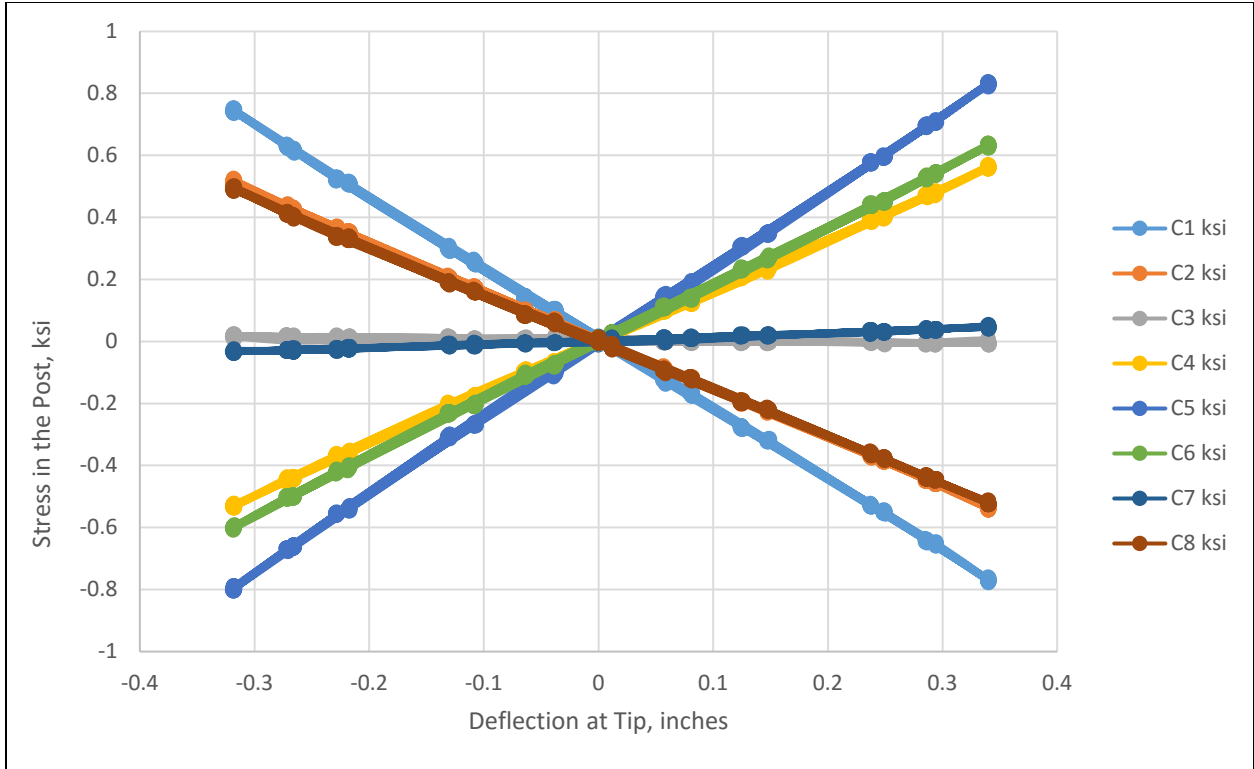

Figure 3.46 - Post Stress vs. Deflection

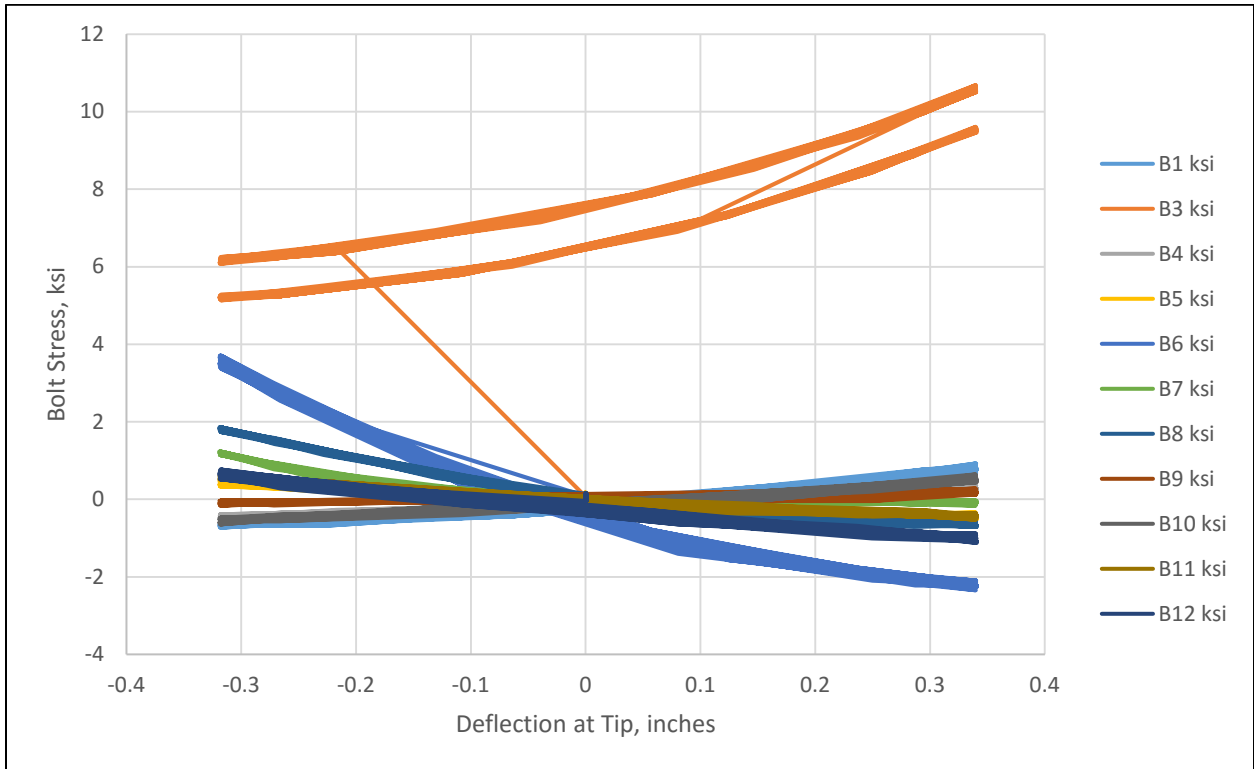

Figure 3.47 - Bolt Stress vs. Deflection

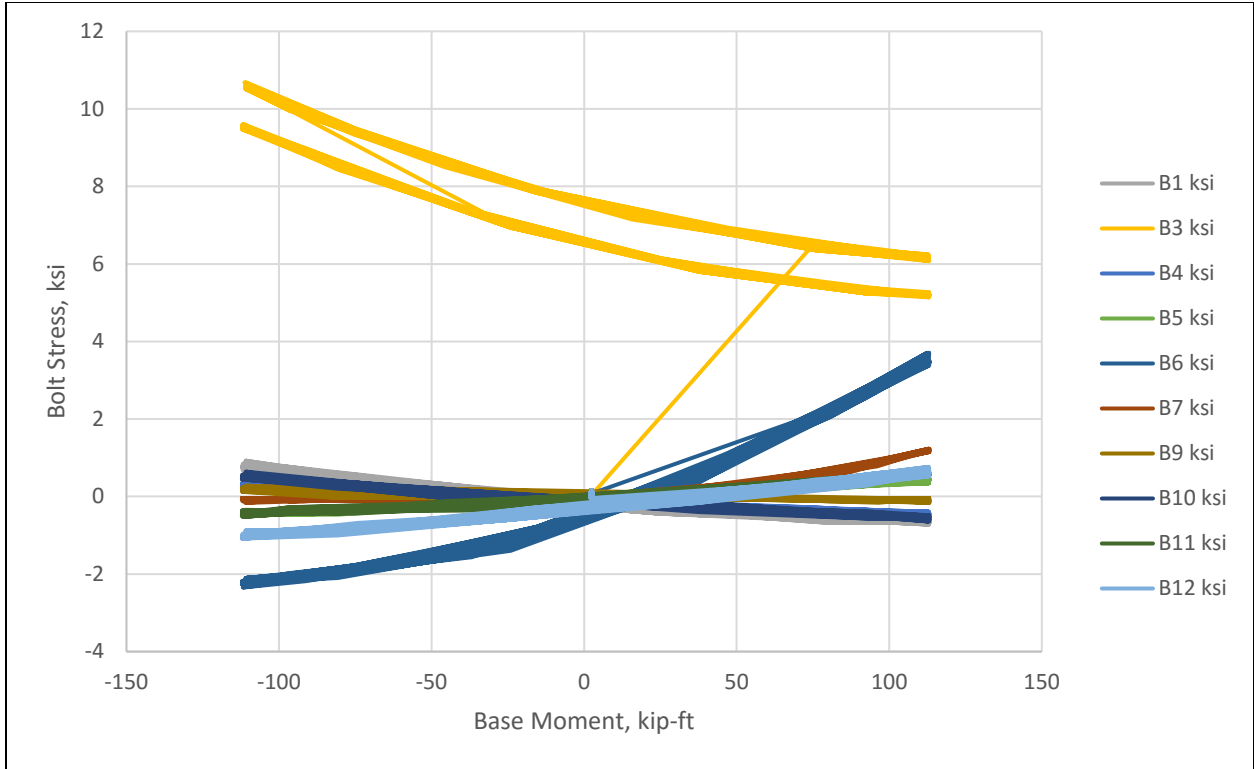

Figure 3.48 - Bolt Stress vs. Base Moment

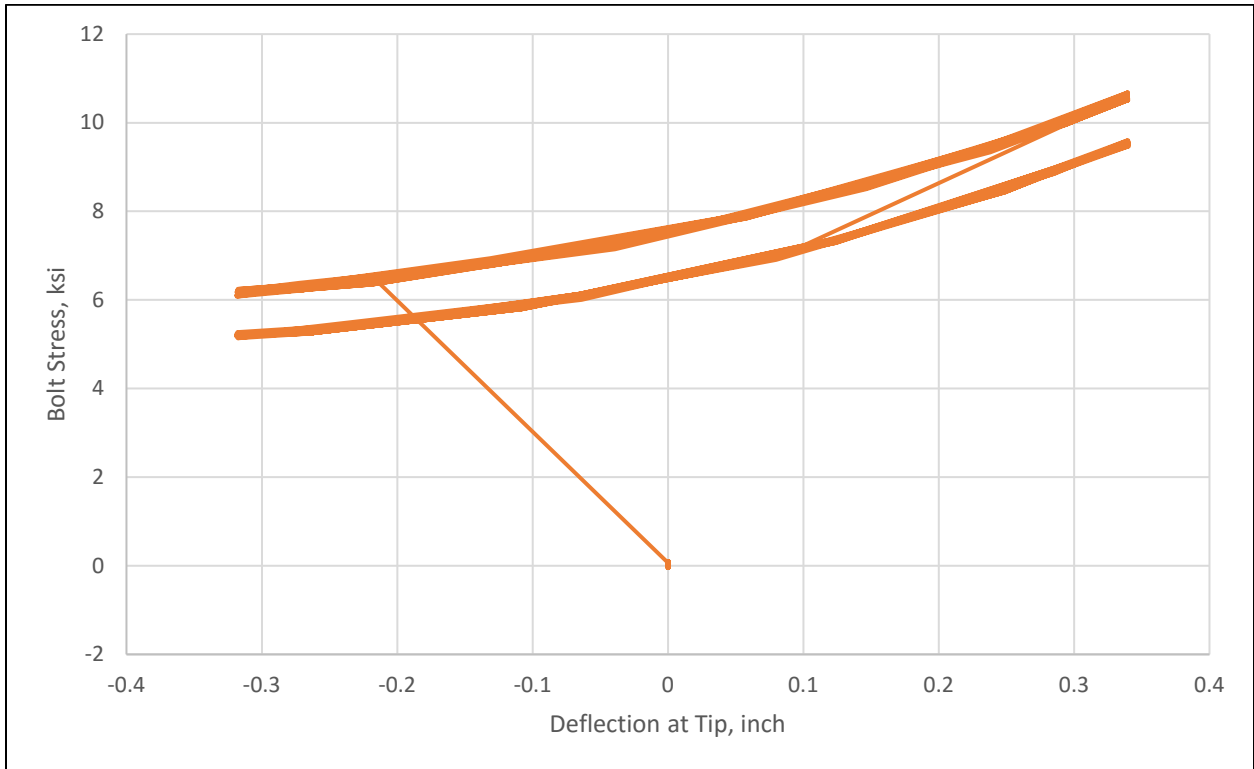

Figure 3.49 - Bolt 3 Stress vs. Deflection

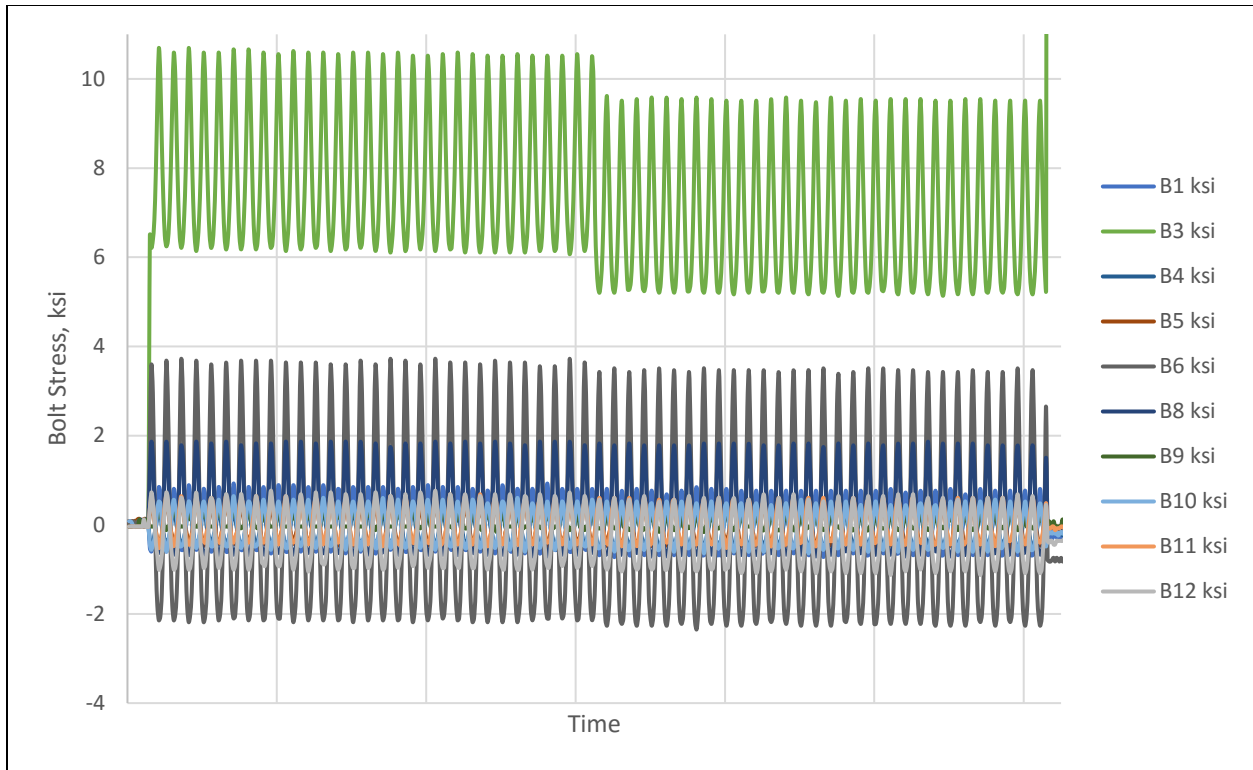

Figure 3.50 - Bolt Stress vs. Time

At higher pretension values, one can expect to see a major shift in how load is transferring through the bolts when one becomes loose. However, with the low pretension values during testing, the transfer of load was much smaller. In *Figure 3.50*, Bolt 3 almost immediately begins carrying more tension than the remaining bolts, and drifts back towards compression approximately halfway through testing. Since most of the load is carried by the interior bolts (2, 3, 7, 8), it seems appropriate that Bolt 3 and Bolt 6 would carry additional load as others come loose. Since the wires in Bolt 2 and Bolt 7 failed between the static and fatigue tests, it is difficult to have a clear picture of the exact amounts of load being transferred to other bolts when Bolt 7 and Bolt 8 became loose. With the data from Bolt 2 and Bolt 7, it would be very clear where the load was transferring to. It is presumed that Bolt 7 was loose at the leveling nut, and thus there would not be a significant shift in stresses in the other bolts. In the case of Bolt 8, it became loose at the tightening nut during the fatigue loading. Bolt 8 is a corner bolt, and thus

takes a very small amount of stress compared to the interior bolts. For reference, Bolts 1, 4, and 5 were the other corner bolts and took an average stress range of 0.87 ksi. As Bolt 8 became loose and load transferred to the other bolts, only a very small range would be added per bolt. This small range is challenging to see in the data set, as the measurements have roughly 0.2 ksi of noise throughout testing.

*Figure 3.46* shows the relationship between the post gages and deflection at the tip of the post. This relationship was used to ensure that stresses in the post remained constant during loading. *Figure 3.47*, *Figure 3.48*, and *Figure 3.49* all show the stress ranges the bolts experience during testing. The ranges remained constant, though it began to drift to a new zero at approximately half the testing time. Again, the tensile stress jump is visible for Bolt 3.

Following the test at 6 ksi, a test with a 1 ksi stress range was used. This test was to determine if the more common stress range would lead to bolt loosening while using MnDOT's previous specification. The bolts were retightened with 450 ft-lbs, and then the fatigue test was run.

After 179,000 cycles, the actuator speed was increased to 2 Hz. After 1,235,918 total cycles, the testing was stopped. No movement of the washers, and therefore no loosening of the nuts was observed. It is believed that the greater magnitude of bolt stress, leading to greater deformation in the grip length, led to the early loosening seen with MnDOT's previous specification.

### **General Conclusions**

The main conclusions of the field monitoring and lab testing are as follows:

1. MnDOT's previous tightening specification of 450 ft-lbs was producing severely under-tightened bolts (*Table 3.1*).
2. The nut factors,  $K$ , and  $k_s$  values from Skidmore Wilhelm testing were validated.

3. The CAFL of 7 ksi is appropriate for anchor bolts of MnDOT sign structures.
4. Monitored anchor bolts demonstrated an effective stress range of 1 ksi, with an adjusted stress range of 5.9 ksi.
5. A design nut factor,  $K$ , or 0.12 is appropriate and conservative for MnDOT structures (*Table 3.1* and *Table 3.3*).
6. Using MnDOT's previous tightening specification, nuts became loose at a stress range of 6 ksi.
7. Using MnDOT's previous tightening specification, nuts did not become loose at a stress range of 1 ksi.
8. Interior bolts carry more stress than corner bolts during pure bending.
9. The star pattern presented more consistent bolt pretensions during the tightening sequence.

These conclusions will be used to create an effective and safe tightening specification for MnDOT sign structures.

## CHAPTER 4. FINITE ELEMENT MODELING

### Introduction

The finite modeling completed for MnDOT was a joint operation between researchers at North Dakota State University (NDSU) and Iowa State University (ISU). The development of the different models was completed by Mr. Shree Paudel (NDSU) and Mr. Yinglong Zhang (ISU). This chapter will discuss the validation of the models compared to field and lab data, as that was the portion I was responsible for. For detailed description of the modeling methodology and construction, see the final MnDOT report titled Re-tightening the Large Anchor Bolts of Support Structures for Signs and Luminaires.

### Modeling Objectives

In situ anchor bolts of sign, signal, and luminaire structures continue to come loose during service loads. This loosening is a dynamic effect, and is very difficult to quantify through traditional methods. Through finite modeling, one can examine the degradation of bolt pretension to discern the loosening of the bolt and baseplate connection. The goal of the finite element models is to develop finite models that can predict the torque-tension relationship, validate static test results, and prepare for fatigue modeling. Due to the time limitations of fatigue modeling, it was not feasible to complete the necessary modeling for 100 million cycles of fatigue.

### Modeling of Field Structure

#### Results

For one case, the pretension force is introduced through the predefined prestress, while the other case is modeled by adding a preloading step, which is able to reflect the initial preloading in the pretension force history. The model geometry, loading, and boundary conditions are shown in Figure 4.1. The stresses generated in the bolts are shown in Figure 4.2,

while the reaction forces generated are shown in Figure 4.4 and Figure 4.5. From Figure 4.4 and Figure 4.5, we could see that the modeling can accurately predict the trend of the pretension force time history under wind loading. Figure 4.3 is included for reference when examining Figure 4.4 and Figure 4.5.

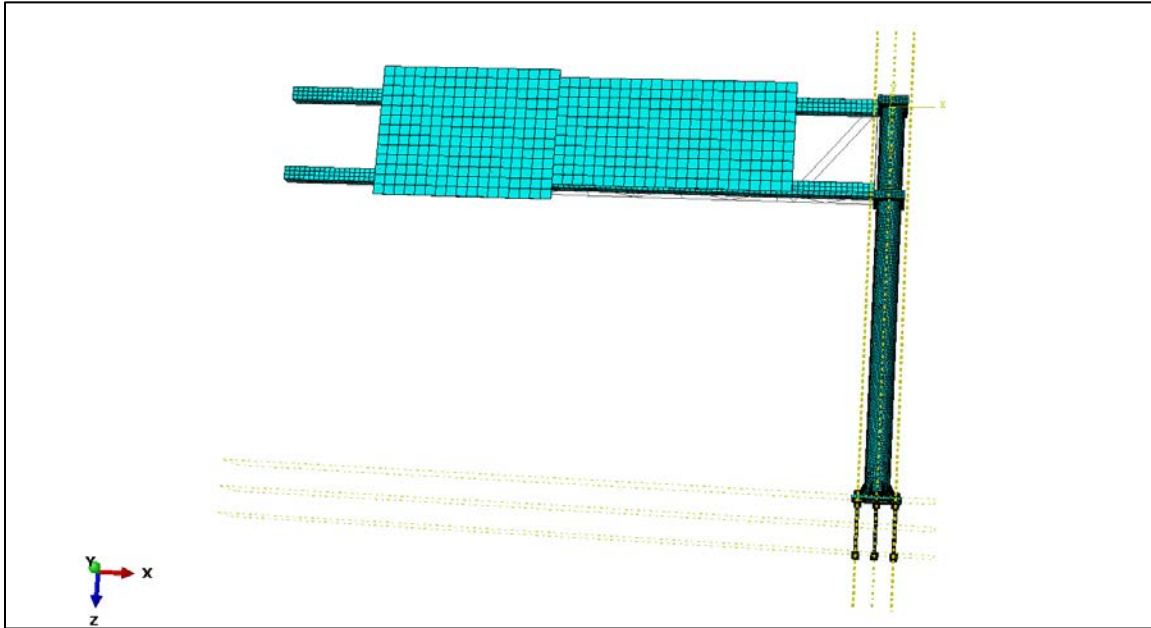

Figure 4.1 - *Mesh Generation for Sign Structure*

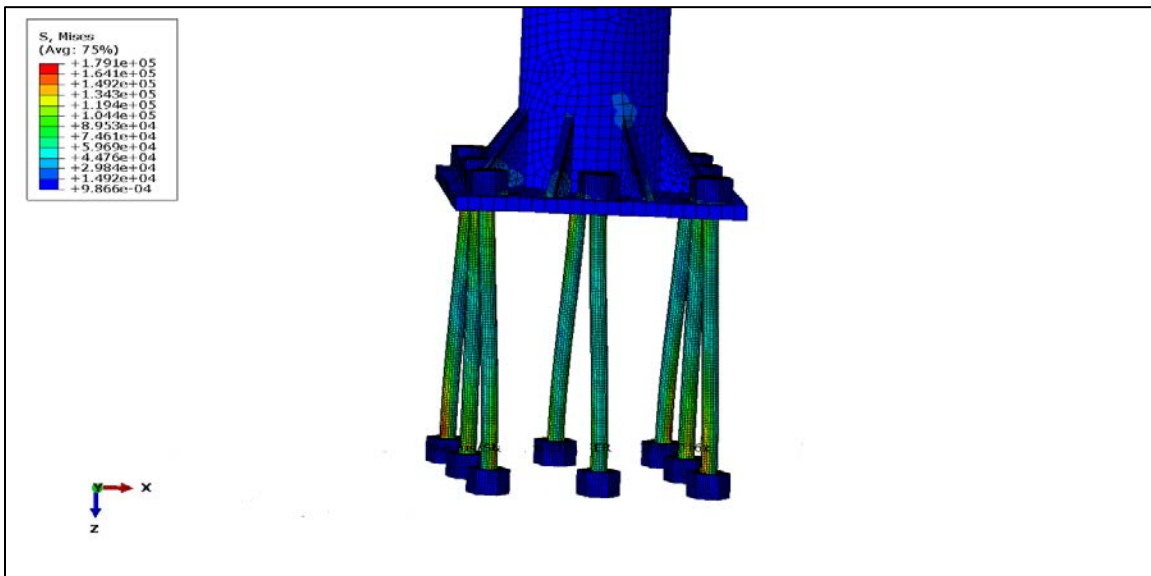

Figure 4.2 - *Stress in Bolts Under 20 PSF Wind*

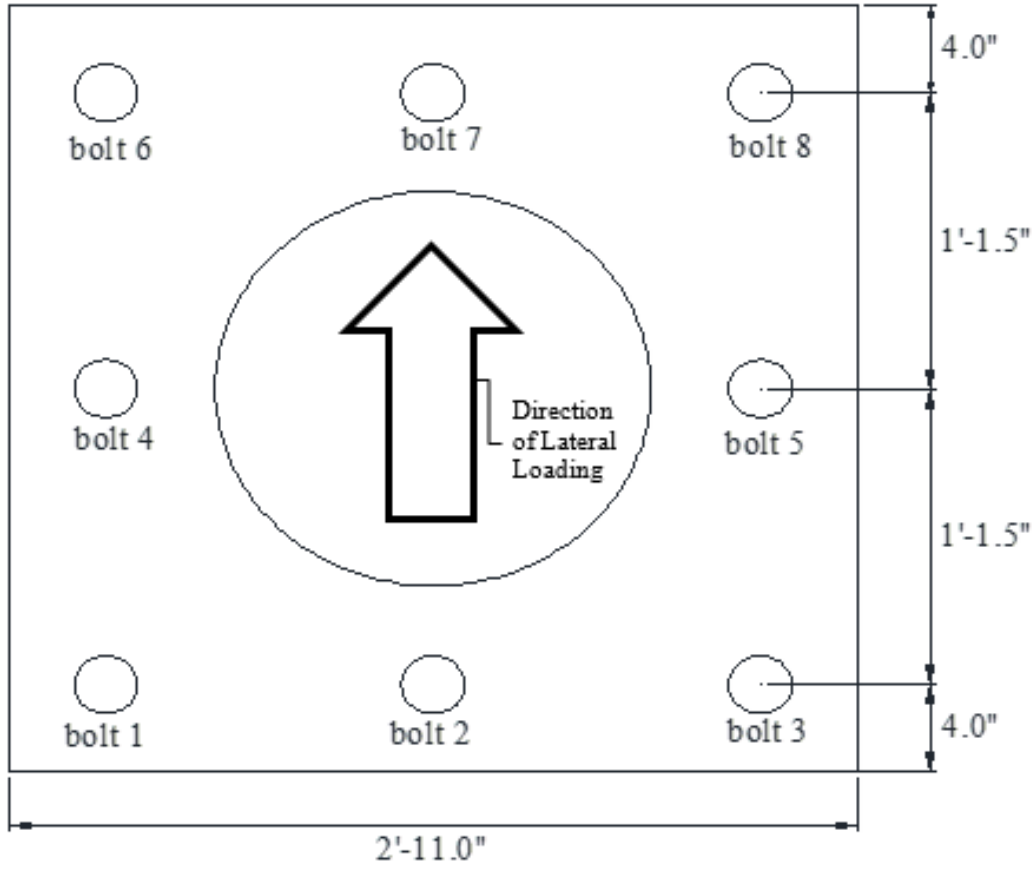

Figure 4.3 - Bolt Numbering Plan

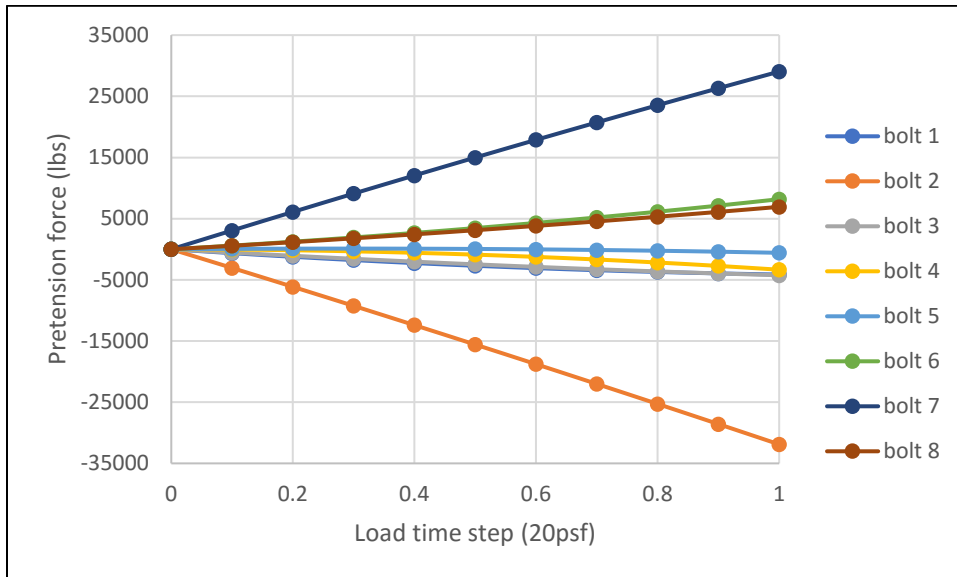

Figure 4.4 - Reaction Force in 8 Anchors Using Predefined Prestress Option



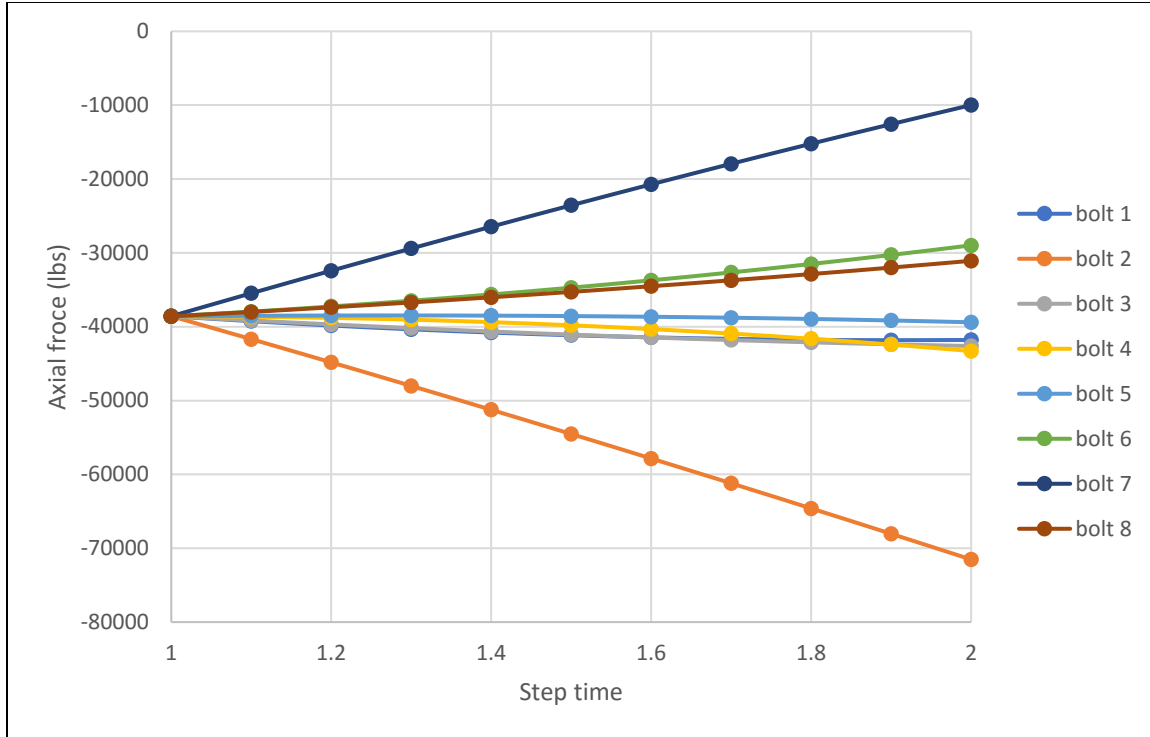

Figure 4.5 - Reaction Force in Anchor Bolts Using Predefined Preload Step

There is a difficulty in calibrating a model using field monitoring data. The main issue is the impact of wind direction on the magnitude of stresses in the anchor bolts. Without the use of pressure sensors on the sign panel in the field, one cannot efficiently draw relationships between wind speed and direction, pressure on the sign panel, and stresses in the anchor bolt.

Furthermore, the loading is dynamic in nature, and these effects cannot be captured in a static model. If future projects intend to create models of field structures, the field monitoring should include measuring pressure along the sign panel and sign post face, and the modeling should be done with dynamic effects considered.

### Modeling of a Single Bolt

#### Results

Two cases are simulated. One case is with lubricant, which is modeled with a friction coefficient of 0 between the contact surfaces of the bolt and nut threads, while the other case is

without lubricant, which is modeled with a friction coefficient of 0.3 between the contact surfaces of bolt and nut threads. The model geometry, loading, and boundary conditions are shown in *Figure 4.6*, while the reaction force generated at the top surface of the middle, leveling nut is shown in *Figure 4.7*. The reaction force at the top surface of the leveling nut will be equal and opposite to the tension in the bolt. Comparison of the torque and the pretension forces of these two cases are shown in *Figure 4.8*. From *Figure 4.8*, we could see that the modeling gives a lower prediction than experimental results, partially due to the over-constrained boundary condition applied at the top surface of the middle, “leveling” nut. This boundary condition will prevent the pretension values from reaching those seen during Skidmore Wilhelm testing.

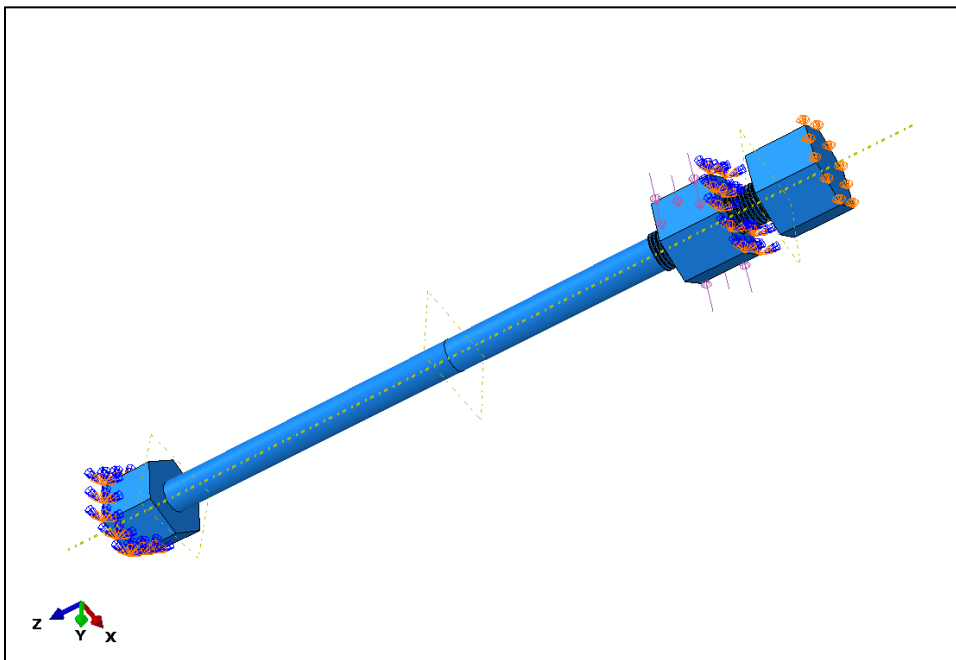

Figure 4.6 - *Single Bolt Model with Boundary Conditions*

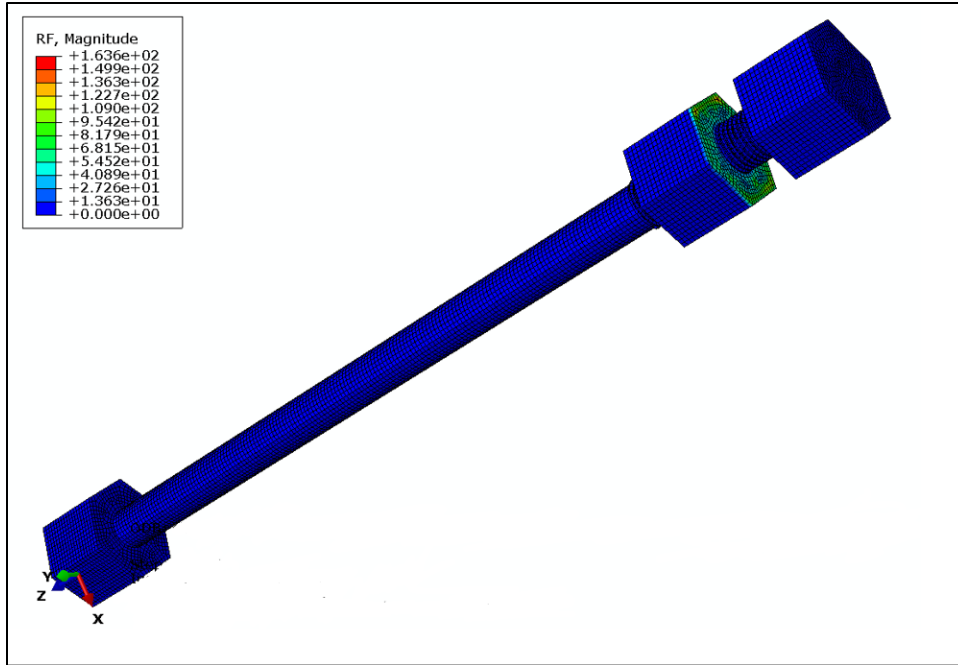

Figure 4.7 - Reaction Force on the Top Surface of Leveling Nut

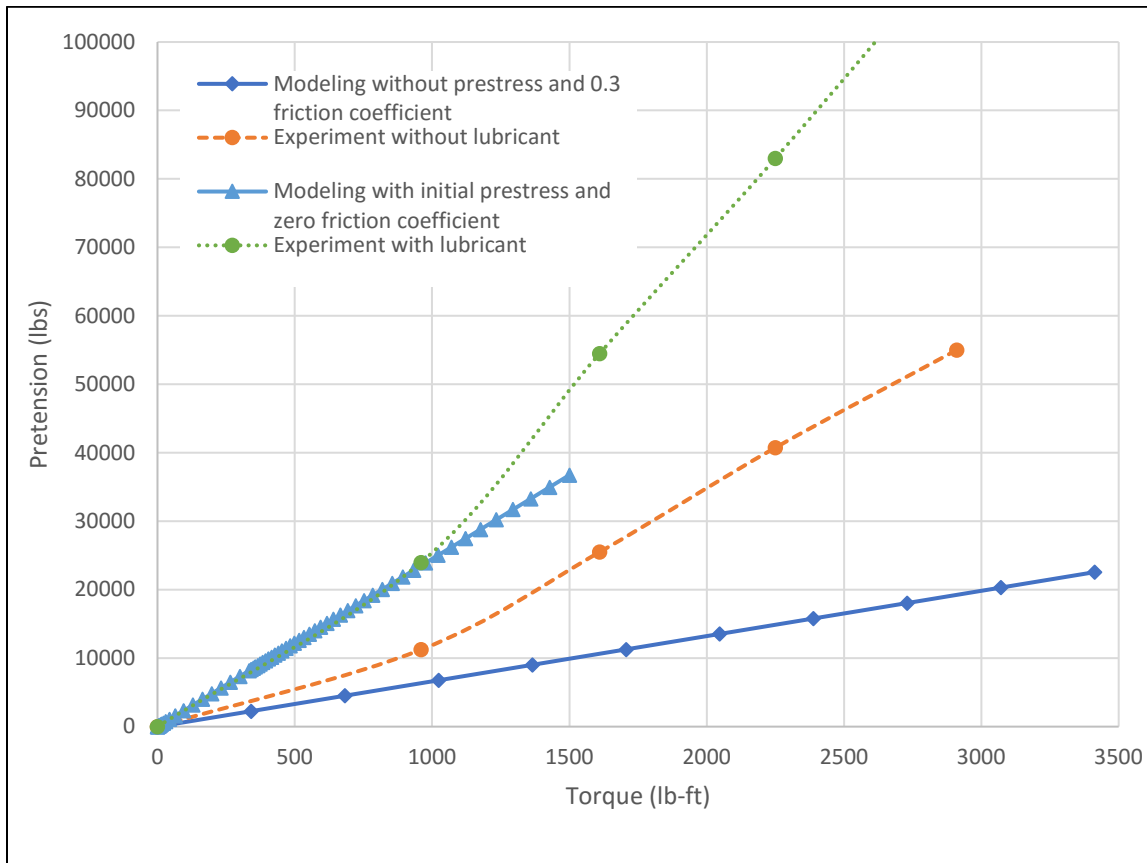

Figure 4.8 - Comparison of Experiment and Modeling

## Modeling of Lab Specimen

### Results

It should be noted that since a pressure is being applied at the end of the post, the base moment is slightly different than using a point load at the end of the post. The comparison of base moment vs. deflection for the static test and finite model are shown in *Figure 4.9*. The comparison of testing data and the FE model for the stress at 4'-0" from the baseplate is shown in *Figure 4.10*. The comparison of FE results and testing data for stresses in bolt 6 are shown in *Figure 4.11*.

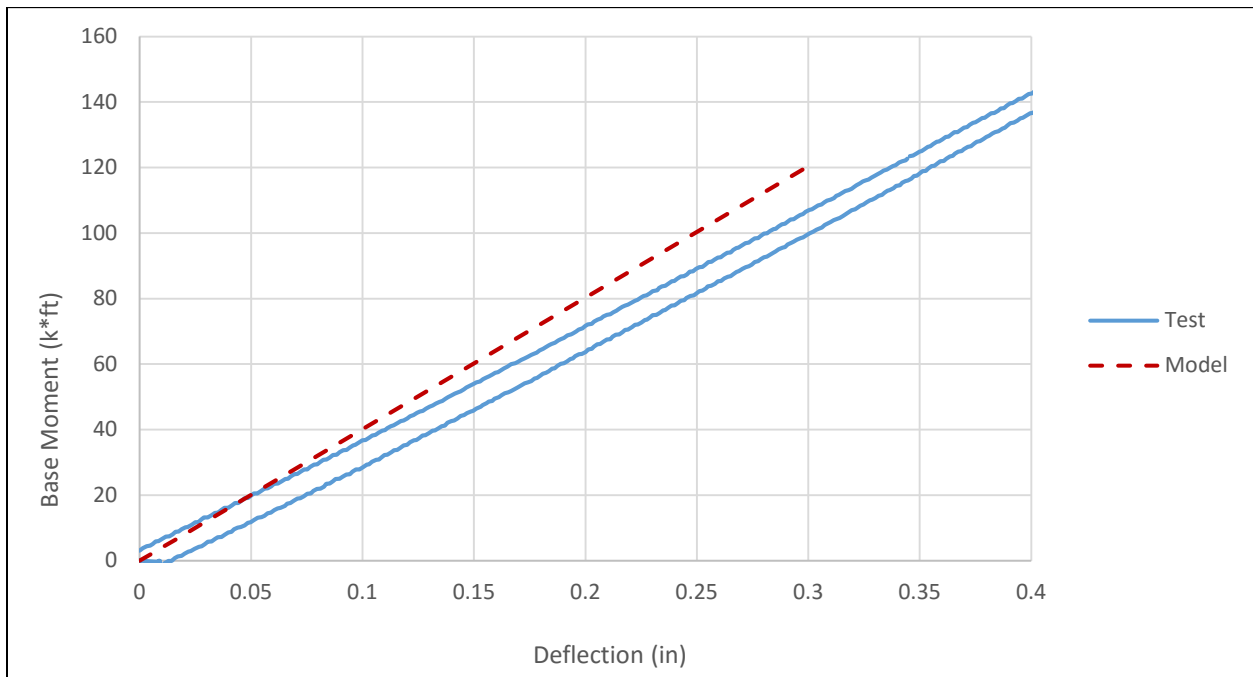

Figure 4.9 – *Deflection vs. Base Moment*

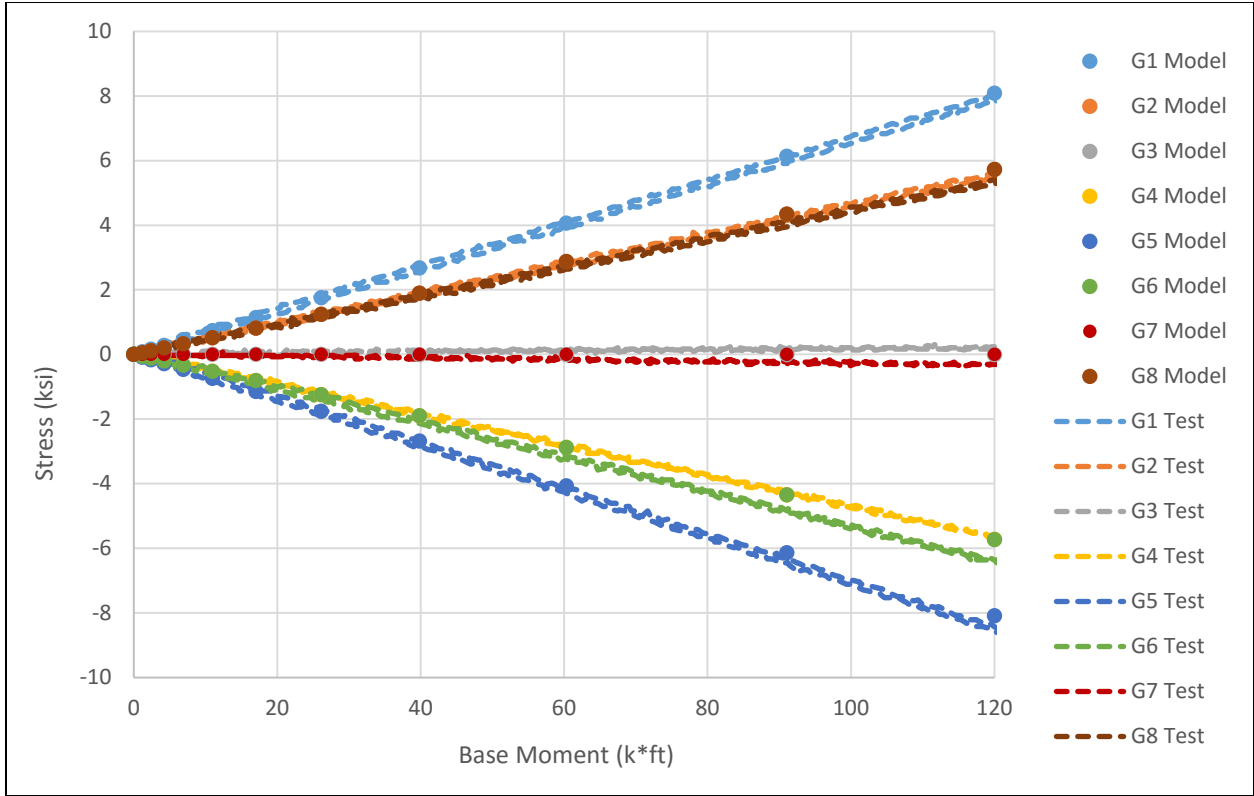

Figure 4.10 - Base Moment vs. Stresses in the Pole

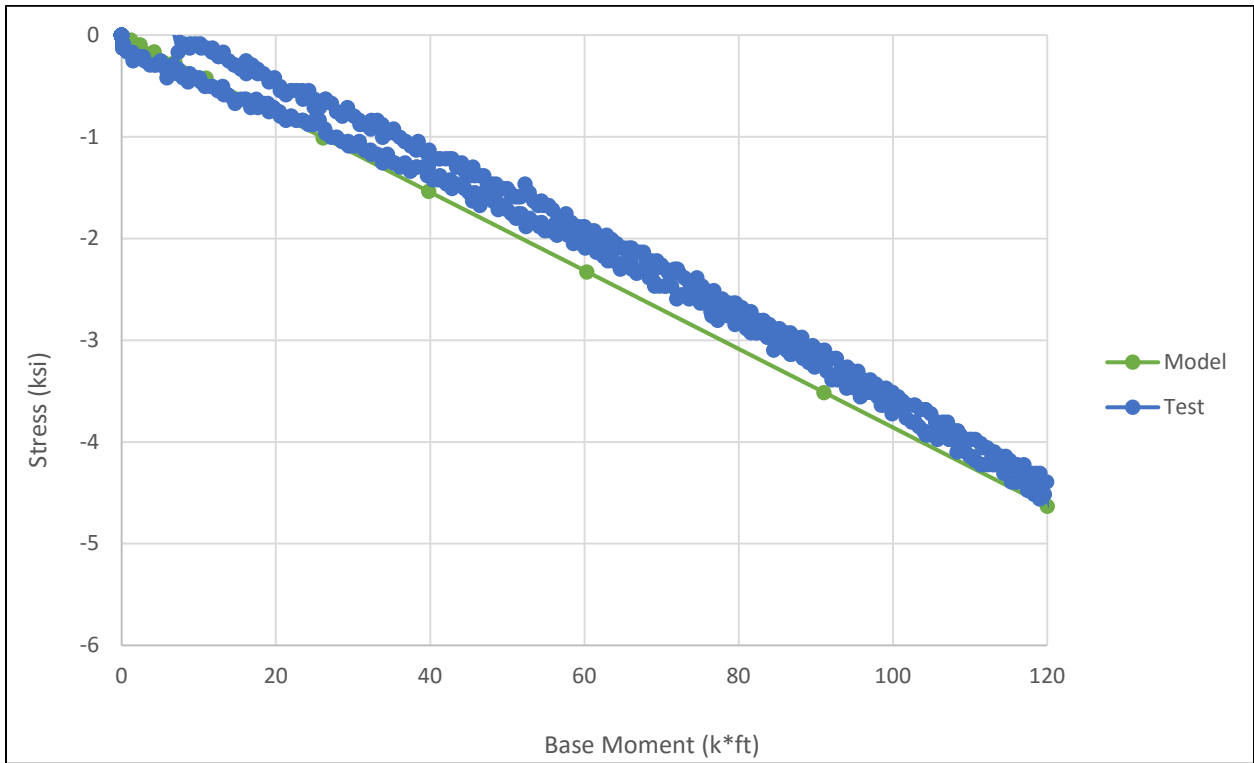

Figure 4.11 - Base Moment vs. Stress in Bolt 6

The results in *Figure 4.9*, *Figure 4.10*, and *Figure 4.11* provide confidence that the model is functioning correctly. There are many variables that can affect the load path to the bolts, including the effect of tightness and stiffeners. If one of the bolts was tighter than another, it will carry a higher portion of the load than if all the bolts are tightened to the same amount. The model assumes that all bolts are tightened the same amount, but that everything is in firm contact and will deform elastically.

The stress distribution on the anchor bolts is shown in *Figure 4.12*. The stress distribution shown in *Figure 4.12* demonstrates that bolts in the direction of loading are in axial compression, and have magnitudes similar and opposite to the tensile forces in the other bolts. The maximum stress area and potential failure zone is just below the bottom nut, a typical result in pretensioned double nut moment connections. The clamping force on the nuts is shown in *Figure 4.13* and *Figure 4.14*.

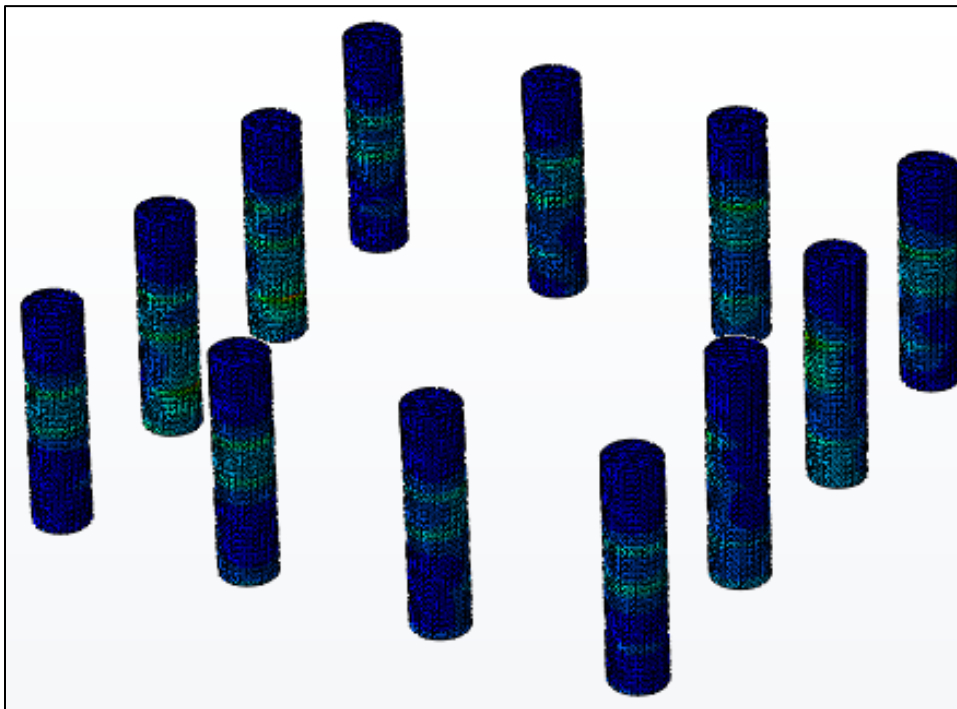

Figure 4.12 - *Anchor Bolt Stresses*

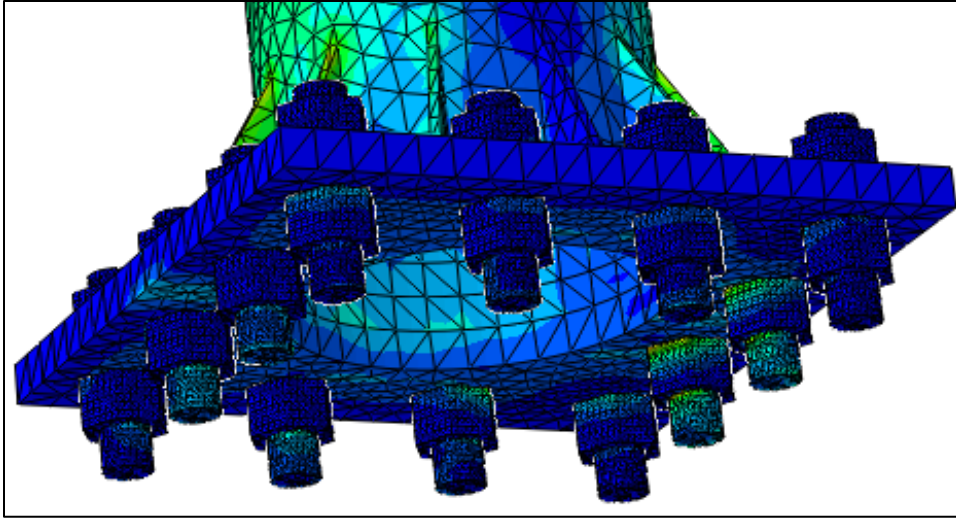

Figure 4.13 - *Stresses on Bottom Nuts*

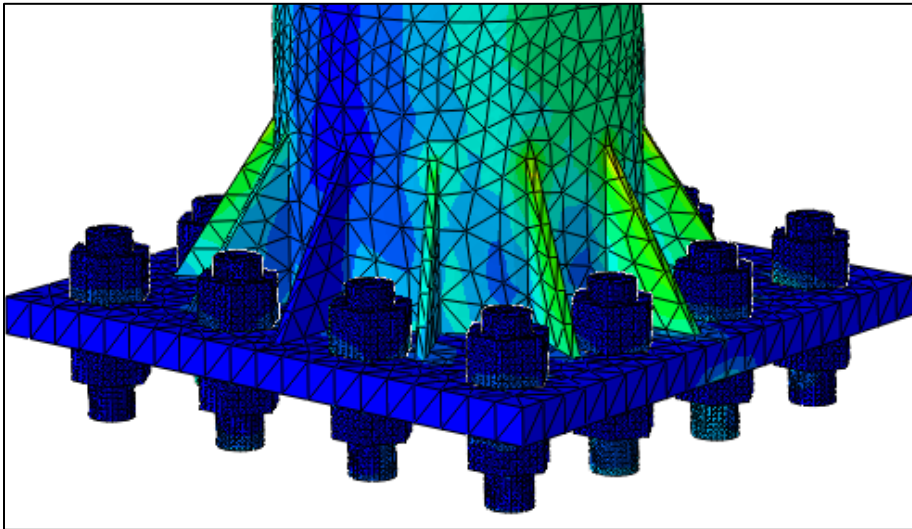

Figure 4.14 - *Stresses on Top Nuts*

### **General Conclusions**

It is difficult to draw conclusions based on the field monitored structure, for the reasons described above. At this time, the single bolt model shows it is clear that lubrication of the threads greatly reduces the effect of friction during tightening. Finally, the research team feels strongly that the lab specimen model is in working order. In order to improve anything in the lab specimen model, a trial and error approach for bolt tightness would be required. A trial and error approach would be very time consuming and inefficient, and was foregone.

## CHAPTER 5. RECOMMENDATIONS FOR NEW SPECIFICATIONS

### Specification Basis

Throughout the project, it became apparent that AASHTO's Standard Specifications for Structural Supports for Highway Signs, Luminaires, and Traffic Signals (LTS-1) had a sufficient process, but was limited in three key areas:

1. Controlling snug-tight values.
2. Accounting for varying grip lengths.
3. Recommendations for verifying correct installation.

The research team concluded that a modified version of the tightening process in LTS-1 would result in a more effective specification, shown in Appendix F.

### Controlling Snug-tight

When specifying Turn-of-Nut tightening, having an accurate achieved snug-tight is critical. Skidmore Wilhelm testing demonstrated that an accurate approximation for the actual snug-tight value is 10% of yield stress. The Skidmore Wilhelm testing also showed that the achievable snug-tight values for smaller bolts ( $< 1\text{-}1/4$ " diameter) can easily be 2-6 times the actual snug-tight value if snugging is not controlled. The testing also demonstrated that larger diameter bolts ( $\geq 1\text{-}1/2$  diameter) may not reach the actual snug-tight value. Therefore, snug control is necessary to prevent the yielding of smaller diameter bolts, and to ensure adequate pretension in larger diameter bolts.

### Methods of Controlling Snug-tight

Due to the variability in force applied when snug-tightening, controlling the snug-tight value is not simple. The two methods that appear the most feasible are:

1. Specify a minimum and maximum wrench length for snugging.
2. Specify a maximum snugging torque.



Using the snug-tightening data from Skidmore Wilhelm testing, field monitoring, and laboratory testing. This can be accomplished by using the known nut factor, K, and the length of wrench used for snugging. The nut factor and snug-tight force can be used to calculate a snugging torque, and then that snugging torque and wrench length can be used to calculate the force at the end of the wrench. The aggregate data set demonstrated that the average force applied to the end of the wrench was nearly 125 lbs.

Table 5.1 shows the calculated wrench lengths in inches to achieve 10% of yield for various F1554 anchor rods. The table uses a nut factor, K, or 0.12, and a force of 125 lbs applied to the end of the wrench. It should be noted that for smaller wrench lengths (< 12”), it is difficult to apply the full 125 lbs of force. For these smaller wrenches, it is likely that the applied force is between half and two-thirds the design force. Even with this considered, it is obvious that there are limitations to specifying a wrench length. The three major concerns are geometric limitations (minimum and maximum lengths) of commercial wrenches, the accuracy of the 125 lb estimate, and the requirement of proper lubrication for a nut constant of 0.12.

Table 5.1 - *Calculated Wrench Lengths (inches) for F1554 Anchors*

		Anchor Gr. (Yield Stress)		
		36	55	105
Diameter	0.75	1	1	3
	1	2	3	6
	1.25	4	6	12
	1.5	7	11	21
	1.75	11	18	34
	2	17	26	50
	2.25	25	39	74
	2.5	35	53	101

Due to the three concerns above, it is recommended that a maximum snugging torque be specified. By using the nut constant of 0.12, maximum torque values to meet 10% yield stress can be calculated. The maximum torque values in ft-lbs for F1554 anchors are shown in *Table*

5.2. Again, it is clear that small diameter, low grade bolts and large diameter, high grade bolts will pose challenges. Torques above 500 ft-lbs are best achieved using a hydraulic wrench, while torque values below 25 ft-lbs are almost not achievable with commercial torque wrenches. For these cases, the achieved snug-tight value will likely not be near the target value of 10% of yield stress.

Table 5.2- *Maximum Snugging Torque (ft-lbs) Values for F1554 Anchor Bolts*

		Anchor Gr. (Yield Stress)		
		36	55	105
Diameter	0.75	9	14	26
	1	22	33	64
	1.25	44	67	127
	1.5	76	116	221
	1.75	120	183	349
	2	180	275	525
	2.25	263	402	768
	2.5	360	550	1050

### Accounting for Grip Length

The main consideration when discussing grip length is bolt stiffness. As the Skidmore-Wilhelm testing demonstrated, bolt stiffness plays a critical role in determining the required rotation beyond snug-tight to reach the target pretension. The recommended specification will have turn values specific to MnDOT structures, based on the bolt diameter and grip length. It would be short sighted to provide specific turn angles but not include adequate information to develop accurate turn angles for future MnDOT designs. For future designs, *Figure 5.1*, *Figure 5.2*, and *Figure 5.3* can be used to calculate the required turn angle beyond snug-tight. An example is shown in Appendix E.

*Figure 5.1* compares bolt stiffness to a design  $k_s$  value for the aggregate data sets of Skidmore-Wilhelm testing, field monitoring, laboratory testing, testing by Till & Lefke (1994), and monitoring by Hamels & Hoisington (2014). It is important to note that  $k_s$  values are

influenced by the ratio between bolt stiffness and the stiffness of the clamped material. For different bolt diameters, the stiffness of the material being clamped will change. Due to this, it is more accurate to compare bolt stiffness and  $k_s$  on an individual bolt diameter basis.

*Figure 5.2* compares bolt stiffness and design  $k_s$  values for bolt sizes in which at least three data points were available, as finding trends for data series of fewer than three points is futile. The data set includes all of the sources for *Figure 5.1*. One can clearly see that a per bolt diameter comparison is more accurate. This also demonstrates the need to grow the data set for different bolt diameters and grip lengths. Until more data points are available to fill in the gaps, *Figure 5.1* and *Figure 5.3* will be required.

*Figure 5.3* compares the ratio of bolt diameter to grip length and design  $k_s$  values. This is synonymous for bolt stiffness, but does not take into account the smaller area due to the threads. The demonstrated fit was better than that of *Figure 5.1*, and calculating D/L can be cleaner than a bolt stiffness is thousands of kips/in.

It is important to highlight that a higher design  $k_s$  is more conservative. If the design  $k_s$  value is higher than the actual value, then the design pretension will be higher than the actual pretension. While this can lead to under-tightened bolts, the verification torque should compensate for this. However, if the design  $k_s$  value is lower than the actual value, there is a risk of yielding during tightening and permanent elongation under service loads. One can always re-tighten loose bolts, but permanent elongation is final.

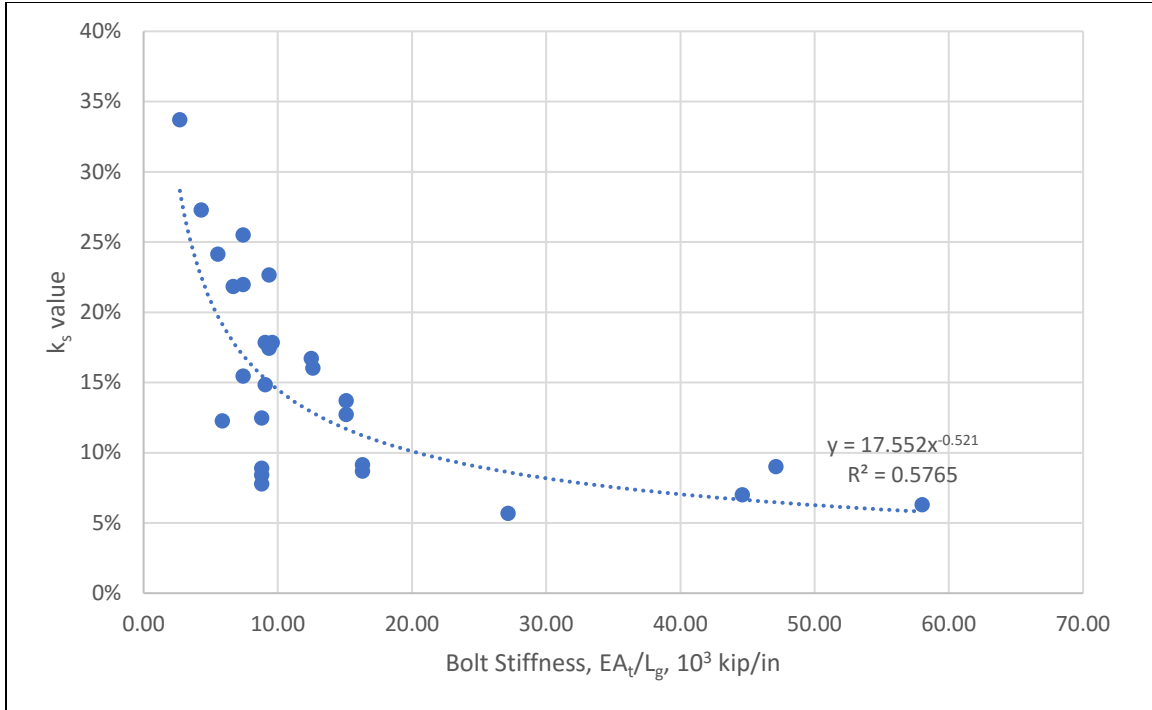

Figure 5.1 - *k<sub>s</sub> Value vs. Bolt Stiffness*

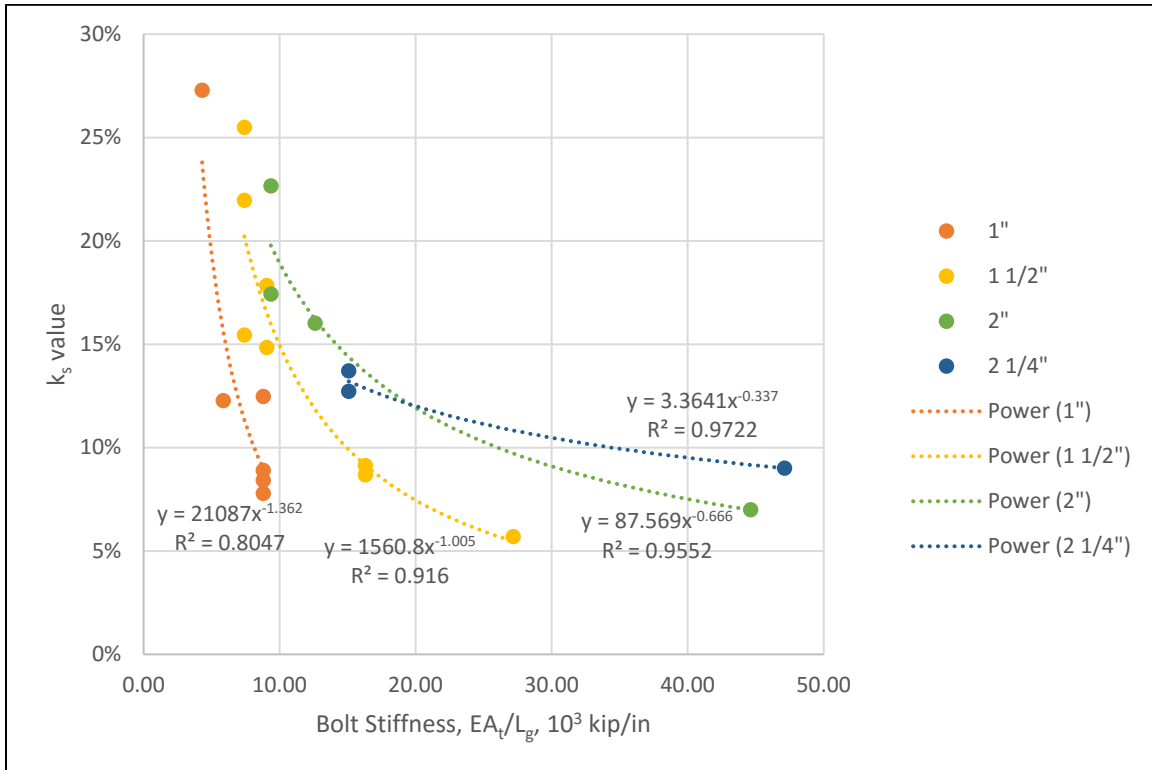

Figure 5.2 - *k<sub>s</sub> Values vs. Bolt Stiffness and Diameter*

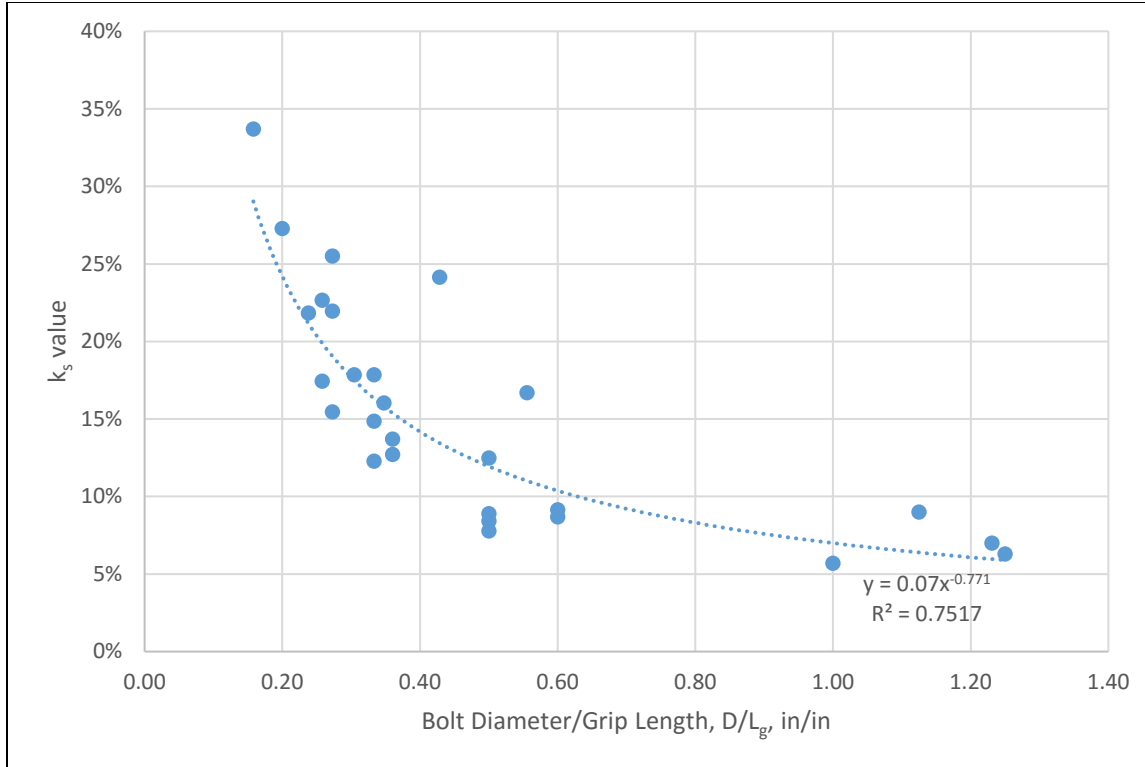

Figure 5.3 -  $k_s$  Values vs. Ratio of Bolt Diameter to Grip Length

### Recommendations for Verification

One of the issues consistently raised by MnDOT personnel and other State DOT officials was verifying that contractors install and tighten anchor bolts correctly. The ideal verification process would:

1. Be informative for contractors
2. Hold contractors accountable
3. Be simple for inspectors and limit role of MnDOT maintenance

Common verification methods, such as use of verification torque or examining reference marks, can be misleading when not used in conjunction with other verification techniques. For example, improper lubrication eliminates the effectiveness of a verification torque. Without properly snugging, turning the nut the specified amount will not lead to a correct pretension. If snugging was not completed, the reference marks have no real meaning.

During the survey process, an engineer with the Wisconsin DOT shared WisDOT form dt2321. The form solved many issues WisDOT was experiencing, and seemed like an excellent baseline for a MnDOT verification form. The form can be used as both an instructional tool and verification process. It clearly lays out each step of the tightening process, includes figures of star patterns, tables of verification torque values, and boxes for the contractor to initial and sign. A version of the form modified to meet MnDOT's specification is the recommended verification procedure.

Another issue to consider when discussing verification is final pretension values. Seeing that Turn-of-Nut specifications and torque specifications both have clear limitations, it is recommended that a specification include features of both. Specifically, the specification should contain rotation angles beyond snug-tight and a maximum torque value. The combination of rotation angles, maximum torque values, and a verification torque gives the best chance at reaching an adequate pretension value without causing bolt yielding.

Using torque values requires accurate nut constants, and thus consistent levels of lubrication. Verifying proper lubrication is simple, as the specified lubricant, Bostik Mariner's Choice Never Seez, is visible on threads following lubrication.

With this verification procedure, MnDOT inspectors will need to be present to verify proper tightening. The inspector will ensure bolts are properly lubricated, and that the contractor uses the verification form to follow all steps for proper tightening.

## CHAPTER 6. TESTING OF LOAD MEASURING SENSOR

As research for MnDOT was being completed, it became clear that there was a need for accurate, digital measurement of pretension and in situ bolt tension. This led to a National Cooperative Highway Research Program (NCHRP) sponsored project. The research team was made up of faculty and graduate students in the Civil Engineering and Electrical Engineering departments at Iowa State University. The prototype sensor design was completed by Xiangchen Che. This document will summarize the design for reference sake, and then discuss the testing and results of the prototype.

### Organic Sensor Design

#### Design of the Capacitor

This design is focused on cost savings and minimizing the changes to commercially available washers. A schematic drawing of the capacitor is illustrated in Figure 6.1(a). Washers 1 and 3 are supplied with charges, and then act as two parallel plates. Washer 1 is a traditional direct tension indicator (DTI), and is used as the positive plate, while Washer 3 is given a negative charge. Capacitance change is caused by the change of the gap,  $D$ , between Washers 1 and 3 as the DTI protrusions flatten. Washer 2 has a smaller outer diameter and serves the dual functions of distributing pretension force from the DTI protrusions and increasing the distance between Washers 1 and 3. The increased gap will lead to greater magnitudes of capacitance change as the protrusions flatten during tightening. In order to ensure proper insulation, all three washers are coated with a thin layer of insulating paint. To determine if the bolt is loose, the capacitor must be able to return to its original position with the original gap. To cause the capacitor to restore to its initial deformation, memory foam or rubber is added to serve as a dielectric and elastic material. The dielectric material increases the magnitude of the change of capacitance. In Figure 6.1(c), a capacitor design with optimized insulation is shown. During

loading, any small crack or damage to the insulation layer will lead to an unstable capacitance. The electrical tape is add redundancy to the insulation system and help mitigate damage to the insulation.

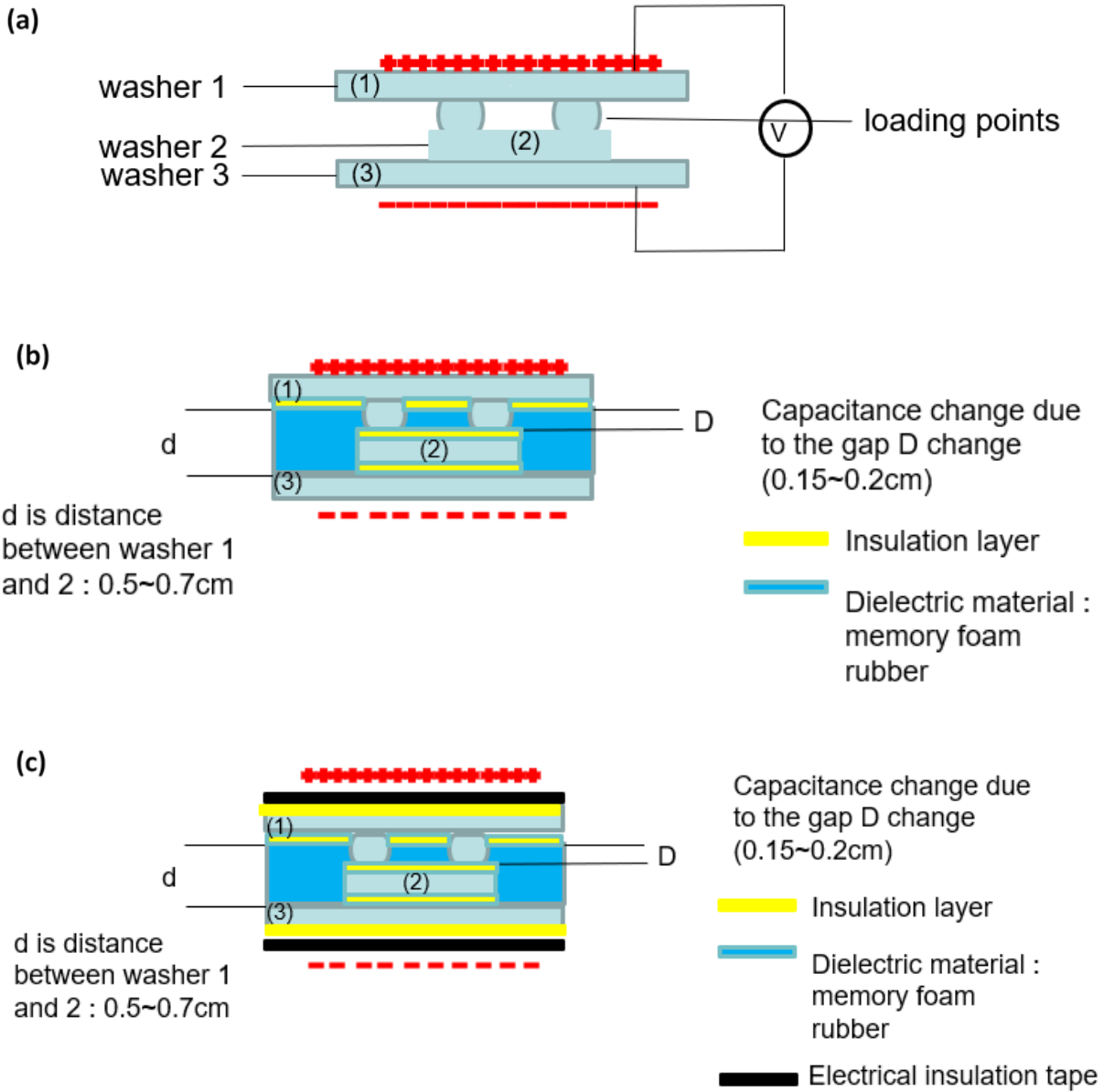

Figure 6.1 – Development of Prototype Capacitor Scheme



## Testing of Capacitor Design

### Testing Using MTS Machine

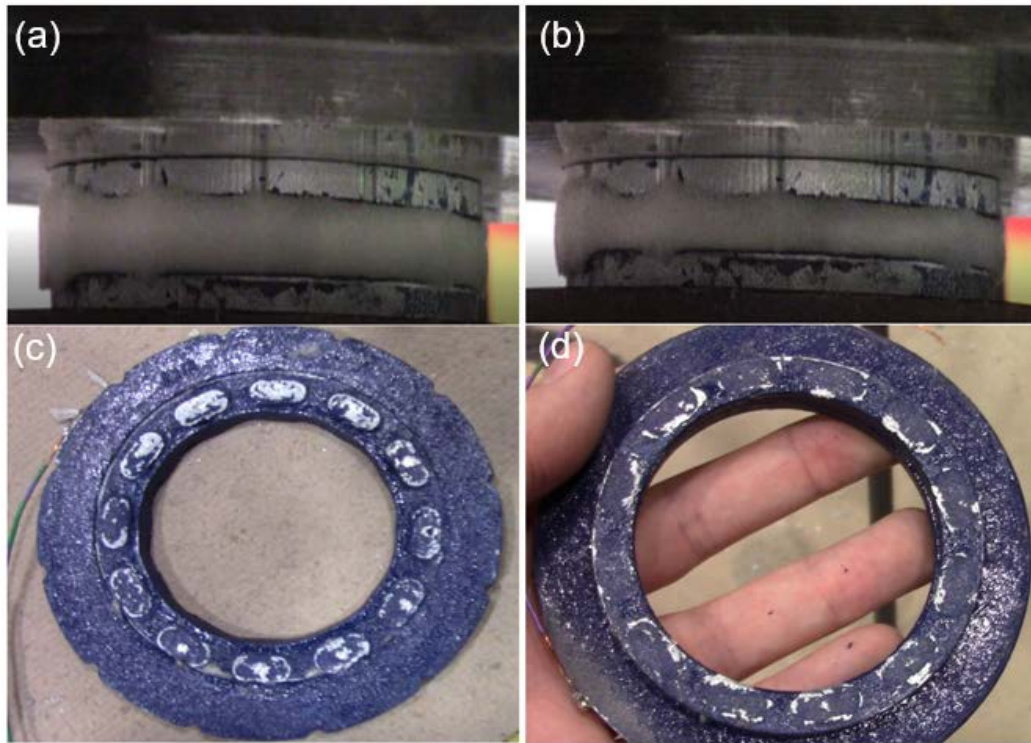

Figure 6.2 – *MTS Test and Resulting Damage*

One of the loading tests conducted was using a MTS machine. A load of 200 kips was applied on the memory foam capacitor. It can be seen from Figure 6.2 that the gap of the memory foam capacitor decreased during loading. One can also see that the top DTI protrusions have been flattened and the gap between the top DTI and Washer 2 is minimal. There was no observed bending of the DTI around Washer 2. The insulation layers were damaged at the contact points between the DTI and Washer 2. This is expected, as these points are where all of the load travels. Capacitance was measured before and after loading. The initial capacitance was 11.13522 pF. This reading is taken before loading. After loading and the memory foam returning to its original shape, the capacitance is 11.42046 pF. This indicates the whole system was still providing measurements even after the insulation was damaged. A capacitance of 208.5991 pF

was read when the top DTI is pressed until meeting Washer 2. Note that the manual force was applied to ensure the gap between the DTI and Washer 2 is the same as during loading with the MTS. The 200 kip load and DTI deformation are similar to the design values for a 2-1/4" F1554 Gr. 105 bolt.

*Testing Using Skidmore-Wilhelm Tension Measurement Device*

Following MTS testing, another test was completed using a Skidmore-Wilhelm Tension Measurement device as shown in *Figure 6.3*. The Skidmore-Wilhelm allows for the bolts to be tightened with traditional wrenches (*Figure 6.4*), similar to those used in the field. In order to test the stability of the assembled capacitors, both memory foam and rubber prototypes were tested. Approximately 20 kips of pretension was applied using a pipe wrench. The memory foam capacitor had an initial capacitance value of 13.69pF before loading, and capacitance increased to 14.71pF after loading. The rubber capacitor did not function properly. The capacitance drops from its initial value of 25.85pF to a negative value of -241.74pF. The abnormal capacitance value was caused by a damaged insulation system. It is believed that the rotating nut caused damage to the insulation layer of the top DTI. Once voltage was applied, current passed through the damaged area and made the capacitor conductive. Therefore, the capacitance values could not be used. A photo of the memory foam capacitor during loading is shown in *Figure 6.5*.

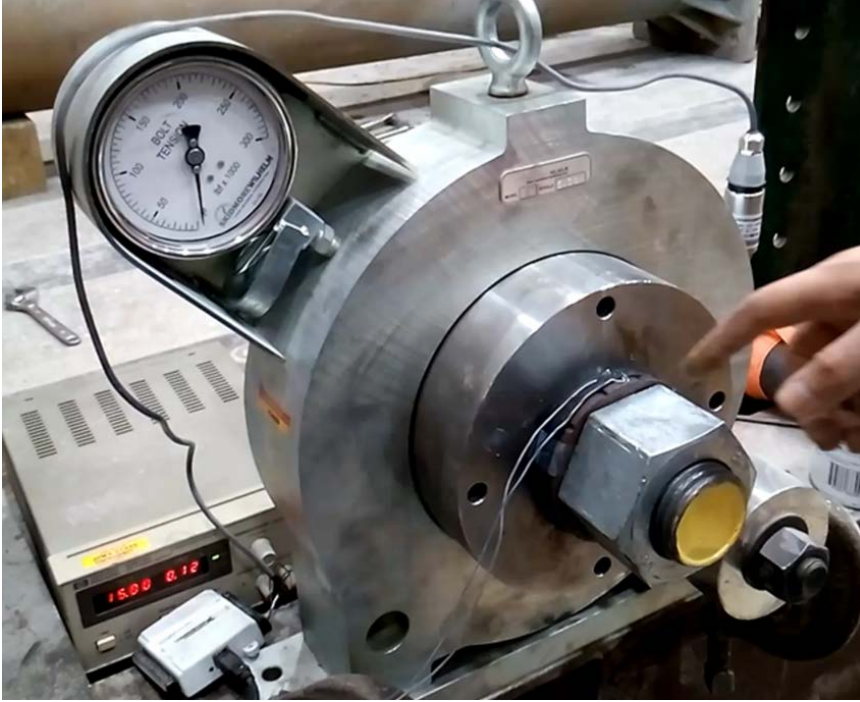

Figure 6.3 – *Testing using Skidmore-Wilhelm*



Figure 6.4 – *Load Application*



Figure 6.5 - *Memory Foam Capacitor during Loading*

In order to resolve the issue of damage caused by the rotating nut, the insulation was reinforced with insulation tape where the nut and DTI meet. The electrical insulation tape not only serves as an additional insulation layer, but it also reduces physical damage caused by the rotating nut. More testing using a pipe wrench was completed on the memory foam capacitor. The capacitance increased from an initial value of 24.50pF to 71.87pF, falling back to 28.92pF after load was removed. The insulating tape layer helped provide a more stable value of capacitance. Another rubber capacitor was tested, but it continued to show a negative value of 246.62pF when 20 kips was applied on the capacitor. These results demonstrate that a memory foam capacitor is more stable than a rubber capacitor when used in this prototype design. Insulation has proven to be the key factor in affecting the quality of the capacitor.

#### *System Level Testing on Laboratory Specimen*

Following the testing with the Skidmore-Wilhelm, it was decided to attempt to test a capacitor using a bolt from the laboratory specimen (Figure 6.6). A memory foam capacitor was



tested, and a hydraulic wrench was used for tightening. At very low torque values (under 500 ft-lbs) the Keysight capacitance measuring device began to read out of range. The insulation was insufficient, and it was causing the capacitance to be unstable. Essentially, the insulation was insufficient, and the baseplate and nut began to use the bolt to create a circuit. In order to create additional insulation, small neoprene washers were machined and placed above and below the capacitor. This added some stability, but the insulation between the washers and bolt was still insufficient. In an attempt to mitigate this issue, some insulation was added to the bolt where it would touch the capacitor. Another issue that was encountered was the neoprene deformation. At very low pretension values, the neoprene was compressed and began to squeeze out from around the capacitor. The capacitor design continues to be optimized to decrease the issues with insulation.



Figure 6.6 - *Examining the Capacitor after Loading*

## CHAPTER 7. GENERAL CONCLUSIONS, LIMITATIONS, AND RECOMMENDATIONS FOR FUTURE TESTING

### Conclusions

The general conclusions are summarized as follows:

1. Minnesota is not the only state experiencing loose nuts on sign, signal, and luminaire support structures.
2. Maintenance of these structures is a time consuming and costly procedure that leads to varying levels of success.
3. Multiple states believe that improper installation by contractors is leading to poor performance by the structures.
4. It is very possible that contractors do not have the proper training or past experience to complete adequate Turn-of-Nut pretensioning.
5. The two common beliefs as to what causes loosening is inadequate pretension (under-tightening) or causing yielding during tightening (over-tightening).
6. MnDOT's previous specification for large diameter bolts was leading to under-tightened bolts.
7. It is very possible that smaller diameter bolts are yielding during snugging in MnDOT sign and signal structures.
8. AASHTO's current specifications provide an adequate process, but should be modified to quantify snug-tight, account for variable grip length, and provide further recommendations for verification.
9. A design nut factor, K, or 0.12 is conservative for lubricated bolts of MnDOT structures.
10. The actual snug-tight condition is reached when pretension is near 10% of yield

stress.

11. The CAFL of 7 ksi is appropriate for anchor bolts of MnDOT sign structures.
12. Monitored anchor bolts demonstrated an effective stress range of 1 ksi, with an adjusted stress range of 5.9 ksi.
13. The organic sensor works conceptually, but requires future design modifications to make the technology practical for field use.

The loosening of large diameter anchor bolts on MnDOT's sign structures has been due to insufficient tightening. The old specification was not adequate for reaching 60% of yield stress. Laboratory testing, field monitoring, and finite modeling were used to develop a new specification for MnDOT. The specification modifies the process outlined in AASHTO LTS-1 to account for the specific geometry of MnDOT structures. The findings of the study, particularly the nut constant,  $K$ , and stiffness constant,  $k_s$ , will be useful for MnDOT and other state DOT's in developing future tightening specifications. It was also found that a better understanding of actual versus achievable snug-tight, and how to reach the target snug-tight value, would greatly benefit DOT's in preventing loose anchors.

### **Limitations to Testing**

There were four major limitations to the findings of the project:

1. As discussed, the Skidmore-Wilhelm machines experience decreased precision when below 20 kips. This will impact the torque, rotation, and tension testing for small diameter bolts.
2. The yielding of Bolts 1, 5, and 8 of the lab specimen should be kept in mind when examining the testing data. None of the bolts experienced necking, but there could still be an unknown effect on the static and fatigue results.

3. The stiffener plates on the Type V sign post caused geometric issues when tightening with a hydraulic wrench and pipe wrench. Some bolts could not be tightened with a hydraulic wrench, and this impacted the amount of data collected during the tightening test.
4. While the BTM strain gages used were very useful, the wiring was very fickle. This was the most feasible commercial option, but having to cut out defective gages and re-gage the bolts can impact results. Future testing should consider this when planning to use BTM strain gages on large diameter bolts.

### **Future Testing**

The research team believes that this research could be continued to add conclusions and lead to a better specification for MnDOT and in AASHTO LTS-1.

1. Improve the data set for  $k_s$  values. Due to the geometric limitations of a Skidmore-Wilhelm, only certain grip lengths could be tested for different bolt diameters. In many cases, the grip lengths for large diameter bolts are smaller than what the Skidmore-Wilhelm would allow. Growing the data set would require simple procedures, and the use of BTM strain gages. For a given bolt diameter, spacers could be used to increase the grip length. A broader data set would lead to more accurate  $k_s$  values at higher bolt stiffnesses.
2. Continued monitoring of OH MN51-013 to gather a larger data set, and capture bolt stresses during major wind events.
3. Further fatigue testing, using new specification to various target pretension stress ranges. The fatigue testing would look for loosening during service loads based on field monitoring.
4. Implementation during new construction season, and monitoring of performance



based on new specification.

5. Testing to further understand the two limit states (under/over-tightening) for small and large diameter bolts, and how to mitigate both cases for all sizes of anchor bolts.
6. Continued revision to design of the organic sensor.

**REFERENCES**

American Association of State Highway and Transportation Officials. Standard Specifications for Structural Supports for Highway Signs, Luminaires, and Traffic Signals. AASHTO, 2015.

American Society of Civil Engineers, Minimum Design Loads for Buildings and other Structures. Reston, VA: ASCE, 2010.

Bickford, J. H. An Introduction to the Design and Behavior of Bolted Joints. CRC Press, 1995.

Collins, T. J., and M. J. Garlich, "Sign Structures Under Watch," Roads and Bridges, July 1997.

Dexter, R.J. and M. J. Ricker. Publication NCHRP 469. Fatigue-Resistant Design of Cantilever Signal, Sign, and Light Supports. Transportation Research Board, Washington, D.C., 2002.

El-Tawil, S., and J. McCormick, Field Manual For Structural Bolting, Bridges and Structures Research Center of Excellence, University of Michigan, Ann Arbor, MI, April 2014.

Garlich, M. J. and J. W. Koonce, "Anchor Rod Tightening for Highmast Light Towers and Cantilever Sign Structures," in Transportation Research Board 90th Annual Meeting, Washington, D.C., 2010, vol. 11-2030.

Garlich, Michael J. and Eric R. Thorkildsen. Guidelines for the Installation, Inspection, Maintenance and Repair of Structural Supports for Highway Signs, Luminaires, and Traffic Signals. Publication FHWA NHI 05-036. Federal Highway Administration, Washington, D.C., Mar. 2005.

Hamel, S.E. & D.B. Hoisington. High-Mast Light Poles Anchor Nut Loosening in Alaska. Report 24-739439. Pacific Northwest Transportation Consortium (PACTRANS), Seattle, WA, Sep. 2014.

Hoisington, D. B. Investigation of anchor nut loosening in high-mast light poles using field monitoring and finite-element analysis. M.Sc. thesis, Univ. of Alaska Anchorage, Anchorage, AK. 2014.

James, R. W., P. B. Keating, R. W. Bolton, F. C. Benson, D. E. Bray, R. C. Abraham, and J. B. Hodge. Tightening Procedures for Large-Diameter Anchor Bolts. Publication 1472-1F. Texas Transportation Institute, Texas A&M University System, College Station, TX, 1997.

Johns, K. W., and R. J. Dexter, Fatigue Related Wind Loads on Highway Support Structures, Final Report to New Jersey Department of Transportation, ATLSS Report No. 98-03, Lehigh University, April 1998.

Kaczinski, M. R., R. J. Dexter, and J. P. Van Dien, NCHRP Report 412: Fatigue-Resistant Design of Cantilevered Signal, Sign, and Light Supports, Transportation Research Board, National Research Council, Washington, D.C., 1998.

Nassar, S.A. and P. H. Matin, "Clamp Load Loss due to Fastener Elongation Beyond its Elastic Limit," J. Pressure Vessel Technol., vol. 128, no. 3, pp. 379–387, Aug. 2005.

NHDOT, Supplemental Specification for Anchor Rods, NHDOT, NH, 2012.

Phares, B., Lee, Y., Brockman, T., and J. Rooney, Investigation of High-Strength Bolt-Tightening Verification Techniques, Bridge Engineering Center, InTrans, Iowa State University, Ames, IA, March 2016.

Research Council on Structural Connections. Specification for Structural Joints Using High-Strength Bolts. AISC, Chicago, IL, 2014.

Till, R. D. and N.A. Lefke. The Relationship Between Torque, Tension, and Nut Rotation of Large Diameter Anchor Bolts. Publication R-1330. Michigan Dept. of Transportation, Lansing, MI, Oct. 1994.

Wang, Shengchun, et al. "Investigation into the Self-Loosening Trend of Bolt Joints on the Tower Crane." Proceedings of the 2nd International Conference on Advances in Mechanical Engineering and Industrial Informatics (AMEII 2016), 2016..

Yu, Q.m., and H.l. Zhou. "Finite Element Study on Pre-Tightening Process of Threaded Connection and Failure Analysis for Pressure Vessel." Procedia Engineering, vol. 130, 2015, pp. 1385–1396. 2015.

Zhang, Ming, et al. "Finite Element Modeling of Self-Loosening of Bolted Joints." Analysis of Bolted Joints, 2004.

APPENDIX A. MNDOT OH SIGNS AND ANCHOR BOLT DETAILS

POST IDENTIFICATION			
POST IDENTIFICATION NUMBER	BASEPLATE DESIGN	PERMISSIBLE PIPE SECTIONS	
		OUTSIDE DIAMETER (INCH)	WALL THICKNESS (INCH)
1	A	18	0.250
2	A	18	0.312
3	A	18	0.375
4	A	18	0.500
5	B	20	0.500
6	B	22	0.500
7	B	24	0.500

WALL THICKNESS IS MINIMUM, THINNER WALLS WILL NOT BE APPROVED

Figure A.1 - Sign Post Dimensions

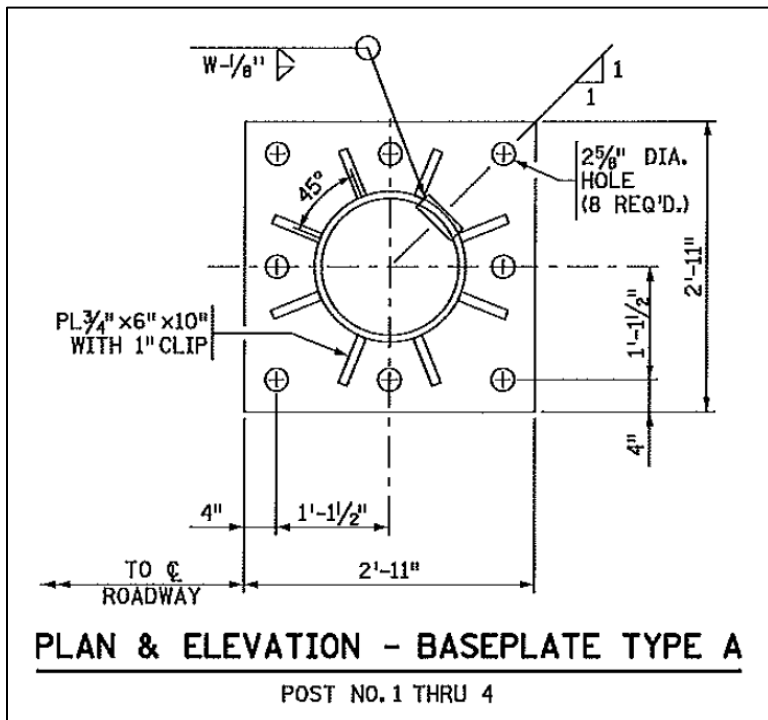
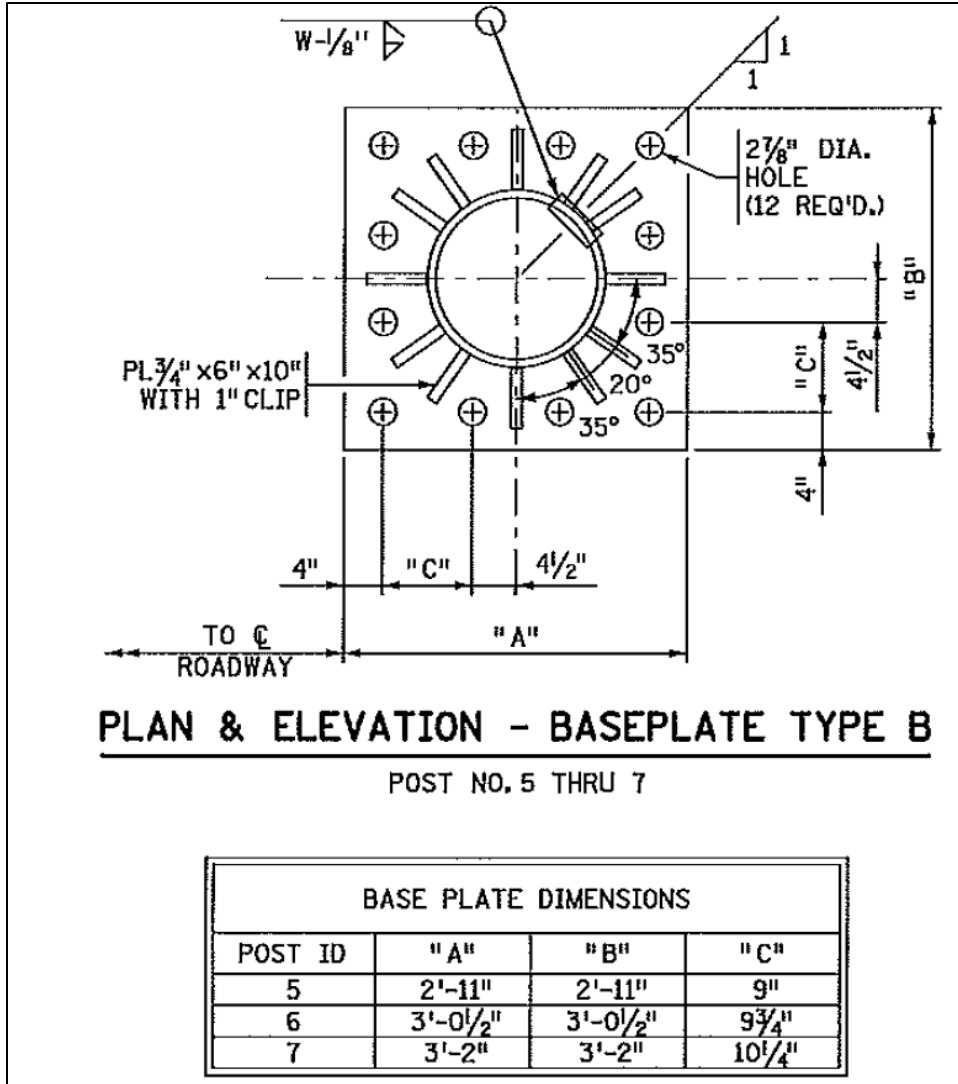

Figure A.2 - Type IV Baseplate Dimensions



BASE PLATE DIMENSIONS			
POST ID	"A"	"B"	"C"
5	2'-11"	2'-11"	9"
6	3'-0 1/2"	3'-0 1/2"	9 3/4"
7	3'-2"	3'-2"	10 1/4"

Figure A.3 - Type V Baseplate Dimensions

FOUNDATION DATA													
POST ID.	SPREAD FOOTING DIMENSIONS					DRILLED SHAFT DIMENSIONS				ANCHOR BOLTS			
	A	B	C	D	E	AA	BB	CC	DD	F	G	H	BOLT DIA.
1-4	14'-0"	9'-0"	3'-6"	3'-6"	2'-0"	3'-0"	23'-0"	3'-6"	3'-6"	38"	8.5"	46.5"	2.25"
5-7	18'-0"	12'-6"	3'-9"	3'-9"	2'-0"	4'-3"	29'-0"	4'-3"	4'-3"	39"	9.0"	48"	2.50"

Figure A.4 - Anchor Bolt Dimensions

**APPENDIX B. DISTRICT SURVEY****Purpose of the Survey**

This survey is a part of a research project titled *Re-tightening the Large Anchor Bolts of Support Structures for Signs and Luminaries* sponsored by Minnesota Department of Transportation (MnDOT). The objectives of this project are to investigate causes of loose nuts for anchor bolts used in support structures (e.g., overhead signs, high mast light tower (HMLT), and tall traffic signals) and develop the best practical procedures to retighten the loose anchor bolts. The research team includes Iowa State University and North Dakota State University.

We ask that you take a brief moment with this survey to help us achieve the objectives of this project. Your input is invaluable for the successful completion of this project, and we appreciate your kind response. Please fill out the following information:

Name:	Position:
Division:	Telephone:
Street Address:	E-mail:
City, State, Zip:	

Please return this survey and direct any questions to either:

Connor Schaeffer; [connorws@iastate.edu](mailto:connorws@iastate.edu)  
An Chen, Ph.D., P.E.; [achen@iastate.edu](mailto:achen@iastate.edu)  
Department of Civil, Construction and Environmental Engineering  
Iowa State University  
Phone: (515) 294-3460  
Fax: (515) 294-8216

**Survey on Anchor Bolt Tightening Practice from Iowa State University**

How many overhead signs, light poles, high mast light towers and traffic signals are there in your district?

What is the anchor bolt tightening method used during new construction and maintenance retightening?

Turn-of-Nut Pretensioning

Calibrated Wrench Pretensioning

Direct Tension Indicator (DTI)

Other

If other, please explain:

What tools or equipment are used to tighten the anchor bolts?

How are bolts and nuts lubricated during the tightening?

What tightening level is used in the practice?

Do you verify proper tightening of the anchor bolts after they are tightened? If so, what method do you use?

Do you have any special requirements on the tightening procedure other than that specified in the AASHTO Specifications? If yes, please attach a copy of these requirements.



Have you seen loose nuts for the anchor bolts during the inspection? If yes, what is the approximate percentage of the support structures that have loose nuts? How soon after tightening was it observed? Please share additional relevant information or inspection reports if available.

What method have you used to retighten/retrofit the anchor bolts if loose nuts were found?

Retighten existing nuts

Replace with new nuts

Replace with new nuts and weld the nuts to the anchor shaft

Use double top nuts

Other

If other, please explain:

Does your district keep a record of the maximum possible wind speed, wind frequency, and temperature variations?

Any additional comments you would like to make on the subject? Any input is greatly appreciated.

**APPENDIX C. STATE SURVEY****Purpose of the Survey**

This survey is a part of a research project titled *Re-tightening the Large Anchor Bolts of Support Structures for Signs and Luminaries* sponsored by Minnesota Department of Transportation (MnDOT). The objectives of this project are to investigate causes of loose nuts for anchor bolts used in support structures (e.g., overhead signs, high mast light tower (HMLT), and tall traffic signals) and develop the best practical procedures to retighten the loose anchor bolts. The research team includes Iowa State University and North Dakota State University.

We ask that you take a brief moment with this survey to help us achieve the objectives of this project. Your input is invaluable for the successful completion of this project, and we appreciate your kind response. Please fill out the following information:

Name:	Position:
Agency:	Telephone:
Street Address:	E-mail:
City, State, Zip:	

Please return this survey and direct any questions to either:  
Connor Schaeffer; [connorws@iastate.edu](mailto:connorws@iastate.edu)  
An Chen, Ph.D., P.E.; [achen@iastate.edu](mailto:achen@iastate.edu)  
Department of Civil, Construction and Environmental Engineering  
Iowa State University  
Phone: (515) 294-3460  
Fax: (515) 294-8216

**Survey on Anchor Bolt Tightening Practice from Iowa State University**

Part I: Tightening Practice and Details

How many overhead signs, light poles, high mast light towers and traffic signals are there in your state?

What is the anchor bolt tightening method used during new construction and maintenance retightening?

Turn-of-Nut Pretensioning

Calibrated Wrench Pretensioning

Direct Tension Indicator (DTI)

Other

If other, please explain:

What tools or equipment are used to tighten the anchor bolts?

How are bolts and nuts lubricated during the tightening?

What tightening level is used in the practice?

Do you verify proper tightening of the anchor bolts after they are tightened? If so, what method do you use?

Do you have any special requirements on the tightening procedure other than that

specified in the AASHTO Specifications? If yes, please attach a copy of these requirements.

Part II - Loose Nuts and Retightening Practice

- (a) Have you seen loose nuts for the anchor bolts during the inspection?
- (b) If the answer is yes to question (a), what is the approximate percentage of the support structures that have loose nuts?
- (c) How soon after tightening was it observed? Please share additional relevant information or inspection reports if available.

What method have you used to retighten/retrofit the anchor bolts if loose nuts were found?

Retighten existing nuts

Replace with new nuts

Replace with new nuts and weld the nuts to the anchor shaft

Use double top nuts

Other

If other, please explain:

Can you comment on the time, labor and cost spent on retightening the anchor bolts with loose nuts?

Any additional comments you would like to make on the subject of loose nuts for large anchor bolts of support structures for signs and luminaries? Any input is greatly appreciated.

**APPENDIX D. INDUSTRY SURVEY****Purpose of the Survey**

This survey is a part of a research project titled *Re-tightening the Large Anchor Bolts of Support Structures for Signs and Luminaries* sponsored by Minnesota Department of Transportation (MnDOT). The objectives of this project are to investigate causes of loose nuts for anchor bolts used in support structures (e.g., overhead signs, high mast light tower (HMLT), and tall traffic signals) and develop the best practical procedures to retighten the loose anchor bolts. The research team includes Iowa State University and North Dakota State University.

We ask that you take a brief moment with this survey to help us achieve the objectives of this project. Your input is invaluable for the successful completion of this project, and we appreciate your kind response. Please fill out the following information:

Name:	Position:
Agency:	Telephone:
Street Address:	E-mail:
City, State, Zip:	

Please return this survey and direct any questions to either:  
Connor Schaeffer; [connorws@iastate.edu](mailto:connorws@iastate.edu)  
An Chen, Ph.D., P.E.; [achen@iastate.edu](mailto:achen@iastate.edu)  
Department of Civil, Construction and Environmental Engineering  
Iowa State University  
Phone: (515) 294-3460  
Fax: (515) 294-8216

**Survey on Anchor Bolt Tightening Practice from Iowa State University**

Part I: Tightening Practice and Details

Are anchor bolt tightening procedures for transmission towers specified by your company? Can you attach a copy of the tightening procedures?

Is pretensioning of anchor bolts specified?

What type of bolts are used?

Headed anchor bolt

Anchor bolt with heavy hex nut

Anchor with plate washer and heavy hex nut

Bent bar anchor bolt

Other

If other, please describe:

What is the anchor bolt tightening method used during new construction and maintenance retightening?

Turn-of-Nut Pretensioning

Calibrated Wrench Pretensioning

Direct Tension Indicator (DTI)

Other

If other, please explain:

What tools or equipment are used to tighten the anchor bolts?

Are bolts and nuts lubricated during the tightening? If so, how?

What tightening level or tightening torque is used in the practice?

What anchor grade is used in practice?

Do you verify proper tightening of the anchor bolts after they are tightened? If so, what method do you use?

Do you have any special requirements on the anchor bolt or tightening procedure that you would like to share now?

Part II - Loose Nuts and Retightening Practice

(a) Have you seen loose nuts for the anchor bolts during the inspection?

(b) If the answer is yes to question (a), what is the approximate percentage of the support structures that have loose nuts?

(c) How soon after tightening was it observed? Please share additional relevant information or inspection reports if available.

If loose nuts are found, what method is used to retighten/retrofit the anchor bolts?

Retighten existing nuts

Replace with new nuts

Replace with new nuts and weld the nuts to the anchor shaft

Use double top nuts

Other

If other, please explain:

Any additional comments you would like to make on the subject of loose nuts for large anchor bolts of transmission towers? Any input is greatly appreciated.

## APPENDIX E. EXAMPLE CALCULATIONS

### Determining Snug-tight Torque

Determine the maximum snug-tightening torque for a lubricated 1.5" diameter F1554 Gr. 105 rod.

D (in):	1.5
$f_y$ (ksi):	105
$A_t$ (in <sup>2</sup> ):	1.405
K:	0.12

Calculate the force corresponding to 10% of yield.

$$0.1F_y = 0.1 * 1.405 * 105 = 14.75 \text{ kips}$$

Calculate the required torque.

$$T = 0.12 * 14.75 * 1.5 * (1000/12) = \underline{\underline{221.3 \text{ ft-lbs}}}$$

### Determine Rotation beyond Snug-tight

Determine the necessary rotation beyond snug-tight for a 1.5" diameter F1554 Gr. 105 rod with a 2" baseplate and typical washers.

D (in):	1.5
$f_y$ (ksi):	105
$A_t$ (in <sup>2</sup> ):	1.405
E (ksi):	29000
$L_g$ (in):	2
P (threads/in):	6

Determine the design snug-tight force

$$0.1F_y = 0.1 * 105 * 1.405 = 14.75 \text{ kips}$$

Determine the axial force necessary to reach target pretension

$$0.6F_y = 0.6 * 105 * 1.405 = 88.5 \text{ kips}$$

$$0.6F_y - 0.1F_y = 88.5 \text{ kips} - 14.75 \text{ kips} = 73.75 \text{ kips.}$$

Determine the induced axial deformation



$$\Delta_{\text{bolt}} = PL/AE = 73.75 \cdot 2 / (29000 \cdot 1.405) = 0.0036 \text{ inches}$$

Determine the  $k_s$  value

$$D/L = 1.5/2 = 0.75 \text{ in/in}$$

$$k_b = EA/L = 29000 \cdot 1.405/2 = 20,732.5 \text{ kips/in}$$

Based on *Figure 5.1*, *Figure 5.2*, and *Figure 5.3*, the most conservative (maximum) design  $k_s$  value is most nearly 9%.

Determine required rotation

$$\Delta_{\text{bolt}} = k_s \cdot (\alpha/360) \cdot (1/P) = \alpha \cdot (41.67 \cdot 10^{-6}) \text{ inches}$$

$$\alpha \cdot (41.67 \cdot 10^{-6}) = 0.0036; \alpha = 86.4 \text{ degrees. } \underline{\text{Use a design value of 90 degrees (1/4 turn)}}$$

Note: The same process can be followed with different assumptions of snug-tight,  $k_s$ , or target pretension

## APPENDIX F. RECOMMENDATIONS FOR SPECIFICATION

The following procedure is recommended in AASHTO's LTS-1, and based on the procedure from Garlich and Thorkildsen (2005). It is noted by \* where modifications have been made to the AASHTO specification.

1. Verify that the nuts can be turned onto the bolts past the elevation corresponding to the bottom of each in-place leveling nut and be backed off by the effort of one person using a 12-in. long wrench or equivalent (i.e., without employing a pipe extension on the wrench handle).
2. Clean and lubricate the exposed threads of all anchor bolts and leveling nuts. Re-lubricate the exposed threads of the anchor bolts and the threads of the leveling nuts if more than 24 hours has elapsed since earlier lubrication, or if the anchor bolts and leveling nuts have become wet since they were first lubricated.
3. Turn leveling nuts onto the anchor bolts and align the nuts to the same elevation. Place structural washers on top of the leveling nuts (one washer corresponding to each bolt).
4. Install the base plate atop the structural washers that are atop the leveling nuts, place structural washers on top of the base plate (one washer corresponding to each anchor bolt), and turn the top nuts onto the anchor bolts.
5. Tighten top nuts to a snug-tight condition in a star pattern. \*Snug-tight is defined as the maximum nut rotation resulting from the full effort of one person using a wrench within the lengths of Table F.1, or with the snugging-torque in Table F.2\*. A star tightening pattern is one in which the nuts on opposite or near-opposite sides of the anchor bolt circle are successively tightened in a pattern resembling a star. (e.g., For an 8-bolt circle with anchor bolts sequentially numbered 1 to 8, tighten nuts in the

following bolt order: 1, 5, 7, 3, 8, 4, 6, 2.)

6. Tighten leveling nuts to a snug-tight condition in a star pattern.
7. Before final tightening of the top nuts, mark the reference position of each top nut in a snug-tight condition with a suitable marking on one flat with a corresponding reference mark on the base plate at each bolt \*Then incrementally turn the top nuts using a star pattern until achieving the required nut rotation specified in Table F.2. Turn the nuts in at least two full tightening cycles (passes). Do not exceed the verification torque during tightening. After tightening, verify the nut rotation. Using a torque wrench, the verification torque, shown in the Table F.2, should be applied to the top nuts\*. Inability to achieve the verification torque may indicate thread stripping.
8. Re-tightening of installation by use of torque is recommended 48 hours after bolt tightening to account for any creep in the galvanizing within the threads. \*The re-tightening torque is 110 percent of the verification torque, and shown in Table F.2\*.

Table F.1 – *Wrench Lengths for Snugging*

		Anchor Gr. (Yield Stress)		
		36	55	105
Diameter	0.75	1	1	3
	1	2	3	6
	1.25	4	6	12
	1.5	7	11	21
	1.75	11	18	34
	2	17	26	50
	2.25	25	39	74
	2.5	35	53	101

Table F.2 – Torque and Turns for MnDOT Structures

Signals & Lighting Structures							
LIGHTING							
Anchor Bolt $\phi$	Bolt Type (galvanized to Spec. 3392)	Base Plate Thickness	Pole Type	Verification Torque, $T_v$ (ft-lbs)	Snug Torque (ft-lbs)	Re-tightening Torque, $T_r$ 48 Hours After Tightening	Rotation Beyond Snug
3/4 Inch	ASTM A325 10 UNC Hex Head Bolt	3/8 Inch→ 1/2 Inch→ 5/8 Inch→ 3/4 Inch→	Pedestrian Walkway Light Poles	138	23	152	1/12 1/12 1/6 1/6
3/4 Inch	Type A Grade 36 Spec. 3385.2A	3/8 Inch→ 1/2 Inch→ 5/8 Inch→ 3/4 Inch→	Pedestrian Walkway Light Poles	45	9	50	1/3 1/3 1/2 1/2
1 Inch	Type B Grade 55 Spec. 3385.2B	1/4 Inch	40' Stainless Steel Light Poles	200	33	220	1/18
1 Inch	ASTM A325 8 UNC Hex Head Bolt	1/4 inch	40' Stainless Steel Light Poles	335	56	368	1/12
1 Inch	Type B Grade 55 Spec. 3385.2B	1 Inch	40' or 49' Single Arm or Twin Arm 9' < Galvanized Steel Light Poles	200	33	220	1/12
1 Inch	Type C Grade 105 Spec. 3385.2C	1 Inch	49' Twin Arm 10' $\geq$ Galvanized Steel Light Poles	382	64	420	1/6

Anchor Bolt $\phi$	Type	Base Plate Thickness	Pole Type	Verification Torque, $T_v$ (ft-lbs)	Snug Torque (ft-lbs)	Re-tightening Torque, $T_r$ 48 Hours After Tightening	Rotation Beyond Snug
1 Inch	Type D Stainless Type 304 or 316 Spec. 3385.2D	1 Inch	40' or 49' Single Arm or Twin Arm 9' < Galvanized Steel Light Poles	127	25	140	1/18
1- 1/4 Inch	Type B Grade 55 Spec. 3385.2B	1/4 Inch	50' Stainless Steel Light Poles	400	67	440	1/18
1- 1/4 Inch	ASTM A325 7UNC Hex Head Bolt	1/4 Inch	50' Stainless Steel Light Poles	589	98	648	1/18
2 Inch	Type C Grade 105 Spec. 3385C	2 Inch	High Mast Towers	3150	525	3465	1/6
1 Inch	Type A Grade 36 Pole-Safe Coupling	1/4 Inch→ 1 Inch→	40' Steel & Stainless Steel Light Poles	109	22	120	1/18 1/12
1-1/4 Inch	Type A Grade 36 Pole-Safe Coupling	1/4 Inch→ 1 Inch→	50' Steel & Stainless Steel Light Poles	218	44	240	1/18 1/12
SIGNALS							
1- 1/2 Inch	Type C Grade 105 Spec. 3385.2C	1-1/4 Inches	Signal Mast Arm Pole	1328	221	1460	1/4
1- 1/2 Inch	Type C Grade 105 Spec. 3385.2C	1-1/4 Inches	Signal Mast Arm Pole	1328	221	1460	1/4

Anchor Bolt $\emptyset$	Bolt Type (galvanized to Spec. 3392)	Base Plate Thickness	Pole Type	Verification Torque, $T_v$ (ft-lbs)	Snug Torque (ft-lbs)	Re-tightening Torque, $T_r$ 48 Hours After Tightening	Rotation Beyond Snug
1- 1/2 Inch	Type C Grade 105 Spec. 3385.2C	3 Inches	BA60 Signal Mast Arm Pole	1328	221	1460	1/4
1- 3/4 Inch	Type C Grade 105 Spec. 3385.2C	3 Inches	BA65 Signal Mast Arm Pole	2095	349	2304	1/6
2 Inch	Type C Grade 105 Spec. 3385.2C	2 Inches	Mono-Tube Round Overhead Span with T-Base	3150	525	3465	1/6
2 Inch	Type C Grade 105 Spec. 3385.2C	3 Inches	BA70 & 75 Signal Mast Arm Pole	3150	525	3465	1/6
2-1/4 Inch	Type C Grade 105 Spec. 3385.2C	2 Inches	Mono-Tube Round Overhead Span with "A"-Base	4607	768	5068	1/6
2- 1/4 Inch	Type C Grade 105 Spec. 3385.2C	3 Inches	BA80 Signal Mast Arm Pole	4607	768	5068	1/6
<b>OH Signs Anchor Bolts &amp; Grip Lengths</b>							
2-1/4 Inch	Type B Grade 55 Spec. 3385.2B	2 Inches	Type 1-4 Sign Truss	2413	402	2654	1/12
2-1/2 Inch	Type B Grade 55 Spec. 3385.2B	2 Inches	Type 5-7 Sign Truss	3300	550	3630	1/12



# HIGH STRENGTH STEEL ANCHOR ROD INSTALLATION TENSIONING RECORD

Minnesota Department of Transportation  
FORMID# 2/2018

**Purpose:** Submit this form to ensure proper installation under the standard specifications for sign bridges and overhead sign supports. Requires "Yes" answers to steps 1 thru 7.

Procedure	Question	Yes	No
<b>Step 1</b> Verify F1554 anchor bolt grade is as specified for the project. Verify nuts are ASTM A563 heavy hex and washers are F436.	Were the correct grade of anchor rod, nut and washer used?	<input type="checkbox"/>	<input type="checkbox"/>
<b>Step 2</b> Verify anchor rods are clean and not damaged and plumb – not more than 1:40 slope or 1/4" in 10" (if rods are out of plumb or damaged contact project engineer).	Was anchor rod clean and undamaged and slope $\leq$ 1:40 or 1/4" in 10"?	<input type="checkbox"/>	<input type="checkbox"/>
<b>Step 3</b> Lubricate anchor rods with Bostik Mariner's Choice Never Seez (within 24 hours of tensioning) and turn nut down to foundation – this should run freely with little resistance $\approx$ 20 ft.-lbs. or less.	Was Bostik Mariner's Choice Never Seez applied and did leveling nut run down freely?	<input type="checkbox"/>	<input type="checkbox"/>
<b>Step 4</b> Level leveling nuts – make sure nuts are less than one anchor rod diameter from the foundation (unless stated otherwise on the plans).	Were the leveling nuts installed $\leq$ 1 anchor rod diameter from the foundation?	<input type="checkbox"/>	<input type="checkbox"/>
<b>Step 5</b> Install structure with an F436 washer below and above base plate and snug top nuts. When snugging use snugging torque or maximum open end wrench length on both the top nut and leveling nut following the star pattern. Two cycles of snugging shall be performed prior to Step 6.	Was snugging (2 cycles) performed properly?	<input type="checkbox"/>	<input type="checkbox"/>
<b>Step 6</b> Mark the nuts and adjacent base plate and turn the minimum required turn per Table F.2, but do not exceed the verification torque.	Was turn of the nut performed properly?	<input type="checkbox"/>	<input type="checkbox"/>
<b>Step 7</b> Confirm verification torque was achieved per Table F.2, or continue to turn nut until verification torque is achieved.	Was verification torque per Appendix A confirmed?	<input type="checkbox"/>	<input type="checkbox"/>
<b>Step 8</b> 48 hours after initial tightening, apply re-tightening torque. The re-tightening torque is 110% of verification torque (1.1*T <sub>v</sub> ).	Was re-tightening torque applied correctly?	<input type="checkbox"/>	<input type="checkbox"/>

**REFERENCE MARK EXAMPLE**

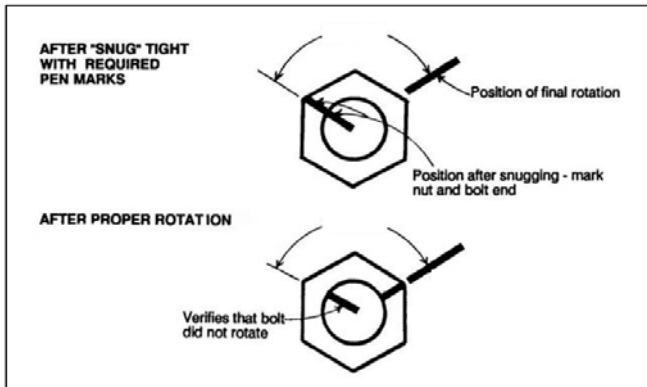

**STAR PATTERN EXAMPLES**

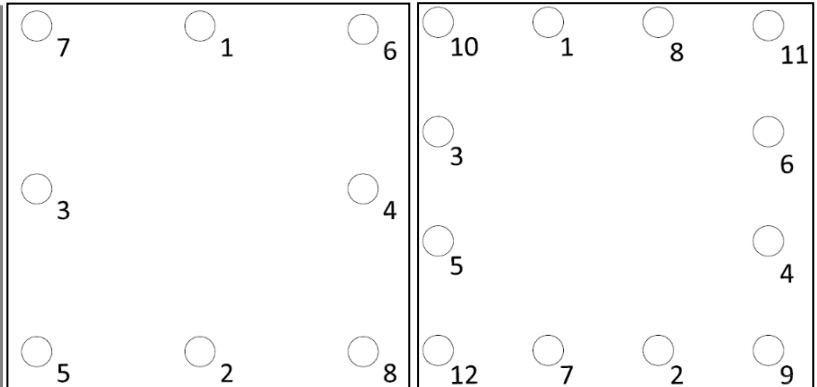

Make, Model and Serial Number of Torque or Hydraulic Wrench		
Wrench Calibration Date (m/d/yyyy) (Calibration Date MUST be Within 1 Year)	Structure ID Number	Project ID
Contractor Name		
Date (m/d/yyyy)	Contractors Representative (QC) Name	Contractors Representative (QC) Signature <b>X</b>
Date (m/d/yyyy)	Minnesota Department of Transportation Representative (QA) Name	MnDOT Representative (QA) Signature <b>X</b>
Comments		