

3-23-2016

# Water Metering in Rural, Piped, Community-Managed Water Systems in the Developing World

Simona Platukyte

Follow this and additional works at: <http://scholarcommons.usf.edu/etd>

 Part of the [Environmental Engineering Commons](#), [Sustainability Commons](#), and the [Water Resource Management Commons](#)

---

## Scholar Commons Citation

Platukyte, Simona, "Water Metering in Rural, Piped, Community-Managed Water Systems in the Developing World" (2016). *Graduate Theses and Dissertations*.

<http://scholarcommons.usf.edu/etd/6130>

This Thesis is brought to you for free and open access by the Graduate School at Scholar Commons. It has been accepted for inclusion in Graduate Theses and Dissertations by an authorized administrator of Scholar Commons. For more information, please contact [scholarcommons@usf.edu](mailto:scholarcommons@usf.edu).

Water Metering in Rural, Piped, Community-Managed Water Systems in the Developing World

by

Simona Platukyte

A thesis submitted in partial fulfillment  
of the requirements for the degree of  
Master of Science of Engineering Science  
Department of Civil and Environmental Engineering  
College of Engineering  
University of South Florida

Major Professor: Qiong Zhang, Ph.D.  
James R. Mihelcic, Ph.D.  
Mahmood Nachabe, Ph.D.

Date of Approval:  
March 16, 2016

Keywords: sustainable development goals, gravity-flow water supply, revenue recovery, field guide, multiple criteria decision analysis (MCDA)

Copyright © 2016, Simona Platukyte

## **DEDICATION**

To my parents, for their sacrifices so that I could have the opportunities they could not.  
And, to the memory of Joan Newcomb, who saw the best in everyone.

## ACKNOWLEDGEMENTS

My deepest gratitude is to Dr. Mihelcic and Dr. Zhang. Without Dr. Mihelcic's vision and tireless efforts for making sustainable development engineering education accessible to non-engineers, neither my studies nor this work would have been possible. Dr. Zhang's commitment to developing students professionally and personally is unparalleled and has inspired me during many difficult times. She has spent many hours guiding me and urging me not to give up!

I would also like to thank Dr. Nachabe for reading this thesis and providing thoughtful comments for its improvement. A special "thank you" goes to all the students of Dr. Zhang's research group for their help and friendship over the years.

Certainly, I would be nowhere without the support of family, friends, and colleagues who have encouraged and supported me during my studies and while writing this thesis.

Finally, I would like to acknowledge Assured Automation, B Meter, Badger Meter, Sensus, and the Water Research Foundation for granting permission to reprint images. I am especially grateful to [www.flows.com](http://www.flows.com) for their exceptional responsiveness to my requests and for thoughtfully sending a meter. I can only imagine what treatment their paying clients receive.

This material is based upon work supported by the National Science Foundation under Grant Number 0965743. Any opinions, findings, and conclusions or recommendations expressed in this material are those of the author and do not necessarily reflect the views of the National Science Foundation.

## TABLE OF CONTENTS

|                                                                                       |     |
|---------------------------------------------------------------------------------------|-----|
| LIST OF TABLES.....                                                                   | iii |
| LIST OF FIGURES .....                                                                 | iv  |
| ABSTRACT.....                                                                         | vi  |
| CHAPTER 1 INTRODUCTION .....                                                          | 1   |
| CHAPTER 2 METHODOLOGY .....                                                           | 5   |
| 2.1 Methodology for Literature Review .....                                           | 5   |
| 2.2 Methodology for the Multiple Criteria Decision Analysis (MCDA).....               | 7   |
| 2.2.1 The Analytical Hierarchy Process (AHP).....                                     | 7   |
| 2.2.1.1 AHP Step 1: Evaluation Matrix .....                                           | 8   |
| 2.2.1.2 AHP Step 2: Priority Matrix .....                                             | 8   |
| 2.2.1.3 AHP Step 3: Consistency Ratio Calculation.....                                | 9   |
| 2.2.2 Direct Scoring of Alternatives .....                                            | 10  |
| 2.2.3 Weighted Sum Approach.....                                                      | 10  |
| CHAPTER 3 COMPILATION OF METER INFORMATION .....                                      | 16  |
| 3.1 Types of Meters Commonly Used for Residential Metering and How They<br>Work ..... | 16  |
| 3.1.1 Displacement Meters .....                                                       | 17  |
| 3.1.1.1 Oscillating Piston Meters .....                                               | 18  |
| 3.1.1.2 Nutating Disc Meters .....                                                    | 18  |
| 3.1.2 Non-Displacement Meters .....                                                   | 19  |
| 3.1.2.1 Single-Jet Meters .....                                                       | 20  |
| 3.1.2.2 Multi-Jet Meters.....                                                         | 21  |
| 3.2 Summary of Meter Characteristics and Their Implications for Rural Systems .....   | 21  |
| 3.3 Meters Not Typically Used in Residential Applications .....                       | 25  |
| CHAPTER 4 RESULTS OF MULTIPLE CRITERIA DECISION ANALYSIS (MCDA).....                  | 38  |
| 4.1 Identifying Goal and Criteria for MCDA .....                                      | 38  |
| 4.2 Weighting Criteria, Indicators, and Scoring Alternatives.....                     | 40  |
| 4.2.1 Weighting Criteria .....                                                        | 40  |
| 4.2.2 Identifying and Weighting Indicators .....                                      | 41  |
| 4.2.3 Scoring Alternatives.....                                                       | 44  |
| 4.3 Weighted Scores of Alternatives .....                                             | 45  |
| CHAPTER 5 PRACTICAL INSTALLATION TIPS.....                                            | 51  |
| 5.1 Service Line Sizing for Meter Installation Example.....                           | 51  |

|                                                                                                                 |     |
|-----------------------------------------------------------------------------------------------------------------|-----|
| 5.2 Practical Tips for Meter Installation .....                                                                 | 58  |
| 5.2.1 Size Notation.....                                                                                        | 58  |
| 5.2.2 Example Valve Box Design and Shutoff Valves.....                                                          | 59  |
| 5.2.2.1 Location of Valve Box.....                                                                              | 61  |
| CHAPTER 6 STRATEGIES FOR INCORPORATING METERING INTO THE<br>COMMUNITY MANAGEMENT MODEL.....                     | 64  |
| 6.1 Rationale for Including Protection and Enforcement of Metering into<br>Community-Managed System Design..... | 64  |
| 6.2 The Metering Decision Tree .....                                                                            | 67  |
| 6.3 Possible Pricing Schemes and Their Enforcement .....                                                        | 71  |
| 6.4 Economic Considerations of Beginning a Metering Program .....                                               | 75  |
| CHAPTER 7 CONCLUSIONS AND RECOMMENDATIONS.....                                                                  | 80  |
| 7.1 Conclusions.....                                                                                            | 80  |
| 7.2 Recommendations.....                                                                                        | 82  |
| LIST OF REFERENCES.....                                                                                         | 84  |
| APPENDIX A: BACKGROUND INFORMATION.....                                                                         | 92  |
| A.1 Current Design Features for Rural Water Supply Systems and Water<br>Committee Training Manuals.....         | 92  |
| A.2 Brief History and Current Situation of Meters.....                                                          | 97  |
| A.3 Additional Meter Installation Details.....                                                                  | 100 |
| A.3.1 Meter Mounting Position .....                                                                             | 100 |
| A.3.2 Post-installation Inspection .....                                                                        | 102 |
| A.3.3 Meter Accessories.....                                                                                    | 103 |
| A.4 Community-management Model .....                                                                            | 103 |
| APPENDIX B: COPYRIGHT PERMISSIONS.....                                                                          | 110 |

## LIST OF TABLES

|                                                                                                                                                                                   |     |
|-----------------------------------------------------------------------------------------------------------------------------------------------------------------------------------|-----|
| Table 1 Summary of meters commonly used for residential metering .....                                                                                                            | 27  |
| Table 2 Meters used for water measurement not discussed in this work.....                                                                                                         | 30  |
| Table 3 AHP Criteria evaluation matrix. ....                                                                                                                                      | 41  |
| Table 4 AHP Criteria priority matrix.....                                                                                                                                         | 41  |
| Table 5 AHP Consistency evaluations for criteria weighting.....                                                                                                                   | 41  |
| Table 6 Evaluation matrix for the Durability criterion indicators. ....                                                                                                           | 42  |
| Table 7 Priority matrix for the Durability criterion indicators. ....                                                                                                             | 43  |
| Table 8 Evaluation matrix for the Durability criterion indicators. ....                                                                                                           | 43  |
| Table 9 Priority matrix for the Usability criterion indicators. ....                                                                                                              | 44  |
| Table 10 MCDA indicators and scoring of criteria. ....                                                                                                                            | 49  |
| Table 11 Data for use in the weighted sum approach.....                                                                                                                           | 50  |
| Table 12 Summary of possible water pricing schemes typically used by utilities and their effects on user consumption. ....                                                        | 76  |
| Table 13 Cost of meters relative to the total cost of project materials. ....                                                                                                     | 79  |
| Table A.1 Examples of gravity-fed system components and considerations that have received exclusive attention and evolved over time to become part of standard system design..... | 93  |
| Table A.2 Example benefits and drawbacks of community-management model in rural water supply work. ....                                                                           | 108 |

## LIST OF FIGURES

|                                                                                                                                    |    |
|------------------------------------------------------------------------------------------------------------------------------------|----|
| Figure 1 A timeline representation of the various activities that may take place during a field worker's stay in a community. .... | 4  |
| Figure 2 Example of generic MCDA setup. ....                                                                                       | 11 |
| Figure 3 General MCDA process. ....                                                                                                | 12 |
| Figure 4 Step one in AHP: the evaluation matrix. ....                                                                              | 13 |
| Figure 5 Step two in AHP: priority matrix. ....                                                                                    | 13 |
| Figure 6 Step three in AHP: consistency calculations. ....                                                                         | 13 |
| Figure 7 Direct scoring of alternatives for each indicator. ....                                                                   | 14 |
| Figure 8 Weighted sum approach to calculating the final score for alternative. ....                                                | 15 |
| Figure 9 General components of residential flow meters. ....                                                                       | 26 |
| Figure 10 Four meters commonly used residentially grouped by mechanism. ....                                                       | 26 |
| Figure 11 Possible characteristics of water flow meters. ....                                                                      | 28 |
| Figure 12 Cross-sectional view of the oscillating piston metering chamber. ....                                                    | 29 |
| Figure 13 Cross-sectional view of a nutating disc metering chamber. ....                                                           | 29 |
| Figure 14 Exploded view of the oscillating piston meter. ....                                                                      | 31 |
| Figure 15 Exploded view of the nutating disc meter assembly. ....                                                                  | 32 |
| Figure 16 Cross-sectional top view of single jet mechanism. ....                                                                   | 33 |
| Figure 17 Cross-sectional top view of multi jet mechanism. ....                                                                    | 33 |
| Figure 18 Typical components of a single-jet meter. ....                                                                           | 34 |
| Figure 19 Typical components of a multi-jet meter. ....                                                                            | 35 |
| Figure 20 Instructions for reading dial and odometer style registers of meters. ....                                               | 36 |



|                                                                                                                                 |     |
|---------------------------------------------------------------------------------------------------------------------------------|-----|
| Figure 21 Another variation of meter register display and instructions for reading it. ....                                     | 37  |
| Figure 22 Example of a plastic oscillating piston type of meter.....                                                            | 37  |
| Figure 23 A summary of MCDA inputs for this work. ....                                                                          | 47  |
| Figure 24 MCDA results: relative contributions of weighted indicator scores. ....                                               | 48  |
| Figure 25 Example of a pressure drop curve for a multi-jet bronze-body meter.....                                               | 55  |
| Figure 26 An example of a flow rate table that appears in a meter's specifications sheet.....                                   | 56  |
| Figure 27 Sketch of example problem evaluating head loss due to installation of meter. ....                                     | 57  |
| Figure 28 Side cross-section view of suggested design of valve box.....                                                         | 62  |
| Figure 29 Top view of suggested valve box. ....                                                                                 | 63  |
| Figure 30 An example of a good idea but faulty design.....                                                                      | 66  |
| Figure 31 Metering decision tree. ....                                                                                          | 77  |
| Figure 32 Example monthly small system O&M budget. ....                                                                         | 78  |
| Figure A.1 Example rural water supply system.....                                                                               | 99  |
| Figure A.2 Example of a meter that may be mounted vertically, horizontally, and on its<br>side.....                             | 100 |
| Figure A.3 Example of a meter that should only be mounted horizontally.....                                                     | 100 |
| Figure A.4 Example instructions for application of thread seal tape printed in<br>accompanying meter specifications sheet. .... | 101 |
| Figure A.5 A typical register display with emphasis added to highlight the flow sensor. ....                                    | 102 |
| Figure A.6 Summary of the community-management model applied to rural water<br>systems. ....                                    | 109 |

## **ABSTRACT**

In the early 1990s, the United Nations (UN) recognized water as a finite resource to the entire ecosystem with an economic value that should be developed and managed based on the participatory approach using the Integrated Water Resource Management (IWRM) strategy. Many studies on water management practices have thus emerged in the developing world. Of particular interest to this work is the management of water through metering, price-setting, and rule enforcement in the rural setting in piped, community-owned water systems. There is very little published information regarding metering, enforcement experiments, and experiences in these systems. This is because metering and enforcement mechanisms are not typically included in rural piped community-managed water supply system design and water committee training schemes. Along with an increase in population growth and changing climate patterns, there is a burgeoning interest to manage demand and reduce non-revenue water (NRW) in urban utilities in developing countries. Metering is often the demand management tool considered because it has been reported to increase customer payment rates as well as social equity. Rural, community-managed systems often suffer high failure rates due to the lack of preventative maintenance, which maybe closely linked to customer dissatisfaction and non-payment of tariffs. The inclusion of a metering and enforcement program to such systems may help to address the problem of high rates of premature failure.

An inclusion of a metering program for rural community-managed water supply systems is a non-trivial task in terms of cost as well as the system designer's time, thus there is significant

interest in ensuring such a program's success. Many field workers may have familiarity with water system design but not specifically in the area of water flow metering and currently no beginner-level resources are publicly available. This work is ultimately intended to facilitate the inclusion of metering into rural, piped, community-managed water supply systems through: 1) compilation of technical information regarding metering which would be accessible to field practitioners and relevant to the rural community-managed setting, 2) a proposed decision-making tool to facilitate the selection of the most appropriate meter for the community, 3) proposed installation tips, and 4) suggested strategies for including metering into the community-management model. Objectives 1, 3, and 4 were pursued via review of industry, peer-reviewed, and field literature along with the author's personal experience. Multiple criteria decision analysis (MCDA) was the method proposed for aiding in the selection of the most appropriate meter type. It was determined that four types of meters are used for residential metering in developed and developing urban utility-managed systems: the nutating disc, oscillating piston, multi-jet, and single-jet. The nutating disc and oscillating piston meters operate through a volumetric or displacement mechanism, while the single- and multi-jet meters function through a velocity or non-displacement mechanism. While a lot of variation between models of meters exists, there are fewer characteristics that can be used to differentiate between mechanisms. After applying the multiple-criteria decision analysis to aid in the selection of the most appropriate meter for a rural, community-managed systems, the nutating disc and oscillating piston types of meters were most preferred under the set of criteria chosen by the author for the purpose of example in this analysis. It is recommended that meter selection be performed on a site-specific basis with local stakeholder involvement for criteria determination. Meter installation is similar for all four types of meters and whichever type of meter is chosen, it should be protected from

tampering. Increasing-block pricing is recommended to accompany metering in order to motivate water conservation. The size and price of the initial block of water should be determined according to the system's operation and maintenance costs as well as users' willingness to pay information. Field practitioners should prepare the community to take over the metering program by providing basic training to the users and selected meter readers/technicians.

## CHAPTER 1 INTRODUCTION

Partly thanks to the attention generated by the UN's Millennium Development Goal 7, the number of people without access to improved drinking water has reduced and “of the 2.6 billion people who have gained access since 1990, 1.9 billion use a piped drinking water supply on premises” (MDG Report, 2015). Admittedly, while some of this increase may be a statistical phenomenon attributed to the movement of rural peoples to urban areas with infrastructure, it is also true that the international aid community has taken a great interest in addressing this problem through “hydrophilanthropy” – donating time and resources to implement water improvement projects (Kreamer, 2010). Particularly in rural areas, the field development workers design and build small water supply and distribution systems in response to the lack of effective government locally. Once the construction is completed, ownership and management responsibilities are transferred the community itself, and this concept is known as the community-management model (Annis, 2006; Behailu et al., 2015; Hanson, 1985; Lockwood, 2004; Okun & Ernst, 1987; Sy, 2011). While these projects often are popular with international donors and aid agencies, community-managed systems are characterized by high rates of tariff payment delinquency, lack of maintenance, and too often, even failure (Annis, 2006; Harvey & Reed, 2007; Schweitzer & Mihelcic, 2012). One of the contributing factors to failure is the lack of maintenance due to non-payment of tariffs by the users of the system. Although the community-management model stresses the need for capacity building of communities and one of the exercises is the codification of rules or statutes written by the water committee under the

guidance of the field worker. Such codes address the consequences of nonpayment and other violations of the committee rules, however, they are rarely enforced (Messenger, 2004). Too often the community's abilities to impose sanctions through social means are glorified or "mythologized" by hydrophilanthropists (Cleaver & Toner, 2006; Johnson, 2002). Water system designs, therefore, do not include management mechanisms through which the community could pursue equity and enforcement once the external aid entity departs. Specifically, in developed countries the utilities that provide water services have an interest in keeping those services functional and this requires continued revenue collection. This is often achieved through universal metering, consumption-based pricing of water, and enforcement through suspension of service in return for non-payment. There are arguments that suspension of service in rural communities in the developing world is not only punitive but also presents a health risk (World Health Organization (WHO), 2000). However, there is also clearly a need for equitable demand management through metering in rural community water systems, and there is evidence that international aid agencies are already implementing such projects (Johnson, 2002; Water for People, no date; Wright, 2013), however, there is almost no publicly available information for how meters are evaluated or chosen for these systems. Metering has also been mentioned as being a possible solution by other field practitioners but without specific suggestions (Louise, 2004; Sy, 2011). It was the author's experience in the field that abundant industry information regarding metering exists, but is often geared for a utility or municipality audience assuming a certain level of knowledge. Figure 1 represents a general timeline of ongoing activities that the author experienced while serving as a water and sanitation Peace Corps Volunteer (PCV) in the Dominican Republic. The purpose of this chart is intended to illustrate that the development workers in developing projects and communities typically do not have a lot of free time for

independent research, especially when telecommunication services are seldom available. Thus, the goal of this thesis is to help development workers in incorporating metering into community-managed systems by providing a practical guide. This thesis is not intended to address every aspect of metering, and there are many data and knowledge gaps that cannot be addressed without further studies.

To achieve the goal, four specific objectives are proposed. Firstly, to compile information on residential metering technologies, terminology and summary of characteristics relevant to rural community-manages systems (Chapter 3). Secondly, to propose the multiple criteria decision analysis (MCDA) in aiding the selection of the most appropriate meter type (Chapter 4). Thirdly, to provide practical tips for meter sizing and installation in the field (Chapter 5). And, finally, to suggest strategies for incorporating metering into the community management model in Chapter 6. The methodology for pursuing all objectives is discussed in Chapter 2. Conclusions and recommendations follow in Chapter 7.

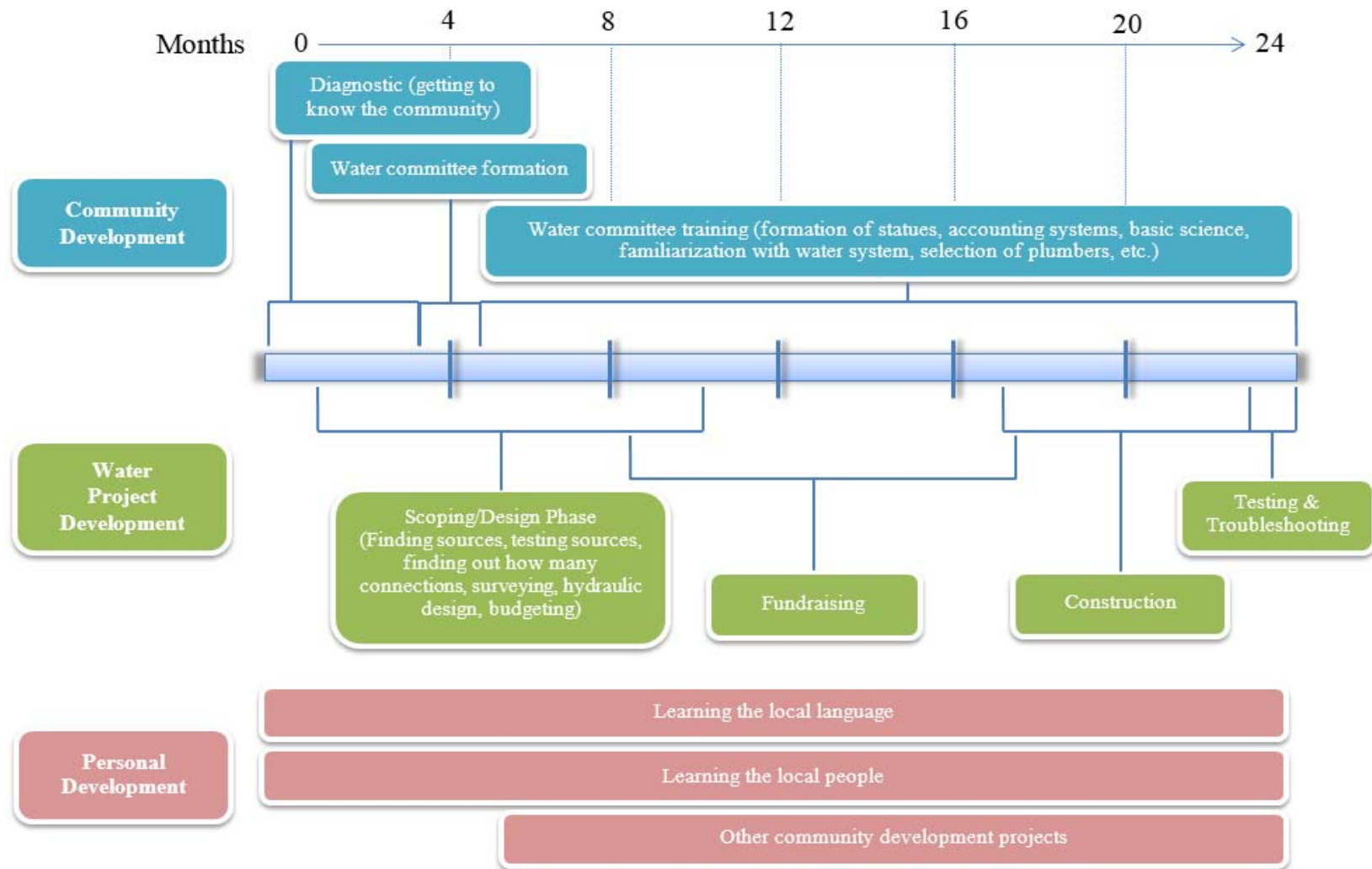

Figure 1 A timeline representation of the various activities that may take place during a field worker’s stay in a community. This is representative of the author’s experience as a United States Peace Corps Volunteer serving as a water and sanitation specialist in the Dominican Republic, 2012 to 2014.



## **CHAPTER 2 METHODOLOGY**

Objectives one, three, and four (compilation of technical information regarding metering, installation tips, and strategies for incorporating metering into community-management, respectively) were all pursued primarily through literature review and author's personal experience. Almost all of the literature sources reviewed was in English with the exception of one water committee training manual being in Spanish.

### **2.1 Methodology for Literature Review**

Literature sources reviewed for objectives one and three included industry documents. Primarily, the manual on metering compiled by the American Water Works Association (AWWA) was reviewed to identify meters most often used residentially in the United States (AWWA, 2012). AWWA, a non-regulatory entity, is the primary organization in the United States which publishes recommended standards for cold-water, residential meters. AWWA's materials are intended for entities such as private utilities or municipalities managing public water resources. Review of references in AWWA's meter manual also led to the discovery of an extensive study published by the Water Research Foundation (WRF). This is the first study examining long-term performance of various sizes and types of meters which are produced by different manufacturers (Barfuss et al., 2011). Results relevant to residential meter performance were extracted and used in the indicator compilation for the decision-making tool. WRF is an organization that originated from AWWA, whose research is also geared for utilities, manufacturers and consultants in the drinking water supply field. The Engineering Village

(Compendex) database was used to search for peer-reviewed literature using the key words “water meter” and “developing country”. This yielded 200 articles; 9 were identified to be relevant because they addressed residential water metering in the developing world and provided sound background information, however, only 2 directly addressed water meter performance in an urban utility setting (Mutikanga et al., 2009, 2011). The references cited in these studies as well as references citing these studies were reviewed and additional five studies were identified examining meter selection and performance (Arregui et al., 2005; Mutikanga, 2014; Mutikanga et al., 2013; Richards et al., 2010; Shields et al., 2012). A search for “water metering” and “community-management” yielded only one source which was not directly relevant. Many product specification sheets provided by meter manufacturers online were examined and technical performance information was synthesized along with the information obtained from the peer-reviewed studies.

Additionally, the term “metering in community-managed water systems” was searched in the Google search engine in order to locate any possible field reports which would not be found through the Engineering Village database. Several personal accounts were located in the form of blogs and reports testifying to the occurrence of metering projects in rural community managed systems by various international aid organizations (Davis, 2013; Johnson, 2002; Wright, 2013). Searching for guidance documents regarding selection of meters from the websites of the international aid organizations that reported the installation of metering projects in rural communities did not yield results.

The first page of the Google search also yielded a study examining factors that affect sustainability of rural community-managed systems (Schweitzer & Mihelcic, 2012). The references cited in this study led to many peer-reviewed papers and field manuals concerning the

community management model as well as appropriate technology selection criteria. One of the 9 peer-reviewed sources identified in the Engineering Village search, described successes of community-management in a small town (having 1000 connections) where 100% connections were metered (Dahanayake, 2007) and information relevant for rural settings was used for suggesting strategies for incorporating metering into the community-management model.

## **2.2 Methodology for the Multiple Criteria Decision Analysis (MCDA)**

The process for carrying out the multiple criteria decision analysis (MCDA) has four general steps: summarizing the goal, identifying criteria, selecting indicators, and finding possible alternatives (Belton & Stewart, 2002; De Montis et al., 2004). A representation of a generic setup is depicted in Figure 2. Within MCDA there are many tools for deciding how to weight the importance of criteria and indicators for evaluating alternatives. While more computationally and cognitively intense tools tend to be more reflective of realistic decision-making (for example, the Multiattribute Utility Theory (MAUT)), simpler tools are often preferred, especially for developing world settings (Cinelli et al., 2014; Hajkowicz & Higgins, 2008; Olson, 2008). In this work, the Analytical Hierarchy Process (AHP) is used to determine the relative weights of criteria and indicators. The alternatives are scored directly for each indicator. The scores for each alternative are multiplied by the relative weights of the criteria (and indicators where applicable) and summed to determine the final weighted score. These steps are illustrated in the flowchart in Figure 3 and explained further in the following subsections.

### **2.2.1 The Analytical Hierarchy Process (AHP)**

The method for the Analytical Hierarchy Process (AHP) is explained in the following subsections to obtain the final weights of example criteria. If a criterion contains more than one indicator, the weights should also be determined comparing the indicators within a given

criterion. The final step of the AHP is a consistency calculation which is performed when the number of criteria (or indicators) evaluated is greater than two.

### **2.2.1.1 AHP Step 1: Evaluation Matrix**

In this step, an evaluation matrix (E) is set up where the identified criteria are listed in column and in row form (C1-C3 corresponds to Criterion 1-3) (Figure 4). This analysis was performed using Microsoft Excel software, but could be done with pen and paper. Each criterion in the column is compared to each criterion in the row in a pairwise fashion and a number is assigned in the corresponding cell representative of the evaluator's relative preference, on a scale from 1 to 9 (Teknomo, 2006). On the preference scale, 1 represents equal importance and 9 represents extreme importance of one criterion over another. The numbers in between 1 and 9 represent various degrees of preference. The evaluator begins by deciding the relative importance of C1 over C1 and in this case the value assigned is 1, because the C1 is equally important to itself. Moving to the right, the importance of C1 is judged to be only slightly more important than C2, thus a value of 2 is assigned. This process is repeated row by row, until all the cells in the matrix are filled out. Where the criterion being evaluated is determined to be less important than the one it is compared to, an inverse number (rather than a whole number) is assigned ( $E_{ij} = 1/E_{ji}$ ). For example, where in the first row of the Evaluation Matrix C1 was determined to be more important than C2 in the second column, it logically follows that in the second row, C2 should be less important than C1 in the first column, thus a value of  $\frac{1}{2}$  is assigned.

### **2.2.1.2 AHP Step 2: Priority Matrix**

Once the Evaluation Matrix is completed, all numeric values are summed by column. A second matrix, the Priority Matrix (P), is set up similarly with the criteria in column and row

form, for determining the final weights of each criterion (Figure 5). Each value in the Evaluation Matrix is divided by the column total and entered in the Priority Matrix in the cell that

corresponds to the same position ( $P_{ij} = E_{ij} / \sum_{i=1}^n E_{ij}$ , where  $n$  is the number of criteria). This is

performed for each cell in the matrix, and the values are then summed by row. The row total is

divided by the number of criteria considered to obtain the final weight vector  $W$  ( $W_i = \sum_{j=1}^n P_{ij} / n$ ).

### 2.2.1.3 AHP Step 3: Consistency Ratio Calculation

After the weighting of criteria is completed, a final calculation is performed to determine whether the evaluator was consistent in rating the importance of criteria. This is done by calculating the Consistency Index (CI) and then comparing it to the Random Index (RI) which is obtained from literature (Teknomo, 2006). The CI is calculated using Equation 1

$$CI = \frac{Eigen - n}{n - 1} \quad (1)$$

where Eigen is the Eigen value and calculated using Equation 2

$$Eigen = \frac{\sum_{i=1}^n \left( Ws_i \times \frac{1}{W_i} \right)}{n} \quad (2)$$

where  $Ws$  is the cross product of the Evaluation Matrix  $E$  and the weight vector  $W$

( $Ws_i = \sum_{j=1}^n E_{ij} \times W_j$ ) (Figure 6). Additionally, a value for the RI is selected from the AHP

method's list which corresponds to the number of criteria considered, in the case of 3 criteria,

this value equals to 0.58 (Teknomo, 2006). Finally the Consistency Ratio (CR) is determined by

dividing the CI by the RI. If the resulting number is smaller than 0.1, the consistency

requirement is thought to be met. If the CR is greater than 0.1, then the relative importance of criteria should be reevaluated and the calculations re-worked.

### 2.2.2 Direct Scoring of Alternatives

Once the indicators are selected and their relative weights (if any) determined, the acceptable ranges are set for each indicator by the evaluator (for example, the “Measure” column in Figure 7). The indicators can be evaluated numerically and categorically where numeric data are lacking (this is exemplified in the “Alternative – Score” column in Figure 7). Categorical values are then assigned a numeric value between 0 and 1, where 1 indicates highest preference and 0 indicates lowest preference. Numerical values must be rescaled because they are presented in different units (e.g., dollars and number of parts). This is done by applying the simple formula displayed in Equation 3 so that all values fall between 0 and 1 (shown in “Alternative – Rescaled” column in Figure 7).

$$\text{Rescaled Score} = \frac{|(\text{score of alternative}) - (\text{least preferred score in range})|}{|(\text{most preferred score in range}) - (\text{least preferred score})|} \quad (3)$$

### 2.2.3 Weighted Sum Approach

Once the scoring of alternatives is completed, the final step in this MCDA method is to determine the final weighted scores of each alternative through the weighted sum approach. An example setup of an Excel spreadsheet for organizing the information on criteria and sub-criteria weights along with alternative scores is shown in Figure 8. The relative weights of criteria are multiplied by the relative weights of each indicator within that criterion (if any, and by 1 if only one indicator is present). The resulting final weight for each indicator is multiplied by the rescaled score for each alternative to determine the weighted score by indicator. To calculate total weighted score for each alternative, all of the weighted scores by indicator are added

together (Equation 4). The alternatives can be compared by total weighted score or by weighted score by indicator.

$$Score_{Ai} = \sum_{j=1}^n W_j \times A_{ij} \quad (4)$$

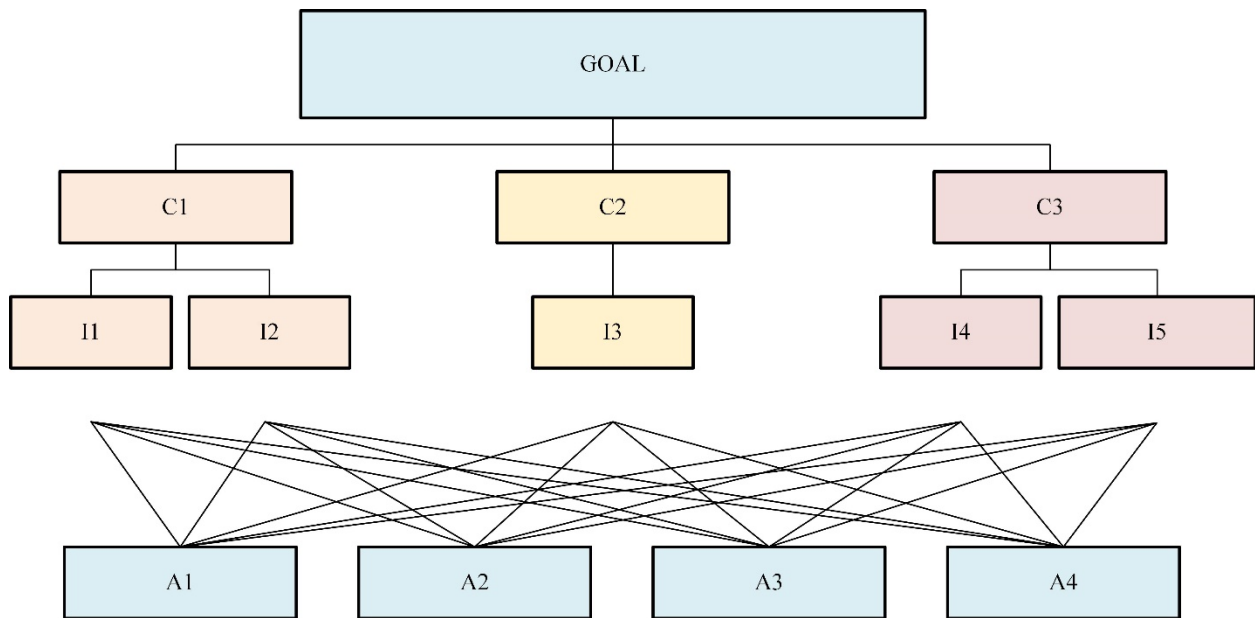

Figure 2 Example of generic MCDA setup. The goal is set based on the main problem being addressed. Criteria are identified for evaluating the alternatives, in this case C1 – C3 refers to Criterion 1 - 3. Some criteria may need to be deconstructed further, thus indicators are chosen and are represented by I1-I5. Finally, alternatives being evaluated are represented by A1-A4. The lines connecting alternatives to criteria and criteria to the goal represent different tools that can be used for assigning value for final numeric comparison of alternatives.

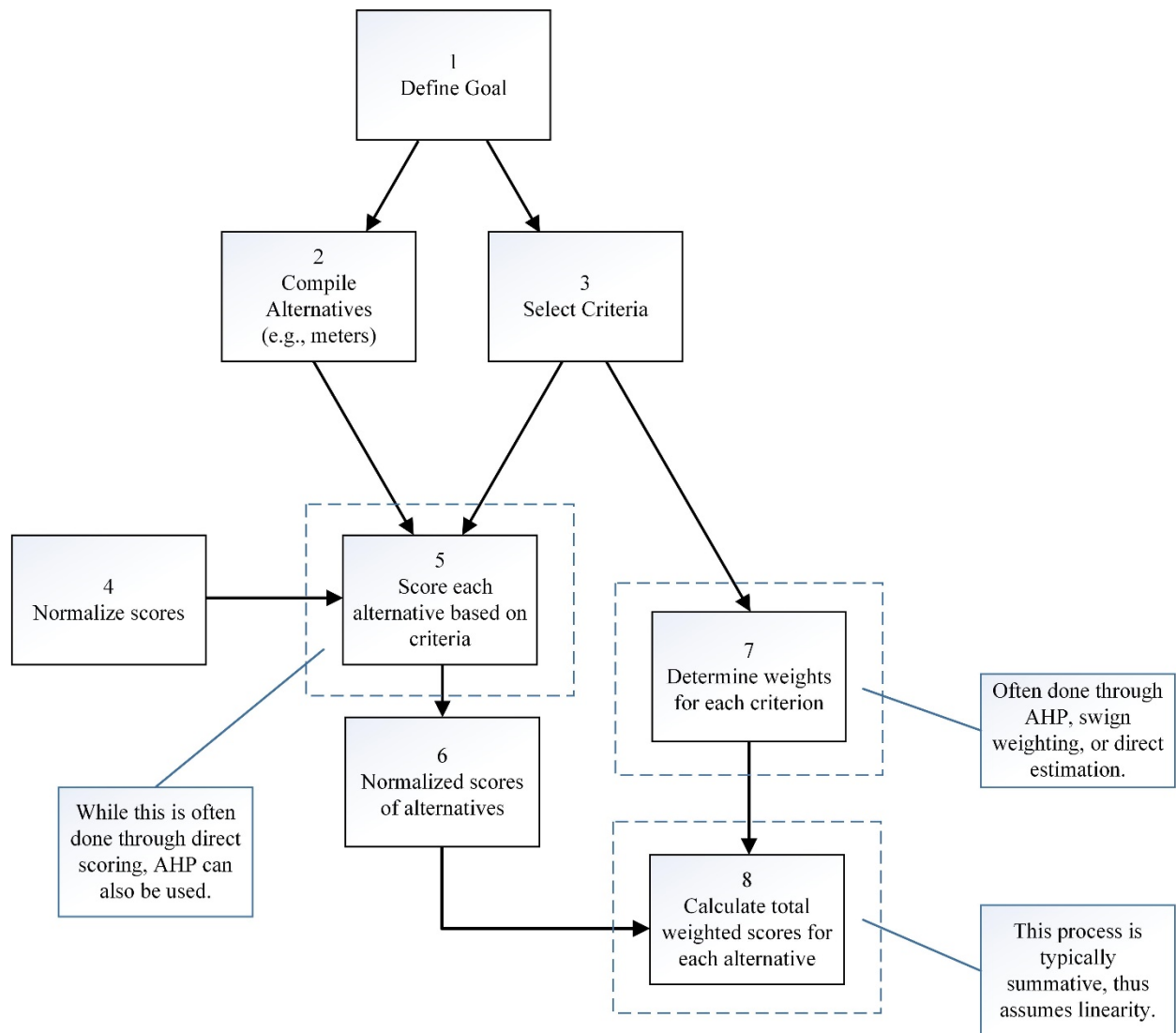

Figure 3 General MCDA process. Adapted from (Bardos, no date; Belton & Stewart, 2002; Bouyssou, 2000; Olson, 2008).



| Evaluation Matrix |      |      |       |
|-------------------|------|------|-------|
|                   | C1   | C2   | C3    |
| C1                | 1    | 2    | 5     |
| C2                | 1/2  | 1    | 5     |
| C3                | 1/5  | 1/5  | 1     |
| Sum               | 1.70 | 3.20 | 11.00 |

**Degree of Preference:**  
**1=equal**  
**3=moderate**  
**5=strong**  
**7=very strong**  
**9=extreme**

Figure 4 Step one in AHP: the evaluation matrix. C1-C3 represent criteria identified during the MCDA process. The numbers are assigned in row form, corresponding to the degree of preference. Even numbers may be used to indicate slight preference between two odd numbers.

| Priority Matrix |      |      |      |       |            |
|-----------------|------|------|------|-------|------------|
|                 | C1   | C2   | C3   | Total | Weight (W) |
| C1              | 0.59 | 0.63 | 0.45 | 1.67  | 0.56       |
| C2              | 0.29 | 0.31 | 0.45 | 1.06  | 0.35       |
| C3              | 0.12 | 0.06 | 0.09 | 0.27  | 0.09       |

= Total/n

Figure 5 Step two in AHP: priority matrix. The Total value is the sum of values assigned to each criterion by row. The weight (W) is the Total value divided by n, the number of criteria evaluated (in this example, 3).

| Consistency Calculations          |          |      |            |          |  |
|-----------------------------------|----------|------|------------|----------|--|
| Sum of (WxEvaluation Matrix) (Ws) | Ws*(1/W) | CI   | RI for n=3 | CR=CI/RI |  |
| 1.72                              | 3.09     | 0.03 |            | 0.05     |  |
| 1.08                              | 3.06     |      |            |          |  |
| 0.27                              | 3.01     |      | 0.58       |          |  |
| eigen value (average of Ws*(1/W)) | 3.05     |      |            |          |  |

Figure 6 Step three in AHP: consistency calculations. These calculations are performed with values derived from the previous two steps and ensure that the evaluator did not evaluate the importance of criteria inconsistently.

| Indicator                            | Measure                                                                                                   | Alternative - Direct Score    | Alternative Rescored |
|--------------------------------------|-----------------------------------------------------------------------------------------------------------|-------------------------------|----------------------|
| C1: Indicator 1 (more is preferable) | Not Likely affected = 1<br>No Data = 0.5<br>Likely affected = 0                                           | Likely affected               | 0                    |
| C1: Indicator 2 (less is preferable) | 0 % - 10%                                                                                                 | 7%                            | 0.30                 |
| C3: Indicator 1 (less is preferable) | Maintenance & Calibration required = 0<br>Maintenance Required = 0.5<br>No maintenance or calibration = 1 | No maintenance or calibration | 1                    |
| C3: Indicator 2 (less is preferable) | 10 – 30                                                                                                   | 15                            | 0.75                 |
| C2: Indicator (less is preferable)   | \$25 – \$100                                                                                              | 55                            | 0.60                 |

Figure 7 Direct scoring of alternatives for each indicator. Categorical values must be converted into numerical terms and numerical values must be rescaled so that all values are between 0 and 1, where 1 indicates a most preferable outcome and 0 indicates the least preferable outcome.

| Indicator                                                       | Relative Criterion Weight | Relative Subcriterion Weight | Final Weight | Alternative 1 -Score | Alternative 1 - Weighted Score |
|-----------------------------------------------------------------|---------------------------|------------------------------|--------------|----------------------|--------------------------------|
| C1: Indicator 1 -Tolerance of Particulates (more is preferable) | 0.56                      | x 0.13                       | = 0.07       | x 0.00               | = 0.00                         |
| C1: Indicator 2 - Estimated Failure Rates (less is preferable)  | 0.56                      | 0.88                         | 0.49         | 0.30                 | 0.15                           |
| C3: Indicator 1 - Maintenance Required (less is preferable)     | 0.35                      | 0.75                         | 0.27         | 1.00                 | 0.27                           |
| C3: Indicator 2 - Total Number of Parts (less is preferable)    | 0.35                      | 0.25                         | 0.09         | 0.75                 | 0.07                           |
| C2: Indicator - Estimated Price (less is preferable)            | 0.09                      | 1.00                         | 0.09         | 0.60                 | 0.05                           |
| Final Weighted Alternative Score:                               |                           |                              |              |                      | → 0.53                         |

Figure 8 Weighted sum approach to calculating the final score for alternative. A red box was added to demonstrate that the relative criterion weight should be multiplied by the relative subcriterion weight. The resulting final weight is then multiplied by the alternative's score for that indicator and the result is the alternative's weighted score for that indicator. All of the weighted indicator scores are summed for each alternative to determine the final weighted alternative score.

## CHAPTER 3 COMPILATION OF METER INFORMATION

### 3.1 Types of Meters Commonly Used for Residential Metering and How They Work

Meters evolved in an unorganized environment, thus there are many variations (AWWA, 2012). The selection of residential meters, however, may be narrowed to a choice of four types based on common application: single and multi-jet, nutating disc, and oscillating piston (Table 1). Several manufacturers in different countries make meters that employ these mechanisms and each mechanism will be addressed individually with a general description of the components of a meter (Figure 9). All the meters considered by this work function via one of two mechanisms: displacement or non-displacement, but are all mechanical in nature (Figure 10). Some meters measure and record the water passing through them directly in terms of some pre-determined volume, while others do this indirectly by sensing the motion and converting it to a volumetric unit based on some internal calibration. As water flows through the device, either a volumetric (displacement) or inferential (non-displacement) mechanism senses the flow (located in the part of the meter that is often referred to as meter or sensor chamber), records, and displays it for the reader. These types of residential water meters are often called “in-line” meters, because they connect to the water service line on each end, much like a valve. Unlike valves which are intended to regulate flow, water meters are intended to allow water to pass through and there is no “on/off” position. Water meters are often called “water flow meters” to indicate that they measure the volume of water based on its movement through a pipe. It is worth to clarify, however, that technically, residential water meters are concerned with measuring the volume of

water (no data regarding the rate of volume, which is also known as flow, is gathered or stored). Specialized meters to monitor the rate of volume exist and are called flowrate meters. They may be inline or in some cases sophisticated remote sensing technologies may be used externally. In these cases, the meters may be equipped with the capability to measure flow rate but will need an additional electronic device to read and display it. In keeping with the convention, this work will continue referring to the metering devices as water flow meters.

### **3.1.1 Displacement Meters**

These meters are also known as volumetric meters. They receive water into a chamber of known volume and record the number of those volumes needed to pass the water in terms of common volume units in the register for the reader to view. Yet another name that is commonly used is positive displacement meters, because originally these meters were fashioned after positive displacement pumps (AWWA, 2012). The two displacement meters used in residential metering are oscillating piston (OP) and nutating disk (ND). Early versions of these meters often leaked and suffered from inaccuracies because the movements of the metering chambers were not able to adjust to increased or decreased velocities. These meters also experienced slippage or an occurrence of unregistered water passing through the chamber. This is no longer a big concern because the seals of modern meters have improved. The materials used in the manufacturing of all modern meters vary. For instance, casing of the meter may be made of metal or plastic (typically each model by a manufacturer is offered in both materials with plastic being the “economy” option), while most internal parts are often plastic. Large pressure drops and sediment can cause premature failure of these types of meters (Barfuss et al., 2011; Flowmeters.com, no date; Mutikanga et al., 2011). This technology was predominantly developed in the United States, and the displacement type of meters are thought to be the most

common in residential metering (AWWA, 2012). Displacement meters often have the registering mechanism separated from the meter chamber and water never comes in contact with the register. These types of registers are known as “dry registers”. The display units vary (may be in meters cubed, gallons, or feet cubed) in the register and are moved either through magnets or through direct mechanisms. (A reminder that while AWWA publishes copyrighted standards for the manufacturing of water meters, there are no standards for which meters should be used under which conditions). The American standard for this technology may be found under ANSI/AWWA C700, Standard for Cold-Water Meters – Displacement Type (separate standards exist for Bronze Main Case and Plastic Main Case meters).

#### **3.1.1.1 Oscillating Piston Meters**

A cross-sectional image of the metering chamber in an oscillating piston type meter is presented in Figure 12. The water flows into the chamber of known volume, positioned horizontally, and continues to fill it until the piston is displaced, the inlet is momentarily blocked off and water is allowed to flow out. This happens repeatedly and each oscillation is recorded, added, and displayed in volumetric units such as gallons, cubed meters or feet, depending on where the meter is manufactured. The typical components of such meters are presented in Figure 14. This particular example shows about 15 components that make up the meter. The moving parts of the metering mechanism are not typically disassembled for volumetric meters.

#### **3.1.1.2 Nutating Disc Meters**

A cross-sectional image of a nutating disk meter chamber is presented in Figure 13. Water enters through the inlet into a chamber of known volume while the outlet is blocked by a portion of a disc, which sits on top of a ball bearing, and rotates about a vertical axis. Water continues to fill the chamber until displacement of the disc positioned on a ball bearing occurs

and the outlet is opened for the water to flow out, temporarily blocking off the inlet. This action is repeated and the “packets” of water sent through the metering chamber are recorded and displayed in the register. A diagram of a plastic model of a nutating disc meter is provided in Figure 15. This model shows 14 parts (but a metal-case model from the same manufacturer had extra plates and rings, totaling 16 parts). The measuring mechanism of nutating disc meters is enclosed and is not typically disassembled.

### **3.1.2 Non-Displacement Meters**

This category includes many more choices (see Table 2) but only two types, single jet (SJ) and multi-jet (MJ) are commonly used for residential metering (AWWA, 2012). Meters in this category may also be known as velocity or impeller meters. They employ a rotor which turns about a vertical shaft as water moves in and out of the meter chamber and the shaft drives a recorder device. The revolutions of the shaft are calibrated to volumetric units at the factory and require periodic recalibration. Multi-jet meters have been commonly used in the United States since the 1960s and the single jet technology originated and has been used most commonly in Europe (AWWA, 2012). Dry and wet registers for jet-style meters are common. A “wet register” is the one that is not sealed away from the metering chamber but immersed in water and the dials are moved directly rather than by magnets. A “semi-dry” register means that the reading device is completely immersed in water but the display dial is sealed away and dry (BMeters.com, no date). Reading meters is fairly intuitive because they resemble analog vehicle odometers in their simplest form, but some registers include additional dials that indicate volume measure, in some cases, to a hundredth of a gallon. Examples with instructions are shown in Figure 20, Figure 21, and Figure 22.

The impeller is easily moved by water and has been employed by other types of meters which should not be confused with single and multi-jet meters. In an attempt to disambiguate, following is a brief summary of meters which share jet meters impeller technology or may have similar names, but are based on different mechanisms:

- Turbine meters also use impeller, but it is positioned to spin about a horizontal axis in the pipe and produces an electrical pulse which is recorded and converted into volumetric units.
- Propeller meters are situated in a piped similar to turbine meters, but the vanes are designed differently.
- Paddle-wheel meters (sometimes also called Pelton-wheel meters), which again employ an impeller but in this case only part of the paddle wheel is submerged in water at any time, similar to the paddle-wheel of a river-boat.
- Vane-style meters are not impeller-style meters at all and only employ one vane which does not rotate but rather functions as a “flap” inside the pipe.

### **3.1.2.1 Single-Jet Meters**

A top view of a cross section of a single jet meter is presented in Figure 16. It is estimated that only about 1 -2% of meters in the United States are of this type (Barfuss et al., 2011) . This type of meter estimates the volume of flow passing through the chamber indirectly - an impeller is positioned inside the metering chamber and turns about a vertical shaft which when a single stream or “jet” of water hits the vanes of the impeller, this in turn drives the registering device which is calibrated to convert the revolutions to volumetric units. A dissected view of a single jet meter is presented in Figure 18 in order to show its components. This example shows the meter is composed of 12 parts. The American standard for single jet meters



can be found in ANSI/AWWA C712, Standard for Cold-water Meters – Singlejet Type (AWWA, 2012).

### **3.1.2.2 Multi-Jet Meters**

A top view of a cross section of a multi-jet meter is presented in Figure 17. It is estimated that about 15% of meters in the United States are of this type (Barfuss et al., 2011). The multi-jet meter functions are very similar to the single jet meter, however the principle of a multi-jet meter is that multiple jets of water hit the vanes of the impeller as water entering the metering chamber is forced through a capsule with a series of openings. Figure 19 shows typical components of a multi-jet meter having a total of 21 parts; however the adjusting bolt should only be adjusted at the time of calibration. The American standard for multi-jet meters can be found in ANSI/AWWA C708, Standard for Cold-water Meters – Multijet Type (AWWA, 2012).

## **3.2 Summary of Meter Characteristics and Their Implications for Rural Systems**

All of the four prevailing residential meter types are mechanical in their mechanisms and have moving parts. There is some variation in the characteristics of the mechanism that each meter employs and this has effects on the meter's ability to measure water flow (for example, whether volume is measured inferentially or directly determines the accuracy of measurement). There is a lot more variation between meters produced by different manufacturers (Figure 11). For example, the material composition of meters can vary greatly among different models. There are also certain characteristics that vary by mechanism and model. For example, volumetric meters tend to be more expensive than velocity meters but there will still be variation among models. These characteristics are identified in order to target those which may be used to differentiate between meter mechanisms in the decision analysis. Many manufacturers advertise that their products are made to meet AWWA standards, however it has been shown that a

significant portion of those meters do not meet these standards when independent quality testing is performed (Barfuss et al., 2011). A brief summary of the four typical residential water meters is presented in Table 1 and one of the most important observations is that there is very little numeric data available for technical meter comparison. For example, effects of particulates on meter performance are not usually quantified; instead meters are classified only in relative terms (e.g., the nutating disc type of meter is more tolerant to passing particulates than the oscillating piston type).

It should also be noted that meters are designed and manufactured with urban water supply systems in mind which tend to be characterized by many connections, large-diameter distribution lines and short, flows and pressures are often regulated and may be low in supply lines, and (especially in developing world urban systems) particulates are often a concern.

Rural water systems tend to have different characteristics than urban systems which should not be overlooked when selecting a meter. There is a lot of variation among individual piped rural water supply systems when it comes to the number of connections, pumping mechanisms, storage tanks, etc. There is also very little centralized data because these systems are by their nature decentralized. There are, however, several features worth noting that distinguish these systems from typical urban or utility-managed systems. Primarily, community-managed systems are usually small in terms of geographic extent and in terms of the user base, thus distribution and supply lines tend to have smaller diameters. The piping is usually plastic (specifically, of polyvinylchloride (PVC) pipe) and there is rarely water treatment between source and distribution except for sedimentation tanks in cases of highly turbid water. As discussed previously, because systems are managed by the community, proper and timely maintenance may not be carried out, resulting in leaks and pipe breaks. Additionally, there is

typically no treatment of water prior to distribution. In systems with good-quality water (e.g., a well or a spring) and few pipe breaks, particulates in pipe are not expected to be a concern. However, if the source tends towards high turbidity or sediment is sucked into pipes due to breaks, particulates should be considered in the selection of meter and a filter upstream of the meter should be installed regardless of type of meter.

Due to the simple design of rural systems, flows are typically not regulated and pressures also tend to vary depending on the production of the source and user demand. (While the design minimum is at least 10 meters of head at each tap and no more than 70m of head under static conditions, these assumptions may not always be true). Typically, however, ultra-low flows that may be expected in urban systems (around 0.25 gallons per minute) are not a concern in rural systems, but the water supply may be intermittent. In many developing countries water services tend to be intermittent thus the practice of storing water tanks for later use at the household level is common. Storage tank filling may affect single jet meter accuracy, specifically it may result in significant under-registration of flow (Arregui et al., 2005). The effects of partial-pipe flow, intermittent flow or system pressure variations on meters' long-term performance have not been well studied.

Volumetric meters tend to be more accurate, especially at low flows, which is what makes them attractive to urban system managers. Accuracy is important in large systems because even small errors can mean significant losses of water and potential revenue when multiplied by many connections. But particulates in water and pressure drops as well as flows outside of the manufacturer's specified range are especially dangerous to their mechanisms. Velocity meters tend to be more tolerant of particulates; however they are less accurate and should be re-

calibrated after a long period of use. In rural systems, high accuracy may not be as important as long as relative accuracy is consistent.

AWWA recommends that utilities test 95% of their meters periodically and that of those meters tested, 95% should conform to AWWA's standards (2011). Although AWWA recommends meter standards for manufacturers to voluntarily adopt, there is little independent quality testing. Research has shown that many new meters advertised to meet AWWA's quality and performance standards do not meet them, thus is likely that they will be even less reliable with time (Barfuss et al., 2011). All types of meters experience high failure rates (5.7 – 7%) (Barfuss et al., 2011). (Failure rates refer to the percentage of new meters that do not function directly after installation). Price of meters varies based on manufacturing quality and materials used, but volumetric meters tend to be more expensive than inferential meters.

There is also little data regarding meters' useful life. AWWA recommends replacing meters every 10 years. European standards are less conservative, recommending that inferential meters should be tested and recalibrated every ten years (BMeters.com, no date). Because monitoring programs are resource-intensive, there is currently no indication that meter testing is taking place regularly either for newly manufactured meters or those that have been installed at such high rates in developed countries. In the developing world, there are particular problems with waterworks infrastructure management and maintenance (Mutikanga et al., 2009). It is therefore unlikely that in the rural community-managed setting the monitoring and calibration of meters would happen more frequently. Additionally, high failure rates are particularly alarming because resources in rural communities are already scarce, thus the purchase of 7 unusable meters out of 100 is especially wasteful.

It has been previously suggested that developing world urban systems may need a specially-designed meter due to the characteristics that differentiate them from developed country systems (Jigabha, 1992; Mutikanga et al., 2009). Rural community water systems are differentiated by yet another set of characteristics and may therefore benefit from development of an alternative flow meter. Because no such alternative is currently available, it is important to consider the characteristics of existing meter types (and the characteristics of specific models based on availability) so as to maximize the benefits of the technology and minimize the risks of premature failure.

Because systems are managed by the community which often lacks resources and technical skills, there is a strong argument for finding a meter that will be durable/last a long time, with minimal maintenance if a metering program is to be adopted. Multiple factors would affect a meter's appropriateness for this setting, so a decision matrix will be used to aid the decision making. The information from Table 1 will be used in the decision analysis in an attempt to determine the most suitable meter for a rural community-managed water system.

### **3.3 Meters Not Typically Used in Residential Applications**

Finally, there are meters that may be infrequently encountered in residential metering such as fluidic oscillator and compound meters (especially where a big range of flows is expected). There are also meters that should be avoided, especially those relying on electricity to function or record readings. Because many of these meters are used in different applications it is unlikely that they might be available for purchase in a developing country hardware store, however they are included in Table 2 so that the reader may be aware of their existence.

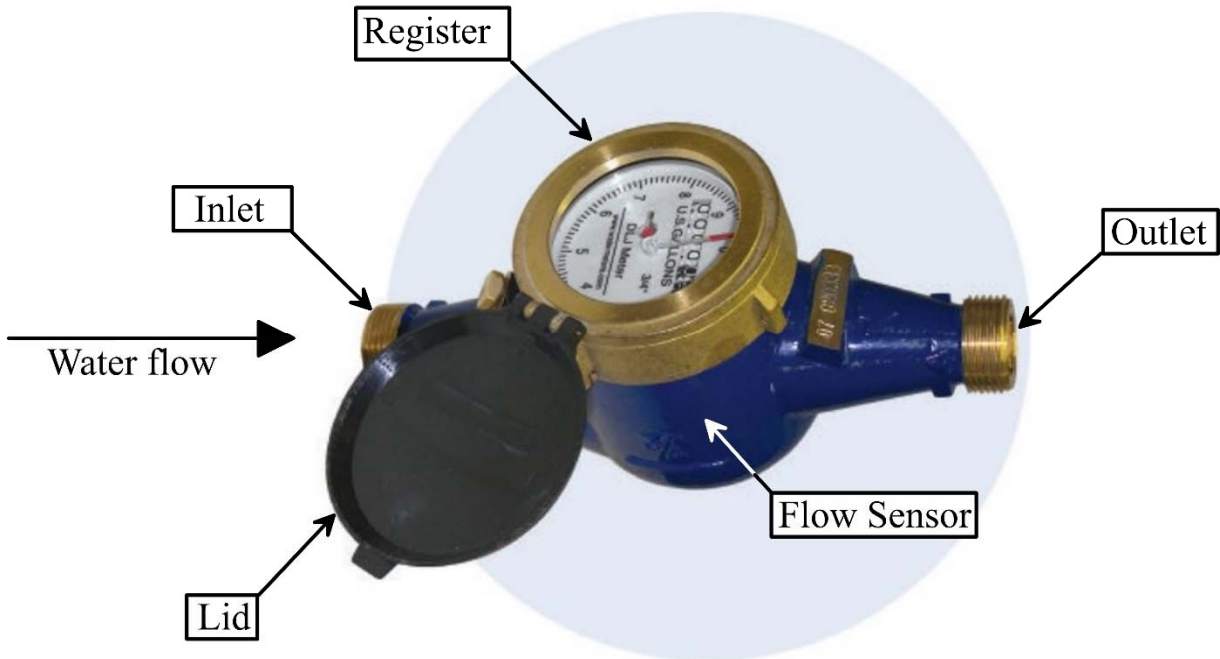

Figure 9 General components of residential flow meters. This is a photograph of Assured Automation’s multi-jet meter, however, the labels show the general components representative of all residential meters that are discussed in this work. Modified and reprinted with permission from [www.flows.com](http://www.flows.com).

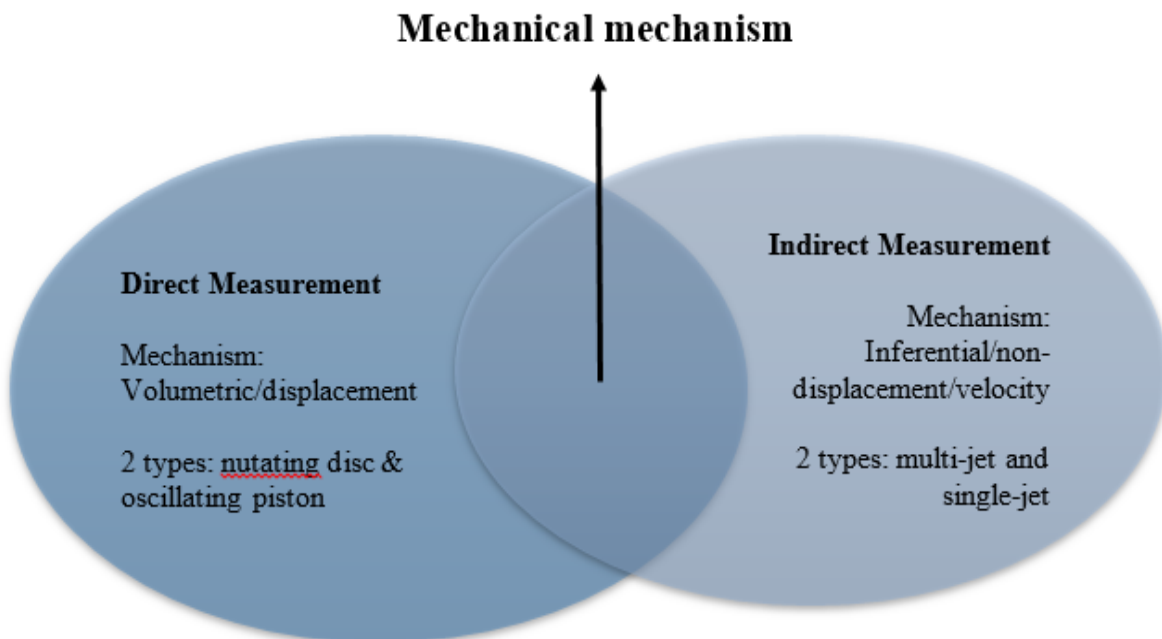

Figure 10 Four meters commonly used residentially grouped by mechanism. Both meter mechanism have one area of overlap – they all function mechanically.

Table 1 Summary of meters commonly used for residential metering. Organized by type of mechanism; adapted from AWWA’s M6 (2012) with performance data from (Barfuss et al., 2011).

| Category         | Type                    | Price* (USD) | Notes                                                                                                                                                                                                                                                                                                                                                                                                                                                                                                                                                              |
|------------------|-------------------------|--------------|--------------------------------------------------------------------------------------------------------------------------------------------------------------------------------------------------------------------------------------------------------------------------------------------------------------------------------------------------------------------------------------------------------------------------------------------------------------------------------------------------------------------------------------------------------------------|
| Displacement     | Nutating Disc (ND)      | 90           | <ul style="list-style-type: none"> <li>• Particulates are a concern – recommend a filter upstream of meter</li> <li>• Pressure drops outside of the manufacturer’s specifications may damage the measuring device and seals</li> <li>• Not accurate in partially-full pipes</li> <li>• No maintenance or calibration required (except for upstream filter)</li> <li>• Good accuracy at low flows</li> <li>• Failure rates: OP - 7%; ND – 5.7%</li> <li>• Flow sensing mechanisms are not disassembled thus the total number of parts (around 15) is low</li> </ul> |
|                  | Oscillating Piston (OP) | 55           |                                                                                                                                                                                                                                                                                                                                                                                                                                                                                                                                                                    |
| Non-Displacement | Multi-jet (MJ)          | 50           | <ul style="list-style-type: none"> <li>• Accuracy degrades over time</li> <li>• Require periodic recalibration</li> <li>• Require internal filter to be cleaned (meter must be disconnected from line)</li> <li>• Multi-jet meter has many parts</li> <li>• If water is turbid, may also require a filter upstream</li> <li>• Failure rates: MJ – 7.5%; SJ – no data</li> <li>• Flow sensing mechanisms are easily accessible and the MJ meter tends to have many parts (more than 20)</li> </ul>                                                                  |
|                  | Single-jet (SJ)         | 45           |                                                                                                                                                                                                                                                                                                                                                                                                                                                                                                                                                                    |

\*Accurate price estimates are difficult to obtain and prices may vary based on the number of meters ordered from the supplier or manufacturer and the location of purchase. In some regions, prices of jet meters may be as low as 20-25USD. The costs of the recommended valve box and the upstream filter are not included in these cost estimates. Additional costs may also be associated with meter transport after purchase.

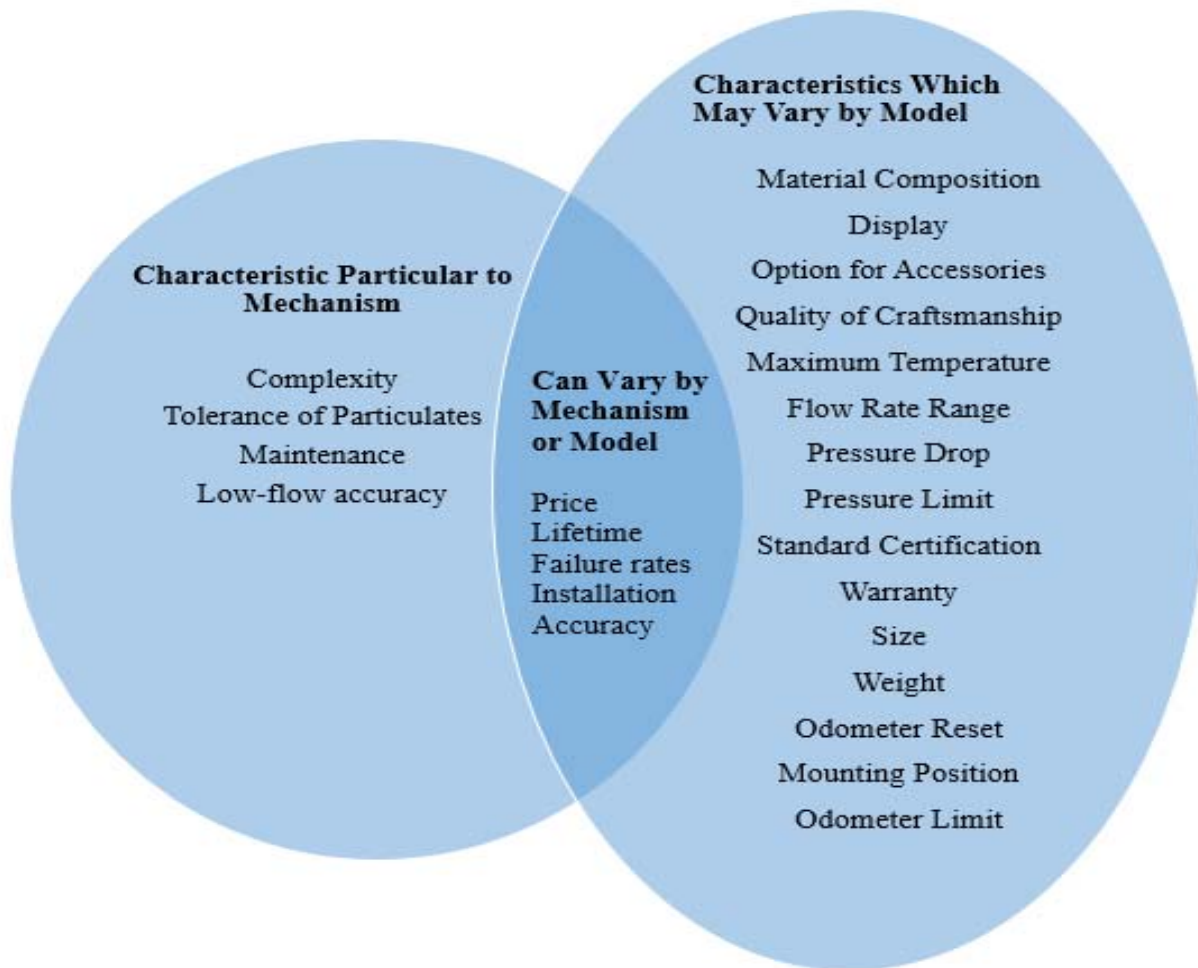

Figure 11 Possible characteristics of water flow meters. The importance of these characteristics for community-managed systems may vary.



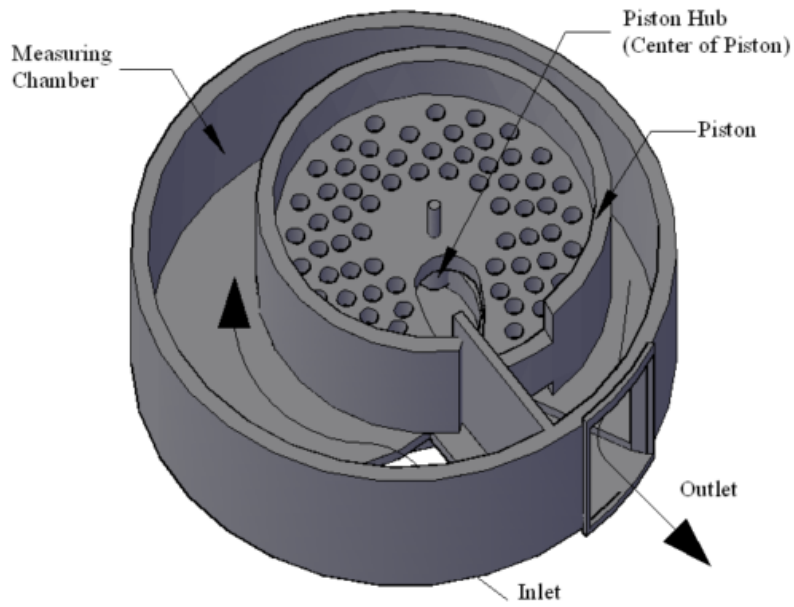

Figure 12 Cross-sectional view of the oscillating piston metering chamber. Barfuss, S.L., M.C. Johnson, and M.A. Neilsen. 2011. *Accuracy of In-Service Water Meters at Low and High Flow Rates*. Denver, Colo: Water Research Foundation. Reprinted with permission.

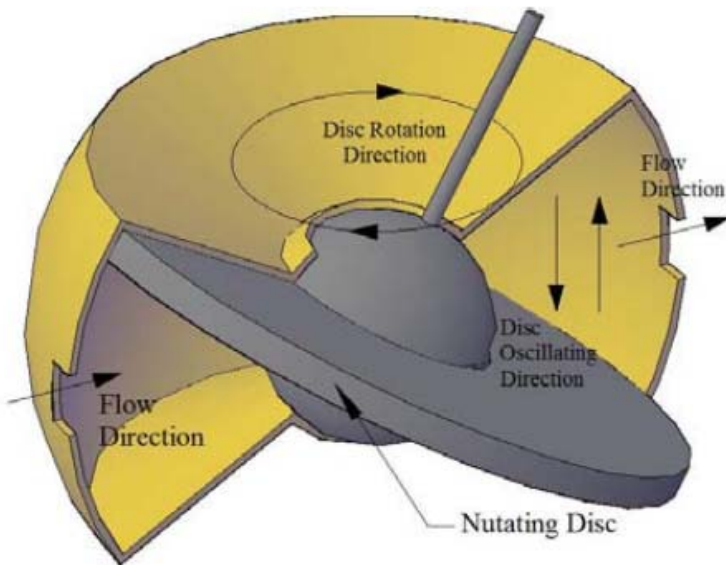

Figure 13 Cross-sectional view of a nutating disc metering chamber. Barfuss, S.L., M.C. Johnson, and M.A. Neilsen. 2011. *Accuracy of In-Service Water Meters at Low and High Flow Rates*. Denver, Colo: Water Research Foundation. Reprinted with permission.

Table 2 Meters used for water measurement not discussed in this work. Adapted from AWWA's M6 (2012).

| <b>Category</b>  | <b>Group</b>          | <b>Type</b>                                                                                                                              |
|------------------|-----------------------|------------------------------------------------------------------------------------------------------------------------------------------|
| Non-Displacement | Velocity              | Fluidic oscillator<br>Magnetic-pickup turbine<br>Turbine<br>Propeller<br>proportional                                                    |
|                  | Differential Pressure | Fixed opening, variable differential<br>Orifice<br>Venturi, flow nozzle, flow tube<br>Pitot Tube<br>Variable opening; fixed differential |
|                  | Electronic Velocity   | Electromagnetic<br>Ultrasonic                                                                                                            |
|                  | Level Measurement     | Weir, Parshall flume, etc.                                                                                                               |
| Compound         | Standard Compound     | Standard Compound                                                                                                                        |
|                  | Fire Service          | Fire Service                                                                                                                             |

| ILL. No. | Name of Part                                                                            |
|----------|-----------------------------------------------------------------------------------------|
| 1A       | Register Cover                                                                          |
| 1B       | Electronic Register Lid                                                                 |
| 1C       | Electronic Register TR Cover                                                            |
| 2A       | Hinge Pin                                                                               |
| 2B       | Electronic Register Magnet                                                              |
| 3A       | ICE-Opto Register <sup>1</sup>                                                          |
| 3B       | Electronic Register Bonnet                                                              |
| 4        | Maincase <sup>2</sup>                                                                   |
| 5A       | Locking Ring 1 of 2 (2 required for complete unit)                                      |
| 5B       | Electronic Register Lock                                                                |
| 5C       | Electronic Register Screw                                                               |
| 6        | Screen                                                                                  |
| 7A       | Measuring Chamber, Complete, Tested (Rocksyn™) with rubber division plate <sup>3</sup>  |
| 7B       | Measuring Chamber, Complete, Tested (Rocksyn™) with plastic division plate <sup>3</sup> |
| 8        | Spacer                                                                                  |
| 8A       | Seal (only on 3/4" and 1")                                                              |
| 9        | Spring Ring (only on 5/8")                                                              |
| 10       | O-Ring                                                                                  |
| 11       | Seal 1 of 2 (2 required for complete seal)                                              |
| 12       | Bottom Plate                                                                            |

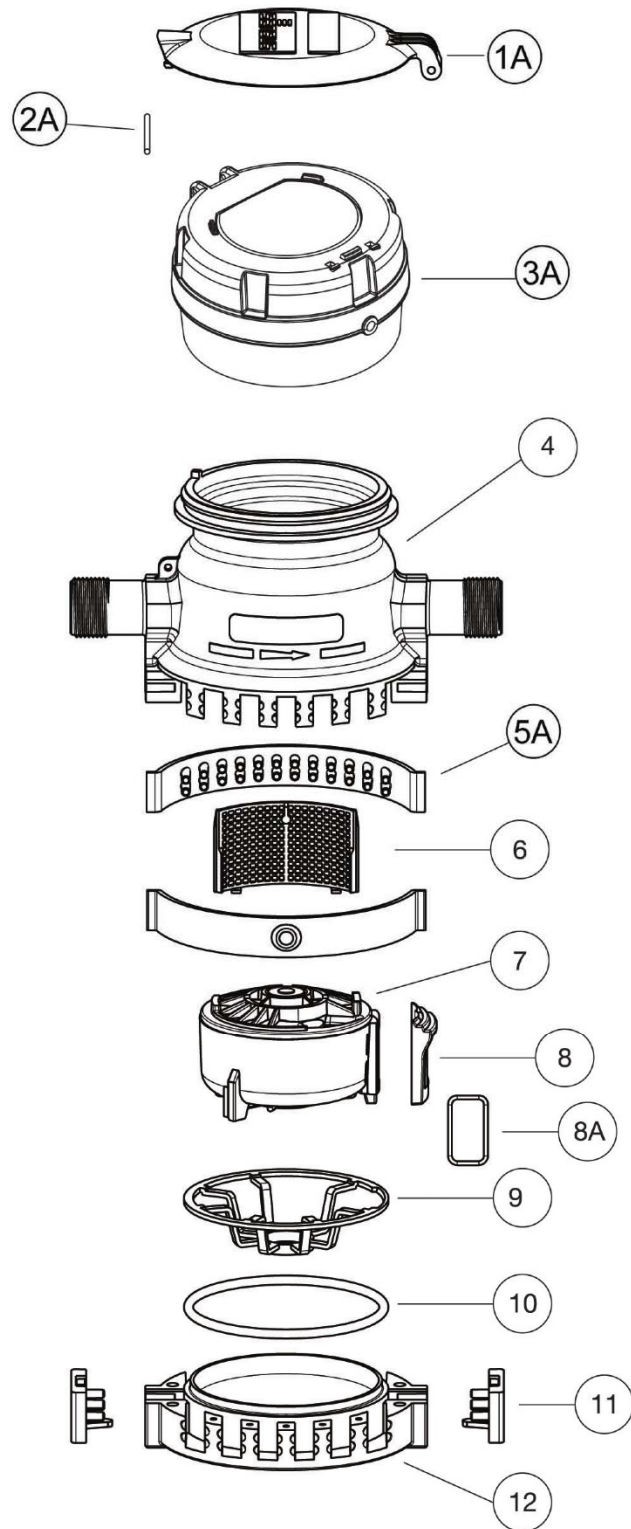

Figure 14 Exploded view of the oscillating piston meter. Reprinted with permission from Sensus. This particular meter model is shown to have an electronic register but for a developing world setting electronic parts are not recommended.

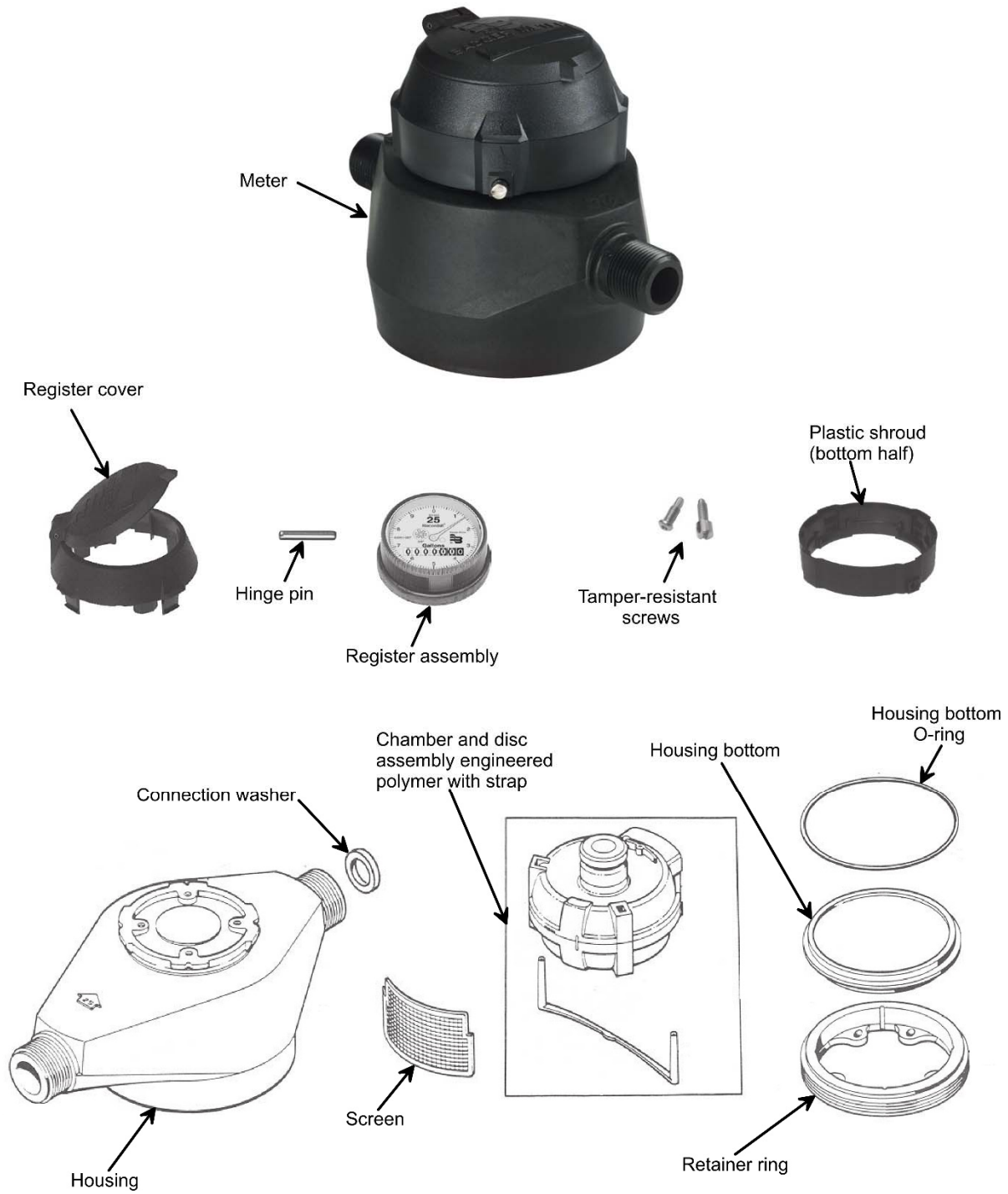

Figure 15 Exploded view of the nutating disc meter assembly. Reprinted with permission from Badger Meter.

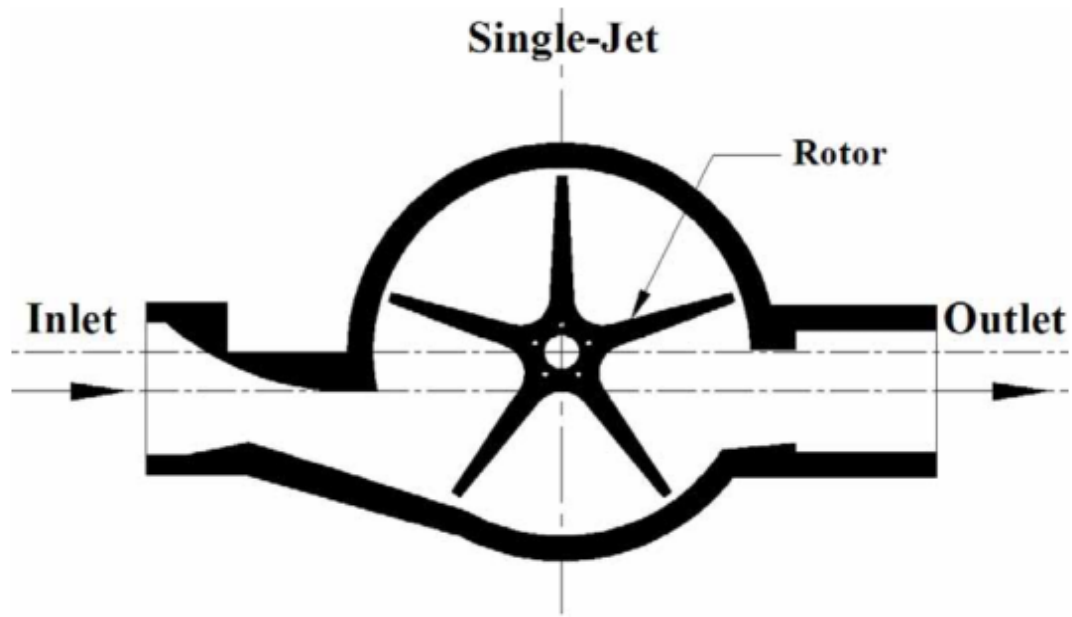

Figure 16 Cross-sectional top view of single jet mechanism. Barfuss, S.L., M.C. Johnson, and M.A. Neilsen. 2011. *Accuracy of In-Service Water Meters at Low and High Flow Rates*. Denver, Colo: Water Research Foundation. Reprinted with permission.

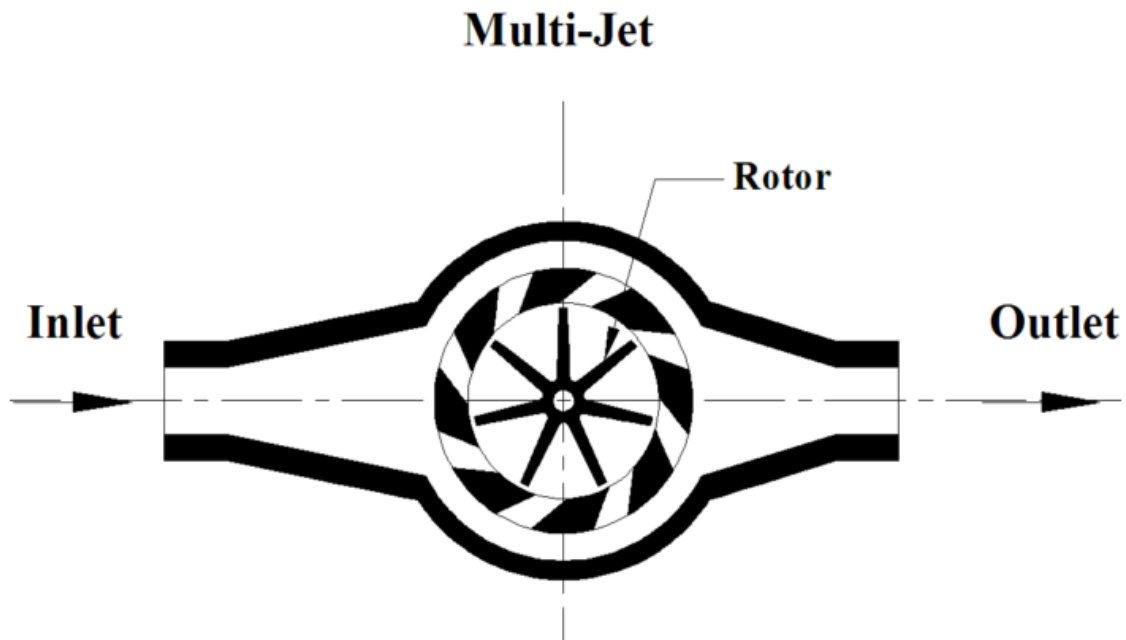

Figure 17 Cross-sectional top view of multi jet mechanism. Barfuss, S.L., M.C. Johnson, and M.A. Neilsen. 2011. *Accuracy of In-Service Water Meters at Low and High Flow Rates*. Denver, Colo: Water Research Foundation. Reprinted with permission.

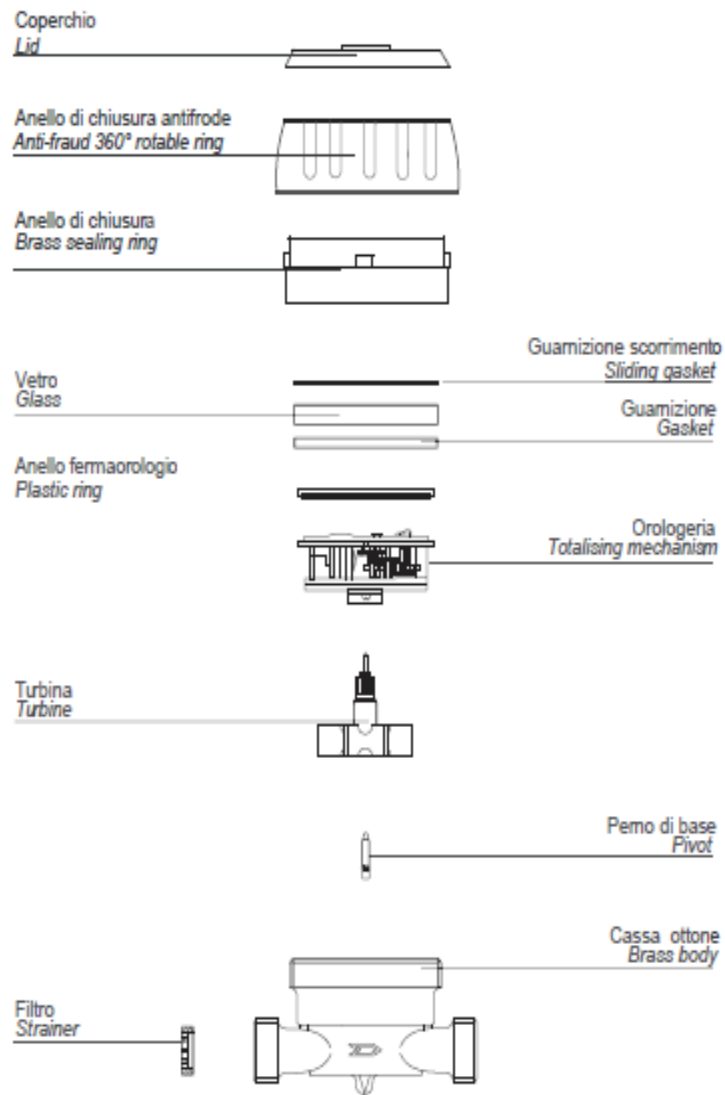

Figure 18 Typical components of a single-jet meter. Reprinted with permission from BMeters.

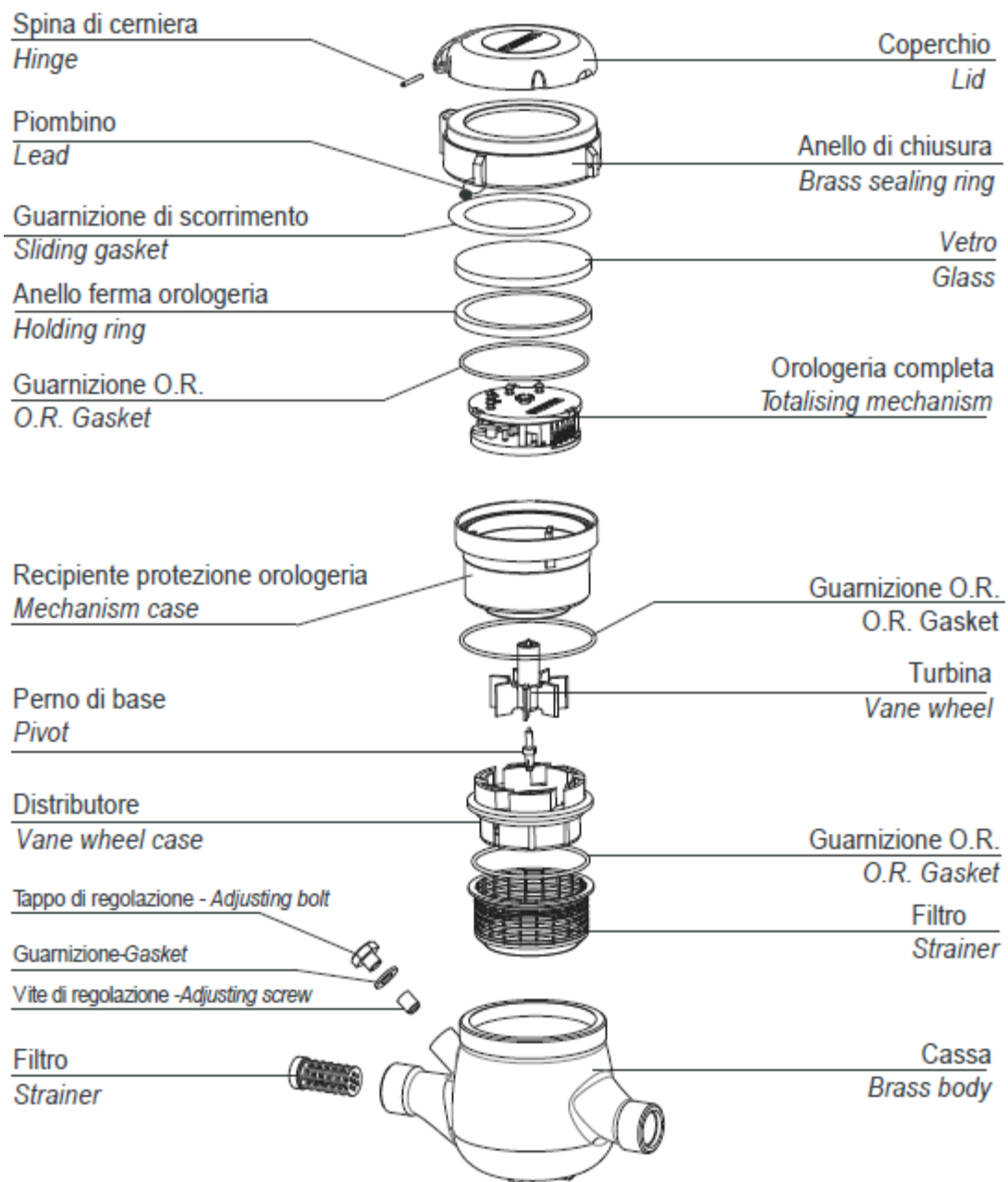

Figure 19 Typical components of a multi-jet meter. Reprinted with permission from BMeters.

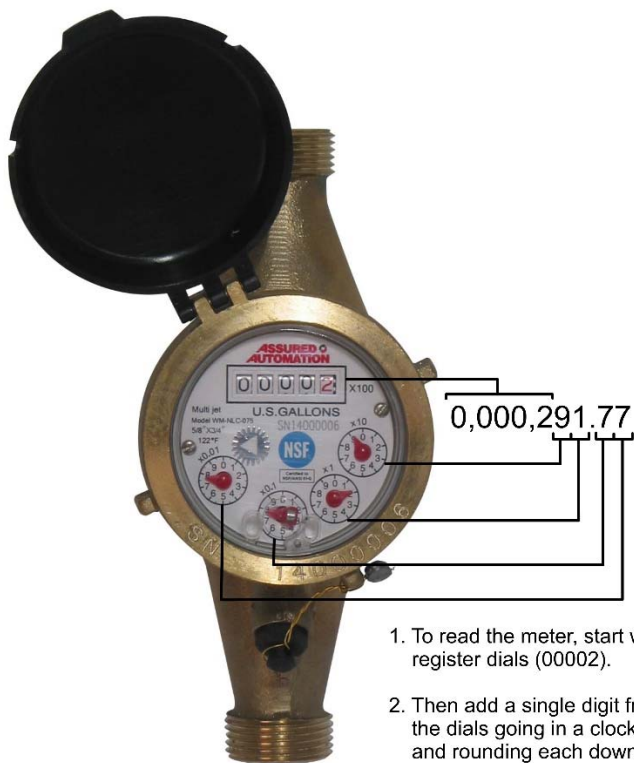
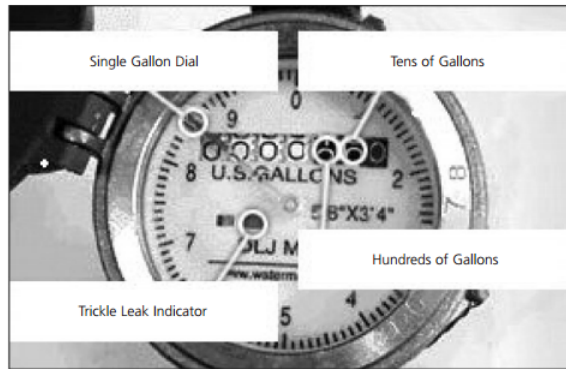

Figure 20 Instructions for reading dial and odometer style registers of meters. Reprinted with permission from [www.flows.com](http://www.flows.com), © Assured Automation 2015.



5/8" to 1" Residential Meters



Example (maximum registration is 9,999,999 gallons):

1 2 3 4 5 6 0 = 1,234,560 gallons

Note: To convert gallons to cubic feet multiply the gallons reading by 0.1337 to get cubic feet (there are 7.48052 gallons per cubic foot).

1-1/2" to 2" Residential Meters, 1-1/2" to 3" Turbine Meters

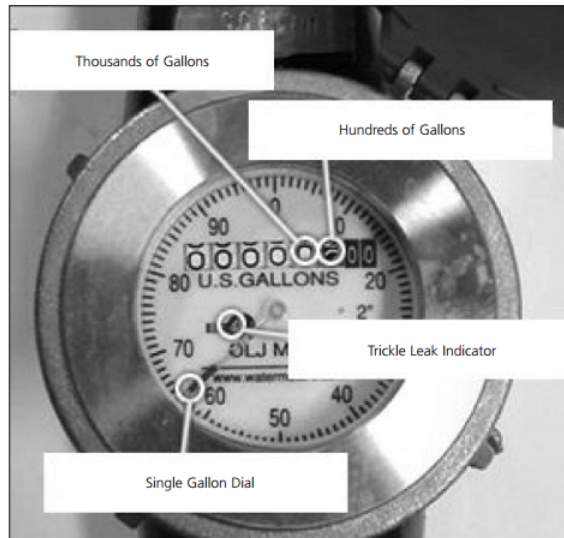

Example (maximum registration is 99,999,900 gallons):

1 2 3 4 5 6 00 = 12,345,600 gallons

Figure 21 Another variation of meter register display and instructions for reading it. Reprinted with permission from [www.flows.com](http://www.flows.com), © Assured Automation 2015.

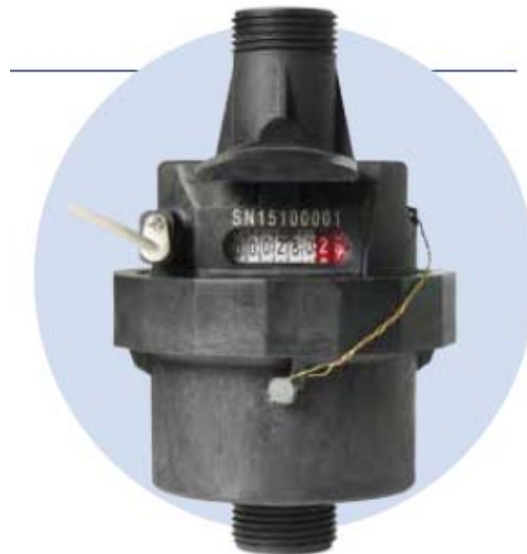

Figure 22 Example of a plastic oscillating piston type of meter. Register is different from dial-style displays and can be read from left to right, with the red digits indicating volume to the hundredth of a gallon. Reprinted with permission from [www.flows.com](http://www.flows.com), © Assured Automation 2015.

## **CHAPTER 4 RESULTS OF MULTIPLE CRITERIA DECISION ANALYSIS (MCDA)**

### **4.1 Identifying Goal and Criteria for MCDA**

In order to identify the goal and criteria for choosing one of the four meter types identified in the previous chapter, appropriate technology (AT) literature was consulted. Recent AT studies have evolved from attempting to produce a single list of characteristics for all technologies, to considering appropriateness of a technology by field or discipline, and the goal is clear – sustainability of those technologies and the communities using them (Hazeltine & Bull, 2003; Murphy et al., 2009; Sara & Katz, 1997; Sianipara et al., 2013). In particular, frameworks have been developed to determine which characteristics of a technology (or in some cases technology-related projects) affect how sustainable it will ultimately be (Aarras et al., 2014; Bauer & Brown, 2014; Gumbo et al., 2005; McConville & Mihelcic, 2007; Saeed, 1990; Schweitzer & Mihelcic, 2012). While many resources already exist and new studies are published every year, it is not the goal of this work to review the body of literature on AT but to adopt some of its best practices as they apply to water technologies and projects in the developing world. As such, sustainability for the purposes of this examination can be broadly thought of as the community's ability to operate their water supply system independently and in the long-term and the broad characteristics of water technologies affecting that ability can be generally summarized as:

- Social: community empowerment, capacity building, user acceptability and support
- Technical: ease of use, reparability, durability, complexity

- Economic: affordability, generating income and employment opportunities
- Environmental: impacts and the use of natural resources

The study of Mutikanga (2014) in Kampala, Uganda (Mutikanga, 2014) laid the groundwork for this research. The goal of that study was to determine the most cost-effective type of residential meter for an urban utility managing a system characterized by low flows, in order to “maximize ... revenue by reducing meter under-registration and failures...” (Mutikanga, 2014). In order to evaluate the goal, the author considered only technical criteria and found that the most economical solution was not the most appropriate. Additionally, it has been suggested that the cheapest technological solution may not be the most appropriate when it comes to rural water and sanitation projects in developing countries. The decision-making criteria proposed for rural water projects in developing countries suggest considering social and management aspects along with local availability of materials (Garfi & Ferrer-Martí, 2011). Because the focus of this work is on a rural community-managed system, not a utility-managed system, a different analysis goal and criteria may be important. Based on the literature examining success of projects and technologies in the developing world and the author’s experience, the goal of this analysis is to select a meter that can be operated most independently in rural, community-managed system.

The Analytical Hierarchy Process (AHP) tool is customizable thus different criteria for different goals can be evaluated and the field practitioner is encouraged to include the community considering the metering project to elicit the goal and the criteria most important to them (Murphy et al., 2009). Criteria proposed here are only suggestions compiled from the author’s field experience and best practices recommended by appropriate technology literature. Thus, when examining the possibility of adoption of water meters into the design of rural water

systems, criteria in addition to meter's performance and cost should be considered. Three of the four broad AT criteria are considered for this study so as to maximize the technology's success and its intended benefits: "Durability" is the focus of the technical criterion, "Usability" is the focus of the social criterion, and "Affordability" is the focus of the economic criterion. The environmental criterion will not be considered; while solid waste disposal may be an issue at the end of useful life of meters, there is currently no data to indicate that environmental impacts on the community would differ based on meter types. Figure 23 represents the collection of parameters (goal, criteria, indicators and alternatives) for this multiple criteria decision making analysis (MCDA).

## **4.2 Weighting Criteria, Indicators, and Scoring Alternatives**

### **4.2.1 Weighting Criteria**

The weights of criteria were determined using the methodology described in Chapter 2 and the results are presented in Tables 3-5. The author evaluated the importance of selected criteria based on appropriate technology (AT) literature and personal experience. Usability of a technology has been cited as one of the most important factors in its success (Aarras et al., 2014; Garfi & Ferrer-Martí, 2011) however the author rated Durability to be slightly more important than Usability (value of 2). Usability of a meter can be improved through training, whereas Durability of a meter is a fixed quality. Durability was judged to be strongly more important than Affordability (assigned a value of 5) because a rural community would likely be receiving initial support from an external entity which would lessen the financial burden. Also, if meters are durable they are expected to last a long time so expenditures for replacement of meters should be infrequent. Because it has been shown that the most affordable alternative may not be the most appropriate, Usability was chosen as strongly more important than Affordability. The weights of

the criteria were calculated to be 0.56 for Durability, 0.35 for Usability, and 0.09 for Affordability. The consistency ratio for these evaluations was equal to 0.05, thus the final weights were accepted.

Table 3 AHP Criteria evaluation matrix.

| <b>Criteria Evaluation Matrix</b> |                   |                  |                      |
|-----------------------------------|-------------------|------------------|----------------------|
|                                   | <b>Durability</b> | <b>Usability</b> | <b>Affordability</b> |
| <b>Durability</b>                 | 1                 | 2                | 5                    |
| <b>Usability</b>                  | 1/2               | 1                | 5                    |
| <b>Affordability</b>              | 1/5               | 1/5              | 1                    |
| <b>Sum</b>                        | <b>1.70</b>       | <b>3.20</b>      | <b>11.00</b>         |

Table 4 AHP Criteria priority matrix.

| <b>Criteria Priority Matrix</b> |                   |                  |                      |              |                   |
|---------------------------------|-------------------|------------------|----------------------|--------------|-------------------|
|                                 | <b>Durability</b> | <b>Usability</b> | <b>Affordability</b> | <b>Total</b> | <b>Weight (W)</b> |
| <b>Durability</b>               | 0.59              | 0.63             | 0.45                 | 1.67         | 0.56              |
| <b>Usability</b>                | 0.29              | 0.31             | 0.45                 | 1.06         | 0.35              |
| <b>Affordability</b>            | 0.12              | 0.06             | 0.09                 | 0.27         | 0.09              |

Table 5 AHP Consistency evaluations for criteria weighting.

| <b>Consistency Calculations</b>          |                 |           |                            |  |             |
|------------------------------------------|-----------------|-----------|----------------------------|--|-------------|
| <b>Sum of (WxEvaluation Matrix) (Ws)</b> | <b>Ws*(1/W)</b> | <b>CI</b> | <b>CR=CI/RI</b>            |  |             |
| 1.72                                     | <b>3.09</b>     | 0.03      | <b>RI for n=3<br/>0.58</b> |  |             |
| 1.08                                     | <b>3.06</b>     |           |                            |  |             |
| 0.27                                     | <b>3.01</b>     |           |                            |  |             |
| <b>Eigen value (average of Ws*(1/W))</b> | 3.05            |           |                            |  | <b>0.05</b> |

#### 4.2.2 Identifying and Weighting Indicators

Based on the types of residential meters used in the United States, Europe, and studies performed in Africa, four meters to be evaluated include the Nutating Disc (ND), Oscillating

Piston (OP), Multi-jet (MJ), and Single-jet (SJ). To evaluate each alternative, indicators were selected where the criteria were too broad to evaluate directly. The indicators were selected based on data available regarding the meter alternatives and weighted following the same methodology as for weighting criteria (explained in Chapter 2). Admittedly, data were limited, thus some of the indicators do not represent the criteria perfectly.

For the Durability criterion two indicators (or sub-criteria) were identified based on available data: tolerance of particulates and failure rates (Table 6). Ideally, data on meters' useful life would be used for this criterion, however, no such data were available. A meter's tolerance of particulates was evaluated as very strongly less important than the failure rates associated with that type of meter (assigned a value of 1/7) because if the meter fails to register flow upon installation, then its ability to pass particulates is irrelevant. The relative weights for each indicator were calculated as: 0.125 for tolerance of particulates and 0.875 for failure rates (Table 7).

Table 6 Evaluation matrix for the Durability criterion indicators. "SC" refers to "sub-criterion" in the column headings.

**Criterion 1: Durability**  
Evaluation  
Matrix

|                              | <b>SC1:<br/>particulates</b> | <b>SC2: failure rates</b> |
|------------------------------|------------------------------|---------------------------|
| <b>SC1:<br/>particulates</b> | 1                            | 1/7                       |
| <b>SC2: failure rates</b>    | 7                            | 1                         |
|                              |                              |                           |
| sum                          | 8                            | 1.14                      |

Table 7 Priority matrix for the Durability criterion indicators. "SC" refers to "sub-criterion" in the column headings.

**Criterion 1: Durability**

Priority Matrix

|                                       | <b>SC1: Tolerance of particulates</b> | <b>SC2: Failure rates</b> | Total | Weight |
|---------------------------------------|---------------------------------------|---------------------------|-------|--------|
| <b>SC1: Tolerance of particulates</b> | 0.13                                  | 0.13                      | 0.25  | 0.125  |
| <b>SC2: Failure rates</b>             | 0.88                                  | 0.88                      | 1.75  | 0.875  |

For the Usability criterion two indicators were identified: maintenance requirement and the total number of parts (Table 8). Least amount of maintenance is preferred because technologies requiring frequent maintenance often fail, this indicator was therefore evaluated to be moderately more important than the total number of parts (assigned a value of 3). Ideally, data about either the performance of moving parts or availability of replacement parts would be included as a second indicator, however, no such data were available, thus the total number of parts was selected to represent the complexity of the meter type. The final weights were calculated for the indicators as: 0.75 for the maintenance requirement and 0.25 for the total number of parts (Table 9).

Table 8 Evaluation matrix for the Durability criterion indicators."SC" refers to "sub-criterion" in the column headings.

**Criterion 2: Usability**

Evaluation Matrix

|                                   | <b>SC1: maintenance</b> | <b>SC2: total number of parts</b> |
|-----------------------------------|-------------------------|-----------------------------------|
| <b>SC1: maintenance</b>           | 1                       | 3                                 |
| <b>SC2: total number of parts</b> | 1/3                     | 1                                 |
|                                   |                         |                                   |
| sum                               | 1.33                    | 4.00                              |

Table 9 Priority matrix for the Usability criterion indicators. "SC" refers to "sub-criterion" in the column headings.

**Criterion 2: Usability**

Priority Matrix

|                                   | <b>SC1: Maintenance</b> | <b>SC2: Total number of parts</b> | Total | Weight |
|-----------------------------------|-------------------------|-----------------------------------|-------|--------|
| <b>SC1: Maintenance</b>           | 0.75                    | 0.75                              | 1.50  | 0.75   |
| <b>SC2: Total number of parts</b> | 0.25                    | 0.25                              | 0.50  | 0.25   |

Price of meter was identified as the indicator for the Affordability criterion and its weight is 1 by default because there are no other indicators in this criterion. To represent the Affordability criterion, data from a willingness- and ability-to-pay assessments of the community may be more appropriate but these will vary based on the community and no such data were available. The estimated price of meter was used which is expected to have comparable costs in different locations.

No consistency ratio calculations were necessary for any of the indicator weighting because the number of sub-criteria considered was less than 3. The weights of criteria determined by an evaluator, who is a representative of an international aid organization, may not match the values of the local community (Bauer & Brown, 2014). This analysis is adaptable and simple, therefore user and expert participation should be considered.

**4.2.3 Scoring Alternatives**

Alternatives were scored directly for each of the indicators and scores were rescaled (following methodology described in Chapter 2) and the results are shown in Table 10. Numeric data could be obtained for the estimated failure rates, total number of parts, and estimated price indicators. Upper and lower range numbers were defined for each of the indicators based on the author's experience. The lower range for estimated failure rates was set at 0% and the highest



failure rate accepted was set to 10%. Lower failure rates are preferred. More complex technologies are less desirable in the developing world context, thus the preference is for an alternative with fewest parts. The lowest number of parts may be expected to be around 10 and the highest acceptable was set at 30. A meter costing more than 100USD may not be acceptable to users in a developing community and any alternative costing less than 25USD may not be considered as a serious contender because its quality may also be much lower.

Two indicators were evaluated categorically: tolerance of particulates and maintenance requirement. Preference was given to meters that are more likely to be tolerant to particulates with no preference given to those likely to be affected by particulates. Alternatives not requiring maintenance or calibration were most preferred, whereas no preference was given to alternatives that require both.

#### **4.3 Weighted Scores of Alternatives**

The weighted scores of alternatives were calculated according to the weighted sum methodology described in Chapter 2 (Table 11). The nutating disc (ND) type of meter received the highest score of 0.63. The oscillating piston (OP) received the second-highest score of 0.53. Single-jet (SJ) and multi-jet (MJ) meters had similar scores of 0.31 and 0.29, respectively. The relative contributions of weighted scores by indicator are represented in Figure 24. The ND meter was most preferred because it scored relatively high for the least maintenance required and lowest failure rates. It received a relatively high value for the greatest tolerance of particulates and the lowest number of parts. It scored poorly in terms of lowest price. The OP meter scored similarly to the ND meter in all areas except for price and tolerance of particulates. The OP meter is less expensive than the ND, therefore it was preferred in the area of lowest price but received no preference for tolerance of particulates. The MJ and SJ meters received very similar

scores to each other, and scored well in areas of lowest price and lowest failure rates. The SJ meter was slightly preferred over MJ because it has less parts. The MJ meter received better score for tolerance of particulates. Neither the MJ nor the SJ meter received any preference in the area of maintenance because both require periodic maintenance and calibration.

In the Mutikanga (2014) study, the multi-jet type of meter was selected as the best choice in terms of performance. This study preferred the MJ meter over other alternatives for its ability to pass particulates and to maintain a steady accuracy-degradation curve. It did not score highly in the area of low-flow accuracy. The nutating disc meter was the second choice because of its accuracy at low flows and relatively high ability to maintain a steady accuracy-degradation curve. The results of this study are not easily compared to the Mutikanga study because different criteria were considered. One noticeable similarity is that none of the alternatives in either study received high weighted scores. The highest-scoring alternative in this study received 0.63 out of 1 and in Mutikanga's study, the MJ received the highest weighted score of 0.42 out of 1.

All meters examined in this work had similar failure rates, which indicates that this may not be a relevant indicator for future analyses. A limitation of the direct scoring method of alternatives is that for numeric indicators the allowable range set by the evaluator may affect the overall preference of certain indicators. Also, the values selected for the range must never equal the value of any of the alternatives. For categorical data, an assumption that preference of possibilities follows a linear model is assumed and this may not be reflective of reality (Bouyssou, 2000). Additionally, assumptions of the Analytic Hierarchy Process require that all possible alternatives be evaluated (regardless of their practicality) and that indicator or criteria correlation may be problematic (De Montis et al., 2004). In this study, there are indicators that are likely to co-vary. For example, there may be direct links between an alternative's price and

quality. In spite of these well-known limitations, the AHP and direct scoring methods have remained popular due to their ease of use. These sort of methods are especially attractive to be used with stakeholders (Bauer & Brown, 2014; Garfi & Ferrer-Martí, 2011). This study could be improved by gathering input from decision analysis experts as well as other field practitioners and community stakeholders.

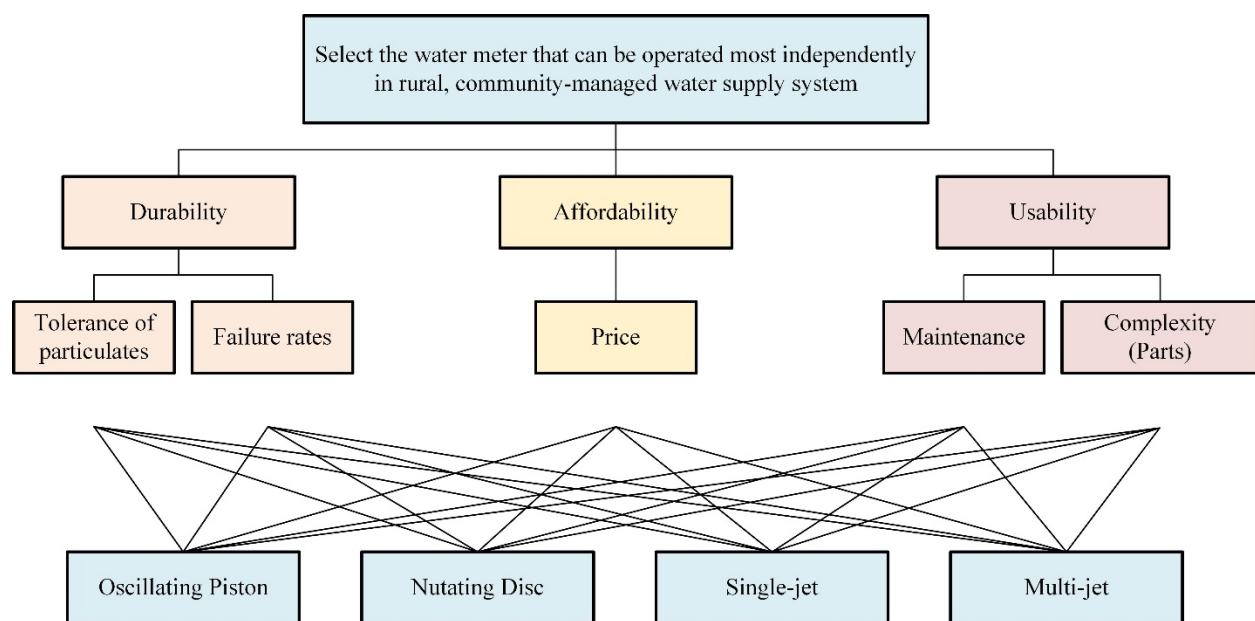

Figure 23 A summary of MCDA inputs for this work.

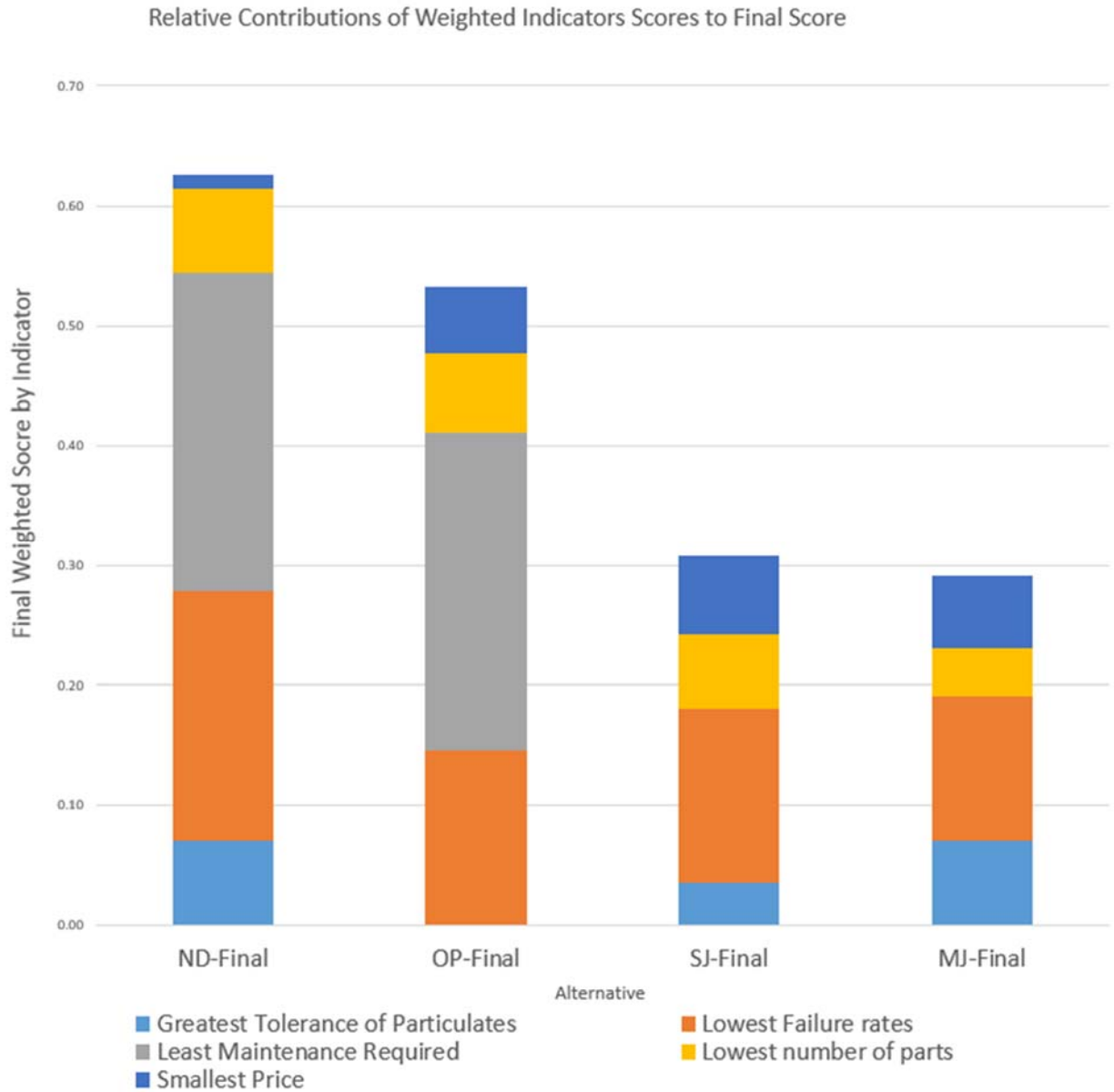

Figure 24 MCDA results: relative contributions of weighted indicator scores.

Table 10 MCDA indicators and scoring of criteria. This table shows all indicators considered for each criterion. Each alternative is represented by its initials and “DS” means “direct score” assigned to that alternative. Rescaled values are represented by “R” next to the bolded alternative abbreviations.

| Indicator                                                               | Measure                                                                                                   | OP - DS                       | OP - R      | ND - DS                       | ND - R      | SJ - DS                              | SJ - R      | MJ - DS                              | MJ - R      |
|-------------------------------------------------------------------------|-----------------------------------------------------------------------------------------------------------|-------------------------------|-------------|-------------------------------|-------------|--------------------------------------|-------------|--------------------------------------|-------------|
| C1: Indicator 1 - <b>Tolerance of Particulates</b> (more is preferable) | Not Likely affected = 1<br>No Data = 0.5<br>Likely affected = 0                                           | Likely affected               | <b>0</b>    | Not Likely affected           | <b>1</b>    | No Data                              | <b>0.5</b>  | Not Likely affected                  | <b>1</b>    |
| C1: Indicator 2 - <b>Estimated Failure Rates</b> (less is preferable)   | 0 % - 10%                                                                                                 | 7%                            | <b>0.30</b> | 5.70%                         | <b>0.43</b> | 7%*                                  | <b>0.30</b> | 7.50%                                | <b>0.25</b> |
| C3: Indicator 1 - <b>Maintenance Required</b> (less is preferable)      | Maintenance & Calibration required = 0<br>Maintenance Required = 0.5<br>No maintenance or calibration = 1 | No maintenance or calibration | <b>1</b>    | No maintenance or calibration | <b>1</b>    | Maintenance and Calibration required | <b>0</b>    | Maintenance and Calibration required | <b>0</b>    |
| C3: Indicator 2 - <b>Total Number of Parts</b> (less is preferable)     | 10 – 30                                                                                                   | 15                            | <b>0.75</b> | 14                            | <b>0.80</b> | 16                                   | <b>0.70</b> | 21                                   | <b>0.45</b> |
| C2: Indicator - <b>Estimated Price</b> (less is preferable)             | \$25 – \$100                                                                                              | 55                            | <b>0.60</b> | 90                            | <b>0.13</b> | 45                                   | <b>0.73</b> | 50                                   | <b>0.67</b> |

\*No data were available for SJ failure rates therefore an average of the remaining three alternatives’ failure rates was used.

Table 11 Data for use in the weighted sum approach.

| Indicator                                                               | Relative Criterion Weight | Relative Sub-criterion Weight | Final Weight | OP - Score | OP- Weighted Score | ND - Score | ND- Weighted Score | SJ- Score | SJ- Weighted Score | MJ - Score | MJ- Weighted Score |
|-------------------------------------------------------------------------|---------------------------|-------------------------------|--------------|------------|--------------------|------------|--------------------|-----------|--------------------|------------|--------------------|
| <b>C1: Indicator 1 - Tolerance of Particulates (more is preferable)</b> | 0.56                      | 0.13                          | <b>0.07</b>  | 0.00       | 0.00               | 1.00       | 0.07               | 0.50      | 0.03               | 1.00       | 0.07               |
| <b>C1: Indicator 2 - Estimated Failure Rates (less is preferable)</b>   | 0.56                      | 0.88                          | <b>0.49</b>  | 0.30       | 0.15               | 0.43       | 0.21               | 0.30      | 0.15               | 0.25       | 0.12               |
| <b>C3: Indicator 1 - Maintenance Required (less is preferable)</b>      | 0.35                      | 0.75                          | <b>0.27</b>  | 1.00       | 0.27               | 1.00       | 0.27               | 0.00      | 0.00               | 0.00       | 0.00               |
| <b>C3: Indicator 2 - Total Number of Parts (less is preferable)</b>     | 0.35                      | 0.25                          | <b>0.09</b>  | 0.75       | 0.07               | 0.80       | 0.07               | 0.70      | 0.06               | 0.45       | 0.04               |
| <b>C2: Indicator - Estimated Price (less is preferable)</b>             | 0.09                      | 1.00                          | <b>0.09</b>  | 0.60       | 0.05               | 0.13       | 0.01               | 0.73      | 0.07               | 0.67       | 0.06               |
|                                                                         |                           |                               |              |            | <b>0.53</b>        |            | <b>0.63</b>        |           | <b>0.31</b>        |            | <b>0.29</b>        |

## CHAPTER 5 PRACTICAL INSTALLATION TIPS

### 5.1 Service Line Sizing for Meter Installation Example

In pipe flow, there are also losses associated with friction created through the contact of flowing water with the surrounding pipe, fittings, and machines, such as meters, and a field practitioner designing a water supply system should be familiar with this concept and the calculation of the HGL (hydraulic grade line). Typically, because the fittings used in rural water system design are simple, their effects on loss due to friction are considered negligible when compared to frictional losses of flow through pipes and machines. While a meter may not appear to be a machine in the typical sense that it does useful work, all of the meters discussed here function through mechanical mechanisms whereby the flow of water agitates a flow sensor, which turns the register dials, either directly via shaft in a wet-register design or by moving magnets, thus some of the energy from the movement of water in the pipe is “lost” before it continues toward its final destination. It is therefore important to consider the impact of meter installation on the final pressure at the tap.

In cases where water pressure in the service line is already low, undersized meters can cause pressure drops in service lines affecting users’ satisfaction; oversized meters (which is a common occurrence because the intention is to preempt consumption demand) tend to significantly under-register the flow of water passing through them; however, despite these negative consequences, meters are often installed without properly analyzing for these possibilities (AWWA, 2012; Mutikanga et al., 2009). In its manual for selecting and sizing

residential meters, AWWA recommends selecting meter size based on estimated household demand and pressure-loss data, rather than on the service-line pipe size alone (AWWA, 2012). Demand estimations are typically performed during the scoping and design phase of the water system project. The field worker typically performs a census of the community and the current household demand is estimated by multiplying the average number of household number by a about 80 liters per person per day in piped systems, although this number may be higher or lower (120 to 60 liters per person per day) (Nauges & Whittington, 2009). This figure will also depend on the daily production of the source which should meet at least the daily minimum demand of the community (Jordan Jr., 1984). Future population growth is predicted by equations and these figures can vary quite a bit based on location (Arnalich, 2010; Nauges & Whittington, 2009). After demand is considered, the system designer then plans the normal and peak flow rates for the branches and nodes of the distribution network. Considering the demand information is important in meter installation and most residential service lines can be accommodated by a 5/8” meter. While AWWA recommends against using 1/2” service lines, in rural water systems these are not uncommon. After household peak flows are determined, a meter’s pressure drop curve (Figure 25) can be examined to determine whether the resulting pressure drop is acceptable for the peak flow. Meter specification sheets also contain information about a specific model’s minimum detectable, normal, and maximum allowable flows (Figure 26). All meter types tend to under-register at very low flows, so the smallest allowable model should be installed, without compromising the pressure head available at the end of the line or exposing the meter to undue wear by installing one that is too small (i.e., the service line’s design flow exceeds the meter’s maximum flow rate). Following is an example that addresses the effects of meter installation on service line design.



Assume that the main water pipe is buried under a public road, 1 meter below the surface. From the main line, a ½ inch, schedule-40 PCV service line splits off to carry water to a single tap at the end of the line, about 30.5 meters away from the main connection which is also 2 meters above grade at the main connection. The tap stand is about 1 meter tall. It is determined that the best location to place a water meter is 10 meters away from the main connection, in the direction of the house. The water meter installed will be a 5/8''x1/2'', plastic body, multi-jet meter. (For meters whose size is noted as 5/8''x1/2'' or 5/8''x ¾'', the first number – 5/8'' – refers to the inside diameter of the meter's inlet and outlet. The second number indicates what size pipe the meter will readily connect to with the included connectors). The service line must be elevated to 0.45 meters below the ground surface in order to connect the meter and install a valve box, which is approximately 0.5 meter long. (The service line is elevated to 0.45 meters because installing a meter at a lower depth will be uncomfortable to the technician and impractical for the meter reader). This is done by using 90-degree elbows and sections of pipe. Ball valves are placed before and after the meter and the service line is lowered down again to a depth of 1 meter below grade until it reaches the tap. The desired minimum pressure head at the tap is 10 meters and a flow of about 0.4 liters/second. The flow rate is a conservative estimate of discharge from a single bronze spigot. If more than one connection is present on the service line that will be metered, then the peak flow demand should be used for this calculation. The goal is to determine what minimum pressure head is required at the main connection in order to meet the minimum pressure requirement.

The first step is to sketch a graphic representation of this problem and then gather data to estimate the head losses due to friction, height, and meter (Figure 27). While precise calculations can be done by solving Bernoulli's energy equation, this will require more calculation and

conservative estimate calculations may be done in the field more quickly by hand using pressure drop estimations. In this example, an Excel spreadsheet was used to record data and perform the calculations and AutoCAD software was used to produce the sketch.

AWWA provides tables for residential meters by size (5/8 inch, 3/4 inch, and 1 inch) to determine estimated pressure losses according to flow, similar to pipe Friction Factor tables. For a 5/8" meter at 6GPM flow, a loss of 0.89 psi is expected. If the field practitioner is not able to access these tables, however, the manufacturer's sheet for any meter will have a graph with a pressure drop curve. Particular care should be taken to ensure that all of the data are in correct units (in this case, meters). If working with English units, they may be in gallons per minutes (GPM) for flow or Pounds per Square Inch (psi) for pressure. It is very common for gravity-fed system manuals to use metric units for everything except pipe diameter. Friction factor tables and pressure loss table are available either from manufacturers of pipe or in gravity-fed design texts which the field practitioner presumably has access to. Pressure losses to valves and fittings are not considered here because these are likely minimal.

Figure 25 shows an example of pressure drop information attached with a 5/8" bronze-body multi-jet meter and the pressure drop is estimated at 0.7 meters of head (after converting from psi). Pressure drops for all types of 5/8" and 3/4" meters tend to be small at flows typically seen in rural community-managed systems. The biggest contribution to head loss is actually friction due to water movement in pipe. In this example, a 1/2" PVC pipe service line was used despite AWWA's recommendation not to use service lines smaller than 3/4". Due to high friction losses associated with small pipe diameter. In rural community systems, however, 1/2" lines may be quite common. Thus, at least 30 meters of head would have to be available at the main connection in this example. If less pressure head is available, it is recommended that the size of

the line be upgraded to ¾ inch. Pressure loss due to installation of meters tends to be very low as compared to other head losses at the flow conditions expected in rural, community-managed systems. However, this type of analysis is still recommended because it is quick and fairly simple, can be automated in an Excel spreadsheet and can help the practitioner avoid making mistakes, especially in situations where less than 10 meters of head will be available for the user.

In some situations fire-flow conditions may need to be considered when installing meters on service lines, however, this consideration is beyond the scope of this work and other references are available for sizing service lines and meters to meet these demands (Arnalich, 2010; AWWA, 2012).

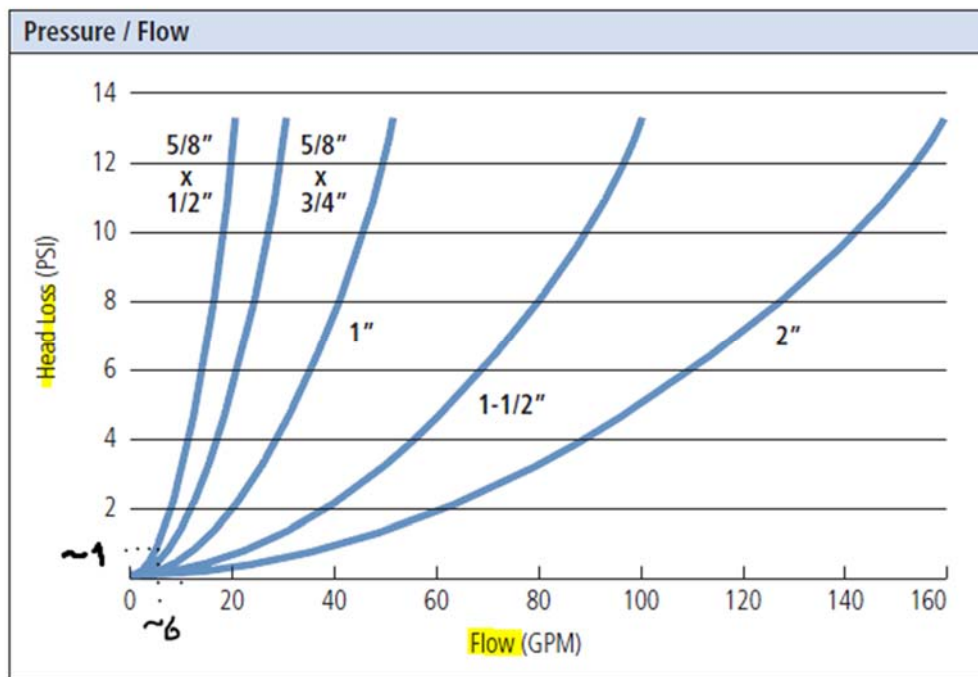

Figure 25 Example of a pressure drop curve for a multi-jet bronze-body meter. Reprinted with permission from [www.flows.com](http://www.flows.com).

| Model No.  | Size        | Flow Rate (GPM) |            |      | Normal Flow (GPM) |
|------------|-------------|-----------------|------------|------|-------------------|
|            |             | High            | Continuous | Low  |                   |
| WM-NLC-050 | 5/8" x 1/2" | 20              | 10         | 0.25 | 1-20              |
| WM-NLC-075 | 5/8" x 3/4" | 20              | 10         | 0.25 | 1-20              |
| WM-NLC-100 | 1"          | 50              | 25         | 0.75 | 3-50              |

Figure 26 An example of a flow rate table that appears in a meter's specifications sheet. This particular table corresponds to a multi-jet bronze-body meter from Assured Automation but all meters will have similar information in the accompanying specification sheet. Reprinted with permission from [www.flows.com](http://www.flows.com).

| Head needed after main connection                | In meters    | Notes                                |
|--------------------------------------------------|--------------|--------------------------------------|
| minimum head at tap                              | 10           |                                      |
| height of tap                                    | 1            |                                      |
| height above grade                               | 2            |                                      |
| head loss due to pipe length (30m)               | 15.9         | FF for 0.5" PVC @ Q=0.4L/s: 53m/100m |
| height above main                                | 1            |                                      |
| <b>Minimum head needed at main without meter</b> | <b>29.9</b>  |                                      |
| head loss due to meter                           | 0.63         |                                      |
| <b>Minimum head needed at main with meter</b>    | <b>30.53</b> |                                      |
| headloss with meter if 3/4" pipe used instead    |              | FF for 0.75" PVC @ Q=0.4L/s:         |

10m head = 14.2 psi  
0.4 L/s = 6.3 GPM  
0.89 psi = 0.63 m head  
1 psi = 0.7 m head

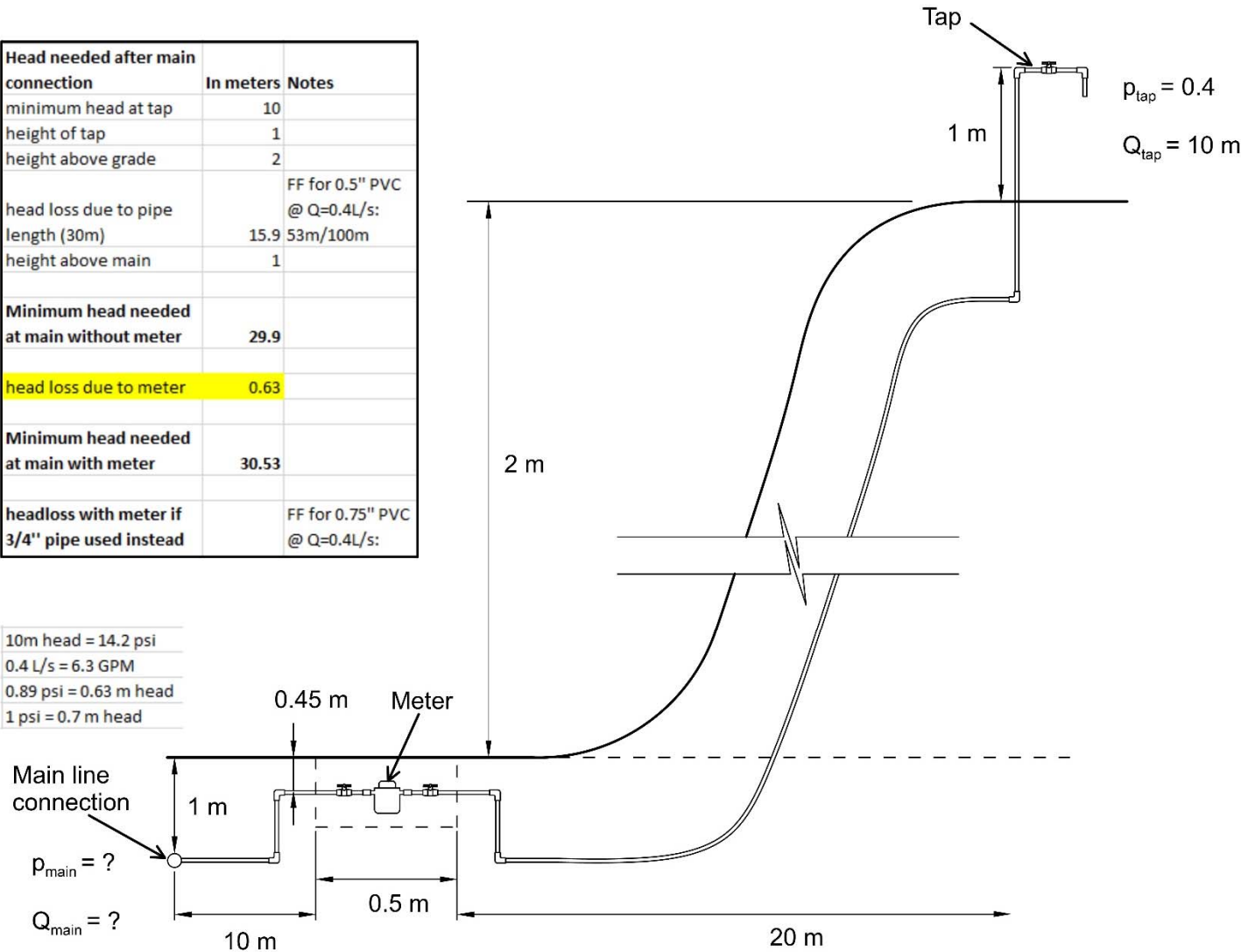

Figure 27 Sketch of example problem evaluating head loss due to installation of meter.  $P_{main}$  and  $Q_{main}$  refer to pressure and flow at the main line connection, respectively, and will vary based on site.

## 5.2 Practical Tips for Meter Installation

### 5.2.1 Size Notation

Once the type of meter and size of the meter have been selected, the actual installation of the meter is quite simple and does not vary significantly between types of meters. There are a few important installation considerations that can affect the meter's performance. Firstly, it should be noted that for typical residential meters, the size labeling convention is not straightforward. For meters whose size is noted as 5/8''x1/2'' or 5/8''x 3/4'', the first number – 5/8'' – refers to the inside diameter of the meter's inlet and outlet. The second number indicates what size pipe the meter will readily connect to with the included connectors. These are the two most prevalent sizes, however a 3/4''x 3/4'' meter also exists. It should be noted that 5/8'' equals to 0.625'' and this is the true inside diameter of the meter's connections. The inside diameter of a 1/2'' Schedule -40 PCV pipe is about 0.602'' and the inside diameter of 3/4'' Schedule-40 PVC pipe is 0.804''. The manufacturer's sheet should be consulted to determine the appropriate flow ranges for the meter being considered to ensure that it is compatible with the designed service line flow and the associated pressure drop can be tolerated without resulting in service interruptions for the user. The only difference between volumetric and velocity meter installation is that the volumetric meters (especially the piston-type) are more susceptible to failure from particulates and may require an extra strainer to be installed upstream of the meter if the water is known to carry particulates and if the manufacturer's specifications recommend it. The line upstream from the meter should be flushed to remove possible particulates. For jet-type meters, the technician should check to make sure that the in-line strainer included with the meter is installed in the meter inlet. There is an arrow on the body of the meter indicating the direction in

which water should flow through it. Another way to differentiate the inlet on all jet meters is by locating the bypass valve (used in calibration) which is always positioned above the inlet.

### **5.2.2 Example Valve Box Design and Shutoff Valves**

A sample design of a meter's valve box is included in Figure 28. The valve box should be long enough to accommodate the length of the meter, plus the length of associated connectors and slip coupling on each side of the meter. The actual installation of the meter between the pipe and the meter is depicted in Figure 28. A slip coupling accepts the threaded part of the meter connector and is then glued (slipped) into the open side of the pipe. The slip coupling should have straight threads rather than tapered because the use of a tapered coupling might increase the chance of leaking. Thread sealing tape should be used on the threads of the connector going into the slip coupling but not in the threads on the meter's inlet or outlet going into the connector. There should be at least the length of three diameters of pipe that being used for the service line on each side of the slip coupling, before a ball valve. For example, if  $\frac{3}{4}$ " pipe is being used for the service line, then the distance of pipe between slip coupling and ball valve should be at least 2.4" (inside diameter of  $\frac{3}{4}$ " pipe 0.804" multiplied by a factor of 3). While a gate valve is actually preferred because it can be opened and closed gradually, these are not commonly used in combination with plastic pipe, therefore ball valves should be opened and closed slowly so as to minimize the water hammer effects on the meter's flow sensor.

There should also be enough length of pipe on each side of the shutoff valves in case they need to be exchanged. A shutoff valve positioned prior to the meter allows the water coming in from the main line to be stopped when the meter is installed or uninstalled and is a must. Installing a shutoff valve after the meter is optional but highly recommended. If the meter ever needs to be serviced or replaced, this valve can be closed thus avoiding backflow of water into

the valve box pit once the meter is disconnected. If the valve is not present, most of the water could also be drained from the tap but there will still be some water left in the line. A bypass line is also optional but recommended in situations where water supply should be maintained even if the meter fails or needs to be disconnected (e.g., clinics or schools). It should be installed before the first shutoff valve on the inlet side of the meter and reconnected to the service line after the second shutoff valve on the outlet side of the meter (Figure 29).

Materials available for valve box construction will vary depending on location, thus the design will need to be adapted. The design proposed in Figure 28, however, shows the components of a typical valve box and a basic materials list without the calculated quantities since the dimensions will also vary based on the materials and location. Valve box design specifications are based on recommendations from Satterfield & Bhardwaj (2004) and the author's experience. A rectangular design is recommended, but depending on the available choice for lid, the box may also be square. The difference in height from the lid of the meter should be between 18 and 24 inches. The box lid should never touch the lid of the meter. Installing a meter at a depth of more than 24 inches is not recommended because depth lower than that will be awkward for the technician to work in. The meter itself should rest on a concrete paver or brick so that the line on either end of the meter is elevated off the bottom of the valve box and the meter itself is not dangling and causing undue stress on the connections or the line. A layer of 6 to 12 inches of gravel is recommended underneath the meter. Sides of the valve box may be constructed from block, brick, or stone, and mortar. The valve box should also be wide enough for the technician to be able to use wrenches and pipe cutters comfortably inside of it. If a large increase in future water demand in the area is expected, it may also be wise to size up the valve box expecting the sizing up of the meter. The cost of the valve box materials and



labor in in the United States is estimated to be 60USD (Satterfield & Bhardwaj, 2004). This estimate does not include the costs of additional plumbing, such as shutoff valves, upstream filters, or pressure regulators. One of biggest contributors to meter accuracy degradation is the stress created on meters due to improper positioning and mounting (AWWA, 2012; Barfuss et al., 2011; Mutikanga et al., 2009, 2011). With a few exceptions, all meters are designed to be mounted horizontally, with the register pointing up (Figure 29).

### **5.2.2.1 Location of Valve Box**

It is recommended that the lid for the valve box have a trustworthy locking mechanism, for example, sturdy eyelets for padlock. This is done to ensure protection of the meter from tampering or theft. The valve box that the meter will be located in should not be placed in an area that floods. Generally, the valve box lid should be flush with the ground or just slightly raised, but not so much where it may create a tripping hazard if there is nearby traffic. The valve box should be accessible because the meter should be read on a regular basis, but out of the way of paths. While placing the meter valve box close to the tap may seem like an attractive option because the service line could be elevated once rather than twice, this is not recommended because the area around a tap outside of the house may get wet and messy. There is also a lot of activity centered around the tap so a valve box placed close by may be obtrusive or aesthetically unappealing for the users. The meter box should thus be placed considering stormwater runoff conditions, traffic patterns, and meter reader ease of access. If freezing temperatures are a concern, the meter may be placed in a location such as the basement of the user's house. Access for meter readers should also be considered.

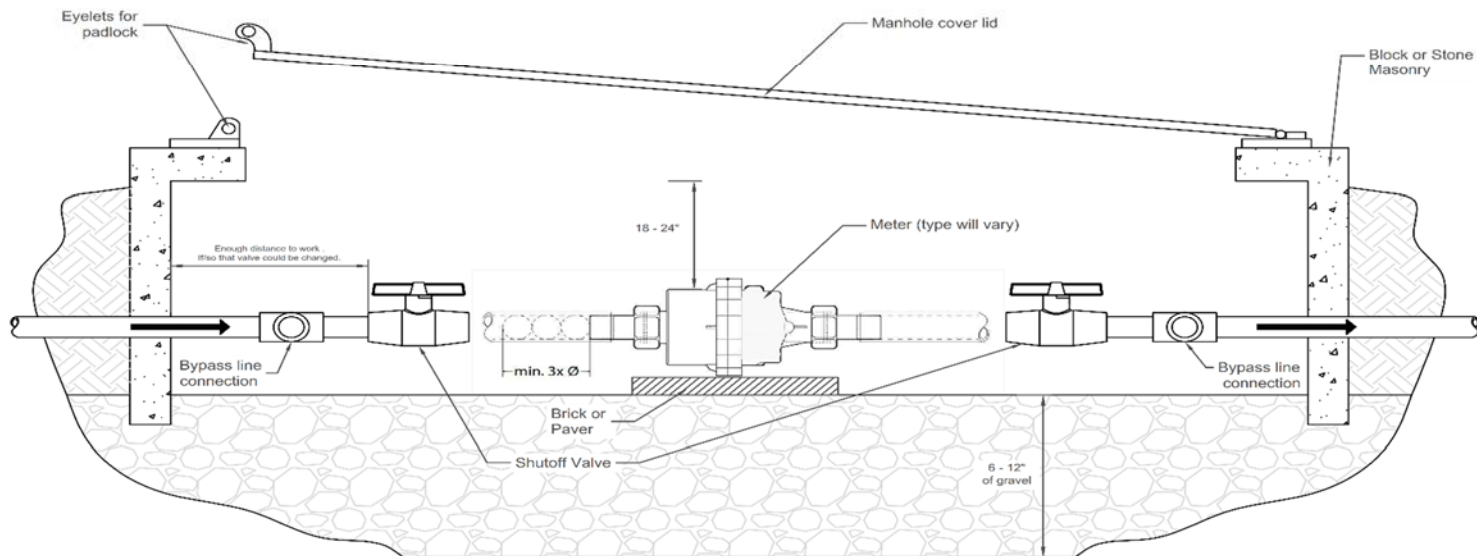

| Possible Materials & Tools List   |                                          |
|-----------------------------------|------------------------------------------|
| Cement                            | Scrap pieces of wood (for form building) |
| Sand                              | Field stones & gravel                    |
| Manhole cover with lid            | Pipe wrench                              |
| Manhole cover attachment hardware | Teflon tape                              |
| (2) ½" PVC Shutoff ball valves    |                                          |
| Padlock                           |                                          |

Figure 28 Side cross-section view of suggested design of valve box. The box dimensions will vary by site. If upstream filters are added, the valve box length may need to be extended. Meter image inside the valve box is that of an oscillating piston manufactured by Assured Automation and reprinted with permission from [www.flows.com](http://www.flows.com).

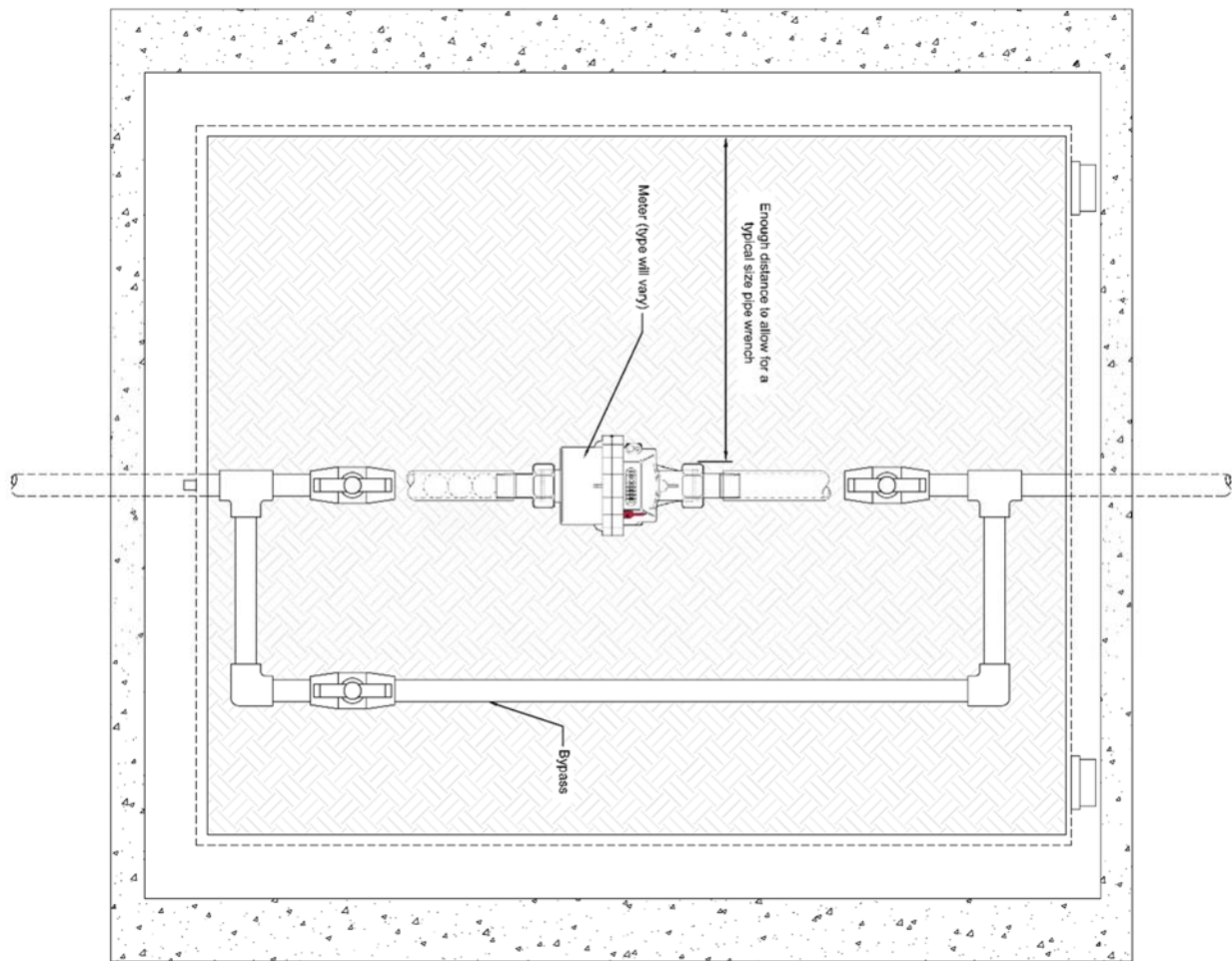

Figure 29 Top view of suggested valve box. The box design includes a bypass line. The box dimensions will vary by site. If upstream filters are added, the valve box length may need to be extended. Meter image inside the valve box is that of an oscillating piston manufactured by Assured Automation and reprinted with permission from [www.flows.com](http://www.flows.com).

## **CHAPTER 6 STRATEGIES FOR INCORPORATING METERING INTO THE COMMUNITY MANAGEMENT MODEL**

### **6.1 Rationale for Including Protection and Enforcement of Metering into Community-Managed System Design**

Water metering is an accepted practice in developed countries to manage user demand through consumption-based pricing, aiding in revenue-recovery for the managing entity when accompanied by meter protection and rule enforcement (AWWA, 2012). As Integrated Water Resources Management is being globalized (Taylor et al., 2005), metering is becoming popular in the developing world in urban settings where systems are managed through public or private utilities (Amiraly & Kanniganti, 2011; Chambouleyron, 2003; Harutyunyan, 2013; Khawam et al., 2006; Mutikanga et al., 2011; Mutikanga et al., 2013). In rural community-managed systems private, for-profit entities have been brought in to manage metering and billing (Kamruzzaman et al., 2014; Kingdom et al., 2006; Pauw, 2003). There is also evidence that meters are being installed in rural community-managed systems in the developing world with the responsibility of management belonging directly to the community but these cases are poorly documented (Johnson, 2002; Water for People, no date). While it appears that hydrophilanthropic organizations have been operating programs in developing countries for years that deal with meter installation, to the best of the author's knowledge no publicly-available guidance exists for selecting and installing meters and basic training for the respective water committees in community-managed, piped, rural water supply systems.

While little field-based literature is publicly-available regarding metering programs in developing countries, it does not mean that field workers have not considered demand management, equity, and enforcement when facilitating rural water supply systems. Louise, a student who worked to design a rural supply system in Madagascar, mentioned including meters on public taps in her design and recommended that the community install meters in the future for all individual taps (2004). Although this acknowledgement for the importance of metering water was made, no recommendations were provided for what meters should be included, how they should be selected, what models are locally available, their cost, and whether the users or the committee would be responsible for purchasing them. Enforcement is another component of the rural water supply that goes along with metering but is not typically included in system design. Enforcement refers to measures taken by the managing water committee to ensure compliance of users with the committee rules (most frequently of payment or uses). Often, however, while the water committee forms rules or statutes, there are no technological mechanisms (e.g., protected or locked shutoff valves) for it to actually enforce those rules and payment delinquency rates are often very high and have been linked to premature system failure (Annis, 2006; Schweitzer & Mihelcic, 2012). Once again, however, other field development workers have thought about this problem as evidenced in Figure 30. In this example, locking spigots were installed by a Peace Corps Volunteer (PCV) who designed and built a system in order to provide the community with a mechanism to enforce the payment of tariffs. While the design idea was novel and seemed to be a good alternative to constructing individual locking valve boxes, the author observed that within less than a year after the system's completion (and the PCVs departure from the community) most of the locking handles had failed and users were using long skinny bolts to open and close the valves. Furthermore, this adaptation was not comfortable to operate when it

came to closing the valve all the way or opening it from the fully-closed position. To avoid discomfort, users were leaving the valves partially open. Not only did the intended technology fail to achieve the design goal, but created a new problem. Since water usage was not metered and users paid a flat monthly fee, there was no incentive for either the individual users or the water committee to spend roughly 5USD per spigot to switch to new, traditional-handle style spigots (for a village of about 56 households).

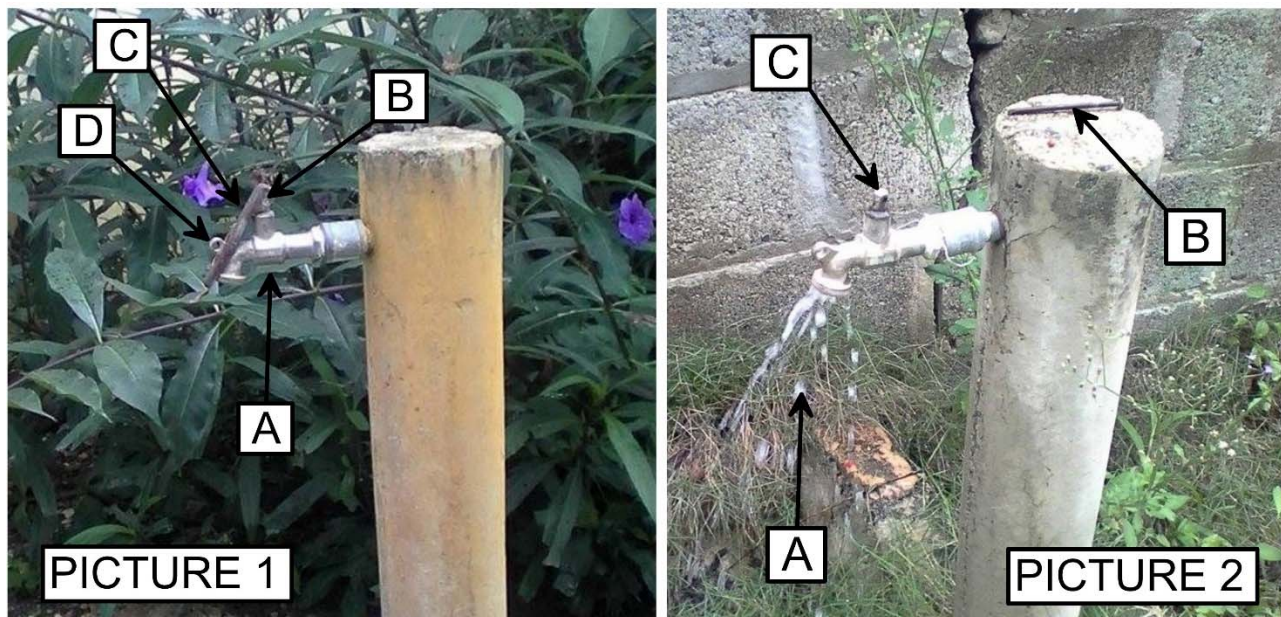

Figure 30 An example of a good idea but faulty design. Picture 1: an example of a good design idea – locking spigot. This is a tapstand in a community-managed system designed and built by a Peace Corps Volunteer in the Dominican Republic. A. A non-traditional spigot was used in order to have the option to lock a user’s access to water in case of non-payment. B. The valve stem to which a handle is attached. C. Typically, a spigot may feature either a round or lever-type handle but in this case the handle is attached to the stem and there is a slot for an eyelet below. D. The eyelet is not a typical feature of a spigot and this is where a padlock would be placed to lock the tap. Picture 2: an example of a good design idea but faulty product - leaking spigot. This is a similar tapstand in the same community but with the handle broken off. C. The point where the handle should attach to the valve stem but is broken. B. The user loops a bolt through the eyelet of the valve stem to open and close the valve. C. Because it is difficult and uncomfortable for the user to open and close the valve using the bolt, users often leave the valve slightly open so as to minimize effort needed to fully close and open. As a result, water is perpetually leaking though the valve.

## 6.2 The Metering Decision Tree

Perhaps the biggest mistake made by well-meaning field workers and donors in developing countries over the years has been to install technologies in communities where there is no social support for their use, technical expertise for their maintenance, or sufficient resources for their operation and replacement (Aarras et al., 2014; Hollick, 1982). Water metering for consumption-based billing is a universally-accepted concept in the developed world. Some communities in developing countries may be aware of the existence of meters and their use in urban settings or for other services (e.g., electricity). In many developing countries, however, people are still not accustomed to the idea of paying for water, much less monitoring the amount of water they use for basing the price of the service. Development of rural water supply systems via the community-management model takes time and in order for the system to be successful in the long term, it is necessary to prepare the community through building its capacities (Gumbo et al., 2005; Sianipara et al., 2013). There have also been strong arguments made that ongoing support from an external organization is key to the success of a community-managed system (Cleaver & Toner, 2006; Harvey & Reed, 2007; RWSN Executive Steering Committee, 2010) which may not always be a possibility. It is, thus, not recommended to include meters in rural, community-managed water supply systems without training, consensus-building, and an enforcement mechanism for their protection and the collection of revenue they are intended to generate.

While this work proposes that including meters into rural system design will help increase the chances of systems being sustainable and presents MCDA for selection of meters to be used in rural, piped, community-managed systems, it should be noted that in keeping with the goal of water system sustainability and good practices recommended by literature, the

community should have choices between different levels of service (Sara & Katz, 1997). In some cases, this might mean the choice between several different meters as a result of MCDA but it may also mean that the community may choose to opt out of a metering program altogether. Care El Salvador, an NGO, that worked to build and support urban and rural water supply systems in El Salvador in the late 1990s and early 2000s was reported to also include meters as an option in some of the systems (Johnson, 2002). While no technical details are provided for choosing the meters themselves, the approach used by Care El Salvador to counsel communities regarding the option for a metering program has been adapted into a flow chart for practicality and to include MCDA as a concrete tool to aid in the selection of the most appropriate meter (see Figure 31).

The first step in the metering decision tree is for the community to have solicited the services of a field worker, either because its members are interested in building a water supply system or already have one but require assistance with its maintenance. If there is already a water system in place with a flat tariff (i.e., the same price is charged no matter the volume of water consumed), the community may be experiencing problems with water quantity and high tariff delinquency. If the community is not experiencing problems or if no water scarcity issues are expected during the design of a new system, then, metering may not be appropriate. If a community is experiencing problems, a public meeting should be held to allow the community to explain the problems it is experiencing and to collect data about the system and the community. No discussion should be had at this point about metering or any other possible solution. If a field practitioner is working with a community on implementing a new water system and water scarcity is identified as an issue, the practitioner would follow the same process. Once the field worker has had a chance to analyze the data, another meeting should be held where three possible solutions may be proposed: 1) increase the current tariff so as to generate sufficient



revenue for development of an additional source or installation of enforcement measures for generation of revenue, 2) planning for intermittent supply – part of the system would have water during certain parts of the day or week, or 3) installing meters and basing pricing on the volume actually consumed. At this point, the community should understand the alternatives proposed, but these alternatives should not be discussed. The community should be given the chance to debate these internally and generate a list of questions. At the next meeting, the field technician should repeat the options proposed and answer the community's questions regarding the three options. If metering is chosen as the preferred option, the field worker would gather any additional data about the system or community needed to plan a metering program. Metering is not appropriate in all situations, if there are shared taps or the water supply is intermittent, then metering should not be considered (Sohail, 2004). The field technician would also gather data about existing options and at the next public meeting the practitioner would facilitate an MCDA beginning with the community's input on what type of meter is preferred (e.g., very accurate, most economical, longest-lasting, etc.). Once the results are tallied, the details of such an undertaking would be explained and the level of support for the program judged.

Prior to the installation of meters, a planning period should include the designation of the committee members who will be responsible for carrying out the program. This is very similar to the committee development process. Relative statutes should be formed – for example, who will own the meters and who will pay for the meters? Consumption-based pricing will be established during this stage of the process. This type of pricing is characterized by a period of time – how often will the meters be read and by whom? How will the information be recorded and stored? The field technician should assist the community in making these preparations and developing the materials needed, such as record-keeping sheets, calculations that will need to be performed,

planning reading routes, etc. To whom will the meter reader report? Will there be another person accompanying the meter reader (for increased transparency)? Should the user be present when the meter is read? Who will keep the keys to the meter boxes and how will they be secured? There are many questions to consider and the field worker should facilitate the elicitation of answers from the community rather than handing over a rigid list of rules prepared in a vacuum or copied from a different context.

Even after a long planning period, it is possible that not every member of the water committee will be enthusiastic about this approach. In fact, there may be strong distrust. In this situation, a field worker should explain that one of the options is an informational metering program. This means that before the program would be fully enforceable, there would be a period where the meters would be read and the results publicly shared and displayed. This process should increase transparency and increase community support. There may be disputes regarding the water consumption numbers and this should be anticipated. For example, users who consume a much larger portion of water (e.g., wealthier households, households with animals, small businesses, etc.) may believe that they consume much less water than they actually do or may be opposed to paying more for their larger consumption and may attempt to discredit the metering program by claiming that the device is over-registering. In these cases, it would be useful to replace some of the meters and continue the informational metering project and the public sharing of results. It is unlikely that two (or even three) meters tested by the same user would be consistently faulty and only in one direction. By performing the informational metering first, a lot of community support may be garnered and the community would have time to prepare for a new pricing scheme based on consumption. It is recommended that all of the meters be purchased and owned by the water committee because this increases the sense of

ownership and the possibility of the metering project's success (Johnson, 2002; Laredo, 1991). Additionally, because a lot of variation between meter models occurs, using the same type of meter should maximize consistency of quality and measurement accuracy. Meter reading can be a significant effort for a single person or even two people, thus it is also recommended that this person be compensated for their service by the water committee. Where employment opportunities are few, this may seem like a popular post for many members thus the best candidate should be decided fairly and transparently. The community water committee should make the final decision but the field worker may suggest that the meter reader have the following qualities: be dependable, be able to read and write (at least numbers), be honest, be able to walk (or have access to transportation) for long distances, and be respected in the community.

### **6.3 Possible Pricing Schemes and Their Enforcement**

In a utility setting, water tariffs are set based on the costs of the system's maintenance and operation, recovery of the cost of building the system, and in some cases profit. Due to philanthropic efforts, rural communities are able to receive a lot of financial help for the building costs which does not need to be re-paid. Typically, the water committee will also be a non-profit entity because its members are also the users. Thus, only the cost of ongoing maintenance and operation needs to be addressed. These costs are also typically computed during the system design phase and may include costs of electricity for pumps, chlorination equipment, replacement of valves, pipes, etc. When a metering program is added, the cost of meter replacement should also be considered. While there is admittedly little data regarding the useful life of meters, AWWA recommends that meter replacement should be scheduled to take place every ten years (AWWA, 2012). There is currently no data regarding whether this recommendation is appropriate for the developing world setting.

Based on the author's experience, a rough calculation was performed using an Excel spreadsheet to estimate the monthly cash flow of the water committee and is represented in Figure 32. With 28 families paying a monthly tariff of 1.2USD, the monthly income of the water committee should be 33.6 USD. With the monthly expenditures budgeted at 22 USD, there should be 11.6USD available for savings every month. Savings are important for community-managed systems because eventually as systems get older additional and more expensive maintenance and replacements will be needed. Systems are designed with population increases in mind, thus savings are also needed for future expansion. There should also be an "emergency fund" in case a major component, such as a storage tank or a pump, breaks. With 11.6USD available for savings at the 100% collection rate, a meter replacement cost can also be calculated in. Through the MCDA analysis it was determined that the nutating disc meter would be the most preferred option costing around 90USD. With a 3% inflation rate, it is estimated that 10 years from now this meter would cost about 121USD. This sum is multiplied by the estimated number of meters (28 based on the current number of households, but this may be higher if population grows) and divided by 120 months to obtain the monthly rate of replacement, 28.2USD. At the 10 year replacement schedule, even if 100% of the users pay their tariffs, the community will not be able to afford the meter replacement nor have a savings fund. A less expensive meter may be considered, a staggered replacement program may be put in place, or the tariff may be raised. In reality, in the developing world, collection rates for community-managed systems are only at about 60% to 80% levels, whereas in the developed world they may be 94% to 99% (Sohail, 2004). With only 18 of the 28 families consistently paying the tariff, the community would be able to almost cover its monthly costs, but would not be able to have a savings fund. There may be several reasons for the low collection rates and an effort should be

made to examine at least some of these reasons (Laredo, 1991; Sohail, 2004). Are users not paying because they cannot afford the water, are they dissatisfied with the level of service, or is there another reason?

Lack of enforcement could be a big reason for the high rates of tariff delinquency. For example, based on the author's experience, it was not standard practice to include a protected shutoff valve in the design of community-managed systems. Although the water committee training program included activities for guiding the community to set up rules for non-payment and breaking of its rules, there was effectively no way to enforce any penalties possibly proposed. It is common for field practitioners to assist communities in setting rules such as "to impose sanctions against subscribers for violations of these statutes. When the sanction consists of the temporary suspension of service, the Treasurer shall authorize the plumber to carry out said suspension" (Messenger, 2004). However, no details are provided for how this would be done technically so that the suspension would be maintained. Many external entities carrying out hydrophilanthropy projects in developing countries naively assume that the communities will be able to undertake the action of enforcement on their own (Cleaver & Toner, 2006; Johnson, 2002; Messenger, 2004). The practice of water service suspension is not without its critics as it could significantly affect the health not only of individual users but the wider community (Pauw, 2003; World Health Organization (WHO), 2000). These criticisms, however, often arise in the context of private-public partnerships, where a private utility operates the water system. The water committee board loses credibility if it is unable or unwilling to carry out its own rules. It is also recognized that the failure to recover cost can lead to lack of maintenance and ultimately failure of the entire system, thus there is a need for tariffs that promote "fairness and equity, sensible incentives, [and] simplicity and comprehensibility" (World Health Organization

(WHO), 2000). It was the author's experience that nearby communities with community-managed systems were already experiencing significant problems due to lack of maintenance and water quality was significantly compromised (due to pipe breaks and illegal connections) in the systems that were less than ten-years-old. A community with a much younger system was also experiencing problems with tariff delinquency and without a way to temporarily suspend service to individual offenders, the water committee board would periodically shut off service to the entire system in order to prompt compliance. The entire community could be without water for several days, thus putting the bigger group's health at risk. It is therefore preferable to include a design component, in the form of a simple, locking valve box to protect individual shutoff valves (and meters if a metering program is chosen). While including individual valve boxes represents an additional expense to the materials budget for the project, if this is done early in the design process, then the fundraising can proceed accordingly.

When it comes to the setting of water tariffs, there are no straightforward formulas that could be used to solve for answers (Laredo, 1991; Sohail, 2004; World Health Organization (WHO), 2000). Basing tariffs for water to cover minimum system maintenance costs and savings is a start. Another option is to look at local government agency recommendations, if they exist, to determine what the recommended local tariff may be (Louise, 2004). There are five recognized tariff schemes described in Table 12 and their associated effects on water consumption. Flat rate schemes have no effect on water conservation, while increased block pricing (where consumption is priced in "blocks" of volumes that become more expensive with increased consumption) is thought to provide the best conservation incentives. Seasonal, uniform, and decreasing block pricing all have some effects on decreasing water consumption but are not thought to be very effective in promoting conservation. It is thus recommended to

associate an increasing block tariff scheme along with a metering program. Because reducing access to clean water for the poorest users through this approach is a concern, a sufficiently-high first block should be allowed, but not so high that the conservation incentive is lost. An average of 50 to 80 liters per person per day could be applied to the estimated number of individuals per household (provided that the system design can accommodate these numbers). If, for example, the household size on average is 5 people, the volume of the first block would be between 250 and 480 liters per day (or between 7.5 and 14.4 cubed meters per month). The price of this first block could be set at the minimum household contribution needed to satisfy the maintenance and savings requirements. Applying the previously-discussed informational metering for a few months may be especially useful before restructuring a flat water tariff.

#### **6.4 Economic Considerations of Beginning a Metering Program**

There is no published guidance for choosing meters to be installed in rural systems, so it is not known exactly what the financial burden of including meters into a system design would be. The author compiled information regarding materials budgets from Peace Corps Volunteers who worked to implement rural water supply systems in the Dominican Republic along with Louise's predicted costs from Madagascar (Table 13). Based on this example, the additional funding needed to include meters would have increased between seven and twenty-nine percent. This example is not intended to be rigorously accurate because the total material costs were provided as anticipated budgets (i.e., the total amount spent on materials may not have been exactly that which was reported here) and all of the Dominican Republic examples were provided in local currency, so the conversion to USD is an estimate based on the currency exchange rates during the times when the systems were being built. This example demonstrates the cost of meters relative to the total materials cost of the system and there is a lot of variation

since the percentage is affected by the total cost of materials and the number of household connections when the price of the meter is constant. There are likely significant regional effects on system design. The Madagascar example is the costliest with a relatively small number of connections, thus bringing down the relative cost of meters, whereas the Dominican Republic examples are less expensive in total, thus the relative cost of meters appears to be higher. Nonetheless, this example is intended to show that the inclusion of meters in rural water system design can have significant economic implications, which supports the rationale to develop an informed meter selection process and adequate protection of such an investment.

Table 12 Summary of possible water pricing schemes typically used by utilities and their effects on user consumption.(Khawam et al., 2006; Sohail, 2004).

|                      |                  | Type of Rate           | How it works                                                                                       | Effect on Consumption                                                                                           |
|----------------------|------------------|------------------------|----------------------------------------------------------------------------------------------------|-----------------------------------------------------------------------------------------------------------------|
| Complexity of Scheme | Least            | Flat                   | Charges a fixed amount regardless of amount used; may be tied to income level in a tiered approach | Provides no incentive to conserve water                                                                         |
|                      |                  | Conservation Incentive | Uniform Block                                                                                      | Charges a fixed amount per volume unit of water                                                                 |
|                      | Decreasing Block |                        | With increased consumption, price decreases per unit of volume                                     | Does not encourage conservation and is recommended for regions without water scarcity concerns; uncommonly used |
|                      | Seasonal         |                        | Increased fixed rate during dry season                                                             | Because the rate is higher per unit volume, encourages some conservation during dry months                      |
|                      | Most             | Increasing Block       | With increased consumption, price increases per unit of volume                                     | Encourages conservation and is recommended for water-scarce regions                                             |



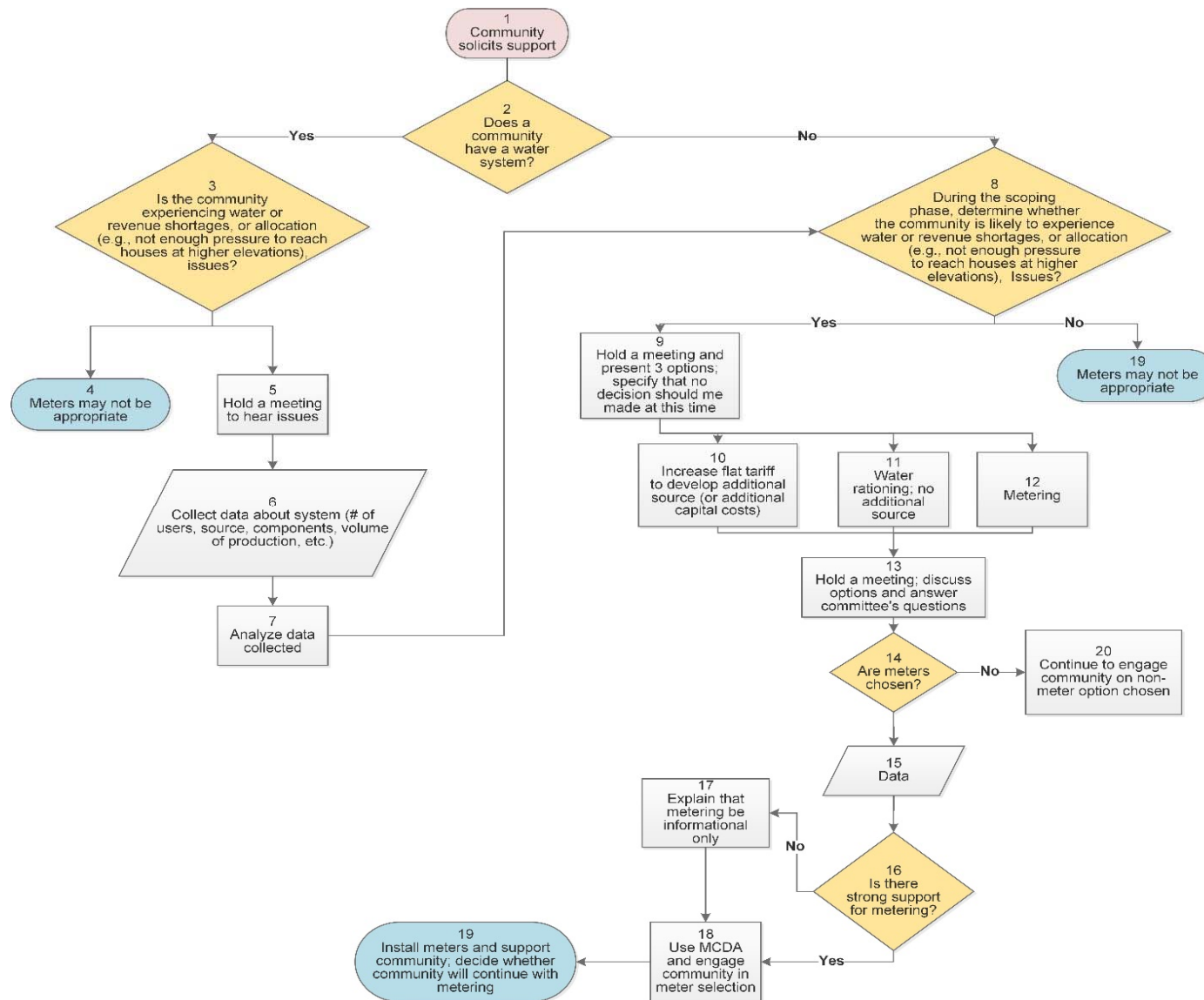

Figure 31 Metering decision tree. Adopted from (Johnson, 2002) with author's contribution to include MCDA.

|                                                    | USD (2014)  | USD (2014) | Collection Ratio |
|----------------------------------------------------|-------------|------------|------------------|
| <b>Number of connections</b>                       | <b>28</b>   | <b>18</b>  | <b>0.64</b>      |
| Monthly tariff/household                           | 1.2         | 1.2        |                  |
| total monthly income of WC                         | 33.6        | 21.6       |                  |
| monthly operating                                  | 0           |            |                  |
| monthly maintenance - parts                        | 10          |            |                  |
| monthly maintenance - labor                        | 12          |            |                  |
| <b>Total Monthly Cost</b>                          | <b>22</b>   |            |                  |
| Savings (tariff collected - cost)                  | 11.6        | -0.4       |                  |
| cost of meter today                                | 90          |            |                  |
| cost of meter in 10 years (based on 3%)            | 121         |            |                  |
| monthly cost of future meter<br>((121*28)/(10*12)) | 28.2        |            |                  |
| <b>Total Monthly Cost (w/meter)</b>                | <b>50.2</b> |            |                  |
| Savings (tariff collected - cost)                  | -16.6       | -28.6      |                  |

Figure 32 Example monthly small system O&M budget.

Table 13 Cost of meters relative to the total cost of project materials.

| <b>System Designation*</b>                                                       | System A                   | System B<br>(Louise,<br>2004)         | System C                                | System D                   | System E                   | System F                                | System G                   |
|----------------------------------------------------------------------------------|----------------------------|---------------------------------------|-----------------------------------------|----------------------------|----------------------------|-----------------------------------------|----------------------------|
| <b>System Characteristics</b>                                                    | Gravity-fed from a spring. | Pumped from a well, then gravity-fed. | Pumped from a spring, then gravity-fed. | Gravity-fed from a spring. | Gravity-fed from a spring. | Pumped from a spring, then gravity-fed. | Gravity-fed from a spring. |
| <b>System Location</b>                                                           | Dominican Republic         | Madagascar                            | Dominican Republic                      | Dominican Republic         | Dominican Republic         | Dominican Republic                      | Dominican Republic         |
| <b>Cost of Project Materials (USD)**</b>                                         | 9600                       | 71300                                 | 11200                                   | 42800                      | 22700                      | 8900                                    | 11300                      |
| <b>Connections</b>                                                               | 30                         | 100***                                | 25                                      | 120                        | 89                         | 52                                      | 60                         |
| <b>Hypothetical Cost per Meter (USD)**</b>                                       | \$50                       | \$50                                  | \$50                                    | \$50                       | \$50                       | \$50                                    | \$50                       |
| <b>Additional cost of meters as compared to total materials budget (as %) **</b> | 16                         | 7                                     | 11                                      | 14                         | 20                         | 29                                      | 27                         |
| <b>Year Completed</b>                                                            | 2014                       | 2004                                  | 2014                                    | 2014                       | 2013                       | 2011                                    | 2011                       |

\*Costs for System A and Systems C through G were obtained from Returned Peace Corps Volunteers from the Dominican Republic.

\*\*Total costs of project materials come from real systems (except for System B- the source reports it as design-only) but the cost of meters varies greatly based on the product and location, thus the sum of 50USD for a meter is chosen as a hypothetical example based on the author's experience. Meters for individual household taps were not installed in any of the systems thus the information is provided here for comparison purposes. Materials budgets and the portion of these budgets that the addition of meters would cost were rounded to the nearest hundred. None of the dollar values were adjusted to present-day dollars.

\*\*\*This is the number of households served by the system but only 20 metered communal taps were part of the original design due to budgetary constraints.

## CHAPTER 7 CONCLUSIONS AND RECOMMENDATIONS

### 7.1 Conclusions

The design of water flow meters has evolved to address the needs of urban water supply and distribution systems. As importance of water resource management is increasingly recognized in rural community-managed systems, metering can offer solutions to manage demand, increase revenue recovery and promote social equity and transparency.

There is evidence that metering programs in rural community water systems are already being implemented through partnerships with private management companies or by international aid organizations and turned over to communities themselves to manage. There is no information available publicly, however, regarding how meters are selected, installed, and their long-term performance in rural systems. In fact, for those unfamiliar with metering concepts and technologies it can be very difficult to enter into a field with its own history and terminology which is passed on through institutional knowledge rather than in clear, relevant and publicly-available formats.

Multiple criteria decision analysis (MCDA), and particularly the Analytical Hierarchy Process (AHP) along with direct scoring of alternatives are tools that are simple enough to be used in the field. While there are concerns about indicator correlation when using these tools, they have become popular in numerically evaluating multiple technological alternatives against multiple criteria in the developing world water sector. A particularly attractive aspect of MCDA is that it can be facilitated by a field practitioner to gain stakeholder input regarding the goal and

criteria for meter selection. This study serves as an example for how MCDA could be applied for meter selection decisions in the field and while the nutating disc type of meter was found to be the most preferred, the result may be different when the analysis is performed with stakeholder and expert input. Because technical characteristics of rural community-managed systems vary and are not well documented, there is no single answer for a choice of meter or a set of specific weighted criteria to be considered. MCDA may also be carried out when more specific, local information is available regarding available models of meters.

Metering and consumption-based pricing are practices that could be well integrated with the community-management model, but ultimately the community should decide whether metering is the correct option. If metering is selected as the preferred option for pricing and demand equity, then community members should be trained in meter reading, use, and recordkeeping of meter reading data. In keeping with the best practices of community development work, the field development worker should involve the community in the meter selection process. Finally, the tariff scheme recommended here, is the increasing block type, in which a certain volume of water should be sufficiently priced to meet the needs of the poorest households. All the consumption beyond the first block would be priced at a higher rate. Individual service suspension is recommended only in cases where payment delinquency is not linked directly to income loss and in cases of blatant violations of water committee rules. While the actions are punitive, lack of action on the part of the water committee board can significantly affect its credibility and authority within the community.

After the meter selection process is complete, it is important to properly size the meter because poorly sized meters may contribute to pressure loss under high flow conditions at the tap where pressure head may be a concern. Oversized meters tend to significantly under-register

demand. Meter placement should be taken into consideration during service line sizing. It is recommended that locking valve boxes be used to house meters and shutoff valves before and after the meter. These boxes should be placed in areas not prone to flooding and not directly in highly-trafficked areas. Particular attention should be paid to the mounting position according to the meter manufacturer's specifications. After the installation, meters should be inspected to verify their functioning and to scope for possible leaks after the meter. After meter installation, accessories may be connected to the meter to determine the flowrate which could be a useful indicator for whether the design flow is achieved.

## **7.2 Recommendations**

Future studies examining the appropriateness of meters in rural, community-managed, piped water supply systems should strive to collect and analyze field data regarding: 1) technical characteristics of such systems, 2) technical performance of meters under various pressure and flow conditions (especially intermittent and partially-full pipe flows), 3) stakeholder preferences and involvement in the selection of a water meter, 4) availability and cost of meters, replacement parts, and maintenance requirements in developing countries. Indicator and criteria selection in meter decision analysis could be improved not only through stakeholder but also with expert participation.

Because implementation of a new metering program could mean significant economic costs, a cost-benefit analysis should be performed to determine whether in small systems metering results in improved revenue recovery and whether that has an effect on overall system maintenance and sustainability rates. Social effects of community-managed metering programs have been studied in urban settings but little information exists for rural, community-managed programs.

Finally, it has been proposed that urban developing world systems could benefit from the development of a new water meter design. The results of this study revealed that no single meter alternative identified as appropriate for residential metering in developed countries scored highly based on the criteria evaluated. There may be a need for a special meter design for rural community-managed systems. The ideal meter for community-managed rural systems in the developing world would be characterized by: 1) high tolerance of flow and pressure variations (this area needs more study), 2) high tolerance of particulates (the level of tolerance should be more specifically determined), 3) low failure rates and longevity (in order to minimize replacement due to scarcity of resources), 4) low- or no-maintenance requirements (with the possibility of local repair if needed) and 5) consistency in relative measurement accuracy (high absolute accuracy may not be as important for small systems because there are fewer users as compared to urban systems).

## LIST OF REFERENCES

- Aarras, N., Rönkä, M., Kamppinen, M., Tolvanen, H., & Vihervaara, P. (2014). Environmental technology and regional sustainability –The role of life-based design. *Technology In Society*, 36, 52-59.
- Ahrens, B. T., & Mihelcic, J. R. (2006). Making Wastewater Construction Projects Sustainable in Urban, Rural, and Peri-Urban Areas. *Journal of Engineering for Sustainable Development: Energy, Environment, Health*, 1(1), 13-32.
- Amiraly, A., & Kanniganti, A. (2011). The impact of a pilot water metering project in an Indian city on users' perception of the public water supply. Retrieved from <http://factsreports.revues.org/831>
- Annis, J. E. (2006). *Assessing Progress of Community Managed Gravity Flow Water Supply Systems Using Rapid Rural Appraisal in the Ikongo District, Madagascar* (Master of Science of Environmental Engineering), Michigan Technological University.
- Arnalich, S. (2010). *Gravity Flow Water Supply*: Arnalich.
- Arnalich, S. (2011a). *Epanet and Development. How to Calculate Water Networks by Computer*: Arnalich.
- Arnalich, S. (2011b). *Equipping a Borehole*: Arnalich.
- Arregui, F., Cabrera, E., Cobacho, R., & García-Serra, J. (2005). Key factors affecting water meter accuracy. *Proc. Leakage*.
- AWWA. (2012). *M6: Water Meters—Selection, Installation, Testing, and Maintenance* (5th ed.). Denver, CO: American Water Works Association.
- Bardos, P. (no date). Tools used in the determination of the wider effects of contaminated land or water management or other activities : Tools for Wider Effects. Retrieved February 26, 2016, from <http://www.eugris.info/FurtherDescription.asp?Ca=2&Cy=0&T=Tools%20for%20Wider%20Effects&e=67>
- Barfuss, S. L., Johnson, M. C., & Neilsen, M. A. (2011). *Accuracy of in-service water meters at low and high flow rates*. Denver, CO: Water Research Foundation.



- Bauer, A. M., & Brown, A. (2014). Quantitative Assessment of Appropriate Technology. *Procedia Engineering*, 78(0), 345-358. doi: <http://dx.doi.org/10.1016/j.proeng.2014.07.076>
- Behailu, B. M., Suominen, A., & Katko, T. S. (2015). Evolution of Community-Managed Water Supply Projects From 1994 to the 2010s in Ethiopia. *Public Works Management & Policy*, 20(4), 379-400. doi: 10.1177/1087724X15593955
- Belton, V., & Stewart, T. (2002). *Multiple criteria decision analysis: an integrated approach*. Springer Science & Business Media.
- BMeters.com. (no date). FAQ. Retrieved February 28, 2016, from <http://www.bmeters.com/en/faq.htm>
- Bouyssou, D. (2000). *Evaluation and decision models: a critical perspective* (Vol. 32): Springer Science & Business Media.
- Braithwaite, B. (2009). *Training Water Committees in Bocas del Toro, Panama: A Case Study of Peace Corps Volunteers' Initiative to Improve Rural Water System Management*. (Master of Science in Civil Engineering), Michigan Technological University.
- Breslin, E. D. (2010). Rethinking Hydrophilanthropy: Smart Money for Transformative Impact. *Journal of Contemporary Water Research & Education*, 145(1), 65-73. doi: 10.1111/j.1936-704X.2010.00084.x
- Brikké, F., & Bredero, M. (2003). Linking technology choice with operation and maintenance in the context of community water supply and sanitation.
- Campana, M. E. (2010). Hydrophilanthropy, WASH, and Experiential Learning in Developing Countries. *Journal of Contemporary Water Research & Education*, 145(1), 36-44. doi: 10.1111/j.1936-704X.2010.00080.x
- Castro, V., Msuya, N., & Makoye, C. (2009). *Sustainable Community Management of Urban Water and Sanitation Schemes (A Training Manual)*.
- Chambouleyron, A. (2003). An incentive mechanism for decentralized water metering decisions. *Water Resources Management*, 17(2), 89-111. doi: 10.1023/A:1023638823691
- Cinelli, M., Coles, S. R., & Kirwan, K. (2014). Analysis of the potentials of multi criteria decision analysis methods to conduct sustainability assessment. *Ecological Indicators*, 46, 138-148.
- Cleaver, F., & Toner, A. (2006). The evolution of community water governance in Uchira, Tanzania: The implications for equality of access, sustainability and effectiveness. *Natural Resources Forum*, 30(3), 207-218. doi: DOI 10.1111/j.1477-8947.2006.00115.x

- Dahanayake, K. (2007). *Community based small town water supplies case study from Sri Lanka*. Paper presented at the 2006 32nd WEDC International Conference: Sustainable Development of Water Resources, Water Supply and Environmental Sanitation, November 1, 2006 - November 1, 2006, Colombo, Sri Lanka.
- Davis, S. (2013). Meters for Management. Retrieved from <https://improveinternational.wordpress.com/2013/06/03/meters-for-management/>
- De Montis, A., De Toro, P., Droste-Franke, B., Omann, I., & Stagl, S. (2004). Assessing the quality of different MCDA methods. *Alternatives for environmental valuation*, 4, 99.
- Flowmeters.com. (no date). Positive Displacement Flowmeter Technology. 2016, from <http://www.flowmeters.com/positive-displacement-technology>
- Fraenkel, P., Barlow, R., Crick, F., Derrick, A., & Bokalders, V. (1993). *Windpumps: a guide for development workers*: Intermediate Technology Publications.
- Garfi, M., & Ferrer-Martí, L. (2011). Decision-making criteria and indicators for water and sanitation projects in developing countries. *Water Science & Technology*, 64(1).
- Guerra, A. J., Naaman, A. E., & Shah, S. P. (1978). *Ferrocement cylindrical tanks: cracking and leakage behavior*. Paper presented at the ACI Journal, Proceedings.
- Gumbo, B., Forster, L., & Arntzen, J. (2005). Capacity building in water demand management as a key component for attaining millennium development goals. *Physics and Chemistry of the Earth*, 30, 984-992.
- Hajkowicz, S., & Higgins, A. (2008). A comparison of multiple criteria analysis techniques for water resource management. *European journal of operational research*, 184(1), 255-265.
- Hanson, B. D. (1985). *Water and Sanitation Technologies: A Trainer's Manual*. . (Peace Corps Information Collection & Exchange Training Manual No. T-32). Washington, DC: Peace Corps.
- Harutyunyan, N. (2013). *The move to universal water metering and volumetric pricing in armenia*. Paper presented at the 2nd Annual International Conference Sustainable Design, Engineering and Construction, ICSDEC 2012, November 7, 2012 - November 9, 2012, Fort Worth, TX, United states.
- Harvey, P. A., & Reed, R. A. (2007). Community-managed water supplies in Africa: sustainable or dispensable? *Community Development Journal*, 42(3), 365-378. doi: 10.1093/cdj/bsl001
- Hazeltine, B., & Bull, C. (2003). *Field guide to appropriate technology*: Academic Press.

- Hollick, M. (1982). The Appropriate Technology Movement and Its Literature: A Retrospective. *Technology In Society*, 4, 213-229.
- ISO. (no date). About ISO. Retrieved Feb. 13, 2016, from <http://www.iso.org/iso/home/about.htm>
- Jeffery, T. D., Thomas, T. H., Smith, A. V., Glover, P. B., & Fountain, P. D. (1992). Hydraulic Ram Pumps: A guide to ram pump water supply systems.
- Jigabha, J. (1992). Water Metering Development in Dar es Salaam, Tanzania. Retrieved from <http://www.ircwash.org/sites/default/files/263-10124.pdf>
- Johnson, E. (2002). A Measured Step Toward Sustainability For Rural Community Water Supply: One Metering Strategy That Works. Retrieved from <http://idbdocs.iadb.org/wsdocs/getdocument.aspx?docnum=966096>
- Jones, G. F. (2010). *Gravity-Driven Water Flow in Networks*: John Wiley & Sons, Inc.
- Jordan Jr., T. D. (1984). *A Handbook of Gravity-Flow Water Systems for Small Communities*. London, UK: Intermediate Technology Publications.
- Kamruzzaman, A., Said, I., & Osman, O. (2014). Performance of Private Sponsors towards Sustainable Piped Water Supply in Rural Bangladesh. *Modern Applied Science*, 8(1), 83.
- Kaplinsky, R. (2011). Schumacher Meets Schumpeter: Appropriate Technology Below the Radar. *Research Policy*, 40, 193-203.
- Khawam, W., Virjee, K., & Gaskin, S. (2006). Water Demand Management Measures: Analysis of Water Tariffs and Metering in Barbados. *Journal of Eastern Caribbean Studies*, 31(2), 1.
- Kingdom, B., Liemberger, R., & Marin, P. (2006). The Challenge of Reducing Non-Revenue Water (NRW) in Developing Countries How the Private Sector Can Help: A Look at Performance-Based Service Contracting.
- Kreamer, D. K. (2010). Hydrophilanthropy and Education. *Journal of Contemporary Water Research & Education*, 145(1), 1-4. doi: 10.1111/j.1936-704X.2010.00077.x
- Laredo, D. (1991). Principles of Tariff Design for Water and Wastewater Services.
- Lockwood, H. (2004). Scaling Up Community Management of Rural Water Supply.
- Louise, A. (2004). *Sustainable Water Supply for the Village of Kpandu Davor, Volta Region, Ghana*. (Master of Water Resources: Hydroscience Concentration), The University of New Mexico, Albuquerque, New Mexico.

- Manser, N., Naughton, C., Prouty, C., Orner, K., Verbyla, M., & Mihelcic, J. R. (2015). Improving the Global Competency of Graduate Engineers Through Peace Corps Partnership and Long-Term International Service *Proceedings of the American Society for Engineering Education (ASEE) National Conference. Making Value for Society*. Washington Convention Center, Seattle, WA.
- McConville, J. R., & Mihelcic, J. R. (2007). Adapting Life Cycle Thinking Tools to Evaluate Project Sustainability in International Water and Sanitation Development Work. *Environmental Engineering Science, 24*(7), 937-948.
- Messenger, D. M. (2004). *Technical, Organizational, and Social Challenges of Project Development In Rural Latin America: A Honduran Case Study*. (Master of Science In Environmental Engineering), Michigan Technological University.
- Mihelcic, J. R. (2010). The Right Thing to Do: Graduate Education and Research in a Global and Human Context. In G. L. Downey & K. Beddoes (Eds.), *What Is Global Engineering Education For? The Making of International and Global Engineering Educators* (pp. 235-250). San Francisco, CA: Morgan & Claypool Publishers.
- Mihelcic, J. R., Fry, L. M., Myre, E. A., Phillips, L. D., & Barkdoll, B. D. (2009). *Field guide to environmental engineering for development workers: water, sanitation, and indoor air*: American Society of Civil Engineers (ASCE).
- Mihelcic, J. R., Phillips, L. D., & Watkins, D. W., Jr. (2006). Integrating a Global Perspective into Education and Research: Engineering International Sustainable Development. *Environmental Engineering Science, 23*(3), 426-438. doi: 10.1089/ees.2006.23.426.
- Murphy, H. M., McBean, E. A., & Farahbakhsh, K. (2009). Appropriate technology – A comprehensive approach for water and sanitation in the developing world. *Technology In Society, 31*, 158-167.
- Mutikanga, H. E. (2014). Residential Water Meter Selection Using the Analytical Hierarchy Process. *Journal - American Water Works Association, 106*, E233-E241. doi: 10.5942/jawwa.2014.106.0026
- Mutikanga, H. E., Sharma, S. K., & Vairavamoorthy, K. (2009). Water loss management in developing countries: Challenges and prospects. *Journal - American Water Works Association, 101*(12), 57-68.
- Mutikanga, H. E., Sharma, S. K., & Vairavamoorthy, K. (2011). Investigating water meter performance in developing countries: A case study of Kampala, Uganda. *Water SA, 37*(4). doi: 10.4314/wsa.v37i4.18

- Mutikanga, H. E., Sharma, S. K., & Vairavamoorthy, K. (2013). Methods and Tools for Managing Losses in Water Distribution Systems. *JOURNAL OF WATER RESOURCES PLANNING AND MANAGEMENT*, 139(March/April), 166-174. doi: 10.1061/(ASCE)WR.1943-5452.0000245
- Nauges, C., & Whittington, D. (2009). Estimation of water demand in developing countries: An overview. *The World Bank Research Observer*, 1-32.
- Okun, D. A., & Ernst, W. R. (1987). Community piped water supply systems in developing countries : a planning manual. Retrieved from <http://documents.worldbank.org/curated/en/1987/04/438801/community-piped-water-supply-systems-developing-countries-planning-manual>
- Olson, D. L. (2008). Chapter 15: Multi-Criteria Decision Support. In F. Burstein & C. W. Holsapple (Eds.), *Handbook On Decision Support Systems I*: Springer.
- Pauw, J. (2003). The Politics of Underdevelopment: Metered To Death—How a Water Experiment Caused Riots and a Cholera Epidemic. *International Journal of Health Services*, 33(4), 819–830.
- Posorski, R. (1996). Photovoltaic water pumps, an attractive tool for rural drinking water supply. *Solar Energy*, 58(4), 155-163.
- Radosevic, S. (1999). *International technology transfer and catch-up in economic development*. Cheltenham, UK: Edward Elgar.
- Richards, G. L., Johnson, M. C., & Barfuss, S. L. (2010). Apparent Losses Caused by Water Meter Inaccuracies at Ultralow Flows (PDF). *Journal-American Water Works Association*, 102(5), 123-132.
- RWSN. (no date). Sustainable Groundwater Development for Rural Water Supplies. Retrieved February 23, 2016, from <http://www.rural-water-supply.net/en/sustainable-groundwater-management>
- RWSN Executive Steering Committee. (2010) Myths of the rural water supply sector. *Rural Water Supply Network Perspectives: Vol. 4*. St. Gallen, Switzerland: The Rural Water supply Network (RWSN).
- Saeed, K. (1990). Managing Technology for Development: a Systems Perspective. *Socio-Economic Planning Sciences*, 24(3), 217-228.
- Sara, J., & Katz, T. (1997). *Making the rural water supply sustainable: Report on the impact of project rules*: UNDP-World Bank Water and Sanitation Program.
- Satterfield, Z., & Bhardwaj, V. (2004). Water Meters: Technical Brief.

- Schweitzer, R. W., & Mihelcic, J. R. (2012). Assessing sustainability of community management of rural water systems in the developing world. *Journal of Water, Sanitation and Hygiene for Development*, 2(1), 20-30. doi: 10.2166/washdev.2012.056
- Shah, S. (1979). Tentative recommendations for the construction of ferrocement tanks. *Special Publication*, 61, 103-114.
- Shields, D. J., Barfuss, S. L., & Johnson, M. C. (2012). Revenue recovery through meter replacement. *American Water Works Association*.
- Sianipara, C. P. M., Yudoko, G., Adhiutama, A., & Dowaki, K. (2013). Community empowerment through appropriate technology: sustaining the sustainable development. *Procedia Environmental Sciences*, 17, 1007-1016.
- Sohail, M. e. (2004). Water and Sanitation Tariffs for The Poor: Guidance Notes.
- Stewart, E. (2003). *How to Select the Proper Human-Powered Pump for Potable Water*. Michigan Technological University.
- Stone, L. J. (2006). *Suspension Canyon and Gully Crossings for Small Scale Community Aqueducts: A Design Guide Based on Experience and Observations From Peace Corps, Dominican Republic*. (Master of Science in Civil Engineering), Michigan Technological University.
- Swamee, P. K., & Sharma, A. K. (2000). Gravity flow water distribution system design. *Journal of Water Services Research and Technology-Aqua*, 49(4), 169-179.
- Sy, J. (2011). *Multi-Village Pooling Project in Indonesia : Handbook for Community-Based Water Supply Organizations*. Washington, DC: World Bank Retrieved from <http://documents.worldbank.org/curated/en/2011/10/15549958/multi-village-pooling-project-indonesia-handbook-community-based-water-supply-organizations>.
- Taylor, P., Jonker, L., Donkor, E., Guio, D., Mbodji, I., Mlingi, C., et al. (2005). Integrated Water Resources Management Plans: Training Manual and Operational Guide.
- Teknomo, K. (2006). Analytic hierarchy process (AHP) tutorial. Retrieved February, 2016, from [http://www.thecourse.us/5/library/AHP/AHP\\_Tutorial.pdf](http://www.thecourse.us/5/library/AHP/AHP_Tutorial.pdf)
- Uckrow, K., & Stephan, Y. (2012). Structure and Functions of WASH committees in rural areas.
- Water for People. (no date, February 25). Water For People's Blog. Retrieved from <http://waterforpeopleblog.tumblr.com/?og=1>
- WaterAid. (2013). Technical brief: Gravity-fed schemes. Retrieved from [www.wateraid.org/technologies](http://www.wateraid.org/technologies)

- Watt, S. (1988). *Ferrocement Tanks: Their construction and use: Intermediate Technology Publications, London.*
- Wicklein, R. C. (1988). Designing for appropriate technology in developing countries. *Technology In Society, 20*, 371-375.
- World Health Organization (WHO). (2000). Guidelines for drinking-water quality training pack. Retrieved from [http://www.who.int/water\\_sanitation\\_health/dwq/S19.pdf](http://www.who.int/water_sanitation_health/dwq/S19.pdf)
- Wright, E. (2013, May 14). Water Meters: The Unsung Heroes in Water Development. Blog Retrieved from [http://www.huffingtonpost.com/erin-wright/water-meters\\_b\\_2880023.html](http://www.huffingtonpost.com/erin-wright/water-meters_b_2880023.html)
- Yannopoulos, S. I., Lyberatos, G., Theodossiou, N., Li, W., Valipour, M., Tamburrino, A., et al. (2015). Evolution of water lifting devices (pumps) over the centuries worldwide. *Water*, 7(9), 5031-5060.

## **APPENDIX A: BACKGROUND INFORMATION**

### **A.1 Current Design Features for Rural Water Supply Systems and Water Committee Training Manuals**

The design for present-day rural water supply systems is guided by water distribution principles based on gravity-fed flow that date back millennia and are well documented (Jones, 2010). Because the principles are easily grasped by non-technical audiences, and the system design is minimalist (including only the necessary features for the system to function), it is no surprise that the gravity-fed design was quickly adopted along with the community-management model and the first manuals emerged midway through the International Drinking Water Supply and Sanitation Decade (Hanson, 1985; Jordan Jr., 1984; Okun & Ernst, 1987). While these manuals are still just as applicable today (and in fact Jordan Jr., 1984 is still used for training in the field) the gravity-fed design has evolved to satisfy different needs and adapted to include new tools and materials (Arnalich, 2010; Brikké & Bredero, 2003; Jones, 2010; Mihelcic et al., 2009; WaterAid, 2013). An example gravity-fed rural water supply system is depicted in Figure A.1 showing many of the components and features that may be included in the design. This example shows a system where water is pumped from low-lying sources to a storage tank on a hill, from which water is distributed via gravity to the users. The system depiction also includes additional components such as bleed valves, break pressure tanks, soak pits, and looped versus branched distribution networks. In fact, various resources have been developed that often focus exclusively on certain aspects of the gravity-fed design (Table A.1). While neither Table A.1 nor Figure A.1



are meant to be exhaustive resources for the various design components of gravity-fed water systems, these are included to highlight that to the author's best knowledge, however there is no such attention devoted to metering and enforcement in rural community-managed water supply systems. By providing technical guidance related to metering to field workers planning and implementing rural community-managed water supply systems, it would allow them to include this feature in the design and cost analysis of the project, thus also providing the opportunity to train and prepare the community to collect revenue and enforce tariff payment and usage rules.

Table A.1 Examples of gravity-fed system components and considerations that have received exclusive attention and evolved over time to become part of standard system design. This is not an exhaustive list but is merely an illustration to show the evolution and adaptation of the design in response to unique needs.

| <b>Aspect of Design</b>            | <b>Reference</b>                                                                                                      |
|------------------------------------|-----------------------------------------------------------------------------------------------------------------------|
| Estimating Demand                  | (Nauges & Whittington, 2009)                                                                                          |
| Pumps                              | (Arnalich, 2011b; Brikké & Bredero, 2003; Fraenkel et al., 1993; Jeffery et al., 1992; Posorski, 1996; Stewart, 2003) |
| Storage tanks                      | (Guerra et al., 1978; Shah, 1979; Watt, 1988)                                                                         |
| Pipeline gully crossings           | (Stone, 2006)                                                                                                         |
| Use of computer software in design | (Arnalich, 2011a)                                                                                                     |
| Tariff Setting                     | (Sohail, 2004)                                                                                                        |
| Water Committee Training           | (Braithwaite, 2009; Castro et al., 2009; Uckrow & Stephan, 2012)                                                      |
| Soak Pits                          | (Ahrens & Mihelcic, 2006)                                                                                             |
| Distribution network design        | (Swamee & Sharma, 2000)                                                                                               |
| Groundwater development            | (RWSN, no date)                                                                                                       |

It is interesting to note some similarities between water pumps and water meters. The lifting of water has a history just as long as the measurement of water, going back millennia and similarly, modern versions of electric pumps began appearing in the early-20<sup>th</sup> century (Yannopoulos et al., 2015). Both technologies (meters and pumps) depend on moving parts and in some cases may use electricity (more modern types of meters require electricity to perform measurements or in some cases only the recording and reading devices that accompany meters may be electric), thus

there are legitimate concerns regarding the operations and maintenance stages of the project with such components. Generally, many consider technologies requiring electricity, having moving parts, not reproducible locally, to be inappropriate for use in the developing world due to the limited local expertise and availability of parts in case of device failure (Radosevic, 1999). While these technologies may not be generally applicable, there is a long track record of successful application of water pumping devices in the developing world (Brikké & Bredero, 2003; Hazeltine & Bull, 2003). Although the goal is often to provide the simplest and cheapest device possible that will perform the desired function, there is also recognition that developing country citizens are actually interested in becoming modernized, especially with the rising incomes of the poor and there is an argument for using “intermediate technology” (Kaplinsky, 2011; Wicklein, 1988). Inherently, there may be risks of introducing a technology with which the community managing the water system is unfamiliar, but often these risks may be addressed through training and capacity building by the field workers, especially with the appeal of modernity motivating the community to accept such technologies.

Although there are many examples of situations where a hydrophilanthropic mission completed the construction of a rural supply system in a short period of time and left without ever providing meaningful training to the community, there is also evidence that many understand the importance of training for local communities as demonstrated through the formation of water committees and existing training manuals (Uckrow & Stephan, 2012). Many community training manuals have been developed by field workers over the years but are often unpublished, and may belong to the agency that employed/supported the field workers. Furthermore, they are often prepared in the language of the target audience, which is often not English. It is therefore difficult to perform an in-depth review of existing materials but key

contents of water committee training manuals are summarized in English and the manual used by the author during her Peace Corps Service, in Spanish. In keeping with the principles of the community management model, water committee training manuals include many capacity-building topics that range from basic understanding of the water cycle and water system composition, to planning and bookkeeping. All the manuals include activities to codify the use of water, payment of tariffs, and roles and responsibilities of water committee members into statute. Some of the proposed rules also mention enforcement, for example “what are the consequences of delinquency in payment?”, “what are the consequences of using water for uses other than those allowed by committee statutes?”, “what are the consequences for illegally connecting to the system?”. The answers to these questions vary by and is often largely left up to the community to decide under the (misguided) notion that the community is united and capable of enforcement on its own statutes (Cleaver & Toner, 2006; Johnson, 2002). In the developed world, it is assumed that users will behave in ways so as to contribute to the greater good by conserving water, paying (on time) for the service they receive, and avoiding tampering with regulated equipment and water utilities, either private or public, have a keen interest in protecting their investment and recovering revenue. Such assumptions would not stand in the developing world setting. While in some cases the water committees may include rules that range from financial penalties, to exclusion from the project, to legal proceedings during the training process, in practice, the community often does not proceed with these enforcement measures because the system design does not include enforcement mechanisms (e.g., meters for measuring the actual amount of water consumed in case of misuse accusations, and locked valve boxes at individual taps to shut off service). Setting of rules by the water committee has been found to have a significant impact on the overall project success (Sara & Katz, 1997). If the water

committee does not enforce its own rules is seen as impotent within the community, additional violations of committee rules by members and users who witness their neighbors getting away without consequences will occur. The author witnessed all communities in surrounding villages struggling with this issue. All of the surrounding villages had been beneficiaries of water systems through the efforts of hydrophilanthropists. In some cases, no water committee had been formed and in some cases it had dissolved, but even in those communities that still had a water committee none had successful mechanisms of enforcing their rules. The water supply to the entire village (i.e., even the users who may have been in compliance) was periodically shut off until the non-compliant users resolved their debts or misuse issues. This easily breeds discontent among the compliant users and even contributes to social and political discord in the community. Many ask, “Why should I suffer for the sins of my neighbor?” (The issues associated with service shut-off are discussed in the following section). Thus, it is proposed that through installation of meters and protective and locking valve boxes accompanied by training of water committees in rural, piped community-managed water systems, the need to measure water can be addressed in order to set fair pricing, manage demand and enforce water committee rules.

Somewhat surprisingly, a water committee manual written for community-based organizations (CBOs) in Indonesia does refer to metering as a pricing and demand-management strategy (Sy, 2011). However, metering is not addressed by in the design section the manual, but only at a high level in the O&M and Financial Reporting phases of the project. The manual is based on participatory, demand-led community management framework, but it also incorporates elements of utility management. For example, members of the water committee board and special teams are employed and compensated (whereas often with rural water committees, these members are often volunteers, especially if the committee does not generate sufficient income).

It is suggested that the meter reader within the water committee organization should report to the head of operations, who in turn reports to the general manager (or president) and tips about performing meter reading in conjunction with billing are provided. Meter rental fees and meter reading routes are briefly mentioned. There is no information provided, however, for what types of meters are to be used, how to install, read (even though a sample meter reading record sheet is provided), and maintain them, when to replace them, how to inspect for evidence of tampering, etc. In contrary, other sections do address pump design and troubleshooting issues, source flow measurement, pipe sizing, demand calculations, and other in detail. No reference is provided for water metering, thus this work could fill at least part of this gap because it is unlikely that local community members or even field workers will have this knowledge independently.

## **A.2 Brief History and Current Situation of Meters**

The recognition of importance of measuring the flow of water delivered via conduit was documented as early as the Roman times but a good understanding of factors influencing the flow of water (i.e., velocity and area of channel/conduit) did not begin to emerge until the early 18<sup>th</sup> century, when Henri Pitot began experimenting with glass tubes in the river Seine (AWWA, 2012). Today, the practice of measuring the flow of water in pipes, the practice also known as metering, is nearly universal in developed countries. Particularly, entities that are in charge of producing and delivering water to users (e.g., utilities) see this practice as being beneficial because metering allows to: recover revenue, determine fair pricing for customers, manage demand, and troubleshoot system problems. When it comes to choosing a meter for installation to monitor residential water consumption, there is almost an unquantifiable number of meters to choose from. The choice is not only in brands of meters, it is also in the types of mechanisms that are employed to detect flow, since it cannot be measured directly. Between 18<sup>th</sup> century and

middle of the 20<sup>th</sup> century, meter development boomed around world, with hundreds of patents being registered in the United States for various technologies at the end of the 19<sup>th</sup> and beginning of the 20<sup>th</sup> century (AWWA, 2012). The standardization of meters, however, began only in 1913 in the United States but remained much less organized abroad (AWWA, 2012). The International Standards Organization produces standards for measuring flow, but it is a private, non-governmental entity made up of a voluntary member body which came about in 1946 (ISO, no date). In Europe, individual countries (e.g., the Danish Standard) may also have their own standardization practices as well as the CEN (European Committee for Standardization), which means that different entities may produce different standards.

It is also important to note that while standards may exist, it would take a significant investment of time for a field worker not familiar with the technical language used in metering to study the defined terminology as well as the underlying concepts. A well-funded, multi-year study evaluating new meter versus used meter performance in the United States cited statistics about which meter brands and types are common not from published sources but from personal interviews with a representative of Master Meter, a prominent manufacturer of water meters in the United States (Barfuss et al., 2011). Unsurprisingly, to an “outsider” designing and implementing a rural water supply system, trying to make sense of the disjointed information about water meters that is generally applicable to urban systems, this can be a daunting task. This work, while not comprehensive, is the first attempt to the author’s best knowledge to give a centralized resource to a development field worker interested in maximizing the sustainability potential of a rural water supply system through the practice of metering.

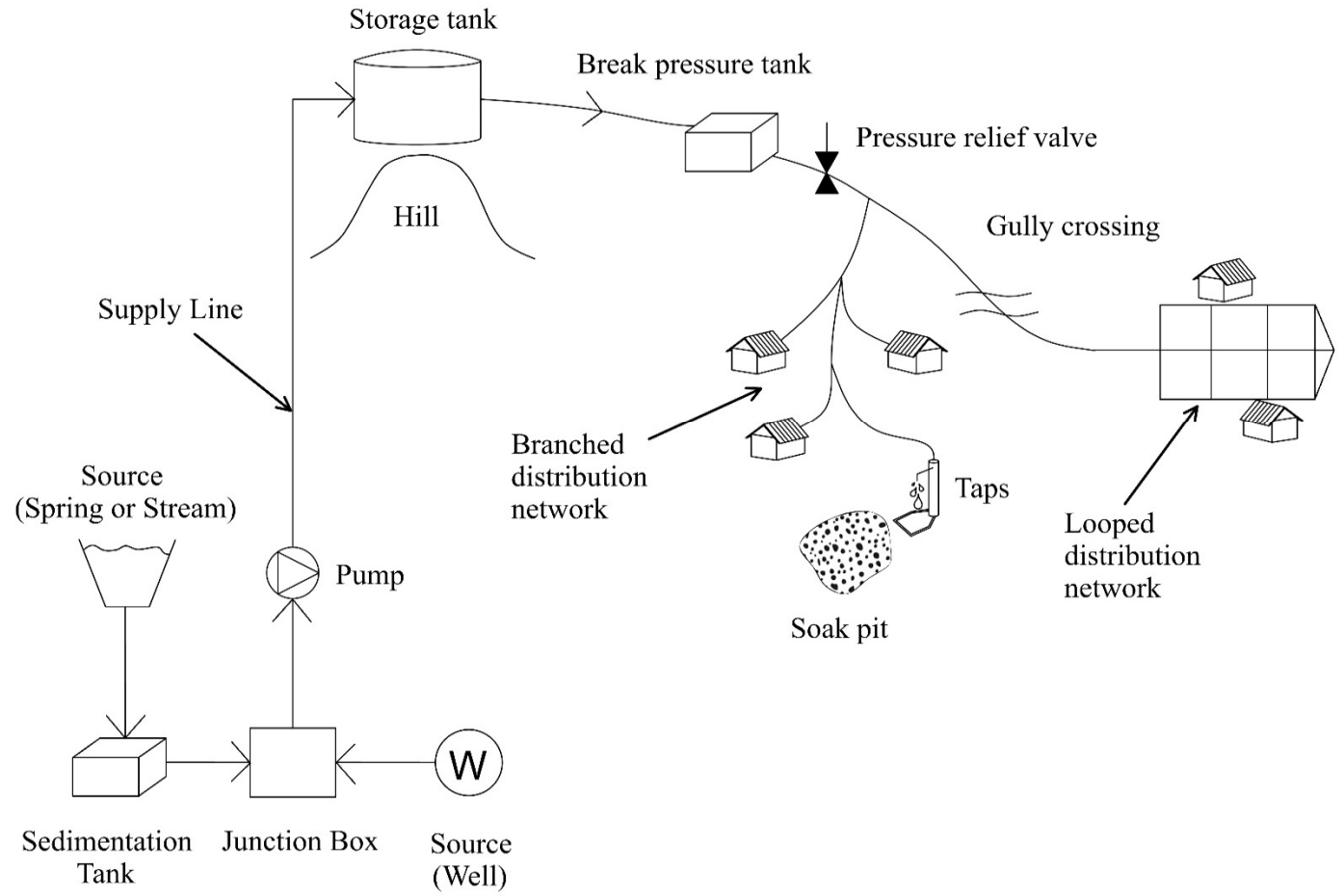

Figure A.1 Example rural water supply system. It is unlikely that an actual system would include all of these components in this order but is presented here merely for purposes of example. Adapted from various sources and the author's experience.

### A.3 Additional Meter Installation Details

#### A.3.1 Meter Mounting Position

One of the biggest contributors to meter accuracy degradation is the stress created on meters due to improper positioning and mounting (AWWA, 2012; Barfuss et al., 2011; Mutikanga et al., 2009, 2011). All meters are designed to be mounted horizontally, with the register pointing up. Some meter models may be designed to be mounted in additional positions such as those shown in Figure A.2 which can be mounted vertically or horizontally but with the register pointed to either side. Very few meters are designed to be installed upside down, which means horizontally with the register pointing down. In fact, most meters have only one mounting position as indicated in Figure A.3 and this is always the preferred position.

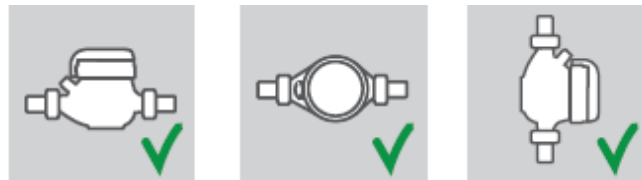

Figure A.2 Example of a meter that may be mounted vertically, horizontally, and on its side. It is important to review the manufacturer's specifications sheet accompanying the meter not only prior to installation, but when deciding their appropriateness. Reprinted with permission from BMeters.

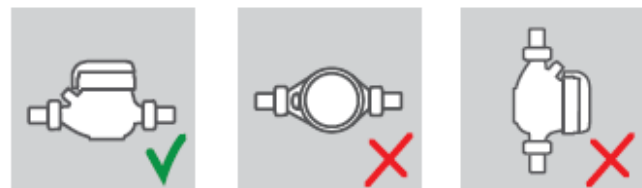
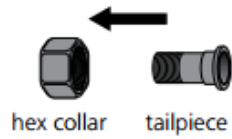

Figure A.3 Example of a meter that should only be mounted horizontally. It is important to review the manufacturer's specifications sheet accompanying the meter not only prior to installation, but when deciding their appropriateness. Reprinted with permission from BMeters.



### INSTALLATION STEPS

1. Insert tailpiece through threaded hexagonal collar.



2. Wrap pipe thread tape around the threads of the tailpiece.

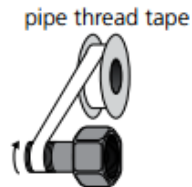

3. Thread tailpiece into pipe or threaded coupling.

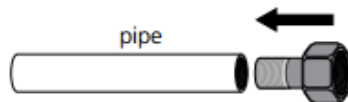

4. Insert soft flat washer seal into hex collar.

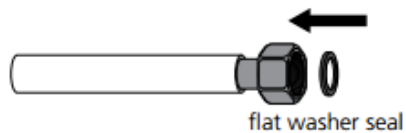

5. Repeat Steps 1 - 4 with the other tailpiece, hex collar, and seal on other pipe.

6. Slide collars back and position meter with the register in desired position.  
Be sure to check the flow direction. (see drawing on front cover for arrow locations)

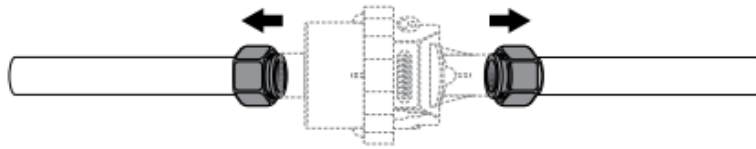

7. Thread collars onto both ports of the meter and tighten by hand. Then hold meter in place and tighten collars 1/4 turn more with a wrench.

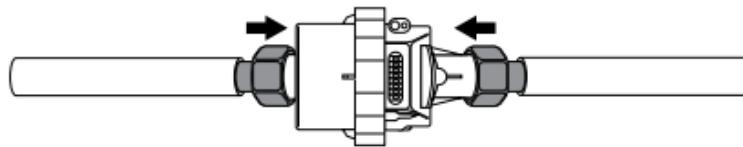

Figure A.4 Example instructions for application of thread seal tape printed in accompanying meter specifications sheet. Reprinted with permission from [www.flows.com](http://www.flows.com), © Assured Automation 2015.

### A.3.2 Post-installation Inspection

After the meter is installed, the connections should be checked for leaks. Also, in the meter dial there is usually a small triangular piece that rotates when water is flowing through the meter (see Figure A.5). This may be referred to as flow or trickle indicator. If water is turned off at the tap, this arrow piece should not move. Movement in the flow indicator when all the connections on the service line are off indicated that there is a leak somewhere between the meter and the tap(s). Conversely, if water is flowing at the tap but the indicator is not moving this is indicative of a “struck” meter (a meter that no longer registers flow). The meter may be dismantled, inspected and possibly repaired if the technician possess the required knowledge and skills, otherwise the meter should be replaced. As with all the other parts of water system project, there should be a surplus of about ten percent with meters. The technician should plan to purchase more meters than the number of metered connections planned anticipating the need for several exchanges. AWWA recommends scheduled meter replacement increments of ten years.



Figure A.5 A typical register display with emphasis added to highlight the flow sensor. Reprinted with permission from [www.flows.com](http://www.flows.com).

### **A.3.3 Meter Accessories**

Many meters have may be equipped with single-use anti-tampering devices meant to indicate whether a meter has been opened or in the case of jet meters, whether the calibration valve has been adjusted. Another option is for connecting a pulse reading device which allows to estimate the flowrate (which may be a useful statistic in trying to evaluate the design flow and diagnose possible system errors and in characterizing many unknown characteristics of rural water systems). A valve box is recommended in lieu of anti-tampering devices in a developing world setting. Once a meter has been tampered with, there is often little that the water committee can do to correct the behavior of the individual. The meter would also need to be replaced. A valve box at once protects the meter and the shutoff valve which can be used as an enforcement mechanism for nonpayment of tariffs or violation of water committee rules.

### **A.4 Community-management Model**

The community-management model is well-documented and has been used for several decades in lieu of publicly owned utilities to install and manage services such as water supply in the developing world (Annis, 2006; Behailu et al., 2015; Hanson, 1985; Lockwood, 2004; Okun & Ernst, 1987; Sy, 2011). It is a particularly attractive model in rural areas with small populations because these settlements are otherwise unlikely to receive attention from their own governments which direct scarce resources to more densely-populated areas. While it is not the goal of this work to analyze the community-management model, it is worthwhile to summarize some of the general concepts and assumptions of this model. These are important to note when considering the incorporation of metering into a rural community-managed water supply system because metering has traditionally been instituted by water utilities which originated in urban settings, with many resources and oversight provided by governments in place, and having

specialized technical expertise – the characteristics which are often in contrast to rural communities in the developing world managing their own water supply systems. The community-management model became popular as a result of the World Health Organization’s (WHO’s) International Drinking-Water Supply and Sanitation Decade (IDWSSD) (proclaimed in 1980) aimed to increase access to improved drinking water around the world (Annis, 2006; Behailu et al., 2015; Lockwood, 2004). Grounded in the demand-responsive and participatory frameworks, the community-management model marked a shift from “supply-driven” to “bottom-led” development, meaning that donors and international actors became more interested in the voices and contributions of the very communities in water projects were being implemented (Annis, 2006; Cleaver & Toner, 2006; Lockwood, 2004). The community-management model can be broadly summarized in Figure A.6 as having three desired outcomes of: empowerment of local communities, efficiency through means of local knowledge and resources, and sustainability of the rural water supply system. The principles for achieving these broad objectives can be summarized as: participation by and broad support of the community, control either through direct management of the water supply system or indirectly through decision-making during all the phases of the project, ownership of the system by the community which includes rules and enforcement, and lastly, sharing of costs for the project since this is thought to increase community buy-in. Four general groups of non-community actors may be involved in driving the community-management model can be summarized as: governments (of the host country) for whom this model is attractive as it allows the already-scarce resources to be maximized, donors who see this as a way to circumvent the often-corrupt government processes, field-development organizations (e.g., non-governmental organizations) who generally advocate for the community and may be services providers assuming a quasi-government role in some

communities, and multilateral lending institutions (such as the World Bank) who find it attractive because it increases the ties between the private and civil sectors. It also needs to be pointed out that the underlying characteristic of the community management model is time – it takes much longer to implement a project following this model as compared to a supply-driven approach, because it takes time to engage the community and carry out the project at the local-community scale (e.g., in terms of material, labor, expertise, etc.) (Lockwood, 2004). Two groups of factors can make it difficult to achieve the objectives: 1.) internal limitations may refer to social or political conflict within the community, insufficient revenue, lack of maintenance, lack of capacity, and 2.) external constraints can mean poor system designs, poor implementation, government interference, unavailability of spare parts, lack of external support after project is completed. Another very important characteristic to note is that while the model is in its third decade of use, it is adaptive or still considered to be evolving (Behailu et al., 2015; Cleaver & Toner, 2006; Lockwood, 2004). Many organizations and individuals involved in rural water system projects have learned a lot of lessons through trial and error in the field over time and this process of what works well and what should be avoided, continues.

Many benefits of the community-management model have been realized, but there are also many examples of where rural water supply systems failed because there is no single approach to be followed in all communities and what works in one may not work in another (Schweitzer & Mihelcic, 2012). Table A.2 includes a brief summary of commonly-cited benefits and drawbacks of the community-management model. One important observation that should be made is that while the community-management model is imperfect and not ideal in all situations, it has endured and continues to evolve. This is because of the nature of the problem – there is a lack of other entities (either governmental or non-governmental) which would be prepared and

willing to take on the management of rural water supply systems in the developing world, thus the responsibility has been transferred to the community itself. In the late 2000s, the term “hydrophilanthropy” was coined by a university professor for “the altruistic efforts of colleagues to provide sustainable, clean water for people and ecosystems worldwide” (Kreamer, 2010). This was not just an academic exercise but in response to academic programs encouraging “experiential learning” for engineering students (the author of this work is one of these students) which combine coursework on campus and practical work often in a developing country (Campana, 2010; Manser et al., 2015; Mihelcic, 2010; Mihelcic et al., 2006). While this term originally referred to academic field workers, it is certainly applicable to all entities doing not-for-profit water development work worldwide and it has been increasingly noted, however, that often philanthropic and altruistic organizations or individuals descending on a community may not have the skills, the time, or the willingness to engage the community properly in a meaningful way (Breslin, 2010; Cleaver & Toner, 2006; RWSN Executive Steering Committee, 2010). There is no single “right answer” when it comes to community-management and it often requires patience on the part of the development worker to adapt it to the community at hand. As an example, the model has been successfully applied on a much larger scale, to a town-sized system in Sri Lanka with several thousand connections, where government support for water supply was absent (Dahanayake, 2007). The benefits and the drawbacks inherent to the model may occur in the pre- and post-construction phases and some may affect the long-term viability of the system. The relationships between those drawbacks and effects on system sustainability have been studied by others and this thesis proposes that some of the drawbacks of the community-management model may be addressed through the adoption of water meters in rural water supply systems.

While many studies have focused on identifying factors affecting sustainability of community-managed systems, Schweitzer and Mihelcic (2012) found that none directly addressed the community management aspect after construction had been completed. One of the eight main factors affecting a system's sustainability that they identified is tariff payment and while in the developed world metering and enforcement are well-accepted methods for setting tariffs and ensuring their collection, these are not common practices in the developing world. The same study found that tariff payment and transparency tended to decrease with the age of community managed systems and suggested that this may be due to the decrease in social capital originally acquired once the project is finished. A correlation was also found between higher incidence of tariff payment and increase in time spent on maintenance of the system as well as money paid out as wages to its stewards (Schweitzer & Mihelcic, 2012). Successfully employing meters for measuring household water consumption might contribute to enhancing transparency in the years after construction and an effective enforcement strategy would encourage continued payment of tariffs. Often, only the perception of inequity is sufficient to stir dissatisfaction and a break in the payment of tariffs, for example, if everyone in the community is being charged a flat fee while some households may be using much more water than others. Whereas if the meters are installed correctly and the community trusts that they are functioning fairly and that they are being charged fairly, based on the amount of water they actually use, they may be less likely to stop paying their tariffs on the grounds of dissatisfaction with (perceived) inequity. Certainly, continuous intake of revenue can mean the difference between a well-maintained system that serves its population or a failed one that no longer delivers improved water to rural households. Due to the adaptive nature of the community-management model and the benefits that metering

promises in terms of system sustainability, this practice could be well suited for integration into community-managed rural water supply systems.

Table A.2 Example benefits and drawbacks of community-management model in rural water supply work.

| <b>Benefits</b>                                                                                                                                                                                                                                                                                                                                                                                                                                                                                                             | <b>Drawbacks</b>                                                                                                                                                                                                                                                                                                                                                                                                                    |
|-----------------------------------------------------------------------------------------------------------------------------------------------------------------------------------------------------------------------------------------------------------------------------------------------------------------------------------------------------------------------------------------------------------------------------------------------------------------------------------------------------------------------------|-------------------------------------------------------------------------------------------------------------------------------------------------------------------------------------------------------------------------------------------------------------------------------------------------------------------------------------------------------------------------------------------------------------------------------------|
| <ul style="list-style-type: none"> <li>- Participatory approach (demand-led, recognizes social norms)</li> <li>- Promotes equity</li> <li>- Seeks participation from local entities and institutions to further longevity of systems</li> <li>- Builds capacity (technical, democratic, administrative, institutional, etc.)</li> <li>- Inclusive of vulnerable populations (e.g., women, the poor)</li> <li>- Seeks transparency and accountability</li> <li>- Inspires ownership of water systems by community</li> </ul> | <ul style="list-style-type: none"> <li>- Participation is not necessarily representative</li> <li>- Glamorizing or “mythologizing” of intra-community dynamics</li> <li>- Lengthy process</li> <li>- Need for strong external actors</li> <li>- No follow-up from those external actors post-construction</li> <li>- Lack of technical expertise in community</li> <li>- Lack of resources within the for tariff payment</li> </ul> |
| Sources: (Behailu et al., 2015; Lockwood, 2004)                                                                                                                                                                                                                                                                                                                                                                                                                                                                             | Sources: (Clever & Toner, 2006; Lockwood, 2004)                                                                                                                                                                                                                                                                                                                                                                                     |



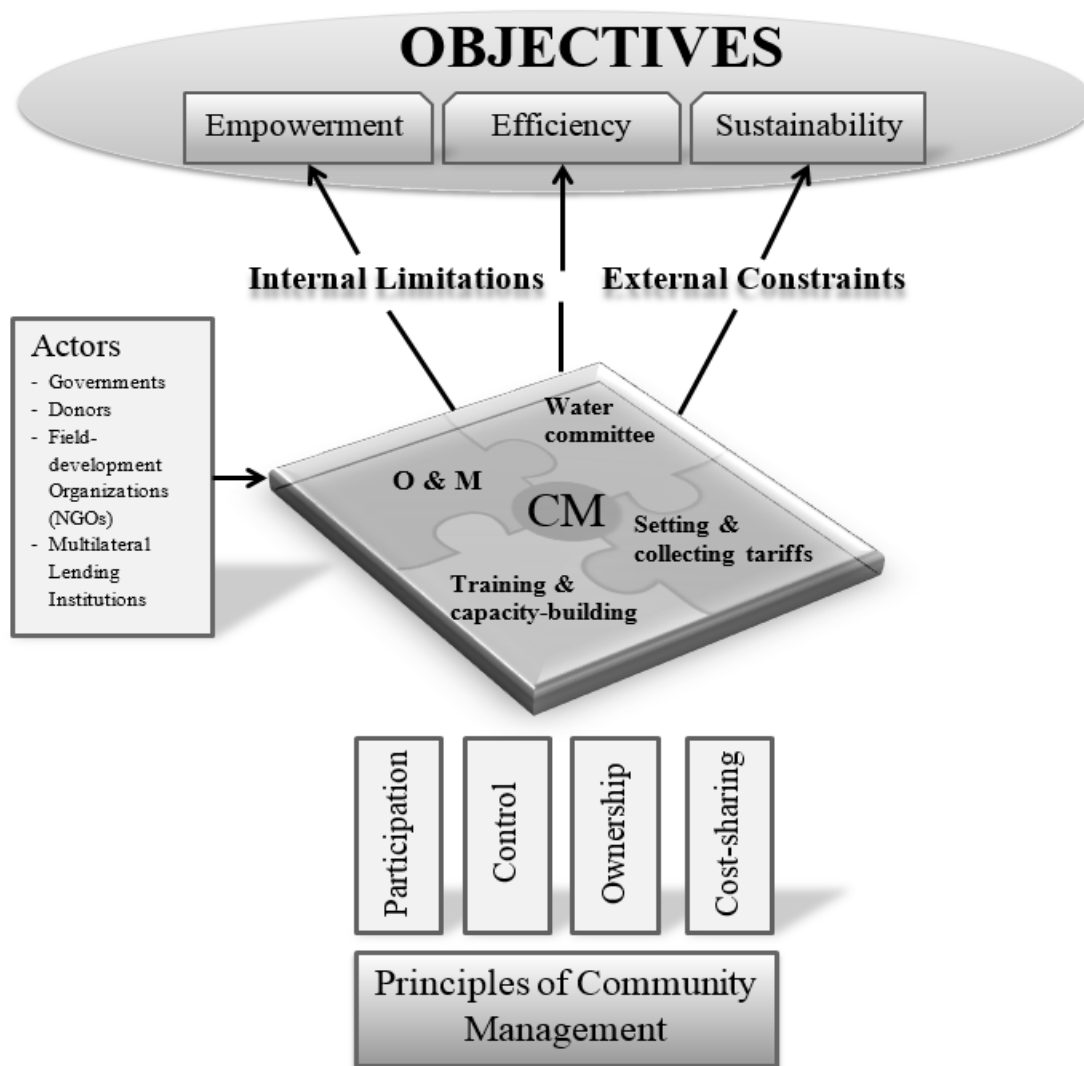

Figure A.6 Summary of the community-management model applied to rural water systems. Adapted from (Annis, 2006; Harvey & Reed, 2007; Lockwood, 2004).

## APPENDIX B: COPYRIGHT PERMISSIONS

Below is permission for the use of material in Figure 15 in Chapter 3. Private information has been redacted.



### MEMORANDUM

To: Simona Platukyte  
From: Megan Karklins  
Date: February 29, 2016  
Re: Copyright permission request

The Water Research Foundation is pleased to grant you permission to reprint Figures 1.1 – 1.4 from the report, *Accuracy of In-Service Water Meters at Low and High Flow Rates*.

This one-time royalty-free permission is for use in your master's thesis.

Please add the following source line to the copyrighted material:

Barfuss, S.L., M.C. Johnson, and M.A. Neilsen. 2011. *Accuracy of In-Service Water Meters at Low and High Flow Rates*. Denver, Colo: Water Research Foundation. Reprinted with permission.

We appreciate your diligence in obtaining permission to use these copyrighted materials.

  
Megan Karklins  
Content Manager

2/29/16  
Date

Below is permission for the use of material in Figure 15 in Chapter 3. Private information has been redacted.



The following materials: Recordall Disc Series Meters Parts List  
[https://bmnorthamericaprod.blob.core.windows.net/public/contact-us/us/84228301-b24f-4757-9180-7fff9352f75a/copyrequest-lead-free%20bronze%20alloy%20models%20120%20and%20170%20parts%20list%20rdm-ps-00051-en%20\(1\).pdf](https://bmnorthamericaprod.blob.core.windows.net/public/contact-us/us/84228301-b24f-4757-9180-7fff9352f75a/copyrequest-lead-free%20bronze%20alloy%20models%20120%20and%20170%20parts%20list%20rdm-ps-00051-en%20(1).pdf)

will be used in (type of media) University of South Florida thesis on water flow metering in the developing world  
developed by (name of company producing materials) Simona Platukyte, student  
are hereby granted (name of company requesting permission) Simona Platukyte, student  
non-exclusive license to all rights including them right to reproduce, prepare derivative works, re-use, publish, publicly display and perform, and distribute the materials and to sublicense these rights. All materials will be credited:

**"Courtesy of Badger Meter, Inc. Milwaukee, WI"**

Badger Meter also waives all rights or claims against your organization and any of its affiliates, subsidiaries, licensees, assignees or distributees resulting from the exercise of this license of use of the above materials. Badger Meter is donating these materials and these license rights and, as such, do not expect any nor will receive any compensation.

Please select one of the following options:

Badger Meter grants the permission to use any picture found on this website: [www.badgermeter.com](http://www.badgermeter.com)

Badger Meter grants the permission to use only the pictures found listed below:

**Badger Meter, Inc.**

Company

**Jay Schoenwaelder** Digitally signed by Jay Schoenwaelder  
Date: 2016.03.03 07:27:24 -06'00'

Authorized Signature

*(Please be sure you checked off one of the above boxes)*

**Jay Schoenwaelder**

Print Name

**3/3/2016**

Date

**Simona Platukyte, student**



**Simona Platukyte**

Print Name





**3/4/16**

Date

**Credit/Permission Form**

Below is permission for the use of material in Figures 18, and 19, in Chapter 3, as well as Figures A.2 and A.3 in Appendix A.

I: Copyright Permission Request Inbox x

 B METERS srl - Export office <  5:46 AM (8 hours ago)   

to me 

Dear Simona,

there's no problem you can use both diagrams.

Good luck for your thesis.

Best regards

LAURA LEOTTA  
Sales department



B METERS s.r.l.  
via Friuli 3 - 33050 GONARS (UD)  
Ph. [+39 0432 931415](tel:+390432931415)  
FAX [+39 0432 992661](tel:+390432992661)  
[export@bmeters.com](mailto:export@bmeters.com)  
[www.bmeters.com](http://www.bmeters.com)

Follow us on  



15-18 Marzo / March 2016 | Fiera Milano

PAD 5 STAND S23 T26

Below is permission for the use of material in Figures 9, 20, 21, 22, 25, 26, 28, and 29, in Chapter 3, as well as Figures A.4 and A.5 in Appendix A. Private information has been redacted.

Michelle Farrell <michellef@flows.com>  
To: Simona Platukyte <splatuky@mail.usf.edu>

Fri, Mar 4, 2016 at 10:04 AM

Simona,

Ok. Here's what I have for you....

Page 2 of AA Copy request: Please use the photo attached to label. In addition, be careful as to which direction the water flows through the meter (in the photo you originally used there is an arrow on the neck of the meter that is visible and it's pointing in the opposite direction of the arrow in your label).

Also, in the text please correct Advanced Automation to Assured Automation.

[Redacted]

Other than the changes indicated, we give you permission to use the photos and images that you've indicated in the attachments you've sent us.

GOOD LUCK!

Best Regards,

3/15/2016 9:  
[Redacted]

*Michelle Farrell*  
www.Flows.com  
855-871-6091  
michellef@flows.com

Below is permission for the use of material in Figure 14, Chapter 3. Private information has been redacted.

contactNA <contactNA@sensus.com> Wed, Mar 9, 2016 at 10:52 AM  
To: "splatuky@mail.usf.edu" <splatuky@mail.usf.edu>

Sensus authorizes the use of the requested diagram as described below. If you need any additional information on water meters, please contact me directly.

Travis Smith | Sr. Product Manager Water Metering  
639 Davs Drive | Morrisville, NC 27560 USA  
T: 919-376-2671 | M: 919-710-1923  
travis.smith@sensus.com | [www.sensus.com](http://www.sensus.com)



From: Simona Platukyte [mailto:splatuky@mail.usf.edu]  
Sent: Tuesday, March 08, 2016 12:46 AM  
To: contactNA  
Subject: Sensus.com Contact Form Submission

From: Simona Platukyte  
[REDACTED]  
Email Address: [splatuky@mail.usf.edu](mailto:splatuky@mail.usf.edu)  
Company: University of South Florida  
Country: United States  
Message:  
Greetings,

3/15/2016 10:1  
ity of South Florida Mail - RE: Sensus.com Contact Form Submi... <https://mail.google.com/mail/u/0/?ui=2&ik=164d4ce0b8&view=pt>

I am graduate environmental engineering student at the University of South Florida, Tampa, FL writing a master's thesis on the topic of water flow metering in the developing world.

I would like to request permission to reprint in my thesis the diagram of an oscillating piston meter that appears on your product specification sheet. The document is a Parts List that corresponds to accuSTREAM meters 5/8", 3/4", 1" (MP-W-SRA-00-01-0911-05-A), with the figure on page 2 of 3 being the particular figure I am interested in.

If granted permission, I would like to modify the diagram only to add the names of some of the major components of the meter, so as not to have to include the accompanying parts list on another page. Full credit will be given to Sensus.

This figure is only intended as illustration of complexity/number of parts and for showing differences between various metering mechanisms.

Please let me know if you require more information.

Thank you in advance,

Simona Platukyte