

2010

Depression in lung cancer patients: Role of perceived stigma

Brian D. Gonzalez
University of South Florida

Follow this and additional works at: <http://scholarcommons.usf.edu/etd>

 Part of the [American Studies Commons](#)

Scholar Commons Citation

Gonzalez, Brian D., "Depression in lung cancer patients: Role of perceived stigma" (2010). *Graduate Theses and Dissertations*.
<http://scholarcommons.usf.edu/etd/1645>

This Thesis is brought to you for free and open access by the Graduate School at Scholar Commons. It has been accepted for inclusion in Graduate Theses and Dissertations by an authorized administrator of Scholar Commons. For more information, please contact scholarcommons@usf.edu.

Depression in Lung Cancer Patients: Role of Perceived Stigma

by

Brian D. Gonzalez

A thesis submitted in partial fulfillment
of the requirements for the degree of
Master of Arts
Department of Psychology
College of Arts & Sciences
University of South Florida

Major Professor: Paul B. Jacobsen, Ph.D.
Jennifer Bosson, Ph.D.
Thomas Brandon, Ph.D.

Date of Approval:
March 1, 2010

Keywords: psycho-oncology, mood disorders, thoracic oncology, smoking, tobacco

© Copyright 2010, Brian D. Gonzalez

Dedication

To my loving wife Rebecca, whose support and understanding throughout this process has been invaluable. I love you forever.

Table of Contents

List of Tables	ii
List of Figures	iii
Abstract	iv
Introduction	1
Lung Cancer	1
Depression in Lung Cancer Patients	2
Correlates of Depression in Lung Cancer Patients	3
Demographic Factors	4
Clinical Factors	4
Psychosocial Factors	5
Smoking Behavior	6
Stigma and Lung Cancer Patients	7
Dyadic Adjustment and Dysfunctional Attitudes	9
Aims	10
Hypotheses	11
Method	11
Participants	11
Procedure	11
Measures	12

Statistical Analyses	16
Results	20
Participants	20
Relationship of Perceived Stigma and Depressive Symptomatology	24
Relationship of Other Psychosocial Variables with Depressive Symptomatology	25
Relationships of Demographic and Clinical Variables with Depressive Symptomatology	26
Regression Analyses of Depressive Symptomatology	29
Relationships of Demographic and Clinical Variables with Perceived Stigma	36
Mediational Analyses	40
Discussion	43
Summary of Results	43
Theoretical and Clinical Implications	45
Limitations	48
Future Directions	49
References	51

List of Tables

Table 1	Demographic Characteristics of the Sample	23
Table 2	Clinical Characteristics of the Sample	24
Table 3	Mean, Standard Deviations, and Internal Consistency Reliabilities of Psychosocial Scales	25
Table 4	Correlations Between Depressive Symptomatology and Perceived Stigma	26
Table 5	Correlations Between Depressive Symptomatology and Psychosocial Variables	27
Table 6	Relationships Between Depressive Symptomatology and Demographic Variables	28
Table 7	Relationships Between Depressive Symptomatology and Clinical Variables	29
Table 8	Summary of Hierarchical Regression Analysis for Variables Predicting Depressive Symptomatology	31
Table 9	Summary of Hierarchical Regression Analysis for Variables Predicting Depressive Symptomatology (CES-D) Among Participants Living With a Spouse or Partner	33
Table 10	Summary of Hierarchical Regression Analysis for Variables Predicting Depressive Symptomatology (CES-D)	35

Table 11	Summary of Hierarchical Regression Analysis for Variables Predicting Depressive Symptomatology (CES-D)	36
Table 12	Relationships Between Perceived Stigma and Demographic Variables	38
Table 13	Relationships Between Perceived Stigma and Clinical Variables	39
Table 14	Summary of Stepwise Regression Analysis for Variables Predicting Perceived Stigma (SIS)	40
Table 15	Correlations Between Perceived Stigma and Psychosocial Variables	41

List of Figures

Figure 1	Path Diagram for the Indirect Effect of a Predictor on a Dependent Variable through a Mediator	18
Figure 2	Participant Flow Chart	21
Figure 3	Proposed Model of Social Support (ESSI) as a Mediator Between Perceived Stigma (SIS) and Depressive Symptomatology (CES-D)	42
Figure 4	Proposed Model of Dyadic Adjustment (DAS-4) as a Mediator Between Perceived Stigma (SIS) and Depressive Symptomatology (CES-D)	43
Figure 5	Proposed Models of Dysfunctional Attitudes (DAS) as a Mediator Between Perceived Stigma (SIS) and Depressive Symptomatology (CES-D)	44

Depression in Lung Cancer Patients: Role of Perceived Stigma

Brian D. Gonzalez

ABSTRACT

Previous research suggests that lung cancer patients are at an increased risk for depressive symptomatology; however, little is known about the possible etiology or correlates of depression among these patients. This study examined the relationship between perceived stigma and depressive symptomatology among lung cancer patients, and sought to find potential mediators of this relationship. It was hypothesized that more perceived stigma would be related to greater depressive symptomatology and that perceived stigma would contribute unique variance to depressive symptomatology above and beyond that contributed by clinical, demographic, and psychosocial variables. A sample of 95 participants receiving chemotherapy for stage II-IV non-small cell lung cancer was recruited during routine outpatient chemotherapy visits. A medical chart review was conducted to assess clinical factors and participants completed a standard demographic questionnaire as well as measures of perceived stigma, depressive symptomatology, and other psychosocial variables. As hypothesized, there was a positive association of perceived stigma to depressive symptomatology. Perceived stigma contributed significant unique variance to depressive symptomatology. In addition dyadic adjustment and dysfunctional attitudes mediated this relationship. Future research should aim to replicate and extend these findings in longitudinal analyses and attempt to

ameliorate lung cancer patients' depressive symptomatology by targeting perceived stigma.

Introduction

It is estimated that 215,020 people will be diagnosed with lung cancer in the United States in 2009 (Jemal et al., 2008). While early-stage lung cancer patients can sometimes be cured, many patients face bouts with lung cancer that can last several years and during which they may receive surgery, chemotherapy, radiation therapy, or all three. The effects of the illness and some of the side-effects of its treatment often make concealing one's illness from others difficult, leaving lung cancer patients vulnerable to stigmatization. The potential contributory role of tobacco use to the development of lung cancer is another factor that may contribute to perceived stigmatization. Patients with this illness are at increased risk for depressive symptomatology, which itself is related to poorer quality of life among cancer patients (Hyodo et al., 1999; Montazeri, Milroy, Hole, McEwen, & Gillis, 1998; Turner, Muers, Haward, & Mulley, 2007; Visser & Smets, 1998). Some correlates of depressive symptomatology in lung cancer patients have been identified; however, the potential contribution of illness-related perceived stigma has yet to be examined. To address this issue, the current study seeks to determine whether perceived stigma is related to depressive symptomatology among lung cancer patients.

Lung Cancer

Lung cancer is one of the most common and deadliest forms of cancer. It accounts for 15% of new cancer cases and 29% of cancer deaths annually (Jemal et al., 2008). It is the leading cause of cancer-related death in males (31%) and females (26%), far

outnumbering the rates of deaths due to prostate cancer (10%) and breast cancer (15%) in males and females, respectively (Jemal et al., 2008). The discrepancy between the prevalence of lung cancer and the percentage of cancer-related deaths attributed to lung cancer is a testament to its lethality. This lethality is exacerbated by the late stage at which lung cancer is often detected, which is partly due to the less-than-optimal detection methods (e.g. chest x-rays); newer methods (e.g., spiral CT scans) remain controversial (Kaneko et al., 1996). In addition, doctors may have difficulty differentiating symptoms of lung cancer from similar smoking-related problems, which may be another factor contributing to the late stage in which lung cancer is often detected. For example, in a recent qualitative study, lung cancer patients reported that their disease-related symptoms were often ignored by medical doctors, sometimes for several years, and attributed instead to “smoker’s cough” (Chapple, Ziebland, & McPherson, 2004).

Depression in Lung Cancer Patients

Lung cancer patients often report experiencing symptoms such as fatigue, insomnia, pain, and depression (Degner & Sloan, 1995; Sarna, 1993; Sarna, 1998). Several studies of lung cancer patients have found high rates of clinically significant depressive symptomatology shortly after diagnosis. For example, in a study of patients in Japan who had recently received a lung cancer diagnosis, 31% exhibited clinically significant levels of depressive symptomatology (Hyodo et al., 1999). Similarly, a study of lung cancer patients in Scotland found that 23% endorsed clinically significant depressive symptomatology when they were informed of their diagnosis (Montazeri et al., 1998). Additionally, a study of lung cancer patients in Britain about to receive radiotherapy found a 21% rate of clinically significant depressive symptomatology

(Turner et al., 2007). Hopwood and Stephens (2000) sampled lung cancer patients recruited into palliative therapy medication trials throughout the United Kingdom and reported a pre-treatment rate of clinically significant depressive symptomatology of 33%. The highest reported rate of depressive symptomatology is 44%, reported in a study of lung cancer patients referred to an Italian specialist center (Buccheri, 1998).

Some evidence suggests that depressive symptomatology in lung cancer patients may remain elevated after treatment completion. For example, a postoperative study of lung cancer patients who had smoked within months of surgery reported a 29% rate of clinically significant depressive symptomatology (Walker, Zona, & Fisher, 2006). Hopwood and Stephens (2000) reported that 29% of lung cancer patients assessed between three and eight weeks after treatment had clinically significant depressive symptomatology. Rates of depressive symptomatology were 34% and 44% in two studies that assessed symptoms three months after the beginning of lung cancer treatment (Montazeri et al., 1998; Nakaya et al., 2006). In addition, a study of elderly lung cancer patients found that rates of clinically significant depressive symptomatology decreased only slightly from 39% at one month after the beginning of treatment to 31% more than one year later (Kurtz, Kurtz, Stommel, Given, & Given, 2002). The rates of depressive symptomatology in lung cancer patients exceed those reported by individuals with other types of cancer. For example, a sample of patients with breast cancer, head and neck cancer, and lymphoma reported an 8% rate of elevated depressive symptomatology (Berard, Boermeester, & Viljoen, 1998), and a sample of thyroid cancer patients reported a 17% rate (Tagay et al., 2006).

Correlates of Depression in Lung Cancer Patients

Demographic Factors. Research on demographic correlates of depression in lung cancer patients is limited and results are mixed. For example, two studies of lung cancer patients have found women to be at higher risk of elevated depressive symptomatology than men (Hopwood & Stephens, 2000; Hyodo et al., 1999), but three other studies found no sex differences (Montazeri et al., 1998; Nakaya et al., 2006; Uchitomi et al., 2003). Similarly, three studies reported that older lung cancer patients were more likely to experience elevated depressive symptomatology compared to younger patients (Hyodo et al., 1999; Walker, Zona, Larsen, & Fisher, 2004; Walker et al., 2006); however, three other studies found no age differences (Montazeri et al., 1998; Nakaya et al., 2006; Uchitomi et al., 2003). One study found that years of education was negatively related to depressive symptomatology in lung cancer patients (Uchitomi et al., 2003); however, two other studies found no relationship for education (Montazeri et al., 1998; Nakaya et al., 2006). Neither income nor marital status has been found to be related to depressive symptomatology among lung cancer patients (Montazeri et al., 1998; Nakaya et al., 2006; Uchitomi et al., 2003). Although female gender, older age, and fewer years of education may be positively related to depressive symptomatology in lung cancer patients, more research is needed to clarify these relationships.

Clinical Factors. More definitive conclusions can be made about the relationships between clinical factors and depressive symptomatology in lung cancer patients, in part because there is more research in this area. Clinical factors studied include performance status (i.e., clinical ratings of overall physical functioning), disease stage, type of cancer treatment, functional impairment, and symptom severity. Studies

have consistently found that poorer performance status is related to greater depressive symptomatology (Hopwood & Stephens, 2000; Hyodo et al., 1999; Nakaya et al., 2006; Uchitomi et al., 2003; Walker et al., 2006). Several studies have reported no relationship between disease stage and depressive symptomatology in lung cancer patients before treatment (Montazeri et al., 1998; Nakaya et al., 2006) and as shortly as a few weeks and as long as 12 months after treatment initiation (Montazeri et al., 1998; Uchitomi et al., 2003; Walker et al., 2006). However, one study found that two weeks after the diagnosis of lung cancer, patients with later disease stages exhibited less depressive symptomatology than those with earlier disease stages (Hyodo et al., 1999). Only two studies have examined whether depressive symptomatology varies as a function of lung cancer treatment type. While Montazeri and colleagues (1998) found no relationship between type of treatment and depressive symptomatology, Hyodo and colleagues (1999) reported that patients who had not received radiotherapy were more depressed than patients who had radiotherapy. Greater functional impairment (Hopwood & Stephens, 2000) and symptom severity (Hopwood & Stephens, 2000; Kurtz et al., 2002) have been found to be positively related to greater depressive symptomatology; however, these findings require further replication.

Psychosocial Factors. The psychosocial correlates of depressive symptomatology in lung cancer patients have only recently begun to be studied. Less adaptive coping (i.e., less problem-focused coping) was found to be related to greater depressive symptomatology in a sample of lung cancer patients who had recently undergone surgical resection and had smoked within three months before surgery (Walker et al., 2006). In addition, two aspects of greater social support have been found to be related to less

depressive symptomatology among lung cancer patients (Fisher Jr, La Greca, Greco, Arfken, & Schneiderman, 1997). In separate studies of postoperative lung cancer patients, nondirective emotional support (i.e., emotionally assisting or cooperating with the patient while allowing the responsibility for behavior and choices to remain with the patient) was associated with less depressive symptomatology, while directive instrumental support (i.e., support that takes responsibility for financial and material matters) was associated with more depressive symptomatology (Walker, Larsen, Zona, Govindan, & Fisher, 2004; Walker et al., 2006). Thus, emerging evidence suggests that coping and social support merit further study as psychosocial correlates of depressive symptomatology in lung cancer patients.

Smoking Behavior. To date, only three studies have investigated the relationship between smoking status and depressive symptomatology in lung cancer patients. One study assessed smoking status before curative resection of non-small cell lung cancer (NSCLC) and examined its relationship to depressive symptomatology one year later; no relationship was evident (Uchitomi et al., 2003). In another study of NSCLC patients, no relationship was found between preoperative smoking status and depressive symptomatology assessed three months after surgery (Nakaya et al., 2006). In a third study of patients who had smoked within the three months before lung cancer resection, there was a trend towards a relationship between postoperative smoking status and depressive symptomatology, such that those who continued smoking after surgery had higher depressive symptomatology than those who had quit (Walker et al., 2004). Although all three studies reported no significant relationship between depression and smoking status, the evidence of such a relationship in the general population (Goodman

& Capitman, 2000) and the potential implications it would carry if a similar relationship were found among lung cancer patients argue for additional research on this topic.

Stigma in Lung Cancer Patients

An important factor that might be related to differences in depressive symptomatology among lung cancer patients is perceived stigma. *Modified Labeling Theory*, which was first used to describe the effects of stigma on individuals with psychiatric disorders (Link, Cullen, Struening, Shrout, & Dohrenwend, 1989), posits that once society labels an individual, they are subject to uniform responses from others. These societal responses can constrain an individual into the role to which they are being subjected, which can cause the individual to accept this role and incorporate it into their identity. This process can often result in psychological harm. Perceived stigma, the perception that one is subject to the uniform responses from others that are to be expected for an individual with a certain label, has been studied in chronically-ill populations, primarily with HIV-positive patients and those infected with Hepatitis C. Individuals with these illnesses often perceive (accurately or inaccurately) that they are undergoing uniform responses from society that are a result of their label (e.g., HIV positive). The potential for stigma originates from the fact that these diseases are often transmitted via unsafe sexual behavior and intravenous drug use (Beyrer et al., 2005; Purcell, Parsons, Halkitis, Mizuno, & Woods, 2001).

Research has examined the relationship of perceived stigma to depressive symptomatology in HIV positive individuals (Berger, Ferrans, & Lashley, 2001; Miles, Burchinal, Holditch-Davis, Wasilewski, & Christian, 1997; Simbayi et al., 2007). One such study sampled HIV positive individuals in South Africa and examined several

potential demographic and psychosocial correlates (Simbayi et al., 2007). In addition to finding a significant positive relationship between internalized stigma and depressive symptomatology, this study also found that internalized stigma contributed unique variance to depressive symptomatology over and above demographic factors (i.e., sex, age, race, drugs and alcohol intake), clinical factors (i.e., taking HIV medications, presence of HIV-related symptoms), and social support (Simbayi et al., 2007). Similar findings were reported in a study of patients with the Hepatitis C virus visiting a clinic in Iowa (Zickmund, Masuda, Ippolito, & LaBrecque, 2003). Findings indicated that a majority of participants believed they had been stigmatized due to their illness and consequently reported greater depressive symptomatology than those who did not perceive stigmatization (Zickmund et al., 2003).

Similarly, lung cancer patients are likely to experience stigma as a function of their disease because a particular behavior, smoking, is strongly associated with lung cancer incidence. Smoking is estimated to cause about 90% of all lung cancer cases (Godtfredsen, Prescott, & Osler, 2005). Because it is an often preventable disease, patients and others may often blame the patient for their lung cancer diagnosis. To date, research on perceived stigma in lung cancer patients is limited. One of the key pieces of evidence is a qualitative study conducted by Chapple and colleagues (2004). In this study, lung cancer patients in the United Kingdom were interviewed about their personal history with the disease. A common theme reported by many patients involved feeling stigmatized because of the strong association between smoking and lung cancer (Chapple et al., 2004). Whereas patients suffering from other cancers (e.g., breast, prostate) may not necessarily be blamed for their disease, these lung cancer patients reported feeling

blamed for their disease by friends, loved ones, and even healthcare professionals (Chapple et al., 2004). Moreover, even patients who reported no history of smoking or had stopped smoking several years before their diagnosis reported that they felt blamed for their illness (Chapple et al., 2004). Perceived stigma may be related to depressive symptomatology in lung cancer patients, as is the case for patients with Hepatitis C ((Zickmund et al., 2003) and HIV (Berger et al., 2001; Miles et al., 1997; Simbayi et al., 2007); however, a search of the published literature suggests that this hypothesis has yet to be tested.

Dyadic Adjustment and Dysfunctional Attitudes

In studying the relationship of stigma to depressive symptomatology in lung cancer patients, it will be important to determine whether stigma accounts for variability in depression distinct from other psychosocial variables often found to be associated with depression. Dyadic adjustment (a measure of relational satisfaction) and dysfunctional attitudes (a measure of cognitive vulnerability to depression) may be related to depressive symptomatology in lung cancer patients, but these relationships have yet to be studied. However, an association between poorer dyadic adjustment and greater depressive symptomatology has been shown in studies of healthy populations (Herr, Hammen, & Brennan, 2007; Jenewein et al., 2008; King & Arnett, 2005; Lewis, Fletcher, Cochrane, & Fann, 2008; Whisman, 2007) as well as in medically-ill populations (Brotto et al., 2008; King & Arnett, 2005). For example, a study of outpatient multiple sclerosis patients and their significant others reported a relationship between poorer dyadic adjustment and greater depressive symptomatology (King & Arnett, 2005). In addition, a trial of a psycho-educational intervention aimed to reduce Female Sexual Arousal

Disorder symptoms in gynecologic cancer patients reported a relationship between poorer dyadic adjustment and greater depressive symptomatology (Brotto et al., 2008).

Similarly, there is evidence for a relationship of dysfunctional attitudes to depressive symptomatology in other populations. In a study of women with and without a history of depression, more dysfunctional attitudes were associated with a greater number of previous episodes of depression and greater likelihood to have a future depressive episode (Otto et al., 2007). Also, in a sample of college undergraduates with and without a history of depression, more dysfunctional attitudes were found to be related to greater depressive symptomatology (Haffel et al., 2005). The relationships between dyadic adjustment, dysfunctional attitudes, and depressive symptomatology merit exploration in lung cancer patient populations.

Aims

The primary aim of this study was to examine the relationship between stigma, as measured by the Social Impact Scale (SIS; Fife & Wright, 2000), and depressive symptomatology, as measured by the Center for Epidemiological Studies Depression Scale (CES-D; Radloff, 1977), in people with lung cancer. The study also aimed to examine relationships between several psychosocial factors found to be related to depression in other populations (i.e., coping, social support, dyadic adjustment, and dysfunctional attitudes) and depressive symptomatology in lung cancer patients. Additionally, this study aimed to determine which demographic and clinical factors are related to perceived stigma. Finally, this study also sought to determine if stigma accounts for variability in depressive symptomatology in lung cancer patients above and beyond psychosocial factors found to be related to depressive symptomatology in other

populations, and if psychosocial factors mediate the relationship between perceived stigma and depressive symptomatology.

Hypotheses

1. It was hypothesized that greater perceived stigma would be related to greater depressive symptomatology.
2. Also, it was hypothesized that more avoidant coping, poorer social support, poorer dyadic adjustment, and more dysfunctional attitudes would be related to greater depressive symptomatology.
3. In addition, it was hypothesized that perceived stigma would explain unique variance in depression over and above that explained by other psychosocial, demographic, and clinical variables related to depressive symptomatology.
4. Finally, further analyses were conducted, based on the result of hypothesis testing, to determine if psychosocial factors mediated the relationship between perceived stigma and depressive symptomatology.

Method

Participants

Eligibility criteria for the current study were: 1) receiving chemotherapy for stage II, III, or IV non-small cell lung cancer 2) ≥ 18 years of age, 3) able to understand, speak, and read English, 4) no history of other cancers with the exception of non-melanoma skin cancer, 5) and able to provide informed consent.

Procedure

Study eligibility was determined via consultation with H. Lee Moffitt Cancer Center Thoracic Oncology Program team members. Potential participants were approached during a routine outpatient visit and had the study protocol explained. Those eligible and interested provided written informed consent. Participants were given the option of filling out the study measures during their outpatient visit or taking them home and returning the completed measures in a self-addressed stamped envelope that was provided. Participants were not compensated for their study participation.

Measures

Demographics and Background Information. Demographics and background information were collected using a standardized self-report form. The variables assessed were: age, sex, race, ethnicity, education, income, marital status, and employment status. In addition, participants' current and past smoking status, number of cigarettes smoked per day, and years of smoking were assessed.

Clinical Information. The following clinical information was assessed via a review of patients' medical records: date of lung cancer diagnosis, disease stage, previous

lung cancer treatment, planned lung cancer treatment, and ECOG performance status (Oken et al., 1982).

Stigma. Experienced stigma was assessed using the Social Impact Scale (SIS; Fife & Wright, 2000), a 24-item Likert-type scale which measures the extent to which individuals with an illness believe they are experiencing social rejection, financial insecurity, internalized shame, and social isolation as a result of their illness. In addition to a total score, the measure yields subscale scores for the four aspects of experienced stigma described above. These four subscales have been shown to have strong internal consistency reliability (α range: .85 - .90), and though they are related, their relatively low zero-order correlations with one another (r range: .28 – .66) suggest that they assess divergent aspects of one's illness-related stigma (Fife & Wright, 2000). In the current study, analyses focused on the total score.

Dyadic Adjustment. Among participants who were living with a spouse or partner, relational adjustment was assessed using the Dyadic Adjustment Scale-4 (DAS-4; Sabourin, Valois, & Lussier, 2005), a Likert-type instrument designed for use with married, unmarried, and same-sex cohabitating couples. It is comprised of 4 items: "How often do you discuss or have you discussed divorce, separation, or terminating your relationship?"; "In general, how often do you think that things between you and your partner are going well?"; "Do you confide in your mate?"; and "Please circle the choice which best describes the degree of happiness, all things considered, of your relationship." The DAS-4 has been shown to have adequate convergent and divergent validity, and a cut-off score of 13 has been posited as optimal for distinguishing between individuals with dyadic distress and those without (Sabourin et al., 2005).

Coping. Coping strategies were assessed using the Coping Responses Inventory (CRI; Moos, 1993), a 48-item Likert-type instrument which assesses specific coping responses via eight subscales. Four subscales assess approach coping styles; two are considered behavioral approach coping styles (seeking guidance and support, problem solving), and two are considered cognitive approach coping styles (logical analysis, positive reappraisal) (Moos, 1993). Four subscales assess avoidant coping styles; two are considered behavioral avoidant coping styles (seeking alternative rewards, emotional discharge), and two are considered cognitive avoidant coping styles (cognitive avoidance, acceptance or resignation) (Moos, 1993). The approach and avoidant scales of the CRI have been shown to have adequate internal consistency reliability (α 's = .74 and .66, respectively) in a sample of breast cancer patients (Hack & Degner, 2004). The eight individual subscales of the CRI have been validated (Moos, 1993) and been shown to have adequate internal consistency reliability (α range: .61 - .74) in a sample of ovarian cancer patients (Chan, Ng, Lee, Ngan, & Wong, 2003). In the present study, analyses focused on the cognitive avoidance subscale.

Social Support. Social support was assessed using the ENRICHD Social Support Instrument (ESSI; Mitchell et al., 2003), a 5-item Likert-type instrument designed to assess emotional support. The ESSI has been shown to have strong internal consistency reliability ($\alpha = .87$), good convergent validity with another measure of social support ($r = .62$), and relatively weak correlations with measures of structural and tangible support (r range: .20 - .25), which is indicative of divergent validity between emotional and other types of social support (Mitchell et al., 2003). Sample questions include "Is there

someone available to give you good advice about a problem?” and “Is there someone available to you who shows you love and affection?” (Mitchell et al., 2003).

Dysfunctional Attitudes. Dysfunctional attitudes were assessed via the Dysfunctional Attitudes Scale (DAS; Weissman & Beck, 1978), a 40-item Likert-type self-report measure of cognitive distortions. Participants will report, on a 1 to 7 scale, the degree to which they agree or disagree with items such as, “If a person asks for help, it is a sign of weakness.” In addition to face validity, the DAS has demonstrated concurrent validity with a measure of depressive symptomatology, including the ability to distinguish between depressed and non-depressed individuals. The DAS also has good internal consistency reliability (α range: .84 - .92) and test-retest reliability (r range: .80 – .84; Weissman & Beck, 1978).

Depressive Symptomatology. Participants’ depressive symptomatology was assessed using the Center for Epidemiological Studies Depression Scale (CES-D; Radloff, 1977), a 20-item Likert-type self-report measure of depressive symptomatology. Participants answered questions about how they felt over the past week. Sample questions include, “I had trouble keeping my mind on what I was doing” and “I had crying spells.” Because it is brief and its queries focus primarily on cognitive and affective symptoms of depression rather than somatic symptoms, it is well-suited for use with the medically-ill, such as lung cancer patients (Hann, Winter, & Jacobsen, 1999). The CES-D has been shown to be a valid measure of depressive symptomatology with excellent internal consistency reliability, as well as adequate test-retest reliability in a sample of cancer patients (Hann et al., 1999).

History of Depression. Participants' history of Major Depressive Disorder (MDD) prior to their lung cancer diagnosis was assessed using the Structured Clinical Interview for DSM-IV (SCID; Gibbon & Williams, 2002). The SCID is a widely-used structured interview which is used to determine diagnoses of numerous mental disorders according to Diagnostic and Statistical Manual of Mental Disorders IV (DSM-IV; (American Psychiatric Association, 2000) criteria. Good inter-rater agreement on diagnoses of MDD ($\kappa = .80$; Zanarini et al., 2000) has been demonstrated using trained raters. The mood episodes section of the SCID was administered by trained and periodically-observed staff to assess lifetime history of MDD prior to the participant's date of diagnosis of lung cancer.

Statistical Analyses

To test the study hypotheses, correlational analyses were conducted to determine the relationships between depressive symptomatology and each of the following: perceived stigma, social support, avoidant coping responses, and dysfunctional attitudes. A correlational analysis was also conducted to determine the relationship between depressive symptomatology and dyadic adjustment among the subset of participants who were living with a spouse or partner and were thus able to complete the measure assessing dyadic adjustment.

In addition, independent samples *t*-tests, ANOVAs, and chi-square tests were performed, as appropriate, to examine relationships between demographic and clinical variables and depressive symptomatology.

Two hierarchical regression analyses were conducted to determine whether perceived stigma accounts for unique variance in depressive symptomatology not

accounted for by other psychosocial variables and by demographic, clinical, and smoking variables related to depressive symptomatology. In the first hierarchical regression analysis, depressive symptomatology was the dependent variable, and independent variables were included in the model in the following 4 steps:

1. Presence of a lifetime (before lung cancer diagnosis) history of depression
2. Any demographic, clinical, or smoking variable related to depressive symptomatology
3. Social support, coping responses, and dysfunctional thoughts, regardless of the significance of their relationship to depressive symptomatology
4. Perceived stigma

In the second hierarchical regression analysis, dyadic adjustment was added as an independent variable in step 3. This analysis was conducted with the subset of participants who were living with a spouse or partner and were able to complete the DAS-4.

Four additional hierarchical regression analyses were conducted to determine which components of perceived stigma contributed unique variance to depressive symptomatology. In these analyses, the four subscales of the Social Impact Scale were added as the independent variable in step 4.

In addition, independent samples *t*-tests, ANOVAs, and chi-square tests were performed, as appropriate, to examine relationships between demographic and clinical variables and perceived stigma.

Finally, mediational analyses were conducted to determine whether social support, dyadic adjustment, coping styles, or dysfunctional attitudes mediated the

relationship between perceived stigma and depressive symptomatology. These analyses followed the established protocol for determining mediation (MacKinnon, Fairchild, & Fritz, 2007). MacKinnon, et al. (2007) lay out the following steps (see Figure 1):

1. The dependent variable (depressive symptomatology) is regressed on the predictor (perceived stigma). The regression coefficient for the independent variable (IV) in this equation is termed c .
2. The proposed mediator (psychosocial factor) is regressed on the predictor. The regression coefficient for the IV in this equation is termed a .
3. The dependent variable is regressed on the predictor and mediator. The regression coefficient for the mediator is termed b , and the new regression coefficient for the predictor in this equation is termed c' .

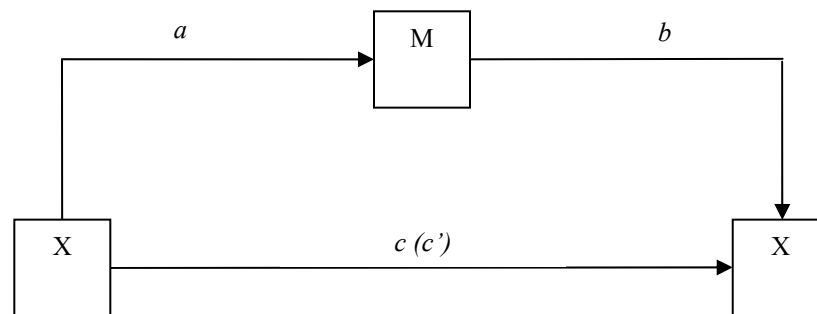

Figure 1. Path diagram for the indirect effect of a predictor on a dependent variable through a mediator.

In order to satisfy the requirements for mediation, c , a , and b must be significant. Also, the decrease from c to c' (indirect effect) must be significant as tested by the Sobel test. The Sobel test divides the value of the indirect effect by its standard error and compares the result to a standard normal distribution (Sobel, 1982).

A power analysis using Power and Precision 2.0 (Biostat, 2000) indicated that for a correlational analysis with a Type I error rate of .05 (two-tailed), the sample size of the current study ($N = 95$) would yield power equal to .85 for detecting a medium-sized effect ($r = .30$). A second analysis was conducted to determine the power of the hierarchical multiple linear regression model described above. It indicated that a model in which Step 1 (i.e., past history of depression) accounts for 10% of the variance in depressive symptomatology, Step 2 (i.e., demographic and clinical variables) accounts for an additional 10% of the variance, Step 3 (i.e., psychosocial variables) accounts for an additional 20% of the variance, power is equal to .82 with a Type I error rate of .05 and 95 participants for detecting a 5% increase in variance accounted for by stigma on Step 4.

Results

Participants

Eight hundred thirty-nine participants were screened for this study; of these, 680 were ineligible based on medical record reviews (e.g., history of other cancer, not receiving chemotherapy). The remaining 159 participants were approached for participation; of these, an additional 17 were deemed ineligible before consent, 33 refused to participate, and 109 agreed to participate (77% of those eligible). Of those who agreed to participate, 4 withdrew from the study, 4 never completed the study measures and could not be reached, and 6 were found to be ineligible after they participated. Thus, analyses were conducted on the 95 participants who had evaluable data, 66 of whom were living with a spouse/partner and were included in the sub-analyses with dyadic adjustment (See Figure 2 for a participant flow chart). The 109 patients who agreed to participate in the study did not differ in terms of age, gender, or race from the 33 patients who declined to participate, $ps \geq .48$.

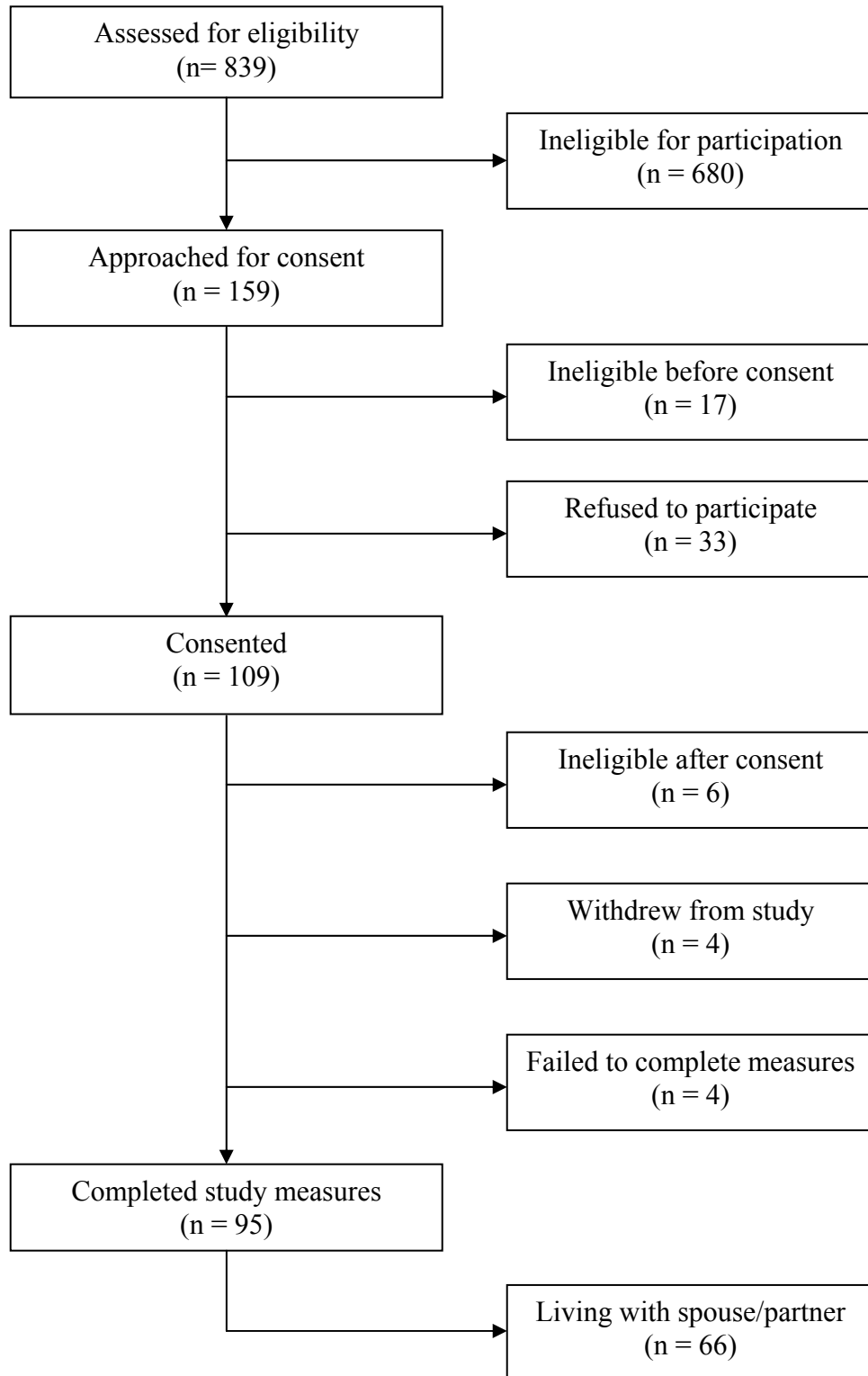

Figure 2. Participant Flow Chart

Participants ranged in age from 42 to 83 years ($M = 64.04$; $SD = 8.79$). The majority of the participants were high school graduates (60%), married (61.1%), and White (92.6%). Mean Body Mass Index for this sample was 26.44 ($SD = 5.18$), which indicates that the average participant was slightly overweight. On average, participants were 18.14 months ($SD = 30.35$) from their original lung cancer diagnosis. Forty-five (47.4%) participants had surgery for this cancer and 41 (43.2%) had been treated with radiation therapy. The possible range of scores on the CES-D is from 0 to 60. The range of scores for this sample was 0 to 44. The mean CES-D score was 14.39 ($SD = 8.26$), and 38% of participants ($n = 36$) met the CES-D cutoff for clinically significant depressive symptoms (≥ 16). Thirteen participants (13.7%) met criteria for a diagnosis of Past Major Depressive Disorder, and 16 (16.8%) were taking antidepressant medications at the time of the study visit. Twelve participants (12.6%) were never smokers, 68 (71.6%) were past smokers, and 15 (15.8%) were current smokers at the time of the study visit (see Tables 1 and 2 for complete demographic and clinical information). All measures had adequate internal consistency reliability, (Cronbach's alphas $\geq .72$; see Table 3 for descriptive statistics and internal consistency reliabilities for each measure).

Table 1

Demographic Characteristics of the Sample (N = 95)

Variable	<i>M</i>	<i>SD</i>
Age, years	64.04	(8.79)
Pack Years ^a	35.43	(23.70)
Variable	<i>n</i>	%
Gender		
Males	39	(41.1%)
Females	56	(58.9%)
Education		
≤ High school graduate	38	(40.0%)
> High school graduate	57	(60.0%)
Race		
White	88	(92.6%)
Non-White	7	(7.4%)
Ethnicity		
Hispanic	3	(3.2%)
Non-Hispanic	92	(96.8%)
Marital Status		
Currently Married	58	(61.1%)
Not Married	37	(38.9%)
Total household income		
< \$ 40,000	22	(23.2%)
≥ \$40,000	44	(46.3%)
Declined to answer	29	(30.5%)
Alcohol use in past month		
No	42	(44.2%)
Yes	53	(55.8%)
Cigarette use		
Never	12	(12.6%)
Previous	68	(71.6%)
Current	15	(15.8%)

^aAmong only past smokers and current smokers (*n* = 83).

Table 2

Clinical Characteristics of the Sample (N = 95)

Variable	<i>M</i>	<i>SD</i>
Body Mass Index	26.44	(5.18)
Months Since Original Diagnosis	18.14	(30.35)
Variable	<i>n</i>	%
Disease Stage		
II	3	(3.2%)
III	29	(30.5%)
IV	63	(66.3%)
ECOG Performance Status		
0	20	(21.0%)
1	62	(65.3%)
2 – 3	13	(13.7%)
Diagnosis of Past Major Depression		
No	82	(86.3%)
Yes	13	(13.7%)
Taking antidepressant medication at time of study visit		
No	79	(83.2%)
Yes	16	(16.8%)
Had Surgery for This Cancer		
No	50	(52.6%)
Yes	45	(47.4%)
Had Radiation Therapy for This Cancer		
Never	54	(56.9%)
Before current course of chemo	33	(34.7%)
Currently	8	(8.4%)

Note: ECOG = Eastern Cooperative Oncology Group.

Table 3

Mean, Standard Deviations, and Internal Consistency Reliabilities of Psychosocial

Scales

Scale	<i>M</i>	<i>SD</i>	α
Social Impact Scale	42.90	11.87	.95
Dyadic Adjustment Scale	16.94	3.55	.83
ENRICH Social Support Instrument	22.74	3.04	.91
CRI – Cognitive Avoidance	7.85	3.94	.72
Dysfunctional Attitudes Scale	103.62	25.92	.89
CES-D	14.39	8.26	.84

Note: CRI = Coping Responses Inventory; CES-D = Center for Epidemiologic Studies

Depression Scale.

Relationship of Perceived Stigma and Depressive Symptomatology

Correlational analyses were conducted to test the hypothesis that perceived stigma would be positively related to depressive symptomatology (see Table 4). As hypothesized, these correlations indicate that more social rejection, financial insecurity, internalized shame, social isolation, and greater overall perceived stigma as a result of one’s lung cancer diagnosis were significantly related to greater depressive symptomatology.

Table 4

Correlations Between Depressive Symptomatology and Perceived Stigma (N = 95)

Variable	Depression (CES-D)	<i>p</i> -value
Perceived Stigma (SIS Total)	.46	< .001
Social Rejection (SocRej)	.29	.004
Financial Insecurity (FinIns)	.43	< .001
Internalized Shame (IntSha)	.27	.010
Social Isolation (SocIso)	.58	< .001

Note: CES-D = Center for Epidemiologic Studies Depression Scale; SIS = Social Impact Scale.

Relationships of Other Psychosocial Variables with Depressive Symptomatology

A second set of correlational analyses was conducted to test the hypotheses that poorer social support, poorer dyadic adjustment, more avoidant coping, and more dysfunctional attitudes would be related to depressive symptomatology (see Table 5). As hypothesized, these correlations indicate that poorer social support, poorer dyadic adjustment, more avoidant coping, and more dysfunctional attitudes were significantly related to greater depressive symptomatology.

Table 5

Correlations Between Depressive Symptomatology and Psychosocial Variables (N = 95)

Variable	Depression (CES-D)	<i>p</i> -value
Social Support (ESSI)	-.33	.001
Dyadic Adjustment (DAS-4) ^a	-.48	< .001
Avoidant Coping (CRI CA)	.36	< .001
Dysfunctional Attitudes (DAS)	.48	< .001

Note: CES-D = Center for Epidemiologic Studies Depression Scale; ESSI = ENRICH Social Support Instrument; DAS-4 = Dyadic Adjustment Scale – 4; CRI CA = Coping Responses Inventory Cognitive Avoidance Subscale; DAS = Dysfunctional Attitudes Scale.

^aAmong only those who were living with a spouse or partner ($n = 66$);

Relationships of Demographic and Clinical Variables with Depressive Symptomatology

In order to determine if demographic and clinical variables were associated with depressive symptomatology, *t*-tests, ANOVAs, and correlational analyses were conducted (see Tables 6 and 7). No demographic variables were found to be related to depressive symptomatology ($ps > .05$). In contrast, two clinical variables were found to be related to depressive symptomatology. Those with a diagnosis of past Major Depressive Disorder reported greater depressive symptomatology ($M = 19.31$; $SD = 11.27$) than those without a diagnosis of past Major Depressive Disorder ($M = 13.60$; $SD =$

= 7.48) ($p = .02$). Also, patients for whom more time had elapsed since their lung cancer diagnosis reported greater depressive symptomatology, $r(93) = .20, p = .048$.

Table 6

Relationships Between Depressive Symptomatology and Demographic Variables (N = 95)

Variable	Depression (CES-D)	p -value
Age (years)	$r = .05$.66
Gender (m, f)	$t = -1.0$.32
Education (< H.S., \geq H.S.)	$t = -1.26$.21
Race (White, non-White)	$t = -1.57$.12
Ethnicity (Hispanic, non-Hispanic)	$t = -0.29$.77
Marital Status (married, not married)	$t = -0.29$.78
Total Household Income (< \$40k, \geq \$40k)	$t = 0.71$.48
Alcohol Use in Past Month (yes, no)	$t = 0.28$.78
Cigarette Use (never, previous, current)	$F = 0.30$.75
Pack Years	$r = .01$.92

^aAmong only past smokers and current smokers ($n = 83$).

Table 7

Relationships Between Depressive Symptomatology and Clinical Variables (N = 95)

Variable	Depression (CES-D)	<i>p</i> -value
Diagnosis of Past Major Depression (yes, no)	$t = 2.37$.02
BMI	$r = .07$.52
Months Since Original Diagnosis	$r = .20$.05
Months Since Recurrence ^a	$r = -.01$.98
Disease Stage (II, III, IV)	$F = 0.23$.80
ECOG Performance Status (0, 1, 2-3)	$F = 0.71$.50
Surgery (yes, no)	$t = -0.40$.69
Months Since Surgery ^b	$r = .23$.12
Radiation Therapy (never, previous, current)	$F = 0.98$.38
Months Since Radiation Therapy ^c	$r = .00$.98
Chemotherapy infusions for this course	$r = -.12$.24
Previous chemotherapy courses ^d	$r = .07$.63
Antidepressant medication (yes, no)	$t = -0.42$.67

Note: ECOG = Eastern Cooperative Oncology Group

^aAmong only those with a recurrence of Non-Small Cell Lung Cancer ($n = 30$); ^bAmong only those who had surgery; ^cAmong only those who received radiation therapy ($n = 41$);

^dAmong only those who received a course of chemotherapy previous to the current course ($n = 45$).

Regression Analysis of Depressive Symptomatology

Based on the findings that perceived stigma was related to depressive symptomatology, a hierarchical regression analysis was conducted to determine if perceived stigma accounted for significant variability in scores on the CES-D above and beyond that accounted for by relevant variables (see Table 8). Diagnosis of past Major Depressive Disorder was specified for inclusion in the model prior to conducting analyses, time since original lung cancer diagnosis was included in the model because of its relationship with depressive symptomatology (see Table 7), and psychosocial variables were included based on the pre-specified model. As shown in Table 8, diagnosis of past Major Depressive Disorder accounted for 5% of the variance and time since original lung cancer diagnosis accounted for 4% of the variance in depressive symptomatology. Social support, avoidant coping, and dysfunctional attitudes were entered into the equation in the third step. Together, they accounted for an additional 35% of the variance in depressive symptomatology. Lastly, perceived stigma was entered into the model in the fourth step. It accounted for an additional 3% of the remaining variance in depressive symptomatology. As hypothesized, perceived stigma accounted for a statistically significant amount of additional variance in depressive symptomatology ($p = .043$). Together, these variables accounted for 47% of the variance in depressive symptomatology.

Table 8

*Summary of Hierarchical Regression Analysis for Variables Predicting Depressive**Symptomatology (CES-D) (N = 95)*

Variable	β	ΔR^2
Step 1		.05
History of MDD	.25*	
Step 2		.04
Time Since Diagnosis	.11	
Step 3		.35
Social Support (ESSI)	-.11	
Avoidant Coping (CRI CA)	.27**	
Dysfunctional Attitudes (DAS)	.33**	
Step 4		.03
Perceived Stigma (SIS)	.19*	

Note. Overall $F(6, 88) = 12.43, p < .001$; CES-D = Center for Epidemiologic Studies Depression Scale; MDD = Major Depressive Disorder; ESSI = ENRICH Social Support Instrument; CRI CA = Coping Responses Inventory Cognitive Avoidance Subscale; DAS = Dysfunctional Attitudes Scale; SIS: Social Impact Scale.

* $p < .05$, ** $p < .01$;

A second hierarchical regression analysis was conducted with a subset of the sample ($n = 66$) that was living with a spouse or partner and was eligible to complete the Dyadic Adjustment Scale – 4 (see Table 9). Diagnosis of past MDD was entered into the model in the first step and accounted for 8% of the variance in depressive symptomatology. Time since original lung cancer diagnosis was entered in the second step and accounted for an additional 5% of the variance. Social support, avoidant coping, dysfunctional attitudes, and dyadic adjustment were added in the third step and accounted for an additional 39% of variance. Perceived stigma was added in the fourth step and accounted for 4% of the remaining variance. As hypothesized, perceived stigma accounted for a statistically significant amount of additional variance in depressive symptomatology ($p = .028$). Together, these variables accounted for 56% of the variance in depressive symptomatology.

Table 9

Summary of Hierarchical Regression Analysis for Variables Predicting Depressive

Symptomatology (CES-D) Among Participants Living With a Spouse or Partner (n = 66)

Variable	β	ΔR^2
Step 1		.08
History of MDD	.14*	
Step 2		.05
Time Since Diagnosis	.18	
Step 3		.39
Social Support (ESSI)	-.15	
Avoidant Coping (CRI CA)	.11	
Dysfunctional Attitudes (DAS)	.30**	
Dyadic Adjustment (DAS-4)	-.11	
Step 4		.04
Perceived Stigma (SIS)	.24*	

Note. Overall $F(7, 58) = 10.42, p < .001$; CES-D = Center for Epidemiologic Studies Depression Scale; MDD = Major Depressive Disorder; ESSI = ENRICH Social Support Instrument; CRI CA = Coping Responses Inventory Cognitive Avoidance Subscale; DAS = Dysfunctional Attitudes Scale; DAS-4 = Dyadic Adjustment Scale – 4; SIS = Social Impact Scale.

* $p < .05$, ** $p < .01$

Additional hierarchical regression analyses were conducted to determine which components of perceived stigma contributed unique variance to depressive symptomatology. The Social Rejection and Internalized Shame subscales did not contribute significant variance to depressive symptomatology ($ps \geq .49$); however, the Financial Insecurity and Social Isolation subscales did contribute significant variance to depressive symptomatology (see Tables 10 and 11). Similar trends were found, in analyses which included the Dyadic Adjustment Scale – 4 among the participants who were living with a spouse or partner (not shown). These findings suggest that financial insecurity and social isolation are the components of perceived stigma that may be most associated with depressive symptomatology.

Table 10

*Summary of Hierarchical Regression Analysis for Variables Predicting Depressive**Symptomatology (CES-D) (n = 95)*

Variable	β	ΔR^2
Step 1		.05
History of MDD	.25**	
Step 2		.04
Time Since Diagnosis	.11	
Step 3		.35
Social Support (ESSI)	-.11	
Avoidant Coping (CRI CA)	.25**	
Dysfunctional Attitudes (DAS)	.37**	
Step 4		.03
Financial Insecurity (SIS FinIns)	.19*	

Note. Overall $F(6, 88) = 12.53, p < .001$; CES-D = Center for Epidemiologic Studies Depression Scale; MDD = Major Depressive Disorder; ESSI = ENRICH Social Support Instrument; CRI CA = Coping Responses Inventory Cognitive Avoidance Subscale; DAS = Dysfunctional Attitudes Scale; DAS-4 = Dyadic Adjustment Scale – 4; SIS = Social Impact Scale.

* $p < .05$, ** $p < .01$

Table 11

*Summary of Hierarchical Regression Analysis for Variables Predicting Depressive**Symptomatology (CES-D) (n = 95)*

Variable	β	ΔR^2
Step 1		.05
History of MDD	.22**	
Step 2		.04
Time Since Diagnosis	.08	
Step 3		.35
Social Support (ESSI)	-.10	
Avoidant Coping (CRI CA)	.24**	
Dysfunctional Attitudes (DAS)	.27**	
Step 4		.07
Social Isolation (SIS SocIso)	.33**	

Note. Overall $F(6, 88) = 12.53, p < .001$; CES-D = Center for Epidemiologic Studies Depression Scale; MDD = Major Depressive Disorder; ESSI = ENRICH Social Support Instrument; CRI CA = Coping Responses Inventory Cognitive Avoidance Subscale; DAS = Dysfunctional Attitudes Scale; DAS-4 = Dyadic Adjustment Scale – 4; SIS = Social Impact Scale.

* $p < .05$, ** $p < .01$

Relationships of Demographic and Clinical Variables with Perceived Stigma

In order to determine if demographic and clinical variables were associated with perceived stigma, *t*-tests, ANOVAs, and correlational analyses were conducted (see Tables 12 and 13). Age was associated with perceived stigma, such that younger patients reported greater perceived stigma. Also, those who reported no alcohol use in the past month ($M = 45.19$, $SD = 11.30$) reported greater perceived stigma than those who reported using alcohol in the past month ($M = 40.00$, $SD = 12.06$). In addition, patients with a diagnosis of past Major Depressive Disorder ($M = 48.91$, $SD = 12.71$) as well as those with an ECOG performance status of 2 or 3 ($M = 50.63$, $SD = 12.70$) reported greater perceived stigma as compared to those without a history of Major Depressive Disorder ($M = 41.86$, $SD = 11.48$) and those with performance statuses of 0 ($M = 40.69$, $SD = 10.35$) or 1 ($M = 41.99$, $SD = 11.70$).

Although no hypotheses were offered, multivariate stepwise analyses were conducted to determine which of these demographic and clinical variables contributed significant variance in perceived stigma (see Table 14). Age and performance status were the only variables that contributed significant variance in perceived stigma above and beyond that contributed by one another.

Table 12

Relationships Between Perceived Stigma and Demographic Variables (N = 95)

Variable	Perceived Stigma (SIS)	p-value
Age (years)	$r = -.21$.04
Gender (m, f)	$t = 1.14$.26
Education (< H.S., \geq H.S.)	$t = -1.01$.32
Race (White, non-White)	$t = -1.19$.24
Ethnicity (Hispanic, non-Hispanic)	$t = 0.38$.71
Marital Status (married, not married)	$t = 0.95$.35
Total Household Income (< \$40k, \geq \$40k)	$t = 0.68$.50
Alcohol Use in Past Month (yes, no)	$t = 2.16$.03
Cigarette Use (never, previous, current)	$F = 0.23$.80
Pack Years	$r = .18$.08

^aAmong only past smokers and current smokers ($n = 83$).

Table 13

Relationships Between Perceived Stigma and Clinical Variables (N = 95)

Variable	Perceived Stigma (SIS)	<i>p</i> -value
Diagnosis of Past Major Depression (yes, no)	$t = 2.09$.04
BMI	$r = -.15$.14
Months Since Original Diagnosis	$r = .12$.25
Months Since Recurrence ^a	$r = .02$.91
Disease Stage (II, III, IV)	$F = 0.63$.54
ECOG Performance Status (0, 1, 2-3)	$F = 3.46$.04
Surgery (yes, no)	$t = -0.60$.55
Months Since Surgery ^b	$r = .12$.45
Radiation Therapy (never, previous, current)	$F = 0.08$.92
Months Since Radiation Therapy ^c	$r = .05$.74
Chemotherapy infusions for this course	$r = .02$.85
Previous chemotherapy courses ^d	$r = .17$.26
Antidepressant medication (yes, no)	$t = 1.38$.17

Note: ECOG = Eastern Cooperative Oncology Group

^aAmong only those with a recurrence of Non-Small Cell Lung Cancer ($n = 30$); ^bAmong only those who had surgery; ^cAmong only those who received radiation therapy ($n = 41$); ^dAmong only those who received a course of chemotherapy previous to the current course ($n = 45$).

Table 14

Summary of Stepwise Regression Analysis for Variables Predicting Perceived Stigma (SIS) (n = 95)

Variable	β	ΔR^2
Step 1		.05
ECOG Performance Status (0, 1, 2-3)	.22*	
Step 2		.05
Age	-.22*	

Note. Overall $F(2, 92) = 4.94, p < .01$; SIS = Social Impact Scale; ECOG = Eastern Cooperative Oncology Group.

* $p < .05$

Mediational Analyses

In order to determine which psychosocial variables would be tested for mediation of the relationship between perceived stigma and depressive symptomatology, correlational analyses were conducted between perceived stigma and social support, avoidant coping, dysfunctional attitudes, and dyadic adjustment (see Table 10). Social support, dysfunctional attitudes, and dyadic adjustment were all significantly correlated with perceived stigma ($ps < .01$); avoidant coping was not ($p = .45$). Thus, three separate mediational analyses were conducted to determine if social support, dysfunctional attitudes, or dyadic adjustment mediated the relationship observed between perceived stigma and depressive symptomatology. The method described by MacKinnon, et al. (2007) was employed to determine if there is a direct effect (c) between the predictor and dependent variable which is mediated by the proposed mediator.

Table 15

Correlations Between Perceived Stigma and Psychosocial Variables (N = 95)

Variable	Perceived Stigma (SIS)	p -value
Social Support (ESSI)	-.35	.001
Dyadic Adjustment (DAS-4) ^a	-.35	.004
Avoidant Coping (CRI CA)	.08	.450
Dysfunctional Attitudes (DAS)	.43	< .001

^aAmong only those living with a spouse or partner ($n = 66$).

The first model tested whether social support mediated the relationship of perceived stigma to depressive symptomatology. Perceived stigma was a significant predictor of depressive symptomatology ($B = .32, p < .001$) as well as social support ($B = -.09, p < .001$). After controlling for social support, there was a reduction in the regression coefficient for perceived stigma ($B = .28, p < .001$), indicating that the effect of perceived stigma on depressive symptomatology was partially mediated by social support; however, the Sobel test was only marginally significant ($z = 1.70, p = .089$), suggesting no mediational relationship (see Figure 3).

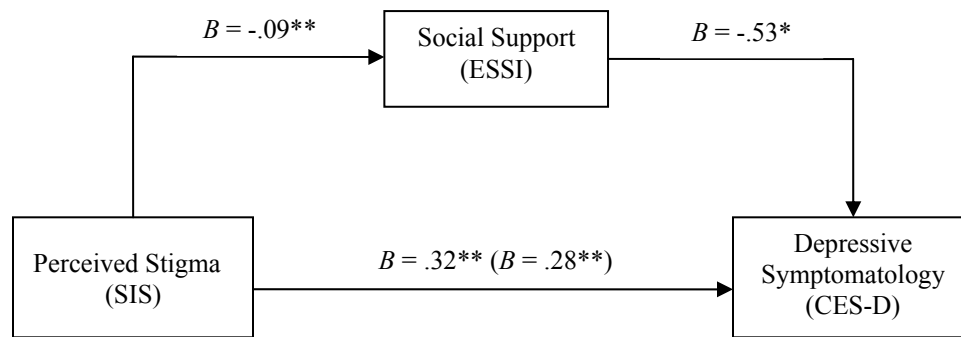

Figure 3. Proposed Model of Social Support (ESSI) as a Mediator Between Perceived Stigma (SIS) and Depressive Symptomatology (CES-D). ESSI: ENRICHD Social Support Instrument; SIS: Social Impact Scale; CES-D: Center for Epidemiologic Studies Depression Scale; Sobel test $z = 1.70, p = .089$.

* $p < .05$, ** $p < .01$

The second model tested whether dyadic adjustment mediated the relationship of perceived stigma to depressive symptomatology. Perceived stigma was a significant predictor of depressive symptomatology, $B = .40, p < .001$, as well as dyadic adjustment, $B = -.10, p = .005$. After controlling for dyadic adjustment, there was a reduction in the

regression coefficient for perceived stigma to $B = .28, p < .001$, indicating that the effect of perceived stigma on depressive symptomatology was partially mediated by dyadic adjustment. Sobel's test was significant ($z = 2.10, p = .036$), adding further support to the mediation model (see Figure 4).

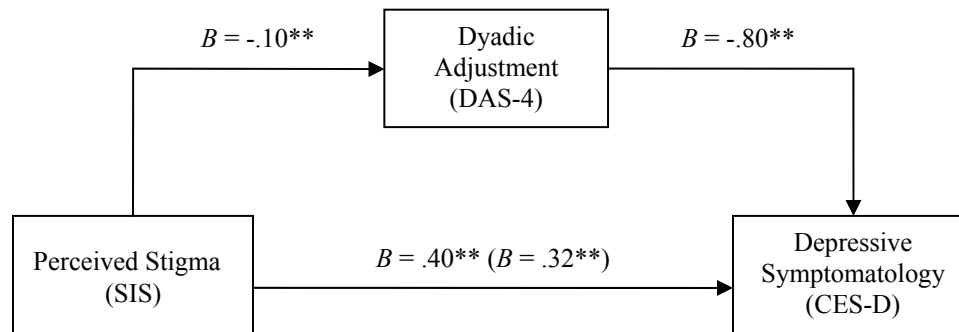

Figure 4. Proposed Model of Dyadic Adjustment (DAS-4) as a Mediator Between Perceived Stigma (SIS) and Depressive Symptomatology (CES-D) ^aAmong only those participants who were living with a spouse or partner ($n = 66$); DAS-4 = Dyadic Adjustment Scale-4; SIS = Social Impact Scale; CES-D = Center for Epidemiologic Studies Depression Scale; Sobel test $z = 2.10, p = .036$.

* $p < .05$, ** $p < .01$

The third model tested whether dysfunctional attitudes mediated the relationship of perceived stigma to depressive symptomatology. Perceived stigma was a significant predictor of depressive symptomatology, $B = .32, p < .001$, as well as dysfunctional attitudes, $B = .94, p < .001$. After controlling for dysfunctional attitudes, there was a reduction in the regression coefficient for perceived stigma to $B = .22, p < .001$, indicating that the effect of perceived stigma on depressive symptomatology was partially

mediated by dysfunctional attitudes. Sobel's test was significant ($z = 2.82, p = .005$), adding further support to the mediation model (see Figure 5).

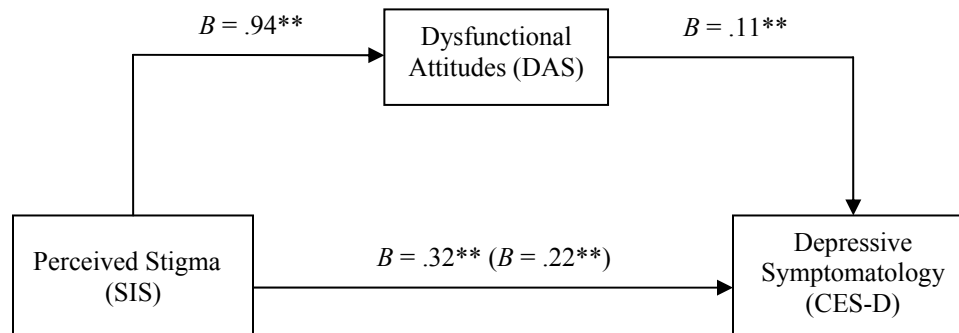

Figure 5. Proposed Models of Dysfunctional Attitudes (DAS) as a Mediator Between Perceived Stigma (SIS) and Depressive Symptomatology (CES-D). DAS = Dysfunctional Attitudes Scale; SIS = Social Impact Scale; CES-D = Center for Epidemiologic Studies Depression Scale; Sobel test $z = 2.82, p = .005$.

$*p < .05, **p < .01$

Discussion

Summary of Results

The primary aim of this study was to examine the relationship between perceived stigma and depressive symptomatology in people with lung cancer. The study also sought to examine relationships between several psychosocial factors that are related to depressive symptomatology in other populations and depressive symptomatology in people with lung cancer. Additionally, it aimed to determine if perceived stigma accounts for variability in depressive symptomatology in lung cancer patients above and beyond that explained by psychosocial factors that have been found to be related to depressive symptomatology in other populations. Lastly, this study sought to determine whether the psychosocial factors assessed mediated the relationship between perceived stigma and depressive symptomatology.

Results generally supported the study hypotheses. As expected, greater perceived stigma was significantly related to higher levels of depressive symptomatology. More avoidant coping, poorer social support, poorer dyadic adjustment, and more dysfunctional attitudes were also significantly related to greater depressive symptomatology. Additional analyses indicated that perceived stigma contributed unique variance in depressive symptomatology above and beyond that accounted for by clinical (time since lung cancer diagnosis), demographic (history of past Major Depressive Disorder), and psychosocial (avoidant coping, social support, dyadic adjustment, and dysfunctional attitudes) factors. Further analyses showed that financial insecurity and social isolation may be the aspects of perceived stigma that most contribute to depressive symptomatology. In addition, younger patients, those who reported no alcohol use in the past month, those with a

history of Major Depressive Disorder, as well as those with poorer performance statuses reported greater perceived stigma; however, only age and performance status contributed significant variance to perceived stigma. Finally, analyses suggested that dyadic adjustment and dysfunctional attitudes mediated the relationship between perceived stigma and depressive symptomatology. The following discussion will consider the theoretical and clinical implications of these findings, describe the study's limitations, and identify future research directions suggested by the study findings.

Theoretical and Clinical Implications

As can best be determined, this is the first study to examine the relationship of perceived stigma to depressive symptomatology in lung cancer patients. This study's findings provide quantitative evidence consistent with the qualitative evidence provided by Chapple and colleagues (2004) which suggested that lung cancer patients experience significant stigma from others as a result of their illness. Moreover, this study extends this finding to provide evidence for a link between perceived stigma and depressive symptomatology as well as possible mediators of this relationship.

Documenting this link among lung cancer patients is important for several reasons. First, it adds further evidence to the growing body of literature suggesting a connection between illness-related stigma and depressive symptomatology. As noted earlier, studies have found that patients with other stigmatizing conditions (e.g., HIV infection) who report more stigma also report greater depressive symptomatology (Simbayi, et al., 2007). Second, it adds to knowledge about the possible etiology of depressive symptomatology among lung cancer patients, a group that is particularly likely to experience depressive symptoms (Buccheri, 1998; Nakaya et al., 2006).

This study's findings are consistent with the Cognitive Theory of Depression, which states that one's experiences may contribute to depressive symptomatology by activating maladaptive schemas, or ways of thinking, from past experiences that are related to the current situation (Beck & Dempster, 1976; Beck, Rush, Shaw, & Emery, 1979). When activated, these maladaptive schemas begin to perpetuate dysfunctional attitudes, or faulty reasoning, within the individual that are evident in their automatic cognitive responses to stimuli. These automatic cognitive responses propagate negative views of oneself, the experiences one undergoes, and one's outlook on the future. These negative thought patterns, the Cognitive Triad, are the most conscious manifestations of the depressive state and are theorized to result in affective and somatic depressive symptoms (Beck et al., 1979). This study's findings suggest that this chain reaction could be activated in lung cancer patients who perceive they are being stigmatized because of their illness. Some lung cancer patients may in fact misperceive that they are being stigmatized because of their illness; however, the effect of misperceived stigma would likely be similar to that of actual stigmatization. Consider, Beck and colleagues' explanation of the effects of misperceiving being rejected and socially alienated – two expressions of stigma:

“For example, if the patient incorrectly *thinks* he is being rejected, he will react with the same negative affect (for example, sadness, anger) that occurs with actual rejection. If he erroneously believes he is a social outcast, he will feel lonely” (Beck et al., 1979, p. 11).

The finding that those experiencing more stigma also reported greater depressive symptomatology provides evidence that this process may be under way in some patients

with lung cancer, an illness for which patients are often stigmatized (Chapple et al., 2004). Moreover, this study also suggested mechanisms by which stigma may contribute to depression in lung cancer patients. Specifically, the mediational effect of dysfunctional attitudes on the relationship between perceived stigma and depressive symptomatology further suggest that Beck's Cognitive Theory of Depression may help explain the etiology of depressive symptoms often experienced by lung cancer patients.

The mediational effects of dyadic adjustment on the relationship between perceived stigma and depressive symptomatology also suggest additional pathways through which perceived stigma may lead to or worsen the severity of depressive symptoms. That is, greater perceived stigma may activate the process which leads to relational problems with close others which, in turn, might worsen one's depressive symptoms. Research in the general population, as well as in chronically-ill populations, has shown that individuals experiencing poorer dyadic adjustment (Berger et al., 2001; Miles et al., 1997; Simbayi et al., 2007) report greater depressive symptomatology.

With regard to clinical implications, the findings suggest psychotherapeutic approaches that might be employed to alleviate or prevent depressive symptoms among lung cancer patients. Most approaches to reducing stigma are focused on reducing the stigma that individuals feel towards people of another group (Couture & Penn, 2003). They are either protests against the injustice of stigmatizing behavior or programs to educate the public about inaccuracies of stereotypes and replace these inaccuracies with facts (Corrigan, Kerr, & Knudsen, 2005). These approaches do not seem very applicable to reducing perceived stigma in lung cancer patients. However, other approaches such as cognitive therapy may be helpful in counteracting the effects of stigma (e.g.,

dysfunctional attitudes) on the stigmatized individual (Corrigan et al., 2005).

Specifically, a modified cognitive therapy approach targeted at altering thoughts and feelings associated with perceived stigma may prove effective in reducing depressive symptomatology.

Self-blame is an important component of perceived stigma that warrants attention. One strategy might involve pointing out to patients that, although it is true that smoking causes many cases of lung cancer, self-blame is a maladaptive coping strategy after lung cancer is diagnosed. To help patients move beyond the self-blame they may experience as a result of perceived stigma, they might be encouraged to present exempting beliefs. For example, not everyone who smokes gets cancer and not everyone who gets cancer smoked. Thus, it is impossible to ascertain whether one's lung cancer diagnosis can be directly attributable to their smoking. Knowing that one may not necessarily have "caused" their cancer might help reduce self-blame. The addictiveness of cigarette smoking and the deception in early tobacco industry advertisements could also be understood by some patients to put them in the position of having been wronged rather than being a wrong-doer. Though self-blame can be targeted and reduced, it may remain in some patients. Those patients should be encouraged to acknowledge the potential for culpability, then move on to more productive uses of their energies. To help facilitate this, a psychotherapeutic approach should assist lung cancer patients with helping their families cope with their illness and its present and future consequences. Patients could also be offered counseling to aid in their understanding of their illness and their oncologists' recommended treatment plan. These and other focuses within the broader

framework of Cognitive Therapy for depression could help patients move past self-blame and other consequences of their illness.

Limitations

This study had several limitations. First, the cross-sectional nature of this study limits the conclusions that can be drawn from its findings. Although the results can be interpreted as suggesting that stigma contributes to depression, the possibility that depression contributes to stigma cannot be ruled out. The use of a longitudinal design would allow the testing of temporal hypotheses. Second, the study's sample was relatively homogenous with respect to race and ethnicity, which limits the ability to generalize to the broader lung cancer patient population. Third, the lung cancer patients in this study were receiving chemotherapy designed to extend life; thus, this study's findings may not generalize to lung cancer patients receiving other types of treatments or receiving no treatment at all. Lastly, although use of antidepressant medication was not related to depressive symptomatology in this study, participants' use of psychotherapy and related services was not assessed.

Future Directions

Because this is the first quantitative study to identify the relationship between perceived stigma and depressive symptomatology among lung cancer patients, it will be important to see if these findings can be replicated in future research. Beyond this, there is a need for longitudinal research that would allow for examination of the temporal relationships between perceptions of stigma and depressive symptomatology.

Based on the findings that psychosocial factors mediate the relationship between perceived stigma and depressive symptomatology, longitudinal study designs should be

employed in future studies. These designs would enable examinations of temporal relationships and would allow stronger causal inferences to be drawn. Also, future studies should examine the potential relationship between the use of psychotherapy services and depressive symptomatology. Future studies should also aim to recruit samples of lung cancer patients that are more diverse with regard to race, ethnicity, and socioeconomic status. Additionally, the use of interventions to reduce depressive symptomatology among lung cancer patients and other stigmatized groups should consider targeting stigma and its direct effects.

References

- American Psychiatric Association. (2000). *Diagnostic and statistical manual of mental disorders* (4th ed.). Washington, DC: American Psychiatric Association.
- Babiss, L. A., & Gangwisch, J. E. (2009). Sports participation as a protective factor against depression and suicidal ideation in adolescents as mediated by self-esteem and social support. *Journal of Developmental & Behavioral Pediatrics, 30*(5), 376-384.
- Beck, A. T., & Dempster, R. (1976). *Cognitive therapy and the emotional disorders*. International Universities Press New York.
- Beck, A. T., Rush, A. J., Shaw, B. F., & Emery, G. (1979). Cognitive theory of depression. *New York, Guilford*,
- Berard, R. M. F., Boermeester, F., & Viljoen, G. (1998). Depressive disorders in an out­ patient oncology setting: Prevalence, assessment, and management. *Psycho-Oncology, 7*(2), 112-120.
- Berger, B. E., Ferrans, C. E., & Lashley, F. R. (2001). Measuring stigma in people with HIV: Psychometric assessment of the HIV stigma scale. *Research in Nursing & Health, 24*(6), 518-529.
- Beyrer, C., Sripaipan, T., Tovanabutra, S., Jittiwutikarn, J., Suriyanon, V., Vongchak, T., Srirak, N., Kawichai, S., Razak, M. H., & Celentano, D. D. (2005). High HIV, hepatitis C and sexual risks among drug-using men who have sex with men in northern thailand. *AIDS, 19*(14), 1535.
- Biostat. (2000). *Power and precision*. Englewood, NJ.

- Brotto, L. A., Heiman, J. R., Goff, B., Greer, B., Lentz, G. M., Swisher, E., Tamimi, H., & Van Blaricom, A. (2008). A psychoeducational intervention for sexual dysfunction in women with gynecologic cancer. *Archives of Sexual Behavior, 37*(2), 317-329.
- Buccheri, G. (1998). Depressive reactions to lung cancer are common and often followed by a poor outcome. *European Respiratory Journal, 11*(1), 173-178.
- Chan, Y. M., Ng, T. Y., Lee, P. W. H., Ngan, H. Y. S., & Wong, L. C. (2003). Symptoms, coping strategies, and timing of presentations in patients with newly diagnosed ovarian cancer. *Gynecologic Oncology, 90*(3), 651-656.
- Chapple, A., Ziebland, S., & McPherson, A. (2004). Stigma, shame, and blame experienced by patients with lung cancer: Qualitative study. *BMJ (Clinical Research Ed.), 328*(7454), 1470. doi:10.1136/bmj.381111.639734.7C
- Corrigan, P. W., Kerr, A., & Knudsen, L. (2005). The stigma of mental illness: Explanatory models and methods for change. *Applied and Preventive Psychology, 11*(3), 179-190.
- Couture, S., & Penn, D. (2003). Interpersonal contact and the stigma of mental illness: A review of the literature. *Journal of Mental Health, 12*(3), 291-305.
- Degner, L. F., & Sloan, J. A. (1995). Symptom distress in newly diagnosed ambulatory cancer patients and as a predictor of survival in lung cancer. *Journal of Pain and Symptom Management, 10*(6), 423-431.
- Fife, B. L., & Wright, E. R. (2000). The dimensionality of stigma: A comparison of its impact on the self of persons with HIV/AIDS and cancer. *Journal of Health and Social Behavior, 41*(1), 50-67.

- Fisher Jr, E. B., La Greca, A. M., Greco, P., Arfken, C., & Schneiderman, N. (1997). Directive and nondirective social support in diabetes management. *International Journal of Behavioral Medicine*, 4(2), 131-144.
- Frasure-Smith, N., Lesperance, F., Gravel, G., Masson, A., Juneau, M., Talajic, M., & Bourassa, M. G. (2000). Social support, depression, and mortality during the first year after myocardial infarction. *Circulation*, 101(16), 1919-1924.
- Gibbon, M., & Williams, J. B. W. (2002). Structured clinical interview for DSM-IV axis I disorders, research version, non-patient edition (SCID-I/NP). *New York: Biometrics Research, New York State Psychiatric Institute*,
- Godtfredsen, N. S., Prescott, E., & Osler, M. (2005). Effect of smoking reduction on lung cancer risk. *JAMA*, 294(12), 1505-1510.
- Goodman, E., & Capitman, J. (2000). Depressive symptoms and cigarette smoking among teens. *Pediatrics*, 106(4), 748-755.
- Hack, T. F., & Degner, L. F. (2004). Coping responses following breast cancer diagnosis predict psychological adjustment three years later. *Psycho-Oncology*, 13(4), 235-247.
- Haffel, G. J., Abramson, L. Y., Voelz, Z. R., Metalsky, G. I., Halberstadt, L., Dykman, B. M., Donovan, P., Hogan, M. E., Hankin, B. L., & Alloy, L. B. (2005). Negative cognitive styles, dysfunctional attitudes, and the remitted depression paradigm: A search for the elusive cognitive vulnerability to depression factor among remitted depressives. *Emotion (Washington, D.C.)*, 5(3), 343-348. doi:10.1037/1528-3542.5.3.343

- Hann, D., Winter, K., & Jacobsen, P. (1999). Measurement of depressive symptoms in cancer patients: Evaluation of the center for epidemiological studies depression scale (CES-D). *Journal of Psychosomatic Research*, 46(5), 437-443.
- Herr, N. R., Hammen, C., & Brennan, P. A. (2007). Current and past depression as predictors of family functioning: A comparison of men and women in a community sample. *JOURNAL OF FAMILY PSYCHOLOGY*, 21(4), 694.
- Hopwood, P., & Stephens, R. J. (2000). Depression in patients with lung cancer: Prevalence and risk factors derived from quality-of-life data. *Journal of Clinical Oncology : Official Journal of the American Society of Clinical Oncology*, 18(4), 893-903.
- Hyodo, I., Eguchi, K., Takigawa, N., Segawa, Y., Hosokawa, Y., Kamejima, K., & Inoue, R. (1999). Psychological impact of informed consent in hospitalized cancer patients. A sequential study of anxiety and depression using the hospital anxiety and depression scale. *Supportive Care in Cancer : Official Journal of the Multinational Association of Supportive Care in Cancer*, 7(6), 396-399.
- Jemal, A., Siegel, R., Ward, E., Hao, Y., Xu, J., Murray, T., & Thun, M. J. (2008). Cancer statistics, 2008. *CA: A Cancer Journal for Clinicians*, 58(2), 71-96.
doi:10.3322/CA.2007.0010
- Jenewein, J., Zwahlen, R. A., Zwahlen, D., Drabe, N., Moergeli, H., & Buchi, S. (2008). Quality of life and dyadic adjustment in oral cancer patients and their female partners. *European Journal of Cancer Care*, 17(2), 127.

- Kaneko, M., Eguchi, K., Ohmatsu, H., Kakinuma, R., Naruke, T., Suemasu, K., & Moriyama, N. (1996). Peripheral lung cancer: Screening and detection with low-dose spiral CT versus radiography. *Radiology*, *201*(3), 798-802.
- King, K. E., & Arnett, P. A. (2005). Predictors of dyadic adjustment in multiple sclerosis. *Multiple Sclerosis*, *11*(6), 700.
- Kurtz, M. E., Kurtz, J. C., Stommel, M., Given, C. W., & Given, B. (2002). Predictors of depressive symptomatology of geriatric patients with lung cancer-a longitudinal analysis. *Psycho-Oncology*, *11*(1), 12-22.
- Lewis, F. M., Fletcher, K. A., Cochrane, B. B., & Fann, J. R. (2008). Predictors of depressed mood in spouses of women with breast cancer. *Journal of Clinical Oncology*, *26*(8), 1289.
- Link, B. G., Cullen, F. T., Struening, E., Shrout, P. E., & Dohrenwend, B. P. (1989). A modified labeling theory approach to mental disorders: An empirical assessment. *American Sociological Review*, *54*(3), 400-423.
- MacKinnon, D. P., Fairchild, A. J., & Fritz, M. S. (2007). Mediation analysis. *Annual Review of Psychology*, *58*, 593-614.
- Miles, M. S., Burchinal, P., Holditch-Davis, D., Wasilewski, Y., & Christian, B. (1997). Personal, family, and health-related correlates of depressive symptoms in mothers with HIV. *Journal of Family Psychology*, *11*(1), 23-34.
- Mitchell, P. H., Powell, L., Blumenthal, J., Norton, J., Ironson, G., Pitula, C. R., Froelicher, E. S., Czajkowski, S., Youngblood, M., Huber, M., & Berkman, L. F. (2003). A short social support measure for patients recovering from myocardial

- infarction: The ENRICHD social support inventory. *Journal of Cardiopulmonary Rehabilitation*, 23(6), 398-403.
- Montazeri, A., Milroy, R., Hole, D., McEwen, J., & Gillis, C. R. (1998). Anxiety and depression in patients with lung cancer before and after diagnosis: Findings from a population in glasgow, scotland. *Journal of Epidemiology and Community Health*, 52(3), 203-204.
- Moos, R. H. (1993). *Coping responses inventory*. Odessa, FL: Psychological Assessment Resources, Inc.
- Nakaya, N., Saito-Nakaya, K., Akizuki, N., Yoshikawa, E., Kobayakawa, M., Fujimori, M., Nagai, K., Nishiwaki, Y., Fukudo, S., & Tsubono, Y. (2006). Depression and survival in patients with non-small cell lung cancer after curative resection: A preliminary study. *Cancer Science*, 97(3), 199-205.
- Oken, M. M., Creech, R. H., Tormey, D. C., Horton, J., Davis, T. E., McFadden, E. T., & Carbone, P. P. (1982). Toxicity and response criteria of the eastern cooperative oncology group. *American Journal of Clinical Oncology*, 5(6), 649-655.
- Otto, M. W., Teachman, B. A., Cohen, L. S., Soares, C. N., Vitonis, A. F., & Harlow, B. L. (2007). Dysfunctional attitudes and episodes of major depression: Predictive validity and temporal stability in never-depressed, depressed, and recovered women. *Journal of Abnormal Psychology*, 116(3), 475.
- Purcell, D. W., Parsons, J. T., Halkitis, P. N., Mizuno, Y., & Woods, W. J. (2001). Substance use and sexual transmission risk behavior of HIV-positive men who have sex with men. *Journal of Substance Abuse*, 13(1-2), 185-200.

- Radloff, L. S. (1977). The CES-D scale: A self-report depression scale for research in the general population. *Applied Psychological Measurement, 1*(3), 385.
- Sabourin, S., Valois, P., & Lussier, Y. (2005). Development and validation of a brief version of the dyadic adjustment scale with a nonparametric item analysis model. *Psychological Assessment, 17*(1), 15-27. doi:10.1037/1040-3590.17.1.15
- Sarna, L. (1993). Correlates of symptom distress in women with lung cancer. *Cancer Practice, 1*(1), 21-28.
- Sarna, L. (1998). Effectiveness of structured nursing assessment of symptom distress in advanced lung cancer. *Oncology Nursing Forum, 25*(6), 1041-1048.
- Simbayi, L. C., Kalichman, S., Strebel, A., Cloete, A., Henda, N., & Mqeketo, A. (2007). Internalized stigma, discrimination, and depression among men and women living with HIV/AIDS in cape town, south africa. *Social Science & Medicine, 64*(9), 1823-1831.
- Sobel, M. E. (1982). Asymptotic confidence intervals for indirect effects in structural equation models. *Sociological Methodology, 13*, 290-312.
- Tagay, S., Herpertz, S., Langkafel, M., Erim, Y., Bockisch, A., Senf, W., & Görges, R. (2006). Health-related quality of life, depression and anxiety in thyroid cancer patients. *Quality of Life Research, 15*(4), 695-703.
- Turner, N. J., Muers, M. F., Haward, R. A., & Mulley, G. P. (2007). Psychological distress and concerns of elderly patients treated with palliative radiotherapy for lung cancer. *Psycho-Oncology, 16*(8), 707-713. doi:10.1002/pon.1109

- Uchitomi, Y., Mikami, I., Nagai, K., Nishiwaki, Y., Akechi, T., & Okamura, H. (2003). Depression and psychological distress in patients during the year after curative resection of non-small-cell lung cancer. *Journal of Clinical Oncology*, *21*(1), 69.
- Visser, M. R. M., & Smets, E. M. A. (1998). Fatigue, depression and quality of life in cancer patients: How are they related? *Supportive Care in Cancer*, *6*(2), 101-108.
- Walker, M. S., Larsen, R. J., Zona, D. M., Govindan, R., & Fisher, E. B. (2004). Smoking urges and relapse among lung cancer patients: Findings from a preliminary retrospective study. *Preventive Medicine*, *39*(3), 449-457.
- Walker, M. S., Zona, D. M., & Fisher, E. B. (2006). Depressive symptoms after lung cancer surgery: Their relation to coping style and social support. *Psycho-Oncology*, *15*(8), 684-693.
- Walker, M. S., Zona, D. M., Larsen, R. J., & Fisher, E. B. (2004). Multilevel analysis of social support and psychological adjustment during the first year following lung cancer surgery. *25th Annual Meeting and Scientific Sessions of the Society of Behavioral Medicine*, Baltimore, MD. , *27*(Supplement) S022.
- Weissman, A. N., & Beck, A. T. (1978). Development and validation of the dysfunctional attitude scale: A preliminary investigation. *Proceedings of the Meeting of the American Educational Research Association*, Toronto, ON.
- Wells, K. J., Booth-Jones, M., & Jacobsen, P. B. (2009). Do coping and social support predict depression and anxiety in patients undergoing hematopoietic stem cell transplantation? *Journal of Psychosocial Oncology*, *27*(3), 297-315.
- Whisman, M. A. (2007). Marital distress and DSM-IV psychiatric disorders in a population-based national survey. *Journal of Abnormal Psychology*, *116*(3), 638.

- Zanarini, M. C., Skodol, A. E., Bender, D., Dolan, R., Sanislow, C., Schaefer, E., Morey, L. C., Grilo, C. M., Shea, M. T., McGlashan, T. H., & Gunderson, J. G. (2000). The collaborative longitudinal personality disorders study: Reliability of axis I and II diagnoses. *Journal of Personality Disorders, 14*(4), 291-299.
- Zickmund, S., Masuda, M., Ippolito, L., & LaBrecque, D. R. (2003). Stigmatization and the quality of life of patients with hepatitis C. *Journal of General Internal Medicine, 18*(10), 835-844.