

A thermohydraulic model that represents the current configuration of the SAFARI-1 secondary cooling system

Ewan
Huisamen

Volume II

2015

A thermohydraulic model that represents the current configuration of the SAFARI-1 secondary cooling system

by

Ewan Huisamen

26043409

Submitted in partial fulfilment of the requirements for the degree

MASTER OF ENGINEERING

in the

Department of Mechanical and Aeronautical Engineering of the Faculty of Engineering, Built Environment and Information Technology
University of Pretoria

Volume II

Volume I: Chapter 1 to 7

Volume II: Appendix I to VII

2015



UNIVERSITEIT VAN PRETORIA
UNIVERSITY OF PRETORIA
YUNIBESITHI YA PRETORIA

Synopsis

Title: A thermohydraulic model that represents the current configuration of the SAFARI-1 secondary cooling system

Author: Ewan Huisamen (26043409)

Supervisors: Prof JFM Slabber and Prof JP Meyer
Department: Mechanical and Aeronautical Engineering University: University of Pretoria

Degree: Master of Engineering (Mechanical Engineering)

This document focuses on the procedure and results of creating a thermohydraulic model of the secondary cooling system of the SAFARI-1 research reactor at the Pelindaba facility of the South African Nuclear Energy Corporation (Necsa) to the west of Pretoria, South Africa.

The secondary cooling system is an open recirculating cooling system that comprises an array of parallel-coupled heat exchangers between the primary systems and the main heat sink system, which consists of multiple counterflow-induced draught cooling towers.

The original construction of the reactor was a turnkey installation, with no theoretical/technical support or verifiability. The design baseline is therefore not available and it is necessary to reverse-engineer a system that could be modelled and characterised.

For the nuclear operator, it is essential to be able to make predictions and systematically implement modifications to improve system performance, such as to understand and modify the control system. Another objective is to identify the critical performance areas of the thermohydraulic system or to determine whether the cooling capacity of the secondary system meets the optimum original design characteristics.

The approach was to perform a comprehensive one-dimensional modelling of all the available physical components, which was followed by using existing performance data to verify the accuracy and validity of the developed model. Where performance data is not available, separate analysis through computational fluid dynamics (CFD) modelling is performed to generate the required inputs.

The results yielded a model that is accurate within 10%. This is acceptable when compared to the variation within the supplied data, generated and assumed alternatives, and when considering the compounding effect of the large amount of interdependent components, each with their own characteristics and associated performance uncertainties.

The model pointed to potential problems within the current system, which comprised either an obstruction in a certain component or faulty measuring equipment. Furthermore, it was found that the current spray nozzles in the cooling towers are underutilised. It should be possible to use the current cooling tower arrangement to support a similar second reactor, although slight modifications would be required to ensure that the current system is not operated beyond its current limits. The interdependent nature of two parallel systems and the variability of the conditions that currently exist would require a similar analysis as the current model to determine the viability of using the existing cooling towers for an additional reactor.

Keywords: *thermohydraulic model, nuclear, one-dimensional modelling, computational fluid dynamics*

Acknowledgements

I would like to thank the following people:

- Mr Ari Hatting (Necsa) for his prompt and effective assistance at all times.
- Dr Andre van Heerden (former Necsa employee) for his undying enthusiasm and commitment to the project.
- Keith Railton (former Esteq employee) for turning a world of Greek into English.
- Prof JFM Slabber (University of Pretoria) for unfailing support, knowledge, friendship and a love for the nuclear fraternity.
- My family, who are the *raison d'être* for this thesis.

Table of contents

Volume I

Synopsis	i
Acknowledgements	iii
List of figures	viii
List of tables.....	x
Nomenclature	xxi
List of abbreviations	xxiii
Glossary	xxiv
1. Introduction	1
1.1 Background.....	1
1.2 Motivation.....	2
1.3 Previous investigations.....	3
1.4 Objectives	3
1.5 Limitations of the study.....	4
2. Literature.....	6
2.1 The secondary cooling subsystems.....	6
3. Method of analysis	14
3.1 Methods of analysis.....	14
3.2 Employed Software	16
3.3 Statistical methods	25
3.4 Conclusion and summary of analysis methods.....	26
4. Results.....	27
4.1 Structures and components	27
4.2 Subsystems.....	47
4.3 Synthesis	48
4.4 Simulation results	49
5. Discussion.....	67
5.1 Calibration.....	67
5.2 Pool heat exchanger (HE-0301).....	67
5.3 Cooling tower nozzles	68
5.4 Chiller and fan coil unit pump (P-603).....	70
6. Conclusion and recommendations	71
7. References.....	72

VOLUME II

Synopsis	i
Acknowledgements	iii
List of figures	viii
List of tables.....	x
8. References.....	79
Appendix I.....	85
A: Cooling tower subsystem.....	85
A I.....	86
A II.....	87
A III.....	88
A IV.....	89
A V.....	90
A VI.....	90
B: Primary heat exchanger pump room.....	91
B I.....	92
B II.....	93
B III.....	94
B IV.....	95
C: Primary heat exchanger room	96
C I.....	97
C II.....	98
C III.....	99
C IV.....	99
D: Tube-cleaning subsystem.....	100
D I.....	101
D II.....	102
D III.....	102
D IV.....	103
E: Pool heat exchanger and fan coil unit subsystem	104
E I.....	105
E II.....	106
E III.....	107
E IV.....	108
F: Chiller heat exchanger units	113
F I.....	114
F II.....	114

Appendix II.....	115
Input variables.....	115
Bend	115
Boundary conditions.....	115
Orifice	117
Pump	118
General empirical relationship	118
Heat exchangers – shell side	123
Heat exchangers – tube side.....	124
T-junctions	125
Nodes	129
Piping.....	153
Reservoirs.....	181
Non-return valves.....	182
Control valves with iterative script.....	184
Variable speed pumps.....	189
Iterative script.....	190
Pipe transition	203
Gate valves	206
Butterfly valves.....	209
Appendix III	212
Results.....	212
Bend	212
Boundary conditions.....	217
Orifice	218
Pump	222
General empirical relationship	228
Heat exchangers – shell side	257
Heat exchangers – tube side.....	263
T-junctions	269
Nodes	274
Piping.....	302
Reservoirs.....	386
Non-return valves.....	387
Control valves with iterative script.....	394
Variable speed pumps.....	413
Iterative script.....	418

Pipe transition	427
Gate valves	445
Butterfly valves.....	458
Appendix IV	465
Methodology of temperature control	465
Secondary cooling system	466
Appendix V	469
Heat exchanger arrangement.....	469
Appendix VI	478
Statistical Method Example: Y-Strainer.....	478
Appendix VII.....	481
Cooling tower analysis and validation.....	481

List of figures

Figure 1: Cooling tower subsystem	8
Figure 2: Primary heat exchanger and tube-cleaning subsystems	9
Figure 3: Pool heat exchanger subsystem	11
Figure 4: Pool heat exchanger subsystem	13
Figure 5: Schematic of the secondary cooling system.....	19
Figure 6: Y-joint flow scenarios	34
Figure 7: Y-joint schematic.....	35
Figure 8: Dividing branch flow schematic	37
Figure 9: Secondary cooling system schematic	50
Figure 10: Cooling tower subsystem schematic	51
Figure 11: Primary heat exchanger pump subsystem schematic.....	54
Figure 12: Fan coil and chiller water unit subsystem schematic	56
Figure 13: Pool heat exchanger subsystem	60
Figure 14: Reactor heat exchanger subsystem schematic	62
Figure 15: Tube-cleaning subsystem schematic	64
Figure 16: Nozzle calibration curves	69
Figure 17: Cooling tower subsystem schematic	85
Figure 18: Schematic figure A I.....	86
Figure 19: Schematic figure A li	87
Figure 20: Schematic figure A lii	88
Figure 21: Schematic figure A Iv	89
Figure 22: Schematic figure A V.....	90
Figure 23: Schematic figure A Vi.....	90
Figure 24: Primary heat exchanger pump room schematic	91
Figure 25: Schematic figure B I.....	92
Figure 26: Schematic figure B li	93
Figure 27: Schematic figure B lii	94
Figure 28: Schematic figure B Iv	95
Figure 29: Primary heat exchanger room schematic	96
Figure 30: Schematic figure C I.....	97
Figure 31: Schematic figure C li	98
Figure 32: Schematic figure C lii	99
Figure 33: Schematic figure C Iv	99
Figure 34: Tube-cleaning subsystem schematic	100
Figure 35: Schematic figure D I.....	101
Figure 36: Schematic figure D li	102

Figure 37: Schematic figure D lii	102
Figure 38: Schematic figure D Iv	103
Figure 39: Pool heat exchanger and fan coil unit subsystem schematic.....	104
Figure 40: Schematic figure E I	105
Figure 41: Schematic figure E li	106
Figure 42: Schematic figure E lii	107
Figure 43: Schematic figure E Iv	108
Figure 44: Schematic figure E V.....	109
Figure 45: Schematic figure E Vi.....	110
Figure 46: Schematic figure E Vii	101
Figure 47: Schematic figure E Viii	102
Figure 48: Chiller heat exchanger schematic	113
Figure 49: Schematic figure F I	114
Figure 50: Schematic figure F li	114
Figure 51: Cooling tower arrangement: parallel vs. series.....	468
Figure 52: Schematic possible arrangements of primary heat exchangers.....	471
Figure 53: Y-Strainer pressure drop vs flow rate	480
Figure 54: Fan static pressure vs. volume flow rate	482
Figure 55: Fan shaft power vs. volume flow rate	482
Figure 56: Louver fill arrangement	486

List of tables

Table 1: Sure Flow basket strainer empirical pressure loss constants.....	29
Table 2: Y-0601, Y-0604, Y0605, Y-0606 basket strainer empirical pressure loss constants ..	29
Table 3: Reactor secondary water pump derating percentage	32
Table 4: Y-joint effective flow	34
Table 5: Y-joint loss coefficient default arrangement	36
Table 6: Y-joint loss coefficient alternative arrangement	36
Table 7: Primary heat exchanger empirical pressure drop constants	36
Table 8: Dividing flow branch loss coefficients	38
Table 9: Ball catcher empirical pressure drop constants	39
Table 10: Ball strainer empirical pressure drop constants	40
Table 11: 200 mm Sure Flow basket Y-strainer empirical pressure loss constants	40
Table 12: Actual 200 mm Y-strainer empirical pressure loss constants.....	41
Table 13: Pool heat exchanger empirical pressure loss constants	41
Table 14: L-bend empirical pressure loss constants.....	42
Table 15: 80 mm Sure Flow Y-strainer empirical pressure loss constants.....	42
Table 16: 80 mm strainer (Y-0603) empirical pressure loss constants	43
Table 17: Fan coil units' empirical pressure loss data	45
Table 18: Carrier chiller unit empirical pressure loss constants	46
Table 19: Cooling tower performance comparison	48
Table 20: Cooling tower subsystem results.....	51
Table 21: Primary heat exchanger pump subsystem results	54
Table 22: Fan coil and chiller unit subsystem results	57
Table 23: Pool heat exchanger subsystem results	60
Table 24: Reactor heat exchanger subsystem results.....	62
Table 25: Tube-cleaning subsystem results	65
Table 26: Pool heat exchanger flow conditions	67
Table 27: Chiller and fan coil unit's pump flow conditions.....	70
Table 28: Bend input - A	115
Table 29: Bend input - B	115
Table 30: Bend input - C	115
Table 31: Boundary conditions input - A.....	115
Table 32: Boundary conditions input - B.....	116
Table 33: Boundary conditions input - C	116
Table 34: Orifice input - A	117
Table 35: Orifice input - B	117
Table 36: Orifice input - C	117

Table 37: Pump input - A 118

Table 38: Pump input - B 118

Table 39: Pump input - C 118

Table 40: General empirical relationship input - A 118

Table 41: General empirical relationship input - B 120

Table 42: General empirical relationship input - C 121

Table 43: Heat exchanger - shell side input- A 123

Table 44: Heat exchanger - shell side input - B 123

Table 45: Heat exchanger - shell side input- C 123

Table 46: Heat exchangers - tube side input - A 124

Table 47: Heat exchangers - tube side input - B 124

Table 48: Heat exchangers - tube side input - C 124

Table 49: T-junctions input - A 125

Table 50: T-junctions input - B 126

Table 51: T-junctions input - C 127

Table 52: T-junctions input - D 128

Table 53: Nodes input - A 129

Table 54: Nodes input - B 135

Table 55: Nodes input - C 141

Table 56: Nodes input - D 147

Table 57: Piping input - A 152

Table 58: Piping input - B 157

Table 59: Piping input - C 161

Table 60: Piping input - D 165

Table 61: Piping input - E 167

Table 62: Piping input - F 171

Table 63: Piping input - G 175

Table 64: Reservoir input - A 179

Table 65: Reservoir input - B 179

Table 66: Reservoir input - C 179

Table 67: Non-return valve input - A 180

Table 68: Non-return valve input - B 180

Table 69: Non-return valve input - C 180

Table 70: Non-return valve input - D 181

Table 71: Non-return valve input - E 181

Table 72: Non-return valve input - E 181

Table 73: Non-return valve input - F 181

Table 74: Control valve with iterative script input - A 182

Table 75: Control valve with iterative script input - B 183

Table 76: Control valve with iterative script input - C 184

Table 77: Control valve with iterative script input - D 185

Table 78: Control valve with iterative script input - E 186

Table 79: Variable speed pump input - A 187

Table 80: Variable speed pump input - B 187

Table 81: Variable speed pump input - C 187

Table 82: Variable speed pump input - D 187

Table 83: Variable speed pump input - E 187

Table 84: Iterative script input - A 188

Table 85: Iterative script input - B 189

Table 86: Iterative script input - C 192

Table 87: Iterative script input - D 195

Table 88: Iterative script input - E 198

Table 89: Iterative script input - F 201

Table 90: Pipe transition input - A 204

Table 91: Pipe transition input - B 205

Table 92: Pipe transition input - C 206

Table 93: Gate valve input - A 207

Table 94: Gate valve input - B 208

Table 95: Gate valve input - C 209

Table 96: Butterfly valve input - A 210

Table 97: Butterfly valve input - B 210

Table 98: Butterfly valve input - C 211

Table 99: Bend results - A 212

Table 100: Bend results - B 212

Table 101: Bend results - C 212

Table 102: Bend results - D 212

Table 103: Bend results - E 213

Table 104: Bend results - F 213

Table 105: Bend results - G 213

Table 106: Bend results - H 213

Table 107: Bend results - I 213

Table 108: Bend results - J 214

Table 109: Bend results - K 214

Table 110: Bend results - L 214

Table 111: Bend results - M..... 214

Table 112: Bend results - N 214

Table 113: Bend results - O 214

Table 114: Bend results - P..... 215

Table 115: Bend results - Q 215

Table 116: Bend results - R 215

Table 117: Bend results - S..... 215

Table 118: Bend results - T 215

Table 119: Bend Results - U 215

Table 120: Bend results - V..... 216

Table 121: Boundary conditions results - A..... 217

Table 122: Boundary conditions results - B..... 217

Table 123: Orifice results - A..... 218

Table 124: Orifice results - B..... 218

Table 125: Orifice results - B..... 218

Table 126: Orifice results - C 218

Table 127: Orifice results - D 218

Table 128: Orifice results - E..... 218

Table 129: Orifice results - F..... 219

Table 130: Orifice results - G 219

Table 131: Orifice results - H 219

Table 132: Orifice results - I..... 219

Table 133: Orifice results - J 219

Table 134: Orifice results - K..... 219

Table 135: Orifice results - L 220

Table 136: Orifice results - M 220

Table 137: Orifice results - N 220

Table 138: Orifice results - O 220

Table 139: Orifice results - P..... 220

Table 140: Orifice results - Q 220

Table 141: Orifice results - R 221

Table 142: Orifice results - S..... 221

Table 143: Orifice results - T 221

Table 144: Pump results - A..... 222

Table 145: Pump results - B..... 222

Table 146: Pump results - C 222

Table 147: Pump results - D 222

Table 148: Pump results - E.....	223
Table 149: Pump results - F.....	223
Table 150: Pump results - G.....	223
Table 151: Pump results - H.....	223
Table 152: Pump results - I.....	224
Table 153: Pump results - J.....	224
Table 154: Pump results - K.....	224
Table 155: Pump results - L.....	224
Table 156: Pump results - M.....	225
Table 157: Pump results - N.....	225
Table 158: Pump results - O.....	225
Table 159: Pump results - P.....	225
Table 160: Pump results - Q.....	226
Table 161: Pump results - R.....	226
Table 162: Pump results - S.....	226
Table 163: Pump results - T.....	226
Table 164: Pump results - U.....	227
Table 165: General empirical relationship results - A.....	228
Table 166: General empirical relationship results - B.....	229
Table 167: General empirical relationship results - C.....	231
Table 168: General empirical relationship results - D.....	232
Table 169: General empirical relationship results - E.....	234
Table 170: General empirical relationship results - F.....	235
Table 171: General empirical relationship results - G.....	237
Table 172: General empirical relationship results - H.....	238
Table 173: General empirical relationship results - I.....	240
Table 174: General empirical relationship results - J.....	241
Table 175: General empirical relationship results - K.....	243
Table 176: General empirical relationship results - L.....	244
Table 177: General empirical relationship results - M.....	246
Table 178: General empirical relationship results - N.....	247
Table 179: General empirical relationship results - O.....	249
Table 180: General empirical relationship results - P.....	250
Table 181: General empirical relationship results - Q.....	252
Table 182: General empirical relationship results - R.....	253
Table 183: General empirical relationship results - S.....	255
Table 184: Heat exchanger - shell side results - A.....	257

Table 185: Heat exchanger - shell side results - B	257
Table 186: Heat exchanger - shell side results - C	257
Table 187: Heat exchanger - shell side results - D	258
Table 188: Heat exchanger - shell side results - E	258
Table 189: Heat exchanger - shell side results - F	258
Table 190: Heat exchanger - shell side results - G	258
Table 191: Heat exchanger - shell side results - H	259
Table 192: Heat exchanger - shell side results - I	259
Table 193: Heat exchanger - shell side results - J	259
Table 194: Heat exchanger - shell side results - K	259
Table 195: Heat exchanger - shell side results - L	260
Table 196: Heat exchanger - shell side results - M	260
Table 197: Heat exchanger - shell side results - N	260
Table 198: Heat exchanger - shell side results - O	260
Table 199: Heat exchanger - shell side results - P	261
Table 200: Heat exchanger - shell side results - Q	261
Table 201: Heat exchanger - shell side results - R	261
Table 202: Heat exchanger - shell side results - S	261
Table 203: Heat exchanger - shell side results - T	262
Table 204: Heat exchanger - shell side results - U	262
Table 205: Heat exchanger - tube side results - A	263
Table 206: Heat exchanger - tube side results - B	263
Table 207: Heat exchanger - tube side results - C	263
Table 208: Heat exchanger - tube side results - D	264
Table 209: Heat exchanger - tube side results - E	264
Table 210: Heat exchanger - tube side results - F	264
Table 211: Heat exchanger - tube side results - G	264
Table 212: Heat exchanger - tube side results - H	265
Table 213: Heat exchanger - tube side results - I	265
Table 214: Heat exchanger - tube side results - J	265
Table 215: Heat exchanger - tube side results - K	266
Table 216: Heat exchanger - tube side results - L	266
Table 217: Heat exchanger - tube side results - M	266
Table 218: Heat exchanger - tube side results - N	266
Table 219: Heat exchanger - tube side results - O	267
Table 220: Heat exchanger - tube side results - P	267
Table 221: Heat exchanger - tube side results - Q	267

Table 222: Heat exchanger - tube side results - R	267
Table 223: Heat exchanger - tube side results - S.....	268
Table 224: T-junction results - A	269
Table 225: T-junction results - B	270
Table 226: T-junction results - C	271
Table 227: T-junction results - D	272
Table 228: T-junction results - E	273
Table 229: Node results - A	274
Table 230: Node results - B	279
Table 231: Node results - C	285
Table 232: Node results - D	290
Table 233: Node results - E	296
Table 234: Piping results - A	302
Table 235: Piping results - B	306
Table 236: Piping results - C	310
Table 237: Piping results - D	314
Table 238: Piping results - E	318
Table 239: Piping results - F	322
Table 240: Piping results - G.....	326
Table 241: Piping results - H.....	330
Table 242: Piping results - I	334
Table 243: Piping results - J.....	338
Table 244: Piping results - K.....	342
Table 245: Piping results - L	346
Table 246: Piping results - M	350
Table 247: Piping results - N.....	354
Table 248: Piping results - O.....	358
Table 249: Piping results - P	362
Table 250: Piping results - Q.....	366
Table 251: Piping results - R.....	370
Table 252: Piping results - S.....	374
Table 253: Piping results - T	378
Table 254: Piping results - U.....	382
Table 255: Reservoir results - A.....	386
Table 256: Reservoir results - B.....	386
Table 257: Reservoir results - C.....	386
Table 258: Reservoir results - D.....	386

Table 259: Reservoir results - E.....	386
Table 260: Non-return valve results - A.....	387
Table 261: Non-return valve results - B.....	387
Table 262: Non-return valve results - C.....	387
Table 263: Non-return valve results - D.....	388
Table 264: Non-return valve results - E.....	388
Table 265: Non-return valve results - F.....	388
Table 266: Non-return valve results - G.....	389
Table 267: Non-return valve results - H.....	389
Table 268: Non-return valve results - I.....	389
Table 269: Non-return valve results - J.....	390
Table 270: Non-return valve results - K.....	390
Table 271: Non-return valve results - L.....	390
Table 272: Non-return valve results - M.....	391
Table 273: Non-return valve results - N.....	391
Table 274: Non-return valve results - O.....	391
Table 275: Non-return valve results - P.....	392
Table 276: Non-return valve results - Q.....	392
Table 277: Non-return valve results - R.....	392
Table 278: Non-return valve results - S.....	393
Table 279: Non-return valve results - T.....	393
Table 280: Control valve with iterative script results - A.....	394
Table 281: Control valve with iterative script results - B.....	395
Table 282: Control valve with iterative script results - C.....	396
Table 283: Control valve with iterative script results - D.....	397
Table 284: Control valve with iterative script results - E.....	398
Table 285: Control valve with iterative script results - F.....	399
Table 286: Control valve with iterative script results - G.....	400
Table 287: Control valve with iterative script results - H.....	401
Table 288: Control valve with iterative script results - I.....	402
Table 289: Control valve with iterative script results - J.....	403
Table 290: Control valve with iterative script results - K.....	404
Table 291: Control valve with iterative script results - L.....	405
Table 292: Control valve with iterative script results - M.....	406
Table 293: Control valve with iterative script results - N.....	407
Table 294: Control valve with iterative script results - O.....	408
Table 295: Control valve with iterative script results - P.....	409

Table 296: Control valve with iterative script results - Q 410

Table 297: Control valve with iterative script results - R 411

Table 298: Control valve with iterative script results - S 412

Table 299: Variable speed pump results - A..... 413

Table 300: Variable speed pump results - B..... 413

Table 301: Variable speed pump results - C 413

Table 302: Variable speed pump results - D 413

Table 303: Variable speed pump results - E..... 414

Table 304: Variable speed pump results - F..... 414

Table 305: Variable speed pump results - G 414

Table 306: Variable speed pump results - H 414

Table 307: Variable speed pump results - I..... 415

Table 308: Variable speed pump results - J 415

Table 309: Variable speed pump results - K..... 415

Table 310: Variable speed pump results - L..... 415

Table 311: Variable speed pump results - M..... 416

Table 312: Variable speed pump results - O 416

Table 313: Variable speed pump results - P..... 416

Table 314: Variable speed pump results - Q 416

Table 315: Variable speed pump results - R 417

Table 316: Variable speed pump results - S..... 417

Table 317: Variable speed pump results - T..... 417

Table 318: Variable speed pump results - U 417

Table 319: Iterative script results - A..... 418

Table 320: Iterative script results - B..... 420

Table 321: Iterative script results - C..... 422

Table 322: Iterative script results - D..... 424

Table 323: Pipe transition results - A..... 427

Table 324: Pipe transition results - B..... 428

Table 325: Pipe transition results - C 429

Table 326: Pipe transition results - D 430

Table 327: Pipe transition results - E..... 431

Table 328: Pipe transition results - F..... 432

Table 329: Pipe transition results - G 433

Table 330: Pipe transition results -H 434

Table 331: Pipe transition results - I..... 435

Table 332: Pipe transition results - J 436

Table 333: Pipe transition results - K..... 437

Table 334: Pipe transition results - L..... 438

Table 335: Pipe transition results - M..... 439

Table 336: Pipe transition results - N 440

Table 337: Pipe transition results - O 441

Table 338: Pipe transition results - P..... 442

Table 339: Pipe transition results - Q 443

Table 340: Pipe transition results - R 444

Table 341: Gate valve results - A..... 445

Table 342: Gate valve results - B..... 446

Table 343: Gate valve results - C..... 447

Table 344: Gate valve results - D..... 448

Table 345: Gate valve results - E 449

Table 346: Gate valve results - F 450

Table 347: Gate valve results - G..... 451

Table 348: Gate valve results - H..... 452

Table 349: Gate valve results - I 453

Table 350: Gate valve results - J..... 454

Table 351: Gate valve results - K..... 455

Table 352: Gate valve results - L 456

Table 353: Gate valve results - M 457

Table 354: Butterfly valve results - A..... 458

Table 355: Butterfly valve results - B..... 458

Table 356: Butterfly valve results - C..... 459

Table 357: Butterfly valve results - D..... 459

Table 358: Butterfly valve results - E..... 460

Table 359: Butterfly valve results - F 460

Table 360: Butterfly valve results - G 461

Table 361: Butterfly valve results - H..... 461

Table 362: Butterfly valve results - I 462

Table 363: Butterfly valve results - J 462

Table 364: Butterfly valve results - K..... 463

Table 365: Butterfly valve results - L 463

Table 366: Butterfly valve results - M 464

Table 367: Butterfly valve results - N..... 464

Table 368: Heat exchanger arrangement #1: boundary conditions 472

Table 369: Heat exchanger arrangement #2: boundary conditions 472

Table 370: Heat exchanger arrangement #3: boundary conditions 472

Table 371: Heat exchanger arrangement #4: boundary conditions 473

Table 372: Heat exchanger arrangement #1; #2; #3; #4: results 473

Table 373: Hypothetical heat exchanger arrangement #1: boundary conditions..... 474

Table 374: Hypothetical heat exchanger arrangement #2: boundary conditions..... 474

Table 375: Hypothetical heat exchanger arrangement #3: boundary conditions..... 474

Table 376: Hypothetical heat exchanger arrangement #4: boundary conditions..... 475

Table 377: Hypothetical heat exchanger arrangement #1; #2; #3; #4: temperature and pressure results 475

Table 378: Hypothetical heat exchanger arrangement #1; #2; #3; #4; #4lp: heat transfer results 475

Table 379: Hypothetical heat exchanger arrangement #1; #2; #3; #4; #4lp: mass flow rate results 476

Table 380: Hypothetical heat exchanger arrangement #1; #2; #3; #4; #4lp: specific heat results 476

Table 381: Hypothetical heat exchanger arrangement #1; #2; #3; #4; #4lp: temperature minimum results..... 476

Table 382: Hypothetical heat exchanger arrangement #1; #2; #3; #4; #4lp: temperature maximum results..... 477

Table 383: Hypothetical heat exchanger arrangement #1; #2; #3; #4; #4lp: effectiveness 477

Table 384: Hypothetical heat exchanger arrangement #1; #2; #3; #4; #4lp: maximum duty results 477

Table 385: Sure Flow Inc: pressure loss graphs 478

Table 386: Empirical pressure loss constants 478

Table 387: Pressure loss constants 479

Table 388: Flow rate vs pressure drop 479

Table 389: Original fan specifications vs. modelled fan specifications..... 481

Table 390: Cooling tower input variables 484

Table 391: Louver constants..... 485

Table 392: Fan static pressure, fan power and fan efficiency: mathematical representation ... 486

Table 393: Cooling tower model results 487

7. References

1. Versteeg, HK and Malalasekera, W. *An introduction to computational fluid dynamics – the finite volume method*. Harlow: Pearson Prentice Hall, 2007.
2. Glaser, A. *About the enrichment limit for research reactor conversion: why 20%?* (pp. 1–12). Boston, MA: Program on Science and Global Security, Princeton University, 2005.
3. McGraw-Hill. *Dictionary of engineering* (2nd edition). New York, NY: McGraw-Hill, 2003.
4. Meier, FA. *A P&ID standard: what, why, how?* Chapel Hill, NC: ISA Transactions (Vol. 41, pp. 389–394), 2002.
5. Dixon, SL. *Fluid mechanics, thermodynamics of turbomachinery* (5th edition). Amsterdam: Elsevier Butterworth Heinemann, 2005.
6. Çengel, Y. *Heat and mass transfer: a practical approach* (3rd edition). s.l.: McGraw-Hill, 2006.
7. Kloppers, JC. *User's manual wetcooling WCTPE – Wet Cooling Tower Performance Evaluation Software Version 2.0*. 2009.
8. Flownex Simulation Environment. *Flownex Library Manual*. 2012.
9. Rizzoni, G. *Principles and applications of electrical engineering*. Boston, MA: McGraw-Hill, 2000.
10. Vladimir, C, Heiliö, M, Krejic, N and Nedeljkov, M. *Mathematical model for efficient water flow management* (3rd edition, Vol. 11, pp. 1600–1612). s.l.: Elsevier, 2010.
11. Ortega, JM and Rheinboldt, WC. *Iterative solution of nonlinear equations in several variables*. Philadelphia, PA: Society for Industrial and Applied Mathematics, 2000.
12. NECSA. SAFARI-1 Reactor Trapogge system: ball catcher. Pelindaba: s.n., 2008.
13. Headley, MC. Guidelines for selecting the proper valve characteristics. *Valve Magazine*, Spring, Vol. 15(2), 2003.
14. Spirax Sarco. Check valves. International Site of Spirax Sarco. [Online] <http://www.spiraxsarco.com/resources/steam-egnineering-tutorials/pipeline->

ancillaries/check- valves.asp [cited: 20 May 2014].

15. Vlok, JWH. Reactor operations at SAFARI-1. Sydney: International Group on Research Reactors (pp. 1–6), 9th Meeting of the International Group on Research Reactors, 2003.
16. Verbeek, P. Report on molybdenum-99 production for nuclear medicine – 2010–2020 (pp. 1–28). s.l.: Association of Imaging Producers & Equipment Suppliers, 2008.
17. World Nuclear News. South African radioisotope production on target, 17 September 2010. [Online] http://www.world-nuclear-news.org/RS-South_African_radioisotope_production_on_target-1709107.html [cited: 4 September 2012].
18. Sonntag, RE, Borgnakke, C and Van Wylen, GJ. *Fundamentals of thermodynamics*. s.l.: Wiley, 2003.
19. Vlok, JWH. SAFARI-1 research reactor safety analysis report. Reactor coolant systems and connected systems (Chapter 6). Pelindaba: s.n., 2010.
20. Janeschitz-Kriegl, J. *Thermo-hydraulic engineering using first principles (a data-oriented approach to thermal equipment design)* (Vol. 27, pp. 177–184). s.l.: Elsevier, 2007.
21. Kruger, JH and Du Toit, CG. *The simulation of a thermal-fluid system* (pp. 1–7). Melbourne: CSIRO, 2006.
22. Olivier, JC. *Network modelling of transient heat exchanger performance* (pp. 11–13). Potchefstroom: North-West University, 2005.
23. Flownex Simulation Environment. [Online] <http://www.flownex.com/about-us/flownex-history.com>.
24. White, FM. *Fluid mechanics*. Boston, MA: McGraw-Hill, 2003.
25. CD-Adapco. *User guide STAR CCM+ Version 6.02.007*. s.l.: CD-Adapco, 2011.
26. Kloppers, JC. Wetcooling software and consulting. Wetcooling, 2010. [Online] <http://www.wetcooling.com/> [cited: 23 January 2013].
27. Kröger, DG. *Air-cooled heat exchangers and cooling towers thermal-flow performance, evaluation and design*. New York, NY: Begell House, 1998.

28. Howden Cooling Fans. *Howden cooling fans selection program CF-P20 Version 6.07* [Software program]. Hengelo: Howden Cooling Fans, 2010.
29. Sure Flow Equipment Inc. Custom engineered strainers. Sure Flow Equipment, 23 February 2010. [Online]
<http://www.sureflowequipment.com/custom-engineered/page7.cfm>.
30. Gas Processors Suppliers Association. *Engineering data book FPS version volumes I & II sections 1-26*. Tulsa: Gas Processors Suppliers Association, 2004.
31. NECSA. *Electrical motor index*. Pelindaba: NECSA, 2012.
32. Du Plessis, K. Recommended heat fractions of pumps. *Personal Communication*. Pretoria: s.n., 2014.
33. Vasava, PR. *Fluid flow in T-junction of pipes*. Lappeenranta: Lappeenranta University of Technology, 2007.
34. Diaz, A and Van Der Walt, R. *PEL 90: the start-up of the SAFARI I research reactor*. Pelindaba: Atomic Energy Board, 1965.
35. KSB Pumps and Valves (Pty) Ltd. *Etabloc type series booklet 50 0p: close-coupled pumps*. Germiston: KSB Pumps and Valves, 2007.
36. Sure Flow Equipment Inc. *Y-strainers*. 2004.
37. Carrier. *Carrier reciprocating chiller rating*. Pelindaba: s.n., 2006.
38. AJM. *Carrier reciprocating chiller rating*. Pelindaba: AJM, 2006.
39. NECSA. Data sheet: induced draft cooling tower. Pretoria: NECSA, 1960.
40. COFIMCO S.p.A. Characteristics 5486-4-35N/33 M. Pelindaba: COFIMCO S.p.A., 1996.
41. NECSA. *SAFARI-1: secondary cooling water history.xls*. Pelindaba: s.n.
42. Unkown. *Spray nozzles for cooling towers: data*. s.l.: s.n.
43. NECSA. *SAFARI-1 research reactor: P&ID diagram*. Pelindaba: s.n.
44. NECSA. *Secondary cooling system piping ISO*. Pelindaba: s.n.
45. NECSA. Data sheet: induced draft cooling tower. Pelindaba: s.n., 1960.

46. NECSA. *Primary water flow FT-0001: 16/07/2011 to 11/04/2012*. Pelindaba: s.n., 2012.
47. NECSA. *Primary water flow FT-0002: 16/07/2011 to 11/04/2012*. Pelindaba: s.n., 2012.
48. NECSA. *Primary water flow FT-0003: 16/07/2011 to 11/04/2012*. Pelindaba: s.n., 2012.
49. NECSA. *Primary water inlet pressure: 16/07/2011 to 11/04/2012*. Pelindaba: s.n., 2012.
50. NECSA. *Primary heat exchanger E-0101 inlet pressure SS: 16/06/2011 to 11/04/2012*. Pelindaba: s.n., 2012.
51. NECSA. *Primary heat exchanger E-0102 outlet pressure SS: 16/06/2011 to 11/04/2012*. Pelindaba: s.n., 2012.
52. NECSA. *Primary heat exchanger E-0102 inlet pressure SS: 16/06/2011 to 11/04/2012*. Pelindaba: s.n., 2012.
53. NECSA. *Primary heat exchanger E-0101 outlet pressure SS: 16/06/2011 to 11/04/2012*. Pelindaba: s.n., 2012.
54. NECSA. *Primary heat exchanger E-0103 inlet pressure SS: 16/06/2011 to 11/04/2012*. Pelindaba: s.n., 2012.
55. NECSA. *Primary heat exchanger E-0104 outlet pressure SS: 16/06/2011 to 11/04/2012*. Pelindaba: s.n., 2012.
56. NECSA. *Primary heat exchanger E-0104 inlet pressure SS: 16/06/2011 to 11/04/2012*. Pelindaba: s.n., 2012.
57. NECSA. *Primary heat exchanger E-0101 inlet temperature SS: 16/06/2011 to 11/04/2012*. Pelindaba: s.n., 2012.
58. NECSA. *Primary heat exchanger E-0101 inlet temperature SS: 16/06/2011 to 11/04/2012*. Pelindaba: s.n., 2012.
59. NECSA. *Primary heat exchanger E-0101 inlet temperature SS: 16/06/2011 to 11/04/2012*. Pelindaba: s.n., 2012.
60. NECSA. *Primary heat exchanger E-0101 outlet temperature SS: 16/06/2011 to 11/04/2012*. Pelindaba: s.n., 2012.

61. NECSA. *Primary heat exchanger E-0102 inlet temperature SS: 16/06/2011 to 11/04/2012*. Pelindaba: s.n., 2012.
62. NECSA. *Primary heat exchanger E-0103 outlet temperature TS: 16/06/2011 to 11/04/2012*. Pelindaba: s.n., 2012.
63. NECSA. *Primary heat exchanger E-0101 outlet temperature SS: 16/06/2011 to 11/04/2012*. Pelindaba: s.n., 2012.
64. NECSA. *Primary heat exchanger E-0103 inlet temperature SS: 16/06/2011 to 11/04/2012*. Pelindaba: s.n., 2012.
65. NECSA. *Primary heat exchanger E-0104 outlet temperature SS: 16/06/2011 to 11/04/2012*. Pelindaba: s.n., 2012.
66. NECSA. *Primary Heat exchanger E-0104 inlet temperature SS: 16/06/2011 to 11/04/2012*. Pelindaba: s.n., 2012.
67. AEC-AEK. *Orifice plate. Reactor secondary flow*. Pelindaba: AEC-AEK, 1997.
68. NECSA. *Estimated performance curve: Harland SNC 3 – reduced Imp. 1450 RPM*. Pelindaba: s.n.
69. NECSA. *Electrical motor index*. Pelindaba: s.n., 2009.
70. Weir Minerals Africa. *Uniglide pump curve: SDC100-125A rev 0*. Johannesburg: Weir Minerals Africa, 2012.
71. NECSA. *Monoglide pump curve: SNC3*. Johannesburg: Weir Minerals Africa, 2010.
72. Carrier. *30HZ 043-280 reciprocating liquid chillers*. Montluel: Carrier SA, 1997.
73. CRANE CO. *E-101 OM specifications*. New York, NY: s.n., 1962.
74. ALLIS-CHALMERS. *E-101 OM specifications*. Washington, DC: s.n., 1960.
75. CRANE CO. *E-301 OM specifications*. New York, NY: s.n., 1962.
76. ALLIS-CHALMERS. *E-301 OM specifications*. Washington, DC: s.n., 1960.
77. Airtec Engineering Co. *16'-0" x 3'-0" Dia heat exchanger tube sheet and baffle details*. Johannesburg: Airtec Engineering Co., 1971.

78. CRANE CO. *Construction details 20 1/4" I.D. Horizontal pool heat exchanger. Hall, Longmore & Co., LTD.* New York, NY: CRANE CO., 1962.
79. NECSA. *Tube layout 20 1/4" I.D. Horizontal pool heat exchanger. Hall, Longmore & Co., LTD.* New York, NY: CRANE CO., 1962.
80. NECSA. *20 1/4" I.D. Horizontal pool heat exchanger. Hall, Longmore & Co., LTD.* New York, NY: CRANCE CO., 1962.
81. NECSA. *26 1/4" I.D. Horizontal primary heat exchanger. Hall, Longmore & Co., LTD.* New York, NY: CRANE CO., 1962.
82. NECSA. *Pool water flow FT-0301: 16/07/2011 to 11/04/2012.* Pelindaba: s.n., 2012.
83. NECSA. *Pool water delta temperature: 16/07/2011 to 11/04/2012.* Pelindaba: s.n., 2012.
84. NECSA. *Pool water inlet temperature: 16/07/2011 to 11/04/2012.* Pelindaba: s.n., 2012.
85. NECSA. *Primary heat exchanger E-0101 inlet temperature TS: 16/06/2011 to 11/04/2012.* Pelindaba: s.n., 2012.
86. NECSA. *Primary heat exchanger E-0101 inlet temperature TS: 16/06/2011 to 11/04/2012.* Pelindaba: s.n., 2012.
87. NECSA. *Primary heat exchanger E-0102 inlet temperature TS: 16/06/2011 to 11/04/2012.* Pelindaba: s.n., 2012.
88. NECSA. *Primary heat exchanger E-0102 outlet temperature TS: 16/06/2011 to 11/04/2012.* Pelindaba: s.n., 2012.
89. NECSA. *Primary heat exchanger E-0103 inlet temperature TS: 16/06/2011 to 11/04/2012.* Pelindaba: s.n., 2012.
90. NECSA. *Primary heat exchanger E-0103 outlet temperature TS: 16/06/2011 to 11/04/2012.* Pelindaba: s.n., 2012.
91. NECSA. *Primary heat exchanger E-0104 inlet temperature TS: 16/06/2011 to 11/04/2012.* Pelindaba: s.n., 2012.
92. NECSA. *Primary heat exchanger E-0104 outlet temperature TS: 16/06/2011 to 11/04/2012.* Pelindaba: s.n., 2012.

93. NECSA. *Equipment numbers*. Pelindaba: s.n., 2009.
94. NECSA. *Ambient dry bulb temperature: measurements 16/06/2011 to 11/04/2012*. Pelindaba: s.n., 2012.
95. NECSA. *Ambient wet bulb temperature: measurements 16/06/2011 to 11/04/2012*. Pelindaba : s.n., 2012.
96. PECl. *The PECl functional testing guide: fundamentals to the field Version 2. PECl*. September 2006. [Online]
http://www.peci.org/ftguide/ftg/SystemModules/AirHandlers/AHU_ReferenceGuide/FTG_Chapters/Chapter_10_Fans_and_Drives.htm [cited: 6 November 2012].
97. HOLST & CO. LTD. *Cooling tower general arrangement*. Watford: HOLST & CO. LTD, 1962.

APPENDIX I

A: COOLING TOWER SUBSYSTEM

(43)

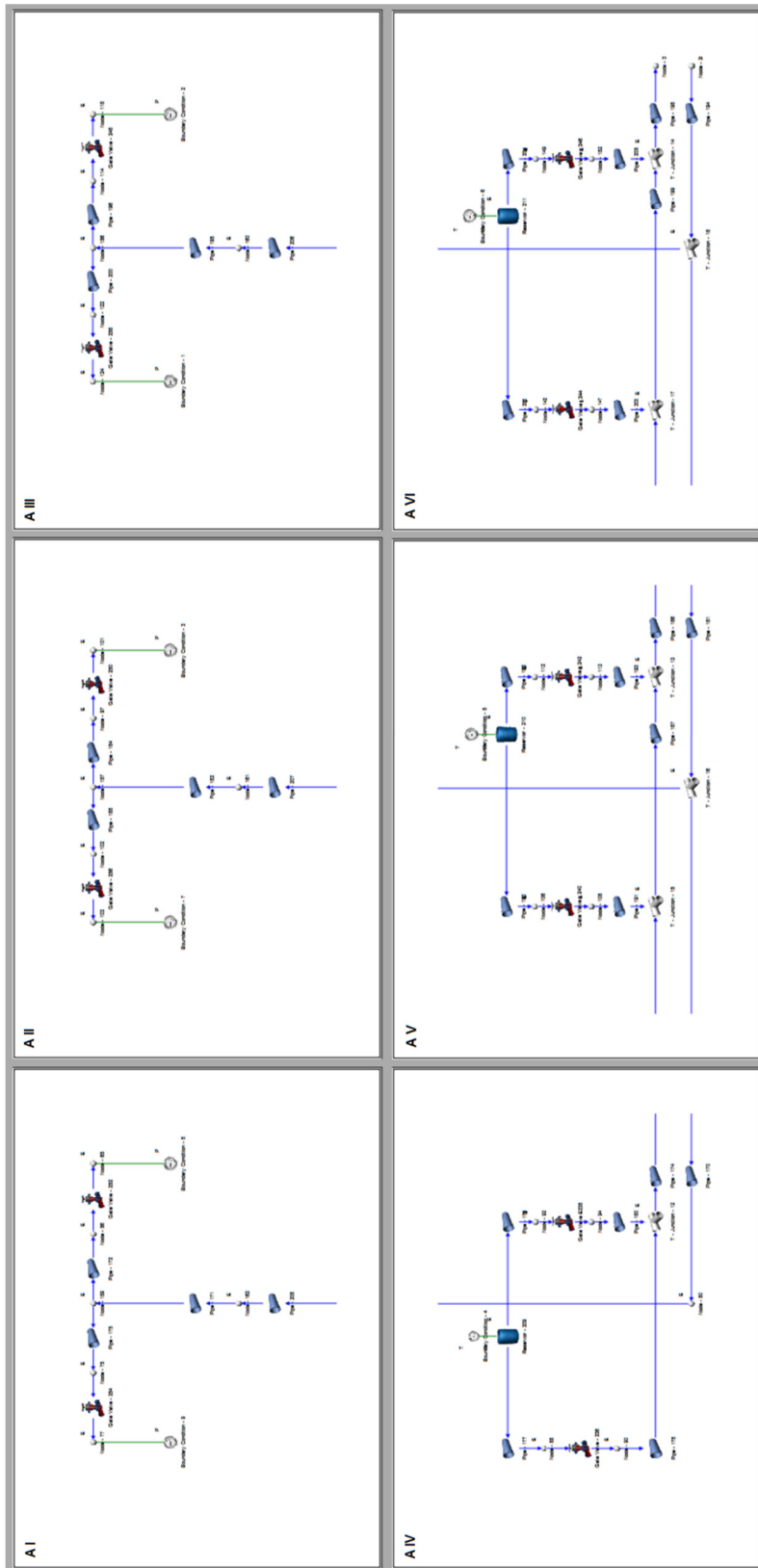

FIGURE 17: COOLING TOWER SUBSYSTEM SCHEMATIC

AI

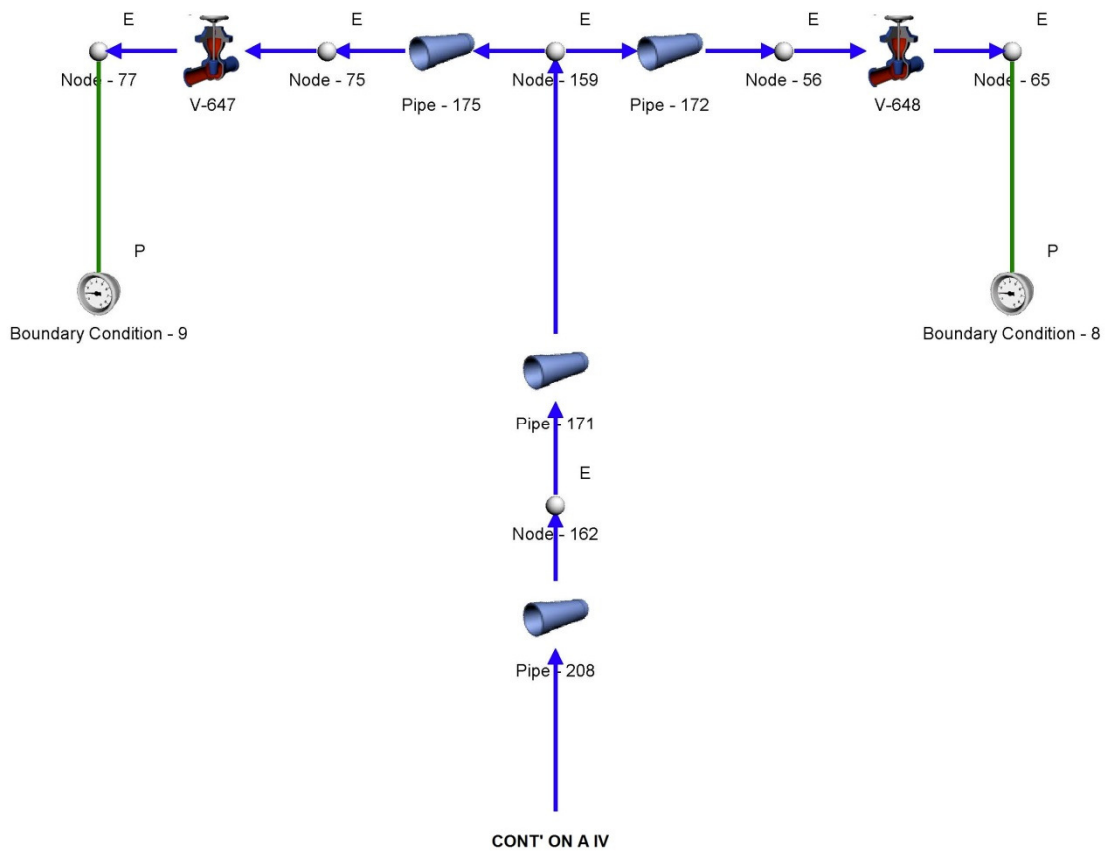

FIGURE 18: SCHEMATIC FIGURE A I

AII

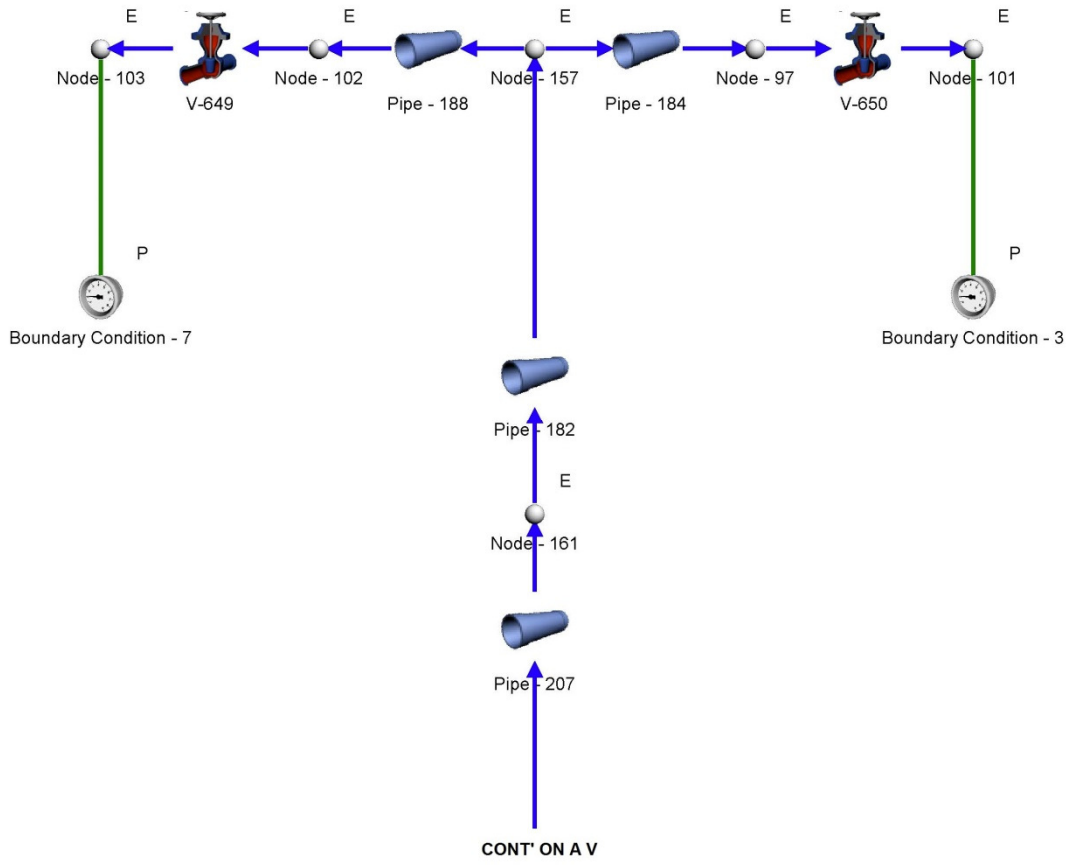

FIGURE 19: SCHEMATIC FIGURE A II

A III

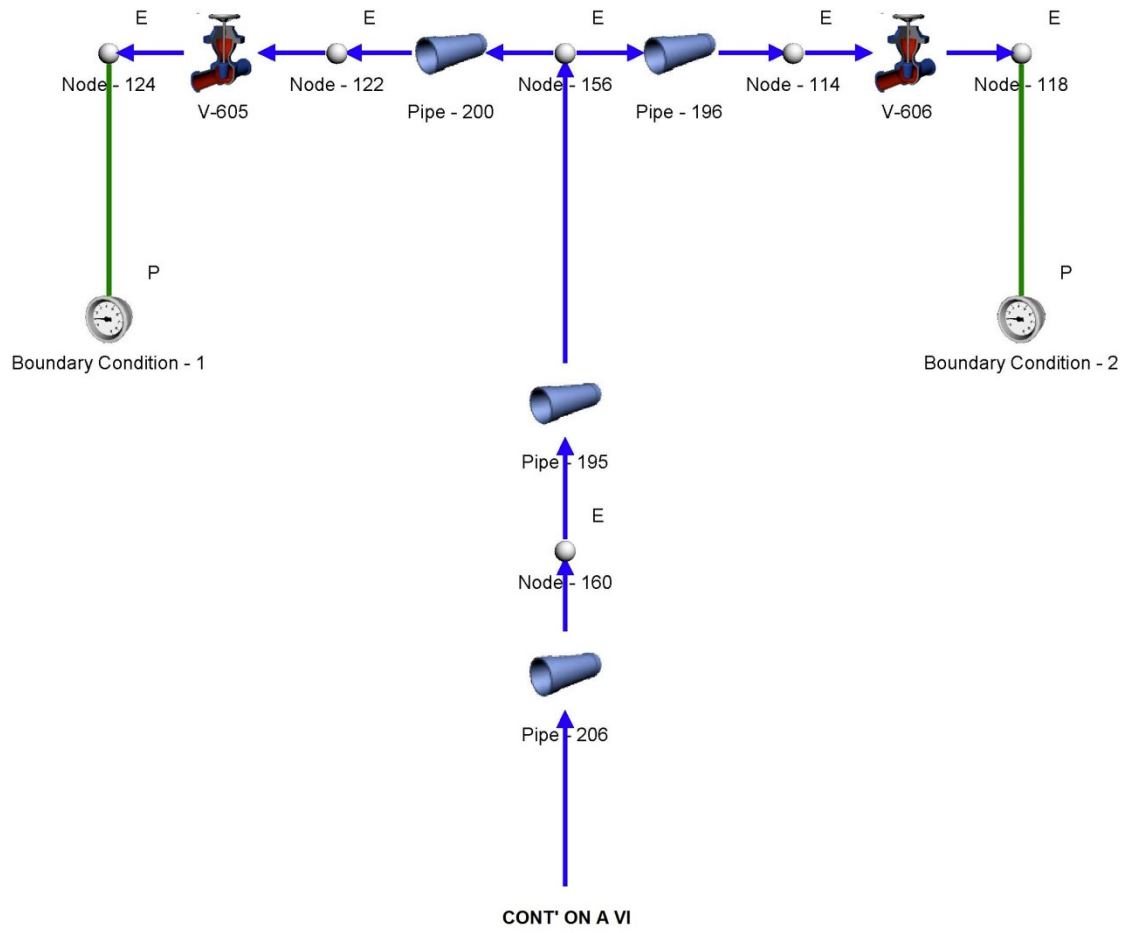

FIGURE 20: SCHEMATIC FIGURE A III

A IV

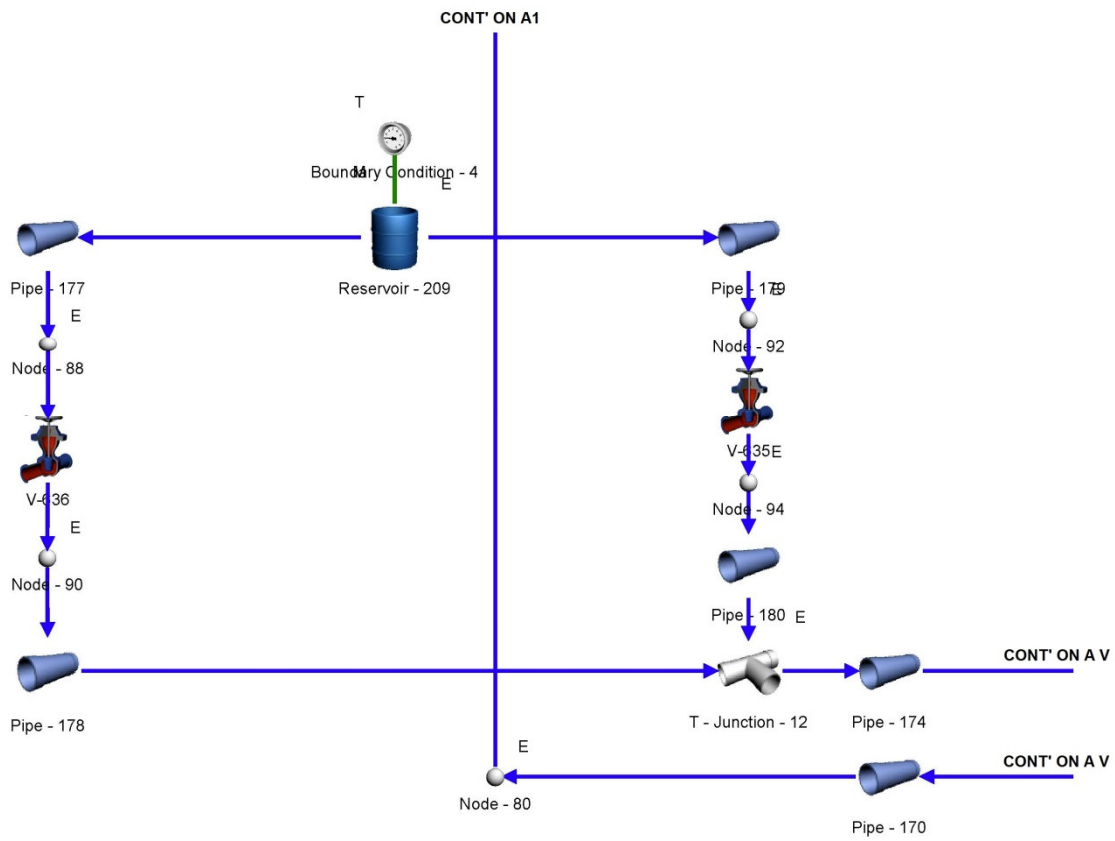

FIGURE 21: SCHEMATIC FIGURE A IV

A V

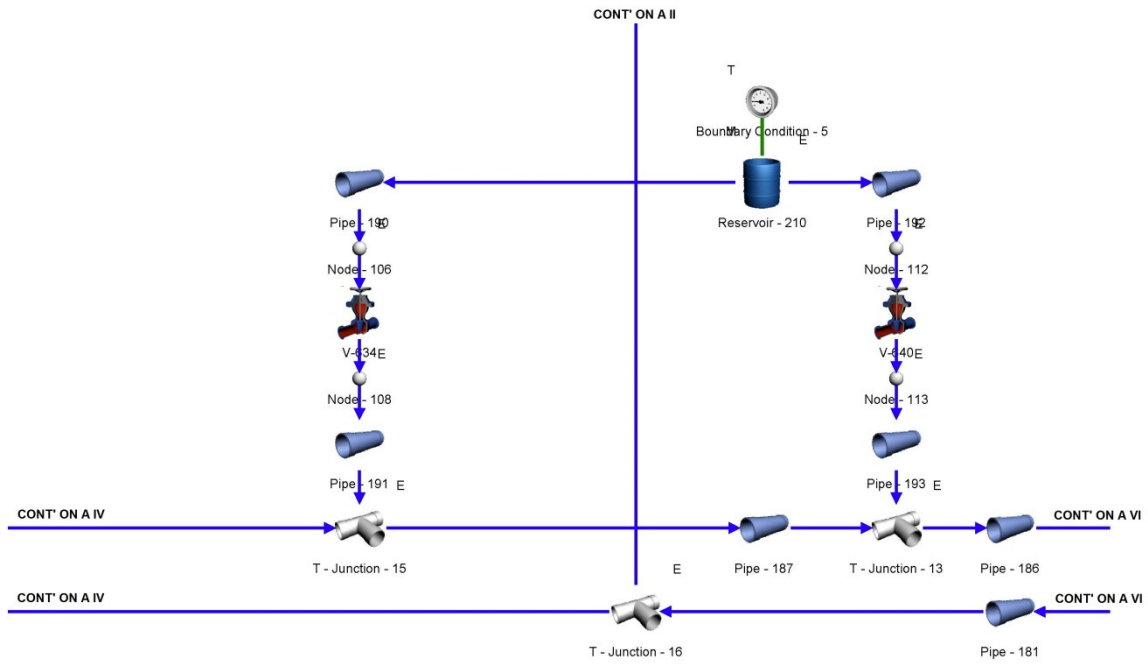

FIGURE 22: SCHEMATIC FIGURE A V

A VI

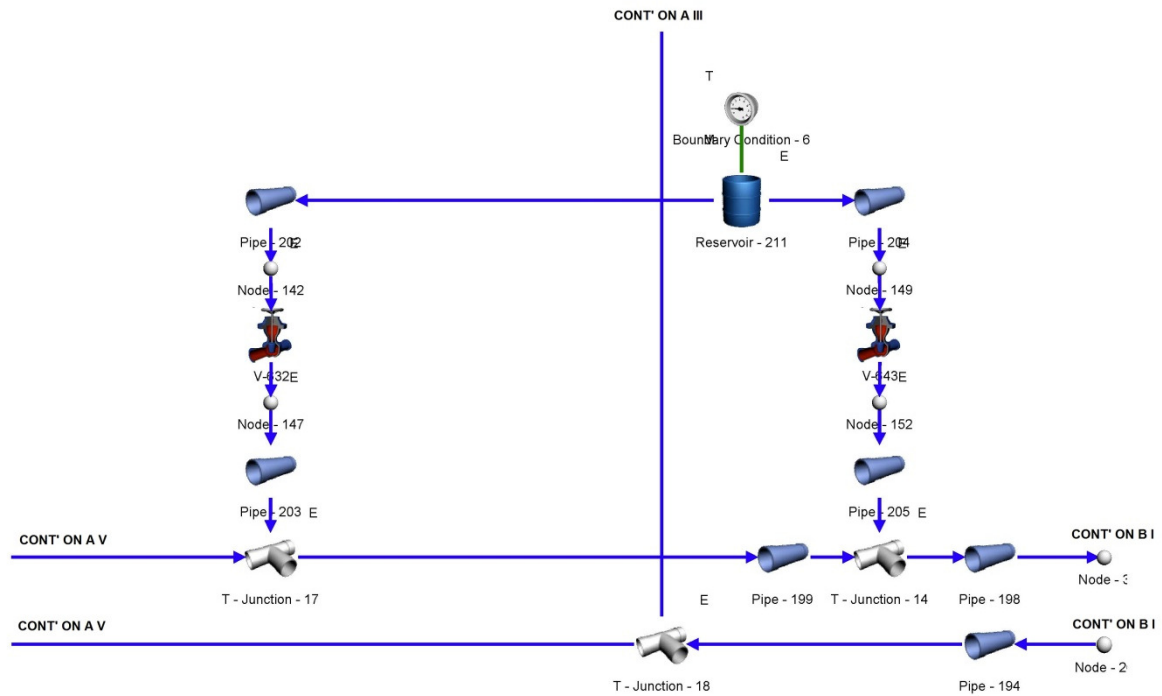

FIGURE 23: SCHEMATIC FIGURE A VI

B: PRIMARY HEAT EXCHANGER PUMP ROOM
(43)

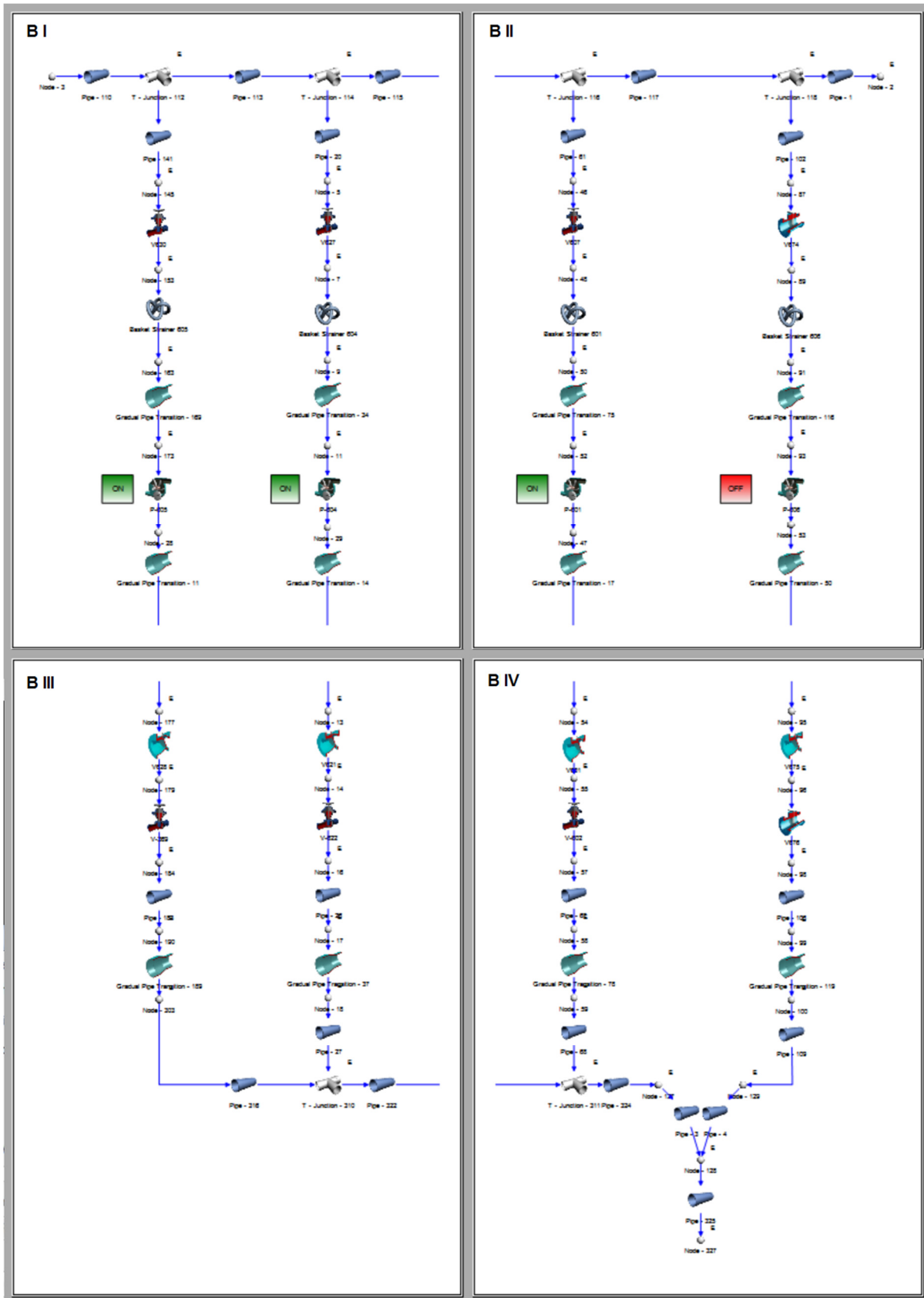

FIGURE 24: PRIMARY HEAT EXCHANGER PUMP ROOM SCHEMATIC

B I

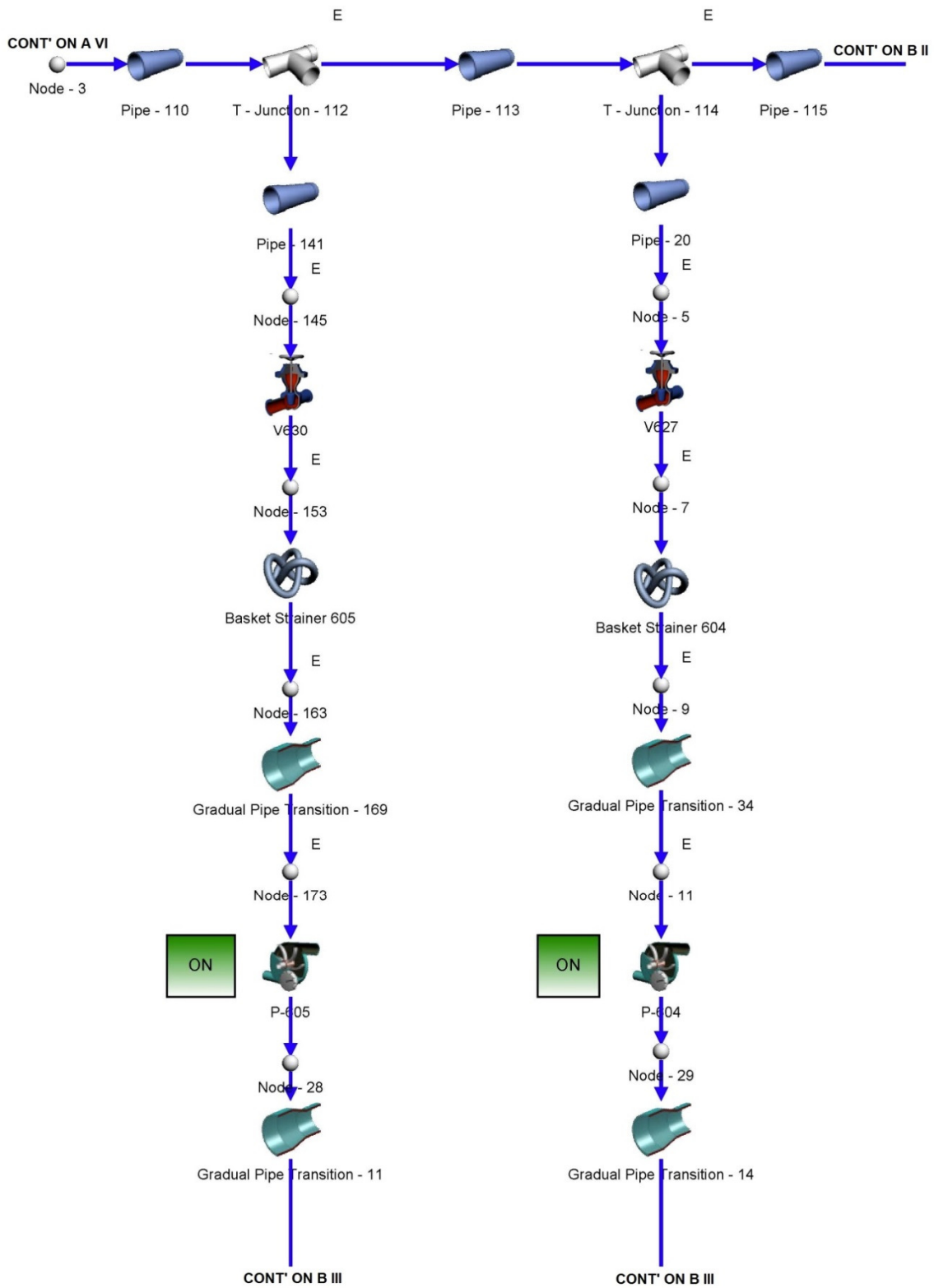

FIGURE 25: SCHEMATIC FIGURE B I

B II

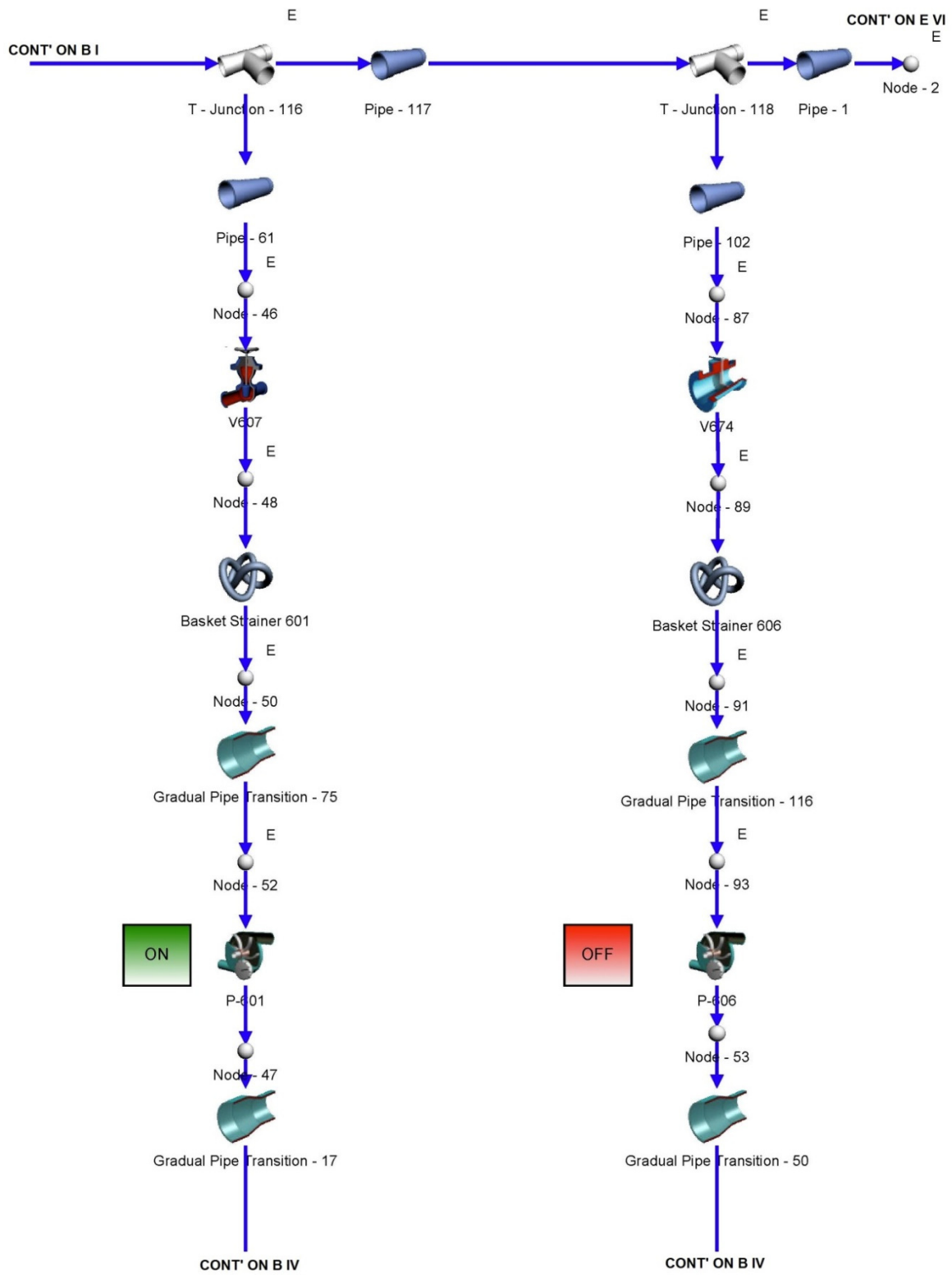

FIGURE 26: SCHEMATIC FIGURE B II

B III

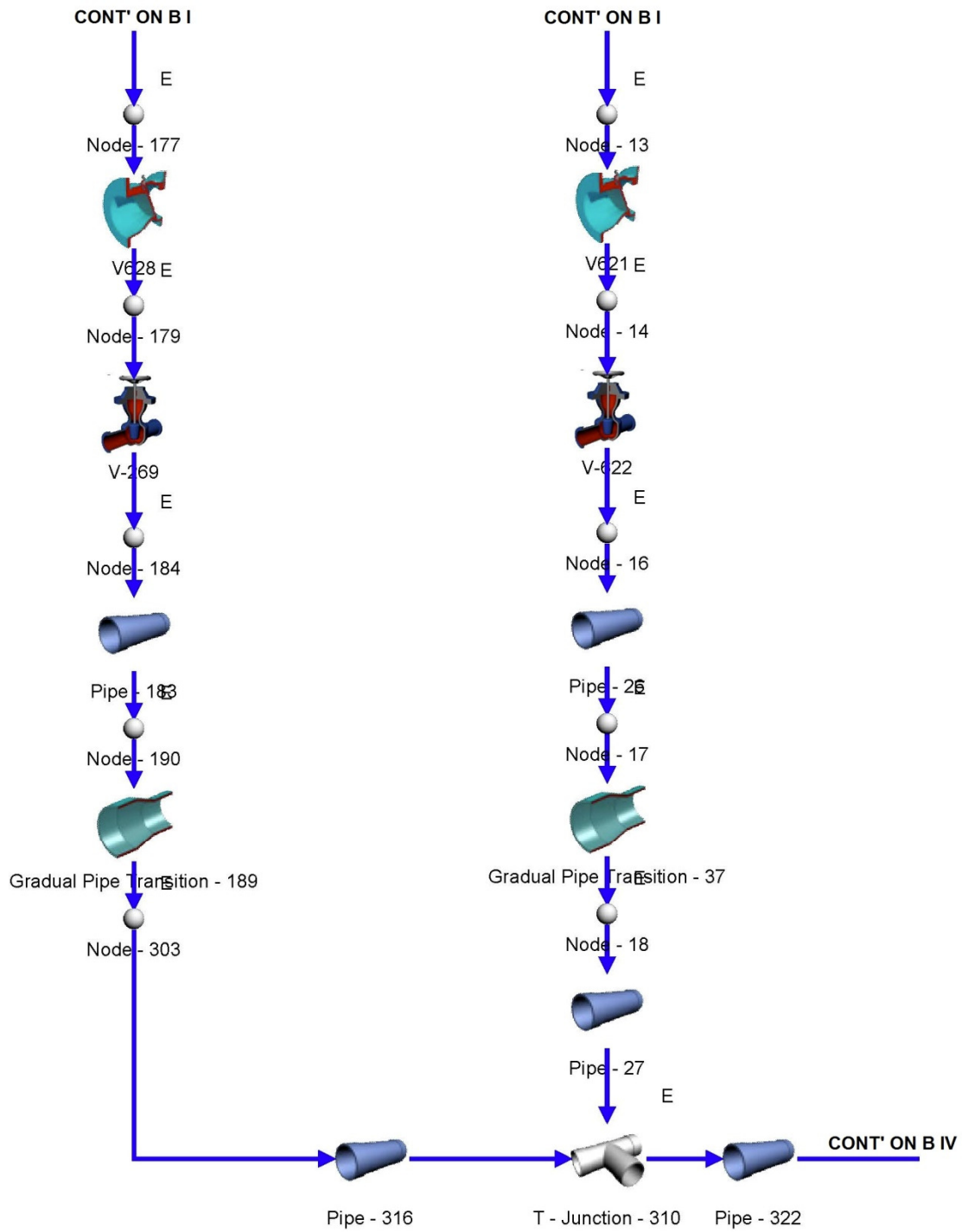

FIGURE 27: SCHEMATIC FIGURE B III

B IV

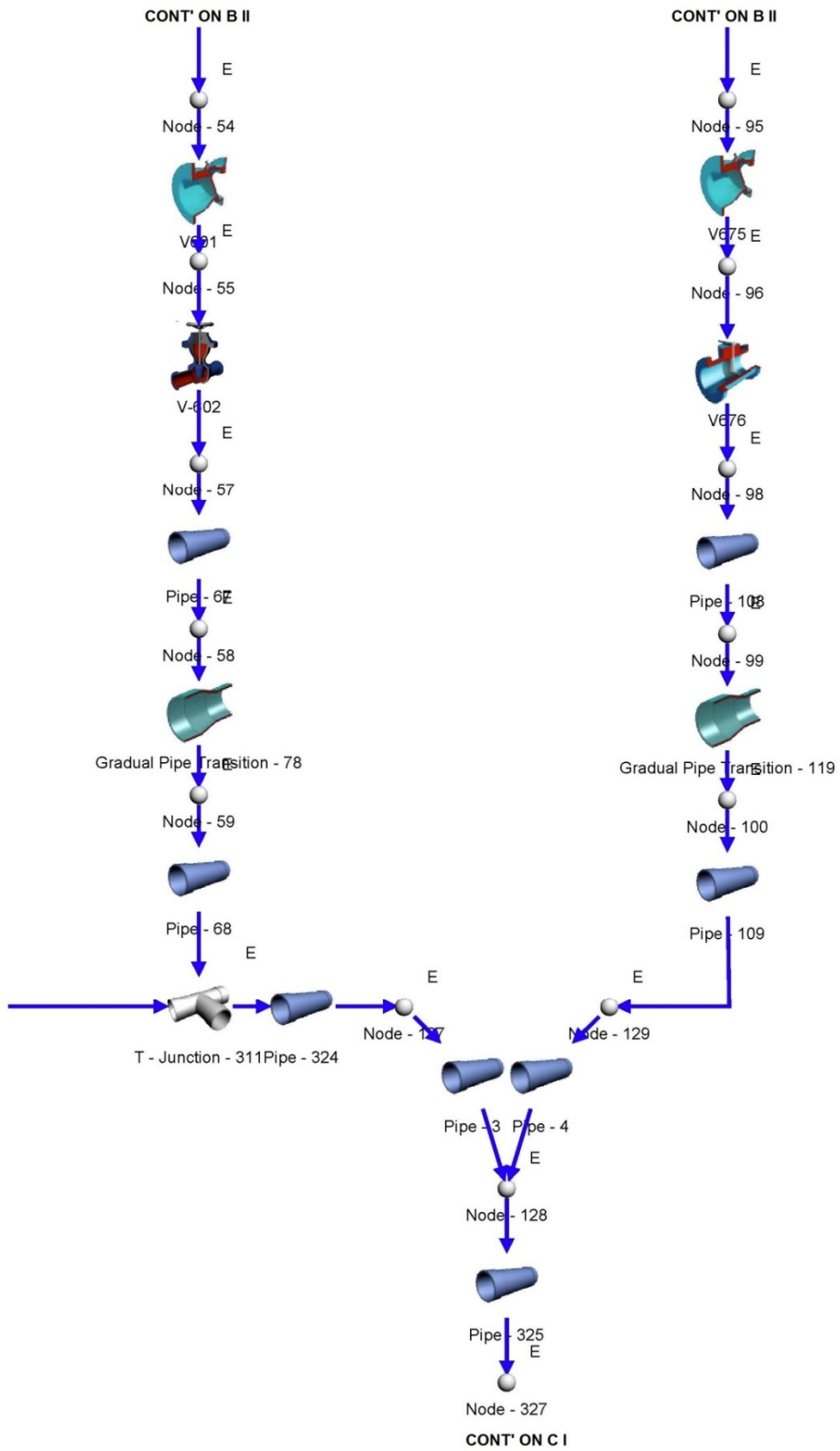

FIGURE 28: SCHEMATIC FIGURE B IV

CI

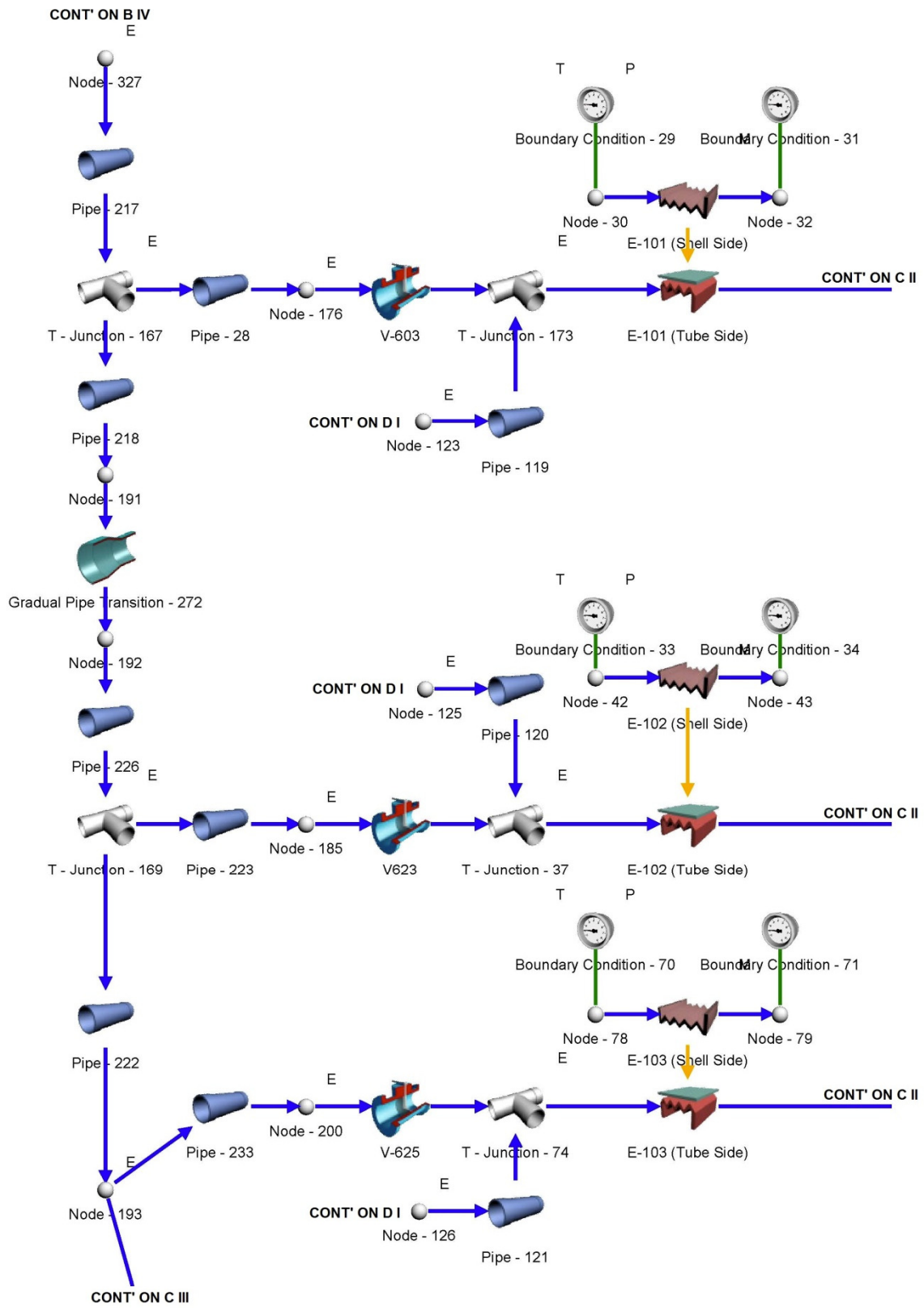

FIGURE 30: SCHEMATIC FIGURE C I

C II

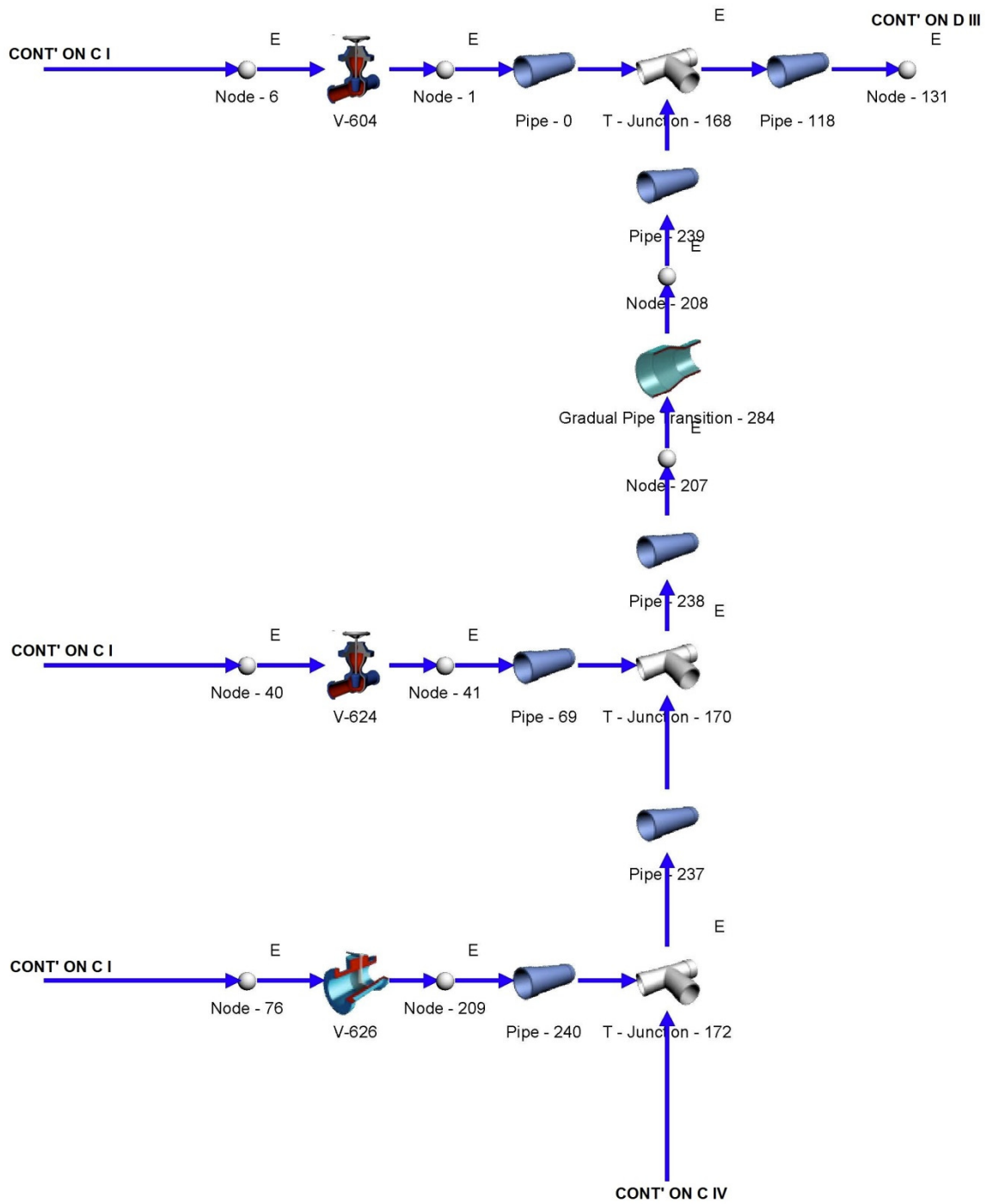

FIGURE 31: SCHEMATIC FIGURE C II

C III

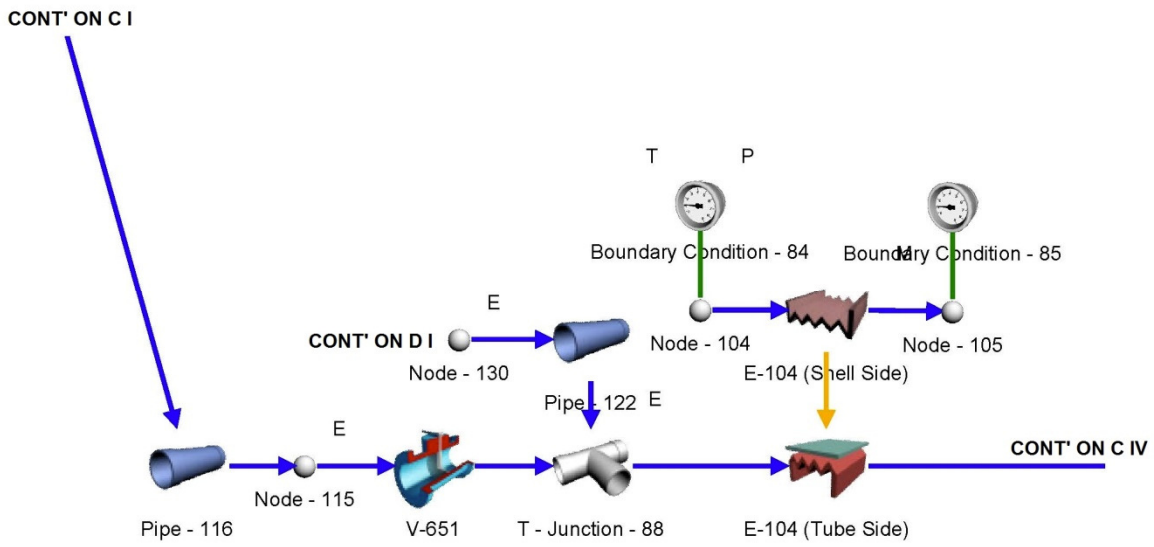

FIGURE 32: SCHEMATIC FIGURE C III

C IV

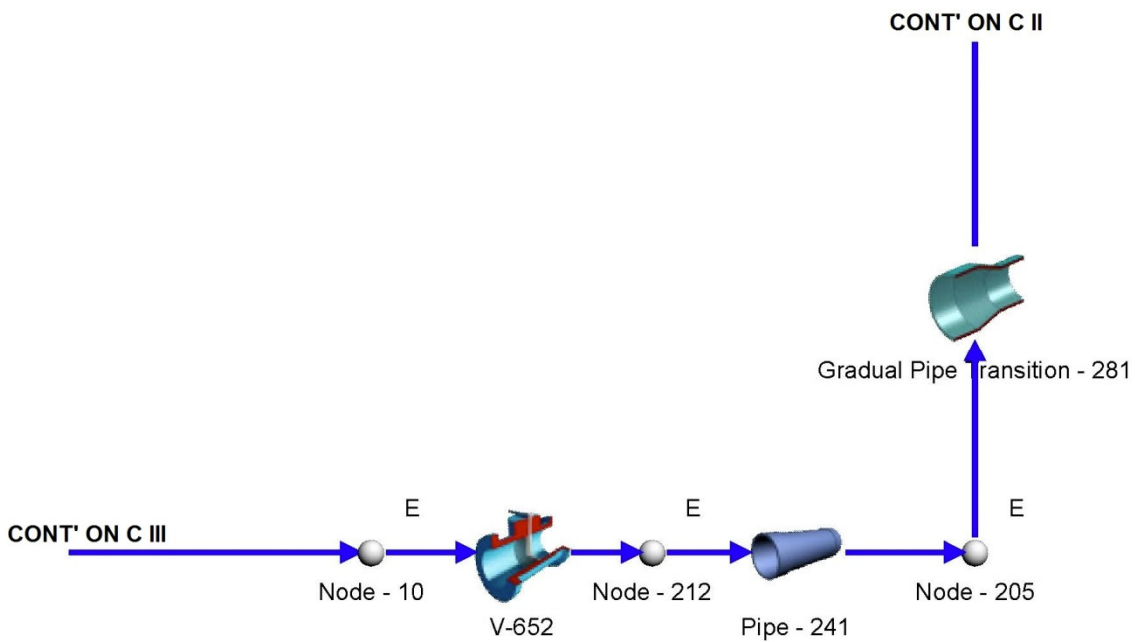

FIGURE 33: SCHEMATIC FIGURE C IV

D: TUBE CLEANING SUBSYSTEM
(43)

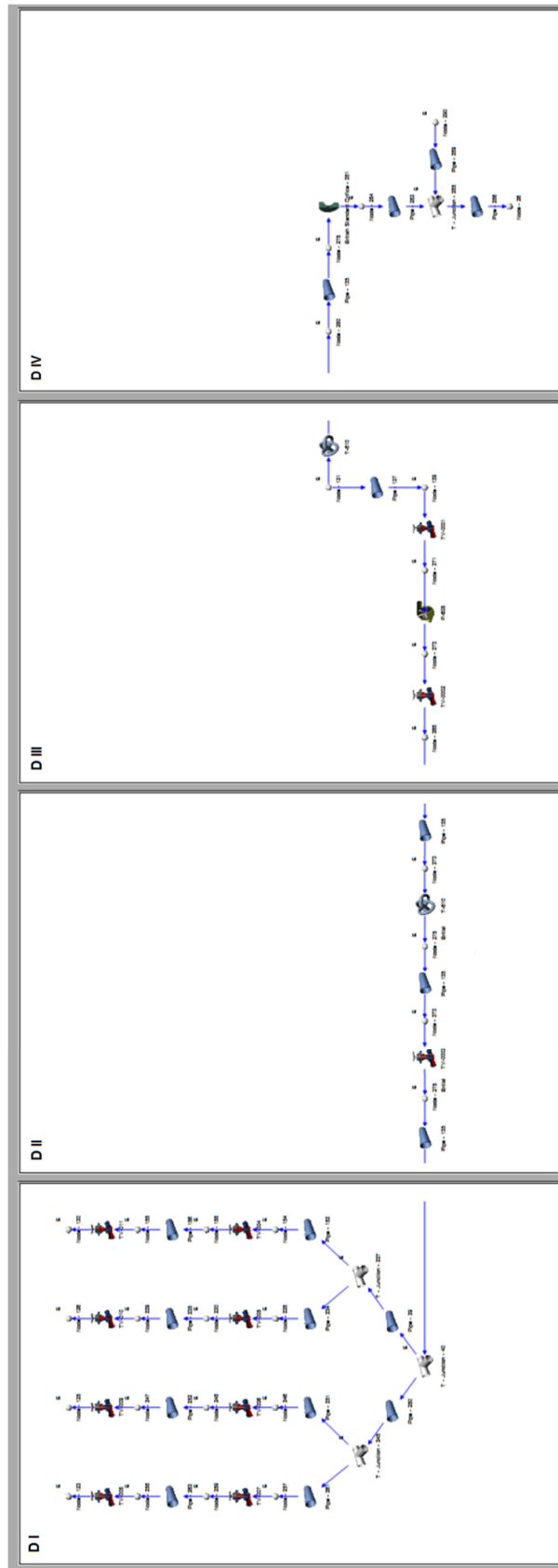

FIGURE 34: TUBE CLEANING SUBSYSTEM SCHEMATIC

DI

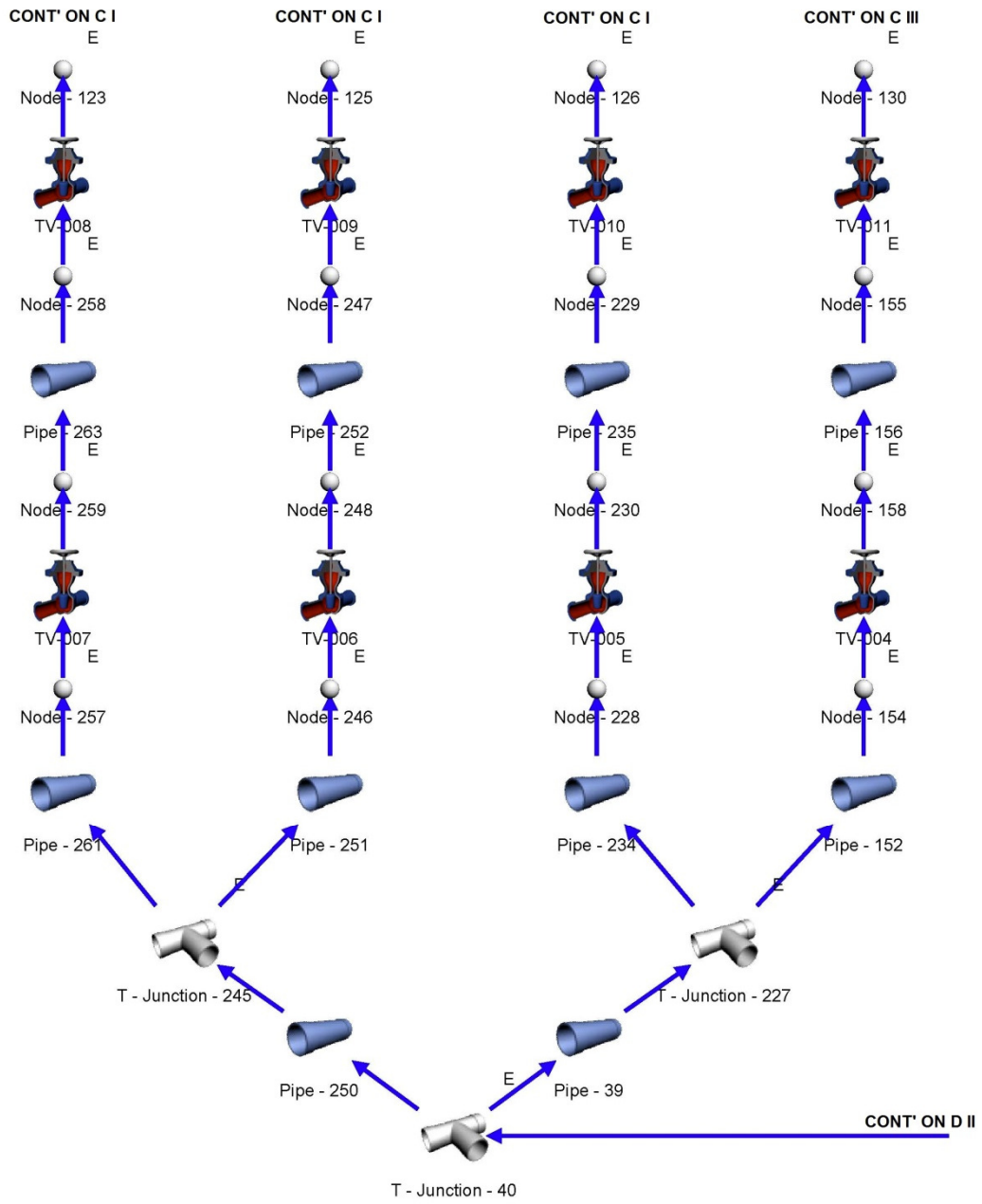

FIGURE 35: SCHEMATIC FIGURE D I

D II

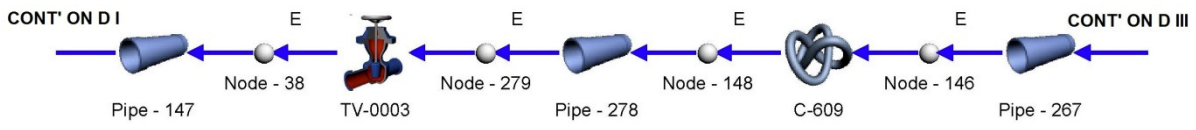

FIGURE 36: SCHEMATIC FIGURE D II

D III

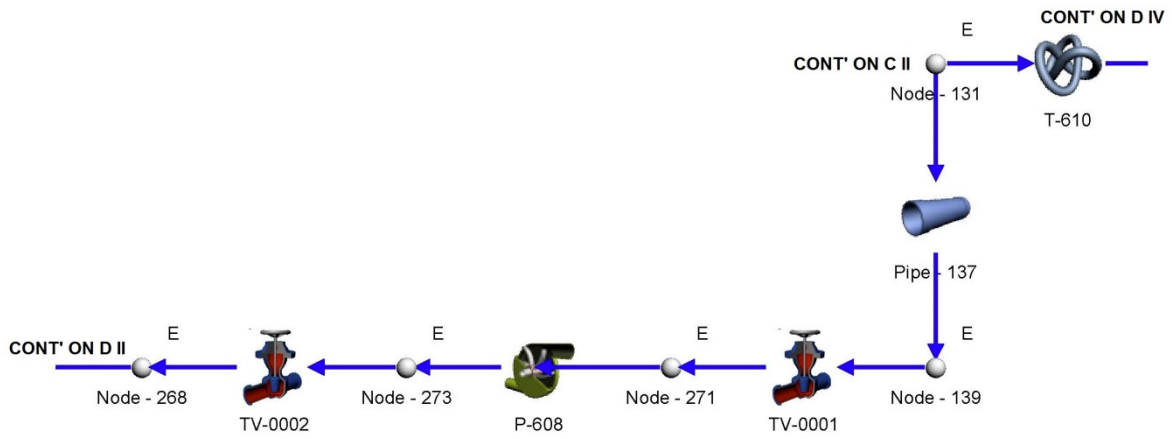

FIGURE 37: SCHEMATIC FIGURE D III

D IV

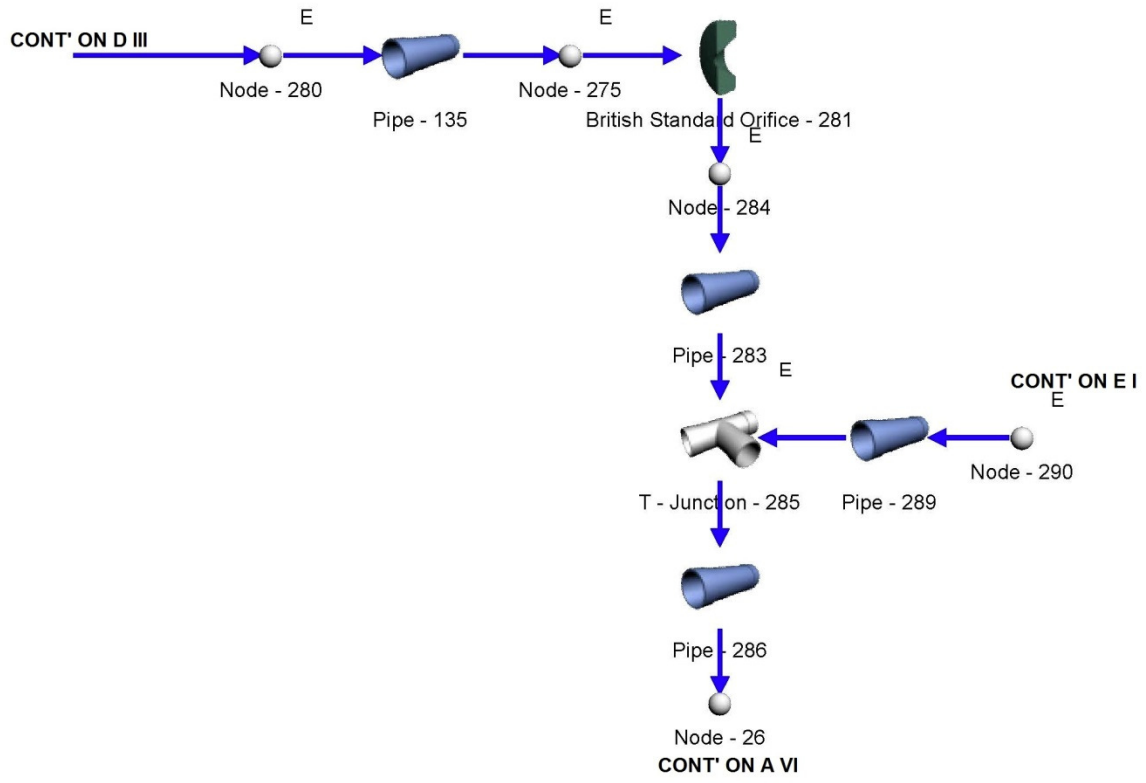

FIGURE 38: SCHEMATIC FIGURE D IV

E: POOL HEAT EXCHANGER AND FAN COIL UNIT SUBSYSTEM
 (43)

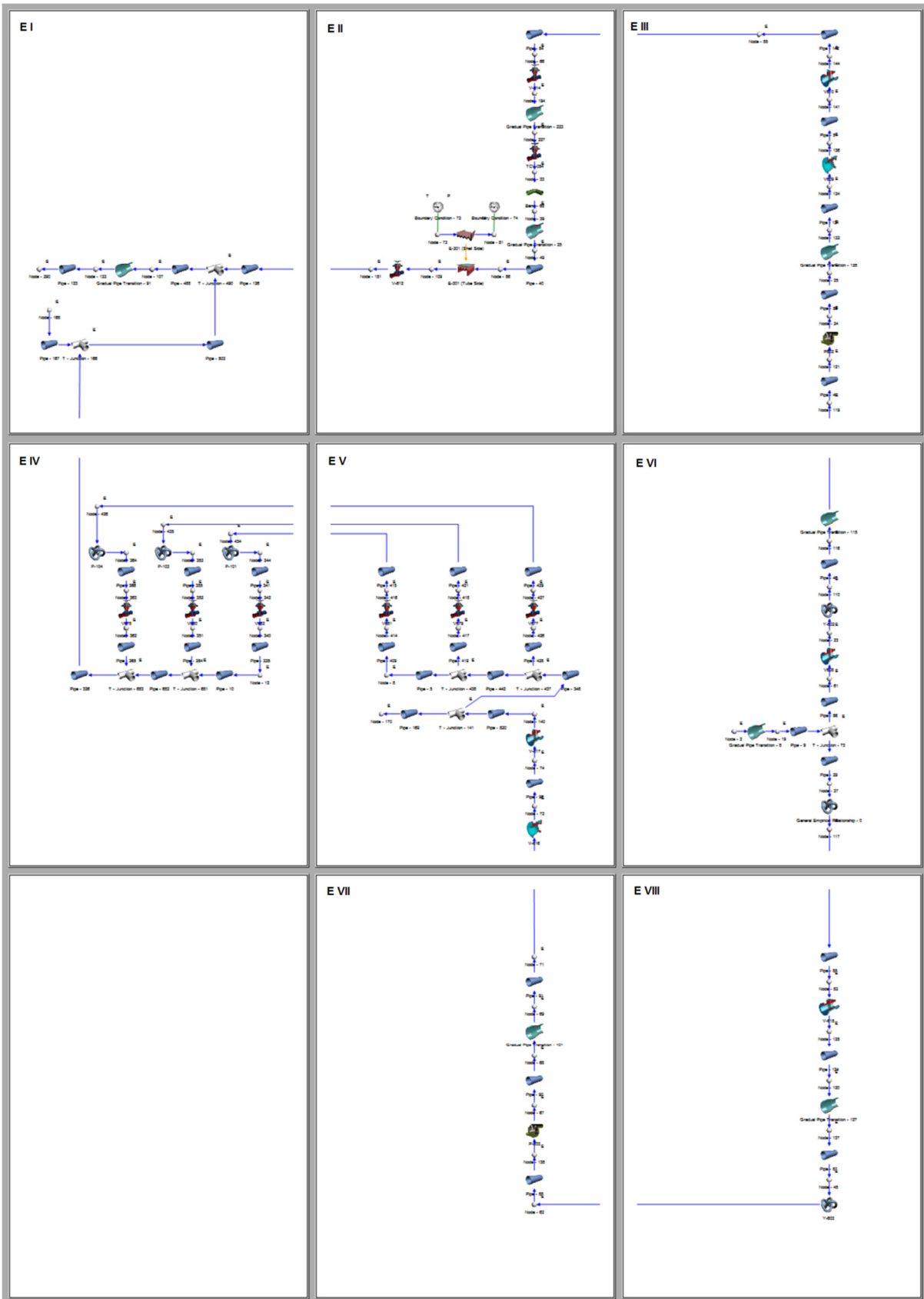

FIGURE 39: POOL HEAT EXCHANGER AND FAN COIL UNIT SUBSYSTEM SCHEMATIC

E I

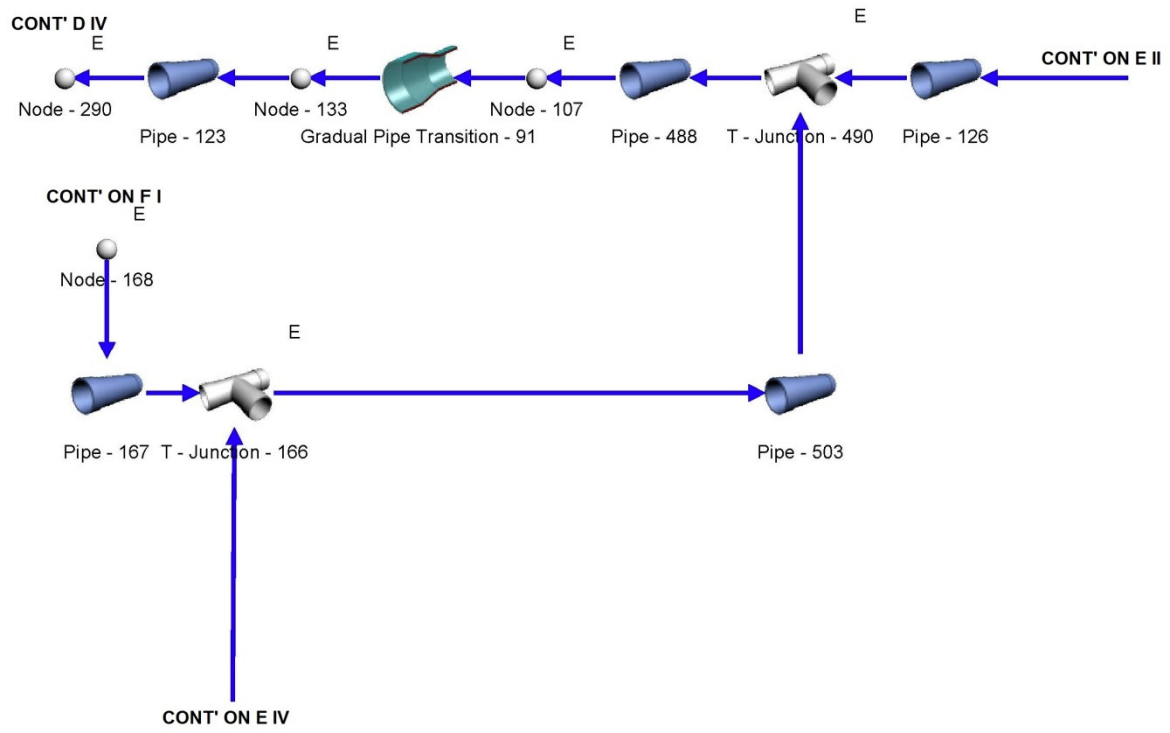

FIGURE 40: SCHEMATIC FIGURE E I

E II

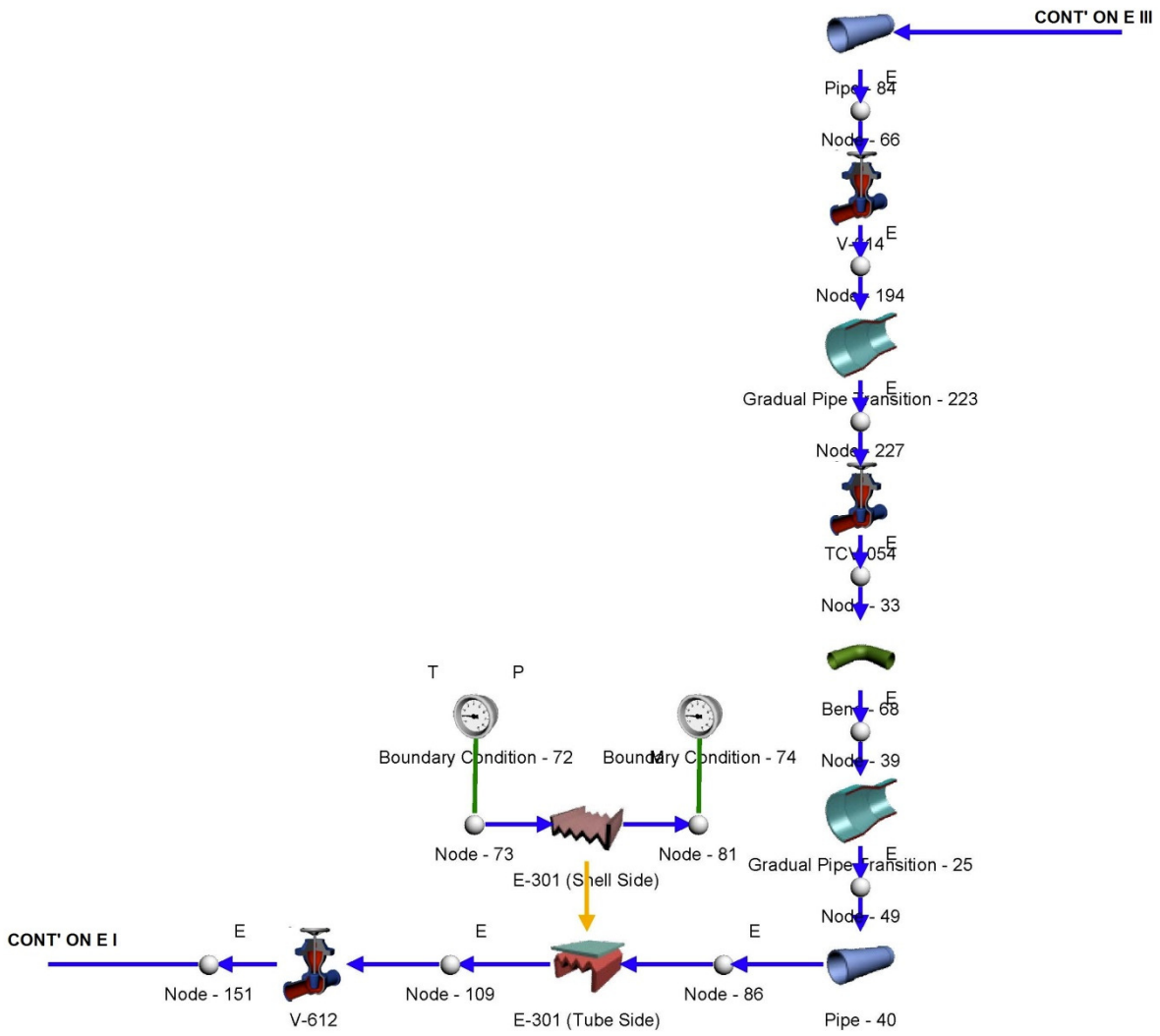

FIGURE 41: SCHEMATIC FIGURE E II

E III

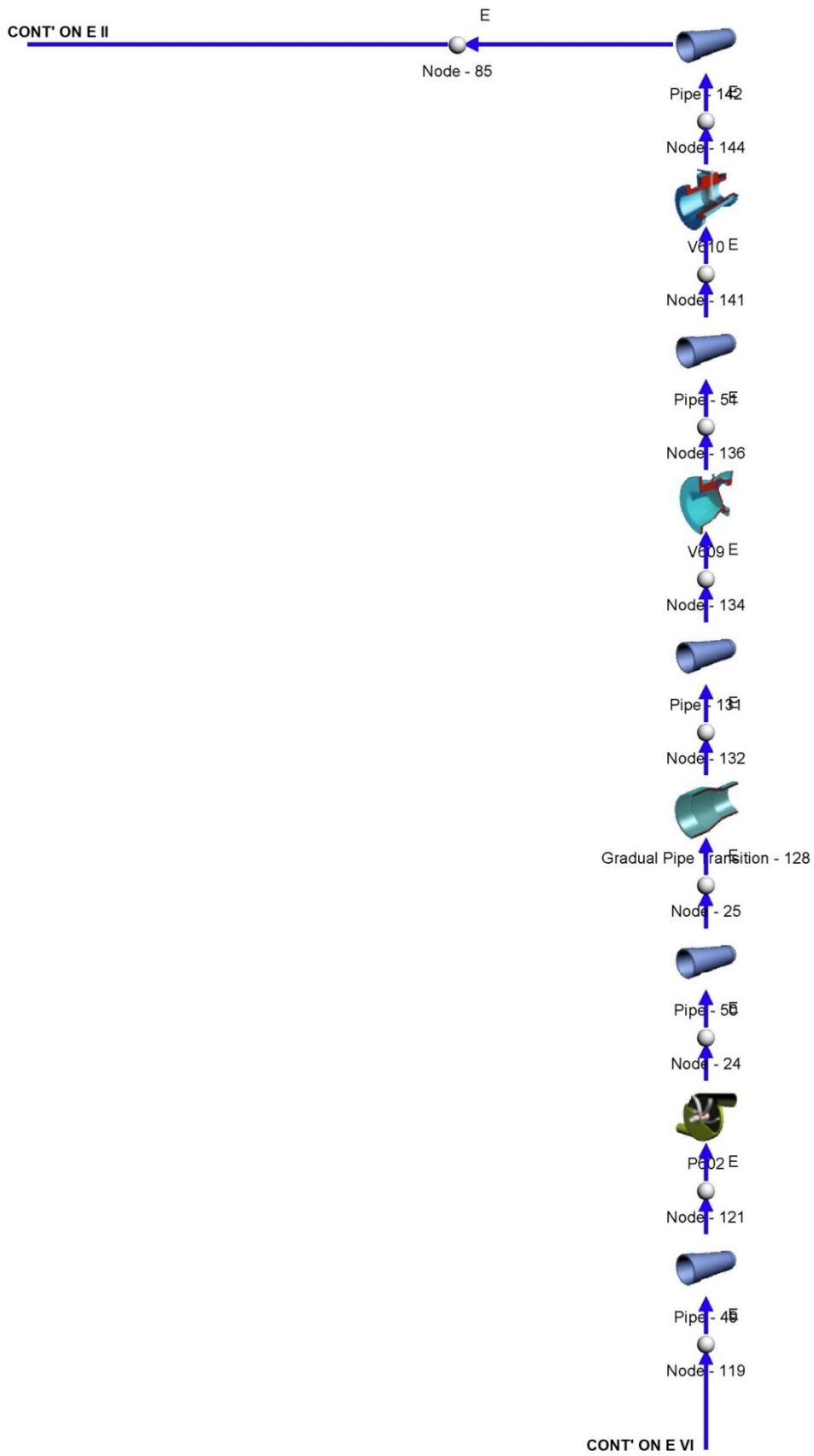

FIGURE 42: SCHEMATIC FIGURE E III

E IV

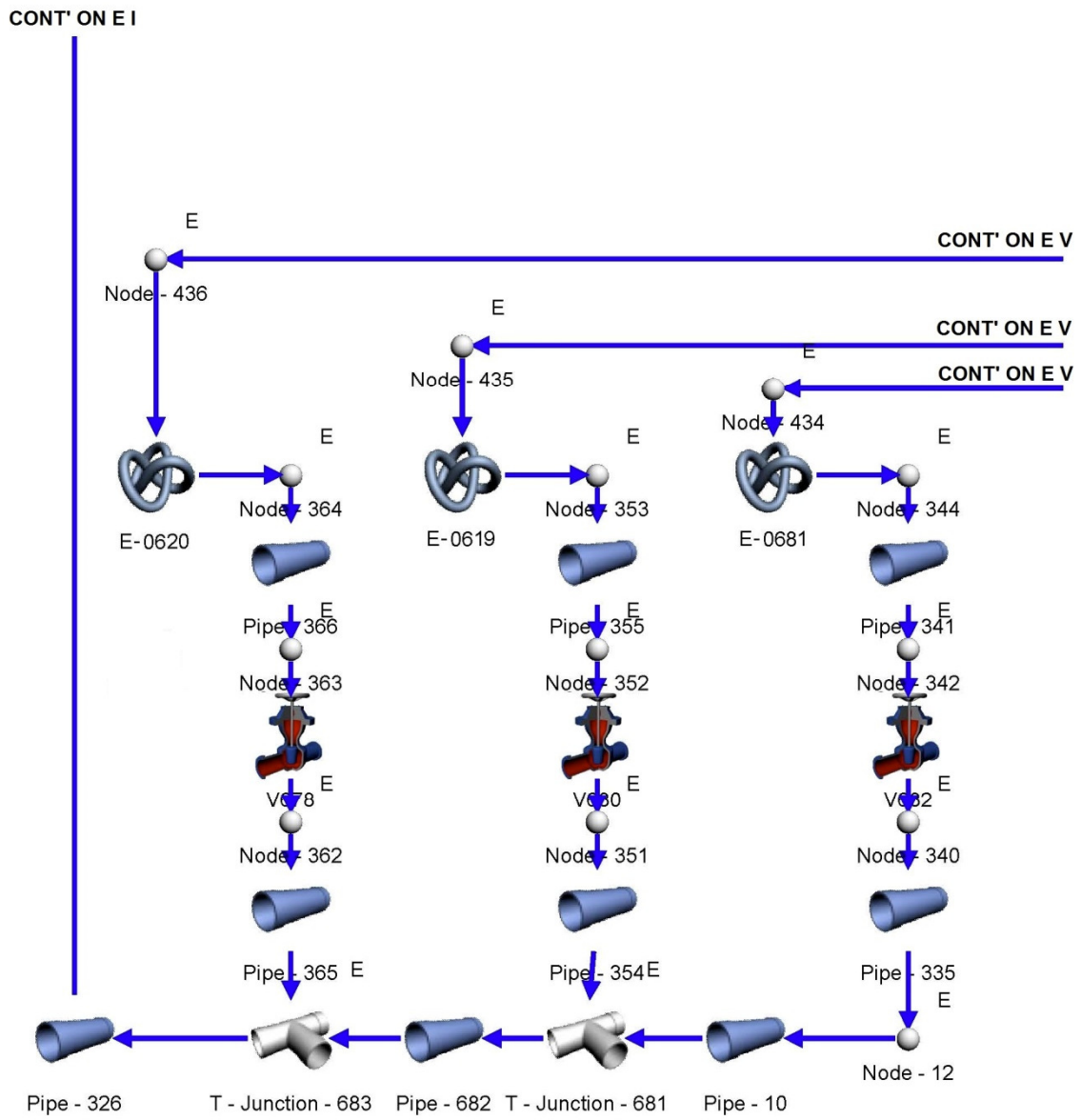

FIGURE 43: SCHEMATIC FIGURE E IV

E V

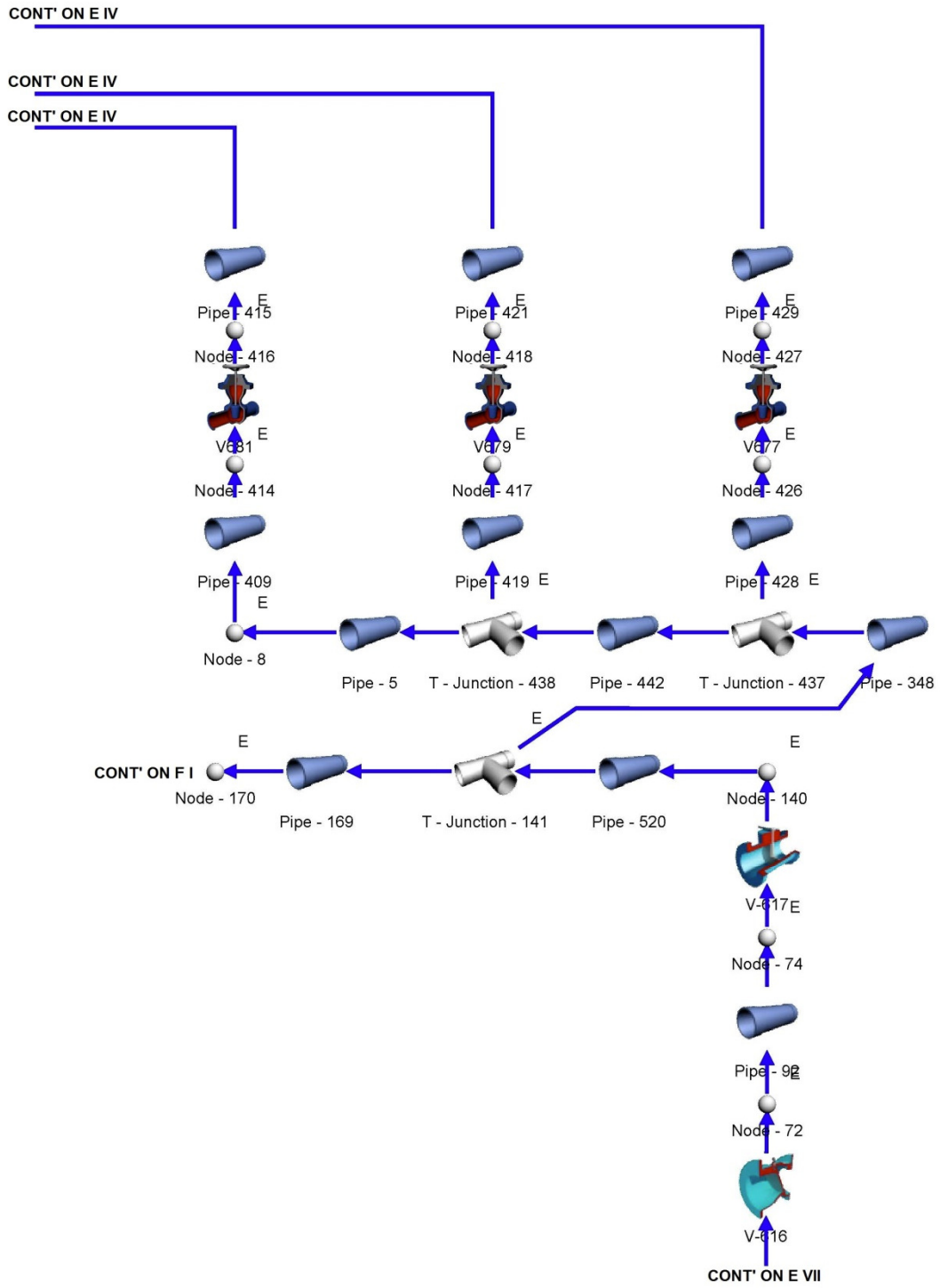

FIGURE 44: SCHEMATIC FIGURE E V

E VI

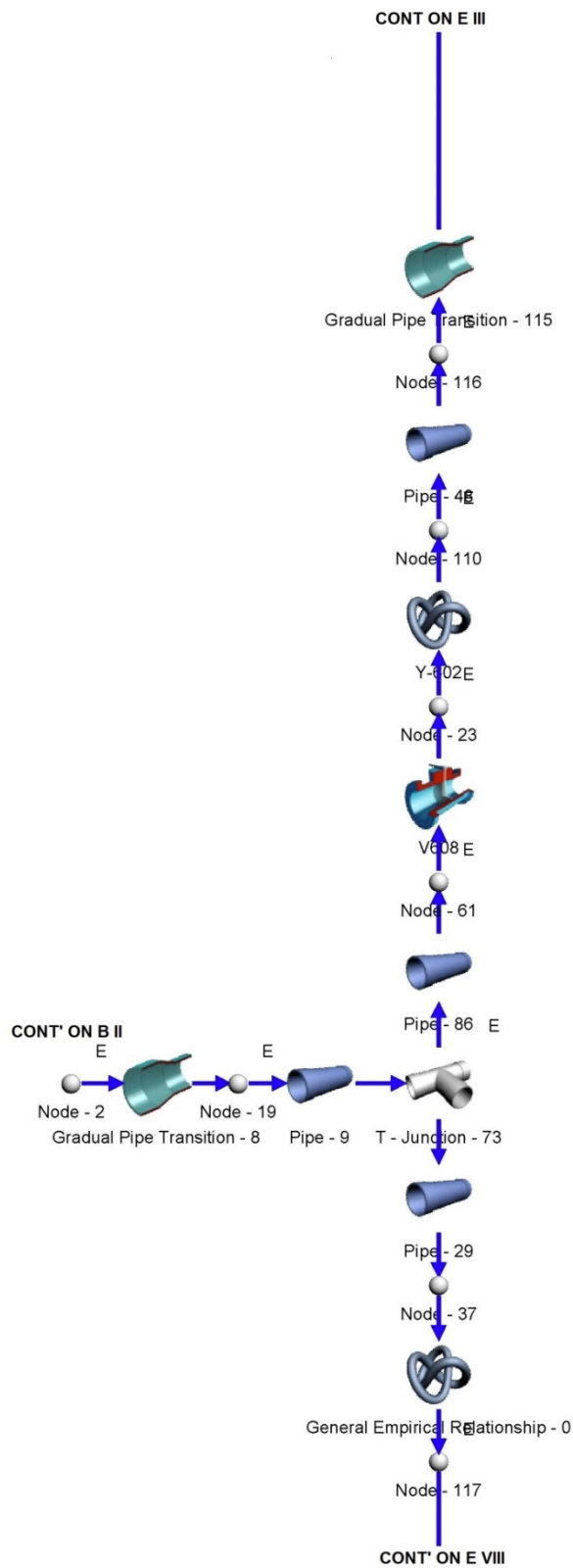

FIGURE 45: SCHEMATIC FIGURE E VI

E VII

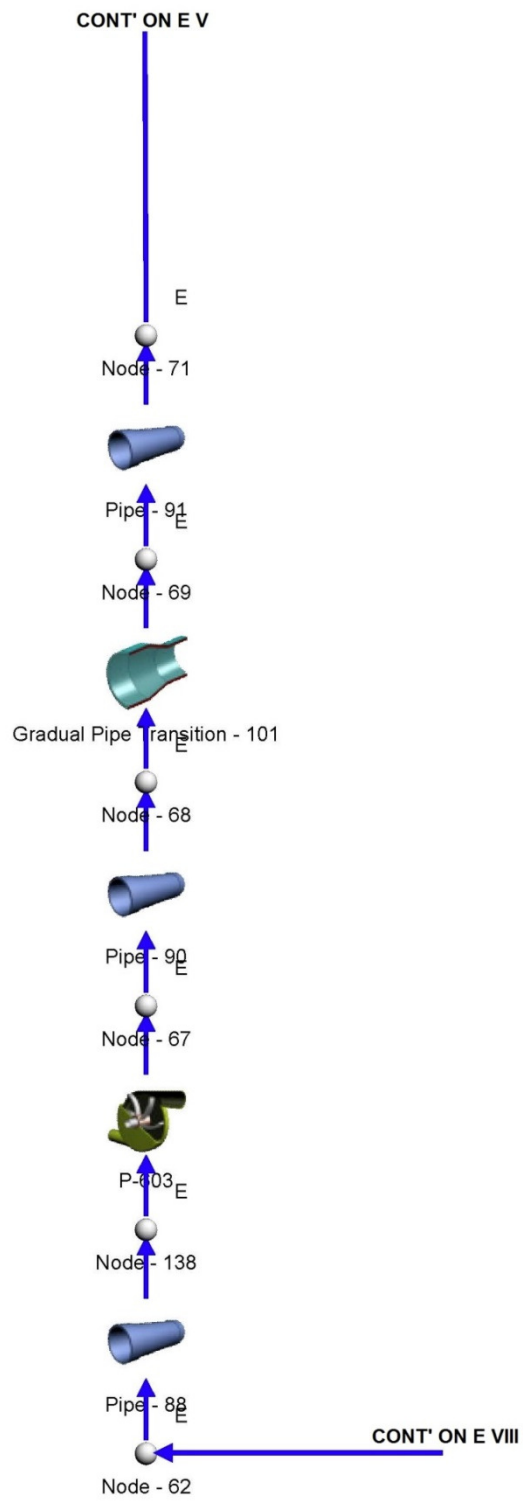

FIGURE 46: SCHEMATIC FIGURE E VII

E VIII

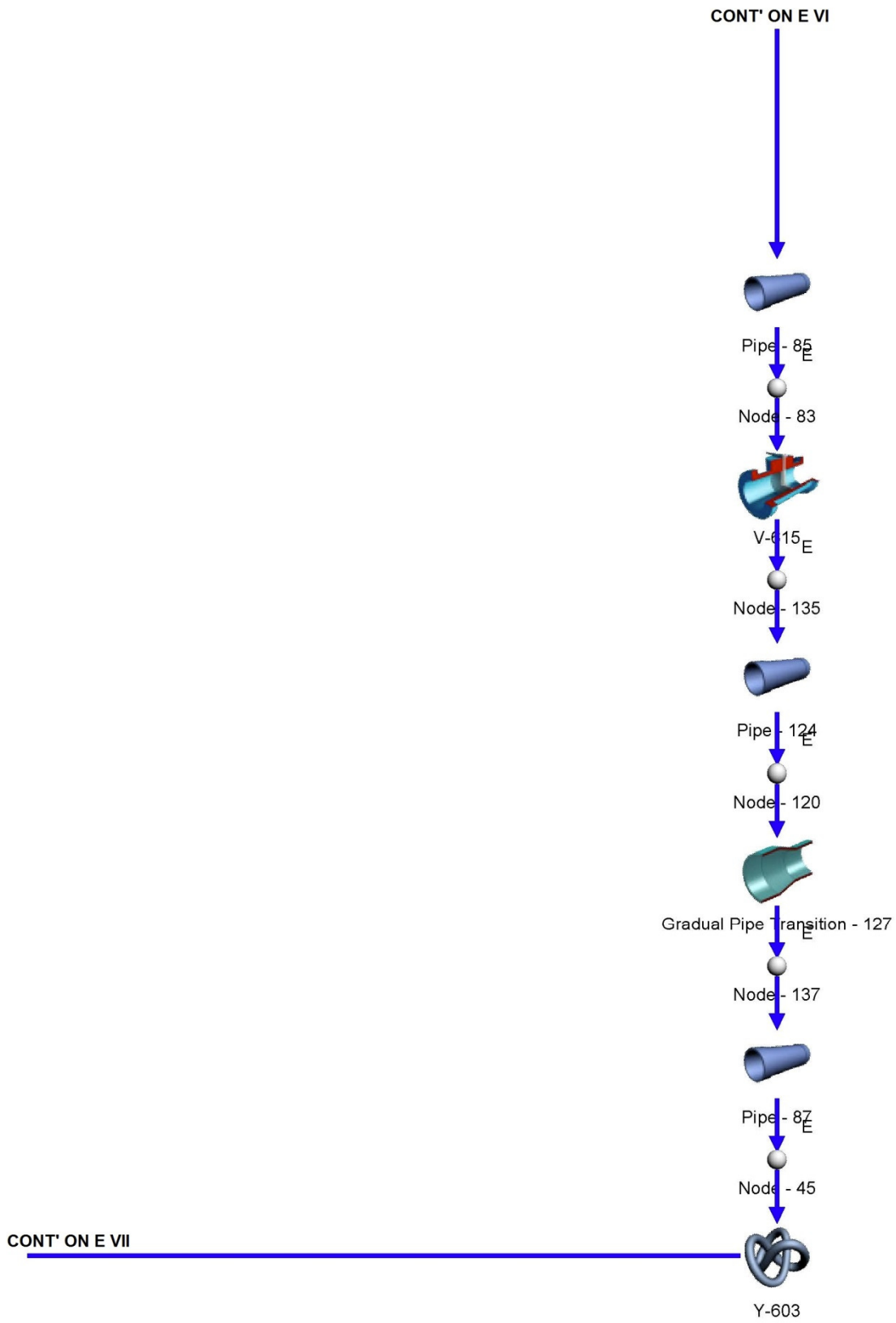

FIGURE 47: SCHEMATIC FIGURE E VIII

F: CHILLER HEAT EXCHANGER UNITS
 (43)

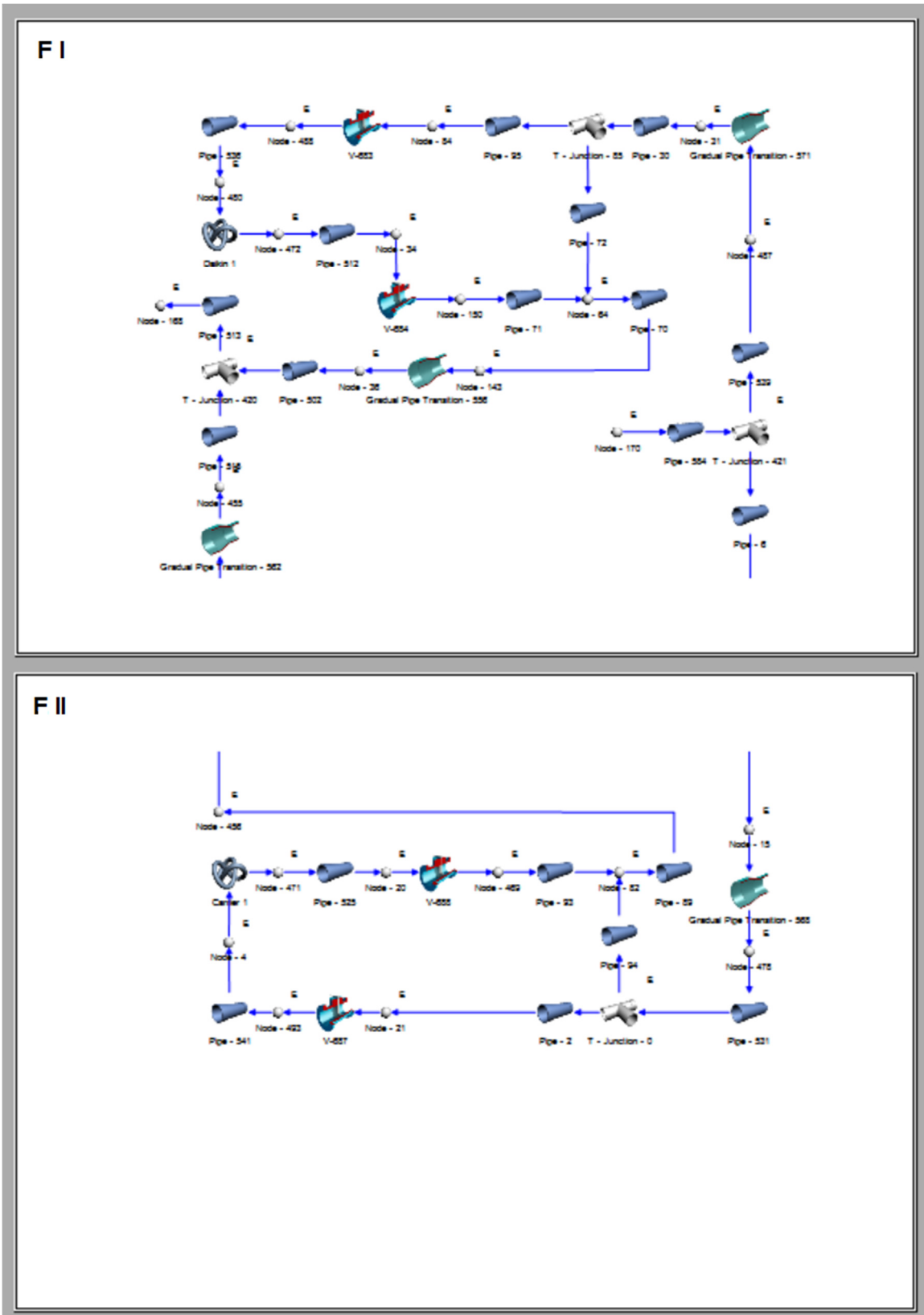

FIGURE 48: CHILLER HEAT EXCHANGER SCHEMATIC

F I

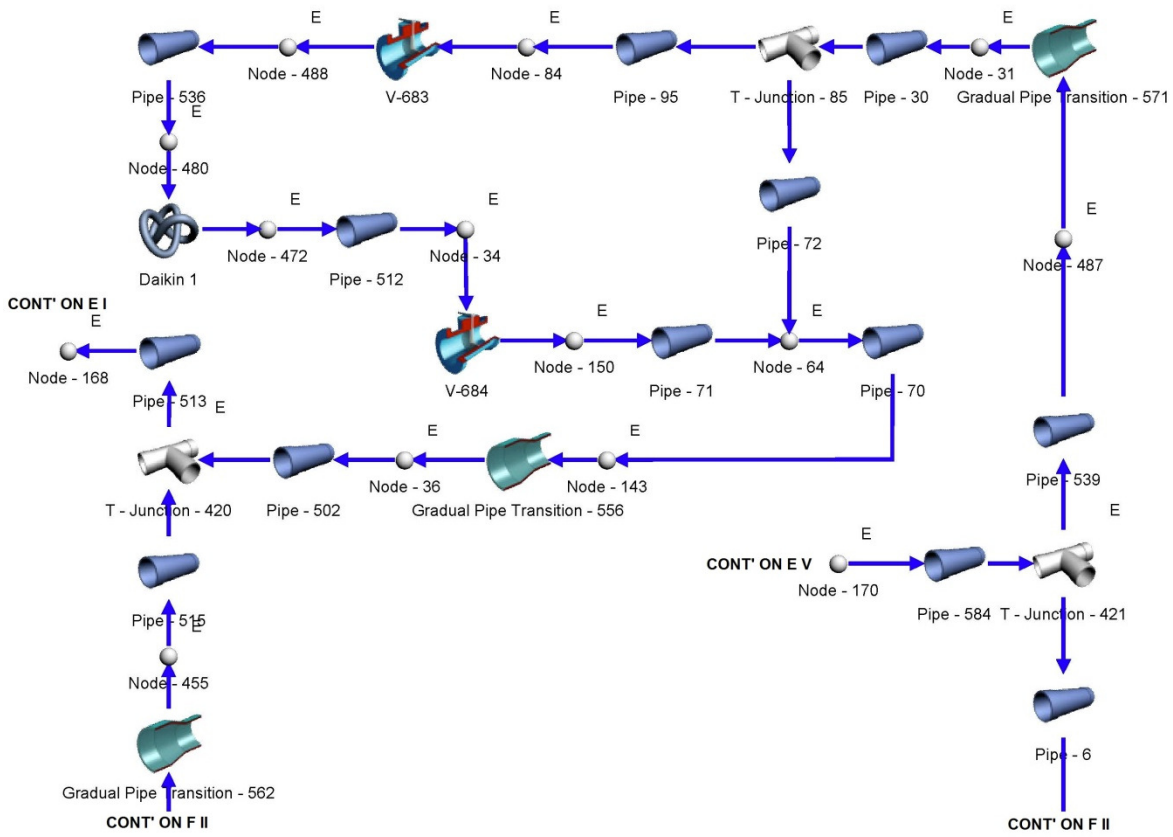

FIGURE 49: SCHEMATIC FIGURE F I

F II

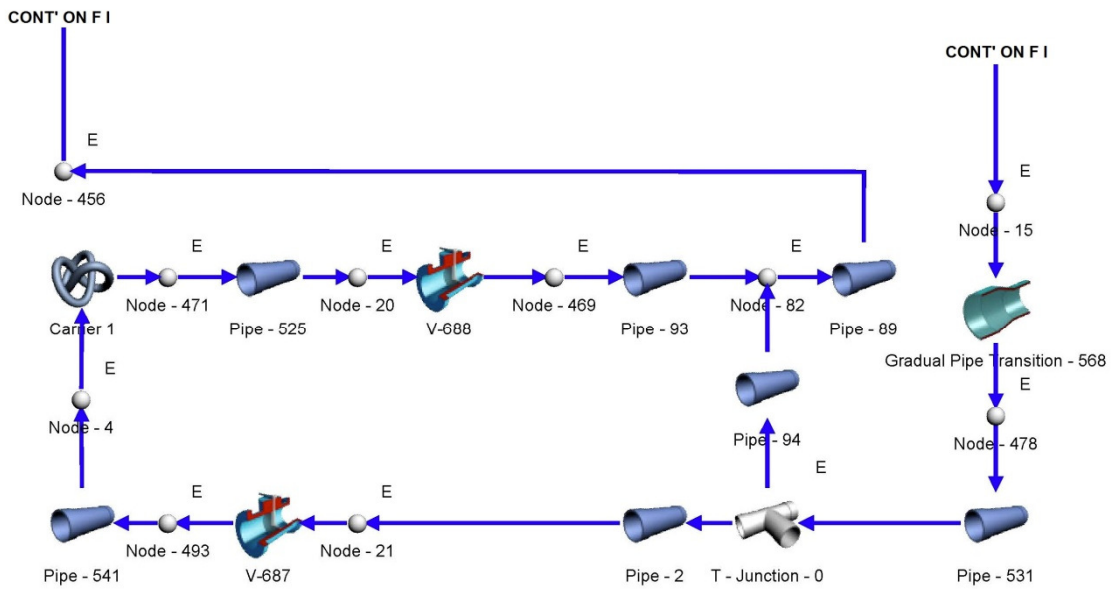

FIGURE 50: SCHEMATIC FIGURE F II

APPENDIX II

INPUT VARIABLES

BEND

(44)

TABLE 28: BEND INPUT - A

General			Connected Nodes		Fluids
Identifier	Solving	Description	Upstream node	Downstream node	Fluid Data Reference
Bend - 68	True	122	Node - 33	Node - 39	H2O - Water Liquids (Pure Fluids)

TABLE 29: BEND INPUT - B

Bend Data					Losses
Geometry option	Diameter (m)	Bend angle (°)	Radius (m)	Number in parallel	Roughness option
Specify geometry	0.1	180	0.5	1	Specify manually

TABLE 30: BEND INPUT - C

Losses	Fixed Options		Momentum Addition
Roughness (µm)	Fixed mass flow	Check valve	Momentum addition
300	False	False	False

BOUNDARY CONDITIONS

(42) (45) (46) (47) (48) (49) (50) (51) (52) (53) (54) (55) (56) (57) (58) (59) (60) (61) (62) (63) (64) (65) (66)

TABLE 31: BOUNDARY CONDITIONS INPUT - A

General			Boundary Conditions	
Identifier	Solving	Description	Pressure boundary condition	Pressure (kPa)
Boundary Condition - 1	True		Fixed on user value	143.77
Boundary Condition - 2	True		Fixed on user value	143.77
Boundary Condition - 29	True		Fixed on user value	418
Boundary Condition - 3	True		Fixed on user value	143.77
Boundary Condition - 31	True			
Boundary Condition - 33	True		Fixed on user value	424.5
Boundary Condition - 34	True			
Boundary Condition - 4	True			
Boundary Condition - 5	True			
Boundary Condition - 6	True			
Boundary Condition - 7	True		Fixed on user value	143.77
Boundary Condition - 70	True		Fixed on user value	403

TABLE 31 CONTINUED: BOUNDARY CONDITIONS INPUT - A

General			Boundary Conditions	
Identifier	Solving	Description	Pressure boundary condition	Pressure (kPa)
Boundary Condition - 71	True			
Boundary Condition - 72	True		Fixed on user value	219
Boundary Condition - 74	True			
Boundary Condition - 8	True		Fixed on user value	87.18
Boundary Condition - 84	True		Fixed on user value	400.5
Boundary Condition - 85	True			
Boundary Condition - 9	True		Fixed on user value	87.18

TABLE 32: BOUNDARY CONDITIONS INPUT - B

Boundary Conditions		
Temperature boundary condition	Temperature (°C)	Mass source boundary condition
Not specified		
Not specified		
Fixed on user value	44.5	
Not specified		
Not specified		Fixed on user value
Fixed on user value	45	
Not specified		Fixed on user value
Fixed on user value	24.911	Fixed on user value
Fixed on user value	24.911	Fixed on user value
Fixed on user value	24.911	Fixed on user value
Not specified		
Fixed on user value	44.5	
Not specified		Fixed on user value
Fixed on user value	33	
Not specified		Fixed on user value
Not specified		
Fixed on user value	45	
Not specified		Fixed on user value
Not specified		

TABLE 33: BOUNDARY CONDITIONS INPUT - C

Boundary Conditions	Mass Source Conditions
Mass source (kg/s)	Specify mass source conditions
	False
	False
	False
-137.4566659	False

TABLE 33 CONTINUED: BOUNDARY CONDITIONS INPUT - C

Boundary Conditions	Mass Source Conditions
Mass source (kg/s)	Specify mass source conditions
-170.6525755	False
154.2975	
154.2975	
308.595	
	False
-146.3630861	False
-35.04	False
	False
-127.8732516	False
	False

ORIFICE

(44) (67)

TABLE 34: ORIFICE INPUT - A

General			Connected Nodes	
Identifier	Description	Solving	Upstream node	Downstream node
British Standard Orifice - 281		True	Node - 275	Node - 284

TABLE 35: ORIFICE INPUT - B

Fluids	British Standard Orifice Data		
Fluid Data Reference	Tappings option	Pipe diameter (m)	Orifice diameter (m)
H2O - Water Liquids (Pure Fluids)	D and D/2 tappings	0.5	0.47

TABLE 36: ORIFICE INPUT - C

British Standard Orifice Data	Fixed Options		Momentum Addition
Number in parallel	Fixed mass flow	Check valve	Momentum addition
1	False	False	False

PUMP

(68) (69) (70) (71)

TABLE 37: PUMP INPUT - A

General			Connected Nodes	
Identifier	Description	Solving	Upstream node	Downstream node
P-602	PUMP	True	Node - 121	Node - 24
P-603	PUMP	True	Node - 138	Node - 67
P-608	Ball Recirculation Pump	True	Node - 271	Node - 273

TABLE 38: PUMP INPUT - B

Fluids	Fan or Pump Data
Fluid Data Reference	Pump or fan curve
H2O - Water Liquids (Pure Fluids)	P602 KSB Pumps - Water (Pump And Fan Charts)
H2O - Water Liquids (Pure Fluids)	P603 KSB Pumps - Water (Pump And Fan Charts)
H2O - Water Liquids (Pure Fluids)	Ball recirculation KSB Pumps - Water (Pump And Fan Charts)

TABLE 39: PUMP INPUT - C

Fan or Pump Data		Fixed Options		Momentum Addition
Heat input (kW)	Apply ANSI 2005 Derating	Fixed mass flow	Check valve	Momentum addition
22.93	False	False	False	False
2.54025	False	False	False	False
1.32	False	False	False	False

GENERAL EMPIRICAL RELATIONSHIP

(12) (72)

TABLE 40: GENERAL EMPIRICAL RELATIONSHIP INPUT - A

General			Connected Nodes
Identifier	Description	Solving	Upstream node
Basket Strainer 601	Basket Strainer	True	Node - 48
Basket Strainer 604	Basket Strainer	True	Node - 7
Basket Strainer 605	Basket Strainer	True	Node - 153
Basket Strainer 606	Basket Strainer	True	Node - 89
C-609	Ball Collector	True	Node - 146
Carrier 1		True	Node - 4
Daikin 1		True	Node - 480
E-618		True	Node - 434
E-619		True	Node - 435
E-620		True	Node - 436
General Empirical Relationship - 0		True	Node - 37

TABLE 40 CONTINUED: GENERAL EMPIRICAL RELATIONSHIP INPUT - A

General			Connected Nodes
Identifier	Description	Solving	Upstream node
Gradual - General Empirical Relationship - 46 - 111		True	Node - 116
Gradual - General Empirical Relationship - 46 - 118		True	Node - 120
Gradual - General Empirical Relationship - 46 - 124		True	Node - 25
Gradual - General Empirical Relationship - 46 - 158		True	Node - 191
Gradual - General Empirical Relationship - 46 - 161		True	Node - 205
Gradual - General Empirical Relationship - 46 - 162		True	Node - 207
Gradual - General Empirical Relationship - 46 - 165		True	Node - 163
Gradual - General Empirical Relationship - 46 - 185		True	Node - 190
Gradual - General Empirical Relationship - 46 - 2		True	Node - 9
Gradual - General Empirical Relationship - 46 - 21		True	Node - 39
Gradual - General Empirical Relationship - 46 - 218		True	Node - 194
Gradual - General Empirical Relationship - 46 - 3		True	Node - 17
Gradual - General Empirical Relationship - 46 - 34		True	Node - 68
Gradual - General Empirical Relationship - 46 - 4		True	Node - 2
Gradual - General Empirical Relationship - 46 - 410		True	Node - 143
Gradual - General Empirical Relationship - 46 - 412		True	Node - 456
Gradual - General Empirical Relationship - 46 - 414		True	Node - 15
Gradual - General Empirical Relationship - 46 - 415		True	Node - 487
Gradual - General Empirical Relationship - 46 - 43		True	Node - 50
Gradual - General Empirical Relationship - 46 - 44		True	Node - 58
Gradual - General Empirical Relationship - 46 - 48		True	Node - 53
Gradual - General Empirical Relationship - 46 - 5		True	Node - 28
Gradual - General Empirical Relationship - 46 - 6		True	Node - 29
Gradual - General Empirical Relationship - 46 - 7		True	Node - 47
Gradual - General Empirical Relationship - 46 - 84		True	Node - 91
Gradual - General Empirical Relationship - 46 - 85		True	Node - 99
Gradual - General Empirical Relationship - 46 - 87		True	Node - 107
T-610	Ball Strainer	True	Node - 131
TABV - 130		True	Node - 87
TABV - 135		True	Node - 96
TABV - 156		True	Node - 176
TABV - 157		True	Node - 185
TABV - 159		True	Node - 115
TABV - 160		True	Node - 200
TABV - 163		True	Node - 76
TABV - 164		True	Node - 10
TABV - 35		True	Node - 83
TABV - 36		True	Node - 74
TABV - 411		True	Node - 34
TABV - 413		True	Node - 20
TABV - 416		True	Node - 84
TABV - 417		True	Node - 21

TABLE 40 CONTINUED: GENERAL EMPIRICAL RELATIONSHIP INPUT - A

General			Connected Nodes
Identifier	Description	Solving	Upstream node
TABV - 667		True	Node - 61
TABV - 672		True	Node - 141
Y-602	104	True	Node - 23
Y-603	135	True	Node - 45

TABLE 41: GENERAL EMPIRICAL RELATIONSHIP INPUT - B

Connected Nodes	Fluids	Empirical Data			
		Coefficients			Heat Transfer
Downstream node	Fluid Data Reference	Ck	Beta	Alpha	Heat input (kW)
Node - 50	H2O - Water Liquids (Pure Fluids)	640	1	2.10969	0
Node - 9	H2O - Water Liquids (Pure Fluids)	640	1	2.10969	0
Node - 163	H2O - Water Liquids (Pure Fluids)	640	1	2.10969	0
Node - 91	H2O - Water Liquids (Pure Fluids)	87.682962	1	2.10969	0
Node - 148	H2O - Water Liquids (Pure Fluids)	78088.62	1	1.9738	0
Node - 471	H2O - Water Liquids (Pure Fluids)	113310	1	1.7649	220.326
Node - 472	H2O - Water Liquids (Pure Fluids)	113310	1	1.7649	0
Node - 344	H2O - Water Liquids (Pure Fluids)	500000	1	2	3.910098
Node - 353	H2O - Water Liquids (Pure Fluids)	500000	1	2	3.910098
Node - 364	H2O - Water Liquids (Pure Fluids)	500000	1	2	3.910098
Node - 117	H2O - Water Liquids (Pure Fluids)	2229.014	1	1.9761	0
Node - 119	H2O - Water Liquids (Pure Fluids)	568.3091315	1	2	0
Node - 137	H2O - Water Liquids (Pure Fluids)	6942.625011	1	2	0
Node - 132	H2O - Water Liquids (Pure Fluids)	1577.589905	1	2	0
Node - 192	H2O - Water Liquids (Pure Fluids)	0.249516789	1	2	0
T - Junction - 172	H2O - Water Liquids (Pure Fluids)	19.47641859	1	2	0
Node - 208	H2O - Water Liquids (Pure Fluids)	0.154076617	1	2	0
Node - 173	H2O - Water Liquids (Pure Fluids)	24.53467821	1	2	0
Node - 303	H2O - Water Liquids (Pure Fluids)	40.98879686	1	2	0
Node - 11	H2O - Water Liquids (Pure Fluids)	24.53467821	1	2	0
Node - 49	H2O - Water Liquids (Pure Fluids)	1.626142403	1	2	0
Node - 227	H2O - Water Liquids (Pure Fluids)	446.8389732	1	2	0
Node - 18	H2O - Water Liquids (Pure Fluids)	40.98879686	1	2	0
Node - 69	H2O - Water Liquids (Pure Fluids)	8702.924721	1	2	0
Node - 19	H2O - Water Liquids (Pure Fluids)	4.450079382	1	2	0
Node - 36	H2O - Water Liquids (Pure Fluids)	8702.924721	1	2	0
Node - 455	H2O - Water Liquids (Pure Fluids)	8702.924721	1	2	0
Node - 478	H2O - Water Liquids (Pure Fluids)	3742.299211	1	2	0
Node - 31	H2O - Water Liquids (Pure Fluids)	3742.299211	1	2	0
Node - 52	H2O - Water Liquids (Pure Fluids)	24.53467821	1	2	0
Node - 59	H2O - Water Liquids (Pure Fluids)	40.98879686	1	2	0
Node - 95	H2O - Water Liquids (Pure Fluids)	6.291492743	1	2	0

TABLE 41 CONTINUED: GENERAL EMPIRICAL RELATIONSHIP INPUT - B

Connected Nodes	Fluids	Empirical Data			
		Coefficients			Heat Transfer
Downstream node	Fluid Data Reference	Ck	Beta	Alpha	Heat input (kW)
Node - 177	H2O - Water Liquids (Pure Fluids)	6.247801821	1	2	0
Node - 13	H2O - Water Liquids (Pure Fluids)	6.247801821	1	2	0
Node - 54	H2O - Water Liquids (Pure Fluids)	6.247801821	1	2	0
Node - 93	H2O - Water Liquids (Pure Fluids)	48.59016349	1	2	0
Node - 100	H2O - Water Liquids (Pure Fluids)	21.41473478	1	2	0
Node - 133	H2O - Water Liquids (Pure Fluids)	66.17145238	1	2	0
Node - 280	H2O - Water Liquids (Pure Fluids)	13.886	1	2.0378	0
Node - 89	H2O - Water Liquids (Pure Fluids)	0	1	2	0
Node - 98	H2O - Water Liquids (Pure Fluids)	0	1	2	0
T - Junction - 173	H2O - Water Liquids (Pure Fluids)	67.34497987	1	2	0
T - Junction - 37	H2O - Water Liquids (Pure Fluids)	67.34497987	1	2	0
T - Junction - 88	H2O - Water Liquids (Pure Fluids)	67.34497987	1	2	0
T - Junction - 74	H2O - Water Liquids (Pure Fluids)	67.34497987	1	2	0
Node - 209	H2O - Water Liquids (Pure Fluids)	67.34497987	1	2	0
Node - 212	H2O - Water Liquids (Pure Fluids)	67.34497987	1	2	0
Node - 135	H2O - Water Liquids (Pure Fluids)	1077.519678	1	2	0
Node - 140	H2O - Water Liquids (Pure Fluids)	1077.519678	1	2	0
Node - 150	H2O - Water Liquids (Pure Fluids)	0	1	2	0
Node - 469	H2O - Water Liquids (Pure Fluids)	13317.73284	1	2	0
Node - 488	H2O - Water Liquids (Pure Fluids)	0	1	2	0
Node - 493	H2O - Water Liquids (Pure Fluids)	270594.1764	1	2	0
Node - 23	H2O - Water Liquids (Pure Fluids)	340.9341485	1	2	0
Node - 144	H2O - Water Liquids (Pure Fluids)	1077.519678	1	2	0
Node - 110	H2O - Water Liquids (Pure Fluids)	5700	1	1.8663	0
Node - 62	H2O - Water Liquids (Pure Fluids)	30000	1	1.9894	0

TABLE 42: GENERAL EMPIRICAL RELATIONSHIP INPUT - C

Fixed Options		Momentum Addition
Fixed mass flow	Check valve	Momentum addition
False	False	False
False	False	False
False	False	False
False	False	False
False	False	False
False	False	False
False	False	False
False	False	False
False	False	False
False	False	False
False	False	False
False	False	False

TABLE 42 CONTINUED: GENERAL EMPIRICAL RELATIONSHIP INPUT - C

Fixed Options		Momentum Addition	
Fixed mass flow	Check valve	Momentum addition	
False	False	False	
False	False	False	
False	False	False	
False	False	False	

HEAT EXCHANGERS – SHELL SIDE

(73) (74) (75) (76) (77) (78) (79) (80) (81) (82) (83) (84) (53)

TABLE 43: HEAT EXCHANGER - SHELL SIDE INPUT- A

General			Connected Nodes	
Identifier	Solving	Description	Upstream node	Downstream node
E-101 (Shell Side)	True		Node - 30	Node - 32
E-102 (Shell Side)	True		Node - 42	Node - 43
E-103 (Shell Side)	True		Node - 78	Node - 79
E-104 (Shell Side)	True		Node - 104	Node - 105
E-301 (Shell Side)	True		Node - 73	Node - 81

TABLE 44: HEAT EXCHANGER - SHELL SIDE INPUT - B

Fluids		Heat Exchange Data		
Fluid Data Reference	Heat exchanger type	AU (W/K)	Number of shell passes	
H2O - Water Liquids (Pure Fluids)	Shell and tube	335311.4584	1	
H2O - Water Liquids (Pure Fluids)	Shell and tube	335311.4584	1	
H2O - Water Liquids (Pure Fluids)	Shell and tube	335311.4584	1	
H2O - Water Liquids (Pure Fluids)	Shell and tube	335311.4584	1	
H2O - Water Liquids (Pure Fluids)	Shell and tube	267.8528122	1	

TABLE 45: HEAT EXCHANGER - SHELL SIDE INPUT- C

Primary Side Flow Data			Fixed Options		Momentum Addition
Ck	Beta	Alpha	Fixed mass flow	Check valve	Momentum addition
1085.530215	1	2	False	False	False
1085.530215	1	2	False	False	False
1085.530215	1	2	False	False	False
1085.530215	1	2	False	False	False
6797.28	1	1.97213	False	False	False

HEAT EXCHANGERS – TUBE SIDE

(73) (74) (75) (76) (78) (80) (81) (85) (86) (87) (88) (89) (90) (91) (92)

TABLE 46: HEAT EXCHANGERS - TUBE SIDE INPUT - A

General			Connected Nodes	
Identifier	Description	Solving	Upstream node	Downstream node
E-101 (Tube Side)	27	True	T - Junction - 173	Node - 6
E-102 (Tube Side)	36	True	T - Junction - 37	Node - 40
E-103 (Tube Side)	36	True	T - Junction - 74	Node - 76
E-104 (Tube Side)	36	True	T - Junction - 88	Node - 10
E-301 (Tube Side)		True	Node - 86	Node - 109

TABLE 47: HEAT EXCHANGERS - TUBE SIDE INPUT - B

Fluids	Secondary Side Flow Data			Fixed Options	
Fluid Data Reference	Ck	Beta	Alpha	Fixed mass flow	Check valve
H2O - Water Liquids (Pure Fluids)	255.564	1	2	False	False
H2O - Water Liquids (Pure Fluids)	255.564	1	2	False	False
H2O - Water Liquids (Pure Fluids)	255.564	1	2	False	False
H2O - Water Liquids (Pure Fluids)	255.564	1	2	False	False
H2O - Water Liquids (Pure Fluids)	7268.98	1	2	False	False

TABLE 48: HEAT EXCHANGERS - TUBE SIDE INPUT - C

Momentum Addition
Momentum addition
False
False
False
False
False

T-JUNCTIONS

(44)

TABLE 49: T-JUNCTIONS INPUT - A

General			Geometry			
			1		0	
			Volume Fraction		Volume Fraction	
Identifier	Solving	Description	Specify	Description	Specify	Description
T - Junction - 0	True		False	Pipe - 2	False	Pipe - 94
T - Junction - 112	True		False	Pipe - 113	False	Pipe - 110
T - Junction - 114	True		False	Pipe - 115	False	Pipe - 113
T - Junction - 116	True		False	Pipe - 117	False	Pipe - 115
T - Junction - 118	True		False	Pipe - 102	False	Pipe - 117
T - Junction - 12	True		False	Pipe - 180	False	Pipe - 174
T - Junction - 13	True		False	Pipe - 187	False	Pipe - 186
T - Junction - 14	True		False	Pipe - 199	False	Pipe - 198
T - Junction - 141	True		False	Pipe - 169	False	Pipe - 520
T - Junction - 15	True		False	Pipe - 191	False	Pipe - 187
T - Junction - 16	True		False	Pipe - 207	False	Pipe - 181
T - Junction - 166	True		False	Pipe - 326	False	Pipe - 503
T - Junction - 167	True		False	Pipe - 28	False	Pipe - 217
T - Junction - 168	True		False	Pipe - 0	False	Pipe - 239
T - Junction - 169	True		False	Pipe - 223	False	Pipe - 222
T - Junction - 17	True		False	Pipe - 199	False	Pipe - 186
T - Junction - 170	True		False	Pipe - 238	False	Pipe - 237
T - Junction - 172	True		False	Pipe - 240	False	Pipe - 237
T - Junction - 173	True		False	TABV - 156	False	Pipe - 119
T - Junction - 18	True		False	Pipe - 181	False	Pipe - 194
T - Junction - 227	True		False	Pipe - 152	False	Pipe - 234
T - Junction - 245	True		False	Pipe - 251	False	Pipe - 250
T - Junction - 285	True		False	Pipe - 286	False	Pipe - 283
T - Junction - 310	True		False	Pipe - 322	False	Pipe - 316
T - Junction - 311	True		False	Pipe - 324	False	Pipe - 322
T - Junction - 37	True		False	TABV - 157	False	Pipe - 120
T - Junction - 40	True		False	Pipe - 39	False	Pipe - 250
T - Junction - 420	True		False	Pipe - 502	False	Pipe - 513
T - Junction - 421	True		False	Pipe - 584	False	Pipe - 539
T - Junction - 437	True		False	Pipe - 442	False	Pipe - 428
T - Junction - 438	True		False	Pipe - 442	False	Pipe - 419
T - Junction - 490	True		False	Pipe - 126	False	Pipe - 488
T - Junction - 681	True		False	Pipe - 682	False	Pipe - 354
T - Junction - 683	True		False	Pipe - 326	False	Pipe - 682
T - Junction - 73	True		False	Pipe - 9	False	Pipe - 86
T - Junction - 74	True		False	TABV - 160	False	Pipe - 121
T - Junction - 85	True		False	Pipe - 72	False	Pipe - 95
T - Junction - 88	True		False	E-104 (Tube Side)	False	Pipe - 122

TABLE 50: T-JUNCTIONS INPUT - B

Geometry		Fluids
2		
Volume Fraction		
Specify	Description	Fluid Data Reference
False	Pipe - 531	H2O - Water Liquids (Pure Fluids)
False	Pipe - 141	H2O - Water Liquids (Pure Fluids)
False	Pipe - 20	H2O - Water Liquids (Pure Fluids)
False	Pipe - 61	H2O - Water Liquids (Pure Fluids)
False	Pipe - 1	H2O - Water Liquids (Pure Fluids)
False	Pipe - 178	H2O - Water Liquids (Pure Fluids)
False	Pipe - 193	H2O - Water Liquids (Pure Fluids)
False	Pipe - 205	H2O - Water Liquids (Pure Fluids)
False	Pipe - 348	H2O - Water Liquids (Pure Fluids)
False	Pipe - 174	H2O - Water Liquids (Pure Fluids)
False	Pipe - 170	H2O - Water Liquids (Pure Fluids)
False	Pipe - 167	H2O - Water Liquids (Pure Fluids)
False	Pipe - 218	H2O - Water Liquids (Pure Fluids)
False	Pipe - 118	H2O - Water Liquids (Pure Fluids)
False	Pipe - 226	H2O - Water Liquids (Pure Fluids)
False	Pipe - 203	H2O - Water Liquids (Pure Fluids)
False	Pipe - 69	H2O - Water Liquids (Pure Fluids)
False	Gradual - General Empirical Relationship - 46 - 161	H2O - Water Liquids (Pure Fluids)
False	E-101 (Tube Side)	H2O - Water Liquids (Pure Fluids)
False	Pipe - 206	H2O - Water Liquids (Pure Fluids)
False	Pipe - 39	H2O - Water Liquids (Pure Fluids)
False	Pipe - 261	H2O - Water Liquids (Pure Fluids)
False	Pipe - 289	H2O - Water Liquids (Pure Fluids)
False	Pipe - 27	H2O - Water Liquids (Pure Fluids)
False	Pipe - 68	H2O - Water Liquids (Pure Fluids)
False	E-102 (Tube Side)	H2O - Water Liquids (Pure Fluids)
False	Pipe - 147	H2O - Water Liquids (Pure Fluids)
False	Pipe - 515	H2O - Water Liquids (Pure Fluids)
False	Pipe - 6	H2O - Water Liquids (Pure Fluids)
False	Pipe - 348	H2O - Water Liquids (Pure Fluids)
False	Pipe - 5	H2O - Water Liquids (Pure Fluids)
False	Pipe - 503	H2O - Water Liquids (Pure Fluids)
False	Pipe - 10	H2O - Water Liquids (Pure Fluids)
False	Pipe - 365	H2O - Water Liquids (Pure Fluids)
False	Pipe - 29	H2O - Water Liquids (Pure Fluids)
False	E-103 (Tube Side)	H2O - Water Liquids (Pure Fluids)
False	Pipe - 30	H2O - Water Liquids (Pure Fluids)
False	TABV - 159	H2O - Water Liquids (Pure Fluids)

TABLE 51: T-JUNCTIONS INPUT - C

Solver Guess Values	Boundary Conditions		Heat Transfer
Specify guess values	Elevation boundary condition	Elevation (m)	Heat input (kW)
False	Specified	12.23	0
False	Specified	0	0
False	Specified	0	0
False	Specified	0	0
False	Specified	0	0
False	Specified	0	0
False	Specified	0	0
False	Specified	0	0
False	Specified	0	0
False	Specified	4.83	0
False	Specified	0	0
False	Specified	0	0
False	Specified	4.8	0
False	Specified	0	0
False	Specified	4	0
False	Specified	0	0
False	Specified	0	0
False	Specified	4	0
False	Specified	4	0
False	Specified	4	0
False	Specified	2.3	0
False	Specified	0	0
False	Specified	2.1	0
False	Specified	2.1	0
False	Specified	4	0
False	Specified	1.5	0
False	Specified	1.5	0
False	Specified	2.3	0
False	Specified	2	0
False	Specified	12.73	0
False	Specified	12.23	0
False	Specified	4.83	0
False	Specified	4.83	0
False	Specified	4.83	0
False	Specified	4.83	0
False	Specified	4.83	0
False	Specified	0	0
False	Specified	1.9	0
False	Specified	12.23	0
False	Specified	3	0

TABLE 52: T-JUNCTIONS INPUT - D

Junction Data	
Specify advanced losses	Joining element
True	Pipe - 94
True	Pipe - 141
True	Pipe - 20
True	Pipe - 61
True	Pipe - 102
True	Pipe - 180
True	Pipe - 193
True	Pipe - 205
True	Pipe - 520
True	Pipe - 191
True	Pipe - 207
True	Pipe - 326
True	Pipe - 28
True	Pipe - 0
True	Pipe - 223
True	Pipe - 203
True	Pipe - 69
True	Pipe - 240
True	Pipe - 119
True	Pipe - 206
True	Pipe - 234
True	Pipe - 251
True	Pipe - 289
True	Pipe - 27
True	Pipe - 68
True	Pipe - 120
True	Pipe - 147
True	Pipe - 515
True	Pipe - 584
True	Pipe - 348
True	Pipe - 419
True	Pipe - 503
True	Pipe - 354
True	Pipe - 326
True	Pipe - 86
True	Pipe - 121
True	Pipe - 72
True	Pipe - 122

NODES

(44)

TABLE 53: NODES INPUT - A

General			Geometry	
			0	
			Volume Fraction	
Identifier	Solving	Description	Specify	Description
Node - 1	True		False	GV - 248
Node - 10	True		False	E-104 (Tube Side)
Node - 100	True		False	Gradual - General Empirical Relationship - 46 - 85
Node - 101	True		False	GV - 219
Node - 102	True		False	Pipe - 188
Node - 103	True		False	GV - 222
Node - 104	True		False	E-104 (Shell Side)
Node - 105	True		False	E-104 (Shell Side)
Node - 106	True		False	Pipe - 190
Node - 107	True		False	Gradual - General Empirical Relationship - 46 - 87
Node - 108	True		False	Pipe - 191
Node - 109	True		False	GV - 66
Node - 11	True		False	Gradual - General Empirical Relationship - 46 - 2
Node - 110	True		False	Pipe - 48
Node - 112	True		False	Pipe - 192
Node - 113	True		False	Pipe - 193
Node - 114	True		False	Pipe - 196
Node - 115	True		False	TABV - 159
Node - 116	True		False	Pipe - 48
Node - 117	True		False	Pipe - 85
Node - 118	True		False	GV - 218
Node - 119	True		False	Gradual - General Empirical Relationship - 46 - 111
Node - 12	True		False	Pipe - 335
Node - 120	True		False	Pipe - 124
Node - 121	True		False	Pipe - 49
Node - 122	True		False	Pipe - 200
Node - 123	True		False	Pipe - 119
Node - 124	True		False	GV - 223
Node - 125	True		False	Pipe - 120
Node - 126	True		False	Pipe - 121
Node - 127	True		False	Pipe - 324
Node - 128	True		False	Pipe - 325
Node - 129	True		False	Pipe - 109
Node - 13	True		False	V-621
Node - 130	True		False	Pipe - 122
Node - 131	True		False	Pipe - 118

TABLE 53 CONTINUED: NODES INPUT - A

General			Geometry	
			0	
			Volume Fraction	
Identifier	Solving	Description	Specify	Description
Node - 132	True		False	Gradual - General Empirical Relationship - 46 - 124
Node - 133	True		False	Pipe - 123
Node - 134	True		False	Pipe - 131
Node - 135	True		False	TABV - 35
Node - 136	True		False	V-609
Node - 137	True		False	Gradual - General Empirical Relationship - 46 - 118
Node - 138	True		False	Pipe - 88
Node - 139	True		False	Pipe - 137
Node - 14	True		False	V-621
Node - 140	True		False	Pipe - 520
Node - 141	True		False	Pipe - 51
Node - 142	True		False	Pipe - 202
Node - 143	True		False	Gradual - General Empirical Relationship - 46 - 410
Node - 144	True		False	Pipe - 142
Node - 145	True		False	GV - 571
Node - 146	True		False	C-609
Node - 147	True		False	Pipe - 203
Node - 148	True		False	C-609
Node - 149	True		False	Pipe - 204
Node - 15	True		False	Gradual - General Empirical Relationship - 46 - 414
Node - 150	True		False	Pipe - 71
Node - 151	True		False	Pipe - 126
Node - 152	True		False	Pipe - 205
Node - 153	True		False	Basket Strainer 605
Node - 154	True		False	Pipe - 152
Node - 155	True		False	Pipe - 156
Node - 156	True		False	Pipe - 195
Node - 157	True		False	Pipe - 188
Node - 158	True		False	Pipe - 156
Node - 159	True		False	Pipe - 172
Node - 16	True		False	Pipe - 26
Node - 160	True		False	Pipe - 195
Node - 161	True		False	Pipe - 182
Node - 162	True		False	Pipe - 171
Node - 163	True		False	Gradual - General Empirical Relationship - 46 - 165
Node - 168	True		False	Pipe - 167
Node - 17	True		False	Gradual - General Empirical Relationship - 46 - 3
Node - 170	True		False	Pipe - 169
Node - 173	True		False	Gradual - General Empirical Relationship - 46 - 165
Node - 176	True		False	TABV - 156
Node - 177	True		False	V-628

TABLE 53 CONTINUED: NODES INPUT - A

General			Geometry	
			0	
			Volume Fraction	
Identifier	Solving	Description	Specify	Description
Node - 179	True		False	V-628
Node - 18	True		False	Gradual - General Empirical Relationship - 46 - 3
Node - 184	True		False	Pipe - 183
Node - 185	True		False	Pipe - 223
Node - 19	True		False	Gradual - General Empirical Relationship - 46 - 4
Node - 190	True		False	Gradual - General Empirical Relationship - 46 - 185
Node - 191	True		False	Gradual - General Empirical Relationship - 46 - 158
Node - 192	True		False	Gradual - General Empirical Relationship - 46 - 158
Node - 193	True		False	Pipe - 233
Node - 194	True		False	GV - 184
Node - 2	True		False	Pipe - 1
Node - 20	True		False	Pipe - 525
Node - 200	True		False	TABV - 160
Node - 205	True		False	Gradual - General Empirical Relationship - 46 - 161
Node - 207	True		False	Pipe - 238
Node - 208	True		False	Gradual - General Empirical Relationship - 46 - 162
Node - 209	True		False	TABV - 163
Node - 21	True		False	Pipe - 2
Node - 212	True		False	Pipe - 241
Node - 227	True		False	GV - 17
Node - 228	True		False	Pipe - 234
Node - 229	True		False	Pipe - 235
Node - 23	True		False	TABV - 667
Node - 230	True		False	Pipe - 235
Node - 24	True		False	P-602
Node - 246	True		False	Pipe - 251
Node - 247	True		False	Pipe - 252
Node - 248	True		False	Pipe - 252
Node - 25	True		False	Pipe - 50
Node - 257	True		False	Pipe - 261
Node - 258	True		False	Pipe - 263
Node - 259	True		False	Pipe - 263
Node - 26	True		False	Pipe - 286
Node - 268	True		False	Pipe - 267
Node - 271	True		False	P-608
Node - 273	True		False	P-608
Node - 275	True		False	Pipe - 135
Node - 279	True		False	Pipe - 278
Node - 28	True		False	P-605
Node - 280	True		False	T-610
Node - 284	True		False	British Standard Orifice - 281

TABLE 53 CONTINUED: NODES INPUT - A

General			Geometry	
			0	
			Volume Fraction	
Identifier	Solving	Description	Specify	Description
Node - 29	True		False	P-604
Node - 290	True		False	Pipe - 289
Node - 3	True		False	Pipe - 110
Node - 30	True		False	E-101 (Shell Side)
Node - 303	True		False	Gradual - General Empirical Relationship - 46 - 185
Node - 31	True		False	Pipe - 30
Node - 32	True		False	E-101 (Shell Side)
Node - 327	True		False	Pipe - 325
Node - 33	True		False	Bend - 68
Node - 34	True		False	Pipe - 512
Node - 340	True		False	Pipe - 335
Node - 342	True		False	GV - 336
Node - 344	True		False	Pipe - 341
Node - 351	True		False	Pipe - 354
Node - 352	True		False	GV - 356
Node - 353	True		False	Pipe - 355
Node - 36	True		False	Pipe - 502
Node - 362	True		False	Pipe - 365
Node - 363	True		False	GV - 367
Node - 364	True		False	Pipe - 366
Node - 37	True		False	Pipe - 29
Node - 38	True		False	GV - 19
Node - 39	True		False	Bend - 68
Node - 4	True		False	Pipe - 541
Node - 40	True		False	GV - 48
Node - 41	True		False	GV - 48
Node - 414	True		False	Pipe - 409
Node - 416	True		False	GV - 410
Node - 417	True		False	Pipe - 419
Node - 418	True		False	GV - 422
Node - 42	True		False	E-102 (Shell Side)
Node - 426	True		False	Pipe - 428
Node - 427	True		False	GV - 430
Node - 43	True		False	E-102 (Shell Side)
Node - 434	True		False	Pipe - 415
Node - 435	True		False	Pipe - 421
Node - 436	True		False	Pipe - 429
Node - 45	True		False	Pipe - 87
Node - 455	True		False	Pipe - 515
Node - 456	True		False	Gradual - General Empirical Relationship - 46 - 412
Node - 46	True		False	GV - 71

TABLE 53 CONTINUED: NODES INPUT - A

General			Geometry	
			0	
			Volume Fraction	
Identifier	Solving	Description	Specify	Description
Node - 469	True		False	TABV - 413
Node - 47	True		False	P-601
Node - 471	True		False	Pipe - 525
Node - 472	True		False	Pipe - 512
Node - 478	True		False	Pipe - 531
Node - 48	True		False	Basket Strainer 601
Node - 480	True		False	Pipe - 536
Node - 487	True		False	Pipe - 539
Node - 488	True		False	TABV - 416
Node - 49	True		False	Gradual - General Empirical Relationship - 46 - 21
Node - 493	True		False	TABV - 417
Node - 5	True		False	GV - 30
Node - 50	True		False	Gradual - General Empirical Relationship - 46 - 43
Node - 52	True		False	Gradual - General Empirical Relationship - 46 - 43
Node - 53	True		False	P-606
Node - 54	True		False	V-601
Node - 55	True		False	V-601
Node - 56	True		False	Pipe - 172
Node - 57	True		False	Pipe - 67
Node - 58	True		False	Gradual - General Empirical Relationship - 46 - 44
Node - 59	True		False	Gradual - General Empirical Relationship - 46 - 44
Node - 6	True		False	E-101 (Tube Side)
Node - 61	True		False	Pipe - 86
Node - 62	True		False	Pipe - 88
Node - 64	True		False	Pipe - 70
Node - 65	True		False	GV - 220
Node - 66	True		False	GV - 184
Node - 67	True		False	P-603
Node - 68	True		False	Pipe - 90
Node - 69	True		False	Gradual - General Empirical Relationship - 46 - 34
Node - 7	True		False	Basket Strainer 604
Node - 71	True		False	Pipe - 91
Node - 72	True		False	V-616
Node - 73	True		False	E-301 (Shell Side)
Node - 74	True		False	Pipe - 92
Node - 75	True		False	Pipe - 175
Node - 76	True		False	E-103 (Tube Side)
Node - 77	True		False	GV - 221
Node - 78	True		False	E-103 (Shell Side)
Node - 79	True		False	E-103 (Shell Side)
Node - 8	True		False	Pipe - 5

TABLE 53 CONTINUED: NODES INPUT - A

General			Geometry	
			0	
			Volume Fraction	
Identifier	Solving	Description	Specify	Description
Node - 80	True		False	Pipe - 170
Node - 81	True		False	E-301 (Shell Side)
Node - 82	True		False	Pipe - 89
Node - 83	True		False	Pipe - 85
Node - 84	True		False	TABV - 416
Node - 85	True		False	Pipe - 84
Node - 86	True		False	E-301 (Tube Side)
Node - 87	True		False	Pipe - 102
Node - 88	True		False	Pipe - 177
Node - 89	True		False	Basket Strainer 606
Node - 9	True		False	Gradual - General Empirical Relationship - 46 - 2
Node - 90	True		False	Pipe - 178
Node - 91	True		False	Gradual - General Empirical Relationship - 46 - 84
Node - 92	True		False	Pipe - 179
Node - 93	True		False	Gradual - General Empirical Relationship - 46 - 84
Node - 94	True		False	Pipe - 180
Node - 95	True		False	V-675
Node - 96	True		False	V-675
Node - 97	True		False	Pipe - 184
Node - 98	True		False	Pipe - 108
Node - 99	True		False	Gradual - General Empirical Relationship - 46 - 85

TABLE 54: NODES INPUT - B

Geometry		
1		
Volume Fraction		
Specify	Description	Geometry specification
False	Pipe - 0	Not specified
False	TABV - 164	Not specified
False	Pipe - 109	Not specified
		Not specified
False	GV - 222	Not specified
		Not specified
		Not specified
		Not specified
False	GV - 214	Not specified
False	Pipe - 488	Not specified
False	GV - 214	Not specified
False	E-301 (Tube Side)	Not specified
False	P-604	Not specified
False	Y-602	Not specified
False	GV - 215	Not specified
False	GV - 215	Not specified
False	GV - 218	Not specified
False	Pipe - 116	Not specified
False	Gradual - General Empirical Relationship - 46 - 111	Not specified
False	General Empirical Relationship - 0	Not specified
		Not specified
False	Pipe - 49	Not specified
False	Pipe - 10	Not specified
False	Gradual - General Empirical Relationship - 46 - 118	Not specified
False	P-602	Not specified
False	GV - 223	Not specified
False	GV - 0	Not specified
		Not specified
False	GV - 1	Not specified
False	GV - 2	Not specified
False	Pipe - 3	Not specified
False	Pipe - 3	Not specified
False	Pipe - 4	Not specified
False	Gradual - General Empirical Relationship - 46 - 6	Not specified
False	GV - 3	Not specified
False	T-610	Not specified
False	Pipe - 131	Not specified
False	Gradual - General Empirical Relationship - 46 - 87	Not specified
False	V-609	Not specified
False	Pipe - 124	Not specified
False	Pipe - 51	Not specified

TABLE 54 CONTINUED: NODES INPUT - B

Geometry		
1		
Volume Fraction		
Specify	Description	Geometry specification
False	Pipe - 87	Not specified
False	P-603	Not specified
False	GV - 11	Not specified
False	GV - 55	Not specified
False	TABV - 36	Not specified
False	TABV - 672	Not specified
False	GV - 216	Not specified
False	Pipe - 70	Not specified
False	TABV - 672	Not specified
False	Pipe - 141	Not specified
False	Pipe - 267	Not specified
False	GV - 216	Not specified
False	Pipe - 278	Not specified
False	GV - 217	Not specified
False	Pipe - 6	Not specified
False	TABV - 411	Not specified
False	GV - 66	Not specified
False	GV - 217	Not specified
False	GV - 571	Not specified
False	GV - 53	Not specified
False	GV - 3	Not specified
False	Pipe - 200	Not specified
False	Pipe - 182	Not specified
False	GV - 53	Not specified
False	Pipe - 171	Not specified
False	GV - 55	Not specified
False	Pipe - 206	Not specified
False	Pipe - 207	Not specified
False	Pipe - 208	Not specified
False	Basket Strainer 605	Not specified
False	Pipe - 513	Not specified
False	Pipe - 26	Not specified
False	Pipe - 584	Not specified
False	P-605	Not specified
False	Pipe - 28	Not specified
False	Gradual - General Empirical Relationship - 46 - 5	Not specified
False	GV - 54	Not specified
False	Pipe - 27	Not specified
False	GV - 54	Not specified
False	TABV - 157	Not specified
False	Pipe - 9	Not specified

TABLE 54 CONTINUED: NODES INPUT - B

Geometry		
1		
Volume Fraction		
Specify	Description	Geometry specification
False	Pipe - 183	Not specified
False	Pipe - 218	Not specified
False	Pipe - 226	Not specified
False	Pipe - 116	Not specified
False	Gradual - General Empirical Relationship - 46 - 218	Not specified
False	Gradual - General Empirical Relationship - 46 - 4	Not specified
False	TABV - 413	Not specified
False	Pipe - 233	Not specified
False	Pipe - 241	Not specified
False	Gradual - General Empirical Relationship - 46 - 162	Not specified
False	Pipe - 239	Not specified
False	Pipe - 240	Not specified
False	TABV - 417	Not specified
False	TABV - 164	Not specified
False	Gradual - General Empirical Relationship - 46 - 218	Not specified
False	GV - 49	Not specified
False	GV - 2	Not specified
False	Y-602	Not specified
False	GV - 49	Not specified
False	Pipe - 50	Not specified
False	GV - 45	Not specified
False	GV - 1	Not specified
False	GV - 45	Not specified
False	Gradual - General Empirical Relationship - 46 - 124	Not specified
False	GV - 41	Not specified
False	GV - 0	Not specified
False	GV - 41	Not specified
False	Pipe - 194	Not specified
False	GV - 15	Not specified
False	GV - 11	Not specified
False	GV - 15	Not specified
False	British Standard Orifice - 281	Not specified
False	GV - 19	Not specified
False	Gradual - General Empirical Relationship - 46 - 5	Not specified
False	Pipe - 135	Not specified
False	Pipe - 283	Not specified
False	Gradual - General Empirical Relationship - 46 - 6	Not specified
False	Pipe - 123	Not specified
False	Pipe - 198	Not specified
		Not specified
False	Pipe - 316	Not specified

TABLE 54 CONTINUED: NODES INPUT - B

Geometry		
1		
Volume Fraction		
Specify	Description	Geometry specification
False	Gradual - General Empirical Relationship - 46 - 415	Not specified
		Not specified
False	Pipe - 217	Not specified
False	GV - 17	Not specified
False	TABV - 411	Not specified
False	GV - 336	Not specified
False	Pipe - 341	Not specified
False	E-618	Not specified
False	GV - 356	Not specified
False	Pipe - 355	Not specified
False	E-619	Not specified
False	Gradual - General Empirical Relationship - 46 - 410	Not specified
False	GV - 367	Not specified
False	Pipe - 366	Not specified
False	E-620	Not specified
False	General Empirical Relationship - 0	Not specified
False	Pipe - 147	Not specified
False	Gradual - General Empirical Relationship - 46 - 21	Not specified
False	Carrier 1	Not specified
False	E-102 (Tube Side)	Not specified
False	Pipe - 69	Not specified
False	GV - 410	Not specified
False	Pipe - 415	Not specified
False	GV - 422	Not specified
False	Pipe - 421	Not specified
		Not specified
False	GV - 430	Not specified
False	Pipe - 429	Not specified
		Not specified
False	E-618	Not specified
False	E-619	Not specified
False	E-620	Not specified
False	Y-603	Not specified
False	Gradual - General Empirical Relationship - 46 - 412	Not specified
False	Pipe - 89	Not specified
False	Pipe - 61	Not specified
False	Pipe - 93	Not specified
False	Gradual - General Empirical Relationship - 46 - 7	Not specified
False	Carrier 1	Not specified
False	Daikin 1	Not specified
False	Gradual - General Empirical Relationship - 46 - 414	Not specified

TABLE 54 CONTINUED: NODES INPUT - B

Geometry		
1		
Volume Fraction		
Specify	Description	Geometry specification
False	GV - 71	Not specified
False	Daikin 1	Not specified
False	Gradual - General Empirical Relationship - 46 - 415	Not specified
False	Pipe - 536	Not specified
False	Pipe - 40	Not specified
False	Pipe - 541	Not specified
False	Pipe - 20	Not specified
False	Basket Strainer 601	Not specified
False	P-601	Not specified
False	Gradual - General Empirical Relationship - 46 - 48	Not specified
False	Gradual - General Empirical Relationship - 46 - 7	Not specified
False	GV - 56	Not specified
False	GV - 220	Not specified
False	GV - 56	Not specified
False	Pipe - 67	Not specified
False	Pipe - 68	Not specified
False	GV - 248	Not specified
False	TABV - 667	Not specified
False	Y-603	Not specified
False	Pipe - 72	Not specified
		Not specified
False	Pipe - 84	Not specified
False	Pipe - 90	Not specified
False	Gradual - General Empirical Relationship - 46 - 34	Not specified
False	Pipe - 91	Not specified
False	GV - 30	Not specified
False	V-616	Not specified
False	Pipe - 92	Not specified
		Not specified
False	TABV - 36	Not specified
False	GV - 221	Not specified
False	TABV - 163	Not specified
		Not specified
		Not specified
False	Pipe - 409	Not specified
False	Pipe - 208	Not specified
		Not specified
False	Pipe - 94	Not specified
False	TABV - 35	Not specified
False	Pipe - 95	Not specified

TABLE 54 CONTINUED: NODES INPUT - B

Geometry		
1		
Volume Fraction		
Specify	Description	Geometry specification
False	Pipe - 142	Not specified
False	Pipe - 40	Not specified
False	TABV - 130	Not specified
False	GV - 212	Not specified
False	TABV - 130	Not specified
False	Basket Strainer 604	Not specified
False	GV - 212	Not specified
False	Basket Strainer 606	Not specified
False	GV - 213	Not specified
False	P-606	Not specified
False	GV - 213	Not specified
False	Gradual - General Empirical Relationship - 46 - 48	Not specified
False	TABV - 135	Not specified
False	GV - 219	Not specified
False	TABV - 135	Not specified
False	Pipe - 108	Not specified

TABLE 56: NODES INPUT - D

Boundary Conditions		Heat Transfer	Radial Pressure Gradient
Elevation boundary condition	Elevation (m)	Heat input (kW)	Radial pressure boundary condition
Specified	3.7	0	False
Specified	3.7	0	False
Specified	1.5	0	False
Specified	10.2376	0	False
Specified	10.2376	0	False
Specified	10.2376	0	False
Not specified		0	False
Not specified		0	False
Specified	1.5	0	False
Specified	4.83	0	False
Specified	1.5	0	False
Specified	2.6	0	False
Specified	1.5	0	False
Specified	1.33	0	False
Specified	1.5	0	False
Specified	1.5	0	False
Specified	10.2376	0	False
Specified	1.7	0	False
Specified	1.33	0	False
Specified	0	0	False
Specified	10.2376	0	False
Specified	1.33	0	False
Specified	4.83	0	False
Specified	1.27	0	False
Specified	1.33	0	False
Specified	10.2376	0	False
Specified	2.3	0	False
Specified	10.2376	0	False
Specified	2.3	0	False
Specified	1.9	0	False
Specified	1.5	0	False
Specified	1.5	0	False
Specified	1.5	0	False
Specified	3	0	False
Specified	4	0	False
Specified	1.33	0	False
Specified	4.83	0	False
Specified	1.33	0	False
Specified	1.27	0	False
Specified	1.33	0	False

TABLE 56 CONTINUED: NODES INPUT - D

Boundary Conditions		Heat Transfer	Radial Pressure Gradient
Elevation boundary condition	Elevation (m)	Heat input (kW)	Radial pressure boundary condition
Specified	1.27	0	False
Specified	1.27	0	False
Specified	1	0	False
Specified	1.5	0	False
Specified	2.5	0	False
Specified	1.33	0	False
Specified	1.5	0	False
Specified	12.73	0	False
Specified	1.33	0	False
Specified	1.5	0	False
Specified	2	0	False
Specified	1.5	0	False
Specified	1	0	False
Specified	1.5	0	False
Specified	12.23	0	False
Specified	11.23	0	False
Specified	2.7	0	False
Specified	1.5	0	False
Specified	1.5	0	False
Specified	2.3	0	False
Specified	3	0	False
Specified	3.7098	0	False
Specified	3.7098	0	False
Specified	2.4	0	False
Specified	3.7098	0	False
Specified	1.5	0	False
Specified	1.5	0	False
Specified	1.5	0	False
Specified	1.5	0	False
Specified	1.5	0	False
Specified	12.73	0	False
Specified	1.5	0	False
Specified	12.23	0	False
Specified	1.5	0	False
Specified	2	0	False
Specified	1.5	0	False
Specified	1.5	0	False
Specified	1.5	0	False
Specified	1.5	0	False
Specified	1.5	0	False
Specified	1.5	0	False
Specified	2	0	False
Specified	0	0	False

TABLE 56 CONTINUED: NODES INPUT - D

Boundary Conditions		Heat Transfer	Radial Pressure Gradient
Elevation boundary condition	Elevation (m)	Heat input (kW)	Radial pressure boundary condition
Specified	1.5	0	False
Not specified		0	False
Not specified		0	False
Specified	0.5	0	False
Specified	2.6	0	False
Specified	0	0	False
Specified	11	0	False
Specified	1.2	0	False
Specified	4	0	False
Specified	4	0	False
Specified	4	0	False
Specified	3.3	0	False
Specified	11.23	0	False
Specified	3.9	0	False
Specified	2.4	0	False
Specified	2.3	0	False
Specified	1.9	0	False
Specified	1.33	0	False
Specified	2.4	0	False
Specified	1.33	0	False
Specified	2.3	0	False
Specified	2.3	0	False
Specified	2.4	0	False
Specified	1.33	0	False
Specified	2.3	0	False
Specified	2.3	0	False
Specified	2.4	0	False
Not specified		0	False
Specified	1	0	False
Specified	1	0	False
Specified	1	0	False
Specified	4	0	False
Specified	1	0	False
Not specified		0	False
Specified	4	0	False
Specified	4	0	False
Not specified		0	False
Specified	4.83	0	False
Not specified		0	False
Not specified		0	False
Specified	1.5	0	False

TABLE 56 CONTINUED: NODES INPUT - D

Boundary Conditions		Heat Transfer	Radial Pressure Gradient
Elevation boundary condition	Elevation (m)	Heat input (kW)	Radial pressure boundary condition
Specified	12.23	0	False
Not specified		0	False
Specified	0	0	False
Specified	2.2	0	False
Specified	11	0	False
Specified	4.83	0	False
Specified	4.83	0	False
Specified	4.83	0	False
Specified	4.83	0	False
Specified	4.83	0	False
Specified	4.83	0	False
Specified	12.73	0	False
Specified	4.83	0	False
Specified	4.83	0	False
Specified	4.83	0	False
Not specified		0	False
Specified	1	0	False
Specified	2.2	0	False
Specified	9.53	0	False
Specified	3.3	0	False
Specified	3.7	0	False
Specified	4.83	0	False
Specified	4.83	0	False
Specified	4.83	0	False
Specified	4.83	0	False
Not specified		0	False
Specified	4.83	0	False
Specified	4.83	0	False
Not specified		0	False
Specified	4.83	0	False
Specified	4.83	0	False
Specified	4.83	0	False
Specified	1.27	0	False
Specified	12.73	0	False
Specified	12.73	0	False
Specified	1.5	0	False
Specified	11.23	0	False
Not specified		0	False
Specified	9.53	0	False
Specified	9.53	0	False
Specified	12.23	0	False

TABLE 56 CONTINUED: NODES INPUT - D

Boundary Conditions		Heat Transfer	Radial Pressure Gradient
Elevation boundary condition	Elevation (m)	Heat input (kW)	Radial pressure boundary condition
Specified	1.5	0	False
Specified	9.53	0	False
Specified	12.23	0	False
Specified	11	0	False
Specified	2.3	0	False
Specified	11	0	False
Specified	1.5	0	False
Specified	1.5	0	False
Specified	1.5	0	False
Not specified		0	False
Specified	1.5	0	False
Specified	1.5	0	False
Specified	10.2376	0	False
Specified	1.5	0	False
Specified	1.5	0	False
Specified	1.5	0	False
Specified	3.3	0	False
Specified	1.33	0	False
Specified	1.27	0	False
Specified	12.23	0	False
Specified	10.2376	0	False
Specified	2.8	0	False
Specified	1.33	0	False
Specified	1.8	0	False
Specified	1.9	0	False
Specified	1.5	0	False
Specified	2.1	0	False
Specified	2.2	0	False
Not specified		0	False
Specified	2.4	0	False
Specified	10.2376	0	False
Specified	3	0	False
Specified	10.2376	0	False
Not specified		0	False
Not specified		0	False
Specified	4.83	0	False
Specified	0	0	False
Not specified		0	False
Specified	12.23	0	False
Specified	1.27	0	False
Specified	11.23	0	False

TABLE 56 CONTINUED: NODES INPUT - D

Boundary Conditions		Heat Transfer		Radial Pressure Gradient	
Elevation boundary condition	Elevation (m)	Heat input (kW)	Radial pressure boundary condition		
Specified	4.83	0	False		
Specified	2.4	0	False		
Specified	1.5	0	False		
Specified	1.5	0	False		
Specified	1.5	0	False		
Specified	1.5	0	False		
Specified	1.5	0	False		
Specified	1.5	0	False		
Specified	1.5	0	False		
Specified	1.5	0	False		
Specified	1.5	0	False		
Specified	1.5	0	False		
Specified	1.5	0	False		
Specified	1.5	0	False		
Specified	10.2376	0	False		
Specified	1.5	0	False		
Specified	1.5	0	False		

PIPING

(44)

TABLE 57: PIPING INPUT - A

General			Connected Nodes		Fluids
Identifier	Solving	Description	Upstream node	Downstream node	Fluid Data Reference
Pipe - 0	True	30	Node - 1	T - Junction - 168	H2O - Water Liquids (Pure Fluids)
Pipe - 1	True	98	T - Junction - 118	Node - 2	H2O - Water Liquids (Pure Fluids)
Pipe - 10	True		Node - 12	T - Junction - 681	H2O - Water Liquids (Pure Fluids)
Pipe - 102	True		T - Junction - 118	Node - 87	H2O - Water Liquids (Pure Fluids)
Pipe - 108	True		Node - 98	Node - 99	H2O - Water Liquids (Pure Fluids)
Pipe - 109	True		Node - 100	Node - 129	H2O - Water Liquids (Pure Fluids)
Pipe - 110	True	1	Node - 3	T - Junction - 112	H2O - Water Liquids (Pure Fluids)
Pipe - 113	True		T - Junction - 112	T - Junction - 114	H2O - Water Liquids (Pure Fluids)
Pipe - 115	True		T - Junction - 114	T - Junction - 116	H2O - Water Liquids (Pure Fluids)
Pipe - 116	True	51	Node - 193	Node - 115	H2O - Water Liquids (Pure Fluids)
Pipe - 117	True		T - Junction - 116	T - Junction - 118	H2O - Water Liquids (Pure Fluids)
Pipe - 118	True	64	T - Junction - 168	Node - 131	H2O - Water Liquids (Pure Fluids)
Pipe - 119	True	89	Node - 123	T - Junction - 173	H2O - Water Liquids (Pure Fluids)
Pipe - 120	True	90	Node - 125	T - Junction - 37	H2O - Water Liquids (Pure Fluids)
Pipe - 121	True	91	Node - 126	T - Junction - 74	H2O - Water Liquids (Pure Fluids)
Pipe - 122	True	92	Node - 130	T - Junction - 88	H2O - Water Liquids (Pure Fluids)
Pipe - 123	True	127	Node - 133	Node - 290	H2O - Water Liquids (Pure Fluids)

TABLE 57 CONTINUED: PIPING INPUT - A

General			Connected Nodes		Fluids
Identifier	Solving	Description	Upstream node	Downstream node	Fluid Data Reference
Pipe - 124	True	132	Node - 135	Node - 120	H2O - Water Liquids (Pure Fluids)
Pipe - 126	True	212	Node - 151	T - Junction - 490	H2O - Water Liquids (Pure Fluids)
Pipe - 131	True	111	Node - 132	Node - 134	H2O - Water Liquids (Pure Fluids)
Pipe - 135	True	93	Node - 280	Node - 275	H2O - Water Liquids (Pure Fluids)
Pipe - 137	True	66	Node - 131	Node - 139	H2O - Water Liquids (Pure Fluids)
Pipe - 141	True	1	T - Junction - 112	Node - 145	H2O - Water Liquids (Pure Fluids)
Pipe - 142	True	115	Node - 144	Node - 85	H2O - Water Liquids (Pure Fluids)
Pipe - 147	True	76	Node - 38	T - Junction - 40	H2O - Water Liquids (Pure Fluids)
Pipe - 152	True	77	T - Junction - 227	Node - 154	H2O - Water Liquids (Pure Fluids)
Pipe - 156	True	79	Node - 158	Node - 155	H2O - Water Liquids (Pure Fluids)
Pipe - 167	True	169	Node - 168	T - Junction - 166	H2O - Water Liquids (Pure Fluids)
Pipe - 169	True	170	T - Junction - 141	Node - 170	H2O - Water Liquids (Pure Fluids)
Pipe - 170	True		T - Junction - 16	Node - 80	H2O - Water Liquids (Pure Fluids)
Pipe - 171	True		Node - 162	Node - 159	H2O - Water Liquids (Pure Fluids)
Pipe - 172	True		Node - 159	Node - 56	H2O - Water Liquids (Pure Fluids)
Pipe - 174	True		T - Junction - 12	T - Junction - 15	H2O - Water Liquids (Pure Fluids)
Pipe - 175	True		Node - 159	Node - 75	H2O - Water Liquids (Pure Fluids)
Pipe - 177	True		Reservoir - 209	Node - 88	H2O - Water Liquids (Pure Fluids)
Pipe - 178	True		Node - 90	T - Junction - 12	H2O - Water Liquids (Pure Fluids)
Pipe - 179	True		Reservoir - 209	Node - 92	H2O - Water Liquids (Pure Fluids)
Pipe - 180	True		Node - 94	T - Junction - 12	H2O - Water Liquids (Pure Fluids)
Pipe - 181	True		T - Junction - 18	T - Junction - 16	H2O - Water Liquids (Pure Fluids)
Pipe - 182	True		Node - 161	Node - 157	H2O - Water Liquids (Pure Fluids)
Pipe - 183	True	14	Node - 184	Node - 190	H2O - Water Liquids (Pure Fluids)
Pipe - 184	True		Node - 157	Node - 97	H2O - Water Liquids (Pure Fluids)
Pipe - 186	True		T - Junction - 13	T - Junction - 17	H2O - Water Liquids (Pure Fluids)
Pipe - 187	True		T - Junction - 15	T - Junction - 13	H2O - Water Liquids (Pure Fluids)
Pipe - 188	True		Node - 157	Node - 102	H2O - Water Liquids (Pure Fluids)
Pipe - 190	True		Reservoir - 210	Node - 106	H2O - Water Liquids (Pure Fluids)
Pipe - 191	True		Node - 108	T - Junction - 15	H2O - Water Liquids (Pure Fluids)
Pipe - 192	True		Reservoir - 210	Node - 112	H2O - Water Liquids (Pure Fluids)
Pipe - 193	True		Node - 113	T - Junction - 13	H2O - Water Liquids (Pure Fluids)
Pipe - 194	True		Node - 26	T - Junction - 18	H2O - Water Liquids (Pure Fluids)
Pipe - 195	True		Node - 160	Node - 156	H2O - Water Liquids (Pure Fluids)
Pipe - 196	True		Node - 156	Node - 114	H2O - Water Liquids (Pure Fluids)
Pipe - 198	True		T - Junction - 14	Node - 3	H2O - Water Liquids (Pure Fluids)
Pipe - 199	True		T - Junction - 17	T - Junction - 14	H2O - Water Liquids (Pure Fluids)
Pipe - 2	True	177	T - Junction - 0	Node - 21	H2O - Water Liquids (Pure Fluids)
Pipe - 20	True		T - Junction - 114	Node - 5	H2O - Water Liquids (Pure Fluids)
Pipe - 200	True		Node - 156	Node - 122	H2O - Water Liquids (Pure Fluids)
Pipe - 202	True		Reservoir - 211	Node - 142	H2O - Water Liquids (Pure Fluids)
Pipe - 203	True		Node - 147	T - Junction - 17	H2O - Water Liquids (Pure Fluids)

TABLE 57 CONTINUED: PIPING INPUT - A

General			Connected Nodes		Fluids
Identifier	Solving	Description	Upstream node	Downstream node	Fluid Data Reference
Pipe - 204	True		Reservoir - 211	Node - 149	H2O - Water Liquids (Pure Fluids)
Pipe - 205	True		Node - 152	T - Junction - 14	H2O - Water Liquids (Pure Fluids)
Pipe - 206	True		T - Junction - 18	Node - 160	H2O - Water Liquids (Pure Fluids)
Pipe - 207	True		T - Junction - 16	Node - 161	H2O - Water Liquids (Pure Fluids)
Pipe - 208	True		Node - 80	Node - 162	H2O - Water Liquids (Pure Fluids)
Pipe - 217	True	21	Node - 327	T - Junction - 167	H2O - Water Liquids (Pure Fluids)
Pipe - 218	True	31	T - Junction - 167	Node - 191	H2O - Water Liquids (Pure Fluids)
Pipe - 222	True	40	T - Junction - 169	Node - 193	H2O - Water Liquids (Pure Fluids)
Pipe - 223	True	32	T - Junction - 169	Node - 185	H2O - Water Liquids (Pure Fluids)
Pipe - 226	True	31b	Node - 192	T - Junction - 169	H2O - Water Liquids (Pure Fluids)
Pipe - 233	True	44	Node - 193	Node - 200	H2O - Water Liquids (Pure Fluids)
Pipe - 234	True	82	T - Junction - 227	Node - 228	H2O - Water Liquids (Pure Fluids)
Pipe - 235	True	83	Node - 230	Node - 229	H2O - Water Liquids (Pure Fluids)
Pipe - 237	True	60	T - Junction - 172	T - Junction - 170	H2O - Water Liquids (Pure Fluids)
Pipe - 238	True	61	T - Junction - 170	Node - 207	H2O - Water Liquids (Pure Fluids)
Pipe - 239	True	63	Node - 208	T - Junction - 168	H2O - Water Liquids (Pure Fluids)
Pipe - 240	True	50	Node - 209	T - Junction - 172	H2O - Water Liquids (Pure Fluids)
Pipe - 241	True	57	Node - 212	Node - 205	H2O - Water Liquids (Pure Fluids)
Pipe - 250	True	84	T - Junction - 40	T - Junction - 245	H2O - Water Liquids (Pure Fluids)
Pipe - 251	True	85	T - Junction - 245	Node - 246	H2O - Water Liquids (Pure Fluids)
Pipe - 252	True	86	Node - 248	Node - 247	H2O - Water Liquids (Pure Fluids)
Pipe - 26	True		Node - 16	Node - 17	H2O - Water Liquids (Pure Fluids)
Pipe - 261	True	87	T - Junction - 245	Node - 257	H2O - Water Liquids (Pure Fluids)
Pipe - 263	True	88	Node - 259	Node - 258	H2O - Water Liquids (Pure Fluids)
Pipe - 267	True	72	Node - 268	Node - 146	H2O - Water Liquids (Pure Fluids)
Pipe - 27	True		Node - 18	T - Junction - 310	H2O - Water Liquids (Pure Fluids)
Pipe - 278	True	74	Node - 148	Node - 279	H2O - Water Liquids (Pure Fluids)
Pipe - 28	True	23	T - Junction - 167	Node - 176	H2O - Water Liquids (Pure Fluids)
Pipe - 283	True	95	Node - 284	T - Junction - 285	H2O - Water Liquids (Pure Fluids)
Pipe - 286	True	96	T - Junction - 285	Node - 26	H2O - Water Liquids (Pure Fluids)
Pipe - 289	True	97	Node - 290	T - Junction - 285	H2O - Water Liquids (Pure Fluids)
Pipe - 29	True	128	T - Junction - 73	Node - 37	H2O - Water Liquids (Pure Fluids)
Pipe - 3	True		Node - 127	Node - 128	H2O - Water Liquids (Pure Fluids)
Pipe - 30	True	193	Node - 31	T - Junction - 85	H2O - Water Liquids (Pure Fluids)
Pipe - 316	True		Node - 303	T - Junction - 310	H2O - Water Liquids (Pure Fluids)
Pipe - 322	True		T - Junction - 310	T - Junction - 311	H2O - Water Liquids (Pure Fluids)
Pipe - 324	True		T - Junction - 311	Node - 127	H2O - Water Liquids (Pure Fluids)
Pipe - 325	True		Node - 128	Node - 327	H2O - Water Liquids (Pure Fluids)
Pipe - 326	True	167	T - Junction - 683	T - Junction - 166	H2O - Water Liquids (Pure Fluids)
Pipe - 335	True	159	Node - 340	Node - 12	H2O - Water Liquids (Pure Fluids)
Pipe - 341	True	157	Node - 344	Node - 342	H2O - Water Liquids (Pure Fluids)
Pipe - 348	True	145	T - Junction - 141	T - Junction - 437	H2O - Water Liquids (Pure Fluids)

TABLE 57 CONTINUED: PIPING INPUT - A

General			Connected Nodes		Fluids
Identifier	Solving	Description	Upstream node	Downstream node	Fluid Data Reference
Pipe - 354	True	162	Node - 351	T - Junction - 681	H2O - Water Liquids (Pure Fluids)
Pipe - 355	True	160	Node - 353	Node - 352	H2O - Water Liquids (Pure Fluids)
Pipe - 365	True	165	Node - 362	T - Junction - 683	H2O - Water Liquids (Pure Fluids)
Pipe - 366	True	163	Node - 364	Node - 363	H2O - Water Liquids (Pure Fluids)
Pipe - 39	True		T - Junction - 40	T - Junction - 227	H2O - Water Liquids (Pure Fluids)
Pipe - 4	True		Node - 129	Node - 128	H2O - Water Liquids (Pure Fluids)
Pipe - 40	True	122b	Node - 49	Node - 86	H2O - Water Liquids (Pure Fluids)
Pipe - 409	True	153	Node - 8	Node - 414	H2O - Water Liquids (Pure Fluids)
Pipe - 415	True	155	Node - 416	Node - 434	H2O - Water Liquids (Pure Fluids)
Pipe - 419	True	150	T - Junction - 438	Node - 417	H2O - Water Liquids (Pure Fluids)
Pipe - 421	True	152	Node - 418	Node - 435	H2O - Water Liquids (Pure Fluids)
Pipe - 428	True	146	T - Junction - 437	Node - 426	H2O - Water Liquids (Pure Fluids)
Pipe - 429	True	148	Node - 427	Node - 436	H2O - Water Liquids (Pure Fluids)
Pipe - 442	True	149	T - Junction - 437	T - Junction - 438	H2O - Water Liquids (Pure Fluids)
Pipe - 48	True	105	Node - 110	Node - 116	H2O - Water Liquids (Pure Fluids)
Pipe - 488	True	125	T - Junction - 490	Node - 107	H2O - Water Liquids (Pure Fluids)
Pipe - 49	True	107	Node - 119	Node - 121	H2O - Water Liquids (Pure Fluids)
Pipe - 5	True		T - Junction - 438	Node - 8	H2O - Water Liquids (Pure Fluids)
Pipe - 50	True	109	Node - 24	Node - 25	H2O - Water Liquids (Pure Fluids)
Pipe - 502	True	209	Node - 36	T - Junction - 420	H2O - Water Liquids (Pure Fluids)
Pipe - 503	True	168	T - Junction - 166	T - Junction - 490	H2O - Water Liquids (Pure Fluids)
Pipe - 51	True	113	Node - 136	Node - 141	H2O - Water Liquids (Pure Fluids)
Pipe - 512	True	200	Node - 472	Node - 34	H2O - Water Liquids (Pure Fluids)
Pipe - 513	True	210	T - Junction - 420	Node - 168	H2O - Water Liquids (Pure Fluids)
Pipe - 515	True	190	Node - 455	T - Junction - 420	H2O - Water Liquids (Pure Fluids)
Pipe - 520	True	144	Node - 140	T - Junction - 141	H2O - Water Liquids (Pure Fluids)
Pipe - 525	True	181	Node - 471	Node - 20	H2O - Water Liquids (Pure Fluids)
Pipe - 531	True	174	Node - 478	T - Junction - 0	H2O - Water Liquids (Pure Fluids)
Pipe - 536	True	198	Node - 488	Node - 480	H2O - Water Liquids (Pure Fluids)
Pipe - 539	True	191	T - Junction - 421	Node - 487	H2O - Water Liquids (Pure Fluids)
Pipe - 541	True	179	Node - 493	Node - 4	H2O - Water Liquids (Pure Fluids)
Pipe - 584	True	171	Node - 170	T - Junction - 421	H2O - Water Liquids (Pure Fluids)
Pipe - 6	True		T - Junction - 421	Node - 15	H2O - Water Liquids (Pure Fluids)
Pipe - 61	True		T - Junction - 116	Node - 46	H2O - Water Liquids (Pure Fluids)
Pipe - 67	True		Node - 57	Node - 58	H2O - Water Liquids (Pure Fluids)
Pipe - 68	True		Node - 59	T - Junction - 311	H2O - Water Liquids (Pure Fluids)
Pipe - 682	True	166	T - Junction - 681	T - Junction - 683	H2O - Water Liquids (Pure Fluids)
Pipe - 69	True	39	Node - 41	T - Junction - 170	H2O - Water Liquids (Pure Fluids)
Pipe - 70	True	205	Node - 64	Node - 143	H2O - Water Liquids (Pure Fluids)
Pipe - 71	True	202	Node - 150	Node - 64	H2O - Water Liquids (Pure Fluids)
Pipe - 72	True	203	T - Junction - 85	Node - 64	H2O - Water Liquids (Pure Fluids)
Pipe - 84	True	116	Node - 85	Node - 66	H2O - Water Liquids (Pure Fluids)

TABLE 57 CONTINUED: PIPING INPUT - A

General			Connected Nodes		Fluids
Identifier	Solving	Description	Upstream node	Downstream node	Fluid Data Reference
Pipe - 85	True	130	Node - 117	Node - 83	H2O - Water Liquids (Pure Fluids)
Pipe - 86	True	101	T - Junction - 73	Node - 61	H2O - Water Liquids (Pure Fluids)
Pipe - 87	True	134	Node - 137	Node - 45	H2O - Water Liquids (Pure Fluids)
Pipe - 88	True	136	Node - 62	Node - 138	H2O - Water Liquids (Pure Fluids)
Pipe - 89	True	186	Node - 82	Node - 456	H2O - Water Liquids (Pure Fluids)
Pipe - 9	True	100	Node - 19	T - Junction - 73	H2O - Water Liquids (Pure Fluids)
Pipe - 90	True	138	Node - 67	Node - 68	H2O - Water Liquids (Pure Fluids)
Pipe - 91	True	140	Node - 69	Node - 71	H2O - Water Liquids (Pure Fluids)
Pipe - 92	True	142	Node - 72	Node - 74	H2O - Water Liquids (Pure Fluids)
Pipe - 93	True	183	Node - 469	Node - 82	H2O - Water Liquids (Pure Fluids)
Pipe - 94	True	184	T - Junction - 0	Node - 82	H2O - Water Liquids (Pure Fluids)
Pipe - 95	True	196	T - Junction - 85	Node - 84	H2O - Water Liquids (Pure Fluids)

TABLE 58: PIPING INPUT - B

Geometry			Geometry		
Geometry option	Wall thickness (mm)	Length (m)	Options		Inlet
			Cross sectional option	Variable area	Diameter (m)
Specify geometry	10.3	0.3	Diameter	False	0.3
Specify geometry	17.4	1	Diameter	False	0.6
Specify geometry	5.4864	3.6	Diameter	False	0.08
Specify geometry	12.7	1.5	Diameter	False	0.4
Specify geometry	10.31	2	Diameter	False	0.3
Specify geometry	15.0	2.9	Diameter	False	0.5
Specify geometry	17.4	51.5	Diameter	False	0.6
Specify geometry	17.4	2.8	Diameter	False	0.6
Specify geometry	17.4	2.8	Diameter	False	0.6
Specify geometry	10.3	1.7	Diameter	False	0.3
Specify geometry	17.4	3.1	Diameter	False	0.6
Specify geometry	15.0	17.9	Diameter	False	0.5
Specify geometry	5.1562	0.1	Diameter	False	0.065
Specify geometry	5.1562	0.1	Diameter	False	0.065
Specify geometry	5.1562	0.1	Diameter	False	0.065
Specify geometry	5.1562	0.1	Diameter	False	0.065
Specify geometry	8.1788	11	Diameter	False	0.2
Specify geometry	7.112	0.2	Diameter	False	0.15
Specify geometry	7.112	48	Diameter	False	0.15
Specify geometry	7.112	0.1	Diameter	False	0.15
Specify geometry	15.0	7.5	Diameter	False	0.5
Specify geometry	5	3	Diameter	False	0.1
Specify geometry	12.7	1.5	Diameter	False	0.4
Specify geometry	7.112	50.327	Diameter	False	0.15
Specify geometry	5.1562	1	Diameter	False	0.065
Specify geometry	5.1562	0.5	Diameter	False	0.065
Specify geometry	5.1562	28	Diameter	False	0.065
Specify geometry	7.112	23.4	Diameter	False	0.15
Specify geometry	7.112	24.2	Diameter	False	0.15
Specify geometry	0.01508	16.4846	Diameter	False	0.5
Specify geometry	0.01508	2.2098	Diameter	False	0.63
Specify geometry	12.7	6.5278	Diameter	False	0.47
Specify geometry	0.01747	8.7884	Diameter	False	0.6
Specify geometry	12.7	6.5278	Diameter	False	0.47
Specify geometry	12.7	3.8	Diameter	False	0.4
Specify geometry	0.0127	10.6962	Diameter	False	0.4
Specify geometry	12.7	3.8	Diameter	False	0.4
Specify geometry	12.7	3	Diameter	False	0.4
Specify geometry	0.01508	18.7846	Diameter	False	0.5
Specify geometry	0.01508	2.2098	Diameter	False	0.63
Specify geometry	10.31	3.8	Diameter	False	0.3
Specify geometry	12.7	6.5278	Diameter	False	0.47

TABLE 58 CONTINUED: PIPING INPUT - B

Geometry			Geometry		
Geometry option	Wall thickness (mm)	Length (m)	Options		Inlet
			Cross sectional option	Variable area	Diameter (m)
Specify geometry	17.4	11.0884	Diameter	False	0.6
Specify geometry	0.01747	7.6962	Diameter	False	0.6
Specify geometry	12.7	6.5278	Diameter	False	0.47
Specify geometry	12.7	3.8	Diameter	False	0.4
Specify geometry	12.7	3	Diameter	False	0.4
Specify geometry	12.7	3.8	Diameter	False	0.4
Specify geometry	12.7	3	Diameter	False	0.4
Specify geometry	0.01508	2	Diameter	False	0.5
Specify geometry	0.01508	2.2098	Diameter	False	0.63
Specify geometry	12.7	6.5278	Diameter	False	0.47
Specify geometry	0.01747	2	Diameter	False	0.6
Specify geometry	17.4	7.6962	Diameter	False	0.6
Specify geometry	5.4864	2.2	Diameter	False	0.08
Specify geometry	12.7	1.5	Diameter	False	0.4
Specify geometry	12.7	6.5278	Diameter	False	0.47
Specify geometry	12.7	3.8	Diameter	False	0.4
Specify geometry	12.7	3	Diameter	False	0.4
Specify geometry	12.7	3.8	Diameter	False	0.4
Specify geometry	12.7	3	Diameter	False	0.4
Specify geometry	0.01508	2	Diameter	False	0.5
Specify geometry	0.01508	2	Diameter	False	0.5
Specify geometry	0.01508	2	Diameter	False	0.5
Specify geometry	15.08	1.9	Diameter	False	0.5
Specify geometry	15.087	1	Diameter	False	0.5
Specify geometry	10.3	2.86	Diameter	False	0.45
Specify geometry	10.3	2	Diameter	False	0.3
Specify geometry	14.274	481	Diameter	False	0.45
Specify geometry	10.3	0.7	Diameter	False	0.3
Specify geometry	5.1562	0.5	Diameter	False	0.065
Specify geometry	5.1562	28	Diameter	False	0.065
Specify geometry	14.2	1	Diameter	False	0.45
Specify geometry	10.3	0.3	Diameter	False	0.45
Specify geometry	15.0	1.181	Diameter	False	0.5
Specify geometry	10.3	1	Diameter	False	0.3
Specify geometry	10.3	0.5	Diameter	False	0.3
Specify geometry	5.1562	0.2	Diameter	False	0.065
Specify geometry	5.1562	0.5	Diameter	False	0.065
Specify geometry	5.1562	28	Diameter	False	0.065
Specify geometry	10.31	2000	Diameter	False	0.3
Specify geometry	5.1562	0.5	Diameter	False	0.065
Specify geometry	5.1562	28	Diameter	False	0.065
Specify geometry	5.1562	1	Diameter	False	65

TABLE 58 CONTINUED: PIPING INPUT - B

Geometry			Geometry		
Geometry option	Wall thickness (mm)	Length (m)	Options		Inlet
			Cross sectional option	Variable area	Diameter (m)
Specify geometry	15.0	2	Diameter	False	0.5
Specify geometry	5.1562	0.5	Diameter	False	0.065
Specify geometry	10.3	2	Diameter	False	0.3
Specify geometry	15.087	2.8	Diameter	False	0.5
Specify geometry	0.01508	45.6	Diameter	False	0.5
Specify geometry	8.1788	17.5	Diameter	False	0.2
Specify geometry	12.7	1.4	Diameter	False	0.4
Specify geometry	15.0	707.107	Diameter	False	0.5
Specify geometry	5.4864	7	Diameter	False	0.08
Specify geometry	15.0	1	Diameter	False	0.5
Specify geometry	15.0	2.8	Diameter	False	0.5
Specify geometry	15.0	0.9	Diameter	False	0.5
Specify geometry	15.0	2.5	Diameter	False	0.5
Specify geometry	5.4864	3	Diameter	False	0.08
Specify geometry	3.3782	7	Diameter	False	0.0254
Specify geometry	3.3782	1	Diameter	False	0.0254
Specify geometry	5.4864	3	Diameter	False	0.08
Specify geometry	3.3782	7	Diameter	False	0.0254
Specify geometry	3.3782	1	Diameter	False	0.0254
Specify geometry	3.3782	7	Diameter	False	0.0254
Specify geometry	3.3782	1	Diameter	False	0.0254
Specify geometry	5.1562	0.2	Diameter	False	0.065
Specify geometry	15.0	707.107	Diameter	False	0.5
Specify geometry	7.112	0.1	Diameter	False	0.15
Specify geometry	3.3782	7	Diameter	False	0.0254
Specify geometry	3.3782	1	Diameter	False	0.0254
Specify geometry	3.3782	7	Diameter	False	0.0254
Specify geometry	3.3782	1	Diameter	False	0.0254
Specify geometry	3.3782	7	Diameter	False	0.0254
Specify geometry	3.3782	1	Diameter	False	0.0254
Specify geometry	5.4864	3.6	Diameter	False	0.08
Specify geometry	8.1788	0.1	Diameter	False	0.2
Specify geometry	7.122	13	Diameter	False	0.15
Specify geometry	6.0198	0.2	Diameter	False	0.125
Specify geometry	5.4864	3.6	Diameter	False	0.08
Specify geometry	6.0198	0.2	Diameter	False	0.1
Specify geometry	7.112	0.01	Diameter	False	0.15
Specify geometry	5.4864	2	Diameter	False	0.15
Specify geometry	7.112	1.3	Diameter	False	0.15
Specify geometry	5.4864	1.47	Diameter	False	0.08
Specify geometry	7.112	3.3	Diameter	False	0.15
Specify geometry	7.112	1	Diameter	False	0.15

TABLE 58 CONTINUED: PIPING INPUT - B

Geometry			Geometry		
Geometry option	Wall thickness (mm)	Length (m)	Options		Inlet
			Cross sectional option	Variable area	Diameter (m)
Specify geometry	7.122	25	Diameter	False	0.15
Specify geometry	5.4864	1.47	Diameter	False	0.08
Specify geometry	5.4864	1.2	Diameter	False	0.08
Specify geometry	5.4864	1.47	Diameter	False	0.08
Specify geometry	7.112	0.01	Diameter	False	0.15
Specify geometry	5.4864	2	Diameter	False	0.08
Specify geometry	7.112	3.3	Diameter	False	0.15
Specify geometry	7.112	1	Diameter	False	0.15
Specify geometry	12.7	1.5	Diameter	False	0.4
Specify geometry	10.31	2000	Diameter	False	0.3
Specify geometry	15.0	2	Diameter	False	0.5
Specify geometry	5.4864	3.6	Diameter	False	0.08
Specify geometry	10.3	0.3	Diameter	False	0.3
Specify geometry	5.4864	7	Diameter	False	0.08
Specify geometry	5.4864	2	Diameter	False	0.08
Specify geometry	5.4864	1	Diameter	False	0.08
Specify geometry	7.112	14.2	Diameter	False	0.15
Specify geometry	7.112	2.2	Diameter	False	0.15
Specify geometry	8.1788	2.5	Diameter	False	0.2
Specify geometry	5.48	0.15	Diameter	False	0.08
Specify geometry	5.4864	0.15	Diameter	False	0.08
Specify geometry	5.4864	1.2	Diameter	False	0.08
Specify geometry	12.7	1.3	Diameter	False	0.4
Specify geometry	5.4864	0.47	Diameter	False	0.08
Specify geometry	7.112	0.2	Diameter	False	0.15
Specify geometry	7.112	0.35	Diameter	False	0.15
Specify geometry	5.4864	2.2	Diameter	False	0.08
Specify geometry	5.4864	1	Diameter	False	0.08
Specify geometry	5.4864	1.5	Diameter	False	0.08

TABLE 60: PIPING INPUT - D

Losses		Discretisation	
Different reverse & forward K values	K forward	Number of increments	Number in parallel
False	0	1	1
False	0	1	1
False	0	1	1
False	0.182	1	1
False	0	1	1
False	0.182	1	1
False	0.504	1	1
False	0	1	1
False	0	1	1
False	0.50925	1	1
False	0	1	1
False	0.336	1	1
False	0	1	1
False	0	1	1
False	0	1	1
False	0	1	1
False	0	1	1
False	0	1	1
False	1.267937008	1	1
False	0	1	1
False	0	1	1
False	0	1	1
False	0.182	1	1
False	0.845291339	1	1
False	0.504	1	1
False	0.252	1	1
False	1.26	1	1
False	1.267937008	1	1
False	1.267937008	1	1
False	0.24	1	1
False	0	1	1
False	0	1	1
False	0	1	1
False	0	1	1
False	0	1	1
False	0.455	1	1
False	0	1	1
False	0.195	1	1
False	0	1	1
False	0	1	1
False	0.183322835	1	1
False	0	1	1

TABLE 60 CONTINUED: PIPING INPUT - D

Losses		Discretisation	
Different reverse & forward K values	K forward	Number of increments	Number in parallel
False	0	1	1
False	0	1	1
False	0	1	1
False	0	1	1
False	0.195	1	1
False	0	1	1
False	0.195	1	1
False	0	1	1
False	0	1	1
False	0	1	1
False	0	1	1
False	0	1	1
False	0	1	1
False	0.714015748	1	1
False	0.182	1	1
False	0	1	1
False	0	1	1
False	0.195	1	1
False	0.5	1	1
False	0.195	1	1
False	0.18	1	1
False	0.18	1	1
False	0.18	1	1
False	0.168	1	1
False	0	1	1
False	0.169984252	1	1
False	0	1	1
False	0.183322835	1	1
False	0.6387723	1	1
False	0.252	1	1
False	1.26	1	1
False	0	1	1
False	0	1	1
False	0	1	1
False	0	1	1
False	0.129778836	1	1
False	0.252	1	1
False	0.252	1	1
False	1.26	1	1
False	0	1	1
False	0.252	1	1
False	1.26	1	1
False	0	1	1

TABLE 61 CONTINUED: PIPING INPUT - E

Orifice	Heat Transfer		Heat Transfer
	Heat option	Heat input (kW)	Heat Distribution Curve
Orifice diameter ratio			Use heat distribution curve
1	Fixed heat transfer	0	False
1	Fixed heat transfer	0	False
1	Fixed heat transfer	0	False
1	Fixed heat transfer	0	False
1	Fixed heat transfer	0	False
1	Fixed heat transfer	0	False
1	Fixed heat transfer	0	False
1	Fixed heat transfer	0	False
1	Fixed heat transfer	0	False
1	Fixed heat transfer	0	False
1	Fixed heat transfer	0	False
1	Fixed heat transfer	0	False
1	Fixed heat transfer	0	False
1	Fixed heat transfer	0	False
0.000001	Fixed heat transfer	0	False
0.000001	Fixed heat transfer	0	False
1	Fixed heat transfer	0	False
1	Fixed heat transfer	0	False
1	Fixed heat transfer	0	False
1	Fixed heat transfer	0	False
1	Fixed heat transfer	0	False
1	Fixed heat transfer	0	False
1	Fixed heat transfer	0	False
0.871382275	Fixed heat transfer	0	False
1	Fixed heat transfer	0	False
1	Fixed heat transfer	0	False
1	Fixed heat transfer	0	False
1	Fixed heat transfer	0	False
1	Fixed heat transfer	0	False
0.000001	Fixed heat transfer	0	False
1	Fixed heat transfer	0	False

RESERVOIRS

(44)

TABLE 64: RESERVOIR INPUT - A

General			Geometry			
			0		1	
			Volume Fraction		Volume Fraction	
Identifier	Solving	Description	Specify	Description	Specify	Description
Reservoir - 209	True		False	Pipe - 179	False	Pipe - 177
Reservoir - 210	True		False	Pipe - 192	False	Pipe - 190
Reservoir - 211	True		False	Pipe - 204	False	Pipe - 202

TABLE 65: RESERVOIR INPUT - B

Geometry				
Geometry option	Vessel shape	Volume (m ³)	Diameter (m)	Cylinder has endcaps
Specify volume	Cylindrical vertical	341	13.14	False
Specify volume	Cylindrical vertical	341	13.14	False
Specify volume	Cylindrical vertical	341	13.14	False

TABLE 66: RESERVOIR INPUT - C

Fluids	Boundary Conditions		Heat Transfer
Fluid Data Reference	Elevation boundary condition	Elevation (m)	Heat input (kW)
H2O - Water Liquids (Pure Fluids)	Specified	3.294344414	0
H2O - Water Liquids (Pure Fluids)	Specified	3.259969598	0
H2O - Water Liquids (Pure Fluids)	Specified	3.222586277	0

NON-RETURN VALVES

(44) (93)

TABLE 67: NON-RETURN VALVE INPUT - A

General			Connected Nodes	
Identifier	Solving	Description	Upstream node	Downstream node
V-601	True	NON-RETURN VALVE	Node - 54	Node - 55
V-609	True	NON-RETURN VALVE	Node - 134	Node - 136
V-616	True	NON-RETURN VALVE	Node - 71	Node - 72
V-621	True	NON-RETURN VALVE	Node - 13	Node - 14
V-628	True	NON-RETURN VALVE	Node - 177	Node - 179
V-675	True	NON-RETURN VALVE	Node - 95	Node - 96

TABLE 68: NON-RETURN VALVE INPUT - B

Fluids	Valve geometry	
Fluid Data Reference	Valve diameter (m)	Number in parallel
H2O - Water Liquids (Pure Fluids)	0.3	1
H2O - Water Liquids (Pure Fluids)	0.15	1
H2O - Water Liquids (Pure Fluids)	0.15	1
H2O - Water Liquids (Pure Fluids)	0.3	1
H2O - Water Liquids (Pure Fluids)	0.3	1
H2O - Water Liquids (Pure Fluids)	0.3	1

TABLE 69: NON-RETURN VALVE INPUT - C

Valve flow characteristics	
Cv Kv at maximum opening (m ³ /sqrt(Pa).s)	
	0.006408421
	0.001542276
	0.001543795
	0.006408421
	0.006408421
	0.006408421

TABLE 70: NON-RETURN VALVE INPUT - D

Valve flow characteristics	
Minimum closing pressure differential (Transient only) (kPa)	
	0
	0
	0
	0
	0
	0
	0

TABLE 71: NON-RETURN VALVE INPUT - E

Valve flow characteristics	
Minimum opening pressure differential (Transient only) (kPa)	
	0
	0
	0
	0
	0
	0
	0

TABLE 72: NON-RETURN VALVE INPUT - E

Valve flow characteristics	
Valve flow characteristics	Check valve steady-state specification
Time for valve to fully open/close (s)	Steady-state opening option
0	Specify opening
0	Calculate open/close
0	Calculate open/close
0	Specify opening
0	Specify opening
0	Specify opening

TABLE 73: NON-RETURN VALVE INPUT - F

Valve flow characteristics	Momentum Addition
Check valve steady-state specification	
Steady-state opening (0-1)	Momentum addition
1	False
	False
	False
1	False
1	False
1	False

CONTROL VALVES WITH ITERATIVE SCRIPT

(44) (93)

TABLE 74: CONTROL VALVE WITH ITERATIVE SCRIPT INPUT - A

General			Connected Nodes		Fluids
Identifier	Solving	Description	Upstream node	Downstream node	Fluid Data Reference
GV - 0	True		Node - 258	Node - 123	H2O - Water Liquids (Pure Fluids)
GV - 1	True		Node - 247	Node - 125	H2O - Water Liquids (Pure Fluids)
GV - 11	True		Node - 139	Node - 271	H2O - Water Liquids (Pure Fluids)
GV - 15	True		Node - 273	Node - 268	H2O - Water Liquids (Pure Fluids)
GV - 17	True		Node - 227	Node - 33	H2O - Water Liquids (Pure Fluids)
GV - 184	True		Node - 66	Node - 194	H2O - Water Liquids (Pure Fluids)
GV - 19	True		Node - 279	Node - 38	H2O - Water Liquids (Pure Fluids)
GV - 2	True		Node - 229	Node - 126	H2O - Water Liquids (Pure Fluids)
GV - 212	True		Node - 88	Node - 90	H2O - Water Liquids (Pure Fluids)
GV - 213	True		Node - 92	Node - 94	H2O - Water Liquids (Pure Fluids)
GV - 214	True		Node - 106	Node - 108	H2O - Water Liquids (Pure Fluids)
GV - 215	True		Node - 112	Node - 113	H2O - Water Liquids (Pure Fluids)
GV - 216	True		Node - 142	Node - 147	H2O - Water Liquids (Pure Fluids)
GV - 217	True		Node - 149	Node - 152	H2O - Water Liquids (Pure Fluids)
GV - 218	True		Node - 114	Node - 118	H2O - Water Liquids (Pure Fluids)
GV - 219	True		Node - 97	Node - 101	H2O - Water Liquids (Pure Fluids)
GV - 220	True		Node - 56	Node - 65	H2O - Water Liquids (Pure Fluids)
GV - 221	True		Node - 75	Node - 77	H2O - Water Liquids (Pure Fluids)
GV - 222	True		Node - 102	Node - 103	H2O - Water Liquids (Pure Fluids)
GV - 223	True		Node - 122	Node - 124	H2O - Water Liquids (Pure Fluids)
GV - 248	True		Node - 6	Node - 1	H2O - Water Liquids (Pure Fluids)
GV - 3	True		Node - 155	Node - 130	H2O - Water Liquids (Pure Fluids)
GV - 30	True		Node - 5	Node - 7	H2O - Water Liquids (Pure Fluids)
GV - 336	True		Node - 342	Node - 340	H2O - Water Liquids (Pure Fluids)
GV - 356	True		Node - 352	Node - 351	H2O - Water Liquids (Pure Fluids)
GV - 367	True		Node - 363	Node - 362	H2O - Water Liquids (Pure Fluids)
GV - 41	True		Node - 257	Node - 259	H2O - Water Liquids (Pure Fluids)
GV - 410	True		Node - 414	Node - 416	H2O - Water Liquids (Pure Fluids)
GV - 422	True		Node - 417	Node - 418	H2O - Water Liquids (Pure Fluids)
GV - 430	True		Node - 426	Node - 427	H2O - Water Liquids (Pure Fluids)
GV - 45	True		Node - 246	Node - 248	H2O - Water Liquids (Pure Fluids)
GV - 48	True		Node - 40	Node - 41	H2O - Water Liquids (Pure Fluids)
GV - 49	True		Node - 228	Node - 230	H2O - Water Liquids (Pure Fluids)
GV - 53	True		Node - 154	Node - 158	H2O - Water Liquids (Pure Fluids)
GV - 54	True		Node - 179	Node - 184	H2O - Water Liquids (Pure Fluids)
GV - 55	True		Node - 14	Node - 16	H2O - Water Liquids (Pure Fluids)
GV - 56	True		Node - 55	Node - 57	H2O - Water Liquids (Pure Fluids)
GV - 571	True		Node - 145	Node - 153	H2O - Water Liquids (Pure Fluids)
GV - 66	True		Node - 109	Node - 151	H2O - Water Liquids (Pure Fluids)
GV - 71	True		Node - 46	Node - 48	H2O - Water Liquids (Pure Fluids)

TABLE 76: CONTROL VALVE WITH ITERATIVE SCRIPT INPUT - C

Valve Characteristics	Control Valve Loss Data	
Force zero flow when fully closed	Valve diameter (m)	Valve lift / Fraction opening
False	0.065	1
False	0.065	1
False	0.1	1
False	0.65	1
True	0.1	0.22
False	0.15	1
False	0.065	1
False	0.065	1
False	0.4	1
False	0.4	1
False	0.4	1
False	0.4	1
False	0.4	1
False	0.4	1
False	0.4	1
True	0.381	1
True	0.381	0.48299772
True	0.381	0
True	0.381	0
True	0.381	0.48299772
True	0.381	1
False	0.3	1
False	0.065	1
False	0.4	1
False	0.025	1
False	0.025	1
False	0.025	1
False	0.065	1
False	0.025	1
False	0.025	1
False	0.025	1
False	0.025	1
False	0.065	1
False	0.3	1
False	0.065	1
False	0.065	1
False	0.3	1
False	0.3	1
False	0.3	1
False	0.4	1
False	0.15	1
False	0.4	1

TABLE 77: CONTROL VALVE WITH ITERATIVE SCRIPT INPUT - D

Control Valve Loss Data		Pressure Drop Factors	
Upstream pipe diameter (m)	Downstream pipe diameter (m)	xT forward	xT reverse
0.065	0.065	1E+30	1E+30
0.065	0.065	1E+30	1E+30
0.1	0.1	1E+30	1E+30
0.65	0.65	1E+30	1E+30
0.1	0.1	1E+30	1E+30
0.15	0.15	1E+30	1E+30
0.065	0.065	1E+30	1E+30
0.065	0.065	1E+30	1E+30
0.4	0.4	1E+30	1E+30
0.4	0.4	1E+30	1E+30
0.4	0.4	1E+30	1E+30
0.4	0.4	1E+30	1E+30
0.4	0.4	1E+30	1E+30
0.4	0.4	1E+30	1E+30
0.4	0.4	1E+30	1E+30
0.47	0.381	1E+30	1E+30
0.47	0.381	1E+30	1E+30
0.47	0.381	1E+30	1E+30
0.47	0.381	1E+30	1E+30
0.47	0.381	1E+30	1E+30
0.47	0.381	1E+30	1E+30
0.3	0.3	1E+30	1E+30
0.065	0.065	1E+30	1E+30
0.4	0.4	1E+30	1E+30
0.025	0.025	1E+30	1E+30
0.025	0.025	1E+30	1E+30
0.025	0.025	1E+30	1E+30
0.065	0.065	1E+30	1E+30
0.025	0.025	1E+30	1E+30
0.025	0.025	1E+30	1E+30
0.025	0.025	1E+30	1E+30
0.065	0.065	1E+30	1E+30
0.3	0.3	1E+30	1E+30
0.065	0.065	1E+30	1E+30
0.065	0.065	1E+30	1E+30
0.3	0.3	1E+30	1E+30
0.3	0.3	1E+30	1E+30
0.3	0.3	1E+30	1E+30
0.4	0.4	1E+30	1E+30
0.15	0.15	1E+30	1E+30
0.4	0.4	1E+30	1E+30

VARIABLE SPEED PUMPS

(69)

TABLE 79: VARIABLE SPEED PUMP INPUT - A

General			Connected Nodes		Fluids
Identifier	Solving	Description	Upstream node	Downstream node	Fluid Data Reference
P-601	True		Node - 52	Node - 47	H2O - Water Liquids (Pure Fluids)
P-604	True		Node - 11	Node - 29	H2O - Water Liquids (Pure Fluids)
P-605	True		Node - 173	Node - 28	H2O - Water Liquids (Pure Fluids)
P-606	True		Node - 93	Node - 53	H2O - Water Liquids (Pure Fluids)

TABLE 80: VARIABLE SPEED PUMP INPUT - B

Variable Speed Pump Chart	
Pump or fan curve	
	Secondary Pumps P-601 Armstrong Variable Speed Pumps (Variable Speed Pump Charts
	Secondary Pumps P-604 Armstrong Variable Speed Pumps (Variable Speed Pump Charts
	Secondary Pumps P-605 Armstrong Variable Speed Pumps (Variable Speed Pump Charts
	Secondary Pumps P-605 Armstrong Variable Speed Pumps (Variable Speed Pump Charts

TABLE 81: VARIABLE SPEED PUMP INPUT - C

Variable Speed Pump Chart	Variable Speed Pump Data		
Apply pump derating model	Rotational speed (rpm)	Heat fraction	Electrical efficiency (0-1)
False	1475	0.85	0.95
False	1475	0.85	0.95
False	1475	0.85	0.95
False	0	0.85	0.95

TABLE 82: VARIABLE SPEED PUMP INPUT - D

Variable Speed Pump Data		
Geometric scaling factor	No flow through allowed below critical speed	Shut Down Speed (rpm)
1	True	100
1	True	100
1	True	100
1	True	100

TABLE 83: VARIABLE SPEED PUMP INPUT - E

Fixed Options			Momentum Addition
Fixed mass flow	Check valve	Apply Density Scaling to chart	Momentum addition
False	False	True	False
False	False	True	False
False	False	True	False
False	False	True	False

ITERATIVE SCRIPT

(44)

TABLE 84: ITERATIVE SCRIPT INPUT - A

General			Script	
			General	
			Flownex® Result	Geometry
Identifier	Solving	Description	Mass Flow (kg/s)	Transition Length (m)
Gate Val - Iterative Script - 32 - 12	True			
Gate Val - Iterative Script - 32 - 16	True			
Gate Val - Iterative Script - 32 - 18	True			
Gate Val - Iterative Script - 32 - 185	True			
Gate Val - Iterative Script - 32 - 20	True			
Gate Val - Iterative Script - 32 - 224	True			
Gate Val - Iterative Script - 32 - 225	True			
Gate Val - Iterative Script - 32 - 226	True			
Gate Val - Iterative Script - 32 - 227	True			
Gate Val - Iterative Script - 32 - 228	True			
Gate Val - Iterative Script - 32 - 229	True			
Gate Val - Iterative Script - 32 - 230	True			
Gate Val - Iterative Script - 32 - 231	True			
Gate Val - Iterative Script - 32 - 232	True			
Gate Val - Iterative Script - 32 - 233	True			
Gate Val - Iterative Script - 32 - 234	True			
Gate Val - Iterative Script - 32 - 235	True			
Gate Val - Iterative Script - 32 - 251	True			
Gate Val - Iterative Script - 32 - 33	True			
Gate Val - Iterative Script - 32 - 337	True			
Gate Val - Iterative Script - 32 - 357	True			
Gate Val - Iterative Script - 32 - 368	True			
Gate Val - Iterative Script - 32 - 4	True			
Gate Val - Iterative Script - 32 - 411	True			
Gate Val - Iterative Script - 32 - 42	True			
Gate Val - Iterative Script - 32 - 423	True			
Gate Val - Iterative Script - 32 - 431	True			
Gate Val - Iterative Script - 32 - 46	True			
Gate Val - Iterative Script - 32 - 49	True			
Gate Val - Iterative Script - 32 - 5	True			
Gate Val - Iterative Script - 32 - 50	True			
Gate Val - Iterative Script - 32 - 54	True			
Gate Val - Iterative Script - 32 - 57	True			
Gate Val - Iterative Script - 32 - 572	True			
Gate Val - Iterative Script - 32 - 58	True			
Gate Val - Iterative Script - 32 - 59	True			
Gate Val - Iterative Script - 32 - 6	True			
Gate Val - Iterative Script - 32 - 67	True			

TABLE 85: ITERATIVE SCRIPT INPUT - B

Script					
General					
Geometry			General		
Upsteam	Downstream	Geometry	mu (kg/m.s)	Valve_ID	Valve_Diameter (m)
Diameter (m)	Diameter (m)	Script Inputs And Outputs			
			0.00076806	GV - 11	0.1
			0.000767769	GV - 15	0.65
			0.000897282	GV - 17	0.1
			0.000897283	GV - 184	0.15
			0.000767672	GV - 19	0.065
			0.000900543	GV - 212	0.4
			0.000900543	GV - 213	0.4
			0.000900543	GV - 214	0.4
			0.000900543	GV - 215	0.4
			0.000900543	GV - 216	0.4
			0.000900541	GV - 217	0.4
			0.000771274	GV - 218	0.381
			0.00077128	GV - 219	0.381
			0.000898999	GV - 220	0.381
			0.000898999	GV - 221	0.381
			0.00077128	GV - 222	0.381
			0.000771274	GV - 223	0.381
			0.000775582	GV - 248	0.3
			0.000900511	GV - 30	0.4
			0.000882902	GV - 336	0.025
			0.00088277	GV - 356	0.025
			0.000882951	GV - 367	0.025
			0.000767537	GV - 0	0.065
			0.00089933	GV - 410	0.025
			0.000767576	GV - 41	0.065
			0.00089933	GV - 422	0.025
			0.00089933	GV - 430	0.025
			0.000767567	GV - 45	0.065
			0.000762917	GV - 48	0.3
			0.000767539	GV - 1	0.065
			0.000767571	GV - 49	0.065
			0.000767579	GV - 53	0.065
			0.000899301	GV - 54	0.3
			0.000900506	GV - 571	0.4
			0.000899322	GV - 55	0.3
			0.00089933	GV - 56	0.3
			0.000767544	GV - 2	0.065
			0.00081601	GV - 66	0.15
			0.000767549	GV - 3	0.065
			0.000900513	GV - 71	0.4

TABLE 85 CONTINUED: ITERATIVE SCRIPT INPUT - B

Script					
General					
Geometry			General		
Upsteam	Downstream	Geometry			
Diameter (m)	Diameter (m)	Script Inputs And Outputs	mu (kg/m.s)	Valve_ID	Valve_Diameter (m)

TABLE 86: ITERATIVE SCRIPT INPUT - C

Script		
General		
rho (kg/m³)	Volume_Flow_Rate (m³/s)	Chart
995.0940815	0.01791628	
995.1287844	0.017915655	
997.0677576	0.03858194	
997.0708439	0.03858182	
995.1040948	0.0179161	
996.9557463	0.077488191	
996.9557468	0.077280464	
996.9556296	0.057365345	
996.9555162	0.097403339	
996.9552042	0.129145366	
996.9546289	0.180392216	
995.1252436	0.155053317	
995.1263406	0.155053207	
996.9563471	0	
996.9563471	0	
995.1263406	0.155053207	
995.1252436	0.155053317	
995.2772001	0.158070303	
996.9508892	0.185798422	
996.7907916	0.001128092	
996.7891031	0.001119004	
996.7914183	0.001131494	
995.0820595	0.005064018	
997.0188028	0.001127834	
995.0885832	0.005063985	
997.0187972	0.001118746	
997.0188074	0.001131236	
995.0871845	0.004259173	
994.9594438	0.144712766	
995.0825231	0.004259193	
995.0878744	0.003993076	
995.0890898	0.004600152	
997.0228657	0.19000719	
996.9503008	0.19002102	
997.0230098	0.185784982	
997.0219876	0.190864288	
995.0853241	0.003993086	
995.8917946	0.038627498	
995.0809413	0.00460019	
996.9511631	0.190877847	

TABLE 86 CONTINUED: ITERATIVE SCRIPT INPUT - C

Script		
General		
rho (kg/m ³)	Volume_Flow_Rate (m ³ /s)	Chart
	0.010415395	Miller Charts Miller Orifice (Generic 4D Charts) {Global
	0.038586405	Miller Charts Miller Orifice (Generic 4D Charts) {Global
	0.038581054	Miller Charts Miller Orifice (Generic 4D Charts) {Global
	0.013793918	Miller Charts Miller Orifice (Generic 4D Charts) {Global
	0.013792598	Miller Charts Miller Orifice (Generic 4D Charts) {Global

TABLE 87 CONTINUED: ITERATIVE SCRIPT INPUT - D

Script			
General			
Valve_Angle (°)	Pipe_Diameter (m)	Force zero flow when fully closed	Density (kg/m³)
41	0.08	False	996.9989707
89.999991	0.2	False	996.9523604
90	0.15	False	997.0906405
90	0.15	False	996.9528054
90	0.15	False	997.0482174

TABLE 88 CONTINUED: ITERATIVE SCRIPT INPUT - E

Script			
General	General		
	Pump Inputs	Pump Outputs	General
Viscosity (kg/m.s)	Pump Speed	Pump Speed	Use repository script
0.000899424			True
0.000900511			True
0.000897371			True
0.000900512			True
0.000899453			True

TABLE 89 CONTINUED: ITERATIVE SCRIPT INPUT - F

Script	
General	
Repository script	Script
AButterflyValve Generated (Component Scripts) {Global}	
AButterflyValve Generated (Component Scripts) {Global}	
AButterflyValve Generated (Component Scripts) {Global}	
AButterflyValve Generated (Component Scripts) {Global}	
AButterflyValve Generated (Component Scripts) {Global}	

PIPE TRANSITION

(44)

TABLE 90: PIPE TRANSITION INPUT - A

General			Empirical Data	Geometry	
Identifier	Solving	Description	Heat Transfer	Downstream	Upstream
			Heat input (kW)	Diameter (m)	Diameter (m)
Gradual Pipe Transition - 101	True	139	0	0.15	0.08
Gradual Pipe Transition - 11	True	7	0	0.3	0.25
Gradual Pipe Transition - 115	True	106	0	0.125	0.2
Gradual Pipe Transition - 116	True		0	0.25	0.4
Gradual Pipe Transition - 119	True		0	0.5	0.3
Gradual Pipe Transition - 127	True	133	0	0.08	0.15
Gradual Pipe Transition - 128	True	110	0	0.15	0.1
Gradual Pipe Transition - 14	True		0	0.3	0.25
Gradual Pipe Transition - 169	True	7	0	0.25	0.4
Gradual Pipe Transition - 17	True		0	0.3	0.25
Gradual Pipe Transition - 189	True	15	0	0.5	0.3
Gradual Pipe Transition - 223	True	119	0	0.1	0.15
Gradual Pipe Transition - 25	True	122a	0	0.15	0.1
Gradual Pipe Transition - 272	True	31a	0	0.45	0.5
Gradual Pipe Transition - 281	True	58	0	0.45	0.3
Gradual Pipe Transition - 284	True	62	0	0.5	0.45
Gradual Pipe Transition - 34	True		0	0.25	0.4
Gradual Pipe Transition - 37	True		0	0.5	0.3
Gradual Pipe Transition - 50	True		0	0.3	0.25
Gradual Pipe Transition - 556	True	208	0	0.15	0.08
Gradual Pipe Transition - 562	True	189	0	0.15	0.08
Gradual Pipe Transition - 568	True	173	0	0.08	0.15
Gradual Pipe Transition - 571	True	192	0	0.08	0.15
Gradual Pipe Transition - 75	True		0	0.25	0.4
Gradual Pipe Transition - 78	True		0	0.5	0.3
Gradual Pipe Transition - 8	True	99	0	0.4	0.6
Gradual Pipe Transition - 91	True	126	0	0.2	0.15

TABLE 91: PIPE TRANSITION INPUT - B

Geometry	Fixed Options		Momentum Addition	Connected Nodes
Transition Length (m)	Fixed mass flow	Check valve	Momentum addition	Downstream node
0.1	False	False	False	Node - 69
0.2	False	False	False	Node - 177
0.1	False	False	False	Node - 119
0.3	False	False	False	Node - 93
0.2	False	False	False	Node - 100
1	False	False	False	Node - 137
0.1	False	False	False	Node - 132
0.2	False	False	False	Node - 13
0.3	False	False	False	Node - 173
0.2	False	False	False	Node - 54
0.2	False	False	False	Node - 303
0.2	False	False	False	Node - 227
100	False	False	False	Node - 49
300	False	False	False	Node - 192
0.3	False	False	False	T - Junction - 172
0.3	False	False	False	Node - 208
0.3	False	False	False	Node - 11
0.2	False	False	False	Node - 18
0.2	False	False	False	Node - 95
0.1	False	False	False	Node - 36
0.1	False	False	False	Node - 455
0.1	False	False	False	Node - 478
0.1	False	False	False	Node - 31
0.3	False	False	False	Node - 52
0.2	False	False	False	Node - 59
0.3	False	False	False	Node - 19
0.3	False	False	False	Node - 133

TABLE 92: PIPE TRANSITION INPUT - C

Connected Nodes	Fluids
Upstream node	Fluid Data Reference
Node - 68	H2O - Water Liquids (Pure Fluids)
Node - 28	H2O - Water Liquids (Pure Fluids)
Node - 116	H2O - Water Liquids (Pure Fluids)
Node - 91	H2O - Water Liquids (Pure Fluids)
Node - 99	H2O - Water Liquids (Pure Fluids)
Node - 120	H2O - Water Liquids (Pure Fluids)
Node - 25	H2O - Water Liquids (Pure Fluids)
Node - 29	H2O - Water Liquids (Pure Fluids)
Node - 163	H2O - Water Liquids (Pure Fluids)
Node - 47	H2O - Water Liquids (Pure Fluids)
Node - 190	H2O - Water Liquids (Pure Fluids)
Node - 194	H2O - Water Liquids (Pure Fluids)
Node - 39	H2O - Water Liquids (Pure Fluids)
Node - 191	H2O - Water Liquids (Pure Fluids)
Node - 205	H2O - Water Liquids (Pure Fluids)
Node - 207	H2O - Water Liquids (Pure Fluids)
Node - 9	H2O - Water Liquids (Pure Fluids)
Node - 17	H2O - Water Liquids (Pure Fluids)
Node - 53	H2O - Water Liquids (Pure Fluids)
Node - 143	H2O - Water Liquids (Pure Fluids)
Node - 456	H2O - Water Liquids (Pure Fluids)
Node - 15	H2O - Water Liquids (Pure Fluids)
Node - 487	H2O - Water Liquids (Pure Fluids)
Node - 50	H2O - Water Liquids (Pure Fluids)
Node - 58	H2O - Water Liquids (Pure Fluids)
Node - 2	H2O - Water Liquids (Pure Fluids)
Node - 107	H2O - Water Liquids (Pure Fluids)

GATE VALVES

(44) (93)

TABLE 93: GATE VALVE INPUT - A

General			Fixed Options		Connected Nodes	
Identifier	Solving	Description	Fixed mass flow	Check valve	Upstream node	Downstream node
TCV-054	True		False	False	Node - 227	Node - 33
TV-0001	True		False	False	Node - 139	Node - 271
TV-0002	True		False	False	Node - 273	Node - 268
TV-0003	True		False	False	Node - 279	Node - 38
TV-004	True		False	False	Node - 154	Node - 158
TV-005	True		False	False	Node - 228	Node - 230
TV-006	True		False	False	Node - 246	Node - 248
TV-007	True		False	False	Node - 257	Node - 259
TV-008	True		False	False	Node - 258	Node - 123
TV-009	True		False	False	Node - 247	Node - 125
TV-010	True		False	False	Node - 229	Node - 126
TV-011	True		False	False	Node - 155	Node - 130
V-269	True	GATE VALVE	False	False	Node - 179	Node - 184
V-602	True	GATE VALVE	False	False	Node - 55	Node - 57
V-604	True	GATE VALVE	False	False	Node - 6	Node - 1
V-605	True		False	False	Node - 122	Node - 124
V-606	True		False	False	Node - 114	Node - 118
V-607	True	GATE VALVE	False	False	Node - 46	Node - 48
V-612	True		False	False	Node - 109	Node - 151
V-614	True	GATE VALVE	False	False	Node - 66	Node - 194
V-622	True	GATE VALVE	False	False	Node - 14	Node - 16
V-624	True	GATE VALVE	False	False	Node - 40	Node - 41
V-627	True	GATE VALVE	False	False	Node - 5	Node - 7
V-630	True	GATE VALVE	False	False	Node - 145	Node - 153
V-632	True		False	False	Node - 142	Node - 147
V-634	True		False	False	Node - 106	Node - 108
V-635	True		False	False	Node - 92	Node - 94
V-636	True		False	False	Node - 88	Node - 90
V-640	True		False	False	Node - 112	Node - 113
V-643	True		False	False	Node - 149	Node - 152
V-647	True		False	False	Node - 75	Node - 77
V-648	True		False	False	Node - 56	Node - 65
V-649	True		False	False	Node - 102	Node - 103
V-650	True		False	False	Node - 97	Node - 101
V-677	True	GATE VALVE	False	False	Node - 426	Node - 427
V-678	True	GATE VALVE	False	False	Node - 363	Node - 362
V-679	True	GATE VALVE	False	False	Node - 417	Node - 418
V-680	True	GATE VALVE	False	False	Node - 352	Node - 351
V-681	True	GATE VALVE	False	False	Node - 414	Node - 416
V-682	True	GATE VALVE	False	False	Node - 342	Node - 340

TABLE 94: GATE VALVE INPUT - B

Fluids	Control Valve Loss Data		
	Fluid Data Reference	Outlet pipe diameter (m)	Fraction open
H2O - Water Liquids (Pure Fluids)	0.1	0.22	0.1
H2O - Water Liquids (Pure Fluids)	0.1	1	0.1
H2O - Water Liquids (Pure Fluids)	0.65	1	0.65
H2O - Water Liquids (Pure Fluids)	0.065	1	0.065
H2O - Water Liquids (Pure Fluids)	0.065	1	0.065
H2O - Water Liquids (Pure Fluids)	0.065	1	0.065
H2O - Water Liquids (Pure Fluids)	0.065	1	0.065
H2O - Water Liquids (Pure Fluids)	0.065	1	0.065
H2O - Water Liquids (Pure Fluids)	0.065	1	0.065
H2O - Water Liquids (Pure Fluids)	0.065	1	0.065
H2O - Water Liquids (Pure Fluids)	0.065	1	0.065
H2O - Water Liquids (Pure Fluids)	0.065	1	0.065
H2O - Water Liquids (Pure Fluids)	0.3	1	0.3
H2O - Water Liquids (Pure Fluids)	0.3	1	0.3
H2O - Water Liquids (Pure Fluids)	0.3	1	0.3
H2O - Water Liquids (Pure Fluids)	0.381	1	0.381
H2O - Water Liquids (Pure Fluids)	0.381	1	0.381
H2O - Water Liquids (Pure Fluids)	0.4	1	0.4
H2O - Water Liquids (Pure Fluids)	0.15	1	0.15
H2O - Water Liquids (Pure Fluids)	0.15	1	0.15
H2O - Water Liquids (Pure Fluids)	0.3	1	0.3
H2O - Water Liquids (Pure Fluids)	0.3	1	0.3
H2O - Water Liquids (Pure Fluids)	0.4	1	0.4
H2O - Water Liquids (Pure Fluids)	0.4	1	0.4
H2O - Water Liquids (Pure Fluids)	0.4	1	0.4
H2O - Water Liquids (Pure Fluids)	0.4	1	0.4
H2O - Water Liquids (Pure Fluids)	0.4	1	0.4
H2O - Water Liquids (Pure Fluids)	0.4	1	0.4
H2O - Water Liquids (Pure Fluids)	0.4	1	0.4
H2O - Water Liquids (Pure Fluids)	0.4	1	0.4
H2O - Water Liquids (Pure Fluids)	0.381	0	0.381
H2O - Water Liquids (Pure Fluids)	0.381	0	0.381
H2O - Water Liquids (Pure Fluids)	0.381	0.48299772	0.381
H2O - Water Liquids (Pure Fluids)	0.381	0.48299772	0.381
H2O - Water Liquids (Pure Fluids)	0.025	1	0.025
H2O - Water Liquids (Pure Fluids)	0.025	1	0.025
H2O - Water Liquids (Pure Fluids)	0.025	1	0.025
H2O - Water Liquids (Pure Fluids)	0.025	1	0.025
H2O - Water Liquids (Pure Fluids)	0.025	1	0.025
H2O - Water Liquids (Pure Fluids)	0.025	1	0.025

TABLE 95: GATE VALVE INPUT - C

Control Valve Loss Data	
Force zero flow when fully closed	Inlet pipe diameter (m)
True	0.1
False	0.1
False	0.65
False	0.065
False	0.065
False	0.065
False	0.065
False	0.065
False	0.065
False	0.065
False	0.065
False	0.065
False	0.3
False	0.3
False	0.3
True	0.47
True	0.47
False	0.4
False	0.15
False	0.15
False	0.3
False	0.3
False	0.4
False	0.4
False	0.4
False	0.4
False	0.4
False	0.4
False	0.4
False	0.4
False	0.4
True	0.47
True	0.47
True	0.47
True	0.47
False	0.025
False	0.025
False	0.025
False	0.025
False	0.025
False	0.025

BUTTERFLY VALVES

(44) (93)

TABLE 96: BUTTERFLY VALVE INPUT - A

General			Fixed Options		Butterfly Valve Loss Data
Identifier	Solving	Description	Fixed mass flow	Check valve	Force zero flow when fully closed
V-603	True	BUTTERFLY VALVE	False	False	False
V-608	True	BUTTERFLY VALVE	False	False	False
V-610	True	BUTTERFLY VALVE	False	False	False
V-615	True	BUTTERFLY VALVE	False	False	False
V-617	True	BUTTERFLY VALVE	False	False	False
V-623	True	BUTTERFLY VALVE	False	False	False
V-625	True	BUTTERFLY VALVE	False	False	False
V-626	True	BUTTERFLY VALVE	False	False	False
V-651	True	BUTTERFLY VALVE	False	False	False
V-652	True	BUTTERFLY VALVE	False	False	False
V-674	True	BUTTERFLY VALVE	False	False	True
V-676	True	BUTTERFLY VALVE	False	False	True
V-683	True	BUTTERFLY VALVE	False	False	True
V-684	True	BUTTERFLY VALVE	False	False	True
V-687	True	BUTTERFLY VALVE	False	False	False
V-688	True	BUTTERFLY VALVE	False	False	False

TABLE 97: BUTTERFLY VALVE INPUT - B

Butterfly Valve Loss Data		Connected Nodes
Pipe Diameter (m)	Valve Angle (0° - Fully Closed, 90° - Fully Open) (°)	Downstream node
0.3	90	T - Junction - 173
0.2	89.999991	Node - 23
0.15	90	Node - 144
0.15	90	Node - 135
0.15	90	Node - 140
0.3	90	T - Junction - 37
0.3	90	T - Junction - 74
0.3	90	Node - 209
0.3	90	T - Junction - 88
0.3	90	Node - 212
0.4	0	Node - 89
0.3	0	Node - 98
0.08	0	Node - 488
0.08	0	Node - 150
0.08	41	Node - 493
0.08	90	Node - 469

TABLE 98: BUTTERFLY VALVE INPUT - C

Connected Nodes	Fluids
Upstream node	Fluid Data Reference
Node - 176	H2O - Water Liquids (Pure Fluids)
Node - 61	H2O - Water Liquids (Pure Fluids)
Node - 141	H2O - Water Liquids (Pure Fluids)
Node - 83	H2O - Water Liquids (Pure Fluids)
Node - 74	H2O - Water Liquids (Pure Fluids)
Node - 185	H2O - Water Liquids (Pure Fluids)
Node - 200	H2O - Water Liquids (Pure Fluids)
Node - 76	H2O - Water Liquids (Pure Fluids)
Node - 115	H2O - Water Liquids (Pure Fluids)
Node - 10	H2O - Water Liquids (Pure Fluids)
Node - 87	H2O - Water Liquids (Pure Fluids)
Node - 96	H2O - Water Liquids (Pure Fluids)
Node - 84	H2O - Water Liquids (Pure Fluids)
Node - 34	H2O - Water Liquids (Pure Fluids)
Node - 21	H2O - Water Liquids (Pure Fluids)
Node - 20	H2O - Water Liquids (Pure Fluids)

APPENDIX III

RESULTS

BEND

TABLE 99: BEND RESULTS - A

General	Flow Element Results		
	Generic Results		
Identifier	Check valve active	Flashing/cavitating	Pressure drop excluding elevation (kPa)
Bend - 68	False	False	10.64712691

TABLE 100: BEND RESULTS - B

Flow Element Results			
Generic Results			
Static temperature (°C)	Incondensable Mass Flow Rate (kg/s)	Element is choked	Mass Flux (kg/m ² .s)
25.10928793	0	False	4898.00074

TABLE 101: BEND RESULTS - C

Flow Element Results	
Flow and Geometry variables	
Total mass flow (kg/s)	Total volume flow (m ³ /s)
38.46880791	0.03858517

TABLE 102: BEND RESULTS - D

Flow Element Results		
Flow and Geometry variables		
Volume flow based on ambient conditions (m ³ /s)	Maximum velocity (m/s)	Mean pressure (kPa)
0.038587245	4.912816444	284.4591556

TABLE 103: BEND RESULTS - E

Flow Element Results			
Flow and Geometry variables			
Node pressure drop (kPa)	Pressure ratio (up/down)	Pressure ratio (down/up)	Total temperature (°C)
10.64712691	1.038143208	0.963258241	25.1095336

TABLE 104: BEND RESULTS - F

Flow Element Results				
Flow and Geometry variables				Energy and Heat Transfer variables
Quality	Total volume (m ³)	Total mass (kg)	Static pressure (kPa)	Total heat transfer (kW)
0	0.012337006	12.2998005	272.4276663	0

TABLE 105: BEND RESULTS - G

Flow Element Results			
Energy and Heat Transfer variables	Non-dimensional variables		
Total power (kW)	Reynolds number	Total non-dimensional mass flow	Mach number
0	54	229.2622561	0

TABLE 106: BEND RESULTS - H

Flow Element Results			
Fluid variables			
Density (kg/m ³)	Conductivity (W/m.K)	Viscosity (kg/m.s)	Static enthalpy (kJ/kg)
996.9842763	0.607248583	0.000896609	105.5297553

TABLE 107: BEND RESULTS - I

Flow Element Results		
Fluid variables		
Specific heat (kJ/kg.K)	Total gas mass fraction - Incondensable + Vapour	Gas constant (kJ/kg.K)
4.180990857	-1	0

TABLE 108: BEND RESULTS - J

Flow Element Results		
Convergence	Upstream Results	
Pressure convergence (kPa)	Velocity (m/s)	Junction pressure loss (kPa)
-1.455E-08	4.912802875	0

TABLE 109: BEND RESULTS - K

Flow Element Results	
Upstream Results	
Upstream Node Total Pressure (kPa)	Upstream Node Static Pressure (kPa)
289.7827191	277.751263

TABLE 110: BEND RESULTS - L

Flow Element Results			
Upstream Results			
Upstream Node Total Temperature (°C)	Upstream Node Static Temperature (°C)	Elevation (m)	Quality
25.10836512	25.10811935	2.2	0

TABLE 111: BEND RESULTS - M

Flow Element Results			
Upstream Results			
Mach number	Area (m ²)	Total enthalpy (kJ/kg)	Static enthalpy (kJ/kg)
0	0.007853982	105.5418232	105.5297554

TABLE 112: BEND RESULTS - N

Flow Element Results		
Upstream Results		Downstream Results
Element Inlet Pressure (kPa)	Element Inlet Enthalpy (kJ/kg)	Velocity (m/s)
289.7827191	105.5418232	4.912830013

TABLE 113: BEND RESULTS - O

Flow Element Results	
Downstream Results	
Junction pressure loss (kPa)	Downstream Node Total Pressure (kPa)
0	279.1355921

TABLE 114: BEND RESULTS - P

Flow Element Results	
Downstream Results	
Downstream Node Static Pressure (kPa)	Downstream Node Total Temperature (°C)
267.1040696	25.11070226

TABLE 115: BEND RESULTS - Q

Flow Element Results				
Downstream Results				
Downstream Node Static Temperature (°C)	Elevation (m)	Quality	Mach number	Area (m ²)
25.11045651	2.2	0	0	0.007853982

TABLE 116: BEND RESULTS - R

Flow Element Results		
Downstream Results		
Total enthalpy (kJ/kg)	Static enthalpy (kJ/kg)	Element Exit Pressure (kPa)
105.5418232	105.5297552	279.1355921

TABLE 117: BEND RESULTS - S

Flow Element Results		
Downstream Results	Forces	
	Forces From Pressure Difference	
Element Exit Enthalpy (kJ/kg)	Magnitude (N)	Parallel to inlet (N)
105.5418232	2687.674375	2687.674375

TABLE 118: BEND RESULTS - T

Flow Element Results		
Forces		
Forces From Pressure Difference		
Perpendicular to inlet (N)	Parallel to outlet (N)	Perpendicular to outlet (N)
1.59452E-13	2687.674375	1.64573E-13

TABLE 119: BEND RESULTS - U

Flow Element Results			
Forces			
Forces From Velocity Change			
Magnitude (N)	Parallel to inlet (N)	Perpendicular to inlet (N)	Parallel to outlet (N)
377.980383	377.980383	2.31447E-14	377.980383

TABLE 120: BEND RESULTS - V

Flow Element Results
Forces
Forces From Velocity Change
Perpendicular to outlet (N)
2.31446E-14

BOUNDARY CONDITIONS

TABLE 121: BOUNDARY CONDITIONS RESULTS - A

General	Flow Node Results			
	Identifier	Pressure (kPa)	Temperature (°C)	Quality
Boundary Condition - 1	143.77	31.67232212	0	132.8490271
Boundary Condition - 2	143.77	31.67232212	0	132.8490271
Boundary Condition - 29	418	44.5	0	186.704135
Boundary Condition - 3	143.77	31.67232212	0	132.8490271
Boundary Condition - 31	397.3236463	37.4467417	0	157.2085248
Boundary Condition - 33	424.5	45	0	188.79956
Boundary Condition - 34	392.616917	39.02402203	0	163.7957433
Boundary Condition - 4	87.17998944	24.911	0	104.5300618
Boundary Condition - 5	87.17998953	24.911	0	104.5300618
Boundary Condition - 6	87.17998991	24.911	0	104.5300618
Boundary Condition - 7	143.77	31.67232212	0	132.8490271
Boundary Condition - 70	403	44.5	0	186.6908975
Boundary Condition - 71	379.5547656	37.95299517	0	159.3081661
Boundary Condition - 72	219	33	0	138.5434
Boundary Condition - 74	209.7969407	28.50959042	0	119.7664343
Boundary Condition - 8	87.18	25.00173058	0	104.909414
Boundary Condition - 84	400.5	45	0	188.77844
Boundary Condition - 85	382.6041007	37.4818859	0	157.3421448
Boundary Condition - 9	87.18	25.00173058	0	104.909414

TABLE 122: BOUNDARY CONDITIONS RESULTS - B

Flow Node Results	
Mass source (kg/s)	
	-154.2974695
	-154.2974695
	137.4566659
	-154.2975305
	-137.4566659
	170.6525755
	-170.6525755
	154.2975
	154.2975
	308.595
	-154.2975305
	146.3630861
	-146.3630861
	35.04
	-35.04
	0
	127.8732516
	-127.8732516
	0

ORIFICE

TABLE 123: ORIFICE RESULTS - A

General	British Standard Orifice Results		
Identifier	Expansion factor (Y)	Discharge coefficient	Approach factor
British Standard Orifice - 281	1	0.512689222	2.13564552

TABLE 124: ORIFICE RESULTS - B

British Standard Orifice Results	Flow Element Results		
	Generic Results		
Loss coefficient	Check valve active	Flashing/cavitating	Pressure drop excluding elevation (kPa)
0.229066176	False	False	0.073477222

TABLE 125: ORIFICE RESULTS - B

Flow Element Results			
Generic Results			
Static temperature (°C)	Incondensable Mass Flow Rate (kg/s)	Element is choked	Mass Flux (kg/m ² .s)
31.90201692	0	False	6351.628221

TABLE 126: ORIFICE RESULTS - C

Flow Element Results	
Flow and Geometry variables	
Total mass flow (kg/s)	Total volume flow (m ³ /s)
564.9693071	0.567762767

TABLE 127: ORIFICE RESULTS - D

Flow Element Results	
Flow and Geometry variables	
Volume flow based on ambient conditions (m ³ /s)	Abs val of maximum velocity (m/s)
0.566708728	6.383033504

TABLE 128: ORIFICE RESULTS - E

Flow Element Results			
Flow and Geometry variables			
Maximum velocity (m/s)	Mean pressure (kPa)	Node pressure drop (kPa)	Pressure ratio (up/down)
6.383033504	222.1936154	0.073477222	1.000330745

TABLE 129: ORIFICE RESULTS - F

Flow Element Results				
Flow and Geometry variables				
Pressure ratio (down/up)	Total temperature (°C)	Quality	Total volume (m ³)	Total mass (kg)
0.999669365	31.9021293	0	0	0

TABLE 130: ORIFICE RESULTS - G

Flow Element Results		
Flow and Geometry variables	Energy and Heat Transfer variables	
Static pressure (kPa)	Total heat transfer (kW)	Total power (kW)
218.070271	0	0

TABLE 131: ORIFICE RESULTS - H

Flow Element Results			
Non-dimensional variables			Fluid variables
Reynolds number	Total non-dimensional mass flow	Mach number	Density (kg/m ³)
1873133.493	4440.261027	0	995.0798812

TABLE 132: ORIFICE RESULTS - I

Flow Element Results			
Fluid variables			
Conductivity (W/m.K)	Viscosity (kg/m.s)	Static enthalpy (kJ/kg)	Specific heat (kJ/kg.K)
0.618504681	0.000768062	133.8757919	4.179633462

TABLE 133: ORIFICE RESULTS - J

Flow Element Results	
Fluid variables	
Total gas mass fraction - Incondensable + Vapour	Gas constant (kJ/kg.K)
-1	0

TABLE 134: ORIFICE RESULTS - K

Flow Element Results		
Convergence	Upstream Results	
Pressure convergence (kPa)	Velocity (m/s)	Junction pressure loss (kPa)
1.47628E-11	2.89159203	0

TABLE 135: ORIFICE RESULTS - L

Flow Element Results	
Upstream Results	
Upstream Node Total Pressure (kPa)	Upstream Node Static Pressure (kPa)
222.230354	218.070271

TABLE 136: ORIFICE RESULTS - M

Flow Element Results			
Upstream Results			
Upstream Node Total Temperature (°C)	Upstream Node Static Temperature (°C)	Elevation (m)	Quality
31.90212138	31.90201692	4	0

TABLE 137: ORIFICE RESULTS - N

Flow Element Results			
Upstream Results			
Mach number	Area (m ²)	Total enthalpy (kJ/kg)	Static enthalpy (kJ/kg)
0	0.196349541	133.8799726	133.8757919

TABLE 138: ORIFICE RESULTS - O

Flow Element Results		
Upstream Results		Downstream Results
Element Inlet Pressure (kPa)	Element Inlet Enthalpy (kJ/kg)	Velocity (m/s)
222.230354	133.8799726	2.891592134

TABLE 139: ORIFICE RESULTS - P

Flow Element Results	
Downstream Results	
Junction pressure loss (kPa)	Downstream Node Total Pressure (kPa)
0	222.1568767

TABLE 140: ORIFICE RESULTS - Q

Flow Element Results	
Downstream Results	
Downstream Node Static Pressure (kPa)	Downstream Node Total Temperature (°C)
217.9967937	31.90213721

TABLE 141: ORIFICE RESULTS - R

Flow Element Results				
Downstream Results				
Downstream Node Static Temperature (°C)	Elevation (m)	Quality	Mach number	Area (m ²)
31.90203274	4	0	0	0.196349541

TABLE 142: ORIFICE RESULTS - S

Flow Element Results		
Downstream Results		
Total enthalpy (kJ/kg)	Static enthalpy (kJ/kg)	Element Exit Pressure (kPa)
133.8799726	133.8757919	222.1568767

TABLE 143: ORIFICE RESULTS - T

Flow Element Results		
Downstream Results	Forces	
	Forces From Pressure Difference	Forces From Velocity Change
Element Exit Enthalpy (kJ/kg)	Magnitude (N)	Magnitude (N)
133.8799726	14.4272481	-5.84804E-05

PUMP

TABLE 144: PUMP RESULTS - A

General	Flow Element Results		
	Generic Results		
Identifier	Check valve active	Flashing/cavitating	Pressure drop excluding elevation (kPa)
P-602	False	False	-404.1605919
P-603	False	False	-250.2485675
P-608	False	False	-95.57609504

TABLE 145: PUMP RESULTS - B

Flow Element Results			
Generic Results			
Static temperature (°C)	Incondensable Mass Flow Rate (kg/s)	Element is choked	Mass Flux (kg/m ² .s)
24.91617876	0	False	0
24.91464251	0	False	0
31.90212076	0	False	0

TABLE 146: PUMP RESULTS - C

Flow Element Results	
Flow and Geometry variables	
Total mass flow (kg/s)	Total volume flow (m ³ /s)
38.46880791	0.038586684
13.75188495	0.013793971
17.82838433	0.017916265

TABLE 147: PUMP RESULTS - D

Flow Element Results		
Flow and Geometry variables		
Volume flow based on ambient conditions (m ³ /s)	Maximum velocity (m/s)	Mean pressure (kPa)
0.038587245	0	286.1953887
0.013794224	0	216.5457614
0.017883274	0	302.7079585

TABLE 148: PUMP RESULTS - E

Flow Element Results				
Flow and Geometry variables				
Node pressure drop (kPa)	Pressure head (m)	Pressure ratio (up/down)	Pressure ratio (down/up)	
-404.1605919	41.34193596	0.172269673	5.804852244	
-249.6620026	25.53804489	0.268661403	3.722157287	
-95.57609504	9.794739406	0.727311885	1.374925971	

TABLE 149: PUMP RESULTS - F

Flow Element Results				
Flow and Geometry variables				
Total temperature (°C)	Quality	Total volume (m³)	Total mass (kg)	Static pressure (kPa)
24.99136879	0	0	0	84.11509271
24.93916211	0	0	0	91.71476013
31.91217915	0	0	0	254.9199109

TABLE 150: PUMP RESULTS - G

Flow Element Results			
Energy and Heat Transfer variables		Non-dimensional variables	
Total heat transfer (kW)	Total power (kW)	Total non-dimensional mass flow	
22.93	-15.59521718	789.5709301	
2.54025	-3.451921537	258.8679154	
1.32	-1.712366656	122.1505014	

TABLE 151: PUMP RESULTS - H

Flow Element Results				
Non-dimensional variables	Fluid variables			
Mach number	Density (kg/m³)	Conductivity (W/m.K)	Viscosity (kg/m.s)	Static enthalpy (kJ/kg)
0	996.9451527	0.60683953	0.000900453	104.548888
0	996.9489374	0.6068403	0.000900481	104.5494764
0	995.0949169	0.61852292	0.000768057	133.9093906

TABLE 152: PUMP RESULTS - I

Flow Element Results		
Fluid variables		
Specific heat (kJ/kg.K)	Total gas mass fraction - Incondensable + Vapour	Gas constant (kJ/kg.K)
4.181819509	-1	0
4.181781075	-1	0
4.179588144	-1	0

TABLE 153: PUMP RESULTS - J

Flow Element Results		
Convergence	Upstream Results	
Pressure convergence (kPa)	Velocity (m/s)	Junction pressure loss (kPa)
1.77178E-08	0	0
-1.03886E-07	0	0
4.15422E-08	0	0

TABLE 154: PUMP RESULTS - K

Flow Element Results	
Upstream Results	
Upstream Node Total Pressure (kPa)	Upstream Node Static Pressure (kPa)
84.11509271	84.11509271
91.71476013	91.71476013
254.9199109	254.9199109

TABLE 155: PUMP RESULTS - L

Flow Element Results			
Upstream Results			
Upstream Node Total Temperature (°C)	Upstream Node Static Temperature (°C)	Elevation (m)	Quality
24.91617876	24.91617876	1.33	0
24.91464251	24.91464251	1.27	0
31.90212076	31.90212076	1	0

TABLE 156: PUMP RESULTS - M

Flow Element Results				
Upstream Results				
Mach number	Area (m ²)	Total enthalpy (kJ/kg)	Static enthalpy (kJ/kg)	Element Inlet Pressure (kPa)
0	0	104.548888	104.548888	84.11509271
0	0	104.5494764	104.5494764	91.71476013
0	0	133.9093906	133.9093906	254.9199109

TABLE 157: PUMP RESULTS - N

Flow Element Results		
Upstream Results	Downstream Results	
Element Inlet Enthalpy (kJ/kg)	Velocity (m/s)	Junction pressure loss (kPa)
104.548888	0	0
104.5494764	0	0
133.9093906	0	0

TABLE 158: PUMP RESULTS - O

Flow Element Results	
Downstream Results	
Downstream Node Total Pressure (kPa)	Downstream Node Static Pressure (kPa)
488.2756847	488.2756847
341.3767627	341.3767627
350.496006	350.496006

TABLE 159: PUMP RESULTS - P

Flow Element Results		
Downstream Results		
Downstream Node Total Temperature (°C)	Downstream Node Static Temperature (°C)	Elevation (m)
25.06655882	25.06655882	1.33
24.96368171	24.96368171	1.33
31.92223753	31.92223753	1

TABLE 160: PUMP RESULTS - Q

Flow Element Results				
Downstream Results				
Quality	Mach number	Area (m ²)	Total enthalpy (kJ/kg)	Static enthalpy (kJ/kg)
0	0	0	105.5503544	105.5503544
0	0	0	104.9846226	104.9846226
0	0	0	134.079477	134.079477

TABLE 161: PUMP RESULTS - R

Flow Element Results		
Downstream Results		Forces
		Forces From Pressure Difference
Element Exit Pressure (kPa)	Element Exit Enthalpy (kJ/kg)	Magnitude (N)
488.2756847	105.5503544	-3250.300918
341.3767627	104.9846226	-1254.938103
350.496006	134.079477	0

TABLE 162: PUMP RESULTS - S

Flow Element Results	Fan Or Pump Results	
Forces		
Forces From Velocity Change		
Magnitude (N)	Pump/Fan Pressure rise (kPa)	Pump/Fan Head (m)
0	404.1605919	41.34193596
0	250.2485675	25.59804489
0	95.57609504	9.794739406

TABLE 163: PUMP RESULTS - T

Fan Or Pump Results		
Fan Or Pump Results		Net Positive Suction Head
Pump/Fan shaft power (kW)	Reference Density (kg/m ³)	NPSH actual (m)
-15.59521718	1000	8.280635499
-3.451921537	997.561	9.058007857
-1.712366656	997.561	25.63495542

TABLE 164: PUMP RESULTS - U

Fan Or Pump Results	
Net Positive Suction Head	
NPSH required (m)	NPSH available (m)
2.049167771	6.231467732
1.777043543	7.280964333
1.796991326	23.8379641

GENERAL EMPIRICAL RELATIONSHIP

TABLE 165: GENERAL EMPIRICAL RELATIONSHIP RESULTS - A

General	Flow Element Results	
	Generic Results	
Identifier	Check valve active	Flashing/cavitating
Basket Strainer 601	False	False
Basket Strainer 604	False	False
Basket Strainer 605	False	False
Basket Strainer 606	False	False
C-609	False	False
Carrier 1	False	False
Daikin 1	False	False
E-618	False	False
E-619	False	False
E-620	False	False
General Empirical Relationship - 0	False	False
Gradual - General Empirical Relationship - 46 - 111	False	False
Gradual - General Empirical Relationship - 46 - 118	False	False
Gradual - General Empirical Relationship - 46 - 124	False	False
Gradual - General Empirical Relationship - 46 - 158	False	False
Gradual - General Empirical Relationship - 46 - 161	False	False
Gradual - General Empirical Relationship - 46 - 162	False	False
Gradual - General Empirical Relationship - 46 - 165	False	False
Gradual - General Empirical Relationship - 46 - 185	False	False
Gradual - General Empirical Relationship - 46 - 2	False	False
Gradual - General Empirical Relationship - 46 - 21	False	False
Gradual - General Empirical Relationship - 46 - 218	False	False
Gradual - General Empirical Relationship - 46 - 3	False	False
Gradual - General Empirical Relationship - 46 - 34	False	False
Gradual - General Empirical Relationship - 46 - 4	False	False
Gradual - General Empirical Relationship - 46 - 410	False	False
Gradual - General Empirical Relationship - 46 - 412	False	False
Gradual - General Empirical Relationship - 46 - 414	False	False
Gradual - General Empirical Relationship - 46 - 415	False	False
Gradual - General Empirical Relationship - 46 - 43	False	False
Gradual - General Empirical Relationship - 46 - 44	False	False
Gradual - General Empirical Relationship - 46 - 48	False	False
Gradual - General Empirical Relationship - 46 - 5	False	False
Gradual - General Empirical Relationship - 46 - 6	False	False
Gradual - General Empirical Relationship - 46 - 7	False	False
Gradual - General Empirical Relationship - 46 - 84	False	False
Gradual - General Empirical Relationship - 46 - 85	False	False
Gradual - General Empirical Relationship - 46 - 87	False	False
T-610	False	False

TABLE 165 CONTINUED: GENERAL EMPIRICAL RELATIONSHIP RESULTS - A

General	Flow Element Results	
	Generic Results	
Identifier	Check valve active	Flashing/cavitating
TABV - 130	False	False
TABV - 135	False	False
TABV - 156	False	False
TABV - 157	False	False
TABV - 159	False	False
TABV - 160	False	False
TABV - 163	False	False
TABV - 164	False	False
TABV - 35	False	False
TABV - 36	False	False
TABV - 411	False	False
TABV - 413	False	False
TABV - 416	False	False
TABV - 417	False	False
TABV - 667	False	False
TABV - 672	False	False
Y-602	False	False
Y-603	False	False

TABLE 166: GENERAL EMPIRICAL RELATIONSHIP RESULTS - B

Flow Element Results		
Generic Results		
Pressure drop excluding elevation (kPa)	Static temperature (°C)	Incondensable Mass Flow Rate (kg/s)
19.38532756	24.91514696	0
18.3130651	24.91515837	0
19.20218562	24.91550673	0
0	25.00707329	0
27.71423034	31.92617948	0
35.85803375	27.51225359	0
0	24.97929722	0
0.634181082	25.38860348	0
0.624002395	25.39196785	0
0.638011964	25.38735721	0
0.46840489	24.9130845	0
0.843588592	24.9160517	0
1.316963493	24.91311504	0
2.341403519	25.06692546	0
0.042621605	24.97392243	0
0.401835439	31.90921517	0

TABLE 166 CONTINUED: GENERAL EMPIRICAL RELATIONSHIP RESULTS - B

Flow Element Results		
Generic Results		
Pressure drop excluding elevation (kPa)	Static temperature (°C)	Incondensable Mass Flow Rate (kg/s)
0.028031872	32.09798824	0
0.883204539	24.9177228	0
1.475401069	24.97295827	0
0.84438811	24.91727205	0
0.002413719	25.11069254	0
0.663195565	25.07289358	0
1.410558975	24.97178524	0
1.650715234	24.96387534	0
0.012172382	24.91302681	0
-2.91038E-14	25.02083796	0
0.942573153	30.05468407	0
0.404746133	24.9627058	0
0	25.00295939	0
0.891188288	24.91738411	0
1.488740235	24.97143837	0
-2.73812E-11	24.96690226	0
0.224889949	24.97245621	0
0.215006351	24.97136922	0
0.226923218	24.97099113	0
0	25.00707329	0
0	24.96857364	0
0.181195312	29.15947799	0
4.359884704	31.90145903	0
0	25.00707329	0
0	24.96851259	0
1.566449488	24.97478627	0
1.319097977	24.97465055	0
1.299574894	24.97406871	0
1.217074774	24.97423608	0
1.292789621	32.11264952	0
1.389453909	31.90900157	0
0.20439726	24.91294535	0
0.2043777	24.96399265	0
-0.000128519	24.98669267	0
1.442365005	30.05367197	0
0.000128834	24.98616644	0
29.26608563	24.96696495	0
0.50607345	24.91301626	0
1.599219316	25.06759205	0
13.07413382	24.91451459	0
5.955132286	24.91395142	0

TABLE 167: GENERAL EMPIRICAL RELATIONSHIP RESULTS - C

Flow Element Results			
Generic Results		Flow and Geometry variables	
Element is choked	Mass Flux (kg/m ² .s)	Total mass flow (kg/s)	Total volume flow (m ³ /s)
False	0	190.2958916	0.190878701
False	0	185.2319023	0.185799208
False	0	189.4415133	0.190021863
False	0	0	0
False	0	17.82838433	0.017915871
False	0	10.38413803	0.010422534
False	0	0	0
False	0	1.12447217	0.001127962
False	0	1.115411221	0.001118874
False	0	1.127863524	0.001131364
False	0	13.75188495	0.01379383
False	0	38.46880791	0.038586673
False	0	13.75188495	0.013793923
False	0	38.46880791	0.038580995
False	0	412.6846521	0.413915514
False	0	143.2846829	0.143992397
False	0	425.473923	0.427604646
False	0	189.4415133	0.190022825
False	0	189.4415133	0.190007073
False	0	185.2319023	0.185800105
False	0	38.46880791	0.038585074
False	0	38.46880791	0.038581743
False	0	185.2319023	0.185784848
False	0	13.75188495	0.013792554
False	0	52.22069286	0.052379964
False	0	0	-1.8315E-09
False	0	10.38413803	0.010429882
False	0	10.38413803	0.010415347
False	0	0	0
False	0	190.2958916	0.190879677
False	0	190.2958916	0.190864142
False	0	0	-2.08928E-06
False	0	189.4415133	0.190006145
False	0	185.2319023	0.185783978
False	0	190.2958916	0.190863233
False	0	0	0
False	0	0	0
False	0	52.22069286	0.052436496
False	0	564.9693071	0.567760967
False	0	0	0
False	0	0	0

TABLE 167 CONTINUED: GENERAL EMPIRICAL RELATIONSHIP RESULTS - C

Flow Element Results			
Generic Results		Flow and Geometry variables	
Element is choked	Mass Flux (kg/m ² .s)	Total mass flow (kg/s)	Total volume flow (m ³ /s)
False	0	152.284655	0.152740787
False	0	139.7450853	0.140163613
False	0	138.7071214	0.139122485
False	0	134.2324454	0.134633932
False	0	138.2059065	0.138898011
False	0	143.2846829	0.143992261
False	0	13.75188495	0.013793918
False	0	13.75188495	0.013792598
False	0	0	0
False	0	10.38413803	0.010429763
False	0	0	0
False	0	10.38413803	0.010415395
False	0	38.46880791	0.038586405
False	0	38.46880791	0.038581054
False	0	38.46880791	0.038586538
False	0	13.75188495	0.013793949

TABLE 168: GENERAL EMPIRICAL RELATIONSHIP RESULTS – D

Flow Element Results		
Flow and Geometry variables		
Volume flow based on ambient conditions (m ³ /s)	Maximum velocity (m/s)	Mean pressure (kPa)
0.190881772	0	86.98413111
0.185802192	0	86.93243696
0.190024764	0	85.35373357
0	0	97.83584323
0.017883274	0	326.7444117
0.010416109	0	204.2421531
0	0	256.3814528
0.001127934	0	263.1972462
0.001118845	0	263.2618882
0.001131336	0	263.1776998
0.013794224	0	112.2494699
0.038587245	0	84.69091354
0.013794224	0	98.63691388
0.038587245	0	486.616492
0.41395522	0	285.5747266
0.143725825	0	235.3795513
0.426783867	0	233.004177
0.190024764	0	75.31103849

TABLE 168 CONTINUED: GENERAL EMPIRICAL RELATIONSHIP RESULTS – D

Flow Element Results		
Flow and Geometry variables		
Volume flow based on ambient conditions (m ³ /s)	Maximum velocity (m/s)	Mean pressure (kPa)
0.190024764	0	278.8965473
0.185802192	0	77.35371036
0.038587245	0	278.6455627
0.038587245	0	447.1865476
0.185802192	0	278.7682757
0.013794224	0	334.9840161
0.052381469	0	112.5103835
0	0	146.7511023
0.010416109	0	147.3023991
0.010416109	0	229.6782364
0	0	229.9847542
0.190881772	0	76.84587319
0.190881772	0	276.4348427
0	0	280.1060263
0.190024764	0	289.1938323
0.185802192	0	288.6737359
0.190881772	0	286.482435
0	0	97.83584323
0	0	272.7734012
0.052381469	0	216.1374345
0.566708728	0	225.3058753
0	0	97.83584323
0	0	272.7734012
0.152753507	0	258.6759673
0.140175331	0	259.2940383
0.13913417	0	259.8071833
0.134645719	0	267.5901008
0.138631413	0	245.8047334
0.143725825	0	239.0269894
0.013794224	0	99.40590812
0.013794224	0	328.0877308
0	0	240.8855361
0.010416109	0	169.507259
0	0	240.8855417
0.010416109	0	222.1937331
0.038587245	0	98.44681929
0.038587245	0	483.5999085
0.038587245	0	91.65671565
0.013794224	0	94.84659627

TABLE 169: GENERAL EMPIRICAL RELATIONSHIP RESULTS - E

Flow Element Results			
Flow and Geometry variables			
Node pressure drop (kPa)	Pressure ratio (up/down)	Pressure ratio (down/up)	Total temperature (°C)
19.38532756	1.250808119	0.799483138	24.9151469
18.3130651	1.235459365	0.809415532	24.9151583
19.20218562	1.253485363	0.79777557	24.9155067
0	1	1	25.0070732
17.95611478	1.056507288	0.946515004	31.9261794
35.85803375	1.192461114	0.838601769	27.5122222
0	1	1	24.9792972
0.634181082	1.002412434	0.997593372	25.3886033
0.624002395	1.002373085	0.997632533	25.3919677
0.638011964	1.002427205	0.997578672	25.3873571
0.46840489	1.004181616	0.995835797	24.913084
0.843588592	1.010010649	0.990088571	24.916051
1.316963493	1.013441361	0.986736913	24.9131150
2.341403519	1.004823203	0.995199949	25.0669254
0.042621605	1.00014926	0.999850763	24.9739224
1.354842442	1.005772604	0.994260528	31.9093177
0.028031872	1.000120314	0.999879701	32.0979882
0.883204539	1.011796597	0.988340941	24.917722
1.475401069	1.005304167	0.994723818	24.9729582
0.84438811	1.010975841	0.98914332	24.9172720
0.980058932	1.003523421	0.99648895	25.1106925
-1.292263697	0.997114405	1.002893946	25.0728935
1.410558975	1.005072804	0.9949528	24.9717852
2.628423789	1.00787732	0.992184247	24.9638753
0.012172382	1.000108195	0.999891817	24.9130268
-2.91038E-14	1	1	25.0208379
0.942573153	1.006419438	0.993621509	30.0546840
0.404746133	1.001763785	0.99823932	24.962705
0	1	1	25.0029593
0.891188288	1.011664726	0.988469771	24.9173841
1.488740235	1.005400042	0.994628961	24.9714383
14.66525023	1.053763491	0.948979547	24.9669022
14.89017999	1.052849144	0.949803688	24.9724562
14.88029712	1.052910811	0.94974806	24.9713692
14.89220063	1.053370113	0.949333941	24.9709911
0	1	1	25.0070732
0	1	1	24.9685736
0.181195312	1.000838685	0.999162017	29.1594779
4.359884704	1.019540018	0.980834477	31.9014590
0	1	1	25.0070732

TABLE 169 CONTINUED: GENERAL EMPIRICAL RELATIONSHIP RESULTS - E

Flow Element Results			
Flow and Geometry variables			
Node pressure drop (kPa)	Pressure ratio (up/down)	Pressure ratio (down/up)	Total temperature (°C)
0	1	1	24.9685125
4.500081064	1.017549244	0.982753421	24.9747863
4.252588556	1.016536244	0.983732755	24.974650
14.00982531	1.055418115	0.947491791	24.9740687
8.061232531	1.030586008	0.970321732	24.9742361
4.219931158	1.017316462	0.982978294	32.1126495
3.341016566	1.014075944	0.986119438	31.9090015
0.20439726	1.002058304	0.997945924	24.9129453
1.182083182	1.003609451	0.99640353	24.9639926
2.248490616	1.009378039	0.990709092	24.9866926
3.687878914	1.021995741	0.978477659	30.0536719
-2.248490616	0.990709092	1.009378038	24.9861664
27.01747409	1.129465341	0.885374667	24.9669649
0.50607345	1.005153824	0.994872602	24.9130162
1.599219316	1.003312383	0.996698553	25.0675920
13.07413382	1.153597131	0.866853751	24.9145145
5.955132286	1.064821978	0.939124117	24.9139514

TABLE 170: GENERAL EMPIRICAL RELATIONSHIP RESULTS - F

Flow Element Results				
Flow and Geometry variables				Energy and Heat Transfer variables
Quality	Total volume (m ³)	Total mass (kg)	Static pressure (kPa)	Total heat transfer (kW)
0	0	0	86.98413111	0
0	0	0	86.93243696	0
0	0	0	85.35373357	0
0	0	0	97.83584323	0
0	0	0	326.7444117	0
0	0	0	204.2421531	220.326
0	0	0	256.3814528	0
0	0	0	263.1972462	3.910098
0	0	0	263.2618882	3.910098
0	0	0	263.1776998	3.910098
0	0	0	112.2494699	0
0	0	0	84.69091354	0
0	0	0	98.63691388	0
0	0	0	486.616492	0
0	0	0	285.5747266	0
0	0	0	235.8560548	0

TABLE 170 CONTINUED: GENERAL EMPIRICAL RELATIONSHIP RESULTS - F

Flow Element Results				
Flow and Geometry variables				Energy and Heat Transfer variables
Quality	Total volume (m ³)	Total mass (kg)	Static pressure (kPa)	Total heat transfer (kW)
0	0	0	233.004177	0
0	0	0	75.31103849	0
0	0	0	278.8965473	0
0	0	0	77.35371036	0
0	0	0	278.6455627	0
0	0	0	447.1865476	0
0	0	0	278.7682757	0
0	0	0	334.9840161	0
0	0	0	112.5103835	0
0	0	0	146.7511023	0
0	0	0	147.3023991	0
0	0	0	229.6782364	0
0	0	0	229.9847542	0
0	0	0	76.84587319	0
0	0	0	276.4348427	0
0	0	0	280.1060263	0
0	0	0	289.1938323	0
0	0	0	288.6737359	0
0	0	0	286.482435	0
0	0	0	97.83584323	0
0	0	0	272.7734012	0
0	0	0	216.1374345	0
0	0	0	225.3058753	0
0	0	0	97.83584323	0
0	0	0	272.7734012	0
0	0	0	258.6762756	0
0	0	0	259.2942757	0
0	0	0	259.8074384	0
0	0	0	267.5903145	0
0	0	0	245.8047334	0
0	0	0	239.0269894	0
0	0	0	99.40590812	0
0	0	0	328.0877308	0
0	0	0	240.8855361	0
0	0	0	169.507259	0
0	0	0	240.8855417	0
0	0	0	222.1937331	0
0	0	0	98.44681929	0
0	0	0	483.5999085	0
0	0	0	91.65671565	0
0	0	0	94.84659627	0

TABLE 171: GENERAL EMPIRICAL RELATIONSHIP RESULTS - G

Flow Element Results			
Energy and Heat Transfer variables	Non-dimensional variables		Fluid variables
Total power (kW)	Total non-dimensional mass flow	Mach number	Density (kg/m³)
0	3398.296	0	996.9467012
0	3328.100	0	996.9466752
0	3444.390	0	996.9458813
0	0	0	996.9271637
0	92.75418	0	995.1168221
0	80.70097	0	996.3160976
0	0	0	997.0114334
0	7.3678697	0	996.9058452
0	7.30684826	0	996.904981
0	7.390585	0	996.9061674
0	211.0701	0	996.9591573
0	780.3159	0	996.9454423
0	239.1041	0	996.9524187
0	136.1897	0	997.0921752
0	2494.965	0	997.0262972
0	1060.168	0	995.0846247
0	3190.13837	0	995.0170722
0	4317.524	0	996.9408306
0	1169.721	0	997.0234798
0	4111.760	0	996.9418579
0	238.0079	0	996.9867564
0	148.7710	0	997.0728443
0	1144.384	0	997.0237325
0	70.60388	0	997.051352
0	801.2731	0	996.9593031
0	0	0	996.9478535
0	122.3604	0	995.6141599
0	77.99348	0	997.003546
0	0	0	996.9930079
0	4250.646	0	996.9416025
0	1185.400	0	997.0227507
0	0	0	997.0256462
0	1102.667	0	997.0283528
0	1080.07437	0	997.0284025
0	1117.851	0	997.0274944
0	0	0	996.9271637
0	0	0	997.0218266
0	419.9102	0	995.8844903
0	4337.672	0	995.0830369
0	0	0	996.9271637
0	0	0	997.0218428

TABLE 171 CONTINUED: GENERAL EMPIRICAL RELATIONSHIP RESULTS - G

Flow Element Results			
Energy and Heat Transfer variables	Non-dimensional variables		Fluid variables
Total power (kW)	Total non-dimensional mass flow	Mach number	Density (kg/m³)
0	1007.714	0	997.0136875
0	922.9879	0	997.014008
0	897.6184	0	997.0143987
0	853.2832	0	997.0179364
0	974.0047	0	995.0171789
0	1039.728	0	995.085997
0	238.5930	0	996.9528054
0	72.24066	0	997.0482174
0	0	0	997.0023392
0	105.5238	0	995.6255306
0	0	0	997.0024789
0	76.06717	0	996.9989707
0	672.8933	0	996.9523604
0	137.142331	0	997.0906405
0	676.3614	0	996.9489455
0	242.7003	0	996.9505125

TABLE 172: GENERAL EMPIRICAL RELATIONSHIP RESULTS – H

Flow Element Results			
Fluid variables			
Conductivity (W/m.K)	Viscosity (kg/m.s)	Static enthalpy (kJ/kg)	Specific heat (kJ/kg.K)
0.606839068	0.000900473	104.547221	4.181805304
0.606839064	0.000900472	104.547221	4.181805564
0.60683895	0.000900466	104.547221	4.181813529
0.606998971	0.000898659	104.9415779	4.181686497
0.618592969	0.000767715	134.074574	4.179486016
0.611268293	0.000849325	115.5129899	4.180347238
0.607021265	0.000899172	104.9716133	4.181129386
0.607715173	0.000891113	106.6889387	4.180828408
0.607720881	0.000891047	106.7030623	4.18082591
0.60771306	0.000891138	106.6837108	4.18082932
0.606846273	0.000900507	104.56193	4.181691436
0.606839575	0.000900456	104.548888	4.181816604
0.606840819	0.000900509	104.5494764	4.181746161
0.607274881	0.000897383	105.5503544	4.180196731
0.607026795	0.000899269	104.9759452	4.181042489
0.618524151	0.00076796	133.9218806	4.179610522
0.618804338	0.000765322	134.7081966	4.179585687
0.606838225	0.000900426	104.547221	4.181864203

TABLE 172 CONTINUED: GENERAL EMPIRICAL RELATIONSHIP RESULTS – H

Flow Element Results			
Fluid variables			
Conductivity (W/m.K)	Viscosity (kg/m.s)	Static enthalpy (kJ/kg)	Specific heat (kJ/kg.K)
0.607021829	0.00089929	104.9657839	4.181063866
0.606838373	0.000900434	104.547221	4.181853894
0.607254061	0.000896579	105.5413329	4.180970691
0.607267205	0.000897276	105.5388814	4.180348509
0.607019786	0.000899313	104.9607624	4.181065064
0.607032801	0.000899453	104.9795235	4.180866441
0.60684628	0.000900508	104.56193	4.18169046
0.607041854	0.000898379	105.0443199	4.181483403
0.615534173	0.00079928	126.0903873	4.180076572
0.606979924	0.000899506	104.8777372	4.18122362
0.607047985	0.000898713	105.0462991	4.181195014
0.606838336	0.000900432	104.547221	4.181856457
0.607018034	0.000899321	104.9571702	4.181072541
0.607012217	0.000899409	104.9415779	4.181064244
0.607026131	0.000899297	104.9731384	4.181032259
0.607024037	0.000899319	104.9681169	4.181034613
0.607022303	0.000899327	104.9645247	4.18104167
0.606998971	0.000898659	104.9415779	4.181686497
0.60701137	0.000899378	104.9418331	4.181085858
0.614053108	0.000816898	122.4101274	4.180061367
0.618507402	0.000768069	133.8799726	4.179624651
0.606998971	0.000898659	104.9415779	4.181686497
0.607011267	0.000899379	104.9415779	4.1810859
0.607014803	0.00089926	104.9548623	4.181125353
0.607014883	0.000899262	104.9548623	4.181123529
0.607014158	0.000899274	104.9529011	4.181122334
0.607018331	0.000899268	104.9607459	4.181098073
0.618832466	0.000765116	134.7809866	4.179568558
0.618525389	0.000767963	133.9238418	4.179606662
0.606840875	0.000900512	104.5494764	4.181742282
0.607029895	0.000899453	104.9736399	4.180893589
0.607025993	0.00089903	104.9883035	4.181172382
0.615541348	0.000799299	126.106224	4.18002394
0.607025106	0.000899041	104.9861036	4.181172743
0.606983367	0.000899424	104.8886709	4.18124392
0.606840568	0.000900511	104.548888	4.181747215
0.607274648	0.000897371	105.5503544	4.180208197
0.606840078	0.000900484	104.548888	4.181781463
0.606840546	0.000900494	104.5494764	4.181765277

TABLE 174 CONTINUED: GENERAL EMPIRICAL RELATIONSHIP RESULTS - J

Flow Element Results		
Convergence	Upstream Results	
Pressure convergence (kPa)	Velocity (m/s)	Junction pressure loss (kPa)
2.17916E-09	0	0
4.47873E-10	0	0
-4.8342E-12	0	0
-9.09228E-10	0	0
7.48396E-10	0	0
-6.11405E-09	0	0
-2.42067E-11	0	0
-2.91038E-14	0	0
-3.533E-09	0	0
-1.52325E-09	0	0
0	0	0
-1.27766E-09	0	0
-2.13453E-09	0	0
-2.73812E-11	0	0
2.99776E-10	0	0
8.07945E-11	0	0
-3.547E-10	0	0
0	0	0
0	0	0
-3.59793E-10	0	0
8.15714E-10	0	0
0	0	0
0	0	0
2.32194E-09	0	0
2.3323E-09	0	0
-5.26627E-09	0	0
1.48376E-09	0	0
1.46555E-09	0	0
-5.08462E-09	0	0
-7.56749E-10	0	0
-7.58795E-10	0	0
-0.000128519	0	0
-5.44426E-09	0	0
0.000128834	0	0
-1.10144E-07	0	0
-6.9701E-10	0	0
-2.20258E-09	0	0
-1.68053E-08	0	0
-2.19313E-08	0	0

TABLE 175: GENERAL EMPIRICAL RELATIONSHIP RESULTS - K

Flow Element Results	
Upstream Results	
Upstream Node Total Pressure (kPa)	Upstream Node Static Pressure (kPa)
96.67679489	96.67679489
96.08896951	96.08896951
94.95482638	94.95482638
97.83584323	97.83584323
335.7224691	335.7224691
222.1711699	222.1711699
256.3814528	256.3814528
263.5143368	263.5143368
263.5738894	263.5738894
263.4967058	263.4967058
112.4836723	112.4836723
85.11270784	85.11270784
99.29539562	99.29539562
487.7871938	487.7871938
285.5960374	285.5960374
236.0569725	236.0569725
233.0181929	233.0181929
75.75264076	75.75264076
279.6342479	279.6342479
77.77590441	77.77590441
279.1355921	279.1355921
446.5404158	446.5404158
279.4735552	279.4735552
336.2982279	336.2982279
112.5164697	112.5164697
146.7511023	146.7511023
147.7736857	147.7736857
229.8806095	229.8806095
229.9847542	229.9847542
77.29146733	77.29146733
277.1792128	277.1792128
287.4386514	287.4386514
296.6389223	296.6389223
296.1138845	296.1138845
293.9285354	293.9285354
97.83584323	97.83584323
272.7734012	272.7734012
216.2280322	216.2280322
227.4858176	227.4858176
97.83584323	97.83584323
272.7734012	272.7734012

TABLE 157 CONTINUED: GENERAL EMPIRICAL RELATIONSHIP RESULTS - K

Flow Element Results	
Upstream Results	
Upstream Node Total Pressure (kPa)	Upstream Node Static Pressure (kPa)
260.9260078	260.9260078
261.4203326	261.4203326
266.812096	266.812096
271.6207171	271.6207171
247.914699	247.914699
240.6974977	240.6974977
99.50810675	99.50810675
328.6787724	328.6787724
242.0097814	242.0097814
171.3511984	171.3511984
239.7612964	239.7612964
235.7024701	235.7024701
98.69985601	98.69985601
484.3995181	484.3995181
98.19378256	98.19378256
97.82416242	97.82416242

TABLE 176: GENERAL EMPIRICAL RELATIONSHIP RESULTS - L

Flow Element Results		
Upstream Results		
Upstream Node Total Temperature (°C)	Upstream Node Static Temperature (°C)	Elevation (m)
24.91300813	24.91300813	1.5
24.91313784	24.91313784	1.5
24.91338811	24.91338811	1.5
25.00707329	25.00707329	1.5
31.9230727	31.9230727	2
24.97068774	24.97068774	9.53
24.98648197	24.98648197	9.53
24.9726328	24.9726328	4.83
24.97261972	24.97261972	4.83
24.97263667	24.97263667	4.83
24.91303272	24.91303272	0
24.91595862	24.91595862	1.33
24.91296973	24.91296973	1.27
25.06666676	25.06666676	1.33
24.97391775	24.97391775	0
31.9091719	31.9091719	4
32.09798522	32.09798522	4

TABLE 176 CONTINUED: GENERAL EMPIRICAL RELATIONSHIP RESULTS - L

Flow Element Results		
Upstream Results		
Upstream Node Total Temperature (°C)	Upstream Node Static Temperature (°C)	Elevation (m)
24.91762535	24.91762535	1.5
24.97279626	24.97279626	1.5
24.91717889	24.91717889	1.5
25.11070226	25.11070226	2.2
25.07280175	25.07280175	2.6
24.97163036	24.97163036	1.5
24.96370205	24.96370205	1.8
24.91302546	24.91302546	0
25.06162936	25.06162936	12.73
30.05458219	30.05458219	12.73
24.96266135	24.96266135	12.23
24.99132574	24.99132574	12.23
24.91728579	24.91728579	1.5
24.9712749	24.9712749	1.5
24.96529192	24.96529192	0
24.97258053	24.97258053	0
24.97149463	24.97149463	0
24.97111521	24.97111521	0
25.00707329	25.00707329	1.5
24.96851259	24.96851259	1.5
29.15945836	29.15945836	4.83
31.90098955	31.90098955	4
25.00707329	25.00707329	1.5
24.96851259	24.96851259	1.5
24.97464406	24.97464406	2
24.9745355	24.9745355	2
24.97405512	24.97405512	1.7
24.97417196	24.97417196	1.2
32.11254708	32.11254708	3
31.90887645	31.90887645	3.7
24.91292279	24.91292279	1.27
24.96397926	24.96397926	2.4
24.99762288	24.99762288	11
30.0535431	30.0535431	11
24.98613728	24.98613728	11.23
24.96372839	24.96372839	11.23
24.91296042	24.91296042	1.33
25.06741536	25.06741536	1.33
24.9130721	24.9130721	1.33
24.91329438	24.91329438	1.27

TABLE 177: GENERAL EMPIRICAL RELATIONSHIP RESULTS – M

Flow Element Results				
Upstream Results				
Quality	Mach number	Area (m²)	Total enthalpy (kJ/kg)	Static enthalpy (kJ/kg)
0	0	0	104.547221	104.547221
0	0	0	104.547221	104.547221
0	0	0	104.547221	104.547221
0	0	0	104.9415779	104.9415779
0	0	0	134.069671	134.069671
0	0	0	104.9042134	104.9042134
0	0	0	105.0016486	105.0016486
0	0	0	104.9503016	104.9503016
0	0	0	104.9503016	104.9503016
0	0	0	104.9503016	104.9503016
0	0	0	104.56193	104.56193
0	0	0	104.548888	104.548888
0	0	0	104.5494764	104.5494764
0	0	0	105.5503544	105.5503544
0	0	0	104.9759452	104.9759452
0	0	0	133.9218806	133.9218806
0	0	0	134.7081966	134.7081966
0	0	0	104.547221	104.547221
0	0	0	104.9657839	104.9657839
0	0	0	104.547221	104.547221
0	0	0	105.5418232	105.5418232
0	0	0	105.5379008	105.5379008
0	0	0	104.9607624	104.9607624
0	0	0	104.9800138	104.9800138
0	0	0	104.56193	104.56193
0	0	0	105.2148611	105.2148611
0	0	0	126.0903873	126.0903873
0	0	0	104.8777372	104.8777372
0	0	0	104.9976646	104.9976646
0	0	0	104.547221	104.547221
0	0	0	104.9571702	104.9571702
0	0	0	104.9415779	104.9415779
0	0	0	104.9804929	104.9804929
0	0	0	104.9754714	104.9754714
0	0	0	104.9718792	104.9718792
0	0	0	104.9415779	104.9415779
0	0	0	104.9415779	104.9415779
0	0	0	122.4101274	122.4101274
0	0	0	133.8799726	133.8799726
0	0	0	104.9415779	104.9415779
0	0	0	104.9415779	104.9415779

TABLE 177 CONTINUED: GENERAL EMPIRICAL RELATIONSHIP RESULTS – M

Flow Element Results				
Upstream Results				
Quality	Mach number	Area (m²)	Total enthalpy (kJ/kg)	Static enthalpy (kJ/kg)
0	0	0	104.9563332	104.9563332
0	0	0	104.9563332	104.9563332
0	0	0	104.959275	104.959275
0	0	0	104.964178	104.964178
0	0	0	134.7824575	134.7824575
0	0	0	133.9248224	133.9248224
0	0	0	104.5494764	104.5494764
0	0	0	104.9741302	104.9741302
0	0	0	105.0350291	105.0350291
0	0	0	126.1073517	126.1073517
0	0	0	104.9849496	104.9849496
0	0	0	104.8875432	104.8875432
0	0	0	104.548888	104.548888
0	0	0	105.5503544	105.5503544
0	0	0	104.548888	104.548888
0	0	0	104.5494764	104.5494764

TABLE 178: GENERAL EMPIRICAL RELATIONSHIP RESULTS - N

Flow Element Results		
Upstream Results		Downstream Results
Element Inlet Pressure (kPa)	Element Inlet Enthalpy (kJ/kg)	Velocity (m/s)
96.67679489	104.547221	0
96.08896951	104.547221	0
94.95482638	104.547221	0
97.83584323	104.9415779	0
335.7224691	134.069671	0
222.1711699	104.9042134	0
256.3814528	105.0016486	0
263.5143368	104.9503016	0
263.5738894	104.9503016	0
263.4967058	104.9503016	0
112.4836723	104.56193	0
85.11270784	104.548888	0
99.29539562	104.5494764	0
487.7871938	105.5503544	0
285.5960374	104.9759452	0
236.0569725	133.9218806	0
233.0181929	134.7081966	0
75.75264076	104.547221	0

TABLE 178 CONTINUED: GENERAL EMPIRICAL RELATIONSHIP RESULTS - N

Flow Element Results		
Upstream Results		Downstream Results
Element Inlet Pressure (kPa)	Element Inlet Enthalpy (kJ/kg)	Velocity (m/s)
279.6342479	104.9657839	0
77.77590441	104.547221	0
279.1355921	105.5418232	0
446.5404158	105.5379008	0
279.4735552	104.9607624	0
336.2982279	104.9800138	0
112.5164697	104.56193	0
146.7511023	105.2148611	0
147.7736857	126.0903873	0
229.8806095	104.8777372	0
229.9847542	104.9976646	0
77.29146733	104.547221	0
277.1792128	104.9571702	0
287.4386514	104.9415779	0
296.6389223	104.9804929	0
296.1138845	104.9754714	0
293.9285354	104.9718792	0
97.83584323	104.9415779	0
272.7734012	104.9415779	0
216.2280322	122.4101274	0
227.4858176	133.8799726	0
97.83584323	104.9415779	0
272.7734012	104.9415779	0
260.9260078	104.9563332	0
261.4203326	104.9563332	0
266.812096	104.959275	0
271.6207171	104.964178	0
247.914699	134.7824575	0
240.6974977	133.9248224	0
99.50810675	104.5494764	0
328.6787724	104.9741302	0
242.0097814	105.0350291	0
171.3511984	126.1073517	0
239.7612964	104.9849496	0
235.7024701	104.8875432	0
98.69985601	104.548888	0
484.3995181	105.5503544	0
98.19378256	104.548888	0
97.82416242	104.5494764	0

TABLE 179: GENERAL EMPIRICAL RELATIONSHIP RESULTS - O

Flow Element Results	
Downstream Results	
Junction pressure loss (kPa)	Downstream Node Total Pressure (kPa)
0	77.29146733
0	77.77590441
0	75.75264076
0	97.83584323
0	317.7663543
0	186.3131362
0	256.3814528
0	262.8801557
0	262.949887
0	262.8586938
0	112.0152674
0	84.26911924
0	97.97843213
0	485.4457903
0	285.5534158
0.953007003	235.6551371
0	232.9901611
0	74.86943622
0	278.1588468
0	76.9315163
0	278.1555332
0	447.8326795
0	278.0629962
0	333.6698042
0	112.5042974
0	146.7511023
0	146.8311125
0	229.4758633
0	229.9847542
0	76.40027904
0	275.6904726
0	272.7734012
0	281.7487423
0	281.2335874
0	279.0363347
0	97.83584323
0	272.7734012
0	216.0468369
0	223.1259329
0	97.83584323

TABLE 179 CONTINUED: GENERAL EMPIRICAL RELATIONSHIP RESULTS - O

Flow Element Results	
Downstream Results	
Junction pressure loss (kPa)	Downstream Node Total Pressure (kPa)
0	272.7734012
0.00061671	256.4265434
0.000474771	257.1682188
0.000510268	252.8027809
0.000427238	263.5599118
0	243.6947678
0	237.3564811
0	99.30370949
0	327.4966892
0	239.7612908
0	167.6633195
0	242.009787
0	208.684996
0	98.19378256
0	482.8002988
0	85.11964874
0	91.86903013

TABLE 180: GENERAL EMPIRICAL RELATIONSHIP RESULTS - P

Flow Element Results	
Downstream Results	
Downstream Node Static Pressure (kPa)	Downstream Node Total Temperature (°C)
77.29146733	24.91728579
77.77590441	24.91717889
75.75264076	24.91762535
97.83584323	25.00707329
317.7663543	31.92928627
186.3131362	30.05375674
256.3814528	24.97211247
262.8801557	25.80457398
262.949887	25.81131578
262.8586938	25.80207755
112.0152674	24.91313628
84.26911924	24.91614477
97.97843213	24.91326034
485.4457903	25.06718416
285.5534158	24.97392711
235.6551371	31.90946368
232.9901611	32.09799126
74.86943622	24.91782024

TABLE 180 CONTINUED: GENERAL EMPIRICAL RELATIONSHIP RESULTS - P

Flow Element Results	
Downstream Results	
Downstream Node Static Pressure (kPa)	Downstream Node Total Temperature (°C)
278.1588468	24.97312027
76.9315163	24.91736522
278.1555332	25.11068282
447.8326795	25.07298541
278.0629962	24.97194013
333.6698042	24.96404863
112.5042974	24.91302815
146.7511023	24.98004657
146.8311125	30.05478595
229.4758633	24.96275025
229.9847542	25.01459303
76.40027904	24.91748244
275.6904726	24.97160184
272.7734012	24.96851259
281.7487423	24.9723319
281.2335874	24.97124384
279.0363347	24.97086706
97.83584323	25.00707329
272.7734012	24.96863468
216.0468369	29.15949761
223.1259329	31.90192851
97.83584323	25.00707329
272.7734012	24.96851259
256.4265434	24.97492861
257.1682188	24.9747657
252.8027809	24.97408243
263.5599118	24.97430029
243.6947678	32.11275195
237.3564811	31.90912668
99.30370949	24.9129679
327.4966892	24.96400604
239.7612908	24.97576247
167.6633195	30.05380084
242.009787	24.98619559
208.684996	24.97020151
98.19378256	24.9130721
482.8002988	25.06776875
85.11964874	24.91595709
91.86903013	24.91460846

TABLE 181: GENERAL EMPIRICAL RELATIONSHIP RESULTS - Q

Flow Element Results				
Downstream Results				
Downstream Node Static Temperature (°C)	Elevation (m)	Quality	Mach number	Area (m²)
24.91728579	1.5	0	0	0
24.91717889	1.5	0	0	0
24.91762535	1.5	0	0	0
25.00707329	1.5	0	0	0
31.92928627	1	0	0	0
30.05375674	9.53	0	0	0
24.97211247	9.53	0	0	0
25.80457398	4.83	0	0	0
25.81131578	4.83	0	0	0
25.80207755	4.83	0	0	0
24.91313628	0	0	0	0
24.91614477	1.33	0	0	0
24.91326034	1.27	0	0	0
25.06718416	1.33	0	0	0
24.97392711	0	0	0	0
31.90925844	4	0	0	0
32.09799126	4	0	0	0
24.91782024	1.5	0	0	0
24.97312027	1.5	0	0	0
24.91736522	1.5	0	0	0
25.11068282	2.3	0	0	0
25.07298541	2.4	0	0	0
24.97194013	1.5	0	0	0
24.96404863	1.9	0	0	0
24.91302815	0	0	0	0
24.98004657	12.73	0	0	0
30.05478595	12.73	0	0	0
24.96275025	12.23	0	0	0
25.01459303	12.23	0	0	0
24.91748244	1.5	0	0	0
24.97160184	1.5	0	0	0
24.96851259	1.5	0	0	0
24.9723319	1.5	0	0	0
24.97124384	1.5	0	0	0
24.97086706	1.5	0	0	0
25.00707329	1.5	0	0	0
24.96863468	1.5	0	0	0
29.15949761	4.83	0	0	0
31.90192851	4	0	0	0
25.00707329	1.5	0	0	0
24.96851259	1.5	0	0	0

TABLE 181 CONTINUED: GENERAL EMPIRICAL RELATIONSHIP RESULTS - Q

Flow Element Results				
Downstream Results				
Downstream Node Static Temperature (°C)	Elevation (m)	Quality	Mach number	Area (m²)
24.97492848	2.3	0	0	0
24.9747656	2.3	0	0	0
24.97408231	3	0	0	0
24.97430019	1.9	0	0	0
32.11275195	3.3	0	0	0
31.90912668	3.9	0	0	0
24.9129679	1.27	0	0	0
24.96400604	2.5	0	0	0
24.97576247	11.23	0	0	0
30.05380084	11.23	0	0	0
24.98619559	11	0	0	0
24.97020151	11	0	0	0
24.9130721	1.33	0	0	0
25.06776875	1.33	0	0	0
24.91595709	1.33	0	0	0
24.91460846	1.27	0	0	0

TABLE 182: GENERAL EMPIRICAL RELATIONSHIP RESULTS - R

Flow Element Results		
Downstream Results		
Total enthalpy (kJ/kg)	Static enthalpy (kJ/kg)	Element Exit Pressure (kPa)
104.547221	104.547221	77.29146733
104.547221	104.547221	77.77590441
104.547221	104.547221	75.75264076
104.9415779	104.9415779	97.83584323
134.079477	134.079477	317.7663543
126.1217665	126.1217665	186.3131362
104.9415779	104.9415779	256.3814528
108.4275757	108.4275757	262.8801557
108.4558231	108.4558231	262.949887
108.41712	108.41712	262.8586938
104.56193	104.56193	112.0152674
104.548888	104.548888	84.26911924
104.5494764	104.5494764	97.97843213
105.5503544	105.5503544	485.4457903
104.9759452	104.9759452	285.5534158
133.9218806	133.9218806	235.6551371
134.7081966	134.7081966	232.9901611
104.547221	104.547221	74.86943622

TABLE 182 CONTINUED: GENERAL EMPIRICAL RELATIONSHIP RESULTS - R

Flow Element Results		
Downstream Results		
Total enthalpy (kJ/kg)	Static enthalpy (kJ/kg)	Element Exit Pressure (kPa)
104.9657839	104.9657839	278.1588468
104.547221	104.547221	76.9315163
105.5408426	105.5408426	278.1555332
105.539862	105.539862	447.8326795
104.9607624	104.9607624	278.0629962
104.9790332	104.9790332	333.6698042
104.56193	104.56193	112.5042974
104.8737786	104.8737786	146.7511023
126.0903873	126.0903873	146.8311125
104.8777372	104.8777372	229.4758633
105.0949337	105.0949337	229.9847542
104.547221	104.547221	76.40027904
104.9571702	104.9571702	275.6904726
104.9415779	104.9415779	272.7734012
104.9657839	104.9657839	281.7487423
104.9607624	104.9607624	281.2335874
104.9571702	104.9571702	279.0363347
104.9415779	104.9415779	97.83584323
104.9420883	104.9420883	272.7734012
122.4101274	122.4101274	216.0468369
133.8799726	133.8799726	223.1259329
104.9415779	104.9415779	97.83584323
104.9415779	104.9415779	272.7734012
104.9533914	104.9533914	256.4265434
104.9533914	104.9533914	257.1682188
104.9465272	104.9465272	252.8027809
104.9573138	104.9573138	263.5599118
134.7795157	134.7795157	243.6947678
133.9228612	133.9228612	237.3564811
104.5494764	104.5494764	99.30370949
104.9731496	104.9731496	327.4966892
104.9415779	104.9415779	239.7612908
126.1050963	126.1050963	167.6633195
104.9872576	104.9872576	242.009787
104.8897986	104.8897986	208.684996
104.548888	104.548888	98.19378256
105.5503544	105.5503544	482.8002988
104.548888	104.548888	85.11964874
104.5494764	104.5494764	91.86903013

TABLE 183: GENERAL EMPIRICAL RELATIONSHIP RESULTS - S

Flow Element Results		
Downstream Results	Forces	
	Forces From Pressure Difference	Forces From Velocity Change
Element Exit Enthalpy (kJ/kg)	Magnitude (N)	Magnitude (N)
104.547221	0	0
104.547221	0	0
104.547221	0	0
104.9415779	0	0
134.079477	59.58390589	0
126.1217665	360.4842705	0
104.9415779	0	0
108.4275757	0.321344294	0
108.4558231	0.316186679	0
108.41712	0.323285431	0
104.56193	1213.327245	0
104.548888	-300.0170747	0
104.5494764	-19.04441487	0
105.5503544	-3752.70768	0
104.9759452	6881.269991	0
133.9218806	0	0
134.7081966	-4907.496524	0
104.547221	0	0
104.9657839	-22117.30633	0
104.547221	0	0
105.5408426	-1728.332321	0
105.539862	0	0
104.9607624	-22109.84481	0
104.9790332	-2924.767315	0
104.56193	1759.48121	0
104.8737786	-574.408984	0
126.0903873	-570.6828165	0
104.8777372	1627.608624	0
105.0949337	1626.891047	0
104.547221	0	0
104.9571702	-21806.17842	0
104.9415779	0	0
104.9657839	0	0
104.9607624	0	0
104.9571702	0	0
104.9415779	0	0
104.9420883	-21544.84129	0
122.4101274	-1573.588603	0
133.8799726	0	0
104.9415779	0	0
104.9415779	0	0

TABLE 183 CONTINUED: GENERAL EMPIRICAL RELATIONSHIP RESULTS - S

Flow Element Results		
Downstream Results	Forces	
	Forces From Pressure Difference	Forces From Velocity Change
Element Exit Enthalpy (kJ/kg)	Magnitude (N)	Magnitude (N)
104.9533914	0	0
104.9533914	0	0
104.9465272	0	0
104.9573138	0	0
134.7795157	0	0
133.9228612	0	0
104.5494764	3.611997699	0
104.9731496	20.88913407	0
104.9415779	11.30214656	0
126.1050963	370.5273614	0
104.9872576	-11.30214656	0
104.8897986	-403.8455578	0
104.548888	0	0
105.5503544	28.26053796	0
104.548888	0	0
104.5494764	29.93375949	0

HEAT EXCHANGERS – SHELL SIDE

TABLE 184: HEAT EXCHANGER - SHELL SIDE RESULTS - A

General	Heat Exchanger Results	Primary Side Flow Data	
Identifier	Effectiveness	Temperature Hot Side 1	Temperature Cold side 1
E-101 (Shell Side)	0.365644246	44.49999756	25.19799326
E-102 (Shell Side)	0.357697609	44.99999763	25.17976169
E-103 (Shell Side)	0.358979527	44.49999748	25.17452402
E-104 (Shell Side)	0.379829834	44.99999748	25.19656923
E-301 (Shell Side)	0.569432608	33	25.11065733

TABLE 185: HEAT EXCHANGER - SHELL SIDE RESULTS - B

Primary Side Flow Data		Flow Element Results	
		Generic Results	
Primary side Temperature	Secondary side Temperature	Check valve active	Flashing/cavitating
0	0	False	False
0	0	False	False
0	0	False	False
0	0	False	False
0	0	False	False

TABLE 186: HEAT EXCHANGER - SHELL SIDE RESULTS - C

Flow Element Results		
Generic Results		
Pressure drop excluding elevation (kPa)	Static temperature (°C)	Incondensable Mass Flow Rate (kg/s)
20.67635374	40.97354254	0
31.88308304	42.01207841	0
23.44523439	41.22666864	0
17.89589926	41.24114721	0
9.203059342	30.754481	0

TABLE 187: HEAT EXCHANGER - SHELL SIDE RESULTS - D

Flow Element Results			
Generic Results		Flow and Geometry variables	
Element is choked	Mass Flux (kg/m ² .s)	Total mass flow (kg/s)	Total volume flow (m ³ /s)
False	0	137.4566659	0.138569048
False	0	170.6525755	0.172109779
False	0	146.3630861	0.147564233
False	0	127.8732516	0.128923445
False	0	35.04	0.035198536

TABLE 188: HEAT EXCHANGER - SHELL SIDE RESULTS - E

Flow Element Results	
Flow and Geometry variables	
Volume flow based on ambient conditions (m ³ /s)	Abs val of maximum velocity (m/s)
0.137879866	0
0.171177978	0
0.146813707	0
0.128266946	0
0.035147881	0

TABLE 189: HEAT EXCHANGER - SHELL SIDE RESULTS - F

Flow Element Results			
Flow and Geometry variables			
Maximum velocity (m/s)	Mean pressure (kPa)	Node pressure drop (kPa)	Pressure ratio (up/down)
0	407.6618231	20.67635374	1.052039072
0	408.5584585	31.88308304	1.081206595
0	391.2773828	23.44523439	1.06177036
0	391.5520504	17.89589926	1.046773935
0	214.3984703	9.203059342	1.031007932

TABLE 190: HEAT EXCHANGER - SHELL SIDE RESULTS - G

Flow Element Results				
Flow and Geometry variables				
Pressure ratio (down/up)	Total temperature (°C)	Quality	Total volume (m ³)	Total mass (kg)
0.950535039	40.97337085	0	0	0
0.924892619	42.01201102	0	0	0
0.94182324	41.22649758	0	0	0
0.955316107	41.24094295	0	0	0
0.969924643	30.75479521	0	0	0

TABLE 191: HEAT EXCHANGER - SHELL SIDE RESULTS - H

Flow Element Results			
Flow and Geometry variables		Energy and Heat Transfer variables	
Static pressure (kPa)	Total heat transfer (kW)	Total power (kW)	
407.6618231	-4054.368232		0
408.5584585	-4266.965716		0
391.2773828	-4007.821075		0
391.5520504	-4019.86128		0
214.3984703	-657.9448767		0

TABLE 192: HEAT EXCHANGER - SHELL SIDE RESULTS - I

Flow Element Results			
Non-dimensional variables		Fluid variables	
Total non-dimensional mass flow	Mach number	Density (kg/m ³)	Conductivity (W/m.K)
586.0895171	0	991.9723655	0.632119
717.0527672	0	991.5332901	0.633449801
647.2930467	0	991.8601768	0.632440181
569.4992442	0	991.8541333	0.632458771
200.3594371	0	995.4959374	0.616786439

TABLE 193: HEAT EXCHANGER - SHELL SIDE RESULTS - J

Flow Element Results			
Fluid variables			
Viscosity (kg/m.s)	Static enthalpy (kJ/kg)	Specific heat (kJ/kg.K)	
0.0006413	171.9563299	4.179229624	
0.000630499	176.2976516	4.179274877	
0.000638593	172.9995318	4.179284129	
0.000638444	173.0602925	4.179284196	
0.000785492	129.1549172	4.179678983	

TABLE 194: HEAT EXCHANGER - SHELL SIDE RESULTS - K

Flow Element Results		
Fluid variables		Convergence
Total gas mass fraction - Incondensable + Vapour	Gas constant (kJ/kg.K)	Pressure convergence (kPa)
-1	0	-2.50984E-11
-1	0	-3.83952E-11
-1	0	-2.47273E-11
-1	0	6.27333E-11
-1	0	7.30142E-12

TABLE 195: HEAT EXCHANGER - SHELL SIDE RESULTS - L

Flow Element Results		
Upstream Results		
Velocity (m/s)	Junction pressure loss (kPa)	Upstream Node Total Pressure (kPa)
0	0	418
0	0	424.5
0	0	403
0	0	400.5
0	0	219

TABLE 196: HEAT EXCHANGER - SHELL SIDE RESULTS - M

Flow Element Results	
Upstream Results	
Upstream Node Static Pressure (kPa)	Upstream Node Total Temperature (°C)
418	44.5
424.5	45
403	44.5
400.5	45
219	33

TABLE 197: HEAT EXCHANGER - SHELL SIDE RESULTS - N

Flow Element Results				
Upstream Results				
Upstream Node Static Temperature (°C)	Elevation (m)	Quality	Mach number	Area (m ²)
44.49999756	0	0	0	0
44.99999763	0	0	0	0
44.49999748	0	0	0	0
44.99999748	0	0	0	0
33	0	0	0	0

TABLE 198: HEAT EXCHANGER - SHELL SIDE RESULTS - O

Flow Element Results		
Upstream Results		
Total enthalpy (kJ/kg)	Static enthalpy (kJ/kg)	Element Inlet Pressure (kPa)
186.704135	186.704135	418
188.79956	188.79956	424.5
186.6908975	186.6908975	403
188.77844	188.77844	400.5
138.5434	138.5434	219

TABLE 199: HEAT EXCHANGER - SHELL SIDE RESULTS - P

Flow Element Results		
Upstream Results	Downstream Results	
Element Inlet Enthalpy (kJ/kg)	Velocity (m/s)	Junction pressure loss (kPa)
186.704135	0	0
188.79956	0	0
186.6908975	0	0
188.77844	0	0
138.5434	0	0

TABLE 200: HEAT EXCHANGER - SHELL SIDE RESULTS - Q

Flow Element Results	
Downstream Results	
Downstream Node Total Pressure (kPa)	Downstream Node Static Pressure (kPa)
397.3236463	397.3236463
392.616917	392.616917
379.5547656	379.5547656
382.6041007	382.6041007
209.7969407	209.7969407

TABLE 201: HEAT EXCHANGER - SHELL SIDE RESULTS - R

Flow Element Results		
Downstream Results		
Downstream Node Total Temperature (°C)	Downstream Node Static Temperature (°C)	Elevation (m)
37.4467417	37.44674169	0
39.02402203	39.02402203	0
37.95299517	37.95299516	0
37.4818859	37.48188591	0
28.50959042	28.50959042	0

TABLE 202: HEAT EXCHANGER - SHELL SIDE RESULTS - S

Flow Element Results				
Downstream Results				
Quality	Mach number	Area (m ²)	Total enthalpy (kJ/kg)	Static enthalpy (kJ/kg)
0	0	0	157.2085248	157.2085248
0	0	0	163.7957433	163.7957433
0	0	0	159.3081661	159.3081661
0	0	0	157.3421448	157.3421449
0	0	0	119.7664343	119.7664344

TABLE 203: HEAT EXCHANGER - SHELL SIDE RESULTS - T

Flow Element Results		
Downstream Results		Forces
		Forces From Pressure Difference
Element Exit Pressure (kPa)	Element Exit Enthalpy (kJ/kg)	Magnitude (N)
397.3236463	157.2085248	0
392.616917	163.7957433	0
379.5547656	159.3081661	0
382.6041007	157.3421449	0
209.7969407	119.7664344	0

TABLE 204: HEAT EXCHANGER - SHELL SIDE RESULTS - U

Flow Element Results	
Forces	
Forces From Velocity Change	
Magnitude (N)	
	0
	0
	0
	0
	0

HEAT EXCHANGERS – TUBE SIDE

TABLE 205: HEAT EXCHANGER - TUBE SIDE RESULTS - A

General	Flow Element Results		
	Generic Results		
Identifier	Check valve active	Flashing/cavitating	Pressure drop excluding elevation (kPa)
E-101 (Tube Side)	False	False	6.349983045
E-102 (Tube Side)	False	False	5.319361157
E-103 (Tube Side)	False	False	4.900920831
E-104 (Tube Side)	False	False	5.267628792
E-301 (Tube Side)	False	False	10.79544184

TABLE 206: HEAT EXCHANGER - TUBE SIDE RESULTS - B

Flow Element Results			
Generic Results			
Static temperature (°C)	Incondensable Mass Flow Rate (kg/s)	Element is choked	Mass Flux (kg/m ² .s)
28.28089187	0	False	0
28.72473453	0	False	0
28.64336104	0	False	0
28.55257657	0	False	0
27.15749788	0	False	0

TABLE 207: HEAT EXCHANGER - TUBE SIDE RESULTS - C

Flow Element Results	
Flow and Geometry variables	
Total mass flow (kg/s)	Total volume flow (m ³ /s)
157.3237684	0.157934783
143.9833336	0.144559559
138.2059065	0.13875564
143.2846829	0.143851687
38.46880791	0.038606274

TABLE 208: HEAT EXCHANGER - TUBE SIDE RESULTS - D

Flow Element Results		
Flow and Geometry variables		
Volume flow based on ambient conditions (m ³ /s)	Maximum velocity (m/s)	Mean pressure (kPa)
0.157808135	0	248.3669038
0.144426628	0	249.6246072
0.138631413	0	255.7370918
0.143725825	0	246.7498842
0.038587245	0	270.7729245

TABLE 209: HEAT EXCHANGER - TUBE SIDE RESULTS - E

Flow Element Results			
Flow and Geometry variables			
Node pressure drop (kPa)	Pressure ratio (up/down)	Pressure ratio (down/up)	Total temperature (°C)
16.11804584	1.067072481	0.937143463	28.280938
15.0862737	1.062318994	0.941336835	28.7249394
15.64478559	1.063105518	0.9406404	28.6435355
12.10477294	1.050290398	0.952117626	28.5527228
12.74965857	1.048221446	0.95399689	27.1574885

TABLE 210: HEAT EXCHANGER - TUBE SIDE RESULTS - F

Flow Element Results				
Flow and Geometry variables				Energy and Heat Transfer variables
Quality	Total volume (m ³)	Total mass (kg)	Static pressure (kPa)	Total heat transfer (kW)
0	0	0	248.3669038	4054.368232
0	0	0	249.6246072	4266.965716
0	0	0	255.7370918	4007.821075
0	0	0	246.7498842	4019.86128
0	0	0	270.7729245	657.9448767

TABLE 211: HEAT EXCHANGER - TUBE SIDE RESULTS - G

Flow Element Results			
Energy and Heat Transfer variables	Non-dimensional variables		Fluid variables
Total power (kW)	Total non-dimensional mass flow	Mach number	Density (kg/m ³)
0	1059.726922	0	996.1312256
0	967.0390686	0	996.0139243
0	905.7168187	0	996.0381177
0	978.9924005	0	996.0584113
0	239.7150822	0	996.4392917

TABLE 212: HEAT EXCHANGER - TUBE SIDE RESULTS - H

Flow Element Results			
Fluid variables			
Conductivity (W/m.K)	Viscosity (kg/m.s)	Static enthalpy (kJ/kg)	Specific heat (kJ/kg.K)
0.612587048	0.000834187	118.7664229	4.180123052
0.613336439	0.00082545	120.6230277	4.180055733
0.613202219	0.000827051	120.2883942	4.180054051
0.613044572	0.000828839	119.9007214	4.180087138
0.610703085	0.000856294	114.0905485	4.180227057

TABLE 213: HEAT EXCHANGER - TUBE SIDE RESULTS - I

Flow Element Results		
Fluid variables		Convergence
Total gas mass fraction - Incondensable + Vapour	Gas constant (kJ/kg.K)	Pressure convergence (kPa)
-1	0	8.57331E-
-1	0	1.02067E-
-1	0	5.52858E-
-1	0	-1.92415E-
-1	0	-1.48675E-

TABLE 214: HEAT EXCHANGER - TUBE SIDE RESULTS - J

Flow Element Results		
Upstream Results		
Velocity (m/s)	Junction pressure loss (kPa)	Upstream Node Total Pressure (kPa)
0	0	256.4259267
0	0	257.167744
0	0	263.5594846
0	0	252.8022706
0	0	277.1477538

TABLE 215: HEAT EXCHANGER - TUBE SIDE RESULTS - K

Flow Element Results	
Upstream Results	
Upstream Node Static Pressure (kPa)	Upstream Node Total Temperature (°C)
256.4259267	25.19799327
257.167744	25.1797617
263.5594846	25.17452402
252.8022706	25.19656923
277.1477538	25.11066947

TABLE 216: HEAT EXCHANGER - TUBE SIDE RESULTS - L

Flow Element Results				
Upstream Results				
Upstream Node Static Temperature (°C)	Elevation (m)	Quality	Mach number	Area (m ²)
25.19799327	2.3	0	0	0
25.1797617	2.3	0	0	0
25.17452402	1.9	0	0	0
25.19656923	3	0	0	0
25.11066947	2.4	0	0	0

TABLE 217: HEAT EXCHANGER - TUBE SIDE RESULTS - M

Flow Element Results		
Upstream Results		
Total enthalpy (kJ/kg)	Static enthalpy (kJ/kg)	Element Inlet Pressure (kPa)
105.8858978	105.8858978	256.4259267
105.8103625	105.8103625	257.167744
105.794331	105.794331	263.5594846
105.8766203	105.8766203	252.8022706
105.539862	105.539862	277.1477538

TABLE 218: HEAT EXCHANGER - TUBE SIDE RESULTS - N

Flow Element Results		
Upstream Results	Downstream Results	
Element Inlet Enthalpy (kJ/kg)	Velocity (m/s)	Junction pressure loss (kPa)
105.8858978	0	0
105.8103625	0	0
105.794331	0	0
105.8766203	0	0
105.539862	0	0

TABLE 219: HEAT EXCHANGER - TUBE SIDE RESULTS - O

Flow Element Results	
Downstream Results	
Downstream Node Total Pressure (kPa)	Downstream Node Static Pressure (kPa)
240.3078809	240.3078809
242.0814703	242.0814703
247.914699	247.914699
240.6974977	240.6974977
264.3980952	264.3980952

TABLE 220: HEAT EXCHANGER - TUBE SIDE RESULTS - P

Flow Element Results		
Downstream Results		
Downstream Node Total Temperature (°C)	Downstream Node Static Temperature (°C)	Elevation (m)
31.36388394	31.36388394	3.3
32.27011713	32.27011713	3.3
32.11254708	32.11254708	3
31.90887645	31.90887645	3.7
29.20430757	29.20430757	2.6

TABLE 221: HEAT EXCHANGER - TUBE SIDE RESULTS - Q

Flow Element Results				
Downstream Results				
Quality	Mach number	Area (m ²)	Total enthalpy (kJ/kg)	Static enthalpy (kJ/kg)
0	0	0	131.6469481	131.6469481
0	0	0	135.4356928	135.4356928
0	0	0	134.7824575	134.7824575
0	0	0	133.9248224	133.9248224
0	0	0	122.6412349	122.6412349

TABLE 222: HEAT EXCHANGER - TUBE SIDE RESULTS - R

Flow Element Results		
Downstream Results		Forces
		Forces From Pressure Difference
Element Exit Pressure (kPa)	Element Exit Enthalpy (kJ/kg)	Magnitude (N)
240.3078809	131.6469481	0
242.0814703	135.4356928	0
247.914699	134.7824575	0
240.6974977	133.9248224	0
264.3980952	122.6412349	0

TABLE 223: HEAT EXCHANGER - TUBE SIDE RESULTS - S

Flow Element Results	
Forces	
Forces From Velocity Change	
Magnitude (N)	
	0
	0
	0
	0
	0

T-JUNCTIONS

TABLE 224: T-JUNCTION RESULTS - A

General	Flow Node Results		
Identifier	Total pressure (kPa)	Total temperature (°C)	Static pressure (kPa)
T - Junction - 0	228.7622849	24.96290696	226.6219825
T - Junction - 112	112.6182537	24.91300296	110.9072705
T - Junction - 114	112.6212018	24.91300231	111.7490242
T - Junction - 116	112.596633	24.91300774	112.051182
T - Junction - 118	112.516988	24.91302535	112.4998803
T - Junction - 12	119.0620058	24.91168254	118.893396
T - Junction - 13	118.6201527	24.91173993	118.1923297
T - Junction - 14	116.8251734	24.9120728	115.1124522
T - Junction - 141	303.6772632	24.96380705	303.4364281
T - Junction - 15	118.9246535	24.91169111	118.7226814
T - Junction - 16	246.1557169	31.67429454	244.9146643
T - Junction - 166	223.1057323	29.01802855	222.8646342
T - Junction - 167	285.5159561	24.97393534	282.3899865
T - Junction - 168	231.2451491	31.90017994	227.9122416
T - Junction - 169	284.880933	24.97407479	282.4545218
T - Junction - 17	117.9830472	24.91184311	117.1233355
T - Junction - 170	233.0534453	32.09797763	230.4692357
T - Junction - 172	234.7021301	32.00941832	233.7659474
T - Junction - 173	256.4259267	25.19799327	256.425629
T - Junction - 18	248.447124	31.67380106	245.6547522
T - Junction - 227	273.3776952	31.93626478	271.4945777
T - Junction - 245	272.582191	31.9364361	270.3619421
T - Junction - 285	221.1792942	31.67028755	216.7801826
T - Junction - 310	277.2433671	24.97272747	276.2161312
T - Junction - 311	275.3829219	24.97264203	272.8786605
T - Junction - 37	257.167744	25.1797617	257.1675661
T - Junction - 40	290.8547554	31.93273552	282.6870115
T - Junction - 420	146.6557294	30.05482386	146.4823189
T - Junction - 421	230.0886463	24.96261566	229.9154776
T - Junction - 437	303.2443387	24.96390278	302.8769617
T - Junction - 438	302.8709072	24.96398535	302.5278802
T - Junction - 490	223.3272779	29.15792057	220.4790098
T - Junction - 681	223.468535	25.81657046	223.1254175
T - Junction - 683	223.1800065	25.81466917	222.8125331
T - Junction - 73	112.4993309	24.91302925	112.2720352
T - Junction - 74	263.5594846	25.17452402	263.5593354
T - Junction - 85	229.9847542	25.01457886	229.9847542
T - Junction - 88	252.8022706	25.19656923	252.8020262

TABLE 225: T-JUNCTION RESULTS - B

Flow Node Results				
Static temperature (°C)	Total mass (kg)	Mass source (kg/s)	Mach number	Heat transfer (kW)
24.96286352	0	0	0	0
24.91297078	0	0	0	0
24.9129859	0	0	0	0
24.91299748	0	0	0	0
24.91302503	0	0	0	0
24.91167937	0	0	0	0
24.91173188	0	0	0	0
24.91204059	0	0	0	0
24.96380252	0	0	0	0
24.91168731	0	0	0	0
31.6742634	0	0	0	0
29.01802289	0	0	0	0
24.97387181	0	0	0	0
31.90009624	0	0	0	0
24.97402548	0	0	0	0
24.91182694	0	0	0	0
32.0979127	0	0	0	0
32.0093948	0	0	0	0
25.19799326	0	0	0	0
31.673731	0	0	0	0
31.93621749	0	0	0	0
31.93638035	0	0	0	0
31.67017716	0	0	0	0
24.9727066	0	0	0	0
24.97259115	0	0	0	0
25.17976169	0	0	0	0
31.93253044	0	0	0	0
30.05481969	0	0	0	0
24.96261215	0	0	0	0
24.96389587	0	0	0	0
24.96397889	0	0	0	0
29.15785341	0	0	0	0
25.81656326	0	0	0	0
25.81466147	0	0	0	0
24.91302498	0	0	0	0
25.17452402	0	0	0	0
25.01457886	0	0	0	0
25.19656923	0	0	0	0