

1-1-2015

# A Framework for Determining Building Water Cycle Resilience Using a Dynamic Water Resilience Assessment Model (WRAM)

Caryssa Joustra

*University of South Florida*, [cjoustra@mail.usf.edu](mailto:cjoustra@mail.usf.edu)

Follow this and additional works at: <http://scholarcommons.usf.edu/etd>

 Part of the [Environmental Engineering Commons](#)

---

## Scholar Commons Citation

Joustra, Caryssa, "A Framework for Determining Building Water Cycle Resilience Using a Dynamic Water Resilience Assessment Model (WRAM)" (2015). *Graduate Theses and Dissertations*.  
<http://scholarcommons.usf.edu/etd/5855>

This Dissertation is brought to you for free and open access by the Graduate School at Scholar Commons. It has been accepted for inclusion in Graduate Theses and Dissertations by an authorized administrator of Scholar Commons. For more information, please contact [scholarcommons@usf.edu](mailto:scholarcommons@usf.edu).

A Framework for Determining Building Water Cycle Resilience  
Using a Dynamic Water Resilience Assessment Model (WRAM)

by

Caryssa M. Joustra

A dissertation submitted in partial fulfillment  
of the requirements for the degree of  
Doctor of Philosophy in Environmental Engineering  
Department of Civil and Environmental Engineering  
College of Engineering  
University of South Florida

Major Professor: Daniel Yeh, Ph.D.  
Delcie Durham, Ph.D.  
James Mihelcic, Ph.D.  
Charles Kibert, Ph.D.  
Christopher Pyke, Ph.D.

Date of Approval:  
March 23, 2015

Keywords: Algorithm, Alternative Water Supplies, STELLA, Sustainability, Water Profiling

Copyright © 2015, Caryssa M. Joustra

## **ACKNOWLEDGMENTS**

I would like to thank Dr. Daniel Yeh for encouraging me to seek new learning opportunities and for his support throughout my collegiate journey. His guidance was instrumental in the fulfillment of this research. Additionally, I acknowledge the past and present members of Dr. Yeh's research group for their encouragement, support, and enthusiasm over the years, especially Pacia Diaz for her insight on the topic of resilience. I would also like to thank Paul Stanek and Tony Lagos at the city of Dunedin for providing me with detailed building water use data. I am grateful to my committee, Dr. Durham, Dr. Mihelcic, Dr. Kibert, and Dr. Pyke, as well as my chair Dr. Wells for their time, support, and critique given to this research; the comments provided have improved this manuscript.

This research is supported by the United States Green Building Council (USGBC) Green Building Research Fund #230. This material is based upon work supported by the National Science Foundation under Grant No. 0965743 (S\_STEM) and Grant No. 0854306 (IRES). Any opinions, findings, and conclusions or recommendations in this material are those of the author(s) and do not necessarily reflect the views of the National Science Foundation. I also acknowledge funding from the U.S. Department of Education Graduate Assistants in Area of National Need (GAANN) Fellowship, project number P200A090162. I thank the Department of Civil and Environmental Engineering for their funding support, especially Barbara Johnson for her assistance throughout my time at the University of South Florida.

## TABLE OF CONTENTS

LIST OF TABLES.....	v
LIST OF FIGURES .....	xi
ABSTRACT.....	xvi
1 INTRODUCTION .....	1
1.1 Vulnerability and System Relationships .....	3
1.2 Building Sustainability and Resilience .....	5
1.3 Significance of Water Failure .....	6
1.4 Building Origin of Failure and Physical Characteristics .....	8
1.5 Orientation to Chapters.....	10
2 BACKGROUND.....	13
2.1 Note to Reader .....	13
2.2 Building Water Cycle and Decision Support Systems .....	13
2.2.1 Introduction.....	13
2.2.2 Smart Building .....	14
2.2.2.1 Building Automation.....	17
2.2.2.2 Relationship to Green Building.....	20
2.2.3 The Building Water Cycle.....	21
2.2.3.1 Building Water Demands .....	23
2.2.3.2 Building Water Sources.....	28
2.2.3.3 Usage Patterns .....	31
2.2.3.4 Integrated Building Water Management (IBWM) .....	32
2.2.4 Decision Support Systems .....	35
2.2.4.1 Advantages and Disadvantages.....	35
2.2.4.2 Role of DSSs in Smart Building Water Reuse and Recycling .....	37
2.2.4.3 Tools for Building Water Management .....	40
2.2.4.4 Incorporating IBWM into Smart Building DSSs.....	43
2.2.5 Conclusion.....	44
2.3 Net-zero and Net-positive Building Water Cycle Management .....	46
2.3.1 Introduction.....	46
2.3.2 Building Water Cycle.....	48
2.3.2.1 End-uses and Water Sources .....	49
2.3.2.2 Influencing Factors and Uncertainty .....	51
2.3.3 Net-zero Water .....	52
2.3.3.1 System Boundary.....	53
2.3.3.2 Water Balance Calculations .....	56
2.3.3.3 Zero Water.....	57
2.3.3.4 Net-zero Water.....	59

2.3.3.5	Life-cycle Zero Water .....	60
2.3.4	Net-positive Water .....	60
2.3.4.1	Quantity .....	61
2.3.4.2	Quality .....	62
2.3.4.3	Location .....	62
2.3.4.4	Time.....	63
2.3.4.5	Conceptual Framework for Net-positive Water .....	64
2.3.5	Conclusion .....	66
2.4	Resilience .....	68
2.4.1	Introduction .....	68
2.4.2	Definitions from Literature .....	68
2.4.3	Properties and Attributes of Resilience .....	74
2.4.4	Considerations for Measuring Resilience .....	76
2.4.5	Measuring Water Resilience .....	77
2.4.6	Conclusion .....	78
3	RESEARCH OVERVIEW .....	80
3.1	Motivation .....	80
3.2	Gaps in Knowledge .....	80
3.3	Hypotheses .....	81
3.4	Main Research Objectives .....	81
3.5	Research Plan .....	82
4	WATER PRIORITIZATION FRAMEWORK .....	85
4.1	Note to Reader .....	85
4.2	Introduction .....	85
4.3	Water Prioritization.....	86
4.4	Methodology .....	88
4.4.1	Sources and Demands .....	89
4.4.2	Baseline Water Prioritization .....	90
4.4.3	Prioritization-based Water Allocation.....	94
4.5	Results and Discussion.....	95
4.5.1	Manipulation of Baseline Prioritization Framework.....	95
4.5.2	Prioritization Algorithm .....	97
4.5.3	Prioritization over Time .....	100
4.5.4	Effect on Water Savings.....	103
4.5.5	Application of Algorithm to Real Building Scenario.....	104
4.6	Conclusion .....	107
5	DUNEDIN WATER USE STUDY .....	109
5.1	Introduction .....	109
5.2	Smart Metering .....	111
5.3	City of Dunedin .....	113
5.3.1	Municipal Urban Water System.....	113
5.3.2	Study Sites.....	113
5.4	Materials and Methods.....	115
5.4.1	Data Collection .....	115
5.4.2	Data Analysis.....	116
5.4.2.1	Calculations Over 24-hour Periods.....	117
5.4.2.2	Trend Calculations .....	119
5.5	Results and Discussion.....	121

5.5.1	Aggregate Hourly-average vs. Daily-average Attributes .....	121
5.5.2	Trends over Time .....	126
5.5.2.1	Peak Flow and Mean Flow .....	132
5.5.2.2	Time to Peak and Time to 50% Consumption .....	133
5.5.2.3	Peak Frequency and Time Duration above Mean Flow .....	135
5.5.2.4	Median Flow and Standard Deviation.....	137
5.6	Conclusion .....	138
6	WATER RESILIENCE ASSESSMENT MODEL FRAMEWORK.....	140
6.1	Note to Reader .....	140
6.2	Introduction .....	140
6.3	Differences between WRAM and IBWM Models .....	141
6.4	Methodology .....	141
6.4.1	Software .....	142
6.4.2	Building Functions.....	142
6.4.3	Water Allocation Prioritization .....	144
6.4.4	Balance around Building Water Demands.....	145
6.4.5	Balance around Building Water Sources.....	147
6.5	Water Resilience Assessment Model (WRAM) .....	149
6.5.1	Demand Subsectors .....	149
6.5.1.1	Irrigation.....	149
6.5.1.2	Green Roof .....	150
6.5.1.3	Cooling Tower.....	151
6.5.1.4	Sinks, Showers, Laundry Machines, and Drinking Fountains .....	151
6.5.1.5	Toilets and Urinals .....	152
6.5.1.6	Flexible Building Subsections.....	153
6.5.2	Source Subsectors.....	155
6.5.2.1	Municipal Sources.....	155
6.5.2.2	Rainwater and Stormwater .....	155
6.5.2.3	Condensate .....	158
6.5.2.4	Recycled Wastewater .....	158
6.5.2.5	Flexible Storage Stock .....	159
6.6	Application of the WRAM for a Net-Zero Feasibility Study.....	160
6.6.1	Net-zero Water Balance.....	161
6.6.2	Zero Water Balance .....	162
6.7	Conclusion .....	164
7	BUILDING WATER CYCLE RESILIENCE ASSESSMENT .....	166
7.1	Introduction .....	166
7.2	Methodology .....	168
7.2.1	Characterizing Disruption.....	168
7.2.2	Resilience Curve.....	171
7.2.3	Resilience Indicators .....	174
7.2.3.1	Diversity.....	174
7.2.3.2	Redundancy.....	174
7.2.3.3	Capacity.....	175
7.2.3.4	Demand .....	175
7.2.3.5	Alternative Water .....	175
7.2.3.6	Passivity .....	176
7.2.3.7	Preparation .....	176

7.2.3.8	Adaptation Potential.....	177
7.2.4	Modeled Scenarios .....	177
7.3	Results and Discussion.....	181
7.3.1	LOS vs. Indicators.....	181
7.3.2	Resilience as a Function of LOS and Disruption .....	191
7.4	Inherent vs. Adaptive Resilience .....	197
7.5	Conclusion .....	199
8	CONCLUSION.....	203
8.1	Consideration of Scale and Responsibility .....	207
8.2	Recommendations for Future Research.....	210
	REFERENCES .....	213
	APPENDICES.....	230
	Appendix A Copyright Permissions.....	231
	Appendix B Model Run Results for the Multi-residential Study (Potable Water Disruption).....	238
	Appendix C Model Run Results for the Multi-residential Study (Potable Water and Central Power Disruption) .....	248
	Appendix D Model Run Results for the Elementary School (Potable Water Disruption).....	262
	Appendix E Model Run Results for the Elementary School (Potable Water and Central Power Disruption) .....	279

## LIST OF TABLES

Table 1.1: Examples of the four types of interdependencies. ....	4
Table 1.2: Building types addressed by LEED rating systems. ....	5
Table 2.1: Smart building definitions. ....	17
Table 2.2: Building water support tools. ....	42
Table 2.3: Potential building water demands and associated fixtures. ....	50
Table 2.4: Potential building water sources and origins. ....	51
Table 2.5: Comparison of the urban water and energy infrastructure networks. ....	54
Table 2.6: Quantity balance check comparing actual flows (Q) with natural flows ( $Q_N$ ), the potential result of an imbalance, and associated methods to create a net- positive response. ....	61
Table 2.7: Definitions of resilience in the natural sciences ....	70
Table 2.8: Definitions of resilience in the social sciences ....	71
Table 4.1: Literature summary of water source preferences for different demands ....	92
Table 4.2: Baseline prioritization of potential water sources (i) and demands (j). ....	94
Table 4.3: Prioritization algorithm. ....	98
Table 4.4: Example application of prioritization algorithm. ....	99
Table 4.5: Prioritization schemes for the hotel scenarios. ....	106
Table 4.6: Percent potable water reductions for the four hotel scenarios. ....	107
Table 5.1: Description of building locations used for water use study. ....	114
Table 5.2: Water meters and associated resolution by building location. ....	114
Table 5.3: Summary of attributes used to evaluate diurnal water use curves. ....	116
Table 5.4: Attribute values for the hourly-average diurnal curve compared to the average attribute values for all daily-average diurnal curves. ....	126



Table 5.5: Percent deviation of each attribute from the average by day of the week to the average for all days .....	127
Table 6.1: Input method options for demands and sources in the WRAM. ....	144
Table 6.2: Inflows in decreasing order of priority and collectable outflows for the irrigation demand stock.....	150
Table 6.3: Inflows in decreasing order of priority and collectable outflows for the green roof demand stock.....	150
Table 6.4: Inflows in decreasing order of priority and collectable outflows for the cooling demand stock.....	151
Table 6.5: Inflows in decreasing order of priority and collectable outflows for bathroom sink (j=Sb), kitchen sink (j =Sk), shower (j =H), laundry (j =L), and drinking (j =D) demand stocks. ....	152
Table 6.6: Inflows in decreasing order of priority and collectable outflows (j=T) and urinal (j =U) demand stocks. ....	153
Table 6.7: Inflows in decreasing order of priority and collectable outflows for process water (j=Pr), cooling (j=Co) low human interaction (j =LHI), and high human interaction (j =HHI) demand stocks. ....	154
Table 6.8: Inflows in decreasing order of priority and collectable outflows for the firefighting demand stock.....	154
Table 6.9: Inflows and outflows in decreasing order of priority for the potable water source stock. ....	156
Table 6.10: Inflows and outflows in decreasing order of priority for the reclaimed water source stock. ....	156
Table 6.11: Inflows and outflows in decreasing order of priority for the rainwater source stock. ....	157
Table 6.12: Inflows and outflows in decreasing order of priority for the stormwater source stock. ....	157
Table 6.13: Inflows and outflows in decreasing order of priority for the condensate source stock.....	158
Table 6.14: Inflows and outflows in decreasing order of priority for the recycled wastewater (WW) source stock. ....	159
Table 6.15: Potential net-zero balance of potable water consumption (PW) compared to on-site rainwater (RW) and reclaimed water (RC) availability .....	162
Table 6.16: Scenario descriptions for zero water IBWM model runs.....	163

Table 7.1: Disruption events considered for the building water cycle resilience assessment.....	170
Table 7.2: Start time (ts) for disruption events used for the resilience assessment.....	171
Table 7.3: Measurable resilience values from the building WRAM response curves. ....	174
Table 7.4: End-uses and hourly water demand as a percentage of total demand for the multi-residential building location.....	178
Table 7.5: Weekday end-uses and hourly water demand as a percentage of total demand for the elementary school building location .....	179
Table 7.6: Multi-residential building scenarios evaluated by the WRAM.....	180
Table 7.7: Correlation values for resilience indicators to LOS for model runs for the multi-residential study subjected to potable water disruption.....	189
Table 7.8: Correlation values for average resilience indicators (grouped by scenario and disruption length) to LOS for model runs for the multi-residential study subjected to potable disruption.....	190
Table 7.9: Correlation values for resilience indicators to LOS for model runs for the multi-residential study subjected to potable water and central power disruption.....	190
Table 7.10: Correlation values for average resilience indicators (grouped by scenario and disruption length) to LOS for model runs for the multi-residential study subjected to potable water and central power disruption. ....	191
Table 7.11: Summary of indicator values to LOS for multi-residential and elementary school studies subjected to potable water disruption .....	201
Table 7.12: Summary of indicator values to LOS for multi-residential and elementary school studies subjected to potable water and central power disruption.....	201
Table 7.13: Summary of average indicator values to LOS for multi-residential and elementary school studies subjected to potable water disruption.....	202
Table 7.14: Summary of average indicator values to LOS for multi-residential and elementary school studies subjected to potable water and central power disruption .....	202
Table 8.1: Resilience indicator examples at various spatial scales.....	208
Table 8.2: Scale of responsibility for incorporating resilience into the built environment.....	210
Table B.1: Resilience indicators for Scenario 1 model runs for the multi-residential neighborhood subjected to potable water disruption.....	238
Table B.2: Resilience indicators for Scenario 2 model runs for the multi-residential neighborhood subjected to potable water disruption.....	239

Table B.3: Resilience indicators for Scenario 3 model runs for the multi-residential neighborhood subjected to potable water disruption.....	240
Table B.4: Resilience indicators for Scenario 4 model runs for the multi-residential neighborhood subjected to potable water disruption.....	241
Table B.5: Resilience indicators for Scenario 5 model runs for the multi-residential neighborhood subjected to potable water disruption.....	242
Table B.6: Resilience indicators for Scenario 6 model runs for the multi-residential neighborhood subjected to potable water disruption.....	243
Table B.7: Resilience indicators for Scenario 7 model runs for the multi-residential neighborhood subjected to potable water disruption.....	244
Table B.8: Resilience indicators for Scenario 8 model runs for the multi-residential neighborhood subjected to potable water disruption.....	245
Table B.9: Resilience indicators for Scenario 9 model runs for the multi-residential neighborhood subjected to potable water disruption.....	246
Table B.10: Average resilience indicators (n=10) by scenario and disruption length for model runs for the multi-residential neighborhood subjected to potable water disruption. ....	247
Table C.1: Resilience indicators for Scenario 1 model runs for the multi-residential neighborhood subjected to potable water and central power disruption.....	252
Table C.2: Resilience indicators for Scenario 2 model runs for the multi-residential neighborhood subjected to potable water and central power disruption.....	253
Table C.3: Resilience indicators for Scenario 3 model runs for the multi-residential neighborhood subjected to potable water and central power disruption.....	254
Table C.4: Resilience indicators for Scenario 4 model runs for the multi-residential neighborhood subjected to potable water and central power disruption.....	255
Table C.5: Resilience indicators for Scenario 5 model runs for the multi-residential neighborhood subjected to potable water and central power disruption.....	256
Table C.6: Resilience indicators for Scenario 6 model runs for the multi-residential neighborhood subjected to potable water and central power disruption.....	257
Table C.7: Resilience indicators for Scenario 7 model runs for the multi-residential neighborhood subjected to potable water and central power disruption.....	258
Table C.8: Resilience indicators for Scenario 8 model runs for the multi-residential neighborhood subjected to potable water and central power disruption.....	259
Table C.9: Resilience indicators for Scenario 9 model runs for the multi-residential neighborhood subjected to potable water and central power disruption.....	260

Table C.10: Average resilience indicators (n=10) by scenario and disruption length for model runs for the multi-residential neighborhood subjected to potable water and central power disruption. ....	261
Table D.1: Elementary school building scenarios evaluated by the WRAM.. ....	262
Table D.2: Resilience indicators for Scenario 1 model runs for the elementary school subjected to potable water disruption .....	268
Table D.3: Resilience indicators for Scenario 2 model runs for the elementary school subjected to potable water disruption .....	269
Table D.4: Resilience indicators for Scenario 3 model runs for the elementary school subjected to potable water disruption .....	270
Table D.5: Resilience indicators for Scenario 4 model runs for the elementary school subjected to potable water disruption .....	271
Table D.6: Resilience indicators for Scenario 5 model runs for the elementary school subjected to potable water disruption .....	272
Table D.7: Resilience indicators for Scenario 6 model runs for the elementary school subjected to potable water disruption .....	273
Table D.8: Resilience indicators for Scenario 7 model runs for the elementary school subjected to potable water disruption .....	274
Table D.9: Resilience indicators for Scenario 8 model runs for the elementary school subjected to potable water disruption .....	275
Table D.10: Resilience indicators for Scenario 9 model runs for the elementary school subjected to potable water disruption .....	276
Table D.11: Average resilience indicators (n=10) by scenario and disruption length for model runs for the elementary school subjected to potable water disruption .....	277
Table D.12: Correlation values for resilience indicators to LOS for model runs for the elementary school subjected to potable disruption .....	278
Table D.13: Correlation values for average resilience indicators (grouped by scenario and disruption length) to LOS for model runs for the elementary school subjected to potable disruption .....	278
Table E.1: Resilience indicators for Scenario 1 model runs for the elementary school subjected to potable water and central power disruption .....	284
Table E.2: Resilience indicators for Scenario 2 model runs for the elementary school subjected to potable water and central power disruption .....	285
Table E.3: Resilience indicators for Scenario 3 model runs for the elementary school subjected to potable water and central power disruption .....	286

Table E.4: Resilience indicators for Scenario 4 model runs for the elementary school subjected to potable water and central power disruption .....	287
Table E.5: Resilience indicators for Scenario 5 model runs for the elementary school subjected to potable water and central power disruption .....	288
Table E.6: Resilience indicators for Scenario 6 model runs for the elementary school subjected to potable water and central power disruption .....	289
Table E.7: Resilience indicators for Scenario 7 model runs for the elementary school subjected to potable water and central power disruption .....	290
Table E.8: Resilience indicators for Scenario 8 model runs for the elementary school subjected to potable water and central power disruption .....	291
Table E.9: Resilience indicators for Scenario 9 model runs for the elementary school subjected to potable water and central power disruption .....	292
Table E.10: Average resilience indicators (n=10) by scenario and disruption length for model runs for the elementary school subjected to potable water and central power disruption.....	293
Table E.11: Correlation values for resilience indicators to LOS for model runs for the elementary school subjected to potable water and central power disruption.....	294
Table E.12: Correlation values for average resilience indicators (grouped by scenario and disruption length) to LOS for model runs for the elementary school subjected to potable water and central power disruption .....	294

## LIST OF FIGURES

Figure 1.1: Building resilience according to origin of disruption and physical characteristics.....	10
Figure 1.2: Outline of chapter relationships. ....	12
Figure 2.1: Comparison of smart and green building concepts. ....	21
Figure 2.2: Evolution of the building water cycle.....	22
Figure 2.3: Inflows and outflows affecting water storage (S) in the natural case (left) and urban development case (right). ....	58
Figure 2.4: Conceptual framework for net-positive water buildings.....	65
Figure 4.1: Nested prioritization algorithm – demand-driven prioritization (DDP) is nested within source-driven prioritization (SDP). ....	95
Figure 4.2: Example of model prioritization manipulation: (a) baseline model prioritization, (b) user-defined prioritization. ....	96
Figure 4.3: Visual representation of nested prioritization algorithm for demands (D1-D5), sources, and rankings in Table 4.4.. ....	99
Figure 4.4: Visual representation of water source prioritization within the model. ....	101
Figure 4.5: Daily water demand profiles (lph) for flushing based on (a) constant, (b) residential, and (c) commercial scenarios. ....	103
Figure 4.6: Daily water source profiles (lph) for flushing demand based on (a) constant, (b) residential, and (c) commercial scenarios.....	103
Figure 4.7 Percent of the flushing demand met by each available water source based on the (a) constant, (b) residential, and (c) commercial scenarios. ....	104
Figure 4.8: Demand-supply profiles for the four hotel scenarios described in Table 4.4. ....	107
Figure 5.1: Transmitter used for water use data collection (left) and smart water meter (right). ....	115

Figure 5.2: Box plots showing distribution of all flows by hour for each of the four building sites – multi-residential (RES), commercial (COM), elementary school (ELM), and community center (CTR). .....	122
Figure 5.3: Box plots showing distribution between the 10 <sup>th</sup> and 90 <sup>th</sup> percentiles of flows by hour for each of the four building sites.....	122
Figure 5.4: The differences illustrated between hourly-average diurnal curves (top row) compared to the diurnal curve for a single day (bottom row) for all four building locations. ....	124
Figure 5.5: Individual daily diurnal curves and composite hourly-average diurnal curve (in bold) by month for the multi-residential building location. ....	128
Figure 5.6: Individual daily diurnal curves and composite hourly-average diurnal curve (in bold) by month for the commercial building location.....	129
Figure 5.7: Individual daily diurnal curves and composite hourly-average diurnal curve (in bold) by month for the elementary school location. ....	130
Figure 5.8: Individual daily diurnal curves and composite hourly-average diurnal curve (in bold) by month for the community center location. ....	131
Figure 5.9: Average hourly flow ( $Q_A$ ), peak hourly flow ( $Q_P$ ), and peak to average factor ( $F_{P/A}$ ) by day for each month for the multi-residential (RES), commercial (COM), elementary school (ELM), and community center (CTR) sites. ....	133
Figure 5.10: Time to peak ( $T_P$ ) and time to 50% water consumption ( $T_{50}$ ) by day for each month for the multi-residential (RES), commercial (COM), elementary school (ELM), and community center (CTR) sites. ....	134
Figure 5.11: Duration that hourly flow is greater than $Q_A$ ( $T_{Q>Q_A}$ ) and number of peaks exceeding $Q_A$ ( $N_P$ ) by day for each month for the multi-residential (RES), commercial (COM), elementary school (ELM), and community center (CTR) sites. ....	136
Figure 5.12: Median hourly flow ( $Q_M$ ) and standard deviation ( $\sigma$ ) by day for each month for the multi-residential (RES), commercial (COM), elementary school (ELM), and community center (CTR) sites. ....	138
Figure 6.1: Potable water source subsector modeled in STELLA.....	143
Figure 6.2: Inflows and outflows for demand stock calculations. ....	147
Figure 6.3: Inflows and outflows for source stock calculations.....	149
Figure 6.4: Basic hydrologic flows for the hotel site. ....	160
Figure 6.5: Water consumption for the hotel case study site separated by estimated end-use.....	161

Figure 6.6: Cumulative potable water consumption for precipitation pattern W1 under the scenarios outlined in Table 6.16. ....	164
Figure 6.7: Total on-site water consumption by source and potable water offset for Scenario 5 in precipitation pattern W1. ....	164
Figure 7.1: Examples of disruption events with different severities based on magnitude and duration.....	169
Figure 7.2: Resilience curve: (1) system equilibrium, (2) disturbance stage, (3) recovery stage, (4) recovered state. ....	171
Figure 7.3: Impact of disruption event on the building water profile and resulting level of service (LOS).....	172
Figure 7.4: Web-based calculator used to estimate condensate production .....	180
Figure 7.5: Level of service (LOS) vs. diversity for multi-residential scenarios subjected to potable water disruption. ....	182
Figure 7.6: Level of service (LOS) vs. redundancy for multi-residential scenarios subjected to potable water disruption. ....	182
Figure 7.7: Level of service (LOS) vs. capacity for multi-residential scenarios subjected to potable water disruption. ....	184
Figure 7.8: Detailed view of level of service (LOS) vs. capacity for multi-residential scenarios subjected to potable water disruption.....	184
Figure 7.9: Level of service (LOS) vs. demand for multi-residential scenarios subjected to potable water disruption. ....	185
Figure 7.10: Level of service (LOS) vs. alternative water for multi-residential scenarios subjected to potable water disruption. ....	186
Figure 7.11: Level of service (LOS) vs. passivity for multi-residential scenarios subjected to potable water disruption. ....	187
Figure 7.12: Level of service (LOS) vs. preparation for multi-residential scenarios subjected to potable water disruption. ....	187
Figure 7.13: Level of service (LOS) vs. adaptation potential for multi-residential scenarios subjected to potable water disruption.....	188
Figure 7.14: Resilience curves for the multi-residential study subjected to potable water disruption.....	194
Figure 7.15: Resilience curves for the multi-residential study subjected to potable water and central power disruption. ....	194
Figure 7.16: Water demand and source profiles for Scenario 6 subject to a 168-hour potable water disruption event on January 5, 2013. ....	195



Figure 7.17: Water demand and source profiles for Scenario 7 subject to a 168-hour potable water disruption event on January 5, 2013. ....	196
Figure 7.18: Effect of conservation and potable water delivery response measures for the multi-residential case study over a 168-hour disruption period. ....	198
Figure C.1: Average level of service (LOS) vs. diversity for multi-residential scenarios subjected to potable water and central power disruption. ....	248
Figure C.2: Average level of service (LOS) vs. redundancy for multi-residential scenarios subjected to potable water and central power disruption. ....	248
Figure C.3: Level of service (LOS) vs. capacity for multi-residential scenarios subjected to potable water and central power disruption. ....	249
Figure C.4: Level of service (LOS) vs. demand for multi-residential scenarios subjected to potable water and central power disruption. ....	249
Figure C.5: Level of service (LOS) vs. alternative water for multi-residential scenarios subjected to potable water and central power disruption. ....	250
Figure C.6: Level of service (LOS) vs. passivity for multi-residential scenarios subjected to potable water and central power disruption. ....	250
Figure C.7: Average level of service (LOS) vs. preparation for multi-residential scenarios subjected to potable water and central power disruption. ....	251
Figure C.8: Average level of service (LOS) vs. adaptation potential for multi-residential scenarios subjected to potable water and central power disruption. ....	251
Figure D.1: Average level of service (LOS) vs. diversity for elementary school scenarios subjected to potable water disruption. ....	262
Figure D.2: Average level of service (LOS) vs. redundancy for elementary school scenarios subjected to potable water disruption. ....	263
Figure D.3: Level of service (LOS) vs. capacity for elementary school scenarios subjected to potable water disruption. ....	263
Figure D.4: Level of service (LOS) vs. capacity (values 0 to 200) for elementary school scenarios subjected to potable water disruption. ....	264
Figure D.5: Level of service (LOS) vs. demand for elementary school scenarios subjected to potable water disruption. ....	264
Figure D.6: Level of service (LOS) vs. alternative water for elementary school scenarios subjected to potable water disruption. ....	265
Figure D.7: Level of service (LOS) vs. passivity for elementary school scenarios subjected to potable water disruption. ....	265

Figure D.8: Average level of service (LOS) vs. preparation for elementary school scenarios subjected to potable water disruption.....	266
Figure D.9: Average level of service (LOS) vs. adaptation potential for elementary school scenarios subjected to potable water disruption.....	266
Figure D.10: Resilience curves for the elementary school study subjected to potable water disruption. ....	267
Figure E.1: Average level of service (LOS) vs. diversity for elementary school scenarios subjected to potable water and central power disruption.....	279
Figure E.2: Average level of service (LOS) vs. redundancy for elementary school scenarios subjected to potable water and central power disruption.....	279
Figure E.3: Level of service (LOS) vs. capacity for elementary school scenarios subjected to potable water and central power disruption.....	280
Figure E.4: Level of service (LOS) vs. capacity (values 0 to 200) for elementary school scenarios subjected to potable water and central power disruption.....	280
Figure E.5: Level of service (LOS) vs. demand for elementary school scenarios subjected to potable water and central power disruption.....	281
Figure E.6: Level of service (LOS) vs. alternative water for elementary school scenarios subjected to potable water and central power disruption.....	281
Figure E.7: Level of service (LOS) vs. passivity for elementary school scenarios subjected to potable water and central power disruption.....	282
Figure E.8: Average level of service (LOS) vs. preparation for elementary school scenarios subjected to potable water and central power disruption.....	282
Figure E.9: Average level of service (LOS) vs. adaptation potential for elementary school scenarios subjected to potable water and central power disruption.....	283
Figure E.10: Resilience curves for the elementary school study subjected to potable water and central power disruption. ....	283

## **ABSTRACT**

The aim of this project was to quantitatively measure the resilience of the building water cycle. In order to accomplish this goal, a framework was developed that outlines how building water resilience can be evaluated. The framework presented assumed that resilience describes the fulfillment of system functions; in this case, the system functions considered are those actualized by the building water system. A building water resilience assessment model (WRAM) was developed with the ability to simulate different building water cycles and resilience scenarios. Resilience is dependent on the type and magnitude of a disturbance. Therefore, unique disruption scenarios were developed to test the building water cycle resilience: (1) loss of municipal potable water and (2) loss of both municipal potable water and power. Under each scenario, the building water cycle was tested based on the type of building and the water management strategies utilized by the building.

The WRAM requires organization of water demand and source connections, and an explicit prioritization framework was produced based on water source and demand preferences found in literature. The framework gives priority to treated wastewater, stormwater, rainwater, condensate, reclaimed water, and potable water, respectively. The baseline prioritization may be manipulated by restricting demand-source connections, and shifting priorities was shown to affect the potential for potable water offsets as a precursor to resilience. Real building water demand profiles were developed from data collected using smart meters at four building sites (multi-residential neighborhood, commercial building, elementary school, and community center). Water source profiles were developed using hourly climate data for the region. Detailed building water demand and supply profiles were developed for the multi-residential and

elementary school building sites for resilience assessment using the WRAM. Each building water profile was adapted into 9 scenarios with each subjected to the two disruption schemes for 5 different disruption durations (1 hour, 6 hours, 24 hours, 72 hours, and 168 hours) at 10 different randomized dates and time throughout the year. The result was 450 model runs for each building subjected to each disruption scheme (potable water loss or potable water and central power loss).

The relationship between resilience and sustainability was examined based on sustainable building practices accepted by the U.S. Green Building Council's (USGBC) Leadership in Environmental and Energy Design (LEED) green building rating system. Building WRAM outcomes include unique water demand and supply profiles used to describe resilience in terms of the level of service (LOS) of building water functions. Analysis of water profiles validated redundancy, diversity, capacity, alternative water, passivity, preparation, and adaptation potential indicators as gauges of the resilience of the building water cycle. Results showed that resilience correlates with alternative water building water management strategies, but high resilience values are still attainable using storage of non-renewable, non-sustainable sources. However, building water cycles utilizing alternative water maintained steadier resilience as disruption lengths increase due to the ability of sources to be replenished during disruption events.

The strongest correlation with LOS was observed for the diversity, redundancy, alternative water, and capacity indicators when scenarios utilizing only potable water were excluded from analysis. For these scenarios, correlation values were 0.56 for diversity, 0.56 for redundancy, 0.60 for capacity, and 1.00 for alternative water for the multi-residential building subjected to potable water loss; and 0.33 for diversity, 0.24 for redundancy, 0.62 for capacity, and 1.00 for alternative water for the multi-residential building subjected to both potable water and central power disruption. For elementary school scenarios that did not utilize potable water storage, correlation values were 0.67 for diversity, 0.64 for redundancy, 0.06 for capacity, and

0.89 for alternative water when subjected to disruption of potable water; and 0.67 for diversity, 0.64 for redundancy, 0.06 for capacity, and 0.80 for alternative water when subjected to disruption of potable water and central power. Passivity correlation to LOS was between 0.77 and 1.00 for all scenarios, building types, and disruption schemes. Passivity correlation with LOS was lower for potable water disruption scenarios, but higher when building water cycles lost power in addition to potable water. The average of each indicator was also calculated for each scenario for each of the five disruption durations by grouping the individual values from each of the 10 randomized disruption start dates and times. The correlation between the average capacity indicator and LOS greatly increased with this method to a range of 0.41 to 0.78 for all buildings subjected to each disruption scheme. In addition, a positive correlation between the preparation indicator and LOS (and corresponding negative correlation between the adaptation potential indicator and LOS) emerged for scenarios that do not utilize potable water storage. For disruption of potable water, the preparation correlation value was 0.94 for the multi-residential building and 0.78 for the elementary school. For disruption of potable water and central power, the preparation correlation value was 0.32 for the multi-residential building and 0.79 for the elementary school.

## 1 INTRODUCTION

Trends in both demographics and climate are increasing the harmful social and economic impacts of disasters (United Nations, 2011). The world population has grown by 87% between 1970 and 2010, while the population in flood-prone regions increased by 114% and the population at risk of weather cyclones increased by 192% (United Nations, 2011). In addition, the urbanization of populations has also affected potential risks; poor planning and disruption of the natural environment further increases the vulnerability of communities to disruption events, whether natural or man-made.

Disaster resilience is an important part of the security of critical systems that serve a community and limits the effects of disruption events (Little, 2003). Critical systems include those related to telecommunications, electrical power systems, gas and oil storage and transport, banking and finance, transportation, water supply, emergency services, and government (Moteff et al., 2003). Issues regarding resource scarcity, such as lack of water or energy, are generally centered on regions without a solid infrastructure. However, natural disasters and anthropogenic emergencies can interrupt services to all areas regardless of location or economic status. Due to the importance of critical systems, the concept of resilience is often applied to infrastructure (Bruneau et al., 2003; Cumming et al., 2005; McDaniels et al., 2008; Cutter et al., 2010). This includes evaluating the potential for breakdowns in these critical systems (Boin and McConnell, 2007) and how to limit the effects of disruption events to these systems by increasing their resilience.

Communities are supported by infrastructure networks where critical services are delivered to the population at the building level, and the complexity of the urban infrastructure

environment must be acknowledged in order to design for sustainability and resilience (Pandit et al., 2015; Anastas, 2012). Building development impacts local urban and natural ecosystems; and these impacts stretch well beyond the building footprint. Buildings not only consume land, they also compromise local habitats and increase impervious surfaces which contribute to stormwater runoff and pollutant loadings. The building location and practices must be integrated in order to limit both infrastructure and environmental impacts, but it is also important to note that the infrastructure and local environment present a risk of disruption to critical services delivered within the building level. During disruption events an interruption of infrastructure services can cause a conventional building to become uninhabitable for its occupants, resulting in failure of the building functions.

The focus of a building's environmental impacts is often on energy. However, buildings utilize large amounts of potable water, as well as discharge wastewater and contribute to pollutant loadings through stormwater runoff (USEPA, 2009). Buildings in the United States utilize 13 percent of the total water used per day, and 8 percent of the national energy demand is directed to the treating, distribution, and heating of water (USEPA, 2009). Sustainable water reuse is a central theme in green building, and an integrated systems approach to building water management allows for the best allocation of potable water drawn from the municipal supply and incorporation of alternative water sources, thereby increasing building sustainability. These options include practices that not only regulate the inflow of water and recycling of water throughout the building system, but also decrease the outflow of water through efficient wastewater and infiltration processes (Lazarova et al., 2001). Water is a finite resource intrinsically linked to energy. Energy is required to pump and move water throughout the building system. Additional direct and indirect energy is consumed by treatment processes that result in water which meets acceptable quality standards. Santana et al. (2014) found that the quality of influent water to a Tampa water treatment plant significantly affected the embodied energy for the plant operations that result in water meeting effluent standards, and the

embodied energy varies based on the source of water (Mo et al., 2011). In addition, the total energy consumed contains an associated cost. This cycle created by building water pathways has an inherent resilience and is unique to individual building systems.

### **1.1 Vulnerability and System Relationships**

System vulnerabilities outline the potential consequences of disaster effects and undermine resilience (Brenkert and Malone, 2005; Vogel et al., 2007). The vulnerabilities of a building can be broken into three types: physical, environmental, and demographic. Physical vulnerabilities are related to the structural components of individual buildings and include the location of critical systems and equipment within the building zone. Environmental vulnerabilities take into account multiple scales and relationships from individual hazardous sites to the geographic characteristics of the area. Proximity to hazardous sites and vulnerable structures affects the vulnerability of the building site (Cutter, 1996). There are also environmental vulnerabilities associated with infrastructure and critical structures. Disruption of the services provided by infrastructure directly affects the served population, and failure at critical points within the system causes extensive damage. Demographic vulnerabilities are directly related to the vulnerable areas defined by the physical and environmental vulnerability assessment; however, additional social and related economic dimensions also contribute to the population's overall vulnerability to hazards (Yeletaysi et al., 2009). Yeletaysi et al. (2009) defines social factors as social equity, social class, age, gender, education, literacy, race and ethnicity, traditional values, and beliefs; economic factors include poverty, economic reserves, debt, and economic diversity. Where people fit into social and economic scales affects their vulnerability. Increasing building resilience can also affect the social resilience of a region.

The magnitude and extent of a disaster's effects depend on the relationships among dependent and interdependent systems (Rinaldi et al. 2001; Little, 2003). A *dependent* system is one that depends on a secondary system, but the secondary system does not depend on the initial system. *Interdependent* systems are dependent on each other. Rinaldi et al. (2001)



outlines four types of interdependencies: physical, cyber, geographic, and logical. Physical interdependencies are created when one system’s output is a necessary input for a second system; cyber interdependencies are similar, but the inputs and outputs are information and not physical items. Geographic interdependencies exist when systems are close enough to be impacted by the same change in environment. Logical interdependencies describe those that are not classified by the previous three types and are generally related to human decisions.

Table 1.1: Examples of the four types of interdependencies (from Rinaldi et al., 2001).

Type	Examples
Physical	<ul style="list-style-type: none"> <li>▪ Flooded rail lines disrupts transport of raw materials to manufacturing plants</li> <li>▪ Floodwaters prevent coal from being delivered to local coal-fired power plants and disrupt the local power supply</li> </ul>
Cyber	<ul style="list-style-type: none"> <li>▪ Floating debris disrupts telecommunications lines disrupting mass transit</li> <li>▪ Broken power lines cause wastewater treatment operators to lose feedback from pumping stations and potential sewer overflow occurs</li> </ul>
Geographic	<ul style="list-style-type: none"> <li>▪ Power and communications lines housed in the same conduit are breached by floodwater and are disrupted</li> <li>▪ A gas line explosion disrupts nearby water and sewer connections</li> </ul>
Logical	<ul style="list-style-type: none"> <li>▪ An imminent flood warning causes people to move from at-risk areas putting stress on the transportation system</li> <li>▪ The movement of people to shelters causes stress on local resources such as food, water, and energy</li> </ul>

Mapping the relationships among systems allows for weak points and connections to be located, as well as associated vulnerabilities based on dependencies. The resilience of a system will directly depend on these vulnerabilities. Previous research on “smart” shelters (Joustra et al., 2011) has shown how a building can be an important component for resilience. A smart shelter must be able to function when there is an interruption to the infrastructure network. The primary function of a smart shelter is that of an everyday building like a workplace, school, recreation center, or other common destination center. The emergency shelter function is secondary. The multifunctional capacity of a building structure seems like a challenge, but understanding the relationships and dependencies among the building functions

allows for innovative opportunities to decrease the vulnerability of the building while increasing its resilience.

## 1.2 Building Sustainability and Resilience

The urban built environment has been recognized as a critical area for the application of sustainable strategies in order to support a sustainable society (Xu et al., 2012). Worldwide, several nonprofit organizations promote sustainability and green design, with one of the most impactful being the U.S. Green Building Council (USGBC). In order to define and promote green buildings, the USGBC created the Leadership in Energy and Environmental Design (LEED) rating and certification system. Participation in LEED is completely voluntary, and programs are available for all building types including new commercial construction, existing building operations, homes, neighborhood development, schools, and retail structures (USGBC, 2011a-c). LEED rating systems set a standard that defines green building based on building type. Rating systems dealing with individual buildings are presented in Table 1.2. Points are awarded in several major categories inherent in green building including sustainable sites, water efficiency, energy and atmosphere, materials and resources, indoor environmental quality, innovation, and regional priority. For the current version, LEED 2012, new categories have been developed that include integrative process, location and transportation, and performance. These new categories show how the LEED process evolves to challenge the market by addressing the integrated impacts that result from the built environment.

Table 1.2: Building types addressed by LEED rating systems.

LEED Rating System	Building Types	
Building Design and Construction (BD&C)	New construction Core and shell Schools Retail	Data centers Retail distribution centers Hospitality Healthcare
Existing Buildings: Operations and Maintenance (EBOM)	Schools Retail Data centers	Warehouses and distribution centers Hospitality
Homes	Single family Low-rise multifamily	Mid-rise multifamily

The USGBC recognizes the threats from a changing climate and believes that the mitigation and adaptation incorporated into green buildings can enhance the resilience of the built environment (Larsen et al., 2011). In a recent report, resilient strategies are defined as those that allow for the absorption of a disruption and maintenance of both the building structure and function. Strategies fall into one of six categories:

- Envelope
- Siting and landscape
- Heating, cooling, and lighting
- Water and waste
- Equipment
- Process and operation.

The report addresses the research need to understand resilient building strategies, including in terms of the benefits, costs, and effectiveness (Larsen et al., 2011). The importance of water is evident based on the designation of its own category based on water management.

### **1.3 Significance of Water Failure**

Water is necessary for daily life. At its core, water is a basic need for survival; the human population requires water for drinking, sanitation, cooking, and cleaning. A disruption in the water supply threatens these life-sustaining functions, especially during long-term events. Ensuring access to a global water supply of adequate quantity and quality has beneficial impacts regarding economics and social health that may be quantified based on reduced illness durations and less time required to travel to and from critical water facilities (Hutton et al., 2007). However, water is also used industrially for heat transfer, contaminant removal, production, and other technical uses (Aubuchon and Morley, 2012). Potable water is generally available at a low cost, but the economic impact associated with disruptions creates a higher cost. FEMA (2009) estimates the value of potable water loss to utilities be \$93 per capita per day (pcpd),

based on losses to businesses and residences. A recent investigation by Aubuchon and Morley (2012) provides a range of \$64 to \$437 pcpd due to economic losses from potable water disruption. The range depends on population and data at the state level, rather than national averages.

It is clear that water disruptions have both a societal and economic impact regardless of the reason for failure. Disruption origin can be natural or anthropogenic, intentional or accidental. The following examples reinforce the importance of the water supply and the negative effects associated with disruption.

- Aging infrastructure. Recent water main ruptures within Baltimore's water utility network have been attributed to the age of the infrastructure (Reutter, 2012). Breaks shut off water to local residents and threatened others with lowered water quality. In addition, flooding from the main breaks affected the transportation network when roads were flooded and became impassable. One water main break is estimated to take \$7 million to repair.
- Natural disasters. Superstorm Sandy continues to disrupt services to residents in the northeast United States. In New York City, some buildings remain detached from central potable supplies, have had service lines turned off, or suffer from leaks along the distribution system into the structure (Wrobieski, 2012). For these buildings, water utility fees and bills have been waived for business owners and residents; however, the economic cost associated with the continued disruption overshadows these waivers. Earthquakes in the southern California area have shut off critical services including water in the past. A new study finds that a long-term disruption based on an earthquake event to the Los Angeles County potable water supply could devastate the region's economy (Rose et al., 2012).
- Cyber terrorism. The Stuxnet worm, developed as a cyber-weapon to damage uranium enrichment facilities in Iran, has illuminated the possibility of similar attacks to large

industrial facilities including water treatment centers (NPR, 2011). The Stuxnet worm manipulates computer control systems that can cause failures in key operations. A cyberattack on a water treatment facility could shut down pumping and treatment processes, thereby compromising the quality and distribution of the water supply.

- Human error. The 1993 cryptosporidium outbreak in Milwaukee, Michigan can partially be attributed to a change in chemical coagulant and unfamiliarity with proper dosing (Institute of Medicine (US) Forum on Microbial Threats, 2009). The outbreak sickened approximately 403,000 people, cause dozens of deaths, and compromised the central potable water supply.
- Power failure. A power failure in southern California not only affected businesses and residents, but also several pumping stations (Medina, 2011). The backup of sewage threatened potable water quality and triggered a boil water warning in order to protect human health. However, boiling water is difficult without power. The reason for the power outage was traced back to human error.

#### **1.4 Building Origin of Failure and Physical Characteristics**

The building system consists of its own interdependent systems, such as the water and energy systems. A single building fits into the community or urban system. Each community is part of a larger infrastructure network, and the built environment sits within the larger natural environment system. A change in one system will affect the other systems. Therefore, an appropriate system boundary must be drawn around the building that allows the building's resilience to be established while also noting the potential links and effects among the other embedded systems.

Testing the resilience of the building system can be broken into two main categories based on where failure can originate. The evaluation of building resilience can be accomplished by including both of these categories. Categories based on the origin of failure include:

- Resilience based on failure originating within the building system boundary (e.g., mechanical error in a building water automation system or plumbing leak) and
- Resilience based on failure originating outside of the building system boundary (e.g., power loss at a municipal potable water facility or water main break).

In addition to origin, important physical characteristics of the building must be considered, which include inputs associated with:

- Building location,
- Internal infrastructure of the building, and
- Infrastructure that supports the building.

The relationships of these categories and characteristics to the building are presented in Figure 1.1. Generally, resilience is viewed as an external shock to a system, and measuring how a building reacts to failures from hazards that occur outside of the boundary; a loss in water pressure or power blackout reflect this view of resilience. However, vulnerabilities also exist within the building. Emphasis on mechanical systems may provide the opportunity for increased failure and decreased resilience. The location of the building also affects its resilience. Hazards are subjective to both the geographical and meteorological conditions of the region (Kar and Hodgson, 2008). When evaluating the resilience of a building based on a hazard, a building located in a region that is less likely affected by the hazard will be more resilient to the event. The same is true for the location of critical infrastructure systems, such as water treatment facilities, pumping stations, and power plants. The location and implementation of the infrastructure serving the building will also affect the overall building resilience. This includes the location and age of pipelines and wiring. If the building is served by resilient infrastructure, the building has the potential to also be resilient.

This project considers the water cycle contained within an individual building site. Therefore, this research focuses on evaluating the level of resilience based on failures

originating within or outside of the building system boundary. This is because these categories directly affect the building; a disruption at either point will alter the water cycle. The disruptions considered include the loss of potable water and power services. The system interdependencies presented Section 1.1 show how a disruption can occur due to a myriad of sources and will depend on attributes of the building, location, and infrastructure. In order to fairly evaluate the resilience of different building types with unique water cycles, the motive behind each disruption will not be considered.

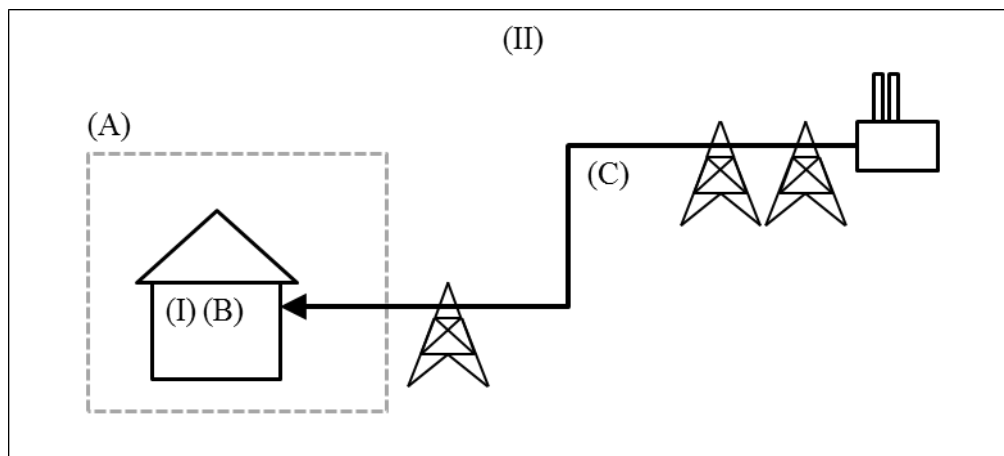

Figure 1.1: Building resilience according to origin of disruption and physical characteristics. Failure may originate from within the building system (I) or outside of the building (II), and resilience depends on characteristics of the building location (A), internal building infrastructure (B), and the infrastructure supporting the building (C).

## 1.5 Orientation to Chapters

Figure 1.2 displays the format of the following chapters and relationship among chapters. Chapter 2 provides literature reviews on

- the building water cycle and decision support systems (Section 2.2),
- the potential for buildings to achieve water neutrality and calculation methods to evaluate net-zero water (Section 2.3), and

- the concept of resilience and necessary components required to measure resilience (Section 2.4).

Section 2.2 defines the building water cycle that forms the foundation of what this research aims to measure the resilience of and identifies the need for decision support tools with specific properties that are lacking in the building water sector. Section 2.3 investigates the advancement of net-zero water buildings that aim to balance water consumption with production. Net-zero buildings further support the need for water-based decision support tools in order to evaluate net-zero performance that depends on the inclusion of alternative water supplies. In addition, the resilience of net-zero buildings to municipal disruptions is increased due to the diminished reliability on centralized sources to fulfill building functions. Section 2.4 reviews the range of definitions and descriptions of resilience and outlines considerations that will be used to measure the resilience of the building water cycle. The qualitative nature of resilience supports the need for quantitative indicators that are introduced in Chapter 7.

The complicated nature of building water cycles described in Sections 2.2 and 2.3 identify the need for prioritization of water flow pathways. The need for water prioritization is addressed in the prioritization framework presented in Chapter 4 which forms the groundwork for the final water resilience assessment model (WRAM).

Chapter 5 reviews a study on water use data collected from building sites in Dunedin, FL, USA. Real water data is necessary to emulate building water cycles that will be exposed to disruption events in order to measure resilience. The water use study also provides insight to the variability associated with building water use.

Chapter 6 provides an overview of the WRAM modeling framework which is based on the prioritization presented in Chapter 4. The WRAM model adds storage components to the prioritization framework and controls potential water flow connections through switches in order to represent a range of building water cycle types. Control of water pathways is necessary in



order to evaluate the water cycle response to disruption events and measure the resilience in Chapter 7.

Chapter 7 presents resilience indicators based on properties of resilience from Section 2.4 and tests the resilience of building water cycles based on water data acquired from Chapter 4. Resilience outcomes for each tested scenario are presented, and trends between the level of functions sustained and indicators are identified and discussed.

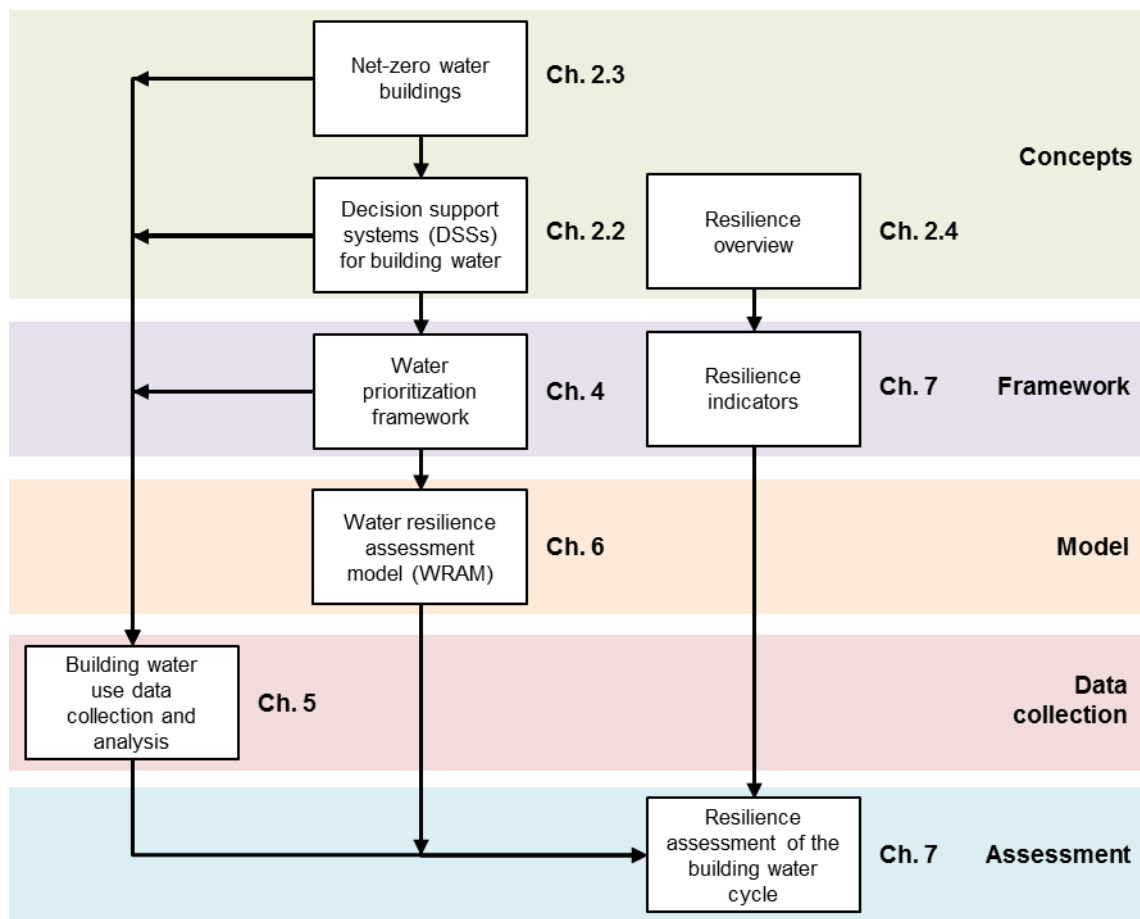

Figure 1.2: Outline of chapter relationships.

## **2 BACKGROUND**

### **2.1 Note to Reader**

Section 2.2 was published in Memon and Ward *Alternative Water Supply Systems* © IWA Publishing, with permission from the copyright holders, IWA Publishing (Joustra and Yeh, 2015a). Section 2.3 is based on the published article “Framework for net-zero and net-positive building water cycle management” that appeared in the journal *Building Research & Information*, volume 43, issue number 1, pages 121-132 (Joustra and Yeh, 2015c). Permissions are included in Appendix A.

### **2.2 Building Water Cycle and Decision Support Systems**

#### **2.2.1 Introduction**

Advancements in information technology, in addition to increased demands placed on comfort control within the built environment led to the pursuit of “intelligent” or “smart” buildings (Wong et al., 2005). Initial focus was placed on the implementation of technologies that allowed for energy efficiency of heating, ventilation, and air conditioning (HVAC) components; however, smart buildings have grown to incorporate all subsystems housed within the building envelope (Snoonian, 2003). With regards to the water subsystem, the building industry is apt to take a somewhat compartmentalized approach to water management. The use of alternative water sources (e.g., rainwater, municipal reclaimed water, air conditioning condensate, or stormwater) or the reuse of wastewaters (grey or black) significantly complicates the building water cycle. An integrated building water management (IBWM) approach that takes into consideration water from various sources, both inside and outside the building, should be implemented in order to enhance the intelligence of buildings. One way to determine outcomes from possible solutions

that aim to alleviate the disparity between supply and demand is the creation and implementation of systems models.

Increased availability of computer systems and decreased technological costs allow information systems to be incorporated by both groups and individual users at all levels of management. Decision support systems (DSS) are tools, often computerized, used to organize and present information for decision making. Therefore, DSS should be considered when decisions will be improved with further information and computer support is necessary and desired (Power, 2002). Depending on the needs of the user, the complexity of DSS ranges from simple excel spreadsheets to multi-program complex computer models. The increased complexity inherent in smart buildings with integrated water components supports the need for scalable, adaptable, and flexible DSS that can track and organize the flow of information, as well as aid decisions regarding water cycle design, operation, and improvements (Chamberlain et al., 2012).

### **2.2.2 Smart Building**

A building generally refers to a single structure and the components that support the structure; however, the term building may also be applied to a group of structures that share the same support structure in a campus setting. Buildings that share similar functions and system traits can be categorized by type and include:

- Residential structures (single family homes, multi-family buildings)
- Commercial structures (offices, retail centers, warehouses, distribution centers, data centers)
- Education facilities (schools, universities)
- Healthcare facilities (hospitals, clinics)
- Hospitality facilities (hotels, restaurants)
- Recreational facilities (theaters, fitness centers, aquariums)

- Government facilities (post offices, prisons, courthouses, police stations, firehouses)
- Industrial facilities (factories, laboratories)
- Utilities (water treatment plants, wastewater treatment plants, power stations)

Any of the aforementioned building types has the opportunity to be a smart or intelligent building with the inclusion of prerequisite components that facilitate communication within the building system and integration of building subsystems. Components vary from building to building, but common building subsystems include:

- Structural
- HVAC
- Lighting
- Electrical
- Water
- Sewage
- Security
- Fire suppression

Definitions describing smart buildings vary among sources, but contain shared elements. Table 2.1 outlines a few definitions used by organizations and found in literature. Certain commonalities can be pulled from the definition summary. First, it is evident that technology is a necessary feature of a smart structure. Technology is often synonymous with intelligence regardless of discipline; it is assumed that technology increases the capacity for the collection, organization, compression, and communication of information. Given the complexity of the building system and associated subsystems, intelligence is desired to accommodate the massive information potential. The implementation of computer technology furnishes a smart building with a synthetic brain that can be programmed to synthesize and share information according to predetermined decision parameters. In this way, the building makes informed

decisions regarding daily operations. Engaging this ability supports the second common attribute of smart buildings: efficiency. Operational efficiency is maximized with the aid of technological triggers creating a high-performance structure. Environmental comfort control can be monitored from a central location and immediately altered based on information inputs from remote sensors, or water flow sensors can discover leaks in water features and tag components for repair. By minimizing system losses, smart buildings also achieve the goal of cost reduction (Snoonian, 2003). Streamlined operations and maintenance practices help offset the expense of developing a smart building, enhancing the bottom line. Systems integration further reinforces building performance and is the third shared feature of smart building. In particular, integrated computer and communications systems are essential components for smart building as they are responsible for information facilitation to each subsystem (Finley et al., 1991). In the case of comfort control, integration of a centralized computerized system allows for efficient command of mechanical ventilation throughout the building structure. Integration should also exist among other building subsystems, whether directly or through computer and communications components. For example, all subsystems may be wired to a centralized computer control hub where the state of each subsystem is evaluated and altered based on the composite information received. The fourth important aspect of a smart building is user interaction. Early definitions of smart buildings were solely based on the use of technology and lacked the integrated component of user interaction (Wong et al., 2005). Technology is used to increase building performance, but it is the users that benefit from the increased efficiencies; and buildings must be designed to support the occupants. Therefore, how occupants interact with the building and associated subsystems is crucial, and a smart building must allow users to alter the structure's state to their specifications. This leads to the need for flexibility of the building system and subsystems. Smart buildings are networked using technology, and technology is a constantly evolving area. As a result, smart buildings must be able to incorporate technological improvements with limited additional costs and effects to productivity

in order to persist (Flax, 1991). The need for flexibility also extends to normal building operations. Modular systems allow smart buildings to quickly and effectively respond to changing environmental conditions. Consequently, this infers that smart buildings should be adaptable dynamic systems in order to meet the changing needs of its users.

Table 2.1: Smart building definitions.

Source	Definition
Smart Buildings Institute (2013)	“Enhances the performance of the building and ease of operation over its life-cycle. The primary goal... is to minimize the long-term costs of facility ownership to owners, occupants and the environment. In a higher performing building all components of the building are integrated in order to work together. This improves operational performance, increases occupant comfort and satisfaction and provides the owner with systems, technologies and tools to manage and minimize energy consumption.”
SmartBuildings, LLC (2012)	“A smart building, aka, integrated building, intelligent building, automated building, high performance building or advanced building, is a building that is designed for longevity. “
Flax (1991)	“Creates an environment that maximizes the efficiency of the occupants... while at the same time allowing effective management of resources with minimum life-time costs.”
Finley et al. (1991)	“Single building or a complex of buildings which offers a coherent set of facilities to both the building managers and to the occupants, to the building managers, an integrated set of management, control maintenance, and intra- and inter-building communications facilities that allow efficient and cost-effective environmental control, security surveillance, alarm monitoring and communications, both inside the building and out to municipal authorities (police, firestations, and hospitals), and to the building occupants in the workplace, an environment ergonomically designed to increase productivity and encourage creativity and in residences and hotels, environments that will foster comfort and a “humanizing” atmosphere as well as provide sophisticated computer and telecommunications services.”
Katz (2012)	“Provides owner, operator and occupant with an environment, which is flexible, effective, comfortable and secure through the use of integration technological building systems, communications and controls”

### 2.2.2.1 Building Automation

Smart buildings require communication between the building system and subsystems, and building automation provides a means to facilitate the transfer of information. Incorporating building automation features allows for increased building efficiency, making automation critical for smart building to reduce operations costs (Snoonian, 2003). For example, automated lighting systems ensure that energy is not wasted during building off-hours by shutting down non-emergency lighting systems.

Building automation refers to any technologies applied to building systems that allow for centralized control and communication. However, automated systems often lack integration and

operate using separate communication standards and control points (Flax, 1991; Snoonian, 2003). For example, building electrical and fire prevention systems may both be automated, but controlled using two different communication standards preventing the use of a shared centralized control point. In addition to this, the lack of a shared communications language keeps both systems isolated from each other and disallows an input-response relationship. In the case of a fire, it would be desirable for the fire prevention system to alert the electrical system and shut down building electrical components. In order for such cause and effect relationships to take place, a shared language or central communications “interpreter” is required to facilitate an integrated systems approach. Completely integrating building systems is challenging due to the wide array of manufacturers involved (Snoonian, 2003). Not only does this expand the number of unique systems and associated controls, but also results in systems, controls, and protocols that are protected property of the manufacturer and cannot be altered. Although a formidable problem, solutions exist that aim to integrate unique building systems.

In the building industry, BACnet and LonWorks represent two common building automation communications standards largely developed in the 1990s that aim to integrate building systems (Snoonian, 2003). BACnet (ASHRAE, 2013) which stands for Building Automation and Control Networks was developed by the American Society of Heating, Refrigerating and Air-Conditioning Engineers (ASHRAE) and is both an American and European standard. LonWorks (Echelon Corporation, 2013), short for Local Operating Network, was developed by Echelon Corp. and is also a standard used in the United States and Europe. Both BACnet and LonWorks are standards recognized by the International Organization for Standardization (ISO).

BACnet was originally developed for the mechanical and electrical systems within the building envelope and is a communications-only protocol; however, the generic nature of the protocol allows for the integration of hardware and software associated with other building systems (Snoonian, 2003). The BACnet protocol utilizes virtual objects that create prioritization

within the system through organization and programming to represent the operations and functionality of the building by describing current operations, desired operating parameters, and resulting commands (Snoonian, 2003). Compatibility with the internet allows BACnet components to be controlled remotely through the web, thus resulting in remote building control from anywhere web-connected; the controller is not tethered to the location of the building systems and has remote and immediate access (Snoonian, 2003). Another benefit of the BACnet protocol is the ability to facilitate communication among diverse building systems; data can be shared and prioritized for system integration and clarity. A command with higher priority, such as shutting down electrical components in the event of a building fire, will be implemented over a command with lower priority, such as running electrical equipment in power-saving mode during building off-hours. Due to its wide acceptance, it is possible to find manufacturers producing devices immediately ready for BACnet implementation.

LonWorks has adapted to building applications after being focused on the transportation and utilities industries. Unlike BACnet, the LonWorks standard includes both a communications protocol and a hardware component; BACnet was developed only as a communications protocol. LonWorks uses the Neuron Chip as a link between a device desired to be controlled and central control system (Snoonian, 2003). Similar to BACnet, LonWorks transmits data using wired connections, as well as web servers; and LonWorks utilizes network variables in order to create the inputs and outputs of building systems, analogous to the virtual objects comprising the BACnet protocol. However, prioritization of system commands is not as direct when using LonWorks because it lacks the inherent levels of priority found in the BACnet system. In order to allow for prioritization in LonWorks, users can define override commands for emergency response or periodic checks to pass to continue normal operations (Snoonian, 2003). Although the methodology to define system priorities is different for LonWorks and BACnet, prioritization is a necessary inherent attribute for successful communication and sustained functionality.



### **2.2.2.2 Relationship to Green Building**

Although smart buildings and green buildings are both referred to as high performance buildings, the terms are not interchangeable; a green building does not necessarily need to be smart, and a smart building is not always green (Figure 2.1). The main differences can be attributed to the presence or absence of sustainable attributes. Green buildings aim to limit environmental impacts (Berardi, 2013), and efficient building operations may help achieve this goal; whereas smart buildings focus on efficient operation of the building system, which may result in reduced environmental impacts. A smart building can achieve efficient water use using communications networks; however, if the water source utilized is non-sustainable, such as water from a limited potable supply, then the building is not also green. A green building limiting effects on the natural hydrologic cycle may be designed with pervious pavement allowing infiltration and a gravity-based rainwater supply system to offset the potable demand. Both sustainable strategies do not require complex control systems; and therefore, this green building is not defined as smart. In addition, while green building requires consideration of the entire building life cycle from design to deconstruction, smart building activities are only applied during the design and operations phases.

Globally, there are more rating systems for green buildings than smart buildings. An industry leader in green building rating systems is the United States Green Building Council (USGBC), which encourages sustainable building practices (USGBC, 2013a-c). Assessment tools for smart buildings are less visible and scarce. However, building intelligence can be evaluated using the Building Intelligence Quotient tool (Katz, 2012). The tool is available online and provides value to smart buildings, integrated design support, and building automation support.

An important similarity between the two building types is the goal of systems integration, and allows for synergy between smart and green strategies. Despite the subtle differences, it is possible for a smart building to also be considered green. Smart building practices can even

enhance the sustainable attributes of a green building. Water components controlled and monitored from a centralized computer location allow building operators to verify that alternative water supply systems are functioning properly. Failures or leaks are easily pinpointed resulting in faster repair times. Green building strategies can also make a smart building smarter. Incorporating alternative supply systems within a smart building allows for increased performance through potable water reductions.

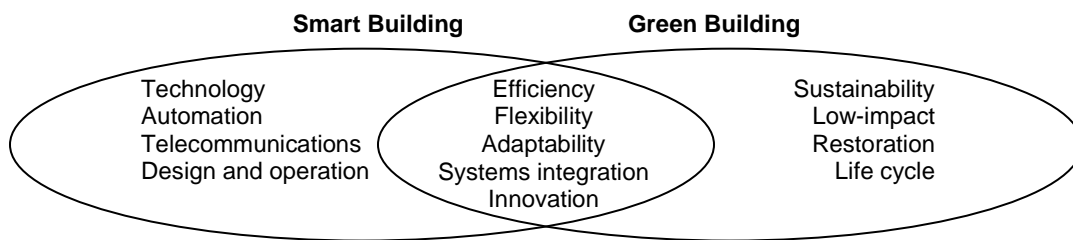

Figure 2.1: Comparison of smart and green building concepts.

### 2.2.3 The Building Water Cycle

Each building is a unique system composed of multiple dynamic subsystems, and each subsystem can be separated into multiple smaller components. The building subsystem based upon water utilization can also be viewed as the building water cycle. Just as the natural, or hydrologic, water cycle maps the flow of water throughout the global system, the building water cycle also contains an inherent map of water flows throughout the building structure. In the former case, the system boundary is global; whereas in the latter cycle, the system boundary is drawn around the building site, which may include the physical building in addition to vegetated spaces, parking areas, and hardscapes. Pathways in the natural water cycle are based on environmental processes in contrast to the physical conveyance and consumption pathways found in the building system; however, the main difference between water cycles is that the global cycle is a closed system while the building cycle is an open system. This fact is illustrated in Figure 2.2. The uninterrupted natural water cycle is represented by a balanced

feedback loop (A). In a simplified view of a conventional building, water is fed into the system boundary from the environment, utilized by the building, and discarded back into the environment (B). In this worst-case scenario, the building water cycle is more linear than cyclical and environmental impacts are at their peak. However, smart and green buildings aim to limit disruption to the environmental water cycle through efficient water use measures (C) and recycling practices that mimic the hydrological cycle (D). The ultimate goal is a net-zero water building, a structure with a water cycle that has evolved into a closed system (E).

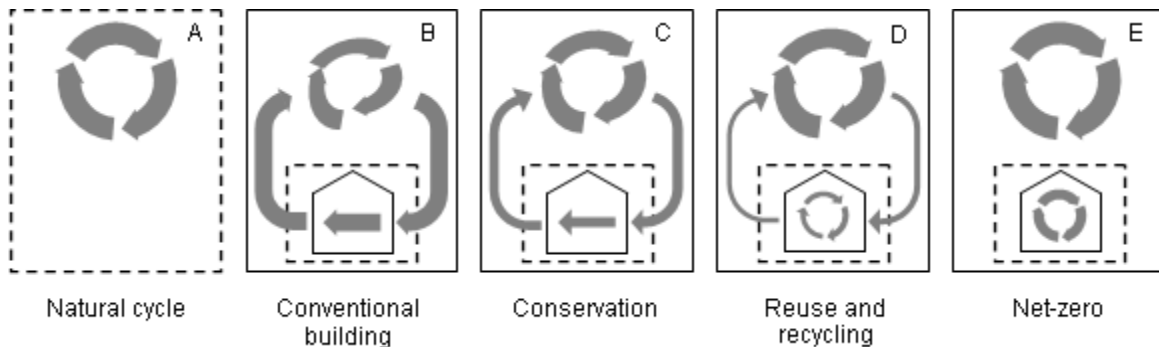

Figure 2.2: Evolution of the building water cycle.

As discussed, the building water cycle ranges from completely open and linear to closed and cyclical. The complexity of the cycle depends on the number of connections and potential routes for water, as well as the magnitude of those flows. Therefore, the building water cycle can be defined based on inherent (1) demands, (2) supply sources, and (3) usage patterns. Water demands, potential supply sources, and allowable interactions among the two are dictated by the building's design. Decisions must be made to first determine the desired water demands of the building system. Then, the connections to available water sources are considered. Finally, based on chosen demands and sources, the connections between each are made. In a conventional building, these decisions are basic; once demands are acknowledged, each is supplied by the potable water source, and remnant water is discarded

from the building boundary as wastewater. Incorporating alternative water sources necessitates further decisions regarding where it will be applied, and also creates opportunities for discarded water to be captured and recycled. The increase in choices regarding the building water cycle provides the opportunity for the implementation of DSSs that aid the decision-making process. DSSs are further desired when usage patterns increase the complexity of the cycle. The building design only determines connections, but usage is determined by human behavior. The changing magnitude of water flows dictated by occupant usage is largely responsible for the dynamic nature of the building water cycle. Estimation of the occupants' effect on water usage further feeds the need for decision support, but understanding of the building water cycle components is a prerequisite for DSS creation.

#### **2.2.3.1 Building Water Demands**

The number and importance of building water demands is dependent on the type of building. In a restaurant, the demand for water used for cooking is higher than in a retail store; a restaurant may have a water demand associated with an ice machine that is not present in a retail store. Even among buildings of the same type, demands can vary. One residential home may include a swimming pool that creates a water demand due to periodic refilling, whereas a neighboring home may not. A school containing an on-site garden project would have a water demand for growing crops that would not be included in the water cycles of other schools. Therefore, water demands are site-specific. The quantity of water utilized by a demand depends on the device efficiency used to meet the demand. As a result, the magnitude of the water required for an individual demand can be minimized through conservation strategies.

In regions of limited rainfall, a large portion of a building's water use is directed towards the *irrigation* demand. In the United States, about one third of the water used in the residential sector is for landscaping (USEPA, 2013). Traditionally landscaped building sites incorporate large tracts of water-thirsty turfgrasses, but switching to native landscaping practices by planting water-efficient grasses, groundcover, shrubs, and trees can substantially decrease the demand.

Additional irrigation demands may arise in the presence of gardens, whether for aesthetics or food production. In addition to the type of vegetation planted, the density and proximity to the building and other vegetated areas affects the water demand by altering complex evapotranspiration processes. Choices exist regarding existing technologies for irrigation. Sprinkler systems that disperse water through the air are less efficient than drip systems dispensing water underground. The cost to install rainfall or moisture sensing equipment limits inefficiencies and may be offset through water cost savings. Increasing the ratio of vegetated space to hardscapes allows for increased rainwater infiltration rates on-site, thereby reducing the water leaving the building boundary as runoff and moving towards a closed system. However, if the green spaces developed require additional irrigation beyond rainfall, the demand for water sources located outside of the building system boundary may increase, moving away from the closed system goal.

Generally the cultivation of green spaces takes place at the ground level surrounding a building structure, neglecting the remaining hardscape produced by the building itself. However, practices that literally green the building, such as vegetated walls and roofs, soften the effects of the hard building exterior. The green roof is often used as an example of integrated design in sustainable construction because of its effects on the building system. Benefits are seen in water management, energy efficiency, and air quality (Carter and Fowler, 2008; VanWoert et al., 2005). Like all vegetated spaces, a green roof mitigates runoff quantities through water retention by plants and substrate. This method also increases the quality of water leaving the green roof, protecting the environment from high pollutant loads. Insulation and evaporation allow a green roof to even out building temperatures over time. In addition to reducing heat outdoors, vegetative roofs may also have positive impacts on the indoor conditions of the building while providing an aesthetically pleasing environment for workers and guests. Here the potential connections among building subsystems is evident. Implementation of a green roof may affect the irrigation demand and alter the building water subsystem.

Additional irrigation components will need to be integrated into the existing system. Ensuring the roof system can carry the vegetative roof load and facilitate proper drainage affects the structural system. The evapotranspiration and insulation associated with a green roof alters the HVAC loadings; these effects change the parameters input into the design and operation of the building energy subsystem. Green roofs are especially encouraged in urban areas where green space is limited, such as in the cities of Chicago, Seattle, and New York City. In Toronto, green roofs are required for new construction meeting height and size standards (City of Toronto, 2013). DSSs can easily organize potential vegetation types by water demand and allow users to estimate the total amount of water needed for irrigation based on planted area and placement in order to choose the optimal design. Further effects, such as the potential for shading or insulation of the building structure can be input into energy calculators. However, DSSs may neglect qualitative considerations, such as aesthetics and social acceptance. Overlooking qualitative effects may skew cost-to-benefit results and produce a design choice that is not necessarily the most advantageous. This stresses that DSSs are truly for support, and final decisions require interpretation and assessment by the user.

Within the building structure, most fixtures focus on supplying water for essential human needs, such as *drinking, hygiene, cooking, and cleaning*. The fixture type affects water efficiency, and standards determine maximum values allowable by fixture in the form of flow rates or volume per use event; however, green and high-performance buildings aim to install hardware fixtures that exceed the efficiencies set forth by these standards. Low-flow faucets used in kitchens and bathrooms aim to eliminate wasted water by creating a manageable water stream. Most, if not all, buildings include a demand for hygienic practices like hand-washing, but not all will contain a demand for cooking activities, such as washing foods and utensils. Residential buildings will have a higher demand for showering than commercial structures, although this demand is not exempt from all non-residential areas. Schools may provide showering facilities for students, or commercial and industrial structures may include showers

for employees. The design choice of how many showering structures to include depends on the expected demand. An urban office building with a large group of employees that commute by bicycle will expect a higher showering demand than an office staffed with all vehicular commuters; in both cases it is unlikely that all occupants will shower, but the demand is steadily expected in residential areas where occupants likely shower daily. In the case of showering, building designers have a choice of fixtures to curb the water demand. Choosing the fixture with lowest flow is assumed to provide the highest water savings, but the initial investment can be higher. A DSS can easily find the optimal balance of water savings and cost for a fixture based on lifetime and payback periods, but personal preference is also a factor.

*Sanitation* is another essential water demand. Buildings are designed with some form of sewage conveyance for toilet or urinal flushing. Each of these two fixtures is designed with a set water volume utilized to accomplish this goal. Like faucet fixtures, the amount of water needed per event can be reduced using high-efficiency options; ultra low-flow toilets and urinals can use less than half the water per flush as set forth by maximum standards. However, toilet and urinal fixtures exist that eliminate the use of water and still accomplish the sewage conveyance goal, unlike their faucet counterparts. This is possible for two reasons. First, the demands met by faucets are consumptive, and cannot be fulfilled without water; water is consumed for drinking and cooking, and water is a prerequisite for sustainable cleanliness. Second, the delivery of water to faucets requires pressurization, whereas sewage conveyance can be accomplished using gravity. In the case of waterless urinals, gravity facilitates the movement of liquid waste through a secondary liquid seal. The seal prevents odors from escaping and floats on top of the urine due to a density difference. In this case, the water demand for urinal flushing is eliminated from the building water cycle; however, a limited water stream may still exit the building boundary through the sewer system. A waterless toilet has the ability to eliminate both the water entering and exiting the building system. Also referred to as composting toilets, these fixtures are designed to degrade wastes on-site. User acceptance is

crucial for the success of waterless sewage conveyance practices that aid in closing the building water cycle; and additional arrangements for maintenance and nutrient recycling must be considered and integrated (Wilbur, 2014). Further impediments to installation include energy and financial costs, which may be significant in vacuum-based drainage systems.

*Process water* demands vary, but cooling is commonly included. Often mechanical, cooling systems contribute to the comfort of building occupants. Due to fluctuating environmental conditions, the water demand associated with cooling can vary annually, seasonally, and diurnally. For cooling towers, demand is correlated to the makeup water, which depends on multiple losses found within the tower. A portion of water exits through evaporation processes. Water leaving the tower through uptake air flows, rather than through direct evaporation, is referred to as drift. Evaporation and drift cause the concentration of dissolved solids to increase within the cooling tower. In order to reduce the concentration of solids, water is drained periodically in a process referred to as bleed-off and replaced by clean water. Bleed-off is an intermittent process, whereas evaporation and drift constantly occur. Although challenging, limiting evaporation and bleed-off will decrease the cooling demand. Chemical additives can inhibit scaling within the tower; thereby prolonging residence time of the recycled water and reducing the frequency of bleed-off events. Decisions regarding cooling tower design and operation require optimization of chemical use, costs, and water savings. Additional process water demands include thermal cooling, boilers, steamers, or industrial dishwashers, ice machines, and pre-rinse spray valves.

Buildings require a degree of *safety* in order to protect the structure, interior elements, and human occupants. Fire suppression systems dispense water when activated under emergency circumstances; and therefore, the demand associated with firefighting is rarely incurred. However, if the water demand is activated, the volume required to meet the demand is appreciable and causes this demand to be notable in the building water cycle. Unlike the



other water demands discussed, conservation measures cannot be applied to the fire suppression system.

Often overlooked are water demands regarding *recreation and aesthetics*. Examples such as sports fields or flower gardens are better listed under irrigation demands; rather this category focuses on aspects such as swimming pools, fountains, and other water features. After supplying the initial water volume needed in order to enact each feature, evaporation, infiltration, and usage losses consequently fuel a consistent operational water demand. This category best demonstrates the trade-offs between function and form. Aesthetic demands focus on leisure and beautification of the building site over practical and essential functions, but this does not mean they are without value. Increasing the building appeal can add financial value to the property and increase occupant productivity through heightened morale. Some of these benefits can be quantified in economic terms, while qualitative benefits based on psychological benefits are difficult to assess. DSSs can weigh the costs of implementing aesthetic water features, but the final decision cannot be made without consideration of immeasurable qualities. In this case, the information organized and presented by a DSS then becomes an informational input and assists the decision maker.

### **2.2.3.2 Building Water Sources**

Once demands have been established, available sources must be investigated and chosen to meet the demands. The accessibility of water sources depends on the location of the building site, available infrastructure connections, and the demands outlined as part of the building's water cycle. The meteorology and hydrology of the region encompassing the building dictates whether certain conventional or alternative sources exist. Structures atop natural water reserves may be able to bore through the surface and construct on-site wells for groundwater recovery. Areas with substantial precipitation events provide buildings with potential rainwater and stormwater sources. Rainwater is assumed to be the water captured before interacting at the ground level, and is therefore assumed to have a higher water quality than stormwater and

with appropriate treatment can be used for potable or non-potable applications. The state of the infrastructure supplied to the building determines potential municipally supplied sources, such as potable or reclaimed water. Reclaimed water is a high-quality water source produced after intensive treatment of municipal wastewater at (de)centralized treatment facilities. Additional alternative water sources are produced within the building boundary by the fixtures associated with demands. Wastewaters can be separated into two streams, greywater and blackwater, depending on the discharge quality. Greywater exits from sinks, showers, and other low-strength sources, whereas blackwater contains higher amounts of organic material and includes water flushed from toilets and urinals. Buildings with a cooling demand also contain a potential condensate water source. The quality of condensate collected from air handling equipment is comparable to distilled water, requiring little to no treatment for non-potable applications (Licina and Sekhar, 2012). Conventionally, easily-attainable high quality sources are pursued for all building water demands; however, focus has shifted to alternative water sources to meet the needs of green and smart buildings.

Traditionally buildings are designed to shed rainwater from the building site as stormwater runoff and lose this volume as an alternative water source. Regulations regarding treatment and mitigation of runoff volumes that mimic the predevelopment hydrologic cycle also form the basis for augmentation within the building water cycle by capturing the water in cisterns, rain barrels, detention and retention ponds, or other natural water bodies. One barrier to rainwater use within buildings, especially in the United States, is the lack of regulation regarding application of this source. As a result, codes and statutes often limit uses to irrigation. However, in many island nations, such as the United States Virgin Islands, water is an especially scarce resource, and rainwater is the primary and sometimes only available source for potable applications (Solomon and Smith, 2007).

Sources dependent upon wastewater streams have the benefit of being continuous, as opposed to natural sources dependent upon meteorological and hydraulic conditions.

Limitations are often imposed on these sources due to associated human and ecological risks in order to ensure public safety (Anderson et al., 2001). Reclaimed water is generally considered a safe and sustainable option within water-critical regions (Wintgens et al., 2005). The majority of reclaimed water in the United States is applied to landscaping, both in residential and commercial structures. However, dual-plumbing systems can serve other non-potable fixtures with this source. Nearly all reclaimed water produced at the city's wastewater treatment facility in Dunedin, Florida makes it to lawns within the city limits. During dry months, demand can even surpass available supply. Wastewater treatment and reuse can also be accomplished on-site by compact packaged systems. Membrane bioreactors (MBR) accomplish wastewater treatment within a small footprint by replacing secondary and tertiary treatment trains found in municipal facilities with membranes. High quality MBR effluents produced from either greywater or blackwater influents have the potential for recycling within the building water cycle (Atasoy et al., 2007; Boehler et al., 2007; Ghisi and Ferreira, 2007; Sorgini, 2004). The Helena Building in New York City includes an MBR system that recycles wastewater for cooling, toilets flushing, and irrigation applications, reducing the demand for municipal potable water (Clerico, 2007). Cooling and dehumidification of buildings in warm climates produces a high-quality condensate source usually considered a waste stream. Condensate flows can be directed to existing storage components, such as a rainwater cistern, or collected and distributed separately. In San Antonio, condensate capture systems have become standard; the shopping mall produces 950 liters per day, and the central library produces about 163,000 liters per month (Guz, 2005). Common recycling applications include cooling tower makeup water, irrigation, and aesthetic water features, although the high quality of the source allows for varied applications.

Having on-site alternative sources implies a need for storage since the time of source production does not necessarily coincide with the time of demand; and any treatment following collection delays the delivery of the source to the demand. Storage builds flexibility into the building water cycle by allowing it to respond to changes in the magnitude of water demands

using alternative sources. Even storage of conventional sources, such as municipal potable water, provides flexibility and security. Elevated water towers also ensure delivery of a water source by creating pressure within the building water system when the pressure within municipal pipelines is intermittent.

### **2.2.3.3 Usage Patterns**

The building design component partially contributes to the expected interaction of the building water cycle. The remaining element largely affecting the movement of water is human behavior. The same individual has different interactions with unique building types, and even among buildings of the same type depending on the role of the individual within that system. An individual in their residence will create a higher overall demand for water than in a commercial building. Unique demands within each cycle are also affected differently. In a residence, the occupant is assumed to use more water for kitchen and bathroom uses, as well as discharge more water from these applications than in the commercial structure. The effect that the role taken by the individual has on the building water cycle is evident in a retail structure. As an employee, the individual would spend most of the day within the building system and exert a higher stress on the water subsystem than a visitor. It is possible for the visitor to have no effect on the building water cycle within their short stay, whereas the employee is likely to interact with drinking, cooking, sanitation, and hygiene demands. The application of certain water demands also depends on the individual's preference. One employee may prefer to take a premade meal to work from home, whereas another employee may prefer to make lunch at the office, thereby shifting the associated demands from the residential to the commercial building water cycle.

Human behavior further affects the performance of individual water fixtures. Fixtures are rated based on the amount of water they are designed to use per application, and building owners install fixtures under the pretense that each application will fulfil the design standard. However, human interaction can override expected water demand operations. It is assumed that low-flow faucets reduce overall water consumption, and this is true if the time required to

fulfil a demand is the same for the low-flow feature as it would be for a conventional faucet with higher flow. In reality, the low-flow faucet may be active for a longer time period to accomplish a similar task due to the lower magnitude flowrate. Even the installation of automatic features does not guarantee design performance. For example, a sensor-activated toilet flushes with a predetermined volume after activation by the sensor. False sensor readings can result in multiple flushes per use event. A delayed flush response can cause a human user to override the flushing mechanism causing an additional volume to be lost during the application. Further human interaction affecting automated flush volumes was verified in a school study (Joustra, 2010). Automated toilets installed as part of a rainwater collection and reuse system at a green-certified school were rated to use 4.8 liters per flush (lpf). However, data collection based on individual flush events found multiple instances of flushes that exceeded the rating. An investigation found that the pressure exerted on the manual flush *override button* changed the volume consumed, and holding the button down caused a continuous flow of water. In addition, students were urged to utilize the *override button* to eliminate all waste as a social courtesy. This example shows how human interference alters the design state. It is important to acknowledge that the magnitude of water use according to demand can be estimated based on the building type, role of the occupant, and water fixture design, but precise usage patterns would best be evaluated using sensors tied to smart building networks. Collecting the usage patterns unique to the building system would allow for better decisions regarding water efficiency.

#### **2.2.3.4 Integrated Building Water Management (IBWM)**

Integrated building water management acknowledges the interrelationships among water sources and demands and aims to operate the building water sector on a systems level. This requires that the water demands and potential sources for an individual building are first inventoried. Then, decisions regarding proper allocation of water sources to meet specific demands can be accomplished. In a conventional building, potable water is often the sole

source used to meet all demands. However, water meeting potable standards is not necessary to accomplish non-potable applications, such as flushing of toilets or urinals. Utilizing an integrated systems approach, IBWM first observes the potential for alternative water sources to meet demands as part of a fit-for-purpose approach, before drawing from on-site or municipally supplied potable water. Efficient and integrated source allocation manages the inflow of water into the building system, the recycling of water throughout the building system, and outflow of water from the building site. Measures taken as part of an IBWM aim to decrease the inflow of water, particularly potable water, as well as decrease the outflow of water using efficient wastewater and infiltration processes (Lazarova et al., 2001). The efficiency pursued as part of an IBWM approach is shared with both green and smart building concepts. IBWM implementation strongly aligns with green building goals by promoting sustainable management through water reuse and recycling practices. Due to the increased complexity of the green building water cycle, total water use is reduced by reusing water for non-potable demands and recycling wastewater streams after treatment. Closing these flows transitions the building water cycle toward a net-zero water system leading to the maintenance of the natural hydrologic cycle and lowered environmental impact.

As discussed, the building water cycle is comprised of a complex web connecting water sources with demands. Deciding how to match sources to each demand creates the need for prioritization based on preference. When the same source is available for multiple demands, prioritization by demand is necessary. Drivers affecting demand prioritization are based around public acceptance and include perception of alternative water sources, knowledge about the source, previous experience with the water source, and interaction or influence from friends, family, and colleagues (Dolnicar et al., 2011). Public acceptance is also driven by the perceived cleanliness of the water source; for recycled water allocation, the aesthetic quality is an important consideration factor (Jefferson et al., 2004). In decreasing order of preference, potential demands met by alternative water sources include irrigation, cooling, industrial

processes, recreational water use, non-potable public water uses, and potable public water uses (Howell, 2004; Asano, 2002). Surveys conducted regarding alternative water use are in general agreement; the highest support again focuses on irrigation followed by toilet flushing, laundry, cooking, and drinking, respectively (Browning-Aiken et al., 2011; Campbell and Scott, 2011). However, the aesthetics of a particular water source may alter the demand preference. Jefferson *et al.* (2004) observed that recycled water with a poor appearance caused the allocation preference to change from irrigation to toilet flushing. The highest priority demand for greywater alternates between irrigation and flushing of fixtures. Ludwig (2006) prefers applying greywater for landscaping due to treatment processes that occur within the soil, whereas Jamrah *et al.* (2006) argue the best use is for flushing toilets. However, both agree that demands with higher human interaction, such as clothes laundering, have a lower priority. According to Hauber-Davidson (2007), acceptable uses for rainwater include irrigation, cooling, bathroom uses, laundry, and refilling swimming pools; less acceptable demands include kitchen use and food preparation. Condensate is a high quality alternative water source, and due to its proximity to the cooling system, Licina and Sekhar (2012) propose cooling make up water as the top priority for allocation. The preferences discussed demonstrate that the preference of utilizing alternative water sources for reuse and recycling is highest for water demands with the least amount of direct human contact, although additional social factors can alter the desired prioritization.

Additional prioritization based on source is required when multiple sources can meet one demand. The logic employed by green building and IBWM assumes a higher preference for alternative water sources over potable sources. Often a demand served by alternative water sources also contains a potable water backup supply. In this case, the potable supply is given the lowest use priority. The prioritization by source should be defined given the number of potential alternative water sources, diverse water quality parameters, and public perception. For example, the priority given to greywater use may be elevated because its treated quality

quickly degrades over time (Al-Jayyousi, 2003). Rainwater may be assigned a lower priority than greywater due to its longer storage potential with proper collection. Although public views of water sources tend to drive prioritization, green buildings often challenge this perception by pioneering new technologies. Building designers have the opportunity to change the building water cycle prioritization framework based on their own preferences and decision-making aids. IBWM forms the foundation for a DSS capable of taking an integrated systems approach towards this goal.

#### **2.2.4 Decision Support Systems**

Decision support systems (DSSs) come in various forms and complexities utilizing multiple programs and platforms. Models can be qualitative, quantitative, or a combination of both. Qualitative DSS models include decision-making trees and or diagrams outlining strengths, weaknesses, opportunities, and threats (SWOT); information is based on observable data. Quantitative DSS models utilize mathematical inputs in order to produce numerical outputs used for decision-making. Both qualitative and quantitative attributes can be incorporated into water management models. The volume and rate of water delivery is quantifiable; evaluation of water quality depends on quantifiable parameters that can be assessed using analytical methods and qualitative parameters such as color, taste, and odor. The quality of water can also be assessed qualitatively based on treatment (primary standards, secondary standards, tertiary standards) or regulated and accepted end uses.

##### **2.2.4.1 Advantages and Disadvantages**

The inherent advantages of DSSs result in widespread application (Power, 2002). Time savings are accomplished by quick decision-making accomplished by using DSS models. Creation of a user-controlled model can be quicker than waiting for and recording real-time observations. For example, the decision to enact water conservation measures prior to a drought can be made earlier and faster using prediction models rather than waiting for deteriorating conditions to reach a critical point. In addition, the use of models can be cost-



effective due to lower infrastructure, technology, and labor costs. Building a computer model for decision support is less intensive than constructing a pilot-scale system; modelling the impact of various alternatives can eliminate poor solutions from being considered for further studies or final implementation, saving time, labor, and cost. Further savings are accomplished with flexible DSS models that allow input parameters to be easily changed for running multiple scenarios. Increased effectiveness of decision making and improved communication are two additional advantages. A DSS model organizes information and presents a scenario as one complete picture that is shared with all users; everyone is given the same results from which to form a decision.

Potential disadvantages can decrease the value of DSS outputs (Power, 2002). It is important to remember that DSSs should be used as a support tool, and not as the sole source for decision-making. Generally DSSs do not incorporate social and political impacts of a potential decision; and therefore, consequences related to these areas must be taken into account when using purely technical forms of DSSs. Decision authority may be applied to DSS tools, but final decisions should be made by humans using input from the DSS outcomes. Users must also acknowledge the boundary wherein information input and output by a DSS is applicable as decisions made outside of these bounds lose validity. It is possible for systems to be overloaded with information, or provide excess information that interferes with coherent decision-making. However, properly formed support systems organize vast information inputs for simplicity. Information outputs depend on the information inputs; bad inputs result in bad outputs. Therefore, care should be taken to reduce poor information from entering the support system and producing bad results. Users of DSSs must also prevent over-reliance on support systems, which can reduce the effectiveness of decision-making. If reliance is high, it is also possible that users may overlook low quality results or place high importance on complex results. In both instances, decision-making effectiveness is reduced. This leads in the potential for false objectivity. The ultimate responsibility regarding decisions lies with people and not

computers. DSSs are assumed to be rational and objective, but the same assumption cannot be made of people. The manipulative nature of DSSs can allow users to come to subjective decisions rationalized using the support systems outcomes. When implementing a DSS model, all advantages and disadvantages should be considered and addressed.

#### **2.2.4.2 Role of DSSs in Smart Building Water Reuse and Recycling**

The building water cycle consists of a labyrinth of connections among demands and sources, which increases in complexity in smart building systems that incorporate water reuse and recycling strategies, elevating the appeal of support systems to aid in the decision-making process regarding design and operation. Aiming for efficient resource consumption and utilizing green building practices to meet high-performance standards, such as alternative water allocation, creates a number of variant building water cycle combinations. DSSs provide the opportunity for water cycle optimization based on user-defined parameters of interest including water savings, energy use, cost reduction, and social acceptance. Individual decisions to be made include:

- Water demands served by the building
- Potential water sources available to meet demands, including alternative supplies
- Connections between demands and sources
- Priority of demands met by same source
- Priority of sources meeting same demand
- Design components
- Alternative water management strategies
- Operation parameters
- Estimated water usage

Certain decisions regarding water demands and sources within the building water cycle are made implicitly and are historically expected. Building codes and statutes outline required

fixtures based on building type and number of occupants. Residential structures are expected to have fixtures for bathing, cooking, cleaning, hygiene, and sanitation; whereas small commercial structures may only be mandated to include bathroom facilities. Required inclusion of water fixtures based on regulations introduces the associated demands into the building facility and often includes minimum performance standards for each fixture. Although installation of specific fixtures cannot be eliminated, the opportunity exists to choose devices that limit water consumption, and this is where DSSs can aid users in choosing appropriate hardware. The addition of other demands remains at the discretion of the building design team. These largely include demands associated with building aesthetics, such as water features and decorative landscaping. Decisions regarding these features balance water consumption with measurable quantitative benefits including worker productivity and financial value of the building site (Montalto et al., 2007). DSSs that compare expected benefits to buildings with similar aesthetic features may aid the design of these additional non-essential demands, although immeasurable social benefits require a human component to synthesize all benefits before weighting against potential costs.

Control regarding connections between water sources and demands is also largely regulated. In most cases it is expected that a potable water supply exists to meet all demands. At a minimum, all demands are supplied by the potable water source and discharge to a sanitation system. However, the inclusion of alternative water sources resulting from water reuse and recycling schemes presents designers with a myriad of water cycle arrangements based on choices that direct water throughout the subsystem. This also leads to decisions associated with the prioritization of unique demands and sources. Designers must decide which demand or demands should be met by each alternative source, or whether more than one alternative source should be grouped to meet a demand. Variables affecting these decisions include the magnitude of the alternative source, quality of the source, costs of implementing the alternative water supply system, and public acceptance of the source. These variables not only

dictate which sources will be viable in general, but also which sources are viable for each water demand. DSSs that compile information and present the best potential alternative water strategies still require a final weighting based on human interpretation in order to rank the best connection scenarios.

In addition to flow connections and design components, water reuse and recycling strategies modify the movement and quality of water within the building water cycle. Certain sources may be established as acceptable for a set group of demands, but the wisest allocation method can depend on the volume of the source attainable, cost, and energy use based on the technology or strategy considered. A packaged wastewater treatment and recycling system may provide enough water to offset half of all sewage conveyance needs, but implementation of low-flow and waterless fixtures may accomplish the same goal at a lower initial and annual cost. Based on the efficiency standards pursued by the building, a compromise involving both strategies may help achieve higher performance goals. The opportunity to define and alter these design attributes determines best methods to achieve targets and leads into the need for appropriate design parameters to ensure proper operation. The computer and communication network within a smart building will require boundary conditions for individual systems to run, as well as triggers based on shared information. For example, a water equalization tank installed as part of a rainwater collection system may need to have the pressure monitored to ensure the alternative water can be supplied to interior fixtures. In addition, the lowest water level allowed should be determined and programmed into the intelligent system to allow for the inclusion of makeup water when the supply is low. Emphasis on integration within smart buildings further encourages support that identifies water connection relationships and the relationships among the water subsystem and other building subsystems. For example, the operation parameters set for the cooling system will dictate the water bled from and added to the system in order to meet desired environmental conditions.

Even the best designed water system is still susceptible to fluctuations and environmental changes. Occupation by building inhabitants and visitors will create a dynamic and sometimes unexpected demand profile, thereby creating a need to estimate human behavior effects on the system. Using DSSs, the water subsystem can be tested against a range of potential demand arrangements and magnitudes in order to verify flexibility and strength. The establishment of maximum and minimum loadings determines the limits of the designed building water cycle and can be re-evaluated under different design conditions. An estimation of water patterns is a prerequisite to accomplish these goals. Current use cycles can be described through the use of meters which can be implemented within the smart building framework. Using current information, projection scenarios developed using DSSs can prepare building owners for potential changes or upgrades to the system to meet future demands, building the adaptive capacity expected of a smart building.

#### **2.2.4.3 Tools for Building Water Management**

The development and use of support tools aimed at the building water cycle are limited (Table 2.2). Although still scarce, research on DSSs focusing on sustainable water management at larger scales has produced more detailed and integrated frameworks. For example, Chamberlain et al. (2014) presents a DSS prototype capable of evaluating the environmental, economic, and social effects for sustainable wastewater strategies at the community level. The inclusion of impacts beyond measurable water use is an important component often lacking when the scope is narrowed to building structures and further limited to the water subsystem.

The trend for building-specific water support tools consists of calculators that track estimated water consumption, and thereby view the building water subsystem as a series of divided inflows. These water use calculators are prevalent online, with many published by organizations linked to water awareness and conservation. Homeowners are the main audience for simple calculators; current design patterns or human habits are exposed by

informing water users of their water consumption habits. The most basic calculators use estimated volumes and flows for water demand applications and allow users to fill in the number of times each application occurs within a given time frame. For example, a user may be asked how often laundry is done or how often a bath is taken during a week. The input parameters provided by the user are fed into equations that produce the amount of water used by the individual either by water sector, all household activities, or both. The time frame may also be changed to reflect daily, weekly, monthly or annual usage. These tools focus on water consumption by demand and are generally not concerned with alternative water sources.

Support tools that incorporate water reuse and recycling or relationships to energy and costs are generally separated from software addressing the entire building. In the case of rainwater, some calculators consider annual precipitation that meets a portion of the irrigation demand, while other programs provide the option for rainwater collection, storage, and use for landscaping or interior building water demands. However, it is easier to find calculators specifically programmed around the design of a rainwater storage and collection system. Some allow users to input specific parameters regarding their building footprint and potential collection area, resulting in the maximum possible volume of rainwater that could be collected. Other tools incorporate storage and cost components to provide better information to users. Calculators developed around a specific water component, such as cooling or irrigation, tend to include a higher level of detail used to model water use for that demand. The Leadership in Energy and Environmental Design (LEED) series of rating systems produced by the USGBC includes calculations outlined to determine water reductions for landscaping and interior building fixtures (USGBC, 2013a-c; USGBC, 2012). As a green building rating system, alternative water supplies are incorporated as strategies to offset potable water demands. However, the current system still relies on a budget approach where water volumes for demands are tallied and compared to available water sources; alternative sources are subtracted from the total demand to determine the total potable water needed by water sector and the percent reduction.

Table 2.2: Building water support tools.

Name	Scale, software	Alternative sources	Description
Water Footprint Calculator (National Geographic, 2013)	Single residential, web-based	Natural rainwater for landscaping	Daily water use calculated based on household water consumption, personal diet considerations, energy consumption, and consumer spending
WECalc (Pacific Institute, 2010)	Single residential, web-based	Greywater for landscaping	Extensive questionnaire that calculates total water demand, hot water demand, energy demand, and carbon footprint by end use; also includes costs associated with energy use. Suggestions that reduce energy and water are presented with benefits, costs, and payback periods.
HouseWater Expert (CSIRO, 2004)	Single residential, web-based	Rainwater storage, greywater diversion, on-site treated wastewater	Water consumption, wastewater generation, and runoff amounts are calculated for Australian regions based on a graphical platform that allows users to choose water demands and sources found both inside and outside of the building structure. The tool includes options for alternative water sources. Wastewater applications are limited to landscaping and toilet flushing.
Assessment tool (Fidar et al., 2010)	Single residential, basic tool	Greywater reuse, rainwater harvesting	Water consumption, energy use, and greenhouse gas emissions are calculated and compared for 8000 scenarios for an average residence in England. Interior micro-components (water demands) are varied.
WaterSmart Scenario Builder (POLIS, 2010)	Community, spreadsheet	Input for undisclosed non-potable source (rainwater, greywater, wastewater recycling)	Impacts associated with future water use scenarios for a community are estimated. The community is broken down into residential, commercial and institutions, industrial, agricultural, and non-revenue sectors. Users view impacts of chosen water efficiency scenarios in terms of water, energy, and greenhouse gas emissions reductions.
IBWM Model for Green Building (Joustra, 2010)	Generic building, STELLA model (iSee systems)	Rainwater, stormwater, recycled wastewaters, reclaimed water	The model provides users with the ability to analyze the effects that water management options have on a building's water cycle. Various building types are evaluated by changing demand portfolios. Alternative water supplies are incorporated. All demands and sources are networked.

The thoroughness and amount of information both received from and presented to the user dictates the amount of options the user perceives. Calculators that present water usage by sector allow the user to view areas of highest consumption and decide whether design or habitual changes can alter the usage patterns. The user is increasingly exposed to parameters affecting the water cycle when DSS tools require more information from the user. Exposure to

alternative water sources and demands that can be met by those sources can open the design possibilities available to the user. The fragmented nature of tools that address alternative water supply systems and links to energy and cost hinders the potential for decision-making based on integration. A systems approach allowing for the complete interaction among water sources and demands while identifying the affects to other subsystem will result in DSS tools that are robust and flexible.

#### **2.2.4.4 Incorporating IBWM into Smart Building DSSs**

Existing DSS tools specifically addressing water within buildings contain deficiencies that limit their implementation potential. Easily accessible programs addressing building water use are often directed at the residential level, although all building types exert a water demand. The models assume a limited variety of building systems and lack the ability to accommodate buildings with different occupant loadings. Models also tend to separate building demands and focus only on water consumption when wastewater generation is an integral part of the water subsystem. Inclusion of alternative water sources is extremely limited; even when sources are available, demand applications are controlled. Smart building and IBWM share concepts related to systems integration, and the intelligence of buildings can be enhanced with DSS models that combine IBWM practices. Smart buildings recognize relationships among building subsystems and aim to manage the building as a coordinated system, whereas IBWM accomplishes the same goal at the building water subsystem level.

The perception of the building water subsystems should be similar to that of the hydrologic cycle, where all outputs are potential inputs for other components. In this view, wastes become potential resources. DSSs utilizing an IBWM approach should monitor all inflows and outflows from each water demand and note the change in water quality that occurs. Water quality parameters affect how sources will be allocated by the user, and whether decisions regarding treatment or disposal will be made. All potential water demands and sources should be allowed to interact in order to fully incorporate all potential water cycle



arrangements and easily alter connections to create new configurations. More options built into the DSS result in more possibilities for the user to investigate and allow for models that cover conventional water cycles to potential compositions that result in a net-zero water structure.

Inputs fed into IBWM DSSs should allow for flexibility. Tools capable of modelling different building types with various water demands, sources, and flow magnitudes decrease the development of repetitive models which can be costly and time-consuming. Options presented to users allow for comparisons between different building types or variations of the same building type to be made. This flexibility also allows modelling of future scenarios, such as company growth, space utilization changes, or building additions. Additional scenarios can be created that evaluate the adaptive capacity of the building water cycle to short-term or long-term changes. An example of a short-term stressor is the loss of a water supply source due to a pipe break, whereas decreased precipitation events due to drought conditions is an example of a long-term event.

IBWM and smart building operations both benefit from monitoring equipment and sensors. Incorporating submetering practices provides information about water usage and operation parameters that can be fed into DSSs. With respect to IBWM, submetering assesses whether water cycle design goals are being met by logging information about the amount of water directed towards specific fixtures and applications (Tamaki et al., 2001). This data accounts actual water use within the subsystem which can be compared to the expected amounts estimated from support models. The resolution resulting from submetered water systems aids building operators in tagging inefficiencies in the system. Usage patterns captured by the monitoring system can also be used to improve modelling of the building in DSSs and produce better results when evaluating future scenario projections.

### **2.2.5 Conclusion**

Decision support systems are powerful tools that organize and present information to users for improving the quality and effectiveness of decision-making; however, the development

of DSSs addressing the intricacy of the building water cycle is limited. Building-level DSSs regarding the building water cycle should follow the concepts of IBWM and:

- recognize potential water demands, sources, and the connections between them,
- incorporate the use of alternative water supply systems,
- simulate building water cycles for multiple building types and buildings of different magnitude,
- be dynamic,
- project outputs based on input scenarios,
- consider effects on related subsystems, and
- enhance building automation procedures.

Smart buildings encourage increased efficiency and adaptability of building systems, thereby creating a demand for buildings that are flexible and dynamic. Incorporating water reuse and recycling systems within the building water cycle assists in achieving these goals. Inclusion of alternative water supplies to meet non-potable water demands increases the efficiency of potable water use and protects potable sources. The increased water use efficiency also allows the building water cycle to better adapt to changes in potable water availability, whether due to varying natural or regulatory conditions, and to changes within the building, such as fluctuating occupancy and behavior. The complexity and dynamic nature of the building water cycle means frequent decisions are required regarding (re)design and operation. DSSs should be used to efficiently determine optimum design parameters and to adeptly direct building automation operations. Operating parameters (irrigation schedules, storage volumes, overflow triggers, treatment specifications, and cooling tower cycles) can be determined based on outcomes from decision support tools, and information collected from smart building computer monitoring should form the basis for DSS inputs. Finally, DSSs should

increase the intelligence of smart buildings, and smart buildings should be flexible enough to adapt integrated alternative water systems.

## **2.3 Net-zero and Net-positive Building Water Cycle Management**

### **2.3.1 Introduction**

The built environment is supported by resources supplied from the natural environment in terms of raw materials, energy, and water. Consequently, the construction and operation of building structures significantly impact the quality of both the human system in which they reside and natural systems to which they are linked. The magnitude of the built environment's effect is evident by the substantial portion of electricity consumption, greenhouse gas emissions, material use, waste output, and potable water consumption attributed to the industry (Kibert, 2008; USEPA, 2009). In the United States, 40% of all energy and 13% of all water consumption is directed to buildings. In addition, occupant health may be compromised by pollutants that reduce indoor environmental air quality in structures where people spend the majority of their time (USEPA, 2009). As a result, organizations and groups aim to limit the impacts of the built environment and protect human health by challenging building projects to meet rigorous standards through integrated sustainable solutions.

At its core, net-zero emphasizes balance so that the sum of all inputs is offset by comparable outputs, thereby stabilizing the consumption and production of resources, which embodies the core concept of sustainability by maintaining development without compromising the availability of resources required in the future (World Commission on Environment and Development, 1987). The persistence of resources external and internal to the site encourages the sustainability of raw resources and building operation. Net-zero strategies protect resource availability in two possible ways. First, balancing the net-zero equation is easier when the inflow of resources is reduced or eliminated through demand and on-site management, thereby causing the required source production output to decrease (Boland, 1997; Hoekstra, 2008). Examples include implementing conservation practices, recycling resources on-site in order to

reduce overall demand, or producing renewable resources for utilization on-site (Atasoy et al., 2007; Boehler et al., 2007; Chang et al., 2007; Cheng, 2003; Clerico, 2007; Ghisi and Ferreira, 2007). Second, consumed resources may be replaced by the generation of substitute sources of similar value and quality in order to preserve net-zero balance and ensure future availability (Hoekstra, 2008). Sites connected to an infrastructure grid that serves both the building site and accepts resources produced by the site for allocation off-site provide the opportunity for offset (Voss et al., 2010). By ensuring availability, net-zero promotes resource security; and as a result, protects on-site building functions and overall development.

The energy sector receives the majority of net-zero applications (Hernandez and Kenny, 2010; Marszal et al., 2011; Sartori et al., 2010; Torcellini et al., 2006; Voss et al., 2010). However, the importance of responsible management of emissions, waste, and water has been acknowledged (Novotny, 2013); and interest in applying the net-zero equation within these sectors is increasing, both individually and collectively. For example, the United States Army is piloting net-zero facilities, including net-zero energy, net-zero waste, and net-zero water, with the goal of having 25 net-zero sites by 2030 (United States Army, 2014). The Army recognizes the critical advantage of security of both resources and the facility inherent in net-zero projects. Additional benefits include better control of future resource costs, better predictability of resource costs, and flexibility to meet new building standards (Booth et al., 2010).

Building certification programs include the Leadership in Energy and Environmental Design (LEED) set of rating systems and the Living Building Challenge (LBC) program (International Living Future Institute, 2012; USGBC, 2014). Developed by the United States Green Building Council (USGBC), the LEED analytical framework evaluates the degree to which projects accomplish desired positive goals based on achievable credits (Owens et al., 2013). Many LEED credits specify a requirement that aims to limit initial resource use or reduce overall consumption through reuse and recycling. Examples include reducing energy and water use through the installation of high-efficiency fixtures, offsetting energy consumption through on-site

or off-site renewable generation, or offsetting potable water consumption by utilizing rainwater or recycling on-site wastewater sources (USGBC, 2009). LBC consists of performance-based standards that certify projects that at a minimum meet net-zero conditions, but ideally are regenerative and restorative (International Living Future Institute, 2012). LEED and LBC both rely on a set of credits for certification. However, all LBC credits are required; whereas projects pursuing LEED certification are given flexibility in the number and type of credits pursued. Both programs act as drivers to transform the building industry. LEED strategies address traditional linear consumption of resources and persuade building sites to implement actions that take steps toward cyclical, or closed loop, solutions; but the rigorous approach taken by the LBC system is enforced by net-zero compliance that makes closed loop systems a requirement.

The program schemes produced by the USGBC and LBC support the shifting view of buildings as consumptive and environmentally deteriorating structures to potential restoration facilities that revive the environment (Cole, 2012; du Plessis, 2012). Net-zero water applications are currently limited. However, developments within the energy field provide a foundation for evaluation within the water sector. The feasibility for net-positive water management schemes that exceed the net-zero threshold may then be considered. This section investigates the calculation of net-zero water, discusses components required for water neutrality and investigates the opportunity for net-positive building water cycles.

### **2.3.2 Building Water Cycle**

Familiarity with the drivers and pathways within the building site is prerequisite for water assessment. A building is a system operated by multiple subsystems, including energy and water, and the movement of resources to, within, and from the building site creates individual resource cycles (Cole et al., 2012). The subsystem created by the movement of water throughout the site can be described as the building water cycle. Historical management of the building water cycle mirrors a paradigm shift in water resources management that can be compared to the natural hydrologic cycle. The building system boundary that houses its water

cycle includes the building structure in addition to applicable vegetation and hardscapes. Both the natural and building water cycles map water flows throughout the system. In the natural cycle, water is contained within the global system boundary representing the net-zero goal. Recycling within the natural cycle ensure that water consumption is matched by water production. Conventional building design imports potable water flows from environmental sources for consumption within the building. Once used, water is labelled as waste and discharged from the building site. Managing water using linear processes results in higher environmental impacts through resource depletion. Sustainable design encourages conservation measures in order to decrease overall water use. Water reuse and recycling techniques that mimic natural processes further reduce the need for potable water supplies. Both conservation and the creation of balanced water feedback loops are necessary in order to achieve the same net-zero efficiency as the natural cycle.

The building energy framework consists of individual loads that exert a demand, as well as available energy sources that serve the loads. Similarly, the building water cycle is formed by water fixture demands served by available water sources. Opportunities to increase water efficiency or create closed loops towards net-zero water accomplishment depend on the existing components of the building water cycle, such as building demands, available water sources, and occupant behavior patterns.

#### **2.3.2.1 End-uses and Water Sources**

Designed water demands (Table 2.3), or end uses, and their magnitude depend on the type of building and affect the overall quantity of consumption (Dziegielewski et al., 2000). For example, a residential home includes water demands related to cooking and showering that may be non-existent in commercial or industrial facilities, and a shower in an office building will likely demand less water than showers in a multi-family residence. Demand existence and magnitude also varies among buildings of the same type, such as the presence of swimming pools in certain homes or aesthetic water features in specific office complexes. Therefore,

demands found in the building water cycle are site-specific, and the varying magnitude of water consumption by demand causes outcomes from similar water efficiency strategies to also be unique to the building site. Multiple demand-based conservation measures exist that decrease overall building water use and guide the building water cycle toward the net-zero ideal (Inman and Jeffrey, 2006).

Table 2.3: Potential building water demands and associated fixtures.

Water demands	Fixtures
Irrigation	Sprinklers Hoses Underground drip-systems
Drinking	Faucets Water fountains Water dispensers
Hygiene	Bathroom sinks Kitchen sinks Showerheads Bath faucets
Cooking	Kitchen faucets Dishwashers
Cleaning	Faucets Clothes washers
Sanitation	Toilets Urinals
Process water	Mechanical cooling Boilers Steamers Industrial dishwashers Ice machines Pre-rinse spray valves
Safety	Fire sprinklers
Recreation and aesthetics	Swimming pools Fountains Ornamental ponds

Accessibility to individual water sources (Table 2.4) is necessary to meet the unique building water demands dependent on the supporting infrastructure, climate at the location of the building site, and building demands. Centralized sources supplied by extensive infrastructure networks include potable water and reclaimed water. Climate at the building location affects the availability of rainwater and stormwater supplied by precipitation. In

addition to driving overall consumption, demands within the building also determine the availability of wastewater sources (greywater or blackwater) generated on-site. Meteorological conditions and the presence of a mechanical cooling demand affect the availability of condensate as an alternative water source. Condensate is ideal for non-potable water demands due to its high quality and limited treatment requirements (Licina and Sekhar, 2012). Potable water has traditionally been utilized for all building demands; however, net-zero water buildings need to incorporate additional alternative sources within the building’s water source portfolio.

Table 2.4: Potential building water sources and origins.

Source	Origin
Potable water	Centralized treatment of groundwater, surface waters, or desalinated water
Reclaimed water	Treated wastewater from centralized wastewater treatment facilities
Rainwater	Precipitation intercepted before interacting with the ground
Stormwater	Precipitation collected after interacting with ground surfaces; runoff
Condensate	Condensed water vapor resulting from cooling processes
Greywater	Wastewater from faucets, showers
Blackwater	Wastewater from toilets and urinals

### 2.3.2.2 Influencing Factors and Uncertainty

Identifying the magnitude of demands and available sources within the building water cycle allows for simple demand-source matching in order to fulfil the building water functions, but uncertainty affects demand and source profiles thereby introducing variability into the actual building water cycle performance and impeding consistent net-zero accomplishment. The vast variability in climate greatly affects the potential for alternative water use, such as rainwater harvesting and condensate production, thereby reducing the options available to offset potable water (Licina and Sekhar, 2012). Further imbalance results when climate increases the water required for weather-sensitive demands such as irrigation, cooling, and water features (Boland, 1997). Expanding climate variability is also making it increasingly difficult to predict future patterns based on historical records or stationarity (Dessai and Hulme, 2007; Salas et al.,



2012). In addition, unforeseen failures in the system including pipe breaks, fixture malfunctions, power interruptions, and treatment deficiencies instantly exclude the associated source from the water cycle for the duration of the failure.

Another major source of uncertainty is a result of socio-economic factors (Huang et al., 2013). The interactions undertaken by building occupants with the fixtures serving the building demands directly impact consumption and wastewater generation resulting in unique patterns over time used for demand forecasting (Alvisi et al., 2007). The behavior and resulting water consumption of an occupant varies based on the building in which they currently reside (Pieterse-Quirijns et al., 2013; Stoker and Rothfeder, 2014). For example, it is likely an occupant will exert a higher hygienic demand at home rather than in a commercial setting due to social purpose of each structure. Specific variables controlled by occupants include the number of use events for a demand fixture and the duration of the use event (Blokker et al., 2010; Wong and Mui, 2007). The variability among occupant groups should be acknowledged when predicting water consumption and generation for net-zero analysis.

### **2.3.3 Net-zero Water**

Terms describing energy balance have been thoroughly investigated (Kibert and Fard, 2012), but definitions regarding net-zero water buildings are limited. The U.S. Army defines net-zero water buildings as facilities that maintain the same quantity and quality of natural water resources, such as groundwater and surface water, by decreasing consumption and directing water to the same watershed (United States Army, 2014). Ecosystem protection is also stressed within the LBC net-zero water standard, which mandates that the building only use harvested precipitation or recycling loops to meet all of the building needs (International Living Future Institute, 2012). The LBC standard prohibits the use of chemical treatment, presumably due to assumed detrimental environmental impacts, thereby limiting acceptable technologies for recycling and reuse that are necessary to fulfil the target goal. However, the standard currently exempts the highest-quality potable water demands, such as sinks, faucets, and

showers, in order to address and moderate the current regulatory difficulty for complete water recycling implementation. In a related LBC standard, the ecological component of net-zero water is further defined as on-site management, or hydrologically acceptable off-site management, of all stormwater and used project water. Olmos and Loge (2013) define net-zero water use as the balance between annual potable water use and annual rainfall. According to their study, the collection of precipitation into a wetland area for local groundwater recharge defines the level of offset available for municipal water consumption in order to achieve net-zero. Hoekstra (2008) does not limit water neutrality to quantitative constraints, but instead allows quantity imbalance to be offset by positive impacts within the larger hydrologic context. All definitions are applicable to individual building sites, or larger campuses and communities. However, the quantitative standard in each example differs based on the considered flows and system boundary.

#### **2.3.3.1 System Boundary**

Outlining resource movement within the water and energy infrastructure networks that serve buildings presents distinct differences between the two systems (Table 2.5). Smart energy grids allow for bidirectional flows of energy, which subsequently permits on-site energy generation and offsets. Water pipelines only allow for unidirectional flow, and therefore water cannot be re-introduced into the existing system in order to offset consumption. The inclusion of a disposal step within the water network which is omitted in the energy sector highlights contrasts in the properties of each resource. Energy consists of many forms, beginning with natural sources which are transformed into convenient forms, such as electricity, in order to serve building end uses or functions. At the end use, the energy flow may again be transformed to meet the function, whether as motion, light, or heat. Conversely, water does not change forms, but mixes with impurities at different points in the network. Water generally serves a temporary purpose within the building that affects its quality, and the constant demand for high-

quality water requires low-quality wastewaters to be discharged for treatment and eventual reuse.

Table 2.5: Comparison of the urban water and energy infrastructure networks.

	Water	Energy
Natural sources	Surface water (lakes, rivers, streams) Groundwater (aquifer) Seawater (desalination)	Fossil fuels Solar radiation Wind Biomass Geothermal gradients Gravity
Production methods	Water treatment plant Desalination plant On-site groundwater wells	Power plant Hydropower facility Solar panels Wind turbines
Distribution system	Unidirectional pipe flows	Bi-directional network
Building end use	Consumption	Electricity Heat Light Motion
Discharge methods	Wastewater infrastructure Wastewater treatment plant Stormwater infrastructure	

When the boundary is drawn such that it includes the environment holding the water source, municipal water production, and subsequent treatment and discharge, building water use appears to be a minor factor. In this case, the environment becomes the resource stock that requires net-zero balance – water consumed must equal water generated in order to preserve the volume. Within this wide view of water use, water is removed from its natural source and conditioned at a centralized water treatment facility in order to meet quality standards. Treated water is then distributed to building structures through a pipeline network to meet customer demands. On-site water is consumed by a variety of end uses, and wastewater is generated simultaneously. Using a separate sewer infrastructure network, wastewater flows are directed to a centralized wastewater treatment facility where the water quality is improved before returning to the natural source stock. In cases where buildings are not served by a

municipal sewer network, wastewater treatment and discharge occur on-site, such as through the use of septic systems.

The municipal water cycle agrees with the ecological protection mandated by some net-zero water requirements. Water consumed by buildings equals wastewater generated. The two streams are comparable due to shared quality standards that occur at the beginning and end of the cycle, making wastewater a renewable water source. However, this wide water cycle view includes challenges that limit efficiency and support net-zero approaches at the building scale. The transportation of water within the pressurized distribution system results in leakage losses; and therefore, not all of the water produced is delivered and consumed by the customer resulting in a system imbalance. In addition, the natural water source used for water production is often different from the location where treated wastewater is discharged. For example, pumping water from an underground aquifer for potable consumption and returning the used flow to a surface river disrupts the ecological cycle. In this case, the availability of the resource has changed and may no longer be fairly compared for net-zero balance. Pursuing net-zero by incorporating municipal facilities also affects infrastructure networks and security. Aging infrastructure networks incur stress due to changing population demands and require continuing maintenance. Vulnerable distribution systems and centralized treatment facilities reduce security of connected building sites; and facilities reliant on centralized processes are sensitive to service disruptions and variable pricing, whereas self-sufficient sites can better control resource flows and costs.

Minimizing the system boundary to the building site highlights potential flows that must be addressed in order to evaluate net-zero water. Distribution losses are limited, and water quantities are easier to verify within the smaller system boundary. Inflows include potable water, municipal reclaimed water, and precipitation, while wastewaters and runoff outflow from the boundary. Net-zero analysis requires water consumption to be compared to water generation, in which the demands within the building drive consumption that can be met by any

municipal or alternative water source production. However, water generated on-site is constrained to wastewater and precipitation flows. Wastewater results from the building operation and is therefore an internally generated source that can be freely utilized. Precipitation occurs regardless of the building's existence and initially contributes to an existing natural cycle. Utilizing captured precipitation in order to offset or eliminate municipal supplies supports building self-sufficiency, but may affect overall resource availability. Therefore, preservation of hydrologic flows is a necessary component for net-zero water analysis (Hoekstra, 2008).

### **2.3.3.2 Water Balance Calculations**

The scale of the system boundary chosen for water neutrality calculations dictates the variables that must be included in the balance equation. In all cases, both mechanical pumping pathways and hydrologic flows must result in equilibrium, such that the sum of inflow consumption equals the sum of outflow production. A water mass balance, such as that developed by Kenway et al. (2011) and presented in Equation 2.1, is necessary in order to account for urban and hydrologic flows.

$$\Delta S = C + D + P - (W + R_S + G + ET) \quad (2.1)$$

In Equation 2.1, the change in stored (S) water for a defined city boundary is defined by the difference in input and output flows in units of volume per time. C is the inflow of centralized water sources (e.g., municipally treated groundwater, surface waters, or desalinated seawater); D is decentralized flows into the system, including decentralized groundwater production ( $D_G$ ) or rainwater harvesting tanks ( $D_R$ ); P is all forms of precipitation; W is wastewater discharge,  $R_S$  is stormwater runoff, G is the infiltration flow to groundwater, and ET is evapotranspiration. The resulting storage of water includes moisture within the soil, water in conveyance pipelines, and water reservoirs.

Equation 2.1 effectively communicates the movement of water within a city due to its simplification of often complex and unknown water movement and interactions. The

simplification also allows Equation 2.1 to be scalable and applicable to regional, city, and building levels. However, the equation does not clearly include natural or stormwater runoff volumes that may cross into the boundary from an adjacent region and considers water from rainwater tanks as an input into the system without specifying whether this volume is then removed from the inflow precipitation volume. As a result, this paper revises Equation 2.1 into Equation 2.2 in order to identify the components necessary for water balance.

$$\Delta S = I + C + D + P - (W + R + G + ET) \quad (2.2)$$

In Equation 2.2, I is added to the list of inputs and represents the inflow of surface water from adjacent systems including natural over-surface flows and stormwater runoff. For consistency,  $R_S$  has been replaced with R in order to reflect the inclusion of runoff volumes associated with over-surface flows in addition to stormwater runoff. C, W, G, and ET still represent centralized water inflows, wastewater outflows, groundwater infiltration, and evapotranspiration, respectively. D still represents decentralized water, but is limited to on-site groundwater withdrawals and excludes rainwater harvesting. Instead, rainwater harvesting becomes a resultant storage volume due to P representing the condensation of water vapor into liquid forms, which includes rainwater, snowfall, and condensate. Relevant flows from equation 2 for the natural and urban case are shown on Figure 2.3.

### 2.3.3.3 Zero Water

Zero-energy buildings produce and generate all energy on-site and without reliance on grid services (Hernandez and Kenney, 2010). Similarly, zero-water compliance requires that the building water cycle operates independently from water and wastewater municipal systems as shown in Figure 2.3, thus eliminating C and W from equation 2.2 and resulting in equation 2.3.

$$\Delta S = I + D + P - (R + G + ET) \quad (2.3)$$

Input sources are constrained to runoff inflows from adjacent sites (I), on-site groundwater wells (D), and precipitation (P). Internal “generation” and reuse of sources is necessary in order to

balance Equation 2.3 while fulfilling the water demands within the building. However, the inability to utilize the continuously produced municipal water supply requires precise management of variable on-site water sources in terms of storage. Stored water (S) within the building system may result from rainwater harvesting (RW), stormwater ponds (SW), or condensate collection (CC). The appearance of wastewater within the building system results from the transformation that water streams undergo at the end uses resulting in a drop in water quality. Therefore, an increase in available wastewater must correlate with a decrease in the original utilized source. On-site wastewater recycling is crucial to zero-water success as the only renewable and reliable water source within the building boundary. The availability and quantity of supplemental alternative sources, such as rainwater and condensate, rely on climatic conditions at the building location. Therefore, the difficulty of achieving zero water balance greatly increases in regions with imbalanced precipitation patterns or dry climates.

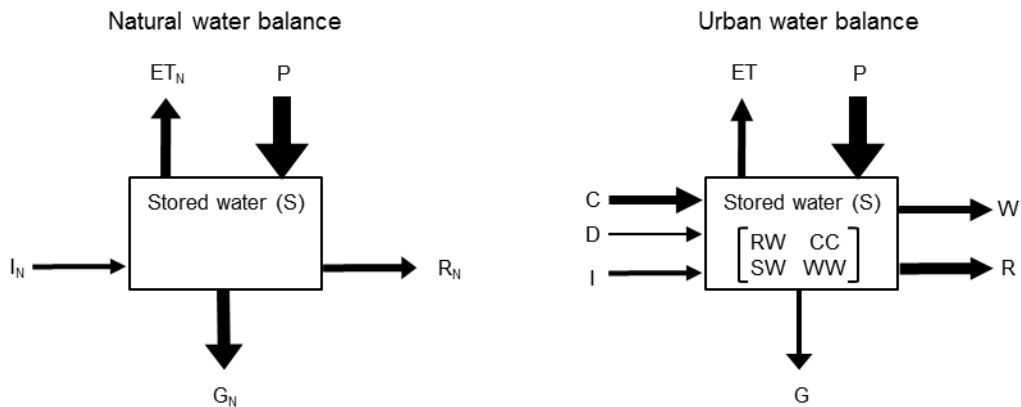

Figure 2.3: Inflows and outflows affecting water storage (S) in the natural case (left) and urban development case (right). Hydrologic flows include precipitation (P), runoff (R), groundwater flows (G), evapotranspiration (ET), and surface inflows from adjacent parcels (I). Additional urban flows include centralized water (C), decentralized water (D), and wastewater (W). In the urban case, rainwater (RW), stormwater (SW), condensate (CC), and wastewater (WW) represent harvested alternative water volumes available for reuse and recycling within the system.

#### **2.3.3.4 Net-zero Water**

The difference between net-zero water and zero water is the amount of interaction with infrastructure. In regards to energy, the term net is used to compare inputs and outputs of the grid system (Hernandez and Kenney, 2010). A net-zero energy building sells to the grid as much energy as it acquires from the grid on an annual basis. The grid requires that the same electrical currency is used in order to facilitate bidirectional flow ensuring consistent quality; electricity produced by centralized power plants and electricity sold back to the grid by building sites maintains the same functionality.

The lack of a bidirectional water distribution system places buildings pursuing a net-zero water goal at a disadvantage, and the quality of water exiting the building system is generally much lower than the water entering the boundary due to the acquisition of contaminants from end uses. In practice, the quality difference is evident by separate water delivery and water discharge infrastructures. Conceptually, the inequality of the building input and output streams does not allow for mathematical computations regarding offsets, but quantity balance may be achievable using Equation 2.2 by expanding the building boundary so that it includes centralized water facilities that directly affect flows  $C$  and  $W$ . For example, in regions that provide municipal reclaimed water, utilizing this centralized source ( $C$ ) is analogous to wastewater recycling; the origin and termination points are the same, and balance results. Therefore, the volume of wastewater generated by the building ( $W$ ) and treated at a centralized reclaimed water facility may be offset by utilizing reclaimed water from that facility ( $C$ ) for building demands.

The example implies that net-zero compliance not only relies on quantity and quality equivalence of building consumption and generation streams, but also the timely return of water sources to the natural origin location. The equality presented by the net-zero equation infers that nothing has changed, yet relocating water sources alters the original water cycle. Therefore, demonstrating that water generated from a centrally-served building site ( $W$ ) is returned to the ecosystem from which it originated is necessary for full net-zero credit. In some



cases, the originating ecosystem may encompass the building site, which would allow for on-site treatment and infiltration (G) to count towards the net-zero goal.

#### **2.3.3.5 Life-cycle Zero Water**

The term life-cycle zero water building (LC-ZWB) follows the life-cycle zero energy building (LC-ZEB) concept (Hernandez and Kenney, 2010). Evaluating net-zero over the lifetime of the building shows whether net-zero resource balance is achieved within the life-cycle. For net-zero energy analysis, the embodied energy of all building materials is annualized and added to the annual operation energy for comparison to renewable energy generated by the building (Hernandez and Kenney, 2010). The same framework, when applied to water, requires that the embodied water required for the manufacture and transport of materials be considered over the building lifetime as direct water use may only account for a small portion of the life cycle water consumption (Crawford and Pullen, 2011; Stephan and Crawford, 2014). Achievement of net-zero water over the building lifetime may be an unachievable objective without innovative techniques for on-site renewable water generation. Unharnessed energy sources in terms of solar radiation, gravity, temperature differentials, wind velocities, and other natural phenomena are largely available for the fulfilment of building energy demands; whereas water sources are confined to a sensitive circuit that relies on temporal and spatial applications.

#### **2.3.4 Net-positive Water**

The discussion regarding balanced water management reveals the opportunity for net-positive building water performance as a result of restorative impacts. Maintaining a balanced system prevents the accelerated deterioration of resources and environments, but growth is encouraged by net-positive water schemes which increase the sustainability, resilience, and carrying capacity of urban and natural environments through responsible water management based on quantity, quality, location, and time.

### 2.3.4.1 Quantity

Overall water quantity is generally fixed in natural and urban water cycles; water is not created, transformed, or destroyed. As a result, water management requires efficient transportation and consumption. Efficiency is also integral to balanced or positive energy use, but energy production exceeding consumption is possible due to the opportunities for energy generation from renewable sources. Natural forms of energy, such as solar radiation or wind, may be harnessed and transformed to useful forms. In contrast, water may only be created from hydrogen and oxygen components with a large energy input, such as in a hydrogen fuel cell. The cost of this practice to increase water quantities greatly exceeds the benefit. The condensation of water from atmospheric reserves is not a creation event, but rather a transfer of water from one phase to another.

Table 2.6: Quantity balance check comparing actual flows (Q) with natural flows (Q<sub>N</sub>), the potential result of an imbalance, and associated methods to create a net-positive response.

Quantity check		Result	Net-positive strategies
$R - R_N$	+	Runoff exceeds the natural volume; excess urban runoff	Mitigation Infiltrate stormwater Collect runoff and use
	-	Runoff is below the natural threshold	Augment and mimic natural flows
$I - I_N$	+	Inflow exceeds the natural volume; excess urban runoff	Runoff mitigation Restore natural surface flows
	-	Inflow from adjacent boundaries is below the natural threshold	Restore natural surface flows
$G - G_N$	+	Increased groundwater storage Engineered changes in surface water flows	Verify groundwater surplus flows are not outweighed by negative environmental impacts
	-	Groundwater sources not being replenish Engineered changes in surface water flows	Increase infiltration Decrease groundwater use
$ET - ET_N$	+	Change in evapotranspiration rates due to changes in environmental design (building orientation, vegetation types, shading, etc.)	Further analysis is required in parallel with evaluation of changes in the other flow pathways

The inability to create new water stocks challenges the plausibility of net-positive water production within natural networks. However, net-positive water quantities may occur when location is considered and distinct boundaries are compared. The current urban flows (I, R, G,

ET) and natural flows ( $I_N$ ,  $R_N$ ,  $G_N$ ,  $ET_N$ ) presented on Figure 2.3 can be evaluated as part of a net-positive water quantity check because the same boundary is considered in both instances. Resulting positive or negative values describe the current state of the urban system and provide the opportunity for the implementation of strategies that result in net-positive quantity outcomes (Table 2.6). In all cases, it is assumed that net-positive impacts occur when management strategies are taken that improve the deteriorated state of the natural hydrologic cycle and aim to restore system balance.

#### **2.3.4.2 Quality**

Quality accounting of water flows is another prerequisite for net-positive water impacts. Water returned to natural systems should at least match existing quality parameters of the system for net-zero compliance, and net-positive buildings should produce water with a quality that encourages restoration of hydrologic environments. Water quality is also crucial within the building water cycle, as available water sources enter the building system at a set quality that is subsequently affected by individual water components. Use of indoor fixtures lowers water qualities by introducing impurities through their use. The significance of the quality change depends on the function of the fixture. Fixtures that perform sewage conveyance functions, such as toilets and urinals, will create a larger quality decrease than fixtures used for hygiene, such as sinks and showers. Quality may be improved by implementing water treatment strategies that allow for water reuse, recycling, or maintenance of hydrologic cycles. For stormwater runoff in particular, the use of green stormwater infrastructure systems, such as bioretention swales and permeable surfaces, increases water quality with low environmental and economic costs (Wang et al., 2013).

#### **2.3.4.3 Location**

Sustainable water management requires spatial considerations of water sources and discharge points. At the municipal level, pumping water from one source location for treatment and discharging it to another location for disposal affects both the initial and final districts.

Negative impacts may occur even if production and discharge points are within the same watershed. Potable water produced from a river source point upstream and discharged at the mouth of the river reduces the natural flow between those two points, which may cause negative environmental effects. Existence of the building structure also distorts pre-existing flows, and care must be taken to limit flow disturbances or restore natural flows in order to improve environmental conditions. Flooding from stormwater runoff may be alleviated by restoring natural surface flows that are more effective than constructed drainage, and reducing impervious surfaces re-directs water to shallow underground flows which feed streams (Novotny, 2013). Therefore, evaluation of the building water cycle must consider initial source and discharge locations in order to mimic natural hydrologic flows and restore ecological environments.

#### **2.3.4.4 Time**

The time of water allocation or discharge affects the system. Municipal water treatment facilities ensure potable water is always available to meet demands, but alternative water source production may not always coincide with consumption profiles. Fluctuating precipitation patterns affect available rainwater supplies, but incorporating storage elements into the building water cycle allows for water demands to be met by alternative water sources at the correct time intervals. Similarly, water demands exerted by natural systems are time-sensitive. Water flows should mimic desired patterns in terms of quantity, quality, location, and time in order to ensure restorative outcomes.

It is important to recognize that the four aspects for net-positive water discussed may harmonize or conflict with one another. Shifting the quantity of water may positively affect the allocation location, such as when water-deficient ecosystems receive augmented flows. In contrast, changing water quality may conflict with spatial and temporal applications. For example, an on-site detention pond may treat stormwater runoff and increase the quality; however, the treatment pond retains water on-site and prevents the flow from following existing

pathways. Whether a net-positive or negative impact occurs depends on the needs of the urban and natural environments that support the building system.

#### **2.3.4.5 Conceptual Framework for Net-positive Water**

An understanding of current and ideal hydrologic and urban water flows connecting the building system to the anthropogenic and natural environments is prerequisite in order to design and manage a net-positive building water system (Figure 2.4). Desirable positive outcomes must be explicitly determined based on the current conditions and needs of the urban and natural systems supporting the building; and distinct volume, quality, spatial, and temporal thresholds must be developed in order to achieve net-positive results. The baseline hydrologic conditions should be identified in order to determine spatial and temporal thresholds for the maintenance or revival of supporting ecosystems. Specific project outcomes may be further defined based on the needs identified from the baseline study.

Building water consumption depends on the sum of all end uses and degree of water recycling. Building water demands should be catalogued and grouped by importance, as well as all potential sources. The resulting inventory of building demands and available sources creates the foundation for fit-for-purpose connections to be made for water balance attainment and discloses the magnitude of water offset that the project goal requires. A zero water building project will require the total water demand to be balanced solely by sources acquired on-site. A net-zero project served by municipal water within a shared watershed may determine that consumption volumes exceeding precipitation require offset from alternative water reuse or wastewater recycling strategies for net-zero balance. Net-positive buildings require the tracking of quality, discharge, and time of allocation in addition to water flows, and must demonstrate improvement in the combination of these areas. Therefore, net-zero and zero water balance become prerequisite for net-positive success.

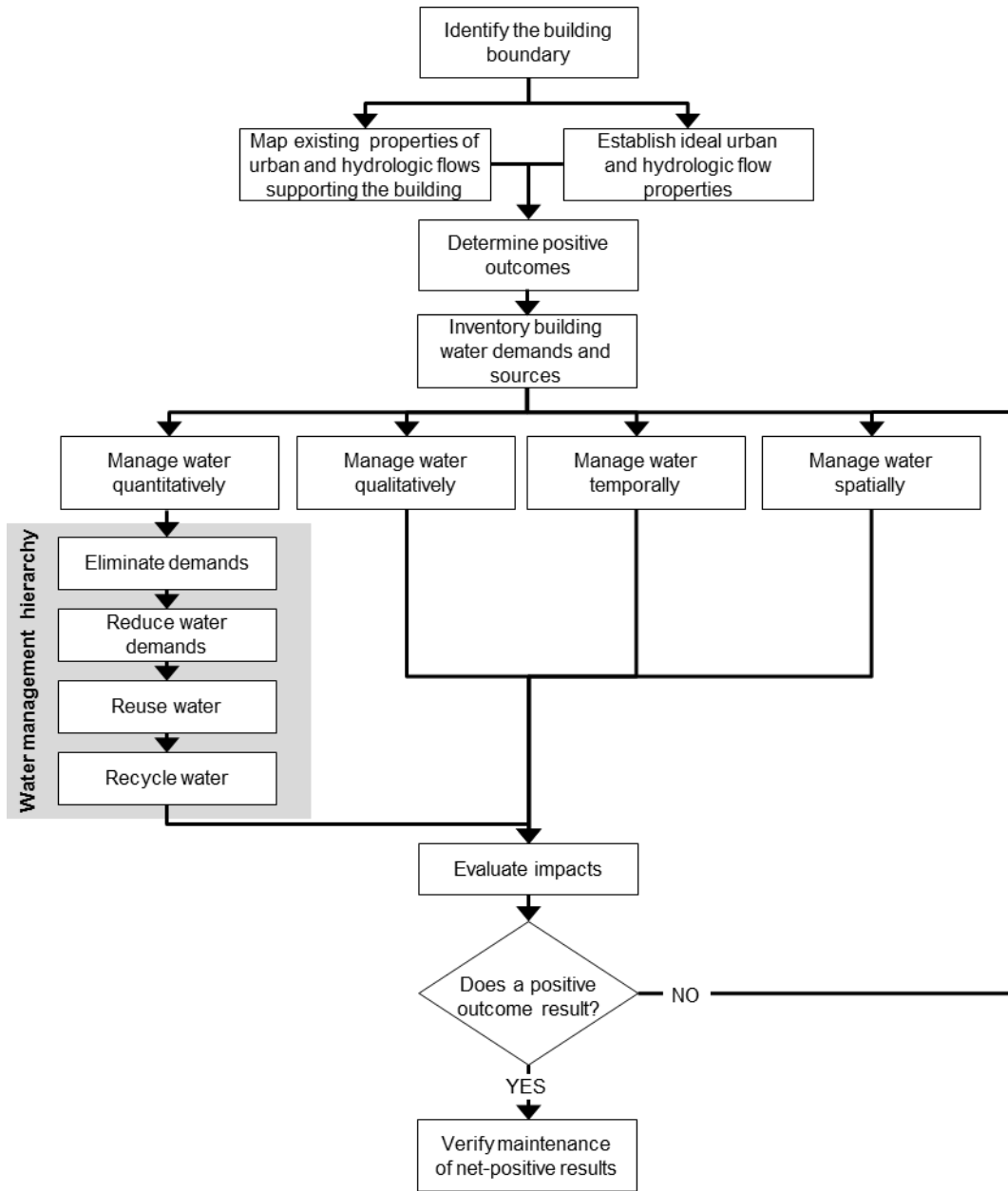

Figure 2.4: Conceptual framework for net-positive water buildings

Quantitative water management steps follow the hierarchy used in other resource management schemes, such as those adopted by the U.S. Environmental Protection Agency and the U.S. Army (United States Army, 2014; USEPA, 2013). An additional explicit step is added to evaluate whether all building water demands are necessary, such as landscape irrigation or aesthetic features, and eliminate avoidable consumption (Hoekstra, 2008).

Reducing source consumption is accomplished using conservation measures directed at water fixture installations and occupant water use habits. Further water offsets require water reuse, followed by water recycling. Water reuse measures require limited treatment of source waters and extend the residence time of water within the building through repurposing. Water recycling is achieved by creating closed loop water cycles that require treatment stages in order to maintain water quality. Irrigation using low-strength greywater from showers and faucets is considered a reuse strategy; a water recycling loop is achieved by collecting, treating, and re-applying blackwater from toilets for flushing. Conservation, reuse, and recycling measures should be revisited until the project goal is realized.

Integration of quantitative, qualitative, spatial, and temporal water management is necessary in order to achieve a combine net-positive result; and if the building water management scheme does not yield a positive response, these four properties must be evaluated to identify weak performance areas and revisited in order to improve deficiencies. If final evaluation determines that the building generates a net-positive effect, frequent verification and monitoring ensures that the building water system operates as intended and remains restorative.

### **2.3.5 Conclusion**

Decision support frameworks regarding net-zero water are limited due to generally recent interest, but existing groundwork associated with net-zero energy provides a basis for water application. Based on research from the energy sector, building water neutrality may be evaluated in terms of net-zero water, zero water, and life-cycle zero water, whereby the location and time period of production and generation of water sources determines the designation. Additional considerations for net-positive building water cycles include temporal and spatial applications of specific water quantities meeting appropriate quality requirements. A conceptual framework for exceeding water neutrality and achieving net-positive water has been presented

that includes quantitative management based on existing hierarchical approaches and includes the employment of conservation, reuse, and recycling measures, respectively.

The net-positive framework presented requires balance calculations and offsets to be considered within the hydrologic and urban systems in which the building resides so that net-positive strategies utilized within these systems produce restorative impacts applied to the same systems. Further areas of investigation and definition regarding water neutrality addressed by Hokestra (2008) also apply to net-positive frameworks and include:

- feasibility of accomplishing full water consumption offsets
- approved offset strategies
- measurement frameworks to quantify environmental impacts
- region-specific value of water savings
- duration considered for net-positive performance
- verification of net-positive performance

Details used to explain the remaining unsettled areas regarding net-positive water may be provided by comprehensive case studies that thoroughly evaluate the complex relationships among the building, built environment, and natural system. In many cases resulting answers, such as the value of saved water or favorable offset strategies, will be region-specific and compel the need for regional considerations. In addition, case studies should recognize and identify challenges to net-positive achievement due to inherent uncertainties in environmental conditions such as climate, human behavior, and design operations.

Integration is necessary for successful net-positive design, and an integrated approach to water management is prerequisite for a net-positive water outcome. However, integration among all building resource subsystems, such as energy and materials, is necessary to prevent positive regenerative impacts from becoming outweighed by unintended effects in neglected sectors. Resource management should be addressed collectively in order to identify and



address the interdependencies among systems for true net-zero and net-positive reactions to materialize.

## **2.4 Resilience**

### **2.4.1 Introduction**

The term resilience has been investigated by ecologists since the 1970s (Holling, 1973). Research in this discipline has focused on the integrity of ecosystems. However, managing ecosystems includes more than policy and strategies taking aim directly at an ecosystem. It includes changing how society manages resources and develops – spatially, structurally, institutionally, and infrastructurally. Demands placed on critical infrastructure increase the stress on ecosystems through resource depletion. Changes in ecosystems send shock waves into the anthropogenic environment. Increasing the resilience of the built environment will allow for absorption of shocks from ecosystem changes; and taking action towards a responsible resilient and sustainable state will positively affect the health of ecosystems. An example is given using the water cycle. Climate change may lead to decreased rainfall in certain areas, which in turn also decreases the amount of water available to recharge a local aquifer. Stress had already been placed on the nearby ecosystems from excessive pumping of aquifer water to meet the demands of the built environment. The community adapts by implementing water reuse measures that in turn increase the sustainability and resilience of the area and also reduce the amount of water pumped from the aquifer, thereby also increasing the resilience of the ecosystem (through decreased stress and increased capacity to absorb precipitation shifts).

### **2.4.2 Definitions from Literature**

Many definitions and descriptions of resilience have been introduced into literature since the 1970s (Plodinec, 2009; Brand and Jax, 2007). A summary of definitions found in literature is provided in Tables 2.7 and 2.8. Plodinec (2009) presents multiple methods of classifying resilience definitions: being vs. becoming, adaptation vs. resistance, in terms of trajectory, in terms of predictability, or by temporal nature. Being vs. becoming separates definitions based

on whether resilience is described as ability or attribute, rather than a phenomenon or process. Adaptation vs. resistance separates definitions based on how the subject of the definition behaves when undergoing adversity. The subject or system can adapt by changing functions or how resources are utilized; contrarily, the subject can resist change to the system through the expenditure of resources. Definitions may also be grouped based on trajectory. Some definitions assume that a surviving system is resilient, regardless of a positive or negative path. Other definitions require that a system maintains its functionality and travels along a positive trajectory. In terms of predictability, some definitions allow for a system to be compared to others and for projections about how the system will react to be made. Predictions cannot be made from other definitions, mainly because these definitions describe evaluating resilience after an event. Temporally, definitions can be split into groups based on whether resilience emerges as a result of a shock or event, is also apparent in the time after the event, or is an inherent attribute always active in the system.

Definitions can be organized based on whether they are descriptive, normative, or a hybrid of both (Brand and Jax, 2007). Descriptive facets include specifications of the current case, whereas normative facets include instructions for how the case should be, or what the desirable case is (Brand and Jax, 2007). For example, Holling (1973) defines resilience in ecological science as the ability of a system to absorb change and persist while maintaining relationships among state variables. In this case, resilience is descriptive because the persistence and capacity for the system to absorb changes describes the current state. On the other hand, Pickett et al. (2004) defines resilience as a normative concept, in which resilience correlates with long-term flexibility; long-term flexibility is desired.

Table 2.7: Definitions of resilience in the natural sciences. (Table adapted from Brand and Jax 2007; Plodinec, 2009)

First author, year	Domain	Definition
Gordon, 1978	Physical	The ability to store strain energy and deflect elastically under a load without breaking or being deformed
Bodin, 2004	Physical	The speed with which a system returns to equilibrium after displacement irrespective of how many oscillations are required
Holling, 1973	Ecological system	Buffer capacity or the relationships within a system; a measure of the ability of systems to absorb changes of state variables, driving variables, and parameters, and still persist
Holling, 1995	Ecological system	Buffer capacity or the ability of a system to absorb perturbation, or the magnitude of disturbance that can be absorbed before a system changes its structure
Abel, 2001	Ecological system	The ability to persist through future disturbances
Holling, 2001	Ecological system	Quantitative property that changes throughout ecosystem dynamics and occurs on each level of an ecosystem's hierarchy.
Waller, 2001	Ecological system	Positive adaptation in response to adversity; it is not the absence of vulnerability, not an inherent characteristic, and not static
Brock, 2002	Ecological system	The transition probability between states as a function of the consumption and production activities of decision makers
Gunderson, 2002	Ecological system	The magnitude of disturbance that can be absorbed before the system changes its structure by changing the variables and processes that control behavior
Klein, 2003	Ecological system	The ability of a system that has undergone stress to recover and return to its original state; more precisely (i) the amount of disturbance a system can absorb and still remain within the same state or domain of attraction and (ii) the degree to which the system is capable of self-organization
Anderies, 2004	Ecological system	The amount of change or disruption that is required to transform the maintenance of a system from one set of mutually reinforcing processes and structures to a different set of processes and structures
Ott, 2004	Ecological system	Maintenance of natural capital (as the basis for social systems' functioning) in the long run
Walker, 2004	Ecological system	The capacity of a system to absorb disturbance and recognize while undergoing change so as to still retain essentially the same function, structure, identity, and feedbacks
Adger, 2005	Ecological system	The capacity of linked social-ecological systems to absorb recurrent disturbances... so as to retain essential structures, functions, and feedbacks
Cumming, 2005*	Ecological system	The ability of a system to maintain its identity in the face of internal change and external shocks and disturbances
Longstaff, 2005	Ecological system	The ability by an individual, group, or organization to continue its existence (or remain more or less stable) in the face of some sort of surprise... Resilience is found in systems that are highly adaptable (not locked into specific strategies) and have diverse resources
Resilience Alliance, 2006	Ecological system	The capacity of a system to absorb disturbance and reorganize while undergoing change so as to still retain essentially the same function, structure, and feedbacks 0 and therefore the same identity
Resilience Alliance, 2009	Ecological system	The capacity of a system to tolerate disturbance without collapsing into a qualitatively different state that is controlled by a different set of processes
Adger, 2000	Ecological and social systems	The ability of communities to withstand extern shocks to their social infrastructure
Folke, 2002	Ecological and social systems	The underlying capacity of an ecosystem to maintain desired ecosystem services in the face of fluctuating environment and human use
Adger, 2003	Ecological and social systems	The ability to persist (i.e., to absorb shocks and stresses and still maintain the functioning of society and the integrity of ecological systems) and the ability to change, unforeseen circumstances, and risks
Pickett, 2004	Ecological and social systems	Flexibility over the long term

Table 2.8: Definitions of resilience in the social sciences. (Table adapted from Brand and Jax, 2007; Plodinec, 2009)

First author, year	Domain	Definition
Comfort, 1999	Community	The capacity to adapt existing resources and skills to new systems and operating conditions
Mileti, 1999	Community	(The ability to) withstand an extreme event without suffering devastating losses, damage, diminished productivity, or quality of life without a large amount of assistance from outside the community
Bruneau, 2003	Community	The ability of social units to mitigate hazards, contain the effects of disasters when they occur, and carry out recovery activities in ways that minimize social disruption and mitigate the effects of future earthquakes
Godschalk, 2003	Community	A sustainable network of physical systems and human communities, capable of managing extreme events; during disaster, both must be able to survive and function under extreme stresses
Timmerman, 1981	Community	A system's capacity to absorb and recover from the occurrence of a hazardous event; reflective of a society's ability to cope and to continue to cope in the future
Wildavsky, 1991	Community	The capacity to cope with unanticipated dangers after they have become manifest; learning to bounce back
Brown, 1996/97	Community	The ability to recover from or adjust easily to misfortune or sustained life stress
Sonn, 1998	Community	The process through which mediating structures (schools, peer groups, family) and activity settings moderate the impacts of oppressive systems
Paton, 2001	Community	The capability to bounce back and to use physical and economic resources effectively to aid recovery following exposure to hazards
Center for Community Enterprise, 2000	Community	Intentional action to enhance the personal and collective capacity of its citizens and institutions to respond to, and influence the course of, social and economic change
Chenoweth, 2001	Community	The ability to respond to crises in ways that strengthen community bonds, resources, and the community's capacity to cope
Ganor, 2003	Community	The ability of individuals and communities to deal with a state of continuous long-term stresses; the ability to find unknown inner strengths and resources in order to cope effectively; the measure of adaptation and flexibility
Kofinas, 2003	Community social resilience	Two types of social resilience: (1) a social system's capacity to facilitate human efforts to deduce the trends of change, reduce vulnerabilities, and facilitate adaptation and (2) the capacity of a [social-ecological system] to sustain preferred modes of economic activity
Quinlan, 2003	Community	Resilience consists of (1) the amount of change a system can undergo and still retain essentially the same structure, function, identity, and feedbacks on function and structure, (2) the degree to which a system is capable of self-organization (and re-organize after disturbance) and (3) the degree to which a system expresses capacity for learning and adaptation
Ahmed, 2004	Community	The development of material, physical, socio-political, socio-cultural, and psychological resources that promote safety of residents and buffer adversity
Kimhi, 2004	Community	Individuals' sense of the ability of their own community to deal successfully with the ongoing political violence
Coles, 2004	Community	A community's capacities, skills, and knowledge that allow it to participate fully in recovery from disasters
Allenby, 2005	Community	The capability of a system to maintain its function and structure in the face of internal and external change and to degrade gracefully when it must
Gunderson, 2005	Community	The return or recovery time of a social-ecological system, determined by (1) that system's capacity for renewal in a dynamic environment and (2) the people's ability to learn and change (which, in turn, is partially determined by the institutional context for knowledge sharing, learning, and management, and partially by the social capital among people)
Pfefferbaum, 2005	Community	The ability of community members to take meaningful, deliberate, collective action to remedy the impact of a problem, including the ability to interpret the environment, intervene, and move on

Table 2.8 (Continued)

First author, year	Domain	Definition
Subcommittee on Disaster Reduction, 2005	Community Society	The capacity of a system, community, or society potentially exposed to hazards to adapt, by resisting or changing, in order to reach and maintain an acceptable level of functioning and structure
UN/ISDR, 2005	Community	The capacity of a system, community, or society potentially exposed to hazards to adapt, by resisting or changing in order to reach and maintain an acceptable level of functioning and structure
Perrings, 2006	Community	The ability of the system to withstand either market or environmental shocks without losing the capacity to allocate resources efficiently
Liu, 2007	Community	The capability to retain similar structures and functioning after disturbances for continuous development
Norris, 2008	Community Individual	A process linking a set of adaptive capacities to a positive trajectory of functioning and adaptation after a disturbance
EPA, 2014a	Community	Resilient communities are better prepared to rapidly recover from water service interruptions because they have identified critical independencies and focused on building relationships between water utilities and the communities they serve
EPA, 2014b	Community	Ability of a system (e.g., a human community, a supply chain, or an ecosystem) to continue functioning in the face of disruptions
USGS, 2013	Community (or system)	Resilience is the ability of a system or a community to absorb shocks and still retain the same basic structure and functions. Management for ecological resilience seeks flexible system behaviors that can deliver ecosystem goods and services on a sustained basis.
Rose, 2007	Economic	(Dynamic) Resilience: the speed at which an entity or system recovers from a severe shock to achieve a desired state Static economic resilience: the ability of an entity or system to maintain function (e.g., continue producing) when shocked Inherent resilience: the ability to deal with crises Adaptive resilience: the ability (of an entity or system) in crises situations to maintain function on the basis of ingenuity or extra effort
Masten, 1990	Individual	The process of, capacity for, or outcome of successful adaptation despite challenging or threatening circumstances
Egeland, 1993	Individual	The capacity for successful adaptation, positive functioning, or competence... despite high-risk status, chronic stress. Or following prolonged or severe trauma
Butler, 2007	Individual	Good adaptation under extenuating circumstances; a recovery trajectory that returns to baseline functioning following a challenge

Brand and Jax (2007) submit that resilience has become a “boundary object,” and that this designation carries both benefits and drawbacks. As a boundary object, resilience opens communication among various disciplines using the term, resulting in information-sharing among disciplines, streamlined coordination between science and policy, and political adoption and success (Brand and Jax, 2007). However, the adjustability of the resilience term also becomes a detriment. As the number of applications of resilience increase, the specific meaning becomes diluted, and as a broad concept, normative facets tend to blend into resilience. Further uncertainty results when resilience is defined as a perspective rather than a

defined concept (Brand and Jax, 2007). Another prejudice of resilience as a boundary object stems from the aspect each discipline chooses to stress; for example, ecologists stress ecological features whereas sociologists may stress political or institutional features (Brand and Jax, 2007). In order to best address these issues, Brand and Jax (2007) argue that:

- When resilience is presented as a descriptive concept, the term should be made clear and specific. In addition, the resilience concept should (a) outline what specifically is referred to within the definition, (b) discern if a state is resilient or nonresilient, and (c) assess the degree to which a state is resilient. This type of meaning is labeled as ecological resilience or ecosystem resilience in ecological systems, or simply resilience in other realms.
- Resilience as a boundary object, with a vague, but broad application, is important for continued interdisciplinary research and information-sharing. This type of meaning is labeled as social-ecological resilience.

Specific characteristics used to define resilience vary among researchers, but most agree that resilience depends on how well a system can absorb external hazards or shocks and recover in a timely manner (Holling, 1996; De Bruijn, 2004; McDaniels et al., 2008). Time is a major component of resilience not just in terms of recovery, but also in relation to the duration of a hazard that resilience is being evaluated against. In addition to short-term disasters, some studies evaluate system resilience to long-term stressors such as climate change (Brenkert and Malone, 2005).

Two interpretations of resilience include engineering resilience and ecological resilience (Holling, 1996). One way to measure resilience is by establishing an equilibrium; the components of resilience under this method include the distance that the system varies from and how long it takes the system to return to the constant equilibrium when under external pressure. Holling (1996) describes this as engineering resilience. An alternative is to focus on the fulfillment of the system functions rather than on their efficiency; this is a shift to ecological

resilience (Holling, 1996). Focus on function is also the priority for other definitions of resilience (Rose, 2007). An initial investigation on smart shelters focused on the functions that would be required of the building space. Under disaster conditions, the productivity or efficiency of the building was not considered the priority, but instead the focus was how the building could meet critical needs. Diverse and redundant strategies were considered as solutions to meet the smart shelter's functional requirement. As a result, these strategies also enhance the ecological resilience. For evaluation of a building system, the definition of resilience, the state of the building system, and hazard scenarios applied to the building are all important factors to measure resilience (Carpenter et al., 2001).

### **2.4.3 Properties and Attributes of Resilience**

Bruneau et al. (2003) breaks down resilience into four properties that expand upon the general definition:

- Robustness – the ability of a system to maintain operation under stress
- Redundancy – the extent that system operations can be met through substitution
- Resourcefulness – the ability to utilize resources in order to deter threats to the system
- Rapidity – the capacity to respond quickly to threats in order to minimize system effects

The “4Rs” listed provide some characteristics of resilience, and this framework can be further expanded. Fiksel (2003) defined the fundamental properties of resilience as diversity, efficiency, adaptability, and cohesion. Common characteristics of resilient systems defined by Goschalk (2003) and Rose (2007) include redundancy, diversity, efficiency, autonomy, strength, interdependence, adaptability, and collaboration. These characteristics echo the properties contained with the 4Rs, but separate the properties into additional attributes. Definition of individual attributes is necessary in order to develop indicators capable of assessing the resilience of systems.

Richards et al. (2007) makes the distinction between two types of survivability that can be mirrored to resilience: passive and active. In this sense, passive resilience can be defined as inherent qualities of a system and may also describe inherent resilience (Rose, 2007). Active resilience is defined by the actions taken by a system under disaster stress; active resilience may also be described as adaptive resilience, or the ability of the system to respond to a stress event (Rose, 2007). Using these definitions, passive resilience can be characterized as proactive, resistant, robust, redundant, and diverse; and active resilience can be characterized as reactive, flexible, adaptive, restorative, and evolving (Richards et al., 2007).

The attributes that compose resilience are also linked to sustainability, passive survivability, and adaptive capacity. Recovery, flexibility, and adaptability have been applied to both resilience and adaptive capacity, thereby linking the two concepts (Engle and Lemos, 2010). The definition provided for passive resilience is directly in line with passive survivability; both ideas apply to properties that the system inherently has or possesses. Tobin (1999) links sustainability and resilience by proposing that both concepts depend on the available capacity for disaster recovery and mitigation. Norris et al. (2008) also integrates adaptive capacity with resilience, and Cutter (2008) discusses sustainability as central to research regarding resilience. These examples of linkages show how attributes of resilience extend into related qualities.

The Community and Regional Resilience Institute (CARRI) research goals revolve around increasing resilience at the community level (Plodinec, 2009). From a compilation of definitions of resilience found in literature, CARRI suggests that the definition of resilience regarding communities contain the following principles (Plodinec, 2009):

- Resilience is an attribute of the community that is both inherent and dynamic.
- Adaptability, either in response to or in preparation of an event, is at the core of resilience.
- Adaptation must result in a positive trajectory for the community after an event.



- Resilience should be defined so that communities can evaluate resilience, make predictions, and act to improve resilience.

#### **2.4.4 Considerations for Measuring Resilience**

If the resilience of a system is to be evaluated, then the probabilistic nature of the inputs to the system and associated probabilistic outputs must be considered (Haimes, 2009). This research recognizes the importance of both identifying the threat and tracking the associated outputs from the system. Various unique events with equally varied magnitudes threaten a system, each with an inherent probability. The range in inputs produces a range in the system outputs; and therefore, the system's resilience can only be quantified with the inclusion of probabilities (Haimes, 2009). In addition, care must be taken if a metric is designed that assigns resilience scores to systems for comparison. A fair comparison of the resilience of multiple systems can only be made if each system undergoes the same threat at the same magnitude with the same probability of occurrence (Haimes, 2009). This stipulation causes the assignment of absolute resilience values to individual systems to be a challenge due to the large uncertainties in probabilities, system functions, system configurations, threats, and system outputs (Haimes, 2009). In order to overcome this obstacle, the scope of this research will address the resilience of building water management strategies to the same threats (e.g., disruption of water supply and disruption of power supply)

Decreasing the vulnerability of a system may not always increase the system's resilience (Haimes, 2009). For example, investing in increased security for water infrastructure, such as fencing off exposed pump lines and stations or improving personnel admittance policies reduces the vulnerability of the system to specific threats; however, the hardening measures may not improve the system's resilience if recovery time is decreased. Similarly, increasing system resilience may not necessarily lead to a decrease in vulnerability (Haimes, 2009). For example, a regional water utility may expand its source portfolio and build redundancy into the water

distribution system to increase the system resilience, but if redundant water source lines travel through multiple threat areas, the vulnerability of the system increases.

It is not possible to simply answer whether a system is resilient. Commenting on resilience implies a set of parameters that form a boundary in which the resilience of a system can be determined (Haimes, 2009). For example, a city may improve the reliability and capacity of its wastewater treatment system through improvement projects, and in turn increase the resilience of the system to disruptions from pipe failures. However, if the treatment facility at the end of the collection system sits in a low-lying coastal area, there is a risk of flooding. A storm event may flood the facility causing the cessation of treatment and ultimate failure of the system. In this case, the type of event is important when commenting on the resilience. In addition, it is also possible that the treatment facility and collection network are resilient to lesser storm events. Therefore, the severity of the event (input or threat) is another important parameter that defines the resilience of a system.

#### **2.4.5 Measuring Water Resilience**

Researchers have addressed the measurement of resilience in the water sector, but generally at the larger infrastructure or community level. Rose and Liao (2005) evaluated the impact of water disruption in the Portland area in economic terms. The resilience of water conservation or substitution strategies was calculated based on financial losses in larger economic sectors. However, the study did not include uncertainty in the analysis. Milman and Short (2008) incorporated resilience indicators into existing sustainability indicators using the urban water sector as an example. However, the indicators relied on a qualitative questionnaire and relied on a point system. Indicator categories addressed the larger urban water system and included supply, infrastructure, service, finance, water quality, and governance. Cutter et al. (2010) utilized quantitative indicators in economic, institutional, infrastructure, and community categories to measure disaster resilience of counties in the southeast United States. Although indicators were quantitative, final resilience values for each county were assigned based on the

range of values for the study region; therefore, final resilience values are not absolute. In addition, the resilience assessment did not consider specific threats and the authors acknowledge that it is difficult to attain all the data necessary for the presented indicators. Zhou et al. (2010) used a case study to evaluate the resilience of a county in China. Surveys were used to collect information regarding the resilience of the county to drought. The study supports that there is a geographic component to disaster resilience and included temporal and spatial differences in the analysis.

The U.S. Environmental Protection Agency (EPA) specifically addresses the need for water resilience in its Community-Based Water Resiliency (CBWR) initiative (EPA, 2014a). The goal of the CBWR initiative is to increase community preparedness and resilience by addressing the interdependencies of the water sector to other systems and developing tools that increase the resilience of drinking water and wastewater infrastructure. The CBWR initiative specifically addresses the need for the water sector to prepare for service interruptions and to consider alternative strategies to increase water resilience.

#### **2.4.6 Conclusion**

Existing sustainability assessment strategies evaluate the state of the system, but resilience analyses shift the focus to measuring the ability of the system to maintain function when faced with disruption events (EPA, 2014b). The same systems approach applied to sustainability forms the necessary foundation for also evaluating the resilience of dynamic, adaptive, and interdependent systems; and as a result, there is a need for models and tools that incorporate the dynamic and adaptable features of systems in sustainability and resilience assessments (Fiksel, 2006). Resilience may be measured using system dynamics modeling or with a set of indicators (EPA, 2014b; Fiksel, 2006), and the studies previously discussed utilize both methods. Indicators used vary among researchers, but there is interest in a set of standardized indicators for resilience assessment, as evident by United Nations Office for Disaster Risk Reduction (UNISDR) plans to develop an indicator-based ISO Standard for

resilient and sustainable cities – ISO 37120 (UNISDR, 2015). The properties and characteristics of resilience discussed in Section 2.4.3 provide a baseline for the development of resilience indicators for assessment of various systems at different spatial levels, and the characteristics will be used to define a set of indicators that may be applied to the building water cycle.

## **3 RESEARCH OVERVIEW**

### **3.1 Motivation**

The literature review in Chapter 2 indicates the need for decision support tools that aid in the design and operation of building water cycles. The need is driven by the increased complexity of building water cycles due to the advancement of high-efficiency buildings (e.g., smart, sustainable, and net-zero buildings) that incorporate alternative water sources and integrated systems management for potable water reduction. The increased demand-source matches available require prioritization within the building system that may be controlled through the use of building automation programs. The priority of resource utilization is also a necessary consideration for resilient systems in order to maintain critical functions. Sustainable building water strategies and associated impacts have been calculated, but the resilience of building water schemes has not been quantitatively appraised. Methods that aim to evaluate demand and source interactions within building water cycles may also be used to determine the resilience associated with unique water cycles.

### **3.2 Gaps in Knowledge**

Research interest in resilience has exponentially increased since the 1980s (Janssen, 2007). The term resilience, once focused on ecology, has since expanded and permeated other disciplines including engineering. However, resilience is still mostly applied at the community and larger infrastructure level, with limited studies regarding water. The following deficiencies regarding building water resilience exist, which this research project aims to address:

- Lack of a quantitative characterization of resilience
- Lack of a quantitative tool to accomplish building water resilience characterization

- Uncertainties regarding the resilience of water management strategies
- Lack of building water resilience indicators

### **3.3 Hypotheses**

In order to address the research gaps regarding resilience and the building water cycle, the following major hypotheses will be tested:

- Building water resilience can be quantified in absolute terms
- Resilience can be quantified by comparing supply and demand profiles
- Resilience is measurable as the level of service of building water functions
- The level of resilience is unique to specific disruption scenarios
- Building water resilience depends on a set of attributes (redundancy, diversity, capacity, demand, sustainability, passivity, preparation, adaptation potential)
- The attributes that describe building water cycle resilience can be quantified
- A tool can be developed that measures the resilience of the building water cycle
- Sustainability has a positive impact on resilience
- Resilient systems do not need to be sustainable

### **3.4 Main Research Objectives**

This research topic focuses on water resilience within the building scale by addressing potential water sources and how demands are fulfilled. The goal of the project is to develop a framework to measure the resilience of the building water cycle and to develop an associated model and set of indicators to quantitatively evaluate this resilience. Sustainability has been the prime focus of green building, and a potential underlying assumption is that green buildings are also resilient. The strategies implemented as part of a green building framework may enhance the resilience of the building and externally linked systems, but this hypothesis has not been measured quantitatively. The project can be broken down into six main objectives:

1. Develop a quantifiable description for water resilience within buildings.

2. Develop a methodology and associated tool to quantify and characterize water resilience in buildings.
3. Develop a set of water resilience indicators to evaluate the resilience of the building water cycle.
4. Determine the water profiles associated with common water management strategies to mitigate losses of water services.
5. Map the developed water resilience indicators (Obj. 3) based on the water management strategy profiles (Obj. 4).
6. Determine whether sustainable water management strategies encouraged by the LEED rating system are also resilient.

### **3.5 Research Plan**

The LEED rating system developed by the USGBC provides the starting state for the building system and accepted water management strategies that increase efficiency and sustainability. Features of these water management strategies can be broken into resilience characteristics based on their attributes. For example, dual plumbing systems that substitute reclaimed water over potable water or rainwater collection systems that are augmented by a potable supply create redundancy within the building water cycle. The storage component of a rainwater collection system also includes a capacity element which may help buffer the effect of a potable water disruption. Water resilience indicators, such as water source portfolio diversity and capacity, can be chosen based on the attributes that emerge from these and other strategies. The effect on resilience that these indicators possess can then be assessed by running model simulations of building water cycles that undergo stress in the form of potable water and/or energy disruption. Testing each building water strategy will not only evaluate its resilience, but will also validate the indicators. However, additional groundwork based on the needs identified in the literature review is required to support the development of the WRAM.

The objective of Chapter 4 is to develop a prioritization framework that addresses the order of use for alternative sources. The order will come from a literature review of water source and demand preferences. The prioritization framework is a prerequisite for the creation of the WRAM and supports the fulfillment of Research Objective 2. Tasks undertaken within this chapter include

- Identification of potential water demands and sources,
- Identification of existing water prioritization schemes,
- Development of a demand and source-driven water prioritization framework, and
- Development of a demand-source water allocation tracking algorithm.

The objective of Chapter 5 is to determine the diurnal water use patterns of different building types over a long-term period. The water use patterns identified are required inputs into the WRAM model in order to emulate real building demand scenarios, and thereby support Research Objective 4. Tasks within this chapter include

- Evaluation of smart metering as a feasible method to track, record, and extract water use data,
- Identification of diurnal water use patterns for unique building locations using an hourly timestep, and
- Evaluation of variations in water use for unique building locations over time.

The objective of Chapter 6 is to develop the building water framework for the WRAM based on the prioritization scheme developed in Chapter 4. The resultant model is used to fulfill Research Objective 2. Tasks include:

- Creation of water demand and source subsystems based on mass balance,
- Integration of the prioritization framework from Chapter 4, and
- Definition of inputs that drive demand and source stocks.



The objective of Chapter 7 is to develop the framework capable of defining and evaluating the resilience of the building water cycle to disruptions founded on the foundational elements established in Chapters 4 through 6. Model runs conducted using the building WRAM will determine the validity of using a set of defined resilience indicators. Indicators chosen describe the current resilience state of the building water system and project the expected resilience of that system to disturbance; therefore, the indicators must be measurable at all times. Chapter 7 directly addresses Research Objectives 1, 3, 5, and 6.

## **4 WATER PRIORITIZATION FRAMEWORK**

### **4.1 Note to Reader**

This chapter is based on the published article “Demand- and source-drive prioritization framework toward integrated building water management (IBWM)” that appeared in the journal *Sustainable Cities and Society*, volume 14, pages 114-125 (Joustra and Yeh, 2015b). Permission is included in Appendix A.

### **4.2 Introduction**

Building focus is often on energy. However, buildings utilize large amounts of potable water, as well as discharge wastewater and contribute to pollutant loadings through stormwater runoff (USEPA, 2009). As our population increases and expands, the demand for water consequently increases and infrastructure networks multiply. Increased stress on water resources due to increasing demands on clean water leads to growing interest in more efficient water uses (Lazarova et al., 2001; Postel, 2000). Through the implementation of water management strategies, such as water reclamation, conservation, or decentralized water reuse, the issues associated with increased water demand may be alleviated (Lazarova et al., 2001).

Water cannot be infinitely pumped from potable sources to meet community demands (Postel, 2000). Sustainable solutions are required that meet current and projected demand, as well as preserve natural and human cycles (Guendert and Jordan, 2004). One way to determine outcomes from possible solutions that aim to alleviate the disparity between supply and demand is the creation and implementation of a systems model. Models are currently used by planning and regulatory agencies to predict future water demand and potential management outcomes. A system dynamics model therefore operates as a decision-making tool (Thompson

and Lawrence, 2010). However, support tools generated based on integrated water management largely focus on the community or regional level (Hardy et al., 2005; Mackay and Last, 2010; Makropoulos et al., 2008; Mitchell et al., 2001; POLIS, 2010; Willuweit and O’Sullivan, 2013). Within the subset of water-based tools applied at the building level, most focus on conservation strategies, exclude or limit alternative water source allocation, only consider the residential sector, and assign static values to sources and demands (CSIRO, 2012; National Geographic Society, 2013; Pacific Institute, 2010). In addition, the distribution of included alternative water sources is limited, thereby reducing competition among water demands for a single source or multiple sources allocated to a single demand. This paper reviews the need for prioritization within buildings due to the increasing complexity of building water cycles and presents an example baseline prioritization scheme based on literature. The objective of this chapter is to develop an algorithm that applies fit-for-purpose water allocation based on user prioritization in order to track dynamic water demands and supply consumption. The algorithm is tested quantitatively and graphically in order to verify successful water accounting based on the presented baseline prioritization scheme.

### **4.3 Water Prioritization**

Prioritization is an inherent prerequisite of resource management and occurs when decisions regarding resource allocation are made. Matching consumption with production is necessary in order to sustain desired outcomes or processes (Naimi-Ait-Aoudia and Berezowska-Azzag, 2014). When multiple production sources exist to meet varying consumption demands, the fit-for-purpose framework pairs sources with demands based on shared values; best-matched source-demand pairs are given higher priority. Priorities assigned to resource allocation affect system efficiencies and growth. For example, giving priority to a fluctuating surface water source to meet all system needs forces the system to operate based on the available supply which varies seasonally from abundant to inadequate. The system must decrease its activity if back-up sources with subsequent priorities are unavailable. Similarly,

affixing a limited potable water supply with the highest use priority can decrease the carrying capacity of the system as the source is diminished over time, thereby reducing the magnitude and lifetime of the system.

Explicit prioritization is absent from traditional building water cycle management because potable water is assumed to be an infinite source that is allocated to all demands. The antiquated practice of assigning potable water with the highest and only priority to all consumptive demands leads to issues with efficiency, persistence, and the overall sustainability of the system (Naimi-Ait-Aoudia and Berezowska-Azzag, 2014). A prioritization framework is encouraged by green buildings due to the inclusion of alternative water sources that create competition among supplies to meet building demands. However, green buildings assert the utilization of non-potable water sources first, thereby assigning higher priority to these sources for the non-potable demands they fulfill.

Prioritization is an integral component of water modeling, and decision-making processes regarding water management have been studied (Chung and Lee, 2009; Yang et al., 2012). Diverse decision-making factors affect water use and priority. Regulations restrict the employment of specific water sources and potential applications. The accessibility and availability of the water source affects usage opportunities. A source may be easily accessible, but contain a limited supply volume. Contrarily, an abundant source may exist that requires extensive effort to obtain. The quality of the water source influences the potential priority it may be assigned for unique demands. In general, high-quality sources are expected to have a higher priority when applied to demands with high-quality needs. The competition among water demands affects priority when individual water sources are inadequate. In the case when a primary source is exhausted before all demands are met, a secondary source must be substituted to meet the unfulfilled demands. Additional factors regarding social and economic aspects must be considered (Yang et al., 2012). Public opinion or consequential environmental impacts, whether to the natural or human environments, may override existing priorities based

on quantitative analyses. However, Yang et al. (2012) found financial cost to be the most critical factor when considering water management alternatives. Although each decision-making factor may be considered separately, it is important to acknowledge the interdependencies among criteria. For example, regulations depend on quality, availability, and environmental impacts. Recycled wastewater streams may be prohibited for potable applications due to the quality disparity between the source and demand. Additionally, potable water consumption may be constrained due to limited natural supplies and potential environmental consequences for depleting those supplies.

Prioritization is evident within previous water models. The WEAP21 model discussed by Yates et al. (2005) considers water resource management within the watershed level at different temporal and spatial scales. The hydrologic-based model may also include building sectors that exert a demand based on building type and end-uses. Water sources considered within the model include surface waters and groundwater, which are assigned first or second priority to each demand component by the user for water distribution. User-defined priorities are also included in the Urban Water Optioneering Tool (UWOT) (Makropoulos et al., 2008). Unlike the WEAP21 model, UWOT focuses on the urban environment. Therefore, building water usage is central to the model, and individual building blocks contain various water end-uses. Water sources considered within the model include potable water, greywater, treated greywater, wastewater (blackwater), and runoff. Similar to WEAP21 model, users identify the priority of the available sources to meet each end-use. Although more detailed than the WEAP21 model, UWOT aggregates the water use from each component. Both models demonstrate the need for water prioritization and that the capacity for absolute prioritization is currently restrained although many potential water allocation schemes exist.

#### **4.4 Methodology**

A prioritization framework first requires the identification of common building water demands and sources and the potential connections among them. Acceptable priorities,

defined by compliance with codes and regulations, adoption of treatment standards, responsible consumption of available water sources, cost-effectiveness, and social acceptance, must then be assigned to competing demand-source interactions. Finally, water accounting based on defined priorities must be developed.

#### **4.4.1 Sources and Demands**

Fourteen potential water demand stocks are considered within the framework. The stocks were chosen based on typical water demands created within buildings and commonly found in literature for water reuse. Demand stocks include landscaping, urinals, toilets, showers, kitchen sinks, cooling towers, and process water. Demands using process water may include dishwashers, ice machines, food steamers, or pre-rinse spray valves. Additional demands include drinking, laundry, firefighting, and a potential green roof. There are also two flexible demand stocks that represent water scenarios with either low or high interaction with the public. A low-human interaction (LHI) demand may include aesthetic water features or ornamental gardens. A high-human interaction (HHI) demand may include refilling swimming pools or irrigating above-ground food crops. These generic stocks allow users to individualize building characteristics, thereby recreating the water cycle unique to the building.

The baseline prioritization framework considers seven potential water sources: blackwater, greywater, stormwater, rainwater, condensate, municipal reclaimed water, and potable water. Water reuse is fundamental to IBWM, and four storage stocks are provided to facilitate building water reuse under normal conditions. A flexible storage component, such as for firefighting, represents a fifth storage stock that can potentially partake in building water reuse, but these reuse flows are non-existent during normal operations. Stormwater is collected singularly in a stock that can be altered to represent either an open or closed storage system. Rainwater can be added to the stormwater storage, or collected in a cistern scenario. Condensate can be routed to supplement the rainwater cistern or collected separately for high-quality demands, such as cooling tower make-up water. The final storage stock is available for

the collection of blackwater, greywater, or a combination of both sources. Alternative water sources included in the baseline framework are assumed to be available for all water demand applications, recognizing that some sources (e.g., blackwater) require heavier treatment or may not be regulated for use within buildings in some situations.

#### **4.4.2 Baseline Water Prioritization**

Traditionally building water demands are fulfilled entirely using high quality municipal potable water, which is then discarded as wastewater after its first use. However, not all building water applications require the same water quality inherent in potable water. Matching appropriate alternative water sources to suitable building demands alleviates stress placed on the potable supply and lays the foundation for an IBWM approach. Alternative water supply options include rainwater, stormwater runoff, condensate, municipal reclaimed water, greywater and blackwater. Raw water designated under each of these categories has a different level of quality that may be altered through treatment to appropriate standards required dictated by its final application. Rainwater and stormwater both originate from precipitation. Rainwater is assumed to be captured before interacting with surfaces at the ground level, and is therefore also assumed to have a higher water quality than stormwater. The quality of condensate collected from air handling equipment is comparable to distilled water, requiring little to no treatment for non-potable applications (Licina and Sekhar, 2012). Reclaimed water is another high quality water source produced after rigorous treatment of municipal wastewater at a centralized treatment facility. Greywater and blackwater are two substreams of wastewater exiting a building. Greywater consists of water from sinks, showers, and other low-strength sources. Blackwater contains higher amounts of organic material and exits from toilets and urinals. Categorization of water containing kitchen waste depends on regulations adopted by the community; some codes do not consider kitchen waste as greywater, whereas other sources incorporate it as a greywater stock.

Prioritization by water *demands* is important if there are multiple demands that may be met by the same source, and public acceptance drives source prioritization. Major factors affecting public acceptance include perception of the alternative water source, knowledge about the source, previous experience with the water source, and interaction or influence from friends, family, and colleagues (Dolnicar et al., 2011). Aesthetic quality is another potential factor that affects public acceptance to use recycled water for various demand (Jefferson et al., 2004). Public acceptance diminishes if a water source is perceived to look dirty. Asano (2002) identifies seven major categories for alternative water reuse including agricultural irrigation, landscape irrigation, groundwater recharge, industrial reuse, environmental and recreational uses, non-potable urban uses, and indirect or direct potable uses. Non-potable uses include flushing and fire protection, whereas potable uses include those requiring drinking water standards. Generally irrigation is the most acceptable application for alternative water sources, followed by cooling, industrial processes, recreational water use, non-potable public water uses, and potable public water uses (Howell, 2004). The level of public acceptance for general water reuse applications presented by Howell (2004) mirrors the popularity of reclaimed water reuse categories discussed by Asano (2002). Additional public surveys are also in agreement, showing high support for irrigation and decreasing support for toilet flushing, laundry, cooking, and drinking, respectively (Browning-Aiken et al., 2011; Campbell and Scott, 2011). However, Jefferson et al. (2004) found that recycling water for flushing is preferred over irrigation when the water has a poor aesthetic quality. Firefighting is often assumed to require potable water, but Browning-Aiken et al. (2011) found firefighting to be a highly acceptable potential reuse option. There is disagreement over the best primary use of greywater. Jamrah et al. (2006) describe flushing toilets as the best use for greywater, whereas Ludwig (2006) presents landscaping as the primary use due to treatment accomplished within the soil. Both agree that using greywater for laundry purposes has a lower priority. Hauber-Davidson (2007) presents a prioritization for both rainwater and stormwater by grouping demands as acceptable, possible,



or not recommended. Acceptable uses for rainwater include irrigation, cooling, bathroom uses, laundry, and supplementing swimming pools. Possible demands met by rainwater include kitchen uses and food preparation. Consequently, stormwater's lowered quality lowers the preference of potential demands. Acceptable uses for stormwater include irrigation and cooling. Bathroom uses and laundry shift to possible rainwater reuse demands, while supplementing pool water and cooking demands are listed as not recommended. Licina and Sekhar (2012) suggest using condensate as cooling make up water first due to its high quality and proximity to cooling systems, although the same quality attributes allow condensate to be applied to other demands. The preferences discussed are summarized in Table 4.1.

Table 4.1: Literature summary of water source preferences for different demands. Blackwater and greywater sources are assumed to undergo treatment before application. Numbers indicate the order in which each water source is applied to each set of water demands.

Water source	Landscaping	Cooling	Low-human interaction (LHI) – water features and fountains	Flushing	Laundry	High-human interaction (HHI) – recreational water uses, swimming pools	Firefighting	Drinking, showers, sinks	Reference
Blackwater and greywater	1	2		4	5	3		5	Howell (2004)
Greywater and rainwater	2			1				3	Jefferson et al, (2004)
Greywater			2	1	3				Jamrah et al. (2006)
Greywater	1			2	2				Ludwig (2006)
Stormwater	1	1		2	2	3		3	Hauber-Davidson (2007)
Rainwater	1	1		1	1	1		2	Hauber-Davidson (2007)
Reclaimed water	1	2	3	4	4		4	5	Asano (2002)
Reclaimed water	2			3	4	5	1	6	Browning-Aiken et al. (2011)
Reclaimed water	1			2	3	4		5	Campbell and Scott (2011)
Condensate	2	1							Licina and Sekhar (2012)

Prioritization by water source is also important when multiple sources can meet one demand. Given the option of multiple alternative water sources, preferences must be assigned that outline which sources should be utilized first. IBWM assigns a higher preference to alternative sources than potable sources. The same logic is employed by the Leadership in

Energy and Environmental Design (LEED) green building rating systems issued by the U.S. Green Building Council (USGBC, 2009a-b). Within this group, certain alternative sources should be utilized before others. An Australian study found that treated rainwater was a preferred potential alternative potable water source over treated stormwater or reclaimed water due to public risk perceptions (Marks et al., 2008). Green buildings often challenge public perception by pioneering new technologies, and other factors affecting water preference exist. For example, greywater should be used soon after treatment to ensure proper quality (Al-Jayyousi, 2003). This results in greywater having a higher preference than rainwater, which can be stored for longer periods of time if collected properly. It is suggested that that low quality sources should be utilized first and have a higher preference when available high quality sources can accommodate prolonged storage.

Multiple building water flow configurations based on a fit-for-purpose scheme necessitate an inherent:

- Demand-driven prioritization – prioritization by demand for each water source, and
- Source-driven prioritization – prioritization by source within each demand.

The previous literature review summarized in Table 4.1 forms the basis of the prioritization arrangement presented in Table 4.2. This distinct sequence represents only one possible ordering of rankings, recognizing that prioritization schemes containing varying water demands, sources, and rankings exist. Building type, costs, user preference, and the regulatory environment will dictate site-specific prioritization scenarios. If sources are combined, as described in the previous section, it is assumed that the prioritization of the lower-quality source is adopted. The source-driven prioritization presented presumes that if multiple sources are available to meet a demand, all sources must meet the demand's quality standards. Therefore, water that originated from a lower quality source should be used first due to the generally higher energy and investment costs required to meet the demand standard. Additionally, alternative water sources that originate within the building (blackwater or greywater) have a higher priority

than sources originating from the exterior of the building (rainwater or stormwater) due to conveniences for on-site distribution, minimized impacts on natural hydrologic cycles, and reduced infrastructure costs. On-site recycling sources are preferred over water sources introduced from municipal installations as a result of analogous reasoning. Once defined, the preference and prioritization relationships form the foundation for an IBWM framework that may be manipulated through user interactions.

Table 4.2: Baseline prioritization of potential water sources (i) and demands (j).

Water Demand	Treated blackwater 1	Treated greywater 2	Stormwater 3	Rainwater 4	Condensate 5	Reclaimed water 6	Potable water 7	Flexible storage 8
Landscaping	j=1	1	1	1	2	1	14	14
Green roof	2	2	2	2	3	2	13	13
Cooling	5	5	3	3	1	3	12	10
Low-human interaction (LHI) stock	6	6	4	4	4	4	11	12
Urinals	3	3	5	5	5	5	10	8
Toilets	4	4	6	6	6	6	9	7
Laundry	7	7	7	7	7	7	8	11
High-human interaction (HHI) stock	8	8	8	8	8	8	7	9
Firefighting	9	9	9	9	9	9	6	1
Showers	10	10	10	10	10	10	5	6
Bathroom sinks	11	11	11	11	11	11	4	5
Kitchen sinks	12	12	12	12	12	12	3	4
Process water	13	13	13	13	13	13	2	3
Drinking	14	14	14	14	14	14	1	2

#### 4.4.3 Prioritization-based Water Allocation

The conceptual prioritization evaluation operations are shown on Figure 4.1. For each iteration, the source with highest priority  $i$  is evaluated first. If the source is exhausted or has no value, the source with the next highest priority,  $i+1$ , is considered. If the source exists, it is assigned first to the demand with highest priority  $j$ . If the source is not completely used by demand  $j$ , the remnant supply is directed to the demand with the next highest priority,  $j+1$  until either all demands are fulfilled or the source is exhausted. If an excess source volume exists after all demands are met, the surplus is released as an overflow before moving on to the next source in the sequence. When all sources have been evaluated, the iteration ends for the

specified time step. The resulting algorithm consists of nested prioritization loops; demand-driven prioritization (DDP) is nested within source-driven prioritization (SDP).

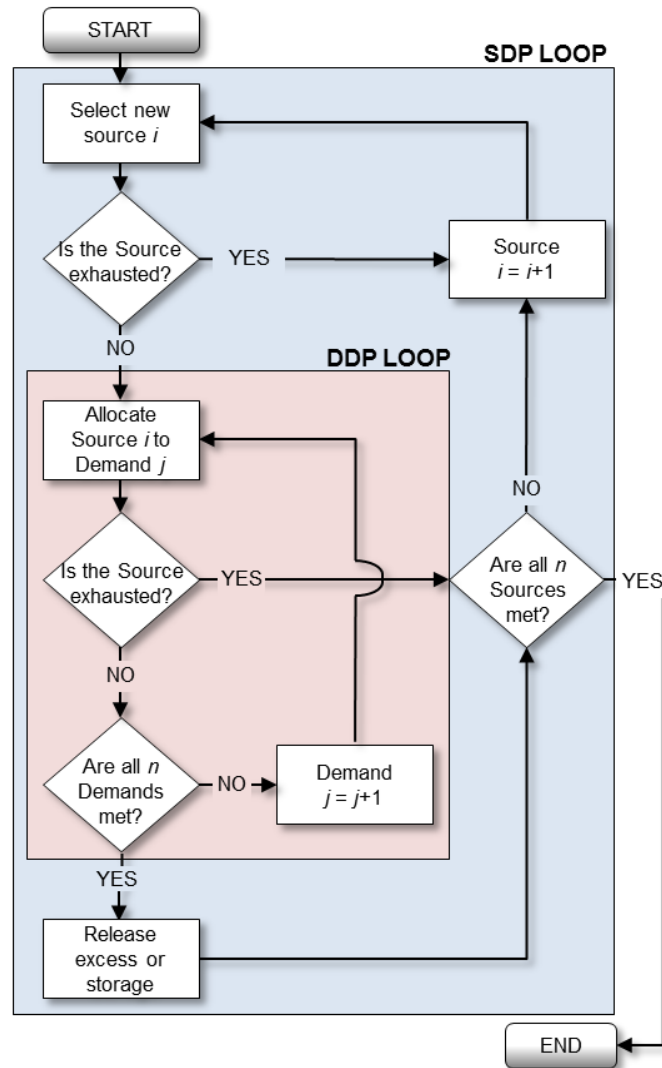

Figure 4.1: Nested prioritization algorithm – demand-driven prioritization (DDP) is nested within source-driven prioritization (SDP).

## 4.5 Results and Discussion

### 4.5.1 Manipulation of Baseline Prioritization Framework

The baseline prioritization presented in Section 4.4.2 is adjustable through the use of a series of on-off switches triggered by user preferences. Control over each unique demand-

source flow allows users to identify and animate active demand, supply, and reuse flows within the building water cycle. An example is provided using the first five demands within the condensate source prioritization. The remaining demands are not shown for simplicity. The user first activates potential water sources. In this example, condensate, rainwater, municipal reclaimed water and potable water are the only sources considered. The baseline prioritization is shown on Figure 4.2(a) where condensate is directed to cooling, landscaping, irrigation of a green roof, a flexible LHI demand stock, and urinals, respectively. Each demand stock then pulls water from the available sources based on the prioritization presented in Section 4.4.2.

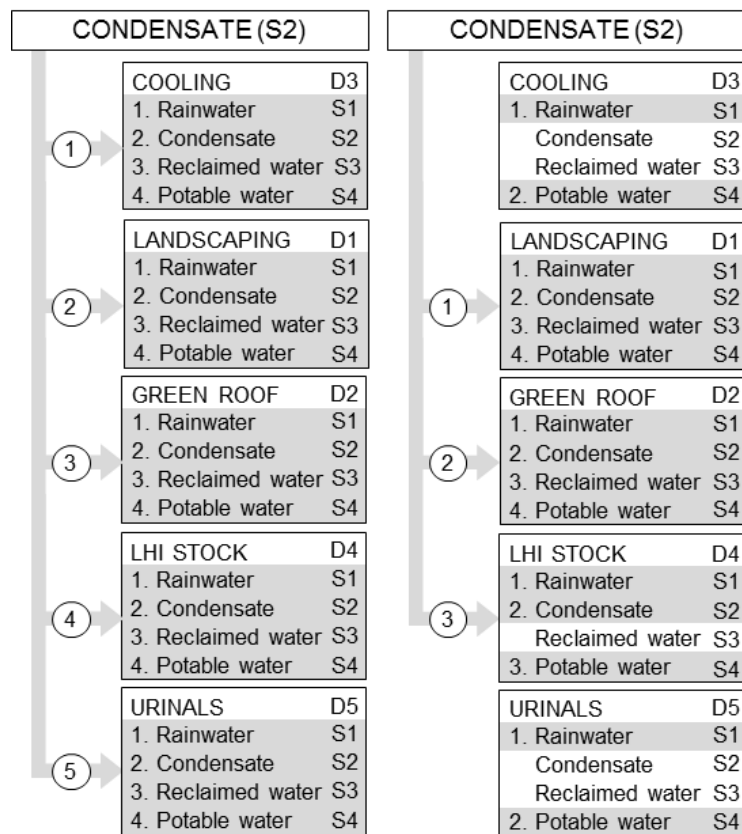

Figure 4.2: Example of model prioritization manipulation: (a) baseline model prioritization, (b) user-defined prioritization. If a source is not available (or desired), then the priority shifts to the next source in sequence. Labels D1-D5 and S1-S4 correspond to the example in Table 4.4.

The prioritization framework dictates that recycled building wastewater is used first, followed by stormwater, rainwater, condensate, municipal reclaimed water, municipal potable water, and water within the flexible storage volume. Figure 4.2(b) shows the effect that user manipulation has on the baseline framework. Collected condensate is used for landscaping, irrigation of the green roof, and the LHI stock only. This changes the prioritization of the condensate source; the landscaping demand is now priority 1 for condensate instead of priority 2, the priority for the green roof changes from 3 to 2, and the priority for the LHI stock changes from 4 to 3. The exclusivity of potential sources also alters the demand priorities within each source. If all four water sources are applied to the demand, such as for landscaping and the green roof, potable water has the fourth priority. However, potable water is used second for the cooling and urinal flushing demands due to the exclusion of the condensate and reclaimed water sources.

#### **4.5.2 Prioritization Algorithm**

The algorithm for building water accounting is presented in Table 4.3 and represents calculations undertaken for one time step. The DDP and SDP iterations are described as nested loops in which demands are fulfilled by available supplies according to assigned priorities. The algorithm is applied and presented in Table 4.4 where four water sources (S1, S2, S3, and S4) and five water demands (D1, D2, D3, D4, and D5) with varying priorities are considered over a one-hour time step. The prioritization scheme manipulated in Table 4.4 matches that presented on Figure 4.2(b). The algorithm populates resulting demand and source amounts at each intersection based on initial values.

In Table 4.4, SDP is represented by the order of sources listed in the first row; nested DDP associated with each source is represented within the corresponding column. The ranking order within each source column represents the order in which the source is allocated to each demand. The varying order and total number of rankings within each column represents the potential for changing preferences based on the source. For example, it is noted that for the

source with first priority  $S_1$ , the demand with rank 1 ( $D_1$ ) corresponds to demand D1. However, for the source with fourth priority  $S_4$ , the demand with rank 1 ( $D_1$ ) corresponds to demand D5. This means that source S1 is first allocated to demand D1, but source S4 is first allocated to a different demand D5. The nested prioritization loops described in Table 4.4 are visually represented on Figure 4.3 where source-demand interactions result in a spiral pattern. Growing concentric circles represent sources with decreasing priority ( $i$ ), and intersecting axes represent demands with unique priorities ( $j$ ). The plot begins at the intersection of the source with highest priority ( $i=1$ ) and demand with highest priority ( $j=1$ ), and places a marker denoting the demand associated with the current priority ( $D_1$ ). The algorithm continues to each subsequent demand within the first source before moving up to the next source. Unranked demands within a source column are displayed as empty markers. The changing priority placement of individual demands within each source ring reiterates the algorithm's ability to accommodate alternating nested priorities.

Table 4.3: Prioritization algorithm.

<p>LOOP WHILE <math>i \leq I</math></p> <p><math>i = 1</math></p> <p>LOOP WHILE <math>j \leq J</math></p> <p><math>j = 1</math></p> $D(D_j, S_i) = \begin{cases} D(D_j, S_{(i-1)}) - S(D_{(j-1)}, S_i), & D(D_j, S_{(i-1)}) - S(D_{(j-1)}, S_i) \geq 0 \\ 0, & D(D_j, S_{(i-1)}) - S(D_{(j-1)}, S_i) < 0 \end{cases}$ $S(D_j, S_i) = \begin{cases} S(D_{(j-1)}, S_i) - D(D_j, S_{(i-1)}), & S(D_{(j-1)}, S_i) - D(D_j, S_{(i-1)}) \geq 0 \\ 0, & S(D_{(j-1)}, S_i) - D(D_j, S_{(i-1)}) < 0 \end{cases}$ <p><math>j = j+1</math></p> <p>END LOOP</p> <p>IF RANK=null</p> $D(D_j, S_i) = D(D_j, S_{(i-1)})$ $S(D_j, S_i) = S(D_{(j-1)}, S_i)$ <p><math>i = i + 1</math></p> <p>END LOOP</p>	<p>Continue until all sources, <math>I</math>, are met</p> <p>Begin with the source with highest priority, <math>i</math></p> <p>Continue until all ranked demands, <math>J</math>, are met</p> <p>Begin with the demand with highest priority, <math>j</math></p> <p>Remaining demand is amount supply did not fulfill</p> <p>Remaining supply is amount demand did not consume</p> <p>Move on to the demand with next priority, <math>j + 1</math>, and repeat</p> <p>End iterations when all ranked demands are evaluated</p> <p>For unranked demands: Demand carries over from previous demand value Source carries over from previous supply value</p> <p>Move on to the source with next priority, <math>i + 1</math>, and repeat</p> <p>End iterations when all sources have been allocated</p>
---	--

Table 4.4: Example application of prioritization algorithm. Column (D) displays the demand remaining after the available supply source has been applied. Column (S) displays the remaining source available after the application to the demand. All calculations occur within one time step (1 hour), and values are displayed in lph.

$D_j$	$S_i$	$S_o$	$S_1=S1$ (Rainwater)			$S_2=S2$ (Condensate)			$S_3=S3$ (Reclaimed)			$S_4=S4$ (Potable)		
			Rank, $j$	(D)	(S)	Rank	(D)	(S)	Rank	(D)	(S)	Rank	(D)	(S)
		(Initial)	0	100		0	80		0	500		0	220	
D1 (Landscaping)	20		1	0	80	1	0	80	1	0	500	5	0	
D2 (Green roof)	30		2	0	50	2	0	80	2	0	500	4	0	
D3 (Cooling)	100		3	50	0	null	50	80	null	50	500	3	0	
D4 (LHI stock)	150		4	150	0	3	70	0	null	70	500	2	0	
D5 (Urinals)	100		5	100	0	null	100	0	null	100	500	1	0	
				0			0			500			120	

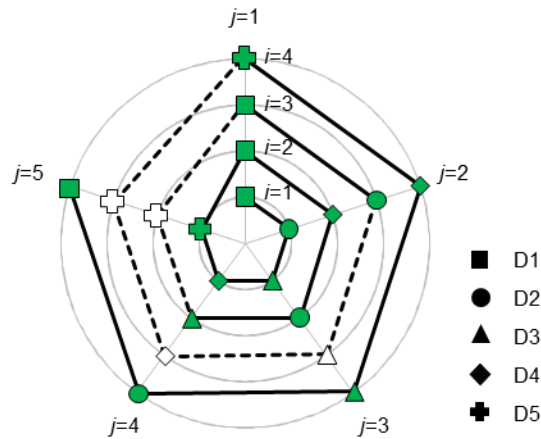

Figure 4.3: Visual representation of nested prioritization algorithm for demands (D1-D5), sources, and rankings in Table 4.4. Empty markers correlate with unranked demands.

In order to complete Table 4.4, the algorithm begins with the first column corresponding to the source with first priority ( $S_1=S1$ ). Within this column, the demand with the first priority, or rank, is selected ( $D_1=D1$ ) and interacts with the source. The new remaining demand



( $D(D_1, S_1)=0$  lph) and supply ( $S(D_1, S_1)=80$  lph) is calculated by comparing the previous supply ( $S(D_0, S_1)=100$  lph) and previous demand ( $D(D_1, S_0)=20$  lph). For these cells, the source exceeds the required demand; and therefore, the remaining demand is 0 lph, and the remnant source available to meet the next ranked demand is 80 lph. The algorithm continues for each ranked demand in order until all ranked demands are met. In the event that a demand is not allowed by the user to interact with a source and not ranked, previous values for the remaining demand and source are carried over into the current cells. After the column is completed, the algorithm moves onto the source with the next priority and repeats until the table is filled. The final water allocation scheme provides a breakdown of unique water source consumption by each demand within the prioritization scenario for a desired time step. The resolution of water use patterns may be controlled by altering the length of the time step, and repeating the algorithm describes dynamic water profile over a desired time period.

#### **4.5.3 Prioritization over Time**

Baseline supply prioritization is visually illustrated on Figure 4.4, where one constant demand of 100 liters per hour (lph) is considered over a 24-hour period. All supply sources are available to meet the demand and follow the inherent prioritization framework. Initially all source flows are turned off; over time, each source is turned on and has a constant value of 40 lph. Sources are triggered individually at each three hour interval in increasing order of prioritization. At hour three, the potable water source is triggered, and all potable water is utilized by the demand. The municipal reclaimed water supply is then triggered at hour six. The total flow of water supply remains less than the required demand, and thus all potable and reclaimed water supplies are utilized. However, reclaimed water possesses a higher priority than potable water and is consumed first, as shown by the position replacement with the potable supply. At hour nine, condensate is added as the third available source and now has first priority to meet the demand; the priority of reclaimed water shifts to second place, and potable water is assigned third priority. Allocating all potable water to the demand stock will exceed the demand value;

therefore, only the portion required to fill the deficit is directed to the demand. This same pattern is repeated for the inclusion of rainwater, stormwater, and on-site recycled wastewater (WW) sources, respectively. In all cases, the addition of a source with higher priority shifts previous water sources and alters the overall prioritization structure.

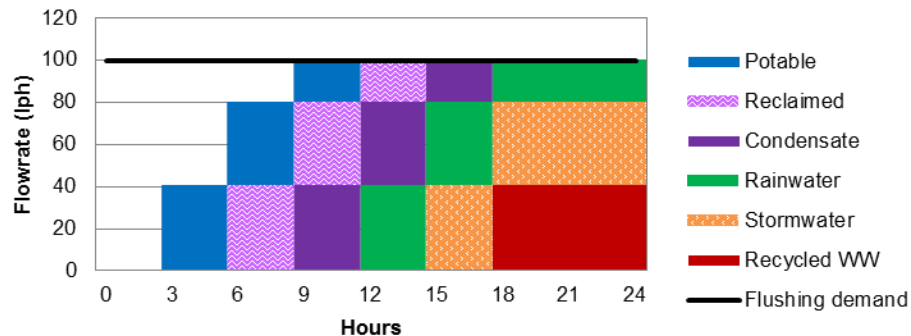

Figure 4.4: Visual representation of water source prioritization within the model.

The dynamic assessment capabilities of the prioritization algorithm are further examined by altering water flows over different temporal scales. For example, the demand for flushing fixtures within the building may be fulfilled using recycled wastewater, rainwater, condensate, and potable water, respectively. The prioritization used follows the scheme proposed in Table 4.2. The fulfillment of the demand function by available sources depends both on the water demand profile (Figure 4.5) and the water source profiles (Figure 4.6). Three different types of water profiles are examined: (a) constant (e.g., a 24-hour industrial operation); (b) residential (e.g., a dormitory); and (c) commercial (e.g., an office building). Archived diurnal curves were used as a reference (American Water Works Association, 1989). The constant, residential, and commercial daily demand patterns presented share equivalent water source profiles. The potable water supply can solely meet the flushing demand and is also constant; however, the alternative water supplies develop throughout the day and carry higher priority.

Alternative water sources are best utilized in the constant demand scenario (Figure 4.6a). The initial absence of alternative sources triggers the potable supply to solely meet the flushing demand. The addition of rainwater at hour two offsets the potable supply due to rainwater's higher priority over potable water as previously noted. Over the day the potable water offset is affected by the presence of all three alternative water sources with higher priority – recycled wastewater, rainwater, and condensate, respectively. Similarly, the difference between condensate supply and condensate consumption results when the condensate supply exceeds the demand remaining after consumption of recycled wastewater. Because the purpose of this paper is to explore the need for and effects of water prioritization, the algorithm utilizes instantaneous matching of sources and demands without storage.

The residential demand profile fluctuates over the day with peaks in the morning and evening hours (Figure 4.5b). The source profile peaks deviate from the demand peaks, thereby underutilizing the alternative water supplies (Figure 4.6b). Rainwater inflow reaches maximum flow before the morning demand peak value, and the recycled wastewater profile falls between the morning and evening maximum demand points. Potable consumption follows the general trend of this residential demand pattern in order to fulfill the remnant demand unsettled during peak times.

Demand fluctuates between two steady states in the daily commercial scenario (Figure 4.5c). Building occupancy is assumed constant and occurs during operating hours, whereas the building is unoccupied at night. In this scenario, the recycled wastewater source occurring during building occupancy is fully consumed. Like the residential scenario, the rainwater source largely remains outside of the peak demand period and is underutilized. The same occurs with the condensate source that persists beyond the building occupancy hours.

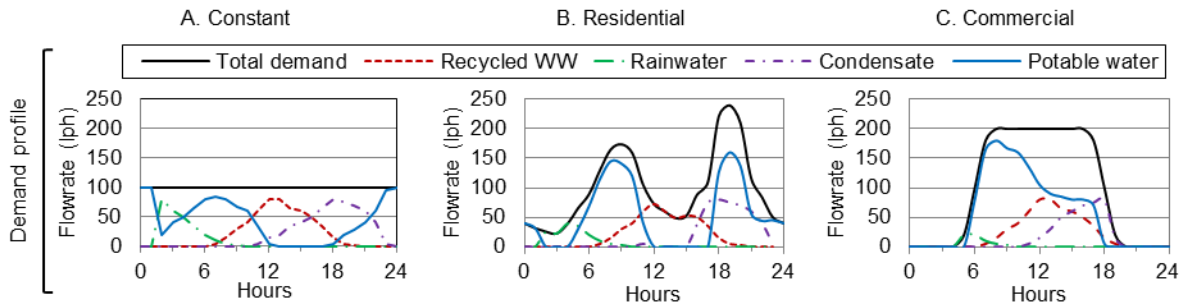

Figure 4.5: Daily water demand profiles (lph) for flushing based on (a) constant, (b) residential, and (c) commercial scenarios. Total demand is fulfilled according to the prioritization of available water sources.

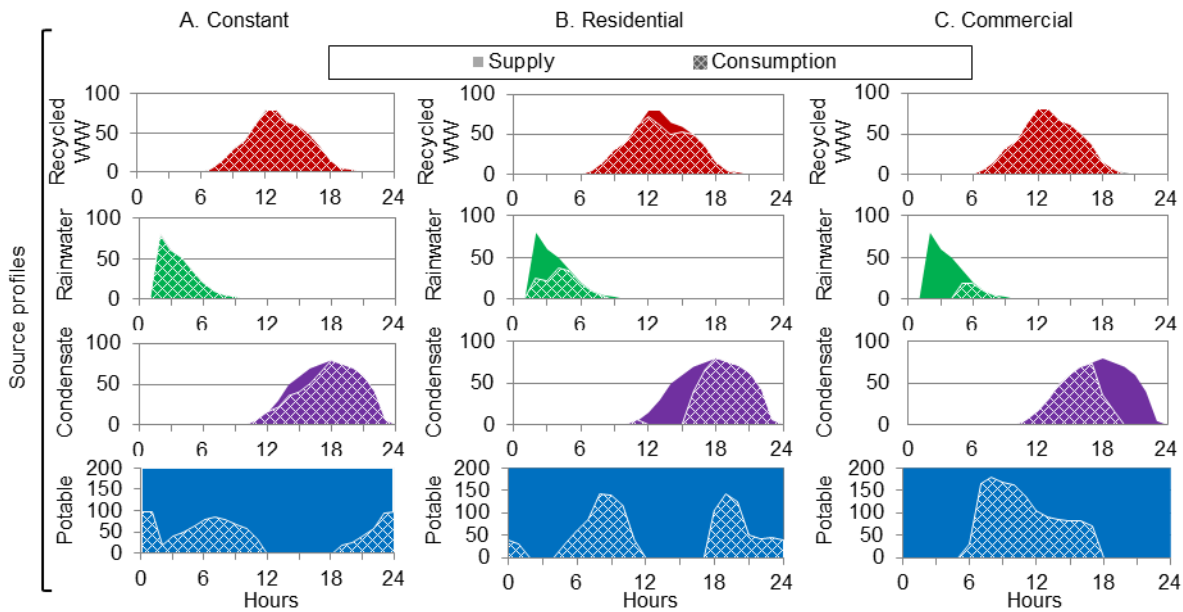

Figure 4.6: Daily water source profiles (lph) for flushing demand based on (a) constant, (b) residential, and (c) commercial scenarios. Available source supplies are consumed based on the associated demand profile and prioritization of competing sources.

#### 4.5.4 Effect on Water Savings

Demand attainment can further be compared based on the percent of the demand met by each source (Figure 4.7). All three demand scenarios were fulfilled using the same supply profiles, but result in different potable water savings. The overall potable water reduction is 56.9% for the constant demand case, 45.8% for the residential demand case, and 41.6% for the commercial demand case. Each demand scenario generates a unique visual representation of

potable water savings over time. As expected, dynamic water flows result in wavering water savings projections. Singular numeric figures used to describe water efficiency are averages over a fixed time period, but it is unlikely that efficiency remains constant.

In all scenarios potable water is necessary to satisfy the demand deficit; however, the alternative sources are not efficiently managed. Matching demand profiles to source profiles identifies durations when alternative water sources exist, but diverge from the demand arrangement. When synchronization does not exist, allocation of water of the right quantity at the correct time requires a storage element. Design considerations for alternative water allocation and storage rely on water prioritization and building water cycle profiles.

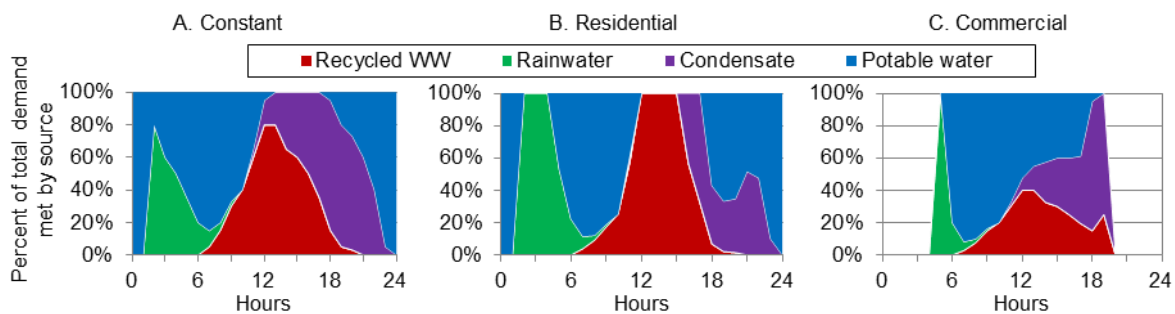

Figure 4.7 Percent of the flushing demand met by each available water source based on the (a) constant, (b) residential, and (c) commercial scenarios.

#### 4.5.5 Application of Algorithm to Real Building Scenario

A hotel building located in Dunedin, Florida, USA was used to apply multiple demand-source pathways to the water prioritization framework. The 3900 m<sup>2</sup> building houses 76 living units over three floors. Demands exerted by the facility include toilet-flushing, showering, cooking, clothes-washing, hand-washing, air conditioning, ice-making, irrigation, pool maintenance, and other miscellaneous operations. Indoor water demands are met by municipal potable water, and outdoor irrigation is sub-metered and met by municipal reclaimed water. Daily data collected for overall indoor water consumption and outdoor irrigation from August

2010 through July 2011 serve as the baseline for the exercise. A study on water end-uses by Gleick et al. (2003) was used to divide metered total indoor water consumption into individual water demand components for the hotel.

Four scenarios are applied to the hotel's water cycle (Table 4.5), which consider variant prioritization schemes for three alternative water sources (recycled WW, rainwater, and reclaimed water) that may offset potable water use for three potential water demands (landscaping, cooling, and toilets). Potable water fulfils all other demands. The potential recycled WW supply is calculated as 75% of greywater from showers and faucets. Although municipal reclaimed water currently meets the landscaping demand throughout the year, a limit of approximately 568,000 liters a month is enacted for this analysis. Monthly available rainwater is calculated based on the building roof catchment area, catchment efficiency, and average monthly rainfall data.

The resultant demand-supply profiles produced by the prioritization water allocation algorithm are shown on Figure 4.8. In scenarios 1 and 2, the volume of alternative water was not high enough to meet the landscaping demand in any month. Therefore, alternative water allocation to the subsequent demands with lower priority could not occur. Scenario 3 presents the allocation of reclaimed water. During times when reclaimed water fulfils the entire landscaping demand, the remaining volume is allocated to cooling followed by toilet flushing due to the demand prioritization. The variation in demand magnitudes over the year affects the consumption and allocation of the reclaimed water supply. When the landscaping demand is relatively low, excess reclaimed water fulfils subsequent demands; potable water is required when high landscaping demands utilize the entire reclaimed water source. Scenario 4 exhibits the algorithm's capability of evaluating multiple water demands and sources with unique priorities. Recycled WW is evaluated first and may only be applied to landscaping. The rainwater source is evaluated next. The exclusion of rainwater for landscaping shifts demand rankings and causes cooling to have first priority. Remaining rainwater is applied to the toilet

demand with second priority. Reclaimed water allocation is considered third. It is first applied to the landscaping demand not met by the recycled WW source. The remaining reclaimed supply is then apportioned to the remaining cooling and toilet demands, respectively, if rainwater was insufficient.

Table 4.5: Prioritization schemes for the hotel scenarios. Numbers indicate the priority for each demand to use the source associated with that column.

Demands	Baseline				Scenario 1				Scenario 2				Scenario 3				Scenario 4			
	WW	RW	RE	PW	WW	RW	RE	PW	WW	RW	RE	PW	WW	RW	RE	PW	WW	RW	RE	PW
Landscaping	1	1	1	3	1	-	-	3	-	1	-	3	-	-	1	3	1	-	1	3
Cooling	3	2	2	2	3	-	-	2	-	2	-	2	-	-	2	2	-	1	2	2
Toilets	2	3	3	1	2	-	-	1	-	3	-	1	-	-	3	1	-	2	3	1

WW = Recycled WW; RW = Rainwater; RE = Reclaimed water; PW = Potable water

Potable water offsets due to the prioritization scenarios are presented in Table 4.6. Percent potable reduction calculated as an annual average does not capture the variation that occurs within that duration. The water supply profile determined the annual percent potable water reductions in scenarios 1 and 2 due to the absolute consumption of the water source in each case. However, monthly variations occurred due to the fluctuating magnitudes of both water sources and demands over time. The range of monthly percent potable water reductions varied from 3.2 percentage points for scenario 1 to 21.8 percentage points for scenario 3. Alternative water sources are underutilized in scenarios 3 and 4 when the supply volumes exceed the sum of all acceptable demands and result in the release of excess water. Fulfilment of all demands occurs in the first four months for both scenarios, although the sources accomplishing fulfilment vary. The increase in annual potable water reduction from 43.1% in scenario 3 to 51.6% in scenario 4 is a result of the inclusion of the recycled WW and rainwater sources that allowed for additional potable water offsets in the last eight months of the year period.

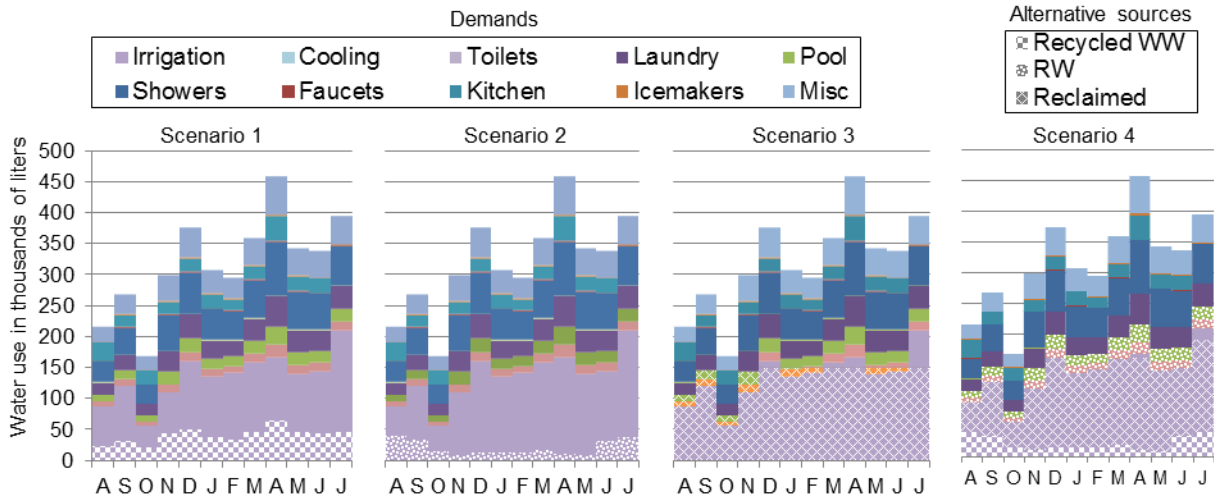

Figure 4.8: Demand-supply profiles for the four hotel scenarios described in Table 4.4. Alternative sources considered include recycled wastewater (WW), rainwater (RW) and reclaimed water.

Table 4.6: Percent potable water reductions for the four hotel scenarios.

Month	Scenario 1	Scenario 2	Scenario 3	Scenario 4
August	12.6%	20.5%	53.4%	53.4%
September	12.3%	12.9%	54.4%	54.4%
October	14.6%	10.2%	46.0%	46.0%
November	14.4%	3.5%	46.7%	46.7%
December	13.1%	3.8%	38.8%	51.4%
January	12.5%	4.8%	48.5%	53.7%
February	11.9%	5.1%	49.8%	56.0%
March	12.7%	5.2%	40.8%	52.9%
April	14.3%	2.6%	32.6%	47.2%
May	13.4%	2.9%	42.9%	50.3%
June	13.0%	9.7%	43.7%	51.9%
July	11.4%	9.5%	35.2%	55.1%
Annual average	13.0%	6.8%	43.1%	51.6%

## 4.6 Conclusion

Water conservation and reuse are often compartmentalized; each water-saving technique is assessed individually. However, an integrated approach evaluates the outcomes of different water management techniques or more importantly a combination of techniques. This information is crucial to making decisions based on water use, and these decisions are made by individuals involved in the construction and operation of both green and conventional



buildings. Water prioritization is necessary for IBWM in order to appropriately allocate water sources to water demands within the building water cycle. The prioritization algorithm presented calculates water appropriation based on flexible user-defined priorities, thereby producing water profiles for various water cycle schemes at desired time scales. Resultant profiles may be used to estimate potable water savings and best water source-demand matches, both spatially and temporally. However, further development must include storage elements and complete mapping of water reuse and recycling loops in order to fully emulate physical building water cycles and produce data relevant to the decision-making process regarding building water management and efficiency.

The water prioritization framework addresses known water demand and supply flows. However, individual building water demands and alternative water sources are frequently unknown. Sub-metering is required to validate building water flows that are currently estimated based on influencing factors that include building functions, building design, fixture installations, occupant behavior, urban infrastructure, and the natural environment. Future work regarding IBWM should acknowledge the variability that is introduced into the building water cycle by variations in these influencing factors and support the need for adaptable buildings designed with inherent flexibility. Thus, uncertainty must be included in order to develop a range of water profiles and associated water use efficiencies based on prioritization schemes.

## 5 DUNEDIN WATER USE STUDY

### 5.1 Introduction

Utilities ensure the timely delivery of water of adequate quantity and quality to end-use customers, but the difficulty of utilities maintaining the needs of their customers is amplified due to population growth, increasing urbanization, and climate change variability. These factors stress available water quantities by increasing the demand for water resources and altering the amount available over time, thereby threatening the security of water supplies managed by the utility. Water delivery accomplished by distribution and storage components within the infrastructure network must successfully meet peak flow demands while ensuring quality standards are maintained throughout the system. The quality of water depends on the inherent amount of disinfection within the water stream directly related to water age, which varies across the network based on the retention time of water within the distribution grid. Increasing water age resulting from increased distance from centralized treatment and variations in diurnal consumption patterns produced by growing population dynamics leads to decreasing disinfection residuals, the formation of DBPs, pipeline corrosion, nitrification, and bacterial growth (CBCL, 2011). The development and maintenance of water supply systems must optimally balance the economic production of water to meet user's demands with efficient land, energy, and chemical utilization (CBCL, 2011).

As a result of anthropogenic and natural pressures, the goal of sustainable urban water management (SUWM), in which water is responsibly managed and recognized as a cycle influenced by the urban form, has increasingly been adopted by water utilities. Consequently, the focus of operations undertaken by utilities has expanded from exclusive supply-side

supervision to widespread demand management strategies, such as water accounting, conservation, pricing, and education (Boyle et al., 2013). Managing urban water from the demand side often proves to be cost-effective compared to supply side options which require expensive capital investments for the construction and maintenance of large installations necessary for the movement, treatment, and storage of supplementary water sources. The increased emphasis on demand-side management drives the need for economic data recording, collection, and interpretation which may be accomplished using meters that allow utilities to account for water demands and losses throughout the network (Boyle et al., 2013). In particular, SUWM encourages the implementation of widespread metering that produces data at a higher frequency with increased resolution that is remotely accessible in order to promote system efficiency through timely and detailed data analysis (Boyle et al., 2013).

It is recognized that water demanded by utility customers is dynamic, resulting in a diurnal water use pattern based on the composition of structures served by the urban water infrastructure. The regional diurnal water use pattern provides water utilities with necessary design criteria, such as peak factors, necessary for ensuring that user demands are matched with an adequate supply throughout the network. However, evaluating the diurnal pattern at the system-level does not capture the variable demand patterns produced by individual customers which may greatly differ from the observed cumulative pattern (Luca et al., 2010) and contribute to the creation of unique microsystems within the water network. The impact of different building types (residential, commercial, industrial) on the utility demand is disguised without a tool capable of capturing water use at the scale and resolution necessary to reveal unique diurnal patterns over time.

Previous studies focused on measuring building water demands include limitations by the resolution of collected data and reporting of aggregate results. Studies conducted over long time durations often report findings at low resolutions, such as in monthly averages or aggregate end-use distributions, whereas studies that collect data more frequently are limited by

the short duration of the data collection period. The data-logging intervals achieved by meter readings restrict the detail of demand patterns and usability of collected data. Water end-use disaggregation may be accomplished with frequent smart meter readings on the order of seconds, but produce vast amounts of data requiring extensive analysis and quickly deplete battery-powered loggers. When high-resolution data has been captured, trends are lost in the reporting of averages that neglect the inherent variation in water demand necessary for successful timely and efficient delivery of water supplies. The objective of this chapter is to determine the validity of smart water metering to capture diurnal water use profiles for different building types in Dunedin, Florida at an appropriate resolution and duration in order to evaluate building and temporal differences. Diurnal water use patterns will be evaluated using attributes that describe curve features in order to identify the variability and shift in water use patterns over time for each building type.

## **5.2 Smart Metering**

Water metering links customers to the utility resulting in shared benefits for both parties, such that the customer receives potable water access and compensates the utility appropriately, whereby the responsibility of water management is distributed among all stakeholders (Boyle et al., 2013). The potential for transformation of current urban water management schemes is limited by the functions of the water meter in terms of the frequency and resolution of the data that can be generated. Smart water metering stems from the energy sector and consists of a range of available technologies and installation networks of varying degrees of monitoring, control, and automation based on the needs of the utility and customers it serves (Boyle et al., 2013). Essentially, a smart (intelligent) meter has the ability to capture, store, and communicate detailed water use data more frequently than can be accomplished by traditional meters. Smart metering can be classified as either automated meter reading (AMR) or advanced metering infrastructure (AMI) depending on the data transfer method (Boyle et al., 2013). AMR consists of one-way communication in which data collection from the meter is

automated, but requires initiation by a meter reader. AMI utilizes two-way communication channels and allows utilities more control over the collection of data and control of water flow through the meter.

Smart metering implementation and SUWM share overlapping drivers, such as water scarcity, conservation support, identification of system losses, utility operation schemes, energy use, climate uncertainty, and financial costs; and thus culminate in shared benefits regarding water savings, economics, customer satisfaction, and community engagement (Beal and Flynn, 2015; Loeff and Fox, 2010). The ability to capture flows at higher time resolutions, such as at the hourly intervals, allows constant water consumption to be flagged as potential leaks in the system, thereby reducing water loss and improving customer relationships by preventing potentially inflated water bills (Loeff and Fox, 2010). In addition to leak detection, smart metering improves customer service by producing more accurate billing amounts and aiding in the response to bill inquiries. Remote AMR prevents the need for water meters to visit each individual property site, and thus is a less intrusive and labor intensive method for water consumption data collection. Utilities reduce expenditures due to operating costs, deferral of capital project costs, quicker meter reads, and less frequent customer complaints while increasing revenue as a result of the improved accuracy of meter reading and identification of deficits between water produced and water billed, e.g. non-revenue water (NRW). NRW is a result of pumping, treatment, and distribution efficiencies throughout the municipal water system; up to 20% of source water consumption is lost as NRW in the developed world, and the value may reach up to 50% (60%) in the developing world (Loeff and Fox, 2010). An acceptable amount of NRW is about 5% or less, which is allocated to authorized uses including utility operations (e.g., backwashing or system flushing) and firefighting. Traditional meters identify the difference between water produced by the utility and water that reaches customers, but smart metering allows for proactive loss prevention through leak detection and response, reduction in data reading errors, and confirmed meter operation and accuracy calibration.

## **5.3 City of Dunedin**

### **5.3.1 Municipal Urban Water System**

The city of Dunedin is home to approximately 35,000 residents within a 10.36 mi<sup>2</sup> urban footprint located on the west coast of Florida. The region averages 52 in. of rainfall per year, with the majority occurring during the summer months. The city is unique to the region in that its urban hydrologic cycle is largely contained, connected, and operated within the city limits; and as a result, the city is invested in detailed historic and current monitoring of water production, consumption, and recycling.

Municipal water consumption in the city is monitored using AMR meters at each billing address. Each meter is equipped with a radio transmitter that is activated monthly when a meter-reading vehicle is driven near the building location and sends the aggregate consumption data to a computer within the vehicle for data collection. Final consumption and billing records are completed at a central building location. In order to acquire detailed water use records from the meter, direct contact to the data-logger is needed by a transmitting device.

### **5.3.2 Study Sites**

Buildings providing different arrays of functions to the community were considered for data collection in order to capture and compare consumption patterns. Candidate buildings had to exist within the city boundary and be served by municipal utility connections. In addition, each building needed to fulfill a uniform purpose within the site boundary and be served by a water meter specific to the building. A range of building sites of different sizes was desired in order to represent different scales at which on-site water management may occur, whether as a singular structure or campus.

Four locations were chosen to represent a residential, commercial, institutional (school), and multi-use case (Table 5.1). Evaluating a single household for the residential case would not provide enough data to support a residential trend, and thus a multi-residential complex was used so that household water consumption could be captured for multiple households thereby

producing more reliable patterns. The multi-residential complex consists of 94 owned units with either two or three bedrooms. The commercial location chosen was a single-building bank with customer transactions taking place on the first floor and permanent offices housed on the second floor. The combination of uses allows for the capture of water consumption in an office setting by a steady number of full-time occupants combined with the effects incurred by transient customer use. The elementary school site includes two buildings and captures water consumption not only by the student population, but also teachers and faculty who occupy the campus longer than the students. A community center was chosen as a representation of a multi-use facility due to the range of services the building provides to the population. The single-story building houses a fitness center, basketball court, dance studio, and other multipurpose rooms. Occupancy is driven by visitors that may attend scheduled events, such as summer camps or parties, or use open facility amenities as needed.

Table 5.1: Description of building locations used for water use study.

Building	Size	Occupancy	Hours of operation	Water fixtures
RES	11 buildings	94 units	All	
COM	1 building (17,600 ft <sup>2</sup> )	Full-time employees Transient customer base	Lobby: Mon-Thur 9am-4pm Lobby: Fri 9am-6pm Closed Saturday and Sunday	27
ELM	2 buildings (256,400 ft <sup>2</sup> )	Students Teachers Staff	Mon,Tue,Thu,Fri 8:35am-2:50pm (2013-14) Wed 8:35am-1:35pm (2012-13) Mon-Fri 8:35am-2:35am (2013-14) Closed Saturday and Sunday	236
CTR	1 building (43,000 ft <sup>2</sup> )	Full-time employees Large transient base	Mon-Thur 6am-9pm Fri 6am-6pm Saturday 7am-4pm Sunday 10am-2pm	54

Table 5.2: Water meters and associated resolution by building location.

Building	Meter	Volume resolution
Multi-residential	71308647 (small)	10 gal
	71526903 (large)	100 gal
Commercial	80437632	10 gal
Elementary school	83217193 (small)	1 gal
	81492448 (large)	100 gal
Community center	71271349 (small)	1 gal
	71356594 (large)	100 gal

## 5.4 Materials and Methods

### 5.4.1 Data Collection

Data regarding water consumption at each meter location may be recorded at predetermined time intervals ranging from minutes to hours. However, data at these higher resolutions must be collected at the device location, and the duration of historical data available decreases at increasing resolutions due to the increased number of saved data points. For this study, water consumption at each location was collected based on an hourly time step, which is the standard preset in most of the city's water meters. The hourly time step allows for data collection at a high enough resolution to identify diurnal trends while also providing historical data for at least two years.



Figure 5.1: Transmitter used for water use data collection (left) and smart water meter (right).

On-site collection of water consumption data occurred at each meter location. A transmitter (Figure 5.1) downloaded data from the meter via an infrared connection made by direct contact with the transmitter to the meter information portal. The transmitter was then brought back to a central computer where the data was downloaded in Comma Separated Values (CSV) format. The resolution at which volumes were collected by the meter varied from 1 gallon to 100 gallons among location. The multi-residential unit, elementary school, and



community center were each served by two potable water meters – one collecting small flow events and a second activated during large flow events. At these sites, both potable meter values were summed and reported as the total potable water consumption.

#### 5.4.2 Data Analysis

Data files in CSV format were analyzed using Microsoft Excel and Access 2010. Potable water consumption at each location was evaluated from March 11, 2012 through August 16, 2014 at each hourly time step for all locations.

Table 5.3: Summary of attributes used to evaluate diurnal water use curves.

Characteristic	Notation	Units	Definition
Average hourly flow	$Q_A$	gph	Average flow over a 24-hour day
Peak hourly flow	$Q_P$	gph	Maximum flow observed in a one-hour period over a 24-hour day
Peak factor (peak to average factor)	$F_{P/A}$	-	Ratio of maximum one-hour flow to average hourly flow
Time to peak flow	$t_p$	hr	Hour at which the PHF first occurs
Time to 50% consumption	$t_{50}$	hr	Time in hours that it takes to reach half of the daily water use
Duration that hourly flow is greater than $Q_A$	$T_{Q>Q_A}$	hr	Duration in non-consecutive hours when the hourly flow exceeds the MHF
Number of peaks exceeding $Q_A$	$N_P$	-	The number of events in which a peak flow occurs and exceeds the MHF
Median hourly flow	$Q_M$	gph	The median flow over a 24-hour day
Peak to median factor	$F_{P/M}$	-	Ratio of the maximum one-hour flow to median hourly flow
Standard deviation	$\sigma, S$	gph	The variation in flows observed over a 24-hour day

Statistical values are necessary in order to describe and quantify the variability among diurnal water curves of different building types and temporal changes of diurnal curves produced by the same building. Attributes used to characterize diurnal patterns must represent unique traits of the resultant daily demand curves in terms of intensity, duration, and frequency (Buchberger and Wells, 1996). The attributes identified and developed for this study are listed in Table 5.3 and depend on the analysis of logged flowrates ( $Q$ ) tagged for each date ( $d$ ) and hour ( $h$ ) denoted as  $Q(d,h)$  in gallons per hour (gph).

#### 5.4.2.1 Calculations Over 24-hour Periods

The calculations for the following attributes are developed using data for unique dates consisting of 24 flow values representing each sequential hour within that date, beginning with hour 1 representing the time between 12:00 AM and 1:00 AM. A value for each attribute was produced, when applicable, for each of the 889 dates from March 11, 2012 through August 16, 2014 and for demand curves representing the average flow at each hour for combined dates.

The total daily water demand is represented as a mean or average hourly flow ( $Q_A$ ) normalized over 24 hours as calculated by

$$Q_A = \frac{1}{n} \sum_{h=1}^n Q(d,h) \quad (5.1)$$

where the flow for each hour on the given date is summed and divided by the total number of  $n$  hours (24). Although the  $Q_A$  does not describe diurnal changes for the building at the given date, it is useful for evaluating seasonal trends in water use and comparing the intensity of daily water use for each building site. Furthermore, establishing a mean hourly value provides a baseline by which to compare hourly water use magnitudes in terms of deviation from the average throughout the day.

The peak hour flow ( $Q_P$ ) is determined by identifying the maximum hourly flow value within each date,

$$Q_P = \max\{Q(d,h)\}_{h=1}^n. \quad (5.2)$$

Peak flows are important for the design of water supply systems in order to ensure that water successfully meets customer demands at all times. Identification of the  $Q_P$  within the diurnal curve is essential to the sizing and operation of water network components such as pipe diameters and pressure thresholds.

The magnitude of the  $Q_P$  may be normalized by division with the  $Q_A$  in order to accurately report the intensity of the peak for the building on that day as a peak to average factor ( $F_{P/A}$ ). While changes in the  $Q_A$  indicate a change in the magnitude of water use by the

building, the  $F_{P/A}$  tracks the significance of the peak event. A low  $F_{P/A}$  indicates a steadier water use pattern with less variance from the mean, whereas a high  $F_{P/A}$  alludes to a fluctuating profile.

The time at which the  $Q_p$  is reached, or the time to peak ( $T_p$ ), is marked by the hour at which the  $Q_p$  occurs. In the event that the  $Q_p$  occurs more than once in the 24-hour period, the first occurrence is marked as the  $T_p$ . The appearance of a peak requires that the flow exceed the average value, and thus  $T_p$  values were not recorded for dates that did not record measurable water flow.

Another term developed to indicate the intensity of water use is the time required to fulfill 50% of the date's total daily water use ( $T_{50}$ ). Similar to the  $T_p$ , the  $T_{50}$  marks the hour at which at least 50% of the daily water use has been achieved. The hour value indicates both the time of day at which the  $T_{50}$  is achieved and the duration it took to reach the  $T_{50}$  value. By splitting the day's water use such that half is achieved before the  $T_{50}$  and half fulfilled afterward, the value acts as a center of mass and is calculated as

$$T_{50} = \frac{\sum_{h=1}^n Q(d,h)h}{\sum_{h=1}^n Q(d,h)} \quad (5.3)$$

Expanding the center of mass definition to a 2-dimensional area results in the intersection of the AHF and  $T_{50}$  summarizing the diurnal curve profile as a single point at time  $T_{50}$  with flow AHF. It is expected that the  $T_{50}$  nears the  $T_p$  as the  $F_{P/A}$  ratio increases due to the increasing concentration of water volume around the peak. Similar to the  $T_p$ , the  $T_{50}$  was not recorded for dates with no measurable water flow.

Another indicator of water use intensity is the amount of time that the hourly flow exceeds the  $Q_A$  ( $T_{Q>Q_A}$ ). This value is calculated by counting each hour in which  $Q(d,h) > Q_A$ . The resulting count represents the amount of time in hours that the water use by the building exceeded the mean and may be consecutive or non-consecutive. In either instance, a shorter

duration recorded as the  $T_{Q>Q_A}$  indicates events with higher intensity. It is expected that short  $T_{Q>Q_A}$  values correlate with higher  $F_{P/A}$  ratios.

Identifying characteristics of the highest peak flow event provides designers and operators with the most severe event that the system must be able to accommodate, but the appearance of additional peak events, although not necessarily of the same intensity, increases the stress placed on the system by decreasing the amount of time available to respond and recover between events. A higher frequency of intense peak events requires increased buffering capacity in the water supply system in the form of storage and affects pressure within the pipe network. The frequency of high-intensity peak events ( $N_P$ ) is determined by counting the number of peak events that exceed the  $Q_A$  and result in a  $F_{P/A}$  greater than 1.

Additional diurnal curve attributes considered include the median hourly flow ( $Q_M$ ) and the peak to median factor ( $F_{P/M}$ ) representing the ratio of the  $Q_P$  to  $Q_M$ . Flow data that follows a normal distribution will result in a  $Q_M$  near to the  $Q_A$  and consequently a  $F_{P/A}$  close to the  $F_{P/M}$ . Disagreement between mean flow attributes and median flow attributes indicates the presence of extreme outliers in the data, such as short-term high-consumption events.

The amount of variation within each diurnal curve is represented by the standard deviation ( $\sigma$ ) of the 24-hour flow data defined as

$$\sigma = \sqrt{\frac{1}{n} \sum_{h=1}^n [Q(d,h) - Q_A(d)]^2} \quad (5.4)$$

Demand profiles with relatively constant water flow throughout the day have small standard deviation values, whereas the standard deviation will increase as the range of observed flows throughout the day increases.

#### 5.4.2.2 Trend Calculations

Two methods exist for estimating the average value for each attribute based on the data. The first method is based on the demand pattern produced by averaging the flow across all

dates in the data set for each hour in order to create an hourly-average diurnal curve. The flow at each hour of the hourly-average curve follows the equation

$$Q(d_i, h) = \frac{\sum_{d=1}^m Q(d, h)}{m} \quad (5.5)$$

where  $Q(d_i, h)$  is the average flow for hour  $h$  within the set of dates  $d$  associated within set  $i$ . Set  $i$  may include all dates of the study or represent a subset of dates separated by day of the week or month of the year. Computing each attribute based on this demand profile and using the procedures described in Section 5.4.2.1 results in a set of *hourly-average values*. In the second method, attribute values for each daily diurnal curve are calculated and subsequently averaged thereby producing a set of *daily-average values*. The daily-average attribute values depend on the number of dates included in the set and are calculated as

$$\bar{X}_i = \frac{\sum_{d=1}^m X_i(d)}{m} \quad (5.6)$$

where  $X_i$  indicates the attribute  $i$  being evaluated for a set of dates  $d$  from 1 to  $m$ . The collected water flow data represents a sample of all potential water flows, and thus the standard deviation for daily-average attributes was calculated as

$$S = \sqrt{\frac{1}{(n-1)} \sum_{h=1}^n [Q(d, h) - Q_A(d)]^2} \quad (5.7)$$

in order to capture variation within each attribute for the set of dates. By grouping dates into subsets separated by day of the week or month of the year, temporal trends regarding diurnal curve daily-average attributes will be evaluated.

When comparing the set of hourly-average attributes to the total daily-average attributes,  $Q_A$  and  $T_P$  values should remain constant regardless of the calculation method because, by definition, each value is an average of the water use (mean flow and mean time) of the entire date set. However, it is expected that the hourly-average diurnal curve will dampen the intensity

and frequency of hourly flows and result in measurable differences between the remaining hourly-average and daily-average attributes.

## **5.5 Results and Discussion**

### **5.5.1 Aggregate Hourly-average vs. Daily-average Attributes**

As expected, a range of individual daily diurnal curves is produced from the collected data and results in an hourly-average demand profile that describes each building type. Box plots are used in Figures 5.2 and 5.3 to illustrate the distribution of flows for each hour of the day for each building type with the composite hourly-average demand profile drawn on top of the distribution. Figure 5.3 limits the distribution sets between the 10<sup>th</sup> and 90<sup>th</sup> percentile ranges for better clarity. For all sites, the distributions plotted in Figure 5.2 are for all days during the study period, and therefore aggregate usage patterns may be different depending on day and month. The median flow at each hour is generally lower than the average flow for each of the four building sites due to high-flow outlier events that drive up the average. The effect of outliers on the average is best presented at the commercial site in Figure 5.2 where at least 75% of values indicate no flow during the early morning hours (hours 1-9 and 19-24). However, infrequent water use events presumably due to irrigation during this time period result in an average flow that represents the presence of a relatively constant use of water which is not correct. The outlier flow values cause the largest difference in median and average flows in the community center throughout the 24-hour period, thereby indicating wide fluctuations in the time and magnitude of peak flows. Fluctuating water use in the community center is a result of the dynamic population that utilizes the building's many amenities; scheduled events that influence building occupancy and water use vary seasonally, monthly, and day-by-day. The distribution of water use for the commercial site is assumed to be the result of the transient occupants comprised of people visiting the building for only a short amount of time to complete business transactions. The number of full-time occupants in the building has remained relatively constant throughout the study period. The hourly-average demand profile and median hourly flows best

align at the multi-residential site and result in the expected diurnal curve. However, the high distribution of values outside of the 50% of values about the mean indicate intense flow events that greatly exceed those within the average pattern.

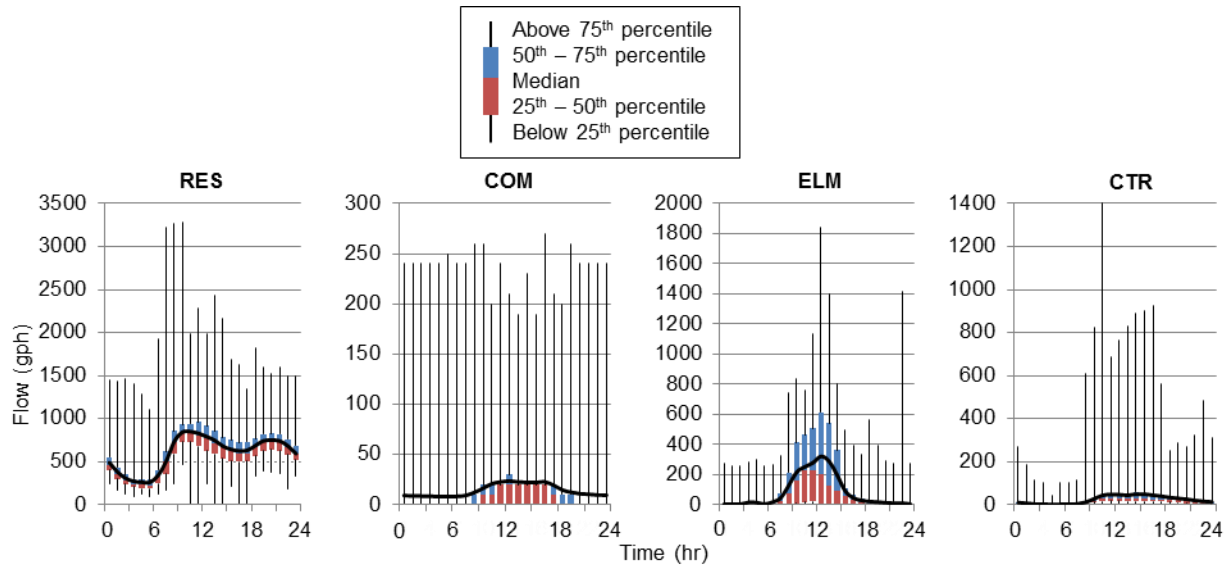

Figure 5.2: Box plots showing distribution of all flows by hour for each of the four building sites – multi-residential (RES), commercial (COM), elementary school (ELM), and community center (CTR).

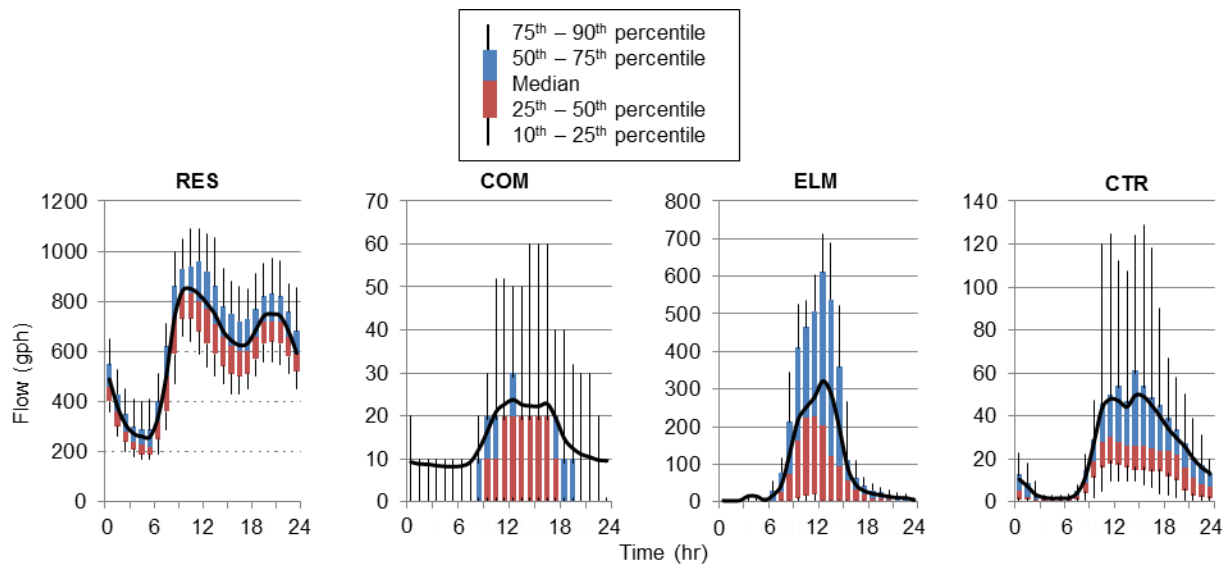

Figure 5.3: Box plots showing distribution between the 10<sup>th</sup> and 90<sup>th</sup> percentiles of flows by hour for each of the four building sites.

The irregularities normally observed in daily demand profiles for all building sites are lost when the flows are averaged at each hour. An example is shown in Figure 5.4 where the daily diurnal curve for a singular 24-hour day is compared to the hourly-average diurnal curve. The single-day curves for the multi-residential and elementary school sites follow the general trend of each hourly-average curve. Contrarily, the single-day curves for the commercial building and community center locations do not align with the relatively plateaued features of the hourly-average curves. In all cases, the single-day curves indicate that water use includes peak flow rates higher than those captured by the hourly-average curve and that additional curve attributes greatly differ between the two curves.

The resultant hourly-average diurnal curve for each study site is unique to the building it describes. The multi-residential location hourly-average curve follows the pattern expected for residential water use where peak flows are observed once during the morning hours and again in the evening. The highest peak occurs at hour 11 (between 10:00 AM and 11:00 AM) with the second peak occurring at hour 21 (between 8:00 PM and 9:00 PM). The hourly-average curve for the commercial site may be defined by either low-flow or high-flow durations. Water use is low during the closed hours between hours 1 – 8 (12:00 AM – 8:00 AM) and 21 – 24 (8:00 PM – 12:00 AM). During hours of normal operation, water use increases in the morning and plateaus to a relatively constant high-flow state between hours 11 – 17 (10:00 AM – 5:00 PM) before decreasing back to the low-flow state. Similar to the commercial site, the elementary school hourly-average water use pattern has the highest usage during school hours when the majority of occupants consist of students. A steep increase in water use is observed in the morning between hours 8 – 10 (7:00 AM – 10:00 AM) which coincides with the arrival of the students. Water use continues to increase until the peak at hour 13 (12:00 PM – 1:00 PM) during the lunchtime hour and then sharply decreases between hours 15 – 17 (2:00 PM – 4:00 PM). Gradually decreasing low flow values are still observed through the evening hours which may correspond to after-school programs or teachers working beyond the scheduled school day.



The hourly-average diurnal curve for the community center does not have restricted water use during the normal hours of operation. Water flow is low during the early morning hours, but sharply increases beginning near the opening time at hour 8 (7:00 AM – 8:00 AM) and plateauing near hour 12 (11:00 AM – 12:00 PM). Water flow begins to gradually decrease at hour 16 (3:00 PM – 4:00 PM) and continues a gradual downward trend through the end of the day and into the early morning. A considerable amount of water flow remains after the 9:00 PM closing hour for the community center. Water use outside of normal operating hours may be attributed to events that are scheduled beyond regular closing times or cleaning and maintenance activities undertaken during off-hours.

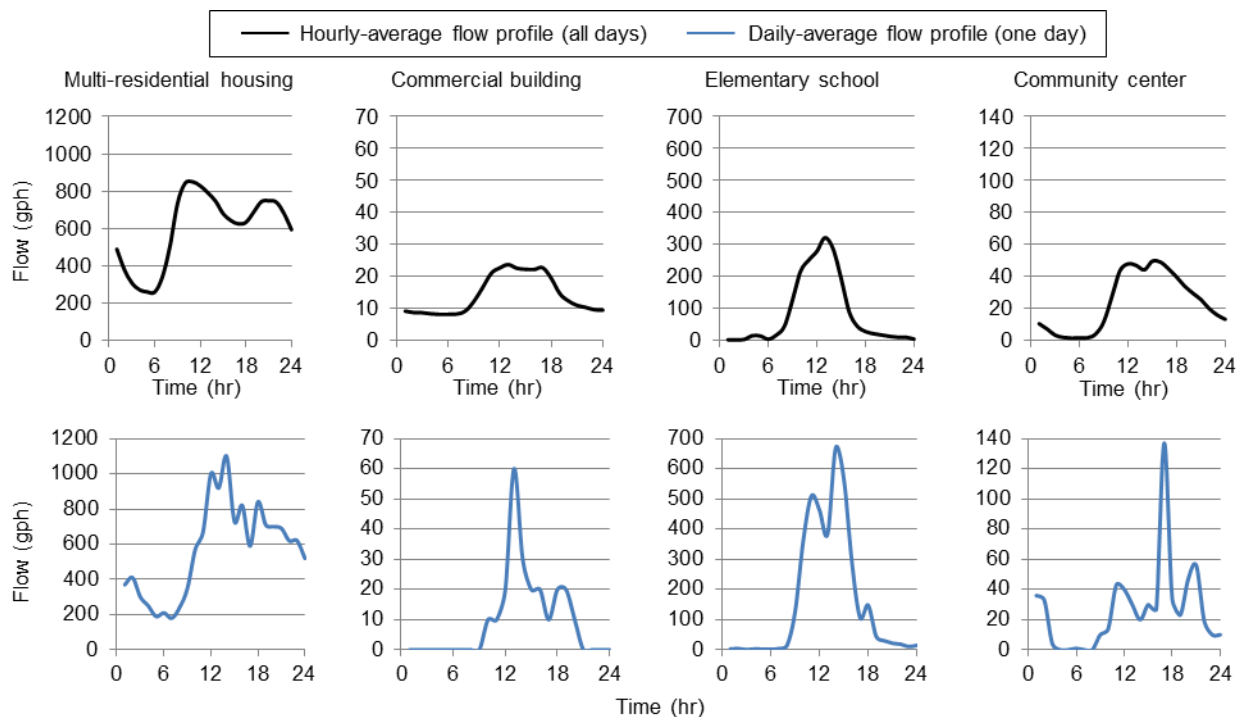

Figure 5.4: The differences illustrated between hourly-average diurnal curves (top row) compared to the diurnal curve for a single day (bottom row) for all four building locations.

The difference between attributes calculated based on the hourly-average diurnal curve and collection of daily-average diurnal curves is shown in Table 5.4. The percent error

evaluates the deviation of the values from the hourly-average diurnal curve from the daily-average values. The  $Q_P$  was underestimated by the hourly-average diurnal curve by 20%, 59%, 14%, and 63% for the multi-residential (MR), commercial building (COM), elementary school (ELM), and community center (CTR), respectively. Consequently, the  $F_{P/A}$  was also underestimated by between 22% and 76% for all locations. The peak flow is an important design element for designing water supply systems in order to ensure the delivery of water, and underestimating this value compromises the ability of the system to fulfill the demand with water at the proper magnitude and pressure. The time at which the peak flow occurs is equally as important for system design because it dictates when the system must be ready to accommodate extreme events. The combination of the  $Q_P$  and  $T_P$  indicates the amount of storage that may be required for the system to meet the high-demand event and when that storage amount must be ready for use. The hourly-average  $T_P$  diverged from the daily-average by -15%, -2%, 10%, and -0.3% for the RES, COM, ELM, and CTR sites, respectively. Deviation in the  $T_{50}$  values is attributed to the exclusion of days with no flow for the daily-average calculation but values remain in close agreement. There is a lack of correlation between the duration that flows exceed the  $Q_A$  and the number of peaks greater than the  $Q_A$  ( $N_P$ ). For all four building sites, the hourly-average overestimates the duration when the flow is above the  $Q_A$ , but for three sites (RES, ELM, and CTR) the hourly-average underestimates the number of peak flow events above the  $Q_A$ . These cases indicate that the daily diurnal patterns are fluctuating above and below the  $Q_A$  more frequently than expected, but maintaining high flows for shorter durations. The appearance of more peaks in the diurnal curve means there is less time available between peaks for the system to recover and prepare to meet the next event, and therefore, increased storage capacities may be necessary to fulfill the water demand through times of multiple peaks within short time periods.

Table 5.4: Attribute values for the hourly-average diurnal curve compared to the average attribute values for all daily-average diurnal curves. Shown are all four building locations– multi-residential (RES), commercial (COM), elementary school (ELM) and community center.

Building		Q <sub>A</sub>	Q <sub>P</sub>	F <sub>P/A</sub>	T <sub>P</sub>	T <sub>50</sub>	T <sub>Q&gt;Q<sub>A</sub></sub>	N <sub>P</sub>	Q <sub>M</sub>	F <sub>P/M</sub>	σ
RES	Hourly-average	600	850	1.4	11.0	13.9	15.0	2.0	662	1.3	197.4
	Daily-average	600	1064	1.8	13.0	13.9	12.6	4.1	617	1.7	240.4
	<b>Percent error</b>	<b>0%</b>	<b>-20%</b>	<b>-20%</b>	<b>-15%</b>	<b>0%</b>	<b>19%</b>	<b>-51%</b>	<b>7%</b>	<b>-26%</b>	<b>-18%</b>
COM	Hourly-average	14	24	1.7	13.0	13.4	10.0	2.0	12	2.0	6.0
	Daily-average	14	58	6.9	13.3	14.3	7.2	1.9	9	2.8	13.8
	<b>Percent error</b>	<b>0%</b>	<b>-59%</b>	<b>-76%</b>	<b>-2%</b>	<b>-6%</b>	<b>38%</b>	<b>7%</b>	<b>36%</b>	<b>-27%</b>	<b>-56%</b>
ELM	Hourly-average	85	322	3.8	13.0	12.6	8.0	1.0	20	16.0	109
	Daily-average	85	373	4.8	11.9	12.4	7.8	2.7	20	28.6	118
	<b>Percent error</b>	<b>0%</b>	<b>-14%</b>	<b>-22%</b>	<b>10%</b>	<b>2%</b>	<b>2%</b>	<b>-63%</b>	<b>-1%</b>	<b>-44%</b>	<b>-8%</b>
CTR	Hourly-average	24	50	2.1	15.0	15.1	12.0	2.0	23	2.2	18.2
	Daily-average	24	134	5.8	15.1	14.9	8.5	3.5	14	15.0	32.6
	<b>Percent error</b>	<b>0%</b>	<b>-63%</b>	<b>-64%</b>	<b>-0.3%</b>	<b>1%</b>	<b>42%</b>	<b>-44%</b>	<b>68%</b>	<b>-86%</b>	<b>-44%</b>

### 5.5.2 Trends over Time

All daily diurnal curves for each building locations are presented in Figures 5.5 through 5.8. A summary of the percent deviation for each attribute based on the comparison of the average of all days to each individual day of the week is presented in Table 5.5. Building-specific and temporal trends regarding individual curve attributes are discussed and graphically presented in the following sections.

Table 5.5: Percent deviation of each attribute from the average by day of the week to the average for all days. Shading indicates absolute deviation between 10% and 25% (light shading), 26% and 50% (medium shading), and above 50% (dark shading).

Building	Attribute	Mon	Tue	Wed	Thu	Fri	Sat	Sun
RES	Q <sub>A</sub>	1%	-3%	-2%	-3%	-1%	2%	7%
	Q <sub>P</sub>	2%	-1%	0%	-3%	4%	-3%	1%
	F <sub>P/A</sub>	1%	0%	-1%	-3%	2%	2%	0%
	T <sub>P</sub>	-3%	-3%	6%	2%	-9%	1%	5%
	T <sub>50</sub>	0%	0%	0%	0%	-1%	0%	2%
	T <sub>Q&gt;Q<sub>A</sub></sub>	-1%	0%	-2%	1%	-2%	0%	4%
	N <sub>P</sub>	1%	0%	0%	-1%	3%	-4%	0%
	Q <sub>M</sub>	0%	-4%	-2%	-3%	-2%	2%	11%
	σ	0%	-6%	-7%	-7%	-3%	9%	14%
COM	Q <sub>A</sub>	9%	6%	17%	23%	22%	-35%	-43%
	Q <sub>P</sub>	13%	33%	29%	24%	29%	-58%	-63%
	F <sub>P/A</sub>	-19%	-28%	-37%	-29%	-31%	152%	119%
	T <sub>P</sub>	5%	2%	4%	-6%	5%	-14%	-1%
	T <sub>50</sub>	3%	-2%	2%	-5%	0%	-3%	13%
	T <sub>Q&gt;Q<sub>A</sub></sub>	21%	30%	36%	31%	33%	-73%	-82%
	N <sub>P</sub>	13%	32%	26%	23%	28%	-53%	-60%
	Q <sub>M</sub>	8%	-24%	-4%	22%	10%	5%	-16%
	σ	27%	27%	39%	37%	34%	-82%	-82%
ELM	Q <sub>A</sub>	29%	48%	42%	46%	18%	-92%	-93%
	Q <sub>P</sub>	-3%	-3%	-3%	-2%	-5%	9%	8%
	F <sub>P/A</sub>	-8%	-10%	-7%	-7%	-9%	-23%	64%
	T <sub>P</sub>	6%	9%	6%	7%	2%	-27%	-2%
	T <sub>50</sub>	2%	2%	1%	1%	1%	-4%	-4%
	T <sub>Q&gt;Q<sub>A</sub></sub>	1%	0%	0%	1%	5%	38%	-44%
	N <sub>P</sub>	-8%	-15%	-8%	-6%	-4%	81%	-36%
	Q <sub>M</sub>	26%	39%	33%	56%	16%	-86%	-85%
	Σ	29%	47%	45%	44%	17%	-91%	-91%
CTR	Q <sub>A</sub>	-2%	22%	0%	17%	-2%	6%	-39%
	Q <sub>P</sub>	4%	4%	1%	-3%	-2%	-6%	3%
	F <sub>P/A</sub>	-3%	-11%	-6%	-4%	-4%	7%	19%
	T <sub>P</sub>	2%	1%	-1%	1%	4%	1%	-7%
	T <sub>50</sub>	3%	3%	0%	1%	-1%	0%	-6%
	T <sub>Q&gt;Q<sub>A</sub></sub>	11%	9%	7%	2%	2%	-8%	-24%
	N <sub>P</sub>	9%	13%	10%	5%	3%	-15%	-29%
	Q <sub>M</sub>	11%	49%	20%	30%	-3%	-34%	-72%
	Σ	-3%	10%	-7%	12%	-3%	14%	-20%

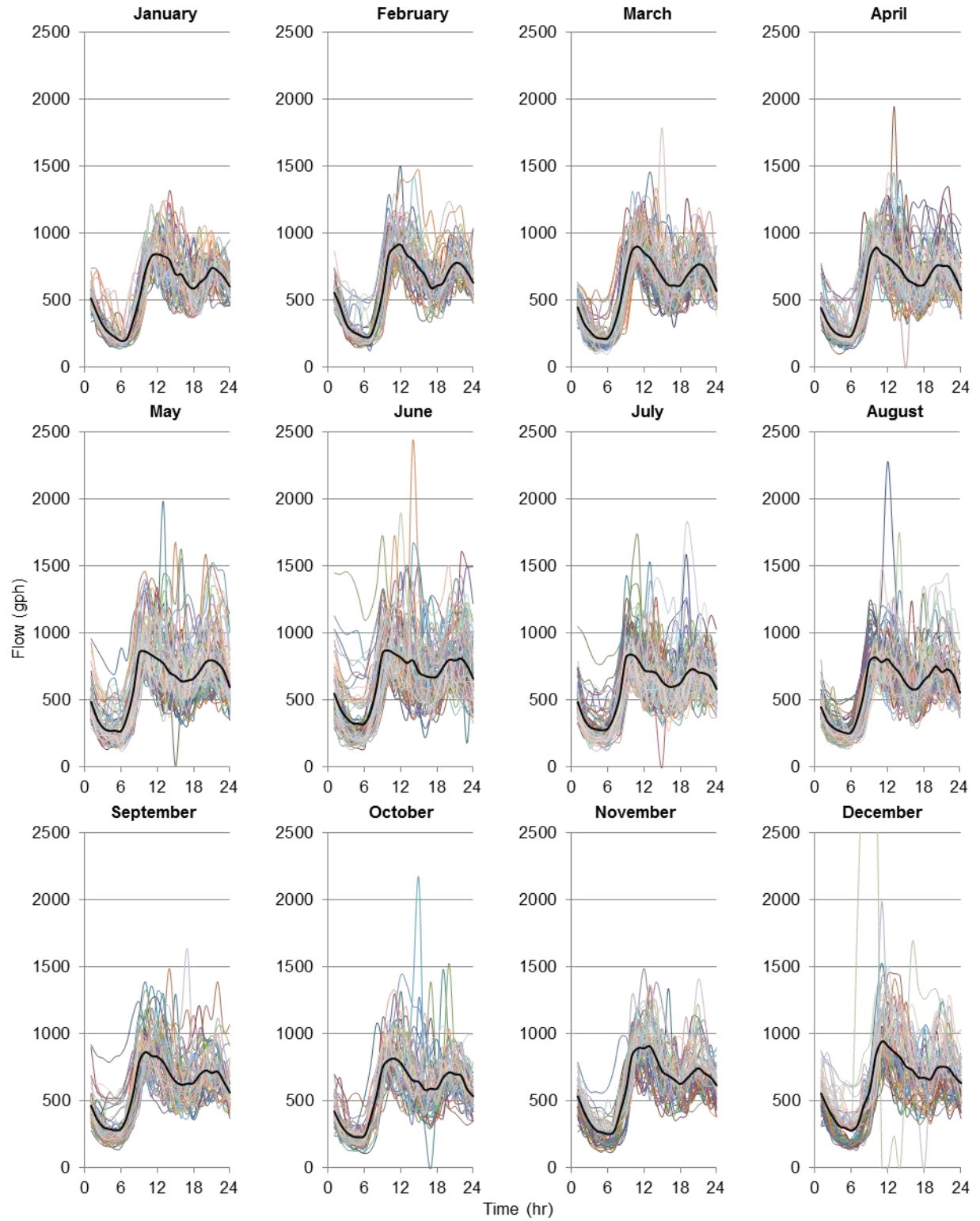

Figure 5.5: Individual daily diurnal curves and composite hourly-average diurnal curve (in bold) by month for the multi-residential building location.

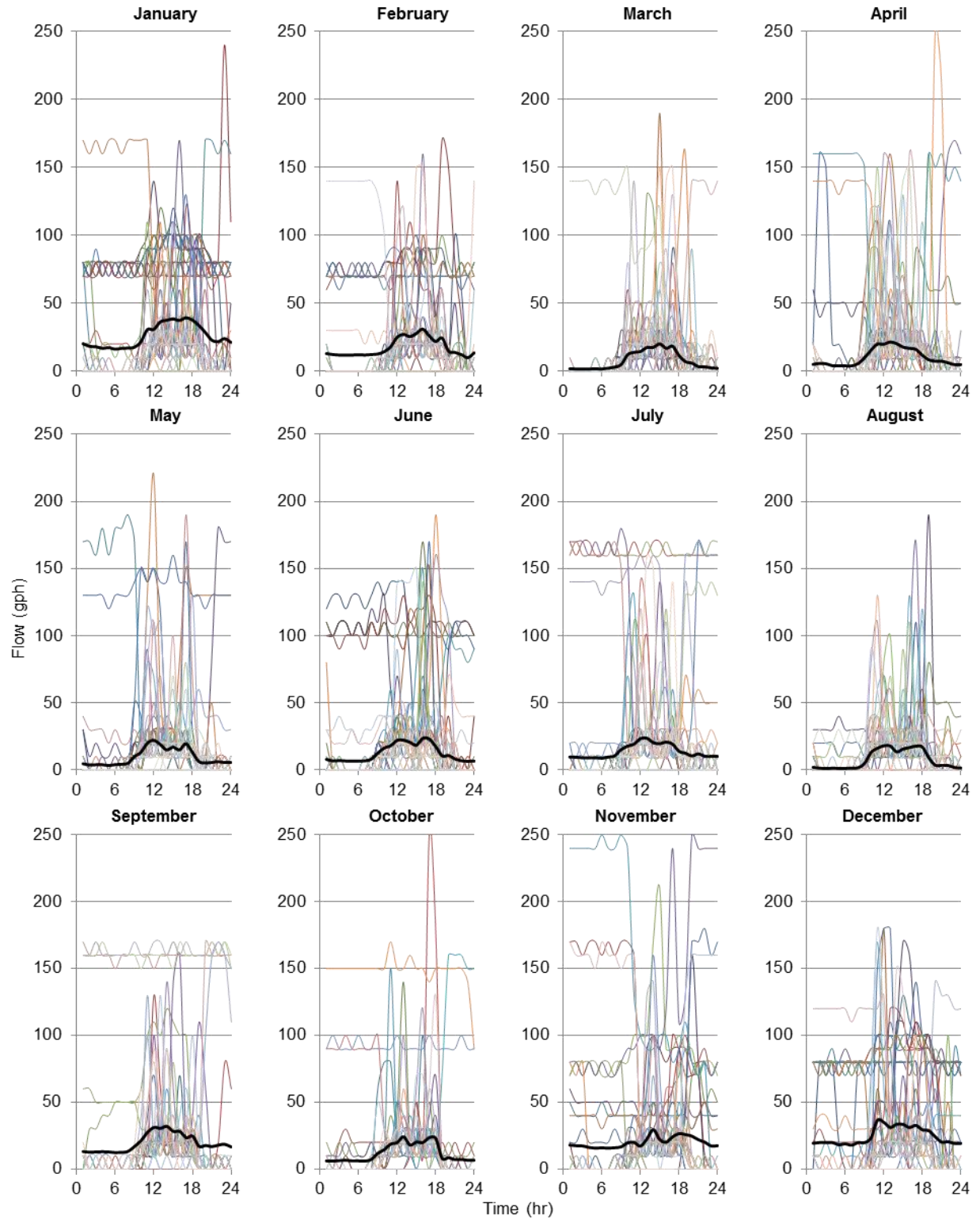

Figure 5.6: Individual daily diurnal curves and composite hourly-average diurnal curve (in bold) by month for the commercial building location.

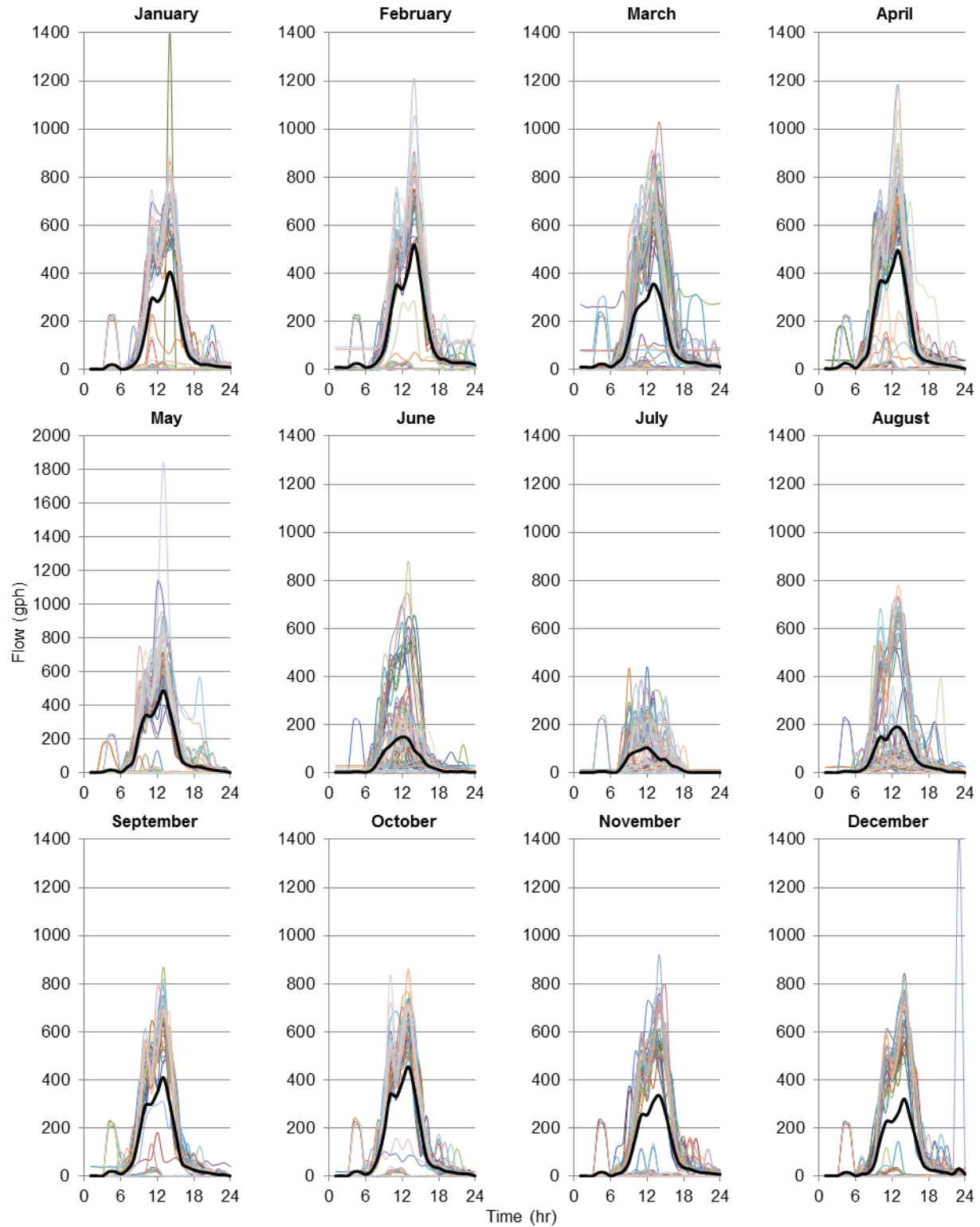

Figure 5.7: Individual daily diurnal curves and composite hourly-average diurnal curve (in bold) by month for the elementary school location.

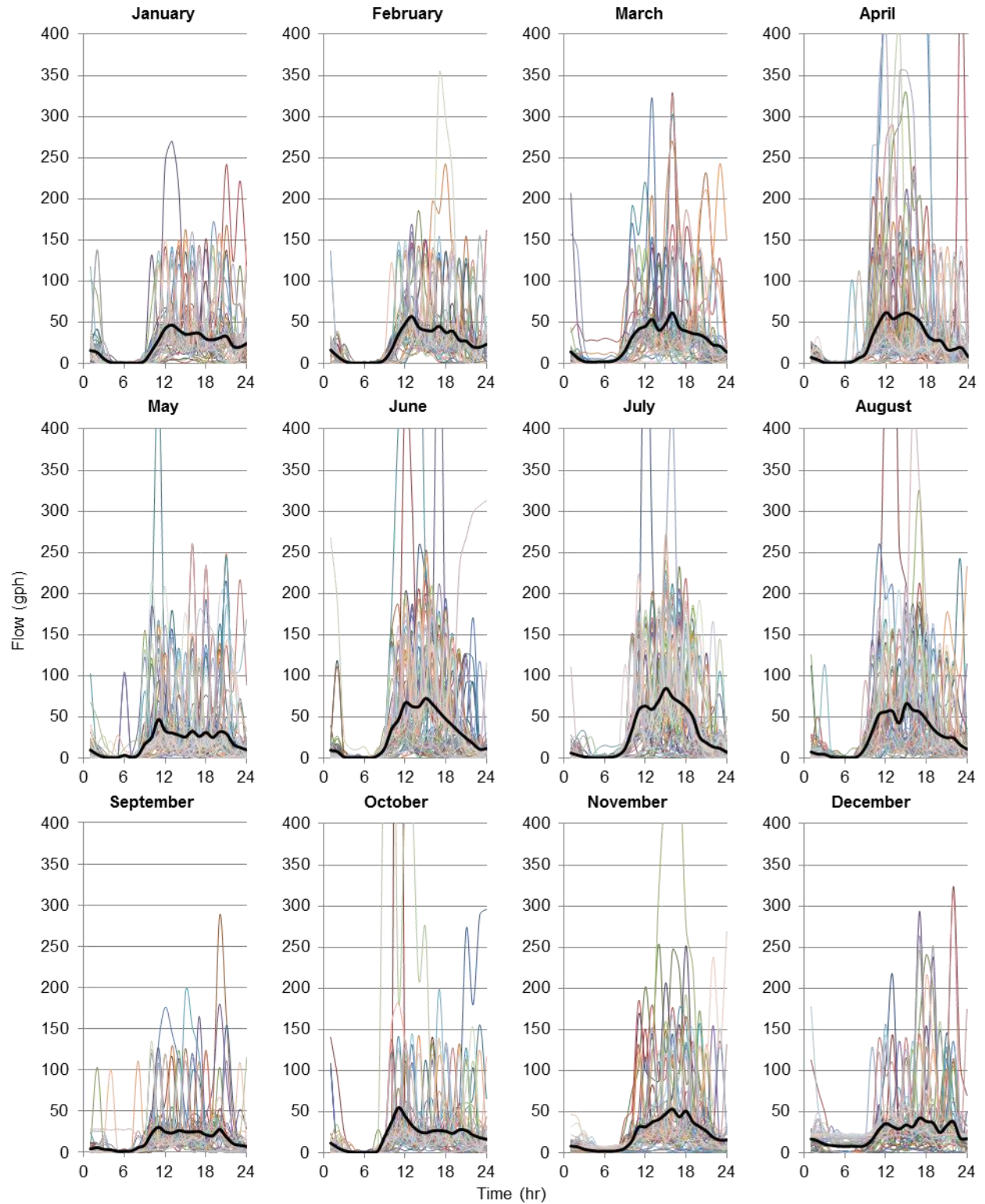

Figure 5.8: Individual daily diurnal curves and composite hourly-average diurnal curve (in bold) by month for the community center location.



### 5.5.2.1 Peak Flow and Mean Flow

The monthly average mean flow ( $Q_A$ ), peak flow ( $Q_P$ ), and peak factor ( $F_{P/A}$ ) for each day of the week is plotted in Figure 5.9 for each building location. The multi-residential site has the least percent variation among  $Q_A$ ,  $Q_P$ , and  $F_{P/A}$  values based on both month of the year and day of the week compared to the other sites. In all cases,  $Q_A$  and  $Q_P$  follow a similar trend over the 12 months, resulting in a relatively stable  $F_{P/A}$  over time for most days of the week; however, the remaining three building locations have  $Q_A$  and  $Q_P$  values that fluctuate depending on the time of the year.

The commercial building site has slightly higher water use in the winter months (November through January), and the average attribute values are skewed due to the unusual water usage patterns on the weekends when the building is closed. Water use captured on the weekends for the commercial site is attributed to the irrigation system and produces diurnal curves with low  $Q_A$  values compared to  $Q_P$ . The resultant high  $F_{P/A}$  values shift the average curve higher than the weekday  $F_{P/A}$  values.

Water use for the elementary school drops during the summer months (June through August) when school is not in session, but measurable water use persists during the summer due to occupancy by teachers and staff. Similar to the commercial building, the elementary school is closed on weekends and the meter captures water use for irrigation on these days.

Contrary to the elementary school, the community center has the highest water use during the summer months (June through August) which may be attributed to the array of summer programs hosted by the center to accommodate children during the summer break. The reduced number of building operating hours on Sunday results in lower water use on these days, both in terms of  $Q_A$  and  $Q_P$ . However, there is a greater difference between the average and peak values which results in higher  $F_{P/A}$  for Sundays.

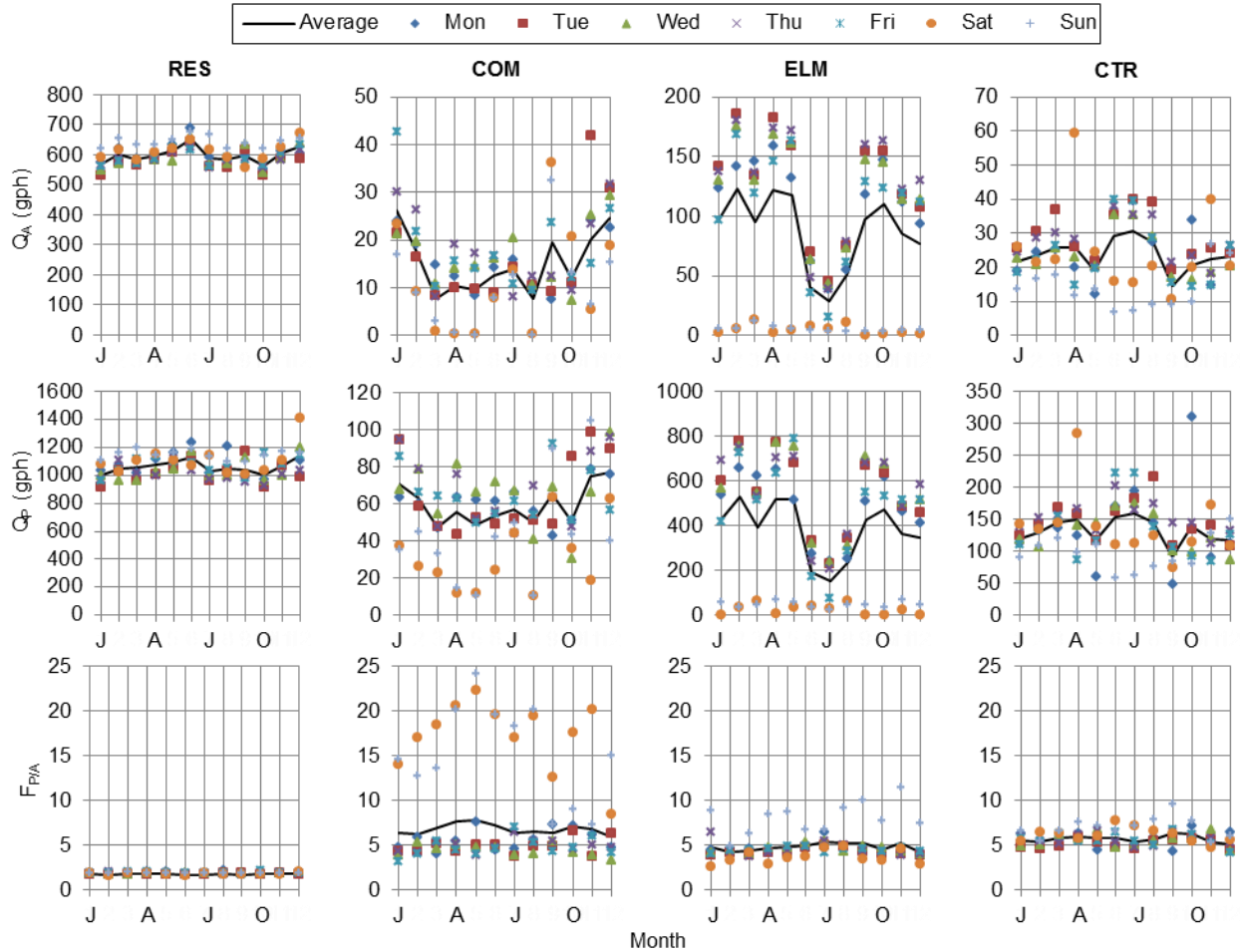

Figure 5.9: Average hourly flow ( $Q_A$ ), peak hourly flow ( $Q_P$ ), and peak to average factor ( $F_{P/A}$ ) by day for each month for the multi-residential (RES), commercial (COM), elementary school (ELM), and community center (CTR) sites.

### 5.5.2.2 Time to Peak and Time to 50% Consumption

Residential diurnal curves are expected to peak in the morning or afternoon, and the  $T_P$  for the multi-residential location shows that the average hour of highest flow varies between hours 11 and 16 (10:00 AM – 6:00 PM). Therefore, the  $T_P$  is not constant and may shift from a morning peak to an afternoon peak or vice versa. Despite the change in  $T_P$ , the  $T_{50}$  remains constant for all months and days for the multi-residential site around hour 14 (1:00 PM – 2:00 PM) indicating a constant time for water use symmetry.

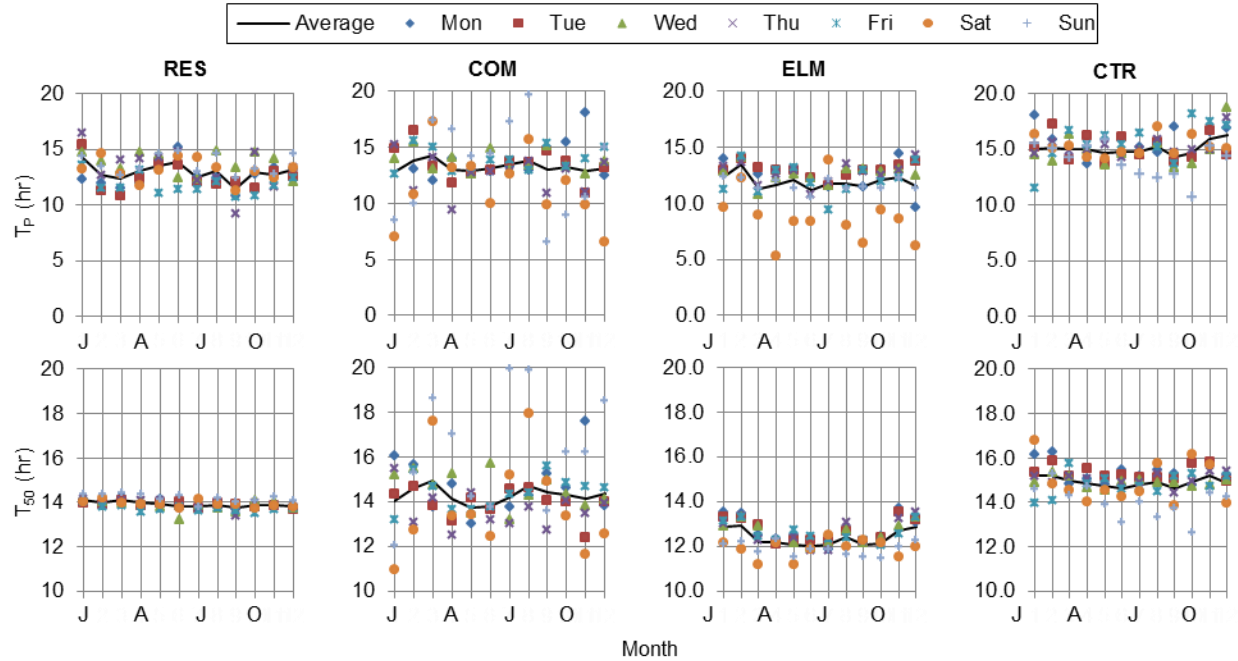

Figure 5.10: Time to peak ( $T_P$ ) and time to 50% water consumption ( $T_{50}$ ) by day for each month for the multi-residential (RES), commercial (COM), elementary school (ELM), and community center (CTR) sites.

The commercial building and elementary school also have varying  $T_P$  values, but weekend  $T_P$  values tend to occur in the morning or later in the day and coincide with common times for irrigating. The average  $T_{50}$  for the elementary school is around hour 12 (11:00 AM to 12:00 PM) for months March through October and around hour 13 (12:00 PM to 1:00 PM) for hours November through February. The average weekday  $T_{50}$  is slightly less than the average weekday  $T_P$  for the elementary school, but both still occur during the lunch hours when the highest demand for water is expected due to a break in classes for students. The commercial building has the largest variation in  $T_{50}$  values of all the building sites, and average weekday values range from hour 13 to hour 17 (12:00 PM – 5:00 PM). Unlike the consistent occupancy at the elementary school, visitors to the commercial building may have a large impact on the time and intensity of water use resulting in the large range of  $T_{50}$  values. The average  $T_{50}$

values occur during the latter half of the open hours for the building, thereby inferring a higher occupancy during these hours.

The community center has the largest average  $T_P$  and  $T_{50}$  values which indicate higher water use later in the day around hour 15 (2:00 PM – 3:00 PM). However,  $T_P$  ranges from hour 11 to hour 18 (10:00 AM – 6:00 PM), and the majority of  $T_{50}$  values fall between hours 13 and 16 (1:00 PM – 4:00 PM). The earlier closing time on Sunday results in lower  $T_P$  and  $T_{50}$  values for this day over the year.

### **5.5.2.3 Peak Frequency and Time Duration above Mean Flow**

For the multi-residential site, values for  $T_{Q>Q_A}$  are maintained between 12 and 13 hour non-consecutive durations throughout the year which indicates that roughly half of the hours each day observe water use that is above  $Q_A$  and the remaining hours observe water use below  $Q_A$ . In the commercial setting, weekday  $T_{Q>Q_A}$  values vary between 7 and 12 hours per day, while weekend values are much lower and mostly fall between 1 and 6 hours per day. The low weekend  $T_{Q>Q_A}$  values can be attributed to irrigation that occurs on the weekend during short watering periods. Weekday  $T_{Q>Q_A}$  values for weekdays at the elementary school average around 8 hours per day, which coincides with the time when the school is occupied by students. Sunday diurnal patterns for the elementary school show consistent water use in the late morning between hours 10 and 13 (9:00 AM – 1:00 PM) and correlate with  $T_{Q>Q_A}$  values between 4 and 6 hours as a result of these events. Saturday water use captured by the meters was often above 0 gph but below 10 gph as supported by  $Q_A$  values, which is very low for the size of the campus. The low fluctuating flowrates observed on Saturdays produced  $T_{Q>Q_A}$  values higher than weekday values due to the relatively constant water use profiles observed. Average  $T_{Q>Q_A}$  for the community center is about 8 or 9 hours per day with a range of 6 hours to almost 11 hours. As expected,  $T_{Q>Q_A}$  values for Sundays are lower than the other days due to the reduced number of open hours for the building.

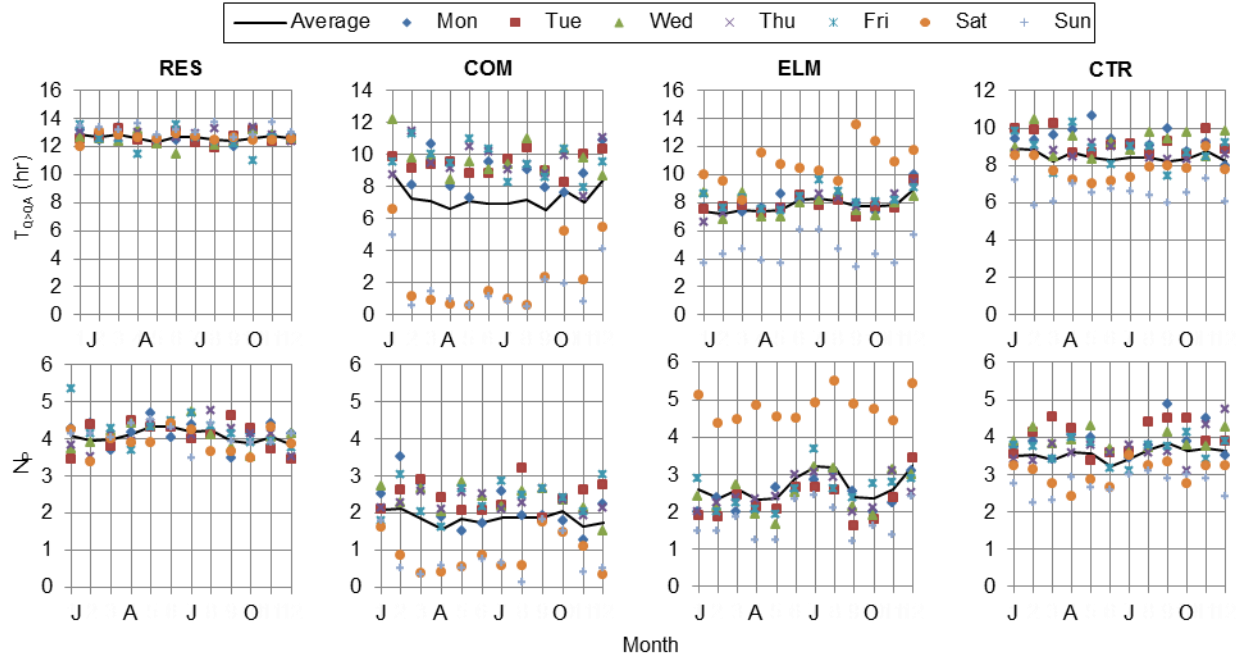

Figure 5.11: Duration that hourly flow is greater than  $Q_A$  ( $T_{Q>Q_A}$ ) and number of peaks exceeding  $Q_A$  ( $N_P$ ) by day for each month for the multi-residential (RES), commercial (COM), elementary school (ELM), and community center (CTR) sites.

The  $N_P$  values calculated for each building location indicate that the diurnal water use patterns are not smooth curves, but rather include multiple peak events that result in craggy shapes. Although two peaks are expected for the multi-residential building,  $N_P$  values averaged about 4.1, twice the amount expected, and were relatively constant throughout the year, falling between 3 and 5. The  $N_P$  values for the commercial building averaged about 1.9, with higher  $N_P$  values occurring on weekdays and low  $N_P$  values occurring on weekends due to short intense irrigation events. Similar to  $T_{Q>Q_A}$ , Saturday  $N_P$  values for the elementary school were observed to be higher than on weekdays. Again, this data may infer the occurrence of many high intensity water use events, but in reality flows for these days were low (low  $Q_A$ ) and therefore slight elevated changes in water use were captured as multiple  $N_P$  events. Weekday  $N_P$  values for the elementary school were near 1.4 for months January through May and September

through November; a slight increase in  $N_P$  was observed in the summer for months June through August and again in December where values were closer to 3 peaks. The multi-use functions of the community center resulted in a range of average  $N_P$  values between 2.3 and 4.9. Fewer peaks were observed on weekends than on weekdays. For all building locations,  $N_P$  was not constant and exceeded expected values.

#### **5.5.2.4 Median Flow and Standard Deviation**

In most cases, the median daily-average flow ( $Q_M$ ) is less than  $Q_A$  due to large outlier flow events that inflate the  $Q_A$  value. The least amount of difference between  $Q_M$  and  $Q_A$  is observed for the multi-residential building, which indicates observed hourly water flowrates follow a normal distribution and should contain fewer outlier flow events.  $Q_M$  values for the commercial building were often 0 for Saturdays when irrigation occurred as a short duration event. The elementary school and community center have the largest shift in  $Q_M$  values compared to  $Q_A$  values due to the short-duration high-flowrate peaks observed for the elementary school and numerous outlier events observed at the community center. For all sites, the trends in water use over the year in terms of  $Q_M$  follow the average monthly trend for  $Q_A$  values.

The difference in  $Q_M$  and  $Q_A$  for each building location is also evident by the standard deviation ( $\sigma$ ) for each site. The multi-residential building has the highest daily-average standard deviation in absolute terms, but the smallest deviation when normalized to  $Q_A$ . The great difference in  $Q_M$  and  $Q_A$  for the remaining sites is reiterated by the high  $\sigma$  values for the commercial building, elementary school, and community center. Low  $\sigma$  values observed for weekends for the commercial and elementary school buildings are a result of prolonged periods of no flow during these time periods.

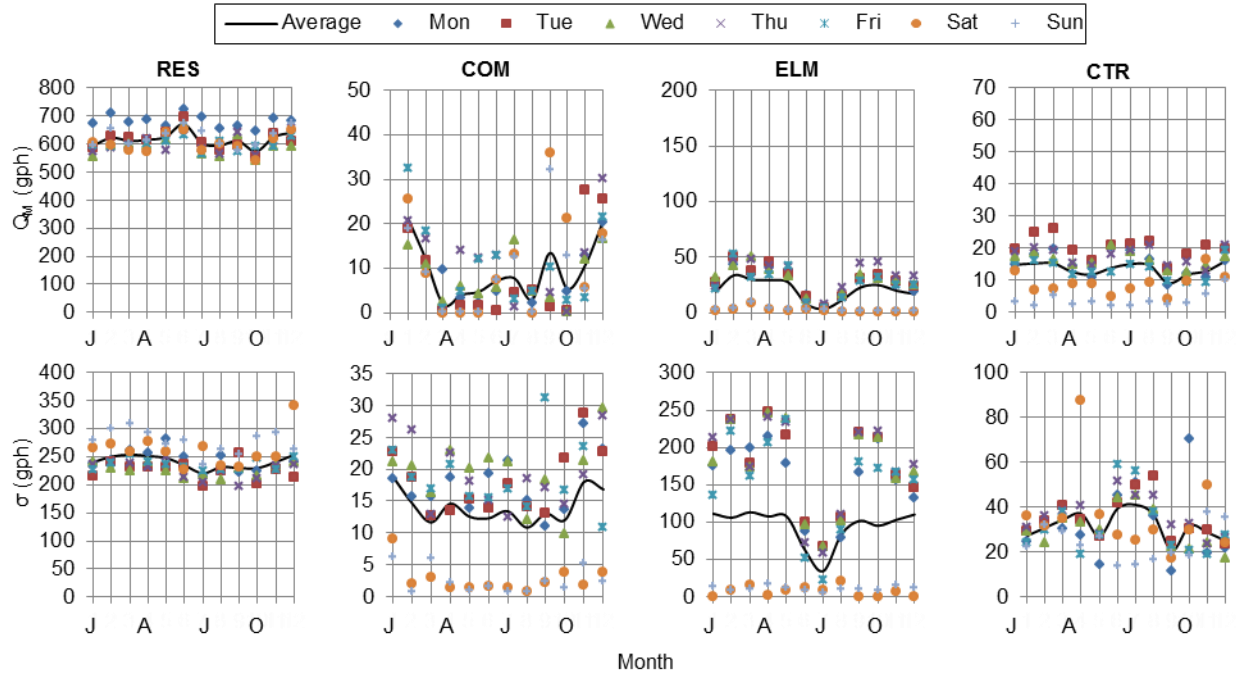

Figure 5.12: Median hourly flow ( $Q_M$ ) and standard deviation ( $\sigma$ ) by day for each month for the multi-residential (RES), commercial (COM), elementary school (ELM), and community center (CTR) sites.

## 5.6 Conclusion

The water management shift from strict supply-side provider to integrated operations regarding demand-side management has driven the need for the efficient collection and evaluation of high-resolution water data. The smart meters using AMR technology in this study have been shown to adequately collect, record, and disseminate water use data at an hourly timestep, which provides sufficient resolution to capture diurnal water use trends for unique building locations for a fair time duration that may capture seasonal trends. The resultant diurnal water use curves were exclusive to each building, and hourly-average curves contained expected features that aligned with diurnal curves from literature (e.g., two-peak residential curve and plateauing commercial curve). However, the hourly-average curves smoothed attributes of the daily water use curves, such as  $Q_P$ ,  $F_{P/A}$ ,  $T_P$ ,  $T_{Q>Q_A}$ , and  $N_P$ . Separating diurnal water use curves by day and month showed how water use for each building site varied over

time. Throughout the year the multi-residential building had the least variation while the multi-use functions of the community center resulted in the most variation among values. Seasonal water use was clearly evident at the elementary school, where water use fell during summer months when school is not in session for students. However, evaluating diurnal curves over time shows that water use is dynamic and individual to each study site.

Buildings were chosen as a representative of a building type, but do not aim to depict the usage profile of every building within its associated type. Each building exerts a unique water demand profile impacted by the building design, occupants, and climate. The variety of drivers of water use within each building supports the need for sub-metering in order to understand where water is consumed within the building and which end-uses are having the largest impact on overall building water use over time, especially during intense water use events. Knowledge about water end-use consumption will allow for more precise demand-side management strategies directed at high-use activities and efficient allocation of available water sources to meet specific demands. For example, pricing schemes that raise the appeal of using reclaimed water rather than potable water for irrigation may reduce the amount of potable water directed to a low-quality end-use while preserving the potable source to meet other high-quality end-uses. Understanding real building water demand profiles is necessary for supply-demand prioritization matching discussed in Chapter 4, and the real demand profiles will be used to evaluate resilience in Chapter 7.



## 6 WATER RESILIENCE ASSESSMENT MODEL FRAMEWORK

### 6.1 Note to Reader

This chapter is based on the published article “Decision support modeling for net-zero water buildings” that appeared in the *Proceedings of the 2014 Winter Simulation Conference*, pages 3176-3187, IEEE Press (Joustra and Yeh, 2014). Permission is included in Appendix A.

### 6.2 Introduction

Previous sections have defined the need for decision support tools in water sector and the need for high-resolution data tracking prerequisite for demand-source matching. In order to evaluate resilience the fulfillment of building water functions must be understood; therefore, there is a need for a tool that can evaluate demand-source interactions which indicates the degree of function fulfillment. Sub-metered data not readily available, so the tool needs to be flexible enough to emulate different building water cycles based on information available and future information inputs. The objective of this chapter is to develop a building water cycle modeling framework that allows for flexible interactions among water demands and supplies. The framework is based on the algorithm presented in Chapter 4, but expands upon the algorithm with the inclusion of storage capacities that allow for delayed application of water sources to fulfill demands at the time required. The resultant model is referred to as the water resilience assessment model (WRAM) and will be used to evaluate the resilience of building water cycle scenarios in Chapter 7.

### **6.3 Differences between WRAM and IBWM Models**

The resulting building WRAM, although based on previous work on IBWM modeling, has been improved and contains unique features required to evaluate building water cycle resilience. Differences include:

- Expanded number of demand stocks that include additional two generic demand stocks for increased flexibility to emulate different building water demand scenarios,
- Additional flexible source that may be a fraction of an original source, combination of the original available sources or defined as a new source,
- Inclusion of potential storage volumes for all sources defined in the model,
- Increased flexibility to collect water sources in shared storage volumes (e.g., choice to collect condensate separately or with rainwater)
- Explicit prioritization framework for demand-source water pathways and ability to alter the baseline prioritization through on-off switches, and
- Incorporation of time delays for the allocation of sources due to treatment required (e.g., delay in allocation of produced blackwater to accommodate treatment).

The improved WRAM features are necessary to track and record the degree of fulfillment of building water functions in order to quantify resilience. Contrarily, the IBWM model focused only on the reduction of potable water supplies and was not as robust, flexible, or detailed as the WRAM. Features of the WRAM support the formation of water supply and demand profile mapping and allow for easier incorporation of flow variation in the model.

### **6.4 Methodology**

The building water subsystem consists of conveyance, treatment, and storage components that fulfill designated water demands using available water sources. The complexity of the resultant building water cycle depends on the number of demands and sources linked within the system. The variety and magnitude of demands varies by building type. For example, residential structures include demands associated with bathing, whereas

commercial structures commonly do not. Restaurants and residences both contain a cooking demand, but the magnitude of water used for this purpose is much higher in a restaurant than in a home. Water demands also vary among buildings within the same category. An office building that promotes alternative transportation may include showering facilities, or other office structures may include a water feature that requires water replacement due to evaporation. Flexibility is a necessary trait for a successful decision support model due to the numerous configurations of potential water demands.

#### **6.4.1 Software**

The WRAM framework is defined using the *Systems Thinking Experimental Learning Laboratory with Animation* (STELLA) visual modeling software version 10.0.6 ([www.iseesytsems.com](http://www.iseesytsems.com)). The STELLA program was chosen due to its intuitive interface based on stock and flow connections. Although the STELLA program is used for this study, the WRAM framework may be applied and defined using other programs capable of tracking flows and volumes. An example of part of the model in STELLA is shown on Figure 6.1.

#### **6.4.2 Building Functions**

Buildings fulfill specific functions such as shelter, protection, sanitation, and comfort. Water-related functions vary among buildings. Building water functions, or demands, must be identified in order to establish baseline water demand profiles for the building site. In addition, potential water sources that may meet the specified demands must be catalogued. The inventory of building demands and sources outlines the potential demand-source connections available within the building water cycle, and Table 6.1 presents potential water demands and sources found in different building types and included in the WRAM. Not all functions exist within all buildings, and the individual demands and sources may be excluded for simulations of various building water cycles.

The STELLA program allows for demands and sources to be defined via multiple methods. Table 6.1 defines the water demands and sources that currently have the option of

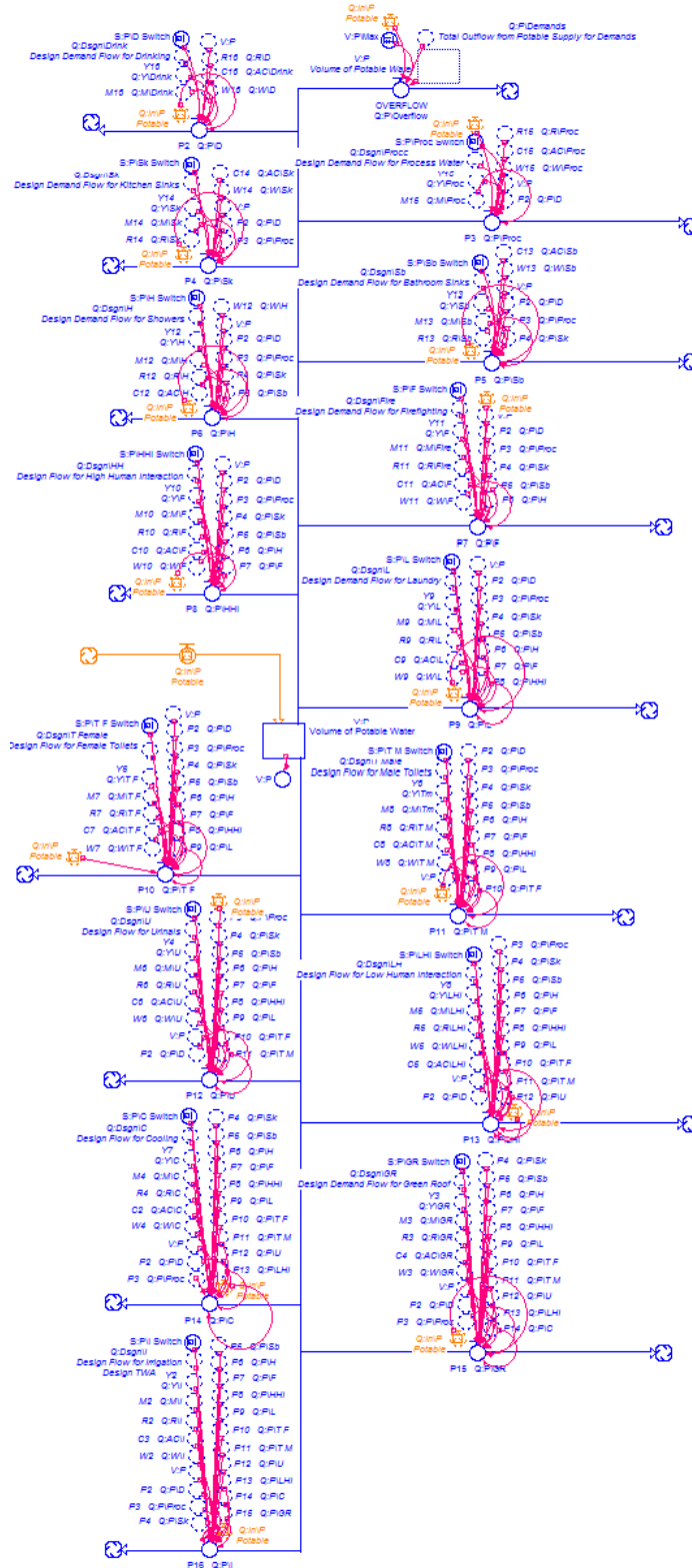

Figure 6.1: Potable water source subsector modeled in STELLA. The subsector is centered around a storage volume with prioritized outflows to meet individual water demands.

being defined by existing equation parameters or internal calculations undertaken by the model using STELLA. All demands and sources may be defined by user-defined patterns input in either graphical or tabular form.

Table 6.1: Input method options for demands and sources in the WRAM.

Water demands	Input options		Water sources	Input options	
	Calculation	Tables/Graph		Calculation	Tables/Graph
Landscaping	X	X	Greywater	X	X
Green roof		X	Blackwater	X	X
Cooling		X	Stormwater	X	X
Urinals	X	X	Rainwater	X	X
Toilets	X	X	Condensate		X
Laundry		X	Reclaimed water		X
Firefighting		X	Potable water		X
Showers	X	X	Flexible source		X
Bathroom sinks	X	X			
Kitchen sinks	X	X			
Process water		X			
Drinking		X			
Flexible stock 1		X			
Flexible stock 2		X			

### 6.4.3 Water Allocation Prioritization

Connecting available sources to fulfill building demands creates an environment for competition within the building water cycle. In the simplest case, each demand is met by a unique source, and there is no competition among sources or demands. However, examples where competition is nonexistent require few demands or many sources within the building water subsystem and are uncommon. It is possible for a single source to be applied to more than one demand, thereby creating competition for the source. Contrarily, competition for the demand is created when multiple sources may be applied to the same demand. The final possible scenario is that a source supplies multiple demands, and multiple sources are connected to each demand. The resultant competition requires a prioritization framework that engages connections sequentially and allows for user manipulation. The WRAM presented is based on a previously defined water prioritization framework presented in Chapter 4 and consists of various flows and volumes that can be separated into individual water demand and

source subsections. Each section can be broken up into its own control volume with balanced and prioritized inflows and outflows. Once defined, all individual sections are connected in order to create a whole building system that defines all possible routes of water.

#### 6.4.4 Balance around Building Water Demands

The WRAM model developed is demand-driven. Each building water function exerts a demand which drives the allocation of sources to meet that demand. Therefore, building water demands must be defined first. Equation-based calculations are based on United States Green Building Council (USGBC) materials (USGBC 2009). Although the assumptions may not accurately represent the water usage for a specific projection, the WRAM allows users to alter assumptions to values that feel more accurately portray water usage for their site or to apply direct graphical or tabular inputs through the STELLA interface.

Each demand subsector consists of balanced inflows and outflows that are matched in order to fulfill the demand function. The density of water is assumed to be constant throughout the system, and therefore, for all demands

$$\int Q_{in}^j dt - \int Q_j^{out} dt = V_j \quad (6.1)$$

where  $Q_{in}^j$  is the inflow to demand stock  $j$ ,  $Q_j^{out}$  is the outflow from demand stock  $j$ , and  $V_j$  is the volume of demand stock  $j$ . The demand stock represents the point where water undergoes a quality transformation and may be divided into different pathways. No water may be created or destroyed at this intersection. The appearance of a water volume in the stock occurs due to any time delays input into the system and represents water contained within the pipelines of the building system or progressing through equalization storage, such as before MBR treatment. The mass balance calculated around each demand stock is similar to the calculations undertaken at the city-level by Kenway et al. (2011), and both result in some storage held within the system by pipeline networks. Water losses from the subsector, such as leaks, human consumption, or runoff, are accounted for by an outflow pathway from the demand stock.

The total inflow into the demand stock consists of the sum of flows from each source  $i$  to fulfill the demand  $j$  and is defined as

$$Q_{in}^j = \sum_{i=1}^n S_i^j Q_i^j \quad (6.2)$$

where  $Q_{in}^j$  is the total inflow to demand  $j$ ,  $Q_i^j$  is the flow from source  $i$  allocated to demand  $j$ , and  $S_i^j$  is the switch defined by 0 or 1 that controls the flow pathway  $Q_i^j$ . The order of allocation of each  $Q_i^j$  is based on the prioritization framework, and binary switches allow for the manipulation of the base prioritization and creation of different building water cycles.

The total outflow from each demand stock is based on the total inflow  $Q_{in}^j$ , but may be delayed based on user defined inputs. The result is that

$$Q_j^{out}(t) = Q_{in}^j(t - \Delta t) \quad (6.3)$$

where  $Q_j^{out}(t)$  is the outflow at time  $t$ ,  $\Delta t$  is the delay duration, and  $Q_{in}^j(t - \Delta t)$  is the inflow at time  $t - \Delta t$ . The outflow may be further broken down into subflows dependent on the final destination of the water. However, the sum of outflow subflows, such as those due to losses or consumption, must equal the total outflow. In the model the option exists to direct collectable outflows, such as those from indoor water fixtures, to storage volumes associated with water sources  $i$ . The collectable outflow  $Q_{collect}^j(t)$  is defined as

$$Q_{collect}^j = Q_j^{out} - Q_{loss}^j \quad (6.4)$$

where  $Q_{loss}^j$  represents the amount of water lost from the original outflow. Switches are used in the model to direct a collectable outflow to storage volumes associated with each source  $i$  or block collection and direct the flow into the sewer system. Balance is maintained so that

$$S_j^{NC} Q_j^{NC} + \sum_{i=1}^n S_j^i Q_i^j = Q_{collect}^j(t) \quad (6.5)$$

where  $S_j^{NC}$  is the binary switch controlling the pathway of the collectable flow from demand  $j$  to the sewer resulting in no collection,  $Q_j^{NC}$  is the flow of collectable flow from demand  $j$  to the sewer,  $S_j^i$  is the binary switch controlling the pathway of the collectable flow from demand  $j$  to storage collection for source  $i$ , and  $Q_j^i$  is the flow of collectable water from demand  $j$  to storage collection for source  $i$ . The switches are chained in the model so that

$$S_j^{NC} + \sum_{i=1}^n S_j^i = 1 \quad (6.6)$$

due to the model definition that only one switch may be active at one time resulting in a value of 1 for the active switch and value of 0 for all other chained switches.

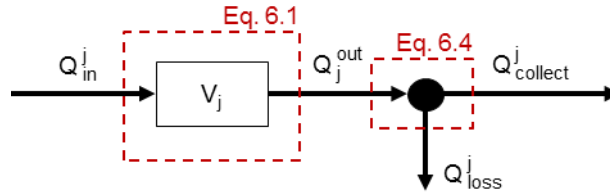

Figure 6.2: Inflows and outflows for demand stock calculations.

#### 6.4.5 Balance around Building Water Sources

Conceptual flows for the source stock are defined in Figure 6.2. The density of water is assumed to be constant throughout the system, and therefore, for all sources

$$\int Q_{in}^j dt - \int Q_i^{out} dt - \int Q_i^{over} dt = V_i \quad (6.7)$$

where  $Q_{in}^j$  is the inflow to source stock  $i$ ,  $Q_i^{out}$  is the outflow from source stock  $i$ ,  $Q_i^{over}$  is the overflow from source stock  $i$ , and  $V_i$  is the volume of source stock  $i$ .

The total inflow into the source stock consists of the sum of flows from each demand  $j$  with an allowable pathway to feed the source stock or predetermined flow profile. The total inflow is calculated as



$$Q_{in}^i = Q_{base}^i + \sum_{j=1}^n S_j^i Q_j^i \quad (6.8)$$

where  $Q_{in}^i$  is the total inflow to source  $i$ ,  $Q_{base}^i$  is a predetermined inflow of source  $i$ ,  $Q_j^i$  is the flow from demand  $j$  to source stock  $i$ , and  $S_j^i$  is the switch defined by 0 or 1 that controls the flow pathway  $Q_j^i$ .

Unlike the demand stocks where the volume in the stock is determined by the delay in inflows and outflows, the source stock volume depends on the maximum volume defined by the user ( $V_i^{max}$ ) and includes an overflow to restrict the source stock to this maximum volume. The outflow from the source stock is determined based on the water prioritization framework and is calculated as

$$Q_i^{out} = \sum_{j=1}^m S_j^i Q_i^j \quad (6.9)$$

where  $Q_i^j$  is the flow from source stock  $i$  to demand  $j$  and  $S_j^i$  is the switch defined by 0 or 1 that controls the flow pathway  $Q_i^j$ . The order of allocation of each  $Q_i^j$  is based on the prioritization framework, and binary switches allow for the manipulation of the base prioritization and creation of different building water cycles.

Overflow calculations first determine the available water to meet all demands within the timestep as is the sum of water stored in the tank ( $V_i$ ) and the additional inflow of water ( $Q_{in}^i$ ) during that time step. The inflow of water remaining after all demands have been met ( $Q_{in}^i - Q_i^{out}$ ) may be stored if the volume of water in the tank ( $V_i$ ) is below the maximum volume ( $V_i^{max}$ ). Excess water must exit the system as an overflow. In the model, the overflow is activated first and is calculated as

$$Q_i^{over} = \begin{cases} 0, & (Q_{in}^i - Q_i^{out}) < (V_i^{max} - V_i) \\ (Q_{in}^i - Q_i^{out}) - (V_i^{max} - V_i), & (Q_{in}^i - Q_i^{out}) \geq (V_i^{max} - V_i) \end{cases} \quad (6.10)$$

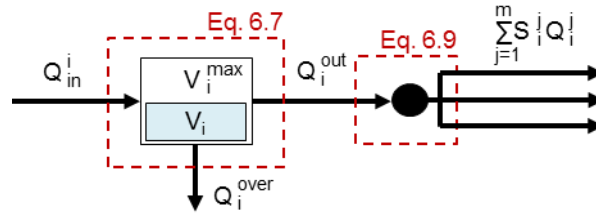

Figure 6.3: Inflows and outflows for source stock calculations.

## 6.5 Water Resilience Assessment Model (WRAM)

### 6.5.1 Demand Subsectors

#### 6.5.1.1 Irrigation

The baseline amount of water demanded for irrigation may be calculated based on the type of vegetation, area of the vegetation, vegetation characteristics, and evapotranspiration (ET). Water applied to landscaping is either utilized by the vegetation through ET processes or exits the subsystem as runoff. The water requirement for all irrigated landscaping requires the demand exerted by each vegetation type  $k$  to be considered. The total demand is calculated as

$$Q_{\text{Dem}}^I = CF \times ET_0 \times \sum_{k=1}^n \left( \frac{K_k A_k}{CE_k} \right) \quad (6.11)$$

where  $Q_{\text{Dem}}^I$  is the water demand for irrigation,  $CF$  is a conversion factor,  $ET_0$  is the baseline evapotranspiration rate for the site in inches or millimeters per desired time duration,  $K_k$  is the composite landscape coefficient between 0 and 1 for vegetation type  $k$ ,  $A_k$  is the area of vegetation type  $k$ , and  $CE_k$  is the controller efficiency between 0 and 1 for the irrigation system for vegetation type  $k$ .

Inflows and collectable outflows for the irrigation demand stock are defined in Table 6.2. Inflows are listed in decreasing order of priority.

Table 6.2: Inflows in decreasing order of priority and collectable outflows for the irrigation demand stock.

Inflows ( $Q_{in}^i = \sum_{i=1}^n S_i^i Q_i^i$ )				
1	$S_Y^i$	Switch for flow of recycled wastewater to irrigation	$Q_Y^i$	Flow of recycled wastewater to irrigation
2	$S_M^i$	Switch for flow of stormwater to irrigation	$Q_M^i$	Flow of stormwater to irrigation
3	$S_R^i$	Switch for flow of rainwater to irrigation	$Q_R^i$	Flow of rainwater to irrigation
4	$S_C^i$	Switch for flow of condensate to irrigation	$Q_C^i$	Flow of condensate to irrigation
5	$S_W^i$	Switch for flow of reclaimed water to irrigation	$Q_W^i$	Flow of reclaimed water to irrigation
6	$S_P^i$	Switch for flow of potable water to irrigation	$Q_P^i$	Flow of potable water to irrigation
7	$S_F^i$	Switch for flow of flexible storage to irrigation	$Q_F^i$	Flow of flexible storage to irrigation
Collectable outflows ( $Q_{collect}^i = S_j^{NC} Q_j^{NC} + \sum_{i=1}^n S_j^i Q_j^i$ )				
	$S_{Gr}^{NC}$	Switch for outflow from irrigation to sewer	$Q_{Gr}^{NC}$	Outflow from irrigation to sewer
	$S_{St}^M$	Switch for outflow from irrigation to stormwater collection	$Q_{St}^M$	Outflow from irrigation to stormwater collection

### 6.5.1.2 Green Roof

A green roof, containing native and drought-tolerant landscaping, should optimally only require natural rainfall for sustainability. However, if irrigation is required, the inflows and assumptions follow the same format as the irrigation subsystem. Of this water, an amount is lost to the vegetation through evapotranspiration which varies seasonally. Additional water may exit the green roof as runoff, and the option exists for runoff to be collected for use within the building system. Inflows and collectable outflows for the green roof demand stock are defined in Table 6.3. Inflows are listed in decreasing order of priority.

Table 6.3: Inflows in decreasing order of priority and collectable outflows for the green roof demand stock.

Inflows ( $Q_{in}^i = \sum_{i=1}^n S_i^i Q_i^i$ )				
1	$S_Y^{Gr}$	Switch for flow of recycled wastewater to green roof	$Q_Y^{Gr}$	Flow of recycled wastewater to green roof
2	$S_M^{Gr}$	Switch for flow of stormwater to green roof	$Q_M^{Gr}$	Flow of stormwater to green roof
3	$S_R^{Gr}$	Switch for flow of rainwater to green roof	$Q_R^{Gr}$	Flow of rainwater to green roof
4	$S_C^{Gr}$	Switch for flow of condensate to green roof	$Q_C^{Gr}$	Flow of condensate to green roof
5	$S_W^{Gr}$	Switch for flow of reclaimed water to green roof	$Q_W^{Gr}$	Flow of reclaimed water to green roof
6	$S_P^{Gr}$	Switch for flow of potable water to green roof	$Q_P^{Gr}$	Flow of potable water to green roof
7	$S_F^{Gr}$	Switch for flow of flexible storage to green roof	$Q_F^{Gr}$	Flow of flexible storage to green roof
Collectable outflows ( $Q_{collect}^i = S_j^{NC} Q_j^{NC} + \sum_{i=1}^n S_j^i Q_j^i$ )				
	$S_{Gr}^{NC}$	Switch for outflow from green roof to sewer	$Q_{Gr}^{NC}$	Outflow from green roof to sewer
	$S_{St}^M$	Switch for outflow from green roof to stormwater collection	$Q_{St}^M$	Outflow from green roof to stormwater collection
	$S_{R}^R$	Switch for outflow from green roof to rainwater collection	$Q_{R}^R$	Outflow from green roof to rainwater collection

### 6.5.1.3 Cooling Tower

The cooling volume requires replenishment due to evaporation, drift, and bleed-off. Evaporation within the tower increases the concentration of dissolved solids; therefore, water from the tower is drained, or bled-off, into the sewer in order to return the concentration to a safe and reasonable value. Additionally, the model incorporates potential condensate capture from heating, ventilation, and air conditioning (HVAC) systems for reuse within the building. Inflows and collectable outflows for the cooling demand stock are defined in Table 6.4. Inflows are listed in decreasing order of priority.

Table 6.4: Inflows in decreasing order of priority and collectable outflows for the cooling demand stock.

Inflows ( $Q_{in}^j = \sum_{i=1}^n S_i^j Q_i^j$ )				
1	$S_Y^{Co}$	Switch for flow of recycled wastewater to cooling	$Q_Y^{Co}$	Flow of recycled wastewater to cooling
2	$S_M^{Co}$	Switch for flow of stormwater to cooling	$Q_M^{Co}$	Flow of stormwater to cooling
3	$S_R^{Co}$	Switch for flow of rainwater to cooling	$Q_R^{Co}$	Flow of rainwater to cooling
4	$S_C^{Co}$	Switch for flow of condensate to cooling	$Q_C^{Co}$	Flow of condensate to cooling
5	$S_W^{Co}$	Switch for flow of reclaimed water to cooling	$Q_W^{Co}$	Flow of reclaimed water to cooling
6	$S_P^{Co}$	Switch for flow of potable water to cooling	$Q_P^{Co}$	Flow of potable water to cooling
7	$S_F^{Co}$	Switch for flow of flexible storage to cooling	$Q_F^{Co}$	Flow of flexible storage to cooling
Collectable outflows ( $Q_{collect}^j = S_j^{NC} Q_j^{NC} + \sum_{i=1}^n S_i^j Q_i^j$ )				
	$S_{Co}^{NC}$	Switch for outflow from cooling to sewer	$Q_{Co}^{NC}$	Outflow from cooling to sewer
	$S_{Co}^M$	Switch for outflow from cooling to stormwater collection	$Q_{Co}^M$	Outflow from cooling to stormwater collection
	$S_{Co}^R$	Switch for outflow from cooling to rainwater collection	$Q_{Co}^R$	Outflow from cooling to rainwater collection
	$S_{Co}^C$	Switch for outflow from cooling to condensate collection	$Q_{Co}^C$	Outflow from cooling to condensate collection
	$S_{Co}^Y$	Switch for outflow from cooling to recycled wastewater collection	$Q_{Co}^Y$	Outflow from cooling to recycled wastewater collection

### 6.5.1.4 Sinks, Showers, Laundry Machines, and Drinking Fountains

Sinks, showers, laundry machines, and drinking water fountains produce greywater. Generally, potable water is assumed to be the only appropriate source for these fixtures. However, the opportunity exists to utilize alternative sources for these needs. Water enters these fixtures before exiting as untreated greywater. The collected water can be sent through a treatment system, such as a MBR, and can then be reused within the building system for applications such as cooling, toilet flushing, urinal flushing, or irrigation. In a conventional

setting, water exiting these fixtures is sent to centralized or decentralized wastewater collection and treatment.

For flow-based fixtures such as bathroom sinks, kitchen sinks, and showers, the water demand is calculated as

$$Q_{Dem}^j = Q_k t N_k X \quad (6.12)$$

where  $Q_{Dem}^j$  is the water demand for demand  $j$ ,  $Q_k$  is the flowrate for fixture  $k$  fulfilling the function for demand  $j$ ,  $t$  is the duration of each user-application of fixture  $k$ ,  $N_k$  is the number of applications by occupants during the desired time period, and  $X$  is the number of occupants. For volume-based fixtures, the  $Q_k t$  expression is replaced by a single term for the volume of each fixture use event,  $V_k$ . Inflows and collectable outflows are the same for bathroom sink, kitchen sink, shower, laundry, and drinking demand stocks and are defined in Table 6.5. Inflows are listed in decreasing order of priority.

Table 6.5: Inflows in decreasing order of priority and collectable outflows for bathroom sink ( $j=Sb$ ), kitchen sink ( $j=Sk$ ), shower ( $j=H$ ), laundry ( $j=L$ ), and drinking ( $j=D$ ) demand stocks.

Inflows ( $Q_{in}^j = \sum_{i=1}^n S_i^j Q_i^j$ )			
1	$S_Y^{Sb}$	Switch for flow of recycled wastewater to bathroom sinks	$Q_Y^{Sb}$ Flow of recycled wastewater to bathroom sinks
2	$S_M^{Sb}$	Switch for flow of stormwater to bathroom sinks	$Q_M^{Sb}$ Flow of stormwater to bathroom sinks
3	$S_R^{Sb}$	Switch for flow of rainwater to bathroom sinks	$Q_R^{Sb}$ Flow of rainwater to bathroom sinks
4	$S_C^{Sb}$	Switch for flow of condensate to bathroom sinks	$Q_C^{Sb}$ Flow of condensate to bathroom sinks
5	$S_W^{Sb}$	Switch for flow of reclaimed water to bathroom sinks	$Q_W^{Sb}$ Flow of reclaimed water to bathroom sinks
6	$S_P^{Sb}$	Switch for flow of potable water to bathroom sinks	$Q_P^{Sb}$ Flow of potable water to bathroom sinks
7	$S_F^{Sb}$	Switch for flow of flexible storage to bathroom sinks	$Q_F^{Sb}$ Flow of flexible storage to bathroom sinks
Collectable outflows ( $Q_{collect}^j = S_j^{NC} Q_j^{NC} + \sum_{i=1}^n S_i^j Q_i^j$ )			
	$S_{Sb}^{NC}$	Switch for outflow from bathroom sinks to sewer	$Q_{Sb}^{NC}$ Outflow from bathroom sinks to sewer
	$S_{Sb}^Y$	Switch for outflow from bathroom sinks to recycled wastewater collection	$Q_{Sb}^Y$ Outflow from bathroom sinks to recycled wastewater collection

### 6.5.1.5 Toilets and Urinals

Water used in toilets and urinals exits as blackwater. The resulting blackwater is tracked and collected as a separate possible recyclable source that is combined with greywater when this source is also active, or released and lost into the sewer system. Water demand can be

decreased by installing fixtures that use fewer gallons per flush or utilizing waterless fixtures.

The demand for these flushing demands may be calculated as

$$Q_{Dem}^j = V_k N_k X \quad (6.13)$$

where  $Q_{Dem}^j$  is the water demand for demand  $j$ ,  $V_k$  is the volume of each fixture use event  $k$  fulfilling the function for demand  $j$ ,  $N_k$  is the number of fixture applications by occupants during the desired time period, and  $X$  is the number of occupants. Inflows and collectable outflows are the same for toilet and urinal demand stocks and are defined in Table 6.6. Inflows are listed in decreasing order of priority.

Table 6.6: Inflows in decreasing order of priority and collectable outflows ( $j=T$ ) and urinal ( $j=U$ ) demand stocks.

Inflows ( $Q_{in}^j = \sum_{i=1}^n S_i^j Q_i^j$ )				
1	$S_Y^T$	Switch for flow of recycled wastewater to toilets	$Q_Y^T$	Flow of recycled wastewater to toilets
2	$S_M^T$	Switch for flow of stormwater to toilets	$Q_M^T$	Flow of stormwater to toilets
3	$S_R^T$	Switch for flow of rainwater to toilets	$Q_R^T$	Flow of rainwater to toilets
4	$S_C^T$	Switch for flow of condensate to toilets	$Q_C^T$	Flow of condensate to toilets
5	$S_W^T$	Switch for flow of reclaimed water to toilets	$Q_W^T$	Flow of reclaimed water to toilets
6	$S_P^T$	Switch for flow of potable water to toilets	$Q_P^T$	Flow of potable water to toilets
7	$S_F^T$	Switch for flow of flexible storage to toilets	$Q_F^T$	Flow of flexible storage to toilets
Collectable outflows ( $Q_{collect}^j = S_j^{NC} Q_j^{NC} + \sum_{i=1}^n S_i^j Q_i^j$ )				
	$S_T^{NC}$	Switch for outflow from toilets to sewer	$Q_T^{NC}$	Outflow from toilets to sewer
	$S_T^Y$	Switch for outflow from toilets to recycled wastewater collection	$Q_T^Y$	Outflow from toilets to recycled wastewater collection

### 6.5.1.6 Flexible Building Subsections

The model incorporates separate sections that are not defined by a specific set of equations. Water demands can vary drastically from building to building, but additional subsections are included so that the model can be expanded to building sites with more intricate building cycles. Subsections exist for firefighting, process water, cooling, a generic demand with low human interaction, and a generic demand with high human interaction. The two generic stocks set aside for low or high human interaction demands have the potential for storage, such as an aesthetic water feature or swimming pool. Linkages also exist within the

model to allow water exiting from all four flexible subsections to be defined and collected within the recycled wastewater, rainwater, stormwater, condensate, flexible stock or directed to the sewer. Inflows and collectable outflows are the same for process water, low human interaction, and high human interaction demand stocks and are defined in Table 6.7. Inflows and collectable outflows for the firefighting stock are defined in Table 6.8. Inflows are listed in decreasing order of priority.

Table 6.7: Inflows in decreasing order of priority and collectable outflows for process water ( $j=Pr$ ), cooling ( $j=Co$ ) low human interaction ( $j=LHI$ ), and high human interaction ( $j=HHI$ ) demand stocks.

Inflows ( $Q_{in}^j = \sum_{i=1}^n S_i^j Q_i^j$ )				
1	$S_{Y}^{Pr}$	Switch for flow of recycled wastewater to process water	$Q_{Y}^{Pr}$	Flow of recycled wastewater to process water
2	$S_{M}^{Pr}$	Switch for flow of stormwater to process water	$Q_{M}^{Pr}$	Flow of stormwater to process water
3	$S_{R}^{Pr}$	Switch for flow of rainwater to process water	$Q_{R}^{Pr}$	Flow of rainwater to process water
4	$S_{C}^{Pr}$	Switch for flow of condensate to process water	$Q_{C}^{Pr}$	Flow of condensate to process water
5	$S_{W}^{Pr}$	Switch for flow of reclaimed water to process water	$Q_{W}^{Pr}$	Flow of reclaimed water to process water
6	$S_{P}^{Pr}$	Switch for flow of potable water to process water	$Q_{P}^{Pr}$	Flow of potable water to process water
7	$S_{F}^{Pr}$	Switch for flow of flexible storage to process water	$Q_{F}^{Pr}$	Flow of flexible storage to process water
Collectable outflows ( $Q_{collect}^j = S_j^{NC} Q_j^{NC} + \sum_{i=1}^n S_i^j Q_i^j$ )				
	$S_{Pr}^{NC}$	Switch for outflow from process water to sewer	$Q_{Pr}^{NC}$	Outflow from process water to sewer
	$S_{Pr}^M$	Switch for outflow from process water to stormwater collection	$Q_{Pr}^M$	Outflow from process water to stormwater collection
	$S_{Pr}^R$	Switch for outflow from process water to rainwater collection	$Q_{Pr}^R$	Outflow from process water to rainwater collection
	$S_{Pr}^C$	Switch for outflow from process water to condensate collection	$Q_{Pr}^C$	Outflow from process water to condensate collection
	$S_{Pr}^Y$	Switch for outflow from process water to recycled wastewater collection	$Q_{Pr}^Y$	Outflow from process water to recycled wastewater collection

Table 6.8: Inflows in decreasing order of priority and collectable outflows for the firefighting demand stock.

Inflows ( $Q_{in}^j = \sum_{i=1}^n S_i^j Q_i^j$ )				
1	$S_{Y}^{Ff}$	Switch for flow of recycled wastewater to firefighting	$Q_{Y}^{Ff}$	Flow of recycled wastewater to firefighting
2	$S_{M}^{Ff}$	Switch for flow of stormwater to firefighting	$Q_{M}^{Ff}$	Flow of stormwater to firefighting
3	$S_{R}^{Ff}$	Switch for flow of rainwater to firefighting	$Q_{R}^{Ff}$	Flow of rainwater to firefighting
4	$S_{C}^{Ff}$	Switch for flow of condensate to firefighting	$Q_{C}^{Ff}$	Flow of condensate to firefighting
5	$S_{W}^{Ff}$	Switch for flow of reclaimed water to firefighting	$Q_{W}^{Ff}$	Flow of reclaimed water to firefighting
6	$S_{P}^{Ff}$	Switch for flow of potable water to firefighting	$Q_{P}^{Ff}$	Flow of potable water to firefighting
7	$S_{F}^{Ff}$	Switch for flow of flexible storage to firefighting	$Q_{F}^{Ff}$	Flow of flexible storage to firefighting
Collectable outflows ( $Q_{collect}^j = S_j^{NC} Q_j^{NC} + \sum_{i=1}^n S_i^j Q_i^j$ )				
	$S_{Ff}^{NC}$	Switch for outflow from firefighting to sewer	$Q_{Ff}^{NC}$	Outflow from firefighting to sewer

## 6.5.2 Source Subsectors

Seven potential water source storage subsectors exist within the model. Blackwater and greywater collection share a recycled wastewater storage volume. The remaining sources are stormwater, rainwater, condensate, reclaimed water, potable water, and a flexible storage stock.

### 6.5.2.1 Municipal Sources

Municipal sources in the model include potable water and reclaimed water. Both sources have the ability to be stored in a storage stock, but the volume collection may be turned off so that each source is simulated as a single pipe inflow by default. Inflows and outflows for the potable water stock are defined in Table 6.9. Inflows and outflows for the reclaimed water stock are defined in Table 6.10. Outflows are listed in decreasing order of priority.

### 6.5.2.2 Rainwater and Stormwater

Rainwater and stormwater source flows may be defined by equations based on collection area ( $A$ ), collection efficiency ( $CE$ ), height of rainfall event ( $R$ ). The natural rainwater inflow to a cistern is

$$Q_{\text{base}}^R = (CF \times CE \times A \times R) - V_{\text{ff}} \quad (6.14)$$

where  $Q_{\text{base}}^R$  is the baseline flow of rainwater to the rainwater storage stock,  $CF$  is a volume conversion factor and  $V_{\text{ff}}$  is the first flush volume removed at the start of a rainfall event. Stormwater inflow into a pond storage system follows the same equation but lacks the first flush term. The model recognizes pond outflows, such as evaporation and infiltration, which are better estimated using detailed hydrologic models.

Inflows and outflows for the reclaimed water stock are defined in Table 6.11. In addition to the baseline flow of rainwater, the rainwater storage stock may also accommodate outflows from process water, LHI, HHI, cooling, and green roof demands and include the baseline flow of condensate. The stormwater stock may include outflows from process water, LHI, HHI, cooling,



green roof, and irrigation demands. Inflows and outflows for the reclaimed water stock are defined in Table 6.12.

Table 6.9: Inflows and outflows in decreasing order of priority for the potable water source stock.

Inflows ( $Q_{in}^i = Q_{base}^i + \sum_{j=1}^n S_j^i Q_j^i$ )				
			$Q_{Base}^P$	Base flow of potable water
Outflows ( $Q_i^{out} = \sum_{j=1}^m S_j^i Q_j^i$ )				
1	$S_P^D$	Switch for outflow from potable stock to drinking demand	$Q_P^D$	Outflow from potable stock to drinking demand
2	$S_P^{Pr}$	Switch for outflow from potable stock to process water	$Q_P^{Pr}$	Outflow from potable stock to process water
3	$S_P^{Sk}$	Switch for outflow from potable stock to kitchen sinks	$Q_P^{Sk}$	Outflow from potable stock to kitchen sinks
4	$S_P^{Sb}$	Switch for outflow from potable stock to bathroom sinks	$Q_P^{Sb}$	Outflow from potable stock to bathroom sinks
5	$S_P^H$	Switch for outflow from potable stock to showers	$Q_P^H$	Outflow from potable stock to showers
6	$S_P^{Ff}$	Switch for outflow from potable stock to firefighting	$Q_P^{Ff}$	Outflow from potable stock to firefighting
7	$S_P^{HHI}$	Switch for outflow from potable stock to HHI demand	$Q_P^{HHI}$	Outflow from potable stock to HHI demand
8	$S_P^L$	Switch for outflow from potable stock to laundry	$Q_P^L$	Outflow from potable stock to laundry
9	$S_P^T$	Switch for outflow from potable stock to toilets	$Q_P^T$	Outflow from potable stock to toilets
10	$S_P^U$	Switch for outflow from potable stock to urinals	$Q_P^U$	Outflow from potable stock to urinals
11	$S_P^{LHI}$	Switch for outflow from potable stock to LHI demand	$Q_P^{LHI}$	Outflow from potable stock to LHI demand
12	$S_P^{Co}$	Switch for outflow from potable stock to cooling	$Q_P^{Co}$	Outflow from potable stock to cooling
13	$S_P^{Gr}$	Switch for outflow from potable stock to green roof	$Q_P^{Gr}$	Outflow from potable stock to green roof
14	$S_P^I$	Switch for outflow from potable stock to irrigation	$Q_P^I$	Outflow from potable stock to irrigation

Table 6.10: Inflows and outflows in decreasing order of priority for the reclaimed water source stock.

Inflows ( $Q_{in}^i = Q_{base}^i + \sum_{j=1}^n S_j^i Q_j^i$ )				
			$Q_{Base}^W$	Base flow of reclaimed water
Outflows ( $Q_i^{out} = \sum_{j=1}^m S_j^i Q_j^i$ )				
1	$S_W^I$	Switch for outflow from potable stock to irrigation	$Q_W^I$	Outflow from potable stock to irrigation
2	$S_W^{Gr}$	Switch for outflow from potable stock to green roof	$Q_W^{Gr}$	Outflow from potable stock to green roof
3	$S_W^{Co}$	Switch for outflow from potable stock to cooling	$Q_W^{Co}$	Outflow from potable stock to cooling
4	$S_W^{LHI}$	Switch for outflow from potable stock to LHI stock	$Q_W^{LHI}$	Outflow from potable stock to LHI stock
5	$S_W^U$	Switch for outflow from potable stock to urinals	$Q_W^U$	Outflow from potable stock to urinals
6	$S_W^T$	Switch for outflow from potable stock to toilets	$Q_W^T$	Outflow from potable stock to toilets
7	$S_W^L$	Switch for outflow from potable stock to laundry	$Q_W^L$	Outflow from potable stock to laundry
8	$S_W^{HHI}$	Switch for outflow from potable stock to HHI stock	$Q_W^{HHI}$	Outflow from potable stock to HHI stock
9	$S_W^{Ff}$	Switch for outflow from potable stock to firefighting	$Q_W^{Ff}$	Outflow from potable stock to firefighting
10	$S_W^H$	Switch for outflow from potable stock to showers	$Q_W^H$	Outflow from potable stock to showers
11	$S_W^{Sb}$	Switch for outflow from potable stock to bathroom sinks	$Q_W^{Sb}$	Outflow from potable stock to bathroom sinks
12	$S_W^{Sk}$	Switch for outflow from potable stock to kitchen sinks	$Q_W^{Sk}$	Outflow from potable stock to kitchen sinks
13	$S_W^{Pr}$	Switch for outflow from potable stock to process water	$Q_W^{Pr}$	Outflow from potable stock to process water
14	$S_W^D$	Switch for outflow from potable stock to drinking	$Q_W^D$	Outflow from potable stock to drinking

Table 6.11: Inflows and outflows in decreasing order of priority for the rainwater source stock.

Inflows ( $Q_{in}^i = Q_{base}^i + \sum_{j=1}^n S_j^i Q_j^i$ )				
			$Q_{Base}^R$	Base flow of rainwater
			$Q_{Base}^C$	Base flow of condensate
	$S_{Pr}^R$	Switch for outflow from process water to rainwater stock	$Q_{Pr}^R$	Outflow from process water to rainwater stock
	$S_{LHI}^R$	Switch for outflow from LHI stock to rainwater stock	$Q_{LHI}^R$	Outflow from LHI stock to rainwater stock
	$S_{HHI}^R$	Switch for outflow from HHI stock to rainwater stock	$Q_{HHI}^R$	Outflow from HHI stock to rainwater stock
	$S_C^R$	Switch for outflow from cooling to rainwater stock	$Q_C^R$	Outflow from cooling to rainwater stock
	$S_{Gr}^R$	Switch for outflow from green roof to rainwater stock	$Q_{Gr}^R$	Outflow from green roof to rainwater stock
Outflows ( $Q_i^{out} = \sum_{j=1}^m S_j^i Q_j^i$ )				
1	$S_R^I$	Switch for outflow from rainwater stock to irrigation	$Q_R^I$	Outflow from rainwater stock to irrigation
2	$S_R^{Gr}$	Switch for outflow from rainwater stock to green roof	$Q_R^{Gr}$	Outflow from rainwater stock to green roof
3	$S_R^{Co}$	Switch for outflow from rainwater stock to cooling	$Q_R^{Co}$	Outflow from rainwater stock to cooling
4	$S_R^{LHI}$	Switch for outflow from rainwater stock to LHI stock	$Q_R^{LHI}$	Outflow from rainwater stock to LHI stock
5	$S_R^U$	Switch for outflow from rainwater stock to urinals	$Q_R^U$	Outflow from rainwater stock to urinals
6	$S_R^T$	Switch for outflow from rainwater stock to toilets	$Q_R^T$	Outflow from rainwater stock to toilets
7	$S_R^L$	Switch for outflow from rainwater stock to laundry	$Q_R^L$	Outflow from rainwater stock to laundry
8	$S_R^{HHI}$	Switch for outflow from rainwater stock to HHI stock	$Q_R^{HHI}$	Outflow from rainwater stock to HHI stock
9	$S_R^{Ff}$	Switch for outflow from rainwater stock to firefighting	$Q_R^{Ff}$	Outflow from rainwater stock to firefighting
10	$S_R^H$	Switch for outflow from rainwater stock to showers	$Q_R^H$	Outflow from rainwater stock to showers
11	$S_R^{Sb}$	Switch for outflow from rainwater stock to bathroom sinks	$Q_R^{Sb}$	Outflow from rainwater stock to bathroom sinks
12	$S_R^{Sk}$	Switch for outflow from rainwater stock to kitchen sinks	$Q_R^{Sk}$	Outflow from rainwater stock to kitchen sinks
13	$S_R^{Pr}$	Switch for outflow from rainwater stock to process water	$Q_R^{Pr}$	Outflow from rainwater stock to process water
14	$S_R^D$	Switch for outflow from rainwater stock to drinking	$Q_R^D$	Outflow from rainwater stock to drinking

Table 6.12: Inflows and outflows in decreasing order of priority for the stormwater source stock.

Inflows ( $Q_{in}^i = Q_{base}^i + \sum_{j=1}^n S_j^i Q_j^i$ )				
			$Q_{Base}^M$	Base flow of stormwater
	$S_{Pr}^M$	Switch for outflow from process water to stormwater stock	$Q_{Pr}^M$	Outflow from process water to stormwater stock
	$S_{LHI}^M$	Switch for outflow from LHI stock to stormwater stock	$Q_{LHI}^M$	Outflow from LHI stock to stormwater stock
	$S_{HHI}^M$	Switch for outflow from HHI stock to stormwater stock	$Q_{HHI}^M$	Outflow from HHI stock to stormwater stock
	$S_{Co}^M$	Switch for outflow from cooling to stormwater stock	$Q_{Co}^M$	Outflow from cooling to stormwater stock
	$S_{Gr}^M$	Switch for outflow from green roof to stormwater stock	$Q_{Gr}^M$	Outflow from green roof to stormwater stock
	$S_I^M$	Switch for outflow from irrigation to stormwater stock	$Q_I^M$	Outflow from irrigation to stormwater stock
Outflows ( $Q_i^{out} = \sum_{j=1}^m S_j^i Q_j^i$ )				
1	$S_M^I$	Switch for outflow from stormwater stock to irrigation	$Q_M^I$	Outflow from stormwater stock to irrigation
2	$S_M^{Gr}$	Switch for outflow from stormwater stock to green roof	$Q_M^{Gr}$	Outflow from stormwater stock to green roof
3	$S_M^{Co}$	Switch for outflow from stormwater stock to cooling	$Q_M^{Co}$	Outflow from stormwater stock to cooling
4	$S_M^{LHI}$	Switch for outflow from stormwater stock to LHI stock	$Q_M^{LHI}$	Outflow from stormwater stock to LHI stock
5	$S_M^U$	Switch for outflow from stormwater stock to urinals	$Q_M^U$	Outflow from stormwater stock to urinals
6	$S_M^T$	Switch for outflow from stormwater stock to toilets	$Q_M^T$	Outflow from stormwater stock to toilets
7	$S_M^L$	Switch for outflow from stormwater stock to laundry	$Q_M^L$	Outflow from stormwater stock to laundry
8	$S_M^{HHI}$	Switch for outflow from stormwater stock to HHI stock	$Q_M^{HHI}$	Outflow from stormwater stock to HHI stock
9	$S_M^{Ff}$	Switch for outflow from stormwater stock to firefighting	$Q_M^{Ff}$	Outflow from stormwater stock to firefighting
10	$S_M^H$	Switch for outflow from stormwater stock to showers	$Q_M^H$	Outflow from stormwater stock to showers
11	$S_M^{Sb}$	Switch for outflow from stormwater stock to bathroom sinks	$Q_M^{Sb}$	Outflow from stormwater stock to bathroom sinks
12	$S_M^{Sk}$	Switch for outflow from stormwater stock to kitchen sinks	$Q_M^{Sk}$	Outflow from stormwater stock to kitchen sinks
13	$S_M^{Pr}$	Switch for outflow from stormwater stock to process water	$Q_M^{Pr}$	Outflow from stormwater stock to process water
14	$S_M^D$	Switch for outflow from stormwater stock to drinking	$Q_M^D$	Outflow from stormwater stock to drinking

### 6.5.2.3 Condensate

High-quality condensate is ideal for offsetting potable water consumption in cooling towers and a plentiful source in hot and humid climates (Guz 2005, Licina and Sekhar 2012). Estimating condensate production is difficult due to fluctuating variables, including humidity, temperature, and equipment runtimes. Condensate source inflow may be defined by static or dynamic production profiles provided by the user.

Inflows and outflows for the condensate stock are defined in Table 6.13. In addition to the baseline flow of condensate, the condensate storage stock may also accommodate outflows from process water, LHI, HHI, and cooling demands.

Table 6.13: Inflows and outflows in decreasing order of priority for the condensate source stock.

Inflows ( $Q_{in}^i = Q_{base}^i + \sum_{j=1}^n S_j^i Q_j^i$ )			
			$Q_{base}^C$ Base flow of condensate
	$S_{Pr}^C$	Switch for outflow from process water to condensate stock	$Q_{Pr}^C$ Outflow from process water to condensate stock
	$S_{LHI}^C$	Switch for outflow from LHI stock to condensate stock	$Q_{LHI}^C$ Outflow from LHI stock to condensate stock
	$S_{HHI}^C$	Switch for outflow from HHI stock to condensate stock	$Q_{HHI}^C$ Outflow from HHI stock to condensate stock
	$S_{Co}^C$	Switch for outflow from cooling to condensate stock	$Q_{Co}^C$ Outflow from cooling to condensate stock
Outflows ( $Q_{out}^i = \sum_{j=1}^m S_j^i Q_j^i$ )			
1	$S_{Co}^C$	Switch for outflow from condensate stock to cooling	$Q_{Co}^C$ Outflow from condensate stock to cooling
2	$S_{Irr}^C$	Switch for outflow from condensate stock to irrigation	$Q_{Irr}^C$ Outflow from condensate stock to irrigation
3	$S_{Gr}^C$	Switch for outflow from condensate stock to green roof	$Q_{Gr}^C$ Outflow from condensate stock to green roof
4	$S_{M}^{LHI}$	Switch for outflow from condensate stock to LHI stock	$Q_{M}^{LHI}$ Outflow from condensate stock to LHI stock
5	$S_{U}^C$	Switch for outflow from condensate stock to urinals	$Q_{U}^C$ Outflow from condensate stock to urinals
6	$S_{M}^T$	Switch for outflow from condensate stock to toilets	$Q_{M}^T$ Outflow from condensate stock to toilets
7	$S_{L}^C$	Switch for outflow from condensate stock to laundry	$Q_{L}^C$ Outflow from condensate stock to laundry
8	$S_{C}^{HHI}$	Switch for outflow from condensate stock to HHI stock	$Q_{C}^{HHI}$ Outflow from condensate stock to HHI stock
9	$S_{C}^{Ff}$	Switch for outflow from condensate stock to firefighting	$Q_{C}^{Ff}$ Outflow from condensate stock to firefighting
10	$S_{C}^H$	Switch for outflow from condensate stock to showers	$Q_{C}^H$ Outflow from condensate stock to showers
11	$S_{C}^{Sb}$	Switch for outflow from condensate stock to bathroom sinks	$Q_{C}^{Sb}$ Outflow from condensate stock to bathroom sinks
12	$S_{C}^{Sk}$	Switch for outflow from condensate stock to kitchen sinks	$Q_{C}^{Sk}$ Outflow from condensate stock to kitchen sinks
13	$S_{C}^{Pr}$	Switch for outflow from condensate stock to process water	$Q_{C}^{Pr}$ Outflow from condensate stock to process water
14	$S_{M}^D$	Switch for outflow from stormwater stock to drinking	$Q_{M}^D$ Outflow from stormwater stock to drinking

### 6.5.2.4 Recycled Wastewater

Recyclable wastewater sources include greywater and blackwater. Like all other source inflows, both may be statically or dynamically defined. However, these recycled sources may

be calculated based on user-defined demand-source interactions. Wastewater from indoor building water fixtures may be directed to the recycled wastewater stock and re-allocated to demands within the building, thereby forming closed loop systems. Inflows and outflows for the condensate stock are defined in Table 6.14.

Table 6.14: Inflows and outflows in decreasing order of priority for the recycled wastewater (WW) source stock.

Inflows ( $Q_{in}^i = Q_{base}^i + \sum_{j=1}^n S_j^i Q_j^i$ )				
	$S_T^Y$	Switch for outflow from toilets to recycled WW	$Q_T^Y$	Outflow from toilets to recycled WW
	$S_U^Y$	Switch for outflow from urinals to recycled WW	$Q_U^Y$	Outflow from urinals to recycled WW
	$S_H^Y$	Switch for outflow from showers to recycled WW	$Q_H^Y$	Outflow from showers to recycled WW
	$S_{Sk}^Y$	Switch for outflow from kitchen sinks to recycled WW	$Q_{Sk}^Y$	Outflow from kitchen sinks to recycled WW
	$S_{Sb}^Y$	Switch for outflow from bathroom sinks to recycled WW	$Q_{Sb}^Y$	Outflow from bathroom sinks to recycled WW
	$S_L^Y$	Switch for outflow from laundry to recycled WW	$Q_L^Y$	Outflow from laundry to recycled WW
	$S_D^Y$	Switch for outflow from drinking to recycled WW	$Q_D^Y$	Outflow from drinking to recycled WW
	$S_{Pr}^Y$	Switch for outflow from process water to recycled WW	$Q_{Pr}^Y$	Outflow from process water to recycled WW
	$S_{LHI}^Y$	Switch for outflow from LHI stock to recycled WW	$Q_{LHI}^Y$	Outflow from LHI stock to recycled WW
	$S_{HHI}^Y$	Switch for outflow from HHI stock to recycled WW	$Q_{HHI}^Y$	Outflow from HHI stock to recycled WW
	$S_{Co}^Y$	Switch for outflow from cooling to recycled WW	$Q_{Co}^Y$	Outflow from cooling to recycled WW
Outflows ( $Q_i^{out} = \sum_{j=1}^m S_j^i Q_j^i$ )				
1	$S_Y^I$	Switch for outflow from recycled WW to irrigation	$Q_Y^I$	Outflow from recycled WW to irrigation
2	$S_Y^{Gr}$	Switch for outflow from recycled WW to green roof	$Q_Y^{Gr}$	Outflow from recycled WW to green roof
3	$S_Y^U$	Switch for outflow from recycled WW to urinals	$Q_Y^U$	Outflow from recycled WW to urinals
4	$S_Y^T$	Switch for outflow from recycled WW to toilets	$Q_Y^T$	Outflow from recycled WW to toilets
5	$S_Y^{Co}$	Switch for outflow from recycled WW to cooling	$Q_Y^{Co}$	Outflow from recycled WW to cooling
6	$S_Y^{LHI}$	Switch for outflow from recycled WW to LHI	$Q_Y^{LHI}$	Outflow from recycled WW to LHI
7	$S_Y^L$	Switch for outflow from recycled WW to laundry	$Q_Y^L$	Outflow from recycled WW to laundry
8	$S_Y^{HHI}$	Switch for outflow from recycled WW to HHI stock	$Q_Y^{HHI}$	Outflow from recycled WW to HHI stock
9	$S_Y^{Ff}$	Switch for outflow from recycled WW to firefighting	$Q_Y^{Ff}$	Outflow from recycled WW to firefighting
10	$S_Y^H$	Switch for outflow from recycled WW to showers	$Q_Y^H$	Outflow from recycled WW to showers
11	$S_Y^{Sb}$	Switch for outflow from recycled WW to bathroom sinks	$Q_Y^{Sb}$	Outflow from recycled WW to bathroom sinks
12	$S_Y^{Sk}$	Switch for outflow from recycled WW to kitchen sinks	$Q_Y^{Sk}$	Outflow from recycled WW to kitchen sinks
13	$S_Y^{Pr}$	Switch for outflow from recycled WW to process water	$Q_Y^{Pr}$	Outflow from recycled WW to process water
14	$S_Y^D$	Switch for outflow from recycled WW to drinking	$Q_Y^D$	Outflow from recycled WW to drinking

### 6.5.2.5 Flexible Storage Stock

An additional flexible source storage stock allows users to collect water from other sources or combination of wastewater from demands for model adaptability. The stock may represent a building water tower or additional alternative water storage facility. The flexible

storage stock may accommodate all potential inflows from demand stocks and outflows may be directed back to all demands.

## 6.6 Application of the WRAM for a Net-Zero Feasibility Study

The feasibility of achieving water neutrality is evaluated by applying the WRAM to a hotel building site in central Florida. The basic hydrology flows for the site and region are presented on Figure 6.4. The building is currently serviced by potable from the city water treatment plant (WTP) and reclaimed water supplied by the city wastewater treatment plant (WWTP). The city forms its own urban hydrologic system boundary. The 3-floor, 76-unit building structure is contained within a 6,500 m<sup>2</sup> (70,000 ft<sup>2</sup>) site. The hotel includes a swimming pool, landscaped areas, and central air conditioning.

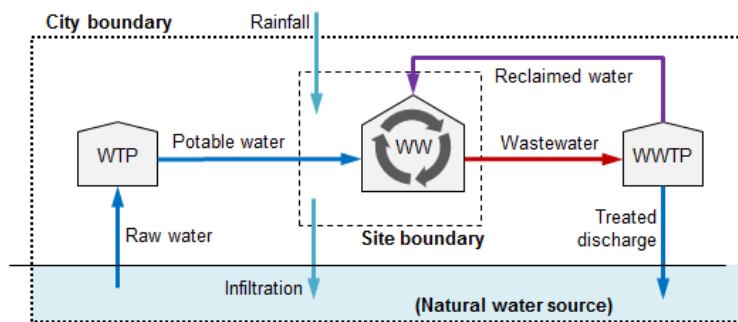

Figure 6.4: Basic hydrologic flows for the hotel site. Water use neutrality requires water cycles to be balanced. Net-zero fulfillment balances water flows at the larger urban scale, and zero water achievement requires balance within the building site.

Model runs take place over a year (from December 2011 through November 2012) with water allocation calculations occurring at a daily time step. Real-building water use data is used for total indoor and landscaping water consumption. Consumption by individual end-uses is estimated based on data from Gleick et al. (2003). The baseline water consumption for the building site is displayed on Figure 6.5.

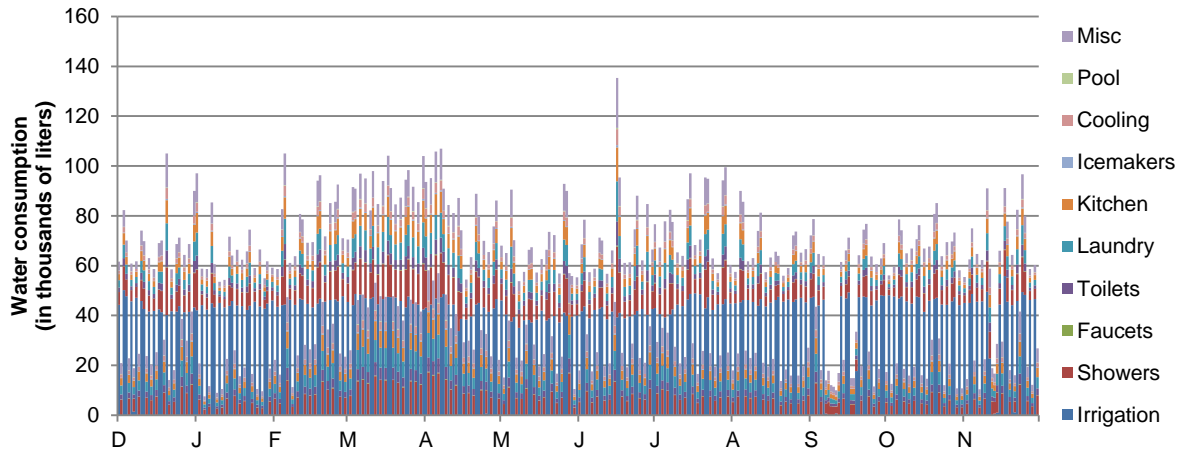

Figure 6.5: Water consumption for the hotel case study site separated by estimated end-use.

### 6.6.1 Net-zero Water Balance

For net-zero water balance, the building may utilize municipal water sources. Similar to the argument made by Olmos and Loge (2013), municipal potable water may be utilized if rainwater entering the site is managed so that it returns to the natural water source where the municipal supply originates. In this case, the urban water infrastructure creates another potentially balanced loop between the building and wastewater treatment plant, whereby wastewater is treated for reuse applications as reclaimed water. Climate is a fluctuating factor, and thus ten precipitation scenarios were considered for potential net-zero water achievement – three wet (W) patterns, four normal (N) patterns, and three dry (D) patterns. The model was used to calculate the annual on-site rainwater available for offsetting the potable water consumption. The model was also utilized to estimate the amount of wastewater exiting the building that could represent the amount of reclaimed water available for use in order to maintain balance.

Results for the ten precipitation runs are presented in Table 6.15. When all indoor and outdoor water demands are considered, net-zero balance cannot be met without the inclusion of

reclaimed water sources; and even with the addition of reclaimed water, net-zero balance is only achieved for the model runs conducted under wet patterns. When outdoor demands are eliminated by implementing native and drought-tolerant landscaping, net-zero balance based solely on on-site rainwater is accomplished for the wet years. The addition of reclaimed water exceeds net-zero balance for all wet, normal, and dry years.

Table 6.15: Potential net-zero balance of potable water consumption (PW) compared to on-site rainwater (RW) and reclaimed water (RC) availability. Instances where the net-zero threshold has been exceeded are shown in bold. The percent potable water use reduction.

Run	Annual RW		Indoor and outdoor use				Indoor use only		
	Inches	Liters	RW-PW	PW Red.	RC – (RW - PW)	PW Red.	RW-PW	PW Red.	RC – (RW - PW)
W1	69.59	11,494,988	-7,667,728	76%	<b>1,660,892</b>		<b>1,377,555</b>		<b>10,706,175</b>
W2	62.83	10,378,360	-8,784,356	87%	<b>544,265</b>		<b>260,927</b>		<b>9,589,548</b>
W3	61.92	10,228,045	-8,934,671	88%	<b>393,949</b>		<b>110,612</b>		<b>9,439,232</b>
N1	53.66	8,863,645	-10,299,071	102%	-970,451	10%	-1,253,788	12%	<b>8,074,832</b>
N2	52.03	8,594,399	-10,568,317	104%	-1,239,697	12%	-1,523,034	15%	<b>7,805,586</b>
N3	50.71	8,376,359	-10,786,357	107%	-1,457,736	14%	-1,741,074	17%	<b>7,587,547</b>
N4	48.03	7,933,673	-11,229,043	111%	-1,900,423	19%	-2,183,760	22%	<b>7,144,860</b>
D1	45.53	7,520,718	-11,641,997	115%	-2,313,377	23%	-2,596,714	26%	<b>6,731,906</b>
D2	42.75	7,061,514	-12,101,202	120%	-2,772,582	27%	-3,055,919	30%	<b>6,272,701</b>
D3	41.85	6,912,850	-12,249,866	121%	-2,921,246	29%	-3,204,583	32%	<b>6,124,038</b>

## 6.6.2 Zero Water Balance

Only on-site water sources may be utilized for zero water balance, and zero water analysis for the case study site only considered indoor water demands. From the net-zero water results, it is clear that the landscaping demand decreases the likelihood of water balance. Five alternative water use scenarios are considered (Table 6.16). Although Florida state regulations (Chapter 62-610) exist regarding the reuse of municipal reclaimed water for a variety of purposes (i.e., irrigation, fire suppression, laundry, toilet flushing), specific regulations regarding rainwater application are lacking. Rainwater harvesting is largely encouraged within the region in order to offset household irrigation water use. Routing rainwater to indoor water

applications generally requires compliance with building codes, protection measures to prevent contamination of potable systems, and disinfection at a minimum. However, the lack of explicit regulation results in the interpretation of technical requirements for approval by local agencies. This study assumes that rainwater is allowed to meet the demands specified in each scenario and is treated accordingly. A collection area of 930 m<sup>2</sup> (10,000 ft<sup>2</sup>) , cistern storage volume of 190,000 liters (50,000 gallons), collection efficiency of 0.90, and first flush volume of 76 liters (20 gallons) are used as model inputs for rainwater collection. The W1 precipitation pattern is used for the analysis.

Table 6.16: Scenario descriptions for zero water IBWM model runs.

Scenario	Description
Scenario 1	Rainwater (RW) to toilets and pool
Scenario 2	RW to toilets, pool, cooling and misc.
Scenario 3	RW to showers, laundry and pool; Recycled wastewater (WW) collected from showers, sinks, and kitchen for use in toilets, cooling and misc.
Scenario 4	RW to showers and sinks; WW collected from showers, sinks, kitchen, toilets and laundry for use in toilets, cooling, misc., pool and laundry
Scenario 5	RW to showers, cooling, laundry, misc. and pool; WW from showers, sinks, kitchen, toilets, laundry and misc. for use in toilets, cooling, misc., pool, laundry and showers

The results show that potable water use decreases as water reuse and recycling connections are increased (Figure 6.6). Potable water was the only source considered acceptable to meet water demands associated with sinks, cooking, and ice-making. Only the most extreme water reuse and recycling scenario achieved zero water balance for the case study site, but balance did not occur throughout the year (Figure 6.7). The net-zero water evaluation shows that enough rainwater falls within the site to offset all potable water demands. However, the limited rainwater collection area and cistern storage greatly reduce the accessible volume. Potable water is required to meet the demands when stored rainwater and recycled wastewater streams are inadequate.



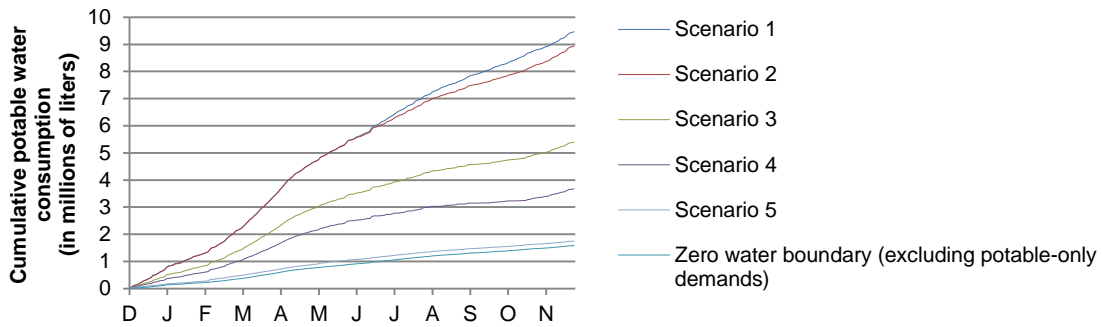

Figure 6.6: Cumulative potable water consumption for precipitation pattern W1 under the scenarios outlined in Table 6.16.

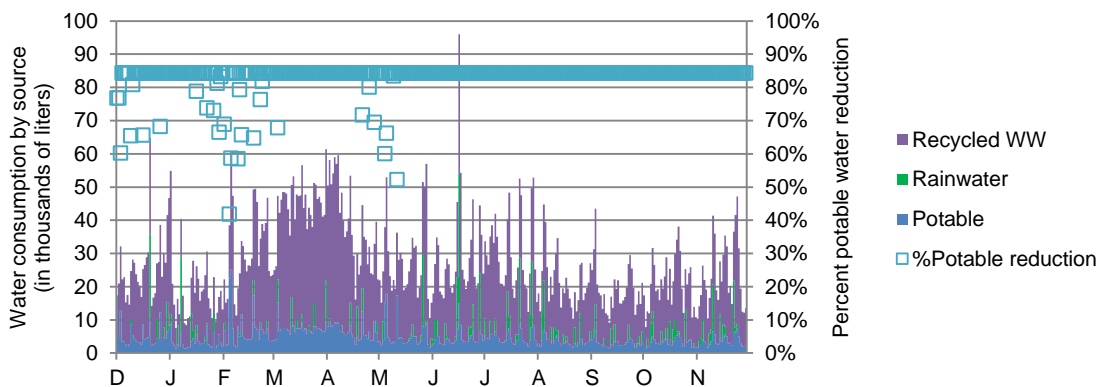

Figure 6.7: Total on-site water consumption by source and potable water offset for Scenario 5 in precipitation pattern W1.

## 6.7 Conclusion

A WRAM has been introduced and utilized to evaluate the feasibility of net-zero water achievement for a building site. The control of water demand-source pathways within the model framework allows for the simulation of various building water cycles and evaluation of water neutrality within hydrologic cycles at distinct system levels. Although net-zero water and zero water evaluations of the case study site considered a limited number of variant scenarios, the WRAM has the ability to address the variability introduced by climate, fixture design, and human behavior. Variations in both water demand and supply profiles are required in order to evaluate

whether net-zero water or zero water goals are feasible under a range of possible conditions. The same variations are also necessary for evaluation of system resilience under unique scenarios.

## 7 BUILDING WATER CYCLE RESILIENCE ASSESSMENT

### 7.1 Introduction

The attributes that compose resilience are also linked to sustainability, passive survivability, and adaptive capacity. The concept of passive survivability describes the ability of an entity to maintain the operation of critical systems, such as water, ventilation, and sanitation. The Louisiana Superdome, used as an emergency shelter after Hurricane Katrina, is a common example used to describe a structure with low passive survivability because lack of power caused the degradation of ventilation and comfort within the building making it inhabitable (Wilson, 2005). Adaptive capacity is defined as the capability of a system to change and cope with outside stressors (Cutter et al., 2008). Adaptive capacity is often applied to climate change adaptation strategies.

Conflicts and synergies exist among these attributes (Coaffee, 2008). Recovery, flexibility, and adaptability have been applied to both resilience and adaptive capacity, thereby linking the two concepts (Engle and Lemos, 2010). The definition provided for passive resilience is directly in line with passive survivability; both ideas apply to properties that the system inherently has or possesses. Tobin (1999) links sustainability and resilience by proposing that both concepts depend on the available capacity for disaster recovery and mitigation. Norris et al. (2008) also integrates adaptive capacity with resilience, and Cutter (2008) discusses sustainability as central to research regarding resilience. These examples of linkages show how attributes of resilience extend into related topics. However, it is not always clear whether an increase in resilience, sustainability, passive survivability, or adaptive capacity will have a positive effect on all these aspects.

The Superdome is an example of how the resilience of a structure is linked to the fulfillment of required functions. Before the Hurricane Katrina landfall, the city of New Orleans utilized the Louisiana Superdome as a “refuge of last resort.” This designation established the site as a shelter for use only during the event to protect the population from the hurricane-related hazards of wind and rain (Nigg et al. 2006). The resulting failure of the shelter can be attributed to the non-intended functions it was forced to fulfill after the hurricane event. The Superdome was able to protect the population from the hazards incurred during the hurricane, but it was unable to provide appropriate housing for the population displaced afterward. Temperature rose to 42°C in the very building that was intended to protect the disaster victims. The failure of the Superdome to comfortably and properly accommodate Katrina victims has given rise to the concept of incorporating passive survivability into the design of buildings, and especially shelters, as described in the *New Orleans Principles* (Wilson, 2005). In addition, a change in the desired building functions will affect the resilience of the building.

The framework to measure the building water resilience revolves around the definition chosen to describe this resilience. The definition of resilience used for this project will be based on the ability of a system to absorb shocks and within a specified time period. Tracking these components can be accomplished by evaluating the fulfillment of desired functions (Holling, 1996; Rose, 2007). Within this definition, resilience is assumed to be both an inherent and dynamic quality that can be defined in order for resilience to be evaluated, predicted, and improved (Plodinec, 2009). The objective of this chapter is to develop a framework capable of evaluating the resilience of the building water cycle to utility disruptions. As part of this objective, the type of disruption will need to be defined in addition to water resilience indicators that describe the state of resilience for different building water cycles. The resulting methodology is applied to the WRAM (Chapter 6), and results will be presented in Chapter 8.

## **7.2 Methodology**

The first step in the developed framework is to identify the functions whose resilience will be tested. Second, the function must be broken into a demand and supply components that can be quantified using appropriate input parameters. For example, the demand for drinking water depends on the number of occupants and per capita water consumption. It is also important to consider the probabilistic nature of these inputs and associated outputs; therefore, resilience can only be quantified with the inclusion of probabilities (Haimes, 2009). Resilience can be measured by integrating the difference in demand and supply over a set time period. The resulting volume represents times when supply was lacking or the function was not fulfilled. Larger volumes correspond to systems with lower resilience. Chapter 4 outlined the functions that water fulfills in the building, and the building water profiles recorded in Chapter 5 will form the basis for evaluating the resilience of real demand patterns when water source disruptions are incurred. Additional attributes that describe the size and shape of the resulting curves and volumes will also provide a better description of the system resilience.

### **7.2.1 Characterizing Disruption**

The measured resilience of a system is only applicable to the event that the resilience is being measured against. Therefore, it is necessary to quantitatively characterize the disruption event being used to evaluate resilience, and conclusions regarding system responses and the resultant resilience may only be applied to that specific event. The disruption events considered for this project involve the limitation of water sources, mainly municipal potable water, available to meet building water demands. Even with the disruption event defined, an array of possible interruption profiles are possible depending on the length of the interruption and restriction placed on the water source.

Disruption events vary in terms of the severity of the event, and the severity of a disruption event can be defined as a function of the magnitude of the disruption and the duration that it persists. Events of different severities are illustrated in Figure 7.1, where the magnitude

(M) is measured as the percent of the source that is depleted and the duration (dt) is measured as the difference between the start of the disruption event ( $t_s$ ) and the end of the disruption event ( $t_e$ ). The severity (S) can then be calculated as

$$S = \int_{t_s}^{t_e} M(t) dt. \quad (7.1)$$

In most shock events, the water supply flow impacted by disruption immediately changes from fully available to none available, or the source depletion instantaneously changes from 0% to 100% depletion at the start of the disruption event ( $t_s$ ). The severity then increases linearly as the duration increases. It is also possible for the magnitude M of an event to be below the 100% depletion threshold. However, the severity is not necessarily lower for low magnitude events as shown in Figure 7.1 due to the difference in event duration; the low-magnitude long-duration event C results in a higher severity value than the high-magnitude short-duration event B. Different building water cycles may be better at averting impacts from one type of disruption event over another, and thus it is important to test systems against events with a range of severities. Systems that maintain high functionality regardless of the severity of the disruption event are desirable systems with high resilience.

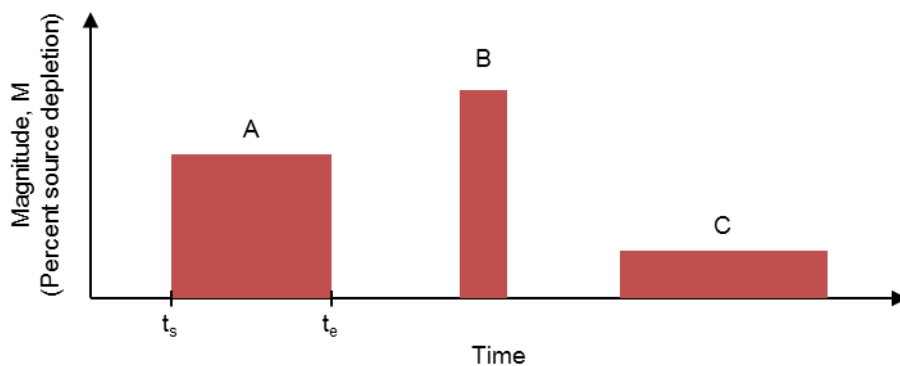

Figure 7.1: Examples of disruption events with different severities based on magnitude and duration.

The spectrum of the severity of disruption events for this study is defined by specific magnitude and duration parameters listed in Table 7.1. The WRAM model will assesses demand-source allocation at hourly timesteps, and therefore 1 hour is the shortest duration that will be evaluated. For non-critical building functions, loss of water for one hour may not have a significant impact because certain water uses, such as cooking, cleaning, or sewage conveyance may be delayed without harming system components. However, loss of water for 1 hour may still be long enough for building failure for demand critical to building operations. For example, an interruption in cooling water for servers can harm hardware and damage data resulting in economic and operational losses. Emergency service providers, such as hospitals, are also vulnerable to short disruption events due to the immediate and constant need for high-quality water. Durations will be increased between 6 hours and 168 hours to emulate scenarios such as schedule repairs, broken pipelines, utility failures and the subsequent short-term loss of associated resources.

Table 7.1: Disruption events considered for the building water cycle resilience assessment.

Magnitude	Duration	
100% potable water depletion	1 hour	24 hours (1 day)
	6 hours	72 hours (3 days)
		168 hours (1 week)
100% potable water depletion and 100% central power depletion	1 hour	24 hours (1 day)
	6 hours	72 hours (3 days)
		168 hours (1 week)

For this assessment, ten random  $t_s$  times were selected at which the different disruption events will be applied in order to capture a range of resilience profiles that vary due to changes in water demand and supply profiles over time. Table 7.2 lists the  $t_s$  dates and times that will be utilized.

Table 7.2: Start time ( $t_s$ ) for disruption events used for the resilience assessment.

Date	Month	Day	Hour
1/5/2013	January	Saturday	13
2/1/2013	February	Friday	12
3/15/2013	March	Friday	2
4/22/2013	April	Monday	9
5/14/2013	May	Tuesday	22
6/6/2013	June	Thursday	5
7/23/2013	July	Tuesday	18
8/21/2013	August	Wednesday	9
10/14/2013	October	Monday	2
12/11/2013	December	Wednesday	12

### 7.2.2 Resilience Curve

A common curve that plots system quality or functionality over time is used to describe the resilience of a system when it has undergone a shock event as shown in Figure 7.2 (Henry and Ramirez-Marquez, 2012; Cimellaro et al., 2010; McDaniels et al., 2008; Wang and Blackmore, 2009; Chang and Shinozuka, 2004; Bruneau et al., 2003). The curve can be separated into four main stages based on the level of functionality of the system and current trend (Richards et al., 2007). The initial state of the system is considered the system equilibrium, and the functional requirement is being met. The application of a shock or disturbance to the system results in a decreased level of performance. Eventually the system reacts and undergoes a recovery stage until it reaches a recovered state, which may not be the same as the initial system equilibrium.

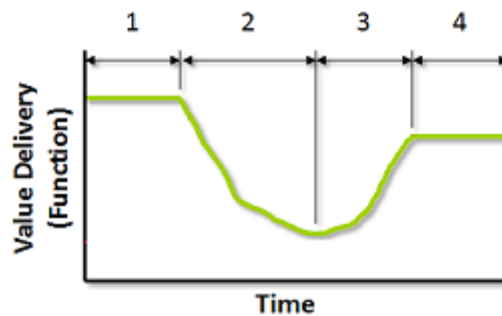

Figure 7.2: Resilience curve: (1) system equilibrium, (2) disturbance stage, (3) recovery stage, (4) recovered state.



Fulfillment of functions is the priority if the building system is subject to a shock, and this emphasizes ecological resilience. However, the extent to which functions are fulfilled can be a measurement of efficiency, which is seen as a component of engineering resilience. Therefore, the resilience of a building is assumed to be a combination of both engineering and ecological resilience. The framework for resilience for this project specifically measures the fulfillment of functions in terms of demand and supply profiles. Past discussions have revealed that both demand and supply are dynamic flows due to the dynamic nature of dependent factors (e.g., climate, design, and human behavior). Therefore, the same disruption event applied to the same building water cycle, but at different times will result in an array of resilience responses.

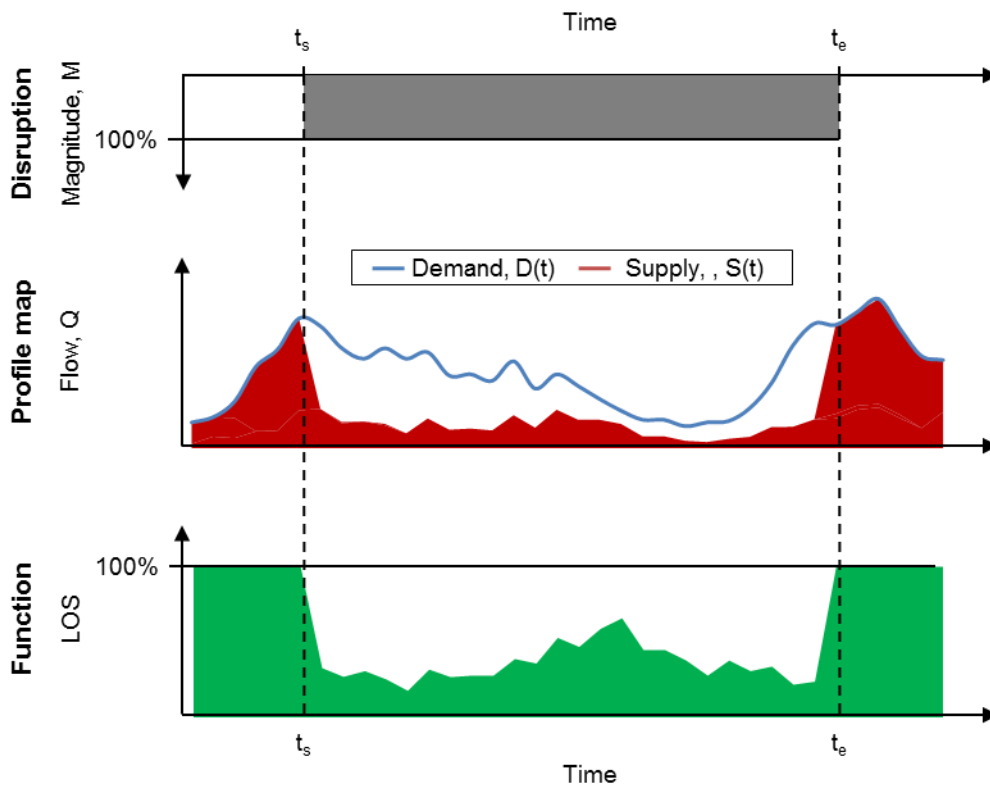

Figure 7.3: Impact of disruption event on the building water profile and resulting level of service (LOS).

Figure 7.3 summarizes the modeling steps taken for the resilience assessment. Baseline building water cycles broken into demand and supply components are subjected to a disruption event. Mapping the demand and supply flows during the disruption event identify deficiencies in water function fulfillment when the supply is less than demand. Plotting the ratio of water supply to demand normalizes the functional fulfillment of the building water cycle during the disruption event in order to compare different building water cycles under various scenarios. The ratio of water supply to water demand is defined as the level of service (LOS) provided by the building water system.

The function curves produced for this assessment are similar to the common resilience curve shown on Figure 7.2. However, the pulse input of the disruption event will cause sharp changes in the LOS at the start ( $t_s$ ) and end ( $t_e$ ) of each event as illustrated in Figure 7.3. Resilience values may be calculated using both the water profile map and LOS plots as summarized in Table 7.3, but the values only apply to the curve under the specific disruption event. Using these terms singularly limits the understanding of the system resilience due to the narrow view of system performance under stress and thus functional fulfillment by the system needs to be evaluated over a range of disruption events. For clarity, the resilience of a building water cycle to an individual disruption event will be defined in terms of LOS for that event, and the term resilience will be used when the LOS is plotted as a function of disruption severity. As a result, resilience is now defined as

$$\text{Resilience} = f(\text{LOS}, \text{disruption event}) \quad (7.2)$$

where the LOS depends on resilience attributes, such as resourcefulness, redundancy, and rapidity. Indicators chosen to assess the resilience of building water cycles should align with the LOS produced by disruption events, such that

$$\text{LOS} = f(\text{indicators}). \quad (7.3)$$

$$\text{LOS} = f(\text{redundancy, diversity, capacity, demand, alternative water, passivity, preparation, adaptation potential}) \quad (7.4)$$

Relationships between the indicators described in the following section and resulting LOS will be determined.

Table 7.3: Measurable resilience values from the building WRAM response curves.

Name	Variable	Equation	Description
Level of service (percent)	LOS	$\frac{S(t)}{D(t)}$	The degree to which supply meets demand at a point in time
Total loss of function (percent)	L	$\frac{\int_{t_0}^t (D-S) dt}{\int_{t_0}^t (D) dt}$	The area resulting when supply cannot meet demand over a time period
Total resilience (percent)	R	1-L or $\frac{\int_{t_0}^t (S) dt}{\int_{t_0}^t (D) dt}$	The area representing how well supply met demand (or how well the function was met) over the time period.

## 7.2.3 Resilience Indicators

### 7.2.3.1 Diversity

The diversity is related to the resourcefulness of the system. High diversity is achieved by utilizing multiple sources and results in a lowered risk to the system due to the existence of additional sources if one source pathway fails. For this assessment, diversity is calculated as the number of unique water sources utilized by the building water cycle.

### 7.2.3.2 Redundancy

Redundancy is a measure of substitution within the system and takes the form of backup supplies. For this assessment, redundancy is calculated as the average number of sources allocated to each demand. Redundancy differs from diversity by incorporating the number of unique building water demands within the system, resulting in

$$\text{Redundancy} = \frac{\sum_{j=1}^m ((\text{sources}) / (\text{demand } j))}{m} \quad (7.5)$$

### 7.2.3.3 Capacity

Higher storage volumes provide more capacity for building systems to meet demands and should result in higher LOS values during disruption events. In order to compare different disruption events and different water use profiles, capacity is determined based on a ratio of the average total water storage during the disruption event to the average demand during the disruption event, calculated as

$$\text{Capacity} = \frac{\int_{t_s}^{t_e} (\sum_{i=1}^n V_i) dt}{\int_{t_s}^{t_e} (\sum_{j=1}^m Q_{\text{Dem}}^j) dt} \quad (7.6)$$

where  $V_i$  is the storage volume associated with source  $i$  and  $Q_{\text{Dem}}^j$  is the water required to meet demand  $j$ . The volumes associated with sources from  $i=1$  to  $n$  are summed to calculate the total volume available, and the total demand requires the summation of all demands from  $j=1$  to  $m$ .

### 7.2.3.4 Demand

An indicator capable of capturing the significance of the demand during the disruption event is necessary in order to establish trends between LOS and magnitude of the demand profile. It is expected that the LOS should increase when demands are low due to the increased ease of achieving function fulfillment. The average demand during the disruption event is

$$\text{Demand} = \int_{t_s}^{t_e} (\sum_{j=1}^m Q_{\text{Dem}}^j) dt. \quad (7.7)$$

### 7.2.3.5 Alternative Water

This assessment is based on water flow pathways, and thus the alternative water indicator is defined by the utilization of sources that are often utilized in order to increase the environmental sustainability of the building water cycle. For this assessment alternative water sources included in model runs are recycled wastewater, rainwater, and condensate. The degree to which these sources fulfill the building water demand is calculated as

$$\text{Alternative water} = \frac{\int_{t_s}^{t_e} \left( \sum_{j=1}^m Q_Y^j + Q_R^j + Q_C^j \right) dt}{\int_{t_s}^{t_e} \left( \sum_{j=1}^m Q_{\text{Dem}}^j \right) dt} \quad (7.8)$$

where  $Q_Y^j$  is the flow of recycled wastewater to demand  $j$ ,  $Q_R^j$  is the flow of rainwater to demand  $j$ , and  $Q_C^j$  is the flow of condensate to demand  $j$ .

### 7.2.3.6 Passivity

The indicator equation for passivity is based on the sustainability equation, in which the amount of passive water sources utilized is normalized to the average demand. Model runs in this assessment assume that, when stored, rainwater and stormwater are appropriated using gravity systems that ensure pressure and delivery within the building systems so that

$$\text{Passivity} = \frac{\int_{t_s}^{t_e} \left( \sum_{j=1}^m \left( Q_R^j + Q_P^j \right) \right) dt}{\int_{t_s}^{t_e} \left( \sum_{j=1}^m Q_{\text{Dem}}^j \right) dt} \quad (7.9)$$

where  $Q_P^j$  is the flow of potable water to demand  $j$  during the disruption event.

### 7.2.3.7 Preparation

Qualitative attributes such as preparation, adaptation, and recovery are difficult to quantify in engineering terms due to their reliance on societal organizational response strategies and times (Marjanishvili, 2014). For this assessment, the preparation undertaken by the building water system is based on the utilization of alternative water sources compared to a baseline case where potable water is the only utilized source. Preparation is therefore calculated as the percent of annual demand met by alternative water sources. For this assessment recycled wastewater, condensate, and rainwater were the alternative water sources considered such that

$$\text{Preparation} = \frac{\int_0^{1\text{yr}} \sum_{j=1}^m \left( Q_Y^j + Q_R^j + Q_C^j \right) dt}{\int_0^{1\text{yr}} \left( \sum_{j=1}^m Q_{\text{Dem}}^j \right) dt} \quad (7.10)$$

### 7.2.3.8 Adaptation Potential

The estimation of preparation undertaken by the building water cycle is a measure of proactive design considerations, whereas the adaptation potential is associated with reactive measures to disruption events. The adaptation potential is estimated by evaluating the amount of alternative water sources that are available at the building site, but are not currently utilized within the building water cycle. The ability for underutilized sources to meet demand is calculated as

$$\text{Adaptation potential} = \frac{\int_0^{1\text{yr}} \left( (Q_{\text{in}}^Y - \sum_{j=1}^m Q_Y^j) + (Q_{\text{in}}^R - \sum_{j=1}^m Q_R^j) + (Q_{\text{in}}^C - \sum_{j=1}^m Q_C^j) \right) dt}{\int_0^{1\text{yr}} \left( \sum_{j=1}^m Q_{\text{Dem}}^j \right) dt} \quad (7.11)$$

where  $Q_{\text{in}}^Y$  is the potential inflow of recycled wastewater sources,  $Q_{\text{in}}^R$  is the potential inflow of rainwater, and  $Q_{\text{in}}^C$  is the potential inflow of condensate.

### 7.2.4 Modeled Scenarios

From the water use study discussed in Chapter 5, two building types were chosen for the resilience assessment: a multi-residential neighborhood and elementary school. The two locations represent locations with a higher need for confident persistence of water services due to the functions that each building provides to the population.

Demand profiles for each building location were developed using the hourly water use data from Chapter 5 for dates from December 1, 2012 through January 31, 2014. The base year for this assessment is 2013; however one month was added before and after the study as a buffer for model runs.

The water use profiles selected from Chapter 5 include variability of overall water demand over time; however, individual water consumption by end-use also varies throughout the day. End-uses and associated water demand as a percentage of overall demand for the multi-residential building location are based on a study by the American Water Works Association Research Foundation (Mayer et al., 1999) and presented in Table 7.4. For the

elementary school location, aggregate water consumption by end-use was based on data from Gleick et al. (2003). Hourly estimations for water use by end-use were based on the duration of the school day and scheduled lunch break. The resultant breakdown of water demand by end-use for weekdays is presented in Table 7.5. Water use occurring on weekdays was attributed to irrigation. For both buildings, the hourly percent breakdown of water used by each end-use was allowed to vary randomly around the base distribution in order to introduce variability into modeled results. Results from the multi-residential neighborhood study are provided in this chapter, while detailed results from the elementary school study are provided in Appendices D and E.

Table 7.4: End-uses and hourly water demand as a percentage of total demand for the multi-residential building location (end-use data adapted from Mayer et al., 1999).

Hour of Day	End-use				
	Toilets	Hygiene	Laundry	BathSink	KitSink
1	54%	15%	15%	12%	3%
2	63%	13%	13%	11%	1%
3	67%	17%	0%	15%	2%
4	60%	20%	0%	18%	2%
5	50%	38%	0%	10%	3%
6	35%	48%	4%	9%	4%
7	29%	49%	8%	8%	5%
8	29%	37%	16%	8%	10%
9	26%	30%	26%	8%	9%
10	24%	24%	34%	8%	10%
11	23%	21%	39%	10%	8%
12	24%	20%	37%	10%	9%
13	26%	16%	38%	13%	7%
14	27%	14%	39%	13%	8%
15	29%	15%	37%	10%	9%
16	31%	14%	33%	11%	10%
17	31%	16%	31%	10%	12%
18	31%	18%	27%	11%	13%
19	29%	20%	25%	14%	11%
20	28%	21%	26%	16%	9%
21	31%	21%	25%	17%	6%
22	35%	22%	22%	16%	6%
23	42%	18%	18%	15%	6%
24	46%	19%	12%	15%	8%

Table 7.5: Weekday end-uses and hourly water demand as a percentage of total demand for the elementary school building location (end-use data adapted from Gleick et al., 2003).

Hour of Day	End-use				
	Irrigation	Toilets	Urinals	BathSink	KitSink
1	100%	0%	0%	0%	0%
2	100%	0%	0%	0%	0%
3	100%	0%	0%	0%	0%
4	100%	0%	0%	0%	0%
5	100%	0%	0%	0%	0%
6	100%	0%	0%	0%	0%
7	15%	43%	11%	4%	27%
8	0%	67%	17%	6%	10%
9	0%	59%	15%	6%	20%
10	0%	48%	12%	5%	35%
11	0%	41%	10%	4%	45%
12	0%	37%	9%	4%	50%
13	0%	41%	10%	4%	45%
14	0%	44%	11%	4%	40%
15	0%	59%	15%	6%	20%
16	0%	67%	17%	6%	10%
17	0%	74%	19%	7%	0%
18	0%	74%	19%	7%	0%
19	70%	15%	4%	1%	10%
20	80%	10%	3%	1%	6%
21	100%	0%	0%	0%	0%
22	100%	0%	0%	0%	0%
23	100%	0%	0%	0%	0%
24	100%	0%	0%	0%	0%

The availability of alternative water sources is based on climate. Hourly climate data including temperature, humidity, and rainfall was acquired from MesoWest data website (University of Utah, 2012) that compiles weather data from the National Weather Service. Missing data points were extrapolated from climate values before and after missing durations. Condensate production was estimated using an air conditioning condensate calculator web interface (Building Green, 2015) displayed in Figure 7.4.

Using the developed demand and source profiles, different building water scenarios were created in order to vary the value of the indicators defined in Section 7.2.3 and evaluate the corresponding LOS. Scenarios are defined by the inclusion of alternative water sources, storage capacity, and reliance on centralized power. Rainwater storage cisterns and potable



water tanks are assumed to be gravity-based systems capable of serving the building when centralized power is disrupted. However, power disruption will stop the production of condensate which relies on power-dependent HVAC systems and the distribution of recycled wastewater from an MBR system. The scenarios developed for the multi-residential building location are listed in Table 7.6.

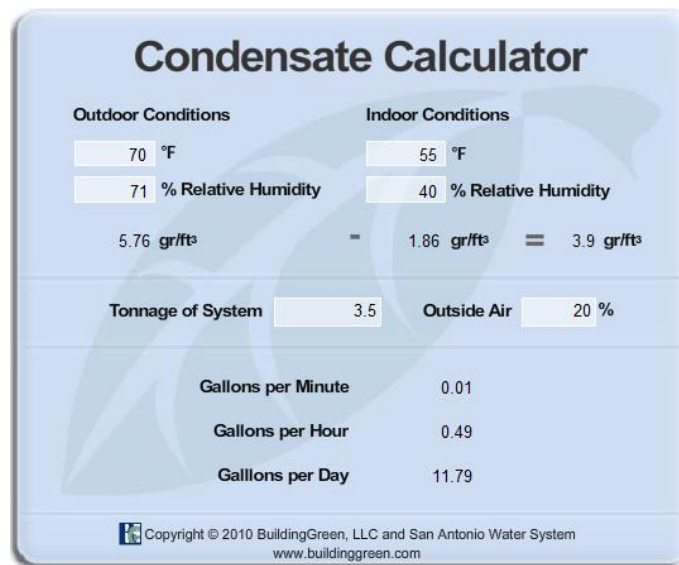

Figure 7.4: Web-based calculator used to estimate condensate production (Building Green, 2015).

Table 7.6: Multi-residential building scenarios evaluated by the WRAM.

Scenario	Description of water flows	Power source
1	Potable water for all demands	Central power
2	Rainwater (25,000-gallon cistern) for toilet flushing	Gravity
3	Rainwater (50,000-gallon cistern) for toilet flushing	Gravity
4	Rainwater and condensate (50,000-gallon cistern) for toilet flushing	Gravity
5	Rainwater and condensate (50,000-gallon cistern) for toilets and laundry	Gravity
6	Recycled wastewater from bathroom sinks, kitchen sinks, showers and toilets (10,000-gallon MBR) to toilets	Central power
7	Recycled wastewater from bathroom sinks, kitchen sinks, showers and toilets (10,000-gallon MBR) to toilets Rainwater and condensate (50,000 gallon cistern) to bathroom sinks, kitchen sinks, laundry and showers	Central power Gravity
8	Potable water storage (25,000-gallon tank)	Gravity
9	Potable water storage (50,000-gallon tank)	Gravity

## 7.3 Results and Discussion

### 7.3.1 LOS vs. Indicators

Clear trends between LOS and indicator values emerged from the model runs. Figure 7.5 displays the average LOS versus the diversity indicator for the multi-residential study. Diversity indicator values were constant for all disruption events, and thus the average LOS for the 10 random  $t_s$  times is plotted for each disruption duration length ( $n=5$ ) for clarity of results. Scenario 1 consists of all demands being met by potable water, and thus the diversity indicator is 1 and LOS fell to 0% for all disruption events due to the inability to meet demands with another source. For Scenarios 2 through 7 which incorporate alternative water sources and thereby increase the diversity of the building water system, the LOS generally increased as the diversity indicator increased. However, LOS values were restricted based on the ability of alternative sources to meet allowable demands. Scenarios 2, 3, and 6 have a diversity value of 2; and Scenarios 4 and 5 have a diversity value of 3. Scenarios 2 and 3 have similar average LOS values between 15% and 22% for different disruption lengths despite the difference in rainwater storage. Limiting the amount of alternative sources available by limiting the storage resulted in lower LOS values, such as supported by the higher LOS values observed for Scenario 3 (50,000-gallon cistern) over Scenario 2 (25,000-gallon cistern). Scenario 6 had a larger range of average LOS values between 12% and 38%. The magnitude of demands available to accommodate the supply also restricted the LOS as seen in higher LOS values for Scenario 5 over Scenario 4. Scenario 4 and 5 both use the same sized cistern for rainwater storage (50,000 gallons), but allocation of the rainwater source is expanded to laundry in addition to toilets for Scenario 5, resulting in more demand being met and an elevated LOS. Diversity was not a strong indicator for the LOS for Scenarios 8 and 9 which relied on potable water storage during disruptions.

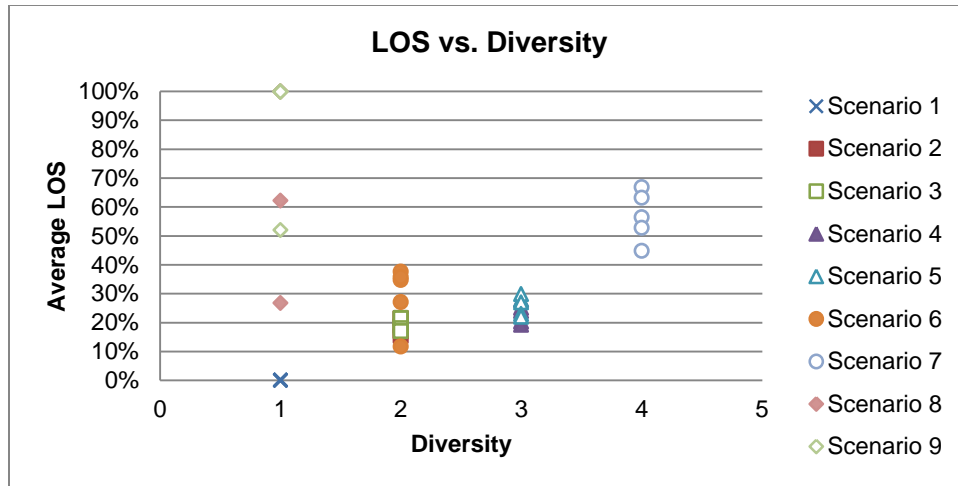

Figure 7.5: Level of service (LOS) vs. diversity for multi-residential scenarios subjected to potable water disruption.

Figure 7.6 displays the average LOS versus redundancy indicator values for the multi-residential study. Similar trends are found regarding redundancy compared to diversity, and the effect that the allocation of the same source to additional demands on the LOS is better presented for Scenarios 4 and 5. Again, capacity appears to drive the wide range in LOS values for low redundancy associated with potable water Scenarios 8 and 9.

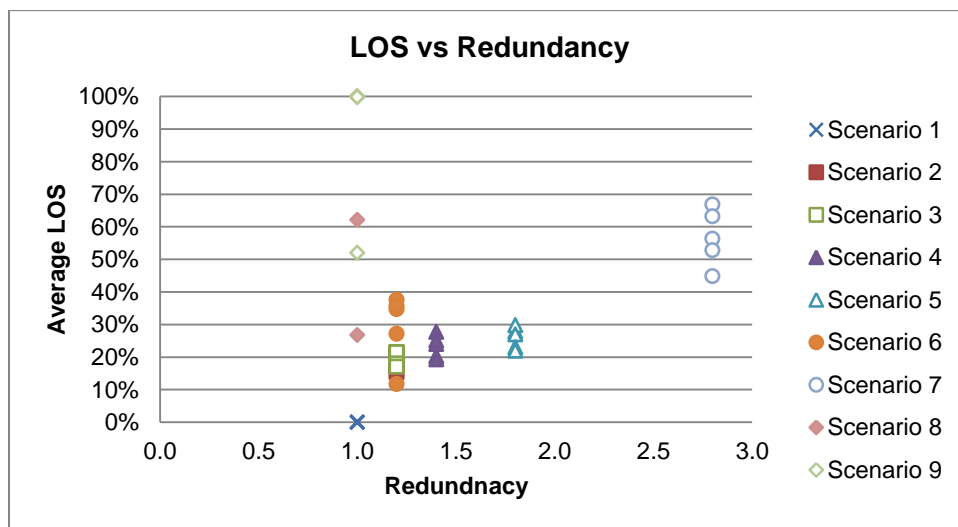

Figure 7.6: Level of service (LOS) vs. redundancy for multi-residential scenarios subjected to potable water disruption.

Figures 7.7 and 7.8 plot the LOS as a function of the capacity indicator for each model run (n=450) for the multi-residential study. For each scenario, the LOS increases as capacity increases before plateauing at a maximum threshold indicating saturation of the source. Scenario 7, 8, and 9 had the highest available storage volumes, but were also capable of allocating stored sources to all demands during disruption periods; as a result these scenarios quickly reach 100% LOS as capacity increases. Scenarios 4 and 5 have the same storage available (50,000-gallon cistern), but the laundry demand serviced in addition to toilet flushing by rainwater in Scenario 5 results in LOS values reaching a higher threshold. A similar pattern results when comparing Scenarios 6 and 7. Scenario 7 has a higher storage volume than Scenario 6 and approaches 100% LOS at lower capacities than Scenario 6.

Multiplication of storage volumes did not result in an even increase in the LOS for all scenarios. From Scenario 2 to Scenario 3, the rainwater cistern size was increased from 25,000 gallons to 50,000 gallons (100% increase), and the capacity indicator increased by an average of about 155%. The difference is due to the increased availability of water that the larger cistern was able to accommodate. However, the average LOS from Scenario 2 to Scenario 3 only had an average increase of 3% across all disruption events. The divergence indicates the limitation enforced by the demand available to consume the supply. In both scenarios the demand remained constant and did not increase the rate of source consumption during the disruption durations. Comparing Scenarios 4 and 5 further supports the importance of the magnitude of water demand. Both scenarios utilize a 50,000 gallon MBR for water recycling, but Scenario 5 allocates the water to more demands than Scenario 4. As a result, the capacity indicators of the MBR storage system in Scenario 5 are about 43% lower than Scenario 4, not due to a change in maximum storage, but rather because the average volume of the available recycled wastewater source is lower due to higher consumption by the increased demands. Despite the decrease by the capacity indicator, the average LOS increases by 8% from Scenario 4 to Scenario 5.

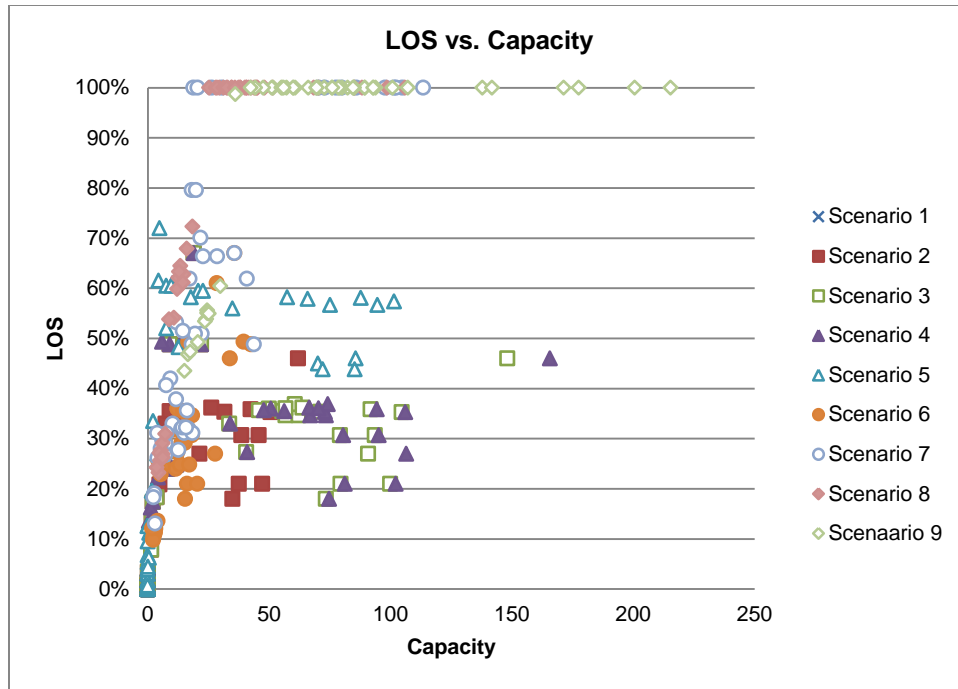

Figure 7.7: Level of service (LOS) vs. capacity for multi-residential scenarios subjected to potable water disruption.

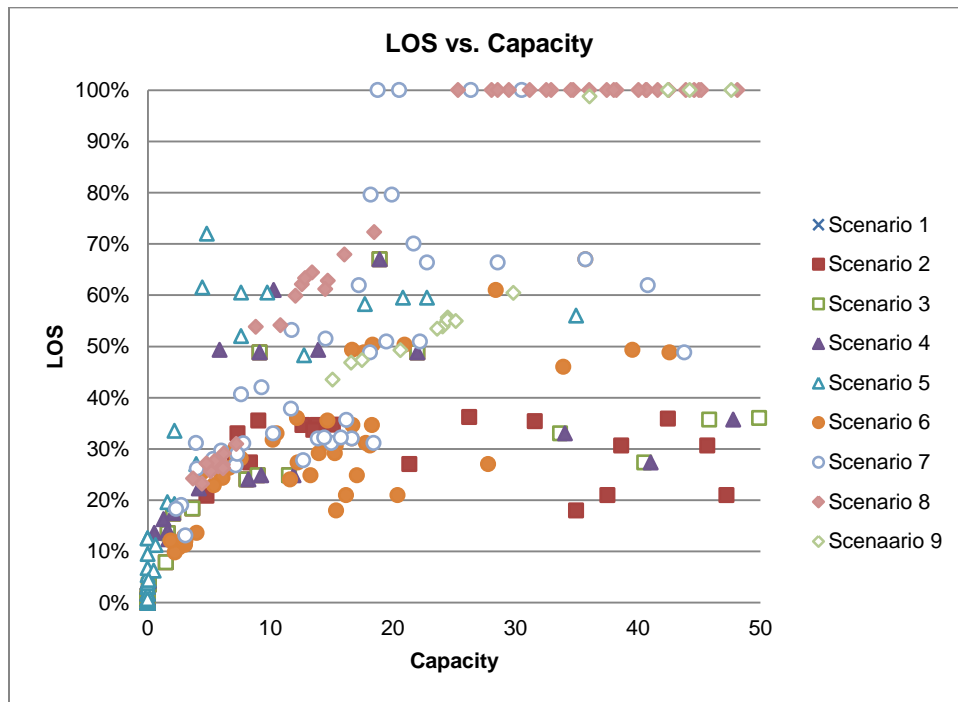

Figure 7.8: Detailed view of level of service (LOS) vs. capacity for multi-residential scenarios subjected to potable water disruption.

The relationship between the demand indicator and LOS is displayed in Figure 7.9 for the multi-residential study site subjected to potable water disruption. Correlation between the indicator and LOS is weak for the results from the model runs. It is possible that the poor correlation is a result of the variation in the other indicators that affect the LOS of each run and are not easily separated from the demand indicator for a direct relationship to appear.

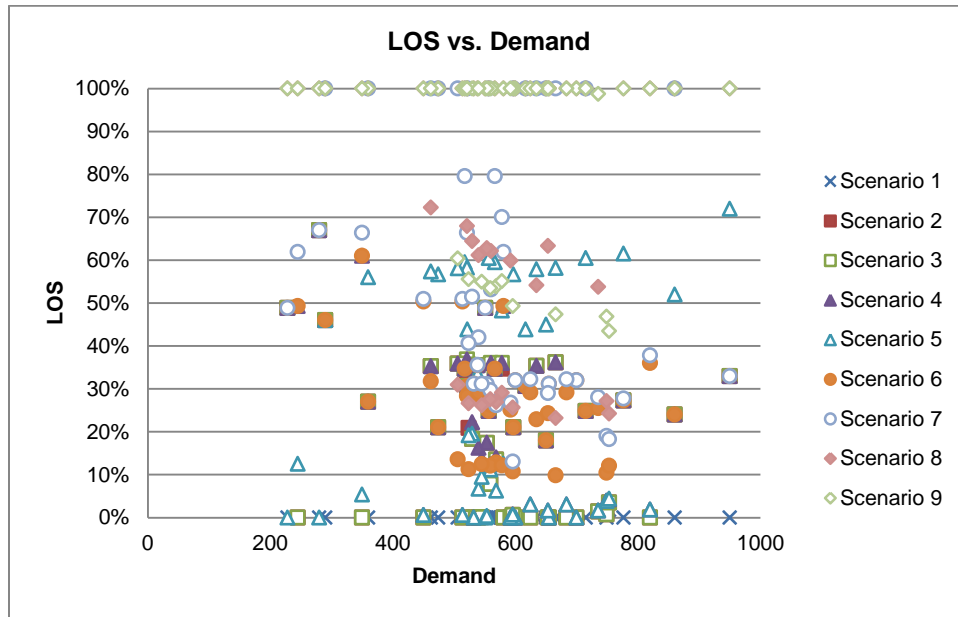

Figure 7.9: Level of service (LOS) vs. demand for multi-residential scenarios subjected to potable water disruption.

Figure 7.10 displays the average LOS versus the alternative water indicator for the multi-residential study. For scenarios utilizing alternative water sources, the average LOS increases as the alternative water indicator increases. The resultant correlation shows that the inclusion of environmentally sustainable water management strategies does increase the resilience of the building water cycle to individual potable water disruption events compared to the baseline Scenario 1 case. However, the high average LOS values for Scenarios 8 and 9 show that alternative water sources are not a necessary component to achieve high resilience in terms of

LOS for individual disruption events, but rather high LOS values may be achieved solely through increased capacity.

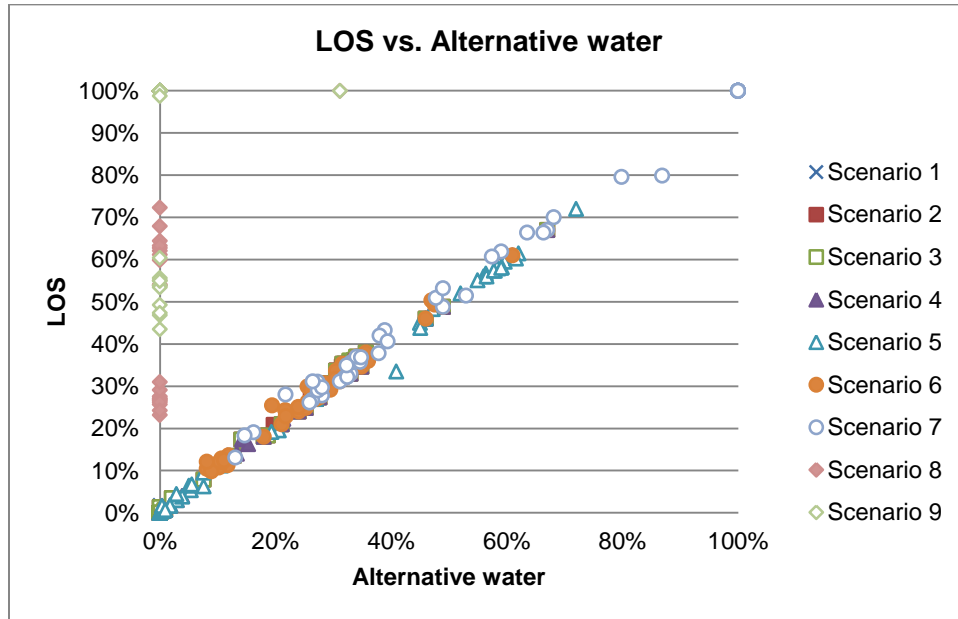

Figure 7.10: Level of service (LOS) vs. alternative water for multi-residential scenarios subjected to potable water disruption.

Figure 7.11 displays the LOS as a function of the passivity indicator for the multi-residential study. For scenarios where passive sources are directed to demands, LOS increases as the passivity indicator increases. Scenarios 2, 3, 8 and 9 represent ideal cases where demands are met only with passive sources, and therefore the LOS equals the passivity indicator. Instances where the LOS exceeds the value of the passivity indicator are due to an additional storage capacity available to meet demand during the disruption period, such as the availability of stored condensate in Scenarios 4, 5, and 7. The impact of capacity is best illustrated by Scenario 6 which always has a passivity value of 0. Despite the low passivity score, LOS values for Scenario 6 are well above 0% due to storage in the MBR system and availability of energy for water distribution.

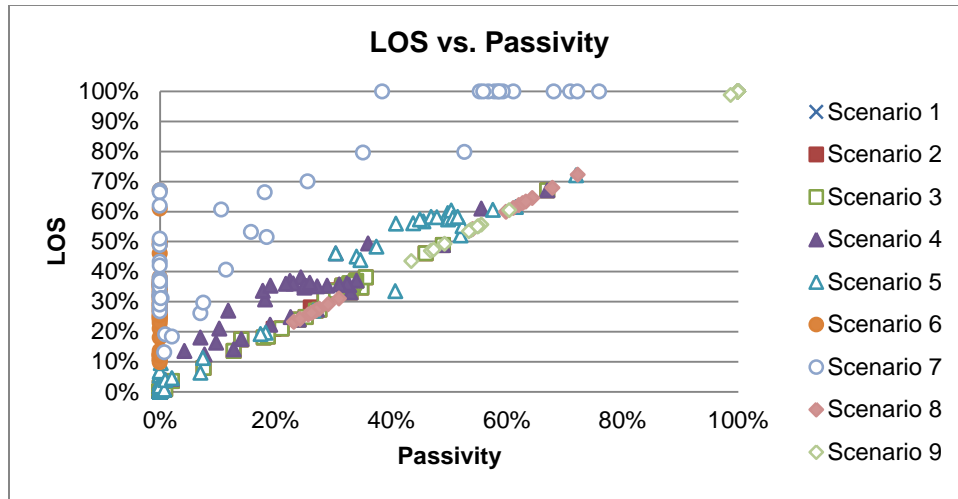

Figure 7.11: Level of service (LOS) vs. passivity for multi-residential scenarios subjected to potable water disruption.

Figure 7.12 displays the average LOS as a function of the preparation indicator for the multi-residential study. The preparation indicator only included alternative water sources, and therefore the trend of increasing LOS with increasing preparation indicator values is only evident for Scenarios 1 through 7. The preparation indicator increases as utilization of alternative water sources increases. Scenarios 2, 3, 3, 5, 6, and 7 had preparation values of 15%, 18%, 19%, 26%, 33%, and 61%, respectively.

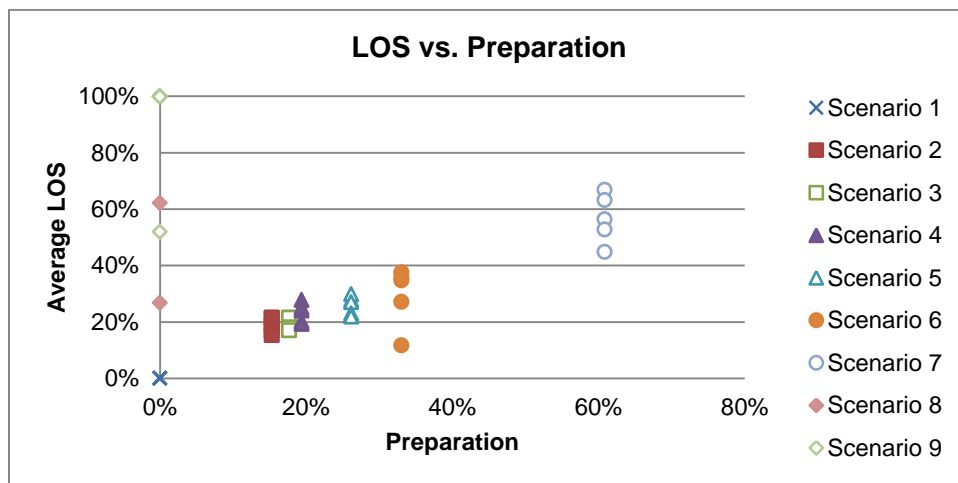

Figure 7.12: Level of service (LOS) vs. preparation for multi-residential scenarios subjected to potable water disruption.



Figure 7.13 displays the average LOS as a function of the adaptation potential indicator for the multi-residential study. As expected, the average LOS decreases as the adaptation potential increases for Scenarios 1 through 7 – the opposite of the LOS trend for the preparation indicator. Scenarios 8 and 9 disrupt the observed trend because of the high LOS values possible by relying solely on potable water storage while not utilizing available alternative supplies. As a result, Scenarios 8 and 9 have the highest adaptation potential value aligned with the Scenario 1 baseline case with a value of 144%. Scenario 7, 6, 5, 3, and 2, and 4 have adaptation potential values of 83%, 111%, 118%, 126%, 128%, and 129% respectively.

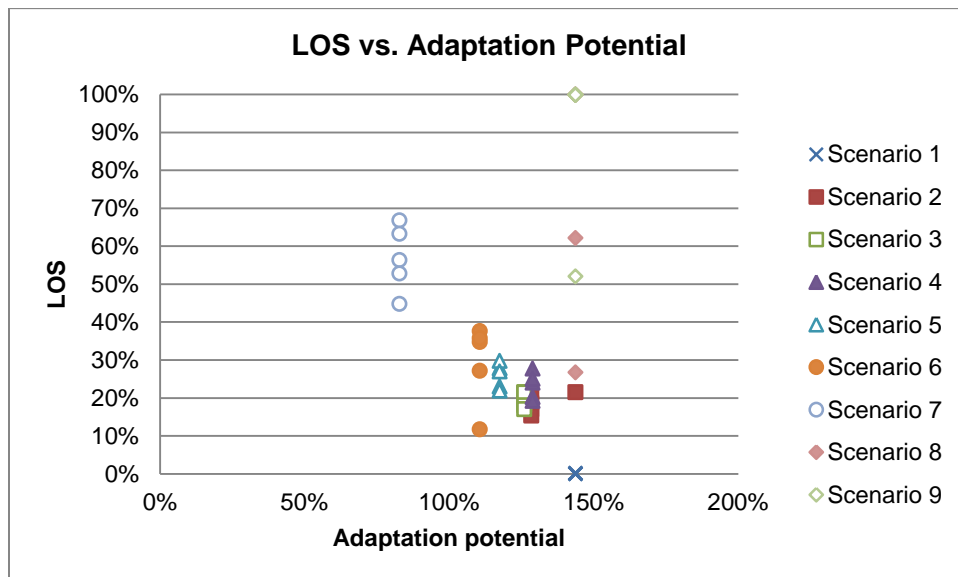

Figure 7.13: Level of service (LOS) vs. adaptation potential for multi-residential scenarios subjected to potable water disruption.

Correlations between indicators and LOS for all potable disruption scenarios are presented in Table 7.7. Values were calculated for all Scenario 1 through 9 and separately for Scenarios 1 through 7 in order to eliminate the bias introduced by the outlier Scenarios 8 and 9 which rely solely on storage to fulfill building water functions. For all scenarios, passivity was found to have the highest correlation with LOS (0.91) indicating a strong relationship between

passivity and resilience. When the non-sustainable Scenarios 8 and 9 are removed, there is also a strong correlation between sustainability and average LOS (1.00). Capacity, (0.60), diversity (0.56), and redundancy (0.56) also emerges as strong indicators for Scenarios 1-7.

Table 7.7: Correlation values for resilience indicators to LOS for model runs for the multi-residential study subjected to potable water disruption. Lower and upper values are given for a 95% confidence interval.

		Diversity	Redundancy	Capacity	Demand	Alt. water	Passivity	Avg LOS
Scenario 1-9 (n=450)	(Lower)	-0.23	-0.04	0.59	-0.21	0.20	0.89	
		-0.14	0.05	0.65	-0.12	0.29	0.91	1.00
	(Upper)	-0.05	0.14	0.70	-0.03	0.37	0.92	
Scenario 1-7 (n=350)	(Lower)	0.48	0.48	0.53	-0.27	1.00	0.72	
		0.56	0.56	0.60	-0.17	1.00	0.77	1.00
	(Upper)	0.63	0.63	0.66	-0.07	1.00	0.81	

Correlation values were also calculated by comparing the average indicator for the 10 random disruption dates to the average LOS. Results are presented in Table 7.8 for the average indicator values and disruption duration. As expected, there is a negative correlation between the disruption duration and the LOS (-0.26 for Scenarios 1 through 9 and -0.22 for Scenarios 1-7); as the disruption duration increases, the average LOS decreases. A weak correlation between demand and LOS is calculated (-0.19 for Scenarios 1 through 9 and -0.14 for Scenarios 1 through 7). For Scenarios 1 through 7, diversity (0.85) and redundancy (0.85) have a strong correlation with the LOS. The average preparation indicator also correlates strongly with the LOS for Scenarios 1 through 7 (0.94), and conversely, the adaptation potential has a strong negative correlation (-0.93). Similar to the correlation for all model runs, passivity strongly correlates with the LOS (0.91), and capacity correlations slightly increase when the averages are used to 0.78 for all scenarios and 0.64 for Scenarios 1 through 7.

Table 7.8: Correlation values for average resilience indicators (grouped by scenario and disruption length) to LOS for model runs for the multi-residential study subjected to potable disruption. Lower and upper values are given for a 95% confidence interval.

		Disruption	Diversity	Redundancy	Capacity	Demand	Alternative water	Passivity	Preparation	Adaptation potential	LOS
Scenario 1-9 (n=45)	(Lower)	-0.51	-0.43	-0.24	0.63	-0.46	-0.34	0.84	-0.36	-0.24	
		-0.26	-0.16	0.06	0.78	-0.19	-0.05	0.91	-0.07	0.06	1.00
	(Upper)	0.04	0.14	0.35	0.87	0.11	0.25	0.95	0.23	0.35	
Scenario 1-7 (n=35)	(Lower)	-0.52	0.72	0.72	0.39	-0.45	1.00	0.15	0.88	-0.96	
		-0.22	0.85	0.85	0.64	-0.14	1.00	0.46	0.94	-0.93	1.00
	(Upper)	0.12	0.92	0.92	0.80	0.20	1.00	0.69	0.97	-0.86	

Model runs were repeated for all scenarios but subjected to disruption of both potable water and power for the same set of disruption durations. Detailed model results for these runs are provided in Appendix C. The resultant correlation between the indicators and average LOS for this set of model runs is presented in Table 7.9. The correlation between alternative water (1.00) and capacity (0.62) to the average LOS for Scenarios 1 through 7 is largely unchanged from the correlation calculated based on potable water only disruptions. However, passivity becomes increasingly important in the absence of central power to treat and distribute water as shown by the high correlation (1.00).

Table 7.9: Correlation values for resilience indicators to LOS for model runs for the multi-residential study subjected to potable water and central power disruption. Lower and upper values are given for a 95% confidence interval.

		Diversity	Redundancy	Capacity	Demand	Alt. water	Passivity	LOS
Scenario 1-9 (n=450)	(Lower)	-0.41	-0.28	0.57	-0.16	0.16	1.00	
		-0.33	-0.19	0.63	-0.07	0.25	1.00	1.00
	(Upper)	-0.25	-0.10	0.68	0.02	0.33	1.00	
Scenario 1-7 (n=350)	(Lower)	0.23	0.14	0.55	-0.21	1.00	1.00	
		0.33	0.24	0.62	-0.11	1.00	1.00	1.00
	(Upper)	0.42	0.34	0.68	-0.01	1.00	1.00	

Table 7.10: Correlation values for average resilience indicators (grouped by scenario and disruption length) to LOS for model runs for the multi-residential study subjected to potable water and central power disruption.

		Disruption	Diversity	Redundancy	Capacity	Demand	Alternative water	Passivity	Preparation	Adaptation potential	LOS
Scenario 1-9 (n=45)	(Lower)	-0.47	-0.61	-0.48	0.60	-0.42	-0.51	1.00	-0.64	0.13	
		-0.20	-0.38	-0.22	0.76	-0.15	-0.26	1.00	-0.42	0.41	1.00
	(Upper)	0.10	-0.10	0.08	0.86	0.15	0.04	1.00	-0.14	0.63	
Scenario 1-7 (n=35)	(Lower)	-0.48	0.46	0.20	0.40	-0.42	1.00	1.00	-0.01	-0.57	
		-0.18	0.69	0.50	0.65	-0.10	1.00	1.00	0.32	-0.29	1.00
	(Upper)	0.16	0.83	0.71	0.81	0.24	1.00	1.00	0.59	0.05	

Correlation between values averaged across the 10 disruption dates and the average LOS for the multi-residential neighborhood subjected to both potable water and central power disruption is provided in Table 7.10. Again, the correlation with passivity to LOS is nearly ideal (1.00) for all scenarios. For Scenarios 1 through 7, alternative water also maintains high correlation with LOS (1.00). The correlation values for capacity are similar to those calculated for the potable water only disruption (0.76 for Scenarios 1 through 9 and 0.65 for Scenarios 1 through 7) and indicate that the importance of capacity is consistent for both disruption schemes.

### 7.3.2 Resilience as a Function of LOS and Disruption

The previous section revealed how the LOS depends on the defined indicators separated by individual disruption events, but the resilience of a system is dependent on the change in LOS for a variety of disruption events. A resilient system should maintain high LOS for a range of disruption event severities, and the resultant resilience curves for the multi-residential study are plotted as the average LOS versus disruption duration in Figure 7.14 for the potable disruption case. Scenarios 8 and 9 exhibit 100% LOS for disruption events with short durations due to the high storage capacity of potable water available to meet all demands.

However, the average LOS sharply drops for longer disruption events when all stored potable water has been consumed. Scenarios 2, 3, 4, and 5 have lower LOS values, but the decreasing slope is more gradual than Scenarios 8 and 9. The difference in slope is attributed to the water sources utilized within the different building water cycle scenarios. Water sources that may be replenished without a centralized potable water flow maintain water functions for longer periods of time. Scenarios 2, 3, 4, and 5 largely use rainwater to meet demands, and the rainwater storage is supplemented if precipitation events occur during the disruption period. Scenario 6 and 7 differ only by the addition of a rainwater cistern included in the latter scenario. The MBR systems distributing recycled wastewater depend on outputs from high-quality water demands. In Scenario 6 the disruption of potable water stops the inflow into the MBR from demands that are no longer serviced. However, in Scenario 7 rainwater is capable of meeting the high-quality demands and producing source water for the MBR system. As a result, the slope of the resilience curve for Scenario 7 is more gradual than the slope for Scenario 6. The resilience curves produced infer that implementation of water storage is a good strategy to increase resilience for short-term disruption events. However, renewable alternative water sources are necessary for the building water cycle to withstand long-term disruptions.

Figure 7.15 plots the resilience curves for multi-residential study for scenarios subjected to both a disruption of potable water and central power. For Scenarios 2, 3, 4, and 6 the resultant curves are similar to the ones displayed in Figure 7.14 for the disruption of only potable water. The similarity is due to the persistence of the rainwater supply during both types of disruption events. LOS values are occasionally slightly lower for these scenarios when subjected to both potable water and power disruption due to the exclusion of condensate collection during the disruption period. However, condensate collected in the cistern before the disruption event is still available for allocation during the event. Resilience curves for Scenarios 8 and 9 remain the same for both types of disruption events because the potable supply available during the disruption event is constant and distribution of the source is not reliant on

inflows or power. The greatest difference in resilience for the different disruption events is observed for Scenarios 6 and 7 which include MBR wastewater recycling. The power disruption prevents distribution of the stored wastewater source, and thus Scenario 6 maintains 0% LOS for all duration of disruption events. In Scenario 7, the LOS drops but is maintained above 0% due to the inclusion of the primary rainwater source.

The effect of different water sources on final resilience curves can be better illustrated by the demand and source profiles defining the disruption events. Figures 7.16 and 7.17 illustrate the demand and source interactions for Scenarios 6 and 7, respectively, subjected to a 168-hour potable disruption on January 5, 2013. In both scenario, wastewater generated from bathroom sinks, kitchen sinks, showers, and laundry is recycled through an MBR and allocated to the toilet flushing demand. Therefore, the amount of recycled wastewater available is dependent on the wastewater generation of the other demands and is deemed a *secondary* alternative water source. In Scenario 6 the volume of recycled wastewater begins to diminish after the potable supply is interrupted until the volume stock is depleted and the system can no longer support any of its demands. Scenario 7 includes collection of rainwater, a *primary* alternative water source, within the building water cycle. Although highly dependent on regional climate, rainwater is a freely available source that does not rely on other building water components and feeds the recycled wastewater volume thereby increasing the overall volume of sources available during the disruption period and prolonging the functions provided by building demands. Like rainwater, condensate depends on climatic factors, but is categorized as a secondary alternative water source due to its dependence on HVAC equipment.

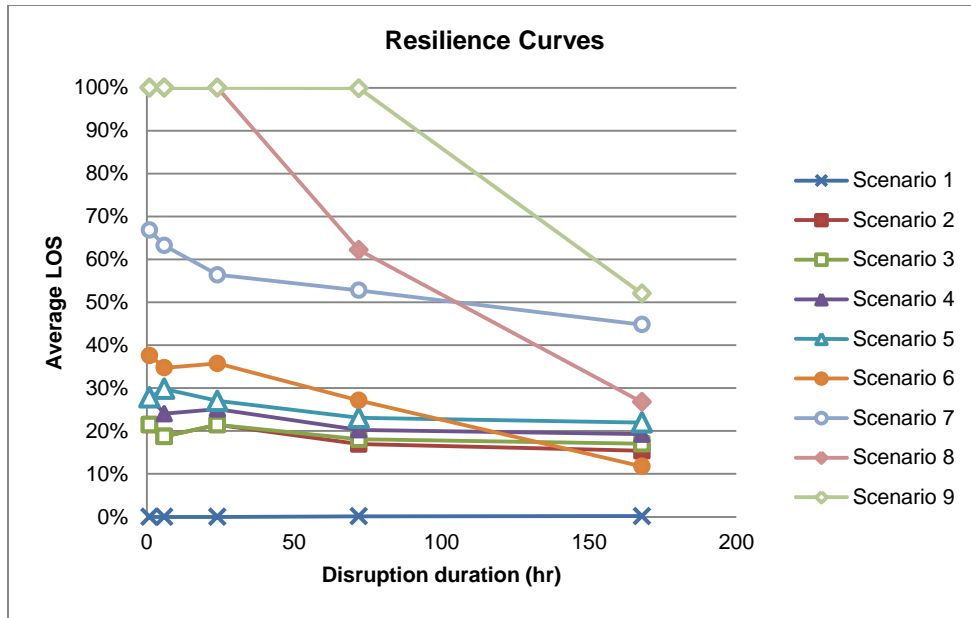

Figure 7.14: Resilience curves for the multi-residential study subjected to potable water disruption.

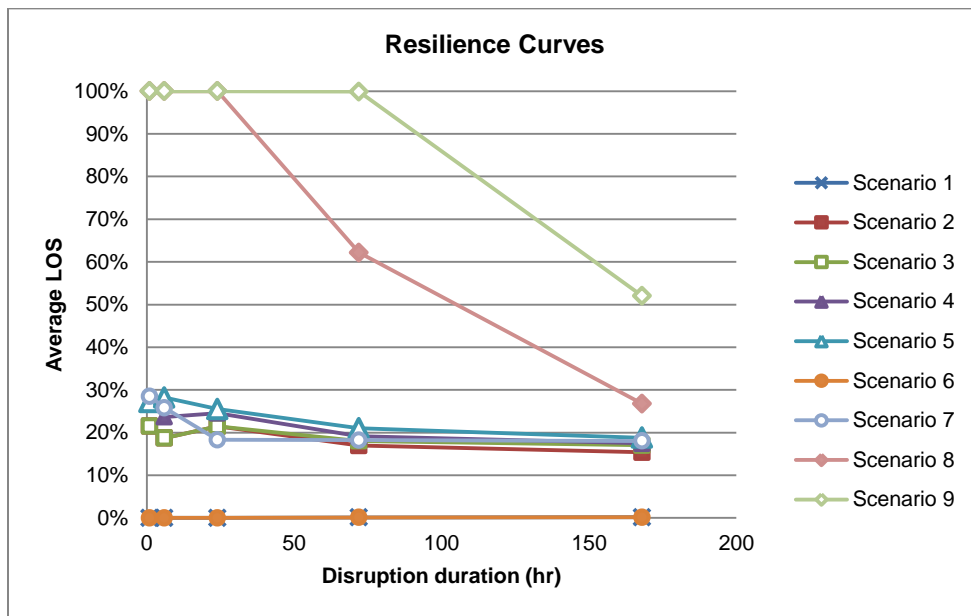

Figure 7.15: Resilience curves for the multi-residential study subjected to potable water and central power disruption.

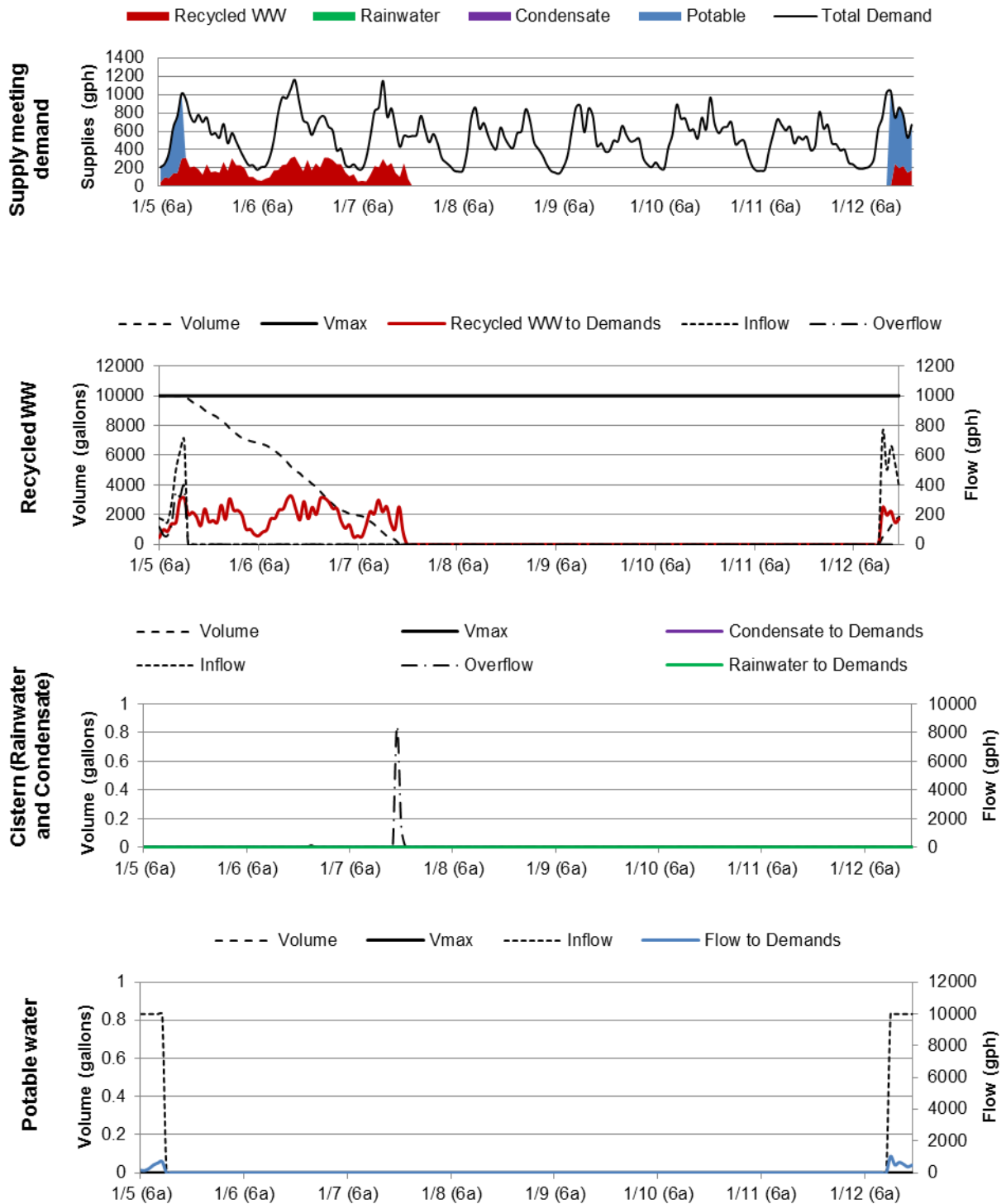

Figure 7.16: Water demand and source profiles for Scenario 6 subject to a 168-hour potable water disruption event on January 5, 2013.



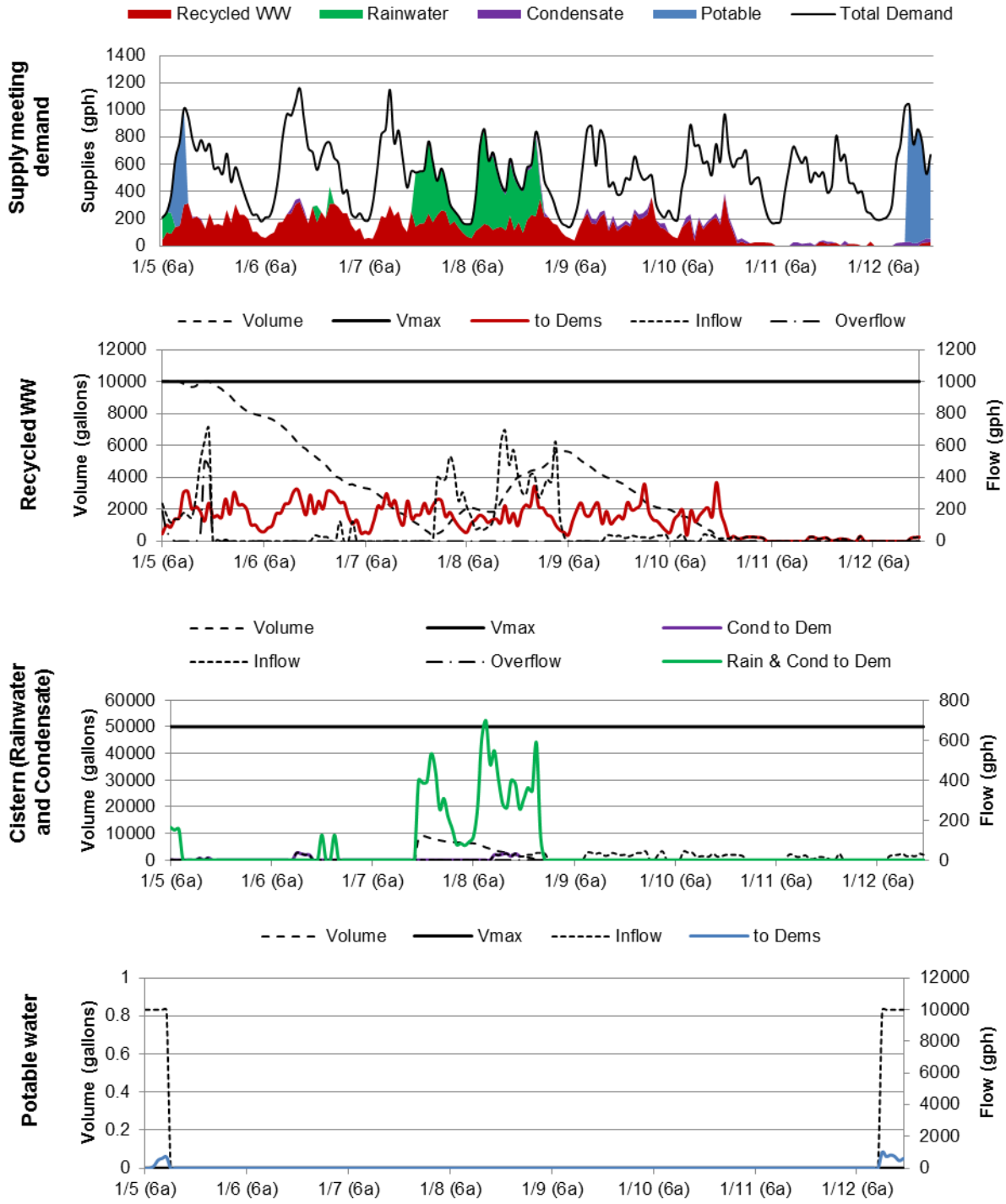

Figure 7.17: Water demand and source profiles for Scenario 7 subject to a 168-hour potable water disruption event on January 5, 2013.

#### **7.4 Inherent vs. Adaptive Resilience**

The previous scenarios modeled using the WRAM evaluate the inherent resilience of the building water cycle, or the resilience that results from attributes that the system included as part of preparation. The potential for adaptive resilience was determined using the adaptation potential indicator, but response measures were not included in the scenarios in order to allow for a fair comparison among building types and water cycles. However, adaptive resilience measures may be assessed using the WRAM framework. In order to demonstrate the inclusion of response measures, a potable water disruption event that occurred in the city of Dunedin is used as a case study (Caldwell and Porter, 2010). Potable water was disrupted to a section of the city for 12 days due to damage to an underground pipeline during construction. Buildings in the area did not have an existing alternative to the municipal potable water source and were asked to conserve water. As an additional response, the city received water tankers from nearby cities and municipalities to meet potable water demands and provide fire protection. The city installed a temporary pipeline beside the existing damaged pipeline in order to restore the municipal potable supply, but at an emergency cost. However, the city plans to retain the temporary pipeline even after repairs to the existing pipeline are made in order to create redundancy in the system and prevent a similar disruption event.

The disruption event described is applied to the multi-residential building site used for the previous resilience assessment. The site is near to where the disruption event occurred and mirrors the building types that were mostly affected by the disruption – residential structures near the water. The baseline scenario assesses a 168-hour disruption as a result of the loss of potable water from the pipeline damage and does not include response measures. The additional scenarios consider response measures in terms of conservation (reduction in demand) and water source substitution (increased supply).

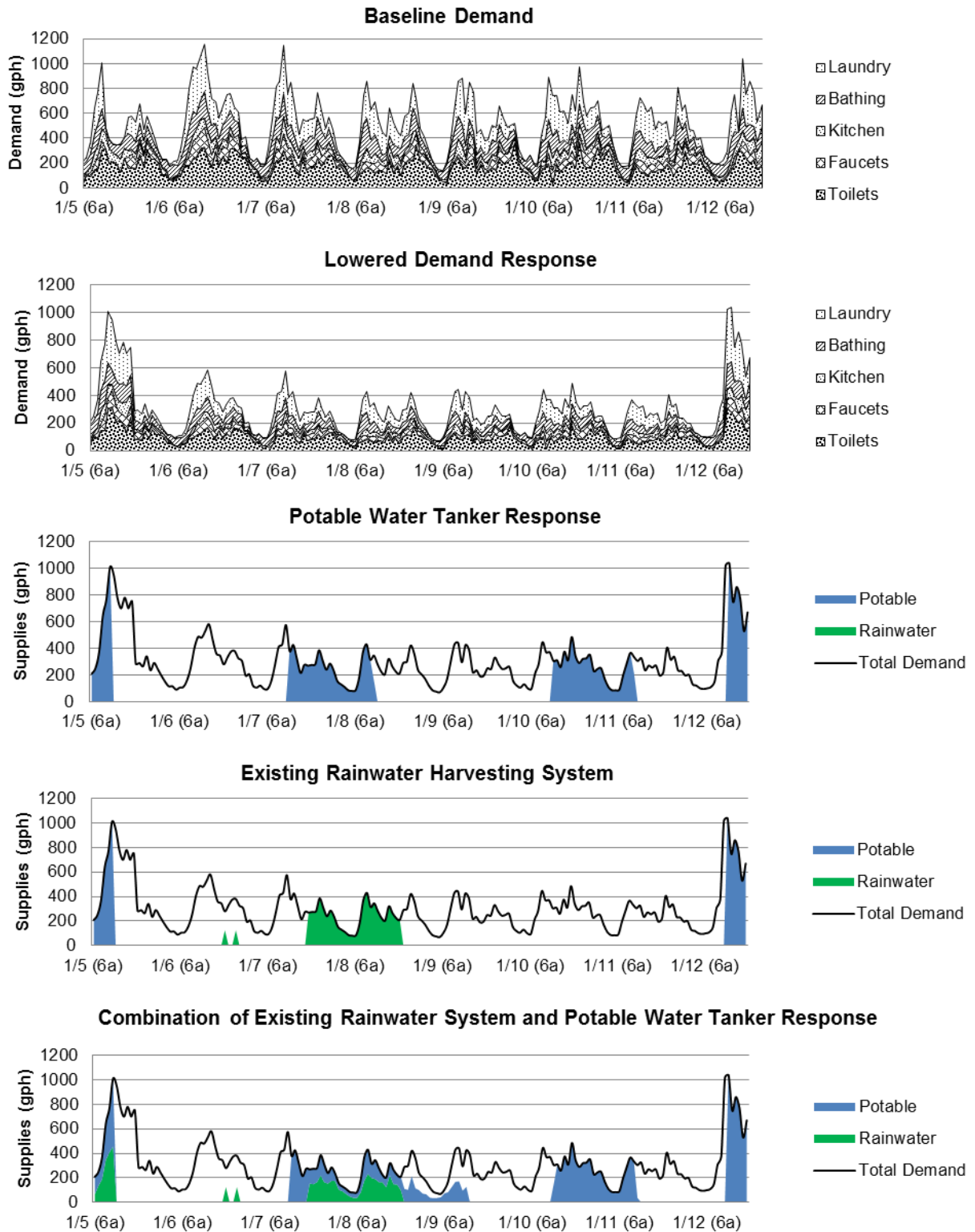

Figure 7.18: Effect of conservation and potable water delivery response measures for the multi-residential case study over a 168-hour disruption period.

The results of model runs are provided in Figure 7.18. The baseline demand for the building site is first decreased through conservation undertaken by the building occupants in response to the loss of water, which lowers the demand threshold to achieve 100% LOS. In the first scenario, the building does not have any preparation measures to minimize the impact of the disruption event. A response to increase the available water supply is modeled as a 6,000-gallon water tanker delivery that occurs on the third and sixth day of the disruption. The results show that this increase in supply is not enough to maintain 100% LOS for the duration of the event and that either additional supply is needed, or demand must be further decreased. In the second scenario, the building has an existing rainwater harvesting system that may alleviate some of the water loss and decrease the need for emergency water services. The last scenario combines the existing rainwater harvesting system with the potable water tanker delivery response. The inclusion of the rainwater preparation measure extends the usefulness of the emergency potable water supply and maintains a higher LOS during the disruption event. Although additional demand decreases or supply increases are necessary, the preparation measure offsets the additional emergency need.

## **7.5 Conclusion**

The WRAM framework from Chapter 6 has been used to successfully evaluate the resilience of unique building water cycles based on outputs of building demand and supply profiles. Indicators capable of tracking redundancy, diversity, capacity, demand, alternative water, passivity, preparation, and adaptation potential were developed based on attributes of resilience. The resilience of individual disruption events was defined as the level of service (LOS) and measured the ratio of supply meeting demand. The redundancy, diversity, capacity, alternative water, passivity, preparation, and adaptation potential indicators had clear correlations with the LOS for the scenarios tested and may be used to predict the resilience of the building water system. However, the high resilience values for the system did not require high scores for all indicators. Rather, resilience for short-term and long-term durations differed

based on the capacity of the building water system and the renewable sources included in the water cycle. For short term disruptions, storing water regardless of source, provided high LOS to building functions, but maintaining functions through long-term disruption requires water recycling or replenishment through climate-dependent sources.

For individual model runs, strong correlation appeared between diversity, redundancy, alternative water, and passivity for scenarios utilizing non-potable water sources (Scenarios 1 through 7) for both the multi-residential and elementary school studies as shown in Tables 7.11 and 7.12. The correlation of the alternative water indicator to LOS ranged from 0.80 and 1.00 for both set of disruption schemes – disruption of potable water and disruption of potable water and central power – supporting the hypothesis that incorporating alternative water sources as part of an environmentally sustainable practice may increase resilience. The weaker correlation between alternative water and LOS when all scenarios were included (Scenarios 1 through 9) shows that although alternative water aids resilience, it is not always a necessary component; a highly resilient system does not necessarily need to contain environmentally sustainable attributes, but is limited by storage capacity. The passivity indicator also strongly correlated with LOS with a range of values between 0.77 and 1.00 for both building study sites under both utility disruption schemes. As expected, passivity values are higher when the buildings are subjected to the loss of central power and must rely on passive water treatment and distribution to fulfill building water demands.

Summaries of the average indicator values to LOS are given in Tables 7.13 and 7.14. When the average value for each scenario tested at each disruption duration (n=10) is compared to the LOS, stronger correlation values result from diversity (0.69 – 0.91) and redundancy (0.50 – 0.86) for Scenarios 1 through 7. A positive correlation is calculated between preparation and the LOS (0.32 – 0.94), and contrarily a negative correlation is calculated between adaptation potential and the LOS (-0.29 – -0.93) for Scenarios 1 through 7. In addition, stronger correlation values emerge between capacity and LOS for all scenarios and

disruption schemes (0.41 – 0.78) indicating that larger volumes of water storage can increase the resilience of the building water cycle to disruptions in potable water and central power supplies.

Table 7.11: Summary of indicator values to LOS for multi-residential and elementary school studies subjected to potable water disruption. Shading indicates absolute correlation between 0.20 and 0.39 (light shading), 0.40 and 0.79 (medium shading), and above 0.79 (dark shading).

Building	Scenarios	Correlation values						
		Diversity	Redundancy	Capacity	Demand	Alt. water	Passivity	LOS
Multi-residential	1-9 (n=450)	-0.14	0.05	0.65	-0.12	0.29	0.91	1.00
	1-7 (n=350)	0.56	0.56	0.60	-0.17	1.00	0.77	1.00
Elementary school	1-9 (n=450)	0.00	0.08	0.08	0.07	0.22	0.89	1.00
	1-7 (n=350)	0.67	0.64	0.06	0.09	0.89	0.76	1.00

Table 7.12: Summary of indicator values to LOS for multi-residential and elementary school studies subjected to potable water and central power disruption. Shading indicates absolute correlation between 0.20 and 0.39 (light shading), 0.40 and 0.79 (medium shading), and above 0.79 (dark shading).

Building	Scenarios	Correlation values						
		Diversity	Redundancy	Capacity	Demand	Alt. water	Passivity	LOS
Multi-residential	1-9 (n=450)	-0.33	-0.19	0.63	-0.07	0.25	1.00	1.00
	1-7 (n=350)	0.33	0.24	0.62	-0.11	1.00	1.00	1.00
Elementary school	1-9 (n=450)	0.00	0.08	0.09	0.07	0.20	0.91	1.00
	1-7 (n=350)	0.67	0.64	0.06	0.09	0.80	0.81	1.00

Outcomes from this assessment indicate that alternative water sources may be categorized as primary or secondary based on origin and dependence to other building components. In the scenarios considered, rainwater is a primary source because it was not limited by disruptions in power or potable supply. Condensate is a secondary supply because production relies on energy-based HVAC equipment. Recycled wastewater is also labeled as a secondary source due to its reliance on other sources for production and is unique in that it multiplies the usefulness of the original source water within the building water system. A

combination of primary rainwater and secondary recycled wastewater sources resulted in stable resilience curves providing relatively constant LOS over a range of disruption events and is the preferred strategy for long-term resilience.

Table 7.13: Summary of average indicator values to LOS for multi-residential and elementary school studies subjected to potable water disruption. Shading indicates absolute correlation between 0.20 and 0.39 (light shading), 0.40 and 0.79 (medium shading), and above 0.79 (dark shading).

Building	Scenarios	Correlation values									
		Disruption	Diversity	Redundancy	Capacity	Demand	Alternative water	Passivity	Preparation	Adaptation potential	LOS
Multi-residential	1-9 (n=45)	-0.26	-0.16	0.06	0.78	-0.19	-0.05	0.91	-0.07	0.06	1.00
	1-7 (n=35)	-0.22	0.85	0.85	0.64	-0.14	1.00	0.46	0.94	-0.93	1.00
Elementary school	1-9 (n=45)	-0.06	-0.01	0.09	0.42	0.02	0.04	0.04	-0.12	0.12	1.00
	1-7 (n=35)	0.04	0.91	0.87	0.53	-0.03	0.94	0.83	0.78	-0.78	1.00

Table 7.14: Summary of average indicator values to LOS for multi-residential and elementary school studies subjected to potable water and central power disruption. Shading indicates absolute correlation between 0.20 and 0.39 (light shading), 0.40 and 0.79 (medium shading), and above 0.79 (dark shading).

Building	Scenarios	Correlation values									
		Disruption	Diversity	Redundancy	Capacity	Demand	Alternative water	Passivity	Preparation	Adaptation potential	LOS
Multi-residential	1-9 (n=45)	-0.20	-0.38	-0.22	0.76	-0.15	-0.26	1.00	-0.42	0.41	1.00
	1-7 (n=35)	-0.18	0.69	0.50	0.65	-0.10	1.00	1.00	0.32	-0.29	1.00
Elementary school	1-9 (n=45)	-0.24	-0.02	0.08	0.41	0.18	0.02	0.93	-0.13	0.13	1.00
	1-7 (n=35)	-0.18	0.91	0.87	0.52	0.16	0.80	0.79	0.79	-0.79	1.00

## 8 CONCLUSION

This research quantified building water cycle resilience in absolute terms of functionality based on the fulfillment of water demands by water sources. The results of this research include a framework and metrics for measuring building resilience. Developments in the conventional and high-efficiency (green building, smart building, net-zero building) building industry affect the builders and users of building projects, as well as the social and ecological environments. This framework can be a powerful tool for designers and managers to evaluate and increase both existing and future building resilience, thereby also improving the resilience of communities and protecting human health. Analysis of water management strategies and attributes that enhance resilience resulted in a set of indicators used to evaluate a building's water cycle resilience.

Chapter 4 introduced a water prioritization framework necessary for the allocation of water sources to water demands when multiple connections exist to fulfill demand functions. Prioritization is a prerequisite step for the development of models that aim to evaluate the building water cycle and is also necessary in building design for building automation systems. Different prioritization schemes were shown to affect demand-source allocations of water within the building water cycle and consequently vary potable water offsets and demand fulfillment by non-potable sources. Correspondingly, prioritization schemes also affect the resilience of building water cycles by limiting source availability for demand fulfillment. Chapter 4 also identified the importance of storage to prolong available water sources for consumption when source profiles are not synchronized with demand profiles. The prioritization scheme in Chapter 4 forms the foundation of the WRAM in Chapter 6.



Chapter 5 resulted in real building water demand profiles acquired using AMR smart meters. The smart meters were successful at collecting hourly data capable of capturing diurnal water use patterns for the four building types studied (multi-residential neighborhood, commercial building, elementary school, and community center). Tracking changes in diurnal curve features over time established different degrees of variation for each building site based on day of the week and month of the year. The multi-residential neighborhood had the least variation among curve attributes due to the relatively stable diurnal pattern, whereas variation increased for the building sites due to restricted operating hours and increased impacts associated with transient occupancy. The hourly water use data proved to be an optimal resolution to capture diurnal patterns over long-term duration, and the data for the multi-residential and elementary school locations was used as baseline demand profiles for the resilience assessment by the WRAM in Chapter 7.

Chapter 6 developed the WRAM used to quantify the resilience of building water cycles by incorporating the prioritization framework from Chapter 4 and adding storage elements and variable time delays to water pathways to accommodate transit and treatment. Chapter 2 identified that building water decision support tools must recognize water-demand connections, allow for the inclusion of alternative water sources, be flexible enough to emulate different building water cycles for unique building types, have dynamic capabilities, and project output profiles based on input parameters. The WRAM produced fulfills these prerequisites by the inclusion of 14 demand and 8 source subsectors that may be manipulated based on user preferences by allowing or restricting demand-source pathways that alter the baseline prioritization framework. Flexibility is further supported by the ability for users to directly input varying end-use and source profiles at a range of resolutions.

Chapter 7 utilized the WRAM and evaluated the resilience of the multi-residential neighborhood and elementary school to disruption of potable water and central power supplies. Aggregate water demand patterns from Chapter 5 were separated by end-use based on

previous studies at an hourly resolution. Source profiles were developed using climate data for the region. In each study, the fulfillment of five end-use demands was determined under scenarios that varied the availability of potable water, recycled wastewater, rainwater, and condensate. The resilience of each scenario was described in terms of the level of service (LOS) maintained during the disruption event. Indicators of redundancy, diversity, capacity, alternative water, passivity, preparation, and adaptation potential resulted in strong correlations with LOS values for individual disruption events of discrete disruption lengths ranging from 1 hour to 168 hours (7 days). However, the water demand indicator did not have a clear correlation which may be a result of interference by the variation of the other indicators. Resilience curves were produced by plotting the average LOS over the range of disruption lengths. Scenarios that relied heavily on storage resulted in high resilience (100% LOS) for short duration disruptions, but had steep declines when disruption lengths were longer. Contrarily, scenarios that included renewable water sources resulted in resilience curves with gradually decreasing slopes as the disruption length increased and are the preferred strategy for maintenance of system functions for the long-term.

The resilience curves of the scenarios tested revealed the impact that the type of water source utilized has on system resilience, and two types of alternative water sources have been introduced: primary sources and secondary sources. Rainwater has been defined as a primary source because it does not depend on energy or other building water component outputs for production. Secondary sources such as condensate and recycled wastewater are restricted when the power supply is interrupted, and recycled wastewater is also dependent on outflows from the water demands that supply the source. Therefore, not all alternative water sources have the same impact. Similar to the prioritization found in Chapter 4, it is recommended that the alternative water sources considered in the resilience assessment be categorized based on support of building water cycle resilience. Although a secondary alternative water source, recycled wastewater has the potential for the greatest impact by maintaining water in the system

for a number of usable cycles. Recycling water at higher levels allows for more flexibility and increased resilience of the building water cycle, but at the energy and financial cost of increased treatment. As a primary source, rainwater has the second greatest impact on the building water cycle, but its impact can only be multiplied through capture and recycling after its initial use. Condensate is given last priority due to its reliance on temperature and building HVAC components. When available, it is a good supplement to rainwater collection.

Although rainwater was shown to be a plentiful and crucial source to increase the resilience of the scenarios presented in Chapter 7, precipitation is directly dependent on regional climate. As also identified in Chapter 2 for net-zero buildings, dry regions are at a disadvantage for high-resilience achievement and must further rely on water recycling at a higher energy cost. This disadvantage may be compared using the adaptation potential indicator as a measure of available alternative water sources to the average building demand. Future work regarding water resilience should consider and identify the regional limitations associated with resilience.

Scenario outcomes from the resilience assessment in Chapter 7 support the allegation that sustainability is linked to resilience. Scenarios utilizing sustainable water sources resulted in increased resilience compared to the baseline case. The redundancy, diversity, and capacity of the alternative water sources utilized affected the magnitude of resilience and drop in LOS over time. Contrarily, high resilience did not require alternative water strategies within the building water cycle. Storage of non-alternative water (potable water) successfully maintained building water operations while storage remained; however, LOS values sharply dropped when disruption events exceed the time when storage had been depleted.

Outcomes from Chapter 4, 5, 6, and 7 all identify a need for expanded water sub-metering in order to produce a better understanding of water end-uses, source production, and efficiency of demand-source allocation. The resilience assessment did not include efficiency losses in calculations in order to simplify results. However, losses through the system

increased the difficulty of meeting water demands through the decreased supplies available and thereby will also decrease the resilience of the system. Optimally, sub-metered data should capture diurnal trends in water demand and source production for more accurate predictions of building water cycle efficiencies and resulting resilience.

The resilience assessment in Chapter 7 largely focused on supply-side scenarios and accommodated variation in demand through the randomization of the time that the disruption events occurred. However, future work regarding the quantification of water resilience should incorporate the change in water demand profiles that may occur in response to the disruption event. In addition, the baseline prioritization used for the resilience assessment was fixed, and therefore manipulation was present, but limited. The flexibility and robustness of the WRAM may be increased through the development of dynamic prioritization that captures changing preferences for demand-source connections over time. Implications regarding changes in demand profiles may also be studied with the inclusion of human behavior modeling that captures how building occupants interact with building water components under different stressors.

### **8.1 Consideration of Scale and Responsibility**

The building boundary was chosen as a manageable system for this research, but system functions are also present at community and regional levels in urban, suburban, rural, developed, and undeveloped areas. Therefore, the resilience framework is also scalable. The indicators used for the resilience assessment were defined at the building scale for the specific scenarios considered, but examples of indicator considerations at the urban neighborhood, city, and regional scale are provided in Table 8.1. The range of available water sources, demands, and management strategies is dependent on the spatial scale considered. For example at the building scale, both on-site (rainwater, stormwater, condensate, recycled wastewater) and off-site (municipal reclaimed water, potable water) water sources are available to improve diversity within the building water cycle. However, the water sources at the larger city-scale may be

limited to the production of municipal potable and reclaimed water, as collection and distribution of other alternative supplies is contained to smaller spatial footprints. At the regional level, water source diversity depends on the natural origin of water volumes, such as groundwater, surface waters, or seawater. With the flexibility to track function fulfillment at various levels, the WRAM presented may be utilized by groups with interests at different scales.

Table 8.1: Resilience indicator examples at various spatial scales.

		Scale			
		Local (Building)	Neighborhood	City	Region
Indicator	Diversity	Rainwater harvesting Condensate MBR (wastewater recycling) Reclaimed water Potable water	Rainwater harvesting MBR (wastewater recycling) Reclaimed water Potable water	Potable water Reclaimed water	Groundwater Surface water Seawater (desalination)
	Redundancy	Dual-plumbing Alternative water with potable backup	Alternative water with potable backup	“Smart” grids Circular water loops (limit dead-ends)	Well fields Multiple treatment facilities
	Capacity	Cistern	Water tower	Equalization basins Storage tanks	Reservoir
	Demand	End-uses Interior use Exterior use	End-uses Interior use Exterior use	Residential Commercial Industrial	Agriculture Industry Power generation Urban vs. rural
	Alternative water	Rainwater Condensate Stormwater Recycled wastewater	Rainwater Condensate Stormwater Recycled wastewater	Reclaimed water	Reclaimed water
	Passivity	Elevated storage On-site power generation	Water tower storage		
	Adaptation potential	Uncaptured precipitation, runoff	Water truck delivery	Conservation potential	Development of new sources

The ability to adapt indicators to different scales shows that resilience may be evaluated and improved based on different system scales. Consequently, the responsibility and optimal system level planning for ensuring resilient system functions is brought into question. For example, capacity has been shown to be an important component for building water cycle resilience; and at the building level, capacity can be increased through on-site water storage systems that serve the building. However, capacity can also be increased at the neighborhood-

level through the installation of water towers or at the regional level using reservoirs. In all cases, capacity has been increased to meet the water demands of the population, but the responsibility for operations and maintenance of the storage systems is at different levels of the community. In addition, the cost of implementing resilience measures may be undertaken by different parties before, during, and after a disruption event. Table 8.2 presents some groups at the individual and societal level that have the opportunity to implement resilient preparation measures at a present cost or incur a response cost in the future. Building designers and owners can implement resilience measures at the individual building-level to minimize disruption impacts. In addition, building occupants may also affect the resilience through a change in behavior within the building system. At the societal level, government officials, researchers, and business leaders can drive the adoption of preparation measures within the built environment through persuasion or regulation. If preparation measures are not implemented, the cost to respond to disruption events (in the future) is transferred to emergency management services, including first responders and federal assistance agencies. In addition, the cost of action before disruption or response after disruption is not the same, but rather the contingency cost of regaining function after a disruption event may be higher than maintaining the same level of service during normal conditions. As a result, policy questions arise regarding the role of individuals and society in implementing resilience strategies – at what point in time should resilience measures be implemented (in preparation or response) and who is responsible for the cost associated with these measures?

The resilience assessment evaluated different building water cycle scenarios each with an associated cost in comparison to the baseline building water system. The benefit of each scenario was evident when the building water cycle was subjected to a disruption. However, the resilience benefit is lost if the disruption does not occur. Therefore, it is desirable to incorporate measures that increase both the resilience and environmental sustainability of the system. In this way, benefits are gained in terms of efficient water management and decreased

environmental impacts, and increased resilience is an additional asset. The need for a disruption event to occur in order to evaluate the payback benefit from the inclusion of resilience measures diminishes the value of a potable water storage strategy because there is no added benefit; if a disruption event never occurs, the potable water storage system is not necessary. Preferably, utilizing alternative water sources with a potable backup may incur added benefits in potable water offsets and reduced environmental impacts. Therefore, resilience should not be a singular goal, but rather included as part of a larger sustainable goal.

Table 8.2: Scale of responsibility for incorporating resilience into the built environment. Costs may be incurred in preparation of (present) or in response to (future) potential disruption events at the individual or societal level.

		Scale	
		Individual	Societal
Cost	Present	Designer Building owner Occupant Code developers Financial institutions (investment, insurance)	City managers Politicians Researchers Business leaders
	Future		Emergency management (local, state, federal) Police, fire, rescue

## 8.2 Recommendations for Future Research

This research has found that the resilience of the building water cycle can be quantified in absolute terms based on the level of service of functions. However, limitations were identified within the developed framework and application of the WRAM that support the need for further research. Expanded knowledge is desired in the following areas:

- Dynamic prioritization. The prioritization framework in Chapter 4 is based on a set baseline prioritization scheme which is manipulated by allowing or disallowing demand-source water connections. Connections may change over time, but the baseline priorities are constant. In reality, the baseline prioritization should contain the ability to adapt in response to changes in regulation, cost, availability, or user preferences. The

opportunity exists to develop a dynamic prioritization framework that has a baseline customizable to water use drivers in any region and may adjust to external pressures.

- Sub-metered water use. Only two of the four buildings in which water use data was collected (Chapter 5) were used for the resilience assessment. Average diurnal water use patterns exist, but it is difficult to obtain detailed water use data at a high resolution and for a long duration. Detailed aggregate water use data was used for this research, but specific water consumption by end-use was not available. The water demand and source patterns are not the same for all buildings or constant over time. The magnitude of demands and sources, in addition to demand-source connections, affects the efficiency of water allocation, environmental sustainability, and resilience of the building; and therefore, knowledge about the drivers, benefits, variability, and collection methods for on-site water source production and consumption of water by end-uses will help validate performance.
- Resilience quantification and indicators. A set of building water cycle resilience indicators was presented in Chapter 7. The list of indicators is not inclusive, and additional research may present new indicators with different definitions. Although the resilience framework in this study is developed based on a building water cycle, the steps taken to create a scheme for the quantitative evaluation of resilience can be applied to other building functions because the foundation of the framework analyzes how well a function is being met, or how well supply meets demand. Resilience associated with other building functions is measurable if the function can be defined in absolute terms. Current energy models allow for the estimation of building demand loads and track daily and seasonal changes and thus provide energy demand profiles that can be applied to the resilience assessment framework. Energy pathways are commonly controlled with building automation systems and have an inherent priority, but an explicit prioritization framework that assigns unique preferences to individual energy



pathways is the basis for development of an energy resilience assessment model. The water demand-source pathways rely on energy inputs to move and treat water, and energy production requires water inputs. Coupling the shared synergistic elements of separate water and energy resilience models allows for the future development of a balanced energy-water nexus model capable of evaluating resilience of both systems simultaneously.

- Effect of response strategies. This research largely focused on the instantaneous capabilities, or inherent resilience, within the building water cycle. However, additional strategies may be in place that are inherent within the system, but require a delay before full activation. Analysis of additional scenarios that implement other (inherent or response) technologies and strategies not included in this research may result in revised indicators and best practices for resilient design. As previously discussed, there are implications for policy addressing responsible parties and the scale of responsibility regarding resilience.

## REFERENCES

- Abel, N., and Langston, A. (2001). Evolution of a social-ecological system: Adaptation and resilience in the New South Wales Rangelands 1850 to 2020. Manuscript available at [URL]: [http://www.cse.csiro.au/research/nswrangelands/pubs/popular\\_articles/Draft\\_Paper.pdf](http://www.cse.csiro.au/research/nswrangelands/pubs/popular_articles/Draft_Paper.pdf).
- Adger, W. (2000). Social and ecological resilience: Are they related? *Progress in Human Geography*, 24, 347-364.
- Adger, W. N. (2003). Social capital, collective action and adaptation to climate change. *Economic Geography*, 79, 387-404.
- Adger, W. N., Hughes, T., Folke, C., Carpenter, S. R., and Rockström, J. (2005). Social-ecological resilience to coastal disasters. *Science*, 309, 1036-1039.
- Ahmed, R., Seedat, M., van Niekerk, A., and Bulbulia, S. (2004). Discerning community resilience in disadvantaged communities in the context of violence and injury prevention. *South African Journal of Psychology*, 34, 386-408.
- Al-Jayyousi, O. R. (2003) Greywater reuse: towards sustainable water management. *Desalination*, 156(1-3), 181-192.
- Allenby, B., and Fink, J. (2005). Toward inherently and secure resilience societies. *Science*, 309, 1034-1036.
- Alvisi, S., Franchini, M., and Marinelli, A. (2007). A short-term, pattern-based model for water-demand forecasting. *Journal of Hydroinformatics*, 9(1), 39-50.
- American Water Works Association. (1989). *AWWA manual M32-Distribution network analysis for water utilities*. Denver: AWWA.
- Anastas, P. T. (2012). Fundamental changes to EPA's research enterprise: The path forward. *Environmental science & technology*, 46(2), 580-586.
- Anderies, J. M., Janssen, M. A., and Ostrom, E. (2004). A framework to analyze the robustness of social-ecological systems from an institutional perspective. *Ecology and Society*, 9(18); online at <http://www.ecologyandsociety.org/vol9/iss1/art18>.
- Anderson, J., Adin, A., Crook, J., Davis, C., Hultquist, R., Jimenez-Cisneros, B., Kennedy, W., Sheikh, B., and Van der Merwe, B. (2001) Climbing the ladder: A step by step approach to international guidelines for water recycling. *Wat. Sci. Tech.* 43(10), 1-8.

- Asano, T. (2002). Water from (waste)water – the dependable water resource. *Water Science and Technology*, 45(8), 23-33.
- ASHRAE (2013) BACnet. <http://www.bacnet.org/> (accessed 31 May 2013)
- Atasoy, E., Murat, S., Baban, A., and Tiris, M. (2007). Membrane bioreactor (MBR) treatment of segregated household wastewater for reuse. *CLEAN – Soil, Air Water*, 35(5), 465-472.
- Aubuchon, C. P., and Morley, K. M. (2012). Lessons from short-term supply disruptions: Providing confidence and context to FEMA's methodology. Prepared for Industrial Economics Incorporated under EPA contract number EP-W-10-002, subcontract number 8070-Aubuchon.
- Beal, C. D., and Flynn, J. (2015). Toward the digital water age: Survey and case studies of Australian water utility smart-metering programs. *Utilities Policy*, 32, 29-37.
- Berardi, U. (2013). Clarifying the new interpretations of the concept of sustainable building. *Sustainable Cities and Society*, 8, 72-78.
- Blokker, E., Vreeburg, J. H. G., and van Dijk, J. C. (2010). Simulating residential water demand with a stochastic end-use model. *Journal of Water Resources Planning and Management*, 136(1), 19-26. doi: 10.11061/(ASCE)WR.1943-5452.0000002
- Bodin, P., and Wiman, B. (2004). Resilience and other stability concepts in ecology: Notes on their origin, validity, and usefulness. *ESS Bulletin*, 2, 33-43.
- Boehler, M., Joss, A., Buetzer, S., Holzapel, M., Mooser, H., and Siengrist, H. (2007). Treatment of toilet wastewater for reuse in a membrane bioreactor. *Water Science and Technology*, 56(5), 63-70.
- Boin, A., and McConnell, A. (2007) Preparing for critical infrastructure breakdowns: the limits of crisis management and the need for resilience. *Journal of Contingencies and Crisis Management*, 15(1), 50-59.
- Boland, J. J. (1997). Assessing urban water use and the role of water conservation measures under climate uncertainty. *Climatic Change*, 37, 157-176.
- Bolund, P., and Hunhammar, S. (1999). Ecosystem services in urban areas. *Ecological Economics*, 29(2), 293-301.
- Booth, S., Barnett, J., Burman, K., Hambrick, J., and Westby, R. (2010). "Net Zero Energy Military Installations – A Guide to Assessment and Planning." Technical report NREL/TP-7A2-48876.
- Boyle, T., Giurco, D., Mukheibir, P., Liu, A., Moy, C., White, S., and Stewart, R. (2013). Intelligent metering for urban water: A review. *Water*, 5(3), 1052-1081.
- Brand, F. S., and Jax, K. (2007). Focusing the meaning(s) of resilience: Resilience as a descriptive concept and a boundary object. *Ecology and Society*, 12(1), 23. [online] URL: <http://www.ecologyandsociety.org/vol12/iss1/art23/>.

- Brenkert, A. L., and Malone, E. L. (2005) Modeling vulnerability and resilience to climate change: a case study of India and Indian states. *Climatic Change*, 72(1-2), 57-102.
- Brock, W. A., Mäler, K.-G., and Perrings, C. (2002). Resilience and sustainability: The economic analysis of nonlinear systems. In *Panarchy: Understanding Transformations in Systems of Humans and Nature*, Gunderson, L. H. and Holling, C. S., eds., Island Press, Washington, D.C., pp. 261-289.
- Brown, D., and J. Kulig (1996/97). The concept of resiliency: Theoretical lessons from community research. *Health and Canadian Society*, 4, 29-52.
- Browning-Aiken, A., Ormerod, K. J., and Scott, C. A. (2011). Testing the climate for non-potable water reuse: opportunities and challenges in water-scarce urban growth corridors. *Journal of Environmental Policy & Planning*, 13(3), 253-275.
- Bruneau, M., Chang, S. E., Eguchi, R. T., Lee, G. C., O'Rourke, T. D., Reinhorn, A. M., Shinozuka, M., Tierney, K., Wallace, W. A., and von Winterfeldt, D. (2003). A Framework to quantitatively assess and enhance the seismic resilience of communities. *Earthquake Spectra*, 19(4), 733-752.
- Building Green. (2015). Air conditioning condensate calculator. Retrieved from [http://www.buildinggreen.com/calc/calc\\_condensate.cfm](http://www.buildinggreen.com/calc/calc_condensate.cfm)
- Buchberger, S. G., and Wells, G. J. (1996). Intensity, duration, and frequency of residential water demands. *Journal of Water Resources Planning and Management*, 122(1), 11-19.
- Butler, L., Morland, L., and Leskin, G. (2007). Psychological resilience in the face of terrorism. In Bongar, B., Brown, L., Beutler, L., Beckenridge, J., and Zimbardo, P. (eds.), *Psychology of terrorism*. Oxford University Press, New York, pp. 400-417.
- Caldwell, A., and Porter, S. (2010). Commission expresses gratitude. *Tampa Bay Newspapers*. Retrieved from [http://www.tbnweekly.com/pubs/dunedin\\_beacon/content\\_articles/022510\\_dun-03.txt](http://www.tbnweekly.com/pubs/dunedin_beacon/content_articles/022510_dun-03.txt) (accessed 28 March 2015).
- Campbell, A. C., and Scott, C. A. (2011). Water reuse: policy implications of a decade of residential reclaimed water use in Tucson, Arizona. *Water International*, 36(7), 908-923.
- Carpenter, S., B. Walker, J. M. Anderies and N. Abel (2001). From metaphor to measurement: resilience of what to what? *Ecosystems*, 4(8), 765-781.
- Carter, T., and Fowler, L. (2008) Establishing green roof infrastructure through environmental policy instruments. *Environ. Manage.* 42(1), 151-164.
- Cassidy, R. (Ed.). (2003). White paper on sustainability. *Building Design & Construction*, 1-48.
- CBCL (2011). Study on water quality and demand on public water supplies with variable flow regimes and water demand. [http://www.env.gov.nl.ca/env/waterres/reports/drinking\\_water/Demand\\_Study\\_Jan\\_2012.pdf](http://www.env.gov.nl.ca/env/waterres/reports/drinking_water/Demand_Study_Jan_2012.pdf) (accessed 2 February 2015)

- Center for Community Enterprise (2000).  
<http://www.cedworks.com/files/pdf/free/MW100410.pdf>.
- Chamberlain, B. C., Carenini, G., Öberg, G., Poole, D. and Taheri, H. (2014) A decision support system for the design and evaluation of sustainable wastewater solutions. *IEEE T. Comput.* 63(1), 1-14.
- Chang, N.-B., Rivera, B. J., and Wanielista, M. P. (2011). Optimal design for water conservation and energy savings using green roofs in a green building under mixed uncertainties. *Journal of Cleaner Production*, 19(11), 1180-1188. doi: 10.1016/j.jclepro.2011.02.008
- Chang, S. E., and Shinozuka, M. (2004). Measuring improvements in the disaster resilience of communities. *Earthquake Spectra*, 20(3), 739-755.
- Cheng, C.-L. (2003). Evaluating water conservation measures for green building in Taiwan. *Building and Environment*, 38(2), 369-379. doi: 10.1016/S0360-1323(02)00062-8. doi: 10.1016/S0360-1323(02)00062-8
- Chenoweth, L., and Stehlik, D. (2001). Building resilient communities: Social work practice and rural Queensland. *Australian Social Work*, 54(2), 47-54.
- Chung, E.-S., and Lee, K. S. (2009). Prioritization of Water Management for Sustainability Using Hydrologic Simulation Model and Multicriteria Decision Making Techniques. *Journal of Environmental Management*, 90(3):1502-1511.
- Cimellaro, G. P., Reinhorn, A. M., and Bruneau, M. (2010). Framework for analytical quantification of disaster resilience. *Engineering Structures*, 32(11), 3639-3649.
- City of Toronto (2013) Green roof bylaw. <http://www.toronto.ca/greenroofs/overview.htm> (accessed 31 May 2013)
- Clark, C., Adriaens, P., and Talbot, F. B. (2008). Green roof valuation: a probabilistic economic analysis of environmental benefits. *Environmental Science Technology*, 42(6), 2155-2161.
- Clerico, E. (2007). The future of water reuse in NYC. Retrieved from [http://allianceenvironmentalllc.com/pdfs/AE\\_NYC\\_Incentives\\_White\\_Paper\\_final.pdf](http://allianceenvironmentalllc.com/pdfs/AE_NYC_Incentives_White_Paper_final.pdf)
- Coaffee, J. (2008). Risk, resilience, and environmentally sustainable cities. *Energy Policy*, 36(12), 4633-4638.
- Cole, R. J. (2012). Transitioning from green to regenerative design. *Building Research & Information*, 40(1), 39-53. doi:10.1080/09613218.2011.610608
- Cole, R. J., Busby, P., Guenther, R., Briney, L., Blaviesciunaite, A., and Alencar, T. (2012). A regenerative design framework: setting new aspirations and initiating new discussions. *Building Research & Information*, 40(1), 95-111. doi:10.1080/09613218.2011.616098
- Coles, E., and Buckle, P. (2004). Developing community resilience as a foundation for effective disaster recovery. *Australian Journal of Emergency Management*, 19, 6-15.

- Comfort, L. (1999). *Shared Risk: Complex Systems in Seismic Response*, Pergamon, New York
- Crawford, R. H., and Pullen, S. (2011). Life Cycle Water Analysis of a Residential Building and Its Occupants. *Building Research & Information*, 39(6), 589-602.
- Crawley, D. B., Hand, J. W., Kummert, M., and Griffith, B. T. (2008). Contrasting the Capabilities of Building Energy Performance Simulation Programs. *Building and Environment*, 43(4), 661-673.
- Crook, J., and Surampalli, R. Y. (1996). Water reclamation and reuse criteria in the U.S. *Water Science and Technology*, 33(10-11), 451-462.
- CSIRO. (2012). House Water Expert Software. Retrieved from. <http://www.csiro.au/products/House-Water-Expert> (accessed 13 May 2014)
- Cumming, G. S., Barnes, G., Perz, S., Schmink, M., Sieving, K. E., Southworth, J., Binford, M., Holt, R. D., Stickler, C., and van Holt, T. (2005). An exploratory framework for the empirical measurements of resilience. *Ecosystems*, 8(8), 975-987.
- Cutter, S. L. (1996). Vulnerability to environmental hazards. *Progress in Human Geography*, 20(4), 529-539.
- Cutter, S. L. (2008). A place-based model for understanding community resilience to natural disasters. *Global Environmental Change*, 18(4), 598-606.
- Cutter, S. L., Burton, C. G., and Emrich, C. T. (2010). Disaster resilience indicators for benchmarking baseline conditions. *Journal of Homeland Security and Emergency Management*, 7(1), article 51.
- Davis, A. P. (2005). Green engineering principles promote low-impact development. *Environmental Science and Technology*, 39(16), 338A-344A.
- De Bruijn, K. M. (2004). Resilience indicators for flood risk management systems of lowland rivers. *International Journal of River Basin Management*, 2(3), 199-210.
- Dessai, S., and Hulme, M. (2007). Assessing the robustness of adaptation decisions to climate change uncertainties: A case study on water resources management in the East of England. *Global Environmental Change*, 17(1), 59-72. doi: 10.1016/j.gloenvcha.2006.11.005
- Dolnicar, S., Hurlimann, A., and Grün, B. (2011). What affects public acceptance of recycled and desalinated water? *Water Research*, 45(2), 933-943.
- du Plessis, C. (2012). Towards a regenerative paradigm for the built environment. *Building Research & Information*, 40(1), 7-22. doi:10.1080/09613218.2012.628548
- Dziegielewski, B., Kiefer, J. C., Optiz, E. M., DeOreo, W. B., Mayer, P., and Nelson, J. O. (2000). Commercial and institutional end uses of water. *American Water Works Association*.

- Echelon Corporation (2013) LonWorks. <http://www.echelon.com/technology/lonworks/> (accessed 31 May 2013)
- Egeland, B., Carlson, E., and Sroufe, L. (1993). Resilience as process. *Development and Psychopathology*, 5, 517-528.
- Engle, N. L. and M. C. Lemos (2010). Unpacking governance: building adaptive capacity to climate change of river basins in Brazil. *Global Environmental Change*, 20(1), 4-13.
- FEMA [Federal Emergency Management Agency] (2009). BCA Reference Guide: Final. Prepared by URS group.
- Fidar, A., Memon, F. A., and Butler, D. (2010) Environmental implications of water efficient microcomponents in residential buildings. *Sci. Total Environ.* 408(23), 5828-5835.
- Fiksel, J. (2003). Designing resilient, sustainable systems. *Environmental Science & Technology*, 37(23), 5330-5339.
- Fiksel, J. (2006). Sustainability and resilience: toward a systems approach. *Sustainability: Science Practice and Policy*, 2(2), 14-21.
- Finley, M. R., Karakura, A., and Nbogani, R. (1991) Survey of intelligent building concepts. *IEEE Commun. Mag.* 29(4), 18-23.
- Flax, B. M. (1991) Intelligent buildings. *IEEE Commun. Mag.* 29(4), 24-27.
- Folke, C., Carpenter, S. R., Elmqvist, T., Gunderson, L., Holling, C. S., Walker, B., ... and Svedin, U. (2002). Resilience and sustainable development. *Building Adaptive Capacity in a World of Transformations. Scientific Background Paper on Resilience for the process of The World Summit on Sustainable Development on behalf of The Environmental Advisory Council to the Swedish Government. Stockholm, Sweden.*
- Ganor, M., and Ben-Lavy, Y. (2003). Community resilience: Lessons derived from Giló under fire. *Journal of Jewish Communal Service*, Winter/Spring, 105-108.
- Ghisi, E., and Ferreira, D. F. (2007). Potential for potable water savings by using rainwater and greywater in a multi-storey residential building in southern Brazil. *Building and Environment*, 42(7), 2512-2522.
- Gleick, P. H., Haasz, D., Henges-Jeck, C., Srinivasan, V., Wolff, G., Cushing, K. K., and Mann, A. (2003). *Waste Not, Want Not: The Potential for Urban Water Conservation in California*. Oakland: Pacific Institute.
- Godschalk, D. (2003). Urban hazard mitigation: Creating resilient cities. *National Hazards Review*, 4, 136-143.
- Gordon, J. (1978). *Structures*. Penguin Books, Harmondsworth, UK.
- Gosling, J., Sassi, P., Naim, M., and Lark, R. (2013). Adaptable buildings: A systems approach. *Sustainable Cities and Society*, 7, 44-51.

- Guendert, D., and Jordan, E. (2004). Urban reuse: bringing water treatment where it's needed most. *American Water Works Association Journal*, 96(6), 52-56.
- Gunderson, L. H., and C. S. Holling, editors (2002). *Panarchy: Understanding transformations in human and natural systems*. Island Press, Washington, D.C.
- Gunderson, L. H., and Folke, C. (2005). Resilience – Now More than Ever (editorial). *Ecology and Society*, 10(2), at <http://www.ecologyandsociety.org/vol10/iss2/art22/>.
- Guz, K. (2005). Condensate Water Recovery. *ASHRAE Journal*, 47(6):54-56.
- Haimes, Y. Y. (2009). On the definition of resilience in systems. *Risk Analysis*, 29(4), 498-501.
- Hardy, M. J., Kuczera, G., and Coonbes, P. J. (2005). Integrated urban water cycle management: the UrbanCycle model. *Water Science and Technology*, 52(9), 1-9.
- Hauber-Davidson, G. (2007). Large commercial rainwater harvesting projects. *13th International Rainwater Capture Systems Conference* Sydney, Australia.
- Helfand, G. E., Park, J. S., Nassauer, J. I., and Kosek, S. (2006). The economics of native plants in residential landscape designs. *Landscape and Urban Planning*, 78(3), 229-240.
- Henry, D., and Ramirez-Marquez, J. E. (2012). Generic metrics and quantitative approaches for system resilience as a function of time. *Reliability Engineering & System Safety*, 99, 114-122.
- Hernandez, P., and Kenny, P. (2010). From net energy to zero energy buildings: defining life cycle zero energy buildings (LC-ZEB). *Energy and Buildings*, 42(6), 815-821. doi: 10.1016/j.enbuild.2009.12.001
- Hoekstra, A. Y. (2008). Water neutral: Reducing and offsetting the impacts of water footprints. *Value of Water Research Report Series No. 28*.
- Holling, C. (1973). Resilience and stability of ecological systems. *Annual Review of Ecology and Systematics*, 4, 1-23.
- Holling, C. S., Schindler, D. W., Walker, B. W., and Roughgarden, J. (1995). Biodiversity in the functioning of ecosystems: an ecological synthesis. In Perrings, C., Maler, K. G., Folke, C., Holling, C. S., and Jansson, B. O. (eds.), *Biodiversity loss: economic and ecological issues*. Cambridge University Press, Cambridge, pp. 44-83.
- Holling, C. S. (1996). Engineering resilience versus ecological resilience. In: Schulze, P. editor. *Engineering within ecological constraints*. Washington (DC): National Academy Press, 31-44.
- Holling, C.S. (2001). Understanding the complexity of economic, ecological, and social systems. *Ecosystems*, 4, 390-405.
- Howell, J. A. (2004). Future of membranes and membrane reactors in green technologies and for water reuse. *Desalination*, 162(10), 1-11.



- Huang, C.-L., Vause, J., Ma, H.-W., and Yu, C.-P. (2013). Urban water metabolism efficiency assessment: Integrated analysis of available and virtual water. *Science of the Total Environment*, 452-453, 19-27. doi: 10.1016/j.scitotenv.2013.02.044
- Hutton, G., Haller, L., and Bartram, J. (2007). Global cost-benefit analysis of water supply and sanitation interventions. *Journal of water and health*, 5(4), 481-502.
- Inman, D., and Jeffrey, P. (2006). A review of residential water conservation tool performance and influences on implementation effectiveness. *Urban Water Journal*, 3(3), 127-143. doi: 10.1080/15730620600961288
- Institute of Medicine (US) Forum on Microbial Threats (2009). Lessons from waterborne disease outbreaks. In *Global issues in water, sanitation, and health: Workshop summary*. Washington, DC: National Academies Press. Retrieved from: <http://www.ncbi.nlm.nih.gov/books/NBK28459/>.
- International Living Future Institute. (2012). Living building challenge 2.1. Retrieved from [http://living-future.org/sites/default/files/LBC/LBC\\_Documents/LBC%202\\_1%2012-0501.pdf](http://living-future.org/sites/default/files/LBC/LBC_Documents/LBC%202_1%2012-0501.pdf)
- James, P., Tzoulas, K., Adams, M. D., Barber, A., Box, J., Breuste, J., ... and Thompson, C. W. (2009). Towards an integrated understanding of green space in the European built environment. *Urban Forestry & Urban Greening*, 8(2), 65-75.
- Jamrah, A., Al-Omari, A., Al-Qasem, L., and Ghani, N.A. (2006) Assessment of availability and characteristics of greywater in Amman. *Water Int.* 31(2), 210-220.
- Janssen, M. A. (2007). An update on the scholarly networks on resilience, vulnerability, and adaptation within the human dimensions of global environmental change. *Ecology and Society*, 12(2), 9. [online] URL: <http://www.ecologyandsociety.org/vol12/iss2/art9>.
- Jefferson, B., Palmer, A., Jeffrey, P., Stuetz, R. and Judd, S. (2004). Grey water characterisation and its impact on the selection and operation of technologies for urban reuse. *Wat. Sci. Tech.* 50(2), 157-164.
- Joustra, C. (2010) An integrated building water management model for green building. M.Sc. thesis, Dept Civil & Environ. Eng., Univ. of South Florida, Tampa, United States.
- Joustra, C., Zevengergen, C., Brandenburg, E., Yeh, D. (2011). *Decision support system for smart shelter implementation*. Final research report for NSF International Research Experience for Students at UNESCO-IHE.
- Joustra, C., and Yeh, D. (2014). Decision support modeling for net-zero water buildings. In *Proceedings of the 2014 Winter Simulation Conference* (pp. 3176-3187). IEEE Press.
- Joustra, C. M., and Yeh, D. H. (2015a). Decision support systems for water reuse in smart building water cycle management. In F. A. Memon, & S. Ward (Eds.), *Alternative Water Supply Systems* (pp. 393-419). London: IWA Publishing.

- Joustra, C. M., and Yeh, D. H. (2015b). Demand-and source-driven prioritization framework toward integrated building water management (IBWM). *Sustainable Cities and Society*, 14, 114-125.
- Joustra, C. M., and Yeh, D. H. (2015c). Framework for net-zero and net-positive building water cycle management. *Building Research & Information*, 43(1), 121-132
- Kar, B. and Hodgson, M. E. (2008). A GIS-based model to determine site suitability of emergency evacuation shelters. *Transaction in GIS*, 12(2), 227-248.
- Katz, D. (2012) Building intelligence quotient 2.0 development update. Presented at *High-Performance Buildings Conf.*, Falls Church, 11-12 September.
- Kenway, S., Gregory, A., and McMahon, J. (2011). Urban water mass balance. *Journal of Industrial Ecology*, 15(5), 693-706. doi: 10.1111/j.1530-9290.2011.00357.x
- Kibert, C. J. (2013). *Sustainable construction: Green building design and delivery* (3rd ed.). Hoboken: John Wiley & Sons.
- Kibert, C. J., and Fard, M. M. (2012). Differentiating among low-energy, low-carbon and net-zero-energy building strategies for policy formulation. *Building Research & Information*, 40(5), 625-637. doi:10.1080/09613218.2012.703489
- Kimhi, S., and M. Shamai (2004). Community resilience and the impact of stress: Adult response to Israel's withdrawal from Lebanon. *Journal of Community Psychology*, 32, 439-451.
- Klein, R. J., Nicholls, R. J., and Thomalla, F. (2003). Resilience to natural hazards: How useful is this concept?. *Global Environmental Change Part B: Environmental Hazards*, 5(1), 35-45.
- Kofinas, G. (2003). Resilience of human-rangifer systems: Frames off resilience help to inform studies of human dimensions of change and regional sustainability. *IHDP Update*, 2, 6-7.
- Kumar, R., and Kaushik, S. C. (2005). Performance evaluation of green roof and shading for thermal protection of buildings. *Building and Environment*, 40(11), 1505-1511.
- Larsen, L., Rajkovich, N., Leighton, C., McCoy, K., Calhoun, K., Mallen, E., Bush, K., Pyke, C., McMahon, S., and Kwok, A. (2011). *Green building and climate resilience: Understanding impacts and preparing for changing conditions*.
- Lazarova, V., Levine, B., Sack, J., Cirelli, G., Jeffrey, P., Muntau, H., et al. (2001). Role of water reuse for enhancing integrated water management in Europe and Mediterranean countries. *Water Science and Technology*, 43(10), 25-33.
- Lazzarin, R. M., Castellotti, F., and Busato, F. (2005). Experimental measurements and numerical modeling of a green roof. *Energy and Buildings*, 37(12), 1260-1267.
- Licina, D., and Sekhar, C. (2012). Energy and water conservation from air handling unit condensate in hot and humid climates. *Energy and Buildings*, 45, 257-263.

- Little, R. G. (2003). Toward more robust infrastructure: observations on improving the resilience and reliability of critical systems. *Proceedings of the 36<sup>th</sup> Hawaii International Conference on System Sciences (HICSS'03)*.
- Loeff, B., and Fox, J. (2010). Smart Water Meters, Advanced Metering Infrastructure for Water Utilities: Market Drivers, Technology Issues, Deployment Case Studies, Key Industry Players, and Market Forecasts. *Pike Research*.
- Longstaff, P. (2005). *Security, resilience, and communication in unpredictable environments such as terrorism, natural disasters, and complex technology*. Author, Syracuse, New York.
- Liu, J., Dietz, T., Carpenter, S. R., Alberti, M., Folke, C., Moran, E., ... and Taylor, W. W. (2007). Complexity of coupled human and natural systems. *science*, 317(5844), 1513-1516.
- Liu, K., and Minor, J. (2005). Performance evaluation of an extensive green roof. *Greening Rooftops for Sustainable Communities* Washington, D.C., May 5-6, (pp. 1-11).
- Lucas, S., Coombes, P., and Sharma, A. (2010). The impact of diurnal water use patterns, demand management and rainwater tanks on water supply network design.
- Ludwig, A. (2006). *Create an oasis with greywater* (5th ed.). Santa Barbara: Oasis Design.
- Mackay, R., and Last, E. (2010). SWITCH city water balance: a scoping model for integrated urban water management. *Reviews in Environmental Science and Biotechnology*, 9(4), 291-296.
- Makropoulos, C. K., Natsis, K., Liu, S., Mittas, K., and Butler, D. (2008). Decision support for sustainable option selection in integrated urban water management. *Environmental Modelling & Software*, 23(12), 1448-1460.
- Marks, J., Martin, B., and Zadoroznyj, M. (2008). How Australians order acceptance of recycled water. *Journal of Sociology*, 44(1), 83-89.
- Marszal, A. J., Heiselberg, P., Bourrelle, J. S., Musall, E., Voss, K., Sartori, I., and Napolitano, A. (2011). Zero energy building – A review of definitions and calculation methodologies. *Energy and Buildings*, 43, 971-979. doi: 10.1016/j.enbuild.2010.12.022
- Masten, A. S., Best, K. M., and Garmezy, N. (1990). Resilience and development: Contributions from the study of children who overcome adversity. *Development and psychopathology*, 2(04), 425-444.
- McCulloch, J., MacCarthy, P., Guru, S. M., Peng, W., Hugo, D., and Terhorst, A. (2008). Wireless sensor network deployment for water use efficiency in irrigation. *Proceedings of the workshop on real-world wireless sensor networks* Glasgow, Scotland, (pp. 46-50).
- McDaniels, T., Chang, S., Cole, D., Mikawoz, J., and Longstaff, H. (2008). Fostering resilience to extreme events within infrastructure systems: Characterizing decision contexts for mitigation and adaptation. *Global Environmental Change*, 18(2), 310-318.

- Medina, J. (2011, 9 September). Human error investigated in California blackout's spread to six million. *The New York Times*. Retrieved from <http://www.nytimes.com/2011/09/10/us/10power.html>.
- Mengshan, L., Tansel, B., and Balbin, M. (2011). Goal based water conservation projections based on historical water use data and trends in Miami-Dade County. *Sustainable Cities and Society*, 1, 97-103.
- Mileti, D. (1999). *Disasters by Design: A Reassessment of Natural Hazards in the United States*. Joseph Henry Press, Washington, DC.
- Milman, A., and Short, A. (2008). Incorporating resilience into sustainability indicators: An example for the urban water sector. *Global Environmental Change*, 18(4), 758-767.
- Mitchell, V. G., Mein, R. G., and McMahon, T. A. (2001) Modelling the urban water cycle. *Environmental Modelling & Software*, 16(7), 615-629.
- Mo, W., Zhang, Q., Mihelcic, J. R., and Hokanson, D. R. (2011). Embodied energy comparison of surface water and groundwater supply options. *water research*, 45(17), 5577-5586.
- Montalto, F., Behr, C., Alfredo, K., Wolf, M., Arye, M. and Walsh, M. (2007). Rapid assessment of the cost-effectiveness of low impact development for CSO control. *Landscape Urban Plan*. 82(3), 117-131.
- Moteff, J., Copeland, C., and Fischer, J. (2003). Critical infrastructures: what makes an infrastructure critical? *Report for Congress*.
- Naimi-Ait-Aoudia, M., & Berezowska-Azzag, E. (2014). Algiers carrying capacity with respect to per capita domestic water use. *Sustainable Cities and Society*, 13, 1-11.
- National Geographic Society (2013) *Change the course: Reducing water use*. Retrieved from <http://environment.nationalgeographic.com/environment> (accessed 29 May 2013)
- New Buildings Institute. (2014). *Getting to Zero Status Update: A Look at the Projects, Policies and Programs Driving Net Zero Energy Performance in Commercial Buildings*. Retrieved from [http://newbuildings.org/sites/default/files/2014\\_Getting\\_to\\_Zero\\_Update.pdf](http://newbuildings.org/sites/default/files/2014_Getting_to_Zero_Update.pdf)
- Nigg, J. M., Barnshaw, J., and Torres, M. R. (2006). Hurricane Katrina and the flooding of New Orleans: Emergent issues in sheltering and temporary housing. *The Annals of the American Academy of Political and Social Science*, 604(1), 113-128.
- Norris, F. H., Stevens, S. P., Pfefferbaum, B., Wyche, K. F., and Pfefferbaum, R. L. (2008). Community resilience as a metaphor, theory, set of capacities, and strategy for disaster readiness. *American journal of community psychology*, 41(1-2), 127-150.
- Novotny, V. (2013). Water-energy nexus: retrofitting urban areas to achieve zero pollution. *Building Research & Information*, 41(5), 589-604. doi: 0.1080/09613218.2013.804764
- NPR [National Public Radio] (2011, 2 November). Stuxnet raises 'blowback' risk in cyberwar. *NPR*. Retrieved from <http://www.npr.org/2011/11/02/141908180/stuxnet-raises-blowback-risk-in-cyberwar>.

- Oberndorfer, E., Lundholm, J., Bass, B., Coffman, R. R., Doshi, H., Dunnett, N., ... and Rowe, B. (2007). Green roofs as urban ecosystems: ecological structures, functions, and services. *BioScience*, 57(10), 823-833.
- Olmos, K. C., and Loge, F. J. (2013). Offsetting Water Conservation Costs to Achieve Net-Zero Water Use. *American Water Works Association Journal*, 105(2):41-42.
- Ott, K., and Döring, R. (2004). *Theorie und Praxis starker Nachhaltigkeit*. Metropolis (Theory and Practice of Strong Sustainability), Marburg, Germany.
- Owens, B., Macken, C., Rohloff, A., and Rosenberg, H. (2013). LEED v4: Impact category and point allocation development process. Retrieved from <http://www.usgbc.org/resources/leed-v4-impact-category-and-point-allocation-process-overview>
- Pacific Institute. (2010). "WECalc: Your Home Water-Energy-Climate Calculator." Retrieved from <http://www.wecalc.org/>
- Pandit, A., Lu, Z., and Crittenden, J. C. (2015). Managing the complexity of urban systems. *Journal of Industrial Ecology*.
- Paton, D., and Johnston, D. (2001). Disasters and communities: Vulnerability, resilience, and preparedness. *Disaster Prevention and Management*, 10, 270-277.
- Peretti, G., and La Rocca, F. (2000). The water 'in' and 'around' the building: The integration between bioclimatic water savings, and aesthetic aspects. *Renewable Energy*, 19(1-2), 1-5.
- Perrings, C. A. (2006). Resilience and sustainable development. *Environment and Development Economics*, 11, 417-427.
- Pfefferbaum, B. J., Reissman, D. B., Pfefferbaum, R. L., Klomp, R. W., and Gurwitch, R. H. (2005). Building resilience to mass trauma events. In L. Doll, S. Bonzo, J. Mercy, and D. Sleet (eds.), *Handbook on injury and violence prevention interventions*. Kluwer Academic Publishers, New York.
- Pickett, S. T. A., Cadenasso, M. L., and Grove, J. M. (2004). Resilient cities: Meanings, models, and metaphor for integrating the ecological, socio-economic, and planning realms. *Landscape and Urban Planning*, 69, 369-384.
- Pieterse-Quirijns, E. J., Blokker, E. J. M., van der Blom, E., and Vreenburg, J. H. G. (2013). Non-residential water demand model validates with extensive measurements and surveys. *Drink. Water Eng. Sci.*, 6, 99-114. doi: 10.5194/dwes-6-99-2013
- Plodinec, M. J. (2009). Definitions of resilience: An analysis. *Community and Regional Resilience Institute*.
- POLIS Project on Ecological Governance. (2010). WaterSmart Scenario Builder. Retrieved from <http://poliswaterproject.org/publication/362>

- Postel, S. L. (2000). Entering an era of scarcity: the challenges ahead. *Ecological Applications*, 10(4), 941-948.
- Power, D.J. (2002) Decision support systems: Concepts and resources for managers. Quorum Books, Westport.
- Quinlan, A. (2003). Resilience and adaptive capacity: Key components of sustainable social-ecological systems. *IHDP Update*, 2, 4-5.
- Reutter, M. (2012, 12 November). New water main break floods at Madison Street beneath I-83. *Baltimore Brew*. Retrieved from <http://www.baltimorebrew.com/2012/11/12/new-water-main-break-floods-at-madison-street-beneath-i-83/>.
- Richards, M., Hastings, D., Rhodes, D., and Weigel, A. (2007). Defining survivability for engineering systems. *Proceedings conference on systems engineering research (CSEA), March 14-16, Hoboken, NJ*.
- Rinaldi, S. M., Peerenboom, J. P., and Kelly, T. K. (2001). Identifying, understanding, and analyzing critical infrastructure interdependencies. *IEEE Control Systems Magazine*, 21(6), 11-25.
- Rockström, J. (2003). Resilience building and water demand management for drought mitigation. *Physics and Chemistry of the Earth*, 28(20-27), 869-877.
- Rose, A. (2007). Economic resilience to natural and man-made disasters: multidisciplinary origins and contextual dimensions. *Environmental Hazards*, 7(4), 383-398.
- Rose, A., and Liao, S. Y. (2005). Modeling regional economic resilience to disasters: A computable general equilibrium analysis of water service disruptions\*. *Journal of Regional Science*, 45(1), 75-112.
- Rose, A., Wing, I. S., Wei, D., and Avetisyan, M. (2012). Total regional economic losses from water supply disruptions to the Los Angeles County economy. Final report to the Los Angeles County Economic Development Corporation.
- Rushton, B. T. (2001). Low-impact parking lot design reduces runoff and pollutant loads. *Journal of Water Resources Planning and Management*, 127(3), 172-179.
- Salas, J. D., Rajagopalan, B., Saito, L., and Brown, C. (2012). Special section on climate change and water resources: Climate nonstationarity and water resources management. *Journal of Water Resources Planning and Management*, 138(5), 385-388. doi: 10.1061/(ASCE)WR.1943-5452.0000279
- Santana, M. V., Zhang, Q., and Mihelcic, J. R. (2014). Influence of Water Quality on the Embodied Energy of Drinking Water Treatment. *Environmental Science & Technology*, 48(5), 3084-3091.
- Sartori, I., Napolitano, A., Marszal, A. J., Pless, S., Torcellini, P., and Voss, K. (2010). Criteria for Definition of Net Zero Energy Buildings. In *Proceedings of the EUROSUN 2010 International Conference on Solar Heating, Cooling and Buildings*.

- Smart Buildings Institute (2013) Overview. <http://www.smartbuildingsinstitute.org/> (accessed 31 May 2013)
- SmartBuildings, LLC (2012) Smart building FAQs. <http://www.smart-buildings.com/faqs.html> (accessed 31 May 2013)
- Snoonian, D. (2003) Smart buildings. *IEEE Spectrum* 40(8), 18-23.
- Solomon, H. and Smith, H. H. (2007) Effectiveness of mandatory law of cistern construction for rainwater harvesting on supply and demand of public water in U.S. Virgin Islands. In *Proc. Of the 7<sup>th</sup> Caribbean Island Water Resources Congress*, St. Croix, 25-26 October.
- Sonn, C., and Fisher, A. (1998). Sense of community: Community resilient responses to oppression and change. *Journal of Community Psychology*, 26, 457-472.
- Sorgini, L. (2004). Packaged membrane systems offer cost-effective solutions. *American Water Works Association Journal*, 96(11), 48-50.
- Stephan, A., and Crawford, R. H. (2014). A comprehensive life cycle water analysis framework for residential buildings. *Building Research & Information*, 42(6), 685-695.
- Stoker, P., and Rothfeder, R. (2014). Drivers of urban water use. *Sustainable Cities and Society*, 12, 1-8.
- Subcommittee on Disaster Reduction (2005). *Grand Challenges for Disaster Reduction*. National Science & Technology Council, Committee on Environment and Natural Resources, Washington, D.C.
- Tamaki, H., Silva, G., and Goncalves, O. (2001) Submetering as an element of water demand management in water conservation programs. In *Proc. of the 27<sup>th</sup> International Symposium on Water Supply and Drainage for Buildings*, Portoroz, 17-20 September.
- Thompson, B. P., and Lawrence, C. B. (2010). Use of system dynamics as a decision-making tool in building design and operation. *Building and Environment*, 45(4), 1006-1015.
- Timmerman, P. (1981). *Vulnerability, resilience, and the collapse of society: A review of models and possible climatic applications*. Institute of Environmental Studies, University of Toronto, Toronto.
- Tobin, G. A. (1999). Sustainability and community resilience: the holy grail of hazards planning? *Global Environmental Change Part B: Environmental Hazards*, 1(1), 13-25.
- Torcellini, P., Pless, S., Deru, M., and Crawley, D. (2006). Zero energy buildings: a critical look at the definition. *National Renewable Energy Laboratory and Department of Energy, US*.
- UNISDR [United Nations Office for Disaster Risk Reduction]. (2015). ISO 37120 briefing note: the first ISO International Standard on city indicators
- United Nations (2011). *Global Assessment Report on Disaster Risk Reduction 2011: Revealing Risk, Redefining Development*. 2<sup>nd</sup> edition. Retrieved from: <http://www.preventionweb.net/english/hyogo/gar/2011/en/home/download.html>.

- United States Army. (2014). Army Vision for Net Zero. Retrieved from <http://army-energy.hqda.pentagon.mil/netzero/>
- University of Utah. (2012). Retrieved from <http://mesowest.utah.edu/index.html> (accessed 30 March 2015)
- USEPA [United States Environmental Protection Agency]. (2013). Water sense: Outdoor water use in the United States. <http://www.epa.gov/WaterSense/pubs/outdoor.html> (accessed 31 May 2013)
- USEPA. (2014a). Community-based water resiliency. Retrieved from <http://water.epa.gov/infrastructure/watersecurity/communities/index.cfm> (accessed 28 March 2015)
- USEPA. (2014b). Resilience analysis. Retrieved from <http://www.epa.gov/sustainability/analytics/resilience.htm> (accessed 28 March 2015)
- USEPA. (2013). Non-hazardous waste management hierarchy. Retrieved from <http://www.epa.gov/wastes/nonhaz/municipal/hierarchy.htm>
- USEPA (2009) Buildings and their impact on the environment: a statistical summary. <http://www.epa.gov/greenbuilding/pubs/gbstats.pdf> (accessed 31 May 2013)
- USGBC [United States Green Building Council]. (2013a) LEED 2009 for Existing Buildings Operations and Maintenance Rating System [http://www.usgbc.org/sites/default/files/LEED%202009%20Rating\\_EBOM-GLOBAL\\_07-2012\\_8d\\_0.pdf](http://www.usgbc.org/sites/default/files/LEED%202009%20Rating_EBOM-GLOBAL_07-2012_8d_0.pdf) (accessed 31 May 2013)
- USGBC (2013b) LEED 2009 for New Construction and Major Renovations Rating System. [http://www.usgbc.org/sites/default/files/LEED%202009%20RS\\_NC\\_04.01.13\\_current.pdf](http://www.usgbc.org/sites/default/files/LEED%202009%20RS_NC_04.01.13_current.pdf) (accessed 31 May 2013)
- USGBC (2013c) LEED for Homes Rating System. [http://www.usgbc.org/sites/default/files/LEED%20for%20Homes%20Rating%20System\\_updated%20Apr1A%202013.pdf](http://www.usgbc.org/sites/default/files/LEED%20for%20Homes%20Rating%20System_updated%20Apr1A%202013.pdf) (accessed 31 May 2013)
- USGBC (2012) Water use reduction additional guidance. <http://www.usgbc.org/Docs/Archive/General/Docs6493.pdf> (accessed 31 May 2013)
- USGBC. (2009a). *LEED reference guide for green building design and construction*.
- USGBC. (2009b). *LEED reference guide for green building operations and maintenance*.
- USGS [U.S. Geological Society]. (2013). Resilience. Retrieved from <http://www.usgs.gov/sdc/resilience.html> (accessed 28 March, 2015).
- VanWoert, N. D., Rowe, D. B., Andresen, J. A., Rugh, C. L., Fernandez, R. T., and Xiao, L. (2005). Green roof stormwater retention. *Journal of environmental quality*, 34(3), 1036-1044.



- Vogel, C., Moser, S. C., Kasperson, R. E., and Dabelko, G. D. (2007). Linking vulnerability, adaptation, and resilience science to practice: Pathways, players, and partnerships. *Global environmental change*, 17(3), 349-364.
- Voss, K., Sartori, I., Napolitano, A., Geier, S., Gonçalves, H., Hall, M., ... and Torcellini, P. (2010). Load matching and grid interaction of net zero energy buildings. In *Proceedings of the EUROSUN 2010 International Conference on Solar Heating, Cooling and Buildings*.
- Walker, B., Holling, C. S., Carpenter, S. R., and Kinzig, A. (2004). Resilience, adaptability and transformability in social-ecological systems. *Ecology and society*, 9(2), 5.
- Waller, M. (2001). Resilience in ecosystemic context: Evolution of the concept. *American Journal of Orthopsychiatry*, 71, 290-297.
- Wang, C. H., and Blackmore, J. M. (2009). Resilience concepts for water resource systems. *Journal of Water Resources Planning and Management*, 135(6), 528-536.
- Wang, R., Eckelman, M. J., and Zimmerman, J. B. (2013). Consequential environmental and economic life cycle assessment of green and gray stormwater infrastructures for combined sewer systems. *Environmental Science & Technology*, 47(19), 11189-11198.
- Wilbur, P. A. (2014). An Evaluation of the Use of Composting Latrines and the Perceptions of Excrement in Ngabe Communities in Panama. University of South Florida.
- Wildavsky, M. (1991). *Searching for Safety*. Transaction, New Brunswick, New Jersey.
- Wilson, A., ed. (2005). The New Orleans principles: celebrating the rich history of New Orleans through commitment to a sustainable future.
- Willuweit, L., and O'Sullivan, J. J. (2013). A decision support tool for sustainable planning of urban water systems: Presenting the dynamic urban water simulation model. *Water Research*, In Press.
- Wintgens, T., Melin, T., Schäfer, A., Khan, S., Muston, M., Bixio, D., and Thoeye, C. (2005) The role of membrane processes in municipal wastewater reclamation and reuse. *Desalination*, 178(1-3), 1-11.
- Wong, J.K.W., Li, H. and Wang, S.W. (2005) Intelligent building research: a review. *Automat. Constr.*, 14(1), 143-159.
- World Commission on Environment and Development. (1987). Report of the world commission on environment and development: Our Common Future. Retrieved from <http://www.un-documents.net/our-common-future.pdf>
- Wrobieski, T. (2012, 30 November). NYC to give Hurricane Sandy victims more time to pay water bills. *Staten Island Advance*. Retrieved from [http://www.silive.com/news/index.ssf/2012/11/city\\_to\\_give\\_hurricane\\_sandy\\_v.html](http://www.silive.com/news/index.ssf/2012/11/city_to_give_hurricane_sandy_v.html).

- Xu, M., Weissburg, M., Newell, J. P., and Crittenden, J. C. (2012). Developing a science of infrastructure ecology for sustainable urban systems. *Environmental Science & Technology*, 46(15), 7928-7929.
- Yang, J. S., Chung, E. S., Kim, S. U., and Kim, T. W. (2012). Prioritization of water management under climate change and urbanization using multi-criteria decision making methods. *Hydrology and Earth System Sciences*, 16(3), 801-814.
- Yates, D., Sieber, J., Purkey, D., and Huber-Lee, A. (2005). WEAP21—A demand-, priority-, and preference-driven water planning model: part 1: model characteristics. *Water International*, 30(4), 487-500.
- Yeletaysi, S., Ozceylan, D., Fiedrich, F., Harrald, J. R., and Jefferson, T. (2009, June). A framework to integrate social vulnerability into catastrophic natural disaster preparedness planning. In *The International Emergency Management Society-TIEMS 16th Annual Conference* (pp. 9-11).
- Zhao, J., and Lam, K. P. (2012). Influential factors analysis on LEED building markets in U.S. East Coast cities by using Support Vector Regression. *Sustainable Cities and Society*, 5, 37-43.
- Zhou, H., Wan, J., and Jia, H. (2010). Resilience to natural hazards: a geographic perspective. *Natural Hazards*, 53(1), 21-41.

## APPENDICES

## Appendix A Copyright Permissions

Below is permission for the use of material in Section 2.2.



Alliance House  
12 Caxton Street  
London SW1H 0QS  
United Kingdom  
Tel: +44 (0)20 7654 5500  
Fax: +44 (0)20 7654 5555  
Email:  
[publications@iwap.co.uk](mailto:publications@iwap.co.uk)  
[www.iwapublishing.com](http://www.iwapublishing.com)

Caryssa Joustra, EI, LEED AP BD+C  
Department of Civil & Environmental Engineering  
University of South Florida

20 February 2015

Dear Caryssa,

Permissions request relating to material published in IWAP Publications:

In response to your request for copyright clearance to reproduce the following materials:

Memon and Ward (2015) *Alternative Water Supply Systems* © IWA Publishing 2015.  
[Chapter 19, Decision Support Systems for Water Reuse in Smart Building Water Cycle Management.](#)

Into your dissertation, *A Framework for Determining Building Water Cycle Resilience Using a Dynamic Water Resilience Assessment Model*, we are very happy to grant you permission to reproduce the material specified above without charge, provided that:

- the material to be used has appeared in our publication without credit or acknowledgement to another source;
- suitable acknowledgement to the source is given in accordance with standard editorial practice, e.g.,

“Reproduced Memon and Ward (2015) *Alternative Water Supply Systems* © IWA Publishing 2015, with permission from the copyright holders, IWA Publishing”.

- Reproduction of this material is confined to the purpose for which this permission is given.

I trust this permission will be satisfactory; if any point needs clarification or you have any further queries, please do not hesitate to contact us again.

Yours sincerely



Alex Cruden  
Digital Marketing Assistant

## Appendix A (Continued)

Below is the copyright agreement for the material used in Section 2.3.

RBRI 961002 Framework for net-zero and net-positive building water cycle management



### AGREEMENT IN RELATION TO COPYRIGHT IN AN ARTICLE

In order to ensure both the widest dissemination and protection of material published in our Journal, we ask Authors to transfer to Informa UK Limited trading as Taylor & Francis Group the rights of copyright in the Articles they contribute. This enables us to ensure protection against infringement. The transfer of copyright must be clearly stated in writing.

**PLEASE PROVIDE US WITH THE FOLLOWING INFORMATION, REVIEW OUR POLICIES, AND CONFIRM YOUR ACCEPTANCE OF THE TERMS OF THE ATTACHED ARTICLE PUBLISHING AGREEMENT BY SIGNING THIS FORM AS INDICATED BELOW.**

Article (the "Article") entitled: <i>Framework for net-zero and net-positive building water cycle management</i> Author(s): <i>Caryssa H. Joustra, Daniel H. Vehl</i> To be published in the journal (the "Journal"): <i>Building Research &amp; Information</i>
--

#### YOUR STATUS

- I am the sole author of the Article**  
 Please indicate if any of the statements below also apply to you:
- I am UK, Canadian or Australian Government employee and claim Crown Copyright
  - I am a US Government employee and there is no copyright to transfer
  - I am an NIH employee and there is no copyright to transfer. I am not required to sign this form and attach the NIH addendum
  - I am a contractor of the US Government (includes NIH contractors) under contract number: .....
- I am one of [insert number] co-authors of the Article and confirm I have the consent of my co-authors to sign this agreement on their behalf**  
 Please indicate if any of the below also apply to you and your co-authors:
- All of my co-authors are UK, Canadian or Australian Government employees and Crown Copyright is claimed/not claimed
  - One or more of my co-authors, but not all of them, are UK, Canadian or Australian Government employees and Crown Copyright is claimed/not claimed
  - All of my co-authors are US Governmental employees and there is no copyright to transfer
  - The work was performed by contractors of the US Government under contract number .....
- The copyright in the Article belongs to my employer (is a 'work made for hire') and I am granting licence to publish as an authorized representative of my employer  
 Name and job title of assignee if different from the Author named above: .....

#### FUNDING

- The research reported in the Article was funded by the US National Institutes of Health
- The research reported in the Article was funded by a third party other than the US National Institutes of Health

Name of third party funder(s): *U.S.E.O.C. Green Building Research Fund #230*  
*National Science Foundation Grant No. 0365743*

#### ASSIGNMENT OF PUBLISHING RIGHTS

I hereby assign to Informa UK Limited trading as Taylor & Francis Group the copyright in the above specified manuscript (government authors not transferring copyright hereby assign a non-exclusive licence to publish) and any accompanying tables, illustrations, data and any other supplementary information intended for publication in all forms and all media (whether known at this time or developed at any time in the future) throughout the world, in all languages, for the full term of copyright, to take effect if and when the article is accepted for publication. If I am one of several co-authors, I hereby confirm that I am authorized by my co-authors to grant this Licence as their agent on their behalf. For the avoidance of doubt, this assignment includes the rights to supply the article in electronic and online forms and systems.

**I confirm that I have read and accept the full terms of the Journal's article publishing agreement attached to this form including my author warranties, and have reviewed the Journal's policies on Author Rights, Publishing Ethics and Conflicts of Interest Disclosure.**

Signed: [REDACTED] Name Printed: *CARYSSA JOUSTRA*  
 Title and Company (if employer representative): ..... Date: *9/2/14*

Please return the completed and signed original of this form and the Agreement that is attached to it by post or fax. You may email a scanned copy of the signed Agreement for convenience, but please return the original copy signed copy by post. Please send to the following address:

4 Park Square | Milton Park | Abingdon | Oxon OX14 4RN | UK  
 | Fax: +44 (0) 207 017 6336

THIS FORM WILL BE RETAINED BY THE PUBLISHER FOR ADMINISTRATIVE PURPOSES.

## Appendix A (Continued)

Search:

Home Journals website Society publishing Book authors Editor Resources Contact

 **Taylor & Francis**  
Author Services

▼ **Author guides:**  
Before article acceptance

▼ **Author guides:**  
After article acceptance

---

**Browse:**

**Author guides**

- Preparation
- Submission
- Review
- Production
- Copyright and you
  - ▶ Publishing agreements and your options
  - ▶ Sharing your work
  - ▶ Using third party material
  - ▶ Author rights pilot
- Publication
- Beyond publication

**Resources**

- Benefits for authors
- News and events
- Author feedback

You are in: [Home](#) > [Copyright](#) > Copyright and you

### Copyright and you

#### What is copyright?



**Copyright gives the copyright holder exclusive rights over how others use their work.**

As an author, this means that which copyright option you choose defines how researchers, scientists, policy makers, journalists, corporations, or anyone else who has an interest in your research can use your work.

Copyright has a time limit (usually life of the author plus 50–70 years for a journal article) and the level and type of protection offered varies between countries. Local and international laws and conventions mean that the copyright is recognized and protected, to varying degrees, in almost every country in the world.

In a digital world, how others want to read and reuse content is evolving rapidly. Understanding what your copyright options are is becoming ever more important, especially with the growth of open access publishing.

[back to top](#)

#### What does it mean for you?

Copyright allows you to protect your original material and stop others from using your work without your permission. It means others will generally need to credit you and your work properly, increasing its impact.

[back to top](#)

#### Copyright at Taylor & Francis

When publishing in a subscription journal published by Taylor & Francis, we ask you to assign copyright to us. Alternatively, any author publishing with us can also opt to retain their own copyright and sign a License to Publish ([sample](#)).

If you choose to assign copyright to us, as part of the publication process, you will be asked to sign a publishing agreement. This will be after your manuscript has been through the peer review process, has been accepted, and moves into production. Details will be sent to you via email, from the journal's Production Editor.

[Sample publishing agreement](#)

Find out more about what defines a conflict of interest and how to declare it

[back to top](#)

#### Why do we ask you to assign copyright to us?

Asking you to assign copyright means we are showing our commitment to:

- Act as **stewards** of the **scholarly record** of your work
- **Defend** your article against plagiarism and copyright infringement
- Enable you to **share** your article (using your **free eprints** and **Green Open Access** at Taylor & Francis)
- Assure attribution of your work, by making sure you are **identified** as the author

We encourage you to:

- **Share your work**
- Make **printed copies** of your article to use for lecture or classroom purposes
- Include your article in a thesis or dissertation
- **Present your article at a meeting or conference** and distribute printed copies of the article
- Republish the article (making sure you cite the original article)
- Adapt and expand your published journal article to make it suitable for your thesis or dissertation

---

### Page content

View the page content by selecting any of the links below

- [What is copyright?](#)
- [What does it mean for you?](#)
- [Copyright at Taylor & Francis](#)
- [Why do we ask you to assign copyright to us?](#)
- [Useful definitions](#)
- [Useful links](#)

 Find us on **Facebook**

 **twitter**  
FOLLOW ME

---

**English language editing**

**Translation**

---

**Share your 50 free eprints**

[Find out how](#)

---





**Routledge and CRC Press Books**

**30% OFF**

for Routledge/Taylor & Francis authors

## Appendix A (Continued)

Below is copyright permission for use of the material in Chapter 4.

ELSEVIER Type here to search on Elsevier.com Advanced search Follow us:     Help & Contact

Journals & books Solutions Authors, editors & reviewers About Elsevier Community Store

**For Authors**

- Journal authors' home
- Author Rights**
- Ethics
- Agreements
- Open access
- Author services
- Early career researchers
- Authors' Update
- Book authors' home
- Sharing your article
- Journal and article metrics
- Promote your article

**Author Rights**

Elsevier supports the need for authors to share, disseminate and maximize the impact of their research. We take our responsibility as stewards of the online record seriously, and work to ensure our policies and procedures help to protect the integrity of scholarly works.

Author's rights to reuse and post their own articles published by Elsevier are defined by Elsevier's copyright policy. For our proprietary titles, the type of copyright agreement used depends on the author's choice of publication:

**For subscription articles:** These rights are determined by a copyright transfer, where authors retain scholarly rights to post and use their articles.

**For open access articles:** These rights are determined by an exclusive license agreement, which applies to all our open access content.

In both cases, the fundamental rights needed to publish and distribute an article remain the same and Elsevier authors will be able to use their articles for a wide range of scholarly purposes.

Details on how authors can reuse and post their own articles are provided below.

**Help and support**

For reuse and posting not detailed below, please see our posting policy, or for authors who would like to:

- Include material from other sources in your work being published by Elsevier, please visit: [Permission seeking guidelines for Elsevier authors.](#)
- Obtain permission to re-use material from Elsevier books, journals, databases, or other products, please visit: [Obtaining permission to reuse Elsevier material](#)
- Or if you are an Elsevier author and are contacted by a requestor who wishes to re-use all or part of your article or chapter, please also refer them to our [Obtaining Permission to Re-Use Elsevier Material page.](#)
- See our [FAQ on posting and copyright queries.](#)
- Contact us directly, please email our [Permissions Help Desk.](#)

Definitions Author Posting Author Use

How authors can use their own journal articles

Authors can use their articles for a wide range of scholarly, non-commercial purposes as outlined below. These rights apply for all Elsevier authors who publish their article as either a subscription article or an open access article.

We require that all Elsevier authors always include a full acknowledgement and, if appropriate, a link to the final published version hosted on Science Direct.

For open access articles these rights are separate from how readers can reuse your article as defined by the author's choice of Creative Commons user license options.

Authors can use either their accepted author manuscript or final published article for:	
<input checked="" type="checkbox"/>	Use at a conference, meeting or for teaching purposes
<input checked="" type="checkbox"/>	Internal training by their company
<input checked="" type="checkbox"/>	Sharing individual articles with colleagues for their research use* (also known as 'scholarly sharing')
<input checked="" type="checkbox"/>	Use in a subsequent compilation of the author's works
<input checked="" type="checkbox"/>	Inclusion in a thesis or dissertation

## Appendix A (Continued)

Below is the copyright agreement for the materials used in Chapter 6.

### IEEE COPYRIGHT AND CONSENT FORM

To ensure uniformity of treatment among all contributors, other forms may not be substituted for this form, nor may any wording of the form be changed. This form is intended for original material submitted to the IEEE and must accompany any such material in order to be published by the IEEE. Please read the form carefully and keep a copy for your files.

TITLE OF PAPER/ARTICLE/REPORT, INCLUDING ALL CONTENT IN ANY FORM, FORMAT, OR MEDIA (hereinafter, "The Work"): **Decision Support Modeling for Net-Zero Water Buildings**

COMPLETE LIST OF AUTHORS: **Caryssa Joustra and Daniel Yeh**

IEEE PUBLICATION TITLE (Journal, Magazine, Conference, Book): **Winter Simulation Conference**

### COPYRIGHT TRANSFER

1. The undersigned hereby assigns to The Institute of Electrical and Electronics Engineers, Incorporated (the "IEEE") all rights under copyright that may exist in and to: (a) the above Work, including any revised or expanded derivative works submitted to the IEEE by the undersigned based on the Work; and (b) any associated written or multimedia components or other enhancements accompanying the Work.

### CONSENT AND RELEASE

2. In the event the undersigned makes a presentation based upon the Work at a conference hosted or sponsored in whole or in part by the IEEE, the undersigned, in consideration for his/her participation in the conference, hereby grants the IEEE the unlimited, worldwide, irrevocable permission to use, distribute, publish, license, exhibit, record, digitize, broadcast, reproduce and archive, in any format or medium, whether now known or hereafter developed: (a) his/her presentation and comments at the conference; (b) any written materials or multimedia files used in connection with his/her presentation; and (c) any recorded interviews of him/her (collectively, the "Presentation"). The permission granted includes the transcription and reproduction of the Presentation for inclusion in products sold or distributed by IEEE and live or recorded broadcast of the Presentation during or after the conference.

3. In connection with the permission granted in Section 2, the undersigned hereby grants IEEE the unlimited, worldwide, irrevocable right to use his/her name, picture, likeness, voice and biographical information as part of the advertisement, distribution and sale of products incorporating the Work or Presentation, and releases IEEE from any claim based on right of privacy or publicity.

4. The undersigned hereby warrants that the Work and Presentation (collectively, the "Materials") are original and that he/she is the author of the Materials. To the extent the Materials incorporate text passages, figures, data or other material from the works of others, the undersigned has obtained any necessary permissions. Where necessary, the undersigned has obtained all third party permissions and consents to grant the license above and has provided copies of such permissions and consents to IEEE.

[ X ] Please check this box if you do not wish to have video/audio recordings made of your conference presentation.

See below for Retained Rights/Terms and Conditions, and Author Responsibilities.

### AUTHOR RESPONSIBILITIES

The IEEE distributes its technical publications throughout the world and wants to ensure that the material submitted to its publications is properly available to the readership of those publications. Authors must ensure that their Work meets the requirements as stated in section 8.2.1 of the IEEE PSPB Operations Manual, including provisions covering originality, authorship, author responsibilities and author misconduct. More information on



## Appendix A (Continued)

IEEES publishing policies may be found at [http://www.ieee.org/publications\\_standards/publications/rights/authorrightsresponsibilities.html](http://www.ieee.org/publications_standards/publications/rights/authorrightsresponsibilities.html). Authors are advised especially of IEEE PSPB Operations Manual section 8.2.1.B12: "It is the responsibility of the authors, not the IEEE, to determine whether disclosure of their material requires the prior consent of other parties and, if so, to obtain it." Authors are also advised of IEEE PSPB Operations Manual section 8.1.1B: "Statements and opinions given in work published by the IEEE are the expression of the authors."

### RETAINED RIGHTS/TERMS AND CONDITIONS

#### General

1. Authors/employers retain all proprietary rights in any process, procedure, or article of manufacture described in the Work.
2. Authors/employers may reproduce or authorize others to reproduce the Work, material extracted verbatim from the Work, or derivative works for the author's personal use or for company use, provided that the source and the IEEE copyright notice are indicated, the copies are not used in any way that implies IEEE endorsement of a product or service of any employer, and the copies themselves are not offered for sale.
3. In the case of a Work performed under a U.S. Government contract or grant, the IEEE recognizes that the U.S. Government has royalty-free permission to reproduce all or portions of the Work, and to authorize others to do so, for official U.S. Government purposes only, if the contract/grant so requires.
4. Although authors are permitted to re-use all or portions of the Work in other works, this does not include granting third-party requests for reprinting, republishing, or other types of re-use. The IEEE Intellectual Property Rights office must handle all such third-party requests.
5. Authors whose work was performed under a grant from a government funding agency are free to fulfill any deposit mandates from that funding agency.

#### Author Online Use

6. Personal Servers. Authors and/or their employers shall have the right to post the accepted version of IEEE-copyrighted articles on their own personal servers or the servers of their institutions or employers without permission from IEEE, provided that the posted version includes a prominently displayed IEEE copyright notice and, when published, a full citation to the original IEEE publication, including a link to the article abstract in IEEE Xplore. Authors shall not post the final, published versions of their papers.
7. Classroom or Internal Training Use. An author is expressly permitted to post any portion of the accepted version of his/her own IEEE-copyrighted articles on the authors personal web site or the servers of the authors institution or company in connection with the authors teaching, training, or work responsibilities, provided that the appropriate copyright, credit, and reuse notices appear prominently with the posted material. Examples of permitted uses are lecture materials, course packs, e-reserves, conference presentations, or in-house training courses.
8. Electronic Preprints. Before submitting an article to an IEEE publication, authors frequently post their manuscripts to their own web site, their employers site, or to another server that invites constructive comment from colleagues. Upon submission of an article to IEEE, an author is required to transfer copyright in the article to IEEE, and the author must update any previously posted version of the article with a prominently displayed IEEE copyright notice. Upon publication of an article by the IEEE, the author must replace any previously posted electronic versions of the article with either (1) the full citation to the IEEE work with a Digital Object Identifier (DOI) or link to the article abstract in IEEE Xplore, or (2) the accepted version only (not the IEEE-published version), including the IEEE copyright notice and full citation, with a link to the final, published article in IEEE Xplore.

### INFORMATION FOR AUTHORS

#### IEEE Copyright Ownership

It is the formal policy of the IEEE to own the copyrights to all copyrightable material in its technical publications and to the individual contributions contained therein, in order to protect the interests of the IEEE, its authors and their employers, and, at the same time, to facilitate the appropriate re-

## Appendix A (Continued)

use of this material by others. The IEEE distributes its technical publications throughout the world and does so by various means such as hard copy, microfiche, microfilm, and electronic media. It also abstracts and may translate its publications, and articles contained therein, for inclusion in various compendiums, collective works, databases and similar publications.

### Author/Employer Rights

If you are employed and prepared the Work on a subject within the scope of your employment, the copyright in the Work belongs to your employer as a work-for-hire. In that case, the IEEE assumes that when you sign this Form, you are authorized to do so by your employer and that your employer has consented to the transfer of copyright, to the representation and warranty of publication rights, and to all other terms and conditions of this Form. If such authorization and consent has not been given to you, an authorized representative of your employer should sign this Form as the Author.

### GENERAL TERMS

1. The undersigned represents that he/she has the power and authority to make and execute this form.
2. The undersigned agrees to identify and hold harmless the IEEE from any damage or expense that may arise in the event of a breach of any of the warranties set forth above.
3. In the event the above work is not accepted and published by the IEEE or is withdrawn by the author(s) before acceptance by the IEEE, the foregoing grant of rights shall become null and void and all materials embodying the Work submitted to the IEEE will be destroyed.
4. For jointly authored Works, all joint authors should sign, or one of the authors should sign as authorized agent for the others.

Caryssa M. Joustra  
Author/Authorized Agent For Joint Authors

28-07-2014  
Date(dd-mm-yy)

THIS FORM MUST ACCOMPANY THE SUBMISSION OF THE AUTHOR'S MANUSCRIPT.

Questions about the submission of the form or manuscript must be sent to the publication's editor. Please direct all questions about IEEE copyright policy to:

IEEE Intellectual Property Rights Office, [copyrights@ieee.org](mailto:copyrights@ieee.org), +1-732-562-3966 (telephone)

## Appendix B Model Run Results for the Multi-residential Study (Potable Water Disruption)

Table B.1: Resilience indicators for Scenario 1 model runs for the multi-residential neighborhood subjected to potable water disruption.

Date	Hour	Disruption	Diversity	Redundancy	Capacity	Demand	Sustainability	Passivity	LOS
1/5/13 Sat	13	1	1	1	0	950	0%	0%	0%
2/1/13 Fri	12	1	1	1	0	700	0%	0%	0%
3/15/13 Fri	2	1	1	1	0	280	0%	0%	0%
4/22/13 Mon	9	1	1	1	0	860	0%	0%	0%
5/14/13 Tue	22	1	1	1	0	600	0%	0%	0%
6/6/13 Thu	5	1	1	1	0	290	0%	0%	0%
7/23/13 Tue	18	1	1	1	0	360	0%	0%	0%
8/21/13 Wed	9	1	1	1	0	650	0%	0%	0%
10/14/13 Mon	2	1	1	1	0	350	0%	0%	0%
12/11/13 Wed	12	1	1	1	0	820	0%	0%	0%
1/5/13 Sat	13	6	1	1	0	777	0%	0%	0%
2/1/13 Fri	12	6	1	1	0	655	0%	0%	0%
3/15/13 Fri	2	6	1	1	0	228	0%	0%	0%
4/22/13 Mon	9	6	1	1	0	715	0%	0%	0%
5/14/13 Tue	22	6	1	1	0	450	0%	0%	0%
6/6/13 Thu	5	6	1	1	0	522	0%	0%	0%
7/23/13 Tue	18	6	1	1	0	567	0%	0%	0%
8/21/13 Wed	9	6	1	1	0	597	0%	0%	0%
10/14/13 Mon	2	6	1	1	0	245	0%	0%	0%
12/11/13 Wed	12	6	1	1	0	683	0%	0%	0%
1/5/13 Sat	13	24	1	1	0	538	0%	0%	0%
2/1/13 Fri	12	24	1	1	0	532	0%	0%	0%
3/15/13 Fri	2	24	1	1	0	551	0%	0%	0%
4/22/13 Mon	9	24	1	1	0	557	0%	0%	0%
5/14/13 Tue	22	24	1	1	0	514	0%	0%	0%
6/6/13 Thu	5	24	1	1	0	617	0%	0%	0%
7/23/13 Tue	18	24	1	1	0	518	0%	0%	0%
8/21/13 Wed	9	24	1	1	0	474	0%	0%	0%
10/14/13 Mon	2	24	1	1	0	580	0%	0%	0%
12/11/13 Wed	12	24	1	1	0	625	0%	0%	0%
1/5/13 Sat	13	72	1	1	0	561	0%	0%	0%
2/1/13 Fri	12	72	1	1	0	592	0%	0%	0%
3/15/13 Fri	2	72	1	1	0	553	0%	0%	0%
4/22/13 Mon	9	72	1	1	0	530	0%	0%	0%
5/14/13 Tue	22	72	1	1	0	653	0%	0%	0%
6/6/13 Thu	5	72	1	1	0	635	0%	0%	0%
7/23/13 Tue	18	72	1	1	0	521	0%	0%	0%
8/21/13 Wed	9	72	1	1	0	462	0%	0%	0%
10/14/13 Mon	2	72	1	1	0	540	0%	0%	0%
12/11/13 Wed	12	72	1	1	0	735	0%	0%	1%
1/5/13 Sat	13	168	1	1	0	524	0%	0%	0%
2/1/13 Fri	12	168	1	1	0	596	0%	0%	0%
3/15/13 Fri	2	168	1	1	0	569	0%	0%	0%
4/22/13 Mon	9	168	1	1	0	559	0%	0%	0%
5/14/13 Tue	22	168	1	1	0	749	0%	0%	0%
6/6/13 Thu	5	168	1	1	0	666	0%	0%	0%
7/23/13 Tue	18	168	1	1	0	578	0%	0%	0%
8/21/13 Wed	9	168	1	1	0	506	0%	0%	0%
10/14/13 Mon	2	168	1	1	0	545	0%	0%	0%
12/11/13 Wed	12	168	1	1	0	753	0%	0%	2%

## Appendix B (Continued)

Table B.2: Resilience indicators for Scenario 2 model runs for the multi-residential neighborhood subjected to potable water disruption.

Date	Hour	Disruption	Diversity	Redundancy	Capacity	Demand	Sustainability	Passivity	LOS
1/5/13 Sat	13	1	2	1.2	7	950	33%	33%	33%
2/1/13 Fri	12	1	2	1.2	0	700	0%	0%	0%
3/15/13 Fri	2	1	2	1.2	19	280	67%	67%	67%
4/22/13 Mon	9	1	2	1.2	8	860	24%	24%	24%
5/14/13 Tue	22	1	2	1.2	0	600	0%	0%	0%
6/6/13 Thu	5	1	2	1.2	62	290	46%	46%	46%
7/23/13 Tue	18	1	2	1.2	21	360	27%	27%	27%
8/21/13 Wed	9	1	2	1.2	35	650	18%	18%	18%
10/14/13 Mon	2	1	2	1.2	0	350	0%	0%	0%
12/11/13 Wed	12	1	2	1.2	0	820	0%	0%	0%
1/5/13 Sat	13	6	2	1.2	8	777	28%	28%	27%
2/1/13 Fri	12	6	2	1.2	0	655	0%	0%	0%
3/15/13 Fri	2	6	2	1.2	22	228	49%	49%	49%
4/22/13 Mon	9	6	2	1.2	9	715	25%	25%	25%
5/14/13 Tue	22	6	2	1.2	0	450	0%	0%	0%
6/6/13 Thu	5	6	2	1.2	46	522	29%	29%	31%
7/23/13 Tue	18	6	2	1.2	13	567	35%	35%	35%
8/21/13 Wed	9	6	2	1.2	38	597	21%	21%	21%
10/14/13 Mon	2	6	2	1.2	0	245	0%	0%	0%
12/11/13 Wed	12	6	2	1.2	0	683	0%	0%	0%
1/5/13 Sat	13	24	2	1.2	9	538	33%	33%	36%
2/1/13 Fri	12	24	2	1.2	0	532	0%	0%	0%
3/15/13 Fri	2	24	2	1.2	6	551	34%	34%	37%
4/22/13 Mon	9	24	2	1.2	9	557	32%	32%	35%
5/14/13 Tue	22	24	2	1.2	0	514	0%	0%	0%
6/6/13 Thu	5	24	2	1.2	39	617	33%	33%	35%
7/23/13 Tue	18	24	2	1.2	11	518	36%	36%	38%
8/21/13 Wed	9	24	2	1.2	49	474	30%	30%	34%
10/14/13 Mon	2	24	2	1.2	0	580	0%	0%	0%
12/11/13 Wed	12	24	2	1.2	0	625	0%	0%	0%
1/5/13 Sat	13	72	2	1.2	7	561	26%	26%	28%
2/1/13 Fri	12	72	2	1.2	0	592	0%	0%	0%
3/15/13 Fri	2	72	2	1.2	2	553	14%	14%	17%
4/22/13 Mon	9	72	2	1.2	4	530	19%	19%	18%
5/14/13 Tue	22	72	2	1.2	0	653	0%	0%	0%
6/6/13 Thu	5	72	2	1.2	32	635	33%	33%	35%
7/23/13 Tue	18	72	2	1.2	14	521	31%	31%	34%
8/21/13 Wed	9	72	2	1.2	51	462	32%	32%	35%
10/14/13 Mon	2	72	2	1.2	0	540	0%	0%	0%
12/11/13 Wed	12	72	2	1.2	0	735	0%	0%	1%
1/5/13 Sat	13	168	2	1.2	5	524	20%	20%	21%
2/1/13 Fri	12	168	2	1.2	0	596	1%	1%	1%
3/15/13 Fri	2	168	2	1.2	2	569	13%	13%	14%
4/22/13 Mon	9	168	2	1.2	1	559	8%	8%	8%
5/14/13 Tue	22	168	2	1.2	0	749	1%	1%	1%
6/6/13 Thu	5	168	2	1.2	26	666	34%	34%	36%
7/23/13 Tue	18	168	2	1.2	15	578	31%	31%	35%
8/21/13 Wed	9	168	2	1.2	42	506	33%	33%	36%
10/14/13 Mon	2	168	2	1.2	0	545	0%	0%	0%
12/11/13 Wed	12	168	2	1.2	0	753	2%	2%	4%

## Appendix B (Continued)

Table B.3: Resilience indicators for Scenario 3 model runs for the multi-residential neighborhood subjected to potable water disruption.

Date	Hour	Disruption	Diversity	Redundancy	Capacity	Demand	Sustainability	Passivity	LOS
1/5/13 Sat	13	1	2	1.2	34	950	33%	33%	33%
2/1/13 Fri	12	1	2	1.2	0	700	0%	0%	0%
3/15/13 Fri	2	1	2	1.2	19	280	67%	67%	67%
4/22/13 Mon	9	1	2	1.2	8	860	24%	24%	24%
5/14/13 Tue	22	1	2	1.2	0	600	0%	0%	0%
6/6/13 Thu	5	1	2	1.2	148	290	46%	46%	46%
7/23/13 Tue	18	1	2	1.2	91	360	27%	27%	27%
8/21/13 Wed	9	1	2	1.2	73	650	18%	18%	18%
10/14/13 Mon	2	1	2	1.2	0	350	0%	0%	0%
12/11/13 Wed	12	1	2	1.2	0	820	0%	0%	0%
1/5/13 Sat	13	6	2	1.2	41	777	28%	28%	27%
2/1/13 Fri	12	6	2	1.2	0	655	0%	0%	0%
3/15/13 Fri	2	6	2	1.2	22	228	49%	49%	49%
4/22/13 Mon	9	6	2	1.2	9	715	25%	25%	25%
5/14/13 Tue	22	6	2	1.2	0	450	0%	0%	0%
6/6/13 Thu	5	6	2	1.2	94	522	29%	29%	31%
7/23/13 Tue	18	6	2	1.2	57	567	35%	35%	35%
8/21/13 Wed	9	6	2	1.2	79	597	21%	21%	21%
10/14/13 Mon	2	6	2	1.2	0	245	0%	0%	0%
12/11/13 Wed	12	6	2	1.2	0	683	0%	0%	0%
1/5/13 Sat	13	24	2	1.2	55	538	33%	33%	36%
2/1/13 Fri	12	24	2	1.2	0	532	0%	0%	0%
3/15/13 Fri	2	24	2	1.2	6	551	34%	34%	37%
4/22/13 Mon	9	24	2	1.2	9	557	32%	32%	35%
5/14/13 Tue	22	24	2	1.2	0	514	0%	0%	0%
6/6/13 Thu	5	24	2	1.2	79	617	33%	33%	35%
7/23/13 Tue	18	24	2	1.2	59	518	36%	36%	38%
8/21/13 Wed	9	24	2	1.2	102	474	30%	30%	34%
10/14/13 Mon	2	24	2	1.2	0	580	0%	0%	0%
12/11/13 Wed	12	24	2	1.2	0	625	0%	0%	0%
1/5/13 Sat	13	72	2	1.2	50	561	33%	33%	36%
2/1/13 Fri	12	72	2	1.2	0	592	0%	0%	0%
3/15/13 Fri	2	72	2	1.2	2	553	14%	14%	17%
4/22/13 Mon	9	72	2	1.2	4	530	19%	19%	18%
5/14/13 Tue	22	72	2	1.2	0	653	0%	0%	0%
6/6/13 Thu	5	72	2	1.2	71	635	33%	33%	35%
7/23/13 Tue	18	72	2	1.2	61	521	34%	34%	37%
8/21/13 Wed	9	72	2	1.2	105	462	32%	32%	35%
10/14/13 Mon	2	72	2	1.2	0	540	0%	0%	0%
12/11/13 Wed	12	72	2	1.2	0	735	0%	0%	1%
1/5/13 Sat	13	168	2	1.2	46	524	33%	33%	36%
2/1/13 Fri	12	168	2	1.2	0	596	1%	1%	1%
3/15/13 Fri	2	168	2	1.2	2	569	13%	13%	14%
4/22/13 Mon	9	168	2	1.2	1	559	8%	8%	8%
5/14/13 Tue	22	168	2	1.2	0	749	1%	1%	1%
6/6/13 Thu	5	168	2	1.2	64	666	34%	34%	36%
7/23/13 Tue	18	168	2	1.2	57	578	33%	33%	36%
8/21/13 Wed	9	168	2	1.2	92	506	33%	33%	36%
10/14/13 Mon	2	168	2	1.2	0	545	0%	0%	0%
12/11/13 Wed	12	168	2	1.2	0	753	2%	2%	4%

## Appendix B (Continued)

Table B.4: Resilience indicators for Scenario 4 model runs for the multi-residential neighborhood subjected to potable water disruption.

Date	Hour	Disruption	Diversity	Redundancy	Capacity	Demand	Sustainability	Passivity	LOS
1/5/13 Sat	13	1	3	1.4	34	950	33%	33%	33%
2/1/13 Fri	12	1	3	1.4	0	700	0%	0%	0%
3/15/13 Fri	2	1	3	1.4	19	280	67%	67%	67%
4/22/13 Mon	9	1	3	1.4	8	860	24%	24%	24%
5/14/13 Tue	22	1	3	1.4	0	600	0%	0%	0%
6/6/13 Thu	5	1	3	1.4	166	290	46%	30%	46%
7/23/13 Tue	18	1	3	1.4	107	360	27%	12%	27%
8/21/13 Wed	9	1	3	1.4	75	650	18%	7%	18%
10/14/13 Mon	2	1	3	1.4	10	350	61%	56%	61%
12/11/13 Wed	12	1	3	1.4	0	820	2%	0%	2%
1/5/13 Sat	13	6	3	1.4	41	777	28%	27%	27%
2/1/13 Fri	12	6	3	1.4	0	655	0%	0%	0%
3/15/13 Fri	2	6	3	1.4	22	228	49%	49%	49%
4/22/13 Mon	9	6	3	1.4	9	715	25%	23%	25%
5/14/13 Tue	22	6	3	1.4	0	450	1%	0%	1%
6/6/13 Thu	5	6	3	1.4	95	522	29%	18%	31%
7/23/13 Tue	18	6	3	1.4	67	567	35%	25%	35%
8/21/13 Wed	9	6	3	1.4	81	597	21%	10%	21%
10/14/13 Mon	2	6	3	1.4	14	245	48%	36%	49%
12/11/13 Wed	12	6	3	1.4	0	683	3%	0%	3%
1/5/13 Sat	13	24	3	1.4	56	538	33%	33%	36%
2/1/13 Fri	12	24	3	1.4	0	532	0%	0%	0%
3/15/13 Fri	2	24	3	1.4	6	551	34%	34%	37%
4/22/13 Mon	9	24	3	1.4	9	557	32%	29%	35%
5/14/13 Tue	22	24	3	1.4	0	514	1%	0%	1%
6/6/13 Thu	5	24	3	1.4	80	617	33%	25%	35%
7/23/13 Tue	18	24	3	1.4	71	518	36%	24%	38%
8/21/13 Wed	9	24	3	1.4	103	474	30%	18%	34%
10/14/13 Mon	2	24	3	1.4	4	580	32%	27%	35%
12/11/13 Wed	12	24	3	1.4	0	625	1%	0%	1%
1/5/13 Sat	13	72	3	1.4	51	561	33%	32%	36%
2/1/13 Fri	12	72	3	1.4	0	592	0%	0%	0%
3/15/13 Fri	2	72	3	1.4	2	553	14%	14%	17%
4/22/13 Mon	9	72	3	1.4	4	530	21%	19%	22%
5/14/13 Tue	22	72	3	1.4	0	653	2%	0%	2%
6/6/13 Thu	5	72	3	1.4	73	635	33%	25%	35%
7/23/13 Tue	18	72	3	1.4	74	521	34%	23%	37%
8/21/13 Wed	9	72	3	1.4	106	462	32%	19%	35%
10/14/13 Mon	2	72	3	1.4	1	540	15%	10%	16%
12/11/13 Wed	12	72	3	1.4	0	735	0%	0%	2%
1/5/13 Sat	13	168	3	1.4	48	524	33%	31%	36%
2/1/13 Fri	12	168	3	1.4	0	596	1%	1%	1%
3/15/13 Fri	2	168	3	1.4	2	569	13%	13%	14%
4/22/13 Mon	9	168	3	1.4	2	559	11%	8%	12%
5/14/13 Tue	22	168	3	1.4	0	749	4%	1%	4%
6/6/13 Thu	5	168	3	1.4	67	666	34%	26%	36%
7/23/13 Tue	18	168	3	1.4	70	578	33%	23%	36%
8/21/13 Wed	9	168	3	1.4	94	506	33%	22%	36%
10/14/13 Mon	2	168	3	1.4	1	545	12%	4%	14%
12/11/13 Wed	12	168	3	1.4	0	753	3%	2%	4%

## Appendix B (Continued)

Table B.5: Resilience indicators for Scenario 5 model runs for the multi-residential neighborhood subjected to potable water disruption.

Date	Hour	Disruption	Diversity	Redundancy	Capacity	Demand	Sustainability	Passivity	LOS
1/5/13 Sat	13	1	3	1.8	5	950	72%	72%	72%
2/1/13 Fri	12	1	3	1.8	0	700	0%	0%	0%
3/15/13 Fri	2	1	3	1.8	0	280	0%	0%	0%
4/22/13 Mon	9	1	3	1.8	8	860	52%	52%	52%
5/14/13 Tue	22	1	3	1.8	0	600	0%	0%	0%
6/6/13 Thu	5	1	3	1.8	86	290	46%	30%	46%
7/23/13 Tue	18	1	3	1.8	35	360	56%	41%	56%
8/21/13 Wed	9	1	3	1.8	70	650	45%	34%	45%
10/14/13 Mon	2	1	3	1.8	0	350	5%	0%	5%
12/11/13 Wed	12	1	3	1.8	0	820	2%	0%	2%
1/5/13 Sat	13	6	3	1.8	4	777	62%	62%	62%
2/1/13 Fri	12	6	3	1.8	0	655	0%	0%	0%
3/15/13 Fri	2	6	3	1.8	0	228	0%	0%	0%
4/22/13 Mon	9	6	3	1.8	8	715	60%	58%	61%
5/14/13 Tue	22	6	3	1.8	0	450	1%	0%	1%
6/6/13 Thu	5	6	3	1.8	85	522	45%	35%	44%
7/23/13 Tue	18	6	3	1.8	21	567	60%	50%	60%
8/21/13 Wed	9	6	3	1.8	75	597	56%	46%	57%
10/14/13 Mon	2	6	3	1.8	0	245	12%	0%	13%
12/11/13 Wed	12	6	3	1.8	0	683	3%	0%	3%
1/5/13 Sat	13	24	3	1.8	2	538	41%	41%	34%
2/1/13 Fri	12	24	3	1.8	0	532	0%	0%	0%
3/15/13 Fri	2	24	3	1.8	0	551	0%	0%	0%
4/22/13 Mon	9	24	3	1.8	5	557	55%	52%	55%
5/14/13 Tue	22	24	3	1.8	0	514	1%	0%	1%
6/6/13 Thu	5	24	3	1.8	77	617	58%	50%	57%
7/23/13 Tue	18	24	3	1.8	19	518	62%	50%	60%
8/21/13 Wed	9	24	3	1.8	96	474	56%	44%	56%
10/14/13 Mon	2	24	3	1.8	0	580	5%	0%	6%
12/11/13 Wed	12	24	3	1.8	0	625	1%	0%	1%
1/5/13 Sat	13	72	3	1.8	4	561	27%	27%	27%
2/1/13 Fri	12	72	3	1.8	0	592	0%	0%	0%
3/15/13 Fri	2	72	3	1.8	0	553	0%	0%	0%
4/22/13 Mon	9	72	3	1.8	2	530	21%	18%	20%
5/14/13 Tue	22	72	3	1.8	0	653	2%	0%	2%
6/6/13 Thu	5	72	3	1.8	66	635	59%	51%	58%
7/23/13 Tue	18	72	3	1.8	18	521	58%	47%	58%
8/21/13 Wed	9	72	3	1.8	102	462	58%	45%	57%
10/14/13 Mon	2	72	3	1.8	0	540	6%	0%	7%
12/11/13 Wed	12	72	3	1.8	0	735	0%	0%	2%
1/5/13 Sat	13	168	3	1.8	2	524	19%	17%	19%
2/1/13 Fri	12	168	3	1.8	0	596	1%	1%	1%
3/15/13 Fri	2	168	3	1.8	0	569	8%	7%	6%
4/22/13 Mon	9	168	3	1.8	1	559	11%	7%	11%
5/14/13 Tue	22	168	3	1.8	0	749	4%	1%	4%
6/6/13 Thu	5	168	3	1.8	57	666	59%	51%	58%
7/23/13 Tue	18	168	3	1.8	13	578	47%	37%	48%
8/21/13 Wed	9	168	3	1.8	88	506	59%	48%	58%
10/14/13 Mon	2	168	3	1.8	0	545	8%	0%	10%
12/11/13 Wed	12	168	3	1.8	0	753	3%	2%	4%

## Appendix B (Continued)

Table B.6: Resilience indicators for Scenario 6 model runs for the multi-residential neighborhood subjected to potable water disruption.

Date	Hour	Disruption	Diversity	Redundancy	Capacity	Demand	Sustainability	Passivity	LOS
1/5/13 Sat	13	1	2	1.2	11	950	33%	0%	33%
2/1/13 Fri	12	1	2	1.2	14	700	32%	0%	32%
3/15/13 Fri	2	1	2	1.2	36	280	67%	0%	67%
4/22/13 Mon	9	1	2	1.2	12	860	24%	0%	24%
5/14/13 Tue	22	1	2	1.2	17	600	32%	0%	32%
6/6/13 Thu	5	1	2	1.2	34	290	46%	0%	46%
7/23/13 Tue	18	1	2	1.2	28	360	27%	0%	27%
8/21/13 Wed	9	1	2	1.2	15	650	18%	0%	18%
10/14/13 Mon	2	1	2	1.2	28	350	61%	0%	61%
12/11/13 Wed	12	1	2	1.2	12	820	36%	0%	36%
1/5/13 Sat	13	6	2	1.2	12	777	28%	0%	27%
2/1/13 Fri	12	6	2	1.2	14	655	31%	0%	31%
3/15/13 Fri	2	6	2	1.2	43	228	49%	0%	49%
4/22/13 Mon	9	6	2	1.2	13	715	25%	0%	25%
5/14/13 Tue	22	6	2	1.2	21	450	47%	0%	50%
6/6/13 Thu	5	6	2	1.2	18	522	29%	0%	31%
7/23/13 Tue	18	6	2	1.2	17	567	35%	0%	35%
8/21/13 Wed	9	6	2	1.2	16	597	21%	0%	21%
10/14/13 Mon	2	6	2	1.2	40	245	48%	0%	49%
12/11/13 Wed	12	6	2	1.2	14	683	29%	0%	29%
1/5/13 Sat	13	24	2	1.2	15	538	33%	0%	36%
2/1/13 Fri	12	24	2	1.2	14	532	35%	0%	36%
3/15/13 Fri	2	24	2	1.2	15	551	34%	0%	37%
4/22/13 Mon	9	24	2	1.2	14	557	32%	0%	35%
5/14/13 Tue	22	24	2	1.2	16	514	32%	0%	34%
6/6/13 Thu	5	24	2	1.2	13	617	33%	0%	35%
7/23/13 Tue	18	24	2	1.2	15	518	36%	0%	38%
8/21/13 Wed	9	24	2	1.2	17	474	30%	0%	34%
10/14/13 Mon	2	24	2	1.2	14	580	34%	0%	37%
12/11/13 Wed	12	24	2	1.2	12	625	34%	0%	36%
1/5/13 Sat	13	72	2	1.2	7	561	26%	0%	26%
2/1/13 Fri	12	72	2	1.2	6	592	24%	0%	25%
3/15/13 Fri	2	72	2	1.2	7	553	26%	0%	30%
4/22/13 Mon	9	72	2	1.2	8	530	27%	0%	28%
5/14/13 Tue	22	72	2	1.2	6	653	22%	0%	24%
6/6/13 Thu	5	72	2	1.2	5	635	22%	0%	23%
7/23/13 Tue	18	72	2	1.2	7	521	27%	0%	28%
8/21/13 Wed	9	72	2	1.2	10	462	30%	0%	32%
10/14/13 Mon	2	72	2	1.2	7	540	26%	0%	29%
12/11/13 Wed	12	72	2	1.2	4	735	19%	0%	25%
1/5/13 Sat	13	168	2	1.2	3	524	12%	0%	11%
2/1/13 Fri	12	168	2	1.2	3	596	10%	0%	11%
3/15/13 Fri	2	168	2	1.2	3	569	11%	0%	13%
4/22/13 Mon	9	168	2	1.2	3	559	11%	0%	12%
5/14/13 Tue	22	168	2	1.2	2	749	8%	0%	10%
6/6/13 Thu	5	168	2	1.2	2	666	9%	0%	10%
7/23/13 Tue	18	168	2	1.2	3	578	10%	0%	12%
8/21/13 Wed	9	168	2	1.2	4	506	12%	0%	14%
10/14/13 Mon	2	168	2	1.2	3	545	11%	0%	12%
12/11/13 Wed	12	168	2	1.2	2	753	8%	0%	12%



## Appendix B (Continued)

Table B.7: Resilience indicators for Scenario 7 model runs for the multi-residential neighborhood subjected to potable water disruption.

Date	Hour	Disruption	Diversity	Redundancy	Capacity	Demand	Sustainability	Passivity	LOS
1/5/13 Sat	13	1	4	2.8	10	950	33%	0%	33%
2/1/13 Fri	12	1	4	2.8	14	700	32%	0%	32%
3/15/13 Fri	2	1	4	2.8	36	280	67%	0%	67%
4/22/13 Mon	9	1	4	2.8	19	860	100%	76%	100%
5/14/13 Tue	22	1	4	2.8	17	600	32%	0%	32%
6/6/13 Thu	5	1	4	2.8	105	290	100%	38%	100%
7/23/13 Tue	18	1	4	2.8	31	360	100%	58%	100%
8/21/13 Wed	9	1	4	2.8	73	650	100%	71%	100%
10/14/13 Mon	2	1	4	2.8	29	350	66%	0%	66%
12/11/13 Wed	12	1	4	2.8	12	820	38%	0%	38%
1/5/13 Sat	13	6	4	2.8	13	777	28%	0%	28%
2/1/13 Fri	12	6	4	2.8	15	655	31%	0%	31%
3/15/13 Fri	2	6	4	2.8	44	228	49%	0%	49%
4/22/13 Mon	9	6	4	2.8	21	715	100%	72%	100%
5/14/13 Tue	22	6	4	2.8	22	450	48%	0%	51%
6/6/13 Thu	5	6	4	2.8	102	522	100%	61%	100%
7/23/13 Tue	18	6	4	2.8	18	567	80%	35%	80%
8/21/13 Wed	9	6	4	2.8	78	597	100%	68%	100%
10/14/13 Mon	2	6	4	2.8	41	245	59%	0%	62%
12/11/13 Wed	12	6	4	2.8	14	683	32%	0%	32%
1/5/13 Sat	13	24	4	2.8	16	538	33%	0%	36%
2/1/13 Fri	12	24	4	2.8	16	532	35%	0%	36%
3/15/13 Fri	2	24	4	2.8	15	551	34%	0%	37%
4/22/13 Mon	9	24	4	2.8	21	557	87%	53%	80%
5/14/13 Tue	22	24	4	2.8	18	514	32%	0%	35%
6/6/13 Thu	5	24	4	2.8	92	617	100%	59%	100%
7/23/13 Tue	18	24	4	2.8	19	518	57%	11%	61%
8/21/13 Wed	9	24	4	2.8	98	474	100%	57%	100%
10/14/13 Mon	2	24	4	2.8	15	580	39%	0%	43%
12/11/13 Wed	12	24	4	2.8	13	625	35%	0%	37%
1/5/13 Sat	13	72	4	2.8	12	561	49%	16%	53%
2/1/13 Fri	12	72	4	2.8	7	592	26%	0%	27%
3/15/13 Fri	2	72	4	2.8	8	553	27%	0%	31%
4/22/13 Mon	9	72	4	2.8	15	530	53%	18%	51%
5/14/13 Tue	22	72	4	2.8	7	653	27%	0%	29%
6/6/13 Thu	5	72	4	2.8	80	635	100%	59%	100%
7/23/13 Tue	18	72	4	2.8	23	521	64%	18%	66%
8/21/13 Wed	9	72	4	2.8	114	462	100%	55%	100%
10/14/13 Mon	2	72	4	2.8	9	540	38%	0%	42%
12/11/13 Wed	12	72	4	2.8	5	735	22%	0%	28%
1/5/13 Sat	13	168	4	2.8	8	524	39%	11%	41%
2/1/13 Fri	12	168	4	2.8	3	596	13%	1%	13%
3/15/13 Fri	2	168	4	2.8	4	569	26%	7%	26%
4/22/13 Mon	9	168	4	2.8	6	559	28%	7%	30%
5/14/13 Tue	22	168	4	2.8	3	749	16%	1%	19%
6/6/13 Thu	5	168	4	2.8	70	666	100%	59%	100%
7/23/13 Tue	18	168	4	2.8	22	578	68%	26%	70%
8/21/13 Wed	9	168	4	2.8	102	506	100%	56%	100%
10/14/13 Mon	2	168	4	2.8	4	545	26%	0%	31%
12/11/13 Wed	12	168	4	2.8	2	753	15%	2%	18%

## Appendix B (Continued)

Table B.8: Resilience indicators for Scenario 8 model runs for the multi-residential neighborhood subjected to potable water disruption.

Date	Hour	Disruption	Diversity	Redundancy	Capacity	Demand	Sustainability	Passivity	LOS
1/5/13 Sat	13	1	1	1	25	950	0%	100%	100%
2/1/13 Fri	12	1	1	1	35	700	0%	100%	100%
3/15/13 Fri	2	1	1	1	88	280	0%	100%	100%
4/22/13 Mon	9	1	1	1	28	860	0%	100%	100%
5/14/13 Tue	22	1	1	1	41	600	0%	100%	100%
6/6/13 Thu	5	1	1	1	85	290	31%	100%	100%
7/23/13 Tue	18	1	1	1	68	360	0%	100%	100%
8/21/13 Wed	9	1	1	1	37	650	0%	100%	100%
10/14/13 Mon	2	1	1	1	70	350	0%	100%	100%
12/11/13 Wed	12	1	1	1	29	820	0%	100%	100%
1/5/13 Sat	13	6	1	1	29	777	0%	100%	100%
2/1/13 Fri	12	6	1	1	35	655	0%	100%	100%
3/15/13 Fri	2	6	1	1	106	228	0%	100%	100%
4/22/13 Mon	9	6	1	1	31	715	0%	100%	100%
5/14/13 Tue	22	6	1	1	52	450	0%	100%	100%
6/6/13 Thu	5	6	1	1	45	522	0%	100%	100%
7/23/13 Tue	18	6	1	1	41	567	0%	100%	100%
8/21/13 Wed	9	6	1	1	38	597	0%	100%	100%
10/14/13 Mon	2	6	1	1	99	245	0%	100%	100%
12/11/13 Wed	12	6	1	1	33	683	0%	100%	100%
1/5/13 Sat	13	24	1	1	33	538	0%	100%	100%
2/1/13 Fri	12	24	1	1	33	532	0%	100%	100%
3/15/13 Fri	2	24	1	1	34	551	0%	100%	100%
4/22/13 Mon	9	24	1	1	31	557	0%	100%	100%
5/14/13 Tue	22	24	1	1	37	514	0%	100%	100%
6/6/13 Thu	5	24	1	1	28	617	0%	100%	100%
7/23/13 Tue	18	24	1	1	36	518	0%	100%	100%
8/21/13 Wed	9	24	1	1	38	474	0%	100%	100%
10/14/13 Mon	2	24	1	1	32	580	0%	100%	100%
12/11/13 Wed	12	24	1	1	27	625	0%	100%	100%
1/5/13 Sat	13	72	1	1	13	561	0%	62%	62%
2/1/13 Fri	12	72	1	1	12	592	0%	60%	60%
3/15/13 Fri	2	72	1	1	15	553	0%	63%	63%
4/22/13 Mon	9	72	1	1	13	530	0%	64%	64%
5/14/13 Tue	22	72	1	1	13	653	0%	63%	63%
6/6/13 Thu	5	72	1	1	11	635	0%	54%	54%
7/23/13 Tue	18	72	1	1	16	521	0%	68%	68%
8/21/13 Wed	9	72	1	1	18	462	0%	72%	72%
10/14/13 Mon	2	72	1	1	14	540	0%	61%	61%
12/11/13 Wed	12	72	1	1	9	735	0%	54%	54%
1/5/13 Sat	13	168	1	1	6	524	0%	27%	27%
2/1/13 Fri	12	168	1	1	5	596	0%	26%	26%
3/15/13 Fri	2	168	1	1	6	569	0%	27%	27%
4/22/13 Mon	9	168	1	1	5	559	0%	28%	28%
5/14/13 Tue	22	168	1	1	5	749	0%	27%	27%
6/6/13 Thu	5	168	1	1	4	666	0%	23%	23%
7/23/13 Tue	18	168	1	1	6	578	0%	29%	29%
8/21/13 Wed	9	168	1	1	7	506	0%	31%	31%
10/14/13 Mon	2	168	1	1	6	545	0%	26%	26%
12/11/13 Wed	12	168	1	1	4	753	0%	24%	24%

## Appendix B (Continued)

Table B.9: Resilience indicators for Scenario 9 model runs for the multi-residential neighborhood subjected to potable water disruption.

Date	Hour	Disruption	Diversity	Redundancy	Capacity	Demand	Sustainability	Passivity	LOS
1/5/13 Sat	13	1	1	1	52	950	0%	100%	100%
2/1/13 Fri	12	1	1	1	70	700	0%	100%	100%
3/15/13 Fri	2	1	1	1	178	280	0%	100%	100%
4/22/13 Mon	9	1	1	1	57	860	0%	100%	100%
5/14/13 Tue	22	1	1	1	82	600	0%	100%	100%
6/6/13 Thu	5	1	1	1	171	290	31%	100%	100%
7/23/13 Tue	18	1	1	1	138	360	0%	100%	100%
8/21/13 Wed	9	1	1	1	76	650	0%	100%	100%
10/14/13 Mon	2	1	1	1	142	350	0%	100%	100%
12/11/13 Wed	12	1	1	1	60	820	0%	100%	100%
1/5/13 Sat	13	6	1	1	61	777	0%	100%	100%
2/1/13 Fri	12	6	1	1	73	655	0%	100%	100%
3/15/13 Fri	2	6	1	1	215	228	0%	100%	100%
4/22/13 Mon	9	6	1	1	66	715	0%	100%	100%
5/14/13 Tue	22	6	1	1	107	450	0%	100%	100%
6/6/13 Thu	5	6	1	1	93	522	0%	100%	100%
7/23/13 Tue	18	6	1	1	85	567	0%	100%	100%
8/21/13 Wed	9	6	1	1	80	597	0%	100%	100%
10/14/13 Mon	2	6	1	1	201	245	0%	100%	100%
12/11/13 Wed	12	6	1	1	70	683	0%	100%	100%
1/5/13 Sat	13	24	1	1	79	538	0%	100%	100%
2/1/13 Fri	12	24	1	1	80	532	0%	100%	100%
3/15/13 Fri	2	24	1	1	79	551	0%	100%	100%
4/22/13 Mon	9	24	1	1	76	557	0%	100%	100%
5/14/13 Tue	22	24	1	1	86	514	0%	100%	100%
6/6/13 Thu	5	24	1	1	69	617	0%	100%	100%
7/23/13 Tue	18	24	1	1	85	518	0%	100%	100%
8/21/13 Wed	9	24	1	1	91	474	0%	100%	100%
10/14/13 Mon	2	24	1	1	75	580	0%	100%	100%
12/11/13 Wed	12	24	1	1	67	625	0%	100%	100%
1/5/13 Sat	13	72	1	1	51	561	0%	100%	100%
2/1/13 Fri	12	72	1	1	48	592	0%	100%	100%
3/15/13 Fri	2	72	1	1	55	553	0%	100%	100%
4/22/13 Mon	9	72	1	1	56	530	0%	100%	100%
5/14/13 Tue	22	72	1	1	44	653	0%	100%	100%
6/6/13 Thu	5	72	1	1	42	635	0%	100%	100%
7/23/13 Tue	18	72	1	1	60	521	0%	100%	100%
8/21/13 Wed	9	72	1	1	70	462	0%	100%	100%
10/14/13 Mon	2	72	1	1	56	540	0%	100%	100%
12/11/13 Wed	12	72	1	1	36	735	0%	99%	99%
1/5/13 Sat	13	168	1	1	24	524	0%	56%	56%
2/1/13 Fri	12	168	1	1	21	596	0%	49%	49%
3/15/13 Fri	2	168	1	1	24	569	0%	54%	54%
4/22/13 Mon	9	168	1	1	24	559	0%	53%	53%
5/14/13 Tue	22	168	1	1	17	749	0%	47%	47%
6/6/13 Thu	5	168	1	1	17	666	0%	47%	47%
7/23/13 Tue	18	168	1	1	24	578	0%	55%	55%
8/21/13 Wed	9	168	1	1	30	506	0%	60%	60%
10/14/13 Mon	2	168	1	1	25	545	0%	55%	55%
12/11/13 Wed	12	168	1	1	15	753	0%	44%	44%

## Appendix B (Continued)

Table B.10: Average resilience indicators (n=10) by scenario and disruption length for model runs for the multi-residential neighborhood subjected to potable water disruption.

Scenario	Disruption	Diversity	Redundancy	Capacity	Demand	Sustainability	Passivity	Preparation	Adaptation potential	LOS
1	1	1	1	0	586	0%	0%	0%	144%	0%
1	6	1	1	0	544	0%	0%	0%	144%	0%
1	24	1	1	0	551	0%	0%	0%	144%	0%
1	72	1	1	0	578	0%	0%	0%	144%	0%
1	168	1	1	0	604	0%	0%	0%	144%	0%
2	1	2	1.2	15	586	22%	22%	15%	128%	22%
2	6	2	1.2	14	544	19%	19%	15%	128%	19%
2	24	2	1.2	12	551	20%	20%	15%	128%	21%
2	72	2	1.2	11	578	15%	15%	15%	128%	17%
2	168	2	1.2	9	604	14%	14%	15%	128%	15%
3	1	2	1.2	37	586	22%	22%	18%	126%	22%
3	6	2	1.2	30	544	19%	19%	18%	126%	19%
3	24	2	1.2	31	551	20%	20%	18%	126%	21%
3	72	2	1.2	29	578	16%	16%	18%	126%	18%
3	168	2	1.2	26	604	16%	16%	18%	126%	17%
4	1	3	1.4	42	586	28%	23%	19%	129%	28%
4	6	3	1.4	33	544	24%	19%	19%	129%	24%
4	24	3	1.4	33	551	23%	19%	19%	129%	25%
4	72	3	1.4	31	578	18%	14%	19%	129%	20%
4	168	3	1.4	28	604	18%	13%	19%	129%	19%
5	1	3	1.8	20	586	28%	23%	26%	118%	28%
5	6	3	1.8	19	544	30%	25%	26%	118%	30%
5	24	3	1.8	20	551	28%	24%	26%	118%	27%
5	72	3	1.8	19	578	23%	19%	26%	118%	23%
5	168	3	1.8	16	604	22%	17%	26%	118%	22%
6	1	2	1.2	21	586	38%	0%	33%	111%	38%
6	6	2	1.2	21	544	34%	0%	33%	111%	35%
6	24	2	1.2	14	551	33%	0%	33%	111%	36%
6	72	2	1.2	7	578	25%	0%	33%	111%	27%
6	168	2	1.2	3	604	10%	0%	33%	111%	12%
7	1	4	2.8	34	586	67%	24%	61%	83%	67%
7	6	4	2.8	37	544	63%	24%	61%	83%	63%
7	24	4	2.8	32	551	55%	18%	61%	83%	56%
7	72	4	2.8	28	578	51%	17%	61%	83%	53%
7	168	4	2.8	22	604	43%	17%	61%	83%	45%
8	1	1	1	51	586	3%	100%	0%	144%	100%
8	6	1	1	51	544	0%	100%	0%	144%	100%
8	24	1	1	33	551	0%	100%	0%	144%	100%
8	72	1	1	13	578	0%	62%	0%	144%	62%
8	168	1	1	5	604	0%	27%	0%	144%	27%
9	1	1	1	103	586	3%	100%	0%	144%	100%
9	6	1	1	105	544	0%	100%	0%	144%	100%
9	24	1	1	79	551	0%	100%	0%	144%	100%
9	72	1	1	52	578	0%	100%	0%	144%	100%
9	168	1	1	22	604	0%	52%	0%	144%	52%

**Appendix C Model Run Results for the Multi-residential Study (Potable Water and Central Power Disruption)**

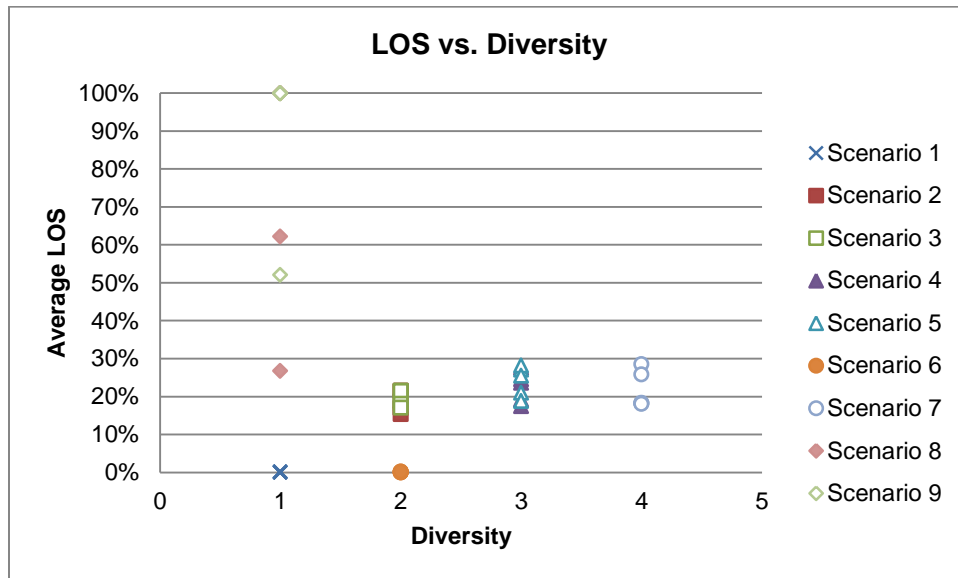

Figure C.1: Average level of service (LOS) vs. diversity for multi-residential scenarios subjected to potable water and central power disruption.

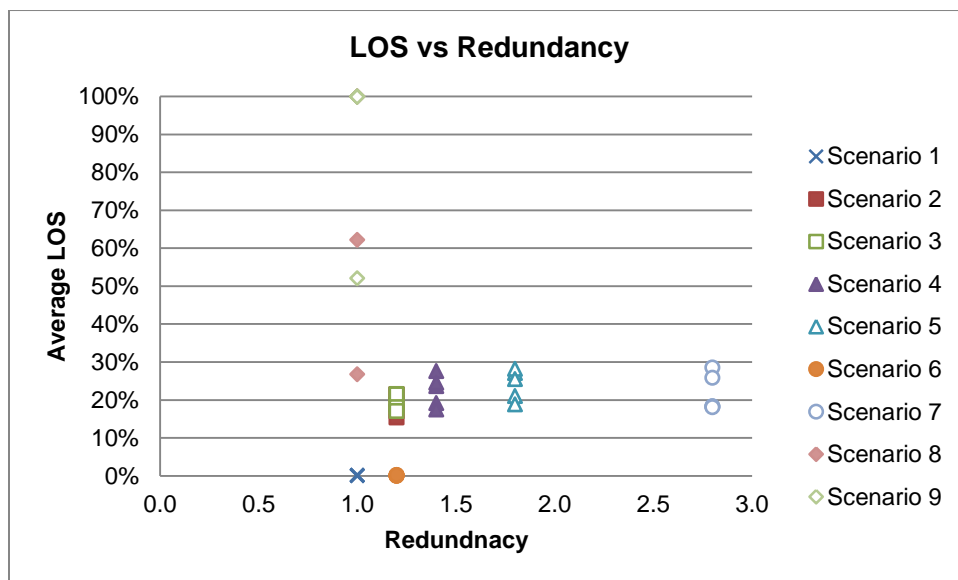

Figure C.2: Average level of service (LOS) vs. redundancy for multi-residential scenarios subjected to potable water and central power disruption.

Appendix C (Continued)

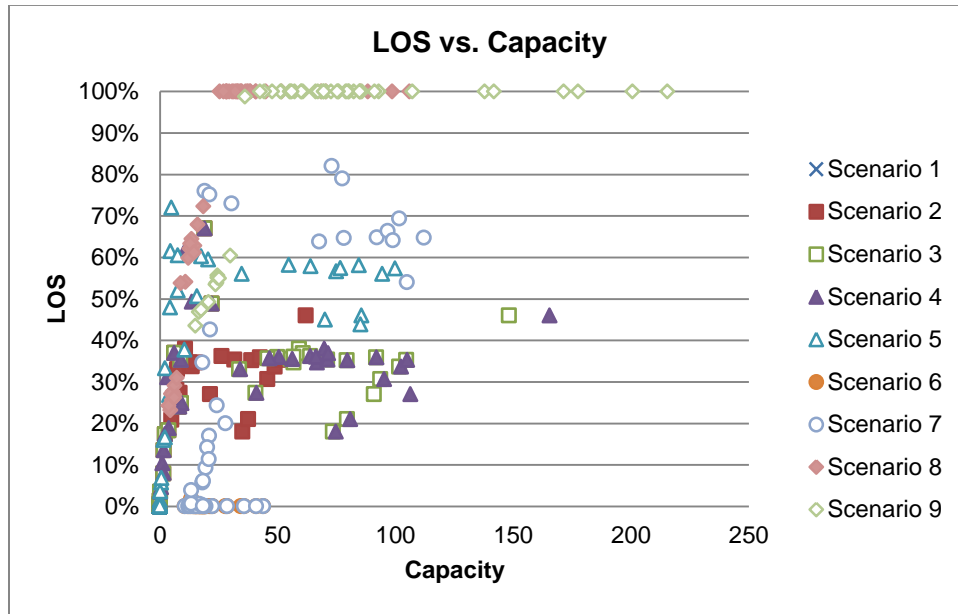

Figure C.3: Level of service (LOS) vs. capacity for multi-residential scenarios subjected to potable water and central power disruption.

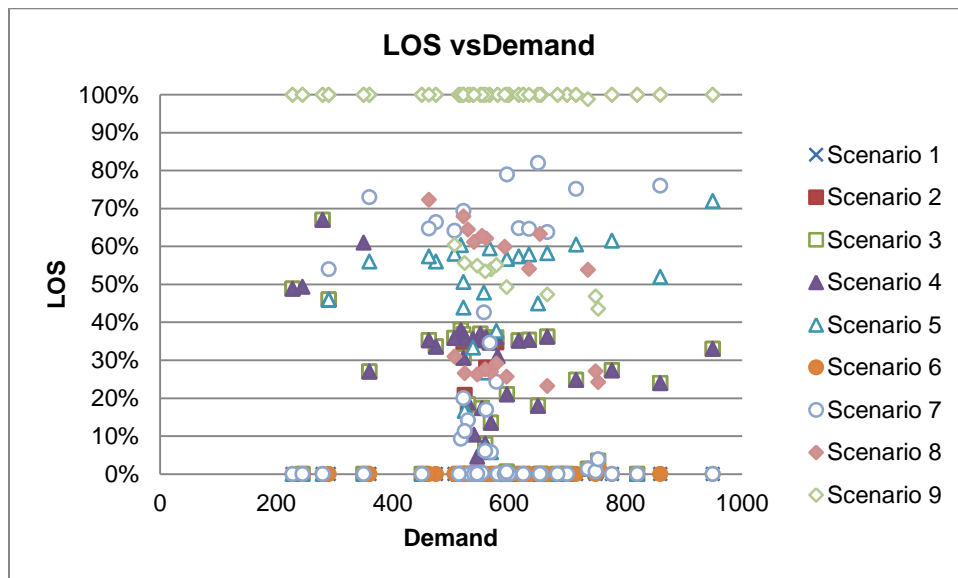

Figure C.4: Level of service (LOS) vs. demand for multi-residential scenarios subjected to potable water and central power disruption.

Appendix C (Continued)

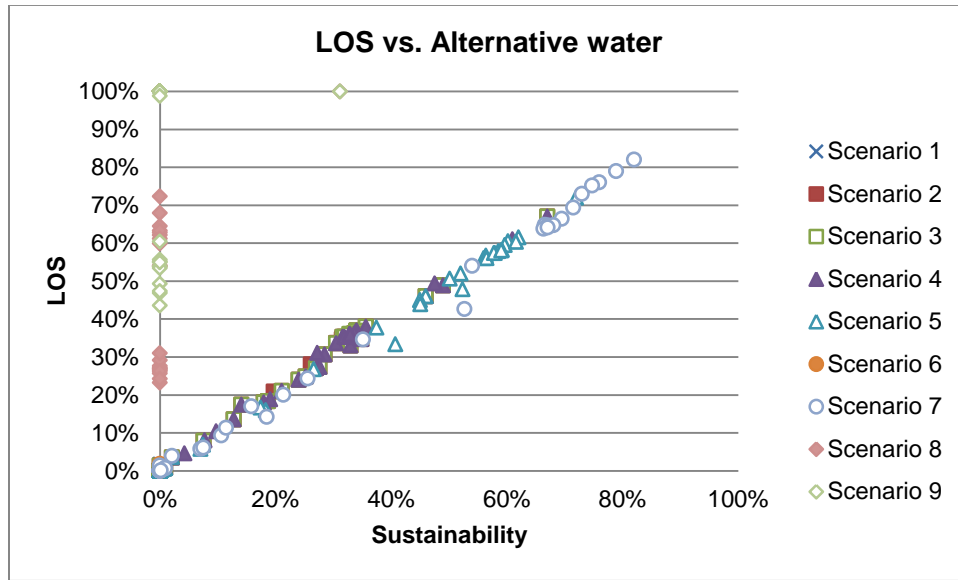

Figure C.5: Level of service (LOS) vs. alternative water for multi-residential scenarios subjected to potable water and central power disruption.

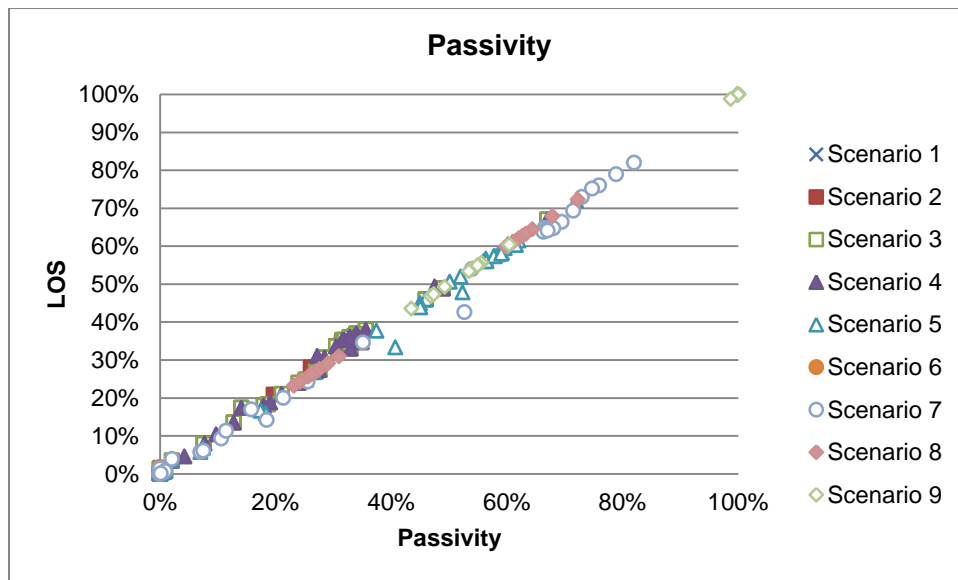

Figure C.6: Level of service (LOS) vs. passivity for multi-residential scenarios subjected to potable water and central power disruption.

Appendix C (Continued)

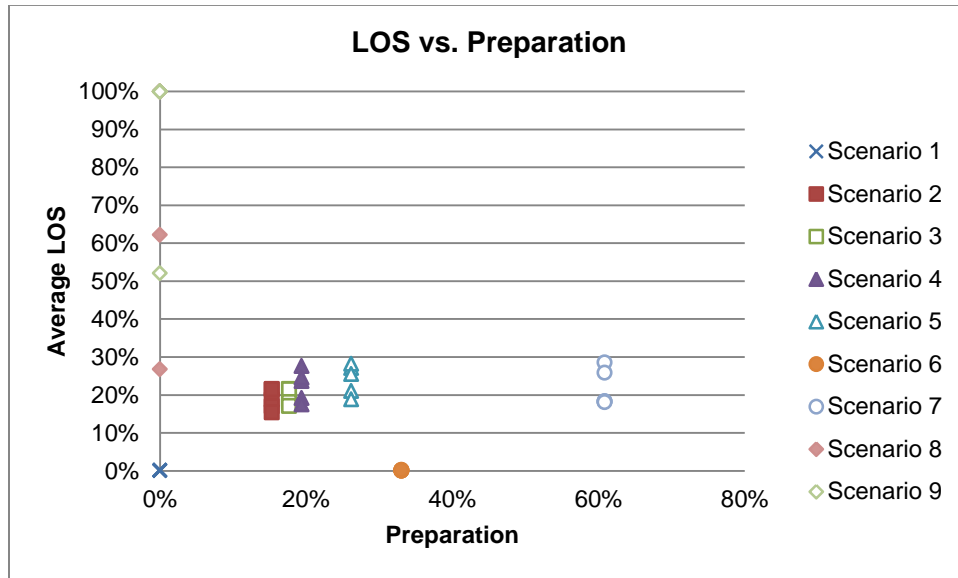

Figure C.7: Average level of service (LOS) vs. preparation for multi-residential scenarios subjected to potable water and central power disruption.

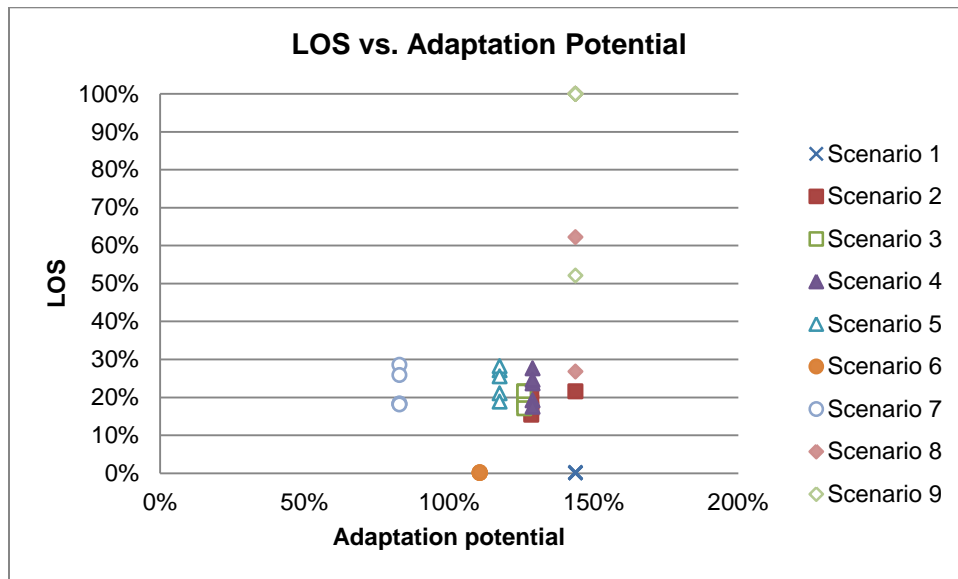

Figure C.8: Average level of service (LOS) vs. adaptation potential for multi-residential scenarios subjected to potable water and central power disruption.



## Appendix C (Continued)

Table C.1: Resilience indicators for Scenario 1 model runs for the multi-residential neighborhood subjected to potable water and central power disruption.

Date	Hour	Disruption	Diversity	Redundancy	Capacity	Demand	Sustainability	Passivity	LOS
1/5/13 Sat	13	1	1	1	0	950	0%	0%	0%
2/1/13 Fri	12	1	1	1	0	700	0%	0%	0%
3/15/13 Fri	2	1	1	1	0	280	0%	0%	0%
4/22/13 Mon	9	1	1	1	0	860	0%	0%	0%
5/14/13 Tue	22	1	1	1	0	600	0%	0%	0%
6/6/13 Thu	5	1	1	1	0	290	0%	0%	0%
7/23/13 Tue	18	1	1	1	0	360	0%	0%	0%
8/21/13 Wed	9	1	1	1	0	650	0%	0%	0%
10/14/13 Mon	2	1	1	1	0	350	0%	0%	0%
12/11/13 Wed	12	1	1	1	0	820	0%	0%	0%
1/5/13 Sat	13	6	1	1	0	777	0%	0%	0%
2/1/13 Fri	12	6	1	1	0	655	0%	0%	0%
3/15/13 Fri	2	6	1	1	0	228	0%	0%	0%
4/22/13 Mon	9	6	1	1	0	715	0%	0%	0%
5/14/13 Tue	22	6	1	1	0	450	0%	0%	0%
6/6/13 Thu	5	6	1	1	0	522	0%	0%	0%
7/23/13 Tue	18	6	1	1	0	567	0%	0%	0%
8/21/13 Wed	9	6	1	1	0	597	0%	0%	0%
10/14/13 Mon	2	6	1	1	0	245	0%	0%	0%
12/11/13 Wed	12	6	1	1	0	683	0%	0%	0%
1/5/13 Sat	13	24	1	1	0	538	0%	0%	0%
2/1/13 Fri	12	24	1	1	0	532	0%	0%	0%
3/15/13 Fri	2	24	1	1	0	551	0%	0%	0%
4/22/13 Mon	9	24	1	1	0	557	0%	0%	0%
5/14/13 Tue	22	24	1	1	0	514	0%	0%	0%
6/6/13 Thu	5	24	1	1	0	617	0%	0%	0%
7/23/13 Tue	18	24	1	1	0	518	0%	0%	0%
8/21/13 Wed	9	24	1	1	0	474	0%	0%	0%
10/14/13 Mon	2	24	1	1	0	580	0%	0%	0%
12/11/13 Wed	12	24	1	1	0	625	0%	0%	0%
1/5/13 Sat	13	72	1	1	0	561	0%	0%	0%
2/1/13 Fri	12	72	1	1	0	592	0%	0%	0%
3/15/13 Fri	2	72	1	1	0	553	0%	0%	0%
4/22/13 Mon	9	72	1	1	0	530	0%	0%	0%
5/14/13 Tue	22	72	1	1	0	653	0%	0%	0%
6/6/13 Thu	5	72	1	1	0	635	0%	0%	0%
7/23/13 Tue	18	72	1	1	0	521	0%	0%	0%
8/21/13 Wed	9	72	1	1	0	462	0%	0%	0%
10/14/13 Mon	2	72	1	1	0	540	0%	0%	0%
12/11/13 Wed	12	72	1	1	0	735	0%	0%	1%
1/5/13 Sat	13	168	1	1	0	524	0%	0%	0%
2/1/13 Fri	12	168	1	1	0	596	0%	0%	0%
3/15/13 Fri	2	168	1	1	0	569	0%	0%	0%
4/22/13 Mon	9	168	1	1	0	559	0%	0%	0%
5/14/13 Tue	22	168	1	1	0	749	0%	0%	0%
6/6/13 Thu	5	168	1	1	0	666	0%	0%	0%
7/23/13 Tue	18	168	1	1	0	578	0%	0%	0%
8/21/13 Wed	9	168	1	1	0	506	0%	0%	0%
10/14/13 Mon	2	168	1	1	0	545	0%	0%	0%
12/11/13 Wed	12	168	1	1	0	753	0%	0%	2%

## Appendix C (Continued)

Table C.2: Resilience indicators for Scenario 2 model runs for the multi-residential neighborhood subjected to potable water and central power disruption.

Date	Hour	Disruption	Diversity	Redundancy	Capacity	Demand	Sustainability	Passivity	LOS
1/5/13 Sat	13	1	2	1.2	7	950	33%	33%	33%
2/1/13 Fri	12	1	2	1.2	0	700	0%	0%	0%
3/15/13 Fri	2	1	2	1.2	19	280	67%	67%	67%
4/22/13 Mon	9	1	2	1.2	8	860	24%	24%	24%
5/14/13 Tue	22	1	2	1.2	0	600	0%	0%	0%
6/6/13 Thu	5	1	2	1.2	62	290	46%	46%	46%
7/23/13 Tue	18	1	2	1.2	21	360	27%	27%	27%
8/21/13 Wed	9	1	2	1.2	35	650	18%	18%	18%
10/14/13 Mon	2	1	2	1.2	0	350	0%	0%	0%
12/11/13 Wed	12	1	2	1.2	0	820	0%	0%	0%
1/5/13 Sat	13	6	2	1.2	8	777	28%	28%	27%
2/1/13 Fri	12	6	2	1.2	0	655	0%	0%	0%
3/15/13 Fri	2	6	2	1.2	22	228	49%	49%	49%
4/22/13 Mon	9	6	2	1.2	9	715	25%	25%	25%
5/14/13 Tue	22	6	2	1.2	0	450	0%	0%	0%
6/6/13 Thu	5	6	2	1.2	46	522	29%	29%	31%
7/23/13 Tue	18	6	2	1.2	13	567	35%	35%	35%
8/21/13 Wed	9	6	2	1.2	38	597	21%	21%	21%
10/14/13 Mon	2	6	2	1.2	0	245	0%	0%	0%
12/11/13 Wed	12	6	2	1.2	0	683	0%	0%	0%
1/5/13 Sat	13	24	2	1.2	9	538	33%	33%	36%
2/1/13 Fri	12	24	2	1.2	0	532	0%	0%	0%
3/15/13 Fri	2	24	2	1.2	6	551	34%	34%	37%
4/22/13 Mon	9	24	2	1.2	9	557	32%	32%	35%
5/14/13 Tue	22	24	2	1.2	0	514	0%	0%	0%
6/6/13 Thu	5	24	2	1.2	39	617	33%	33%	35%
7/23/13 Tue	18	24	2	1.2	11	518	36%	36%	38%
8/21/13 Wed	9	24	2	1.2	49	474	30%	30%	34%
10/14/13 Mon	2	24	2	1.2	0	580	0%	0%	0%
12/11/13 Wed	12	24	2	1.2	0	625	0%	0%	0%
1/5/13 Sat	13	72	2	1.2	7	561	26%	26%	28%
2/1/13 Fri	12	72	2	1.2	0	592	0%	0%	0%
3/15/13 Fri	2	72	2	1.2	2	553	14%	14%	17%
4/22/13 Mon	9	72	2	1.2	4	530	19%	19%	18%
5/14/13 Tue	22	72	2	1.2	0	653	0%	0%	0%
6/6/13 Thu	5	72	2	1.2	32	635	33%	33%	35%
7/23/13 Tue	18	72	2	1.2	14	521	31%	31%	34%
8/21/13 Wed	9	72	2	1.2	51	462	32%	32%	35%
10/14/13 Mon	2	72	2	1.2	0	540	0%	0%	0%
12/11/13 Wed	12	72	2	1.2	0	735	0%	0%	1%
1/5/13 Sat	13	168	2	1.2	5	524	20%	20%	21%
2/1/13 Fri	12	168	2	1.2	0	596	1%	1%	1%
3/15/13 Fri	2	168	2	1.2	2	569	13%	13%	14%
4/22/13 Mon	9	168	2	1.2	1	559	8%	8%	8%
5/14/13 Tue	22	168	2	1.2	0	749	1%	1%	1%
6/6/13 Thu	5	168	2	1.2	26	666	34%	34%	36%
7/23/13 Tue	18	168	2	1.2	15	578	31%	31%	35%
8/21/13 Wed	9	168	2	1.2	42	506	33%	33%	36%
10/14/13 Mon	2	168	2	1.2	0	545	0%	0%	0%
12/11/13 Wed	12	168	2	1.2	0	753	2%	2%	4%

## Appendix C (Continued)

Table C.3: Resilience indicators for Scenario 3 model runs for the multi-residential neighborhood subjected to potable water and central power disruption.

Date	Hour	Disruption	Diversity	Redundancy	Capacity	Demand	Sustainability	Passivity	LOS
1/5/13 Sat	13	1	2	1.2	34	950	33%	33%	33%
2/1/13 Fri	12	1	2	1.2	0	700	0%	0%	0%
3/15/13 Fri	2	1	2	1.2	19	280	67%	67%	67%
4/22/13 Mon	9	1	2	1.2	8	860	24%	24%	24%
5/14/13 Tue	22	1	2	1.2	0	600	0%	0%	0%
6/6/13 Thu	5	1	2	1.2	148	290	46%	46%	46%
7/23/13 Tue	18	1	2	1.2	91	360	27%	27%	27%
8/21/13 Wed	9	1	2	1.2	73	650	18%	18%	18%
10/14/13 Mon	2	1	2	1.2	0	350	0%	0%	0%
12/11/13 Wed	12	1	2	1.2	0	820	0%	0%	0%
1/5/13 Sat	13	6	2	1.2	41	777	28%	28%	27%
2/1/13 Fri	12	6	2	1.2	0	655	0%	0%	0%
3/15/13 Fri	2	6	2	1.2	22	228	49%	49%	49%
4/22/13 Mon	9	6	2	1.2	9	715	25%	25%	25%
5/14/13 Tue	22	6	2	1.2	0	450	0%	0%	0%
6/6/13 Thu	5	6	2	1.2	94	522	29%	29%	31%
7/23/13 Tue	18	6	2	1.2	57	567	35%	35%	35%
8/21/13 Wed	9	6	2	1.2	79	597	21%	21%	21%
10/14/13 Mon	2	6	2	1.2	0	245	0%	0%	0%
12/11/13 Wed	12	6	2	1.2	0	683	0%	0%	0%
1/5/13 Sat	13	24	2	1.2	55	538	33%	33%	36%
2/1/13 Fri	12	24	2	1.2	0	532	0%	0%	0%
3/15/13 Fri	2	24	2	1.2	6	551	34%	34%	37%
4/22/13 Mon	9	24	2	1.2	9	557	32%	32%	35%
5/14/13 Tue	22	24	2	1.2	0	514	0%	0%	0%
6/6/13 Thu	5	24	2	1.2	79	617	33%	33%	35%
7/23/13 Tue	18	24	2	1.2	59	518	36%	36%	38%
8/21/13 Wed	9	24	2	1.2	102	474	30%	30%	34%
10/14/13 Mon	2	24	2	1.2	0	580	0%	0%	0%
12/11/13 Wed	12	24	2	1.2	0	625	0%	0%	0%
1/5/13 Sat	13	72	2	1.2	50	561	33%	33%	36%
2/1/13 Fri	12	72	2	1.2	0	592	0%	0%	0%
3/15/13 Fri	2	72	2	1.2	2	553	14%	14%	17%
4/22/13 Mon	9	72	2	1.2	4	530	19%	19%	18%
5/14/13 Tue	22	72	2	1.2	0	653	0%	0%	0%
6/6/13 Thu	5	72	2	1.2	71	635	33%	33%	35%
7/23/13 Tue	18	72	2	1.2	61	521	34%	34%	37%
8/21/13 Wed	9	72	2	1.2	105	462	32%	32%	35%
10/14/13 Mon	2	72	2	1.2	0	540	0%	0%	0%
12/11/13 Wed	12	72	2	1.2	0	735	0%	0%	1%
1/5/13 Sat	13	168	2	1.2	46	524	33%	33%	36%
2/1/13 Fri	12	168	2	1.2	0	596	1%	1%	1%
3/15/13 Fri	2	168	2	1.2	2	569	13%	13%	14%
4/22/13 Mon	9	168	2	1.2	1	559	8%	8%	8%
5/14/13 Tue	22	168	2	1.2	0	749	1%	1%	1%
6/6/13 Thu	5	168	2	1.2	64	666	34%	34%	36%
7/23/13 Tue	18	168	2	1.2	57	578	33%	33%	36%
8/21/13 Wed	9	168	2	1.2	92	506	33%	33%	36%
10/14/13 Mon	2	168	2	1.2	0	545	0%	0%	0%
12/11/13 Wed	12	168	2	1.2	0	753	2%	2%	4%

## Appendix C (Continued)

Table C.4: Resilience indicators for Scenario 4 model runs for the multi-residential neighborhood subjected to potable water and central power disruption.

Date	Hour	Disruption	Diversity	Redundancy	Capacity	Demand	Sustainability	Passivity	LOS
1/5/13 Sat	13	1	3	1.4	34	950	33%	33%	33%
2/1/13 Fri	12	1	3	1.4	0	700	0%	0%	0%
3/15/13 Fri	2	1	3	1.4	19	280	67%	67%	67%
4/22/13 Mon	9	1	3	1.4	8	860	24%	24%	24%
5/14/13 Tue	22	1	3	1.4	0	600	0%	0%	0%
6/6/13 Thu	5	1	3	1.4	165	290	46%	46%	46%
7/23/13 Tue	18	1	3	1.4	106	360	27%	27%	27%
8/21/13 Wed	9	1	3	1.4	75	650	18%	18%	18%
10/14/13 Mon	2	1	3	1.4	10	350	61%	61%	61%
12/11/13 Wed	12	1	3	1.4	0	820	0%	0%	0%
1/5/13 Sat	13	6	3	1.4	41	777	28%	28%	27%
2/1/13 Fri	12	6	3	1.4	0	655	0%	0%	0%
3/15/13 Fri	2	6	3	1.4	22	228	49%	49%	49%
4/22/13 Mon	9	6	3	1.4	9	715	25%	25%	25%
5/14/13 Tue	22	6	3	1.4	0	450	0%	0%	0%
6/6/13 Thu	5	6	3	1.4	95	522	29%	29%	31%
7/23/13 Tue	18	6	3	1.4	67	567	35%	35%	35%
8/21/13 Wed	9	6	3	1.4	81	597	21%	21%	21%
10/14/13 Mon	2	6	3	1.4	14	245	48%	48%	49%
12/11/13 Wed	12	6	3	1.4	0	683	0%	0%	0%
1/5/13 Sat	13	24	3	1.4	56	538	33%	33%	36%
2/1/13 Fri	12	24	3	1.4	0	532	0%	0%	0%
3/15/13 Fri	2	24	3	1.4	6	551	34%	34%	37%
4/22/13 Mon	9	24	3	1.4	9	557	32%	32%	35%
5/14/13 Tue	22	24	3	1.4	0	514	0%	0%	0%
6/6/13 Thu	5	24	3	1.4	80	617	33%	33%	35%
7/23/13 Tue	18	24	3	1.4	70	518	36%	36%	38%
8/21/13 Wed	9	24	3	1.4	102	474	30%	30%	34%
10/14/13 Mon	2	24	3	1.4	3	580	27%	27%	31%
12/11/13 Wed	12	24	3	1.4	0	625	0%	0%	0%
1/5/13 Sat	13	72	3	1.4	51	561	33%	33%	36%
2/1/13 Fri	12	72	3	1.4	0	592	0%	0%	0%
3/15/13 Fri	2	72	3	1.4	2	553	14%	14%	17%
4/22/13 Mon	9	72	3	1.4	4	530	19%	19%	19%
5/14/13 Tue	22	72	3	1.4	0	653	0%	0%	0%
6/6/13 Thu	5	72	3	1.4	71	635	33%	33%	35%
7/23/13 Tue	18	72	3	1.4	71	521	34%	34%	37%
8/21/13 Wed	9	72	3	1.4	105	462	32%	32%	35%
10/14/13 Mon	2	72	3	1.4	1	540	10%	10%	10%
12/11/13 Wed	12	72	3	1.4	0	735	0%	0%	1%
1/5/13 Sat	13	168	3	1.4	47	524	33%	33%	36%
2/1/13 Fri	12	168	3	1.4	0	596	1%	1%	1%
3/15/13 Fri	2	168	3	1.4	2	569	13%	13%	14%
4/22/13 Mon	9	168	3	1.4	2	559	8%	8%	8%
5/14/13 Tue	22	168	3	1.4	0	749	1%	1%	1%
6/6/13 Thu	5	168	3	1.4	64	666	34%	34%	36%
7/23/13 Tue	18	168	3	1.4	66	578	33%	33%	36%
8/21/13 Wed	9	168	3	1.4	92	506	33%	33%	36%
10/14/13 Mon	2	168	3	1.4	0	545	4%	4%	5%
12/11/13 Wed	12	168	3	1.4	0	753	2%	2%	4%

## Appendix C (Continued)

Table C.5: Resilience indicators for Scenario 5 model runs for the multi-residential neighborhood subjected to potable water and central power disruption.

Date	Hour	Disruption	Diversity	Redundancy	Capacity	Demand	Sustainability	Passivity	LOS
1/5/13 Sat	13	1	3	1.8	5	950	72%	72%	72%
2/1/13 Fri	12	1	3	1.8	0	700	0%	0%	0%
3/15/13 Fri	2	1	3	1.8	0	280	0%	0%	0%
4/22/13 Mon	9	1	3	1.8	8	860	52%	52%	52%
5/14/13 Tue	22	1	3	1.8	0	600	0%	0%	0%
6/6/13 Thu	5	1	3	1.8	86	290	46%	46%	46%
7/23/13 Tue	18	1	3	1.8	35	360	56%	56%	56%
8/21/13 Wed	9	1	3	1.8	70	650	45%	45%	45%
10/14/13 Mon	2	1	3	1.8	0	350	0%	0%	0%
12/11/13 Wed	12	1	3	1.8	0	820	0%	0%	0%
1/5/13 Sat	13	6	3	1.8	4	777	62%	62%	62%
2/1/13 Fri	12	6	3	1.8	0	655	0%	0%	0%
3/15/13 Fri	2	6	3	1.8	0	228	0%	0%	0%
4/22/13 Mon	9	6	3	1.8	8	715	60%	60%	61%
5/14/13 Tue	22	6	3	1.8	0	450	0%	0%	0%
6/6/13 Thu	5	6	3	1.8	85	522	45%	45%	44%
7/23/13 Tue	18	6	3	1.8	20	567	60%	60%	60%
8/21/13 Wed	9	6	3	1.8	75	597	56%	56%	57%
10/14/13 Mon	2	6	3	1.8	0	245	0%	0%	0%
12/11/13 Wed	12	6	3	1.8	0	683	0%	0%	0%
1/5/13 Sat	13	24	3	1.8	2	538	41%	41%	33%
2/1/13 Fri	12	24	3	1.8	0	532	0%	0%	0%
3/15/13 Fri	2	24	3	1.8	0	551	0%	0%	0%
4/22/13 Mon	9	24	3	1.8	4	557	52%	52%	48%
5/14/13 Tue	22	24	3	1.8	0	514	0%	0%	0%
6/6/13 Thu	5	24	3	1.8	77	617	58%	58%	57%
7/23/13 Tue	18	24	3	1.8	18	518	62%	62%	60%
8/21/13 Wed	9	24	3	1.8	94	474	56%	56%	56%
10/14/13 Mon	2	24	3	1.8	0	580	0%	0%	0%
12/11/13 Wed	12	24	3	1.8	0	625	0%	0%	0%
1/5/13 Sat	13	72	3	1.8	4	561	27%	27%	27%
2/1/13 Fri	12	72	3	1.8	0	592	0%	0%	0%
3/15/13 Fri	2	72	3	1.8	0	553	0%	0%	0%
4/22/13 Mon	9	72	3	1.8	2	530	18%	18%	16%
5/14/13 Tue	22	72	3	1.8	0	653	0%	0%	0%
6/6/13 Thu	5	72	3	1.8	64	635	59%	59%	58%
7/23/13 Tue	18	72	3	1.8	16	521	50%	50%	51%
8/21/13 Wed	9	72	3	1.8	100	462	58%	58%	57%
10/14/13 Mon	2	72	3	1.8	0	540	0%	0%	0%
12/11/13 Wed	12	72	3	1.8	0	735	0%	0%	1%
1/5/13 Sat	13	168	3	1.8	2	524	17%	17%	17%
2/1/13 Fri	12	168	3	1.8	0	596	1%	1%	1%
3/15/13 Fri	2	168	3	1.8	0	569	7%	7%	6%
4/22/13 Mon	9	168	3	1.8	1	559	7%	7%	7%
5/14/13 Tue	22	168	3	1.8	0	749	1%	1%	1%
6/6/13 Thu	5	168	3	1.8	55	666	59%	59%	58%
7/23/13 Tue	18	168	3	1.8	10	578	37%	37%	38%
8/21/13 Wed	9	168	3	1.8	84	506	59%	59%	58%
10/14/13 Mon	2	168	3	1.8	0	545	0%	0%	0%
12/11/13 Wed	12	168	3	1.8	0	753	2%	2%	4%

## Appendix C (Continued)

Table C.6: Resilience indicators for Scenario 6 model runs for the multi-residential neighborhood subjected to potable water and central power disruption.

Date	Hour	Disruption	Diversity	Redundancy	Capacity	Demand	Sustainability	Passivity	LOS
1/5/13 Sat	13	1	2	1.2	11	950	0%	0%	0%
2/1/13 Fri	12	1	2	1.2	14	700	0%	0%	0%
3/15/13 Fri	2	1	2	1.2	36	280	0%	0%	0%
4/22/13 Mon	9	1	2	1.2	12	860	0%	0%	0%
5/14/13 Tue	22	1	2	1.2	17	600	0%	0%	0%
6/6/13 Thu	5	1	2	1.2	34	290	0%	0%	0%
7/23/13 Tue	18	1	2	1.2	28	360	0%	0%	0%
8/21/13 Wed	9	1	2	1.2	15	650	0%	0%	0%
10/14/13 Mon	2	1	2	1.2	29	350	0%	0%	0%
12/11/13 Wed	12	1	2	1.2	12	820	0%	0%	0%
1/5/13 Sat	13	6	2	1.2	13	777	0%	0%	0%
2/1/13 Fri	12	6	2	1.2	15	655	0%	0%	0%
3/15/13 Fri	2	6	2	1.2	44	228	0%	0%	0%
4/22/13 Mon	9	6	2	1.2	14	715	0%	0%	0%
5/14/13 Tue	22	6	2	1.2	22	450	0%	0%	0%
6/6/13 Thu	5	6	2	1.2	19	522	0%	0%	0%
7/23/13 Tue	18	6	2	1.2	18	567	0%	0%	0%
8/21/13 Wed	9	6	2	1.2	17	597	0%	0%	0%
10/14/13 Mon	2	6	2	1.2	41	245	0%	0%	0%
12/11/13 Wed	12	6	2	1.2	15	683	0%	0%	0%
1/5/13 Sat	13	24	2	1.2	19	538	0%	0%	0%
2/1/13 Fri	12	24	2	1.2	19	532	0%	0%	0%
3/15/13 Fri	2	24	2	1.2	18	551	0%	0%	0%
4/22/13 Mon	9	24	2	1.2	18	557	0%	0%	0%
5/14/13 Tue	22	24	2	1.2	19	514	0%	0%	0%
6/6/13 Thu	5	24	2	1.2	16	617	0%	0%	0%
7/23/13 Tue	18	24	2	1.2	19	518	0%	0%	0%
8/21/13 Wed	9	24	2	1.2	21	474	0%	0%	0%
10/14/13 Mon	2	24	2	1.2	17	580	0%	0%	0%
12/11/13 Wed	12	24	2	1.2	16	625	0%	0%	0%
1/5/13 Sat	13	72	2	1.2	18	561	0%	0%	0%
2/1/13 Fri	12	72	2	1.2	17	592	0%	0%	0%
3/15/13 Fri	2	72	2	1.2	18	553	0%	0%	0%
4/22/13 Mon	9	72	2	1.2	19	530	0%	0%	0%
5/14/13 Tue	22	72	2	1.2	15	653	0%	0%	0%
6/6/13 Thu	5	72	2	1.2	16	635	0%	0%	0%
7/23/13 Tue	18	72	2	1.2	19	521	0%	0%	0%
8/21/13 Wed	9	72	2	1.2	22	462	0%	0%	0%
10/14/13 Mon	2	72	2	1.2	19	540	0%	0%	0%
12/11/13 Wed	12	72	2	1.2	14	735	0%	0%	1%
1/5/13 Sat	13	168	2	1.2	19	524	0%	0%	0%
2/1/13 Fri	12	168	2	1.2	17	596	0%	0%	0%
3/15/13 Fri	2	168	2	1.2	18	569	0%	0%	0%
4/22/13 Mon	9	168	2	1.2	18	559	0%	0%	0%
5/14/13 Tue	22	168	2	1.2	13	749	0%	0%	0%
6/6/13 Thu	5	168	2	1.2	15	666	0%	0%	0%
7/23/13 Tue	18	168	2	1.2	17	578	0%	0%	0%
8/21/13 Wed	9	168	2	1.2	20	506	0%	0%	0%
10/14/13 Mon	2	168	2	1.2	18	545	0%	0%	0%
12/11/13 Wed	12	168	2	1.2	13	753	0%	0%	2%

## Appendix C (Continued)

Table C.7: Resilience indicators for Scenario 7 model runs for the multi-residential neighborhood subjected to potable water and central power disruption.

Date	Hour	Disruption	Diversity	Redundancy	Capacity	Demand	Sustainability	Passivity	LOS
1/5/13 Sat	13	1	4	2.8	11	950	0%	0%	0%
2/1/13 Fri	12	1	4	2.8	14	700	0%	0%	0%
3/15/13 Fri	2	1	4	2.8	36	280	0%	0%	0%
4/22/13 Mon	9	1	4	2.8	19	860	76%	76%	76%
5/14/13 Tue	22	1	4	2.8	17	600	0%	0%	0%
6/6/13 Thu	5	1	4	2.8	105	290	54%	54%	54%
7/23/13 Tue	18	1	4	2.8	30	360	73%	73%	73%
8/21/13 Wed	9	1	4	2.8	73	650	82%	82%	82%
10/14/13 Mon	2	1	4	2.8	29	350	0%	0%	0%
12/11/13 Wed	12	1	4	2.8	12	820	0%	0%	0%
1/5/13 Sat	13	6	4	2.8	13	777	0%	0%	0%
2/1/13 Fri	12	6	4	2.8	15	655	0%	0%	0%
3/15/13 Fri	2	6	4	2.8	44	228	0%	0%	0%
4/22/13 Mon	9	6	4	2.8	21	715	75%	75%	75%
5/14/13 Tue	22	6	4	2.8	22	450	0%	0%	0%
6/6/13 Thu	5	6	4	2.8	102	522	71%	71%	69%
7/23/13 Tue	18	6	4	2.8	18	567	35%	35%	35%
8/21/13 Wed	9	6	4	2.8	77	597	79%	79%	79%
10/14/13 Mon	2	6	4	2.8	41	245	0%	0%	0%
12/11/13 Wed	12	6	4	2.8	15	683	0%	0%	0%
1/5/13 Sat	13	24	4	2.8	19	538	0%	0%	0%
2/1/13 Fri	12	24	4	2.8	19	532	0%	0%	0%
3/15/13 Fri	2	24	4	2.8	18	551	0%	0%	0%
4/22/13 Mon	9	24	4	2.8	21	557	53%	53%	43%
5/14/13 Tue	22	24	4	2.8	19	514	0%	0%	0%
6/6/13 Thu	5	24	4	2.8	92	617	67%	67%	65%
7/23/13 Tue	18	24	4	2.8	19	518	11%	11%	9%
8/21/13 Wed	9	24	4	2.8	97	474	70%	70%	66%
10/14/13 Mon	2	24	4	2.8	17	580	0%	0%	0%
12/11/13 Wed	12	24	4	2.8	16	625	0%	0%	0%
1/5/13 Sat	13	72	4	2.8	21	561	16%	16%	17%
2/1/13 Fri	12	72	4	2.8	17	592	0%	0%	0%
3/15/13 Fri	2	72	4	2.8	18	553	0%	0%	0%
4/22/13 Mon	9	72	4	2.8	20	530	18%	18%	14%
5/14/13 Tue	22	72	4	2.8	15	653	0%	0%	0%
6/6/13 Thu	5	72	4	2.8	78	635	67%	67%	65%
7/23/13 Tue	18	72	4	2.8	28	521	21%	21%	20%
8/21/13 Wed	9	72	4	2.8	112	462	68%	68%	65%
10/14/13 Mon	2	72	4	2.8	19	540	0%	0%	0%
12/11/13 Wed	12	72	4	2.8	14	735	0%	0%	1%
1/5/13 Sat	13	168	4	2.8	21	524	11%	11%	11%
2/1/13 Fri	12	168	4	2.8	17	596	1%	1%	1%
3/15/13 Fri	2	168	4	2.8	18	569	7%	7%	6%
4/22/13 Mon	9	168	4	2.8	18	559	7%	7%	6%
5/14/13 Tue	22	168	4	2.8	13	749	1%	1%	1%
6/6/13 Thu	5	168	4	2.8	68	666	66%	66%	64%
7/23/13 Tue	18	168	4	2.8	24	578	26%	26%	24%
8/21/13 Wed	9	168	4	2.8	99	506	67%	67%	64%
10/14/13 Mon	2	168	4	2.8	18	545	0%	0%	0%
12/11/13 Wed	12	168	4	2.8	13	753	2%	2%	4%

## Appendix C (Continued)

Table C.8: Resilience indicators for Scenario 8 model runs for the multi-residential neighborhood subjected to potable water and central power disruption.

Date	Hour	Disruption	Diversity	Redundancy	Capacity	Demand	Sustainability	Passivity	LOS
1/5/13 Sat	13	1	1	1	25	950	0%	100%	100%
2/1/13 Fri	12	1	1	1	35	700	0%	100%	100%
3/15/13 Fri	2	1	1	1	88	280	0%	100%	100%
4/22/13 Mon	9	1	1	1	28	860	0%	100%	100%
5/14/13 Tue	22	1	1	1	41	600	0%	100%	100%
6/6/13 Thu	5	1	1	1	85	290	31%	100%	100%
7/23/13 Tue	18	1	1	1	68	360	0%	100%	100%
8/21/13 Wed	9	1	1	1	37	650	0%	100%	100%
10/14/13 Mon	2	1	1	1	70	350	0%	100%	100%
12/11/13 Wed	12	1	1	1	29	820	0%	100%	100%
1/5/13 Sat	13	6	1	1	29	777	0%	100%	100%
2/1/13 Fri	12	6	1	1	35	655	0%	100%	100%
3/15/13 Fri	2	6	1	1	106	228	0%	100%	100%
4/22/13 Mon	9	6	1	1	31	715	0%	100%	100%
5/14/13 Tue	22	6	1	1	52	450	0%	100%	100%
6/6/13 Thu	5	6	1	1	45	522	0%	100%	100%
7/23/13 Tue	18	6	1	1	41	567	0%	100%	100%
8/21/13 Wed	9	6	1	1	38	597	0%	100%	100%
10/14/13 Mon	2	6	1	1	99	245	0%	100%	100%
12/11/13 Wed	12	6	1	1	33	683	0%	100%	100%
1/5/13 Sat	13	24	1	1	33	538	0%	100%	100%
2/1/13 Fri	12	24	1	1	33	532	0%	100%	100%
3/15/13 Fri	2	24	1	1	34	551	0%	100%	100%
4/22/13 Mon	9	24	1	1	31	557	0%	100%	100%
5/14/13 Tue	22	24	1	1	37	514	0%	100%	100%
6/6/13 Thu	5	24	1	1	28	617	0%	100%	100%
7/23/13 Tue	18	24	1	1	36	518	0%	100%	100%
8/21/13 Wed	9	24	1	1	38	474	0%	100%	100%
10/14/13 Mon	2	24	1	1	32	580	0%	100%	100%
12/11/13 Wed	12	24	1	1	27	625	0%	100%	100%
1/5/13 Sat	13	72	1	1	13	561	0%	62%	62%
2/1/13 Fri	12	72	1	1	12	592	0%	60%	60%
3/15/13 Fri	2	72	1	1	15	553	0%	63%	63%
4/22/13 Mon	9	72	1	1	13	530	0%	64%	64%
5/14/13 Tue	22	72	1	1	13	653	0%	63%	63%
6/6/13 Thu	5	72	1	1	11	635	0%	54%	54%
7/23/13 Tue	18	72	1	1	16	521	0%	68%	68%
8/21/13 Wed	9	72	1	1	18	462	0%	72%	72%
10/14/13 Mon	2	72	1	1	14	540	0%	61%	61%
12/11/13 Wed	12	72	1	1	9	735	0%	54%	54%
1/5/13 Sat	13	168	1	1	6	524	0%	27%	27%
2/1/13 Fri	12	168	1	1	5	596	0%	26%	26%
3/15/13 Fri	2	168	1	1	6	569	0%	27%	27%
4/22/13 Mon	9	168	1	1	5	559	0%	28%	28%
5/14/13 Tue	22	168	1	1	5	749	0%	27%	27%
6/6/13 Thu	5	168	1	1	4	666	0%	23%	23%
7/23/13 Tue	18	168	1	1	6	578	0%	29%	29%
8/21/13 Wed	9	168	1	1	7	506	0%	31%	31%
10/14/13 Mon	2	168	1	1	6	545	0%	26%	26%
12/11/13 Wed	12	168	1	1	4	753	0%	24%	24%



## Appendix C (Continued)

Table C.9: Resilience indicators for Scenario 9 model runs for the multi-residential neighborhood subjected to potable water and central power disruption.

Date	Hour	Disruption	Diversity	Redundancy	Capacity	Demand	Sustainability	Passivity	LOS
1/5/13 Sat	13	1	1	1	52	950	0%	100%	100%
2/1/13 Fri	12	1	1	1	70	700	0%	100%	100%
3/15/13 Fri	2	1	1	1	178	280	0%	100%	100%
4/22/13 Mon	9	1	1	1	57	860	0%	100%	100%
5/14/13 Tue	22	1	1	1	82	600	0%	100%	100%
6/6/13 Thu	5	1	1	1	171	290	31%	100%	100%
7/23/13 Tue	18	1	1	1	138	360	0%	100%	100%
8/21/13 Wed	9	1	1	1	76	650	0%	100%	100%
10/14/13 Mon	2	1	1	1	142	350	0%	100%	100%
12/11/13 Wed	12	1	1	1	60	820	0%	100%	100%
1/5/13 Sat	13	6	1	1	61	777	0%	100%	100%
2/1/13 Fri	12	6	1	1	73	655	0%	100%	100%
3/15/13 Fri	2	6	1	1	215	228	0%	100%	100%
4/22/13 Mon	9	6	1	1	66	715	0%	100%	100%
5/14/13 Tue	22	6	1	1	107	450	0%	100%	100%
6/6/13 Thu	5	6	1	1	93	522	0%	100%	100%
7/23/13 Tue	18	6	1	1	85	567	0%	100%	100%
8/21/13 Wed	9	6	1	1	80	597	0%	100%	100%
10/14/13 Mon	2	6	1	1	201	245	0%	100%	100%
12/11/13 Wed	12	6	1	1	70	683	0%	100%	100%
1/5/13 Sat	13	24	1	1	79	538	0%	100%	100%
2/1/13 Fri	12	24	1	1	80	532	0%	100%	100%
3/15/13 Fri	2	24	1	1	79	551	0%	100%	100%
4/22/13 Mon	9	24	1	1	76	557	0%	100%	100%
5/14/13 Tue	22	24	1	1	86	514	0%	100%	100%
6/6/13 Thu	5	24	1	1	69	617	0%	100%	100%
7/23/13 Tue	18	24	1	1	85	518	0%	100%	100%
8/21/13 Wed	9	24	1	1	91	474	0%	100%	100%
10/14/13 Mon	2	24	1	1	75	580	0%	100%	100%
12/11/13 Wed	12	24	1	1	67	625	0%	100%	100%
1/5/13 Sat	13	72	1	1	51	561	0%	100%	100%
2/1/13 Fri	12	72	1	1	48	592	0%	100%	100%
3/15/13 Fri	2	72	1	1	55	553	0%	100%	100%
4/22/13 Mon	9	72	1	1	56	530	0%	100%	100%
5/14/13 Tue	22	72	1	1	44	653	0%	100%	100%
6/6/13 Thu	5	72	1	1	42	635	0%	100%	100%
7/23/13 Tue	18	72	1	1	60	521	0%	100%	100%
8/21/13 Wed	9	72	1	1	70	462	0%	100%	100%
10/14/13 Mon	2	72	1	1	56	540	0%	100%	100%
12/11/13 Wed	12	72	1	1	36	735	0%	99%	99%
1/5/13 Sat	13	168	1	1	24	524	0%	56%	56%
2/1/13 Fri	12	168	1	1	21	596	0%	49%	49%
3/15/13 Fri	2	168	1	1	24	569	0%	54%	54%
4/22/13 Mon	9	168	1	1	24	559	0%	53%	53%
5/14/13 Tue	22	168	1	1	17	749	0%	47%	47%
6/6/13 Thu	5	168	1	1	17	666	0%	47%	47%
7/23/13 Tue	18	168	1	1	24	578	0%	55%	55%
8/21/13 Wed	9	168	1	1	30	506	0%	60%	60%
10/14/13 Mon	2	168	1	1	25	545	0%	55%	55%
12/11/13 Wed	12	168	1	1	15	753	0%	44%	44%

## Appendix C (Continued)

Table C.10: Average resilience indicators (n=10) by scenario and disruption length for model runs for the multi-residential neighborhood subjected to potable water and central power disruption.

Scenario	Disruption	Diversity	Redundancy	Capacity	Demand	Sustainability	Passivity	Preparation	Adaptation potential	LOS
1	1	1	1	0	586	0%	0%	0%	144%	0%
1	6	1	1	0	544	0%	0%	0%	144%	0%
1	24	1	1	0	551	0%	0%	0%	144%	0%
1	72	1	1	0	578	0%	0%	0%	144%	0%
1	168	1	1	0	604	0%	0%	0%	144%	0%
2	1	2	1.2	15	586	21%	21%	15%	128%	21%
2	6	2	1.2	14	544	19%	19%	15%	128%	19%
2	24	2	1.2	12	551	20%	20%	15%	128%	21%
2	72	2	1.2	11	578	15%	15%	15%	128%	17%
2	168	2	1.2	9	604	14%	14%	15%	128%	15%
3	1	2	1.2	37	586	21%	21%	18%	126%	21%
3	6	2	1.2	30	544	19%	19%	18%	126%	19%
3	24	2	1.2	31	551	20%	20%	18%	126%	21%
3	72	2	1.2	29	578	16%	16%	18%	126%	18%
3	168	2	1.2	26	604	16%	16%	18%	126%	17%
4	1	3	1.4	42	586	28%	28%	19%	129%	28%
4	6	3	1.4	33	544	23%	23%	19%	129%	24%
4	24	3	1.4	33	551	23%	23%	19%	129%	25%
4	72	3	1.4	30	578	17%	17%	19%	129%	19%
4	168	3	1.4	27	604	16%	16%	19%	129%	17%
5	1	3	1.8	20	586	27%	27%	26%	118%	27%
5	6	3	1.8	19	544	28%	28%	26%	118%	28%
5	24	3	1.8	20	551	27%	27%	26%	118%	25%
5	72	3	1.8	19	578	21%	21%	26%	118%	21%
5	168	3	1.8	15	604	19%	19%	26%	118%	19%
6	1	2	1.2	21	586	0%	0%	33%	111%	0%
6	6	2	1.2	22	544	0%	0%	33%	111%	0%
6	24	2	1.2	18	551	0%	0%	33%	111%	0%
6	72	2	1.2	18	578	0%	0%	33%	111%	0%
6	168	2	1.2	17	604	0%	0%	33%	111%	0%
7	1	4	2.8	34	586	28%	28%	61%	83%	28%
7	6	4	2.8	37	544	26%	26%	61%	83%	26%
7	24	4	2.8	34	551	20%	20%	61%	83%	18%
7	72	4	2.8	34	578	19%	19%	61%	83%	18%
7	168	4	2.8	31	604	19%	19%	61%	83%	18%
8	1	1	1	51	586	3%	100%	0%	144%	100%
8	6	1	1	51	544	0%	100%	0%	144%	100%
8	24	1	1	33	551	0%	100%	0%	144%	100%
8	72	1	1	13	578	0%	62%	0%	144%	62%
8	168	1	1	5	604	0%	27%	0%	144%	27%
9	1	1	1	103	586	3%	100%	0%	144%	100%
9	6	1	1	105	544	0%	100%	0%	144%	100%
9	24	1	1	79	551	0%	100%	0%	144%	100%
9	72	1	1	52	578	0%	100%	0%	144%	100%
9	168	1	1	22	604	0%	52%	0%	144%	52%

## Appendix D Model Run Results for the Elementary School (Potable Water Disruption)

Table D.1: Elementary school building scenarios evaluated by the WRAM..

Scenario	Description of water flows	Power source
1	Potable water for all demands	Central power
2	Rainwater (5,000 gallon cistern) for toilet flushing	Gravity
3	Rainwater (10,000 gallon cistern) for toilet flushing	Gravity
4	Rainwater and condensate (10,000 gallon cistern) for toilet flushing	Gravity
5	Rainwater and condensate (10,000 gallon cistern) for toilets and urinals	Gravity
6	Recycled wastewater from bathroom sinks and kitchen sinks (2,000 gallon MBR) to toilets	Central power
7	Recycled wastewater from bathroom sinks and kitchen sinks (2,000 gallon MBR) to toilets Rainwater and condensate (10,000 gallon cistern) to bathroom sinks and kitchen sinks	Central power Gravity
8	Potable water storage (5,000 gallon tank)	Gravity
9	Potable water storage (10,000 gallon tank)	Gravity

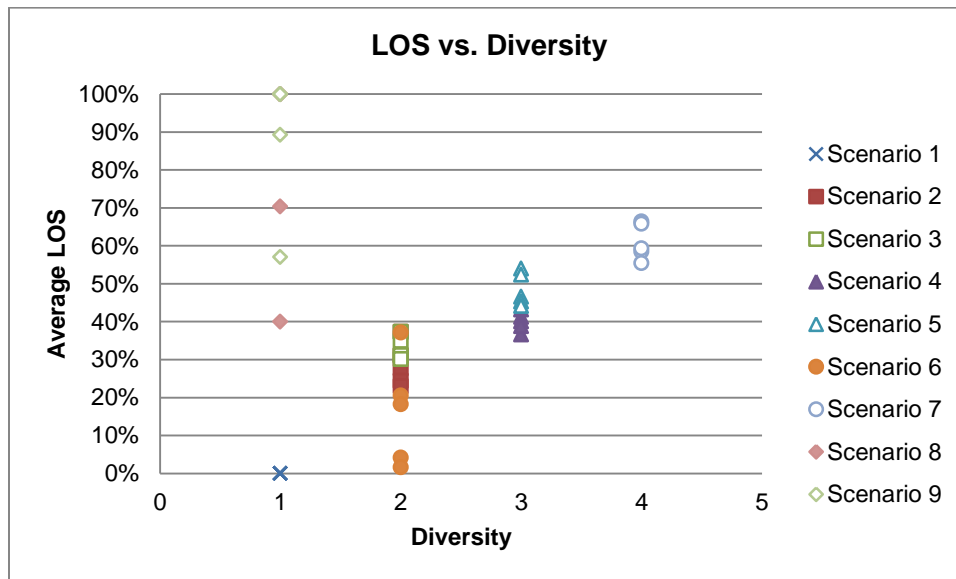

Figure D.1: Average level of service (LOS) vs. diversity for elementary school scenarios subjected to potable water disruption.

Appendix D (Continued)

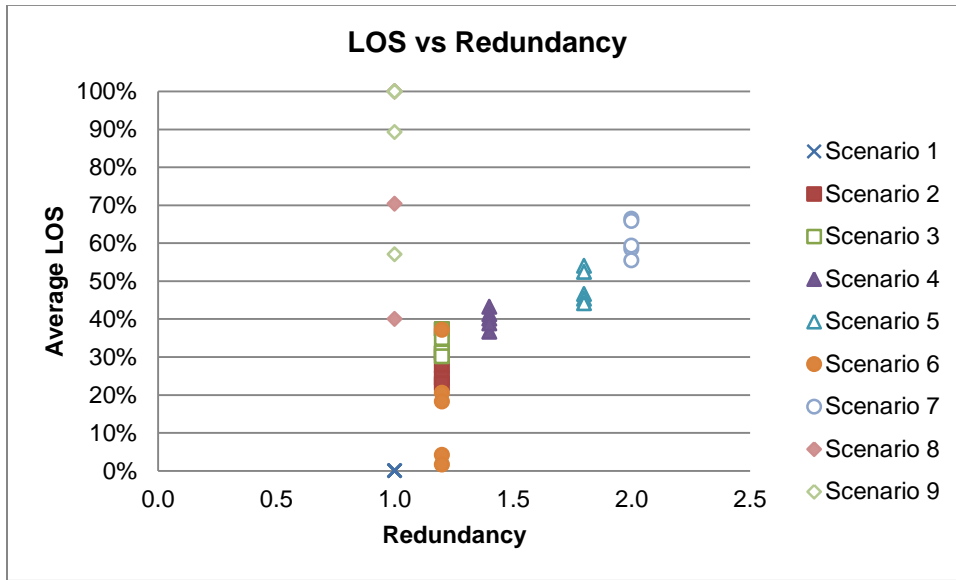

Figure D.2: Average level of service (LOS) vs. redundancy for elementary school scenarios subjected to potable water disruption.

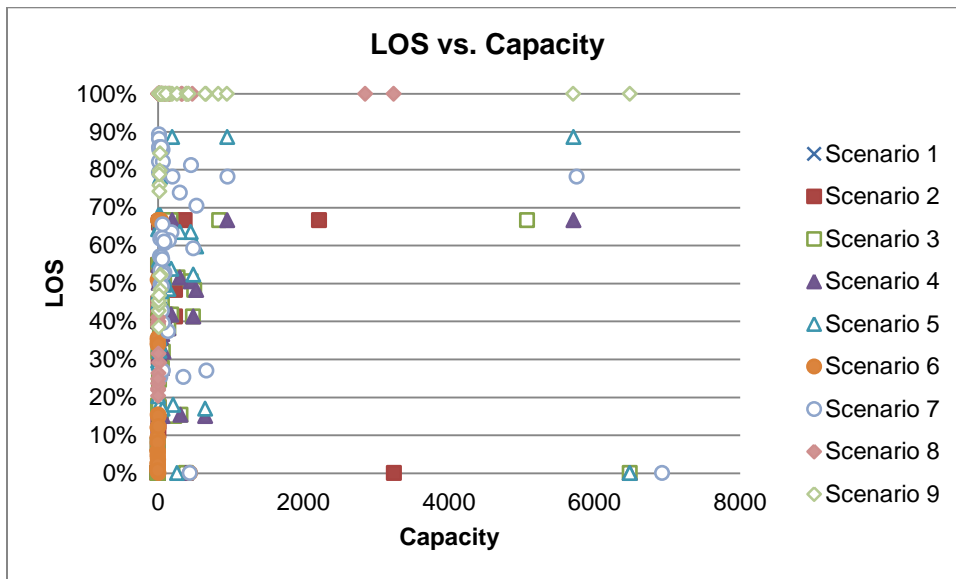

Figure D.3: Level of service (LOS) vs. capacity for elementary school scenarios subjected to potable water disruption.

Appendix D (Continued)

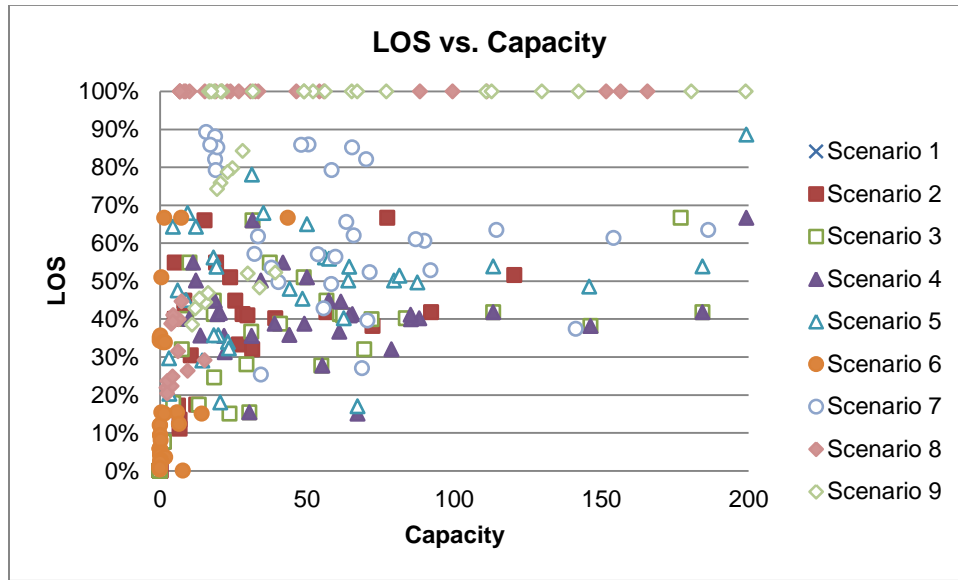

Figure D.4: Level of service (LOS) vs. capacity (values 0 to 200) for elementary school scenarios subjected to potable water disruption.

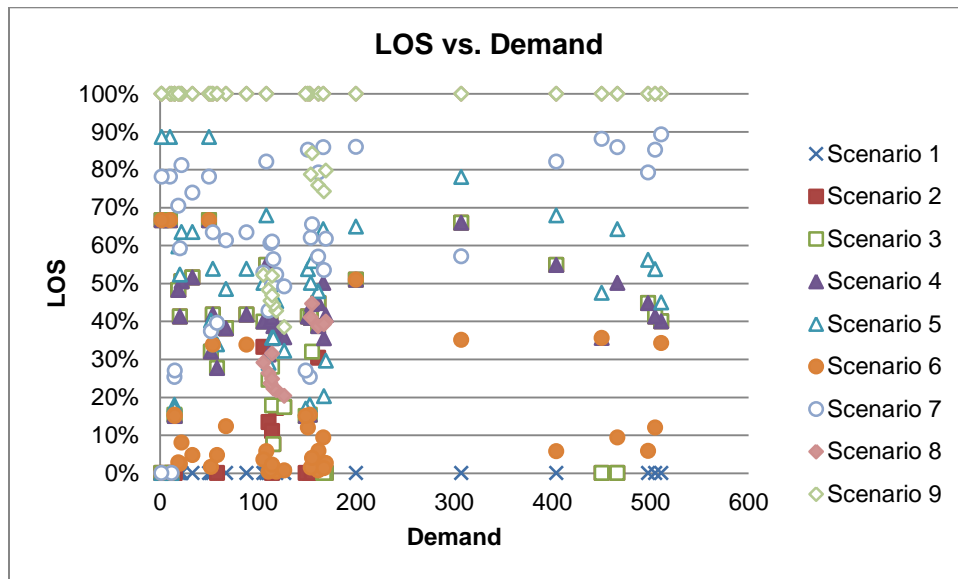

Figure D.5: Level of service (LOS) vs. demand for elementary school scenarios subjected to potable water disruption.

Appendix D (Continued)

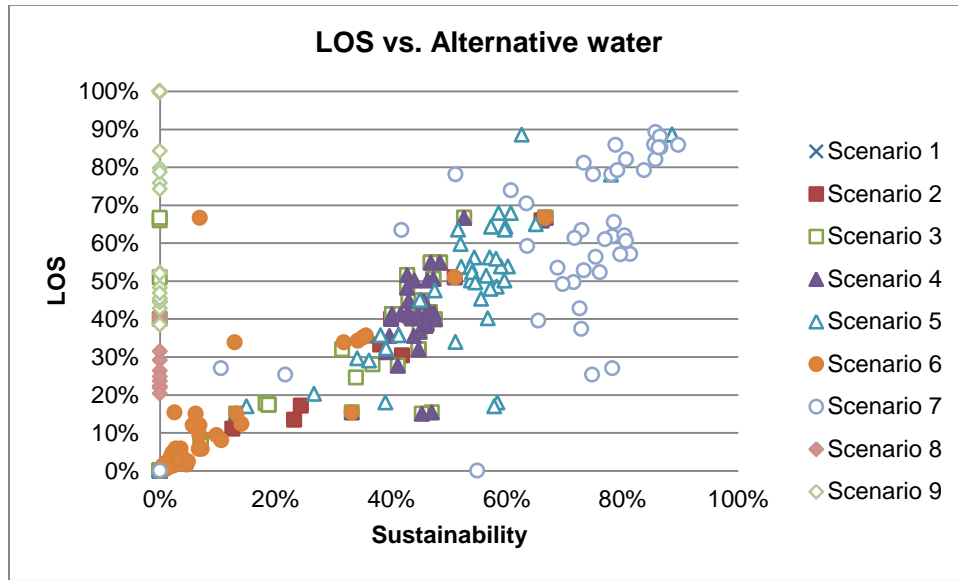

Figure D.6: Level of service (LOS) vs. alternative water for elementary school scenarios subjected to potable water disruption.

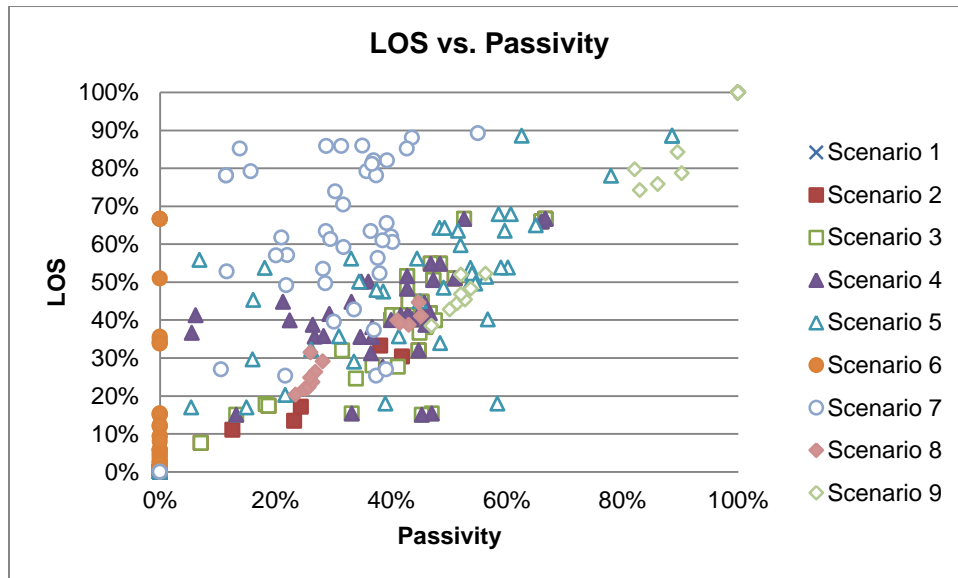

Figure D.7: Level of service (LOS) vs. passivity for elementary school scenarios subjected to potable water disruption.

Appendix D (Continued)

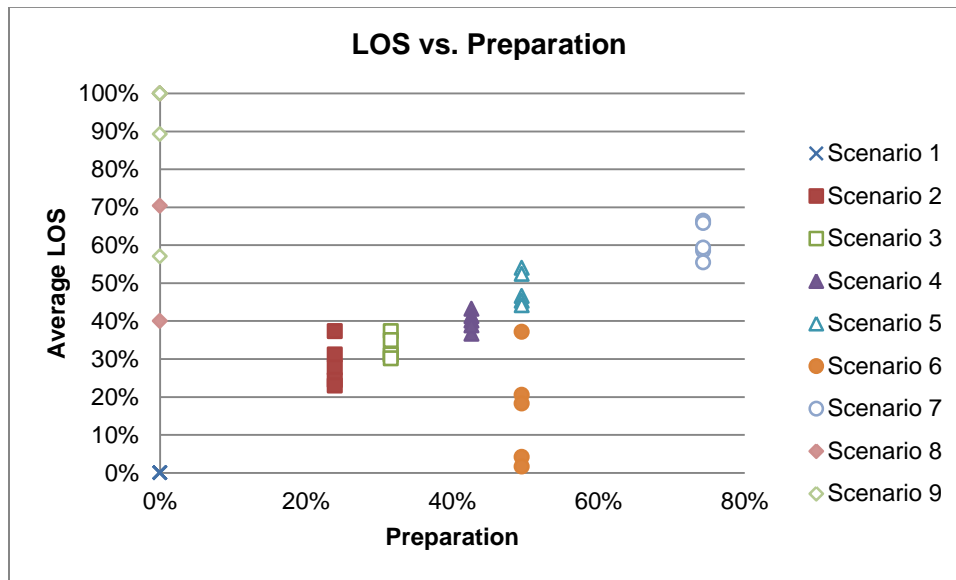

Figure D.8: Average level of service (LOS) vs. preparation for elementary school scenarios subjected to potable water disruption.

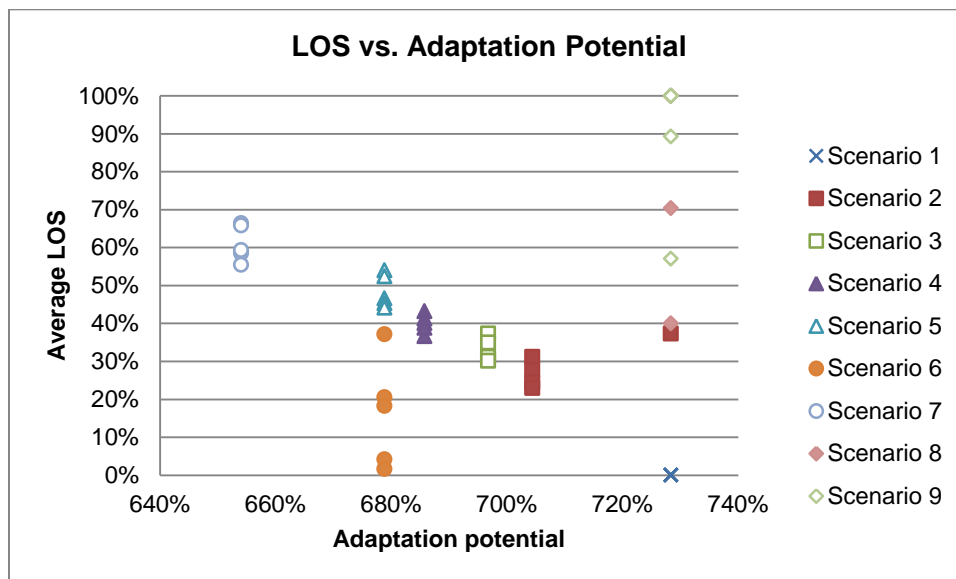

Figure D.9: Average level of service (LOS) vs. adaptation potential for elementary school scenarios subjected to potable water disruption.

**Appendix D (Continued)**

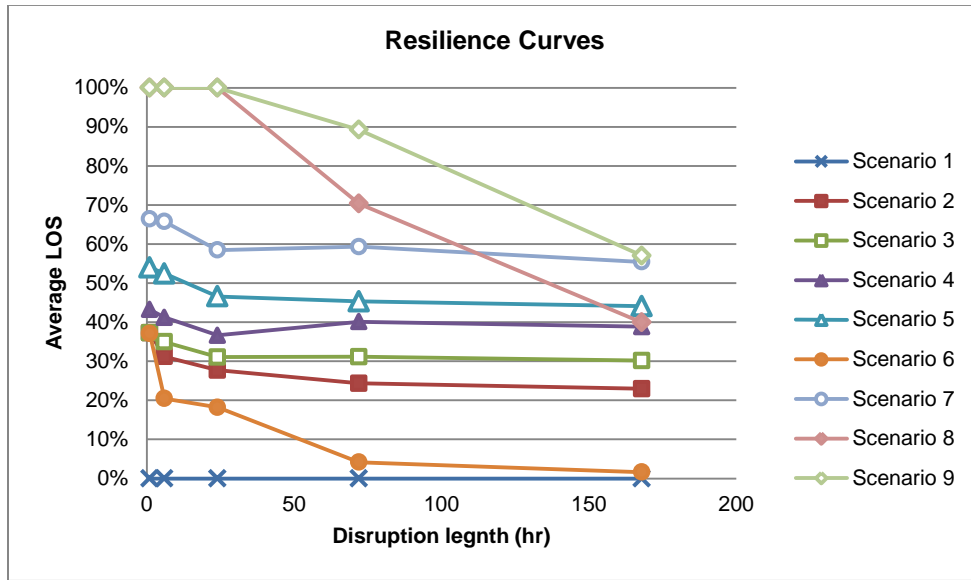

Figure D.10: Resilience curves for the elementary school study subjected to potable water disruption.

Tables D.2 through D.10 provide the resilience indicators for each model run for the elementary school study subjected to a range of potable water disruptions (1 hour, 6 hours, 24 hours, 72 hours, and 168 hours). A total of 450 model runs were conducted. Blank cells indicate model runs where no water demand was present and thus the resilience indicator could not be calculated. Blank cells were not included in correlation analyses.



## Appendix D (Continued)

Table D.2: Resilience indicators for Scenario 1 model runs for the elementary school subjected to potable water disruption.

Date	Hour	Disruption	Diversity	Redundancy	Capacity	Demand	Sustainability	Passivity	LOS
1/5/13 Sat	13	1	1	1	0	0			
2/1/13 Fri	12	1	1	1	0	511	0%	0%	0%
3/15/13 Fri	2	1	1	1	0	12	0%	0%	0%
4/22/13 Mon	9	1	1	1	0	307	0%	0%	0%
5/14/13 Tue	22	1	1	1	0	0			
6/6/13 Thu	5	1	1	1	0	0			
7/23/13 Tue	18	1	1	1	0	11	0%	0%	0%
8/21/13 Wed	9	1	1	1	0	200	0%	0%	0%
10/14/13 Mon	2	1	1	1	0	0			
12/11/13 Wed	12	1	1	1	0	450	0%	0%	0%
1/5/13 Sat	13	6	1	1	0	0			
2/1/13 Fri	12	6	1	1	0	404	0%	0%	0%
3/15/13 Fri	2	6	1	1	0	15	0%	0%	0%
4/22/13 Mon	9	6	1	1	0	498	0%	0%	0%
5/14/13 Tue	22	6	1	1	0	0			
6/6/13 Thu	5	6	1	1	0	88	0%	0%	0%
7/23/13 Tue	18	6	1	1	0	2	0%	0%	0%
8/21/13 Wed	9	6	1	1	0	505	0%	0%	0%
10/14/13 Mon	2	6	1	1	0	15	0%	0%	0%
12/11/13 Wed	12	6	1	1	0	466	0%	0%	0%
1/5/13 Sat	13	24	1	1	0	2	0%	0%	0%
2/1/13 Fri	12	24	1	1	0	108	0%	0%	0%
3/15/13 Fri	2	24	1	1	0	153	0%	0%	0%
4/22/13 Mon	9	24	1	1	0	162	0%	0%	0%
5/14/13 Tue	22	24	1	1	0	193	0%	0%	0%
6/6/13 Thu	5	24	1	1	0	54	0%	0%	0%
7/23/13 Tue	18	24	1	1	0	50	0%	0%	0%
8/21/13 Wed	9	24	1	1	0	151	0%	0%	0%
10/14/13 Mon	2	24	1	1	0	149	0%	0%	0%
12/11/13 Wed	12	24	1	1	0	167	0%	0%	0%
1/5/13 Sat	13	72	1	1	0	67	0%	0%	0%
2/1/13 Fri	12	72	1	1	0	52	0%	0%	0%
3/15/13 Fri	2	72	1	1	0	58	0%	0%	0%
4/22/13 Mon	9	72	1	1	0	161	0%	0%	0%
5/14/13 Tue	22	72	1	1	0	169	0%	0%	0%
6/6/13 Thu	5	72	1	1	0	22	0%	0%	0%
7/23/13 Tue	18	72	1	1	0	33	0%	0%	0%
8/21/13 Wed	9	72	1	1	0	154	0%	0%	0%
10/14/13 Mon	2	72	1	1	0	155	0%	0%	0%
12/11/13 Wed	12	72	1	1	0	167	0%	0%	0%
1/5/13 Sat	13	168	1	1	0	106	0%	0%	0%
2/1/13 Fri	12	168	1	1	0	111	0%	0%	0%
3/15/13 Fri	2	168	1	1	0	114	0%	0%	0%
4/22/13 Mon	9	168	1	1	0	119	0%	0%	0%
5/14/13 Tue	22	168	1	1	0	116	0%	0%	0%
6/6/13 Thu	5	168	1	1	0	21	0%	0%	0%
7/23/13 Tue	18	168	1	1	0	19	0%	0%	0%
8/21/13 Wed	9	168	1	1	0	113	0%	0%	0%
10/14/13 Mon	2	168	1	1	0	114	0%	0%	0%
12/11/13 Wed	12	168	1	1	0	127	0%	0%	0%

## Appendix D (Continued)

Table D.3: Resilience indicators for Scenario 2 model runs for the elementary school subjected to potable water disruption.

Date	Hour	Disruption	Diversity	Redundancy	Capacity	Demand	Sustainability	Passivity	LOS
1/5/13 Sat	13	1	2	1.2	0	0			
2/1/13 Fri	12	1	2	1.2	5	511	40%	40%	40%
3/15/13 Fri	2	1	2	1.2	0	12	0%	0%	0%
4/22/13 Mon	9	1	2	1.2	15	307	66%	66%	66%
5/14/13 Tue	22	1	2	1.2	0	0			
6/6/13 Thu	5	1	2	1.2	0	0			
7/23/13 Tue	18	1	2	1.2	370	11	67%	67%	67%
8/21/13 Wed	9	1	2	1.2	24	200	51%	51%	51%
10/14/13 Mon	2	1	2	1.2	0	0			
12/11/13 Wed	12	1	2	1.2	0	450	0%	0%	0%
1/5/13 Sat	13	6	2	1.2	0	0			
2/1/13 Fri	12	6	2	1.2	5	404	48%	48%	55%
3/15/13 Fri	2	6	2	1.2	0	15	0%	0%	0%
4/22/13 Mon	9	6	2	1.2	8	498	43%	43%	45%
5/14/13 Tue	22	6	2	1.2	0	0			
6/6/13 Thu	5	6	2	1.2	57	88	46%	46%	42%
7/23/13 Tue	18	6	2	1.2	2218	2	67%	67%	67%
8/21/13 Wed	9	6	2	1.2	8	505	40%	40%	41%
10/14/13 Mon	2	6	2	1.2	0	15	0%	0%	0%
12/11/13 Wed	12	6	2	1.2	0	466	0%	0%	0%
1/5/13 Sat	13	24	2	1.2	3243	2	0%	0%	0%
2/1/13 Fri	12	24	2	1.2	19	108	47%	47%	55%
3/15/13 Fri	2	24	2	1.2	0	153	0%	0%	0%
4/22/13 Mon	9	24	2	1.2	26	162	45%	45%	45%
5/14/13 Tue	22	24	2	1.2	0	193	0%	0%	
6/6/13 Thu	5	24	2	1.2	92	54	47%	47%	42%
7/23/13 Tue	18	24	2	1.2	77	50	53%	53%	67%
8/21/13 Wed	9	24	2	1.2	28	151	42%	42%	41%
10/14/13 Mon	2	24	2	1.2	0	149	0%	0%	0%
12/11/13 Wed	12	24	2	1.2	0	167	0%	0%	0%
1/5/13 Sat	13	72	2	1.2	72	67	46%	46%	38%
2/1/13 Fri	12	72	2	1.2	31	52	45%	45%	32%
3/15/13 Fri	2	72	2	1.2	0	58	0%	0%	0%
4/22/13 Mon	9	72	2	1.2	11	161	42%	42%	30%
5/14/13 Tue	22	72	2	1.2	0	169	0%	0%	0%
6/6/13 Thu	5	72	2	1.2	224	22	47%	47%	51%
7/23/13 Tue	18	72	2	1.2	120	33	43%	43%	52%
8/21/13 Wed	9	72	2	1.2	30	154	43%	43%	41%
10/14/13 Mon	2	72	2	1.2	0	155	0%	0%	0%
12/11/13 Wed	12	72	2	1.2	0	167	0%	0%	0%
1/5/13 Sat	13	168	2	1.2	27	106	38%	38%	33%
2/1/13 Fri	12	168	2	1.2	7	111	23%	23%	13%
3/15/13 Fri	2	168	2	1.2	7	114	13%	13%	11%
4/22/13 Mon	9	168	2	1.2	6	119	24%	24%	17%
5/14/13 Tue	22	168	2	1.2	1	116	7%	7%	8%
6/6/13 Thu	5	168	2	1.2	239	21	43%	43%	41%
7/23/13 Tue	18	168	2	1.2	236	19	43%	43%	48%
8/21/13 Wed	9	168	2	1.2	39	113	44%	44%	40%
10/14/13 Mon	2	168	2	1.2	0	114	0%	0%	0%
12/11/13 Wed	12	168	2	1.2	12	127	19%	19%	17%

## Appendix D (Continued)

Table D.4: Resilience indicators for Scenario 3 model runs for the elementary school subjected to potable water disruption.

Date	Hour	Disruption	Diversity	Redundancy	Capacity	Demand	Sustainability	Passivity	LOS
1/5/13 Sat	13	1	2	1.2	0	0			
2/1/13 Fri	12	1	2	1.2	9	511	0%	40%	40%
3/15/13 Fri	2	1	2	1.2	388	12	0%	0%	0%
4/22/13 Mon	9	1	2	1.2	31	307	0%	66%	66%
5/14/13 Tue	22	1	2	1.2	0	0			
6/6/13 Thu	5	1	2	1.2	0	0			
7/23/13 Tue	18	1	2	1.2	846	11	0%	67%	67%
8/21/13 Wed	9	1	2	1.2	49	200	0%	51%	51%
10/14/13 Mon	2	1	2	1.2	0	0			
12/11/13 Wed	12	1	2	1.2	0	450	0%	0%	0%
1/5/13 Sat	13	6	2	1.2	0	0			
2/1/13 Fri	12	6	2	1.2	10	404	48%	48%	55%
3/15/13 Fri	2	6	2	1.2	310	15	33%	33%	15%
4/22/13 Mon	9	6	2	1.2	18	498	43%	43%	45%
5/14/13 Tue	22	6	2	1.2	0	0			
6/6/13 Thu	5	6	2	1.2	113	88	46%	46%	42%
7/23/13 Tue	18	6	2	1.2	5075	2	67%	67%	67%
8/21/13 Wed	9	6	2	1.2	18	505	40%	40%	41%
10/14/13 Mon	2	6	2	1.2	229	15	13%	13%	15%
12/11/13 Wed	12	6	2	1.2	0	466	0%	0%	0%
1/5/13 Sat	13	24	2	1.2	6486	2	0%	0%	0%
2/1/13 Fri	12	24	2	1.2	37	108	47%	47%	55%
3/15/13 Fri	2	24	2	1.2	30	153	47%	47%	15%
4/22/13 Mon	9	24	2	1.2	57	162	45%	45%	45%
5/14/13 Tue	22	24	2	1.2	0	193	0%	0%	
6/6/13 Thu	5	24	2	1.2	184	54	47%	47%	42%
7/23/13 Tue	18	24	2	1.2	177	50	53%	53%	67%
8/21/13 Wed	9	24	2	1.2	61	151	42%	42%	41%
10/14/13 Mon	2	24	2	1.2	24	149	45%	45%	15%
12/11/13 Wed	12	24	2	1.2	0	167	0%	0%	0%
1/5/13 Sat	13	72	2	1.2	146	67	46%	46%	38%
2/1/13 Fri	12	72	2	1.2	69	52	45%	45%	32%
3/15/13 Fri	2	72	2	1.2	55	58	41%	41%	28%
4/22/13 Mon	9	72	2	1.2	41	161	46%	46%	39%
5/14/13 Tue	22	72	2	1.2	0	169	0%	0%	0%
6/6/13 Thu	5	72	2	1.2	451	22	47%	47%	51%
7/23/13 Tue	18	72	2	1.2	272	33	43%	43%	52%
8/21/13 Wed	9	72	2	1.2	62	154	43%	43%	41%
10/14/13 Mon	2	72	2	1.2	7	155	32%	32%	32%
12/11/13 Wed	12	72	2	1.2	0	167	0%	0%	0%
1/5/13 Sat	13	168	2	1.2	72	106	48%	48%	40%
2/1/13 Fri	12	168	2	1.2	18	111	34%	34%	25%
3/15/13 Fri	2	168	2	1.2	29	114	37%	37%	28%
4/22/13 Mon	9	168	2	1.2	31	119	45%	45%	37%
5/14/13 Tue	22	168	2	1.2	1	116	7%	7%	8%
6/6/13 Thu	5	168	2	1.2	482	21	43%	43%	41%
7/23/13 Tue	18	168	2	1.2	501	19	43%	43%	48%
8/21/13 Wed	9	168	2	1.2	84	113	44%	44%	40%
10/14/13 Mon	2	168	2	1.2	5	114	18%	18%	18%
12/11/13 Wed	12	168	2	1.2	13	127	19%	19%	17%

## Appendix D (Continued)

Table D.5: Resilience indicators for Scenario 4 model runs for the elementary school subjected to potable water disruption.

Date	Hour	Disruption	Diversity	Redundancy	Capacity	Demand	Sustainability	Passivity	LOS
1/5/13 Sat	13	1	3	1.4	0	0			
2/1/13 Fri	12	1	3	1.4	10	511	40%	40%	40%
3/15/13 Fri	2	1	3	1.4	388	12	0%	0%	0%
4/22/13 Mon	9	1	3	1.4	31	307	66%	66%	66%
5/14/13 Tue	22	1	3	1.4	0	0			
6/6/13 Thu	5	1	3	1.4	0	0			
7/23/13 Tue	18	1	3	1.4	952	11	67%	67%	67%
8/21/13 Wed	9	1	3	1.4	50	200	51%	51%	51%
10/14/13 Mon	2	1	3	1.4	0	0			
12/11/13 Wed	12	1	3	1.4	14	450	36%	27%	36%
1/5/13 Sat	13	6	3	1.4	0	0			
2/1/13 Fri	12	6	3	1.4	11	404	48%	48%	55%
3/15/13 Fri	2	6	3	1.4	310	15	33%	33%	15%
4/22/13 Mon	9	6	3	1.4	19	498	43%	33%	45%
5/14/13 Tue	22	6	3	1.4	0	0			
6/6/13 Thu	5	6	3	1.4	113	88	46%	46%	42%
7/23/13 Tue	18	6	3	1.4	5714	2	67%	67%	67%
8/21/13 Wed	9	6	3	1.4	20	505	40%	6%	41%
10/14/13 Mon	2	6	3	1.4	652	15	13%	13%	15%
12/11/13 Wed	12	6	3	1.4	12	466	46%	35%	50%
1/5/13 Sat	13	24	3	1.4	6486	2	0%	0%	0%
2/1/13 Fri	12	24	3	1.4	42	108	47%	47%	55%
3/15/13 Fri	2	24	3	1.4	30	153	47%	47%	15%
4/22/13 Mon	9	24	3	1.4	57	162	45%	21%	45%
5/14/13 Tue	22	24	3	1.4	29	193	47%	42%	
6/6/13 Thu	5	24	3	1.4	184	54	47%	47%	42%
7/23/13 Tue	18	24	3	1.4	199	50	53%	53%	67%
8/21/13 Wed	9	24	3	1.4	65	151	42%	42%	41%
10/14/13 Mon	2	24	3	1.4	67	149	45%	45%	15%
12/11/13 Wed	12	24	3	1.4	34	167	44%	36%	50%
1/5/13 Sat	13	72	3	1.4	146	67	46%	37%	38%
2/1/13 Fri	12	72	3	1.4	79	52	45%	45%	32%
3/15/13 Fri	2	72	3	1.4	55	58	41%	39%	28%
4/22/13 Mon	9	72	3	1.4	49	161	46%	26%	39%
5/14/13 Tue	22	72	3	1.4	20	169	47%	29%	42%
6/6/13 Thu	5	72	3	1.4	454	22	47%	47%	51%
7/23/13 Tue	18	72	3	1.4	303	33	43%	43%	52%
8/21/13 Wed	9	72	3	1.4	65	154	43%	43%	41%
10/14/13 Mon	2	72	3	1.4	62	155	46%	46%	45%
12/11/13 Wed	12	72	3	1.4	22	167	40%	35%	36%
1/5/13 Sat	13	168	3	1.4	85	106	48%	22%	40%
2/1/13 Fri	12	168	3	1.4	22	111	39%	36%	31%
3/15/13 Fri	2	168	3	1.4	31	114	44%	37%	35%
4/22/13 Mon	9	168	3	1.4	61	119	45%	6%	37%
5/14/13 Tue	22	168	3	1.4	39	116	46%	46%	39%
6/6/13 Thu	5	168	3	1.4	487	21	43%	43%	41%
7/23/13 Tue	18	168	3	1.4	529	19	43%	43%	48%
8/21/13 Wed	9	168	3	1.4	88	113	44%	44%	40%
10/14/13 Mon	2	168	3	1.4	85	114	45%	45%	41%
12/11/13 Wed	12	168	3	1.4	44	127	41%	28%	36%

## Appendix D (Continued)

Table D.6: Resilience indicators for Scenario 5 model runs for the elementary school subjected to potable water disruption.

Date	Hour	Disruption	Diversity	Redundancy	Capacity	Demand	Sustainability	Passivity	LOS
1/5/13 Sat	13	1	3	1.8	0	0			
2/1/13 Fri	12	1	3	1.8	9	511	45%	45%	45%
3/15/13 Fri	2	1	3	1.8	262	12	0%	0%	0%
4/22/13 Mon	9	1	3	1.8	31	307	78%	78%	78%
5/14/13 Tue	22	1	3	1.8	0	0			
6/6/13 Thu	5	1	3	1.8	0	0			
7/23/13 Tue	18	1	3	1.8	952	11	89%	89%	89%
8/21/13 Wed	9	1	3	1.8	50	200	65%	65%	65%
10/14/13 Mon	2	1	3	1.8	0	0			
12/11/13 Wed	12	1	3	1.8	6	450	48%	39%	48%
1/5/13 Sat	13	6	3	1.8	0	0			
2/1/13 Fri	12	6	3	1.8	9	404	61%	61%	68%
3/15/13 Fri	2	6	3	1.8	210	15	39%	39%	18%
4/22/13 Mon	9	6	3	1.8	18	498	54%	44%	56%
5/14/13 Tue	22	6	3	1.8	0	0			
6/6/13 Thu	5	6	3	1.8	113	88	60%	60%	54%
7/23/13 Tue	18	6	3	1.8	5714	2	89%	89%	89%
8/21/13 Wed	9	6	3	1.8	19	505	52%	18%	54%
10/14/13 Mon	2	6	3	1.8	652	15	15%	15%	17%
12/11/13 Wed	12	6	3	1.8	4	466	60%	48%	64%
1/5/13 Sat	13	24	3	1.8	6486	2	0%	0%	0%
2/1/13 Fri	12	24	3	1.8	35	108	59%	59%	68%
3/15/13 Fri	2	24	3	1.8	21	153	58%	58%	18%
4/22/13 Mon	9	24	3	1.8	56	162	57%	33%	56%
5/14/13 Tue	22	24	3	1.8	11	193	49%	44%	
6/6/13 Thu	5	24	3	1.8	184	54	59%	59%	54%
7/23/13 Tue	18	24	3	1.8	199	50	63%	63%	89%
8/21/13 Wed	9	24	3	1.8	64	151	54%	54%	54%
10/14/13 Mon	2	24	3	1.8	67	149	58%	5%	17%
12/11/13 Wed	12	24	3	1.8	12	167	57%	49%	64%
1/5/13 Sat	13	72	3	1.8	146	67	58%	49%	49%
2/1/13 Fri	12	72	3	1.8	63	52	57%	57%	40%
3/15/13 Fri	2	72	3	1.8	23	58	51%	48%	34%
4/22/13 Mon	9	72	3	1.8	44	161	57%	37%	48%
5/14/13 Tue	22	72	3	1.8	3	169	34%	16%	30%
6/6/13 Thu	5	72	3	1.8	454	22	60%	60%	63%
7/23/13 Tue	18	72	3	1.8	303	33	52%	52%	64%
8/21/13 Wed	9	72	3	1.8	64	154	54%	54%	50%
10/14/13 Mon	2	72	3	1.8	57	155	58%	7%	56%
12/11/13 Wed	12	72	3	1.8	3	167	27%	22%	20%
1/5/13 Sat	13	168	3	1.8	80	106	60%	34%	50%
2/1/13 Fri	12	168	3	1.8	14	111	36%	34%	29%
3/15/13 Fri	2	168	3	1.8	20	114	38%	31%	36%
4/22/13 Mon	9	168	3	1.8	48	119	56%	16%	45%
5/14/13 Tue	22	168	3	1.8	18	116	41%	41%	36%
6/6/13 Thu	5	168	3	1.8	487	21	54%	54%	52%
7/23/13 Tue	18	168	3	1.8	529	19	52%	52%	60%
8/21/13 Wed	9	168	3	1.8	87	113	55%	55%	50%
10/14/13 Mon	2	168	3	1.8	81	114	56%	56%	51%
12/11/13 Wed	12	168	3	1.8	23	127	39%	26%	32%

## Appendix D (Continued)

Table D.7: Resilience indicators for Scenario 6 model runs for the elementary school subjected to potable water disruption.

Date	Hour	Disruption	Diversity	Redundancy	Capacity	Demand	Sustainability	Passivity	LOS
1/5/13 Sat	13	1	2	1.2	0	0			
2/1/13 Fri	12	1	2	1.2	0	511	34%	0%	34%
3/15/13 Fri	2	1	2	1.2	8	12	0%	0%	0%
4/22/13 Mon	9	1	2	1.2	0	307	35%	0%	35%
5/14/13 Tue	22	1	2	1.2	0	0			
6/6/13 Thu	5	1	2	1.2	0	0			
7/23/13 Tue	18	1	2	1.2	7	11	67%	0%	67%
8/21/13 Wed	9	1	2	1.2	1	200	51%	0%	51%
10/14/13 Mon	2	1	2	1.2	0	0			
12/11/13 Wed	12	1	2	1.2	0	450	36%	0%	36%
1/5/13 Sat	13	6	2	1.2	0	0			
2/1/13 Fri	12	6	2	1.2	0	404	7%	0%	6%
3/15/13 Fri	2	6	2	1.2	6	15	33%	0%	15%
4/22/13 Mon	9	6	2	1.2	0	498	4%	0%	6%
5/14/13 Tue	22	6	2	1.2	0	0			
6/6/13 Thu	5	6	2	1.2	1	88	32%	0%	34%
7/23/13 Tue	18	6	2	1.2	43	2	67%	0%	67%
8/21/13 Wed	9	6	2	1.2	0	505	7%	0%	12%
10/14/13 Mon	2	6	2	1.2	14	15	13%	0%	15%
12/11/13 Wed	12	6	2	1.2	0	466	10%	0%	9%
1/5/13 Sat	13	24	2	1.2	445	2	0%	0%	0%
2/1/13 Fri	12	24	2	1.2	0	108	7%	0%	6%
3/15/13 Fri	2	24	2	1.2	1	153	3%	0%	15%
4/22/13 Mon	9	24	2	1.2	0	162	3%	0%	6%
5/14/13 Tue	22	24	2	1.2	1	193	5%	0%	
6/6/13 Thu	5	24	2	1.2	2	54	13%	0%	34%
7/23/13 Tue	18	24	2	1.2	2	50	7%	0%	67%
8/21/13 Wed	9	24	2	1.2	0	151	6%	0%	12%
10/14/13 Mon	2	24	2	1.2	1	149	6%	0%	15%
12/11/13 Wed	12	24	2	1.2	0	167	7%	0%	9%
1/5/13 Sat	13	72	2	1.2	7	67	14%	0%	12%
2/1/13 Fri	12	72	2	1.2	0	52	5%	0%	2%
3/15/13 Fri	2	72	2	1.2	0	58	2%	0%	5%
4/22/13 Mon	9	72	2	1.2	0	161	1%	0%	1%
5/14/13 Tue	22	72	2	1.2	0	169	2%	0%	3%
6/6/13 Thu	5	72	2	1.2	0	22	11%	0%	8%
7/23/13 Tue	18	72	2	1.2	0	33	3%	0%	5%
8/21/13 Wed	9	72	2	1.2	0	154	2%	0%	1%
10/14/13 Mon	2	72	2	1.2	0	155	2%	0%	4%
12/11/13 Wed	12	72	2	1.2	0	167	2%	0%	1%
1/5/13 Sat	13	168	2	1.2	2	106	4%	0%	4%
2/1/13 Fri	12	168	2	1.2	0	111	1%	0%	0%
3/15/13 Fri	2	168	2	1.2	0	114	0%	0%	1%
4/22/13 Mon	9	168	2	1.2	0	119	1%	0%	0%
5/14/13 Tue	22	168	2	1.2	0	116	1%	0%	1%
6/6/13 Thu	5	168	2	1.2	0	21	5%	0%	2%
7/23/13 Tue	18	168	2	1.2	0	19	3%	0%	3%
8/21/13 Wed	9	168	2	1.2	0	113	1%	0%	1%
10/14/13 Mon	2	168	2	1.2	0	114	1%	0%	2%
12/11/13 Wed	12	168	2	1.2	0	127	1%	0%	1%

## Appendix D (Continued)

Table D.8: Resilience indicators for Scenario 7 model runs for the elementary school subjected to potable water disruption.

Date	Hour	Disruption	Diversity	Redundancy	Capacity	Demand	Sustainability	Passivity	LOS
1/5/13 Sat	13	1	4	2	0	0			
2/1/13 Fri	12	1	4	2	16	511	86%	55%	89%
3/15/13 Fri	2	1	4	2	438	12	55%	0%	0%
4/22/13 Mon	9	1	4	2	32	307	81%	22%	57%
5/14/13 Tue	22	1	4	2	0	0			
6/6/13 Thu	5	1	4	2	0	0	74%		
7/23/13 Tue	18	1	4	2	960	11	78%	11%	78%
8/21/13 Wed	9	1	4	2	51	200	86%	35%	86%
10/14/13 Mon	2	1	4	2	0	0	24%		
12/11/13 Wed	12	1	4	2	19	450	87%	44%	88%
1/5/13 Sat	13	6	4	2	0	0			
2/1/13 Fri	12	6	4	2	19	404	86%	39%	82%
3/15/13 Fri	2	6	4	2	350	15	22%	22%	25%
4/22/13 Mon	9	6	4	2	19	498	84%	36%	79%
5/14/13 Tue	22	6	4	2	0	0			
6/6/13 Thu	5	6	4	2	114	88	42%	29%	63%
7/23/13 Tue	18	6	4	2	5758	2	51%	11%	78%
8/21/13 Wed	9	6	4	2	20	505	87%	14%	85%
10/14/13 Mon	2	6	4	2	666	15	11%	11%	27%
12/11/13 Wed	12	6	4	2	17	466	90%	29%	86%
1/5/13 Sat	13	24	4	2	6931	2	0%	0%	0%
2/1/13 Fri	12	24	4	2	70	108	81%	37%	82%
3/15/13 Fri	2	24	4	2	34	153	75%	37%	25%
4/22/13 Mon	9	24	4	2	58	162	79%	16%	79%
5/14/13 Tue	22	24	4	2	38	193	82%	36%	
6/6/13 Thu	5	24	4	2	186	54	73%	36%	63%
7/23/13 Tue	18	24	4	2	201	50	75%	37%	78%
8/21/13 Wed	9	24	4	2	65	151	86%	43%	85%
10/14/13 Mon	2	24	4	2	69	149	78%	39%	27%
12/11/13 Wed	12	24	4	2	48	167	79%	31%	86%
1/5/13 Sat	13	72	4	2	154	67	72%	29%	61%
2/1/13 Fri	12	72	4	2	141	52	73%	37%	37%
3/15/13 Fri	2	72	4	2	71	58	65%	30%	40%
4/22/13 Mon	9	72	4	2	54	161	80%	20%	57%
5/14/13 Tue	22	72	4	2	33	169	78%	21%	62%
6/6/13 Thu	5	72	4	2	455	22	73%	37%	81%
7/23/13 Tue	18	72	4	2	304	33	61%	30%	74%
8/21/13 Wed	9	72	4	2	66	154	80%	40%	62%
10/14/13 Mon	2	72	4	2	63	155	79%	39%	66%
12/11/13 Wed	12	72	4	2	38	167	69%	28%	53%
1/5/13 Sat	13	168	4	2	92	106	73%	12%	53%
2/1/13 Fri	12	168	4	2	56	111	73%	34%	43%
3/15/13 Fri	2	168	4	2	40	114	72%	29%	50%
4/22/13 Mon	9	168	4	2	71	119	76%	38%	52%
5/14/13 Tue	22	168	4	2	60	116	75%	38%	56%
6/6/13 Thu	5	168	4	2	488	21	64%	32%	59%
7/23/13 Tue	18	168	4	2	530	19	63%	32%	70%
8/21/13 Wed	9	168	4	2	90	113	81%	40%	61%
10/14/13 Mon	2	168	4	2	87	114	77%	38%	61%
12/11/13 Wed	12	168	4	2	58	127	70%	22%	49%

## Appendix D (Continued)

Table D.9: Resilience indicators for Scenario 8 model runs for the elementary school subjected to potable water disruption.

Date	Hour	Disruption	Diversity	Redundancy	Capacity	Demand	Sustainability	Passivity	LOS
1/5/13 Sat	13	1	1	1	0	0			
2/1/13 Fri	12	1	1	1	9	511	0%	100%	100%
3/15/13 Fri	2	1	1	1	416	12	0%	100%	100%
4/22/13 Mon	9	1	1	1	15	307	0%	100%	100%
5/14/13 Tue	22	1	1	1	0	0			
6/6/13 Thu	5	1	1	1	0	0			
7/23/13 Tue	18	1	1	1	475	11	0%	100%	100%
8/21/13 Wed	9	1	1	1	24	200	0%	100%	100%
10/14/13 Mon	2	1	1	1	0	0			
12/11/13 Wed	12	1	1	1	10	450	0%	100%	100%
1/5/13 Sat	13	6	1	1	0	0			
2/1/13 Fri	12	6	1	1	8	404	0%	100%	100%
3/15/13 Fri	2	6	1	1	332	15	0%	100%	100%
4/22/13 Mon	9	6	1	1	7	498	0%	100%	100%
5/14/13 Tue	22	6	1	1	0	0			
6/6/13 Thu	5	6	1	1	54	88	0%	100%	100%
7/23/13 Tue	18	6	1	1	2851	2	0%	100%	100%
8/21/13 Wed	9	6	1	1	7	505	0%	100%	100%
10/14/13 Mon	2	6	1	1	324	15	0%	100%	100%
12/11/13 Wed	12	6	1	1	7	466	0%	100%	100%
1/5/13 Sat	13	24	1	1	3242	2	0%	100%	100%
2/1/13 Fri	12	24	1	1	31	108	0%	100%	100%
3/15/13 Fri	2	24	1	1	33	153	0%	100%	100%
4/22/13 Mon	9	24	1	1	21	162	0%	100%	100%
5/14/13 Tue	22	24	1	1	26	193	0%	100%	100%
6/6/13 Thu	5	24	1	1	88	54	0%	100%	100%
7/23/13 Tue	18	24	1	1	99	50	0%	100%	100%
8/21/13 Wed	9	24	1	1	23	151	0%	100%	100%
10/14/13 Mon	2	24	1	1	33	149	0%	100%	100%
12/11/13 Wed	12	24	1	1	19	167	0%	100%	100%
1/5/13 Sat	13	72	1	1	56	67	0%	100%	100%
2/1/13 Fri	12	72	1	1	46	52	0%	100%	100%
3/15/13 Fri	2	72	1	1	27	58	0%	100%	100%
4/22/13 Mon	9	72	1	1	4	161	0%	43%	39%
5/14/13 Tue	22	72	1	1	6	169	0%	41%	40%
6/6/13 Thu	5	72	1	1	166	22	0%	100%	100%
7/23/13 Tue	18	72	1	1	111	33	0%	100%	100%
8/21/13 Wed	9	72	1	1	5	154	0%	45%	41%
10/14/13 Mon	2	72	1	1	7	155	0%	45%	45%
12/11/13 Wed	12	72	1	1	4	167	0%	42%	39%
1/5/13 Sat	13	168	1	1	15	106	0%	28%	29%
2/1/13 Fri	12	168	1	1	9	111	0%	27%	26%
3/15/13 Fri	2	168	1	1	6	114	0%	26%	31%
4/22/13 Mon	9	168	1	1	2	119	0%	25%	22%
5/14/13 Tue	22	168	1	1	4	116	0%	26%	22%
6/6/13 Thu	5	168	1	1	152	21	0%	100%	100%
7/23/13 Tue	18	168	1	1	157	19	0%	100%	100%
8/21/13 Wed	9	168	1	1	3	113	0%	26%	24%
10/14/13 Mon	2	168	1	1	4	114	0%	26%	25%
12/11/13 Wed	12	168	1	1	3	127	0%	23%	20%



## Appendix D (Continued)

Table D.10: Resilience indicators for Scenario 9 model runs for the elementary school subjected to potable water disruption.

Date	Hour	Disruption	Diversity	Redundancy	Capacity	Demand	Sustainability	Passivity	LOS
1/5/13 Sat	13	1	1	1	0	0			
2/1/13 Fri	12	1	1	1	19	511	0%	100%	100%
3/15/13 Fri	2	1	1	1	832	12	0%	100%	100%
4/22/13 Mon	9	1	1	1	32	307	0%	100%	100%
5/14/13 Tue	22	1	1	1	0	0			
6/6/13 Thu	5	1	1	1	0	0			
7/23/13 Tue	18	1	1	1	951	11	0%	100%	100%
8/21/13 Wed	9	1	1	1	49	200	0%	100%	100%
10/14/13 Mon	2	1	1	1	0	0			
12/11/13 Wed	12	1	1	1	21	450	0%	100%	100%
1/5/13 Sat	13	6	1	1	0	0			
2/1/13 Fri	12	6	1	1	21	404	0%	100%	100%
3/15/13 Fri	2	6	1	1	665	15	0%	100%	100%
4/22/13 Mon	9	6	1	1	17	498	0%	100%	100%
5/14/13 Tue	22	6	1	1	0	0			
6/6/13 Thu	5	6	1	1	111	88	0%	100%	100%
7/23/13 Tue	18	6	1	1	5708	2	0%	100%	100%
8/21/13 Wed	9	6	1	1	17	505	0%	100%	100%
10/14/13 Mon	2	6	1	1	650	15	0%	100%	100%
12/11/13 Wed	12	6	1	1	18	466	0%	100%	100%
1/5/13 Sat	13	24	1	1	6485	2	0%	100%	100%
2/1/13 Fri	12	24	1	1	77	108	0%	100%	100%
3/15/13 Fri	2	24	1	1	65	153	0%	100%	100%
4/22/13 Mon	9	24	1	1	52	162	0%	100%	100%
5/14/13 Tue	22	24	1	1	52	193	0%	100%	100%
6/6/13 Thu	5	24	1	1	181	54	0%	100%	100%
7/23/13 Tue	18	24	1	1	199	50	0%	100%	100%
8/21/13 Wed	9	24	1	1	56	151	0%	100%	100%
10/14/13 Mon	2	24	1	1	67	149	0%	100%	100%
12/11/13 Wed	12	24	1	1	49	167	0%	100%	100%
1/5/13 Sat	13	72	1	1	130	67	0%	100%	100%
2/1/13 Fri	12	72	1	1	142	52	0%	100%	100%
3/15/13 Fri	2	72	1	1	113	58	0%	100%	100%
4/22/13 Mon	9	72	1	1	21	161	0%	86%	76%
5/14/13 Tue	22	72	1	1	25	169	0%	82%	80%
6/6/13 Thu	5	72	1	1	392	22	0%	100%	100%
7/23/13 Tue	18	72	1	1	262	33	0%	100%	100%
8/21/13 Wed	9	72	1	1	23	154	0%	90%	79%
10/14/13 Mon	2	72	1	1	28	155	0%	90%	84%
12/11/13 Wed	12	72	1	1	19	167	0%	83%	74%
1/5/13 Sat	13	168	1	1	39	106	0%	56%	52%
2/1/13 Fri	12	168	1	1	34	111	0%	54%	48%
3/15/13 Fri	2	168	1	1	30	114	0%	52%	52%
4/22/13 Mon	9	168	1	1	12	119	0%	50%	43%
5/14/13 Tue	22	168	1	1	15	116	0%	51%	44%
6/6/13 Thu	5	168	1	1	395	21	0%	100%	100%
7/23/13 Tue	18	168	1	1	421	19	0%	100%	100%
8/21/13 Wed	9	168	1	1	13	113	0%	53%	45%
10/14/13 Mon	2	168	1	1	16	114	0%	52%	47%
12/11/13 Wed	12	168	1	1	11	127	0%	47%	38%

**Appendix D (Continued)**

Table D.11: Average resilience indicators (n=10) by scenario and disruption length for model runs for the elementary school subjected to potable water disruption.

Scenario	Disruption	Diversity	Redundancy	Capacity	Demand	Sustainability	Passivity	Preparation	Adaptation potential	LOS
1	1	1	1	0	149	0%	0%	0%	728%	0%
1	6	1	1	0	199	0%	0%	0%	728%	0%
1	24	1	1	0	119	0%	0%	0%	728%	0%
1	72	1	1	0	104	0%	0%	0%	728%	0%
1	168	1	1	0	96	0%	0%	0%	728%	0%
2	1	2	1.2	41	149	37%	0%	24%	704%	22%
2	6	2	1.2	230	199	31%	24%	24%	704%	25%
2	24	2	1.2	349	119	23%	24%	24%	704%	25%
2	72	2	1.2	49	104	27%	24%	24%	704%	24%
2	168	2	1.2	57	96	25%	24%	24%	704%	23%
3	1	2	1.2	132	149	0%	0%	32%	697%	22%
3	6	2	1.2	577	199	36%	32%	32%	697%	28%
3	24	2	1.2	706	119	33%	32%	32%	697%	28%
3	72	2	1.2	110	104	34%	32%	32%	697%	31%
3	168	2	1.2	124	96	34%	32%	32%	697%	30%
4	1	3	1.4	145	149	43%	43%	43%	686%	26%
4	6	3	1.4	685	199	42%	43%	43%	686%	33%
4	24	3	1.4	720	119	42%	43%	43%	686%	33%
4	72	3	1.4	125	104	44%	43%	43%	686%	40%
4	168	3	1.4	147	96	44%	43%	43%	686%	39%
5	1	3	1.8	131	149	54%	50%	50%	679%	32%
5	6	3	1.8	674	199	54%	50%	50%	679%	42%
5	24	3	1.8	714	119	51%	50%	50%	679%	42%
5	72	3	1.8	116	104	51%	50%	50%	679%	45%
5	168	3	1.8	139	96	49%	50%	50%	679%	44%
6	1	2	1.2	2	149	37%	0%	50%	679%	22%
6	6	2	1.2	6	199	22%	0%	50%	679%	16%
6	24	2	1.2	45	119	6%	0%	50%	679%	16%
6	72	2	1.2	1	104	4%	0%	50%	679%	4%
6	168	2	1.2	0	96	2%	0%	50%	679%	2%
7	1	4	2	152	149	71%	37%	74%	654%	40%
7	6	4	2	696	199	59%	37%	74%	654%	53%
7	24	4	2	770	119	71%	37%	74%	654%	53%
7	72	4	2	138	104	73%	37%	74%	654%	59%
7	168	4	2	157	96	72%	37%	74%	654%	55%
8	1	1	1	95	149	0%	0%	0%	728%	60%
8	6	1	1	359	199	0%	0%	0%	728%	80%
8	24	1	1	362	119	0%	0%	0%	728%	90%
8	72	1	1	43	104	0%	0%	0%	728%	70%
8	168	1	1	35	96	0%	0%	0%	728%	40%
9	1	1	1	190	149	0%	0%	0%	728%	60%
9	6	1	1	721	199	0%	0%	0%	728%	80%
9	24	1	1	728	119	0%	0%	0%	728%	90%
9	72	1	1	116	104	0%	0%	0%	728%	89%
9	168	1	1	99	96	0%	0%	0%	728%	57%

## Appendix D (Continued)

Table D.12: Correlation values for resilience indicators to LOS for model runs for the elementary school subjected to potable disruption.

	Diversity	Redundancy	Capacity	Demand	Sustainability	Passivity	Avg LOS
Scenario 1-9 (n=450)	0.00	0.08	0.08	0.07	0.22	0.89	1.00
Scenario 1-7 (n=350)	0.67	0.64	0.06	0.09	0.89	0.76	1.00

Table D.13: Correlation values for average resilience indicators (grouped by scenario and disruption length) to LOS for model runs for the elementary school subjected to potable disruption.

	Disruption	Diversity	Redundancy	Capacity	Demand	Sustainability	Passivity	Preparation	Adaptation potential	Avg LOS
Scenario 1-9 (n=45)	-0.06	-0.01	0.09	0.42	0.02	0.04	0.04	-0.12	0.12	1.00
Scenario 1-7 (n=35)	0.04	0.91	0.87	0.53	-0.03	0.94	0.83	0.78	-0.78	1.00

**Appendix E Model Run Results for the Elementary School (Potable Water and Central Power Disruption)**

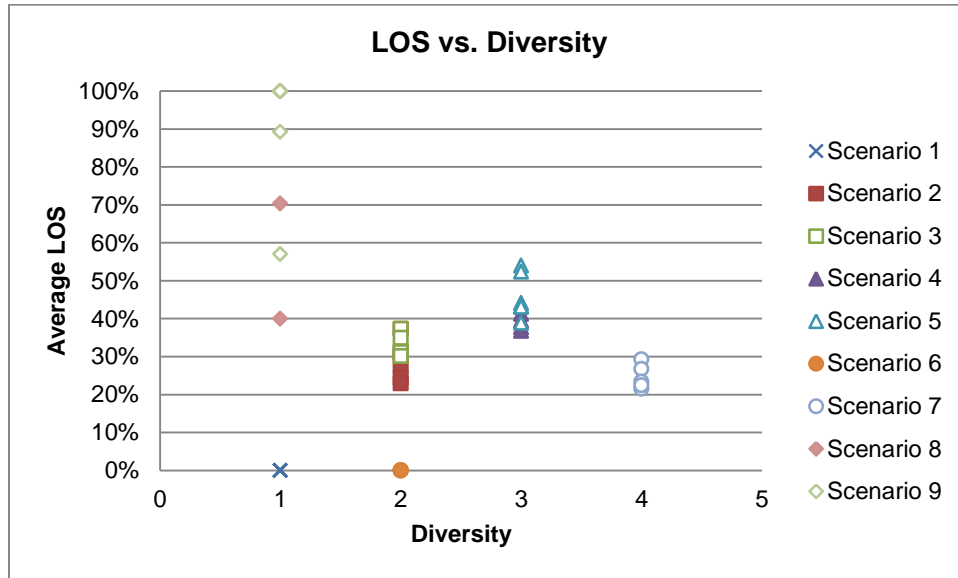

Figure E.1: Average level of service (LOS) vs. diversity for elementary school scenarios subjected to potable water and central power disruption.

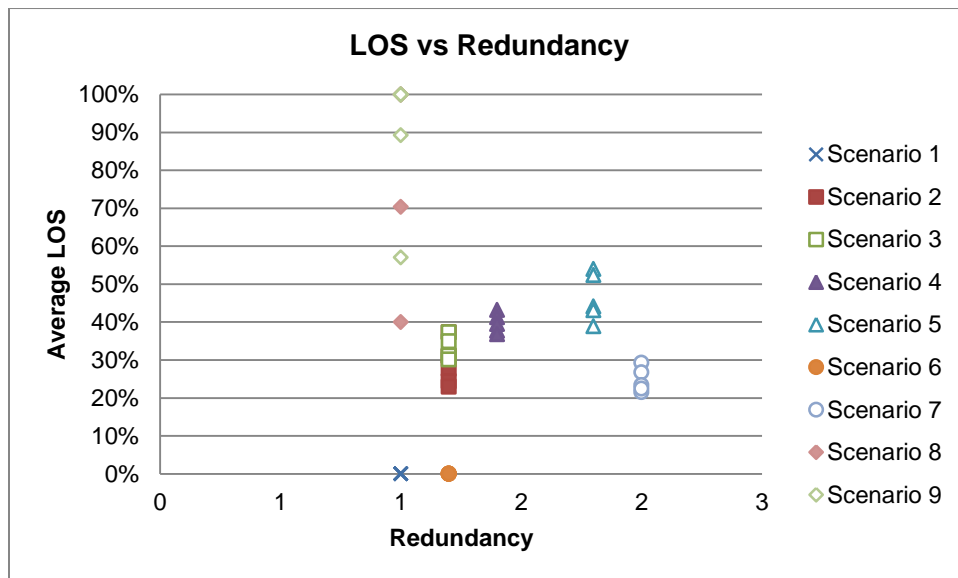

Figure E.2: Average level of service (LOS) vs. redundancy for elementary school scenarios subjected to potable water and central power disruption.

Appendix E (Continued)

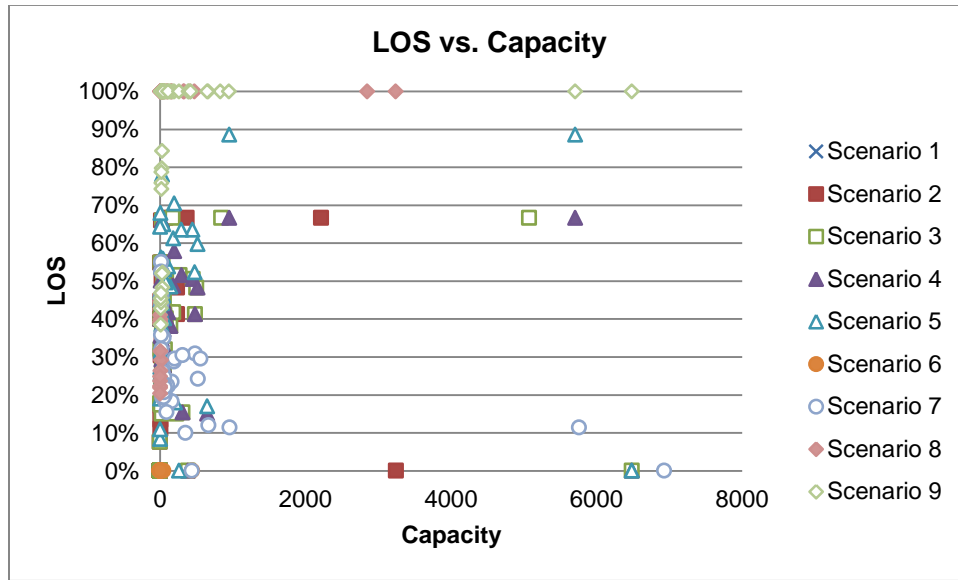

Figure E.3: Level of service (LOS) vs. capacity for elementary school scenarios subjected to potable water and central power disruption.

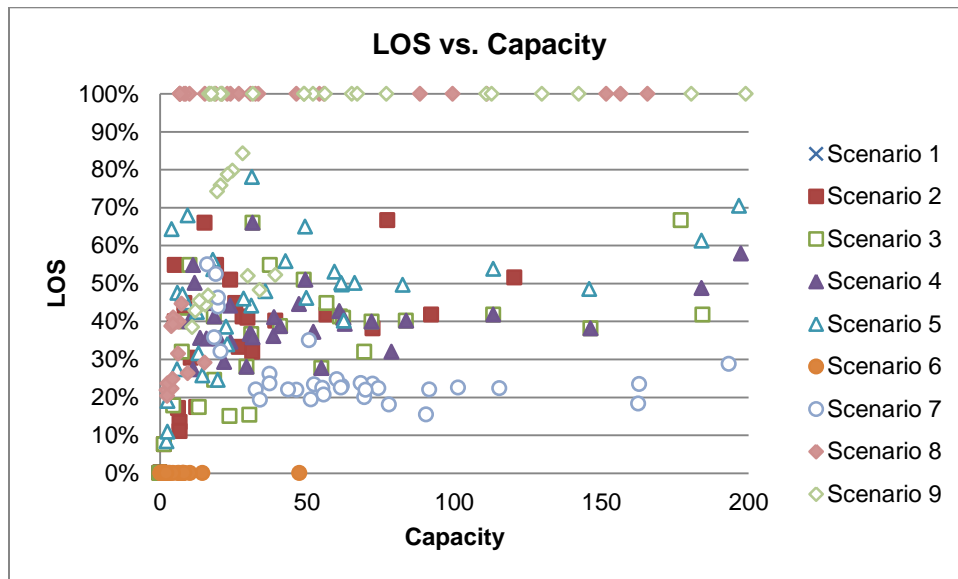

Figure E.4: Level of service (LOS) vs. capacity (values 0 to 200) for elementary school scenarios subjected to potable water and central power disruption.

Appendix E (Continued)

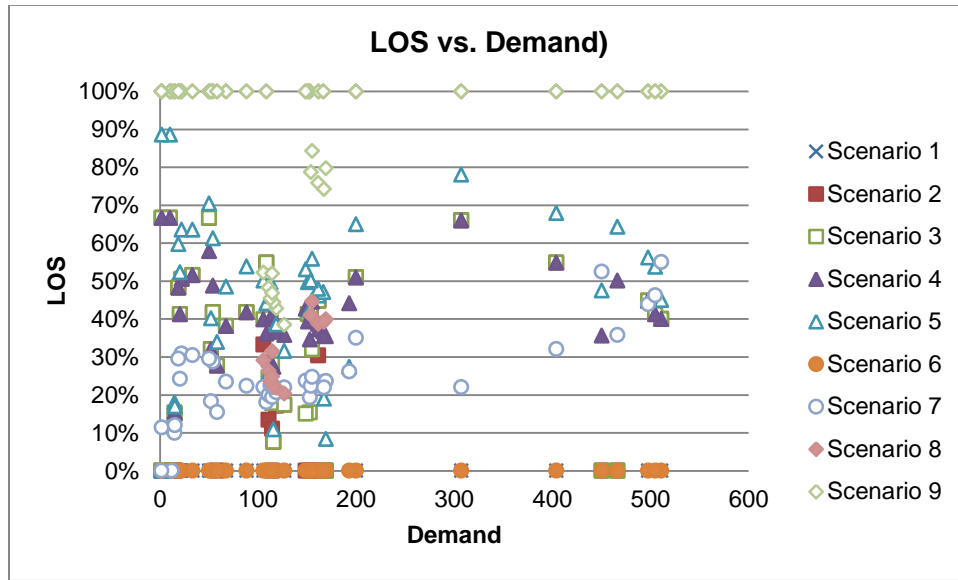

Figure E.5: Level of service (LOS) vs. demand for elementary school scenarios subjected to potable water and central power disruption.

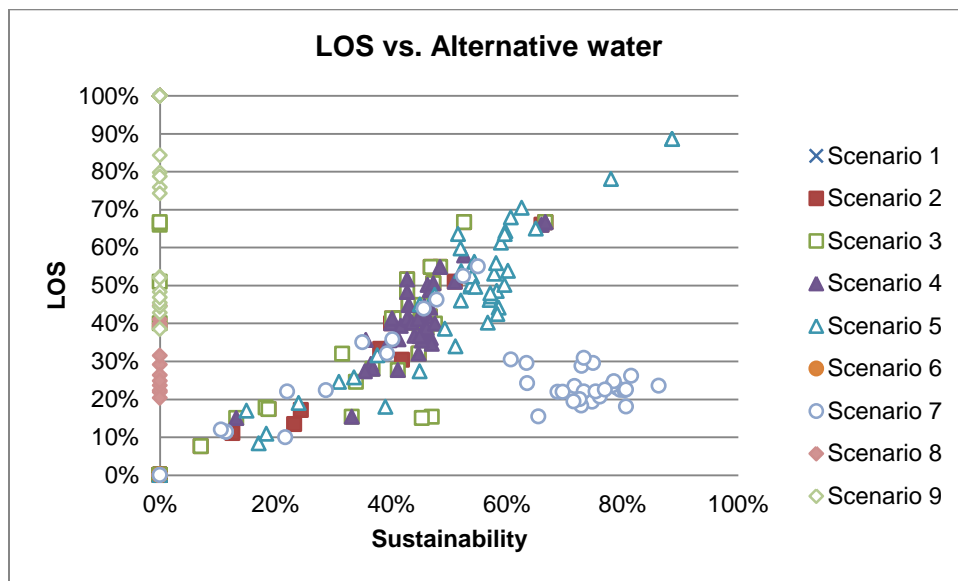

Figure E.6: Level of service (LOS) vs. alternative water for elementary school scenarios subjected to potable water and central power disruption.

Appendix E (Continued)

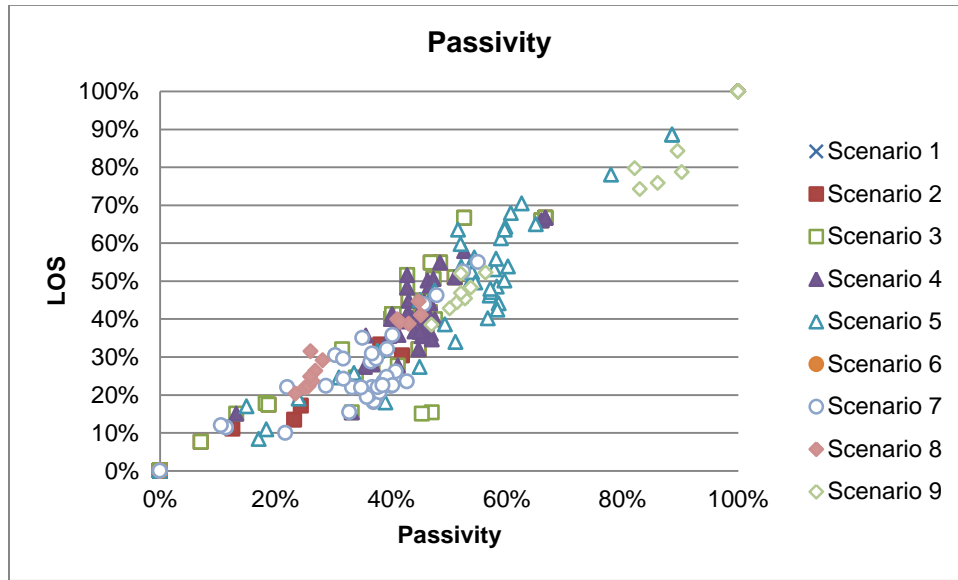

Figure E.7: Level of service (LOS) vs. passivity for elementary school scenarios subjected to potable water and central power disruption.

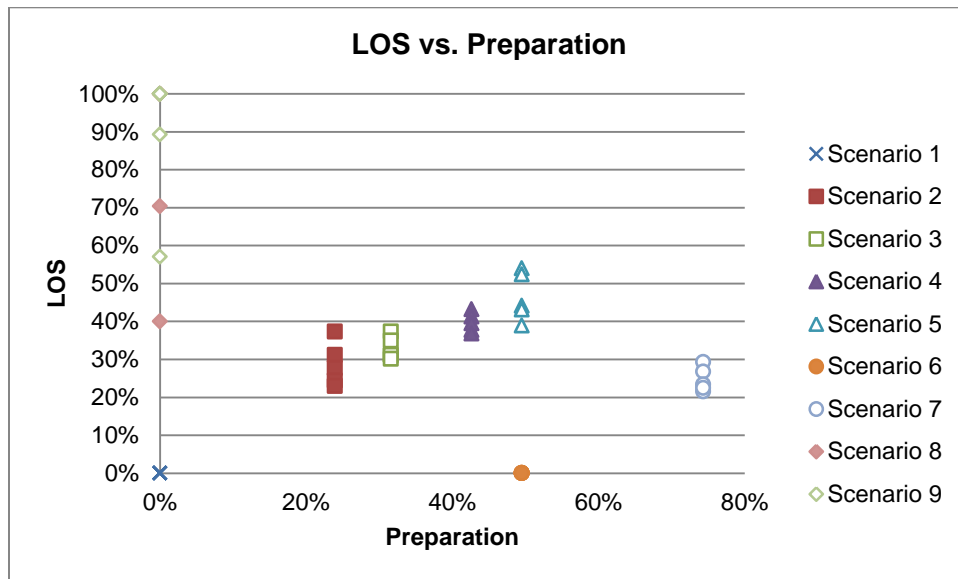

Figure E.8: Average level of service (LOS) vs. preparation for elementary school scenarios subjected to potable water and central power disruption.

Appendix E (Continued)

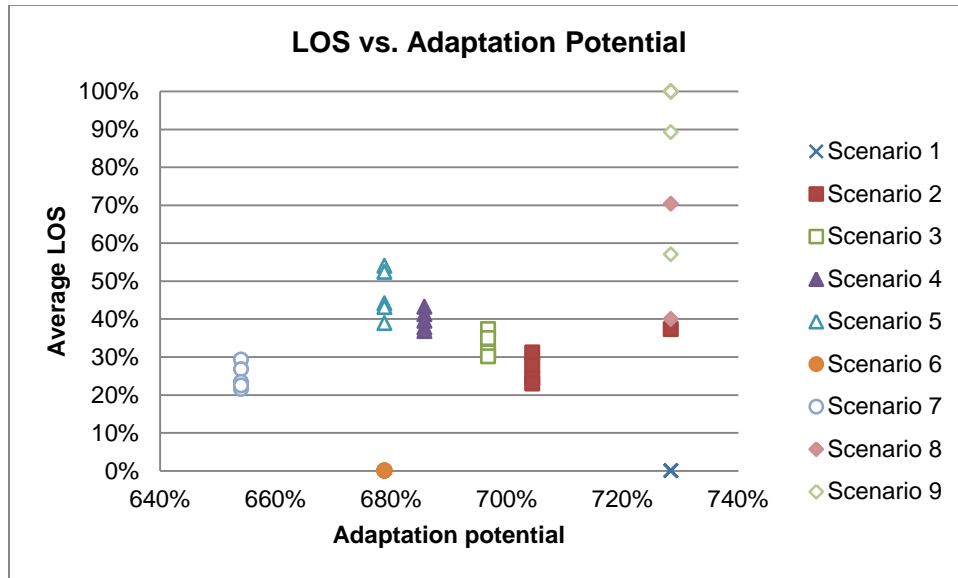

Figure E.9: Average level of service (LOS) vs. adaptation potential for elementary school scenarios subjected to potable water and central power disruption.

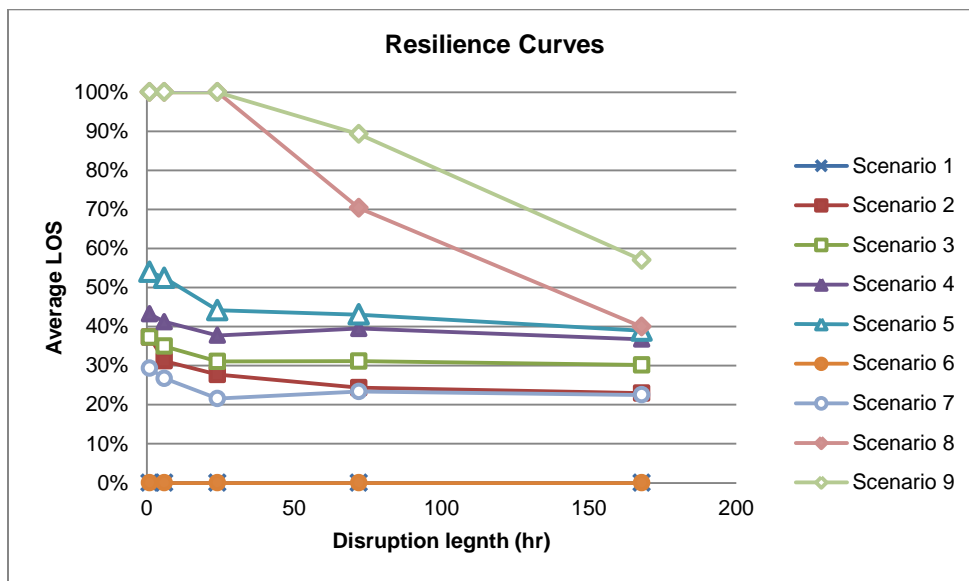

Figure E.10: Resilience curves for the elementary school study subjected to potable water and central power disruption.



## Appendix E (Continued)

Table E.1: Resilience indicators for Scenario 1 model runs for the elementary school subjected to potable water and central power disruption.

Date	Hour	Disruption	Diversity	Redundancy	Capacity	Demand	Sustainability	Passivity	LOS
1/5/13 Sat	13	1	1	1	0	0			
2/1/13 Fri	12	1	1	1	0	511	0%	0%	0%
3/15/13 Fri	2	1	1	1	0	12	0%	0%	0%
4/22/13 Mon	9	1	1	1	0	307	0%	0%	0%
5/14/13 Tue	22	1	1	1	0	0			
6/6/13 Thu	5	1	1	1	0	0			
7/23/13 Tue	18	1	1	1	0	11	0%	0%	0%
8/21/13 Wed	9	1	1	1	0	200	0%	0%	0%
10/14/13 Mon	2	1	1	1	0	0			
12/11/13 Wed	12	1	1	1	0	450	0%	0%	0%
1/5/13 Sat	13	6	1	1	0	0			
2/1/13 Fri	12	6	1	1	0	404	0%	0%	0%
3/15/13 Fri	2	6	1	1	0	15	0%	0%	0%
4/22/13 Mon	9	6	1	1	0	498	0%	0%	0%
5/14/13 Tue	22	6	1	1	0	0			
6/6/13 Thu	5	6	1	1	0	88	0%	0%	0%
7/23/13 Tue	18	6	1	1	0	2	0%	0%	0%
8/21/13 Wed	9	6	1	1	0	505	0%	0%	0%
10/14/13 Mon	2	6	1	1	0	15	0%	0%	0%
12/11/13 Wed	12	6	1	1	0	466	0%	0%	0%
1/5/13 Sat	13	24	1	1	0	2	0%	0%	0%
2/1/13 Fri	12	24	1	1	0	108	0%	0%	0%
3/15/13 Fri	2	24	1	1	0	153	0%	0%	0%
4/22/13 Mon	9	24	1	1	0	162	0%	0%	0%
5/14/13 Tue	22	24	1	1	0	193	0%	0%	0%
6/6/13 Thu	5	24	1	1	0	54	0%	0%	0%
7/23/13 Tue	18	24	1	1	0	50	0%	0%	0%
8/21/13 Wed	9	24	1	1	0	151	0%	0%	0%
10/14/13 Mon	2	24	1	1	0	149	0%	0%	0%
12/11/13 Wed	12	24	1	1	0	167	0%	0%	0%
1/5/13 Sat	13	72	1	1	0	67	0%	0%	0%
2/1/13 Fri	12	72	1	1	0	52	0%	0%	0%
3/15/13 Fri	2	72	1	1	0	58	0%	0%	0%
4/22/13 Mon	9	72	1	1	0	161	0%	0%	0%
5/14/13 Tue	22	72	1	1	0	169	0%	0%	0%
6/6/13 Thu	5	72	1	1	0	22	0%	0%	0%
7/23/13 Tue	18	72	1	1	0	33	0%	0%	0%
8/21/13 Wed	9	72	1	1	0	154	0%	0%	0%
10/14/13 Mon	2	72	1	1	0	155	0%	0%	0%
12/11/13 Wed	12	72	1	1	0	167	0%	0%	0%
1/5/13 Sat	13	168	1	1	0	106	0%	0%	0%
2/1/13 Fri	12	168	1	1	0	111	0%	0%	0%
3/15/13 Fri	2	168	1	1	0	114	0%	0%	0%
4/22/13 Mon	9	168	1	1	0	119	0%	0%	0%
5/14/13 Tue	22	168	1	1	0	116	0%	0%	0%
6/6/13 Thu	5	168	1	1	0	21	0%	0%	0%
7/23/13 Tue	18	168	1	1	0	19	0%	0%	0%
8/21/13 Wed	9	168	1	1	0	113	0%	0%	0%
10/14/13 Mon	2	168	1	1	0	114	0%	0%	0%
12/11/13 Wed	12	168	1	1	0	127	0%	0%	0%

## Appendix E (Continued)

Table E.2: Resilience indicators for Scenario 2 model runs for the elementary school subjected to potable water and central power disruption.

Date	Hour	Disruption	Diversity	Redundancy	Capacity	Demand	Sustainability	Passivity	LOS
1/5/13 Sat	13	1	2	1.2	0	0			
2/1/13 Fri	12	1	2	1.2	5	511	40%	40%	40%
3/15/13 Fri	2	1	2	1.2	0	12	0%	0%	0%
4/22/13 Mon	9	1	2	1.2	15	307	66%	66%	66%
5/14/13 Tue	22	1	2	1.2	0	0			
6/6/13 Thu	5	1	2	1.2	0	0			
7/23/13 Tue	18	1	2	1.2	370	11	67%	67%	67%
8/21/13 Wed	9	1	2	1.2	24	200	51%	51%	51%
10/14/13 Mon	2	1	2	1.2	0	0			
12/11/13 Wed	12	1	2	1.2	0	450	0%	0%	0%
1/5/13 Sat	13	6	2	1.2	0	0			
2/1/13 Fri	12	6	2	1.2	5	404	48%	48%	55%
3/15/13 Fri	2	6	2	1.2	0	15	0%	0%	0%
4/22/13 Mon	9	6	2	1.2	8	498	43%	43%	45%
5/14/13 Tue	22	6	2	1.2	0	0			
6/6/13 Thu	5	6	2	1.2	57	88	46%	46%	42%
7/23/13 Tue	18	6	2	1.2	2218	2	67%	67%	67%
8/21/13 Wed	9	6	2	1.2	8	505	40%	40%	41%
10/14/13 Mon	2	6	2	1.2	0	15	0%	0%	0%
12/11/13 Wed	12	6	2	1.2	0	466	0%	0%	0%
1/5/13 Sat	13	24	2	1.2	3243	2	0%	0%	0%
2/1/13 Fri	12	24	2	1.2	19	108	47%	47%	55%
3/15/13 Fri	2	24	2	1.2	0	153	0%	0%	0%
4/22/13 Mon	9	24	2	1.2	26	162	45%	45%	45%
5/14/13 Tue	22	24	2	1.2	0	193	0%	0%	
6/6/13 Thu	5	24	2	1.2	92	54	47%	47%	42%
7/23/13 Tue	18	24	2	1.2	77	50	53%	53%	67%
8/21/13 Wed	9	24	2	1.2	28	151	42%	42%	41%
10/14/13 Mon	2	24	2	1.2	0	149	0%	0%	0%
12/11/13 Wed	12	24	2	1.2	0	167	0%	0%	0%
1/5/13 Sat	13	72	2	1.2	72	67	46%	46%	38%
2/1/13 Fri	12	72	2	1.2	31	52	45%	45%	32%
3/15/13 Fri	2	72	2	1.2	0	58	0%	0%	0%
4/22/13 Mon	9	72	2	1.2	11	161	42%	42%	30%
5/14/13 Tue	22	72	2	1.2	0	169	0%	0%	0%
6/6/13 Thu	5	72	2	1.2	224	22	47%	47%	51%
7/23/13 Tue	18	72	2	1.2	120	33	43%	43%	52%
8/21/13 Wed	9	72	2	1.2	30	154	43%	43%	41%
10/14/13 Mon	2	72	2	1.2	0	155	0%	0%	0%
12/11/13 Wed	12	72	2	1.2	0	167	0%	0%	0%
1/5/13 Sat	13	168	2	1.2	27	106	38%	38%	33%
2/1/13 Fri	12	168	2	1.2	7	111	23%	23%	13%
3/15/13 Fri	2	168	2	1.2	7	114	13%	13%	11%
4/22/13 Mon	9	168	2	1.2	6	119	24%	24%	17%
5/14/13 Tue	22	168	2	1.2	1	116	7%	7%	8%
6/6/13 Thu	5	168	2	1.2	239	21	43%	43%	41%
7/23/13 Tue	18	168	2	1.2	236	19	43%	43%	48%
8/21/13 Wed	9	168	2	1.2	39	113	44%	44%	40%
10/14/13 Mon	2	168	2	1.2	0	114	0%	0%	0%
12/11/13 Wed	12	168	2	1.2	12	127	19%	19%	17%

## Appendix E (Continued)

Table E.3: Resilience indicators for Scenario 3 model runs for the elementary school subjected to potable water and central power disruption.

Date	Hour	Disruption	Diversity	Redundancy	Capacity	Demand	Sustainability	Passivity	LOS
1/5/13 Sat	13	1	2	1.2	0	0			
2/1/13 Fri	12	1	2	1.2	9	511	0%	40%	40%
3/15/13 Fri	2	1	2	1.2	388	12	0%	0%	0%
4/22/13 Mon	9	1	2	1.2	31	307	0%	66%	66%
5/14/13 Tue	22	1	2	1.2	0	0			
6/6/13 Thu	5	1	2	1.2	0	0			
7/23/13 Tue	18	1	2	1.2	846	11	0%	67%	67%
8/21/13 Wed	9	1	2	1.2	49	200	0%	51%	51%
10/14/13 Mon	2	1	2	1.2	0	0			
12/11/13 Wed	12	1	2	1.2	0	450	0%	0%	0%
1/5/13 Sat	13	6	2	1.2	0	0			
2/1/13 Fri	12	6	2	1.2	10	404	48%	48%	55%
3/15/13 Fri	2	6	2	1.2	310	15	33%	33%	15%
4/22/13 Mon	9	6	2	1.2	18	498	43%	43%	45%
5/14/13 Tue	22	6	2	1.2	0	0			
6/6/13 Thu	5	6	2	1.2	113	88	46%	46%	42%
7/23/13 Tue	18	6	2	1.2	5075	2	67%	67%	67%
8/21/13 Wed	9	6	2	1.2	18	505	40%	40%	41%
10/14/13 Mon	2	6	2	1.2	229	15	13%	13%	15%
12/11/13 Wed	12	6	2	1.2	0	466	0%	0%	0%
1/5/13 Sat	13	24	2	1.2	6486	2	0%	0%	0%
2/1/13 Fri	12	24	2	1.2	37	108	47%	47%	55%
3/15/13 Fri	2	24	2	1.2	30	153	47%	47%	15%
4/22/13 Mon	9	24	2	1.2	57	162	45%	45%	45%
5/14/13 Tue	22	24	2	1.2	0	193	0%	0%	
6/6/13 Thu	5	24	2	1.2	184	54	47%	47%	42%
7/23/13 Tue	18	24	2	1.2	177	50	53%	53%	67%
8/21/13 Wed	9	24	2	1.2	61	151	42%	42%	41%
10/14/13 Mon	2	24	2	1.2	24	149	45%	45%	15%
12/11/13 Wed	12	24	2	1.2	0	167	0%	0%	0%
1/5/13 Sat	13	72	2	1.2	146	67	46%	46%	38%
2/1/13 Fri	12	72	2	1.2	69	52	45%	45%	32%
3/15/13 Fri	2	72	2	1.2	55	58	41%	41%	28%
4/22/13 Mon	9	72	2	1.2	41	161	46%	46%	39%
5/14/13 Tue	22	72	2	1.2	0	169	0%	0%	0%
6/6/13 Thu	5	72	2	1.2	451	22	47%	47%	51%
7/23/13 Tue	18	72	2	1.2	272	33	43%	43%	52%
8/21/13 Wed	9	72	2	1.2	62	154	43%	43%	41%
10/14/13 Mon	2	72	2	1.2	7	155	32%	32%	32%
12/11/13 Wed	12	72	2	1.2	0	167	0%	0%	0%
1/5/13 Sat	13	168	2	1.2	72	106	48%	48%	40%
2/1/13 Fri	12	168	2	1.2	18	111	34%	34%	25%
3/15/13 Fri	2	168	2	1.2	29	114	37%	37%	28%
4/22/13 Mon	9	168	2	1.2	31	119	45%	45%	37%
5/14/13 Tue	22	168	2	1.2	1	116	7%	7%	8%
6/6/13 Thu	5	168	2	1.2	482	21	43%	43%	41%
7/23/13 Tue	18	168	2	1.2	501	19	43%	43%	48%
8/21/13 Wed	9	168	2	1.2	84	113	44%	44%	40%
10/14/13 Mon	2	168	2	1.2	5	114	18%	18%	18%
12/11/13 Wed	12	168	2	1.2	13	127	19%	19%	17%

## Appendix E (Continued)

Table E.4: Resilience indicators for Scenario 4 model runs for the elementary school subjected to potable water and central power disruption.

Date	Hour	Disruption	Diversity	Redundancy	Capacity	Demand	Sustainability	Passivity	LOS
1/5/13 Sat	13	1	3	1.4	0	0			
2/1/13 Fri	12	1	3	1.4	10	511	40%	40%	40%
3/15/13 Fri	2	1	3	1.4	388	12	0%	0%	0%
4/22/13 Mon	9	1	3	1.4	31	307	66%	66%	66%
5/14/13 Tue	22	1	3	1.4	0	0			
6/6/13 Thu	5	1	3	1.4	0	0			
7/23/13 Tue	18	1	3	1.4	952	11	67%	67%	67%
8/21/13 Wed	9	1	3	1.4	49	200	51%	51%	51%
10/14/13 Mon	2	1	3	1.4	0	0			
12/11/13 Wed	12	1	3	1.4	14	450	36%	36%	36%
1/5/13 Sat	13	6	3	1.4	0	0			
2/1/13 Fri	12	6	3	1.4	11	404	48%	48%	55%
3/15/13 Fri	2	6	3	1.4	310	15	33%	33%	15%
4/22/13 Mon	9	6	3	1.4	18	498	43%	43%	45%
5/14/13 Tue	22	6	3	1.4	0	0			
6/6/13 Thu	5	6	3	1.4	113	88	46%	46%	42%
7/23/13 Tue	18	6	3	1.4	5710	2	67%	67%	67%
8/21/13 Wed	9	6	3	1.4	19	505	40%	40%	41%
10/14/13 Mon	2	6	3	1.4	652	15	13%	13%	15%
12/11/13 Wed	12	6	3	1.4	12	466	46%	46%	50%
1/5/13 Sat	13	24	3	1.4	6486	2	0%	0%	0%
2/1/13 Fri	12	24	3	1.4	39	108	47%	47%	55%
3/15/13 Fri	2	24	3	1.4	24	153	47%	47%	15%
4/22/13 Mon	9	24	3	1.4	52	162	45%	45%	45%
5/14/13 Tue	22	24	3	1.4	24	193	47%	47%	
6/6/13 Thu	5	24	3	1.4	184	54	47%	47%	42%
7/23/13 Tue	18	24	3	1.4	197	50	53%	53%	67%
8/21/13 Wed	9	24	3	1.4	63	151	42%	42%	41%
10/14/13 Mon	2	24	3	1.4	61	149	45%	45%	15%
12/11/13 Wed	12	24	3	1.4	30	167	44%	44%	50%
1/5/13 Sat	13	72	3	1.4	146	67	46%	46%	38%
2/1/13 Fri	12	72	3	1.4	79	52	45%	45%	32%
3/15/13 Fri	2	72	3	1.4	55	58	41%	41%	28%
4/22/13 Mon	9	72	3	1.4	41	161	46%	46%	39%
5/14/13 Tue	22	72	3	1.4	16	169	45%	45%	42%
6/6/13 Thu	5	72	3	1.4	451	22	47%	47%	51%
7/23/13 Tue	18	72	3	1.4	296	33	43%	43%	52%
8/21/13 Wed	9	72	3	1.4	62	154	43%	43%	41%
10/14/13 Mon	2	72	3	1.4	47	155	46%	46%	45%
12/11/13 Wed	12	72	3	1.4	20	167	40%	40%	36%
1/5/13 Sat	13	168	3	1.4	72	106	48%	48%	40%
2/1/13 Fri	12	168	3	1.4	22	111	36%	36%	31%
3/15/13 Fri	2	168	3	1.4	29	114	37%	37%	35%
4/22/13 Mon	9	168	3	1.4	31	119	45%	45%	37%
5/14/13 Tue	22	168	3	1.4	11	116	35%	35%	39%
6/6/13 Thu	5	168	3	1.4	482	21	43%	43%	41%
7/23/13 Tue	18	168	3	1.4	519	19	43%	43%	48%
8/21/13 Wed	9	168	3	1.4	84	113	44%	44%	40%
10/14/13 Mon	2	168	3	1.4	39	114	45%	45%	41%
12/11/13 Wed	12	168	3	1.4	31	127	41%	41%	36%

## Appendix E (Continued)

Table E.5: Resilience indicators for Scenario 5 model runs for the elementary school subjected to potable water and central power disruption.

Date	Hour	Disruption	Diversity	Redundancy	Capacity	Demand	Sustainability	Passivity	LOS
1/5/13 Sat	13	1	3	1.8	0	0			
2/1/13 Fri	12	1	3	1.8	9	511	45%	45%	45%
3/15/13 Fri	2	1	3	1.8	262	12	0%	0%	0%
4/22/13 Mon	9	1	3	1.8	31	307	78%	78%	78%
5/14/13 Tue	22	1	3	1.8	0	0			
6/6/13 Thu	5	1	3	1.8	0	0			
7/23/13 Tue	18	1	3	1.8	951	11	89%	89%	89%
8/21/13 Wed	9	1	3	1.8	49	200	65%	65%	65%
10/14/13 Mon	2	1	3	1.8	0	0			
12/11/13 Wed	12	1	3	1.8	6	450	48%	48%	48%
1/5/13 Sat	13	6	3	1.8	0	0			
2/1/13 Fri	12	6	3	1.8	9	404	61%	61%	68%
3/15/13 Fri	2	6	3	1.8	210	15	39%	39%	18%
4/22/13 Mon	9	6	3	1.8	18	498	54%	54%	56%
5/14/13 Tue	22	6	3	1.8	0	0			
6/6/13 Thu	5	6	3	1.8	113	88	60%	60%	54%
7/23/13 Tue	18	6	3	1.8	5709	2	89%	89%	89%
8/21/13 Wed	9	6	3	1.8	18	505	52%	52%	54%
10/14/13 Mon	2	6	3	1.8	652	15	15%	15%	17%
12/11/13 Wed	12	6	3	1.8	4	466	60%	60%	64%
1/5/13 Sat	13	24	3	1.8	6486	2	0%	0%	0%
2/1/13 Fri	12	24	3	1.8	31	108	59%	59%	68%
3/15/13 Fri	2	24	3	1.8	13	153	58%	58%	18%
4/22/13 Mon	9	24	3	1.8	50	162	57%	57%	56%
5/14/13 Tue	22	24	3	1.8	6	193	45%	45%	
6/6/13 Thu	5	24	3	1.8	184	54	59%	59%	54%
7/23/13 Tue	18	24	3	1.8	197	50	63%	63%	89%
8/21/13 Wed	9	24	3	1.8	62	151	54%	54%	54%
10/14/13 Mon	2	24	3	1.8	59	149	58%	58%	17%
12/11/13 Wed	12	24	3	1.8	8	167	57%	57%	64%
1/5/13 Sat	13	72	3	1.8	146	67	58%	58%	49%
2/1/13 Fri	12	72	3	1.8	63	52	57%	57%	40%
3/15/13 Fri	2	72	3	1.8	23	58	51%	51%	34%
4/22/13 Mon	9	72	3	1.8	36	161	57%	57%	48%
5/14/13 Tue	22	72	3	1.8	2	169	17%	17%	30%
6/6/13 Thu	5	72	3	1.8	450	22	60%	60%	63%
7/23/13 Tue	18	72	3	1.8	294	33	52%	52%	64%
8/21/13 Wed	9	72	3	1.8	62	154	54%	54%	50%
10/14/13 Mon	2	72	3	1.8	43	155	58%	58%	56%
12/11/13 Wed	12	72	3	1.8	3	167	24%	24%	20%
1/5/13 Sat	13	168	3	1.8	66	106	60%	60%	50%
2/1/13 Fri	12	168	3	1.8	14	111	34%	34%	29%
3/15/13 Fri	2	168	3	1.8	20	114	31%	31%	36%
4/22/13 Mon	9	168	3	1.8	22	119	49%	49%	45%
5/14/13 Tue	22	168	3	1.8	3	116	18%	18%	36%
6/6/13 Thu	5	168	3	1.8	481	21	54%	54%	52%
7/23/13 Tue	18	168	3	1.8	516	19	52%	52%	60%
8/21/13 Wed	9	168	3	1.8	82	113	55%	55%	50%
10/14/13 Mon	2	168	3	1.8	28	114	52%	52%	51%
12/11/13 Wed	12	168	3	1.8	13	127	38%	38%	32%

## Appendix E (Continued)

Table E.6: Resilience indicators for Scenario 6 model runs for the elementary school subjected to potable water and central power disruption.

Date	Hour	Disruption	Diversity	Redundancy	Capacity	Demand	Sustainability	Passivity	LOS
1/5/13 Sat	13	1	2	1.2	0	0			
2/1/13 Fri	12	1	2	1.2	0	511	0%	0%	34%
3/15/13 Fri	2	1	2	1.2	8	12	0%	0%	0%
4/22/13 Mon	9	1	2	1.2	0	307	0%	0%	35%
5/14/13 Tue	22	1	2	1.2	0	0			
6/6/13 Thu	5	1	2	1.2	0	0			
7/23/13 Tue	18	1	2	1.2	8	11	0%	0%	67%
8/21/13 Wed	9	1	2	1.2	1	200	0%	0%	51%
10/14/13 Mon	2	1	2	1.2	0	0			
12/11/13 Wed	12	1	2	1.2	1	450	0%	0%	36%
1/5/13 Sat	13	6	2	1.2	0	0			
2/1/13 Fri	12	6	2	1.2	0	404	0%	0%	6%
3/15/13 Fri	2	6	2	1.2	6	15	0%	0%	15%
4/22/13 Mon	9	6	2	1.2	0	498	0%	0%	6%
5/14/13 Tue	22	6	2	1.2	0	0			
6/6/13 Thu	5	6	2	1.2	2	88	0%	0%	34%
7/23/13 Tue	18	6	2	1.2	47	2	0%	0%	67%
8/21/13 Wed	9	6	2	1.2	0	505	0%	0%	12%
10/14/13 Mon	2	6	2	1.2	14	15	0%	0%	15%
12/11/13 Wed	12	6	2	1.2	1	466	0%	0%	9%
1/5/13 Sat	13	24	2	1.2	445	2	0%	0%	0%
2/1/13 Fri	12	24	2	1.2	2	108	0%	0%	6%
3/15/13 Fri	2	24	2	1.2	1	153	0%	0%	15%
4/22/13 Mon	9	24	2	1.2	1	162	0%	0%	6%
5/14/13 Tue	22	24	2	1.2	1	193	0%	0%	
6/6/13 Thu	5	24	2	1.2	3	54	0%	0%	34%
7/23/13 Tue	18	24	2	1.2	2	50	0%	0%	67%
8/21/13 Wed	9	24	2	1.2	1	151	0%	0%	12%
10/14/13 Mon	2	24	2	1.2	1	149	0%	0%	15%
12/11/13 Wed	12	24	2	1.2	2	167	0%	0%	9%
1/5/13 Sat	13	72	2	1.2	10	67	0%	0%	12%
2/1/13 Fri	12	72	2	1.2	3	52	0%	0%	2%
3/15/13 Fri	2	72	2	1.2	2	58	0%	0%	5%
4/22/13 Mon	9	72	2	1.2	1	161	0%	0%	1%
5/14/13 Tue	22	72	2	1.2	1	169	0%	0%	3%
6/6/13 Thu	5	72	2	1.2	8	22	0%	0%	8%
7/23/13 Tue	18	72	2	1.2	3	33	0%	0%	5%
8/21/13 Wed	9	72	2	1.2	1	154	0%	0%	1%
10/14/13 Mon	2	72	2	1.2	1	155	0%	0%	4%
12/11/13 Wed	12	72	2	1.2	2	167	0%	0%	1%
1/5/13 Sat	13	168	2	1.2	6	106	0%	0%	4%
2/1/13 Fri	12	168	2	1.2	2	111	0%	0%	0%
3/15/13 Fri	2	168	2	1.2	1	114	0%	0%	1%
4/22/13 Mon	9	168	2	1.2	1	119	0%	0%	0%
5/14/13 Tue	22	168	2	1.2	2	116	0%	0%	1%
6/6/13 Thu	5	168	2	1.2	8	21	0%	0%	2%
7/23/13 Tue	18	168	2	1.2	4	19	0%	0%	3%
8/21/13 Wed	9	168	2	1.2	2	113	0%	0%	1%
10/14/13 Mon	2	168	2	1.2	2	114	0%	0%	2%
12/11/13 Wed	12	168	2	1.2	2	127	0%	0%	1%

## Appendix E (Continued)

Table E.7: Resilience indicators for Scenario 7 model runs for the elementary school subjected to potable water and central power disruption.

Date	Hour	Disruption	Diversity	Redundancy	Capacity	Demand	Sustainability	Passivity	LOS
1/5/13 Sat	13	1	4	2	0	0			
2/1/13 Fri	12	1	4	2	16	511	55%	55%	89%
3/15/13 Fri	2	1	4	2	438	12	0%	0%	0%
4/22/13 Mon	9	1	4	2	33	307	22%	22%	57%
5/14/13 Tue	22	1	4	2	0	0			
6/6/13 Thu	5	1	4	2	0	0			
7/23/13 Tue	18	1	4	2	960	11	11%	11%	78%
8/21/13 Wed	9	1	4	2	51	200	35%	35%	86%
10/14/13 Mon	2	1	4	2	0	0			
12/11/13 Wed	12	1	4	2	19	450	52%	52%	88%
1/5/13 Sat	13	6	4	2	0	0			
2/1/13 Fri	12	6	4	2	21	404	39%	39%	82%
3/15/13 Fri	2	6	4	2	351	15	22%	22%	25%
4/22/13 Mon	9	6	4	2	20	498	46%	46%	79%
5/14/13 Tue	22	6	4	2	0	0			
6/6/13 Thu	5	6	4	2	115	88	29%	29%	63%
7/23/13 Tue	18	6	4	2	5762	2	11%	11%	78%
8/21/13 Wed	9	6	4	2	20	505	48%	48%	85%
10/14/13 Mon	2	6	4	2	666	15	11%	11%	27%
12/11/13 Wed	12	6	4	2	18	466	40%	40%	86%
1/5/13 Sat	13	24	4	2	6931	2	0%	0%	0%
2/1/13 Fri	12	24	4	2	78	108	81%	37%	82%
3/15/13 Fri	2	24	4	2	34	153	75%	37%	25%
4/22/13 Mon	9	24	4	2	62	162	79%	40%	79%
5/14/13 Tue	22	24	4	2	37	193	82%	41%	
6/6/13 Thu	5	24	4	2	193	54	73%	36%	63%
7/23/13 Tue	18	24	4	2	201	50	75%	37%	78%
8/21/13 Wed	9	24	4	2	72	151	86%	43%	85%
10/14/13 Mon	2	24	4	2	68	149	78%	39%	27%
12/11/13 Wed	12	24	4	2	52	167	79%	39%	86%
1/5/13 Sat	13	72	4	2	163	67	72%	39%	61%
2/1/13 Fri	12	72	4	2	162	52	73%	37%	37%
3/15/13 Fri	2	72	4	2	90	58	65%	33%	40%
4/22/13 Mon	9	72	4	2	55	161	80%	40%	57%
5/14/13 Tue	22	72	4	2	37	169	78%	39%	62%
6/6/13 Thu	5	72	4	2	481	22	73%	37%	81%
7/23/13 Tue	18	72	4	2	312	33	61%	30%	74%
8/21/13 Wed	9	72	4	2	74	154	80%	40%	62%
10/14/13 Mon	2	72	4	2	60	155	79%	39%	66%
12/11/13 Wed	12	72	4	2	46	167	69%	33%	53%
1/5/13 Sat	13	168	4	2	92	106	73%	37%	53%
2/1/13 Fri	12	168	4	2	69	111	73%	36%	43%
3/15/13 Fri	2	168	4	2	51	114	72%	36%	50%
4/22/13 Mon	9	168	4	2	56	119	76%	38%	52%
5/14/13 Tue	22	168	4	2	44	116	75%	38%	56%
6/6/13 Thu	5	168	4	2	523	21	64%	32%	59%
7/23/13 Tue	18	168	4	2	558	19	63%	32%	70%
8/21/13 Wed	9	168	4	2	101	113	81%	40%	61%
10/14/13 Mon	2	168	4	2	62	114	77%	38%	61%
12/11/13 Wed	12	168	4	2	70	127	70%	35%	49%

## Appendix E (Continued)

Table E.8: Resilience indicators for Scenario 8 model runs for the elementary school subjected to potable water and central power disruption.

Date	Hour	Disruption	Diversity	Redundancy	Capacity	Demand	Sustainability	Passivity	LOS
1/5/13 Sat	13	1	1	1	0	0			
2/1/13 Fri	12	1	1	1	9	511	0%	100%	100%
3/15/13 Fri	2	1	1	1	416	12	0%	100%	100%
4/22/13 Mon	9	1	1	1	15	307	0%	100%	100%
5/14/13 Tue	22	1	1	1	0	0			
6/6/13 Thu	5	1	1	1	0	0			
7/23/13 Tue	18	1	1	1	475	11	0%	100%	100%
8/21/13 Wed	9	1	1	1	24	200	0%	100%	100%
10/14/13 Mon	2	1	1	1	0	0			
12/11/13 Wed	12	1	1	1	10	450	0%	100%	100%
1/5/13 Sat	13	6	1	1	0	0			
2/1/13 Fri	12	6	1	1	8	404	0%	100%	100%
3/15/13 Fri	2	6	1	1	332	15	0%	100%	100%
4/22/13 Mon	9	6	1	1	7	498	0%	100%	100%
5/14/13 Tue	22	6	1	1	0	0			
6/6/13 Thu	5	6	1	1	54	88	0%	100%	100%
7/23/13 Tue	18	6	1	1	2851	2	0%	100%	100%
8/21/13 Wed	9	6	1	1	7	505	0%	100%	100%
10/14/13 Mon	2	6	1	1	324	15	0%	100%	100%
12/11/13 Wed	12	6	1	1	7	466	0%	100%	100%
1/5/13 Sat	13	24	1	1	3242	2	0%	100%	100%
2/1/13 Fri	12	24	1	1	31	108	0%	100%	100%
3/15/13 Fri	2	24	1	1	33	153	0%	100%	100%
4/22/13 Mon	9	24	1	1	21	162	0%	100%	100%
5/14/13 Tue	22	24	1	1	26	193	0%	100%	100%
6/6/13 Thu	5	24	1	1	88	54	0%	100%	100%
7/23/13 Tue	18	24	1	1	99	50	0%	100%	100%
8/21/13 Wed	9	24	1	1	23	151	0%	100%	100%
10/14/13 Mon	2	24	1	1	33	149	0%	100%	100%
12/11/13 Wed	12	24	1	1	19	167	0%	100%	100%
1/5/13 Sat	13	72	1	1	56	67	0%	100%	100%
2/1/13 Fri	12	72	1	1	46	52	0%	100%	100%
3/15/13 Fri	2	72	1	1	27	58	0%	100%	100%
4/22/13 Mon	9	72	1	1	4	161	0%	43%	39%
5/14/13 Tue	22	72	1	1	6	169	0%	41%	40%
6/6/13 Thu	5	72	1	1	166	22	0%	100%	100%
7/23/13 Tue	18	72	1	1	111	33	0%	100%	100%
8/21/13 Wed	9	72	1	1	5	154	0%	45%	41%
10/14/13 Mon	2	72	1	1	7	155	0%	45%	45%
12/11/13 Wed	12	72	1	1	4	167	0%	42%	39%
1/5/13 Sat	13	168	1	1	15	106	0%	28%	29%
2/1/13 Fri	12	168	1	1	9	111	0%	27%	26%
3/15/13 Fri	2	168	1	1	6	114	0%	26%	31%
4/22/13 Mon	9	168	1	1	2	119	0%	25%	22%
5/14/13 Tue	22	168	1	1	4	116	0%	26%	22%
6/6/13 Thu	5	168	1	1	152	21	0%	100%	100%
7/23/13 Tue	18	168	1	1	157	19	0%	100%	100%
8/21/13 Wed	9	168	1	1	3	113	0%	26%	24%
10/14/13 Mon	2	168	1	1	4	114	0%	26%	25%
12/11/13 Wed	12	168	1	1	3	127	0%	23%	20%



## Appendix E (Continued)

Table E.9: Resilience indicators for Scenario 9 model runs for the elementary school subjected to potable water and central power disruption.

Date	Hour	Disruption	Diversity	Redundancy	Capacity	Demand	Sustainability	Passivity	LOS
1/5/13 Sat	13	1	1	1	0	0			
2/1/13 Fri	12	1	1	1	19	511	0%	100%	100%
3/15/13 Fri	2	1	1	1	832	12	0%	100%	100%
4/22/13 Mon	9	1	1	1	32	307	0%	100%	100%
5/14/13 Tue	22	1	1	1	0	0			
6/6/13 Thu	5	1	1	1	0	0			
7/23/13 Tue	18	1	1	1	951	11	0%	100%	100%
8/21/13 Wed	9	1	1	1	49	200	0%	100%	100%
10/14/13 Mon	2	1	1	1	0	0			
12/11/13 Wed	12	1	1	1	21	450	0%	100%	100%
1/5/13 Sat	13	6	1	1	0	0			
2/1/13 Fri	12	6	1	1	21	404	0%	100%	100%
3/15/13 Fri	2	6	1	1	665	15	0%	100%	100%
4/22/13 Mon	9	6	1	1	17	498	0%	100%	100%
5/14/13 Tue	22	6	1	1	0	0			
6/6/13 Thu	5	6	1	1	111	88	0%	100%	100%
7/23/13 Tue	18	6	1	1	5708	2	0%	100%	100%
8/21/13 Wed	9	6	1	1	17	505	0%	100%	100%
10/14/13 Mon	2	6	1	1	650	15	0%	100%	100%
12/11/13 Wed	12	6	1	1	18	466	0%	100%	100%
1/5/13 Sat	13	24	1	1	6485	2	0%	100%	100%
2/1/13 Fri	12	24	1	1	77	108	0%	100%	100%
3/15/13 Fri	2	24	1	1	65	153	0%	100%	100%
4/22/13 Mon	9	24	1	1	52	162	0%	100%	100%
5/14/13 Tue	22	24	1	1	52	193	0%	100%	100%
6/6/13 Thu	5	24	1	1	181	54	0%	100%	100%
7/23/13 Tue	18	24	1	1	199	50	0%	100%	100%
8/21/13 Wed	9	24	1	1	56	151	0%	100%	100%
10/14/13 Mon	2	24	1	1	67	149	0%	100%	100%
12/11/13 Wed	12	24	1	1	49	167	0%	100%	100%
1/5/13 Sat	13	72	1	1	130	67	0%	100%	100%
2/1/13 Fri	12	72	1	1	142	52	0%	100%	100%
3/15/13 Fri	2	72	1	1	113	58	0%	100%	100%
4/22/13 Mon	9	72	1	1	21	161	0%	86%	76%
5/14/13 Tue	22	72	1	1	25	169	0%	82%	80%
6/6/13 Thu	5	72	1	1	392	22	0%	100%	100%
7/23/13 Tue	18	72	1	1	262	33	0%	100%	100%
8/21/13 Wed	9	72	1	1	23	154	0%	90%	79%
10/14/13 Mon	2	72	1	1	28	155	0%	90%	84%
12/11/13 Wed	12	72	1	1	19	167	0%	83%	74%
1/5/13 Sat	13	168	1	1	39	106	0%	56%	52%
2/1/13 Fri	12	168	1	1	34	111	0%	54%	48%
3/15/13 Fri	2	168	1	1	30	114	0%	52%	52%
4/22/13 Mon	9	168	1	1	12	119	0%	50%	43%
5/14/13 Tue	22	168	1	1	15	116	0%	51%	44%
6/6/13 Thu	5	168	1	1	395	21	0%	100%	100%
7/23/13 Tue	18	168	1	1	421	19	0%	100%	100%
8/21/13 Wed	9	168	1	1	13	113	0%	53%	45%
10/14/13 Mon	2	168	1	1	16	114	0%	52%	47%
12/11/13 Wed	12	168	1	1	11	127	0%	47%	38%

## Appendix E (Continued)

Table E.10: Average resilience indicators (n=10) by scenario and disruption length for model runs for the elementary school subjected to potable water and central power disruption.

Scenario	Disruption	Diversity	Redundancy	Capacity	Demand	Sustainability	Passivity	Preparation	Adaptation potential	LOS
1	1	1	1	0	149	0%	0%	0%	728%	0%
1	6	1	1	0	199	0%	0%	0%	728%	0%
1	24	1	1	0	119	0%	0%	0%	728%	0%
1	72	1	1	0	104	0%	0%	0%	728%	0%
1	168	1	1	0	96	0%	0%	0%	728%	0%
2	1	2	1.2	41	149	37%	37%	24%	704%	37%
2	6	2	1.2	230	199	31%	31%	24%	704%	31%
2	24	2	1.2	349	119	23%	23%	24%	704%	28%
2	72	2	1.2	49	104	27%	27%	24%	704%	24%
2	168	2	1.2	57	96	25%	25%	24%	704%	23%
3	1	2	1.2	132	149	0%	37%	32%	697%	37%
3	6	2	1.2	577	199	36%	36%	32%	697%	35%
3	24	2	1.2	706	119	33%	33%	32%	697%	31%
3	72	2	1.2	110	104	34%	34%	32%	697%	31%
3	168	2	1.2	124	96	34%	34%	32%	697%	30%
4	1	3	1.4	144	149	43%	43%	43%	686%	43%
4	6	3	1.4	685	199	42%	42%	43%	686%	41%
4	24	3	1.4	716	119	42%	42%	43%	686%	37%
4	72	3	1.4	121	104	44%	44%	43%	686%	40%
4	168	3	1.4	132	96	42%	42%	43%	686%	39%
5	1	3	1.8	131	149	54%	54%	50%	679%	54%
5	6	3	1.8	673	199	54%	54%	50%	679%	52%
5	24	3	1.8	710	119	51%	51%	50%	679%	47%
5	72	3	1.8	112	104	49%	49%	50%	679%	45%
5	168	3	1.8	125	96	44%	44%	50%	679%	44%
6	1	2	1.2	2	149	0%	0%	50%	679%	37%
6	6	2	1.2	7	199	0%	0%	50%	679%	20%
6	24	2	1.2	46	119	0%	0%	50%	679%	18%
6	72	2	1.2	3	104	0%	0%	50%	679%	4%
6	168	2	1.2	3	96	0%	0%	50%	679%	2%
7	1	4	2	152	149	29%	29%	74%	654%	66%
7	6	4	2	697	199	31%	31%	74%	654%	66%
7	24	4	2	773	119	71%	35%	74%	654%	58%
7	72	4	2	148	104	73%	37%	74%	654%	59%
7	168	4	2	163	96	72%	36%	74%	654%	55%
8	1	1	1	95	149	0%	100%	0%	728%	100%
8	6	1	1	359	199	0%	100%	0%	728%	100%
8	24	1	1	362	119	0%	100%	0%	728%	100%
8	72	1	1	43	104	0%	72%	0%	728%	70%
8	168	1	1	35	96	0%	41%	0%	728%	40%
9	1	1	1	190	149	0%	100%	0%	728%	100%
9	6	1	1	721	199	0%	100%	0%	728%	100%
9	24	1	1	728	119	0%	100%	0%	728%	100%
9	72	1	1	116	104	0%	93%	0%	728%	89%
9	168	1	1	99	96	0%	62%	0%	728%	57%

## Appendix E (Continued)

Table E.11: Correlation values for resilience indicators to LOS for model runs for the elementary school subjected to potable water and central power disruption.

	Diversity	Redundancy	Capacity	Demand	Sustainability	Passivity	Avg LOS
Scenario 1-9 (n=450)	0.00	0.08	0.09	0.07	0.20	0.91	1.00
Scenario 1-7 (n=350)	0.67	0.64	0.06	0.09	0.80	0.81	1.00

Table E.12: Correlation values for average resilience indicators (grouped by scenario and disruption length) to LOS for model runs for the elementary school subjected to potable water and central power disruption.

	Disruption	Diversity	Redundancy	Capacity	Demand	Sustainability	Passivity	Preparation	Adaptation potential	Avg LOS
Scenario 1-9 (n=45)	-0.24	-0.02	0.08	0.41	0.18	0.02	0.93	-0.13	0.13	1.00
Scenario 1-7 (n=35)	-0.18	0.91	0.87	0.52	0.16	0.80	0.79	0.79	-0.79	1.00