

**EXPLORING SOLUTION STRATEGIES THAT CAN ENHANCE THE
ACHIEVEMENT OF LOW-PERFORMING GRADE 12 LEARNERS IN
SOME MATHEMATICAL ASPECTS**

by

Eric Machisi

submitted in accordance with the requirements for

the degree of

Master of Science in Mathematics, Science and Technology Education

in the subject

Mathematics Education

at the

University of South Africa

Supervisor: **Professor L. D. Mogari**

Co-supervisor: **Doctor U. I. Ogbonnaya**

June 2013

DEDICATION

To the Almighty God for giving me the strength to plod on despite my constitution wanting to give up and throw in the towel

To my sons Hillary and Harry who endured missing my attention for the duration of this study

To my late father Timothy Machisi who believed in diligence and pursuit of academic excellence, though he never lived to see this piece of work

DECLARATION OF ORIGINALITY

I declare that **EXPLORING SOLUTION STRATEGIES THAT CAN ENHANCE THE ACHIEVEMENT OF LOW-PERFORMING GRADE 12 LEARNERS IN SOME MATHEMATICAL ASPECTS** is my own work and that all the sources that I have used or quoted have been indicated and acknowledged by means of complete references.



June 2013

SIGNATURE

DATE

(Mr Eric Machisi)
(47021136)

ACKNOWLEDGEMENTS

This research would not have been possible without several individuals who in one way or another contributed and extended their valuable assistance towards the completion of this study.

First of all, I am deeply grateful to Professor David Mogari and Doctor Ugorji Ogbonnaya, my gracious mentors who demonstrated that rigorous scholarship is accessible to everyone. To work with you has been a pleasurable and unforgettable exciting experience to me. You have oriented and supported me with promptness and care and have always been patient and encouraging in times of new ideas and difficulties. I could not have survived this long journey without your unwavering support, motivation and immense knowledge. You really made my time at the University of South Africa (UNISA) enjoyable.

Besides my advisors, I take this opportunity to record and extend my sense of gratitude to the rest of the Institute for Science and Technology Education (ISTE) staff members: Professor Harrison Ifeanyichukwu Atagana, Professor Jeanne Kriek, and Doctor Chukunoye Enunuwe Ochonogor, for their encouragement, thoughtful criticism and insightful comments that refined this product.

I am highly indebted to Refilwe Makgae and Victor Oliveira, both from the UNISA Student Funding Office, who provided me with financial support. This thesis would not have been accomplished without your help. I also place on record my deepest appreciation to Petunia Ramodipa, for her tremendous logistical support throughout the duration of my studies.

My appreciation also extends to the University of South Africa Research Ethics Committee, the Circuit Manager (Pietersburg Circuit of Limpopo), the Principal, the School Governing Body and parents of the school where this study was conducted, for granting the permission to proceed with this research. To my Grade 12 mathematics learners of the year 2012, you really deserve my special appreciation for your voluntary participation in this project. I had pleasure working with you and your relationship with me left indelible marks in my memories. This thesis would not have succeeded without your participation.

To Roger Cupido, IBM SPSS technical analyst in South Africa, I say thank you very much for providing the SPSS software that was used to analyse statistical data in this study. You are such a blessing to me!

Finally, I am very grateful to all who, directly or indirectly, have lent a helping hand in this venture. Not forgetting my parents and siblings, for their unceasing encouragement and infinitive support. Your value to me grows with age.

ABSTRACT

The purpose of this study was to explore solution strategies that can enhance the achievement of low-performing Grade 12 learners in the following mathematical aspects: finding the general term of a quadratic sequence, factorising third degree polynomials, determining the centre and radius of a circle, and calculating the angle between two lines. A convenience sample of twenty-five low-performing Grade 12 learners from a secondary school in Capricorn District of Limpopo Province participated in the study which adopted a repeated-measures research design. Learners were exposed to multiple solution strategies and data were collected using achievement tests. Findings indicated significant differences in learners' average scores due to the solution strategies used. In determining the general term of a quadratic sequence, learners' scores were significantly higher when they used formula and the table method than with the method of residues and solving simultaneous equations. Synthetic division made learners to achieve better scores than long division and equating coefficients in factorising third degree polynomials. The use of formulae to find the centre and radius of a circle made learners to have better achievement scores than completing the square. In calculating the angle between two lines learners' scores were better using formula and the cosine rule than using theorems. It was concluded that exposing low-performing Grade 12 learners to multiple solution strategies would enhance their achievement in the mathematical aspects explored in the study. Some of the solution strategies that made learners to achieve better results were not in the prescribed mathematics textbooks. The study therefore recommends that mathematics teaching should not be textbook-driven and that low-performing Grade 12 learners should not be regarded as beyond redemption.

Keywords: *solution strategies, mathematics achievement, low-performing learners, mathematical aspects, problem solving, secondary schools, mathematics education, repeated-measures ANOVA, sphericity*

TABLE OF CONTENTS

Title page.....	i
Declaration.....	iii
Acknowledgements.....	iv
Abstract.....	vi
Table of Contents.....	vii
List of acronyms.....	xii
List of Tables.....	xiv
List of Appendices.....	xv
CHAPTER ONE.....	1
INTRODUCTION.....	1
1.1 Background to the study.....	1
1.2 The mathematical aspects in context.....	3
1.3 Statement of the problem.....	4
1.4 Research questions.....	4
1.5 Hypotheses.....	4
1.6 Scope and delimitations of the study.....	5
1.7 Significance of the study.....	5
1.8 Definition of terms.....	6
1.9 Structure of the dissertation.....	7
CHAPTER TWO.....	9
THEORETICAL FRAMEWORK AND LITERATURE REVIEW.....	9
2.1 Introduction.....	9
2.2 Theoretical framework of the study.....	9
2.2.1 Behaviourism.....	9
2.2.2 Cognitivism.....	10
2.2.3 Constructivism.....	11
2.3 Mathematics instruction for low-performing learners.....	12
2.4 Integrating various theoretical perspectives.....	13
2.5 Summary of the Theoretical framework.....	14

2.6	Review of Related Literature.....	16
2.6.1	Studies on learners' mathematics achievement in South Africa.....	16
2.6.1.1	Trends in International Mathematics and Science Study (TIMSS).....	16
2.6.1.2	Southern and East Africa Consortium for Monitoring Educational Quality (SACMEQ).....	17
2.6.1.3	Monitoring Learning Achievement (MLA).....	18
2.6.1.4	Systemic Evaluation Studies (SES).....	19
2.6.1.5	Annual National Assessment (ANA).....	19
2.6.2	What South Africa can learn from National and International Comparative Studies.....	20
2.6.3	Reasons for South Africa's poor performance in mathematics.....	21
2.6.3.1	Educators' qualifications and subject competence.....	21
2.6.3.2	Learner discipline.....	22
2.6.3.3	Educators' commitment.....	22
2.6.3.4	Inequalities of educational opportunities.....	22
2.6.3.5	Curriculum issues.....	23
2.6.3.6	Policy issues.....	23
2.6.3.7	Parental involvement.....	23
2.6.4	Mathematics curriculum reforms and their effectiveness.....	24
2.6.4.1	Outcome-Based Education.....	24
2.6.4.2	The new Further Education and Training (FET) System.....	25
2.6.4.3	The National Curriculum Statement (NCS) Grades 10- 12.....	26
2.6.4.4	Curriculum and Assessment Policy Statement (CAPS).....	27
2.6.5	Emerging Issues.....	28
2.6.6	Some empirical studies with low-performing students.....	30
2.6.7	Trends in Mathematics Education.....	31
2.6.7.1	Mathematical problem solving and multiple strategies.....	32
2.6.7.2	Cognitive-constructivism and mathematics education.....	32
2.6.8	Chapter conclusion.....	33

CHAPTER THREE.....	35
SOME MATHEMATICAL ASPECTS AND RELATED SOLUTION STRATEGIES.....	35
3.1 Introduction.....	35
3.2 Finding the general term of a quadratic sequence.....	35
3.3 Factorising third degree polynomials.....	39
3.4 Determining the centre and radius of a circle.....	41
3.5 Finding the angle between two lines.....	42
CHAPTER FOUR.....	46
RESEARCH DESIGN AND METHODOLOGY.....	46
4.1 Introduction.....	46
4.2 Research design.....	46
4.3 Population.....	47
4.4 Sampling.....	47
4.5 Data collection instruments.....	47
4.6 Development of instruments.....	48
4.7 Data collection procedures.....	48
4.8 Reliability and validity of instruments.....	49
4.8.1 Reliability of the test instrument.....	49
4.8.2 Validity of the test instrument.....	50
4.9 Data analysis and interpretation.....	51
4.10 Ethical considerations.....	52
4.10.1 Minimising the risk of harm.....	52
4.10.2 Obtaining informed consent.....	53
4.10.3 Anonymity and confidentiality.....	53
4.10.4 Provision of debriefing and additional information.....	53
4.11 Pilot Study.....	54
4.12 Operational definition of concepts.....	54
CHAPTER FIVE.....	56
RESULTS, ANALYSIS AND INTERPRETATION.....	56
5.0 Introduction.....	56
5.1 Session One results.....	56

5.1.1	Results of repeated-measures ANOVA.....	57
5.1.1.1	Descriptive Statistics.....	57
5.1.1.2	Sphericity.....	58
5.1.1.3	ANOVA F-test.....	59
5.1.1.4	Bonferroni Pair wise Comparisons.....	60
5.1.1.5	95% Confidence interval of the means.....	61
5.2	Session Two results.....	62
5.2.1	Results of repeated-measures ANOVA.....	63
5.2.1.1	Descriptive Statistics.....	63
5.2.1.2	Sphericity.....	64
5.2.1.3	ANOVA F-test.....	65
5.2.1.4	Bonferroni post hoc analysis.....	65
5.2.1.5	95% Confidence Intervals of the means.....	67
5.3	Session Three results.....	67
5.3.1	Kolmogorov-Smirnov and Shapiro-Wilk's Tests of normality.....	68
5.3.2	Results of the Wilcoxon Signed-Ranks Test.....	69
5.4	Session Four results.....	70
5.4.1	Results of repeated-measures ANOVA.....	71
5.4.1.1	Descriptive Statistics.....	71
5.4.1.2	Sphericity.....	72
5.4.1.3	ANOVA F-test.....	72
5.4.1.4	Bonferroni post hoc analysis.....	73
5.4.1.5	95% Confidence intervals of the means.....	74
	CHAPTER SIX.....	75
	SUMMARY OF THE STUDY, DISCUSSIONS, CONCLUSION AND RECOMMENDATIONS.....	75
6.1	Introduction.....	75
6.2	Summary of the study.....	75
6.2.1	Aims of the study.....	75
6.2.2	The methodology of the study.....	75
6.2.3	The results of the study.....	75
6.3	Discussions and conclusions.....	77

6.4	Recommendations for future research.....	79
6.5	Limitations of the study.....	79
6.6	Concluding remarks.....	80
	REFERENCES.....	81
	APPENDICES.....	92

LIST OF ACRONYMS

ANA	Annual National Assessment
BERA	British Educational Research Association
CA	Consistency and Accuracy
CAPS	Curriculum and Assessment Policy Statement
CVI	Content Validity Index
CVR	Content Validity Ratio
DoBE	Department of Basic Education
df	Degrees of freedom
DoE	Department of Education
ed	editor, edited by
eds	editors
et al	and others
FET	Further Education and Training
GET	General Education and Training
HG	Higher Grade
INSET	In-Service Training
IEA	International association for Evaluation of Educational Achievement
KR	Kuder-Richardson
LoTL	Language of Teaching and Learning
LTSM	Learning and Teaching Support Material
MLA	Monitoring Learning Achievement
NCS	National Curriculum Statement
n.d	No publication date given
NSC	National Senior Certificate
OBE	Outcomes-Based Education
PC	Personal Computer
RM ANOVA	Repeated-measures Analysis of Variance
SACMEQ	Southern and East Africa Consortium for Monitoring Educational quality
SAIDE	South African Institute for Distance Education
S. d	Standard deviation

SERA	Scottish Educational Research Association
SES	Systemic Evaluation Studies
SG	Standard Grade
Sig.	Significance
SPSS	Statistical Package for Social Sciences
Std	Standard
TIMSS	Trends in International Mathematics and Science Study

LIST OF TABLES

Table	1: Learners achieving 40% or above in Grade 12 Mathematics by Province: 2008-2012.....	1
Table	2: Percentages of South African Grade 6 pupils reaching mathematics competency levels in SACMEQ II and SACMEQ III.....	18
Table	3: Monitoring Learning Achievement (MLA): 1999 numeracy results for South African fourth-graders.....	18
Table	4: Average percentage scores attained in Grade 3 and Grade 6 systemic evaluations.....	19
Table	5: Overall achievement rates in NSC Mathematics at 40% or above: 2008-2012.....	25
Table	6: Kuder-Richardson Reliability estimates.....	50
Table	7: Learners' percentage scores per strategy (Session One).....	57
Table	8: Descriptive Statistics.....	58
Table	9: Mauchly's Test of Sphericity.....	58
Table	10: ANOVA F-test.....	59
Table	11: Bonferroni Pair wise Comparisons.....	60
Table	12: Confidence intervals of the means.....	61
Table	13: Learners' percentage scores per strategy (Session Two).....	63
Table	14: Descriptive Statistics.....	64
Table	15: Mauchly's Test of Sphericity.....	64
Table	16: ANOVA F-test.....	65
Table	17: Bonferroni Pair wise Comparisons.....	66
Table	18: Confidence intervals of the means.....	67
Table	19: Learners' percentage scores per strategy (Session Three).....	68
Table	20: Kolmogorov-Smirnov and Shapiro-Wilk's Tests of Normality	69
Table	21: Wilcoxon Signed-Ranks Test Statistic.....	69
Table	22: Wilcoxon Signed-Ranks Table.....	70
Table	23: Learners' percentage scores per strategy (Session Four).....	71
Table	24: Descriptive Statistics.....	71
Table	25: Mauchly's Test of Sphericity.....	72
Table	26: ANOVA F-test.....	73
Table	27: Bonferroni pair wise comparisons.....	73
Table	28: Confidence intervals of the means.....	74

LIST OF APPENDICES

A.	Data collection instruments.....	92
A1.	Tests and marking guides.....	92
A2.	Item content rating forms.....	165
B.	Calculations of reliability estimates and content validity indices.....	169
B1.	Kuder-Richardson 20 reliability estimates calculations.....	168
B2.	Calculating content validity ratios and indices.....	176
C.	Letters of permission and consent.....	178

CHAPTER ONE

INTRODUCTION

1.1 Background to the study

Learners' performance in mathematics in South Africa has not been very impressive over the years (*See Table 1*). Available evidence shows that learners have been achieving below the expected level in Grade 12 examinations over the past years (Keeton, 2010; Parker, 2012). The following table substantiates this view:

Table 1: Learners achieving 40% or above in Grade 12 Mathematics by province (2008-2012) (DoBE, 2011a; DoBE, 2012a)

Province	% Achieved at 40% and above				
	2008	2009	2010	2011	2012
Eastern Cape	22.2	21.3	21.3	19.6	21.9
Free State	35.6	32.9	31.1	34.6	43.3
Gauteng	39.5	39.6	43.6	45	52.4
KwaZulu-Natal	27.3	27.3	29.4	23.2	29.6
Limpopo	22.7	23.4	23.9	27.3	34
Mpumalanga	25.3	23.7	26.6	29.9	34.7
North West	30.8	33.7	35.1	34.2	37.7
Northern Cape	33.5	25.6	34.7	31.2	36.5
Western Cape	50.2	48.8	50.6	54.2	56.9
National	30.5	29.4	30.9	30.1	35.7

From Table 1 above, it can be seen that the mathematics pass rates for learners in Limpopo (where this study was conducted) have consistently been among the lowest. This has prompted researchers to look into the state of mathematics teaching and learning in the province. A survey by Rakumako and Laugksch (2010) on the demographic profile of mathematics educators in Limpopo province reveals that most mathematics educators in the province are “academically under qualified and professionally ill-prepared for their classroom responsibilities as they have Standard 10 (Grade 12) as their highest academic qualification with a three year teaching diploma” (p. 148). This confirms earlier reports by

Mukadam (2009) that mathematics educators are not adequately equipped to effectively teach the new mathematics syllabus.

Low levels of teachers' subject knowledge coupled with the additional challenge of implementing a new curriculum have made the teaching of mathematics ineffective in secondary schools (Fricke, 2008). According to Cai, Mamona-Downs and Weber (2005), limitations in educators' mathematical knowledge have resulted in them sticking to traditional teaching methods. According to Bayona (2010), educators have to try different strategies from the ones that have failed them in the past if they are to succeed in their teaching. It is the researcher's observation that educators with limited knowledge of mathematics tend to confine their teaching to only solution strategies in the prescribed mathematics textbook and those learners who fail to understand what is in the textbook are regarded as unable to learn mathematics. Mathematics educators seem to take no responsibility for low-performing learners due to the perception that such learners will never do well in mathematics (Elmore, 2002).

The growing demand for scientists and engineers in the country requires that even the low-performing learners should be trained to fill those posts (McCrocklin & Stern, 2006). This has prompted the South African government to consider implementing intervention programmes to forestall the high failure rate in mathematics and science. However, there is little empirical evidence of the strategies that could improve the achievement of low-performing mathematics learners in secondary schools (NCEE, 2009). The current study seeks to make a contribution in this regard. As observed by Maree (2010), South Africa is in danger of falling further behind unless educators find ways to rescue those learners who are underperforming in mathematics and science.

Contemporary mathematics education advocates the use of teaching and learning approaches which allow learners to construct mathematical knowledge for themselves, develop problem-solving and reasoning skills, and use heuristic procedures (Donovan & Bransford, 2005). Naroth (2010, p. 44) has this to say;

Learners should be given the opportunity to apply multiple strategies to solve given problems if they are to become proficient in mathematics problem-solving. By discussing several methods in the classroom learners would begin to understand how and why different methods work and they would consider the efficiency and reliability of the respective methods.

Cai et al. (2005) assert that educators fail to expose their mathematics learners to multiple problem-solving strategies because they are inadequately prepared to deal with open-ended problems, doubt their ability to explain concepts and have the perception that multiple strategies and heuristics will only serve to confuse learners. A task team appointed by the Minister of Basic Education to review the implementation of the National Curriculum Statement (NCS) in South Africa concluded that although problem-solving methods are advocated in the mathematics curriculum, “there is little guidance as to the mechanisms of such an approach” (DoE, 2009a, p. 49).

The situation prevailing in South African schools is that learners are being pushed from one Grade to another without having mastered the mathematics skills and knowledge of previous Grade levels. The learners reach Grade 12 with cumulative learning deficits. To help remedy the situation, Grade 12 Mathematics educators try to offer extra classes, but some learners seem not to benefit from the extra tuition. This has led Grade 12 Mathematics educators to give up on the crisis as they hold the perception that their low-performing learners are beyond redemption (Shindler, 2004). The increasing number of learners failing mathematics in Grade 12 is frustrating to educators and the community at large. On the other hand, persistent failure to achieve success in mathematics has made learners to develop a negative attitude towards the subject and mathematics is now regarded as a ‘killer subject’ in South African secondary schools.

Given that not all Grade 12 Mathematics educators in South African secondary schools have the mathematical knowledge and level of proficiency that is required to effectively deal with low-performing learners in their classes (Long, 2007), exploring solution strategies that can enhance Grade 12 learners’ achievement in some mathematical aspects (especially those that seem to pose problems to learners) could make a significant contribution to mathematics education in the country. According to Ferrance (2000), research studies conducted by educators themselves, in familiar school settings, with their own learners, could help improve mathematics teaching and learners’ achievement.

1.2 The mathematical aspects in context

From my discussions with fellow mathematics educators during cluster meetings, analyses of examiners’ reports, and my personal observations as a mathematics teacher, the

following are some of the mathematical aspects that tend to pose problems to low-performing Grade 12 learners: determining the general term of a quadratic sequence, factorising third degree polynomials, determining the centre and radius of a circle, and calculating the angle between two lines.

The Grade 12 educators discussed with claimed that they try to offer extra lessons but the learners seem not to benefit from the extra tuition. This has led the educators to conclude that their low-performing Grade 12 learners cannot do better in the mathematical aspects stated above, hence this study.

1.3 Statement of the problem

The problem of this study was to explore solution strategies that can enhance the achievement of low-performing Grade 12 learners in the following mathematical aspects: finding the general term of a quadratic sequence, factorising third degree polynomials, determining the centre and radius of a circle, and finding the angle between two lines.

1.4 Research questions

The following research questions were explored in this study:

Research Question One: Which solution strategies can enhance the achievement of low-performing Grade 12 learners in determining the general term of a quadratic sequence?

Research Question Two: Which solution strategies can enhance the achievement of low-performing Grade 12 learners in factorising third degree polynomials?

Research Question Three: Which solution strategies can enhance the achievement of low-performing Grade 12 learners in determining the centre and radius of a circle?

Research Question Four: Which solution strategies can enhance the achievement of low-performing Grade 12 learners in calculating the angle between two lines?

1.5 Hypotheses

In seeking answers to the above stated research questions, the following null hypotheses were tested:

- i. There is no significant difference in learners' scores due to the effect of the solution strategies used in determining the general term of a quadratic sequence ($H_0 : \bar{x}_1 = \bar{x}_2 = \bar{x}_3 = \bar{x}_4$)
- ii. There is no significant difference in learners' scores due to the effect of the solution strategies used in factorising third degree polynomials ($H_0 : \bar{x}_1 = \bar{x}_2 = \bar{x}_3$)
- iii. There is no significant difference in learners' scores due to the effect of the solution strategies used in determining the centre and radius of a circle ($H_0 : \bar{x}_1 = \bar{x}_2$)
- iv. There is no significant difference in learners' scores due to the effect of the solution strategies used in calculating the angle between two lines ($H_0 : \bar{x}_1 = \bar{x}_2 = \bar{x}_3$)

1.6 Scope and delimitations of the study

This study was delimited to poor performing Grade 12 learners at a particular secondary school in Capricorn District of Limpopo Province, in South Africa. Learners who had a record of scoring above 50% in mathematics were excluded from the study. The study was delimited to the analysis of learners' achievement scores in the following mathematical aspects: finding the general term of a quadratic sequence, factorising third degree polynomials, determining the centre and radius of a circle, and finding the angle between two lines.

1.7 Significance of the study

Reducing high mathematics failure rate in secondary schools in South Africa is a contemporary issue to which definite solutions are yet to be found. This study seeks to contribute in this regard by exploring solution strategies that can enhance the achievement of low-performing Grade 12 learners in some mathematical aspects. The study is pragmatic in nature and addresses mathematics educators' pedagogical concern about ways to effectively deal with low-performing learners in their classes. Findings of this study would possibly initiate innovations in current mathematics intervention programmes. It is also intended to help educators reflect on their pedagogical practices and raise their awareness of the learning needs of low-performing learners in their classes. The findings of the study could help debunk educators' perceptions that low-performing learners are

beyond redemption and that exposing mathematics learners to multiple solution strategies confuses learners.

Since the researcher in this study is a practising mathematics educator in South Africa, the study would provide valuable first-hand information on real matters of the classroom and forms a basis for making recommendations to the Department of Basic Education (DoBE) on ways to mitigate high failure in mathematics in South African secondary schools.

1.8 Definitions of terms

Below are the definitions of terms as used in this study;

Solution strategies: Solution strategies are processes or ways of determining answers to mathematics problems.

Mathematics achievement: Mathematics achievement is a level of mathematical ability that a learner has attained as a result of a teaching-learning process within a certain time in the form of change in behaviour, skills and knowledge and measured numerically.

Low-performing learners: Low-performing learners are learners whose performance falls below expectation. In this study, all learners scoring below 50% in mathematics examinations for the past two years are regarded as underachievers. Such learners show very little progress in learning mathematics. It could be due to limited academic skills as a result of their previous education, or perhaps there is a mismatch between the educator's pedagogical style and the learners' expectations. Such learners are also labelled as 'at-risk' and constitute the greatest percentage of failure in mathematics.

Mathematical aspect: A mathematical aspect as used in this study refers to one of the several components of a broad mathematics topic. For example, determining the general term of a quadratic sequence is one of the several parts of the broad topic-Number patterns and factorising cubic functions is one of the several components of the broad topic-Polynomials.

Mathematical problem solving: According to Lester (2013), mathematical problem solving is an activity that requires learners to engage in cognitive actions which require some knowledge and skill in order to get answers to mathematical problems. The learners do not immediately know the series of actions they have to perform to get the answer to the mathematical problem.

Mathematics: According to the DoBE (2011b, p. 8);

Mathematics is a language that makes use of symbols and notations for describing numerical, geometric and graphical relationships. It is a human activity that involves observing, representing and investigating patterns and qualitative relationships in physical and social phenomena and between mathematical objects themselves. It helps to develop mental processes that enhance logical and critical thinking, accuracy and problem solving that will contribute in decision-making.

Mathematics education: Mathematics education is the study of practices and strategies of teaching and learning mathematics.

Secondary school: Secondary school is the level of school between primary and tertiary which provides educational instruction for learners from the ages of about fourteen to eighteen. In South Africa, secondary school begins in Grade 8 and goes up to Grade 12. Learners spend five years in secondary school at the end of which they sit for the National Senior Certificate (NSC) examination also known as the Matriculation examination.

1.9 Structure of the dissertation

Chapter One- Introduction

This chapter contains the background to the study, the statement of the problem, and the research questions. It provides the assumptions, delimitations and significance of the study. The definitions of key terms are also presented here.

Chapter Two- Theoretical framework and literature review

This chapter provides the theoretical framework of the study together with a review of the related literature. The chapter concludes by identifying the gap in research that demands further study.

Chapter Three- Some mathematical aspects and related solution strategies

This chapter provides the mathematical aspects and solution strategies explored in the study.

Chapter Four- Research design and methodology

This chapter discusses the research design and methodology for the study. It also presents the rationale for the design and the methodology adopted and adapted for this study.

Chapter Five- Results, analyses and interpretation

This chapter presents the data obtained in the study, its analyses and interpretation.

Chapter Six- Summary of the study, discussions, conclusions and recommendations

This chapter summarises the findings of the study and discusses their implications for classroom practice. The limitations of the study are also discussed here and finally, recommendations and suggestions for future research are presented to conclude the thesis.

CHAPTER TWO

THEORETICAL FRAMEWORK AND LITERATURE REVIEW

2.1 Introduction

This chapter is divided into two parts. Part One presents and discusses the theoretical foundations that guided this study. Part Two presents a review of the literature about mathematics education and learners' achievement in South Africa. The chapter concludes by proposing the current study, a move towards developing classroom based ways to turn around the high failure rate in mathematics.

2.2 Theoretical framework of the study

This study is grounded on a combination of ideas from the three theories of learning namely Behaviourism, Cognitivism and Constructivism. The theoretical perspectives and pedagogical implications to mathematics education of each theory are discussed, followed by a discussion of how the three theories are integrated in this study.

2.2.1 Behaviourism

The behaviourist view of learning is rooted in the work of Thorndike, Pavlov, Skinner, Watson and Hull (Mergel, 1998; Kim & Axelrod, 2005). It regards learning as the change in the student's observable behaviour due to an external event (stimulus) from the environment (Good & Brophy, 1990). The learner's thoughts and feelings are ignored since they are considered to be too subjective (Merwin, 2003; Van Liet, 2005). Instructional strategies based on the use of the behaviourist approach in mathematics education include drill and practice with emphasis on strict adherence to procedures, memorization of formulas and the use of one-way methods to solve mathematical problems (Holt & Willard-Holt, 2000). In view of the present study, the behaviourist mathematics educator would try to improve learners' achievement in determining the general term of a quadratic sequence, factoring third degree polynomials, calculating centre and radius of a circle, and determining the angle between two lines, by insisting on more practice on the procedures and methods presented in the textbook.

The behaviourist approach has been criticized for ignoring human beings' cognitions and emotions. By disregarding the activities of the mind, behaviourism does not account for all kinds of learning. According to Bandura (1977), human cognitions cannot be ignored if learning is to be understood. Mathematics educators employing the behaviourist approach in their teaching may focus on covering the syllabus, leaving no time to engage their learners in critical thinking (Holt & Willard-Holt, 2000). Low-performing Grade 12 learners who cannot find the general term of a quadratic sequence, factor third degree polynomials, calculate the centre and radius of a circle, and determine the angle between two lines, risk being neglected as they are regarded as unable to learn these mathematics aspects.

Critics of behaviourism argue that not all learning is observable. As a result, there has been a shift in the thinking about the nature of human learning from the deterministic behaviourist theory to cognitivism.

2.2.2 Cognitivism

Cognitivism emerged in the late 1950s and became a dominant theory of learning in the late 1970s (Mergel, 1998). The cognitive approach to learning is a prominent school of thought that appears to make up for the weaknesses of the behaviourist theory. Whilst behaviourism emphasises external behaviour, cognitive science is concerned with internal mental processes of the mind and how they are utilized to promote learning. According to Lewandowsky, Little and Kalish (2007), the cognitive learning theory is concerned with how information is acquired, organized, stored and retrieved by the brain. The two key assumptions underlying the cognitive approach are: that the memory is an active processor of information, and that the learner's existing knowledge structure plays an important role in learning. The main strength of the cognitive theory of learning comes from recognising that the human mind is not a passive recipient of knowledge. Learners interpret knowledge and give meaning to it (Anderson, 2005). Mathematics teaching and learning should therefore take into account individual learners' perceptions or cognitive maps, making sure that learners understand what they learn (Anderson, 2005). A weakness of the cognitive learning theory is that the learner learns a way to accomplish a task, but it might not be the best way suited to the learner (Mergel, 1998).

According to Bednar, Cunningham, Duffy and Perry in Anglin (1995), a common feature between cognitivism and behaviourism is that both view knowledge as being objective in nature and that the goal of teaching is to communicate or transfer knowledge in the most effective way possible. According to Mayer (1996), both behaviourism and cognitivism fail to acknowledge either the active role of the learner or the influence of social interaction in the learning process. In the context of the current study, cognitivists mathematics educators would deal with learners who are failing to determine the general term of a quadratic sequence, factor third degree polynomials, determine the centre and radius of a circle, and calculate the angle between two lines by trying new strategies and breaking down the concepts in a way they think would help learners to master these mathematical aspects.

Elmore (2002) observes that the prevailing situation in many mathematics classrooms is that the learners who do not make it are left out of the instructional model as their problem is perceived to be a problem of aptitude. In recent years, new theories have been proposed to compensate and complement to behaviourism and cognitivism. One of such theories is constructivism.

2.2.3 Constructivism

The trend in understanding how students learn has moved away from behaviourism to the cognitive approach and now to constructivism (Bolt & Brassard, 2004). Constructivism offers a sharp contrast to the behaviourist model of teaching and learning. According to the constructivist theory, learners create their own new understanding on the basis of an interaction between what they already know and the ideas, events and activities they come in contact with (Boudourides, 2003). Constructivists hold the perception that all humans have the ability to create knowledge in their own minds through discovery and problem solving. Learners are more likely to remember what they learn if they are encouraged to make their own discoveries (Bruner, 1960).

The theory of constructivism has several implications for mathematics education. The role of the educator in the constructivist classroom is to facilitate learning by creating an environment that encourages free exploration within a given framework (Devries & Zan, 2003). The mathematics educator is no longer a mere 'purveyor of knowledge' or 'provider of facts' but is rather a co-explorer who encourages learners to question,

challenge and formulate their own opinions and conclusions (Hill, 2002, p. 78). Learners are encouraged to participate actively in the process of understanding mathematics concepts (Van de Walle, 2001). According to Mahoney (2003), the educator is there to provide a variety of learning activities from which learners can select what suits their individual needs. In a constructivist classroom, learners are encouraged to use their own methods to solve problems whereas traditional instruction, on the other hand, values only established mathematical techniques (Cobb, 1988). Learners learn by exploring and making their own inferences, discoveries and conclusions rather than being told what will happen.

The benefits of constructivism are that it is learner-centred and learners are actively engaged in the learning process (Tudor, 1996). It offers differentiated learning to all learners and develops problem solving skills. There is higher retention of the learned material and it encourages diversity of thoughts (Silberman, 1996). In the context of the present study, the constructivist mathematics educator would deal with Grade 12 learners who cannot find the general term of a quadratic sequence, factor third degree polynomials, calculate the centre and radius of a circle, and determine the angle between two lines, by letting them explore multiple solution strategies rather than confine them to methods prescribed in their textbooks as is the case with the behaviourist educator.

However, critics have questioned the effectiveness of the constructivist approach when teaching learners with little or no proper knowledge of the subject (Mayer, 2004; Kirschner, Sweller & Clark, 2006). Kirschner et al. (2006) argue that there is no empirical evidence in support of constructivist teaching methods for these learners. In addition, Mayer (2004) asserts that not all learners possess the underlying mental models required for learning the constructivist way. The results of the current study will shed light on these issues.

2.3 Mathematics instruction for low-performing learners

The focus of the present study is on learners who have difficulties learning mathematics. According to Kroesbergen (2002), low-achieving learners require special instruction adapted to suit their needs. Although this group of learners may be heterogeneous, educators argue that most of the learners with difficulties learning mathematics have more or less the same educational needs as their learning patterns do not differ from each other

(Kavale & Forness, 1992; Van Lieshout, Jasper, & Landewé, 1994). Rivera (1997) identifies the areas in which low-achieving learners encounter the most difficulties. These include automaticity, strategy use and meta-cognitive skills.

Learners who have difficulties learning mathematics need help with the evaluation of the effectiveness of chosen solution strategies (Kroesbergen, 2002). Jones, Wilson and Bhojwani (1997) recommend explicit instruction for learners who have difficulties learning mathematics. According to Kroesbergen (2002, p. 6), “research shows carefully constructed explicit instruction to be very effective for students with mathematics learning difficulties”. The difference between explicit instruction and regular instruction is that nothing is left to chance in the former (Ruijsenaars (1992).

However, there is no agreement on the type of pedagogy that low-performing learners may need (Kroesbergen, 2002). Behaviourists will focus on changing the learner’s environment and the behaviour of the teacher when the learner does not perform well. Cognitivists will concentrate on the mental processes of the learner and try to improve the learner’s strategy use. Constructivists will try to build the learner’s repertoire of strategies through exposure and practice with different problems. According to Mercer and Mercer (1998), the majority of constructivists are shifting towards the explicit end of the implicit-explicit instruction continuum to address the learning needs of low-achieving mathematics students.

2.4 Integrating various theoretical perspectives

It is increasingly being recognised that there is no unified theory of mathematics education that will suit all the learners we teach. According to Lester (2005), the best we can do is to combine ideas from a range of theoretical perspectives rather than adhere to one particular theory. Hence, this study draws its theoretical underpinnings from the three theoretical perspectives discussed in section 2.2.

Firstly, the researcher’s choice of the research topic, research questions and the target population was largely influenced by Bruner’s cognitive theory and Van de Walle’s constructivist view of mathematics education. According to Bruner (1960), any mathematical idea can be presented in a form simple enough for any learner to understand

as long as it is adapted to the learner's intellectual capacity and experience. Van de Walle (2004, p. 15) has the following to say:

All learners are capable of learning all the mathematics we want them to learn and they can learn it in a meaningful manner that makes sense to them if they are given an opportunity to do so.

Thus, even those learners who are viewed as unable to learn mathematics due to their persistent failure in mathematics, are capable of learning mathematics as long as we offer them an opportunity to do so. This is one of the ideas that gave impetus to conducting this study. However, the question that remains is: How can educators offer low-achieving learners an opportunity to learn mathematics? This is an area that demands investigation.

Secondly, the research design of this study is rooted in the behaviourist assumption that learning can be objectively measured (Mergel, 1998). By focusing only on behaviour that can be observed and manipulated, behaviourism allows the experimental method to be used in research and findings can therefore be proven right or wrong. Data becomes easier to collect, quantify and analyse using statistical methods. The behaviourist approach is also reflected in this study by the use of tests to measure learning success. However, in designing the test items, the researcher was informed by the constructivist theory which emphasizes the use of open ended questions to allow learners to use different solution strategies rather than one way methods.

Thirdly, in designing instruction for the low-performing learners, the researcher adopts the exogenous constructivist stance which emphasizes the provision of explicit instruction through worked examples, explanations, guided practice and feedback (Mercer, Jordan & Miller, 1996). According to Sweller (1999), low-achieving learners can be better at solving mathematics problems when they study worked examples and engage in guided discovery.

2.5 Summary of the Theoretical Framework

In this section, the main theoretical views of learning were reviewed and key issues relating to each were discussed. It is concluded that no single learning theory would suit all the learners we teach. Perhaps the best we can do is to integrate ideas from the various

views of learning rather than adhere to one particular learning perspective. The following ideas constitute the theoretical framework for this study:

The researcher agrees with the view that all learners are capable of learning mathematics (including those without a natural mathematical ability) as long as we offer them opportunity to do so. This is a view of learning derived from Bruner's cognitive theory and Van de Walle's constructivist views of learning (Bruner, 1960; Van de Walle, 2004).

It is acknowledged that the educator and what goes on inside the classroom are key determinants of learners' mathematics achievement (Barwell, Barton & Setati, 2007; Arnold & Bartlett, 2010). However, knowledge of how exactly educators can improve mathematics learning and achievement particularly for low-performing learners is an area that demands further investigation since there is very little empirical evidence in this regard.

The role of the educator is to provide a variety of learning activities from which learners can select what suits their individual needs (Mahoney, 2003). The educator should create an environment that encourages learners to explore within a given framework and make their own inferences and conclusions (Devries & Zan, 2003). This is a view of learning based on constructivists' pedagogical practices.

Low-performing learners need special instruction designed to suit their learning needs (Kroesbergen, 2002). Explicit instruction (which leaves nothing to chance) is likely to be effective for learners with mathematics learning difficulties (Jones, Wilson & Bhojwani, 1997; Kroesbergen, 2002)

Lastly, the study is also grounded in the behaviourist view that learning success can be objectively measured (Mergel, 1998). This is the idea that influenced the researcher's choice of methodology for the present study.

The next section places this study in context and presents a review of the related literature.

2.6 Review of Related Literature

This section presents a review of the literature related to this study. It begins with evidence of low mathematics achievement in South Africa and then discusses the reasons for the poor state of mathematics education in the country. This is followed by analyses of curriculum reforms that have been implemented to date and how they have impacted on mathematics education in the country. A review of some empirical studies on low-performing learners is also presented and the chapter concludes by identifying the research gap and proposing the present study.

2.6.1 Studies on learners' mathematics achievement in South Africa

Since 1994, South Africa has conducted a number of national learner achievement assessments and has also participated in international surveys of learner performance. These studies include the Trends in International Mathematics and Science Study (TIMSS), the Southern and East Africa Consortium for Monitoring Educational Quality (SACMEQ), the Monitoring Learning Achievement (MLA) project, the Systemic Evaluation Study (SES) and the recently introduced Annual National Assessment (ANA). The apparent convergence of findings from these studies is that South African learners perform far much below expectations in mathematics and science.

2.6.1.1 The Trends in International Mathematics and Science Study (TIMSS)

The Trends in International Mathematics and Science Study (TIMSS) is a cross-national assessment conducted by the International Association for the Evaluation of Educational Achievement (IEA) every four years to compare the mathematics and science performance of learners in different countries (Lorimer, 2010). TIMSS surveys rank countries on the basis of average scores of learners' performance in standardised tests. South Africa participated in the TIMSS surveys conducted in 1995, 1999, 2003 and 2011 involving Grade 8 and 9 learners. In all first three studies, South African learners came last in the mathematics rankings of participating countries (Gonzales, Mullis, Martin & Chrostowski, 2004; SAIDE, 2008). In the 2011 TIMSS rankings, South African Grade 9 learners ranked second from last in mathematics (IEA, 2011). Analysis of TIMSS results per province shows that Limpopo continues to be among the three lowest performing provinces.

It is important to note that South Africa is not the only African country participating in the TIMSS. Ghana, Botswana, Morocco, Tunisia and Egypt have also taken part in the TIMSS and these countries have scored better than South Africa. It is therefore irrefutable that TIMSS results reflect a crisis in South Africa's mathematics education.

2.6.1.2 Southern and East Africa Consortium for Monitoring Educational Quality (SACMEQ)

According to Hungi, Makuwa, Ross, Saito, Dolata, Capelle, Pavliot and Vellien (2010), SACMEQ is a collaborative network of education ministries in Southern and Eastern Africa. It undertakes integrated research that generates evidence-based information which can be used by decision makers to evaluate the quality of their primary education systems.

SACMEQ has undertaken three research projects to date: SACMEQ I (1995-1998), SACMEQ II (1998-2004) and SACMEQ III (2005-2010). South African Grade 6 learners participated in SACMEQ II and SACMEQ III and in both surveys, results have been disappointing. South Africa achieved below the SACMEQ II mean score of 500 and ranked ninth out of the 14 participating countries (SACMEQ, 2005). In the SACMEQ III survey, South African Grade 6 learners' mathematics score is more or less as bad as in SACMEQ II, achieving the eighth spot out of 15 participating countries (SACMEQ, 2011). The SACMEQ results also show that South Africa is outperformed by surrounding countries, many of which, including Uganda, Mozambique, Tanzania and Kenya have far fewer resources and spend less on education than South Africa. The implication here is that it is the quality of mathematics teaching that need to be improved in South African schools and not just an increase in allocation of resources towards mathematics education.

Unlike the TIMSS studies which report learners' achievement merely on the basis of mean scores, SACMEQ studies use the Rasch model to further organise learners' achievement in a hierarchy of competency levels (Moloi & Strauss, 2005). However, this hierarchical organisation of data only serves to amplify the view that mathematics education in South African schools is in a bad state.

Table 2: Percentages of South African Grade 6 pupils reaching mathematics competency levels in SACMEQ II and SACMEQ III (Moloi, & Strauss, 2005)

		SACMEQ II	SACMEQ III
Level 1	Pre-Numeracy	7.8%	5.5%
Level 2	Emergent Numeracy	44.4%	34.7%
Level 3	Basic Numeracy	23.8%	29.0%
Level 4	Beginning Numeracy	8.8%	15.4%
Level 5	Competent Numeracy	6.1%	7.1%
Level 6	Mathematically Skilled	5.8%	5.9%
Level 7	Concrete Problem Solving	2.1%	1.9%
Level 8	Abstract Problem Solving	1.3%	0.6%

From Table 2 above, about 85% of the South African sixth-graders who took part in the SACMEQ II study only reached the lower half of the eight levels of competence on the SACMEQ continuum (Moloi & Strauss, 2005).

2.6.1.3 Monitoring Learning Achievement (MLA)

According to Chinapah (2003), the Monitoring Learning Achievement (MLA) project is a UNESCO-UNICEF joint effort to assist member states in developing systems for monitoring and assessing learning outcomes. It was started in the early 1990s and several African countries including Botswana, Mozambique, Uganda, South Africa, Malawi and Zambia among others, have participated in the MLA project. The MLA project on the numeracy of fourth-graders in several African countries was conducted in 1999 and South Africa's performance indicated serious shortcomings compared to other African countries, achieving the lowest percentage average numeracy score out of the 12 participating countries (Strauss, 1999).

Table 3: MLA -1999 numeracy results of South African fourth-graders (Strauss, 1999)

Mark range	0-<25	25-<50	50-<75	75-100	Total
Percentage of learners	43.93	45.79	8.83	1.45	100

Analysis of the MLA-1999 numeracy results in Table 3 shows that 89.72% of the South African fourth-graders exhibited poor numeracy abilities. Only a small proportion (10.28%) of the learners demonstrated a high level of numeracy competency, scoring 50% or higher.

2.6.1.4 Systemic Evaluation Studies (SES)

Other than the international comparative studies, most countries have their own internal mechanisms to monitor the educational progress of learners in the school system at regular intervals. In South Africa, the Systemic Evaluation was a national assessment programme conducted by the Department of Education (DoE) focusing on grade 3 and 6 learners, to monitor learning overtime. About 54 000 grade 3 learners were assessed in Numeracy, Literacy and Life Skills in 2001 and 2007 (DoE, 2009b). Around 34 000 grade 6 learners were assessed in the Language of teaching and learning (LoTL), Mathematics and Natural Sciences in 2004.

Table 4: Average percentage scores attained in the Grade 3 and Grade 6 Systemic Evaluations (DoE, 2009b)

	Average percentage score
Grade 3: 2001-Numeracy	30%
Grade 3: 2007-Numeracy	35%
Grade 6: 2004-Mathematics	27%

The results in Table 4 show that in all the three systemic evaluations, learners' performance was poor.

2.6.1.5 Annual National Assessment (ANA)

The Annual National Assessment (ANA) is a measure for monitoring learner progress in literacy and numeracy (DoBE, 2012b). According to the DoBE (2010, p. 4), ANA has four key effects on schools:

...to expose teachers to better assessment practices, make it easier for districts to identify schools in most need of assistance, encourage schools to celebrate outstanding performance and empower parents with important information about their children's performance.

The first ANA tests were written in 2011 by learners in Grades 1 to 6. In 2012, Grade 9 learners were added to the list. "The overall performance of learners as reflected in the ANA 2011 results was very low with average scores of 30% and lower in languages and mathematics at each grade" (DoBE, 2011c, p. 2). The 2012 ANA results for grade nine

were below expectation and are a cause for great concern. The ANA 2012 results show that grade nine learners scored on average a disappointing 13% in mathematics (Nkosi & John, 2012). Grade 9 learners in the province of Limpopo scored the lowest with an average 8.5 %.

The implication of the ANA findings is that learners are moving from one grade to the next without acquiring the basic literacy and numeracy skills (DoBE, 2011c).

2.6.2 What South Africa can learn from National and International Comparative Studies

The purpose of national and international comparative surveys of learners' performance is to help countries assess the quality of their educational systems in order to identify needs and allocate resources (Nasser Abu-Alhija, 2007).

The emerging trend of consistently low scores in mathematics has prompted debate amongst policy-makers, academics, school teachers and the general public about the quality of mathematics education in South African schools. South Africa's policy makers today wonder why South African learners are outperformed by learners from much poorer countries (Basset, 2011). Taylor (2007, p. 10) says, "This is a demonstration of the lesson that, while in general, poverty is strongly associated with performance, many school systems achieve higher quality with far fewer resources than South Africa has".

The publication of TIMSS, SACMEQ, MLA and SES results prompted government to increase resource allocation towards mathematics and science education at the school level (Reddy, 2010). However, this increased investment towards mathematics and science education has not provided answers to the mathematics crisis in South Africa, as reflected in the 2011 and 2012 annual national assessment (ANA) results. Reddy (2010) observes that there are some schools classified as having adequate resources for effective learning of mathematics which are not performing at the expected higher level. Conversely, there are some schools categorised as under-resourced which are producing very good mathematics results. This has the implication that the educator and the quality of teaching determine learners' mathematics achievement.

According to Arnold and Bartlett (2010), the most powerful determinant of students' achievement in developing countries is what actually goes on within the classroom and this outweighs all other factors as a predictor of learners' achievement. Long (2007, p. 3), asserts that 'while information provided by large-scale external evaluation might result in motivation for the teachers, it does not necessarily provide the means to improve, especially in a conceptually complex subject like mathematics'. This offers an opportunity for further inquiry.

2.6.3 Reasons for South Africa's poor performance in mathematics

Vast evidence of low mathematics achievement in South Africa has led to a proliferation of studies seeking explanations for the poor state of mathematics education in the country. Van der Westhuizen, Mosoge, Nieuwoudt, Steyn, Legotlo, Maaga and Sebege (2002), Bernstein (2004), Mukadam (2009), Rakumako and Laugksch (2010) among others, made significant contributions in this regard. Some of the findings are:

2.6.3.1 Educators' qualifications and subject matter competence

A survey conducted by Rakumako and Laugksch (2010) on the demographic profile of secondary school mathematics educators in Limpopo province, reports that most mathematics educators are "academically under-qualified and professionally ill-prepared for their classroom responsibilities as they have Standard 10 (grade 12) as their highest academic qualification with a three year teaching diploma" (p. 148). The situation is reportedly worse in rural schools. These findings confirm earlier reports by Mukadam (2009) that many mathematics educators are not adequately equipped to effectively teach the new syllabus. In an article by The Good News (2010), the Head of the KwaZulu-Natal Education Department blames educators for poor Grade 12 results in mathematics and says that they are avoiding teaching certain topics in the subject because they do not know them. In earlier findings by Van der Westhuizen et al. (2002), learners report that some educators do not know how to explain some concepts in mathematics. Darling-Hammond, Berry and Thoreson (2001) agree that the educator's knowledge regarding pedagogy, learners, subject content and curriculum strongly influences learners' level of achievement. According to Stoffels (n.d), educators with low knowledge of subject matter teach from the textbook (in a superficial way), rush through topics and neglect those topics in which they are not competent.

2.6.3.2 Learner discipline

In a study by Van der Westhuizen et al. (2002), educators and school principals view learner discipline as the second major cause of poor performance in South African schools. They argue that learners are uncontrollable, deliberately ignore instructions from educators, leave classrooms during lessons, come to school late and leave school before time. However, it is important to note that low-achieving learners may adopt delinquency to express their frustration at persistent failure to achieve at schools. Balow (1961) concludes that the less they learn the more negative their behaviour becomes. Carlie (2002) asserts that academic failure for some learners results in low self-esteem which may lead to classroom disruptions, aggression, truancy and dropping out of school. It is therefore important for educators to investigate ways to ensure that most if not all of their learners achieve success in learning.

2.6.3.3 Educators' commitment

According to Van der Westhuizen et al. (2002), lack of educator commitment and low morale as shown by high rate of absenteeism, late-coming and non-performance of duties is the third major cause of poor performance in South African schools. As a result, precious time is lost and in some instances learners are left without educators for several days. Poor working conditions, unclear and confusing government policies and inadequate curriculum materials, are some of the causes of low educator morale in South Africa (Van der Westhuizen et al., 2002).

2.6.3.4 Inequalities of educational opportunities

Bernstein (2004) contends that South Africa is yet to eradicate the legacy of apartheid in its education system. Black learners, who constitute the larger part of the learner population in the country still have limited access to schools with functioning mathematics and science departments. A study by Rakumako and Laugksch (2010) indicates that more experienced and better qualified mathematics and science educators are found in urban schools rather than in township and rural schools. In addition to inadequately trained mathematics educators, learners in rural schools have to put up with inadequate textbooks, overcrowded classrooms and inadequate parental involvement among other adversities. Research has since found a correlation between these factors and low mathematics achievement (Pscharopoulos & Woodhall, 1985; Lockhead & Verspoor, 1991).

2.6.3.5 Curriculum issues

Historically, limited success in school mathematics in South Africa has been largely attributed to a curriculum that was skewed in favour of a minority of learners. According to Moloï and Strauss (2005), “The curriculum was heavily content-laden, encouraged rote learning of mathematical techniques and algorithms and lent itself to very little application in everyday experiences of learners.” The study (Moloï & Strauss, 2005) shows significant gaps between what the official mathematics curriculum requires and what is presented in textbooks. This has serious effects on disadvantaged rural school learners given that the textbook is the only form of learning and teaching support material (LTSM) available to them (Moloï & Strauss, 2005).

2.6.3.6 Policy issues

The Ministry of Education (1998, p. 22) admission policy number 31 states that:

In principle, learners should progress with their age cohort. Repetition of grades seldom results in significant increases in learning attainment and frequently has the opposite result. The norm for repetition is one year per school phase where necessary. Multiple repetitions in one grade are not permissible.

In many schools, some learners are being promoted from one grade to another even when they have not mastered the basic skills and knowledge of a particular grade. No measures are being taken to bring those learners up to standard in their early stages of learning. According to Muoneke and Shankland (2009), the majority of learners exit primary school not having mastered the basic mathematical knowledge required for success in secondary school mathematics. Keating (2007) asserts that when learners come to high school without the necessary skills, it implies that high school teachers have to spend time trying to clear the backlog of work that should have been covered in lower grades and this takes up time that should be spent on covering the syllabus.

2.6.3.7 Parental involvement

The level of parental involvement in some schools today is unacceptably low yet the crisis in mathematics education demands a joint effort between educators and parents for learners to improve. According to Van der Westhuizen et al. (2002), parents can make a

difference by showing interest in their children's schoolwork and encouraging them to achieve. Parents can help by checking that children do their homework, providing the right books, praising good teachers and confronting the bad ones as well as ensuring that their own children are not responsible for disrupting lessons at school.

Analysis of the preceding literature shows that the factors that contribute to low mathematics achievement in South African schools are not only complex but also intertwined. The following section looks at the major reforms in South Africa's education system and their impact on mathematics education.

2.6.4 Mathematics curriculum reforms and their effectiveness

Over the years, the South African government has made several reforms to address some of the issues noted above in a bid to improve the state of education in the country. Some of the reforms and their effects on mathematics education in the country are discussed here.

2.6.4.1 Outcome-Based Education (OBE)

According to Vellupillai (2007, p. iv), "Outcomes-Based Education (OBE) is a learner-centred, result-orientated approach premised on the perception that all learners can learn and succeed". This was introduced in 1997 to get rid of a content-loaded mathematics curriculum and replace it with minimum mathematics content that learners must command to show they have achieved the learning outcomes (Moloi & Strauss, 2005). Many systems of education today are moving away from a content-based mathematics curriculum to one that upholds measurable outcomes. However, 'dipstick' surveys conducted after the introduction of Outcomes-Based Education (OBE) system reveal worrying levels of mathematics achievement in South African schools (Moloi & Strauss, 2005). The idea behind OBE is that learners must be encouraged to work on their own and think for themselves but then, it has been found that this only works in well-resourced schools and with learners of high ability. Vithal and Volmink (2005, p. 17) comment that, "It is the last category of people, the poorest of the poor, that has not been considered in our mathematics curriculum visions and reconstructions".

The OBE has failed to address learners' needs particularly in under-resourced schools. While the DoBE offered many training workshops to help educators teach the OBE way, the classroom is a very different environment from a training seminar, especially when a

teacher is dealing with a very large class in which it is difficult to give individual attention to all children who need it (Moloi & Strauss, 2005). The unanticipated consequences of implementing new policies and new curricula have left policy implementers frustrated. Van der Westhuizen et al. (2002) conclude that “little attention was paid to the harsh realities of the poorest rural settings” (p. 117).

Whilst the adoption of an outcomes based curriculum was commendable, “the quality of the mathematics textbooks seemed not to be supportive of the ideals of the curriculum” (Moloi & Strauss, 2005, p. 25). Analysis of the local mathematics textbooks shows serious gaps between what texts present and what the official curriculum requires and this seriously affects learners in disadvantaged rural and township schools, given that textbooks are often the only resource available to them (Moloi & Strauss, 2005).

2.6.4.2 The New Further Education and Training (FET) system, introduced in 2006

A new FET syllabus was implemented in 2006, starting in grade 10. It replaced Higher Grade (HG) and Standard Grade (SG) mathematics with two new subjects called Mathematics and Mathematical Literacy, making it compulsory for all learners to study one of them. The first National Senior Certificate (NSC) examinations in this new dispensation were written in 2008. The following table highlights how learners have performed in mathematics since then.

Table 5: Overall achievement rates in NSC Mathematics at 40% or above: 2008-2012 (DoBE, 2011a; DoBE, 2012a, p. 120).

Year	% Achieved at 40% and above
2008	29.9
2009	29.4
2010	30.9
2011	30.1
2012	35.7

The results in the Table 5 indicate that South Africa is still far from turning around the mathematics crisis. Mukadam (2009, p. 6) asserts that “many mathematics educators are not at par with the new syllabus; so how can our learners gain access to the new mathematics when our educators are not adequately equipped to provide that access”.

Several other publications echo the same voice. An article published by Mail and Guardian Online (August 3, 2008), states that the new mathematics curriculum “was rushed through and completely ignores the dire shortage of trained and qualified mathematics educators in the country” (p. 1). Some educators’ knowledge of certain mathematical aspects is little better than that of their learners (Barwell et al., 2007). According to Foulds (2002, p. 1), “Whatever the quality of the curriculum itself, success or failure depends largely on developing teacher quality”. However, little research has been conducted to find ways to help educators improve the quality of mathematics teaching and learning in South African schools. In-service training workshops have been sporadic and marred by poor attendance.

Barwell et al. (2007, p. 46) have this to say, “Despite all the best intentions to bring South African science education into the 21st century, the reforms have not achieved the success planned for them”. Studies of various programmes of curriculum change provide evidence that where these processes do not involve teachers from the beginning, they are much less likely to succeed (Barwell et al., 2007).

2.6.4.3 The National Curriculum Statement (NCS): Mathematics Grades 10-12

The National Curriculum Statement Grades 10-12 Mathematics was made up of the following documents: Subject Statements, Learning Programme Guidelines and the Subject Assessment Guidelines. It was based on the principle of Outcomes-Based Education (DoE, 2003). The mathematics curriculum was broadly defined by four learning outcomes: Learning Outcome 1-Number and Number Relationships; Learning Outcome 2- Functions and Algebra; Learning Outcome 3: Space, Shape and Measurement and; Learning Outcome 4- Data Handling and Probability. Each Learning Outcome had Assessment Standards that described what learners were expected to know and be able to do. Topics such as Probability, Recursive Sequences and Euclidean Geometry, were optional (examined only in Paper 3).

Other than being mediators of learning, educators were expected to interpret policy documents (Subject Statements, Learning Programme Guidelines and Subject Assessment Guidelines) and design teaching and learning materials (DoE, 2003). Educators had to do detailed lesson planning which involved giving details of the learning outcome, assessment standard(s), topic and concept(s), educator and learners’ activities, teaching and learning

resources, expanded opportunities and remedial measures to be taken, as well as the form(s) of assessment to be used.

Badugela (2012) conducted a study (in Limpopo) to figure out the challenges educators encountered in implementing the NCS. The study identified the following challenges: inadequate training and resources; low quality of teaching and learning support materials; increased workload due to a lot of paperwork; lack of teacher involvement in the decision to adopt the new curriculum; too much emphasis on outcomes, leaving issues of content to individual educators and ignoring that not every educator has the skill to develop appropriate learning content.

In 2009, the Minister of Education, Angie Motshekga appointed a Ministerial Task Team to identify the challenges that negatively impacted on the quality of teaching and the implementation of the NCS (Badugela, 2012). The Task Team's Report recommended the development of a single comprehensive curriculum policy document "to replace Subject Statements, Learning Programme Guidelines and Subject Assessment Guidelines in Grades R-12" (DoBE, 2011, p. 3). This is intended to address educators' concerns about the various challenges they faced in the implementation of the National Curriculum Statement Grades 10-12.

The next section presents the details of the new Curriculum and Assessment Policy Statement (CAPS) launched in 2012.

2.6.4.4 The Curriculum and Assessment Policy Statement (CAPS): Mathematics Grades 10-12

While educators were still trying to come to terms with the NCS Grades 10-12, the Department of Basic Education (DoBE) launched a new version of the NCS called CAPS, in 2012. The Curriculum and Assessment Policy Statement (CAPS) brings several changes to the existing mathematics curriculum. The terminology 'Learning Outcomes' and 'Assessment Standards' has been replaced with 'Content' and 'Skills' (Variend, 2011). The main change across the FET phase is that topics that were previously covered in the Optional Paper 3 are now included in the core mathematics curriculum. These are: Probability and Euclidean Geometry. To allow for these changes, Transformation

Geometry, Linear Programming and Recursive Sequences have been removed from the curriculum (Maskew Miller Longman, 2012).

According to Bowie (2010), reasons for these changes are that: universities call for the return of Euclidean Geometry; attempts to encourage Dinaledi schools to prepare their best learners to write Paper 3 have failed; concern about overload prompted removal of certain topics which are internationally excluded from the grade 12 curricula. CAPS aims to reduce administrative load on educators and provide clear detailed guidance with regards to what educators should teach (Variend, 2011). New textbooks have already been developed that are aligned and organised according to the CAPS teaching plan. The CAPS is to be implemented in three phases: January 2012 Grades R-3 and Grades 10; January 2013 Grades 4-6 and Grade 11; and January 2014 Grades 7-9 and Grades 12.

However, this new curriculum has already been criticised before full implementation. According to De Villiers, cited in Bowie (2010, p. 12);

...our problem in this country is NOT so much the curriculum as the lack of good mathematics teachers; that is the bottom line! ... No curriculum will be successful until massive in-service training on a continual basis is implemented. Specifically, their Pedagogic Content Knowledge needs to be drastically improved..., and unfortunately tinkering a little here, and a little there, or importing a different curriculum is not going to help much.

2.6.5 Emerging Issues

From the foregoing discussion, it can be concluded that the educational transformations that have taken place in South Africa hitherto, have not fully addressed the needs of mathematics educators and mathematics learners. Mathematics remains inaccessible to most learners in disadvantaged communities due to the acute shortage of qualified mathematics teachers and the poor quality of learning and teaching support material. Mathematics reforms have focused more on changing the curriculum than improving the quality of mathematics teaching in the classroom. The OBE has failed particularly in rural and township schools due to lack of resources and training. The introduction of Mathematics and Mathematical literacy in place of Higher and Standard Grade mathematics has also not brought significant gains for the country, as reflected in 2008-2012 Grade 12 matriculation results. Success of the recently launched CAPS FET

Mathematics curriculum will largely depend on in-service training (INSET) for educators to effectively implement this new curriculum. There is international consensus that success of any curriculum largely depends on developing teacher quality (Darling-Hammond et al., 2001; Foulds, 2002; Barwell et al., 2007). According to Long (2007, p. 3), “The situation at present is that not all teachers of mathematics have adequate knowledge of the field.” Persistence of high mathematics failure rate in rural and township secondary schools today is an urgent call to all stakeholders to find ways to avert the crisis.

Government policies have resulted in some learners being pushed through the system and reaching Grade 12 without having mastered the mathematics concepts of previous grade levels. According to Prinsloo (2008), cumulative learning deficits ‘seriously hamper current performance and the ability of learners to benefit from extra tuition in secondary schools’ (p. 5). Mathematics educators teaching Grade 12 classes are frustrated at trying to recover lost ground and then to cover the prescribed content (Prinsloo, 2008). The learners themselves are frustrated at not coping with the new work and ‘being pulled into putting in lots of effort and energy where it is not productive’ (Prinsloo, 2008, p. 8).

The increasing number of learners failing mathematics in secondary schools is unacceptable given that there is growing demand for scientists and engineers in the country. To curb the situation, educators try to offer extra classes, but some learners seem not to benefit from the extra tuition. Some educators have given up on the crisis as they hold the perception that the majority of the low-performing learners can never do well in mathematics (Keeton, 2010). However, contemporary views of learning assert that even the worst mathematics performance can be improved considerably provided compensatory strategies are instituted to remediate deficiencies (Centre for Teaching and Learning of Mathematics, 1986). The perception that all children can learn mathematics, even those in the most challenging school settings, is becoming institutional reality (McCrocklin & Stern, 2006). Unfortunately, little is known about the kind of strategies educators could employ in their classrooms to ensure that most if not all of their learners succeed in mathematics. The current study seeks to make a contribution in this regard. It is a pity that current mathematics teaching seems to weed out the low-performing learners and yet, the growing demand for scientists and engineers requires that even such learners be trained to fill those posts (McCrocklin & Stern, 2006).

Although several national and international studies have been conducted on the mathematics achievement of learners in South Africa (for example, TIMSS, SACMEQ, MLA, SES and ANA), researchers have concentrated much on assessing learners' levels of mathematics achievement and issues of curriculum relevance. There is little empirical evidence of pedagogical practices that can enhance the mathematics achievement of South African learners in secondary schools. Despite making several changes and amendments to the existing mathematics curriculum (for example replacing Standard and Higher Grade Mathematics with Mathematics and Mathematical Literacy), South African learners still perform below expectations as reflected in recent national and international surveys of learner performance. This has led researchers to conclude that changing the mathematics curriculum is not going to help much in improving learners' achievement (De Villiers in Bowie, 2010). South Africa needs good mathematics educators with a high level of proficiency in teaching mathematics to curb the high rate of failure in the subject (Barwell et al., 2007). However, there is not enough evidence that links such educators' classroom activities with learners' achievement in the case of low-ability students. The question that remains is: How can educators ensure that even those learners who seemingly lack a natural mathematical ability achieve success in mathematics? The current study sought to find a possible answer to this question.

There is not enough research into possible ways to improve the mathematics achievement of low-performing learners in secondary schools.

2.6.6 Some empirical studies with low-performing students

Circumstances surrounding the learning situation will help us select the most appropriate approach to learning. Different learning theories may apply to different learners and situations (Mergel, 1998). According to Schwier (1995), some learning problems require highly prescriptive solutions whereas others demand less structured environments. Cronbach and Snow (1977) assert that highly-structured learning environments are most successful with learners of low ability whereas low-structured learning environments result in better learning for students of high ability.

In a study conducted in Finland involving low-achieving students, it was concluded that explicit instruction produced significant improvement in learner performance compared to

a constructivist approach (Kroesbergen, Van Luit & Maas, 2004). In another study involving sixth-graders, Kim (2005) found that constructivist teaching methods resulted in better learner achievement than traditional teaching methods. Doğru and Kalendar (2007) compared traditional (teacher-centred) approaches to constructivist (learner-centred) approaches in science classrooms and found that, learners who learned through constructivist methods had better retention of knowledge than those who learned through traditional approaches.

An experimental study involving 75 000 children from 170 different communities in America, was designed to evaluate different approaches to educating learners at risk of academic failure (Stebbins, St Pierre & Proper, 1977). The results showed that learners who were taught using teacher-centred (traditional) outcome based models significantly outperformed those who were taught using learner-centred (constructivist) models (Stebbins et al., 1977).

It can be concluded from the above literature that empirical evidence of the best teaching practices for low-ability students is far from being conclusive. Analyses of the various learning theories show that there is no single best learning theory that would suit all the learners we teach. Hence, the present study proposes a theoretical framework that combines ideas from the various learning perspectives rather than adhere to a particular view of learning. Nevertheless, it is necessary to consider emerging trends in mathematics education in our efforts to find solutions to the crisis facing South African mathematics education. The following section highlights views on contemporary mathematics education.

2.6.7 Trends in Mathematics Education

There is growing consensus about the essentials of mathematics teaching and learning (Naroth, 2010). Research studies have provided insights into how children learn mathematics (for example, Bruner, 1960; Devries & Zan, 2003; Donovan & Bransford, 2005).

2.6.7.1 Mathematical problem solving and multiple strategies

Mathematical problem solving has become a fundamental and central goal in mathematics education (Stacey, 2005). It advocates a change from traditional practices to practices that emphasise inquiry and discovery learning. The role of the teacher in problem-solving instruction is to create a learning environment that engages learners and provide them with an opportunity to explore multiple strategies of solving mathematical problems (Naroth, 2010). Naroth (2010) asserts that discussing with learners several solution strategies in the classroom would help learners understand how and why certain strategies work. As learners consider the efficiency and reliability of each solution strategy, they are likely to become proficient in their mathematical problem solving skills. Donovan and Bransford (2005), report that giving learners the opportunity to apply multiple solution strategies serves as a scaffold as learners move from their own conceptual understanding to more abstract approaches of doing mathematics which involve their own reasoning and strategy development. This is one of the ideas upon which the current study is founded.

Cai et al. (2005) conclude that due to limited mathematical knowledge, educators tend to stick to traditional teaching practices as they are inadequately prepared to explain various concepts and deal with open-ended problems. According to Naroth (2010, p. 44), some educators hold the perception that “multiple methods and heuristics will serve to confuse learners”. The results of the present study could be drawn to prove whether or not such views hold substance.

2.6.7.2 Cognitive-constructivism and mathematics education

Cognitive-constructivism is a teaching and learning theory based on Piaget’s perception that learners are not passive recipients of knowledge but build their own knowledge and meaning through their past and present learning experiences (Derry, 1996). The role of the cognitive-constructivist teacher is to provide learning experiences for the learners through which learners participate, extract and develop new mathematical knowledge. This involves giving learners several representations of mathematical ideas to encourage them to develop multiple ways to succeed in solving mathematical problems presently and in future. According to Von Glaserfeld in Derry (1996, p. 165), educators should “view themselves as midwives who facilitate the birth of understanding, not as engineers of knowledge transfer”. The implication for classroom practice is that educators should

actively engage learners in the construction of mathematical knowledge rather than regard learners as empty vessels to be filled with knowledge.

Analyses of the above literature sheds light on the possible reforms required to turn around the crisis in South African mathematics education. The foregoing discussion gives insight into how learners learn mathematics and the role educators should play to enhance effective learning in the classroom. However, while problem solving is the central goal of the mathematics curriculum (as advocated in curriculum documents both at GET and FET levels), it appears to be increasingly difficult to achieve (Stacey, 2005; Naroth, 2010). A report by the task team appointed by the Minister of Basic Education to review the NCS in South Africa concluded that “there is little guidance as to the mechanisms of such an approach” (DoE, 2009a, p. 49). It is the researcher’s opinion that lack of empirical evidence to support current teaching practices (such as problem solving and cognitive-constructivism) has resulted in educators sticking to traditional teaching practices.

2.6.8 Conclusion

Analyses of available literature point to the view that the persistent high failure rate in mathematics in South African secondary schools demands a change in our teaching and learning practices. A view of the present study is that it is possible for educators to curb the high failure rate in Grade 12 Mathematics classes. The researcher (in the current study) holds the perception that even those Grade 12 learners who have a previous record of underachieving in mathematics can learn and understand mathematics. This view is largely influenced by Bruner and Van de Walle’s cognitive and constructivist theories of learning (Bruner, 1960; Van de Walle, 2004). One definite conclusion that can be drawn from available research findings is that what takes place between the educator and the learner is critical in addressing the problem of low mathematics achievement (Foulds, 2002; Barwell et al., 2007; Arnold & Bartlett, 2010). However, available studies on effective pedagogy for low-performing learners have concentrated on primary school learners and little is known about what could enhance mathematics learning and achievement for learners in secondary schools. Hence, the present study explores solution strategies that can enhance the achievement of low-performing Grade 12 learners in some problematic mathematical aspects. Low-performing Grade 12 learners were targeted in this study because educators

have the perception that these learners are beyond redemption. Findings of this study would help to confirm whether or not such perceptions hold substance.

Since there is no one best theory of mathematics education, the present study combines ideas from the three views of learning (namely, behaviourism, cognitivism and constructivism) rather than adhere to one particular theory (Lester, 2005). The design of the study together with the data analyses procedures are influenced by the behaviourist principle that learning success can be objectively measured (Mergel, 1998). The researcher adopts the cognitive-constructivist approach to teaching and learning mathematics as opposed to passive learning. The view proposed by Narooh (2010) that learners are likely to become more proficient in mathematical problem solving when exposed to multiple solution strategies of solving mathematical problems is the philosophy upon which the present study is founded.

The next chapter presents the mathematical aspects and solution strategies explored in the study.

CHAPTER THREE

SOME MATHEMATICAL ASPECTS AND RELATED SOLUTION STRATEGIES

3.1 Introduction

This chapter provides the details of the mathematical aspects and solution strategies on which the study was based. The purpose of the study was to find solution strategies that can enhance mathematics learning and achievement for low-performing Grade 12 learners. In this chapter, the researcher presents the possible multiple solution strategies in the following mathematical aspects: finding the general term of a quadratic sequence, factorising third degree polynomials, determining the centre and radius of a circle, and calculating the angle between two lines. However, it is acknowledged that there may be other strategies as well not presented in this chapter. Discussions with fellow mathematics educators during cluster meetings and peer lesson observations influenced the choice of mathematical aspects and solution strategies explored in this study.

3.2 Finding the general term of a quadratic sequence

A quadratic sequence is a number pattern in which the second difference is constant. For example: 3; 8; 15; 24; 35; ...

Sequence	3		8		15		24		35
1 st difference		5		7		9		11	
2 nd difference			2		2		2		

The above sequence is a quadratic sequence because the second difference is constant. To find the general term (T_n) of this sequence, here are four different solution strategies that can be used:

Strategy number 1

Quadratic sequences (2007)

Retrieved June 27, 2011, from <http://www.skool.co.za/studynotes/maths/id635.htm>

The general term of a quadratic sequence is given by:

$$T_n = a + (n-1)d_1 + \frac{1}{2}(n-1)(n-2)d_2 *$$

Where $a = 1^{st}$ term, $d_1 = 1^{st}$ term of the 1^{st} differences, and $d_2 = 2^{nd}$ difference

Now let us consider the sequence: 3;8;15;24;35;...

$$a = 3; d_1 = 5; d_2 = 2$$

Substituting these values into formula (*) above gives the following result:

$$\therefore T_n = 3 + (n-1)5 + \frac{1}{2}(n-1)(n-2)2 = 3 + 5n - 5 + n^2 - 3n + 2 = 2n + n^2$$

This method involves use of formula which is not in the current formula sheet used in Grade 12 mathematics examinations. Learners are therefore expected to learn the formula by heart. In addition, the method involves removing brackets, working with fractions and manipulating algebraic terms by grouping, adding and subtracting where applicable.

Strategy number 2

The general term of a quadratic sequence (n. d)

Retrieved June 27, 2011, from <http://www.MATHHELPER.CO.UK>

The general term of the quadratic sequence can also be obtained using the method of the residue. The procedure is as follows:

Step 1: Halve the second difference to get the term in n^2 . That is the coefficient of n^2 is half the second difference.

Step 2: Substitute $n=1;2;3;4;...$ into an^2 to generate terms to be subtracted from the original sequence.

Step 3: Write out the original sequence above the terms generated from an^2 .

Step 4: Subtract the terms of an^2 from the original sequence to get the residue.

Step 5: The residue will either be constant or a linear sequence. If it is linear, then work out its formula by using: $T_n = a + (n-1)d$

Step 6: Finally add an^2 to the formula for the residue and this will be the formula for the original sequence.

Now applying these steps to the sequence 3;8;15;24;35;... gives the following results:

Step 1: $2 \div 2 = 1$.So the 1^{st} term of the general formula of the sequence is $1.n^2$

Step 2: Now substitute $n = 1;2;3;4;5;\dots$ into $1.n^2$ to get the terms that must be subtracted from the original terms in order to get the residue. In this case, we obtain
 $1;4;9;16;25;\dots$

Step 3 and 4: We write out the original sequence and the terms obtained in Step 2 and then subtract to obtain the following results:

Sequence	3	8	15	24	35
n^2	1	4	9	16	25
residue	2	4	6	8	10

Step 5: The residues $2;4;6;8;10;\dots$ form a linear sequence.

The formula of this linear sequence is: $T_n = a + (n - 1)d = 2 + (n - 1)2 = 2 + 2n - 2 = 2n$

Step 6: Therefore the overall formula for the quadratic sequence is: $T_n = n^2 + 2n$ as previously obtained.

Here, learners are expected to be able to square numbers correctly and subtract correctly. Learners should also be able to identify and apply the formula for the general term of a linear sequence from the formula sheet. The method relies heavily on learners' ability to find the term in n^2 . Everything else will follow from this result.

Strategy number 3

(Adams, Blyth & Williams, 2010)

Suppose we have an arbitrary quadratic sequence $T_n = an^2 + bn + c$, then the differences will look like this:

$n = 1$		$n = 2$		$n = 3$
$a + b + c$		$4a + 2b + c$		$9a + 3b + c$
	$3a + b$		$5a + b$	
		$2a$		

Now considering the sequence: $3;8;15;24;35;\dots$, we obtain the following results:

$$a + b + c = 3$$

$$3a + b = 5$$

$$2a = 2$$

Working from the bottom to the top, we have $a = 1, b = 2$ and $c = 0$. Therefore the required formula is $T_n = n^2 + 2n$ as before.

In using this method, learners are expected to be able to correctly find the first and second differences of the given sequence. Then, they have to know that $2a =$ the constant second difference, $3a + b =$ the first term of the sequence of first differences and, $a + b + c =$ the first term of the original sequence. Learners will then work from the bottom to the top (that is, finding a first, then b , then c).

Strategy number 4

Quadratic sequences (n. d). Retrieved June 27, 2011 from <http://www.cbv.ns.ca/mathhelp/quadratic1.htm>)

The general form of a quadratic sequence is $T_n = an^2 + bn + c$. Using the table method with $n = 4, n = 5$ and $n = 6$, we obtain the following results:

$n = 4$		$n = 5$		$n = 6$
$16a + 4b + c$		$25a + 5b + c$		$36a + 6b + c$
	$9a + b$		$11a + b$	
		$2a$		

We discover from the table above and the one in strategy number 3 that the second difference remains constant. That is, the second difference is always equal to $2a$.

Applying this to the sequence: 3;8;15;24;35;... gives the following results:

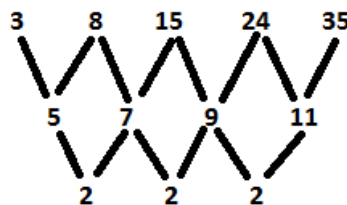

$$2a = 2 \Rightarrow a = 1$$

$$T_n = 1.n^2 + bn + c...(*)$$

Since $T_1 = 3$ and $T_2 = 8$, we can make two ordered pairs of the form $(n; T_n)$, that is $(1;3)$ and $(2;8)$. Substituting these points into equation (*) gives the following results:

$$\begin{aligned} 3 &= 1(1)^2 + b + c \\ 2 &= b + c \dots (1) \\ 8 &= 1(2)^2 + b(2) + c \\ 4 &= 2b + c \dots (2) \end{aligned}$$

Now solving equation (1) and equation (2) simultaneously gives: $b = 2$ and $c = 0$.

Therefore the formula for the general term of the sequence 3;8;15;24;35;... is $T_n = n^2 + 2n$ as required.

Here, learners are expected to be able to correctly find the constant second difference. Learners should know that the second constant difference $d_2 = 2a$. This helps them find the value of a . Substituting the value of a in $T_n = an^2 + bn + c$ reduces the number of missing values in the general formula to two. Learners are then expected to use knowledge of ordered pairs to formulate and solve simultaneous linear equations to obtain the values of b and c . The last piece of knowledge required from them will be to correctly substitute the values of, b and c back into the general formula to complete the solution.

3.3 Factorising third degree polynomials

A third degree (cubic) polynomial has the form $ax^3 + bx^2 + cx + d$ where a, b, c and d are known coefficients and $a \neq 0$. When factorising cubic polynomials, we first spot one factor by inspection and then use any of the following strategies:

- Equating coefficients
- Long division
- Synthetic division

Worked example:

Question: Factorise $x^3 - 6x^2 + 11x - 6$ completely given that $(x - 1)$ is a factor

Strategy number 1: Equating coefficients

Solution: Let

$$\begin{aligned} x^3 - 6x^2 + 11x - 6 &= (x - 1)(ax^2 + bx + c) \\ &= ax^3 + bx^2 + cx - ax^2 - bx - c \\ &= ax^3 + x^2(b - a) + x(c - b) - c \end{aligned}$$

Equating coefficients of x^3 : $a = 1$

Equating coefficients of x^2 : $b - a = -6$

But $a = 1, \therefore b = -5$

Equating coefficients of x : $c - b = 11$

But $b = -5, \therefore c = 6$

$$\therefore x^3 - 6x^2 + 11x - 6 = (x-1)(x^2 - 5x + 6) = (x-1)(x-3)(x-2)$$

Learners' success in using this method depends on their ability to simplify brackets and group like terms. Learners need to understand what is meant by the term *coefficient*. The method also requires learners to formulate and solve linear equations.

Strategy number 2: Long division

$$\begin{array}{r} x^2 - 5x + 6 \\ (x-1) \overline{\sqrt{x^3 - 6x^2 + 11x - 6}} \\ \underline{-(x^3 - x^2)} \\ -5x^2 + 11x \\ \underline{-(-5x^2 + 5x)} \\ 6x - 6 \\ \underline{-(6x - 6)} \\ 0 \end{array}$$

$$\therefore x^3 - 6x^2 + 11x - 6 = (x-1)(x^2 - 5x + 6) = (x-1)(x-3)(x-2)$$

Success in using this method depends on learners' knowledge of laws of exponents, particularly those relating to multiplication and division. Learners should also be able to subtract algebraic terms and work with brackets.

Strategy number 3: Synthetic division

Given that $(x-1)$ is a factor of $x^3 - 6x^2 + 11x - 6$, it follows that $x = 1$ is a root of the polynomial.

$$\begin{array}{r|rrrr} 1 & 1 & -6 & 11 & -6 \\ & \downarrow & & & \\ \hline & 1 & -5 & 6 & 0 \\ \hline & \mathbf{a} & \mathbf{b} & \mathbf{c} & \end{array}$$

$$\therefore x^3 - 6x^2 + 11x - 6 = (x - 1)(x^2 - 5x + 6) = (x - 1)(x - 3)(x - 2)$$

This strategy only requires learners to understand the synthetic division algorithm, which involves multiplying and adding integers repeatedly.

3.4 Determining the centre and radius of a circle

Strategy number 1: Using formulae

Suppose we have an arbitrary equation of a circle $x^2 + y^2 + 2gx + 2fy + c = 0$ then the centre of the circle is:

$$\begin{aligned} (-g; -f) &= \left[-\frac{1}{2}(2g); -\frac{1}{2}(2f) \right] \\ &= \left(-\frac{1}{2} \text{coefficient of } x; -\frac{1}{2} \text{coefficient of } y \right) \end{aligned}$$

$$\text{The radius of the circle is: } r = \sqrt{g^2 + f^2 - c}$$

(Gonin, Du Plessis, Kuyler, De Jager, Hendricks, Hawkins, Slabber, Archer, 1987)

This strategy seems short but relies heavily on learners' ability to memorise the formulae for the centre and radius of a circle since these formulae are not in the formula sheet used in Grade 12 mathematics examinations. Understanding the meaning of the term coefficient is also important here since substituting a wrong coefficient leads to a wrong solution. The formula for finding the radius uses the results obtained for the centre. The implication here is that if a learner gets a wrong answer for the centre then the result for the radius will also be incorrect. However, consistency and accuracy (CA) will be applied.

Worked example:

Question: Determine the centre and the radius of the circle with equation

$$x^2 + y^2 + 8x + 4y - 38 = 0 \quad (\text{DoE, 2010, p. 7})$$

Solution:

$$\text{The centre of the circle} = \left(-\frac{1}{2}(8); -\frac{1}{2}(4) \right) = (-4; -2)$$

$$\text{The radius} = \sqrt{(-4)^2 + (-2)^2 - (-38)} = \sqrt{58}$$

Strategy number 2: Completing the square

By completing the square, we can express the equation of the circle in the form

$(x - a)^2 + (y - b)^2 = r^2$ where $(a; b)$ is the centre and r is the radius.

Solution:

$$x^2 + y^2 + 8x + 4y - 38 = 0$$

$$x^2 + 8x + 16 + y^2 + 4y + 4 = 38 + 16 + 4$$

$$(x + 4)^2 + (y + 2)^2 = 58$$

$$\therefore \text{Centre} = (-4; -2), \text{radius} = \sqrt{58}$$

Here, learners are expected to be able to follow the procedures for completing the square. That is, dividing +8 and +4 by 2, squaring the results and, adding the squares on both sides of the equation. Learners are also expected to be able to factorise quadratic expressions, that is $x^2 + 8x + 16 = (x + 4)^2$ and $y^2 + 4y + 4 = (y + 2)^2$. In addition, learners should then be able to rewrite $(x + 4)^2$ as $(x - (-4))^2$ and $(y + 2)^2$ as $(y - (-2))^2$ following the general form of an equation of a circle given in the formula sheet. Failure to do this results in learners writing (4;2) for the centre instead of (-4;-2). Learners should also be able to match their result after completing the square with the general form of the equation of a circle given in the formula sheet in order to see that $r^2 = 58$, then, they solve for r to get $r = \sqrt{58}$

3.5 Finding the angle between two lines

Strategy number 1: Using formula

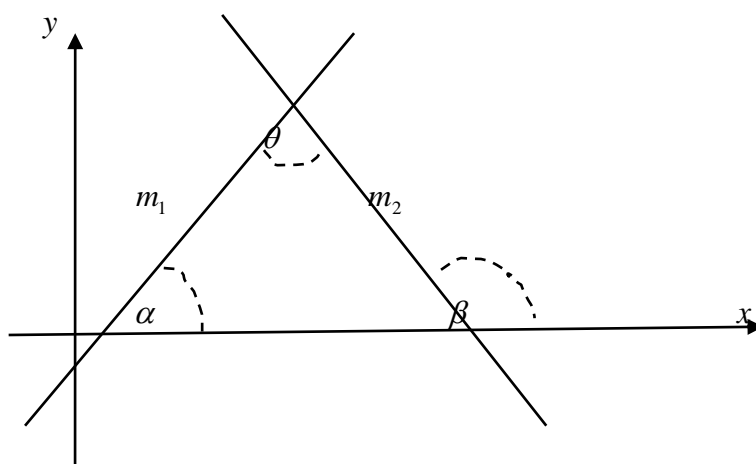

It follows from the figure that $\beta = \alpha + \theta$ hence $\theta = \beta - \alpha$

$$\Rightarrow \tan \theta = \tan(\beta - \alpha) = \frac{\tan \beta - \tan \alpha}{1 + \tan \beta \tan \alpha} = \frac{m_2 - m_1}{1 + m_2 m_1}$$

(Gonin et al., 1987)

Worked example:

Question: $A(-5;-3)$, $B(7;2)$ and $C(3;9)$ are the vertices of $\triangle ABC$ in the Cartesian plane.

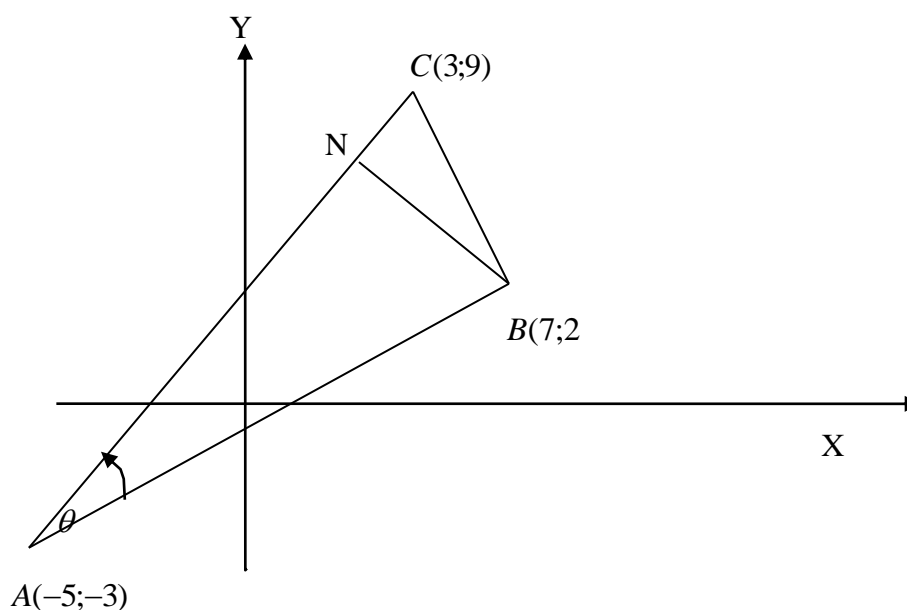

Calculate the measure of θ correct to 1 decimal place. (DoE, 2008a, p.3)

Solution:

$$\tan \theta = \frac{m_2 - m_1}{1 + m_2 m_1}$$

$$m_2 = m_{AC} = \frac{y_C - y_A}{x_C - x_A} = \frac{9 - (-3)}{3 - (-5)} = \frac{12}{8} = \frac{3}{2}$$

$$m_1 = m_{AB} = \frac{y_B - y_A}{x_B - x_A} = \frac{2 - (-3)}{7 - (-5)} = \frac{5}{12}$$

$$\tan \theta = \frac{m_2 - m_1}{1 + m_2 m_1} = \frac{\frac{3}{2} - \frac{5}{12}}{1 + \left(\frac{3}{2}\right)\left(\frac{5}{12}\right)} = \frac{2}{3}$$

$$\therefore \theta = \tan^{-1}\left(\frac{2}{3}\right) = 33.7^\circ$$

When using this method, learners are expected to be able to correctly find the gradients of the two lines that intersect at the required angle. Learners should also learn the formula by heart because it is not in the formula sheet. Knowledge of how to use their calculators to find θ is also required.

Strategy number 2: Using the theorem that the exterior angle of a triangle equals the sum of the two interior opposite angles

Solution:

Let β be the inclination of AC and α be the inclination of AB .

$$m_{AC} = \frac{3}{2}$$

$$\therefore \tan \beta = \frac{3}{2} \Rightarrow \beta = \tan^{-1}\left(\frac{3}{2}\right) = 56.30993247^\circ$$

$$m_{AB} = \frac{5}{12} \therefore \tan \alpha = \frac{5}{12} \Rightarrow \alpha = \tan^{-1}\left(\frac{5}{12}\right) = 22.61986495^\circ$$

$$\therefore \theta = \beta - \alpha = 56.30993247^\circ - 22.61986495^\circ = 33.7^\circ(1d.p)$$

Here, learners are expected to know the theorem that the exterior angle of a triangle equals the sum of the two opposite interior angles. That is, if we let β be the exterior angle and, θ and α to be the two opposite interior angles, then $\beta = \theta + \alpha$. This theorem can therefore be used to find any of the three angles (that is, β, θ or α). Learners should know that they must not round off until they get the final answer to avoid increasing the error margin.

Strategy number 3: Cosine Rule

Solution:

$$AC^2 = (9 - (-3))^2 + (3 - (-5))^2 = 208$$

$$AB^2 = (7 - (-5))^2 + (2 - (-3))^2 = 169$$

$$BC^2 = (9 - 2)^2 + (3 - 7)^2 = 65$$

Using the cosine rule:

$$BC^2 = AC^2 + AB^2 - 2(AB)(AC)\cos A$$

$$\Rightarrow \cos A = \frac{AC^2 + AB^2 - BC^2}{2(AC)(AB)} = \frac{208 + 169 - 65}{2(\sqrt{208})(\sqrt{169})} = 0.8320502943$$

$$A = \cos^{-1}(0.8320502943) = 33.7^\circ$$

This method depends on learners' ability to use the distance formula provided in the formula sheet. Although the cosine rule is there in the formula sheet, learners are expected to be able to adjust the formula, depending on the particular problem they are working with. Knowledge of change of subject is also important here.

The next chapter describes how the study was conducted.

CHAPTER FOUR

RESEARCH DESIGN AND METHODOLOGY

4.1 Introduction

This chapter describes how the study was conducted. It presents the research design, the research population and sample, data collection techniques, procedures and analyses methods. It also discusses issues of reliability and validity as well as ethical considerations involved in the study. The study adopts the quantitative research approach.

4.2 Research Design

This study uses the *repeated-measures design*, a stalwart of scientific research (Shuttleworth, 2009). A repeated-measures research design is defined as: “a design in which a single sample of subjects is used for each treatment condition” (University of New England, 2000). It involves each participant being tested under all levels of the independent variable (Shuttleworth, 2009). Thus, each condition of the experiment includes the same group of participants and each person is tested on more than one occasion. A repeated-measures design is sometimes known as *within-subjects* design because we are making a comparison within one group of people (Research Methods in Psychology, 2007). The repeated-measures design was chosen for this study because it requires fewer participants and resources. It allows statistical inference to be made with fewer subjects. According to Minke (1997), the primary strengths of the repeated-measures design are that it makes an experiment more efficient, maintains low variability and keeps the validity of the results higher while allowing for a smaller than usual subject sample to be used. Also, each participant acts as their own control, reducing chances of confounding variables such as age, gender and lifestyle, skewing the results (Shuttleworth, 2009). It also means that fewer participants are required to achieve the same degree of statistical power (Research Methods in Psychology, 2007). The design also allows the researcher to monitor the effect of each treatment upon individuals more easily.

However, problems can arise when using a repeated-measures design. The design is prone to carryover effects, where the first test adversely influences the outcome of subsequent tests (Research Methods in Psychology, 2007). Examples of this are fatigue and practice effects. As participants are repeatedly tested, they may get better with practice, or become

tired or bored (Shuttleworth 2009). This could adversely affect their performance on the last study. To minimise the possibility of carry-over effects, the researcher allowed a ‘wash-out’ time of five days between the periods in which participants wrote the tests as recommended by Conaway (1999).

4.3 The population

The population for this study is all low-performing Grade 12 learners in Capricorn District of Limpopo Province.

4.4 Sampling

Being a mathematics educator at one of the secondary schools in Capricorn District of Limpopo, the researcher’s own low-performing learners were a convenient sample for this study. A convenient sample of twenty-five Grade 12 learners participated in this study. According to Tabachnick and Fidell (2006), the minimum sample size for detecting treatment effects in a repeated-measures research design is 10+ the number of dependent variables. A sample size of twenty-five participants was therefore adequate for the research design adopted in this study. Convenience sampling was used because it is inexpensive and participants are readily available (Castillo, 2009). Also, Ferrance (2000) asserts that research studies conducted by educators themselves, in a familiar school setting, with their own learners, would help solve real problems experienced in schools and thus contribute towards improving teaching and learner achievement.

4.5 Data collection instruments

To answer the research questions and establish the effect of the independent variable (solution strategy) on the dependent variable (mathematics achievement), four achievement tests were used in this study. The first test was intended to measure learners’ achievement in determining the general term of a quadratic sequence. The second test measured learners’ achievement in factorising third degree polynomials. The third test measured learners’ achievement in finding the centre and radius of a circle and the fourth and last test, measured learners’ achievement in finding the angle between two straight lines.

The test items were generated based on the topics, aspects and depth of knowledge specified in the National Curriculum Statement, Mathematics Grades 10-12 (DoE, 2008b).

4.6 Development of the instruments (tests and validation forms)

Each test comprised of ten related items that sought to measure learners' mathematical knowledge and skills in the content domain of the study. The test questions were 'open ended' to allow learners to explore different solution strategies rather than confine them to one-way methods of the textbook. The tests were then given to six mathematics educators who had at least five years of mathematics teaching experience to evaluate the appropriateness of the test items (*see Appendix A2*). The tests were then pilot tested on a sample of ten learners from another school in order to detect and correct any errors and ambiguities in the instruments before the actual fieldwork. The final tests instruments are attached (*see Appendix A1*).

4.7 Data collection procedures

The data for this study were collected in four sessions:

Session One: In Session One of the study, the researcher sought to find out which solution strategies for determining the general term of a quadratic sequence would enhance learning and achievement for low-performing Grade 12 learners. Learners were exposed to four different solution strategies for determining the general term of the quadratic sequence. Learners were given time to practise, discuss and reflect on each of the methods used. A 10-item researcher-developed test was then administered to assess individual learners' ability to use each of the four strategies. Learners wrote the test four times, using a different solution strategy each time, in their own order of preference. By the end of the session, each learner had used all the four solution strategies, resulting in four different scores being recorded for each participant. The duration of the test was 1 hour and test was marked out of 50. The scripts were marked by the researcher and moderated by a colleague. Marks were converted to percentages for convenience of statistical interpretations.

Session Two: In the second session, the researcher sought to find out which solution strategies for factorising third degree polynomials would enhance learning and achievement with the participants. The twenty-five participants were exposed to three different solution strategies for factorising third degree polynomials: by equating coefficients, by long division and by synthetic division. Participants were given time to

explore, discuss and reflect on each strategy used. A 10-item researcher-developed test was then administered to assess learners' ability with each strategy. The total possible marks for the test were 50 and the duration of the test was one hour. Because there were three alternative solution strategies here, participants wrote the test three times, sticking to one chosen strategy each time. This generated three scores for each participant. The test scripts were marked by the researcher and moderated by a colleague. The scores obtained were converted to percentages for convenience of statistical interpretations.

Session Three: In the third session of the study, the researcher wanted to find out which solution strategies for determining the centre and radius of a circle made learners to learn and achieve better in the test. There were only two different solution strategies here; one that used formula and the other one that required participants to complete the square. The procedures for collecting the data were as described in Session One and Session Two except that the test used here was marked out of 60 and the duration of the test was increased to one hour fifteen minutes. The scores were converted to percentages for convenience of statistical interpretations.

Session Four: In this session, the researcher wanted to find out which solution strategies for calculating the angle between two lines made learners to learn and achieve better results in the test. The data collection procedures in this session were as described in Session Two, with three different solution strategies. However, eight participants decided to withdraw their participation here. So the sample size was reduced to seventeen. Nevertheless, the remaining sample size still satisfied the '10+ the number of levels of the repeated factor' as recommended by Tabachnick and Fidell (2006) for repeated-measures designs.

4.8 Reliability and validity of the instruments

4.8.1 Reliability of the test instruments

The reliability of the achievement tests was established by calculating Kuder-Richardson 20 (*KR20*) reliability estimates, using data from a pilot study involving ten volunteer Grade 12 learners from another school. The Kuder-Richardson method was chosen because it is less time consuming (Badget & Christmann, 2008). The method "requires only the administration of a single test and does away with any bias that might arise when a test is split any one of a number of ways as in the split-half method" (Lenke, Wellens &

Oswald ,1977, p. 3). The results of the Kuder-Richardson 20 calculations are shown below (see Table 6).

Table 6: Kuder-Richardson reliability estimates (See Appendix B1 for the calculations)

	KR20 Value
Assessment Test One	0.87
Assessment Test Two	0.71
Assessment Test Three	0.91
Assessment Test Four	0.71

According to Gay, Mill and Airasian (2011), a test is acceptable for use if its reliability coefficient exceeds 0.60. Hence, the results in the table above indicate that the four tests were reliable.

4.8.2 Validity of the test instruments

The validity of an instrument is the degree to which it measures what it is intended to measure (Joppe, 2000). To check content validity of the test items for this study, tests were given to experts in the field of mathematics education to validate them. This panel comprised of one subject advisor for Mathematics, one Head of Department (Mathematics) and four mathematics educators who were teaching Grade 12 at the time the data was collected. A purposive sampling technique was used here in selecting the experts. The experts were asked to independently judge if the test items reflected the content domain of the study. According to Gronlund (1998), this is just a matter of determining whether the tasks represent the larger domain of tasks it is supposed to represent. The researcher then calculated the content validity ratios of each test item using the following formula:

$$CVR_i = \frac{\left[n_e - \left(\frac{N}{2} \right) \right]}{\left(\frac{N}{2} \right)}$$

CVR_i is the content validity ratio for the i^{th} term.

n_e is the number of judges rating the item as ‘essential’ to the domain and N is the total number of judges in the panel (Lawshe, 1975).

The mean of the test items was computed in order to find the content validity index (*CVI*) of the test. A *CVI* value of +1.00 was obtained in each of the 4 tests used in this study (*See Appendix B2*). This indicated that there was complete agreement among the judges that the items of the 4 tests reflected the content domain of study (Wynd, Schmidt & Schaefer, 2003).

4.9 Data analysis and interpretation

To determine the effect of the independent variable (solution strategy) on the dependent variable (mathematics achievement), a one-way repeated-measures ANOVA was performed in Session One, Session Two and Session Four, where there were more than two levels of the independent variable (DeCoster, 2004). Pallant (2005) states that one-way repeated-measures ANOVA is most suitable for comparing participants' responses to different questions measured using the same scale (likert scale). The Wilcoxon Signed-Ranks Test was used in Session Three because there were only two sets of data for analysis and the data violated the assumption of normality (Laerd, 2012). Another reason for using the non-parametric data analysis technique (Wilcoxon Signed Ranks Test) was the sample size (25).

According to DeCoster (2004), repeated-measures analysis is more powerful than multivariate analysis. However, it assumes that correlations between the repeated-measures factor levels are all the same. This assumption is called the assumption of sphericity. The researcher performed Mauchly's Test on the data collected in Session One, Session Two and Session Three to check if the assumption of sphericity had not been violated. Where the result of the Mauchly test was significant ($p < .05$), it was concluded that sphericity had been violated. To account for the violation of sphericity, the degrees of freedom of the ANOVA F-test ratio were adjusted using the Huynh-Feldt epsilon value. The Huynh-Feldt correction was used because ϵ was greater than .75 (See Field, 2008, p. 8).

To determine if there was a statistically significant difference in learners' average percentage scores due to the effect of the different strategies used, the researcher looked at the significance value in the SPSS output for Repeated-measures ANOVA. Where the significance value was greater than .05, it was concluded that there was no statistically

significant difference between the mean scores of the learners. The differences between the means were considered minimal, probably due to chance. Where the significance value was less than .05, it was concluded that there was a statistically significant difference between the mean scores of the learners due to manipulation of the independent variable. The Bonferroni pair wise comparison was then performed to determine exactly where the differences between the mean scores lied.

The Wilcoxon Signed-Ranks Test (a non-parametric test equivalent to the paired-samples t-test) was used to analyse data in Session Four. The test served the same purpose as the repeated-measures ANOVA. The Wilcoxon Signed-Ranks Test was used because there were only two sets of data for analysis and the data had violated the assumption of normality. The SPSS output for the Wilcoxon Signed-Ranks Test had a p -value less than .05. This was significant and implied that there was a statistically significant difference in the scores of the learners due to the effect of the solution strategies used. By looking at the mean ranks in the Ranks Table, the researcher could ascertain the solution strategy which made learners to learn and achieve better scores in the test.

4.10 Ethical considerations

According to SERA (2005, p. 3), “Since education has the fundamental ethical purpose of improving the lives of individuals, communities and society, ethical considerations must lie at the core of educational research.” Whilst principles of research ethics may differ across countries, it is generally agreed that all forms of research should aim to (a) do good (principle of beneficence) and (b) do no harm (principle of non-maleficence) (SERA, 2005).

The practical implication of these ethical principles is that a researcher needs to: minimise the risk of harm to participants; obtain informed consent from the research participants; protect their anonymity and confidentiality; avoid deceptive practices; and give participants the right to withdraw at any stage in the research process (Laerd, 2010).

4.10.1 Minimising the risk of harm

This study was unlikely to cause distress and harm to participants since it involved the study of normal educational practices and curricula, and was conducted in the natural educational setting. The study did not interfere with normal teaching as it was conducted

after school hours, on Saturdays and during school holidays in consultation with the participants.

4.10.2 Obtaining informed consent

Although this study made use of a conveniently chosen sample of participants, participation was based on the principle of informed consent. Informed consent implies that participants understood that they were taking part in research and knew what was required of them (Laerd, 2010). To obtain informed consent, the researcher designed a consent form for the participants (*See Appendix C*). The consent form included among others, information on the aims of the study, the processes involved as well as the associated demands and inconveniences participants might face. In cases where the participant's age limited the extent to which they understood or agreed voluntarily to take part in the research, the researcher sought the approval of the parents of the participants as recommended by BERA (2004).

The researcher made known to participants, how the information gathered would be used and to whom the results would be reported. Participants were made aware of any changes in the programme of research and that they were free to withdraw their participation at any time or stage of the research for any or no reason. Participants who chose to withdraw from the research process were not coerced in any way to stop them from withdrawing.

4.10.3 Anonymity and confidentiality

The researcher made sure that the data collected from this study is stored safely and treated confidentially at all stages in the research process. In sampling, data collection and writing up the research report, the researcher used proxies instead of participants' names in order to ensure that the identity of the participant is not discernible to any other party. The researcher informed participants that the data collected in this study is only accessible to the researcher's supervisors. This was made known to the research subjects in the Consent Form.

4.10.4 Provision of debriefing and additional information

According to SERA (2005), all research participants have the right to receive feedback on the outcomes of the research. As such, the researcher would debrief participants at the

conclusion of the research and provide them with a copy of the research report (SERA (2005).

4.11 Pilot study

According to Brownlee, Pathmanathan and Varkevisser (2003), a pilot study is the process of conducting a small-scale trial run of the entire research procedure with a small sample, for purposes of identifying potential problems in the proposed study. In this study the researcher conducted a pilot study with a group of ten volunteer participants in another school. This enabled the researcher to evaluate the validity and reliability of the data collection tools, the appropriateness of statistical procedures for data analysis, the reactions of the research participants to the research procedures, and the accuracy of the scheduling of the various research activities (Brownlee, Pathmanathan & Varkevisser, 2003). The pilot study helped the researcher to detect and correct mistakes in the research tools before the actual fieldwork.

4.12 Operational definitions of concepts

The following are definitions of concepts as used in the present study:

Null hypothesis: In the context of this study, it is the statement that there is no statistical difference in the sample means. It states that all means are equal.

P – Value: is a measure of how much evidence is there against the null hypothesis. The general rule is that a p value less than .05 is evidence against the null hypothesis while a p value greater than .05 would mean little evidence against the null hypothesis.

Hypothesis: a statement that expresses the probable relationship between variables

Post-hoc test: is a test used in conjunction with ANOVA to determine which specific group pair is statistically different from each other (Silicon Genetics, 2003).

Mauchly's Test: is used to test the hypothesis that the variances of differences between conditions are equal. In other words, it checks if the data satisfies the condition of sphericity (Field, 2008).

Degrees of freedom: is the number of independent units of information in a sample used in the calculation of a statistic (Meniscus Educational Institute, 2011)

SPSS (Statistical Package for Social Sciences): is a computer program that runs on PCs and used by researchers for statistical analysis.

The next chapter presents the results of the study.

CHAPTER FIVE

RESULTS, ANALYSIS AND INTERPRETATION

5.0 Introduction

This chapter presents the results obtained and the analyses conducted to answer the research questions. The purpose of the study was to explore solution strategies that can enhance the achievement of low-performing Grade 12 learners in the following mathematical aspects: determining the general term of a quadratic sequence, factorising third degree polynomials, determining the centre and radius of a circle, and finding the angle between two straight lines. Hence, the study was carried out in four sessions. Four researcher-developed achievement tests were used to collect data on learners' mathematics achievement. The use of tests to measure learning success was influenced by the behaviourist assumption that learning can be objectively measured (Mergel, 1998). Quantitative data analyses techniques were used to analyse data. Twenty-five Grade 12 learners took part in the study. However, not all of them participated in all sessions of the study. Eight learners withdrew their participation in the last session, reducing the sample size to seventeen.

The findings of the study are presented in the order of the research sessions and questions.

5.1 Session one results

The first research question was: Which solution strategies can enhance the achievement of low-performing Grade 12 learners in determining the general term of a quadratic sequence?

Table 7 shows the achievement test scores of the learners after using four different solution strategies.

Table 7: Learners' percentage scores per strategy

Learners	Scores			
	S ₁	S ₂	S ₃	S ₄
L ₁	94	98	96	78
L ₂	90	90	92	94
L ₃	98	96	100	78
L ₄	50	70	88	20
L ₅	88	92	100	86
L ₆	100	34	86	100
L ₇	78	96	100	64
L ₈	82	68	90	90
L ₉	58	54	68	48
L ₁₀	100	72	92	52
L ₁₁	54	80	68	40
L ₁₂	60	14	32	12
L ₁₃	94	68	82	44
L ₁₄	60	76	98	86
L ₁₅	90	100	92	44
L ₁₆	72	92	88	56
L ₁₇	52	40	80	2
L ₁₈	94	100	100	80
L ₁₉	92	100	88	84
L ₂₀	80	74	90	68
L ₂₁	76	64	70	54
L ₂₂	92	90	100	88
L ₂₃	70	60	76	6
L ₂₄	76	50	84	6
L ₂₅	78	64	100	34

A one-way repeated-measures analysis of variance (RM ANOVA) in SPSS was performed on the data to evaluate the following hypotheses:

$H_0 : \bar{x}_1 = \bar{x}_2 = \bar{x}_3 = \bar{x}_4$ (There are no significant differences among the mean scores)

$H_A : \bar{x}_i \neq \bar{x}_k$ some i, k (At least one of the mean scores is significantly different from the others)

5.1.1 Results of repeated-measures ANOVA

5.1.1.1 Descriptive statistics

Table 8 shows the initial output from the repeated-measures ANOVA analysis.

Table 8: Descriptive statistics

Descriptive Statistics			
	Mean	Std. Deviation	N
S ₁	79.12	15.94	25
S ₂	73.68	22.90	25
S ₃	86.40	15.20	25
S ₄	56.56	30.38	25

Table 8 contains the number of cases available for analysis per each level of the independent variable. Since this number (25) is greater than 10 + the number of levels in the repeated factor, the minimum sample size required for repeated-measures ANOVA is satisfied (Tabachnick & Fidell, 2006).

5.1.1.2 Sphericity

Sphericity is the condition where the variances of the differences between all combinations of the repeated-measures levels are equal. Violation of this assumption causes the repeated-measures ANOVA test to increase Type I error rate (Laerd, 2012). The SPSS computed significance value for the ANOVA test would be too low and thus we risk rejecting the null hypothesis when actually we should not.

Table 9: Mauchly's Test of Sphericity

Mauchly's Test of Sphericity^a							
Measure: MEASURE_1							
Within Subjects Effect	Mauchly's W	Approx. Chi-Square	df	Sig.	Epsilon ^b		
					Greenhouse-Geisser	Huynh-Feldt	Lower-bound
Strategy	.563	13.064	5	.023*	.761	.845	.333

The Mauchly's Test of Sphericity tests the null hypothesis that the variances of the differences between levels of the repeated-measures factor are equal. The above test indicated that the assumption of sphericity had been violated because the significance

value $(\chi^2(5) = 13.1, p = .023)$ is less than the criterion value of .05. To account for the violation of sphericity, the degrees of freedom of the F-test were corrected using Huynh-Feldt epsilon value ($\epsilon = .845$) The Huynh-Feldt correction was used because ϵ was greater than .75 (see Field, 2008, p. 8).

Table 10 shows the main results of the RM ANOVA test, with the corrected F values.

5.1.1.3 ANOVA F-test

Table 10 shows the repeated-measures ANOVA. The Huynh-Feldt corrected results indicate that there was a statistically significant main effect of the independent variable (strategy) on the dependent variable (learners' mathematics scores) ($F(2.54, 60.8) = 16.74, p = .000$) Therefore the null hypothesis that the average scores for the four solution strategies are the same is rejected and we conclude that at least one of the means (\bar{x}_i) is significantly different.

Table 10: ANOVA F-test

Tests of Within-Subjects Effects						
Measure: MEASURE_1						
Source		Type III Sum of Squares	df	Mean Square	F	Sig.
Strategy	Sphericity Assumed	12105.40	3	4035.133	16.744	.000
	Greenhouse-Geisser	12105.40	2.282	5304.767	16.744	.000
	Huynh-Feldt	12105.40	2.535	4775.786	16.744	.000*
	Lower-bound	12105.40	1.000	12105.400	16.744	.000
Error (strategy)	Sphericity Assumed	17351.60	72	240.994		
	Greenhouse-Geisser	17351.60	54.768	316.822		
	Huynh-Feldt	17351.60	60.834	285.229		
	Lower-bound	17351.60	24.000	722.983		

Since a statistically significant result was found the Bonferroni post hoc test was conducted to compare the mean scores of each strategy with every other strategy in order to determine where exactly the significant differences exist.

5.1.1.4 Bonferroni Pair wise Comparisons

Table 11: Bonferroni pair wise comparisons

Pair-wise Comparisons						
Measure: MEASURE_1						
(I) Strategy	(J) Strategy	Mean Difference (I-J)	Std. Error	Sig. ^b	95% Confidence Interval for Difference ^b	
					Lower Bound	Upper Bound
1	2	5.44	4.281	1.000	-6.868	17.748
	3	-7.28	3.064	.155	-16.088	1.528
	4	22.56	4.813	.001*	8.722	36.398
2	1	-5.44	4.281	1.000	-17.748	6.868
	3	-12.72	3.225	.004*	-21.991	-3.449
	4	17.12	5.315	.022*	1.837	32.403
3	1	7.28	3.064	.155	-1.528	16.088
	2	12.72	3.225	.004*	3.449	21.991
	4	29.84	5.113	.000*	15.139	44.541
	1	-22.56	4.813	.001*	-36.398	-8.722
	2	-17.12	5.315	.022*	-32.403	-1.837
	3	-29.84	5.113	.000*	-44.541	-15.139
*. The mean difference is significant at the .05 level.						
b. Adjustment for multiple comparisons: Bonferroni.						

From the significance values of each pair wise comparison, we obtain the following:

The difference between Strategy number 1 ($\bar{x} = 79.12, s.d = 15.94$) and Strategy number 2 ($\bar{x} = 73.68, s.d = 22.90$) is not significant. The difference (5.44) had a probability ($p = 1.000$) far greater than alpha .05. The null hypothesis that these two means were equal was not rejected. Thus, the difference between the two means would be considered a minimal difference.

The difference between Strategy number 1 ($\bar{x} = 79.12, s.d = 15.94$) and Strategy number 3 ($\bar{x} = 86.40, s.d = 15.20$) had a probability ($p = .155$) greater than alpha .05. This also implies that the difference is not significant. Thus, the null hypothesis that these two means were equal was not rejected.

The difference between Strategy number 1 ($\bar{x} = 79.12, s.d = 15.94$) and Strategy number 4 ($\bar{x} = 56.56, s.d = 30.38$) is statistically significant. The difference (22.56) had a probability ($p = .001$) less than alpha .05 . Hence, the null hypothesis that these two means were equal was rejected.

The difference between Strategy number 2 ($\bar{x} = 73.68, s.d = 22.90$) and Strategy number 3 ($\bar{x} = 86.40, s.d = 15.20$) had a probability ($p = .004$) less than alpha .05 meaning that the difference between the two means is statistically significant. Hence, the null hypothesis that these two means were equal was rejected.

The difference between Strategy number 2 ($\bar{x} = 73.68, s.d = 22.90$) and Strategy number 4 ($\bar{x} = 56.56, s.d = 30.38$) is statistically significant. The difference (17.12) had a probability ($p = .022$) less than alpha.05 . The null hypothesis that these two means were equal was rejected.

The difference between Strategy number 3 ($\bar{x} = 86.40, s.d = 15.20$) and Strategy number 4 ($\bar{x} = 56.56, s.d = 30.38$) is statistically significant. The difference (29.84) had a probability ($p = .000$) far less than alpha.05 . The difference between the two means would be considered a substantial difference. Therefore, the null hypothesis that these two means were equal was rejected.

5.1.1.5 95% confidence intervals of the means

Table 12 shows the 95% confidence intervals of the mean percentage scores of each of the four methods.

Table 12: Confidence intervals of the means

Strategy	Mean	Std. Error	95% Confidence Interval	
			Lower Bound	Upper Bound
1	79.12	3.188	72.54	85.70
2	73.68	4.581	64.23	83.13
3	86.40	3.040	80.13	92.67
4	56.56	6.076	44.02	69.10

The results in Table 12 indicate that if we were to take repeated samples of 25 participants from the population of low-performing Grade 12 learners and subject them to the same conditions; we could be 95% confident that the learners' mean percentage score with Strategy number 1 would lie between 72.54% and 85.70%. We could also be 95% sure that their mean percentage score with Strategy number 2 would lie between 64.23% and 83.13%. We could be 95% confident that the learners' mean percentage score with Strategy number 3 would lie between 80.13% and 92.67%. Lastly, we could as well be 95% sure that the mean percentage score with Strategy number 4 would lie between 44.02% and 69.1%.

Taken together, the findings of Session I of the study suggest that Strategy number 1 and Strategy number 3 made the learners to learn and achieve better scores in determining the general term of a quadratic sequence.

5.2 Session Two results

The second research question was: Which solution strategies can enhance the achievement of low-performing Grade 12 learners in factorising third degree polynomials?

Here, learners used three different solution strategies to factorise third degree polynomials, namely by equating coefficients, by long division and by synthetic division. Table 13 shows the results obtained.

Table 13: Learners' percentage scores per strategy

Learners	Scores		
	S ₁	S ₂	S ₃
L ₁	26	30	42
L ₂	30	2	54
L ₃	22	4	54
L ₄	28	6	32
L ₅	32	4	80
L ₆	84	78	84
L ₇	48	18	46
L ₈	24	6	66
L ₉	66	22	92
L ₁₀	78	62	92
L ₁₁	72	28	82
L ₁₂	82	28	84
L ₁₃	62	18	58
L ₁₄	34	34	88
L ₁₅	32	62	94
L ₁₆	66	20	52
L ₁₇	90	78	92
L ₁₈	54	14	88
L ₁₉	76	16	28
L ₂₀	88	54	80
L ₂₁	26	14	30
L ₂₂	70	66	74
L ₂₃	68	56	50
L ₂₄	38	34	68
L ₂₅	64	40	82

A one-way repeated-measures analysis of variance was performed on the data to evaluate the following hypotheses:

$$H_0 : \bar{x}_1 = \bar{x}_2 = \bar{x}_3$$

$$H_A : \bar{x}_i \neq \bar{x}_k \text{ for some } i, k$$

5.2.1 Results of repeated-measures ANOVA

5.2.1.1 Descriptive statistics

Table 14 shows the initial output from the repeated-measures ANOVA analysis.

Table 14: Descriptive statistics

Descriptive Statistics			
	Mean	Std. Deviation	N
S ₁	54.32	23.03	25
S ₂	31.76	23.91	25
S ₃	67.68	21.41	25

The Descriptive Statistics shows that 25 cases are available for analysis per each level of the independent variable. This is greater than 10 + the number of levels in the repeated factor and hence satisfies the minimum sample size required for repeated-measures ANOVA (Tabachnick and Fidell, 2006).

5.2.1.2 Sphericity

Table 15 shows the results of the Mauchly's Test of Sphericity, which checks if the variances between all combinations of the repeated-measures levels are equal.

Table 15: Mauchly's Test of Sphericity

Mauchly's Test of Sphericity^a							
Measure: MEASURE_1							
Within Subjects Effect	Mauchly's W	Approx. Chi-Square	df	Sig.	Epsilon ^b		
					Greenhouse-Geisser	Huynh-Feldt	Lower-bound
Strategy	.959	.974	2	.615*	.960	1.000	.500

Mauchly's Test of Sphericity indicated that the assumption of sphericity had not been violated ($\chi^2(2) = .974, p = .615$), which is non-significant. Hence, there is no need to adjust the degrees of freedom of the repeated-measures ANOVA F-Test and we are to report the results in the row labelled 'Sphericity Assumed' in the table shown below.

5.2.1.3 ANOVA F-test

Table 16 shows the repeated-measures ANOVA. The results in the row labelled ‘Sphericity Assumed’ indicate a statistically significant main effect of the independent variable (strategy) on the dependent variable (learners mathematics scores) ($F(2,48) = 32.066, p = .000$). Therefore the null hypothesis that the average scores for the three strategies are the same is rejected and we conclude that at least one of the means (\bar{x}_i) is significantly different.

Table 16: ANOVA F-test

Tests of Within-Subjects Effects						
Measure: MEASURE_1						
Source		Type III Sum of Squares	df	Mean Square	F	Sig.
Strategy	Sphericity Assumed	16480.747	2	8240.373	32.066	.000*
	Greenhouse-Geisser	16480.747	1.920	8581.923	32.066	.000
	Huynh-Feldt	16480.747	2.000	8240.373	32.066	.000
	Lower-bound	16480.747	1.000	16480.747	32.066	.000
Error(strategy)	Sphericity Assumed	12335.253	48	256.984		
	Greenhouse-Geisser	12335.253	46.090	267.636		
	Huynh-Feldt	12335.253	48.000	256.984		
	Lower-bound	12335.253	24.000	513.969		

Since a statistically significant result was found, the Bonferroni post hoc analysis was conducted to compare the mean scores for the three strategies (S_1, S_2 & S_3) in order to determine exactly where the differences exist.

5.2.1.4 Bonferroni post hoc analysis

Table 17 provides a comparison of the mean scores for all paired combinations of the levels of the repeated factor (solution strategy).

Table 17: Bonferroni pair wise comparisons

Pair wise Comparisons						
Measure: MEASURE_1						
(I) Strategy	(J) Strategy	Mean Difference (I-J)	Std. Error	Sig. ^b	95% Confidence Interval for Difference ^b	
					Lower Bound	Upper Bound
1	2	22.56	4.135	.000*	11.917	33.203
	3	-13.36	4.933	.037*	-26.054	-.666
2	1	-22.56	4.135	.000*	-33.203	-11.917
	3	-35.92	4.500	.000*	-47.500	-24.340
3	1	13.36	4.933	.037*	.666	26.054
	2	35.92	4.500	.000*	24.340	47.500

*. The mean difference is significant at the .05 level.
b. Adjustment for multiple comparisons: Bonferroni.

From the significance values of each pair wise comparison, we obtain the following:

The mean difference between Strategy number 1 ($\bar{x} = 54.32, s.d = 23.03$) and Strategy number 2 ($\bar{x} = 31.76, s.d = 23.91$) is statistically significant. The mean difference (22.56) had a probability ($p = .000$), less than alpha (.05). The difference between the two means would be considered a substantial difference. Hence, the null hypothesis that these two means were equal was rejected.

The mean difference (-13.36) between Strategy number 1 ($\bar{x} = 54.32, s.d = 23.03$) and Strategy number 3 ($\bar{x} = 67.68, s.d = 21.41$) had a probability ($p = .037$), less than alpha (.05). This implies that the difference is also statistically significant. Therefore, the null hypothesis that these two means were equal was rejected.

The mean difference between Strategy number 2 ($\bar{x} = 31.76, s.d = 23.91$) and Strategy number 3 ($\bar{x} = 67.68, s.d = 21.41$) had a probability ($p = .000$) less than alpha (.05) meaning that it is statistically significant. The difference (-35.92) would be considered a substantial difference. Hence, the null hypothesis that these two means were equal was rejected.

5.2.1.5 95% confidence intervals of the means

Table 18 shows the 95% confidence intervals of the mean percentage scores of each of the three methods.

Table 18: confidence intervals of the means

Estimates				
Measure: MEASURE_1				
Strategy	Mean	Std. Error	95% Confidence Interval	
			Lower Bound	Upper Bound
1	54.32	4.607	44.81	63.83
2	31.76	4.781	21.89	41.63
3	67.68	4.283	58.84	76.52

The results in Table 18 indicate that if we were to take repeated samples of 25 participants from the population of low-performing Grade 12 learners, we could be 95% confident that learners' mean score with Strategy number 1 would lie between 44.81% and 63.83%. We could be 95% sure that learners' mean percentage score with Strategy number 2 would lie between 21.89% and 41.63%. We could as well be 95% confident that learners' mean percentage score with Strategy number 3 would lie between 58.84% and 76.52%.

Taken together, the findings of Session Two of the study suggest that synthetic division (Strategy number 3) made low-performing learners to learn and achieve better scores compared to the strategy of equating coefficients and the long division method.

5.3 Session Three results and analysis

The third research question was: Which solution strategies can enhance the achievement of low-performing Grade 12 learners in determining the centre and radius of a circle?

Table 19 shows the test scores of the learners using two different solution strategies. Strategy number 1 (S_1) involved the use of formulae and Strategy number 2 (S_2) involved completing the square.

Table 19: Learners' percentage scores per strategy

Learners	Scores	
	S ₁	S ₂
L ₁	98	77
L ₂	95	97
L ₃	78	75
L ₄	70	80
L ₅	97	65
L ₆	98	88
L ₇	83	73
L ₈	60	38
L ₉	98	77
L ₁₀	78	12
L ₁₁	83	75
L ₁₂	85	20
L ₁₃	70	98
L ₁₄	60	95
L ₁₅	92	47
L ₁₆	90	68
L ₁₇	100	75
L ₁₈	67	30
L ₁₉	100	65
L ₂₀	98	90
L ₂₁	78	58
L ₂₂	98	97
L ₂₃	83	58
L ₂₄	70	38
L ₂₅	98	60

The repeated-measures ANOVA was not applicable here since there were only two levels of data for analysis. A test of normality was performed in SPSS to see if the data followed a normal distribution. Table 20 shows the results of the test of normality.

5.3.1.1 Kolmogorov-Smirnov and Shapiro-Wilk's tests of normality

Hypotheses:

H_0 : There is no difference between the observed data distribution and a normal distribution.

H_A : The data is non-normal.

Since the dataset for Strategy number 1 and Strategy number 2 are smaller than 2000 elements, we are to report the results under Shapiro-Wilk (Zar, 1999).

Table 20: Kolmogorov–Smirnov and Shapiro-Wilk tests of normality

Tests of Normality						
	Kolmogorov-Smirnov			Shapiro-Wilk		
	Statistic	df	Sig.	Statistic	Df	Sig.
S ₁ scores	.177	25	.043	.886	25	.009*
S ₂ scores	.130	25	.200	.935	25	.114

From Table 20 above, the Shapiro-Wilk’s significance value for S₁ scores ($p = .009$) is less than .05. Therefore, the null hypothesis is rejected and we conclude that the scores for Strategy number 1 are not normally distributed. The significance value for S₂ scores ($p = .114$) is greater than the standard alpha (.05). This result is non-significant and hence we fail to reject H₀ and conclude that the distribution of S₂ scores is normal. Since the distribution of S₁ scores violated the assumption of normality, it was inappropriate to analyse the data using the ordinary paired-samples t -test. The Wilcoxon Signed-Rank Test (a nonparametric test equivalent to the paired samples t-test) which does not assume normality in the data was used instead (Laerd, 2012).

5.3.1.2 Results of the Wilcoxon Signed-Ranks Test

The Wilcoxon Signed-Rank Test was performed in SPSS to evaluate the following hypotheses:

H_0 : There is no significant difference in the two sets of scores.

H_A : The two sets of scores are significantly different.

Table 21 shows the main SPSS output for the Wilcoxon Signed- Ranks Test.

Table 21: Wilcoxon Signed-Rank Test Statistic

Test Statistics	
	S ₂ scores - S ₁ scores
Z	-3.176
Asymp. Sig. (2-tailed)	.001

The p-value of the Wilcoxon Signed-Ranks Test is less than alpha (.05) meaning that the difference in the scores for the two strategies is statistically significant. Therefore, we reject H_0 and conclude that the two sets of scores are significantly different ($Z = -3.176, p = .001$).

In order to see which scores were better, we analysed the results from the Wilcoxon Signed-Ranks table.

Table 22: The Wilcoxon Signed-Ranks Table

Ranks				
		N	Mean Rank	Sum of Ranks
S ₂ scores - S ₁ scores	Negative Ranks	21 ^a	13.36	280.50
	Positive Ranks	4 ^b	11.13	44.50
	Ties	0 ^c		
	Total	25		
a. S ₂ scores < S ₁ scores				
b. S ₂ scores > S ₁ scores				
c. S ₂ scores = S ₁ scores				

The Wilcoxon Signed Ranks table (Table 22) shows that 21 of the 25 participants had higher scores for Strategy number 1 than for Strategy number 2. Only 4 participants had higher scores for Strategy number 2 than Strategy number 1. The negative mean rank (13.36) is greater than the positive mean rank (11.13), suggesting that most of the scores for Strategy number 2 were lower than those for Strategy number 1.

It was therefore concluded that Strategy number 1 made the learners to learn and achieve better scores than Strategy number 2.

5.4 Session Four results and analysis

The fourth research question was: Which solution strategies can enhance the achievement of low-performing Grade 12 learners in calculating the angle between two lines?

Table 23 shows the percentage test scores of the learners using three different solution strategies.

Table 23: Learners' percentage scores per strategy

Learners	Scores		
	S ₁	S ₂	S ₃
L ₁	84	94	94
L ₂	98	84	90
L ₃	96	76	72
L ₄	78	94	90
L ₅	94	58	88
L ₆	74	46	100
L ₇	70	38	66
L ₈	96	72	100
L ₉	76	66	58
L ₁₀	56	72	74
L ₁₁	60	52	60
L ₁₂	96	90	92
L ₁₃	96	70	98
L ₁₄	94	82	96
L ₁₅	74	34	76
L ₁₆	90	52	90
L ₁₇	76	72	94

A one-way repeated-measures analysis of variance (RM ANOVA) in SPSS) was performed on the data to evaluate the following hypotheses:

$$H_0 : \bar{x}_1 = \bar{x}_2 = \bar{x}_3$$

$$H_A : \bar{x}_i \neq \bar{x}_k \text{ for some } i, k$$

5.4.1 Results for repeated-measures ANOVA

5.4.1.1 Descriptive statistics

Table 24 shows the initial output from the repeated-measures analysis.

Table 24: Descriptive statistics

Descriptive Statistics			
	Mean	Std. Deviation	N
S ₁	82.82	13.47	17
S ₂	67.76	18.64	17
S ₃	84.59	13.96	17

The table of Descriptive Statistics (Table 24) shows that there were 17 cases available for analysis per each level of the independent variable. Eight learners withdrew their participation here. However, the remaining sample size (17) was still greater than 10 + the number of levels in the repeated factor, which satisfies the minimum sample size required for repeated-measures ANOVA (Tabachnick and Fidell, 2006).

5.4.1.2 Sphericity

The Mauchly's Test of Sphericity was used to check if the assumption of equal variances between different levels of the independent variable was satisfied.

Hypotheses:

H_0 : The variances between all combinations of the repeated-measures factor are equal (sphericity is not violated).

H_A : The variances between all combinations of the repeated-measures factor are not equal (sphericity is violated).

Table 25 shows the results of the Mauchly's test.

Table 25: Mauchly's Test of Sphericity

Mauchly's Test of Sphericity ^a							
Measure: MEASURE_1							
Within Subjects Effect	Mauchly's W	Approx. Chi-Square	df	Sig.	Epsilon ^b		
					Greenhouse-Geisser	Huynh-Feldt	Lower-bound
Strategy	.828	2.825	2	.244	.854	.945	.500

The above test indicated that the assumption of sphericity had not been violated ($\chi^2(2) = 2.825, p = .244$), which is non-significant. Therefore, we are to report the ANOVA F-test results in the row labelled 'Sphericity Assumed' in the table shown below.

5.4.1.3 ANOVA F-test

Table 26 shows the repeated-measures ANOVA. The results in the row labelled 'Sphericity Assumed' indicate that there was a statistically significant main effect of the independent variable (solution strategy) on the dependent variable (mathematics achievement) ($F(2,32) = 10.62, p = .000$). Therefore the null hypothesis that the means are the same is rejected and we conclude that at least one of the mean scores (\bar{x}_i) is significantly different.

Table 26: ANOVA F-test

Tests of Within-Subjects Effects						
Measure: MEASURE_1						
Source		Type III Sum of Squares	df	Mean Square	F	Sig.
Strategy	Sphericity Assumed	2906.510	2	1453.255	10.620	.000*
	Greenhouse-Geisser	2906.510	1.707	1702.696	10.620	.001
	Huynh-Feldt	2906.510	1.890	1537.533	10.620	.000
	Lower-bound	2906.510	1.000	2906.510	10.620	.005
Error(Stratgy)	Sphericity Assumed	4378.824	32	136.838		
	Greenhouse-Geisser	4378.824	27.312	160.326		
	Huynh-Feldt	4378.824	30.246	144.774		
	Lower-bound	4378.824	16.000	273.676		

Since a statistically significant result was found, the Bonferroni post hoc analysis was conducted to compare the scores of each strategy with every other strategy in order to determine where exactly the significant differences lie.

5.4.1.4 Bonferroni post hoc analysis

Table 27 shows the results of the Bonferroni pair wise comparisons.

Table 27: Bonferroni pair wise comparisons

Pair wise Comparisons						
Measure: MEASURE_1						
(I) strategy	(J) strategy	Mean Difference (I-J)	Std. Error	Sig. ^b	95% Confidence Interval for Difference ^b	
					Lower Bound	Upper Bound
1	2	15.06	4.336	.009*	3.470	26.648
	3	-1.77	3.077	1.000	-9.989	6.460
2	1	-15.06	4.336	.009*	-26.648	-3.470
	3	-16.83	4.476	.005*	-28.787	-4.860
3	1	1.77	3.077	1.000	-6.460	9.989
	2	16.83	4.476	.005*	4.860	28.787

*. The mean difference is significant at the .05 level.

b. Adjustment for multiple comparisons: Bonferroni.

From the significance values of each pair wise comparison, we obtain the following:

The mean difference between Strategy number 1 and Strategy number 2 had a probability ($p = .009$) less than alpha (.05) meaning that the difference is statistically significant.

The mean difference between Strategy number 1 and Strategy number 3 had a probability ($p = 1.000$) far greater than alpha (.05). This implies that the difference is not statistically significant.

The mean difference between Strategy number 2 and Strategy number 3 is statistically significant. The difference had a probability ($p = .005$) which is less than the standard alpha (.05).

5.4.1.5 95% Confidence intervals of the means

Table 28 shows the 95% confidence intervals of the means.

Table 28: Confidence intervals of the means

Estimates				
Measure: MEASURE_1				
Strategy	Mean	Std. Error	95% Confidence Interval	
			Lower Bound	Upper Bound
1	82.82	3.268	75.90	89.75
2	67.76	4.521	58.18	77.35
3	84.588	3.386	77.41	91.77

The results in Table 28 indicate that if we were to take repeated samples of 17 participants from the population of low-performing Grade 12 learners and subject them to the same strategies, we are 95% confident that that the mean score for Strategy number 1 would lie between 75.90% and 89.75%. We can be 95% sure that the mean score for Strategy number 2 would lie between 58.18% and 77.35%. We are 95% confident that the mean score for Strategy number 3 would lie between 77.41% and 91.77%.

Taken together, the findings of this session suggest that Strategy number 1 and Strategy number 3 made the learners to learn and achieve better scores.

The next chapter summarises the study, discusses results and their implications, draws conclusions, and makes recommendations for future research.

CHAPTER SIX

SUMMARY OF THE STUDY, DISCUSSIONS, CONCLUSION AND RECOMMENDATIONS

6.1 Introduction

This chapter reviews and summarises the findings of the study, discusses their implications and makes recommendations for practice and policy. The limitations of the study are also highlighted. The chapter ends with suggestions for future research on ways to improve the mathematics achievement of learners in South Africa.

6.2 Summary of the Study

6.2.1 Aims of the study

The aim of the study was to explore solution strategies that can enhance low-performing Grade 12 learners' achievement in the following mathematical aspects: determining the general term of a quadratic sequence, factorising third degree polynomials, determining the centre and radius of a circle, and calculating the angle between two lines.

6.2.2 The methodology of the study

The study was conducted in four sessions. In each session, a repeated-measures design in which the same participants were exposed to all solution strategies was adopted. Data were collected using four researcher-developed achievement tests and analysed by performing repeated-measures ANOVA and Wilcoxon Signed-Ranks Tests in SPSS Version 21.

6.2.3 The results of the study

The first research question was: *Which solution strategies can enhance the achievement of low-performing Grade 12 learners in determining the general term of a quadratic sequence?*

To answer the question above, data were analysed using a one-way repeated-measures ANOVA. Results indicated a statistically significant difference in learners' scores due to the main effect of the different solution strategies used ($F(2.54,60.83) = 16.74, p = .000$). The null hypothesis that the mean scores for the four solution strategies are the same ($H_0 : \bar{x}_1 = \bar{x}_2 = \bar{x}_3 = \bar{x}_4$) was rejected at $\alpha = .05$ and we concluded that at least one of the

mean scores is statistically different. Post hoc analysis results indicated that Strategy number 1 and Strategy number 3 made the learners to have better achievement scores (*See Chapter 3 for details of these two solution strategies*). It is important to note that Strategy number 1 was not in the prescribed Grade 12 mathematics textbooks.

The second research question was: *Which solution strategies can enhance the achievement of low-performing Grade 12 learners in factorising third degree polynomials?*

To answer the question above, learners were exposed to three different solution strategies for factorising third degree polynomials namely: by equating coefficients, by long division, and by synthetic division. The results of the repeated-measures ANOVA indicated that there were significant differences in learners' scores due to the different solution strategies used ($F(2,48) = 32.066, p = .000$). The null hypothesis that the mean scores for the three solution strategies are the same ($H_0: \bar{x}_1 = \bar{x}_2 = \bar{x}_3$) was rejected at $\alpha = .05$ and we concluded that at least one of the mean scores is statistically different. Post hoc analysis of the data showed that learners obtained better scores using the synthetic division strategy than by long division and equating coefficients.

The third research question was: *Which solution strategies can enhance the achievement of low-performing Grade 12 learners in determining the centre and radius of a circle?*

There were only two different solution strategies for comparison here: one that involved the use of formulae and the other one involved completing the square. Results from the Wilcoxon Signed-Ranks Test indicated an overall significant difference in the distribution of the scores for the two solution strategies ($Z = -3.176, p = .001$). The null hypothesis (H_0) that the two sets of scores for the two different solution strategies are the same was rejected. The results from the Wilcoxon Signed-Ranks Table indicated that Strategy number 1 (using formula) made the learners to have better achievement scores than Strategy number 2 (completing the square) (*See Chapter 3 for details*). The strategy that resulted in better performance for the learners here was not in the prescribed Grade 12 mathematics textbooks used in schools.

The fourth research question was: *Which solution strategies can enhance the achievement of low-performing Grade 12 learners in calculating the angle between two lines?*

Here, learners were exposed to three different solution strategies: using the formula $\tan \theta = \frac{m_2 - m_1}{1 + m_2 \cdot m_1}$, using theorems, and using the cosine rule. Results from the one-way repeated-measures ANOVA indicated a significant main effect of the different methods used on learners' achievement scores ($F(2,32) = 10.62, p = .000$). The null hypothesis ($H_0 : \bar{x}_1 = \bar{x}_2 = \bar{x}_3$) was rejected at $\alpha = .05$. Post hoc multiple comparisons (using Bonferroni) showed that Strategy number 1 and Strategy number 3 made the learners to have better achievement scores than Strategy number 2 (*See Chapter 3 for details*). Strategy number 1 was not in the prescribed learners' textbooks used in schools.

6.3 Discussions and conclusion

The study set out to explore solution strategies that can enhance Grade 12 learners' achievement in some mathematical aspects.

The results of the study debunk the perception that the achievement of low-performing mathematics learners' is beyond redemption and that multiple problem-solving strategies will confuse learners. This study has shown that by offering learners opportunities to explore a wide range of solution strategies, educators can reach many of their learners, including those who might have lost hope of doing well in the subject. Eventually, learners will arrive at a strategy they prefer and understand better. This is also in line with contemporary constructivist theories of mathematics teaching and learning which assert that all learners can successfully learn mathematics (Van de Walle, 2004; McCrocklin & Stern, 2006; Vellupillai, 2007).

The evidence from this study suggests that solution strategies in the learners' textbooks may not always be the best methods available. Some of the strategies that proved to be better in this study were not even in the prescribed learners' textbooks. It therefore implies that mathematics teaching and learning should not be textbook driven. This corroborates previous studies by Moloi and Strauss (2005) which found significant gaps between the official mathematics curriculum and what is presented in textbooks. However, given that not all mathematics educators have adequate knowledge of the subject (Long, 2007) and that the textbook might be the only resource available to learners in disadvantaged schools (Moloi & Strauss, 2005); I suggest that more mathematics textbooks with a variety of solution strategies be made available to educators.

Another important practical implication of the findings of this study is that it may take several attempts to see positive results in learners' achievement but we should not give up. If one strategy does not work, we should try another one. This derives from constructivist pedagogical tenets which assert that mathematics teaching and learning is a long developmental process of engaging learners in free exploration until they make sense of each mathematical idea (Devries & Zan, 2003). Thus, mathematics educators have to increase their contact time with low-performing learners and change their pedagogical practices to suit the learning needs of such learners. This calls for commitment on the part of mathematics educators, something which was found to be lacking in some schools in South Africa (Van der Westhuizen et al., 2002).

Trying new ways of teaching and having a greater awareness of learners' individual differences could help educators reach a larger number of learners including those who might say mathematics is not for them. This is supported by Bayona (2010) who posits that educators have to try different strategies from the ones that have failed them in the past if they are to succeed in their teaching. The prevailing situation in many Grade 12 Mathematics classes is that educators seem to take no responsibility for low-performing learners due to the perception that such learners will never do well in mathematics (Elmore, 2002). The findings of this study contradict such perceptions and recommend that educators should not see low-performing Grade 12 learners as beyond redemption.

Educators whose knowledge of mathematics is limited tend to confine their learners to the solution strategies found in the prescribed textbooks. Several studies have found a correlation between the educator's knowledge of the subject matter and learners' academic achievement (for example, Darling-Hammond et al., 2001; Mukadam, 2009; Rakumako & Laugksch, 2010). Low mathematics achievement by learners could be an indication of the low quality of mathematics teaching they are exposed to.

The study has also shown that the exposure to various solution strategies during teaching, improved learners' problem-solving skills, hence the improvement in their achievement. Thus, effective teaching is experienced in the class and learning tends to be more meaningful. The observation is supported by the suggestion made by Lester (2013) that learners tend to improve their problem-solving skills when taught by more proficient

teachers who in the current study are teachers with a wide repertoire of solution strategies. The results are consistent with the proposition made by Naroth (2010) that exposing learners to multiple strategies to solving mathematics problems makes them proficient in problem-solving.

6.4 Recommendations for future research

Based on the conclusions of this study, the following recommendations are put forward for consideration:

A similar study involving a large randomised sample of low-performing Grade 12 learners using the same experimental setup, could provide more definitive evidence to strengthen the discoveries of this research.

Future research should extend this study to other mathematical aspects and Grades to see if similar results are obtainable. The findings from such studies might help to improve the quality of mathematics teaching at all Grade levels and that is crucial in our efforts to turn around the mathematics crisis in South African schools.

Analysis of low-performing learners' views on the solution strategies used may throw further light on the kind of pedagogical practices needed to address their learning needs. A similar study using a qualitative research design could also help strengthen the findings of the current study.

6.5 Limitations of the study

As with all forms of research, there are certain caveats that must be noted when considering the results.

In the present study, learners' success in mathematics was determined by marks obtained on achievement tests. This does not account for all forms of learning and not every behaviour that is desirable in mathematics education can be objectively measured (Anderson, 2005). However, the use of tests to measure learners' mathematics achievement is still a common practice in mathematics education.

The study involved only low-performing Grade 12 learners and was limited to only four mathematical aspects. The findings of the study should therefore be interpreted in this

context and caution must be applied, as the results might not be transferrable to other Grade levels and mathematical aspects.

6.6 Concluding remarks

This study highlights the possibility of enhancing learners' mathematics achievement in South African secondary schools. It confirms that in order to enhance low-performing learners' mathematics achievement, educators should structure the learning environment to offer individual learners' an opportunity to make sense of mathematical knowledge. By exposing learners to a wide range of solution strategies rather than restrict them to only strategies in the prescribed textbooks, educators can reach many of their learners, including those who might have lost hope of passing mathematics. Educators need to make a paradigm shift from teacher-centred pedagogical practices, towards cognitive-constructivist teaching approaches.

Although the findings of this study are not a prescription to mathematics educators who have difficulty dealing with low-performing learners, the results offer empirical classroom-based evidence of strategies that could be implemented in South African secondary schools to forestall high failure rate in mathematics. As the South African government and the Department of Education institute changes and reforms in mathematics education with a view to improving learners' achievement, the present study endorses the need to develop the educator and the quality of teaching as key determinants of learners' mathematics achievement (Foulds, 2002; Arnold & Bartlett, 2010).

REFERENCES

- Adams, R., Blyth, S., & Williams, H. (2010). *Quadratic Sequences-Grade 11*. Retrieved June 27, 2011, from <http://cnx.org/content/m32633/1.2/>
- Anderson, J. R. (2005). Expertise. In Anderson, J. R. (Ed.). *Cognitive psychology and its implications*. 6th Edition. New York: Worth Publishers.
- Arnold, C., & Bartlett, K. (2010). *Improving learning achievement in Early Primary in low-income countries*. Geneva: AGA Foundation.
- Badget, J. L., & Christmann, E. P. (2008). *Interpreting Assessment Data: Statistical techniques you can use*. National Science Teachers Association. Retrieved June 6, 2011, from <http://www.books.google.co.za>
- Badugela, T. M. (2012). *Problems facing educators in implementing the National Curriculum Statement. The case of Tshifhena Secondary School, Vhembe District, Limpopo Province, South Africa*. Unpublished M Ed dissertation. Pretoria: University South Africa.
- Balow, B. (1961). Delinquency and school Failure. *Federal Probation*, June 1961, 25(2): University of Minnesota.
- Bandura, A. (1977). *Social learning theory*. New York: General Learning Press.
- Barwell, R., Barton, B., & Setati, M. (2007). Multilingual issues in mathematics education: introduction. *Educational Studies in Mathematics*, 64(2), 113-119.
- Basset, N. (2011). *South African pupils fail to make the grade*. Retrieved April 23, 2011, from http://www.nosybasset.co.za/2011/04/sa_pupils_fail_to_make_the_grade/
- Bayona, L. M. (2010, 15 March). Spot light on teaching method. *Sowetan*.
- Bednar, A. K., Cunningham, D., Duffy, T. M., & Perry, J.P. (1995). Theory into Practice: How do we link? In G. J. Anglin (Ed.), *Instructional technology: Past, present and future*. 2nd Edition. (pp. 100-111). Englewood, CO: Libraries Unlimited, Inc.
- BERA (2004). *Revised Ethical Guidelines for Educational Research*. Southwell: British Educational Research Association.
- Bernstein, A. (2004). No child left behind: *Mail & Guardian*, November 12,

2004. Retrieved December 03, 2010, from http://www.cde.org.za/article.php?a_id=304
- Bolt, J. F., & Brassard, C. 2004. Learning at the top: how CEOs set the tone for the Knowledge organisation. In Goldsmith, M. H., Morgan, H., & Ogg, A. J. (Eds.). *Leading organisational learning: harnessing the power of knowledge*. 5th Edition. San Francisco: Jossey-Bass.
- Boudourides, M.A. (2003). Constructivism, education, science, and technology. *Canadian Journal of Learning and Technology*. Retrieved January 1, 2013, from http://www.cjlt.ca/content/vol29.3/cjlt29-3_art1.html
- Bowie, L. (2010). *Alison on CAPS FET*. Retrieved January 2, 2013, from <http://www.slideshare.net/LynnBowie/alsion-on-caps-maths-fet-5207177>
- Brownlee, A., Pathmanathan, I., Varkevisser, C. M. (2003). *Designing and Conducting Health Systems Research Projects: Proposal Development and Fieldwork*. Amsterdam: KIT Publishers and the International Development Research Centre.
- Bruner, J. (1960). *The Process of Education*. Cambridge, MA: Harvard University Press.
- Cai, J., Mamona-Downs, J. & Weber, K. (2005). Mathematical problem solving: What we know and where we are going. *Journal of mathematical behavior*. 24, 217-220.
- Carlie, M. (2002). *Into The Abyss: A Personal Journey into the World of Street Gangs*. Retrieved February 2, 2013, from http://people.missouristate.edu/MichaelCarlie/What_i_learned_about/gangs/whyform/school_failure.htm
- Castillo, J. J. (2009). *Simple Random Sampling*. Retrieved August 13, 2011, from <http://www.experiment-resources.com/simple-random-sampling.html>
- Centre for Teaching and Learning Mathematics (1986). Progress of Dr. Ladislav Kosc's work on dyscalculia. *Focus on Learning problems in Mathematics*, 8, 3-4.
- Chinapah, V. (2003). Monitoring Learning Achievement (MLA) Project in Africa. *ADEA Biennial meeting, December 3-6, 2003*. Grand Baie, Mauritius: Association for the Development of Education in Africa.
- Cobb, P. (1988). The Tension between Theories of Learning and Instruction in Mathematics Education. *Educational Psychologist*, 23, 87-103.

- Conaway, M. (1999). *Repeated-measures Design*. Retrieved November 21, 2011, from <http://biostat.mc.vanderbilt.edu/wiki/pub/Main/ClinStat/repmeas.PDF>
- Cronbach, L., & Snow, R. (1977). *Aptitudes and the Instructional Methods: A Handbook for Research on Interactions*. New York: Irvington.
- Darling-Hammond, L., Berry, B., & Thoreson, A. (2001). Does teacher certification matter? Evaluating the Evidence. *Educational Evaluation & Policy Analysis*, 23, 57-77.
- DeCoster, J. (2004). *Data Analysis in SPSS*. Retrieved October 8, 2012, from <http://www.stat-help.com/notes.html>
- Derry, S.J. (1996). Cognitive Schema Theory in the Constructivist Debate. *Educational Psychologist*, 31(3/4), 163-174.
- Devries, B., & Zan, B. (2003). When children make rules. *Educational Leadership*, 61(1), 64-67.
- DoBE (2010). *Report on the Annual National Assessments of 2011*. Pretoria : Department of Basic Education.
- DoBE (2011a). *Report on the National Senior Certificate Examination: Technical Report*. Pretoria: Department of Basic Education
- DoBE (2011b). *National Curriculum Statement (NCS). Curriculum and Assessment Policy Statement. Mathematics Further Education and Training Phase Grades 10-12*. Pretoria: Department of basic Education.
- DoBE (2011c). *Report on the National Senior Certificate Examination: National Diagnostic Report on Learner Performance*. Pretoria: Department of Basic Education.
- DoBE (2012a). *National Senior Certificate Examination. National diagnostic report on learner performance*. Pretoria: Department of Basic Education.
- DoBE (2012b). *Report on the Annual National Assessments 2012. Grades 1 to 6 and 9*. Pretoria: Department of Basic Education.
- DoE (2003). *National Curriculum Statement Grades 10-12 (General) Mathematics*. Pretoria: Department of education.
- DoE (2007). *Fact Sheet: Trends emerging stronger*: Retrieved June 17, 2012
From <http://www.solidaritysearch.co.za/wp-content/.../16-Doc-Fact-Sheet.pdf>
- DoE (2008a). *National Senior Certificate Grade 12 Mathematics Paper 2*,

Additional Exemplar 2008, p.3.

- DoE (2008b). National Curriculum Statement, Grades 10-12 (General): Mathematics. Pretoria: Department of Education
- DoE (2009a). *Report of the Task Team for the Review of the Implementation of the National Curriculum Statement. Final Report.* Pretoria: Department of Education.
- DoE (2009b). *Trends in Education Macro-Indicators Report: South Africa.* Pretoria: Department of Education.
- DoE (2010). *National Senior Certificate Grade 12 Mathematics Paper 2, February/ March 2010, p.7.*
- Doğru, M., & Kalendar, S. (2007). Applying the Subject 'cell' Through Constructivist Approach during Science Lessons and the Teacher's View. *Journal of Environmental & Science Education*, 2 (1), 3-13.
- Donovan, M.S., & Bransford, J.D. (2005). *How Students Learn: Mathematics in the Classroom.* Washington D.C: The National Academies Press.
- Elmore, R. F. (2002). *The Limits of Change.* Retrieved December 28, 2012, from <http://www.edletter.org/current/limitsofchange.shtml>
- Ferrance, E. (2000). *Themes in Education: Action Research.* Providence: Brown University.
- Field, A. (2008). *A Bluffer's Guide to Sphericity. BPS-MSc Newsletter*, 6(1). Sussex: University of Sussex.
- Foulds, S. (2002). *Teacher Development Challenges in the Context of Curriculum Reform: South Africa.* Retrieved December 20, 2010, from http://www.icponline.org/index.php?option=com_content&view=article&id=151:foulds-teacher-development-challenges-in-the-context-of-curric-reform-south-africa&catid=32:general&Itemid=54.
- Fricke, N. I. (2008). *The effect of a mentoring programme targeting science and mathematics teachers in a developmental context.* Unpublished MEd dissertation. Pretoria: University of Pretoria.
- Gay, L. R., Mill, G. E., & Airasian, P. (2011). *Educational Research: Competencies for Analysis and Application.* Upper Saddle River, N J: Pearson Education.
- Gonin, A.A., Du Plessis, N.M., Kuyler, H.A., De Jager, C.W., Hendricks, W.E., Hwakins, F.C.W., Slabber, G.P.L., & Archer, I.J.M. (1987). *Modern Graded Mathematics Standard 10 for Higher and Standard Grade New syllabus.* Western Cape: Nasou.

- Gonzales, E. J., Mullis, I. V. S., Martin, M. O., & Chrostowski, S. J. (2004). *TIMSS & PIRLS International Study Centre*. Boston College: Chrestnut Hill.
- Gronlund, N.E. (1998). *Assessment of student achievement*. Massachusetts: Allyn & Bacon.
- Good, T. L., & Brophy, J. E. (1990). *Educational psychology: A realistic Approach*. (4th ed.). White Plains, New York: Longman.
- Hill, W.F. (2002). *Learning: A survey of psychological interpretation*. (7th ed.). Boston, MA: Allyn and Bacon.
- Holt, D. G., & Willard-Holt, C. (2000). Let's get real: students solving authentic corporate problems. *Phi Delta Kappan*, 82(3), 243-246.
- Hungi, N., Makuwa, D., Ross, K., Saito, M., Dolata, S., Cappelle, F.V., Pavliot, L., Vellien, L. (2010). *SACMEQ III Project Results: Pupil achievement levels in reading and mathematics, Working Document Number 1*.
- IEA. (2011). *Highlights from TIMSS 2011: The South African Perspective*. Cape Town: HSRC.
- Jones, E. D., Wilson, R., & Bhojwani, S. (1997). Mathematics instruction for secondary students with learning disabilities. *Journal of Learning Disabilities*, 30, 151-163.
- Joppe, M. (2000). *The Research Process*. Retrieved March 15, 2010, from <http://www.ryeson.ca/~nyoppe/rp.htm>
- Kavale, K. A., & Forness, S.R. (1992). History, definition, and diagnosing. In N.N. Singh & I. L. Beale (Eds.). *Learning disabilities: Nature, theory, and treatment*, (pp. 3-43). New York: Springer-Verlag.
- Keating, C. (2007, October 12). *Learners can't master maths*. Independent Online, Retrieved March 17, 2010, from http://www.iol.co.za/index.php?set_id=1&click_id=13&art_id=vn20071012111506425C4...
- Keeton, M. (2010). *Grade 12 results-not good enough, must do better*. Tshikululu Social Investments. Retrieved April 5, 2010, from <http://www.tshikululu.org.za>
- Kim, T., & Axelrod, S. (2005). Direct Instruction: An Educator's Guide and a plea for Action. *The Behaviour Analyst Today*, 6(2), 111.
- Kim, J. S. (2005). The effects of a constructivist teaching approach on student academic achievement, self-concept, and learning strategies. *Asia Pacific Education Review*, 6 (1), 7-19.

- Kirschner, P. A., Sweller, J., & Clark, R. E. (2006). Why minimal guidance during instruction does not work: an analysis of the failure of the constructivist, discovery, problem-based, experiential, and inquiry based teaching. *Educational Psychologist*, 41(2), 75-86.
- Kroesbergen, E. H. (2002). *Mathematics education for low-achieving students. Effects of different instructional principles on multiplication learning*. Doetinchem: Graviant.
- Kroesbergen, E. H., Van Luit, J. E. H., & Maas, C. M. (2004). Effectiveness of explicit and constructivist mathematics instruction for low-achieving students in The Netherlands. *Elementary School Journal*, 104, 233-251.
- Laerd (2010). *Principles of research ethics*. Retrieved March 20, 2012, from <http://dissertation.laerd.com/articles/principles-of-research-ethics.php>
- Laerd (2012). *Wilcoxon Signed Rank Test using SPSS*. Retrieved November 13, 2012, from <https://statistics.laerd.com/tc.php>
- Lawshe, C. H. (1975). A quantitative approach to content validity. *Personnel Psychology*, 28, 563-575.
- Lenke, J. M., Wellens, B. & Oswald, J. H. (1977). *Difference between Kuder-Richardson Formula 20 and Formula 21. Reliability Coefficients for Short Tests with different item variabilities*. New York: The psychological Corporation.
- Lester, F. (2005). On the theoretical, conceptual, and philosophical foundations for research in mathematics education. *Zentralblatt für Didaktik der Mathematik*, 37, 457-467.
- Lester, F.(2013).Thoughts About Research On Mathematical Problem-Solving Instruction. *The Mathematics Enthusiast*, 10(2), 245-278.
- Lewandowsky, S., Little, D., & Kalish, M. (2007). Knowledge and expertise. In F. T. Durso, R. Nickerson, S. Dumais, S. Lewandowsky, & T. Perfect (Eds.), *Handbook of applied cognition*. Second Edition. New York: Wiley.
- Lockhead, M. E., & Verspoor, A. M. (1991). *Improving education in developing countries*. New York: Oxford University press
- Long, C. (2007). *TIMSS 2003: Informing teaching*. Pretoria: Centre for Evaluation and Assessment (CEA).
- Lorimer, J. (2010). Minister must re-enter South Africa into TIMSS-DA. Politics Web. Retrieved June 8, 2012, from <http://www.politicsweb/view/politicsweb/en/page71656?oid=163465&sn=Detail&pid=71656>

- Mahoney, M. J. (2003). *What is Constructivism and why is it growing?*
Retrieved January 1, 2013, from <http://www.constructivism.123.com/>
- Mail & Guardian Online (2008, 3 August). *Teachers flunk maths*. Retrieved March 20, 2010, from <http://www.mg.co.za/article/2008-08-03-teachers-flunk-maths>
- Maree, J. G. (2010). *The challenge of under-achievement in mathematics: Focus on a meta-approach: Science, Technology, Engineering and Mathematics Education (STEM)*. Cape Town: University of Pretoria.
- Maskew Miller Longman (2012). *Survival Guide to the FET Curriculum and Assessment Policy Statement (CAPS)*. Retrieved February 1, 2013, from <http://www.mml.co.za/docs/FET-CAPS-GUIDE-2012.pdf>
- Mayer, R. (2004). Should there be a three-strikes rule against pure discovery learning? The case for guided Solution strategies for instruction. *American Psychologist*, 59(1), 14-19.
- Mayer, R. E. (1996). History of Instructional Psychology. In E., De Corte & F. E., Weinert (Eds.). *International Encyclopaedia of Developmental & Instructional Psychology*, pp. 29-33. Pergamon Press.
- McCrocklin, E., & Stern, A. L. (2006). *A report on the National science Urban Systemic Program: What works best in Science and Mathematics Education Reform*. Washington DC: National Science Foundation.
- Meniscus Educational Institute (2011). *Glossary of selected statistical Terms*
Retrieved August 9, 2012, from <http://www.meniscus.com>
- Mercer, C. D. (1997). *Students with learning disabilities*. Upper Saddle River, N J: Merrill Prentice Hall.
- Mercer, C.D., & Mercer, A. R. (1998). *Teaching students with learning problems*. Upper Saddle River, N J: Merrill Prentice Hall.
- Mercer, C. D., Jordan, L., & Miller, S. P. (1996). Constructivist math Instruction for diverse learners. *Learning Disabilities Research & Practice*, 11,147-156.
- Mergel, B. (1998). *Instructional design & Learning Theory*. University of Saskatchewan. Retrieved December 28, 2012, from <http://www.usask.ca/education/coursework/802papers/mergel/brenda.htm#The%20Basics%20of%20Cognitivism>
- Merwin, M. M. (2003). Forbidden words: A strategy for studying psychology. *Teaching of Psychology*, 30, 242-244.
- Ministry of Education (1998). Education Rights Project: Admission Policy for

- Ordinary Public Schools. *Government Gazette*, 400 (19377).
- Minke, A. (1997). *Conducting Repeated-measures Analyses: Experimental Design Considerations*. Retrieved August 17, 2012, from <http://ericae.net/ft/tamu/Rm.htm>
- Moloi, M., & Strauss, J. (2005). *A study of the conditions of schooling and the quality of education: South African Working Report*. Harare & Pretoria: SACMEQ and Ministry of Education.
- Mukadam, A. (2009). *Accessibility of Maths Education in South Africa. Paper delivered at the 3rd Annual Education Conference in Southern Africa-4* March 2009. Retrieved June 10, 2010, from <http://www.mathsexcellence.co.za/paper/ACCESSIBILITY%20OF%20MATHS%20EDUCATION%20%4Feb%202009.pdf>
- Muoneke, A., & Shankland, L. (2009). Uncharted Territory: Using Tiered Intervention to improve High School Performance. *SEDL Letter*, 21(1). Texas: SEDL.
- Naroth, C. (2010). *Constructive Teacher feedback for enhancing Learner Performance in Mathematics*. Unpublished Masters dissertation. Bloemfontein: University of the Free State.
- Nasser, Abu-Alhija, F. (2007). Large-scale testing: Benefits and pitfalls. *Studies in Educational Evaluation*, 33, 50-68.
- NCEE (2009). *Assisting Students Struggling with Mathematics: Response to Intervention for Elementary and Middle Schools*. Washington DC: Institute of Education Sciences.
- Nkosi, B., & John, V. (2012, 3 December). Do the mathematics; we are facing a national crisis. *Mail & Guardian Online*. Retrieved February 30, 2013 from <http://mg.co.za/article/2012-12-03-do-the-maths-we're-facing-a-nationalcrisis>
- Parker, F. (2012). *Myth busting Grade 12 pass rate*. Retrieved August 28, 2012, from <http://mg.co.za/author/faranaz-parker>
- Pallant, J.F. (2005). *SPSS Survival Manual*. Australia: Allen & Unwin.
- Prinsloo, C. H. (2008). *Extra classes, extra marks? Report on the Plus Time Project*. Western Cape: Human Sciences Research Council.
- Pscharopoulos, G., & Woodhall, M. (1985). *Education for development: an analysis of investment choices*. New York: Oxford University Press.

- Quadratic Sequences*. (2007). Retrieved June 27, 2011, from <http://www.skool.co.za/studynotes/maths/id635.htm>
- Quadratic sequences*. (n.d). Retrieved June 27, 2011 from <http://www.cbv.ns.ca/mathhelp/quadratic1.htm>
- Rakumako, A., & Laugksch, R. (2010). Demographic profile & perceived INSET needs of secondary school mathematics teachers in Limpopo province. *South African Journal of Education*, 30, 139-152.
- Reddy, V. (2010). Cross national achievement studies: Learning from South Africa's participation in the Trends in International Mathematics and Science Study (TIMSS). *Human Science Research Council*, 35(1), 63-77.
- Research Methods in Psychology (2007). *Problems with Repeated Measures Designs*. Retrieved November 22, 2011, from <http://www.researchmethodsinpsychology.com/wiki/index.php?title=Section2.6>
- Rivera, D. P. (1997). Mathematics education and students with learning disabilities: Introduction to the special series. *Journal of Learning Disabilities*, 30, 2-19.
- Ruijssenaars, A. J. J. M. (1992). *Rekenproblemen, Theorie, diagnostiek, behandeling* [Mathematics problems. Theory, diagnosis, treatment]. Rotterdam, The Netherlands: Lemniscaat.
- SACMEQ (2011). *About SACMEQ*, Retrieved April 23, 2011, from <http://www.sacmeq.org/about.htm>
- SACMEQ (2005). *Indicators*. Retrieved April 23, 2011, from <http://www.sacmeq.org/indicators.htm>
- SAIDE (2008). *Exploring what it means to 'do' mathematics*. Retrieved 25 July 2010, from <http://www.oerafrica.org/.../Unit%201%20SAIDE%20ACEMaths%20Aug%202008%20fin.doc>
- Schwier, R.A. (1995). Issues in emerging interactive technologies. In G. J. Anglin (Ed.), *Instructional technology: Past, present and future*. (2nd ed., pp. 119-127). Englewood, CO: Libraries Unlimited.
- SERA (2005). *Scottish Educational Research Association: Ethical guidelines for Educational Research*. Retrieved 14 August 2011, from <http://www.sera.ac.uk/docs/oocurrent/SERA/%20Ethical%20GuidelinesWeb.PDF>

- Shindler, J. (2004). *Teaching for the success of all- Learning Styles: Five Principles of Promoting greater teacher effectiveness and Higher Student Achievement for all students*. Los Angeles: California State University.
- Shuttleworth, M. (2009). *Repeated-measures Design*. Retrieved July 07, 2011, from <http://www.experiment-resources.com/repeated-measures-design.html>
- Silberman, A. (1996). *Active Learning*. Boston: Allyn & Bacon.
- Silicon Genetics (2003). *Statistical Analysis (1-way ANOVA)*. Retrieved August 20, 2012, from <http://www.Silicongenetics.com>
- Stacey, K. (2005). The place of problem solving in contemporary mathematics curriculum documents. *Journal of Mathematical Behaviour*, 24,341–350.
- Stebbins, L. B., St Pierre, R.G., & Proper, E. C. (1977). *Education as Experimentation: A planned variation model. Effects of follow through models*. Cambridge, MA: Abt Associates.
- Stoffels, N. T. (n. d). *Why teachers do what they do. Exploring teacher decision making frames in the context of curriculum change in South Africa*. Pretoria: University of Pretoria.
- Strauss, J. P. (1999). *Results of the Monitoring Learning Achievement Project: Discussion*. Bloemfontein: Research Institute for Educational Planning, University of Free State.
- Sweller, J. (1999). *Instructional Design in Technical Areas*. Camberwell, Victoria, Australia: Australian Council for Educational Research.
- Tabachnick, B.G., & Fidell, L. S (2006). *Using multivariate statistics*. 5th Edition. New Jersey: Prentice-Hall Inc.
- Taylor, W. (2007). Equity, efficiency and development in South African Schools: In *International handbook of school effectiveness and improvement*, T. Townsend (Ed.). 2007, 523-540.
- The general term of a quadratic sequence*. (n. d). Retrieved June 27, 2011, from <http://www.MATHHELPER.CO.UK>
- The Good News (2010, 7 January). *Interventions helped KZN to improve Grade 12 results* .Retrieved December 03, 2010, from http://www.sagoodnews.co.za/education/interventions_helped_kzn_to_improve_Grade_12_re...
- Tudor, I. (1996). *Learner-Centredness as Language Education*. Cambridge: Cambridge University Press.
- University of New England (2000). *Research Designs: Between group vs*

- Repeated-measures designs*. Retrieved November 22, 2011, from http://www.une.edu.au/webStat/unit_materials/c2_research_design/index.html
- Van de Walle, J. A. (2001). *Elementary & middle school mathematics: Teaching developmentally* (4th Ed.). New York: Addison Wesley Longman.
- Van de Walle, J. A. (2004). *Elementary and middle school mathematics: Teaching developmentally*. New York: Pearson.
- Van der Westhuizen, P.C., Mosoge, M. J., Nieuw oudt, H. D., Steyn, H. J., Legotlo, M. W., Maaga, M. P., & Sebege, G. M. (2002). Perceptions of stakeholders on causes of poor performance in Grade 12 in a province in South Africa: *South African Journal of Education*, 22 (2), 113-118.
- Van Lieshout, E. C. D. M., Jaspers, M. W. M., & Landewé, B. H. M. (1994). Mathematical word problem solving of normally achieving and mildly mentally retarded children. In J. E. H. Van Luit (Ed.), *Research on learning and instruction of mathematics in kindergarten and primary school*, (pp. 344-365). Doetinchem, The Netherlands: Graviant.
- Van Liet, B. (2005). Student-developed problem-based learning cases: Preparing for rural healthcare practice. *Education for Health: Change in Learning and Practice*, 18, 416-426.
- Variend, A. (2011, 24 May). *What you need to know about CAPS*. Retrieved February 1, 2013, from <http://maskewmillerlongman.ning.com/profile/AntheaVariend>
- Vellupillai, V. (2007). *An investigation into how Mathematics educators teach the Outcomes-based curriculum*. Unpublished MSc thesis. Pretoria: University of Pretoria.
- Vithal, R., & Volmink, J. (2005). Mathematics curriculum roots, reforms, reconciliation and relevance. In R. Vithal, J. Adler, & C. Keitel (Eds.), *Mathematics education research in South Africa: Challenges and possibilities*, (pp. 3-27). Pretoria: Human Sci.
- Wynd, C. A., Schmidt, B., & Schaefer, M.A. (2003). Two Quantitative approaches for Estimating Content Validity. *Western Journal of Nursing Research*, 25(5), 508-518.
- Zar, J. H. (1999). *Bio statistical Analysis*. 4th ed. Upper Saddle River, N J: Prentice-Hall.

APPENDIX A: Data Collection Instruments

A 1: Tests and Marking Guides

SESSION 1 ASSESSMENT TEST: GRADE 12 MATHEMATICS

Broad Topic : Number patterns/Sequences
Sub-topic : Determining the n^{th} term of a quadratic sequence

MARKS :50 TIME ALLOWED : 1 hour

INSTRUCTIONS TO THE CANDIDATE:

- Attempt **ALL** questions
- Show **ALL** your working procedures
- Write neatly & legibly
- Write your answers on the separate answer sheets provided

QUESTION: Determine a formula for the n^{th} term of each sequence.

- | | | |
|--------|--------------------|-----|
| (1.1) | 2; 6; 12; 20; ... | (5) |
| (1.2) | 3; 6; 11; 18; ... | (5) |
| (1.3) | 2; 8; 18; 32; ... | (5) |
| (1.4) | 7; 13; 23; 37; ... | (5) |
| (1.5) | 4; 14; 30; 52; ... | (5) |
| (1.6) | 1; 4; 9; 16; ... | (5) |
| (1.7) | 0; 3; 8; 15; ... | (5) |
| (1.8) | 1; 3; 6; 10; ... | (5) |
| (1.9) | 1; 7; 17; 31; ... | (5) |
| (1.10) | 26; 17; 10; 5; ... | (5) |

Thanks for your participation!

SESSION 2 ASSESSMENT TEST: GRADE 12 MATHEMATICS

Broad Topic :Third degree polynomials
Sub topic: : Factorising third degree polynomials

MARKS: :50 TIME ALLOWED :1 hour

INSTRUCTIONS TO THE CANDIDATE:

- Attempt **ALL** questions
- Show **ALL** your working procedures
- Write neatly & legibly
- Write your answers on the separate answer sheets provided
- Write **ALL** your work in ink

QUESTION Factorise the following expressions completely

- (1.1) $x^3 - 2x^2 - 9x + 18$, given that $(x - 2)$ is a factor (5)
- (1.2) $x^3 - 2x^2 - 5x + 6$, given that $(x - 1)$ is a factor (5)
- (1.3) $x^3 - 4x^2 - 3x + 18$, given that $(x - 3)$ is a factor (5)
- (1.4) $x^3 - 2x^2 + 4x - 8$, given that $(x - 2)$ is a factor (5)
- (1.5) $x^3 - 12x + 16$, given that $(x - 2)$ is a factor (5)
- (1.6) $x^3 + 2x^2 - 5x - 6$, given that $(x - 2)$ is a factor (5)
- (1.7) $3x^3 - 7x + 4$, given that $(x - 1)$ is a factor (5)
- (1.8) $x^3 - 19x + 30$, given that $(x + 5)$ is a factor (5)
- (1.9) $2x^3 - x^2 - 13x - 6$, given that $(x + 2)$ is a factor (5)
- (1.10) $2x^3 - 3x^2 - 8x - 3$, given that $(x + 1)$ is a factor (5)

Thanks for your participation!

SESSION 3 ASSESSMENT TEST: GRADE 12-MATHEMATICS

Broad Topic	: Analytical Geometry		
Sub topic	: Determining the centre and radius of a circle		
Marks	:60	Time Allowed	1 hour 15 minutes

INSTRUCTIONS TO THE CANDIDATE:

- Attempt **ALL** questions
- Show **ALL** your working procedures
- Write neatly and legibly
- Write your answers on the answer sheets provided
- Write **ALL** your work in ink

QUESTION Determine the centre and radius of each circle

(1.1) $x^2 - 4x + y^2 + 2y - 20 = 0$ (6)

(1.2) $x^2 - 2x + y^2 + 4y - 31 = 0$ (6)

(1.3) $x^2 + 6x + y^2 - 4y - 12 = 0$ (6)

(1.4) $x^2 + y^2 + 4x + 6y - 3 = 0$ (6)

(1.5) $x^2 + y^2 - 8x - 2y - 20 = 0$ (6)

(1.6) $x^2 + y^2 - 3x + 4y - 3\frac{3}{4} = 0$ (6)

(1.7) $x^2 + y^2 + 6x - 5y - \frac{3}{4} = 0$ (6)

(1.8) $x^2 + y^2 - x - 2y - 5 = 0$ (6)

(1.9) $x^2 + y^2 + 8x - 2y - 47 = 0$ (6)

(1.10) $x^2 + y^2 - 6y - 27 = 0$ (6)

Thanks for your participation!

SESSION 4 ASSESSMENT TEST: GRADE 12 MATHEMATICS

Broad Topic : Coordinate Geometry
Subtopic : Finding the angle between two lines

Marks : 50 Time Allowed : 1 hour

INSTRUCTIONS TO THE CANDIDATE:

- Attempt ALL questions
- Show ALL your working procedures
- Write neatly and legibly
- Write your answers on the separate answer sheets provided

QUESTION: Calculate θ , correct to one decimal digit

(1.1)

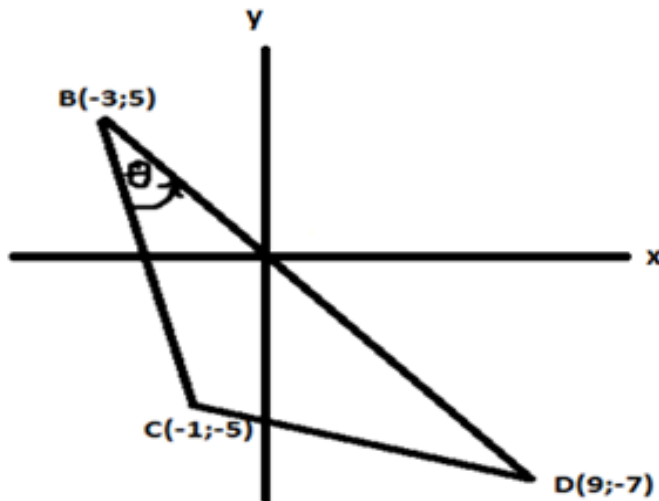

(5)

(1.2)

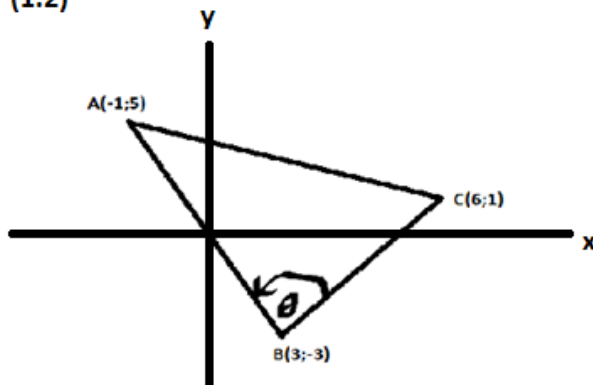

(5)

(1.3)

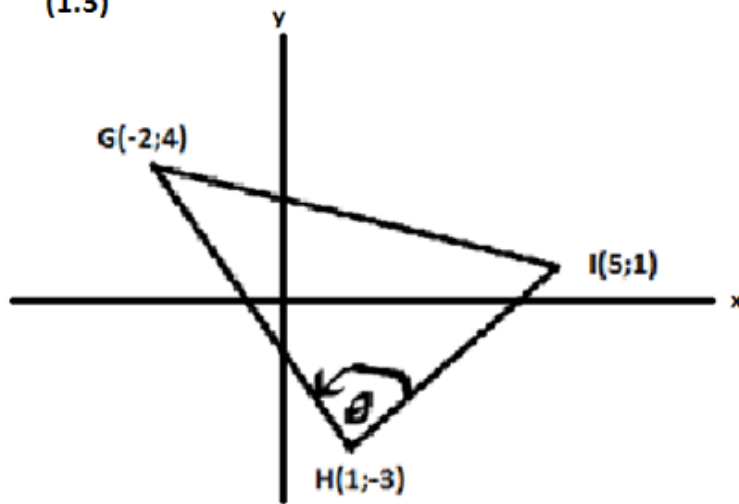

(5)

(1.4)

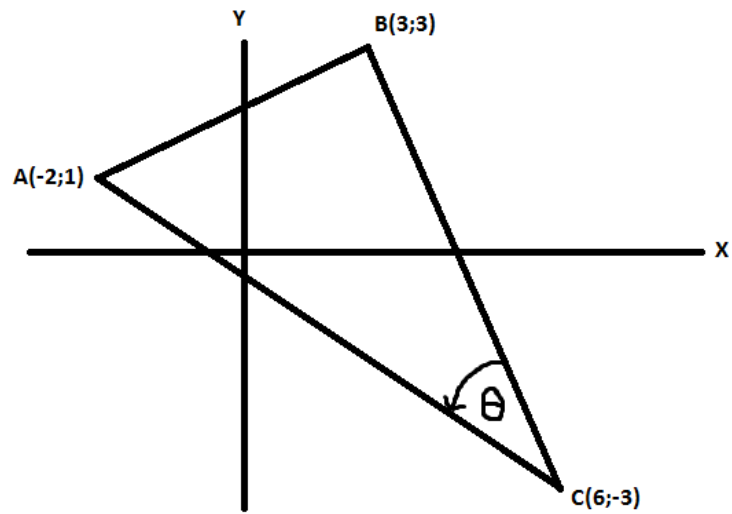

(1.5)

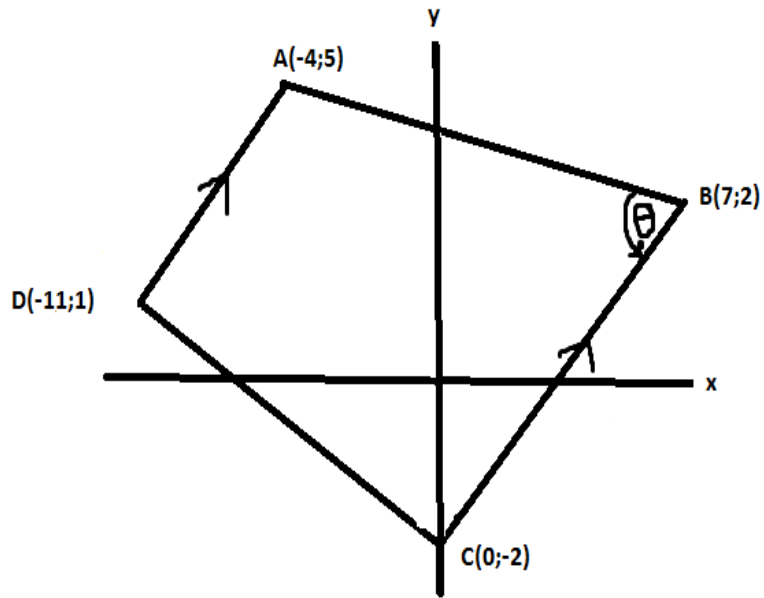

(5)

(1.6)

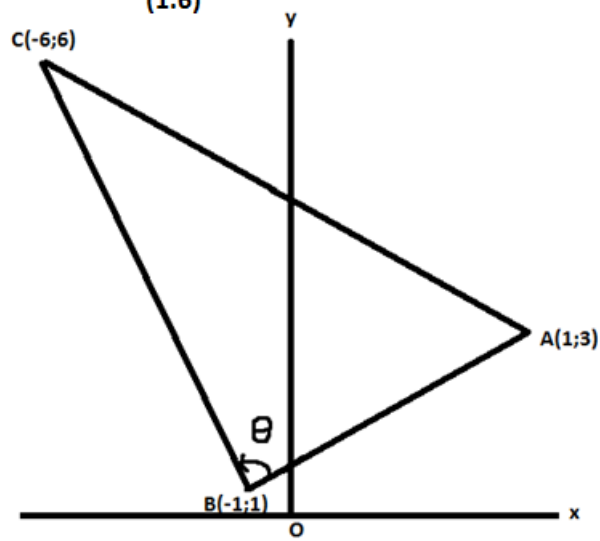

(5)

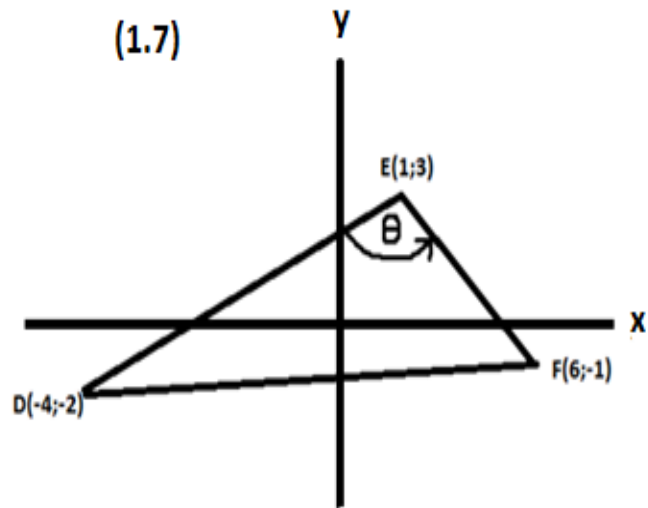

(5)

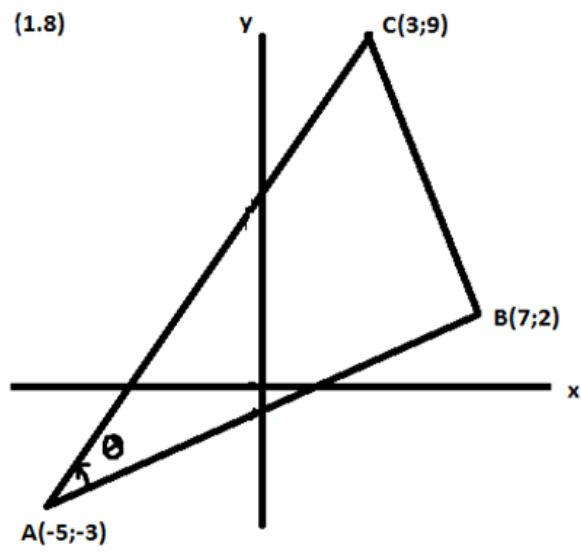

(5)

(1.9)

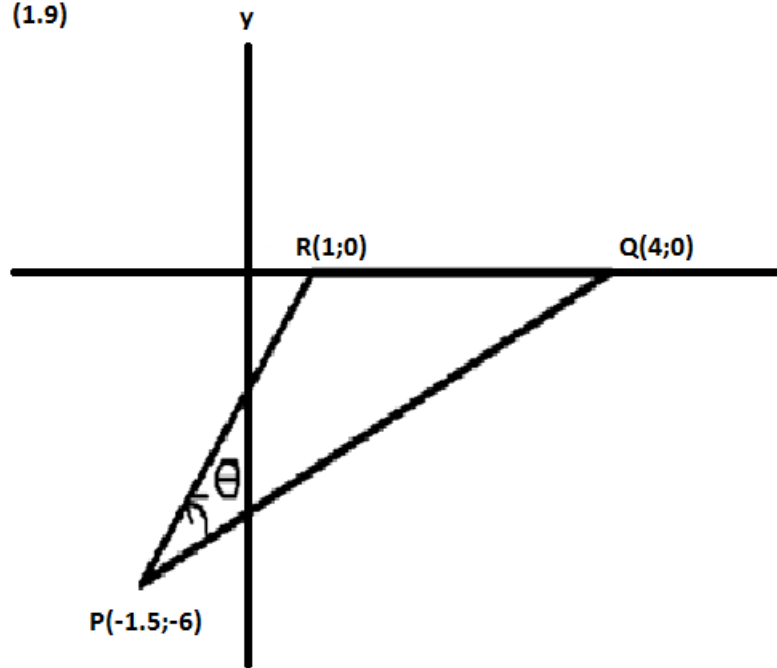

(5)

(1.10)

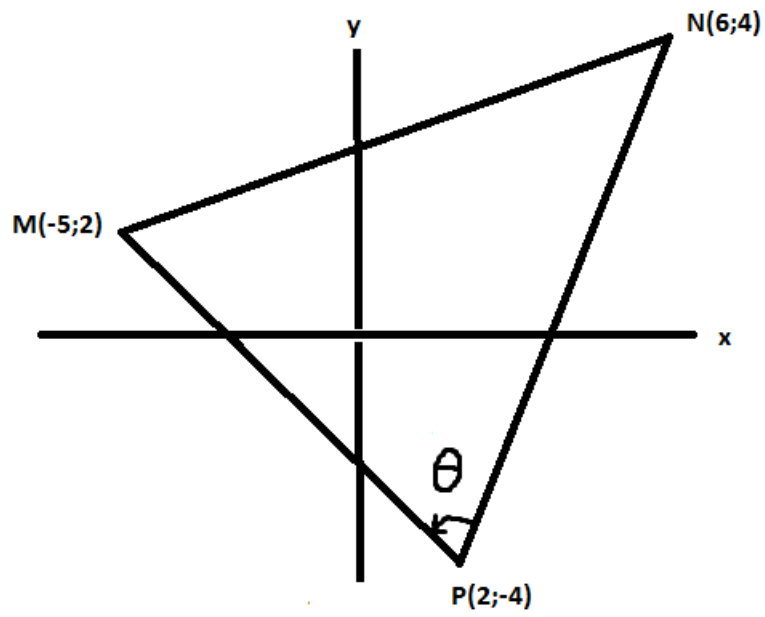

(5)

Marking Guides

ASSESSMENT TEST 1 MARKING GUIDE

METHOD (1)

(1.1)

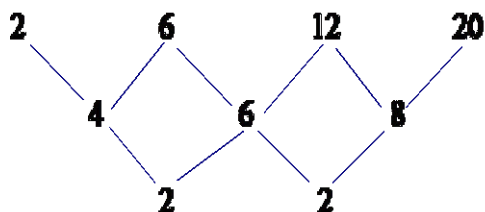

✓

$$a = 2; d_1 = 4; d_2 = 2$$

$$\begin{aligned} \therefore T_n &= a + (n-1)d_1 + \frac{1}{2}(n-1)(n-2)d_2 \\ &= 2 + (n-1)(4) + \frac{1}{2}(n-1)(n-2)(2) \\ &= 2 + 4n - 4 + n^2 - 2n - n + 2 \\ &= n^2 + n \end{aligned}$$

✓✓

✓

✓

[5]

(1.2)

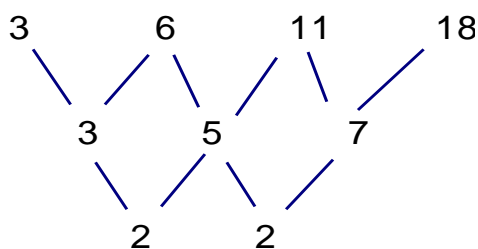

✓

$$a = 3; d_1 = 3; d_2 = 2$$

$$\begin{aligned} \therefore T_n &= a + (n-1)d_1 + \frac{1}{2}(n-1)(n-2)d_2 \\ &= 3 + (n-1)(3) + \frac{1}{2}(n-1)(n-2)(2) \end{aligned}$$

✓✓

$$= 3 + 3n - 3 + n^2 - 2n - n + 2 \quad \checkmark$$

$$= n^2 + 2 \quad \checkmark$$

[5]

(1.3)

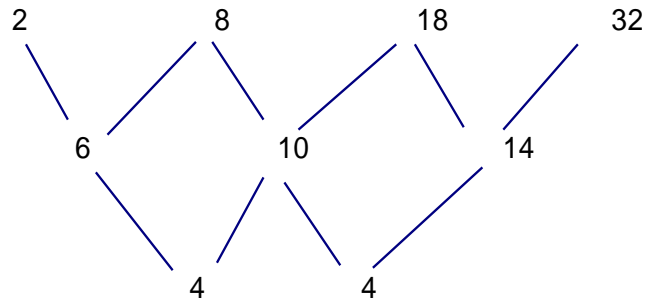

✓

$$a = 2; d_1 = 6; d_2 = 4$$

$$\begin{aligned} \therefore T_n &= a + (n-1)d_1 + \frac{1}{2}(n-1)(n-2)d_2 \\ &= 2 + (n-1)(6) + \frac{1}{2}(n-1)(n-2)(4) \quad \checkmark\checkmark \\ &= 2 + 6n - 6 + 2n^2 - 4n - 2n + 4 \quad \checkmark \\ &= 2n^2 \quad \checkmark \end{aligned}$$

[5]

(1.4)

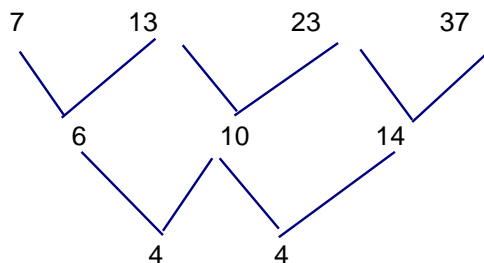

✓

$$a = 7; d_1 = 6; d_2 = 4$$

$$\begin{aligned}
\therefore T_n &= a + (n-1)d_1 + \frac{1}{2}(n-1)(n-2)d_2 \\
&= 7 + (n-1)(6) + \frac{1}{2}(n-1)(n-2)(4) \\
&= 7 + 6n - 6 + 2n^2 - 4n - 2n + 4 \\
&= 2n^2 + 5
\end{aligned}$$

✓✓
✓
✓
(1.5)
[5]

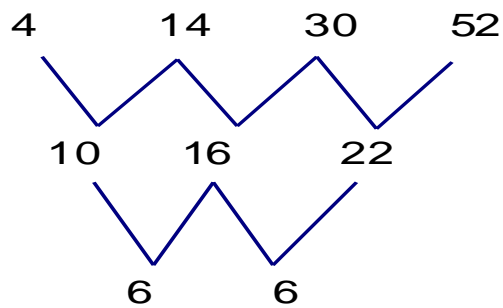

✓

$$a = 4; d_1 = 10; d_2 = 6$$

$$\begin{aligned}
\therefore T_n &= a + (n-1)d_1 + \frac{1}{2}(n-1)(n-2)d_2 \\
&= 4 + (n-1)(10) + \frac{1}{2}(n-1)(n-2)(6) \\
&= 4 + 10n - 10 + 3n^2 - 6n - 3n + 6 \\
&= 3n^2 + n
\end{aligned}$$

✓✓
✓
✓
(1.6)
[5]

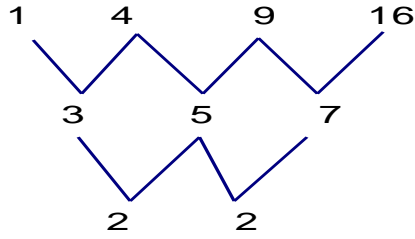

✓

$$a = 1; d_1 = 3; d_2 = 2$$

$$\begin{aligned} \therefore T_n &= a + (n-1)d_1 + \frac{1}{2}(n-1)(n-2)d_2 \\ &= 1 + (n-1)(3) + \frac{1}{2}(n-1)(n-2)(2) \\ &= 1 + 3n - 3 + n^2 - 2n - n + 2 \\ &= n^2 \end{aligned}$$

✓✓

✓

✓

[5]

(1.7)

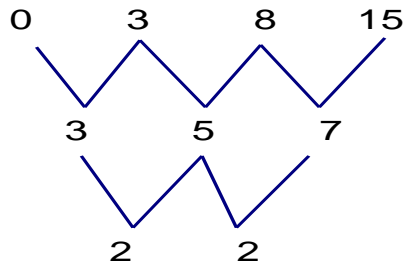

✓

$$a = 0; d_1 = 3; d_2 = 2$$

$$\begin{aligned} \therefore T_n &= a + (n-1)d_1 + \frac{1}{2}(n-1)(n-2)d_2 \\ &= 0 + (n-1)(3) + \frac{1}{2}(n-1)(n-2)(2) \\ &= 3n - 3 + n^2 - 2n - n + 2 \\ &= n^2 - 1 \end{aligned}$$

✓✓

✓

✓

[5]

(1.8)

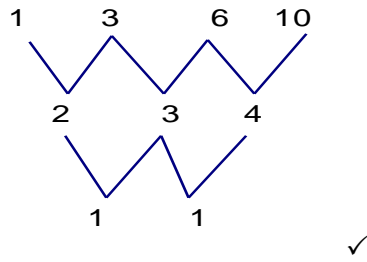

$$a = 1; d_1 = 2; d_2 = 1$$

$$\begin{aligned} \therefore T_n &= a + (n-1)d_1 + \frac{1}{2}(n-1)(n-2)d_2 && \checkmark\checkmark \\ &= 1 + (n-1)(2) + \frac{1}{2}(n-1)(n-2)(1) \\ &= 1 + 2n - 2 + \frac{1}{2}(n^2 - 3n + 2) \\ &= 2n - 1 + \frac{1}{2}n^2 - \frac{3}{2}n + 1 && \checkmark \\ &= \frac{1}{2}n^2 + \frac{1}{2}n && \checkmark \end{aligned}$$

[5]

(1.9)

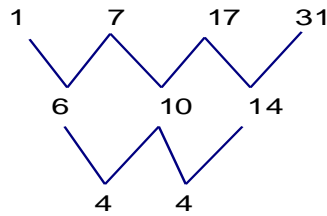

$$a = 1; d_1 = 6; d_2 = 4$$

$$\begin{aligned} \therefore T_n &= a + (n-1)d_1 + \frac{1}{2}(n-1)(n-2)d_2 && \checkmark\checkmark \\ &= 1 + (n-1)(6) + \frac{1}{2}(n-1)(n-2)(4) \\ &= 1 + 6n - 6 + 2n^2 - 4n - 2n + 4 && \checkmark \\ &= 2n^2 - 1 && \checkmark \end{aligned}$$

[5]

(1.10)

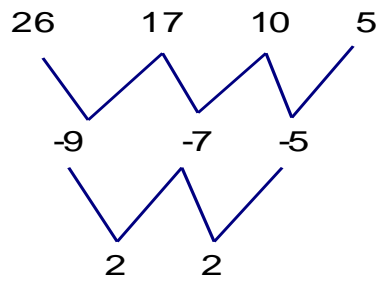

✓

$$a = 26; d_1 = -9; d_2 = 2$$

$$\begin{aligned} \therefore T_n &= a + (n-1)d_1 + \frac{1}{2}(n-1)(n-2)d_2 \\ &= 26 + (n-1)(-9) + \frac{1}{2}(n-1)(n-2)(2) \\ &= 26 - 9n + 9 + n^2 - 3n + 2 \\ &= n^2 - 12n + 37 \end{aligned}$$

✓✓

✓

✓

[5]

METHOD (2)

(1.1)

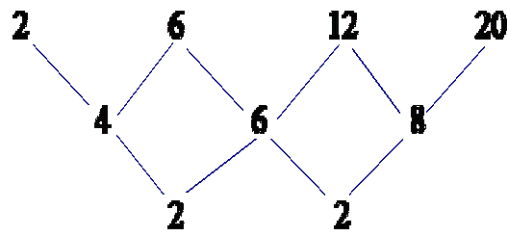

$$2a = 2 \Rightarrow a = 1 \checkmark$$

Sequence	2	6	12	20	
$1. n^2$	1	4	9	16	✓
Residue	1	2	3	4	✓

$$\begin{aligned} \text{Residue: } T_n &= a + (n-1)d \\ &= 1 + (n-1)1 \\ &= n \\ \therefore T_n &= n^2 + n \end{aligned} \quad \begin{array}{l} \checkmark \\ \checkmark \end{array}$$

[5]

(1.2)

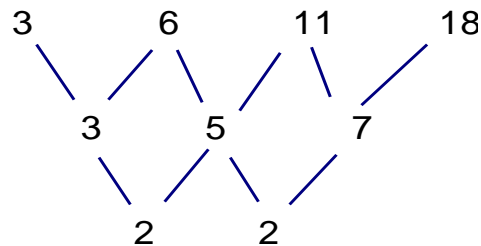

$$2a = 2 \Rightarrow a = 1 \checkmark$$

Sequence	3	6	11	18	
$1. n^2$	1	4	9	16	✓
Residue	2	2	2	2	✓

$$\begin{aligned} \text{Residue is constant} &\Rightarrow c = 2 \quad \checkmark \\ \therefore T_n &= n^2 + 2 \quad \checkmark \end{aligned} \quad [5]$$

(1.3)

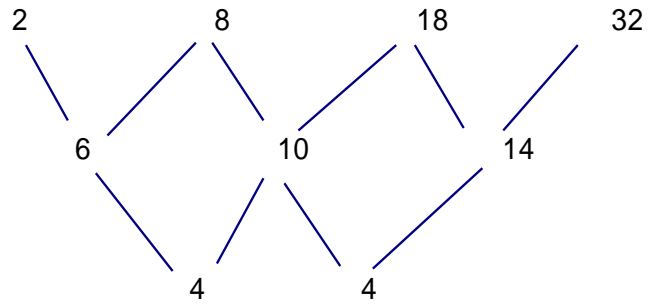

$$2a = 4 \Rightarrow a = 2 \checkmark$$

Sequence	2	8	18	32	
$2 \cdot n^2$	2	8	18	32	✓
Residue	0	0	0	0	✓

$$\begin{aligned} \text{Residue is constant} &\Rightarrow c = 0 \quad \checkmark \\ \therefore T_n &= 2n^2 \quad \checkmark \end{aligned} \quad [5]$$

(1.4)

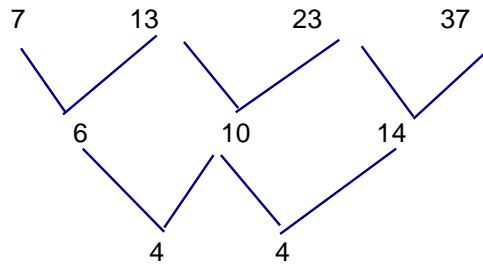

$$2a = 4 \Rightarrow a = 2 \checkmark$$

Sequence	7	13	23	37	
$2 \cdot n^2$	2	8	18	32	✓
Residue	5	5	5	5	✓

$$\begin{aligned} \text{Residue is constant} &\Rightarrow c = 5 \quad \checkmark \\ \therefore T_n &= 2n^2 + 5 \quad \checkmark \end{aligned} \quad [5]$$

(1.5)

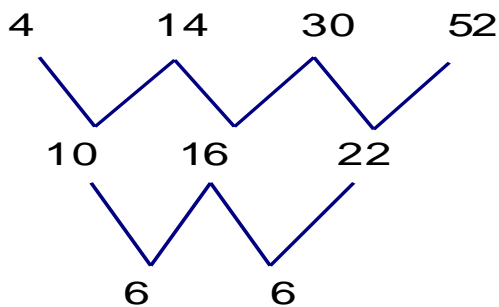

$$2a = 6 \Rightarrow a = 3 \checkmark$$

Sequence	4	14	30	52	
$3 \cdot n^2$	3	12	27	48	✓
Residue	1	2	3	4	✓

$$\begin{aligned} \text{Residue: } T_n &= a + (n-1)d \\ &= 1 + (n-1)1 \\ &= n \quad \checkmark \\ \therefore T_n &= 3n^2 + n \quad \checkmark \end{aligned}$$

[5]

(1.6)

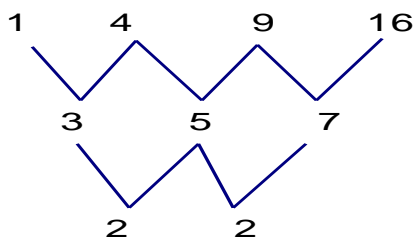

$$2a = 2 \Rightarrow a = 1 \checkmark$$

Sequence	1	4	9	16	
$1 \cdot n^2$	1	4	9	16	✓
Residue	0	0	0	0	✓

$$\begin{aligned} \text{Residue is constant} &\Rightarrow c = 0 \quad \checkmark \\ \therefore T_n &= n^2 \quad \checkmark \end{aligned}$$

[5]

(1.7)

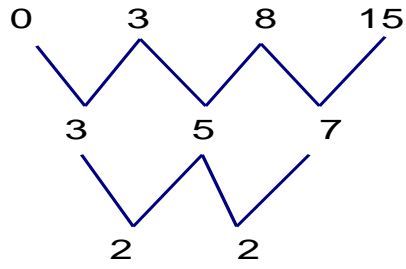

$$2a = 2 \Rightarrow a = 1 \checkmark$$

Sequence	0	3	8	15	
$1 \cdot n^2$	1	4	9	16	✓
Residue	-1	-1	-1	-1	✓

Residue is constant $\Rightarrow c = -1 \checkmark$
 $\therefore T_n = n^2 - 1 \checkmark$
[5]

(1.8)

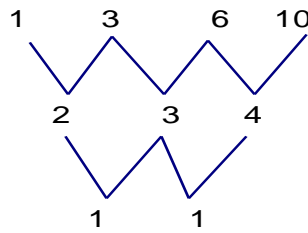

$$2a = 1 \Rightarrow a = \frac{1}{2} \checkmark$$

Sequence	1	3	6	10	
$\frac{1}{2}n^2$	$\frac{1}{2}$	2	$\frac{9}{2}$	8	✓
Residue	$\frac{1}{2}$	1	$\frac{3}{2}$	2	✓

Residue: $T_n = a + (n-1)d$
 $= \frac{1}{2} + (n-1)\frac{1}{2}$
 $= \frac{1}{2}n \checkmark$
 $\therefore T_n = \frac{1}{2}n^2 + \frac{1}{2}n \checkmark$
[5]

(1.9)

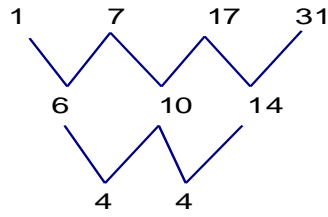

$$2a = 4 \Rightarrow a = 2 \checkmark$$

Sequence	1	7	17	31	
$2 \cdot n^2$	2	8	18	32	✓
Residue	-1	-1	-1	-1	✓

$$\begin{aligned} \text{Residue is constant} &\Rightarrow c = -1 \quad \checkmark \\ \therefore T_n &= 2n^2 - 1 \quad \checkmark \end{aligned} \quad [5]$$

(1.10)

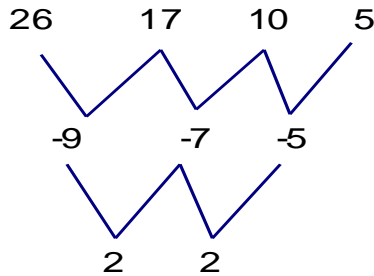

$$2a = 2 \Rightarrow a = 1 \checkmark$$

Sequence	26	17	10	5	
$1 \cdot n^2$	1	4	9	16	✓
Residue	25	13	1	-11	✓

$$\begin{aligned} \text{Residue:} \quad T_n &= a + (n-1)d \\ &= 25 + (n-1)(-12) \\ &= 37 - 12n \quad \checkmark \\ \therefore T_n &= n^2 - 12n + 37 \quad \checkmark \end{aligned} \quad [5]$$

METHOD (3)

(1.1)

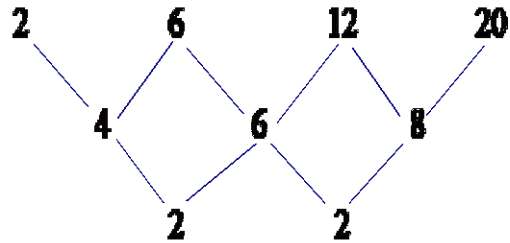

✓

$$2a = 2$$

$$\Rightarrow a = 1 \quad \checkmark$$

$$3a + b = 4$$

$$3(1) + b = 4$$

$$\Rightarrow b = 1 \quad \checkmark$$

$$a + b + c = 2$$

$$1 + 1 + c = 2$$

$$\Rightarrow c = 0 \quad \checkmark$$

$$\therefore T_n = n^2 + n \quad \checkmark$$

[5]

(1.2)

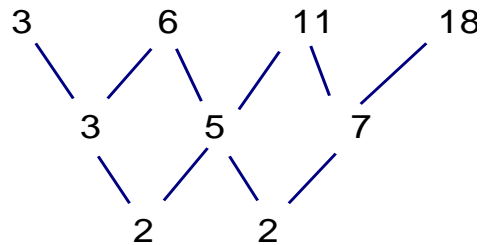

✓

$$2a = 2$$

$$\Rightarrow a = 1 \quad \checkmark$$

$$3a + b = 3$$

$$\begin{aligned}
 3(1)+b &= 3 \\
 \Rightarrow b &= 0 \quad \checkmark
 \end{aligned}$$

$$\begin{aligned}
 a+b+c &= 2 \\
 1+0+c &= 3 \\
 \Rightarrow c &= 2 \quad \checkmark
 \end{aligned}$$

$$\therefore T_n = n^2 + 2 \quad \checkmark$$

[5]

(1.3)

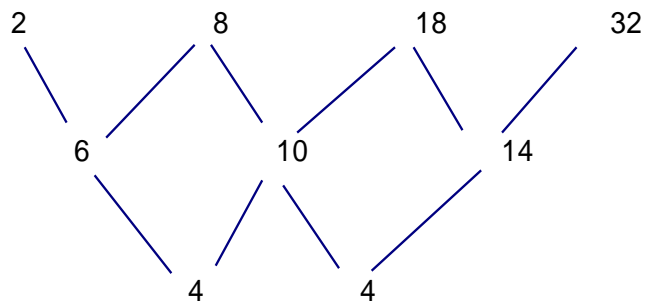

✓

$$\begin{aligned}
 2a &= 4 \\
 \Rightarrow a &= 2 \quad \checkmark
 \end{aligned}$$

$$\begin{aligned}
 3a+b &= 6 \\
 3(2)+b &= 6 \\
 \Rightarrow b &= 0 \quad \checkmark
 \end{aligned}$$

$$\begin{aligned}
 a+b+c &= 2 \\
 2+0+c &= 2 \\
 \Rightarrow c &= 0 \quad \checkmark
 \end{aligned}$$

$$\therefore T_n = 2n^2 \quad \checkmark$$

[5]

(1.4)

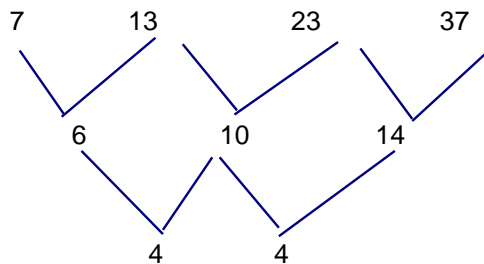

✓

$$\begin{aligned} 2a &= 4 \\ \Rightarrow a &= 2 \end{aligned} \quad \checkmark$$

$$\begin{aligned} 3a + b &= 6 \\ 3(1) + b &= 6 \\ \Rightarrow b &= 0 \end{aligned} \quad \checkmark$$

$$\begin{aligned} a + b + c &= 7 \\ 2 + 0 + c &= 7 \\ \Rightarrow c &= 5 \end{aligned} \quad \checkmark$$

$$\therefore T_n = 2n^2 + 5 \quad \checkmark$$

[5]

(1.5)

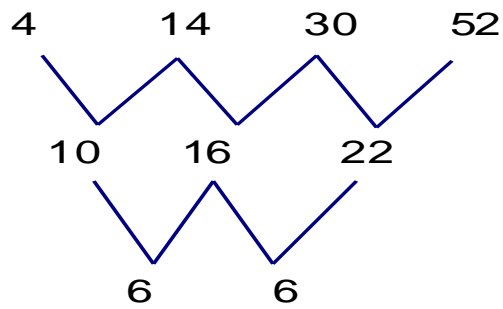

✓

$$\begin{aligned} 2a &= 6 \\ \Rightarrow a &= 3 \end{aligned} \quad \checkmark$$

$$\begin{aligned} 3a + b &= 10 \\ 3(3) + b &= 10 \\ \Rightarrow b &= 1 \end{aligned} \quad \checkmark$$

$$\begin{aligned} a + b + c &= 4 \\ 3 + 1 + c &= 4 \\ \Rightarrow c &= 0 \end{aligned} \quad \checkmark$$

$$\therefore T_n = 3n^2 + n \quad \checkmark$$

[5]

(1.6)

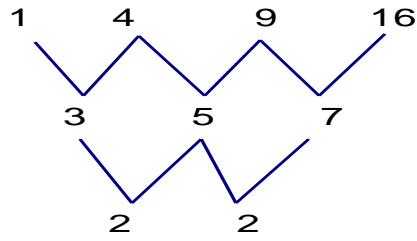

✓

$$\begin{aligned} 2a &= 2 \\ \Rightarrow a &= 1 \end{aligned}$$

✓

$$\begin{aligned} 3a + b &= 3 \\ 3(1) + b &= 3 \\ \Rightarrow b &= 0 \end{aligned}$$

✓

$$\begin{aligned} a + b + c &= 1 \\ 1 + 0 + c &= 1 \\ \Rightarrow c &= 0 \end{aligned}$$

✓

$$\therefore T_n = n^2$$

✓

[5]

(1.7)

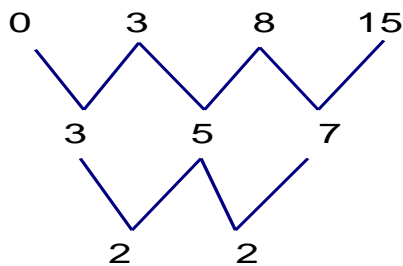

✓

$$\begin{aligned} 2a &= 2 \\ \Rightarrow a &= 1 \end{aligned}$$

✓

$$\begin{aligned} 3a + b &= 3 \\ 3(1) + b &= 3 \\ \Rightarrow b &= 0 \end{aligned}$$

✓

$$\begin{aligned} a + b + c &= 0 \\ 1 + 0 + c &= 0 \\ \Rightarrow c &= -1 \end{aligned}$$

✓

$$\therefore T_n = n^2 - 1$$

✓

[5]

(1.8)

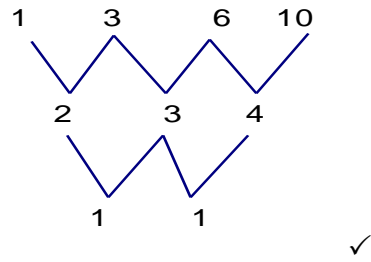

$$\begin{aligned} 2a &= 1 \\ \Rightarrow a &= \frac{1}{2} \end{aligned} \quad \checkmark$$

$$\begin{aligned} 3a + b &= 2 \\ 3\left(\frac{1}{2}\right) + b &= 2 \\ \Rightarrow b &= \frac{1}{2} \end{aligned} \quad \checkmark$$

$$\begin{aligned} a + b + c &= 1 \\ \frac{1}{2} + \frac{1}{2} + c &= 1 \\ \Rightarrow c &= 0 \end{aligned} \quad \checkmark$$

$$\therefore T_n = \frac{1}{2}n^2 + \frac{1}{2}n \quad \checkmark$$

[5]

(1.9)

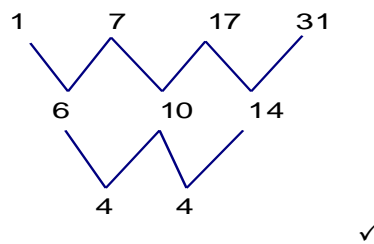

$$\begin{aligned} 2a &= 4 \\ \Rightarrow a &= 2 \end{aligned} \quad \checkmark$$

$$\begin{aligned} 3a + b &= 6 \\ 3(2) + b &= 6 \\ \Rightarrow b &= 0 \end{aligned} \quad \checkmark$$

$$\begin{aligned}
 a + b + c &= 1 \\
 2 + 0 + c &= 1 \\
 \Rightarrow c &= -1 \quad \checkmark \\
 \\
 \therefore T_n &= 2n^2 - 1 \quad \checkmark \\
 & \quad \quad \quad \mathbf{[5]}
 \end{aligned}$$

(1.10)

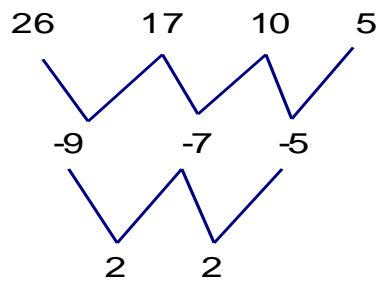

✓

$$\begin{aligned}
 2a &= 2 \\
 \Rightarrow a &= 1 \quad \checkmark \\
 \\
 3a + b &= -9 \\
 3(1) + b &= -9 \\
 \Rightarrow b &= -12 \quad \checkmark \\
 \\
 a + b + c &= 26 \\
 1 - 12 + c &= 26 \\
 \Rightarrow c &= -37 \quad \checkmark \\
 \\
 \therefore T_n &= n^2 - 12n + 37 \quad \checkmark \\
 & \quad \quad \quad \mathbf{[5]}
 \end{aligned}$$

METHOD (4)

(1.1)

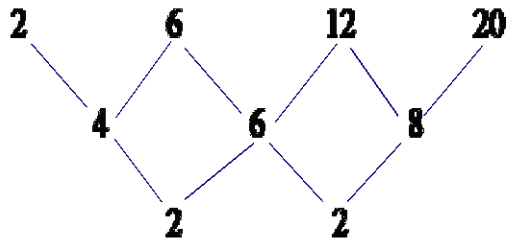

$$\begin{aligned}
 2a &= 2 && \\
 \Rightarrow a &= 1 && \checkmark \\
 \therefore T_n &= 1 \cdot n^2 + bn + c && \\
 (1;2): 1(1)^2 + b(1) + c &= 2 && \\
 b + c &= 1 \dots (1) && \\
 (2;6): 1(2)^2 + b(2) + c &= 6 && \\
 2b + c &= 2 \dots (2) && \checkmark \\
 (2) - (1): b &= 1 && \checkmark \\
 \text{From (1): } c &= 1 - b && \\
 &= 1 - 1 && \\
 &= 0 && \checkmark \\
 \therefore T_n &= n^2 + n && \checkmark \\
 &&& [5]
 \end{aligned}$$

(1.2)

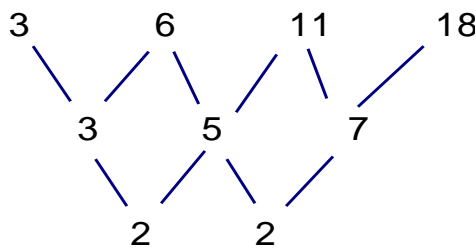

$$\begin{aligned}
 2a &= 2 && \\
 \Rightarrow a &= 1 && \checkmark \\
 \therefore T_n &= 1 \cdot n^2 + bn + c && \\
 (1;3): 1(1)^2 + b(1) + c &= 3 && \\
 b + c &= 2 \dots (1) && \\
 (2;6): 1(2)^2 + b(2) + c &= 6 && \\
 2b + c &= 2 \dots (2) && \checkmark \\
 (2) - (1): b &= 0 && \checkmark \\
 \text{From (1): } c &= 2 - b &&
 \end{aligned}$$

$$\begin{aligned}
 &= 2 - 0 \\
 &= 2 \\
 \therefore T_n &= n^2 + 2
 \end{aligned}
 \begin{array}{l}
 \checkmark \\
 \checkmark \\
 [5]
 \end{array}$$

(1.3)

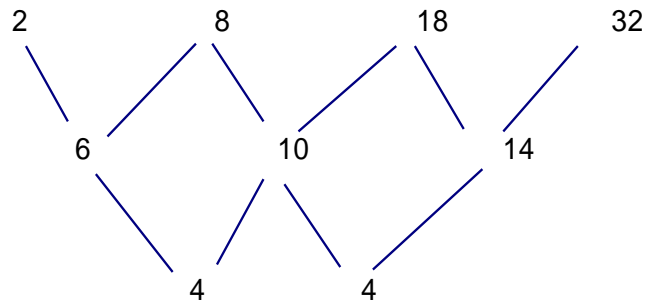

$$\begin{aligned}
 2a &= 4 \\
 \Rightarrow a &= 2 \\
 \therefore T_n &= 2n^2 + bn + c \\
 (1;2): 2(1)^2 + b(1) + c &= 2 \\
 b + c &= 0 \dots (1) \\
 (2;8): 2(2)^2 + b(2) + c &= 8 \\
 2b + c &= 0 \dots (2) \\
 (2) - (1): b &= 0 \\
 \text{From (1): } c &= 0 - b \\
 &= 0 - 0 \\
 &= 0 \\
 \therefore T_n &= 2n^2
 \end{aligned}
 \begin{array}{l}
 \checkmark \\
 \checkmark \\
 \checkmark \\
 \checkmark \\
 \checkmark \\
 \checkmark \\
 [5]
 \end{array}$$

(1.4)

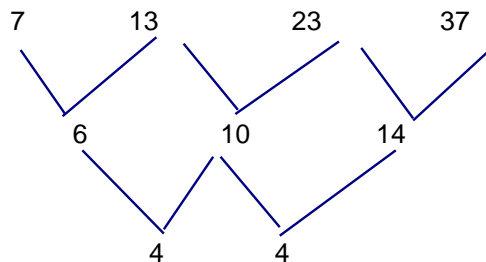

$$\begin{aligned}
 2a &= 4 \\
 \Rightarrow a &= 2 \\
 \therefore T_n &= 2n^2 + bn + c \\
 (1;7): 2(1)^2 + b(1) + c &= 7 \\
 b + c &= 5 \dots (1) \\
 (2;13): 2(2)^2 + b(2) + c &= 13 \\
 2b + c &= 5 \dots (2)
 \end{aligned}
 \begin{array}{l}
 \checkmark \\
 \checkmark \\
 \checkmark \\
 \checkmark \\
 \checkmark
 \end{array}$$

$$\begin{aligned}
 (2) - (1): \quad b &= 0 && \checkmark \\
 \text{From (1):} \quad c &= 5 - b && \\
 &= 5 - 0 && \\
 &= 5 && \checkmark \\
 \therefore T_n &= 2n^2 + 5 && \checkmark \\
 &&& \mathbf{[5]}
 \end{aligned}$$

(1.5)

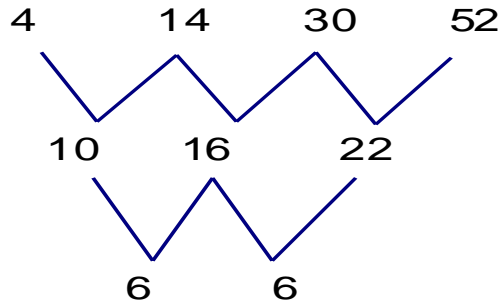

$$\begin{aligned}
 2a &= 6 && \\
 \Rightarrow a &= 3 && \checkmark \\
 \therefore T_n &= 3n^2 + bn + c && \\
 (1;4): \quad 3(1)^2 + b(1) + c &= 4 && \\
 \quad b + c &= 1 \dots (1) && \\
 (2;14): \quad 3(2)^2 + b(2) + c &= 14 && \\
 \quad 2b + c &= 2 \dots (2) && \checkmark \\
 (2) - (1): \quad b &= 1 && \checkmark \\
 \text{From (1):} \quad c &= 1 - b && \\
 &= 1 - 1 && \\
 &= 0 && \checkmark \\
 \therefore T_n &= 3n^2 + n && \checkmark \\
 &&& \mathbf{[5]}
 \end{aligned}$$

(1.6)

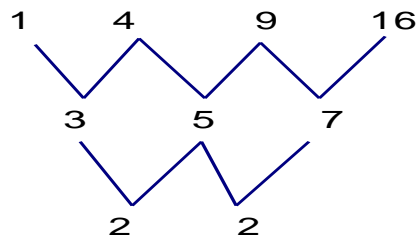

$$\begin{aligned}
 2a &= 2 && \\
 \Rightarrow a &= 1 && \checkmark
 \end{aligned}$$

$$\begin{aligned}
& \therefore T_n = 1 \cdot n^2 + bn + c \\
(1;1): \quad & 1(1)^2 + b(1) + c = 1 \\
& \quad \quad \quad b + c = 0 \dots (1) \\
(2;4): \quad & 1(2)^2 + b(2) + c = 4 \\
& \quad \quad \quad 2b + c = 0 \dots (2) \quad \checkmark \\
(2) - (1): \quad & \quad b = 0 \quad \checkmark \\
\text{From (1):} \quad & \quad c = 0 - b \\
& \quad \quad \quad = 0 - 0 \\
& \quad \quad \quad = 0 \quad \checkmark \\
& \therefore T_n = n^2 \quad \checkmark
\end{aligned}$$

[5]

(1.7)

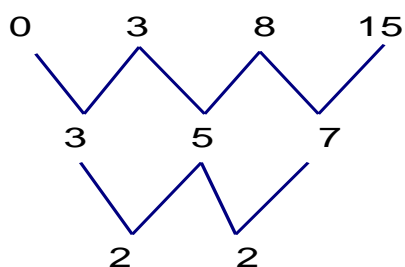

$$\begin{aligned}
& 2a = 2 \\
& \Rightarrow a = 1 \quad \checkmark \\
& \therefore T_n = 1 \cdot n^2 + bn + c \\
(1;0): \quad & 1(1)^2 + b(1) + c = 0 \\
& \quad \quad \quad b + c = -1 \dots (1) \\
(2;3): \quad & 1(2)^2 + b(2) + c = 3 \\
& \quad \quad \quad 2b + c = -1 \dots (2) \quad \checkmark \\
(2) - (1): \quad & \quad b = 0 \quad \checkmark \\
\text{From (1):} \quad & \quad c = -1 - b \\
& \quad \quad \quad = -1 - 0 \\
& \quad \quad \quad = -1 \quad \checkmark \\
& \therefore T_n = n^2 - 1 \quad \checkmark
\end{aligned}$$

[5]

(1.8)

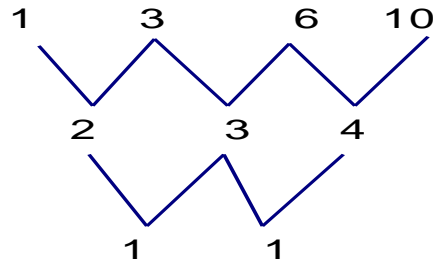

$$\begin{aligned}
 2a &= 1 \\
 \Rightarrow a &= \frac{1}{2} \quad \checkmark \\
 \therefore T_n &= \frac{1}{2} \cdot n^2 + bn + c \\
 (1;1): \frac{1}{2} (1)^2 + b(1) + c &= 1 \\
 b + c &= \frac{1}{2} \dots (1) \\
 (2;3): \frac{1}{2} (2)^2 + b(2) + c &= 3 \\
 2b + c &= 1 \dots (2) \quad \checkmark \\
 (2) - (1): \quad b &= \frac{1}{2} \quad \checkmark \\
 \text{From (1):} \quad c &= \frac{1}{2} - b \\
 &= \frac{1}{2} - \frac{1}{2} \\
 &= 0 \quad \checkmark \\
 \therefore T_n &= \frac{1}{2}n^2 + \frac{1}{2}n \quad \checkmark \\
 & \quad \quad \quad [5]
 \end{aligned}$$

(1.9)

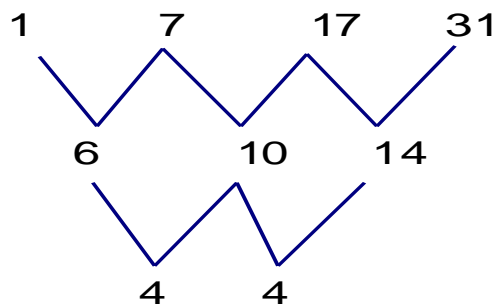

$$\begin{aligned}
 2a &= 4 \\
 \Rightarrow a &= 2 \quad \checkmark \\
 \therefore T_n &= 2 \cdot n^2 + bn + c \\
 (1;1): 2(1)^2 + b(1) + c &= 1 \\
 b + c &= -1 \dots (1) \\
 (2;7): 2(2)^2 + b(2) + c &= 7
 \end{aligned}$$

$$\begin{aligned}
2b + c &= -1 \dots (2) && \checkmark \\
(2) - (1): \quad b &= 0 && \checkmark \\
\text{From (1):} \quad c &= -1 - b && \\
&= -1 - 0 && \\
&= -1 && \checkmark \\
\therefore T_n &= 2n^2 - 1 && \checkmark \\
&&& \mathbf{[5]}
\end{aligned}$$

(1.10)

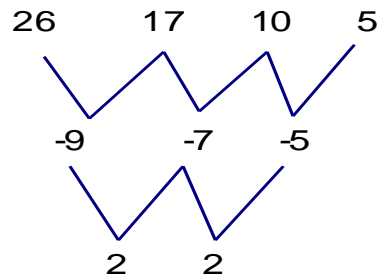

$$\begin{aligned}
2a &= 2 && \\
\Rightarrow a &= 1 && \checkmark \\
\therefore T_n &= 1 \cdot n^2 + bn + c && \\
(1; 26): \quad 1(1)^2 + b(1) + c &= 26 && \\
b + c &= 25 \dots (1) && \\
(2; 17): \quad 1(2)^2 + b(2) + c &= 17 && \\
2b + c &= 13 \dots (2) && \checkmark \\
(2) - (1): \quad b &= -12 && \checkmark \\
\text{From (1):} \quad c &= 25 - b && \\
&= 25 - (-12) && \\
&= 37 && \checkmark \\
\therefore T_n &= n^2 - 12n + 37 && \checkmark \\
&&& \mathbf{[5]}
\end{aligned}$$

ASSESSMENT TEST 2 MARKING GUIDE

METHOD (1): EQUATING COEFFICIENTS

(1.1)

$$\begin{aligned}
 x^3 - 2x^2 - 9x + 18 &= (x - 2)(ax^2 + bx + c) \\
 &= ax^3 + bx^2 + cx - 2ax^2 - 2bx - 2c
 \end{aligned}$$

Equating coefficients of x^3 : $1 = a$ ✓

Equating coefficients of x^2 : $-2 = b - 2a$

$$\begin{aligned}
 -2 &= b - 2(1) \\
 -2 + 2 &= b \\
 \therefore 0 &= b \quad \checkmark
 \end{aligned}$$

Equating coefficients of x : $-9 = c - 2b$

$$\begin{aligned}
 -9 &= c - 2(0) \\
 \therefore -9 &= c \quad \checkmark
 \end{aligned}$$

Or equating constants: $18 = -2c$

$$\begin{aligned}
 -9 &= c \\
 \therefore x^3 - 2x^2 - 9x + 18 &= (x - 2)(x^2 - 9) \quad \checkmark \\
 &= (x - 2)(x - 3)(x + 3) \quad \checkmark
 \end{aligned}$$

[5]

(1.2)

$$\begin{aligned}
 x^3 - 2x^2 - 5x + 6 &= (x - 1)(ax^2 + bx + c) \\
 &= ax^3 + bx^2 + cx - ax^2 - bx - c
 \end{aligned}$$

Equating coefficients of x^3 : $1 = a$ ✓

Equating coefficients of x^2 : $-2 = b - a$

$$\begin{aligned}
 -2 &= b - 1 \\
 -2 + 1 &= b \\
 \therefore -1 &= b \quad \checkmark
 \end{aligned}$$

Equating coefficients of x : $-5 = c - b$

$$\begin{aligned}
 -5 &= c - (-1) \\
 \therefore -6 &= c \quad \checkmark
 \end{aligned}$$

Or equating constants: $6 = -c$

$$\begin{aligned}
 -6 &= c \\
 x^3 - 2x^2 - 5x + 6 &= (x - 1)(x^2 - x - 6) \quad \checkmark \\
 &= (x - 1)(x - 3)(x + 2) \quad \checkmark
 \end{aligned}$$

[5]

(1.3)

$$\begin{aligned}
 x^3 - 4x^2 - 3x + 18 &= (x - 3)(ax^2 + bx + c) \\
 &= ax^3 + bx^2 + cx - 3ax^2 - 3bx - 3c
 \end{aligned}$$

Equating coefficients of x^3 : $1 = a$ ✓

Equating coefficients of x^2 : $-4 = b - 3a$

$$\begin{aligned}
 -4 &= b - 3(1)
 \end{aligned}$$

$$\begin{aligned}
-4 + 3 &= b && \checkmark \\
\therefore -1 &= b && \checkmark \\
\text{Equating coefficients of } x: -3 &= c - 3b \\
-3 &= c - 3(-1) \\
\therefore -6 &= c && \checkmark \\
\text{Or equating constants: } 18 &= -3c \\
-6 &= c \\
\therefore x^3 - 4x^2 - 3x + 18 &= (x - 3)(x^2 - x - 6) && \checkmark \\
&= (x - 3)(x - 3)(x + 2) && \checkmark \\
&&& [5]
\end{aligned}$$

(1.4)

$$\begin{aligned}
x^3 - 2x^2 + 4x - 8 &= (x - 2)(ax^2 + bx + c) \\
&= ax^3 + bx^2 + cx - 2ax^2 - 2bx - 2c \\
\text{Equating coefficients of } x^3: 1 &= a && \checkmark \\
\text{Equating coefficients of } x^2: -2 &= b - 2a \\
-2 &= b - 2(1) \\
-2 + 2 &= b \\
\therefore 0 &= b && \checkmark \\
\text{Equating coefficients of } x: 4 &= c - 2b \\
4 &= c - 2(0) \\
\therefore 4 &= c && \checkmark \\
\text{Or equating constants: } -8 &= -2c \\
4 &= c \\
x^3 - 2x^2 + 4x - 8 &= (x - 2)(x^2 + 4) && \checkmark \checkmark \\
&&& [5]
\end{aligned}$$

(1.5)

$$\begin{aligned}
x^3 - 12x + 16 &= (x - 2)(ax^2 + bx + c) \\
&= ax^3 + bx^2 + cx - 2ax^2 - 2bx - 2c \\
\text{Equating coefficients of } x^3: 1 &= a && \checkmark \\
\text{Equating coefficients of } x^2: 0 &= b - 2a \\
0 &= b - 2(1) \\
\therefore 2 &= b && \checkmark \\
\text{Equating coefficients of } x: -12 &= c - 2b \\
-12 &= c - 2(2) \\
\therefore -8 &= c && \checkmark \\
\text{Or equating constants: } 16 &= -2c \\
-8 &= c \\
x^3 - 12x + 16 &= (x - 2)(x^2 + 2x - 8) && \checkmark \\
&= (x - 2)(x - 2)(x + 4) && \checkmark \\
&&& [5]
\end{aligned}$$

(1.6)

$$\begin{aligned}x^3 + 2x^2 - 5x - 6 &= (x - 2)(ax^2 + bx + c) \\ &= ax^3 + bx^2 + cx - 2ax^2 - 2bx \\ &\quad - 2c\end{aligned}$$

Equating coefficients of x^3 : $1 = a$ ✓

Equating coefficients of x^2 : $2 = b - 2a$

$$2 = b - 2(1)$$

$$\therefore 4 = b$$

Equating coefficients of x : $-5 = c - 2b$ ✓

$$-5 = c - 2(4)$$

$$\therefore 3 = c$$

Or equating constants: $-6 = -2c$

$$3 = c$$

$$x^3 + 2x^2 - 5x - 6 = (x - 2)(x^2 + 4x + 3)$$

$$= (x - 2)(x + 3)(x + 1)$$

[5]

(1.7)

$$\begin{aligned}3x^3 - 7x^2 + 4 &= (x - 1)(ax^2 + bx + c) \\ &= ax^3 + bx^2 + cx - ax^2 - bx - c\end{aligned}$$

Equating coefficients of x^3 : $3 = a$ ✓

Equating coefficients of x^2 : $-7 = b - a$

$$-7 = b - 3$$

$$-7 + 3 = b$$

$$\therefore -4 = b$$

Equating coefficients of x : $0 = c - b$

$$0 = c - (-4)$$

$$\therefore -4 = c$$

Or equating constants: $4 = -c$

$$-4 = c$$

$$\therefore 3x^3 - 7x^2 + 4 = (x - 1)(3x^2 - 4x - 4)$$

$$= (x - 1)(3x + 2)(x - 2)$$

[5]

(1.8)

$$\begin{aligned}x^3 - 19x + 30 &= (x + 5)(ax^2 + bx + c) \\ &= ax^3 + bx^2 + cx + 5ax^2 + 5bx \\ &\quad + 5c\end{aligned}$$

Equating coefficients of x^3 : $1 = a$ ✓

Equating coefficients of x^2 : $0 = b + 5a$

$$0 = b + 5(1)$$

$$\therefore -5 = b$$

$$\begin{aligned}
\text{Equating coefficients of } x: -19 &= c + 5b \\
-19 &= c + 5(-5) \\
\therefore 6 &= c && \checkmark \\
\text{Or equating constants: } 30 &= 5c \\
6 &= c \\
x^3 - 19x + 30 &= (x + 5)(x^2 - 5x + 6) && \checkmark \\
&= (x + 5)(x - 3)(x - 2) && \checkmark \\
&&& [5]
\end{aligned}$$

(1.9)

$$\begin{aligned}
2x^3 - x^2 - 13x - 6 &= (x + 2)(ax^2 + bx + c) \\
&= ax^3 + bx^2 + cx + 2ax^2 + 2bx + 2c \\
\text{Equating coefficients of } x^3: 2 &= a && \checkmark \\
\text{Equating coefficients of } x^2: -1 &= b + 2a \\
-1 &= b + 2(2) \\
\therefore -5 &= b && \checkmark \\
\text{Equating coefficients of } x: -13 &= c + 2b \\
-13 &= c + 2(-5) \\
-3 &= c && \checkmark \\
\text{Or equating constants: } -6 &= 2c \\
-3 &= c \\
\therefore 2x^3 - x^2 - 13x - 6 &= (x + 2)(2x^2 - 5x - 3) && \checkmark \\
&= (x + 2)(2x + 1)(x - 3) && \checkmark \\
&&& [5]
\end{aligned}$$

(1.10)

$$\begin{aligned}
2x^3 - 3x^2 - 8x - 3 &= (x + 1)(ax^2 + bx + c) \\
&= ax^3 + bx^2 + cx + ax^2 + bx + c \\
\text{Equating coefficients of } x^3: 2 &= a && \checkmark \\
\text{Equating coefficients of } x^2: -3 &= b + a \\
-3 &= b + 2 \\
\therefore -5 &= b && \checkmark \\
\text{Equating coefficients of } x: -8 &= c + b \\
-8 &= c - 5 \\
-3 &= c && \checkmark \\
\text{Or equating constants: } -3 &= c \\
\therefore 2x^3 - 3x^2 - 8x - 3 &= (x + 1)(2x^2 - 5x - 3) && \checkmark \\
&= (x + 1)(2x + 1)(x - 3) && \checkmark \\
&&& [5]
\end{aligned}$$

METHOD (2): LONG DIVISION

(1.1)
$$\begin{array}{r} x^2 - 9 \\ (x - 2) \overline{\sqrt{x^3 - 2x^2 - 9x + 18}} \\ \underline{-(x^3 - 2x^2)} \\ (-9x + 18) \\ \underline{-(-9x + 18)} \\ 0 \end{array}$$
 ✓

$$\begin{aligned} \therefore x^3 - 2x^2 - 9x + 18 &= (x - 2)(x^2 - 9) && \checkmark \\ &= (x - 2)(x - 3)(x + 3) && \checkmark \\ &&& \mathbf{[5]} \end{aligned}$$

(1.2)
$$\begin{array}{r} x^2 - x - 6 \\ (x - 1) \overline{\sqrt{x^3 - 2x^2 - 5x + 6}} \\ \underline{-(x^3 - x^2)} \\ -x^2 - 5x \\ \underline{-(-x^2 + x)} \\ -6x + 6 \\ \underline{-(6x + 6)} \\ 0 \end{array}$$
 ✓

$$\begin{aligned} \therefore x^3 - 2x^2 - 5x + 6 &= (x - 1)(x^2 - x - 6) && \checkmark \\ &= (x - 1)(x - 3)(x + 2) && \checkmark \\ &&& \mathbf{[5]} \end{aligned}$$

(1.3)
$$\begin{array}{r} x^2 - x - 6 \\ (x - 3) \overline{\sqrt{x^3 - 4x^2 - 3x + 18}} \\ \underline{-(x^3 - 3x^2)} \\ -x^2 - 3x \\ \underline{-(-x^2 + 3x)} \\ -(6x + 18) \\ \underline{-(6x + 18)} \\ 0 \end{array}$$
 ✓

$$\begin{aligned} \therefore x^3 - 4x^2 - 3x + 18 &= (x - 3)(x^2 - x - 6) && \checkmark \\ &= (x - 3)(x - 3)(x + 2) && \checkmark \\ &&& \mathbf{[5]} \end{aligned}$$

(1.4)

$$\begin{array}{r} \sqrt{x^3 - 2x^2 + 4x - 8} \\ \underline{x^2 + 4} \\ x^3 - 2x^2 + 4x - 8 \\ \underline{-(x^3 - 2x^2)} \\ 4x - 8 \\ \underline{-(-4x - 8)} \\ 0 \end{array}$$

✓

✓

✓

$$\therefore x^3 - 2x^2 + 4x - 8 = (x - 2)(x^2 + 4)$$

✓✓

[5]

(1.5)

$$\begin{array}{r} \sqrt{x^3 - 12x + 16} \\ \underline{x^2 + 2x - 8} \\ x^3 - 12x + 16 \\ \underline{-(x^3 - 2x^2)} \\ 2x^2 - 12x \\ \underline{-(2x^2 - 4x)} \\ -8x + 16 \\ \underline{-(-8x + 16)} \\ 0 \end{array}$$

✓

✓

✓

✓

$$\begin{aligned} \therefore x^3 - 12x + 16 &= (x - 2)(x^2 + 2x - 8) \\ &= (x - 2)(x - 2)(x + 4) \end{aligned}$$

✓

[5]

(1.6)

$$\begin{array}{r} \sqrt{x^3 + 2x^2 - 5x - 6} \\ \underline{x^2 + 4x + 3} \\ x^3 + 2x^2 - 5x - 6 \\ \underline{-(x^3 - 2x^2)} \\ 4x^2 - 5x \\ \underline{-(4x^2 - 8x)} \\ 3x - 6 \\ \underline{-(3x - 6)} \\ 0 \end{array}$$

✓

✓

✓

✓

$$\begin{aligned} \therefore x^3 + 2x^2 - 5x - 6 &= (x - 2)(x^2 + 4x + 3) \\ &= (x - 2)(x + 3)(x + 1) \end{aligned}$$

✓

[5]

(1.7)

$$(x-1)\sqrt{3x^2-4x-4}$$

$$-(3x^3-3x^2)$$

$$-4x^2+4$$

$$(-4x^2+4x)$$

$$-4x+4$$

$$-(-4x+4)$$
$$0$$

$$\begin{aligned} \therefore 3x^3-7x^2+4 &= (x-1)(3x^2-4x-4) \\ &= (x-1)(3x+2)(x-2) \end{aligned}$$

✓

✓

✓

✓

✓
[5]

(1.8)

$$(x+5)\sqrt{x^2-5x+6}$$

$$-(x^3+5x^2)$$

$$-5x^2-19x$$

$$-(-5x^2-25x)$$

$$6x+30$$

$$-(6x+30)$$
$$0$$

$$\begin{aligned} \therefore x^3-19x+30 &= (x+5)(x^2-5x+6) \\ &= (x+5)(x-3)(x-2) \end{aligned}$$

✓

✓

✓

✓

✓

[5]

(1.9)

$$(x+2)\sqrt{2x^3-x^2-13x-6}$$

$$-(2x^3+4x^2)$$

$$-5x^2-13x$$

$$-(-5x^2-10x)$$

$$-3x-6$$

$$-(-3x-6)$$
$$0$$

$$\begin{aligned} \therefore 2x^3-x^2-13x-6 &= (x+2)(2x^2-5x-3) \\ &= (x+2)(2x+1)(x-3) \end{aligned}$$

✓

✓

✓

✓

✓
[5]

(1.10)

$$\begin{array}{r} (x+1) \sqrt{2x^3 - 3x^2 - 8x - 3} \\ \underline{-(2x^3 + 2x^2)} \\ -5x^2 - 8x \\ \underline{-(-5x^2 - 5x)} \\ -3x - 3 \\ \underline{-(-3x - 3)} \\ 0 \end{array} \quad \begin{array}{l} \checkmark \\ \checkmark \\ \checkmark \\ \checkmark \end{array}$$

$$\begin{aligned} \therefore 2x^3 - 3x^2 - 8x - 3 &= (x+1)(2x^2 - 5x - 3) \\ &= (x+1)(2x+1)(x-3) \end{aligned} \quad \begin{array}{l} \checkmark \\ \checkmark \\ \text{[5]} \end{array}$$

METHOD (3): SYNTHETIC DIVISION

(1.1)

$$\begin{array}{r|rrrr}
 2 & 1 & -2 & -9 & 18 \\
 & \downarrow & & & \\
 & 1 & 0 & -9 & -18 \quad \checkmark \\
 \hline
 & 1 & 0 & -9 & 0 \\
 & \text{(a)} & \text{(b)} & \text{(c)} & \checkmark
 \end{array}$$

$$\begin{aligned}
 \therefore x^3 - 2x^2 - 9x + 18 &= (x-2)(ax^2 + bx + c) \\
 &= (x-2)(x^2 - 9) \\
 &= (x-2)(x-3)(x+3)
 \end{aligned}$$

✓

✓

[5]

(1.2)

$$\begin{array}{r|rrrr}
 1 & 1 & -2 & -5 & 6 \\
 & \downarrow & & & \\
 & 1 & 1 & -1 & -6 \quad \checkmark \\
 \hline
 & 1 & -1 & -6 & 0 \\
 & \text{(a)} & \text{(b)} & \text{(c)} & \checkmark
 \end{array}$$

$$\begin{aligned}
 \therefore x^3 - 2x^2 - 5x + 6 &= (x-1)(ax^2 + bx + c) \\
 &= (x-1)(x^2 - x - 6) \\
 &= (x-1)(x-3)(x+2)
 \end{aligned}$$

✓

✓

[5]

(1.3)

$$\begin{array}{r|rrrr}
 3 & 1 & -4 & -3 & 18 \\
 & \downarrow & & & \\
 & 1 & 3 & -3 & -18 \quad \checkmark \\
 \hline
 & 1 & -1 & -6 & 0 \quad \checkmark \\
 & \text{(a)} & \text{(b)} & \text{(c)} &
 \end{array}$$

$$\begin{aligned}
 \therefore x^3 - 4x^2 - 3x + 18 &= (x-3)(ax^2 + bx + c) \\
 &= (x-3)(x^2 - x - 6) \\
 &= (x-3)(x-3)(x+2)
 \end{aligned}$$

✓

✓

[5]

(1.4)

$$\begin{array}{r|rrrr} \checkmark & 1 & -2 & 4 & -8 \\ & \downarrow & & & \\ \hline & 1 & 0 & 4 & 0 \checkmark \\ & \text{(a)} & \text{(b)} & \text{(c)} & \end{array}$$

$$\begin{aligned} \therefore x^3 - 2x^2 + 4x - 8 &= (x-2)(ax^2 + bx + c) \\ &= (x-2)(x^2 + 4) \end{aligned}$$

✓✓
[5]

(1.5)

$$\begin{array}{r|rrrr} \checkmark & 1 & 0 & -12 & 16 \\ & \downarrow & & & \\ \hline & 1 & 2 & -8 & 0 \checkmark \\ & \text{(a)} & \text{(b)} & \text{(c)} & \end{array}$$

$$\begin{aligned} \therefore x^3 - 12x + 16 &= (x-2)(ax^2 + bx + c) \\ &= (x-2)(x^2 + 2x - 8) \\ &= (x-2)(x-2)(x+4) \end{aligned}$$

✓
✓
[5]

(1.6)

$$\begin{array}{r|rrrr} \checkmark & 1 & 2 & -5 & -6 \\ & \downarrow & & & \\ \hline & 1 & 4 & 3 & 0 \checkmark \\ & \text{(a)} & \text{(b)} & \text{(c)} & \end{array}$$

$$\begin{aligned} \therefore x^3 + 2x^2 - 5x - 6 &= (x-2)(ax^2 + bx + c) \\ &= (x-2)(x^2 + 4x + 3) \\ &= (x-2)(x+3)(x+1) \end{aligned}$$

✓
✓
[5]

(1.7)

1	3	-7	0	4	
	↓	3	-4	-4	✓
	3	-4	-4	0	✓
	(a)	(b)	(c)		

$$\begin{aligned}\therefore 3x^3 - 7x^2 + 4 &= (x-1)(ax^2 + bx + c) \\ &= (x-1)(3x^2 - 4x - 4) \\ &= (x-1)(3x+2)(x-2)\end{aligned}$$

✓

✓

[5]

(1.8)

-5	1	0	-19	30	
	↓	-5	25	-30	✓
	1	-5	6	0	✓
	(a)	(b)	(c)		

$$\begin{aligned}\therefore x^3 - 19x + 30 &= (x+5)(ax^2 + bx + c) \\ &= (x+5)(x^2 - 5x + 6) \\ &= (x+5)(x-3)(x-2)\end{aligned}$$

✓

✓

[5]

(1.9)

-2	2	-1	-13	-6	
	↓	-4	10	6	✓
	2	-5	-3	0	✓
	(a)	(b)	(c)		

$$\begin{aligned}\therefore 2x^3 - x^2 - 13x - 6 &= (x+2)(ax^2 + bx + c) \\ &= (x+2)(2x^2 - 5x - 3) \\ &= (x+2)(2x+1)(x-3)\end{aligned}$$

✓

✓

[5]

(1.10)

-1 ✓	2	-3	-8	-3
↓		-2	5	3 ✓
	2	-5	-3	0 ✓
	(a)	(b)	(c)	

$$\begin{aligned}\therefore 2x^3 - 3x^2 - 8x - 3 &= (x+1)(ax^2 + bx + c) \\ &= (x+1)(2x^2 - 5x - 3) \\ &= (x+1)(2x+1)(x-3)\end{aligned}$$

✓

✓

[5]

ASSESSMENT TEST 3 MARKING GUIDE

METHOD (1)

(1.1)

$$\begin{aligned}x^2 - 4x + y^2 + 2y - 20 &= 0 \\ \text{Centre} &= \left(-\frac{1}{2} \text{coefficient of } x; -\frac{1}{2} \text{coefficient of } y\right) \quad \checkmark \\ &= \left(-\frac{1}{2}(-4); -\frac{1}{2}(2)\right) \quad \checkmark\checkmark \\ &= (2; -1) \quad \checkmark \\ \\ \text{Radius} &= \sqrt{f^2 + g^2 - c} \\ &= \sqrt{2^2 + (-1)^2 - (-20)} \quad \checkmark \\ &= \sqrt{25} \\ &= 5 \quad \checkmark \\ & \quad \quad \quad \mathbf{[6]}\end{aligned}$$

(1.2)

$$\begin{aligned}x^2 - 2x + y^2 + 4y - 31 &= 0 \\ \text{Centre} &= \left(-\frac{1}{2} \text{coefficient of } x; -\frac{1}{2} \text{coefficient of } y\right) \quad \checkmark \\ &= \left(-\frac{1}{2}(-2); -\frac{1}{2}(4)\right) \quad \checkmark\checkmark \\ &= (1; -2) \quad \checkmark \\ \\ \text{Radius} &= \sqrt{f^2 + g^2 - c} \\ &= \sqrt{1^2 + (-2)^2 - (-31)} \quad \checkmark \\ &= \sqrt{36} \\ &= 6 \quad \checkmark \\ & \quad \quad \quad \mathbf{[6]}\end{aligned}$$

(1.3)

$$\begin{aligned}x^2 + 6x + y^2 - 4y - 12 &= 0 \\ \text{Centre} &= \left(-\frac{1}{2} \text{coefficient of } x; -\frac{1}{2} \text{coefficient of } y\right) \quad \checkmark \\ &= \left(-\frac{1}{2}(6); -\frac{1}{2}(-4)\right) \quad \checkmark\checkmark \\ &= (-3; 2) \quad \checkmark \\ \\ \text{Radius} &= \sqrt{f^2 + g^2 - c} \\ &= \sqrt{(-3)^2 + (2)^2 - (-12)} \quad \checkmark \\ &= \sqrt{25}\end{aligned}$$

$$= 5 \quad \checkmark$$

[6]

(1.4)

$$x^2 + y^2 + 4x + 6y - 3 = 0$$

Centre = $\left(-\frac{1}{2} \text{coefficient of } x; -\frac{1}{2} \text{coefficient of } y\right) \quad \checkmark$

$$= \left(-\frac{1}{2}(4); -\frac{1}{2}(6)\right) \quad \checkmark \checkmark$$

$$= (-2; -3) \quad \checkmark$$

Radius = $\sqrt{f^2 + g^2 - c}$

$$= \sqrt{(-2)^2 + (-3)^2 - (-3)} \quad \checkmark$$

$$= \sqrt{16} \quad \checkmark$$

$$= 4 \quad \checkmark$$

[6]

(1.5)

$$x^2 + y^2 - 8x - 2y - 20 = 0$$

Centre = $\left(-\frac{1}{2} \text{coefficient of } x; -\frac{1}{2} \text{coefficient of } y\right) \quad \checkmark$

$$= \left(-\frac{1}{2}(-8); -\frac{1}{2}(-2)\right) \quad \checkmark \checkmark$$

$$= (4; 1) \quad \checkmark$$

Radius = $\sqrt{f^2 + g^2 - c}$

$$= \sqrt{(4)^2 + (1)^2 - (-20)} \quad \checkmark$$

$$= \sqrt{37} \quad \checkmark$$

[6]

(1.6)

$$x^2 + y^2 - 3x + 4y - 3\frac{3}{4} = 0$$

Centre = $\left(-\frac{1}{2} \text{coefficient of } x; -\frac{1}{2} \text{coefficient of } y\right) \quad \checkmark$

$$= \left(-\frac{1}{2}(-3); -\frac{1}{2}(4)\right) \quad \checkmark \checkmark$$

$$= \left(\frac{3}{2}; -2\right) \quad \checkmark$$

Radius = $\sqrt{f^2 + g^2 - c}$

$$= \sqrt{\left(\frac{3}{2}\right)^2 + (-2)^2 - \left(-3\frac{3}{4}\right)} \quad \checkmark$$

$$= \sqrt{10} \quad \checkmark$$

[6]

(1.7)

$$\begin{aligned}x^2 + y^2 + 6x - 5y - \frac{3}{4} &= 0 \\ \text{Centre} &= \left(-\frac{1}{2} \text{coefficient of } x; -\frac{1}{2} \text{coefficient of } y\right) \quad \checkmark \\ &= \left(-\frac{1}{2}(6); -\frac{1}{2}(-5)\right) \quad \checkmark\checkmark \\ &= \left(-3; \frac{5}{2}\right) \quad \checkmark \\ \text{Radius} &= \sqrt{f^2 + g^2 - c} \\ &= \sqrt{(-3)^2 + \left(\frac{5}{2}\right)^2 - \left(-\frac{3}{4}\right)} \quad \checkmark \\ &= 4 \quad \checkmark\end{aligned}$$

[6]

(1.8)

$$\begin{aligned}x^2 + y^2 - x - 2y - 5 &= 0 \\ \text{Centre} &= \left(-\frac{1}{2} \text{coefficient of } x; -\frac{1}{2} \text{coefficient of } y\right) \quad \checkmark \\ &= \left(-\frac{1}{2}(-1); -\frac{1}{2}(-2)\right) \quad \checkmark\checkmark \\ &= \left(\frac{1}{2}; 1\right) \quad \checkmark \\ \text{Radius} &= \sqrt{f^2 + g^2 - c} \\ &= \sqrt{\left(\frac{1}{2}\right)^2 + (1)^2 - (-5)} \quad \checkmark \\ &= \frac{5}{2} \quad \checkmark\end{aligned}$$

[6]

(1.9)

$$\begin{aligned}x^2 + y^2 + 8x - 2y - 47 &= 0 \\ \text{Centre} &= \left(-\frac{1}{2} \text{coefficient of } x; -\frac{1}{2} \text{coefficient of } y\right) \quad \checkmark \\ &= \left(-\frac{1}{2}(8); -\frac{1}{2}(-2)\right) \quad \checkmark\checkmark \\ &= (-4; 1) \quad \checkmark\end{aligned}$$

$$\begin{aligned}
 \text{Radius} &= \sqrt{f^2 + g^2 - c} \\
 &= \sqrt{(-4)^2 + (1)^2 - (-47)} && \checkmark \\
 &= \sqrt{64} \\
 &= 8 && \checkmark \\
 &&& \mathbf{[6]}
 \end{aligned}$$

(1.10)

$$\begin{aligned}
 x^2 + y^2 - 6y - 27 &= 0 \\
 \text{Centre} &= \left(-\frac{1}{2} \text{coefficient of } x; -\frac{1}{2} \text{coefficient of } y \right) && \checkmark \\
 &= \left(-\frac{1}{2}(0); -\frac{1}{2}(-6) \right) && \checkmark\checkmark \\
 &= (0; 3) && \checkmark \\
 \\
 \text{Radius} &= \sqrt{f^2 + g^2 - c} \\
 &= \sqrt{(0)^2 + (3)^2 - (-27)} && \checkmark \\
 &= \sqrt{36} \\
 &= 6 && \checkmark \\
 &&& \mathbf{[6]}
 \end{aligned}$$

METHOD (2)

(1.1)

$$\begin{aligned}x^2 - 4x + y^2 + 2y - 20 &= 0 \\x^2 - 4x + 4 + y^2 + 2y + 1 &= 20 + 4 + 1 \quad \checkmark \\(x-2)^2 + (y+1)^2 &= 25 \quad \checkmark\checkmark\checkmark \\ \text{centre} &= (2;-1) \quad \checkmark \\ \text{radius} &= \sqrt{25} \\ &= 5 \quad \checkmark\end{aligned}$$

[6]

(1.2)

$$\begin{aligned}x^2 - 2x + y^2 + 4y - 31 &= 0 \\x^2 - 2x + 1 + y^2 + 4y + 4 &= 31 + 1 + 4 \quad \checkmark \\(x-1)^2 + (y+2)^2 &= 36 \quad \checkmark\checkmark\checkmark \\ \text{centre} &= (1;-2) \quad \checkmark \\ \text{radius} &= \sqrt{36} \\ &= 6 \quad \checkmark\end{aligned}$$

[6]

(1.3)

$$\begin{aligned}x^2 + 6x + y^2 - 4y - 12 &= 0 \\x^2 + 6x + 9 + y^2 - 4y + 4 &= 12 + 9 + 4 \quad \checkmark \\(x+3)^2 + (y-2)^2 &= 25 \quad \checkmark\checkmark\checkmark \\ \text{centre} &= (-3;2) \quad \checkmark \\ \text{radius} &= \sqrt{25} \\ &= 5 \quad \checkmark\end{aligned}$$

[6]

(1.4)

$$\begin{aligned}
x^2 + y^2 + 4x + 6y - 3 &= 0 \\
x^2 + 4x + 4 + y^2 + 6y + 9 &= 3 + 4 + 9 && \checkmark \\
(x+2)^2 + (y+3)^2 &= 16 && \checkmark\checkmark\checkmark \\
\text{centre} &= (-2; -3) && \checkmark \\
\text{radius} &= \sqrt{16} \\
&= 4 && \checkmark \\
&&& [6]
\end{aligned}$$

(1.5)

$$\begin{aligned}
x^2 + y^2 - 8x - 2y - 20 &= 0 \\
x^2 - 8x + 16 + y^2 - 2y + 1 &= 20 + 16 + 1 && \checkmark \\
(x-4)^2 + (y-1)^2 &= 37 && \checkmark\checkmark\checkmark \\
\text{centre} &= (4; 1) && \checkmark \\
\text{radius} &= \sqrt{37} \\
&&& \checkmark \\
&&& [6]
\end{aligned}$$

(1.6)

$$\begin{aligned}
x^2 + y^2 - 3x + 4y - 3\frac{3}{4} &= 0 \\
x^2 - 3x + \frac{9}{4} + y^2 + 4y + 4 &= 3\frac{3}{4} + \frac{9}{4} + 4 && \checkmark \\
(x-\frac{3}{2})^2 + (y+2)^2 &= 10 && \checkmark\checkmark\checkmark \\
\text{centre} &= \left(\frac{3}{2}; -2\right) && \checkmark \\
\text{radius} &= \sqrt{10} && \checkmark \\
&&& [6]
\end{aligned}$$

(1.7)

$$\begin{aligned}
x^2 + y^2 + 6x - 5y - \frac{3}{4} &= 0 \\
x^2 + 6x + 9 + y^2 - 5y + \frac{25}{4} &= \frac{3}{4} + 9 + \frac{25}{4} && \checkmark \\
(x+3)^2 + (y-\frac{5}{2})^2 &= 16 && \checkmark\checkmark\checkmark
\end{aligned}$$

$$\text{centre} = \left(-3; \frac{5}{2}\right) \quad \checkmark$$

$$\text{radius} = \frac{\sqrt{16}}{4} \quad \checkmark$$

[6]

(1.8)

$$x^2 + y^2 - x - 2y - 5 = 0$$

$$x^2 - x + \frac{1}{4} + y^2 - 2y + 1 = 5 + \frac{1}{4} + 1 \quad \checkmark$$

$$\left(x - \frac{1}{2}\right)^2 + (y - 1)^2 = \frac{25}{4} \quad \checkmark\checkmark\checkmark$$

$$\text{centre} = \left(\frac{1}{2}; 1\right) \quad \checkmark$$

$$\text{radius} = \sqrt{\frac{25}{4}} \quad \checkmark$$

$$= \frac{5}{2}$$

[6]

(1.9)

$$x^2 + y^2 + 8x - 2y - 47 = 0$$

$$x^2 + 8x + 16 + y^2 - 2y + 1 = 47 + 16 + 1 \quad \checkmark$$

$$(x + 4)^2 + (y - 1)^2 = 64 \quad \checkmark\checkmark\checkmark$$

$$\text{centre} = (-4; 1) \quad \checkmark$$

$$\text{radius} = \sqrt{64} \quad \checkmark$$

$$= 8$$

[6]

(1.10)

$$x^2 + y^2 - 6y - 27 = 0$$

$$x^2 + y^2 - 6y + 9 = 27 + 9 \quad \checkmark$$

$$(x - 0)^2 + (y - 3)^2 = 36 \quad \checkmark\checkmark\checkmark$$

$$\text{centre} = (0; 3) \quad \checkmark$$

$$\text{radius} = \sqrt{36} \quad \checkmark$$

$$= 6$$

ASSESSMENT TEST 4 MARKING GUIDE

METHOD (1)

(1.1)

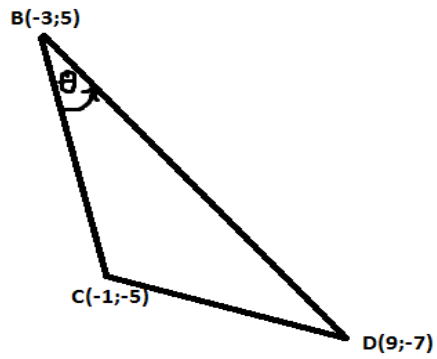

$$\begin{aligned} m_{BC} &= \frac{-5 - 5}{-1 + 3} \\ &= \frac{-10}{2} \\ &= -5 \end{aligned}$$

✓

$$\begin{aligned} m_{BD} &= \frac{-7 - 5}{9 + 3} \\ &= \frac{-12}{12} \\ &= -1 \end{aligned}$$

✓

$$\begin{aligned} \tan \theta &= \frac{-1 - (-5)}{1 + (-1)(-5)} \\ &= \frac{2}{3} \end{aligned}$$

✓

✓

$$\begin{aligned} \theta &= \tan^{-1}\left(\frac{2}{3}\right) \\ &\approx 33.7^\circ \end{aligned}$$

✓

[5]

(1.2)

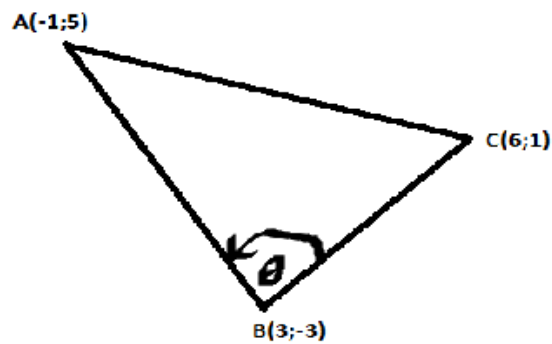

$$\begin{aligned}
m_{BC} &= \frac{1 - (-3)}{6 - 3} \\
&= \frac{4}{3} \quad \checkmark \\
m_{BA} &= \frac{5 - (-3)}{-1 - 3} \\
&= -2 \quad \checkmark \\
\tan \theta &= \frac{-2 - \frac{4}{3}}{1 + (-2)\left(\frac{4}{3}\right)} \quad \checkmark \\
&= 2 \quad \checkmark \\
\theta &= \tan^{-1}(2) \quad \checkmark \\
&\approx 63.4^\circ \quad \checkmark
\end{aligned}$$

[5]

(1.3)

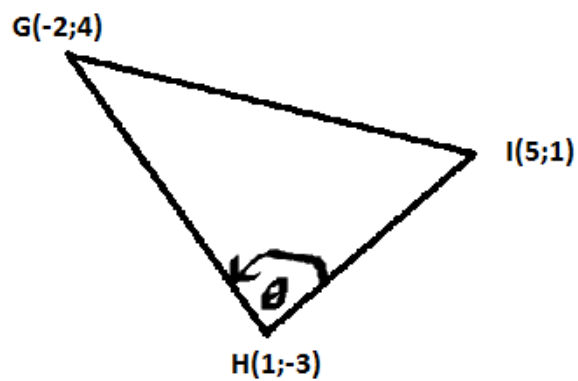

$$\begin{aligned}
m_{HI} &= \frac{1 - (-3)}{5 - 1} \\
&= 1 \quad \checkmark \\
m_{GH} &= \frac{-3 - 4}{1 - (-2)} \\
&= -\frac{7}{3} \quad \checkmark \\
&= \frac{-\frac{7}{3} - 1}{1 + \left(-\frac{7}{3}\right)(1)} \quad \checkmark \\
\tan \theta &= \frac{5}{2} \quad \checkmark \\
\theta &= \tan^{-1}\left(\frac{5}{2}\right) \\
&\approx 68.2^\circ \quad \checkmark
\end{aligned}$$

[5]

(1.4)

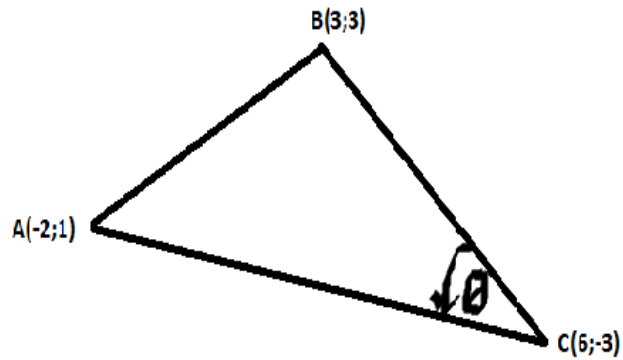

$$\begin{aligned} m_{BC} &= \frac{3 - (-3)}{3 - 6} \\ &= -2 \end{aligned} \quad \checkmark$$

$$\begin{aligned} m_{AC} &= \frac{1 - (-3)}{-2 - 6} \\ &= -\frac{1}{2} \end{aligned} \quad \checkmark$$

$$\begin{aligned} \tan \theta &= \frac{-\frac{1}{2} - (-2)}{1 + \left(-\frac{1}{2}\right)(-2)} \\ &= \frac{3}{4} \end{aligned} \quad \checkmark$$

$$\begin{aligned} \theta &= \tan^{-1}\left(\frac{3}{4}\right) \\ &\approx 36.9^\circ \end{aligned} \quad \checkmark$$

[5]

(1.5)

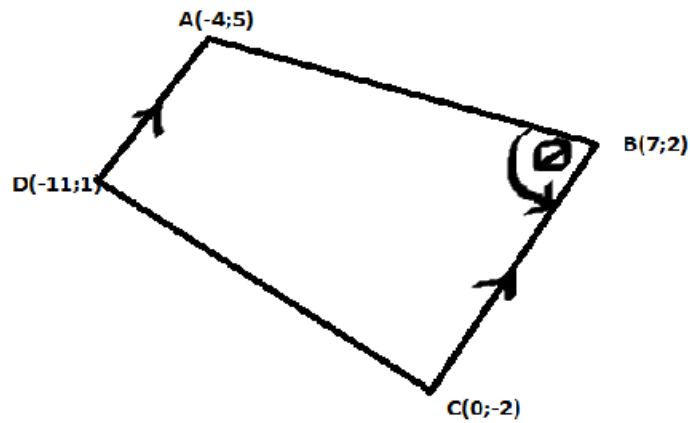

$$\begin{aligned} m_{BA} &= \frac{5 - 2}{-4 - 7} \\ &= -\frac{3}{11} \end{aligned} \quad \checkmark$$

$$\begin{aligned}
 m_{BC} &= \frac{2 - (-2)}{7 - 0} \\
 &= \frac{4}{7} \quad \checkmark \\
 \tan\theta &= \frac{\frac{4}{7} - \left(-\frac{3}{11}\right)}{1 + \left(\frac{4}{7}\right)\left(-\frac{3}{11}\right)} \quad \checkmark \\
 &= 1 \quad \checkmark \\
 \theta &= \tan^{-1}(1) \\
 &\approx 45^\circ \quad \checkmark
 \end{aligned}$$

[5]

(1.6)

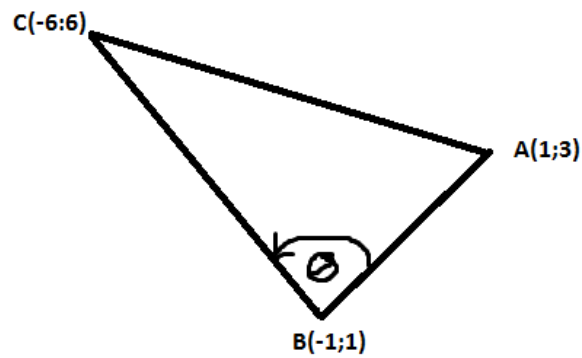

$$\begin{aligned}
 m_{CB} &= \frac{6 - 1}{-6 - (-1)} \\
 &= -1 \quad \checkmark \\
 m_{BA} &= \frac{3 - 1}{1 + 1} \\
 &= 1 \quad \checkmark \\
 \tan\theta &= \frac{-1 - 1}{1 + (-1)(1)} \quad \checkmark \\
 &= -\frac{2}{0} \text{ (undefined)} \quad \checkmark \\
 \therefore \theta &= 90^\circ \quad \checkmark
 \end{aligned}$$

[5]

(1.7)

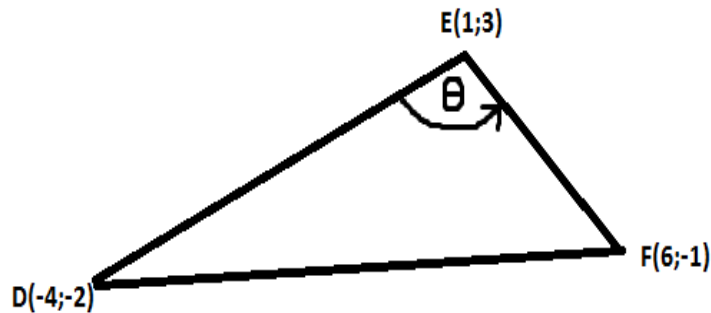

$$\begin{aligned}
m_{EF} &= \frac{3 - (-1)}{1 - 6} \\
&= -\frac{4}{5} \quad \checkmark \\
m_{DE} &= \frac{3 - (-2)}{1 - (-4)} \\
&= 1 \quad \checkmark \\
\tan\theta &= \frac{-\frac{4}{5} - 1}{1 + \left(-\frac{4}{5}\right)(1)} \quad \checkmark \\
&= -9 \quad \checkmark \\
\theta &= \tan^{-1}(-9) + 180^\circ \\
&= 96.3^\circ \quad \checkmark \\
&\quad \quad \quad [5]
\end{aligned}$$

(1.8)

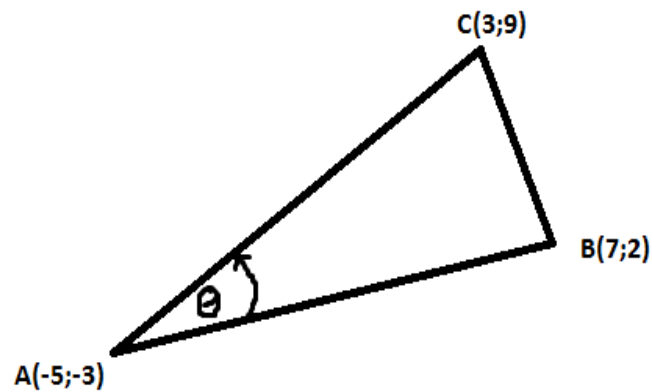

$$\begin{aligned}
m_{AC} &= \frac{9 - (-3)}{3 - (-5)} \\
&= \frac{3}{2} \quad \checkmark \\
m_{AB} &= \frac{2 - (-3)}{7 - (-5)} \\
&= \frac{5}{12} \quad \checkmark \\
\tan\theta &= \frac{\frac{3}{2} - \frac{5}{12}}{1 + \left(\frac{3}{2}\right)\left(\frac{5}{12}\right)} \quad \checkmark \\
&= \frac{2}{3} \quad \checkmark \\
\theta &= \tan^{-1}\left(\frac{2}{3}\right) \\
&\approx 33.7^\circ \quad \checkmark \\
&\quad \quad \quad [5]
\end{aligned}$$

(1.9)

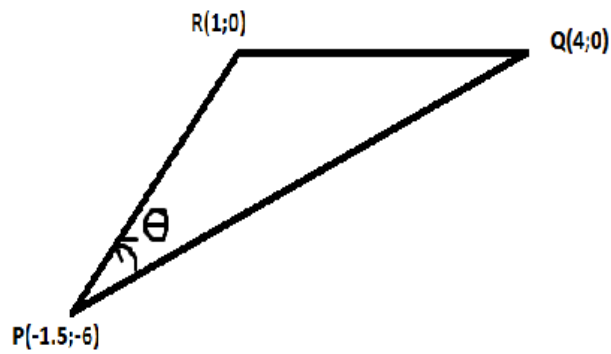

$$\begin{aligned} m_{PR} &= \frac{0 - (-6)}{1 - (-1.5)} \\ &= \frac{12}{5} \end{aligned}$$

✓

$$\begin{aligned} m_{PQ} &= \frac{0 - (-6)}{4 - (-1.5)} \\ &= \frac{12}{11} \end{aligned}$$

✓

$$\begin{aligned} \tan \theta &= \frac{\frac{12}{5} - \frac{12}{11}}{1 + \left(\frac{12}{5}\right)\left(\frac{12}{11}\right)} \\ &= \frac{72}{199} \end{aligned}$$

✓

✓

$$\begin{aligned} \theta &= \tan^{-1}\left(\frac{72}{199}\right) \\ &\approx 19.9^\circ \end{aligned}$$

✓

[5]

(1.10)

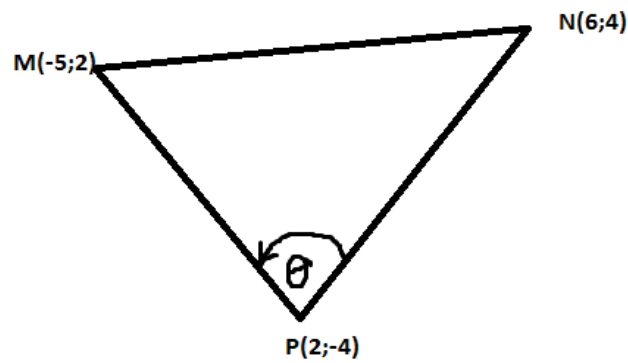

$$\begin{aligned}
m_{PM} &= \frac{2 - (-4)}{-5 - 2} \\
&= -\frac{6}{7} && \checkmark \\
m_{PN} &= \frac{4 - (-4)}{6 - 2} \\
&= 2 && \checkmark \\
\tan \theta &= \frac{-\frac{6}{7} - 2}{1 + \left(-\frac{6}{7}\right)(2)} && \checkmark \\
&= 4 && \checkmark \\
\theta &= \tan^{-1}(4) \\
&\approx 76.0^\circ && \checkmark
\end{aligned}$$

[5]

METHOD (2)

(1.1)

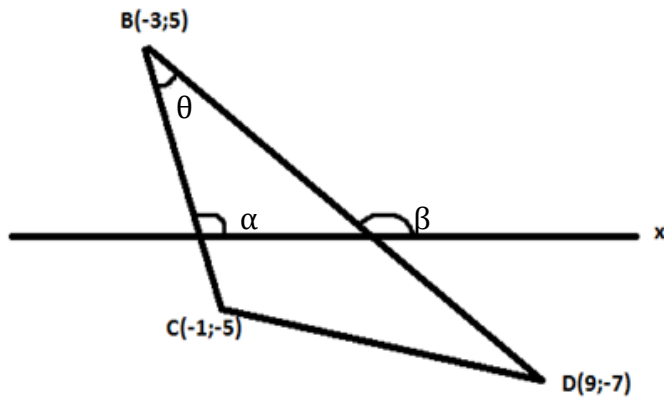

$$\begin{aligned}
 m_{BD} &= \frac{5 - (-7)}{-3 - 9} && \checkmark \\
 &= -1 && \\
 \tan \beta &= m_{BD} && \checkmark \\
 &= -1 && \\
 \therefore \beta &= \tan^{-1}(-1) + 180^\circ && \\
 &= 135^\circ && \checkmark \\
 m_{BC} &= \frac{5 - (-5)}{-3 - (-1)} && \checkmark \\
 &= -5 && \\
 \tan \alpha &= m_{BC} && \\
 &= -5 && \\
 \alpha &= \tan^{-1}(-5) + 180^\circ && \checkmark \\
 &= 101.3099325^\circ && \\
 \theta &= \beta - \alpha && \\
 &= 135^\circ - 101.3099325^\circ && \\
 &= 33.6900675^\circ && \\
 &\approx 33.7^\circ && \checkmark
 \end{aligned}$$

[5]

(1.2)

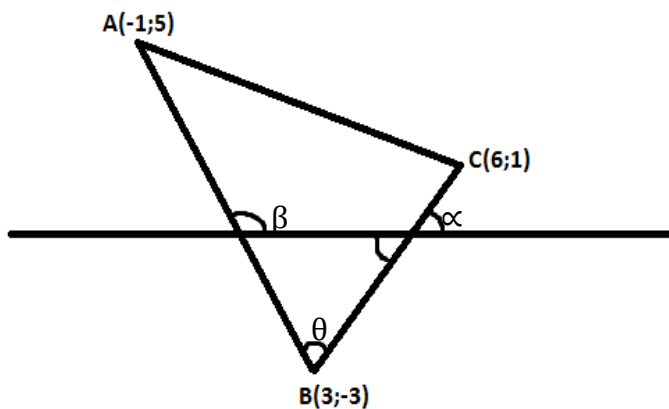

$$\begin{aligned}
m_{BC} &= \frac{1 - (-3)}{6 - 3} \\
&= \frac{4}{3} \quad \checkmark \\
\tan \alpha &= m_{BC} \\
&= \frac{4}{3} \\
\alpha &= \tan^{-1}\left(\frac{4}{3}\right) \\
&= 53.13010235^\circ \quad \checkmark \\
m_{AB} &= \frac{5 - (-3)}{-1 - 3} \\
&= -2 \quad \checkmark \\
\tan \beta &= m_{AB} \\
&= -2 \\
\beta &= \tan^{-1}(-2) + 180^\circ \\
&= 116.5650512^\circ \quad \checkmark \\
\theta &= \beta - \alpha \\
&= 116.5650512^\circ - 53.13010235^\circ \\
&= 63.43494882^\circ \\
&\approx 63.4^\circ \quad \checkmark
\end{aligned}$$

[5]

(1.3)

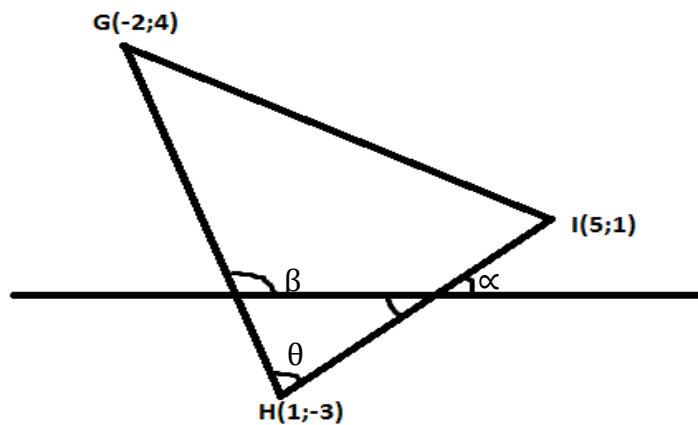

$$\begin{aligned}
m_{HI} &= \frac{1 - (-3)}{5 - 1} \\
&= 1 \quad \checkmark \\
\tan \alpha &= m_{HI} \\
&= 1 \\
\alpha &= \tan^{-1}(1) \\
&= 45^\circ \quad \checkmark \\
m_{GH} &= \frac{4 - (-3)}{-2 - 1} \\
&= -\frac{7}{3} \quad \checkmark \\
\tan \beta &= m_{GH}
\end{aligned}$$

$$\begin{aligned}
 &= -\frac{7}{3} \\
 \beta &= \tan^{-1}\left(-\frac{7}{3}\right) + 180^\circ \\
 &= 113.1985905^\circ \\
 \theta &= 113.1985905^\circ - 45^\circ \\
 &= 68.19859051^\circ \\
 &\approx 68.2^\circ
 \end{aligned}$$

✓
✓
[5]

(1.4)

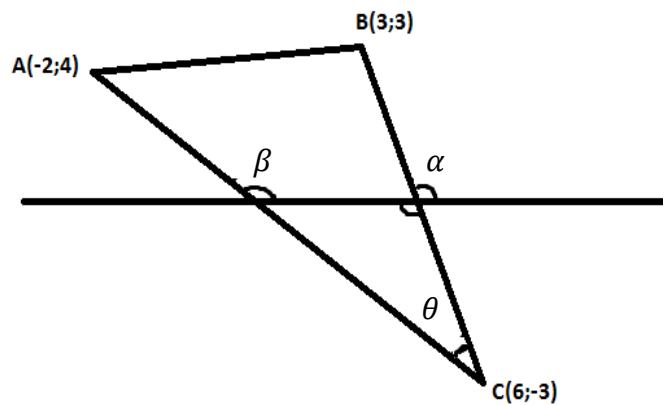

$$\begin{aligned}
 m_{BC} &= \frac{3 - (-3)}{3 - 6} \\
 &= -2 \\
 \tan \alpha &= m_{BC} \\
 &= -2 \\
 \alpha &= \tan^{-1}(-2) + 180^\circ \\
 &= 116.5650512^\circ \\
 m_{AC} &= \frac{1 - (-2)}{-2 - 6} \\
 &= -\frac{1}{2} \\
 \tan \beta &= m_{AC} \\
 &= -\frac{1}{2} \\
 \beta &= \tan^{-1}\left(-\frac{1}{2}\right) + 180^\circ \\
 &= 153.4349488^\circ \\
 \theta &= \beta - \alpha \\
 &= 36.86989765^\circ \\
 &\approx 36.9^\circ
 \end{aligned}$$

✓
✓
✓
✓
✓
[5]

(1.5)

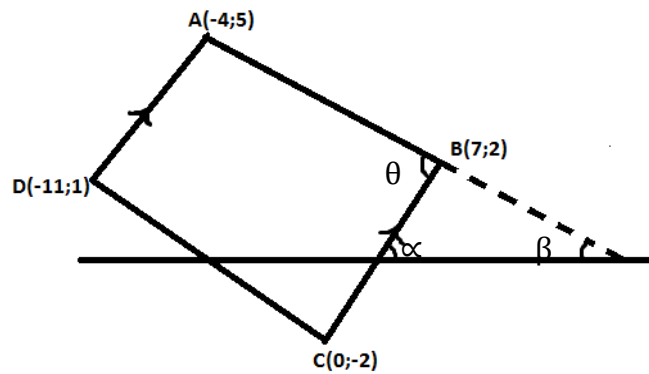

$$\begin{aligned} m_{BC} &= \frac{2 - (-2)}{7 - 0} \\ &= \frac{4}{7} \quad \checkmark \\ \tan \alpha &= m_{BC} \\ &= \frac{4}{7} \\ \alpha &= \tan^{-1}\left(\frac{4}{7}\right) \\ &= 29.7448813^\circ \quad \checkmark \\ m_{AB} &= \frac{5 - 2}{-4 - 7} \\ &= -\frac{3}{11} \quad \checkmark \\ \beta &= \tan^{-1}\left(-\frac{3}{11}\right) \\ &= -15.2551187^\circ \quad \checkmark \\ \theta &= \alpha + \beta \\ &= 29.7448813^\circ + 15.2551187^\circ \\ &= 45^\circ \quad \checkmark \end{aligned}$$

[5]

(1.6)

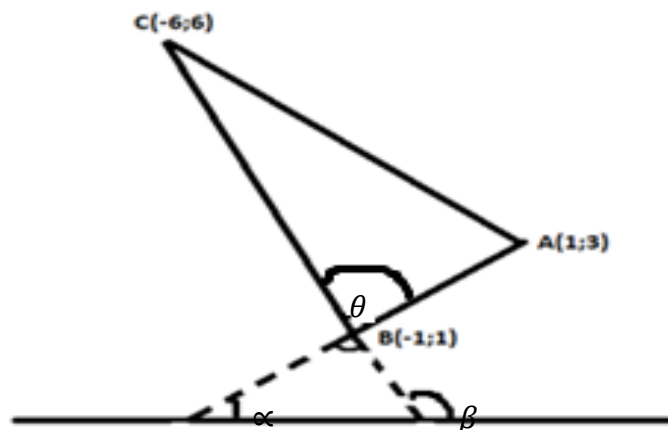

$$\begin{aligned}
m_{BA} &= \frac{3 - 1}{1 - (-1)} \\
&= 1 && \checkmark \\
\tan \alpha &= m_{BA} \\
&= 1 \\
\alpha &= \tan^{-1}(1) \\
&= 45^\circ && \checkmark \\
m_{BC} &= \frac{6 - 1}{-6 - (-1)} \\
&= -1 && \checkmark \\
\tan \beta &= m_{BC} \\
&= -1 \\
\beta &= \tan^{-1}(-1) + 180^\circ \\
&= 135^\circ && \checkmark \\
\theta &= \beta - \alpha \\
&= 135^\circ - 45^\circ \\
&= 90^\circ && \checkmark
\end{aligned}$$

[5]

(1.7)

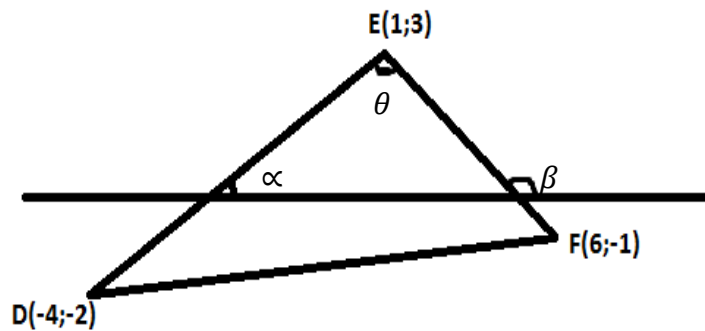

$$\begin{aligned}
m_{EF} &= \frac{3 - (-1)}{1 - 6} \\
&= -\frac{4}{5} && \checkmark \\
\tan \beta &= m_{EF} \\
&= -\frac{4}{5} \\
\beta &= \tan^{-1}\left(-\frac{4}{5}\right) + 180^\circ \\
&= 141.3401917^\circ && \checkmark \\
m_{DE} &= \frac{3 - (-2)}{1 - (-4)} \\
&= 1 && \checkmark \\
\tan \alpha &= m_{DE} \\
&= 1 \\
\alpha &= \tan^{-1}(1) = 45^\circ && \checkmark \\
\theta &= \beta - \alpha
\end{aligned}$$

$$\begin{aligned}
 &= 141.3401917^\circ - 45^\circ = \\
 &= 96.34019175^\circ \\
 &\approx 96.3^\circ
 \end{aligned}$$

✓
[5]

(1.8)

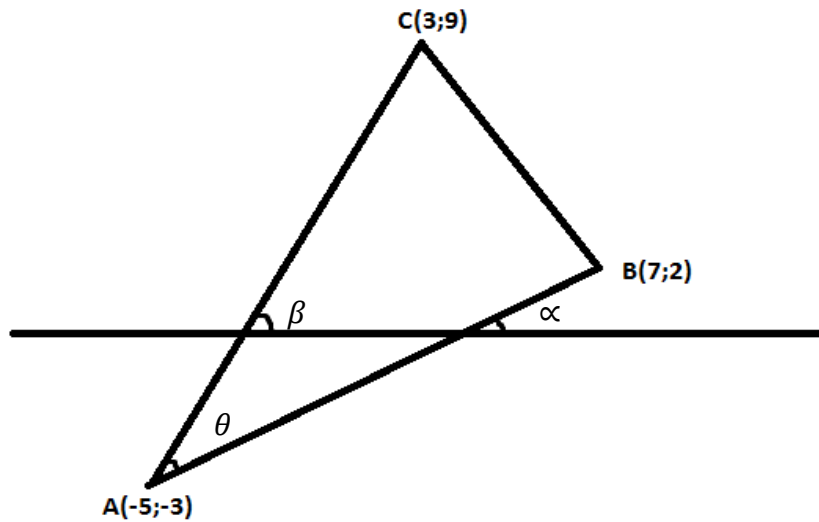

$$\begin{aligned}
 m_{AB} &= \frac{2 - (-3)}{7 - (-5)} \\
 &= \frac{5}{12} \\
 \tan \alpha &= m_{AB} \\
 &= \frac{5}{12}
 \end{aligned}$$

✓

$$\begin{aligned}
 \alpha &= \tan^{-1}\left(\frac{5}{12}\right) \\
 &= 22.61986495^\circ \\
 m_{AC} &= \frac{9 - (-3)}{3 - (-5)} \\
 &= \frac{3}{2} \\
 \tan \beta &= m_{AC} \\
 &= \frac{3}{2} \\
 \beta &= \tan^{-1}\left(\frac{3}{2}\right) \\
 &= 56.30993247^\circ \\
 \theta &= \beta - \alpha \\
 &= 33.69006753^\circ \\
 &\approx 33.7^\circ
 \end{aligned}$$

✓

✓

✓

✓
[5]

(1.9)

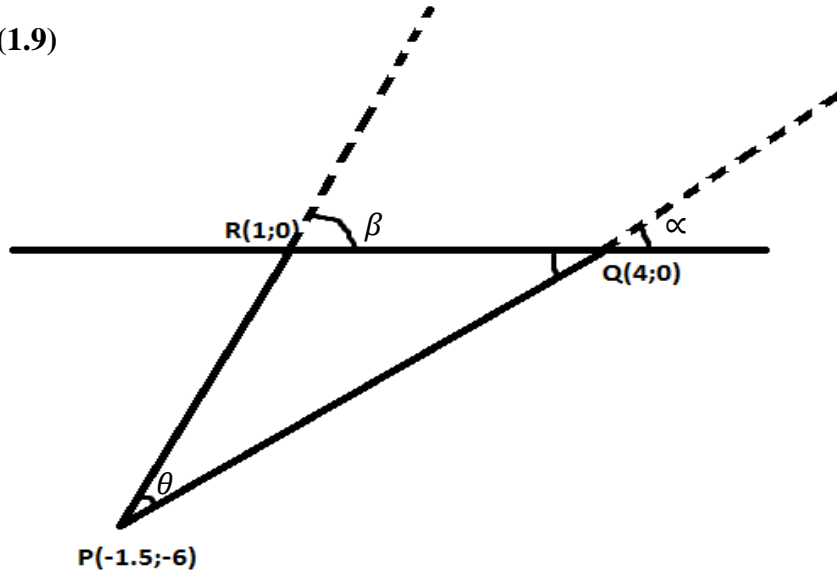

$$\begin{aligned} m_{PQ} &= \frac{0 - (-6)}{4 - (-1.5)} \\ &= \frac{12}{11} && \checkmark \\ \tan \alpha &= m_{PQ} \\ &= \frac{12}{11} \\ \alpha &= \tan^{-1}\left(\frac{12}{11}\right) \\ &= 47.48955292^\circ && \checkmark \\ m_{PR} &= \frac{0 - (-6)}{1 - (-1.5)} \\ &= \frac{12}{5} && \checkmark \\ \tan \beta &= m_{PR} \\ &= \frac{12}{5} \\ \beta &= \tan^{-1}\left(\frac{12}{5}\right) \\ &= 67.38013505^\circ && \checkmark \\ \theta &= \beta - \alpha \\ &= 67.38013505^\circ - 47.48955292^\circ \\ &= 19.89058213^\circ \\ &\approx 19.9^\circ && \checkmark \end{aligned}$$

[5]

(1.10)

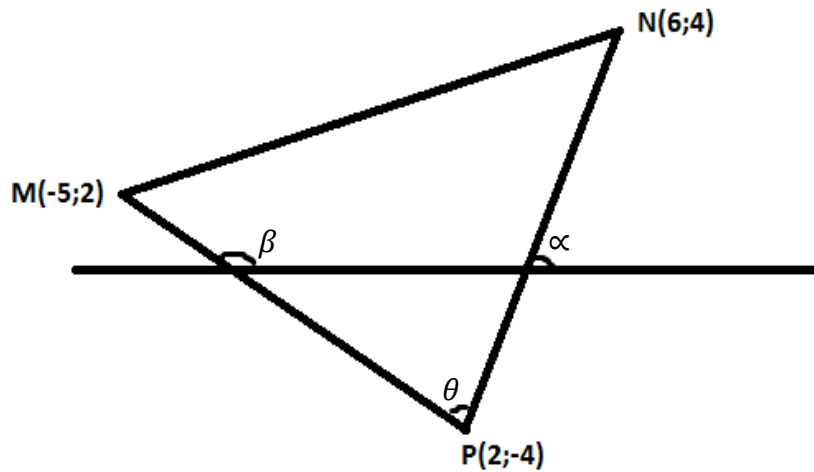

$$\begin{aligned} m_{PN} &= \frac{4 - (-4)}{6 - 2} \\ &= 2 && \checkmark \\ \tan \alpha &= m_{PN} \\ &= 2 \\ \alpha &= \tan^{-1}(2) \\ &= 63.43494882^\circ && \checkmark \\ m_{PM} &= \frac{2 - (-4)}{-5 - 2} \\ &= \frac{6}{-7} && \checkmark \\ \tan \beta &= m_{PM} \\ &= -\frac{6}{7} \\ \beta &= \tan^{-1}\left(-\frac{6}{7}\right) + 180^\circ \\ &= 139.3987054^\circ && \checkmark \\ \theta &= \beta - \alpha \\ &= 139.3987054^\circ - 63.43494882^\circ \\ &= 75.96375658^\circ \\ &\approx 76.0^\circ && \checkmark \end{aligned}$$

[5]

METHOD (3)

(1.1)

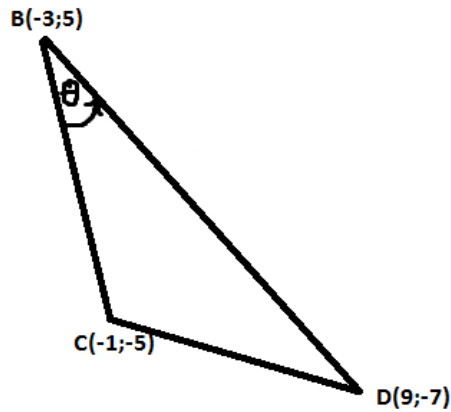

$$\begin{aligned}
 BD &= \sqrt{x_D - x_B)^2 + (y_D - y_B)^2} \\
 &= \sqrt{(9 - (-3))^2 + (-7 - 5)^2} \\
 &= 12\sqrt{2} \quad \checkmark \\
 BC &= \sqrt{x_B - x_C)^2 + (y_B - y_C)^2} \\
 &= \sqrt{(-3 - (-1))^2 + (5 - (-5))^2} \\
 &= 2\sqrt{26} \quad \checkmark \\
 CD &= \sqrt{x_D - x_C)^2 + (y_D - y_C)^2} \\
 &= \sqrt{(9 - (-1))^2 + (-7 - (-5))^2} \\
 &= 2\sqrt{26} \quad \checkmark \\
 \cos \theta &= \frac{BC^2 + BD^2 - CD^2}{2(BC)(BD)} \\
 &= \frac{(2\sqrt{26})^2 + (12\sqrt{2})^2 - (2\sqrt{26})^2}{2(2\sqrt{26})(12\sqrt{2})} \\
 &= \frac{3\sqrt{13}}{13} \quad \checkmark \\
 \theta &= \cos^{-1}\left(\frac{3\sqrt{13}}{13}\right) \\
 &= 33.69006753^\circ \\
 &\approx 33.7^\circ \quad \checkmark
 \end{aligned}$$

[5]

(1.2)

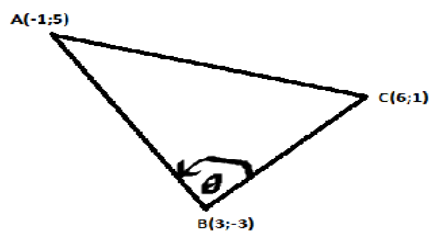

$$\begin{aligned}
AB &= \sqrt{x_B - x_A)^2 + (y_B - y_A)^2} \\
&= \sqrt{(3 - (-1))^2 + (-3 - 5)^2} \\
&= 4\sqrt{5} \quad \checkmark \\
BC &= \sqrt{x_C - x_B)^2 + (y_C - y_B)^2} \\
&= \sqrt{(6 - 3)^2 + (1 - (-3))^2} \\
&= 5 \quad \checkmark \\
AC &= \sqrt{x_C - x_A)^2 + (y_C - y_A)^2} \\
&= \sqrt{(6 - (-1))^2 + (1 - 5)^2} \\
&= \sqrt{65} \quad \checkmark \\
\cos \theta &= \frac{BC^2 + AB^2 - AC^2}{2(BC)(AB)} \\
&= \frac{(5)^2 + (4\sqrt{5})^2 - (\sqrt{65})^2}{2(5)(4\sqrt{5})} \\
&= \frac{\sqrt{5}}{5} \quad \checkmark \\
\theta &= \cos^{-1}\left(\frac{\sqrt{5}}{5}\right) \\
&= 63.43494882^\circ \\
&\approx 63.4^\circ \quad \checkmark
\end{aligned}$$

[5]

(1.3)

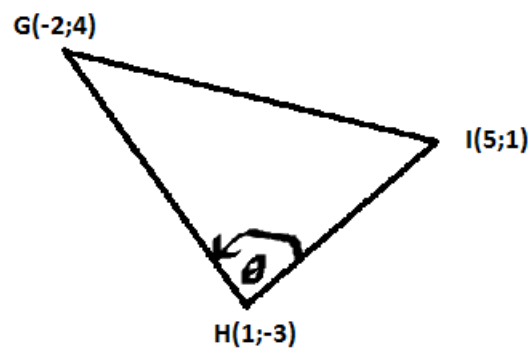

$$\begin{aligned}
GI &= \sqrt{x_I - x_G)^2 + (y_I - y_G)^2} \\
&= \sqrt{(5 - (-2))^2 + (1 - 4)^2} \\
&= \sqrt{58} \quad \checkmark \\
GH &= \sqrt{x_H - x_G)^2 + (y_H - y_G)^2} \\
&= \sqrt{(1 - (-2))^2 + (-3 - 4)^2} \\
&= \sqrt{58} \quad \checkmark \\
HI &= \sqrt{x_I - x_H)^2 + (y_I - y_H)^2} \\
&= \sqrt{(5 - 1)^2 + (1 - (-3))^2} \\
&= 4\sqrt{2} \quad \checkmark \\
\cos \theta &= \frac{GH^2 + HI^2 - GI^2}{2(GH)(HI)}
\end{aligned}$$

$$\begin{aligned}
&= \frac{(\sqrt{58})^2 + (4\sqrt{2})^2 - (\sqrt{58})^2}{2(\sqrt{58})(4\sqrt{2})} \\
&= \frac{2\sqrt{29}}{29} \quad \checkmark \\
\theta &= \cos^{-1}\left(\frac{2\sqrt{29}}{29}\right) \\
&= 68.19859051^\circ \\
&\approx 68.2^\circ \quad \checkmark \\
&\quad [5]
\end{aligned}$$

(1.4)

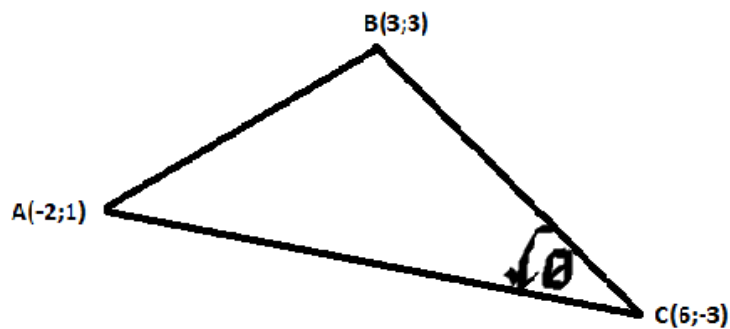

$$\begin{aligned}
AB &= \sqrt{x_B - x_A)^2 + (y_B - y_A)^2} \\
&= \sqrt{(3 - (-2))^2 + (3 - (-2))^2} \\
&= \sqrt{29} \quad \checkmark \\
AC &= \sqrt{x_C - x_A)^2 + (y_C - y_A)^2} \\
&= \sqrt{(6 - (-2))^2 + (-3 - 1)^2} \\
&= 4\sqrt{5} \quad \checkmark \\
BC &= \sqrt{x_C - x_B)^2 + (y_C - y_B)^2} \\
&= \sqrt{(6 - 3)^2 + (-3 - 3)^2} \\
&= 3\sqrt{5} \quad \checkmark
\end{aligned}$$

$$\begin{aligned}
\cos \theta &= \frac{AC^2 + BC^2 - AB^2}{2(AC)(BC)} \\
&= \frac{(4\sqrt{5})^2 + (3\sqrt{5})^2 - (\sqrt{29})^2}{2(4\sqrt{5})(3\sqrt{5})} \\
&= \frac{4}{5} \quad \checkmark \\
\theta &= \cos^{-1}\left(\frac{4}{5}\right) \\
&= 36.86989765^\circ \\
&\approx 36.9^\circ \quad \checkmark \\
&\quad [5]
\end{aligned}$$

(1.5)

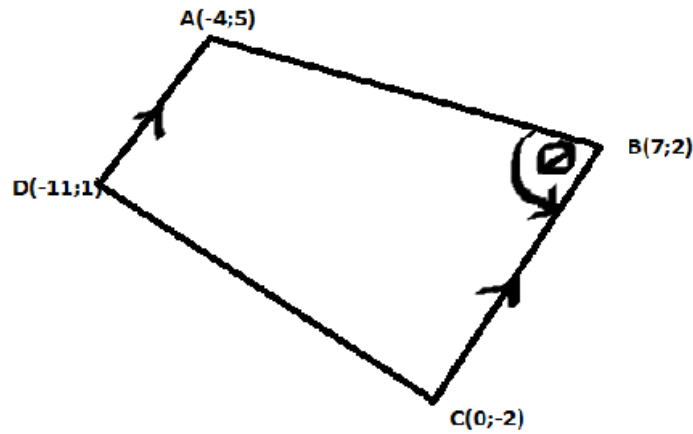

$$\begin{aligned} AB &= \sqrt{x_B - x_A)^2 + (y_B - y_A)^2} \\ &= \sqrt{(7 - (-4))^2 + (2 - 5)^2} \\ &= \sqrt{130} \quad \checkmark \\ AC &= \sqrt{x_C - x_A)^2 + (y_C - y_A)^2} \\ &= \sqrt{(0 - (-4))^2 + (-2 - 5)^2} \\ &= \sqrt{65} \quad \checkmark \\ BC &= \sqrt{x_C - x_B)^2 + (y_C - y_B)^2} \\ &= \sqrt{(0 - 7)^2 + (-2 - 2)^2} \\ &= \sqrt{65} \quad \checkmark \\ \cos \theta &= \frac{AB^2 + BC^2 - AC^2}{2(AB)(BC)} \\ &= \frac{(\sqrt{130})^2 + (\sqrt{65})^2 - (\sqrt{65})^2}{2(\sqrt{130})(\sqrt{65})} \\ &= 0.7071067812 \quad \checkmark \\ \theta &= \cos^{-1}(0.7071067812) \\ &= 45^\circ \quad \checkmark \end{aligned}$$

[5]

(1.6)

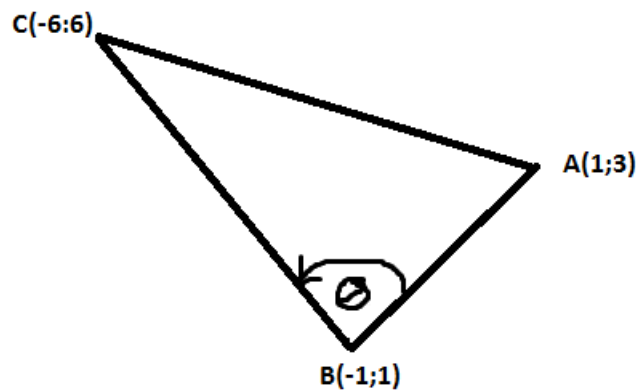

$$\begin{aligned}
AB &= \sqrt{x_B - x_A)^2 + (y_B - y_A)^2} \\
&= \sqrt{(-1 - 1)^2 + (1 - 3)^2} \\
&= 2\sqrt{2} \quad \checkmark \\
AC &= \sqrt{x_C - x_A)^2 + (y_C - y_A)^2} \\
&= \sqrt{(-6 - 1)^2 + (6 - 3)^2} \\
&= \sqrt{58} \quad \checkmark \\
BC &= \sqrt{x_C - x_B)^2 + (y_C - y_B)^2} \\
&= \sqrt{(-1 - (-6))^2 + (1 - 6)^2} \\
&= 5\sqrt{2} \quad \checkmark \\
\cos \theta &= \frac{AB^2 + BC^2 - AC^2}{2(AB)(BC)} \\
&= \frac{(2\sqrt{2})^2 + (5\sqrt{2})^2 - (\sqrt{58})^2}{2(2\sqrt{2})(5\sqrt{2})} \\
&= 0 \quad \checkmark \\
\theta &= \cos^{-1}(0) \\
&= 90^\circ \quad \checkmark
\end{aligned}$$

[5]

(1.7)

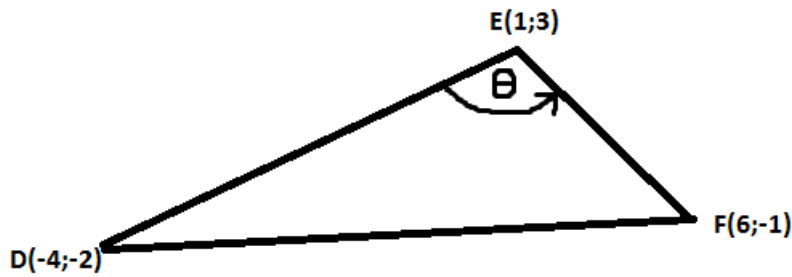

$$\begin{aligned}
DE &= \sqrt{x_E - x_D)^2 + (y_E - y_D)^2} \\
&= \sqrt{(1 - (-4))^2 + (-1 - 3)^2} \\
&= 5\sqrt{2} \quad \checkmark \\
EF &= \sqrt{x_F - x_E)^2 + (y_F - y_E)^2} \\
&= \sqrt{(6 - 1)^2 + (-1 - 3)^2} \\
&= \sqrt{41} \quad \checkmark \\
DF &= \sqrt{x_F - x_D)^2 + (y_F - y_D)^2} \\
&= \sqrt{(6 - (-4))^2 + (-1 - (-2))^2} \\
&= \sqrt{101} \quad \checkmark
\end{aligned}$$

$$\begin{aligned}
\cos \theta &= \frac{DE^2 + EF^2 - DF^2}{2(DE)(EF)} \\
&= \frac{(5\sqrt{2})^2 + (\sqrt{41})^2 - (\sqrt{101})^2}{2(5\sqrt{2})(\sqrt{41})} = \\
&= -\frac{\sqrt{82}}{82} \quad \checkmark \\
\theta &= \cos^{-1}\left(-\frac{\sqrt{82}}{82}\right) \\
&= 96.34019175 \\
&\approx 96.3^\circ \quad \checkmark
\end{aligned}$$

[5]

(1.8)

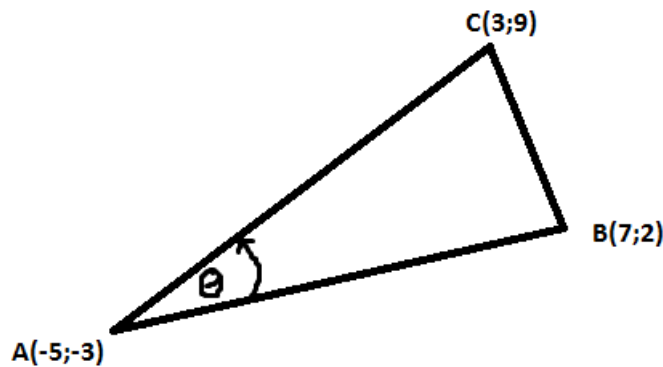

$$\begin{aligned}
AB &= \sqrt{x_B - x_A)^2 + (y_B - y_A)^2} \\
&= \sqrt{(7 - (-5))^2 + (2 - (-3))^2} \\
&= 13 \quad \checkmark \\
AC &= \sqrt{x_C - x_A)^2 + (y_C - y_A)^2} \\
&= \sqrt{(3 - (-5))^2 + (9 - (-3))^2} \\
&= 4\sqrt{13} \quad \checkmark \\
BC &= \sqrt{x_C - x_B)^2 + (y_C - y_B)^2} \\
&= \sqrt{(3 - 7)^2 + (9 - 2)^2} \\
&= \sqrt{65} \quad \checkmark \\
\cos \theta &= \frac{AB^2 + AC^2 - BC^2}{2(AB)(AC)} \\
&= \frac{(13)^2 + (4\sqrt{13})^2 - (\sqrt{65})^2}{2(13)(4\sqrt{13})} \\
&= 0.8320502943 \quad \checkmark \\
\theta &= \cos^{-1}(0.8320502943) \\
&= 33.69006753^\circ \\
&\approx 33.7^\circ \quad \checkmark
\end{aligned}$$

(1.9)

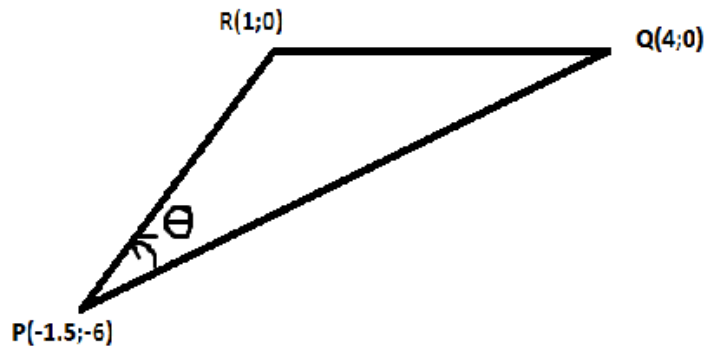

$$\begin{aligned} PR &= \sqrt{x_R - x_P)^2 + (y_R - y_P)^2} \\ &= \sqrt{(1 - (-1.5))^2 + (0 - (-6))^2} \\ &= \frac{13}{2} \quad \checkmark \\ PQ &= \sqrt{x_Q - x_P)^2 + (y_Q - y_P)^2} \\ &= \sqrt{(4 - (-1.5))^2 + (0 - (-6))^2} \\ &= \frac{\sqrt{265}}{2} \quad \checkmark \\ RQ &= \sqrt{x_Q - x_R)^2 + (y_Q - y_R)^2} \\ &= \sqrt{(4 - 1)^2 + (0 - 0)^2} \\ &= 3 \quad \checkmark \\ \cos \theta &= \frac{PR^2 + PQ^2 - RQ^2}{2(PR)(PQ)} \\ &= \frac{\left(\frac{13}{2}\right)^2 + \left(\frac{\sqrt{265}}{2}\right)^2 - (3)^2}{2\left(\frac{13}{2}\right)\left(\frac{\sqrt{265}}{2}\right)} \\ &= 0.9403440635 \quad \checkmark \\ \theta &= \cos^{-1}(0.9403440635) \\ &= 19.89058213^\circ \\ &\approx 19.9^\circ \quad \checkmark \end{aligned}$$

[5]

(1.10)

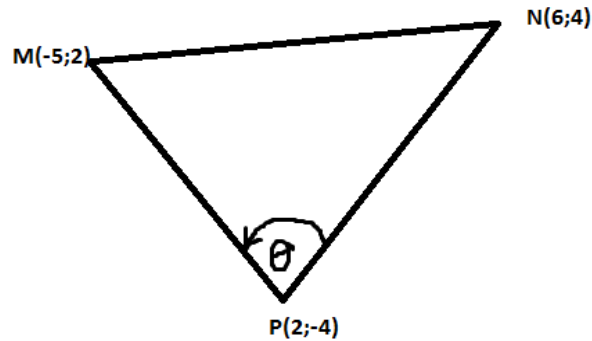

$$\begin{aligned} MN &= \sqrt{x_N - x_M)^2 + (y_N - y_M)^2} \\ &= \sqrt{(6 - (-5))^2 + (4 - 2)^2} \\ &= 5\sqrt{5} \end{aligned} \quad \checkmark$$

$$\begin{aligned} MP &= \sqrt{x_P - x_M)^2 + (y_P - y_M)^2} \\ &= \sqrt{(2 - (-5))^2 + (-4 - 2)^2} \\ &= \sqrt{85} \end{aligned} \quad \checkmark$$

$$\begin{aligned} PN &= \sqrt{x_N - x_P)^2 + (y_N - y_P)^2} \\ &= \sqrt{(6 - 2)^2 + (4 - (-4))^2} \\ &= 4\sqrt{5} \end{aligned} \quad \checkmark$$

$$\begin{aligned} \cos \theta &= \frac{MP^2 + PN^2 - MN^2}{2(MP)(PN)} \\ &= \frac{(\sqrt{85})^2 + (4\sqrt{5})^2 - (5\sqrt{5})^2}{2(\sqrt{85})(4\sqrt{5})} \\ &= \frac{\sqrt{17}}{17} \end{aligned} \quad \checkmark$$

$$\begin{aligned} \theta &= \cos^{-1}\left(\frac{\sqrt{17}}{17}\right) \\ &= 75.96375653^\circ \\ &\approx 76.0^\circ \end{aligned} \quad \checkmark$$

[5]

A 2: Item content rating forms

Topic	Specifications	
Number Patterns	Determining the general term of a quadratic sequence	
Item Number	Is the item essential to the domain/topic of the study? (Please encircle your choice)	Suggested item revisions
1.1	Yes / No	
1.2	Yes / No	
1.3	Yes / No	
1.4	Yes / No	
1.5	Yes / No	
1.6	Yes / No	
1.7	Yes / No	
1.8	Yes / No	
1.9	Yes / No	
1.10	Yes / No	

Topic	Specifications	
Third degree polynomials	Factorising third degree polynomials	
Item Number	Is the item essential to the domain/topic of the study? (Please encircle your choice)	Suggested item revisions
1.1	Yes / No	
1.2	Yes / No	
1.3	Yes / No	
1.4	Yes / No	
1.5	Yes / No	
1.6	Yes / No	
1.7	Yes / No	
1.8	Yes / No	
1.9	Yes / No	
1.10	Yes / No	

Topic	Specifications	
Analytical Geometry	Determining the centre and radius of a circle	
Item Number.	Is the item essential to the domain? (Please encircle your choice)	Suggested item revisions
1.1	Yes / No	
1.2	Yes / No	
1.3	Yes / No	
1.4	Yes / No	
1.5	Yes / No	
1.6	Yes / No	
1.7	Yes / No	
1.8	Yes / No	
1.9	Yes / No	
1.10	Yes / No	

Topic	Specifications	
Coordinate Geometry	Finding the angle between two lines	
Item Number	Is the item essential to the domain/topic of the study? (Please encircle your choice)	Suggested item revisions
1.1	Yes / No	
1.2	Yes/No	
1.3	Yes / No	
1.4	Yes/No	
1.5	Yes / No	
1.6	Yes / No	
1.7	Yes / No	
1.8	Yes / No	
1.9	Yes / No	
1.10	Yes / No	

APPENDIX B:

Calculations of reliability estimates and Content validity indices

B 1: Kuder-Richardson 20 reliability estimates calculations

Assessment test 1 items													
Learners	1.1	1.2	1.3	1.4	1.5	1.6	1.7	1.8	1.9	1.10		<i>X</i>	<i>X</i> ²
L₁	1	0	0	0	1	1	0	1	0	1		5	25
L₂	1	0	0	0	0	0	0	0	0	0		1	1
L₃	1	1	1	0	1	1	1	0	0	0		6	36
L₄	0	0	0	0	0	0	0	0	0	0		0	0
L₅	1	1	1	1	1	1	1	1	1	1		10	100
L₆	1	1	0	1	1	1	1	0	1	1		8	64
L₇	1	1	1	1	0	0	0	1	0	0		5	25
L₈	1	1	1	1	1	1	1	1	1	0		9	81
L₉	1	1	1	1	1	1	0	1	1	1		9	81
L₁₀	1	0	1	1	1	1	1	0	1	0		7	49
p	0.9	0.6	0.6	0.6	0.7	0.7	0.5	0.5	0.5	0.4	∑	60	462
q	0.1	0.4	0.4	0.4	0.3	0.3	0.5	0.5	0.5	0.6			
pq	0.09	0.24	0.24	0.24	0.21	0.21	0.25	0.25	0.25	0.24			

Key: 1-Correct solution
2-Wrong solution

Kuder-Richardson formula 20 calculations:

$$p = \frac{\text{Number of correct responses for an item}}{\text{Number of people taking the test}}$$

$$q = \frac{\text{Number of incorrect responses for an item}}{\text{Number of people taking the test}}$$

$$\begin{aligned}\sum pq &= 0.09 + 0.24 + 0.24 + 0.24 + 0.21 + 0.21 + 0.25 + 0.25 + 0.25 + 0.24 \\ &= 2.22\end{aligned}$$

$$\sigma^2 = \frac{\sum x^2 - \frac{(\sum x)^2}{n}}{n}$$

$$= \frac{462 - \frac{(60)^2}{10}}{10}$$

$$= 10.2$$

$$\therefore KR20 = \left(\frac{K}{K-1} \right) \left(1 - \frac{\sum pq}{\sigma^2} \right)$$

$$= \left(\frac{10}{9} \right) \left(1 - \frac{2.22}{10.2} \right)$$

$$= 0.8692810458$$

$$\approx 0.87$$

The reliability estimate indicates a **very strong** relationship between the test items.

Learners	Assessment test 2 items										X	X ²	
	1.1	1.2	1.3	1.4	1.5	1.6	1.7	1.8	1.9	1.10			
L ₁	0	1	0	1	0	1	0	0	0	0		3	9
L ₂	1	0	0	0	0	1	1	1	0	1		4	16
L ₃	1	1	1	1	1	1	1	1	1	1		10	100
L ₄	1	0	0	0	0	1	1	1	1	1		6	36
L ₅	1	1	1	0	1	1	0	1	0	0		6	36
L ₆	1	0	0	0	0	0	0	0	0	0		1	1
L ₇	1	0	1	1	0	1	0	1	1	0		6	36
L ₈	1	1	0	0	1	1	0	0	1	1		6	36
L ₉	1	1	0	0	0	1	0	0	0	0		3	9
L ₁₀	1	0	0	1	0	0	0	1	0	0		3	9
p	0.9	0.5	0.3	0.4	0.3	0.8	0.3	0.6	0.4	0.4	∑	48	288
q	0.1	0.5	0.7	0.6	0.7	0.2	0.7	0.4	0.6	0.6			
pq	0.09	0.25	0.21	0.24	0.21	0.16	0.21	0.24	0.24	0.24			

Key: **1**-Correct solution

0-Wrong solution

Kuder-Richardson formula 20 calculations:

$$p = \frac{\text{Number of correct responses for an item}}{\text{Number of people taking the test}}$$

$$q = \frac{\text{Number of incorrect responses for an item}}{\text{Number of people taking the test}}$$

$$\begin{aligned}\sum pq &= 0.09 + 0.25 + 0.21 + 0.24 + 0.21 + 0.16 + 0.21 + 0.24 + 0.24 + 0.24 \\ &= 2.09\end{aligned}$$

$$\sigma^2 = \frac{\sum x^2 - \frac{(\sum x)^2}{n}}{n}$$

$$= \frac{288 - \frac{(48)^2}{10}}{10}$$

$$= 5.76$$

$$\therefore KR20 = \left(\frac{K}{K-1} \right) \left(1 - \frac{\sum pq}{\sigma^2} \right)$$

$$= \left(\frac{10}{9} \right) \left(1 - \frac{2.09}{5.76} \right)$$

$$= 0.7079475309$$

$$\approx 0.71$$

The Kuder-Richardson 20 value indicates a **strong** relationship between the test items.

Learners	Assessment 3 test items										X	X ²	
	1.1	1.2	1.3	1.4	1.5	1.6	1.7	1.8	1.9	1.10			
L ₁	1	1	1	0	1	1	1	0	0	1		7	49
L ₂	1	1	1	1	1	1	1	0	0	1		8	64
L ₃	1	1	1	1	1	1	1	0	0	1		8	64
L ₄	1	1	1	0	0	1	0	0	0	1		5	25
L ₅	1	1	1	1	1	1	1	0	0	0		7	49
L ₆	0	0	0	0	0	0	0	0	0	0		0	0
L ₇	1	0	0	1	1	1	0	0	0	0		4	16
L ₈	0	0	0	0	0	0	0	0	0	0		0	0
L ₉	1	1	1	1	1	1	1	0	0	1		8	64
L ₁₀	1	1	1	1	1	1	1	0	0	1		8	64
p	0.8	0.7	0.7	0.6	0.7	0.8	0.6	0	0	0.6	∑	55	395
q	0.2	0.3	0.3	0.4	0.3	0.2	0.4	1	1	0.4			
pq	0.16	0.21	0.21	0.24	0.21	0.16	0.24	0	0	0.24			

Key: 1-Correct solution

0-Wrong solution

Kuder-Richardson Formula 20 calculations:

$$p = \frac{\text{Number of correct responses for an item}}{\text{Number of people taking the test}}$$

$$q = \frac{\text{Number of incorrect responses for an item}}{\text{Number of people taking the test}}$$

$$\begin{aligned}\sum pq &= 0.16 + 0.21 + 0.21 + 0.24 + 0.21 + 0.16 + 0.24 + 0 + 0 + 0.24 \\ &= 1.67\end{aligned}$$

$$\sigma^2 = \frac{\sum x^2 - \frac{(\sum x)^2}{n}}{n}$$

$$= \frac{395 - \frac{(55)^2}{10}}{10}$$

$$= 9.25$$

$$\therefore KR20 = \left(\frac{K}{K-1} \right) \left(1 - \frac{\sum pq}{\sigma^2} \right)$$

$$= \left(\frac{10}{9} \right) \left(1 - \frac{1.67}{9.25} \right)$$

$$= 0.9105105105$$

$$\approx 0.91$$

The reliability estimate indicates a **very strong** relationship between the test items.

Assessment test 4 items													
Learners	1.1	1.2	1.3	1.4	1.5	1.6	1.7	1.8	1.9	1.10		X	X ²
L ₁	1	0	0	1	0	0	0	0	0	0		2	4
L ₂	0	0	0	1	0	1	0	1	0	1		4	16
L ₃	0	0	0	0	0	0	0	0	0	0		0	0
L ₄	1	1	0	0	0	0	0	0	0	1		3	9
L ₅	0	0	0	0	0	0	0	0	0	0		0	0
L ₆	0	0	0	0	0	0	0	0	0	0		0	0
L ₇	0	0	0	0	0	0	0	0	0	0		0	0
L ₈	0	0	0	0	0	0	0	0	0	0		0	0
L ₉	0	0	0	0	0	0	0	0	0	0		0	0
p	0.22	0.11	0	0.22	0	0.11	0	0.11	0	0.22	∑	9	29
q	0.78	0.89	1	0.78	1	0.89	1	0.89	1	0.78			
pq	0.17	0.10	0	0.17	0	0.10	0	0.10	0	0.17			

Key: 1-Correct solution

0-Wrong solution

Kuder-Richardson Formula 20 Calculations:

$$p = \frac{\text{Number of correct responses for an item}}{\text{Number of people taking the test}}$$

$$q = \frac{\text{Number of incorrect responses for an item}}{\text{Number of people taking the test}}$$

$$\begin{aligned}\sum pq &= 0.17 + 0.10 + 0 + 0.17 + 0 + 0.10 + 0 + 0.10 + 0 + 0.17 \\ &= 0.81\end{aligned}$$

$$\sigma^2 = \frac{\sum x^2 - \frac{(\sum x)^2}{n}}{n}$$

$$= \frac{29 - \frac{(9)^2}{9}}{10}$$

$$= 2.22$$

$$\therefore KR20 = \left(\frac{K}{K-1} \right) \left(1 - \frac{\sum pq}{\sigma^2} \right)$$

$$= \left(\frac{10}{9} \right) \left(1 - \frac{0.81}{2.22} \right)$$

$$= 0.7057057057$$

$$\approx 0.71$$

The reliability estimate reflects a **strong** relationship between the test items.

B 2: Calculating Content Validity Ratios and Content Validity Indices of the test instruments

The content validity ratio was calculated using the following formula:

$$CVR_i = \frac{\left[n_e - \left(\frac{N}{2} \right) \right]}{\left(\frac{N}{2} \right)}$$

CVR_i is the CVR for the i^{th} item, n_e is the number of judges indicating the test item is ‘essential’ and N is the total number of judges on the panel. The content validity index (CVI) for the whole test is the mean of the CVR values of the retained items (Lawshe, 1975).

Assessment test 1			
Item Number	n_e	N	CVR_i
1.1	6	6	1.00
1.2	6	6	1.00
1.3	6	6	1.00
1.4	6	6	1.00
1.5	6	6	1.00
1.6	6	6	1.00
1.7	6	6	1.00
1.8	6	6	1.00
1.9	6	6	1.00
1.10	6	6	1.00
Content Validity Index (Mean CVR_i)			$= \frac{10.00}{10} =$ 1.00

A CVI of 1.00 indicates that there was complete agreement by the judges that the items were only measuring the intended objectives. We can therefore conclude that the content of the items reflected the content of the domain of interest. The results for test 2, test 3 and 4 were same as the above.

APPENDIX C: Letters of Permission and Consent

C 1: Letter to the Circuit Manager

Enquiries: Machisi Eric

Contact: 072 147 4618

E-mail: 47021136@mylife.unisa.ac.za

2929 Zone 2

Seshego

0742

May 2012

The Circuit Manager
Limpopo Department of Education
Pietersburg circuit
Capricorn District
113 Biccard Street
0700

Dear Sir/Madam

RE: REQUEST FOR PERMISSION TO CONDUCT RESEARCH IN ONE OF THE SECONDARY SCHOOLS IN YOUR CIRCUIT

My name is Eric Machisi. I am a Master of Science in Mathematics Education student at University of South Africa. The research I wish to conduct involves exploring solution strategies that can enhance the achievement of low-performing Grade 12 learners in some mathematical aspects. The project is supervised by Professor LD Mogari and Doctor Ugorji Ogbonnaya of the Institute for Science and Technology Education (ISTE) Department, University of South Africa.

I am hereby seeking your consent to approach one of the secondary schools in your circuit to provide participants for this project.

Attached herewith is a copy of the **Project Information Statement** together with copies of the consent forms to be used in the study.

On completion of my studies, I undertake to provide the Department of Basic Education (DoBE) with a copy of my full research report. For any further information, please feel free to contact me on 072 147 4 618 or e-mail at 47021136@mylife.unisa.ac.za

Thank you for your time and consideration in this matter.

Yours faithfully

A handwritten signature in black ink, appearing to read 'Eric Machisi', with a stylized flourish at the end.

Eric Machisi (UNISA STUDENT)

For the attention of the Circuit Manager:

Project Information Statement

Project Title:

Exploring solution strategies that can enhance the achievement of low-performing Grade 12 learners in some mathematical aspects

Aims of the Research

The research aims to:

- Explore solution strategies that can enhance the achievement of low-performing Grade 12 learners in some mathematical aspects, with a view to improving learners' achievement and the quality of mathematics teaching and learning in secondary schools of Capricorn District in Limpopo Province.

Significance of the Research

The study is significant in the following ways:

- It seeks to develop possible ways to deal with low-performing Grade 12 learners in mathematics.
- It seeks to help secondary school mathematics educators obviate high failure in the subject.
- It will possibly initiate innovations in the current mathematics intervention programmes.
- It provides valuable first hand information on real matters of the classroom and forms a basis for making recommendations to the Department of Basic Education on ways to mitigate high mathematics failure particularly in disadvantaged secondary schools.

Benefits of the Research to the School

- The study is likely to improve the mathematics achievement of participating learners in selected topics.

- The study acts as a remedial programme for low-performing Grade 12 learners who have lost hope of passing mathematics.
- The study will debunk the perception among many educators that low-performing Grade 12 learners cannot do well in mathematics.
- The study is likely to change learners' perception of mathematics as a difficult subject.
- Findings of the study will inform curriculum and staff development programs of the school on possible ways to mitigate high failure rate in mathematics.

Research Plan and Method

Data will be collected through administering assessment tests to learners and content validation forms to educators. Participants will be expected to attend tutorial sessions conducted by the researcher before writing each test. Permission will be sought from the learners and their parents prior to their participation in the research. Only those who consent and whose parents consent will participate. The data collection process is expected to run over a period of at most three months. All information collected will be treated in the strictest confidence. Neither the school nor individual learners will be identifiable in any reports that are written. Participants may withdraw from the study at any time with no penalty. The role of the school is voluntary and the school principal may decide to withdraw the school's participation at any time. There are no known risks to participation in this study. No recording devices will be used and no identifying information will be collected.

If a learner requires support as a result of their participation in this research, steps will be taken to accommodate this.

School Involvement

Once I have received permission to approach learners to participate in the study, I will:

- Obtain informed consent from participants.
- Arrange for informed consent to be obtained from participants' parents.

- Arrange a time with participants for data collection to take place between April and July 2012.

Thank you for taking your time to read this information.

Eric Machisi [Researcher]

Professor L. D Mogari [Supervisor]

Doctor U. I Ogbonnaya [Co-Supervisor]

C 2: Letter to Chairperson of the School Governing Body

For the attention of the School Governing Body:

Enquiries: Machisi Eric

Cell: 072 147 4618

E-mail: 47021136@mylife.unisa.ac.za

May 2012

Dear Chairperson and Members of the S G B

My name is Eric Machisi. I am a mathematics educator at your school. I am currently pursuing a Master of Science degree in Mathematics Education with the University of South Africa.

I wish to seek the permission of the School Governing Body (S G B) to carry out an educational project with Grade 12 learners at your school. I would be very much grateful if permission is granted.

The project aims to explore solution strategies that can enhance the achievement of low-performing Grade 12 learners in some mathematical aspects. My data collection will include administering tests to learners and content validation forms to mathematics educators.

I have sought and gained the permission of the Circuit Manager and I guarantee total confidentiality of all the information collected in my project. Neither the school nor individual learners will be identifiable in any reports that are written. I will only report information that is in the public interest and within the law.

Please sign the permission slip on the next page indicating whether or not you allow the researcher to carry out the project at your school. Please feel free to contact me about any queries you may have.

Thank you for your cooperation

Yours Sincerely



Eric Machisi [Researcher]

To whom it may concern

Eric Machisi has /does not have (**strike out one**) the permission of the School Governing Body (S G B) to carry out a research in this school, as described above.

Signature: Date:

Chairperson of the School Governing Body (S G B)

C 3: Letter to the School Principal

For the attention of the School Principal:

Enquiries: Machisi Eric

Cell: 072 147 4618

E-mail: 47021136@mylife.unisa.ac.za

May 2012

Dear Sir

As you are aware that I am currently pursuing a course leading to a Master of Science degree in Mathematics Education with the University of South Africa, I wish to carry out an educational research project involving Grade 12 learners at your school in fulfilment of my studies.

I am requesting your permission to conduct my research at your school. I would be very much grateful to receive your support in this regard. The project seeks to explore solution strategies that can enhance the achievement of low-performing Grade 12 learners in some mathematical aspects.

I have sought and gained permission from the Circuit Manager to involve the learners in my studies. I guarantee total confidentiality of all the information collected in my research. Neither the school nor individual learners will be identifiable in any reports that are written. I will only report information that is in the public domain and within the law.

Please find attached herewith, the **Project Information Statement** outlining the details of the study, the **School Principal Consent** form and the Circuit Manager's **approval letter**, for your attention.

Thank you for taking your time to read this letter.

Yours Sincerely



Eric Machisi [UNISA STUDENT]

For the attention of the School Principal:

Project Information Statement

Project Title:

Exploring solution strategies that can enhance the achievement of low-performing Grade 12 learners in some mathematical aspects

Aims of the Research

The research aims to:

- Explore solution strategies that can enhance the achievement of low-performing Grade 12 learners in some mathematical aspects, with a view to improving learners' achievement and the quality of mathematics teaching and learning in secondary schools of Capricorn District in Limpopo Province.

Significance of the Research

The study is significant in the following ways:

- It seeks to develop possible ways to deal with low-performing Grade 12 learners in mathematics.
- It seeks to help secondary school mathematics educators obviate high failure in the subject.
- It will possibly initiate innovations in the current mathematics intervention programmes.
- It provides valuable first hand information on real matters of the classroom and forms a basis for making recommendations to the Department of Basic Education on ways to mitigate high mathematics failure particularly in rural and township secondary schools.

Benefits of the Research to the School

- The study is likely to improve the mathematics achievement of participating learners in selected topics.
- The study acts as a remedial programme for low-performing Grade 12 learners who have lost hope of passing mathematics.

- The study will debunk the perception among many educators that low-performing Grade 12 learners cannot do well in mathematics.
- The study is likely to change learners' perception of mathematics as a difficult subject.
- Findings of the study will inform curriculum and staff development programs of the school on possible ways to mitigate high failure rate in mathematics.

Research Plan and Method

Data will be collected through administering assessment tests to learners and content validation forms to educators. Participants will be expected to attend tutorial sessions conducted by the researcher before writing each test. Permission will be sought from the learners and their parents prior to their participation in the research. Only those who consent and whose parents consent will participate. The data collection process is expected to run over a period of at most three months. All information collected will be treated in the strictest confidence. Neither the school nor individual learners will be identifiable in any reports that are written. Participants may withdraw from the study at any time with no penalty. The role of the school is voluntary and the school principal may decide to withdraw the school's participation at any time. There are no known risks to participation in this study. No recording devices will be used and no identifying information will be collected.

If a learner requires support as a result of their participation in this research, steps will be taken to accommodate this.

School Involvement

Once I have received permission to approach learners to participate in the study, I will:

- Obtain informed consent from participants.
- Arrange for informed consent to be obtained from participants' parents.
- Arrange a time with participants for data collection to take place between April and July 2012.

Invitation to Participate

If you agree that your school should participate in this research, please complete and return the attached consent form.

Thank you for taking your time to read this information

Eric Machisi [Researcher]

Professor L. D Mogari [Supervisor]

Doctor U.I Ogbonnaya [Co-Supervisor]

School Principal Consent Form

I give permission to Eric Machisi to approach learners in this school to participate in exploring solution strategies that can enhance low-performing Grade 12 learners' learning and achievement in some mathematical aspects.

I have read the **Project Information Statement** explaining the purpose of the research project and understand that:

- The role of the school is voluntary.
- I may decide to withdraw the school's participation at any time.
- Grade 12 learners will be invited to participate and that permission will be sought from them and also from their parents.
- Only learners who consent and whose parents consent will participate in this research.
- All information obtained will be treated in strictest confidence.
- The learners' names will not be used and individual learners will not be identifiable in any reports about the study.
- There are no known risks to participation in this study.
- The school will not be identifiable in any reports about the study.
- Participants may withdraw from the study at any time without penalty.
- A report of findings will be made available to the school.
- I may seek further information on the project from the researcher on 072 147 4618 or e-mail at 47021136@mylife.unisa.ac.za

Signature: _____ Date: _____

(School Principal)

Please return to: Eric Machisi
2929 Zone 2
Seshego
0742

C 4: Letter to Parents/guardians

For the attention of parents/guardians:

Enquiries: Machisi Eric

Cell: 072 147 4618

E-mail: 47021136@mylife.unisa.ac.za

2929 Zone 2

Seshego

0742

May 2012

Dear Parent/Guardian

My name is Eric Machisi. I teach Mathematics in Grade 12 at the school where your child is attending. I am a University of South Africa student pursuing a Master of Science degree in Mathematics Education.

I am delighted to take this opportunity to seek your permission to involve your child in my research project. The objective of the project is to explore solution strategies that can enhance learners' learning and achievement in some mathematical aspects. Data generated in this project will help me to be a better mathematics teacher and to provide better mathematics education to your child.

As a high school mathematics educator, my job is not only to teach but also to research better ways to improve the teaching and practices of mathematics education. This I can only achieve through the involvement of the learners I teach.

During this project, I will be offering free tutorial sessions which will be compulsory for all the learners who volunteer to participate in the project. Learners will be exposed to a wide range of approaches to mathematics solutions including those that do not appear in their mathematics textbooks. Learners will then be asked to write assessment tests after each tutorial session and their scores will be recorded and analysed.

The project will run between April and July 2012. No identifying information will be used throughout the study. Only the researcher and his supervisors, Professor LD Mogari and

Doctor U.I Ogbonnaya, will have access to the collected research data. All information collected will be treated with utmost confidentiality.

There are no known risks to participation in this study and participation is voluntary. Please note that you have the right to refuse permission for your child to take part in this project. Should you wish to do so, I guarantee that your refusal will not in any way affect my relationship with you or your child. Your child will still have all the benefits that would be otherwise available to learners at the school. Your child may stop participating at any time they wish, for any or no reason without losing any of their rights.

Please sign the permission slip below, indicating whether I may or may not involve your child in this project. Please feel free to come and talk to me about any queries you may have. For any questions about the study, please feel free to contact the researcher at 072 147 4618 or e-mail him at 47021136@mylife.unisa.ac.za

Thank you for taking your time to read this letter

Yours faithfully



Eric Machisi (UNISA STUDENT)

Please tick (✓) the appropriate category. Then sign and have your child return this slip.
Thank you in advance!

Yes, you may involve my child in your research.

No, please do not involve my child in your research.

Signature of Parent and/or Guardian

Date

C 5: Participant Information and Consent Form

Name of Institution: University of South Africa (UNISA)

Department: Institute for Science and Technology Education (ISTE)

Researcher: Eric Machisi

Supervisors: Professor L. D Mogari and Doctor U. I Ogbonnaya

Researcher's Contact: 072 147 4618

Email: 47021136@mylife.unisa.ac.za

This consent form is for Grade 12 learners aged 18+ who are being invited to participate in a study to explore solution strategies that can enhance learners' learning and achievement in some mathematical aspects.

This Consent form has two parts:

- Information sheet (which gives you information about the study)
- Certificate of consent (where you sign if you agree to participate)

Part One: Information Sheet.

Introduction

My name is Eric Machisi. I am a Master of Science in Mathematics Education student at the University of South Africa (UNISA). As a high school mathematics educator, my job is not only to teach but also to research and develop better ways of doing mathematics in order to improve the teaching and practices of mathematics education.

In this section, I am going to provide you with all the necessary information and invite you to take part in the project. You may discuss anything in this form with your parents, friends or anyone else you feel comfortable talking to before you decide whether or not you want to participate in the study. You do not have to decide immediately.

If there are any words or issues that you may want me to explain more about, I will be readily available at any time.

Purpose: What is the purpose of the Study?

This study seeks to find out from within the classroom, solution strategies that can enhance mathematics learning and achievement for Grade 12 learners who are at risk of failing the subject. High failure rate in mathematics is a long standing concern in South Africa's rural and township secondary schools. Mathematics educators in these school settings seem to have no definite answers to the crisis. It is the researcher's conviction that research conducted by the educators themselves, in their natural school settings with their own learners, will provide empirical evidence of what works and what does not work in our efforts to avert the crisis.

Choice of Participants: How have I been selected for this study?

Grade 12 learners who have a traceable record of obtaining Level 1(0 – 29%) and Level 2 (30 – 39%) in mathematics are at risk of failing the subject at the end of the year. Such learners need special attention and some kind of intervention from their educators. It is unfortunate that some educators seem to give up on low-performing learners and regard them as 'unsolvable puzzles'. Therefore the population for this study is all Grade 12 mathematics learners who have a traceable record of underperforming in mathematics.

Voluntary Participation: Do I have to participate?

Please note that you have the right to refuse to participate in this project. Should you wish to do so, I guarantee that your refusal will not in any way affect my relationship with you. You do not have to be in this research if you do not want to be involved. The choice to participate is yours. You do not have to decide immediately. Give yourself time to think about it.

Procedures: What is going to happen?

Participants will be exposed to a wide range of approaches to mathematics solutions in 4 selected topics. This will be done in compulsory tutorial sessions to be conducted outside normal school hours. The research is not going to interfere with normal daily activities of the school. Participants will write assessment tests using different approaches to mathematics solutions and their scores will be recorded for analysis. The results of the tests will be withheld until the study is over.

Benefits: What are the benefits of participating in the study?

The study is likely to broaden your knowledge of strategies to mathematics solutions in the selected mathematical aspects and consequently improve your overall mathematics achievement. The study is likely to boost your confidence and change your perception about mathematics ahead of your final mathematics examination. Participating in this study will help you realise that mathematics is not restricted to the textbook.

Risks: Are there any risks involved?

This study is considered safe and free from any harm to participants. If anything unusual happens to you in the course of the study, I would need to know and you should feel free to contact me anytime with your questions or concerns.

Reimbursements: Do I get anything for being in this research?

You will not be paid for taking part in this study. However, you will only be provided with R 10 each time as a reimbursement for time lost and travel expenses incurred as a result of participating in this study.

Confidentiality: Is everybody going to know about this?

I will not tell people that you are in this research and I will not share any information about the study with anyone except my supervisors, Professor L. D Mogari and Doctor U. I Ogbonnaya. Information collected from this study will be kept confidential. Throughout the study, Participants will be identified by numbers instead of names. The results of the study will be presented to the University of South Africa for academic purposes and later published in order that interested people may learn from the research.

Sharing of findings: Will you tell me the results?

When the research is done, I will let you know what I have discovered and learnt from the study by making available a written report about the research results.

Right to refuse or withdraw: Can I choose not to take part in this research? Can I change my mind?

You do not have to take part in this research if you do not wish to do so. Choosing not to participate will not affect you in any way. You will still have the benefits that would be available to learners at the school. You may withdraw your participation at any time that you wish for any or no reason without losing your rights.

Who to contact: Who can I talk to or ask questions about the study?

If you have any questions, you may ask them now or later, even when the study has started. If you wish to ask questions later, you may contact the researcher at 072 147 4618 or e-mail at 47021136@mylife.unisa.ac.za

Part two: Certificate of Consent

I have accurately read and understood the forgoing information sheet. I have had the opportunity to ask questions and I am happy with the answers I have been given. I know that I can ask questions later if I have them.

I understand that taking part in this research is voluntary (my choice) and that I may withdraw from the study at any time for any or no reason. I understand that if I withdraw from the study at any time, this will not affect me in any way.

I understand that my participation in this study is confidential and that no material that could identify me will be used in any reports on this study.

I had time to consider whether or not I should take part in this study and I know who to contact if I have questions about the study.

I consent/agree to take part in this study.

I agree /do not agree (**strike out one**) to allowing the researcher to contact me if a follow up study is planned.

Participant's Signature: _____

Date: _____

I wish to receive a summary of the results of the study:

Yes [] No [] *Please tick (✓) the appropriate category.