

2011

# Effectiveness of reflectorized strips on vehicle speed and lateral placement during day and night on US 52

Huishan Duan  
*Iowa State University*

Follow this and additional works at: <https://lib.dr.iastate.edu/etd>

 Part of the [Civil and Environmental Engineering Commons](#)

---

## Recommended Citation

Duan, Huishan, "Effectiveness of reflectorized strips on vehicle speed and lateral placement during day and night on US 52" (2011).  
*Graduate Theses and Dissertations*. 10096.  
<https://lib.dr.iastate.edu/etd/10096>

This Thesis is brought to you for free and open access by the Iowa State University Capstones, Theses and Dissertations at Iowa State University Digital Repository. It has been accepted for inclusion in Graduate Theses and Dissertations by an authorized administrator of Iowa State University Digital Repository. For more information, please contact [digirep@iastate.edu](mailto:digirep@iastate.edu).

**Effectiveness of reflectorized strips on vehicle speed and lateral placement during day  
and night on US 52**

by

**Huishan Duan**

A thesis submitted to the graduate faculty  
in partial fulfillment of the requirements for the degree of  
**MASTER OF SCIENCE**

Major: Civil Engineering (Transportation Engineering)

Program of Study Committee

Shauna Hallmark, Major Professor

Konstantina Gkritza

Alicia Carriquiry

Iowa State University

Ames, Iowa

2011

Copyright © Huishan Duan, 2011. All rights reserved.

## TABLE OF CONTENTS

LIST OF FIGURES .....	iv
LIST OF TABLES .....	vii
ACKNOWLEDGMENTS .....	viii
ABSTRACT .....	ix
Chapter 1. INTRODUCTION .....	1
1.1 Background and problem statement .....	1
1.2 Research objectives .....	3
1.3 Thesis organizations .....	4
Chapter 2. LITERATURE REVIEW .....	6
2.1 Background .....	6
2.2 Evaluation of countermeasure effectiveness .....	7
2.2.1 Speed .....	7
2.2.2 Lateral placement .....	10
2.3 Curve countermeasures .....	13
2.3.1 Rumble strip effects .....	13
2.3.2 Delineators and signs .....	17
2.3.3 Pavement marking effect .....	28
2.3.4 Curvature effects .....	35
2.3.5 Human factors .....	40
2.4 Summary .....	40
Chapter 3. FIELD STUDY .....	43
3.1 Site selection .....	43
3.2 Study location .....	44
3.3 Evaluation method .....	46
3.4 Research design .....	48
3.5 Data collection .....	50
3.5.1 Data collection equipment .....	50
3.5.2 Data collection procedure and schedule .....	53
Chapter 4. METHODOLOGY AND RESULTS .....	59
4.1 Assumptions .....	59
4.2 Description .....	59
4.2.1 Data reduction process .....	61
4.2.2 Lateral placement calculations .....	70
4.3 Methodology .....	71
4.3.1 Statistical method overview .....	71
4.3.2 Analysis .....	74
4.4 Results .....	81
4.4.1 Speed data analysis .....	81
4.4.2 Lateral placement data analysis .....	86
4.4.3 Correlations between vehicle speed and lateral placement .....	92
4.5 Summary .....	94
4.5.1 Speed study .....	94
4.5.2 Lateral placement study .....	95

4.5.3	Correlation study.....	96
Chapter 5.	CONCLUSIONS.....	97
5.1	Summary of the study .....	99
5.1.1	Vehicle speed.....	99
5.1.2	Vehicle lateral placement.....	99
5.1.3	Correlation .....	100
5.1.4	Conclusion .....	101
5.2	Recommendations .....	102
	REFERENCE.....	105
	APPENDIX A STUDY INFORMATION.....	110
	APPENDIX B STATISTICAL RESULTS FOR VEHICLE SPEEDS .....	120
	APPENDIX C STATISTICAL RESULTS FOR VEHICLE LATERAL PLACEMENT ...	132
	APPENDIX D CORRELATIONS BETWEEN VEHICLE SPEED AND LATERL PLACEMENT.....	144

## LIST OF FIGURES

Figure 1.1 Iowa vehicle fatalities associate with key attributes (Iowa comprehensive highway safety plan) .....	2
Figure 2.1 Optical speed bars (Virginia DOT) .....	9
Figure 2.2 Optical speed bars close range (Virginia DOT) .....	10
Figure 2.3 Overall layout of tape switch.....	11
Figure 2.4 Layout of tape switch (Bowman and Brinkman) .....	12
Figure 2.5 Tape switch layout (Mahoney et al 2003) .....	16
Figure 2.6 Detailed tape switch layout (Mahoney et al 2003).....	17
Figure 2.7 Programmer and Traffic data record (TDR) (Jennings and Demetsky 1985) .....	18
Figure 2.8 experimental information pictures (a) instrument vehicle and (b) driving course map.....	23
Figure 2.9 Baseline on (a) curve 1 and (b) curve 4.....	23
Figure 2.10 Curve 1 (a) chevron signs and (b) chevron full.....	24
Figure 2.11 Different PMD treatments on curve (a) fully-reflectorized PMD and (b) dot-reflectorized PMD.....	24
Figure 2.12 Data collection location.....	26
Figure 2.13 Data collection layout from Chrysler et al. (2009).....	26
Figure 2.14 FM 15 (a) without edgeline and (b) with edgeline .....	29
Figure 2.15 Example of (a) fiducially marks on FM850 and (b) video camera in an instrument vehicle on FM 15 .....	29
Figure 2.16 Data collection configuration from Cottrell, Jr. (1986).....	31
Figure 2.17 Layout of presence detectors .....	33
Figure 2.18 Data collection site and equipment.....	35
Figure 2.19 Lateral placement measurement (Gawron and Ranney) .....	38
Figure 3.1 Study location (a) GIS map and (b) in vehicle picture .....	45
Figure 3.2 ArcGIS crash map on US 52 .....	46
Figure 3.3 Layout of Z-configuration from Texas Transportation Institute (TTI) .....	48
Figure 3.4 Layout of Z-configuration in one lane.....	49
Figure 3.5 Counter Set Up (From CTRE roadtube manual).....	52
Figure 3.6 Roadtube Layout (From CTRE roadtube manual) .....	52
Figure 3.7 Total numbers of days during data collection .....	55
Figure 4.1 Illustrations of Z-Configurations.....	60
Figure 4.2 Vehicle headway scheme (Traffic Control Systems Handbook 2005) .....	62
Figure 4.3 Vehicle classification scheme (FHWA, TMG2001) .....	64
Figure 4.4 Different movement of one axle .....	67
Figure 4.5 driving on (a) a tangent section and (b) a curve .....	68
Figure 4.6 Correlations relation between X and Y (a) positive (b) negative.....	80
Figure 4.7 Correlations relation between X and Y (a) no correlation (b) nonlinear.....	80
Figure 4.8 Vehicle median speed comparison in before-and-after during day and night.....	83
Figure 4.9 Vehicle speed standard deviation comparison in before-and-after treatment during day and night .....	85

Figure 4.10 Median of vehicle lateral placement comparison in before-and-aafter during day and night.....	88
Figure 4.11 Vehicle lateral placement standard deviation comparison in before-and-after treatment during day and night .....	90
Figure A. 1 Study location GIS map.....	110
Figure A. 2 Study location GIS crash map .....	111
Figure A. 3 Traffic counter (Source: SunWize Technologies, Inc.).....	112
Figure A. 4 Pneumatic road tube (Source: The Traffic Group, Inc. Service).....	112
Figure A. 5 Driving along US 52 during the day without treatment .....	113
Figure A. 6 Chevron signs without treatment at night (from TTI) .....	114
Figure A. 7 Chevron signs with reflectorized post at night (from TTI) .....	114
Figure A. 8 Dubuque county AADT in 2009 .....	115
Figure B. 1 Speed Box Plot and Normal Quantile Plot for Daytime at Z1.....	120
Figure B. 2 Speed Box Plot and Normal Quantile Plot for Daytime at Z2.....	121
Figure B. 3 Speed Box Plot and Normal Quantile Plot for Daytime at Z3.....	122
Figure B. 4 Speed Box Plot and Normal Quantile Plot for Nighttime at Z1 .....	123
Figure B. 5 Speed Box Plot and Normal Quantile Plot for Nighttime at Z2 .....	124
Figure B. 6 Speed Box Plot and Normal Quantile Plot for Nighttime at Z3 .....	125
Figure B. 7 Histogram of vehicle before and after speed in daytime at Z1 .....	126
Figure B. 8 Histogram of vehicle before and after speed in daytime at Z2.....	127
Figure B. 9 Histogram of vehicle before and after speed in daytime at Z3 .....	128
Figure B. 10 Histogram of vehicle before and after speed in nighttime at Z1 .....	129
Figure B. 11 Histogram of vehicle before and after speed in nighttime at Z2 .....	130
Figure B. 12 Histogram of vehicle before and after speed in nighttime at Z3 .....	131
Figure C. 1 Lateral placement box plot and normal quantile plot for daytime at Z1 .....	132
Figure C. 2 Lateral placement box plot and normal quantile plot for daytime at Z2 .....	133
Figure C. 3 Lateral placement box plot and normal quantile plot for daytime at Z3 .....	134
Figure C. 4 Lateral placement box plot and normal quantile plot for nighttime at Z1 .....	135
Figure C. 5 Lateral placement box plot and normal quantile plot for nighttime at Z2.....	136
Figure C. 6 Lateral placement box plot and normal quantile plot for nighttime at Z3 .....	137
Figure C. 7 Histogram of vehicle before and after lateral placement in daytime at Z1.....	138
Figure C. 8 Histogram of vehicle before and after lateral placement in daytime at Z2.....	139
Figure C. 9 Histogram of vehicle before and after lateral placement in daytime at Z3.....	140
Figure C. 10 Histogram of vehicle before and after lateral placement in nighttime at Z1 ...	141
Figure C. 11 Histogram of vehicle before and after lateral placement in nighttime at Z2 ...	142
Figure C. 12 Histogram of vehicle before and after lateral placement in nighttime at Z3 ...	143
Figure D. 1 Correlations at Z1 under before treatment at daytime.....	144
Figure D. 2 Correlations at Z1 under after treatment at daytime.....	144
Figure D. 3 Correlations at Z2 under before treatment at daytime.....	145
Figure D. 4 Correlations at Z2 under after treatment at daytime.....	145
Figure D. 5 Correlations at Z3 under before treatment at daytime.....	146
Figure D. 6 Correlations at Z3 under after treatment at daytime.....	146
Figure D. 7 Correlations at Z1 under before treatment at nighttime .....	147
Figure D. 8 Correlations at Z1 under after treatment at nighttime .....	147
Figure D. 9 Correlations at Z2 under before treatment at nighttime .....	148

Figure D. 10 Correlations at Z2 under after treatment at nighttime .....	148
Figure D. 11 Correlations at Z3 under before treatment at nighttime .....	149
Figure D. 12 Correlations at Z3 under after treatment at nighttime .....	149

## LIST OF TABLES

Table 2.1 Explanation of each independent variable .....	20
Table 3.1 Summary of study site .....	45
Table 3.2 Data collection date and time in May .....	54
Table 3.3 Data collection date and time in September .....	54
Table 3.4 Sunrise and sunset time on May 2010 in Sageville, Iowa .....	56
Table 3.5 Sunrise and sunset time on September 2010 in Sageville, Iowa .....	56
Table 3.6 Before treatment data selection period .....	57
Table 3.7 After treatment data selection period.....	57
Table 4.1 Z-configuration detailed dimensions .....	60
Table 4.2 Motorcycle example (from before Z1).....	66
Table 4.3 Two-axle four-tire passenger car example (from before Z1) .....	66
Table 4.4 problematic example (from Z1 before).....	68
Table 4.5 Example data for a bus (from Z1 before) .....	69
Table 4.6 Goodness-of-fit tests for speed .....	77
Table 4.7 Goodness-of-fit tests for lateral placement.....	77
Table 4.8 Median of vehicle speed in mph.....	82
Table 4.9 Normal approximation tests for lateral placement median.....	82
Table 4.10 Vehicle speed standard deviation .....	84
Table 4.11 Chi Square approximation for standard deviation of speed.....	84
Table 4.12 Median of vehicle lateral placement in inches.....	87
Table 4.13 Normal approximation tests for median lateral placement.....	88
Table 4.14 Vehicle lateral placement standard deviation .....	90
Table 4.15 Chi square tests for standard deviation of lateral placement .....	90
Table 4.16 Correlations table under before treatment in daytime .....	93
Table 4.17 Correlations table under after treatment in daytime .....	93
Table 4.18 Correlations table under before treatment in nighttime .....	93
Table 4.19 Correlations table under after treatment in nighttime.....	94
Table A. 1 Rise and Set for the Sun in May 2010 in Sageville, Iowa .....	116
Table A. 1 Rise and Set for the Sun in May 2010 in Sageville, Iowa (continued).....	117
Table A. 2 Rise and Set for the Sun in September 2010 in Sageville, Iowa.....	118
Table A. 2 Rise and Set for the Sun in September 2010 in Sageville, Iowa (continued).....	119



## ACKNOWLEDGMENTS

First of all, I would like to take this great opportunity to thank my committee members:

Dr. Shauna Hallmark, Associate Professor, Department of Civil, Construction, & Environmental Engineering; Associate Director, Institute for Transportation

Dr. Konstantina Gkritza, Assistant Professor, Department of Civil, Construction, & Environmental Engineering

Dr. Alicia Carriquiry, Distinguished Professor, Department of Statistics & Statistical Laboratory

Thank you all for the time spent on this thesis, and your suggestions were very beneficial in completing this thesis. I would like to specially thank to my major professor Dr. Shauna Hallmark for giving me the guidance and advice.

Secondly, I would like to thank Mr. Nick Hinnerichs and other colleagues from Institute for Transportation (InTrans) for helping in data collection for this project. Also thanks to Dr. Konstantina Gkritza, Dr. Reginald Souleyrette, and Mr. Zach Hans for arousing my interest in transportation when I was in undergraduate and recommending me to work at InTrans as an undergraduate assistant. Lastly, I would greatly thank to my parents who are willing to support me unconditionally.

## ABSTRACT

Run-off-road (ROR) crashes are a serious transportation issue, especially single vehicle run-off-road (SVROR) crashes on horizontal curves. Improving safety on horizontal curves helps to lower collisions numbers, prevent injuries, decrease costs, and save lives. From Federal Highway Administration (FHWA), many countermeasures have been applied to reduce crashes on curves, such as edgeline rumble strips, edgeline delineators, chevron signs, optical speed bars, and widening shoulders, etc.

The purpose of this research was to assess the effectiveness of low cost measure, which is reflectorized strip, to reduce speeds and to improve lateral placement of vehicles on a horizontal curve in Iowa. A segment of US52, Sageville, Iowa, has been chosen as a study location. A before-and-after study concept was used to compare the effectiveness of a new treatment, adding reflectorized strips to the existing chevron posts.

Three locations were selected for data collection spots: south point of curvature which was denote as Z1, center of curvature which was denote as Z2, and north point of curvature which was denote as Z3 on US 52. A Wilcoxon signed tank test has been used to test the median of speed and lateral placement since the data were not normally distributed. A bivariate t-test was used to find the correlation between vehicle speed and lateral placement under each treatment and lighting condition.

## **Chapter 1. INTRODUCTION**

### **1.1 Background and problem statement**

As indicated by Safe Transportation Research and Education Center at University of California, Berkeley, in the total U.S. road mileage, the percentages of rural roads is 80 percent. According to Fatality Analysis Reporting System (FARS), 61% of all fatalities in 2001 and 56% fatalities in 2008 occurred on rural roads. And there were 19.9% of passenger cars hit on a fixed object in 2009. Golembiewski and Chandler (2011) evaluated 17,818 vehicle lane departure crashes in the U.S. that occurred in 2008 and results showed that at least 28% of all fatalities were on horizontal curves. The average crash rate of horizontal curves was three times that for tangent sections. Approximately 75% of fatality crashes on horizontal curves were single vehicle run-off-road crashes.

Based on National Safety Council Human capital costs, Iowa DOT provided the economic impact of \$1.3 billion caused by vehicle crashes. In 2006, Iowa Comprehensive Highway Safety Plan (CHSP) reported that the second largest group of single fatal and injury crashes was lane departures and as a result, lane departures are one of the top eight safety program areas for the Iowa CHSP. In Iowa, more than 50% of fatal crashes involve lane departures. In addition, 15% of single vehicle run-off-road (SVROR) fatal crashes and 25% of serious injury crashes involved on curves. Figure 1.1 shows Iowa vehicle crash trends and attributes from the year of 1996 to the year of 2005. From typically 400 to 450 yearly fatalities, lane departure crashes were responsible for 1,012 deaths from 1996 to 2000, and 1289 deaths from 2001 to 2005. It also can be seen that lane departure crash fatalities increased by 277 deaths during a four-year interval. The statistical and historical crash

numbers indicate lane departure crashes is the most important problem of the U.S. vehicle crash fatalities.

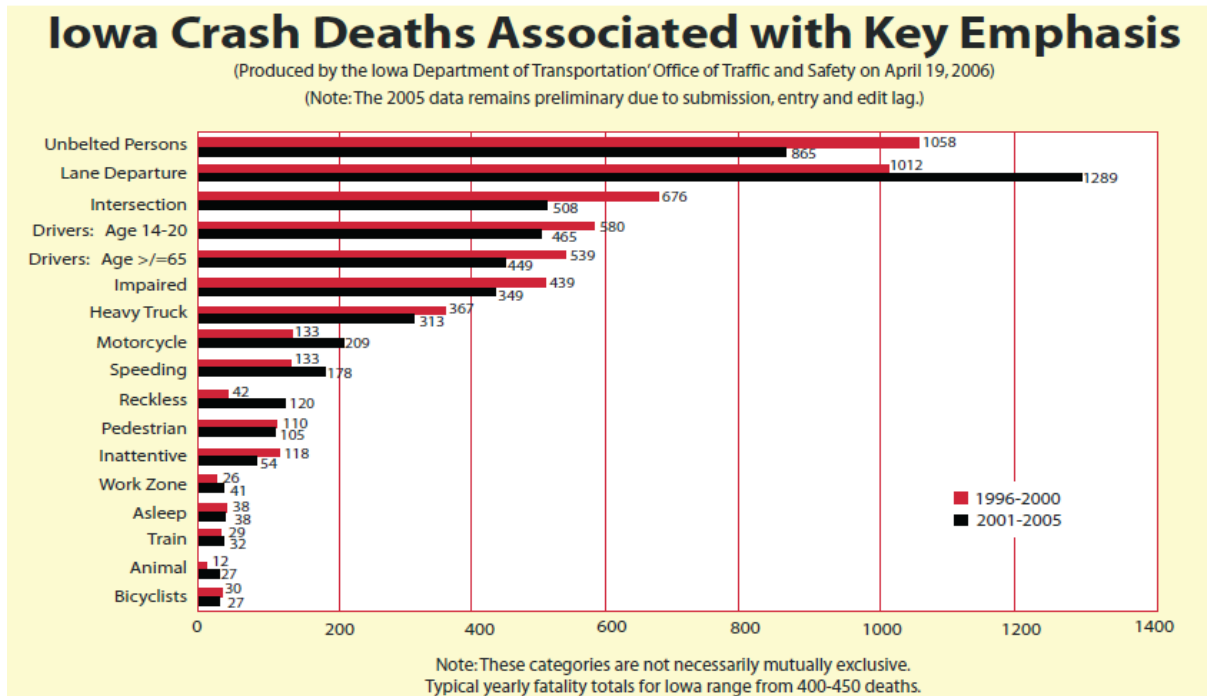

Figure 1.1 Iowa vehicle fatalities associate with key attributes (Iowa comprehensive highway safety plan)

In order to enhance driver awareness and to reduce higher crash rates especially on two-lane curves with narrow shoulders, several low-cost improvements have been implemented in Iowa. The improvements may consist of rumble strips and stripes, median barriers, clear zones, lighting, flattened curves, etc. In 2004, a paved shoulder and rumble strip policy have been implemented on selected two-lane and four-lane roadways in Iowa.

## 1.2 Research objectives

Low cost countermeasures have been applied at horizontal curves to reduce curve frequency and severity. Low-cost improvements have verified to be effective when systematical approach have been implemented. The systematical approach mainly based on crash types and verified countermeasures. Golembiewski and Chandler (2011) said “Installing the same countermeasure at multiple locations (where appropriate) could, in many cases, increase the cost effectiveness of the safety improvement, allowing an increased number of treatments to be applied.” However, crashes are rare events and as a result the effectiveness of countermeasures can only be determined through occurred crashes. And even crashes occurred, the sample size is too small to be analyzed within a limited time period. This is a major problem of measuring the effectiveness of safety countermeasure by using crash data. One of methods that conquer the difficulties of inadequate crash data is crash surrogate (alternative) analysis. Vehicle speed and lateral placement are the most often used surrogate of measures in determining the countermeasures effectiveness.

The purpose of this thesis is to evaluate how effective adding reflectorized strips to existing chevron post were on rural two-lane horizontal curve in Iowa. The main emphasis of this study is measuring crash surrogates, which are vehicle speed and lateral placement, to reduce lane departures, especially on single vehicle run-off-road (SVROR). The reflectorized strips were installed to an existing chevron sign posts as after treatment. The single vehicle speed and time stamp data were collected from the field twice by using counters to achieve a before-and-after comparison. Also, the data have been categorized into daytime and nighttime with the purpose of comparing the effectiveness of reflectorized strips

in different lighting condition. There were 5840 vehicles observed during the daytime and 2661 vehicle observed during the nighttime.

### **1.3 Thesis organizations**

This thesis is divided into five chapters. The first chapter (this chapter) introduced the background information and problems that related with horizontal curve safety. Then followed by the purpose of the study, research objects followed after the problem statement.

The second chapter covered literature review on evaluation of low cost countermeasures effectiveness based on the measurement of vehicle speed and lateral placement. In this chapter, most common curve countermeasures, such as rumble strips, signs, delineators, pavement markings, have been summarized and the methods of measuring speed and lateral placement are reviewed.

The third chapter serves a field study on testing the effectiveness of reflectorized strips on US 52 in Iowa. This chapter includes how and why US 52 is the target site for the research, and how to collect the speed and lateral placement data and how the experiment designed.

The fourth chapter describes the methodology of processing raw data and experiment results. Processing the raw data is the most time consuming part of this study. The raw data need to be screened and classified into the desired automobile type, which is two-axle passenger vehicle. In addition, motorcycle, and three or more than three-axle vehicles are not included in the data set. Statistical methods and JMP software are applied for analyzing data.

The fifth chapter summarized the results and gave a conclusion of this study. Finally, the recommendations are provided for the future research.

## Chapter 2. LITERATURE REVIEW

### 2.1 Background

Run-off-road (ROR) crashes are considered as a severe issue in highway system. Especially, single vehicle run-off-road crashes events an important challenge to transportation engineers in the United States. FHWA defined single-vehicle run-off-road crashes include vehicles that hit utility poles, tress, fixed objects along the road, or overturn. Wants and Knipling (1993) stated almost 15,000 people died each year due to single vehicle run-off-road crashes in the United State. And most of the crashes are caused by inattentive or impaired drivers. In actual, various causal factors could lead to run-off-road (ROR) crashes and head-on crashes. Back to 1980, there were 18,792 run-off-road crashes due to drunken driving behavior and darkness in Virginia rural areas.

Improving safety on horizontal curves helps to lower collisions, reduce injuries, and save lives. A Federal Highway Administration (FHWA) sponsored research, which was done by Hugh and Hanscom (2006), described series of low cost treatments to reduce road departure crashes. They classified basic treatments for horizontal curves, enhanced basic treatments, other traffic control device treatments and rumble strips, innovative and experimental treatments, etc. as low cost treatments. Curve signs, advisory speed signs, and chevron signs are basic treatments, and flashing beacons, raised pavement markers are enhanced basic treatments. Several of other treatments are widening shoulders, optical speed bars, dynamic curve warning systems, delineate roadside objects, etc. Edge line pavement markings and shoulder rumble strips are other countermeasures that have been applied to mitigate run-off-road crashes.



## **2.2 Evaluation of countermeasure effectiveness**

When countermeasures are applied, agencies want to evaluate the effectiveness of the countermeasure. The best measure is reduction in crashes but this requires several years of crash data after implementation of the countermeasure and agencies frequently want to see the immediate impact. As a result, speed and lateral placement are two surrogates that have been used in lieu of crashes to evaluate the safety impacts of countermeasures.

### **2.2.1 Speed**

A report, named Synthesis of Safety Research Related to Speed and Speed Management (July, 1998) from FHWA, comprehensively summarized the relation on speed and safety studies. Stuster and Coffman (1998) estimated two possible reasons that speed could be related to safety. One reason was higher vehicle's velocity limits less time for drivers to react and the second reason was vehicle mass and speed result in kinetic energy. If the first reason exists, then the relative frequency that crashes happened would be based on speed. If the second reason exists, the relative crash severity would be based on speed. The authors claimed that there was evidence showing that speed and safety are correlated and higher crash risk would occur if vehicle travelling speed is higher or lower than average speed. In addition, if a crash happened on site, the crash severity depends on vehicle speed. Solomon (1964) did a research on the relation of driver, vehicle characteristics and speed on rural highways in 1950's. He found that increasing in vehicle speeds would result in increasing in crash severity on rural road. However, most of speed related crashes are from higher vehicle speed rather than lower speed. Stuster and Coffman (1998) reported crashes

severity and number of crashes increased when vehicle at higher speed. Since speed and safety are correlated, so we assume that if slow down drivers, crashes will be reduced and crash severity would be reduced as well.

Real speed only is measured under normal condition, while measured speed may or may not be equivalent to real speed. If any speed measuring devices are laying down or, aside the road, such as road tubes, radar guns, laser guns, and drivers may notice them and drive differently than normal. For instance they may slow down or brake. The doubts about the relationship between measured speed and true speed have been raised by researchers. In view of the above issues which may exist, Crowther et al. (1961) investigated the effect of pneumatic road tubes on vehicle speeds. Three roadway types, four-lane divided concrete, two-lane concrete and two-lane macadam, were selected for experiment sites. A few assumptions have been prepared before collecting and processing field work data. The assumptions were including measured speed will be less than real speed, drivers see the tube before they will react, the speed selected from different time of the day will show significant difference. In addition, researchers assumed the differences between real speed and measured speeds were from driver's perception of the tube configuration. Although every research has its own focus area and objective, the similarities of it compared with our research were investigators took four-wheeled passenger vehicles as research object and no vehicles with trailer attachment of any kind were included in the observations. It turned out that there were existence of bias between measured speed and real speed, and measured speed was lower than real speed. Tube spacing, speed limit, tube color, and average "real" speed of vehicles

have an effect on the magnitude of error in measured speeds. Additionally, black tubes gave more reaction than grey tubes no matter what colors were of highway surface.

In order to make drives slow down when entering a curve, speed bars provide an illusion for drivers that they are driving faster than they actually are. Research Scientists, Arnold and Lantz (2007), from Virginia Transportation Research Council conducted a research of safety operations of optical speed bars on curves. A before-and-after data collection and evaluation has been done to test the functionality, practicability and efficiency. Figure 2.1 and Figure 2.2 are showing the sites with optical speed bars. It was turned out that there was a statistically significant difference in decreasing vehicle speed when optical speed bars were painted on sites. Optical speed bars had positive impact on vehicle speed reduction, but the reduction is smaller. Nevertheless, cost and benefit analysis pointed out the costs of installing it was less than the benefits in respect of crash reduction if only one crash was avoided.



Figure 2.1 Optical speed bars (Virginia DOT)



Figure 2.2 Optical speed bars close range (Virginia DOT)

### 2.2.2 Lateral placement

Vehicle lateral placement is another surrogate that has been used to determine whether a countermeasure is effective in addressing run-off-road crashes. Use of lateral position, assumes that there is a correlation between lane position and likelihood of running off the roadway. Theoretically, drivers should keep vehicles within the lane markings when they driving on the roadways. However drivers have the potential of driving vehicle to the edge or the center of the roadway. Suh et al. (2006) said that “lateral placement is defined by the distance between the lane edge of highway and the middle of vehicle”. Lateral position can be measured from a straight roadway or on a curve. The smaller lateral placement, the closer vehicles drive on the edge of road, and the higher potential of accidents happening. Lateral placement analysis is one of the tools to measure the tendency of vehicle crashes on the roadway.

Academically, lateral placement is also named lateral position. Lateral placements have not been determined yet until recently due to equipments restrained and insufficient accuracy. Historically, induction loops were used at Baltimore, Maryland in 1928 (Blana, 2002), electromechanical speedometer and placement detector were used in 1958 and mechanical traffic counters were used in 1971 (Sun et al., 2007) to determine vehicle lateral placement. In recent years, new equipments are gradually used for measuring lateral placement of traveling vehicles, such as video recording equipment in 2000, portable speed detectors (Suh et al., 2006), road tubes, instrumental vehicles, autoscope software program (Taylor et al. 2005), etc. Bowman and Brinkman (1988) conducted a research on the effectiveness of low-cost countermeasures, which were pavement markings, raised pavement markers, roadside delineators, advanced warning signs, etc., at 18 narrow bridges. A before-and-after study has been taken to measure vehicle speed and lateral placement. Figure 2.3 and Figure 2.4 demonstrates the configuration for speed and lateral placement measuring.

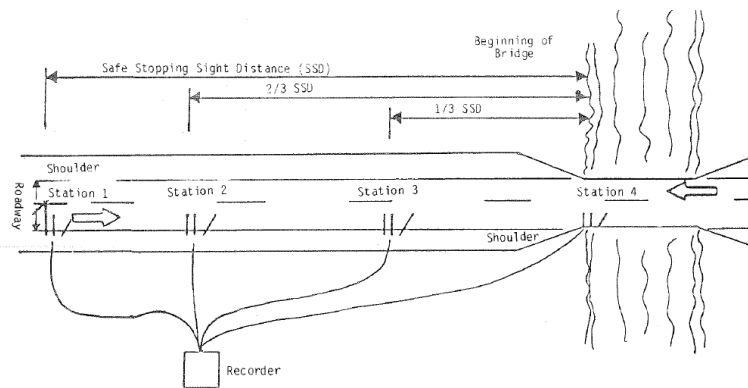

Figure 2.3 Overall layout of tape switch

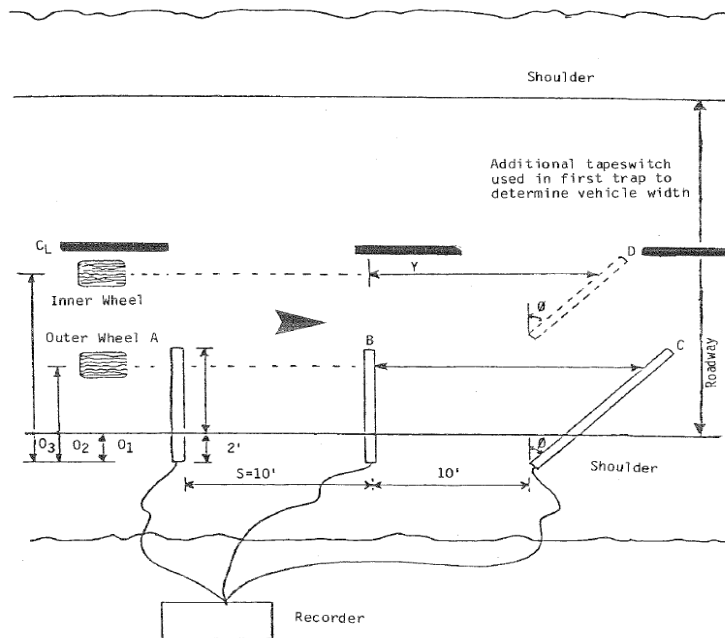

Figure 2.4 Layout of tape switch (Bowman and Brinkman)

It can be seen from Figure 2.4 that three tape switches laid 10 ft apart among those three and the distances were measured as horizontally along the edge. Tape switches have two copper strips and a plastic divider. Traffic Evaluation System (TES) is an automatic data collection program and it was used to record input throughout tape switches. As a vehicle driver over the tape switches, the electrical impulse will be generated and transmitted to a rheostat right after generation process, and then the system can identify the time, location code, switch code from resultant current. Finally, vehicle speed and lateral placement can be determined from TES and unique layout of tape switches.

In the following, the data collection layout and brief descriptions of how studies have been done by researchers on vehicle speed and lateral placement of measuring countermeasures effectiveness will be discussed.

## **2.3 Curve countermeasures**

### **2.3.1 Rumble strip effects**

Rumble strips are well known as one of roadway safety countermeasures. They are a continuous segment along the edge of road or in the center of the roadway that alert drivers who inadvertently cross the lane line by producing tactile vibration and audible sound when drivers travel over them. It has been widely used in most of States on roadways and highways to ensure the drivers safety and prevent accidents. According to National Cooperative Highway Research Program (NCHRP) Report 641, rumble strips are categorized into four types based on installation method: milled, rolled, formed and raised. And they are divided into four types based on use of functions: shoulder rumble strips (SRS), centerline rumble strips (CRS), mid-lane rumble strips, transverse rumble strips. The definition of a shoulder rumble strip is “a longitudinal design feature installed on a paved roadway shoulder near the travel lane” and it was given by Umbs (2001). From the website of New York State Department of Transportation, rumble strips are a cost-effective countermeasure to reduce roadway crashes. Shoulder rumble strips cost \$0.60 per centerline-foot and centerline rumble strips cost \$0.30 per centerline-foot with an assumption of 10 years resurfacing cycle. Also, the NCHRP Report 641 concluded that most of agencies use shoulder rumble strips (SRS) and centerline rumble strips (CRS) as the countermeasures for encroachment crashes and to reduce single-vehicle run-off-road (SVROR) and head-on crashes.

There are both advantages and disadvantages for both SRS and CRS. SRS placed near or on the edge line to prevent vehicle encroachment to the edge of roadway. But SRS could increase the probability of head-on crashes. Finley et al. (2009) from Texas Department of

Transportation performed a study on the impact of shoulder rumble strips (SRS) and center rumble strips (CRS) on vehicle lateral placement on two-lane undivided roadways and determined the minimum shoulder width that can ensure drivers adjust errant vehicle if once they pass over SRS. They used Z-configuration piezoelectric sensors to obtain speed, volume, and lateral position data in each direction. After finishing field study, researchers have found that CRS on two-lane undivided roadway with minimum 10ft lane width do not have negative impact on vehicle lateral placement. And drivers tried to keep in the center of the lane when shoulder widths were one feet or two feet. CRS prevent vehicles traveled to the center line and reduced the crashes from oncoming traffic. However, if the lane width is equal to or less than 12ft, CRS did not decrease the likely of ROR crashes.

The Colorado Department of Transportation (CDOT) compared the effectiveness of installing CRS on two-lane, undivided highway. During over three years before-after case observation, the data showing that head-on crashes reduced by 22 percent and opposing direction sideswipe crashes reduced by 25 percent. The State of Colorado has a program called Hazard Elimination and Safety (HES) to identify the potential location of crashes and to reduce lane departure crashes. In 2003, the Missouri Department of Transportation (MODOT) also installed CRS on two-lane undivided roadway. A 24 months before-and after- study indicated there was a reduction of crossover centerline crashes. MODOT used a series of countermeasures to reduce the crash rate by 25%. The countermeasures were taken to widen roadway edge line, providing at least four feet paved shoulder on major roads, using curve speed sign and using guardrail along the major road, etc. Massachusetts conducted a study of the effectiveness of CRS on three different undivided roadways. It was conclude that



CRS are effective to install and CRS have a large possibility of reducing crashes. The Insurance Institute for Highway Safety (IIHS) accomplished more comprehensive research on the effectiveness of before-and-after installation of CRS in 2003. The project conducted 98 sites of rural two-lane roadways in seven States. Not only finishing the comparison of before-and-after CRS installed, Empirical-Bayes also has been used as the other method in order to get more precise crash reduction. Empirical-Bayes was applying to get the expected number of crashes and then compare with the actual crashes that were observed. The results illustrated that all injury reduced by 15 percent, and head-on and opposing-direction sideswipe injury crashes reduced by 25 percent.

Porter et al. (2004) demonstrated the relationship between how centerlines rumble strips effect lateral vehicle placement and speed. The project data were collected from before and after rumble strips presented at four different locations. Lateral placement data were obtained from tape switches and a video camera. Video camera was placed at a spot where it didn't affect drivers driving performance. The result showed centerline rumble strips (CRS) reduced the vehicles travel toward to the center of road and head-on crashes. The numerical results indicated mean lateral placement moved 5.5 in. and 3in. from the center of roadway for 12 ft lanes and 11ft lanes, respectively. The research group didn't establish a trajectories model because there were some unknown factors and it was not included in the project.

Mahoney et al. (2004) from Pennsylvania Department of Transportation conducted a project on the relation of center line rumble strips to vehicle lateral placement and vehicle speed on two-lane highway. A before-and-after study has been done and data were gathered before and after using CRS. As shown in *Figure 2.5*, four tape switch sensors were used to

record speed and lateral displacement data in one lane. Speed data can be collected from two parallel tape switches which were perpendicular with edge line. The distance of two parallel tape switch sensors were 60 ft as denoted as  $L$  in *Figure 2.5*.

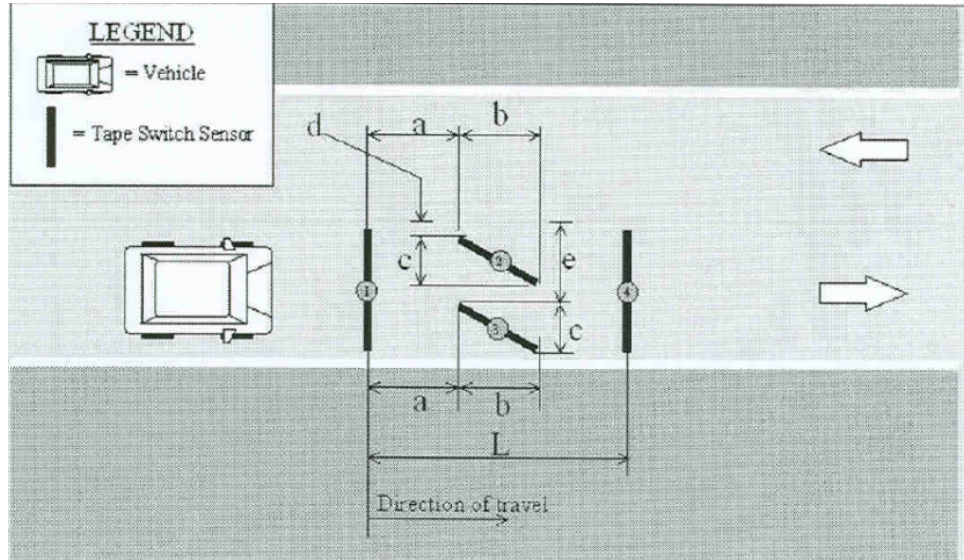

Figure 2.5 Tape switch layout (Mahoney et al 2003)

And Figure 2.6 shows the detailed dimension and layout of tape switches in the study of Mahoney et al. (2004). Time stamp can be recorded from the middle of two tape switches. The two tape switches were angled  $45^\circ$  with centerline and edge line, respectively to record the time of vehicle's left front tire and right front tire passing over them. Then vehicle lateral position data can be calculated from time stamp data by using basic geometry. As tape switch has been used throughout the study, a video recorder was used to record data at the same time as the study done during daylight.

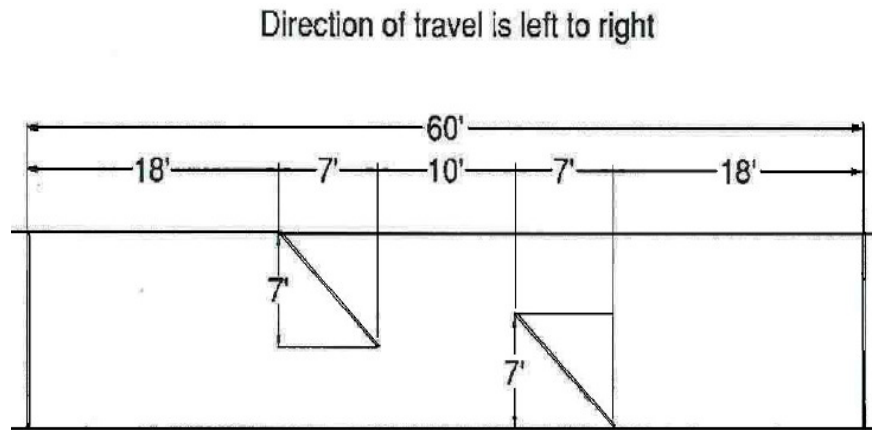

Figure 2.6 Detailed tape switch layout (Mahoney et al 2003)

The Penn DOT provided numerical evidence of CRS effect on vehicle lateral placement on undivided two-lane roadways. The results showed center vehicles path shift to the right about 6 inches and 2 inches from edge line for 11-ft and 12-ft lanes compared with before CRS installed, correspondingly. And center vehicles path shift to the right about 9 inches and 7.5 inches from edge line for 11-ft and 12-ft lanes after CRS installed. After doing data analysis and statistical testing, the results showed CRS increased the probability of putting vehicle travel away from centerline. But no significant change can be found in before-after variances of lateral vehicle placement for two comparison sites. Further study of lateral vehicle placement should use large sample size and different highway sites.

### 2.3.2 Delineators and signs

Jennings and Demetsky (1985) from Virginia Highway and Transportation Research Council completed a research on the effect of curve delineation signs on rural highways. In

the study, vehicle speed and placement have been considered as performance measures for drivers' reaction to different delineations.

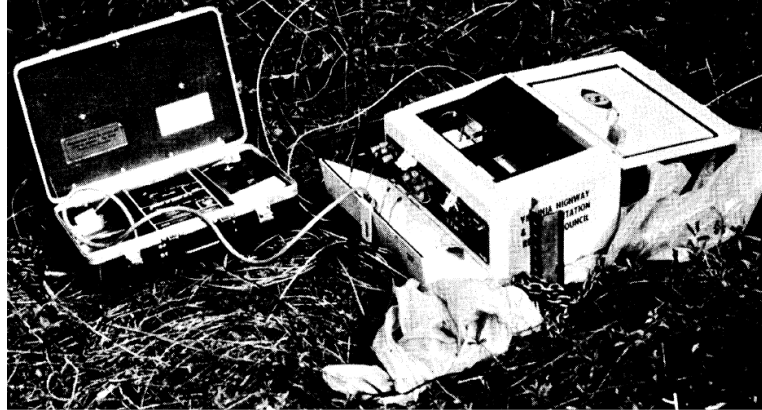

Figure 2.7 Programmer and Traffic data record (TDR) (Jennings and Demetsky 1985)

First three tape switches were laid paralleled among each other with 3 inches spacing between the first two and with 6 ft spacing between the last two. The fourth tape switch angled 45° with the edge line. Vehicle speed can be determined by using tape switch 1, 2, and 3 based on the time spent and the distance. And vehicle lateral placement can be calculated as the following equation that generated by Leopold and Stevens:

$$\text{Lateral placement} = 6 * \text{Tan } (\theta) * ((S1/S2) - 1)$$

In this equation,  $\theta=45^\circ$ , S1 is vehicle speed from speed switch, and S2 is vehicle speed from lateral placement switch. The final output data contained volume, velocity and vehicle type. Figure 2.7 shows Leopold and Stevens traffic data recorder (TDR) were used to record speed and placement data. TDR was left on the side of roadway with lock after tape switches have been set up and TDR can directly output the data into a computer for the future analysis. However, TDR almost cannot be used under wet or cold circumstances unless circuit

connections were covered by plastic bags when encountering heavy dew condition. Three delineation signs were used. They were chevrons, PMDs, and a special road edge delineator. Chi-squared goodness-of-fit test was used to test the effectiveness of the delineation treatments in the study. It showed that there was no significant difference in vehicle speed between before and after treatment. While, there were significant changes in lateral placement. Among three different delineations, it turned out chevrons provided better guidance to drivers on sharp curves (curve degree  $\geq 7^{\circ}$ ). For moderate curve (curve degree  $< 7^{\circ}$ ), standard edge delineators helped drivers more than chevrons.

Krammes and Tyer (1991) from Texas conducted an impact study of post-mounted delineators (PMDs) and raised pavement markers (RPMs) on vehicle operations and they also assessed RPMs and PMDs from operational and costs perspective. PMD was taken as an existing treatment and RPM was taken as a new treatment in the study. A data collection system with tape switch was used to collect vehicle speed and lateral placement data. The data were measured at both two lanes and at beginning, midpoint, and end of each five horizontal curves. A statistical test proved that there was no significant differences on vehicle operations on the inside lane between the two treatments. Mean lateral placement was further from the centerline with one to two feet on the midpoint of the curve while RPMs placed on site. For both short term and intermediate term evaluation periods, it is suggested that RPMs gave better delineation than the existing treatment.

Zador et al. (1987) conducted a research on the effectiveness of post-mounted delineators (PMDs), raised pavement markers (RPMs), and chevrons signs on curves. Speed and lateral placement data were collected from 46 horizontal curves in Georgia and five

curves in New Mexico. In the site of Georgia, researchers designed a factorial design with four aspects: modification (M), turning direction (T), vertical alignment (G), and sharpness of curve (C). The University of New Mexico Engineering Research Institute sponsored traffic data record (TDR) to collect data. In order to measure any changes in variables, general linear model (GLM) has been developed by SAS Institute in analysis procedure. In GLM, the expression of the equation was

$$MV1_{mtgc} = A + B_m + C_t + D_g + E_c + F_{mt} + G_{mg} + H_{mc} + Error_{mtgc}$$

Where MV1 was the dependent variable named as average approach speed, and Table 2.1 explains the meaning of each independent variable. It can be seen from the equation, the relation of curve treatment and curve characteristic was the main focus in the study of Zador et al (1987).

Table 2.1 Explanation of each independent variable

Alphabet	Value	Meaning
m	0	no change
	1	chevrons
	2	PMDs
	3	RMPs
t	1	left curves
	2	right curves
g	1	downhill grades
	2	level grades
	3	uphill grades
c	1	less sharp curves
	2	more sharp curves

Regarding the site of New Mexico, t-test has been used to test the significant changes of speed and lateral placement due to the effect of chevrons. And a paired t-test was used to compare the effect from modification groups of Georgia and New Mexico. The results turned out that vehicle speed increased about 2 ft/sec at night when PMDs installed and about 1ft/sec at night when RPMs installed in the site of New Mexico. For right curves, lateral placement increased when PMDs were used. In general, vehicles shifted toward to the edge line when RPMs and chevrons were used.

In 1972, David, R.E. from National Cooperative Highway Research Program (NCHRP) conducted a study of how PMD, RPM, and pavement markings impact vehicle speed and lateral placement on two-lane rural horizontal curves. Total of eleven treatment combinations were evaluated. After two phases experiments performed, the results turned out that RPMs combined with PMDs came to smaller lateral placement than centerline and PMD presented on the roadway. David also recommended that RPMs would be used at risky curve locations.

In 1988, Freedman et al. conducted a study on centerlines, edge lines, RPMs, chevrons, and PMDs. Both simulation and field work were applied into the project. He concluded a similar results with David that combinations of PMDs, or RPMs and pavement markings have the most beneficial effects on lane position.

Another research was from Stimpson et al., which was completed in 1977, and it studied the effectiveness of combinations of RPMs and PMDs, and different dimensions of centerlines, edge lines. Five tangents, two roadways, and two isolated curves were including

in total of nine sites. The results showed that there was no evidence indicated that lateral placement changed if the width of centerline or edge line was modified from four to two inches. PMDs did not affect lateral placement when vehicles were on tangent segments. On the other hand, PMDs reduced lateral placement along outside lane of horizontal curves.

Chrysler et al. (2009) from Texas Department of Transportation spent two years studying how drivers react to delineation on horizontal curves on two-lane roads. A closed-course nighttime study was performed in Texas to evaluate how driver response to the countermeasures in nighttime conditions. The study site was at the Texas A&M University Riverside Campus which has 2000 acres of concrete runways which previously belonged to the Air Force Base. Human factor based study data were acquired by 2006 Toyota and DEWE5000 data acquisition system which was installed in the experimental vehicle. Figure 2.8(a) shows inside view of the instrumented vehicle. Data they obtained were accelerator displacement, brake pedal, lateral accelerations, and GPS location. Like Figure 2.8(b) illustrates the investigators made four curves from which curve 1 and curve 3 had the same geometric attributes, and curve 2 and curve 4 had the same geometric attributes. Curve 1 and 3 had length of 250 ft and deflection angle of 51 degrees; curve 2 and curve 4 had curve length of 250ft and deflection angle of 90 degrees. Curve 1 and curve2 with the same baseline treatment were yellow double centerline. Curve 3 and curve 4 with the same baseline treatment were white edge line and yellow double centerline. Edgelines and centerlines were all made of foil-backed temporary tape.



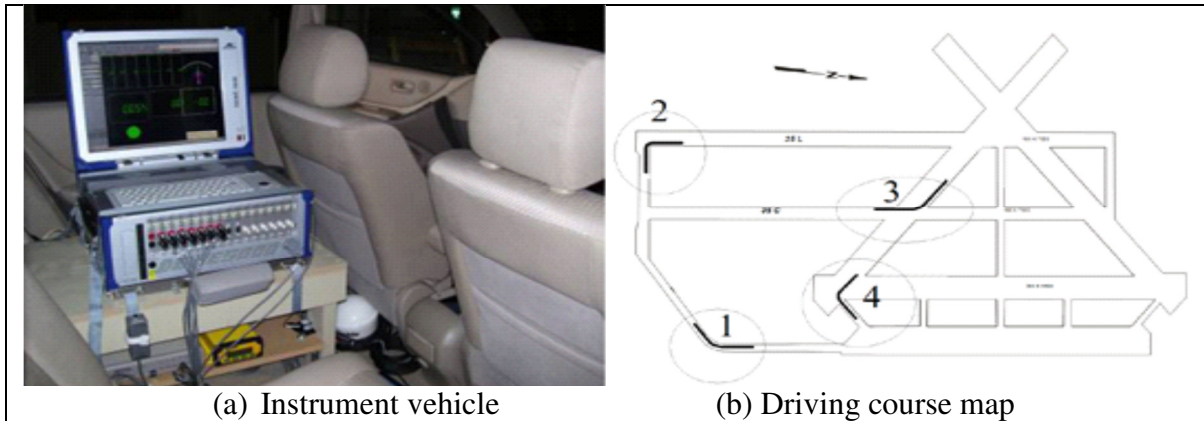

Figure 2.8 experimental information pictures (a) instrument vehicle and (b) driving course map

Full PMD and Dot PMD were installed on curves from point of curvature to point of tangent. Another treatment was high intensity sheeting chevron signs. Five treatments were baseline treatment, post-mounted delineation with fully-reflectorized post-mounted delineators (Full PMD) and dot-reflectorized post-mounted delineators (Dot PMD), standard chevron signs (Chevron) and chevrons signs with fully reflectorized posts (FullChev). Figure 2.9 (a) and (b) are demonstrating the baseline treatment on curve 1 and curve 4, respectively.

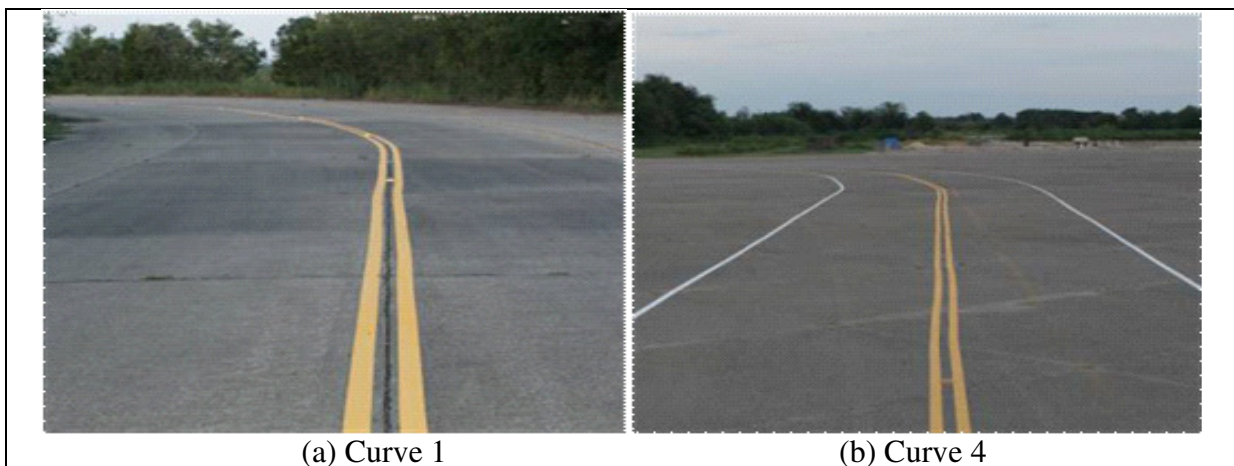

Figure 2.9 Baseline on (a) curve 1 and (b) curve 4

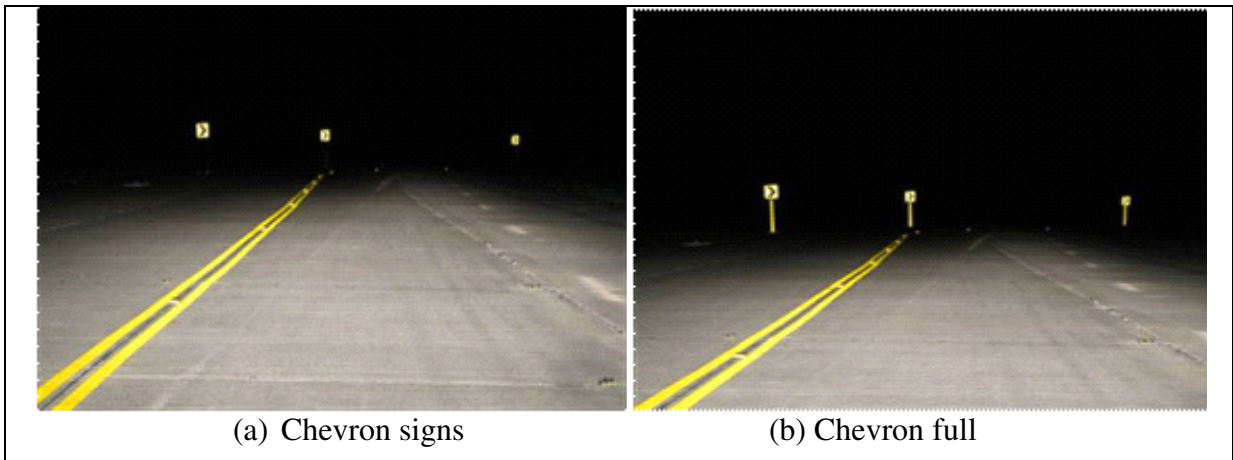

Figure 2.10 Curve 1 (a) chevron signs and (b) chevron full

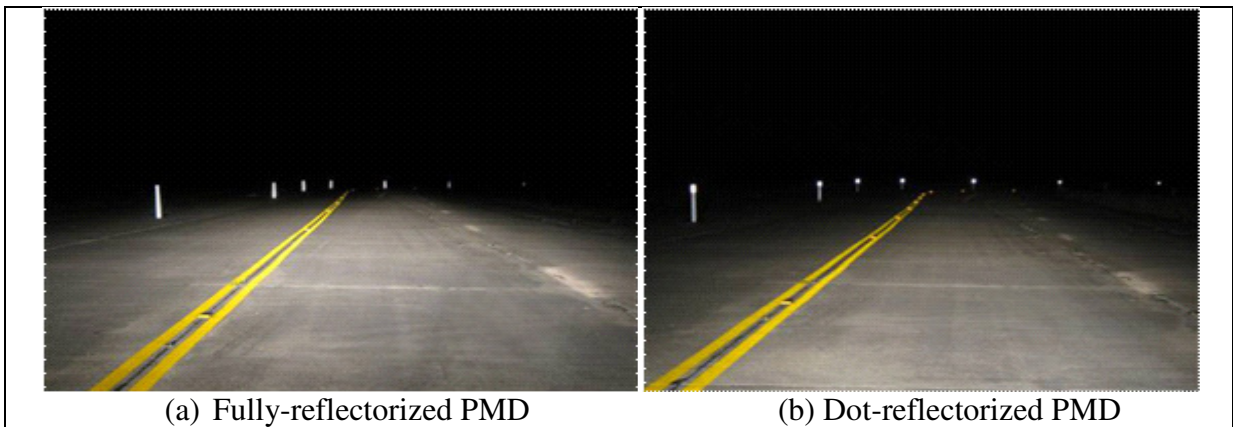

Figure 2.11 Different PMD treatments on curve (a) fully-reflectorized PMD and (b) dot-reflectorized PMD

Figure 2.10 (a) shows only chevrons sign and Figure 2.10 (b) shows chevron signs with fully reflectorized posts at nighttime. Figure 2.11 (a) and (b) are displaying the photos of fully-reflectorized PMD (Full PMD) and dot-reflectorized PMD (Dot PMD), respectively.

Researchers decided to make 40 trials to achieve all combinations. Based on the 20 participants feedback, driver first aware the sharpness of curves when Full PMDs were used.

The results turned out fully reflectorized post-mounted delineators (Full PMDs) were the most effective treatment among the five treatments in negotiating a curve for licensed participants. And chevrons with fully reflectorized posts gave better view than the regular chevrons. However, the baseline treatment without edgeline was the worst in participants preferences test.

After a closed-course nighttime test has been done, then Chrysler et al. (2009) conducted a before-and-after field study to evaluate the delineation treatments. A before condition was the treatment with baseline and an after treatment was the effect that from the added treatment. Five different horizontal curves (4 sites) were selected as study site. Vehicle speed and lateral placement data were collected as safety surrogates for crashes to measure the effectiveness of treatments. A baseline condition was using to measure vehicle performance without any modifications and after conditions was including standard chevron signs, chevron signs with fully reflectorized posts (ChevFull), dot-reflectorized post mounted delineators (Dot PMDs), and fully-reflectorized post mounted delineators (Full PMDs).

Traffic classifiers and Z-shaped piezoelectric sensors were used in data collection process as

Figure 2.12 and Figure 2.13 showing. Point of curvature (PC) and middle point of curve (MP) were selected for two testing points on both outside curve (left-hand) and inside curve (right-hand). A passing vehicle's self weight pressed the sensors and generated air pulse to traffic classifier.

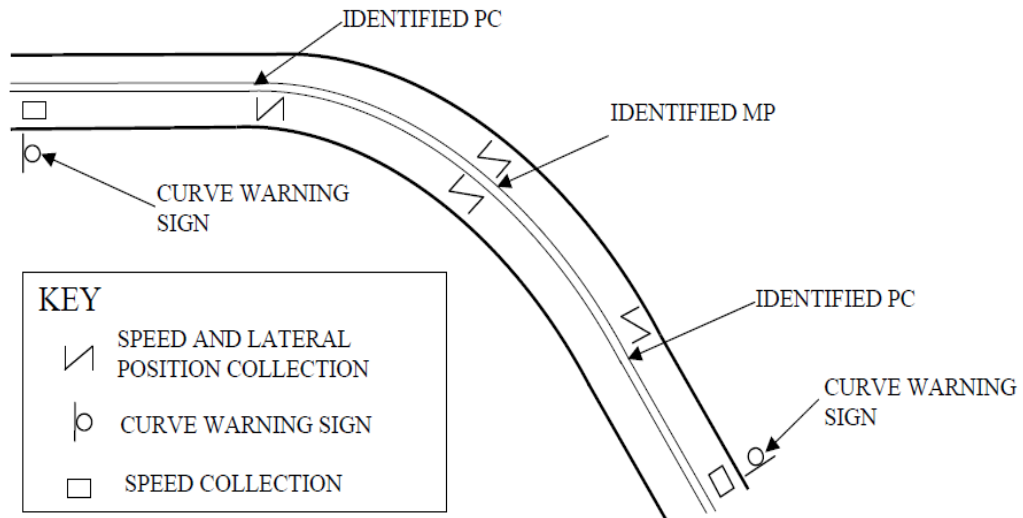

Figure 2.12 Data collection location

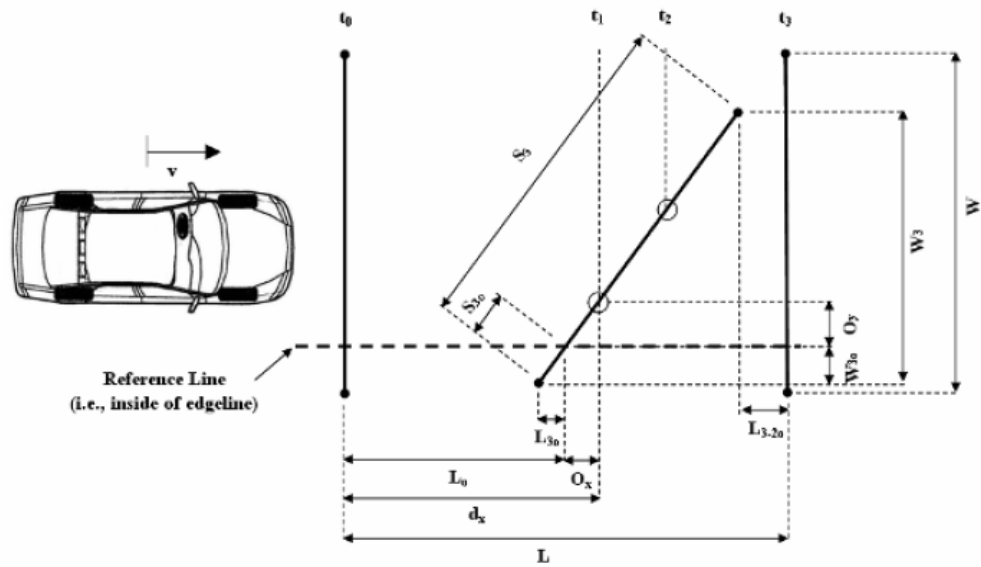

Figure 2.13 Data collection layout from Chrysler et al. (2009)

Significant level of five percent was used to conduct the tests. The univariate Analysis of Variance (ANOVA) test applied to investigate the differences in speed and lateral placement. Two-sample t-test was used to compare the mean speed and lateral position to evaluate the effectiveness of the different treatments. Z-test was used to test the differences in proportions of speed and lateral placement and F-test was used to test the variances of two samples. Findings were chevrons and the ChevFull treatment impacted and improved lateral placement more highly than baseline treatments and the effects were different. Regular chevron and chevron signs with fully reflectorized posts have the similar effect in helping vehicle keep in a lane even though vehicles were more likely to drive close to the centerline on an outside curve. And vehicle speeds were statistically lower when chevrons and chevron full treatments were installed than the speed under baseline treatment. The finding indicated ChevFull treatment reduced the speed more than the standard chevron signs on a horizontal curve. In conclusion, chevrons and ChevFull delineations adjust vehicles lateral position well. Dot PMD and Full PMD treatments keep vehicles in the middle of the lane and substantially decrease centerline encroachment. However, Full PMDs generated more uniform lane keeping results on outside curve and inside curve than the results from Dot PMDs. Speed results were not consistent, for example, there was no evidence to show that Dot PMDs or Full PMDs reduced vehicle speed on site 3 or site 4. Overall findings showed that Dot PMDs and Full PMDs did not help in speed reduction.

### 2.3.3 Pavement marking effect

Tsyganov et al. (2006) reported that 59 percent of highways have edge lines in Texas. On accident-prone sections, highways without edge lines have an 8 percent higher mean accident ratio than similar sections with edge lines. For 9 feet lane width, there was 1.74 accidents per million vehicle miles traveled (AMVMT) on highways without edge lines and 1.60 AMVMT on highways with edge lines. And for 10 feet lane width, the mean accident ratio was 1.60 accidents per million vehicle miles traveled (AMVMT) on highways without edge lines and 1.59 AMVMT on highways with edge lines. For a section with lane widths of 11 feet, the mean accident ratios were 1.42 AMVMT and 1.37 AMVMT, accordingly for highways with and without edge lines. No matter how wide the lane was, the numbers of accidents per million vehicle miles traveled (AMVMT) was usually lower on highways with painted edge lines.

Tsyganov et al. (2006) also performed a before-and-after study on the effect of edge lines on rural two-lane highways in Texas. Vehicle speed and lateral roadway position were taken as the measure of surrogates to evaluate the effectiveness of edge lines. Three highways, FM 850, FM 15, and FM 13, were chosen for study locations with roadway widths of 9ft, 10ft, and 11ft, respectively. As Figure 2.14 (a) shows, a before treatment did not have edge lines and Figure 2.14 (b) shows an after treatment has edge markings. And fiducially marks (Figure 2.17 (a)) and a video camera installed in an observation vehicle (Figure 2.15 (b)) were used to collect speed and lateral position on total of three sites for both daytime and nighttime periods.



Figure 2.14 FM 15 (a) without edgeline and (b) with edgeline

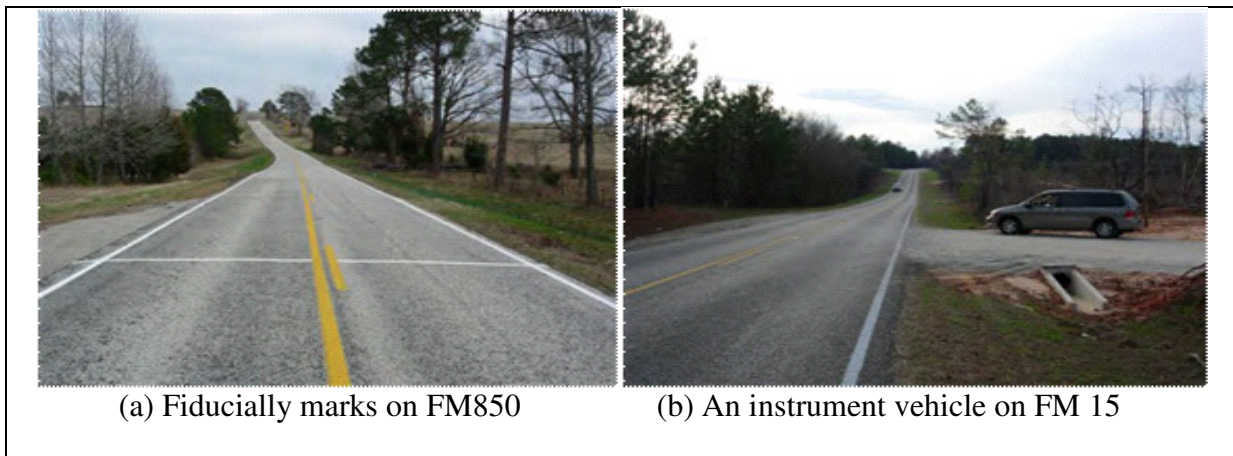

Figure 2.15 Example of (a) fiducially marks on FM850 and (b) video camera in an instrument vehicle on FM 15

Lateral position can be calculated by using observation of the position of a vehicle's left front tire and the centerline when the vehicle drive over the fiducial mark, as shown in Figure 2.15 (b), in the video. A confidence interval of 95% was used for t-test to test the mean speeds and an F-test was conducted to test the variance of the data in both daytime and nighttime on three highways. The study found that speeds decreased by 3.4 mph after treatment in daytime, and speed variance was higher after edge line placed but the difference was not statistically significant. Overall speeds were decreased by 4mph after edge lines were added for both

daytime and nighttime. It was also found that vehicle's lateral placement decreased in both daytime and nighttime on FM 15 and FM 13 with lane width of 10ft and 11ft, respectively. However, the changes in vehicle lateral placements were not significant whether during daytime or nighttime on FM 850.

Researchers, Benjamin H. Cottrell, Jr. (1986), from Virginia Highway and Transportation Research Council, conducted a project on the effects of wide edge lines on vehicle lateral placement on two-lane rural roads. Edge lines were used to warn drivers and to provide guidance for them driving away from the edge of roadways. Cottrell (1986) chose four study locations from four different counties in Virginia and divided them into 12 sites based on travelling direction and roadway geometry. The assumption he made was any changes of vehicle speed and vehicle lateral placement in before-and-after study were due to the width of edge line. The researchers collected vehicle speed and lateral placement data by using Leupold and Stevens traffic data recorder (TDR). TDR was using to detect vehicle lateral placement and speed data, and data were recorded on a magnetic cassette tape. Virginia Highway and Transportation Research Council developed a TDR report generator programs to obtain mean, standard deviation, and distribution on speed and lateral placement data from the raw data from field. As shown in Figure 2.16, TDR has three sensor cables and one cassette tape. Researcher used vinyl tape to fixed two six-foot apart sensor cables which were perpendicular to the edge of the pavement and were belonged to Channel A, and the third sensor cable was laid with a certain angle to the edge line.



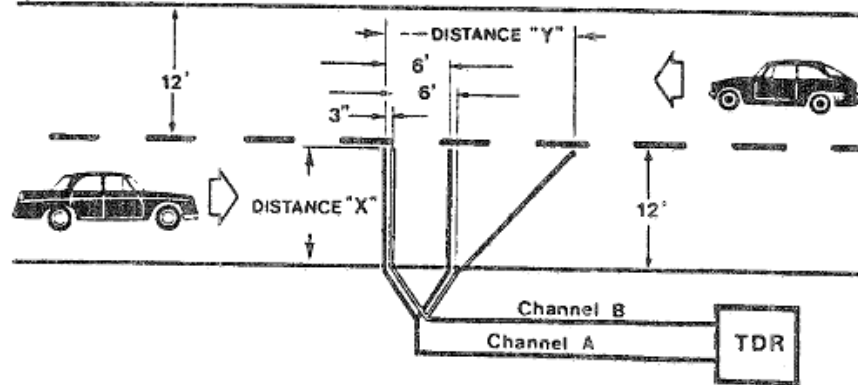

Figure 2.16 Data collection configuration from Cottrell, Jr. (1986)

In before case study, there was 4-in wide edge line and data were collected in Fall 1983. And in after case study, there was 8-in edge line and data were collected in 1984. An F-test was used to test statistical significant lateral placement variance during day and night condition. Results of a Wilcoxon test showed there was no significant difference in lateral placement variance for 4-in and 8-in edge lines. On the whole, the mean lateral placement was lower when 8-in edge lines presented, but there was no statistically significant difference in lateral placement between 4-in edge line and 8-in edge line.

Michigan State University researchers Taylor et al. (2000) conducted a project on the effect of pavement marking with single edge line and double edge line and shoulder rumble strips on vehicle lateral placement. The studies areas were selected from two four-lane divided freeway segments. One was a 30-mile section on I-96 between Portland and Grand Rapids, Michigan and the other one was a 10-mile section on US-131 between Grand Rapids and Big Rapids, Michigan. The project has two phases. The first phase was to place a standard edge line and edge rumbles strips were used on the two freeways. Rumble strips

were milled in 24in from the edge of the lane for both directions. And single edge line painted for one direction and double edge line painted for the other direction. The second phase was a 10 miles segment and it was painted with a single edge line and with rumble strips. Researchers collected vehicle lateral placement data under day and night, and dry and wet conditions using a video recorder and Autoscope software. Vehicle lateral position was determined by seven presence detectors that were placed on the side of highway, as Figure 2.17 shows below. Seven presence detectors were placed with 6 inch intervals. Take edge line as the measured based line, the layout of presence detectors extend left 1 ft toward shoulder and 2 ft inside the lane. Results indicated that on a straight segment by using single painted edge line, vehicles moved toward to the edge line during daytime in dry weather. In contrast, vehicle moved closer to centerline in daytime and in dry condition on a straight section. On a curve section with single painted edge line, vehicles moved away from the paint line in nighttime. And vehicles shifted to the left when double paint line present on a curve. In conclusion, vehicles shifted to the right under the single edge line paved, and vehicles moved to the left under the doubled edge line paved. Under wet weather condition, vehicles moved to the edge line as well as in the dry weather. Generally speaking, vehicles moved to the right under the single edge line, and vehicles drove to the left under the doubled edge line. Edge line marking has impact the vehicle lateral placement and doubled edge line reduced the vehicles moved to the edge. Drivers feel more secure when the doubled edge line was present.

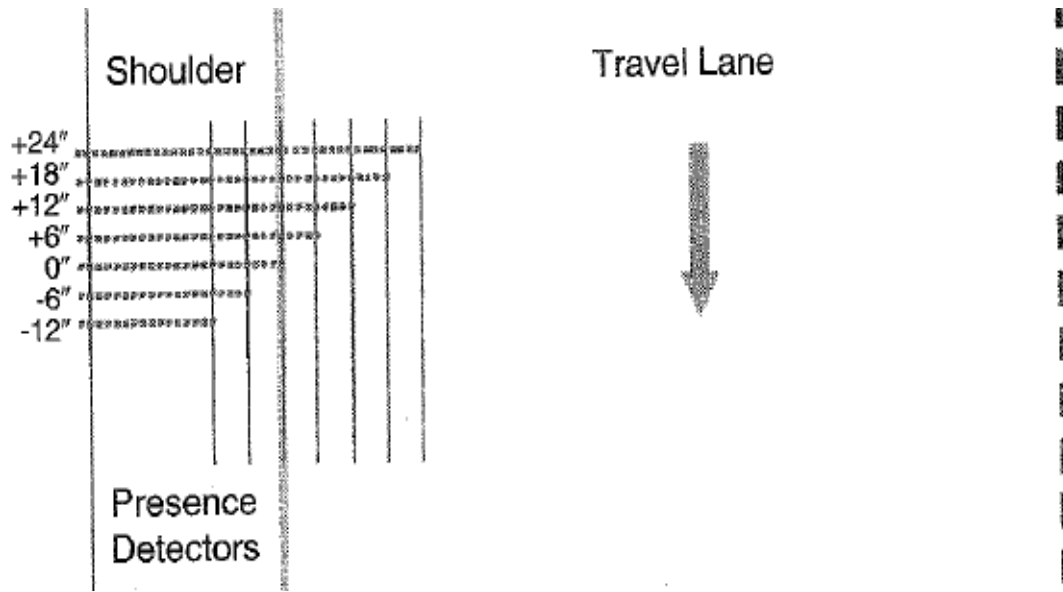

Figure 2.17 Layout of presence detectors

Based on curve issues, transportation researchers Charlton (2007) from New Zealand conducted two experiments. First experiment was testing four different combinations of warning signs on curve to exam the speed reduction and the second group of experiment was using distinct pavement marking to evaluate vehicle speed and lateral placement on curve. Pavement marking types were dashed white centerline, double yellow centerline, rumble strip, and herringbones. Following literature review mainly focus on the second experiment. 24 participants, including 10 men and 14 women, from the local region with full New Zealand driving licenses accepted the experiment. The simulator was from University of Waikato. Two types of road experiments were evaluated: one was advance warning signs accompanied with dashed white centerline, and the other combined advance warning signs with chevron sight board, repeater arrow treatment and herringbone pavement markings. Statistical analysis reported vehicles traveled to left at point of entry on a curve under the combination condition described above. And pavement marking, especially herringbone

shaped pavement markings, has a significant impact on lane position. Pavement markings narrow the actual lane width and would have an effect of reducing vehicle speed. The result showed vehicle shifted 0.37m to the left when they were entering a curve. In the middle point of curve, vehicle shifted 0.22m further to the left on average. In regard to this research and lane position, herringbone pavement marking influenced drivers operating vehicle slightly from right to left and guided drivers to keep vehicles in the lane.

Another study performed by Dudek et al. (1988) emphasized the effectiveness pavement markings had at night at different sites in Arkansas, Colorado, Oklahoma, and Texas. There were seven sites in total and four sites were in Texas, and the rest of three sites were in Arkansas, Colorado, and Oklahoma respectively. An automatic data collection system, which developed by Texas Transportation Institute, was used to collect vehicle performance on 1-ft, 2-ft, and 4-ft broken line pavement marking on speed, lateral distance and lane encroachment data. The lateral distance was different from lateral placement and it was measured from the centerline to the edge of the vehicle left front tire. Figure 2.18 shows data collection configuration at site that conducted by Dudek et al. (1988). As can be see, each study site contains one curve section and one tangent section. Two tape switches were installed and used to measure speed and time. One Z-type at upstream was used to measure time, speed, lateral distance and encroachments of each vehicle. Three sets of Z-Type were used to recorded speed, lateral position and vehicle type. All raw data were extracted from an automated system that was from Golden River Corp. environmental computer. Regarding to findings of average vehicle speed among 1-ft, 2-ft, and 4-ft pavement marking patterns, there were no significant differences based on the statistical analysis. And there were no statistical

differences in lateral distance from centerline among 1-ft, 2-ft, and 4-ft pavement marking patterns.

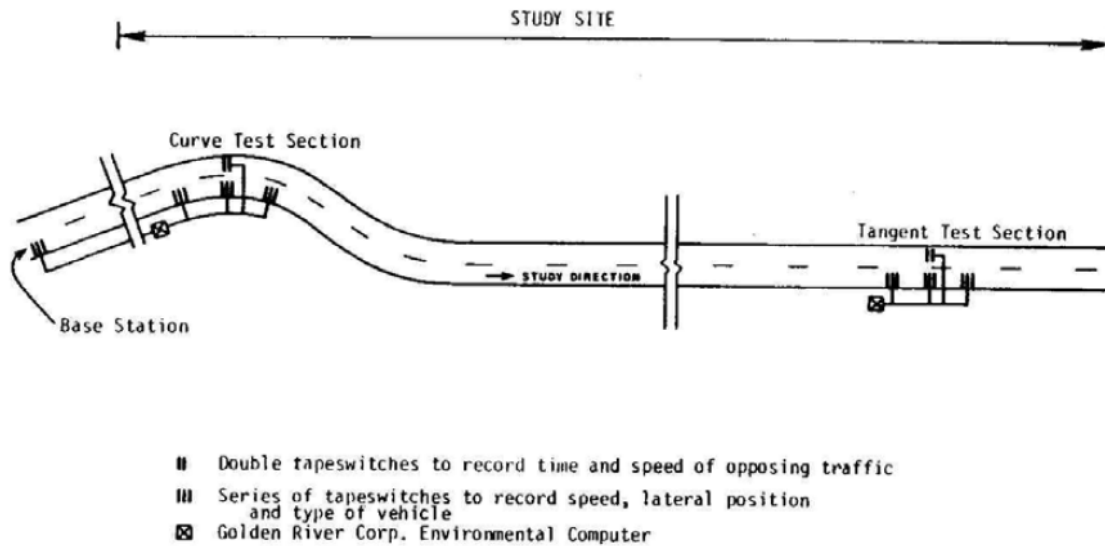

Figure 2.18 Data collection site and equipment

### 2.3.4 Curvature effects

Horizontal curves, especially on two-lane undivided rural roads, are considered as the sites which have important safety issues. The larger degree of curvature in a horizontal curve, the higher accident rates presented in the curve. The accidents were caused by drivers' inattention, wrong deception of speed and curvature; driver encroached to edge of road, and errant driving behavior, etc. Frank Julian, who is from the FHWA Resource Center's Safety and Design Technical Service Team, says "If you are going to solve the roadway departure problem, you have to solve the horizontal curve problem. The most cost-effective approach to solving roadway departure crashes is to focus on horizontal curves because they make up a small percentage of the road miles but account for one-quarter of all highway fatalities."

Basic treatments for ensuing safety of horizontal curves are edge lines, horizontal alignment signs, advisory speed signs, chevron alignment signs, etc.

In Northern Ireland, Gunay and Woodward conducted a project on lateral position of vehicle on road curvature and at roundabout in 2005. They collected vehicle position data by using screen ruler software from five roundabouts and three horizontal curves. They found that drivers were more likely to use inside lane rather than outside lane. Due to little vehicle speed variation, and no evidence to verify that vehicle speed and lateral position have certain relationship. The smaller lane widths were, the smaller the lateral freedom was. They also found that expected wheel path was different from the real observed wheel path on eight different sites. On most horizontal curves, vehicles have potential of driving convex side of the curve and vehicles shifted more to convex side when curve radius decreased.

On a horizontal curve, when the curve radius decreases, most vehicle paths have the tendency of shifting to convex side. It is recommended by using more sensors to measure vehicle lateral position and to make data more reliable and more capable. However the study results cannot be exactly applied to the U.S. circumstance because of different driving rules between North America and Europe.

In South Korea, Park et al. (2007) evaluated the safety of curves in rural highways. Researchers used Sony DCR TRV530 digital cameras to record vehicle lateral placement and Auto CAD combined with spline interpolation in program to develop vehicle trajectories. Regression analysis and t-test were used to find the variances in vehicle lateral placement standard deviation. They concluded that the bigger speed differences could result in bigger

deviation of lateral placement of a vehicle on a curve. And the curve geometric characteristics have a large effect on deviation of vehicle lateral placement than vehicle speed. Then they summarized that most of drivers had difficulties steering vehicles in the lane on a sharper a curve. Finally, the researchers recommended larger sample size could help to explain the relation of vehicle lateral placement and driver's driving behavior on a curve.

Gawron and Ranney (1990) from Calspan Advanced Technology Center, Buffalo, New York, performed a study on driver behavior on curves by using driver simulator. 12 male drivers, whose ages were from 21 to 55, with full driver license were tested for uninterrupted two hours before driving task. Each two hours period, there were 150 curves to be negotiated. Driving tasks were road signs reactions, curve respondents and obstacle avoidance. Five curves with different radii were chosen. Between-trial factors and within-session factors were applied in the study. Blood Alcohol Content (BAC) and driving scenarios were in between-trial factor group; edge line width and type of curve warning signs were within-session factors group. In specify, curve warning signs were chevron, raised delineator, flashing beacon, road marking, or no curve warning sign. Curve warning signs changed every 20 minutes interval to display 25 various combinations. Finally, simulator displayed 150 curves which were including six time intervals by five spot treatments by five curve types. Lateral position in the project was recorded percentage of time that the vehicle was in each lateral-position interval and it was recorded constantly during the experiment. As shown in Figure 2.19, a 12-ft lane in one direction was divided into 12 numbered intervals and each interval was one feet apart. Number 10 and 11 was located in the other lane and

direction, and interval numbers 1 to 9 fell in the travel lane. Speed was measured at the end of curve transition and lateral placement can be measured from the point to the location of the curve sign with every 100 foot intervals. Main findings indicated as curve radius decreased, curve cuttings, called lateral position error, and increased. In conclusion, as curve radius decrease, curve entering speed decrease. Conversely, vehicle speed increase as curve radius increase. Specifically, drivers slow down when entering a curve when the curve getting sharper. Vehicle lateral placement error has a highest value with the smaller curve radius and lowest value with the shortest curve length. Meanwhile, it was found that there was no relationship between curve radius and lateral acceleration.

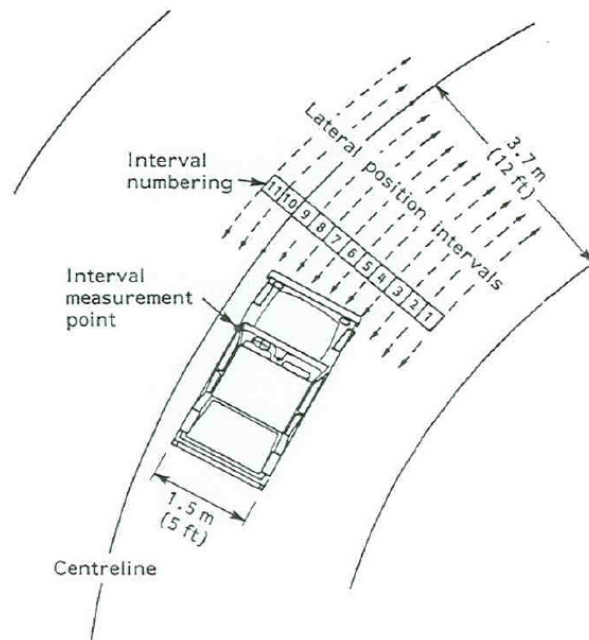

Figure 2.19 Lateral placement measurement (Gawron and Ranney)

Roadway geometry could affect driver's visibility when driving on a curve. Drivers are aware of the left and the right of roadway and they also can view scenery at left and right



on a straight roadway segment. They can simply fix the eyes on markings and adjust the vehicle lateral movement under a straight roadway. However, curves have different geometry characteristics, such as radius, degrees, reflection angles, etc. and most of curves are parabolic shape instead of arcs with constant radius. It requires much more signs and cues for drivers to drive through it. Shinar et al. (1977) conducted a project on driver's eye movement when they driving on a curve. This project was to decide driver's reactions and search patterns on a curve. Three male and two female participants from Ohio State University were tested. All five of them had good vision and none of them wore glasses or contact lens. A total of 22 curves were selected for study purposes. Three of them had high accident rate and 11 with no accident during 1969 and 1971. Eye movement recording system was calibrated before the site study and suggested speed was about 60 mph (97 km/h) to minimized visual fixations. Statistical analysis was applied for five visual performance measures: fixation durations, travel distance, location of each fixation, concentration index and separate analysis. After analyzing driver's visual search patterns, the researchers found that driver's reaction and searching patterns on curve and straight are different. Driver put more attentions on vehicle lateral position of curves and the position of the road ahead of them. When drivers drove a car approach to a curve, cues on curve gave hints of keeping the vehicle in right position of the lane. Shinar et al. (1977) concluded that curve sight distance should be increased so that driver may have more time to access to the curve and negotiate the speed. And signs or cues should not only be placed at the beginning of a curve because drivers are already making the adjustment and fixation prior to a curve.

Crisler et al. (2008) came up lane variability position increased when driver using wireless communication devices, which were iPod, text message conversation, and text message word games. The data were extracted from a simulator and the project was conducted on fourteen licensed drivers with age from 18 to 22 who have experience using modern wireless communication devices. Another research indicated average speed decreased and percentage of drivers traveled outside of lane increased, and crash rate increased compared with no cell phone used (Schattler et al., 2000). In conclusion, driving engaged with cell phone users definitely will impact drivers' behaviors and diminish driving capabilities, and decreased the lateral placement of travel vehicles.

### **2.3.5 Human factors**

Shinar et al. (1977) recommended curve signs might be placed prior to the beginning of the curve. This would work better for drivers and they would have more time to switch their visual search strategy. Lots of previous studies have explored the relationship between speed and lane position on a curve. Suh et al. have (2006) completed a study to exam driver's behaviors on eye-moment under different roadway geometric and lighting condition. The experiment was done by using instrumented vehicle with an eye movement tracking system. Regression model was used to develop the relationship in data and they concluded there were statistically significant differences in driver's eye movement under different curve conditions.

## **2.4 Summary**

Golembiewski and Chandler (2011) thoroughly summarized most often used roadway departure countermeasures mainly based on the relative time to complete, estimated

costs and crash reduction factor. They addressed clear zones for reducing roadway departure crashes, provided more spaces for under controlled vehicles to stop or regain the control. Although creating a clear zone could reduce crashes by 13-44%, it requires right-of-way along the roadway and costs will be relatively high. Centerline rumble strip/stripes can be milled on any roadway, unlike centerline rumble strips, edge line rumble stripes/strips narrowed the range of applications. They should be used on roads where departure crashes are recorded in history. The cost of edge line rumble strips/strips is lower than clear zone, but crash reduction factor is only from 10 to 22%. Centerline and edge line pavement markings are other countermeasures. The crash reduction factor has a range of 33 to 44% and the costs were relative higher than edge line rumble strips/stripes.

The methods that most of researchers used were t-test and F-test. T-test was used to determine if the mean speed or mean lateral position were significantly different. And an F-test was applied to test if the variance in speed or lateral placement significant. A univariate Analysis of Variance (ANOVA) test applied to investigate the differences in mean lateral placement data. And regression analysis was used to find the variances in vehicle lateral placement standard deviation.

Researchers were most likely to find the relationship among curve radius, vehicle speed and lateral placement. They have found that curve radius and lateral acceleration didn't correlate and there was no relationship between speed and lateral placement. Investigator summarized that lowest total lateral position error happened on the curve with the shortest length and biggest radius, and vice versa. As curve radius increase, curve entering speed increase as well. This was because driver speed up when entering a curve with smoother

segment. Drivers drove faster on left hand curve and vehicles moved closer to center line. The hypothesis reason that made by investigator was driver look inside of curve since there's no obstructions. It was found that there was no significantly evidence showed wider edge lines can reduce crash data. Generally, chevrons, PMDs, edge lines move vehicle path away from roadway.

However, the relationship of reflectorized strips and vehicle speed and lateral placement haven't been studied and found in the State of Iowa. This project paper will discuss how reflectorized strip impact on vehicle speed and vehicle lateral placement on horizontal curves in Iowa.

## **Chapter 3. FIELD STUDY**

### **3.1 Site selection**

The treatment applied to US 52 was part of a larger project to evaluate treatments to reduce speed and crashes on rural two-lane roads. Sites were selected according to the following methodology.

The Iowa Department of Transportation's roadway inventory database was used to identify all secondary (county maintained) road segments containing at least one curve with a posted advisory speed sign. Crashes occurring along these secondary road segments between 2002 and 2007 were then identified and associated with each road segment. The crashes were then hierarchically classified as: animal, intersection, speed-related, single vehicle and multiple-vehicle. With the exception of the single vehicle and multiple vehicle crashes, the crash classifications were not necessarily mutually exclusive. An attempt was made to identify speed related crashes but this information is not well documented in the crash database. The total crash frequency along each road segment was calculated, and the road segments were ranked based on the total crash frequency. Maps of the top 45 segments were prepared for review. Each map included the road segment of interest, proximate roads, a recent aerial image of the area and crash locations (presented thematically and stacked).

Sites which were not feasible for application of treatments were removed from the list. This included factors, such as having a railroad crossing or major intersection within the curve. The remaining sites were ranked by number of non-animal crashes and the top locations selected for one of four treatments:

- Dynamic speed feedback signs
- Addition of reflectorized material to existing chevron posts
- On-pavement curve warning signs
- Use of larger chevrons

US 52 was selected to receive addition of reflectorized material to existing chevron posts.

### **3.2 Study location**

A segment of US52, which is in Northwest of Sageville, Dubuque, Iowa, was been chosen as a study location. Speed and lateral placement data were collected at the site to assess the effectiveness of reflectorized strips to existing chevron posts. The section of US 52 with upstream of Clay Hill Road and downstream of Sherrill Road. Table 3.1 summarizes the characteristic information of study site. The portion has two-lane undivided rural roadway with 12ft lane width in each direction and has asphalt pavement surface. The posted speed limit is 50 mph in both directions. The study location GIS map is showing in Figure 3.1 (a) below. Based on Iowa Department of Transportation, traffic flow of Dubuque County has Annual Average Daily Traffic (AADT) of 2130 vehicles in the year of 2009 on US 52. From Figure 3.1 (b), the study site has plenty of trees and drivers' views are partially obstructed by trees so that drivers driving along a curve may not be able to see oncoming vehicles well. A number of private driveways are also present along the curve. Curvature combined with trees are the most potential safety hazard for drivers.

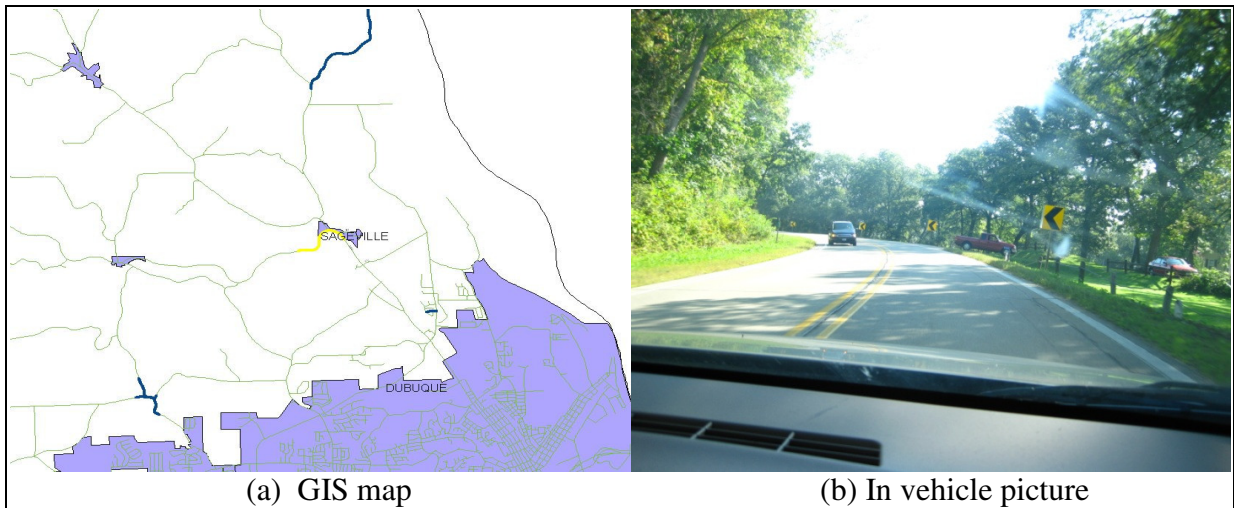

Figure 3.1 Study location (a) GIS map and (b) in vehicle picture

Table 3.1 Summary of study site

Item type	Property
Area Type	Rural
Terrain	No Restriction
Highway Function	Rural Highway
Posted Speed	50 mph
Lane Width	12ft
Lanes Number	2
Pavement Type	Asphalt
Pavement Condition	Good
Volume (AADT)	2130

The major criteria used for site selection was number of crashes. According to Iowa DOT crash database, there were seven crashes on the segment from 2002 to 2007. ArcGIS crash map was developed and shown in Figure 3.2. Among seven crashes, five of them were single vehicle crashes, five of them were property damage only crashes, and one was single vehicle fatality crash.

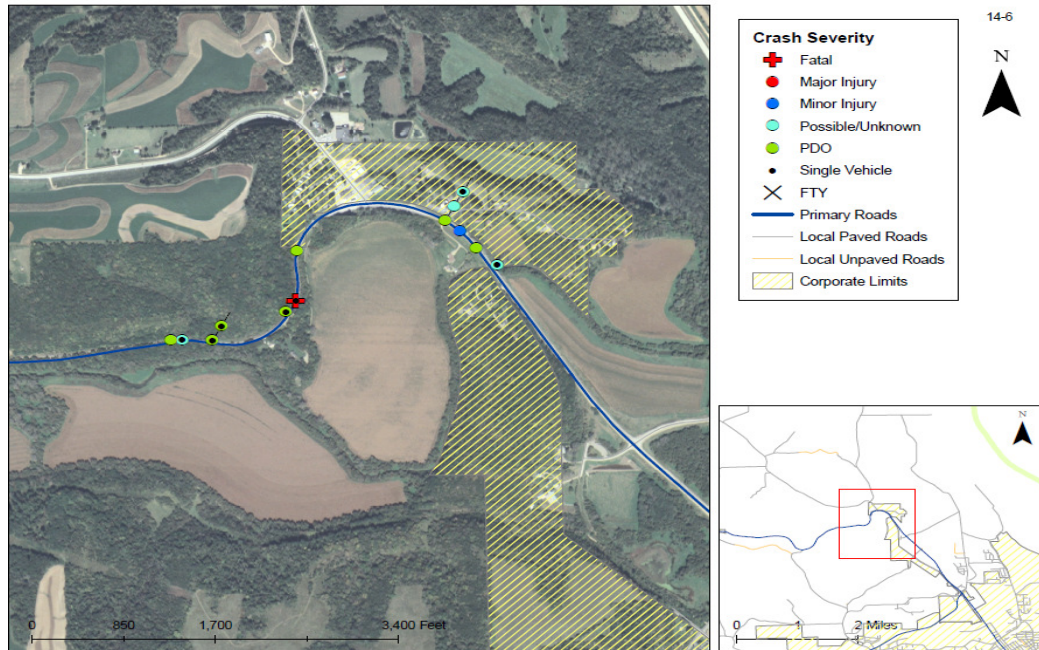

Figure 3.2 ArcGIS crash map on US 52

### 3.3 Evaluation method

Crashes occur infrequently and reasons for causing crashes vary and agencies should identify the appropriate and effective countermeasures to deal with roadway departure issues. FHWA Roadway Departure Safety reported the decision of installing countermeasures to accomplish roadway safety can be a challenge object and Horizontal Curve Safety stated that ways to judge the selection of countermeasures are speed limit compliance, geometric characteristics, sight distance and traffic volume, etc. The basic countermeasures are centerline, edge line, centerline rumble stripes/strips, edge line rumble stripes/strips, and enhanced countermeasures are advisory speed plaque, chevron signs, flashing beacons, basic device with high retroreflectivity and fluorescence, dynamic curve warning signs, rumble



strips, safety edge, widen shoulder, etc. In this study, reflectorized strips were installed to the existing chevron post as a new treatment.

Since crashes are infrequent and complicated events, safety surrogate measurements are used to assess the effectiveness of a curve treatment. While a crash based measures of effectiveness (MOEs) requires a long period to gain crash data for statistical analysis. Operational assessment can be used after countermeasure accomplishment, usually within one or two months and need more than two days of data collection period for before and after treatment. Vehicle speed and vehicle lateral placements were often used as safety surrogate measurements to assess how effective the treatment was. There were couples of studies have been done by using lateral placement to evaluate treatments. As previously mentioned, Dudek et al. (1988) conducted a research on the effectiveness of pavement markings on measuring vehicle speed and lateral distance from the centerline to the edge of vehicle left front tire. Porter et al. (1995) conducted a study on centerline rumble strips by looking at lateral placement of vehicles. Miles et al. (2005) evaluated the effectiveness of milled edge line rumble strips and centerline rumble strips by finding the lateral placement of vehicles on a rural two-lane roadway. A Texas Department of Transportation sponsored study, which was from Finley et al (2009), investigated how shoulder and centerline rumble strips impact on the vehicle lateral placements as well.

In this study, vehicle speed and lateral placement will be used as the two safety surrogate measures to investigate the effectiveness of reflectorized strips.

### 3.4 Research design

Lateral position has been collected by several researchers using a road tube configuration referred to as the z-configuration. The layout of road tubes for this study was based on a study of Texas Transportation Institute (TTI) (Chrysler et al. (2009) ). Figure 3.3 illustrates the Z-configuration layout used by TTI. The motivations of using Z-configuration were vehicle speed can be easily calculated from time and the known distance of two parallel road tubes, as well as vehicle lateral placement can be derived from two similar right triangles and time stamp by utilizing simple geometry.

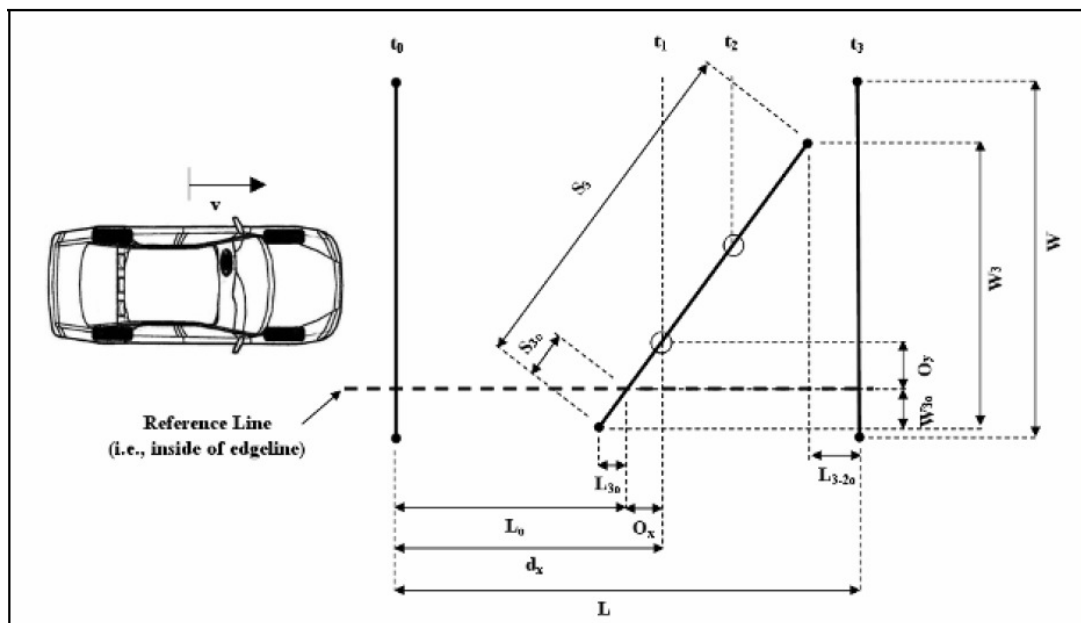

Figure 3.3 Layout of Z-configuration from Texas Transportation Institute (TTI)

As noted in Figure 3.4, the Z-configuration for this research differs slightly from TTI's. There were two primary differences between layouts of two studies. As shown in

Figure 3.4, three tubes ends were placed just inside of the edge line instead of stretching outside of it as Figure 3.3 shows. And the other end of diagonal tube reached to the center line. In order not to miss any data, which was generated by a vehicle's left front tire, diagonal tube (tube 3) extended to the center line. The purpose of one end not extending over to the centerline was to avoid complicated and erroneous data. If all three tube ends extend over to the centerline, it may hit by left tires from a oncoming vehicle and extra data would be added to the normal data. For the sake of testing exact distance between vehicle's tire and the edge line, three tubes stretched to the edge line. According to the vehicle driving direction, one of the two perpendicular road tubes which was first hit by the vehicle was denoted as tube 1, and the other one was denoted as tube 2. The middle diagonal one was denoted as tube 3. A before-and-after study design concept has been used through the project to compare effectiveness of treatment on vehicle speed and lateral placement. On the curve, three locations are selected for data collection. South point of curvature (South PC) denoted as Z1, center of curvature denoted as Z2, and north point of curvature denoted as Z3 in data sheet.

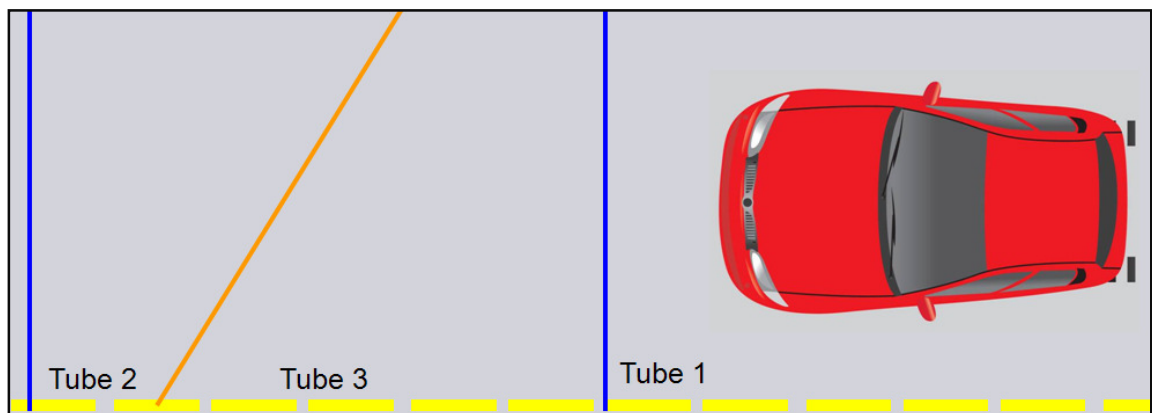

Figure 3.4 Layout of Z-configuration in one lane

Data were collected approximately one month before installation of the treatment and approximately one month after resulting for each data collection location. Chevrons were in place prior to application of the treatment. The treatment consisted of adding reflectorized strips on the post of the existing chevron signs along the curve. The reflectorized strip was an aluminum diamond grade panel with yellow color which met MUTCD requirements. The treatment has an estimated outdoor life of ten years and the price is from \$13.95-\$18.95.

The additional reflector material is expected to provide additional curve delineation which is expected to result in possible speed reductions and improved lane keeping. A one month acclimation period was provided. The goal for leaving one month between after treatment and data collection for after treatment was to provide adaption period for drivers when they are facing a new device along the roadside and to make data more reliable.

### **3.5 Data collection**

#### **3.5.1 Data collection equipment**

Before performing data collection, equipments and materials should be well prepared for data collection process. The main equipments for the research were counters, tapes and pneumatic road tubes. Counters were used to collect individual vehicle speed and lateral placement data. A pneumatic road tube is a rubber tube and the operation principle of pneumatic road tube is utilizing vehicles passing over it and generates air pressure changes which indicate vehicle passage. It was used for measuring number of axle movement and vehicle speed. Tape was used to fasten the road tubes to the pavement surface.

### **3.5.1.1 Counter**

Each counter, as shown in Appendix A Figure A. 3, was charged in the office before use in the field. Each counter also has a solar panel that provides additional power so that the counters can be left in the field for up to a week.

A counter is used for recording every single vehicle's time stamp, date, number of axle of a vehicle and vehicle travel speed. The data were obtained from passing vehicle's exact time stamp that counter detected. As introduced above, passing vehicle's tires apply pressure on the tubes and then generate air pulse to the counter. Counter will record the movement and progress of each vehicle, and save the information. Speed can be acquired from the time that a vehicle used to cross the tube and the known distance of two parallel tubes.

### **3.5.1.2 Road tubes**

Black pneumatic road tubes, as shows in Appendix A Figure A. 4, were set up at each data collection location across one of the two lanes by using tapes to make sure all tubes were fixed well and pulled tight. Since the road tubes are made from elastic rubber, if a tube comes loose counter will receive erroneous data. Additionally, if any of a tube looses, it is possible for a vehicle wheel to catch the tube and drag it away from testing point. If that happens, tubes might spin into wheels and cause safety problems. Bend ends of tubes should be placed toward the direction of traffic flow. Counter should be locked and put aside of road when everything has been set up and ready for recording. After finishing data collection, counter was turned off before removing road tube to avoid misfires. Tapes cannot be laid

during rainy days due to loss of adhesiveness. Additionally, vehicles may drive differently during storm events so rain was avoided when possible.

Base on Figure 3.5 counter set up, the tubes which are perpendicular to edge line go for port A and port B. And the middle one which has an angle with edge line goes to port C on counter. Figure 3.6 is an example layout of tubes on the surface ground after everything has been set up before testing.

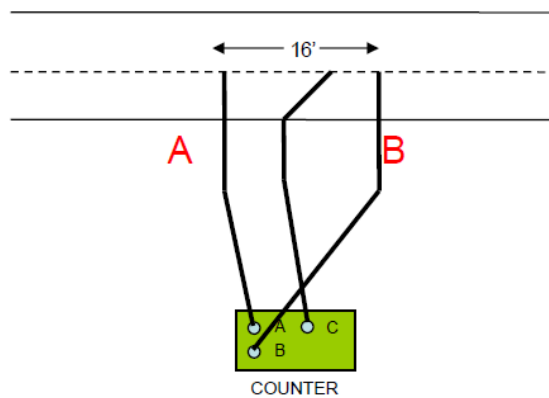

Figure 3.5 Counter Set Up (From CTRE roadtube manual)



Figure 3.6 Roadtube Layout (From CTRE roadtube manual)

### **3.5.2 Data collection procedure and schedule**

Data were collected at the same location along US 52 on May 2010 and September 2010, respectively. All before data was collected from May 20<sup>th</sup>, 2010 to May 23<sup>rd</sup>, 2010. And all after data collection phase was from September 8<sup>th</sup>, 2010 and September 13<sup>th</sup>, 2010. At each site, researchers used tapes, counters and black pneumatic tubes to shape a Z-configuration and to collect speed and time stamp data. Field data collection process took a lot of time compared with other parts of study. Typically, it took about three hours driving from InTrans to the study site and another three hours driving back.

#### **3.5.2.1 Full data collection**

Under before data collection condition, researchers collected vehicle speed and lateral placement data without any application of treatments on site. After reflectorized strip has been mounted at least one month, then after period data were obtained. Table 3.2 and

Table 3.3 showing that counter have whole sets of data on May and September. Basically, each recorded time started and ended up about noon. Before data recorded took three days and after data record period was five days. The dates for before and after data collection were randomly selected and weekend data were included. Recorded time represents when the counter started working.

Table 3.2 Data collection date and time in May

US52	Before treatment date and time in May			
	Start		End	
	Date	Time	Date	Time
Z1 (South PC)	5/20/2010	11:52:58 AM	5/23/2010	11:28:52 AM
Z2 (Center)	5/20/2010	10:43:03 AM	5/23/2010	10:51:05 AM
Z3 (PC1)	5/20/2010	11:24:52 AM	5/23/2010	11:20:50 AM

Table 3.3 Data collection date and time in September

US52	After treatment date and time in September			
	Start		End	
	Date	Time	Date	Time
Z1 (South PC)	9/8/2010	12:56:08 PM	9/13/2010	11:53:28 AM
Z2 (Center)	9/8/2010	12:51:45 PM	9/13/2010	11:59:35 AM
Z3 (PC1)	9/8/2010	1:21:21 PM	9/13/2010	12:15:59 PM

And Figure 3.7 shows number of days that have been used for collecting data in before and after analysis. The data collection period was varied from three to five days at each site depending on the weather and traffic volume. In general, before analysis has three days time span and after analysis period has five days time span.



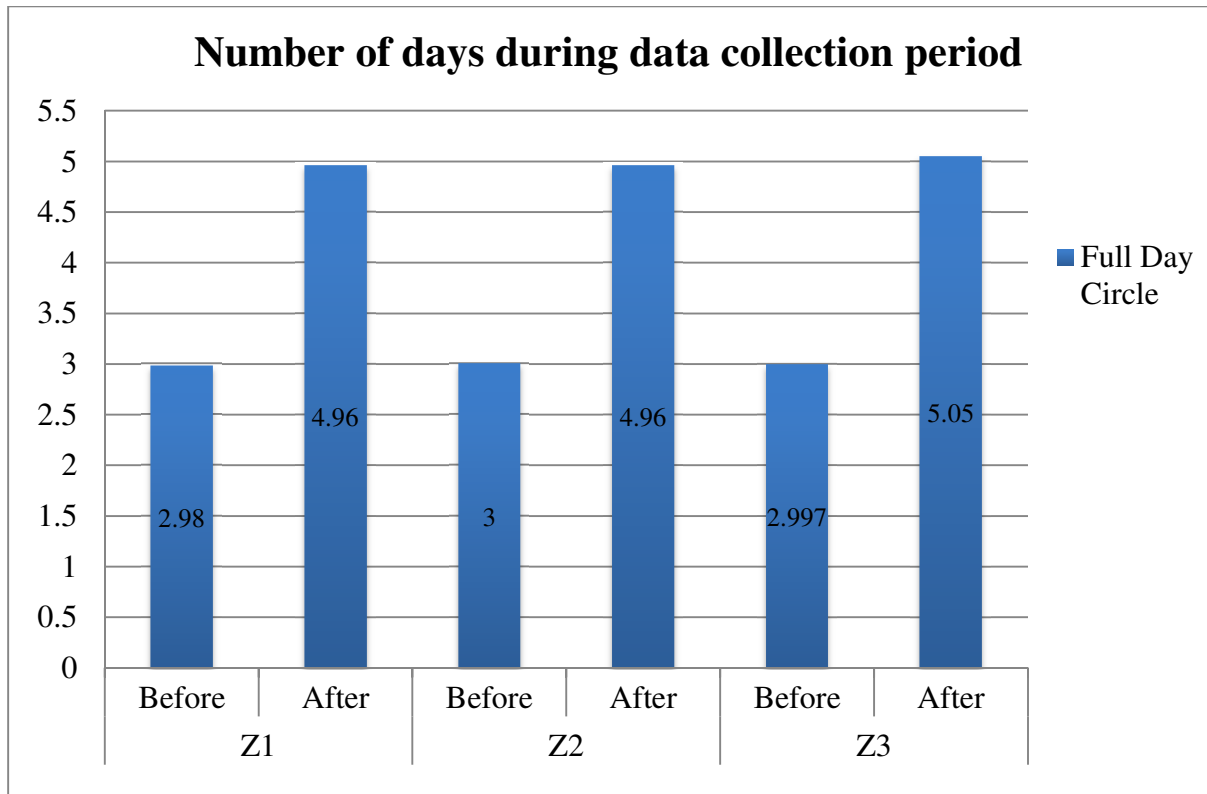

Figure 3.7 Total numbers of days during data collection

### 3.5.2.2 Data classification

Since the data reduction process was so time consuming, only the data for passenger vehicles were included. The treatment is likely to be more visible during nighttime, data were also grouped by day and night.

Daytime and nighttime were determined by consulting the United States Naval Observatory (USNO) website of sunrise and sunset time for 2010 for Sageville, Iowa. Table 3.4 and Table 3.5 showed sunrise and sunset time from USNO. Scientifically, USNO gave a brief definition for sunrise and sunset of “the times when the upper edge of the disk of the Sun is on the horizon, considered unobstructed relative to the location of interest.” While in

transportation and driver's point of view, the morning period referred to the hours in a day that has sufficient sunlight and evening period indicated that the hours in a night that were lacking of natural sunlight. Table 3.4 demonstrates the precise sunrise time and sunset time on each of day from May 20<sup>th</sup> to May 23<sup>rd</sup>. Sunrise and sunset time of each day was various, but the differences are not obvious. It can be seen that sunrise was around 04:35 and sunset time was around 19:25. And Table 3.5 is showing clearly that sunrise time and sunset time from September 8<sup>th</sup> to September 13<sup>th</sup> were roughly at 05:37 and 18:21, respectively.

Table 3.4 Sunrise and sunset time on May 2010 in Sageville, Iowa

Sageville, Iowa (USNO)										
Rise and Set for the Sun in May for 2010 (Central Standard Time)										
Date	Jan		Feb		Mar		Apr		May	
Sun	Rise	Set	Rise	Set	Rise	Set	Rise	Set	Rise	Set
Time	h:mm	h:mm	h:mm	h:mm	h:mm	h:mm	h:mm	h:mm	h:mm	h:mm
20	7:27	17:01	6:52	17:41	6:06	18:15	5:14	18:50	4:36	19:23
21	7:26	17:02	6:51	17:43	6:04	18:16	5:12	18:52	4:35	19:24
22	7:26	17:04	6:49	17:44	6:03	18:17	5:11	18:53	4:34	19:25
23	7:25	17:05	6:48	17:45	6:01	18:19	5:09	18:54	4:34	19:26

Table 3.5 Sunrise and sunset time on September 2010 in Sageville, Iowa

Sageville, Iowa										
Rise and Set for the Sun in September for 2010 (Central Standard Time)										
	May		June		July		Aug		Sep	
	Rise	Set	Rise	Set	Rise	Set	Rise	Set	Rise	Set
Date	h:mm	h:mm	h:mm	h:mm	h:mm	h:mm	h:mm	h:mm	h:mm	h:mm
8	4:49	19:11	4:25	19:39	4:33	19:42	5:02	19:14	5:35	18:25
9	4:47	19:12	4:25	19:39	4:34	19:42	5:03	19:13	5:36	18:23
10	4:46	19:13	4:25	19:40	4:35	19:41	5:04	19:11	5:37	18:21
11	4:45	19:14	4:25	19:40	4:36	19:41	5:05	19:10	5:38	18:20
12	4:44	19:15	4:25	19:41	4:36	19:40	5:06	19:08	5:39	18:18

Table 3.6 Before treatment data selection period

Before treatment data selection time					
Morning			Evening		
Date	Sunrise Time	Selected Data Time	Date	Sunset Time	Selected Data Time
May21	4:35am	5:00am-10:00am	May20	19:24pm	8:00pm-1:00am*
May22	4:34am	5:00am-10:00am	May21	19:25pm	8:00pm-1:00am*
May23	4:34am	5:00am-10:00am	May22	19:26pm	8:00pm-1:00am*

Note:\* refers to the morning of the next day.

Table 3.7 After treatment data selection period

After treatment data selection time					
Morning			Evening		
Date	Sunrise Time	Selected Data Time	Date	Sunset Time	Selected Data Time
Sep09	5:36am	6:00am-11:00am	Sep08	18:23pm	7:00pm-00:00am*
Sep10	5:37am	6:00am-11:00am	Sep09	18:21pm	7:00pm-00:00am*
Sep11	5:38am	6:00am-11:00am	Sep10	18:20pm	7:00pm-00:00am*
Sep12	5:39am	6:00am-11:00am	Sep11	18:18pm	7:00pm-00:00am*
Sep13	5:41am	6:00am-11:00am	Sep12	18:16pm	7:00pm-00:00am*

Note:\* refers to the morning of the next day.

For the daytime period, the sunrise time in May was almost one hour earlier than the rise time in September. For the nighttime period, the sunset time in September was about one hour earlier than the set time in May. Even though each day has its own sunrise and sunset time, they were off a couple of minutes or so and the differences were not noticeable. In consideration of sunrise and sunset time were various in time of a day and day of a month, then a unified data collection time is setting up for morning and evening of May and September to keep data set consistent. Table 3.6 and Table 3.7 illustrate the specific time period for both morning section and evening section on before and after treatment. Take each own sunrise and sunset time as a base line, the time data usually postpone about half an hour and to an integer time. Each treatment has the same duration of five hours. For instance,

sunrise time on May 21<sup>st</sup>, 2010 was 4:35, and a uniform morning period was determined between the hours of 5:00am to 10:00am for all morning data assessment. And a uniform evening period was established between the hours of 8:00pm to 1:00am of the next day. For after analysis phase, 6:00am to 11:00am is set as a uniform morning period and 7:00pm to 00:00am of the next day as a uniform evening period.

## Chapter 4. METHODOLOGY AND RESULTS

This chapter discusses the research methodology and scope.

### 4.1 Assumptions

Before conducting an analysis, the necessary assumptions should be discussed. All kinds of variables can influence a drivers' perception and reaction were not considered into the research. It is assumed sun position, ambient noise, tree shadow patterns, roadtube, etc. do not affect driver's reaction. Any changes in the measure of speed and lateral position would be attributable to the existence of reflectorized strips.

### 4.2 Description

Data were collected using the road tube configuration as well as detailed dimension, shown in Figure 4.1, vehicle traveled from from right to left. The tube which is first hit by vehicle's tires is denoted as tube 1, and the tube which is last hit by vehicle's tires is denoted as tube 2. The angled tube is denoted as tube 3. Tube 1 and tube 2 were 16ft apart, and length of tube 1 and tube 2 was 12 feet and it was the same as lane width. A thorough description of dimensions in each parameter is demonstrated by Table 4.1.  $t_1$ ,  $t_2$ ,  $t_3$  were time stamps that a vehicle's front tire passed over tube one, two, three, respectively. They were recorded by the counter and denoted by sensor number in a spreadsheet. An algorithm analysis was developed to calculate the distance between point of contact of right front tire and the edgeline of each two-axles vehicle. Similar right triangle and proportion theory has been applied through the entire computations.

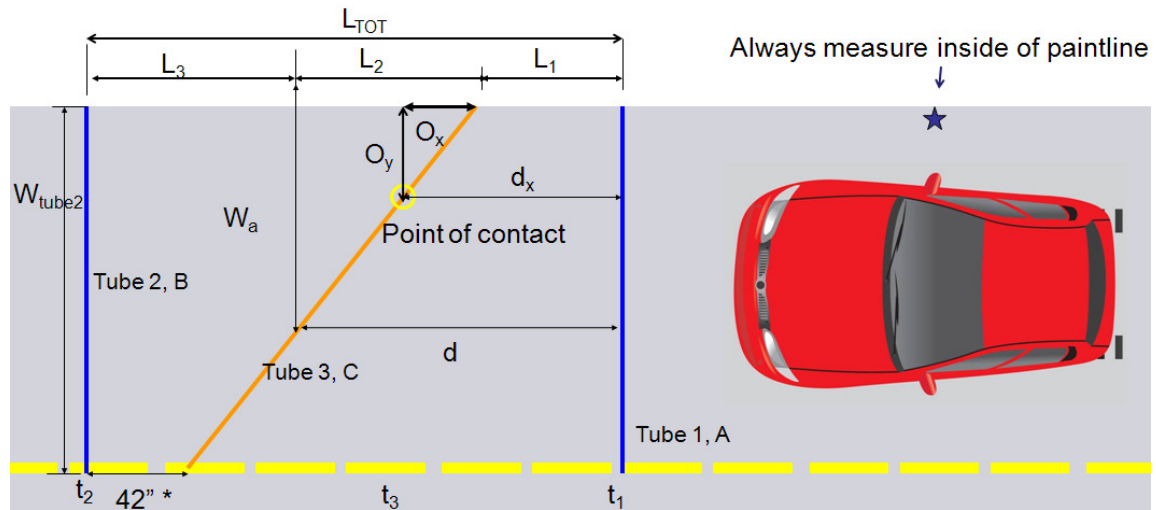

Note: \* should check and it was not always 42 inches.

Figure 4.1 Illustrations of Z-Configurations

Table 4.1 Z-configuration detailed dimensions

Dimension	Length (inches)	Detailed description
$L_1$	48	Distance between the end of tube 1 and the end of tube 3 along the road edge
$L_2$	Varies by Site	Distance between end of tube 3 along edge line and the point on tube 3 hit by a vehicle's left front tire corresponding perpendicular spot
$L_3$	Varies by Site	Distance between the point on tube 3 hit by vehicle left front tire corresponding perpendicular spot and end of tube 2 along edge line
$L_{TOT}$	192	Horizontal distance between the end of tube 1 and the end of tube 2 along the road edge
$t_1$	Varies	Time stamp that vehicle's front tire pass over tube 1
$t_2$	Varies	Time stamp that vehicle's front tire pass over tube 2
$t_3$	Varies	Time stamp that vehicle's front tire pass over tube 3
$d_x$	Varies	Horizontal distance between point of contact on tube 1 of a vehicle's right front tire and point of contact on tube 3 of a vehicle's right front tire

Table 4.1 Z-configuration detailed dimensions (continued)

Dimension	Length (inches)	Description
Wa	Varies	Perpendicular distance corresponding to d
d	Varies**	Sum of L1 and L2
O <sub>x</sub>	Varies	Horizontal offset distance of first point of contact on tube 3 in the direction of flow
O <sub>y</sub>	Varies	Offset distance of first point of contact on tube 3 perpendicular to the direction of flow
W <sub>tube 2</sub>	144	Length of tube 2 or lane width

Note: \*\*Theoretically, d should be 120 inches instead of 118 inches in actual if Wa=84 inches. There were 2 inches offset due to measurement and diameter of tube.

#### 4.2.1 Data reduction process

After the field test was conducted, raw and full set of data were downloaded from the counters. Raw vehicle data can be downloaded and transferred onto a computer by making use of a specialized software. The software was capable of generating date, time, number of vehicle axles, vehicle class, vehicle gap in second, and vehicle speed in mph. A spreadsheet was used for additional processing and formatting. Each location on the curve has its own spread sheet, and there were three spreadsheets in one curve per treatment. Therefore, there will be a total six spread sheets on account of the two treatments. Each spread sheet contained the data from a counter start recording to a counter stop recording.

#### 4.2.1.1 Primary data reviewing

Every single spread sheet contained data for several thousand vehicles. Which varied by the number of days data collection equipment were used. Since the reduction process is quite time consuming, it was decided to reduce data for a as minimum of at least five hundred two-axle passenger cars as possible. In most cases this sample size is sufficient to conduct statistical tests such as a t-test. The next stage will be screening raw data to new set of data with above characteristics.

#### 4.2.1.2 Vehicle headway

Gordon and Tighe (2005) defined vehicle headway as the time between front of vehicles to successively pass over the same point. Figure 4.2 demonstrates vehicle headway. If two vehicles driving closer, it would not reflect the real driving behavior of the vehicle behind. This is mostly because a passenger vehicle driving behind a slow moving or fast moving car may following the speed of the car ahead of it.

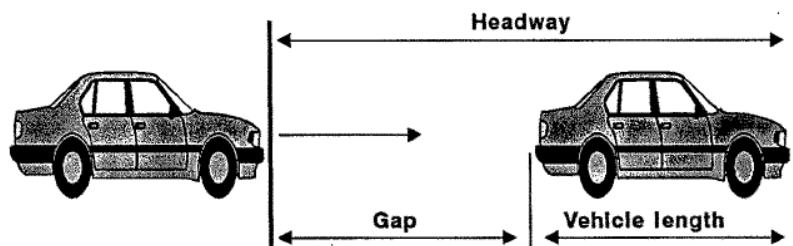

Figure 4.2 Vehicle headway scheme (Traffic Control Systems Handbook 2005)

And the speed of the car behind may not be the driver's preferred speed. After the sunset, a driver's driving behavior may be affected by the the rear stop light of the vehicle in front of it.



Or drivers may react differently when there are vehicle headlights behind them at night.

While Chrysler et al. (2009) mentioned that experienced TTI researcher consented minimum headway of 3 seconds to 5 seconds was considered as an acceptable headway. Lower bound of headway has a small value and can be neglected. As mentioned in the assumption, vehicle headway was not considered into data screening process. All reaction differences that made by drivers are from the existence of treatment.

#### **4.2.1.3 Passenger vehicle**

Two axles with four-tire passenger vehicles were selected for target data. Heavy vehicles, buses, motorcycles, trailers were separated and deleted from data. Those type of vehicles performed differently from passenger vehicles. Vehicle classes have been defined by Federal Highway Administration (FHWA) Traffic Monitoring Guide (2001). The definitions of passenger cars were “all sedans, coupes, and station wagons manufactured primarily for the purpose of carrying passengers and including those passenger cars pulling recreational or other light trailers.” According to the Traffic Monitoring Guide from FHWA, vehicles can be classified into 13 classes (FHWA 2001). Among them, class 1 is motorcycle, class 2 and 3 are passenger cars, class 4 is buses and the rest are heavy trucks, as is shown in Figure 4.3. Two-axle and four-tire passenger cars can be determined by permutation and combinations of sensor number.

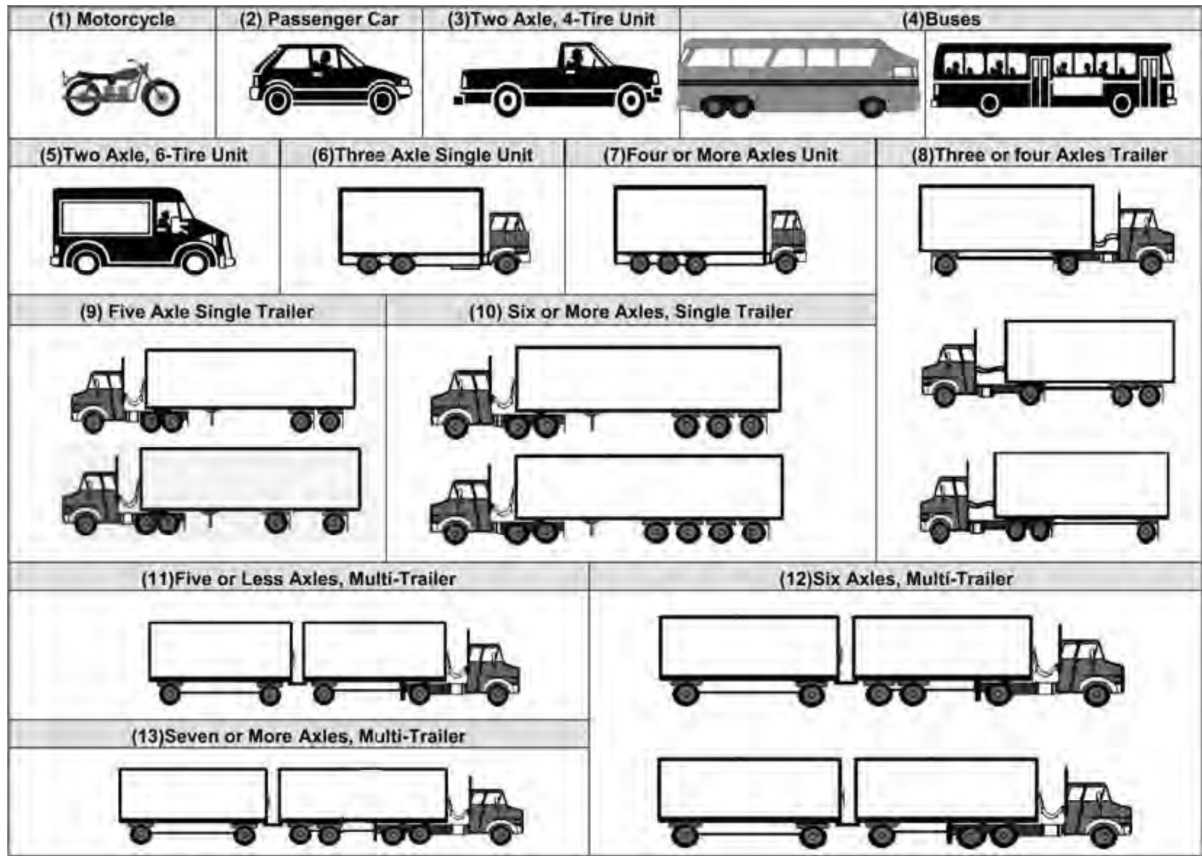

Figure 4.3 Vehicle classification scheme (FHWA, TMG2001)

#### 4.2.1.4 Data formatting

Each column of raw data contained date, time, time stamp, and sensor number in the spread sheet. The date and time at the beginning referred to the date and time that counter was activated to record. Time stamp indicated the cumulative time from the beginning to the end of data collection process. And the accuracy of time stamp was up to one tenth of a millisecond. Data in spreadsheet include all vehicles that drove over road tube. Based on the requirement for passenger cars, two-axle with four-tire passenger cars were found from raw data. Only three tubes were used during the experiment, which are sensor one, sensor two

and sensor three. If sensor number four appeared in the spread sheet, it implies there will be an error term in the data. In order to make sure the data is right at the very beginning.

Vehicles were removed from the dataset when the 4<sup>th</sup> sensor appeared. Second step was to separate every single vehicle from the raw data. It was obvious to separate each individual vehicle in the raw data and two key criterions that need to be obeyed for partition process: time and sensor. Single vehicle passes over road tubes usually within one or two seconds and time for each vehicle passing by is a discrete factor rather than a continuous factor. Each individual vehicle can be separated vehicles by telling the time differences. If two vehicles have a very short headway and travelled too close, individual vehicle cannot be divided by using time, then sensor number can inform researchers the distinction. Sensor number two must be separate from sensor number one since it was the last one hit by a vehicle, and at the same time sensor number two should belonged to the previous vehicle and sensor number one was included in the next vehicle behind. After separation, unwanted data which included motorcycles, buses, trailers or any other vehicles types will not be counted in the final data. At last, if vehicle type cannot be determined by pattern of sensor, Excel filter function was used to sort vehicles with characteristics of two axles and class two and/or three in Trax file that was downloaded from counter.

Theoretically, it should have one tire strikes on tube one and one tire strikes on tube two, and up to two strikes on tube three for each axle. Tube three was laid diagonally so tires on the same axle would necessarily cross the tube at the same time. The order of sensor in a set of vehicle generates different configurations and patterns, from which a vehicle type was known. As is shown in **Error! Reference source not found.**, sensor ordered as 113322 means a

vehicle's first axle went over tube 1, then second axle went over tube 1, the first axle went over tube 3, then second axle went over tube 3, then first axle went over tube 2, then second axle went over tube 2. There were two strikes on all tubes indicates vehicle type was motorcycle. Another configuration of a motorcycle was 113232. It means a motorcycle's first axle went over tube 1, then second axle went over tube 1, the first axle went over tube 3 then tube 2, the second axle went over tube 3 then tube 2. Table 4.3 illustrates an example of the configuration of two axles with four tires passenger vehicle that went over all three tubes. Overall, there were two strikes on both tube 1 and tube 2, and four strikes on tube 3. First axle went over tube 1, then one tire hit tube 3 then the other, second axle went over tube 1, then first axle went over tube 2, then one tire of the second axle hit tube 3 then the other, then second axle went over tube 2.

Table 4.2 Motorcycle example (from before Z1)

Sensor	Date	Time	Time Stamp
1	5/22/2010	9:57:21 AM	165921.701
1	5/22/2010	9:57:21 AM	165921.7745
3	5/22/2010	9:57:21 AM	165921.8371
3	5/22/2010	9:57:21 AM	165921.9108
2	5/22/2010	9:57:21 AM	165921.9468
2	5/22/2010	9:57:22 AM	165922.0205

Table 4.3 Two-axle four-tire passenger car example (from before Z1)

Sensor	Date	Time	Time Stamp
1	5/21/2010	8:43:01 AM	75061.7681
3	5/21/2010	8:43:01 AM	75061.8607
3	5/21/2010	8:43:01 AM	75061.8787
1	5/21/2010	8:43:01 AM	75061.9207
2	5/21/2010	8:43:01 AM	75061.9882
3	5/21/2010	8:43:02 AM	75062.0135
3	5/21/2010	8:43:02 AM	75062.0301
2	5/21/2010	8:43:02 AM	75062.1412

However, data were not always following the regular pattern. Counters used the principal of air pulse that generated from passing vehicle's tire when tires compress the tube. Possible reasons that we didn't get "normal" data because a single tire can generate either one strike or two strikes on any tubes. If considered a tire compresses tube forms a rectangular plane, the results will be quite different based on the time sequence of a tire hit tube. Then each axle with two tires can generate up from two strikes to four strikes on tube one and tube two. Figure 4.4 demonstrating how each axle can generate one strike or two strikes on tube 1 or tube 2, and up to four strikes on tube 3.

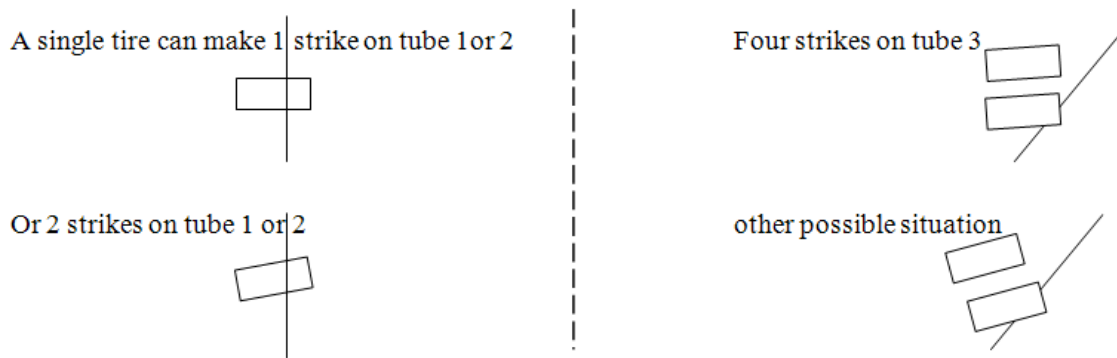

Figure 4.4 Different movement of one axle

Also, the roadway has curvature and this makes the problem more complicated as usual. As shown in both Figure 4.5 (a) and (b) below, they are illustrating the different behavior of vehicles traveled on a tangent section and on a curve segment.

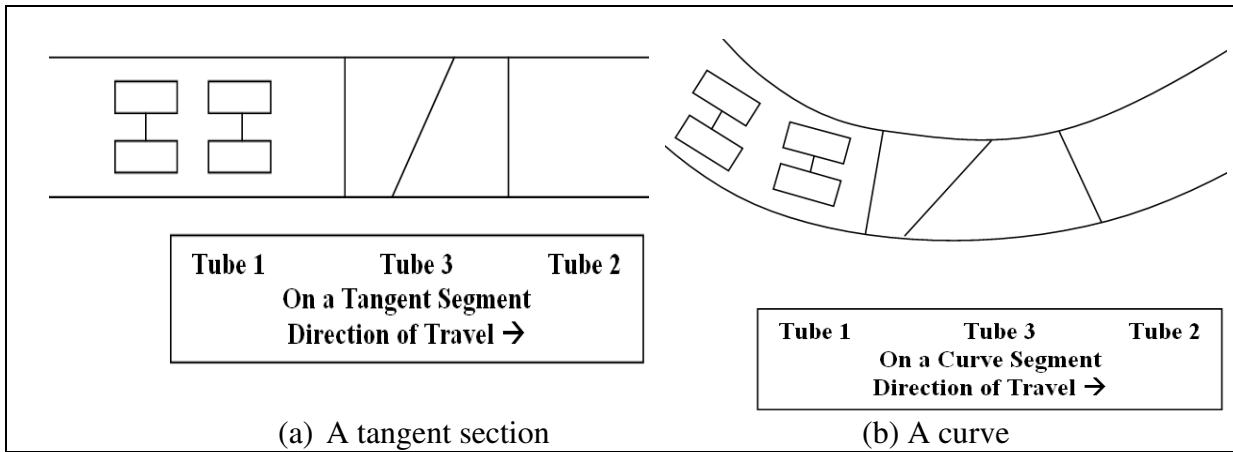

Figure 4.5 driving on (a) a tangent section and (b) a curve

In spite of this, there were some questionable or problematic data in spreadsheet. The problematic data were vehicle with a speed of zero mph, axle spacing doesn't make sense, lateral placement has a negative value, or counter could not detect vehicle information. Questionable data would be removed and does not count into passenger cars. Table 4.4 is an example of erroneous data from which can be told only one axle went over tube 1 and tube 2, but there were two axles went over tube 3.

Table 4.4 problematic example (from Z1 before)

Sensor	Date	Time	Time Stamp
1	5/20/2010	7:39:19 PM	28039.8554
3	5/20/2010	7:39:19 PM	28039.9427
3	5/20/2010	7:39:19 PM	28039.962
3	5/20/2010	7:39:20 PM	28040.0276
3	5/20/2010	7:39:20 PM	28040.043
2	5/20/2010	7:39:20 PM	28040.1144

Table 4.5 Example data for a bus (from Z1 before)

Sensor	Date	Time	Time Stamp
1	9/10/2010	8:49:51 AM	158151.79
3	9/10/2010	8:49:51 AM	158151.8968
3	9/10/2010	8:49:51 AM	158151.923
3	9/10/2010	8:49:51 AM	158151.9331
3	9/10/2010	8:49:51 AM	158151.9879
3	9/10/2010	8:49:52 AM	158152.0108
2	9/10/2010	8:49:52 AM	158152.0658
1	9/10/2010	8:49:52 AM	158152.1533
3	9/10/2010	8:49:52 AM	158152.2575
3	9/10/2010	8:49:52 AM	158152.2966
3	9/10/2010	8:49:52 AM	158152.306
3	9/10/2010	8:49:52 AM	158152.3796
2	9/10/2010	8:49:52 AM	158152.4294
2	9/10/2010	8:49:52 AM	158152.4495

Overall rules for data screening and formatting are selecting data with two strikes on tube 1 and tube 2, and at least four strikes on tube 3 and at most eight strikes on tube 3 at the same time. Although the total of two strikes on tube 1 can not be far apart and the second strike on tube 1 can not be followed by tube 2. Otherwise this is probably a bus like Table 4.5 demonstrates.

#### 4.2.2 Speed and lateral placement calculations

In lateral placement equations,  $t$  represents the total time that one vehicle used to pass over three tubes. Vehicle speed can be calculated from distance between tube 1 and tube 2, which was 16 feet, divided by the total time that a vehicle used to pass over tubes. The distance between tube1 and tube2 was 192 inches (16 feet) and it was a fixed number on three testing points along the curve. Distance of  $dx$  can be easily obtained from speed times the time differences that vehicles used to pass tube 3 and tube 1. Lateral placement was calculated step by step and equations that used were:

$$t = t_2 - t_1 \quad (1)$$

Equation 1 can find out the total time that a vehicle used to drive over the entire tube set.

$$V = \frac{L_1 + L_2 + L_3}{t_2 - t_1} = \frac{L_{tot}}{t} \quad (2)$$

where  $L_{tot}$  is the horizontal distance between tube 1 and tube 2 and holding a value of 192 inches (16 feet). Vehicle speed can be obtained from total distance divided by total time which is shown in Equation 2.

$$dx = V \times (t_3 - t_1) \quad (3)$$

where  $dx$  is defined as the horizontal distance between point of contact on tube 1 and point of contact on tube 3 based on a vehicle's right front tire.  $dx$  can be obtained from vehicle speed multiplied by the time that a vehicle used to drive over tube 1 and tube 3.

$$O_x = dx - L_1 \quad (4)$$



where L1 holds a value of 48 inches. From Equation 4,  $O_x$  can be calculated by subtracting L1 from dx.

$$O_y = \frac{O_x \times W_a}{L_2} \quad (5)$$

where  $W_a$  equals 84 inches and  $L_2$  equals 72 inches. From similarity right triangle and plane trigonometry, a proportional formula is found to be  $\frac{O_x}{O_y} = \frac{72}{84}$ . And Equation 5 is obtained by transforming the equation of  $\frac{O_x}{O_y} = \frac{72}{84}$  to an expression of  $O_y$ .

$$LP = \frac{O_y}{12} \quad (6)$$

Lateral placement (LP) can be acquired from  $O_y$ . In equation 5, the unit of  $O_y$  was in inches and  $O_y$  can be converted into feet dividing by 12. Then Equation 6 is the expression of vehicle lateral placement.

### **4.3 Methodology**

#### **4.3.1 Statistical method overview**

Statistical analyses are important for transportation data analysis and are widely used for determining the significance of treatments or improvements. Following is a summary of related literatures.

Cottrell (1986) performed a before-and-after operational analysis to evaluate the effectiveness of wide edge lines on vehicle lateral placement and speed on two-lane rural roads. They conducted t-tests for evaluating vehicle mean speed and mean lateral position, and F-tests for estimating speed variance and lateral position variance from sample size of 12.

In a report by Krammes and Tyer (1991), the vehicle operation effect on post-mounted delineators and raised pavement markers were evaluated. They investigated vehicle speeds and lateral placement at the midpoint on rural two-lane highways from five horizontal curves. They performed t-tests for mean speed and lateral position and F-tests for variance in speed and lateral position.

Mahoney et al. (2003) conducted a research on the effect of centerline rumble strips on lateral placement and speed. The data were collected on two-lane rural highway tangent locations rather than horizontal curves. They performed a before-and-after comparison studies based on eight sample size and t-tests on vehicle mean speed as well as lateral placement. And F-tests were used to test variance in speed and lateral position.

Chrysler et al. (2009) performed a One-Sample Kolmogorov-Smirnov (K-S) Test to test the normality of speed and lateral position data. At the same time, histograms and Q-Q Plots were plotted for visual inspection of normality. The distribution of speed and lateral position were normally distributed by visual assessment, but the results proved that the distribution of speed and lateral data were not normal. Two methods were introduced to remedy non-normal distributed data: transformation and segmenting. Transformation means non-normal distributed data can be transferred to normal distributed, and segmenting refers a set of data can be divided into numerous sub-groups and theoretically each small sub-group fits for normality. Even though, these two approaches are undesirable and impractical to this study, segmenting method has been used in the study of Porter et al. (2004). It was turned out that the results were close by using either t-test or segmenting method. It concluded “the

independent sampled T-test is robust enough to accurately draw statistical conclusions from the data, even with the departure from the normal distribution.”

In the study of Miles et al. (2005), five horizontal curves with two-lane rural highway were chosen as study sites. A before-and-after study was designed to evaluate the effects of transverse, centerline, and edge line rumble strips. In this study, a Chi-Square test and Wilcoxon Rank Sum test were used in evaluating effectiveness of centerline rumble strips. A Chi-Square test was used to test if gap distance and centerline crossing time were correlated. And a Wilcoxon Rank Sum test was performed to test any changes in measure of effectiveness (MOEs) due to gap distance and/or centerline crossing time. A t-test was used to test the mean vehicle lateral position and the multifactor analysis of variance (ANOVA) was conducted to test the effect of transverse rumble strips on vehicle speed reduction.

From the above summarizations, the most frequently used type of study was a before-and-after analysis and the most common statistical methods were t-test and F-test. 95 percent confidence intervals or significance level of 0.05 was used for testing the results. A T-test was used for evaluating mean speed and lateral position to determine significance and an F-test was used for investigating variance in speed and lateral position. While statistical analyses were varied according to the research. Quite a few researches used an analysis of variance (ANOVA), Chi-Square, Wilcoxon rank sum test, bonferroni method for multiple comparison, etc.

Vehicles' lateral placement data were analyzed after the systemic and comprehensive data screening and formatting process. Four groups of vehicle lateral placement data sets,

which are day-before, night-before, day-after and night-after from six spreadsheets, are ready for analysis procedure. Statistical analysis methods were used to verify if reflectorized strips have statistically significant in vehicle performance. The statistical software JMP is one of the most widely used statistical packages and it is being used in this study. Mean, average, median, standard deviations, variance of lateral placement can be calculated in both Excel file and JMP.

### **4.3.2 Analysis**

#### **4.3.2.1 Sample size**

As previously mentioned, the before data were acquired between May 20<sup>th</sup> and May 23<sup>rd</sup>, 2010, and the after data were collected between September 8<sup>th</sup> and September 13<sup>th</sup>, 2010. There will be 12 data sets based on the status of time of a day, location on a curve and before-and-after treatment. The distribution of lateral placement observations lists as following and detailed sample size data is showing in Table 4.6:

- 1,826 vehicle lateral placements (31.3 percent) during before treatment was observed in the day (5AM-10AM)
- 4,014 vehicle lateral placements (68.7 percent) during after treatment was observed in the day (6AM-11AM)
- 810 vehicle lateral placements (30.4 percent) during before treatment was observed in the night (8PM-1AM)
- 1,851 vehicle lateral placements (69.6 percent) during after treatment was observed in the night (7PM-12AM)

Table 4.6 Observed sample size

Number of observed sample size in US 52 (two-axle passenger vehicles only)				
Compare	Day		Night	
Status	Before (May)	After (Sep)	Before(May)	After(Sep)
Time	5AM-10AM	6AM-11AM	8PM-1AM	7PM-12AM
Z1	616	1355	270	627
Z2	613	1339	271	613
Z3	597	1320	269	611
Sub Total	1826 (31.3%)	4014 (68.7%)	810 (30.4%)	1851 (69.6%)
Total	5840		2661	

#### 4.3.2.2 Data analysis

By definition, a continuous variable can take on any value between its minimum value and its maximum value. Take a view of complete data set, vehicle speed held a maximum value of 74.5 mph and a minimum value of 24.0 mph. Vehicle speeds can be any value between the two. And vehicle lateral placement has a maximum value of 7.6 inches and a minimum value of 0 inch. Lateral placements can be any values between the two as well. Speed and lateral placement data are defined as continuous variables from the definition. In addition, vehicle speed data of each vehicle is independent of others speeds, likewise, vehicle lateral placement data of every single vehicle is independent of each other. While, vehicle speed for before treatment and after treatment, as well as vehicle lateral placement for before treatment and after treatment, are correlated.

#### 4.3.2.3 Test for normality

Before processing vehicle speed and lateral placement data, the primary step was to find out if the data were normally distributed. Lateral placement and speed for each dataset were plotted in a histogram and visually inspected to determine whether it appeared to be normally distribution. A normal ditribution is observed with bell-shaped distribution curve and minimal skewness. In addition, normal quantile plot or a Q-Q plot is visualizing tool for demonstrating whether variables were normally distributed. Thus, normal quantil plots were generated by using JMP to visualize if the lateral placement data sets are normally ditributed. If a variable is normal, the Q-Q plot approximate a diagonal straight line. Shapiro-Wilk W Test was used for goodness-of-fit test for normal distribution. Detailed normal quantile plots and histograms of vehicle speeds and lateral placements during day and night for before-and-after treatment can be found in Appendix B (pg120) and Appendix C (pg 132), respectively. As shown in Appendix B, normal quantile plot has a fairly diagonal straight line by visual estimation.

The bell-shaped histogram were plotted and they were normally distributed by visual assesment. However, the test satistic results demonstrated visual assesment is not always right. **Error! Reference source not found.** and

Table 4.7 illustrate the results of goodness-of-fit test.  $H_0$  represents the data from the normal distribution and small p-values reject  $H_0$ . That is to say, if the p-value has a value of smaller than 0.05, the the null hypothesis has been rejected and the distribution is not from the normal distribution. It can be seen from

Table 4.7 that all of lateral placement data are not fitted for normal distribution during both day and night condition, but the before treatment data during night at Z1 was an exemption. And nearly all of speed data are not from normal distribution during both day and night condition from Table 4.7. Only three conditions: night before at Z1, night before at Z3 and night after at Z2 satisfy the normally distributed requirement. In conclusion, most of speeds and lateral placements data were not qualified for normal distribution, and regular t-tests that designed for normal distribution were not suitable to use for analysis procedure.

Table 4.6 Goodness-of-fit tests for speed

Goodness-of-fit test for Speed	Day		Night	
	Before	After	Before	After
	P<W	P<W	P<W	P<W
Z1	<0.01	<0.01	0.6554	0.0095
Z2	<0.0001	<0.0001	0.0296	0.0619
Z3	0.0043	0.0000	0.1137	0.0001

Table 4.7 Goodness-of-fit tests for lateral placement

Goodness-of-fit test for lateral placement	Day		Night	
	Before	After	Before	After
	P<W	P<W	P<W	P<W
Z1	<0.0001	<0.0001	0.086	<0.0001
Z2	<0.0001	<0.0001	<0.0001	<0.0001
Z3	<0.0001	0.0003	0.0002	<0.0001

#### 4.3.2.4 Test statistics

Since the speed and lateral placement data were not Gaussian or normally distributed, a Wilcoxon signed rank test, which is a non-parametric test, was used to compare data.

Washinton et al (2011) stated a non-parametric test should be considered if the “requirements

of parametric tests such as approximate normality, large sample sizes, and interval or ratio scale data, are grossly violated". Non-parametric test does not require the assumptions to be normal distributed and non-parametric methods are often named as distribution-free methods. The stringent assumptions of non-parametric methods are less fewer than parametric methods. Thus non-parametric methods increase the probability of committing a type II error. Even though non-parametric tests are not as robust as parametric tests, they are powerful enough to get almost equal p-value that from parametric tests since the sample size has a sufficient large number (over 200 samples).

Wilcoxon signed rank test was employed to compare two populations which are paired (before and after treatment case). A two-sample, and approximately normal test was performed to evaluate the statistically differences in median of speed and lateral placement for before and after treatment. It is a hypothesis test for testing the median that from vehicle speed and lateral placement of before and after treatment from a normal distribution. The null hypothesis was the median difference between before treatment and after treatment is zero. And it was used to determine if the speed reduction was significant and vehicle lateral placements statistically changed due to the existence of reflectorized strips. The principle of the Wilcoxon T statistic is choosing the smaller value of the two sums of ranks, as shown in Equation (7).

$$T = \text{Min} [\Sigma (+), \Sigma (-)] \quad (7)$$

Where  $\Sigma (+)$  is the sum of the ranks for the positive differences between two treatments;  $\Sigma (-)$  is the sum of the ranks for the negative differences between two treatments.



The one-way, and Chi-Square approximation test was also conducted on the distribution of lateral placement and speed to determine significance in the two treatments. The one way analysis of speed and lateral placement with a different mean for each comparison group illustrate in Appendix B (pg120) and Appendix C (pg132), respectively. Stability of traffic conditions can be indicated by sample variance, which is squared of standard deviation.

All statistical tests were conducted at a 95% confidence interval or significance level of 0.05 ( $\alpha=0.05$ ). Easton and McColl (1997) said “the probability value (p-value) of a statistical hypothesis test is the probability of getting a value of the test statistic as extreme as or more extreme than that observed by chance alone, if the null hypothesis  $H_0$ , is true.” If a  $p > |Z|$  less than or equal to 0.05, then there is a statistical evidence of showing that the two medians are not centered at the same position. That indicates the effects of reflectorized strips are considered statistically significant on vehicle speed and lateral placement. If a  $p > \text{Chi Squared}$  less than or equal to 0.05, then there is a statistical evidence of showing that the two distributions are not centered at the same position. That indicates the effects of reflectorized strips are considered statistically significant on the variance of vehicle speed and lateral placement.

#### **4.3.2.5 Correlations**

Bivariate test was used to test a correlation exists between the two variables of vehicle speed and lateral placement. The density ellipse was applied to compute the bivariate normal distribution fit to the vehicle speed (X) and lateral placement (Y). And the bivariate

normal density operates to calculate the means and standard deviations of two variables and the correlation between those two. The approximate parametric test applied with null hypothesis ( $H_0$ ) of zero linear correlation between vehicle speed and lateral placement. The alternative hypothesis ( $H_a$ ) assumed that there is positive (negative, or either) correlation between vehicle speed and lateral placement.

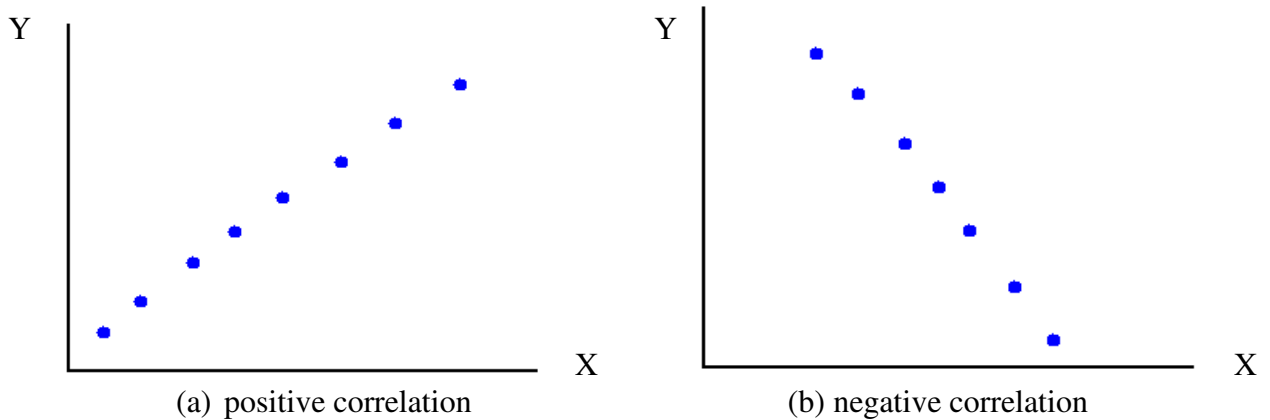

Figure 4.6 Correlations relation between X and Y (a) positive (b) negative

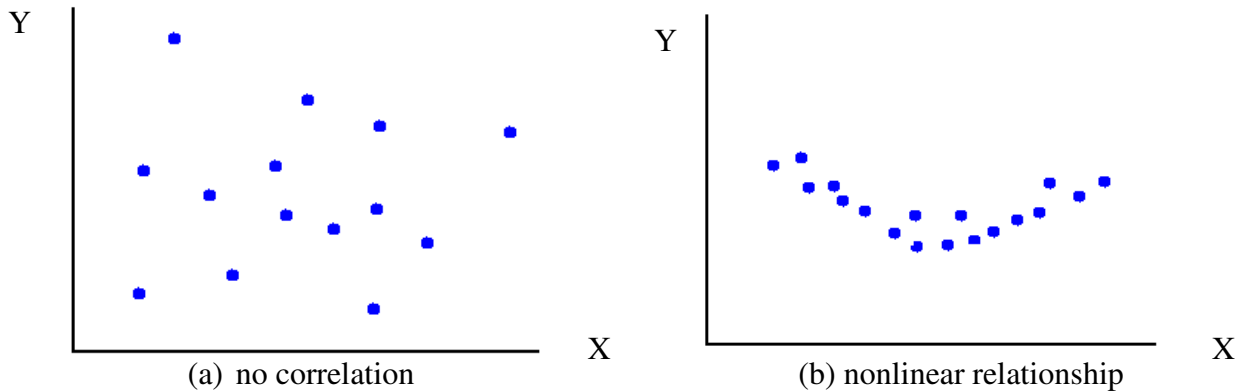

Figure 4.7 Correlations relation between X and Y (a) no correlation (b) nonlinear

Figure 4.6 (a) and (b) show the example of two variables with either positive correlation or negative correlation, respectively. If the two variables shift in the same direction, they have a positive correlation and hold correlation coefficient from zero to one. If

the two variables shift in the opposite directions, they have a negative correlation and hold correlation coefficient from negative one to zero. Correlation coefficient is also named as the Pearson linear correlation coefficient and it is employed to measure the power of the linear relationship between two variables, X and Y. If the positive correlation coefficient closer to 1, the correlation is stronger. If the negative correlation coefficient closer to -1, the correlation is stronger. Figure 4.7 (a) shows there is no relationship at all between variables X and Y. And Figure 4.7 (b) illustrates variables X and Y have relationships but not a linear relationship. The density ellipsoid is an indicator for showing the correlation between speed and lateral placement. The ellipsoid is more circular if two variables are uncorrelated, vice versa. The density ellipse probability has been set for 0.95.

## **4.4 Results**

### **4.4.1 Speed data analysis**

The median speed and standard deviation of speed under each condition on three locations of a curve display in Table 4.8 and Table 4.9. And the corresponding bar charts are contained in Figure 4.8 and Figure 4.9. The differences in median of speed between before and after treatments are shown in Table 4.8 as well. A positive value indicates median speeds increased in after treatment and a negative value signifies a reduction in speed because of after treatment situation, and it implies that the reflectorized strip has benefit on speed reduction. It is observed that vehicle median speed decreased by 0.08 mph at beginning of the curve (Z1) during day time. And vehicle median speed increased by 0.97 mph and 0.44 mph at the middle of curve (Z2) and the end of curve (Z3) during day time, respectively. It is also observed vehicle median speed decreased by 0.06 mph and 0.21 mph at the beginning of

curve (Z1) and the middle of curve (Z2) respectively, during night time. But median speed increased about 2 mph at the end of curve (Z3) at night. Overall median speeds during night time were lower than the median speeds during the day time. It can be seen that drivers drove slower and more carefully in the night compare the measuring speed at the day. Regarding to the variance of vehicle speed, there was a slightly difference in speed variance during the day of three locations on curve. And overall speed variance during the night increased when reflectorized strips were installed.

Table 4.8 Median of vehicle speed in mph

Speed Median (mph)	Day			Night		
	Before	After	A-B	Before	After	A-B
Z1	49.11	49.03	-0.08	47.02	46.96	-0.06
Z2	47.00	47.97	0.97	46.03	45.82	-0.21
Z3	47.76	48.21	0.44	45.45	47.31	1.86

Table 4.9 Normal approximation tests for lateral placement median

Test Speed Median Normal Approximation	Day	Night
	P> z	P> z
Z1	0.1806	0.9188
Z2	0.0002	0.8098
Z3	0.2590	0.0001

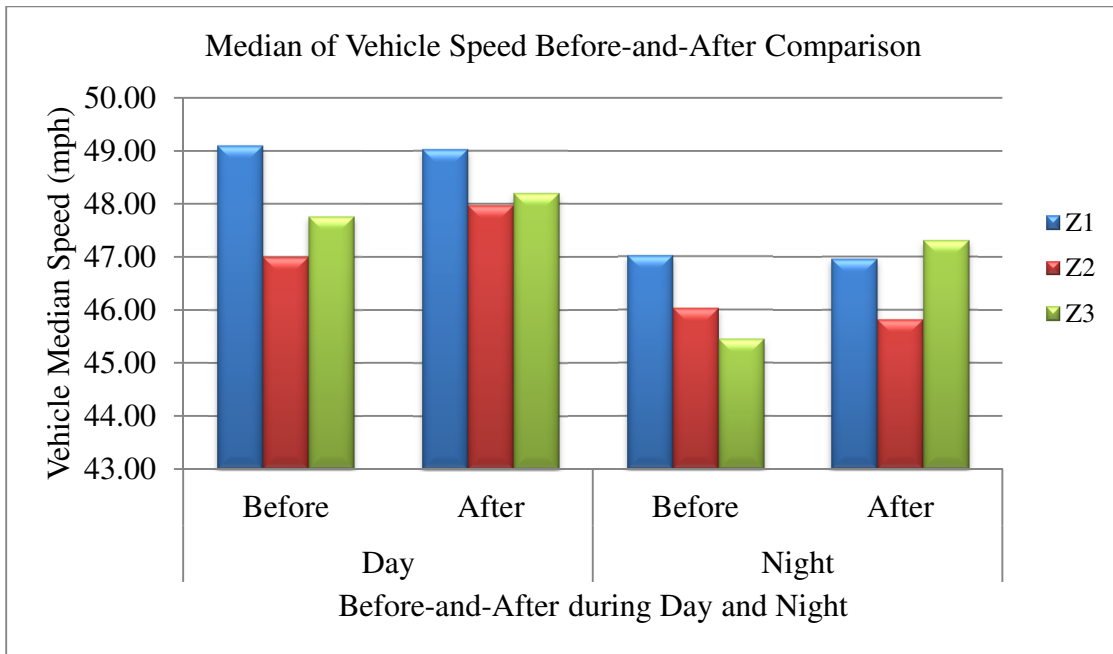

Figure 4.8 Vehicle median speed comparison in before-and-after during day and night

As Table 4.9 shows, two sample and approximate normal test was performed to test the differences in medians of vehicle speed. The null hypothesis ( $H_0$ ) would be there is no difference between the speed of before treatment and after treatment and the alternative hypothesis ( $H_a$ ) would be they have differences on two speeds. P value is the probability of wrongly reject  $H_0$  (or accept  $H_a$ ) if the null hypothesis is true. If a p-value less than or equal to 0.05, then  $H_0$  has been rejected and it concludes that the differences between two medians of speed are unlikely to be a coincidence and they are statistically significant different at 95% confidence intervals.

As previously mentioned, vehicle median speed increased by 0.97 mph at middle of curve (Z2) for daytime and the P-value is less than 0.05. It can be concluded that a small but statistically significant increase in speed at middle of curve (Z2) during the day and it can be

decided that reflectorized strips did not reduce speeds at middle of curve (Z2) during the day. And it has a similar effect at north point of curve (Z3). It can be seen that vehicle median speed increased by 1.86 mph at north of curve (Z3) for nighttime and the P-value is less than 0.001. The statistical test demonstrated that there is a strong evidence to show the medians of speed are statistically increases after reflectorized strips were installed. The speed decreased for a certain number at Z1 during day and night, and at Z2 during the night, respectively. However, the reductions were not statistically significant.

For rest of circumstances, the median speeds either increased or decreased, and the results were varied. The statistical test validated that there were no evidences to show the median speeds are different.

Table 4.10 Vehicle speed standard deviation

Speed Standard Deviation	Day			Night		
	Before	After	A-B	Before	After	A-B
Z1	4.5493	4.5178	-0.0315	5.1111	5.4036	0.2925
Z2	4.7141	4.4162	-0.2979	4.8269	5.4614	0.6345
Z3	4.5671	4.5436	-0.0235	5.0607	4.9311	-0.1296

Table 4.11 Chi Square approximation for standard deviation of speed

Test Variance of Lateral Placement Chi Square Approximation	Day	Night
	P>ChiSq	P>ChiSq
Z1	0.1805	0.9187
Z2	0.0002	0.8097
Z3	0.2590	0.0001

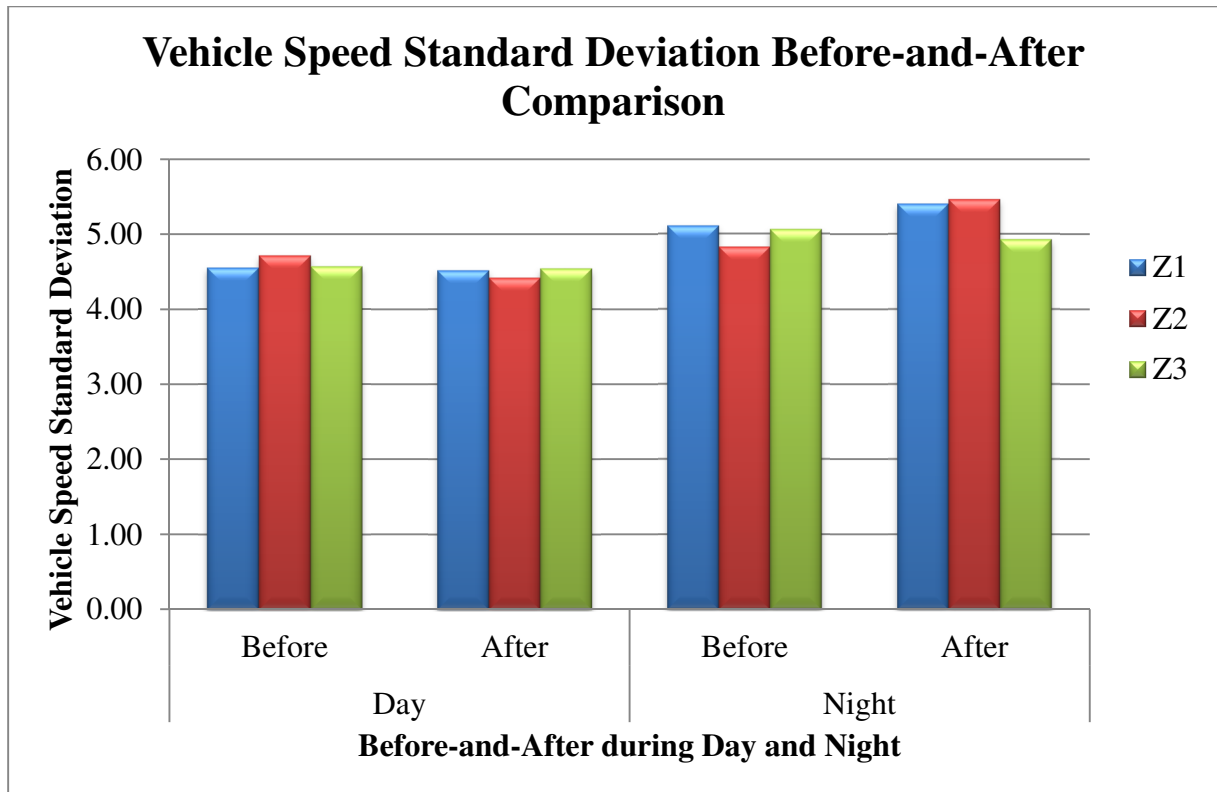

Figure 4.9 Vehicle speed standard deviation comparison in before-and-after treatment during day and night

From Table 4.11, one-way and approximate Chi Square test was conducted to test the differences in distributions of vehicle speed. The null hypothesis ( $H_0$ ) is defined as the distributions of vehicle speed are centered at the same location of before and after treatment and the alternative hypothesis ( $H_a$ ) would be the distribution of speeds are different.  $P > \text{ChiSq}$  is the probability of wrongly reject  $H_0$  (or accept  $H_a$ ) if the null hypothesis is true. If a p-value less than or equal to 0.05, then  $H_0$  has been rejected and it considered as two distributions of speed are statistically significant not centered at the same location with 95% confidence intervals.

P-values at middle of curve (Z2) for daytime are less than 0.05. It can be concluded that there is a statistical evidence to show the distribution of speed was different. And the speeds under after treatment were more stable than the ones under before treatment group. For nighttime, p-values at north point of curve (Z3) has the value less than 0.0001. There is a statistical evidence to show the distribution of speed is statistically significant different with 95% confidence intervals. There is strong evidence of showing that reflectorized strips significantly impacted the distribution of vehicle speed at north point of curve (Z3) during night. And the speeds were more centered at Z3 during night under after treatment condition rather than before treatment. For rest of results, the changes of speed standard deviations were not statistically significant.

#### **4.4.2 Lateral placement data analysis**

The median lateral placement and variance of vehicle lateral placement under each condition for the three locations are shown in Table 4.12 and Table 4.13. And the corresponding generated bar charts are demonstrating in Figure 4.10 and Figure 4.11. The differences in median lateral placement between two treatments are shown in Table 4.12 as well. A negative value under A-B column in Table 4.12 signifies that vehicle's lateral placement decreased and it implies vehicle drove closer to the edge of the curve. A positive value indicates median lateral placement increased in after treatment and it indicates that vehicles shift away from the edgeline due to the installation of reflectorized strips. And it also implies that reflectorized strips have beneficial effects on run-off road crash reduction. It is observed that vehicle median lateral placement increased by 0.21 inches and 0.15 inches at the middle of curve (Z2) and the end of curve (Z3) during day time, respectively. The median



lateral placement at the beginning of curve (Z1) increased slightly by 0.01 inches during the day. It is also observed that vehicle median lateral placement increased by 0.06 inches and 0.33 inches at the beginning of curve (Z1) and the middle of curve (Z2) during night time, respectively. However, median lateral placement decreased about 0.20 inches at the end of curve (Z3) at night. In general, vehicle median lateral placement during day and night were increased along the curve except a negative value at the end of the curve (Z3) at night.

Overall, the values of median lateral placements were larger at night than the median lateral placements during the day time. It implies that drivers drove away from the edge of the curve at night compare with the value during the day. Regarding the variance of vehicle lateral placement, there was a slight difference in speed variance during the day of three locations on curve.

Table 4.12 Median of vehicle lateral placement in inches

Lateral Placement Median (inches)	Day			Night		
	Before	After	A-B	Before	After	A-B
Z1	2.62	2.63	0.01	2.85	2.91	0.06
Z2	2.38	2.60	0.21	2.69	3.01	0.33
Z3	2.41	2.56	0.15	3.00	2.80	-0.20

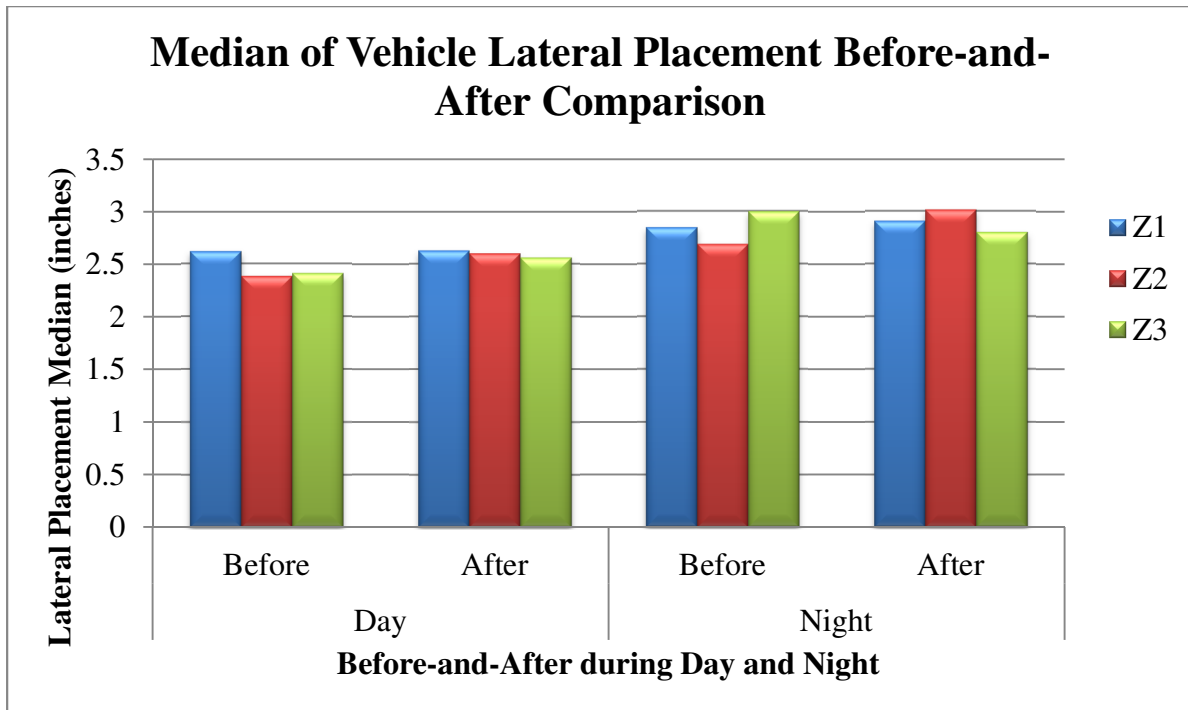

Figure 4.10 Median of vehicle lateral placement comparison in before-and-after during day and night

Table 4.13 Normal approximation tests for median lateral placement

Test Median Lateral Placement Normal Approximation	Day	Night
	P> z	P> z
Z1	0.7702	0.3990
Z2	<0.0001	<0.0001
Z3	<0.0001	<0.0001

As Table 4.13 shows, two sample and approximate normal test was performed to test the differences in medians of lateral placement. P value is the probability of wrongly reject  $H_0$  (or accept  $H_a$ ) if the null hypothesis is true. If a p-value less than or equal to 0.05, then  $H_0$  has been rejected and it concludes that two medians of lateral placement are statistically significantly different at 95% confidence intervals.

P-values at middle of curve (Z2) and north point of curve (Z3) for daytime are less than 0.0001. It can be concluded that there is statistical evidence to show the medians of lateral placement are different and the increases were statistically significant. Reflectorized strips help driver to drive away from the edge of the curve at both middle of curve (Z2) and north of the curve (Z3) during the day. However, lateral placement increased at Z1 during the day, the increases were not statistically significant at 95% confident interval.

For nighttime, p-values at middle of curve (Z2) and north point of curve (Z3) are less than 0.0001 as well. There is a statistical evidence to show the medians of lateral placement are significantly different with 95% confidence intervals. There is strong indication that the reflectorized strips significantly increased vehicle lateral placement at middle of curve (Z2) during night. Contrarily, there is a surprising finding that reflectorized strips significantly reduced vehicle lateral placement at north of curve (Z3). Even though, lateral placement increased at Z1 during the night, the increases were not statistically significant at 95% confident interval.

At south point of curvature (Z1) during daytime condition, the p-value of 0.7702 implies that the medians of lateral placement are not statistically significantly different with 95% confidence intervals under before and after treatment. Even though, the lateral placement was off 0.01 inches at south point of curve (Z1) during the day, reflectorized strips did not effect the changing of lateral placements too much. And the same theory applies during the night condition at the same location (Z1) as well.

Table 4.14 Vehicle lateral placement standard deviation

Lateral Placement Standard Deviation	Day			Night		
	Before	After	A-B	Before	After	A-B
Z1	0.8398	0.8426	0.0028	0.9323	0.8934	-0.0389
Z2	0.8379	0.8715	0.0336	0.9245	0.8986	-0.0259
Z3	0.8996	0.7786	-0.1210	0.9808	0.8881	-0.0927

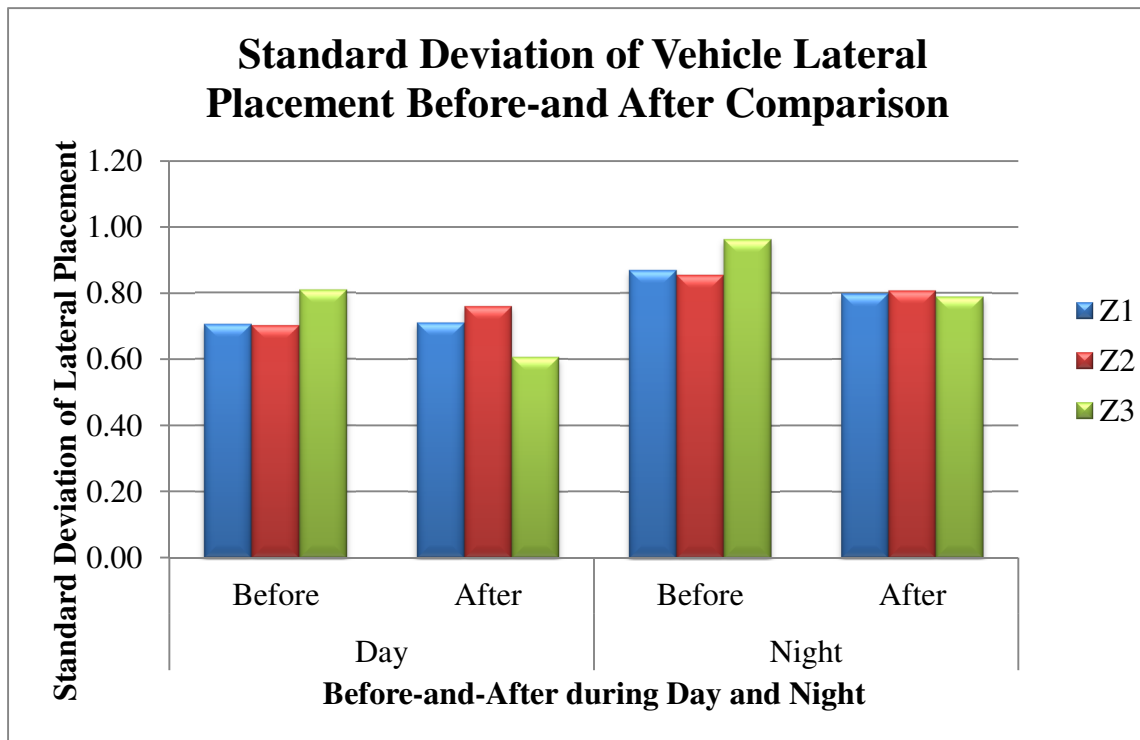

Figure 4.11 Vehicle lateral placement standard deviation comparison in before-and-after treatment during day and night

Table 4.15 Chi square tests for standard deviation of lateral placement

Test Standard Deviation of Lateral Placement Chi Square Approximation	Day	Night
	P>ChiSq	P>ChiSq
Z1	0.7702	0.3989
Z2	<0.0001	<0.0001
Z3	<0.0001	<0.0001

As **Error! Reference source not found.** shows, one-way and approximate Chi Square test was conducted to test the differences in distributions of lateral placement.  $P > \text{ChiSq}$  is the probability of wrongly rejecting  $H_0$  (or accepting  $H_a$ ) if the null hypothesis is true. If a p-value less than or equal to 0.05, then  $H_0$  has been rejected and it was considered as two distributions of lateral placement as statistically significant not centered at the same location different with 95% confidence intervals.

P-values at middle of curve (Z2) and north point of curve (Z3) for daytime are less than 0.0001. It can be concluded that there is a statistical evidence to show the distribution of lateral placement are different. For nighttime, p-values at middle of curve (Z2) and north point of curve (Z3) are less than 0.0001 as well. There is a statistical evidence to show the distribution of lateral placement are significant different with 95% confidence intervals. There is strong evidence of showing that reflectorized strips significantly impacted the distribution of vehicle lateral placement at middle of curve (Z2) and north point of curve (Z3) during night. At south point of curvature (Z1) during daytime condition, the p-value of 0.7702 implies that the distribution of lateral placement are not statistically significant different with 95% confidence intervals under before and after treatment. Even though, the lateral placement standard deviation increased by 0.0028 inches at south point of curve (Z1) during the day, reflectorized strips did not affect the distribution of lateral placements too much. And the same theory applies during the night condition at the same location (Z1) as well.

#### 4.4.3 Correlations between vehicle speed and lateral placement

Significant probability is the probability of getting a correlation if no linear relationship exists between vehicle speed and lateral placement. If a significant probability has a value less than 0.05, then the null hypothesis have been rejected. In other words, higher significant probability means less relationship between two variables. And if the correlation close to 1 or -1, it means two variables are more correlated. Table 4.16 to Table 4.19 show the correlation coefficient and significant probably of the 12 estimates under different treatments and lighting conditions.

For the correlations under before treatment during the day time in Table **4.16**, there are some correlations between vehicle speed and lateral placement at middle of curve (Z2) and the end of curve (Z3). However, this relation is not high enough. For the correlation under after treatment during the night time in Table **4.19**, there is a little relationship between speed and lateral placement at middle of curve (Z2). For the rest of conditions in Table **4.17** and Table **4.18**, probability of accepting alternative hypothesis is fairly low and correlation coefficients are less than 0.05. It can be seen that the correlations are various from -0.16 to 0.17 and the absolute values of any of them are less than 0.20. Also, the majority of the significant probabilities are greater than 0.05.

Table 4.16 Correlations table under before treatment in daytime

Location	Treatment condition	Correlation	Significant probability
Z1	Speed day before	-0.1180	0.0034
	LP day before		
Z2	Speed day before	0.1334	0.0009
	LP day before		
Z3	Speed day before	0.1703	<0.0001
	LP day before		

Table 4.17 Correlations table under after treatment in daytime

Location	Treatment condition	Correlation	Significant probability
Z1	Speed day after	0.0493	0.0695
	LP day after		
Z2	Speed day after	-0.0337	0.2179
	LP day after		
Z3	Speed day after	-0.0425	0.1229
	LP day after		

Table 4.18 Correlations table under before treatment in nighttime

Location	Treatment condition	Correlation	Significant probability
Z1	Speed night before	0.0471	0.4405
	LP night before		
Z2	Speed night before	0.0637	0.2963
	LP night before		
Z3	Speed night before	-0.1383	0.2330
	LP night before		

Table 4.19 Correlations table under after treatment in nighttime

Location	Treatment condition	Correlation	Significant probability
Z1	Speed night after	-0.0823	0.0394
	LP night after		
Z2	Speed night after	-0.1613	<0.0001
	LP night after		
Z3	Speed night after	-0.0335	0.4081
	LP night after		

The output graphs of fit density ellipse are demonstrating in Appendix D (pg 144). The visual inspections illustrate that most of the graphs more shaped in circulars instead of ellipses or even elongated shapes and it indicate two variables are uncorrelated. From the outputs of correlation tables, vehicle speed and lateral placement are somewhat related but not highly correlated and they are not shaped with liner relationship neither. The proportions of probability of getting a correlation of two variables with no linear relationship are larger than the proportions of obtaining a liner relationship.

## 4.5 Summary

### 4.5.1 Speed study

Vehicle speed did not decrease after application of the reflectorized strips at both middle of curve (Z2) and the north of curve (Z3) during the day and the increases were significant at middle of curve (Z2) in daytime. The only speed decrease at daytime was at the beginning of curve (Z1), but it was not statistically significant. Vehicle speeds also increased at the end of curve (Z3) after sunset period and the increase was very significant. The two



decrease speeds during nighttime were at the beginning of curve (Z1) and middle of curve (Z2), but they were not all significantly different.

Generally, there was no strong evidence showing that reflectorized strips significantly reduce vehicle speed on curve either at day time or night time. In other words, reflectorized strips were not effective in vehicle speed reduction on the US 52.

#### **4.5.2 Lateral placement study**

Reflectorized strips increased vehicle lateral placements at all three locations on curve and the increases were significant at both middle of curve (Z2) and the north of curve (Z3) during the day. Moreover reflectorized strips increased vehicle lateral placement at south of curve (Z1) and middle of curve (Z2), and the increases were significant at middle of curve (Z2) during the night. The only decrease was at the north of the curve (Z3) during the night. And the lateral placement distribution converged more during the night.

Overall, the benefit and effectiveness of reflectorized strips were significant and the treatment were helpful in lane keeping during the day time. Drivers were more likely to drive away from the edge and the percentage of single vehicle run-off-road will be decreased. The reflectorized strips have benefit for drivers in lane keeping during the night, while the effects were not statistically significant.

### **4.5.3 Correlation study**

Through the correlation coefficient, vehicle speed and lateral placement are correlated in some way, but the correlations are not robust. In summary, nearly all the density ellipses formed circular shapes. Also, the correlation coefficients between vehicle speed and lateral placement are extremely low. Another corroborative evidence show the majority of significant probabilities are greater than 0.001. It can be seen that there is no correlation between vehicle speed and lateral placement.

## Chapter 5. CONCLUSIONS

According to Federal Highway Administration's (FHWA) local and rural road safety program, The majority of highway fatalities occurred on rural roads and approximately 57 percentage of fatalities were association with rural road. Additionally, more than 25 percent of fatalities occurred on horizontal curves and most of them were roadway departures. The data showed that about 75 percent of curve related crashes were single vehicle run-off road and included hitting objects on side of road, leaving roadway, or overturning. From which, it can be seen single vehicle run-off road (SVROR) on a horizontal curve of rural highway addresses safety issues to engineers. From FHWA, a horizontal curve safety report stated by Joseph Cheung, some aspects to judge the selection of countermeasures are speed limit compliance, geometric characteristics, sight distance and traffic volume, etc. Most countermeasures have been applied at horizontal curves to reduce curve crashes. The most often used countermeasures are centerline, edge line, advisory speed plaque, chevron alignment sign, flashing beacons, basic device with high retroreflectivity and fluorescence, dynamic curve warning system, rumble strips, safety edge, shoulder widening, etc. Since crashes are infrequent and complicated events, safety surrogate measurements are used to assess the effectiveness of a curve treatment, and vehicle speed and vehicle lateral placements are two of them.

A couple of studies, which were from Cottrell (1986), Krammers and Tyer (1991), and Mahoney et. al. (2003), have used a before-and-after comparison to evaluate the treatment. In this thesis, a before-and-after comparison experiment was conducted to investigate the impact of adding reflectorized strips to existing chevrons on vehicle speed

and lateral placement along a curve. The curve was chosen from two-lane undivided rural highway with relative high percentage crashes on rural highways. A segment of US 52 in Sageville, Iowa has been selected for the study location. Before treatment was an existing chevron sign posted along the curve and before treatment vehicle speeds and time stamps were collected between May 20<sup>th</sup> and May 23<sup>rd</sup>, 2010. After treatment was adding reflectorized strips to the existing chevron sign posts and after treatment vehicle data were collected from September 8<sup>th</sup> to September 13<sup>th</sup> in 2010. Counters and z-shaped road tubes were used in the field to record and collect raw data at three spots along the curve. In this research, road tubes were used to obtain raw data and two ends were placed inside of the paint line in order to keep measurement orderly and easier for math procedure. Z-configuration is designed for measuring vehicle speeds, especially vehicle lateral placements. Vehicle placements referred to the vertical distances between point of contact of a vehicle's right front tire and the tube end along inside of edgeline in this thesis. After data sets have been classified into the day and the night, vehicle speeds and lateral placements were able to be calculated from time stamps and two similar right triangles based on basic geometry.

After acquiring vehicle raw data, data was reviewed, screened, and formatted to get two-axle passenger vehicles. Then vehicle speed and lateral placement were calculated by using the developed equations. Then statistical tests and JMP software are used in the data analysis procedure and the results are described in the following section.

## **5.1 Summary of the study**

### **5.1.1 Vehicle speed**

The posted speed limit on US 52 is 50 mph and this research measured vehicle speed for before and after treatment. Approximate normal test and approximate Chi Squared test were utilized to evaluate the effectiveness of reflectorized strips. The speed findings were assorted and various, and the findings recommended that the reflectorized strips did not significantly reduce or lower vehicle speed and they may have an insignificant effect on vehicle speed on curvature of US 52. Statistical tests of the median vehicle speed was performed and all speed reduction were not significant. Instead of reduction, speed increase was significantly different. The speed standard deviation test provided a similar result with speed and the majority of tests were not significantly different. The results supported a conclusion that reflectorized strips were not effective on speed reduction on US 52. Since the speed reduction were not obvious after reflectorized strips has been added, it is not worth to install reflectorized strips on the existing chevron sing post to reduce vehicle speed in practical aspect.

### **5.1.2 Vehicle lateral placement**

Lateral placement has been measured and calculated for individual vehicles to evaluate the effectiveness of reflectorized strip. Even though vehicle lateral placements increased at site Z1 for both day and night after reflectorized strips have been installed, and it was found that the changes were not statistically significant. In statistical point of view, reflectorized strip treatments may have a negligible effect on a vehicle lateral placement at south of curve or beginning of the curve (Z1).

It was also found that the treatment significantly improved vehicle median lateral placement during day and night at middle of the curve (Z2). It can be concluded that reflectorized strips provide a good guidance for driver and the benefit of reflectorized strips were effective no matter in daytime or nighttime at middle of curve.

At the end of curve or north point of curve (Z3), lateral placement increase during daytime was statistically significant. Contrarily, the reduction of lateral placement was statistically significant at the same location during the night. It provided an indication that reflectorized strip was effective on improving vehicle lateral placement at the end of curve in day time, but it was not effective during night time.

On the whole, the overall lateral placements were increased under reflectorized strips have been installed. And the generally lateral placements hold the value night higher during the night than the day time. In conclusion, reflectorized strips were effective in lane keep under both day and night conditions. The speed and lateral placement findings are for curve section on US 52 in Iowa, and the statistical results should not be applied or generalized to other sites that haven't been tested yet.

### **5.1.3 Correlation**

Vehicle speed and lateral placement are not highly correlated in this study. In practical aspect, vehicle speed along with lateral placement can not be analyze together to evaluate the effectiveness of the treatment. The two variables should be taken as an isolated component with each other to assess the significant of the treatment.

#### 5.1.4 Conclusion

In order to achieve a distinguished conclusion, the conclusion from a previous study, which was from Chrysler et. al. (2009), and the findings of this study are compared. Chrysler et. al. (2009) from Texas Transportation Institute (TTI) conducted a research to evaluate the effectiveness of the five different treatments for both closed-course study and a field study and it was similar to this study. Standard chevron signs and chevrons with fully reflectorized posts (Chev Full) were two of the five treatments. The main differences between the previous study and this study were baseline treatment, vehicle type selection. The baseline treatments and selected vehicle types were roadway with edgeline, and passenger vehicles and heavy vehicles in TTI study. While the baseline treatments and selected vehicle types existed chevron signs and two-axle passenger vehicles. Even though the two studies have the different treatment types, different curve segment, and targeted vehicle types, the findings and results can draw lessons from each other. The findings from TTI study concluded that the effects were similar for chevron signs and chevron with fully reflectorized posts (Chev Full) for passenger vehicles and heavy vehicles. Also, standard chevrons and Chev Full statistically reduced vehicle speed and Chev Full reduced speed more than the regular chevrons did. In this study, the results showed the chevrons with reflectorized strips did not reduce vehicle speed statistically. The reason of getting distinctive results on vehicle speed reduction was different baseline treatment. Regarding to vehicle lateral placement improvement, the TTI study found vehicle shifted toward to the edgeline at point of curvature (PC) and middle point of the curve (MP) on an outside curve (left-hand) from closed-course study at night. In this study, it was found that vehicle drove away from

edgeline on beginning of the curve (Z1) and middle of the curve (Z2) at nighttime. The reasons of obtaining the different results were study sites and the drivers. TTI took a closed airport to simulate the field sites and the numbers of participants were only 20. However, two-axle passenger vehicles' data were drawing from the entire population and the US 52 is the real curve with horizontal and vertical alignment characters.

## **5.2 Recommendations**

In this thesis, test analysis depend on the independent variable which are any parameters could have the effect of changing of speed and lateral placement. For the future analysis, more variables and parameters could be considered into the analysis procedure. Such as driver's gender, driver's age, weather condition (e.g. rain, snow, etc.), pavement condition (e.g. icy road, etc.), model of a car, year of a car, etc. The examples are listed because driving speed may differ depending on driver's gender and age. Also, the new models of the cars have more powerful engines and could be speeding up easier than other cars.

As mentioned previously, any reductions in vehicle speeds and changes in lateral placements would result from the existence of reflectorized strips. And then the results are subject to the assumptions that are approved in this thesis. The limitation of this thesis is that vehicle headway were not taken into the consideration of this study. If two vehicles drive closely, the vehicle behind would follow the driving behavior of the front vehicle. Two speeds and lateral placements could be similar or even doubled (cloned) due to smaller headway



effect. In the future research, it is essential to take headway into considerations and to assess uninhibited vehicles that are not impacted by an automobile ahead or behind them.

Third, data sets were including both weekdays and weekends dates. In data screening procedure, weekend vehicle data sets were not eliminated or separated from the entire data set. However, weekend traffic condition may slightly change compared with weekday traffic characteristics. In the future study, weekday and weekend data can be analyzed separately to achieve a comprehensive research if possible.

Fourth, vertical and horizontal curve alignment characteristics were not accounted for in the research since only one site was represented. Horizontal curve characteristics include curve radius, degree of curvature, length of horizontal curve, and vertical curves characteristics consist of incoming grade, outgoing grade, tangent offset, length of vertical curve, etc. The above described curve characteristics may effect vehicle speed and lateral placement. Also, there might some differences between inside (right-hand) curve and outside(left-hand) curves with respect to vehicle speed and lateral placement. In the future, these factors may be considered in the research to conduct a systematic study on the effectiveness of reflectorized strips.

The last limitaion would be the scope and site selection of the research are relative small. Five hours duration were selected randomly for day and night period. In the future, the duration could expand into a longer period to obtain more vehicle speed and lateral placement data. The testing results only applied for the US 52 and not for other curves. In

order to get the comprehensive results on the effectiveness of reflectorized strips, more cruves should be selected as testing sites for the future research work.

**REFERENCE**

Benjamin H. Cottrell, Jr. *The Effects of Wide Edge Lines on Lateral Placement and Speed on Two-Lane Rural Roads*. In Transportation Research Record 1069, TRB, National Research Council, Washington, D.C., 1986, pp. 1-6.

R.J. Porter, Eric T. Donnell, and Kevin M. Mahoney. *Evaluation of Effects of Centerlines Rumble Stripes on Lateral Vehicle Placement and Speed*. In Transportation Research Record 1862, TRB, National Research Council, Washington, D.C., 2004, pp. 10-16.

Eric T. Donnell and Masion D. Gemar. *Safety and Operational Effects of Pavement Markings*. PennDOT/MAUTC Partnership, Work Order No.4, Research Agreement No. 510401, Commonwealth of Pennsylvania Department of Transportation, December 2, 2005.

Matthew C. Crisler, Johnell O. Brooks, Jennifer H. Ogle, Chris D. Guirl, Priyanka Alluri, and Karen K. Dixon. *Effect of Wireless Communication and Entertainment devices on Simulated Driving Performance*. In Transportation Research Record 2069, TRB, National Research Council, Washington, D.C., 2008, pp. 48-54.

Xiaoduan Sun, Jaehyun Park, V.O. "Dean" Tekell, Jr., and Nina S. Ludington. *Evaluation of Pavement Edge Lines on Narrow Highways with Low Traffic Volume in Louisiana*. In Transportation Research Record 1989, Volume 1 TRB, National Research Council, Washington, D.C., 2007, pp. 115-122.

William C. Taylor, Ghassan Abu-Lebdeh, and Sachin Rai. *Effect of Continuous Shoulders Rumble Strips and Pavement Marking on Lateral Placement of Vehicles*. In Transportation Research Record 1911 TRB, National Research Council, Washington, D.C., 2005, pp. 105-112.

Kerrie L. Schattler, Joseph Pellerito, Jr., Deborah McAvoy, and tapan K. Datta. *Assessing Drive Distraction from Cell Phone Use*. In Transportation Research Record 1980 TRB, National Research Council, Washington, D.C., 2006, pp. 87-94.

Dudek, C. L., R. D. Huchingson, F. T. Creasey, and O. Pendleton. *Field Studies of Temporary Pavement Markings at Overlay Project Work Zones on Two-Lane, Two-Way, Rural Highways*. Transportation Research Record 1160, TRB, National Research Council, Washington, D. C., 1988, pp. 22-32.

Bowman, B. L. and P. Brinkman. *Effect of Low-Cost Accident Countermeasures on Vehicle Speed and Lateral Placement at Narrow bridges*. Transportation Research Record 1185, TRB, National Research Council, Washington, D. C., 1988, pp. 11-23.

Wonho Suh, Peter Young-Jin Park, Chang Ho Park, and Kyung Soo Chon (Aug, 2006). *Relationship between Speed, Lateral Placement, and Drivers' Eye Movement at Two-Lane Rural Highways*, Journal of Transportation Engineering, ASCE. 132 (8), 649-653.

B. Gunay and D. Woodward. *Lateral Position of Traffic Negotiating Horizontal Bends*. Journal of TRI February 2007, pp. 1-11.

Young-Jin Park, Chang-Ho Park, and Kyung-Soo Chon (May, 2007). *Development of Potential Measures to Evaluate the Safety of Curves in Rural Highway*, Journal of Civil Engineering, KSCE. Vol. 7, No. 3, pp. 233-242.

Gawron, V.J. and T.A. Ranney. *Curve negotiation performance in a driving simulator as a function of curve geometry*. Liberty Mutual Research Center. Applied Ergonomics 1990, 21.1, pp. 33-38.

Samuel G. Charlton (2007). *The role of attention in horizontal curves: A comparison of advance warning, delineation, and road marking treatments*. Accident Analysis and Prevention. Volume 39, Issue 5, September 2007. pp. 873-885.

Wants, J.S. and Knipling, R.R. (1993). *Single Vehicle Roadway Departure Crashes: Problem Size Assessment and Statistical Description*. National Highway Traffic Safety Administration Technical Report DTNH-22-91-C-03121.

Richard F. Crowther, Robert P. Shemate and R. Dean Smith. *The Effect of Pneumatic Road Tubes on Vehicle Speeds*. Traffic Safety Vol5, No.3, September 1961.

Melisa D. Finley, Dillon S. Funkhouser, and Marcus A. Brewer. *Studies to Determine the Operational Effects of Shoulder and Centerline Rumble Strips on Two-lane Undivided Roadways*. Report No. FHWA/TX-09/0-5577-1, Technical Report: August 2009. Texas Transportation Institute, The Texas A&M University System College Station, Texas.

Susan T. Chrysler, Jon Re, Keith S. Knapp, Dillon S. Funkhouser, Beverly T. Kuhn (May 2009). *Driver Response to Delineation Treatment on Horizontal Curves on Two-lane Roads*. Report No. FHWA/TX-09/0-5772-1. Technical Report: May 2009. Texas Transportation Institute, The Texas A&M University System College Station, Texas.

David Shinar, Edward D. McDowell, and Thomas H. Rockwell. *Eye Moments in Curve Negotiation*. *Human Factors*. 1977, Volume 19 (1), Pg 63-71.

B. Gunay and D. Woodward. *Lateral Position of Traffic Negotiating Horizontal Bends*. Issue TR1 Pages 1-11. February 2007.

Cathy Satterfield, Hugh W. McGee, and Fred R. Hanscom. *Low-Cost Safety Improvements For Horizontal Curves*. March/April 2009, Vol 72, No. 5. Retrieved from <http://www.fhwa.dot.gov/publications/publicroads/09mar/05.cfm>

E. D. Arnold, Jr., and K. E. Lantz, Jr. Evaluation of Best Practices in Traffic Operations and Safety: Phase I: Flashing LED Stop Sign and Optical Speed Bars. Report No. FHWA/VTRC 07-R34. June 2007. Virginia Transportation Research Council and Virginia Department of Transportation.

Barton E. Jennings and Michael J. Demetsky. *Evaluation of Curve Delineation Signs on Rural Highways*. Transportation Research Record No. 1010, Transportation Research Board, Washington, D.C., 1985, pp. 53-61.

Eric R. Petersen and Eric J. Fitzsimmons. CTRE Pneumatic Road Tube Manual, Volume 2, for use with laptop usb come port 6 download.

Iowa DOT 2009 AADT count. Retrieved from <http://www.iowadotmaps.com/msp/traffic/2009/counties/DUBUQUE.pdf>

Safety, Roadway, Shoulder Rumble Strips. New York State Department of Transportation. Retrieved from <https://www.nysdot.gov/programs/rumblestrips>

Aluminum Diamond Grade Reflective Post Panel: Yellow Reflective Post Panels. MyParkingSign.com, A SmartSign Store, 32 Court Street, Suite 2200, Brooklyn, NY Retrieved from <http://www.myparkingsign.com/Parking-Signs-Accessories/Reflective-Post-Panels-Sign/SKU-K-2192-Y.aspx>

Feng Hong, Jorge A. Prozzi, and Jolanda Prozzi. (Summer 2007). A New Approach for Allocating Highway Costs. *Journal of the Transportation Research Forum*, Vol. 46, No. 2, pp. 5-19. Retrieved from <http://journals.oregondigital.org/trforum/article/viewFile/1011/906>

Federal Highway Administration, U.S. Department of Transportation. *Traffic Monitoring Guide*, Washington, D.C., 2001.

Umbs, Rudolph M (2001, December 20). Road Departure Safety, Police/Guidance, Rumble Strips Guidance, Roadway Shoulder Rumble Strips. T 5040.35. December 20, 2001. Retrieved from [http://safety.fhwa.dot.gov/roadway\\_dept/policy\\_guide/t504035.cfm](http://safety.fhwa.dot.gov/roadway_dept/policy_guide/t504035.cfm)

Paul Zador, Howard S Stein, Paul Wright, and Jerome Hall. *Effects of Chevrons, Post-Mounted Delineators, and Raised Pavement Markers on Driver Behavior at Roadway Curves*. In *Transportation Research Record 1114*, TRB, National Research Council, Washington, D.C., 1987, pp. 1-10.

Mary Stahlhut. (2007). *Iowa Comprehensive Highway Safety Plan (CHSP)*. Retrieved from <http://www.iowadot.gov/traffic/chsp/background.html>

Fatality Analysis Reporting System (FARS). (2011). FARS data table. Retrieved from <http://www-fars.nhtsa.dot.gov/Main/reportslinks.aspx>

*Golembiewski, G.A. and Chandler, B. Roadway Departure Safety: A Manual for Local Rural Road Owners. Report No. FHWA-SA-11-09. Science Applications International Corporation (SAIC), McLean, VA, January, 2011.*

University of California – Berkeley, Safe Transportation Research and Education Center, *SafeTrec –Rural Road Safety* web page, updated on October 2009. Retrieved from <http://www.tsc.berkeley.edu/research/ruralroads.html>

W. A. Stimpson, H. W. McGee, W. K. Kittelson, and R. H. Ruddy. *Field Evaluation of Selected Delineation Treatments on Two-Lane Rural Highways*. Report FHWA 77-118. U.S. Department of Transportation, 1977.

Freedman, M., Staplin, L. K., Gilfillan, D. P., and Byrnes, A. M. (1988). *Noticeability Requirements for Delineation on Non-Illuminated Highways*. Technical Report No. FHWA-RD-88-028. Washington, D.C.: Federal Highway Administration.

David, R. E. National Cooperative Highway (NCHRP) Research Results Digest. *Roadway Delineation Systems*. Issue 36, 1972, p17.

Krammes, R.A. and Kevin D. Tyer. *Post-Mounted Delineators and Raised Pavement Markers: Their Effect on Vehicle Operations at Horizontal Curves on Two-Lane Rural Highways*. Transportation Research Record 1324, TRB, National Research Council, Washington, D.C. (1991): 59-71.

Sageville, Iowa, Rise and Set for the Sun for 2010. Astronomical Applications Department, U.S. Naval Observatory, Washington, DC. Retrieved from [http://aa.usno.navy.mil/data/docs/RS\\_OneYear.php](http://aa.usno.navy.mil/data/docs/RS_OneYear.php)

Kevin M. Mahoney, R.J. Porter, Eric T. Donnell, D. Lee, and M.T. Pietrucha. *Evaluation of Effects of Centerlines Rumble Stripes on Lateral Vehicle Placement and Speed on Two-Lane Highways*. Report No. FHWA-PA-2002-034-97-04. Pennsylvania Transportation Institute, University Park, PA, 2003.

Miles, J.D., P. J. Carlson, M.P. Pratt, and T.D. Thompson. *Traffic Operational Impacts of Transverse, Centerline, and Edgeline Rumble Strips*. Report No. FHWA/TX-05/0-4472-2. Texas Transportation Institute, College Station, TX, March 2005.

Alexei R. Tsyganov, Randy B. Machemehl, Nicholas M. Warrenchuk, and Yue Wang. *Before-After Comparison of Edgeline Effects on Rural Two-Lane Highways*. Report No. FHWA/TX-07/0-5090-2. Center for Transportation Research, The University of Texas at Austin, Austin, TX. November 2006.

Paul J. Carlson and Jeff D. Miles. *Effectiveness of Rumble Strips on Texas Highways: First Year Report*. Report No. FHWA/TX-05/0-4472-1. Texas Transportation Institute, College Station, TX, March 2005.

Joseph Cheung. *Horizontal Curve Safety*. FHWA Office of Safety, Roadway Departure Team, U.S. Department of Transportation, Federal Highway Administration. Retrieved from [http://safety.fhwa.dot.gov/roadway\\_dept/horicurves/cmhoricurves/](http://safety.fhwa.dot.gov/roadway_dept/horicurves/cmhoricurves/)

D. J. Torbic, J. M. Hutton, C. D. Bokenkroger, K. M. Bauer, D. W. Harwood, D. K. Gilmore J. M. Dunn, J. J. Ronchetto, E. T. Donnell, H. J. Sommer III, P. Garvey, B. Persaud, and C. Lyon. *Guidance for the Design and Application of Shoulder and Centerline Rumble Strips*. National Cooperative Highway Research Program (NCHRP) Report 641. Retrieved from [http://onlinepubs.trb.org/onlinepubs/nchrp/nchrp\\_rpt\\_641.pdf](http://onlinepubs.trb.org/onlinepubs/nchrp/nchrp_rpt_641.pdf)

Robert L. Gordon and Warren Tighe. *Traffic Control Systems Handbook: Chapter 3 Control Concepts - Urban and Suburban Streets*. Report No. FHWA-HOP-06-006. Dunn Engineering Associates, P.C. Westhampton Beach, NY, October 2005.

Golembiewski, G.A. and Chandler, B. *Roadway Departure Safety: A Manual for Local Rural Road Owners*. Report No. FHWA-SA-11-09. Science Applications International Corporation (SAIC), McLean, VA, January, 2011.

McGee, Hugh W. and Hanscom, Fred R. *Low-Cost Treatments for Horizontal Curve Safety*. Report No. FHWA-SA-07-002. Transportation Research Corporation, Markham, VA and Vanasse Hangen Brustlin, Inc (VHB), Vienna, VA, December 2006.

N.N. Bowie, Jr. and M. Waltz, "Data Analysis of the Speed-Related Crash Issue," *Auto and Traffic Safety*, Vol. 2, Winter 1994.

Jack Stuster, Zail Coffman, and Davey Warren. *Synthesis of Safety Research Related to Speed and Speed Management*. Publication No. FHWA-RD-98-154. Federal Highway Administration McLean, VA, July 1998. Retrieved from <http://www.fhwa.dot.gov/publications/research/safety/98154/speed.cfm#ssrel>

D. Solomon. *Accidents on Main Rural Highways Related to Speed, Driver, and Vehicle*. Federal Highway Administration, Washington, DC, July 1964 (Reprinted 1974).

Valerie J. Easton and John H. McColl (September, 1997). *Statistics Glossary*. Retrieved from <http://www.stats.gla.ac.uk/steps/glossary/index.html>

Simon P. Washington, Matthew G. Karlaftis, and Fred L. Mannering (2011). *Statistical and econometric methods for transportation data analysis – 2<sup>nd</sup> ed.* Boca Raton, FL: CRC Press.

**APPENDIX A STUDY INFORMATION**



Figure A. 1 Study location GIS map



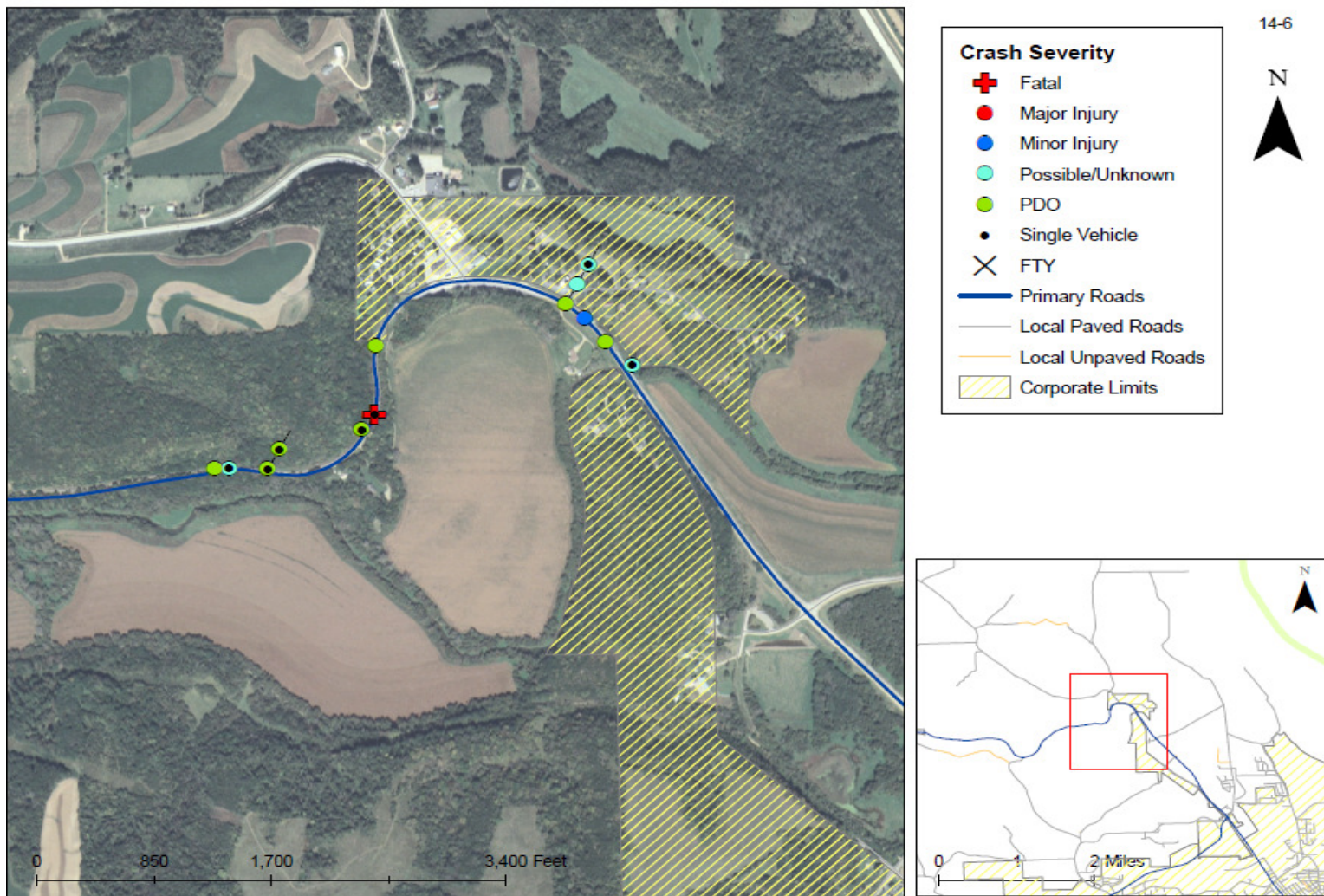

Figure A. 2 Study location GIS crash map



Figure A. 3 Traffic counter (Source: SunWize Technologies, Inc.)



Figure A. 4 Pneumatic road tube (Source: The Traffic Group, Inc. Service)



Figure A. 5 Driving along US 52 during the day without treatment



Figure A. 6 Chevron signs without treatment at night (from TTI)



Figure A. 7 Chevron signs with reflectorized post at night (from TTI)

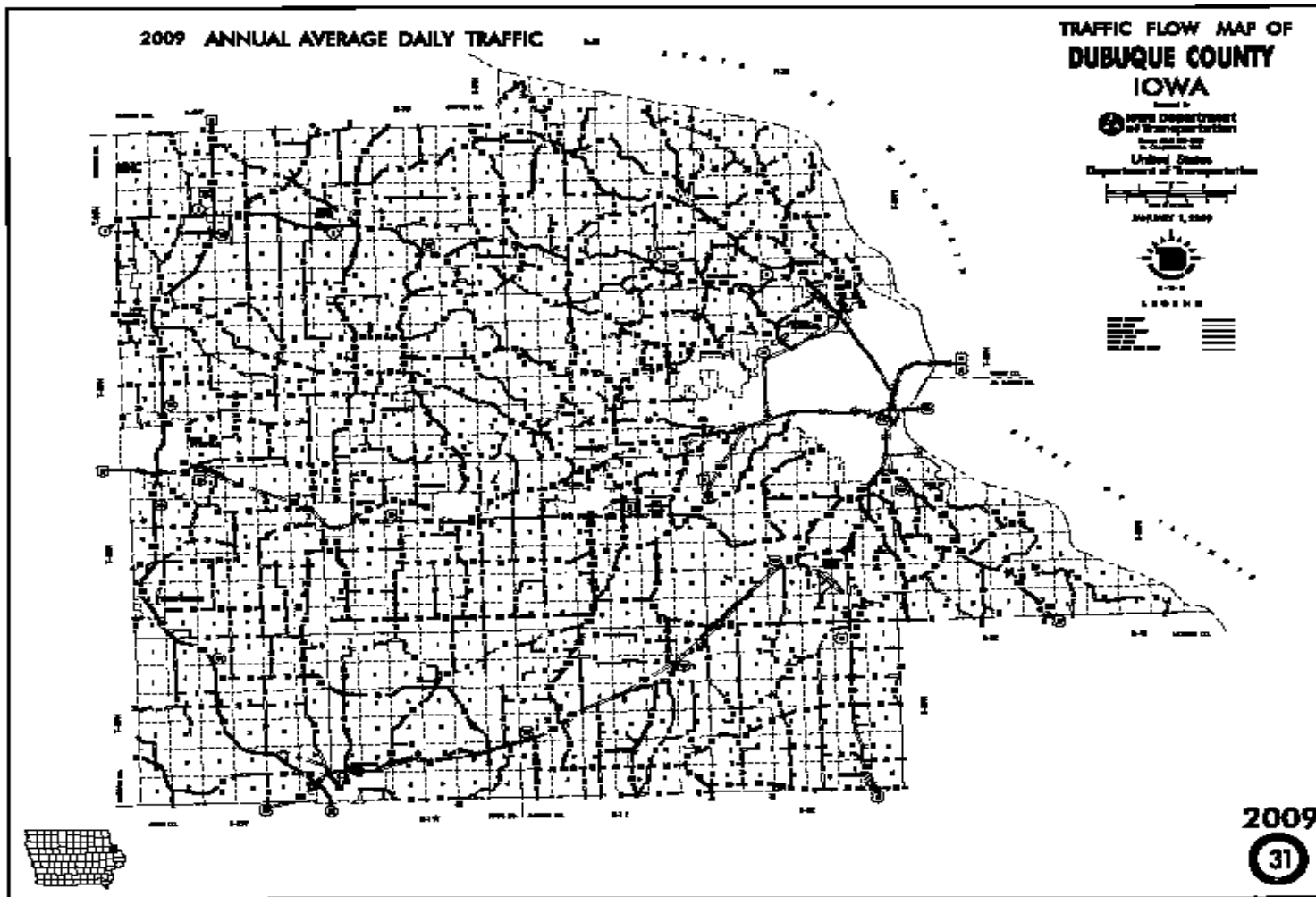

Figure A. 8 Dubuque county AADT in 2009

Table A. 1 Rise and Set for the Sun in May 2010 in Sageville, Iowa

Sageville, Iowa																								
Rise and Set for the Sun for May 2010 (Central Standard Time)																								
	Jan		Feb		May		Apr		May		June		July		Aug		Sep		Oct		Nov		Dec	
Day	Ri se	Set	Ri se	Set	Ri se	Set	Ri se	Set	Ri se	Set	Ri se	Set	Ri se	Set	Ri se	Set	Ri se	Set	Ri se	Set	Ri se	Set	Ri se	Set
	h m	h m	h m	h m	h m	h m	h m	h m	h m	h m	h m	h m	h m	h m	h m	h m	h m	h m	h m	h m	h m	h m	h m	h m
16	72 9	16 56	65 8	17 36	61 3	18 10	52 0	18 46	44 0	19 19	42 5	19 42	44 0	19 38	51 1	19 03	54 4	18 11	61 7	17 19	65 5	16 39	72 6	16 31
17	72 9	16 57	65 7	17 37	61 1	18 12	51 8	18 47	43 9	19 20	42 5	19 43	44 1	19 37	51 2	19 01	54 5	18 09	61 8	17 17	65 7	16 39	72 7	16 31
18	72 8	16 59	65 5	17 39	61 0	18 13	51 7	18 48	43 8	19 21	42 5	19 43	44 1	19 36	51 3	19 00	54 6	18 07	61 9	17 16	65 8	16 38	72 8	16 31
19	72 8	17 00	65 4	17 40	60 8	18 14	51 5	18 49	43 7	19 22	42 5	19 43	44 2	19 36	51 4	18 58	54 7	18 05	62 1	17 14	65 9	16 37	72 8	16 32
20	72 7	17 01	65 2	17 41	60 6	18 15	51 4	18 50	43 6	19 23	42 5	19 44	44 3	19 35	51 5	18 57	54 8	18 04	62 2	17 13	70 0	16 36	72 9	16 32
21	72 6	17 02	65 1	17 43	60 4	18 16	51 2	18 52	43 5	19 24	42 5	19 44	44 4	19 34	51 6	18 55	54 9	18 02	62 3	17 11	70 1	16 36	72 9	16 33
22	72 6	17 04	64 9	17 44	60 3	18 17	51 1	18 53	43 4	19 25	42 6	19 44	44 5	19 33	51 7	18 53	55 0	18 00	62 4	17 10	70 3	16 35	73 0	16 33
23	72 5	17 05	64 8	17 45	60 1	18 19	50 9	18 54	43 4	19 26	42 6	19 44	44 6	19 32	51 8	18 52	55 1	17 58	62 5	17 08	70 4	16 34	73 0	16 34

Table A. 2 Rise and Set for the Sun in May 2010 in Sageville, Iowa (continued)

Sageville, Iowa																								
Rise and Set for the Sun for 2010 (Central Standard Time)																								
	Jan		Feb		Ma		Apr		May		June		July		Aug		Sep		Oct		Nov		Dec	
Day	Ri se	Set	Ri se	Set	Ri se	Set	Ri se	Set	Ri se	Set	Ri se	Set	Ri se	Set	Ri se	Set	Ri se	Set	Ri se	Set	Ri se	Set	Ri se	Set
	h m	h m	h m	h m	h m	h m	h m	h m	h m	h m	h m	h m	h m	h m	h m	h m	h m	h m	h m	h m	h m	h m	h m	h m
24	72 4	17 06	64 6	17 46	55 9	18 20	50 8	18 55	43 3	19 27	42 6	19 44	44 7	19 31	51 9	18 50	55 2	17 57	62 7	17 07	70 5	16 34	73 1	16 34
25	72 3	17 07	64 5	17 48	55 7	18 21	50 6	18 56	43 2	19 28	42 7	19 44	44 8	19 30	52 0	18 49	55 3	17 55	62 8	17 05	70 6	16 33	73 1	16 35
26	72 3	17 09	64 3	17 49	55 6	18 22	50 5	18 57	43 1	19 29	42 7	19 44	44 9	19 29	52 1	18 47	55 4	17 53	62 9	17 04	70 7	16 33	73 1	16 36
27	72 2	17 10	64 2	17 50	55 4	18 23	50 3	18 58	43 1	19 30	42 7	19 44	45 0	19 28	52 2	18 45	55 6	17 51	63 0	17 02	70 8	16 32	73 2	16 36
28	72 1	17 11	64 0	17 51	55 2	18 24	50 2	18 59	43 0	19 30	42 8	19 44	45 1	19 27	52 3	18 44	55 7	17 49	63 2	17 01	71 0	16 32	73 2	16 37
29	72 0	17 13			55 0	18 25	50 0	19 01	43 0	19 31	42 8	19 44	45 2	19 26	52 5	18 42	55 8	17 48	63 3	17 00	71 1	16 31	73 2	16 38
30	71 9	17 14			54 9	18 27	45 9	19 02	42 9	19 32	42 9	19 44	45 3	19 25	52 6	18 40	55 9	17 46	63 4	16 58	71 2	16 31	73 2	16 39
31	71 8	17 15			54 7	18 28			42 8	19 33			45 4	19 24	52 7	18 39			63 5	16 57			73 3	16 39

Table A. 3 Rise and Set for the Sun in September 2010 in Sageville, Iowa

Sageville, Iowa																								
Rise and Set for the Sun for September 2010 (Central Standard Time)																								
	Jan		Feb		Ma		Apr		May		June		July		Aug		Sep		Oct		Nov		Dec	
Day	Ri se	Set	Ri se	Set	Ri se	Set	Ri se	Set	Ri se	Set	Ri se	Set	Ri se	Set	Ri se	Set	Ri se	Set	Ri se	Set	Ri se	Set	Ri se	Set
	h m	h m	h m	h m	h m	h m	h m	h m	h m	h m	h m	h m	h m	h m	h m	h m	h m	h m	h m	h m	h m	h m	h m	h m
1	73 3	16 40	71 7	17 16	63 8	17 53	54 5	18 29	18 8	45 03	19 8	19 34	42 9	19 44	45 5	19 23	52 8	18 37	60 0	17 44	63 7	16 56	71 3	16 31
2	73 3	16 41	71 6	17 18	63 7	17 54	54 3	18 30	18 6	45 04	19 7	19 35	43 0	19 44	45 6	19 22	52 9	18 35	60 1	17 42	63 8	16 54	71 4	16 30
3	73 3	16 42	71 5	17 19	63 5	17 55	54 2	18 31	18 5	45 05	19 7	19 35	43 0	19 44	45 7	19 20	53 0	18 34	60 2	17 41	63 9	16 53	71 5	16 30
4	73 3	16 43	71 3	17 20	63 3	17 56	54 0	18 32	18 4	45 06	19 7	19 36	43 1	19 43	45 8	19 19	53 1	18 32	60 3	17 39	64 0	16 52	71 6	16 30
5	73 3	16 44	71 2	17 22	63 2	17 57	53 8	18 33	18 2	45 07	19 6	19 37	43 1	19 43	45 9	19 18	53 2	18 30	60 4	17 37	64 2	16 51	71 7	16 30
6	73 3	16 45	71 1	17 23	63 0	17 59	53 7	18 34	18 1	45 08	19 6	19 37	43 2	19 43	50 0	19 17	53 3	18 28	60 6	17 36	64 3	16 50	71 8	16 30
7	73 2	16 46	71 0	17 24	62 8	18 00	53 5	18 36	18 0	45 09	19 6	19 38	43 3	19 42	50 1	19 15	53 4	18 27	60 7	17 34	64 4	16 48	71 9	16 30
8	73 2	16 47	70 9	17 26	62 7	18 01	53 3	18 37	18 9	44 11	19 5	19 39	43 3	19 42	50 2	19 14	53 5	18 25	60 8	17 32	64 5	16 47	72 0	16 29
9	73 2	16 48	70 8	17 27	62 5	18 02	53 2	18 38	18 7	44 12	19 5	19 39	43 4	19 42	50 3	19 13	53 6	18 23	60 9	17 30	64 7	16 46	72 1	16 29



Table A. 4 Rise and Set for the Sun in September 2010 in Sageville, Iowa (continued)

Sageville, Iowa																								
Rise and Set for the Sun for September 2010 (Central Standard Time)																								
	Jan		Feb		Ma		Apr		May		June		July		Aug		Sep		Oct		Nov		Dec	
D ay	Ri se	Set	Ri se	Set	Ri se	Set	Ri se	Set	Ri se	Set	Ri se	Set	Ri se	Set	Ri se	Set	Ri se	Set	Ri se	Set	Ri se	Set	Ri se	Set
	h m	h m	h m	h m	h m	h m	h m	h m	h m	h m	h m	h m	h m	h m	h m	h m	h m	h m	h m	h m	h m	h m	h m	h m
10	73 2	16 49	70 6	17 28	62 3	18 03	53 0	18 39	44 6	19 13	42 5	19 40	43 5	19 41	50 4	19 11	53 7	18 21	61 0	17 29	64 8	16 45	72 2	16 30
11	73 2	16 50	70 5	17 30	62 2	18 05	52 8	18 40	44 5	19 14	42 5	19 40	43 6	19 41	50 5	19 10	53 8	18 20	61 1	17 27	64 9	16 44	72 3	16 30
12	73 1	16 52	70 4	17 31	62 0	18 06	52 7	18 41	44 4	19 15	42 5	19 41	43 6	19 40	50 6	19 08	53 9	18 18	61 2	17 25	65 0	16 43	72 3	16 30
13	73 1	16 53	70 2	17 32	61 8	18 07	52 5	18 42	44 3	19 16	42 5	19 41	43 7	19 40	50 7	19 07	54 1	18 16	61 4	17 24	65 2	16 42	72 4	16 30
14	73 0	16 54	70 1	17 34	61 7	18 08	52 3	18 44	44 2	19 17	42 5	19 42	43 8	19 39	50 9	19 06	54 2	18 14	61 5	17 22	65 3	16 41	72 5	16 30
15	73 0	16 55	70 0	17 35	61 5	18 09	52 2	18 45	44 1	19 18	42 5	19 42	43 9	19 38	51 0	19 04	54 3	18 13	61 6	17 21	65 4	16 40	72 6	16 30

## APPENDIX B STATISTICAL RESULTS FOR VEHICLE SPEEDS

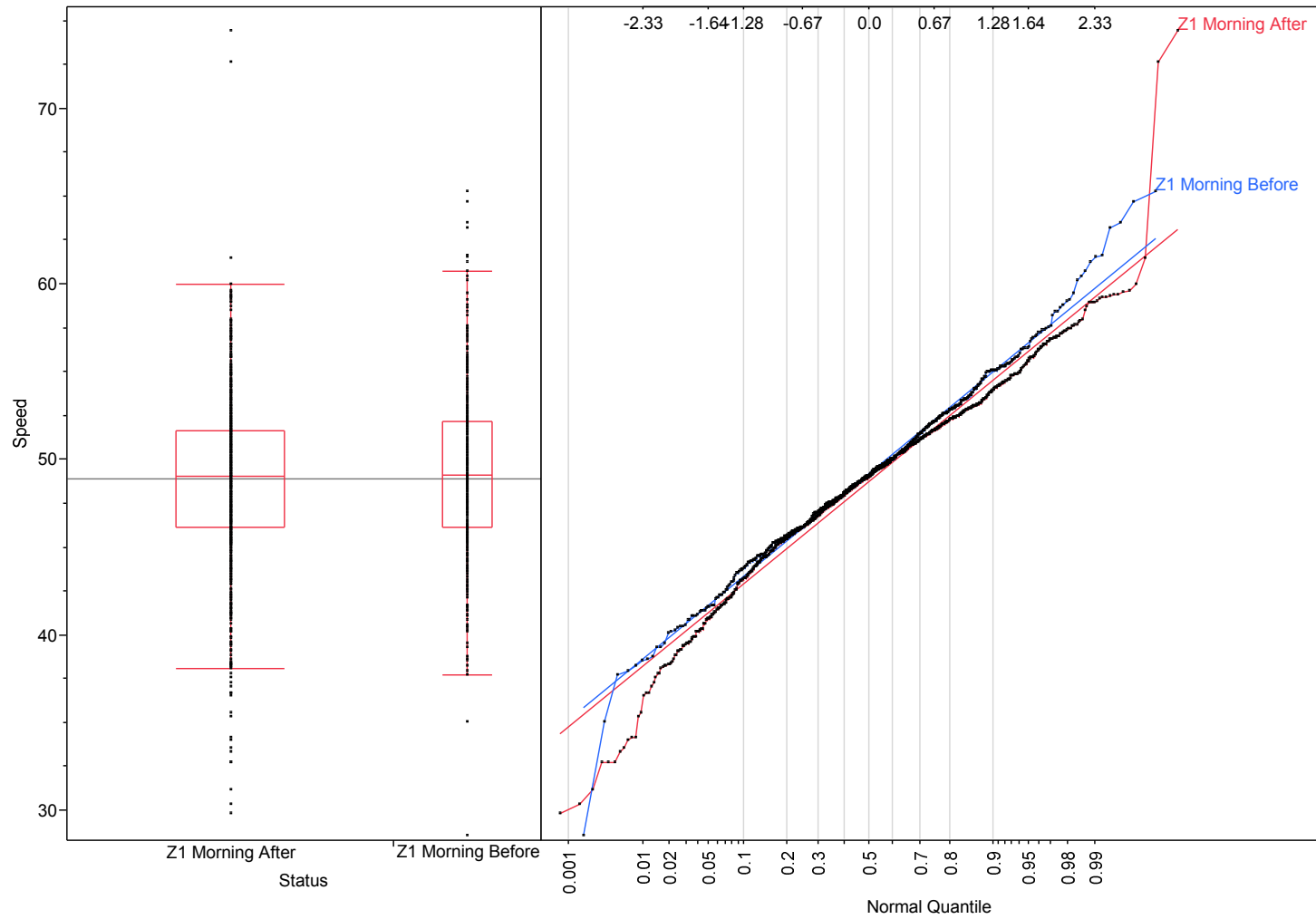

Figure B. 1 Speed Box Plot and Normal Quantile Plot for Daytime at Z1

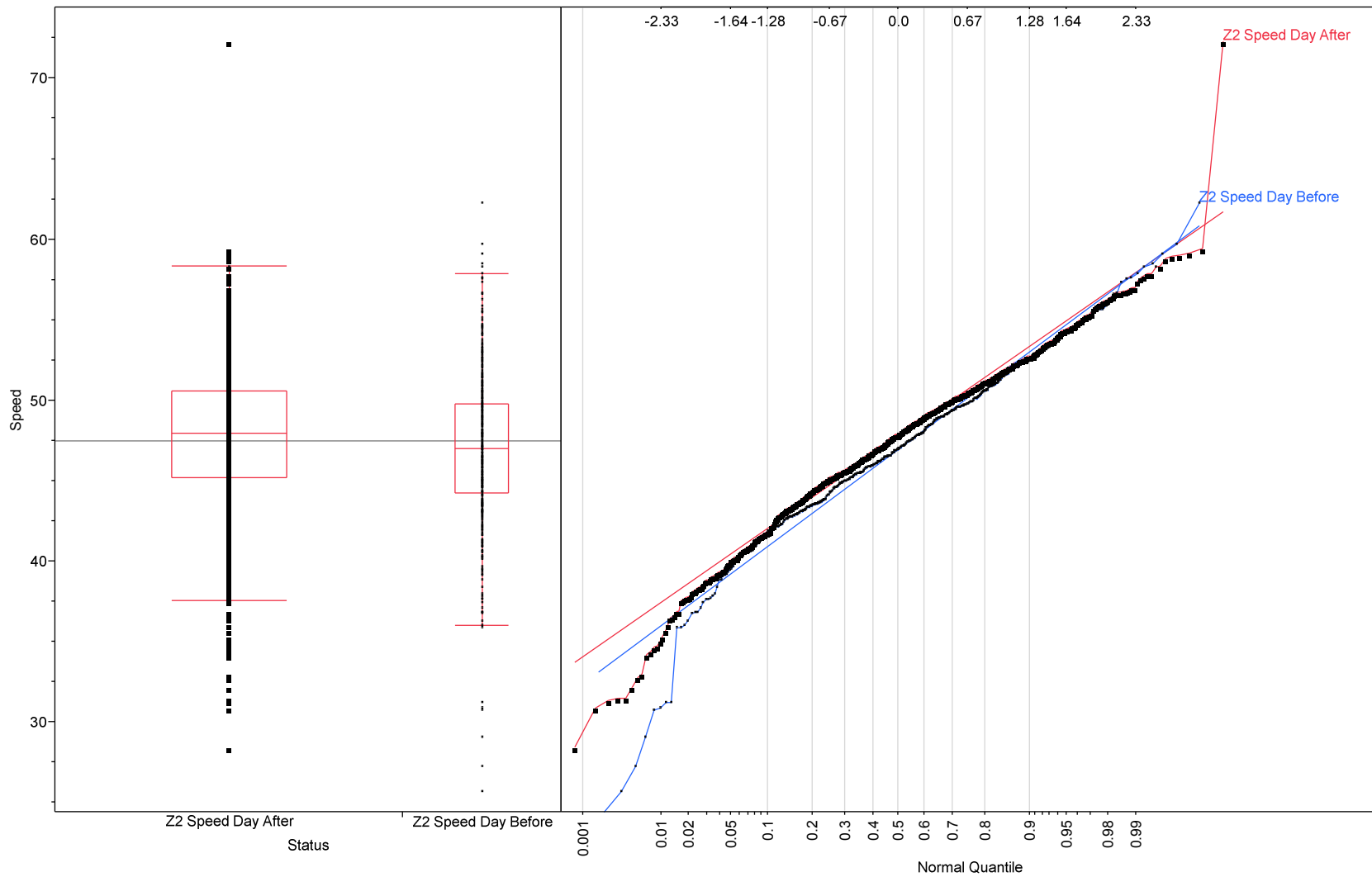

Figure B. 2 Speed Box Plot and Normal Quantile Plot for Daytime at Z2

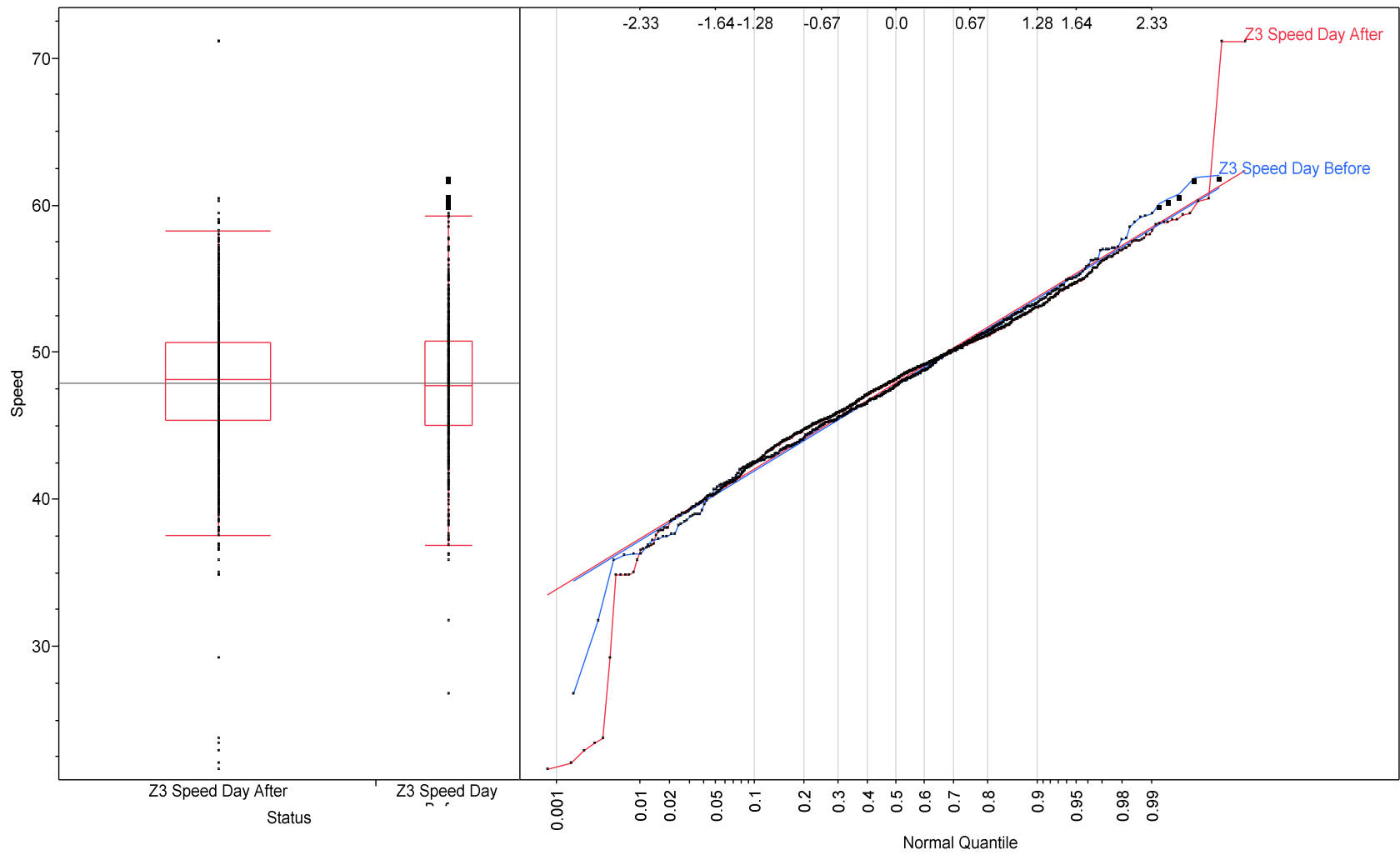

Figure B. 3 Speed Box Plot and Normal Quantile Plot for Daytime at Z3

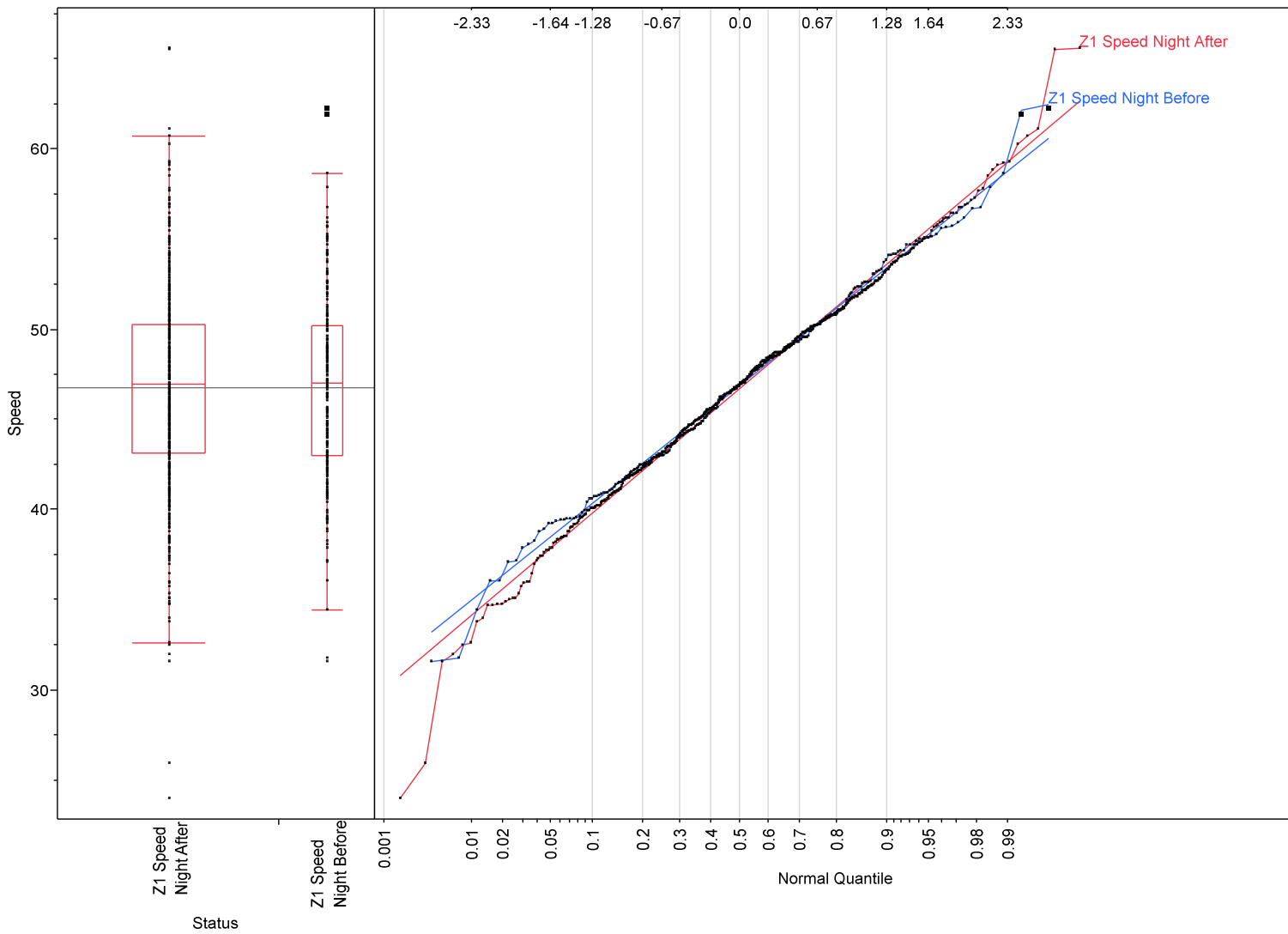

Figure B. 4 Speed Box Plot and Normal Quantile Plot for Nighttime at Z1

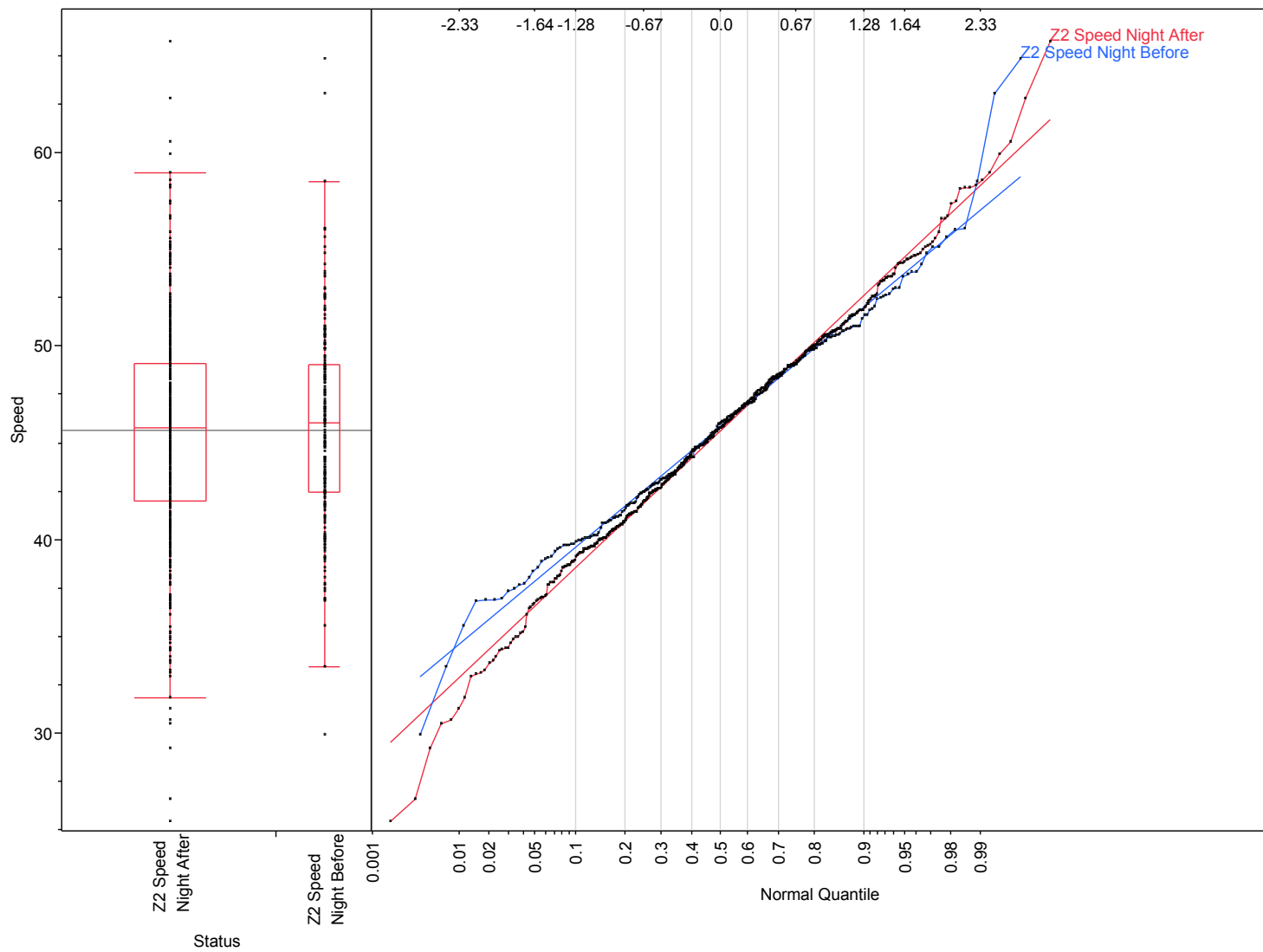

Figure B. 5 Speed Box Plot and Normal Quantile Plot for Nighttime at Z2

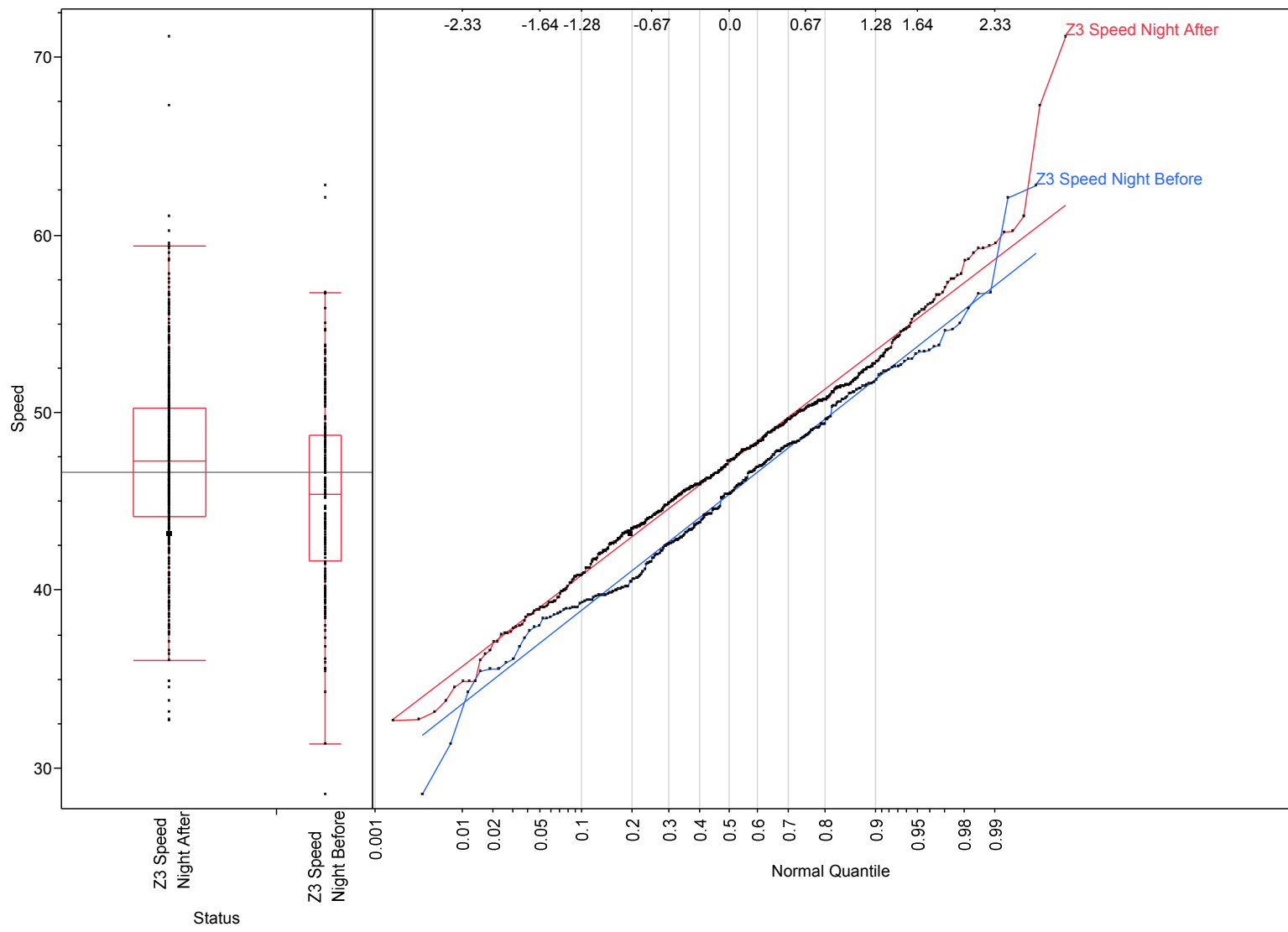

Figure B. 6 Speed Box Plot and Normal Quantile Plot for Nighttime at Z3

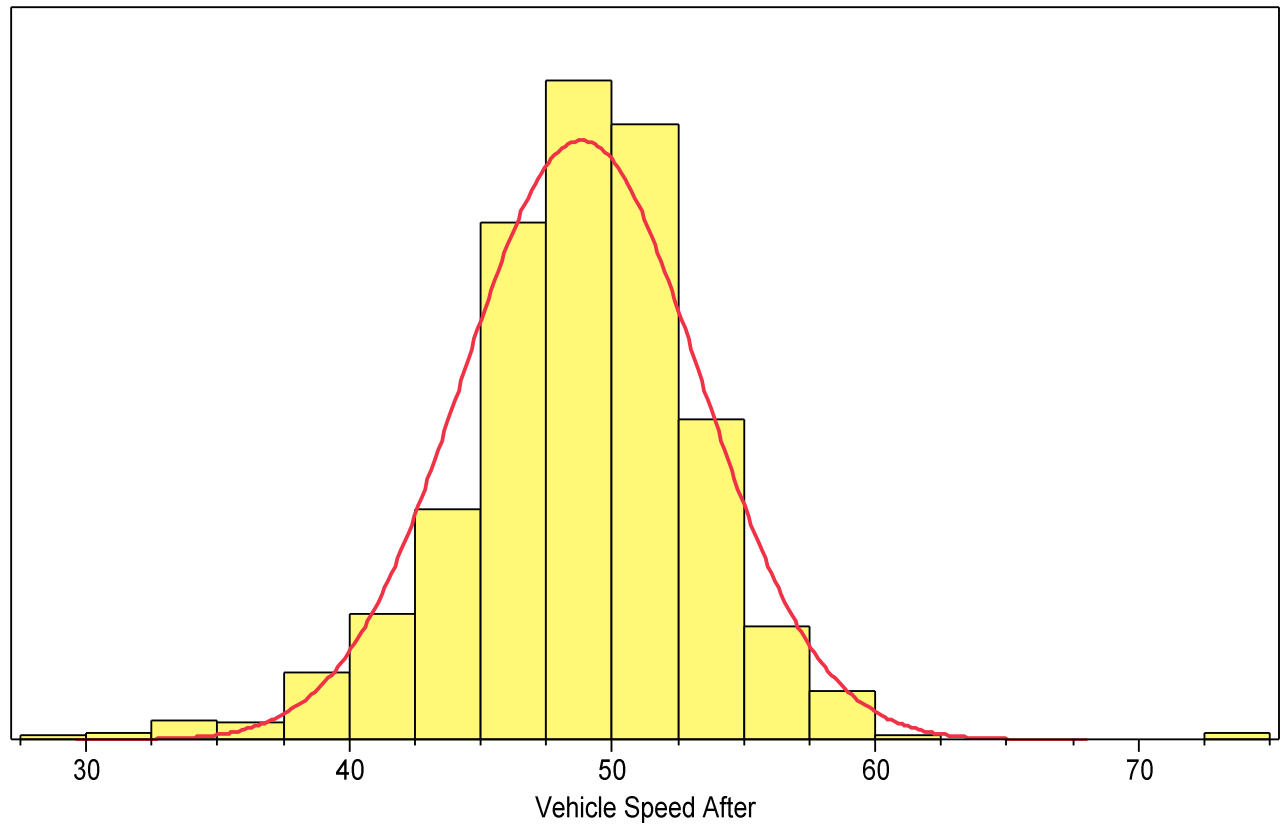
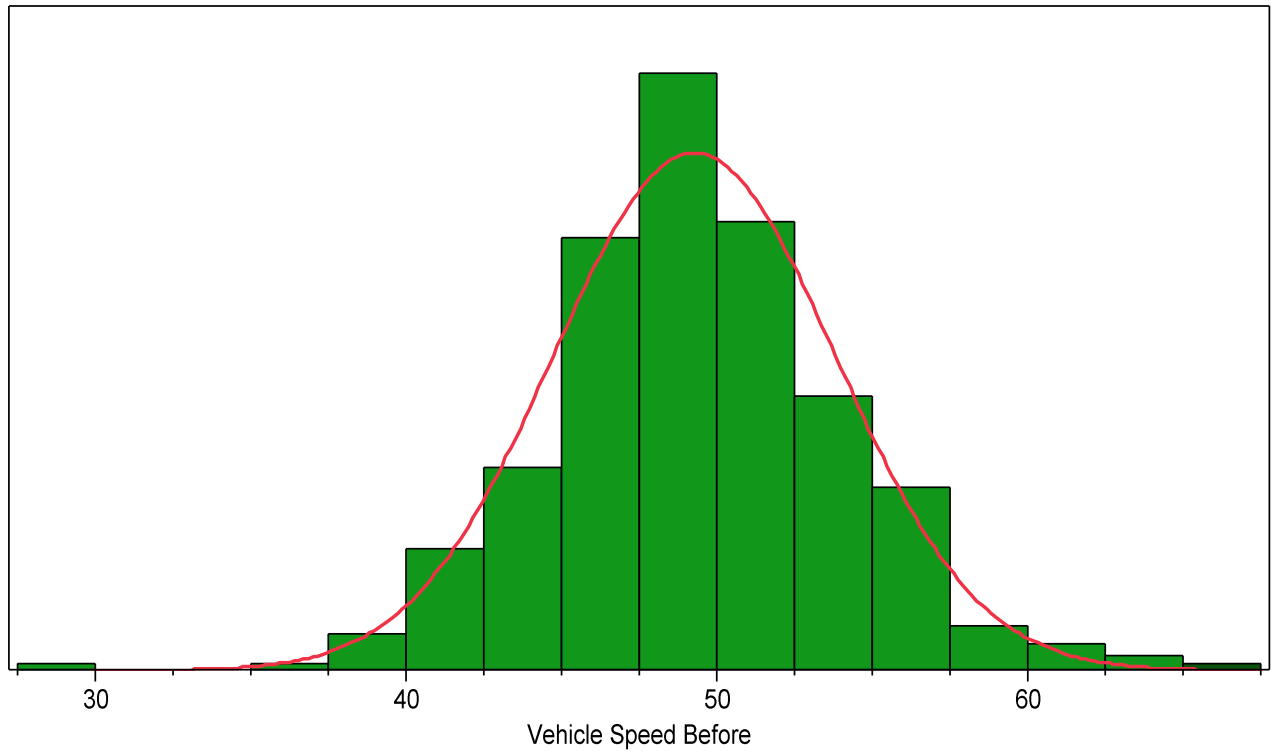

Figure B. 7 Histogram of vehicle before and after speed in daytime at Z1



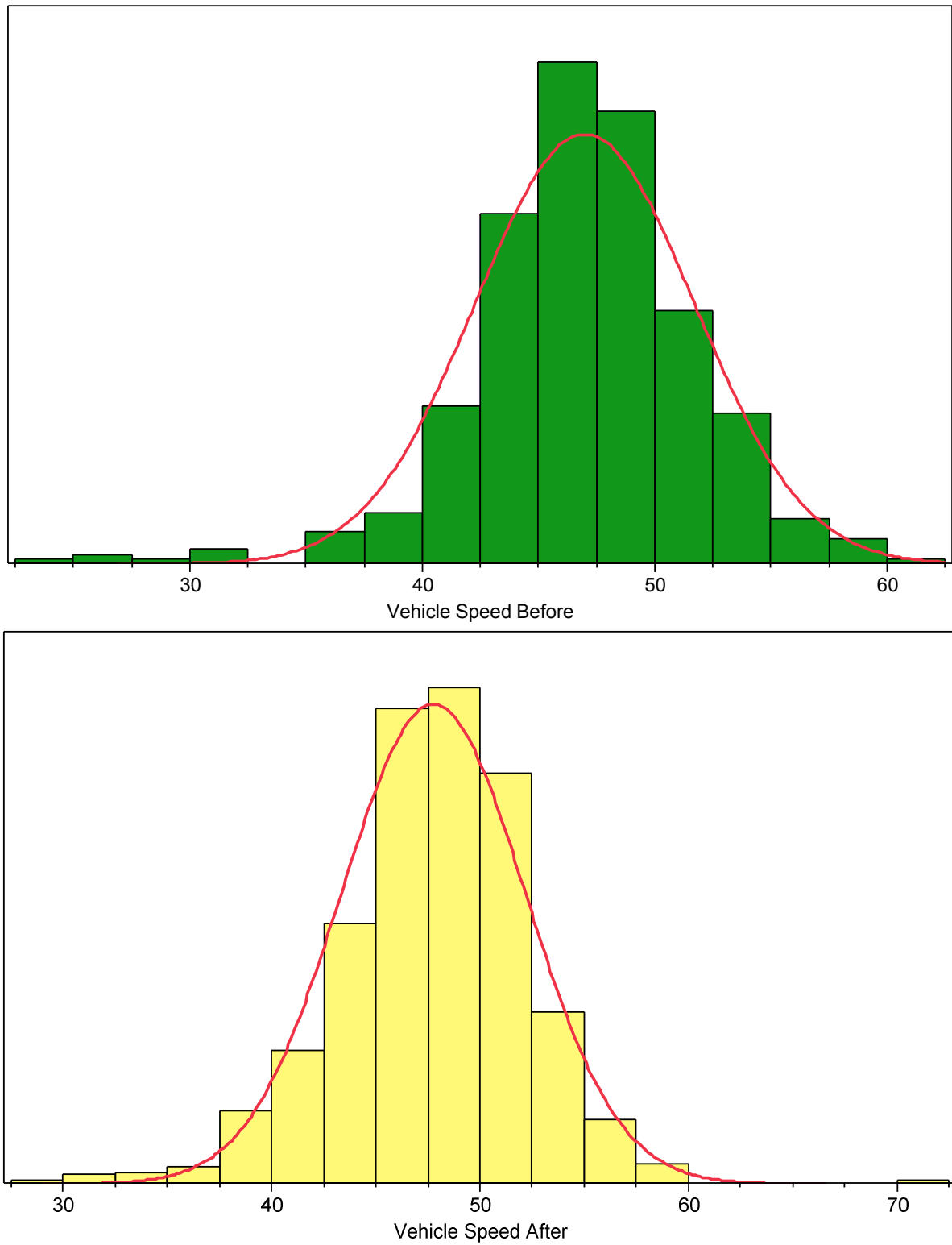

Figure B. 8 Histogram of vehicle before and after speed in daytime at Z2

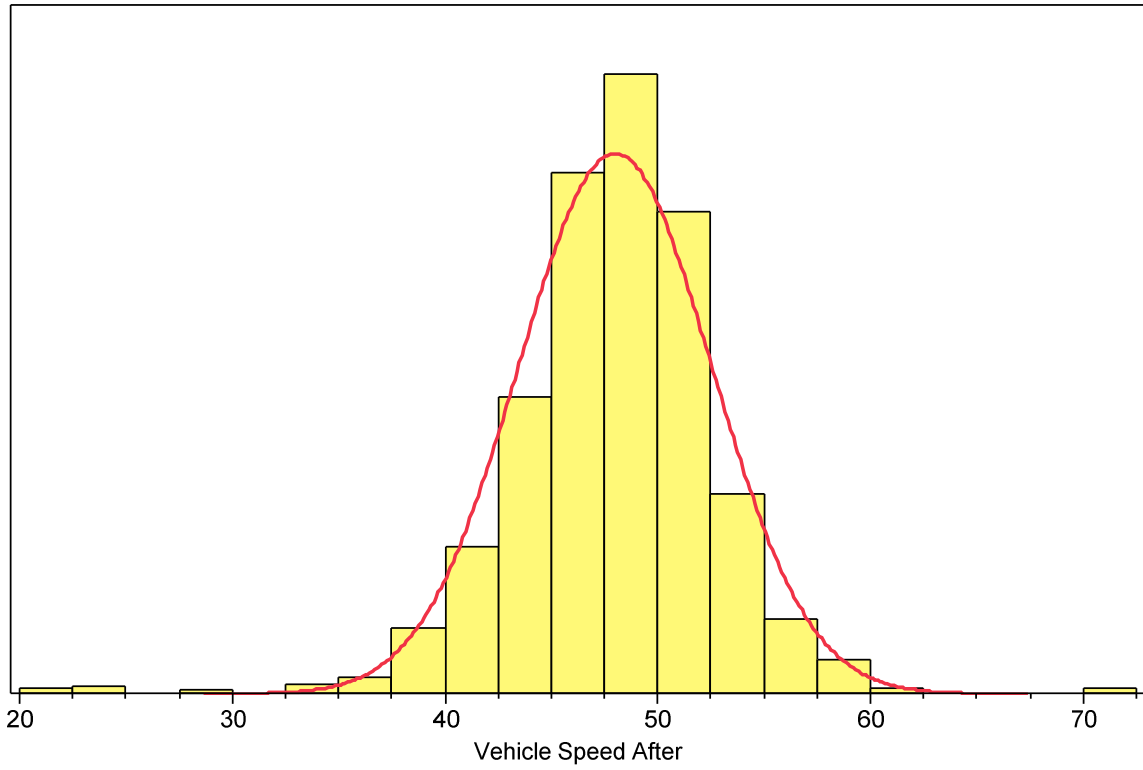
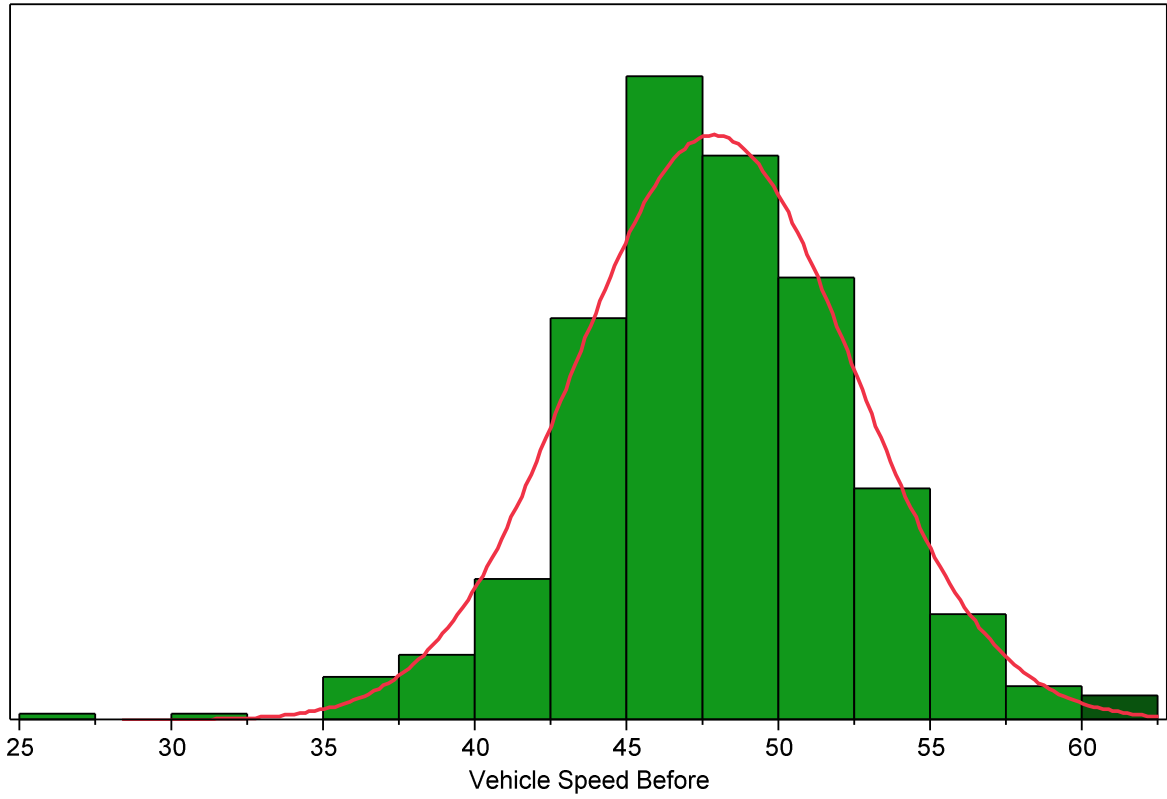

Figure B. 9 Histogram of vehicle before and after speed in daytime at Z3

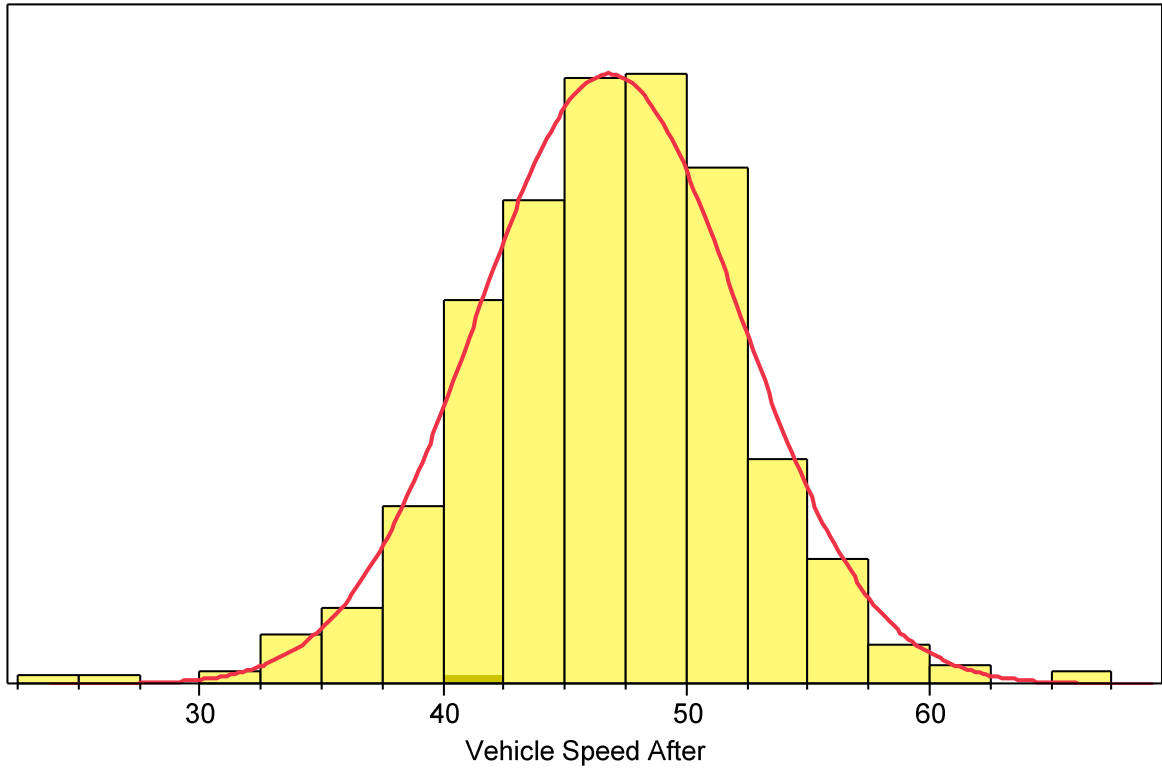
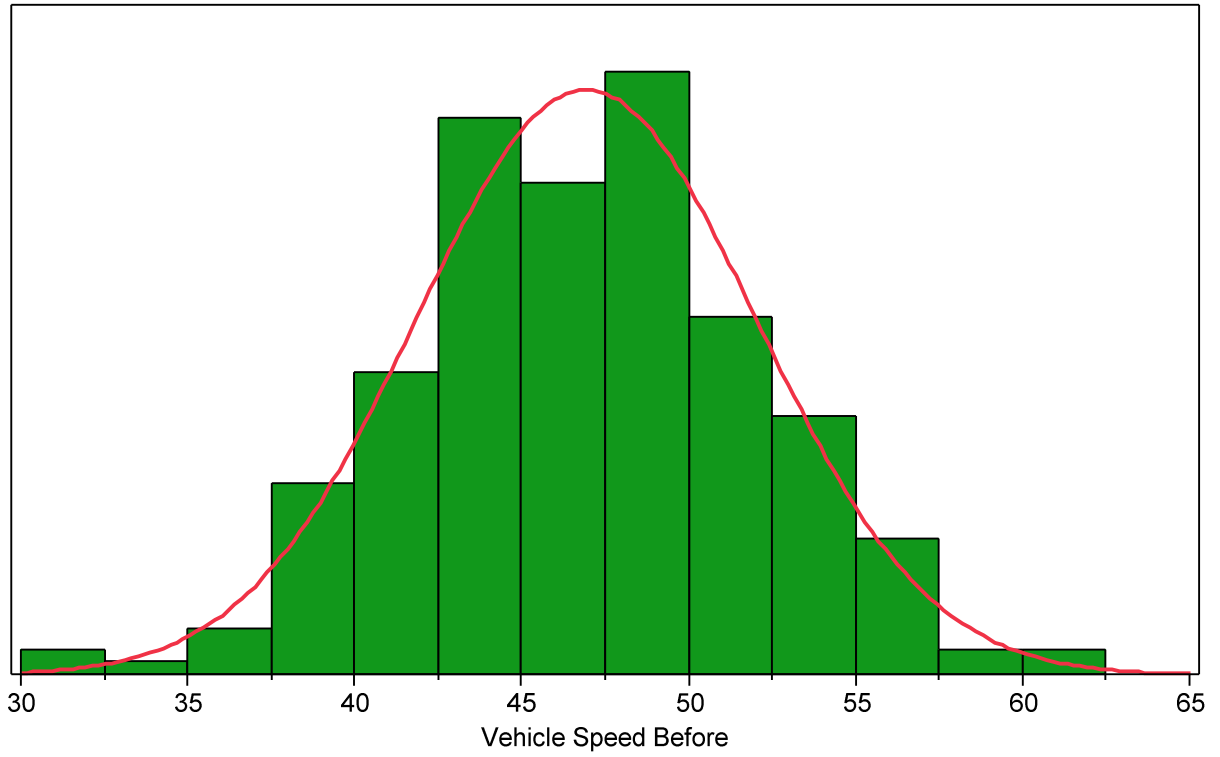

Figure B. 10 Histogram of vehicle before and after speed in nighttime at Z1

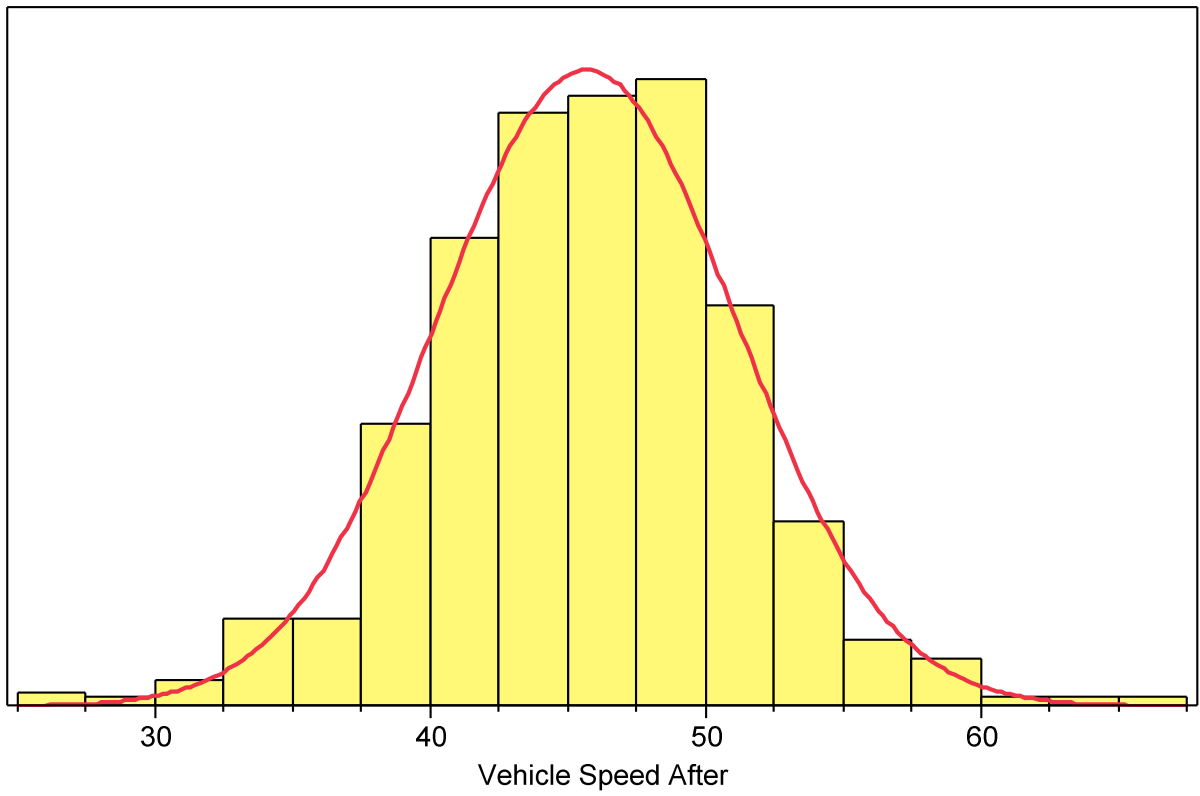
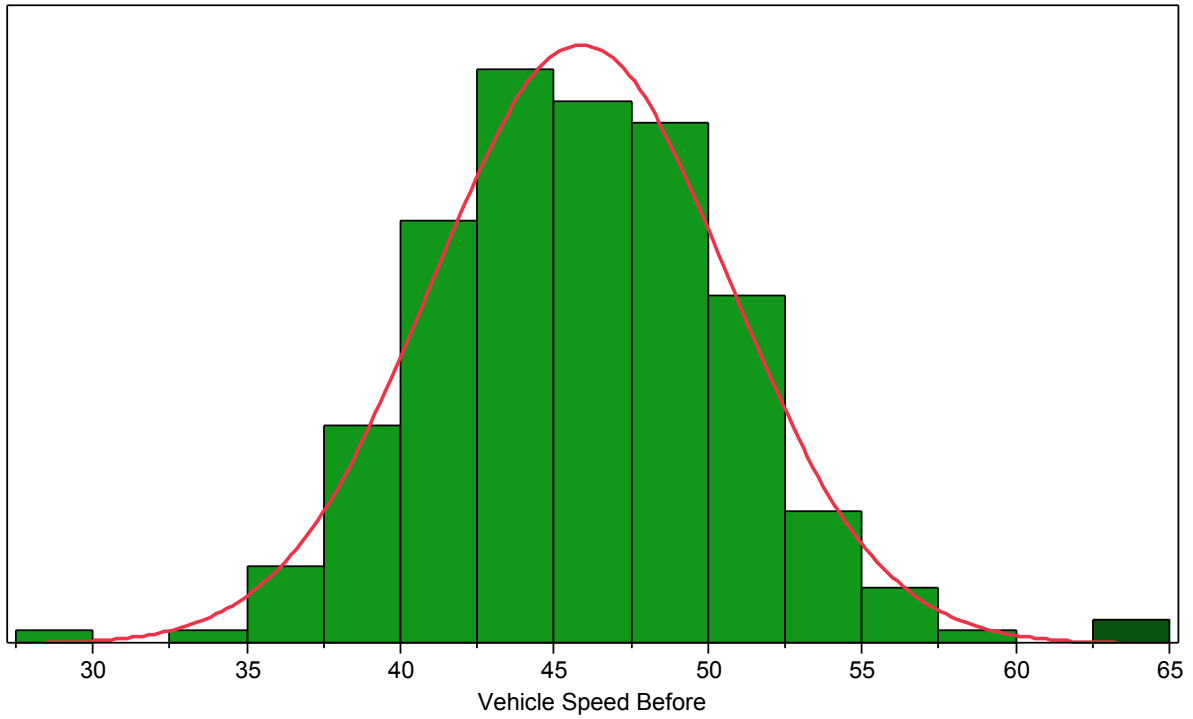

Figure B. 11 Histogram of vehicle before and after speed in nighttime at Z2

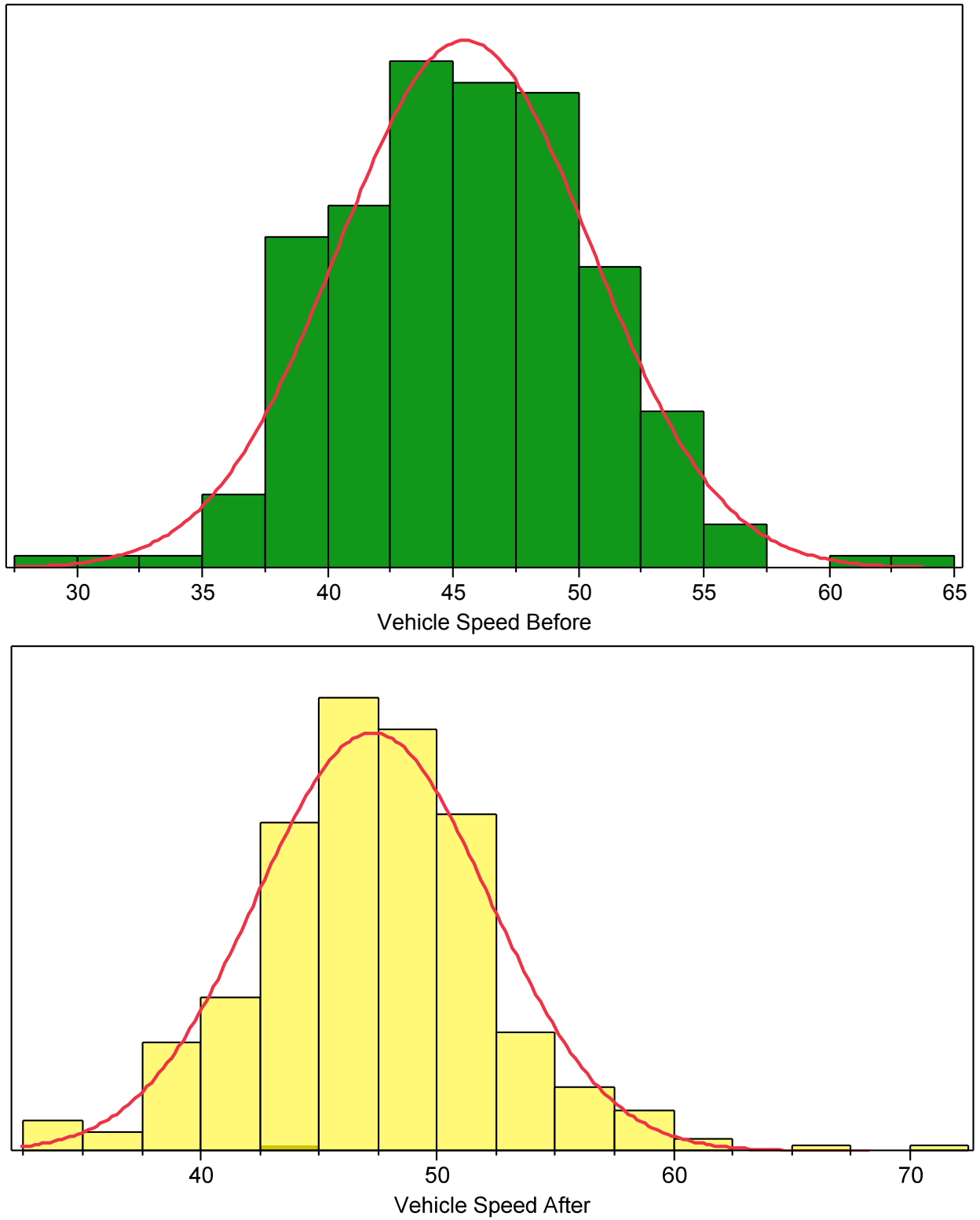

Figure B. 12 Histogram of vehicle before and after speed in nighttime at Z3

### APPENDIX C STATISTICAL RESULTS FOR VEHICLE LATERAL PLACEMENT

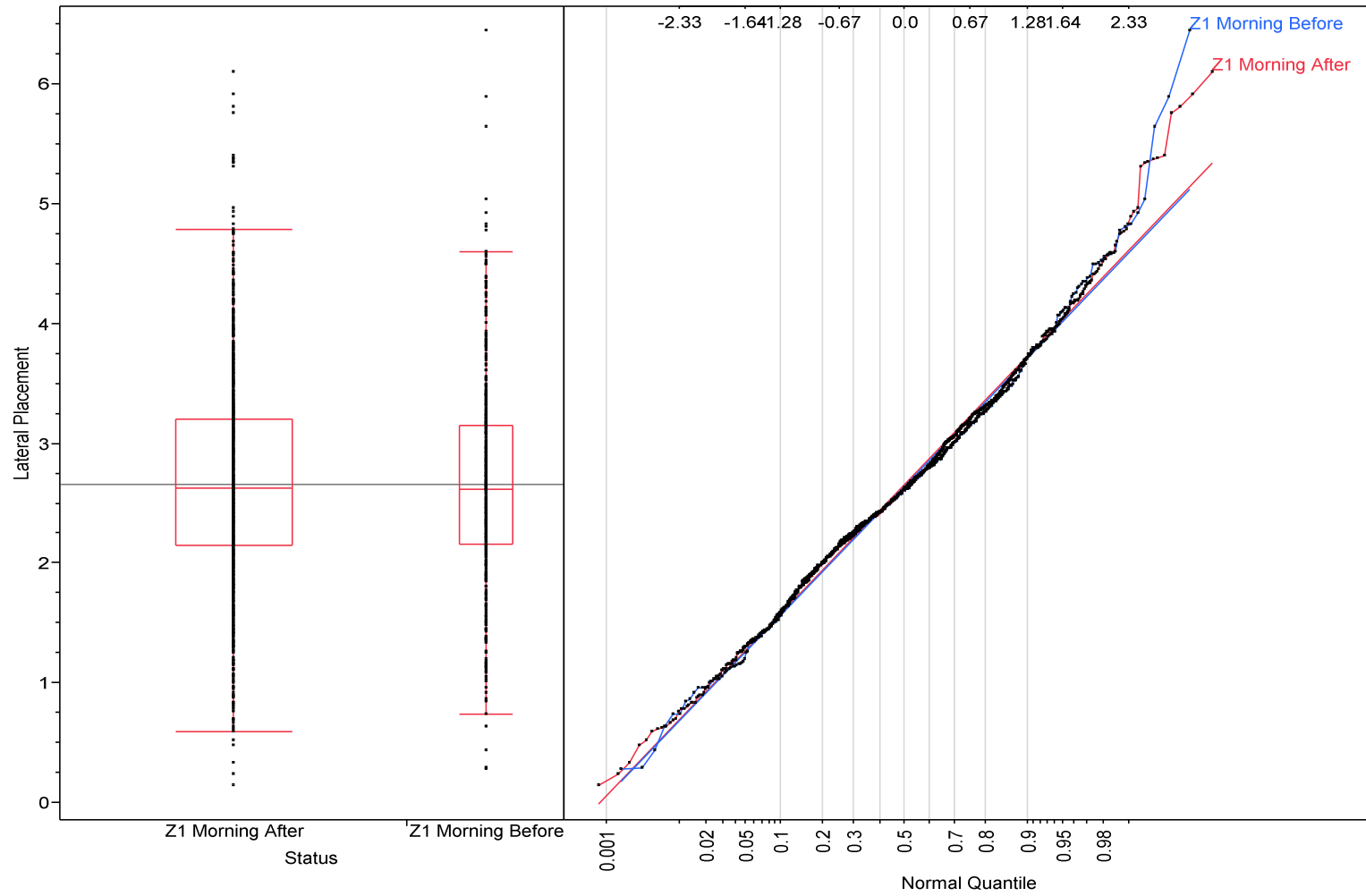

Figure C. 1 Lateral placement box plot and normal quantile plot for daytime at Z1

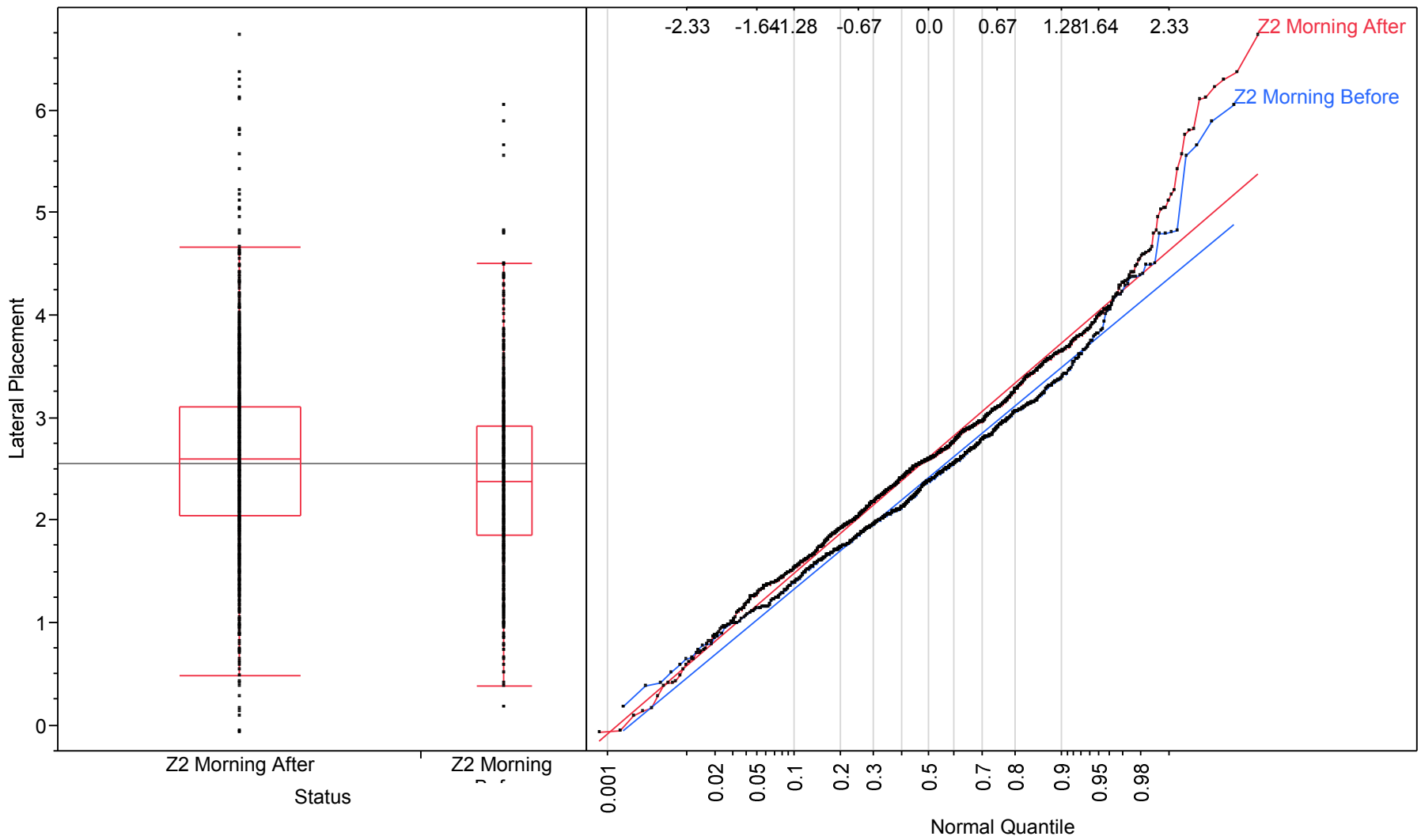

Figure C. 2 Lateral placement box plot and normal quantile plot for daytime at Z2

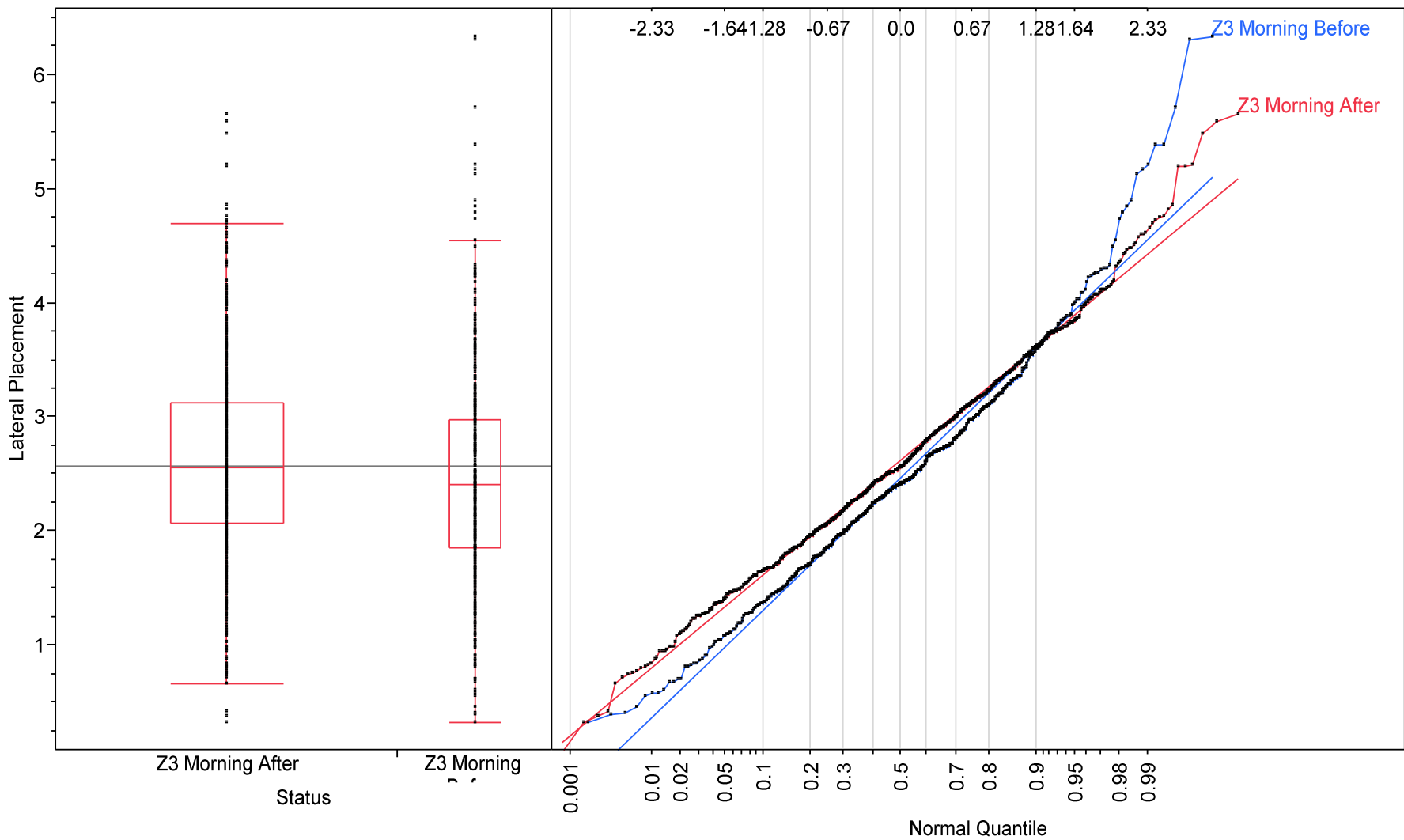

Figure C. 3 Lateral placement box plot and normal quantile plot for daytime at Z3



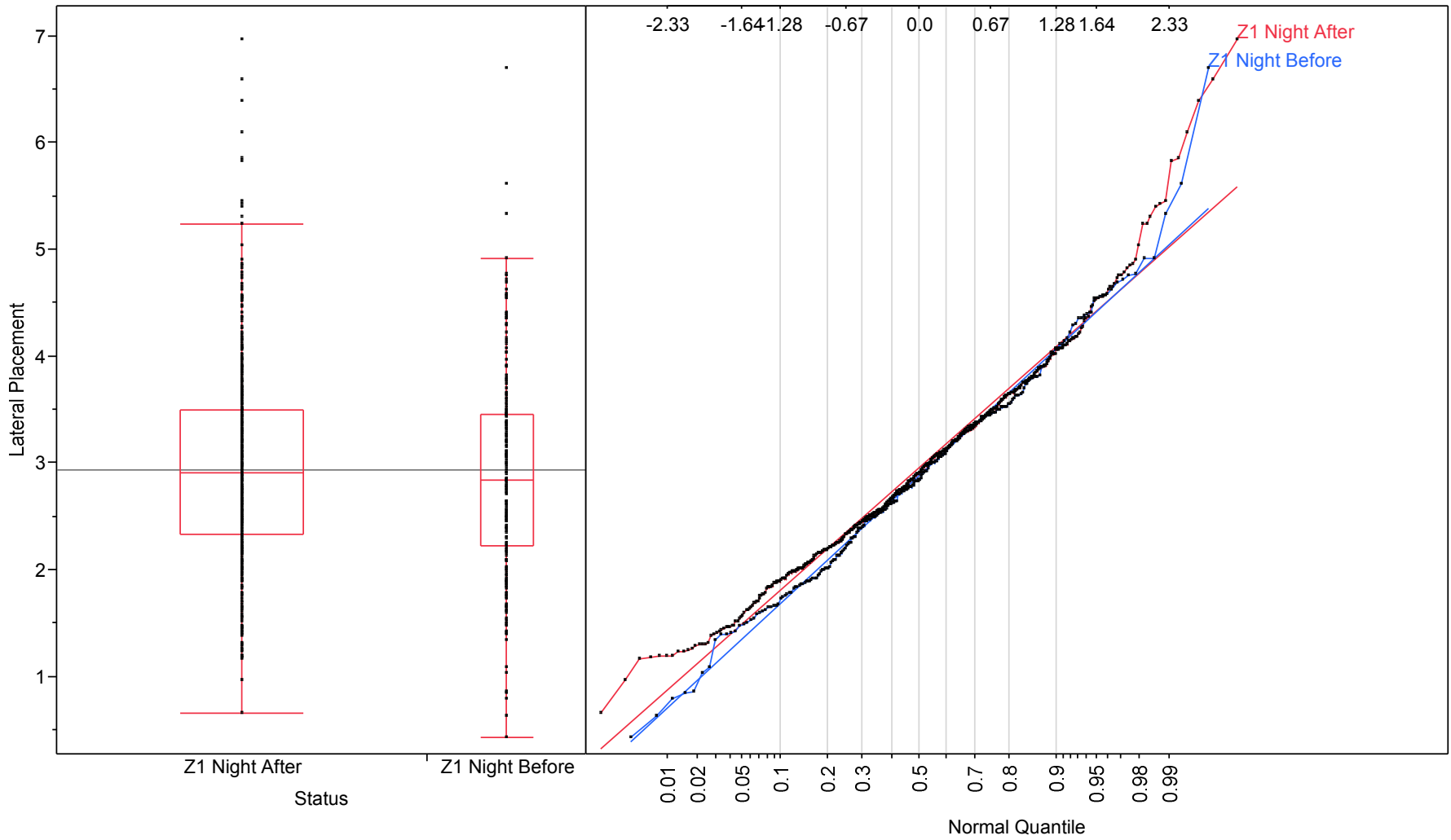

Figure C. 4 Lateral placement box plot and normal quantile plot for nighttime at Z1

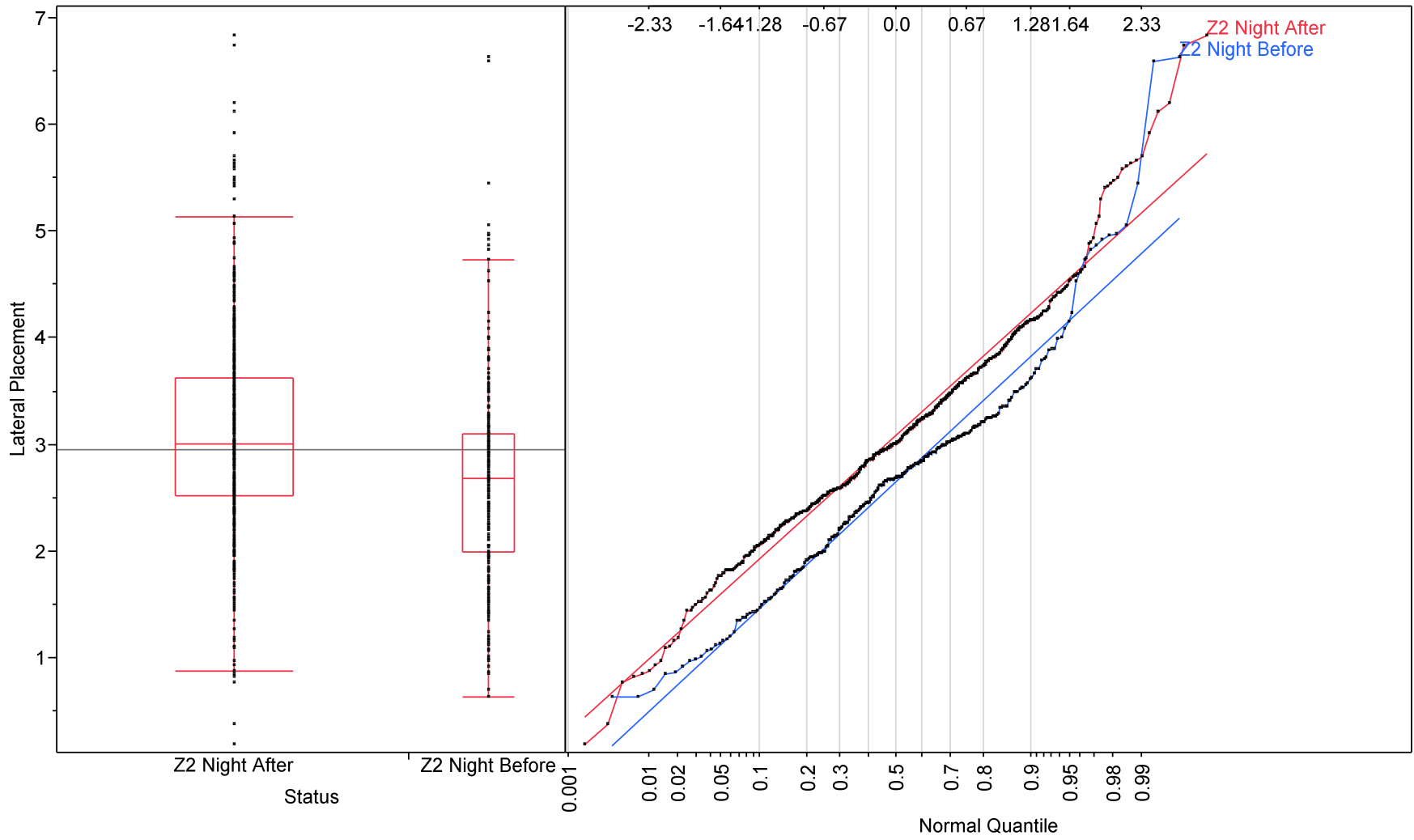

Figure C. 5 Lateral placement box plot and normal quantile plot for nighttime at Z2

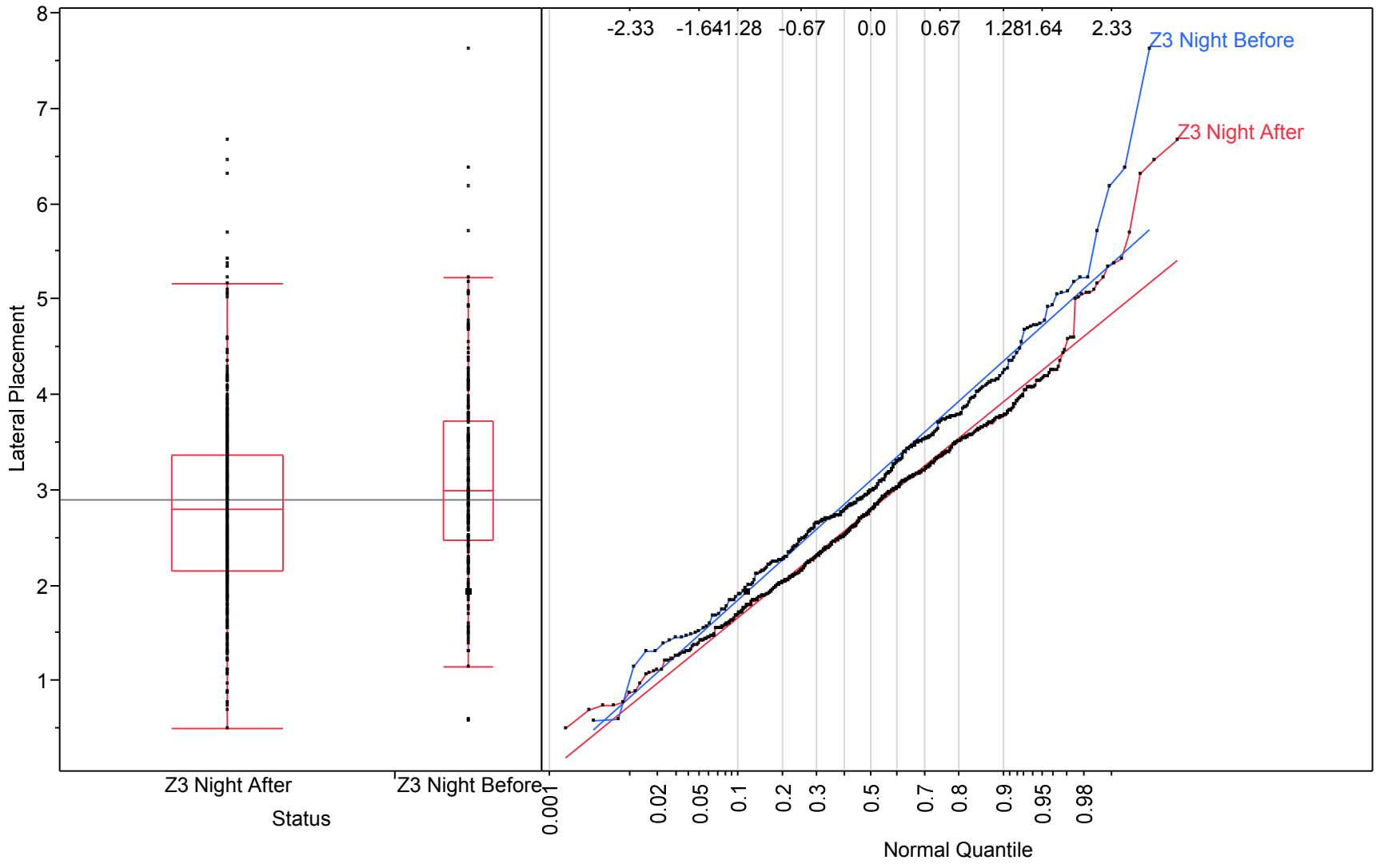

Figure C. 6 Lateral placement box plot and normal quantile plot for nighttime at Z3

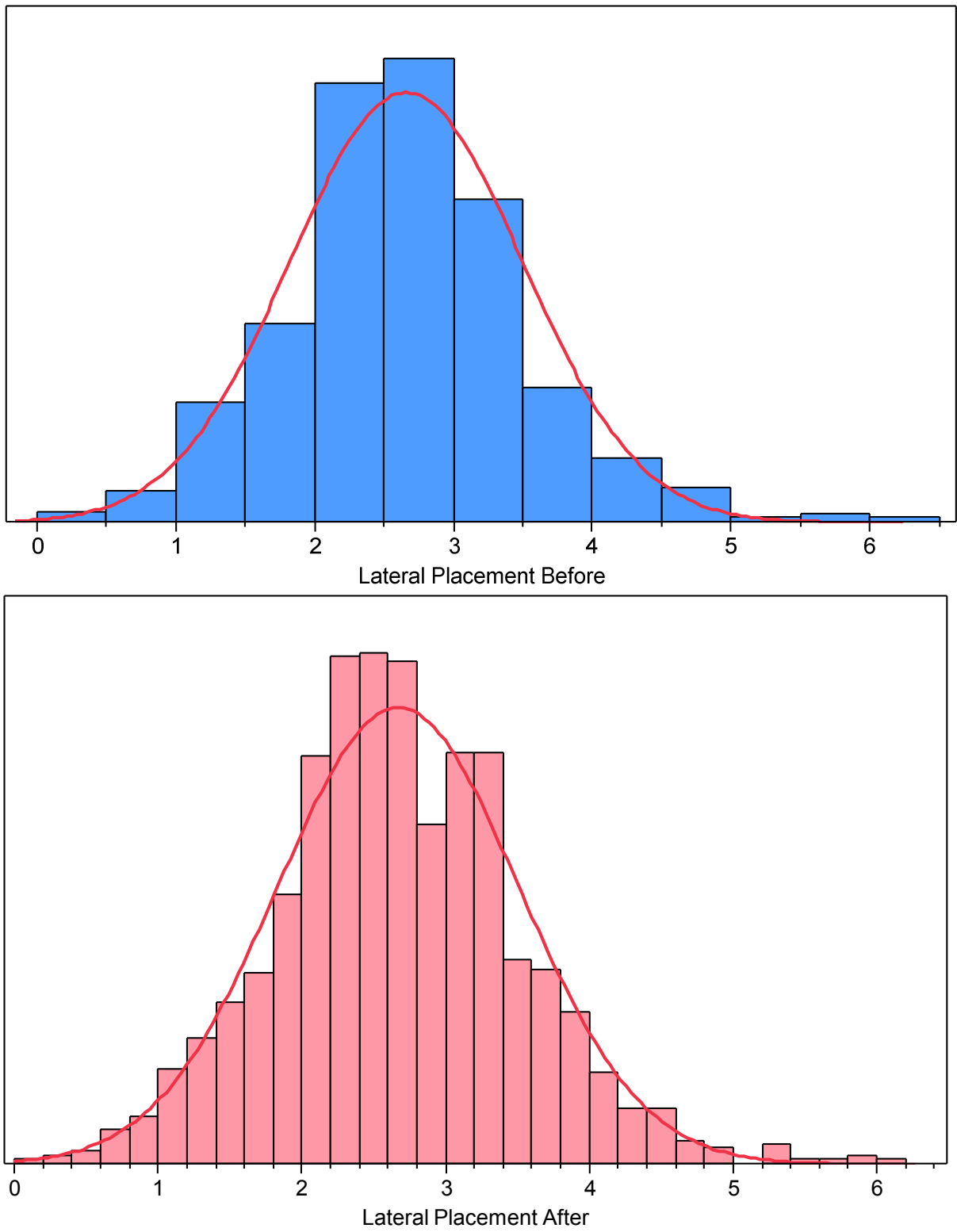

Figure C. 7 Histogram of vehicle before and after lateral placement in daytime at Z1

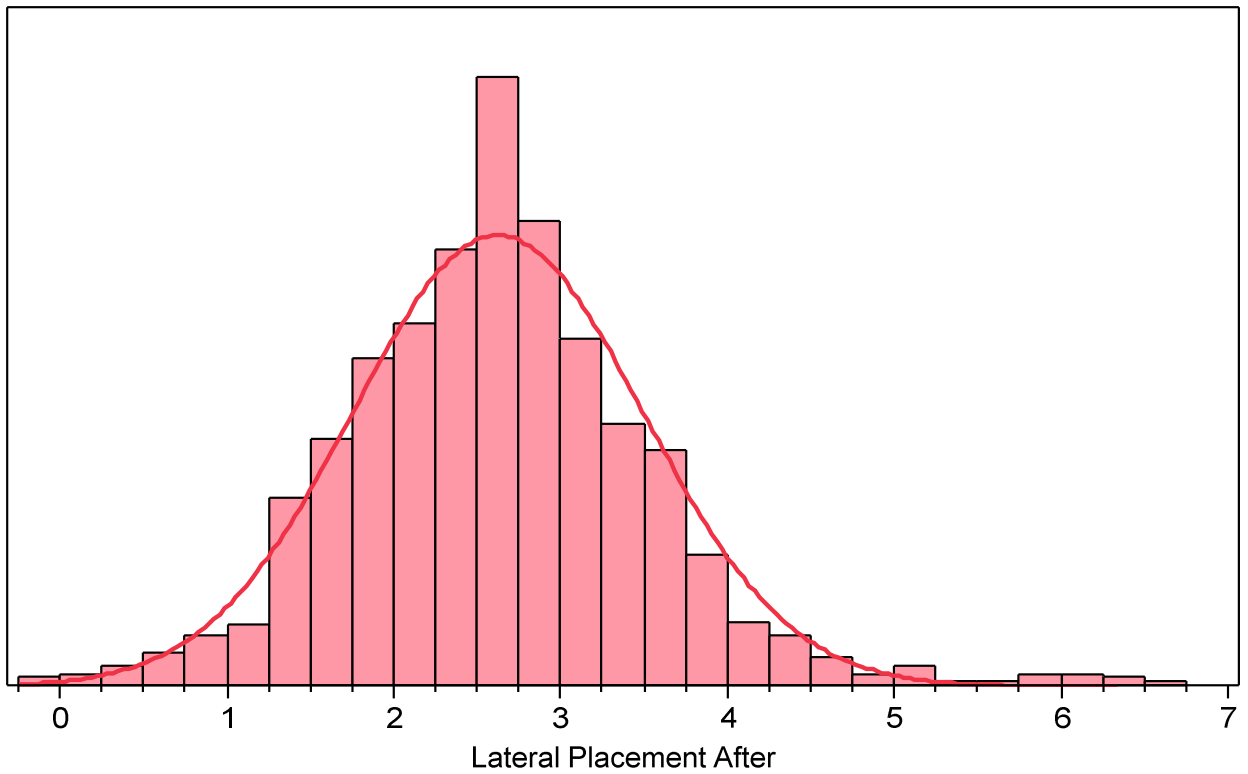
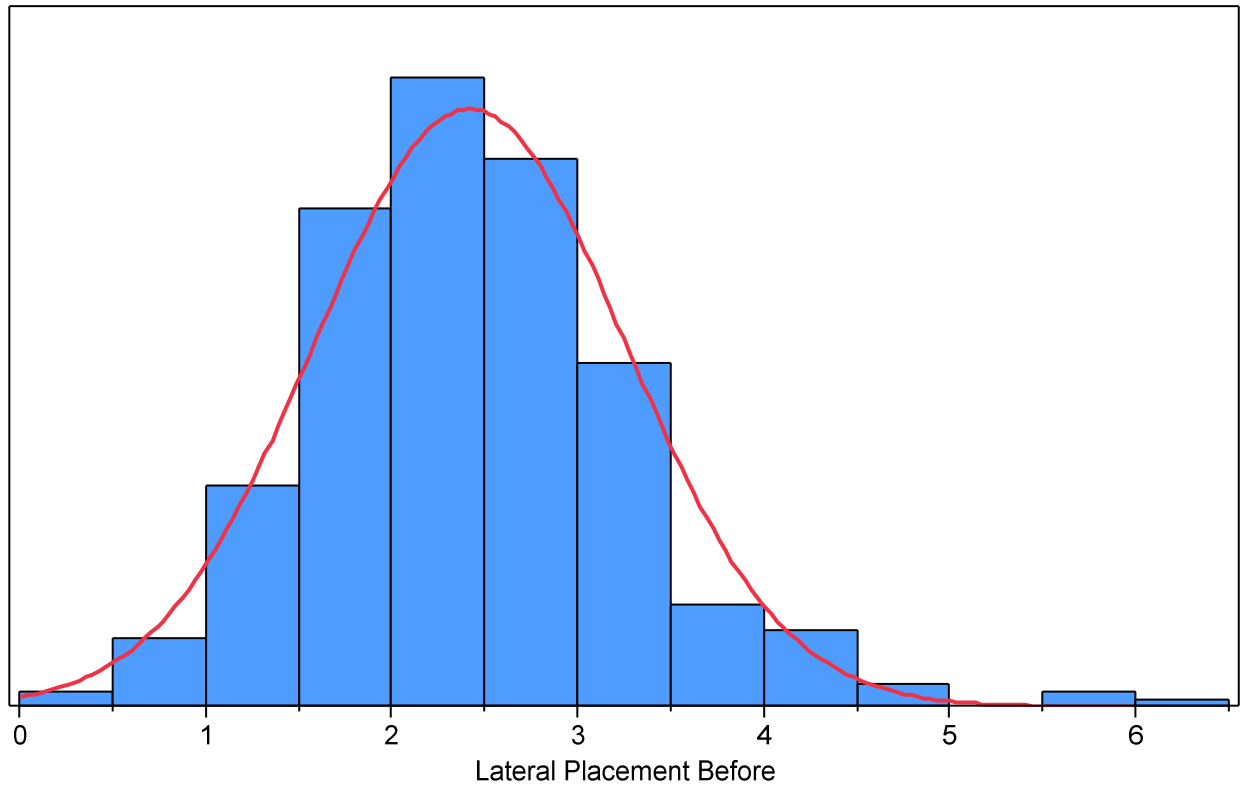

Figure C. 8 Histogram of vehicle before and after lateral placement in daytime at Z2

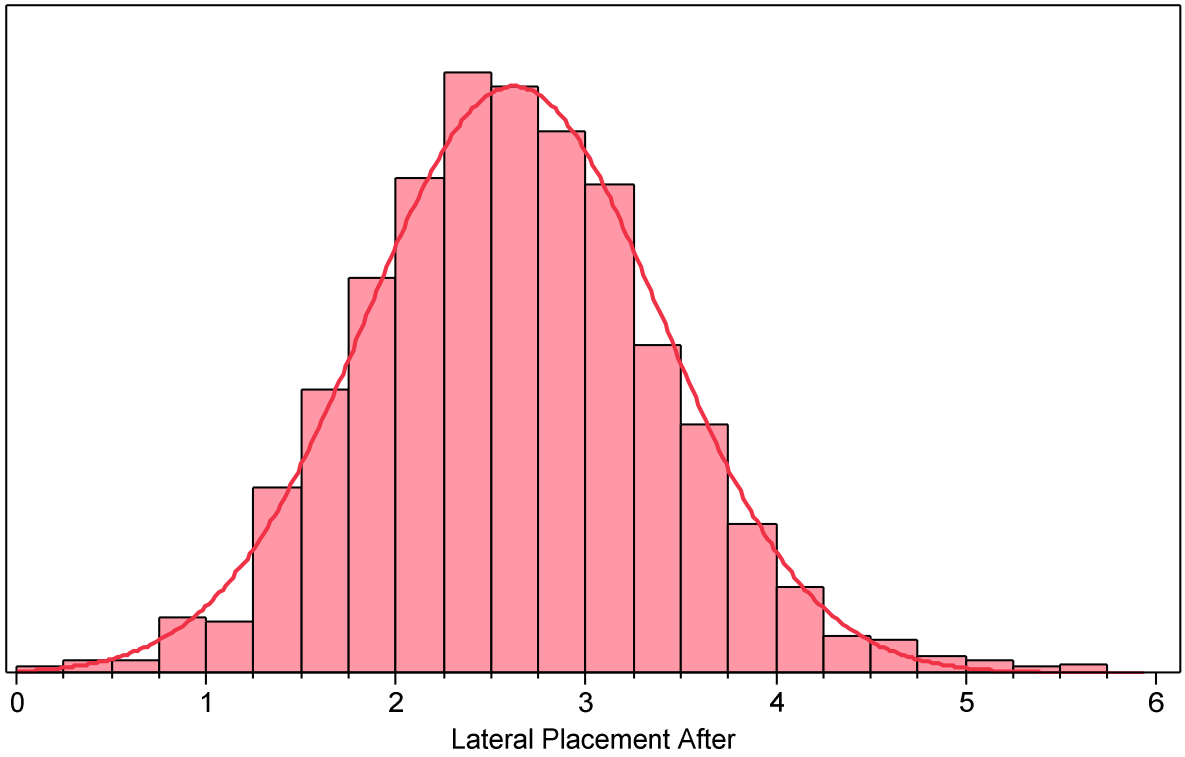
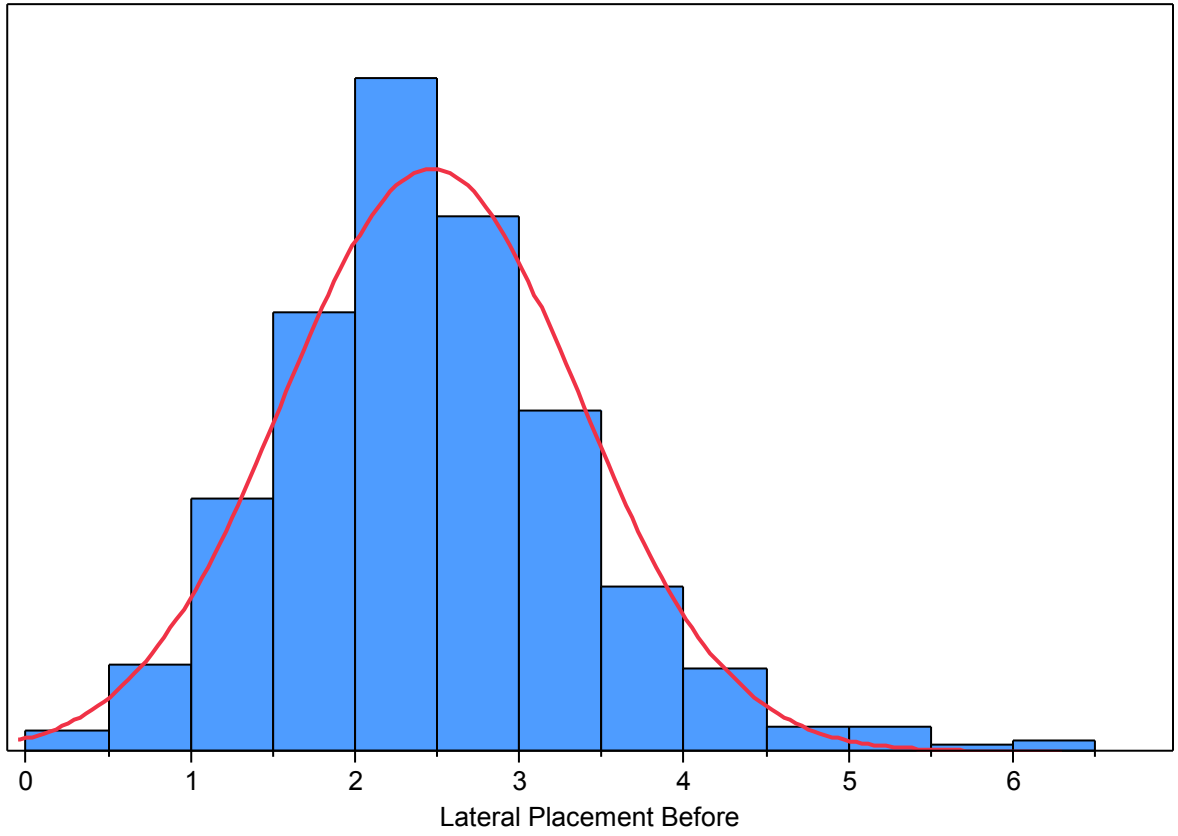

Figure C. 9 Histogram of vehicle before and after lateral placement in daytime at Z3

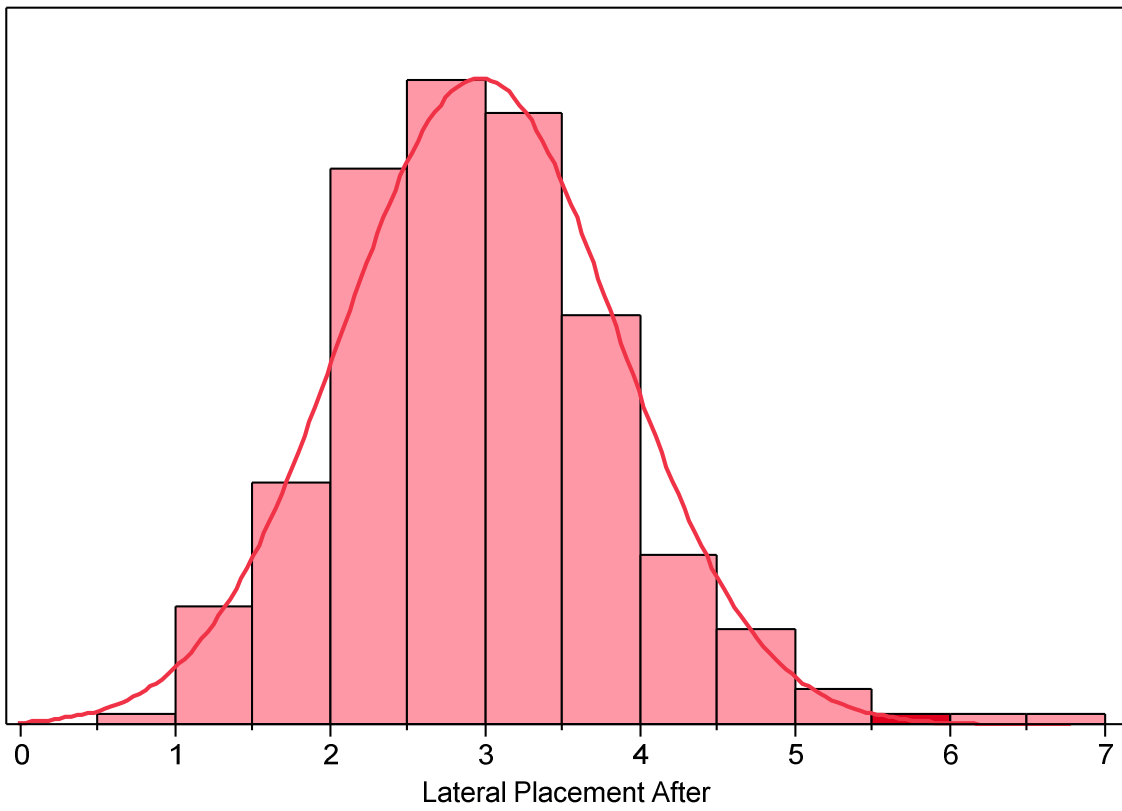
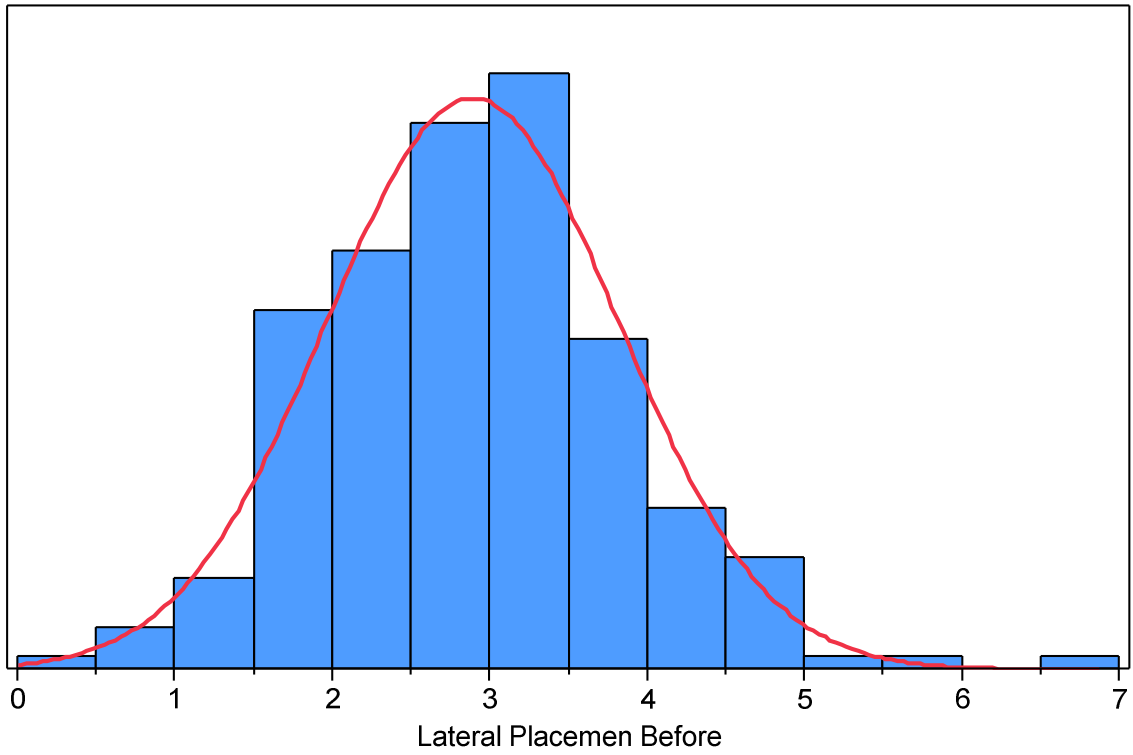

Figure C. 10 Histogram of vehicle before and after lateral placement in nighttime at Z1

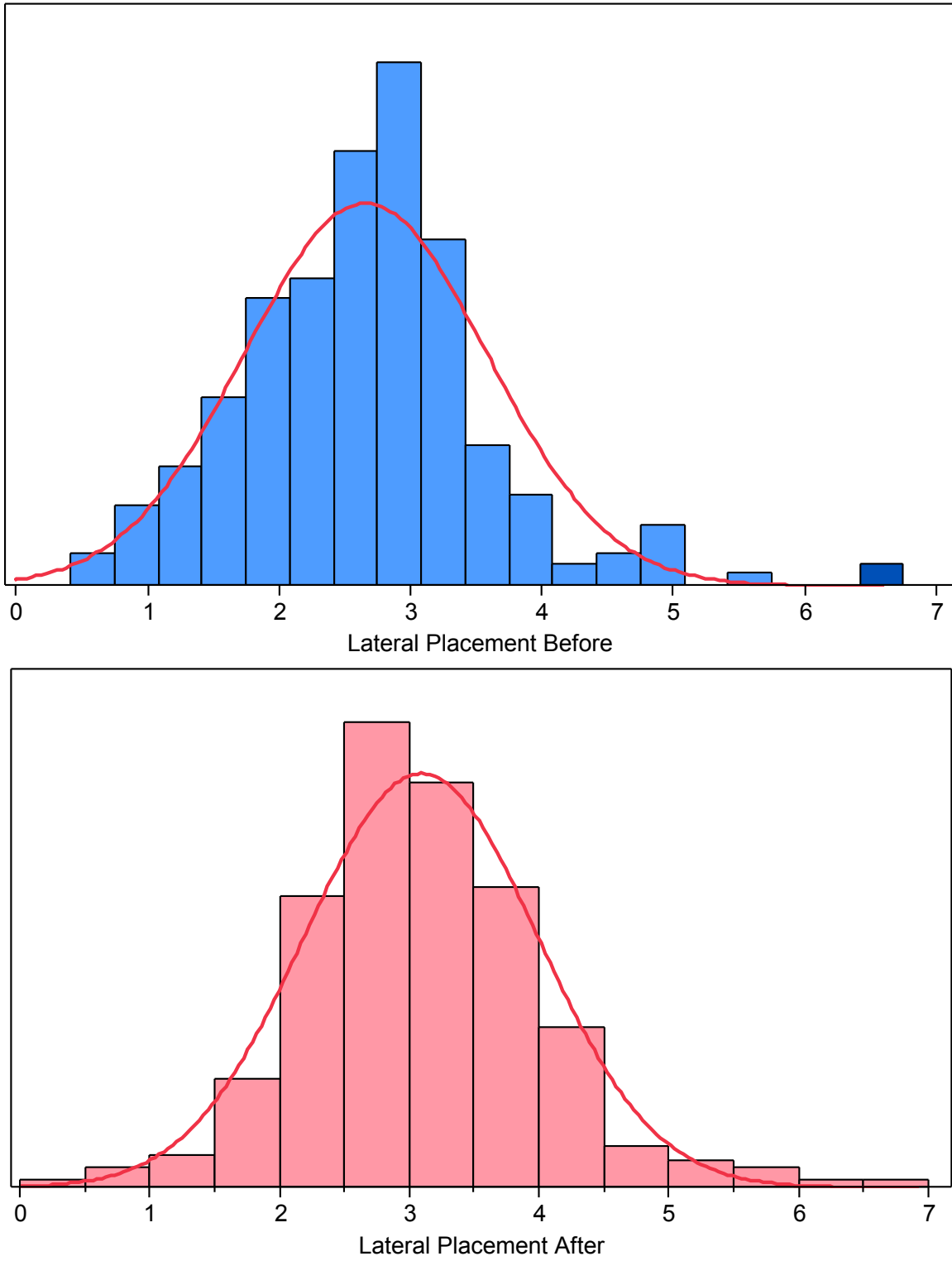

Figure C. 11 Histogram of vehicle before and after lateral placement in nighttime at Z2



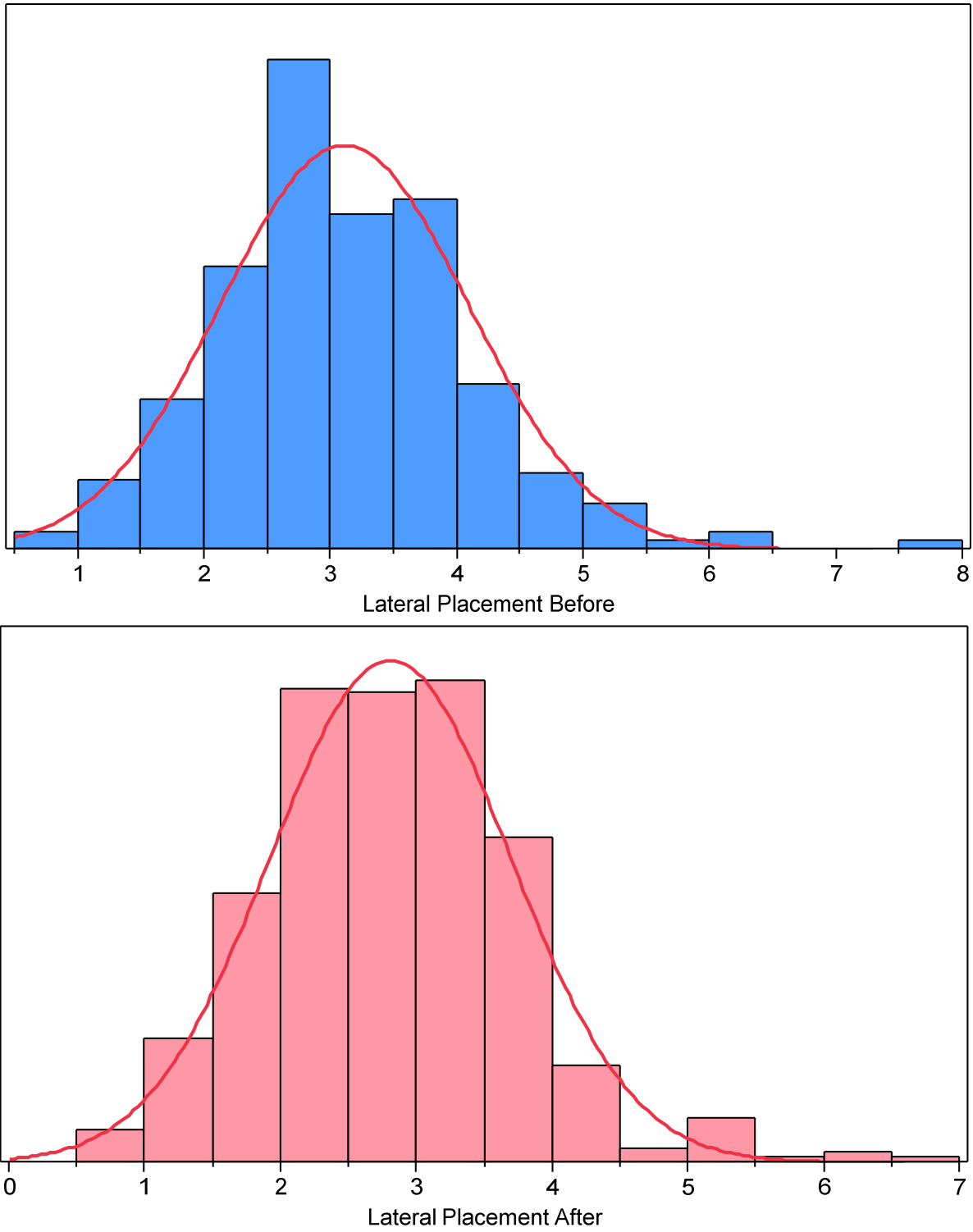

Figure C. 12 Histogram of vehicle before and after lateral placement in nighttime at Z3

**APPENDIX D CORRELATIONS BETWEEN VEHICLE SPEED AND LATERL PLACEMENT**

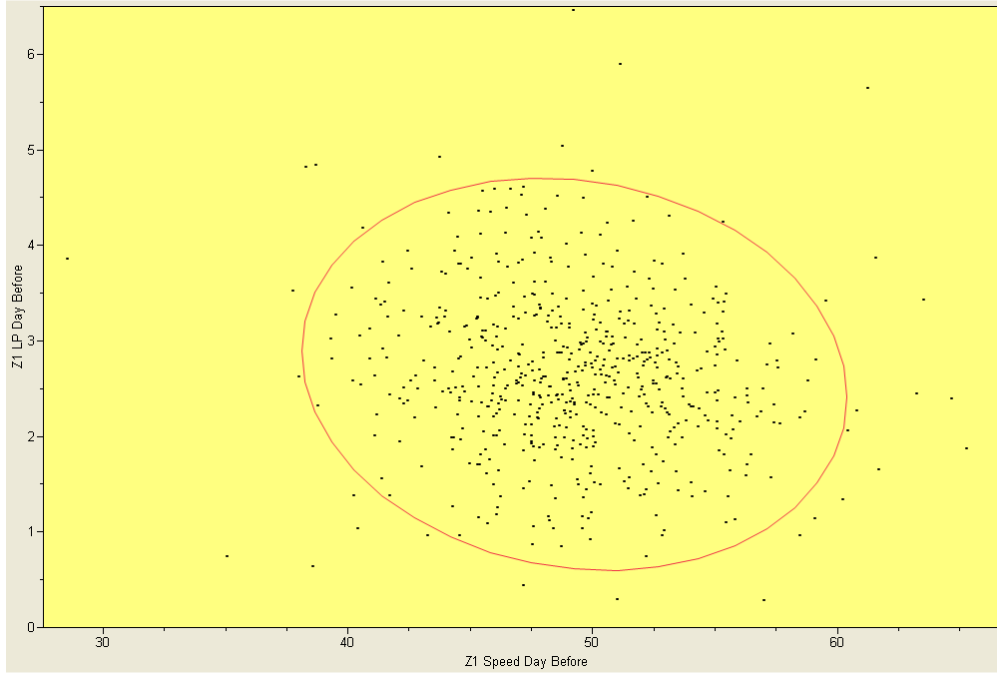

Figure D. 1 Correlations at Z1 under before treatment at daytime

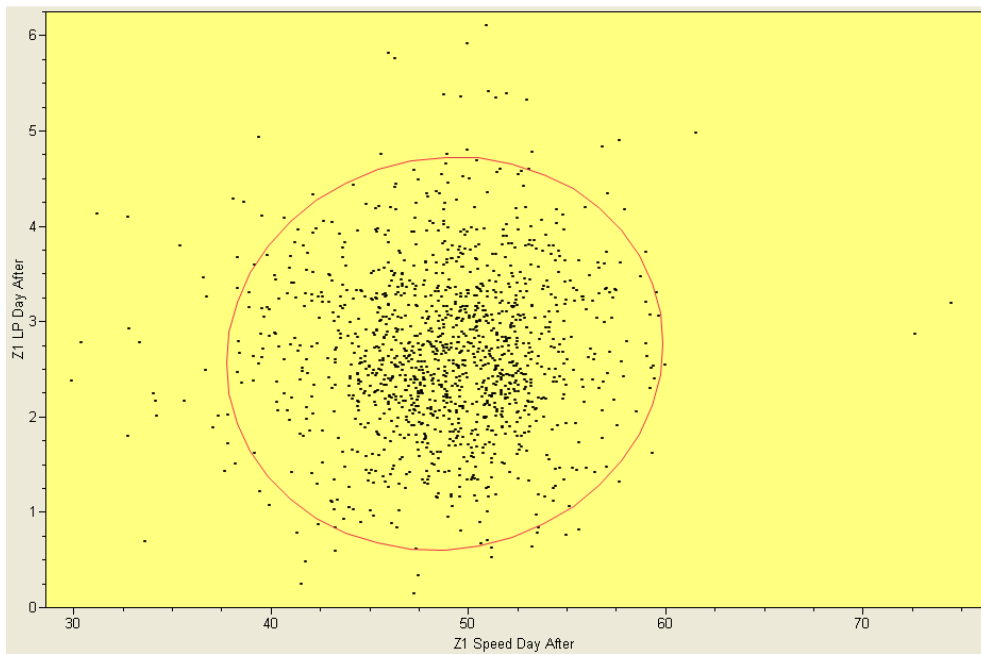

Figure D. 2 Correlations at Z1 under after treatment at daytime

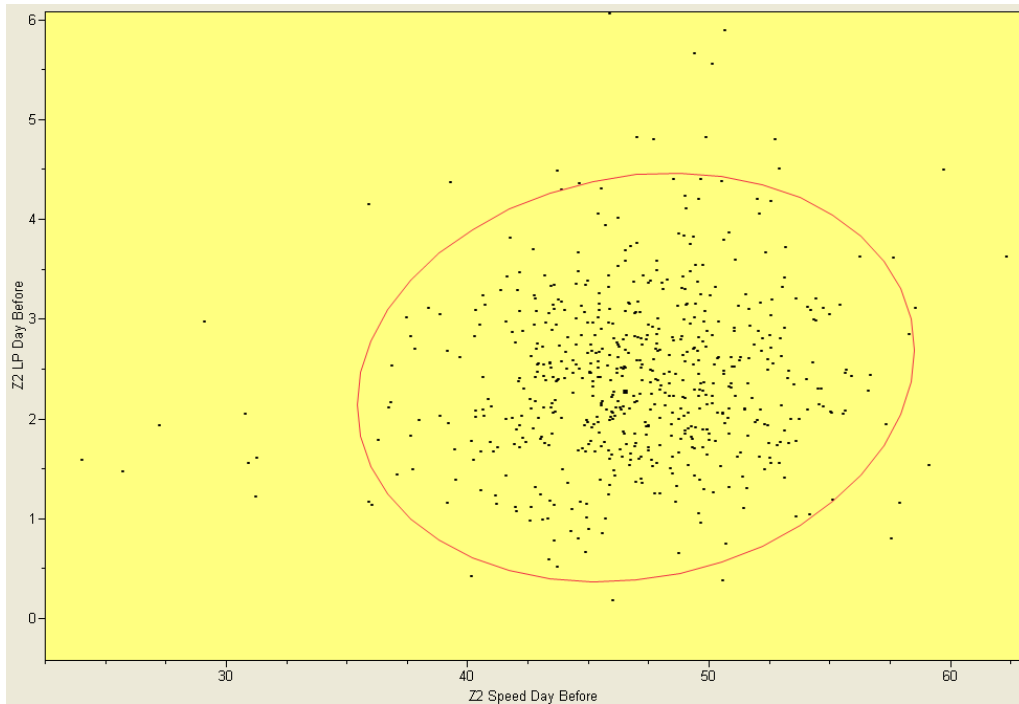

Figure D. 3 Correlations at Z2 under before treatment at daytime

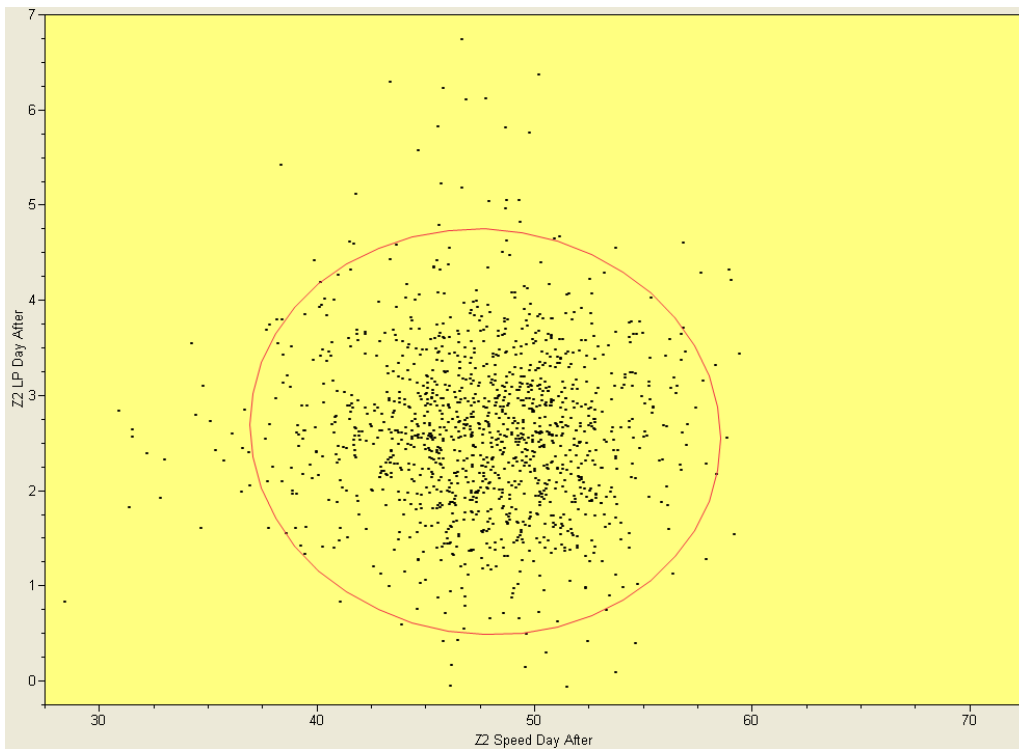

Figure D. 4 Correlations at Z2 under after treatment at daytime

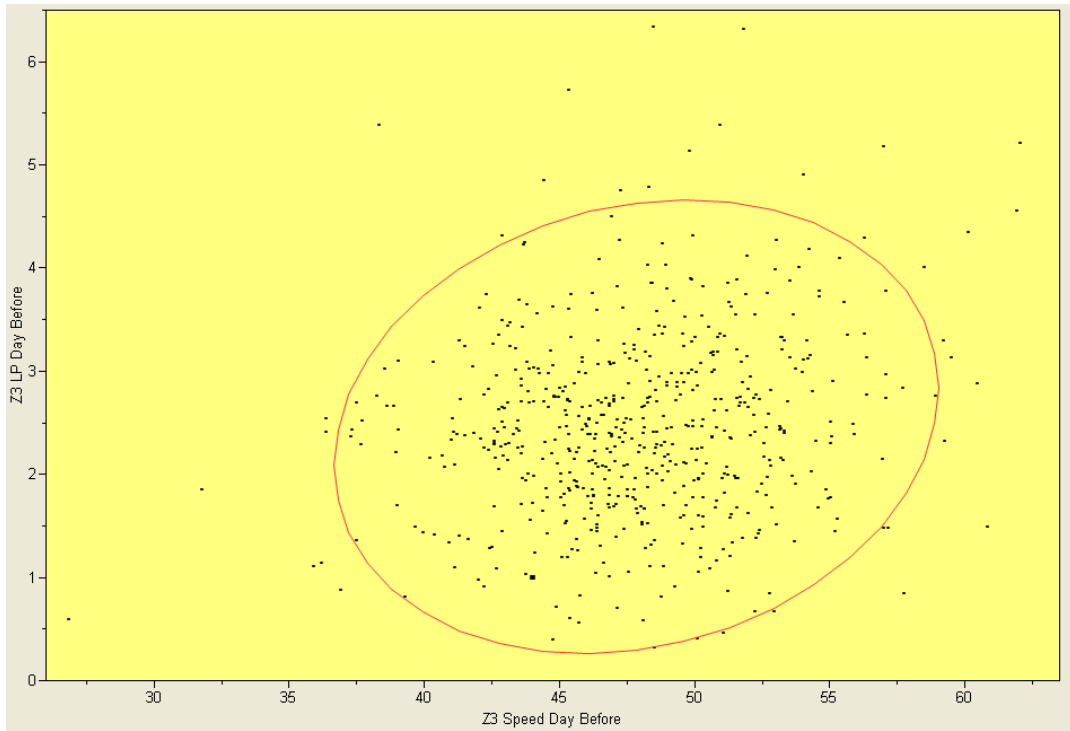

Figure D. 5 Correlations at Z3 under before treatment at daytime

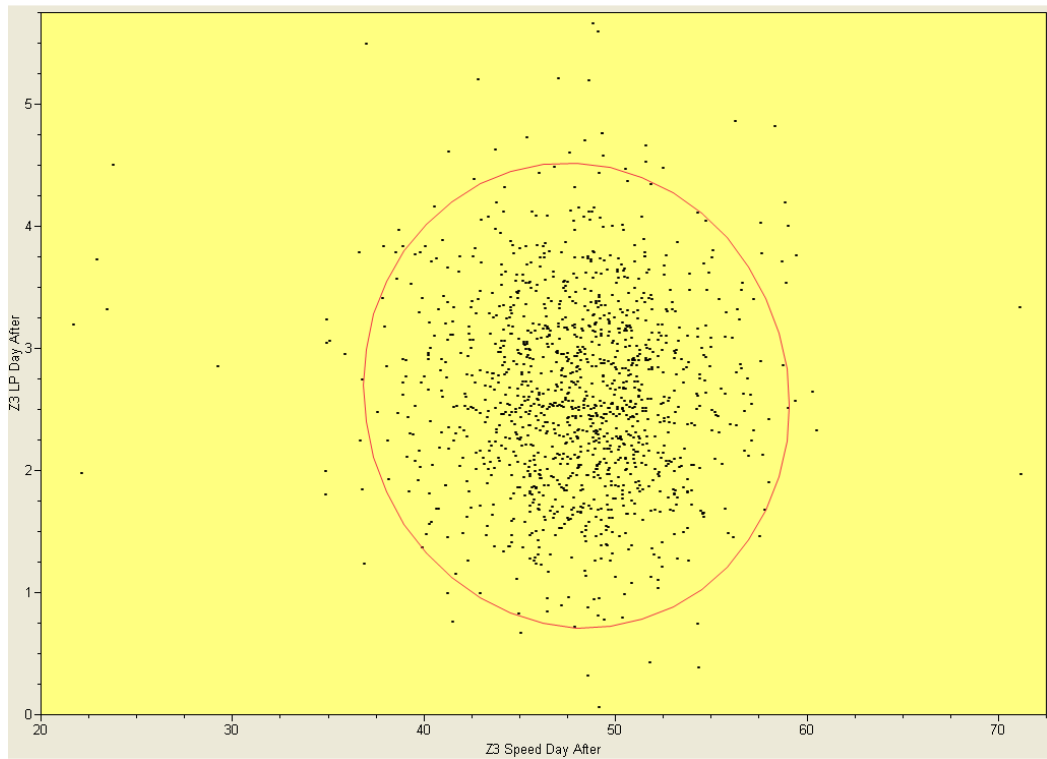

Figure D. 6 Correlations at Z3 under after treatment at daytime

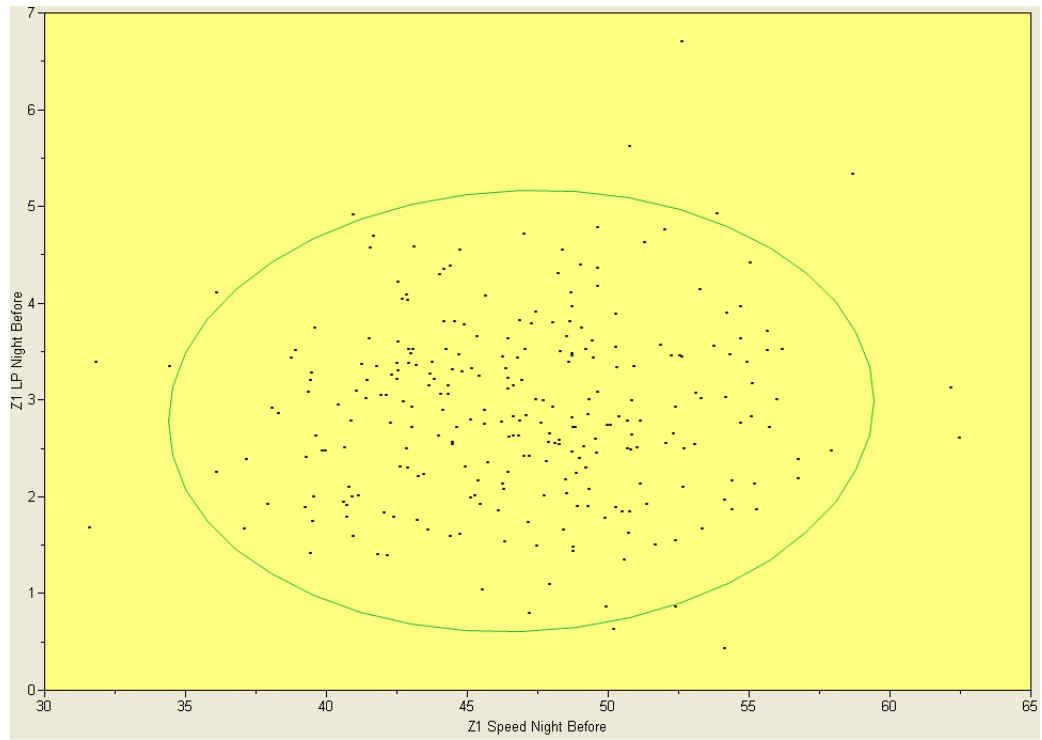

Figure D. 7 Correlations at Z1 under before treatment at nighttime

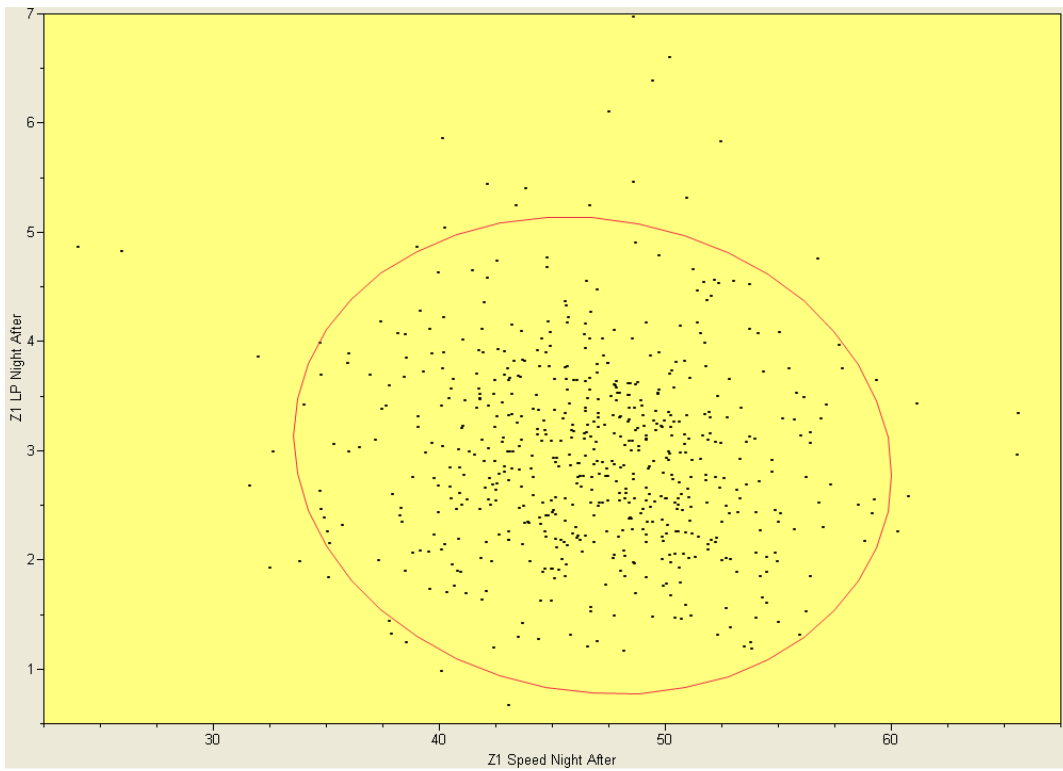

Figure D. 8 Correlations at Z1 under after treatment at nighttime

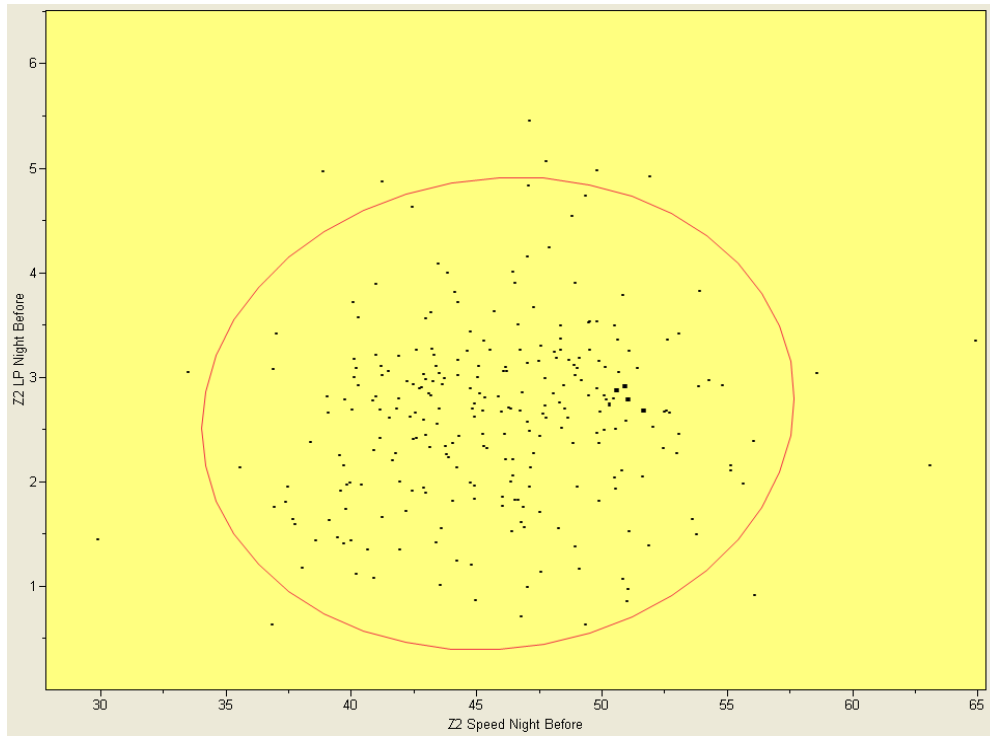

Figure D. 9 Correlations at Z2 under before treatment at nighttime

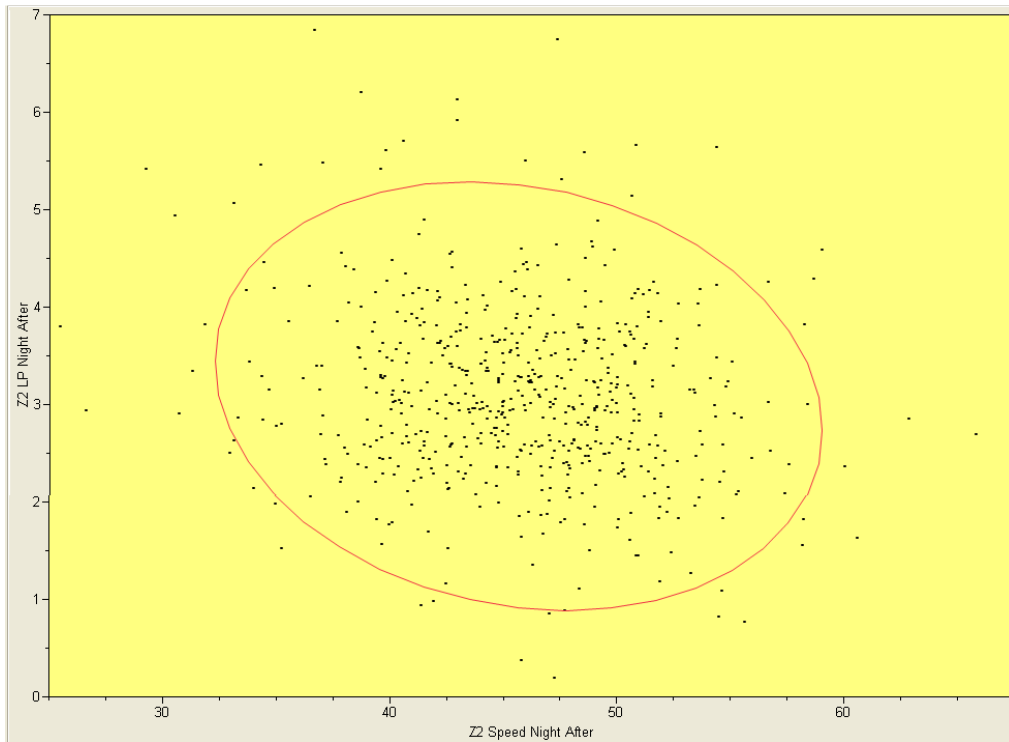

Figure D. 10 Correlations at Z2 under after treatment at nighttime

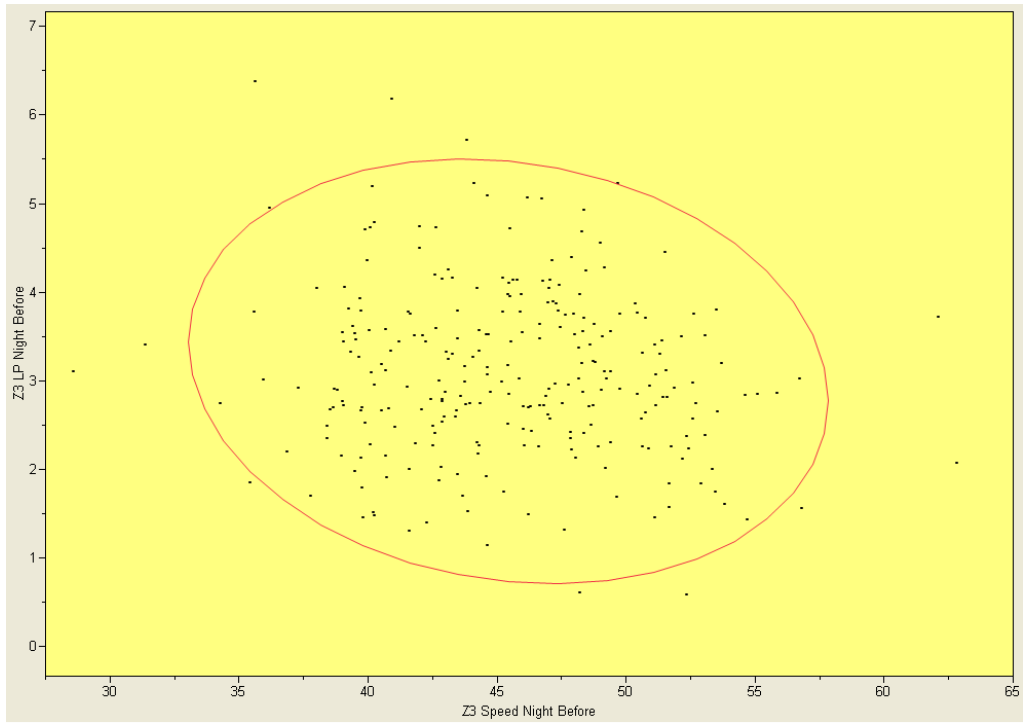

Figure D. 11 Correlations at Z3 under before treatment at nighttime

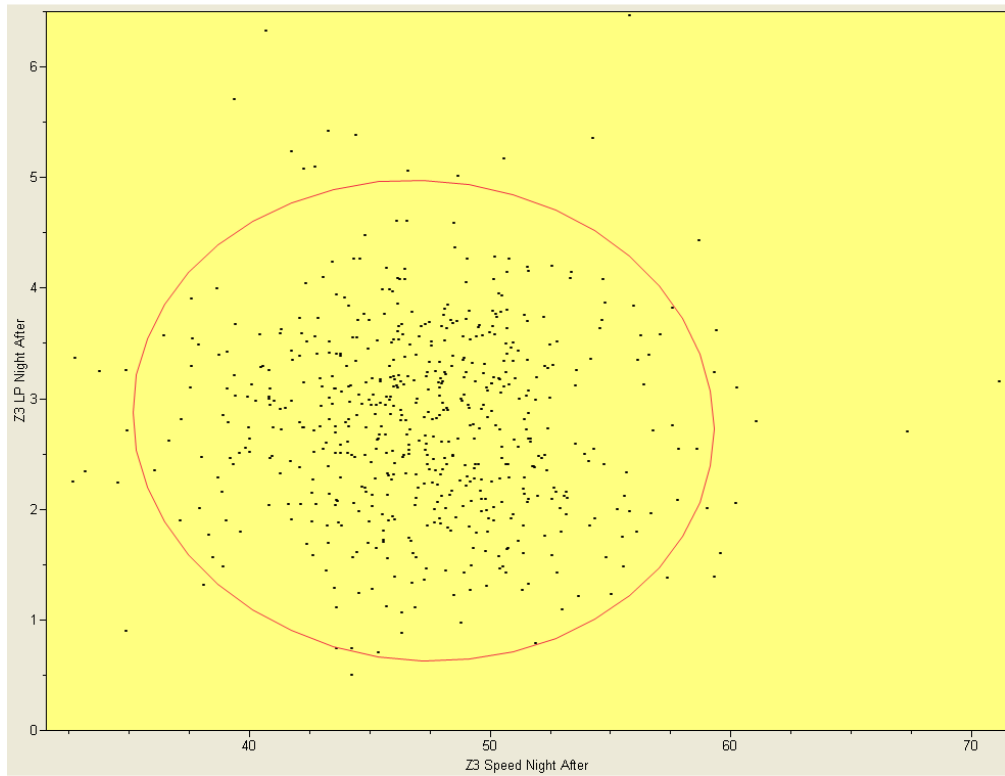

Figure D. 12 Correlations at Z3 under after treatment at nighttime