

2008

Manatee sound localization: Performance abilities, interaural level cues, and usage of auditory evoked potential techniques to determine sound conduction pathways

Debborah Colbert
University of South Florida

Follow this and additional works at: <http://scholarcommons.usf.edu/etd>

 Part of the [American Studies Commons](#)

Scholar Commons Citation

Colbert, Debborah, "Manatee sound localization: Performance abilities, interaural level cues, and usage of auditory evoked potential techniques to determine sound conduction pathways" (2008). *Graduate Theses and Dissertations*.
<http://scholarcommons.usf.edu/etd/183>

This Dissertation is brought to you for free and open access by the Graduate School at Scholar Commons. It has been accepted for inclusion in Graduate Theses and Dissertations by an authorized administrator of Scholar Commons. For more information, please contact scholarcommons@usf.edu.

Manatee Sound Localization:
Performance Abilities, Interaural Level Cues, and Usage of Auditory Evoked Potential
Techniques to Determine Sound Conduction Pathways

by

Deborah Colbert

A dissertation submitted in partial fulfillment
of the requirements for the degree of
Doctor of Philosophy
Department of Psychology
College of Arts and Sciences
University of South Florida

Co-Major Professor: Toru Shimizu, Ph.D.
Co-Major Professor: David Mann, Ph.D.
Steven Stark, Ph.D.
Theresa Chisolm, Ph.D.
Gordon B. Bauer, Ph.D.

Date of Approval:
April 15, 2008

Keywords: Trichechus, audition, AEP, head related transfer function, binaural hearing

© Copyright 2008, Deborah E. Colbert

Dedication

This dissertation is dedicated in loving memory of my father-in-law, Lawrence William Colbert, Sr. In every heart he touched, his love lives on. In every life he changed, he continues to inspire. In every thought he shared, his voice still echoes. I am privileged to have been a part of his life.

Acknowledgments

This dissertation was made possible through the assistance of numerous people. The faculty serving on my committee has been instrumental in the development and completion of the investigations included, and I would like to extend my gratitude to my major professors, Dr. Toru Shimizu and Dr. David Mann, as well as Dr. Stephen Stark, Dr. Theresa Chisolm and Dr. Gordon Bauer for their valuable assistance.

The completion of the research included in this dissertation would not have been possible without the assistance of the staff at the two facilities data were acquired. Manatee care staff, Joseph Gaspard, Kimberly Dziuk and Adrienne Cardwell, provided vital assistance in the collection of all data with Hugh and Buffett at Mote Marine Laboratory and Aquarium. Mote staff member Jay Sprinkle provided invaluable assistance in creating the localization polar plots. I would also like to thank Mote volunteer trainer Jann Warfield; Mote interns Emily Copeland, Nicki Shumway, Taryn Roberts, Anne Johnson and LaTashia Read, and New College students that assisted with the manatee training at Mote Anne Schmiege, Amanda Vennare, Ammanda Stansbery, Kara Tyler, Marc Silpa, Christina Gambacorta, and Beverly Fortner for their assistance. Animal care staff, Dr. Andy Stamper, Patrick Berry, Kim Odell, David Feuerbach, Leslie Larsen, Cathy Goonen, Wendi Fellner and Barb Losch provided the crucial assistance needed to collect data with Mo and Bock at Walt Disney World's The Living Seas at EPCOT. My deepest gratitude is extended to all of you for making these investigations possible!

I would like to acknowledge the United States Fish and Wildlife Service for granting the permits needed to conduct these investigations and express my gratitude to

those that funded these studies including the Avoidance Technology Grant from the Florida Wildlife Research Institute, the University of Florida, and the Thurell Family.

Finally, I have to acknowledge that the completion of this dissertation would not have been possible without the love and support of my incredible family. My husband Larry, daughters Katie, Alyssa and Lauren, and mother-in-law Mary, have all provided unending support throughout the entire process. Each day I continue to find that I am humbled by their love and strength and consider myself incredibly fortunate to be so blessed.

Table of Contents

List of Tables	iii
List of Figures	iv
ABSTRACT	viii
Chapter One: The Importance of Understanding the Auditory Sensory System of the Florida Manatee, <i>Trichechus manatus latirostris</i> : An Introduction	1
References Cited	9
Chapter Two: Eight-Choice Sound Localization Abilities of Two Florida Manatees, <i>Trichechus manatus latirostris</i>	13
Abstract	13
Introduction	15
Hypotheses	27
Materials and Methods	29
Subjects	29
Subject Training	30
Experimental Design	35
Acoustic Stimuli	37
Signal Generation & Programming	39
Data Recording	41
Experimental Controls	42
Results	45
Discussion	55
References Cited	64
Chapter Three: Head/Body Related Transfer Functions of the Florida Manatee, <i>Trichechus manatus latirostris</i>	73
Abstract	73
Introduction	75
Hypotheses	87
Materials and Methods	88
Subjects	88
Experimental Design	89
Signal Generation & Programming	92
Results	94
Discussion	106
References Cited	113
Chapter Four: Potential Sound Conduction Pathways for the Florida Manatee, <i>Trichechus manatus latirostris</i>	123

Abstract	123
Introduction	126
Hypotheses	138
Materials and Methods	140
Subjects	140
Experimental Design	142
Signal Generation and Programming	145
Results	147
Discussion	163
References Cited	171
Chapter Five: The Importance of Understanding the Auditory Sensory System of the Florida Manatee, <i>Trichechus manatus latirostris</i> : Concluding Remarks	176
References Cited	191
Appendices	195
Appendix A: RPvds language used to generate signals used in the manatee sound localization experiment.	196
Appendix B: Computer protocols used for setting up the manatee sound localization and head/body related transfer function experimental conditions.	199
Appendix C: Data recording protocols used to document each sound localization session.	202
Appendix D: MATLAB program used to determine and chart the manatee head/body related transfer functions.	204
About the Author	End Page

List of Tables

Table 1.1. Number of manatee deaths and their causes from 2002 through 2007.	2
Table 2.1. Overall performance within and between location, duration and frequency conditions of Gerstein's (1999) four-choice localization experiment.	22
Table 2.2. Overall performance within and between the duration and frequency conditions of Colbert's (2005) four-choice localization experiment.	24
Table 2.3. Frequency, duration and level conditions of the eight-choice manatee localization experiment.	38
Table 2.4. Results for the conditions of the eight-choice localization experiment with chance level at 12.5%.	47
Table 2.5. Average percents correct by front, back and side regions.	54
Table 2.6. Number of confusions made between contralateral pairs for each subject.	60
Table 3.1. Level differences (in dB) between subjects of averaged 'animal absent' minus 'animal present' signals for left and right hydrophones with 0.2-1.5, 0.2-5 and 18-30 kHz bands of frequencies.	105
Table 4.1. AEP amplitudes (nV) obtained from the areas surrounding the external auditory meatus and zygomatic process for all subjects.	167
Table 4.2. AEP amplitudes (nV) obtained from points along the vertebral column and lateral ribs	169

List of Figures

Figure 2.1. Interaural distances vs. maximum frequency perceived at 60 dB SPL	20
Figure 2.2. Testing configuration for Colbert's (2005) four-choice localization experiment.	23
Figure 2.3. Percent correct and distribution of sound localization errors by frequency collapsed across duration in Colbert's (2005) 4-choice sound localization study.	25
Figure 2.4. Diagram of the 265,000 L manatee exhibit composed of a Medical Pool, Shelf Area, and Exhibit Area.	30
Figure 2.5. Training setup comparison for the Colbert's four-choice and eight-choice sound localization experiments	31
Figure 2.6. Power spectra (top) and spectrograms (bottom) of the secondary reinforcement signals.	32
Figure 2.7. Stationing apparatus used in the eight-choice sound localization study	34
Figure 2.8. Testing setup for the eight-choice sound localization experiment.	35
Figure 2.10. Electronic button box used to run the sessions and automatically download each trial into a digital excel file.	41
Figure 2.11. Data entry screen used to enter session information into the Access database.	42
Figure 2.12. Subject accuracy before and after speaker normalization calibration.	46
Figure 2.13. Selection distribution with the 0.2-24 kHz, 3,000 ms, 95 dB re 1 μ Pa test signal.	48
Figure 2.14. Selection distribution with the 0.2-24 kHz, 200 ms, 95 dB re 1 μ Pa test signal.	50
Figure 2.15. Selection distribution with the 18-24 kHz, 3,000 ms, 80 dB re 1 μ Pa test signal.	51

Figure 2.16. Selection distribution with the 0.2-1.5 kHz, 3,000 ms, 110 dB re 1 μ Pa test signal.	52
Figure 2.17. Selection distribution with the 4 kHz, 200 ms, 101 dB re 1 μ Pa test signal.	53
Figure 3.1. Interaural time (ITD), phase (IPD), and level (ILD) cues used for sound localization.	78
Figure 3.2. Azimuth, elevation and medial planes used to integrate the vertical, horizontal and distance dimensions with a sound's temporal, phase and level cues.	79
Figure 3.3 Cone of confusion caused from sounds originating in different locations.	82
Figure 3.4. Interpretation of how signals presented from the 135° and 225° locations reflect off the manatees' elliptically shaped body.	87
Figure 3.5. Testing setup for the manatee body related transfer function experiment.	89
Figure 3.6. Stationing apparatus used to measure manatee body related transfer functions	90
Figure 3.8. Comparisons of left vs. right received signals as a function of signal source location and the presence (red line) or absence (blue line) with Hugh.	95
Figure 3.9. Comparisons of left vs. right received signals as a function of signal source location and the presence (red line) or absence (blue line) with Buffett.	96
Figure 3.10. Left (270°) vs. right (90°) head/body related transfer functions for Buffett.	97
Figure 3.11. Head/body related transfer functions for Hugh	98
Figure 3.12. Head/body related transfer functions for Buffett.	99
Figure 3.13. Interaural level difference magnitudes between the left and right hydrophones	101
Figure 3.14. Interaural level difference magnitudes between the left and right hydrophones	102

Figure 3.15. Interaural level difference magnitudes between the left and right hydrophones	104
Figure 3.16. Simulated shadow effects created from the manatee head and body.	108
Figure 4.1. Diagrammatic illustration of manatee auditory anatomy based on multiple cross-sections through the transverse plane.	128
Figure 4.2. Manatee ossicles from the right ear.	130
Figure 4.3. Right lateral view of a three dimensional reconstruction of a CT scanned manatee head	132
Figure 4.4. Potential sound pathways where a sound wave will experience the least amount of reflection.	133
Figure 4.5. Schematic illustrations of the manatee diaphragm and lung.	136
Figure 4.6. Testing setup for voluntary auditory evoked potential measurements used to map sound conduction pathways with subjects at Mote Marine Laboratory & Aquarium.	141
Figure 4.6. Testing setup for restrained auditory evoked potential measurements used to map sound conduction pathways with subjects at	142
Figure 4.7. Voluntary AEP measurements with Hugh.	143
Figure 4.8. Restrained AEP measurements with Bock.	144
Figure 4.9. A typical auditory evoked potential found at the 600 Hz AM frequency using the 15 kHz carrier.	147
Figure 4.10. A typical auditory evoked potential found at the 600 Hz AM frequency using the 24 kHz carrier.	148
Figure 4.11. In-water auditory evoked potential response measurements for Hugh.	149
Figure 4.12. Estimated in-water sound pressure level measurements for Hugh.	150
Figure 4.13. In-water auditory evoked potential response measurements for Buffett.	151
Figure 4.14. Estimated in-water sound pressure level measurements for Buffett.	151
Figure 4.15. In-water auditory evoked potential response measurement comparison of common positions for Hugh and Buffett.	152

Figure 4.16. In-air auditory evoked potential response measurements for Bock.	153
Figure 4.17. Estimated in-air sound pressure level measurements for Bock.	154
Figure 4.18. In-air auditory evoked potential response measurements for Hugh.	155
Figure 4.19. Estimated in-air sound pressure level measurements for Hugh.	156
Figure 4.20. In-air auditory evoked potential response measurements for Mo.	158
Figure 4.21. Estimated in-air sound pressure level measurements for Mo.	159
Figure 4.22. In-air auditory evoked potential response measurement comparison of common positions for Hugh, Mo, and Bock.	161
Figure 4.23. In-water vs.in-air auditory evoked potential response measurement comparison of common positions for Hugh, Buffett, Mo and Bock.	162
Figure 5.1. Contralateral comparison between ILD magnitudes and sound localization selection distributions at 0° and 180°.	183
Figure 5.2. Contralateral comparison between ILD magnitudes and sound localization selection distributions at 45° and 225°.	184
Figure 5.3. Contralateral comparison between ILD magnitudes and sound localization selection distributions at 90° and 270°.	185
Figure 5.4. Contralateral comparison between ILD magnitudes and sound localization selection distributions at 315° and 135°.	186
Figure A-1. Rpvds language used to generate each subject's call to station.	196
Figure A-2. Rpvds language used to generate the initiation of each trial.	197
Figure A-3. Rpvds language used to generate each subject's secondary bridge when correct.	197
Figure A-4. Rpvds language used to document when incorrect selections were made.	198
Figure B-1. The graphical user interface screen (programmed in Visual C) used to setup the experimental conditions and automatically download the results into an Excel file during the testing sessions.	201
Figure C-1. The tank-side data-recording sheet used to document each session.	203

Manatee Sound Localization:
Performance Abilities, Interaural Level Cues, and Usage of Auditory Evoked Potential
Techniques to Determine Sound Conduction Pathways

Deborah Colbert

ABSTRACT

Three experiments investigated the ability and means by which Florida manatees determine sound source directionality. An eight-choice discrimination paradigm determined the sound localization abilities of two manatees within a 360° array of speakers. Five conditions were tested including a 3,000 and 200 ms, 95 dB, 0.2-24 kHz signal, a 3,000 ms, 80 dB, 18-24 kHz signal, a 3000 ms, 110 dB, 0.2-1.5 kHz signal and a 200 ms, 101 dB, 4 kHz tonal signal. A sixth condition attenuated the level of the 3,000 ms, 95 dB, 0.2-24 kHz signal in 3 dB increments until accuracy reached 75%. Subjects performed above the 12.5% chance level for all broadband frequencies and were able to localize over a large level range. Errors were typically located to either side of the signal source location when presented in the front 180° but were more dispersed when presented from the 135°, 180° and 225° locations. Front-to-back confusions were few and accuracy was greater when signals originated from the front 180°.

Head/body related transfer functions determined how different frequencies were filtered by the manatees' head/torso to create frequency-specific interaural level differences (ILDs). Hydrophones were suspended next to each manatee ear and Fast Fourier transform (FFT) ratios compared received signals with and without the subject's

presence. ILD magnitudes were derived for all frequencies, as well as specific 0.2-1.5, 0.2-5, and 18-30 kHz bands of frequencies. ILDs were found for all frequencies as a function of source location, although they were largest with frequencies above 18 kHz and when signals originated at 90° and 270°. Larger ILDs were found when the signals originated behind the subjects as compared to in front of them.

Auditory evoked potential (AEP) techniques were used to map manatee sound conduction pathways in-water and in-air using 15 and 24 kHz carriers. All subjects produced AEPs at each position the transducer was placed, however specific sound conduction pathway(s) were not identified. AEP amplitudes were usually greater with the 24 kHz carrier, however patterns between carriers at identical body positions were highly variable between subjects.

Chapter One: The Importance of Understanding the Auditory Sensory System of the Florida Manatee, *Trichechus manatus latirostris*: An Introduction

The Florida manatee (*Trichechus manatus latirostris*) is a sub-species of the West Indian manatee (*Trichechus manatus*) that is typically found in the coastal waterways surrounding the peninsula of Florida, but can range as far north as Massachusetts and as far west as Louisiana. In the summer months, it lives in turbid saltwater habitats, grazing primarily on sea grass (Reynolds & Odell, 1991). In colder months, it migrates to freshwater springs or power plant discharge sites where water remains at a warmer temperature, feeding primarily on water hyacinth, hydrilla, and other freshwater vegetation (Reynolds & Wilcox, 1986). It is considered a semi-social species, often grazing or traveling alone, although females with calves will often congregate together and males will frequently mass around estrous females for mating purposes (Reynolds, 1979). Although manatee ecology and population biology field studies validate that these behavior patterns are typical (Hartman, 1979; U.S. Fish and Wildlife Service, 2001), the means by which they navigate and locate one another within their vast habitat remains unclear.

The Florida manatee is an endangered species, currently protected by both the Marine Mammal Protection Act (1972) and the Endangered Species Act (1973). The February 2007 synoptic survey estimated the Florida manatee population to be approximately 2,817 animals (Florida Fish and Wildlife Research Institute, 2007a). It is

known to be threatened by naturally occurring events such as cold stress and red tide and by human-influenced events such as boat strikes, canal lock compression, and habitat degradation (Odell & Reynolds, 1979). Over 1,027,000 boats were registered in the state of Florida in 2007 (Florida Department of Highway Safety and Motor Vehicles, 2007) and many manatees are hit by vessels numerous times throughout their lives as evidenced by a multitude of scar patterns on their bodies (Beck & Reid, 1995). The frequency of deaths caused specifically by watercraft remains relatively stable ranging between 19-31% of the annual mortalities (Florida Fish and Wildlife Research Institute, 2007b; Table 1.1). Because the annual number of undetermined causes of death and unrecovered carcasses is high, the annual percentage of deaths caused by watercraft is likely underestimated.

Table 1.1. Number of manatee deaths and their causes from 2002 through 2007.

Year	Watercraft	Gates/Locks	Other Human	Perinatal	Cold Stress	Natural	Undetermined	Unrecovered	Total
2002	95	5	9	53	17	59	65	2	305
2003	73	3	7	71	47	102	67	10	380
2004	69	3	4	72	50	24	51	3	276
2005	80	6	8	89	31	88	90	4	396
2006	92	3	6	70	22	81	116	27	417
2007	73	2	5	59	18	81	67	12	317

Since the Florida manatee lives in a habitat where boats are found in high numbers and conspecifics are often out of visual range, it is important to gain a detailed understanding of how the manatee perceives its environment. Although no information has been published regarding the manatee's gustatory and olfactory sensory systems,

several anatomical and behavioral studies have provided considerable insight into the manatee's visual, tactile, and auditory sensory processes.

Anatomical investigations of the small 18 mm diameter manatee eye reveal that it possesses two types of cones (Cohen et al., 1982; Ahnelt & Kolb, 2000; Ahnelt & Bauer, 2000), has relatively few retinal ganglion cells, lacks an accommodation mechanism, and has limited resolution with a minimum angle of 20 minutes of visual arc (Walls, 1963; Piggins et al., 1983; West et al., 1991; Mass et al., 1997). Behavioral investigations of the manatee's visual sensory system using discrimination testing paradigms found that subjects were able to distinguish blue and green from a series of comparably bright grays (Griebel & Schmid, 1996) and differentiate brightness with a Weber fraction of 0.35 (Griebel & Schmid, 1997). A visual acuity study using gratings of various widths found that one subject possessed a minimum angle of 21 minutes of visual arc, while the second subject's was over a degree (Bauer et al., 2003). Results from this behavioral study in confluence with ganglion cell density anatomical data suggest that the 21 minutes of visual arc is probably typical for manatees.

Anatomical investigations of the manatee's facial vibrissae show that each is composed of a dense connective tissue capsule with a prominent blood sinus complex and substantial innervation. Six fields of perioral bristles have been identified (Reep et al., 2001) and those located on the upper lip are used in a prehensile manner during feeding (Marshall et al., 1998 & 2003). Each postcranial body vibrissae also contains a blood sinus and is innervated by 20-50 axons (Reep et al., 2002). Behavioral investigations of the manatee's facial tactile sensory system using discrimination testing paradigms found that an Antillean manatee possessed good sensitivity with a Weber

fraction of 0.14 (Bachteler & Dehnhardt, 1999) and two Florida manatees had excellent sensitivity with a Weber fraction of 0.025 for one subject and 0.075 for the other (Bauer et al., 2005), sensitivity comparable to that of a human index finger (Weber fraction of 0.028) (Gaydos, 1958).

Anatomical investigations of the manatee's ear demonstrate that the external pinna flange is absent and that the external auditory meatus is of minute size, occluded with cellular debris that reaches a blind end separated from the tympanic membrane, and is an unlikely channel for sound transmission (Ketten et al., 1992; Chapla et al., 2007). Behavioral investigations of the manatee's auditory sensory system have been conducted using discrimination and auditory evoked potential testing techniques. Gerstein et al. (1999) obtained a behavioral audiogram for two manatees and found that hearing thresholds ranged from 0.5–38 kHz for one subject and 0.4–46 kHz for the other. The frequency range of best hearing was between 10–20 kHz and maximum sensitivity was ~50 dB re: 1 μ Pa at 16 and 18 kHz, decreasing by ~20 dB re: 1 μ Pa per octave from 0.8 to 0.4 kHz and 40 dB re: 1 μ Pa per octave above 26 kHz. Auditory evoked potential investigations found the frequency range of detection reached up to 35 kHz when tested in air (Bullock et al., 1980; 1982; Popov & Supin, 1990) and 60 kHz when tested in water (Klishen et al., 1990). More recently, Mann et al. (2005) found an upper limit of detection at 40 kHz when tested in water.

The information gained from sensory investigations with animals in a controlled setting offer indications about how their sensory systems function in natural settings. These results suggest that manatee vision is built for sensitivity in dim light conditions with the ability to distinguish brightness differences and differentiate blues from greens,

but that acuity is poor and not useful for fine details. Tactile sensitivity appears to be superior, but like vision, is probably designed to function with nearby tasks. Audition is excellent and spans a wide range of frequencies seemingly fulfilling a crucial role for functioning in both nearby and distant scenarios. This capability likely facilitates the capacity for sound localization which would be of great importance for tasks such as navigation, finding conspecifics and boat avoidance. Therefore, the localization abilities of the manatee warrant further investigation.

Initial estimations of manatee sound localization abilities were determined by comparing manatee interaural time delays (the distance sound travels from one ear to the other divided by the speed of sound) to those of other species. Heffner and Heffner (1992) generated a regression equation that described the relationship between interaural time delays and the upper frequency hearing limits for a variety of species. Animals with narrower heads had smaller interaural time delays and typically needed higher frequency sensitivity to be able to localize sounds. Ketten et al. (1992) calculated the manatee intermeatal distance as 278 mm with a maximum acoustic travel time of 258 μ sec, and the intercochlear distance as 82 mm with a maximum acoustic travel time of 58 μ sec. When these time delays were plotted on Heffner and Heffner's regression line, it appeared that manatees would need a 50–90 kHz upper frequency limit to be able to localize sound. Given that behavioral investigations indicated that the upper limit of manatee's hearing likely lies between 40 -60 kHz, below or bordering the 50–90 kHz interaural upper frequency limit estimates needed for localization, it was predicted that manatees may not possess "good" sound localization abilities (Ketten et al., 1992).

This calculation however, was not supported by the results of two distinct behavioral sound localization studies. Gerstein (1999) tested one manatee's ability to localize in a four-choice (45° , 90° , 270° and 315°) testing paradigm. Stimuli included 0.5, 1.6, 3, 6, or 12 kHz tonal signals, pulsed for either 200 or 500 ms, paused for 400 ms, and then repeated. Results indicated that the subject was capable of localizing all signals but accuracy increased with the higher frequencies and at the 90° angles. Given the subject's poorer performance with the low frequency stimuli, Gerstein suggested that low frequency sounds typical of recreational boat engine noises might be difficult to localize. Colbert (2005) also conducted a four-choice localization experiment (45° , 90° , 270° and 315°) with two manatees. Stimuli included three broad-band noises of 0.2-20, 6-20, and 0.2-2 kHz tested at four durations (3,000, 1,000, 500 and 200 ms) and two tonal signals of 4 and 16 kHz tested at 3,000 ms. Results indicated that the subjects were able to localize all of the broad-band stimuli at each duration and location, including the lowest frequencies which conflicted with Gerstein's predictions. Both subjects also performed above chance levels with the tonal signals but with lower accuracy.

As often happens when conducting research, although one question may be answered, many more arise. These localization investigations demonstrated that subjects were able to localize high, medium and low frequency test signals from four speakers located at 45° , 90° , 270° and 315° . The goal of this dissertation is to expand upon these studies and determine the manatee's ability to determine sound source directionality within all 360° of the azimuth plane and identify the possible means by which they do so.

Chapter Two investigates the manatee's ability to localize test signals at 45° angles within the 360° of the azimuth plane. In this study, two male captive-born

manatees at Mote Marine Laboratory in Sarasota Florida, Hugh and Buffett, were conditioned to participate in an eight-choice localization project. The experimental design of this study expands upon a previous manatee sound localization study (Colbert, 2005) by incorporating a broadband stimulus that spanned a wider range of frequencies (from 0.2-20 kHz to 0.2-24 kHz), one restricted to higher frequencies (from 6-20 kHz to 18-24 kHz), and one limited to lower frequencies (from 0.2-2 kHz to 0.2-1.5 kHz). In addition, a 4 kHz tonal signal was tested at a shorter duration (from 3,000 ms to 200 ms) and the level of the 0.2-24 kHz signal was incrementally reduced to investigate the effects of decreased amplitude.

Chapter Three considers how different frequencies of a test signal, presented at 45° angles within the 360° of the azimuth plane, are filtered by the manatee's head and body to provide interaural level difference cues that may aid sound localization. The same two male captive-born manatees at Mote Marine Laboratory in Sarasota Florida, Hugh and Buffett, participated in this study. These are the first body related transfer function data collected for any Sirenian species.

Chapter Four investigates how auditory evoked potential techniques can be used to evaluate the potential existence sound conduction pathways, outside of the traditional pinna-to-cochlea pathway, which might be used by the manatee since the external auditory meatus is occluded with cellular debris and is separated from the tympanic membrane (Chapla et al., 2007). Four male manatees participated in this study including Hugh and Buffett at Mote Marine Laboratory in Sarasota Florida, and Mo and Bock at Walt Disney World's The Living Seas at EPCOT in Lake Buena Vista, Florida. .

Chapter Five provides a brief summary of the experiments detailed in Chapters Two, Three, and Four, each of which are formatted for individual journal publication. Concluding remarks tie the three Chapters together and address the questions of how well manatees are able to localize sound sources, how interaural intensity cues may facilitate sound localization, and what sound conduction pathways may be used for hearing.

References Cited

- Ahnelt, P.K. & Bauer, G.B. (2000). Unpublished data reported in Ahnelt, P. K. & Kolb, H. (2000). The mammalian photoreceptor mosaic-adaptive design. *Progress in Retinal and Eye Research*, 19, 711-777.
- Ahnelt, P.K. & Kolb, H. (2000). The mammalian photoreceptor mosaic-adaptive design. *Progress in Retinal and Eye Research*, 19, 711-777.
- Bachteler, D. & Dehnhardt, G. (1999). Active touch performance in the Antillean manatee: Evidence for a functional differentiation of the facial tactile hairs. *Zoology*, 102, 61-69.
- Bauer, G.B., Colbert, D.E., Gaspard, J.C. & Littlefield, B. & Fellner, W. (2003). Underwater visual acuity of Florida manatees (*Trichechus manatus latirostris*). *International Journal of Comparative Psychology*, 16, 130-142.
- Bauer, G.B., Gaspard III, J.C., Colbert, D.E., Leach, J. B. & Reep, R. (2005, March). *Tactile Discrimination of Textures by Florida Manatees, Trichechus manatus latirostris*. Paper presented at the 12th annual International Conference on Comparative Cognition, Melbourne, Florida.
- Beck, C.A. & Reid, J.P. (1995). An automated photo-identification catalog for studies of the life history of the Florida manatee. In T. J. O'Shea, B. B. Ackerman, & H. E. Percival (Eds.) *Population Biology of the Florida Manatee*. U.S. Department of the Interior, National Biological Service, Information and Technology Report 1, pp. 120-134.
- Bullock, T.H., Domning, D.P. & Best, R.C. (1980). Evoked potentials demonstrate hearing in a manatee (*Trichechus inunguis*). *Journal of Mammalogy*, 61 (1), 130-133.
- Bullock, T.H., O'Shea, T.J. & McClune, M.C. (1982). Auditory evoked potentials in the West Indian manatee (Sirenia: *Trichechus manatus*). *Journal of Comparative Physiology*, 148, 547-554.
- Chapla, M., Nowacek, D., Rommel, S. & Sadler, V. (2007). CT scans and 3D reconstructions of Florida manatee (*Trichechus manatus latirostris*) heads and ear bones. *Hearing Research*, 228, 123-135.
- Cohen, J.L., Tucker, G.S., & Odell, D.K. (1982). The photoreceptors of the West Indian

- manatee. *Journal of Morphology*, 173, 197-202.
- Colbert, D. (2005). Sound Localization Abilities of Two Florida Manatees, *Trichechus manatus latirostris*. Unpublished Masters Thesis, University of South Florida, Tampa, FL.
- Florida Department of Highway Safety and Motor Vehicles (2007). *Annual vessel statistics*. <http://www.hsmv.state.fl.us/dmv/vslfacts.html>
- Florida Fish & Wildlife Research Institute (2007a). *Annual synoptic surveys*. http://research.myfwc.com/features/view_article.asp?id=15246
- Florida Fish & Wildlife Research Institute (2007b). *Annual mortality rates*. http://research.myfwc.com/features/view_article.asp?id=12084
- Gaydos, H.F. (1958). Sensitivity in the judgement of size by finger span, *The American Journal of Psychology*, 71, 557-562.
- Gerstein, E. (1999). Psychoacoustic Evaluations of the West Indian manatee (*Trichechus manatus latirostris*). Unpublished Doctoral Dissertation, Florida Atlantic University, Boca Raton, FL.
- Gerstein, E., Gerstein, L., Forsythe, S. & Blue, J. (1999). The underwater audiogram of the West Indian manatee (*Trichechus manatus*). *Journal of the Acoustical Society of America*, 105, 3575-3583.
- Griebel, U. & Schmid, A. (1996). Color vision in the manatee (*Trichechus manatus*). *Vision Research*, 36, 2747-2757.
- Griebel, U. & Schmid, A. (1997). Brightness discrimination ability in the West Indian manatee (*Trichechus manatus*). *Journal of Experimental Biology*, 200, 1587-1592.
- Hartman, D.S. (1979). *Ecology and Behavior of the manatee (Trichechus Manatus) in Florida*. Special publication No. 5 (153 pp.) The American Society of Marine Mammalogists.
- Heffner, R.S. & Heffner, E.H. (1992). Evolution of sound localization in Mammals. In D. Webster, R. Fay & A. Popper (Eds.) *The Biology of Hearing*. New York, Springer-Verlag, pp. 691-715.
- Ketten, D.R., Odell, D.K. & Domning, D.P. (1992). Structure, function, and adaptation of the manatee ear. In J.A. Thomas, R.A. Kastelein, & A.Y. Supin (Eds.) *Marine Mammal Sensory Systems* (pp.77-79). NY: Plenum Press.

- Klishen, V.O., Diaz, R.P., Popov, V.V. & Supin, A.Y. (1990). Some characteristics of hearing of the Brazilian manatee, *Trichechus inunguis*. *Aquatic Mammals*, 16 (3), 139-144.
- Mann, D., Colbert, D.E., Gaspard, J.C. III, Casper, B., Cook, M.L.H., Reep, R.L. & Bauer, G.B. (2005). Temporal resolution of the Florida manatee (*Trichechus manatus latirostris*) auditory system. *Journal of Comparative Physiology*, 191, 903-908.
- Marshall, C.D., Huth, G.D., Edmonds, V.M. Halin, D.L. & Reep, R.L. (1998). Prehensile use of perioral bristles during feeding and associated behaviors of the Florida manatee (*Trichechus manatus latirostris*). *Marine Mammal Science*, 14, 274-289.
- Marshall, C.D., Maeda, H., Iwata, M., Furuta, M., Asano, A., Rosas, F. & Reep, R.L. (2003). Orofacial morphology and feeding behavior of the dugong, Amazonian, West African, and Antillean manatees (Mammalia: Sirenia): Functional morphology of the muscular-vibrissal complex. *Journal of Zoology*, 259, 245-260.
- Mass, A.M., Odell, D.K., Ketten, D.R. & Supin, A.Y. (1997). Ganglion layer topography and retinal resolution of the Caribbean manatee *Trichechus manatus latirostris*. *Doklady Biological Sciences*, 355, 392-394.
- Odell, D. K., & Reynolds, J. E. III. (1979). Observations on manatee mortality in South Florida. *Journal of Wildlife Management*, 28 (3), 572-577.
- Piggins, D.J., Muntz, W.R.A. & Best, R.C. (1983). Physical and morphological aspects of the eye of the manatee, *Trichechus inunguis*. *Marine Behaviour and Physiology*, 9, 111-130.
- Popov, V.V. & Supin, A.Y. (1990). Electrophysiological studies on hearing in some cetaceans and a manatee. In J.A. Thomas, & R. A. Kastelein (Eds.), *Sensory Abilities of Cetaceans: Laboratory and Field Evidence*. NY: Plenum Press.
- Reep, R.L., Marshall, C.D., Stoll, M.L., Homer, B.L. & Samuelson, D.A. (2001). Microanatomy of facial vibrissae in the Florida manatee: the basis for specialized sensory function and oripulation. *Brain Behavior and Evolution*, 58, 1-14.
- Reep, R.L., Marshall, C.D. & Stoll, M.L. (2002). Tactile hairs on the postcranial body in Florida manatees: a mammalian lateral line? *Brain Behavior and Evolution*, 59, 141-154.
- Reynolds, J.E. III. (1979). The semisocial manatee. *Natural History*, 88 (2), 44-53.
- Reynolds, J.E. & Odell, D.K. (1991). *Manatees and Dugongs* (192 pp.). NY: Checkmark Books.

- Reynolds, J.E. III, & Wilcox, J.R. (1986). Distribution and abundance of the West Indian manatee, *Trichechus manatus*, around selected Florida power plants following winter cold fronts: 1984-1985. *Biological Conservation*, 38, 103-113.
- U.S. Fish and Wildlife Service (2001). *Florida Manatee Recovery Plan, (Trichechus manatus latirostris), Third Revision*. U.S. Fish and Wildlife Service, Atlanta, Georgia. 144 pp.
- Walls, G.L. (1963). *The vertebrate eye and its adaptive radiation*. NY: Hafner.
- West, J.A., Sivak, J.G., Murphy, C.J. & Kovacs (1991). A comparative study of the anatomy of the iris and ciliary body in aquatic mammals. *Canadian Journal of Zoology*, 69, 2594-2607.

**Chapter Two: Eight-Choice Sound Localization Abilities of Two Florida Manatees,
*Trichechus manatus latirostris***

Abstract

An eight-choice discrimination paradigm was used to determine the sound localization abilities of two Florida manatees (*Trichechus manatus latirostris*) within a 360° array of speakers positioned 45° apart. Five conditions were tested including a 3,000 ms and 200 ms, 95 dB, 0.2-24 kHz broadband signal, a 3,000 ms, 80 dB, 18-24 kHz broadband signal that was restricted to frequencies with wavelengths shorter than a manatee's interaural time distances, a 3000 ms, 110 dB, 0.2-1.5 kHz broadband signal that was limited to frequencies with wavelengths longer than their interaural time distances, and a 200 ms, 101 dB, 4 kHz tonal stimulus that's an approximate midpoint of the fundamental frequency range of manatee vocalizations. A sixth condition attenuated the spectrum level of the 3,000 ms, 95 dB, 0.2-24 kHz signal in 3 dB increments until accuracy reached 75%.

Both subjects performed well above the 12.5% chance level for all broadband frequencies tested. They also were able to localize over a fairly large sound level range with Hugh's accuracy at 48% and Buffett's at 56% when the signal was presented at 80 dB re 1 μ Pa. Accuracy deteriorated to 14 % for Hugh and 20 % for Buffett when the 4 kHz, 200 ms, 101 dB re 1 μ Pa signal was tested. Errors were primarily located at the

“nearest neighbor” locations on either side of the signal source location when presented in the front 180° but became more dispersed when signals originated from the 135° , 180° and 225° locations. Very few front to back confusions were made and accuracy was greater when test signals originated from the front 180° and with the longer 3,000 ms duration of the 0.2-24 kHz signal.

Results from this study demonstrate that the subjects could localize short duration and low intensity test signals within the frequency ranges of recreational boat engines and conspecifics in all 360° of the azimuth plane at distances of at least 3 meters.

Introduction

The Florida manatee (*Trichechus manatus latirostris*) is a sub-species of the West Indian manatee (*Trichechus manatus*) protected by both the Marine Mammal Protection Act (1972) and the Endangered Species Act (1973). It is the only marine mammal that is euryhaline, living in both saltwater and freshwater habitats depending on the time of year (Reynolds & Wilcox, 1986; Reynolds & Odell, 1991). It has been described as a semi-social species, often grazing or traveling alone, although females with calves will often congregate together and males will frequently mass around an estrous female for mating purposes (Reynolds, 1979). It is threatened by naturally occurring events such as cold stress and red tide, as well as by human-influenced events such as canal lock compression, habitat degradation, and boat strikes (Odell & Reynolds, 1979). The frequency of deaths caused specifically by watercraft remains relatively stable ranging between 19-31% of the annual mortalities (Florida Fish and Wildlife Research Institute, 2007; Table 1-1).

Although field research has provided crucial information about the manatee's social structure, habitat usage and annual migratory behaviors, the means by which they are able to find one another, determine directionality, and avoid danger in their vast habitat is unclear. Research has not been published regarding the manatee's gustatory and olfactory sensory systems, however anatomical and behavioral studies have gained considerable insight into the manatee's visual and tactile sensory processes. The manatee visual sensory system is built for sensitivity in dim light conditions with the ability to

differentiate brightness differences (Griebel & Schmid, 1997) and blues from greens (Cohen et al., 1982; Griebel & Schmid, 1996; Ahnelt & Kolb, 2000; Ahnelt & Bauer, 2000), but acuity is poor (Walls, 1963; Piggins et al., 1983; West et al., 1991; Mass et al., 1997; Bauer et al., 2003) and not useful for fine details. Tactile sensitivity appears to be excellent (Bachteler & Dehnhardt, 1999; Reep et al., 2002; Bauer et al., 2005), but like vision, is probably designed to function with nearby tasks.

It seems likely that the manatee's auditory sensory system plays a crucial role with functioning not only in close proximity, but also in more distant scenarios and that the ability to determine conspecific and boat engine sound source directionality would be of great importance. Manatee vocalizations are characterized as short harmonic complexes that range from almost pure tones to broad-band noise and have a fundamental frequency that ranges between 2.5 – 5.9 kHz, but can extend to 15 kHz (Nowacek, et al., 2003). The dominant recreational boat engine frequency ranges between 0.01 – 2 kHz, but can reach over 20 kHz with the estimated 1/3-octave source levels at 120-160 dB re 1 μ Pa at 1 m for small motorboats (Gerstein, 2002; Richardson et al., 1995) and at approximately 9 dB quieter for personal watercraft, such as jet-skis (Buckstaff, 2004). Boats traveling at rapid speeds typically produce higher frequency cavitating noise, while those traveling at idle and slow speeds produce lower frequency non-cavitating noise (Ross, 1976; Miksis-Olds, 2006).

Sound localization is the auditory system's ability to process the frequency, level, and phase of a sound and associate it with the spatial location of that sound's source (Yost, 2000). Sound can be localized from the vertical, distance and azimuth (horizontal) planes using interaural time, phase, and/or level difference cues. Interaural

time differences compare the time the sound arrives at each ear; since the speed of sound is relatively constant and not effected by frequency wavelength, frequency variations do not have an effect on the perception of interaural time differences. Interaural phase differences compare the period of the sound as it arrives at each ear and is affected by frequency wavelength. Interaural level differences compare the level or amplitude of a sound as it reaches each ear and is also affected by wavelength with higher frequencies having shorter wavelengths and greater sound shadows (Yost, 2000).

The ability to localize sounds is considered a primary source of selective pressure in the evolution of mammalian hearing (Masterson et al., 1969) and is vital for many species' ability to find food and conspecifics while avoiding predation. Behavioral testing of sound localization abilities has typically been investigated by measuring the species' minimum audible angle (MAA) (Brown, 1994; Brown & May, 1990). This method determines the smallest detectable angular difference between two sound source locations positioned in front of the subject in the azimuth plane (Mills, 1958).

Numerous in-air auditory localization studies have been conducted with terrestrial mammals including humans (Stevens & Newman, 1936; Mills, 1972), monkeys (Don & Star, 1972; Houben & Gourevitch, 1979; Brown et al., 1980), the domestic cat (Casseday & Neff, 1973; Wakeford & Robinson, 1974; Heffner & Heffner, 1988b), red fox (Isley & Gysel, 1975), hedgehog (Masterson et al., 1975), elephant, horse, Norway rat, pig, gerbil, Northern grasshopper mouse, pocket gopher, goat and cattle (Heffner & Heffner, 1982; 1984; 1985; 1988a; 1988c; 1989; Heffner & Masterson, 1990; Heffner & Heffner, 1992b respectively). Results from these studies suggest that some combination of interaural time, level and phase difference cues are used to localize sounds although some species

have reduced or lost the ability to use one or two of them, and one species (pocket gopher) cannot use any of them and is incapable of sound localization.

While in-air localization may be difficult or impossible for some terrestrial species, the ability to localize sounds underwater presents additional challenges to marine mammals. The speed of sound in water (1500 m/second) travels approximately five times faster than in air (340m/second) (Urlick, 1996) requiring marine mammal auditory systems to process interaural time, phase and level differences much more rapidly than terrestrial mammals. Although most acoustic energy propagates more efficiently in water than light, thermal or electromagnetic energy (Au, 1993), in shallow waters, higher frequencies become more directional, reflecting off the surface and bottom and hindering sound wave travel efficiency and very low frequencies may not propagate well (Medwin & Clay, 1998). Marine mammals likely utilize underwater acoustic information for reproduction and territorial purposes (Watkins & Schevill, 1979; Cleator & Stirling, 1990; Bartsh et al., 1992; Hanggi & Schusterman, 1994; Rogers et al., 1996; Smolker & Pepper, 1996; Van Parijs et al., 1999; Van Parijs et al., 2000a; Van Parijs et al., 2000b; Serrano & Terhune, 2002; Van Parijs et al., 2003; Bjørgesaeter et al., 2004; Hayes et al., 2004), individual identification (Caldwell & Caldwell, 1965; Sayigh et al., 1990; Sayigh et al., 1995), prey detection (Barrett-Lennard et al., 1996; Tyack & Clark, 2000; Gannon et al., 2005), predator avoidance (Deecke et al., 2002) and navigation (Norris, 1967).

Minimum audible angle measurements have also been assessed for some marine mammals including pinnipeds (Gentry, 1967; Anderson, 1970; Moore, 1974; Terhune, 1974; Moore & Au, 1975; Babushina and Poliakov, 2004; Holt et al., 2004) and cetaceans (Renaud & Popper, 1975; Moore & Pawloski, 1993; Moore and Brill, 2001).

More recently, some pinniped sound localization investigations have required subjects to identify sound sources relative to different locations surrounding the subject's body. This has been done by presenting signals in the frontal 180° or complete 360° of the horizontal plane surrounding a stationary subject (Kastelein et al., 2007) or by having the subject swim along a half circle diameter and orient towards a sound source when presented (Bodson et al., 2006). All three designs assess sound localization abilities, however the latter two have enhanced real-life scenario applications by addressing the subject's ability to determine sound source directionality as sounds originate from different angles surrounding the body.

Given that the Florida manatee's visual and tactile sensory systems are better adapted for use with tasks in close proximity to their bodies, it seems likely that their auditory sensory system has developed to function with both near-field and far-field scenarios and that the ability to determine sound source directionality would be of great importance. This area of research however, has not been widely investigated and is relatively new.

Heffner and Heffner (1992a) generated a regression equation that described the relationship between interaural time delays, the distance sound travels from one ear to the other divided by the speed of sound, and the upper frequency hearing limits for a variety of species (Figure 2.1). Animals with narrower heads had smaller interaural time delays and typically needed higher frequency sensitivity to be able to localize sounds. Ketten et al. (1992) calculated the manatee intermeatal distance as 278 mm with a maximum acoustic travel time of 258 μ sec, and the intercochlear distance as 82 mm with a maximum acoustic travel time of 58 μ sec. When these time delays were plotted on

Heffner and Heffner's regression line, it appeared that manatees would need to be able to hear in the 50–90 kHz frequency range to be able to localize sounds (Figure 2.1).

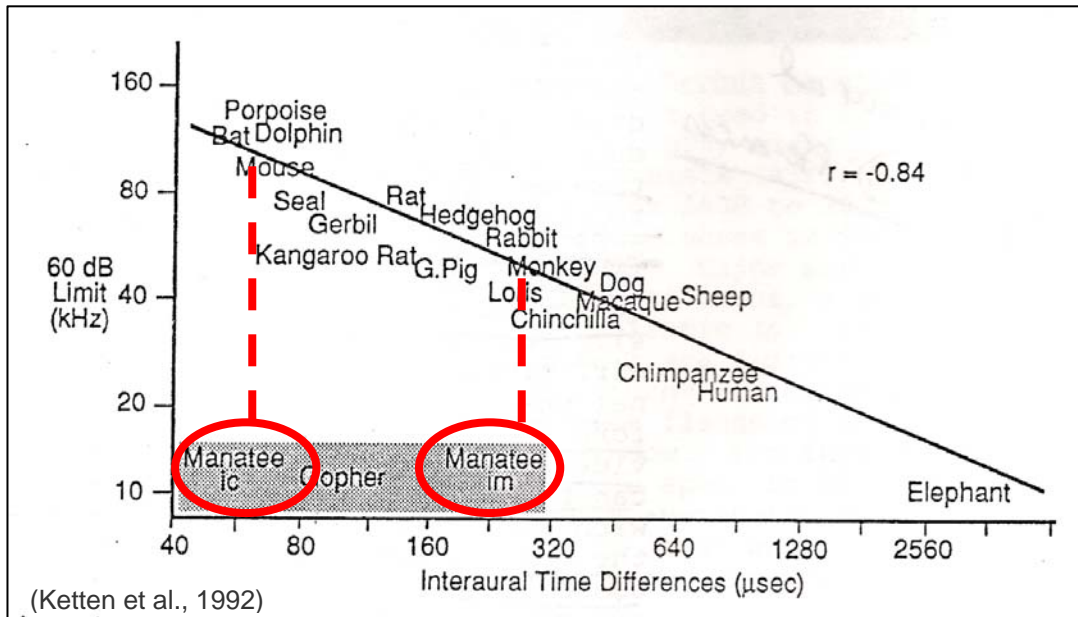

Figure 2.1. Interaural distances vs. maximum frequency perceived at 60 dB SPL (from Ketten et al., 1992). Behavioral audiogram sensitivity data are plotted by each species' interaural time distances. The gopher's and manatee's (ic=intercochlear; im=intermental) maximum perceived frequency varied significantly from the regression.

The hearing range of the manatee has been assessed through the development of an audiogram and by utilizing auditory evoked potential techniques. Gerstein et al. (1999) obtained a behavioral audiogram for two manatees, which showed hearing thresholds that ranged from 0.5–38 kHz for one subject and 0.4–46 kHz for the other. The frequency range of best hearing was between 10–20 kHz and maximum sensitivity was ~50 dB re: 1 μPa at 16 and 18 kHz, decreasing by ~20 dB per octave from 0.8 to 0.4 kHz and 40 dB per octave above 26 kHz. Auditory evoked potential measurements have been obtained in several studies. Bullock et al. (1980; 1982) and Popov and Supin (1990) found that the highest frequency detection reached 35 kHz when tested in air and Klishen et al. (1990) found it reached 60 kHz when tested in water. More recently, Mann et al.

(2005) found that detection reached 40 kHz when tested in water, results similar to those found by Bullock (1980; 1982), and Popov and Supin (1990).

Given that the upper end of the manatee's hearing range lies between 40 -60 kHz, below or bordering the 50–90 kHz frequency range estimate needed for localization, the prediction was made that manatees may not possess effective sound localization abilities (Ketten et al., 1992). This prediction however, was not supported by the results of two separate four-choice (45°, 90°, 270°, 315°) sound localization studies (Gerstein, 1999; Colbert, 2005).

Gerstein (1999) tested the ability of one manatee, Stormy, to localize 0.5, 1.6, 3, 6, or 12 kHz tonal test signals from four speakers located 1 m away from the subject at a depth of 1.5 m below the surface. All signals were presented at 125 dB re: 1 uPa, approximately 30 dB above white noise that was also projected through the speakers. The signals were pulsed for either 200 or 500 ms, paused for 400 ms, and then repeated, thereby creating a 400 ms signal which spanned an 800 ms duration and a 1,000 ms signal which spanned a 1,400 ms duration. Each condition was composed of 80 trials.

Results indicated that conditional accuracy was well above the 25% chance level (Table 2.1). Overall accuracy for frequency ranged from 58-78% with the 400 ms signals and 56-88% with the 1,000 ms signals. Overall accuracy for location ranged from 62-68% with the 400 ms signals and 68-74% with the 1,000 ms signals. Subject performance decreased as frequency and duration decreased. Given the subject's reduced level of performance with the low frequency stimuli, Gerstein suggested that manatees may have difficulty localizing low frequency boat engine noise.

Table 2.1. Overall performance within and between location, duration and frequency conditions of Gerstein's (1999) four-choice localization experiment. Results are based on 80 trials per condition with chance at 25%.

400 ms Signal (over an 800 ms duration)						
Location	0.5 kHz	1.6 kHz	3 kHz	6 kHz	12 kHz	<i>Overall Accuracy by Location</i>
45°	60%	65%	65%	70%	80%	68%
90°	60%	60%	60%	60%	75%	63%
270°	55%	60%	60%	65%	70%	62%
315°	55%	60%	60%	65%	85%	65%
<i>Overall Accuracy by Frequency</i>	58%	61%	61%	65%	78%	
1,000 ms Signal (over a 1,400 ms duration)						
45°	55%	65%	80%	80%	90%	74%
90°	55%	65%	65%	70%	85%	68%
270°	55%	60%	70%	70%	85%	68%
315°	60%	60%	75%	85%	90%	72%
<i>Overall Accuracy by Frequency</i>	56%	63%	73%	76%	88%	

Colbert (2005) expanded upon the previous four-choice sound localization task (Gerstein, 1999) by testing the abilities of two manatees, Hugh and Buffett, to localize sounds that were systematically varied across dimensions of bandwidth and duration. Two tonal signals were used, a 4 kHz tone that was midway between the 2.5–5.9 kHz fundamental frequency range of typical manatee vocalizations (Nowacek et al., 2003) and a 16 kHz tone that was in the 10–20 kHz range of manatee best hearing (Gerstein et al., 1999). Broadband stimuli were also introduced which spanned a wide range of frequencies (0.2–20 kHz) as well as those restricted to high frequencies that had wavelengths that were shorter than their interaural time distances (6–20 kHz) and low frequencies with wavelengths that were longer than their interaural time distances (0.2–2 kHz). Duration was manipulated within the broadband conditions and included signal

lengths of 200 ms that prohibited head movement as well as 500, 1,000, and 3,000 ms. All stimuli were tested at 100 dB re: 1 uPa (± 1.5 dB) from four speakers located 1.05 m away from the subject at a depth of 0.75 m below the surface (Figure 2.2). Although white noise was not introduced, exhibit background noise was continuous and typically below 500 Hz, indicating the possibility of masking at lower frequencies.

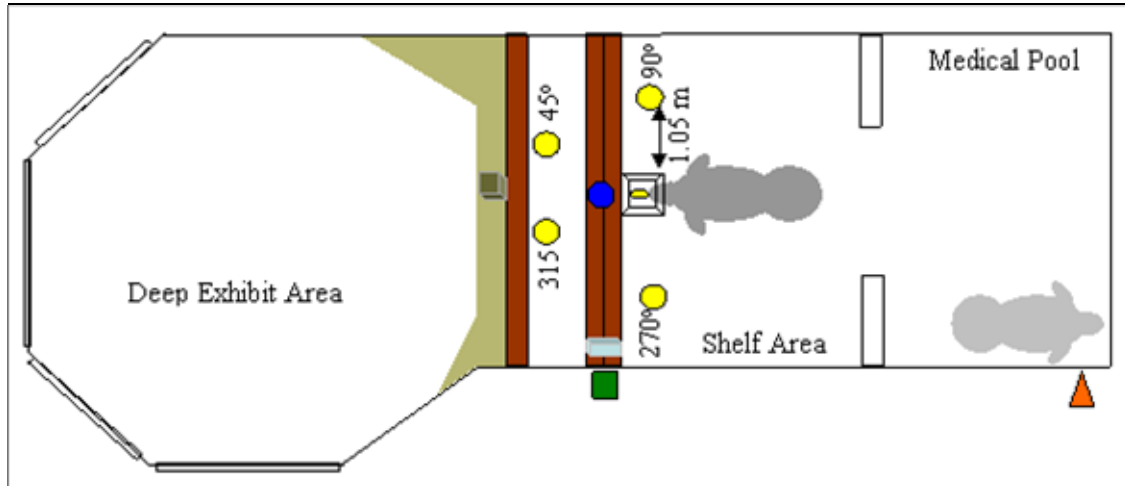

Figure 2.2. Testing configuration for Colbert's (2005) four-choice localization experiment. Test speakers (yellow circles) were located 105cm from the subject and .75m below the surface. The blue octagon represents the Test Trainer's position, the green square represents the Data Recorder's position and the orange triangle represents the Stationing Trainer's position.

Each of the 14 conditions was composed of 72 trials. Both subjects performed well above the 25% chance level for all of the broadband frequency conditions (Table 2.2). Hugh showed a drop in percentage correct as the broadband signal duration decreased, but this result was not observed with Buffett. Both animals also performed above chance levels with the tonal signals, but with lower accuracy than with the broadband signals.

Table 2.2. Overall performance within and between the duration and frequency conditions of Colbert's (2005) four-choice localization experiment. Results are based on 72 trials per condition with chance at 25%.

Frequency (kHz)						
Duration:	0.2 - 20	6 - 20	0.2 - 2	Mean	4	16
Hugh						
200 ms	64%	51%	58%	58%		
500 ms	71%	63%	57%	64%		
1000 ms	74%	71%	65%	70%		
3000 ms	93%	86%	81%	87%	49%	32%
<i>Mean</i>	76%	68%	65%			
Buffett						
200 ms	93%	89%	85%	89%		
500 ms	85%	92%	86%	88%		
1000 ms	93%	79%	92%	88%		
3000 ms	88%	82%	92%	87%	44%	33%
<i>Mean</i>	90%	86%	89%			

The overall broadband error rate, derived from the complete data set (excluding tonal results) collapsed across all conditions, was only 11% for Buffett and 22% for Hugh. Frequency selection distributions (percent of location selections by frequency, collapsed across duration) revealed that although differences in performance accuracy were found between subjects within the broadband signal conditions, errors were generally consistent, with most equally distributed to the locations adjacent to the correct location, however error distribution for the tonal signal conditions were almost equally scattered among the four locations (Figure 2.3). Similar results were found for duration selection distributions (percent of location selections by duration, collapsed across frequency) and those calculated for each of the individual broadband conditions (percent of location selections within the 12 individual broadband conditions).

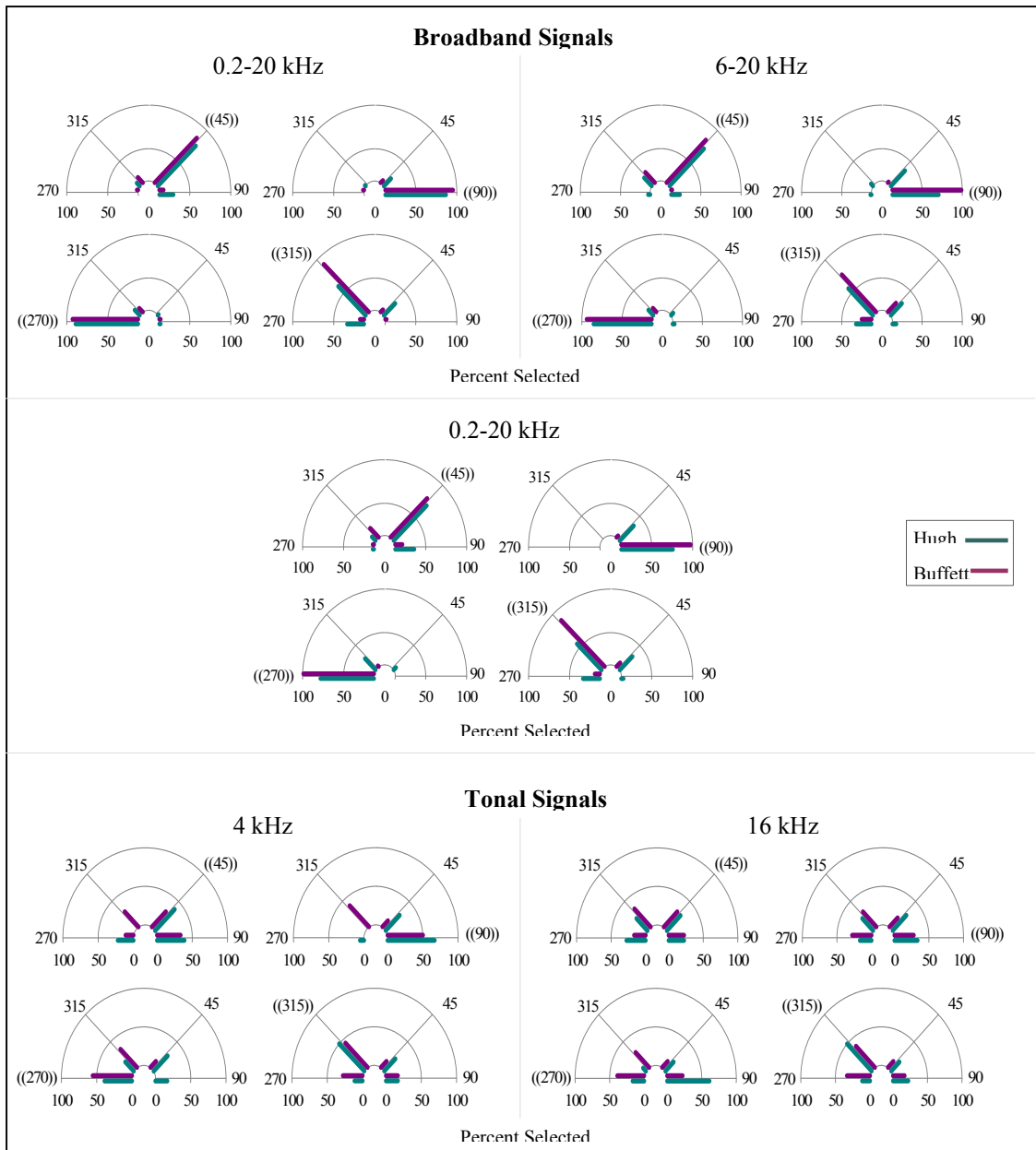

Figure 2.3. Percent correct and distribution of sound localization errors by frequency collapsed across duration in Colbert's (2005) 4-choice sound localization study. Tonal conditions are presented in the bottom row. Correct speaker location is notated by double parentheses. Buffett's results are presented above the grid lines in magenta and Hugh's below in teal.

The results from Colbert's (2005) sound localization study suggested that although manatees could localize tonal signals, they were better able to localize broadband noises as is typical with many species (Stevens & Newman 1936; Marler, 1955; Casseday & Neff, 1973), which likely accounted for higher accuracy as compared

to those in Gerstein's (1999) study. While results from both sound localization studies indicated that manatees were able to localize test signals that originated from a distance of ~1 m to the front 180° of the azimuth plane, questions remain regarding their ability to localize sounds within all 360°.

The objective of this study was to investigate the manatee's ability to localize test signals that were systematically varied across dimensions of bandwidth, duration and level as they originated from 45° angles within all 360° of the azimuth plane at a distance ~3 times greater than previously tested.

Hypotheses

Five hypotheses were made. The first posited that subjects would be able to localize all of the broadband test signals above the 12.5% chance level at all eight locations within the 360°. Prior manatee localization studies (Gerstein, 1999; Colbert, 2005) demonstrated that subjects were able to determine the origin of sound sources to the front 180°, but had difficulty with tonal signals. A field study which investigated manatee responses to controlled boater approaches suggested that manatees angled away from, increased swimming speed, and oriented towards deeper channel waters when boats with broadband engine noise approached from all directions (Nowacek et al., 2004).

The second hypothesis declared that subjects would have greater localization accuracy with the 0.2-24 kHz test signal at the 3,000 ms duration versus the 200 ms duration. Colbert's (2005) four choice manatee sound localization study found that subject accuracy decreased as duration decreased. The 0.2-24 and 4 kHz signals presented in the current investigation serves as a means to determine manatee localization abilities without their ability to orient towards the sound source during its presentation.

The third hypothesis stated that subjects would have greater localization accuracy to the anterior 180° than to the posterior 180°. Previous studies have suggested that the ability to localize a sound source may be influenced by multimodal sensory systems and be a function of visual orientation responses (Heffner, 1997). Reflexive visual

orientation towards startling sounds have been found in a wide variety of species at birth (or when their auditory systems become functional) including humans, gulls, ducks, cats, rats and guinea pigs (Brown, 1994).

The fourth hypothesis asserted that subject errors would have a higher distribution to the correct locations “nearest neighbors” rather than to other locations. Colbert’s (2005) previous manatee localization study demonstrated that error distribution was highest amongst the two speakers neighboring the test speaker than the other speakers when broadband frequency signals were tested.

The final hypothesis contended that subjects would make more differentiation errors between speakers located at 0° and 180° than any other contralateral pairs. Middlebrooks and Green (1991) demonstrated that front to back sound localization confusions were typical with human subjects and attributed these results to the fact that stimulus locations lie in mirror symmetry with respect to the subject’s ears which eliminate interaural time of arrival, phase and level cues.

Materials and Methods

Subjects

The subjects of this study were two captive-born male Florida manatees (*Trichechus manatus latirostris*) that reside at Mote Marine Laboratory and Aquarium in Sarasota, Florida. All procedures used were permitted through the United States Fish and Wildlife Service (Permit # MA837923-6) and approved by the Institutional Animal Care and Use Committee of Mote Marine Laboratory and Aquarium. At the inception of this study Hugh was 23 years of age, weighed 547 kg and was 310 cm in length, while Buffett was 20 years of age, weighed 773 kg and was 334 cm in length. They were housed in a 265,000 liter exhibit that was composed of three inter-connected sections: a 3.6 x 4.5 x 1.5 m Medical Pool, a 4.3 x 4.9 x 1.5 m Shelf Area, and a 9.1 x 9.1 x 3 m Exhibit Area (Figure 2.4). Both animals had acquired an extensive training history over the previous seven years and participated in an auditory evoked potential study (Mann et al., 2005) and a four-choice sound localization study (Colbert, 2005), making them excellent candidates for this project. In addition, they had been behaviorally conditioned for husbandry procedures (Colbert et al., 2001), a serum and urine creatinine study (Manire et al., 2003), a visual acuity study (Bauer et al., 2003), a lung capacity study (Kirkpatrick et al., 2002), and a vibrissae tactile sensitivity study (Bauer et al., 2005).

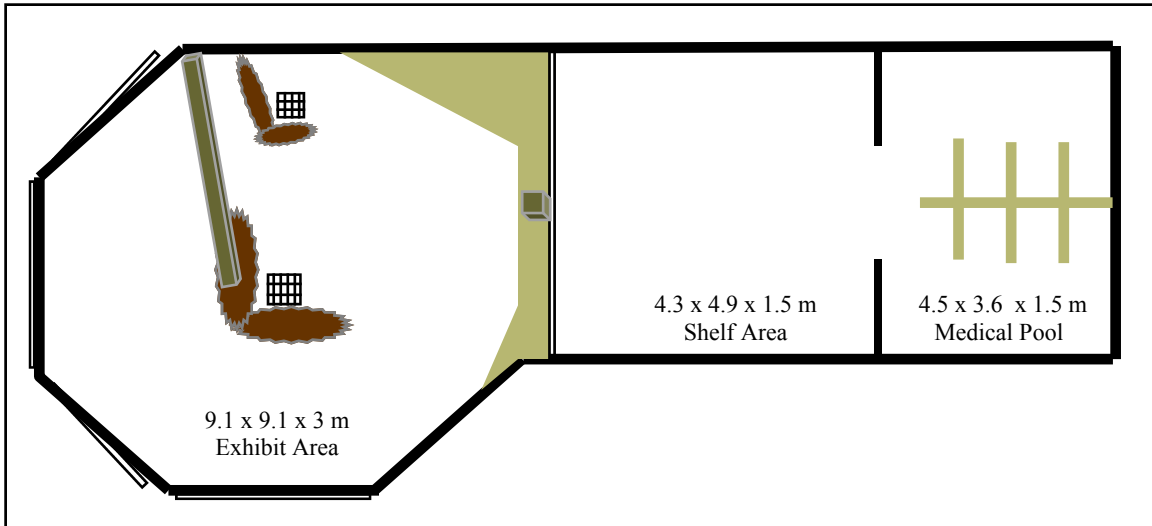

Figure 2.4: Diagram of the 265,000 L manatee exhibit composed of a Medical Pool, Shelf Area, and Exhibit Area. The lines in the Medical Pool represent a distance scale, used in a previous study that was painted on the floor of the exhibit. The oval masses in the Exhibit Area represent outcroppings in the bottom terrain (built of cement) to conceal the two floor-level filtration drains (gratings). The rectangles represent a tree log and stump (built of cement).

Subject Training

The majority of animal training procedures utilized in Colbert's (2005) four-choice sound localization study were maintained in this study, although some modifications were necessary (see Colbert, 2005 for the specific animal training procedures). The testing set-up was moved from the Shelf Area to the Exhibit Area where the stationing bar and test speakers were lowered from a depth of 0.75 m to 1.5 m, half way between the water's surface and the exhibit bottom. Eight underwater speakers (Aquasonic AC 339) were positioned 45° apart at 0°, 45°, 90°, 135°, 180°, 225°, 270° and 315°. The distance between the stationing apparatus and the test speakers was increased from 1.05 m to 3.05 m. Because the water in the deep area had a strong counter-current circulation originating at ~160°, the subjects needed to face east rather than south to reduce drag (Figure 2.5).

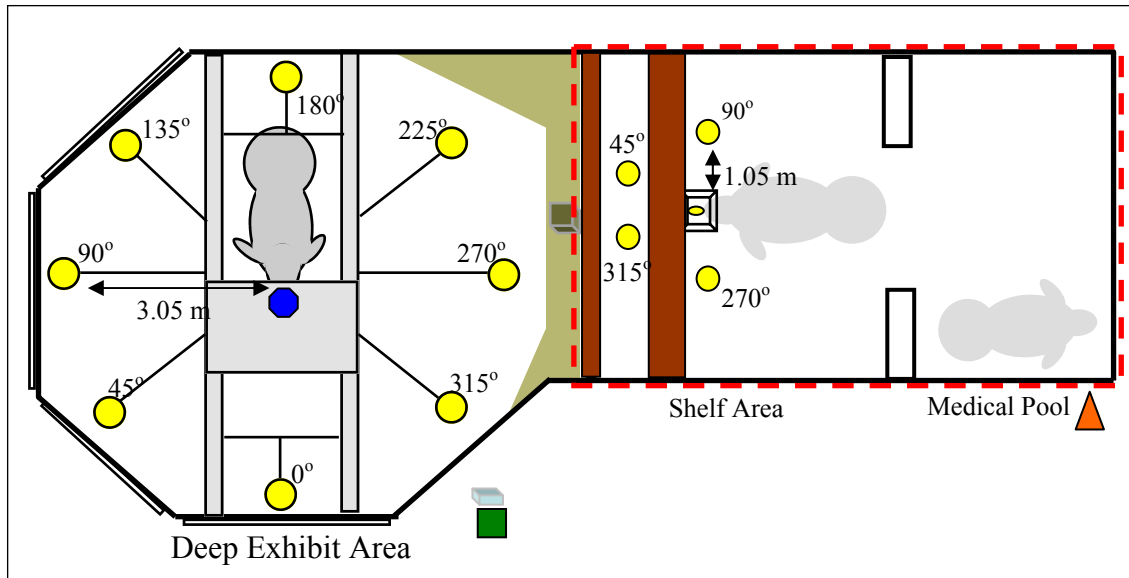

Figure 2.5. Training setup comparison for the Colbert's four-choice and eight-choice sound localization experiments. The setup was moved from the Shelf Area (outlined by red dashed line) to the Exhibit Area where the subjects faced east rather than south, the stationing bar and test speakers were lowered from a depth of 0.75 m to 1.5, and the distance between the two was increased from 1.05 m to 3.05 m.

The procedures utilized in Colbert's (2005) four-choice sound localization study required that the subjects be trained to respond to a unique station signal that was played from a speaker located on a stationing apparatus. The call-to-station signal ranged from 10 to 20 kHz and played for a 2000 ms duration, however Buffett's repeated at a slower rate of 1.5/sec while Hugh's repeated at a faster rate of 5/sec. In response to their stationing signal, each subject was trained to position the crease on the top of its rostrum (approximately 10 cm posterior to the nostrils) up against a stationing bar located at the bottom of the stationing apparatus. The manatee remained stationed until a test signal was played from one of the four underwater speakers that were suspended from poles that pivoted, whereupon he swam to and pushed the speaker from which the sound originated. If correct, a secondary reinforcer signal was emitted from the test speaker and the subject returned to the stationing device to be fed primary food reinforcement. The secondary reinforcement signals were programmed in RPs and matched the unique whistles used

to bridge each animal (Appendix A). Buffett's reinforcement signal ranged from 14 to 120 kHz with a peak at 53 kHz, while Hugh's had more of a warble to it and ranged from 12 to 110 kHz with a peak at 27 kHz (Figure 2.6). If incorrect, the stationing signal was played from the stationing apparatus speaker and the subject re-positioned correctly with no primary or secondary reinforcement given, and waited a minimum of 60 seconds for the initiation of the next trial.

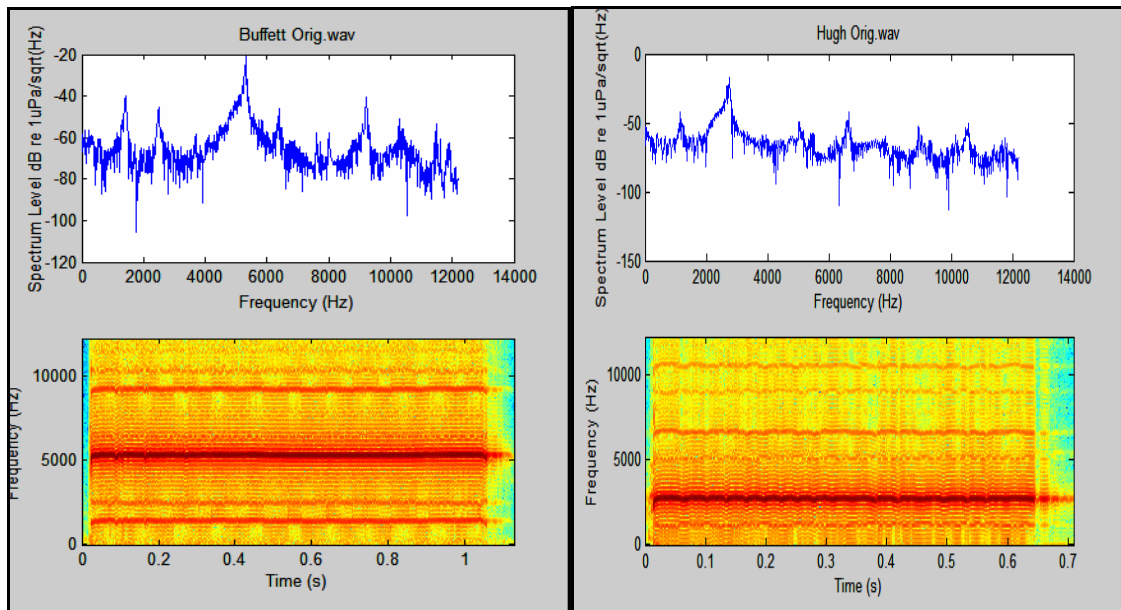

Figure 2.6. Power spectra (top) and spectrograms (bottom) of the secondary reinforcement signals. Buffett's ranged from 14 to 120 kHz with a peak at 53 kHz, while Hugh's had more of a warble to it and ranged from 12 to 110 kHz with a peak at 27 kHz.

Although these same procedures were used with the eight-choice sound localization study, several behaviors needed to be re-shaped to meet the change in stationing direction (from south to east), increased stationing depth (from 0.75 m to 1.5 m), and extended test speaker distance (from 1.05 m to 3.05 m) criteria. All new behaviors were trained using standard positive classical and operant conditioning techniques. Each animal's unique secondary reinforcement whistle was used to bridge correct behaviors as they occurred and primary reinforcers included bite size pieces of

apples, beets and baby peeled carrots. Zupreem monkey biscuits, one of the manatees preferred foods, were used to reward especially desired behaviors during shaping procedures. In addition, verbal and tactile secondary reinforcers were used. All new or modified behaviors were shaped by reinforcement of successive approximations (Pepper & Defran, 1975). Undesirable behaviors were ignored and time-outs, (Pepper & Defran, 1975; Domjan, 1998) or the removal of the opportunity to receive reinforcement, were used if a string of undesirable behaviors occurred.

Both animals had previously been trained to station and follow their own personal target, and in the early stages of shaping the stationing behavior when facing east, the trainer used the subject's target to guide him to the shorter, four-choice sound localization stationing bar which was adapted to fit over a platform suspended across the Exhibit Area. Shaping of the correct position was facilitated by the trainer's reaching into the water to help maneuver the manatee into the correct position. When this was accomplished, the 23 cm wide stationing apparatus, constructed from 2.54 cm diameter polyvinyl chloride (PVC) pipe, was modified to reach 1.5 m below the surface of the water (Figure 2.7). Shaping of the stationing behavior at the 1.5 m depth was accomplished by lowering the stationing apparatus in gradual steps.

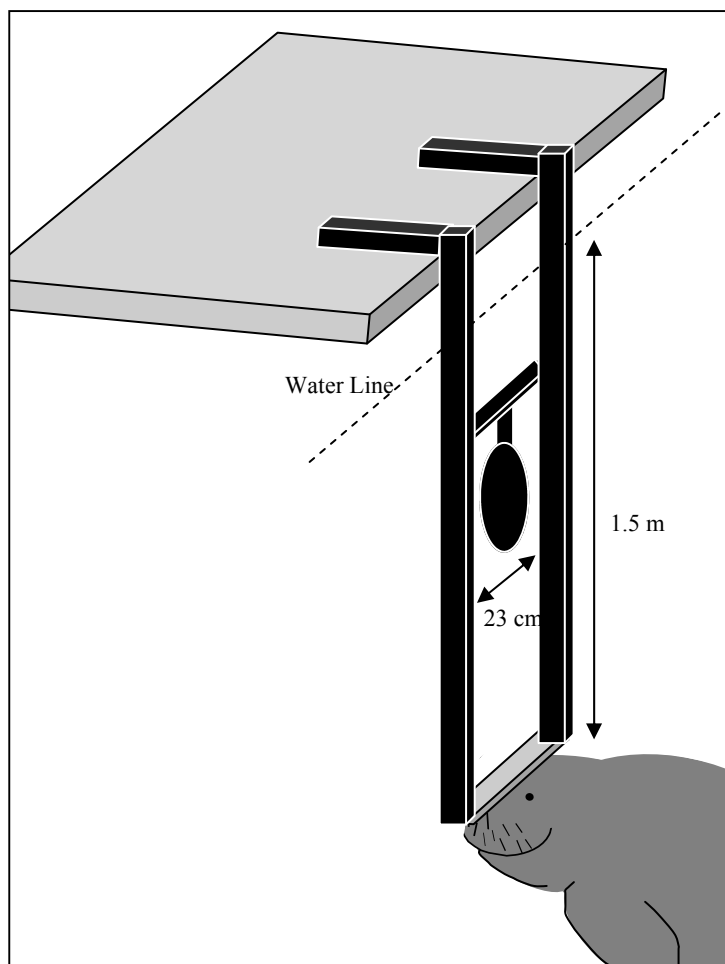

Figure 2.7. Stationing apparatus used in the eight-choice sound localization study. The black circle represents the speaker that played the stationing tones. The subject pressed the crease of his rostrum up against the gray stationing bar on the bottom.

Eight underwater speakers (Aquasonic AC 339) were positioned 45° apart at 0° , 45° , 90° , 135° , 180° , 225° , 270° and 315° (with the subject facing 0°) (Figure 2.8). Each speaker was suspended from a 1.88 cm diameter PVC rod at a depth of 1.5 m. The rods were bolted to aluminum beams that radiated out from two suspension supports spanning the Exhibit Area, and were designed to pivot so that the speaker at the bottom of the rod could be pushed backwards while the top of the rod tilted forward in a pendulum motion. A 0.2-24 kHz, 3000 ms broadband signal was used to train the subjects to swim to the speakers at the increased distance, and to those introduced behind them. Distance

increases were initiated by introducing only the 45°, 90°, 270° and 315° test speakers at a distance of 2 m and subject responses were assisted by the trainer's use of the subject's target to guide him towards the speaker if needed. When subject responses were reliable, the distance was increased to 3.05 m and shaping continued until their reactions were again consistent. Test speakers 0°, 135°, 180° and 225° were then introduced at the 3.05 m distance and subjects were guided by their target towards the correct test speaker until each reliably oriented towards the 90° region the signal originated from.

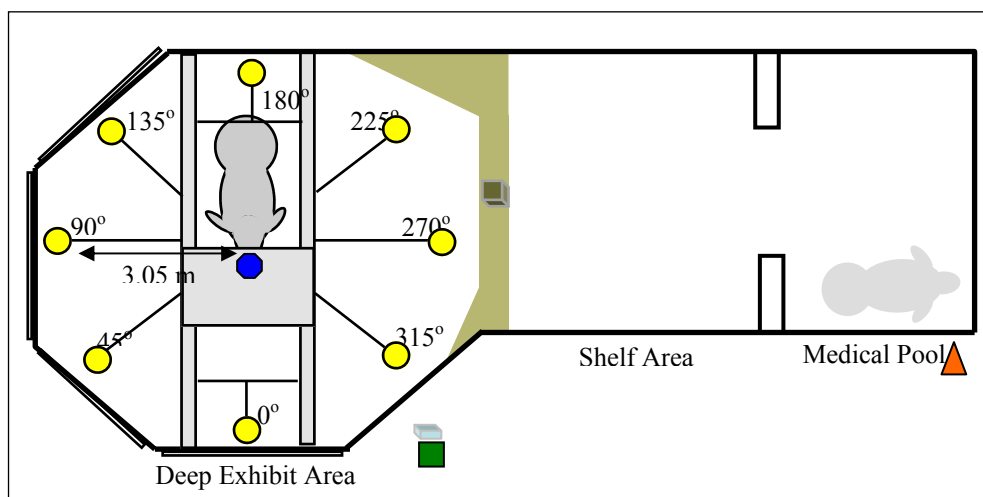

Figure 2.8. Testing setup for the eight-choice sound localization experiment. Subjects stationed facing 0° and test speakers were suspended from pivoting rods at 45°, 90°, 135°, 180°, 225°, 270°, and 315°. The blue octagon represents the Test Trainer's location, the green square represents the Data Recorder's location, and the orange triangle represents the Stationing Trainer's location.

Experimental Design

An eight alternative forced-choice discrimination paradigm was used to test the sound localization abilities of two Florida manatees, *Trichechus manatus latirostris*.

Eight underwater test speakers (Aquasonic AC 339) were positioned in a 6.10 m diameter circle surrounding a stationing/listening apparatus at 0°, 45°, 90°, 135°, 180°, 225°, 270° and 315° and a depth of 1.5 m. (Figure 2.8). Each subject was trained to position the top of its rostrum, approximately 10 cm posterior to the nostrils, up against a stationing bar

positioned at mid-water depth (1.5 m) in response to his stationing signal. The subject remained stationed facing 0° until a test signal was played from one of the eight test speakers. Upon hearing the test signal, the subject would swim to and push the speaker from which he believed the sound originated. If correct, a secondary reinforcer signal (1.4 - 12 kHz with a peak at 5.3 kHz for Buffett, 1.2 - 11 kHz with a peak at 2.7 kHz for Hugh) was emitted from the test speaker and the subject returned to the stationing device to be fed a primary reinforcement of food (apples, beets and carrots). If incorrect, the stationing tone was played from the stationing apparatus speaker and the subject re-stationed correctly with no reinforcement given, to await a minimum of 30 seconds before the initiation of the next trial.

All training and testing sessions were run between 0700 and 1000 h five days per week before the Aquarium was open to the public. The manatees' daily ration of food (72 heads of romaine lettuce and 12 bunches of kale) was fed to the animals from 1200 to 1400 h and was usually consumed by 1700 h, leaving a 14 to 16 hour overnight fast before training was initiated the following morning.

Three people were required to run the experiment: a Test Trainer, Data Recorder, and Station Trainer (Figure 2.8). The Test Trainer, "blind" to the test stimulus locations, wore noise-masking headphones and was positioned facing 180° on a platform suspended across the Exhibit Area. The Test Trainer ensured that a minimum 30 second inter-trial interval was met, the subject was positioned correctly, initiated each trial by verbally stating "tone" to the Data Recorder, informed the Data Recorder which location the subject selected, determined if the subject was correct by looking at the Data-recorder when he/she came into view for the appropriate head nod or shake, provided the subject

primary reinforcement if he was correct, and requested the subject to station by stating “station” to the Data Recorder.

The Data Recorder was positioned behind a laptop computer, out of sight of the Test Trainer and subject, and set up the experimental conditions needed for each session on the computer using a graphical user interface that was programmed in Visual C (see Appendix A for set up protocols). The Data Recorder initiated trials when instructed to do so by the Test Trainer, informed the Test Trainer and subject if the location selection was correct by leaning out from behind the computer to provide a head nod to the Test Trainer and playing the subject’s secondary reinforcer signal, or incorrect by providing a head shake and playing the station signal, recorded all data on a tank-side session sheet (Appendix B), and ran the video equipment.

The Station Trainer was positioned at the northeast end of the Medical Pool out of the test subject’s line of sight and was responsible for holding the non-test animal at station throughout the subject’s session. The Station Trainer was unaware of the correct locations and unable to see the subject during testing.

Acoustic Stimuli

A total of six experimental conditions were tested (Table 2.3). A speaker frequency response normalization procedure (see experimental controls section) generated test signals which were presented at the same spectrum level, meaning that signals with broader frequency spectra had louder root mean square (rms) amplitudes (Figure 2.9). The average spectrum level (dB re 1 μ Pa/sqrt (Hz)) of each stimulus was defined by condition (Table 2.3).

Table 2.3. Frequency, duration and level conditions of the eight-choice manatee localization experiment.

Frequency (kHz)	Duration (ms)	Averaged Level (dB re 1 μ Pa/sqrt (Hz))
4	200	101
0.2-24	200	95
0.2-24	3000	95
18-24	3000	80
0.2-1.5	3000	110
0.2-24	3000	95 then decreasing to < 75%

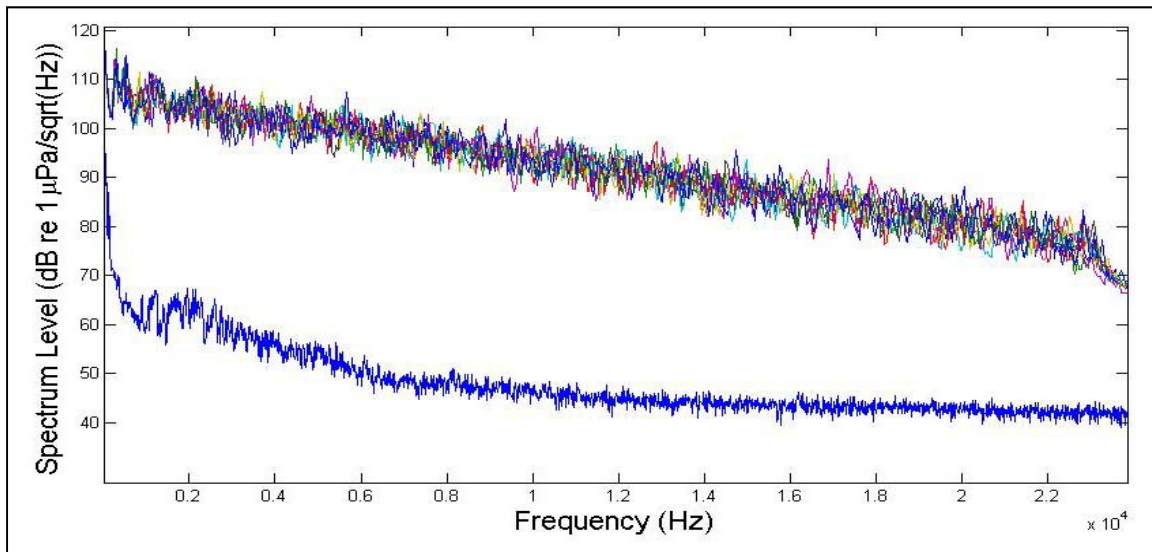

Figure 2.9. Sound calibration from the eight test speakers that were normalized with a 500-tap FIR filter (top) and spectrum level of the background exhibit noise (bottom) in the eight choice localization experiment. Sound from each speaker was normalized to approximately follow the shape of the manatee audiogram, with decreasing sound levels at higher frequencies. Each curve shows the recording from one of the eight speakers.

The 0.2-24 kHz stimulus was tested at both 3000 ms and 200 ms durations and spanned a wider range of frequencies than had been previously tested (0.2-20 kHz). The 18-24 kHz stimulus was tested at a 3,000 ms duration and was composed of a more extreme higher frequency range than previously tested (6-20 kHz) with wavelengths that were shorter than a manatee's interaural distance. The 0.2-1.5 kHz stimulus was presented at a 3,000 ms duration and was comprised of a slightly smaller range of low

frequencies than previously tested (0.2-2 kHz) with wavelengths that were greater than a manatee's interaural distance.

The 4 kHz tonal signal was midway between the 2.5–5.9 kHz fundamental frequency range of typical manatee vocalizations (Nowacek et al., 2003) and was presented at 200 ms, a duration shorter than had previously been tested (3,000 ms) which prohibited subject head movement adjustments while it was presented. The 4 and 16 kHz, tonal signals used in Colbert's (2005) four-choice localization study were only tested at a 3,000 ms duration because the subjects exhibited strong signs of behavioral frustration at lower durations. To prevent this frustration from occurring with the shorter 200 ms 4 kHz signal at the more distant speaker locations, four tonal probes were included in 16-trial blocks of 0.2-24 kHz, 3,000 ms signals until 80 trials were completed (Appendix B).

In the sixth condition, the level of the 0.2-24 kHz, 3,000 ms, 95 dB test signal was attenuated in 3 dB increments per block until each subject's overall percent correct within a 16-trial block fell below 75%. A total of 80 trials were collected at the level in which the subject fell below 75% accuracy to ensure consistency.

Signal Generation & Programming

All signals including each subject's station and secondary reinforcement signals and the test stimuli were programmed in RPvds language (Appendix A), digitally generated by a Tucker-Davis Technologies real-time processor (RP2.1), and attenuated with a programmable attenuator (PA5) to control level. Signals were amplified with a Hafler power amplifier and switched to the eight test speakers through a power multiplexer (PM2R). A separate digital to analog channel was used to generate the

stationing signal from the speaker located on the stationing apparatus in the center of the array.

MATLAB programming was used to generate blocks of sixteen trials that were counterbalanced between the eight speaker locations in a quasi-random order, meaning that the test signal location was randomized, but had a criterion of no more than two trials in a row from the same location.

A Dell laptop computer (model Latitude D505) with Windows XP was used to run the signal generation equipment, set up the testing conditions and to automatically download the parameters of each trial into an Excel file (Appendix B). Trials were initiated and completed through an electronic control box which was connected to the RP2 unit, and then into the laptop computer (Figure 2.9). The control box had four buttons with corresponding colored LED lights built into it. The station signal button was used to call the subject to station and the actual speaker switching occurred while the station signal was played. The test signal button was used to play each condition's test signal once per trial. The correct button was used to play the subject's unique secondary reinforcement signal for correct location selections. The wrong button was used to digitally record incorrect location selections and was immediately followed by playing the station signal. The four LED lights provided visual verification that their corresponding signals were played and that the trial was downloaded into the Excel file.

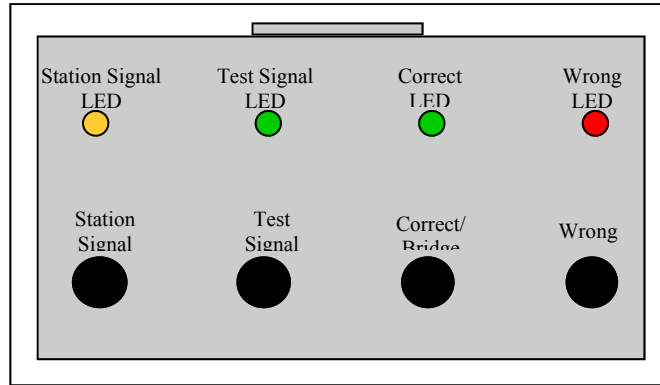

Figure 2.10. Electronic button box used to run the sessions and automatically download each trial into a digital excel file.

Data Recording

Data from each session were recorded in three ways. Automated digital computer reports were uploaded into an Excel file as each trial occurred in real-time on the laptop computer. The Data Recorder documented session information by completing a tank-side data sheet (Appendix C). This information was then manually entered into a Microsoft Access database created on a Dell desktop computer (model Dimension 8300) after the completion of each session. This database was designed specifically for this experiment and had a user-friendly data entry screen (Figure 2.10). All data entered into the database were double-checked for accuracy by a second trainer after they were entered. Finally, each test block was video recorded. A Sony variable zoom, high resolution, outdoor weather proof, color dome camera (model SCW-CD358DVP) was attached to the trainer's platform directly over the subject's head and connected to a Sony digital video camera (model DCR-TRV50). Pre-printed data sheets which identified the date, subject, test frequency, and sound duration were video recorded prior to the initiation of each block to stipulate each blocks parameters as they occurred.

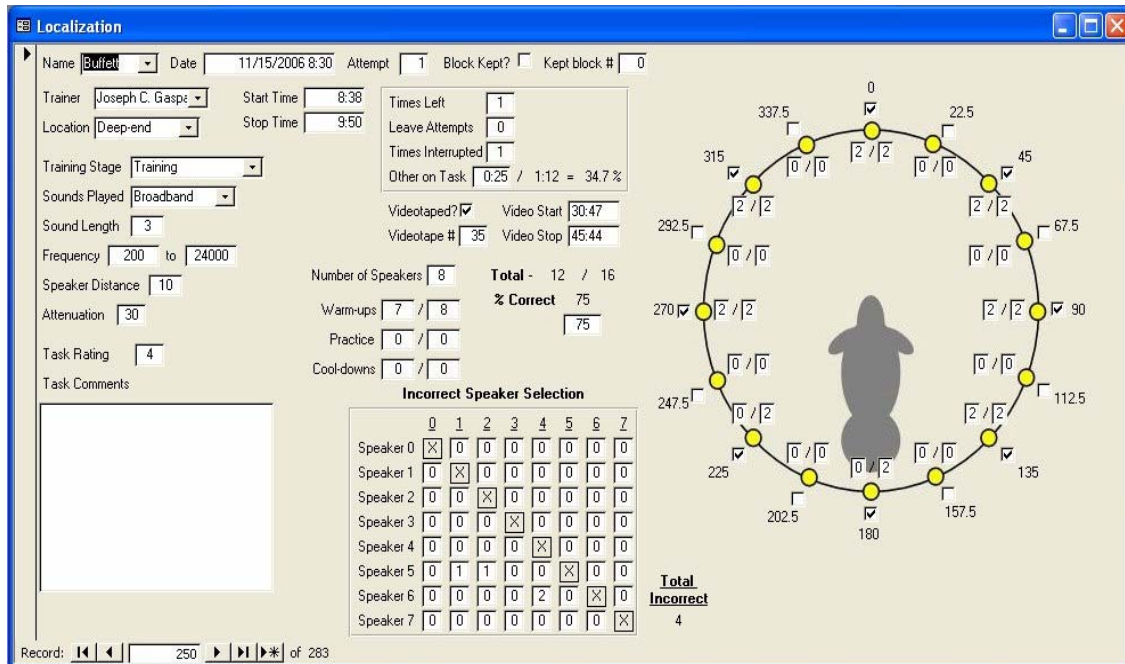

Figure 2.11. Data entry screen used to enter session information into the Access database.

Experimental Controls

Several experimental controls were put into place to ensure that cues which might possibly arise from trainers, test signals, speakers and their locations were avoided, and that the subjects were motivated for each testing session. All personnel were positioned out of the test subject's line of sight except for the Test Trainer. The Test Trainer was required to wear sound-dampening headphones to avoid the possibility of hearing the test signals and was ignorant of the test signal's location. The Data Recorder was the only individual who knew which location the test signal would originate from and only obtained this knowledge at the initiation of each trial. The Data Recorder was seated approximately 6 m to the back of the Test Trainer behind the laptop computer screen and was not visible until after the subject had made his location selection at the end of each trial. At this point the Test Trainer would look backwards towards the Data Recorder who would move into view to indicate if the subject's choice was correct or incorrect.

All test signals had a 100 ms rise-fall time to eliminate transients and levels were randomly presented ± 1.5 dB over the nominal acoustic pressure to eliminate level cues. A speaker frequency response normalization procedure was developed to eliminate the possibility that small differences in the speakers and their locations in the exhibit would produce localization cues that could be detected by the manatees (Figure 2.9). This was accomplished by measuring each speaker's frequency response from the stationing apparatus via a hydrophone (HTI 96 min; sensitivity -164 dBV/ μ Pa from 0.2 Hz to 37 kHz) and then developing a 500-tap FIR filter for each speaker to produce normalized responses over the frequency bands. Note that the frequency response was not flat, but louder at lower sound frequencies, similar to the spectra produced by boats. The signal also tracked the manatee audiogram which was more sensitive at higher frequencies (Gerstein et al., 1999). No effort was made to test the subjects in an anechoic setting, in fact, the exhibit background noise (pumps for filtration) was continuous throughout testing. The spectrum level of the exhibit noise was ~ 30 -50 dB re 1 μ Pa lower than the normalized speaker outputs (Figure 2.9).

To control for motivational effects, each animal's session was started with eight "warm-up" trials, one from each location in a randomized order, and ended with four "cool-down" trials, the locations of which were randomly generated via the computer program. The signal stimulus used for these trials was the same 3000 ms, 0.2–24 kHz, broadband noise used throughout training. In addition, two criteria were defined as reasons to drop a test block. The first stipulated that a minimum performance accuracy of 75% was required on the warm-up and cool-down trials. The second defined a maximum allowance of any combination of three interruptions from the non-test manatee

and/or leaves or attempted leaves from the test subject per block. If a block was dropped, the experimental condition was repeated in the next session.

Results

Training was initiated on July 7, 2006 and completed for Hugh on September 1, 2006 and for Buffett on August 18, 2006. Both manatees learned the new requirements of the task easily. Testing with the 0.24-24 kHz, 3,000 ms signal took place from September 4 to October 20, 2006 for Hugh and from August 21 to October 12, 2006 for Buffett. Testing that attenuated the 0.24-24 kHz, 3,000 ms signal took place from October 23 to November 20, 2006 for Hugh and from October 13 to December 15, 2006 for Buffett. Testing with the 18-24 kHz, 3,000 ms signal took place from November 22 to December 5, 2006 for Hugh and from December 20, 2006 to January 2, 2007 for Buffett. Testing with the 0.2-1.5 kHz, 3,000 ms signal took place from December 6, 2006 to January 16, 2007 for Hugh and from January 3 to January 18, 2007 for Buffett. Testing with the 0.2-24 kHz, 200 ms signal took place from February 6 to February 20, 2007 for Hugh and from January 31 to February 20, 2007 for Buffett. Testing with the 4 kHz, 200 ms signal took place from February 21 to April 19, 2007 for Hugh and from February 21 to April 2, 2007 for Buffett. A total of 27 blocks were dropped from both manatees as they met the pre-defined drop criteria. Buffett dropped 17 and Hugh dropped 10.

Three data analyses were conducted for each subject including one that examined the possibility of speaker artifact or location cues, one that determined overall performance accuracy, and one that investigated selection distribution. The frequency response normalization procedure was integrated during the training of the eight choice

sound localization study as a safeguard to eliminate the possibility that small differences arising from the speakers themselves and/or their positions in the exhibit would be detected and used to facilitate the subject's response (Figure 2.11). Determination of accuracy by speaker location before and after the speaker frequency normalization calibration was done showed no large or consistent differences in performance, suggesting that the manatees did not use other cues for sound localization (Figure 2.12).

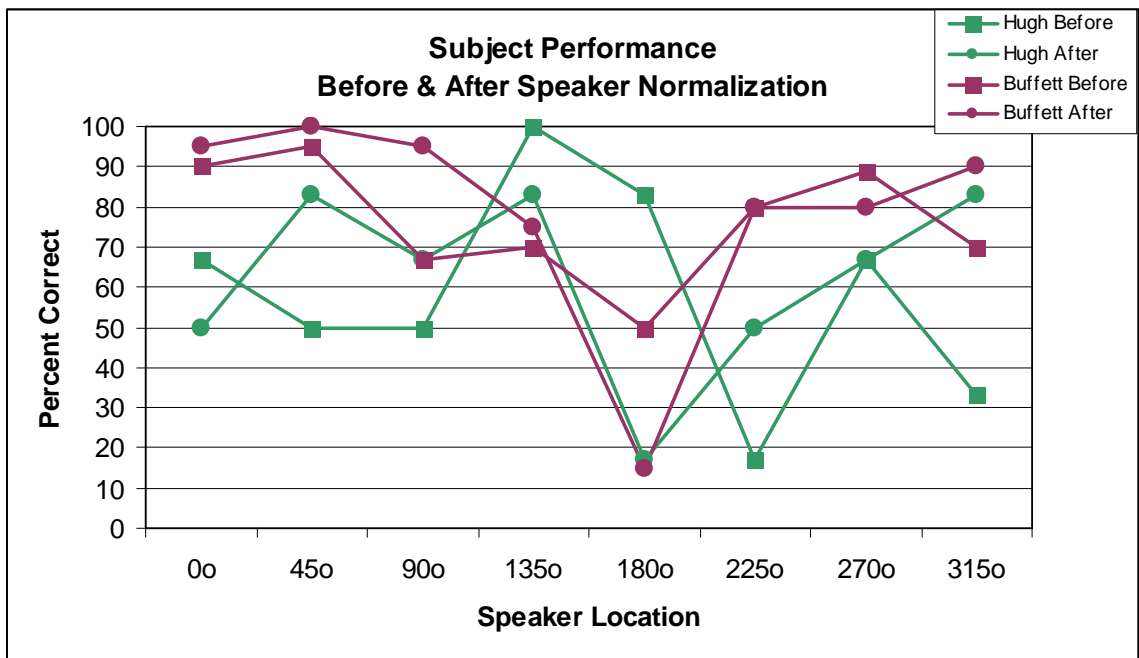

Figure 2.12. Subject accuracy before and after speaker normalization calibration. Note that the speaker at 180 degrees is biased by multiple presentations during the 'before' calibration.

Overall performance accuracy was determined and described in Table 2.4.

Percentage correct was calculated for each subject based on 15 trials per speaker for the 0.2-24 kHz, 200 ms condition and 10 trials per speaker for all other conditions. The level of the 0.2-24 kHz, 3,000 ms, 95 dB signal was decreased in 3 dB increments if the subject achieved 75 % correct or greater for two consecutive blocks. Five blocks were completed when accuracy fell below 75% (86 dB), and then five additional blocks were

completed at a level that was 6 dB lower than this point to examine how performance changed in these increments.

Table 2.4. Results for the conditions of the eight-choice localization experiment with chance level at 12.5%. Percentages are based on 15 trials/speaker for the 0.2-24 kHz, 200 ms condition and 10 trials/speaker for all other conditions. Trials which measured accuracy as level was decreased are shown in italics.

	Frequency & Averaged Level (dB re 1µPa/sqrt (Hz))			
	4 kHz 101 dB	0.2-24 95 dB	18-24 kHz 80 dB	0.2-1.5 kHz 110 dB
Duration	Hugh			
200 ms	14%	55%		
3000 ms		69%	40%	46%
<i>3000 ms; 86 dB</i>		72%		
<i>3000 ms; 80 dB</i>		48%		
	Buffett			
200 ms	20%	65%		
3000 ms		79%	60%	64%
<i>3000 ms; 86 dB</i>		77%		
<i>3000 ms; 80 dB</i>		56%		

Both subjects performed well above the 12.5% chance level for all of the broadband frequencies tested. When the 4 kHz tonal signal was tested however, performance decreased dramatically for both subjects with Hugh’s accuracy at only 14% Buffett’s at 20%. When level was decreased with the 0.2-24 kHz signal, both were able to localize the signal over a fairly large sound level range, however, Hugh’s performance deteriorated more than Buffett’s.

Selection distribution was investigated for each of the conditions tested. The 0.2-24 kHz, 3,000 ms signal was composed of the widest range of frequencies presented at the longest duration tested, making it the easiest discernible signal. The 3,000 ms duration allowed subjects to move their heads to physically and visually orient towards speaker locations to the front 180° during signal presentation, but did not provide enough time for orientation towards speakers behind them. Results showed that the few errors

made were primarily located at the “nearest neighbor” of the test speaker for both subjects but became somewhat more dispersed when they originated from 135° and 180° for Buffett and more widely dispersed when they came from 180° and 225°. Hugh never selected the 180° location and made back to front confusions on 20% of the trials when the signal originated at 180° (Figure 2.13).

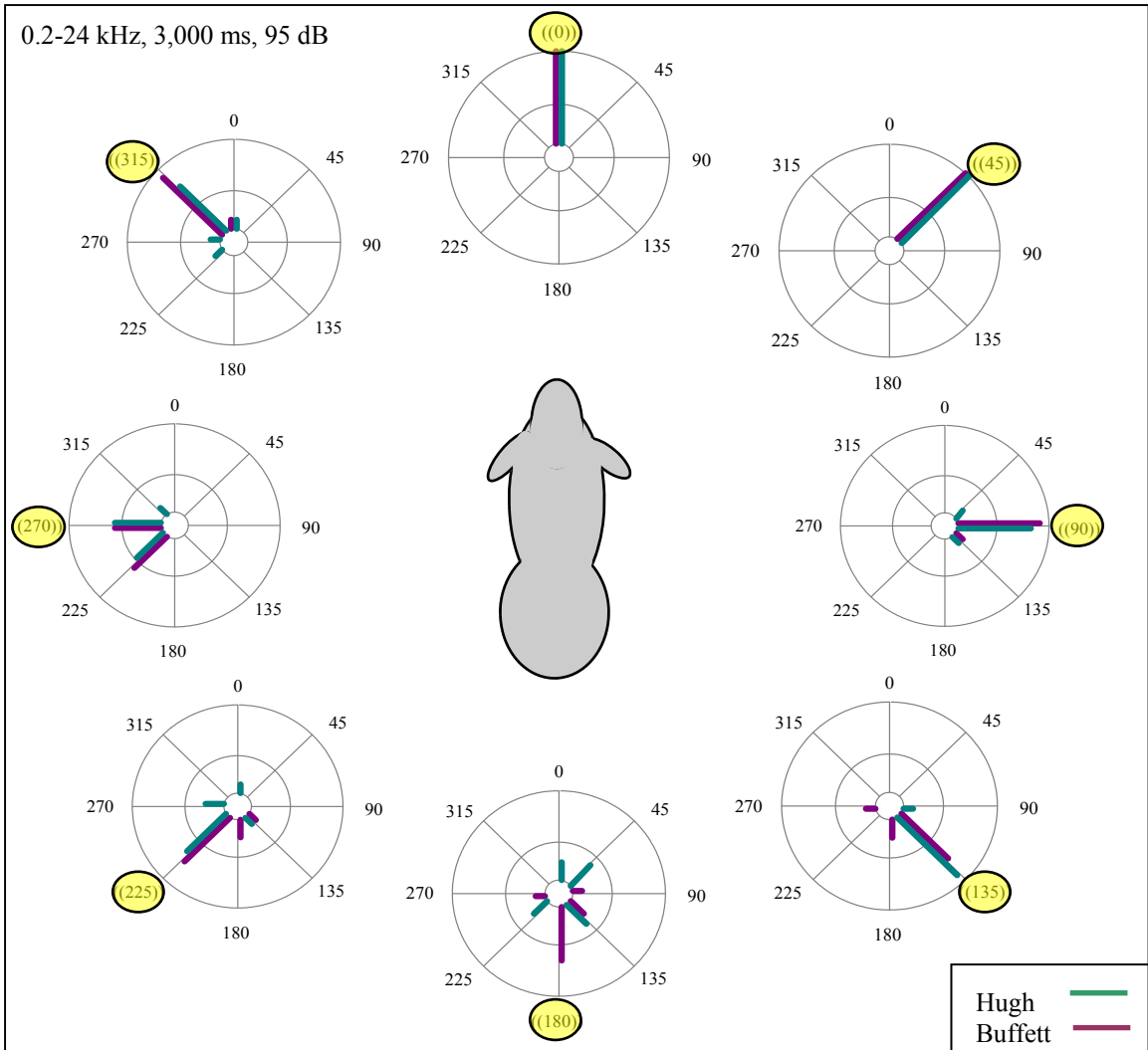

Figure 2.13. Selection distribution with the 0.2-24 kHz, 3,000 ms, 95 dB re 1 μ Pa test signal. The percent correct is notated at the locations demarked by the yellow circles. Hugh's results are always presented to the right of the graph lines in teal and Buffett's are to the left in maroon. The exterior circle of the grid represents 100% accuracy, the middle 50% and the inner 0%.

The 0.2-24 kHz, 200 ms signal was also composed of the widest range of frequencies, however the shorter duration did not provide enough time for subjects to physically or visually orient towards any of the speaker locations. Errors tended to be to the “nearest neighbor” of the test speaker for both subjects but became somewhat more dispersed when signals came from 135°, 180° and 270° for Buffett and more widely dispersed when they came from 180° for Hugh. Hugh never selected the 180° location and made back to front confusions on 27% of the trials when the signal originated at 180°. Hugh also made contralateral confusions on 7% of the trials when the signal originated from 315° (Figure 2.14).

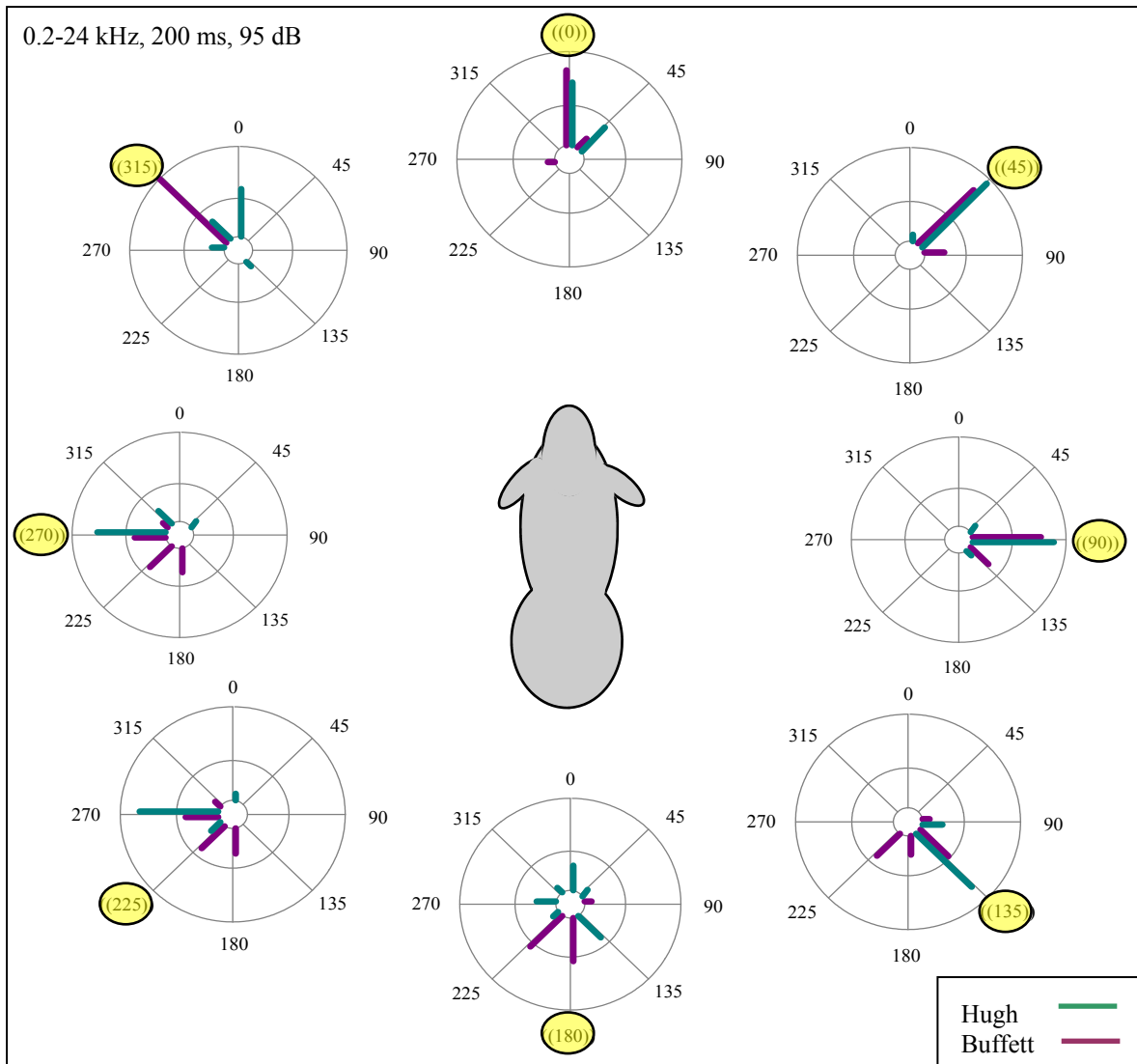

Figure 2.14. Selection distribution with the 0.2-24 kHz, 200 ms, 95 dB re 1 μ Pa test signal. The percent correct is notated at the locations demarked by the yellow circles. Hugh's results are always presented to the right of the graph lines in teal and Buffett's are to the left in maroon. The exterior circle of the grid represents 100% accuracy, the middle 50% and the inner 0%.

The 18-24 kHz, 3,000 ms signal was composed of higher frequencies with wavelengths that were shorter than the manatee's intermeatal or intercochlear distances. Errors tended to be to the "nearest neighbor" of the test speaker with both subjects but became more dispersed when signals came from 135° and 270° for Buffett and more widely dispersed when they came from 135°, 180°, 225° and 270° for Hugh. Buffett made contralateral confusions on 10% of the trials when the signal originated from 90°

and 180°. Hugh never selected the 180° location and made back to front confusions on 10% of the trials when the signal originated at 180°. Hugh also made contralateral confusions on 10 % of the trials when the signal originated from 225° and 270° (Figure 2.15).

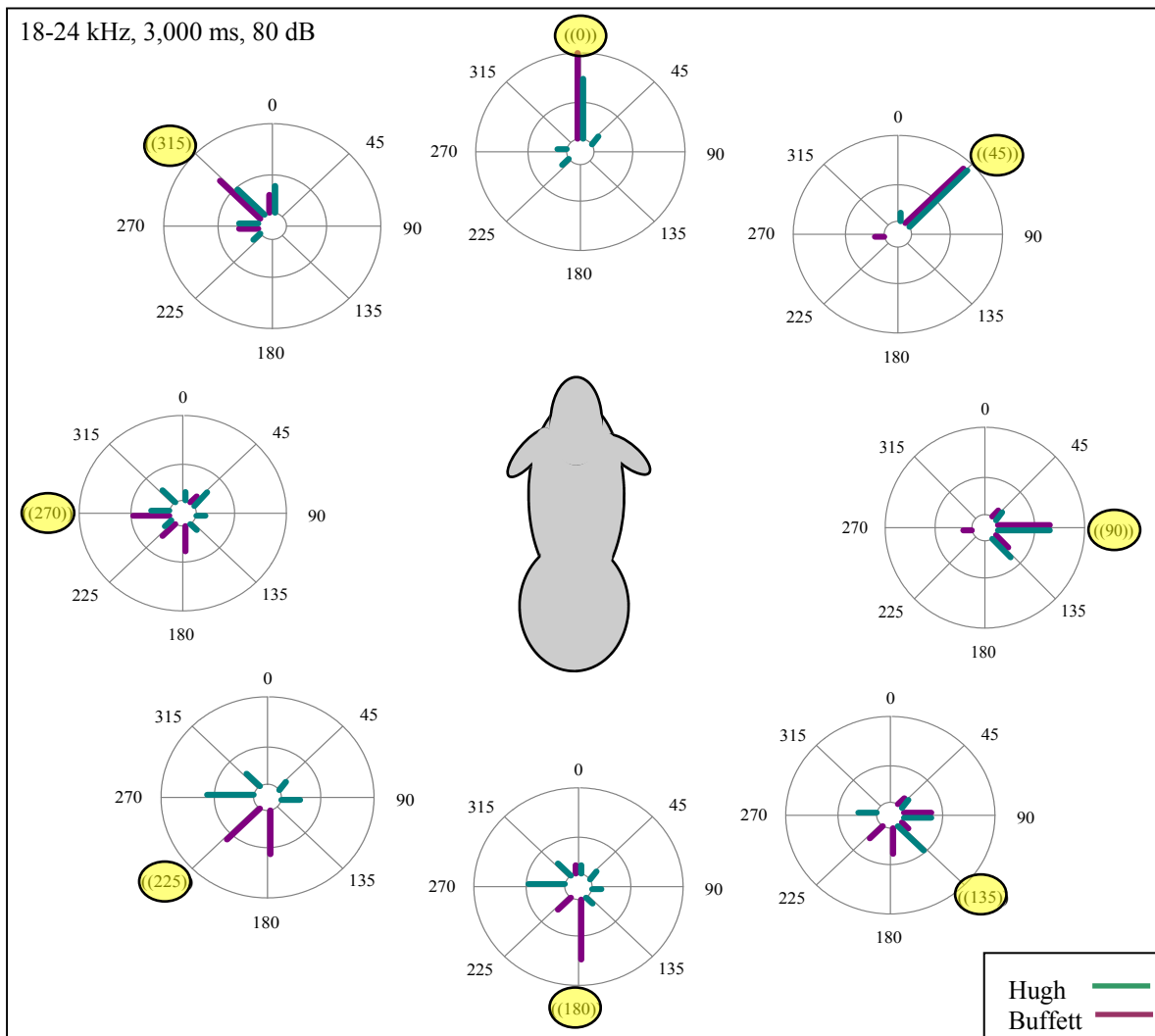

Figure 2.15. Selection distribution with the 18-24 kHz, 3,000 ms, 80 dB re 1 μ Pa test signal. The percent correct is notated at the locations demarked by the yellow circles. Hugh's results are always presented to the right of the graph lines in teal and Buffett's are to the left in maroon. The exterior circle of the grid represents 100% accuracy, the middle 50% and the inner 0%.

The 0.2-1.5 kHz, 3,000 ms signal was composed of lower frequencies with wavelengths that were longer than the manatee's intermeatal or intercochlear distances.

Errors tended to be to the “nearest neighbor” for all speaker locations but became more dispersed when signals originated from 180°, 225° and 270° for both Hugh and Buffett. Hugh never selected the 180° location and made back to front confusions on 10% of the trials when the signal originated at 180° (Figure 2.16).

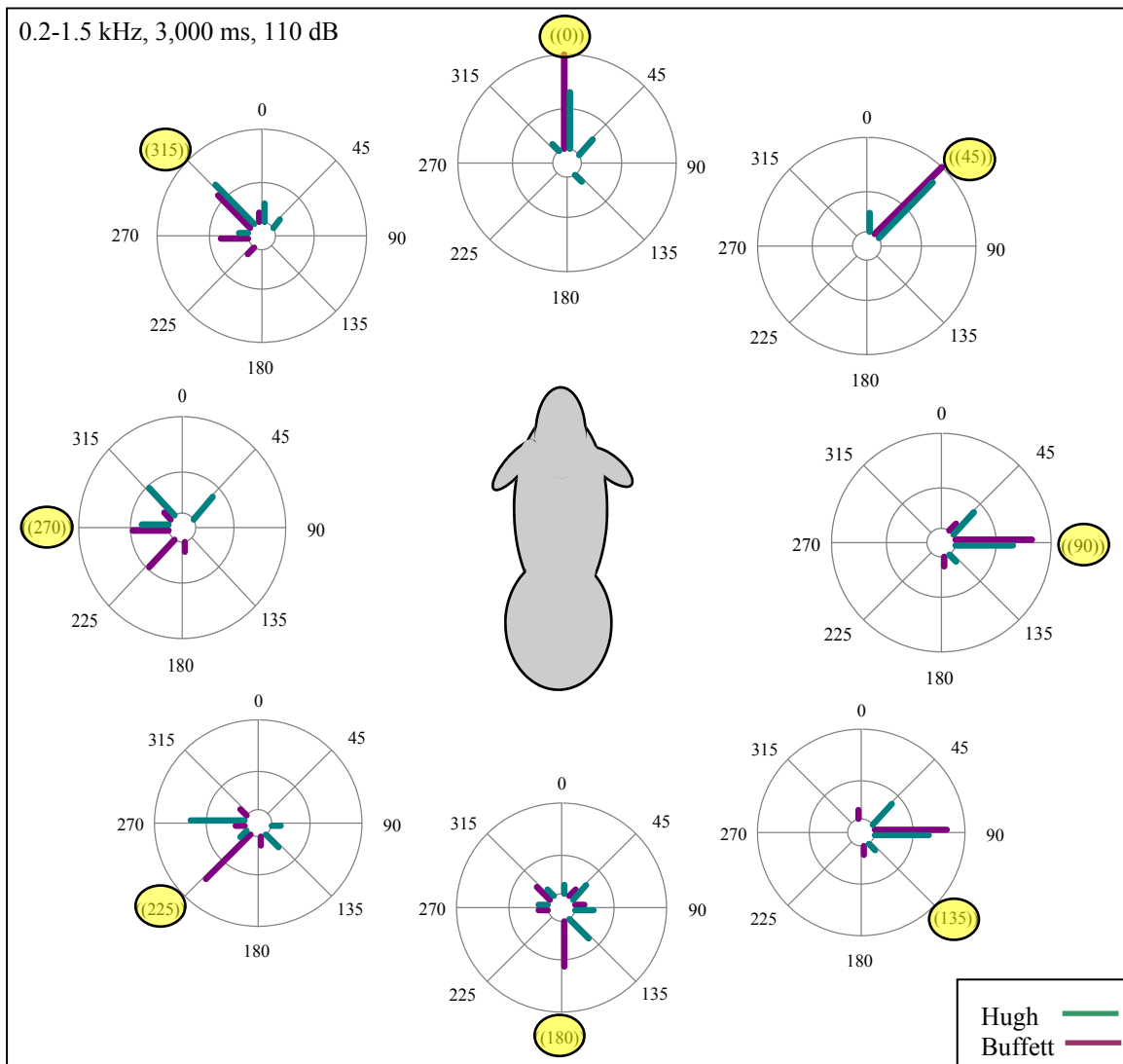

Figure 2.16. Selection distribution with the 0.2-1.5 kHz, 3,000 ms, 110 dB re 1 μ Pa test signal. The percent correct is notated at the locations demarked by the yellow circles. Hugh’s results are always presented to the right of the graph lines in teal and Buffett’s are to the left in maroon. The exterior circle of the grid represents 100% accuracy, the middle 50% and the inner 0%.

The 4 kHz, 200 ms tonal signal had a wavelength longer than the manatee’s intermental or intercochlear distances and was presented at a duration that did not provide

enough time for subjects to physically or visually orient towards any of the speaker locations. Errors were scattered among the locations with no obvious patterns observed for both subjects. Contralateral confusions were not considered due to the high variability of speaker location selections (Figure 2.17).

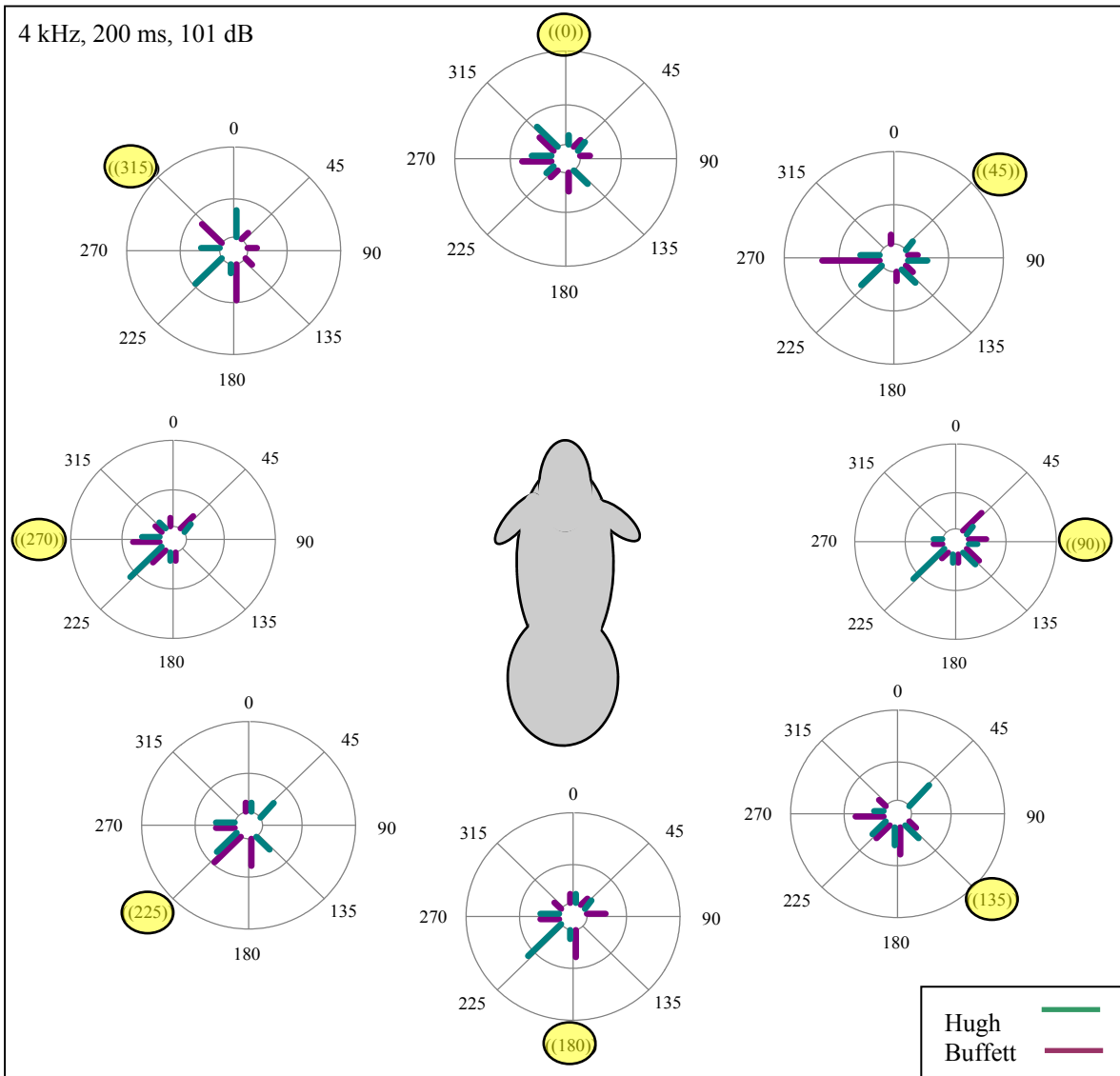

Figure 2.17. Selection distribution with the 4 kHz, 200 ms, 101 dB re 1 μ Pa test signal. The percent correct is notated at the locations demarked by the yellow circles. Hugh's results are always presented to the right of the graph lines in teal and Buffett's are to the left in maroon. The exterior circle of the grid represents 100% accuracy, the middle 50% and the inner 0%.

The data were also evaluated by determining the number correct for each of the broadband stimuli and separating these results into three regions: front, back and side. These numbers were averaged by the total number of trials presented at each location for each stimulus (15 trials for the 0.2-24 kHz, 200 ms stimulus; 10 trials for the remaining stimuli) (Table 2.5). Buffett's accuracy ranged between 83% - 97% when the stimuli were presented in front (0°, 45°, 315°), 40% - 67% when presented in back (135°, 180°, 225°), and 60% - 75% when presented to the sides (90° and 270°). Hugh's accuracy ranged between 62% - 90% when the stimuli were presented in front, 13% - 51% when presented in back, and 45% - 80% when presented to the sides.

Table 2.5. Average percents correct by front, back and side regions. The numbers of correct trials were averaged by the total number of trials presented at each location for each stimulus. Averages were based upon 15 trials per location with the 0.2-24 kHz, 200 ms stimulus and 10 trials per location for the remaining stimuli.

Hugh											
	Front				Back				Side		
	0°	45°	315°		135°	180°	225°		90°	270°	
0.2-24 kHz, 200 ms	10	14	4	62%	12	0	11	51%	13	11	80%
0.2-24 kHz, 3000 ms	10	10	7	90%	9	0	6	50%	8	5	65%
18-24 kHz, 3000 ms	7	9	4	67%	4	0	0	13%	6	2	40%
0.2-1.5 kHz, 3000 ms	6	8	6	67%	7	0	1	27%	6	3	45%
Buffett											
	Front				Back				Side		
	0°	45°	315°		135°	180°	225°		90°	270°	
0.2-24 kHz, 200 ms	12	12	15	87%	6	7	5	40%	11	10	70%
0.2-24 kHz, 3000 ms	10	10	9	97%	7	6	7	67%	9	5	75%
18-24 kHz, 3000 ms	10	9	6	83%	1	7	5	43%	6	4	50%
0.2-1.5 kHz, 3000 ms	10	10	5	83%	2	5	7	47%	8	4	60%

Discussion

The results of this study provide information about the manatee's ability to localize specific broad-band and tonal signals of specific durations and levels in a controlled environment. Numerous controls were put in place to avoid test signal distortions and/or the projection and recognition of speaker artifact or location cues. These included the incorporation of a 100 ms rise-fall time within signals to eliminate transients, the addition of a +/- 1.5 dB randomization of signal levels between trials to eliminate level cues, switching the test signal location during the presentation of the stationing tone to avoid transients, and the frequency response normalization procedure done between speakers. Analysis of the test signals showed no obvious temporal or harmonic distortions and performance prior to and after frequency normalization calibration procedures showed no large or consistent differences, suggesting that the subjects were localizing the actual test signals and not artifact or spatial cues.

The subjects of this study were readily able to adapt behaviors learned in a prior four-choice sound localization study (Colbert, 2005) to meet the change in stationing direction (from south to east), increased stationing depth (from 0.75 m to 1.5 m), and extended test speaker distance (from 1.05 m to 3.05 m) criteria for the eight choice paradigm. Reshaping of these behaviors took approximately six weeks to complete. Testing was completed in approximately eight months. Results indicated that the subjects were able to localize all of the test signals specified within the conditions and, similarly to the two prior four choice sound localization studies (Gerstein, 1999; Colbert,

2005), do not support the anatomical hypothesis that suggested manatees may be poor at sound localization (Ketten, 1992).

The first hypothesis posited that subjects would be able to localize all of the broadband test signals above the 12.5% chance level at all eight locations within the 360°. Results indicated that Buffett was capable of localizing all of the broad-band signals, even the 0.2-24 kHz, 200 ms shorter signal, when they originated from all angles including behind him. Hugh demonstrated that he was able to localize all of same signals when they originated from all locations except 180°. Hugh never selected the 180° speaker when the broadband signals were tested but seemed to instead default to the speakers located at 135° or 270° most of the time. Both subjects had difficulty localizing the 4 kHz, 200 ms tonal signal at all locations and their speaker selections were distributed randomly. Hugh did select the 180° speaker in this condition, however these selections also appeared to be random. This hypothesis was supported by the subjects' performance with the broadband stimuli except for Hugh's performance at the 180° location. Interestingly, both subjects were able to localize the 0.2-24 kHz test signal over a fairly large sound level range although Hugh's accuracy decreased more rapidly than Buffett's.

Although psychoacoustic studies often use tonal sound stimuli in a controlled setting, studies with many species have demonstrated that broadband signals are easier to localize than tonal signals (Stevens & Newman 1936; Marler, 1955; Casseday & Neff, 1973). The manatee's natural environment contains a multitude of complex sounds that are primarily broadband and have rapid amplitude, frequency and bandwidth fluctuations on an ongoing basis. Recreational boat engine noise is characterized as broadband with

a typical dominant frequency range of 0.01–2 kHz although it can reach over 20 kHz with the 1/3-octave source levels at 1 m for small motorboats estimated at 120-160 dB re 1 μ Pa (Miksis-Olds, 2006; Gerstein, 1999; Richardson et al., 1995). The subjects' ability to localize broadband test signals ranging from a 80 - 110 dB re 1 μ Pa spectrum level suggests that they are able to localize typical recreational boat engine noises.

Manatee vocalizations, categorized as chirps, squeaks and squeals, are characteristically short tonal complexes which contain several harmonics. The fundamental frequencies of manatee vocalizations range from 2.5–5.9 kHz, but can extend up to 15 kHz (Nowacek et al., 2003). Although Buffett's 20% accuracy with the 4 kHz, 200 ms test signal was above the 12.5% chance level, Hugh's accuracy was only 14%. The decreased accuracy with the 4 kHz tonal signal might imply that localization of manatee tonal vocalizations would be difficult, however the harmonics of different frequencies contained within these vocalizations likely provide additional cues to aid in this capacity. Some vocalizations transition from a tonal harmonic complex to more strongly modulated calls covering a greater frequency range and are often produced by calves, facilitating localization (Nowacek, et al., 2003; Mann et al., 2005; O'Shea & Poche, 2006).

The second hypothesis declared that subjects would have greater localization accuracy with the 3,000 ms, 0.2-24 kHz test signal than the 200 ms, 0.2-24 kHz test signal. This hypothesis was supported by both subjects' performance. Hugh had 69% accuracy with the 3,000 ms duration and 55% accuracy with the 200 ms duration. Buffett had 79% accuracy with the 3,000 ms duration and 65% accuracy with the 200 ms duration. The performance differences found between Hugh and Buffett are

characteristic of the results found in previous sensory studies conducted with the same subjects (Bauer et al., 2003; 2005; Mann et al., 2005) and are assumed to represent normal variation (Ridgway & Carder, 1997; Brill et al., 2001).

Videotape analysis of the test trials demonstrated that the subjects remained at the stationing bar for a minimum of 270 ms before they began to move in response to the presentation of the test signal. The 200 ms test signals, presented at 0.2-24 and 4 kHz, impeded head and/or body movements, requiring the subjects to navigate all 3.05 m to the test speakers without the presence of the test signal. Underwater studies conducted with human divers have demonstrated that sounds are easier to localize if the head is allowed to move during the sound presentation (Wells & Ross, 1980) due to the accentuation of interaural cue differences (Thurlow et al., 1967; Richardson et al., 1995; Yost & Dye 1997). The longer 3,000 ms duration with the 0.2-24 kHz signal allowed the manatees to utilize interaural cues while traversing the $\sim >2$ m distance towards the sound source and likely accounts for the increased accuracy as compared to the 200 ms duration.

The third hypothesis stated that subjects would have greater localization accuracy to the anterior 180° than to the posterior 180° . The data were separated into three regions (front, back and side) and the number correct for each of the broadband stimuli were found for each location (Table 2.5). This hypothesis was supported as results indicated that both subjects had greater localization accuracy to the anterior 180° than to the posterior 180° with the exception of Hugh's higher side performance with the 0.2-24 kHz, 200 ms stimulus.

Previous studies have suggested that the ability to localize a sound source may be influenced by multimodal sensory systems and be a function of visual orientation responses (Brown, 1994; Heffner, 1997). The subjects of this study were unable to see the test speakers located behind them while at station and even signals tested at the maximum 3,000 ms duration condition did not allow enough time for them to turn and see the speakers before the signal ceased. The increased number and dispersal of errors found when test signals originated from the 135°, 180° and 225° locations suggest that manatees utilize visual orienting responses to assist with localization.

The fourth hypothesis asserted that subject errors would have a higher distribution to the correct locations “nearest neighbors” rather than to other locations as was found in a prior four choice localization study (Colbert, 2005). Results from this experiment show that errors are typically distributed to the correct locations nearest neighbors for the front 180° for both subjects, however increased selection confusion was found at the 135° location for Buffett and at the 180° and 225° locations for Hugh. The data derived from Buffett suggests that he is able to localize the region if not the source from which the signal originated, which supports this hypothesis, but Hugh’s performance at the 180° and 225° locations suggest that he has difficulty determining sound source directionality directly behind and to the left posterior regions of his body.

The final hypothesis contended that subjects would make more differentiation errors between speakers located at 0° and 180° than any other contralateral pairs. The data were separated into four contralateral pairs (0° & 180°; 45° & 225°; 90° & 270°; and 135° & 315°) and the number of confusion instances that occurred for each were calculated for each of the broadband stimuli conditions (Table 2.6). Of the 360 trials run

for each subject, only eleven contralateral confusions were made by Hugh and three by Buffett. This hypothesis was supported by Hugh's performance as eight of these confusions were made between the 0° and 180° pair (all were made when test signals originated from 180°), while the remaining three were found spread between different pairs. This hypothesis was not supported by Buffett's performance however, who had only one confusion between the 0° and 180° pair, but two confusions between the 90° and 270° pair.

Table 2.6. Number of confusions made between contralateral pairs for each subject. Numbers were derived from a possible 45 trials per pair when tested with the 0.2-24 kHz, 200 ms, 0.2-24 kHz, 3000 ms, 18-24 kHz, 3000 ms, and 0.2-1.5, 3000 ms stimuli.

	Hugh	Buffett
Signal @ 0; Selected 180		
Signal @ 45; Selected 225		
Signal @ 90; Selected 270		2
Signal @ 135; Selected 315		
Signal @ 180; Selected 0	8	1
Signal @ 225; Selected 45	1	
Signal @ 270; Selected 90	1	
Signal @ 315; Selected 135	1	

Middlebrooks and Green (1991) demonstrated that front and back sound localization confusions were typical with human subjects and attributed these results to the fact that stimulus locations lie in mirror symmetry with respect to the subject's ears which eliminate interaural time of arrival, phase and intensity cues. Out of the possible 90 trials that front to back confusions would have the opportunity to occur, results demonstrated Buffett had only one and Hugh had just eight. These results suggest that the manatees may have been able to use some type of interaural cue(s) to assist with these discriminations even though the stimuli were presented symmetrically.

Almost all localization studies conducted with terrestrial and marine mammals utilize minimal audible angle techniques in which subjects identify a just detectable change of a sound source from a particular reference point (Mills, 1958). The design used in this study instead required subjects to locate sound sources relative to their own location. This testing paradigm, similar to those used recently with a harbor seal (Bodson et al., 2006) and a harbor porpoise (Kastelein et al., 2007), has more realistic applications which address the subjects' ability to determine the directionality of sounds as they originate from different angles surrounding their bodies.

Experiments in controlled settings provide valuable information about the specific conditions tested. Results from this study demonstrate that the subjects could localize short and solitary test signals within the frequency ranges of recreational boat engines and conspecifics in all 360° of the azimuth plane at distances of at least 3 meters. Attenuation of the level showed that both subjects were able to localize the test signal well above the 12.5% chance level (Hugh, 48%; Buffett, 56%) at 80 dB re 1 μ Pa, a relatively quiet level.

Understanding how the manatee's sensory systems assimilate information and react to environmental stimuli is an important factor that should be considered in conservation management strategies that are incorporated into the Florida Manatee Recovery Plan (US Fish and Wildlife Service, 2001). Implications derived from this controlled study suggest that manatees would be better able to localize sounds in their natural environment considering most stimuli are repetitive and/or of longer duration than the test signals. Natural sounds provide increased opportunities to alter head or body orientation to better utilize interaural cue differences. This study provides strong

evidence that manatees are capable of localizing the sounds produced by boats and conspecifics. Their ability to successfully localize sounds at the 110 dB re 1 μ Pa level as well as when it was attenuated implies that manatees are able to localize the loud sounds of nearby stimuli as well as the quieter sounds of distant stimuli. Norris (1967) suggested that marine mammals may even localize sounds derived from abiotic sources (shore waves) to assist with navigation. Manatees may also utilize auditory landmarks to facilitate their biannual migrations.

Several areas of study should be considered for future investigations that would enhance our knowledge about the ability and means by which manatees are able to localize sounds. Localization tasks with manatees to date have only investigated their abilities within the azimuth plane. Field tests that measured manatee responses to controlled boater approaches found that manatees increased swim speed and oriented to deeper channel waters as boats approached (Nowacek et al., 2004). Localization ability assessments in the remaining dimensions may find that interaural cues in the vertical plane hold equal or more salience than those in the azimuth plane, partially explaining why these animals increase their depth in response to surface threats.

Manatee localization investigations to date demonstrate their ability to determine sound source directionality in all 360 $^{\circ}$, including a capacity to interpret sounds originating directly to the front and back of them. The means by which they accomplish these tasks however, remain unclear. Most terrestrial mammals utilize some combination of interaural time, level, and phase difference cues to localize sounds, however several species have reduced or lost the ability to use one or even all of them (Heffner & Heffner, 1992a). Head related transfer function measurements for signals presented in different

locations on the azimuth plane may provide clues as to how interaural level and frequency differences might be used to facilitate sound localization.

References Cited

- Ahnelt, P.K. & Bauer, G.B. (2000). Unpublished data reported in Ahnelt, P. K. & Kolb, H. (2000). The mammalian photoreceptor mosaic-adaptive design. *Progress in Retinal and Eye Research*, 19, 711-777.
- Ahnelt, P.K. & Kolb, H. (2000). The mammalian photoreceptor mosaic-adaptive design. *Progress in Retinal and Eye Research*, 19, 711-777.
- Anderson, S. (1970). Directional hearing in the harbor porpoise, *Phocoena phocoena*. In G. Pilleri (Ed.), *Investigations on Cetacea*, Vol II. Berne, Benteli Ag.
- Au, W. (1993). *The Sonar of Dolphins*. NY: Springer-Verlag.
- Babushina, E.S. & Poliakov, M.A. (2004). The underwater and airborne sound horizontal localization by the northern fur seal. *Biophysics*, 49, 723–726.
- Bachteler, D. & Dehnhardt, G. (1999). Active touch performance in the Antillean manatee: Evidence for a functional differentiation of the facial tactile hairs. *Zoology*, 102, 61-69.
- Barrett-Lennard, L.G., Ford, J.K.B. & Heise, K. A. (1996). The mixed blessing of echolocation: Differences in sonar use by fish-eating and mammal eating killer whales. *Animal Behavior*, 51, 553–565.
- Bartsh, S.S., Johnston, S.D. & Siniff, D.B. (1992). Territorial behavior and breeding frequency of male Weddell seals, *Leptonychotes weddelli*, in relation to age, size, and concentrations of serum testosterone and cortisol. *Canadian Journal of Zoology*, 70, 680–692.
- Bauer, G.B., Colbert, D.E., Gaspard, J.C., Littlefield, B. & Fellner, W. (2003). Underwater visual acuity of Florida manatees (*Trichechus manatus latirostris*). *International Journal of Comparative Psychology*, 16, 130-142.
- Bauer, G.B., Gaspard III, J.C., Colbert, D.E., Leach, J.B. & Reep, R. (2005, March). *Tactile Discrimination of Textures by Florida Manatees, Trichechus manatus latirostris*. Paper presented at the 12th annual International Conference on Comparative Cognition, Melbourne, Florida.

- Bjørgesaeter, A., Ugland, K.I. & Bjørge, A. (2004). Geographic variation and acoustic structure of the underwater vocalization of harbor seal, *Phoca vitulina*, in Norway, Sweden and Scotland. *Journal of the Acoustical Society of America*, 116, 2459–2468.
- Bodson, A., Miersch, L., Mauck, B. & Dehnhardt, G. (2006). Underwater auditory localization by a swimming harbor seal (*Phoca vitulina*). *Journal of the Acoustical Society of America*, 120 (3) 1550-1557.
- Brill, R.L., Moore, W.B. & Dankiewicz, L.A. (2001). Assessment of dolphin (*Tursiops truncatus*) auditory sensitivity and hearing loss using jawphones. *Journal of the Acoustical Society of America*, 109 (4): 1717-1722
- Brown, C.H. (1994). Sound Localization. In R. R. Fay and A. N. Popper (Eds.) *Comparative Hearing: Mammals*, New York, Springer-Verlag, pp. 57-97.
- Brown, C.H., Beecher, M.D., Moody, D.B. & Stebbins, W.C. (1980). Localization of noise bands by old world monkeys. *Journal of the Acoustical Society of America*, 68, 127-132.
- Brown, C.H. & May, B.J. (1990). Sound localization and binaural processes. In M. A. Berkley and W. C. Stebbins (Eds.) *Comparative Perception*, Vol I, New York, John Wiley and Sons, pp. 247-284.
- Buckstaff, K.C. (2004). Effects of watercraft noise on the acoustic behavior of bottlenose dolphins, *Tursiops truncatus*, in Sarasota Bay Florida. *Marine Mammal Science*, 20, 709-725.
- Bullock, T.H., Domning, D.P. & Best, R.C. (1980). Evoked potentials demonstrate hearing in a manatee (*Trichechus inunguis*). *Journal of Mammalogy*, 61 (1), 130-133.
- Bullock, T.H., O’Shea, T.J. & McClune, M.C. (1982). Auditory evoked potentials in the West Indian manatee (Sirenia: *Trichechus manatus*). *Journal of Comparative Physiology*, 148, 547-554.
- Caldwell, M.C. & Caldwell, D.K. (1965). Individualized whistle contours in bottlenosed dolphins (*Tursiops truncatus*) *Nature*, 207, 434 - 435
- Casseday, J.H. & Neff, W.D. (1973). Localization of pure tones. *Journal of Acoustical Society of America*, 54, 365-372.
- Cleator, H.J. & Stirling, I. (1990). Winter distribution of bearded seals, *Erignathus barbatus*, in the Penny Strait Area, Northwest Territories, as determined by underwater vocalizations. *Canadian Journal of Fish and Aquatic Science*, 47, 1071–1076.

- Cohen, J.L., Tucker, G.S. & Odell, D.K. (1982). The photoreceptors of the West Indian manatee. *Journal of Morphology*, 173, 197-202.
- Colbert, D.E., Fellner, W., Bauer, G. B., Manire, C. & Rhinehart, H. (2001). Husbandry and research training of two Florida manatees, *Trichechus manatus latirostris*. *Aquatic Mammals*, 27 (1), 16-23.
- Colbert, D. (2005). *Sound Localization Abilities of Two Florida Manatees, Trichechus manatus latirostris*. Unpublished Masters Thesis, University of South Florida, Tampa, FL.
- Deecke, V.B., Slater, P.J.B. & Ford, J.K.B. (2002). Selective habituation shapes acoustic predator recognition in harbour seals. *Nature*, 420, 171–173.
- Domjan, M. (1998). The principles of learning and behavior. Pacific Grove, CA: Brooks-Cole Publishing Company.
- Don, M. & Starr, A. (1972). Lateralization performance of the squirrel monkey (*Samiri sciureus*) to binaural click signals. *Journal of Neurophysiology*, 35, 493-500.
- Florida Fish & Wildlife Research Institute (2006). *Annual mortality rates*. http://research.myfwc.com/features/view_article.asp?id=12084
- Gannon, D.P., Barros, N.B., Nowacek, D.P., Read, A.J., Waples, D.M. & Wells, R.S. (2005). Prey detection by bottlenose dolphins, *Tursiops truncatus*: an experimental test of the passive listening hypothesis. *Animal Behavior*, 69, 709–720.
- Gentry, R.L. (1967). Underwater auditory localization in the California seal lion (*Zalophus californianus*), *Journal of Auditory Research*, 7, 187-193
- Gerstein, E. (1999). *Psychoacoustic Evaluations of the West Indian manatee (Trichechus manatus latirostris)*. Unpublished Doctoral Dissertation, Florida Atlantic University, Boca Raton, FL.
- Gerstein, E., Gerstein, L., Forsythe, S. & Blue, J. (1999). The underwater audiogram of the West Indian manatee (*Trichechus manatus*). *Journal of the Acoustical Society of America*, 105, 3575-3583.
- Gerstein, E.R. (2002). Manatees, bioacoustics and boats. *American Scientist*, 90, 154-163.
- Griebel, U. & Schmid, A. (1996). Color vision in the manatee (*Trichechus manatus*). *Vision Research*, 36, 2747-2757.

- Griebel, U. & Schmid, A. (1997). Brightness discrimination ability in the West Indian manatee (*Trichechus manatus*). *Journal of Experimental Biology*, 200, 1587-1592.
- Hanggi, E.B. & Schusterman, R.J. (1994). Underwater acoustic displays and individual variation in male harbour seals, *Phoca vitulina*. *Animal Behavior*, 48, 1275-1283.
- Hayes, S.A., Kumar, A., Daniel, P.C., Mellinger, D.K., Harvey, J.T., Southall, B.L. & LeBoeuf, B.J. (2004). Evaluating the function of the male harbour seal, *Phoca vitulina*, roar through playback experiments. *Animal Behavior*, 67, 1133-1139.
- Heffner, R.S. (1997). Comparative study of sound localization and its anatomical correlates in mammals. *Acta Otolaryngologica*, 532, 46-53.
- Heffner, R.S. & Heffner, E.H. (1982). Hearing in the elephant (*Elephas maximus*): Absolute sensitivity, frequency discrimination, and sound localization. *Journal of Comparative and Physiological Psychology*, 96 (6), 926-944.
- Heffner, R.S. & Heffner, E.H. (1984). Sound localization in large mammals: Localization of complex sounds by horses. *Behavioral Neuroscience*, 98 (3), 541-555.
- Heffner, R.S. & Heffner, E.H. (1985). Sound localization in wild Norway rats (*Rattus Norvegicus*). *Hearing Research*, 19, 151-155.
- Heffner, R.S. & Heffner, E.H. (1988a). Sound localization and use of binaural cues by the gerbil (*Meriones unguiculatus*). *Behavioral Neuroscience*, 102 (3), 422-428.
- Heffner, R.S. & Heffner, E.H. (1988b). Sound localization acuity in the cat: Effect of azimuth, signal duration and test procedure. *Hearing Research*, 36, 221-232.
- Heffner, R.S. & Heffner, E.H. (1988c). Sound localization in a predatory rodent, the Northern Grasshopper mouse (*Onychomys leucogaster*). *Journal of Comparative Psychology*, 102 (1), 66-71.
- Heffner, R.S. & Heffner, E.H. (1989). Sound localization, use of binaural cues and the superior olivary complex in pigs. *Brain Behavior Evolution*, 33, 248-258.
- Heffner, R.S. & Heffner, E.H. (1992a). Evolution of sound localization in mammals. In, D. Webster, R. Fay and A. Popper (Eds.) *The Biology of Hearing*, Springer-Verlag, pp. 691-715.
- Heffner, R.S. & Heffner, E.H. (1992b). Hearing in large mammals: Sound localization acuity in cattle (*Bos taurus*) and goats (*Capra hircus*). *Journal of Comparative Psychology*, 106 (2), 107-113.

- Heffner, R.S. & Masterson, R.B. (1990). Sound localization in mammals: Brain stem mechanisms. In M. A. Berkley, & W. C. Stebbins (Eds.) *Comparative Perception*, New York, John Wiley and Sons, pp. 285-314.
- Heffner, R.S. (1997). Comparative study of sound localization and its anatomical correlates in mammals. *Acta Otolaryngologica*, 532, 46-53.
- Holt, M.M., Schusterman, R.J., Southall, B.L. & Kastak, D. (2004). Localization of aerial broadband noise by pinnipeds. *Journal of the Acoustical Society of America*, 115, 2339-2345.
- Houben, D. & Gourevitch, G. (1979). Auditory lateralization in monkeys: An examination of two cues serving directional hearing. *Journal of Acoustical Society of America*, 66, 1057-1063.
- Isley, T.E. & Gysel, L.W. (1975). Sound source localization by the red fox. *Journal of Mammalogy*, 56, 397-404.
- Kastelein, R.A., de Haan, D. & Verboom, W.C. (2007). The influence of signal parameters on the sound source localization ability of a harbor porpoise (*Phocena phocena*). *Journal of the Acoustical Society of America*, 122 (2), 1238-1248.
- Ketten, D.R., Odell, D.K. & Domning, D.P. (1992). Structure, function and adaptation of the manatee ear. In J. A. Thomas, R. A. Kastelein, & A. Y. Supin (Eds.) *Marine Mammal Sensory Systems* (pp.77-79). NY: Plenum Press.
- Kirkpatrick, B., Colbert, D.E., Dalpra, D., Newton, E.A.C., Gaspard, J., Littlefield B. & Manire, C.A. (2002). Florida Red Tides, Manatee Brevetoxicosis, and Lung Models. In K. A. Steidinger, J. H. Landsberg, C. R. Tomas, and G. A. Vargo (Eds.) *Xth International Conference on Harmful Algae*. Florida Fish and Wildlife Conservation Commission and Intergovernmental Oceanographic Commission of UNESCO.
- Klishen, V.O., Diaz, R.P., Popov, V.V. & Supin, A.Y. (1990). Some characteristics of hearing of the Brazilian manatee, *Trichechus inunguis*. *Aquatic Mammals*, 16 (3), 139-144.
- Manire, C.A., Walsh, C.J., Rhinehart, H.L., Colbert, D.E., Noyes, D.R. & Luer, C.A. (2003). Alterations in blood and urine parameters in two Florida manatees, *Trichechus manatus latirostris*, from simulated conditions of release following rehabilitation. *Zoo Biology*, 22, 103-120.
- Mann, D., Colbert, D.E., Gaspard, J.C. III, Casper, B., Cook, M.L.H., Reep, R.L. & Bauer, G.B. (2005). Temporal resolution of the Florida manatee (*Trichechus manatus latirostris*) auditory system. *Journal of Comparative Physiology*, 191, 903-908.

- Marler, P. (1955). Some characteristics of animals calls. *Nature*, 176, 6, 6-8.
- Mass, A.M., Odell, D.K., Ketten, D.R. & Supin, A.Y. (1997). Ganglion layer topography and retinal resolution of the Caribbean manatee *Trichechus manatus latirostris*. *Doklady Biological Sciences*, 355, 392-394.
- Masterson, B., Heffner, H. & Ravizza, R. (1969). The evolution of human hearing. *Journal of the Acoustical Society of America*, 45, 966-985.
- Masterson, B., Thompson, G.C., Bechtold, J.K. & RoBards, M.J. (1975). Neuroanatomical basis of binaural phase-difference analysis for sound localization: A comparative study. *Journal of Comparative Physiological Psychology*, 89, 379-386.
- Medwin, H. & Clay, C.S. (1998). *Fundamentals of Acoustical Oceanography*. NY: Academic Press.
- Middlebrooks, J.C. & Green, D.M. (1991). Sound localization by human listeners. *Annual Review of Psychology*, 42, 135-159.
- Miksis-Olds, J.L. (2006). Manatee Response to Environmental Noise. Unpublished Doctoral Dissertation. University of Rhode Island, Narragansett, RI.
- Mills, A.W. (1958). On the minimum audible angle. *Journal of the Acoustical Society of America*, 30, 127-246.
- Mills, A.W. (1972). Auditory localization. In J. V. Tobias (Ed.) *Foundations of Modern Auditory Theory: Vol. II*, (pp. 3030-348). NY: Academic Press.
- Moore, P.W.B. (1974). Underwater localization of click and pulsed pure-tone signals by the California sea lion (*Zalophus californianus*). *Journal of the Acoustical Society of America*, 57 (2), 406-410.
- Moore, P.W.B. & Au, W.L. (1975). Underwater localization of pulsed pure tones by the California sea lion (*Zalophus californianus*). *Journal of the Acoustical Society of America*, 58 (2), 721-727.
- Moore, P.W.B. & Brill, R.L. (2001). Binaural hearing in dolphins. *The Journal of the Acoustical Society of America*, 109 (5), 2330-2331.
- Moore, P.W.B. and Pawloski, D.A. (1993). Interaural time discrimination in the bottlenose dolphin. *The Journal of the Acoustical Society of America*, 94 (3), 1829-1830.

- Norris, K.S. (1967). Some observations on the migration and orientation of marine mammals. In: *Animal Orientation and Navigation*, Proceedings of the 27th Annual Biology Colloquium, Oregon State., Corvallis, OR, pp. 101–131.
- Nowacek, D.P., Casper, B.M., Wells, R.W., Nowacek, S.M. & Mann, D.A. (2003). Intraspecific and geographic variation of West Indian manatee (*Trichechus manatus spp.*) vocalizations. *Journal of the Acoustical Society of America*, 114 (1), 66-69.
- Nowacek, S.M., Wells, R.S., Owen, E.C.G., Speakman, T.R., Flam, R.O. & Nowacek, D.P. (2004). Florida manatees, *Trichechus manatus latirostris*, respond to approaching vessels. *Biological Conservation* 119, 517-523.
- Odell, D.K. & Reynolds, J.E. III. (1979). Observations on manatee mortality in South Florida. *Journal of Wildlife Management*, 28 (3), 572-577.
- O’Shea T.J. & Poche L.B. (2006). Aspects of underwater sound communication in Florida manatees (*Trichechus manatus latirostris*). *Journal of Mammalogy*, 87 (6): 1061-1071.
- Pepper, R.L. & Defran, R.H. (1975). *Dolphin Trainer’s Handbook*, Part 1: Basic Training (50p). Naval Undersea Center, San Diego, CA.
- Piggins, D.J., Muntz, W.R.A. & Best, R.C. (1983). Physical and morphological aspects of the eye of the manatee, *Trichechus inunguis*. *Marine Behaviour and Physiology*, 9, 111-130.
- Popov, V.V. & Supin, A.Y. (1990). Electrophysiological studies on hearing in some cetaceans and a manatee. In J.A. Thomas, & R. A. Kastelein (Eds.), *Sensory Abilities of Cetaceans: Laboratory and Field Evidence*. NY: Plenum Press.
- Richardson, W., Greene, C., Malme, C. & Thompson, D. (1995). *Marine Mammals and Noise*. San Diego, CA: Academic Press.
- Ridgway S.H. & Carder D.A. (1997). Hearing deficits measured in some *Tursiops truncatus*, and discovery of a deaf/mute dolphin. *Journal of the Acoustical Society of America*, 101: 590-594
- Reep, R.L., Marshall, C.D. & Stoll, M.L. (2002). Tactile hairs on the postcranial body in Florida manatees: a mammalian lateral line? *Brain Behavior and Evolution*, 59, 141-154.
- Renaud, D.L. & Popper, A.N. (1975). Sound localization by the bottlenose porpoise *Tursiops truncatus*. *Journal of Experimental Biology*, 63, 569-585.
- Reynolds, J.E. III. (1979). The semisocial manatee. *Natural History*, 88 (2), 44-53.

- Reynolds, J.E. & Odell, D.K. (1991). *Manatees and Dugongs* (192 pp.). NY: Checkmark Books.
- Reynolds, J.E. III, & Wilcox, J.R. (1986). Distribution and abundance of the West Indian manatee, *Trichechus manatus*, around selected Florida power plants following winter cold fronts: 1984-1985. *Biological Conservation*, 38, 103-113.
- Richardson, W.J., Greene, C.R., Malme, C.I. & Thomson, D.H. (1995). *Marine Mammals and Noise*. Academic, San Diego.
- Rogers, T.L., Cato, D.H. & Bryden, M.M. (1996). Behavioral significance of underwater vocalizations of captive leopard seals, *Hydrurga leptonyx*. *Marine Mammal Science*, 12 (3), 414-427.
- Ross, D. (1976). *Mechanics of Underwater Noise*. NY: Pergamon.
- Sayigh, L.S., Tyack, P.L., Wells, R.S. & Scott, M.D. (1990). Signature whistles of free-ranging bottlenose dolphins *Tursiops truncatus*: stability and mother-offspring comparisons. *Behavioral Ecology and Sociobiology*, 26 (4), 247-260.
- Sayigh, L.S., Tyack, P.L., Wells, R.S., Scott, M.D. & Irvine, A.B. (1995). Sex difference in signature whistle production of free-ranging bottlenose dolphins, *Tursiops truncatus*. *Behavioral Ecology and Sociobiology*, 36 (3), 171-177.
- Serrano, A. & Terhune, J.M. (2002). Anti-masking aspects of harp seal, *Pagophilus groenlandicus*, underwater vocalizations. *Journal of the Acoustical Society of America*, 112, 3083-3090.
- Stevens, S.S. & Newman, E.B. (1936). The localization of actual sources of sound. *American Journal of Psychology*. 48, 297-306.
- Smolker, R. & Pepper, J.W. (1999). Whistle Convergence among allied male bottlenose dolphins (Delphinidae, *Tursiops* sp.). *Ethology*, 105 (7), 595-617.
- Terhune, J.M. (1974). Directional hearing of a harbor seal in air and water. *Journal of the Acoustical Society of America*, 56 (6), 1862-1865.
- Thurlow, W.R., Mangels, J.W. & Runge, P.S. (1967). Head movements during sound localization. *Journal of the Acoustical Society of America*, 42, 489-493.
- Tyack, P.L. & Clark, C.W. (2000). Communication and acoustic behavior of dolphins and whales. In: Au, W.W.L. , Popper, A.N. & Fay, R.R. (Eds.) *Hearing by Whales and Dolphins*, Springer, New York, pp. 156-224.

- Urick, R.J. (1996). *The Principles of Underwater Sound*, 3rd Edition (423 pp.). CA: Peninsula Publications.
- U.S. Fish and Wildlife Service (2001). *Florida Manatee Recovery Plan, (Trichechus manatus latirostris), Third Revision*. U.S. Fish and Wildlife Service, Atlanta, Georgia. 144 pp.
- Van Parijs, S.M., Hastie, G.D. & Thompson, P.M. (1999). Geographic variation in temporal and spatial vocalization patterns of male harbour seals in the mating season. *Animal Behavior*, 58, 1231–1239.
- Van Parijs, S.M., Hastie, G.D. & Thompson, P.M. (2000 a). Individual and geographical variation in display behaviour of male harbour seals in Scotland. *Animal Behavior*, 59, 559–568.
- Van Parijs, S.M., Janik, V.M. & Thompson, P.M. (2000 b). Display area size, tenure length, and site fidelity in the aquatically mating male harbour seal, *Phoca vitulina*. *Canadian Journal of Zoology*. 78, 2209–2217.
- Van Parijs, S.M., Lyderson, C. & Kovacs, K.M. (2003). Vocalizations and movements suggest alternative mating tactics in male bearded seals. *Animal Behavior*, 65, 273–283.
- Wakeford, O.S. & Robinson, D.E. (1974). Lateralization of tonal stimuli by the cat. *Journal of the Acoustical Society of America*, 55, 649-652.
- Walls, G.L. (1963). *The vertebrate eye and its adaptive radiation*. NY: Hafner.
- Watkins, W.A. & Schevill, W.E. (1979). “Distinctive characteristics of underwater calls of the harp seal, *Phoca groenlandica*, during the breeding season, *Journal of the Acoustical Society of America* 66, 983–988.
- Wells, M.J. & Ross, H. (1980). Distortion and adaptation in underwater sound localization. *Aviation, Space, and Environmental Medicine*. 51, 767–774.
- West, J.A., Sivak, J.G., Murphy, C.J. & Kovacs (1991). A comparative study of the anatomy of the iris and ciliary body in aquatic mammals. *Canadian Journal of Zoology*, 69, 2594-2607.
- Yost, W.A. (2000). Sound localization and binaural hearing. In *Fundamentals of Hearing: An Introduction*. San Diego, CA: Academic Press (pp. 179-192).
- Yost, W.A. & Dye, R.H. (1997). Fundamentals of directional hearing, *Seminars in Hearing*, 18, 321–344.

Chapter Three: Head/Body Related Transfer Functions of the Florida Manatee, *Trichechus manatus latirostris*

Abstract

Head and body related transfer function measurements were investigated for two Florida manatees (*Trichechus manatus latirostris*) to determine how different frequencies of a test signal, presented in different locations on the azimuth plane, are filtered by the manatee's head and torso. A previous investigation demonstrated that manatees were capable of localizing sounds in all 360° of the azimuth plane and may be able to differentiate signals originating directly in front or behind them (Chapter 2). The means by which manatees determine sound source directionality however are unknown.

To determine if different frequencies are filtered by the manatee's head and torso, thereby providing level cues which may aid sound localization, subjects were positioned in the center of a 360° array of speakers positioned 45° apart with one hydrophone suspended next to but not touching each external auditory meatus. The test stimulus presented was a 0.2-30 kHz, 3000 ms broadband noise burst.

Head/body related transfer functions were determined by subtracting the averaged 'animal present' FFTs (10 Hz frequency resolution) from the averaged 'animal absent' FFTs (10 Hz frequency resolution). The magnitude of interaural level differences was

then derived for all frequencies in addition to specific 0.2-1.5, 0.2-5 and 18-30 kHz bands of frequencies.

Results indicated that interaural level differences were found for all frequencies, starting below 1 kHz and extending up to 30 kHz, as a function of source location. Interaural level differences were of the greatest magnitude with frequencies above 18 kHz which have wavelengths shorter than the manatee's intercochlear distance. Test signals originating at 90° and 270° provided greater ILD cues than those originating from other locations, however ILDs were greater when the signal originated behind the subject at 180°, 225° and 135° than in front of them at 0°, 45° and 315°. These results suggest that the manatees' torso provided greater shadowing effects than the head, thereby increasing ILD cue salience to facilitate localization when sounds originate behind them.

Introduction

The Florida manatee (*Trichechus manatus latirostris*) is an endangered species, protected by both the Marine Mammal Protection Act (1972) and the Endangered Species Act (1973). It is the only marine mammal known to migrate considerable distances from fresh water habitats to salt water habitats in the summer months, and the opposite in winter months. It is considered a semi-social species, often grazing or traveling alone with conspecifics out of visual range, although females with calves will congregate together and males will mass around estrous females (Reynolds, 1979). The Florida manatee also lives in a habitat where boats are found in high numbers with over 1,027,000 registered in the state of Florida in 2007 (Florida Department of Highway Safety and Motor Vehicles, 2007). The means by which manatees are able to find one another, navigate and avoid danger in their vast habitat is unclear. Research has not been published regarding the manatee's gustatory and olfactory sensory systems, however anatomical and behavioral studies have provided insight into the manatee's visual, tactile, and auditory sensory processes.

The manatee visual sensory system appears to be built for sensitivity in dim light conditions with the ability to differentiate brightness differences (Griebel & Schmid, 1997) and blues from greens (Cohen et al., 1982; Griebel & Schmid, 1996; Ahnelt & Kolb, 2000; Ahnelt & Bauer, 2000), but acuity is poor (Walls, 1963; Piggins et al., 1983; West et al., 1991; Mass et al., 1997; Bauer et al., 2003) and not useful for fine details. The tactile sensitivity of the manatee's facial vibrissae is excellent and comparable to that

of the human index finger (Bachteler & Dehnhardt, 1999; Bauer et al., 2005), and the vibrissae hairs dispersed across the torso are also sensitive and may act similarly to a fish's lateral line (Reep et al., 2002). The manatee's hearing threshold is quite wide and ranges between 0.4-40 kHz (Bullock et al., 1980, 1982; Popov & Supin, 1990; Gerstein et al., 1999; Mann et al., 2005) although one investigation estimates it reaches 60 kHz (Klishen et al., 1990). An audiogram demonstrates that the range of best hearing lies between 10–20 kHz with maximum sensitivity at ~50 dB re: 1 μ Pa with 16 and 18 kHz, decreasing by ~20 dB re: 1 μ Pa per octave from 0.8 to 0.4 kHz and 40 dB re: 1 μ Pa per octave above 26 kHz (Gerstein et al., 1999). These hearing capabilities indicate that manatees have the capacity to detect conspecific vocalizations which typically range between 2.5–5.9 kHz (Nowacek, et al., 2003) and boat engine noise which typically range between 0.01–2 kHz (Gerstein, 2002; Richardson et al., 1995).

These results suggest that the manatee's senses of vision and touch are probably designed to function with tasks in close proximity to its body. It seems likely that the manatee's auditory system plays a crucial role with functioning in both nearby and distant scenarios and that the ability to localize or determine sound source directionality would be of great importance for tasks such as navigation, finding conspecifics and boat avoidance.

Sound localization is the auditory system's ability to process the frequency, level and phase of a sound and associate it with the spatial location of that sound's source (Yost, 2000). The ability to localize sounds is considered a primary source of selective pressure in the evolution of mammalian hearing (Masterson et al., 1969) and is vital for many species' ability to find food and conspecifics while avoiding predation. Previous

studies have suggested that the ability to localize a sound source may be influenced by multimodal sensory systems and be a function of visual orientation responses (Brown, 1994; Heffner, 1997). Numerous species, including humans, gulls, ducks, cats, rats and guinea pigs possess a reflexive visual orientation response towards startling sounds at birth or shortly thereafter when their auditory systems become functional (Brown, 1994). Many species, including cats, mice, rats, chinchillas, guinea pigs and horses, also possess a Preyer reflex, which is a distinctive movement of the pinna towards a sudden sound to assist with localization (Francis, 1979; Ehret, 1983). These multi-modal arrangements are extremely beneficial for determining the location of an acoustic stimulus when it is of a long enough duration to do so. However, the ability to localize sounds that are of shorter durations and cannot be tracked or scanned using head, eye, or pinna movements provides obvious additional advantages.

In our three dimensional world, sounds can be localized from the vertical, horizontal (azimuth) and distance dimensions by extracting information from the sound's temporal, phase and level cues with each of our two ears (Middlebrooks & Green, 1991; Hartman, 1999). Interaural time differences (ITD), also known as time of arrival cues, compare the sound's time of arrival at each ear (Figure 3.2). Because the speed of sound is relatively constant, variations in frequency do not have an effect on the perception of interaural time differences.

Interaural level differences (ILD) are interpreted when the sound is one level when it reaches the closest ear but due to the shadowing effect of the pinna, head, or body, is a lower level when it reaches the farthest ear (Figure 3.2). The level difference is dependent on sound wave lengths. Higher frequencies have shorter wavelengths causing

a greater sound shadow. Sounds are generally perceived to be closer to the ear they arrive earliest and with the greatest amplitude.

Interaural phase differences (IPD) are interpreted when the sound that arrives in the first ear is in one period of the frequency but is out of phase when it hits the second ear (Figure 3.1). The phase difference is also dependent on sound wave lengths.

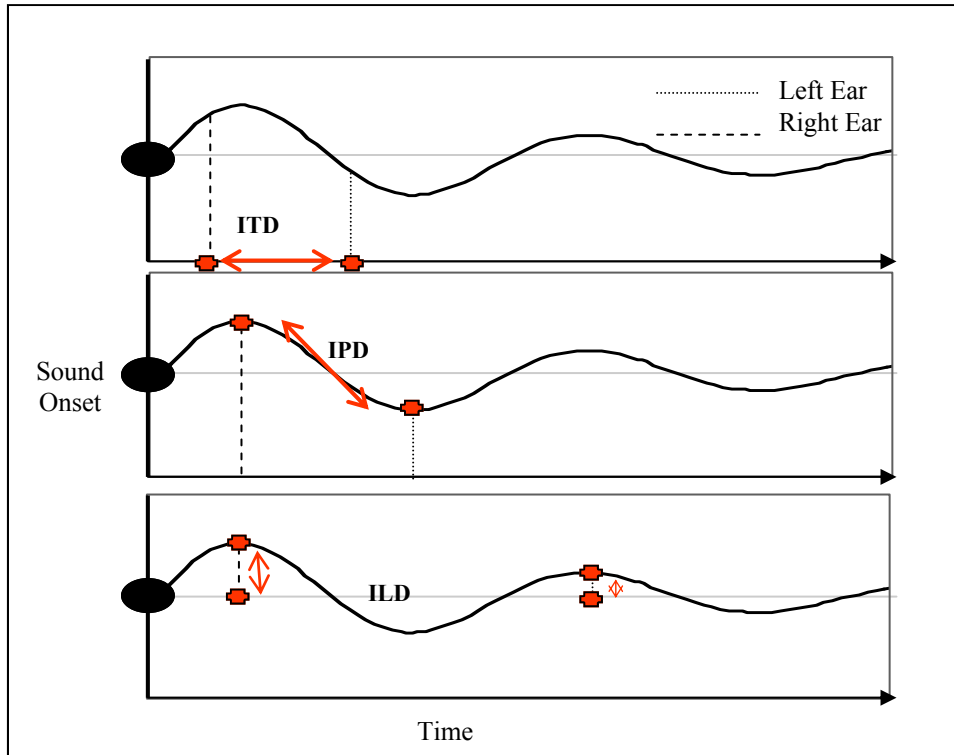

Figure 3.1. Interaural time (ITD), phase (IPD), and level (ILD) cues used for sound localization.

Several divisional planes have been identified around an organism which facilitate dimension and cue integration (Figure 3.2). The elevation plane, also called the vertical plane, runs vertically through the body, dividing the left and right sides, and provides information about a sound's location as it is positioned anywhere in a circumference above or below the body. The azimuth plane also called the horizontal plane, runs laterally around the body and provides information about a sound's location as it is positioned anywhere in a circumference from the left to the right. The medial plane runs

vertically through the body, dividing the anterior and posterior portions, and provides information about a sound's location as it is positioned anywhere in a circumference from front to back (Figure 3.1). Monaural ear signal attributes (those derived from only one ear) provide information about anterior and posterior areas of the median plane as well as the elevation angle and distance of the sound source location. Interaural signal attributes (those derived from both ears) provide information about lateral displacement of the sound source location. The combination of monaural and interaural ear signal attributes provides angular information about a sound's distance and location in the azimuth and elevation planes.

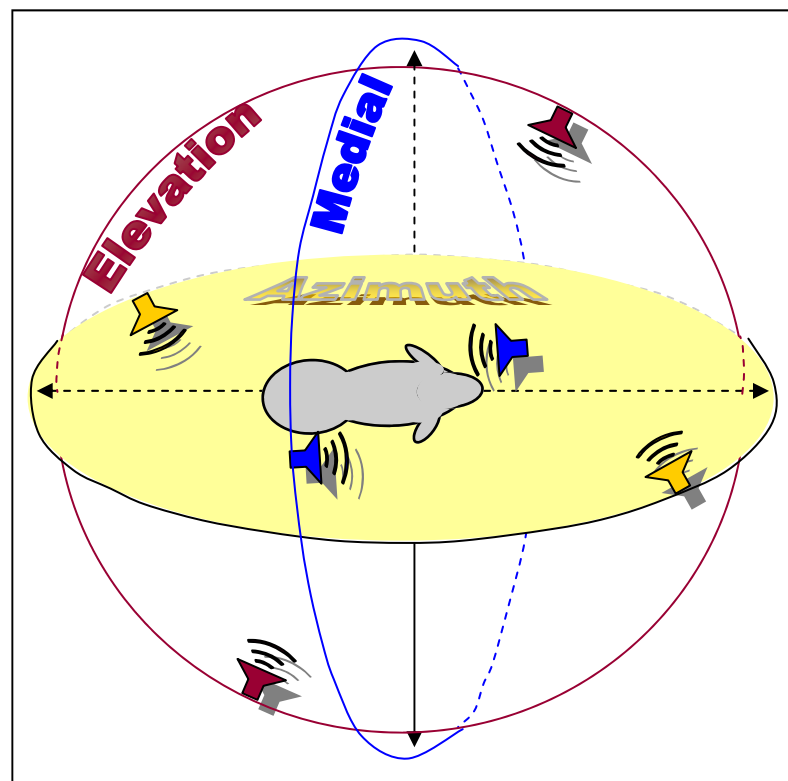

Figure 3.2. Azimuth, elevation and medial planes used to integrate the vertical, horizontal and distance dimensions with a sound's temporal, phase and level cues.

Behavioral testing of sound localization abilities has typically been investigated by measuring the species' minimum audible angle (MAA) (Brown, 1994; Brown & May,

1990). This method determines the smallest detectable angular difference between two sound source locations positioned in front of the subject in the azimuth plane (Mills, 1958). Numerous in-air auditory MAA studies have been conducted with terrestrial mammals including humans (Stevens & Newman, 1936; Mills, 1972), monkeys (Don & Star, 1972; Houben & Gourevitch, 1979; Brown et al., 1980), the domestic cat (Casseday & Neff, 1973; Wakeford & Robinson, 1974; Heffner & Heffner, 1988b), red fox (Isley & Gysel, 1975), hedgehog (Masterson et al., 1975), elephant, horse, Norway rat, pig, gerbil, Northern grasshopper mouse, pocket gopher, goat and cattle (Heffner & Heffner, 1982; 1984; 1985; 1988a; 1988c; 1989; Heffner & Masterson, 1990; Heffner & Heffner, 1992b respectively).

Although less common, MAA measurements have been assessed for marine mammals including pinnipeds (Gentry, 1967; Anderson, 1970; Moore, 1974; Terhune, 1974; Moore & Au, 1975; Babushina and Poliakov, 2004; Holt et al., 2004) and cetaceans (Renaud & Popper, 1975; Moore & Pawloski, 1993; Moore & Brill, 2001; Branstetter et al., 2003; Branstetter, 2005; Branstetter & Mercado, 2006; Branstetter et al., 2007). More recently, some pinniped and manatee sound localization investigations have required subjects to identify sound sources relative to different locations surrounding the subject's body. This has been done by presenting signals in the frontal 180° or complete 360° of the horizontal plane surrounding a stationary subject (Kastelein et al., 2007; Gerstein, 1999; Colbert 2005; Chapter 2) or by having the subject swim along a half circle diameter and orient towards a sound source when presented (Bodson et al., 2006). All three designs assess sound localization abilities, however the latter two

have more realistic applications by addressing the subjects ability to localize sounds that originate from different angles surrounding their bodies.

Although these testing paradigms provide valuable information about a species' localization abilities, they do not address the means by which they are able to accomplish these tasks. The first investigation that examined how the shape of the human head affects sounds within the azimuth plane was conducted by Lord Rayleigh (Strutt, 1907). Lord Rayleigh modeled the head as a rigid sphere and measured how sound waves propagated around it. His early results provided considerable information about interaural level and time differences. He found that ILD's were not linear with frequency. Frequencies with wavelengths greater than the diameter of the head (<1500 Hz) were not filtered or shadowed as much as frequencies with wavelengths smaller than the diameter of the head (>1500 Hz). These data suggested that higher frequency components of a sound were more salient than lower frequency components when the brain evaluated ILD's. He also found that lower frequency components of a sound were more important for evaluating ITD's because independent comparisons of points within one phase of the sound wave could be interpreted by the brain.

The spherical head model has been used by many researchers to explain how sounds from various locations within the azimuth dimension are filtered by the human head (Hartley & Fry, 1921; Kuhn, 1977, 1987; Brungart & Rabinowitz, 1999). It did not, however address how sounds originating from several different locations can produce identical ITDs and ILDs to create a cone of confusion (Figure 3.3), how sounds are filtered in the remaining dimensions or how sounds are filtered by the by the pinna or torso.

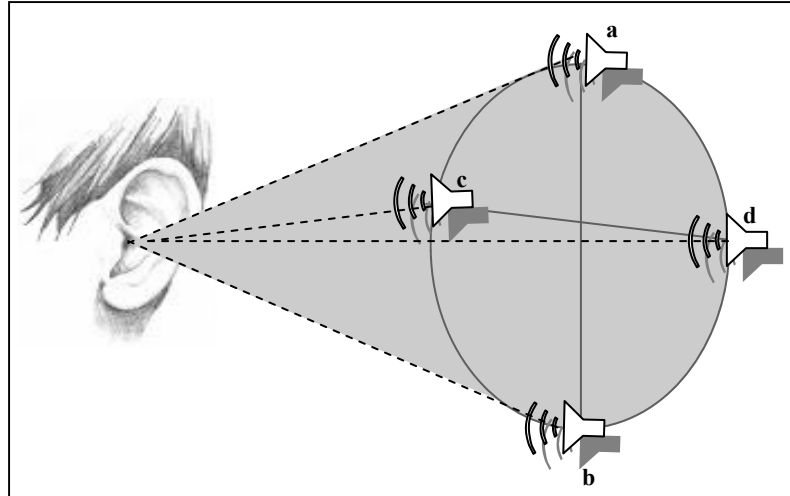

Figure 3.3 Cone of confusion caused from sounds originating in different locations. Sounds from sources a & b as well as c & d have identical interaural time and level differences.

Head-related transfer functions (HRTFs) have been comprehensively studied to understand the mechanisms of spatial hearing (Blauert, 1997; Wightman & Kistler, 1997). HRTFs are determined by identifying differences between the sound's characteristics at its source and at the point of the ears as a function of frequency (Blauert, 1997). HRTFs with terrestrial animals have commonly been conducted by playing bursts of broadband noise from different spatial locations surrounding a fixed head and measuring the sound's spectral characteristics from small microphones that were implanted deep in the ear canal.

HRTFs illustrate how sound waves are filtered by the diffraction and reflection properties of the head, pinna, and torso before they reach the inner ear (Searle et al., 1975; Middlebrooks et al., 1989), and how the conundrum of the cone of confusion is resolved. For species with pinnae, sounds may travel directly into the ear canal or be reflected off the pinna and travel into the ear canal fractions of a second later. Because sounds are typically composed of multiple frequencies, many copies of the signal enter the ear at different times depending on their frequency. Some copies overlap and have

matching phase signals that are enhanced, while others have non-matching phase signals that are canceled out. Studies with humans have demonstrated that the pinna has substantial effects on HRTFs at higher frequencies with wavelengths smaller than the pinna size (>3 Hz) but that these effects were minimized with lower frequencies (Mehrgardt & Mellert, 1977; Wightman & Kistler, 1989). The pinna was also found to provide substantial information about the elevation of the sound source (Batteau, 1967; Wright et al., 1974). Similarly, the human torso influenced HRTFs, although not as significantly as the pinna, and primarily with lower frequencies (Kuhn & Gurnsey, 1983; Kuhn, 1987). Algazi et al. (2001; 2002) demonstrated that the torso produced reflections and shadows that also provided elevation cues.

Measurements of how interaural time, phase and level difference cues are interpreted has been investigated with many terrestrial species including humans (Stevens & Newman, 1936; Mills, 1972; Middlebrooks & Green, 1991), rats (Heffner & Heffner, 1985), Northern grasshopper mouse (Heffner & Heffner, 1988c), gerbils (Kelly & Potas, 1986; Heffner & Heffner, 1988a; Maki & Furukawa, 2005), guinea pigs (Carlile & Pettigrew, 1987), pocket gopher (Heffner & Heffner, 1992a), ferrets (Carlile, 1990), hedgehog (Masterson et al., 1975), Tammar wallabies (Coles & Guppy, 1986), monkeys (Don & Star, 1972; Houben & Gourevitch, 1979; Brown et al., 1980; Spezio et al., 2000), cats (Casseday & Neff, 1973; Wakeford & Robinson, 1974; Roth et al., 1980; Phillips et al., 1982; Irvine, 1987; Heffner & Heffner, 1988b; Musicant et al., 1990; Rice et al., 1992), fox (Isley & Gysel, 1975), elephant (Heffner & Heffner, 1982), horse (Heffner & Heffner, 1984), pig (Heffner & Heffner, 1989), goat and cattle (Heffner & Heffner,

1992b), bats (Jen & Chen, 1988; Obrist et al., 1993; Fuzessery, 1996; Firzlaff & Schuller, 2003), and barn owls (Knudsen & Konishi, 1979; Moiseff, 1989; Keller et al., 1998).

Results from these investigation indicate that most terrestrial mammals, including humans, gerbils, squirrel monkeys, Norway rats, macaques, red fox, and the domestic cat utilize some combination of all three interaural cues. Some species, however, only use two interaural cues. For instance, the hedgehog and the Northern grasshopper mouse use only interaural time and level difference cues and the elephant, horse, pig, goat and cattle use only interaural time and phase difference cues. At least one species, the pocket gopher, is incapable of using any of the interaural cues and it has been suggested that this may be a result of this fossorial species' adaptation to living in an underground environment where azimuth cues have little meaning (Burda et al., 1990).

While the ability to interpret interaural cues for localization may be difficult or impossible for some terrestrial mammals, the ability for marine mammals to use these cues for underwater localization is complicated by several factors. The speed of sound in water (1500 m/second) is approximately five times faster than in air (340m/second) (Urick, 1996) requiring marine mammal auditory systems to process interaural time, phase and level differences much more rapidly than those of terrestrial mammals. Although acoustic energy propagates more efficiently in water than light, thermal or electromagnetic energy (Au, 1993), higher frequencies become more directional, reflecting off the surface and bottom and low frequencies may not propagate well in shallow waters (Medwin & Clay, 1998).

It is apparent that sound characteristics differ between the source and inner ear due to attenuation from refraction, reflection, scattering and absorption caused by objects

in the environment as well as by the shape of the pinna, head and torso of terrestrial mammals (Urlick, 1996). Fully aquatic marine mammals however, have become streamlined for hydrodynamic efficiency and lack the very important pinna terrestrial mammals and even semi-aquatic marine mammals such as the sea lion use to facilitate localization. Investigations with dolphins have shown that they are very competent at localization tasks (Renaud & Popper, 1975; Moore & Pawloski, 1993; Moore & Brill, 2001; Branstetter et al., 2003; Branstetter, 2005; Branstetter & Mercado, 2006; Branstetter et al., 2007), but only one study has measured their interaural time and level difference thresholds. Moore et al. (1995) investigated the dolphin's ability to utilize ITDs and ILDs by presenting binaural stimuli through jaw phones (hydrophones embedded in rubber suction cups) that were attached to the right and left lower jaws. Results found ITDs and ILDs were salient cues dolphins could detect and suggest that they likely use the same interaural differential sound cues as terrestrial mammals. It has been shown that dolphins receive sonar echoes through complex fat channels in their lower jaw which may function as a pinna analogue (Brill, 1988; Ketten et al., 1992; Møhl et al., 1999).

The Florida manatee spends a significant amount of time grazing in shallow water where sounds tend to have more reflection off the surface of the water and bottom terrain making localization more challenging. The localization abilities of the manatee have only recently been investigated and results indicate that they are quite proficient at localizing sounds over a wide range of frequencies (Gerstein, 1999; Colbert, 2005) and within all 360° (Chapter 2). These findings are somewhat perplexing given that the manatee lacks pinnae, but also possesses an external auditory meatus (ear canal) that is of

minute size, completely occluded with cellular debris, and reaches a blind end that is separated from the tympanic membrane (Chapla et al., 2007).

The means by which manatees determine sound source directionality have not been investigated as yet. It may be that the manatee's elliptical and rotund body shape plays a more important role as a filter for generating interaural level cues than its much smaller head. The objective of this study was to measure head/body related transfer functions (HBRTF) from two Florida manatees.

Hypotheses

Two hypotheses were made. The first posited that subjects would have greater sound shadows present when the test stimulus was presented at the 135° and 225° locations than when presented at other locations. The manatee's small head and elongated elliptical body is fashioned in such a way that in the azimuth plane, there is more surface area for the signal to reflect off of when sounds are presented to the posterior angles of the body (Figure 3.4).

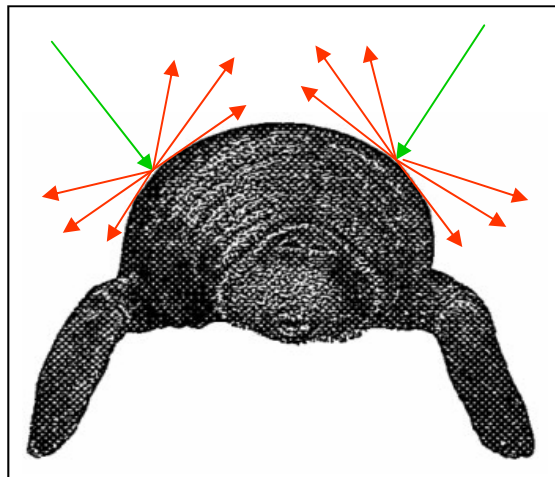

Figure 3.4. Interpretation of how signals presented from the 135° and 225° locations reflect off the manatees' elliptically shaped body.

The second hypothesis declared that interaural differences in level cues would be greater with higher frequencies than lower frequencies. ILDs are found when the level of the sound wave that reaches the ear nearest the source is greater than when it reaches the ear farthest from the source. ILDs are most effective with shorter wavelengths (higher frequencies), especially those that are shorter than the species' inter-meatal distance (Brown & May, 1990; Brown, 1994; Blauert, 1997).

Materials and Methods

Subjects

The subjects of this study were two captive-born male Florida manatees (*Trichechus manatus latirostris*), Hugh and Buffett, that reside at Mote Marine Laboratory and Aquarium in Sarasota, Florida. All procedures used were permitted through the United States Fish and Wildlife Service (Permit # MA837923-6) and approved by the Institutional Animal Care and Use Committee of Mote Marine Laboratory and Aquarium. At the inception of this study Hugh was 23 years of age, weighed 547 kg, and was 310 cm in length, while Buffett was 20 years of age, weighed 773 kg, and was 334 cm in length. They were housed in a 265,000 liter exhibit that was composed of three inter-connected sections: a 3.6 x 4.5 x 1.5 m Medical Pool, a 4.3 x 4.9 x 1.5 m Shelf Area, and a 9.1 x 9.1 x 3 m Exhibit Area.

Both animals had acquired an extensive training history over the previous seven years and had been behaviorally conditioned for husbandry procedures (Colbert et al., 2001) and studies which investigated lung capacity (Kirkpatrick et al., 2002), serum and urine creatinine levels as a function of release conditions (Manire et al., 2003), visual acuity (Bauer et al., 2003), facial vibrissae tactile sensitivity (Bauer et al., 2005), auditory evoked potentials (Mann et al., 2005) and four-choice (Colbert, 2005) and eight-choice sound localization studies (Chapter 2).

Experimental Design

An eight alternative forced-choice discrimination paradigm was used to measure the head/body related transfer functions (HBRTFs) of two Florida manatees, *Trichechus manatus latirostris*. Testing was conducted in the center of the exhibit area of the manatee habitat where eight underwater speakers (Aquasonic AC 339) were positioned in a 6.10 m diameter circumference at 0°, 45°, 90°, 135°, 180°, 225°, 270° and 315° (Figure 3.5). Each speaker was suspended from a 1.88 cm diameter PVC rod at a depth of 1.5 m. The rods were bolted to aluminum beams that radiated out from two suspension supports spanning the Exhibit Area, and were designed to pivot so that the speaker at the bottom of the rod could be pushed backwards while the top of the rod tilted forward in a pendulum motion.

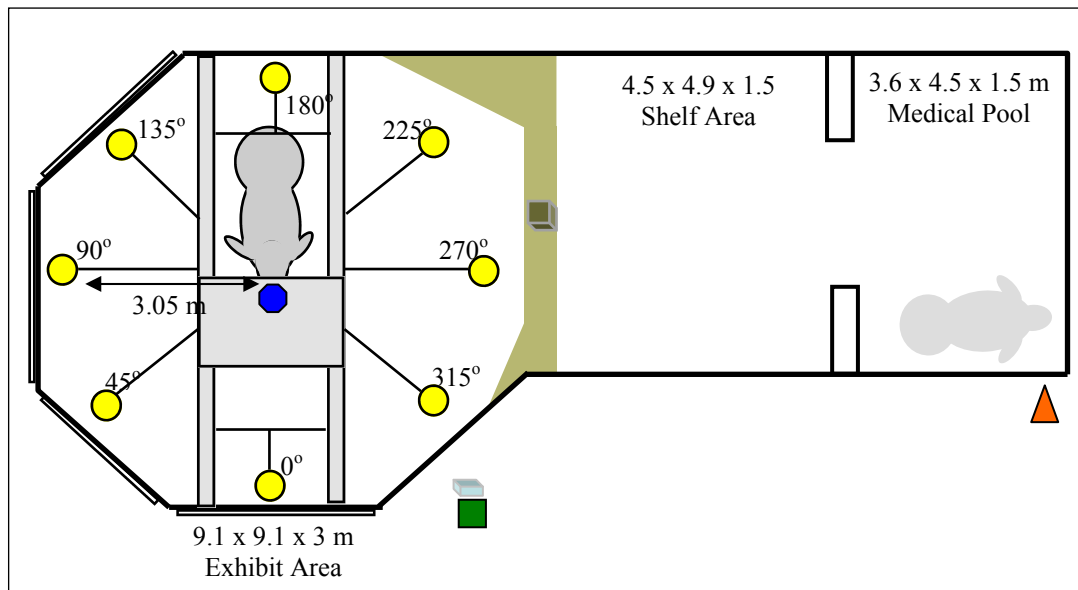

Figure 3.5. Testing setup for the manatee body related transfer function experiment. Subjects stationed facing 0° and test speakers were suspended from pivoting rods at 45°, 90°, 135°, 180°, 225°, 270° and 315°. The blue octagon represents the Test Trainer's location, the green square represents the Data Recorder's location, and the orange triangle represents the Stationing Trainer's location.

A 23 cm x 1.5 m stationing apparatus was constructed from 2.54 cm diameter polyvinyl chloride (PVC) pipe and positioned in the center of the circular array, 3.05 m

away from the speakers. Each subject had been previously trained to position the top of its rostrum, approximately 10 cm posterior to the nostrils, up against a stationing bar located at the bottom of the stationing apparatus in response to an individualized stationing tone. For this experiment, the stationing apparatus was modified such that two hydrophones (HTI 96 min; sensitivity -164 dBV/ μ Pa from 0.2 Hz to 37 kHz) were suspended next to but not touching each of the subject's external auditory meatus (Figure 3.6).

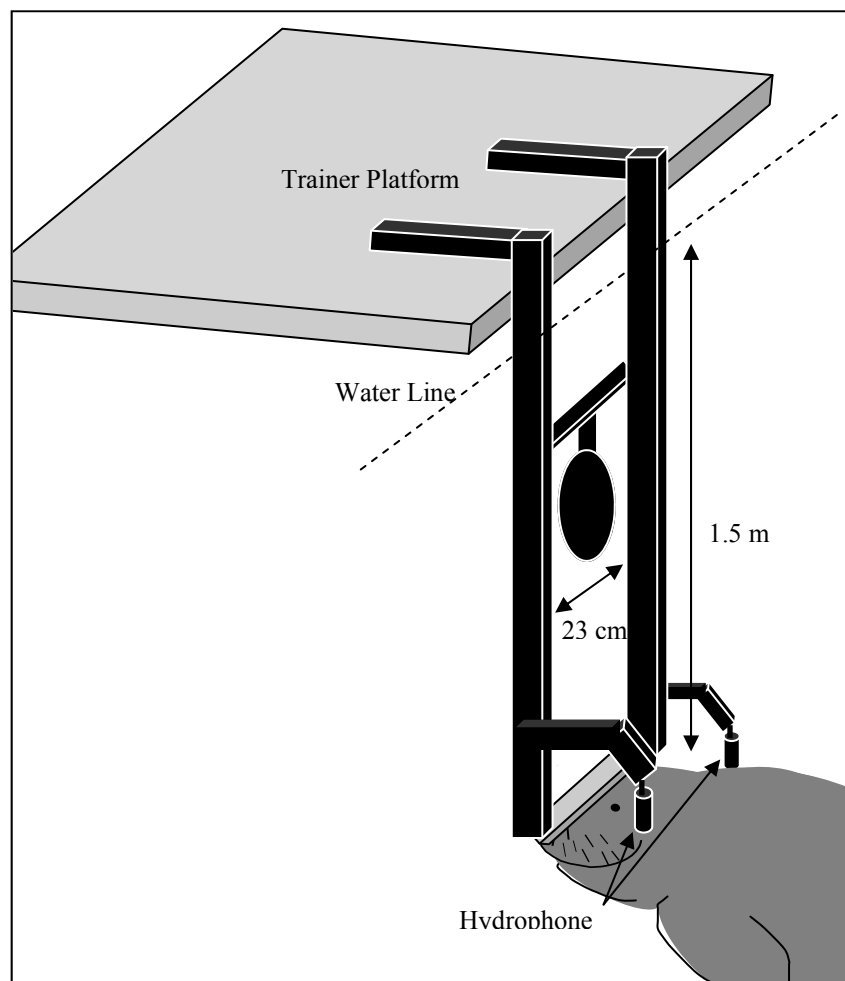

Figure 3.6. Stationing apparatus used to measure manatee body related transfer functions. The black circle represents the speaker that played the stationing tones. The subject pressed the crease of his rostrum up against the gray stationing bar on the bottom. Two hydrophones were suspended next to but not touching each external auditory meatus.

The subject remained stationed facing 0° until a 0.2-30 kHz, 3,000 ms test signal was played from one of the eight test speakers. Upon hearing the test signal, the subject would swim to and push the speaker from which he believed the sound originated. If correct, a secondary reinforcer signal (1.4-12 kHz with a peak at 5.3 kHz for Buffett, 1.2-11 kHz with a peak at 2.7 kHz for Hugh) was emitted from the test speaker and the subject returned to the stationing device to be fed a primary reinforcement of food (apples, beets, and carrots). If incorrect, the stationing tone was played from the stationing apparatus speaker and the subject re-stationed correctly with no reinforcement given to await a minimum of 30 seconds before the initiation of the next trial.

Three people were required to run the experiment: a Test Trainer, Data Recorder, and Station Trainer (Figure 3.5). The Test Trainer was positioned on a platform suspended across the Exhibit Area and ensured that the subject stationed properly, initiated trials, indicated which speaker the subject selected, and provided reinforcement when the subject selected the correct speaker location. The Data Recorder was positioned behind a laptop computer out of sight of the Test Trainer and subject, and set up the session's experimental conditions, informed the Test Trainer if the subject was correct or incorrect, recorded all data on a tank-side session sheet (see Appendix C), and ran the video equipment. The Station Trainer was positioned at northeast end of the Medical Pool and was responsible for holding the non-test animal at station throughout the subject's session. Although the personnel and experimental design protocols put in place to avoid cuing the subjects in the eight choice localization study were replicated, the subject's speaker selection choices were not the topic of this investigation and therefore not recorded.

Testing sessions were run between 0700 and 1000 h. The manatees' daily ration of food (72 heads of romaine lettuce and 12 bunches of kale) was fed to the animals from 1200 to 1400 h and was usually consumed by 1700 h, leaving a 14 to 16 hour overnight fast before training was initiated the following morning.

Signal Generation & Programming

All signals including each subject's station and secondary reinforcement signals as well as the 0.2-30 kHz, 3,000 ms test stimulus were programmed in RPvds language, digitally generated by a Tucker-Davis Technologies real-time processor (RP2.1). The signal were amplified with a Hafler power amplifier and the test stimulus was switched to the eight test speakers during the presentation of the stationing tone through a power multiplexer (PM2R). Three separate digital to analog channels were used; one to generate the signal to the stationing speaker at the center of the array and two to record from the hydrophones. MATLAB programming was used to generate blocks of sixteen trials that were counterbalanced between the eight speaker locations in a quasi-random order, meaning that the test signal location was randomized, but had a criterion of no more than two trials in a row from the same location.

Test trials were initiated and completed through an electronic control box which was connected to the RP2 unit, and then into a Dell laptop computer (model Latitude D505) with Windows XP. Test signals received by each hydrophone were digitally recorded to the real time processor. The laptop computer was used to run the signal generation equipment and to automatically download the parameters of all hydrophone recordings into separate .wav files. All test trials were visually recorded through a Sony variable zoom, high resolution, outdoor weather proof, color dome camera (model SCW-

CD358DVP) that was attached to the trainer's platform directly over the subject's head and connected to a Sony digital video camera (model DCR-TRV50).

Raw data were analyzed to remove any sounds of subject movement and only segments in which there was no extraneous noise were kept. Test trials were collected until the kept segments from each speaker provided a minimum of 3,000 ms of data. Fast Fourier transforms (FFT's) using 9,766 points were used to convert the signal from the time domain to the frequency domain. The FFTs from each location were averaged together using a 10 Hz frequency resolution. All data analyses were programmed in MatLab (Appendix D).

Results

Testing was conducted from April 25-30, 2007. Both subjects readily adapted to the presence of the hydrophones on the stationing apparatus and additional conditioning was not needed for them to complete the localization task in their usual manner.

Three data analyses were conducted per subject. The first compared power spectra received at the left and right hydrophones as a function of sound source location with 'animal absent' and 'animal present' conditions. HBRTFs were determined by subtracting the averaged 'animal present' FFTs from the averaged 'animal absent' FFTs. The second determined the magnitude of interaural level differences for all frequencies. The final analysis determined the magnitude of interaural level differences for specific 0.2-1.5, 0.2-5, and 18-30 kHz bands of frequencies.

Comparisons were made between the power spectra acquired at the left hydrophone to that acquired at the right hydrophone (simulating the manatee's left and right ears) when the signals originated from the eight different locations. These data were then compared to the same data collected in the absence of the subject at the stationing bar (Figures 3.8 and 3.9). Results demonstrated interaural level differences for all frequencies ranging from 0.2 to 30 kHz (the output limits of the test speakers) as a function of source location.

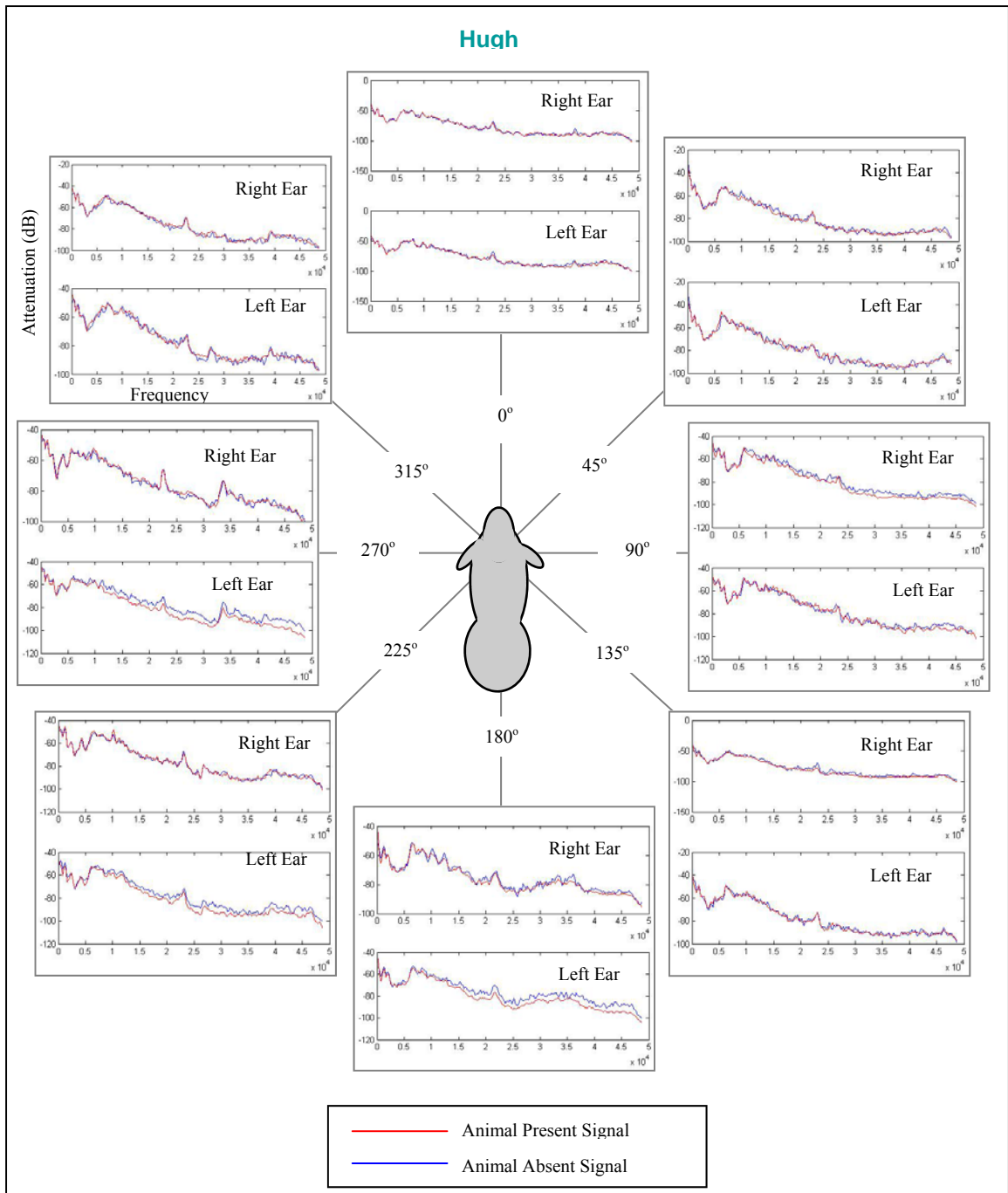

Figure 3.8. Comparisons of left vs. right received signals as a function of signal source location and the presence (red line) or absence (blue line) with Hugh. The Y axis represents the amount of signal attenuation (dB) and the x-axis represents frequency (Hz) for each graph in the figure.

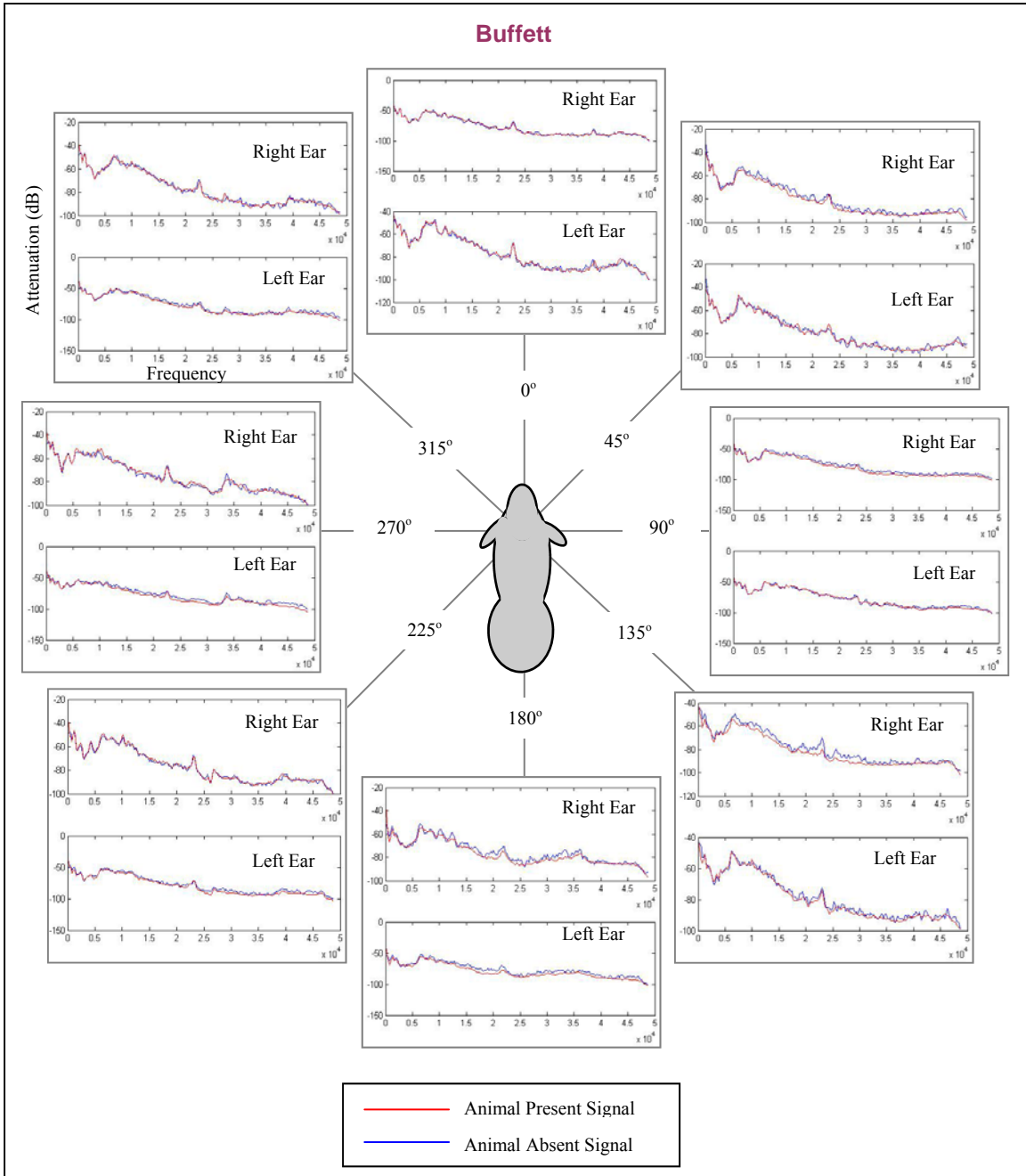

Figure 3.9. Comparisons of left vs. right received signals as a function of signal source location and the presence (red line) or absence (blue line) with Buffett. The Y axis represents the amount of signal attenuation (dB) and the x-axis represents frequency (Hz).

Head/body related transfer functions were then derived from these data by subtracting the averaged ‘animal present’ FFTs from the averaged ‘animal absent’ FFTs received by each hydrophone as a function of sound source location. Figure 3.10

demonstrates how the test signal was attenuated across frequencies by the subject's (Buffett) head and torso when the sound originated on the opposite side. The red lines of the plots represent the averaged 'animal absent' minus the 'animal present' signals received by the right hydrophone and the blue lines indicate the same for the left hydrophone. The y-axis corresponds to the amount of signal attenuation and the x-axis denotes frequency. Results demonstrated that signals originating from 90° were attenuated by the subjects body across all frequencies by as much as 8 dB re 1 μ Pa when received at the left hydrophone. Likewise, signals originating from 270° were attenuated when received at the right hydrophone.

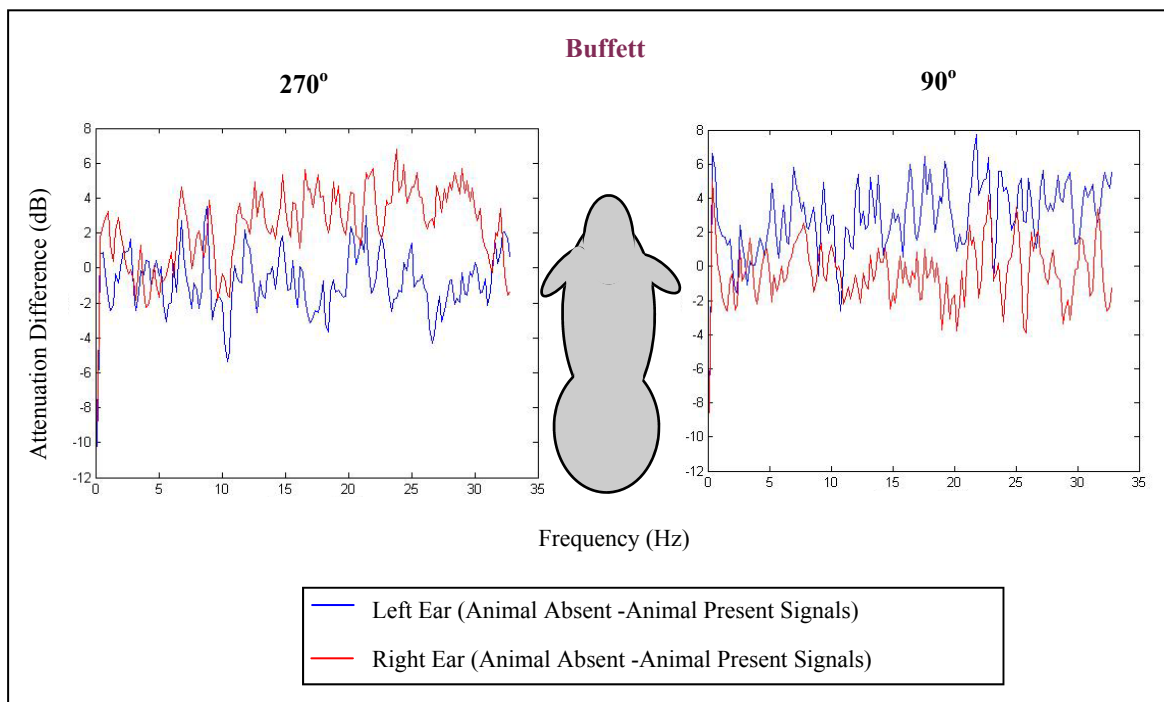

Figure 3.10. Left (270°) vs. right (90°) head/body related transfer functions for Buffett. Red lines represent 'animal absent' averaged signals minus 'animal present' signals for the right hydrophone and blue lines represent the same for the left hydrophone. The Y axis represents the amount of attenuation difference (dB) between ears and the x-axis represents frequency (Hz).

Similar ILD results were found with both subjects (Figures 3.11 & 3.12).

Shadowing effects from the manatee head and torso created signal differences that

covered a broad frequency range, starting at frequencies below 1 kHz and extending up to the 30 kHz output limits of the test speakers.

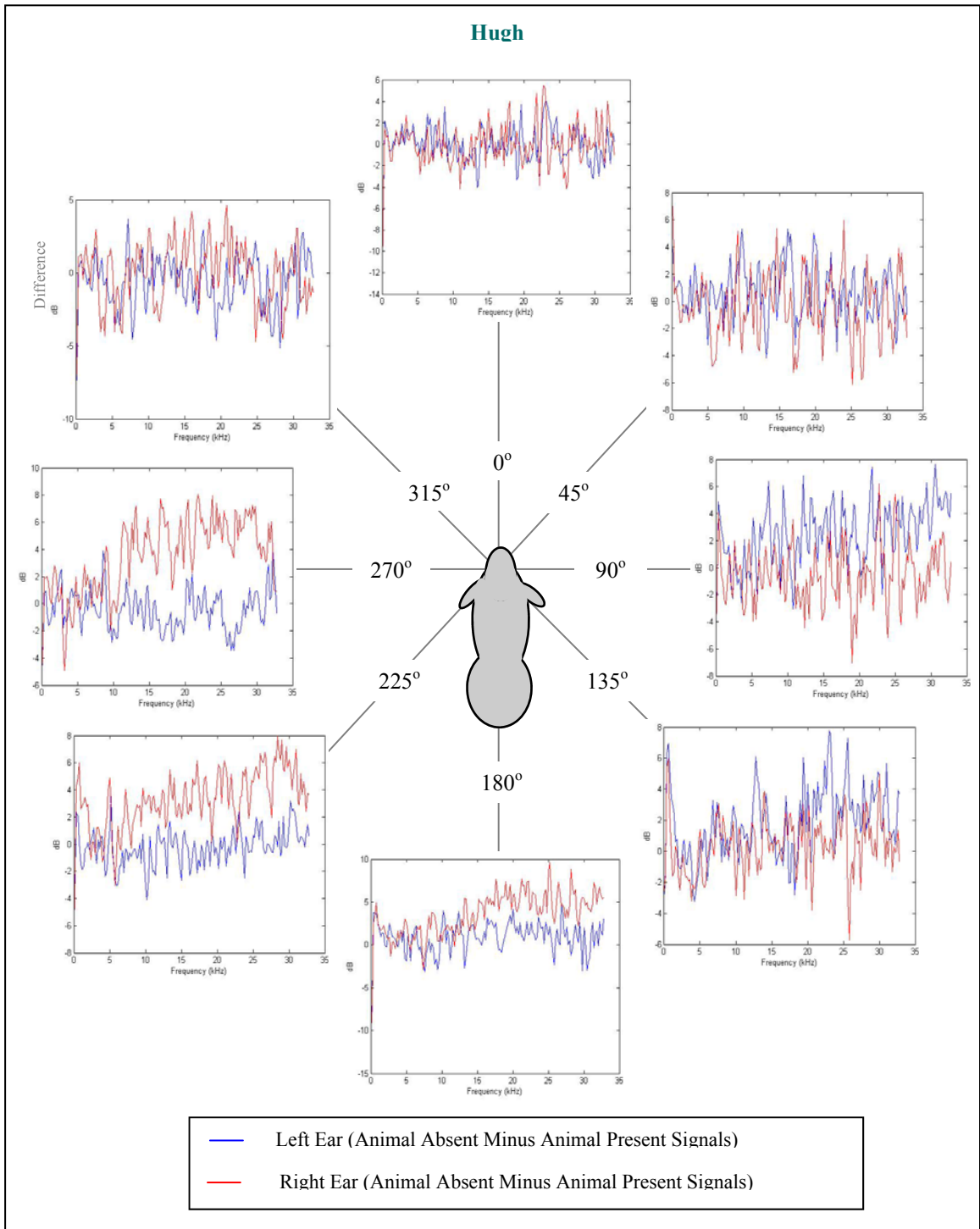

Figure 3.11. Head/body related transfer functions for Hugh. Red lines represent ‘animal absent’ averaged signals minus ‘animal present’ signals for the right hydrophone and blue lines represent the same for the left hydrophone. The Y axis represents the amount of attenuation difference (dB) between ears and the x-axis represents frequency (Hz).

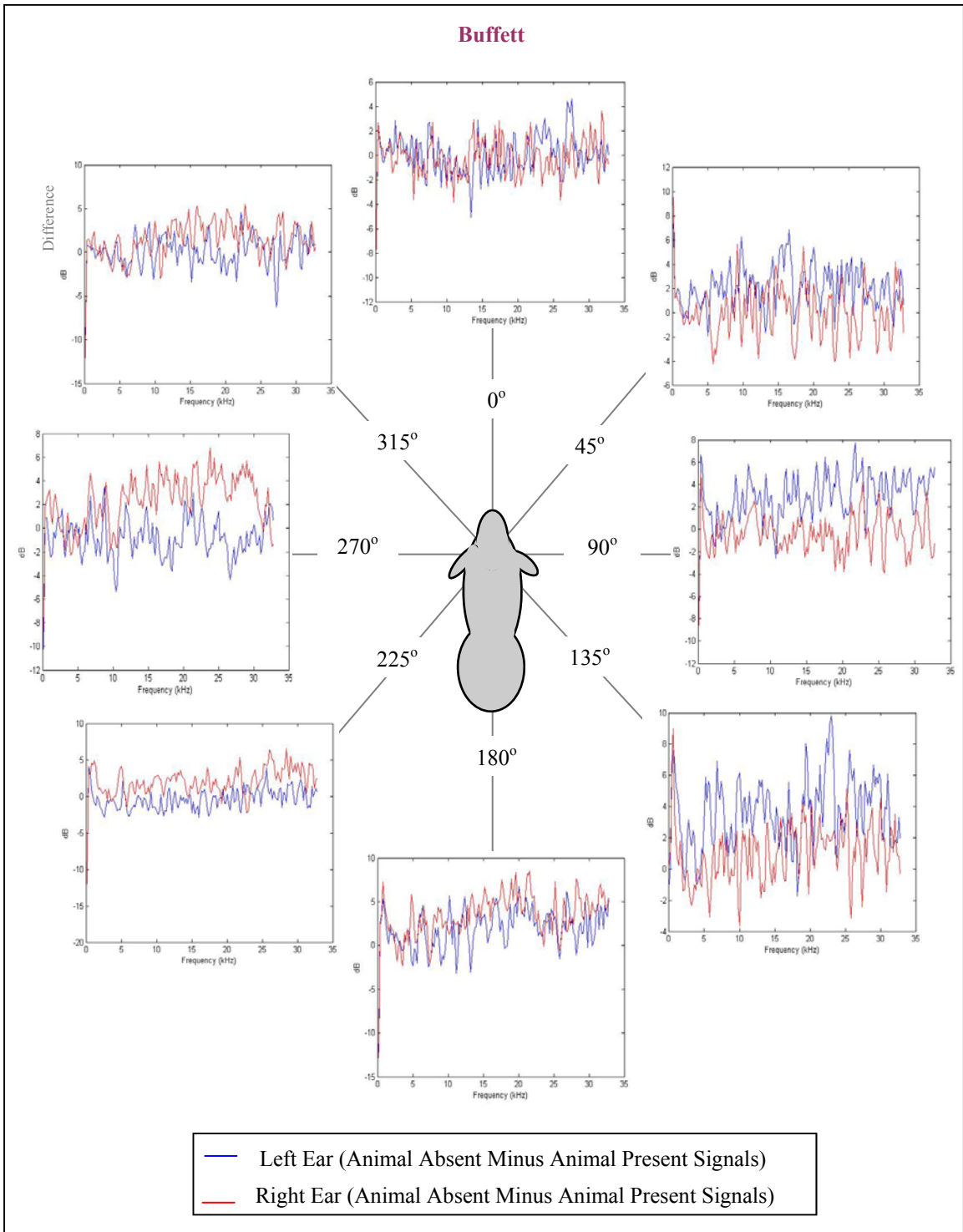

Figure 3.12. Head/body related transfer functions for Buffett. Red lines represent ‘animal absent’ averaged signals minus ‘animal present’ signals for the right hydrophone and blue lines represent the same for the left hydrophone. The Y axis represents the amount of attenuation difference (dB) between ears and the x-axis represents frequency (Hz).

The magnitude of the level differences (dB) found between the signals received at the left and right hydrophones as a function of frequency and sound source location were found by subtracting the ‘animal absent’ averaged signals minus ‘animal present’ signals received from the right hydrophone from the ‘animal absent’ averaged signals minus ‘animal present’ signals for the right hydrophone (Figures 3.13 & 3.14). Results showed that received signals had a large amount of variability in decibel gain and loss depending upon the frequency and sound source location.

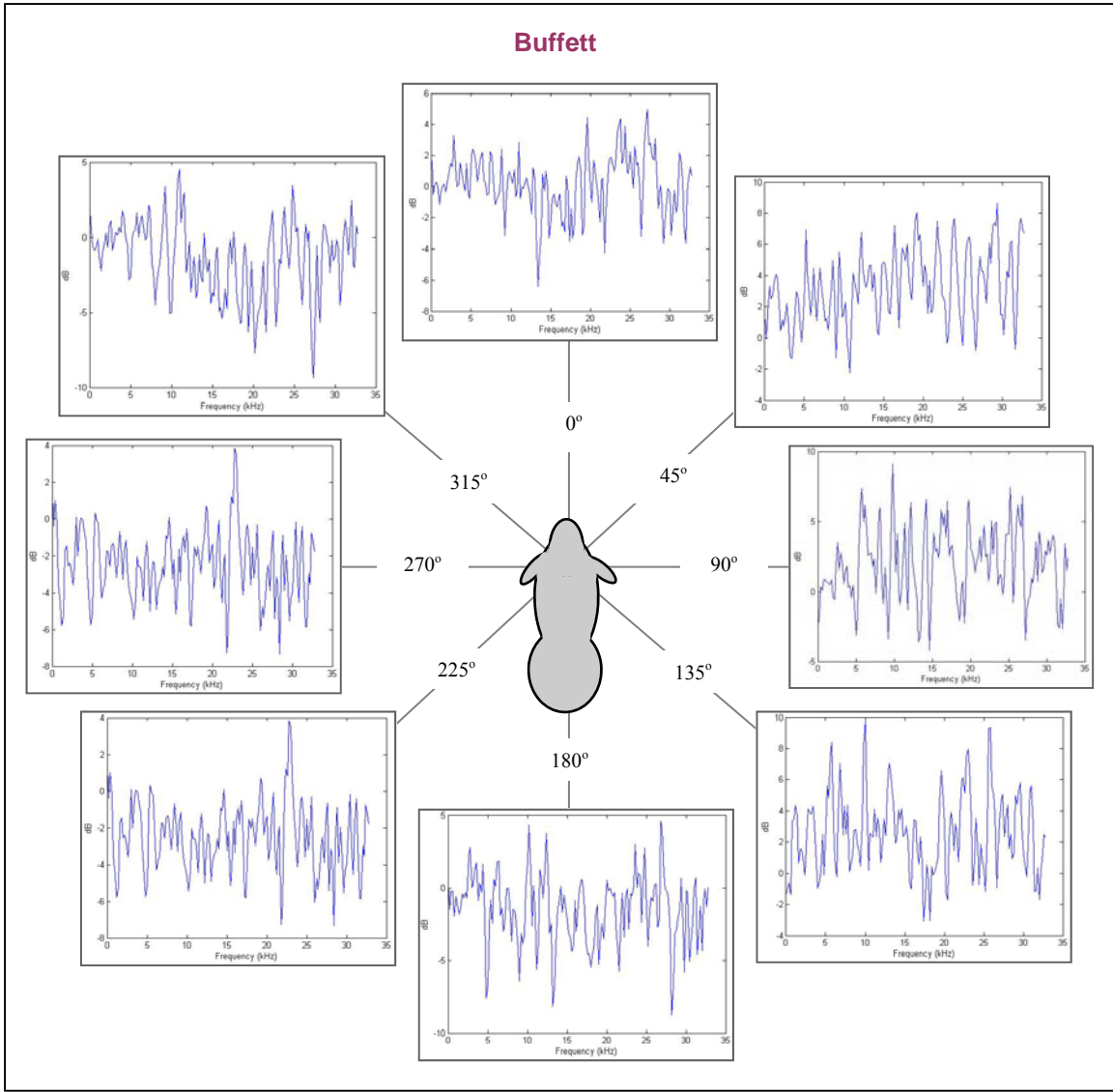

Figure 3.13. Interaural level difference magnitudes between the left and right hydrophones for all frequencies with Buffett. ‘Animal absent’ averaged signals minus ‘animal present’ signals for the right hydrophone were subtracted from the ‘animal absent’ averaged signals minus ‘animal present’ signals for the right hydrophone. The ILD spectrum represents the difference in a decibel scale. The x-axis represents frequency (Hz) and the y-axis represents level gain or loss (dB). A positive ILD indicates level in the right ear was higher than in the left ear.

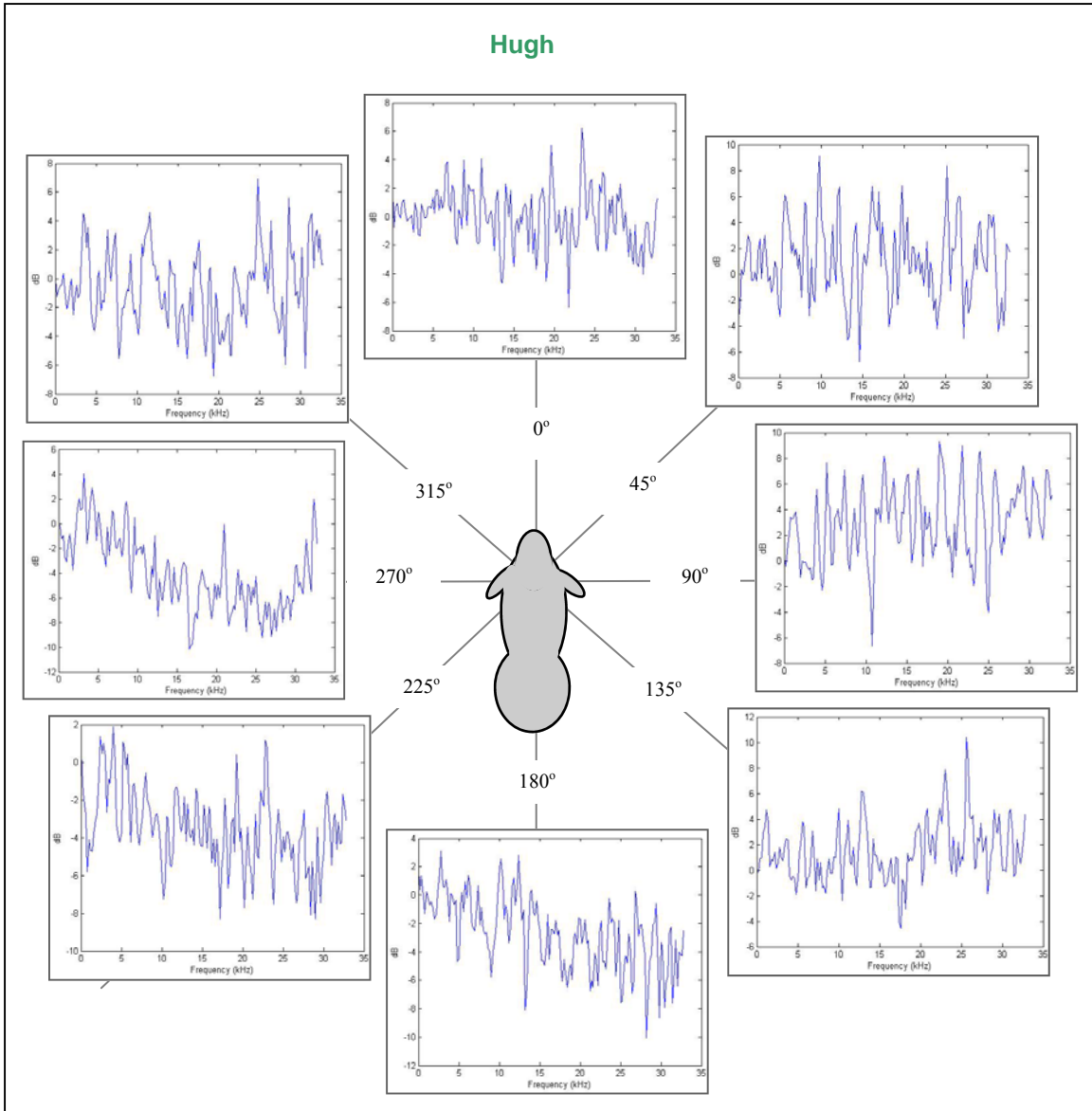

Figure 3.14. Interaural level difference magnitudes between the left and right hydrophones for all frequencies with Hugh. ‘Animal absent’ averaged signals minus ‘animal present’ signals for the right hydrophone were subtracted from the ‘animal absent’ averaged signals minus ‘animal present’ signals for the right hydrophone. The ILD spectrum represents the difference in a decibel scale. The x-axis represents frequency (Hz) and the y-axis represents level gain or loss (dB). A positive ILD indicates level in the right ear was higher than in the left ear.

The magnitude of interaural level differences (dB) as a function of sound source locations were also calculated for specific 0.2-1.5, 0.2-5 and 18-30 kHz bands of frequencies (Figure 3.15; Table 3.1). Positive ILDs, which indicated that level was higher in the right ear, were found when the test signal originated to the right of the

subjects and negative ILDs were found when it originated to their left. The 0.2-1.5 kHz frequency range was the same low frequency test stimuli used in the 8-choice manatee sound localization investigation (Chapter 2). The 0.2-5 kHz frequency range was composed of stimuli with wavelengths longer than the manatee's intermeatal distance. The 18-30 kHz frequency range included stimuli that were shorter than the manatee's intercochlear distance. Results for both subjects demonstrated that ILD magnitudes were greatest with the higher 18-30 kHz frequency band, however the lowest 0.2-1.5 kHz frequency band had larger magnitudes than the 0.2-5 kHz frequency band (Figure 3.15).

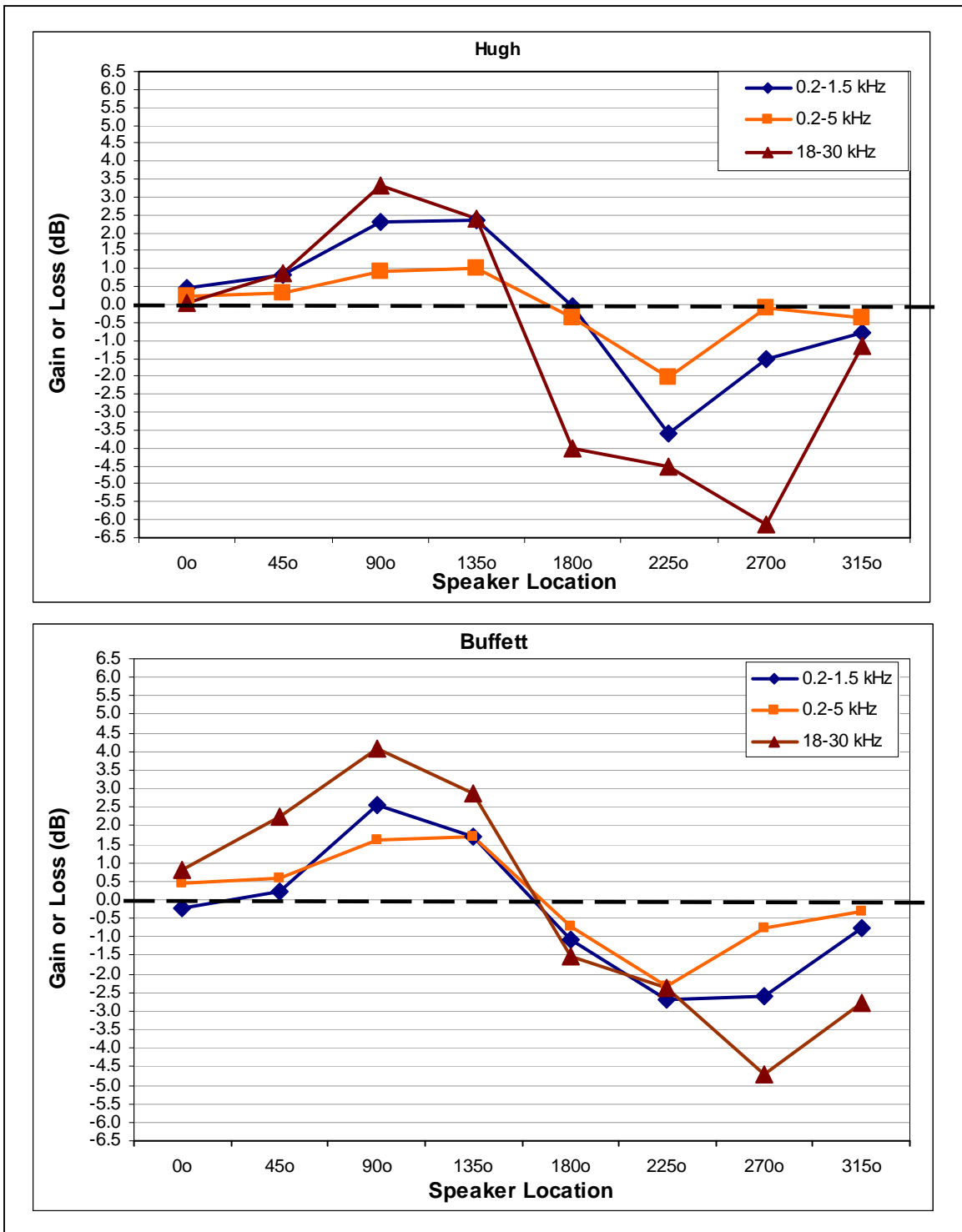

Figure 3.15. Interaural level difference magnitudes between the left and right hydrophones with 0.2-1.5, 0.2-5 and 18-30 kHz bands of frequencies. ‘Animal absent’ averaged signals minus ‘animal present’ signals for the right hydrophone were subtracted from the ‘animal absent’ averaged signals minus ‘animal present’ signals for the right hydrophone. The x-axis represents sound source location and the y-axis represents level gain or loss (dB). A positive ILD indicates level in the right ear was higher than in the left ear.

ILD magnitudes were greatest when the test signal originated at 90° and 270°, and were smallest when they originated at 0°. When these data were compared in contralateral pairs, ILDs were overwhelmingly greater when signals originated in the back (Table 3.1). Although ILD magnitude was greatest when signals originated from the 90° and 270° pair, greater magnitudes between the frequency bands were equally distributed between these two locations.

Table 3.1. Level differences (in dB) between subjects of averaged ‘animal absent’ minus ‘animal present’ signals for left and right hydrophones with 0.2-1.5, 0.2-5 and 18-30 kHz bands of frequencies. Data are presented in contralateral pairs with locations in the posterior 180° in italics. A positive ILD indicates level in the right ear was higher than in the left ear. Shaded areas represent the larger ILD of the pair.

	0.2-1.5 kHz		0.2-5 kHz		18-30 kHz	
	Hugh	Buffett	Hugh	Buffett	Hugh	Buffett
0°	0.46 dB	-0.22 dB	0.21 dB	0.46 dB	0.05 dB	0.79 dB
<i>180°</i>	<i>-0.04 dB</i>	<i>-1.06 dB</i>	<i>-0.37 dB</i>	<i>-0.72 dB</i>	<i>-4.00 dB</i>	<i>-1.51 dB</i>
45°	0.83 dB	0.24 dB	0.30 dB	0.57 dB	0.86 dB	2.26 dB
<i>225°</i>	<i>-3.61 dB</i>	<i>-2.68 dB</i>	<i>-2.01 dB</i>	<i>-2.34 dB</i>	<i>-4.50 dB</i>	<i>-2.39 dB</i>
315°	-0.79 dB	-0.76 dB	-0.38 dB	-0.32 dB	-1.13 dB	-2.80 dB
<i>135°</i>	<i>2.36 dB</i>	<i>1.7 dB</i>	<i>1.02 dB</i>	<i>1.71 dB</i>	<i>2.41 dB</i>	<i>2.88 dB</i>
90°	2.32 dB	2.54 dB	0.93 dB	1.61 dB	3.34 dB	4.07 dB
270°	-1.54 dB	-2.59 dB	-0.08 dB	-0.74 dB	-6.14 dB	-4.72 dB

Discussion

The results from this study provided information about the means by which manatees were able to generate interaural level difference cues via head and torso filtering effects. In order to capitalize on the previously learned behaviors of stationing in the center of a 6.10 m diameter circumference with eight test speakers positioned at 45° apart (Chapter 2), the subjects, Hugh and Buffett, completed localization trials, however, their speaker location selections were not recorded and only head/body related transfer functions were measured. Due to the subjects experience at the localization task, testing was completed in only four sessions.

Results indicated that level differences were found for all frequencies, starting below 1 kHz and extending up to the 30 kHz output limits of the test speakers, as a function of source location due to the shadowing effect of the subjects' head and torso. This is remarkable given that a 1 kHz frequency has a wavelength of 1.5 m in water. These findings demonstrate that ILDs are relevant cues which manatees may be able to detect and suggest that manatees, like the dolphin, likely use the same interaural differential sound cues as terrestrial mammals.

The first hypothesis posited that subjects would have greater sound shadows present when the test stimulus was presented at the 135° and 225° locations than when presented at other locations. Specific ILDs were determined for both subjects with 0.2-1.5, 0.2-5, and 18-30 kHz bands of frequencies, with positive ILDs indicating that the received level in the right ear was greater than the left (Table 3.1). Results showed test

signals originating at 90° and 270° provided greater ILD cues than those originating from other locations, refuting this hypothesis. Interestingly, ILDs were greater when the signal originated behind the subject at 180°, 225° and 135° than in front of them at 0°, 45° and 315°.

Manatees have a unique body shape. Their head is small in comparison to the remainder of their large torso which is elongated and elliptically-shaped. At the caudal end of their body is their paddle, or tail, which is laterally compressed and less than 2 cm thick along its edge. During this study, Hugh weighed 547 kg and was 310 cm in length, while Buffett weighed 773 kg and was 334 cm in length. The circumference of Hugh's head was 90 cm while the widest part of his torso, located at the umbilicus, was 204 cm. Buffett's head circumference was 101 cm and his torso was 237 cm. The ~ 2.3 : 1 body to head size ratio demonstrates that the torso provides more surface area for sounds to reflect, refract, or scatter off of or be absorbed by than the head. When positioned horizontally in the azimuth plane, which is typical for this species, the shape of their torso provides more shadowing effects when sounds originate from the lateral and posterior angles of the body as compared to anterior angles (Figure 3.12).

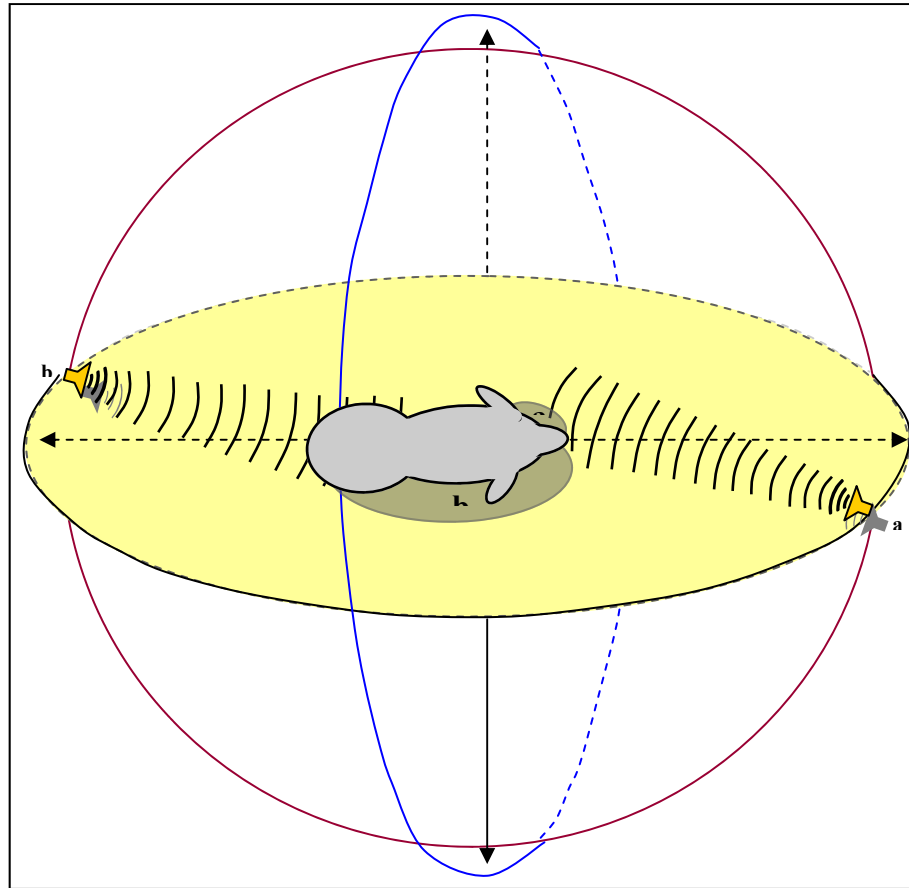

Figure 3.16. Simulated shadow effects created from the manatee head and body. Sounds originating from posterior angles of the body, such as shown from speaker (b) have more surface area to reflect off and create a larger shadow effect than those originating from anterior angles of the body such as shown from speaker (a).

Previous studies have suggested that the ability to localize a sound source may be influenced by multimodal sensory systems and be a function of visual orientation responses (Brown, 1994; Heffner, 1997) or for those species possessing muscularized pinnae, a Preyer reflex (Francis, 1979; Ehret, 1983). Investigations with terrestrial mammals have shown that the pinna provides elevation cues (Batteau, 1967; Wright et al., 1974) and has substantial effects on HRTFs with wavelengths smaller than the pinna size (Mehrgardt & Mellert, 1977; Wightman & Kistler, 1997). Studies with humans demonstrate that the pinna has a stronger effect on HRTFs than the torso (Kuhn & Gurnsey, 1983; Kuhn, 1987). Manatees, like dolphins, lack pinnae and therefore do not

benefit from the spectral cues they provide. Dolphins however, unlike manatees, seem to have compensated for this deficit with their ability to receive sonar echoes through the fat channels located in their lower jaw. This mechanism likely functions as a pinna analogue (Brill, 1988; Ketten et al., 1992; Møhl et al., 1999) and provides relevance for the ITDs and ILDs found by Moore et al. (1995).

Investigations with manatees suggested that they were able to localize sounds over a wide frequency range including those in the frequency range of boats and conspecifics (Gerstein, 1999; Colbert, 2005) and within all 360° (Chapter 2). Results from the 360° testing paradigm demonstrated that although subjects were able to localize from points behind them and made few front to back confusions, the number and dispersal of errors was greater than when test signals originated behind them. These results suggest that manatees utilize visual orienting responses to assist with localization from locations within their visual field increasing their accuracy, but still have compensated for the absence of these responses when sounds originated behind them through the use of amplified ILD cues produced by their body shape.

The second hypothesis declared that ILDs would be greater with higher frequencies than lower frequencies. Results found that ILDs were greater for the higher 18-30 kHz frequency range than the 0.2-1.5 or 0.2-5 kHz frequency ranges (Figure 3.15; Table 3.1). These results suggest that frequencies above 18 kHz, provide more salient cues for localization than those below it, supporting this hypothesis. ILDs have been shown to be most effective with higher frequencies, especially those that are shorter than the intermeatal distance for terrestrial species (Brown & May, 1990; Brown, 1994; Blauert, 1997) and the intercochlear distance for cetaceans (Dudok van Heel, 1962;

Ketten et al., 1992). Ketten et al. (1992) found that the manatee's average intermeatal distance was 0.278 m and intercochlear distance was 0.082 m. When both distances are considered, it appears that frequencies 5.4 kHz (wavelength = 0.78 m) or higher would provide more effective ILD cues when using the intermeatal distance, and those 18 kHz (wavelength = 0.08 m) or higher would be more effective when using the intercochlear distance. ILD magnitudes were calculated with high frequency bands (18-30 kHz) having wavelengths shorter than the manatee's intercochlear distance and low frequency bands (0.2-5) having wavelengths longer than their intermeatal distances. Results from these analyses show that the higher frequency band produced more effective ILD than the lower frequency and followed a pattern similar to terrestrial mammals and cetaceans. Surprisingly, results found for the lowest 0.2-1.5 kHz frequency band used in the eight-choice manatee localization experiment (Chapter 2) deviate from the typical mammalian pattern and demonstrate greater ILDs than the wider range of low frequencies from 0.2-5 kHz.

Since Florida manatees spend a significant amount of time grazing in shallow water, interpretation of ILD cues from higher frequencies might be hindered due to attenuation from refraction, reflection, scattering and absorption caused by objects in the environment as well as the surface of the water and bottom terrain (Medwin & Clay, 1998). The combined effects of multiple reflective sound paths can sometimes be as loud as or louder than sound traveling directly from the source. The precedence effect (also called the Haas Effect or Law of the First Wavefront) provides a solution for this problem however, by weighing the preceding sound more heavily than the reflection or echoes that arrive shortly thereafter (Blauert, 1997).

The information gained from this study demonstrates how different frequencies of a 0.2-30 kHz test signal, presented at 45° angles within the 360° of the azimuth plane, are filtered by the manatee's body to provide ILD cues which may be used to facilitate sound localization. All measurements were obtained when the subjects' head and body were stationary, however in the natural environment, animals have the ability to move as sounds occur allowing the monaural and interaural characteristics of the sound to change at the inner ear thereby reducing the cone of confusion and magnifying ILD cue strength (Blauert, 1997).

These are the first head/body related transfer function data collected for any Sirenian species and future investigations should be conducted to supplement this knowledge. Although ILDs are typically more effective with frequencies having wavelengths shorter than an animal's intermeatal or intercochlear distance, the anomalous results found for the 0.2-1.5 kHz frequency band that produced greater ILDs than the 0.2-5 kHz range warrants further research. Most HRTF investigations introduce sound sources that are at least 1 m away from the subject because HRTFs become independent of distance beyond this. As sound sources originate at distances less than 1 m, ILDs increase dramatically and ITDs remain constant. Investigations in which sound sources originate at a distance less than 1 m would be beneficial to determine if this pattern will hold true for manatees. Manatees live in a habitat where acoustic stimuli may occur above and below them as often as around them. Field tests that measured manatee responses to controlled boater approaches found that manatees increased swim speed and oriented to deeper channel waters as boats approached (Nowacek et al., 2004). Algazi et al. (2002) compared HRTFs with acoustic measurements in the horizontal,

median and frontal planes and demonstrated that reflections and shadows from the human torso provided important elevation cues. The study of manatee HRTFs using test signals that originate in the elevation plane would provide valuable information about the salience of interaural difference cues in this dimension. This information may provide insight into the importance of determining sound source directionality from dangerous sources such as boats at the surface.

References Cited

- Ahnelt, P.K. & Bauer, G.B. (2000). Unpublished data reported in Ahnelt, P.K. & Kolb, H. (2000). The mammalian photoreceptor mosaic-adaptive design. *Progress in Retinal and Eye Research*, 19, 711-777.
- Ahnelt, P.K. & Kolb, H. (2000). The mammalian photoreceptor mosaic-adaptive design. *Progress in Retinal and Eye Research*, 19, 711-777.
- Algazi, V.R., Avendano, C. & Duda, R.O. (2001). Elevation localization and head-related transfer function analysis at low frequencies. *Journal of the Acoustical Society of America*, 109, 1110–1122.
- Algazi, V.R., Duda, R.O., Duraiswami, R., Gumerov, N.A. & Tang, Z. (2002). Approximating the head-related transfer function using simple geometric models of the head and torso. *Journal of the Acoustical Society of America*, 112 (5), 2053-2064.
- Anderson, S. (1970). Directional hearing in the harbor porpoise, *Phocoena phocoena*. In G. Pilleri (Ed.), *Investigations on Cetacea*, Vol II. Berne, Benteli Ag.
- Au, W. (1993). *The Sonar of Dolphins*. NY: Springer-Verlag.
- Babushina, E.S. & Poliakov, M.A. (2004). The underwater and airborne sound horizontal localization by the northern fur seal. *Biophysics*, 49, 723–726.
- Bachteler, D. & Dehnhardt, G. (1999). Active touch performance in the Antillean manatee: Evidence for a functional differentiation of the facial tactile hairs. *Zoology*, 102, 61-69.
- Batteau, D.W. (1967). The role of the pinna in human localization. *Proceedings of the Royal Society*, London, 168, 158–180.
- Bauer, G.B., Colbert, D.E., Gaspard, J.C., Littlefield, B. & Fellner, W. (2003). Underwater visual acuity of Florida manatees (*Trichechus manatus latirostris*). *International Journal of Comparative Psychology*, 16, 130-142.
- Bauer, G.B., Gaspard III, J.C., Colbert, DE., Leach, J.B. & Reep, R. (2005, March). *Tactile Discrimination of Textures by Florida Manatees, Trichechus manatus latirostris*. Paper presented at the 12th annual International Conference on Comparative Cognition, Melbourne, Florida.

- Blauert, J. (1997). *Spatial Hearing: The Psychophysics of Human Sound Localization*. Massachusetts Institute of Technology Press, Massachusetts.
- Bodson, A., Miersch, L., Mauck, B. & Dehnhardt, G (2006). Underwater auditory localization by a swimming harbor seal (*Phoca vitulina*) *Journal of the Acoustical Society of America*, 120 (3) 1550-1557.
- Branstetter, B.K. (2005). *Sound localization and auditory perception by an echolocating bottlenose dolphin (Tursiops truncatus)*. Unpublished Doctoral Dissertation, University of Hawaii, Manoa.
- Branstetter, B.K. & Mercado III, E. (2006). Sound localization by cetaceans. *International Journal of Comparative Psychology*, 19, 25–61.
- Branstetter, B.K., Mevissen, S.J., Herman, L.M., Pack, A.A. & Roberts, S.P. (2003). Horizontal angular discrimination by an echolocating bottlenose dolphin *Tursiops truncatus*. *Bioacoustics* 14, 15–34.
- Branstetter, B.K., Mevissen, S.J., Pack, A.A., Herman, L.M., Roberts, S.R. & Carsrud, L.K. (2007). Dolphin (*Tursiops truncatus*) echoic angular discrimination: Effects of object separation and complexity. *Journal of the Acoustical Society of America*, 121 (1), 626-635.
- Brill, R.L. (1988). The jaw-hearing dolphin: Preliminary behavioral and acoustical evidence. In P.E. Nachtigall, & P.W.B. Moore (Eds) *Animal Sonar Processes and Performance*, Plenum Press, New York, pp. 281-287.
- Brown, C.H. (1994). Sound Localization. In R.R. Fay and A.N. Popper (Eds.) *Comparative Hearing: Mammals*, New York, Springer-Verlag, pp. 57-97.
- Brown, C.H., Beecher, M.D., Moody, D.B. & Stebbins, W.C. (1980). Localization of noise bands by old world monkeys. *Journal of the Acoustical Society of America*, 68, 127-132.
- Brown, C.H. & May, B.J. (1990). Sound localization and binaural processes. In M.A. Berkley and W.C. Stebbins (Eds.) *Comparative Perception*, Vol I, New York, John Wiley and Sons, pp. 247-284.
- Brungart, D.S. & Rabinowitz, W.R. (1999). Auditory localization of nearby sources. Head-related transfer functions. *Journal of the Acoustical Society of America*, 106, 1465–1479.
- Bullock, T.H., Domning, D.P. & Best, R.C. (1980). Evoked potentials demonstrate hearing in a manatee (*Trichechus inunguis*). *Journal of Mammalogy*, 61 (1), 130-133.

- Bullock, T.H., O'Shea, T.J. & McClune, M.C. (1982). Auditory evoked potentials in the West Indian manatee (Sirenia: *Trichechus manatus*). *Journal of Comparative Physiology*, 148, 547-554.
- Burda, H., Bruns, V. & Muller, M. (1990). Sensory adaptations in subterranean mammals. In E. Nevo & O. A. Reig (Eds.), *Evolution of Subterranean Mammals at the Organismal and Molecular Levels*. Wiley-Liss, NY, pp. 269-293.
- Carlile, S. & Pettigrew, A.G. (1987). Directional properties of the auditory periphery in the guinea pig. *Hearing Research*, 31, 111-122.
- Carlile, S. (1990). The auditory periphery of the ferret.: Directional response properties and the pattern of interaural level differences, *Journal of the Acoustical Society of America*, 88, 2180-2195.
- Casseday, J. H. & Neff, W. D. (1973). Localization of pure tones. *Journal of Acoustical Society of America*, 54, 365-372.
- Chapla, M., Nowacek, D., Rommel, S. & Sadler, V. (2007). CT scans and 3D reconstructions of Florida manatee (*Trichechus manatus latirostris*) heads and ear bones. *Hearing Research*, 228, 123-135.
- Cohen, J.L., Tucker, G.S. & Odell, D.K. (1982). The photoreceptors of the West Indian manatee. *Journal of Morphology*, 173, 197-202.
- Colbert, D.E., Fellner, W., Bauer, G.B., Manire, C. & Rhinehart, H. (2001). Husbandry and research training of two Florida manatees, *Trichechus manatus latirostris*. *Aquatic Mammals*, 27 (1), 16-23.
- Colbert, D. (2005). *Sound Localization Abilities of Two Florida Manatees, Trichechus manatus latirostris*. Unpublished Masters Thesis, University of South Florida, Tampa, FL.
- Coles, R.B. & Guppy, A. (1986). Biophysical aspects of directional hearing in the Tammar wallaby, *Macropus Eugenii*. *Journal of Experimental Biology*, 121, 371-394.
- Don, M. & Starr, A. (1972). Lateralization performance of the squirrel monkey (*Samiri sciureus*) to binaural click signals. *Journal of Neurophysiology*, 35, 493-500.
- Dudok van Heel, W.H. (1962) Sound in cetacea, *Netherlands Journal of Sea Research*, 1, 407-507.
- Ehret, G. (1983). Psychoacoustics. In: J.F. Willot & I.L. Springfield (Eds) *The auditory psychobiology for the mouse*. Charles C. Thomas.

- Firzlaff, U. & Schuller, G. (2003). Spectral directionality of the external ear of the lesser spear-nosed bat, *Phyllostomus discolor*. *Hearing Research*, 181, 27–39.
- Florida Department of Highway Safety and Motor Vehicles (2007). *Annual vessel statistics*. <http://www.hsmv.state.fl.us/dmv/vslfacts.html>
- Francis, R.L. (1979). The Preyer reflex audiogram of several rodents and its relation to the “absolute” audiogram in the rat. *Journal of Auditory Research*, 19, 217-233.
- Fuzessery, Z.M. (1996), Monaural and binaural spectral cues created by the external ears of the pallid bat. *Hearing Research*, 95, 1–17.
- Gentry, R.L. (1967). Underwater auditory localization in the California seal lion (*Zalophus californianus*), *Journal of Auditory Research*, 7, 187-193.
- Gerstein, E. (1999). *Psychoacoustic Evaluations of the West Indian manatee (Trichechus manatus latirostris)*. Unpublished Doctoral Dissertation, Florida Atlantic University, Boca Raton, FL.
- Gerstein, E., Gerstein, L., Forsythe, S. & Blue, J. (1999). The underwater audiogram of the West Indian manatee (*Trichechus manatus*). *Journal of the Acoustical Society of America*, 105, 3575-3583.
- Gerstein, E.R. (2002). Manatees, bioacoustics and boats. *American Scientist*, 90, 154-163.
- Griebel, U. & Schmid, A. (1996). Color vision in the manatee (*Trichechus manatus*). *Vision Research*, 36, 2747-2757.
- Griebel, U. & Schmid, A. (1997). Brightness discrimination ability in the West Indian manatee (*Trichechus manatus*). *Journal of Experimental Biology*, 200, 1587-1592.
- Hartmann, W.M. (1999). How we localize sound. *Physics Today*, 11, 24-29.
- Hartley, R.V.L. & Fry, T.C. (1921). The binaural localization of pure tones. *Physical Review*. 18, 431–442.
- Heffner, R.S. (1997). Comparative study of sound localization and its anatomical correlates in mammals. *Acta Otolaryngologica*, 532, 46-53.
- Heffner, R.S. & Heffner, E.H. (1982). Hearing in the elephant (*Elephas maximus*): Absolute sensitivity, frequency discrimination, and sound localization. *Journal of Comparative and Physiological Psychology*, 96 (6), 926-944.

- Heffner, R.S. & Heffner, E.H. (1984). Sound localization in large mammals: Localization of complex sounds by horses. *Behavioral Neuroscience*, 98 (3), 541-555.
- Heffner, R.S. & Heffner, E.H. (1985). Sound localization in wild Norway rats (*Rattus Norvegicus*). *Hearing Research*, 19, 151-155.
- Heffner, R.S. & Heffner, E.H. (1988a). Sound localization and use of binaural cues by the gerbil (*Meriones unguiculatus*). *Behavioral Neuroscience*, 102 (3), 422-428.
- Heffner, R.S. & Heffner, E.H. (1988b). Sound localization acuity in the cat: Effect of azimuth, signal duration and test procedure. *Hearing Research*, 36, 221-232.
- Heffner, R.S. & Heffner, E.H. (1988c). Sound localization in a predatory rodent, the Northern Grasshopper mouse (*Onychomys leucogaster*). *Journal of Comparative Psychology*, 102 (1), 66-71.
- Heffner, R.S. & Heffner, E.H. (1989). Sound localization, use of binaural cues and the superior olivary complex in pigs. *Brain Behavior Evolution*, 33, 248-258.
- Heffner, R.S. & Heffner, E.H. (1992a). Evolution of sound localization in mammals. In, D. Webster, R. Fay and A. Popper (Eds.) *The Biology of Hearing*, Springer-Verlag, pp. 691-715.
- Heffner, R.S. & Heffner, E.H. (1992b). Hearing in large mammals: Sound localization acuity in cattle (*Bos Taurus*) and goats (*Capra hircus*). *Journal of Comparative Psychology*, 106 (2), 107-113.
- Heffner, R.S. & Masterson, R.B. (1990). Sound localization in mammals: Brain stem mechanisms. In M. A. Berkley, & W. C. Stebbins (Eds.) *Comparative Perception*, New York, John Wiley and Sons, pp. 285-314.
- Holt, M.M., Schusterman, R.J., Southall, B.L. & Kastak, D. (2004). Localization of aerial broadband noise by pinnipeds. *Journal of the Acoustical Society of America*, 115, 2339-2345.
- Houben, D. & Gourevitch, G. (1979). Auditory lateralization in monkeys: An examination of two cues serving directional hearing. *Journal of Acoustical Society of America*, 66, 1057-1063.
- Irvine, D.R. (1987). Interaural intensity differences in the cat: Changes in sound pressure intensity level at the two ears associated with azimuthal displacements in the frontal horizontal plane. *Hearing Research*. 26, 267-286.
- Isley, T.E. & Gysel, L.W. (1975). Sound source localization by the red fox. *Journal of Mammalogy*, 56, 397-404.

- Jen, P.H. & Chen, D.M. (1988). Directionality of sound pressure transformation at the pinna of echolocating bats. *Hearing Research*, 34, 101–117.
- Kastelein, R.A., de Haan, D. & Verboom, W.C. (2007). The influence of signal parameters on the sound source localization ability of a harbor porpoise (*Phocena phocena*). *Journal of the Acoustical Society of America*, 122 (2), 1238-1248.
- Keller, C.H., Hartung, K. & Takahashi, T.T. (1998). Head-related transfer functions of the barn owl: Measurement and neural responses. *Hearing Research*, 118, 13–34.
- Kelly, J.B. & Potas, M. (1986). Directional responses to sounds in young gerbils, *Meriones unguiculatus*. *Journal of Comparative Psychology*, 100, 37–45.
- Ketten, D.R., Odell, D.K. & Domning, D.P. (1992). Structure, function, and adaptation of the manatee ear. In J. A. Thomas, R. A. Kastelein, & A. Y. Supin (Eds.) *Marine Mammal Sensory Systems*. Plenum Press, NY, pp.77-79.
- Kirkpatrick, B., Colbert, D.E., Dalpra, D., Newton, E.A.C., Gaspard, J., Littlefield B. & Manire, C.A. (2002). Florida Red Tides, Manatee Brevetoxicosis, and Lung Models. In K. A. Steidinger, J. H. Landsberg, C. R. Tomas, and G. A. Vargo (Eds.) *Xth International Conference on Harmful Algae*. Florida Fish and Wildlife Conservation Commission and Intergovernmental Oceanographic Commission of UNESCO.
- Klishen, V.O., Diaz, R.P., Popov, V.V. & Supin, A.Y. (1990). Some characteristics of hearing of the Brazilian manatee, *Trichechus inunguis*. *Aquatic Mammals*, 16 (3), 139-144.
- Knudsen, E.I. & Konishi, M. (1979). Mechanisms of sound localization in the barn owl (*Tyto alba*). *Journal of Comparative Physiology*, 133, 13–21.
- Kuhn, G.F. (1977). Model for the interaural time differences in the azimuthal plane. *Journal of the Acoustical Society of America*, 62, 157–167.
- Kuhn, G.F. (1987). Physical acoustics and measurements pertaining to directional hearing. In W.A. Yost & G. Gourevitch (Eds.) *Directional Hearing*, Springer Verlag, New York, pp. 3–25.
- Kuhn, G.F. & Guernsey, R.M. (1983). Sound pressure distribution about the human head and torso. *Journal of the Acoustical Society of America*, 73, 95–105.
- Maki, K. & Furukawa, S. (2005). Acoustical cues for sound localization by the Mongolian gerbil, *Meriones unguiculatus*. *Journal of the Acoustical Society of America*, 118 (2), 872-886.

- Manire, C.A., Walsh, C.J., Rhinehart, H.L., Colbert, D.E., Noyes, D.R. & Luer, C.A. (2003). Alterations in blood and urine parameters in two Florida manatees, *Trichechus manatus latirostris*, from simulated conditions of release following rehabilitation. *Zoo Biology*, 22, 103-120.
- Mann, D., Colbert, D.E., Gaspard, J.C. III, Casper, B., Cook, M.L.H., Reep, R.L. & Bauer, G.B. (2005). Temporal resolution of the Florida manatee (*Trichechus manatus latirostris*) auditory system. *Journal of Comparative Physiology*, 191, 903-908.
- Mass, A.M., Odell, D.K., Ketten, D.R. & Supin, A.Y. (1997). Ganglion layer topography and retinal resolution of the Caribbean manatee *Trichechus manatus latirostris*. *Doklady Biological Sciences*, 355, 392-394.
- Masterson, B., Heffner, H. & Ravizza, R. (1969). The evolution of human hearing. *Journal of the Acoustical Society of America*, 45, 966-985.
- Masterson, B., Thompson, G.C., Bechtold, J.K. & RoBards, M.J. (1975). Neuroanatomical basis of binaural phase-difference analysis for sound localization: A comparative study. *Journal of Comparative Physiological Psychology*, 89, 379-386.
- Medwin, H. & Clay, C.S. (1998). *Fundamentals of Acoustical Oceanography*. NY: Academic Press.
- Mehrgardt, S. & Mellert, V. (1977). Transformation characteristics of the external human ear. *Journal of the Acoustical Society of America*. 61, 1567-1576.
- Middlebrooks, J.C., Makous, J.C. & Green, D.M. (1989). Directional sensitivity of sound-pressure intensity levels in the human ear canal. *Journal of the Acoustical Society of America*, 86, 89-108.
- Middlebrooks, J.C. & Green, D.M. (1991). Sound localization by human listeners. *Annual Review of Psychology*, 42, 135-159.
- Mills, A.W. (1958). On the minimum audible angle. *Journal of the Acoustical Society of America*, 30, 127-246.
- Mills, A.W. (1972). Auditory localization. In J. V. Tobias (Ed.) *Foundations of Modern Auditory Theory*: Vol. II, (pp. 3030-348). NY: Academic Press.
- Møhl, B., Au, W.W.L., Pawloski, J. & Nachtigall, P.E. (1999). Dolphin hearing: Relative sensitivity as a function of point of application of a contact sound source in the jaw and head region. *Journal of the Acoustical Society of America* 105, 3421-3424.

- Moiseff, A. (1989). Binaural disparity cues available to the barn owl for sound localization. *Journal of the Acoustical Society of America*, 59, 1222–1226.
- Moore, P.W.B. (1974). Underwater localization of click and pulsed pure-tone signals by the California sea lion (*Zalophus californianus*). *Journal of the Acoustical Society of America*, 57 (2), 406-410.
- Moore, P.W.B. & Au, W.L. (1975). Underwater localization of pulsed pure tones by the California sea lion (*Zalophus californianus*). *Journal of the Acoustical Society of America*, 58 (2), 721-727.
- Moore, P.W.B. & Brill, R.L. (2001). Binaural hearing in dolphins. *The Journal of the Acoustical Society of America*, 109 (5), 2330-2331.
- Moore, P.W.B. and Pawloski, D.A. (1993). Interaural time discrimination in the bottlenose dolphin. *The Journal of the Acoustical Society of America*, 94 (3), 1829-1830.
- Moore, P.W.B., Pawloski, D.A. & Dankiewicz, (1995). Interaural time and intensity difference thresholds in the bottlenose dolphin (*Tursiops truncatus*). In R.A. Kastelein, J.A. Thomas & P.E. Nachtigall (Eds.) *Sensory Systems of Aquatic Mammals*, De Spil Publishers, The Netherlands, pp 11- 24.
- Musicant, A.D., Chan, J.C. & Hind, J.E. (1990). Direction-dependent spectral properties of cat external ear: New data and cross-species comparisons. *Journal of the Acoustical Society of America*, 87, 757–781.
- Nowacek, D.P., Casper, B.M., Wells, R.W., Nowacek, S.M. & Mann, D.A. (2003). Intraspecific and geographic variation of West Indian manatee (*Trichechus manatus spp.*) vocalizations. *Journal of the Acoustical Society of America*, 114 (1), 66-69.
- Nowacek, S.M., Wells, R.S., Owen, E.C.G., Speakman, T.R., Flam, R.O. & Nowacek, D.P. (2004). Florida manatees, *Trichechus manatus latirostris*, respond to approaching vessels. *Biological Conservation* 119, 517-523.
- Obrist, M.K., Fenton, M.B., Eger, J.L. & Schlegel, P.A. (1993). What ears do for bats: A comparative study of pinna sound pressure transformation in chiroptera. *Journal of Experimental Biology*, 180, 119-152.
- Phillips, D.P., Calford, M.B., Pettigrew, J.D., Aitkin, L.M. & Semple, M.N. (1982). Directionality of sound pressure transformation at the cat's pinna. *Hearing Research*, 8, 13–28.

- Piggins, D.J., Muntz, W.R.A. & Best, R.C. (1983). Physical and morphological aspects of the eye of the manatee, *Trichechus inunguis*. *Marine Behaviour and Physiology*, 9, 111-130.
- Popov, V.V. & Supin, A.Y. (1990). Electrophysiological studies on hearing in some cetaceans and a manatee. In J.A. Thomas, & R. A. Kastelein (Eds.), *Sensory Abilities of Cetaceans: Laboratory and Field Evidence*. NY: Plenum Press.
- Reep, R.L., Marshall, C.D. & Stoll, M.L. (2002). Tactile hairs on the postcranial body in Florida manatees: a mammalian lateral line? *Brain Behavior and Evolution*, 59, 141-154.
- Renaud, D.L. & Popper, A.N. (1975). Sound localization by the bottlenose porpoise *Tursiops truncatus*. *Journal of Experimental Biology*, 63, 569-585.
- Reynolds, J.E. III. (1979). The semisocial manatee. *Natural History*, 88 (2), 44-53.
- Rice, J.J., May, B.J., Spirou, G.A. & Young, E.D. (1992). Pinna-based spectral cues for sound localization in cat. *Hearing Research*, 58, 132-152.
- Richardson, W., Greene, C., Malme, C. & Thompson, D. (1995). *Marine Mammals and Noise*. San Diego, CA: Academic Press.
- Roth, G.L., Kochhar, R.K. & Hind, J.E. (1980). Interaural time differences: Implications regarding the neurophysiology of sound localization. *Journal of the Acoustical Society of America*, 68, 1643-1651.
- Searle, C.L., Braida, L.D., Cuddy, D.R. & Davis, M.F. (1975). Binaural pinna disparity: Another auditory localization cue. *Journal of the Acoustical Society of America*, 57, 448-455.
- Spezio, M.L., Keller, C.H., Marrocco, R.T. & Takahashi, T.T. (2000). Head-related transfer functions of the rhesus monkey. *Hearing Research*, 144, 73-88.
- Stevens, S.S. & Newman, E.B. (1936). The localization of actual sources of sound. *American Journal of Psychology*. 48, 297-306.
- Strutt, J.W. (Lord Rayleigh) (1907). On our perception of sound direction. *Philosophical Magazine*, 13, 214-232.
- Terhune, J.M. (1974). Directional hearing of a harbor seal in air and water. *Journal of the Acoustical Society of America*, 56 (6), 1862-1865.
- Urick, R.J. (1996). *The Principles of Underwater Sound*, 3rd Edition (423pp.). CA: Peninsula Publications.

- Wakeford, O.S. & Robinson, D. E. (1974). Lateralization of tonal stimuli by the cat. *Journal of the Acoustical Society of America*, 55, 649-652.
- Walls, G.L. (1963). *The vertebrate eye and its adaptive radiation*. NY: Hafner.
- West, J.A., Sivak, J.G., Murphy, C.J. & Kovacs (1991). A comparative study of the anatomy of the iris and ciliary body in aquatic mammals. *Canadian Journal of Zoology*, 69, 2594-2607.
- Wright, D., Hebrank, J.H. & Wilson, B. (1974). Pinna reflections as cues for localization. *Journal of the Acoustical Society of America*, 56, 957-962.
- Wightman, F.L. & Kistler, D.J. (1997). Factors effecting the relative salience of sound localization cues. In R.H. Gilkey & T.R. Anderson (Eds.) *Binaural and Spatial Hearing in Real and Virtual environments*, Lawrence Erlbaum, Mahwah, NJ, pp. 1-23.
- Yost, W.A. (2000). Sound localization and binaural hearing. In *Fundamentals of hearing: An introduction*. San Diego, CA: Academic Press (pp. 179-192).

**Chapter Four: Potential Sound Conduction Pathways for the Florida Manatee,
*Trichechus manatus latirostris***

Abstract

Behavioral investigations have demonstrated that manatees possess the capacity to detect and localize sounds over a wide range of frequencies (Bullock et al., 1980; 1982; Klishen et al., 1990; Popov & Supin, 1990; Gerstein, 1999; Gerstein et al., 1999; Colbert, 2005; Mann et al., 2005). Paradoxically, anatomical investigations have established that the manatee's external and middle ear is formed in a manner atypical of most mammalian species (Ketten et al., 1992; Chapla et al., 2007). The external auditory meatus is occluded and separated from the tympanic membrane making it an unlikely channel for sound transmission, the tympanoperiotic complex is located intracranially but not ossified to the skull, and the ossicles are massive. Several sound conduction pathways outside the traditional pinna-to-cochlea conduit have been proposed to explain these anatomical anomalies, however the specific means by which manatees hear remains unknown.

Auditory evoked potential (AEP) techniques, using 15 kHz (154.9 dB re 1 μ Pa) and 24 kHz (158.8 dB re 1 μ Pa) carrier tone bursts that were amplitude modulated (AM) with a 600 Hz rate, were used to map possible sound conduction pathways with four Florida manatees (*Trichechus manatus latirostris*). Voluntary AEP measurements were obtained from positions on the heads of two subjects, Hugh and Buffett, while all portions of their body, excluding the electrodes, were positioned in the water. Restrained

evoked potential measurements were obtained from various positions on the heads and torsos of three subjects, Hugh, Mo, and Bock, while all portions of their bodies were in air. Data included in this study were collected prior to the development of a formal methodological plan to investigate the possible existence of manatee sound conduction pathways and should be considered with caution. Transducer positions were coded by video analysis and results were derived through the compilation and organization of the data already collected.

Results demonstrated that all four subjects, regardless of being positioned in air or in water, produced AEPs at every position the transducer was placed on their bodies, however no obvious sound conduction pathway was identified. Estimated effective sound pressure levels between body positions were found to be proportionally the same. AEP amplitudes were usually greater with the 24 kHz carrier when tested in both the in-air and in-water mediums, however patterns between carriers at identical body positions were highly variable between subjects. In-water testing demonstrated identical or similar AEP amplitudes at six of seven common positions with the 24 kHz carrier, however amplitudes were inconsistent for all but one of the common positions with the 15 kHz carrier. In-air testing showed that Bock and Mo had similar AEP amplitudes at four of five common positions with both carriers, however Hugh shared only one similar AEP amplitude out of the nine positions common to the three subjects with the 15 kHz carrier.

Evoked potentials, averaged together from positions along the vertebral column and lateral ribs that were more than 20 cm caudal to the scapula, were greater than those averaged together from positions at and dorsal to the meatus, those averaged from

positions along the zygomatic process, and those averaged from positions along the vertebral column and lateral ribs that were cranial to 20 cm behind the scapula.

Introduction

The Florida manatee (*Trichechus manatus latirostris*) is an endangered species protected by both the Marine Mammal Protection Act (1972) and the Endangered Species Act (1973). Investigations of the manatee's sensory processes reveal that vision and touch likely function best with tasks in close proximity, while audition functions effectively for tasks that are both nearby and at a distance (Chapters 2 & 3).

The hearing range of the manatee has been assessed through the development of an audiogram and by utilizing auditory evoked potential techniques. Gerstein et al. (1999) obtained a behavioral audiogram for two manatees which showed hearing thresholds that ranged from 0.5–38 kHz for one subject and 0.4–46 kHz for the other. The frequency range of best hearing was between 10–20 kHz and maximum sensitivity was ~50 dB re: 1 μ Pa at 16 and 18 kHz, decreasing by ~20 dB per octave from 0.8 to 0.4 kHz and 40 dB per octave above 26 kHz. Auditory evoked potential measurements have been obtained in several studies. Bullock et al. (1980; 1982) and Popov & Supin (1990) found that the highest frequency detection reached 35 kHz when tested in air and Klishen et al. (1990) found it reached 60 kHz when tested in water. More recently, Mann et al. (2005) found that detection reached 40 kHz when tested in water, results similar to those found by Bullock (1980; 1982), Popov & Supin (1990). These results indicate that manatees are able to detect conspecific vocalizations which typically range between 2.5–5.9 kHz (Nowacek, et al., 2003) and boat engine noises which typically range between 0.01–2 kHz (Gerstein, 2002; Richardson et al., 1995).

The localization abilities of the manatee have been investigated through four-choice discrimination paradigms that presented acoustic stimuli in the frontal 180° (Gerstein, 1999; Colbert 2005) and an eight-choice paradigm with stimuli presented in all 360° of the horizontal plane surrounding a stationary subject (Chapter 2). Results indicated that they were proficient at localizing broadband stimuli over a wide range of frequencies (0.2-24 kHz) as well as those restricted to high (6-20 kHz) and low frequencies (0.2–2 kHz) at various durations and levels as well as tonal stimuli. Performance accuracy was decreased with lower levels, decreased durations and tonal stimuli, but still remained above chance levels. These results suggested that manatees were able to localize frequencies having wavelengths that were both shorter and longer than their interaural distances.

Head related transfer functions were measured with two manatees to investigate if interaural level difference (ILD) cues facilitated their ability to determine sound source directionality (Chapter 3). Results indicated that ILDs were found for all frequencies as a function of source location and that the torso provided greater shadowing effects than the head. ILDs appeared to be magnified when sounds originated behind the subjects and may have compensated for their inability to visually orient towards these locations as stimuli were presented.

The findings of these behavioral investigations might suggest that the manatee auditory system is built and functions similarly to that of typical mammalian species. This assumption however, is false and anatomical examination of the manatee ear has provided evidence to the contrary. Unlike most terrestrial mammals, but similar to fully aquatic marine mammals such as cetaceans, the manatee's external pinna flange is absent

(Ketten et al., 1992; Chapla et al., 2007). The entrance to the external auditory meatus (EAM) is only 1 mm in diameter and the EAM is ~61 mm long and has a ~3.6 mm diameter at its widest point (Chapla et al., 2007). In contrast to most terrestrial and marine mammals, the manatee's EAM is occluded by cellular debris and reaches a blind end that is separated from the tympanic membrane which makes it an unlikely channel for sound transmission (Ketten et al., 1992; Chapla et al., 2007) (Figure 3).

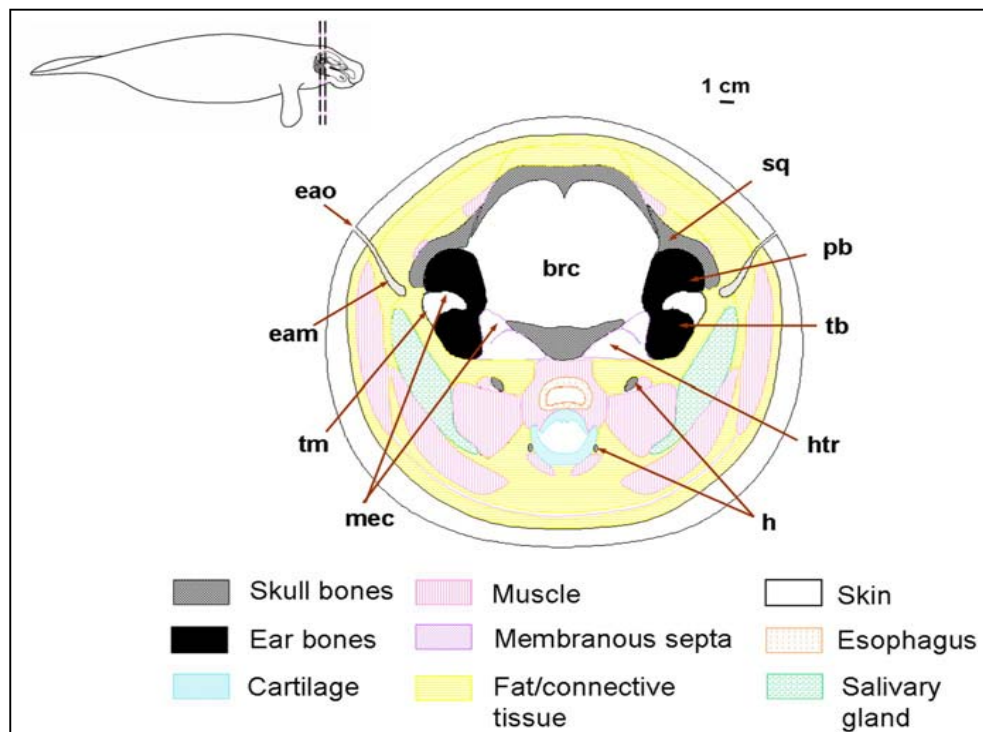

Figure 4.1. Diagrammatic illustration of manatee auditory anatomy based on multiple cross-sections through the transverse plane. eam, external auditory meatus; eao, external auditory opening; h, hyoid bones; htr, hypotympanic recess; mec, middle ear cavity; pb, periotic bone; sq, squamosal bone; tb, tympanic bone; tm, tympanic membrane. Figure used with permission from Chapla et al., 2007.

The manatee middle ear is composed of a large bilobed periotic bone and the tympanic bone. The two are connected to one another at two small locations that may act as a hinge and are called the tympanoperiotic complex (Fleischer, 1978; Ketten et al., 1992). Cetaceans have a tympanoperiotic complex that is located extracranially and has no bony attachment to the skull (Ketten, 1992). Manatees have a tympanoperiotic

complex that is located intracranially, however it is not ossified to the skull and the periotic is only attached to the occipital bone by a small ~ 5 mm cartilage disc and to the squamosal bone by an even smaller ~2.5 mm cartilage disc (Ketten et al., 1992; Chapla et al., 2007).

The middle ear cavity is composed of two main sections, the epitympanic recess and the mesotympanum (Ketten et al., 1992). The epitympanic recess is filled with soft tissue and surrounds the short arm of the incus. The mesotympanum is divided into two chambers that are separated by a membranous septum. The lateral chamber contains the ossicular chain and abuts the tympanic membrane. The medial chamber includes the round window and is bordered ventrally by soft tissue and dorsomedially and caudally by the skull. The hypotympanic recess connects to the middle ear cavity, is bound ventrally by soft tissues, and allows air to pass between it and the nasopharynx via the eustachian tube (Fleischer, 1978; Ketten et al., 1992; Domning, 2001).

The tympanic membrane is multilayered, has an elliptical shape, and is laterally convex (Ketten et al., 1992). The ossicles are massive with most of their 5400 mg mass centered in the large malleus head (Figure 3.2). The cross-sectional area of the ossicular chain has been found to be proportional to the area of the tympanic membrane for most terrestrial mammals (Nummela, 1995) and for cetaceans (Nummela et al., 1999). A greater tympanic membrane area intensifies the amount of energy collected by the membrane so the ossicular chain must become modified and enlarged as a means to endure the increased membrane vibration forces. Nummela (1995) found area proportions to be ~ 0.1, for species ranging in size from the elephant to the shrew, however the area proportion was found to be greatly increased to 0.4 for seals whose

ossicular chain was significantly larger than the area of the tympanic membrane. The manatee ossicular chain shows a similar deviation and is overly massive compared to the tympanic membrane area as well as the other tympanic and periotic ear bones (Chapla, et al., 2007).

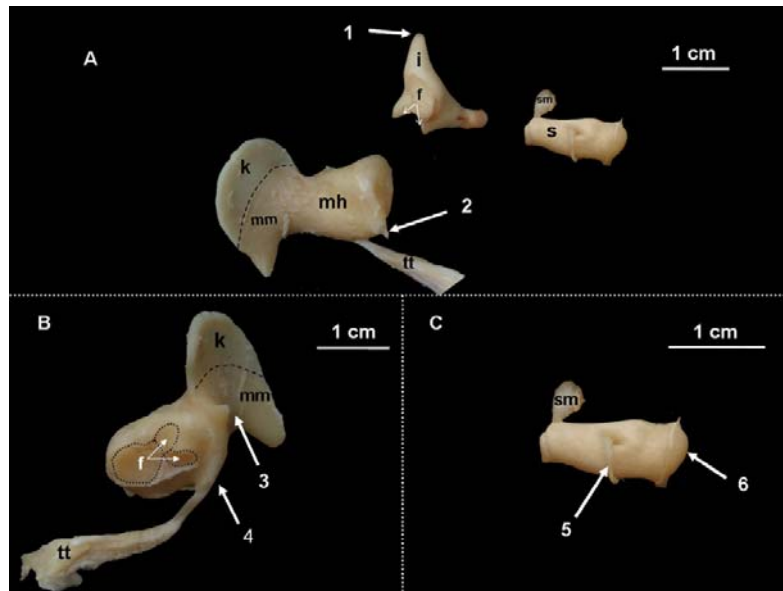

Figure 4.2. Manatee ossicles from the right ear. (A) Malleus, incus, and stapes; (B) malleus magnified; (C) stapes magnified; 1. tip of incus short arm (weakly fuses within epitympanic recess of periotic); 2. malleus rostral ossification (connects with tympanic bone); 3. malleus caudal process (attachment site for tympanic membrane); 4. malleus medial process (attachment site for tensor tympani muscle); 5. ligamentary vestige of the stapedia artery (traverses stapes dorsoventral foramen); 6. stapedia footplate (abuts the oval window); f, facets by which malleus and incus articulate (arrows denote small facets and dotted line in B defines outline); i, incus; k, cartilaginous keel (dashed line marks the border of the keel and the malleus manubrium); mh, malleus head; mm, malleus manubrium; s, stapes; sm, stapedius muscle; tt, tensor tympani muscle. Figure used with permission from Chapla et al., 2007.

The anatomical anomalies found in the manatee's outer and middle ears of indicate that their auditory system functions in a manner dissimilar to that of the typical terrestrial or marine mammal species. Several sound conduction pathways outside the traditional pinna-to-cochlea course have been proposed that use the zygomatic process, cranial tissues, cranial bones, vertebrae and/or lungs to directly stimulate the tympanic membrane.

The manner by which sound is transmitted between water and soft body tissue, or between soft body tissue and bone, is complex and somewhat dependent upon the elastic, reflective and absorptive properties of the tissues and bones. The velocity of sound traveling through terrestrial mammal soft tissues has been found to be linearly related to the density of the tissues (Mast, 2000). Soft tissue density varies ~10% from that of seawater and velocity varies ~15% (Aroyan, 1996). Tissues containing increased structural elements such as collagen retain higher densities and sound velocities than water (Goold & Clarke, 2000), while those composed of greater fat or lipid content retain lower densities and sound velocities (Mast, 2000). Investigations with cetaceans have shown that fatty tissue has a density and sound velocity less than that of sea water, muscle has a density and sound velocity similar to that of seawater, and connective tissue has a density and sound velocity greater than that of seawater (Soldevilla et al., 2005).

Cetaceans have acoustic fats located in their mandible and melon that are less dense than the surrounding blubber tissues. Soldevilla et al. (2005) suggested that the velocity change which occurs as sound travels from seawater to blubber tissue and then to the acoustic fat, likely plays an important impedance matching role as sound is channeled to the middle ear complex.

Investigations with manatees have shown that the tympanoperiotic complex is connected to the squamosal bone, which in turn, is connected to the zygomatic process (Figure 4.3) (Ketten et al., 1999; Chapla et al., 2007). Ketten et al. (1999) found that the zygomatic process differed from all other cranial bones and was a lipid-filled bony sponge that may serve a unique function to enhance sound transmission much like the acoustic fat found with cetaceans. The zygomatic process was found to have

significantly lower density than other bones (Fawcett, 1942; Caldwell & Caldwell, 1985; Domning & de Buffre'nil, 1991), however the lipids it contained were composed almost entirely of triacylglycerols (Ames et al., 2002) and not the isovaleric acid typical of cetacean acoustic fat by which sounds are conducted (Varanasi & Malins, 1971). Chapla et al. (2007) suggest that the distinctive composition of the zygomatic process causes it to be less rigid than other dense bones. This increased elasticity may enhance sound wave propagation along the zygomatic process to stimulate the tympanic membrane and tympanic bone.

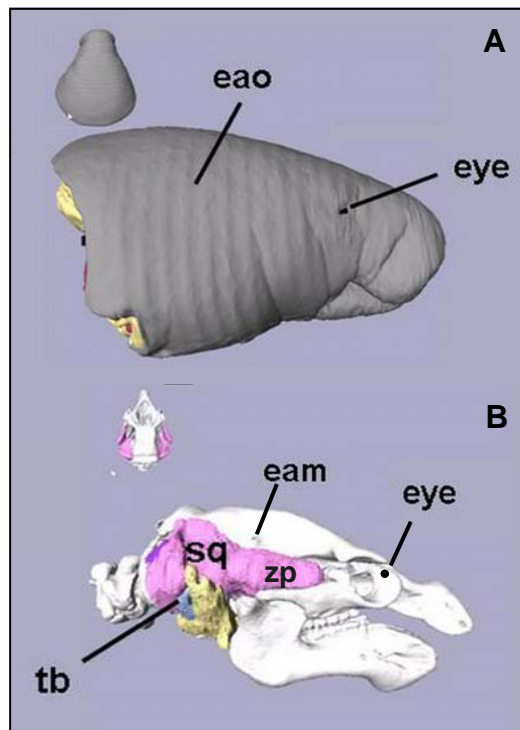

Figure 4.3. Right lateral view of a three dimensional reconstruction of a CT scanned manatee head (MSW0058). (A) Skin layer showing relation of external auditory opening (eao) to eye. (B) Skeletal layer showing relation of squamosal bone (sq, pink) and the zygomatic process (zp, pink) which is filled with fats and blood vessels to external auditory meatus (eam), eye, and tympanic bone (tb). Figure edited from Fig. 4 of, and used with permission from, Chapla et al., 2007.

Chapla et al. (2007) found that the soft tissues of the manatee head have a density similar to that of seawater suggesting that sound waves could propagate easily from one

medium to the other. In addition, these authors suggest that these soft tissues are arranged in a manner that allows sounds to be transmitted to the manatee's inner ear with a minimal amount of reflection (Figure 4.4). Sound waves with azimuth angles between 45° and 90° (this includes the area surrounding the external auditory meatus) and elevation angles between $\sim 43^\circ$ and 73° should be able to propagate through these soft tissues, without reflecting off of the squamosal bone, to stimulate the tympanic membrane directly.

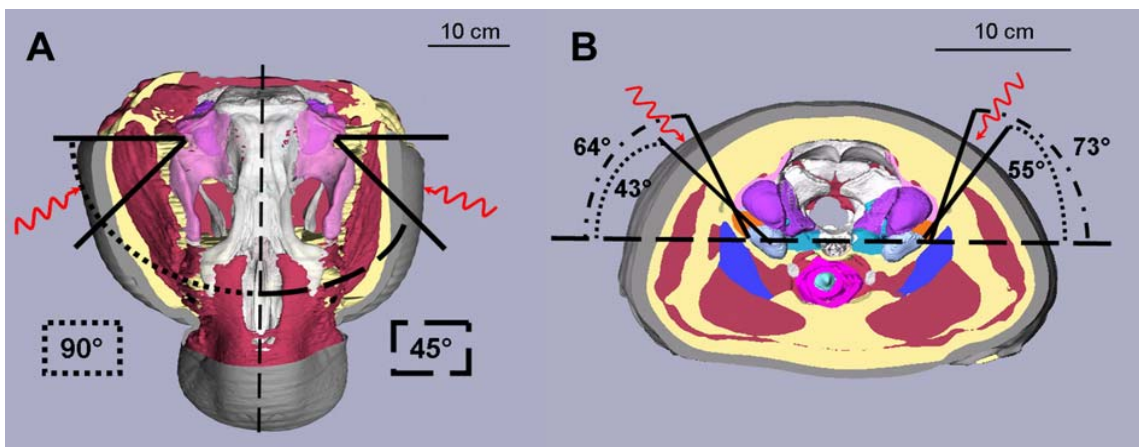

Figure 4.4. Potential sound pathways where a sound wave will experience the least amount of reflection. (A) Dorsal view showing that soundwaves with angles of incidence between 45° and 90° from the mid-sagittal line, on both the left and right sides of the head, may reach the ear without reflecting off of the squamosal. (B) Rostral view with an axial cut at the level of the ear showing that sound waves with angles of incidence (measured from the horizontal) between 43° and 64° (on the right side of the head) and between 55° and 73° (on the left side of the head) have only dermis and fatty tissue to pass through in order to reach the ears. The external auditory meatus is also present within this area, but is composed only of soft tissue and has no connection with the tympanic membrane. Airspaces, teal; cartilage, fuchsia; fatty tissue, yellow; malleus, green; muscle, dark red; periotic, purple; salivary glands, dark blue; skin, gray; squamosal, pink; tympanic bone, light blue; tympanic membrane, orange. Figure used with permission from Chapla et al., 2007.

Sound can also be transmitted to the inner ear through bone. Sound waves can cause the bones of the skull to vibrate through inertial, compressional, and osseotympanic movements (Tonndorf, 1966; Yost, 2000; Gelfand, 2004). In humans, inertial bone conduction occurs with assistance from the middle ear and with frequencies below 800 Hz which causing the skull to vibrate as one unit while the ossicular chain lags behind it

due to its inertia. The lagging motion of the ossicular chain causes the stapes to stimulate the oval window in a manner identical to air conduction. Compressional bone conduction occurs with assistance from the inner ear and with frequencies above 800 Hz and causes the temporal bone to vibrate in such a manner that the cochlear capsule compresses and expands simultaneously. These compressions cause the round window to oscillate and send a traveling wave through the cochlea. Osseotympanic bone conduction occurs with the assistance of the outer ear and at frequencies below 1,000 Hz which causes the external auditory canal to vibrate and radiate along the length of the canal to stimulate the tympanic membrane. An occlusion effect occurs when the external auditory canal is blocked. Bone-conducted sound vibrations are prevented from radiating out of the ear canal and are instead reflected back toward the tympanic membrane. The occlusion effect has been found to boost sound pressure in the ear canal by 20 dB with frequencies below 500 Hz.

Investigations with cetaceans have suggested that high frequencies may cause the thinner portion of the tympanic bone to vibrate with greater amplitude than the thicker portion (Hemila et al., 1999). These vibrations would in turn be conducted to the ossicular chain causing the tympanic bone to act much like a tuning fork (Fleischer, 1978). Chapla et al., (2007) suggest that the manatee's massive ossicular chain may have evolved to function in a similar manner by increasing movement relative to the tympanoperiotic complex and skull.

Several investigations have revealed that the lungs and skeletal system of snakes and turtles play important roles in hearing (Hartline, 1971; Lenhardt, 1982; Lenhardt et al., 1983). These reptiles have lungs that lie in a horizontal plane along the body's length

instead of the transverse plane typical for mammals. This positioning was found to facilitate sound wave vibrations to be received by the lungs and skeletal system and then be conducted to the ears. The position of the manatee's pleural cavity and lungs also diverge from the typical mammalian arrangement and are similar to those found in many reptiles (Chapla et al., 2007). The manatee lungs extend the full length of the body cavity and lie dorsal to the heart (Figure 4.5) (Rommel & Lowenstine, 2000). The pleural cavities are supported by two separate diaphragms (hemidiaphragms) instead of the typical single mammalian diaphragm (Rommel & Reynolds, 2000). The cranial portion of the hemidiaphragms are attached to the first three ribs and extend from the sixth cervical vertebra to the 26th vertebra, spanning an incredible 40% of the total body length (Rommel & Reynolds, 2000). Chapla et al. (2007) suggest that vibrations from sound waves may be transmitted through the lungs, ribs and/or spinal column to the skull and ear bones. Rommel & Reynolds (2000) further suggest that the separation of the hemidiaphragms may provide individualized cues to aid in sound localization.

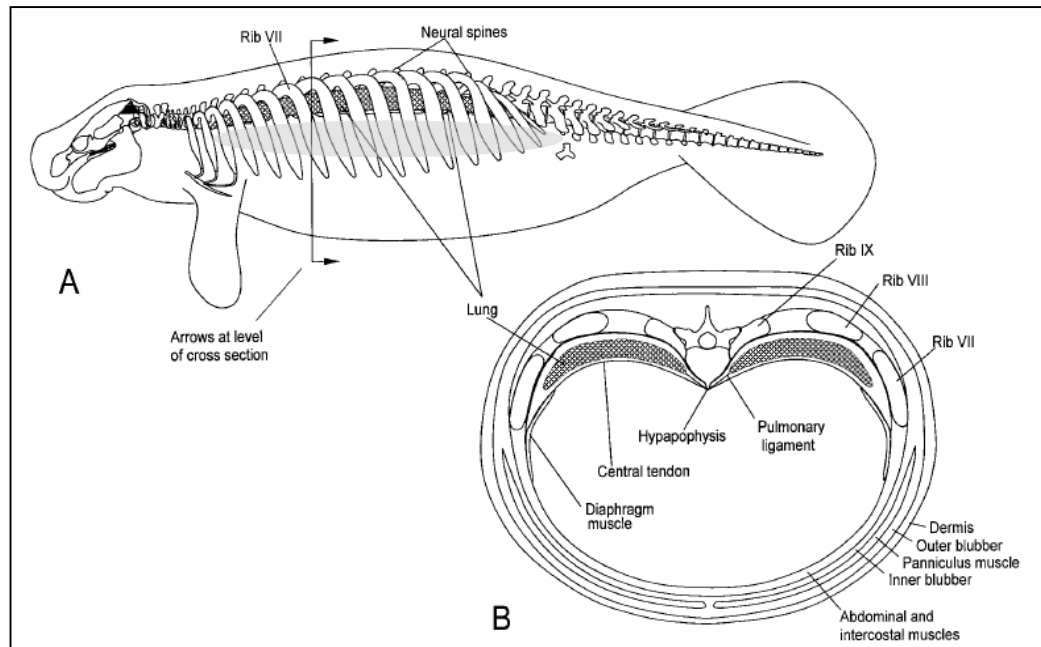

Figure 4.5 Schematic illustrations of the manatee diaphragm and lung. A: In left lateral view, the manatee lung is a relatively flattened and elongate structure that occupies the dorsal region of the pleural cavity. B: In cross section the manatee body is an ellipse, with the diaphragm stretched almost horizontally from the hypapophyses at the midline to the ribs at mid shaft. Figure used with permission from Rommel & Reynolds, 2000.

Behavioral investigations with the manatee have demonstrated that they are able to hear and localize sounds over a wide range of frequencies (Chapter 2) and that interaural level cues likely assist in localization (Chapter 3). The unusual anatomy of the manatee ear however, causes speculation as to how these sounds are received by their auditory system. Auditory evoked potential (AEP) techniques may be a valuable tool for clarifying which sound conduction pathways are most prominent for the manatee.

AEPs are neural electrical firing responses that spontaneously occur when an acoustic stimulus is received. Although individual AEPs have amplitudes that only range up to several microvolts, they can be detected through electrodes placed on the head (Ferraro & Durrant, 1994). To amplify these AEPs, amplitude modulated tones are presented rapidly which result in an envelope following response (EFR) in which neural

responses are phase-locked with the stimulus and averaged together to make it easily distinguishable from electrical noise (Dolphin, 1996, 1997).

AEP techniques have been traditionally used to determine hearing thresholds and have been used with birds (Lucas et al., 2002), terrestrial mammals (Corwin et al., 1982) cetaceans (Ridgway, et al., 1981; Szymanski et al., 1999; Cook et al., 2006), and manatees (Bullock et al., 1980, 1982; Klishen et al., 1990; Popov & Supin, 1990; Mann et al., 2005). Bullock et al. (1982) conducted a cursory investigation to determine if specific areas of the manatee head had increased acoustic sensitivity when they measured the in-air hearing thresholds of four West Indian manatees (*Trichechus manatus*) using AEP techniques. Results suggested that the area surrounding the external auditory meatus showed only a slightly higher sensitivity than “a considerable area in front of it, suggesting that acoustic energy may be received over a large area” (Bullock et al., 1982).

The manatee’s ability to detect and localize sounds and the atypical anatomy of its ear seems paradoxical and signifies an area that merits further research. Results found by Bullock et al. (1982) represent a limited sound conduction pathway evaluation but introduce the potential for utilizing AEP techniques to more fully evaluate the existence of sound conduction pathways outside of the traditional pinna-to-cochlea conduit. The objective of this study was to evaluate if AEP measurements that were previously obtained using in-air and in-water when acoustic stimuli were presented on various positions of the heads and torsos of four manatees would identify the existence of specific sound conduction pathways.

Hypotheses

Two hypotheses were made. The first posited that auditory evoked potentials would be of greater magnitude at the position of the external auditory meatus than at the zygomatic process. The zygomatic process is a lipid-filled bony sponge (Ketten et al. 1999) that has a lower density than other bones (Fawcett, 1942; Caldwell & Caldwell, 1985; Domning & de Buffre'nil, 1991). It has been suggested that the uniqueness of this bone may enhance sound transmission much like the acoustic fat found in the cetacean mandible and melon (Varanasi & Malins, 1971), however the lipids in the zygomatic process differ from that of cetacean acoustic fat (Ames et al., 2002). Chapla et al. (2007) suggested that manatee inter-cranial tissue arrangements near the external auditory meatus had impedance properties similar to that of water and had a minimal amount of reflection which may facilitate sound transmission to their inner ears (Figure 4.4).

The second hypothesis stated that auditory evoked potentials would be of greater magnitude at points along the vertebral column and lateral ribs that are more than 20 cm caudal to the scapula than those located cranial to, at the level of, or up 20 cm caudal to the scapula. Hartline (1971), Lenhardt (1982), and Lenhardt et al. (1983) found that several reptiles (snakes and turtles) had lungs that lay in a horizontal plane along the body's length through which vibratory stimulation was transferred from the lungs and skeletal system to the ears. Rommel & Reynolds (2000) found that the manatee's lungs also lie in a horizontal plane along the body's length, and are composed of two pleural cavities that are ventrally supported by hemidiaphragms. The hemidiaphragms are

attached to the first three ribs and extend back to the 26th vertebra which accounts for approximately 40% of the manatee's total body length (Figure 4.5). Chapla et al. (2007) suggest that vibrations from sound waves may be transmitted through the manatee's lungs, ribs and/or spinal column to the skull and ear bones. The manatee's large scapulas may provide a "deaf-spot" that sound waves reflect from.

Materials and Methods

Subjects

The subjects for this study included four male Florida manatees (*Trichechus manatus latirostris*), Hugh and Buffett who reside at Mote Marine Laboratory and Aquarium in Sarasota, Florida, and Mo and Bock who reside at Walt Disney World's The Living Seas at EPCOT in Lake Buena Vista, Florida. All procedures used with these subjects were permitted through the United States Fish and Wildlife Service (Permit # MA837923-6) and approved by the Institutional Animal Care and Use Committees of each facility.

Hugh and Buffett were both captive-born animals. Hugh was 20 years of age, weighed 547 kg, and was 310 cm in length, while Buffett was 17 years of age, weighed 773 kg, and was 334 cm in length. They were housed in a 265,000 liter exhibit that was composed of three inter-connected sections: a 3.6 x 4.5 x 1.5 m Medical Pool, a 4.3 x 4.9 x 1.5 m Shelf Area, and a 9.1 x 9.1 x 3 m Exhibit Area (Figure 4.6). Both animals had acquired an extensive training history and were conditioned to voluntarily participate in a prior auditory evoked potential study, making them excellent candidates for this investigation (Mann et al., 2005). In addition, they had been behaviorally conditioned for husbandry procedures (Colbert et al., 2001) and studies which investigated lung capacity (Kirkpatrick et al., 2002), serum and urine creatinine levels as a function of release conditions (Manire et al., 2003), visual acuity (Bauer et al., 2003), facial vibrissae tactile

sensitivity (Bauer et al., 2005), as well as a four-choice (Colbert, 2005) and an eight-choice sound localization study (Chapter 2). Voluntary evoked potentials measurements were obtained from the cranial regions of Hugh and Buffett while all portions of their body, excluding the electrodes, were in the water. Restrained evoked potential measurements were also collected from Hugh when he was dry-docked in the drained medical pool with all portions of his body in air.

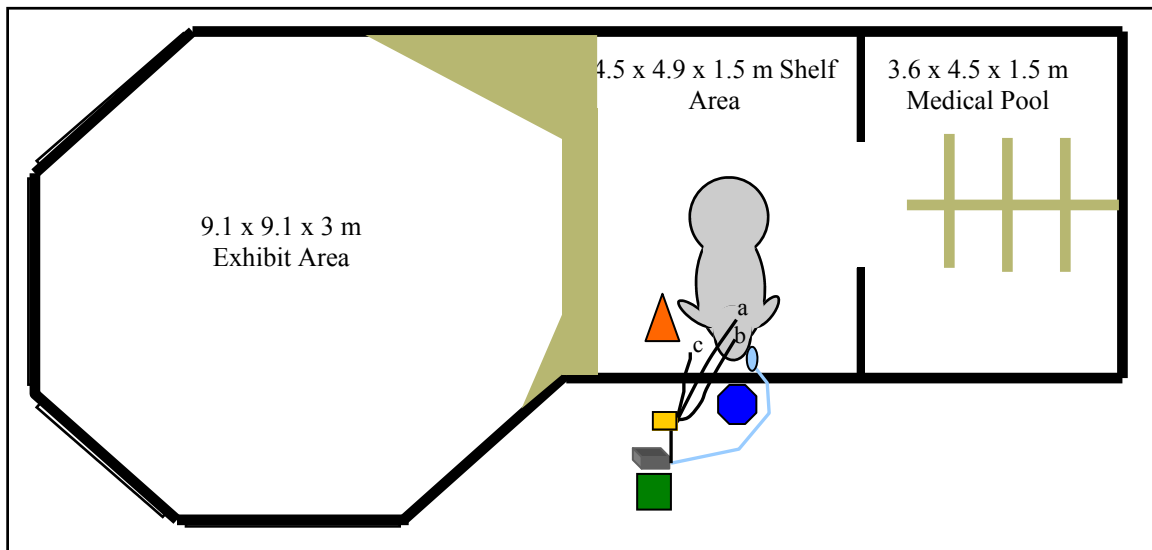

Figure 4.6. Testing setup for voluntary auditory evoked potential measurements used to map sound conduction pathways with subjects at Mote Marine Laboratory & Aquarium. Subjects stationed facing the northeast wall of the Shelf Area. The blue octagon represents the Test Trainer's location, the green square represents the Data Recorder's location, and the orange triangle represents the Subject Handler. Lines a, b, and c represent the reference, recording and ground electrode leads respectively, that travel to the amplifier housed in a water resistant case (yellow rectangle) which was connected to the Workstation. The blue line represents the transducer.

Mo and Bock were both orphaned shortly after birth. Mo was 10 years of age, weighed 458 kg and was 280 cm in length. Bock was 4 years of age, weighed 346 kg and was 247 cm in length. They were housed with a variety of fish species in a 465,605 liter exhibit that was composed of two inter-connected sections: a 14.17 m x 7.16 m x 3.27 m Public Display Pool and a 8.23 m x 4.42 m x 3.70 m adjoining Off-display Medical Pool (Figure 4.7). All evoked potential measurements obtained from these subjects were

collected when they were restrained in the drained off-display medical pool with all portions of their bodies in air.

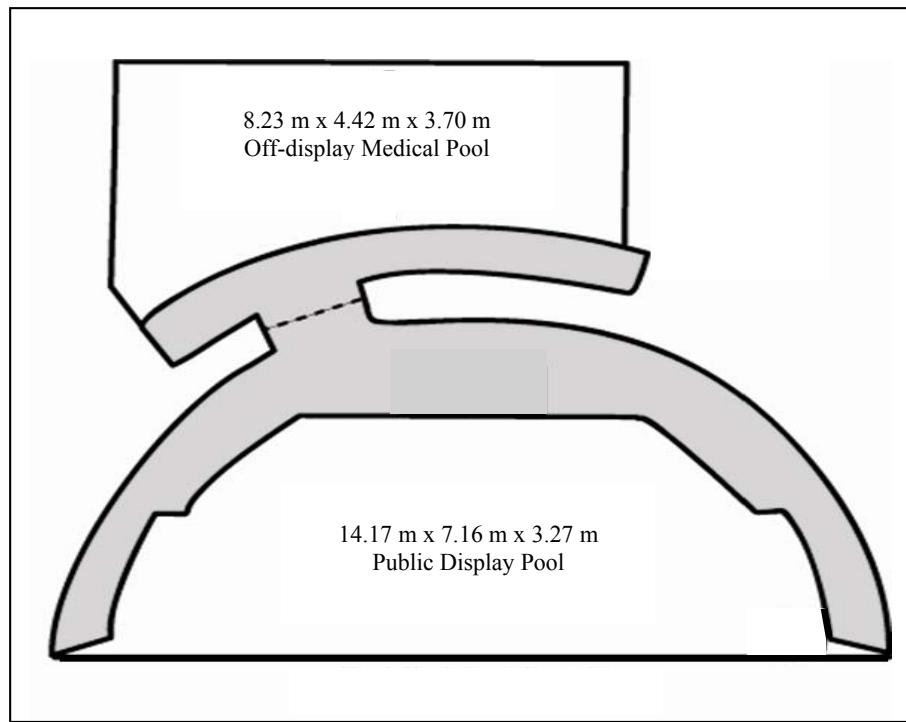

Figure 4.6. Testing setup for restrained auditory evoked potential measurements used to map sound conduction pathways with subjects at Walt Disney World's The Living Seas at EPCOT. Subjects were restrained out of water in the Off-display Medical Pool. Gray shaded areas represent walkways and the dashed line represents a gate that connects the two pools under the walkway.

Experimental Design

All data included in this study were collected between September, 2003 and February, 2005, prior to the development of a formal methodological plan to investigate the possible existence of manatee sound conduction pathways. Transducer positions were coded by video analysis and results were derived through the compilation and organization of these data.

Voluntary AEP measurements with Hugh and Buffett had been previously obtained (Mann et al., 2005). The subjects had been trained to station motionless at a target placed against the northeast wall of the shelf area (Figure 4.1). Through a process

of counter-conditioning (Pearce & Dickinson 1975; Domjan 2003), they were desensitized to surgical scrub preparation of the skin which consisted of isopropyl alcohol and betadine scrubs that were alternated three times each, and insertion of two 27-gauge needle electrodes (Rochester Electro-Medical). The recording electrode was inserted 0.7–1.0 cm into the skin above the cranium, approximately 5 cm cranial to the back of the skull and the reference electrode was inserted to the same skin depth approximately 20 cm caudal to the recording electrode. A third electrode, the ground, was placed in the water. The aversive properties of the needle insertions were countered by the immediate presentation of food reinforcement including apples, carrots, beets and monkey biscuits if they remained motionless. Subjects were trained to remain still for a duration of 2 minutes during recording bouts and while the transducer was placed underwater at different positions located cranial to the scapula (Figure 4.7).



Figure 4.7. Voluntary AEP measurements with Hugh.

Three personnel were needed to obtain voluntary AEP measurements, including a Test Trainer, Data Recorder and Subject Handler (Figure 4.5). The Test Trainer

maintained the subject's proper behavior, performed the surgical scrubs, inserted the electrodes and positioned the transducer. The Data Recorder initiated and recorded each trial via the computer. The Subject Handler was positioned in the water to the right of the subject with his/her knee positioned under the subject's sternum to ensure that the electrodes remained above water and provided the subject primary food reinforcement between recording bouts.

Restrained measurements with Hugh, Mo and Bock required that each subject be dry-docked out of the water and confined as much as possible to avoid movement. Subjects were placed on closed cell foam pads and their skin was kept moist with wet towels or water from a garden hose. The surgical scrub procedures and needle electrode positions were identical to those used with voluntary recordings, however the ground electrode was also inserted into a surgically scrubbed area approximately 10 cm lateral to the reference electrode. The transducer was positioned on different locations of their entire bodies (Figure 4.8).



Figure 4.8. Restrained AEP measurements with Bock.

Restrained AEP procedures required 7-10 personnel including the Test Trainer, Data Recorder and numerous Subject Handlers. The Test Trainer was responsible for performing the surgical scrubs, inserting the electrodes, and positioning the transducer. The Data Recorder was responsible for initiating and recording each trial via the computer. The Subject Handlers were responsible for keeping the subject as motionless as possible and hi skin moist.

Signal Generation and Programming

A Tucker-Davis Technologies AEP workstation and laptop computer (Dell Latitude D505) with SigGen and BioSig software were used to present and collect all evoked potential data. The same workstation had been previously used to investigate cetacean AEPs (Cook, 2006; Cook, et al., 2006).

Signals were generated with a 100 kHz sample rate, amplified by a Hafler amplifier (P1000) and delivered via a piezoceramic transducer (ITC-1042) that was embedded in a suction cup (VI-SIL V-1062, Rhodia, Inc.) constructed of a silicone-based material that had an acoustic impedance similar to water (Brill et al. 2001). A 15 kHz carrier tone burst was presented at 154.9 dB re 1 μ Pa and a 24 kHz carrier tone burst was presented at 158.8 dB re 1 μ Pa. These tone bursts had 5 ms cosine-squared rise-fall times that were amplitude modulated (AM) with a 600 Hz rate that were 40.96 ms and presented 14.5 times per second. The 600 Hz AM rate was found to have produced the largest AEPs with 15 and 24 kHz carrier frequencies in a study that investigated the temporal resolution of Hugh and Buffett (Mann et al., 2005). The frequencies and levels that were presented were chosen because they produced the largest AEPs.

AEP electrical responses received through the electrodes were returned to a differential amplifier (TDT-RP2.1) that was housed in a water-resistant case that could be easily positioned next to the subject. These signals were differentially amplified and averaged with an acquisition sample rate of 25 kHz. Amplified signals were sent via fiber optic cable to the TDT Workstation for data analysis using the BioSig software.

Evoked potentials were collected in response to 200–1,000 presentations of the stimulus. Underwater calibration was performed from within the BioSig software by playing the test signal from the transducer and recording the received level from a hydrophone (HTI 96 min; sensitivity -164 dBV/ μ Pa from 2 to 37 kHz) that was positioned 2 cm away from it and 10 cm below the surface.

Evoked potential magnitudes were calculated by performing a Hanning window on the (EFR) signal followed by a 2,048-point Fast Fourier Transform (FFT) with a measuring amplitude at 600Hz. Equivalent sound pressure levels (SPL) were estimated for evoked potential measurement amplitudes within each carrier frequency and at each transducer location by dividing previously obtained input/output functions (Mann et al., 2005) by 20 log.

Results

Voluntary evoked potential measurements were obtained from Hugh and Buffett for positions on the body that were cranial to the scapula while underwater on March 3, 2004. Restrained evoked potential measurements were obtained for positions over the entire body while in air for Hugh on September 17, 2003, Mo on February 17, 2004, and Bock on February 22, 2005.

All four subjects, whether positioned in air or in water, produced EFRs at the 600 Hz AM rate with both the 15 kHz (Figure 4.9) and 24 kHz carrier signals (Figure 4.10).

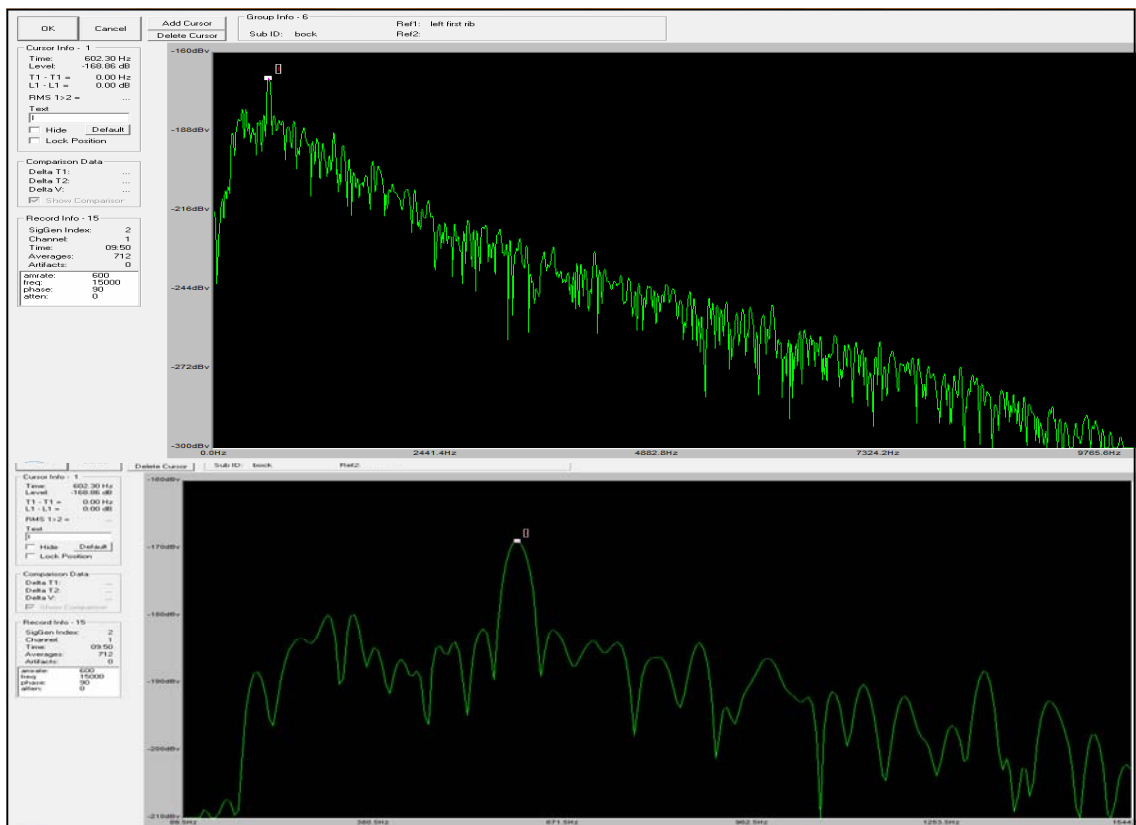

Figure 4.9. A typical auditory evoked potential found at the 600 Hz AM frequency using the 15 kHz carrier. Frequency is defined along the X-axis and signal strength (dB volts) is defined along the Y-axis. Results are from Bock's rib 5 cm caudal to the scapula. Top shows complete measurement, bottom shows same AEP signal magnified.

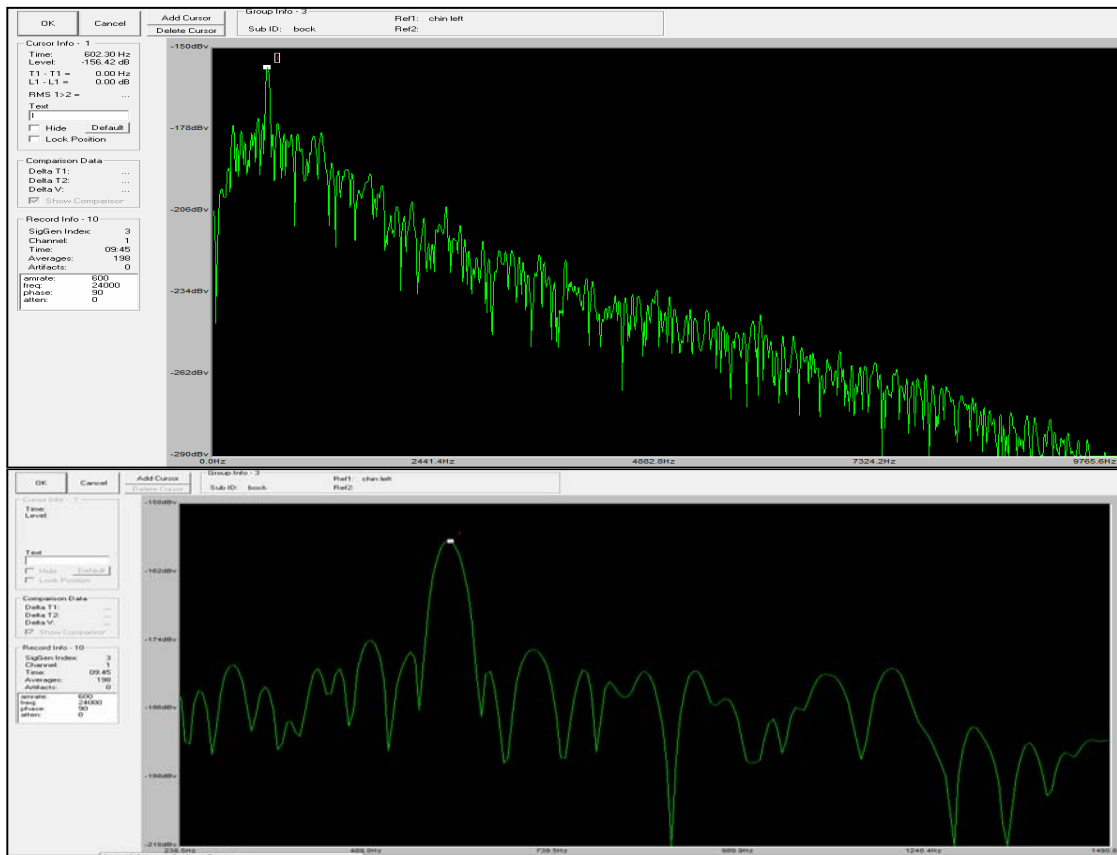

Figure 4.10. A typical auditory evoked potential found at the 600 Hz AM frequency using the 24 kHz carrier. Frequency is defined along the X-axis and signal strength (dB volts) is defined along the Y-axis. Results are from the hinge of Bock's chin. Top shows complete measurement, bottom shows same AEP signal magnified.

A total of 17 in-water AEPs were measured for Hugh, with nine derived from the 15 kHz carrier frequency and eight from the 24 kHz carrier frequency (Figure 4.11 & 4.12). EFR amplitudes and SPLs were determined for positions both dorsal and ventral to the eye, the hinge and center of the lower jaw, both meatuses and the vertebrae located between the scapulas.

The pattern of EFR amplitudes and equivalent SPLs varied between carrier frequencies but were higher with the 24 kHz carrier frequency for all positions except 5 cm dorsal to the left eye, the left meatus and the vertebrae between the scapulas.

Measurements found with the 15 kHz carrier frequency ranged from 1.4 nV / 118.2 dB (5

cm ventral to the right eye) to 8.2 nV / 126.6 dB (5 cm dorsal to the left eye).

Measurements found with the 24 kHz carrier frequency ranged from 2 nV / 119 dB (left meatus and 5 cm ventral to the right eye) to 7.7 nV / 126 dB (5 cm ventral to the left eye).

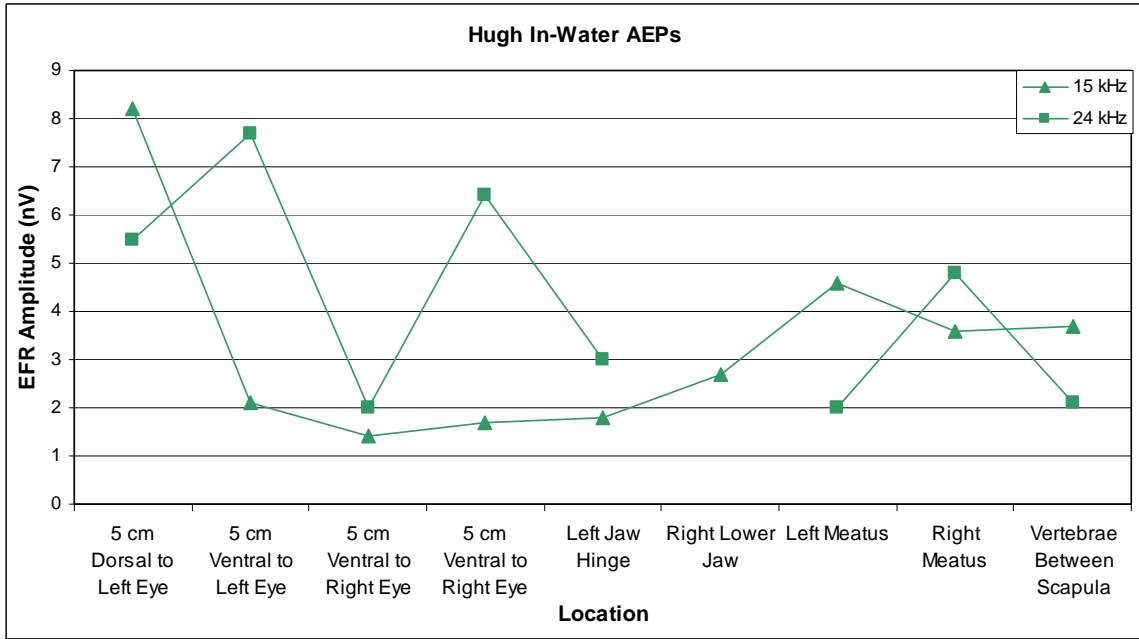

Figure 4.11. In-water auditory evoked potential response measurements for Hugh. Body locations the transducer was positioned on are listed along the X-axis and envelope following response amplitudes (nV) are defined along the Y-axis. Measurements obtained with the 15 kHz carrier are denoted by triangles while those obtained with the 24 kHz carrier are demarked by squares. *Note that some locations may be duplicated or absent for one or both carrier frequencies.

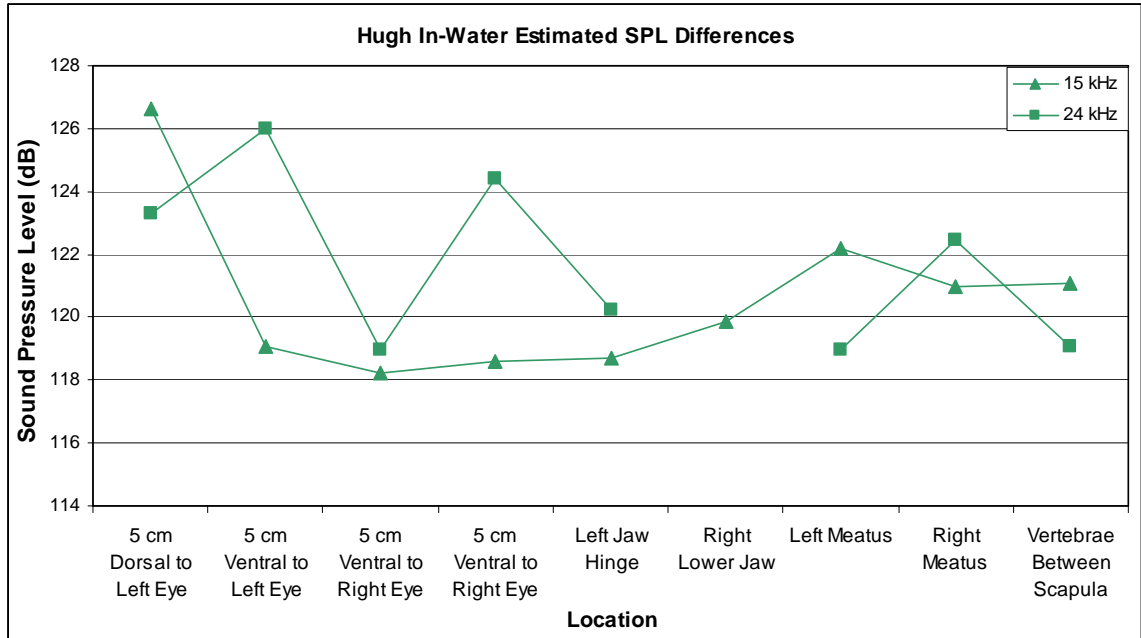

Figure 4.12. Estimated in-water sound pressure level measurements for Hugh. Body locations the transducer was positioned on are listed along the X-axis and the sound pressure levels (dB) are defined along the Y-axis. Measurements obtained with the 15 kHz carrier are denoted by triangles while those obtained with the 24 kHz carrier are demarked by squares. *Note that some locations may be duplicated or absent for one or both carrier frequencies.

A total of 16 in-water AEPs and SPLs were measured for Buffett, eight each from the 15 and 24 kHz carrier frequencies (Figure 4.13 & 4.14). EFR amplitudes and SPLs were determined for positions both dorsal and ventral to the eye, the jaw hinges and center of the lower jaw, both meatuses and the vertebrae located between the scapulas.

The pattern of EFR amplitudes and SPLs between carrier frequencies was similar; those found with the 24 kHz carrier frequency were higher or equal (center of lower jaw and left meatus) to those found with the 15 kHz frequency carrier. Measurements found with the 15 kHz carrier frequency ranged from 0.3 nV / 11.9 dB (5 vertebrae between the scapulas) to 4.8 nV / 122.4 dB (hinge of the left jaw). Measurements found with the 24 kHz carrier frequency ranged from 1.4 nV / 119.7 dB (hinge of right jaw) to 7.1 nV / 125.3 dB (hinge of left jaw).

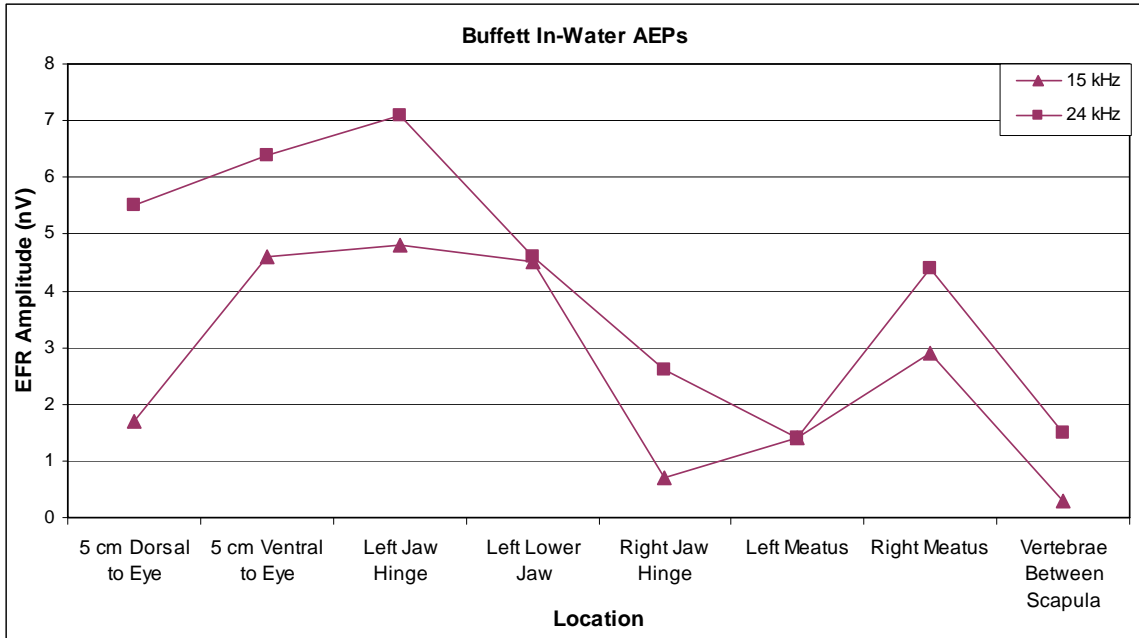

Figure 4.13. In-water auditory evoked potential response measurements for Buffett. Body locations the transducer was positioned on are listed along the X-axis and envelope following response amplitudes (nV) are defined along the Y-axis. Measurements obtained with the 15 kHz carrier are denoted by triangles while those obtained with the 24 kHz carrier are denoted by squares.

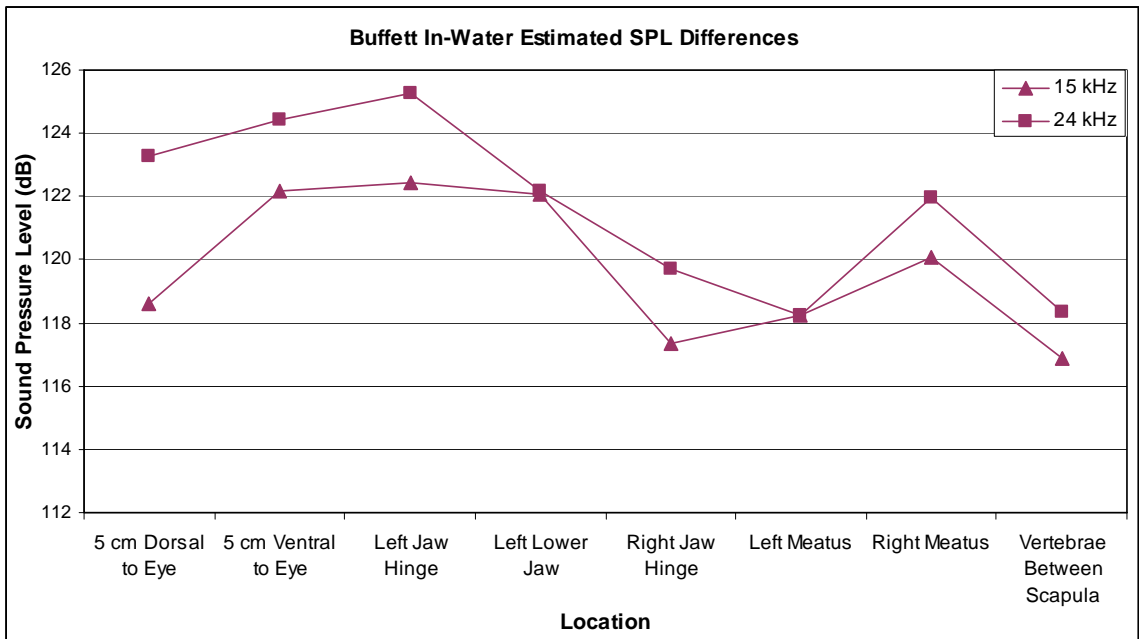

Figure 4.14. Estimated in-water sound pressure level measurements for Buffett. Body locations the transducer was positioned on are listed along the X-axis and the sound pressure levels (dB) are defined along the Y-axis. Measurements obtained with the 15 kHz carrier are denoted by triangles while those obtained with the 24 kHz carrier are denoted by squares.

EFR amplitudes of the 7 common positions between Hugh and Buffett, when tested in-water and using both the 15 and 24 kHz carrier frequencies, were plotted together to examine similarities and discrepancies (Figure 4.15). Patterns within the 15 kHz carrier were inconsistent and amplitudes varied by as much as 6.5 nV (5 cm dorsal to the eye) at all locations except the right meatus which only had a 0.7 nV difference between subjects. Patterns within the 24 kHz carrier were identical or similar (within 0.6 nV) at all locations except the hinge of the left jaw which had a 4.1 nV difference between subjects (note that the data for the left lower jaw with the 24 kHz carrier is absent for Hugh).

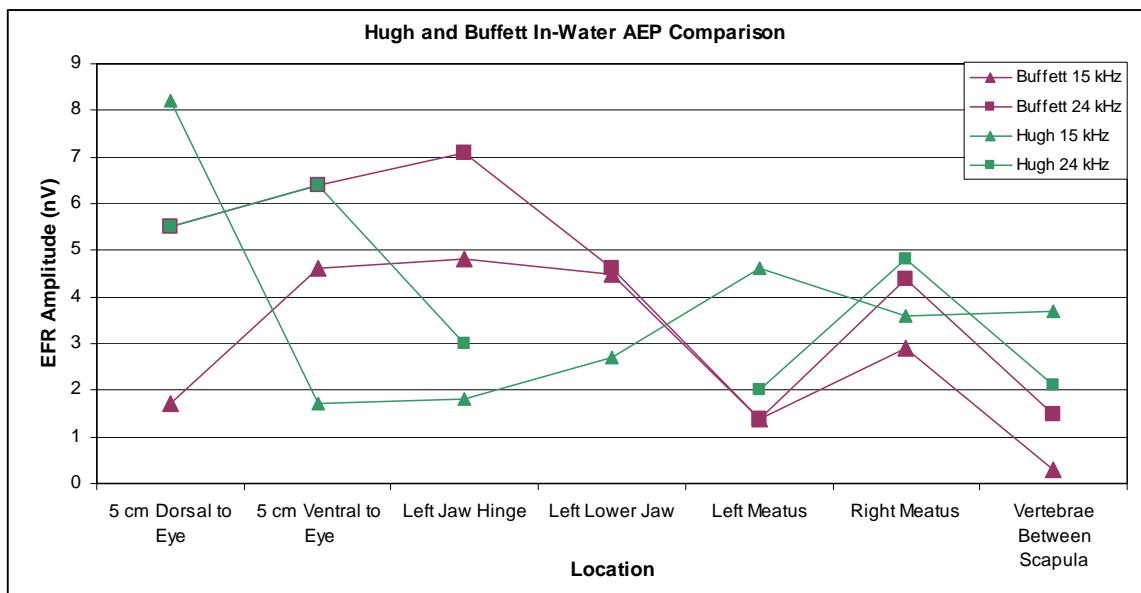

Figure 4.15. In-water auditory evoked potential response measurement comparison of common positions for Hugh and Buffett. Body locations the transducer was positioned on are listed along the X-axis and envelope following response amplitudes (nV) are defined along the Y-axis. Measurements obtained with the 15 kHz carrier are denoted by teal triangles for Hugh and maroon triangles for Buffett while those obtained with the 24 kHz carrier are denoted by teal squares for Hugh and maroon squares for Buffett.

A total of 18 in-air AEPs and SPLs were measured for Bock, nine each from the 15 and 24 kHz carrier frequencies (Figure 4.16 & 4.17). EFR amplitudes and SPLs were determined for positions caudal to the nares, the hinge of the jaw, ventral to the eye, the

meatus, on the zygomatic process ventral to the meatus, caudal to the meatus, on the lateral side of the ribs caudal to the scapula and on the last vertebrae of the tail.

The pattern of EFR amplitudes and SPLs between carrier frequencies was similar; those found with the 24 kHz carrier frequency were higher than those found with the 15 kHz frequency carrier for all positions except ventral to the meatus on the zygomatic process and 10 cm caudal to the meatus. Measurements found with the 15 kHz carrier frequency ranged from 2 nV / 119 dB (ventral to the meatus on the zygomatic process) to 9.7 nV / 128.5 dB (hinge of the jaw). Measurements found with the 24 kHz carrier frequency ranged from 0.7 nV / 117.4 dB (10 cm caudal to the meatus) to 15.1 nV / 135.2 dB (hinge of jaw).

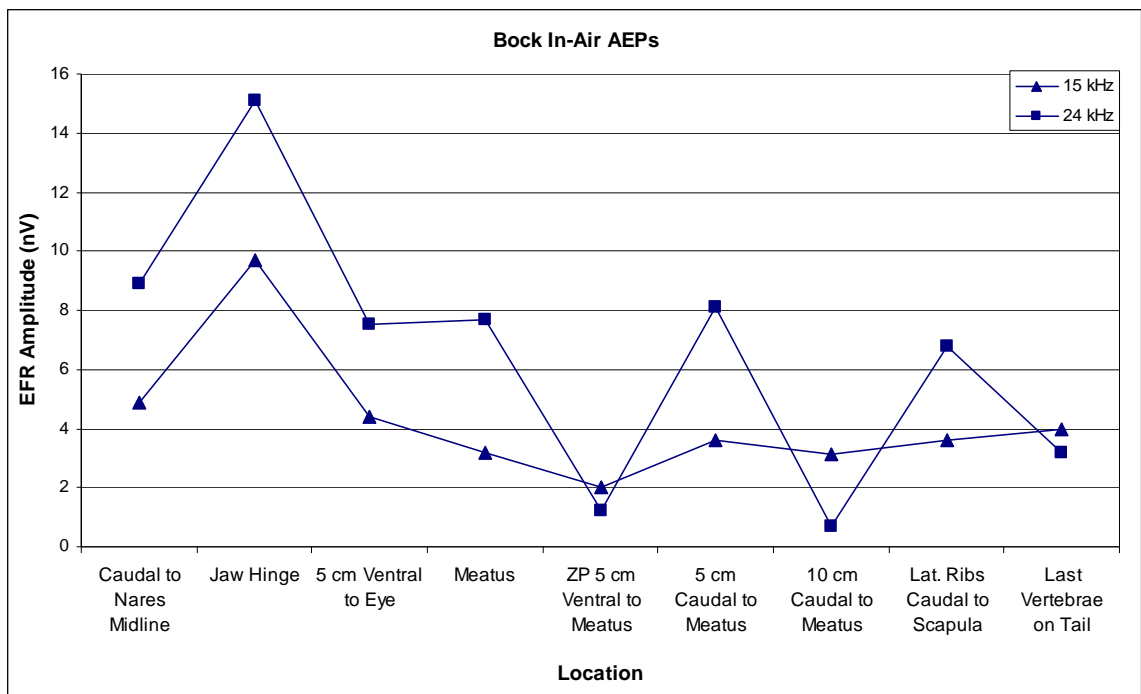

Figure 4.16. In-air auditory evoked potential response measurements for Bock. Body locations the transducer was positioned on are listed along the X-axis and envelope following response amplitudes (nV) are defined along the Y-axis. Measurements obtained with the 15 kHz carrier are denoted by triangles while those obtained with the 24 kHz carrier are denoted by squares. ‘ZP’ denoted zygomatic process and ‘Lat.’ denoted lateral.

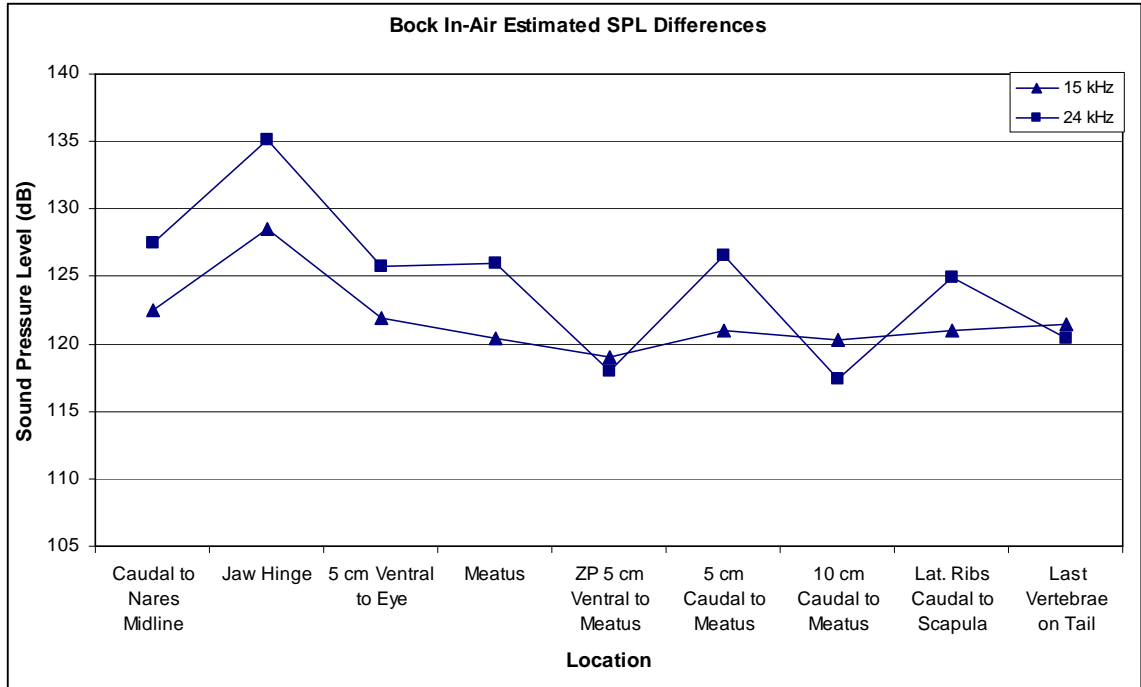

Figure 4.17. Estimated in-air sound pressure level measurements for Bock. Body locations the transducer was positioned on are listed along the X-axis and the sound pressure levels (dB) are defined along the Y-axis. Measurements obtained with the 15 kHz carrier are denoted by triangles while those obtained with the 24 kHz carrier are denoted by squares. ‘ZP’ denoted zygomatic process and ‘Lat.’ denoted lateral.

A total of 32 in-air AEPs and SPLs were measured for Hugh at only the 15 kHz carrier frequency (Figure 4.18 & 4.19). EFR amplitudes and SPLs were determined for positions surrounding the jaw, eye, meatus, zygomatic process, scapula, the vertebrae midway down the length of the spine and the tail, as well as every 10 cm along the lateral side of the ribcage.

AEPs were found at every position tested but amplitudes were highest at the vertebrae located midway down the length of the tail (15 nV / 135 dB) and the spine (13.3 nV / 132.9 dB). Amplitudes were lowest at the lateral side of the ribs, 10 cm caudal to the scapula (1.4 nV / 118.2 dB) and the meatus (2.3 nV / 119.3 dB).

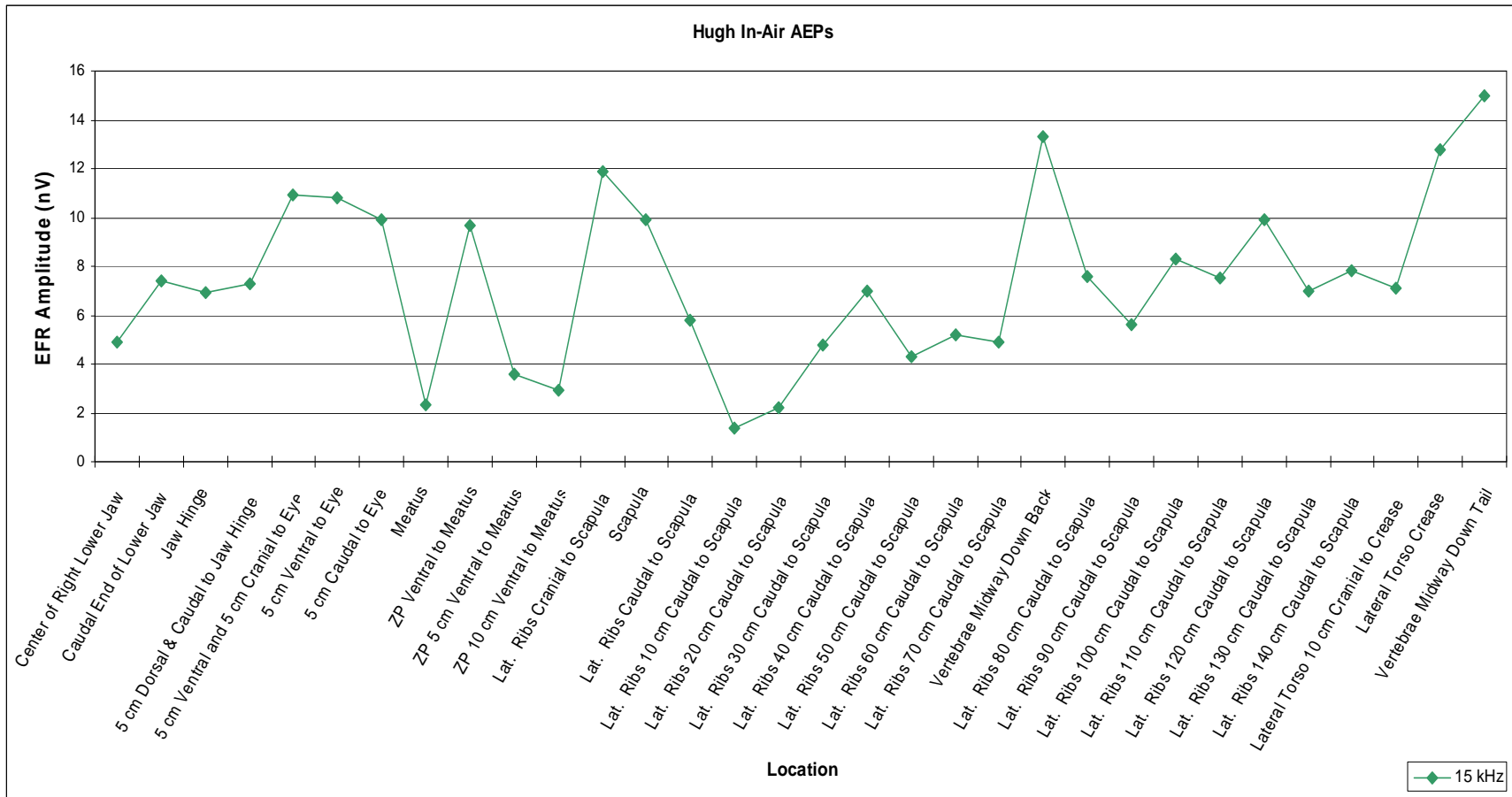

Figure 4.18. In-air auditory evoked potential response measurements for Hugh. Body locations the transducer was positioned on are listed along the X-axis and envelope following response amplitudes (nV) are defined along the Y-axis. All measurements were obtained with the 15 kHz carrier frequency. ‘ZP’ denoted zygomatic process and ‘Lat.’ denoted lateral.

0

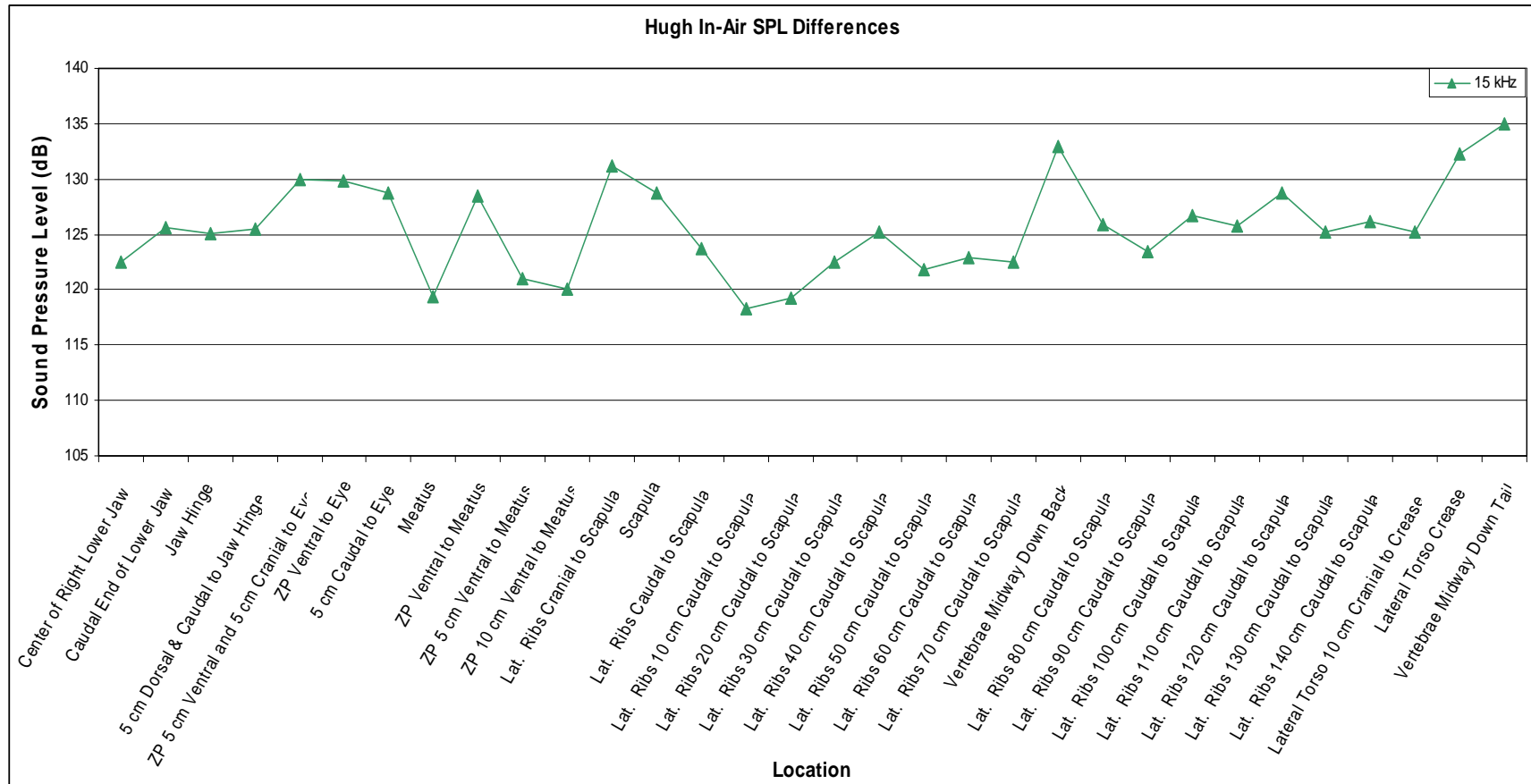

Figure 4.19. Estimated in-air sound pressure level measurements for Hugh. Body locations the transducer was positioned on are listed along the X-axis and the sound pressure levels (dB) are defined along the Y-axis. Measurements were obtained only with the 15 kHz carrier. 'ZP' denoted zygomatic process and 'Lat.' denoted lateral.

A total of 27 in-air AEPs and SPLs were measured for Mo, with 14 derived from the 14 kHz carrier frequency and 13 from the 24 kHz carrier frequency (Figure 4.20 & 4.21). EFR amplitudes and SPLs were determined for positions on the center of the lower jaw, areas surrounding the eye and meatus, the last vertebrae on the tail, as well as positions along the lateral side of the ribcage.

The pattern of EFR amplitudes and SPLs varied and amplitudes with the 24 kHz carrier frequency were not always higher than those found with the 15 kHz frequency carrier. Amplitudes with the 24 kHz carrier frequency was higher for all positions except the center of the lower jaw, 5 cm ventral to the eye, 15 cm ventral and 10 cm caudal to the eye, and on the last vertebrae of the tail. Measurements found with the 15 kHz carrier frequency ranged from 0.6 nV / 117.2 dB (10 cm ventral and caudal to eye) to 7.7 nV / 126 dB (meatus). Measurements found with the 24 kHz carrier frequency ranged from 1.1 nV / 117.9 dB (center of lower jaw) to 9 nV / 127.6 dB (5 cm caudal to the meatus).

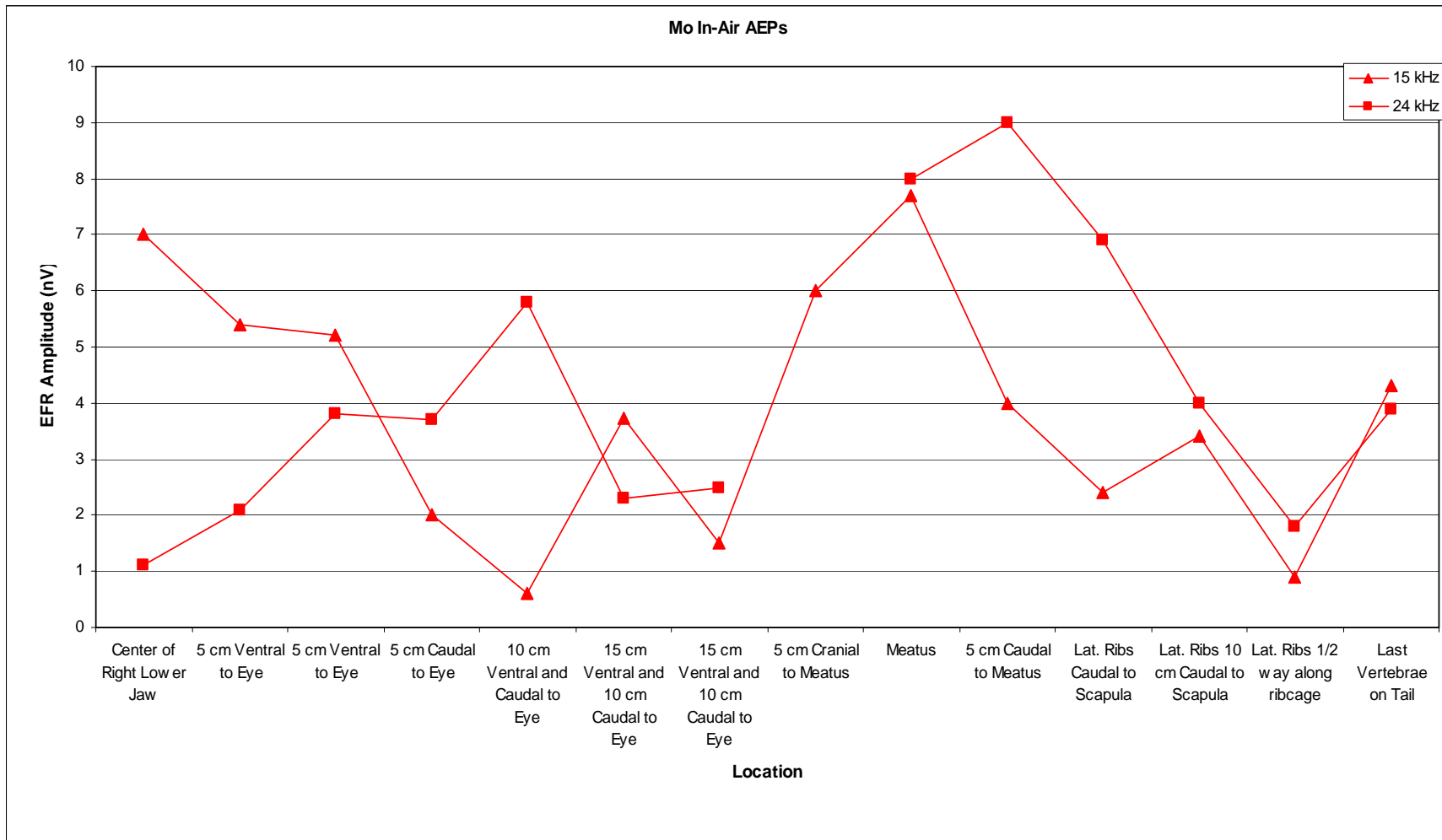

Figure 4.20. In-air auditory evoked potential response measurements for Mo. Body locations the transducer was positioned on are listed along the X-axis and envelope following response amplitudes (nV) are defined along the Y-axis. Measurements obtained with the 15 kHz carrier are denoted by triangles while those obtained with the 24 kHz carrier are denoted by squares. 'ZP' denoted zygomatic process and 'Lat.' denoted lateral. *Note that some locations may be duplicated or absent for one or both carrier frequencies.

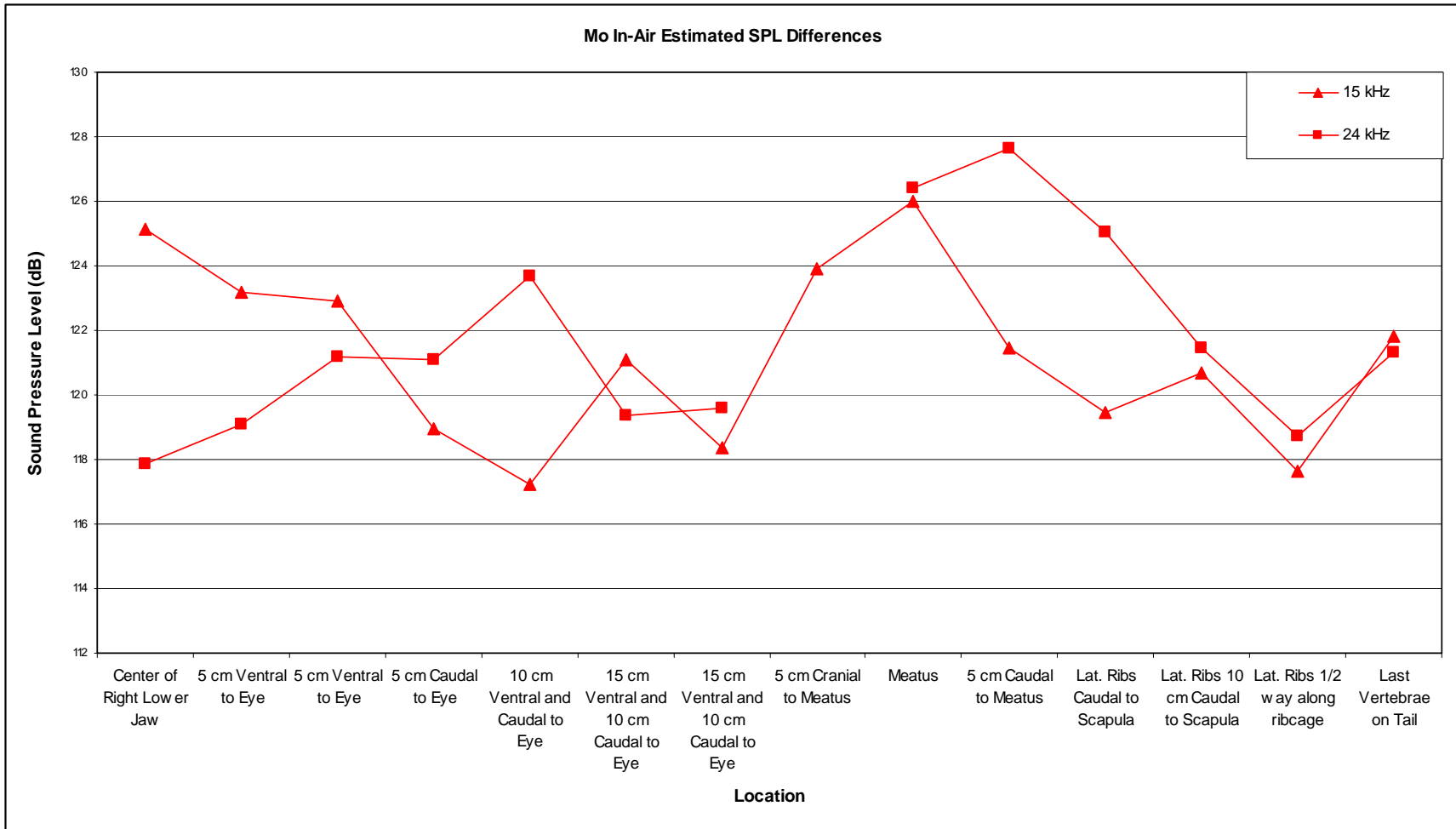

Figure 4.21. Estimated in-air sound pressure level measurements for Mo. Body locations the transducer was positioned on are listed along the X-axis and the sound pressure levels (dB) are defined along the Y-axis. Measurements obtained with the 15 kHz carrier are denoted by triangles while those obtained with the 24 kHz carrier are denoted by squares. ‘ZP’ denoted zygomatic process and ‘Lat.’ denoted lateral. *Note that some locations may be duplicated or absent for one or both carrier frequencies.

EFR amplitudes of the 12 positions that were common between at least two of the three subjects, when tested in-air, were plotted together to examine similarities and discrepancies between Hugh, Mo & Bock (Figure 4.22). Comparisons were made with the 15 and 24 kHz carrier frequencies for Mo and Bock, but only included the 15 kHz carrier frequency with Hugh.

Patterns within the 15 kHz carrier were similar and had less than 1 nV difference only when positioned 5 cm ventral to the eye between Mo and Bock, the meatus between Hugh and Bock, 5 cm caudal to the meatus between Mo and Bock, and on the last vertebrae on the tail between Mo and Bock. Patterns within the 24 kHz carrier were similar (within 0.9 nV) at all locations except 5 cm ventral to the eye which had a 3.7 nV difference between Mo and Bock.

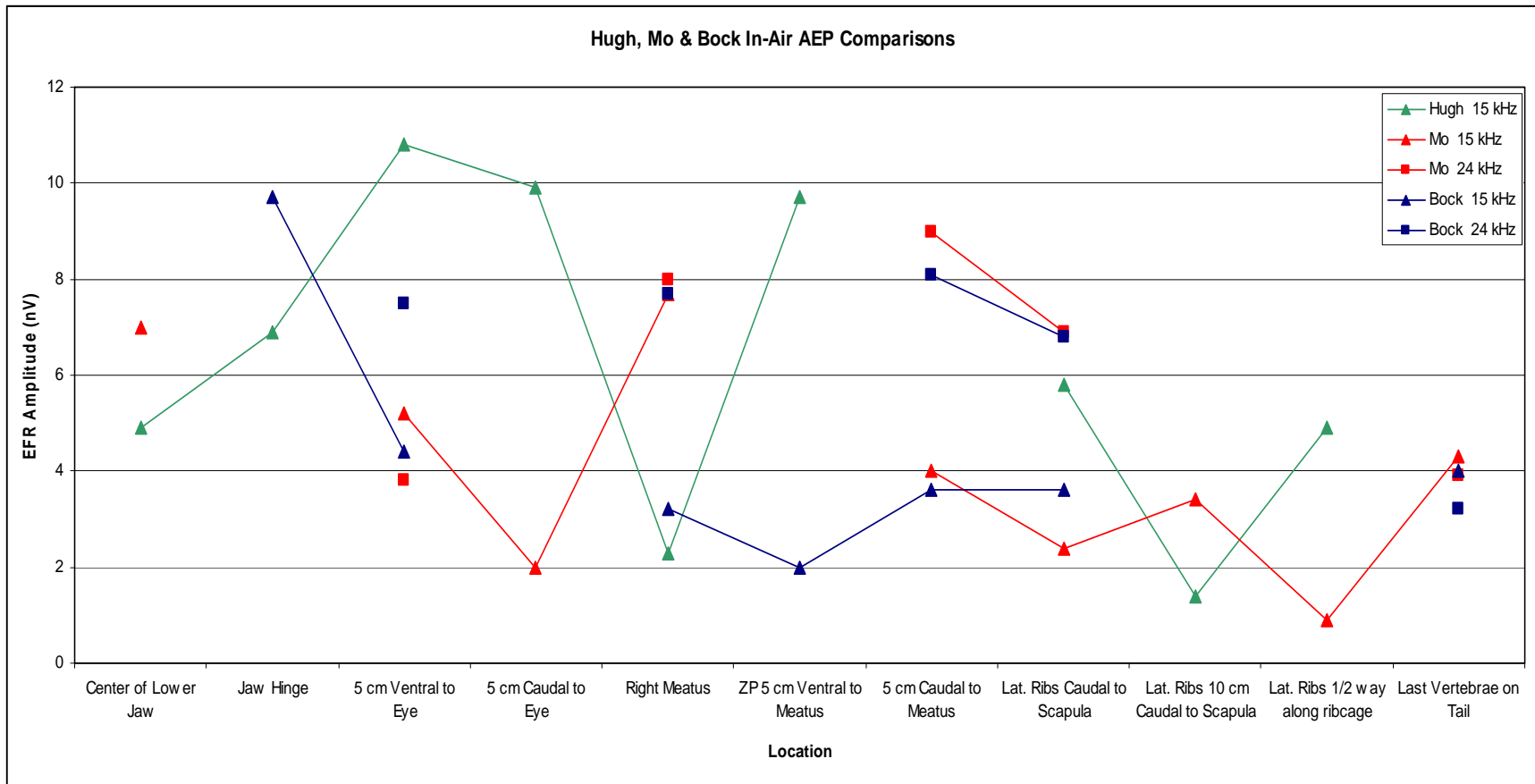

Figure 4.22. In-air auditory evoked potential response measurement comparison of common positions for Hugh, Mo, and Bock. Body locations the transducer was positioned on are listed along the X-axis and envelope following response amplitudes (nV) are defined along the Y-axis. Measurements obtained with the 15 kHz carrier are denoted by teal triangles for Hugh and red triangles for Mo and blue triangles for Bock while those obtained with the 24 kHz carrier are denoted by red squares for Mo and blue squares for Bock (24 kHz carrier not used with Hugh). ‘ZP’ denoted zygomatic process and ‘Lat.’ denoted lateral.

EFR amplitudes of the 4 positions common between at least one subject when measured in-air and at least one subject when measured in-water, were plotted together (Figure 4.23). Comparisons were made with the 15 and 24 kHz carrier frequencies in-air for Mo and Bock but only the 15 kHz carrier frequency with Hugh, and the 15 and 24 kHz carrier frequencies for Hugh and Buffett in-water. Amplitudes were typically greater within the 15 and 24 kHz carrier frequencies when tested in-air with up to a 9 nV and 12.3 nV differences (respectively) found at the jaw hinge between Bock and Buffett. Bock and Hugh demonstrated greater in-air amplitudes at the jaw hinge and 5 cm ventral to the eye, however the remaining amplitudes were more symmetrical between subjects, positions, carrier frequencies and the medium in which testing was conducted.

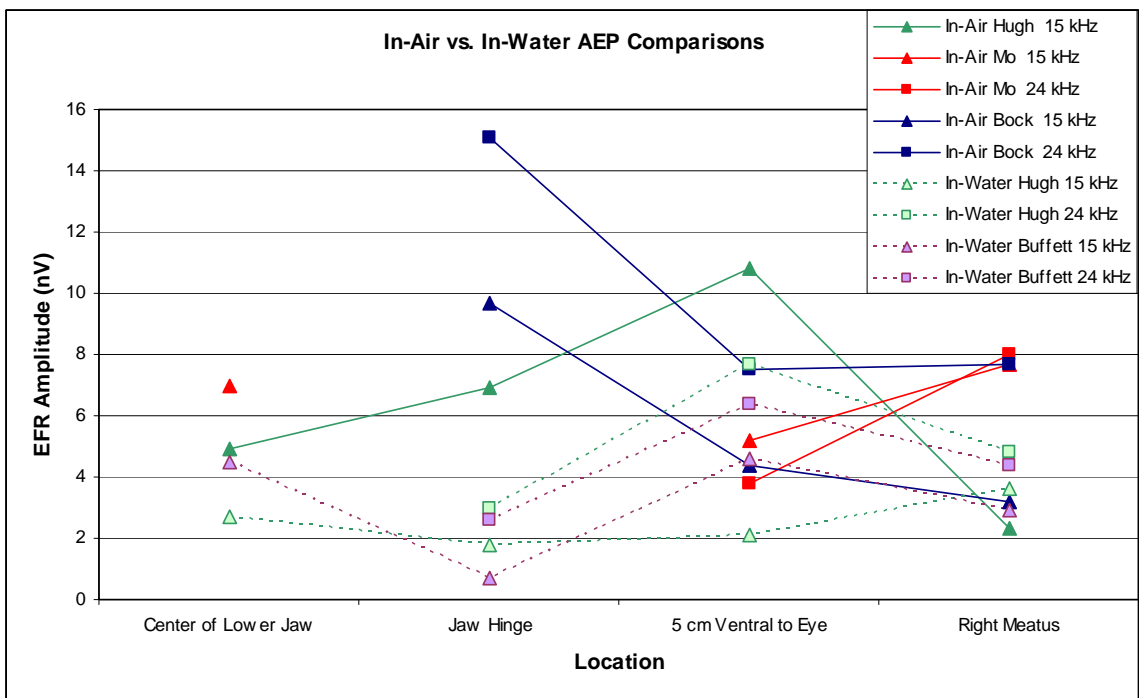

Figure 4.23. In-water vs.in-air auditory evoked potential response measurement comparison of common positions for Hugh, Buffett, Mo and Bock. Body locations the transducer was positioned on are listed along the X-axis and envelope following response amplitudes (nV) are defined along the Y-axis. Measurements obtained with the in-air 15 kHz carrier are denoted by solid teal triangles for Hugh, solid red triangles for Mo and solid blue triangles for Bock, while those obtained with the in-air 24 kHz carrier are denoted by solid teal squares for Hugh, solid red squares for Mo and solid blue squares for Bock. Measurements obtained with the in-water 15 kHz carrier are denoted by shaded teal triangles for Hugh and shaded maroon triangles for Buffett, while those obtained with the in-water 24 kHz carrier are denoted by shaded teal squares for Hugh and shaded maroon squares for Buffett.

Discussion

This investigation used auditory evoked potential techniques to evaluate if sound conduction pathways, outside of the typical mammalian pinna-to-cochlea conduit, may be used by manatees to detect sounds. A 600 Hz signal was used to amplitude modulate 15 and 24 kHz carrier tone bursts. AEP responses were collected as test signals were delivered in-water to several positions on the subjects' heads, and in-air to a variety of positions on the subjects' heads and torsos. Transducer positions were coded by video analysis and results were derived through the compilation and organization of the data already collected.

Hugh and Buffett had been previously conditioned to remain motionless in the water at a target for a prior AEP investigation (Mann et al., 2005). This training was capitalized upon to obtain voluntary in-water AEP measurements from these subjects as test signals were presented to several areas on the head that could be easily reached from the side of the exhibit. In-air measurements were obtained from three subjects, Hugh, Mo and Bock, as the test signal(s) were presented to many of the same areas on their heads in addition to numerous areas on their torsos. For the in-air testing, the 15 and 24 kHz carrier frequencies were used with Mo and Bock however only the 15 kHz carrier frequency was used with Hugh.

Overall findings demonstrated that all subjects, regardless being positioned in air or in water, produced AEPs with the 15 and 24 kHz carriers at the 600 AM rate at every position the transducer was placed on their bodies. Sound pressure levels mirrored

amplitude variations between body positions and did not attenuate at positions further away from the meatus. This is an interesting phenomenon, considering some measurements were obtained at a distance of 3 m from the meatus, and supports the AEP results which suggest that sound waves may be received across the entire body. Results found between subjects, body positions, carrier frequencies and in-air vs. in-water mediums should be interpreted with caution. Data were collected in an unsystematic manner that did not permit many identical comparisons to be made.

Results found between subjects when AEPs were collected in-water demonstrated identical or similar amplitudes (within 0.6 nV) at six of the seven common positions using the 24 kHz carrier, however amplitudes were inconsistent for all but one of the common positions using the 15 kHz carrier. Results between subjects when collected in-air showed that Bock and Mo had similar amplitudes (within 0.9 nV) at four of their five common positions with both the 15 and 24 kHz carriers, however Hugh had only one similar amplitude (0.9 nV difference) with Bock out of the nine positions that were common to Hugh, Mo, and Bock.

Results found between the 15 and 24 kHz carrier frequencies generally demonstrated that amplitudes were higher with the 24 kHz carrier when tested in both in-air and in-water. It is important to recall that all amplitudes are represented in nanovolts, so these differences are quite small when compared to differences found with cetacean AEP investigations that were measured in microvolts (Cook et al., 2006). Patterns between carriers at identical positions were highly variable between subjects, with Buffett and Bock showing more similarities than Hugh and Mo.

Of the possible four positions that were common to the four subjects in both the in-air and in-water mediums, amplitude was typically greater within the 15 and 24 kHz carrier frequencies when tested in-air. In comparison to the other subjects, Bock had a considerably greater amplitude with both carriers at one of the four locations and Hugh had greater amplitude with the 15kHz carrier at two of the four locations when tested in-air. All remaining amplitudes were more symmetrical between subjects, positions, carrier frequencies and the medium in which testing was conducted.

The first hypothesis posited that auditory evoked potentials would be of greater magnitude at the position of the external auditory meatus than at the zygomatic process. Anatomical investigation of the zygomatic process has shown that it lies ventral to the external auditory opening (EAO) and extends cranially to a point about half way between the EAO and the eye. It is connected to the squamosal bone, which in turn, is connected to the tympanoperiotic complex (Figure 4.3) (Ketten et al., 1999; Chapla et al., 2007). The zygomatic process is a bony sponge filled with lipids and blood vessels that has less density and rigidity than other bones (Fawcett, 1942; Caldwell & Caldwell, 1985; Domning & de Buffre'nil, 1991; Ketten et al., 1999), however the lipids it contains are not considered acoustic fats (Ames et al., 2002). It may be that the composition of the zygomatic process and its geometric position relative to the ear bones may serve as an acoustic channel.

The manatee's inter-cranial tissue arrangements near the external auditory meatus has been found to have an impedance similar to that of water with a minimal amount of bone for sound waves to reflect off of (Figure 4.4) (Chapla et al., 2007). Sound waves arriving from azimuth angles between 45° and 90° and elevation angles between ~43° and

73° may be able to propagate through the soft tissue surrounding the external auditory meatus area to stimulate the tympanic membrane directly.

The AEP amplitudes (nV) for areas surrounding the external auditory meatus and zygomatic process were defined from the data collected and averaged by the positions defined in the hypothesis (Table 4.1). Note that data for some positions may have been duplicated or never obtained between subjects. Positions defined as caudal to the meatus are likely to have been presented over the edge of the zygomatic process or the squamosal bone as it extends dorsally and caudally and were included in the zygomatic process average. The one measurement obtained cranial to the meatus was included in the meatus average. Measurements from the jaw hinge should also be considered as the transducer may have been positioned on the ventral edge of the zygomatic process, however this positioning was not certain and it was averaged on its own.

Results did not support the hypothesis that suggested AEPs would be of greater magnitude at the position of the external auditory meatus than at the zygomatic process. The averaged AEPs were found to be identical and suggest that one area does not represent a stronger sound conduction pathway. Interestingly, averaged measurements obtained from the jaw hinge were of greater magnitude than those found in the areas of the zygomatic process or meatus.

Table 4.1. AEP amplitudes (nV) obtained from the areas surrounding the external auditory meatus and zygomatic process for all subjects. The averaged AEP amplitudes for each position are listed in the end column. Note that data for some positions may be duplicated or absent.

Location	In-Water				In-Air					
	Hugh		Buffett		Hugh	Mo		Bock		
	15 kHz	24 kHz	15 kHz	24 kHz	15 kHz	15 kHz	24 kHz	15 kHz	24 kHz	
Meatus	4.6	2	1.4	1.4	2.3	7.7	8	3.2	7.7	4.3
Meatus	3.6	4.8	2.9	4.4						
5 cm Cranial to Meatus						6				
5 cm Caudal to Meatus						4	9	3.6	8.1	4.3
10 cm Caudal to Meatus								3.1	0.7	
ZP / Just Ventral to Meatus					9.7					
ZP / 5 cm Ventral to Meatus					3.6			2	1.2	
ZP / 10 cm Ventral to Meatus					2.9					5.6
Jaw Hinge	1.8	3	4.8	7.1				9.7	15.1	
Jaw Hinge			0.7	2.6						

The second hypothesis stated that subjects would demonstrate greater evoked potentials at points along the vertebral column and lateral ribs that are more than 20 cm caudal to the scapula than those located cranial to, at the level of, or up to 20 cm caudal to the scapula. The manatee lung structure is composed of two pleural cavities that are supported ventrally by hemidiaphragms which lie in a horizontal plane along the body's length (Rommel & Reynolds, 2000). The manatee's hemidiaphragms are attached to the first three ribs and extend back to the 26th vertebra which accounts for approximately 40% of the manatee's total body length. This anatomical arrangement is not typical for mammals but is similar to that found with many reptiles that use their lungs and skeletal system as a conduit for acoustic vibratory stimulation to be transferred to the ears (Hartline, 1971; Lenhardt, 1982; Lenhardt et al., 1983). This arrangement provides a huge surface area for acoustic sound wave vibrations to be received by the manatee's lungs, ribs and/or spinal column and transmitted to the skull and ear bones. The manatee's large scapulas however, may provide a "deaf-spot" that sound waves will reflect from rather than be received through.

The AEP amplitudes (nV) for points along the vertebral column and lateral ribs were defined from the data collected and averaged by the areas defined in the hypothesis (Table 4.2). Results showed that evoked potentials from positions along the vertebral column and lateral ribs that were more than 20 cm caudal to the scapula (6.3 nV) were greater than those located in cranial to, at the level of, or up to 20 cm caudal to the scapula (4.4 nV). These findings substantiate the hypothesis and suggest that the spinal column and lateral ribs, positioned caudal to the scapula, may serve as an important conduit for sound transmission to the ear bones. It is important to note that the averages, particularly those that include positions greater than 20 cm caudal to the scapula, are composed of numerous single data points from Hugh. The evoked potentials obtained from Hugh were characteristically found to be greater than those obtained from other subjects and these results should be interpreted cautiously.

Table 4.2. AEP amplitudes (nV) obtained from points along the vertebral column and lateral ribs that are more than 20 cm caudal to the scapula than those located cranial to, at the level of, or up 20 cm caudal to the scapula. The averaged AEP amplitudes for each area are listed in the end column. Note that data for some positions may be duplicated or absent and many positions have only one data point.

Location	In-Water				In-Air					
	Hugh		Buffett		Hugh	Mo		Bock		
	15 kHz	24 kHz	15 kHz	24 kHz	15 kHz	15 kHz	24 kHz	15 kHz	24 kHz	
Lat. Ribs Cranial to Scapula					11.9					4.4
Scapula					9.9					
Lat. Ribs Just Caudal to Scapula					5.8	2.4	6.9	3.6	6.8	
Lat. Ribs 10 cm Caudal to Scapula					1.4	3.4	4			
Lat. Ribs 20 cm Caudal to Scapula					2.2					
Vertebrae Between Scapula	3.7	2.1	0.3	1.5						
Lat. Ribs 30 cm Caudal to Scapula					4.8					6.3
Lat. Ribs 40 cm Caudal to Scapula					7					
Lat. Ribs 50 cm Caudal to Scapula					4.3	0.9	1.8			
Lat. Ribs 60 cm Caudal to Scapula					5.2					
Lat. Ribs 70 cm Caudal to Scapula					4.9					
Lat. Ribs 80 cm Caudal to Scapula					7.6					
Lat. Ribs 90 cm Caudal to Scapula					5.6					
Lat. Ribs 100 cm Caudal to Scapula					8.3					
Lat. Ribs 110 cm Caudal to Scapula					7.5					
Lat. Ribs 120 cm Caudal to Scapula					9.9					
Lat. Ribs 130 cm Caudal to Scapula					7					
Lat. Ribs 140 cm Caudal to Scapula					7.8					
Vertebrae Midway Down Back					13.3					
Vertebrae Midway Down Tail					15					
Last Vertebrae on Tail						4.3	3.9	4	3.2	

The information gained from this study demonstrates how AEP techniques may be used to evaluate the existence of sound conduction pathway outside of the traditional pinna-to-cochlea conduit. EFRs can be isolated using in at the 600 Hz AM rate with 15 and 24 kHz carrier signals, although those in the 24 kHz carrier generally produced potentials with greater amplitudes. AEPs were found for all positions tested with all four subjects, regardless of their being positioned in air or in water. These results suggest that manatees have evolved a way to compensate for their occluded external auditory meatus; the exact means by which they have accomplished this however, remains a conundrum that requires further investigation. AEP techniques offer potential insight for solving this

puzzle and future AEP investigations should incorporate systematic and multiple measurements of identical positions on each subject's body.

References Cited

- Ames, A.L., Van Vleet, E.S. & Reynolds J.E. (2002). Comparison of lipids in selected tissues of the Florida manatee (Order Sirenia) and bottlenose dolphin (Order Cetacea; Suborder Odontoceti). *Comparative Biochemistry and Physiology*, Part B 132, 625-634.
- Aroyan, J.L. (1996). *Three-Dimensional Numerical Simulation of Biosonar Signal Emission and Reception in the Common Dolphin*. Unpublished Ph.D. Dissertation, University of California, Santa Cruz.
- Bauer, G.B., Colbert, D.E., Gaspard, J.C., Littlefield, B. & Fellner, W. (2003). Underwater visual acuity of Florida manatees (*Trichechus manatus latirostris*). *International Journal of Comparative Psychology*, 16, 130-142.
- Bauer, G.B., Gaspard III, J.C., Colbert, D.E., Leach, J.B. & Reep, R. (2005, March). *Tactile Discrimination of Textures by Florida Manatees, Trichechus manatus latirostris*. Paper presented at the 12th annual International Conference on Comparative Cognition, Melbourne, Florida.
- Brill R.L., Moore P.W.B. & Dankiewicz L.A. (2001) Assessment of dolphin (*Tursiops truncatus*) auditory sensitivity and hearing loss using jawphones. *Journal of the Acoustical Society of America*, 109:1717-1722
- Bullock, T.H., Domning, D.P. & Best, R.C. (1980). Evoked potentials demonstrate hearing in a manatee (*Trichechus inunguis*). *Journal of Mammalogy*, 61 (1), 130-133.
- Bullock, T.H., O'Shea, T.J. & McClune, M.C. (1982). Auditory evoked potentials in the West Indian manatee (Sirenia: *Trichechus manatus*). *Journal of Comparative Physiology*, 148, 547-554.
- Caldwell, D.K. & Caldwell, M.C. (1985). Manatees: *Trichechus manatus* (Linnaeus, 1758); *Trichechus senegalensis* (Link, 1795); and *Trichechus inunguis* (Natterer, 1883). In S.H. Ridgway & R. Harrison (Eds.) *Handbook of Marine Mammals; The Sirenians and Baleen Whales*, Vol. 3. Academic Press, London, pp. 33-66.
- Chapla, M., Nowacek, D., Rommel, S. & Sadler, V. (2007). CT scans and 3D reconstructions of Florida manatee (*Trichechus manatus latirostris*) heads and ear bones. *Hearing Research*, 228, 123-135.

- Colbert, D. (2005). *Sound Localization Abilities of Two Florida Manatees, Trichechus manatus latirostris*. Unpublished Masters Thesis, University of South Florida, Tampa, FL.
- Colbert, D.E., Fellner, W., Bauer, G.B., Manire, C. & Rhinehart, H. (2001). Husbandry and research training of two Florida manatees, *Trichechus manatus latirostris*. *Aquatic Mammals*, 27 (1), 16-23.
- Cook, M.L.H. (2006). *Behavioral and Auditory Evoked Potential (AEP) Hearing Measurements in Odontocete Cetaceans*. Unpublished Masters Thesis, University of South Florida, Tampa, FL.
- Cook, M.L.H., Varela, R.A., Goldstein, J.D., McCulloch, S.D., Bossart, G.D., Finneran, J.J., Houser, D. & Mann, D.A. (2006). Beaked whale auditory evoked potential hearing measurements. *Journal of Comparative Physiology A*, 192, 489-495.
- Corwin, J.T., Bullock, T.H. & Schweitzer, J. (1982). The auditory brain stem response in five vertebrate classes. *Electroencephalography and Clinical Neurophysiology*, 54, 629-641.
- Dolphin, W.F. (1996). Auditory evoked responses to amplitude modulated stimuli consisting of multiple envelope components. *Journal of Comparative Physiology A*, 179, 113-121.
- Dolphin, W.F. (1997). The envelope following response to multiple tone pair stimuli. *Hearing Research*, 110, 1-14.
- Domjan, M. (1998). *The principles of learning and behavior*. Pacific Grove, CA: Brooks-Cole Publishing Company.
- Domning, D.P. (2001). Evolution of the Sirenia and Desmostylia. In Mazin, J.M. & de Buffrenil, V. (Eds.) *Secondary Adaptation of Tetrapods to Life in the Water*. Verlag, Munchen, pp. 151-168.
- Domning, D.P. & de Buffrenil, V. (1991). Hydrostasis in the Sirenia: quantitative data and functional interpretations. *Marine Mammal Science*, 7 (4), 331-368.
- Fawcett, D.W. (1942). The amedullary bones of the Florida Manatee (*Trichechus latirostris*). *American Journal of Anatomy*, 71, 271-309.
- Ferraro, J.A. & Durrant, J.D. (1994). Auditory evoked potentials: overview and basic principles. In Katz, J (Ed) *Handbook of Clinical Audiology*. Williams and Wilkens, London, pp317-338.
- Fleischer, G. (1978). *Evolutionary Principles of the Mammalian Middle Ear*. Springer, Berlin.

- Gelfand, A.G. (2004). *Hearing: An Introduction to Psychological and Physiological Acoustics*, 4th Edition. Marcel Dekker, New York, pp 98-102.
- Gerstein, E. (1999). *Psychoacoustic Evaluations of the West Indian manatee (Trichechus manatus latirostris)*. Unpublished Doctoral Dissertation, Florida Atlantic University, Boca Raton, FL.
- Gerstein, E., Gerstein, L., Forsythe, S. & Blue, J. (1999). The underwater audiogram of the West Indian manatee (*Trichechus manatus*). *Journal of the Acoustical Society of America*, 105, 3575-3583.
- Goold, J.C. & Clarke, M.R. (2000). Sound velocity in the head of the dwarf sperm whale, *Kogia sima*, with anatomical and functional discussion. *Journal of the Marine Biological Association of the U.K.* 80, 535–542.
- Hartline, P.H. (1971). Physiological basis for detection of sound and vibration in snakes. *Journal of Experimental Biology*, 54, 349–371.
- Hemila, S., Nummela, S. & Reuter, T. (1999). A model of the odontocete middle ear. *Hearing Research*, 133, 82–97.
- Ketten, D.R. (1992). The marine mammal ear: Specializations for aquatic audition and echolocation. In R. Fay, W. Webster & A. Popper (Eds.) *The biology of Hearing*. Springer-Verlag, pp 717-754.
- Ketten, D.R., Odell, D.K. & Domning, D.P. (1992). Structure, function, and adaptation of the manatee ear. In J.A. Thomas, R.A. Kastelein & A.Y. Supin (Eds.) *Marine Mammal Sensory Systems*. Plenum Press, NY, pp.77-79.
- Kirkpatrick, B., Colbert, D.E., Dalpra, D., Newton, E.A.C., Gaspard, J., Littlefield B. & Manire, C.A. (2002). Florida Red Tides, Manatee Brevetoxicosis, and Lung Models. In K. A. Steidinger, J. H. Landsberg, C. R. Tomas, and G. A. Vargo (Eds.) *Xth International Conference on Harmful Algae*. Florida Fish and Wildlife Conservation Commission and Intergovernmental Oceanographic Commission of UNESCO.
- Klishen, V.O., Diaz, R.P., Popov, V.V. & Supin, A.Y. (1990). Some characteristics of hearing of the Brazilian manatee, *Trichechus inunguis*. *Aquatic Mammals*, 16 (3), 139-144.
- Lenhardt, M.L. (1982). Bone conduction in turtles. *Journal of Auditory Research*. 22, 153–160.

- Lenhardt, M.L., Bellmund, S., Byles, R.A., Harkins, S.W. & Musick, J.A. (1983). Marine turtle reception of bone-conducted sound. *Journal of Auditory Research*, 23, 119–125.
- Lucas, J.R., Freeberg, T.M., Krishnan, A. & Long, G.R. (2002). A comparative study of avian auditory brainstem responses: Correlations with phylogeny and vocal complexity and seasonal effects. *Journal of Comparative Physiology A*, 188, 981–992.
- Manire, C.A., Walsh, C.J., Rhinehart, H.L., Colbert, D.E., Noyes, D.R. & Luer, C.A. (2003). Alterations in blood and urine parameters in two Florida manatees, *Trichechus manatus latirostris*, from simulated conditions of release following rehabilitation. *Zoo Biology*, 22, 103–120.
- Mann, D., Colbert, D.E., Gaspard, J.C. III, Casper, B., Cook, M.L.H., Reep, R.L. & Bauer, G.B. (2005). Temporal resolution of the Florida manatee (*Trichechus manatus latirostris*) auditory system. *Journal of Comparative Physiology*, 191, 903–908.
- Mast, T.D. (2000). Empirical relationships between acoustic parameters in human soft tissues. *Acoustic Research Letters Online*, 1 (2), 37–42.
- Nowacek, D.P., Casper, B.M., Wells, R.W., Nowacek, S.M. & Mann, D.A. (2003). Intraspecific and geographic variation of West Indian manatee (*Trichechus manatus spp.*) vocalizations. *Journal of the Acoustical Society of America*, 114 (1), 66–69.
- Nummela, S. (1995). Scaling of the mammalian middle ear. *Hearing Research*, 85, 18–30.
- Nummela, S., Wagar, T., Hemila, S. & Reuter, T. (1999). Scaling of the cetacean middle ear. *Hearing Research*, 133, 71–81.
- Pearce, J.M. & Dickinson, A. (1975). Pavlovian counterconditioning: changing the suppressive properties of shock by association with food. *Journal of Experimental Psychology: Animal Behavior Proceedings*, 1, 170–177.
- Popov, V.V. & Supin, A.Y. (1990). Electrophysiological studies on hearing in some cetaceans and a manatee. In J.A. Thomas & R. A. Kastelein (Eds.), *Sensory Abilities of Cetaceans: Laboratory and Field Evidence*. NY: Plenum Press.
- Richardson, W., Greene, C., Malme, C. & Thompson, D. (1995). *Marine Mammals and Noise*. San Diego, CA: Academic Press.
- Ridgway, S.H., Bullock, T.H., Carder, D.A., Seeley, R.L., Woods, D. & Galambos, R. (1981). Auditory brainstem response in dolphins. *Neurobiology*, 78, 1943–1947.

- Rommel, S.A. & Lowenstine, L.J. (2000). Gross and microscopic anatomy. In Dierauf, L.A. & Gulland, M.D. (Eds.), *CRC Handbook of Marine Mammal Medicine*, Second Edition. CRC Press, Boca Raton, FL, pp 129-158.
- Rommel, S. & Reynolds, J.E. III (2000). Diaphragm structure and function in the Florida manatee (*Trichechus manatus latirostris*). *Anatomical Record* 259(1):41–51.
- Ruggero, M.A. & Temchin, A.N. (2002). The roles of the external, middle, and inner ears in determining the bandwidth of hearing. *Proceedings of the National Academy of Sciences of the United States*, 99.20: 13206(5).
- Soldevilla, M.S., McKenna, M.F., Wiggins, S.M., Shadwick, R.E., Cranford, T.W. & Hildebrand, J.A. (2005). Cuvier's beaked whale (*Ziphius cavirostris*) head tissues: physical properties and CT imaging. *Journal of Experimental Biology*, 208, 2319–2332.
- Szymanski, M.D., Bain, D.E., Kiehl, K. Pennington, S., Wong, S. & Henry, K.R. (1999). Killer whale (*Orcinus orca*) hearing: Auditory brain stem response and behavioral audiograms. *Journal of the Acoustical Society of America*, 106, 1134-1141.
- Tonndorf, J. (1966). Bone conduction: studies in experimental animals. *Acta Otolaryngologica*, Stockholm Supplement, 213, pp. 1–132.
- Varanasi, U. & Malins, D.C. (1971). Unique lipids of the porpoise (*Tursiops gilli*): Differences in triacyl glycerols and wax esters of acoustic (mandibular canal and melon) and blubber tissues. *Biochimica Biophysica Acta*, 231 (2), 415–418.
- Yost, W.A. (2000). *Fundamentals of hearing: An introduction*. 4th Edition. Academic Press, San Diego, CA, pp.71-77.

Chapter Five: The Importance of Understanding the Auditory Sensory System of the Florida Manatee, *Trichechus manatus latirostris*: Concluding Remarks

The Florida manatee (*Trichechus manatus latirostris*) is protected by both the Marine Mammal Protection Act (1972) and the Endangered Species Act (1973). It is the only marine mammal known to annually migrate from turbid saltwater habitats to freshwater springs during the winter months and reverse this pattern during the summer months (Reynolds & Wilcox, 1986; Reynolds & Odell, 1991). The manatee is a semi-social species, often grazing or traveling alone, but able to find conspecifics for socialization or reproductive purposes (Reynolds, 1979). Manatee mortality caused specifically by watercraft remains relatively stable ranging between 19-31% of the annual mortalities (Table 1.1) (Florida Fish and Wildlife Research Institute, 2007).

While field research has provided information about the manatee's social structure, habitat usage, and annual migratory behaviors. Sensory biology investigations have indicated that the manatee's auditory system almost certainly plays a principal role in their ability to find one another, determine directionality and avoid danger in their vast habitat. The manatee's hearing range has been found to be quite wide, spanning between 0.2-40 kHz (Bullock et al., 1980, 1982; Popov & Supin, 1990; Gerstein et al., 1999; Mann et al., 2005) and perhaps as high as 60 kHz (Klishen et al., 1990). Previous investigations have shown that manatees have the capacity to localize broadband and tonal stimuli of various durations and levels within a 0.2-20 kHz frequency range from

four locations in the frontal 180° of the azimuth plane (Gerstein, 1999; Colbert 2005). These capabilities indicate that manatees are able to detect and localize, at least from some directions, conspecific vocalizations which typically range between 2.5–5.9 kHz (Nowacek, et al., 2003) and recreational boat engine noise which generally range between 0.01–2 kHz (Gerstein, 2002; Richardson et al., 1995).

Given this information, it could be assumed that the manatee auditory system is constructed and functions similarly to that of typical mammalian species, however, this assumption is inaccurate. The manatee's external and middle ears have been found to be unusually structured. The external auditory meatus is occluded and separated from the tympanic membrane making it an unlikely channel for sound transmission, the tympanoperiotic complex is located intracranially but not ossified to the skull, and the ossicles are massive (Ketten, 1992; Ketten et al., 1992; Chapla et al., 2007).

Although much has been learned about the manatee's auditory system, a plethora of questions remain. The primary objective of this dissertation was to address some of these uncertainties by ascertaining if manatees have the ability to determine sound source directionality within all 360° of the azimuth plane and to identify the possible means by which they do so.

Chapter Two investigated the manatees' abilities to localize test signals that were systematically varied across dimensions of bandwidth, duration and level as they originated from 45° angles within all 360° of the azimuth plane at a distance of 3.05 m. Test signals included a tonal stimulus and three broadband stimuli, one of which spanned a wide range of frequencies, one that was restricted to higher frequencies that had wavelengths shorter than a manatee's interaural time distances, and one that was

restricted to lower frequencies that had wavelengths longer than a manatee's interaural time distances (Table 2.3).

Both subjects performed well above the 12.5% chance level for all of the broadband stimuli, however performance decreased dramatically (14% and 20%) with the 4 kHz tonal stimulus. Both were able to localize the broadband stimuli at a short duration that prohibited head movement and over a large level range and little contralateral confusion occurred. Accuracy decreased with the shorter duration and when signals originated from the posterior locations. Errors were typically located at the speakers neighboring the test speaker but became somewhat more dispersed when they originated from 135° and 180° for Buffett and more widely dispersed when they originated from 180° and 225° for Hugh. Although accuracy was lower when signals came from behind them, the subjects were able to localize from these positions (with the exception of Hugh at 180°) without the aide of visually orienting towards these areas and front to back confusions were minimal.

Results from this study indicate that manatees have good directional hearing capabilities, at least with broadband sounds which are typical in their natural environment, in all azimuth angles relative to their bodies, including those in the frequency range of boats and conspecifics. Their ability to localize may be a function of visual orientation responses when sounds originate in their visual field (Brown, 1994; Heffner, 1997), however it is likely that some type of interaural cue(s) are also interpreted to assist with discriminations from all angles, but particularly from those outside of their visual field.

Chapter Three investigated how different frequencies of a test signal, presented in different locations on the azimuth plane, are filtered by the manatees' head and torso by measuring head/body related transfer functions. Head/body related transfer functions were determined by subtracting the averaged 'animal present' FFTs from the averaged 'animal absent' FFTs and the magnitude of interaural level differences was derived for all frequencies in addition to specific 0.2-1.5, 0.2-5 and 18-30 kHz bands of frequencies.

These are the first head/body related transfer function data collected for any Sirenian species and results demonstrated that interaural level differences (ILD) were present for all frequencies as a function of source location. ILDs were of the greatest magnitude with frequencies in the 18-30 kHz noise band which had wavelengths shorter than the manatee's intercochlear distance, however the 0.2-1.5 kHz noise band, which had wavelengths longer than the manatee's intermeatal distance, produced greater ILDs than the wider 0.2-5 kHz noise band of low frequencies. Test signals originating at 90° and 270° provided the greatest ILD cues however, ILDs were greater when the signal originated behind the subjects than when it originated in front of them.

Results from this study suggest that manatees are able to utilize ILD cues to localize sounds via head and torso filtering effects. The amplified ILD cues produced by their unique body shape when sounds originate from the lateral and posterior angles of the body may compensate for the inability to utilize visual orienting responses when sounds originated from these angles. Although ILDs are typically found with wavelengths shorter than a species' interaural distances, manatees may also have the ability to utilize ILDs with wavelengths longer than their interaural distances.

Chapter Four utilized auditory evoked potential (AEP) techniques to investigate the possible existence of sound conduction pathways that manatees may use as a means to overcome outer ear limitations and benefit from the middle ear's unique structure and geometry. AEPs were collected in-water for positions on the manatee head, and in-air for positions on the head and torso using 15 and 24 kHz carrier tone bursts that were amplitude modulated (AM) with a 600 Hz rate.

Results demonstrated that AEPs were found at every position the transducer was placed on their bodies, regardless of whether they were positioned in water or air. AEP amplitudes were usually greater with the 24 kHz carrier however patterns between carriers at identical body positions were highly variable between subjects. Data from the 24 kHz carrier showed that identical or similar AEP amplitudes were found at six of seven positions that were common between subjects when tested in-water, and four of five positions when tested in-air. Data from the 15 kHz carrier showed that AEP amplitudes were inconsistent for all but one of the common positions when tested in-water, and two subjects (out of the three) had similar amplitudes at four of five common positions, however the third subject had similar amplitudes at only one of nine common positions. Evoked potentials, averaged together from positions along the vertebral column and lateral ribs that were more than 20 cm caudal to the scapula, were greater than those averaged together from positions at and dorsal to the meatus, those averaged from positions along the zygomatic process, and those averaged from positions along the vertebral column and lateral ribs that were cranial to 20 cm behind the scapula.

Results indicate that manatees demonstrate AEPs from all parts of their body and have evolved a means to compensate for their occluded external auditory meatus. The

increased AEP amplitudes found along the vertebral column and lateral ribs which were more than 20 cm caudal to the scapula may suggest that the unique structure of the manatee's plural cavities and ribs may facilitate bone conduction to the inner ear, however the data included in this study should be considered cautiously.

The information gained from the individual experiments presented in Chapters 2, 3, and 4 provide valuable knowledge about how the manatee's ability to localize sounds of different frequencies, durations and intensities in all 360° of the azimuth plane, how interaural intensity cues may facilitate this ability, and how sounds may be received across their entire body and not through only one primary sound conduction pathway. Additional consideration should be given however, to the information that can be learned when the results of all three experiments are taken into account together.

Investigations with many terrestrial species have shown that ILDs provide cues for sound localization, but they are typically only found with frequencies having wavelengths shorter than intermeatal or intercochlear distances (Brown & May, 1990; Brown, 1994; Blauert, 1997). Anatomical investigation of the manatee ear has shown that the tympanoperiotic complex is located intracranially, thereby creating a shorter intercochlear distances than would be found if it were located extracranially as is the case with cetaceans (Ketten et al., 1992; Chapla et al., 2007).

Using the manatee's intercochlear measurement, it appears that only frequencies of 18 kHz or higher would provide useful ILDs. Results from the sound localization study however, demonstrate that manatees are able to localize frequencies well below this range in all azimuth directions. Head/body related transfer measurements show that ILDs can be found for all frequencies as a function of sound source location and suggest that

ILD cues are being used to facilitate this localization ability. Comparisons between ILD magnitudes found from contralateral speaker pairs when noise bands of 18-30 kHz (wavelengths < intercochlear distance), 0.2-5 kHz and 0.2-1.5 kHz (both with wavelengths > intermeatal distance) and the sound localization selection distributions found with the 18-24 kHz and 0.2-1.5 broadband test signals demonstrate how ILDs may facilitate localization (Figures 5.1, 5.2, 5.3 & 5.4). ILD magnitudes were greatest when the test signal originated at 90° and 270° and were smallest when they originated at 0°. These results suggest that ILDs play an important role in sound localization especially when sounds originate from the lateral and posterior half of the manatee's large body.

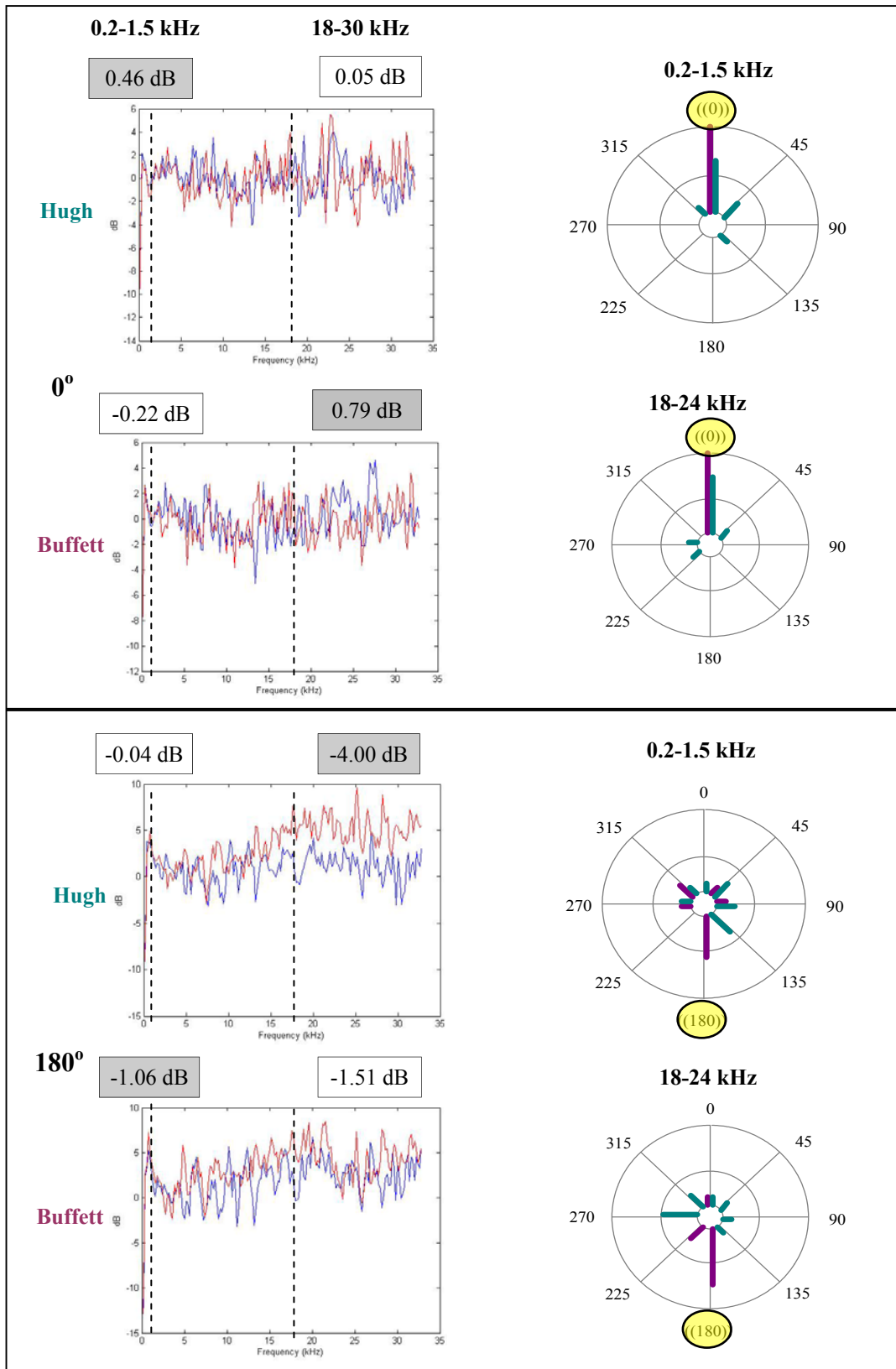

Figure 5.1 Contralateral comparison between ILD magnitudes and sound localization selection distributions at 0° and 180° . ILD differences are shown in 0.2-1.5 kHz, 0.2-5 kHz, and 18-30 kHz noise bands. Sound localization selection distributions are shown for the 0.2-1.5 kHz and 18-24 kHz test signals.

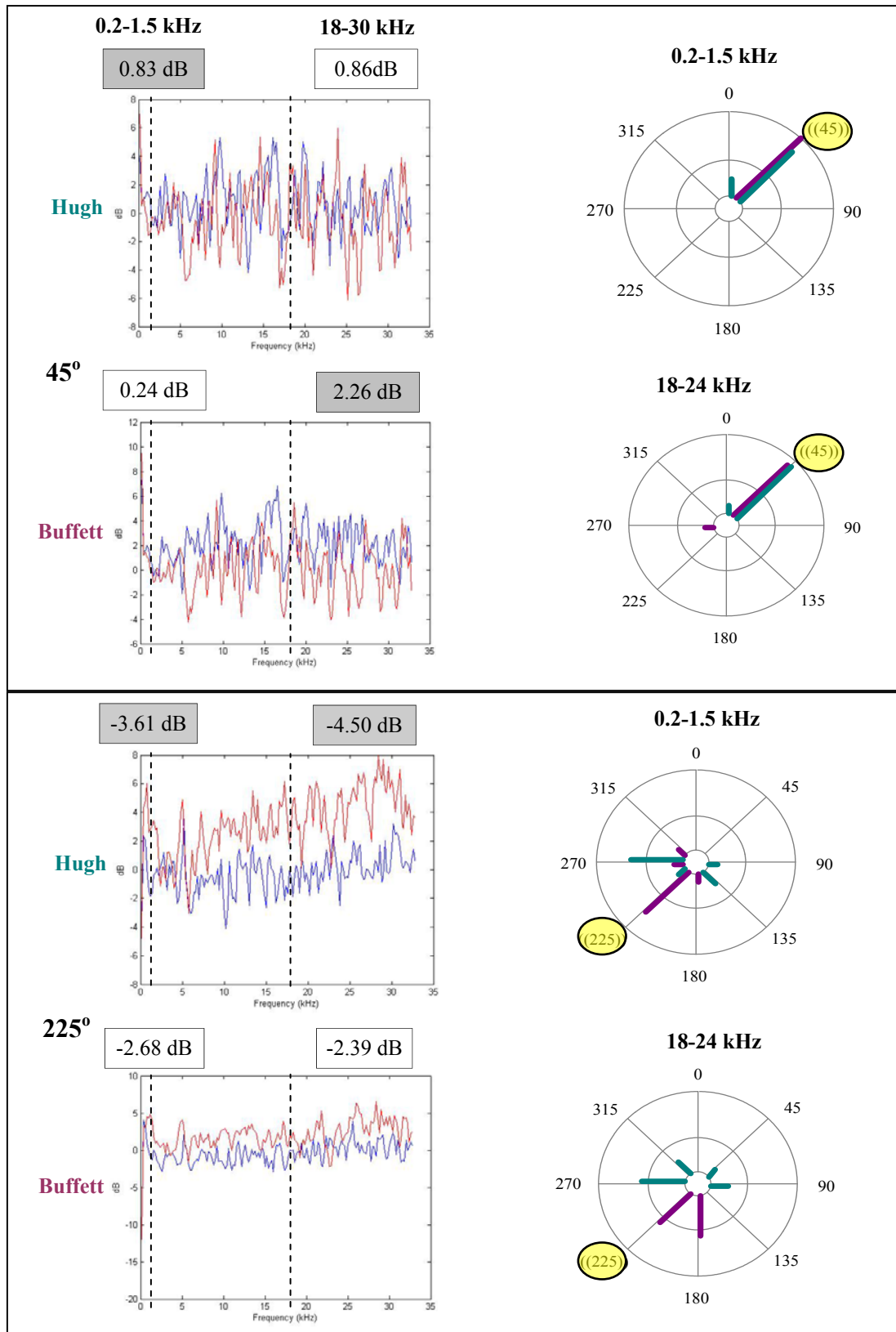

Figure 5.2 Contralateral comparison between ILD magnitudes and sound localization selection distributions at 45° and 225°. ILD differences are shown in 0.2-1.5 kHz, 0.2-5 kHz, and 18-30 kHz noise bands. Sound localization selection distributions are shown for the 0.2-1.5 kHz and 18-24 kHz test signals.

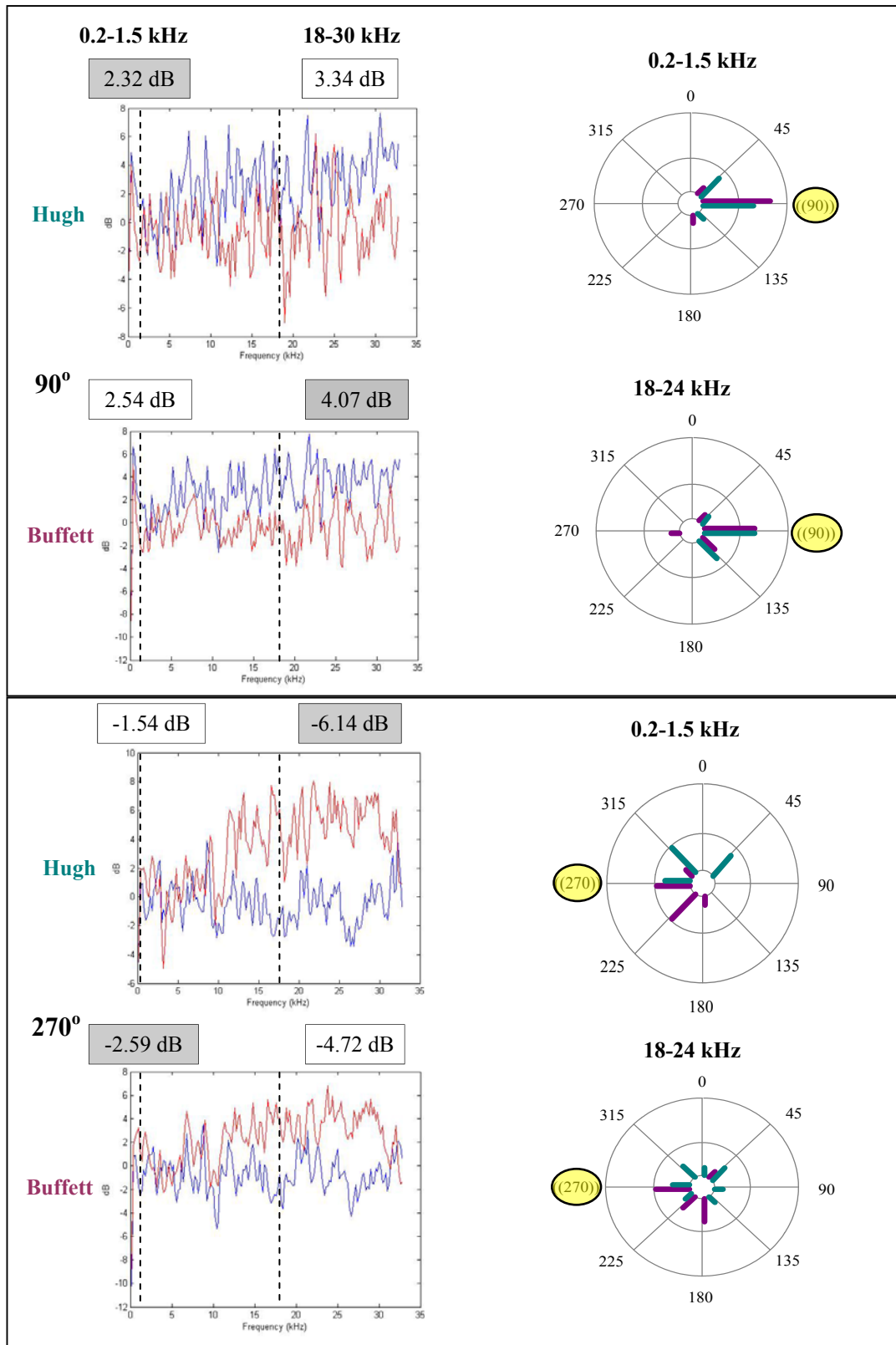

Figure 5.3 Contralateral comparison between ILD magnitudes and sound localization selection distributions at 90° and 270°. ILD differences are shown in 0.2-1.5 kHz, 0.2-5 kHz, and 18-30 kHz noise bands. Sound localization selection distributions are shown for the 0.2-1.5 kHz and 18-24 kHz test signals.

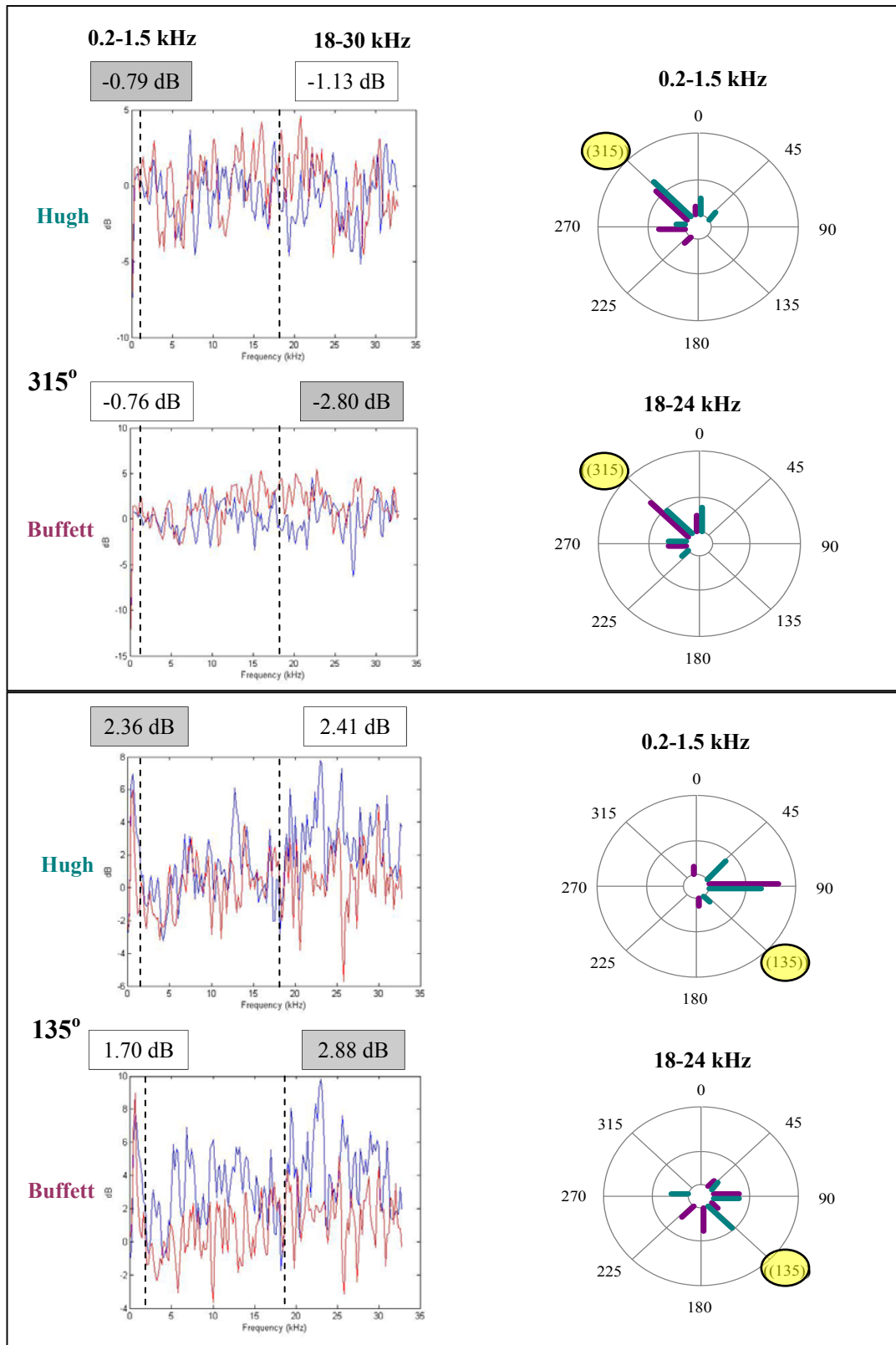

Figure 5.4 Contralateral comparison between ILD magnitudes and sound localization selection distributions at 315° and 135°. ILD differences are shown in 0.2-1.5 kHz, 0.2-5 kHz, and 18-30 kHz noise bands. Sound localization selection distributions are shown for the 0.2-1.5 kHz and 18-24 kHz test signals.

ILD magnitudes were also greatest with the high frequency 18-30 kHz stimuli, however the 0.2-1.5 kHz stimuli had larger magnitudes than the 0.2-5 kHz stimuli (Figure 3.15). These results are surprising given that the wavelengths of these frequencies are longer than the manatee's interaural distances. In humans, an occlusion effect occurs when the external auditory canal is blocked and bone-conducted sound vibrations cannot radiate out of the ear canal (Gelfand, 2004). The sound vibrations are instead reflected back toward the tympanic membrane and have been found to boost sound pressure in the ear canal by 20 dB with frequencies below 500 Hz. Since the manatee's external auditory meatus is occluded, this effect may serve an important role for amplifying ILDs with frequencies longer than their interaural distances.

When considering the anatomical means by which manatees are able to detect and localize sounds, Chapla et al. (2007) have suggested that the large $3.1 \times 10^4 \text{ mm}^3$ airspace which ventrally surrounds each cochlear capsule and the independent hypotympanic recesses may play an important role in both tasks. Investigations have demonstrated that tympanoperiotic complex of cetaceans are isolated and shielded from the dorsal, medial and posterior surfaces of the skull by air-filled sinuses which provide reflective barriers to the passage of sounds between the ears (Dudok van Heel, 1962; Fleischer, 1980; Oelschläger, 1986; Houser et al., 2004). The separation of the tympanoperiotic complexes from each other and the skull likely facilitates sound localization by enhancing interaural level differences resulting from the shadowing effects of the cetacean's head and torso (Houser et al., 2004). Aroyan (1996) found that airspaces within soft tissues, such as those found surrounding the manatee cochlear capsules, act as acoustic energy reflectors. Similar to cetaceans, it may be that the resonance vibrations

found in the airspaces surrounding the manatee's cochlear capsules and the independent hypotympanic recesses serve to isolate the middle ears from one another. This anatomical design may facilitate sound localization by providing the means to interpret ILD cues caused by the shadowing effects of the manatee's head and torso.

The unusual arrangement of the manatee's pleural cavities, which are supported by two independent hemidiaphragms, instead of the typical single mammalian diaphragm may also play an important role in determining the means by which manatees detect and localize sounds. The airspaces of the lungs may also act as acoustic energy reflectors and the resonance vibrations found in these airspaces may be transmitted to the ribs and/or spinal column and to the skull and ear bones (Chapla et al., 2007). Rommel & Reynolds (2000) have further suggested that the separation of the hemidiaphragms may provide additional cues to aid in sound localization.

The results from the investigations included in this manuscript have provided critical information about the manatee's ability to localize sounds and the means by which it may accomplish this to find conspecifics, determine directionality and avoid danger in its vast habitat. This information augments our knowledge of how the manatee's auditory sensory system assimilates information and reacts to environmental stimuli and should be considered when making conservation management decisions about this endangered species. Additional knowledge about the manatee auditory sensory system however, could be gained through future investigations.

Manatee sound localization investigations (Gerstein, 1999; Colbert, 2005; Chapter 2) and head/body related transfer function measurements (Chapter 3) have only investigated within the azimuth plane to date. Controlled boater approaches to free-

ranging manatees demonstrated that subjects typically increased their swim speed and oriented to deeper channel waters as boats approached (Nowacek et al., 2004).

Localization ability assessments and head/body related transfer function measurements obtained in the vertical plane may demonstrate that ILD cues hold equal or more salience to those in the azimuth plane. This information may provide insight into the importance of determining sound source directionality above and below the animals and may partially explain why they increase depth in response to boater approaches.

Auditory evoked potential techniques have been shown to be a valuable tool for assessing possible sound conduction pathways (Chapter 4). Future investigations should incorporate systematic and multiple measurements of identical positions on each subject's body. In addition, the resonance frequencies for the manatee's lungs and air spaces surrounding the cochlear capsules should be measured to determine if these anatomical characteristics facilitate more pronounced sound conduction pathways.

Finally, anatomical investigations of the human inner ear have demonstrated that the tonotopic organization of the cochlea plays an important role in determining the range of hearing (Ruggero & Temchin, 2002). Bandwidth of hearing in the cochlea is determined by the tonotopic frequency map found along the length of the basilar membrane by which higher frequencies stimulate the base stereocilia and lower frequencies stimulate the apex stereocilia. Studies with cetaceans have shown that functional morphometric analyses of basilar membrane measurements and auditory ganglion cell density counts within the cochlea provide a reliable estimate of hearing sensitivity (Wever, et al., 1971; Parks, et al., 2004). Mann et al. (2005) measured the manatee's auditory system temporal resolution through envelope following response

techniques and found they have a temporal resolution of 600 Hz which is approximately half the 1,200 Hz resolution of cetaceans (Dolphin et al., 1995; Supin & Popov, 1995) but over ten times the 50 Hz resolution of humans (Kuwada et al., 1986). Although the manatee's resolution is half that of the dolphins, it is still impressive considering that manatees cannot echolocate which is what the dolphins high temporal resolution is thought to be an adaptation for. The anatomy and physiology of the manatee's inner ear has not been investigated to date, but may provide information about how their auditory ganglion cell density may be correlated to their range of hearing, frequency resolution abilities, and possibly an increased sensitivity to timing accuracy.

References Cited

- Aroyan, J.L. (1996). *Three-dimensional numerical simulation of biosonar signal emission and reception in the common dolphin*. Unpublished Ph.D. Dissertation, University of California, Santa Cruz, CA.
- Blauert, J. (1997). *Spatial Hearing: The Psychophysics of Human Sound Localization*. Massachusetts Institute of Technology Press, Massachusetts.
- Bullock, T.H., Domning, D.P. & Best, R.C. (1980). Evoked potentials demonstrate hearing in a manatee (*Trichechus inunguis*). *Journal of Mammalogy*, 61 (1), 130-133.
- Bullock, T.H., O'Shea, T.J. & McClune, M.C. (1982). Auditory evoked potentials in the West Indian manatee (Sirenia: *Trichechus manatus*). *Journal of Comparative Physiology*, 148, 547-554.
- Brown, C.H. (1994). Sound Localization. In R.R. Fay and A.N. Popper (Eds.) *Comparative Hearing: Mammals*, New York, Springer-Verlag, pp. 57-97.
- Brown, C.H. & May, B.J. (1990). Sound localization and binaural processes. In M.A. Berkley and W.C. Stebbins (Eds.) *Comparative Perception*, Vol I, New York, John Wiley and Sons, pp. 247-284.
- Chapla, M., Nowacek, D., Rommel, S. & Sadler, V. (2007). CT scans and 3D reconstructions of Florida manatee (*Trichechus manatus latirostris*) heads and ear bones. *Hearing Research*, 228, 123-135.
- Colbert, D. (2005). *Sound Localization Abilities of Two Florida Manatees, Trichechus manatus latirostris*. Unpublished Masters Thesis, University of South Florida, Tampa, FL.
- Dolphin W.F., Au, W.W.L., Nachtigall, P.E. & Pawloski, J. (1995). Modulation rate transfer functions to low-frequency carriers in three species of cetaceans. *Journal of Comparative Physiology A*, 177, 235-245.
- Dudok van Heel, W. H. (1962). Sound and cetaceans. *Netherlands Journal of Sea Research*, 1 (4), 407-507.

- Fleischer, G. (1980). Low-frequency receiver of the middle ear in mysticetes and odontocetes. In R.G. Busnel and J.F. Fish (Eds.) *Animal Sonar Systems*, Plenum, New York, pp. 891–893.
- Florida Fish & Wildlife Research Institute (2007). *Annual mortality rates*. http://research.myfwc.com/features/view_article.asp?id=12084
- Gelfand, A.G. (2004). *Hearing: An Introduction to Psychological and Physiological Acoustics*, 4th Edition. Marcel Dekker, New York, pp 98-102.
- Gerstein, E. (1999). *Psychoacoustic Evaluations of the West Indian manatee (Trichechus manatus latirostris)*. Unpublished Doctoral Dissertation, Florida Atlantic University, Boca Raton, FL.
- Gerstein, E., Gerstein, L., Forsythe, S. & Blue, J. (1999). The underwater audiogram of the West Indian manatee (*Trichechus manatus*). *Journal of the Acoustical Society of America*, 105, 3575-3583.
- Gerstein, E.R. (2002). Manatees, bioacoustics and boats. *American Scientist*, 90, 154-163.
- Heffner, R.S. (1997). Comparative study of sound localization and its anatomical correlates in mammals. *Acta Otolaryngologica*, 532, 46-53.
- Houser, D.S., Finneran, J., Carder, D., Van Bonn, W., Smith, C., Hoh, C., Mattrey, R. & Ridgway, S. (2004). Structural and functional imaging of bottlenose dolphin (*Tursiops truncatus*) cranial anatomy. *Journal of Experimental Biology*, 207, 3657–3665.
- Ketten, D.R. (1992). The marine mammal ear: Specializations for aquatic audition and echolocation. In R. Fay, W. Webster & A. Popper (Eds.) *The Biology of Hearing*. Springer-Verlag, pp 717-754.
- Ketten, D.R., Odell, D.K. & Domning, D.P. (1992). Structure, function, and adaptation of the manatee ear. In J.A. Thomas, R.A. Kastelein & A.Y. Supin (Eds.) *Marine Mammal Sensory Systems*. Plenum Press, NY, pp.77-79.
- Klishen, V.O., Diaz, R.P., Popov, V.V. & Supin, A.Y. (1990). Some characteristics of hearing of the Brazilian manatee, *Trichechus inunguis*. *Aquatic Mammals*, 16 (3), 139-144.
- Kuwada, S., Batra, R., Maher, V.L. (1986). Scalp potentials of normal and hearing-impaired subjects in response to sinusoidally amplitude-modulated tones. *Hearing Research*, 21179–192.

- Mann, D., Colbert, D.E., Gaspard, J.C. III, Casper, B., Cook, M.L.H., Reep, R.L. & Bauer, G.B. (2005). Temporal resolution of the Florida manatee (*Trichechus manatus latirostris*) auditory system. *Journal of Comparative Physiology*, 191, 903-908.
- Nowacek, D.P., Casper, B.M., Wells, R.W., Nowacek, S.M. & Mann, D.A. (2003). Intraspecific and geographic variation of West Indian manatee (*Trichechus manatus spp.*) vocalizations. *Journal of the Acoustical Society of America*, 114 (1), 66-69.
- Nowacek, S.M., Wells, R.S., Owen, E.C.G., Speakman, T.R., Flam, R.O. & Nowacek, D.P. (2004). Florida manatees, *Trichechus manatus latirostris*, respond to approaching vessels. *Biological Conservation* 119, 517-523.
- Oelschläger, H.A. (1986). Comparative morphology and evolution of the otic region in toothed whales (Cetacea, Mammalia). *American Journal of Anatomy*, 177, 353-368.
- Parks, S., Ketten, D., O'Malley, J., & Arruda, J. (2004). Hearing in the North Atlantic right whale: Anatomical predictions. *The Journal of the Acoustical Society of America*, 115 (5), 2442.
- Popov, V.V. & Supin, A.Y. (1990). Electrophysiological studies on hearing in some cetaceans and a manatee. In J.A. Thomas & R. A. Kastelein (Eds.), *Sensory Abilities of Cetaceans: Laboratory and Field Evidence*. NY: Plenum Press.
- Richardson, W., Greene, C., Malme, C. & Thompson, D. (1995). *Marine Mammals and Noise*. San Diego, CA: Academic Press.
- Reynolds, J.E. III. (1979). The semisocial manatee. *Natural History*, 88 (2), 44-53.
- Reynolds, J.E. & Odell, D.K. (1991). *Manatees and Dugongs* (192 pp.). NY: Checkmark Books.
- Reynolds, J.E. III, & Wilcox, J.R. (1986). Distribution and abundance of the West Indian manatee, *Trichechus manatus*, around selected Florida power plants following winter cold fronts: 1984-1985. *Biological Conservation*, 38, 103-113.
- Rommel, S. & Reynolds, J.E. III (2000). Diaphragm structure and function in the Florida manatee (*Trichechus manatus latirostris*). *Anatomical Record* 259(1):41-51.
- Ruggero, M.A. and A.N. Temchin. (2002). The roles of the external, middle, and inner ears in determining the bandwidth of hearing. *Proceedings of the National Academy of Sciences*, 99 (20), 13206-13210.
- Supin, A.Y., Popov, V.V. (1995). Envelope-following response and modulation transfer function in the dolphin's auditory system. *Hearing Research*, 92, 38-46.

Wever, E., McCormick, J., Palin, J. & Ridgeway, S. (1971). The cochlea of the dolphin, *Tursiops truncatus*: Haircells and ganglion cells. *Proceedings of the National Academy of Science*, 68 (12), 2908-2912.

Appendices

Appendix A: RPvds language used to generate signals used in the manatee sound localization experiment.

In the manatee sound localization experiment, RPvds language was used to generate signals and record trial information via the button box that interfaced with the computer and signal generation equipment. Specific RPvds language was developed to generate each subject's call to station (Figure A-1), the initiation of each trial (Figure A-2), each subject's secondary bridge reinforcement if correct (Figure A-3) and documentation of incorrect selections (Figure A-4).

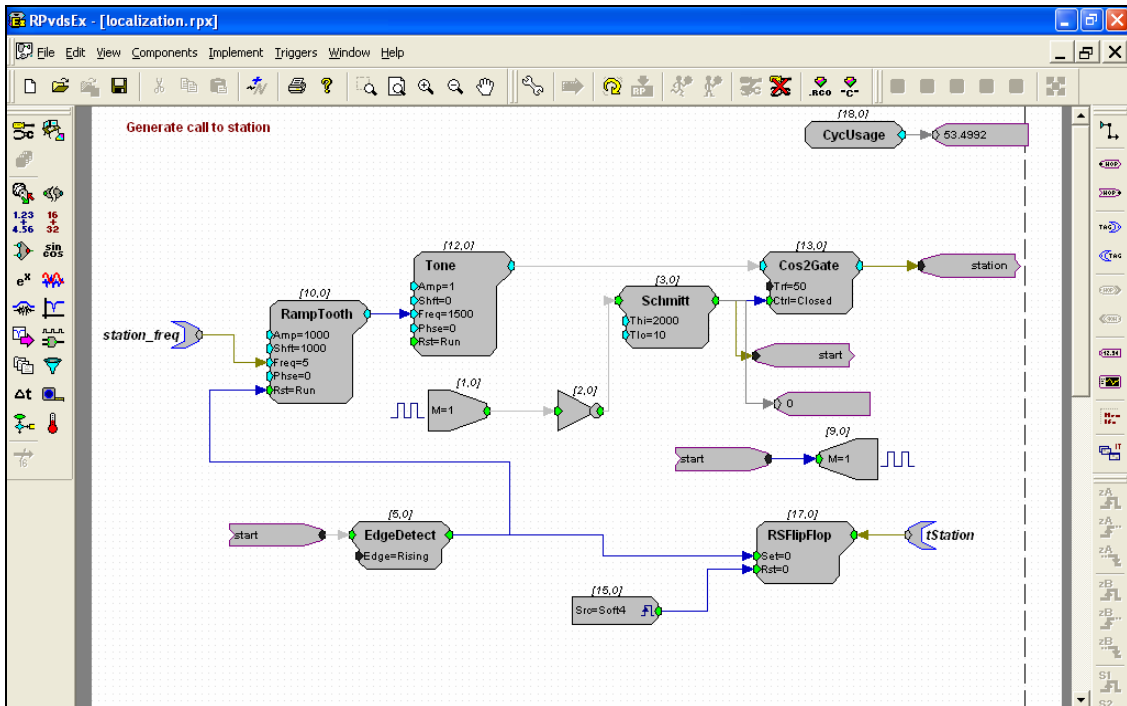

Figure A-1. RPvds language used to generate each subject's call to station.

Appendix A: (Continued)

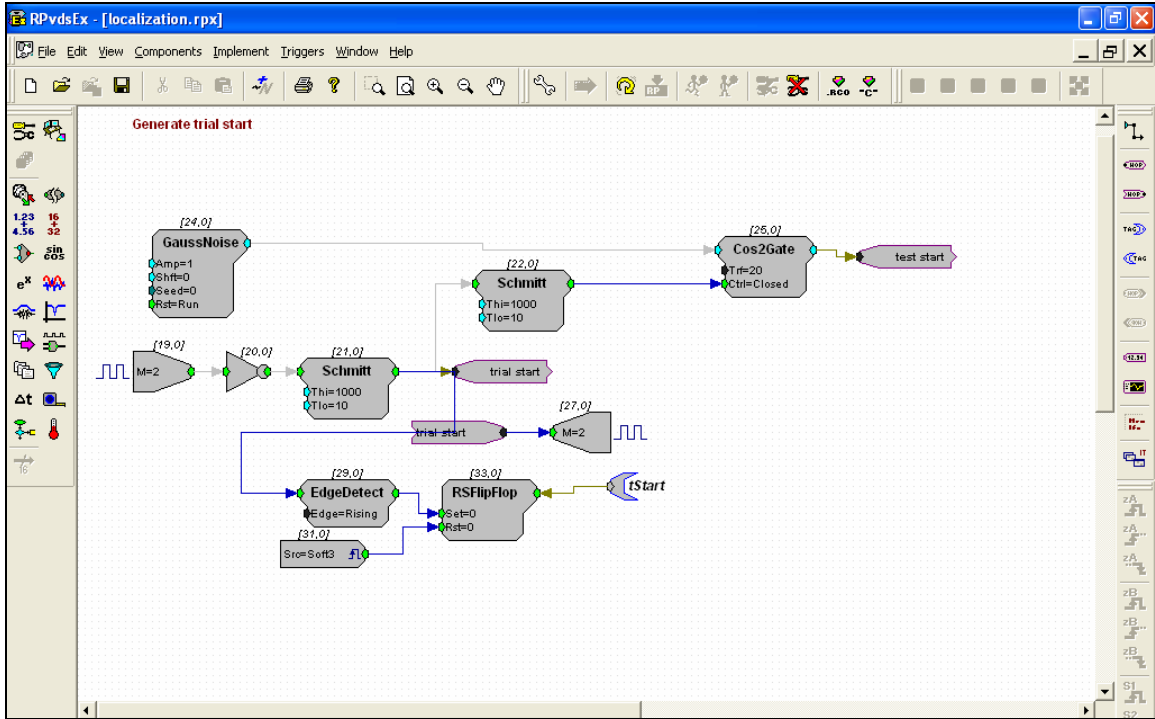

Figure A-2. RPvds language used to generate the initiation of each trial.

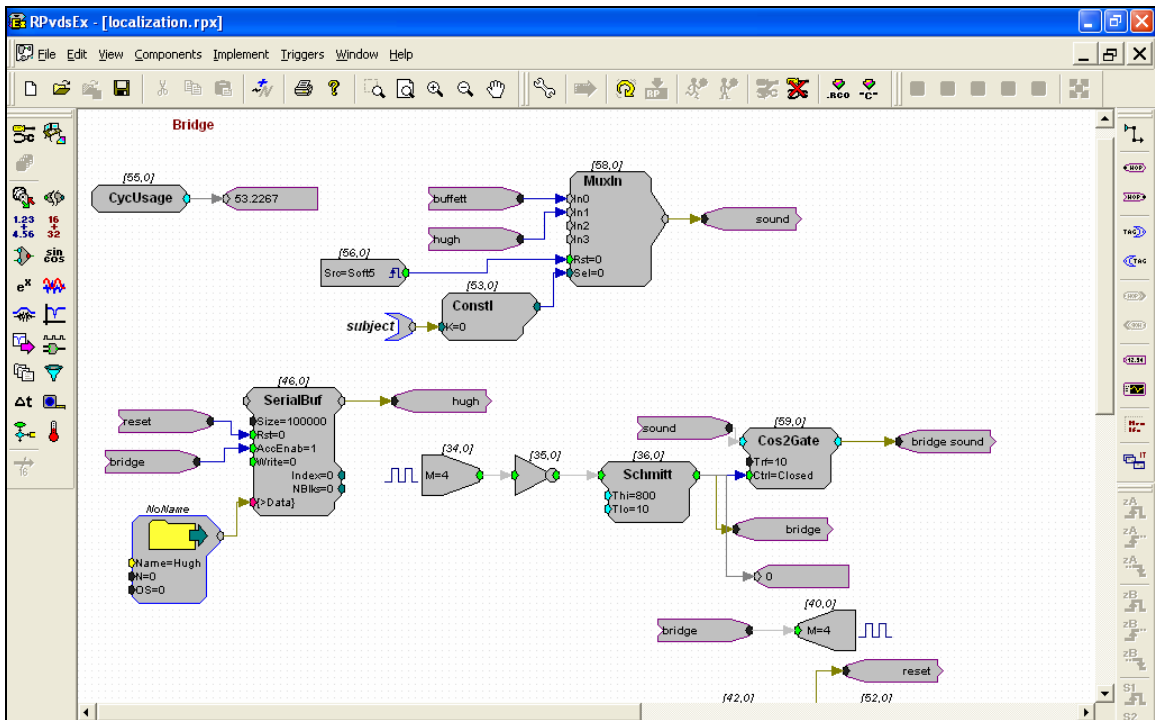

Figure A-3. RPvds language used to generate each subject's secondary bridge when correct.

Appendix A: (Continued)

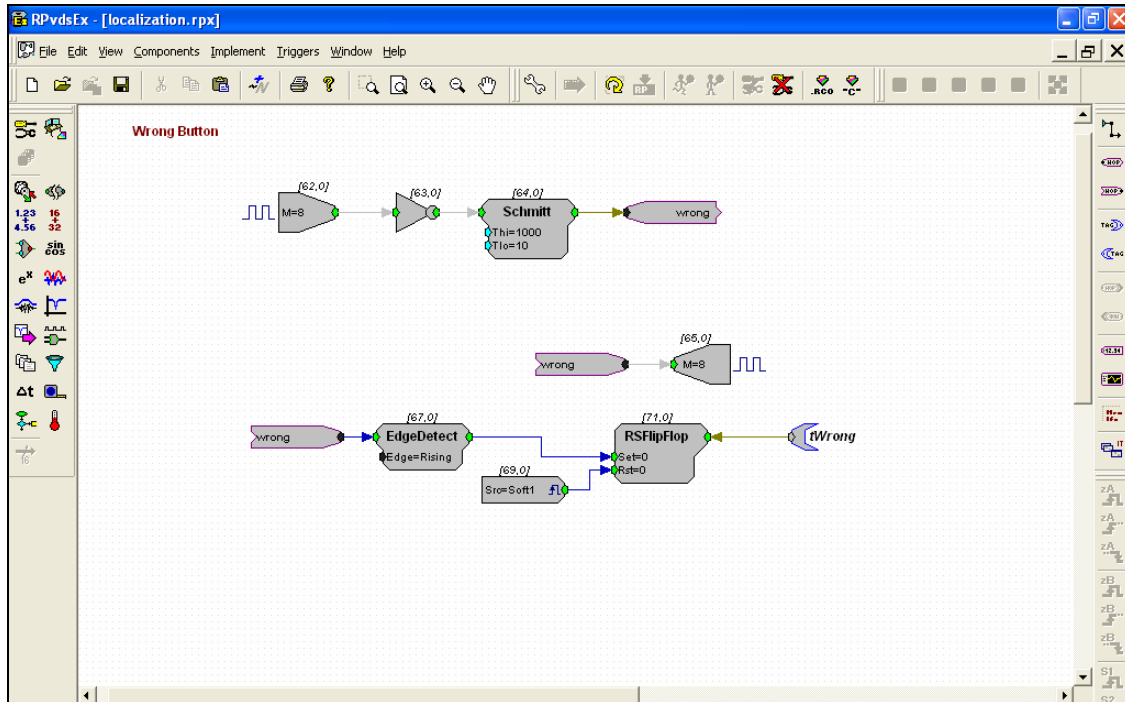

Figure A-4. RPvds language used to document when incorrect selections were made.

Appendix B: Computer protocols used for setting up the manatee sound localization and head/body related transfer function experimental conditions.

A graphical user interface, programmed in Visual C, was designed to run each phase of the experimental conditions (Figure B-1). A drop-down subject menu was designed to distinguish which subject was being tested, and this selection automatically referenced and played that animal's stationing and reinforcement tones throughout the block. A "notes" section allowed any comments to be digitally recorded relative to that block.

The "set-up" section defined how many speaker locations were to be tested, how many trials were to be run from each of those speakers, and how many of the test sounds could be played from the same location in a row. In addition, broad-band noise bursts or tonal signals were defined as were the frequency range to be tested, the sound duration, the dB level and if the sounds were to be automatically digitally recorded. The correct experimental conditions were incorporated for each portion of the session, including the warm-up, testing, and cool-down trials. In all portions of a sound localization and head/body related transfer function session, eight speaker locations and a maximum of two trials in a row per location were held constant.

In the warm-up trials, one trial was set up per speaker for a total of eight trials. The noise button was selected and the frequency range was defined from 24,000-200 Hz. The sound duration was defined as 3 seconds.

In the testing trials, all of the settings for the conditions being tested were defined and the number of trials per speaker was changed from one to two, for a total of sixteen trials. These settings were maintained until five blocks were completed per condition.

Appendix B: (Continued)

In the cool-down trials, one trial was set up per speaker for a total of eight trials. The noise button was selected and the frequency range was defined from 24,000 to 200 Hz. The sound duration was defined as 3 seconds.

In the head/body related transfer function experiment, two trials were set up per speaker for a total of sixteen trials. The noise button was selected and the frequency range was defined from 30,000 to 200 Hz. The sound duration was defined as 3 seconds.

The “speaker” section provided information about which speaker location each test sound was played from. If needed, a manual switching check box was included, which allowed the Data Recorder to select the location of the test sound to be played, rather than the randomized location generated by the program.

The “status” section defined and digitally recorded how many trials had been completed within the block, and of those, how many were correct and how many were wrong. The start button initiated the block of sixteen trials once the subject and conditions were defined, and the stop button was used only if the block had to be ended prior to the completion of the twelve trials.

Appendix B: (Continued)

Buffett Pay attention Kim

Notes

Setup

Speakers 8

Trials Per Speaker 2

Max in Row 2

Attenuation (dB) 0

Speaker 0

Manual Switching

Sound

Noise Tones

Low-Pass Freq (Hz) 24000 (Tone Freq)

High-Pass Freq (Hz) 200

Duration (s) 0.2

Randomize Level (dB) 3

Record Sound

Status

Trials 0

Correct 0

Wrong 0 Amplitude

Start Stop

Figure B-1: The graphical user interface screen (programmed in Visual C) used to setup the experimental conditions and automatically download the results into an Excel file during the testing sessions.

Appendix C: Data recording protocols used to document each sound localization session.

All of the session's general information was documented on a data sheet (Figure C-1). This included the date and the identities of the Test Trainer, Data Recorder and Stationing Trainer. Specific information was documented for all for portions of the session (warm-up, test blocks and cool-down trials) per subject including frequency(ies), duration and level of the stimulus, start and end times of the session and each block, the location of each trials' test sound, if the subject was correct or incorrect and, if incorrect, the location the subject erroneously selected. In the data sheet shown, the 4 kHz tonal probes were randomly distributed on four of the sixteen trials of each block and are denoted by the shaded cells.

Additional information was included for each test block including the video tape number and counter start and stop times, the number of times the test subject left or attempted to leave in that block, the number of times the test subject was interrupted by the other animal, the amount of time the other animal was on task and the test subject's behavioral rating from a scale of one to five, where one indicated that the animal did very poorly and was not able to complete the task and five indicated that he did an excellent job. A comment section was also provided to add additional information if needed.

Appendix C: (Continued)

Sound Localization Task									
Date:									
Hugh					Buffett				
WARM - U P S					WARM - U P S				
<i>Frequency 0.2-24 kHz</i>			<i>Duration - 3000 ms</i>		<i>Frequency 0.2-24 kHz</i>			<i>Duration - 3000 ms</i>	
Trainer:		Speaker	Correct?	Comments	Trainer:		Speaker	Correct?	Comments
# Speakers: 8	1				# Speakers:	1			
Begin Time:	2				Begin Time:	2			
Times Left:	3				Times Left:	3			
Leave Attempts:	4				Leave Attempts:	4			
#Interrupted	5				#Interrupted:	5			
Buf On Task:	6				Hugh On Task:	6			
End Time:	7				End Time:	7			
Rating:	8				Rating:	8			
T E S T I N G					T E S T I N G				
<i>Frequency 4kHz Probes (0.2-24)</i>			<i>Duration -200 ms</i>		<i>Frequency 4kHz Probes (0.2-24)</i>			<i>Duration -200 ms</i>	
Trainer:		Speaker	Correct?	Comments	Trainer:		Speaker		Comments
# Speakers: 8	1	3			# Speakers:	1	3		
Begin Time:	2	5			Begin Time:	2	5		
Tape #:	3	4			Tape #:	3	4		
Tape Start:	4	7			Tape Start:	4	7		
Times Left:	5	2			Times Left:	5	2		
	6	6				6	6		
Leave Attempts:	7	1			Leave Attempts:	7	1		
	8	1				8	1		
#Interrupted:	9	3			#Interrupted:	9	3		
	10	0				10	0		
Buf On Task:	11	2			Hugh On Task:	11	2		
	12	7				12	7		
Tape End:	13	4			Tape End:	13	4		
End Time:	14	5			End Time:	14	5		
Rating:	15	6			Rating:	15	6		
	16	0				16	0		
C O O L - D O W N S					C O O L - D O W N S				
<i>Frequency 0.2-24 kHz</i>			<i>Duration - 3000 ms</i>		<i>Frequency - 0.2-24 kHz</i>			<i>Duration - 3000 ms</i>	
		Speaker	Correct?	Comments			Speaker	Correct?	Comments
Times Left:	1				Times Left:	1			
Leave Attempts:	2				Leave Attempts:	2			
#Interrupted	3				#Interrupted:	3			
Rating:	4				Rating:	4			
= Tonal Probe @ 4 kHz					= Tonal Probe @ 4 kHz				

Figure C-1. The tank-side data-recording sheet used to document each session.

Appendix D: MATLAB program used to determine and chart the manatee head/body related transfer functions.

The data collected for the manatee head/body related transfer function investigation was analyzed and charted via the MatLab program below. Four data analyses were conducted per subject. The first compared FFT ratios received at the left and right hydrophones as a function of sound source location with ‘animal absent’ and ‘animal present’ conditions. The second determined head/body related transfer functions by subtracting the averaged ‘animal present’ FFTs from the averaged ‘animal absent’ FFTs. The third determined the magnitude of interaural level differences for all frequencies. The final analysis determined the magnitude of interaural level differences for specific 0.2-1.5, 0.2-5, and 18-30 kHz bands of frequencies.

MatLab Program:

```
%Code for calculating the FFT's for each fftpts segment of the kept
signals

fftpts=488; %200Hz frequency resolution (srate/150)
cc1=[];
cc2=[];
directoryname = uigetdir;
cd(directoryname);
filenames = dir(directoryname); % allows a directory to pop up to
select all files from animal present trials
for n=3:length(filenames);
    load(filenames(n).name);
    npts=length(channel1chunk);
    x=floor(npts/fftpts);
    cc1=[cc1 channel1chunk(1:x*fftpts)];
    cc2=[cc2 channel2chunk(1:x*fftpts)];
end
%[filename, pathname] = uigetfile({'*.mat'},'File Selector Manatee
Present'); % allows a directory to pop up to select one animal present
file %cd (pathname);
%load (filename);
aa1=[];
aa2=[];
directoryname = uigetdir;
```

Appendix D: (Continued)

```
cd(directoryname);
filenames = dir(directoryname); % allows a directory to pop up to
select all files from animal absent trials

for n=3:length(filenames);
    load(filenames(n).name);
    npts=length(channel1);
    x=floor(npts/fftpts);
    aa1=[aa1 channel1(1:x*fftpts)];
    aa2=[aa2 channel2(1:x*fftpts)];
end
srate=97656.25; %sample rate
binwidth=srate/fftpts;
hpts=fftpts/2;
npts=length(cc1);
w=hann(fftpts)'; % windowing
mALLFFTS1=[];
mALLFFTS2=[];

for n=0:floor(npts/fftpts)-1; %floor rounds down to keep whole
number, ceil rounds up
    startindex=(n*fftpts)+1; %start of each fftpts segment
    endindex=startindex+fftpts-1; %end of each fftpts segment
    SIGNAL1=fft(cc1(startindex:endindex).*w,fftpts); %channel
1(manatee's left ear);Calculates FFT
    SIGNAL1_f=abs(SIGNAL1); % Absolute value, calculates magnitude at
each frequency, gets rid of phase info
    SIGNAL1_s=SIGNAL1_f/hpts; % Scales the results appropriately for y-
axis
    mALLFFTS1=[mALLFFTS1;SIGNAL1_s(1:hpts)];
    SIGNAL2=fft(cc2(startindex:endindex).*w,fftpts);%channel 2
(manatee's right ear);Calculates FFT
    SIGNAL2_f=abs(SIGNAL2);
    SIGNAL2_s=SIGNAL2_f/hpts;
    mALLFFTS2=[mALLFFTS2;SIGNAL2_s(1:hpts)];
end

%Averages FFTs for manatee absent recordings
npts=length(channel1);
npts=length(channel2);
ALLFFTS1=[];
ALLFFTS2=[];

for n=0:floor(npts/fftpts)-1; %floor rounds down to keep whole number,
ceil rounds up
    startindex=(n*fftpts)+1; %start of each fftpts segment
    endindex=startindex+fftpts-1; %end of each fftpts segment
    SIGNAL1=fft(aa1(startindex:endindex).*w,fftpts); %channel
1(manatee's right ear);Calculates FFT
    SIGNAL1_f=abs(SIGNAL1); % Absolute value, calculates magnitude at
each frequency, gets rid of phase info
    SIGNAL1_s=SIGNAL1_f/hpts; % Scales the results appropriately for y-
axis
    ALLFFTS1=[ALLFFTS1;SIGNAL1_s(1:hpts)];
```

Appendix D: (Continued)

```
SIGNAL2=fft(aa2(startindex:endindex).*w,fftpts); %channel 2 (manatee's
right ear);Calculates FFT .*w = windows each point on waveform
    SIGNAL2_f=abs(SIGNAL2);
    SIGNAL2_s=SIGNAL2_f/hpts;
    ALLFFTS2=[ALLFFTS2;SIGNAL2_s(1:hpts)];
end

F=(0:hpts-1)*binwidth; % Creates frequency scale for x axis
MAchannel1=(20*log10(mean(ALLFFTS1))); % Variable for Manatee Absent
Left ear
MPchannel1=(20*log10(mean(mALLFFTS1))); % Variable for Manatee Present
Left ear
MAchannel2=(20*log10(mean(ALLFFTS2))); % Variable for Manatee Absent
Right ear
MPchannel2=(20*log10(mean(mALLFFTS2))); % Variable for Manatee Present
Right ear
Lear=(MAchannel1)-(MPchannel1); % Subtracts Manatee Absent from
Manatee Present in Left ear
Rear=(MAchannel2)-(MPchannel2); % Subtracts Manatee Absent from
Manatee Present in Right ear

HRTFoverlay;
figure(2); % plots frequency averages of left & right ears
hold off;
plot (F(1:165)/1000,Lear(1:165)); %/1000 to plot in kHz
hold on;
plot (F(1:165)/1000,Rear(1:165),'r'); % blue (manatee's left ear), red
(manatee's right ear)
xlabel('Frequency (kHz)')
ylabel('dB');

figure(3) %plots the signal from the right ear subtracted from the
left ear
Dear=Lear-Rear; %diff between ears
plot(F(1:165)/1000,Dear(1:165))
xlabel('Frequency (kHz)')
ylabel('dB');

binHz=200; % 200 Hz bins
startf=floor(200/binHz)+1; % bin corresponding to 200 Hz
endf=floor(1500/binHz)+1;; %Bin corresponding to 1500 Hz; this is what
was used for localization
lowfdiff=mean(Dear(startf:endf))

startf=floor(200/binHz)+1; % bin corresponding to 200 Hz
endf=floor(5000/binHz)+1;; %Bin corresponding to 5000 Hz; this freq has
a wavelength close to intermeatal distance
lowfdiffintermeatal=mean(Dear(startf:endf))

startf=floor(18000/binHz)+1; % bin corresponding to 18000 Hz
endf=floor(30000/binHz)+1;; %Bin corresponding to 30000 Hz
highfdiff=mean(Dear(startf:endf))
```

About the Author

Deborah E. Colbert graduated from New College, the Honors College for the State of Florida, in May 1999 with a Bachelor of Arts degree in Psychology. She was awarded the American Association of University Women's Scholarship and completed an undergraduate thesis entitled "Basic Husbandry Training of Two Florida Manatees (*Trichechus manatus latirostris*)" during her senior year. Her advisors were Dr. Gordon Bauer and Dr. Heidi Harley.

She graduated with a Master of Arts Degree in Psychology, the Cognitive and Neural Science Program, from the University of South Florida in May 2005. Her thesis was titled "Sound Localization Abilities of Two Florida Manatees, *Trichechus manatus latirostris*", and her major advisor was Dr. Sarah Partan.

She has held the Secretary Officer position for the International Marine Animal and Training Association (IMATA) from 2003 through 2006 and is currently Chair of IMATA's Research and Conservation Committee. Debi currently lives with her husband Larry and three daughters, Katie, Alyssa and Lauren in Myakka City, Florida.