

2008

Freeway exit ramp traffic flow research based on computer simulation

Xu Wang

University of South Florida

Follow this and additional works at: <http://scholarcommons.usf.edu/etd>



Part of the [American Studies Commons](#)

Scholar Commons Citation

Wang, Xu, "Freeway exit ramp traffic flow research based on computer simulation" (2008). *Graduate Theses and Dissertations*.
<http://scholarcommons.usf.edu/etd/554>

This Dissertation is brought to you for free and open access by the Graduate School at Scholar Commons. It has been accepted for inclusion in Graduate Theses and Dissertations by an authorized administrator of Scholar Commons. For more information, please contact scholarcommons@usf.edu.

Freeway Exit Ramp Traffic Flow Research

Based on Computer Simulation

by

Xu Wang

A Dissertation submitted in partial fulfillment
of the requirements for the degree of
Doctor of Philosophy
Department of Civil and Environmental Engineering
College of Engineering
University of South Florida

Major Professor: Jian John Lu, Ph.D.
Manjriker Gunaratne, Ph.D.
Huaguo Zhou, Ph.D.
George Yanev, Ph.D.
Pan Liu, Ph.D.

Date of Approval:
December 7, 2007

Keywords: Speed, Lane change, Corsim, ANOVA, Tukey

© Copyright 2008, Xu Wang

Acknowledgements

This dissertation was made possible by the help of many people. Firstly, I would like to thank my main advisor Dr. Jian John Lu for his dedicated help, advice, inspiration, encouragement and criticism throughout my study.

I also express my appreciation to the members of my committee, Dr. Manjriker Gunartne, Huaguo Zhou, George Yanev and Pan Liu. Without their knowledge and assistance this study would not have been successful.

I further express my appreciation to my fellow researchers at the transportation research lab for their help and assistance. Zhenyu Wang, Hongyun Chen, Bin Cao, Tao Pan, and Xiaodong Wang. Special thanks to Linjun Lu for his enlighten discussions and suggestions.

Finally, I would thank my family for their encouragement and support during my time of study. My wife sacrificed too much for my career and success.

Table of Contents

List of Tables	v
List of Figures	xi
Abstract	xv
Chapter 1 Introduction	1
1.1. Background	1
1.2. Problem Statement	3
1.3. Research Objectives and Expected Results	4
1.4. Significance of This Research	5
1.5. Methodology	5
1.6. Organization of This Paper	6
Chapter 2 Literature Review	8
2.1. General	8
2.2. Design Standards	8
2.2.1. One-Lane Taper Type Exit	8
2.2.2. One-Lane Parallel Type Exit	9
2.2.3. Two-Lane Exits	10
2.3. Operation and Safety	11
2.4. Simulation	14
2.5. Other Issues	23
2.6. Summary	26
Chapter 3 Factors Affect Ramp Design	28
3.1. Introduction	28
3.2. Influencing Factors at Ramp Designs	28
3.3. Limitation of Factors in Traffic Simulation	30
3.4. Internal Factors in CORSIM	31
3.5. Sensitivity Study of Internet Factors	32
3.6. External Factors in CORSIM	34
3.7. Selection of Factors for Analysis	35
3.7.1. Number of Lanes of Mainline	37
3.7.2. Number of Lanes of Exit Ramp	37
3.7.3. Free Flow Speed	38
3.7.4. Freeway Grade	38
3.7.5. Truck Percentage	39
3.7.6. Restriction to Lane Usage of Truck	40
3.7.7. Location of Exit Sign	40

3.8. Summary	41
Chapter 4 Data Collection.....	43
4.1. Introduction.....	43
4.2. Input File Production	43
4.3. Affecting Factors in Input Files	44
4.4. Freeway Exit Ramp Configuration	46
4.5. Entry Volume for CORSIM Simulation	48
4.6. Number of Simulation Runs	49
4.7. Data Collection	51
4.8. ANOVA & Tukey.....	52
4.8.1. Assumptions.....	52
4.8.2. Hypotheses.....	53
4.8.3. Grand Mean	53
4.8.4. Total Variation	53
4.8.5. Between Group Variations.....	54
4.8.6. Within Group Variations.....	54
4.8.7. F Test Statistic.....	55
4.8.8. Summary Table.....	55
4.8.9. Tukey Test	56
4.9. Summary	56
Chapter 5 Capacity Comparisons.....	58
5.1. Introduction.....	58
5.2. Mean Discharging Volume Comparisons.....	59
5.2.1. Before Functional Area at Low Entry Volume.....	59
5.2.2. Within Functional Area at Low Entry Volume	60
5.2.3. After Functional Area at Low Entry Volume	62
5.2.4. Before Functional Area at Medium Entry Volume	63
5.2.5. Within Functional Area at Medium Entry Volume	64
5.2.6. After Functional Area at Medium Entry Volume.....	66
5.2.7. Before Functional Area at High Entry Volume.....	67
5.2.8. Within Functional Area at High Entry Volume.....	69
5.2.9. After Functional Area at High Entry Volume	70
5.3. Summary	71
Chapter 6 Traffic Speed Comparisons.....	74
6.1. Introduction.....	74
6.2. Mean Speed Comparisons.....	75
6.2.1. Before Functional Area at Low Entry Volume	75
6.2.2. Within Functional Area at Low Entry Volume.....	76
6.2.3. After Functional Area at Low Entry Volume.....	77
6.2.4. Before Functional Area at Medium Entry Volume	78
6.2.5. Within Functional Area at Medium Entry Volume.....	79
6.2.6. After Functional Area at Medium Entry Volume	81
6.2.7. Before Functional Area at High Entry Volume.....	82

6.2.8. Within Functional Area at High Entry Volume	84
6.2.9. After Functional Area at High Entry Volume	85
6.3. Summary	87
Chapter 7 Lane Change Comparisons.....	89
7.1. Introduction.....	89
7.2. Total Lane Change Number Comparisons.....	90
7.2.1. Before Functional Area at Low Entry Volume	90
7.2.2. Within Functional Area at Low Entry Volume.....	91
7.2.3. After Functional Area at Low Entry Volume	93
7.2.4. Before Functional Area at Medium Entry Volume.....	94
7.2.5. Within Functional Area at Medium Entry Volume.....	95
7.2.6. After Functional Area at Medium Entry Volume	97
7.2.7. Before Functional Area at High Entry Volume	98
7.2.8. Within Functional Area at High Entry Volume	99
7.2.9. After Functional Area at High Entry Volume.....	101
7.3. Summary	102
Chapter 8 Sensitivity Analysis.....	105
8.1. Entry Volume.....	106
8.1.1. Entry Volume Sensitivity before Functional Area.....	106
8.1.2. Entry Volume Sensitivity within Functional Area.....	108
8.1.3. Entry Volume Sensitivity after Functional Area.....	109
8.1.4. Entry Volume Sensitivity Sum up.....	110
8.2. Free Flow Speed	111
8.2.1. Free Flow Speed Sensitivity before Functional Area	111
8.2.2. Free Flow Speed Sensitivity within Functional Area	112
8.2.3. Free Flow Speed Sensitivity after Functional Area	114
8.2.4. Free Flow Speed Sensitivity Sum up	115
8.3. Freeway Grade.....	116
8.3.1. Freeway Grade Sensitivity before Functional Area.....	116
8.3.2. Freeway Grade Sensitivity within Functional Area.....	117
8.3.3. Freeway Grade Sensitivity after Functional Area.....	119
8.3.4. Freeway Grade Sensitivity Sum up.....	121
8.4. Truck Percentage	121
8.4.1. Freeway Truck Percentage Sensitivity before Functional Area	121
8.4.2. Freeway Truck Percentage Sensitivity within Functional Area	122
8.4.3. Freeway Truck Percentage Sensitivity after Functional Area	124
8.4.4. Freeway Truck Percentage Sensitivity Sum up	125
8.5. Restrictions to Truck.....	125
8.5.1. Restrictions to Truck sensitivity before Functional area	126
8.5.2. Restrictions to Truck Sensitivity within Functional Area.....	127
8.5.3. Restrictions to Truck Sensitivity after Functional Area	128
8.5.4. Restrictions to Truck Sensitivity Sum up	130
8.6. Location of Exit Sign.....	130

8.6.1. Location of Exit Sign Sensitivity before Functional Area.....	130
8.6.2. Location of Exit Sign Sensitivity within Functional Area.....	132
8.6.3. Location of Exit Sign Sensitivity after Functional Area	133
8.6.4. Location of Exit Sign Sensitivity Sum up	135
Chapter 9 Summary, Conclusions and Recommendations	141
9.1. Summary	141
9.2. Conclusions.....	143
9.2.1. Volume Discharge Rate	143
9.2.2. Operational Speed	144
9.2.3. Total Lane Change Number	144
9.2.4. Sensitivity Analysis.....	145
9.3. Recommendations	146
9.3.1. Simulation Software.....	147
9.3.2. Exit Ramp	147
References.....	149
About the Author.....	End Page

List of Tables

Table 1 Recommended Parameter Values.....	31
Table 2 CORSIM Capacity and HCS Capacity.....	33
Table 3 Auxiliary Lane Length at Different FFS	36
Table 4 Selected Factors for CORSIM Simulation	41
Table 5 Record Type of Selected Variables	45
Table 6 Notations of Files' Name in the Research.....	46
Table 7 Three Scenarios for Exit Ramp Comparison.....	49
Table 8 One Way ANOVA	55
Table 9 Auxiliary Lane Length of Exit Ramps	59
Table 10 Mean Discharging Volume at LEV before FA	60
Table 11 ANOVA Results of Mean Discharging Volume at LEV before FA.....	60
Table 12 Mean Discharging Volume at LEV within FA	61
Table 13 ANOVA Results of Mean Discharging Volume at LEV within FA.....	61
Table 14 Tukey Results of Mean Discharging Volume at LEV within FA	61
Table 15 Mean Discharging Volume at LEV after FA	62
Table 16 ANOVA Results of Mean Volume at LEV after FA	63
Table 17 Mean Discharging Volume at MEV before FA	63
Table 18 ANOVA Results of Mean Discharging Volume at MEV before FA.....	64
Table 19 Mean Volume at MEV within FA.....	64
Table 20 ANOVA Results of Mean Volume at MEV within FA	65
Table 21 Tukey Results of Mean Volume at MEV within FA	65
Table 22 Mean Discharging Volume at MEV after FA	66
Table 23 ANOVA Results of Mean Discharging Volume at MEV after FA.....	66
Table 24 Mean Volume at HEV before FA	67

Table 25 ANOVA Results of Mean Volume at HEV before FA	68
Table 26 Tukey Results of Mean Volume at HEV before FA	68
Table 27 Mean Discharging Volume at HEV within FA	69
Table 28 ANOVA Results of Mean Discharging Volume at HEV within FA	69
Table 29 Tukey Results of Mean Discharging Volume at HEV within FA.....	69
Table 30 Mean Volume at HEV after FA	70
Table 31 ANOVA Results of Mean Volume at HEV after FA.....	71
Table 32 ANOVA Findings for Discharging Volume	71
Table 33 Tukey Findings for Discharging Volume.....	72
Table 34 Mean Speed at LEV before FA	75
Table 35 ANOVA Results of Mean Speed at LEV before FA	76
Table 36 Mean Speed within Functional Area at LEV within FA	76
Table 37 ANOVA Results of Mean Speed at LEV within FA	76
Table 38 Mean Speed at LEV after FA.....	77
Table 39 ANOVA Results of Mean Speed at LEV after FA	78
Table 40 Mean Speed at MEV before FA	78
Table 41 ANOVA Results of Mean Speed at MEV before FA	79
Table 42 Mean Speed at MEV within FA	80
Table 43 ANOVA Results of Mean Entry Volume at MEV within FA	80
Table 44 Tukey Results of Mean Speed at MEV within FA.....	80
Table 45 Mean Speed at MEV after FA.....	81
Table 46 ANOVA Results of Mean Speed at MEV after FA	81
Table 47 Mean Speed at HEV before FA.....	82
Table 48 ANOVA Results of Mean Speed at HEV before FA	82
Table 49 Tukey Results of Mean Speed at HEV before FA	82
Table 50 Mean Speed at HEV within FA.....	84
Table 51 ANOVA Results of Mean Speed at HEV within FA.....	84
Table 52 Tukey Results of Mean Speed at HEV within FA	84
Table 53 Mean Speed at HEV after FA	86

Table 54 ANOVA Results of Mean Speed at HEV after FA	86
Table 55 Tukey Results of Mean Speed at HEV after FA	86
Table 56 ANOVA Findings for Speed	87
Table 57 Tukey Findings for Speed	87
Table 58 Mean Lane Change Number at LEV before FA.....	90
Table 59 ANOVA Results of Lane Change Number at LEV before FA	91
Table 60 Mean Lane Change Number at LEV within FA	92
Table 61 ANOVA Results of Lane Change Number at LEV within FA	92
Table 62 Tukey Results of Lane Change Number at LEV within FA	92
Table 63 Mean Lane Change Number at LEV after FA	93
Table 64 ANOVA Results of Lane Change Number at LEV after FA.....	93
Table 65 Tukey Results of Lane Change Number at LEV after FA	93
Table 66 Mean Lane Change Number at MEV before FA	95
Table 67 ANOVA Results of Lane Change Number at MEV before FA.....	95
Table 68 Mean Lane Change Number at MEV within FA	95
Table 69 ANOVA Results of Lane Change Number at MEV within FA.....	96
Table 70 Tukey Results of Lane Change Number at MEV within FA	96
Table 71 Mean Lane Change Number at MEV after FA	97
Table 72 ANOVA Results of Mean Lane Change Number at MEV after FA.....	97
Table 73 Mean Lane Change Number at HEV before FA	98
Table 74 ANOVA Results of Mean Lane Change Number at HEV before FA	98
Table 75 Tukey Results of Lane Change Number at HEV before FA.....	98
Table 76 Mean Lane Change Number at HEV within FA	99
Table 77 ANOVA Results of Lane Change Number at HEV within FA.....	100
Table 78 Tukey Results of Lane Change Number at HEV within FA.....	100
Table 79 Mean Lane Change Number at HEV after FA	101
Table 80 ANOVA Results of Mean Lane Change Number at HEV after FA	101
Table 81 Tukey Results of Mean Lane Change Number at HEV after FA.....	101
Table 82 ANOVA Findings for Lane Change Number	104

Table 83 Tukey Findings for Lane Change Number.....	104
Table 84 Entry Volume Sensitivity on Running Speed before FA.....	106
Table 85 Entry Volume Sensitivity on Total Lane Change Number before FA.....	106
Table 86 Entry Volume Sensitivity on Running Speed within FA.....	108
Table 87 Entry Volume Sensitivity on Total Lane Change Number within FA.....	108
Table 88 Entry Volume Sensitivity on Running Speed after FA.....	109
Table 89 Entry Volume Sensitivity on Total Lane Change Number after FA.....	109
Table 90 Free Flow Speed Sensitivity on Link Volume before FA.....	111
Table 91 Free Flow Speed Sensitivity on Total Lane Change Number before FA.....	111
Table 92 Tukey Results of Free Flow Speed on Total Lane Change Number before FA	111
Table 93 Free Flow Speed Sensitivity on Link Volume within FA.....	112
Table 94 Free Flow Speed Sensitivity on Lane Change Number within FA.....	113
Table 95 Free Flow Speed Sensitivity Tukey Analysis.....	113
Table 96 Free Flow Speed Sensitivity on Link Volume after FA.....	114
Table 97 Free Flow Speed Sensitivity on Lane Change Number after FA.....	114
Table 98 Tukey Results of Free Flow Speed on Lane Change Number after FA.....	114
Table 99 Freeway Grade Sensitivity on Running Speed before FA.....	116
Table 100 Tukey Results on Grade Sensitivity on Running Speed before FA.....	116
Table 101 Freeway Grade Sensitivity on Lane Change Number before FA.....	116
Table 102 Tukey Results of Grade on Lane Change Number before FA.....	116
Table 103 Freeway Grade Sensitivity on Running Speed within FA.....	118
Table 104 Tukey Results of Grade Sensitivity on Running Speed within FA.....	118
Table 105 Freeway Grade Sensitivity on Lane Change Number within FA.....	118
Table 106 Tukey Results of Grade on Lane Change Number within FA.....	118
Table 107 Freeway Grade Sensitivity on Running Speed after FA.....	119
Table 108 Tukey Results of Grade Sensitivity on Running Speed after FA.....	119
Table 109 Freeway Grade Sensitivity on Lane Change Number after FA.....	120
Table 110 Tukey Results of Grade Sensitivity on Lane Change Number after FA.....	120

Table 111 Truck Percentage Sensitivity on Running Speed before FA	121
Table 112 Truck Percentage Sensitivity on Lane Change Number before FA	121
Table 113 Tukey Results of Truck Percentage on Lane Change Number before FA	122
Table 114 Truck Percentage Sensitivity on Running Speed within FA	123
Table 115 Truck Percentage Sensitivity on Lane Change Number within FA	123
Table 116 Tukey Results of Truck Percentage on Lane Change Number within FA	123
Table 117 Truck Percentage Sensitivity on Running Speed after FA	124
Table 118 Truck Percentage on Lane Change Number after FA	124
Table 119 Tukey Results of Truck Percentage on Lane Change Number after FA	124
Table 120 Restrictions to Truck Sensitivity on Running Speed before FA	126
Table 121 Restrictions to Truck Sensitivity on Lane Change Number before FA	127
Table 122 Restrictions to Truck Sensitivity on Running Speed within FA	127
Table 123 Restrictions to Truck Sensitivity on Lane Change Number within FA	127
Table 124 Restrictions to Truck Sensitivity on Running Speed after FA	129
Table 125 Restrictions to Truck Sensitivity on Lane Change Number after FA	129
Table 126 Location of Exit Sign Sensitivity on Running Speed before FA	131
Table 127 Location of Exit Sign Sensitivity on Lane Change Number before FA	131
Table 128 Location of Exit Sign Sensitivity on Running Speed within FA	132
Table 129 Location of Exit Sign Sensitivity on Lane Change Number within FA	132
Table 130 Location of Exit Sign Sensitivity on Running Speed after FA	133
Table 131 Location of Exit Sign Sensitivity on Lane Change Number after FA	134
Table 132 LRM for Speed of Tapered One-Lane Exit before FA	136
Table 133 ANOVA of Speed Modeling of Tapered One-Lane Exit before FA	136
Table 134 Coefficients of Speed Modeling of Tapered One-Lane Exit before FA	136
Table 135 LRM for Lane Change Number before FA	137
Table 136 ANOVA of Lane Change Number Modeling Number before FA	137
Table 137 Coefficients of Lane Change Number Modeling before FA	137
Table 138 LRM for Speed within FA	137
Table 139 ANOVA of Running Speed Modeling within FA	137

Table 140 Coefficients of Speed Modeling within FA	138
Table 141 LRM for Lane Change Number within FA	138
Table 142 ANOVA of Lane Change Number Modeling within FA	138
Table 143 Coefficients of Lane Change Number Modeling within FA	138
Table 144 LRM for Speed after FA	139
Table 145 ANOVA of Speed Modeling after FA	139
Table 146 Coefficients of Speed Modeling after FA	139
Table 147 LRM for Lane Change Number after FA	140
Table 148 ANOVA of Lane Change Number Modeling after FA	140
Table 149 Coefficients of Lane Change Number Modeling after FA	140

List of Figures

Figure 1 Taper Type One-Lane Exit Terminal	9
Figure 2 Parallel Type One-Lane Exit Terminal.....	10
Figure 3 Taper Type Two-Lane Exit Terminal.....	10
Figure 4 Parallel Type Two-Lane Exit Terminal.....	11
Figure 5 The Effect of Access Controlled Frontage on Volume	13
Figure 6 Non-Free-Flow Loop and Free-Flow Loop	14
Figure 7 Auxiliary Lanes Terminated with One Lane Exit Ramp	14
Figure 8 Auxiliary Lanes Terminated with Two Lane Exit Ramp	15
Figure 9 Auxiliary Lanes Terminated with Downstream Taper	15
Figure 10 Analysis of Ramp Weaving Section.....	16
Figure 11 A Constraint Operation of a Ramp Weaving Section.....	17
Figure 12 A Multiple Weaving Area with Flow Distribution.....	17
Figure 13 Analysis of a Major Weaving Area	18
Figure 14 Black down Arrow.....	24
Figure 15 Black Right down Arrow.....	24
Figure 16 Black Right up Arrow.....	25
Figure 17 Ideal Paths of Motorists before Exit Ramp.....	25
Figure 18 Unnecessary Lane Changes before Exit Ramp.....	26
Figure 19 Truck Percentage Distributions	39
Figure 20 Tapered One-Lane Exit Ramp	47
Figure 21 Tapered Two-Lane Exit Ramp	47
Figure 22 Parallel One-Lane Exit Ramp	48
Figure 23 Parallel Two-Lane Exit Ramp	48
Figure 24 Mean Volume Comparisons at LEV before FA	60

Figure 25 Mean Volume Comparisons at LEV within FA	61
Figure 26 Mean Volume Comparisons at LEV after FA	63
Figure 27 Mean Volume Comparisons at MEV before FA	64
Figure 28 Mean Volume Comparisons at MEV within FA	66
Figure 29 Mean Volume Comparisons at MEV after FA	67
Figure 30 Mean Volume Comparisons at HEV before FA	68
Figure 31 Mean Volume Comparisons at HEV within FA	70
Figure 32 Mean Volume Comparisons at HEV after FA	71
Figure 33 Mean Speed Comparisons at LEV before FA	76
Figure 34 Mean Speed Comparisons at LEV within FA	77
Figure 35 Mean Speed Comparisons at LEV after FA	78
Figure 36 Mean Speed Comparisons at MEV before FA	79
Figure 37 Mean Speed Comparisons at MEV within FA	80
Figure 38 Mean Speed Comparisons at MEV after FA	81
Figure 39 Mean Speed Comparisons at HEV before FA	83
Figure 40 Mean Speed Comparisons at HEV within FA	85
Figure 41 Mean Speed Comparisons at HEV after FA	86
Figure 42 Mean Lane Change Comparisons at LEV before FA	91
Figure 43 Mean Lane Change Comparisons at LEV within FA	93
Figure 44 Mean Lane Change Comparisons at LEV after FA	94
Figure 45 Mean Lane Change Comparisons at MEV before FA	95
Figure 46 Mean Lane Change Comparison at MEV within FA	96
Figure 47 Mean Lane Change Comparisons at MEV after FA	97
Figure 48 Mean Lane Change Comparisons at HEV before FA	99
Figure 49 Lane Change Comparisons at HEV within FA	100
Figure 50 Mean Lane Change Comparisons at HEV after FA	102
Figure 51 Entry Volume Sensitivity on Running Speed before FA	107
Figure 52 Entry Volume Sensitivity on Total Lane Change Number before FA	107
Figure 53 Entry Volume Sensitivity on Running Speed within FA	108

Figure 54	Entry Volume Sensitivity on Total Lane Change Number within FA	109
Figure 55	Entry Volume Sensitivity on Running Speed after FA	110
Figure 56	Entry Volume Sensitivity on Total Lane Change Number after FA	110
Figure 57	Free Flow Speed Sensitivity on Link Volume before FA	112
Figure 58	Free Flow Speed Sensitivity on Total Lane Change Number before FA	112
Figure 59	Free Flow Speed Sensitivity on Link Volume within FA	113
Figure 60	Free Flow Speed Sensitivity on Lane Change Number within FA	113
Figure 61	Free Flow Speed Sensitivity on Link Volume after FA	115
Figure 62	Free Flow Speed Sensitivity on Lane Change Number after FA	115
Figure 63	Freeway Grade Sensitivity on Running Speed before FA	117
Figure 64	Freeway Grade Sensitivity on Lane Change Number before FA	117
Figure 65	Freeway Grade Sensitivity on Running Speed within FA	118
Figure 66	Freeway Grade Sensitivity on Lane Change Number within FA	119
Figure 67	Freeway Grade Sensitivity on Speed after FA	120
Figure 68	Freeway Grade Sensitivity on Lane Change Number after FA	120
Figure 69	Truck Percentage Sensitivity on Running Speed before FA	122
Figure 70	Truck Percentage Sensitivity on Lane Change Number before FA	122
Figure 71	Truck Percentage Sensitivity on Running Speed within FA	123
Figure 72	Truck Percentage Sensitivity on Lane Change Number within FA	124
Figure 73	Truck Percentage Sensitivity on Speed after FA	125
Figure 74	Truck Percentage Sensitivity on Lane Change Number after FA	125
Figure 75	Restrictions to Truck Sensitivity on Running Speed	126
Figure 76	Restrictions to Truck Sensitivity on Lane Change Number before FA	127
Figure 77	Restrictions to Truck Sensitivity on Running Speed within FA	128
Figure 78	Restrictions to Truck Sensitivity on Lane Change Number within FA	128
Figure 79	Restrictions to Truck Sensitivity on Running Speed after FA	129
Figure 80	Restrictions to Truck Sensitivity on Lane Change Number after FA	129
Figure 81	Location of Exit Sign Sensitivity on Running Speed before FA	131
Figure 82	Location of Exit Sign Sensitivity on Lane Change Number before FA	131

Figure 83 Location of Exit Sign Sensitivity on Running Speed within FA.....	132
Figure 84 Location of Exit Sign Sensitivity on Lane Change Number within FA	133
Figure 85 Location of Exit Sign Sensitivity on Running Speed after FA.....	134
Figure 86 Location of Exit Sign Sensitivity on Lane Change Number after FA.....	134

Freeway Exit Ramp Traffic Flow Research
Based on Computer Simulation

Xu Wang

ABSTRACT

Interstate highways are one of the most important components of the transportation infrastructure in America. Freeway ramps play an important role in the whole interstate transportation system.

This paper researches the traffic flow characteristics of four typical exit ramps in USA, which are tapered one-lane exit, tapered two-lane exit, parallel one-lane exit and parallel two-lane exit. Computer simulation software, such as CORSIM and HCS are applied as the main tools in this research. ANOVA and Tukey are used for statistical purpose.

It compares the maximum capacity, average running speed and the total lane change number of those four exit ramps. It is found that no matter in terms of traffic discharging rate or total lane charging number; the tapered two-lane exit has the best operational performance. Tapered one-lane exit ramp has the least capacity.

Parallel one-lane exit and parallel two-lane exit have very limited traffic operational difference in terms of capacity and running speed. It is recommended that parallel two-lane exit ramp should not be designed along the freeway if the right of way along arterial road is enough.

It is observed from the simulation data that the grade of freeway, truck percentage, restricted to the truck use of certain lane(s) and the location of exit sign have significant impact on the running speed and total lane change number. An uphill can decrease the

running speed dramatically while more truck brings more lane change, causing safety concerns.

It is found that when trucks are restricted to the right two most lane, there will be less lane change number comparing with trucks are not restricted.

Location of exit sign operates well at the distance between 4000 ft to 5000 ft. does have a significant impact on the operational speed and total lane change number before, within or after functional area of an exit, based on the data analysis of simulation runs.

Chapter 1 Introduction

1.1. Background

Interstate freeways are one of the most important components of the transportation infrastructure in America. Freeway ramps are the main connection facilities between freeway and arterial road in the whole interstate transportation system.

The rapid growth of transportation in many States, such as Florida, has caused and is causing queues and delays on freeway mainline as well as on ramps. The freeway off-ramp, or exit ramp, serving as the discharging tool from freeway mainline to local arterial road, is observed to be the bottleneck and heavy crash spot of the freeway system. The queuing vehicles along the exit ramps sometimes even spill back onto the freeway mainline. Spillback of traffic flow along the freeway may neither creates safety issues where high-speed traffic on the freeway suddenly comes upon stop but also creates operational and environmental problems, such as decreased running speed, more oil consumptions and heavy air pollution.

Different freeway exit ramps may have different safety concerns and operational performance in dealing with the increasing traffic volume and congestions based on some researches. In order to better understand the traffic flow characteristics of different ramp types, a research is necessary to investigate the traffic features and queue discharging ability of each ramp type.

Exit ramp terminals are classified as either single lane or multilane, according to the number of lanes on the ramp at the terminal and as either a tapered or parallel type, according to the configuration of the speed change lane. Typically, there are four main types of exit ramp based on the combination of exit lane number and exit lane

configurations: tapered one-lane exit, tapered two-lane exit, parallel one-lane exit and parallel two-lane exit.

General, one-lane exit can deal with low exiting volume; two-lane exit can deal with relatively higher exiting volume. Tapered type gives motorists an optional on exiting or continuing while parallel type gives motorists no choice but have to leaving. The tapered type has been found to operate smoothly on relatively heavy volume freeway because there are less unnecessary lane change maneuver needed. The parallel type has higher crash rate caused by more lane change maneuver but it can offer a storage area for exiting vehicles when something happened at local arterial road access point, making the queuing vehicles spillback to the ramp terminals.

Many studies and researches have tried to study the traffic operation and safety characteristics of different exit ramp terminals. The past researches for exit ramp can be categorized into two groups. One is to collect the field traffic and crash data, classifying the crash data as crash number, crash rate and crash type, then attributing the different classifications to each exit ramp, evaluating the safety performance of different ramp by their crash index. Another group is to analyze the traffic flow characteristics of different ramp types by field data or computer simulation, trying to get the capacity, density, running speed and LOS (Level of Service) of researched exit types under certain traffic and geometry conditions.

To be compared with freeway mainline traffic flow characteristics, the traffic flow features along the exit ramp are much more complicated. Apart from the conventional factors, such as the volume and free flow speed, etc, the traffic flow along the exit ramp has its own particular variables impacting its characteristics, such as the percentage of exiting traffic volume, the location of exit sign to the terminal gore area, the restriction to truck usage of certain lane, etc.

Furthermore, some factors along the exit ramp are easy to identify, such as the ramp posted speed, other factors are very difficult to be measured, such as how many

motorists are familiar with the ramp type, the percentage of drivers yielding the right-of-way to lane-changing vehicles attempting to merge ahead, etc.

The traffic flow characteristics along the freeway exit ramp are far from sufficient research, what is the traffic flow features of these four types of exit ramp, what is the traffic flow features along the different segments of a particular exit ramp, and what is the difference of traffic operational performance about these four types of exit ramp needs more researches.

1.2. Problem Statement

Although some research effects have been fulfilled on the traffic flow research of certain exit ramps, it is still far from being specialized study. The research results obtained from one study may not be applicable to other locations.

The engineering problems associated with exit ramp studies can be sorted out into two aspects:

One is the diversity of field scenarios; each exit ramp site for data collection has difference geometry features, such as the freeway curvature, freeway configuration, slope, ramp terminal outer edge alignment, etc, also, each exit ramp site has different traffic and user conditions, such as the fleet information, the familiarity of drivers to that area, the percentage of aggressive drives, etc. the combination of geometry features, user difference and traffic characteristics make each exit ramp unique. A lot of approximations and assumptions must be done to draw a conclusion or conclusions. The results based on approximations are normally with less creditability and comparability.

Further more, the data collected from field allows less or no adjustment for certain variables to evaluate the sensitivity of a certain variable. The collected data are un-continuous variables for most cases.

Another aspect is the huge budget and time associated with the field data collection. Although certain geometry data of exit ramp can be collected by aviation photograph, the traffic data can only be gathered at exit ramp area at certain time periods.

Some exit ramp configurations can offer desirable traffic and geometry conditions for observers, but some can not. Also, the difficulty to collect field data is the complexity of traffic flow features along a certain exit ramp. Significant factors impact the traffic flow characteristics at exit ramp, which make it hard and costly to collect all of the related data. More, the interactions of some variables are very complicated; the value of a variable may change correspondingly to another factor or factors. For instance, the lane distribution (the percentage of total vehicles occupy a certain lane) has direct relation with the restriction to truck usage and reserved carpool lane or lanes.

Based on the mentioned engineering problems associated with exit ramp study, it is realistic to research the traffic flow characteristics by computer simulation. It would be easily and economical to collect all the necessary traffic data. More critical, the researcher can manipulate some factors at will.

1.3. Research Objectives and Expected Results

The primary objective of this research is to explore the traffic flow characteristics of these four types of exit ramp by the means of computer simulation. The interaction of traffic flow factors, such as the free flow speed and some external factors, such as the location of exit sign, will be addressed in details as well.

The expect results may contain the following aspects:

- 1) In terms of the number of exit ramp, what is the difference between tapered type and parallel type of exit ramp? Or more clearly, when the exit ramp is one-lane, what is the good for taper type and what is the good for parallel type? When the exit ramp is two-lane, what is the advantage of taper type and what is the advantage of parallel type?
- 2) In terms of exit type, what is the difference between one-lane exit and two-lane exit ramp? Besides for the traffic volume, any other factors influence the design of exit ramp lane number? In another word, for tapered type exit ramp, what is the

good for one-lane and what is the good for two-lane? For parallel type exit ramp, what is the advantage of one-lane and what is the advantage of two-lane exit ramp?

- 3) What is the sensitivity of design elements, such as the freeway grade, truck percentage, the location of exit sign, on the design of exit types?

1.4. Significance of This Research

This research is very important to the currently increasing exacerbated traffic conditions. The contributions of this research may be applied to the following fields:

One is to make necessary complementarities to the traffic flow theories in terms of microscope speed characteristics, microscope flow characteristics, capacity analysis and queuing analysis;

The other is to offer reference for the evaluation of existing exit ramps.

The third is to support alternatives for new ramp planning and design.

1.5. Methodology

In this study, considerable amount of data are needed for traffic flow analysis, it is unpractical to collect all the necessary data from the field to represent the essential combinations of different traffic characteristics and geometric features. TSIS-CORSIM software and VBA (Visual Basic Application) programs were used to develop and generate most of the input data and output MOEs (Measure of Effectiveness).

Statistics software SPSS 13.0 (Statistical Package for the Social Sciences) and windows excel application were used as well to develop the linear regression models for analyzing the traffic flow characteristics, to analyze the variance of four types of exit ramp in terms of upstream and downstream of exit ramp functional area.

Although from the microscope point of view, it is common sense that two-lane exit ramp has higher capacity than one-lane exit ramp, the microscope index, such as the space-mean speed, speed deduction rate and total lane change number happened within a typical area are still obscure for these four types of exit ramp. This dissertation uses

discharging volume rate, running speed and total lane change number as the main MOEs, trying to reveal the different microscope traffic flow features of these four types of exit ramp before, within and after the functional area.

1.6. Organization of This Paper

The dissertation presents literature review at chapter two, followed by the factor selection and data collection experiment design in Traffic Software Integrated System 6.0. Traffic volume discharging comparing, speed generated comparing and total lane change comparing before, within and after the ramp functional area were performed using ANOVA and Tukey analysis. Entry volume, free flow speed, truck percentage, restriction to truck at main line, grade and location of exit ramp guiding sign were tested for sensitivity analysis. Finally, conclusions, implications of findings, and recommendations for further research were summarized.

Chapter two contained various digests from the current literatures, with an emphasis on design criteria on the geometric features of exit ramp; In addition, some applications of CORSIM simulation in traffic engineering were presented as well.

Chapter three selected the related factors for CORSIM simulation for this research. Although many factors do have impact to the capacity and traffic operational characteristics on the different exit ramp choice, the selected factors were limited by the availability of the software and the research time. In the study, seven factors were selected to input to CORSIM simulation after careful consideration.

Chapter four designed a data collection process in CORSIM, entry Volume, free flow speed, number of Simulation runs and some other default value changed to generate desired data. Along the procedure, the required traffic data could be obtained. The methodology used for ANOVA and Tukey are explained in detail in this chapter also.

Chapter five illustrated the traffic discharging volume based on the traffic data collected from the CORSIM simulation. The traffic discharging volume is compared for three different segments along the freeway for four different exit ramps. The three

segments are before the functional area, within the functional area and after functional area.

Chapter six analyzed the speed patterns at different exit ramp based on the traffic data collected from the CORSIM simulation. It used the same procedures as for the traffic discharging volume.

Chapter seven presented the total lane changing number at different exit ramp based on simulation runs. It also has the same methodology as traffic discharging volume and speed analysis.

Chapter eight offered the sensitivity analysis of entry traffic volume, free flow speed, freeway grade, truck percentage, restrictions to lane usage of truck and location of exit sign. It provided four linear regression models for different exit ramp types too.

Finally, Chapter nine presented a final discussion, summary of the findings and recommendations for further researches.

Chapter 2 Literature Review

2.1. General

Extensive work was conducted to search current rules, design manuals, like AASHTO Green book, standards and regulations, state of practice in Florida and United States. In addition, past research and studies related to the safety and operation issues related to freeway exit ramp were also searched and reviewed. General, this chapter can be divided into three parts: the first is the design aspects of exit ramp types, the second are the safety and operational issues about the freeway exit ramp, the third part is the simulation issues .

2.2. Design Standards

At “A Policy on Geometric Design of Highways and Streets”, published by American Association of State Highway and Transportation Officials, 2004, chapter 10, Grade Separations and Interchanges, page 849, there is a segment address the design issues of single-lane free flow exit terminals. The following is the digest from the green book.

2.2.1. One-Lane Taper Type Exit

The taper type exit fits the direct path preferred by most drivers, permitting them to follow an easy path within the diverging area. The taper-type exit terminal beginning with an outer edge alignment break usually provides a clear indication of the point of departure from the through lane and has general been found to operate smoothly on high-volume freeways. The divergence angle is usually between 2 and 5 degrees.

Studies of this type of terminal show that most vehicles leave the through lane at relatively high speed, thereby reducing the potential for rear-end collisions as a result of

deceleration on the through lane. The speed change can be achieved off the traveled way as the exiting vehicle moves along the taper onto the ramp proper. Figure 1 shows a typical design for a taper type exit.

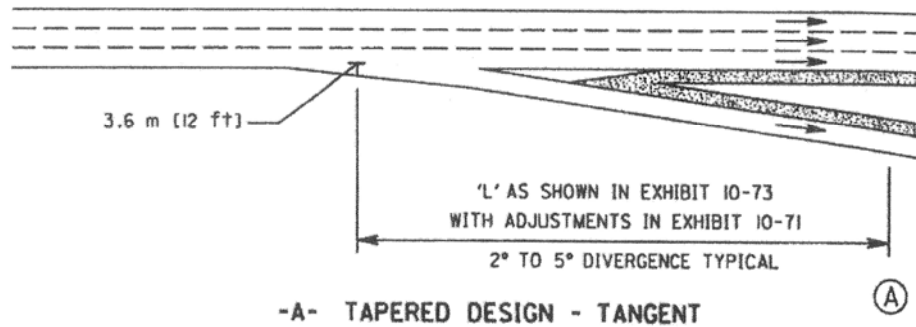

Figure 1 Taper Type One-Lane Exit Terminal

The taper type exit terminal design can be used advantageously in developing the desired long, narrow, triangular emergency maneuver area just upstream from the exit nose located at a proper offset from both the through lane and separate ramp lane. The taper configuration also works well in the length-width super-elevation adjustments to obtain a ramp cross slope different from that of the through lane.

2.2.2. One-Lane Parallel Type Exit

A parallel type exit terminal usually begins with a taper, followed by an added lane that is parallel to the traveled way. A typical parallel-type exit terminal is shown in figure 2. This type of terminal provides an inviting exit area, because the foreshortened view of the taper and the added lane width are very apparent. Parallel-type exits operate best when drivers choose to exit the through lane sufficiently in advance of the exit nose to permit deceleration to occur on the added lane and allow them to follow a path similar to that encouraged by a taper design. Drivers who do not exit the through lane sufficiently in advance of the exit nose will likely utilize a more abrupt reverse-curve maneuver, which is somewhat unnatural and can sometimes result in the driver slowing in the through lane.

In locations where both the mainline and ramp carry high volumes of traffic, the deceleration lane provided by the parallel-type exit provides storage for vehicles that would otherwise undesirably queue up on the through lane or on a shoulder, if available.

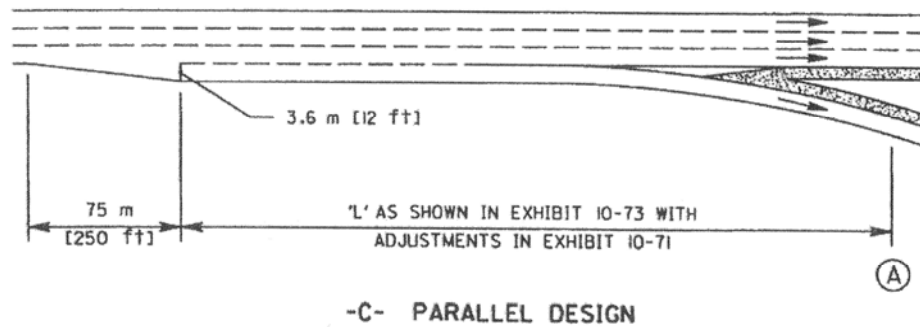

Figure 2 Parallel Type One-Lane Exit Terminal

2.2.3. Two-Lane Exits

Where the traffic volume leaving the freeway at an exit terminal exceeds the design capacity of a single lane, a two-lane exit terminal should be provided. To satisfy lane-balance needs and not to reduce the basic number of through lanes, it is usually appropriate to add an auxiliary lane upstream from the exit. A distance of approximately 1500ft is recommended to develop the full capacity of a two-lane exit. Typical designs for two-lane exit terminals are shown in figure 3 and figure 4, figure 3 is tapered type design, whereas figure 4 is the parallel design.

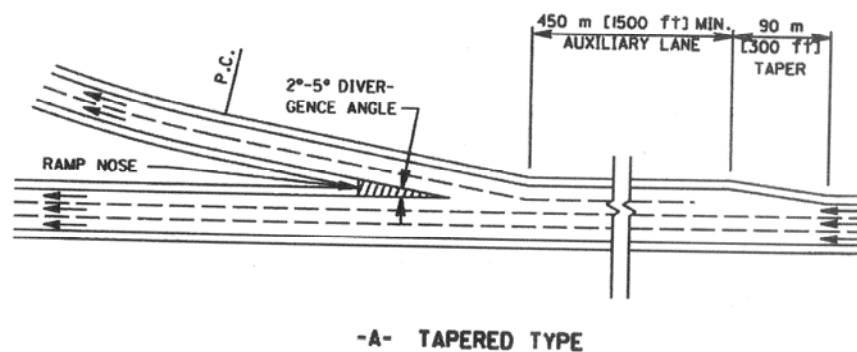

Figure 3 Taper Type Two-Lane Exit Terminal

In cases where the basic number of lanes is to be reduced beyond a two-lane exit, the basic number of lanes should be carried beyond the exit before the outer lane is dropped. This design provides a recovery area for any through vehicles that remain in the lane.

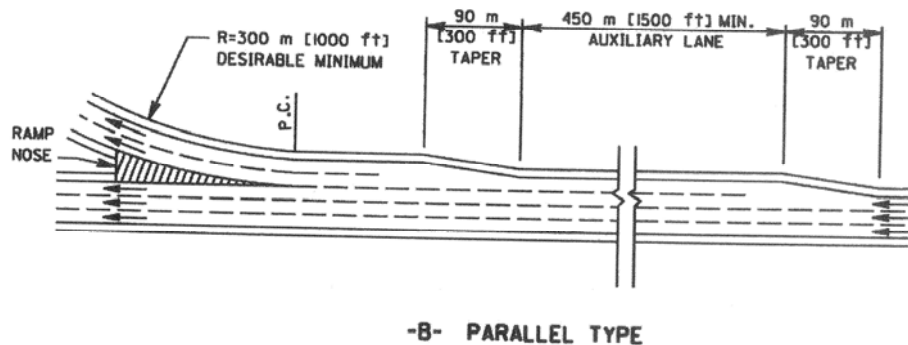

Figure 4 Parallel Type Two-Lane Exit Terminal

With the parallel type of two-lane exit, as shown is figure 4, the operation is different from the taper type in that traffic in the outer through lane of the freeway must change lanes in order to exit. In fact, an exiting motorist is required to move two lanes to the right in order to use the right lane of the ramp. Thus, considerable lane changing is needed in order for the exit to operate efficiently. This entire operation takes place over a substantial length of highway, which is dependent in part on the total traffic volume on the freeway and especially on the volume using the exit ramp. The total length from the beginning of the first taper to the point where the ramp traveled way departs from the right-hand through lane of the freeway should range from 2500 ft for turning volumes of 1500vph or less upward to 3500 ft for turning volumes of 3000vph.

2.3. Operation and Safety

At the sponsor of The U.S. Department of Transportation (DOT) and Federal Highway Administration (FHWA), Turner-Fairbanks Highway Research Center finished a technical report called “statistical model of accidents on interchange ramps and speed change lanes”. The objective of their research was to develop statistical models for

defining the relationship between traffic accidents and highway geometric design elements and traffic volumes for interchange ramps and speed-change lanes. The data base used to develop their models consisted of data for interchange ramps and speed-change lanes in the State of Washington and was obtained from the FHWA Highway Safety Information System. Additional geometric design features were obtained from the review of interchange diagrams. Data on other geometric design features, such as the ramp grades and horizontal curvature, were collected for a sample of ramps from aerial photographs and other existing highway agency files.

The statistical modeling approaches used in their research included Poisson and negative binomial regression. Regression models to determine relationships between accidents and the geometric design and traffic volume characteristics of ramps were difficult to develop because the observed accident frequencies for most ramps and speed-change lanes are very low. The regression models developed, based on the negative binomial distribution, explained between 10 and 42 percent of the variability in the accident data, with the negative binomial distribution providing a poor to moderate fit to the data. However, most of that variability was explained by ramp Annual Average Daily Traffic (AADT). Other variables found to be significant in some models included mainline freeway AADT, area type (rural/urban), ramp type (on/off), ramp configuration, and combined length of ramp and speed-change lane.

The best models obtained for predicting accident frequencies were those obtained when modeling the combined accident frequency for an entire ramp, together with its adjacent speed-change lanes. These models provided a better fit than separate models for ramps and speed-change lanes. Models developed to predict total accidents generally performed slightly better than did models to predict fatal and injury accidents.¹

Kristine Williams, Huaguo Zhou, from CUTR of USF Waddah Farah, and from FDOT research the Benefits/Costs of Access Control Near Interchanges, the concluded that The benefits of acquiring additional LA ROW (Limited Access Right of Way) near an interchange in advance of development far exceed the cost. The minimum length of

LA ROW is 600 feet, the desirable length of LA ROW is 1320 feet. Figure 5 is cut from their research results.^{II}

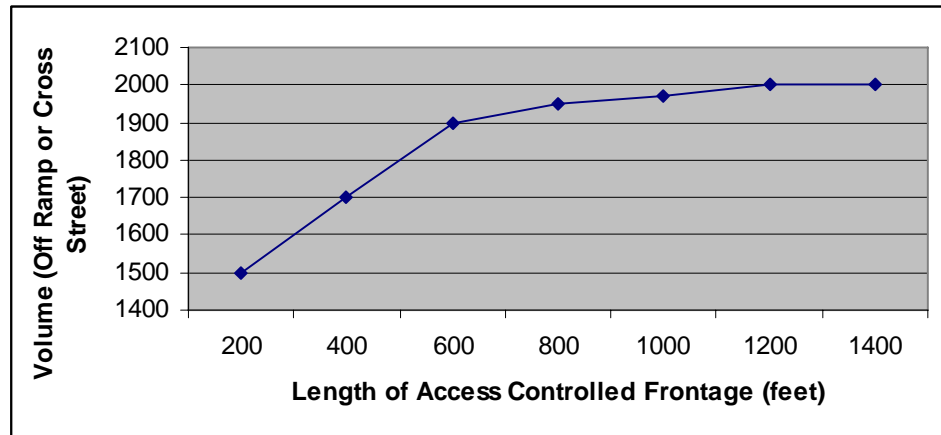

Figure 5 The Effect of Access Controlled Frontage on Volume

Joe Bared, Greg L. Giering and Davey L. Warren researched the relationship between safety and acceleration, deceleration lane lengths, a statistical model of accidents was developed to estimate accident frequencies for entire ramps as a function of speed change lane length among other variables. According to the accident model developed in their study, the longer speed change lane shows the less accident frequency.^{III}

Dominique Load and James A. Bonneson studied the ramp design configurations, they use a predictive model which was already developed with sufficient data, in their paper, 44 ramps are selected and used in the calibration process. The results show that the exit ramp are more dangerous than entrance ramp and the non-free-flow ramp experience twice as many accidents as other types of ramps. The following are the figures cut from their paper explain free-flow ramp and non-free-flow ramp.^{IV}

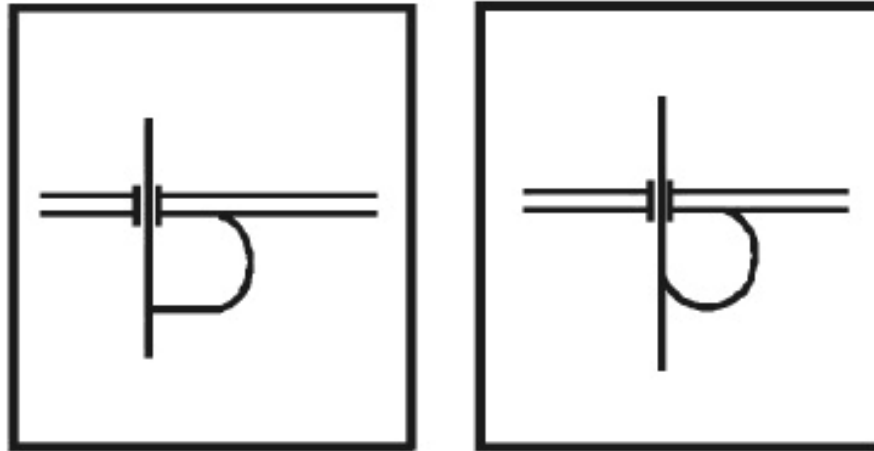

Figure 6 Non-Free-Flow Loop and Free-Flow Loop

2.4. Simulation

Ralph A. Batenhorst, Jeff G. Gerken researches the operational characteristic of terminating freeway auxiliary lanes with one lane exit and two lane exits. They summarized the findings of a case study on the operational analysis of weaving areas created by auxiliary lanes between two successive interchanges. For auxiliary lanes less than 1,500 feet in length, AASHTO lane balance principles permit the termination of the auxiliary lane with a one-lane exit ramp. For auxiliary lanes greater than 1,500 feet in length, the lane balance principles require that the auxiliary lane be dropped with a two-lane exit ramp or tapered into the through roadway downstream of a one-lane exit ramp.

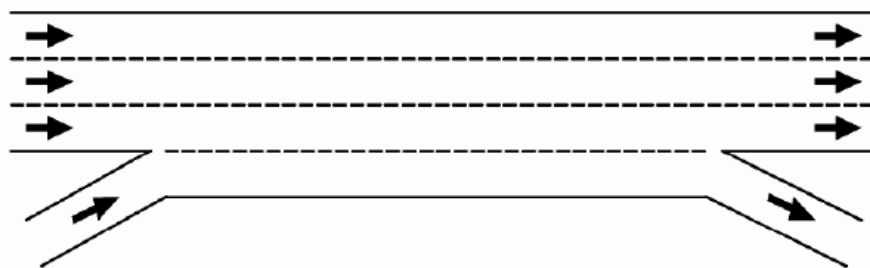

Figure 7 Auxiliary Lanes Terminated with One Lane Exit Ramp

The three illustrations, which are figure 6, figure 7 and figure 8 are the typically three scenarios the paper applied.

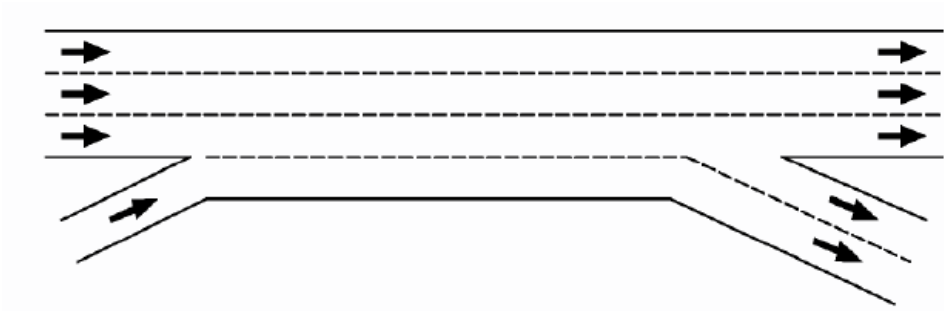

Figure 8 Auxiliary Lanes Terminated with Two Lane Exit Ramp

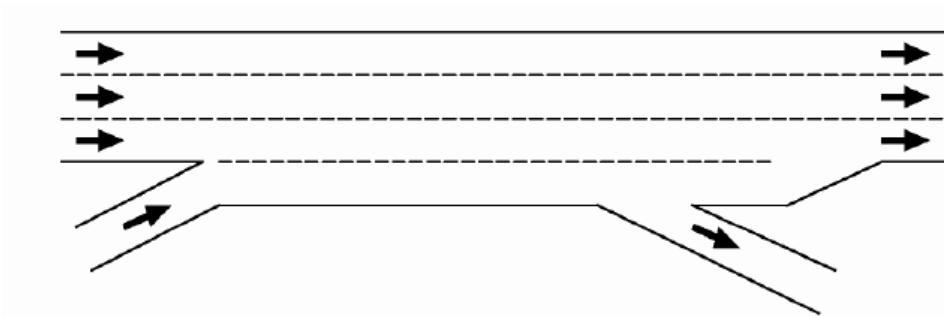

Figure 9 Auxiliary Lanes Terminated with Downstream Taper

The operational analyses of the case study were conducted as part of a Major Investment Study (MIS) in Dallas, Texas. As part of the study, auxiliary lanes were recommended at various locations along two major freeway corridors. At twenty of these locations, additional analyses were conducted to compare the quality-of-service provided by a one-lane exit ramp versus a two-lane exit ramp. The range of traffic and geometric conditions among the twenty sites varied. The analyses were conducted using three software packages: the Highway Capacity Software (HCS), CORSIM and Sim-traffic.

The findings of the case study suggest that a one-lane exit ramp may provide the best traffic operations regardless of weaving length. The experience gained from the case study is presented to aid practitioners in the design of safe and efficient freeway facilities and to aid researchers in current and future efforts to define and understand the operational effects of geometric design.^v

A master student called Suresh Ramachandran from the Virginia Polytechnic Institute finished his master thesis which focused on the simulation comparing of

CORSIM and HCS. Normally, weaving exist at the ramp function area, for on-ramp function area, the upstream vehicle weave and make lane change before the physical gore to avoid the impact from the incoming vehicle of the ramp, the incoming vehicle weave and make lane change trying merge into the main traffic stream. For off-ramp area, the upstream vehicle weave and make lane change, preparing to exit or avoid the exiting vehicle; after the physical gore area, vehicles may weave and make lane change again to back to “normal” traffic flow. He compared the traditional way, which is HCS, with the “new” simulation method, which is CORSIM; by identify the different results in the same inputs.

He set 4 different scenarios; each scenario has different geometric design and traffic volume. By running HCS and CORSIM respectively, he compared the results derived from each scenario. The following figure 9, 10, 11, and 12 are the four illustrations.

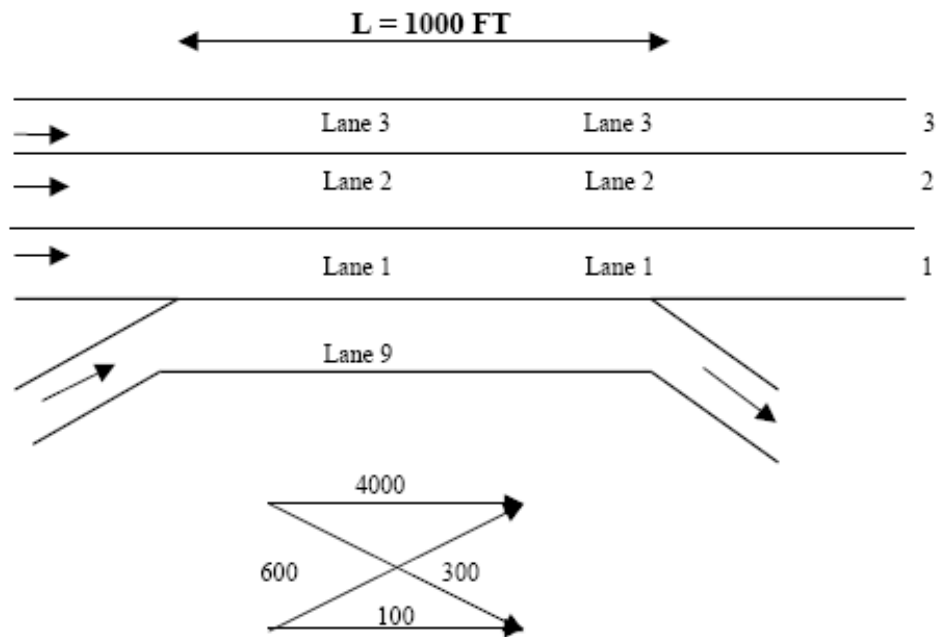

Figure 10 Analysis of Ramp Weaving Section

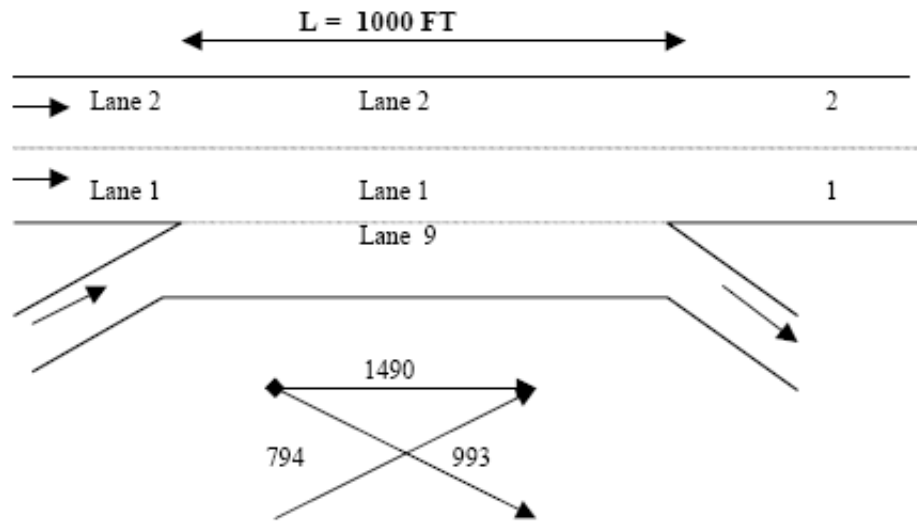

Figure 11 A Constraint Operation of a Ramp Weaving Section

He concluded that CORSIM are not sensitive to various geometric factors such as length of the acceleration lane, deceleration lane etc. While higher volume estimates are produced by CORSIM, it also produces lower density and higher speed estimates than the 94HCM.

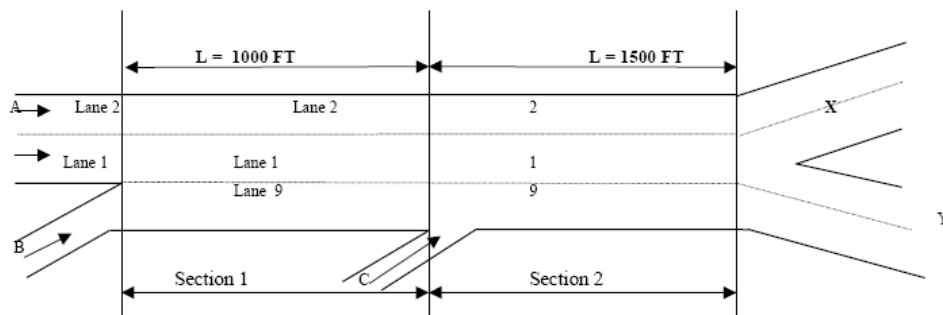

Figure 12 A Multiple Weaving Area with Flow Distribution

He also recommends that the anticipatory warning sign distance should be controlled by the user. In the current version of CORSIM, this distance is set as 1500 ft from the end of the on-ramp, and this value cannot be changed.

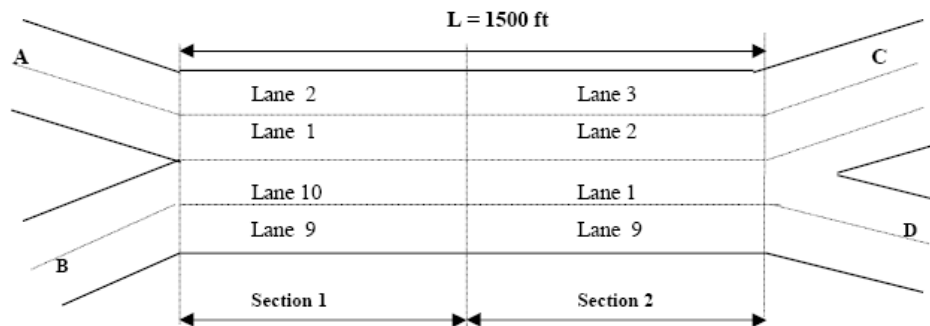

Figure 13 Analysis of a Major Weaving Area

More than one warning sign should be posted for a vehicle in the mainline indicating an off-ramp destination. In the present case, the simulation software allows for one warning sign only. This is not true in real life scenario.

Variation of desired free-flow speed over different time periods should be possible. In a real situation desired free-flow speed may vary for different time periods. In the current version of CORSIM, desired free-flow speed is fixed for all time periods.

Different types of weaving configurations like Type A or Type B or Type C etc. should be considered while designing a weaving model. Because FRESIM cannot simulate two freeway systems connecting each other directly, the simulation software supports only a Type A configuration.

Some existing weaving situations like two freeway merging or two freeway diverging cannot be modeled using CORSIM. In the current software only a ramp and freeway are allowed to merge.

The logic use for modeling the behavior of driver yielding to lane changes should be modified. The logic behind this state is if there is a vehicle trying to change lanes, the cooperative driver code of its putative follower in the adjacent lane will be checked. For a cooperative driver a risk value of -8 ft/sec is assigned while a value of -10 ft/sec is assigned to a non-cooperative driver. However in the current version of the program logic assigns this code to the vehicle trying to change lanes rather than to the follower.

O-D based output should be generated. In the current version of CORSIM origin destination study can be conducted. In order to test the validity of O-D logic a user has to view the graphics. However a user cannot obtain an O-D volume for each node.

Lots of assumptions need to be done in order to make a comparison analysis between CORSIM and HCM.

The variation of random seed number to generate traffic flow conditions did not have effect on the model. This shows that there is a discrepancy in the generation of traffic using random seed numbers. ^{VI}

Kay Fitzpatrick, Marcus A. Brewer, and Steven Venglar from Texas Transportation Institute research the roadway design issues and the managed lane ramp by plenty of literature review; they found that of the 23 states that had all or part of their design manuals online, 12 had some material available concerning the design of ramps. As part of this research project, members of the research team visited the New Jersey Turnpike. Simulation was used to obtain an appreciation of the effects on corridor operations when several pairs of ramps are modeled.

Speed was the primary measure of effectiveness used to evaluate the effects of different ramp spacing, volume levels, and weaving percentages. The research found that a direct connect ramp between a generator and the managed lane facility should be considered when 400veh/hr is anticipated to access the managed lanes. If a more conservative approach to preserving freeway performance is desired, then a direct connect ramp should be considered at 275veh/hr, which reflects the value when the lowest speeds on the simulated corridor for the scenarios examined were at 45 mph or less. ^{VII}

Mark D.Middleton and Scott A. Cooner from Texas transportation institute evaluated the simulation model performance for congested freeway operations, they focused on three aspects: speed-flow relationships for un-congested and congested conditions on freeway; freeway simulation model and freeway simulation model applications. In order to have a good basis for comparison, they selected three simulation

models from many simulation software based on some criteria, the three models are **FREQ**, **INTEGRATION** and **CORSIM**. Three sites were selected for comparison by run three different models respectively. They found that the models all performed relatively well for un-congested conditions; however, the performance became sporadic and mostly unreliable for congested conditions. It appears that the models function better when allowed to begin simulation prior to the onset of congestion. Having data upstream and downstream of a freeway bottleneck (each of the three sites in their project had congestion caused by geometric bottlenecks) or for a location of recurrent congestion helps the models perform better.

It is apparent that people drive differently in congested versus un-congested conditions. None of the models tested allowed the user to dynamically change key model parameters (e.g., headway, lane changing, and driver behavior) to account for this driving difference.

The **CORSIM** simulation model was found the most robust in terms of input and output capabilities among the three models. The **TRAF-VU** animation program is an invaluable source of information to the user when attempting to determine if the model is performing as expected and for verifying that the network is coded properly.

The limitation that was most frustrating was that capacity is not an input or output variable. This distinction made the model hard to calibrate because the user never knows capacity. Capacity could not be adjusted on a link-by-link basis as with the others.

Nevertheless, The calibration of **CORSIM** was most easily done by modifying parameters such as car-following sensitivity, lane changing, driver aggressiveness, etc., which are all very important in evaluating operations in a congested environment.

They think the **CORSIM** program had the best overall performance in this project and shows promise for future application for the operational evaluation of congested freeway facilities. **CORSIM** has dramatically improved in the past several years and is continuing to be refined and updated under the direction of the Federal Highway Administration.

They recommend that CORSIM be used at locations that are fairly simple geometrically, such as single freeway-to-freeway direct connection ramps.

The proper and effective calibration of CORSIM for a congested site requires that the users have good and extensive volume and travel time data, as well as origin and destination data. The user must collect data over a time period that begins prior to the onset of congestion and ends after the congestion has dissipated. Also, the data collection effort must extend over an area that covers the length of the traffic queues formed by the congestion. If the user cannot provide existing data or project future conditions, then the calibration and results of the CORSIM model cannot be expected to be reliable.^{VIII}

Panos D. Prevedouros, Ph.D. researched the data gathering for freeway simulation using un-intrusive sensors and satellite telemetry; it provides a summary of data needs and field data collection technologies used in the simulation of traffic on freeways. Sensor test results, and successful deployments of traffic sensor data retrieval via satellite communication for use in simulation, archival or planning applications are presented. Regardless of the type of freeway simulation model used (micro or macro-simulation model), the data needed fall into two major categories: essential data for running the model and desirable data for calibrating the model. Essential data include: Freeway volumes on several screen lines; Volumes are required for all freeway on-ramps and off ramps. Data on freeway segment lengths, number of lanes and other alignment details such as curves, uphill/downhill sections and shoulder availability and width are needed. Vehicle classification denotes the mix of traffic in terms of light duty. Desirable data may include the following: Freeway speed measurements at specific sections which can be compared with model outputs. On ramp survey of motorists' destinations or complete origin-destination data are desirable when freeway scenarios are planned that include modifications to the freeway that affect demand (i.e., ramp closures, ramp metering, ramp or mainline widening, etc.)

Other data that was available for our specific study and are likely to be beneficial for similar large-scale freeway studies: Comparisons of data from more than one source

to determine volume count accuracy. Helicopter observations during congested periods offered valuable, nearly simultaneous insights on freeway operations and queuing areas.

Historical data throughout the 1990s showed trends in volume growth, reduction or stability on on-ramps and freeway cross-sections. Traffic accident reports are invaluable for removing data from days or periods affected by accidents or other non-recurring events.

He conclude that the major data needed for freeway traffic simulation are traffic volumes from all freeway entry and exit points and average speeds at selected cross-sections for the calibration of the models. These data can be collected with intrusive (on- or under-pavement) sensors or with un-intrusive (overhead -mounted) sensors. Several sensors were tested in various conditions and configurations. Data collection with fiber-optic (Flex-sense) and piezoelectric (RoadTrax BL) sensors can be accurate but their deployment is dangerous for the field crew and expensive in the long term because of the rapid deterioration of the on-pavement components, particularly so for the fiber-optic sensor tested. Pneumatic tubes tend to provide unreliable data if the traffic is not free-flowing. Tests of un-intrusive detectors including the acoustic (SAS-1) and microwave (RTMS XI) revealed that these two sensors have a combination of positive attributes such as being reasonably accurate, fairly easy to deploy and relatively inexpensive to acquire. Offset and height requirements as well as the presence of medians on the highway may create deployment and detection problems, which may be solved by increasing the number of deployed sensors (one sensor for each direction of traffic in side-fired operation or one sensor per lane in over-lane operation.)

On-site visits for data retrieval are expensive and demanding in terms of staff needs. In addition, on-site data retrieval can be hampered by weather and other adverse conditions. Data collection from field stations via satellite modems and digital pagers (TraflInfo/Orbcomm service) was tested. It was found to be convenient, economical and reliable in most cases.^{IX}

Li Zhang, Peter Holm, and James Colyar published a report “identifying and accessing key weather-related parameters and their impacts on traffic operations using simulation”. The object of their report were to identify how weather events affect traffic operations, to assess the sensitivity of weather-related traffic parameters in the CORSIM model, and to develop guidelines for using the CORSIM model to account for the affects of adverse weather conditions on traffic operations. Their interesting result of the sensitivity analysis was that a number of parameters tested (19 total) had little or no impact on the MOEs. The majority of these were lane changing parameters.^X

2.5. Other Issues

Apart from traffic safety and operational aspect of freeway exit ramp, there are some other issues related to the design of exit ramp, such as pavement marking or guiding sign.

Richard A. Retting, Hugh W. McGee, and Charles M. Farmer checked the Influence of pavement markings on urban freeway exit-ramp traffic speeds; they think Motor vehicle crashes on curved roadway sections occur more frequently and tend to be more severe than those on straight sections. Speed is a significant factor in many crashes that occur on curves. The effects on traffic speeds of special pavement markings intended to reduce speeds on freeway exit ramps with horizontal curves were examined.

An experimental pavement marking pattern was employed that narrowed the lane width of both the curve and a portion of the tangent section leading into the curve by use of a gradual inward taper of existing edge-line or exit gore pavement markings or both. Traffic speeds were analyzed before and after installation of the pavement markings at four experimental ramps in New York and Virginia. Results indicated that the markings were generally effective in reducing speeds of passenger vehicles and large trucks.

The markings were associated with significant reductions in the percentages of passenger vehicles and large trucks exceeding posted exit-ramp advisory speeds.^{XI}

Bijan Behzadi, from FDOT, researched the guiding signing for multilane freeway exits with an optional lane. He found Although previous editions of the MUTCD have

covered the signing requirements for multi-lane exits with an option lane ,there is a tremendous lack of uniformity in sign design for this application throughout the United States, from state to state, and even within individual states, a wide variety of sign designs are in use. Below are some of the instances.



Figure 14 Black down Arrow



Figure 15 Black Right down Arrow



Figure 16 Black Right up Arrow

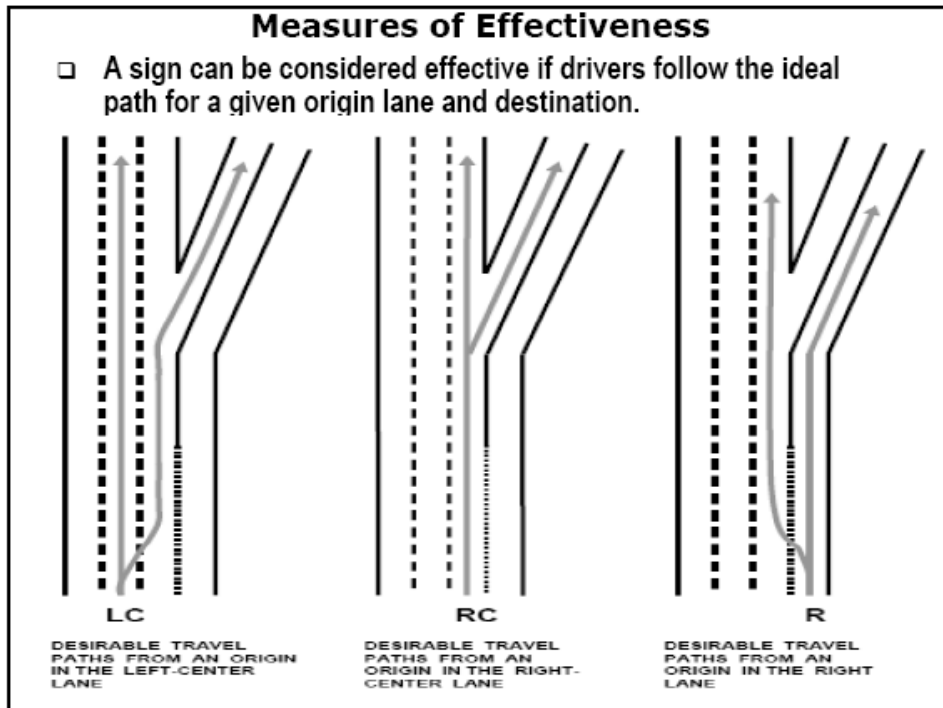

Figure 17 Ideal Paths of Motorists before Exit Ramp

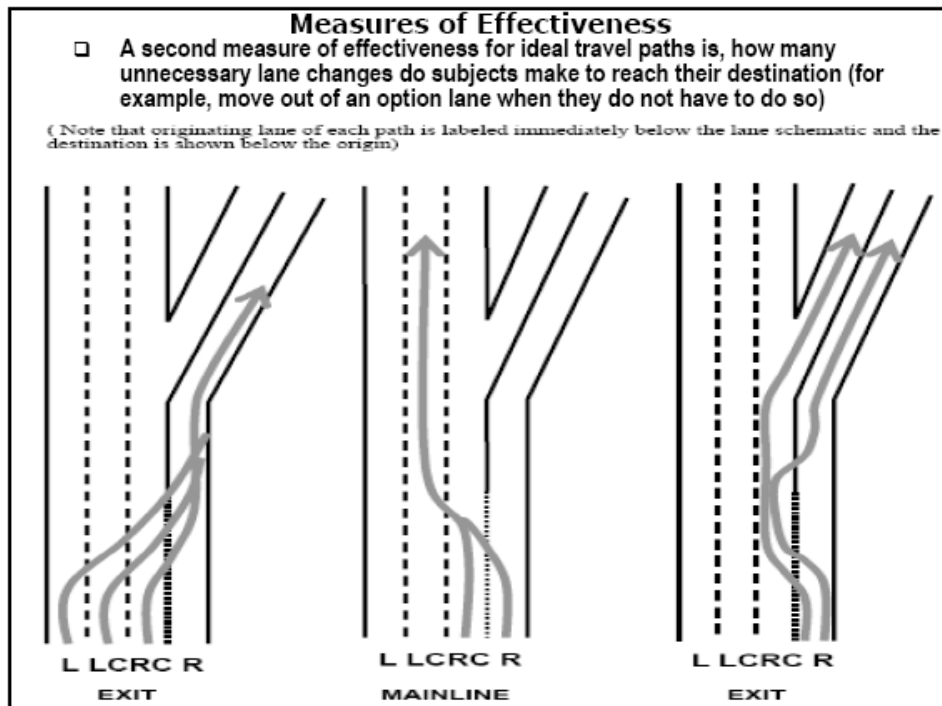

Figure 18 Unnecessary Lane Changes before Exit Ramp

Traffic exit guiding design, should carry at least four concepts, according to Bijan, the first is the concept that a vehicle in the option lane is able to either exit the freeway or continue on the mainline, the second concept is a vehicle in the option lane does not have to change lanes to the left to continue on the mainline, the third concept is a vehicle in the option lane does not have to change lanes to the right in order to exit; and the fourth provision of identifying information about each destination (mainline and exit), such as street name, route number, or destination name.

Bijan compared different types and locations of guiding sign, the MOE (Measure of Effectiveness) are the number of ideal path and how many unnecessary lane change. Check the figure 17 and 18. ^{XII}

2.6. Summary

Apparently, a lot of issues related to the traffic performance of freeway exit ramp, from traffic conditions to geometry conditions, from safety performance to operational concern, guiding sign, pavement marking, etc. To address the operational issues of

freeway exit ramp, Simulation, despite its limitation and shortcomings, seemed is an effective method to compare, analysis the different aspects of freeway traffic operations.

Chapter 3 Factors Affect Ramp Design

3.1. Introduction

Numerous factors affect traffic flow characteristics at freeway exit ramps. From the mathematics or statistics point of view, some factor has several levels while others are continuous variable. For instance, traffic volume is a continuous variable while the grade has several levels from down grade to up grade. It is difficult, sometimes even impossible, to collect all the related traffic data to analyze traffic flow characteristics at exit ramps in field sites.

The traditional research method could only collect a portion of field traffic data which is limited by the field sites, weather condition and research budget. Because of these reasons, it would be advantageous to collect traffic data from traffic simulations, especially for the purpose of design. It is relatively easy and economy to collect traffic data from traffic simulations. In addition, the factors and their levels can be selected according to the requirement of the research, which may be impossible in real exit ramp sites.

3.2. Influencing Factors at Ramp Designs

There are lots of factors affecting the traffic capacity and traffic flow characteristics at exit ramps. Some factors may be easy to measure, such as the grade, sign location and truck percentage in upstream of exit ramps. But some factors are impossible or difficult to accurately measure, such as the driver psychology, perception reaction time, car-following sensitivity etc.

According to the literature review at last chapter, the factors that may affect the traffic capacity and flow characteristics at exit ramp are identified as follows:

- 1) Lane number of freeway main line;
- 2) Lane number of exit ramp;
- 3) Lane width;
- 4) Auxiliary Lane length;
- 5) Curvature of main line and exit ramp;
- 6) Percentage of heavy vehicles in the traffic stream;
- 7) Lane use restriction to heavy trucks;
- 8) Exit ramp guiding sign location;
- 9) Additional guiding sign location;
- 10) Posted speed limit;
- 11) Free flow speed;
- 12) Grade of freeway and ramp;
- 13) Traffic volume at freeway way;
- 14) Traffic volume at exit ramp;
- 15) Lane distribution;
- 16) Driver Population;
- 17) Light Condition (Day versus Night) ;
- 18) Weather Conditions;
- 19) Pavement condition;
- 20) Enforcement condition;
- 21) Land use intensity;
- 22) Exit ramp downstream traffic conditions, such as traffic control type, etc.
- 23) Exit ramp upstream traffic conditions, such as the distance of an on-ramp, etc.

Although all these factors may affect the traffic condition and capacity of exit ramp, the impact intensity are different, some factors such as the freeway grade and entry volume have significant impact while other factors have limited effect to the capacity of exit ramp, such as the pavement condition according to some research. It is reasonable to limit the research factors in traffic simulation experimental design and still have a reliable result.

3.3. Limitation of Factors in Traffic Simulation

From the above chapter, it was obvious that many factors influence exit ramp capacity and traffic flow characteristics. However, because the capacity analysis of exit ramp in this study was performed by traffic simulation software, CORSIM 6.0, the selected factors were greatly limited by the availability of related factors in the software. For example, the weather condition and police presence were two important factors affecting traffic flow characteristics at exit ramps, but in this study the two factors could not be addressed because the CORSIM software could not provide the two factors for traffic simulation runs. In fact, although there were many factors affecting the traffic performance of exit ramps, only a part of the factors can be selected to analyze the traffic flow characteristics at exit ramps because of the limitation of the factors provided by CORSIM software.

Before selecting of related factors, it was necessary to analyze the factors which directly affected the capacity and traffic flow characteristics and the factors which could potentially affect traffic flow characteristics through other factors at exit ramps. The factors were categorized into two types: one was internal factor, such as vehicle type, driver behavior, etc., and the other was external factor. The internal factor means the factors that were directly related to traffic flow characteristics compared with the external factors, which affected the traffic flow characteristics indirectly, such as number of lanes, grade etc.

The following sections discussed the internal and external factors in CORSIM software one by one. The level of different factors is presented also.

3.4. Internal Factors in CORSIM

According to CORSIM 6.0, some factors could be listed as internal factors which were directly related to traffic flow characteristics. The following was the list of these factors in GUI (Graphical User Interface) in Traffic Network Editor (TRAFED):

- 1) Random seeds
- 2) Vehicle types
- 3) Acceleration table
- 4) Environmental table
- 5) Vehicle entry headway
- 6) Driver behavior
- 7) Friction coefficient
- 8) Free-flow speed percentage
- 9) Miscellaneous (e.g., Minimum separation for generation of vehicles, HOVs)
- 10) Lane change parameters
- 11) Lane distribution

Table 1 Recommended Parameter Values

Description	Default Values	Altered Values	Record Type
Maneuver Time (Sec)	3	1	70
Sensitivity factor for car following (sec)	1	1	68
Driver Yielding Percentage	20%	20%	70
Lag To accelerate (sec)	0.3	0.3	69
Lag to Decelerate (sec)	0.3	0.1	69
Minimum Vehicle Separation (sec)	0.2	0.2	70
Desired Free Flow Speed (mph)	65	65	20
Off-ramp Warning Sign Distance (ft)	2500	5400	20
Mean Startup delay (sec)	1	1	20
% of Vehicles in each lane	Average	20, 40, 40	50

CORSIM has default values for the above parameters; however, some researches for the purpose of operational analysis and calibration would change the default values at some special scenarios. Table 1 is the recommended values for CORSIM 4.1 by a research. However, most default values were still used in this study. There were three reasons to use the default values of the software in the study. The first reason was that there were no field data available to the analyses, and the study was not aimed to represent any real freeway segment or project. The second was that, in fact, the default values of the parameters presented the most probable situation in the freeway. The third reason was that, the recommended value by the previous study was run only once, one run do not have enough creditability to change the default value.

3.5. Sensitivity Study of Internet Factors

In order to test the performance of CORSIM software with default parameters, a small experiment was designed to obtain the freeway capacity from CORSIM simulation with default parameters. If the capacity value was close to recommended values by HCM, it means that the default value in CORSIM software was reasonable. Then it was also acceptable to use default values in the study.

This paper according to a similar research finished by Kangyu Zhu, FSU, and a 1200-foot freeway segment with two lanes was designed in CORSIM with all default values except the Vehicle Entry Headway. The default value of Vehicle Entry Headway was Uniform Distribution Type. In the experiment, the value was changed to Normal Distribution Type. The experiment was designed to measure the capacity of freeway. So the entry volume of the freeway segment would be close to the capacity of the freeway. According to the traffic flow theory (Adolf D. May, 1990), “Under heavy-flow conditions, almost all vehicles are interacting, and if an observer stood as a point on the roadway, the time headways would be almost constant.” The normal distribution was a mathematical distribution that could be used when either the time headways were all constant or when drivers attempted to drive at constant time headway but driver errors caused the time headways to vary about the intended constant time headway. It was

reasonable to use Normal Headway Distribution instead of Uniform Distribution in the capacity research in freeways.

The experiment design by Kangyu Zhu from UF^{XIII} uses three levels of free flow speed, 70, 65, 60 mph, and 10 different levels of the entry volume, from 2000 to 2450 vphpl with every incremental step of 50 vphpl. 22 vehicle detectors were deployed along the segment with one in every 100 feet in every lane. The detectors collected the traffic flow characteristics in the segment, including flow rate, speed and time headway. Because of the stochastic simulation, there would be stochastic errors in every time of simulation run. Thirty times of simulation were run for every situation to reduce the stochastic errors.

The flow rate was the average value of results from thirty times of simulation runs. When the entry volume was less than the freeway capacity, almost all the volume in each segment was similar. But when the entry volume was much greater than the freeway capacity, there would be a queue in the freeway. So, although the entry volume was high, the volumes in the segments were limited by the freeway capacity.

Table 2 CORSIM Capacity and HCS Capacity

Segment	FFS=70 mph		FFS=65 mph		FFS=60 mph	
	Capacity from CORSIM	Capacity from HCS	Capacity from CORSIM	Capacity from HCS	Capacity from CORSIM	Capacity from HCS
1	2228	2400	2222	2350	2219	2300
2	2228	2400	2222	2350	2219	2300
3	2229	2400	2222	2350	2220	2300
4	2228	2400	2222	2350	2220	2300
5	2229	2400	2222	2350	2220	2300
6	2228	2400	2222	2350	2220	2300
7	2228	2400	2222	2350	2220	2300
8	2228	2400	2223	2350	2220	2300
9	2228	2400	2222	2350	2220	2300
10	2228	2400	2223	2350	2220	2300
11	2228	2400	2223	2350	2220	2300
Max. Deviation	0.072%		0.054%		0.035%	

If the maximum average volumes in each segment were regarded as the capacity of each section, the capacity from the simulation could be compared with the recommended capacity from HCM (2000) as table 2.

From table 2, it was shown that the capacity from the CORSIM simulation approximates the capacity recommended by HCM. The maximum deviation was less than 8%. Therefore, it is reasonable that the default parameters in CORSIM could be used to analyze the capacity in freeways.

3.6. External Factors in CORSIM

The external factors mean the factors that affect the traffic flow characteristics indirectly by affecting internal factors. For example, freeway grade was an important factor in calculating the capacity and speed in freeways. The grade would first affect the car-following sensitivity and driver psychology which, in turn, would directly affect the capacity and speed in the freeway. Hence influence the exit ramp.

Most of the research in traffic flow characteristics of freeway exit ramp dealt with external factors. Compared with the internal factors, the external factors were easier to measure. Through the review of past research, the following factors were considered as the potential external factors affecting the traffic flow characteristics in freeway exit ramps.

- 1) Heavy Vehicles
- 2) Driver Population
- 3) Light Condition (e.g., Day versus Night)
- 4) Exit Ramp Configuration
- 5) Weather Conditions
- 6) Presence of Police
- 7) Auxiliary Lane Length
- 8) Exit Ramp Sign Location

- 9) Exit Ramp Sign Number
- 10) Freeway Grade
- 11) Exit Ramp grade
- 12) Other Factors, such as downstream traffic control type, etc.

Although all the external factors above potentially affect the traffic flow characteristics, just like the internal factors as well, not all of them could be studied in the study. The first concern was the limited parameters provided by the CORSIM software. The traffic simulation could only select some major factors and express the effect of the factors in mathematical or statistical formulas. The selection of factors was limited by the simulation software itself. The second concern was the limitation of computer capability. Actually, not all of the factors in the simulation software could be used in the analysis. It would be impossible to apply every single factor for simulation runs.

3.7. Selection of Factors for Analysis

According to the analysis above, although numerous internal and external factors influenced traffic operation in freeway exit ramps, only a part of these factors could be selected to analyze traffic flow characteristics at exit ramps based on computer simulation. After careful consideration, the following factors were selected in the study.

- 1) Number of lanes of main line
- 2) Number of lanes of exit ramp
- 3) Freeway Entry Volume
- 4) Free flow speed at freeway
- 5) Freeway grade
- 6) Truck percentage
- 7) Restrictions on the lane usage for trucks
- 8) Location of warning sign

Here, two parameters must be clarified, which are the length of auxiliary and free flow speed at ramp curve. Although both of them been studied at other projects, they are not included in this paper. The reasons are two: for the length of auxiliary length, firstly, some previous study indicated that CORSIM are not sensitivity to the length of auxiliary, secondly, the design of auxiliary lane length has been addressed pretty well in the AASHTO Green book, based on different free flow speed on freeway and exit ramp and traffic volume, the auxiliary length are offered at page 851.

For the issue of free flow speed at exit curve, although it is important also, it can not be considered as a factor in this paper, firstly, this paper focus on the capacity of freeway main lane, the capacity of ramp curve are deemed as infinite, how much is the free flow speed at exit curve makes no difference to the whole analysis, it mainly impact the capacity of ramp curve; secondly, there is a transaction segment between freeway node and exit curve node required by CORSIM which is used for statistic purpose only. From freeway node to transaction node are deemed as freeway segment too, the free flow speed is the same as free flow speed at freeway.

Table 3 is the copy from page 851 of AASHTO Green Book.

Table 3 Auxiliary Lane Length at Different FFS

		Deceleration Length, L(ft) for design speed of exit curve, V_N (mph)								
Highway Design Speed V	Speed Reached V_a		15	20	25	30	35	40	45	50
		For average running speed on exit curve, V_a' (mph)								
		0	14	18	22	26	30	36	40	44
30	28	235	200	170	140	/	/	/	/	/
35	32	280	250	210	185	150	/	/	/	/
40	36	320	295	265	235	185	155	/	/	/
45	40	385	350	325	295	250	220	/	/	/
50	44	435	405	385	355	315	285	225	175	/
55	48	480	455	440	410	380	350	285	235	/
60	52	530	500	480	460	430	405	350	300	240
65	55	570	540	520	500	470	440	390	340	280
70	58	615	590	570	550	520	490	440	390	340
75	61	660	635	620	600	575	535	490	440	390

1) V: Design speed of highway (mph)

- 2) V_a : Average running speed on highway (mph)
- 3) V_N : Design speed of exit curve
- 4) V_a' : Average running speed on exit curve (mph)

The following sections would analyze the main factors chosen in the study one by one. After the analyses of the factors, the levels of each factor were presented according to the real world experiences and the past research.

3.7.1. Number of Lanes of Mainline

Exit ramp capacity and speed might be affected by number of lanes of main line. Normally, at two lane freeway, the traffic volume is low and the speed is also not too fast. At three or more lane freeway, the traffic volume is relatively high and the speed is comparatively faster due to the past research.

It is common sense that more freeway lanes will cause more lane change maneuver. This paper will focus on three-lane main line freeway. For the main line with more than three-lane or less than three-lane, due to the time limitation and another reason related to truck restriction, (which will be mentioned later) this paper omits the research of other than three-lane freeway. For short, the lane number of mainline is not a variable.

3.7.2. Number of Lanes of Exit Ramp

This paper will focus on the number of lanes of exit ramp when it split from main line, here the auxiliary lane along the centerline of freeway mainline and the ramp curve lane after leaving the physical nose are different. For tapered one-lane exit, there are no auxiliary, one lane after the physical nose; for the tapered two-lane exit, there are one auxiliary lane along the centerline and two-lane after the physical nose, for parallel one-lane exit, there are one auxiliary lane along the centerline and one lane after physical nose, for parallel two-lane exit, there are two auxiliary lane (although the length may different) along the centerline and two-lane after the physical nose. Check the figure 1, 2, 3 and 4 at chapter one for details.

The lane number after the physical nose, may keep un-changed till it reaches the downstream intersection, or it may split into more lanes to accommodate the traffic volume. Hence the traffic capacity is different for different curve lane numbers. But this is not the concern of this dissertation. In this dissertation, the capacity of curve lane is assumed to be infinite for the purpose of eliminating the influence of curve lane numbers.

3.7.3. Free Flow Speed

Free flow speed is different from posted speed. The definition of free flow speed (FFS) in HCM (2000) was: the mean speed of passenger cars that could be accommodated under low to moderate flow rates on a uniform freeway segment under prevailing roadway and traffic conditions. Moreover, in HCM (2000) FFS in freeway was divided into five categories: 75 mph, 70 mph, 65 mph, 60 mph, and 55 mph. However, the past research at freeway rarely considered FFS as an important factor to analyze traffic flow characteristics because of the limitation of available traffic data.

Speed limit was the maximum speed that vehicles were permitted to drive in particular freeway segments. Compared with free flow speed, speed limit was much easy to observe. Almost all of the freeway segments had particular speed limit. Some researchers think that it was reasonable that free flow speed was five mph greater than the speed limit.

In CORSIM Software the input freeway speed was free flow speed instead of the speed limit in freeways. In this case, we can take the advantage of computer simulation, the maximum free flow speed provided in CORSIM software was 70 mph. the normal post speed in State freeway is 55mph, and the input speed in simulation is set from 55mph to 70 mph with the step of 5mph. that is 70mph, 65mph, 60mph and 55mph.

3.7.4. Freeway Grade

Freeway grade is believed to have significant effect on the traffic operation. It seems reasonable that freeway grade would affect the capacity and speed because of the presence of grades would exacerbate any flow constriction that would otherwise exist, particularly in the presence of heavy vehicles.

Freeway grade is necessary for sensitivity analysis in this study, since the computer constraints, five levels of freeway grade were selected: -6, -3, 0, +3, and +6.

Heavy vehicle occupy more space on the roadway than passenger cars. Moreover, heavy vehicles accelerate and decelerate slowly and their presence makes other drivers more apprehensive, and they need more operation time to shift lane in freeway. These factors reduce the overall capacity of the freeway ramp. In fact, in most of research on capacity and speed in freeway, including HCM, no matter which year's edition, truck percentage is listed among the most important factors.

3.7.5. Truck Percentage

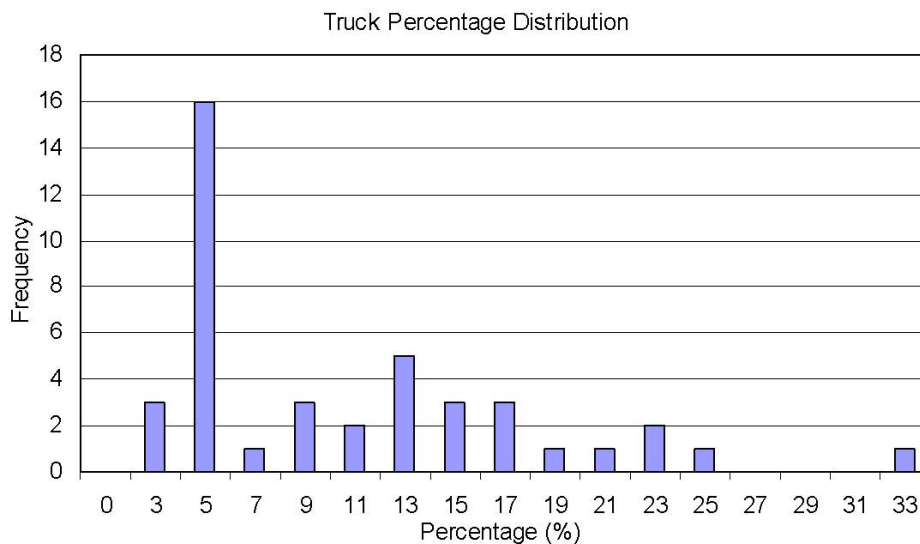

Figure 19 Truck Percentage Distributions

Figure 19 showed that the truck percentage in about 80% of freeway was less than 15%. The maximum truck percentage could reach 33% although this phenomenon happens rarely. In the paper, truck percentage is categorized into five levels: 4%, 8%, and 12%, 16%, 20%. More than 20% are not considered in this paper. Figure 19 is the copy from Kangyuan Zhou's research.

3.7.6. Restriction to Lane Usage of Truck

Many state freeways have certain restrictions to the lane usage for the heavy vehicle, typically the heavy vehicles are restricted to the right two or three lanes, and the left lane is for faster passing vehicles only.

Whether the truck is restricted to a certain lane(s) or not has impact on the capacity and operational characteristics in the exit ramp functional area. Heavy vehicle occupy more space on the roadway than passenger cars. Moreover, heavy vehicles accelerate and decelerate slowly and their presence makes other drivers more apprehensive, if the trucks keep in the right lanes of a freeway, it will make the inner vehicles harder to shift lane to outer lane, especially when the traffic volume is high; if the trucks are not restricted to any lane, when approaching the exit ramp functional area, the truck at inner lane must make at least one lane change maneuver, for three-lane main line, the truck must make at least twice lane change maneuvers. It is common sense that truck need more time/or headway space to fulfill a lane change maneuver. When the traffic volume is too high, the truck sometime will be forced to make a lane change, cause potential traffic accident and turbulence. This issue has not been researched by literature review.

This is the reason why the research scope was limited to three-lane main line only, for two-lane freeway; there are no restrictions to the truck utilization of any special lane.

3.7.7. Location of Exit Sign

Location of exit sign is an important factor in analyzing the traffic flow characteristics at exit ramps. Generally, from the location of exit sign, traffic flow will be disturbed by lane changing vehicles.

Certainly, the effect of location of exit sign depends on how many drivers familiar with the exit type of freeway terminal, if the exit ramp are used for commute drivers, many drivers may shift lane in advance of the exit sign; if the exit ramp are used for tourists, the drivers may only make any necessary lane change after visualizing the exit sign. Further more, when the traffic demand exceeds the capacity of exit ramp, queues may develop backward and pass the advance exit signs, often surprising approaching

traffic and increasing the accident potential. Also, smooth and orderly merging operations may be lost as some drivers remain in the inner lane attempting to squeeze into the outer lane at the head of queue while other drivers try to prevent drivers in the middle lane from passing them by straddling the centerline or traveling slowly in tandem with another vehicle in the middle lane. These maneuvers tend to reduce the capacity of the merging operation and increase the accident potential and road rage among drivers.

CORSIM software provides the default value of location of exit sign. It is 2500 feet upstream of the physical nose of the exit ramp. In the thesis, the location of exit sign is set into 8 levels: 1500ft, 2000ft, 2500ft, 3000ft, 3500ft, 4000ft, 4500ft, and 5000ft. before the physical nose area.

3.8. Summary

The study divided the factors affecting traffic flow characteristics in exit ramps into two types of factors. One was internal factor, which directly affect traffic flow characteristic itself. The other was external factor, which affect traffic flow characteristic through internal factors.

Internal factor and external factor both affected the capacity and speed at freeway exit ramp. This chapter presented the internal and external factors which might be considered as the most important to capacity and speed at freeway exit ramps.

Table 4 Selected Factors for CORSIM Simulation

Factor	Level	Variable Type
Internal Factor		
Vehicle Headway Distribution	Normal Distribution	
External Factor		
Number of Lanes of Main Line	3	Classification Constant
Number of lanes of Exit Ramp	1, 2	Classification Variable
Free Flow Speed in Freeway	70, 65, 60, 55 (mph)	Continuous Variable
Freeway Grade	-6, -3, 0,+3, +6	Continuous Variable
Truck Percentage	4, 8, 12, 16, 20	Continuous Variable
Restriction to Lane Usage of Truck	0, 1	Classification Variable
Location of Exit Sign	1500ft to 5000ft	Continuous Variable

Because of the limitation of filed traffic data available to the research and the research was also not intent to some particular projects, the values in most of the internal factors were default provided by CORSIM software except for vehicle headway distribution. The study conducted a sensitivity analysis of the default internal factors to exit ramp capacity. The simulation results showed that the capacity from simulation approximated to the value from HCM. The maximum deviation was about 7.2%. It showed that the capacity analyses were reasonable with default value in CORSIM simulation.

According to the past research on freeway exit ramps, some potential internal and external factors were selected to analyze traffic flow characteristics at exit ramps in the study. Because of the computer capability and calculation time constraint, some minor factors were omitted, and the levels of every selected factor were discrete, not continuous. Table 4 showed the levels and factors selected in the study.

Chapter 4 Data Collection

4.1. Introduction

The objective of the study was to compare the traffic operational characteristics of tapered one-lane exit ramp, tapered two-lane exit ramp, parallel one-lane exit ramp and parallel two-lane exit ramp, hoping to find a general rule on what kind of exit ramp should be chosen under certain conditions. It analyzes the relationship of traffic capacity and speed with related influencing factors at freeway exit ramps using CORSIM simulation. Seven influencing factors had been identified to having effect on the traffic discharging, speed and total lane change number at freeway exit ramps. In this chapter, the seven factors were further evaluated, and an experiment design was outlined to carry out the research study.

A 7500 feet freeway exit ramp was setup for the traffic simulation based on the methodology offered by Advanced CORSIM Training Manual. Simulation runs and entry volumes were identified according to mean and standard deviation of the capacity in the most adverse scenarios. Total simulation runs of 64,800 were required to perform the study. With so many simulation runs, it would not be possible to produce input files and analyze the output results from the simulation if every step was done by hand. Computer codes have been developed to deal with most of the data collection. Most of the codes were developed with Visual Basic Application in Microsoft Word and Microsoft Excel.

4.2. Input File Production

In TSIS 6.0 there were two tools that could produce CORSIM input files for simulation. One was Traffic Network Editor known as TRAFED. TRAFED tool would produce “*.tno” file for CORSIM simulation. The other was Text Editor, which would

produce “*.trf” file for traffic simulation. The files produced by the two tools could be translated each other by the tool Translator in TSIS.

TRAFED was used to create models of traffic networks using a point-and-click, graphical user interface. It was designed to support users of the Federal Highway Administration's (FHWA's) CORSIM microscopic traffic simulator. TRAFED stored data in an object-oriented manner rather than using the record-oriented structure of CORSIM TRF file format. Because of TRAFED graphical user interface, it was much easier to understand the input file compared with the Text Editor. However, because of the input file produced using point-and-click method in TRAFED, it could only produce one input file at a time. If there were many input files to produce, the user had to produce and save the files one by one.

Text Editor was another tool to edit CORSIM input (TRF) files for simulation. The TSIS Text Editor used Microsoft's rich edit control to provide a generic text editor that operated similar to Microsoft's Notepad application. In addition to the standard text editing capabilities, this editor supported a feature that made the editing of CORSIM input TRF files easier. Specifically, the Text Editor displayed record type information in the T-Shell Output View and allowed you to quickly identify individual fields in the TRF file text. Making use of record type information and having the similar function to Microsoft's Notepad, it was possible to produce many input files simultaneously with Visual Basic Application (VBA) editor in Microsoft Word.

Because a lot of input files were needed in the TSIS software for simulation, it would take a long time to produce the input files if TRAFED tool was used in the process. Therefore, Text Editor Tool was selected instead to produce the input files. With the aid of code developed in VBA using Visual Basic Editor in Microsoft Word, huge numbers of input files were produced for the simulation.

4.3. Affecting Factors in Input Files

A total of seven factors were selected to analyze the effect on the traffic volume, speed and total lane change number of freeway exit ramps. Because Text Editor was used

to produce input the file, it was necessary to introduce Record Type information (RT) to understand the input files.

CORSIM structured its data into records and entries. Each record contained one or more entries. The titles associated with each record could be found in the CORSIM Reference Manual. The GUI components consisted of dialogs, pages, fields, and graphical displays. Each dialog could contain pages, fields, and graphical displays. Each page could contain fields and graphical displays. A tab inside the dialog window designated a page. A field could be an edit box, radio button, check box, drop down edit box, or buttons. A graphical display could be any graphical picture in a dialog that could be manipulated by the users. When Text Editor was used to produce the input file, the variable should be linked with the specific Record Type number. Table 5 illustrated the Record Type number of the selected factors in the Text Editor.

Table 5 Record Type of Selected Variables

Variable	GUI Dialog Name	GUI Page Name	RT	Columns In the Record Type
Number of lanes	Freeway Link	Lanes	19	20
Free flow speed	Freeway Link	General	20	21-22
Grade	Freeway Link	General	20	29-10
Truck Percentage	Entry Properties	N/A	50	13-16
Location of Exit Sign	Freeway Link	Incidents	20	29-33
Volume Entry	Entry Properties	N/A	50	9-12
Off Ramp	Freeway Turn	N/A	25	21-24

It must be indicated herein that the number of exit ramp lanes are not included. Because four different tno file will be built which corresponding to the tapered one-lane exit (TO), tapered two-lane exit (TT), parallel one-lane exit (PO), and parallel two-lane exit(PT), in another word, the number of exit lanes are not a changeable variable in this table.

Also, the number of lanes listed here are for illustrations only, it's not changeable. Fixed on three-lane only.

Changing the values of these variables according to the selected levels would produce different scenarios for input files. Using the program in Visual Basic Application

in Microsoft Word, all the input files associated with the selected factors would be produced.

All the input files could be input to CORSIM software for simulation simultaneously. In TSIS there was a Multiple Run Many Case function, which was useful when “batch” processing a large number of CORSIM cases. For each run of each case, the script in TSIS applied different random number seeds. Because CORSIM was a Monte Carlo type simulation, multiple runs with different random number seeds were required to achieve valid average values for the measures of effectiveness produced by the simulation model.

Because of the huge number of input files and work zone scenarios, it was necessary to develop an effective notation for designing different scenarios. The following notation was selected to depict different scenarios:

AB_CD_EF_GHIJ_K_LMNO_P

Description for the above notations was summarized in Table 6.

Table 6 Notations of Files' Name in the Research

Notation	Description	Level
AB	Free Flow Speed in Freeway, mph	70, 65, 60, 55 (mph)
CD	Freeway Grade, %	-6, -3, 0, 3, 6
EF	Truck Percentage, %	4, 8, 12,16,20
GH IJ	Location of Exit Sign, feet	0500 to 5000 with 500 step
K	Restriction to Truck	No=0, Yes=1
LMNO	Entry Volume, vph	1200-2400 vphpl
PQ	Off Ramp Percentage %	10, 12, 15
R	The Order of Simulation Time	1-5

4.4. Freeway Exit Ramp Configuration

Four different 7500 feet freeway section was designed with a 2500 feet link length for the traffic speed and total lane change number analyses. The four different freeway section are corresponding to TO, TT, PO and PT respectively. The free flow speed in normal freeway was set from 55 mph to 70 mph with 5 mph step. The designed freeway exit could be divided into 3 freeway segments. The first segment was normal freeway

with 2500 feet length. The second segment was exit ramp functional area with 2500 ft length too, the auxiliary lane was expected to happen somewhere within this 2500 ft. The third segment was freeway with 2500 feet downstream of the exit node, the purpose of this link is to compare the traffic characteristics of these four exit ramp after vehicles pass the exit node. The design of the work zone configuration was illustrated in Figure 20 to 23.

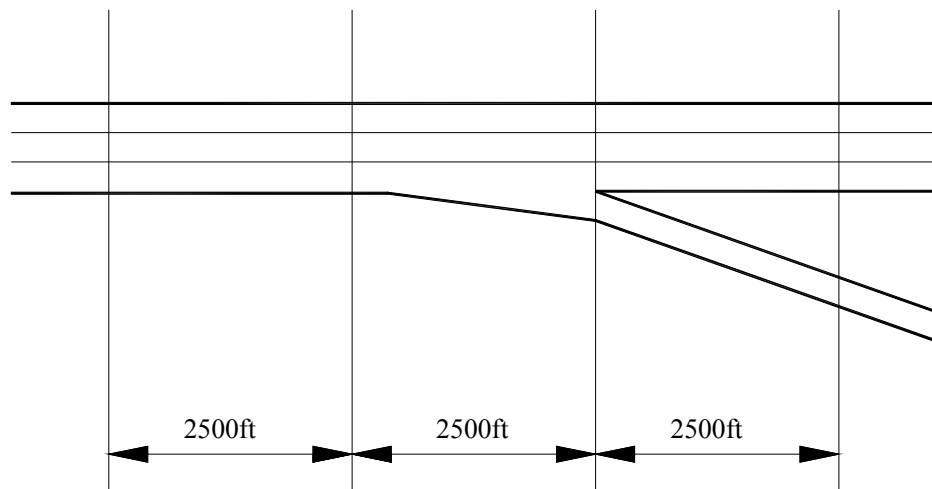

Figure 20 Tapered One-Lane Exit Ramp

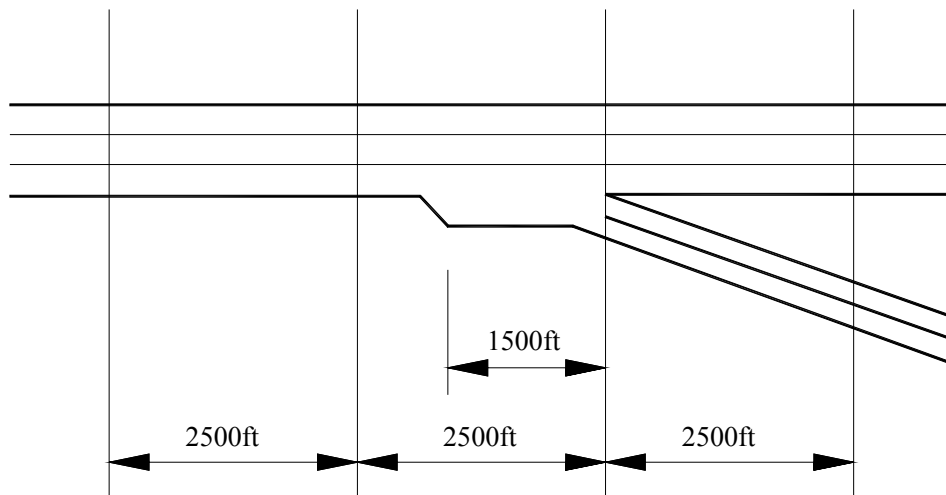

Figure 21 Tapered Two-Lane Exit Ramp

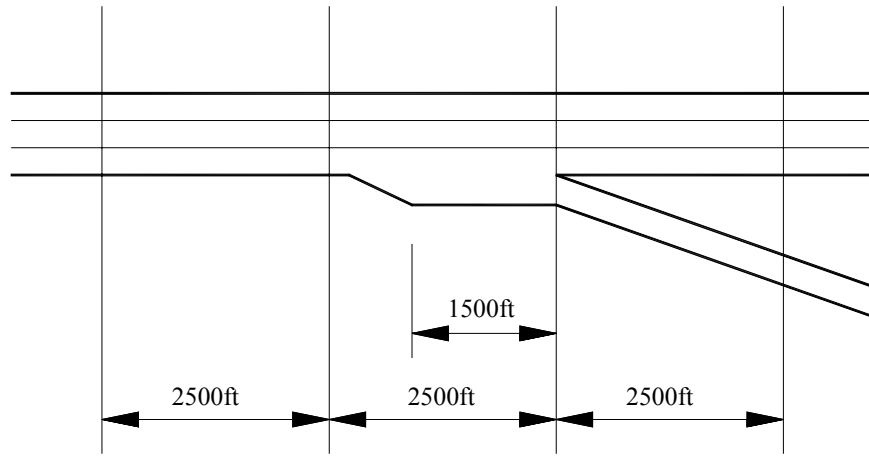

Figure 22 Parallel One-Lane Exit Ramp

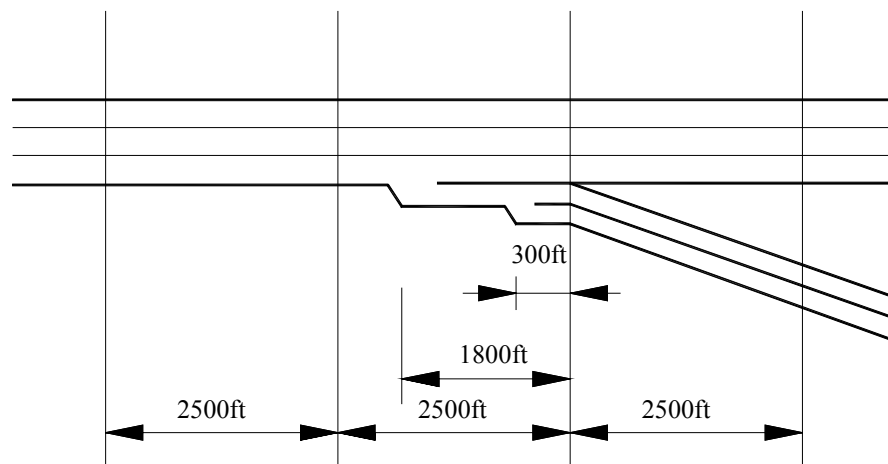

Figure 23 Parallel Two-Lane Exit Ramp

4.5. Entry Volume for CORSIM Simulation

This paper does not try to find the capacity of different exit ramp types, actually, it can be done by HCS with ease, however, The TSIS CORSIM software could not provide the capacity of freeway, it simulated the movement of the individual vehicle according to car following theory and merging theory etc. So when TSIS simulation was used to analyze the capacity, it had to input several levels of entry volumes, and then compare the traffic operational characteristics of the four different exit ramp types. It is obvious that

more reliable conclusions can be drawn if the entry-volume levels vary from smaller than the capacity to greater than the capacity of exit ramps.

Three different scenarios was picked to simulate the traffic volume which was believed from low, medium to high, which also was believed smaller than the capacity, close to the capacity and greater than the capacity. The grade is set to the same for all scenarios.

Table 7 Three Scenarios for Exit Ramp Comparison

Factors	Scenario 1	Scenario 2	Scenario 3
Free Flow Speed in Freeway	70 mph	60 mph	55 mph
Grade	0	0	0
Truck Percentage	4%	8%	12%
Location of Exit Sign	5000ft	2500ft	1000ft
Restricted	0	0	0
Entry Volume	1500vphpl	2000vphpl	2500vphpl
Off Ramp Percentage	10%	12%	15%

4.6. Number of Simulation Runs

The simulation run was a sensitive topic in traffic simulation. Because the TSIS simulation was stochastic, the results from different simulations were not the same. It is very dangerous to use one run result as the final result, just as to judge the face value of a dice by cast it once. To reduce the stochastic errors and get the relative stable results, it is very necessary to run simulation many times instead of only one time. But when the simulation times were increased, the time to simulate the scenarios and analyze the data was also increased. So it was preferred to find particular simulation times, which not only satisfied the precision of the results but also did not increase the simulation time greatly.

Based on the theory of probability and statistics, the equation below could be used to estimate the required number of runs to provide an estimate of the mean with a specified confidence interval and an error range.

$$n = \left[\frac{z_{\alpha/2} \sigma}{E} \right]^2$$

Where,

n) Required number of simulation runs

σ) Sample standard deviation

$Z_{\alpha/2}$) The threshold value for 100(1- α) percentile confidence interval

E) the allowed error range

Based on the experiences, the scenarios with expected maximum standard deviation appeared when extreme levels of each factor are selected. Therefore, the extreme Scenario was selected to evaluate the maximum simulation runs. It was 55_ - 6_20_0500_1_2500.

The scenario 55_-6_20_0500_1_ was run with entry volume from 1200 to 2400 vphpl for 5 times. The standard deviations of the flow rates along the freeway were 100. Assume the allowed error range was 5%.

Maximum standard deviation at the exit ramp: $\sigma = 100$

$$z_{\alpha/2} = 1.96, \text{ when } \alpha = 95\%$$

$$\text{Capacity} = 2314 \text{ vphpl}$$

$$E = 2314 * 5\% = 116 \text{ vphpl}$$

Using Equation 1, the required number of simulation runs was,

$$n = \left[\frac{z_{\alpha/2} \sigma}{E} \right]^2 = \left[\frac{1.96 \times 100}{116} \right]^2 = 2.85$$

Hence, for the comparison of the four exit type, a simulation run with 3 times was sufficient for 5% allowed error range with 95% confidence level. Considering that the

standard deviation in some scenarios would be greater than the values listed above, a simulation run with 5 times was used in the study.

4.7. Data Collection

Because of the huge number of data files, it was not feasible to analyze the data files step by step by hand. In the study some computer codes were developed for data analyses and CORSIM input files production. Almost all of the actions in the data collection, including deleting files and moving files, were done automatically by the codes in Microsoft Word and Microsoft Excel. The general procedure of data collection in the study was as follows.

According to the selected levels of the factors, the codes in Microsoft Word produced the input files for CORSIM simulation. The file names were in the notation of AB_CD_EF_GHIJ_K_LMNO_PQ_R

The corresponding level number was 4_5_5_8_2_7_3_5.

So the total number of files was $4 \times 5 \times 5 \times 8 \times 2 \times 7 \times 3 \times 5 = 168000$ files. At the same time, the “Batch” file was created, which contained the path and name of the files to be processed.

In CORSIM 6.0, Select Multi-Run Many Cases function and input the random number file and the batch file. Simultaneously, the run number of 5 was input. Then the CORSIM would begin to simulate the work zone performances. After the simulation was finished, the TSIS software would produce 168000 CORSIM output files.

The traffic volume, speed and total lane change data can be read respectively from all the Excel files.

8 seconds are needed to obtain the traffic volume and speed value from the above steps, according to the computer speed of generally current personal computer. So the total time needed in the simulation and data analyses was about

$$\frac{168000 \times 8}{3600} = 373 \text{hours}$$

Notice this is the running time needed for one exit type, the main line three-lane have four types of exit ramp, the total base map is 4, and the total time needed is $4 \times 373 = 1492 \text{hours} = 62 \text{days}$

Actually, the separate four exit ramp VBA files can be run at four different computers, which cut the time to 15.5 days.

4.8. ANOVA & Tukey

Traffic discharging volume, as well as the traffic speed and the total lane change number are used as the main MOEs for the purpose of comparisons. Traffic discharging volume has direct relation with the traffic capacity; traffic speed has direct relation with the capacity and LOS; the total lane change number has direct relation with safety issues. Actually, The MOEs are different at each run time interval for the same exit ramp type as well as for the different exit ramp, in order to test if the difference for the same exit ramp are acceptable and the difference for different ramp exit types are statistically significant, ANOVA and Tukey are used for the purpose of comparisons. ANOVA and Tukey method are very powerful statistical solutions to data analysis and data mining.

The following sub-chapter explains the ANOVA and Tukey test in details.

ANOVA is the short for analysis of variance, A One-Way Analysis of Variance is a way to test the equality of three or more means at one time by using variances. It should meet the following criteria:

4.8.1. Assumptions

The populations from which the samples were obtained must be normally or approximately normally distributed.

The samples must be independent.

The variances of the populations must be equal.

The MOEs of this paper meet the assumptions, traffic running speed; discharging volume and total lane change number are distributed normally. And the variances of all the MOEs are equal and independent.

4.8.2. Hypotheses

The null hypothesis will be that all population means are equal; the alternative hypothesis is that at least one means is different. In our case, for example, the average number of lane change may equal for all the four exit ramp types or at least one pair is different.

In the following, lower case letters apply to the individual samples and capital letters apply to the entire set collectively. That is, n is one of many sample sizes, but N is the total sample size.

4.8.3. Grand Mean

The grand mean of a set of samples is the total of all the data values divided by the total sample size. This requires that you have all of the sample data available to you, which is usually the case, but not always. It turns out that all that is necessary to find perform a one-way analysis of variance are the number of samples, the sample means, the sample variances, and the sample sizes.

$$\bar{X}_{GM} = \frac{\sum x}{N}$$

Another way to find the grand mean is to find the weighted average of the sample means. The weight applied is the sample size.

4.8.4. Total Variation

The total variation (not variance) is comprised the sum of the squares of the differences of each mean with the grand mean.

$$SS(T) = \sum (x - \bar{X}_{GM})^2$$

There is the between group variation and the within group variation. The whole idea behind the analysis of variance is to compare the ratio of between group variance to within group variance. If the variance caused by the interaction between the samples is much larger when compared to the variance that appears within each group, then it is because the means aren't the same.

4.8.5. Between Group Variations

The variations due to the interaction between the samples are denoted SS (B) for Sum of Squares Between groups. If the sample means are close to each other (and therefore the Grand Mean) this will be small. There are k samples involved with one data value for each sample (the sample mean), so there are k-1 degrees of freedom.

$$SS(B) = \sum n(\bar{x} - \bar{X}_{GM})^2$$

The variance due to the interaction between the samples is denoted MS(B) for Mean Square Between groups. This is the between group variation divided by its degrees of freedom. It is also denoted by S_b^2 .

4.8.6. Within Group Variations

The variation due to differences within individual samples, denoted SS(W) for Sum of Squares Within groups. Each sample is considered independently, no interaction between samples is involved. The degrees of freedom are equal to the sum of the individual degrees of freedom for each sample. Since each sample has degrees of freedom equal to one less than their sample sizes, and there are k samples, the total degrees of freedom is k less than the total sample size: $df = N - k$.

$$SS(W) = \sum df \cdot S^2$$

The variance due to the differences within individual samples is denoted MS (W) for Mean Square Within groups. This is the within group variation divided by its degrees of

freedom. It is also denoted by S_w^2 . It is the weighted average of the variances (weighted with the degrees of freedom, df in short).

4.8.7. F Test Statistic

Recall that an F variable is the ratio of two independent chi-square variables divided by their respective degrees of freedom. Also recall that the F test statistic is the ratio of two sample variances, well, it turns out that's exactly what we have here. The F test statistic is found by dividing the between group variance by the within group variance. The degrees of freedom for the numerator are the degrees of freedom for the between group (k-1) and the degrees of freedom for the denominator are the degrees of freedom for the within group (N-k).

$$F = \frac{S_b^2}{S_w^2}$$

4.8.8. Summary Table

To sum up, the details for one-way ANOVA are shown at table 8.

Table 8 One Way ANOVA

	SS	df	MS	F
Between	SS(B)	k-1	SS(B)/(k-1)	MS(B)/ MS(W)
Within	SS(W)	N-k	SS(W)/ (N-k)	N/A
Total	SS(W) + SS(B)	N-1	N/A	N/A

The decision will be to reject the null hypothesis if the test statistic from the table is greater than the F critical value with k-1 numerator and N-k denominator degrees of freedom.

If the decision is to reject the null, then at least one of the means is different. However, the ANOVA does not tell you where the difference lies. In our research, for instance, if the ANOVA table tells that the traffic volume are statistically different within the functional area of the four types of exit ramp, it does not indicate which pair are different, maybe only one pair, or all pairs are different. For this, another test, the Tukey test is needed.

4.8.9. Tukey Test

When the decision from the One-Way Analysis of Variance is to reject the null hypothesis, it means that at least one of the means isn't the same as the other means. What needed is a way to figure out where the differences lie, not just that there is a difference.

This is where the Tukey tests come into play. It will analyze pairs of means to see if there is a difference -- much like the difference of two means covered at ANOVA.

Both tests are set up to test if pairs of means are different. The formulas refer to mean i and mean j . The values of i and j vary, and the total number of tests will be equal to a combination of k objects, 2 at a time $C(k,2)$, where k is the number of samples.

$$H_0 : \mu_i = \mu_j$$

$$H_1 : \mu_i \neq \mu_j$$

The Tukey test is only usable when the sample sizes are the same. This research is applicable to this standard.

The Critical Value is looked up in a table. It is a table in the Bluman text. There are actually several different tables, one for each level of significance. The number of samples, k , is used as an index along the top, and the degrees of freedom for the within group variance, $v = N-k$, are used as an index along the left side.

The test statistic is found by dividing the difference between the means by the square root of the ratio of the within group variation and the sample size.

Reject the null hypothesis if the absolute value of the test statistic is greater than the critical value (just like the linear correlation coefficient critical values).

4.9. Summary

This chapter introduced the experiment design for the research in details. The study designed a 7500 feet freeway exit ramp divided into three parts: before functional area, within functional area and after functional area. This chapter also discussed the simulation runs and entry volume for the experiment.

The total simulation runs were 168000 times. And it took about 16 days on CORSIM simulation and computer data analyses. The final results of the simulation and data analyses were the traffic volume, space mean speed and total lane change number for each exit type scenario.

This chapter also introduces the methodology that the whole dissertation will use to analysis discharging volume, speed and total lane change number.

Chapter 5 Capacity Comparisons

5.1. Introduction

The previous chapters introduced the factors affecting the design in freeway exit ramps and the exit ramp experiment design in CORSIM. This chapter mainly compares the difference of four exit ramp types by the traffic discharging volume, speed and total lane change number based on the traffic simulation data from CORSIM. Because there is no output factor in CORSIM called “capacity”, the maximum volume discharging rate are used to substitute the capacity.

Actually, the HCS analysis can give the capacity of these four different exit ramps based on main lane number and exit ramp number. It seemed that the capacity of different exit ramp has direct relation with free flow speed. The auxiliary lane length, the percentage of exit volume has no impact on the main lane and ramp capacity. The HCS analysis will be discussed on the sensitivity chapter, which is at chapter eight.

Different from previous study which focus mainly on the functional area of exit ramp, this paper compares the traffic operational characteristics before, within and after the functional area of exit ramp. The 7500 feet length freeway was divided into three parts for comparison, the first 2500 feet length was believed before the functional area of exit ramp, motorist were assumed to drive similar to a long freeway segment without the influence of on-ramp and exit ramp; the second 2500 feet length was believed within the functional area of exit ramp, actually, the start of auxiliary lane occurs within this segment, the traffic turbulence is believed to happen mostly within this area, traffic volume at different lane, traffic speed and total lane change maneuver is deemed at giant derivation; the third 2500 feet length was believed the exiting vehicle cleared from the freeway mainline (although in some cases, the exiting vehicles are forced to drive along

the freeway mainline because the headway space at the auxiliary lane are too short to make a safe lane change, in another word, they missed their destination), the remaining vehicles will speed up to recover the lost time caused by queuing, avoiding and/or unnecessary lane changing.

5.2. Mean Discharging Volume Comparisons

The designed three scenarios are corresponding to traffic volume less than capacity, close to capacity and greater than capacity respectively. All three scenarios are run 5 times for the four exit ramp types.

The auxiliary lane length is not a variable according to the previous description, the length of auxiliary are set followed by the standard of AASHTO Green book, for the purpose of comparable, the length of auxiliary are not changed with the free flow speed.

Table 9 Auxiliary Lane Length of Exit Ramps

Auxiliary Lane Length	TO	TT	PO	PT
First Auxiliary Lane	N/A	1500 ft	1500 ft	1500 ft
Second Auxiliary Lane	N/A	N/A	N/A	300 ft

Because the simulation results was analyzed by SPSS, the abbreviations for tapered one-lane, tapered two-lane, parallel one-lane, and parallel two-lane., were coded into 1, 2, 3, and 4 respectively.

FA is the abbreviations of functional area appeared in tables and figures.

5.2.1. Before Functional Area at Low Entry Volume

The simulation run results before functional area are list at table 10, the ANOVA analysis are list at table 11. Since F test shows insignificant, Tukey analysis is unnecessary. The LEV is the abbreviation for low entry volume, the MEV is the abbreviation for medium entry volume, and the HEV is the abbreviation for high entry volume in this paper.

It can be concluded that before functional area of an exit ramp, when the entry volume of freeway is lower than the capacity, there were no statistical difference of

traffic discharging volume generated at three-lane freeway for different exit types although it does show the difference in the volume (discharging rate).

Table 10 Mean Discharging Volume at LEV before FA

Ramp Type	N	Mean	Std. Deviation	Std. Error	95% Confidence Interval for Mean		Minimum	Maximum
					Lower Bound	Upper Bound		
1	15	1510.1	102.8	26.5	1453.2	1567.1	1386.4	1677.1
2	15	1510.0	88.8	22.9	1460.8	1559.2	1391.0	1668.7
3	15	1509.9	85.8	22.2	1462.4	1557.5	1407.4	1637.8
4	15	1511.9	96.6	24.9	1458.4	1565.4	1366.3	1661.0
Total	60	1510.5	91.3	11.8	1486.9	1534.1	1366.3	1677.1

Table 11 ANOVA Results of Mean Discharging Volume at LEV before FA

	Sum of Squares	df	Mean Square	F	Sig.
Between Groups	40.3	3	13.4	.002	1.000
Within Groups	492091.2	56	8787.3		
Total	492131.5	59			

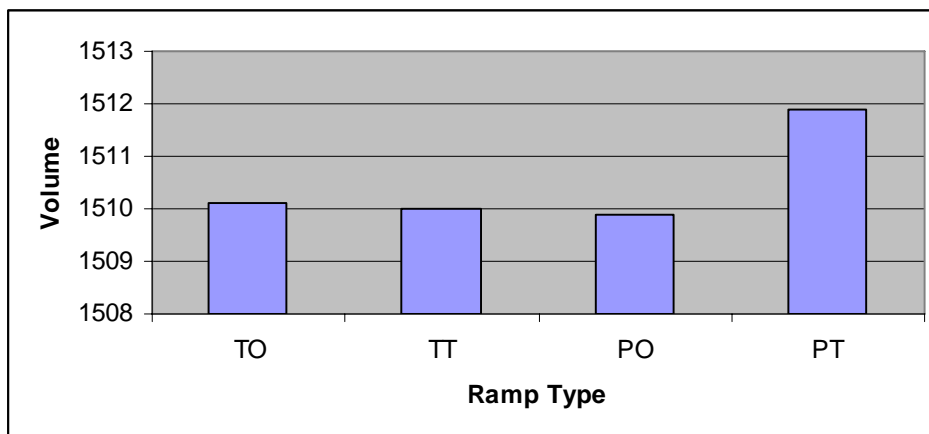

Figure 24 Mean Volume Comparisons at LEV before FA

5.2.2. Within Functional Area at Low Entry Volume

The simulation run results within functional area at scenario 1 are list at table 12, the ANOVA analysis are list at table 13. Since F test shows significant, Tukey analysis is necessary and list at table 14.

Table 12 Mean Discharging Volume at LEV within FA

Ramp Type	N	Mean	Std. Deviation	Std. Error	95% Confidence Interval for Mean		Minimum	Maximum
					Lower Bound	Upper Bound		
1	15	1495.5	135.6	35.0	1420.4	1570.5	1323.9	1741.7
2	15	1441.8	70.7	18.2	1402.6	1480.9	1311.8	1525.5
3	15	1404.5	42.5	11.0	1380.9	1428.0	1335.9	1468.7
4	15	1390.0	63.8	16.5	1354.7	1425.3	1302.3	1532.4
Total	60	1433.0	92.9	12.0	1408.9	1456.9	1302.3	1741.7

Table 13 ANOVA Results of Mean Discharging Volume at LEV within FA

	Sum of Squares	df	Mean Square	F	Sig.
Between Groups	99588.9	3	33196.3	4.541	.006
Within Groups	409399.4	56	7310.7		
Total	508988.3	59			

Table 14 Tukey Results of Mean Discharging Volume at LEV within FA

Sig..	TO	TT	PO	PT
TO	N/A	.324	.026	.007
TT	.324	N/A	.632	.355
PO	.026	.632	N/A	.967
PT	.007	.355	.967	N/A

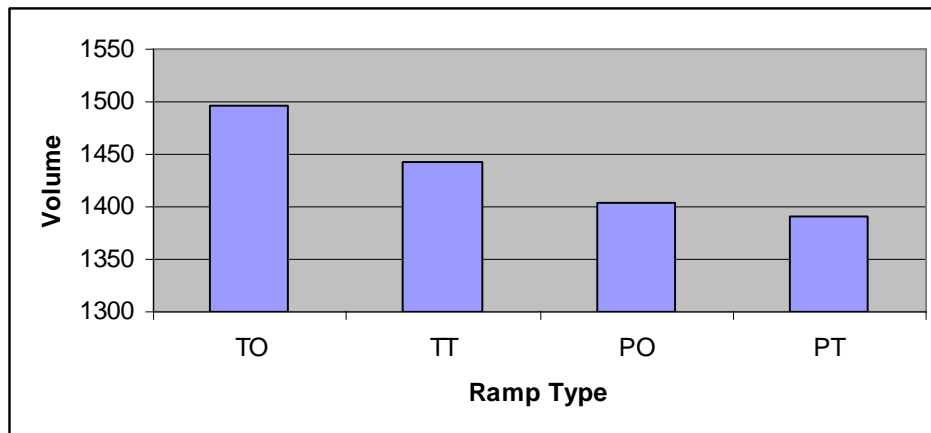

Figure 25 Mean Volume Comparisons at LEV within FA

Figure 25 is the illustration of mean volume comparison. It can be concluded that within functional area of exit ramp, when the entry volume of freeway is lower than the capacity, there are two pairs of exit ramp are statistically significant in traffic volume generated, which are TO-PO and TO-PT. Tapered one-lane exit has more traffic volume than parallel exit type, no matter one-lane or two-lane. It reasonable because there is no

auxiliary lane at tapered one-lane exit while parallel exit type has one or two auxiliary lane, the main line bears less traffic volume as a consequence. PO and PT have less density along the mainline, which is 6.1% and 7.1% lower respectively to compare with TO.

5.2.3. After Functional Area at Low Entry Volume

The simulation run results after functional area are list at table 15, the ANOVA analysis are list at table 16. Since F test shows insignificant, Tukey analysis is unnecessary.

Figure 26 is the illustration of mean volume comparison. It can be concluded that after functional area of exit ramp, the traffic volume at these four types of exit ramp are statistically insignificant. In another word, after the turbulences at the functional area and the leaving of exiting vehicle, the traffic at freeway mainline back to normal in terms of traffic discharging volume.

To sum up, at low entry volume, Tapered one-lane exit has more traffic volume than parallel exit type, no matter one-lane or two-lane exit ramp. It is reasonable because there is no auxiliary lane at tapered one-lane exit while parallel exit type has one or two auxiliary lanes, the main line bears less traffic volume as a consequence.

Table 15 Mean Discharging Volume at LEV after FA

Ramp Type	N	Mean	Std. Deviation	Std. Error	95% Confidence Interval for Mean		Minimum	Maximum
					Lower Bound	Upper Bound		
1	15	1347.9	117.5	30.3	1282.8	1413.0	1193.9	1530.2
2	15	1350.9	90.4	23.3	1300.8	1401.0	1224.7	1471.0
3	15	1347.0	76.8	19.8	1304.5	1389.6	1253.8	1490.6
4	15	1347.5	82.2	21.2	1302.0	1393.0	1223.7	1509.6
Total	60	1348.4	90.7	11.7	1324.9	1371.8	1193.9	1530.2

Table 16 ANOVA Results of Mean Volume at LEV after FA

	Sum of Squares	df	Mean Square	F	Sig.
Between Groups	138.8	3	46.2	.005	.999
Within Groups	484979.3	56	8660.3		
Total	485118.2	59			

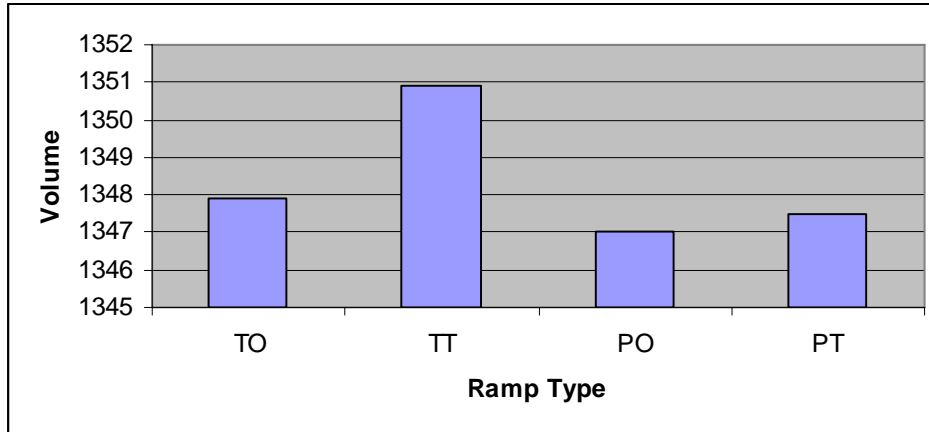

Figure 26 Mean Volume Comparisons at LEV after FA

The traffic performance between tapered two-lane exit and parallel exit are insignificant, in another word, at low entry volume, parallel type exit ramp are no better than tapered two-lane exit ramp even they have extra lane along the freeway.

5.2.4. Before Functional Area at Medium Entry Volume

The simulation run results before functional area at scenario 2, the volume close to the freeway capacity, are list at table 17, the ANOVA analysis are list at table 18. Since F test shows insignificant, Tukey analysis is unnecessary.

Table 17 Mean Discharging Volume at MEV before FA

Ramp Type	N	Mean	Std.	Std.	95% Confidence Interval for Mean		Minimum	Maximum
			Deviation	Error	Lower Bound	Upper Bound		
1	15	2013.3	24.7	6.4	1999.6	2026.9	1967.7	2058.4
2	15	2013.7	33.2	8.6	1995.3	2032.1	1949.5	2062.7
3	15	2014.27	25.6	6.6	2000.1	2028.4	1976.8	2056.8
4	15	2015.2	28.2	7.3	1999.6	2030.8	1960.3	2071.9
Total	60	2014.1	27.4	3.5	2007.0	2021.2	1949.5	2071.9

Table 18 ANOVA Results of Mean Discharging Volume at MEV before FA

	Sum of Squares	df	Mean Square	F	Sig.
Between Groups	30.6	3	10.2	.013	.998
Within Groups	44262.7	56	790.4		
Total	44293.3	59			

Figure 27 is the illustration of mean volume comparison. It can be concluded that before functional area of an exit ramp, when the entry volume of freeway is close to the capacity, there were no significant difference of traffic discharging volume generated at three-lane freeway for different exit types. This phenomenon is very similar to scenario 1.

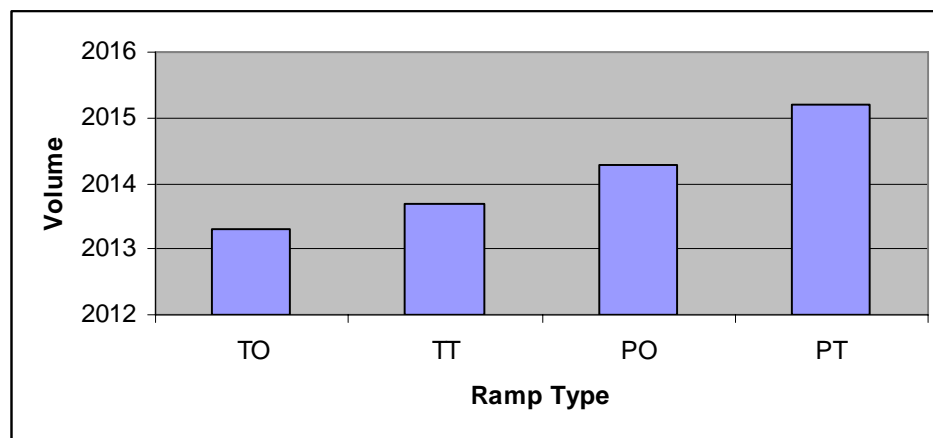

Figure 27 Mean Volume Comparisons at MEV before FA

5.2.5. Within Functional Area at Medium Entry Volume

Table 19 Mean Volume at MEV within FA

Ramp Type	N	Mean	Std. Deviation	Std. Error	95% Confidence Interval for Mean		Minimum	Maximum
					Lower Bound	Upper Bound		
1	15	1995.4	166.7	43.0	1903.1	2087.8	1779.7	2237.1
2	15	1917.2	89.1	23.0	1867.8	1966.6	1726.2	2034.7
3	15	1858.7	38.0	9.8	1837.7	1879.8	1792.0	1928.7
4	15	1828.2	71.0	18.4	1788.9	1867.5	1690.2	1952.5
Total	60	1899.9	119.0	15.4	1869.1	1930.6	1690.2	2237.2

Table 20 ANOVA Results of Mean Volume at MEV within FA

	Sum of Squares	df	Mean Square	F	Sig.
Between Groups	244017.8	3	81339.3	7.702	.000
Within Groups	591385.2	56	10560.4		
Total	835403.1	59			

The simulation run results within functional area at scenario 2, the volume close to the freeway capacity, are list at table 19, the ANOVA analysis are list at table 20. Since F test shows significant, Tukey analysis is necessary.

Table 21 Tukey Results of Mean Volume at MEV within FA

SI.	TO	TT	PO	PT
TO	N/A	.171	.003	.000
TT	.171	N/A	.410	.094
PO	.003	.410	N/A	.848
PT	.000	.094	.848	N/A

Figure 28 is the illustration of mean volume comparison. It can be concluded that within the functional area of an exit ramp, when the entry volume of freeway is close to the capacity, there were significant difference of traffic volume generated at three-lane freeway for different exit types. The exit ramp pairs are TO-PO and TO-PT, which is tapered one-lane exit with parallel one-lane exit, tapered one-lane exit with parallel two-lane exit. Tapered one-lane exit has more traffic volume than parallel exit type, no matter one-lane or two-lane, the difference are 6.9% and 8.4% respectively. It's still the same as that at the scenario 1. It is reasonable because there is no auxiliary lane at tapered one-lane exit while parallel exit type has one or two auxiliary lanes, the main line bears less traffic volume as a consequence. It a little strange that tapered one-lane exit ramp has insignificant difference with tapered two-lane exit. But tapered two-lane exit ramp still has the same traffic performance in terms of traffic discharging volume.

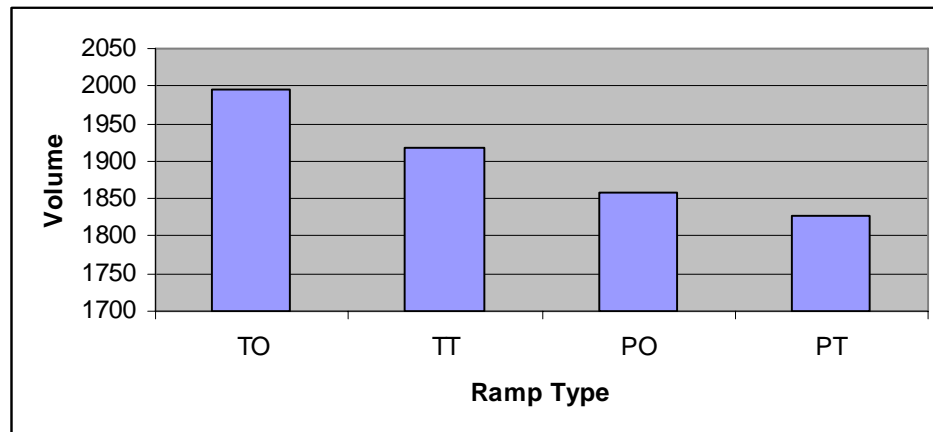

Figure 28 Mean Volume Comparisons at MEV within FA

5.2.6. After Functional Area at Medium Entry Volume

The simulation run results after functional area at scenario 2, the volume close to the freeway capacity, are list at table 22, the ANOVA analysis are list at table 23. Since F test shows insignificant, Tukey analysis is unnecessary.

Table 22 Mean Discharging Volume at MEV after FA

Ramp Type	N	Mean	Std. Deviation	Std. Error	95% Confidence Interval for Mean		Minimum	Maximum
					Lower Bound	Upper Bound		
1	15	1756.6	134.8	34.8	1682.0	1831.2	1540.6	1914.0
2	15	1764.3	88.5	22.8	1715.3	1813.4	1617.7	1895.2
3	15	1759.5	59.7	15.4	1726.4	1792.6	1669.2	1860.3
4	15	1747.7	72.9	18.8	1707.4	1788.1	1662.8	1888.8
Total	60	1757.0	91.2	11.8	1733.5	1780.6	1540.6	1914.0

Table 23 ANOVA Results of Mean Discharging Volume at MEV after FA

	Sum of Squares	df	Mean Square	F	Sig.
Between Groups	2189.3	3	729.8	.084	.969
Within Groups	488520.4	56	8723.6		
Total	490709.8	59			

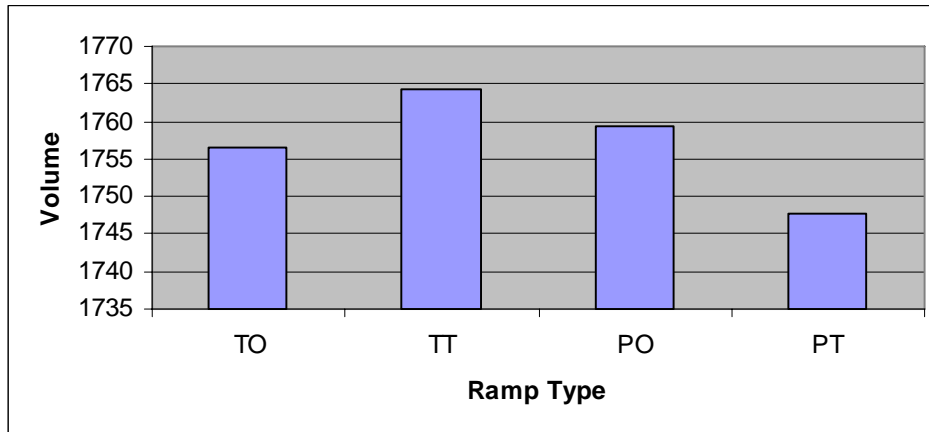

Figure 29 Mean Volume Comparisons at MEV after FA

Figure 29 is the illustration of mean volume comparison. It can be concluded that after functional area of an exit ramp, when the entry volume of freeway is close to the capacity, there were no significant difference of traffic volume generated at three-lane freeway for different exit types. That's the same thing as scenario 1.

To sum up for the scenario 2, the difference between four types of exit ramp is mainly focused within the functional area, tapered one-lane exit has to bear more through traffic while the traffic performance of tapered two-lane has limited difference with parallel exit type. For parallel one-lane or parallel two-lane exit, the traffic performance is almost the same.

5.2.7. Before Functional Area at High Entry Volume

Table 24 Mean Volume at HEV before FA

Ramp Type	N	Mean	Std. Deviation	Std. Error	95% Confidence Interval for Mean		Minimum	Maximum
					Lower Bound	Upper Bound		
1	15	2142.4	53.5	13.8	2112.7	2172.0	1987.5	2207.6
2	15	2185.6	27.7	7.1	2170.3	2201.0	2143.4	2232.5
3	15	2192.7	22.0	5.7	2180.5	2204.9	2160.8	2235.1
4	15	2197.4	21.7	5.6	2185.4	2209.5	2159.7	2255.3
Total	60	2179.5	39.7	5.1	2169.3	2189.8	1987.5	2255.3

Table 25 ANOVA Results of Mean Volume at HEV before FA

	Sum of Squares	df	Mean Square	F	Sig.
Between Groups	28694.7	3	9564.9	8.346	.000
Within Groups	64175.8	56	1146.0		
Total	92870.5	59			

Table 26 Tukey Results of Mean Volume at HEV before FA

Sig.	TO	TT	PO	PT
TO	N/A	.005	.001	.000
TT	.005	N/A	.940	.776
PO	.001	.940	N/A	.981
PT	.000	.776	.981	N/A

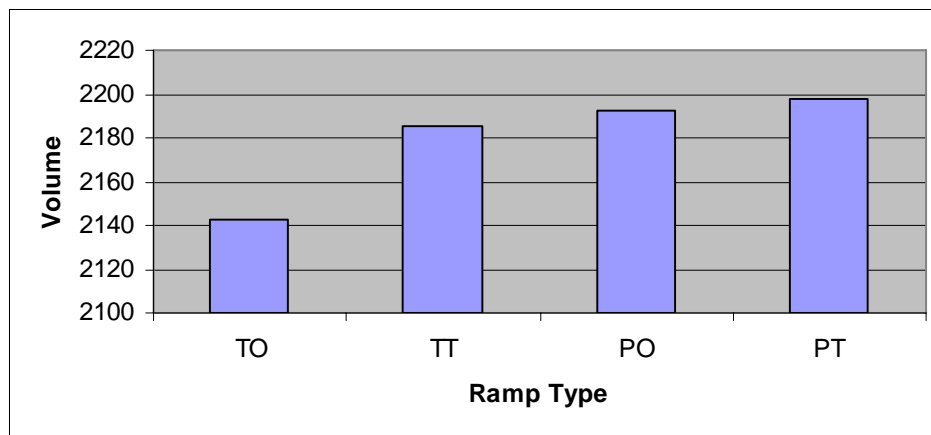

Figure 30 Mean Volume Comparisons at HEV before FA

The simulation run results before functional area at scenario 3, the volume greater than the freeway capacity, are list at table 24, the ANOVA analysis are list at table 25. Since F test shows significant, Tukey analysis is necessary.

Figure 30 is the illustration of mean volume comparison. It can be concluded that before functional area of an exit ramp at high entry volume, there were significant difference of traffic volume generated at three-lane freeway for different exit types. Unlike the previous scenario1 and 2, which have more traffic volume at tapered one-lane exit ramps, this scenario has more traffic volume at two-lane exit and parallel type exit instead of tapered one-lane exit ramp. It comes to one of conclusions; two-lane exit and parallel type exit have higher discharging rate to compare with tapered one lane exit ramp, the difference is 2%, 2.3% and 2.6% respectively. When the entry traffic volume is

greater than the capacity, a part of vehicles will build up at the entry node, the higher the capacity of a given exit type, the less the build up at the entry node, the higher the traffic volume can go through a node pairs, in another word, a link. But the difference between two-lane tapered exit ramps has insignificant difference with parallel type exit in terms of traffic discharging volume.

5.2.8. Within Functional Area at High Entry Volume

The simulation run results within functional area at scenario 3, the volume greater than the freeway capacity, are list at table 27, the ANOVA analysis are list at table 28. Since F test shows significant, Tukey analysis is necessary.

Table 27 Mean Discharging Volume at HEV within FA

Ramp Type	N	Mean	Std. Deviation	Std. Error	95% Confidence Interval for Mean		Minimum	Maximum
					Lower Bound	Upper Bound		
1	15	2099.4	111.5	28.8	2037.6	2161.2	1911.9	2289.6
2	15	2110.7	43.6	11.3	2086.5	2134.9	2002.6	2154.4
3	15	2045.9	38.9	10.0	2024.4	2067.5	1993.7	2135.9
4	15	2032.2	29.1	7.5	2016.0	2048.3	1975.4	2086.3
Total	60	2072.1	71.5	9.2	2053.6	2090.5	1911.9	2289.6

Table 28 ANOVA Results of Mean Discharging Volume at HEV within FA

	Sum of Squares	df	Mean Square	F	Sig.
Between Groups	67753.2	3	22584.4	5.406	.002
Within Groups	233944.3	56	4177.6		
Total	301697.5	59			

Table 29 Tukey Results of Mean Discharging Volume at HEV within FA

Sig.	TO	TT	PO	PT
TO	N/A	.963	.118	.030
TT	.963	N/A	.039	.008
PO	.118	.039	N/A	.937
PT	.030	.008	.937	N/A

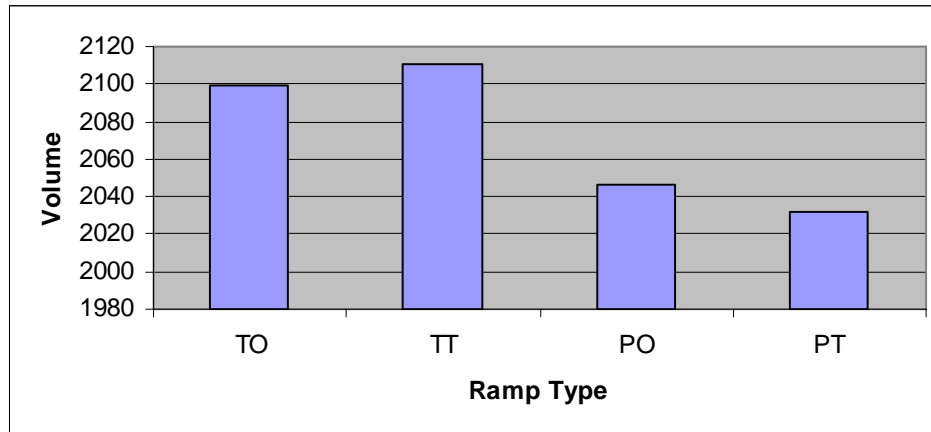

Figure 31 Mean Volume Comparisons at HEV within FA

Figure 31 is the illustration of mean volume comparison. It can be concluded that before functional area of an exit ramp, when the entry volume of freeway is greater than the capacity, there were significant difference of traffic volume generated at three-lane freeway for different exit types. The different exit ramp pairs are TO---PT, TT---PO, and TT---PT, tapered two-lane exit ramp has the highest main line volume while the parallel two-lane exit ramp has the lowest main line volume. In terms of exit type, PT has 2.5% less traffic than TT. That's probably because that tapered type design gives the vehicles along the freeway a higher running speed, the discharging volume of tapered two-lane is the highest.

5.2.9. After Functional Area at High Entry Volume

Table 30 Mean Volume at HEV after FA

Ramp Type	N	Mean	Std. Deviation	Std. Error	95% Confidence Interval for Mean		Minimum	Maximum
					Lower Bound	Upper Bound		
1	15	1774.3	250.1	64.6	1635.8	1912.8	1412.5	2111.3
2	15	1865.4	141.8	36.6	1786.8	1943.9	1665.9	2084.4
3	15	1845.1	42.0	10.8	1821.8	1868.4	1792.5	1928.8
4	15	1849.8	41.6	10.7	1826.8	1872.9	1775.7	1932.7
Total	60	1833.6	147.3	19.0	1795.6	1871.7	1412.5	2111.3

Table 31 ANOVA Results of Mean Volume at HEV after FA

	Sum of Squares	df	Mean Square	F	Sig.
Between Groups	73810.4	3	24603.5	1.142	.340
Within Groups	1206226.1	56	21539.7		
Total	1280036.6	59			

The simulation run results after functional area at scenario 3, the volume greater than the freeway capacity, are list at table 29, the ANOVA analysis are list at table 30. Since F test shows insignificant, Tukey analysis is unnecessary.

Figure 32 is the illustration of mean volume comparison. It can be concluded that after functional area of an exit ramp, when the entry volume of freeway is greater than capacity, there are no significant difference among these four types of exit ramp in terms of traffic discharging volume.

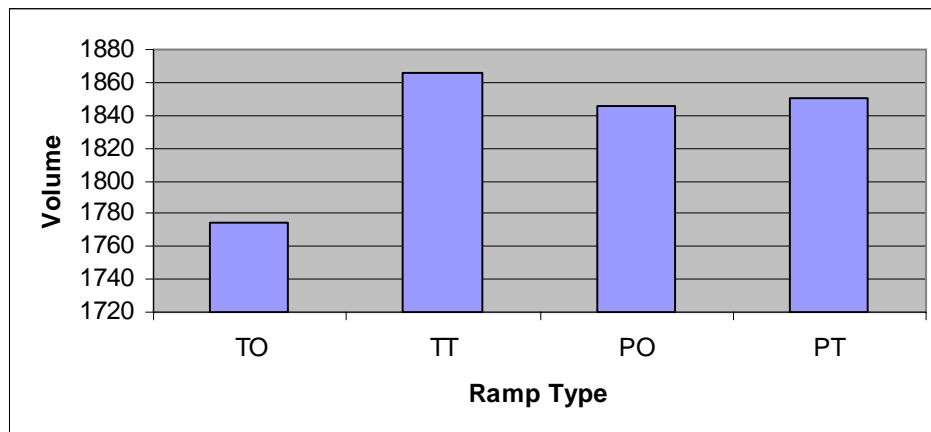

Figure 32 Mean Volume Comparisons at HEV after FA

5.3. Summary

This chapter researched the traffic discharging volume characteristics of four exit ramp types. The finding of this chapter can be summarized at table 32 and 33.

Table 32 ANOVA Findings for Discharging Volume

	Before Functional Area	Within Functional Area	After Functional Area
--	------------------------	------------------------	-----------------------

LEV	N	Y	N
MEV	N	Y	N
HEV	Y	Y	N

Table 33 Tukey Findings for Discharging Volume

	Before Functional Area	Within Functional Area	After Functional Area
LEV	N/A	TO-PT	N/A
MEV	N/A	TO-PO, TO-PT	N/A
HEV	TO-TT, TO-PO, TO-PT	TO-PT, TT-PO, TT-PT	N/A

N/A: not applicable.

It was found that within functional area of exit ramp, no matter how much is the entry volume, the discharging volume are statistically different among these four types of exit ramp. But one exit ramp pair seemed significant at all entry volumes: tapered one-lane and parallel two-lane exit ramp.

Tapered one-lane exit has more traffic volume than parallel exit type, no matter one-lane or two-lane. It reasonable because there is no auxiliary lane at tapered one-lane exit while parallel exit type has one or two auxiliary lane, the main line bears less traffic volume as a consequence.

Normally, the parallel type exit ramp bear less traffic volume, hence has lower traffic density and better LOS comparing with tapered type exit ramp, but for the parallel exit ramp, there are no significant difference between one-lane or two-lane exit ramp. In most cases, it's the same for tapered one-lane exit and two-lane exit, except at high entry volume.

Tapered two-lane exit ramp has the highest main line volume while the parallel two-lane exit ramp has the lowest main line volume. That's probably because that tapered type design gives the vehicles along the freeway a higher running speed, the discharging volume of tapered two-lane is the highest.

In terms of exit type, parallel type has 6.9% and 3.7% less traffic than tapered type when the exit ramp has one lane and two lanes respectively within functional area.

General, in terms of traffic discharging volume, the tapered two-lane exit ramp has the best operational performance. It has the highest discharging rate compared with other three exit type.

Chapter 6 Traffic Speed Comparisons

6.1. Introduction

The previous chapters research the traffic discharging volume characteristics of different exit types. This chapter analyzes the speed patterns at exit ramps based on the traffic data collected from the CORSIM simulation.

The experiment design for speed analyses is the same as that in traffic volume analyses in pervious chapters. A total 7500 feet freeway was deployed to detect the speeds of vehicles passing them.

It compares the traffic operational speed before, within and after the functional area of an exit ramp. The 7500 feet length freeway was divided into three parts for comparison, the first 2500 feet length was believed before the functional area of exit ramp, motorist were assumed to drive similar to a long freeway segment without the influence of on-ramp and exit ramp; the second 2500 feet length was believed within the functional area of exit ramp, actually, the start of auxiliary lane occurs within this segment, the traffic turbulence is believed to happen mostly within this area, traffic speed is deemed at giant derivation; the third 2500 feet length was believed the exiting vehicle cleared from the freeway mainline the remaining vehicles will speed up to recover the lost time caused by queuing, avoiding and/or unnecessary lane changing.

Different from the volume discharging at exit ramps, the definition of speed at work zones is the same as that in freeway. There is no controversial and different between speed at work zones and that on freeway. In classical traffic flow theories there were two methods to record traffic speed in macroscopic speed characteristics. One was time-mean speed and the other was space-mean speed.

Macroscopic speed characteristics were those speed characteristics of vehicle groups passing a point or short segment during a specified period of time or traveling over longer sections of highway. Time-mean speed and space-mean speed were two types of methods to describe the speed conditions.

Time-mean speed was the average or mean of individual speeds recorded for vehicles passing a particular point or short segment over a selected time period. The equation was as follows.

ANOVA and Turkey test are used for the statistical comparisons.

6.2. Mean Speed Comparisons

The designed three scenarios are corresponding to traffic volume less than capacity, close to capacity and greater than capacity respectively. All three scenarios are run 5 times for the four exit ramp types.

6.2.1. Before Functional Area at Low Entry Volume

The simulation run results before functional area at scenario 1, the entry volume are lower than the capacity, are list at table 34, the ANOVA analysis are list at table 35. Since F test shows insignificant, Tukey analysis is unnecessary.

Figure 33 is the illustration of mean speed comparison. It can be concluded that before functional area of exit ramp, when the entry volume of freeway is lower than the capacity, there were no significant difference of traffic speed generated at three-lane freeway. This is the same thing as traffic discharging volume generated.

Table 34 Mean Speed at LEV before FA

Ramp Type	N	Mean	Std. Deviation	Std. Error	95% Confidence Interval for Mean		Minimum	Maximum
					Lower Bound	Upper Bound		
1	15	67.805	.55	.14	67.5	68.1	66.9	68.6
2	15	67.775	.53	.14	67.5	68.1	66.7	68.4
3	15	67.643	.56	.14	67.3	67.9	66.7	68.6
4	15	67.800	.65	.17	67.4	68.2	66.6	68.9
Total	60	67.8	.56	.073	67.6	67.9	66.6	68.9

Table 35 ANOVA Results of Mean Speed at LEV before FA

	Sum of Squares	df	Mean Square	F	Sig.
Between Groups	0.2	3	.086	.261	.853
Within Groups	18.4	56	.329		
Total	18.7	59			

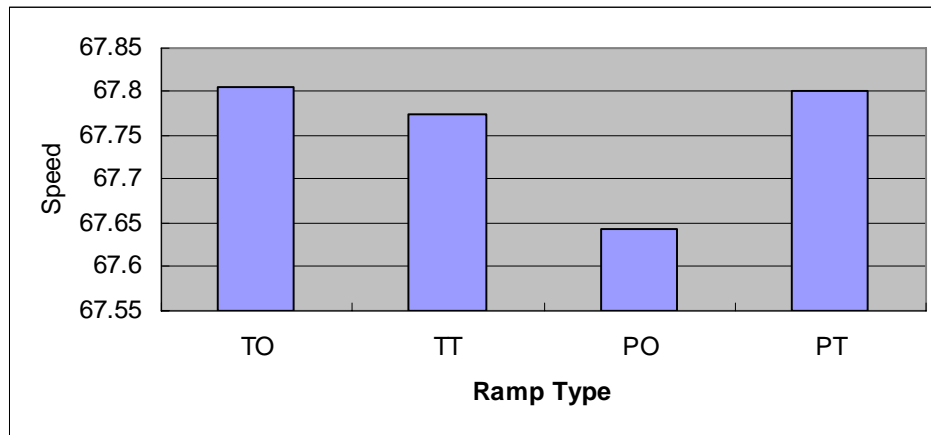

Figure 33 Mean Speed Comparisons at LEV before FA

6.2.2. Within Functional Area at Low Entry Volume

Table 36 Mean Speed within Functional Area at LEV within FA

Ramp Type	N	Mean	Std. Deviation	Std. Error	95% Confidence Interval for Mean		Minimum	Maximum
					Lower Bound	Upper Bound		
1	15	66.611	.846	.22	66.1	67.1	65.4	68.0
2	15	66.702	.674	.17	66.3	67.1	65.6	67.8
3	15	66.735	.701	.18	66.3	67.1	65.8	68.1
4	15	66.851	.758	.20	66.4	67.3	65.6	67.9
Total	60	66.7	.734	.095	66.5	66.9	65.4	68.1

Table 37 ANOVA Results of Mean Speed at LEV within FA

	Sum of Squares	df	Mean Square	F	Sig.
Between Groups	.441	3	.147	.263	.852
Within Groups	31.317	56	.559		
Total	31.758	59			

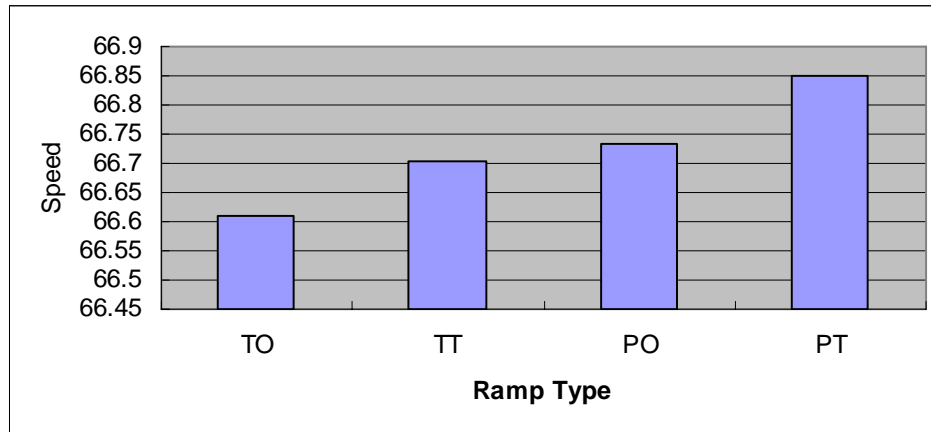

Figure 34 Mean Speed Comparisons at LEV within FA

The simulation run results within functional area at scenario 1, the entry volume are lower than the capacity, are list at table 36, the ANOVA analysis are list at table 37. Since F test shows insignificant, Tukey analysis is unnecessary.

Figure 34 is the illustration of mean speed comparisons. It can be concluded that within functional area of exit ramp, when the entry volume of freeway is lower than the capacity, there were no significant difference of traffic speed generated at three-lane freeway. This is the same thing as traffic volume generated.

6.2.3. After Functional Area at Low Entry Volume

The simulation run results after functional area at scenario 1 are list at table 38, the ANOVA analysis are list at table 39. Since F test shows insignificant, Tukey analysis is unnecessary.

Table 38 Mean Speed at LEV after FA

Ramp Type	N	Mean	Std. Deviation	Std. Error	95% Confidence Interval for Mean		Minimum	Maximum
					Lower Bound	Upper Bound		
1	15	66.582	.547	.14	66.3	66.9	65.8	67.5
2	15	66.521	.466	.12	66.3	66.8	65.7	67.4
3	15	66.560	.635	.16	66.2	66.9	65.5	68.1
4	15	66.653	.672	.17	66.3	67.0	65.5	67.7
Total	60	66.579	.572	.074	66.4	66.7	65.5	68.1

Table 39 ANOVA Results of Mean Speed at LEV after FA

	Sum of Squares	df	Mean Square	F	Sig.
Between Groups	.139	3	.046	.135	.939
Within Groups	19.198	56	.343		
Total	19.337	59			

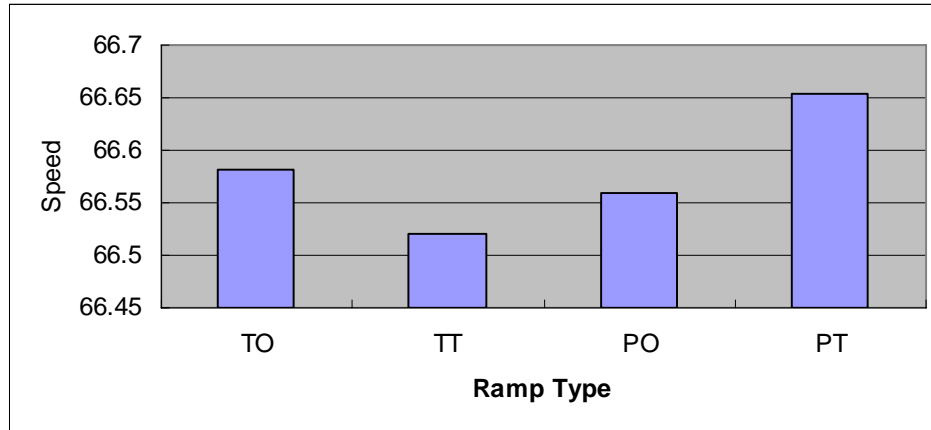

Figure 35 Mean Speed Comparisons at LEV after FA

Figure 35 is the illustration of mean speed comparisons. It can be concluded that after functional area of exit ramp, when the entry volume of freeway is lower than the capacity, there were no significant difference of traffic speed generated at three-lane freeway. This is the same thing as traffic volume generated.

To sum up, in terms of running speed, when the entry volume is lower than the capacity, there is no significant difference among these four types of exit ramp.

6.2.4. Before Functional Area at Medium Entry Volume

Table 40 Mean Speed at MEV before FA

Ramp Type	N	Mean	Std. Deviation	Std. Error	95% Confidence Interval for Mean		Minimum	Maximum
					Lower Bound	Upper Bound		
1	15	57.184	.246	.064	57.0	57.3	56.7	57.5
2	15	57.225	.318	.082	57.0	57.4	56.8	57.8
3	15	57.262	.276	.071	57.1	57.4	56.7	57.7
4	15	57.078	.239	.062	56.9	57.2	56.7	57.4
Total	60	57.187	.274	.035	57.1	57.2	56.7	57.8

Table 41 ANOVA Results of Mean Speed at MEV before FA

	Sum of Squares	df	Mean Square	F	Sig.
Between Groups	.284	3	.095	1.281	.290
Within Groups	4.143	56	.074		
Total	4.428	59			

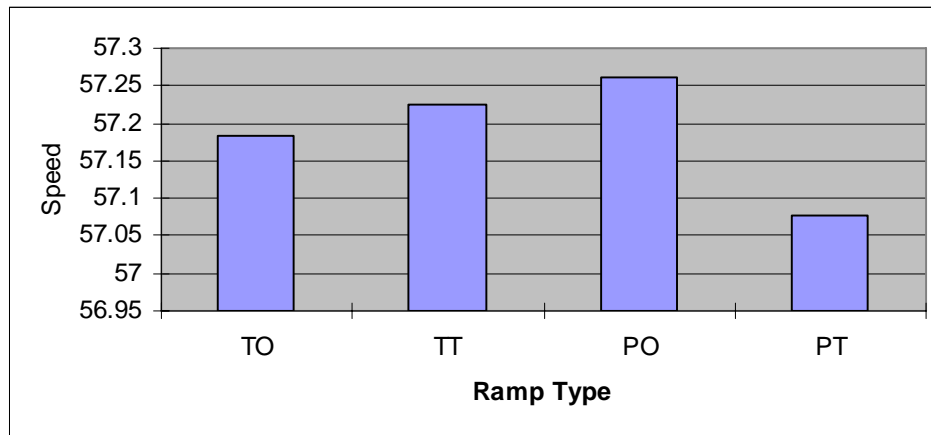

Figure 36 Mean Speed Comparisons at MEV before FA

The simulation run result before functional area at scenario 2, the traffic entry volume close to the capacity, are list at table 40, the ANOVA analysis are list at table 41. Since F test shows insignificant, Tukey analysis is unnecessary.

Figure 36 is the illustration of mean speed comparisons. It can be concluded that before functional area of exit ramp, when the entry volume of freeway is lower than the capacity, there were no significant difference of traffic speed generated at three-lane freeway. This is the same thing as traffic volume generated.

6.2.5. Within Functional Area at Medium Entry Volume

The simulation run results within functional area at scenario 2, the volume close to the freeway capacity, are list at table 42, the ANOVA analysis are list at table 43. Since F test shows significant, Tukey analysis is necessary. Table 44 is the Tukey test results.

Figure 37 is the illustration of mean speed comparisons. It can be concluded that within functional area of exit ramp, when the entry volume is close to the capacity, there are significant difference between different exit ramps, the ramp type pair are TO and PT,

which is tapered one-lane and parallel two-lane exit type, parallel two-lane exit has the faster main line speed than tapered one-lane exit. But there is no significant difference between parallel one-lane or two-lane exit type.

Table 42 Mean Speed at MEV within FA

	N	Mean	Std. Deviation	Std. Error	95% Confidence Interval for Mean		Minimum	Maximum
					Lower Bound	Upper Bound		
1	15	55.359	1.365	.352	54.6	56.1	53.1	56.6
2	15	55.712	.838	.216	55.2	56.2	54.0	56.8
3	15	56.203	.541	.140	55.9	56.5	55.4	57.0
4	15	56.230	.457	.118	56.0	56.5	55.5	56.9
Total	60	55.876	.928	.120	55.6	56.1	53.1	57.0

Table 43 ANOVA Results of Mean Entry Volume at MEV within FA

	Sum of Squares	df	Mean Square	F	Sig.
Between Groups	7.895	3	2.632	3.432	.023
Within Groups	42.940	56	.767		
Total	50.835	59			

Table 44 Tukey Results of Mean Speed at MEV within FA

Sig.	TO	TT	PO	PT
TO	N/A	.690	.051	.042
TT	.690	N/A	.423	.375
PO	.051	.423	N/A	1.00
PT	.042	.375	1.00	N/A

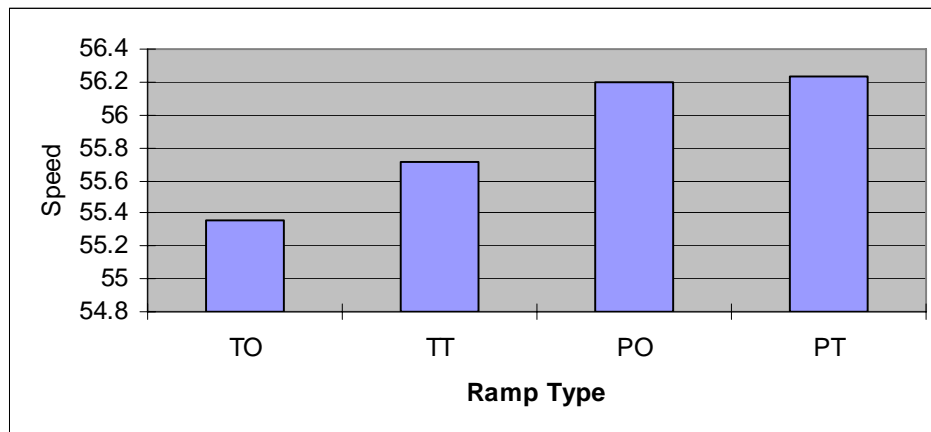

Figure 37 Mean Speed Comparisons at MEV within FA

6.2.6. After Functional Area at Medium Entry Volume

The simulation run results after functional area at scenario 2, the volume close to the freeway capacity, are list at table 45, the ANOVA analysis are list at table 46. Since F test shows insignificant, Tukey analysis is unnecessary.

Figure 38 is the illustration of mean speed comparisons. It can be concluded that after functional area of exit ramp, when the entry volume is close to the capacity, there are no significant difference between different exit ramps.

Table 45 Mean Speed at MEV after FA

	N	Mean	Std.	Std.	95% Confidence Interval for Mean		Minimum	Maximum
			Deviation	Error	Lower Bound	Upper Bound		
1	15	56.277	.382	.099	56.1	56.5	55.5	57.0
2	15	56.097	.540	.139	55.8	56.4	55.3	56.9
3	15	56.209	.489	.126	55.9	56.5	55.1	57.0
4	15	56.236	.473	.122	56.0	56.5	55.5	57.3
Total	60	56.205	.467	.060	56.1	56.3	55.1	57.3

Table 46 ANOVA Results of Mean Speed at MEV after FA

	Sum of Squares	df	Mean Square	F	Sig.
Between Groups	.269	3	.090	.398	.755
Within Groups	12.607	56	.225		
Total	12.876	59			

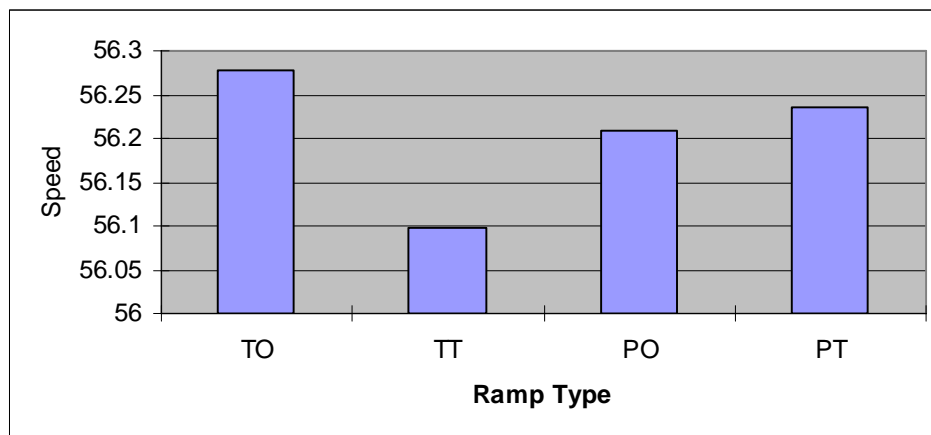

Figure 38 Mean Speed Comparisons at MEV after FA

To sum up, when the entry volume is close to the capacity of exit ramp, there are still has limited difference among difference exit ramps, except the pair of TO-PT within the functional area, tapered one-lane exit has the lowest running speed.

6.2.7. Before Functional Area at High Entry Volume

The simulation run results before functional area at scenario 3, the volume greater than the freeway capacity, are list at table 16, the ANOVA analysis are list at table 17.

Since F test shows significant, Tukey analysis is necessary.

Table 47 Mean Speed at HEV before FA

Ramp Type	N	Mean	Std. Deviation	Std. Error	95% Confidence Interval for Mean		Minimum	Maximum
					Lower Bound	Upper Bound		
1	15	35.257	4.755	1.227	32.6	37.9	25.7	43.9
2	15	46.449	5.908	1.525	43.2	49.7	37.9	52.0
3	15	51.871	.324	.084	51.7	52.0	51.3	52.5
4	15	51.819	.261	.067	51.7	52.0	51.4	52.3
Total	60	46.349	7.767	1.002	44.3	48.3	25.7	52.5

Table 48 ANOVA Results of Mean Speed at HEV before FA

	Sum of Squares	df	Mean Square	F	Sig.
Between Groups	2751.982	3	917.327	63.603	.000
Within Groups	807.666	56	14.423		
Total	3559.648	59			

Table 49 Tukey Results of Mean Speed at HEV before FA

Sig.	TO	TT	PO	PT
TO	N/A	.000	.000	.000
TT	.000	N/A	.001	.002
PO	.000	.001	N/A	1.000
PT	.000	.002	1.000	N/A

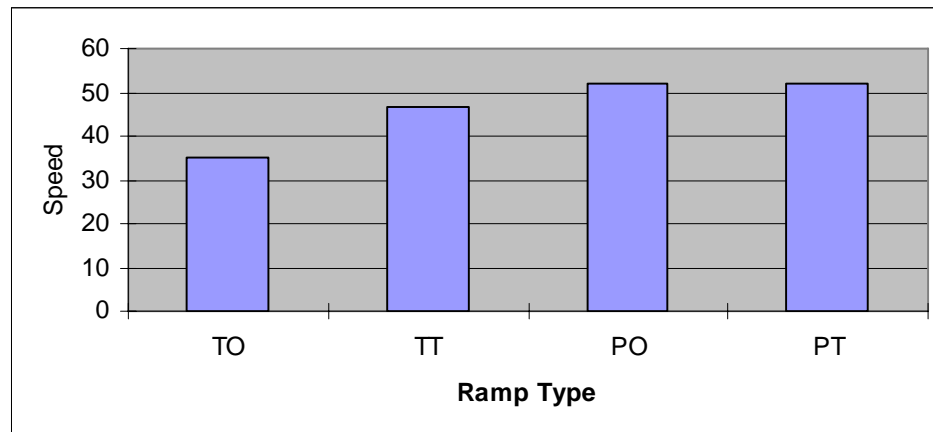

Figure 39 Mean Speed Comparisons at HEV before FA

Figure 39 is the illustration of mean speed comparisons. It can be concluded that before functional area of exit ramp, when the entry volume is greater than the capacity, there are significant difference between different exit ramps. Except the parallel one-lane exit and parallel two-lane exit type, all other exit type pairs are statistically different. Tapered one-lane exit has the lowest running speed, while the parallel exit types have the highest running speed. It can be concluded that parallel type exit ramp can retain higher entry speed (from 60mph to approximately 51 mph), the tapered exit ramp type are easily losing their original speed. But the difference between parallel one-lane and parallel two-lane are insignificant.

In terms of exit type, parallel exit has 32% and 10% higher speed than tapered exit at one-lane and two-lane exit respectively. The percentage is much higher than that of discharging volume.

In terms of exit number, tapered two-lane has 24.1% higher speed than tapered one-lane. That is still much higher than the discharging volume.

It can be concluded from the simulation data that speed are easier to be lost than the discharging volume. They are more sensitive to the entry volume.

6.2.8. Within Functional Area at High Entry Volume

The simulation run results within functional area at scenario 3, the volume greater than the freeway capacity, are list at table 50, the ANOVA analysis are list at table51. Since F test shows significant, Tukey analysis is necessary.

Table 50 Mean Speed at HEV within FA

Ramp Type	N	Mean	Std. Deviation	Std. Error	95% Confidence Interval for Mean		Minimum	Maximum
					Lower Bound	Upper Bound		
1	15	29.184	4.931	1.273	26.4	31.9	21.9	36.3
2	15	39.778	5.172	1.335	36.9	42.6	29.0	48.0
3	15	49.708	.841	.217	49.2	50.2	47.8	50.9
4	15	49.822	.712	.1839	49.4	50.2	48.3	50.6
Total	60	42.123	9.277	1.197	39.7	44.5	21.9	50.9

Table 51 ANOVA Results of Mean Speed at HEV within FA

	Sum of Squares	df	Mean Square	F	Sig.
Between Groups	4345.848	3	1448.616	110.841	.000
Within Groups	731.879	56	13.069		
Total	5077.727	59			

Table 52 Tukey Results of Mean Speed at HEV within FA

Sig.	TO	TT	PO	PT
TO	N/A	.000	.000	.000
TT	.000	N/A	.000	.000
PO	.000	.000	N/A	1.000
PT	.000	.000	1.000	N/A

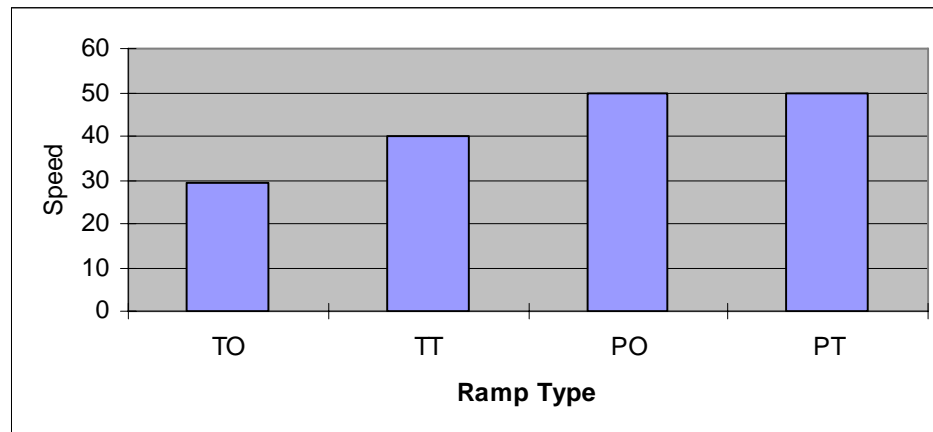

Figure 40 Mean Speed Comparisons at HEV within FA

Figure 40 is the illustration of mean speed comparisons. It can be concluded that within functional area of exit ramp, when the entry volume is greater than the capacity, there are significant difference between different exit ramps. Except the parallel one-lane exit and parallel two-lane exit type, all other exit type pairs are statistically different. Tapered one-lane exit has the lowest running speed, while the parallel exit types have the highest running speed. It can be concluded that parallel type exit ramp can retain higher entry speed (from 60mph to approximately 50 mph), the tapered exit ramp type are easily losing their original speed. That's quite the same as before the functional area of exit ramp. But still, the difference between PO and PT are insignificant.

In terms of exit type, parallel exit has 41.3% and 20.2% higher speed than tapered exit for one-lane and two-lane exit respectively. In terms of exit lane number, two-lane has 26.6% higher speed than one-lane for tapered type. That is still more significant than the discharging volume.

6.2.9. After Functional Area at High Entry Volume

The simulation run results after functional area at scenario 3, the volume greater than the freeway capacity, are list at table 53, the ANOVA analysis are list at table 54. Since F test shows significant, Tukey analysis is necessary.

Table 53 Mean Speed at HEV after FA

Ramp Type	N	Mean	Std. Deviation	Std. Error	95% Confidence Interval for Mean		Minimum	Maximum
					Lower Bound	Upper Bound		
1	15	48.856	.665	.172	48.5	49.2	47.6	50.0
2	15	48.856	.564	.146	48.5	49.2	47.8	49.5
3	15	50.567	.667	.172	50.2	50.9	49.5	52.0
4	15	50.653	.540	.139	50.4	50.9	49.3	51.4
Total	60	49.733	1.067	.138	49.4	50.0	47.6	52.0

Table 54 ANOVA Results of Mean Speed at HEV after FA

	Sum of Squares	df	Mean Square	F	Sig.
Between Groups	46.198	3	15.399	41.129	.000
Within Groups	20.967	56	.374		
Total	67.165	59			

Table 55 Tukey Results of Mean Speed at HEV after FA

Sig.	TO	TT	PO	PT
TO	N/A	1.000	.000	.000
TT	1.000	N/A	.000	.000
PO	.000	.000	N/A	.980
PT	.000	.000	.980	N/A

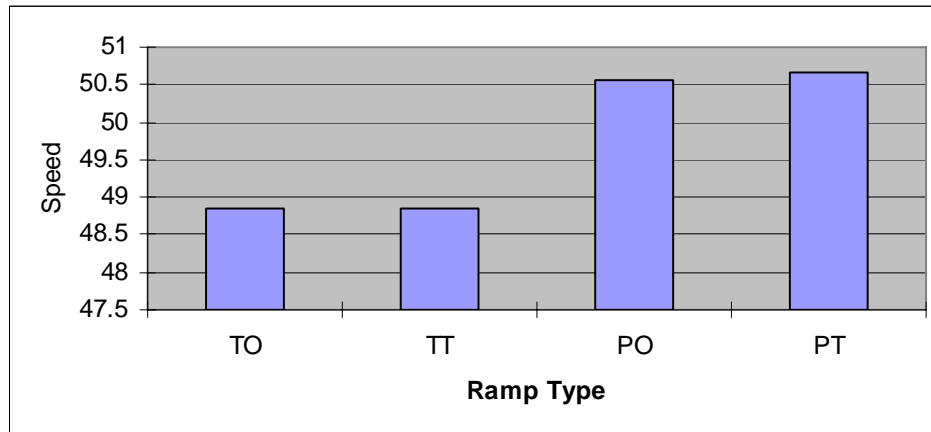

Figure 41 Mean Speed Comparisons at HEV after FA

Figure 41 is the illustration of mean speed comparisons. It can be concluded that after functional area of exit ramp, when the entry volume is greater than the capacity, there are significant difference between different exit ramps. The parallel exit types have

very obviously difference with tapered exit types, but the one-lane exit and two-lane exit has very limited difference.

It is obvious that parallel exit type has faster running speed comparing with tapered exit type.

In terms of exit type, parallel has 3.4% and 3.5% higher speed than tapered exit for one-lane and two-lane respectively. Although it is still significant statistically, but the gap can be omitted comparing with what happened within the functional area.

6.3. Summary

Traffic speed characteristics at different exit ramp are different according to the entry traffic volume, the ANOVA and Tukey findings can be tabled here.

It was found that at high entry volume, no matter it's before, within or after functional area of an exit ramp, there are significant difference between exit ramp pairs. Except the pair of PO-PT, all other pairs are statically different before and within functional area of exit ramp. After functional area, except the pairs of TO-TT and PO-PT, all other pairs are different.

Table 56 ANOVA Findings for Speed

	Before Functional Area	Within Functional Area	After Functional Area
LEV	N	N	N
MEV	N	Y	N
HEV	Y	Y	Y

Table 57 Tukey Findings for Speed

	Before Functional Area	Within Functional Area	After Functional Area
LEV	N/A	N/A	N/A
MEV	N/A	TO-PO TO-PT	N/A
HEV	TO-TT,TO-PO,TO-PT TT-PO,TT-PT	TO-TT,TO-PO,TO-PT TT-PO,TT-PT	TO-PO,TO-PT TT-PO,TT-PT

The running speed has 10% to 32% difference between the tabled pairs before the functional area; it also has 20.2% to 41.3% difference within the functional area. After functional area, the difference is reduced to 3.4% and 3.5% respectively. It seemed that speed is not easily to be preserved as traffic discharging volume.

To sum up, speeds generated are mostly alike at low or medium entry volumes, but at high volumes, parallel type exit ramp can have higher operational speed to compare with tapered type exit ramp. But the difference between parallel two-lane exit and parallel one-lane exit is not significant.

Chapter 7 Lane Change Comparisons

7.1. Introduction

The previous chapters research the traffic speed characteristics of different exit types. This chapter analyzes the lane change characteristics at exit ramps based on the traffic data collected from the CORSIM simulation.

Conventional traffic flow theory dictates that flow on a freeway is usually constrained only by a small number of critical locations or bottlenecks. When active, these bottlenecks cause queues that can stretch for several miles and reduce flow on other parts of the network. Bottlenecks are often thought to arise over short distances and are usually modeled as if they occur at discrete points since the resulting queues are thought to be much longer than the bottleneck region.^{XIV}

Their book presents evidence that the delay causing phenomena may actually occur over extended distances. Some of which may occur downstream of the apparent bottleneck where drivers are accelerating away from the queue, while related phenomena are observed in the queue, over a mile upstream of the apparent bottleneck. It is shown that lane change maneuvers are responsible for some of the losses, reducing travel speed and consuming capacity when vehicles enter a given lane. These losses in one lane are not fully balanced by gains in other lanes.

The lane change maneuver was not clearly researched at exit ramp area. The experiment design for lane change number analyses is the same as that in traffic volume and traffic speed analyses in previous two chapters. A total 7500 feet freeway was deployed to detect the speeds of vehicles passing them.

It compares the average lane change number before, within and after the functional area of an exit ramp. The 7500 feet length freeway was divided into three parts for

comparison, the first 2500 feet length was believed before the functional area of exit ramp, motorist were assumed to drive similar to a long freeway segment without the influence of on-ramp and exit ramp; the second 2500 feet length was believed within the functional area of exit ramp, actually, the start of auxiliary lane occurs within this segment, the traffic turbulence is believed to happen mostly within this area, traffic volume at different lane, traffic speed and total lane change maneuver is deemed at giant derivation ; the third 2500 feet length was believed the exiting vehicle cleared from the freeway mainline (although in some cases, the exiting vehicles are forced to drive along the freeway mainline because the headway space at the auxiliary lane are too short to make a safe lane change, in another word, they missed their destination), the remaining vehicles will speed up to recover the lost time caused by queuing, avoiding and/or unnecessary lane changing.

ANOVA and Turkey test are used for the statistical comparisons.

7.2. Total Lane Change Number Comparisons

The designed three scenarios are corresponding to traffic volume less than capacity, close to capacity and greater than capacity respectively. All three scenarios are run 5 times for the four exit ramp types.

7.2.1. Before Functional Area at Low Entry Volume

The simulation run results before functional area at scenario 1, the volume less than the freeway capacity, are list at table 58, the ANOVA analysis are list at table 59. Since F test shows insignificant, Tukey analysis is unnecessary.

Table 58 Mean Lane Change Number at LEV before FA

Ramp Type	N	Mean	Std. Deviation	Std. Error	95% Confidence Interval for Mean		Minimum	Maximum
					Lower Bound	Upper Bound		
1	5	210.0	24.6	11.0	179.5	240.5	187	240
2	5	203.2	23.4	10.4	174.2	232.2	176	234
3	5	217.6	21.5	9.6	190.9	244.3	196	251
4	5	210.8	10.9	4.9	197.3	224.3	201	227
Total	20	210.4	19.8	4.4	201.1	219.7	176	251

Table 59 ANOVA Results of Lane Change Number at LEV before FA

	Sum of Squares	df	Mean Square	F	Sig.
Between Groups	1560.000	3	520.000	1.404	.251
Within Groups	20744.400	56	370.436		
Total	22304.400	59			

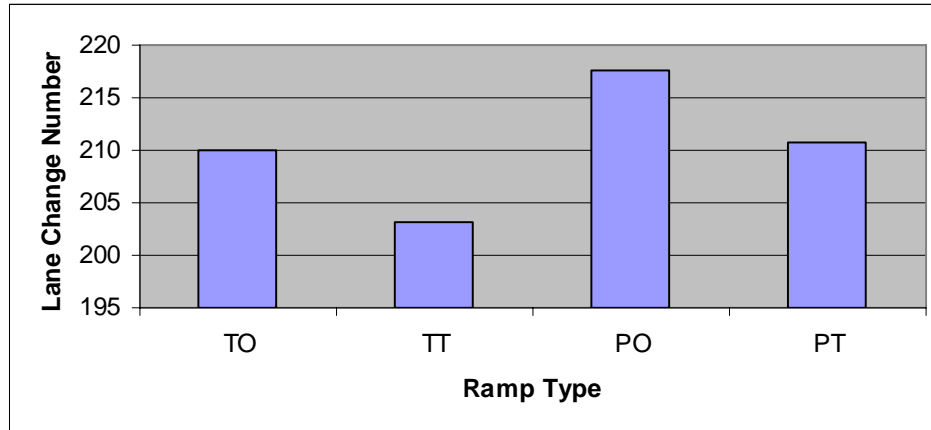

Figure 42 Mean Lane Change Comparisons at LEV before FA

Figure 42 is the illustration of mean lane change number comparisons. It can be concluded that before functional area of exit ramp, when the entry volume is less than the capacity, there are no significant difference between different exit ramps. This is quite the same thing as the traffic discharge volume and speed analysis.

7.2.2. Within Functional Area at Low Entry Volume

The simulation run results within functional area are list at table 60, the ANOVA analysis are list at table 61. Since F test shows the total lane change number of these four types of exit ramp is significant, Tukey analysis is necessary.

It can be concluded that within functional area of exit ramp, when the entry volume of freeway is lower than the capacity, there were significant difference of total lane change number generated at three-lane freeway. It is different from the analysis of discharging volume and speed. That is not difficult to understand, within functional, the lane number for different exit types are different, especially the parallel two-lane exit ramp, it has five-lane when close to the physical nose area (three-lane main line and two

auxiliary lanes). In contrast, the tapered one-lane exit ramp has three-lane all the way in the main line area.

Within Functional Area at Low Entry Volume, in terms of exit type, parallel type has 41.3% and 24% higher lane change number than tapered type for one-lane exit and two-lane exit respectively. In terms of exit number, two-lane exit has 30.1% and 9.5% than one-lane exit for tapered type and parallel type. It seemed that exit type has more impact on the lane change number than the exit lane number.

Table 60 Mean Lane Change Number at LEV within FA

Ramp Type	N	Mean	Std. Deviation	Std. Error	95% Confidence Interval for Mean		Minimum	Maximum
					Lower Bound	Upper Bound		
1	5	168.4	4.9	2.2	162.3	174.4	163	174
2	5	240.8	7.3	3.3	231.7	249.9	234	251
3	5	286.8	13.8	6.2	269.6	303.9	266	302
4	5	317.0	24.1	10.8	287.0	346.9	289	355
Total	20	253.2	59.0	13.2	225.6	280.8	163	355

Table 61 ANOVA Results of Lane Change Number at LEV within FA

	Sum of Squares	df	Mean Square	F	Sig.
Between Groups	62720.950	3	20906.983	98.305	.000
Within Groups	3402.800	16	212.675		
Total	66123.750	19			

Table 62 Tukey Results of Lane Change Number at LEV within FA

Sig.	TO	TT	PO	PT
TO	N/A	.000	.000	.000
TT	.000	N/A	.001	.000
PO	.000	.001	N/A	.022
PT	.000	.000	.022	N/A

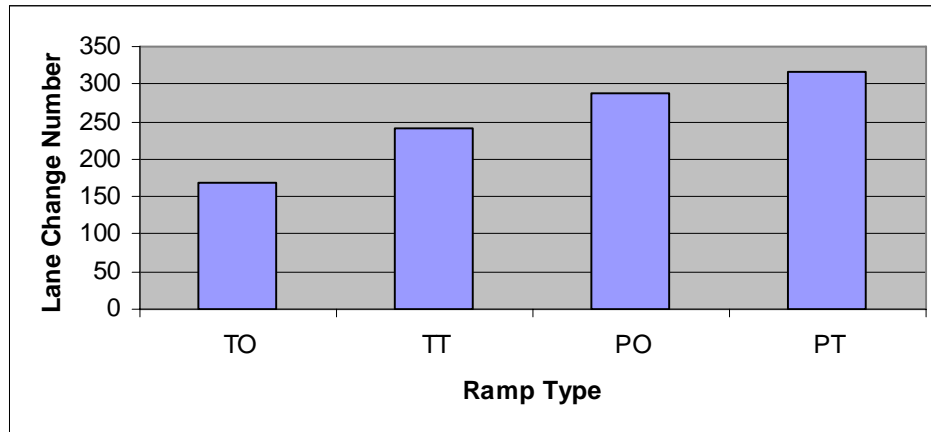

Figure 43 Mean Lane Change Comparisons at LEV within FA

7.2.3. After Functional Area at Low Entry Volume

The simulation run results after functional area are list at table 63, the ANOVA analysis are list at table 64. Since F test shows the total lane change number of these four types of exit ramp is significant, Tukey analysis is necessary.

Table 63 Mean Lane Change Number at LEV after FA

Ramp Type	N	Mean	Std. Deviation	Std. Error	95% Confidence Interval for Mean		Minimum	Maximum
					Lower Bound	Upper Bound		
1	5	156.0	11.0	4.9	142.3	169.7	142	170
2	5	173.4	14.9	6.7	154.9	191.9	163	199
3	5	164.8	10.0	4.5	152.4	177.2	152	178
4	5	150.6	11.0	4.9	137.0	164.2	141	164
Total	20	161.2	14.1	3.1	154.6	167.8	141	199

Table 64 ANOVA Results of Lane Change Number at LEV after FA

	Sum of Squares	df	Mean Square	F	Sig.
Between Groups	1506.000	3	502.000	3.555	.038
Within Groups	2259.200	16	141.200		
Total	3765.200	19			

Table 65 Tukey Results of Lane Change Number at LEV after FA

Sig.	TO	TT	PO	PT
TO	N/A	.136	.653	.888
TT	.136	N/A	.669	.036
PO	.653	.669	N/A	.271
PT	.888	.036	.271	N/A

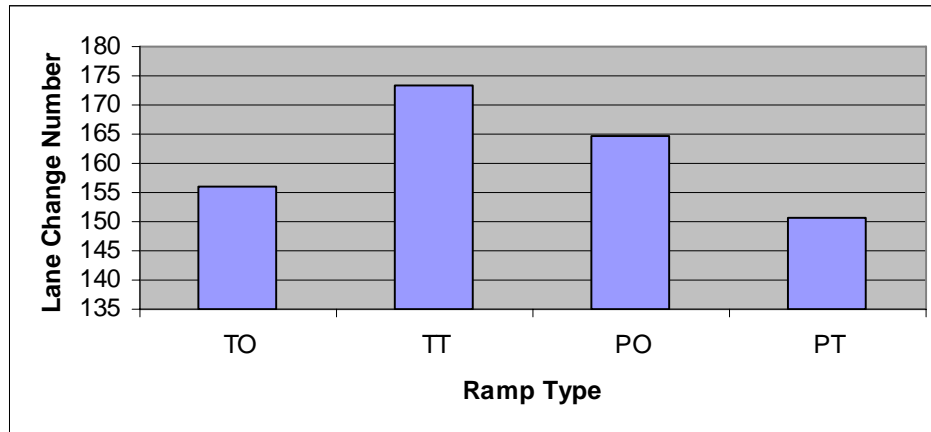

Figure 44 Mean Lane Change Comparisons at LEV after FA

Figure 44 is the illustration of mean lane change comparisons after functional area at low entry volume; it seemed that tapered two-lane and parallel two-lane exit ramp have the significant lane change number. The parallel two-lane exit has the least lane change number while the tapered two-lane exit has the most lane change number.

After functional at low entry volume, in terms of exit type, parallel has 13.1% less lane change number than tapered exit at two-lane.

In terms of exit lane number, two-lane have 10% more lane change number at tapered type, but it has 8.6% less lane change number at parallel type.

To summary, at low entry volume, in terms of total lane change number, there are no significant difference among these four types of exit ramp, except after the functional area. The tapered two-lane has the largest lane change number.

7.2.4. Before Functional Area at Medium Entry Volume

The simulation run results before functional area at scenario 2 are list at table 66, the ANOVA analysis are list at table 67. Since F test shows the total lane change number of these four types of exit ramp is insignificant, Tukey analysis is unnecessary. Figure 45 is the illustration of mean lane change comparisons before functional area at medium entry volume; it seemed although the parallel two-lane exit ramp has the most lane change number before the functional area, it's not statistically different. Parallel two-lane exit ramp has 8% higher lane change number than tapered two-lane exit ramp.

Table 66 Mean Lane Change Number at MEV before FA

Ramp Type	N	Mean	Std. Deviation	Std. Error	95% Confidence Interval for Mean		Minimum	Maximum
					Lower Bound	Upper Bound		
1	5	142.40	6.189	2.768	134.72	150.08	134	150
2	5	140.60	10.015	4.479	128.16	153.04	128	153
3	5	143.80	15.353	6.866	124.74	162.86	125	162
4	5	152.80	13.330	5.962	136.25	169.35	140	175
Total	20	144.90	11.809	2.641	139.37	150.43	125	175

Table 67 ANOVA Results of Lane Change Number at MEV before FA

	Sum of Squares	df	Mean Square	F	Sig.
Between Groups	441.800	3	147.267	1.067	.391
Within Groups	2208.000	16	138.000		
Total	2649.800	19			

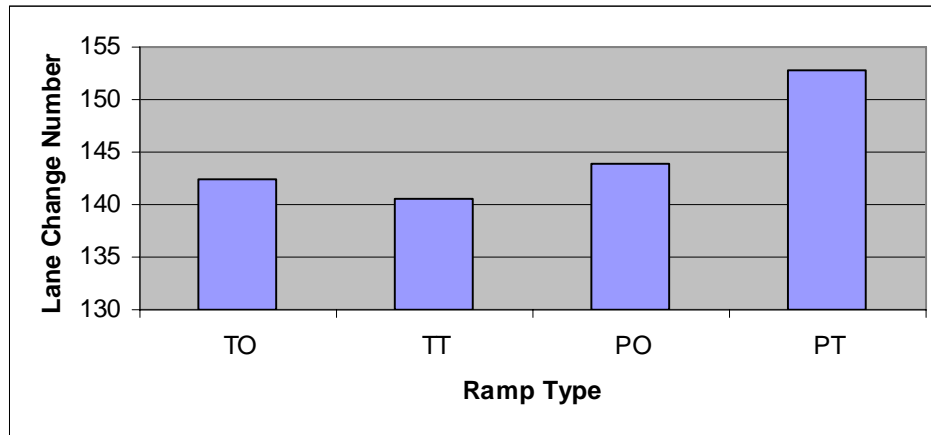

Figure 45 Mean Lane Change Comparisons at MEV before FA

7.2.5. Within Functional Area at Medium Entry Volume

Table 68 Mean Lane Change Number at MEV within FA

Ramp Type	N	Mean	Std. Deviation	Std. Error	95% Confidence Interval for Mean		Minimum	Maximum
					Lower Bound	Upper Bound		
1	5	410.4	23.2	10.4	381.6	439.2	373	430
2	5	497.6	30.4	13.6	459.9	535.3	445	523
3	5	560.6	28.4	12.7	525.3	595.9	536	607
4	5	654.4	36.6	16.4	609.0	699.8	615	703
Total	20	530.7	95.5	21.4	486.0	575.4	373	703

Table 69 ANOVA Results of Lane Change Number at MEV within FA

	Sum of Squares	df	Mean Square	F	Sig.
Between Groups	158816.950	3	52938.983	58.687	.000
Within Groups	14432.800	16	902.050		
Total	173249.750	19			

Table 70 Tukey Results of Lane Change Number at MEV within FA

Sig.	TO	TT	PO	PT
TO	N/A	.002	.000	.000
TT	.002	N/A	.020	.000
PO	.000	.020	N/A	.001
PT	.000	.000	.001	N/A

The simulation run results within functional area at scenario 2 are list at table 68, the ANOVA analysis are list at table 69. Since F test shows the total lane change number of these four types of exit ramp is significant, Tukey analysis is necessary.

Within Functional Area at medium entry volume, in terms of exit type, parallel type has 26.8% and 24% higher lane change number than tapered type for one-lane exit and two-lane exit respectively. In terms of exit number, two-lane exit has 17.5% and 14.3% than one-lane exit for tapered type and parallel type. It seemed that exit type has more impact on the lane change number than the exit lane number.

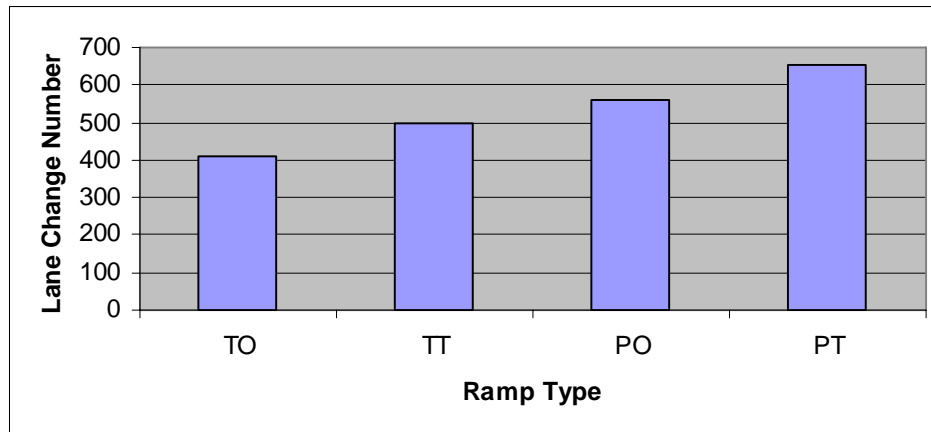

Figure 46 Mean Lane Change Comparison at MEV within FA

Figure 46 is the illustration of mean lane change comparisons within functional area at medium entry volume; it seemed that all these four types of exit ramp are statistically

different. The parallel two-lane exit ramp has the most lane change number within the functional area; the tapered one-lane exit type has the least lane change number.

7.2.6. After Functional Area at Medium Entry Volume

Table 71 Mean Lane Change Number at MEV after FA

Ramp Type	N	Mean	Std. Deviation	Std. Error	95% Confidence Interval for Mean		Minimum	Maximum
					Lower Bound	Upper Bound		
1	5	204.8	9.7	4.3	192.8	216.8	195	216
2	5	214.0	16.7	7.5	193.2	234.8	187	232
3	5	206.6	4.5	2.0	201.0	212.2	200	211
4	5	215.8	17.2	7.7	194.4	237.2	191	234
Total	20	210.3	13.0	2.9	204.2	216.4	187	234

Table 72 ANOVA Results of Mean Lane Change Number at MEV after FA

	Sum of Squares	df	Mean Square	F	Sig.
Between Groups	439.400	3	146.467	.849	.487
Within Groups	2758.800	16	172.425		
Total	3198.200	19			

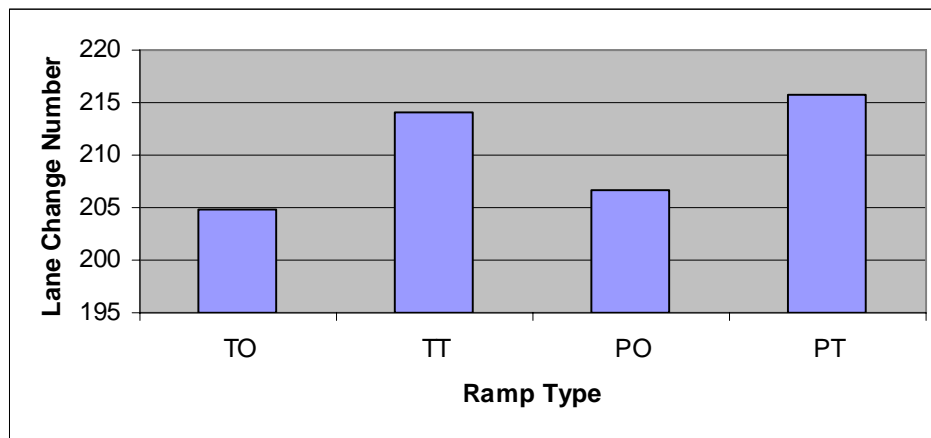

Figure 47 Mean Lane Change Comparisons at MEV after FA

The simulation run results after functional area at scenario 2 are list at table 71, the ANOVA analysis are listed at table 72. Since F test shows the total lane change number of these four types of exit ramp is insignificant, Tukey analysis is unnecessary.

Figure 47 is the illustration of mean lane change comparisons after functional area at medium entry volume; it seemed that all these four types of exit ramp are statistically insignificant.

7.2.7. Before Functional Area at High Entry Volume

Table 73 Mean Lane Change Number at HEV before FA

Ramp Type	N	Mean	Std. Deviation	Std. Error	95% Confidence Interval for Mean		Minimum	Maximum
					Lower Bound	Upper Bound		
1	5	211.8	53.5	23.9	145.4	278.2	168	292
2	5	178.8	50.2	22.4	116.4	241.1	128	248
3	5	142.0	10.6	4.8	128.8	155.2	128	153
4	5	144.4	8.8	3.9	133.5	155.3	135	156
Total	20	169.2	45.1	10.1	148.1	190.3	128	292

The simulation run results before functional area at scenario 3, the volume greater than the freeway capacity, are list at table 73, the ANOVA analysis are list at table 74. Since F test shows the total lane change number of these four types of exit ramp is significant, Tukey analysis is necessary. The Tukey test results are listed at table 75.

Table 74 ANOVA Results of Mean Lane Change Number at HEV before FA

	Sum of Squares	df	Mean Square	F	Sig.
Between Groups	16308.950	3	5436.317	3.900	.029
Within Groups	22300.800	16	1393.800		
Total	38609.750	19			

Table 75 Tukey Results of Lane Change Number at HEV before FA

Sig.	TO	TT	PO	PT
TO	N/A	.519	.042	.051
TT	.519	N/A	.428	.485
PO	.042	.428	N/A	1.000
PT	.051	.485	1.000	N/A

Figure 48 is the illustration of mean lane change comparisons before functional area at high entry volume; it seemed that only tapered one-lane exit ramp has statistically significant difference with parallel one-lane exit ramp. Other ramp types have no significant difference. Unlike the traditional concept, it is the tapered exit type, not the

parallel exit type has the most lane change number. It should not count too much since the deviation of TO be the biggest too.

At high entry volume before the functional area, in terms of exit type, parallel has 33% and 19.2% less lane change number than tapered exit for one-lane and two-lane respectively.

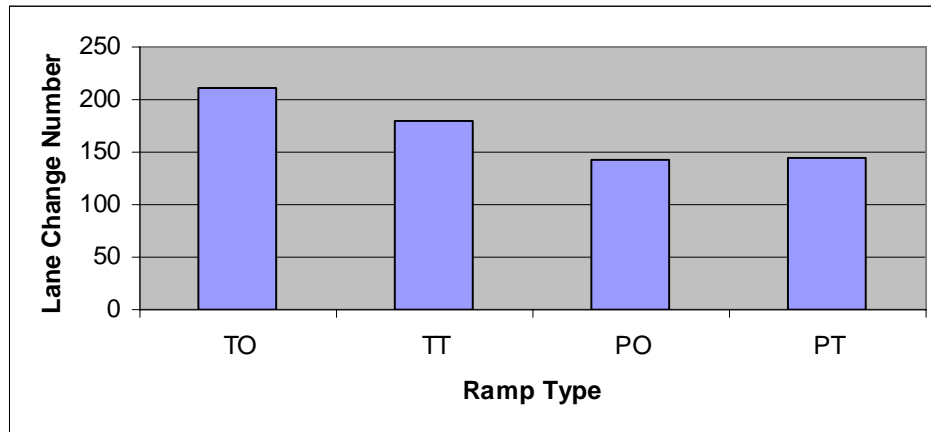

Figure 48 Mean Lane Change Comparisons at HEV before FA

7.2.8. Within Functional Area at High Entry Volume

The simulation run results within functional area at scenario 3, the volume greater than the freeway capacity, are list at table 76, the ANOVA analysis are list at table 77. Since F test shows the total lane change number of these four types of exit ramp is significant, Tukey analysis is necessary.

Table 76 Mean Lane Change Number at HEV within FA

Ramp Type	N	Mean	Std. Deviation	Std. Error	95% Confidence Interval for Mean		Minimum	Maximum
					Lower Bound	Upper Bound		
1	5	635.8	44.7	20.0	580.2	691.3	574	677
2	5	657.0	51.8	23.2	592.6	721.3	614	724
3	5	718.8	37.6	16.8	672.1	765.5	680	770
4	5	815.8	45.8	20.5	758.9	872.7	739	855
Total	20	706.8	82.9	18.5	668.0	745.6	574	855

Table 77 ANOVA Results of Lane Change Number at HEV within FA

	Sum of Squares	df	Mean Square	F	Sig.
Between Groups	97730.150	3	32576.717	15.890	.000
Within Groups	32802.400	16	2050.150		
Total	130532.550	19			

Table 78 Tukey Results of Lane Change Number at HEV within FA

Sig.	TO	TT	PO	PT
TO	N/A	.879	.047	.000
TT	.879	N/A	.177	.000
PO	.047	.177	N/A	.018
PT	.000	.000	.018	N/A

Figure 49 is the illustration of mean lane change comparisons within functional area at high entry volume; it seemed that the following exit ramp pairs are significant different: TO-PO, TO-PT, TT-PT, and PO-PT. The parallel two-lane exit type has the highest lane change number, while the tapered one-lane exit type has the least lane change numbers.

Within functional area at high entry volume, in terms of exit type, parallel has 11.5% and 19.5% higher lane change number to compare with tapered type for one-lane exit and two-lane exit respectively.

In terms of exit lane number, two-lane has 11.9% more lane change maneuver than one-lane exit at parallel type.

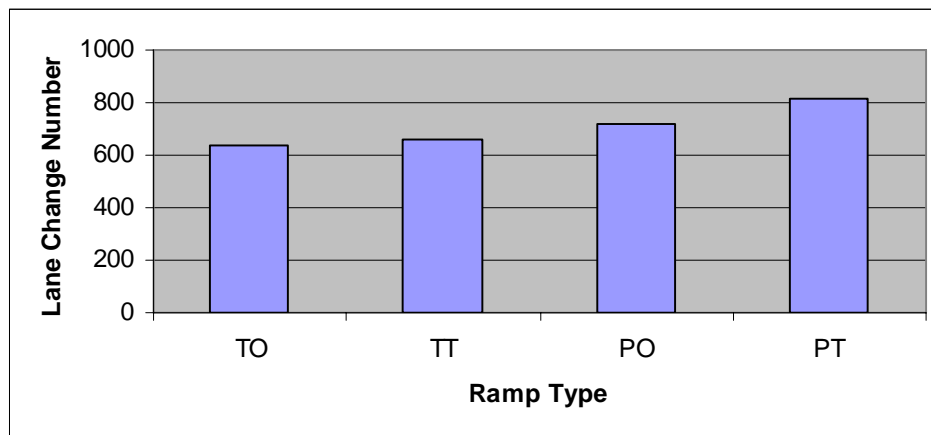

Figure 49 Lane Change Comparisons at HEV within FA

7.2.9. After Functional Area at High Entry Volume

The simulation run results after functional area at scenario 3, the volume greater than the freeway capacity, are list at table 79, the ANOVA analysis are list at table 80. Since F test shows the total lane change number of these four types of exit ramp is significant, Tukey analysis is necessary. Check table 81.

Table 79 Mean Lane Change Number at HEV after FA

Ramp Type	N	Mean	Std. Deviation	Std. Error	95% Confidence Interval for Mean		Minimum	Maximum
					Lower Bound	Upper Bound		
1	5	315.0	15.4	6.9	295.8	334.2	303	339
2	5	275.8	25.9	11.6	243.7	307.9	251	316
3	5	251.4	21.3	9.5	224.9	277.9	223	277
4	5	244.8	11.6	5.2	230.3	259.3	227	257
Total	20	271.7	33.3	7.4	256.1	287.4	223	339

Table 80 ANOVA Results of Mean Lane Change Number at HEV after FA

	Sum of Squares	df	Mean Square	F	Sig.
Between Groups	15136.950	3	5045.650	13.467	.000
Within Groups	5994.800	16	374.675		
Total	21131.750	19			

Table 81 Tukey Results of Mean Lane Change Number at HEV after FA

Sig.	TO	TT	PO	PT
TO	N/A	.026	.000	.000
TT	.026	N/A	.231	.092
PO	.000	.231	N/A	.948
PT	.000	.092	.948	N/A

Figure 50 is the illustration of mean lane change comparisons after functional area at high entry volume; it seemed that the exit ramp pair: TO-TT, TO-PO, and TO-PT are statistically significant. Tapered one-lane exit has the most lane change number after functional area, while the parallel two-lane exit ramp type has the least lane change number.

It is not difficult to understand; tapered one-lane exit ramp has less discharging rate than other exit ramps, especially the parallel exit ramp, when the traffic volume is

relatively low, most vehicles can take exit at the exit ramp area, after functional area, most vehicles still stay at the freeway main line will continue their destination, making the unnecessary lane change number less. Nevertheless, when the entry volume is much higher than the capacity, more amount of vehicles at tapered one-lane exit ramp will not be discharged and forced to continue driving on the main line, making the lane change number more after the functional to compare with other types of exit ramp type.

At high entry volume after functional area, in terms of exit type, parallel has less number of lane changes, the percentage is 25.3% and 12.7% for one-lane and two-lane exit respectively. In terms of exit lane number, two-lane has 14.2 less number of lane change than one-lane at tapered type.

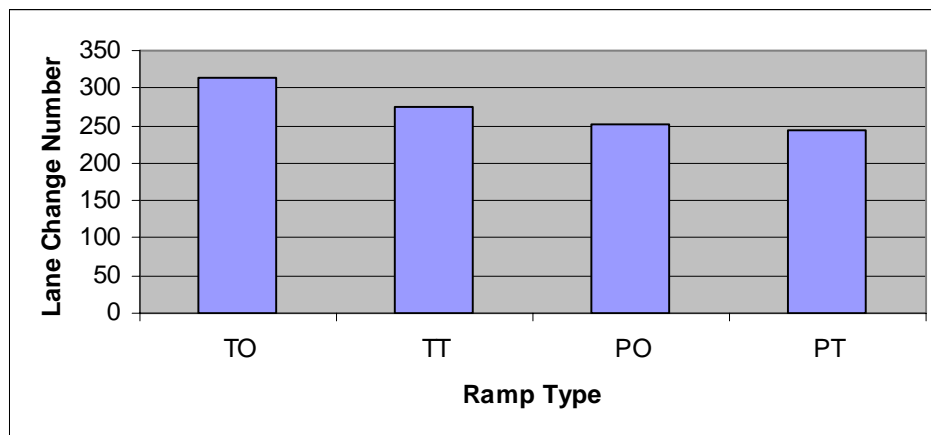

Figure 50 Mean Lane Change Comparisons at HEV after FA

7.3. Summary

The findings from this chapter are summarized at table 82, table 83.

It can be concluded that lane changing number is the most complicated factor, no matter at low entry volume, medium entry volume, or high entry volume, the exit ramp pairs are different except a few ramp pairs.

Within functional area, parallel type exit ramp has more lane changing number; two-lane exit ramp has more lane changing number. From the lane changing number of view,

tapered type exit is better than parallel type exit; one-lane exit ramp is better than two-lane exit ramp.

Within Functional Area at low entry volume, in terms of exit type, parallel type has 41.3% and 24% higher lane change number than tapered type for one-lane exit and two-lane exit respectively. In terms of exit number, two-lane exit has 30.1% and 9.5% than one-lane exit for tapered type and parallel type. It seemed that exit type has more impact on the lane change number than the exit lane number.

Before functional area at medium entry volume, parallel two-lane exit ramp has 8% higher lane change number than tapered two-lane exit ramp.

Within Functional Area at medium entry volume, in terms of exit type, parallel type has 26.8% and 24% higher lane change number than tapered type for one-lane exit and two-lane exit respectively. In terms of exit number, two-lane exit has 17.5% and 14.3% than one-lane exit for tapered type and parallel type. It seemed that exit type has more impact on the lane change number than the exit lane number.

At high entry volume before the functional area, in terms of exit type, parallel has 33% and 19.2% less lane change number than tapered exit for one-lane and two-lane respectively.

Within functional area at high entry volume, in terms of exit type, parallel has 11.5% and 19.5% higher lane change number to compare with tapered type for one-lane exit and two-lane exit respectively. In terms of exit lane number, two-lane has 11.9% more lane change maneuver than one-lane exit at parallel type.

At high entry volume after functional area, in terms of exit type, parallel has less number of lane changes, the percentage is 25.3% and 12.7% for one-lane and two-lane exit respectively. In terms of exit lane number, two-lane has 14.2% less number of lane change than one-lane at tapered type.

Table 82 ANOVA Findings for Lane Change Number

	Before Functional Area	Within Functional Area	After Functional Area
LEV	N	Y	Y
MEV	Y	Y	Y
HEV	Y	Y	Y

Table 83 Tukey Findings for Lane Change Number

	Before Functional Area	Within Functional Area	After Functional Area
LEV	N/A	All	TO-TT, TT-PT, PO-PT
MEV	TT-PT	All	TO-PT
HEV	TO-PO, TO-PT TT-PO, TT-PT	TO-PO, TO-PT, TT-PO TT-PT, PO-PT	TO-TT, TO-PO, TO-PT TT-PO, TT-PT

Chapter 8 Sensitivity Analysis

Sensitivity analysis is used to determine how “sensitive” a model is to changes in the value of the parameters of the model and to changes in the structure of the model. Parameter sensitivity is usually performed as a series of tests in which the modeler sets different parameter values to see how a change in the parameter causes a change in the dynamic behavior of the stocks. By showing how the model behavior responds to changes in parameter values, sensitivity analysis is a useful tool in model building as well as in model evaluation.

.Sensitivity analysis helps to build confidence in the model by studying the uncertainties that are often associated with parameters in models.

In this chapter, the parameter sensitivity was executed for entry volume, free flow speed, grade, truck percentage, restrictions to truck and the location of exit sign. All these factors are the external factors and were not researched well in the past studies. The purpose of sensitivity research at this chapter is trying to compare the impact of these external factors on the design of exit ramp, in another word, for instance, is truck restricted to the right two most lane has more impact on a certain exit type than other types? ANOVA and Tukey methodology were applied for comparisons. Linear regression model were developed also for the change of one variable and all available variables as well. It was found that most these input parameters are sensitive to the traffic discharging volume, operational speed and total lane changing number.

8.1. Entry Volume

To compare the effects of different entry volume on different freeway exit ramps, in terms of traffic volume, operational speed and total lane change number, an analysis of ANOVA and Tukey was conducted on the simulation data.

It is common sense that entry volume has a significant impact on the link traffic volume, running speed and total lane change number generated, but the correlation factor within and the functional area may not necessary be the same for these four types of exit ramp, according to the research results of previous chapter, we focus on the traffic features within the functional area, what happened before and after functional area is not necessary the research interest again..

8.1.1. Entry Volume Sensitivity before Functional Area

Table 84 and figure 51 shows that the impact of entry volume on running speed is significant. With the increase of entry volume, running speed decreases. But after 1800pcphpl (entry volume at more than 5400vph), the impact is insignificant according to Tukey analysis.

The R^2 is 0.981; it indicates a strong relation between entry volume and running speed.

Table 84 Entry Volume Sensitivity on Running Speed before FA

	Sum of Squares	df	Mean Square	F	Sig.
Between Groups	142.959	6	23.827	289.346	.000
Within Groups	16.716	203	.082		
Total	159.676	209			

Table 85 Entry Volume Sensitivity on Total Lane Change Number before FA

	Sum of Squares	df	Mean Square	F	Sig.
Between Groups	11008.029	6	1834.671	13.294	.000
Within Groups	28015.800	203	138.009		
Total	39023.829	209			

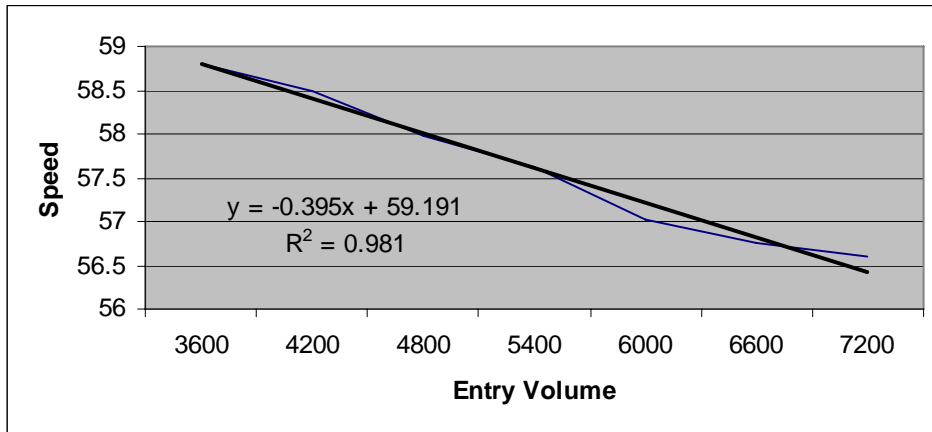

Figure 51 Entry Volume Sensitivity on Running Speed before FA

Table 85 and figure 52 shows that the entry volume has significant impact on total lane change number, the lane change number reaches the highest point at the 1800pcphpl, that means as the increase of entry volume, the lane change number increase until it meet the capacity, 1800pcphpl. After that, although there are more vehicles need make a lane change to exit, the space between vehicles are not sufficient to let exiting vehicles make a lane change.

The R^2 is 0.0095, it indicated than lane change has very limited relation with entry volume before functional area. High volume do not necessary mean large number of lane change, lane change is restricted by the capacity of the given freeway.

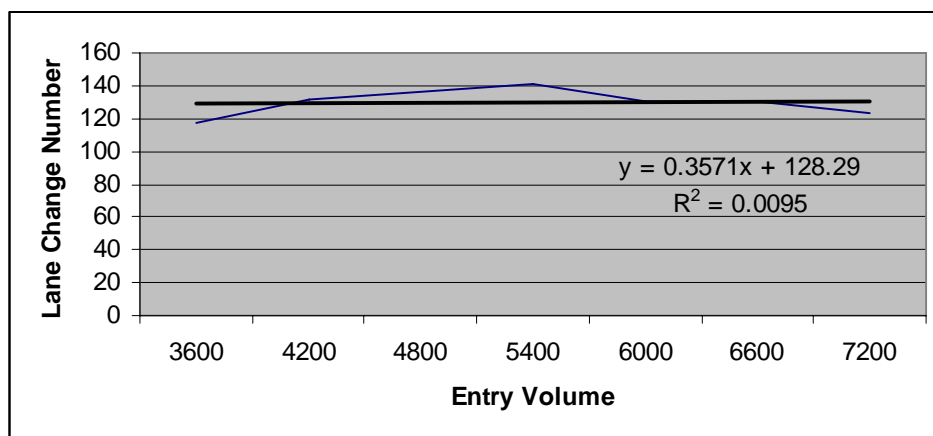

Figure 52 Entry Volume Sensitivity on Total Lane Change Number before FA

8.1.2. Entry Volume Sensitivity within Functional Area

Table 86, 87 and Figure 53, 54 shows the entry volume has significant impact on running speed and total lane change number within functional area, it's almost the same as before functional area in terms of running speed. Although the speed at entry volume 2400pcphl, it is insignificant. But the characteristics of lane change number are different; it seemed that most lane change number will happen at functional area with the increase of entry volume.

The R^2 is 0.9678 and 0.9509 for speed and lane change number respectively, that means within functional area, the linear regression model fit the speed and lane change number quiet well.

Table 86 Entry Volume Sensitivity on Running Speed within FA

	Sum of Squares	df	Mean Square	F	Sig.
Between Groups	380.616	6	63.436	30.019	.000
Within Groups	428.980	203	2.113		
Total	809.596	209			

Table 87 Entry Volume Sensitivity on Total Lane Change Number within FA

	Sum of Squares	df	Mean Square	F	Sig.
Between Groups	767248.629	6	127874.771	148.393	.000
Within Groups	174930.900	203	861.729		
Total	942179.529	209			

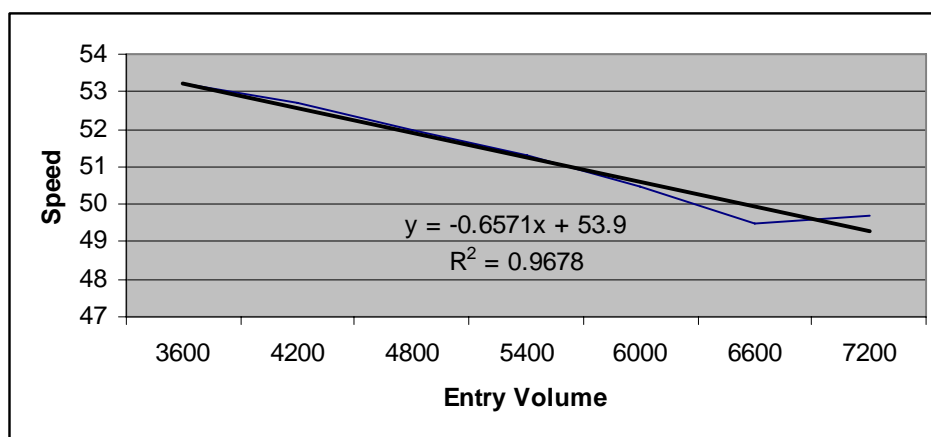

Figure 53 Entry Volume Sensitivity on Running Speed within FA

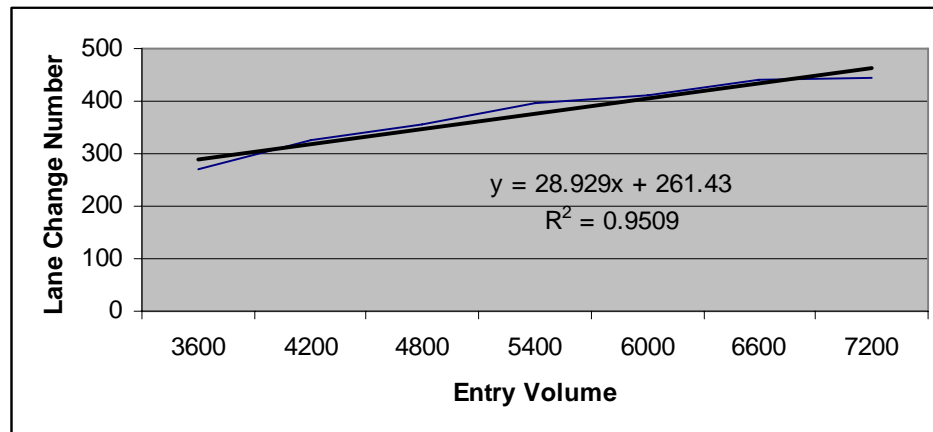

Figure 54 Entry Volume Sensitivity on Total Lane Change Number within FA

8.1.3. Entry Volume Sensitivity after Functional Area

Table 88, 89 and Figure 55, 56 shows the impact on running speed and total lane change number still significant after functional area.

The R2 is 0.9547 and 0.7457 for speed and total lane change respectively. Again, speed is directly controlled by entry volume, while the function of lane change are more complicated.

Table 88 Entry Volume Sensitivity on Running Speed after FA

	Sum of Squares	df	Mean Square	F	Sig.
Between Groups	105.904	6	17.651	86.056	.000
Within Groups	41.637	203	.205		
Total	147.541	209			

Table 89 Entry Volume Sensitivity on Total Lane Change Number after FA

	Sum of Squares	df	Mean Square	F	Sig.
Between Groups	85343.314	6	14223.886	37.574	.000
Within Groups	76848.000	203	378.562		
Total	162191.314	209			

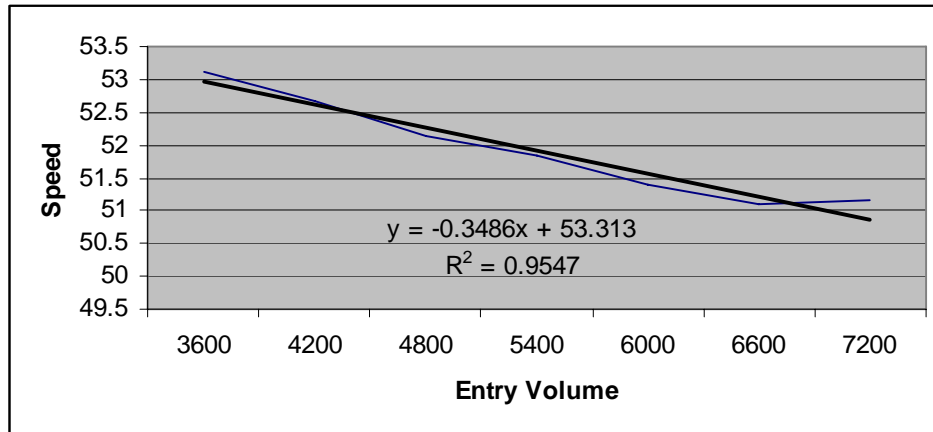

Figure 55 Entry Volume Sensitivity on Running Speed after FA

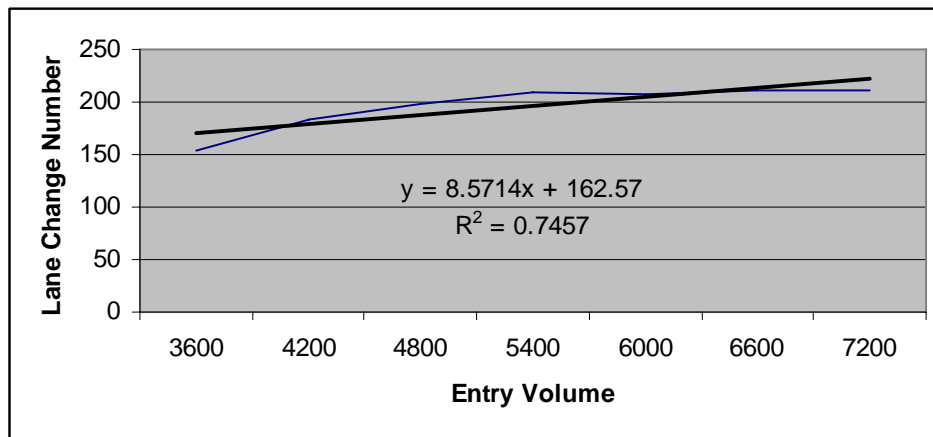

Figure 56 Entry Volume Sensitivity on Total Lane Change Number after FA

8.1.4. Entry Volume Sensitivity Sum up

To sum up, the operational speed and total lane change number are sensitive to the entry volume, no matter for what parts of the functional area.

When the entry volume reaches certain point, say, 1800pcphpl, basically the capacity of freeway, the running speed before functional are almost the same due to the discharging limit of exit ramp. It seemed lane change number goes with the increase of entry volume while the running speed decrease with the increase of entry volume. The lane change number meets a threshold when the entry volume is 1800pcphpl.

8.2. Free Flow Speed

The free flow speed may impact the link traffic volume, operational speed and lane change number; the analysis results are list below at table 90, 91 and 92 for the free flow speed on link traffic volume and total lane change number, before functional area.

In order to eliminate the impact of entry volume, the entry volume was focused on 2000pcphpl.

8.2.1. Free Flow Speed Sensitivity before Functional Area

Table 90, 91 and 92 are the free flow speed sensitivity analysis on freeway exit ramp before functional area. It was found that before functional area, the discharging volume is not sensitive to running speed, but sensitive to the total lane change number. The R^2 is 0.1761 and 0.998 for discharging volume and lane change respectively. With the increase of free flow speed, the lane change number decrease significantly.

Table 90 Free Flow Speed Sensitivity on Link Volume before FA

	Sum of Squares	df	Mean Square	F	Sig.
Between Groups	77.173	3	25.724	.041	.989
Within Groups	35015.001	56	625.268		
Total	35092.174	59			

Table 91 Free Flow Speed Sensitivity on Total Lane Change Number before FA

	Sum of Squares	df	Mean Square	F	Sig.
Between Groups	33082.050	3	11027.350	55.766	.000
Within Groups	11073.600	56	197.743		
Total	44155.650	59			

Table 92 Tukey Results of Free Flow Speed on Total Lane Change Number before FA

Sig.	55mph	60mph	65mph	70mph
55mph	N/A	.001	.000	.000
60mph	.001	N/A	.002	.000
65mph	.000	.002	N/A	.000
70mph	.000	.000	.000	N/A

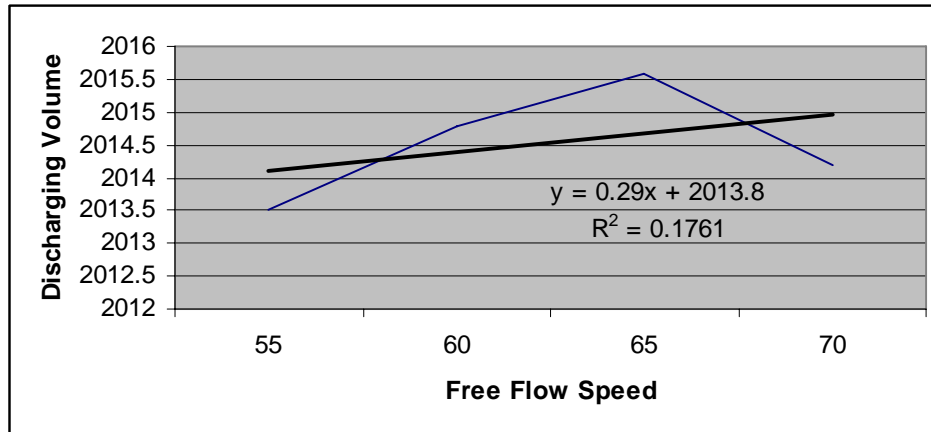

Figure 57 Free Flow Speed Sensitivity on Link Volume before FA

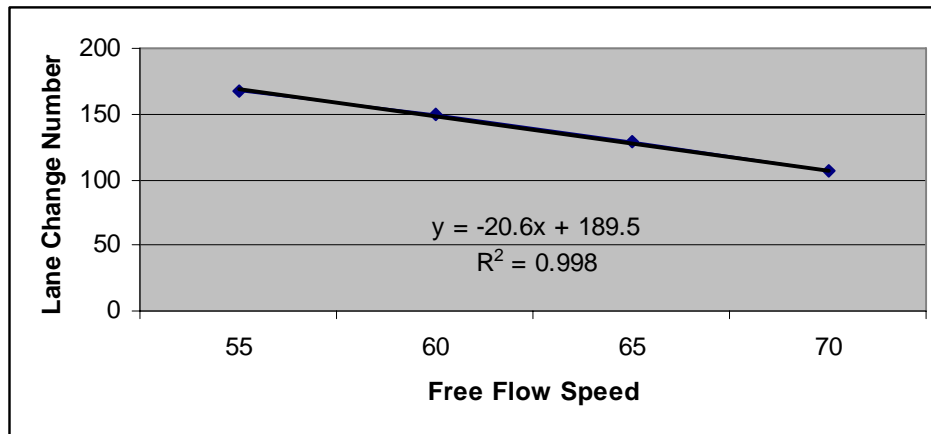

Figure 58 Free Flow Speed Sensitivity on Total Lane Change Number before FA

8.2.2. Free Flow Speed Sensitivity within Functional Area

The free flow speed sensitivity analysis within functional area is summarized at table 93, 94 and 95. Figure 59, 60 are the illustrations. The R^2 is 0.3984 and 0.4393 for discharging volume and lane change maneuver respectively. It indicates that the traffic flow is more complicated within functional area than before functional area.

Table 93 Free Flow Speed Sensitivity on Link Volume within FA

	Sum of Squares	df	Mean Square	F	Sig.
Between Groups	53.898	3	17.966	.001	1.000
Within Groups	1589537.645	56	28384.601		
Total	1589591.542	59			

Table 94 Free Flow Speed Sensitivity on Lane Change Number within FA

	Sum of Squares	df	Mean Square	F	Sig.
Between Groups	18669.000	3	6223.000	11.542	.000
Within Groups	30192.000	56	539.143		
Total	48861.000	59			

Table 95 Free Flow Speed Sensitivity Tukey Analysis

Sig.	55mph	60mph	65mph	70mph
55mph	N/A	.987	.755	.000
60mph	.987	N/A	.911	.000
65mph	.755	.911	N/A	.000
70mph	.000	.000	.000	N/A

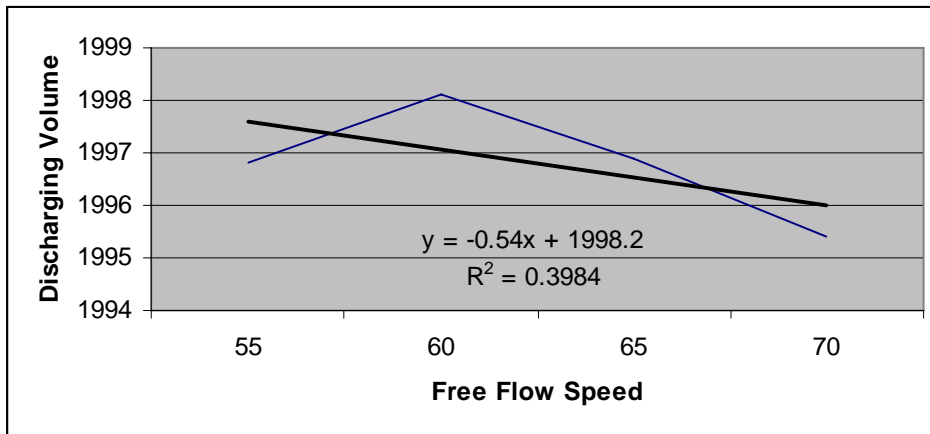

Figure 59 Free Flow Speed Sensitivity on Link Volume within FA

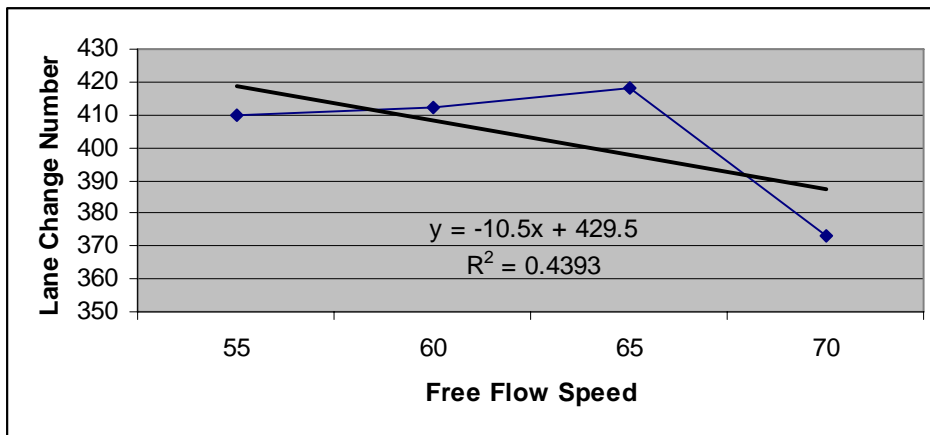

Figure 60 Free Flow Speed Sensitivity on Lane Change Number within FA

It was found that within functional area of exit ramps, the free flow speed was not sensitive to link volume but sensitive to total lane change number. The total lane change number increase with the increase of free flow speed, but decrease after 60mph.

8.2.3. Free Flow Speed Sensitivity after Functional Area

The free flow speed sensitivity analysis after functional area is listed below table 96 and table 97, 98. Figure 61 and 62 are the illustrations of the analysis results. The R^2 is 0.4701 and 0.4709. that means after functional area, the relational between free flow speed and discharging volume and lane change are not easily be explained by a simple linear model.

Table 96 Free Flow Speed Sensitivity on Link Volume after FA

	Sum of Squares	df	Mean Square	F	Sig.
Between Groups	3632.041	3	1210.680	.064	.979
Within Groups	1057962.122	56	18892.181		
Total	1061594.163	59			

Table 97 Free Flow Speed Sensitivity on Lane Change Number after FA

	Sum of Squares	df	Mean Square	F	Sig.
Between Groups	10475.250	3	3491.750	15.519	.000
Within Groups	12600.000	56	225.000		
Total	23075.250	59			

Table 98 Tukey Results of Free Flow Speed on Lane Change Number after FA

Sig.	55mph	60mph	65mph	70mph
55mph	N/A	.003	.956	.000
60mph	.003	N/A	.013	.128
65mph	.956	.013	N/A	.000
70mph	.000	.128	.000	N/A

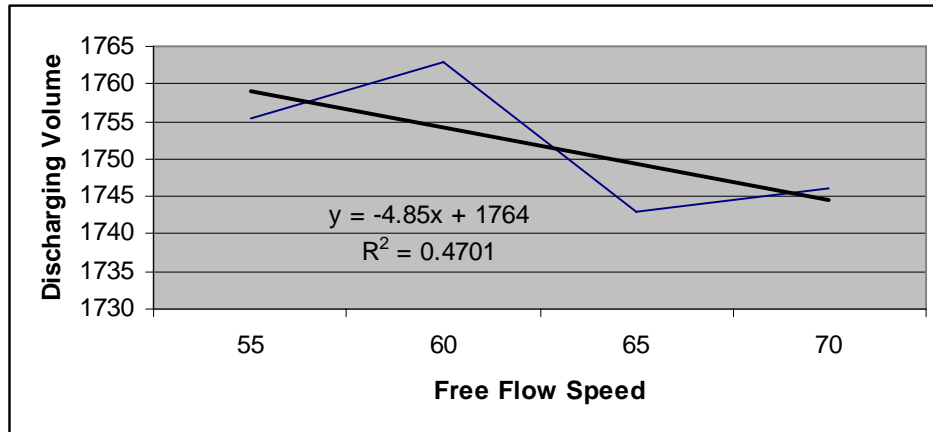

Figure 61 Free Flow Speed Sensitivity on Link Volume after FA

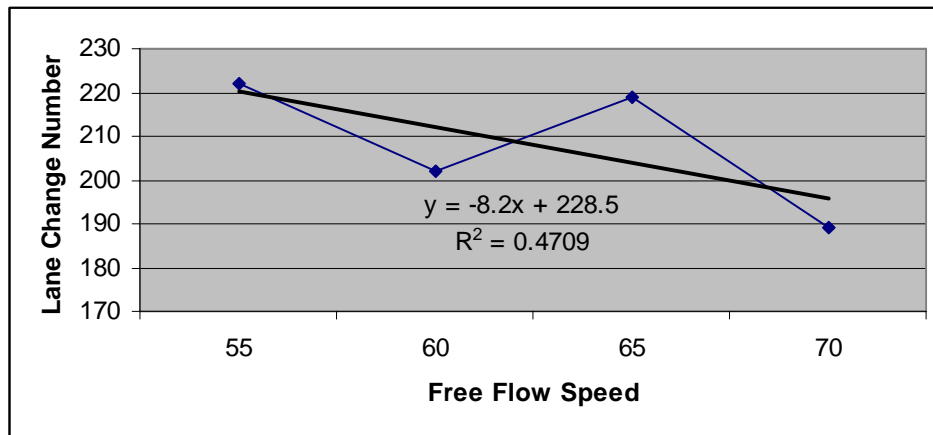

Figure 62 Free Flow Speed Sensitivity on Lane Change Number after FA

8.2.4. Free Flow Speed Sensitivity Sum up

The free flow speed sensitivity analysis summarized here, it seemed that free flow speed has limited impact on the link volume, but has significant impact on the total lane change number, within the increase of free flow speed, the lane change number decrease greatly. That's because in CORSIM simulation, vehicles are forced to change lanes when the headway space is less than 2 seconds, the higher free flow speed will maintain a longer headway space, hence need less lane change number.

8.3. Freeway Grade

Freeway grade has significant impact on traffic operational speed, according to some previous research. Heavy vehicles, especially the trucks, were observed more speed reduction at up-grade.

8.3.1. Freeway Grade Sensitivity before Functional Area

Table 99, 100, 101 and 102 are the ANOVA and Tukey results for the freeway grade impact on speed and total lane change number. The R^2 is 0.5095 and 0.0043 for speed and lane change number respectively, It can be concluded that before functional area of an exit ramp, the up grade has significant impact on the speed, but the impact on the total lane change number are not as significant as that of speed.

Table 99 Freeway Grade Sensitivity on Running Speed before FA

	Sum of Squares	df	Mean Square	F	Sig.
Between Groups	18044.568	4	4511.142	5294.784	.000
Within Groups	59.640	70	.852		
Total	18104.208	74			

Table 100 Tukey Results on Grade Sensitivity on Running Speed before FA

Sig.	-6	-3	0	3	6
-6	N/A	1.000	.996	.000	.000
-3	1.000	N/A	.992	.000	.000
0	.996	.992	N/A	.000	.000
3	.000	.000	.000	N/A	.000
6	.000	.000	.000	.000	N/A

Table 101 Freeway Grade Sensitivity on Lane Change Number before FA

	Sum of Squares	df	Mean Square	F	Sig.
Between Groups	30015.600	4	7503.900	19.936	.000
Within Groups	26348.400	70	376.406		
Total	56364.000	74			

Table 102 Tukey Results of Grade on Lane Change Number before FA

Sig.	-6	-3	0	3	6
-6	N/A	.980	.604	.000	.106
-3	.980	N/A	.905	.000	.317
0	.604	.905	N/A	.000	.834
3	.000	.000	.000	N/A	.000
6	.106	.317	.834	.000	N/A

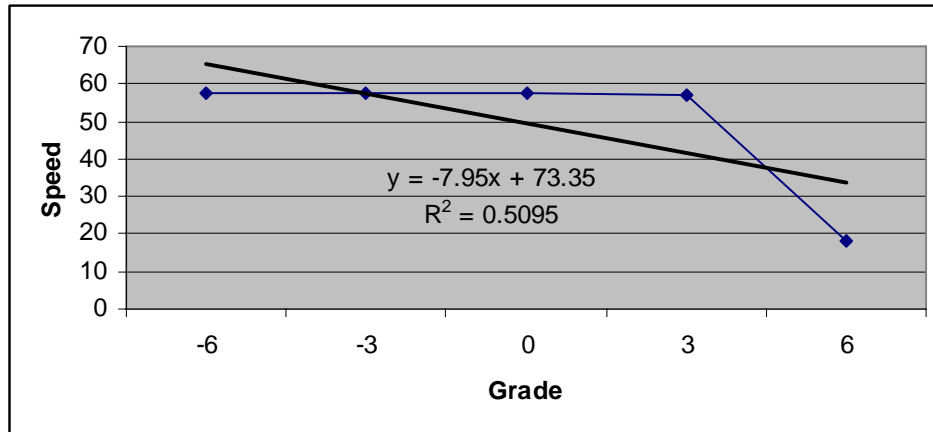

Figure 63 Freeway Grade Sensitivity on Running Speed before FA

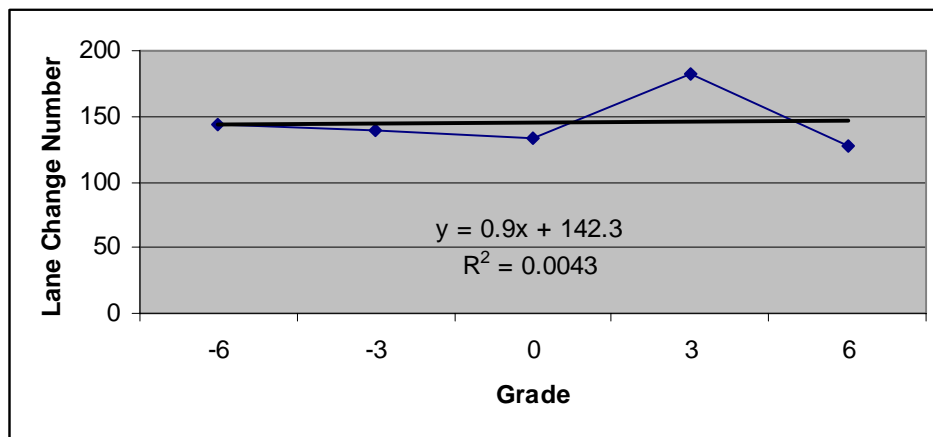

Figure 64 Freeway Grade Sensitivity on Lane Change Number before FA

8.3.2. Freeway Grade Sensitivity within Functional Area

Table 103, 104, 105 and 106 are the ANOVA and Tukey results of freeway grade sensitive analysis on running speed and total lane change number. The R^2 is 0.6835 and 0.8108 for speed and total lane change number respectively. That means grade has significant impact on running speed and total lane change number within functional area. It seemed that negative has limited impact on the running speed, but positive grade has significant impact on the running speed.

Table 103 Freeway Grade Sensitivity on Running Speed within FA

	Sum of Squares	df	Mean Square	F	Sig.
Between Groups	12632.373	4	3158.093	770.628	.000
Within Groups	286.866	70	4.098		
Total	12919.239	74			

Table 104 Tukey Results of Grade Sensitivity on Running Speed within FA

Sig.	-6	-3	0	3	6
-6	N/A	1.000	.814	.000	.000
-3	1.000	N/A	.784	.000	.000
0	.814	.784	N/A	.000	.000
3	.000	.000	.000	N/A	.000
6	.000	.000	.000	.000	N/A

Table 105 Freeway Grade Sensitivity on Lane Change Number within FA

	Sum of Squares	df	Mean Square	F	Sig.
Between Groups	626452.080	4	156613.020	156.606	.000
Within Groups	70003.200	70	1000.046		
Total	696455.280	74			

Table 106 Tukey Results of Grade on Lane Change Number within FA

Sig.	-6	-3	0	3	6
-6	N/A	1.000	.693	.000	.000
-3	1.000	N/A	.734	.000	.000
0	.693	.734	N/A	.000	.000
3	.000	.000	.000	N/A	1.000
6	.000	.000	.000	1.000	N/A

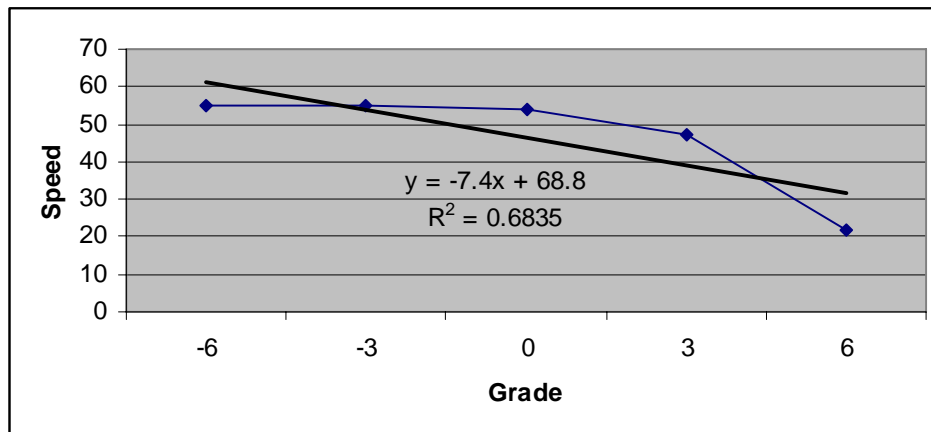

Figure 65 Freeway Grade Sensitivity on Running Speed within FA

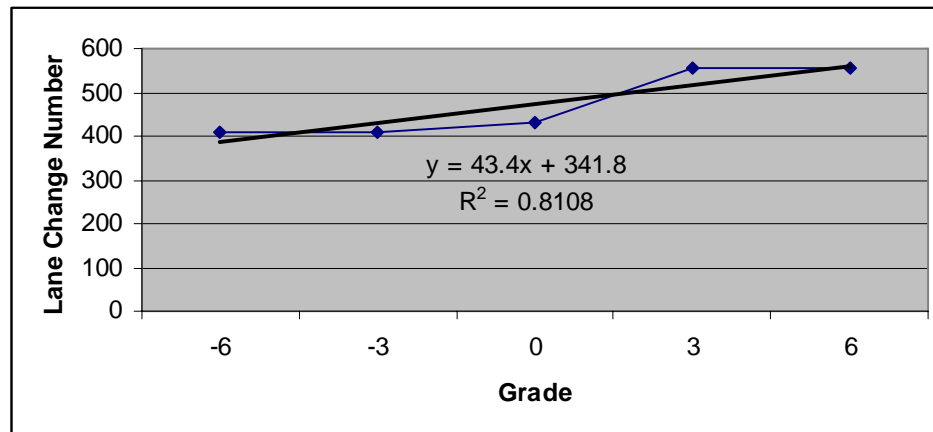

Figure 66 Freeway Grade Sensitivity on Lane Change Number within FA

8.3.3. Freeway Grade Sensitivity after Functional Area

The ANOVA and Tukey results of sensitivity analysis of freeway grade after freeway functional area are listed at table 107,108, 109 and 110. The R^2 is 0.766 and 0.8064 for running speed and total lane change number respectively; the linear model fits it pretty well, that means not like before functional area, the speed and lane change number can be explained by freeway grade if other variables are not considered. It is observed that positive grade has significant impact on the running speed, vehicles experience large speed deduction at up-grade hill, but the negative slope has limit impact on the running speed. The total lane change number increased significantly while the grade increases. In another word, there are more lane changes at uphill.

Table 107 Freeway Grade Sensitivity on Running Speed after FA

	Sum of Squares	df	Mean Square	F	Sig.
Between Groups	8891.772	4	2222.943	1649.270	.000
Within Groups	94.348	70	1.348		
Total	8986.121	74			

Table 108 Tukey Results of Grade Sensitivity on Running Speed after FA

Sig.	-6	-3	0	3	6
-6	N/A	1.000	.457	.000	.000
-3	1.000	N/A	.411	.000	.000
0	.457	.411	N/A	.000	.000
3	.000	.000	.000	N/A	.000
6	.000	.000	.000	.000	N/A

Table 109 Freeway Grade Sensitivity on Lane Change Number after FA

	Sum of Squares	df	Mean Square	F	Sig.
Between Groups	2734584.000	4	683646.000	718.935	.000
Within Groups	66564.000	70	950.914		
Total	2801148.000	74			

Table 110 Tukey Results of Grade Sensitivity on Lane Change Number after FA

Sig.	-6	-3	0	3	6
-6	N/A	.999	.841	.000	.000
-3	.999	N/A	.705	.000	.000
0	.841	.705	N/A	.000	.000
3	.000	.000	.000	N/A	.000
6	.000	.000	.000	.000	N/A

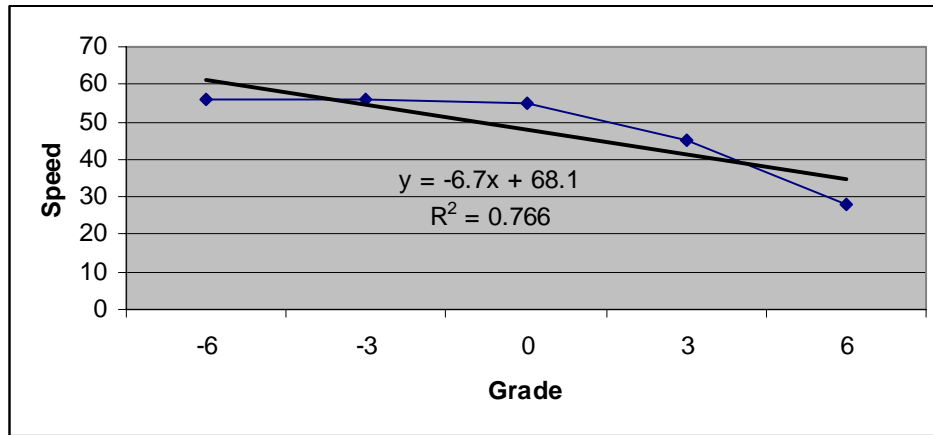

Figure 67 Freeway Grade Sensitivity on Speed after FA

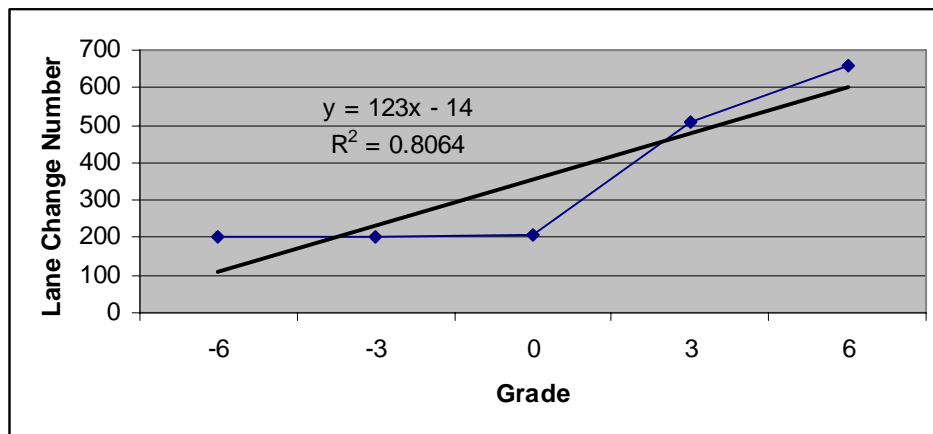

Figure 68 Freeway Grade Sensitivity on Lane Change Number after FA

8.3.4. Freeway Grade Sensitivity Sum up

Vehicles experience significant speed reduction at uphill freeway, no matter before, within or after functional area of freeway exit ramp. Normally, the up grade will impact the heavy truck more because of their weight and the ability of climbing, when the traffic volume is high, heavy truck will block the headway space, leaves less chance for passenger cars to make a lane change, hence the passenger cars suffer speed reduction too.

8.4. Truck Percentage

The sensitivity analysis for truck percentage is listed here. It is natural that more truck makes the fleet less flexibly and runs slower, especially at mountainous area.

8.4.1. Freeway Truck Percentage Sensitivity before Functional Area

The ANOVA and Tukey results for truck percentage sensitive analysis are listed here. The R^2 is 0.7964 and 0.5873 for speed and lane change respectively. It can be concluded that the truck percentage has no impact on the running speed at flat freeway, but more truck percentage means less lane change number before functional area, the results is statistically significant.

Table 111 Truck Percentage Sensitivity on Running Speed before FA

	Sum of Squares	df	Mean Square	F	Sig.
Between Groups	.224	4	.056	.459	.766
Within Groups	8.531	70	.122		
Total	8.755	74			

Table 112 Truck Percentage Sensitivity on Lane Change Number before FA

	Sum of Squares	df	Mean Square	F	Sig.
Between Groups	1822.800	4	455.700	7.341	.000
Within Groups	4345.200	70	62.074		
Total	6168.000	74			

Table 113 Tukey Results of Truck Percentage on Lane Change Number before FA

Sig.	.04	.08	.12	.16	.20
.04	N/A	1.000	1.000	.988	.000
.08	1.000	N/A	1.000	.988	.000
.12	1.000	1.000	N/A	.988	.000
.16	.988	.988	.988	N/A	.002
.20	.000	.000	.000	.002	N/A

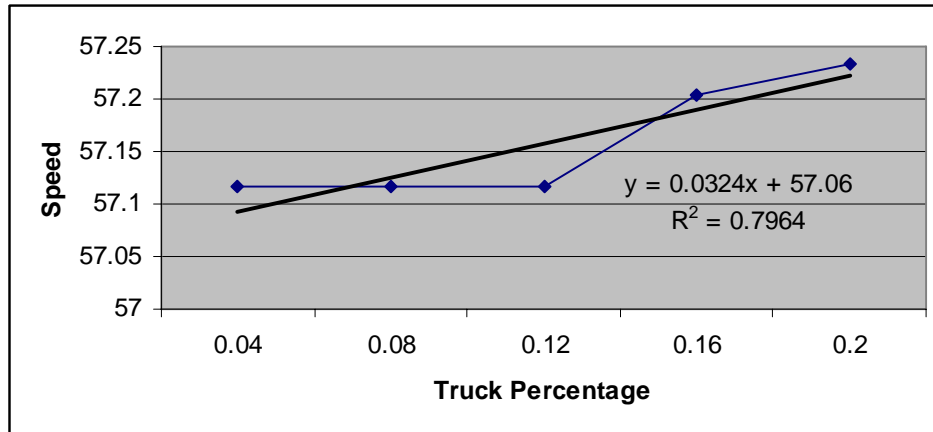

Figure 69 Truck Percentage Sensitivity on Running Speed before FA

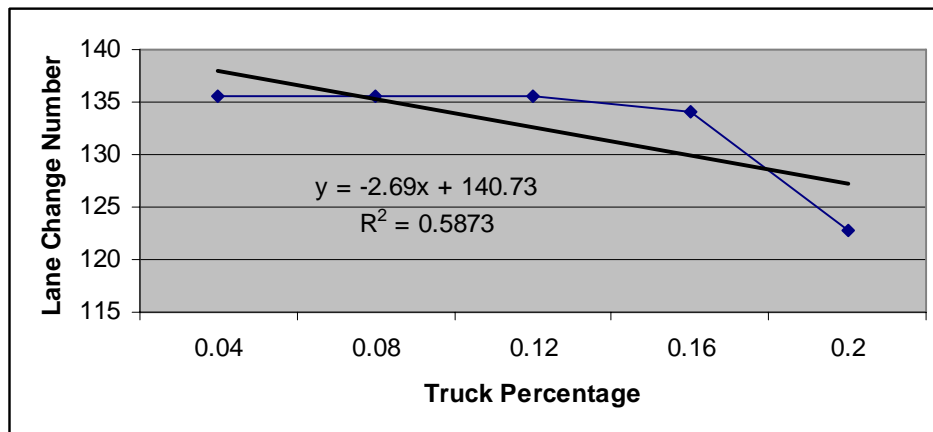

Figure 70 Truck Percentage Sensitivity on Lane Change Number before FA

8.4.2. Freeway Truck Percentage Sensitivity within Functional Area

The ANOVA and Tukey analysis for freeway truck percentage sensitivity within functional area are summarized here. The R^2 is 0.7579 and 0.5973 for speed and lane change respectively. It seemed that truck percentage has limited impact on running speed, but it does impact the total lane change number. More truck along a freeway segment makes less available headway gap, causing bigger speed deviation, when vehicles close

to exit ramp functional area, the exiting vehicles will make more unnecessary lane changes.

Table 114 Truck Percentage Sensitivity on Running Speed within FA

	Sum of Squares	df	Mean Square	F	Sig.
Between Groups	15.282	4	3.820	1.613	.181
Within Groups	165.774	70	2.368		
Total	181.056	74			

Table 115 Truck Percentage Sensitivity on Lane Change Number within FA

	Sum of Squares	df	Mean Square	F	Sig.
Between Groups	38777.520	4	9694.380	10.784	.000
Within Groups	62924.400	70	898.920		
Total	101701.920	74			

Table 116 Tukey Results of Truck Percentage on Lane Change Number within FA

Sig.	.04	.08	.12	.16	.20
.04	N/A	1.000	1.000	.000	.016
.08	1.000	N/A	1.000	.000	.016
.12	1.000	1.000	N/A	.000	.016
.16	.000	.000	.000	N/A	.430
.20	.016	.016	.016	.430	N/A

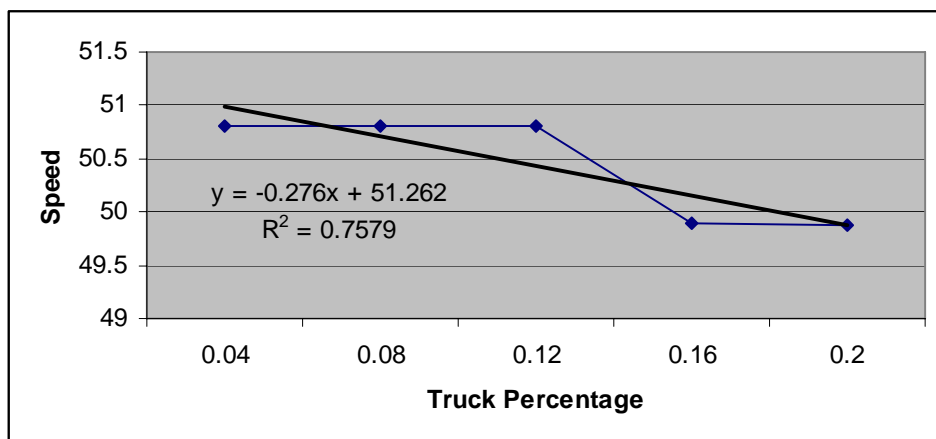

Figure 71 Truck Percentage Sensitivity on Running Speed within FA

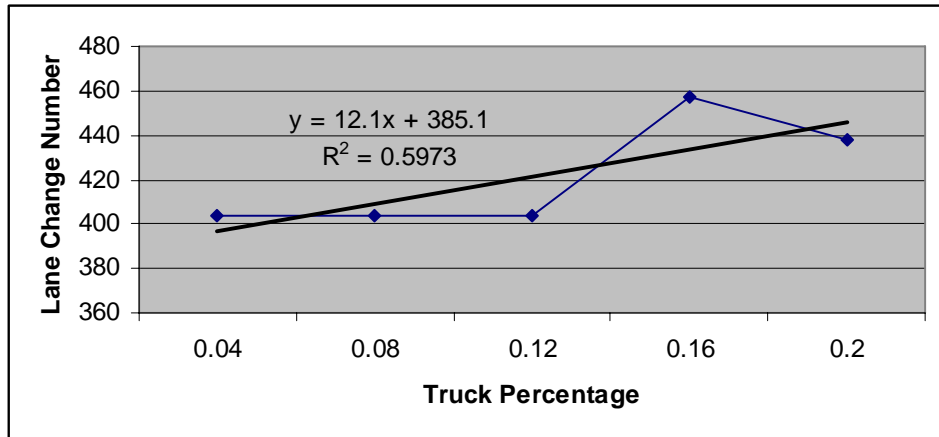

Figure 72 Truck Percentage Sensitivity on Lane Change Number within FA

8.4.3. Freeway Truck Percentage Sensitivity after Functional Area

The ANOVA and Tukey analysis for truck percentage sensitivity are list in this sub-chapter. The R2 is 0.5448 and 0.6465 for speed and lane change number respectively. The truck percentage has limited impact on running speed, but still gave significant impact on the total lane change number. More truck means more lane change, especially unnecessary lane change when the passenger cars are blocked by truck.

Table 117 Truck Percentage Sensitivity on Running Speed after FA

	Sum of Squares	df	Mean Square	F	Sig.
Between Groups	.256	4	.064	.278	.892
Within Groups	16.113	70	.230		
Total	16.368	74			

Table 118 Truck Percentage on Lane Change Number after FA

	Sum of Squares	df	Mean Square	F	Sig.
Between Groups	3659.520	4	914.880	11.517	.000
Within Groups	5560.800	70	79.440		
Total	9220.320	74			

Table 119 Tukey Results of Truck Percentage on Lane Change Number after FA

Sig.	.04	.08	.12	.16	.20
.04	N/A	1.000	1.000	.834	.000
.08	1.000	N/A	1.000	.834	.000
.12	1.000	1.000	N/A	.834	.000
.16	.834	.834	.834	N/A	.000
.20	.000	.000	.000	.000	N/A

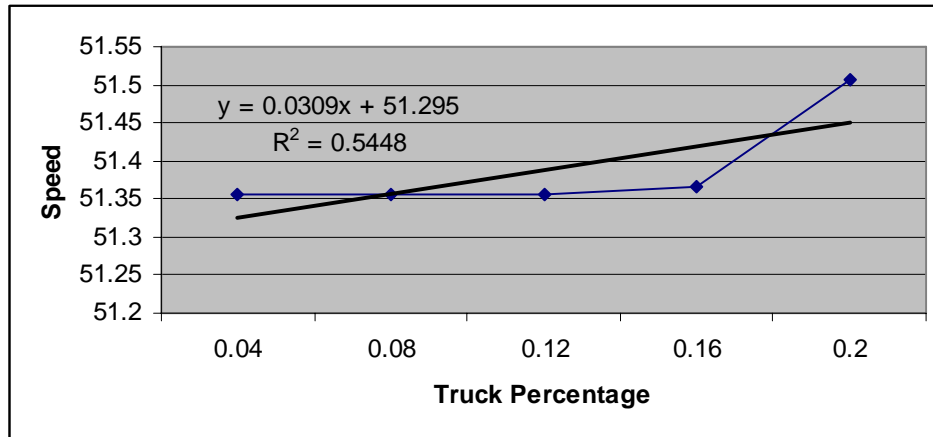

Figure 73 Truck Percentage Sensitivity on Speed after FA

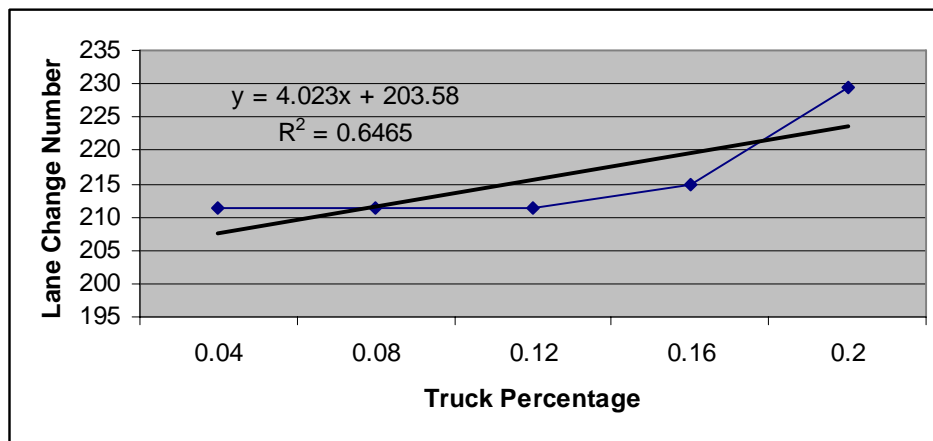

Figure 74 Truck Percentage Sensitivity on Lane Change Number after FA

8.4.4. Freeway Truck Percentage Sensitivity Sum up

It is observed from the simulation data that truck percentage has significant impact on the total lane change number, no matter before, within or after functional area of an exit ramp; more truck percentage means more unnecessary lane change.

Not like the freeway grade, the truck percentage has limited impact on the running speed.

8.5. Restrictions to Truck

The heavy trucks are restricted to a certain lane or lanes may impact the traffic operational characteristics on freeway exit ramp, few researches have focused on this

field. Thanks to the traffic simulation soft, it is easy to compare the difference of restrictions to truck by changing a parameter.

8.5.1. Restrictions to Truck sensitivity before Functional area

Table 120 and 121 summarize the ANOVA results of restrictions to truck sensitivity before exit ramp functional area, because the independent variable has only two values, 0 or 1, the linear model is unnecessary here. Restrictions to truck to a certain lane or lanes seemed has limited impact on the running speed, but will decrease the total lane change number before functional area. it must be noted here that since the variable “restrictions to truck” has only values: 1 for restricted to right two most lanes and 0 for no restrictions for truck, the Tukey can not be performed.

Table 120 Restrictions to Truck Sensitivity on Running Speed before FA

	Sum of Squares	df	Mean Square	F	Sig.
Between Groups	.052	1	.052	.068	.795
Within Groups	159.624	208	.767		
Total	159.676	209			

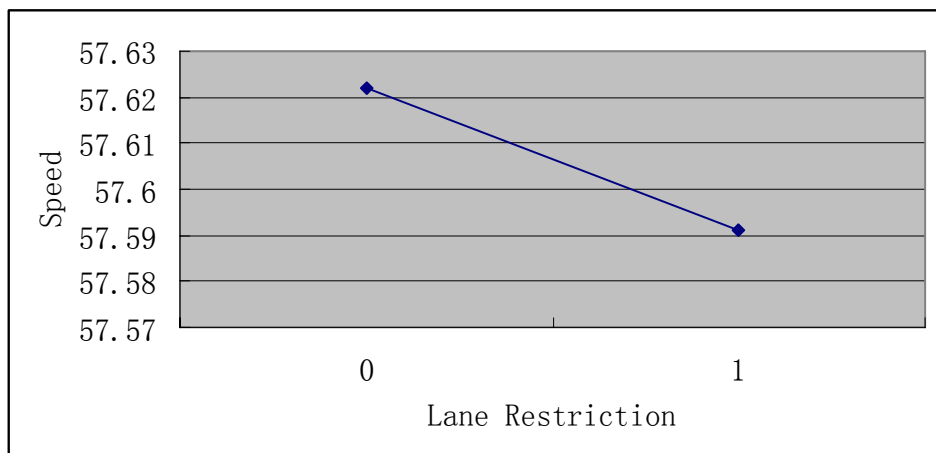

Figure 75 Restrictions to Truck Sensitivity on Running Speed

Table 121 Restrictions to Truck Sensitivity on Lane Change Number before FA

	Sum of Squares	df	Mean Square	F	Sig.
Between Groups	4667.143	1	4667.143	28.256	.000
Within Groups	34356.686	208	165.176		
Total	39023.829	209			

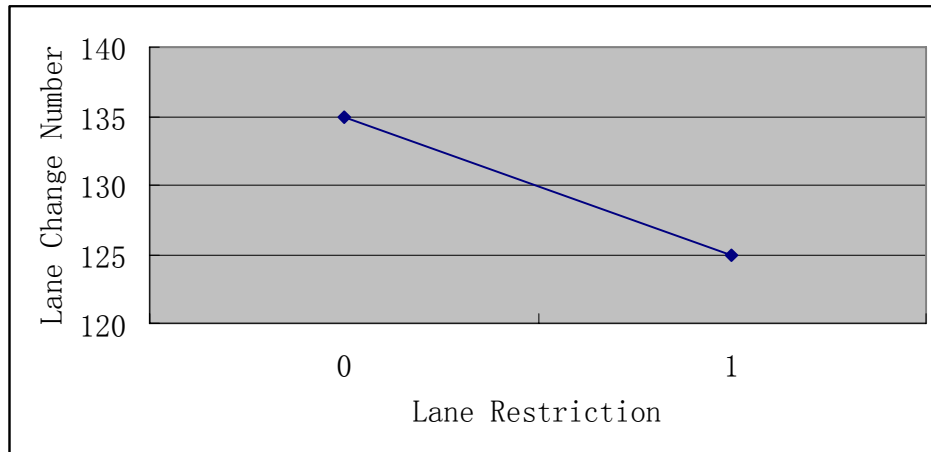

Figure 76 Restrictions to Truck Sensitivity on Lane Change Number before FA

8.5.2. Restrictions to Truck Sensitivity within Functional Area

Table 122 Restrictions to Truck Sensitivity on Running Speed within FA

	Sum of Squares	df	Mean Square	F	Sig.
Between Groups	1.417	1	1.417	.365	.547
Within Groups	808.179	208	3.885		
Total	809.596	209			

Table 123 Restrictions to Truck Sensitivity on Lane Change Number within FA

	Sum of Squares	df	Mean Square	F	Sig.
Between Groups	35568.043	1	35568.043	8.160	.005
Within Groups	906611.486	208	4358.709		
Total	942179.529	209			

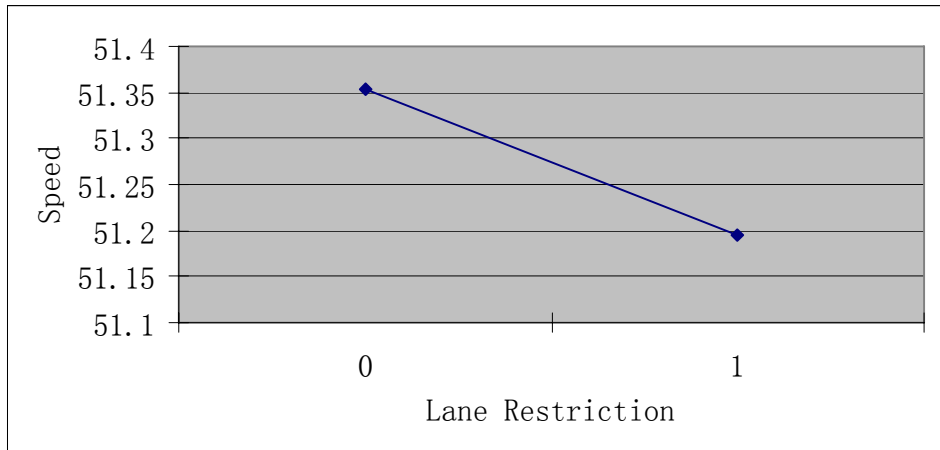

Figure 77 Restrictions to Truck Sensitivity on Running Speed within FA

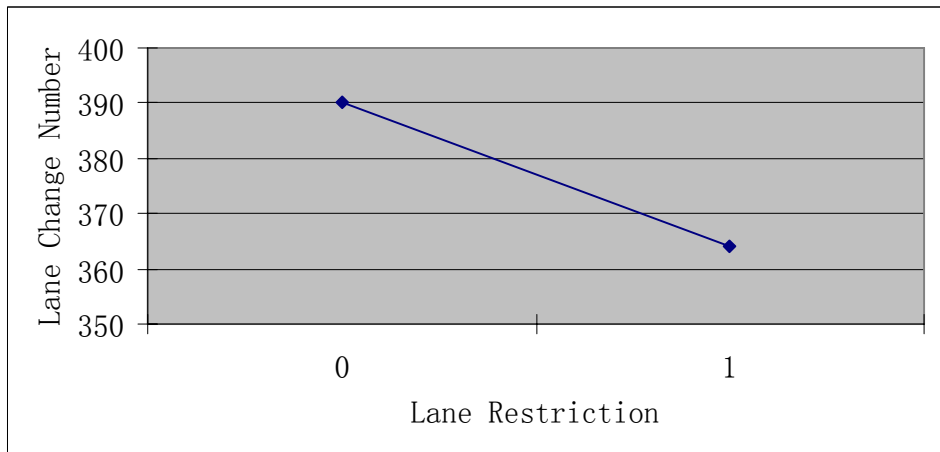

Figure 78 Restrictions to Truck Sensitivity on Lane Change Number within FA

The ANOVA results for restrictions to truck sensitivity within functional area are listed at table 122 and 123. Whether trucks are restricted to a certain lane (lanes) or not have limited impact on the running speed, but have significant impact on the total lane change number. Restricted to the right two most lanes will have less lane change number.

8.5.3. Restrictions to Truck Sensitivity after Functional Area

The ANOVA results for restrictions to truck sensitivity after functional area are listed at table 124 and 125.

Table 124 Restrictions to Truck Sensitivity on Running Speed after FA

	Sum of Squares	df	Mean Square	F	Sig.
Between Groups	1.823	1	1.823	2.602	.108
Within Groups	145.718	208	.701		
Total	147.541	209			

Table 125 Restrictions to Truck Sensitivity on Lane Change Number after FA

	Sum of Squares	df	Mean Square	F	Sig.
Between Groups	27703.543	1	27703.543	42.847	.000
Within Groups	134487.771	208	646.576		
Total	162191.314	209			

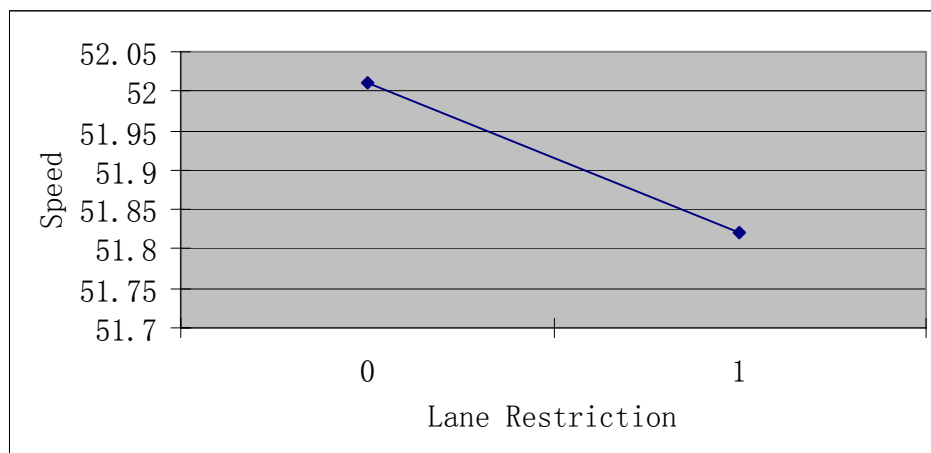

Figure 79 Restrictions to Truck Sensitivity on Running Speed after FA

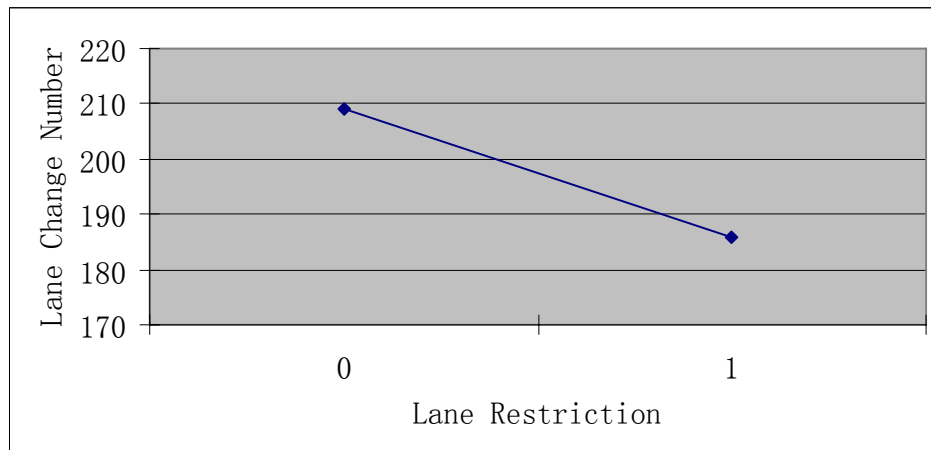

Figure 80 Restrictions to Truck Sensitivity on Lane Change Number after FA

8.5.4. Restrictions to Truck Sensitivity Sum up

The results of restrictions to truck usage of a certain lane or lanes are summarized here, it was found that when trucks are restricted to the right two most lane, there will be less lane change number comparing with trucks are not restricted. But the restrictions seemed has limited impact on the operational speed of automobiles running on the freeway.

It is recommended that when design the exit ramp, trucks should be restricted to the right two most lane, it significant decrease the total lane change number while has slight impact on the vehicles operational speed.

8.6. Location of Exit Sign

Locations of exit sign is important in the design of exit ramp, a too short distance of exit sign from the place it poled to the physical nose of exit ramp may not give the motorists enough reaction time to take the exiting maneuver while motorists experience a too long distance may forget to take a leave when approaching the exit ramp.

The default value in CORSIM is 2500 ft, in this study; it is set from 1500 ft to 5000 ft with 500 ft increment.

8.6.1. Location of Exit Sign Sensitivity before Functional Area

The ANOVA results of location of exit sign sensitivity before functional area are listed at table 126 and 127 for running speed and total lane change number. The Tukey results are too large to be shown in one page. It shows that from 1500 ft to 2500 ft, the total lane change number is not significant, but after 2500 ft of exit sign, with the increase of the distance, the lane change number increase significant.

The R^2 is 0.4245 and 0.9405 for speed and lane change number. The lane change number can be explained pretty well by the location of the exit sign.

Before functional area, the location of exit sign has limited impact on the operational speed at freeway segment.

Table 126 Location of Exit Sign Sensitivity on Running Speed before FA

	Sum of Squares	df	Mean Square	F	Sig.
Between Groups	2.011	7	.287	1.143	.341
Within Groups	28.142	112	.251		
Total	30.153	119			

Table 127 Location of Exit Sign Sensitivity on Lane Change Number before FA

	Sum of Squares	df	Mean Square	F	Sig.
Between Groups	493464.000	7	70494.857	528.051	.000
Within Groups	14952.000	112	133.500		
Total	508416.000	119			

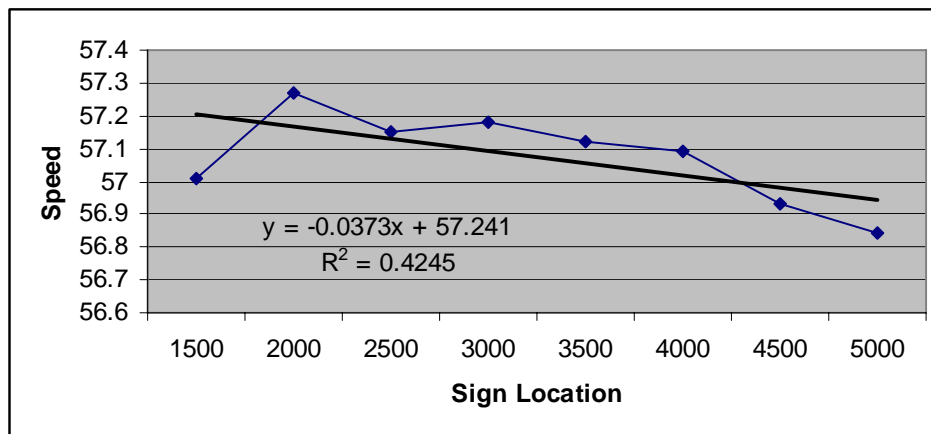

Figure 81 Location of Exit Sign Sensitivity on Running Speed before FA

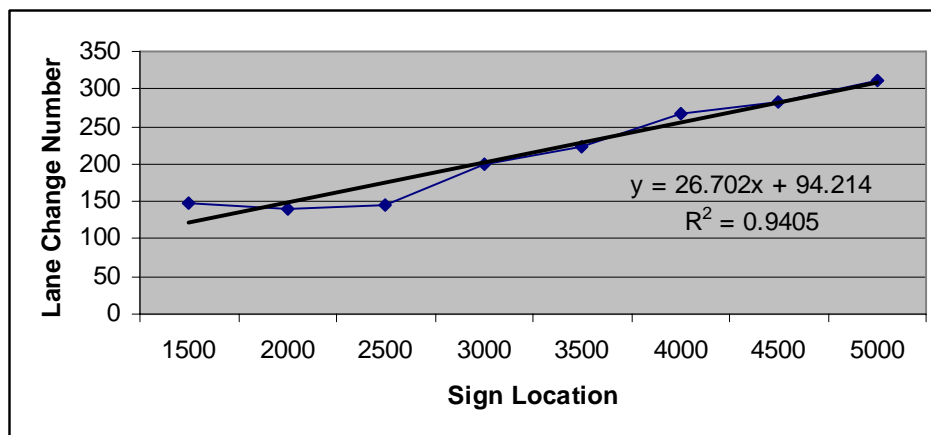

Figure 82 Location of Exit Sign Sensitivity on Lane Change Number before FA

8.6.2. Location of Exit Sign Sensitivity within Functional Area

The ANOVA analysis results of location of exit sign sensitivity within functional area are summarized here. Tukey analysis for the impact on the lane change number was performed; the R2 is 0.6546 and 0.9222 for speed and lane change maneuver respectively. It seemed that the relationship between location of exit sign and the lane change number are very apparent. The ANOVA tells than from 1500 ft to 2000 ft, 2500 ft, the difference is insignificant, the difference of 4500 ft and 5000 ft are not significant too.

Table 128 Location of Exit Sign Sensitivity on Running Speed within FA

	Sum of Squares	df	Mean Square	F	Sig.
Between Groups	16.595	7	2.371	1.355	.231
Within Groups	195.918	112	1.749		
Total	212.513	119			

Table 129 Location of Exit Sign Sensitivity on Lane Change Number within FA

	Sum of Squares	df	Mean Square	F	Sig.
Between Groups	739892.400	7	105698.914	346.611	.000
Within Groups	34154.400	112	304.950		
Total	774046.800	119			

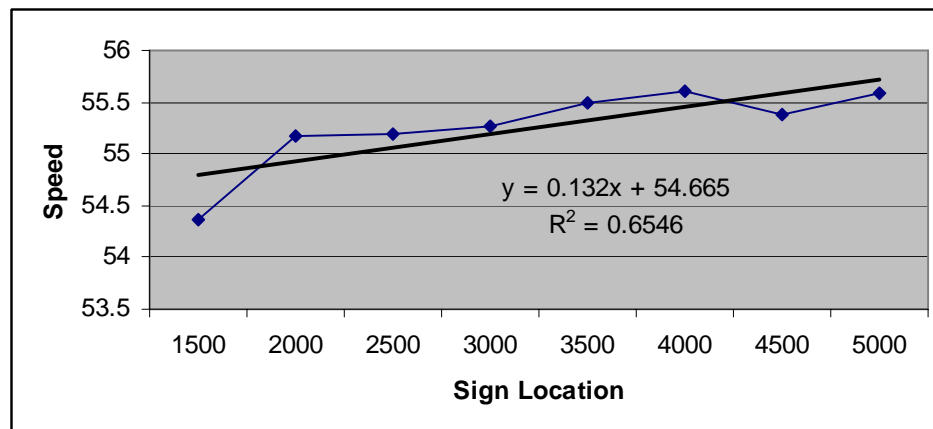

Figure 83 Location of Exit Sign Sensitivity on Running Speed within FA

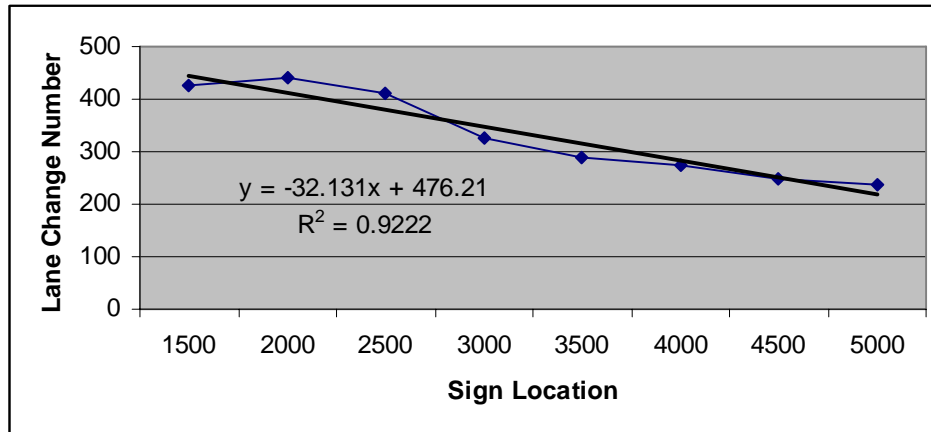

Figure 84 Location of Exit Sign Sensitivity on Lane Change Number within FA

It seemed that within functional area of an exit ramp, the location of exit sign has limited impact on the running speed, but does impact on the total lane change number. The longer the location sign, the less the total lane change number, at 4500 ft, it meet a certain threshold, and the total lane change number are not reduced greatly.

8.6.3. Location of Exit Sign Sensitivity after Functional Area

The ANOVA analysis for the location of exit sign sensitivity after functional area is list here, from table 130 to table 131. Figure 85 and figure 86.

Table 130 Location of Exit Sign Sensitivity on Running Speed after FA

	Sum of Squares	df	Mean Square	F	Sig.
Between Groups	4.360	7	.623	2.533	.019
Within Groups	27.535	112	.246		
Total	31.895	119			

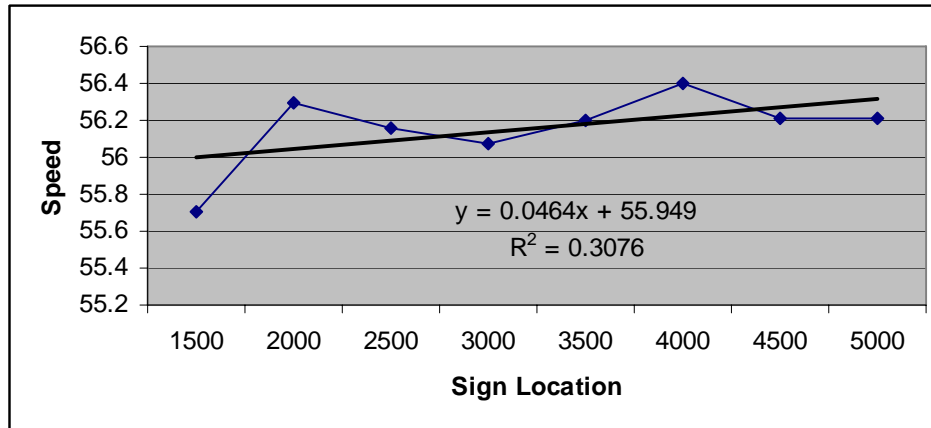

Figure 85 Location of Exit Sign Sensitivity on Running Speed after FA

Table 131 Location of Exit Sign Sensitivity on Lane Change Number after FA

	Sum of Squares	df	Mean Square	F	Sig.
Between Groups	3719.325	7	531.332	1.804	.093
Within Groups	32982.000	112	294.482		
Total	36701.325	119			

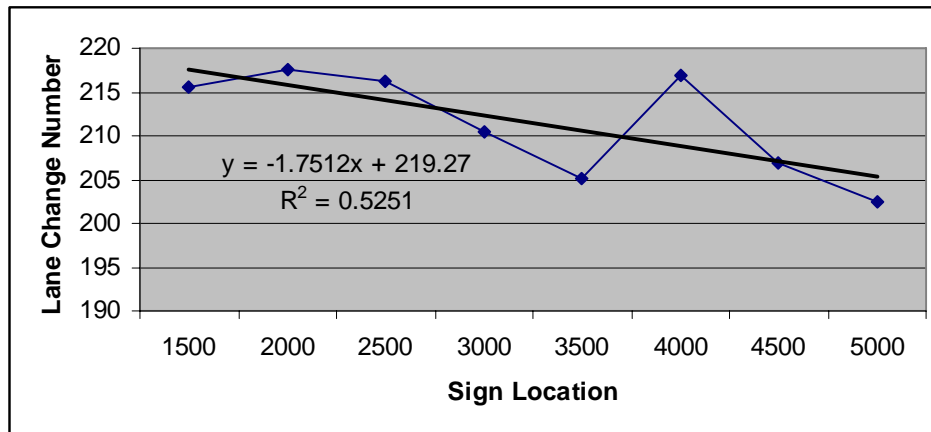

Figure 86 Location of Exit Sign Sensitivity on Lane Change Number after FA

The Tukey test for running speed after functional area shows that at 4000 ft exit sign distance, vehicles have the highest running speed, after that distance, say, the distance is longer than 4000 ft, the difference between running speed are not significant.

After functional area, the R^2 is 0.3076 and 0.5251 for speed and lane change number respectively. It's probably because when the exit sign location is round or above 4000 ft, vehicles has less lane change number within functional area, more vehicles successfully exit from the exit ramp; making the remaining vehicles runs more smooth after functional area, but when the sign location is less than 4000 ft, there are more unprepared motorists that trying to make an exit, some of them may take a jump lane change successfully, some may not, remaining on the freeway segment, making the operational speed after functional area slower.

8.6.4. Location of Exit Sign Sensitivity Sum up

Location of exit sign does have a significant impact on the operational speed and total lane change number before, within or after functional area of an exit.

Before functional area, difference sign distance has limited impact on running speed, but longer sign distance means big lane change number; within the functional area, impact on the running speed is still insignificant but longer sign distance means less lane change number; after functional area, the impact on the total lane change number is limited while sign distance has significant impact on the running speed.

It can be concluded that from 4000 ft to 5000 ft sign distance is desirable in the design of exit ramp.

8.7 Linear Regression Model for Exit Ramp

Four exit ramp types have different traffic operational characteristics, it might be necessary to build four different linear regression models corresponds four different exit ramps. Some finished researches also support that there are no one linear regression model suit for four types of exit ramp.

At this research, the linear regression model is built for tapered one-lane exit only; one reason is the regression model is for illustration purpose only, because the model only involve a few variables, a few variables are not enough to explicate the complication of real world traffic flow.

Because the traffic operation features was studied before, within and after the functional area of an exit ramp, the linear regression model should reflect the different also.

There are two dependent variables in our regression model, one is the running speed and the other is the total lane change number, running speed has direct relation with the LOS while the total lane change number has direct relation with safety issues.

The linear regression model (LRM) for tapered one-lane exit of running speed is summarized at table 132,133 and 134. It's before the functional area.

Table 132 LRM for Speed of Tapered One-Lane Exit before FA

Model	R	R Square	Adjusted R Square	Std. Error of the Estimate
1	.985	.971	.970	.370406

Table 133 ANOVA of Speed Modeling of Tapered One-Lane Exit before FA

Model	Sum of Squares	df	Mean Square	F	Sig.
Regression	2094.600	5	418.920	3053.348	.000
Residual	62.975	459	.137		
Total	2157.575	464			

Table 134 Coefficients of Speed Modeling of Tapered One-Lane Exit before FA

Model	Unstandardized Coefficients		Standardized Coefficients	t	Sig.	95% Confidence Interval for B		Collinearity Statistics	
	B	Std. Error	Beta			Lower Bound	Upper Bound	Tolerance	VIF
Constant	4.592	.506		9.083	.000	3.598	5.585		
Volume	-.000	.000	-.276	-33.778	.000	-.001	-.001	.949	1.053
Speed	.948	.008	.957	119.213	.000	.932	.963	.986	1.014
Truck %	.697	.645	.009	1.082	.280	-.570	1.964	.969	1.032
Sign Location	-8.1E-005	.000	-.025	-3.078	.002	.000	.000	.959	1.042
Lane Restriction	.032	.043	.006	.745	.456	-.052	.116	.916	1.092

From the table results, we can concluded that the model of running speed fit the linear pretty well with R^2 0.971.

Entry volume, initial speed and sign location are significant factors in the linear regression model. The truck percentage and restricted to a certain lane or lanes are not significant factors in the model.

The linear regression model for tapered one-lane exit of total lane change is summarized at table 135,136 and 137. It's before the functional area.

Table 135 LRM for Lane Change Number before FA

Model	R	R Square	Adjusted R Square	Std. Error of the Estimate
1	.925	.855	.854	19.442

Table 136 ANOVA of Lane Change Number Modeling Number before FA

Model	Sum of Squares	df	Mean Square	F	Sig.
Regression	1026940	5	205388.095	543.354	.000
Residual	173502.2	459	378.000		
Total	1200443	464			

Table 137 Coefficients of Lane Change Number Modeling before FA

Model	Unstandardized Coefficients		Standardized Coefficients	t	Sig.	95% Confidence Interval for B		Collinearity Statistics	
	B	Std. Error	Beta			Lower Bound	Upper Bound	Tolerance	VIF
Constant	240.871	26.535		9.078	.000	188.726	293.015		
Volume	.003	.001	.051	2.802	.005	.001	.005	.949	1.053
Speed	-4.255	.417	-.182	-10.199	.000	-5.075	-3.435	.986	1.014
Truck %	-181.206	33.833	-.097	-5.356	.000	-247.693	-114.720	.969	1.032
Sign Location	.064	.001	.841	46.413	.000	.061	.067	.959	1.042
Lane Restriction	-21.901	2.253	-.180	-9.720	.000	-26.329	-17.473	.916	1.092

This model fits the lane change number pretty well too, all independent variables are significant.

The linear regression model for tapered one-lane exit of running speed is summarized at table 138,139 and 140. It's within the functional area.

Table 138 LRM for Speed within FA

Model	R	R Square	Adjusted R Square	Std. Error of the Estimate
1	.776	.602	.597	2.232376

Table 139 ANOVA of Running Speed Modeling within FA

Model	Sum of Squares	df	Mean Square	F	Sig.
Regression	3455.533	5	691.107	138.679	.000
Residual	2287.428	459	4.984		
Total	5742.961	464			

Table 140 Coefficients of Speed Modeling within FA

Model	Unstandardized Coefficients		Standardized Coefficients	t	Sig.	95% Confidence Interval for B		Collinearity Statistics	
	B	Std. Error	Beta			Lower Bound	Upper Bound	Tolerance	VIF
Constant	-7.144	3.047		-2.345	.019	-13.132	-1.157		
Volume	-.001	.000	-.175	-5.785	.000	-.001	.000	.949	1.053
Speed	1.054	.048	.653	22.009	.000	.960	1.148	.986	1.014
Truck %	-24.330	3.885	-.187	-6.263	.000	-31.964	-16.696	.969	1.032
Sign Location	.001	.000	.222	7.381	.000	.001	.001	.959	1.042
Lane Restriction	-2.034	.259	.242	-7.861	.000	-2.542	-1.525	.916	1.092

It can be concluded that the model fits the linear less well than before the functional area. The traffic features are more complicated within functional area than before functional area. Speed is difficult to estimate.

Table 141 LRM for Lane Change Number within FA

Model	R	R Square	Adjusted R Square	Std. Error of the Estimate
1	.897	.804	.802	31.485

Table 142 ANOVA of Lane Change Number Modeling within FA

Model	Sum of Squares	df	Mean Square	F	Sig.
Regression	1864809	5	372961.777	376.230	.000
Residual	455012.7	459	991.313		
Total	2319822	464			

Table 143 Coefficients of Lane Change Number Modeling within FA

Model	Unstandardized Coefficients		Standardized Coefficients	t	Sig.	95% Confidence Interval for B		Collinearity Statistics	
	B	Std. Error	Beta			Lower Bound	Upper Bound	Tolerance	VIF
Constant	389.820	42.971		9.072	.000	305.376	474.264		
Volume	.046	.002	.563	26.546	.000	.043	.050	.949	1.053
Speed	-1.722	.676	-.053	-2.548	.011	-3.049	-.394	.986	1.014
Truck %	355.790	54.789	.136	6.494	.000	248.121	463.459	.969	1.032
Sign Location	-.076	.002	-.716	-33.904	.000	-.080	-.071	.959	1.042
Lane Restriction	-11.813	3.649	-.070	-3.237	.001	-18.983	-4.462	.916	1.092

The linear regression model for tapered one-lane exit of total lane change number is summarized at table 141,142 and 143. It's within the functional area.

It can be concluded that the model fits the linear less well than before the functional area. The traffic features are more complicated within functional area than before functional area. Total lane change number is difficult to estimate. The initial speed is not a significant factor in the modeling of total lane change number.

The linear regression model for tapered one-lane exit of running speed is summarized at table 144,145 and 146. It's after the functional area.

Table 144 LRM for Speed after FA

Model	R	R Square	Adjusted R Square	Std. Error of the Estimate
1	.826	.682	.678	1.821448

Table 145 ANOVA of Speed Modeling after FA

Model	Sum of Squares	df	Mean Square	F	Sig.
Regression	3258.483	5	651.697	196.432	.000
Residual	1522.812	459	3.318		
Total	4781.295	464			

Table 146 Coefficients of Speed Modeling after FA

Model	Unstandardized Coefficients		Standardized Coefficients	t	Sig.	95% Confidence Interval for B		Collinearity Statistics	
	B	Std. Error	Beta			Lower Bound	Upper Bound	Tolerance	VIF
Constant	-9.281	2.486		-3.733	.000	-14.166	-4.396		
Volume	.000	.000	-.052	-1.931	.054	.000	.000	.949	1.053
Speed	1.052	.039	.714	26.918	.000	.975	1.129	.986	1.014
Truck %	-19.019	3.17	-.161	-6.000	.000	-25.248	-12.791	.969	1.032
Sign Location	.001	.000	.215	7.998	.000	.001	.001	.959	1.042
Lane Restriction	-2.032	.211	-.265	-9.626	.000	-2.447	-1.617	.916	1.092

After functional area, the traffic features are not as smooth as before the functional area, some vehicles was forced stay in the freeway mainline make the speed distribution lager and less predicable.

Table 147 LRM for Lane Change Number after FA

Model	R	R Square	Adjusted R Square	Std. Error of the Estimate
1	.701	.491	.486	16.892

Table 148 ANOVA of Lane Change Number Modeling after FA

Model	Sum of Squares	df	Mean Square	F	Sig.
Regression	126452.3	5	25290.451	88.630	.000
Residual	130975.0	459	285.348		
Total	257427.2	464			

Table 149 Coefficients of Lane Change Number Modeling after FA

Model	Unstandardized Coefficients		Standardized Coefficients	t	Sig.	95% Confidence Interval for B		Collinearity Statistics	
	B	Std. Error	Beta			Lower Bound	Upper Bound	Tolerance	VIF
Constant	239.647	23.054		10.395	.000	194.341	284.952		
Volume	.014	.001	.515	15.061	.000	.012	.016	.949	1.053
Speed	-1.776	.362	-.164	-4.899	.000	-2.488	-1.063	.986	1.014
Truck %	76.037	29.395	.087	2.587	.010	18.271	133.803	.969	1.032
Sign Location	-.004	.001	-.105	-3.086	.002	-.006	-.001	.959	1.042
Lane Restriction	-20.130	1.958	-.358	-10.283	.000	-23.977	-16.283	.916	1.092

The linear regression model for tapered one-lane exit of lane change number is summarized at table 147,148 and 149. It's after the functional area.

After functional area, the traffic features are not as smooth as before the functional area, some vehicles was forced stay in the freeway mainline make the lane change number distribution lager and less predicable.

Chapter 9 Summary, Conclusions and Recommendations

The summary, conclusions and recommendations of simulation study on freeway exit ramp are wrapped up in this chapter.

9.1. Summary

This paper researched traffic flow characteristics of different exit ramps by the method of traffic simulation software. The four different exit ramps are tapered one-lane, tapered two-lane, parallel one-lane and parallel two-lane.

The traffic simulation software applied in this paper is TSIS-CORSIM 6.0 and HCS. The internal parameters of CORSIM, such as the headway distribution, the lane distribution, the car-following sensitivity, etc, were validated by HCS for the purpose of creditability and accuracy.

A 7500 feet freeway segment was built for the purpose of analysis and comparisons, in order to focus on the traffic flow characteristics of exit ramp itself, the traffic flow impact from upstream/downstream on-ramp/off-ramp and arterial road access point were eliminated by assuming that there is no closely spaced upstream or downstream on-ramp/off-ramp or other traffic interfere facility. And the capacity of exit ramp terminal with the access point of arterial road is not a concern. That means the length of exit ramp is long enough, no vehicles will backup to the freeway.

Although the keystone is the traffic flow characteristics within functional area of an exit ramp, which is 2500 feet from the exit gore point to freeway upstream, the research scope was extended upstream 2500 feet from the functional area and downstream 2500 feet from the functional area for the purpose of comparisons.

Three MOEs generated directly by CORSIM output file were used as the main parameters to describe the traffic flow characteristics and for the purpose of comparisons for the four types of exit ramp. The three MOEs are volume discharging rate, operational speed and total lane change number. Volume discharging rate and operational speed are used to describe the traffic operation while lane change number

Because CORSIM is a stochastic simulation model, in order to eliminate the random error, sufficient runs must be met to get the reliable results. ANOVA and Tukey analysis were used for statistical purpose. ANOVA was used to test if the difference between exit ramp pairs is statistically significant or just from random errors of each runs. Tukey was used to tell which exit ramp pair or pairs were different from other exit ramp pairs.

Four VBA programs were developed to generate the different combinations of geometry variables, traffic flow factors as well as traffic control factors. Because almost all scenarios are incorporated into the combination, no calibration effect is necessary to revive the real situation.

Three typical scenarios were selected from the CORSIM simulation files. The three scenarios are corresponding to low traffic volume, medium traffic volume and high traffic volume, more specifically, it's the v/c ratio <0.8 , close to 1.0 but <1.2 and greater than 1.4. However, no exact v/c ratio is available in this paper due to the magnificent data process and analysis.

The simulation results support the point of view that microscopic flow theories are befitted well for study of exit ramp areas. CORSIM is good traffic simulation software and has a high accuracy and accountability in simulation the real case traffic.

The researcher found that four typical types of exit ramp do have different traffic performance, no matter at low v/c ratio, medium v/c ratio or high v/c ratio. The factors that affect the performance of each exit ramp are entry volume, free flow speed, truck percentage, grade of freeway, restrictions to truck usage of a special lane/lanes and the location of exit sign.

The functional area has the most complicated traffic flow characteristics comparing with upstream of functional area and downstream of functional area. The capacity of an exit ramp is assumed to be the maximum average flow discharging rate, the operational speed of an exit ramp is controlled by free flow speed at uncongested conditions while the operational speed are more controlled by other factors, such as lane change maneuver, truck percentage and location of exit sign, etc.

General linear models for different factors are set for illustrating the internal relationship of operational speed and related variables. The general linear models for lane change maneuver are set up as well.

9.2. Conclusions

The research results for the traffic flow characteristics of each exit ramp are listed below. The comparisons of volume discharging rate, operational speed and total lane change number for these four exit ramps are summarized also. Sensitivity analysis results of selected factors are concluded as well.

9.2.1. Volume Discharge Rate

At uncongested conditions, the volume discharge rate is statistically the same for all types of exit ramp, but at congested conditions, a ramp with higher capacity has higher volume discharging rate. Although from the macroscope point of view, the parallel type and the tapered type have the same capacity if the exit lane number is the same, the parallel types have higher capacity while tapered types have lower capacity based on microscope simulations.

Normally, the parallel type bear less traffic volume at freeway mainline, hence it has better LOS comparing with tapered type exit ramp, but there are no significant difference between parallel one-lane and parallel two-lane exit ramp.

In terms of exit type, parallel type has 6.9% and 3.7% less traffic than tapered type when the exit ramp has one-lane and two-lane respectively within functional area.

General, in terms of traffic discharging volume, the tapered two-lane exit ramp has the best operational performance. It has the highest discharging rate compared with other three exit type.

9.2.2. Operational Speed

For the research of speed, it was found that the speed are controlled by free flow speed at uncongested conditions, the free flow speed equals to the operational speed statistically, at congested conditions, operational speed are hard to predicate because many other factors impact the running speed and lane change maneuver. The speed deduction rate is more significant than volume discharge rate. The operational speed at parallel types of exit ramp is more easily to be preserved than tapered type exit ramp. The operational speed has 10% to 32% difference between the exit pairs before the functional area; it also has 20.2% to 41.3% difference within the functional area. After functional area, the difference is reduced to 3.4% and 3.5% respectively.

Still, tapered two-lane exit ramp has the best performance in terms of operational speed in most cases.

9.2.3. Total Lane Change Number

Lane change maneuver was found to be the most complicated MOE of exit ramp. No matter for uncongested conditions or congested conditions, the exit ramp pairs are different in most cases. Normally, tapered type has less lane change number while parallel type has significant lane change number. The parallel two-lane has the most number of lane change maneuver.

Within Functional Area at low entry volume, parallel type has 41.3% and 24% higher lane change number than tapered type for one-lane exit and two-lane exit respectively. Two-lane exit has 30.1% and 9.5% than one-lane exit for tapered type and parallel type. It seemed that exit type has more impact on the lane change number than the exit lane number.

Within functional area at medium entry volume, parallel type has 26.8% and 24% higher lane change number than tapered type for one-lane exit and two-lane exit respectively. Two-lane exit has 17.5% and 14.3% than one-lane exit for tapered type and parallel type.

Within functional area at high entry volume, parallel has 11.5% and 19.5% higher lane change number to compare with tapered type for one-lane exit and two-lane exit respectively. Two-lane has 11.9% more lane change maneuver than one-lane exit at parallel type.

It can be concluded that the tapered two-lane exit ramp has the best performance in terms of lane change maneuver.

9.2.4. Sensitivity Analysis

Almost all of the levels in the selected factors are statistically significant as for the operational speed and lane change maneuver, as well as for the volume discharge rate.

It seemed that free flow speed has limited impact on the link volume, but has significant impact on the total lane change number, with the increase of free flow speed, the lane change number decrease greatly.

Freeway grade makes vehicles experience significant speed reduction at uphill freeway, no matter before, within or after functional area of freeway exit ramp, especially for heavy vehicles.

It is observed from the simulation data that truck percentage has significant impact on the total lane change number, no matter before, within or after functional area of an exit ramp; more truck percentage means more unnecessary lane change.

Not like the freeway grade, the truck percentage has limited impact on the running speed. But it causes exceedingly total lane change number, causing safety concerns. It is suggested that a special traffic sign of devices be posted ahead of exit ramp, reminding motorists of the present of large potation of truck.

It was found that when trucks are restricted to the right two most lane, there will be less lane change number comparing with trucks are not restricted. But the restrictions seemed has limited impact on the operational speed of automobiles running on the freeway.

Location of exit sign does have a significant impact on the operational speed and total lane change number before, within or after functional area of an exit, based on the data analysis of simulation runs.

It can be concluded that from 4000 ft to 5000 ft sign distance is desirable in the design of exit ramp.

The linear regression model within the functional area fits the data less well than before the functional area in terms of traffic speed and total lane change number. The traffic features are more complicated within functional area than before functional area. Speed and lane change number is difficult to estimate. The R^2 is .602 and .804 respectively.

9.3. Recommendations

Based on the research results and conclusions, it is recommended to design tapered two-lane exit ramp at all desirable locations. It is practical to design tapered one-lane exit at the first beginning of project and reserve the right of way for future tapered two-lane exit.

Parallel types are only recommended for the limited right of way between the arterial road and the freeway. In another word, parallel type are only good if the designer has to move the ramp structure from adjacent to arterial right of way to freeway right of way due to the geometry restriction.

It is recommended not to build an exit ramp at uphill area, when ramp close to the uphill area, the capacity would be deducted too much making the exit ramp a button neck area.

It is recommended that when design the exit ramp, trucks should be restricted to the right two most lane, it significant decrease the total lane change number while has slight impact on the vehicles operational speed.

It is recommended that the desirable location of exit sign is from 4000 ft to 5000 ft.

The findings and results are based on the traffic simulations and some assumptions, the further researches and improvements are needed in the following two fields, one is about the simulation software, another is about the exit ramp researches.

9.3.1. Simulation Software

The research of volume discharging rate, operational speed and lane change maneuver are based one CORSIM simulation, though CORSIM is very reliable to reproduce the real world situation, there are still certain gap between simulation and field data, calibration and/or validation effect are still necessary to make better results;

Although the user can adjust the distance of exit sign location in CORSIM, only one exit sign is allowed at CORSIM. At real situation, more than one exit sign may exist. CORSIM should design more than one exit sign to reproduce the real situation.

CORSIM has a parameter called “driver familiarity”, which is used to set up the distribution of driver familiarity with paths. But this parameter can only be applied to “NETSIM”, which is arterial road; CORSIM may assign this parameter to freeway also.

Another parameter in CORSIM is called “headway distribution”; it can set up the headway distribution, such as normal distribution, erlang distribution for the whole roadway network. But CORSIM can not set different headway distribution for freeway and for arterial road separately. The CORSIM developer need consider this, because normally freeway and arterial road have different headway distribution characteristics.

9.3.2. Exit Ramp

The traffic flow characteristics may different for two-lane main and three-lane mainline, this study only investigates the traffic flow characteristics and compares the traffic flow difference of different exit ramp at three-lane mainline, more researches is

necessary to investigate the traffic flow characteristics of two-lane mainline and more than three-lane mainline;

This dissertation focus on the exit ramp traffic flow characteristics itself, the impact from upstream and downstream weaving is ignored. If there are closely spaced upstream on-ramp or/and downstream on-ramp/off-ramps, the complicated weaving maneuver will influence the traffic operation of the target off-ramp, which should be very well studied at future research;

This study assume that the capacity of exit terminal with the arterial road is not a concern, at some real case, when the exiting volume is too high to be discharged effectively at the arterial terminal; or the ramp effective length is not long enough, the backed up volume may influence the traffic performance of exit ramp, in this case, the traffic flow characteristics of each ramp type may different from this research, further studies is needed to address this concern;

The traffic operational characterizes of other exit ramp type, such as design an acceleration lane after exit ramp physical area, this kind of design gives the vehicles which accidentally at the exit lane an backup chance to merge into the mainline again. The traffic merging and diverging maneuver happened at that segment may impact the traffic flow within the functional area and after functional area. The traffic flow characteristic should be researched as well.

References

- ^I USDOT, FHWA. Statistical Models of Accidents on Interchange Ramps and Speed Change Lanes. K.M. Bauer and D.W. Harwood
- ^{II} Kristine Williams, Huaguo Zhou, Larry Hagen and Waddah, Farah. Center for Urban Transportation Research, Florida Department of Transportation. Benefit and cost analysis of strategic Acquisition of Limited Access Right-of-Way near Interchanges
- ^{III} ITE Journal, May 1999, p 50-54. Safety of Evaluation of Acceleration and Deceleration Lane Lengths. Joe Bared, Greg L. Giering and Davey L. Warren
- ^{IV} Journal of Transportation Research Board, No.1908, Transportation Research Board of the National Academies, Washington, D.C., 2005, p 88-95. Calibration of Predictive Models for Estimating Safety of Ramp Design Configurations. Dominique Load and James A. Bonneson
- ^V Dallas Area Rapid Transit (DART). Operational Analysis of Terminating Freeway Auxiliary Lanes with One-Lane Exit and Two-Lane Exit Ramps—Case Study. Ralph A.Batenhorst, Jeff G.Gerken
- ^{VI} Virginia Polytechnic Institute and State University. Analysis of Freeway Weaving Areas Using Corridor Simulator and Highway Capacity Manual. Suresh Ramachandran
- ^{VII} Texas Transportation Institute Managed Lane Ramp and Roadway Design Issues. Kay Fitzpatrick, Marcus A. Brewer, and Steven Venglar.
- ^{VIII} Texas Transportation Institute/TTI Communications. The Texas A&M University System. Simulation Model Performance Evaluation for Congested Freeway Operations Mark D. Middleton, P.E., and Scott A. Cooner

^{IX} University of Hawaii at Manoa. Department of Civil and Environmental Engineering. Data Gathering for Freeway Simulation Using Un-intrusive Sensors and Satellite Telemetry Panos D. Prevedouros, Ph.D.

^X FHWA Office of Operations Research and Development. Identifying and Accessing Key Weather-Related Parameters and Their Impacts on Traffic Operations Using Simulation

^{XI} Transportation Research Record 1705 Paper No. 00-3272 Influence of Experimental Pavement Markings on Urban Freeway Exit-Ramp Traffic Speeds. Richard A. Retting, Hugh W. McGee, and Charles M. Farmer

^{XII} Bijan Behzadi, FDOT D7 Session 57. Guide Signing for Multilane Freeway Exits with an Optional Lane.

^{XIII} Kangyuan Zhu, the Florida State University, College of engineering, Traffic capacity and speed analysis of freeway work zones based on computer simulation.

^{XIV} Serge P. Hoogendoorn, Stefan Luding, Piet H. L. Bovy, Michael Schreckenberg and Dietrich E. Wolf. "Lane-Change Maneuvers Consuming Freeway Capacity"

Bibliography

Highway Capacity Manual. Transportation Research Board. National Research Council . Washington, D.C.2000.

A Policy on Geometric Design of Highways and Streets. American Association of State Highway and Transportation Officials. 2004 Edition.

Advanced CORSIM Training Manual. Minnesota Department of Transportation.

Microsoft Office Excel 2003 Programming Inside out. Wayne S. Freeze, Felicia Buckingham. Microsoft Press (03/01/2004).

Statistics for Research third edition chapter 10 Techniques for One-Way Analysis of Variance. Wiley Interscience Shirley Dowdy and Stanley Weardon.

MIT System Dynamics in Education Project by Lucia Breiervoa & Mark ChoudhariAn Introduction to Sensitivity Analysis

Traffic Flow Fundamentals. Adolf D. May. Publisher: Prentice Hall.

TRAFED User's Guide. ITT Industries, Inc., Systems Division. FHWA Office of Operations Research, Development and Technology.

Types and characteristics of ramp-related motor vehicle crashes on urban interstate roadways in Northern Virginia Anne T. McCartt, Veronika Shabanova Northrup and Richard A. Retting.

About the Author

Xu Wang received a Bachelor's Degree in Traffic Engineering from Wuhan Urban Construction Institute in 1991 and a Master's Degree from Southeast University in 2004. He has ten years of roadway construction, site supervision and intersection geometric design from 1991 to 2001 in Zhenjiang New Area.

In the second half of 2004, he worked at China Academy of Urban Planning and Design as a traffic planning engineer until he entered the Ph.D. program at the University of South Florida in 2005.

While in the Ph.D. program at the University of South Florida, he finished a few FDOT and STC project in traffic planning and traffic safety. He also worked for the civil department as a T.A.

He made several oral presentations at regular seminar meetings of civil department of University of South Florida.