Theses and Dissertations

Spring 2016

Design and field construction of Hawkeye Bridge using ultra high performance concrete for accelerated bridge construction

Haena Kim

University of Iowa

Copyright 2016 Haena Kim

This thesis is available at Iowa Research Online: <https://ir.uiowa.edu/etd/3117>

Recommended Citation

Kim, Haena. "Design and field construction of Hawkeye Bridge using ultra high performance concrete for accelerated bridge construction." MS (Master of Science) thesis, University of Iowa, 2016.
<https://ir.uiowa.edu/etd/3117>. <https://doi.org/10.17077/etd.4b9futmh>

Follow this and additional works at: <https://ir.uiowa.edu/etd>



Part of the [Civil and Environmental Engineering Commons](#)

DESIGN AND FIELD CONSTRUCTION OF HAWKEYE BRIDGE USING ULTRA
HIGH PERFORMANCE CONCRETE FOR ACCELERATED BRIDGE
CONSTRUCTION

by

Haena Kim

A thesis submitted in partial fulfillment
of the requirements for the Master of Science
degree in Civil and Environmental Engineering in the
Graduate College of
The University of Iowa

May 2016

Thesis Supervisor: Professor. Hosin “David” Lee

Copyright by

Haena Kim

2016

All Rights Reserved

Graduate College
The University of Iowa
Iowa City, Iowa

CERTIFICATE OF APPROVAL

MASTER'S THESIS

This is to certify that the Master's thesis of

Haena Kim

has been approved by the Examining Committee for
the thesis requirement for the Master of Science degree
in Civil and Environmental Engineering at the May 2016 graduation.

Thesis Committee:

Dr. Hosin "David" Lee, Thesis Supervisor

Dr. Paul Hanley

Rick Fosse

ACKNOWLEDGEMENTS

This research was supported by a grant (13SCIPA02) from Smart Civil Infrastructure Research Program funded by Ministry of Land, Infrastructure and Transport (MOLIT) of Korea government and Korea Agency for Infrastructure Technology Advancement (KAIA).

First, I sincerely thank my professor, mentor and counselor, Dr. Hosin “David” Lee for his guidance and support during my graduate studies at the University of Iowa. I would also thank Dr. Paul Hanley and Rick Fosse for their efforts and time as graduate committee members. I appreciate Dr. Chang-Bin Joh, Dr. Byung-Suk Kim, Dr. Kyung-Taek Koh, and Dr. Gum-Sung Ryu from Korea Institute of Civil Engineering and Building Technology for their supervision and insight throughout this project. I would like to acknowledge Brian Keierleber, Alex Davis, Don Davis, Chuck Kivell and all of the Buchanan County Secondary Roads Department Crew who provided great efforts in building the Hawkeye UHPC Bridge together. For laboratory testing, I would like to thank our undergraduate research assistants including Matthew Gazdzoak, Justin Carrico and Grant Hicks for their assistance.

Finally, I would like to thank my family for their endless love and enduring support.

ABSTRACT

The Ultra High Performance Concrete (UHPC) consists of sand, cement, crushed quartz, silica fume, superplasticizer, water and steel fibers, with water-to cement (w/c) ratio of 0.24 or lower. By omitting coarse aggregates in the mix, density and mechanical homogeneity can be maximized. Also, adding steel fibers increases durability by producing exceptionally high compressive and tensile strengths. As a result, a bridge using UHPC can be designed slimmer and longer with less amount of steel reinforcements than a conventional concrete bridge. UHPC developed by Korea Institute of Civil Engineering and Building Technology (K-UHPC) was used to build a bridge, named “Hawkeye”, in Buchanan County, Iowa. This paper describes the design and construction process of the Hawkeye bridge which is the first bridge using K-UHPC in the United States. A unique pi-girder design, which is similar to the design previously developed at MIT, was adopted for the Hawkeye Bridge.

The Hawkeye Bridge was successfully constructed using K-UHPC, utilizing local cement, sand and ready-mix trucks. Precast pi-girders were made at the Buchanan County, 17 miles (27 km) from the bridge site. A total of six girders were transported to the bridge site and installed in one day. This project not only demonstrated easy field constructability of K-UHPC but also set a great example of Accelerated Bridge Construction (ABC), which would minimize a traffic disruption.

PUBLIC ABSTRACT

The Ultra High Performance Concrete (UHPC) consists of sand, cement, crushed quartz, silica fume, superplasticizer, water and steel fibers, with water-to cement (w/c) ratio of 0.24 or lower. By omitting coarse aggregates in the mix, density and mechanical homogeneity can be maximized. Also, adding steel fibers increases durability by producing exceptionally high compressive and tensile strengths. As a result, a bridge using UHPC can be designed slimmer and longer with less amount of steel reinforcements than a conventional concrete bridge. UHPC developed by Korea Institute of Civil Engineering and Building Technology (K-UHPC) was used to build a bridge, named “Hawkeye”, in Buchanan County, Iowa. This paper describes the design and construction process of the Hawkeye bridge which is the first bridge using K-UHPC in the United States. A unique pi-girder design, which is similar to the design previously developed at MIT, was adopted for the Hawkeye Bridge.

The Hawkeye Bridge was successfully constructed using K-UHPC, utilizing local cement, sand and ready-mix trucks. Precast pi-girders were made at the Buchanan County, 17 miles (27 km) from the bridge site. A total of six girders were transported to the bridge site and installed in one day. This project not only demonstrated easy field constructability of K-UHPC but also set a great example of Accelerated Bridge Construction (ABC), which would minimize a traffic disruption.

TABLE OF CONTENTS

LIST OF TABLES	vii
LIST OF FIGURES	ix
1. INTRODUCTION	1
1.1. Objectives and Scope	2
1.2. Outline of Report.....	2
2. BACKGROUND.....	3
2.1. Ultra High Performance Concrete.....	3
2.2. K-UHPC Materials.....	4
2.3. Project Background.....	6
3. LABORATORY MIXING AND TESTING OF K-UHPC.....	7
3.1. General	7
3.1.1. Mix Design.....	7
3.1.2. Modification to Laboratory Mix Design.....	9
3.1.3. Mixing Process.....	9
3.1.4. Curing	11
3.2. Mix 1: K-UHPC with Double Superplasticizer – 1 ft ³ Volume.....	11
3.2.1. Mix Design.....	11
3.2.2. Mixing Process.....	12
3.2.3. Curing	14
3.2.4. Test results	15
3.3. Mix 2: K-UHPC with “1.5 Times” Superplasticizer – 0.75 ft ³ Volume	20
3.3.1. Mix Design.....	20
3.3.2. Mixing Process.....	20
3.3.3. Curing	22
3.3.4. Test Results.....	22
3.4. Mix 3: K-UHPC with “1.58 Times” Superplasticizer – 1 ft ³ Volume	28
3.4.1. Mix Design.....	28
3.4.2. De-molding & Curing.....	33
3.4.3. Test Results.....	34
3.5. Mix 4: K-UHPC with “1.58 Times” Superplasticizer – 1.5 ft ³ Volume	39

3.5.1.	Mix Design.....	39
3.5.2.	Mixing Process.....	40
4.	DESIGN OF HAWKEYE UHPC BRIDGE.....	45
4.1.	Hawkeye UHPC Bridge	45
4.1.1.	Innovative Pi-girder Design	47
5.	CONSTRUCTION MONITORING.....	51
5.1.	General	51
5.2.	First Girder	52
5.2.1.	Mix desing	52
5.2.2.	Mixing Porcess.....	53
5.2.3.	Pouring	54
5.2.4.	Curing of the first girder	57
5.2.5.	Post-Tensioning	59
5.3.	Second Girder.....	61
5.3.1.	Mixing.....	61
5.3.2.	Pouring.....	61
5.3.3.	Curing	63
5.3.4.	Post-tensioning.....	64
5.4.	Third Girder.....	65
5.4.1.	Mixing.....	65
5.4.2.	Pouring.....	65
5.5.	Fourth Girder.....	66
5.5.1.	Mixing.....	66
5.5.2.	Pouring.....	66
5.5.3.	Curing	67
5.5.4.	Post-tensioning.....	67
5.6.	Fifth Girder.....	67
5.6.1.	Mixing.....	68
5.6.2.	Pouring.....	68
5.7.	Sixth Girder	68
5.7.1.	Mixing.....	68
5.7.2.	Pouring.....	69

5.7.3.	Curing	69
5.8.	Grouting	70
5.9.	Bridge Installation	73
5.10.	Joint filling with K-UHPC.....	77
5.11.	Transverse Post-tensioning.....	80
6.	LABORATORY TESTS ON FIELD SAMPLES	82
6.1.	Compression Test.....	82
6.2.	Compressive strength of joint closer pour mix	84
6.3.	Beam test	85
7.	POST CONSTRUCTION MONITORING.....	87
7.1.	Installation.....	88
7.1.1.	Loading Test and SenScope Strain Analysis	91
8.	SUMMARY AND CONCLUSION	100
	REFERENCES	101
	Appendix A: Pictures of Tested Samples – Mix 1.....	103
	Appendix B: Pictures of Tested Samples – Mix 2.....	110
	Appendix C: Pictures of Tested Samples – Mix 3.....	116

LIST OF TABLES

Table 2-1 Properties of K-UHPC (9)	5
Table 3-1 Summary of Mix Designs.....	7
Table 3-2 Gradation Table of Iowan Mason Sand.....	8
Table 3-3 Modification to Mix Designs.....	9
Table 3-4 Super Concrete (SC180) Mixing Procedure Provided by KICT	10
Table 3-5 Modified K-UHPC Mix Design for Mix 1	12
Table 3-6 Summary of Compressive Strength Test Results (psi).....	16
Table 3-7 Summary of Indirect Tensile Strength Test Results (psi)	19
Table 3-8 Modified K-UHPC Mix Design for Mix 2.....	20
Table 3-9 Compressive Strength Test Results (psi).....	23
Table 3-10 Indirect Tensile Strength Test Results.....	24
Table 3-11 Coefficient of Thermal Expansion Test Results.....	27
Table 3-12 CTE Values of Various Concrete	28
Table 3-13 Modified K-UHPC Mix Design for Mix 3.....	29
Table 3-14 Moisture Content of Sand from the City of Independence.....	30
Table 3-15 Summary of Compressive Strength Test Results (psi).....	36
Table 3-16 Modified K-UHPC Mix Design for Mix 4.....	39
Table 4-1 Material Properties of K-UHPC and Post-tensioning Strands	50
Table 5-1 Constituent Proportion for 5.5 CY K-UHPC	52
Table 5-2 Modified Amount of Wet Sand and Water for Second Girder.....	61
Table 5-3 Modified Amounts of Wet Sand and Water for Third Girder	65
Table 5-4 Modified Amount of Wet Sand and Water for Third Girder.....	66

Table 5-5 Modified Amount of Wet Sand and Water for Fifth and Sixth Girder	67
Table 5-6 Properties of EUCO Grout PTX.....	71
Table 5-7 Modified Amounts of Wet Sand and Water for Joint Filling.....	77
Table 6-1 K-UHPC Compressive Strength of Field Samples from Joint Closure.....	85
Table 6-2 Four Point Bending Test Results of K-UHPC Joint Closure Samples.....	86
Table 6-3 Bending Strength of K-UHPC Field Samples from Joint Closure.....	86
Table 7-1 Loading Test Routes.....	93
Table 7-2 Loading test Routes during Second Test	97

LIST OF FIGURES

Figure 2-1 - Packing Diagrams a) Apollonian Packing b) Spacing Packing (6)	3
Figure 2-2 UHPC Self-Sealing of Microcracks by Clinker Hydration (6)	4
Figure 2-3 Composition of K-UHPC (not to scale) (8)	5
Figure 2-4 Old Multi-Beam Timber Bridge.....	6
Figure 3-1 2ft ³ Rotational Concrete Drum Mixer Covered with Plastic Bag	12
Figure 3-2 Mix 1 Condition after Liquid Additives a) Poor, b) Good.....	13
Figure 3-3 Addition of Steel Fibers	14
Figure 3-4 Casting Test Samples	14
Figure 3-5 Samples in Curing Chamber	14
Figure 3-6 Broken Compressive Strength Test Samples after 1 Day of Curing.....	15
Figure 3-7 Bar Graph of Compressive Strength Test Results.....	16
Figure 3-8 Compressive Strength Test Samples on Day 1	17
Figure 3-9 Broken Indirect Tensile Strength Test Samples after 1 Day of Curing	18
Figure 3-10 Bar Graph of Indirect Tensile Strength Test Results	19
Figure 3-11 Mix 2 Condition after Liquid Additives a) Poor, b) Good.....	21
Figure 3-12 Bar Graph of Compressive Strength Test Results.....	23
Figure 3-13 Bar Graph of Indirect Tensile Strength Test Results	25
Figure 3-14 Coefficient of Thermal Expansion Testing Apparatus.....	26
Figure 3-15 Sand from the City of Independence in a Bucket	29
Figure 3-16 2-Cubic Foot Rotational Concrete Mixer covered with paper towels.....	30
Figure 3-17 Mix after Pre-mixing.....	30
Figure 3-18 Mix 3 Condition after Liquid Additives a) Poor, b) Good.....	31

Figure 3-19 Adding Steel fibers.....	32
Figure 3-20 Mix with Steel Fibers	32
Figure 3-21 Samples in Air Curing.....	33
Figure 3-22 Preparing Test Samples.....	33
Figure 3-23 Cylinder Samples in Oven	34
Figure 3-24 Cylinder Samples	34
Figure 3-25 Samples in Curing Chamber at Room Temp.	34
Figure 3-26 Temperature Check	34
Figure 3-28 Rubber Cap.....	35
Figure 3-27 Smoothing the Surface	35
Figure 3-29 Broken Compressive Strength Test Samples after Two Day of Air Curing.	36
Figure 3-30 Bar Graph of Compressive Strength Test Results.....	37
Figure 3-31 Constituents for 0.5 ft ³ of K-UHPC	40
Figure 3-32 Clumped K-UHPC	41
Figure 3-33 Added 0.5 ft ³ of Dry Constituents.....	41
Figure 3-34 Mixing Process of 1.5 ft ³ of K-UHPC	42
Figure 3-35 Adding Steel Fibers using a Blower.....	43
Figure 3-36 Mix 4 with Steel Fibers	43
Figure 4-1 Layouts of Hawkeye UHPC Bridge.....	46
Figure 4-2 Construction of Substructure of Hawkeye UHPC Bridge.....	47
Figure 4-3 Various Pi-girder Types	49
Figure 5-1 Adding K-UHPC Constituents.....	53
Figure 5-2 Orientation of Two Trucks during Pouring.....	54

Figure 5-3 First Girder Pouring	55
Figure 5-4 Casted First Girder	55
Figure 5-5 Incomplete Second Girder.....	56
Figure 5-6 Additional 2CY of K-UHPC Pouring	57
Figure 5-7 Steam Curing of First Girder.....	58
Figure 5-8 Result of Attempt Second Girder	59
Figure 5-9 Four Point Bending Test on K-UHPC Beam Sample	60
Figure 5-10 Post-tensioning on First Girder	60
Figure 5-11 Second Girder Construction.....	62
Figure 5-12 Completed Second Girder	63
Figure 5-13 Cold Joints Appeared on Second Girder	63
Figure 5-14 Elongation of Post-tensioned Strands	64
Figure 5-15 K-UHPC Pouring for Third Girder	66
Figure 5-16 Casted Third Girder with Improved Support on Form.....	67
Figure 5-17 K-UHPC Pouring for Fifth Girder	68
Figure 5-18 K-UHPC Pouring for Sixth Girder.....	69
Figure 5-19 Steam Curing on Sixth Girder.....	69
Figure 5-20 Opening for Transverse Post-tensioning Strands	70
Figure 5-21 Grout Mixer Manufactured by DSI.....	70
Figure 5-22 Cap with Attached Grout Opening.....	71
Figure 5-23 Grout in a Mixer.....	72
Figure 5-24 Grout Appeared Darker than Surrounding Concrete	72
Figure 5-25 Travel Distance to Bridge Site (Google Map)	73

Figure 5-26 Girder Delivered onto a Truck	73
Figure 5-27 Bridge Installation.....	74
Figure 5-28 Two Installed Girders.....	75
Figure 5-29 Steel Plates between Abutment and Girders	75
Figure 5-30 Gaps Created at Each Joint	75
Figure 5-31 Filled Gap and Connected Post-tensioning Duct	76
Figure 5-32 View from Under the Bridge.....	76
Figure 5-33 Formwork for Joint Filling.....	77
Figure 5-34 Temporary Funnel.....	78
Figure 5-35 Filled Joints with K-UHPC	79
Figure 5-36 Burlaps Put on Each Joint	79
Figure 5-37 Transverse Post-tensioning	80
Figure 5-38 Post-tensioning Calibration Sheet.....	80
Figure 5-39 Post-tensioned Transverse Strands.....	81
Figure 5-40 Post Tensioned Transverse Strands with/without Cap.....	81
Figure 6-1 Compressive Strength of K-UHPC Field Mix	83
Figure 6-2 - K-UHPC Compressive Strength of Field Samples from Joint Closure	84
Figure 6-3 Four Point Bending Test Results of K-UHPC Joint Closure Samples.....	85
Figure 7-1 SenSpot -Strain Gauge (14)	87
Figure 7-2 Complete Resensys Structural Health Monitoring System (14)	88
Figure 7-3 Location of SenSpot sensors	89
Figure 7-4 Sensor Installation.....	90
Figure 7-5 Installed SenSpot Strain Gauge.....	90

Figure 7-6 Installed SenSpot Strain Gauges	91
Figure 7-7 A county Tandem-axial Dump Truck	92
Figure 7-8 Truck Routes	93
Figure 7-9 Test 1: Strain Response during First Loading Test.....	94
Figure 7-10 Test 1: Strain Response of 1R and 1L Sensors on Joint 1	94
Figure 7-11 Test 1: Strain response of 2R and 2L Sensors on Joint 2.....	95
Figure 7-12 Test 1: Strain Response of 3R and 3L Sensors on Joint 3	95
Figure 7-13 Truck Route for 2nd Loading Test.....	96
Figure 7-14 Test 2: Strain Response during Second Loading Test	97
Figure 7-15 Test 2: Strain Response of 1R and 1L Sensors on Joint 1	98
Figure 7-16 Test 2: Strain Response of 2R and 2L Sensors on Joint 2	98
Figure 7-17 Test 2: Strain Response of 3R and 3L Sensors on Joint 3	99

1. INTRODUCTION

The average age of more than 600,000 bridges in the United States is 42 years old. A great number of these bridges are approaching their service lives. Over 10% of the nation's bridges are classified as structurally deficient. (1). Bridge engineers have been seeking for long-lasting materials and innovative technologies to build more durable bridges in a way that maximizes cost effectiveness and public safety while minimizing disruption to the public (2).

Ultra high performance concrete (UHPC) is an evolving material technology that exhibits superior mechanical properties in terms of compressive and tensile strengths, ductility and high followability. Therefore, use of UHPC in bridges can increase bridge life spans while decreasing maintenance costs.

In the United States, there have been three pre-stressed girder bridges using UHPC. In 2006, the first bridge using UHPC was built in Wapello County, Iowa and, in 2008, the second bridge was built in Richmond County, Virginia. Bulb-tee shaped UHPC I-girders' strong tensile strength allowed the elimination of the mild steel reinforcement shear stirrups (3). In 2008, the third bridge was built in Buchanan County, Iowa. This bridge had a unique cross section resembling a Greek letter "π" which is called pi-girders. In 2011, waffle deck slab system, an enhanced bridge redecking system using UHPC, was implemented in Wapello County, Iowa. This two-way ribbed UHPC precast slab system was optimized for creating a resilient lightweight decks (3).

In 2015, the Hawkeye UHPC Bridge was constructed in Buchanan County, Iowa as the first bridge using K-UHPC in the United States. K-UHPC was developed by Korean Institutes of Civil Engineering and Building Technology (KICT) after several years of in-depth research. To

produce K-UHPC in the United States, local sands and cements were obtained in Iowa and other constituents were shipped from Korea. Constituents were then mixed in a ready-mix truck. Six pre-cast pi-girders using K-UHPC were transported and assembled at the bridge site in one day. This project not only demonstrated easy field constructability of K-UHPC but also set a great example of Accelerated Bridge Construction (ABC), which would minimize a traffic disruption.

1.1. Objectives and Scope

The objectives of this research project were to perform strength tests on laboratory and field mixture of K-UHPC, pi-girder design analysis, construction and performance monitoring of the Hawkeye UHPC Bridge. The research included the following tasks to complete the research objectives:

- Documentation of K-UHPC laboratory production using a 2 ft³ drum mixer
- Compressive, split tensile strength and coefficient of thermal expansion tests
- Design analysis of innovative pi-girder design of the Hawkeye UHPC Bridge
- Documentation of K-UHPC field production using two ready-mix trucks
- Pre-fabrication and installation of the pi-girders
- Loading tests and performance monitoring of the Hawkeye UHPC Bridge

1.2. Outline of Report

This paper is divided into eight chapters. Chapter 1 and 2 include an introduction and background information. Chapter 3 introduces laboratory mixing and testing procedures of K-UHPC. Chapter 4 describes the unique design of Hawkeye UHPC Bridge. Chapter 5 summarizes the construction monitoring documentation. Chapter 6 presents the results of laboratory tests on field samples. Chapter 7 presents the post construction monitoring. Finally, Chapter 8 presents the summary and conclusion of this research project.

2. BACKGROUND

2.1. Ultra High Performance Concrete

UHPC mixture consists of sand, cement, crushed quartz, silica fume, superplasticizer, water and steel fibers, with water-to cement (w/c) ratio of 0.24 or lower (4). By omitting coarse aggregates in the mix, UHPC could minimize porosity and maximize density and mechanical homogeneity (5). The particle size distribution in UHPCs is chosen such that, each particle is surrounded by at least one layer of next smallest particle size. As illustrated in Figure 2-1, space packing (b) is formed in UHPC mixture, rather than an apollonian packing (a) and this eliminates stress concentration on individual particles. Therefore, more uniform stress distribution could be achieved when compressive strength is applied (6).

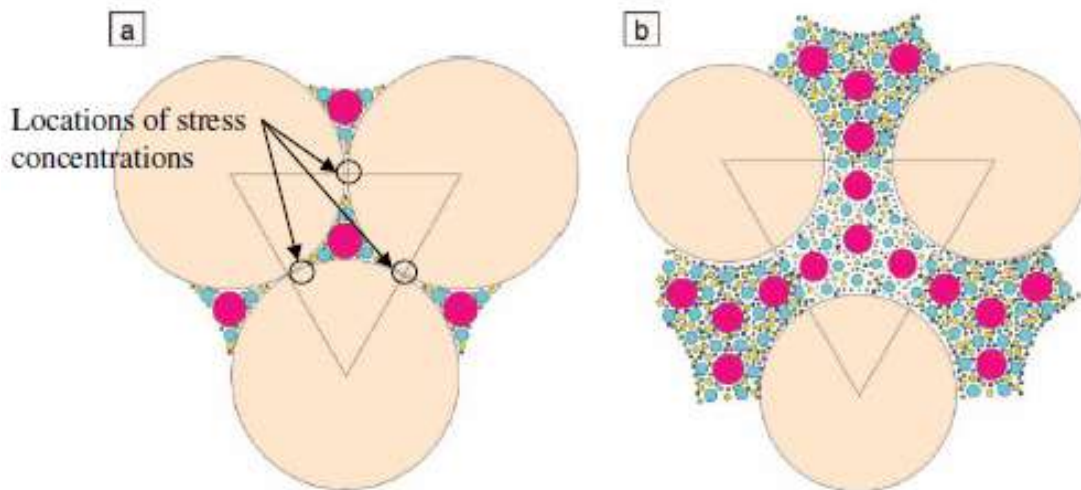

Figure 2-1 - Packing Diagrams a) Apollonian Packing b) Spacing Packing (6)

UHPC also has significantly lower water-to-binder ratio of 0.24 than that of conventional concrete which is about 0.4. Due to this low amount of water, approximately half of the cement

in UHPCs remains un-hydrated which has high-elastic modulus, reinforcing fillers. Those un-hydrated cementitious constituents can hydrate in case of water contact through surface water penetration (7). Such mechanism leads to UHPC's self-healing characteristic when a micro crack progresses on anhydrous surfaces. As shown in Figure 2-2, new hydrates can quickly fill and seal these micro cracks (6).

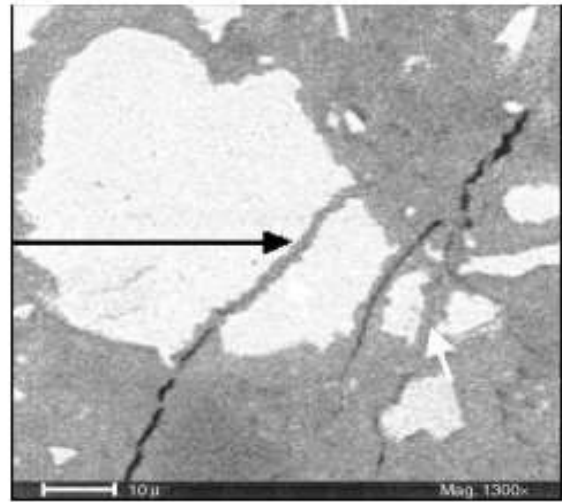

Figure 2-2 UHPC Self-Sealing of Microcracks by Clinker Hydration (6)

Hair-like micro steel fibers provide ultra-high ductility and tensile capacity. UHPC exhibits exceptionally high compressive strength of 28 ksi (193 MPa), tensile strength of 1.3 ksi (9.0 MPa) and elastic modulus of 7,600 ksi (52.4 GPa) (7). Therefore, bridges using UHPC can be thinner and longer than conventional concrete bridges with less amount of steel reinforcement.

2.2. K-UHPC Materials

Various types of UHPC have been developed with different mix proportions and mechanical properties. K-UHPC is the ultra high performance concrete that has been developed by the Korea Institute of Civil Engineering and Building Technology (KICT). As shown in Figure 2-3, K-UHPC contains similar constituents of a typical UHPC such as sand, cement, silica fume, shrinkage reducing agent, superplasticizer, water and fibers. Silica fume in K-UHPC requires the specific surface area above $23250 \text{ in}^2/\text{g}$ ($150,000 \text{ cm}^2/\text{g}$) and SiO_2 content over 96%. Silica Sands with the diameter less than 0.5 mm should be used. To limit shrinkage in K-UHPC normally occurs due to low water-to-binder ratio, the glycol-based shrinkage reducing agent and

calcium sulfa aluminate-based expansive agent are added to K-UHPC. The steel fibers have a diameter of 0.0079 in. (0.2 mm) and the tensile strength above 290,075 psi (2,000 MPa) (8). For this research project, the lengths of the fibers was chosen to be 0.63 in. (16mm) and 0.79 in. (20 mm).

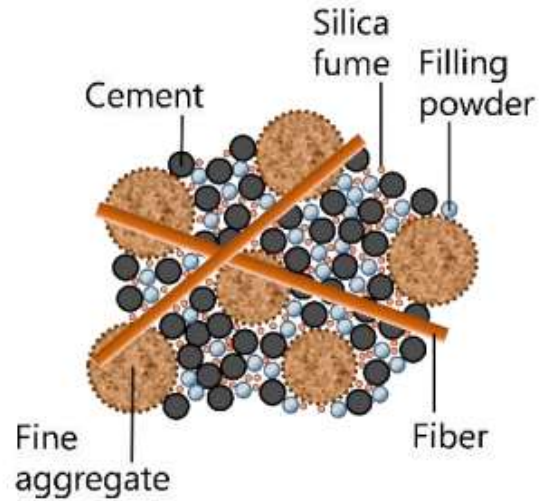

Figure 2-3 Composition of K-UHPC (not to scale) (8)

There are numerous distinctive features of K-UHPC in comparison with other types of UHPCs. Based on comprehensive structural analyses and laboratory experiments, KICT established the manufacturing specifications and

design guidelines of K-UHPC structures. Mechanic properties of K-UHPC is summarized in Table 2-1 (9).

Table 2-1 Properties of K-UHPC (9)

Compressive Strength	Tension	Elastic Modulus	Poisson's ratio	Total shrinkage	Creep coefficient
26 ksi (180 MPa)	1.4 ksi (9.5 MPa)	6500 ksi (45 GPa)	0.2	600 x 10 ⁻⁶	0.45

As shown in Table 2-1, low total shrinkage (autogenous and drying) amount of about 600 micro-strain allows K-UHPC to be used with deformed reinforcing bar without the risk of cracking. Also, the tensile strength and toughness were significantly enhanced by using two different lengths of 0.0079 in. (0.2 mm) diameter steel fibers at a volume ratio of 2% (0.63 in (16 mm) – 1% and 0.79 (20 mm) – 1%). Short fibers restrain the micro cracks at first stage while long fibers prevent macro-cracks by their pull-out energy, creating bridging effect (10).

With numerous advantages of using K-UHPC in bridge construction, K-UHPC has been used for several projects in the world such as South Korea and Myanmar. This research focuses on design and field construction of the Hawkeye UHPC Bridge, the first bridge using K-UHPC in the United States.

2.3. Project Background

Among 259 bridges in Buchanan County, Iowa, a multi-beam timber string bridge in Fairbank, IA was chosen to be replaced with a new bridge using K-UHPC. As shown in Figure 2-4, the old bridge, built in 1899, had 52 ft. (15.8 m) span length with 30 ft. (9.1 m) width. Although the weight limit of 12 tons was posted, it was difficult to patrol all the overweight vehicles.



Figure 2-4 Old Multi-Beam Timber Bridge

Overweight agricultural vehicles are prevalent around the bridge site at 1100 Deacon Avenue, Fairbank, IA. When the old bridge was demolished, it was noticed that piling was provided for the old bridge. Replacement of the old bridge to the new bridge with high strength and durability was necessary to hold up the today's traffic demand in the neighborhood.

3. LABORATORY MIXING AND TESTING OF K-UHPC

To simulate the mixing process using ready-mix trucks in the field, 2-cubic feet rotational concrete mixer with a fixed speed at 20rpm was used to prepare K-UHPC test mix in the laboratory.

3.1. General

3.1.1. Mix Design

Mix Design of K-UHPC laboratory test mix was followed by Super Concrete 180 (SC180) Manual created by KICT. Due to lack of workability of the originally designed mix, additional water and superplasticizer were added during the mixing process. Because the designed mix was based on a pan mixer, some modification on the mix design using a drum mixer was expected. Four batches were produced according to the following mix designs.

- Mix 1: K-UHPC Mix with Double Superplasticizer – 1 ft³ Volume
- Mix 2: K-UHPC Mix with “1.5 Times” Superplasticizer – 0.75 ft³ Volume
- Mix 3: K-UHPC Mix with “1.58 Times” Superplasticizer – 1 ft³ Volume
- Mix 4: K-UHPC Mix with “1.5 Times” Superplasticizer – 1.5 ft³ Volume

The designed and modified amounts of constituents for each mix are summarized and compared in Table 3-1. The volume of Mix 2 and Mix 4 in the table was adjusted to 1 ft³ for the comparison purpose.

Table 3-1 Summary of Mix Designs

Constituents of 1 ft ³ Mix	SC 180 Design (lb.)	Modified Design (lb.)		
		Mix 1 (lb.)	Mix 2 (lb.)	Mix 3 & 4 (lb.)
Fine Sand (dia. 150~600 μm)	56.13 (MC = 4.4%) or 54.91 (MC = 2.1%)	56.13 (MC = 4.4%)	56.1 (MC = 4.4%)	54.91 (MC = 2.1%)
Portland Cement (dia. 15 μm)	48.89	48.89	48.89	48.89
Water	8.73 (w/c = 0.18)	10.73* (w/c = 0.22)	11.40* (w/c = 0.23)	9.95 (w/c = 0.20)

Table 3-1 Continued

Superplasticizer	1.63	3.26**	2.44**	2.58**
Steel Fiber (dia. 200 μm) (0.63 inch long)	2.43	2.43	2.43	2.43
Steel Fiber (dia. 200 μm) (0.78 inch long)	4.87	4.87	4.87	4.87
Defoamer	0.05	0.05	0.05	0.05
Pre-mixing binder	31.05	31.05	31.05	31.05

Fine sands and Portland cement were locally obtained in Iowa and other materials such as superplasticizer, steel fibers, defoamer and pre-mixing binder were shipped from Korea. As shown in Table 3-2, the sizes of fine sands were between 0.0059 in. (0.15 mm) and 0.024 in. (0.6 mm) while a diameter of steel fibers was 0.0079 in. (0.2 mm). Given the similar sizes of the sand and the fibers, the steel fibers should be able to reinforce the concrete matrix on the micro level (7). It should be noted that steel fibers used for K-UHPC were in two different sizes of 0.63 inch (16 mm) and 0.78 inch (20mm), which are longer than other UHPCs used steel fibers with a single length of 0.5 inch (12.7 mm).

Table 3-2 Gradation Table of Iowan Mason Sand

Sieve Size	Weight Retained	% Retained	% Passing
3/8" (9.51 mm)	0	0	100
4 (4.76 mm)	0	0	100
8 (2.38 mm)	0.6	0.1	99.9
16 (1.19 mm)	5.9	1.1	98.8
30 (0.595 mm)	50	9.6	89.2
50 (0.297 mm)	300.6	57.7	31.5
100 (0.149 mm)	154.3	29.6	1.9
200 (0.074 mm)	8.9	1.7	0.2
pan	0.8	0.2	0
Total	521.1	100	0

3.1.2. Modification to Laboratory Mix Design

Although dry sand was required to be used for K-UHPC, it was difficult to obtain dry sand from the local market in Iowa. Therefore, wet sand was used instead of dry sand. Designed amounts of wet sand and water were adjusted depending on the moisture contents of the wet sand. Extra amounts of water and superplasticizer were added to achieve better workability of the mix. Two pounds (2 lb.) of extra water was added to Mix 1 and Mix 2, causing the w/c ratio increase to 0.22 and 0.23 from the original w/c ratio of K-UHPC, 0.18. Modifications to each batch are summarized in the Table 3-3.

Table 3-3 Modification to Mix Designs

Mix	Designed Volume (ft ³)	Moisture Contents of the Wet Sand	Additional amount (lb./ft ³)		w/c ratio	# of batched Cylinder Samples	
			Water	Superplasticizer		3 x 6	4 x 8
Mix 1	1	4.40%	2	1.63	0.22	35	-
Mix 2	0.75	4.40%	2.67	0.81	0.23	21	3
Mix 3	1	2.10%	-	0.95	0.20	10	-
Mix 4	1.5	2.10%	-	0.95	0.20	-	-

3.1.3. Mixing Process

To prepare the K-UHPC mix, 2-cubic feet rotational concrete mixer with a fixed speed at 20 rpm (revolutions per minute) was used. During the mixing process, KICT's mixing guideline for Super Concrete (SC180) was closely followed except amounts of superplasticizer and water and mixing duration.

First, all the dry materials such as cement, sand and pre-mix were mixed for 5 minutes. Then, water and other liquid additives including water, superplasticizer and defoamer were added and mixed for 4 minutes. When the mix is still clumped after the designed mixing time,

additional water and/or superplasticizers were added to improve workability. Between different mixes, the additional amount of mixing time varied from 10 to 20 minutes before the mix had sufficient flow to add steel fibers. Once the mix flows well without clumps, steel fibers were added in the course of 2 minutes and mixed for 1 minute to ensure fibers were well dispersed. The detailed instruction summarized in Table 3-4.

Table 3-4 Super Concrete (SC180) Mixing Procedure Provided by KICT

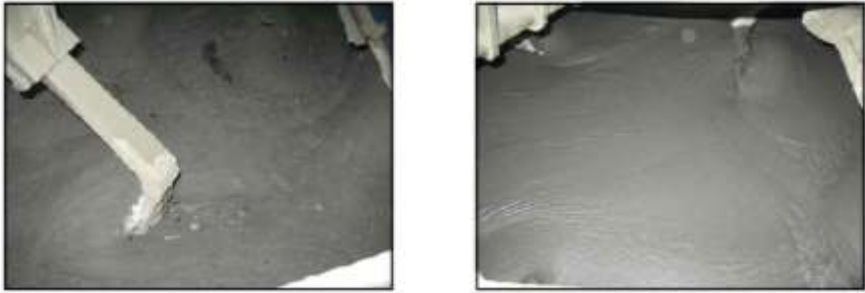
1. Weigh all constituent materials.
2. Place Pre-mix binder, sand and cement in the mixing bowl and mix for 4 minutes (cover the opening not to lose any fine particles).
3. Add water, super plasticizer and defoamer to the mixing bowl slowly over the course of 2 minutes.
4. Continue mixing for 5 minutes as the K-UHPC changes from a dry powder to a thick paste. The time for this process may vary but make sure to continue to mix until the paste looks like the figure on the right.

5. Add fibers to the mix slowly over the course of 2 minutes.
6. After the fibers have been added, continue running mixer for 1 minute to ensure that the fibers are well dispersed.
7. Stop mixer, dump a mix into a secondary pan and scoop it into a mold, making sure to rod the air out or use a vibrating table and screed the top to ensure to level samples.
8. Samples should remain undisturbed until the final set occurs.
De-molding & Curing
9. Put samples into the curing chamber that is filled with water at 90° C (194° F).
10. De-mold the specimens in 24 hours after casting after de-molding

3.1.4. Curing

For Mix 1 and Mix 2, the specimens were cured in a water bath from the time of mixing until the time of testing. The samples were cured in their molds until 24 hours after mixing, at which point they were de-molded and returned to the water bath until they were to be tested. Although K-UHPC recommends steam curing at 90° C (194° F) with 100% relative humidity, due to the limitation of the water tank, it was held at a constant 72 °F (22 °C) throughout the curing process. To verify differences in compressive and splitting tensile strengths depending on curing methods, nine samples from Mix 2 were air cured until they were tested.

For Mix 3, the specimens were cured in their molds until 48 hours after casting. Once the specimens were demolded, they were divided into two groups. One group was for water curing at ambient temperature and the other group was for oven curing at high temperature. For high temperature curing, four cylinder specimens were put into a container filled with water and oven cured at 90° C (194° F) for 48 hours. The rest of specimens were kept in the water tank at room temperature until the testing day.

Mix 4 specimens were not casted because the mixing process was purely for verifying the capacity of drum mixer (2 ft³) when 75% of mixer volume (1.5 ft³) was filled with K-UHPC.

3.2. Mix 1: K-UHPC with Double Superplasticizer – 1 ft³ Volume

3.2.1. Mix Design

Following Super Concrete 180 (SC180) Manual, K-UHPC mix was designed for the volume of 1 cubic foot. Initially, designed amount of superplasticizer was 1.63 lb. and designed water to cement ratio was 0.18. However, due to lack of workability of the originally designed mix, additional water (resulting w/c ratio of 0.22) and superplasticizer (a total of 3.26 lb.) were

added during the mixing process. The design and modified amounts of constituents are summarized in Table 3-5.

Table 3-5 Modified K-UHPC Mix Design for Mix 1

Constituents of 1 ft³ Mix	SC 180 Design (lb.)	Modified Design (lb.)	Modified Design (%)
Fine Sands (dia.150~600 μm)	56.13	56.13	35.7
Portland Cement (dia. 15 μm)	48.89	48.89	31.1
Water	8.73 (w/c = 0.18)	10.73* (w/c = 0.22)	6.8
Superplasticizer	1.63	3.26**	2.1
Steel Fiber (dia. 200 μm) (0.63 inch long)	2.43	2.43	1.5
Steel Fiber (dia. 200 μm) (0.78 inch long)	4.87	4.87	3.1
Defoamer	0.05	0.05	0.03
Pre-mixing binder	31.05	31.05	19.7

*Additional 2 lb. of water was added

** Additional 1.63lb was added

3.2.2. Mixing Process

Due to a poor workability of originally designed mix, additional superplasticizer and water were added. Duration of mixing time was also increased until the mix becomes workable.

a) Preparation

2-cubic feet rotational concrete mixer with a fixed speed at 20rpm was used. A total of thirty five 3 x 6 inch test cylinder molds were prepared. As can be seen in the Figure 3-1, a plastic sheet was used to cover the opening of the rotational concrete mixer to keep dry cement powers during the premixing stage.



Figure 3-1 2ft³ Rotational Concrete Drum Mixer Covered with Plastic Bag

b) Pre-mixing

Pre-mixing binders were shipped from Korea whereas fine sands and Portland cement were obtained in Iowa. After weighing all the materials as designed, pre-mixing binder, sand and cement were mixed in the mixing bowl and mixed for 4 minutes.

c) Adding water and admixtures

Water, superplasticizer, and defoamer were added to the dry mix and mixed for 5 minutes. However, the mix was still very dry and, therefore, additional 1.63 pounds of super plasticizer (double the dosage rate) were added and mixed for another 5 minutes. As shown in Figure 3-2, the mix was still clumped and, therefore, it was mixed for additional 5 minutes. One more pound of water was added and mixed for one more minute. As it was still not thoroughly mixed, one more pound of water was added again and mixed for additional 1 minute until it flowed well as shown in Figure 3-2b.



Figure 3-2 Mix 1 Condition after Liquid Additives a) Poor, b) Good

d) Adding Steel fibers

After obtaining the free flowing mix, half of the steel fibers were added as shown in Figure 3-3. It was then mixed for 1.5 minutes and the rest of the steel fibers were added. After all steel fibers were added, mixing was continued for 1 minute to ensure that they were well dispersed.



Figure 3-3 Addition of Steel Fibers

e) Casting samples

The mixer was stopped after all the materials are mixed thoroughly. As shown in Figure 3-4, UHPC mix was then dumped into a secondary bucket and scooped into plastic molds. Screeding the top was performed to ensure to level samples and the sides of plastic molds were hit lightly to consolidate the specimens.



Figure 3-4 Casting Test Samples

3.2.3. Curing

Thirty five capped plastic molds were put into the curing chamber filled with warm water (72° F) as shown in Figure 3-5. On September 19, 2014, 24 hours after casting, thirty five samples were de-molded and divided into two groups for compressive and indirect tensile strength tests.



Figure 3-5 Samples in Curing Chamber

They were stored back into the curing chamber for wet curing till the testing day.

3.2.4. Test results

The INSTRON testing machine was used to measure both compressive strength and indirect tensile strength of the specimens. Three 3 x 6 inch cylinder samples were tested to measure each of compressive and indirect tensile strength on 1st, 2nd, 4th, 7th, 14th and 28th days after casting. On the 28th day, only two samples were tested for each.

All thirty five specimens were kept in the curing chamber filled with water until each testing day. Overall, compressive and tensile strengths were continuously increased until the 28th day. The 28th compressive and indirect tensile strengths were 26,207.5 psi (181MPa) and 3,632.5 psi (25MPa), respectively.

a) Compressive Strength

Compressive behavior of UHPC was investigated through compressive tests completed in 1 day up to 28 days of curing. As shown in Figure 3-6, cracks were developed vertically due to a high cohesive strength of K-UHPC samples (more pictures are attached in Appendix A).



a. Front



b. Back

Figure 3-6 Broken Compressive Strength Test Samples after 1 Day of Curing

As can be seen in Table 3-6 and Figure 3-7, compressive strength after one day of curing reached 12,740 psi and continued to gain strength for 28 days of curing time. Compressive strength of K-UHPC was significantly higher than a typical Normal Strength Concrete (NSC) with just one day of curing and the strength gain increased significantly up to seven days of curing but it slowed between seven and 28 days. As expected, the average 28 days compressive strength reached 26,208psi (180 MPa).

Table 3-6 Summary of Compressive Strength Test Results (psi)

	Day 1	Day 2	Day 4	Day 7	Day 14	Day 28
C1	14,144	*13,438	18,967	21,928	26,366	25,678
C2	**10,562	18,475	20,014	22,682	24,956	26,737
C3	13,513	17,815	19,087	23,139	24,576	
Average	12,740	16,576	19,356	22,583	25,299	26,208
Standard Deviation	1,561	2,235	468	499	943	748
Strength Gain from Day 1		30%	52%	77%	99%	106%

*Rubber cap was not used at the bottom

**Rubber cap was not used on either end

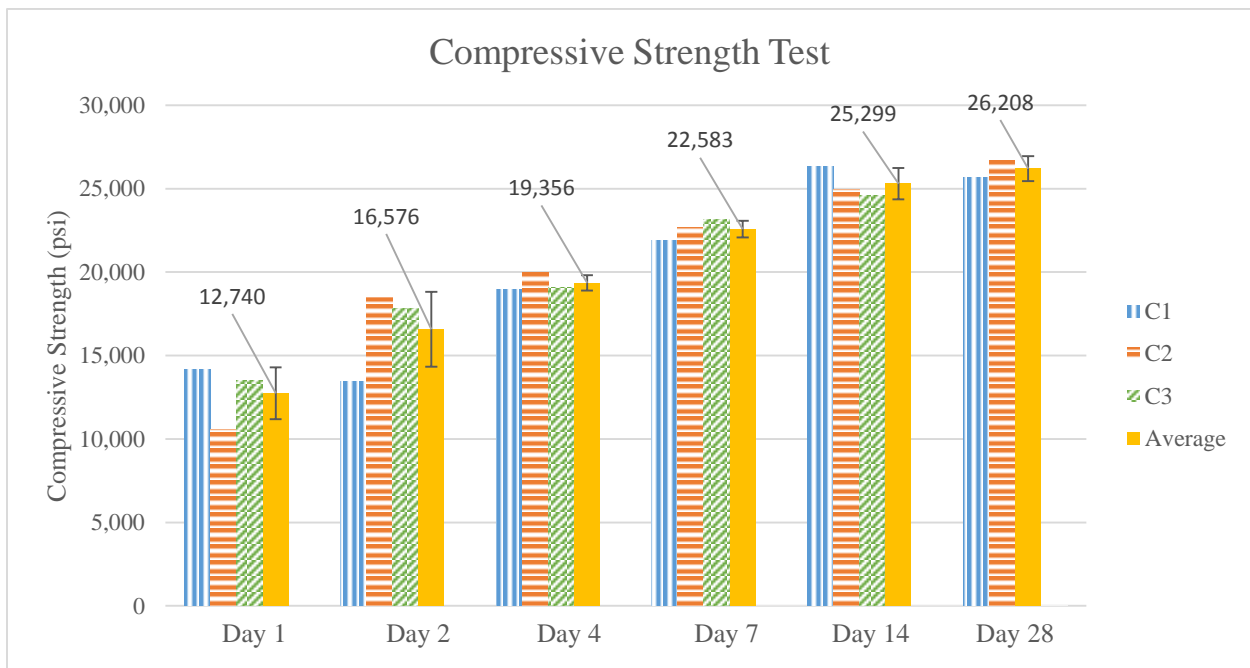
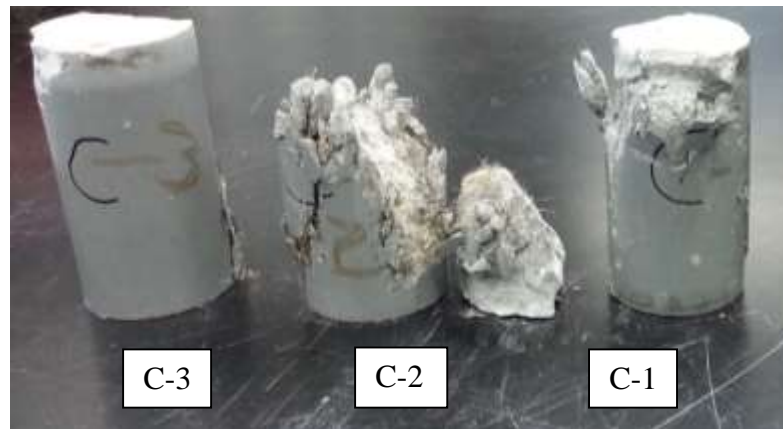
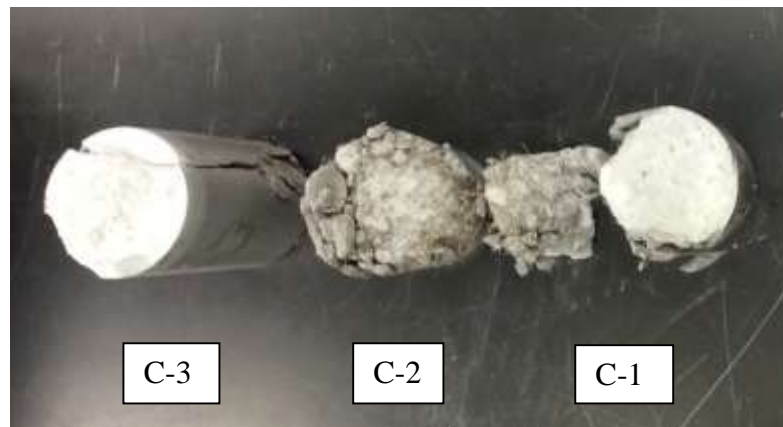

Figure 3-7 Bar Graph of Compressive Strength Test Results

After curing for one day, as shown in Table 3-6, Day 1 C2 specimen failed at significantly lower strength than others possibly due to an eccentric loading caused by missing rubber caps. As can be seen from Figure 3-8, C2 specimen was crushed and large amounts of unhydrated cement particles were exhibited.



a. Front view



b. Top view

Figure 3-8 Compressive Strength Test Samples on Day 1

b) Indirect Tensile Strength

As shown in Figure 3-9, it is interesting to note that only one side of the specimen was cracked (more pictures are attached in Appendix A). It can be postulated that steel fibers arrested cracks effectively at one side of the specimen and, therefore, cracks did not propagate to the other side.



a. Top



b. Bottom

Figure 3-9 Broken Indirect Tensile Strength Test Samples after 1 Day of Curing

The indirect tensile strength results from sixteen cylinder samples are presented in Table 3-7 and plotted in Figure 3-10. It should be noted that T1 sample on the 28th day was excluded due to damage on the sample. The indirect tensile strength is 1,691 psi which is significantly higher than the 28th-day indirect tensile strength of regular concrete. Contrary to the compressive strength test results, however, the indirect tensile strength gain was slow up to 14

days and it increased significantly between 14th and 28th day. On the 28-day, the indirect tensile strength reached 4,383 psi (30MPa).

Table 3-7 Summary of Indirect Tensile Strength Test Results (psi)

	Day 1	Day 2	Day 4	Day 7	Day 14	Day 28
T1	1,634	1,875	2,101	2,877	2,394	
T2	1,852	1,932	2,054	3,035	3,032	4,384
T3	1,589	1,730	1,933	2,048	2,578	
Average	1,691	1,846	2,029	2,653	2,668	4,384
S.D.	115	85	71	433	329	
Increase		9%	20%	57%	58%	159%

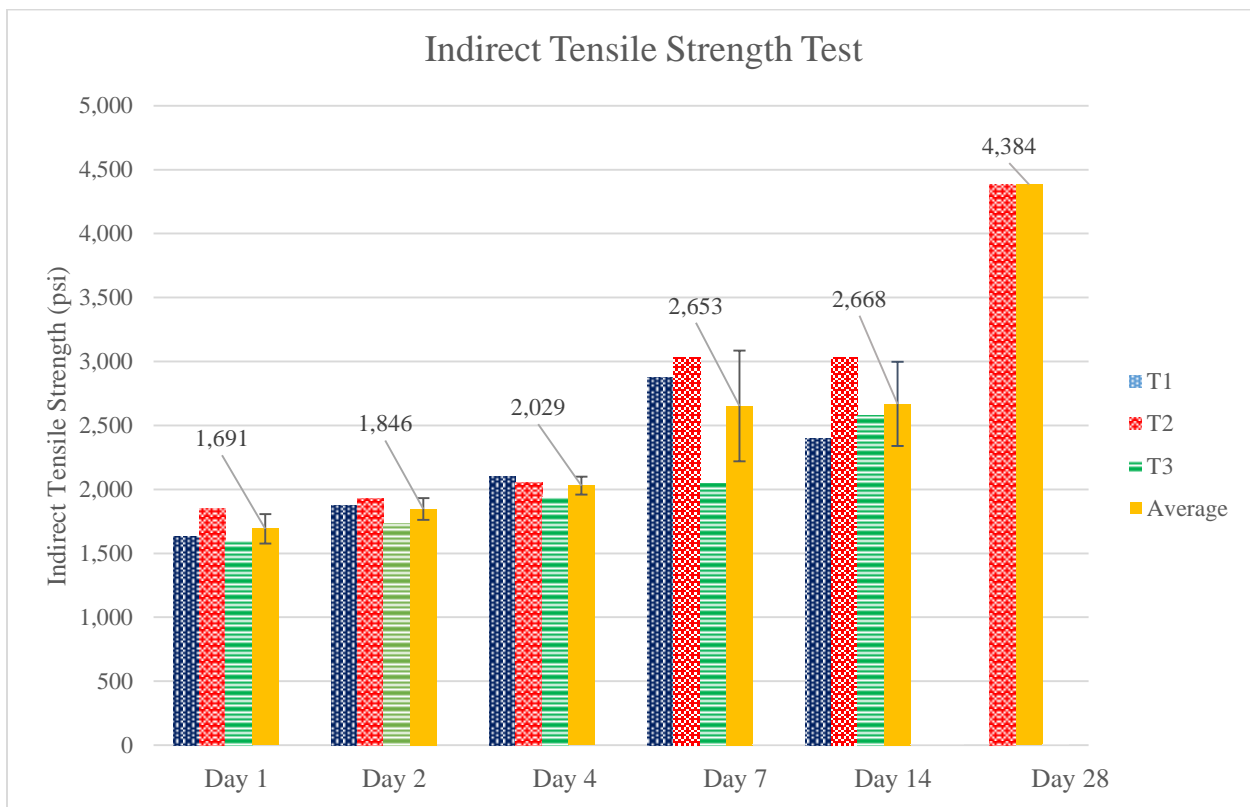

Figure 3-10 Bar Graph of Indirect Tensile Strength Test Results

High indirect tensile strength may be attributed to the steel fibers which would strengthen the bond between the cement paste and the fine sands.

3.3. Mix 2: K-UHPC with “1.5 Times” Superplasticizer – 0.75 ft³ Volume

3.3.1. Mix Design

On September 26th, 2014, K-UHPC concrete mix was prepared for the total amount of 0.75 cubic feet to batch twenty-one 3 x 6 inch and three 4 x 8 inch test cylinders. The same 2-cubic foot rotational concrete mixer was used and similar procedures were followed as described in the earlier for Mix 1. However, in order to obtain workable mix, minor changes were made to the amounts of superplasticizer, water and mixing time. The design and modified amounts of constituents are summarized in Table 3-8.

Table 3-8 Modified K-UHPC Mix Design for Mix 2

Constituents of 0.75 cf Mix	SC 180 Design (lb)	Modified Design (lb)	Modified Design (%)
Fine Sands (dia.150~600 μm)	42.10	42.10	35.7
Portland Cement (dia. 15 μm)	36.67	36.67	31.1
Water	6.55 (w/c = 0.18)	8.55* (w/c = 0.23)	7.2
Superplasticizer	1.22	1.83**	1.6
Steel Fiber (dia. 200 μm) (0.63 inch long)	1.83	1.83	1.5
Steel Fiber (dia. 200 μm) (0.78 inch long)	3.65	3.65	3.1
Defoamer	0.04	0.04	0.03
Pre-mixing binder	23.28	23.28	19.7

*Additional 2 lb of water was added

** Additional 0.61 lb was added

3.3.2. Mixing Process

Additional amount of superplasticizer and water were added as necessary to obtain the good mixing condition for K-UHPC.

a) Preparation

The same procedure as described in Section 3.3.2- Mix 1 a) Preparation was followed.

b) Pre-mixing

The same procedure as described in in Section 3.3.2- Mix 1 b) Pre-mixing was followed.

c) Adding water and admixtures

Water, superplasticizer and defoamer were blended together separately before adding them to the drum mixer. The mixture of liquids was then added to the premix and mixed for 5 minutes. The mix was still very dry after 5 minutes. Additional 1 pound of water and 0.61 pounds of super plasticizer (half of the original amount) were added separately throughout the mix then mixed for 4 minutes. As shown in Figure 3-11, the mix was still clumped and, therefore, 1 more pound of water was added and mixed for another 4 minutes. Finally, the mix started to flow very well and was ready for steel fibers to be added.



Figure 3-11 Mix 2 Condition after Liquid Additives a) Poor, b) Good

d) Casting samples

The same casting process was performed as described in the casting samples part of the previous section 3.2.2. However, the numbers and sizes of the samples were different as follows.

- Twenty one 3 x 6 inch test cylinders were batched for compressive and indirect tensile strength test
- Three 4 x 8 inch (long) test cylinders were batched for the coefficient of thermal expansion (CTE) test

To identify the effects of different curing method, samples were kept in different condition as following.

- Three 4 x 8 inch and twelve 3 x 6 inch samples were kept in the curing chamber filled with water at 72° F.
- Nine 3 x 6 inch samples were kept in the air at room temperature.

3.3.3. Curing

On September 27, 2014, Saturday, in one day after casting, 24 samples were de-molded.

- Six 3 x 6 inch samples (three kept in the curing chamber filled with water, three kept in the air) were tested after 7 days, 14 days for compression and indirect tensile strength tests.
- Three 4 x 8 inch samples (the specimen was cut to 7 inch to follow the AASHTO procedure) were kept in the curing chamber filled with water till 28 days and were tested for the CTE.

3.3.4. Test Results

The INSTRON testing machine with a maximum frame capacity of 1.1 MPa (247,289 lb) was used to measure both compressive and indirect tensile strengths. The compressive strength tests were conducted on the 7th, 14th and 28th day and indirect tensile strength tests were conducted on the 7th days of curing. Three samples were used to measure each of compressive and indirect tensile strengths. For dry curing, no sample was tested on Day 14 due to lack of samples. The experiment was designed determine the effects of dry versus wet curing on the strength development of K-UHPC.

a) **Compressive Strength**

The compressive strength results in different curing conditions are summarized and compared in Table 3-9 and Figure 3-12.

Table 3-9 Compressive Strength Test Results (psi)

	Day 7		Day 14		Day 28	
	Wet Curing	Dry Curing	Wet Curing	Dry Curing	Wet Curing	Dry Curing
C1	23,593	19,266	26,161	n/a	29,671	24,333
C2	23,346	20,294	25,594	n/a	28,781	25,139
C3	n/a	18,727	27,386	n/a	28,925	26,124
Average	23,469	19,429	26,380	n/a	29,126	24,736
SD	124	650	916	n/a	629	570
Increased	n/a	n/a	12%	n/a	24%	27%

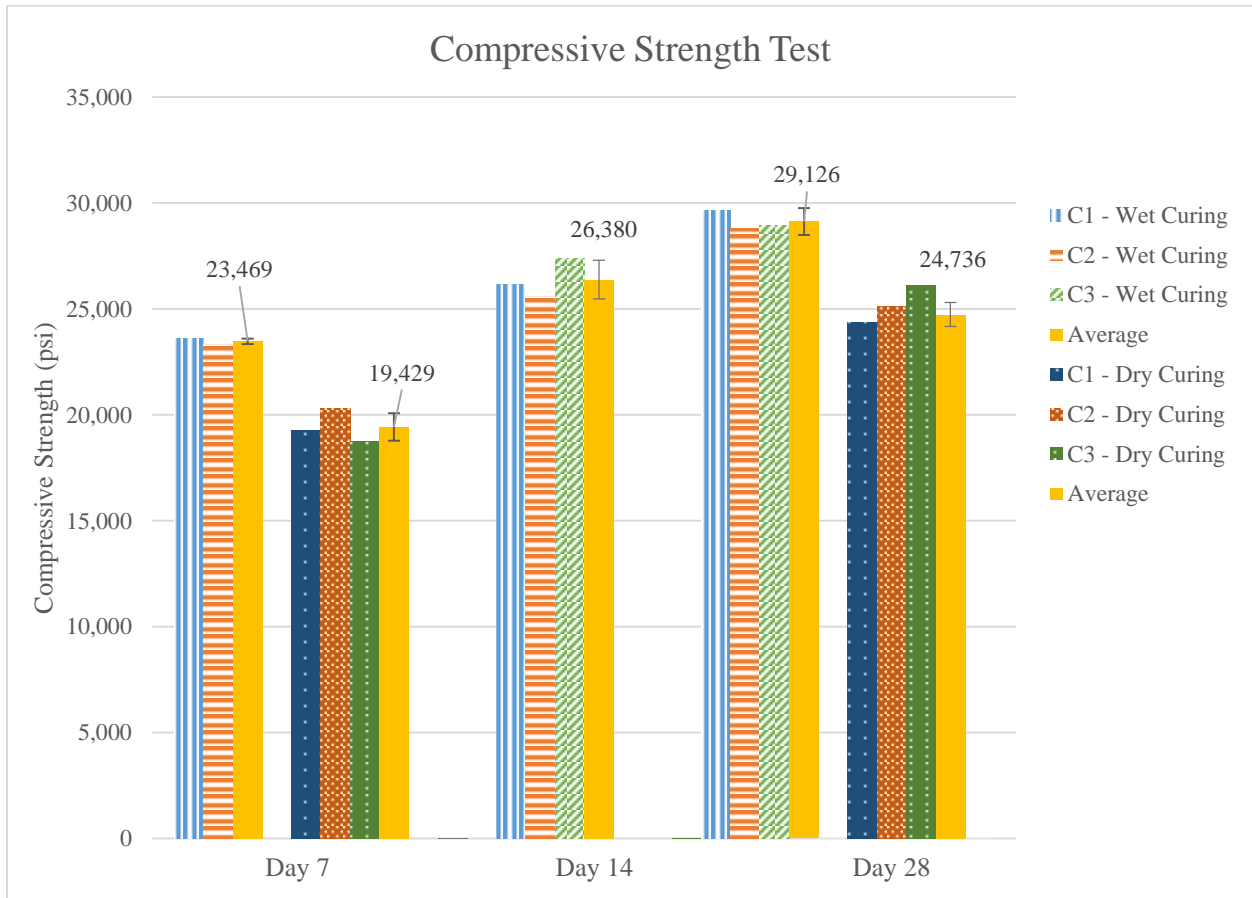

Figure 3-12 Bar Graph of Compressive Strength Test Results

The test results show that compressive strength of dry-cured specimens was lower than wet-cured specimens by 17% on the 7th day and by 15% on the 28th day. This result indicates that the curing condition has substantial impacts on the development of the compressive strength. Given the same wet curing condition, however, the 28-day compressive strength reached 29,125 psi, which was higher than that of the samples (26,207 psi) presented in the previous Section 3.2. It is interesting to note that, with less amounts of superplasticizer and water, second batch mix exhibited higher compressive strength than the first batch.

b) Indirect Tensile Strength

The indirect tensile strength test results of specimens cured for seven days in wet versus dry conditions are summarized in Table 3-10 and plotted in Figure 3-13. As expected, the average indirect tensile strength of the specimens curing in wet condition was higher than samples cured in dry condition. The 7-day indirect tensile strength cured in dry condition was lower by 8% whereas the 7-day compressive strength cured in dry condition decreased by 17%.

Table 3-10 Indirect Tensile Strength Test Results

	Day 7	
	Wet Curing	Dry Curing
T1	3,645	2,473
T2	2,167	2,174
T3	2,642	3,140
Average	2,818	2,595
Standard Deviation	616	404

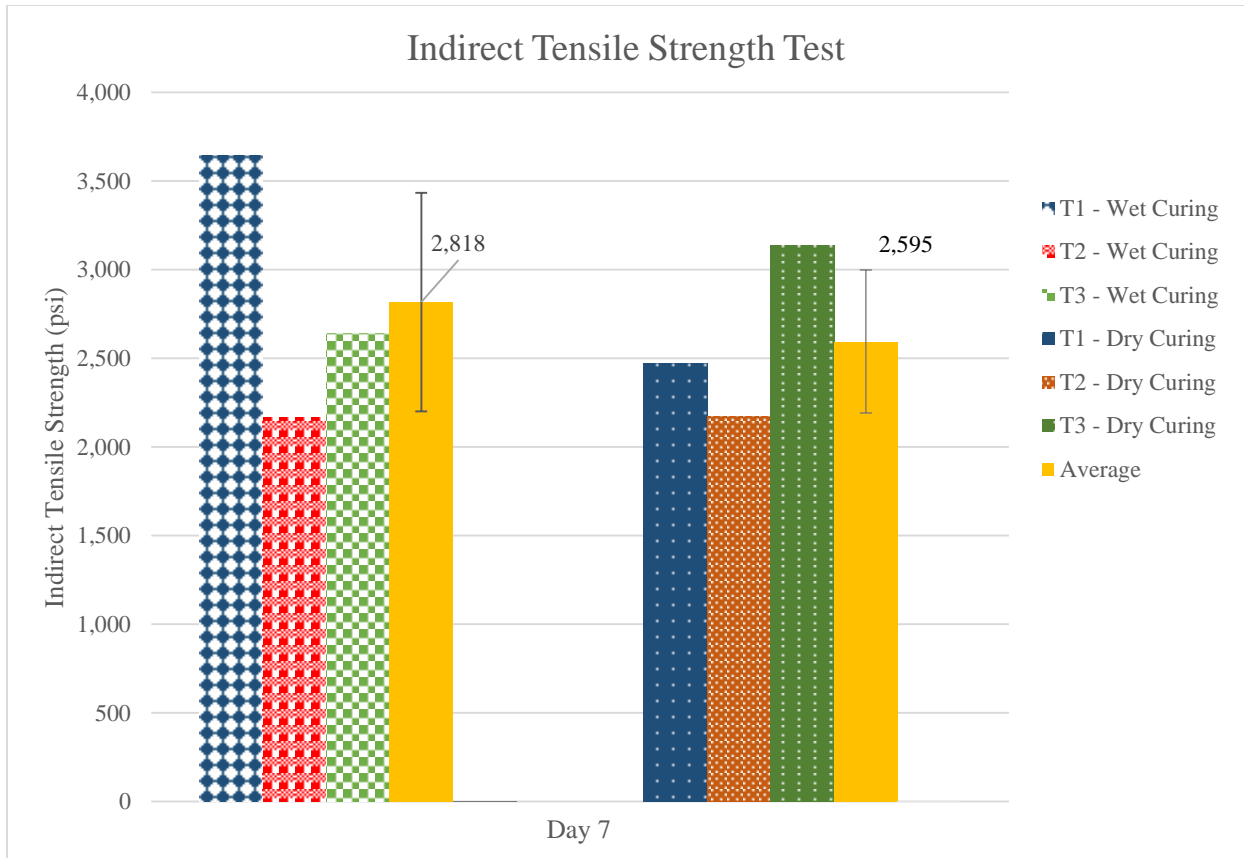

Figure 3-13 Bar Graph of Indirect Tensile Strength Test Results

c) Coefficient of Thermal Expansion Test

The coefficient of thermal expansion (CTE) of a K-UHPC is an important indicator of how it behaves when it is exposed to outdoor environments. The expansion and contraction of K-UHPC should be considered in designing bridges, especially if it is subjected to a wide range of ambient temperature. When designing a bridge, it is important to ensure that the expansion and contraction of K-UHPC will not compromise its structural integrity. For three days from November 5th to 7th, 2014, the CTE's of three 4 by 8 inch cylinder samples of K-UHPC were measured following the standard testing method of AASHTO T 336-11. The laboratory testing was done by the equipment provided at Iowa Department of Transportation (Iowa DOT).

Coefficient of Thermal Expansion Testing Procedure

First, specimens were placed in a water bath held at a constant temperature until it became saturated. Its length and diameter were then measured using a linear variable differential transducer (LVDT). The measurements were recorded every 10 minutes over a 30-minute period to ensure that the results were consistent. Subsequently, the water bath temperature was raised or lowered to another temperature and tests were repeated going from the lower temperature to the higher one or vice versa. For sample 1 and 3, the temperature of the water bath was first set to 10°C (50°F) then changed to 50°C (122°F) and, for sample 2, the temperature of the water bath was first set to 50°C (122°F) then changed to 10°C (50°F). New lengths and diameters of samples were measured as temperature of water bath changed.

The coefficient of thermal expansion was determined by comparing the change in length of the sample to the original sample, divided by the change in temperature the sample experienced. The equation used to calculate the CTE (in micro-strains/ °C) is shown below, where ΔL_a (mm) is the actual change in length of the specimen during temperature change, L_o (mm) is the initial length of the specimen at room temperature, and ΔT (°C) is the change in temperature of the water bath. A picture of the testing apparatus is shown in Figure 3-14.

$$\text{CTE} = (\Delta L_a / L_o) / \Delta T$$



Figure 3-14 Coefficient of Thermal Expansion Testing Apparatus

Coefficient of Thermal Expansion Results

As shown in Table 3-11, the average CTE value of the K-UHPC was 13.994 micro-strain/°C (7.774 micro-strain/°F). Typical values for concrete pavement mixes are in the range of 8 – 10 micro-strains/°C, which are highly dependent on the mix designs. Different proportions and types of aggregates is a major factor on the CTE value since each of the constituents has a different CTE value. The CTE value of K-UHPC is higher than that of typical concretes but it is less than that of polymer concretes.

Such result was expected since K-UHPC mix did not include coarse aggregates and had a larger proportion of fine aggregates than a typical concrete mix. Fine sands have higher CTE values in the range of 11-12 micro-strains/°C than coarse aggregates with CTE values in the range of 6-8 micro-strains/°C. Another contributing factor to a high CTE value of K-UHPC is the amounts of steel fibers, which has a CTE in the range of 11-12 micro-strains/°C. Considering these factors, the measured CTE values of K-UHPC seem reasonable.

Table 3-11 Coefficient of Thermal Expansion Test Results

Sample	Avg. CTE (micro-strain/°C)	Avg. CTE (micro-strain/°F)
1	14.118	7.843
2	14.064	7.813
3	13.801	7.667
Average	13.994	7.774

The average CTE values of K-UHPC, UHPC and polymer concrete with no coarse aggregates were compared and summarized in Table 3-12. It can be seen that CTE value of K-UHPC is similar but lower than typical UHPC but lower than polymer concrete. Also, CTE values slightly varies with different curing methods.

Table 3-12 CTE Values of Various Concrete

	Variables	Sample Age (days)	Avg. CTE (micro-strain/ °C)	Avg. CTE (micro-strain/ °F)
K-UHPC	Water	28	14.0	7.8
Typical UHPC (7)	Steam	60	15.6	8.7
	Untreated	135	14.7	8.2
	Tempered Steam	60	15.4	8.6
	Delayed Steam	60	15.2	8.4
Polymer concrete with 0% Coarse Aggregate (19)	7% polymer		21.7	12.1
	10% polymer		26.7	18.2

3.4. Mix 3: K-UHPC with “1.58 Times” Superplasticizer – 1 ft³ Volume

3.4.1. Mix Design

On May 12, 2015, K-UHPC mix was prepared using the masonry sand. Total volume of 1 cubic feet of K-UHPC mix was produced to cast ten 3” x 6” cylinders and one 6”x6”x22” beam. Three samples were tested for compression strength in 2 days of air curing, four samples were tested in 7 days of 2-day air, 2-day steam and 3-day wet curing. Three samples were tested after 28 days of 2-day air and 26-day wet curing.

Following Super Concrete 180 (SC180) Manual, K-UHPC mix was designed for the volume of 1 cubic feet with the water to cement ratio of 0.20. It should be noted that the designed amount of water was adjusted as wet sand were used instead of dry sand. Due to the lack of workability of the mix, additional superplasticizer of 0.95 lbs was added during the mixing process. Water to cement ratio did not change as no additional water was added as compared to the earlier mixing process at the laboratory. Water to cement ratio did not change as no additional water was added as compared to the earlier mixing process at the laboratory. The

original K-UHPC mix design and the modified amounts of constituents are summarized in Table 3-1.

Table 3-13 Modified K-UHPC Mix Design for Mix 3

Constituents of 1 ft³ Mix	SC 180 Design (lb.)	Modified Design (lb.)	Modified Design (%)
Fine Sand (dia. 150~600 μm)	54.91	54.91	35.5
Portland Cement (dia. 15 μm)	48.89	48.89	31.6
Water	9.95 (w/c = 0.20)	9.95 (w/c = 0.20)	6.4
Superplasticizer	1.63	2.58**	1.7
Steel Fiber (dia. 200 μm) (0.63 inch long)	2.43	2.43	1.6
Steel Fiber (dia. 200 μm) (0.78 inch long)	4.87	4.87	3.1
Defoamer	0.05	0.05	0.0
Premix Package: Silica Fume, Ground Quartz, Shrinkage Reducer & Performance Enhancer	31.05	31.05	20.1

** Additional 0.95lbs of superplasticizer was added

Fine sand that will be used for construction were provided by the City of Independence for testing. Moisture contents of these sand were verified to be 2.1% and the design amount of water in the mix design was adjusted accordingly.



Figure 3-15 Sand from the City of Independence in a Bucket

Table 3-14 Moisture Content of Sand from the City of Independence

Trials	Dry (g)	Wet(g)	MC	Avg. MC
1	580.6	592.7	2.08%	2.10%
2	412.6	421.3	2.11%	

a) Preparation

2-cubic foot rotational concrete mixer with a fixed speed at 20rpm was used to prepare K-UHPC mix. A total of ten 3 x 6 inch test cylinder molds were prepared. As can be seen in the Figure 3-16, a fabric sheet was used to cover the opening of the rotational concrete mixer to keep dry cement powders during the premixing stage.



Figure 3-16 2-Cubic Foot Rotational Concrete Mixer covered with paper towels

d) Pre-mixing

Pre-mixing binders were shipped from Korea and fine sand (from the City of Independence) and Portland cement (Holcim Company) were obtained in Iowa. After weighing all the materials as designed, pre-mixing binder, sand and cement were mixed in the mixing bowl and mixed for 4 minutes.



Figure 3-17 Mix after Pre-mixing

e) Adding water and admixtures

Water, super plasticizer, and defoamer were added to the dry mix and mixed for 5 minutes. However, the mix was still very dry and, therefore, mixing duration was extended for 7 more minutes. As shown in Figure 3-18, the mix was still clumped and, therefore, 0.05lb superplasticizer was added and mixed for another 3 minutes. In order to mix thoroughly, the mixer was flipped to the other side and continued to rotate for 1 more minute. As the good workability was still not observed, 0.4lb of superplasticizer was added over the course of 1 minute. After 5 minutes of rotating, additional 0.5lb of superplasticizer was added again and mixed for another 5 minutes. Then, the mix started to flow well as shown in Figure 3-18.

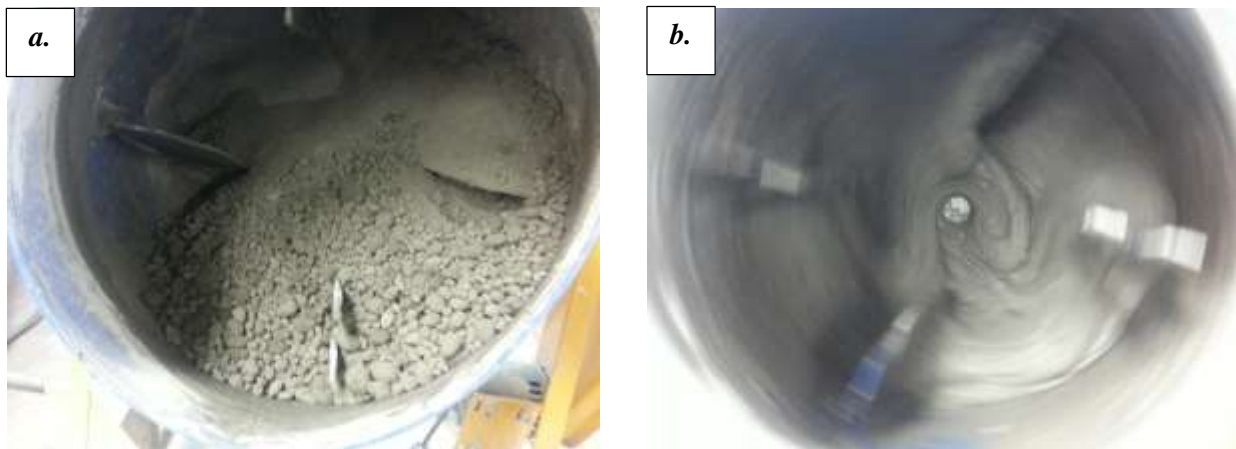

Figure 3-18 Mix 3 Condition after Liquid Additives a) Poor, b) Good

f) Adding Steel fibers

After obtaining the free flowing mix, steel fibers were added over the course of 3 minutes to ensure the fibers are well dispersed. After all steel fibers were added, mixing was continued for 3 minutes to ensure that they were well spread throughout the mix.

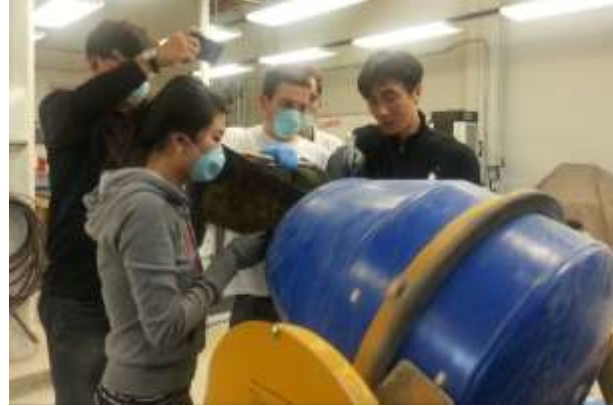

Figure 3-19 Adding Steel fibers



Figure 3-20 Mix with Steel Fibers

e) Casting samples

The mixer was stopped after all the materials are mixed thoroughly. UHPC mix was then dumped into a secondary bucket and scooped into plastic cylinder and beam mold. Screeding the top was performed to ensure to level samples and the sides of plastic molds were hit lightly to consolidate the specimens. Ten (10) capped plastic molds and one beam mold were casted and were left at the room temperature for 48 hours.



Figure 3-22 Preparing Test Samples



Figure 3-21 Samples in Air Curing

3.4.2. De-molding & Curing

On May 14, 2015, Thursday, 48 hours after casting, ten cylinder molds and one beam sample were de-molded and divided into wet curing at high temperature and wet curing at normal room temperature. In order to imitate steam curing at 90 degree Celsius in the field, 4 cylinder samples were put into containers filled with water as shown in Figure 3-24. Then, the samples in water were heated at 90 degree Celsius for 48 hours. As it can be seen in Figure 3-26, water temperature in containers was checked with thermometer to ensure it reached the intended temperature. The rest of three cylinder samples and one beam sample were put into the curing chamber filled with water at normal room temperature of 72 degree Fahrenheit (22 degree Celsius).



Figure 3-23 Cylinder Samples in Oven



Figure 3-24 Cylinder Samples



Figure 3-25 Samples in Curing Chamber at Room Temp.



Figure 3-26 Temperature Check

3.4.3. Test Results

The INSTRON testing machine with a maximum frame capacity of 1.1 MPa (247,289 lb.) was used to measure compressive strength of the K-UHPC specimens. All of ten of 3 x 6 inch cylinder samples were air cured for 48 hours then de-molded.

On May 14, 2015, three cylinder samples were tested for compression strength after de-molding. Other four cylinder samples were wet cured at high temperature of 194 degree Fahrenheit (90 degree Celsius) for 48 hours. Then, they were tested for compressive strength on

May 19, 2015, 7 days after casting. The maximum compressive strength from high temperature curing was 29,668psi after only 7 days.

a) Compressive Strength

Compressive behavior of UHPC was investigated through compressive tests completed in 2 days and 7 days after casting. As shown in Figure 3-27, the surface of cylinder samples were smoothen as the top of each cylinder was not perfectly leveled. To prevent uneven load distributions, rubber cap was used as shown in Figure 3-28.



Figure 3-27 Smoothing the Surface



Figure 3-28 Rubber Cap

Figure 3-29 shows that cracks developed vertically due to a high cohesive strength of K-UHPC samples (more pictures are attached in Appendix A).



a. Front



b. Back

Figure 3-29 Broken Compressive Strength Test Samples after Two Day of Air Curing

The compressive strength results from seven cylinder samples are summarized in Table 3-14 and plotted in Figure 3-30.

Table 3-15 Summary of Compressive Strength Test Results (psi)

	Day 2	Day 7
C1	12,124.0	28,877.0
C2	12,866.8	27,848.5
C3	12,118.4	29,667.8
C4	-	26,892.2
Average	12,369.7	28,321.4
Standard Deviation	430.5	1,209.4

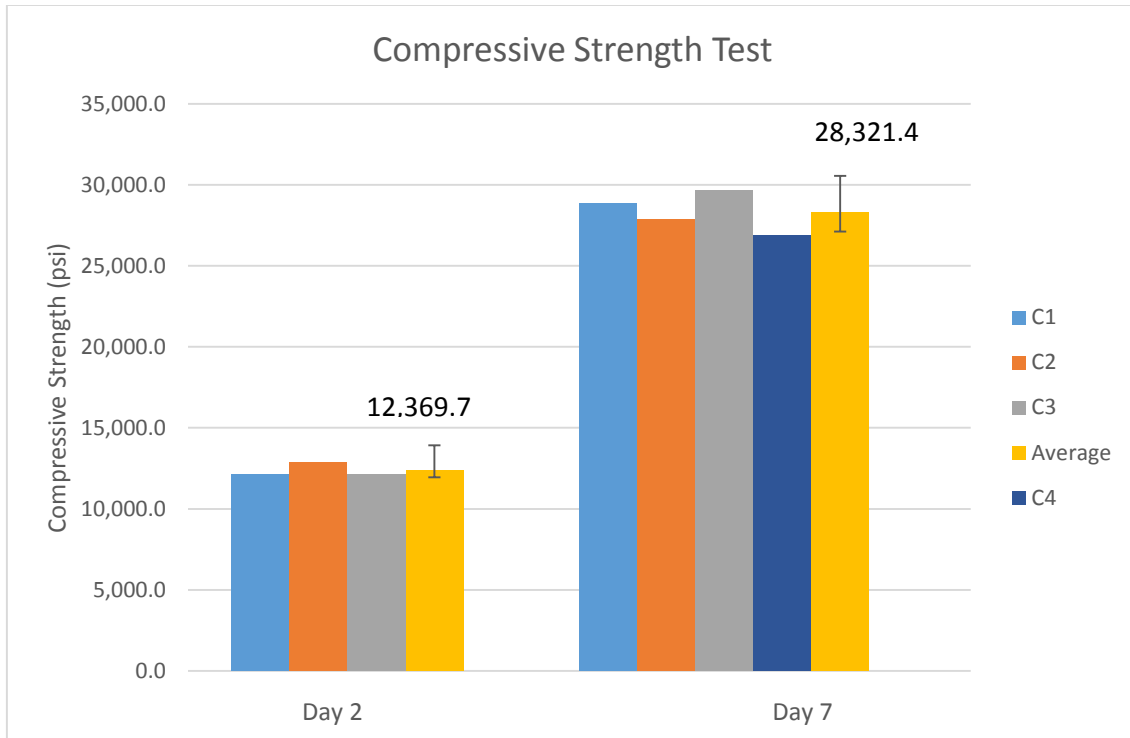

Figure 3-30 Bar Graph of Compressive Strength Test Results

Test results on Day 2 and Day 7 (wet curing at high temperature for 48 hours) showed significant increase in compressive strength. As summarized in Table 3-14 and plotted in Figure 3-30, compressive strength after two days of air curing reached 12,369.7 psi and continued to gain strength. After 48 hours of high temperature wet curing, the compressive strength increased more than double reaching the average of 28,321.4 psi. It is once again confirmed that the compressive strength of K-UHPC is significantly higher than a typical Normal Strength Concrete (NSC) with just two day of air curing and the strength gain increased significantly up to seven days of wet curing.

Based on the past test results, the increase in compressive strength flattens after 7 days but it is expected to gain more strength until 28 days. It should be noted that the compressive strength of 28,321.4 psi on 7 days from this year's test is higher than the test results of 28 days samples with 26,209.0 psi from the last year's test in November 2014. Differences in test

procedure between this year and last year's experiment could have influenced on the difference in compressive strengths. As the amount of water and superplasticizer was less than last year's test, the mix appeared to be thicker and hold steel fibers together better, preventing steel fibers from sinking to the bottom of the specimens. It can be concluded that using correct amounts of water and superplasticizer could improve the compressive strength of K-UHPC.

3.5. Mix 4: K-UHPC with “1.58 Times” Superplasticizer – 1.5 ft³ Volume

On May 14th, 2015, K-UHPC concrete mix was prepared for the total amount of 1.5 cubic feet to test the maximum capacity of 2-cubic foot rotational concrete mixer. The test was intended to check if adding constituents in two separate stages would help producing more mix in total. As the liquid is added in first stage, volume of first mix can be reduced and, therefore, more amount of mix in second stage can be added, resulting the maximum amount of mix.

3.5.1. Mix Design

To obtain workable K-UHPC mix, minor changes were made to the amounts of superplasticizer and mixing time. The additional amount of superplasticizer kept the same as the Section 3. The constituents of 1.5 cubic feet K-UHPC design are summarized in Table 3-15.

Table 3-16 Modified K-UHPC Mix Design for Mix 4

Constituents of 1.5 ft³ Mix	SC 180 Design (lb.)	Modified Design (lb.)	Modified Design (%)
Fine Sand (dia.150~600 μm)	82.36	82.36	35.5
Portland Cement (dia. 15 μm)	73.34	73.34	31.6
Water	14.93 (w/c = 0.20)	14.93 (w/c = 0.20)	6.4
Superplasticizer	2.44	3.87**	1.7
Steel Fiber (dia. 200 μm) (0.63 inch long)	3.65	3.75	1.6
Steel Fiber (dia. 200 μm) (0.78 inch long)	7.30	7.30	3.1
Defoamer	0.07	0.1	0.04
Premix Package: Silica Fume, Ground Quartz, Shrinkage Reducer & Performance Enhancer	46.57	46.57	20.1

** Additional 1.43 lb. of superplasticizer was add

3.5.2. Mixing Process

According to KICT visitors, normal ratio of between normal concrete to K-UHPC production is 1.5:1.3. If a ready mix truck that can produce 10 cubic yard of normal concrete is used, the amount of K-UHPC that can be produced is approximately 8.67 cubic yard. For one girder, the targeted amount of K-UHPC is 9 cubic yard which is little more than the maximum capacity of the ready mix truck that produces 10 cubic yards of normal concrete. This test could confirm that if adding constituents in two stages can be a possible solution to produce a little more mix than expected by lowering the volume of first mix.

a) Preparation

Due to a poor workability of the mix prepared following the original K-UHPC mix design, additional superplasticizer were added. Duration of mixing process was also extended to obtain a workable mix. All constituents were prepared in two groups, first mix for the volume of 1 cubic feet and second mix for the volume of 0.5 cubic feet.



Figure 3-31 Constituents for 0.5 ft³ of K-UHPC

b) Pre-Mixing

The same procedure as described in in Section 3.2.2 - Mix 1 b) Pre-mixing was followed.

c) Adding water and admixtures

All the liquid for 1.5 cubic feet of K-UHPC were mixed together before being added to the mix. Once the liquid was added to the mix, the mixer was rotated for 4 minutes. However, the mix was still very dry after 5 minutes as shown in Figure 3-32. It was mixed for another 2 minutes. 0.5 cubic feet of dry constituents were added as shown in Figure 3-33.



Figure 3-32 Clumped K-UHPC



Figure 3-33 Added 0.5 ft³ of Dry Constituents

Over the course of 17 minutes, the mix was observed as shown in Figure 3-34. Additional dry constituents made the mix clumped together with the first part of the mix. However, with the longer duration of rotations, the mix started to flow better without any additional water or superplasticizer.



Figure 3-34 Mixing Process of 1.5 ft³ of K-UHPC

d) Adding Steel fibers

As an innovative solution, a leaf blower was suggested for distributing steel fibers into a drum mix. As shown in Figure 3-35, steel fibers had to be spread out on the flat pan for the blower to suck the steel fibers in and blow them out to the mixer. Steel fibers were added over the course of 3 minutes while the mixer was still rotating as shown in Figure 3-36.

Using a blower for the mixing process in the field is proven to work however, KICT visitors suggested steel fibers can be added by using a steel mash in the opening of the mixer which would be more helpful than a blower to disperse the steel fibers in the mix.



Figure 3-35 Adding Steel Fibers using a Blower



Figure 3-36 Mix 4 with Steel Fibers

No further casting was performed as strength tests were not intended. By using 2 cubic feet mixer, it was feasible to produce 1.5 cubic feet of K-UHPC. It can be assumed that the 9 cubic yard K-UHPC can produced by using 10 cubic yard capacity ready- mixing truck. However, it was concluded that two ready-mix trucks will be used for construction to be conservative to avoid any unexpected incidents, such as spills on the hills etc.

4. DESIGN OF HAWKEYE UHPC BRIDGE

A unique Pi-girder design for Deacon Avenue Bridge was developed to exploit the material properties of K-UHPC. Design of this pi-girder using K-UHPC was compared with other designs of Pi-girder utilized in the United States.

4.1. Hawkeye UHPC Bridge

The design of the Deacon Avenue Bridge has been completed by the Korea Institute of Civil Engineering and Building Technology (KICT). The total length of the bridge is 52' long and 32'-5" wide, having 30' roadway. As shown in the Figure 3, six of each precast pi-girders using K-UHPC are designed to be 5'-3" wide, 2'-4" deep and 52" long. Each member will be assembled at the construction site. The gap of center will be adjusted to have a 2% transverse crown from the highest point at the centerline of the roadway. Five of transverse cross beams will be constructed at one in every 12'-9" to ensure proper load distribution. Post tensioning will be performed on 14ea. 0.6" diameter longitudinal strands in the bottom of the girders (7ea. on each flange) and 3ea. 0.6" diameter transverse strands in cross beams. 0.5" width gap between girders will be filled with rubber pad while shear ball will be filled with K-UHPC. For substructures, a concrete stub abutment with pile foundation was chosen and the bearing pad will be installed with 2% slope against transverse slope.

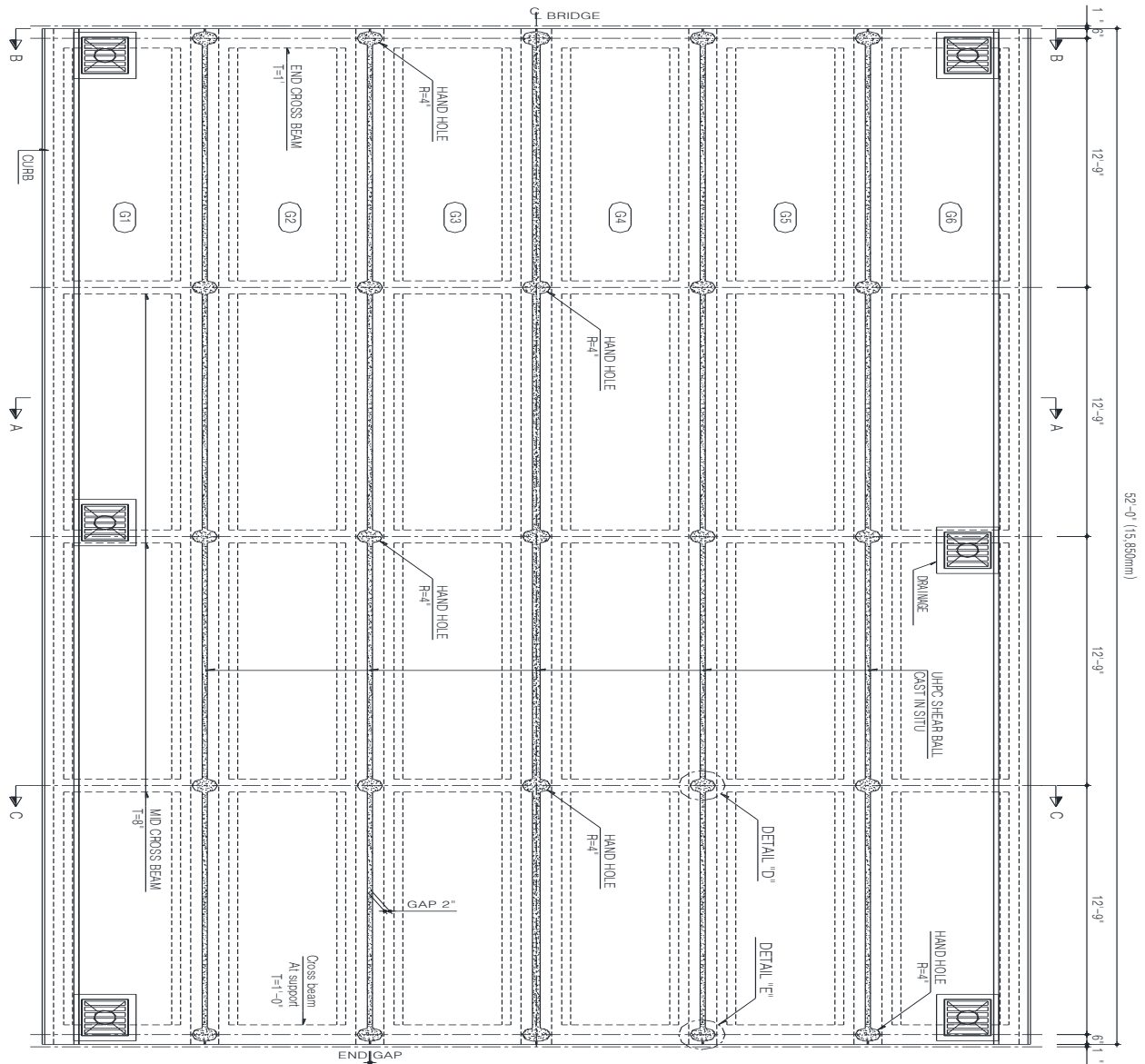
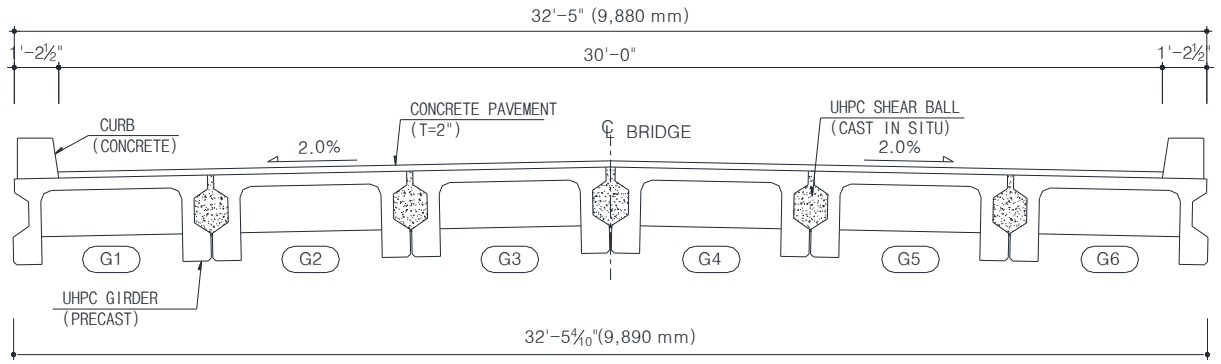

Figure 4-1 Layouts of Hawkeye UHPC Bridge

Construction of substructure of the new bridge has started in early May, 2015 at 1100 Deacon Avenue, Fairbank, Iowa. Six H- shaped steel poles were hammered into the soils approximately 12 ft. deep on each side of the bridge.



Figure 4-2 Construction of Substructure of Hawkeye UHPC Bridge

4.1.1. Innovative Pi-girder Design

The shape of pi girder was optimized for UHPC to minimize the cross section and to exploit the properties of UHPC. The name of pi-girder was from the Greek letter π . Superior tensile, shear and compressive of UHPC allow thinner slab and slimmer girders, making it possible to combine slab and girder in a single piece. Comparing to I section type girders, pi-girders can significantly reduce construction costs. Also, box shaped assembly at the joint between pi-girders reduces the exposure of the pre-stressed bottom flange from aggressive environments (16, 17).

Design of the first generation pi-girder was developed at the Massachusetts Institute of Technology (MIT) and tested by FHWA's Turner-Fairbank Highway Research Center (18). The

first generation pi-girder possess 3 inch top-slab throughout the slab except at the end increases its thickness by double to be 6 inch for connection to an adjacent girder. Its height is 33 inch and bottom flange width is 11" and flange height is 8". Along the web, web thickness varies from 2 inch on the bottom to 3 in at the junction of the web and the top-slab. 24- 0.5" diameter pre-stressing low relaxation strands with 270 ksi (1860MPa) strength were used and was designed for bridges with 70 to 120 ft. span. All of strands were stressed to 29.2 kips (130 kN) and the section does not contain any mild reinforcing steel.

Comparing to the second generation pi-girder, pi-girder designed for Deacon Avenue Bridge has more esthetic cross section of the inner curve with diameter of 7". Also, the height of the Deacon Avenue pi-girder was reduced to 28" from 33" while the thickness of the slab was increased to 4.5" from 4". As can be seen Figure 5c, bottom flange section of Deacon Avenue pi-girder is not recessed which forms circular shear gaps in between girders. These shear balls at each connection will be filled with field-cast K-UHPC. Comparing to connections of the second generation pi-girders with the steel diaphragm on the flange section and UHPC connections at the slab section only, Deacon Avenue pi-girder provides more stable connections by filling the large area of shear balls with K-UHPC. Seven 0.6" diameter longitudinal strands are installed at each bottom flange of the girder with a total force of 591 kips (2,628 kN). To tie six pi-girders together, three 0.6" diameter transverse strands will be post-tensioned through the five cross beams with a total force of 105.5 kips (469 kN).

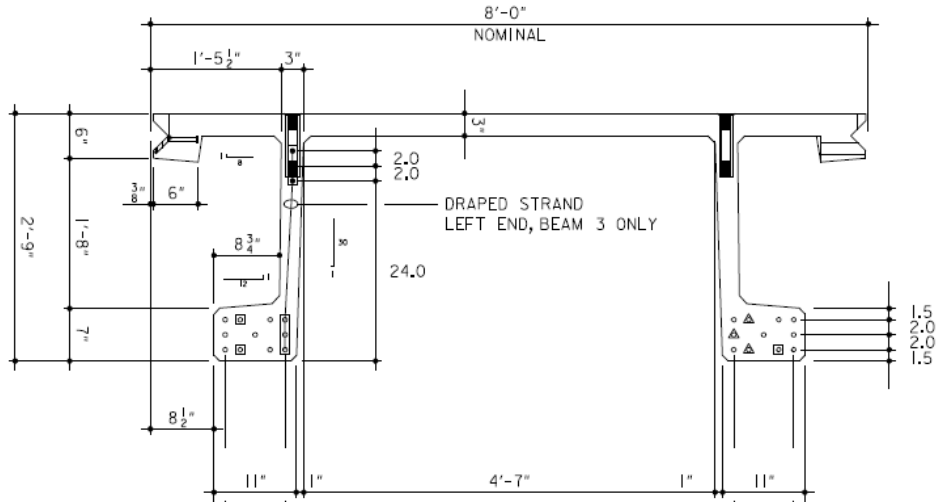

a) First Generation Pi-girder designed by MIT (14)

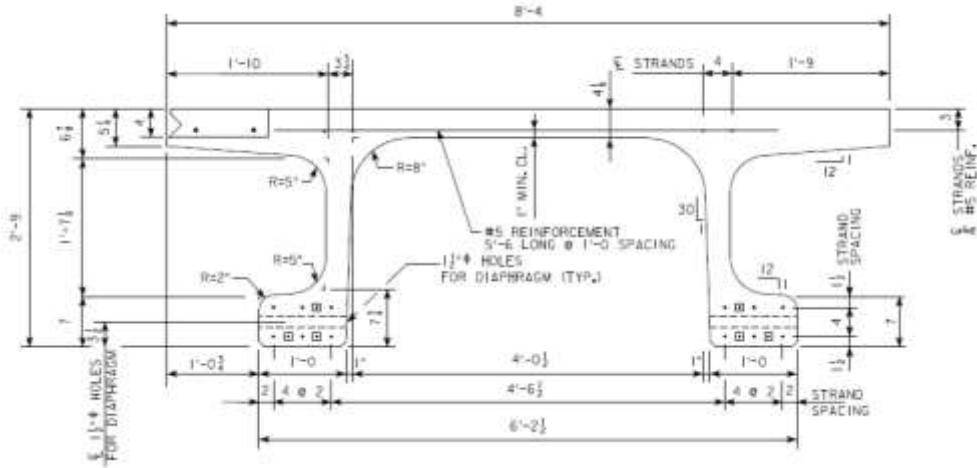

b) Second Generation Pi-girder designed by FHWA (13)

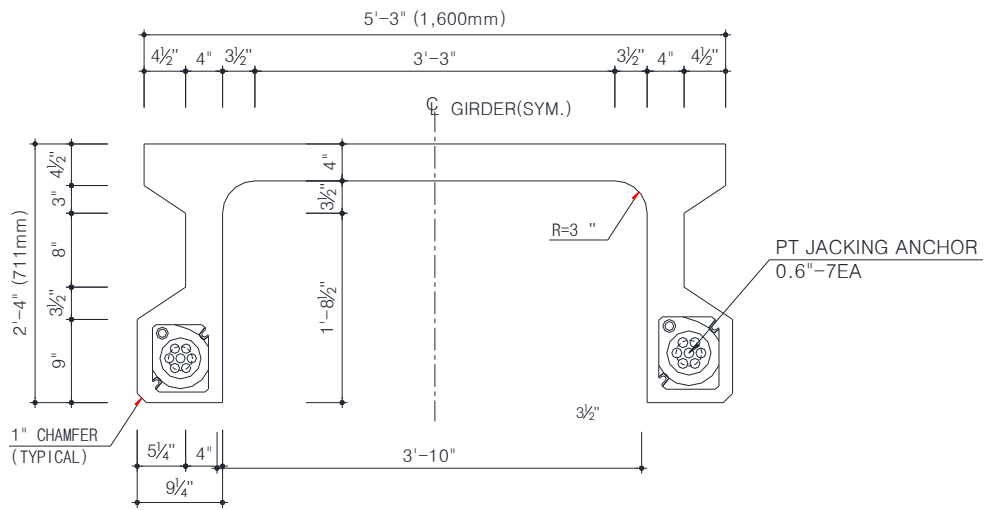

c) Deacon Avenue Pi-girder designed by KICT (KICT design report)

Figure 4-3 Various Pi-girder Types

Detailed material properties of K-UHPC and pre-stressing strands are shown in Table 4-1.

Table 4-1 Material Properties of K-UHPC and Post-tensioning Strands

K-UHPC		Pre-stressing Strands	
Items	Value	Items	Value
Design strength	$f_{ck} = 26.107 \text{ ksi (180MPa)}$	Material of strand	KSD 7002 SWPC 7B $\phi 15.2\text{mm (0.6")}$
Modulus of elasticity	6,526.699 ksi (45,000 MPa)	Type of steel	Low Relaxation Strands
Coefficient of thermal expansion	7.56 micro-strain/ °F (13.6 micro-strain/ °C)	Ultimate stress of tendon	$f_{pu} = 1,880.0\text{MPa}$ (272.671 ksi),
Poisson's ratio	0.2	Yielding stress of tendon	$f_{py} = 1,600.0\text{MPa}$ (232.060 ksi),
Unit weight	202,445.85 lb/ft ³ (25.5 kN/ m ³)	Area of strand	$A_p = 138.71\text{mm}^2$ (0.215in ²)/Strand
Strength on prestressing	26,107 ksi (180 MPa)	Modulus of elasticity	$E_p = 2.0 \times 10^5 \text{ MPa}$ (29007.550 ksi)
Allowable Tensile stress	$f_t = 0.8 \times f_{crk} = 0.8 \times 1232.8 =$ 986 psi (6.8MPa)	Jacking force	0.72 f_{pu} (longitudinal tendon)
Allowable Compressive stress	$f_c = 0.6 \times f_{ck} = 0.6 \times 26106.8 =$ 15,664 psi (108 MPa)		0.60 f_{pu} (lateral tendon)

5. CONSTRUCTION MONITORING

5.1. General

UHPC can be fabricated as either precast members at a plant or cast in place at a construction site. In our research K-UHPC was cast in place at an open backyard of Buchanan County Secondary Roads Departments, approximately 20 miles away from the bridge site. Cast in place pi-girders can be substantially affected by the mixing, placing and curing methods used. In order to control the quality of cast in place K-UHPC structures, all the field samples were cured and kept in the identical condition as the bridge girders. After the curing process, all the samples were taken to the laboratory for compressive strength test to ensure the result satisfy the design strengths.

One of the challenges in mixing UHPC on site is the need for a special portable mixer for mixing process. However, mixing K-UHPC on site is simpler as it could be mixed in a conventional ready mix truck. In order to control the quality of K-UHPC and to minimize the variation within the mixture, mix portion was divided to 5.6 CY in each of two trucks instead of mixing 11 CY in one truck.

Maintaining the ideal curing condition for cast-in place UHPC structure is often challenging. Curing methods on site is often limited to control curing temperature, curing duration and moisture condition in the field. Curing condition of K-UHPC bridge girders were controlled by sufficient water supply by surrounding two perforated water hoses around the structure and constant monitoring of temperature which was applied by heating hoses.

Starting on June 23, 2015, construction of six girders using K-UHPC was performed at Buchanan County field office in Independence, Iowa. Two sets of wooden form were prepared to

produce two girders on each day. Total volume of 11 cubic yard of K-UHPC was produced for one girder by mixing with two ready-mix trucks, each producing 5.5 cubic yard.

5.2. First Girder

5.2.1. Mix design

On June 23, 2015, the construction of the first pi-girder using the K-UHPC was started at 8:30 AM. Based on the last field test mix design on May 29, 2015, K-UHPC mix design for 5.5 cubic yard was designed with 63% of superplasticizer. The original constituent proportion of sand and water was modified according to the moisture content of the wet sand that was 4.2%. Designed proportions and mixing instruction for 5.5 CY K-UHPC is shown in Table 5-1.

Table 5-1 Constituent Proportion for 5.5 CY K-UHPC

No.	SC180 KICT MIX	Total (lb.)	Location	Mixing instruction
1	Pre-mixing binder	4386	County	
2	Cement	7310	Concrete Shop	Mix for 10 min
3	Wet Sand (MC = 4.2%)	8387	Concrete Shop	Mix for 5 min
4	Water	1364	Concrete Shop	Rotate at 10 RPM and move to county shop
5	SRA	73	County	After adding all liquid additives, mix for 5 min
6	Defoamer	5	County	at 10 RPM then,
7	Superplasticizer	106	County	Mix for 5 min at Maximum speed
8	Steel Fiber (0.63 inch long)	362	County	Add for 20 min at 10 RPM
9	Steel Fiber (0.78 inch long)	723	County	Mix for 2 min at Maximum speed

5.2.2. Mixing Process

At 8:30 am, pre-mix was delivered into the ready mix truck by conveyor belt as shown in Figure 5-1 b). At 9:00 am, ready mix truck was then moved to concrete shop to add cement and water. After all the liquid additives were added, steel fibers were added by the similar way using conveyor belt but a mesh and vibrator were used to ensure the fibers do not clump but disperse evenly. The average ambient temperature was in the range between 64 °F to 68 °F.

a) Formworks for K-UHPC



b) Adding Pre-mix



c) Mesh with a vibrator



d) Adding steel fibers



Figure 5-1 Adding K-UHPC Constituents

5.2.3. Pouring

K-UHPC mix was completed around 10:00 AM. Before pouring K-UHPC mix into the form, it was important to prevent the post-tensioning ducts from floating due to the high hydraulic forces generated by K-UHPC mix. To prevent this, post-tensioning strands were kept inside of the ducts throughout the construction. Also, the post-tensioning ducts were being attached to the form by using zip ties as a temporary solution. While the formwork was being secure with extra ties on post-tensioning ducts, the mix was waiting for approximately 40 minutes and ambient temperature was continuously increased around 11:00 AM up to 72 °F. Consequently, additional 25 pounds of superplasticizer was added and mixed for 5 minutes right before pouring to ensure desired fluidity of K-UHPC.



Figure 5-2 Orientation of Two Trucks during Pouring

K-UHPC from the first truck (on the right in Figure 5-2) was poured first, then the second truck started to pour after all the K-UHPC from the first truck was being poured. Vibrating was

applied around the area where K-UHPC from the first and second truck met. The mixture appeared thicker as compared to the past test mixes but it flowed nicely to complete the first K-UHPC girder. To prevent any possible moisture loss, curing agent was coated at the surface of the girder immediately.



Figure 5-3 First Girder Pouring



Figure 5-4 Casted First Girder

Pouring the first girder took about 10 minutes. The total duration of building first pi-girder using K-UHPC took approximately 2 hours; from 8:30 AM till 11:10 AM excluding 40 minutes of waiting for fixing the formwork.

Twelve 3 by 6 in. cylindrical samples from two trucks (six samples each) were made for the strength tests at the laboratory.

Attempt production of Second Girder

At 1:00 PM, construction of second pi-girder using K-UHPC was started. The same procedures were used to make K-UHPC mix with 63% of superplasticizer. However, any additional superplasticizer was added at this time.

K-UHPC mix made for the second girder was poured at 2:00PM. However, the mix appeared very dry and thick. The ambient temperature increased up to 77 °F. Total of 5.5 CY K-UHPC produced was not enough to fill the form.



Figure 5-5 Incomplete Second Girder

As an attempt to fill the form completely, 1 CY of K-UHPC was made additionally. At 3:40 PM, additional K-UHPC was poured as shown in Figure 5-6. The ambient temperature was 77 °F.



Figure 5-6 Additional 2CY of K-UHPC Pouring

5.2.4. Curing of the first girder

After 48 hours of air curing, the form work was taken off and steam curing was applied to the first girder as shown in Figure 5-7. Steam curing was performed by putting heating hoses around the girder and sufficient water was provided by two water hoses. Burlaps were applied to help keeping the moistures inside of the plastic covers. Temperature of the heating hoses was increased at the rate of 59 °F / hour (15 °C / hour) up to 176 °F (80 °C). Due to the limitation of the heating capacity, the recommended temperature of 90 °C was not achieved. Therefore, the maximum temperature of 80 °C was kept for 96 hours, longer than recommended hours of 72 hours.



Figure 5-7 Steam Curing of First Girder

Result of attempted second girder

Due to the lack of fluidity of K-UHPC, the second girder could not be properly built, showing several defects on the girder as shown in Figure 5-8. The second girder was destroyed as it was not usable for the bridge construction.



Figure 5-8 Result of Attempt Second Girder

5.2.5. Post-Tensioning

On June 29, two beam samples were taken to the laboratory for flexural test. The beam's strength of the first crack was higher than 4MPa, considering the girder was strong enough to be post-tensioned.



Figure 5-9 Four Point Bending Test on K-UHPC Beam Sample

Dywidag post-tensioning device was used to apply pre-stressing load of 295.4 kips for 7 strands on each bottom of girders. Gauge reading of 6500 psi was applied for 300 kips on seven 0.6” diameter pre-stressing strands on each flange of the girders. Elongation of strands were recorded by applying spray before and after post-tensioning as shown in Figure 5-10c. The average elongation of the strands was approximately 6 inches.

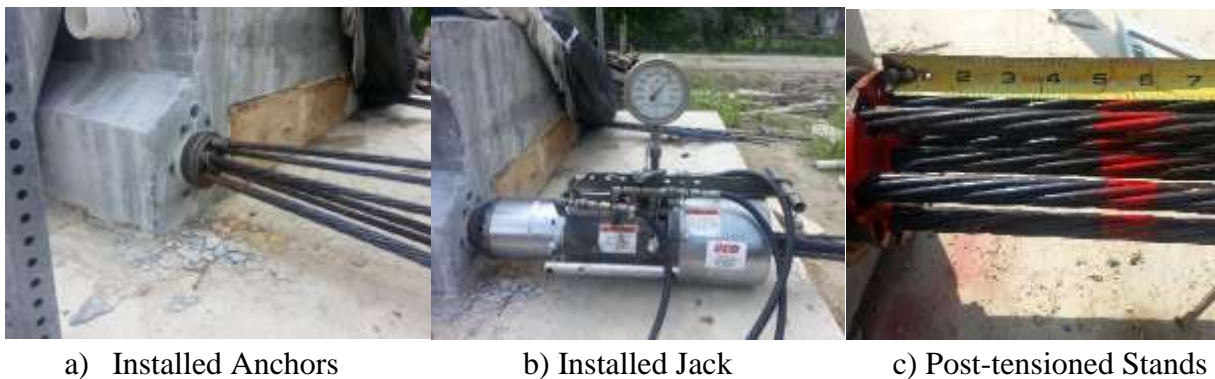

Figure 5-10 Post-tensioning on First Girder

5.3. Second Girder

On July 1, 2015, construction of second girder started at 8:30AM. As the hot summer temperature reduced the fluidity of K-UHPC, the design amount of superplasticizer was increased from 63% to 83%. Additional 10% of superplasticizer was added at the end of mixing if necessary. The moisture content of the wet sand was 4.6% and the amount of sand and water was modified accordingly for 5.5 CY K-UHPC, shown in Table 5-2.

Table 5-2 Modified Amount of Wet Sand and Water for Second Girder

SC180 KICT MIX	Total (lb)
Wet Sand (MC = 4.6%)	8411
Water	1340

5.3.1. Mixing

The same procedure was followed for adding constituents into the ready mix truck for mixing. During the construction from 8:30 AM to 11:00 AM, the ambient temperature increased from 60 °F to 70 °F rapidly.

5.3.2. Pouring

At 10:40 AM, pouring started at the desired flow rate as shown in Figure 5-11. Soon, the left bottom of the formwork broke and K-UHPC leaked through the gap. The main reason was due to the high hydraulic forces produced by K-UHPC.

Quickly, the crane was used to support the form where the leakage happened. Due to the leakage, additional 2 CY of K-UHPC was produced to fill the form completely. A vibrator was used to mix thoroughly. The edge of the form on the right side (opposite side of where the leakage happened) buckled slightly about 0.5 inches (1.27 cm) as shown Figure 5-11.

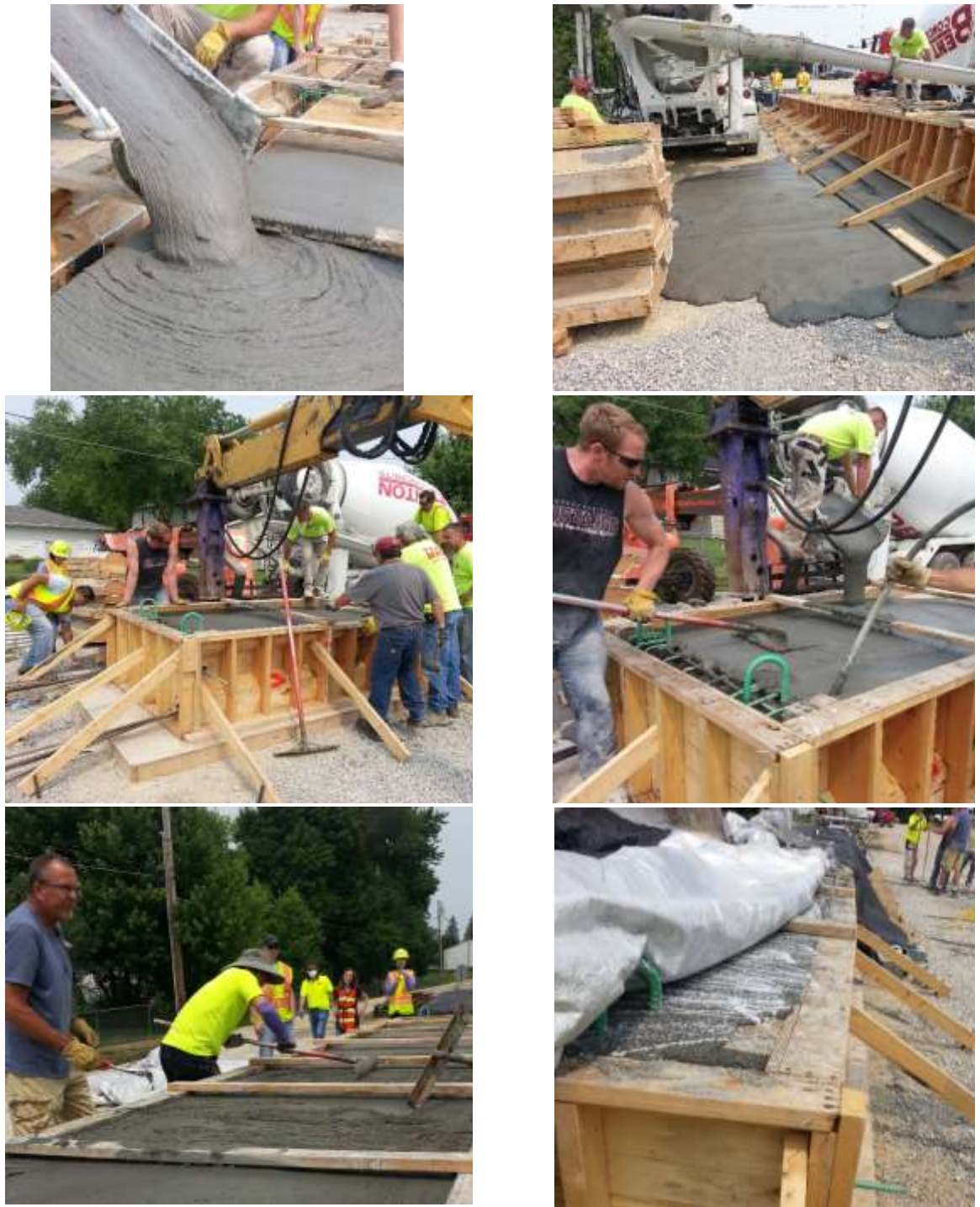

Figure 5-11 Second Girder Construction

5.3.3. Curing

The same curing procedure was used for steam curing. On July 6, 2015, the form was taken off and the area of leakage was observed thoroughly. The surface of the second girder had smooth texture with a subtle indent at the bottom edge as can be seen in Figure 5-12.



Figure 5-12 Completed Second Girder

Minor cold joints were shown at where additional 2CY of K-UHPC was added. However, the second girder was considered to be still usable for the bridge.



Figure 5-13 Cold Joints Appeared on Second Girder



Figure 5 -13 - Continued

5.3.4. Post-tensioning

The same procedure for post-tensioning was performed on July 9, 2015. The average elongation was about 6 inches, matching with the elongation measured for the first girder when the same force was applied.



Figure 5-14 Elongation of Post-tensioned Strands

5.4. Third Girder

On July 16, 2015, construction of third girder started at 6:30 AM to avoid dramatic temperature increase during the construction. The formwork was improved with extra straps around the form to resist high hydraulic force of K-UHPC. Amounts of wet sand and water were adjusted for 5.5 CY K-UHPC based on the moisture contents of the sand of 3.4 % as shown in Table 5-3. The amount of superplasticizer stayed the same as 83% like the construction of second girder.

Table 5-3 Modified Amounts of Wet Sand and Water for Third Girder

SC180 KICT MIX	Total (lb)
Wet Sand (MC = 3.4%)	8315
Water	1437

5.4.1. Mixing

The same procedure was followed for adding constituents into the ready mix truck for mixing. The ambient temperature was consistent as 64 °F from 6:30 AM till 8:15AM.

5.4.2. Pouring

At 8:00AM, K-UHPC was poured achieving the desired fluidity. However, it started to rain when K-UHPC was being poured. The plastic cover was applied to prevent rain from going into the form. As K-UHPC was poured, excess water floated to the top which then lifted out as much as possible.

Iowa State University (ISU) made cylinder and beam samples from this K-UHPC mixture. LACT informed ISU that the samples that they made on this mixture might result in lower strength as excessive rain water collected undesirably. Therefore, ISU was to collect more samples from the next K-UHPC mixture for the fourth girder.

5.5. Fourth Girder

On the same day, July 16, 2015, construction of fourth girder started at 10:00 AM when the rain stopped. Due to rain, the moisture content of the sand increased to 4.0%. Corrected amount of sand and water for 5.5 CY of K-UHPC was calculated and summarized in Table 5-4.

Table 5-4 Modified Amount of Wet Sand and Water for Third Girder

SC180 KICT MIX	Total (lb)
Wet Sand (MC = 4.0%)	8363
Water	1329

5.5.1. Mixing

The same procedure was followed for adding constituents into the ready mix truck for mixing. The ambient temperature increased from 64 °F to 68 °F from 10:00 AM till 11:40AM.

5.5.2. Pouring

At 11:40AM, K-UHPC was poured achieving the desired fluidity. No additional superplasticizer was added.



Figure 5-15 K-UHPC Pouring for Third Girder



Figure 5-16 Casted Third Girder with Improved Support on Form

5.5.3. Curing

The same curing procedure was used for steam curing. On July 20, 2015, the wooden form was taken off and steam curing was applied until July 23, 2015.

5.5.4. Post-tensioning

The same procedure for post-tensioning was performed on July 23, 2015.

5.6. Fifth Girder

On August 4, 2015, construction of fifth girder started at 6:40 AM. As shown in Table 5-5, amounts of water and sand for 5.5 CY of K-UHPC was adjusted according to 3.8% moisture contents of sand.

Table 5-5 Modified Amount of Wet Sand and Water for Fifth and Sixth Girder

SC180 KICT MIX	Total (lb.)
Wet Sand (MC = 3.8%)	8347
Water	1404

5.6.1. Mixing

The same procedure was followed for adding constituents into the ready mix truck for mixing. The ambient temperature varied from 52 °F to 62 °F from 6:40 AM till 8:30 AM.

5.6.2. Pouring

At 8:20 AM, K-UHPC was poured with adequate fluidity as shown in Figure 5-17.



Figure 5-17 K-UHPC Pouring for Fifth Girder

5.7. Sixth Girder

On August 4, 2015, construction of sixth girder started at 9:10 AM. Moisture content of the wet sand stayed consistent as 3.8%, therefore the same amounts of water and wet sand were used as fifth girder.

5.7.1. Mixing

The same procedure was followed for adding constituents into the ready mix truck for mixing. The ambient temperature varied from 66 °F to 73 °F during the construction from 9:10 AM till 11:50 AM.

5.7.2. Pouring

At 10:50 AM, K-UHPC was poured with suitable fluidity as shown in Figure 5-18.



Figure 5-18 K-UHPC Pouring for Sixth Girder

5.7.3. Curing

On August 6, 2015 the form was taken off and the same steam curing procedure was followed until August 10, 2015. As can be seen in Figure 5-19, fifth and sixth girder have connections for guard rails.



Figure 5-19 Steam Curing on Sixth Girder

Figure 5-20 shows the opening where the transverse post tensioning strands could be penetrated out to the side.



Figure 5-20 Opening for Transverse Post-tensioning Strands

5.8. Grouting

On August 11, 2015, grouting was performed on longitudinal post-tensioned ducts of all six girders. As shown in Figure 5-21, Dywidag System International (DSI) mixer was used for mixing high performance cable grout called EUCO Cable Grout PTX made by Euclid Chemical.



Figure 5-21 Grout Mixer Manufactured by DSI

EUCO Cable Grout PTX produces a non-shrink, high strength grout to protect steel cables, anchorages and rods from unparalleled corrosion. General property of EUCO Cable Grout PTX is shown in Table 5-6.

Table 5-6 Properties of EUCO Grout PTX

Property	Result at 1.5 gal/50 lb. (5.7 L /22.7 kg) mix water
Flow Rate ASTM C 939 modified	9 to 20 seconds initial flow 9 to 30 seconds at 30 min
Initial Setting time at 70 °F (21°C) ASTM C 953	8 to 12 hours
Compressive Strength ASTM C 942	7 days: > 3,000 psi (20.7 MPa) 28 days: > 7,000 psi (48.3 MPa)
Hardened Height Change ASTM C 1090	24 hours: 0.0 % to 0.1 % 28 days: 0.0 % to 0.2 %
Plastic Expansion ASTM C 940	0.0 % to 2.0% for up to 3 hours
Chloride Permeability ASTM C 1202	28 days (30V for 6hrs): < 2,500 coulombs

Prior to grout application, each post tensioned strands of all six girders were cut and capped on as shown in Figure 5-22.



Figure 5-22 Cap with Attached Grout Opening

When the grout power was mixed with water, it appeared extremely fluid and darker than surrounding K-UHPC as shown in Figure 5-23 and 5-24.



Figure 5-23 Grout in a Mixer



Figure 5-24 Grout Appeared Darker than Surrounding Concrete

5.9. Bridge Installation

On August 25, 2015, all six girders were installed at the 1100 Deacon Avenue, Fairbanks, IA. At the Buchanan County field shop, two girders were delivered using two semi-trucks (one girder on each truck). The travel distance between the Buchanan County field office to the bridge site is about 17 miles (27 KM) and travel time was approximately 27 minute as shown in Figure 5-25 (Google Map).



Figure 5-25 Travel Distance to Bridge Site (Google Map)



Figure 5-26 Girder Delivered onto a Truck

At the bridge site, girders were moved onto the abutment by two cranes as shown in Figure 5-26 and 5-27.



Figure 5-27 Bridge Installation

At the joints between installed girders created hexagon shaped shear balls as shown in Figure 5-28. In Figure 5-29, steel plates at the edges of each girder and closed caps for longitudinal post-tensioned ducts are shown.



Figure 5-28 Two Installed Girders



Figure 5-29 Steel Plates between Abutment and Girders

At joints, transverse post tensioning ducts were aligned and longitudinal gaps were observed at the bottom of each joint as shown in Figure 5-30.



Figure 5-30 Gaps Created at Each Joint

Prior to joint filling with K-UHPC, the transverse post tensioning ducts were connected as shown in Figure xx. The gaps at the bottom of each joint were closed with expanding foam insulation. To ensure no leakage of K-UHPC during joint filling construction, the closed gap was tested with water on September 1, 2015. It was confirmed that water would not penetrate through the installed foam insulation.



Figure 5-31 Filled Gap and Connected Post-tensioning Duct

At the middle joint, the gaps were bigger than those at other joints due to the curved edge of the second girder. Therefore, the gap was supported with horizontal wooden sticks as shown in Figure 5-32.



Figure 5-32 View from Under the Bridge

5.10. Joint filling with K-UHPC

Prior to joint filling with K-UHPC, wooden formwork was applied on each side of the bridge as shown in Figure 5-33.



Figure 5-33 Formwork for Joint Filling

On September 2, 2015, K-UHPC mixture was made for joint filling, starting from 6:20 AM till 7:30 AM. A total of 11 CY of K-UHPC was created at the Buchanan County field office by using two ready mix truck producing 5.5 CY of K-UHPC each. The same field mixing procedure was used as previously mentioned in mixing section of this chapter. Moisture content of the sand was 2.9% and the amounts of water and sand were adjusted as shown in Table 5-7.

Table 5-7 Modified Amounts of Wet Sand and Water for Joint Filling

SC180 KICT MIX	Total (lb.)
Wet Sand (MC = 2.9%)	8274
Water	1477

At the north side of the bridge, the first truck arrived at the bridge site at 8:00 AM. 10 minutes later, the second truck arrived at the south side of the bridge. For one joint at a time, K-UHPC mixes from two trucks were poured into the joint simultaneously from each end of the bridge.

A temporary funnel was made at each end as shown in Figure xx. K-UHPC mixes were flowing well throughout each joint and it was vibrating using a rod at the point where K-UHPC from each side meet.



Figure 5-34 Temporary Funnel

It should be noted that the north side of the bridge was slightly higher than the south side of the bridge. Therefore, K-UHPC from the south side was delivered by buckets as necessary when there was not enough sufficient flow from the truck at the very end of the construction.



Figure 5-35 Filled Joints with K-UHPC

Joints filled with K-UHPC were covered with wet burlap to prevent any moisture loss. Burlaps were kept on for 7 days.



Figure 5-36 Burlaps Put on Each Joint

5.11. Transverse Post-tensioning

On September 9, 2015, transverse post tensioning strands were post-tensioned. For three 0.6” diameter strands, a total of 105.3 kip was required to post tension. For each strand, 35.1 kip was applied individually. Based on calibration curve provided by the manufacture of the post-tensioning device, gauge pressure for 31.5 kip was about 4,500 psi.



Figure 5-37 Transverse Post-tensioning

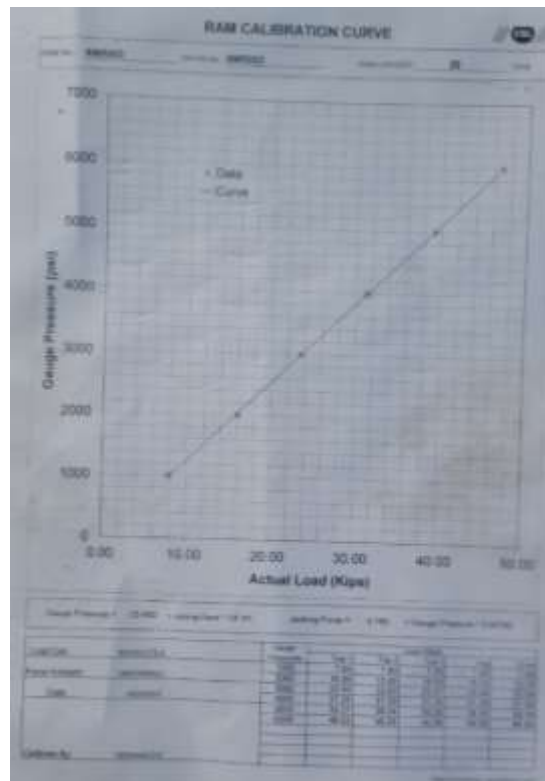

Figure 5-38 Post-tensioning Calibration Sheet



Figure 5-39 Post-tensioned Transverse Strands

It was noted that the only two strands were installed at the mid span of the bridge during the observation. LACT informed Buchanan County that it should be corrected to be three strands instead of two strands for structural purposes.

Due to the delivery waiting time, one strand was added and post tensioned later on September 21, 2015. On the next day, September 22, 2015, all the strands were cut and grouted as shown in Figure 5-40.



Figure 5-40 Post Tensioned Transverse Strands with/without Cap

6. LABORATORY TESTS ON FIELD SAMPLES

6.1. Compression Test

The INSTRON testing machine with a maximum frame capacity of 1.1 MPa (247,289 lb.) was used to measure compressive strength of the K-UHPC field specimens. Six 3” by 6” cylinder samples were made from each truck. Two samples each were to be tested for 7, 14, 28 days strength. Later, however, compressive strengths of two samples were tested after 28 days around the time when the bridge was installed, rather than 14 days.

Test results are summarized in Figure 6-1 and pictures of tested samples are attached in Appendix A. Compressive strengths of field K-UHPC mixtures were similar to those of the laboratory mixtures. Some of the field samples had lower compressive strength as expected as the surface smoothness of field specimens was significantly lower and specimens would have not been thoroughly steam cured in the field. There were slight strength differences between mixtures that were produced by truck 1 and truck 2. Possible reasons for this are increased mixing time and temperature as mixtures in truck 2 has an extra time of mixing during the mixtures from truck 1 is being placed. However, the overall compressive strengths showed the consistency minimal variations as shown in Figure 6-1.

Maximum strength was 30,315 psi from the sample cased on July 1, 2015 and tested on 50 days after casting. Several samples were tested after 28 days to analyze the strength gained at the time of bridge installation. Overall compressive strength was around 27,000 psi which satisfy the strength requirements for the Deacon Avenue Bridge.

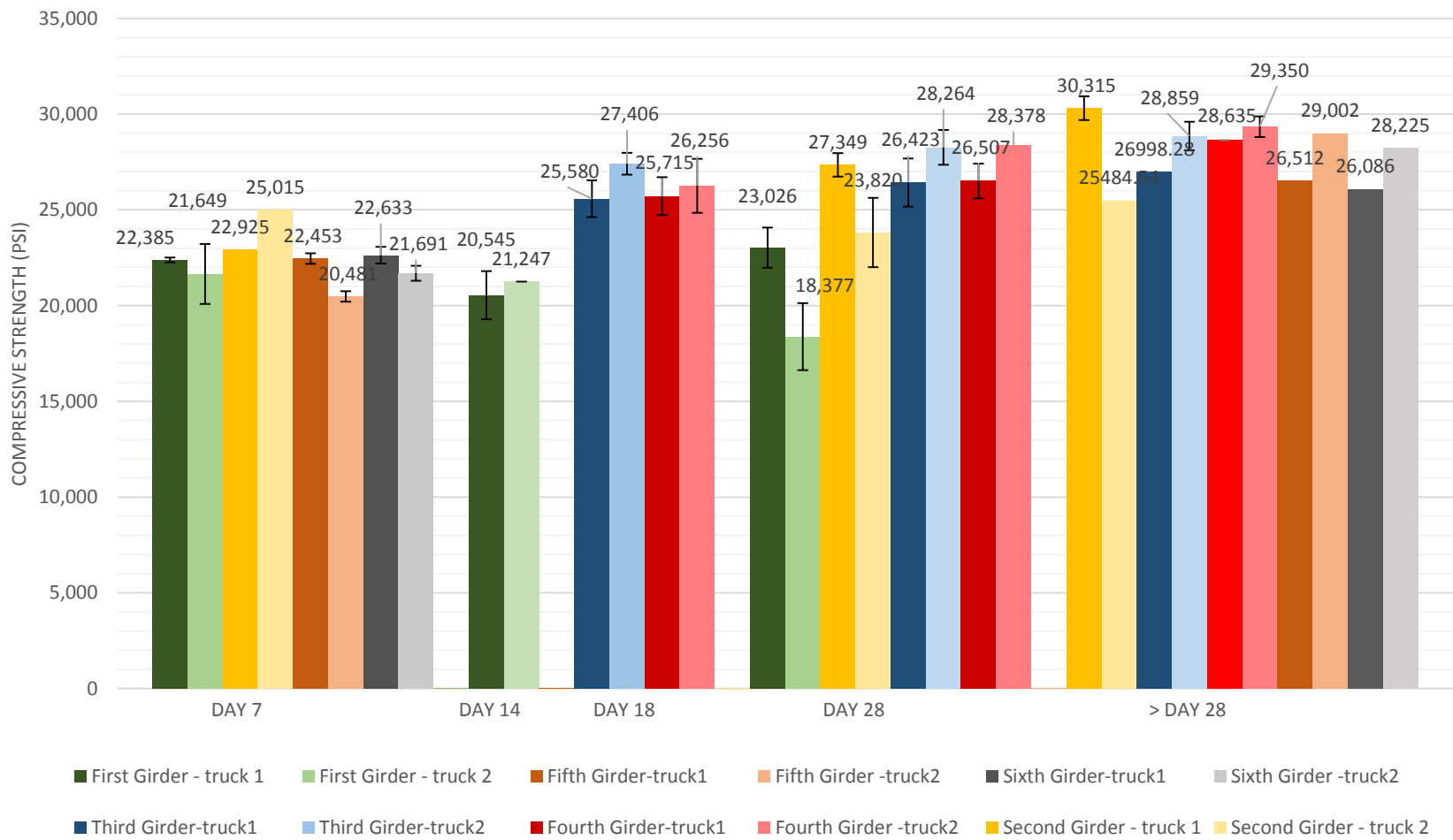

Figure 6-1 Compressive Strength of K-UHPC Field Mix

6.2. Compressive strength of joint closer pour mix

Twelve 3 in. by 6 in. cylindrical samples were air cured in the field and taken to be tested for compressive strength after 30 and 35 days after casting. The average compressive strength of these samples were 23,958 psi for Day 30 and 24,866 psi for Day 35. Standard deviation of the results was very small, indicating the mix was consistent and satisfies the strength requirements. It can be noted that the compressive strengths of non-steam cured samples resulted in slight lower strength than those of steam cured samples.

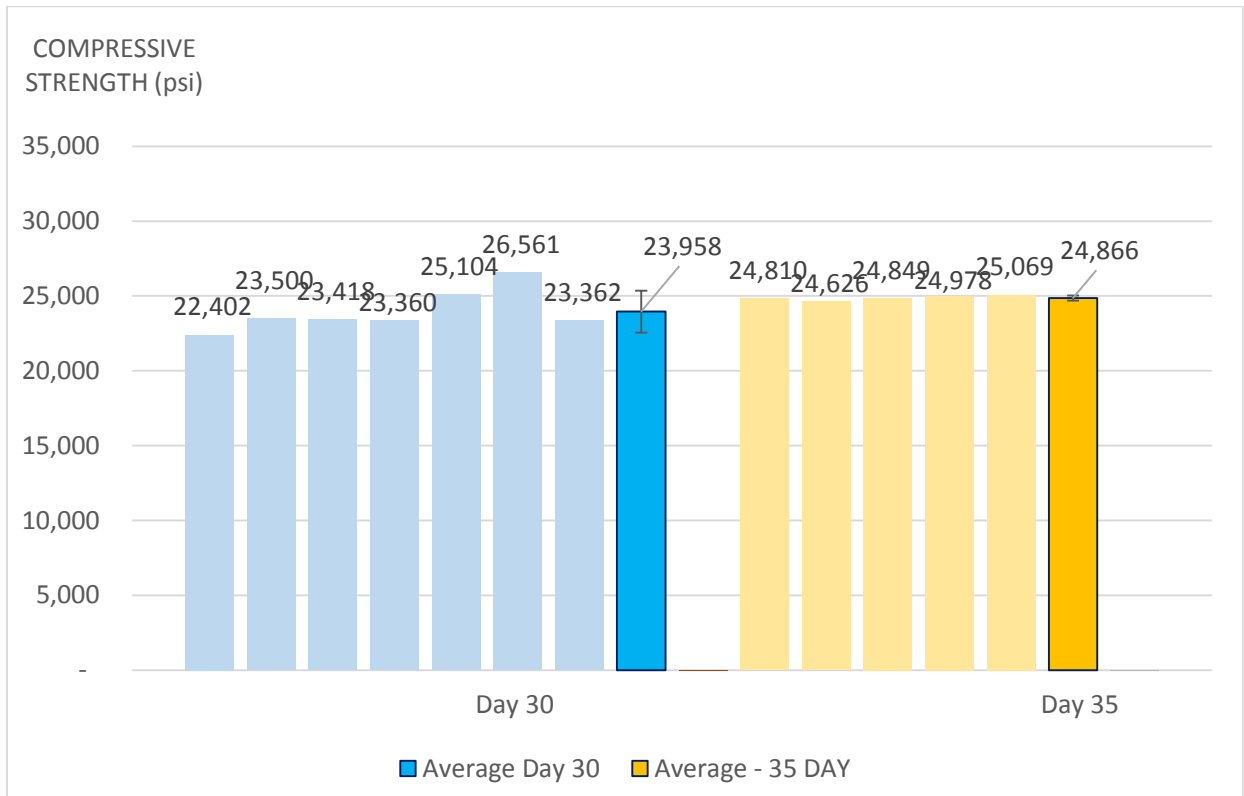

Figure 6-2 - K-UHPC Compressive Strength of Field Samples from Joint Closure

Table 6-1 K-UHPC Compressive Strength of Field Samples from Joint Closure

Casted on Sept. 2 2015	Day 30 (psi)	Day 3 (psi)
S1	22,402	24,810
S2	23,500	24,626
S3	23,418	24,849
S4	23,360	24,978
S5	25,104	25,069
S6	26,561	
S7	23,362	
Average	23,958	24,866
STDEV	1,398	169

6.3. Beam test

Sixteen 4 in. by 4 in. by 14 in beams were fabricated from the same joint closure K-UHPC mix and tested for the maximum bending stresses. First the maximum bending loads were measured from performing four-point bending tests. The maximum bending load and strength were 16,010 lbs. and 3,002 psi respectively. Figure 6-3 and Table 6-2 summarize the test results for maximum bending loads.

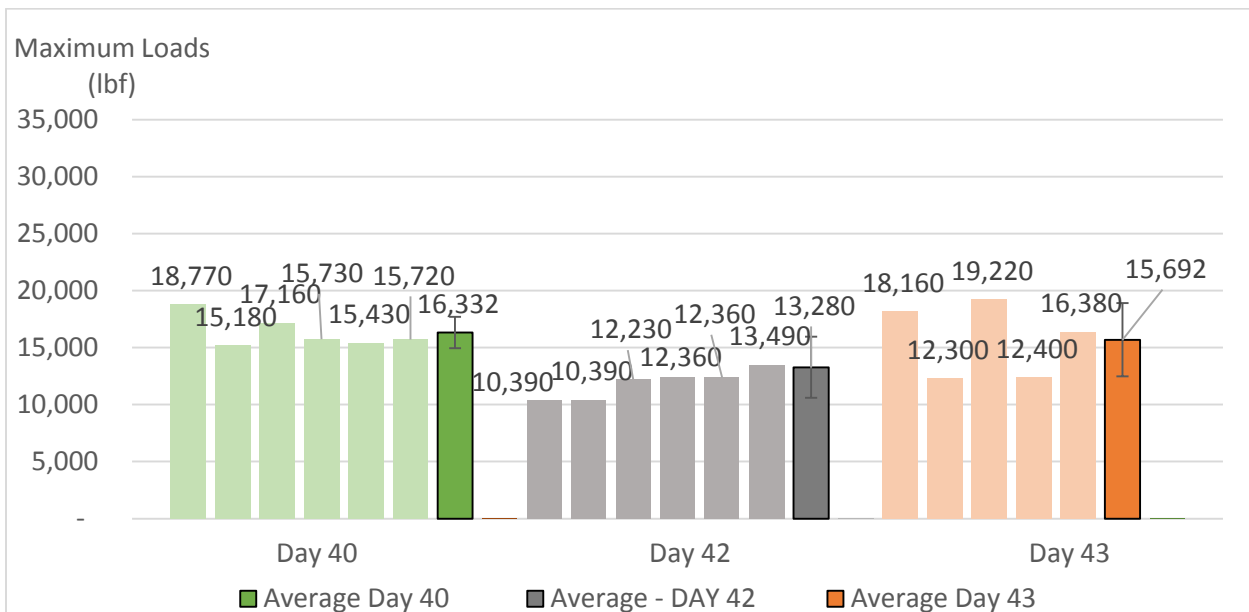

Figure 6-3 Four Point Bending Test Results of K-UHPC Joint Closure Samples

Table 6-2 Four Point Bending Test Results of K-UHPC Joint Closure Samples

Casted on Sept. 2 2015- Bending Load	Day 40 (lb.)	Day 42 (lb.)	Day 43 (lb.)
S1	18,770	10,390	18,160
S2	15,180	17,930	12,300
S3	17,160	12,230	19,220
S4	15,730	12,360	12,400
S5	15,430	13,490	16,380
S6	15,720		
Average	16,010	14,003	15,075
STDEV	779	693	3,426

The bending strength was calculated according to the equation below:

$$I = \frac{bh^3}{12} = \frac{4^4}{12} = 21.33 \text{ in}^4,$$

$$Y = \frac{4}{2} = 2 \text{ in},$$

$$M = P * \frac{4}{2},$$

$$\sigma = \frac{M*y}{I}$$

Table 6-3 Bending Strength of K-UHPC Field Samples from Joint Closure

Casted on Sept. 2 2015 - Bending Strength	Day 40 (psi)	Day 42 (psi)	Day 43 (psi)
Average	3,002	2,626	2,826

7. POST CONSTRUCTION MONITORING

To monitor the performance of Hawkeye Bridge, six wireless strain gauges called ‘SenSpot’ were installed at the mid span of the Hawkeye UHPC Bridge. SenSpot uses Active RF Technology (ART) to offer a high performance method for wireless synchronization and ultra-low power wireless communication. As shown in Figure 7-1, the sensor consists of two different parts, wireless transmitter and displacement sensor with the small size of 1.96” x 1.96” x 1.34” and 4.30” x 1.30” x 0.35”. With its light weight and self-adhesive properties, six SenSpot sensors were easily installed at critical spots of the bridge beam. The sensors are expected to last for a minimum of 10 years without battery replacement.



Figure 7-1 SenSpot -Strain Gauge (14)

Figure 3-5 illustrates the system relationship among sensor called SenSpot, a data transmission gateway called SeniMax and analysis software called SenScope. Wireless transmitter converts analog strain measurement from the sensing element SenSpot to digitized data which can be transmitted wirelessly to the remote transmission gateway called, SeniMax. SeniMax sends the data to a remote cloud server through Cellular service to SenScope, the real-

time monitoring software. SenScope is then used for data analysis and visualization based on measurements from SenSpot.

For a long term observation, SenSpot transmits each data point to the SeniMax every two minutes. For a short term observation such as a loading test, data frequency can be increased to one data point in every 6 seconds.

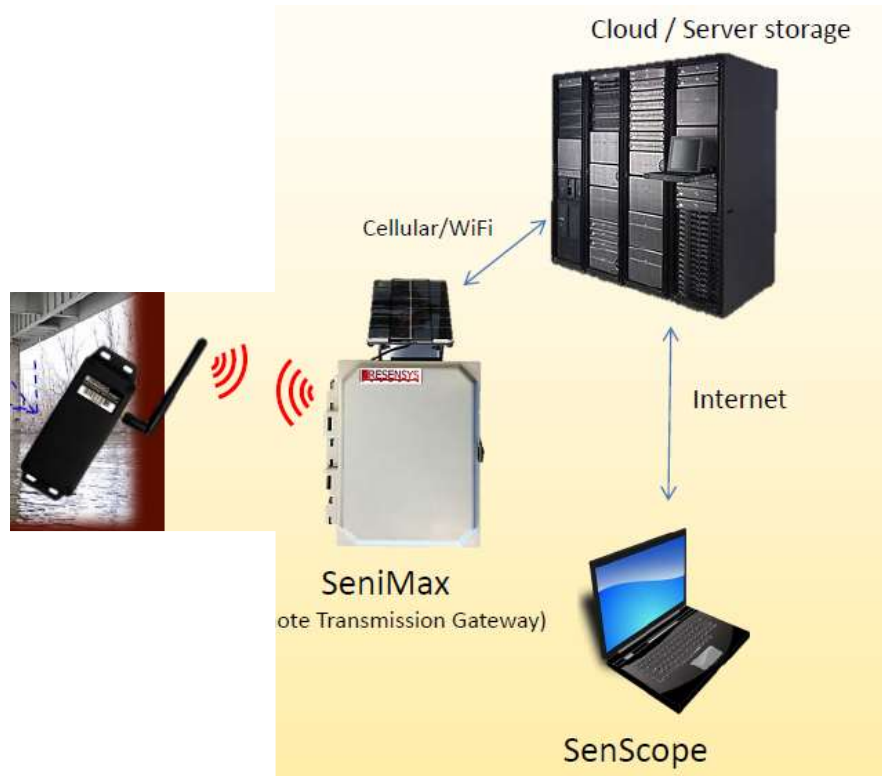

Figure 7-2 Complete Resensys Structural Health Monitoring System (14)

7.1. Installation

On September 4, 2015, in order to monitor behaviors from both sides of the joint, two SenSpot strain gauges were installed at left and right sides of each of three joints. Figure 7-3 shows locations of six sensors: two for both sides of each joint. SenSpot sensors can detect strains with an accuracy of 1 micro strain, temperature and a tilt with a resolution of 0.1 degree.

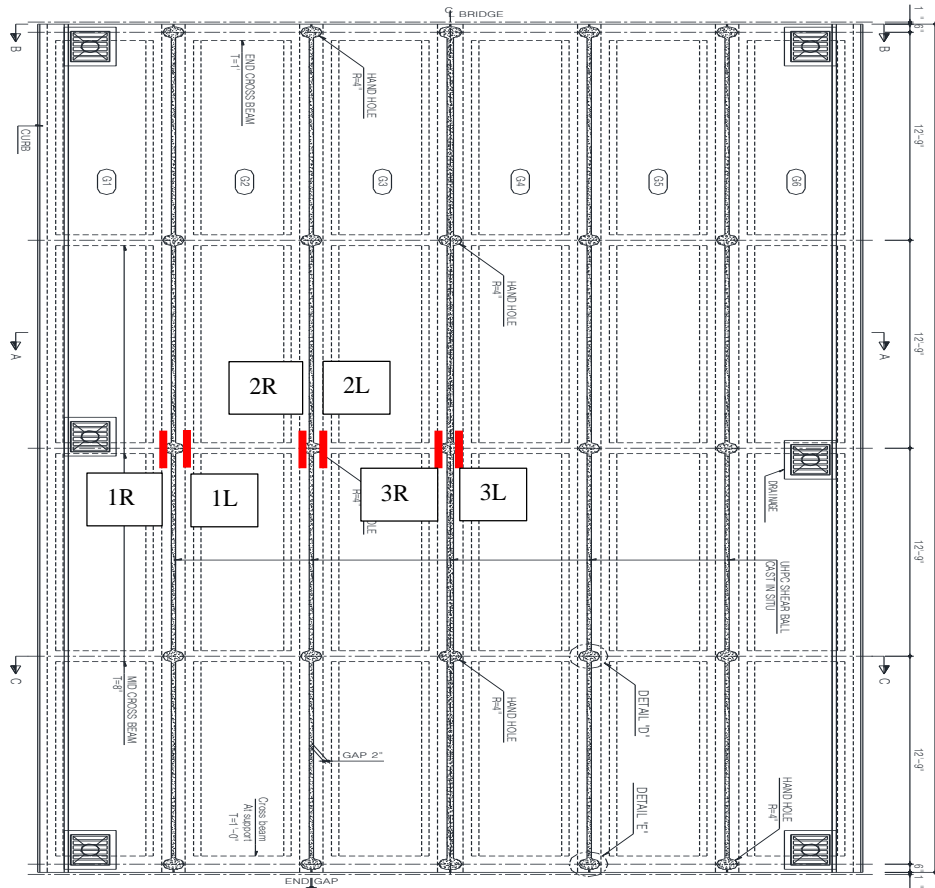

Figure 7-3 Location of SenSpot sensors

Strain gauges were manufactured by Omega Co. and the Senspot transmitter was developed and manufactured by Resensys Co. As shown in Figure 7-4, strain gauges were attached at the bottom of the girder using a superglue and multi-purpose silicon was applied around the edge of the strain gauges as a protection from moisture. Figure 7-5 shows a close-up view of the installed strain gauge and transmitter.



Figure 7-4 Sensor Installation



Figure 7-5 Installed SenSpot Strain Gauge

Each transmitter has a unique number that can be identified by the SenScope software. Individual data from the sensor with a unique number can be calibrated with an appropriate calibration factor. As shown in Figure 7-6, six Sensors/Transmitters can be identified as 15-02-03-19 (1R), 15-02-03-20(1L), 15-02-03-21(2R), 15-03-02-44 (2R), 15-03-02-46 (3L), 15-03-02-46 (3R), which were installed at left and right sides (L and R) of three joints (1,2, and 3).

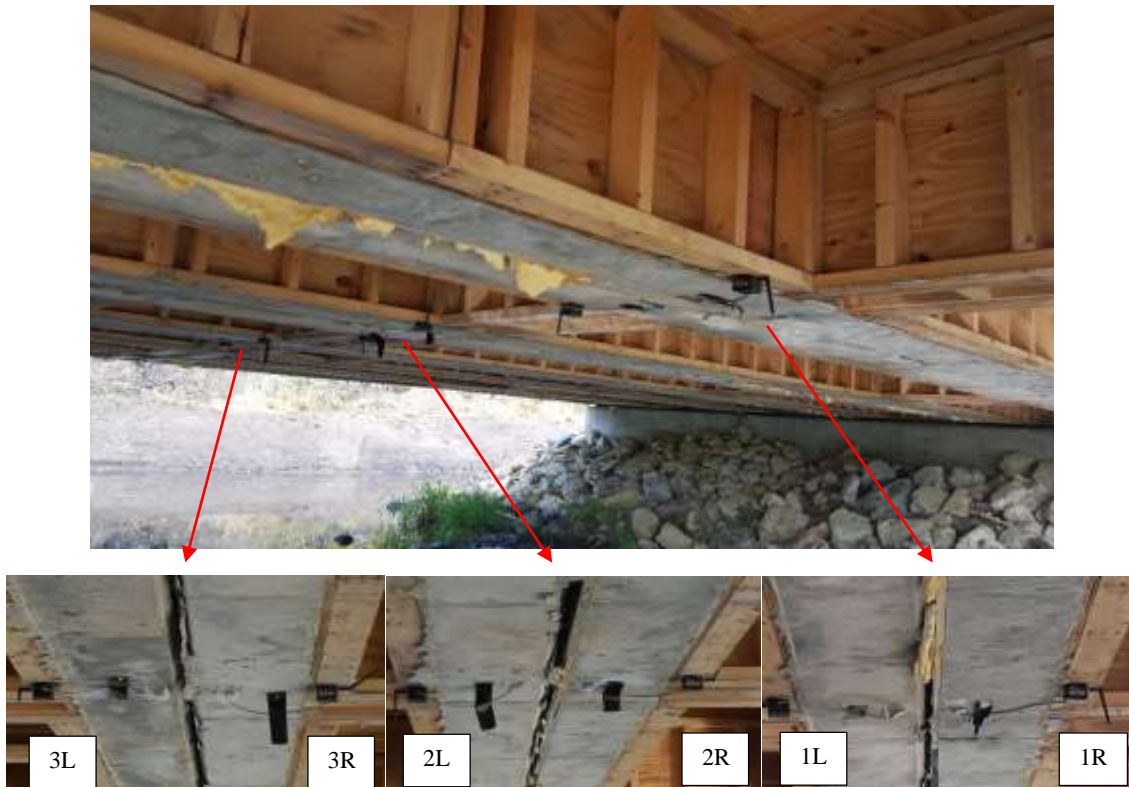

Figure 7-6 Installed SenSpot Strain Gauges

7.1.1. Loading Test and SenScope Strain Analysis

SenScope software could analyze individual sensors in terms of strain, internal temperature, and tilt in x, y and z axis and a battery life. SenScope can be used to reduce large volumes of data under a specific threshold and delete any outliers that can be considered as a noise. SenSpot sensors can monitor long term data trends of the bridge up to 20 years (15).

On October 9, 2015, a loading test was conducted using a county tandem-axial dump truck with the gross weight of 50,320 lbs. The load vehicle was driven at a crawl speed of 1mph. As shown in Figure 7-7, the truck is 26'-8" long and 8' wide and its wheel base is 18'-8" with a tandem axle spacing of 4'-6".

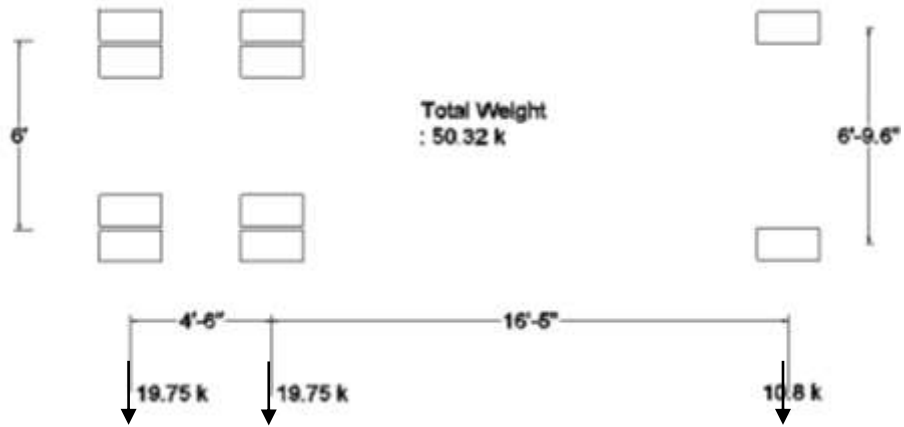

Figure 7-7 A county Tandem-axial Dump Truck

As shown in Figure 7-7 and Table 7-1, the truck was driven on top of a joint (1, 2, and 3) in a way that the left most wheels were placed on each joint.

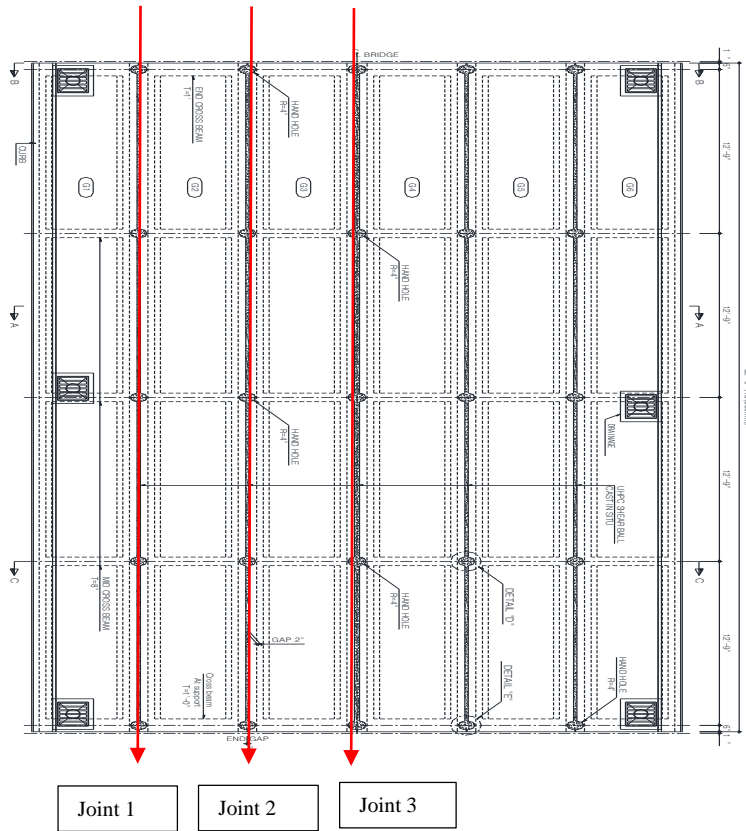





Figure 7-8 Truck Routes

Table 7-1 Loading Test Routes

Joint #	Right	Left	Testing Time	Test truck during the test
Joint 1 (1R&1L)	15-02-03-19	15-02-03-20	10:15 – 10:30	
Joint 2 (2R&2L)	15-02-03-21	15-02-03-44	10:34 – 10:45	
Joint 3 (3R&3L)	15-02-03-46	15-02-03-45	10:49 – 11:00	

As can be seen from Figure 7-9, approximately 40 tensile micro strain values were observed from the sensors under loading. Sensors which were not loaded exhibited small compressive values. These strain values are considered reasonable for this type of bridge and loading condition.

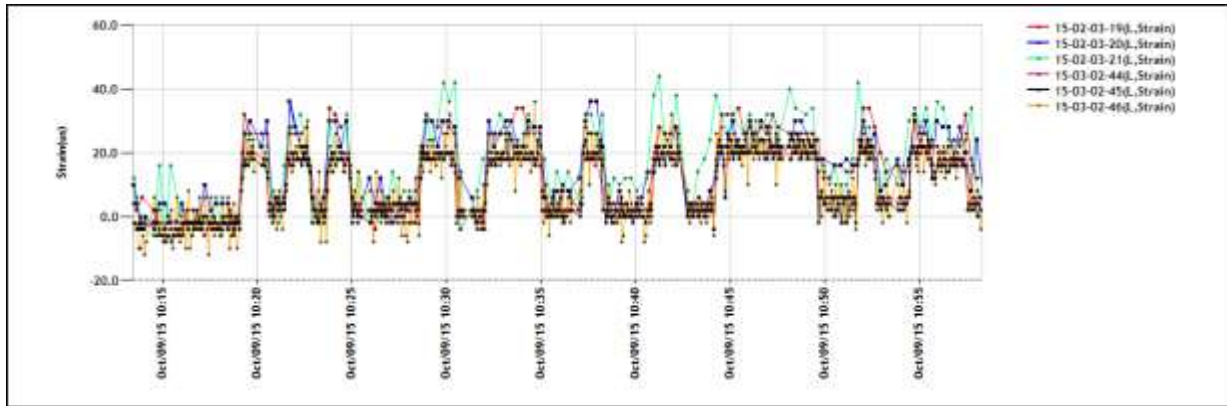

Figure 7-9 Test 1: Strain Response during First Loading Test

As shown in Figure 7-10, when a truck was driven on Joint 1 for four times, both right and left sensors of each joint exhibited nearly identical strain values.

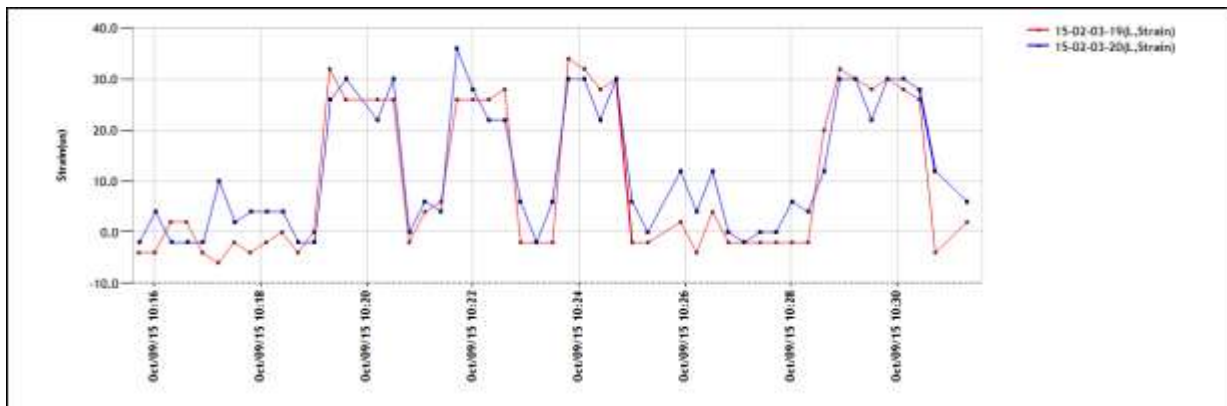

Figure 7-10 Test 1: Strain Response of 1R and 1L Sensors on Joint 1

As can be seen from Figure 7-11, when a truck was driven on Joint 2 for four times, however, strain magnitudes from the right sensor was greater than the ones from the left sensor. It can be postulated that the difference in strain values might have been caused by the wider width of the Joint 2.

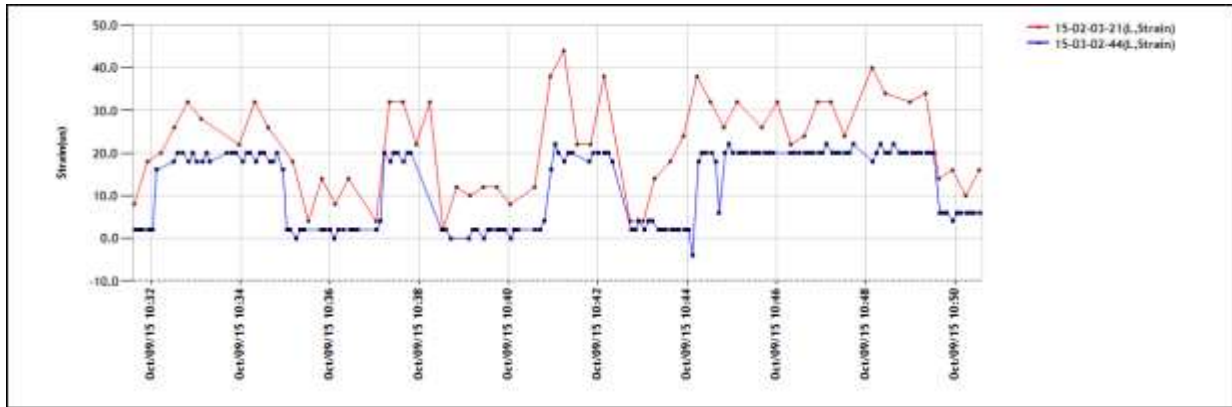

Figure 7-11 Test 1: Strain response of 2R and 2L Sensors on Joint 2

Figure 7-12 also show fairly similar strain values for both right and left sensors when the truck was driven on Joint 3 for two times.

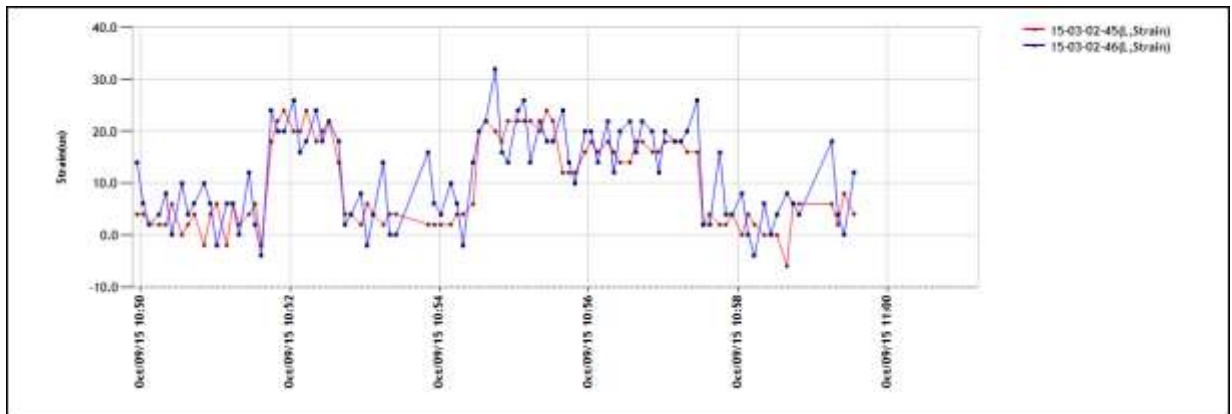

Figure 7-12 Test 1: Strain Response of 3R and 3L Sensors on Joint 3

On March 10, 2016, another loading test was conducted to observe the behavior of Hawkeye Bridge approximately five months after the bridge opening. Similar to the previous loading test, the same county tandem-axial dump truck was used and the load vehicle was driven at a crawl speed of 1mph. As shown in Figure 7-7, the truck is 26’-8” long and 8’ wide and its wheel base is 18’-8” with a tandem axle spacing of 4’-6”.

This time, the truck was driven on top of where the red arrows, 1 through 7 are shown in Figure xx. The left most wheels were placed on areas where each red arrow is shown in Figure

7-13. Areas with odd numbers are located in between the joints 1, 2 and 3 where arrows with even numbers are shown in thicker arrows in Figure 7-13. For each number of routes, the truck was passing twice. First, the truck was driven towards north where the arrows are pointing to. Then, the truck was driven back in south direction on the same route. For the accuracy of the collected data, the truck waited approximately 2 minutes in north, mid, south span of the bridge for each time the truck was on the bridge.

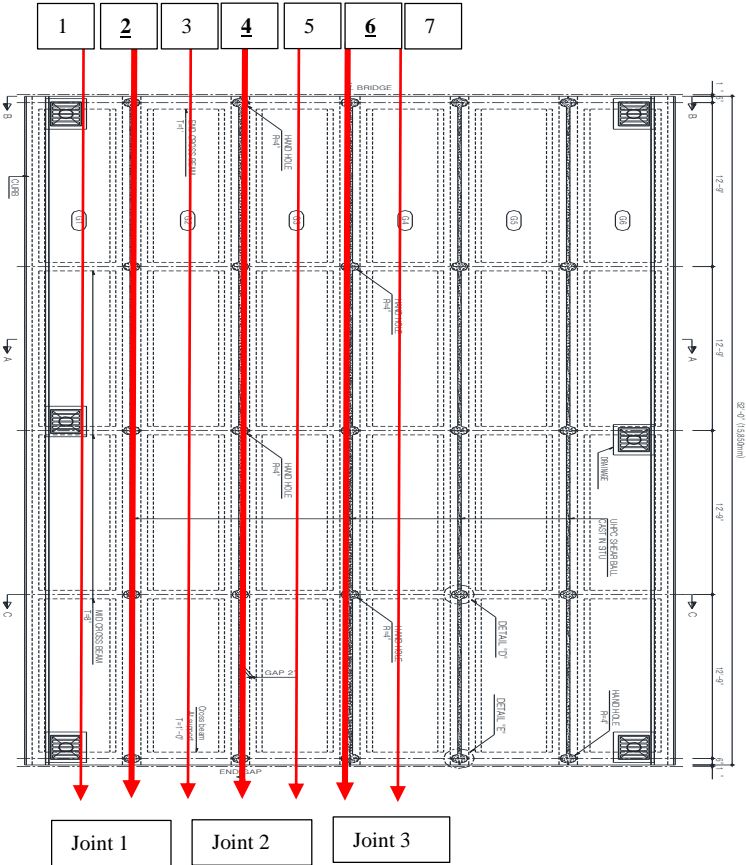

Figure 7-13 Truck Route for 2nd Loading Test

For the simplicity, two adjacent routes around each joints were grouped together in routes with joints. For example in the Table 7-2 Loading test Routes during Second Test, Joint1 includes routes 1, 2, 3, Joint 2 includes routes 3, 4, 5 and Joint 3 includes routes 5, 6, 7.

Table 7-2 Loading test Routes during Second Test

Joint #	Right	Left	Testing Time (PM)
Joint 1 (1R&1L)	15-02-03-19	15-02-03-20	1:40 – 2:10
Joint 2 (2R&2L)	15-02-03-21	15-02-03-44	2:10 – 2:28
Joint 3 (3R&3L)	15-02-03-46	15-02-03-45	2:28 – 2:44

Under loading, Figure 7-14 shows the overall tensile micro strain value is approximately 40 micro strain. As shown in Figure 7-14, the strains seem to increase slightly towards the end of the test. Little variations in strain from the beginning to the end of the test could be due to the temperature changes with a dramatic weather change from rainy to sunny in the afternoon. However, the variation is very small and measured strain values are considered reasonable for this type of bridge and loading condition.

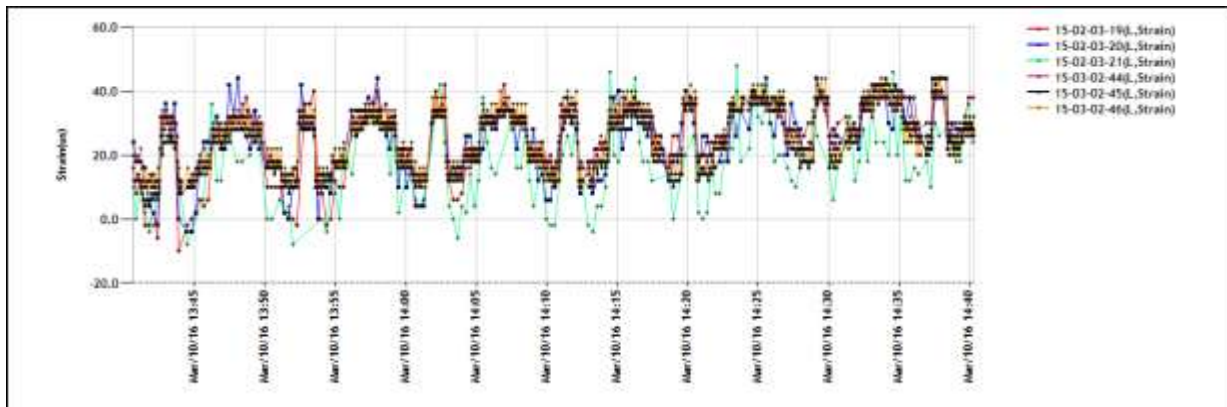

Figure 7-14 Test 2: Strain Response during Second Loading Test

As shown in Figure 7-10, when a truck was driven around Joint 1 for six times, both right and left sensors of each joint exhibited nearly identical strain values.

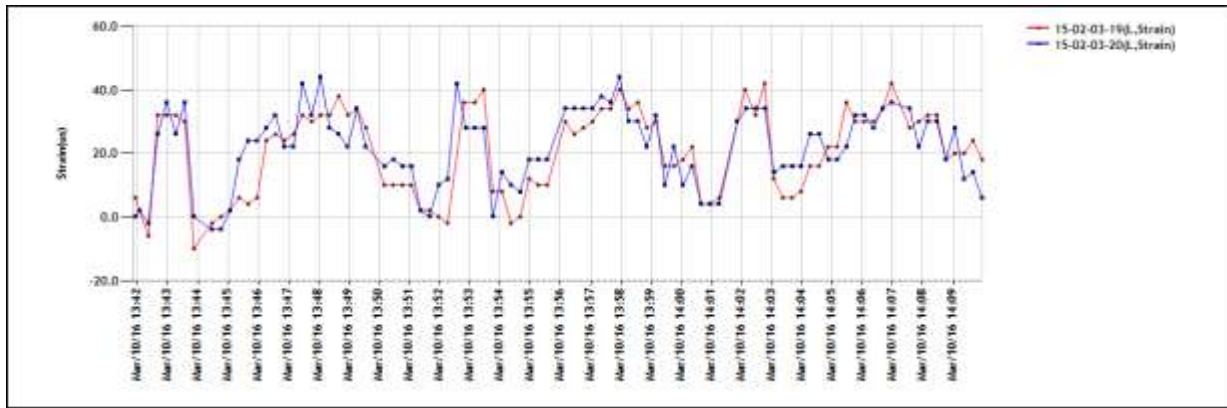

Figure 7-15 Test 2: Strain Response of 1R and 1L Sensors on Joint 1

Around Joint 2, the truck was driven for six times. As can be seen from Figure 7-16, the right sensor measured higher strain values than the ones from the left sensor. The reason for the difference in strain values is once again considered to be because of the wider gap of the Joint 2.

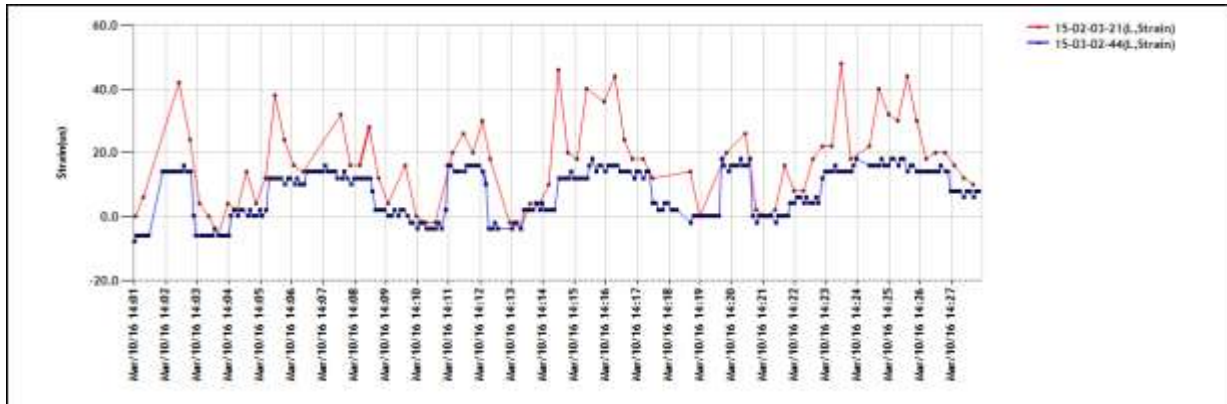

Figure 7-16 Test 2: Strain Response of 2R and 2L Sensors on Joint 2

Figure 7-12 shows almost identical strain values for both right and left sensors when the truck was driven on Joint 3 for two times.

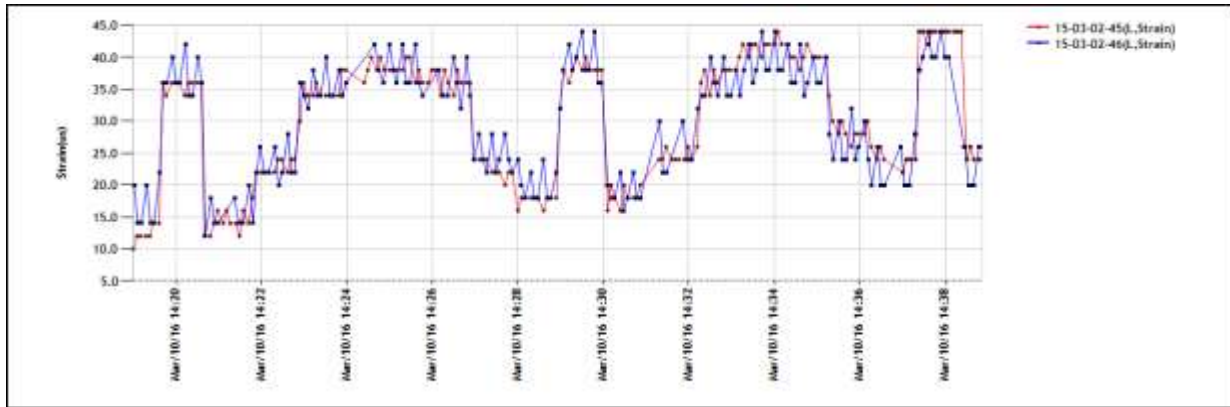

Figure 7-17 Test 2: Strain Response of 3R and 3L Sensors on Joint 3

Based on the results of the two loading tests, it can be concluded that the behavior of Hawkeye Bridge was consistent even after five months from the bridge opening. It should be noted that minor variations in strain values may have been caused by the changes in temperature. For both loading tests, Joint 2 showed highest differences in strain values for right and left sensors. The cause of this issue can be postulated to be the considerably larger gap at Joint 2. However, measured strain values are considered reasonable for this loading condition.

8. SUMMARY AND CONCLUSION

K-UHPC technology provides new opportunity to build more robust and durable bridge than conventional bridge. Performance of K-UHPC in terms of compressive and splitting tensile strengths and coefficient of thermal expansion was evaluated in this research. Evaluation of laboratory and field mixtures of K-UHPC has demonstrated the field constructability and competitiveness of K-UHPC.

As a replacement of a structurally deficient bridge at 1100 Deacon Avenue, Fairbanks, IA, the first bridge using K-UHPC in the United States was successfully constructed in the summer of 2015. The bridge consists of six uniquely designed pi-girders which were longitudinally and transversely post-tensioned. The bridge was christened as “Hawkeye UHPC Bridge” and opened to public in November 2015.

This paper introduces the design and construction process of Hawkeye UHPC Bridge using K-UHPC. Detailed mix designs and mixing procedures of K-UHPC would provide owners and contractors with a guidance to design and construct a new generation bridge using K-UHPC in the US.

Post-construction monitoring was also conducted to observe the behavior of the bridge at the each joint. Under the bridge, six strain gauges were installed in each side of the three joint edges. Two loading tests were performed so that each test was five months apart. All of measured amount of strains were similar between these two loading tests. This indicates the behavior of the bridge is consistent and the results are acceptable and reasonable under the loading condition.

REFERENCES

1. McMcillan, S. K., and Cherilyn, A. Hatfield. Performance of Steel, Concrete, Prestressed Concrete, and Timber Bridges, in Developments in short and medium span bridge engineering „94: *Proc., 4th International conference on short and medium span bridges: 1994; August 8-11;*, Halifax, Nova Scotia, Canada, The Canadian Society for Civil Engineering, Montreal, P.Q., Canada, 1994: pp.341-354
2. ASCE. *Report Card for America's Infrastructure 2013*. American Society of Civil Engineers, Reston, Virginia, 2013
3. Russell, H.G. and B.A.Graybeal, “Ultra High Performance Concrete: A State of the Art Report for the Bridge Community”, FHWA-HRT-13-060, June, 2013
4. Graybeal, B., Development of Non-Proprietary Ultra-High Performance Concrete for Use in the Highway Bridge Sector, FHWA-HRT-13-100, Washington, D.C. October, 2013
5. Aaleti, S., Sritharan, S., Bierwagen, D., and T. J.W., Structural Behavior of Waffle Bridge Deck Panels and Connections of Precast Ultra-High-Performance Concrete: Experimental Evaluation, No. 2251, *Transportation Research Record: Journal of the Transportation Research Board*, Washington, D.C., 2011, pp. 82.92.
6. Vernet, C.P. “Ultra-Durable Concretes: Structure at the Micro- and Nanoscale” , *Materials Research Society*, May 2004
7. Graybeal, B.A. “Material Property Characterization of Ultra-High Performance Concrete”, FHWA-HRT-06-103, August 2006
8. Park, J.S., Y.J. Kim, J.R.Cho, S.J. Jeon, “Early-Age Strength of Ultra-High Performance Concrete in Various Curing Conditions”, *Molecular Diversity Preservation International – Materials*, ISSN 1996-1944, August 2015
9. Joh, C, S.Y. Park, K.T. Koh, S.W. Kim, Y.J. Kim and B.S. Kim, “Development of ultra-high performance concrete and applications to bridges in Korea, *Research and Applications in Structural Engineering, Mechanics and Computation – Zingoni, Taylor & Francis Group, London*, ISBN 978-1-138-00061-2, 2013, pp. 583 – 584
10. Ryu, Gum-Sung, S.T. Kang, J.J. Park, K.T. Koh, S.W. Kim, “Mechanical Behavior of UHPC according to Hybrid use of Steel Fibers”, Korea Institute of Construction Technology, 2009
11. Park, Hesson, Model-Based Optimization of Ultra High Performance Concrete Highway Bridge Girders, MIT Thesis, June 2003.

12. Soh, Melvin, Model-Based Design of a Ultra High Performance Concrete Prototype Highway Bridge Girder, MIT Thesis, June 2003.
13. Keierleber, B., D. Bierwagen, T. J. Wipf, and A. Abu-Hawash. Design of Buchanan County, Iowa Bridge Using Ultra-High Performance Concrete and Pi-Girder Cross Section. Proc., Precast/Prestressed Concrete Institute National Bridge Conference, Orlando, Fla., 2008.
14. Graybeal, B., Development of Non-Proprietary Ultra-High Performance Concrete for Use in the Highway Bridge Sector, FHWA-HRT-13-100, Washington, D.C. October, 2013.
15. Resensys, “Distributed Structural Health Monitoring and Wireless Remote Sensing”, Brochure, 2008
16. Park, Hesson, Model-Based Optimization of Ultra High Performance Concrete Highway Bridge Girders, MIT Thesis, June 2003.
17. Soh, Melvin, Model-Based Design of a Ultra High Performance Concrete Prototype Highway Bridge Girder, MIT Thesis, June 2003.
18. Keierleber, B., D. Bierwagen, T. J. Wipf, and A. Abu-Hawash. Design of Buchanan County, Iowa Bridge Using Ultra-High Performance Concrete and Pi-Girder Cross Section. Proc., Precast/Prestressed Concrete Institute National Bridge Conference, Orlando, Fla., 2008.
19. Jung, Y.S., H.S.Lee, M.J. Lee, S.Choi, Y.H. Cho, New Mix Design Approach For Polymer Concrete As Airport Pavement Repair Material Based On Film Thickness Concept, Transportation Research Record: Journal of the Transportation Research Board, Washington, D.C., 2014.

APPENDIX A
PICTURES OF TESTED SAMPLES – MIX 1

Pictures of tested samples are shown in this section below.

Day 1 Front



Day 1 Top

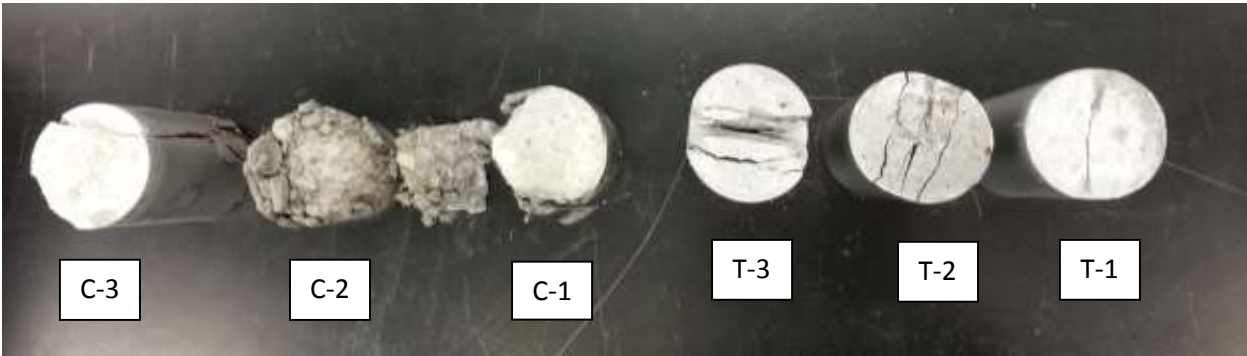

Day 1 Back

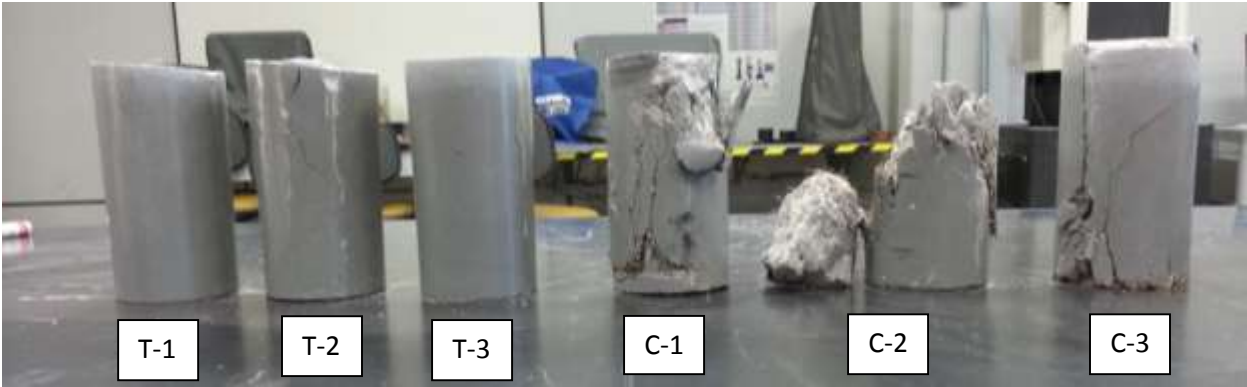

Day 2 Front

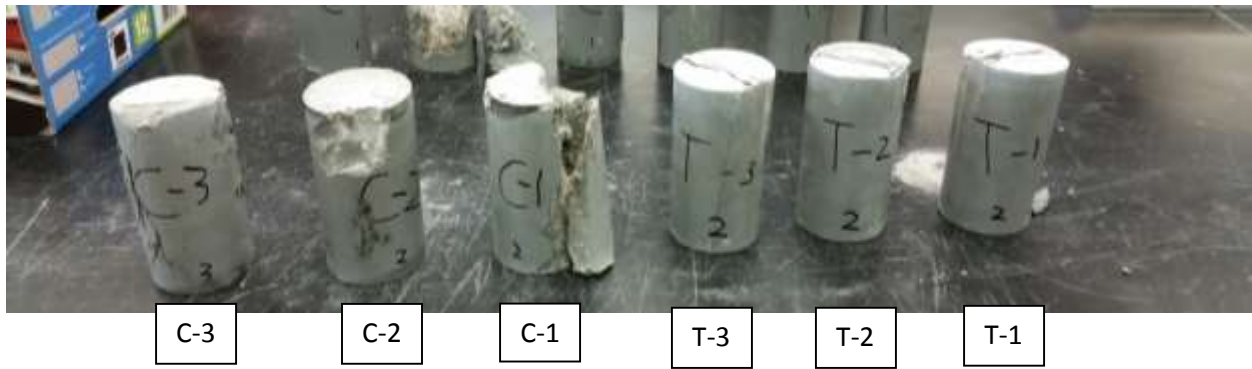

Day 2 Top



Day 2 Back

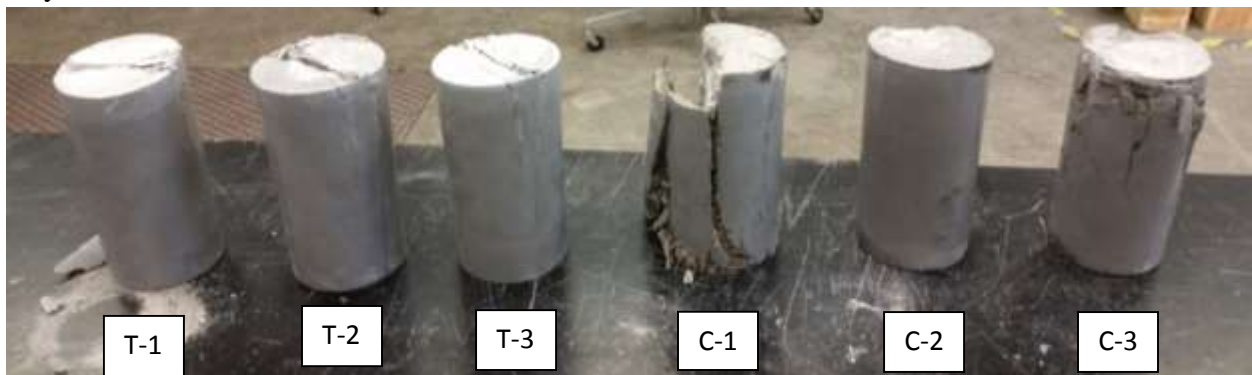

Day 4 Front

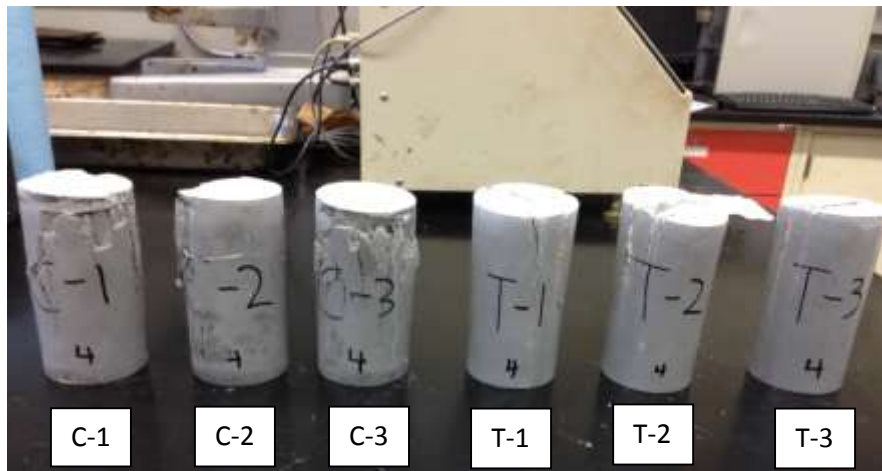

Day 4 Top



Day 4 Back

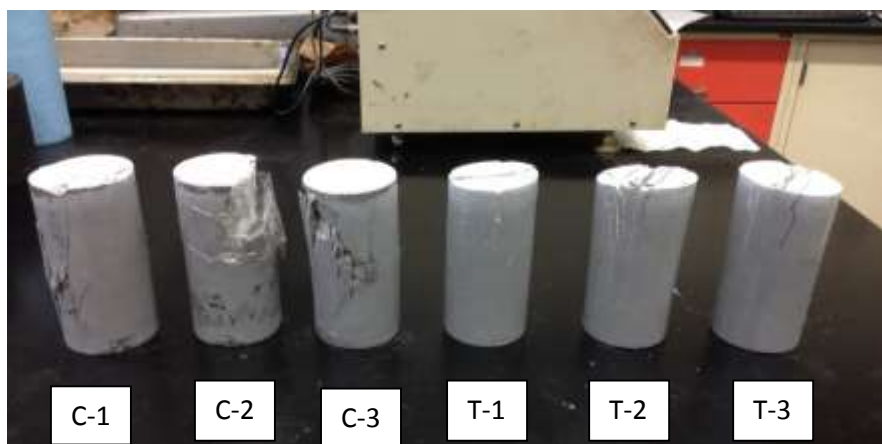

Day 7 Front

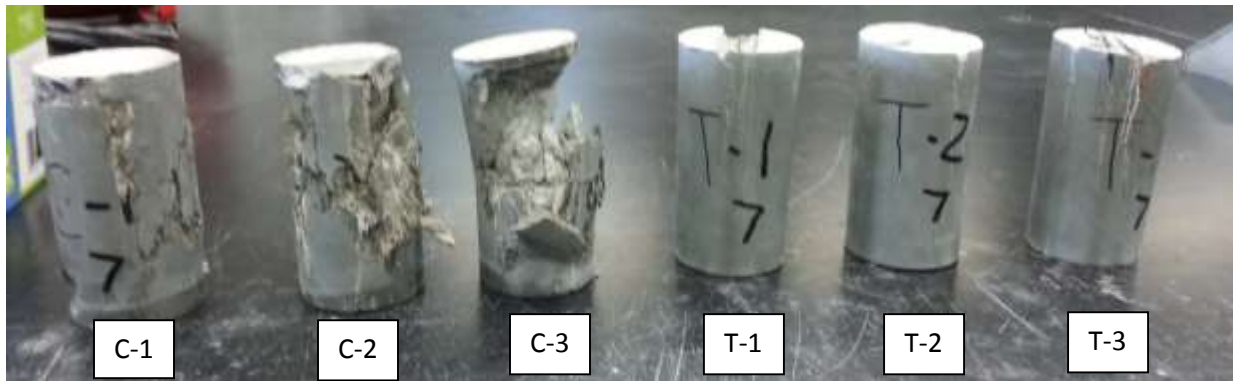

Day 7 Top

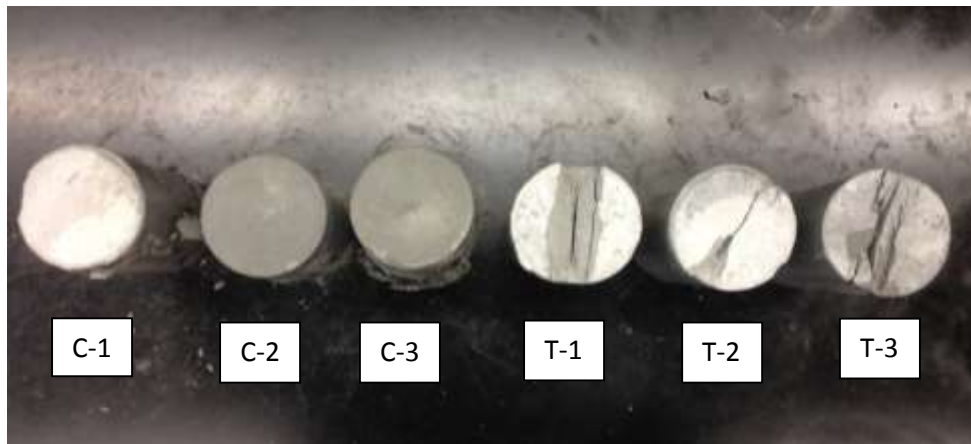

Day 7 Back

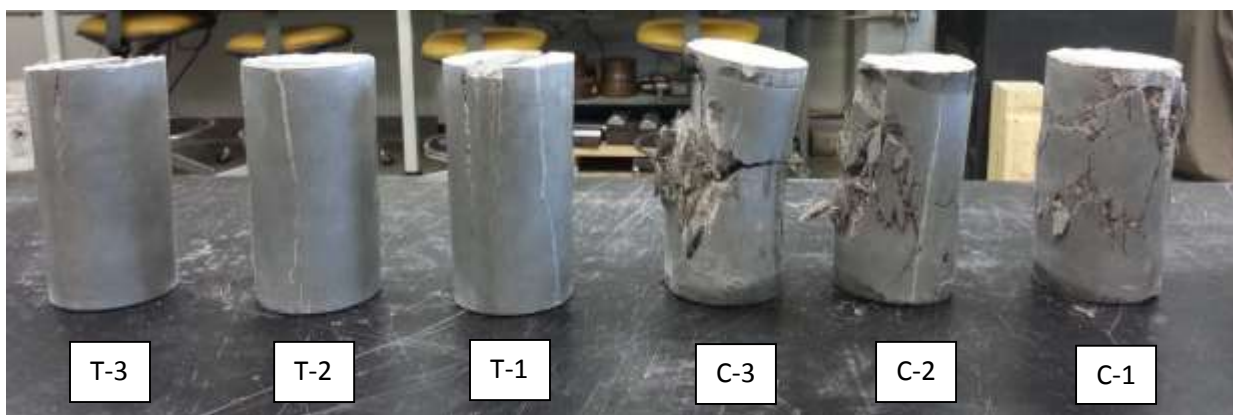

Day 14 Front

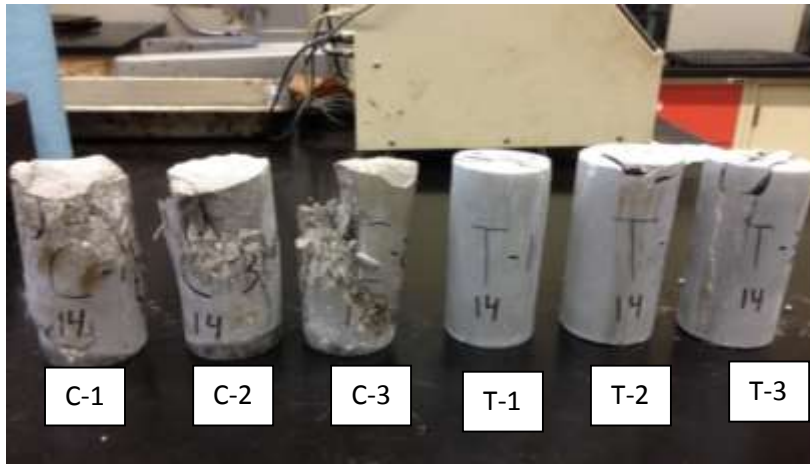

Day 14 Top



Day 14 Back

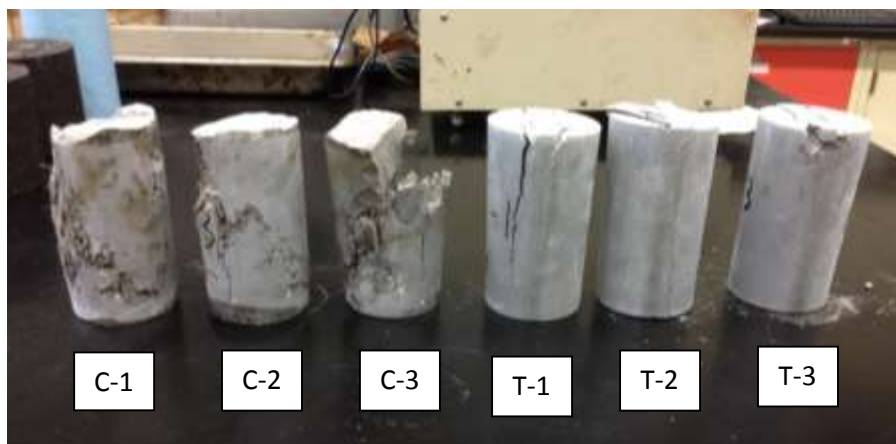

Day 28 Front

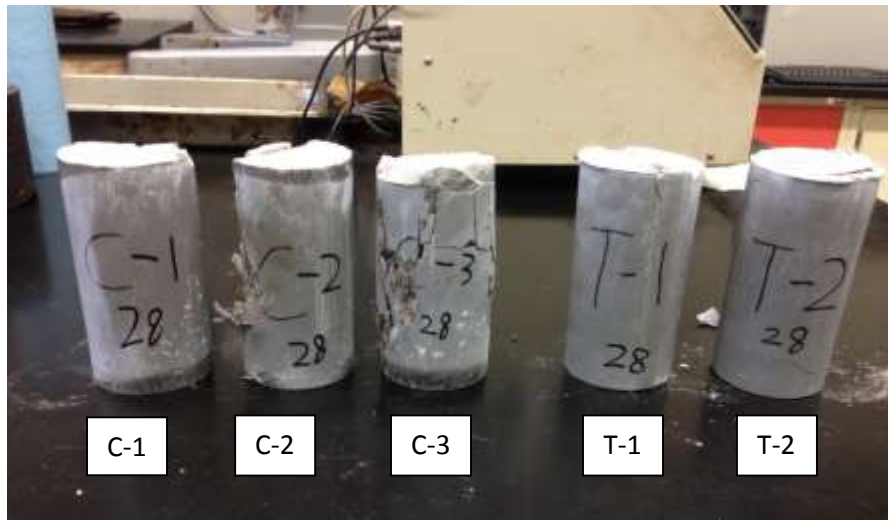

Day 28 Top



Day 28 Back

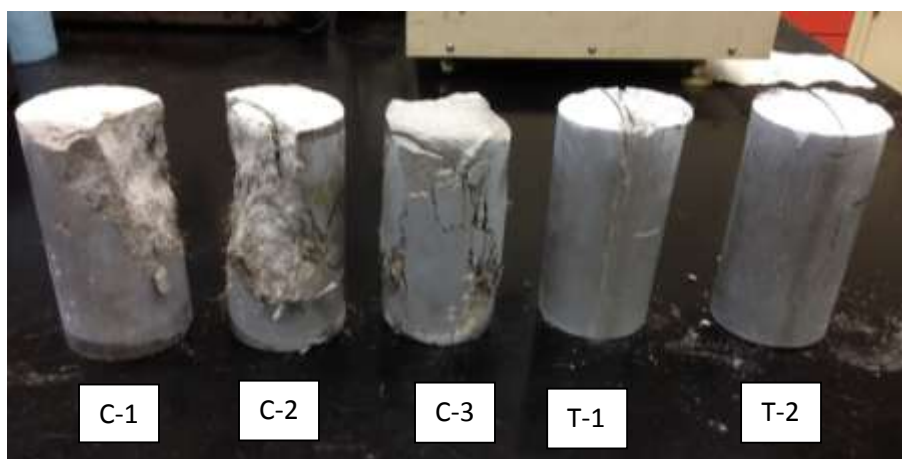

Appendix B
Pictures of Tested Samples – Mix 2

Pictures of tested samples are shown in this section below.

Day 7 Front (Dry Cure)

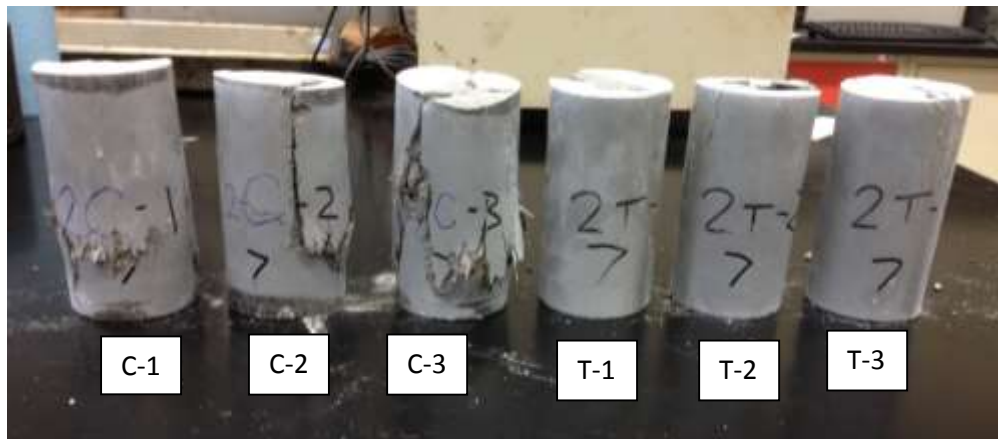

Day 7 Top (Dry Cure)

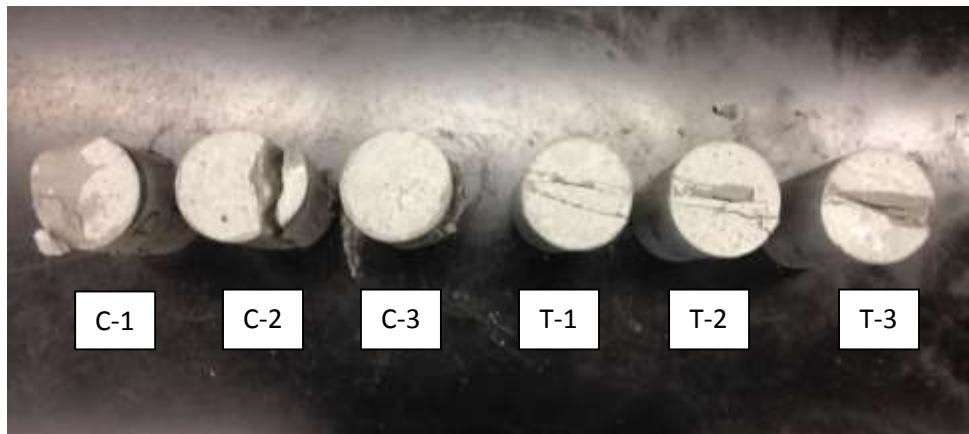

Day 7 Back (Dry Cure)

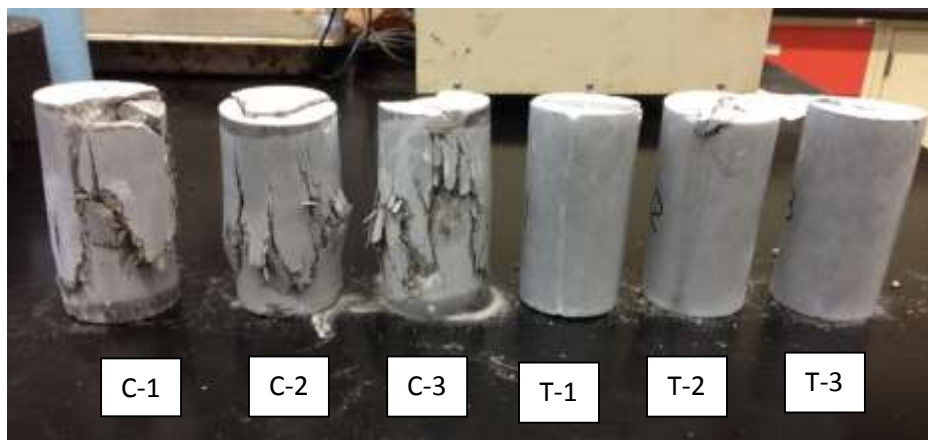

Day 7 Front (Wet Cure)

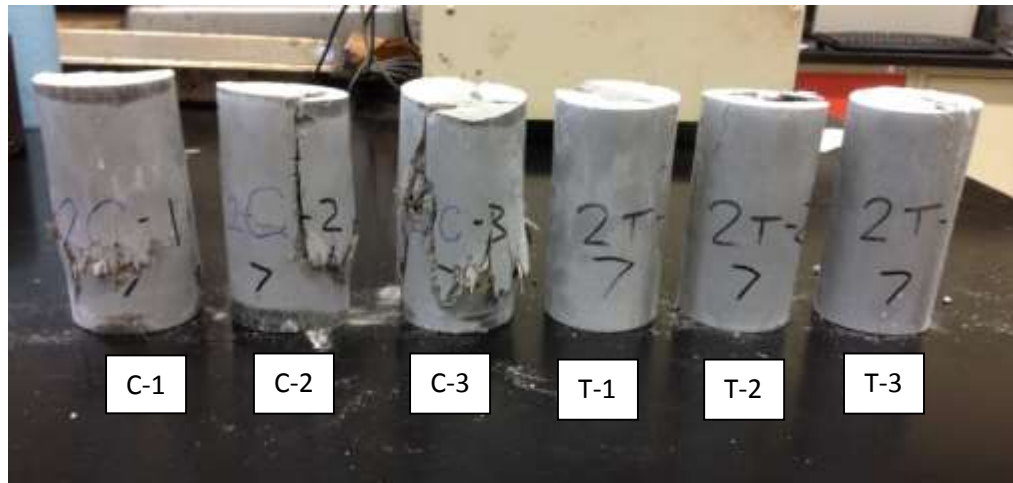

Day 7 Top (Wet Cure)

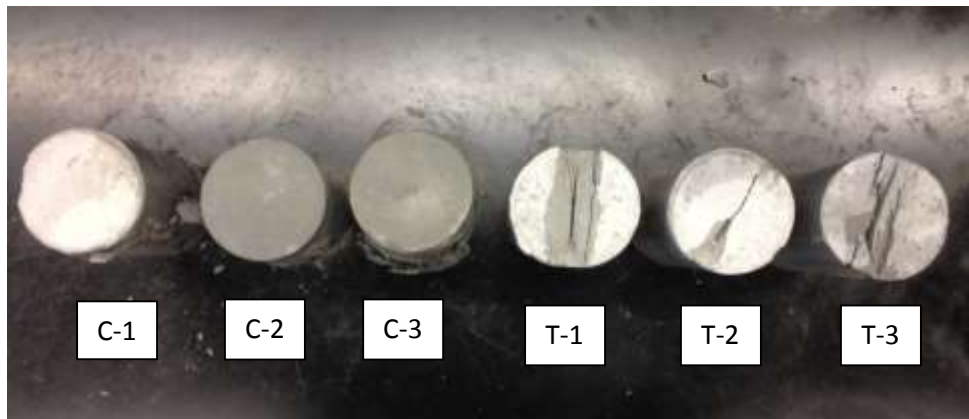

Day 7 Back (Wet Cure)

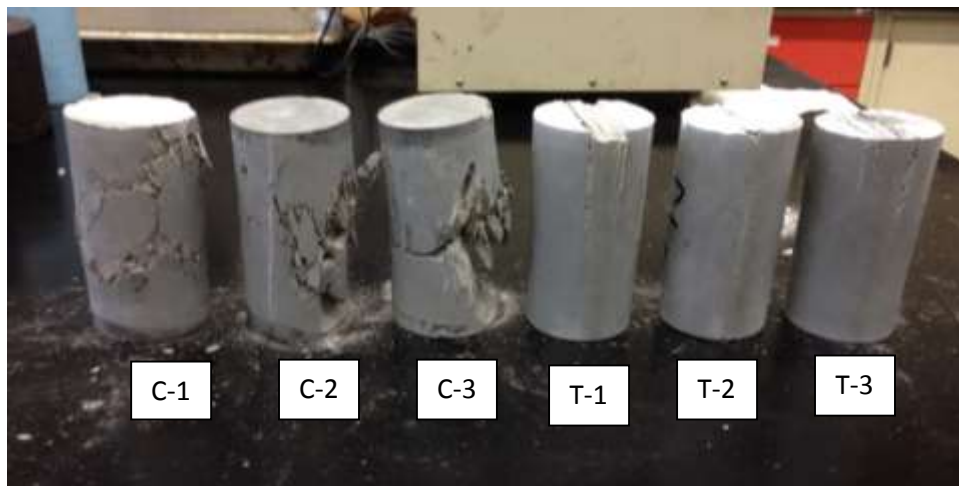

Day 14 Front (Wet Cure)

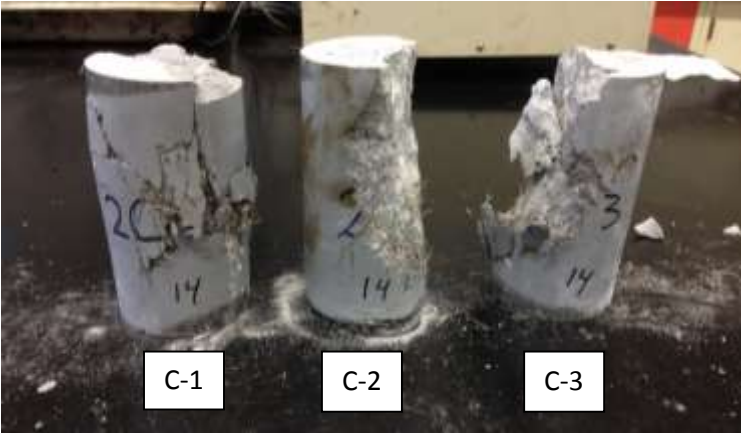

Day 14 Top (Wet Cure)



Day 14 Back (Wet Cure)

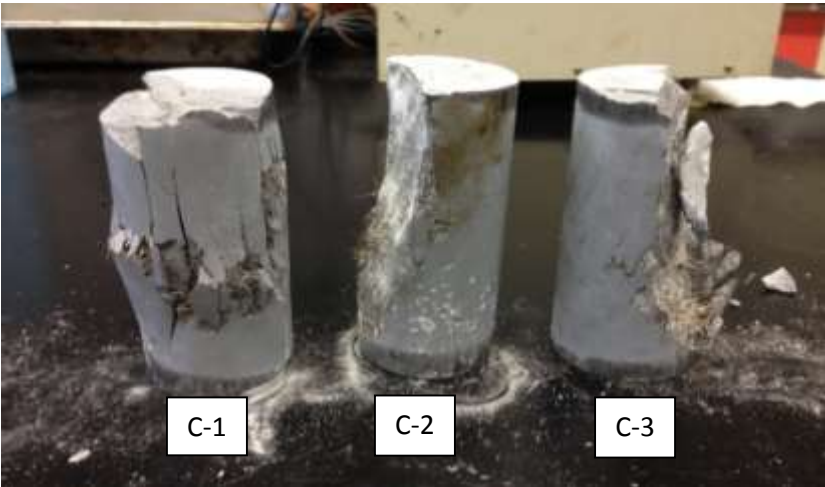

Day 28 Front (Dry Cure)

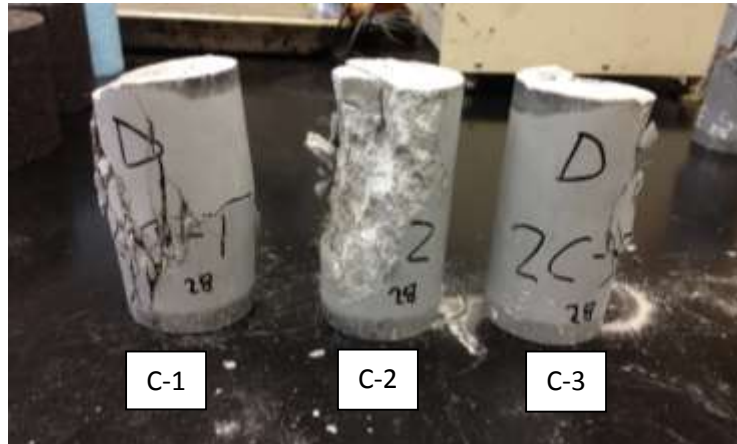

Day 28 Top (Dry Cure)

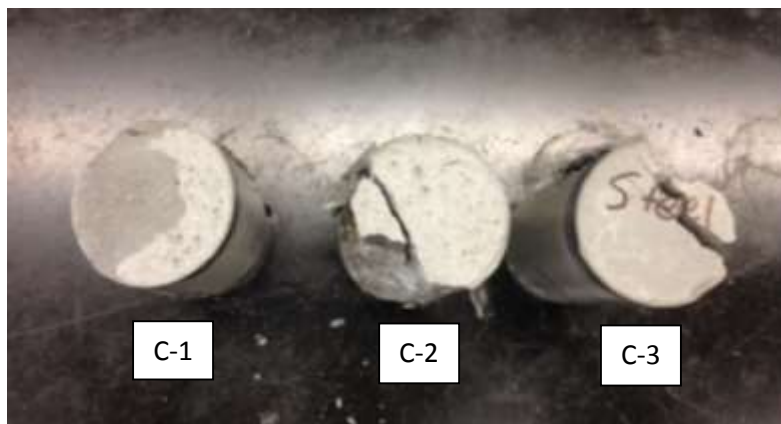

Day 28 Back (Dry Cure)

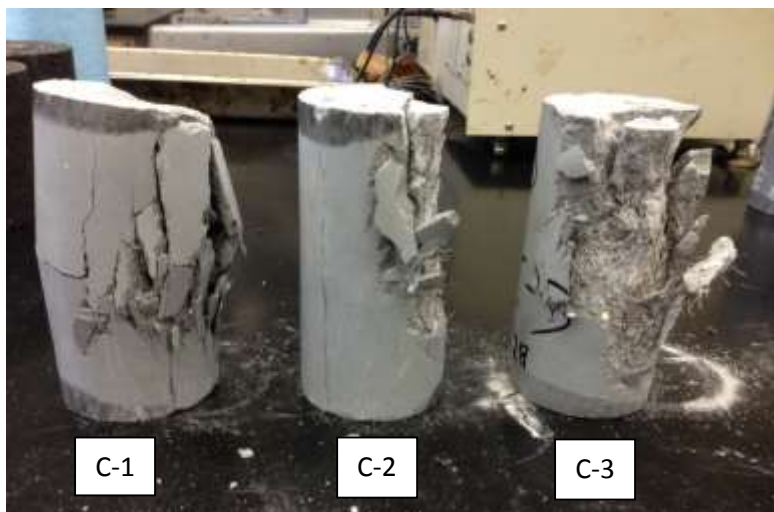

Day 28 Front (Wet Cure)

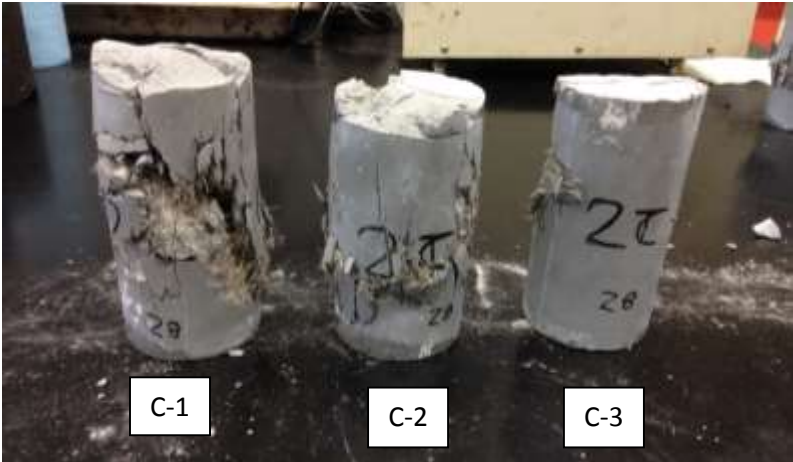

Day 28 Top (Wet Cure)

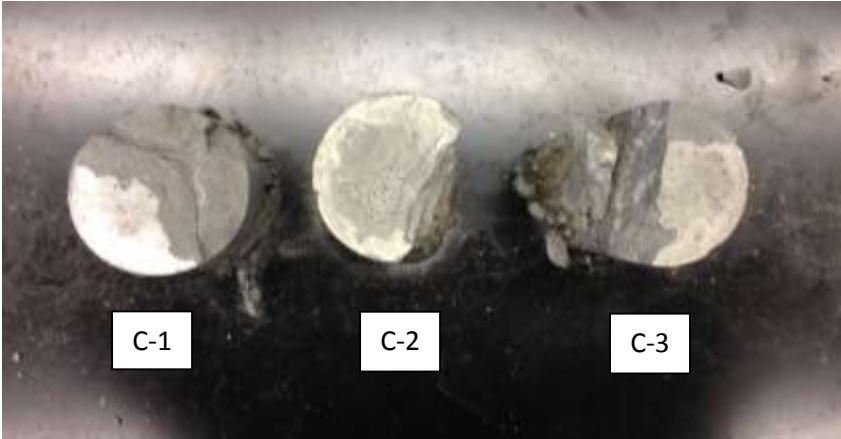

Day 28 Back (Wet Cure)

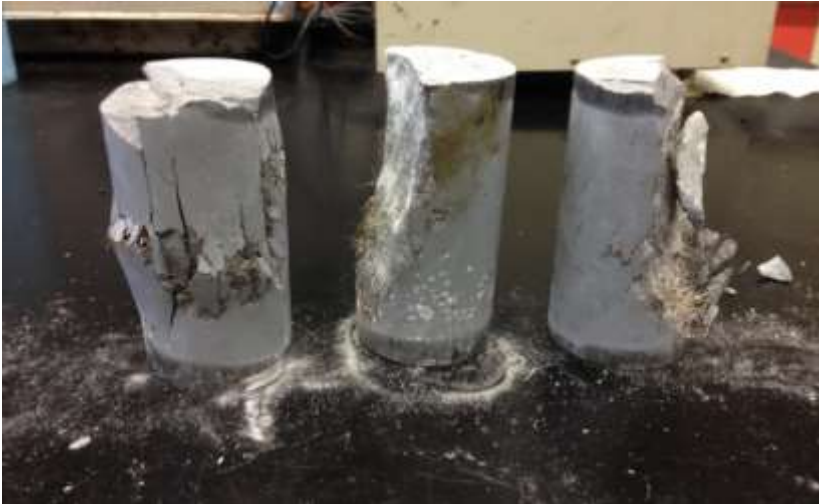

Appendix C
Pictures of Tested Samples – Mix 3

Pictures of tested samples

- *Three tested cylinder samples on 2 days after casting*





Front



Back



- Four tested cylinder samples on 7 days after casting

	Front	Back
Sample Day 7 C-1		
Sample Day 7 C-2		
Sample Day 7 C-3		
Sample Day 7 C-4	