

2008

Improving safety for slow-moving vehicles on Iowa's high speed rural roadways

Caroline Rachel Kinzenbaw
Iowa State University

Follow this and additional works at: <https://lib.dr.iastate.edu/etd>

 Part of the [Civil and Environmental Engineering Commons](#)

Recommended Citation

Kinzenbaw, Caroline Rachel, "Improving safety for slow-moving vehicles on Iowa's high speed rural roadways" (2008). *Graduate Theses and Dissertations*. 11078.
<https://lib.dr.iastate.edu/etd/11078>

This Thesis is brought to you for free and open access by the Iowa State University Capstones, Theses and Dissertations at Iowa State University Digital Repository. It has been accepted for inclusion in Graduate Theses and Dissertations by an authorized administrator of Iowa State University Digital Repository. For more information, please contact digirep@iastate.edu.

**Improving safety for slow-moving vehicles on Iowa's high speed rural
roadways**

by

Caroline Rachel Kinzenbaw

A thesis submitted to the graduate faculty
in partial fulfillment of the requirements for the degree of

MASTER OF SCIENCE

Major: Civil Engineering (Transportation)

Program of Study Committee:
Shauna Hallmark, Major Professor
Nadia Gkritza
David Plazak

Iowa State University

Ames, Iowa

2008

Copyright © Caroline Rachel Kinzenbaw, 2008. All rights reserved.

DEDICATION

This thesis is dedicated to the lives of drivers that have been lost due to crashes involving slow-moving vehicles.

TABLE OF CONTENTS

LIST OF TABLES.....	V
LIST OF FIGURES.....	VI
LIST OF EQUATIONS	VII
ACKNOWLEDGEMENTS	VIII
CHAPTER 1: INTRODUCTION	1
CHAPTER 2: LITERATURE REVIEW	4
BACKGROUND	4
<i>National Statistics</i>	4
Agricultural Equipment.....	4
Horse-Drawn Buggies.....	6
<i>Iowa Crash Statistics for SMVs</i>	8
Agricultural Equipment.....	8
Horse-Drawn Buggies.....	10
<i>International Statistics</i>	13
CURRENT PRACTICES	14
<i>National Practices</i>	14
Agricultural Equipment.....	14
Horse-Drawn Buggies.....	23
<i>Iowa Code Law</i>	31
All-Terrain Vehicles and Off-Road Motorcycles.....	31
SMV Safety Standards & Lighting	35
Licensing Requirements.....	36
CHAPTER 3: CHARACTERISTICS OF SLOW-MOVING VEHICLE CRASHES IN IOWA.....	38
METHODOLOGY.....	38
SMV CRASH ANALYSIS	41
<i>Rural Crash Analysis</i>	43
Crash Severity	43
Night vs. Day	49
Time of Year	51
Speed Limit.....	52
Manner of Crash/Collision.....	52
Vehicle Action	55
Driver Age	58
Major Cause.....	60
Responsibility of Crash	64
CRASH ANALYSIS SUMMARY OF FINDINGS	66
CHAPTER 4: FARM VEHICLE CRASH SEVERITY MODEL.....	68
TRANSFERABILITY TEST – TOTAL VS. SINGLE & MULTIPLE VEHICLE CRASHES	75
<i>Total Crashes Model</i>	76
<i>Single Vehicle Crash Model</i>	76
<i>Multiple Vehicle Crash Model</i>	77
<i>Transferability Likelihood Ratio Test</i>	77
TRANSFERABILITY TEST – TOTAL VS. RURAL & URBAN CRASHES	78
<i>Transferability Test Total Crashes Model</i>	78
<i>Transferability Test Rural Crashes Model</i>	79
<i>Transferability Test Urban Crashes Model</i>	79
<i>Transferability Likelihood Ratio Test</i>	79
FINAL MODELS	80
<i>Urban Crash Severity Model</i>	80

Overall Description	80
Overall Fit	82
Individual Parameter Significance	82
Frequency Comparison	83
Marginal Effects.....	83
Discussion of Coefficients and Marginal Effects	86
<i>Rural Crash Severity Model</i>	87
Overall Description	87
Overall Fit	88
Individual Parameter Significance	89
Frequency Comparison	89
Marginal Effects.....	90
Discussion of Coefficients and Marginal Effects	93
<i>Farm Vehicle Crash Severity Models: Summary of Findings</i>	95
CHAPTER 5: CONCLUSIONS AND RECOMMENDATIONS.....	97
CONCLUSIONS	97
<i>Horse-Drawn Buggies</i>	97
<i>Farm Vehicles</i>	98
<i>Construction and Maintenance Vehicles</i>	99
<i>All-Terrain Vehicles and Mopeds</i>	99
RECOMMENDATIONS	100
FUTURE RESEARCH	103
REFERENCES	105
APPENDIX A: 2004-2006 SMV IOWA CRASH MAPS.....	111
APPENDIX B: SMV ANALYSIS – TOTAL 2004-2006 AND RURAL 2004-2006.....	112
APPENDIX C: COMPLETE VARIABLE DESCRIPTIONS.....	137
APPENDIX D: COMPLETE MODEL OUTPUTS.....	152

LIST OF TABLES

TABLE 1. STATISTICS FOR AMISH BUGGY CRASHES IN OHIO	25
TABLE 2. CRASHES INVOLVING SMVs FROM CRASH NARRATIVES.....	40
TABLE 3. CRASHES INVOLVING SMVs FROM VEHICLE CONFIGURATION.....	40
TABLE 4. TOTAL CRASHES INVOLVING SMVs	40
TABLE 5. TOTAL CRASHES	42
TABLE 6. RURAL SMV CRASHES	43
TABLE 7. RURAL FATALITIES	44
TABLE 8. PERCENTAGE OF RURAL CRASHES AS FATALITIES	44
TABLE 9. DEPENDENT "SEVERITY" VARIABLE OUTCOMES.....	71
TABLE 10. VARIABLE DESCRIPTIONS	71
TABLE 11. SEVERITY VARIABLE DESCRIPTION	81
TABLE 12. URBAN CRASH SEVERITY MODEL ESTIMATION RESULTS.....	81
TABLE 13. MARGINAL EFFECTS	84
TABLE 14. SEVERITY VARIABLE DESCRIPTION	88
TABLE 15. RURAL VARIABLE OUTPUT	89
TABLE 16. MARGINAL EFFECTS	90

LIST OF FIGURES

FIGURE 1. OHIO FARM VEHICLE CRASH STATISTICS	5
FIGURE 2. AMISH BUGGY IN CRASH.....	7
FIGURE 3. HORSE-DRAWN BUGGY CRASH WITH SUV IN SALISBURY, PENNSYLVANIA.....	8
FIGURE 4. TOTAL ADHERENTS TO THE OLDER ORDER AMISH CONGREGATION (2000).....	11
FIGURE 5. TOTAL ADHERENTS TO THE OLDER ORDER MENNONITE CONGREGATION (2000).....	12
FIGURE 6. IOWA AMISH POPULATION.....	13
FIGURE 7. SMV IDENTIFICATION EMBLEM	17
FIGURE 8. SMV IDENTIFICATION EMBLEM: DAY VS. NIGHT	17
FIGURE 9. MULTI-WHEELED TRACTOR DIAGRAM.....	21
FIGURE 10. IMPLEMENT DIAGRAM.....	22
FIGURE 11. TRACTOR DIAGRAM.....	22
FIGURE 12. WAGON DIAGRAM.....	23
FIGURE 13. OHIO HORSE-DRAWN BUGGY CRASH STATISTICS	25
FIGURE 14. BUGGY VIEW	28
FIGURE 15. WAGON VIEW	29
FIGURE 16. CARRIAGE VIEW	30
FIGURE 17. IOWA SMV CRASHES	46
FIGURE 18. RURAL INJURY AND FATALITY CRASHES WITH RURAL CRASH THEMATIC	46
FIGURE 19. RURAL HORSE & BUGGY INJURY & FATALITY CRASHES WITH RURAL HORSE & BUGGY CRASH THEMATIC	47
FIGURE 20. RURAL FARM VEHICLE INJURY & FATALITY CRASHES WITH RURAL FARM VEHICLE CRASH THEMATIC	47
FIGURE 21. RURAL CONSTRUCTION/MAINTENANCE VEHICLE INJURY & FATALITY CRASHES WITH THEMATIC...48	48
FIGURE 22. RURAL MOPED/ATV INJURY & FATALITY CRASHES WITH RURAL MOPED/ATV CRASH THEMATIC .48	48
FIGURE 23. RURAL NIGHT-TO-DAY CRASH RATIO.....	49
FIGURE 24. RURAL PEAK HOUR CRASHES.....	50
FIGURE 25. RURAL CRASHES BY MONTH	51
FIGURE 26. RURAL CRASHES BY SPEED LIMIT	52
FIGURE 27. RURAL HORSE-DRAWN BUGGY CRASHES BY MANNER OF COLLISION	53
FIGURE 28. RURAL FARM VEHICLE CRASHES BY MANNER OF COLLISION	54
FIGURE 29. RURAL CONSTRUCTION/MAINTENANCE VEHICLE CRASHES BY MANNER OF COLLISION	54
FIGURE 30. RURAL MOPED/ATV CRASHES BY MANNER OF COLLISION	55
FIGURE 31. RURAL HORSE-DRAWN BUGGY CRASH VEHICLE ACTION.....	56
FIGURE 32. RURAL FARM VEHICLE CRASH VEHICLE ACTION.....	56
FIGURE 33. RURAL CONSTRUCTION AND MAINTENANCE VEHICLE CRASH VEHICLE ACTION.....	57
FIGURE 34. RURAL MOPED/ATV CRASH VEHICLE ACTION	57
FIGURE 35. RURAL HORSE-DRAWN BUGGY CRASHES BY DRIVER AGE	58
FIGURE 36. RURAL FARM VEHICLE CRASHES BY DRIVER AGE	59
FIGURE 37. RURAL CONSTRUCTION/MAINTENANCE VEHICLE CRASHES BY DRIVER AGE	59
FIGURE 38. RURAL MOPED/ATV CRASHES BY DRIVER AGE	60
FIGURE 39. RURAL HORSE-DRAWN BUGGY CRASHES BY MAJOR CAUSE	62
FIGURE 40. RURAL FARM VEHICLE CRASHES BY MAJOR CAUSE	62
FIGURE 41. RURAL CONSTRUCTION/MAINTENANCE CRASHES BY MAJOR CAUSE	63
FIGURE 42. RURAL MOPED/ATV CRASHES BY MAJOR CAUSE	63
FIGURE 43. PERCENTAGE OF ALL SMV CRASHES WITH SMV RESPONSIBILITY	65
FIGURE 44. PERCENTAGE OF MULTIPLE VEHICLE CRASHES WITH SMV RESPONSIBILITY.....	66
FIGURE 45. "SEVERITY" VARIABLE COMPARISON	83
FIGURE 46. "SEVERITY" VARIABLE COMPARISON	90

LIST OF EQUATIONS

[4-1].....	70
[4-2].....	75
[4-3].....	76
[4-4].....	77
[4-5].....	77
[4-6].....	77
[4-7].....	77
[4-8].....	78
[4-9].....	79
[4-10].....	79
[4-11].....	79
[4-12].....	79
[4-13].....	81
[4-14].....	82
[4-15].....	82
[4-16].....	83
[4-17].....	88
[4-18].....	88

ACKNOWLEDGEMENTS

I would like to thank Dr. Shauna Hallmark, Dr. Nadia Gkritza, and David Plazak for their support, patience, and educated recommendations for the completion of this thesis. These were the committee members of my program of study committee whose help with this document was much appreciated and necessary to the completion of this document.

I would also like to thank Dr. Michael Pawlovich of the Iowa Department of Transportation (Iowa DOT) Office of Traffic Safety for helping me to learn and navigate through the Iowa DOT crash database. I would also like to thank him for his cooperation and patience as I searched through the database.

I would like to thank Zach Hans for helping me to learn the ArcGIS program as well as how to download the crash tables from the Iowa DOT crash database into the program.

I would also like to thank my fiancé and my family for their love and support through this entire process. I want to personally thank my parents for their editing recommendations of this thesis.

I also want to thank Eric Fitzsimmons for his help in editing and formatting. Additionally, I would like to thank all the CTRE students for their friendly advice on writing this document.

DISCLAIMER

This thesis was used in partial fulfillment of the requirements of the Master of Science degree as set forth by Iowa State University. The data used in this report is not exhaustive as an additional year of crashes was added to the Iowa DOT crash database prior to the finalization of this thesis. A thorough analysis using this data could not be completed due to time constraints of the student. The recommendations made herein are the views of the student and do not represent the views of the Iowa Department of Transportation (Iowa DOT), the Center for Research and Education (CTRE), or Iowa State University (ISU).

CHAPTER 1: INTRODUCTION

Federal, State, and local agencies in the United States must plan, design, and maintain roadways which serve a wide variety of users and vehicles. A small percentage of these vehicles include slow-moving vehicles (SMV) such as horse drawn carriages, agricultural vehicles, and other vehicles, such as maintenance equipment, construction equipment, ATVs, etc, which travel slower than regular highway vehicles. According to the Farm Safety Association (2002) an SMV is considered any vehicle that cannot keep a constant speed of 25 mph (40 km/h) or greater. SMVs can be dangerous obstacles on the roadway, particularly on rural two-lane highways which are common in the Midwest.

Farm vehicles are often on the roadway since farmers need to move equipment of various lengths and weights from one location to another. Also, as the population increases in Midwest communities, farmland near urban centers has been developed into residential urban neighborhoods. Since the farmland has moved farther away from the urban centers, farm vehicles have to travel longer distances to access their fields (Lacy et al., 2003). As the number of people moving to rural areas increases, commuting to work in distant communities has increased the likelihood of an SMV crash on public roads connecting communities (Cole et al., 1997).

Horse drawn buggies are not common on many roadways, but do exist nonetheless in communities which have a strong presence of Old Order Amish and Old Order Mennonites. Next to walking, horse drawn buggies are the main, and often times only, form of transportation for these religious communities which are located in the Midwestern and northeastern parts of the United States.

SMVs are allowed to travel on the public roadways while following laws specific to each state as described in the following section which explains current practices in the United States. The most significant problem with SMVs on public roadways is the speed differential between SMVs and regular vehicles on the roadway as well as the large size of machinery

which may require more space than a standard 12 foot lane allows. Shoulders are often not large enough to safely accommodate SMVs while simultaneously allowing other vehicles traveling in the same direction sufficient space to overtake without entering into the opposing travel lane which requires a long gap in oncoming traffic. Therefore, passing maneuvers are often dangerous and risky for three reasons. The first reason is that gaps in the oncoming traffic may be misjudged by a fast moving vehicle driver attempting to pass an SMV. Second, it may be difficult for drivers of other vehicles to see around large SMVs in order to detect traffic in the oncoming lane, resulting in possible head-on crashes while trying to pass the SMV. The last reason is that safety equipment (e.g. tail reflectors, turn signals, head lights, flashers, etc.) on the SMVs may be faulty or nonexistent and the slow moving vehicle's intent, such as intent to turn, is not communicated to other drivers. This results in broadsides between the passing vehicle and the SMV when the SMV is turning left without proper notification to the drivers following the large vehicle. Drivers in regular vehicles may also rear-end SMVs which are not properly marked.

Operators of the SMVs can also misjudge gaps. Sometimes SMVs are forced to cross a public roadway and an SMV operator may misjudge the amount of time necessary it takes for the entire vehicle, including any trailers, to cross and clear all lanes, resulting in a crash.

Rear-end crashes may also occur when the speed differential is great between a vehicle approaching an SMV moving in the same direction. Sight distance issues on rural two-lane roads increase this risk of a crash when a vehicle approaches an SMV from behind just over the crest of a hill and the high speed differential doesn't allow the driver enough reaction time to see the SMV on the downgrade and slow down before a rear-end crash occurs.

The gravity of the situation for vehicles interacting with SMVs becomes apparent when considering the rate of closure between vehicles traveling with a high speed differential. For example, a vehicle traveling at 55 mph will completely close a 500 foot gap on a lead vehicle traveling 45 mph in 34 seconds. If the lead vehicle is traveling at 25 mph, as is the case with many farm vehicles, the time to react goes down to 11.2 seconds. If the lead vehicle is

traveling at 5 mph, as with horse-drawn buggies, the time to react falls to 6.8 seconds. The speed differential between SMVs and normal traffic flow has created a serious transportation safety concern over the last fifty years (Garvey, 2003).

The purpose of this thesis was to investigate ways to improve transportation safety for SMVs on the public roadway system in Iowa. First, a literature was done to review the statistics and different laws concerning SMVs across the country. This provides a background necessary to understand what an SMV. Additionally, a crash study was conducted and analyzed based on three years of crash data. By doing so, commonalities were addressed among crashes within each specific vehicle group and countermeasures can be identified. Developing safety strategies and guidelines could enhance both the safety and effectiveness of the public roadway system for all users. In addition, a crash model analysis was conducted modeling the effects of different crash characteristics on the severity of crashes involving farm vehicles. Determining the significant factors influencing crash severity identifies the areas requiring attention to reduce crash severity. Following these sections are conclusions as well as recommendations for policy change.

CHAPTER 2: LITERATURE REVIEW

This section begins with a background on the statistics of crashes involving agricultural equipment and horse drawn vehicles in the United States, Iowa, and also internationally. The next section discusses the current practices throughout the nation and in Iowa. Then the effectiveness of different strategies is explained in the final section. These include studies on current practices as well as other possible strategies that have not been implemented into state law. These methods have been suggested by research studies or have been patented for the purpose of reducing SMV crashes. In certain cases, these new strategies have been studied and the effectiveness of those methods has also been documented.

Background

National Statistics

Agricultural Equipment

According to the USDA, 2.1 million farms were recorded in the United States during 2002, averaging 441 acres per farm. Of these 2.1 million farms, 1.9 million had at least one motorized tractor in use for farming purposes and pulling agricultural equipment. The average tractor age was 25.7 years old with 50% of all tractors having a rollover protective structure (ROPS) (USDA [National Level], 2002). An ROPS is “a cab or frame that provides a safe environment for the tractor operator in the event of a rollover” (University of Illinois Safety Specialist). From the Fatal Accident Reporting System (FARS), there were 90 fatal crashes involving a farm vehicle which was not a truck in the United States in 2005. While there has been no significant increase in the number of these fatal crashes, there has been a fluctuating, high number of SMV crashes occurring between 1996 and 2005 with the highest being 106 fatal crashes and the lowest being 85.

In Ohio, 1,432 farm vehicles were reported to have been involved in a crash from 1989-1992. Left turning crashes were the most common type of SMV crash in Ohio at 52%. A significant factor of these crashes was the failure by the other driver to recognize that the

farm vehicle was making a left turn. Of the total crashes reported in Ohio, 78% occurred during daylight hours. This statistic was similar to Iowa which has 81% (Glascock, 1993). Glascock also suggested in a similar article a peak of SMV crashes occurred between the hours of 12:00 and 6:00 P.M. Both peaks for Iowa (shown in the next chapter) and Ohio occurred in the afternoon/early evening time periods. The document also shows information on the same study where 42% of the dark crashes from 1989-1992 were rear-end crashes (Glascock, 1995). These similarities may indicate a need for better visibility of agricultural equipment during dark or evening hours. Farmers also need to keep SMV emblems clean and replace them when the colors and retro reflectivity become dull and/or ineffective. More recent farm vehicle crash statistics were displayed through the Agricultural Safety and Health Program at the Ohio State University Extension. Figure 1 shows crash trends involving farm vehicles between the years of 1997-2006 sorted by crash severity. The number of farm vehicle crashes has decreased in Ohio over the last five years overall, but still remains over 170 annually (Agricultural Safety and Health Program, 2008).

Farm Equipment/Motor Vehicle Crashes 1993-2006

Source: Ohio Department of Public Safety

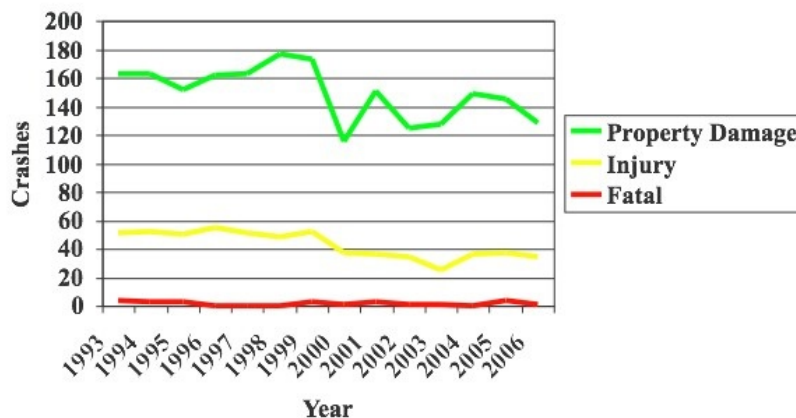

Figure 1. Ohio Farm Vehicle Crash Statistics
(Agricultural Safety and Health Program, 2008)

A North Carolina study showed that the North Carolina farmers' greatest safety concern was driving farm vehicles on public roads. A common opinion amongst the survey respondents

was that sharing public roads had become more dangerous between the years of 1995 and 1999. The increased population in counties that are major agricultural producers has caused increased competition for public road use. A study of crashes during that five year period showed a peak between 3:00 P.M. and 6:00 P.M., which is also consistent with the peak times for Iowa and Ohio as reported in the previous section (Costello et al., 2002). Another North Carolina study of farm vehicle crashes from 1991 through 1999 indicated that rear-end and left-turning crashes made up more than 50% of the crashes reported. This study also indicated that the frequency of farm vehicle crashes over the last 35 years in North Carolina had changed very little. Even though there was little change in crash frequency, the fatality rate for the agricultural industry was still six times higher than the rate for all industries in 1999 (Lacy et al., 2003).

Horse-Drawn Buggies

Old Order Amish and Old Order Mennonite communities commonly use the horse-drawn buggy as a form of transportation for religious reasons as discussed in a previous section. The two religious groups are found in twenty different states as well as Ontario and Canada. In 1990, it was estimated that the Amish population in the United States was 127,800, which was a significant increase from the 3,700 estimated in 1900 (Meyers, 1990).

The average horse-drawn buggy is six feet wide and travels at 5 to 8 mph. Since they are legally allowed to use non-expressway public roadways, the interaction between motor vehicles and horse-drawn buggies can lead to conflicts and decreases in traffic operation. The interaction between buggies and vehicles can be particularly problematic when drivers are not accustomed to horse drawn buggies. According to an Ohio study, tourists who are unfamiliar with the Amish communities tend to drive more slowly while observing buggies due to their unfamiliarity with the road system. Because of this, tourists are seen as less of a problem to the traffic mix than the local motoring public (O'Connor, 2000).

The Ohio State Extension services website gives more statistics for Amish buggy crashes. These statistics come from the Ohio Department of Public Safety. An analysis was

performed on 500 incidences with horse-drawn buggies between 1990 and 1993. Buggy-related crashes were found to occur during both daytime and night time hours between the hours of 5:00 A.M. to 10:00 P.M respectively. Peak periods for crashes were found to occur during the following hours along with the corresponding percentage of total horse-drawn buggy crashes that occurred during that time period: 21% between 5 a.m. and 7 a.m., 18% between 1:00 and 3:00 p.m., and 29% between 5:00 p.m. and 7:00 p.m. With this information, the Ohio State Agricultural Safety and Health program recommends that marking and lighting were found to be effective in low light, full daylight, and night conditions. Of the total horse-drawn buggy crashes, 42% were rear impact crashes and 37% were side impact crashes. Also, 8% of the crashes were fatal crashes (OSU Extension Ag. Safety and Public Health, 2007).

Due to the high speed differential between motorized vehicles and the horse-drawn buggy's lack of resilience in the structure, many horse-drawn buggy collisions with other motor vehicles have a high crash severity. A fire chief responding to a horse-drawn buggy crash in Ohio described the crash as, "The buggy just blew apart, ejecting two adults and seven children onto the roadway." Figure 2 shows a photo of this crash occurring on June 13, 2007 in Middlefield, Ohio.



Figure 2. Amish Buggy in Crash
(Whitaker, 2007)

Another reported horse-drawn buggy crash occurred on October 29, 2006, in Salisbury, Pennsylvania which resulted in two serious injuries to children. Figure 3 shows the remains of the buggy after it was struck from behind by a sport utility vehicle (SUV). The driver of the sport utility vehicle was reported obscured vision when she was blinded by the sun and came up on the buggy too quickly, rear-ending it (Bal, 2007).



Figure 3. Horse-Drawn Buggy Crash with SUV in Salisbury, Pennsylvania
(Bal, 2007)

Iowa Crash Statistics for SMVs

Agricultural Equipment

According to United States Department of Agriculture (USDA), there were 90,655 farms in Iowa with a total of 31,729,490 acres in the 2002 census. The proportion of total land area used as farms is 88.7%, which ranks fifth in the United States. Only ten states have more farm acreage than Iowa (USDA [State Level], 2002).

The percentage of tractor-related crashes in Iowa that resulted in a fatality had increased from 9% in a three-year period including 1988-1990 period to 22% in a two-year period including 1991-1992 (Lehtola et al., 1994). During that same 1988-1990 period, the Iowa Department of Transportation (DOT) reported 1,477 crashes on public road and right-of-ways that involved farm vehicles. This equates to an average of almost 300 crashes per year. These crashes occurred throughout the year with the month of October showing nearly twice as many crashes as any other month. The three most common crash types were left-turn (22% of total), rear-end (20%), and passing (4%). Consistent with national statistics, "Iowa DOT crash data also indicate that a crash involving a slow-moving agricultural vehicle is about five times more likely to result in a fatality than other types of crashes" (Iowa Highway Safety Management System, 2001).

Gerberich et al. investigated injury fatality rate for workers in all occupations in Iowa (nine in 100,000) to the farm fatality rate (48 in 100,000) in 1988. This farm fatality rate was among the highest in the nation in 1988. In 1993 the rates were still eight and 35 in 100,000, respectively, which had not dropped significantly from the previous high rate of 1988. The researchers also suggested from their findings that fatal-crashes involving farm vehicles are related to vehicle and environmental factors that are changeable. These factors include investigating the design characteristics of the farm vehicles with a high percentage of overturns associated with farm vehicle crashes (21%) as compared to non-farm vehicles (9%). Visibility factors are also common as a large percentage of farm vehicle crashes are rear-end crashes compared to 4% of non-farm vehicle crashes. This suggests a need to consider visibility aids to allow for better perception of the farm vehicles by other vehicles on the roadway (Gerberich et al., 1996).

Flynn (1994) reported a conflicting number of SMV crashes in Iowa from 1988-1992 of 1,490 crashes. However, the percentage of reported left turn crashes was found to be 22.4%, which was consistent with the data from the Iowa DOT study. Sideswipe and angle crashes accounted for 38.3% of all crashes, which included crashes caused by left turning vehicles. The road surface conditions were dry in 79.1% of the crashes, indicating that road conditions

were not a contributing factor to the crashes. The age of the driver was also found to be a noncontributing factor in the report. Flynn also reported that of all the reported crashes in Iowa from 1988-1992, 81% occurred during daylight hours with peaks occurring between the hours of 12-4 P.M. and 4-8 P.M (Flynn, 1994). Falb (2008) reported a news release through the Iowa DOT that showed recent data of traffic crashes involving farm vehicles from 2004-2006. There were a total of 586 crashes during that period for an average of just over 195 crashes per year. Of the 586 crashes, 22 resulted in fatalities. Falb (2008) also reported that of all farm vehicle-related traffic crashes in Iowa from 2001-2006, a majority occurred during the month of October with more than 250, followed by November with around 180, and then June with just over 150 crashes.

Horse-Drawn Buggies

Horse drawn buggies are used by the Old Order Amish and Old Order Mennonites. These two groups do not use automobiles in order to remove themselves from easy access to the ways of the world (Pa Dutch, n.d.). The US Census fails to produce data on the religious population throughout the United States. However, the Association of Religion Data Archives (ASARB, 2000) does collect and report this information. The Old Order Amish population in the United States shown in Figure 4 and the Old Order Mennonite population is shown in Figure 5.

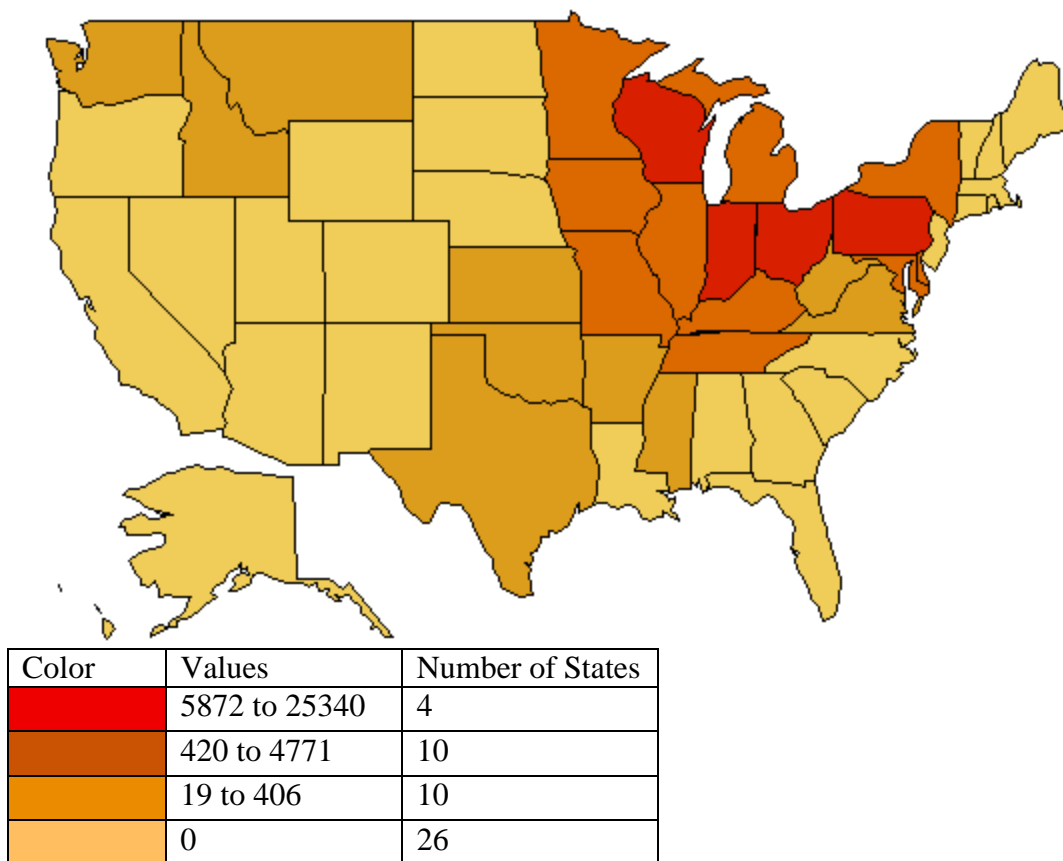

Iowa: 199 (Rank:
10)

Figure 4. Total Adherents to the Older Order Amish Congregation (2000)
(ASARB, 2000)

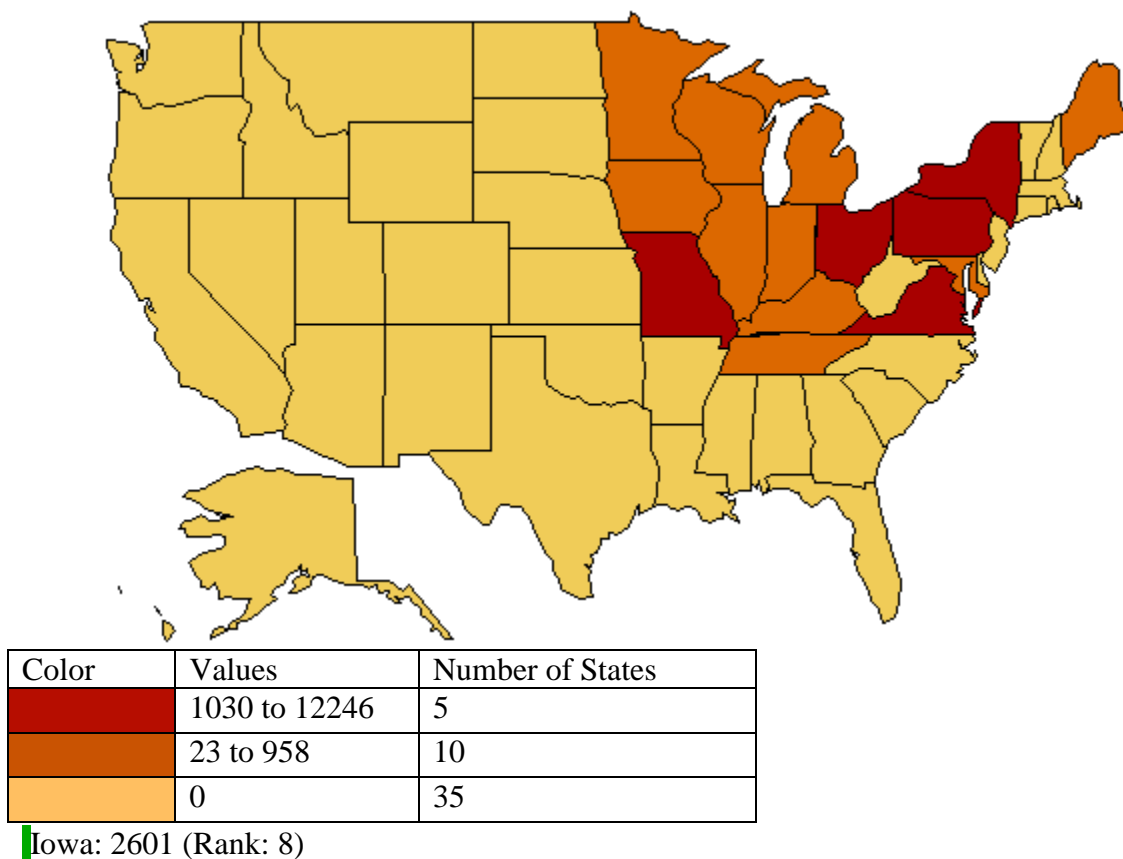

Figure 5. Total Adherents to the Older Order Mennonite Congregation (2000)
(ASARB, 2000)

According to a 2000 study by ASARB, the only county in Iowa in which Old Order Mennonites reside is Howard County with 69 adherents to the church. The totals for both horse-drawn buggy-based populations were sorted by county and can be found in Figure 6. The Old Order communities are located in northeast and south/southeastern Iowa. The most heavily populated Amish county is Washington County in southeastern Iowa with a large Old Order Amish community in the Kalona, IA community with 621 adherents. Davis and Buchanan counties in southern Iowa also have large Old Order Amish populations with communities of 483 and 420 adherents, respectively (State Data Center of Iowa, n.d.).

Iowa 2000 Amish Population

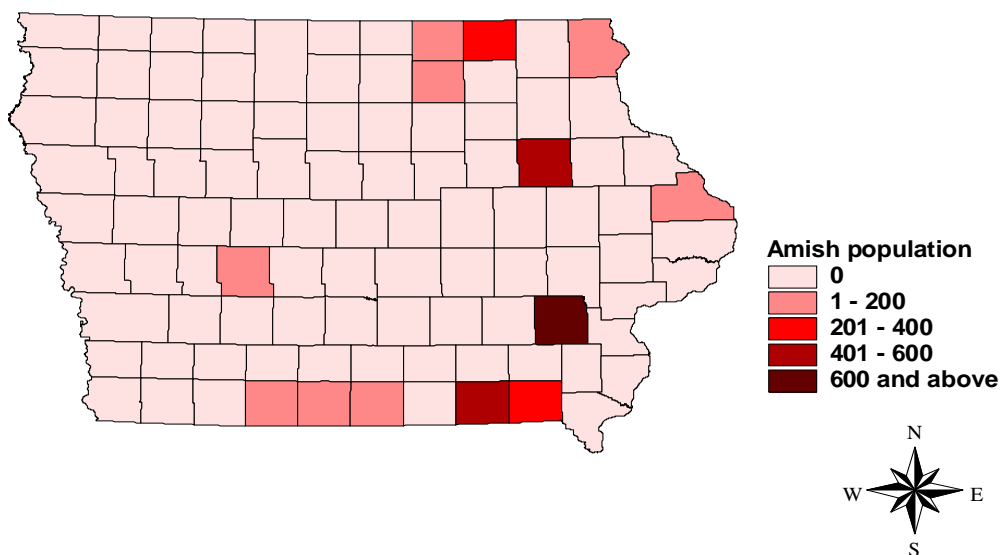

Figure 6. Iowa Amish Population

International Statistics

In Sweden, farm vehicle crashes were analyzed over a period of five years (1992-1996). During each year of the study, SMVs were involved in over 250 crashes with an average of 297. On average, 10 people were killed each year. The most common type of crash (30%) was a vehicle attempting to overtake an SMV at 30%, followed by turning accidents (27%), accidents at crossroads (26%), and oncoming vehicles (17%). Most crashes occurred in June, followed by September and October. A peak occurred from 3:00 PM through 5:00 P.M., which was consistent with the US data stated in previous sections. About 75 % of the crashes happened during daylight and the roads were dry in 60% of the cases. The 297 average crashes per year correspond to about 1.3 % of all persons injured in traffic accidents in Sweden. Just over half of the persons killed in these crashes were persons traveling in a vehicle other than the SMV involved in the crash (52%). This differs from US data in which the majority of persons killed were those traveling in SMVs (Pinzke and Lundqvist, 2003).

Current Practices

National Practices

Agricultural Equipment

The American Society of Agricultural and Biological Engineers (ASABE, 2006) provides advisory standards for the lighting and marking of agricultural field equipment. Despite attempts to create uniform standards for all states to follow regarding SMV lighting and markings, practices still differ from state to state. The current practices for the safety of SMVs should be understood along with the effectiveness of those strategies enforced by different states. Glascock et al. (1995) conducted a study of state traffic codes in which laws for lighting and marking of SMVs were identified in a survey of all 50 states. Lighting and marking strategies that are commonly used on SMVs include: headlights, turn signals, amber flashers, reflectors, taillights, and SMV emblems.

According to the ASABE (2006) standards, headlamps should be used, mounted at the same height, and spaced as widely apart as practicable symmetrically placed on the front of the SMV. Glascock et al. (1995) found that thirteen states required only one headlamp. Thirty-six states required two headlamps. Nine of those states made special provisions for tractors without electrical systems to require only one lamp. Alaska had no code for headlamps. Forty-eight states did not require the use of headlamps during the daytime. Alaska had no code. Eight states required the headlamps to be visible from a distance of no less than 1,000 feet. Twenty-five states required visibility from 500 feet, and ten states required a distance of 200 feet visibility. Vermont required 150 feet, Kentucky and Texas 100 feet, Rhode Island 75 feet, and Maine 50 feet. Alaska and Massachusetts had no requirements.

ASABE (2006) also recommends the use of two red taillights symmetrically mounted to the rear of the machine and widely spaced no farther than 5 feet to the left and right of the machine center and between 1.3 and 10 feet high. According the same study by Glascock et al. (1995), thirty-five states required only one taillight. Fourteen states required two

taillights, two of which allowed the use of two reflectors and one taillight as an alternate if a vehicle had no electrical system. Two others had the same requirements, but additionally required that one lamp or reflector be placed as far left as possible. Kentucky required that taillights must be used during daytime hours while forty-eight states did not. Alaska did not have this requirement. Taillight visibility distance ranged from no requirement up to 1000 feet. The shortest distance requirement was 100 feet. Taillights for agricultural machinery must be red in forty-seven states, while Kentucky allowed white, red, or a combination of the two and Alaska and Oregon have no color requirement (Glascock et al., 1995).

Amber flashing lights are commonly visible on the front of tractors. They are used in conjunction with turn signals for greater visibility. These lights can be used as turn indicators when provided. ASABE (2006) standards recommend using at least two amber flashing warning lamps to flash in unison at a rate of 60 to 85 flashes per minute. They are to be symmetrically mounted and as wide as possible between 1.3 and 12 feet high. On machines more than 12 feet wide, at least two amber flashing lamps shall be mounted between 1.3 and 12 feet high and within 16 inches of the lateral extremities of the machine flashing in unison between 60 and 85 flashes per minute. If a machine is less than 4 feet wide, only one lamp should be used and shall be placed as close to the center as practicable. Eleven states required amber flashing lamps, thirty did not. Three states did not permit the use of amber flashers. Six states had no code for amber flashing lights (Glascock et al., 1995).

ASABE (2006) recommends the use of turn signals to indicate the SMV's intentions to other vehicles. Amber flashing warning lamps may be used for this purpose. In this case, the amber flashing warning lamps in the direction of travel shall increase the flashing frequency while the opposite amber lamp shall burn steadily. Also, a rear-facing red or amber lamp symmetrically mounted and positioned as widely spaced as practicable shall flash in the direction of turn and in unison with the amber flashing warning lamp. The additional rear-facing lamp opposite the turn may remain off, or on, or become brighter but shall not flash. If the vehicle is equipped with stop lamps, the additional rear facing red or amber turn

indicators are not required regardless of velocity. Of the fifty states, turn signals were not required in forty-nine states, while Maine had no code (Glascocock et al., 1995).

SMV emblems are also recommended for use on SMVs by ASABE (2006). The SMV emblem is identified as a “fluorescent, orange equilateral triangle with a red retroreflective tape. The red-orange fluorescent triangle provides for daylight identification. The red retroreflective border “appears as a hollow red triangle in the path of motor vehicle headlights at night” (ASAE, 2005). Dimensioning and other specifics of the emblem can be found in Figure 7. A colored representation of the emblem as is seen in both day and nighttime scenarios is shown in Figure 8. Forty-one states required the use of an SMV emblem, while eight states did not. One state permitted the use of the SMV emblem or a flashing or rotating amber light. Research by Carol Lehtola (2007) determined a lack of consistency in speed maximums requiring an SMV emblem. In other words, there is a difference in how states define an SMV. Iowa requires an SMV emblem on vehicles traveling 35 mph or less, while Minnesota has a speed requirement of 30 mph or less. One other state, not mentioned in the report, requires 25 mph or less to force the use of SMV emblems. Iowa and Minnesota’s speed definitions are different from the definition of an SMV by the Farm Safety Association as was stated in the introduction as a vehicle that cannot keep a speed of 25 mph or higher. This difference indicates a need for consistency in defining an SMV and creating universal safety standards for these types of vehicles across the country.

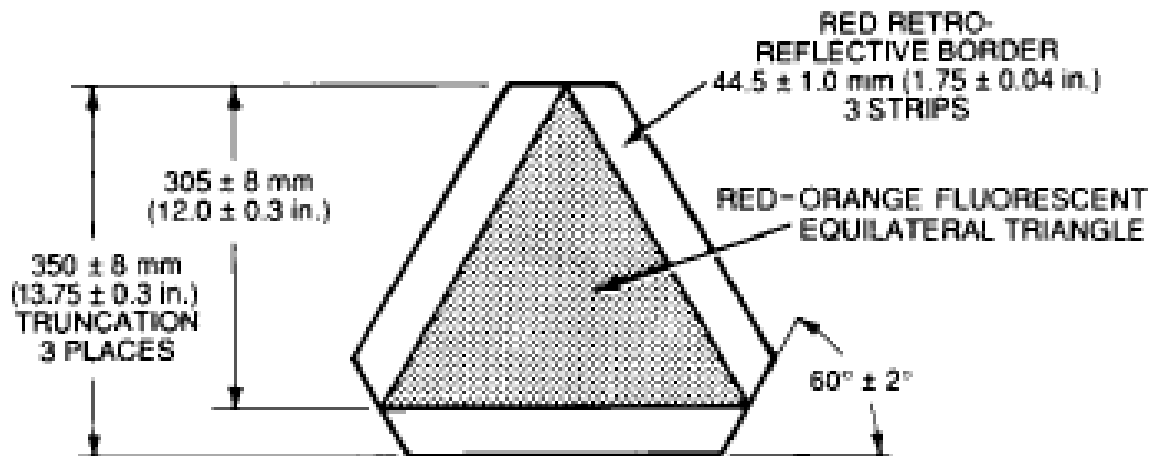

Figure 7. SMV Identification Emblem
(ASAE, 2005)

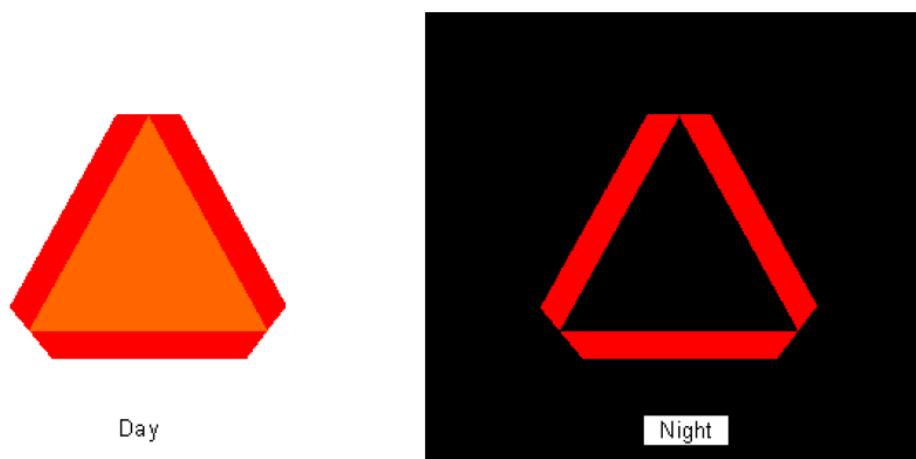

Figure 8. SMV Identification Emblem: Day vs. Night
(Garvey, 2003)

ASABE (2006) recommends that at least two red retroreflective devices be placed on the rear of the vehicle and shall be visible at night from all distances between 100 and 1000 feet. It is recommended that these emblems be spaced horizontally no farther than six feet apart. The study by Glascock et al. (1995) did not inquire the requirement or lack thereof for red retroreflective devices.

In addition to lighting and marking requirements of the SMV self-propelled agricultural equipment (SPA), requirements also exist for the towed agricultural equipment and

implements of husbandry which are non-self-propelled equipment (NSP). ASABE (2006) recommends that NSP equipment obscuring the SMV emblem on the SPAE be equipped with an SMV emblem as well. It also recommends that any NSP equipment that obscures any lighting including any flashing warning lamp, tail lamp, extremity lamp, or stop lamp on the NSP equipment shall be fitted similarly to take the place of the lamp(s) obscured. From a survey by Glascock et al. (1995), eight states had no requirement for taillights on NSP equipment. Thirty states required at least one taillight. Of these, one state required no taillight if the NSP equipment displayed an SMV emblem. Four states required that one light or reflector be placed as far left as practicable. Fifteen states required two taillights on the NSP equipment. Some states had other specific provisions.

Amber flashing lights were not required on the NSP equipment in thirty-five states, three states did not permit their usage, five didn't mention them in the code, and seven required their usage, but three of those seven required their usage only when the flashers of the SPAE equipment are obscured. Forty-four states did not require turn signals on the NSP equipment and six states did not mention turn signals on NSP equipment.

Equipment that is wider than the roadway also has specifications that should be followed. If NSP equipment is wider than 12 feet or extends more than 6 feet to the left or right of the centerline and beyond the left or right of the SPAE, ASABE (2006) says that it shall have lighting in the form of at least two amber flashing warning lamps visible from the front and the rear, two red tail lamps, and turn indicators. Equipment length should also be considered for safety precautions. ASABE also recommends that NSP equipment extending more than 25 feet to the rear of the hitch point shall have the same lighting as described for wide vehicles. Glascock et al. (1995) did not address the width or length of towed vehicles in the survey.

The inconsistent state code requirements suggests a need for a standardization of these codes so as to allow uniform traffic communication among motorists from state to state (Glascock et al., 1995).

In order to inform the public of these laws and to warn the motorists of the potential hazards of SMVs, organizations within many states act as educators by putting together informational brochures and handouts. Local newspapers also educate the public by including articles about the dangers of encountering an SMV and provide tips to be a safe and aware driver on the public highways. The following are such organizations including, but not limited to: The Farm Bureau Safety Program of Georgia (Farm Bureau Safety Program Georgia, n.d.), Alabama A&M and Auburn Universities (LaPrade, n.d.), Kokoma Tribune of Indiana (Slow Moving Vehicles Ahead, 2007), Iowa Department of Public Safety (Iowa Department of Public Safety, 2004), Iowa Department of Transportation (Iowa Department of Transportation, 2003), Ohio State University (Jepsen, 2002), Pennsylvania Farm Bureau (PFB, 2006).

In addition to informing the public on how to drive safely sharing the roads with SMVs, some organizations are attempting to educate the operators of SMVs and informing them on how to drive safely on public highways while sharing the road with other motorists. Such programs include, but are not limited to: Farm Safety 4 Just Kids (Farm Safety 4 Just Kids, n.d.), University of Maine (Cyr and Johnson, 2006), Cornell Agricultural and Health Safety Program, Ohio State University, Pennsylvania State College of Agricultural Sciences (Murphy and Shufran, 1998), Texas Department of Insurance Division of Workers' Compensation Safety Education and Training Programs (Texas Department of Insurance, 2004), and National Ag Safety Database (Karsky, 1998).

The Agricultural Safety and Health Program has established a website through the Ohio State University Extension to educate farmers on using appropriate lighting and marking on their farm equipment. The Ohio Revised Code requires all tractors (non-multi-wheeled) and self-propelled equipment to display the following lighting from "sunset to sunrise or when there is insufficient lighting to render discernable persons, vehicles, and substantial objects at a distance of 1000 feet ahead:

- One white headlight on the front of the vehicle, visible from at least 1,000 feet in front of the vehicle.
- Two red lamps as wide apart as possible on the rear of the vehicle, visible from at least 1,000 feet behind the vehicle or one light and two red reflectors” (Agricultural Safety and Health Program, 2008).

Also within the site, the Ohio House Bill 484 illustrating the lighting and marking requirements for multi-wheeled tractors is described in detail. The bill was revised in 2001 to require the appropriate lighting from sunset to sunrise or when there is “insufficient light to render discernable persons, vehicles, and substantial objects at a distance of 1000 feet ahead;” different from the previous law requiring lighting from ½ hour after sunset to ½ hour before sunrise. Additionally, the revised law requires multi-wheeled tractors to display lighting and marking as follows:

- Two flashing amber lamps visible to the front and to the rear mounted within 16 inches of the left and right extremities of the machine and between 3.3 and 12 feet above the ground.
- Two red reflective strips visible to the rear and two amber reflective strips visible to the front mounted within 16 inches of the left and right extremities of the machine and between 3.3 and 12 feet above the ground (in conjunction with amber flashing lights). Reflective strips must be 2 by 4.5 inches in size for vehicles 6.7 feet wide or less and 2 by 9 inches in size for vehicles wider than 6.7 feet (Agricultural Safety and Health Program, 2008).

The bill also requires that all agricultural equipment model year 2002 and later follow the ASABE lighting and marking standard 279.10.

The site also has lighting and marking diagrams to show the placement of such devices. Figures 9, 10, 11, and 12 show diagrams of lighting and marking placement on a multi-wheeled tractor, implement, tractor, and grain wagon. Another feature is a publications link

in which different fact sheets are offered as helpful safety information. These articles include “Hand Signals for Agricultural Safety,” Rotary Agricultural Mower Safety,” “Preventing Farm Machine Hazards,” and “ATV’s (All-Terrain Vehicles) in Ohio. Youth safety articles are also linked titled, “Tractor Tips,” “Tractor Talk,” and “Machinery Hazards.”

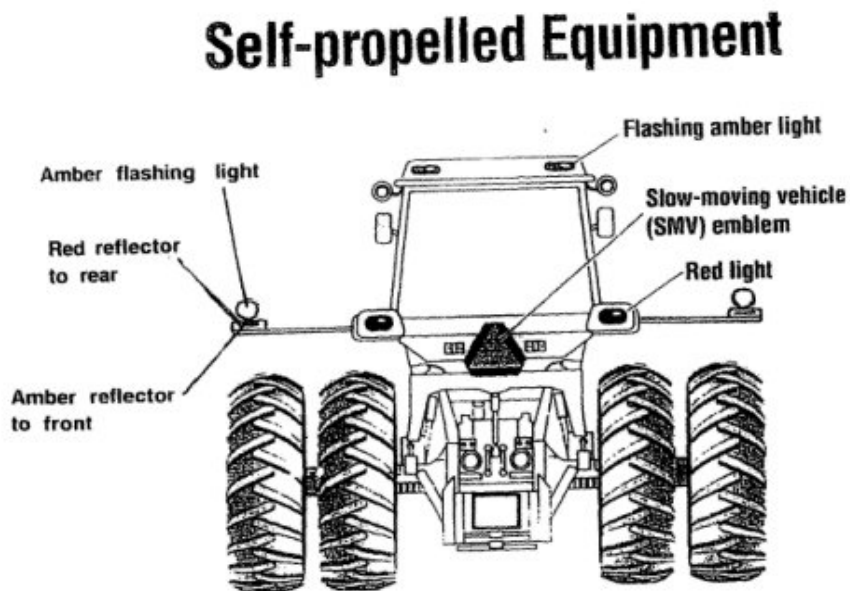

Figure 9. Multi-Wheeled Tractor Diagram
(Agricultural Safety and Health Program, 2008)

Towed Equipment

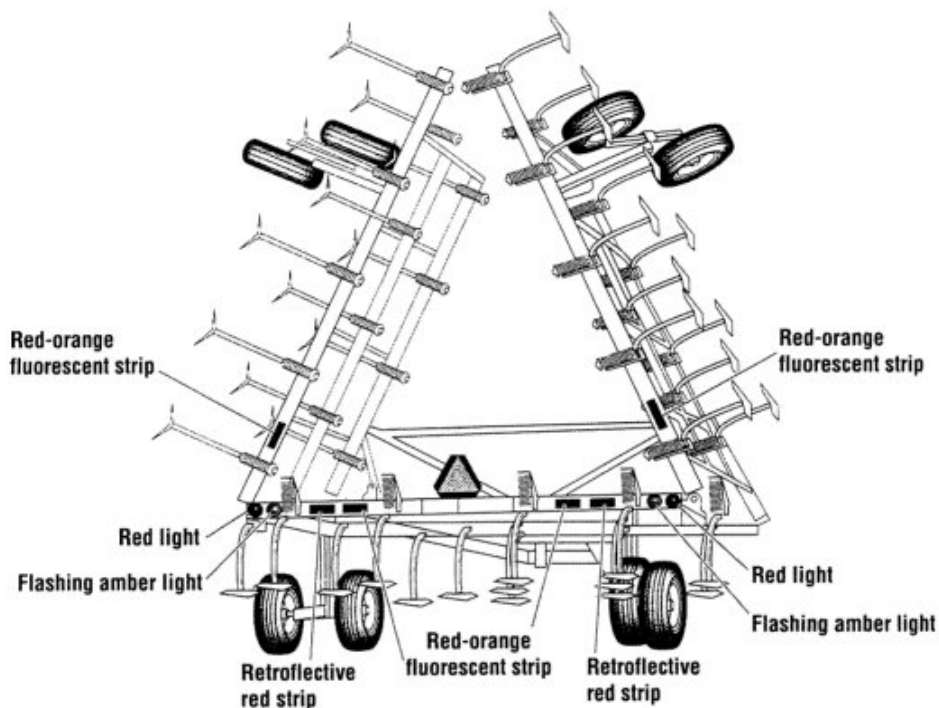

Figure 10. Implement Diagram
(Agricultural Safety and Health Program, 2008)

Self-propelled Equipment

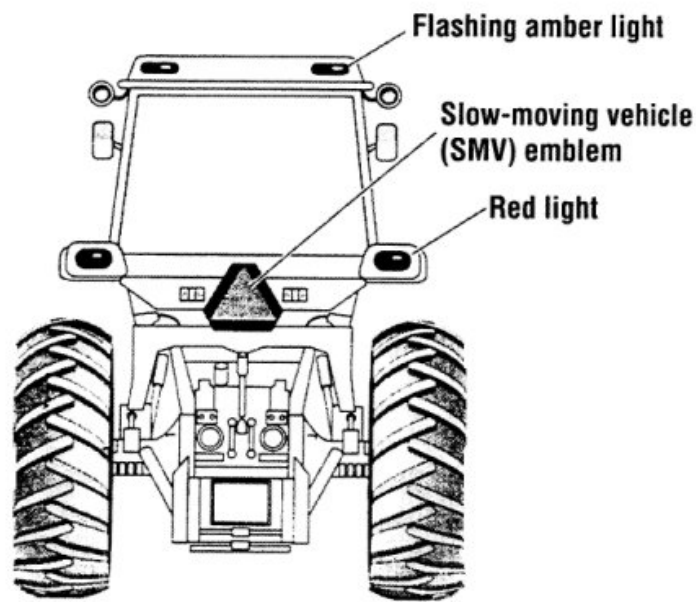

Figure 11. Tractor Diagram

Towed Equipment

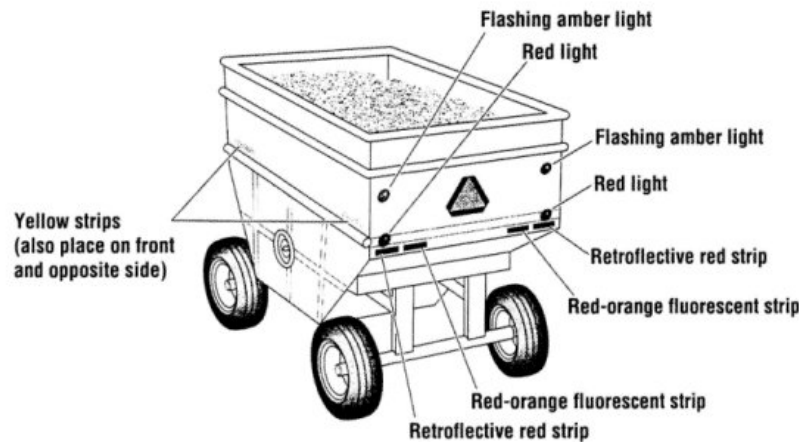

Figure 12. Wagon Diagram
(Agricultural Safety and Health Program, 2008)

Horse-Drawn Buggies

A comparison of laws for horse-drawn buggies will allow a similar assessment of consistency to agricultural equipment laws. Most states classify horse-drawn buggies as SMVs and follow under the corresponding law. For instance, California requires only an SMV Emblem (California DMV, 2007). Some states, however, have additional requirements for horse-drawn vehicles as well. Ohio requires animal-drawn vehicles to have an SMV emblem and/or reflective material that is black, gray or silver in color mounted on the animal-drawn vehicle so as to be visible from a distance of not less than 500 feet to the rear when illuminated by the lawful lower beams of headlamps.

The Jackson County Chronicle in Wisconsin discusses different SMV crashes and potential causes for the crashes. In Wisconsin horse-drawn buggies are not required to carry an SMV emblem, but they do need to have lights and reflectors visible from 500 feet away, according to Wisconsin's Department of Transportation lawyer, Joe Maassen (Hesselberg, 2007). One problem identified by Sheriff Scott Pedley is that the use of red tail lights on horse drawn buggies makes them look like any other vehicle. The driver of a vehicle approaching this

horse-drawn buggy may mistake it for a vehicle traveling at normal speeds and not realize its real identity and speed until the last second, causing the vehicle to slam on the brakes. Many times it is already too late. Another issue to be concerned with is that some Amish believe the SMV emblems violate their religious rights. A possible solution to the problem has been proposed in Green County, Wisconsin of widening the shoulders in the heavily traveled horse-drawn buggy areas to 8 feet. This would also be a benefit to bicyclists and for highway maintenance (Hesselberg, 2007).

From 1999-2003, the State of Ohio holds a Geauga County Sharing the Road with Amish Travelers Forum each year. During this annual meeting, Amish community members meet with state and local officials to discuss possible development to help prevent Amish horse-drawn buggy crashes. It was hoped by officials that public education by targeting local community and visitors could significantly reduce Amish horse-drawn buggy crashes. Before the forum was first held in 1999, Amish horse-drawn buggy crashes and fatalities resulting from those crashes were increasing. Since the forum began, Amish buggy crashes have been decreasing. The specific actions taken to reduce these crashes were not stated. The crash statistics for Ohio are shown according to severity in Table 1 (Grayson, 2003). According to Ohio crash statistics there had not been one Amish horse-drawn buggy fatality from 1999 through the publication of the article. It shows that there were no fatal crashes in 2000 or 2001. Injury crashes were also reduced between 1999 and 2001. Property damage crashes stayed steady and then increased slightly in 2001. The total crashes have decreased as well after a fairly steady increase from 1997 to 1999 (Grayson, 2003). Figure 13 shows a more recent graph describing the number of buggy crashes in Ohio from 1997-2006 by crash severity. This graph depicts an increase in horse-drawn buggy crashes from 2001-2004 followed by a decrease in 2005 and 2006. So although this forum may have indicated signs of improvement over the course of the first five years, the trend was reversed in subsequent years (Agricultural Safety and Health Program, 2008).

Table 1. Statistics for Amish Buggy Crashes in Ohio
(Grayson, 2003).

	1997	1998	1999	2000	2001
Fatal Crashes	2	4	3	0	0
Injury Crashes	68	63	91	68	54
Property Damage Crashes	84	73	67	67	71
Total	154	140	161	135	125

Ohio Buggy Crashes 1997-2006

Source: Ohio Department of Public Safety

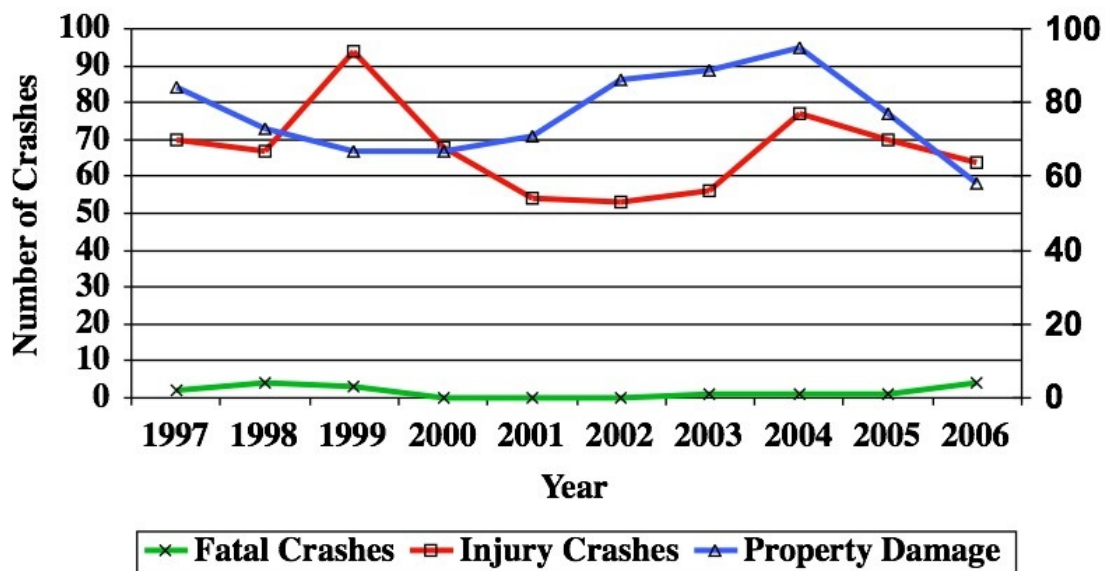

Figure 13. Ohio Horse-Drawn Buggy Crash Statistics
(Agricultural Safety and Health Program, 2008)

Ohio has two of the largest Amish settlements in the United States. Ohio State University Extension has coordinated safety programs for the Amish communities in Ohio. This has been ongoing for the last thirteen years. These programs focus on many safety issues such as roadway safety as well as other important issues.

The Agricultural Safety and Health Program with the Ohio State University Extension has put together a website with the following recommendations for Amish buggy lighting and marking:

“Lighting:

Animal-drawn vehicles should be equipped with a battery operated lighting system or a generator powered lighting system. Batteries may be typical storage, deep cycle or gel cell and should conform to SAE J537.

At least two headlamps, conforming to SAE J975, should be mounted symmetrically about the vehicle centerline facing forward on the front of the vehicle in a position which provides the least blockage from the drawing animal(s).

At least two red tail lamps, conforming to SAE J585, should be mounted symmetrically about the vehicle centerline on the rear of the vehicle and as widely spaced laterally as practical and between .6 and 3 m (2 and 10 ft) high.

At least two flashing amber warning lamps conforming to SAE J974 should be mounted symmetrically about the centerline and as widely spaced laterally as practicable. They should be visible from front and rear, and mounted between 1 and 3.7 m (3.3 and 12 ft) high.

Optional turn signal system may be incorporated into the rear red tail lamps or the flashing amber lamps. If they are incorporated into the flashing amber lamps or rear tail lamps, the lamp that is positioned on the side of the turn should flash and the lamp on the side away from the turn should go to steady burn.

Marking:

Marking for the rear of the vehicle should be 50mm by 230mm (2" by 9") strips alternating between red retroreflective material and red orange fluorescent material.

The material should be used to outline the sides and top of the rear of the vehicle. (See diagrams for examples.)

Where local culture prohibits the use of red and or red orange materials, white retroreflective material with a minimum width of 25mm (1"), may be used. If white retroreflective material is used, two red reflex reflectors should be mounted symmetrically about the centerline as widely spaced laterally as practicable. (See diagrams for examples)

Marking for the front of the vehicle should be 50mm by 230mm (2" by 9") strips of yellow retroreflective material. At least 2 strips should be placed symmetrically about the centerline as widely spaced as practicable on the front of the machine. (See diagrams for examples.)

Where local culture prohibits the use of yellow material, white retroreflective material with a minimum width of 25mm (1"), may be used.

Marking for the side of the vehicle should be 50mm by 230mm (2" by 9") strips of yellow retroreflective material. A minimum of two strips should be symmetrically spaced and mounted along each side of the vehicle frame. If the vehicle is equipped with a tongue or shaft that is visible on the outside of the animal, an additional yellow strip should be placed on it. (See diagrams for examples.)

Where local culture prohibits the use of yellow material, white retroreflective material with a minimum width of 25mm (1"), may be used.

Optional yellow or white retroreflective material may be attached to the harness or to the animal's legs to enhance visibility.”

An SMV identification emblem conforming to ASAB S276 should be placed on the rear of the vehicle. Diagrams for a buggy, wagon, and carriage view were provided by the Agricultural Safety and Health Program and are shown in Figures 14, 15, and 16. (Agricultural Safety and Health Program, 2008)

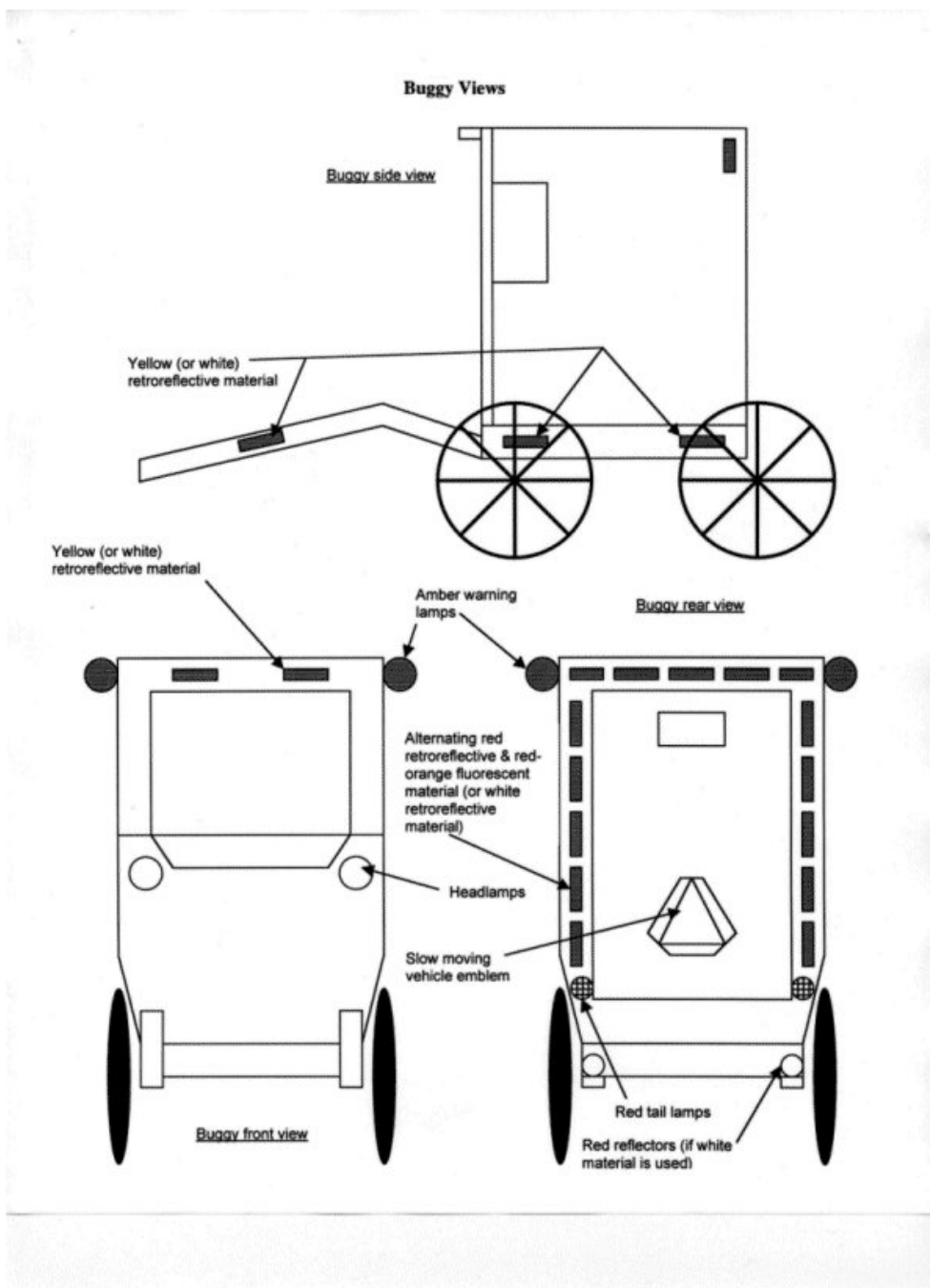

Figure 14. Buggy View
(Agricultural Safety and Health Program, 2008)

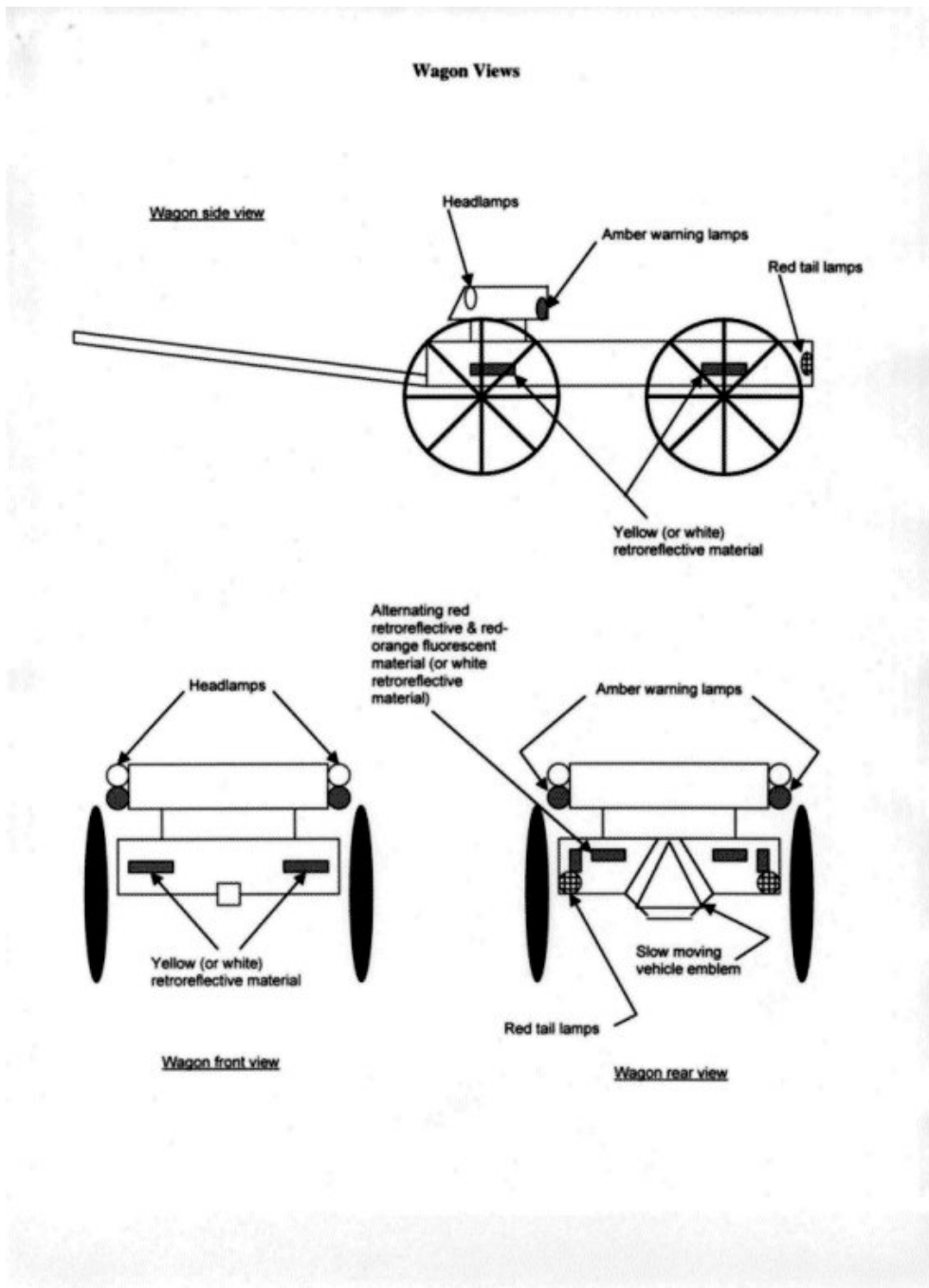
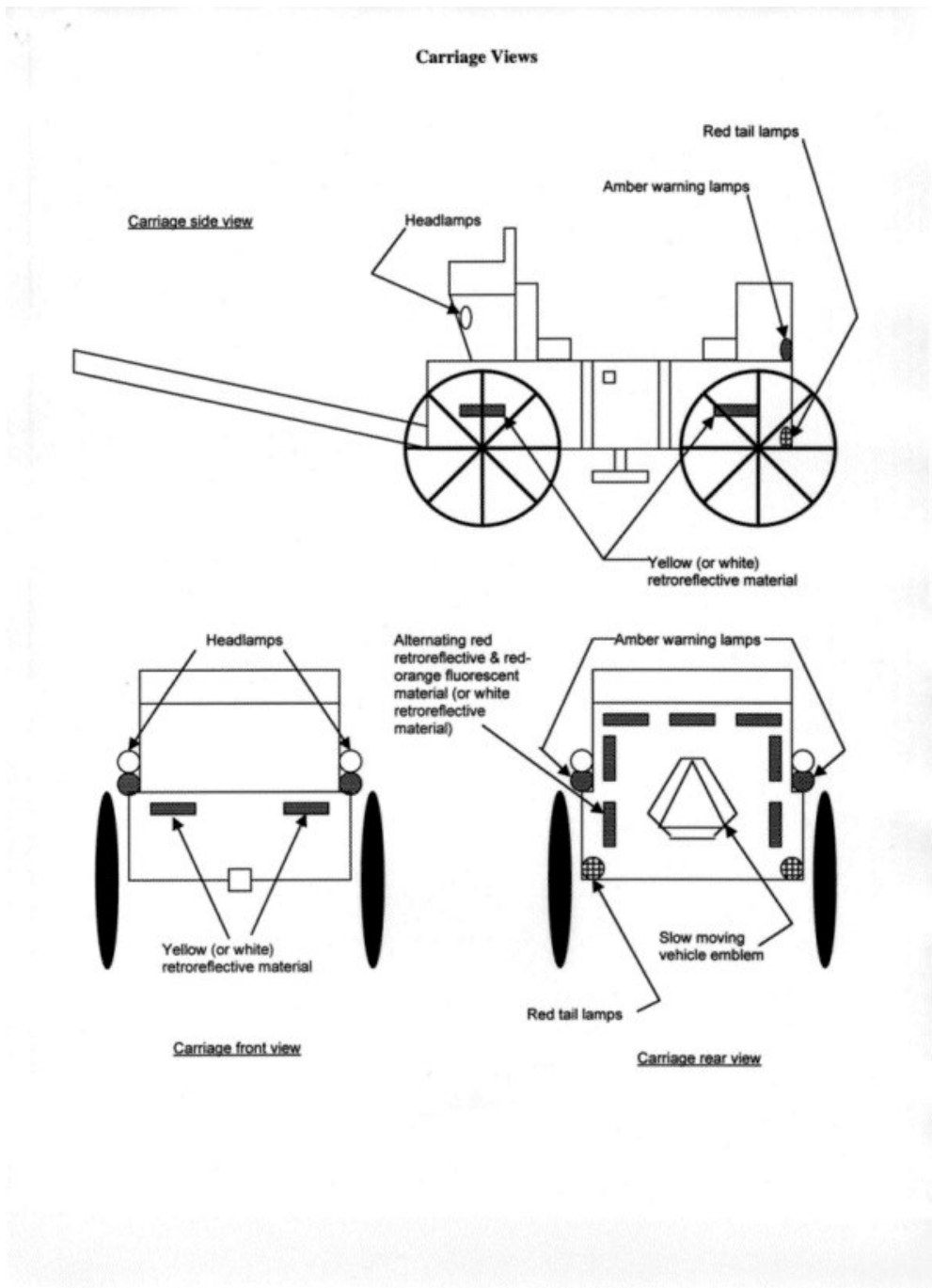

Figure 15. Wagon View
(Agricultural Safety and Health Program, 2008)



Iowa Code Law

The Iowa Code, which functions as the constitution for the State of Iowa, describes the current laws for SMVs. All-terrain vehicles are discussed in a separate section and then grouped together with all other SMVs in other sections. The safety standards for all-terrain vehicles and off-road motorcycles exclusively are discussed first followed by a discussion of the safety standards for all SMVs, including all-terrain vehicles.

All-Terrain Vehicles and Off-Road Motorcycles

The information in this section contains law from the Iowa Code on safety standards for all-terrain vehicles.

321.234A All-terrain vehicle-highway use

1. All-terrain vehicles shall not be operated on a highway unless one or more of the following conditions apply:
 - a. The operation is between sunrise and sunset and is incidental to the vehicle's use for agricultural purposes.
 - b. The operation is incidental to the vehicle's use for the purpose of surveying by a licensed engineer or land surveyor.
 - c. The all-terrain vehicle is operated by an employee or agent of a political subdivision or public utility for the purpose of construction or maintenance on or adjacent to the highway.
 - d. The all-terrain vehicle is operated by an employee or agent of a public agency as defined in section 34.1 for the purpose of providing emergency services or rescue.
 - e. The all-terrain vehicle is operated for the purpose of mowing, installing approved trail signs, or providing maintenance on a snowmobile or all-terrain vehicle trail designated by the department of natural resources.
2. A person operating an all-terrain vehicle on a highway shall have a valid driver's license and the vehicle shall be operated at speeds of thirty-five miles per hour or less.
3. An all-terrain vehicle that is owned by the owner of land adjacent to a highway, other than an interstate road, may be operated by the owner of the all-terrain vehicle, or by a member of the owner's family, on the portion of the highway right-of-way that is between the shoulder of the roadway, or at least five feet from the edge of the roadway, and the owner's property line. A person operating an all-terrain vehicle within the highway right-of-way under this subsection shall comply with the registration, safety, and age requirements under chapter 321I.

4. A person convicted of a violation of this section is guilty of a simple misdemeanor punishable as a scheduled violation under section 805.8A , subsection 3, paragraph "f" (2007 Merged Iowa Code and Supplement – 321.234A, 2007).

321I.4 Registration - fee.

1. The owner of each all-terrain vehicle required to be registered shall register it annually with the department through a county recorder. The department shall develop and maintain an electronic system for the registration of all-terrain vehicles pursuant to this chapter. The department shall establish forms and procedures as necessary for the registration of all-terrain vehicles.

2. The owner of the all-terrain vehicle shall file an application for registration with the department through a county recorder in the manner established by the commission. The application shall be completed by the owner and shall be accompanied by a fee of fifteen dollars and a writing fee as provided in section 321I.29 . An all-terrain vehicle shall not be registered by the county recorder until the county recorder is presented with receipts, bills of sale, or other satisfactory evidence that the sales or use tax has been paid for the purchase of the all-terrain vehicle or that the owner is exempt from paying the tax. An all-terrain vehicle that has an expired registration certificate from another state may be registered in this state upon proper application, payment of all applicable registration and writing fees, and payment of a penalty of five dollars.

3. Upon receipt of the application in approved form accompanied by the required fees, the county recorder shall issue to the applicant a registration certificate and registration decal. The registration decal shall be displayed on the all-terrain vehicle as provided in section 321I.6 . The registration certificate shall be carried either in the all-terrain vehicle or on the person of the operator of the all-terrain vehicle when in use. The operator of an all-terrain vehicle shall exhibit the registration certificate to a peace officer upon request, to a person injured in an accident involving an all-terrain vehicle, to the owner or operator of another all-terrain vehicle or the owner of personal or real property when the all-terrain vehicle is involved in a crash or accident of any nature with another all-terrain vehicle or the property of another person, or to the property owner or tenant when the all-terrain vehicle is being operated on private property without permission from the property owner or tenant (2007 Merged Iowa Code and Supplement – 321I.4, 2007).

321I.10 Operation on roadways and highways - snowmobile trails.

1. A person shall not operate an all-terrain vehicle upon roadways or highways except as provided in section 321.234A and this section.

2. A registered all-terrain vehicle may be operated on the roadways of that portion of county highways designated by the county board of supervisors for such use during a specified period. The county board of supervisors shall evaluate the traffic conditions on all county highways and designate roadways

on which all-terrain vehicles may be operated for the specified period without unduly interfering with or constituting an undue hazard to conventional motor vehicle traffic. Signs warning of the operation of all-terrain vehicles on the roadway shall be placed and maintained on the portions of highway thus designated during the period specified for the operation.

3. Cities may designate streets under the jurisdiction of cities within their respective corporate limits which may be used for the sport of driving all-terrain vehicles.

4. All-terrain vehicles shall not be operated on snowmobile trails except where designated by the controlling authority and the primary snowmobile trail sponsor.

5. The state department of transportation may issue a permit to a state agency, a county, or a city to allow an all-terrain vehicle trail to cross a primary highway. The trail crossing shall be part of an all-terrain vehicle trail designated by the state agency, county, or city. A permit shall be issued only if the crossing can be accomplished in a safe manner and allows for adequate sight distance for both motorists and all-terrain vehicle operators. The state department of transportation may adopt rules to administer this subsection (2007 Merged Iowa Code and Supplement – 321I.10, 2007).

321I.13 Headlamp - tail lamp - brakes.

Every all-terrain vehicle operated during the hours of darkness shall display a lighted headlamp and tail lamp. Every all-terrain vehicle shall be equipped with brakes (2007 Merged Iowa Code and Supplement – 321I.13, 2007).

321I.21 Minors under twelve - supervision.

A person under twelve years of age shall not operate an all-terrain vehicle, including an off-road motorcycle, on a designated riding area or designated riding trail or on ice unless one of the following applies:

1. The person is taking a prescribed safety training course and the operation is under the direct supervision of a certified all-terrain vehicle safety instructor.
2. The operation is under the direct supervision of a responsible parent or guardian of at least eighteen years of age who is experienced in all-terrain vehicle operation or off-road motorcycle operation and who possesses a valid driver's license as defined in section 321.1 (2007 Merged Iowa Code and Supplement – 321I.21, 2007).

321I.14 Unlawful operation.

1. A person shall not drive or operate an all-terrain vehicle:
 - a. At a rate of speed greater than reasonable or proper under all existing circumstances.
 - b. In a careless, reckless, or negligent manner so as to endanger the person or property of another or to cause injury or damage thereto.
 - c. While under the influence of intoxicating liquor or narcotics or habit-forming drugs.

- d.* Without a lighted headlight and taillight from sunset to sunrise and at such other times when conditions provide insufficient lighting to render clearly discernible persons and vehicles at a distance of five hundred feet ahead.
 - e.* In any tree nursery or planting in a manner which damages or destroys growing stock.
 - f.* On any public land, ice, or snow, in violation of official signs of the commission prohibiting such operation in the interest of safety for persons, property, or the environment. Any officer appointed by the commission may post an official sign in an emergency for the protection of persons, property, or the environment.
 - g.* In any park, wildlife area, preserve, refuge, game management area, or any portion of a meandered stream, or any portion of the bed of a nonmeandered stream which has been identified as a navigable stream or river by rule adopted by the department and which is covered by water, except on designated riding areas and designated riding trails. This paragraph does not prohibit the use of ford crossings of public roads or any other ford crossing when used for agricultural purposes; the operation of construction vehicles engaged in lawful construction, repair, or maintenance in a streambed; or the operation of all-terrain vehicles on ice.
 - h.* Upon an operating railroad right-of-way. An all-terrain vehicle may be driven directly across a railroad right-of-way only at an established crossing and, notwithstanding any other provisions of law, may, if necessary, use the improved portion of the established crossing after yielding to all oncoming traffic. This paragraph does not apply to a law enforcement officer or railroad employee in the lawful discharge of the officer's or employee's duties or to an employee of a utility with authority to enter upon the railroad right-of-way in the lawful performance of the employee's duties.
2. A person shall not operate or ride an all-terrain vehicle with a firearm in the person's possession unless it is unloaded and enclosed in a carrying case. However, a nonambulatory person may carry an uncased and unloaded firearm while operating or riding an all-terrain vehicle.
 3. A person shall not operate an all-terrain vehicle with more persons on the vehicle than it was designed to carry.
 4. A person shall not operate an off-road utility vehicle on a designated riding area or designated riding trail unless the riding area or trail is signed by the department as open to off-road utility vehicle operation.
 5. A person shall not operate a vehicle other than an all-terrain vehicle on a designated riding area or designated riding trail unless the riding area or trail is signed by the department as open to such other use (2007 Merged Iowa Code and Supplement – 321I.14, 2007).

321I.9 Exempt vehicles.

Registration shall not be required for the following described all-terrain vehicles:

1. All-terrain vehicles owned and used by the United States, another state, or a political subdivision of another state.
2. All-terrain vehicles used in accordance with section 321.234A , subsection 1, paragraph "a" .
3. All-terrain vehicles used exclusively as farm implements (2007 Merged Iowa Code and Supplement – 321I.9, 2007).

SMV Safety Standards & Lighting

The following section includes Iowa code that pertains to all vehicles that cannot keep a speed of greater than 35 mph.

321.381A Operation of low-speed vehicles.

A low-speed vehicle shall not be operated on a street with a posted speed limit greater than thirty-five miles per hour. This section shall not prohibit a low-speed vehicle from crossing a street with a posted speed limit greater than thirty-five miles per hour (2007 Merged Iowa Code and Supplement – 321.381A, 2007).

321.383 Exceptions - slow vehicles identified.

1. This chapter with respect to equipment on vehicles does not apply to implements of husbandry, road machinery, or bulk spreaders and other fertilizer and chemical equipment defined as special mobile equipment, except as made applicable in this section. However, the movement of implements of husbandry on a roadway is subject to safety rules adopted by the department. The safety rules shall prohibit the movement of any power unit towing more than one implement of husbandry from the manufacturer to the retail seller, from the retail seller to the farm purchaser, or from the manufacturer to the farm purchaser.

2. When operated on a highway in this state at a speed of thirty-five miles per hour or less, every farm tractor, or tractor with towed equipment, self-propelled implement of husbandry, road construction or maintenance vehicle, road grader, horse-drawn vehicle, or any other vehicle principally designed for use off the highway and any such tractor, implement, vehicle, or grader when manufactured for sale or sold at retail after December 31, 1971, shall be identified with a reflective device in accordance with the standards of the American society of agricultural engineers; however, this provision shall not apply to such vehicles when traveling in an escorted parade. If a person operating a vehicle drawn by a horse or mule objects to using a reflective device that complies with the standards of the American society of agricultural engineers for religious reasons, the vehicle may be identified by an alternative reflective device that is in compliance with rules adopted by the

department. The reflective device or alternative reflective device shall be visible from the rear. A vehicle other than those specified in this section shall not display a reflective device or an alternative reflective device. On vehicles operating at speeds above thirty-five miles per hour, the reflective device or alternative reflective device shall be removed or hidden from view.

3. Garbage collection vehicles, when operated on the streets or highways of this state at speeds of thirty-five miles per hour or less, may display a reflective device that complies with the standards of the American society of agricultural engineers. At speeds in excess of thirty-five miles per hour the device shall not be visible (2007 Merged Iowa Code and Supplement – 321.383, 2007).

321.384 When lighted lamps required.

1. Every motor vehicle upon a highway within the state, at any time from sunset to sunrise, and at such other times when conditions such as fog, snow, sleet, or rain provide insufficient lighting to render clearly discernible persons and vehicles on the highway at a distance of five hundred feet ahead, shall display lighted head lamps as provided in section 321.415 , subject to exceptions with respect to parked vehicles as hereinafter stated.

2. Whenever requirement is hereinafter declared as to the distance from which certain lamps and devices shall render objects visible or within which such lamps or devices shall be visible, said provisions shall apply during the times stated in subsection 1 of this section upon a straight level unlighted highway under normal atmospheric conditions unless a different time or condition is expressly stated (2007 Merged Iowa Code and Supplement – 321.384, 2007).

321.398 Lamps on other vehicles and equipment.

All vehicles, including animal-drawn vehicles and including those referred to in section 321.383 not hereinbefore specifically required to be equipped with lamps, shall at the times specified in section 321.384 be equipped with at least one lighted lamp or lantern exhibiting a white light visible from a distance of five hundred feet to the front of such vehicle and, except for animal-drawn vehicles, with a lamp or lantern exhibiting a red light visible from a distance of five hundred feet to the rear. Animal-drawn vehicles shall be equipped with a flashing amber light visible from a distance of five hundred feet to the rear of the vehicle during the time specified in section 321.384 (2007 Merged Iowa Code and Supplement – 321.398, 2007).

Licensing Requirements

Drivers of farm vehicles, construction/maintenance vehicles, and all-terrain vehicles must have an Iowa Driver’s License to operate on the highway. In order to drive a moped, drivers are able to obtain a moped license at 14 years of age or older. Teen drivers need to have

parental consent, and pass a vision and a knowledge exam. Teens under 16 years of age must also undergo an approved moped education course. Once the drivers become 18 years old and have a valid driver's license, they are not required to complete any additional licensing requirements. Electric- or gas-powered scooters are not allowed on the public highway system. Scooters that are two-wheeled motor vehicles with step-through frames are considered a type of motorcycle and are allowed to be driven following the same requirements for operating a motorcycle. There are no licensing requirements for operators of a horse-drawn buggy that were found (DMV.org, 2008).

This section analyzed statistics involving SMVs and then proceeded to discuss the current practices involving SMV laws throughout the United States. There is much variability in the definition of a SMV as well as the requirements for safety features on SMVs. This suggests a need for further research to determine the most effective strategies and a national standard for safety requirements. The literature review discussed the differences in current laws. The next section will provide an analysis of three years of crash data involving SMVs in Iowa. This will help gain insight into the shared characteristics of these crashes and will provide specific areas or problems on which to focus and find solutions.

CHAPTER 3: Characteristics of Slow-Moving Vehicle Crashes in Iowa

This section discusses some of the characteristics of slow moving vehicles in Iowa. Descriptive statistics were used to understand the common characteristics of SMV crashes. Crash data from 2004 to 2006 in Iowa were used to evaluate crashes by vehicle type.

Methodology

SMV crash data in Iowa from 2004-2006 were gathered and analyzed for rural and urban crashes. Rural is defined as being 1 or more miles outside corporate city boundaries. Any crashes with an unknown crash location were sorted out and not included in either the urban or rural crash analysis. A map of rural and urban crashes involving SMVs can be found in Appendix A. The Iowa crash database has a vehicle configuration category for construction/maintenance vehicles, farm vehicles, and moped/all-terrain vehicles. These crashes were extracted from the database and put into excel and ArcGIS databases. Horse-drawn buggies are not identified specifically in the Iowa crash database. They are indicated as “unknown,” “not reported,” or “other.” The narratives for rural crashes involving horse-drawn buggies as well as other types of SMVs where the type of vehicle was indicated as “unknown,” “not reported,” or “other,” were extracted to determine what types of vehicles were involved. Some farm vehicles, construction/maintenance vehicles, and moped/all-terrain vehicle crashes were found in these three categories as they were not originally recorded in the proper vehicle configuration category and were marked as unknown, not reported, or other. Other vehicles that may be considered SMVs such as bicycles, electric wheelchairs, snowmobiles, scooters, lawn mowers, golf carts, floats, go-carts, dirt rockets, and gators were also found only in these three categories through the crash narrative analysis.

Vehicle types for these nonspecific vehicle configuration category crashes were determined for each crash record based on the make and model of the vehicle and also the narrative. In many instances, the make and model were both recorded, but the vehicle configuration was marked as “unknown,” “not reported,” or “other.” Analyzing the narrative allowed

confirmation of the vehicle type. For instance, many crashes involving a horse-drawn buggy will have horse-drawn buggy recorded for the model of vehicle. Horse-drawn buggy crashes that did not have the model recorded were referred to in the narrative section of the crash report.

Crash records for farm vehicles that were not marked as such in the vehicle configuration category were determined to be so by analyzing the make and model of the vehicle and determining the type of vehicle from that information as well as the narrative. The vehicles found in the crash narratives that were determined to be farm vehicles referred to the vehicle as either a “tractor” or “combine” in the description.

Crash records for construction and maintenance vehicles that were not recorded as such in the specific construction and maintenance vehicle configuration category were mostly found in the narrative descriptions. The types of vehicles specifically stated as such in the narrative that were determined to be construction or maintenance vehicle crashes included: fork lifts, road graders, snow plows, street sweepers, construction vehicles, and end loader.

The mopeds and all-terrain vehicles were always referred to specifically in the crash narrative. The following crash descriptions were found in the crash narratives and those crashes were gathered out and included with the moped/all-terrain vehicle configuration category: electric scooter, motorized scooter, and ATV.

Bicycles were always referred to in the crash narrative as either a “bike” or “bicycle.” The bicycle was sometimes included as the model of vehicle. The other types of vehicles such as electric wheelchairs, snowmobiles, scooters, lawn mowers, golf carts, floats, go-carts, dirt rockets, and gators were stated specifically in the crash narrative and were then determined to be another type of SMV by definition of being unable to keep speeds of over 25 mph.

All crashes gathered from the crash narratives were recorded by the specific vehicle type. Since the farm vehicles, construction/maintenance vehicles, and moped/all-terrain vehicles

each had a separate vehicle configuration category, the crashes that were recorded as such under the vehicle configuration category could be queried out of the database and added to the additional crashes found from the crash narrative analysis in the Iowa Crash Database. The other vehicle types did not have a separate vehicle configuration category and were found only through the crash narrative analysis in the Iowa Crash Database. Table 2 shows the number of each vehicle type found for each year using the crash narratives which were recorded as “other,” “not recorded,” or “unknown” vehicle configuration. Table 3 shows the number of crashes for farm vehicles, construction/maintenance vehicles, and moped/all-terrain vehicles that were recorded as such in the vehicle configuration category of the crash report. Table 4 shows the total number of SMV crashes (rural and urban) including the data gathered from the crash narratives and the data from the crash reports.

Table 2. Crashes Involving SMVs from Crash Narratives

<i>Year</i>	<i>Horse- Drawn Buggy</i>	<i>Farm Vehicle</i>	<i>Construction/ Maintenance</i>	<i>Moped/ATV</i>	<i>Bicycle</i>	<i>Other</i>	Total
2004	7	2	4	2	31	10	56
2005	6	3	11	3	35	16	74
2006	5	3	0	4	44	13	69
Total	18	8	15	9	110	39	199

Table 3. Crashes Involving SMVs from Vehicle Configuration

<i>Year</i>	<i>Horse- Drawn Buggy</i>	<i>Farm Vehicle</i>	<i>Construction/ Maintenance</i>	<i>Moped/ATV</i>	<i>Bicycle</i>	<i>Other</i>	Total
2004	0	201	96	116	0	0	413
2005	0	189	70	129	0	0	388
2006	0	196	49	107	0	0	352
Total	0	586	215	352	0	0	1253

Table 4. Total Crashes Involving SMVs

<i>Year</i>	<i>Horse- Drawn Buggy</i>	<i>Farm Vehicle</i>	<i>Construction/ Maintenance</i>	<i>Moped/ATV</i>	<i>Bicycle</i>	<i>Other</i>	Total
2004	7	203	100	118	31	10	469
2005	6	192	81	132	35	16	462
2006	5	199	49	111	44	13	421
Total	18	594	230	361	110	39	1352

Crashes were also spatially located in ArcView GIS 3.3 to evaluate location within the state of Iowa. A map of all crashes involving SMVs can be found in Appendix A for each of the three years as well as a combined map for all three years.

The United States Naval Observatory was used to determine the appropriate dawn and dusk times for each crash. The hours before sunrise and after sunset were used to determine nighttime crashes for the SMVs. The sunset and sunrise times were used to separate nighttime and daytime crashes. The U.S. Naval Observatory gives times for sunrise and sunset for each city in the U.S. for each day of each year. An Iowa east-west midpoint at State Center, IA, was used to determine a common location for each crash. Similarly, the 15th of each month was used to determine the sunrise and sunsets to compare with the times of all crashes within the month.

SMV Crash Analysis

The focus of this research was on rural crashes, so only the types of vehicles which would be expected to be encountered in a rural setting were included in the analysis. This includes farm vehicles, horse-drawn buggies, construction/maintenance vehicles, and mopeds/all-terrain vehicles. The majority of bicycle crashes in Iowa occur in urban areas (100 urban versus 8 rural statewide over the 3-year analysis period), and were therefore not included in the analysis. Certain construction and maintenance vehicles are able to maintain a speed of over 25 mph, however there is only a single category for construction/maintenance vehicles in the Iowa crash database, so they were analyzed together. Mopeds and all-terrain vehicles are also combined in a single vehicle configuration category in the Iowa crash database and were also analyzed as a single group.

After the data were placed into the ArcGIS database, an analysis was completed on the crash characteristics. Each year was analyzed separately according to total, rural, and urban crashes as well as the totals over the three year period from 2004 to 2006. A descriptive statistical analysis was made looking at different crash characteristics including: location,

crash severity, time of day, time of year, surface conditions, speed limit, major cause, crash/collision manner, driver age, responsibility of crash/collision, multiple vehicle crashes, and responsibility of multiple vehicle crashes. The table showing all crashes in Iowa over the three year period as well as the tables for total and rural crashes over the three year period sorted by the different crash characteristics can be found in Appendix B. This section will first briefly discuss the total crash trends and then show rural crash trends as well as an analysis of the different rural crash characteristics.

SMV crashes in the state of Iowa have experienced a downward trend over the three year period from 2004-2006. Table 5 shows the total number of crashes involving one or more SMV(s). This table includes both rural and urban crashes for only the vehicle types that were included in the SMV analysis. Farm vehicle crashes are the most prominent with around 200 crashes per year, followed by moped/all-terrain vehicles with an average of 120 per year, then construction/maintenance vehicle crashes with just under 60 crashes per year, and finally horse-drawn buggy crashes with an average of 6 per year.

Table 5. Total Crashes

<i>Year</i>	<i>Horse-Drawn Buggy</i>	<i>Farm</i>	<i>Construction/Maintenance</i>	<i>Moped/ATV</i>	Total
2004	7	203	100	118	428
2005	6	192	81	132	411
2006	5	199	49	111	364
Total	18	594	230	361	1203

The total SMV crashes has decreased each year, however, the individual types of crashes have not experienced this same trend. Though not significant due to the low number of crashes, horse-drawn buggy crashes have decreased by one crash per year. Farm crashes decreased from 203 crashes in 2004 to 192 crashes in 2005 and then increased again in 2006 up to 199 crashes. Construction/maintenance vehicle crashes have decreased dramatically over the three year period from 100 crashes in 2004, down to 81 crashes in 2005, and then to 49 crashes in 2006. Moped/all-terrain vehicle crashes increased from 118 crashes in 2004 to 132 crashes in 2005 and then decreased down to 111 crashes in 2006.

Rural Crash Analysis

Table 6 shows the number of crashes involving one or more SMV(s) in a rural area according to crash type. Rural crashes followed a similar ranking order as total crashes with farm vehicle crashes being most frequent, followed by moped/all-terrain vehicles, construction/maintenance vehicles, and then horse-drawn buggy crashes.

Table 6. Rural SMV Crashes

<i>Year</i>	<i>Horse-Drawn Buggy</i>	<i>Farm</i>	<i>Construction/Maintenance</i>	<i>Moped/ATV</i>	Total
2004	5	135	22	41	203
2005	3	111	26	43	183
2006	2	136	14	36	188
Total	10	382	62	120	574

The total crashes decreased from 203 crashes in 2004 to 183 crashes in 2005 and then increased up to 188 crashes in 2008. This trend is dissimilar to the trend with rural and urban SMV crashes combined. The only downward trend for any type of crash is the horse-drawn buggy. These crashes decreased from 5 crashes in 2004 to 3 crashes in 2005 and then to 2 crashes in 2006. Farm vehicles, construction/maintenance, and moped/all-terrain vehicles all experienced a staggered trend over the three year period.

Crash Severity

Crash severity numbers were recorded for each type of crash in each of the three years. Rural fatalities are shown in Table 7. The total fatalities have staggered over the three year period with no significant increases or decreases. The percentages of all rural crashes resulting in a fatality in each respective year were calculated and are shown in Table 8. From the analysis, 5.4% of all rural crashes involving at least one SMV resulted in at least one fatality. Farm vehicle fatalities have the highest total number of crashes followed by moped/ATV. No measure of exposure was available by vehicle type so crash rate could not

be determined. Fatal crashes make up 9.2% of moped/ATV crashes compared with 4.7% for farm vehicles.

Table 7. Rural Fatalities

<i>Year</i>	<i>Horse-Drawn Buggy</i>	<i>Farm</i>	<i>Construction/Maintenance</i>	<i>Moped/ATV</i>	Total
2004	0	7	1	4	12
2005	0	4	0	4	8
2006	0	7	1	3	11
Total	0	18	2	11	31

Table 8. Percentage of Rural Crashes as Fatalities

<i>Year</i>	<i>Horse-Drawn Buggy</i>	<i>Farm</i>	<i>Construction/Maintenance</i>	<i>Moped/ATV</i>	Total
2004	0%	5.19%	4.55%	9.76%	5.91%
2005	0%	3.60%	0%	9.30%	4.37%
2006	0%	5.15%	7.14%	8.33%	5.85%
Total	0%	4.71%	3.23%	9.17%	5.40%

A thematic map was prepared with the SMV crashes throughout the state of Iowa. This map can be found in Figure 17. In this map, the background shows a graduated color system depicting the number of injury crashes in each county. The farm vehicle and horse-drawn buggy fatal crashes were overlain on the map to show severe crash locations. Iowa did not have any horse-drawn buggy fatal crashes during the three year period, so none will be found on the map.

A thematic map with a graduated background depicting rural crashes from 2004-2006 involving SMVs is shown in Figure 18. On this map are the locations of all crashes resulting in an injury or fatality shown with blue and red circles, respectively. Kossuth County had a high number of rural crashes, two of them were fatal and three resulted in an injury. Johnson, Sioux and Clayton counties were all in the highest category for rural SMV crashes, one of which resulted in a fatality for each county. Sac County and Story County were in the second highest category in terms of total rural crashes while still experiencing two fatalities in each county. Perhaps an alarming statistic comes from Carroll County and Dallas County which were in the second lowest category in terms of total rural crashes with 3 and 4 crashes, respectively. Of those crashes, two resulted in a fatality for each county. Delaware County

was in the second highest category of total rural SMV crashes, but a large percentage resulted in injuries as well as one fatality.

In order to better understand the characteristics of the individual vehicle types with respect to location, separate maps were made for horse-drawn buggies, farm vehicles, construction/maintenance vehicles, and moped/all-terrain vehicles. These vehicles are the predominant vehicle types involved in SMV crashes in a rural setting. Figures 19-22 are thematic maps of rural crash severity in Iowa specified by vehicle type.

Fatal and Injury Crashes Involving SMVs in the Past Three Years

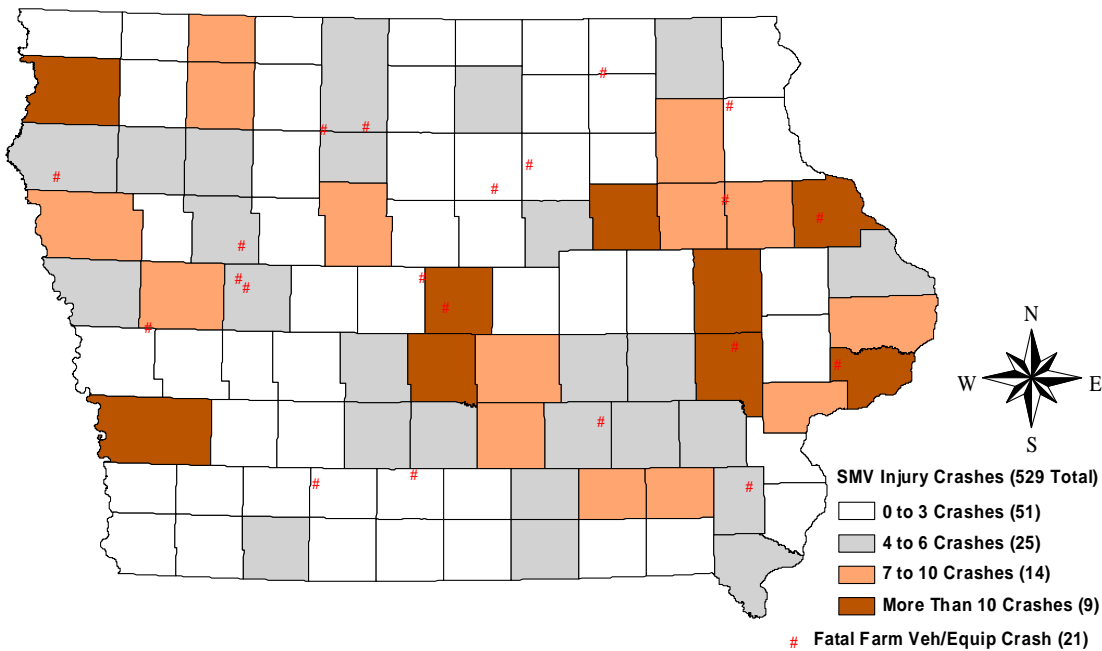
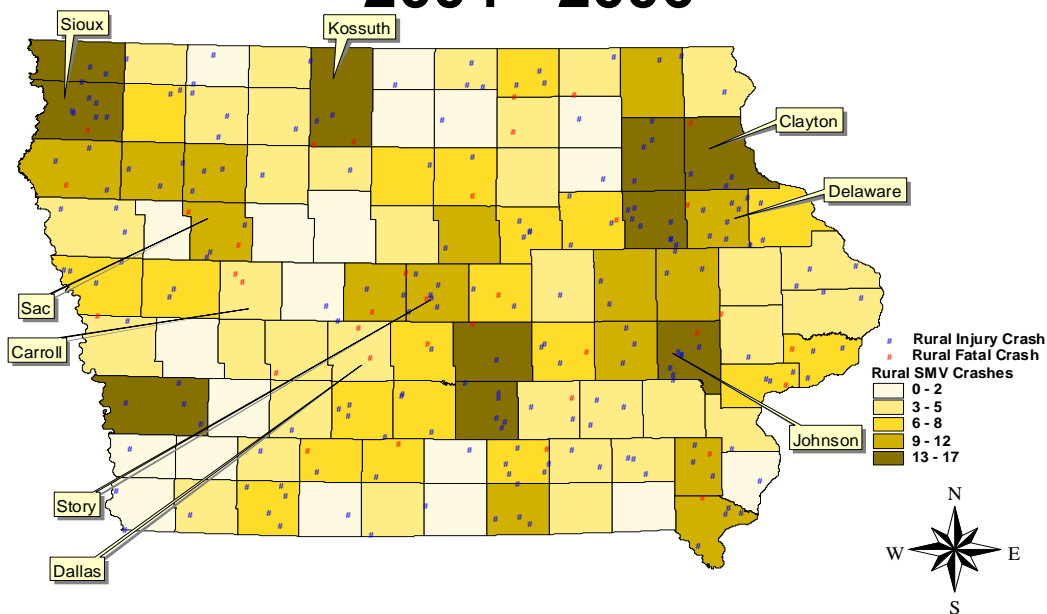

Figure 17. Iowa SMV

Rural SMV Crashes - Crash Severity 2004 - 2006



Crashes

Figure 18. Rural Injury and Fatality Crashes with Rural Crash Thematic

Rural Horse & Buggy Crashes 2004 - 2006

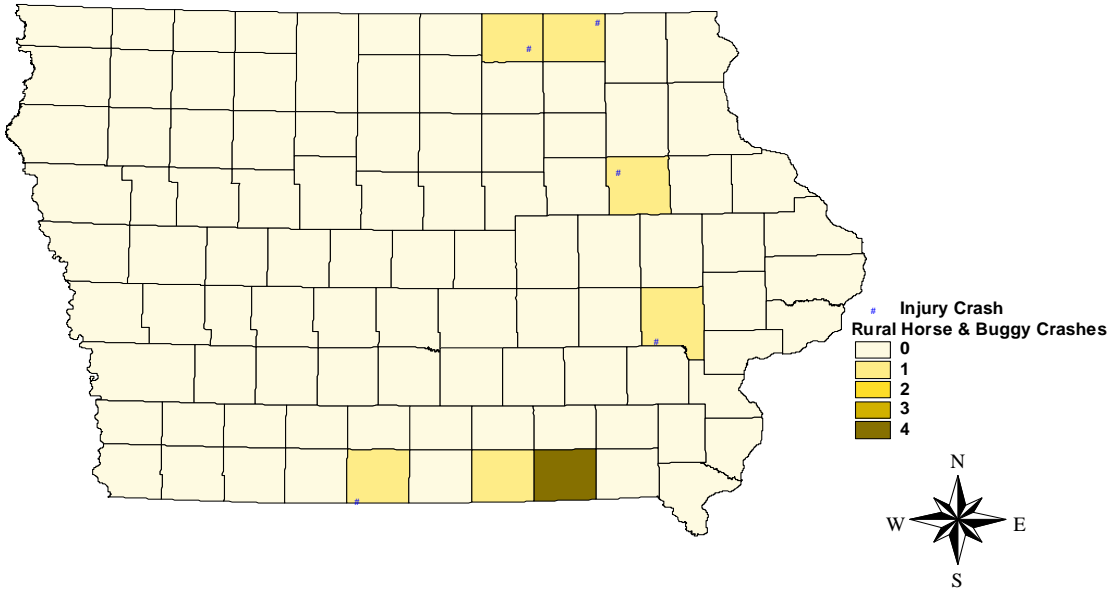

Figure 19. Rural Horse & Buggy Injury & Fatality Crashes with Rural Horse & Buggy Crash Thematic

Rural Farm Vehicle Crashes 2004 - 2006

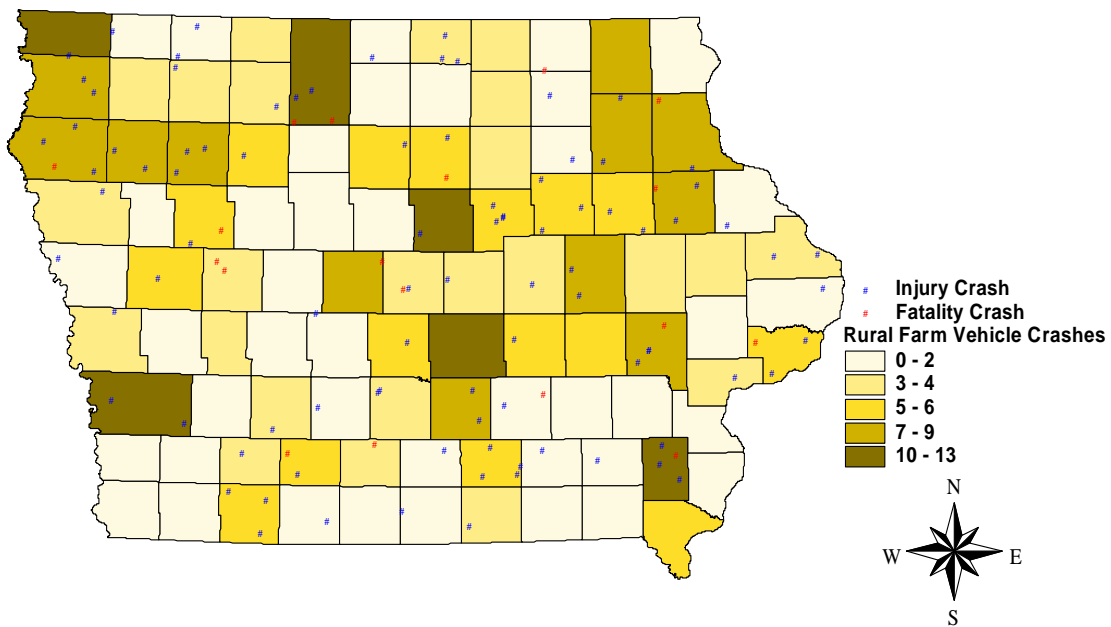

Figure 20. Rural Farm Vehicle Injury & Fatality Crashes with Rural Farm Vehicle Crash Thematic

Rural Construction/Maintenance Crashes 2004 - 2006

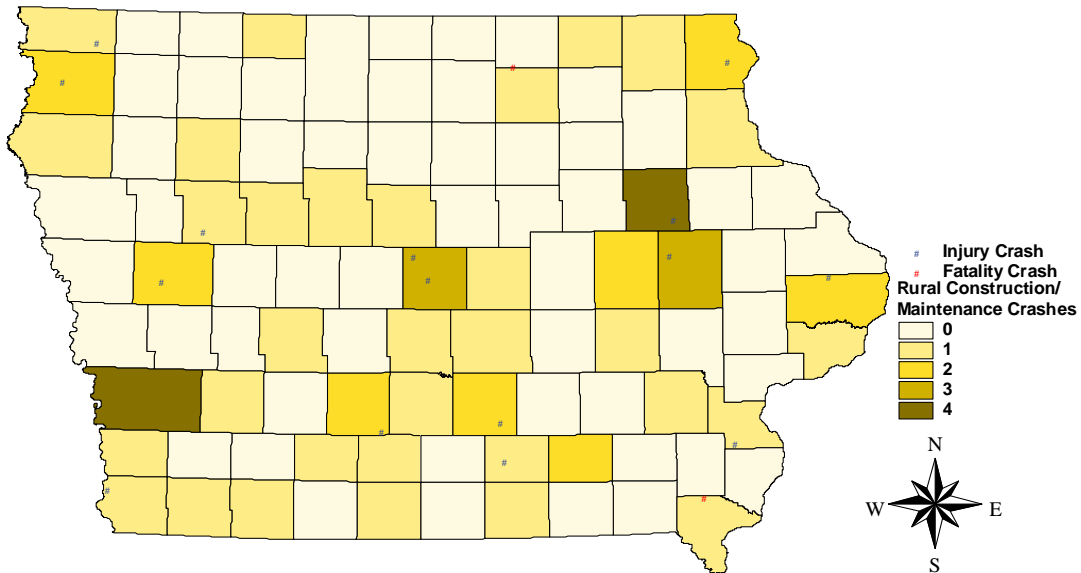

Figure 21. Rural Construction/Maintenance Vehicle Injury & Fatality Crashes with Thematic

Rural Moped/ATV Crashes 2004 - 2006

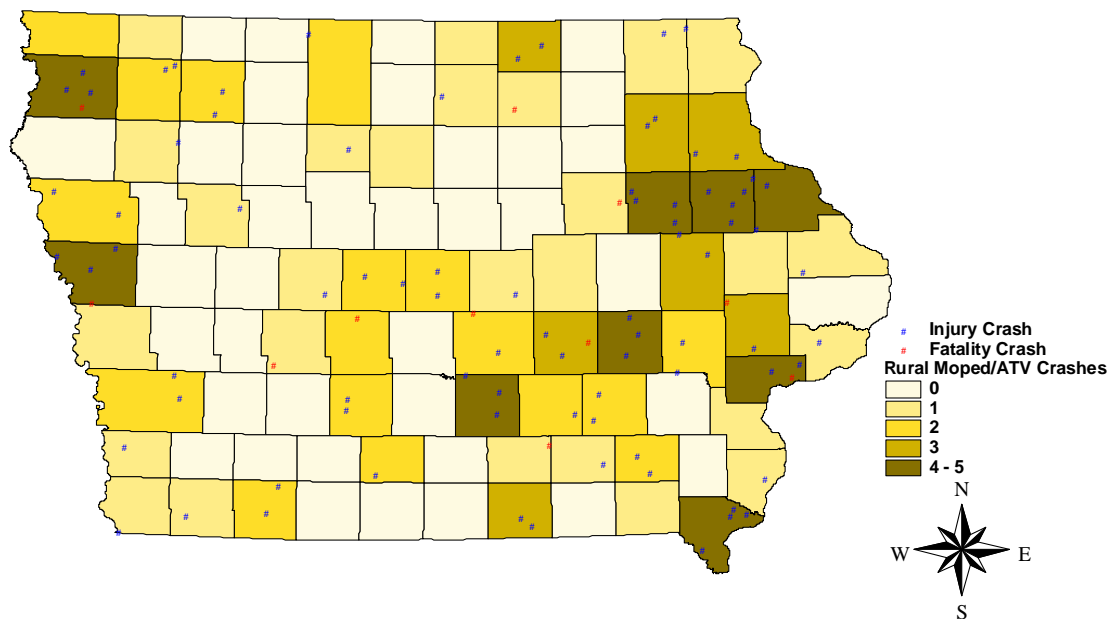

Figure 22. Rural Moped/ATV Injury & Fatality Crashes with Rural Moped/ATV Crash Thematic

Night vs. Day

Night-to-day crash ratios were calculated for each type of vehicle as a function of all rural crashes. Night crashes were defined as any crash occurring before sunrise or after sunset. The United States Naval Observatory was used for the sunrise and sunset times as described in the Methodology section. Figure 23 shows the rural night-to-day crash ratios for each vehicle type over the three-year period from 2004 to 2006. The total night-to-day crash ratio for all vehicle types is 0.277. Horse-drawn buggy vehicles have the highest ratio of night crashes relative to the day crashes at 0.667. Moped/ATVs represent the second highest ratio, followed by farm vehicles, and then construction/maintenance vehicles. The chart demonstrates the majority of rural crashes involving all SMVs occur during daytime hours as none of the night-to-day ratios is greater than one. However, considering the high amount of traffic volume during daytime hours, ratios of less than one are still indicative of nighttime and darkness issues.

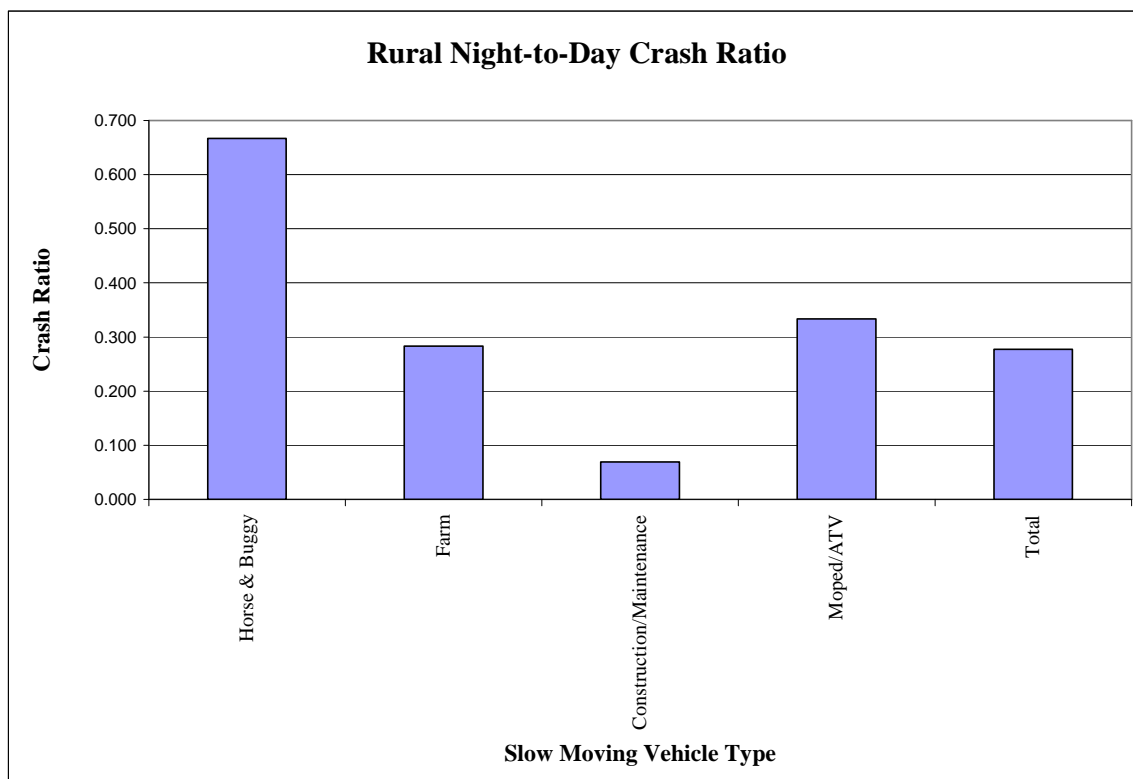

Figure 23. Rural Night-to-Day Crash Ratio

More specifically, the crashes were analyzed according to peak hours. The AM peak time was defined as crashes occurring between the hours of 7:00 and 9:00 a.m., midday off-peak was the period from 11:00 a.m. to 1:00 p.m., while PM Peak period was defined as 4:00 p.m. and 6:00 p.m. Figure 24 shows the number of rural crashes for each vehicle type over the three year period during each peak and off-peak period. More crashes for all vehicle types occurred during the PM peak period and midday off-peak than in the AM peak period. Midday off-peak was the prominent peak period for farm vehicle crashes. More crashes involving moped/all-terrain vehicles occurred during the PM peak period than in the AM peak period or midday off-peak. Alternatively, more of the crashes involving construction/maintenance vehicles occurred during the AM peak period than the PM peak period.

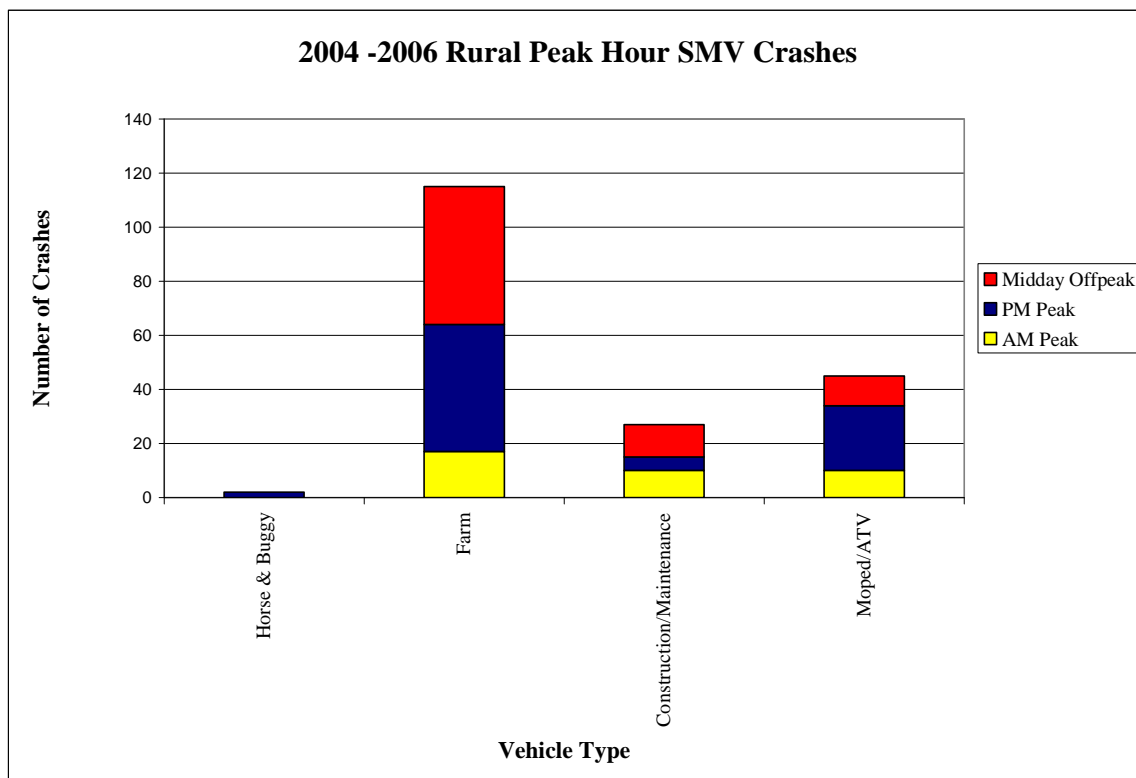

Figure 24. Rural Peak Hour Crashes

Time of Year

Rural crashes involving at least one SMV were analyzed by month. Figure 25 shows a chart describing this data for each type of vehicle over the three-year analysis period. The majority of rural farm vehicle crashes occurred during the month of October, which is during harvest season. November and September follow with the next highest crash volumes, respectively. July and June are the most prominent months for rural moped/all-terrain vehicle crashes followed by May and October. Construction/maintenance vehicle crashes occur more frequently in September and August than during any other month. January and August appear to be the most common months for horse-drawn buggy crashes, though there are not many observances for each month to support that conclusion.

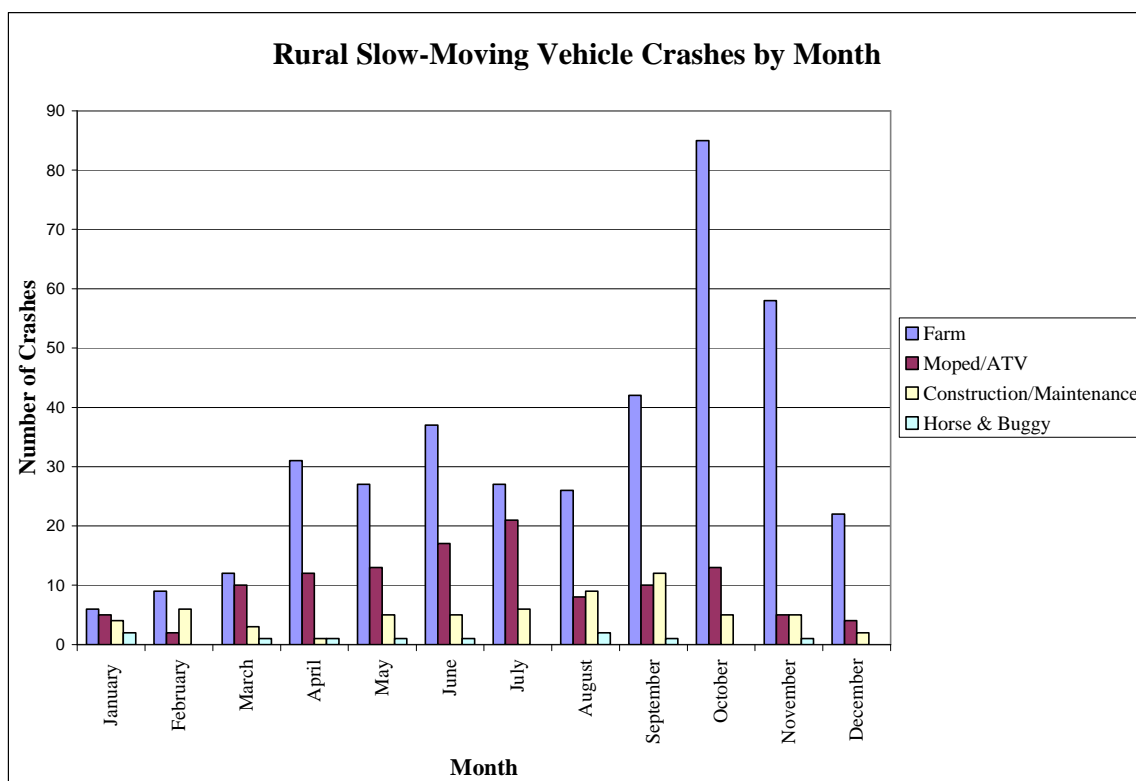

Figure 25. Rural Crashes by Month

Speed Limit

The speed limits of the roads on which the crashes involving one or more SMVs took place were then analyzed. Figure 26 shows the speed limit for each crash involving at least one SMV according to vehicle type. The speed limit is defined for the road on which the SMV was traveling. The most common speed limit for all vehicle types was the 55 and 60 mph range. The second most common speed limit range is 45 or 50 mph, followed by the unknown category, 65 mph and over segment, 35 and 40 mph, 25 and 30 mph, and below 25 mph segments, respectively.

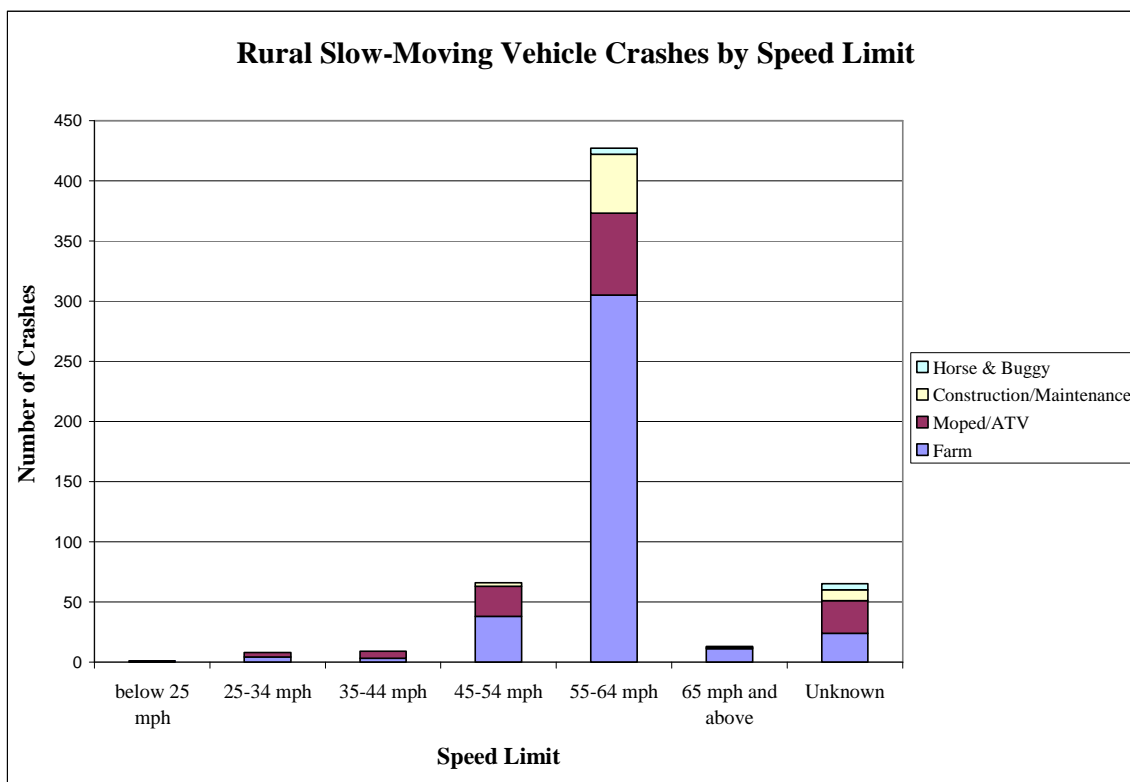

Figure 26. Rural Crashes by Speed Limit

Manner of Crash/Collision

Figures 27-30 show the manner of collision for all crashes involving each type of SMV over the three year period of 2004-2006. The most common manner of collision for rural crashes involving a horse-drawn buggy was the rear-end collision at 40%. Broadside was next with

30% followed by sideswipe, same direction, head-on collisions, and angle, oncoming left turn all at 10%. The most common manner of collision for rural crashes involving a farm vehicle was the rear-end crash at 27%. Sideswipe, same direction was the next most common collision at 23%, followed by non-collision at 19%, broadside at 12%, swideswipe, opposite direction at 9%, angle, oncoming left turn at 5%, head-on at 3%, and unknown and not reported both at 1%. The most common manner of collision for construction/maintenance vehicles was the rear-end collision at 34% followed by sideswipe, same direction at 19%, non-collision and broadside at 13%, head-on at 10%, sideswipe, opposite direction at 6%, unknown at 3%, and not reported at 2%. The most common manner of collision for crashes involving moped/all-terrain vehicles was non-collision at 52%. Broadside was next at 14% followed by rear-end at 13%, head-on and sideswipe, same direction at 7%, angle, oncoming left turn and sideswipe, opposite direction at 3%, and 1% not reported.

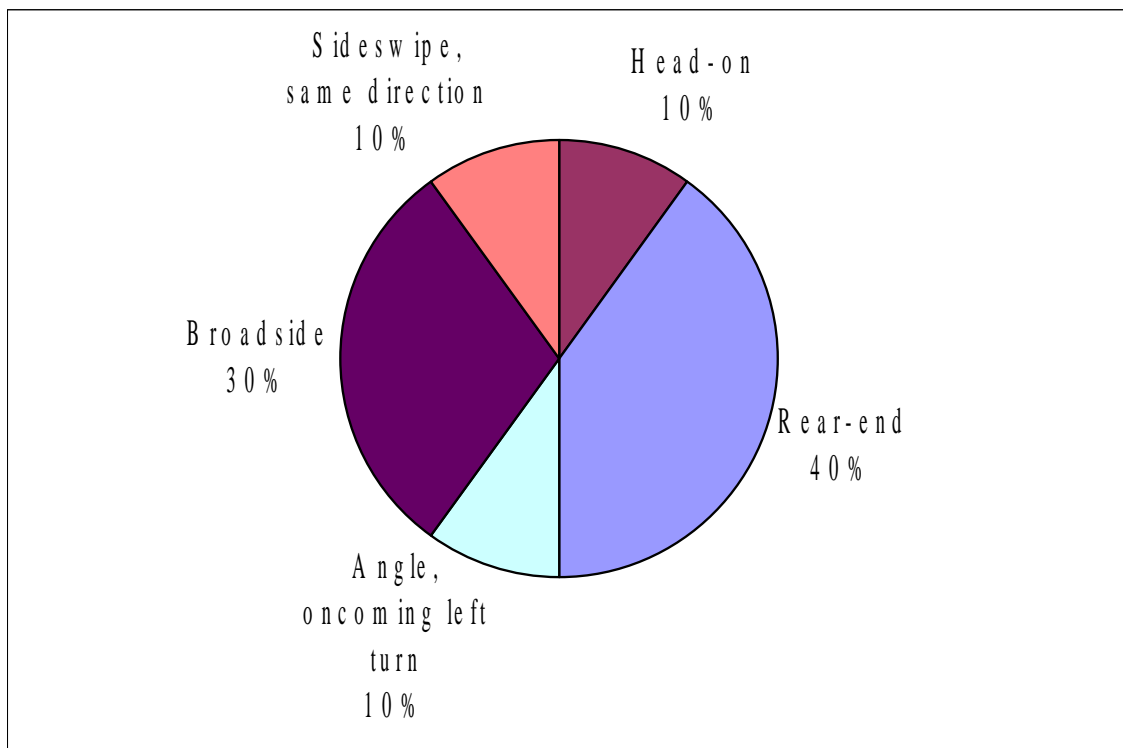

Figure 27. Rural Horse-Drawn Buggy Crashes by Manner of Collision

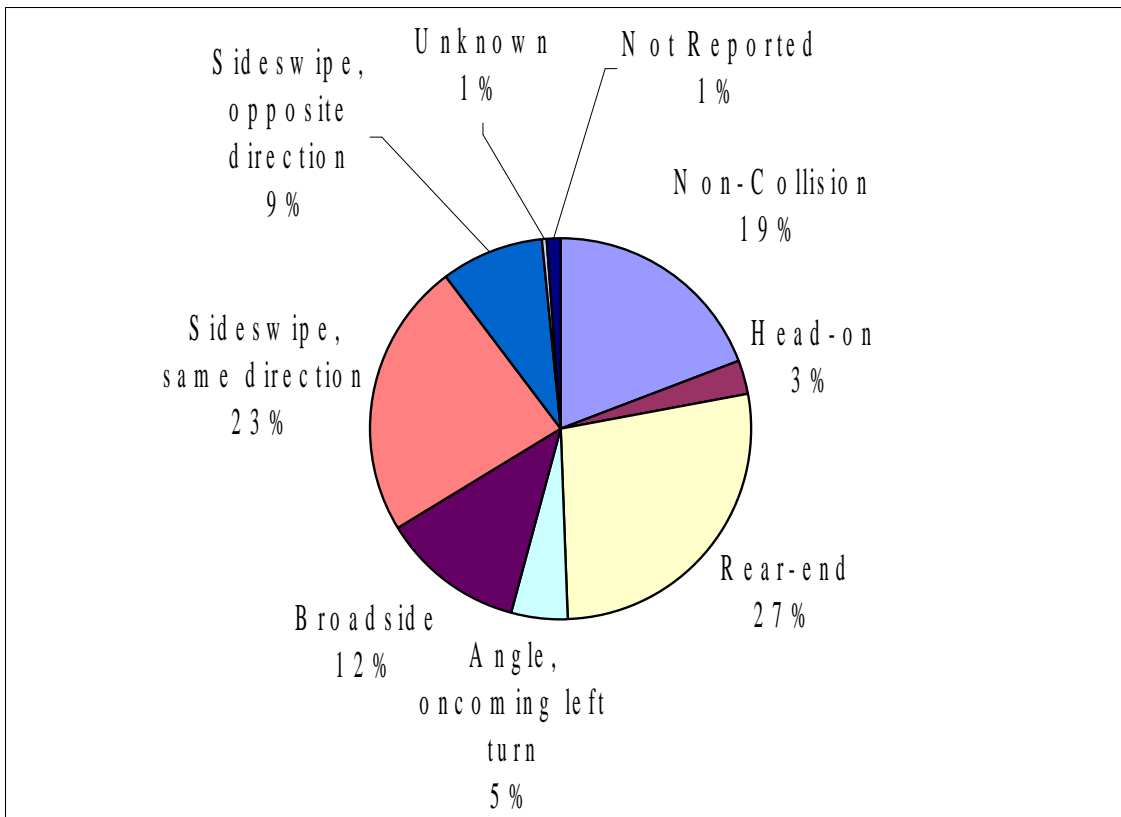

Figure 28. Rural Farm Vehicle Crashes by Manner of Collision

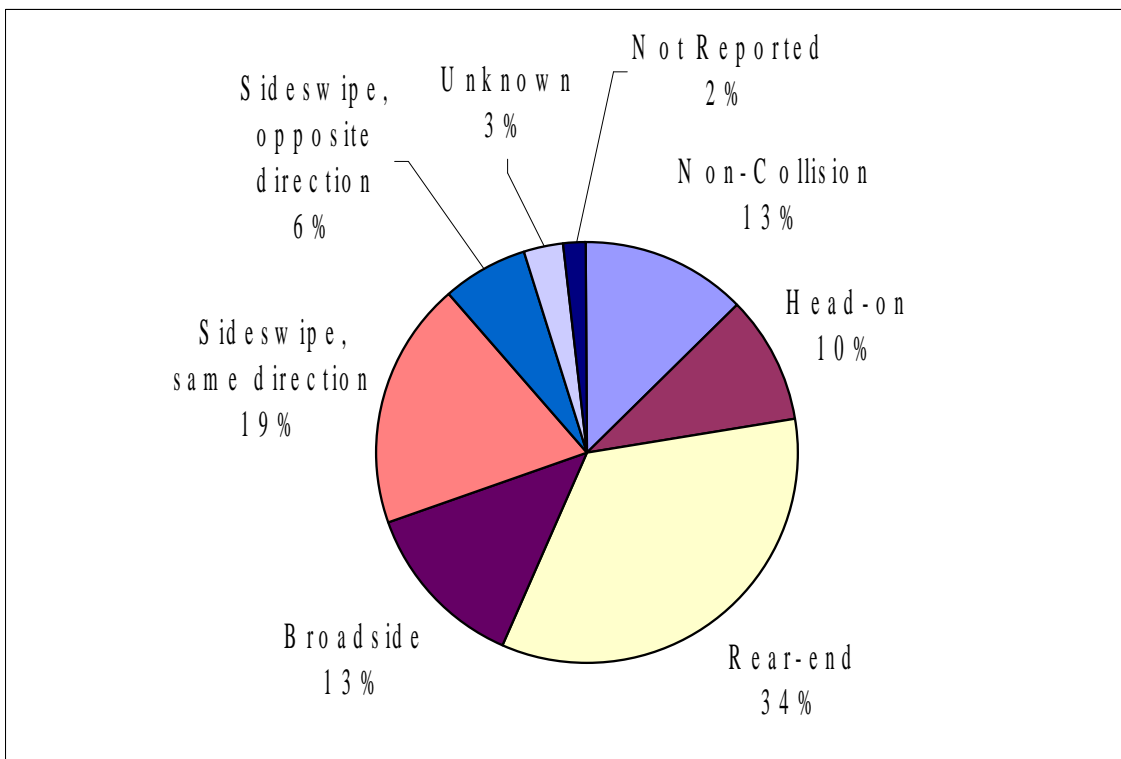

Figure 29. Rural Construction/Maintenance Vehicle Crashes by Manner of Collision

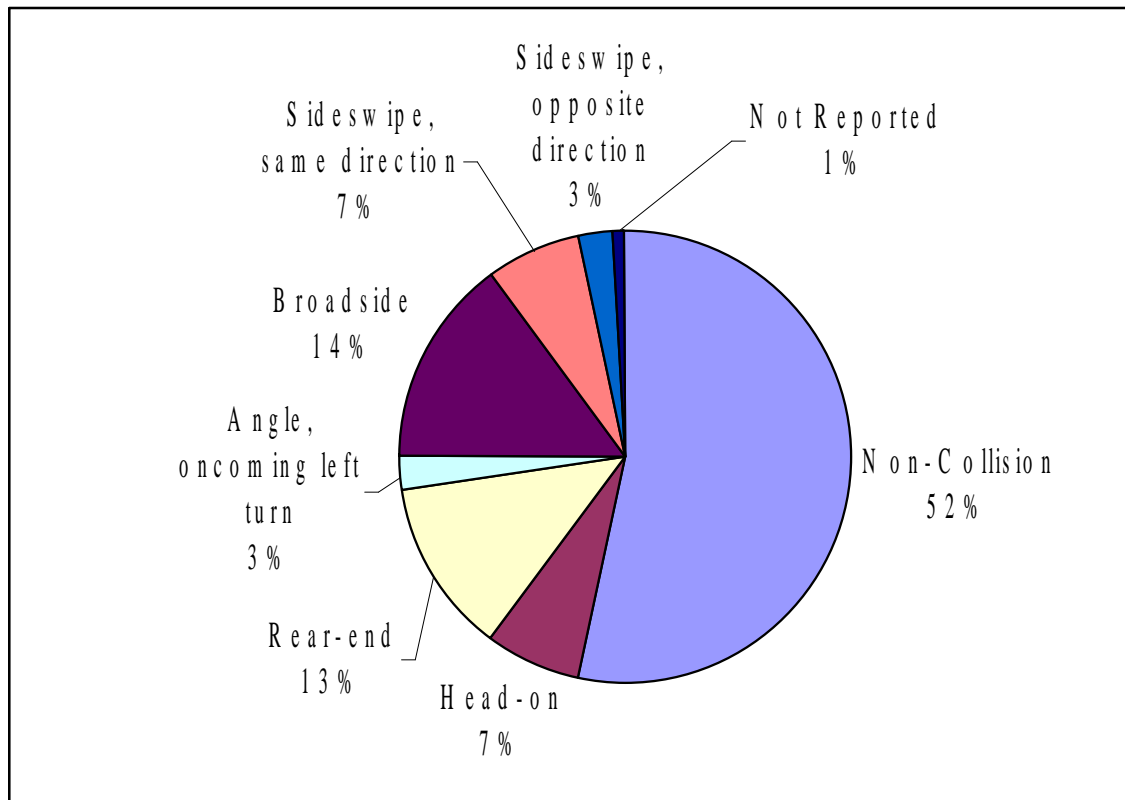

Figure 30. Rural Moped/ATV Crashes by Manner of Collision

Vehicle Action

The actions of the vehicles were analyzed to determine commonality of movements for the specific vehicle types of SMVs. Figures 31-34 display charts describing vehicle action during the crashes for each type of SMV in the analysis along with the percentage of rural crashes corresponding to each action. The horse-drawn buggies were moving essentially straight or were not reported in the majority of the rural crashes. Farm vehicles were moving essentially straight in over half of the rural crashes in which they were involved. Farm vehicles were turning left in 30% of the rural crashes in which they were involved. Construction/maintenance vehicles were moving essentially straight in just less than two-thirds of the rural crashes in which they were involved. They were also turning left and backing in 11% each of the crashes in which they were involved. Moped/ATVs were moving essentially straight in 63% of the rural crashes in which they were involved. They

were turning left in 8% of the rural crashes and turning right and slowing/stopping in 5% each of the rural crashes in which they were involved.

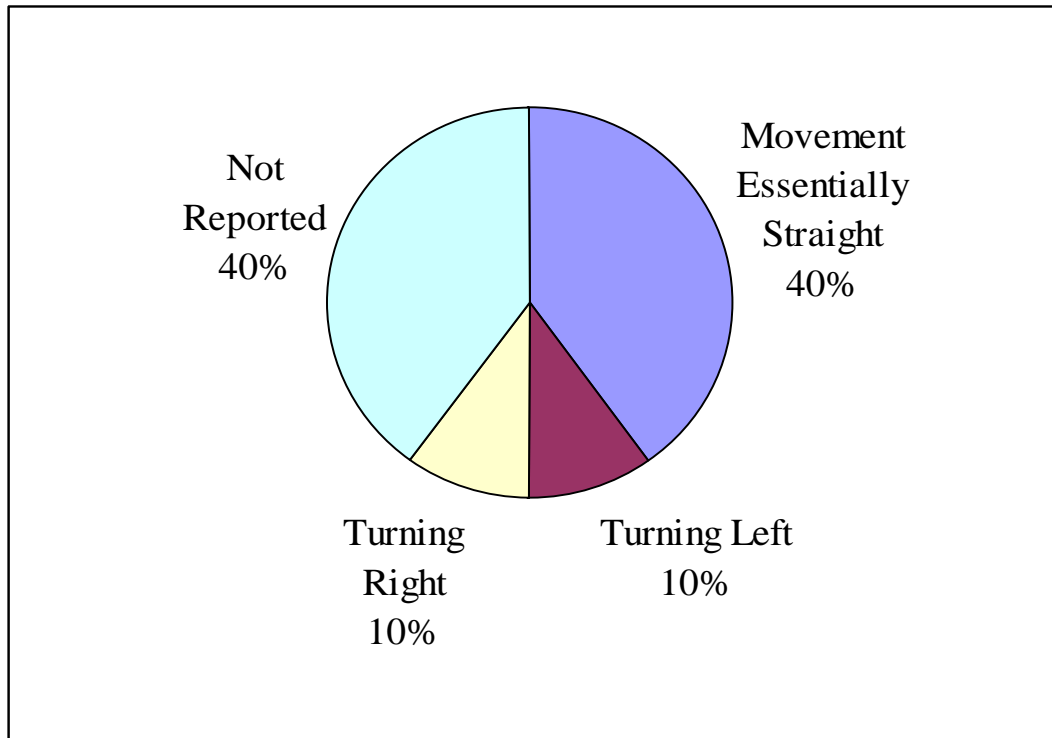

Figure 31. Rural Horse-Drawn Buggy Crash Vehicle Action

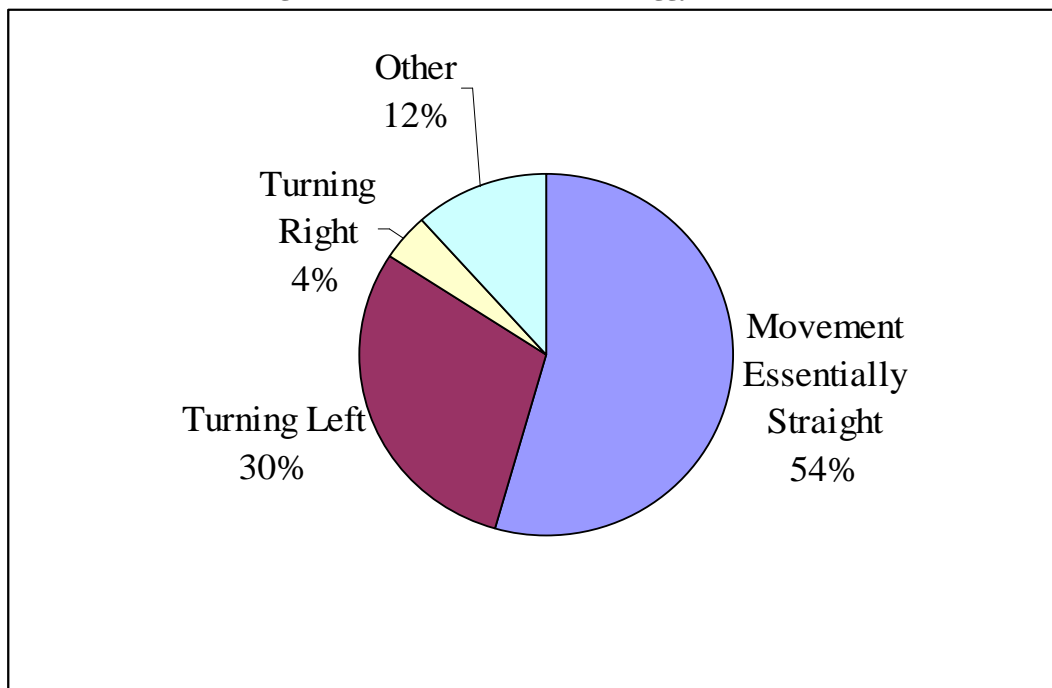

Figure 32. Rural Farm Vehicle Crash Vehicle Action

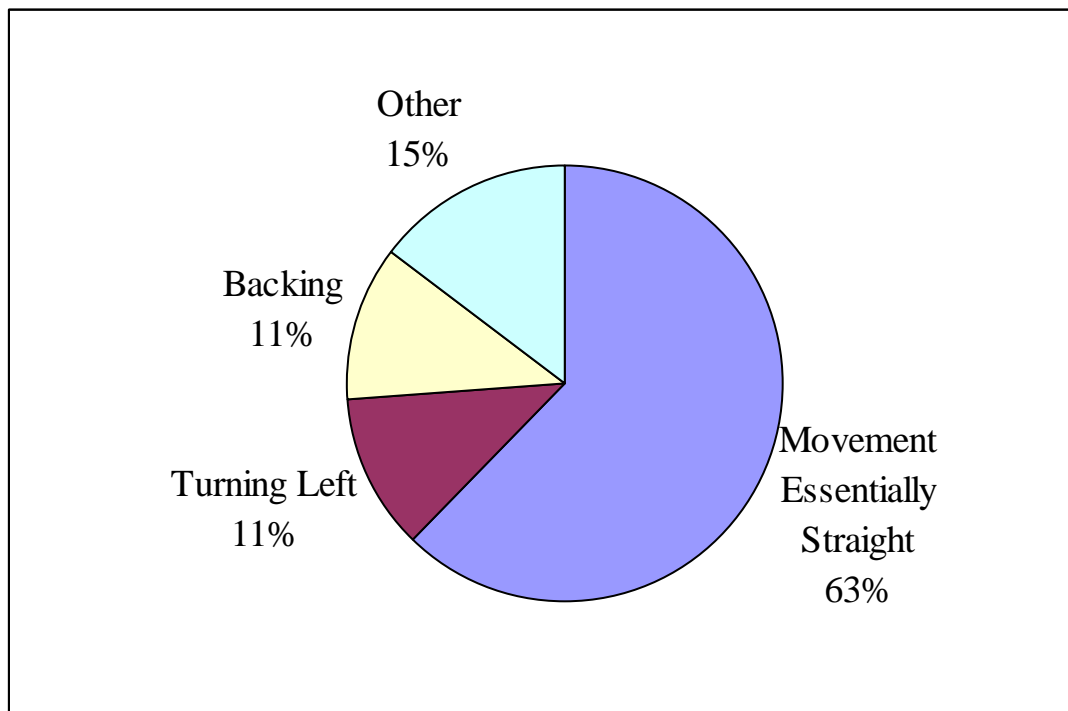

Figure 33. Rural Construction and Maintenance Vehicle Crash Vehicle Action

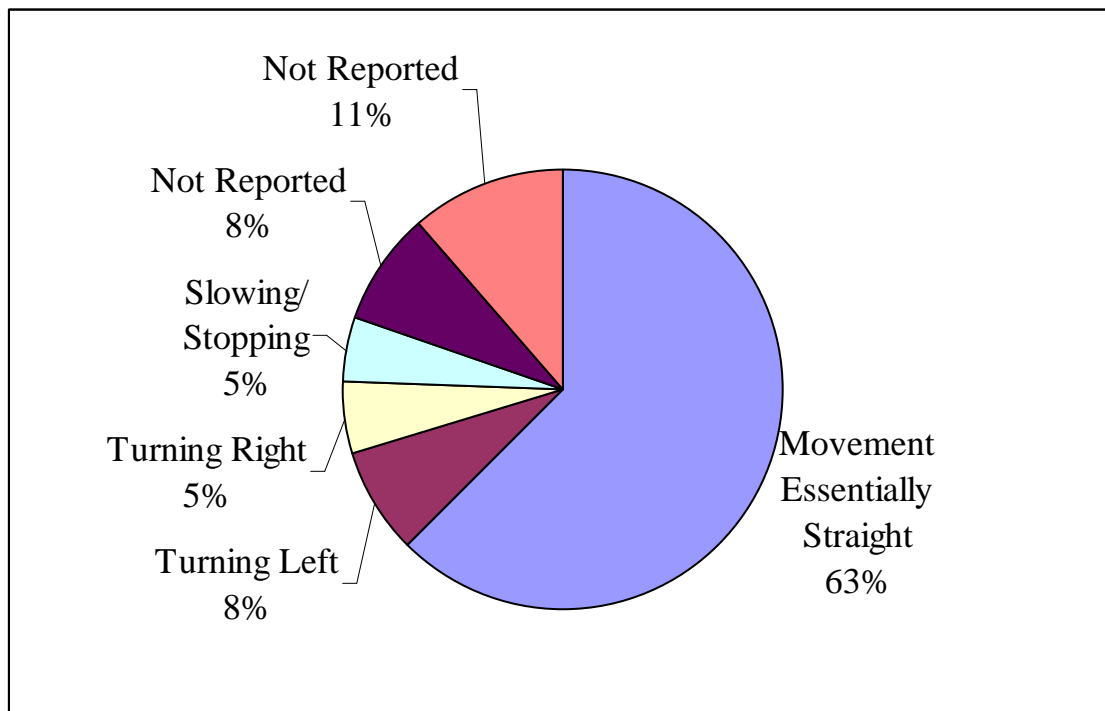

Figure 34. Rural Moped/ATV Crash Vehicle Action

Driver Age

Driver age was another characteristic specific to the SMV that was analyzed. Figures 35-38 display crashes involving each type of SMV according to the age of the driver of the SMV. When the age of the driver was known, the most common age group for rural horse-drawn buggy crashes was the 15-20 age group. Farm vehicles driven by persons between the ages of 45 and 54, which was the most common age group, represented 21% of the rural farm vehicle crashes. Only 17% of the farm vehicle crashes involved drivers under the age of 24. Over half of the crashes involved a driver over the age of 45. Over half of the rural construction/maintenance vehicle crashes involved drivers in the 45-55 age group. Only 26% of the drivers were under the age of 45. The age group most common for rural moped/ATV crashes was 15-20 at 28% of all crashes. Almost 60% of the drivers were under the age of 24. Also, 17% of the rural moped/ATVs involved in crashes were driven by teenagers under the age of 15.

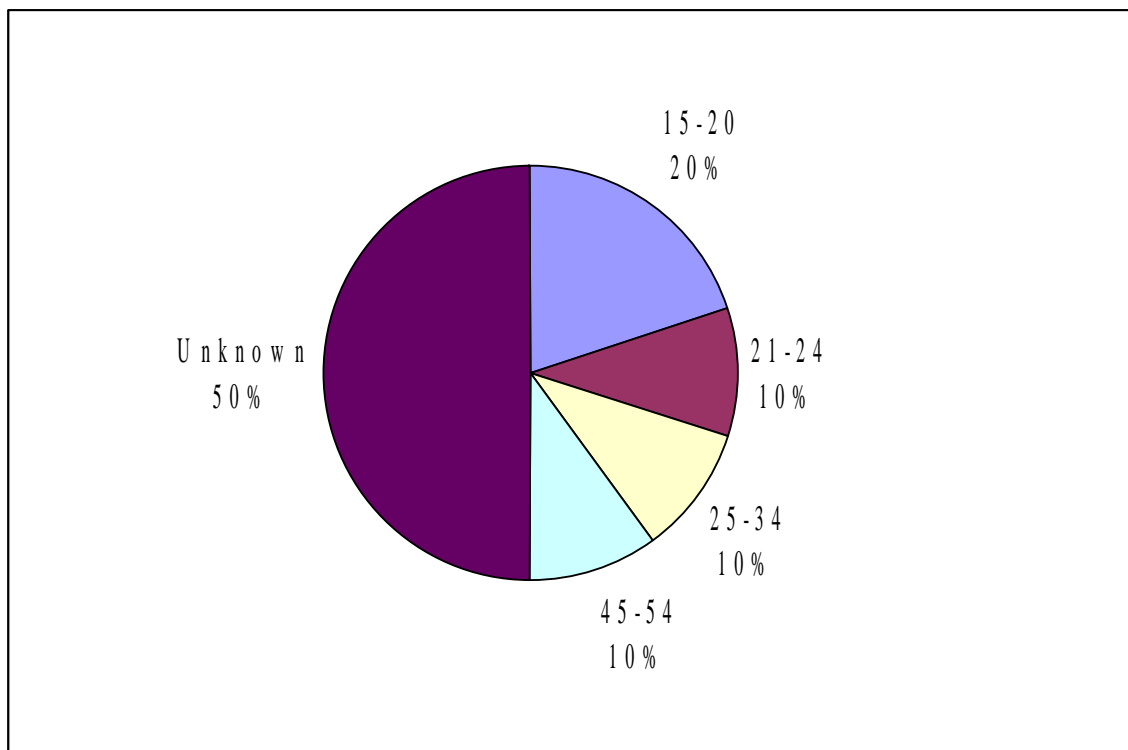

Figure 35. Rural Horse-Drawn Buggy Crashes by Driver Age

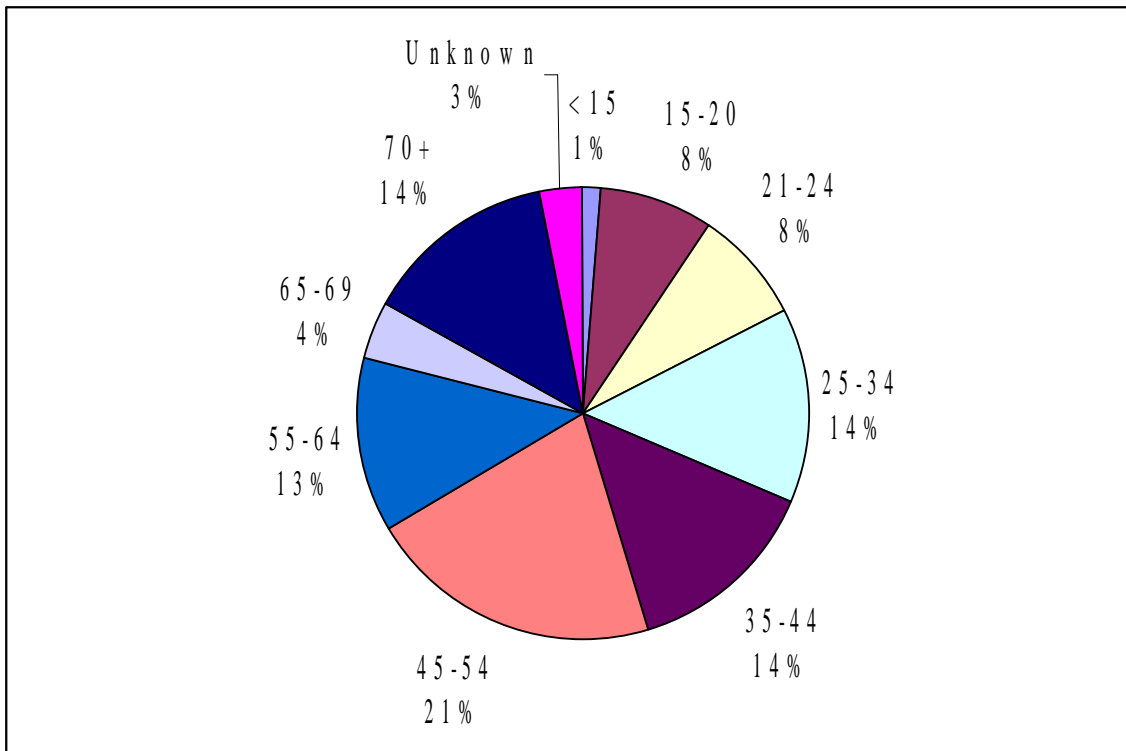

Figure 36. Rural Farm Vehicle Crashes by Driver Age

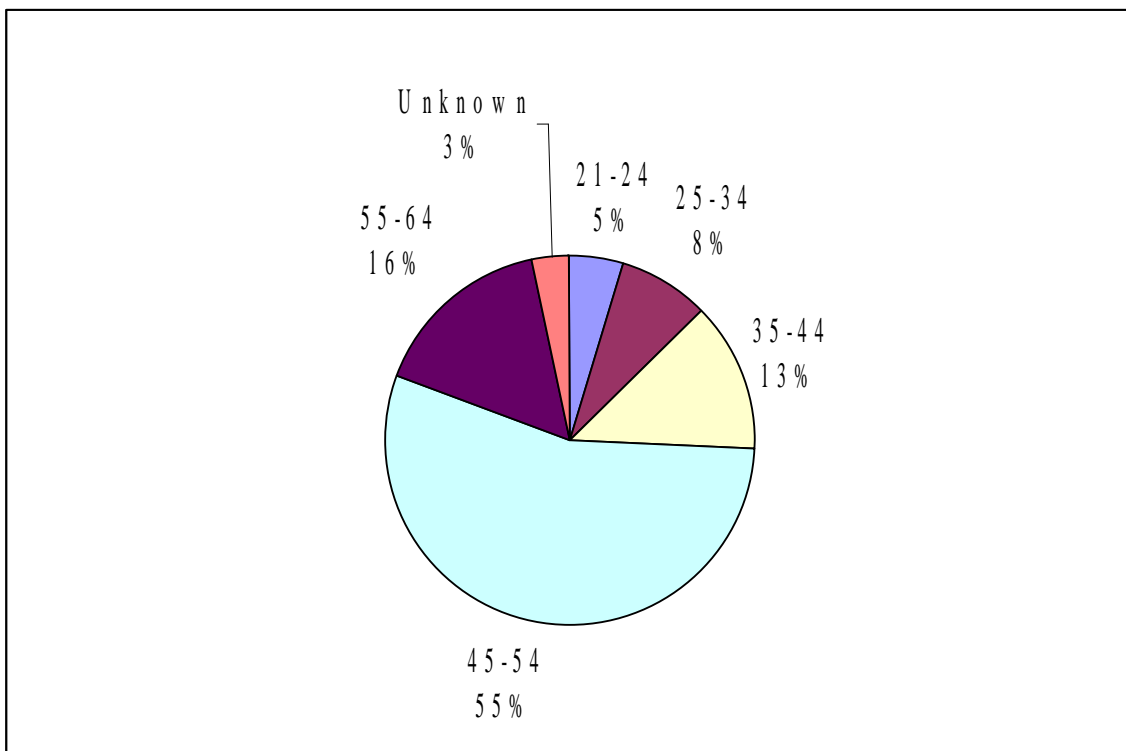

Figure 37. Rural Construction/Maintenance Vehicle Crashes by Driver Age

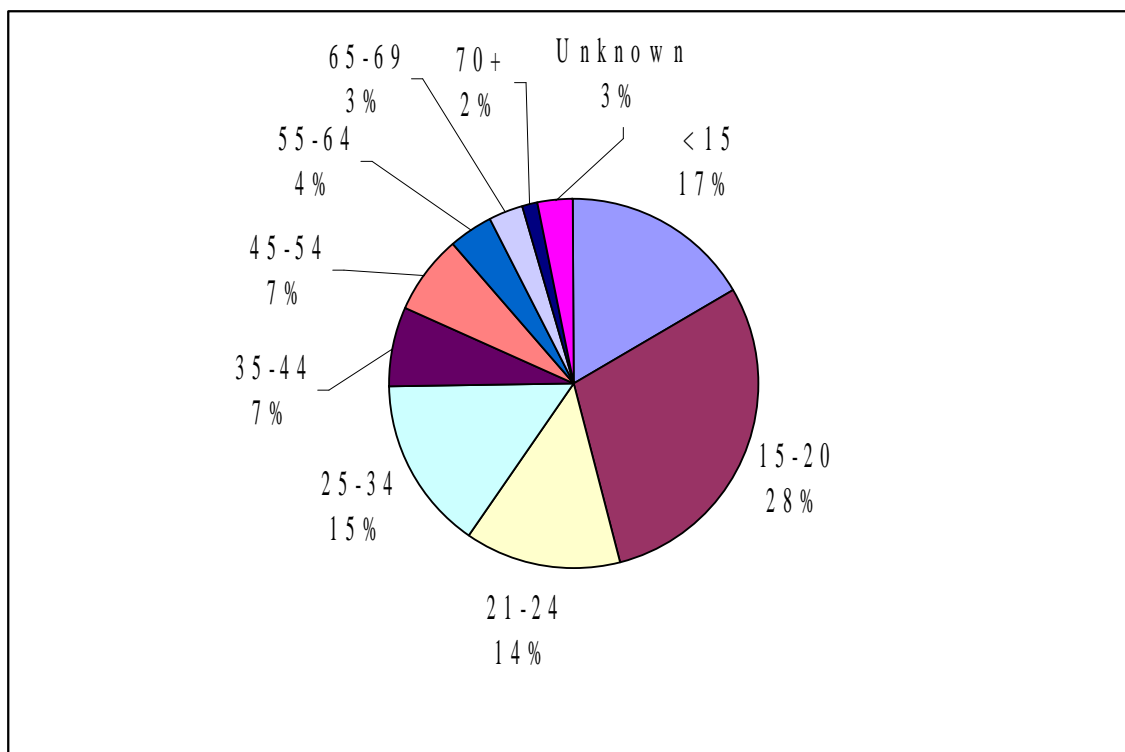

Figure 38. Rural Moped/ATV Crashes by Driver Age

Major Cause

Another factor analyzed was major cause of the collision. Within the Iowa Crash Database there are 44 different major cause categories. The major cause describes the contributing circumstance from any vehicle involved in the crash that was the major cause for the crash. This means that the SMV involved in the crash may or may not have been the major contributor to the cause of the crash. Figure 39 displays a chart describing the different causes for horse-drawn buggy crashes. Animal was the most common cause at 30%, followed by vision obstructed at 20%, and lost control, ran off road to the right, swerving or evasive action, followed to close, and failed to yield the right of way from a stop sign which accounted for the causes of 10% of the rural crashes involving a horse-drawn buggy each. In many cases, the animal(s) the report is referring to as the major cause for the crash is the horse(s) pulling the buggy.

The major causes for rural crashes involving farm vehicles spanned across 31 different categories. Figure 40 shows the most common causes with the smallest percentages grouped into the “other” category while leaving the more common major cause categories as percentages as separate categories. The most common major cause of collision for the farm vehicles was “swerving/evasive” action at 14%, followed by “other: improper action” at 13%, “failed to yield right of way” at 9%, “ran off road - right” at 7%, and “other: no improper action” at 6%.

The same method was used to analyze major cause for construction/maintenance vehicles. The top eight causes were used as separate categories and the remaining categories were grouped into one category titled “other.” Figure 41 shows a chart describing the major causes of crashes involving construction/maintenance vehicles. Next to the “other” category, the most common major cause of collisions were “failed to yield right of way: other” and “other: no improper action” both at 13% each, followed by “driving too fast for conditions” at 11%.

The same method was used to analyze major cause for rural moped/all-terrain vehicle crashes. The top seven causes were listed separately while the remaining causes were grouped into the “other” category. Figure 42 shows the different major causes for all rural crashes involving moped/all-terrain vehicles. The most common major cause of collision was “swerving or evasive action” at 13% of the moped/ATV crashes. “Operating the vehicle in an erratic, reckless, careless, negligent, or aggressive manner” was next at 10%, followed by “failed to yield the right of way: from driveway” at 9%, “driving too fast for conditions” at 8%, “animal” and “traveling wrong way or on wrong side of the road” both at 6%, and “losing control” at 5%. Twenty-one other causes of collision were recorded, but were all under 5% of the rural moped/all-terrain vehicle crashes.

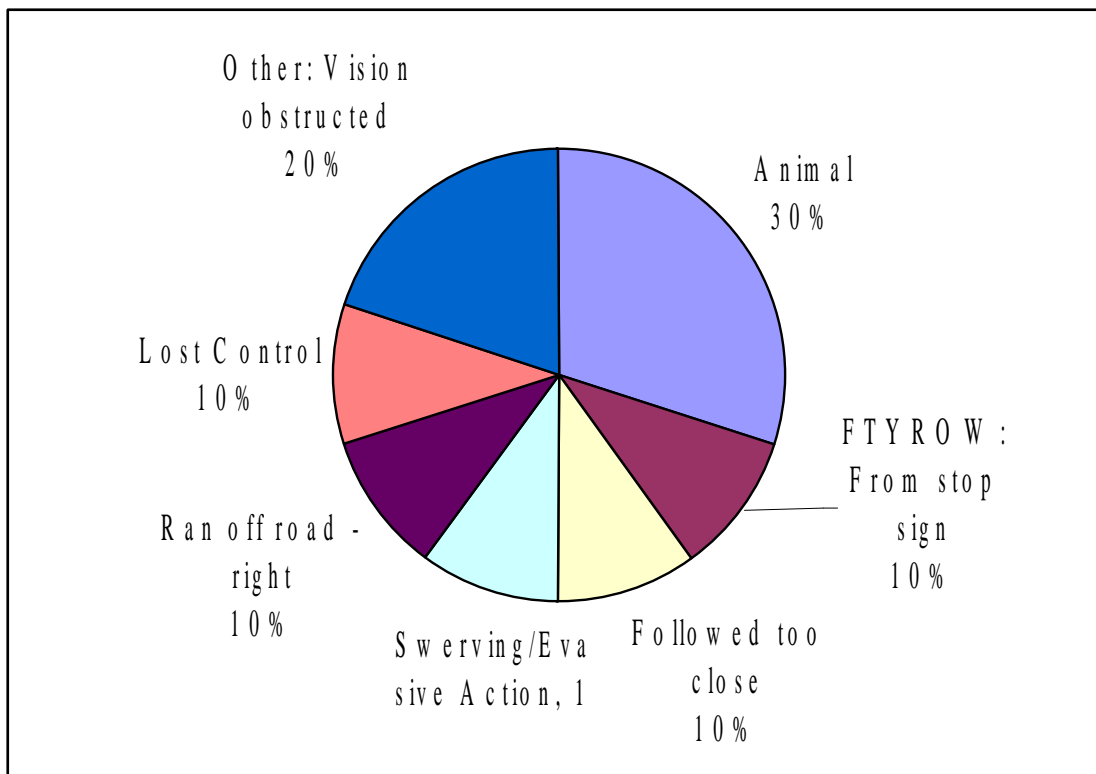

Figure 39. Rural Horse-Drawn Buggy Crashes by Major Cause

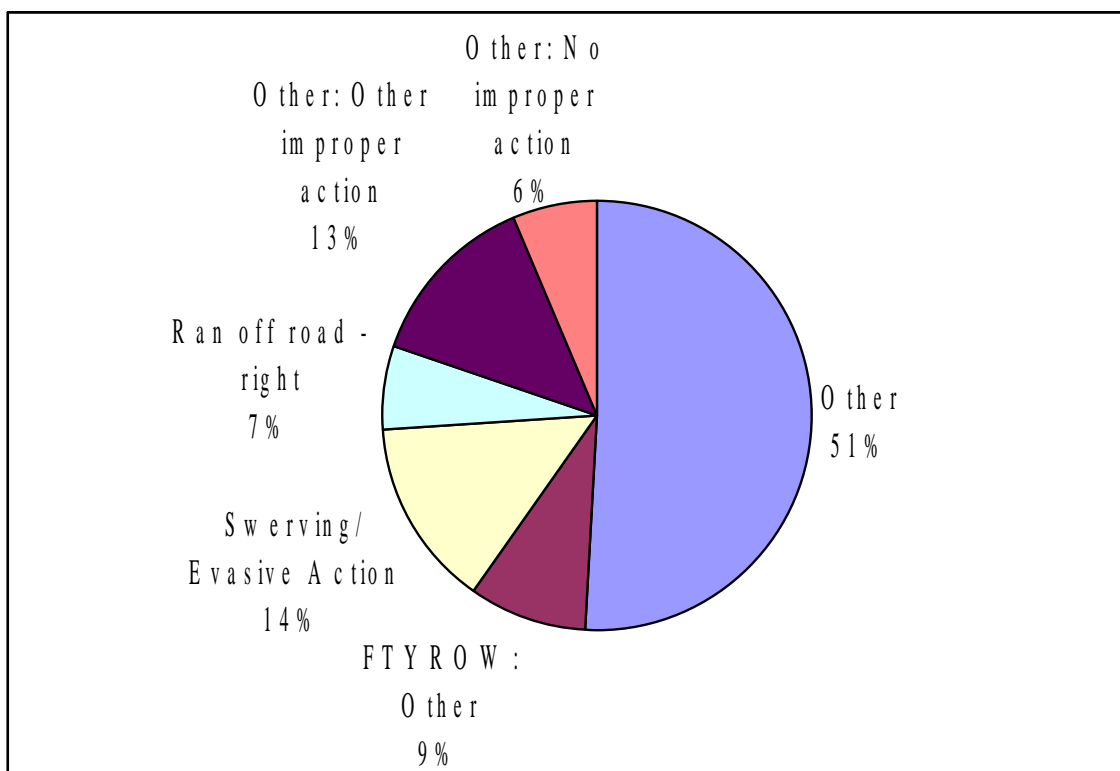

Figure 40. Rural Farm Vehicle Crashes by Major Cause

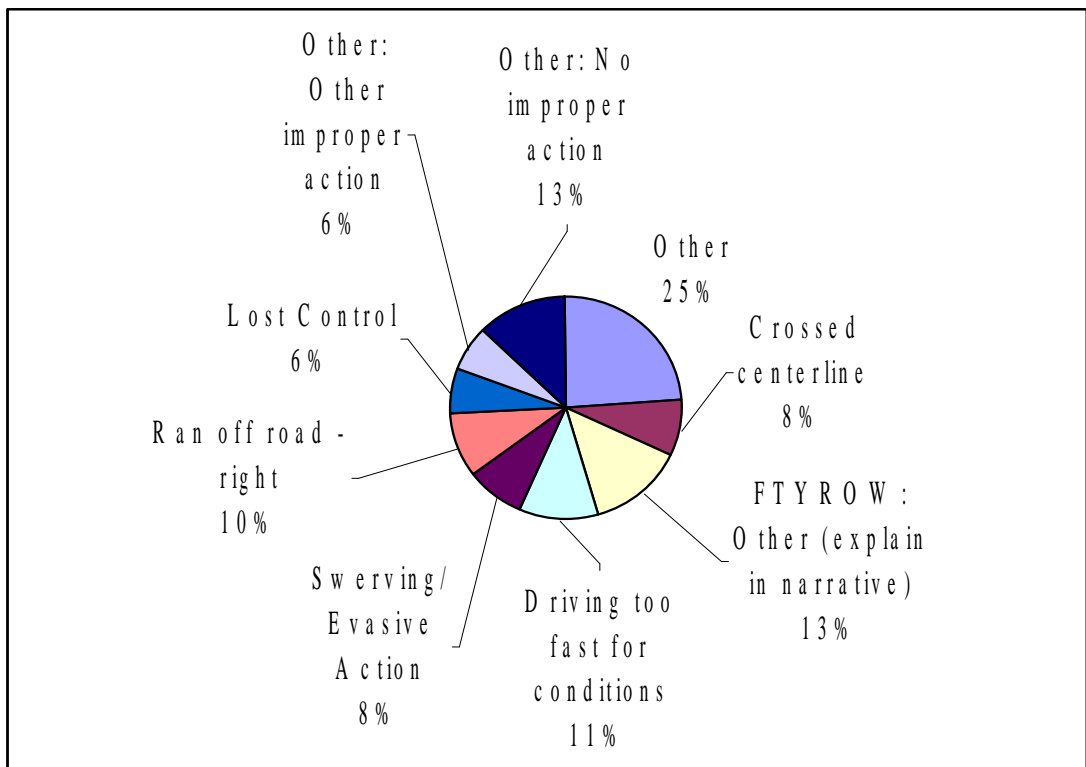

Figure 41. Rural Construction/Maintenance Crashes by Major Cause

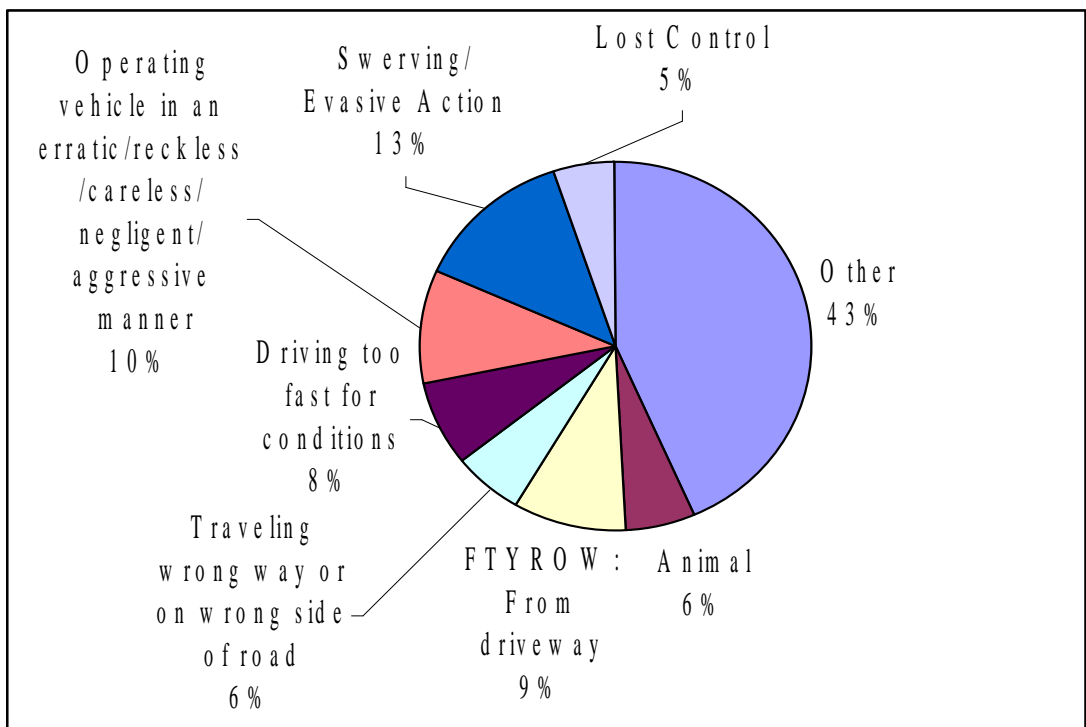

Figure 42. Rural Moped/ATV Crashes by Major Cause

Responsibility of Crash

Responsibility of the crashes was determined by matching the major cause for the crash with the contributing circumstances or sequence of events for the individual vehicle. The major cause derivation used by the Iowa Department of Transportation was used to determine the contributing circumstance or sequence of events that were mainly responsible for the major cause of the crash. Figure 43 depicts all SMV crashes and rural SMV crashes in which the cause of the crash was known where the responsibility lies more with the SMV than any other vehicle involved in the crash. Overall, the responsibility for just fewer than 60% of both the total and rural crashes lies with the SMV involved in the crash. The drivers of the moped/all-terrain vehicles were most likely to have contributed to over 90% of the rural moped/ATV crashes while they were responsible for just over 80% of the total crashes. The drivers of horse-drawn buggies were most likely to have contributed to over 60% of the total crashes in which they were involved while they were responsible for half of the crashes involving horse-drawn buggies in a rural setting. Drivers of farm vehicles were most likely to have contributed to about half of the total and rural crashes in which there were involved. Drivers of construction/maintenance vehicles were most likely to have contributed to over half of the crashes involving construction/maintenance vehicles, while just 40% of the crashes in which they were involved in a rural setting.

Figure 44 shows a similar bar chart, this time depicting the percentage of the total and rural multiple vehicle crashes involving at least one SMV where the cause of the crash was known and the SMV was more responsible for the crash than any other vehicle. Removing the single vehicle crashes allows for a better analysis of the percentage of rural crashes in which the responsibility for the crash could lie with another vehicle, but rather lies with the SMV. Overall, just fewer than 50% of the multiple vehicle crashes and rural crashes involving at least one SMV resulted in more of a contribution to the crash by the SMV than any other vehicle. Moped/all-terrain vehicles were most likely to have contributed to more than 80% of rural multiple vehicle crashes in which they were involved while they were most likely to have contributed to fewer than 70% of the total multiple vehicle crashes involving a moped/all-terrain vehicle. Over 60% of the total multiple vehicle crashes involving a horse-

drawn buggy involved more of a contribution of the horse-drawn buggy than any other vehicle involved in the crash, while they were most likely to have contributed to half of the rural multiple vehicle crashes. Construction/maintenance vehicles were most likely to have contributed to just under half of the total multiple vehicle crashes in which they were involved, while they were most likely to have contributed to fewer than 35% of the rural multiple vehicle crashes involving construction/maintenance vehicles. Farm vehicles were most likely to have contributed to just over 40% of the total multiple vehicle crashes and rural multiple vehicle crashes in which they were involved.

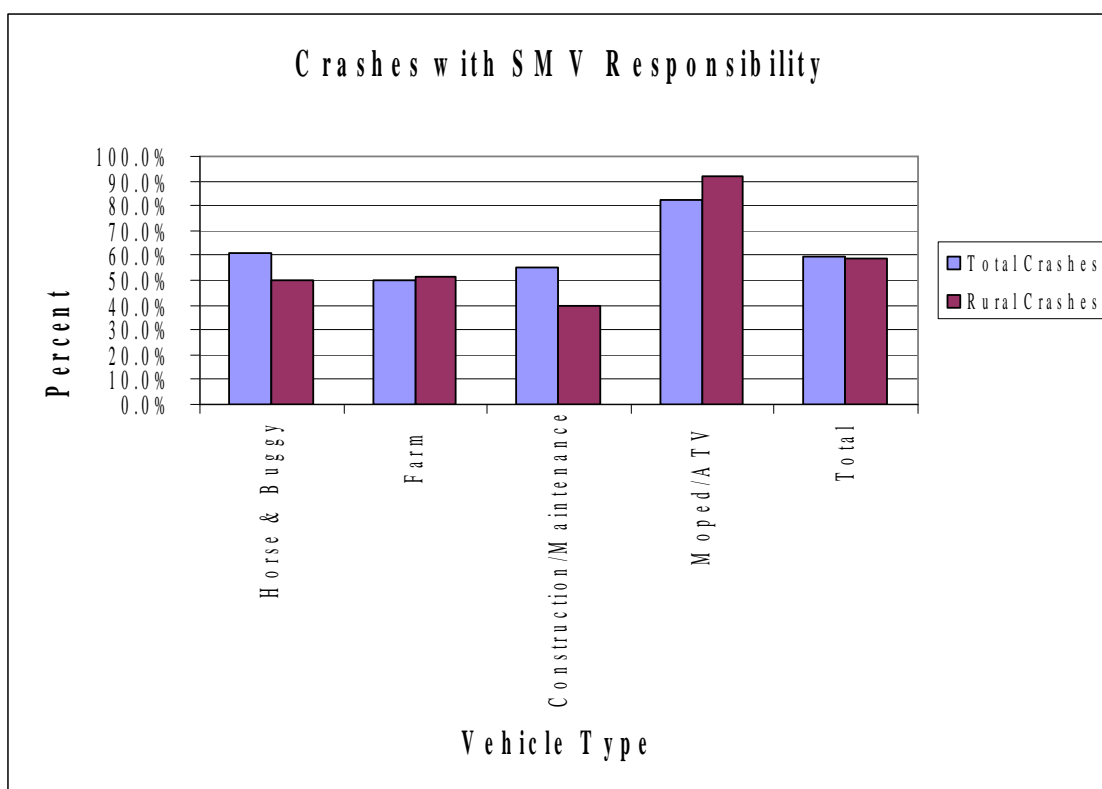

Figure 43. Percentage of all SMV Crashes with SMV Responsibility

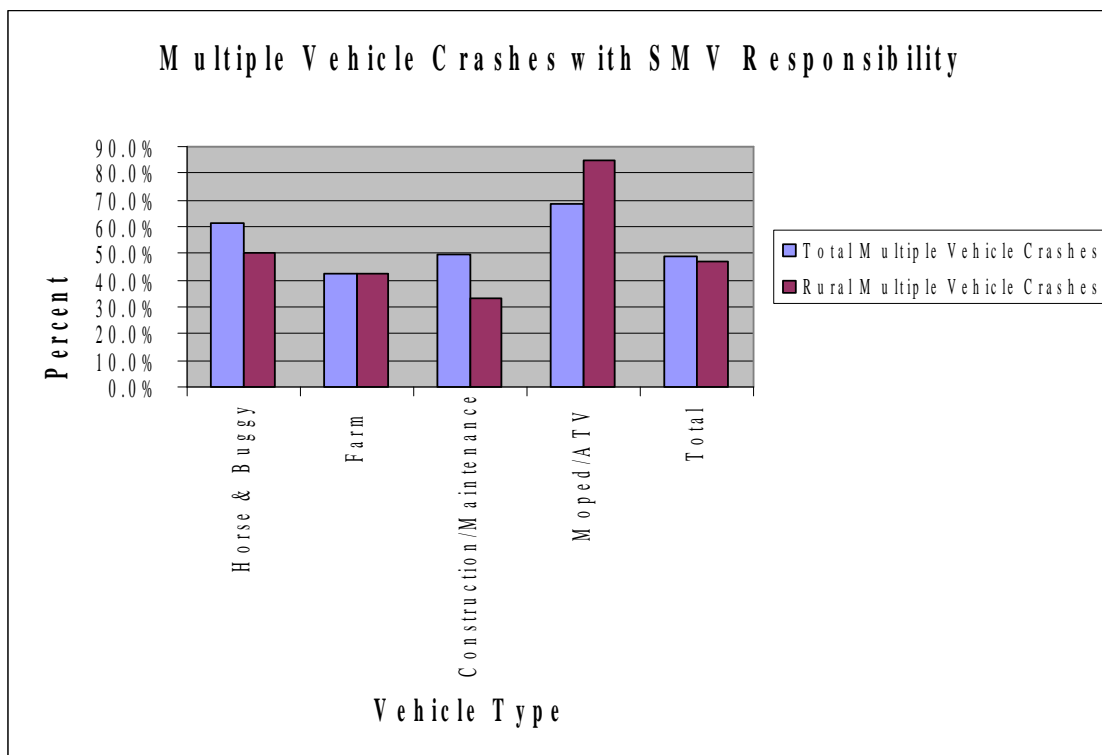

Figure 44. Percentage of Multiple Vehicle Crashes with SMV Responsibility

Crash Analysis Summary of Findings

Around 200 rural crashes involving SMVs occurred each year from 2004 to 2006. Farm vehicles were involved in well over half of these crashes each year, followed by moped/ATVs, construction/maintenance vehicles, and then horse-drawn buggies. A staggering crash trend was found over the three year period for all four vehicle types. Moped/all-terrain vehicles had the highest percentage of crashes resulting in a fatality at just fewer than ten percent. Horse-drawn buggies had a high night-to-day crash ratio at 0.667. The most common month for farm vehicle crashes was October representing over 1/4 of the total crashes throughout the year. The most common manner of collision for horse-drawn buggies, farm vehicles, and construction/maintenance vehicles was the rear-end collision, while the non-collision was the dominant manner of crash for the moped/all-terrain vehicles representing over half of the total rural crashes.

All four vehicle types were moving essentially straight prior to collision in a majority of the rural crashes in which they were involved. Farm vehicles were turning left in 30% of the rural crashes in which they were involved. Construction/maintenance vehicles, horse-drawn buggies, and moped/ATVs were turning left in 11%, 10%, and 8%, respectively, of the rural crashes in which they were involved.

The drivers of moped/ATVs were under the age of 24 in just fewer than 60% of all rural crashes involving moped/ATVs (17% were under the age of 15). Rural farm vehicles and construction/maintenance vehicle crashes typically involved older drivers at 21% and 55%, respectively. Most of the crashes involving horse-drawn buggies had drivers with unknown ages. However, the age group that was most common was 15-20 at 20% (2 crashes) of the rural crashes involving horse-drawn buggies.

Animals were the most common cause for the horse-drawn buggy crashes indicating in most cases a reaction by the horses that resulted in a crash. Swerving/evasive action was the most common cause for crashes involving farm vehicles. The most common cause of construction/maintenance vehicle crashes in a rural setting was from failing to yield the right of way. The most common cause for moped/ATV crashes was swerving or evasive action.

SMVs were most likely to have contributed to just under half of the rural multiple vehicle SMV crashes. Moped-ATVs were most likely to have contributed to fewer than 70% of all rural multiple vehicle crashes involving a moped/ATV. Half of the rural horse-drawn buggy multiple vehicle crashes involved more of a contribution to the crash by the horse-drawn buggy than any other vehicle involved in the crash. Construction/maintenance vehicles were most likely to have contributed to fewer than 35% of the rural multiple vehicle crashes they were involved in. Farm vehicles were most likely to have contributed to over 40% of the rural multiple vehicle crashes in which they were involved.

CHAPTER 4: FARM VEHICLE CRASH SEVERITY MODEL

In order to better understand the factors that are related to severity of farm vehicle crashes, a statistical analysis was conducted. Modeling the data and understanding what factors influence the crash severity of farm vehicle crashes will allow us to start identifying the types of situations in which further countermeasures are needed to lower crash severity. Farm vehicle crashes were the most common type of SMV crash in Iowa as determined per the crash analysis in this thesis. Also, countermeasures can only be determined if we understand why and how crashes are occurring in the first place. Initially, the intent was to model all slow-moving vehicles. However, sample sizes were low for several types of slow moving vehicles so it would be difficult to determine statistical significance. Also, the intent was to model crashes in a rural environment so only those vehicles where crashes occur predominantly in a rural environment were considered for crash modeling. Horse-drawn buggies were involved in 21 crashes over the three year period, which was not a large enough sample size to model with confidence, so they were not modeled. Bicycles had too few crashes in a rural setting which is the environment considered in this thesis, and thus were not chosen to be modeled. Construction/maintenance vehicles had a lot of variability in the types of vehicles involved in crashes. This category included both construction and maintenance vehicles and many different types of these vehicles within each vehicle category. This category could also include vehicles that are not slow-moving such as snow plows. The vehicles in the moped/all-terrain vehicle category follow a similar suit with a lot of variability between the types of vehicles, though not necessarily much variability in the sizes of the vehicles, included in the category. Since mopeds and all-terrain vehicles can be used for completely different purposes, the variability amongst the types of crashes would be great. For instance, all-terrain vehicles are often times used for maintenance purposes, farming purposes, as well as recreational use. Mopeds are usually used for transportation purposes only. Farm vehicles normally include vehicles only used for farm purposes, which include tractors and combines. The tractors can be used by themselves or with a unit in tow such as a plow, planter, or wagon. The types of vehicles were assumed to have similar properties and could be modeled with accuracy. Farm vehicles are predominantly used in a

rural environment, so they were a primary choice for modeling. Also, since farm vehicles were the most predominant crash occurring during the three year period, it may be more important to better understand the factors influencing crash severity of farm vehicles than the other types of SMVs involved in less frequent crashes.

Farm vehicle crash severity was modeled for Iowa using the Iowa DOT crash database. Crashes that involved at least one vehicle which was indicated in the crash database or crash narrative as being a farm vehicle were extracted from the database. Associated variables for each crash were also extracted. The analysis included crash data from 2004 to 2006. These variables include crash type, location of crash, major cause, number of vehicles involved, events involved in contributing to the crash, as well as other information about the specific vehicles involved in the crash and the drivers of those vehicles involved in the crash. The specific variables that were used in the models within this thesis are described in Table 10. The complete list of variables along with their descriptions is shown in Appendix C.

Data were incorporated into a database which would be used in the statistical package Limdep which was used to create the model. There were a total of 69 variables used in initial models. When the data are read into the Limdep database, the program assigns each variable an identification number. For instance, the first variable read into the database was report type and was assigned x1. Each sequential variable after that was assigned an increasing value (x2, x3, x4, etc...). Once the variables were entered into the program, other variables could be created using those initial variables. Another thirteen variables were created from the given data and assigned names. These variables are listed at the bottom of the variable list in Appendix C. Explanations as to how each variable was calculated and what they represent can be found in the variable list in Appendix C as well.

Crash severity was the dependent variable used in the modeling procedure. Since this variable includes discrete ordered outcomes, the ordered logit or the ordered probit model could be used to model the data. In this thesis, the ordered probit model was used. The ordered probit model Model will produce an equation in form of:

$$z = \beta_0 + \beta_1x_1 + \beta_2x_2 + \beta_3x_3 + \dots + \beta(i)x(i)$$

$$Y=0 \text{ if } z \leq 0$$

$$Y=1 \text{ if } 0 < z \leq \mu_1$$

$$Y=2 \text{ if } \mu_1 < z \leq \mu_2$$

$$Y=3 \text{ if } \mu_2 \leq z$$

[4-1]

B: coefficient

X: each independent variable used in the equation

μ_1 and μ_2 : threshold values

The crash severity variable was initially assigned the value x19 by Limdep when it was read into the program's database. The possible outcomes came from the Iowa DOT crash database and were as follows; 1: fatality, 2: major injury, 3: minor injury, 4: possible/unknown injury, 5: property damage only. In order to put the data in a format Limdep can use for the ordered probit model, the outcomes needed to be converted to indicator variables, which have values beginning with 0 and increasing with integer values. In order to adjust the crash severity variable, a new variable was created called "SEVERITY." Since the ordered probit models require that the outcomes be in order, the severity outcomes were ordered to increase with increasing severity. Property damage only was the lowest possible crash severity outcome, so it was assigned the 0 value. Possible/unknown injuries had too few occurrences to be modeled as a separate category. For this reason, those crashes needed to be included with another outcome for crash severity. Possible/unknown injuries are most similar in terms of severity to the minor injuries, so those crashes were added together and assigned the 1 outcome value for the SEVERITY variable. Major injuries and fatality crashes were the highest severity crashes, but separately represented under 10% of the crashes in the multiple and single vehicle crashes as well as the urban and rural crashes. For this reason, the two severities were grouped together into a single category. They were assigned a 2 value. Table 9 shows these values in a table format. Table 10 shows all the variables that were created and used in the crash models throughout

this section. A complete list of the variables read into the Limdep database and used to create the variables in Table 10 can be found in Appendix C.

Table 9. Dependent "SEVERITY" Variable Outcomes

Outcome	Variable
0	Property Damage Only
1	Possible/Unknown Injury and Minor Injury
2	Major Injury/Fatality

Table 10. Variable Descriptions

Variable	Summary	Description
SEVERITY	Crash Severity	0 x19=5; Property Damage Only
		1 x19=3 or x19=4; Minor Injury or Possible/Unknown Injury
		2 x19=2 or x19=1; Major Injury or Fatality
MULTVEH	More than one vehicle in crash	1 x27>1; multiple vehicle collision
		0 x27=1; single vehicle collision
DARK	Dark Environmental Light Conditions	1 x7=4 or x7=5 or x7=6; dark condition with either roadway lighted, roadway not lighted, or unknown roadway lighting conditions
		0 Other conditions
REAREND	Rear-end Collision	1 X3=3; Manner of Collision = Rear-end
		0 Manner of collision was not rear-end
OLDCAR	Age of the vehicle is greater than 29 years (age of vehicle is year of accident minus year of car)	1 (x12-x55)>29; Vehicle is older than 29 years
		0 Vehicle is not older than 29 years
OLD	Age of Driver is older than 59 years	1 x34>59; Driver of SMV is over 59 years old
		0 Driver of SMV is not over 59 years old
STRAIGHT	Movement of SMV was Essentially Straight	1 x60=1; Essentially Straight Vehicle Movement
		0 Other Vehicle Movement
FSTHMOFF	First Harmful Event was off the roadway	1 x14>1 and x14<9; Location of First Harmful Event was either: on the shoulder, median, roadside, gore, or outside the trafficway
		0 x14=1 or x14=9 or x14=77; Location of first harmful event was either on the roadway, unknown, or not reported
FALL	Crash was during Fall Season	1 8<x10<12; Crash month is September, October, or November
		0 Crash Month was in a month other than September, October, or November
SUMMER	Crash was during Summer Season	1 5<x10<9; Crash month is June, July, August
		0 Crash month was in a month other than June, July, or August
YOUNG	Driver of Farm Vehicle is 25 years of age or under	1 x34<26; Driver of Farm Vehicle is 25 years of age or under
		0 Driver of Farm Vehicle is over 25 years of age or unknown
x48	Driver License Class A	1 Driver License Class A Restriction
		0 Other Driver License Restriction Class
x66	Rural	1 Rural
		0 Other

The SEVERITY variable was the dependent variable used in all the models. Many independent variables were created using the crash characteristics from the Iowa Crash Database.

The MULTVEH was an independent variable created to be used in the modeling process. This was an indicator variable which was given a 1 if the crash involved 2 or more vehicles and 0 if the crash did not involve 2 or more vehicles. This variable indicates whether a farm vehicle crash involved another vehicle or if it was a single vehicle crash involving only the farm vehicle. If the number of vehicles recorded in the crash was greater than 1, the MULTVEH indicator variable received a 1 value. If the number of vehicles recorded in the crash was 1, the MULTVEH indicator variable received a 0 value.

The DARK indicator variable was created using the lighting conditions input from the Iowa Crash Database. The officer records what type of lighting conditions existed during the crash. If the officer recorded conditions of dark with roadway lighted, dark without roadway lighted, or dark with unknown roadway lighting conditions, then the DARK variable value is 1. If the lighting conditions are anything other than those three options, the DARK variable is given a 0.

REAREND was another indicator variable. It was created using from the manner of collision category. If the manner of collision of the crash was rear-end, the REAREND indicator variable received a 1 value. If the manner of collision was anything other than a rear-end crash, the REAREND indicator variable was given a 0 value.

OLDCAR was an indicator variable that was created from the year of the farm vehicle and the date the crash occurred. The year of the vehicle was subtracted from the year at the time of the crash to determine the age of the vehicle. If the age was greater than 29 years of age, the OLDCAR variable received a value of 1. If the age was not greater than 29 years of age, the OLDCAR variable received a value of 0. The number 29 came from trial and error to ensure a high enough frequency occurred within that group of variables to be able to have

confidence in using the OLDCAR indicator variable. In order to have confidence in the variable, at least 10% of the total crashes used in each model must have been old. This means that at least 10% of the total farm vehicles involved in crashes were older than 29 years at the time of the crash.

The OLD indicator variable was created to include the age of the driver of the farm vehicle. At least 10% of the crashes needed to have a value of 1 for the OLD variable in order to have confidence in this variable. A trial and error process was used to have enough observations in this category as well as a low P-value when used in the model to get a significant reading in the OLD variable at the 90% confidence level.

The STRAIGHT indicator variable was created using the vehicle movement category recorded in the Iowa Crash Database. If the movement of the farm vehicle was essentially straight, the STRAIGHT variable received a value of 1. If the movement of the farm vehicle was anything but essentially straight, the STRAIGHT variable received a value of 0.

FSTHMOFF was an indicator variable created using the location of the first harmful event (x14) category from the Iowa Crash Database. If the first harmful event was on the shoulder, median, roadside, gore, or outside the trafficway, the FSTHMOFF variable received a value of 1. Any other first harmful event recording received a value of 0 for the FSTHMOFF variable. This variable was created to determine the effect of the first harmful event occurring off the traveled way on crash severity.

FALL was an indicator variable created to indicate a crash occurring during the months of the fall season. If the crash was recorded as occurring during October, November, or December, the FALL indicator variable received a value of 1. If the crash was not recorded as occurring during October, November, or December, the FALL indicator received a value of 0.

SUMMER was an indicator variable created to indicate a crash occurring during the months of the summer season. If the crash was recorded as occurring during June, July, or August, the SUMMER indicator variable received a value of 1. If the crash was not recorded as occurring during June, July, or August, the FALL indicator received a value of 0.

YOUNG was another indicator variable created to indicate whether the driver of the farm vehicle was 25 years of age or younger. This variable was created in the same manner as the OLD variable by trial and error. The age group created received enough observations and a low enough P-value to have significance in the variable at the 90% confidence level. If the driver of the farm vehicle was 25 years of age or under, the YOUNG variable received a value of 1, else 0. The YOUNG and OLD indicator variables were introduced in all models, but were only included in the final specification of the models if they were found statistically significant.

The indicator variable x48 was created to indicate whether or not the driver of the vehicle had a Class A Commercial Driver's License at the time of the crash. This specific license restriction allows a driver to operate any combination of vehicles with a gross combination weight rating (GCWR) of 26,001 or more pounds and a vehicle(s) in tow in excess of 10,000 pounds. The holder of this Class A restriction may also operate vehicles within the Class B and C Commercial Driver's License restrictions. A driver with a Class B restriction is allowed to operate "any single vehicle with a GVWR [gross vehicle weight rating] of 26,001 or more pounds, or any such vehicle towing a vehicle not in excess of 10,000 pounds GVWR" (Iowa Department of Transportation, 2007). The Class C restriction allows a driver to operate "any single vehicle less than 26,001 pounds GVWR, or any such vehicle towing a vehicle not in excess of 10,000 pounds GVWR. This group applies only to vehicles which are placarded for hazardous material or designed to transport 16 or more persons, including the driver (and similar-size passenger vehicles designed to transport a fewer number of handicapped persons and has a GVWR of 10,001 or more pounds)" (Iowa Department of Transportation, 2007).

The rural indicator variable used was x66. This variable was created from the definition of a rural crash that was created in the crash analysis in Chapter 3. The crashes occurring within 1 mile of the city limits were defined as urban, while the crashes occurring outside these boundaries were defined to be rural. The crashes occurring in a rural setting per this definition were assigned a value of 1 for the x66 (rural) indicator variable. The crashes occurring anywhere else were given a value of 0. This variable was created to determine the effect of a farm vehicle crash occurring in a rural environment on crash severity.

Transferability Test – Total vs. Single & Multiple Vehicle Crashes

In order to determine whether single and multiple vehicle crash severity should be modeled together or as separate models using only single vehicle crashes in one model and only multiple vehicle crashes in another, a transferability likelihood ratio test was used. This test is given by the equation:

$$X^2 = -2[LLR(\beta T) - LLR(\beta a) - LLR(\beta b)] \quad [4-2]$$

LLR(βT): Log Likelihood at convergence of the model estimated with the data from both regions a and b

LLR(βa): Log Likelihood at convergence of the model including region a data

LLR(βb): Log Likelihood at convergence of the model including region b data

The model is X^2 statistic is χ^2 distributed with degrees of freedom equal to the summation of the number of estimated parameters in all regional models (a and b) minus the number of estimated parameters in the overall model. The resulting χ^2 statistic provides the probability that the models have different parameters (Washington et al., 2003).

This test shows which option models crash severity with more significance. First, a model was created for total farm vehicle crashes using crash severity as the dependent variable. The total output from the model is shown in Appendix D. All the variables shown in Appendix C were tried in the model. Different dummy variables were created in order to use variables

that would not have much variability and would have an effect on the crash severity. The model shown in Appendix D is the best fit model. There were 598 observations for all farm vehicle crashes. The model created for the total data model is as follows:

Total Crashes Model

$$z = -0.222 - 0.209(\text{MULTVEH}) + 0.355(\text{DARK}) - 0.232(\text{x48}) - 0.368(\text{OLDCAR}) + 0.174(\text{OLD}) + 0.232(\text{STRAIGHT}) + 0.159(\text{FSTHMOFF})$$

$$Y = 0 \text{ if } z \leq 0$$

$$Y = 1 \text{ if } 0 < z \leq 1.107$$

$$Y = 2 \text{ if } 1.07 \leq z$$

[4-3]

Log Likelihood at Convergence = -539.5506

Number of observations = 598

Separate models were then created for single and multiple vehicle crash using crash severity as the dependent variable once again. The same variables were used in those models as were used in the total crashes model except for the multiple vehicle indicator variable. The multiple vehicle indicator variable was removed from the model due to collinearity between it and the dependent variables of single vehicle crash severity and multiple vehicle crash severity. All vehicles in the single vehicle crash model would receive a 0 for the multiple vehicle indicator variable. Similarly, all vehicles in the multiple vehicle crash model would have a value of 1 for the multiple vehicle crash indicator variable. The single vehicle crash model had 80 observations while the multiple vehicle crash model had 518 observations. The total output from the models is shown in Appendix D. The models developed with the same variables, though with less confidence, are as follows:

Single Vehicle Crash Model

$$z = -0.246 + 0.132(\text{DARK}) + 0.0636(\text{x48}) + 0.786(\text{OLDCAR}) + 0.201(\text{OLD}) - 0.149(\text{STRAIGHT}) + 0.453(\text{FSTHMOFF})$$

$$Y = 0 \text{ if } z \leq 0$$

$$Y = 1 \text{ if } 0 < z \leq 1.024$$

$$Y = 2 \text{ if } 1.024 \leq z \quad [4-4]$$

Log Likelihood at Convergence = -78.43699

Number of observations=80

Multiple Vehicle Crash Model

$$z = -0.405 + 0.368(\text{DARK}) - 0.288(\text{x48}) + 0.251(\text{OLDCAR}) + 0.187(\text{OLD}) + 0.264(\text{STRAIGHT}) + 0.0362(\text{FSTHMOFF})$$

$$Y = 0 \text{ if } z \leq 0$$

$$Y = 1 \text{ if } 0 < z \leq 1.137$$

$$Y = 2 \text{ if } 1.137 \leq z \quad [4-5]$$

Log Likelihood at Convergence = -457.1571

Number of observations=518

Transferability Likelihood Ratio Test

To determine whether the total data fits the data more significantly than the single and multiple vehicle crash regions modeled separately, the likelihood ratio test is conducted.

$$\chi^2 = -2[LLR(\beta_T) - LLR(\beta_a) - LLR(\beta_b)] \text{ (Washington et al., 2003)} \quad [4-6]$$

$$\chi^2 = -2[-539.5506 - (-78.43699) - (-457.1571)] = 7.913 \quad [4-7]$$

$$Df = 7 + 7 - 8 = 6$$

$$\chi^2 = 12.592 \text{ with 95\% confidence}$$

$$7.913 < 12.592$$

According to the transferability likelihood ratio test, modeling crash severity using the single and multiple vehicle crash models does not fit the data more significantly than modeling

crash severity using all crashes in a single model. Therefore, the data will be modeled together.

Transferability Test – Total vs. Rural & Urban Crashes

Once the first transferability test was completed, a second transferability test was then conducted to determine if modeling rural and urban crash severity separately has more significance than modeling crash severity with them combined into one model using an indicator variable for rural or urban in the model. The same test was done for these models as was done for the single and multiple vehicle crash models compared to the total data model. The same variables used in the total data model were also used in the rural and urban models but without the rural indicator variable. In order to have the same number of observations in the total data model as are in the urban and rural models, the crashes with unknown location were removed from the total crash dataset, leaving 590 crashes for the total data model. The total output from each run of the total crashes model, rural crashes model, and urban crashes model is located in Appendix D. The models used for the total, rural, and urban models as well as the transferability test are shown below.

Transferability Test Total Crashes Model

$$z = -0.523 + 0.319(\text{DARK}) - 0.241(\text{x48}) + 0.393(\text{OLDCAR}) + 0.171(\text{OLD}) + 0.266(\text{STRAIGHT}) + 0.196(\text{x66})$$

$$Y = 0 \text{ if } z \leq 0$$

$$Y = 1 \text{ if } 0 < z \leq 1.104$$

$$Y = 2 \text{ if } 1.104 \leq z$$

[4-8]

Log Likelihood at Convergence = -540.1444

Number of observations = 590

Transferability Test Rural Crashes Model

$$z = -0.381 + 0.301(\text{DARK}) - 0.161(\text{x48}) + 0.391(\text{OLDCAR}) + 0.203(\text{OLD}) + 0.334(\text{STRAIGHT})$$

$$Y = 0 \text{ if } z \leq 0$$

$$Y = 1 \text{ if } 0 < z \leq 1.123$$

$$Y = 2 \text{ if } 1.123 \leq z \quad [4-9]$$

Log Likelihood at Convergence = -359.7776

Number of observations = 386

Transferability Test Urban Crashes Model

$$z = -0.439 + 0.456(\text{DARK}) - 0.414(\text{x48}) + 0.334(\text{OLDCAR}) + 0.0879(\text{OLD}) + 0.158(\text{STRAIGHT})$$

$$Y = 0 \text{ if } z \leq 0$$

$$Y = 1 \text{ if } 0 < z \leq 1.042$$

$$Y = 2 \text{ if } 1.042 \leq z \quad [4-10]$$

Log Likelihood at Convergence = -171.9083

Number of observations = 204

Transferability Likelihood Ratio Test

To determine whether the total data fits the data more significantly than the rural and urban crash regions modeled separately, a likelihood ratio test was conducted.

$$\chi^2 = -2[-540.1114 - -359.7776 - -171.9083] = 16.851 \quad [4-11]$$

$$\text{Df} = 6+6-7 = 5 \quad [4-12]$$

$$\chi^2 = 11.071 \text{ with 95\% confidence}$$

$$16.851 > 11.071$$

The separate rural and urban crash models fit the data more significantly than modeling all crashes together. Therefore, two models will be created; one for rural crashes and one for urban crashes with single and multiple vehicle crashes combined in both models.

Final Models

The final models were created using the ordered probit model as well. As stated previously, this model can be used when the dependent variable outcomes are ordered. The “severity” variable was used once again as the dependent variable with the same three outcomes numbered from 0 to 2. These outcomes can be found in the following sections in Table 11.

Urban Crash Severity Model

Overall Description

According to the transferability test, more confidence would be found by modeling rural and urban crashes separately. Therefore, crash severity for urban crashes was modeled. There were a total of 204 urban crashes. Using a trial and error process, a model with the best ρ^2 statistic with all independent variables in the model significant at the 90% confidence level was created. In order to ensure enough observations were recorded for each variable used in the model, histograms were created. All variables were required to be found in at least 10% of the total crashes, which means each variable was required to have a frequency of at least 20 crashes. For example, if dark is used as a variable, at least 20 of the crashes would need to have occurred during dark conditions as recorded at the time of the crash in order to include the dark variable in the model. Once again, the dependent variable used is SEVERITY. The mean of the variable is 0.4657. This means, the mean of the SEVERITY variable occurs between property damage only and minor injury or possible/unknown injury, but closer to the former of the two. The frequencies are shown in Table 11 along with the description of each value for the SEVERITY variable. As can be seen, the number of observations in the major injury/fatality category is 19, which is just under the 10%

requirement previously stated. This represents 9.3% of the total crashes, which is close to the 10% and should still allow significant output from the model.

Table 11. SEVERITY Variable Description

<u>Value</u>	<u>Description</u>	<u>Observations</u>
0	Property Damage Only	128
1	Minor Injury or Possible/Unknown Injury	57
2	Major Injury/Fatality	19

The total output from the model is shown in Appendix D. The model is as follows:

$$z = -0.484 + 0.463(REAREND) + 0.466(FALL) - 0.460(x48) - 0.471(YOUNG)$$

$$Y = 0 \text{ if } z \leq 0$$

$$Y = 1 \text{ if } 0 < z \leq 1.074$$

$$Y = 2 \text{ if } 1.074 \leq z$$

[4-13]

$$\text{Log Likelihood Function} = -167.0860$$

$$\text{Restricted Log Likelihood Function} = -177.4383$$

The urban crash severity model estimation results are shown in Table 12. The threshold value was given from the program as μ_1 and is also shown in Table 12. The coefficients are the numbers preceding each variable in the z equation shown above.

Table 12. Urban Crash Severity Model Estimation Results

<u>Variable</u>	<u>Coefficient</u>	<u>P-Value</u>	<u>Mean Value</u>
Constant	-0.484043997	0.0014	
REAREND	0.463093869	0.0131	0.289216
FALL	0.465832938	0.0078	0.397059
X48	-0.459598149	0.0345	0.245098
YOUNG	-0.471309016	0.0660	0.156863
μ_1	1.073768106		

Overall Fit

One common measure of the overall model fit is the ρ^2 statistic. Since the value of the statistic improves with the addition of each variable into the model, the statistic must be corrected for by subtracting the number of variables from the log likelihood function which is created as output from the model. The corrected ρ^2 statistic is defined as:

$$\text{Corrected } \rho^2 = 1 - [\text{LL}(\beta) - K]/\text{LL}(0) \quad [4-14]$$

Where:

LL(β) = Log Likelihood at Convergence with Parameter Vector β

LL(0) = Initial Log Likelihood (with all parameters set to zero)

K = number of parameters estimated in the model (Washington et al., 2003)

The closer the ρ^2 statistic is to 1.0, the more certainty the model has in predicting the outcomes. The computation of the ρ^2 statistic for the single vehicle crash model is:

$$\text{Corrected } \rho^2 = 1 - [(-167.0860 - 5)/-177.4383] = 0.0301643 \quad [4-15]$$

This value is far from 1.0, but it was the highest ρ^2 statistic that was computed from the complete trial and error process. Therefore, this model predicts the values with more certainty than any other model created within the process.

Individual Parameter Significance

The method of individual parameter significance used is the P-value. The variables along with the P-values for each variable are shown in Table 12. All P-values for the variables used in the model are less than 0.1, which means they are all significant at the 90% confidence level. These mean we have confidence in each of the variables at the 90% confidence level.

Frequency Comparison

Another method of determining the overall fit of the model is to compare the actual frequency of the severity variable with the predicted frequency from the model output. Figure 45 shows the comparison of the actual and predicted number of observations in each category. The model is predicting the same number of observations for each value in the SEVERITY variable. This indicates that the model is accurately predicting these outcomes.

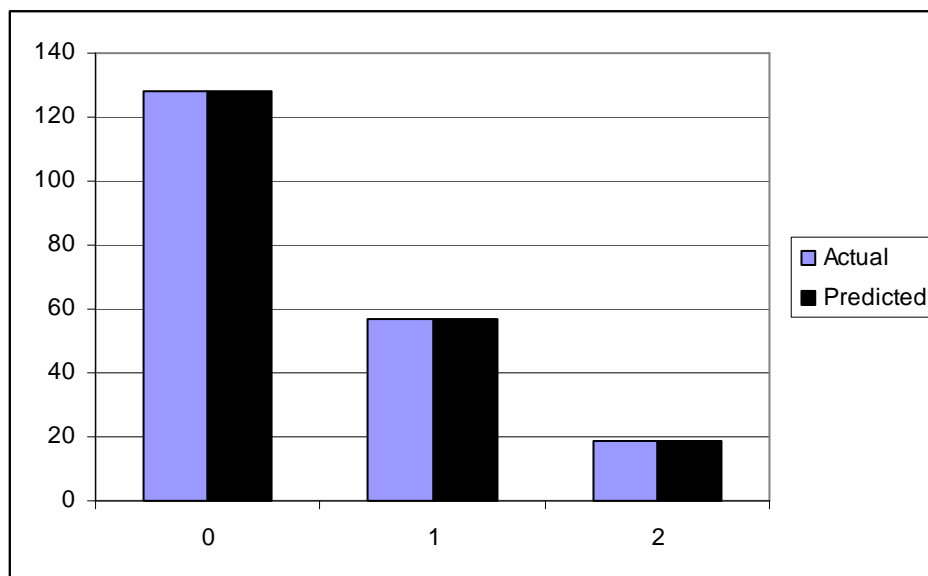

Figure 45. "SEVERITY" Variable Comparison

Marginal Effects

The marginal effects function describes the effect of each variable on each interior outcome for the SEVERITY dependent variable with either a unit change for each independent continuous variable or a change from 0 to 1 for each independent indicator variable. These marginal effects provide the direction of the probability for each category as:

$$P(y = i) / \partial X = [\phi(\mu_{i-1} - \beta X) - \phi(\mu_i - \beta X)] \beta \quad [4-16]$$

Where $\phi(\cdot)$ is the standard normal density.

Table 13 shows the marginal effects for all the independent variables.

Table 13. Marginal Effects

Variable	Y=0	Y=1	Y=2
	(PDO)	(Possible/Unknown Injury and Minor Injury)	(Major Injury/Fatality)
REAREND	-0.1774	0.1004	0.0770
FALL	-0.1760	0.1035	0.0725
X48	0.1631	-0.1067	-0.0565
YOUNG	0.1637	-0.1096	-0.0541

The following is a description of the marginal effects for each variable used in the model for each value of y.

When REAREND changes from 0 to 1, the probability of a PDO crash will decrease by 0.1774.

When REAREND changes from 0 to 1, the probability of a possible/unknown injury or minor injury crash will increase by 0.1004.

When REAREND changes from 0 to 1, the probability of a major injury or fatality crash will increase by 0.0770.

A farm vehicle involved in a rear-end crash in an urban setting would result in an increase in the probability that the crash is a fatality or major injury crash or minor injury or possible/unknown injury crash, in decreasing order of the magnitude of effect. Conversely, a rear-end crash involving a farm vehicle in an urban setting would result in a reduction in the probability that the crash is a property damage only crash.

When FALL changes from 0 to 1, the probability of a PDO crash will decrease by 0.1760.

When FALL changes from 0 to 1, the probability of a possible/unknown injury or minor injury crash will increase by 0.1035.

When FALL changes from 0 to 1, the probability of a major injury or fatality crash will increase by 0.0725.

A farm vehicle involved in a crash in an urban setting during the fall would have an increased probability that the crash is a fatality or major injury crash or minor injury or

possible/unknown crash, in decreasing order of magnitude of effect. Conversely, a farm vehicle crash in an urban setting during the fall will have a reduced probability that the crash is a property damage only crash.

When x48 changes from 0 to 1, the probability of a PDO crash increases by 0.1631.

When x48 changes from 0 to 1, the probability of a possible/unknown injury or minor injury crash decreases by 0.1067.

When x48 changes from 0 to 1, the probability of a major injury or fatality crash decreases by 0.0565.

An urban crash involving a farm vehicle of which the driver has a Class A CDL would have an increased probability that the crash would be a property damage only crash. Conversely, the same type of crash would have a decreased probability that the crash would result in a minor injury or possible/unknown injury crash and fatality or major injury crash in decreasing order of magnitude of effect.

When YOUNG changes from 0 to 1, the probability of a PDO crash increases by 0.1637.

When YOUNG changes from 0 to 1, the probability of a possible/unknown injury or minor injury crash decreases by 0.1096.

When YOUNG changes from 0 to 1, the probability of a major injury or fatality crash decreases by 0.0541.

A single vehicle crash involving a farm vehicle with a driver 25 years of age or younger would result in an increase in the probability that the crash is a property damage only crash. Conversely, it will result in a decrease in the probability that the crash is a minor injury or possible/unknown injury crash, major injury crash, and fatality crash in decreasing order of the magnitude of effect.

Discussion of Coefficients and Marginal Effects

The coefficient on the REAREND variable is positive. This means that a crash in which the manner of collision is a rear-end crash gives the indicator variable a value of 1. This value increases the value of z . This increase in the value of z increases the value of y as it crosses the threshold μ value. This indicates that a farm vehicle involved in a rear-end crash would result in a more severe crash. Similar results were found with the marginal effects test where a rear-end crash is most likely to result in a possible/unknown or minor injury crash. This could be attributed to the high speed differential between other traffic and the SMVs. A high speed differential could result in a greater impact and, therefore, a higher crash severity.

The coefficient on the FALL variable is positive. This means that a value of 1 for the FALL variable would increase the value of z . An increase in the value of z would increase the value of y as it crosses the μ threshold value. This indicates that an urban crash occurring during the months of September, October, or November would tend to result in a higher crash severity. Similarly, the marginal effects test showed that this type of crash is more likely to result in a higher severity crash. This makes sense because the equipment often times used during the fall months is harvesting machinery. This includes combines which often times extend into oncoming lanes of traffic with large corn and bean heads. This large presence on the road not only makes the speed differential an issue, but also makes trying to avoid collision with any of the oversized parts of the combine difficult.

The coefficient on the x48 variable is negative. This means that a value of 1 for the x48 indicator variable would decrease the value of z . This decrease in the value of z would decrease the value of y as it crosses the μ threshold. This indicates that a crash involving a farm vehicle of which the driver has a Class A CDL would tend to result in a less severe crash. A Class A CDL is a specialized license allowing the driver to operate vehicle was a Gross Combination Weight Rating (GVWR) of “26,001 or more pounds, provided the GVWR of the vehicle(s) being towed is in excess of 10,000 pounds. The holders of a Class A license may, with appropriate endorsements, operate vehicles within Types B and C” (Iowa Department of Transportation, 2007). This license requires the most testing and

knowledge, so it makes sense that a driver with a Class A CDL would be involved in less severe crash due to the knowledge and experience that driver has operating a large vehicles. Also, since the driver has a Class A Commercial Driver's License, it could mean that the vehicle was a larger piece of equipment, which would tend to sustain more damage before an injury to the driver would occur. The marginal effects analysis also showed a high likelihood of a crash involving a driver with a Class A CDL of being a property damage only crash. This makes sense because farm vehicle drivers who have received a Class A CDL have been educated about the safety and mechanics of driving heavy machinery down the highway. This license may also be correlated with the experience of the driver. A driver with this license may be more experienced than a driver without such a license and would know how to handle the heavy machinery on the highway better.

The coefficient on the YOUNG variable is negative. This means that a value of 1 for the YOUNG indicator variable would decrease the value of z . This decrease in the value of z decreases the value of y as it crosses the μ threshold. This indicates that a farm vehicle involved in a crash in an urban setting with a driver under the age of 25 would tend to result in a less severe crash. This seems reasonable because younger bodies are better able to handle trauma and can recover quicker. They can typically withstand more damage to their bodies than can older adults. Younger drivers also tend to have better perception-reaction times which would allow more time to make a maneuver to avoid a more serious crash.

Rural Crash Severity Model

Overall Description

Rural crash severity was also modeled using the ordered probability model. There were a total of 386 rural crashes. Using a trial and error process, a model with the best ρ^2 statistic with all variables in the model significant at the 90% confidence level was created. Histograms were made to ensure enough observations existed for each variable for consideration. All variables were required to have at least 10% of the total observations,

which means each variable had at least 39 observations. Once again, the dependent variable used is SEVERITY. The mean of the variable is 0.5933. This is a bit higher than the mean for urban crashes which was 0.4657. According to this data, on average, the rural crashes seem to have a higher crash severity than urban crashes. The frequencies are shown in Table 14 along with the descriptions for each value of the SEVERITY variable.

Table 14. SEVERITY Variable Description

<u>Value</u>	<u>Description</u>	<u>Observations</u>
0	Property Damage Only	205
1	Minor Injury or Possible/Unknown Injury	133
2	Major Injury/Fatality	48

The total output from the model is shown in Appendix D. The model is as follows:

$$z = -0.159 + 0.306(OLDCAR) + 0.283(STRAIGHT) + 0.439(DARK) + 0.401(SUMMER) - 0.352(MULTVEH)$$

$$Y = 0 \text{ if } z \leq 0$$

$$Y = 1 \text{ if } 0 < z \leq 1.142$$

$$Y = 3 \text{ if } 1.142 \leq z \quad [4-17]$$

$$\text{Log Likelihood Function} = -355.5843$$

$$\text{Restricted Log Likelihood Function} = -371.5021$$

Overall Fit

The calculation for the corrected ρ^2 statistic is:

$$\text{Corrected } \rho^2 = 1 - [-355.5843 - 6]/[-371.5021] = 0.026696 \quad [4-18]$$

This value is fairly close to 0, but it is the highest ρ^2 statistic that was computed from the complete trial and error process with all variables in the model being significant according to

the P-values. Therefore, this model predicts the values with more certainty than any other model created within the process.

Individual Parameter Significance

The variables included in the model along with the P-values and mean values for each variable are shown in Table 15. The mean values are the average value of each variable. All the variables are indicator variables. This means that an indicator variable will have values of 0 or 1. For instance, the OLDCAR indicator variable would receive a value of 1 if the farm vehicle involved in a crash was over 29 years old, or a value of 0 if the farm vehicle involved in the crash was not over 29 years old. Therefore, the mean value also indicates the percentage of all multiple vehicle crashes recording that specific variable as an observation. For example, the mean of OLDCAR is 0.13989, which means 14% of the rural crashes involved a farm vehicle that was over 29 years old.

Table 15. Rural Variable Output

Variable	Coefficient	P-Value	Mean Value
Constant	-0.158353581	0.3882	
OLDCAR	0.306113167	0.0736	0.13989637
STRAIGHT	0.283847181	0.0241	0.54404145
DARK	0.439393216	0.0048	0.19430052
SUMMER	0.401118760	0.0054	0.23575130
MULTVEH	-0.351751705	0.0310	0.83678756
μ_1	1.142486576		

All P-values for the independent variables are less than 0.1, which means they are all significant at the 90% confidence level.

Frequency Comparison

The actual frequency of the severity variable and the predicted frequency from the model output are shown in Figure 46. The model is predicting the same number of observations for

each possible outcome in the SEVERITY variable. This indicates that the model is accurate in predicting these outcomes.

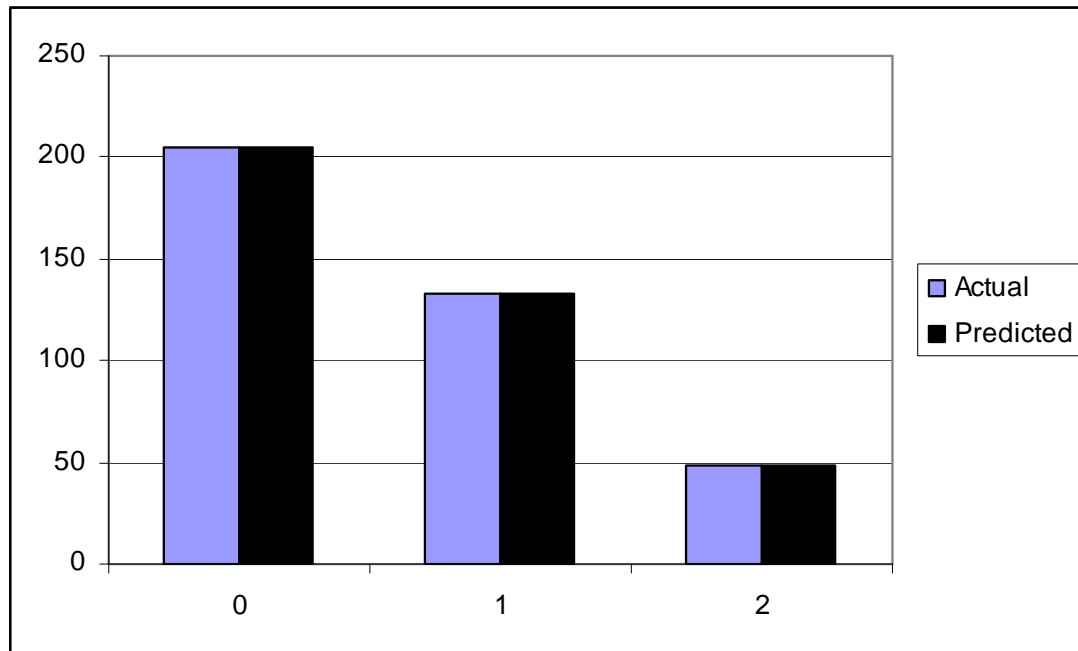

Figure 46. "SEVERITY" Variable Comparison

Marginal Effects

The marginal effects function describes the effect of each variable on each outcome for the SEVERITY dependent variable with either a unit change or indicator change from 0 to 1 in each independent variable. Table 16 shows the marginal effects for all the independent variables.

Variable	Y=0	Y=1	Y=2
OLDCAR	-0.1216	0.0554	0.0662
STRAIGHT	-0.1124	0.0592	0.0532
DARK	-0.1736	0.0760	0.0976
SUMMER	-0.1589	0.0725	0.0864
MULTVEH	0.1395	-0.0627	-0.0768

The following is a description of the marginal effects for each variable used in the model for each value of y.

When OLDCAR changes from 0 to 1, the probability of a PDO crash will decrease by 0.1216.

When OLDCAR changes from 0 to 1, the probability of a possible/unknown injury or minor injury crash will increase by 0.0554.

When OLDCAR changes from 0 to 1, the probability of a major injury or fatality crash will increase by 0.0662.

An older farm vehicle involved in a rural crash would result in an increase in the probability that the crash is a fatality crash, major injury crash, or minor injury or possible/unknown injury crash, in decreasing order of the magnitude of effect. Conversely, a multiple vehicle crash involving a farm vehicle would result in a reduction in the probability that the crash is a property damage only crash.

When STRAIGHT changes from 0 to 1, the probability of a PDO crash decreases by 0.1124.

When STRAIGHT changes from 0 to 1, the probability of a possible/unknown injury or minor injury crash increases by 0.0592.

When STRAIGHT changes from 0 to 1, the probability of a major injury or fatality crash increases by 0.0532.

A rural crash involving a farm vehicle when the farm vehicle's action is essentially straight would decrease the probability that the crash would be property damage only. Conversely, the same type of crash would increase the probability that the crash would be a minor injury or possible/unknown injury crash, major injury crash, and fatality crash in decreasing order of magnitude of effect.

When DARK changes from 0 to 1, the probability of a PDO crash will decrease by 0.1736.

When DARK changes from 0 to 1, the probability of a possible/unknown injury or minor injury crash will increase by 0.0760.

When DARK changes from 0 to 1, the probability of a major injury or fatality crash will increase by 0.0976.

A rural crash involving a farm vehicle in which the lighting conditions are dark is likely to result in a minor injury or possible unknown injury crash, major injury crash, and fatality crash in decreasing order of magnitude of effect. The same type of crash would result in a lower probability that the crash would be property damage only.

When SUMMER changes from 0 to 1, the probability of a PDO crash will decrease by 0.1589.

When SUMMER changes from 0 to 1, the probability of a possible/unknown injury or minor injury crash will increase by 0.0725.

When SUMMER changes from 0 to 1, the probability of a major injury or fatality crash will increase by 0.0864

A rural crash involving a farm vehicle during the summer months of June, July, and August will decrease the probability that the crash will be a property damage only crash. Conversely, this same crash would increase the probability of the crash being a fatality or major injury crash, minor injury or possible unknown injury crash in decreasing order of the magnitude of effect.

When MULTVEH changes from 0 to 1, the probability of a PDO crash will increase by 0.1395.

When MULTVEH changes from 0 to 1, the probability of a possible/unknown injury or minor injury crash will decrease by 0.0627.

When MULTVEH changes from 0 to 1, the probability of a major injury or fatality crash will decrease by 0.0768.

A rural multiple vehicle crash involving a farm vehicle will have a higher probability of resulting in a property damage only crash. The same type of crash would have a low probability of resulting in a fatality or major injury crash or minor injury or possible/unknown injury crash in decreasing order of magnitude of effect.

Discussion of Coefficients and Marginal Effects

The coefficient on the OLDCAR variable is positive. This means that a crash with a 1 value for the OLDCAR variable increases the value of z . This increase in the value of z increases the value of y as it crosses the threshold μ values. This indicates that farm vehicles involved in rural crashes that are over 29 years old tend to increase the severity of the crash. Similar results were found from the marginal effects function. An older farm vehicle involved in a crash resulted in the highest probability of the crash being a major injury or fatality crash. This makes sense because older vehicles have fewer safety features, may not run as well and may be more prone to equipment failure, and may not be physically capable of avoiding some accidents. Many farm vehicles lack a ROPS or any cab overhead at all making crashes in which the vehicle overturns very dangerous.

The coefficient on the STRAIGHT variable is positive. This means that a 1 value for the STRAIGHT variable would increase the value of z . This increase in the value of z would increase the value of y as it crosses the μ thresholds. This indicates that a rural crash involving a farm vehicle in which the action of the farm vehicle is essentially straight would result in a high severity crash. The marginal effects analysis showed the greatest likelihood of a crash involving a farm vehicle traveling straight resulting in a minor injury or possible/unknown injury crash. This could be attributed to the straight movement allowing the vehicle to travel at higher speeds. Farm vehicles traveling at higher speeds require more time to stop and can lose control more easily.

The coefficient on the DARK variable is positive. This would mean that a 1 value for the DARK indicator variable would increase the value of z . This increase in the value of z results in an increase in the value of y as it crosses the μ thresholds. This indicates that a rural crash occurring during dark conditions would tend to result in a more severe crash. The marginal effects analysis showed similar findings with the greatest likelihood of a farm vehicle crash occurring in a dark environment resulting in a major injury or fatality crash.

This could mean that the safety features on farm vehicles may need to be more effective during dark conditions because these crashes are more severe. It could also mean that drivers may have slower reaction times during dark conditions since the sight distance is limited due to the darkness. These slower reaction times could result in higher speed differentials during the impact of the crash and would tend to result in a higher crash severity.

The coefficient on the SUMMER variable is positive. This means that a rural crash with a value of 1 for SUMMER would increase the value of z . An increase in the value of z would increase the value of y as it crosses the μ threshold values. This indicates that a rural crash involving a farm vehicle during the summer months of June, July, and August would result in a higher crash severity. The marginal effects analysis showed similar findings showing the greatest probability of a farm vehicle crash in the summer being a major injury or fatality crash. In the summer months, sprayers are common farm machinery used to spray chemicals on the crops. These machines are more flimsy types of farm vehicles and may result in more severe crashes. This may be one of many different farm vehicles on the road during the summer that may explain the likelihood of high crash severity.

The coefficient on the MULTVEH variable is negative. This would mean that a value of 1 for the MULTVEH indicator variable would decrease the value of z . This decrease in the value of z results in a decrease in the value of y as it crosses the μ thresholds. This indicates that a rural multiple vehicle crash involving a farm vehicle will tend to result in a less severe crash. The marginal effects analysis also showed the highest probability of a farm vehicle crash involving more than one vehicle resulting in a PDO crash. This coefficient does not make sense because a multiple vehicle crash should have a higher probability of being a more severe crash because there are more people involved in the crash.

Farm Vehicle Crash Severity Models: Summary of Findings

The urban farm vehicle crash severity model showed that rear-end crashes were more likely to result in a high crash severity. Since farm vehicles are traveling at such low speeds, they are likely being rear-ended by other traffic. This same model showed that crashes during the months of September, October, and November tend to result in a higher crash severity. The urban farm vehicle crash model showed a decrease in crash severity with crashes involving a farm vehicle where the driver has a Class A CDL. Crashes involving a younger farm vehicle driver were also found to decrease crash severity in the urban farm vehicle crash severity model.

The rural farm vehicle crash severity model showed that older vehicles involved in crashes are more likely to result in a higher crash severity. The same model showed that crashes involving farm vehicles where the farm vehicles were traveling essentially straight at the time of the crash were more likely to result in a higher crash severity. The rural farm vehicle crash severity model also showed that crashes occurring during dark conditions resulted in a high crash severity. The same model showed crashes occurring during the summer months of June, July, and August would result in a high crash severity. Multiple vehicle crashes occurring in a rural environment resulted in a lower crash severity from the rural farm crash severity model.

From the results of the farm vehicle crash models, many observations have been made. From those observations, recommendations could be deduced based on those findings which may help to lower farm vehicle crash severity.

Rear-end crashes could be reduced by enhancing the safety features on the rear of farm vehicles. Requiring more safety features than the current SMV Emblem and rear taillight requirements may help increase warning to other traffic of the presence of the farm vehicles and allow drivers to adjust their speeds accordingly.

Fall crashes were also more severe when they were in an urban environment. This suggests the need to increase awareness during the fall to other drivers of the presence of farm vehicles on the roadway. This could be done through the media, safety brochures, and other informational programs.

Through the urban crash model it was also shown that crashes involving drivers with a higher CDL classification are less severe. Farm vehicle operators could be required to have a higher driver's license classification to drive on the public road system than the standard driver's license.

Older farm vehicles tended to be in higher severity crashes. There are many old farm vehicles being used on farms throughout Iowa. Statistics from the literature review stated that the average tractor age was 25.7 years and that only 50% of all farm vehicles in the United States had an ROPS in 2002. The older farm vehicles could be required to be updated with an ROPS to prevent farm vehicle crashes from being high severity crashes. Updating older farm vehicles to follow these standards may help reduce the severity of rural crashes involving a farm vehicle.

The rural crash model shows a need for increased safety features during dark conditions. Dark conditions limit the visibility of the farm vehicles on the roadway. More emphasis may need to be placed on making the farm vehicle as visible as possible to other vehicles on the roadway. In order to reduce the severity of crashes involving old farm vehicles during dark conditions, all farm vehicles should follow ASABE standards for lighting and marking.

CHAPTER 5: CONCLUSIONS AND RECOMMENDATIONS

Conclusions

This thesis examined farm vehicle crashes in terms of numbers, crash characteristic similarities, and crash severity factors. Many SMV crashes occur each year in the state of Iowa. Much of Iowa's land is used for farming, which results in high farm vehicle traffic on the public roadways during the spring, summer, and fall. Iowa also has many Old Order Amish and Mennonite communities which produce high horse-drawn buggy traffic. Many all-terrain vehicles, mopeds, construction and maintenance vehicles, bicycles, and other SMVs are also using the road system. These vehicles are traveling at very low speeds and must be very visible and leave enough reaction time for other faster moving vehicles on the roadways to see the slow vehicles and avoid a collision. This thesis analyzed the common types of crashes for each vehicle in order to understand how and why the crashes are occurring, and determine strategies to prevent these types of crashes. Some concluding remarks are offered by type of slow moving vehicle.

Horse-Drawn Buggies

The most common manner of collision for the rural horse-drawn buggy crashes was the rear-end collision. Two-thirds of the rural crashes involving horse-drawn buggies occurred during nighttime hours. The vehicles were moving essentially straight in a majority of the rural crashes in which they were involved and turning left in 11% of the crashes.

Animals were the most common cause of crash for the rural multiple vehicle crashes. Half of the rural multiple vehicle crashes involving horse-drawn buggies were the responsibility of the horse-drawn buggy. This indicates not only a necessity to address visibility of the horse-drawn buggies, but also better control of the buggies. If the animals are the most common

cause of the rural multiple vehicle crashes involving horse-drawn buggies, proper training of the horses should be required in order for them to pull a buggy on the public highway system. Also, wider shoulders on public highways in communities with high Old Order Amish and Old Order Mennonite populations would allow more room for error for the horses.

Farm Vehicles

Most farm vehicle crashes occurred in October at over 25% of the total rural crashes. The most common manner of collision for rural farm vehicle crashes was the rear-end collision. The action of the farm vehicles was essentially straight during the time of the crash for most of the rural crashes, while 30% of the farm vehicles involved in rural crashes were turning left. The most common cause for farm vehicle crashes was “swerving/evasive action.” Farm vehicles were responsible for just more than 40% of the rural multiple vehicle crashes in which they were involved.

Crash severity models can also help show the effect of different crash characteristics on another characteristic of a crash. Two separate models were created for urban and rural crashes involving farm vehicles to determine the effect of all different crash characteristics on crash severity. Within these models, there were a number of different factors that have an influence on crash severity that can be considered for safety improvements. Studying and understanding these factors and creating standards for farm vehicles to reduce the severity of those crashes can greatly impact the safety on Iowa’s public roadways. Crash severity of a farm vehicle in an urban environment was found to increase when the crash was a rear-end crash. Crash severity also increased when the urban farm vehicle crash occurred during the fall. Urban farm vehicle crashes where the driver of the farm vehicle had a Class A driver’s license or was under the age of 25 resulted in a less severe crash. Rural farm vehicle crash severity was found to increase when the farm vehicle was over 29 years old as well as when the farm vehicle was traveling essentially straight at the time of the crash. Crash severity was also higher when the crash occurred during dark conditions and also during the summer

months. Rural farm vehicle crash severity was found to be low when the crash was a multiple vehicle crash.

Construction and Maintenance Vehicles

The construction/maintenance vehicles category is a group of vehicles including many different types of vehicles. Therefore, it is difficult to find commonalities in the causes, types, and manners of crashes involving these types of vehicles. Some of these vehicles are SMVs, some are not. Therefore, it is difficult to study these vehicles because they are grouped into one category. The most common manner of collision for rural crashes involving a construction/maintenance vehicle was the rear-end collision. The most common vehicle action during the crash was “moving essentially straight.” Construction/maintenance vehicles were turning left in 11% of the rural crashes in which they were involved. The most common cause of rural crashes involving construction/maintenance vehicles was failure to yield the right of way. These types of vehicles were also responsible for fewer than 35% of the rural crashes in which they were involved.

All-Terrain Vehicles and Mopeds

Moped/ATVs represented the second highest group in terms of number of SMV crashes from 2004-2006. This group had the highest percentage of crashes resulting in a fatality at just fewer than 10%. Moped/ATVs were responsible for just fewer than 70% of the rural multiple vehicle crashes in which they were involved; the highest of all four vehicles types. The most common manner of collision was the non-collision. Moped/ATVs were moving essentially straight in a majority of the rural crashes in which they were involved and turning left in 8% of the crashes. About 60% of the drivers of moped/ATVs who were involved in a rural crash were under the age of 24; 17% were under the age of 15. The most common cause for moped/ATV crashes was swerving/evasive action.

Recommendations

The findings of this thesis included many possible safety recommendations to be used on SMVs. An important aspect of the data analysis found that mopeds/ATVs had the highest fatality rate of all four vehicle types analyzed in this thesis; therefore, crashes within the moped/ATV category may be the most important and necessary to consider for implementing countermeasures. The crash analysis found that a large number of the moped/ATVs involved in crashes were driven by a young driver. Just fewer than 60% of the rural crashes involved a moped/ATV with a driver under the age of 24 years. Drivers 15 years of age and under were involved in 17% of the rural moped/ATV crashes. Since a majority of the rural moped/ATV crashes involved young drivers, emphasis should be placed on stricter licensing requirements for these drivers on the public road system and better enforcement of those laws. Young drivers have often not had proper training to drive, especially when other faster vehicles are present. Younger drivers are not as experienced and will tend to not have proper knowledge of how to handle certain situations by themselves. Also, since 70% of the rural multiple vehicle crashes involving moped/ATVs were the responsibility of the ATV, the emphasis may need to be placed on proper driving techniques of the moped/ATV drivers and not necessarily the visibility of the ATV to other vehicles on the roadway. Once again, this also may be explained by the inexperience of young drivers involved in the crashes.

Another aspect of the data analysis that stands out was that 30% of all rural crashes involving a farm vehicle occurred when the farm vehicles were turning left. Farm vehicles often turn left into field entrances from the roadway. When traveling at slow speeds, vehicles approaching in the same direction are tempted to pass. Without a turn signal, it is impossible for the vehicles behind the farm vehicle to know that the farm vehicle is turning. Therefore, as a vehicle attempts to pass the farm vehicle, the farm vehicle turns left into the passing vehicle resulting in a sideswipe crash, same direction. Many farm vehicles do not have turn signals that operate correctly or do not have turn signals that are visible from vehicles following the farm vehicle. Many do not even have turn signals at all. Due to the frequency of these types of crashes, turn signals should be present, visible, and operating correctly on

the farm vehicles in order to prevent these types of crashes. Many times the turn signals can be hidden from view by a wagon, hay bailer, or any other type of equipment in tow behind the farm vehicle. If this is the case, turn signals should be present on the piece of equipment in tow in order for the turn signal to be visible by vehicles following the farm vehicle.

The crash analysis also found that the majority of the crashes involving horse-drawn buggies were the result of an improper action by the animals pulling the buggies. Proper training could be required for the horses pulling the buggies. If the horses are difficult to control, allowing the horses to pull the buggies is a potentially dangerous situation for the passengers in the buggy as well as other vehicles on the roadway. A program, similar to the Gaeuga County Sharing the Road with Amish Travelers Forum in Ohio, could be initiated in the most heavily populated Old Order Amish and Old Order Mennonite counties within the state of Iowa. These are Washington, Davis, and Buchanan counties; in descending order of Old Order Amish population (none of those counties have Old Order Mennonite communities). During these meetings, state and county officials would be able to address the importance of training the horses properly and operating the horse-drawn buggies in the safest manner possible. Since the crash data analysis indicated a misjudge in gap by the operators of the horse drawn buggies or an inability of the horses to move in an effective manner to avoid collision, instructing the Amish community members to be cautious when pulling into ongoing traffic is an important aspect to cover as well.

Also from the crash analysis, many of the crashes involving horse-drawn buggies occurred during night hours and the most common manner of collision was the rear-end collision. Lack of visibility of the horse drawn buggies from the rear could be an explanation for these types of crashes. The SMV Emblem may not be a sufficient aid for night visibility. Amber flashers may be an effective countermeasure to help prevent horse-drawn buggy crashes during not only nighttime, but also daytime hours. This would also give indication to drivers approaching from the rear that the particular vehicle is traveling more slowly than normal traffic.

Many observations could be incurred from the crash model analysis on farm vehicle severity. Rural crashes involving farm vehicles over 29 years of age resulted in higher crash severity. These types of vehicles often times lack safety features that did not come standard on farm vehicles at the time of their construction. One such safety feature that could potentially lower crash severity in crashes involving farm vehicles is the ROPS. Many farm vehicles lack the device and some even lack a cab overhead at all. Requiring the ROPS on all farm vehicles in the state of Iowa could help lower crash severity in rollover or overturn crashes. Another feature that older farm vehicles may lack is the seat belt. Requiring seat belt use in combination with the ROPS would prevent drivers from being thrown from the farm vehicle and rolled over by the equipment in the event of a rollover or overturn crash.

Also from the crash model analysis, rear-end crashes were found to result in more severe crashes in the urban environment. The ASABE lighting and marking standards would also help increase visibility of the farm vehicles. Making these farm vehicles more visible from the rear would help prevent rear-end crashes. The ASABE standards have suggested that farm vehicles be equipped with these important safety features: 2 headlamps, 2 red taillights, 2 amber flashing lights, 2 turn indicators, and 1 SMV emblem. Not only should farm vehicles be equipped with these features, but they should also be visible from vehicles following the farm vehicle. Any equipment in tow must not block the view of any safety features. If this occurs, the safety features must be placed on the unit in tow in order to be visible by other vehicles behind the farm vehicle.

Another conclusion from the farm vehicle rural crash modeling was the decrease in crash severity when the driver of the farm vehicle had a Class A Commercial Driver's License. Requiring a special driver's classification to operate a farm vehicle on the public roadway could help reduce crash severity of farm vehicles. Intuitively, it could also help reduce the frequency of farm vehicle crashes.

FUTURE RESEARCH

As a result of this thesis, many inferences could be made about the crashes involving farm vehicles. However, some issues concerning farm vehicle crashes were not considered through this thesis because they were not realized until the final stages of the research process. This section describes those shortfalls and suggests those other matters to consider in future research within the study of SMV crashes.

Due to the low number of crashes in the horse-drawn buggy category, more data would be necessary to be able to model the crashes with any confidence. Future research could be done using more years of data and the severity could then be modeled. Also, more years of data would allow more confidence in the results of the crash data analysis as well as crash modeling.

Also, an aspect of this topic that was not researched as a part of this thesis is the number of crashes that were a result of an SMV's existence on the roadway, but were not directly involved in the crash. The SMV would not have been recorded as being a part of the crash because the SMV would not be a vehicle reported in the collision. The SMVs may be referred to in the narratives specific to each vehicle in each crash, but the search would be difficult. One method would be to take a sample of crashes and determine what percent of those crashes reported an SMV being involved in the crash within the crash narrative section. This would give an idea as to how many more crashes resulted from an SMV's existence on the roadway in addition to those crashes with an SMV reported as being directly involved in the crash.

Further research is also recommended to determine the effects of the different safety features on SMVs on driver behavior. This analysis provides evidence to the types of crashes that are most common among crashes involving SMVs, but the actual effects of each safety feature on preventing these types of crashes should also be researched. Analyzing the difference in driver behavior with and without each device installed on an SMV would provide further

evidence to the effect of each device. If the effect of a device is positive and it has a significant influence on driver behavior, the device could become a standard to be used on all SMVs in Iowa.

REFERENCES

1. Farm Safety Association. Changes to the Use of the Slow Moving Vehicle Sign. NASD (National Ag Safety Database), 2002. www.cdc.gov/nasd/docs/d001501-d001600/d001533/d001533.html. Accessed March 3, 2008.
2. Lacy, J.K., W. Hunter, and H. Huang. Study of Farm Vehicle Crashes in North Carolina. In *Transportation Research Record: Journal of the Transportation Research Board, No. 1840*, Transportation Research Board of the National Academies, Washington, D.C., 2003.
3. Cole, H. P., C. J. Lehtola, S. R. Thomas, and M. Hadley. Translating Injury Surveillance Data into Health and Safety Educational Materials and Activities for Farm Workers and Families. University of Florida, Biological and Agricultural Engineering Department, 1997.
4. Garvey, P.M. Motorist Comprehension of the SMV (SMV) Emblem. *Journal of Agricultural Safety and Health*, Vol. 9, Issue 2, 2003, pp. 159-169.
5. United States Department of Agriculture (USDA). U.S. State Level Data: 291. USDA (United States Department of Agriculture - National Agriculture Statistics Service. 2002 Census of Agriculture. USDA, Vol. 1, 2002. http://www.agcensus.usda.gov/Publications/2002/Volume_1,_Chapter_1/st99_1_002_002.pdf. Accessed May, 26, 2007.
6. University of Illinois Extension Safety Specialist. ROPS: Rollover Protective Structure – What You Should Know. agsafety.aces.uiuc.edu/rops.html. Accessed June 18, 2008.
7. National Ag Safety Council.
8. Glascock, L.A., R.K. Wood, T.G. Carpenter, and R.G. Holmes. *Characteristics of SMV Accidents*. Paper No. 931618, ASAE, St. Joseph, MI, 1993.
9. Glascock, L.A., T.L. Bean, K. Wood, T.G. Carpenter, and R.G. Holmes. A Summary of Roadway Accidents Involving Agricultural Machinery. *Journal of Agricultural Safety and Health*. Vol. 2, Issue 1, 1995, pp. 93-104.
10. Agricultural Safety and Health Program. Program Areas: Agricultural Equipment. Ohio State University Extension, 2008. ohioline.osu.edu/~agsafety/ash/programs/agricultural_equipment.html
11. Costello, T.M., M.D. Schulman, and R.C. Luginbuhl. Understanding the Public Health Impacts of Farm Vehicle Public Road Crashes in North Carolina. *Journal of Agricultural Safety and Health*, Vol. 9, Issue 1, 2002, pp. 19-32.
12. Meyers, T. J. Amish. Global Anabaptist Mennonite Encyclopedia Online, 1990. www.gameo.org/encyclopedia/contents/A4574ME.html. Accessed May 21, 2007.
13. O'Connor M. Amish Buggy Safety in Ohio: Status Report and Recommendations. Ohio Department of Public Safety, 2000. www.highwaysafetyoffice.ohio.gov/amishstatus.pdf. Accessed April 10, 2008.
14. Ohio State University (OSU) Extension Agricultural Safety and Public Health. Amish Buggy, 2007. extension.osu.edu/~agsafety/ash/programs/amish_buggy.html. Accessed October 25, 2007.
15. Watiker, M. Ten People Injured When Car Collides with Amish Buggy in Ohio. 2007. cms.firehouse.com/web/online/Photo-Stories/Ten-People-Injured-When-

- Car-Collides-with-Amish-Buggy-in-Ohio/45\$42455. Accessed November 1, 2007.
16. Bal, K. Two Amish Seriously Hurt in Buggy-SUV Crash. *The Tribune Democrat*. 2007. www.tribune-democrat.com/homepage/local_story_303000949.html. Accessed November 1, 2007.
 17. Lehtola, C. J., S. J. Marley, and S. W. Melvin. A Study of Five Years of Tractor-Related Fatalities in Iowa. *Applied Engineering in Agriculture*, Vol. 10, 1994.
 18. Iowa Highway Safety Management System. Toolbox of Highway Safety Strategies, Chap. 15. Reducing Farm Vehicle Crashes. Ames, IA, 2001. www.iowasms.org/reports/toolbox.htm. Accessed May 25, 2007.
 19. Gerberich, S., L. Robertson, R. Gibson, and C. Renier. An Epidemiological Study of Roadway Fatalities Related to Farm Vehicles: United States, 1988 to 1993. *Journal of Occupational and Environmental Medicine*, Vol. 38, Issue 1, 1996, pp. 1135-1140.
 20. Flynn, D. An Analysis of Farm Vehicle-Related Accidents on Iowa Roadways. Unpublished paper. Ames, Iowa: Iowa State University, Department of Agricultural and Biosystems Engineering, 1994.
 21. Falb, S. Watch for Increased Farm Equipment Movement on Roadways. Iowa Department of Transportation, April 22, 2004. www.dot.state.ia.us/morgue/news2004/04220404.html. Accessed May 25, 2007.
 22. Pa Dutch. The Amish and the Plain People. Action Video, Inc., 2007. www.800padutch.com/amish.shtml. Accessed May 19, 2008.
 23. Association of Religion Data Archives [ASARB]. U.S. Congregational Membership: U.S. Maps, 2000. www.thearda.com/mapsReports/maps/USMaps.asp?vargroup=2. Accessed May 19, 2008.
 24. State Data Center of Iowa. Religious Congregations and Membership: 2000. data.iowadatacenter.org/countyreligion2000.html. Accessed April 10, 2008.
 25. Pinzke, S. and P. Lundqvist. SMVs in Swedish Traffic. *Journal of Agricultural Safety and Health*, Vol. 10, Issue 2, 2003.
 26. American Society of Agricultural and Biological Engineers (ASABE). Lighting and Marking of Agricultural Equipment on Highways. ASABE, 2006.
 27. Glascock, L. A., T.L. Bean, K. Wood, T.G. Carpenter, L.C. Eicher, and R.G. Holmes. State Codes for Lighting and Marking of Agricultural Equipment. *Journal of Agricultural Safety and Health*. Vol. 1, No. 1, 1995, pp. 17-27.
 28. American Society of Agricultural Engineers (ASAE). Slow Moving Vehicle Identification Emblem (SMV Emblem). ANSI/ASAE S276.6. January 2005. codes.ohio.gov/oac/4501-13. Accessed May 16, 2008.
 29. Lehtola, C. J. Slow to Catch on to the SMV Emblem. *Journal of Agricultural Safety and Health*, Vol. 13, Issue 1, 2007, pp. 5-7.
 30. Farm Bureau Safety Program Georgia. Sharing the Road with SMV's. 70.150.96.39/safety/smv.htm. Accessed May 21, 2007.
 31. LaPrade, J. SMVs on Alabama Roadways. www.aces.edu/farmsafety/Slow_Moving_Vehicles.pdf. Accessed May 25, 2007
 32. SMVs Ahead. *The Kokomo Tribune*, Kokomo, Ind., May 2, 2007. www.kokomotribune.com/opinion/local_story_122160532.html. Accessed May 25, 2007.

33. Iowa Department of Public Safety. Harvest Season and Slow Moving Vehicles “Implements of Husbandry.” 2004. www.dps.state.ia.us/commis/pib/Releases/2004/implements_of_husbandry_09-13-2004.htm. Accessed June 11, 2007.
34. Iowa Department of Transportation. Be Alert for SMVs on Iowa Roadways During Fall Harvest. 2003. www.dot.state.ia.us/morgue/news2003/10010301.html. Accessed May 26, 2007
35. Jepsen, D. Look for the Sign. The Ohio State University Extension. March 2002. ohioline.osu.edu/aex-fact/pdf/0994_1.pdf. Accessed May 27, 2007
36. Pennsylvania Farm Bureau [PFB]. Rural Roads Safety: It’s a Matter of Life and Death. 2006. www.pfb.com. Accessed May 21, 2007.
37. Farm Safety 4 Just Kids. Teaching Tips: Slow Moving Vehicle (SMV) Emblems. Urbandale, IA. www.fs4jk.org/cgi-bin/fs4jktttdetail.pl?987026549. Accessed May 21, 2007.
38. Cyr, D. L. and S. B. Johnson. Driving Farm Machinery Safely. The University of Maine Cooperative Extension, 2006. www.cdc.gov/nasd/docs/d000901-d001000/d000912/d000912.html. Accessed May 27, 2007.
39. Murphy, D. and J. Shufran. Rx for SMV Highway Safety: Be Conspicuous. Pennsylvania State College of Agricultural Sciences Cooperative Extension, 1998. www.cdc.gov/nasd/docs/d001501-d001600/d001545/d001545.html. Accessed May 27, 2007.
40. Texas Department of Insurance, Division of Workers’ Compensation Safety Education and Training Programs. Tractor Road Safety. Texas Department of Insurance, Division of Workers’ Compensation (TDI/DWC), 2004. www.tdi.state.tx.us/wc/information/videoresources/documents/stptrroad.pdf. Accessed May 21, 2007.
41. Karsky, T. Highway Transport of Agricultural Equipment: Preventing Public Road Accidents. 1998. www.phppo.cdc.gov/nasd/docs/d001501-d001600/d001574/d001574.html. Accessed June 11, 2007.
42. Agricultural Safety and Health Program. Program Areas: Agricultural Equipment. Ohio State University Extension, 2008. ohioline.osu.edu/~agsafety/ash/programs/agricultural_equipment.html. Accessed May 10, 2008.
43. State of California Department of Motor Vehicles (California DMV). *California Driver Handbook*. California: Department of Motor Vehicles, 2007.
44. Hesselberg, G. Amish Buggies in Peril on Roads. *The Chronicle*, Jackson County Chronicle, July 31, 2007. www.jacksoncountychronicle.com/articles/2007/07/31/thisjustin/01crash.prt. Accessed August 9, 2007.
45. Grayson, J. Geauga County Sharing the Road with Amish Travelers Forum. 2003. www.publicsafety.ohio.gov/news/2003/03-10-amishsafetyforum.htm. Accessed October 19, 2007.
46. Agricultural Safety and Health Program. Program Area: Amish Buggy. Ohio State University Extension, 2008. ohioline.osu.edu/~agsafety/ash/programs/amish_buggy.html. Accessed May 9, 2008.
47. 2007 Merged Iowa Code and Supplement > Statutes (Code Chapters & Sections) > 2007 MERGED IOWA CODE AND SUPPLEMENT > TITLE VIII TRANSPORTATION > SUBTITLE 2 VEHICLES > CHAPTER 321 MOTOR

- VEHICLES AND LAW OF THE ROAD > 321.234A All-terrain vehicles - highway use.
48. 2007 Merged Iowa Code and Supplement > Statutes (Code Chapters & Sections) > 2007 MERGED IOWA CODE AND SUPPLEMENT > TITLE VIII TRANSPORTATION > SUBTITLE 2 VEHICLES > CHAPTER 321I ALL-TERRAIN VEHICLES > 321I.4 Registration - fee.
 49. 2007 Merged Iowa Code and Supplement > Statutes (Code Chapters & Sections) > 2007 MERGED IOWA CODE AND SUPPLEMENT > TITLE VIII TRANSPORTATION > SUBTITLE 2 VEHICLES > CHAPTER 321I ALL-TERRAIN VEHICLES > 321I.10 Operation on roadways and highways - snowmobile trails.
 50. 2007 Merged Iowa Code and Supplement > Statutes (Code Chapters & Sections) > 2007 MERGED IOWA CODE AND SUPPLEMENT > TITLE VIII TRANSPORTATION > SUBTITLE 2 VEHICLES > CHAPTER 321I ALL-TERRAIN VEHICLES > 321I.13 Headlamp - tail lamp - brakes.
 51. 2007 Merged Iowa Code and Supplement > Statutes (Code Chapters & Sections) > 2007 MERGED IOWA CODE AND SUPPLEMENT > TITLE VIII TRANSPORTATION > SUBTITLE 2 VEHICLES > CHAPTER 321I ALL-TERRAIN VEHICLES > 321I.21 Minors under twelve - supervision.
 52. 2007 Merged Iowa Code and Supplement > Statutes (Code Chapters & Sections) > 2007 MERGED IOWA CODE AND SUPPLEMENT > TITLE VIII TRANSPORTATION > SUBTITLE 2 VEHICLES > CHAPTER 321I ALL-TERRAIN VEHICLES > 321I.14 Unlawful operation.
 53. 2007 Merged Iowa Code and Supplement > Statutes (Code Chapters & Sections) > 2007 MERGED IOWA CODE AND SUPPLEMENT > TITLE VIII TRANSPORTATION > SUBTITLE 2 VEHICLES > CHAPTER 321I ALL-TERRAIN VEHICLES > 321I.9 Exempt vehicles.
 54. 2007 Merged Iowa Code and Supplement > Statutes (Code Chapters & Sections) > 2007 MERGED IOWA CODE AND SUPPLEMENT > TITLE VIII TRANSPORTATION > SUBTITLE 2 VEHICLES > CHAPTER 321 MOTOR VEHICLES AND LAW OF THE ROAD > 321.381A Operation of low-speed vehicles.
 55. 2007 Merged Iowa Code and Supplement > Statutes (Code Chapters & Sections) > 2007 MERGED IOWA CODE AND SUPPLEMENT > TITLE VIII TRANSPORTATION > SUBTITLE 2 VEHICLES > CHAPTER 321 MOTOR VEHICLES AND LAW OF THE ROAD > 321.383 Exceptions - slow vehicles identified.
 56. 2007 Merged Iowa Code and Supplement > Statutes (Code Chapters & Sections) > 2007 MERGED IOWA CODE AND SUPPLEMENT > TITLE VIII TRANSPORTATION > SUBTITLE 2 VEHICLES > CHAPTER 321 MOTOR VEHICLES AND LAW OF THE ROAD > 321.384 When lighted lamps required.
 57. 2007 Merged Iowa Code and Supplement > Statutes (Code Chapters & Sections) > 2007 MERGED IOWA CODE AND SUPPLEMENT > TITLE VIII TRANSPORTATION > SUBTITLE 2 VEHICLES > CHAPTER 321 MOTOR

- VEHICLES AND LAW OF THE ROAD > 321.398 Lamps on other vehicles and equipment.
58. DMV.org. Other Types. 2008. www.dmv.org/ia-iowa/other-types.php. Accessed September 25, 2008.
 59. Luginbuhl, R.C., V. C. Jones, and R. L. Langley. Farmers' Perceptions and Concerns: The Risks of Driving Farm Vehicles on Rural Roadways in North Carolina. *Journal of Agricultural Safety and Health*, Vol. 9, Issue 4, 2003, pp. 327-348.
 60. NCDOL. Fifth annual Gold Star luncheons: Fixing grower's sights on rural highway safety. *The Cultivator*, North Carolina Department of Labor (NCDOL), Raleigh, N.C., May 1999, pp. 1-2.
 61. Harkness, K. A., and W. E. Stucky. Effective Approaches to Reducing Accidents Involving Slow Vehicles. [Abstract]. TRIS Online Database, Accession No. 00223169. Accessed June 5, 2007.
 62. National Ag Safety Database [NASD]. Changes to the Use of the Slow Moving Vehicle Sign. 2002. www.cdc.gov/nasd/docs/d001501d001600/d001533/d001533.html. Accessed June 5, 2007.
 63. Rooner, P. J. Origin, Diffusion, Acceptance and/or Rejection of the Slow Moving Vehicle Emblem. [Abstract] TRIS Online Database, Accession No. 00221136. Accessed June 4, 2007
 64. Stoutenburg, A. H. Slow Moving Vehicle Warning Apparatus, and Methods of Constructing and Utilizing the Same. United States Patent No. 4,768,690. 1987.
 65. Asper, O. The Detectability of Two Slow Vehicle Warning Devices. [Abstract] TRIS Online Database, Accession No. 00226624. 1972. Accessed June 4, 2007.
 66. Lee, S. E., W.W. Wierwille, and M. C. DeHart. Evolution of an Enhanced Rear Signaling System. *Transportation Research Record*. No. 1843. Paper No. 03-4376. 2003.
 67. Francis, A. J. A Slow Moving Vehicle Symbol. [Abstract]. TRIS Online Database, Accession No. 00080802. Accessed May 14, 2007.
 68. Knoblauch, R.L., and H.N. Tobey. Safety Aspects of Using Vehicle Hazard Warning Lights Volume 1. Executive Summary. [Abstract]. TRIS Online Database, Accession No. 00335994. 1980. Accessed June 4, 2007.
 69. Lanman, M.H., H. S. Lum, and R. W. Lyles Evaluation of Techniques for Warning of SMVs Ahead. [Abstract]. TRIS Online Database, Accession No. 00305731. 1979. Accessed May 24, 2007.
 70. Lyles, R. The Effectiveness of Four-Way Flashers on Stationary and SMVs. *ITE Journal*, April 1982.
 71. Legault, M.L. and E. J. Sheldon. The Farm Equipment Hazard Warning Roadway Sign: An Update. Presented at 2004 ASAE/CSAE Annual International Meeting, Ottawa, Ontario, Canada, 2004.
 72. Federal Highway Administration [FHWA]. Manual on Uniform Traffic Control Devices [MUTCD], 2C-22. 2003.
 73. Price, C. W. All Directional Warning Deice for SMVs. United States Patent No. 856,347, January 4, 1972.
 74. Jaarsma, C.F., H. Botma, and R. Beunen. Passing Bays for slow moving vehicles on rural two-lane roads. *Transport Reviews*, Vol 25, No 4, 2005, pp. 491-509.

75. Gillanders, E. NFU Scotland makes tractor stickers available to help cut rural road deaths. *Farmers Weekly Interactive*, 2007. Accessed June 7, 2007.
76. Bovy, P., and H. Botma. Telematics for Slow Travelers' Safety. [Abstract] TRIS Online Database, Accession No. 00793836. 1999. Accessed May 14, 2007.
77. Guo, L.S., Q. Zhang, and S. Han. Safety Detecting System with Ultrasonic Sensors for Agricultural Machine. Presented at ASAE Annual International Meeting, Sacramento, California, 2001.
78. United States Department of Agriculture (USDA). 2002 Census of Agriculture. U.S. National Level Data. USDA (United States Department of Agriculture - National Agriculture Statistics Service), Vol. 1. Index 1, 2. nass.usda.gov/census/census02/volume1/us/index1.htm. Accessed May, 21 2007.
79. Iowa Department of Transportation. Commercial Driver's License in a Nutshell. September 2007. www.iamvd.com/ods/cdl/cdlnut.pdf. Accessed June 3, 2008.
80. Washington, S. P., M. G. Karlaftis, and F. L. Mannering. *Statistical and Econometric Methods for Transportation Data Analysis*. Chapman & Hall/CRC, Boca Raton, FL, 2003, pp.271-282.

APPENDIX A: 2004-2006 SMV IOWA CRASH MAPS

Slow-Moving Vehicle Crashes 2004 - 2006

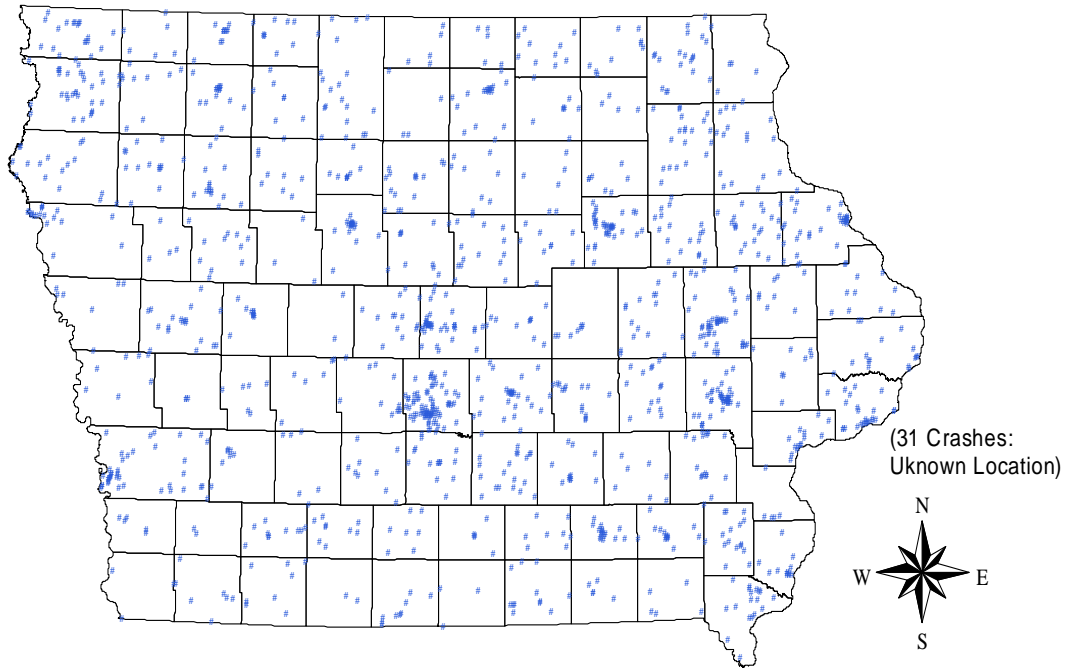

Slow-Moving Vehicle Crashes 2004 - 2006

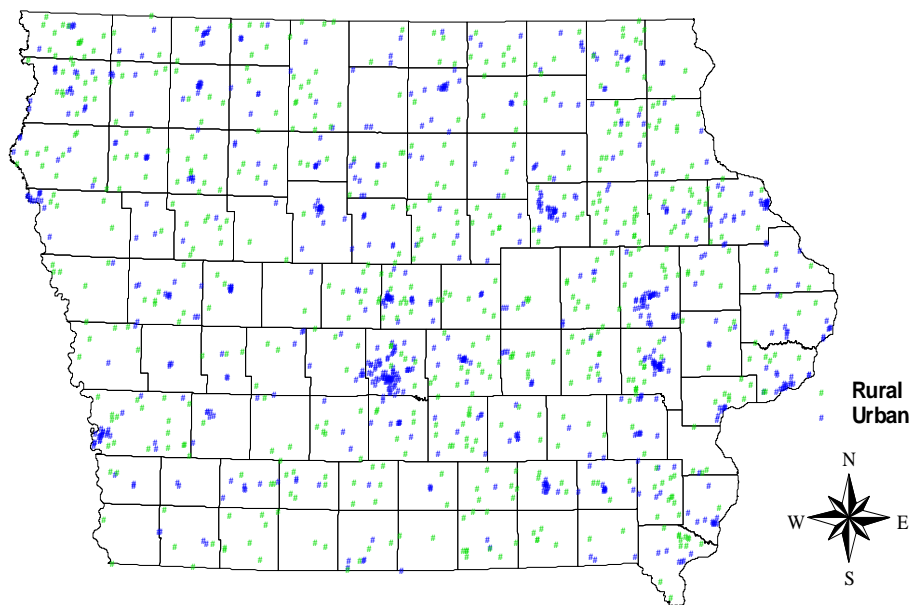

APPENDIX B: SMV ANALYSIS – TOTAL 2004-2006 AND RURAL 2004-2006

Total Iowa SMV Crash Characteristics 2004-2006

Description	SMV Crashes	Horse & Buggy	Farm	Construction/Maintenance	Moped/ATV	Bicycle	Other	Total
# Crashes involving at least one SMV	Total	18	594	230	361	110	39	1352
# SMVs in Crashes in area:	Rural	10	382	62	120	8	9	591
	Urban	8	204	161	229	100	28	730
	Unknown	0	8	7	12	2	2	31
# of SMV Crashes With crash severity of:	Fatality	0	21	4	16	5	1	47
	Major Injury	3	46	11	74	14	3	151
	Minor Injury	4	93	24	158	44	10	333
	Property Damage Only	9	334	157	40	5	15	560
	Possible/Unknown	2	100	34	73	42	10	261
# of Crashes involving one or more SMVs during:	NIGHT (Sunset-Sunrise)	5	125	17	83	28	11	269
	DAY (Sunrise - Sunset)	13	459	212	273	82	28	1067
	Unknown	0	10	1	5	0	0	16
	Night-to-Day Crash Ratio	0.385	0.272	0.080	0.304	0.341	0.393	0.252
# of Crashes involving one or more SMVs during:	AM Peak	2	51	35	24	6	3	121
	PM Peak	3	115	20	84	24	8	254
	Midday (Offpeak)	8	303	150	123	39	14	637
# of Crashes involving one or more SMVs during the following month:	January	3	12	25	9	3	7	59
	February	1	18	26	12	4	1	62
	March	1	20	18	19	3	0	61
	April	1	53	14	32	6	1	107
	May	1	41	12	37	11	2	104
	June	4	64	20	52	13	6	159
	July	0	40	18	52	21	3	134
	August	3	40	25	38	16	8	130
	September	2	64	24	51	16	4	161
	October	0	122	17	31	6	1	177
	November	2	83	17	18	4	3	127
	December	0	37	14	10	7	3	71
# of Crashes involving one or more SMVs with surface conditions of:	Dry	13	460	133	246	97	22	971
	Wet	2	30	20	21	8	4	85
	Ice	0	7	14	4	0	1	26
	Snow	1	14	34	10	1	5	65
	Slush	0	2	2	0	0	0	4
	Sand/mud/dirt/oil/gravel	2	63	19	60	1	2	147
	Water (standing/moving)	0	0	1	0	0	0	1
	Other/Unknown/Not Reported	0	18	7	20	3	5	53

# SMVs in crashes with speed limit of:	below 25 mph	0	3	5	17	1	2	28
	25-34 mph	3	53	80	158	2	14	310
	35-44 mph	1	24	18	27	3	2	75
	45-54 mph	0	66	17	39	0	4	126
	55-64 mph	9	397	74	84	0	6	570
	65 mph and above	0	20	2	1	0	0	23
	Unknown	5	35	35	57	107	11	250
Major cause of crashes involving one or more SMVs	Animal	5	1	1	9	0	0	16
	Ran Traffic Signal	1	1	2	4	0	0	8
	Ran Stop Sign	0	10	3	11	2	0	26
	Crossed centerline	1	30	8	7	0	0	46
	FTYROW: At uncontrolled intersection	0	6	2	9	1	1	19
	FTYROW: Making right turn on red signal	0	0	0	0	5	1	6
	FTYROW: From stop sign	2	17	6	16	3	2	46
	FTYROW: From yield sign	0	1	1	6	0	0	8
	FTYROW: Making left turn	0	28	2	18	2	1	51
	FTYROW: From driveway	0	14	4	15	1	4	38
	FTYROW: From parked position	0	1	1	3	0	0	5
	FTYROW: To pedestrian	0	0	1	1	6	0	8
	FTYROW: Other (explain in narrative)	1	52	23	11	8	6	101
	Traveling wrong way or on wrong side of road	0	10	0	9	0	0	19
	Driving too fast for conditions	0	22	19	20	0	0	61
	Exceeded authorized speed	0	4	2	4	0	0	10
	Made improper turn	0	17	3	4	0	1	25
	Improper Lane Change	0	0	0	0	0	0	0
	Followed too close	2	25	11	15	2	1	56
	Disregarded RR Signal	0	0	1	0	0	0	1
	Disregarded Warning Sign	0	0	1	0	0	0	1
	Operating vehicle in an erratic/reckless/careless/negligent/aggressive manner	0	12	3	26	2	5	48
	Improper Backing	0	0	0	0	0	0	0
	Illegally Parked/Unattended	0	0	0	0	0	0	0
	Swerving/Evasive Action	1	72	13	29	3	4	122
	Over correcting/over steering	0	6	2	3	0	0	11
	Downhill runaway	0	1	3	1	0	0	5
	Equipment failure	0	13	2	5	1	0	21
	Separation of units	0	8	1	0	0	0	9
	Ran off road - right	1	38	11	10	2	0	62
	Ran off road - straight	0	4	0	0	0	0	4
	Ran off road - left	0	19	2	6	0	1	28
Lost Control	1	18	13	52	0	2	86	
Inattentive/distracted by: Passenger	0	1	0	1	1	0	3	

Major cause of crashes involving one or more SMVs (continued)	Inattentive/distracted by: Use of phone or other device	0	4	0	2	0	0	6
	Inattentive/distracted by: Fallen object	0	0	0	0	0	0	0
	Inattentive/distracted by: Fatigued/asleep	0	0	1	0	0	0	1
	Other (explain in narrative): Vision obstructed	2	21	14	5	1	0	43
	Oversized Load/Vehicle	0	0	1	0	0	0	1
	Cargo/equipment loss or shift	0	1	1	1	0	0	3
	Other (explain in narrative): Other improper action	1	71	39	25	6	2	144
	Unknown	0	24	14	17	11	3	69
	Other (explain in narrative): No improper action	0	35	18	14	42	4	113
Not Reported	0	7	1	2	11	1	22	
Manner of Crash/ Collision	Non-Collision	0	95	24	169	66	15	369
	Head-on	2	25	12	10	1	2	52
	Rear-end	6	166	65	51	1	2	291
	Angle, oncoming left turn	1	33	5	18	3	1	61
	Broadside	7	65	46	75	34	14	241
	Sideswipe, same direction	2	150	54	22	0	3	231
	Sideswipe, opposite direction	0	51	12	9	0	0	72
	Unknown	0	6	8	2	4	0	20
Not Reported	0	3	4	5	1	2	15	
Driver age of SMVs involved in crashes	<15	0	8	0	100	0	4	112
	15-20	4	48	5	108	1	7	173
	21-24	1	42	14	39	0	2	98
	25-34	1	77	35	41	0	6	160
	35-44	0	88	45	27	2	3	165
	45-54	1	129	75	25	5	8	243
	55-64	1	77	32	10	1	2	123
	65-69	0	24	4	9	0	2	39
	70+	1	81	1	13	0	1	97
Unknown	9	24	20	11	104	4	172	
Major cause of crashes involving one or more SMVs with matching circumstances from the SMV involved that indicate more responsibility on the particular SMV than any other vehicle involved in the crash	Animal	4	1	1	9	0	0	15
	Ran Traffic Signal	0	0	0	1	0	0	1
	Ran Stop Sign	0	8	2	8	0	0	18
	Crossed centerline	1	16	3	5	0	0	25
	FTYROW: At uncontrolled intersection	0	3	0	7	0	0	10
	FTYROW: Making right turn on red signal	0	0	0	0	0	0	0
	FTYROW: From stop sign	2	13	6	8	0	2	31
	FTYROW: From yield sign	0	1	0	2	0	0	3
FTYROW: Making left turn	0	27	1	6	0	0	34	
FTYROW: From driveway	0	10	3	11	0	3	27	

Major cause of crashes involving one or more SMVs with matching circumstances from the SMV involved that indicate more responsibility on the particular SMV than any other vehicle involved in the crash (continued)	FTYROW: From parked position	0	1	1	2	0	0	4
	FTYROW: To pedestrian	0	0	1	1	1	0	3
	FTYROW: Other (explain in narrative)	1	19	16	10	2	5	53
	Traveling wrong way or on wrong side of road	0	5	0	9	0	0	14
	Driving too fast for conditions	0	7	2	19	0	0	28
	Exceeded authorized speed	0	0	0	3	0	0	3
	Made improper turn	0	15	3	2	0	1	21
	Improper Lane Change	0	0	0	0	0	0	0
	Followed too close	0	2	1	12	0	1	16
	Disregarded RR Signal	0	0	1	0	0	0	1
	Disregarded Warning Sign	0	0	1	0	0	0	1
	Operating vehicle in an erratic/reckless/careless/negligent/aggressive manner	0	3	1	25	0	5	34
	Improper Backing	0	0	0	0	0	0	0
	Illegally Parked/Unattended	0	0	0	0	0	0	0
	Swerving/Evasive Action	1	17	6	22	1	4	51
	Over correcting/over steering	0	4	1	3	0	0	8
	Downhill runaway	0	1	2	1	0	0	4
	Equipment failure	0	12	2	5	1	0	20
	Separation of units	0	7	1	0	0	0	8
	Ran off road - right	1	34	9	10	2	0	56
	Ran off road - straight	0	2	0	0	0	0	2
	Ran off road - left	0	14	1	6	0	1	22
	Lost Control	0	6	6	52	0	2	66
	Inattentive/distracted by: Passenger	0	0	0	1	0	0	1
	Inattentive/distracted by: Use of phone or other device	0	0	0	2	0	0	2
	Inattentive/distracted by: Fallen object	0	0	0	0	0	0	0
	Inattentive/distracted by: Fatigued/asleep	0	0	0	0	0	0	0
	Other (explain in narrative): Vision obstructed	0	9	9	3	0	0	21
	Oversized Load/Vehicle	0	0	1	0	0	0	1
	Cargo/equipment loss or shift	0	1	1	1	0	0	3
	Other (explain in narrative): Other improper action	1	27	26	24	0	2	80
	Unknown	0	15	10	13	2	2	42
	Other (explain in narrative): No improper action	0	27	12	12	0	2	53
	Not Reported	0	0	0	0	0	0	0

Percentage of crashes involving one or more SMVs in which an SMV is considered more responsible for the crash than any other vehicles involved	Animal	80.0%	100.0%	100.0%	100.0%	0.0%	0.0%	93.8%
	Ran Traffic Signal	0.0%	0.0%	0.0%	25.0%	0.0%	0.0%	12.5%
	Ran Stop Sign	0.0%	80.0%	66.7%	72.7%	0.0%	0.0%	69.2%
	Crossed centerline	100.0%	53.3%	37.5%	71.4%	0.0%	0.0%	54.3%
	FTYROW: At uncontrolled intersection	0.0%	50.0%	0.0%	77.8%	0.0%	0.0%	52.6%
	FTYROW: Making right turn on red signal	0.0%	0.0%	0.0%	0.0%	0.0%	0.0%	0.0%
	FTYROW: From stop sign	100.0%	76.5%	100.0%	50.0%	0.0%	100.0%	67.4%
	FTYROW: From yield sign	0.0%	100.0%	0.0%	33.3%	0.0%	0.0%	37.5%
	FTYROW: Making left turn	0.0%	96.4%	50.0%	33.3%	0.0%	0.0%	66.7%
	FTYROW: From driveway	0.0%	71.4%	75.0%	73.3%	0.0%	75.0%	71.1%
	FTYROW: From parked position	0.0%	100.0%	100.0%	66.7%	0.0%	0.0%	80.0%
	FTYROW: To pedestrian	0.0%	0.0%	100.0%	100.0%	16.7%	0.0%	37.5%
	FTYROW: Other (explain in narrative)	100.0%	36.5%	69.6%	90.9%	25.0%	83.3%	52.5%
	Traveling wrong way or on wrong side of road	0.0%	50.0%	0.0%	100.0%	0.0%	0.0%	73.7%
	Driving too fast for conditions	0.0%	31.8%	10.5%	95.0%	0.0%	0.0%	45.9%
	Exceeded authorized speed	0.0%	0.0%	0.0%	75.0%	0.0%	0.0%	30.0%
	Made improper turn	0.0%	88.2%	100.0%	50.0%	0.0%	100.0%	84.0%
	Improper Lane Change	0.0%	0.0%	0.0%	0.0%	0.0%	0.0%	0.0%
	Followed too close	0.0%	8.0%	9.1%	80.0%	0.0%	100.0%	28.6%
	Disregarded RR Signal	0.0%	0.0%	100.0%	0.0%	0.0%	0.0%	100.0%
	Disregarded Warning Sign	0.0%	0.0%	100.0%	0.0%	0.0%	0.0%	100.0%
	Operating vehicle in an erratic/reckless/careless/negligent/aggressive manner	0.0%	25.0%	33.3%	96.2%	0.0%	100.0%	70.8%
	Improper Backing	0.0%	0.0%	0.0%	0.0%	0.0%	0.0%	0.0%
	Illegally Parked/Unattended	0.0%	0.0%	0.0%	0.0%	0.0%	0.0%	0.0%
	Swerving/Evasive Action	100.0%	23.6%	46.2%	75.9%	33.3%	100.0%	41.8%
	Over correcting/over steering	0.0%	66.7%	50.0%	100.0%	0.0%	0.0%	72.7%
	Downhill runaway	0.0%	100.0%	66.7%	100.0%	0.0%	0.0%	80.0%
	Equipment failure	0.0%	92.3%	100.0%	100.0%	100.0%	0.0%	95.2%
	Separation of units	0.0%	87.5%	100.0%	0.0%	0.0%	0.0%	88.9%
	Ran off road - right	100.0%	89.5%	81.8%	100.0%	100.0%	0.0%	90.3%
	Ran off road - straight	0.0%	50.0%	0.0%	0.0%	0.0%	0.0%	50.0%
	Ran off road - left	0.0%	73.7%	50.0%	100.0%	0.0%	100.0%	78.6%
	Lost Control	0.0%	33.3%	46.2%	100.0%	0.0%	100.0%	76.7%
	Inattentive/distracted by: Passenger	0.0%	0.0%	0.0%	100.0%	0.0%	0.0%	33.3%
	Inattentive/distracted by: Use of phone or other device	0.0%	0.0%	0.0%	100.0%	0.0%	0.0%	33.3%
	Inattentive/distracted by: Fallen object	0.0%	0.0%	0.0%	0.0%	0.0%	0.0%	0.0%
	Inattentive/distracted by: Fatigued/asleep	0.0%	0.0%	0.0%	0.0%	0.0%	0.0%	0.0%
	Other (explain in narrative): Vision obstructed	0.0%	42.9%	64.3%	60.0%	0.0%	0.0%	48.8%

Percentage of crashes involving one or more SMVs in which an SMV is considered more responsible for the crash than any other vehicles involved (continued)	Oversized Load/Vehicle	0.0%	0.0%	100.0%	0.0%	0.0%	0.0%	100.0%
	Cargo/equipment loss or shift	0.0%	100.0%	100.0%	100.0%	0.0%	0.0%	100.0%
	Other (explain in narrative): Other improper action	100.0%	38.0%	66.7%	96.0%	0.0%	100.0%	55.6%
	Unknown	0.0%	62.5%	71.4%	76.5%	18.2%	66.7%	60.9%
	Other (explain in narrative): No improper action	0.0%	77.1%	66.7%	85.7%	0.0%	50.0%	46.9%
	Not Reported	0.0%	0.0%	0.0%	0.0%	0.0%	0.0%	0.0%
	Total	61.1%	50.2%	54.8%	82.3%	15.2%	83.9%	59.8%
Major cause of crashes involving one or more SMVs with matching circumstances from the Non-SMV vehicle involved that indicate more responsibility on the particular Non-SMV than any other vehicle involved in the crash	Animal	1	0	0	0	0	0	1
	Ran Traffic Signal	1	1	2	3	0	0	7
	Ran Stop Sign	0	2	1	3	2	0	8
	Crossed centerline	0	14	5	2	0	0	21
	FTYROW: At uncontrolled intersection	0	3	2	2	1	1	9
	FTYROW: Making right turn on red signal	0	0	0	0	5	1	6
	FTYROW: From stop sign	0	4	0	8	3	0	15
	FTYROW: From yield sign	0	0	1	4	0	0	5
	FTYROW: Making left turn	0	1	1	12	2	1	17
	FTYROW: From driveway	0	4	1	4	1	1	11
	FTYROW: From parked position	0	0	0	1	0	0	1
	FTYROW: To pedestrian	0	0	0	0	5	0	5
	FTYROW: Other (explain in narrative)	0	33	7	1	6	1	48
	Traveling wrong way or on wrong side of road	0	5	0	0	0	0	5
	Driving too fast for conditions	0	15	17	1	0	0	33
	Exceeded authorized speed	0	4	2	1	0	0	7
	Made improper turn	0	2	0	2	0	0	4
	Improper Lane Change	0	0	0	0	0	0	0
	Followed too close	2	23	10	3	2	0	40
	Disregarded RR Signal	0	0	0	0	0	0	0
	Disregarded Warning Sign	0	0	0	0	0	0	0
	Operating vehicle in an erratic/reckless/careless/negligent/aggressive manner	0	9	2	1	2	0	14
	Improper Backing	0	0	0	0	0	0	0
	Illegally Parked/Unattended	0	0	0	0	0	0	0
	Swerving/Evasive Action	0	55	7	7	2	0	71
	Over correcting/over steering	0	2	1	0	0	0	3
	Downhill runaway	0	0	1	0	0	0	1
	Equipment failure	0	1	0	0	0	0	1
	Separation of units	0	1	0	0	0	0	1
	Ran off road - right	0	4	2	0	0	0	6
Ran off road - straight	0	2	0	0	0	0	2	
Ran off road - left	0	5	1	0	0	0	6	

Percentage of crashes involving one or more SMVs in which a Non-SMV is considered more responsible for the crash than any other vehicles involved in the crash (continued)	Illegally Parked/Unattended	0.0%	0.0%	0.0%	0.0%	0.0%	0.0%	0.0%
	Swerving/Evasive Action	0.0%	76.4%	53.8%	24.1%	66.7%	0.0%	58.2%
	Over correcting/over steering	0.0%	33.3%	50.0%	0.0%	0.0%	0.0%	27.3%
	Downhill runaway	0.0%	0.0%	33.3%	0.0%	0.0%	0.0%	20.0%
	Equipment failure	0.0%	7.7%	0.0%	0.0%	0.0%	0.0%	4.8%
	Separation of units	0.0%	12.5%	0.0%	0.0%	0.0%	0.0%	11.1%
	Ran off road - right	0.0%	10.5%	18.2%	0.0%	0.0%	0.0%	9.7%
	Ran off road - straight	0.0%	50.0%	0.0%	0.0%	0.0%	0.0%	50.0%
	Ran off road - left	0.0%	26.3%	50.0%	0.0%	0.0%	0.0%	21.4%
	Lost Control	100.0%	66.7%	53.8%	0.0%	0.0%	0.0%	23.3%
	Inattentive/distracted by: Passenger	0.0%	100.0%	0.0%	0.0%	100.0%	0.0%	66.7%
	Inattentive/distracted by: Use of phone or other device	0.0%	100.0%	0.0%	0.0%	0.0%	0.0%	66.7%
	Inattentive/distracted by: Fallen object	0.0%	0.0%	0.0%	0.0%	0.0%	0.0%	0.0%
	Inattentive/distracted by: Fatigued/asleep	0.0%	0.0%	100.0%	0.0%	0.0%	0.0%	100.0%
	Other (explain in narrative): Vision obstructed	100.0%	57.1%	35.7%	40.0%	100.0%	0.0%	51.2%
	Oversized Load/Vehicle	0.0%	0.0%	0.0%	0.0%	0.0%	0.0%	0.0%
	Cargo/equipment loss or shift	0.0%	0.0%	0.0%	0.0%	0.0%	0.0%	0.0%
	Other (explain in narrative): Other improper action	0.0%	62.0%	33.3%	4.0%	100.0%	0.0%	44.4%
	Unknown	0.0%	37.5%	28.6%	23.5%	81.8%	33.3%	39.1%
	Other (explain in narrative): No improper action	0.0%	22.9%	33.3%	14.3%	100.0%	50.0%	53.1%
Not Reported	0.0%	100.0%	100.0%	100.0%	100.0%	100.0%	100.0%	
Total	38.9%	49.8%	45.2%	17.7%	84.8%	16.1%	40.2%	
Total Multiple Vehicle Crashes	Multiple Vehicle Crashes	18	514	209	199	96	25	1061
Major cause of multiple vehicle crashes involving one or more SMVs	Animal	5	0	0	0	0	0	5
	Ran Traffic Signal	1	1	2	4	0	0	8
	Ran Stop Sign	0	10	3	8	2	0	23
	Crossed centerline	1	29	8	7	0	0	45
	FTYROW: At uncontrolled intersection	0	6	2	9	1	1	19
	FTYROW: Making right turn on red signal	0	0	0	0	5	1	6
	FTYROW: From stop sign	2	17	6	16	3	2	46
	FTYROW: From yield sign	0	1	1	5	0	0	7
	FTYROW: Making left turn	0	28	2	18	2	1	51
	FTYROW: From driveway	0	14	4	15	1	4	38
	FTYROW: From parked position	0	0	1	3	0	0	4
	FTYROW: To pedestrian	0	0	0	0	5	0	5
FTYROW: Other (explain in narrative)	1	51	21	11	7	6	97	

Major cause of multiple vehicle crashes involving one or more SMVs (continued)	Traveling wrong way or on wrong side of road	0	10	0	6	0	0	16
	Driving too fast for conditions	0	16	19	5	0	0	40
	Exceeded authorized speed	0	4	2	1	0	0	7
	Made improper turn	0	17	3	3	0	1	24
	Improper Lane Change	0	0	0	0	0	0	0
	Followed too close	2	25	11	15	2	1	56
	Disregarded RR Signal	0	0	1	0	0	0	1
	Disregarded Warning Sign	0	0	0	0	0	0	0
	Operating vehicle in an erratic/reckless/careless/negligent/aggressive manner	0	11	3	11	2	1	28
	Improper Backing	0	0	0	0	0	0	0
	Illegally Parked/Unattended	0	0	0	0	0	0	0
	Swerving/Evasive Action	1	65	12	14	2	0	94
	Over correcting/over steering	0	3	2	0	0	0	5
	Downhill runaway	0	1	2	0	0	0	3
	Equipment failure	0	5	2	2	1	0	10
	Separation of units	0	7	1	0	0	0	8
	Ran off road - right	1	14	4	1	1	0	21
	Ran off road - straight	0	2	0	0	0	0	2
	Ran off road - left	0	10	1	0	0	0	11
	Lost Control	1	15	11	10	0	1	38
	Inattentive/distracted by: Passenger	0	1	0	0	1	0	2
	Inattentive/distracted by: Use of phone or other device	0	4	0	0	0	0	4
	Inattentive/distracted by: Fallen object	0	0	0	0	0	0	0
	Inattentive/distracted by: Fatigued/asleep	0	0	1	0	0	0	1
	Other (explain in narrative): Vision obstructed	2	20	13	5	1	0	41
	Oversized Load/Vehicle	0	0	0	0	0	0	0
	Cargo/equipment loss or shift	0	1	1	0	0	0	2
	Other (explain in narrative): Other improper action	1	69	38	16	6	2	132
	Unknown	0	23	14	9	9	1	56
	Other (explain in narrative): No improper action	0	28	17	5	42	2	94
	Not Reported	0	6	1	0	3	1	11

Major cause of multiple vehicle crashes involving one or more SMVs with matching circumstances from the SMV involved that indicate more responsibility on the SMV than any other vehicle involved	Animal	4	0	0	0	0	0	4
	Ran Traffic Signal	0	0	0	1	0	0	1
	Ran Stop Sign	0	8	2	5	0	0	15
	Crossed centerline	1	15	3	5	0	0	24
	FTYROW: At uncontrolled intersection	0	3	0	7	0	0	10
	FTYROW: Making right turn on red signal	0	0	0	0	0	0	0
	FTYROW: From stop sign	2	13	6	8	0	2	31
	FTYROW: From yield sign	0	1	0	1	0	0	2
	FTYROW: Making left turn	0	27	1	6	0	0	34
	FTYROW: From driveway	0	10	3	11	0	3	27
	FTYROW: From parked position	0	0	1	2	0	0	3
	FTYROW: To pedestrian	0	0	0	0	0	0	0
	FTYROW: Other (explain in narrative)	1	18	14	10	1	5	49
	Traveling wrong way or on wrong side of road	0	5	0	6	0	0	11
	Driving too fast for conditions	0	1	2	4	0	0	7
	Exceeded authorized speed	0	0	0	0	0	0	0
	Made improper turn	0	15	3	1	0	1	20
	Improper Lane Change	0	0	0	0	0	0	0
	Followed too close	0	2	1	12	0	1	16
	Disregarded RR Signal	0	0	1	0	0	0	1
	Disregarded Warning Sign	0	0	0	0	0	0	0
	Operating vehicle in an erratic/reckless/careless/negligent/aggressive manner	0	2	1	10	0	1	14
	Improper Backing	0	0	0	0	0	0	0
	Illegally Parked/Unattended	0	0	0	0	0	0	0
	Swerving/Evasive Action	1	10	5	7	0	0	23
	Over correcting/over steering	0	1	1	0	0	0	2
	Downhill runaway	0	1	1	0	0	0	2
	Equipment failure	0	4	2	2	1	0	9
	Separation of units	0	6	1	0	0	0	7
	Ran off road - right	1	10	2	1	1	0	15
	Ran off road - straight	0	0	0	0	0	0	0
	Ran off road - left	0	5	0	0	0	0	5
	Lost Control	0	3	4	10	0	1	18
	Inattentive/distracted by: Passenger	0	0	0	0	0	0	0
	Inattentive/distracted by: Use of phone or other device	0	0	0	0	0	0	0
	Inattentive/distracted by: Fallen object	0	0	0	0	0	0	0
	Inattentive/distracted by: Fatigued/asleep	0	0	0	0	0	0	0
	Other (explain in narrative): Vision obstructed	0	8	8	3	0	0	19

Percentage of multiple vehicle crashes involving one or more slow moving vehicles in which a SMV is considered more responsible for the crash than any other vehicles involved in the crash (continued)	Ran off road - left	0.0%	50.0%	0.0%	0.0%	0.0%	0.0%	45.5%
	Lost Control	0.0%	20.0%	36.4%	100.0%	0.0%	100.0%	47.4%
	Inattentive/distracted by: Passenger	0.0%	0.0%	0.0%	0.0%	0.0%	0.0%	0.0%
	Inattentive/distracted by: Use of phone or other device	0.0%	0.0%	0.0%	0.0%	0.0%	0.0%	0.0%
	Inattentive/distracted by: Fallen object	0.0%	0.0%	0.0%	0.0%	0.0%	0.0%	0.0%
	Inattentive/distracted by: Fatigued/asleep	0.0%	0.0%	0.0%	0.0%	0.0%	0.0%	0.0%
	Other (explain in narrative): Vision obstructed	0.0%	40.0%	61.5%	60.0%	0.0%	0.0%	46.3%
	Oversized Load/Vehicle	0.0%	0.0%	0.0%	0.0%	0.0%	0.0%	0.0%
	Cargo/equipment loss or shift	0.0%	100.0%	100.0%	0.0%	0.0%	0.0%	100.0%
	Other (explain in narrative): Other improper action	100.0%	36.2%	65.8%	93.8%	0.0%	100.0%	51.5%
	Unknown	0.0%	60.9%	71.4%	55.6%	0.0%	0.0%	51.8%
	Other (explain in narrative): No improper action	0.0%	71.4%	64.7%	60.0%	0.0%	0.0%	36.2%
	Not Reported	0.0%	0.0%	0.0%	0.0%	0.0%	0.0%	0.0%
	Total	61.1%	42.5%	49.7%	68.6%	7.1%	76.2%	48.8%
Vehicle Action	Movement Essentially Straight	10	313	113	248	4	22	710
	Turning Left	1	188	24	34	0	0	247
	Turning Right	1	24	5	29	2	2	63
	Making U-Turn	0	4	4	7	0	4	19
	Overtaking/passing	0	4	0	3	0	0	7
	Changing Lanes	1	2	4	0	0	0	7
	Entering Traffic Lane	0	3	2	0	0	1	6
	Leaving Traffic Lane	0	1	0	0	0	0	1
	Backing	0	7	34	4	0	0	45
	Slowing/Stopping	0	9	2	10	0	0	21
	Stopped for Sign/Signal	0	2	6	1	0	0	9
	Legally Parked	0	9	8	1	0	0	18
	Illegally Parked/Unattended	0	6	2	1	0	0	9
	Not Reported	4	13	8	9	92	5	131
	Other (explain in narrative)	1	9	14	26	0	5	55
	Unknown	0	4	5	10	15	0	34

Rural Iowa SMV Crash Characteristics 2004-2006

Description	SMV Crashes	Horse & Buggy	Farm	Construction/Maintenance	Moped/ATV	Bicycle	Other	Total
# Crashes involving at least one SMV	Total	10	382	62	120	8	9	591
# SMVs in Crashes in area:	Rural	10	382	62	120	8	9	591
	Urban	0	0	0	0	0	0	0
	Unknown	0	0	0	0	0	0	0
# of SMV Crashes With crash severity of:	Fatalities	0	18	2	11	4	1	36
	Major Injuries	2	30	5	37	1	0	75
	Minor Injuries	3	62	10	46	1	4	126
	Possible/Unknown	0	70	9	15	2	3	99
	Property Damage Only	5	202	36	11	0	1	255
# of Crashes involving one or more SMVs during:	NIGHT (Sunset-Sunrise)	4	83	4	30	2	4	127
	DAY (Sunrise - Sunset)	6	293	58	90	6	5	458
	Unknown	0	6	0	0	0	0	6
	Night-to-Day Crash Ratio	0.667	0.283	0.069	0.333	0.333	0.800	0.277
# of Crashes involving one or more SMVs during:	AM Peak	2	27	13	4	1	0	47
	PM Peak	2	86	8	26	2	4	128
	Midday (Offpeak)	0	51	12	11	0	0	74
# of Crashes involving one or more SMVs during the following month:	January	2	6	4	5	0	4	21
	February	0	9	6	2	0	0	17
	March	1	12	3	10	0	0	26
	April	1	31	1	12	0	0	45
	May	1	27	5	13	1	0	47
	June	1	37	5	17	1	1	62
	July	0	27	6	21	2	1	57
	August	2	26	9	8	0	1	46
	September	1	42	12	10	3	2	70
	October	0	85	5	13	0	0	103
	November	1	58	5	5	0	0	69
	December	0	22	2	4	0	0	28
# of Crashes involving one or more SMVs with surface conditions of:	Dry	8	281	36	63	8	4	400
	Wet	1	22	3	6	0	1	33
	Ice	0	3	3	3	0	0	9
	Snow	0	7	5	3	0	2	17
	Slush	0	0	1	0	0	0	1
	Sand/mud/dirt/oil/gravel	1	55	14	37	0	1	108
	Water (standing/moving)	0	0	0	0	0	0	0
	Other/Unknown/Not Reported	0	14	0	8	0	1	23

# SMVs in crashes with speed limit of:	below 25 mph	0	1	0	0	0	0	1
	25-34 mph	0	4	0	4	0	1	9
	35-44 mph	0	3	0	6	0	0	9
	45-54 mph	0	38	3	25	0	1	67
	55-64 mph	5	305	49	68	0	6	433
	65 mph and above	0	11	1	1	0	0	13
	Unknown	5	24	9	27	8	1	74
Major cause of crashes involving one or more SMVs	Animal	3	1	0	7	0	0	11
	Ran Traffic Signal	0	0	0	0	0	0	0
	Ran Stop Sign	0	9	1	2	2	0	14
	Crossed centerline	0	19	5	5	0	0	29
	FTYROW: At uncontrolled intersection	0	5	0	2	0	0	7
	FTYROW: Making right turn on red signal	0	0	0	0	0	0	0
	FTYROW: From stop sign	1	12	2	2	0	0	17
	FTYROW: From yield sign	0	1	0	0	0	0	1
	FTYROW: Making left turn	0	12	0	1	0	0	13
	FTYROW: From driveway	0	12	1	11	0	0	24
	FTYROW: From parked position	0	1	0	1	0	0	2
	FTYROW: To pedestrian	0	0	0	0	0	0	0
	FTYROW: Other (explain in narrative)	0	31	8	5	2	2	48
	Traveling wrong way or on wrong side of road	0	6	0	7	0	0	13
	Driving too fast for conditions	0	19	7	9	0	0	35
	Exceeded authorized speed	0	2	0	2	0	0	4
	Made improper turn	0	14	0	1	0	0	15
	Improper Lane Change	0	0	0	0	0	0	0
	Followed too close	1	11	3	4	1	0	20
	Disregarded RR Signal	0	0	0	0	0	0	0
	Disregarded Warning Sign	0	0	0	0	0	0	0
	Operating vehicle in an erratic/reckless/careless/negligent/aggressive manner	0	7	0	12	1	2	22
	Improper Backing	0	0	0	0	0	0	0
	Illegally Parked/Unattended	0	0	0	0	0	0	0
	Swerving/Evasive Action	1	49	5	16	1	1	73
	Over correcting/over steering	0	5	0	0	0	0	5
	Downhill runaway	0	1	1	1	0	0	3
	Equipment failure	0	11	1	1	0	0	13
	Separation of units	0	2	0	0	0	0	2
	Ran off road - right	1	23	6	4	0	0	34
Ran off road - straight	0	3	0	0	0	0	3	
Ran off road - left	0	15	0	4	0	1	20	
Lost Control	1	10	4	6	0	1	22	
Inattentive/distracted by: Passenger	0	0	0	0	1	0	1	

Major cause of crashes involving one or more SMVs (continued)	Inattentive/distracted by: Use of phone or other device	0	3	0	1	0	0	4
	Inattentive/distracted by: Fallen object	0	0	0	0	0	0	0
	Inattentive/distracted by: Fatigued/asleep	0	0	1	0	0	0	1
	Other (explain in narrative): Vision obstructed	2	14	3	1	0	0	20
	Oversized Load/Vehicle	0	0	1	0	0	0	1
	Cargo/equipment loss or shift	0	0	0	1	0	0	1
	Other (explain in narrative): Other improper action	0	46	4	5	0	0	55
	Unknown	0	12	1	5	0	1	19
	Other (explain in narrative): No improper action	0	22	8	3	0	1	34
Not Reported	0	4	0	1	0	0	5	
Manner of Crash/Collision	Non-Collision	0	73	8	64	3	8	156
	Head-on	1	11	6	8	0	0	26
	Rear-end	4	105	21	15	1	0	146
	Angle, oncoming left turn	1	18	0	3	0	0	22
	Broadside	3	47	8	18	3	1	80
	Sideswipe, same direction	1	89	12	8	0	0	110
	Sideswipe, opposite direction	0	33	4	3	0	0	40
	Unknown	0	2	2	0	1	0	5
Not Reported	0	4	1	1	0	0	6	
Driver age of SMVs involved in crashes	<15	0	5	0	22	0	0	27
	15-20	2	31	0	38	0	5	76
	21-24	1	32	3	18	0	1	55
	25-34	1	53	5	20	0	1	80
	35-44	0	54	8	9	0	0	71
	45-54	1	81	34	9	1	0	126
	55-64	0	49	10	5	0	1	65
	65-69	0	16	0	4	0	1	21
	70+	0	53	0	2	0	0	55
Unknown	5	12	2	4	7	0	30	
Major cause of crashes involving one or more SMVs with matching circumstances from the SMV involved that indicate more responsibility on the particular SMV than any other vehicle involved in the crash	Animal	2	1	0	7	0	0	10
	Ran Traffic Signal	0	0	0	0	0	0	0
	Ran Stop Sign	0	7	1	2	0	0	10
	Crossed centerline	0	11	2	4	0	0	17
	FTYROW: At uncontrolled intersection	0	3	0	2	0	0	5
	FTYROW: Making right turn on red signal	0	0	0	0	0	0	0
	FTYROW: From stop sign	1	9	2	2	0	0	14
	FTYROW: From yield sign	0	1	0	0	0	0	1
FTYROW: Making left turn	0	11	0	1	0	0	12	
FTYROW: From driveway	0	10	1	10	0	0	21	

Major cause of crashes involving one or more SMVs with matching circumstances from the SMV involved that indicate more responsibility on the particular SMV than any other vehicle involved in the crash (continued)	FTYROW: From parked position	0	1	0	1	0	0	2
	FTYROW: To pedestrian	0	0	0	0	0	0	0
	FTYROW: Other (explain in narrative)	0	12	4	5	0	2	23
	Traveling wrong way or on wrong side of road	0	4	0	7	0	0	11
	Driving too fast for conditions	0	6	0	9	0	0	15
	Exceeded authorized speed	0	0	0	1	0	0	1
	Made improper turn	0	13	0	1	0	0	14
	Improper Lane Change	0	0	0	0	0	0	0
	Followed too close	0	0	0	3	0	0	3
	Disregarded RR Signal	0	0	0	0	0	0	0
	Disregarded Warning Sign	0	0	0	0	0	0	0
	Operating vehicle in an erratic/reckless/careless/negligent/aggressive manner	0	2	0	12	0	2	16
	Improper Backing	0	0	0	0	0	0	0
	Illegally Parked/Unattended	0	0	0	0	0	0	0
	Swerving/Evasive Action	1	10	2	12	0	1	26
	Over correcting/over steering	0	3	0	0	0	0	3
	Downhill runaway	0	1	0	1	0	0	2
	Equipment failure	0	10	1	1	0	0	12
	Separation of units	0	1	0	0	0	0	1
	Ran off road - right	1	21	5	4	0	0	31
	Ran off road - straight	0	2	0	0	0	0	2
	Ran off road - left	0	13	0	4	0	1	18
	Lost Control	0	3	0	6	0	1	10
	Inattentive/distracted by: Passenger	0	0	0	0	0	0	0
	Inattentive/distracted by: Use of phone or other device	0	0	0	1	0	0	1
	Inattentive/distracted by: Fallen object	0	0	0	0	0	0	0
	Inattentive/distracted by: Fatigued/asleep	0	0	0	0	0	0	0
	Other (explain in narrative): Vision obstructed	0	6	0	0	0	0	6
	Oversized Load/Vehicle	0	0	1	0	0	0	1
	Cargo/equipment loss or shift	0	0	0	1	0	0	1
	Other (explain in narrative): Other improper action	0	17	2	5	0	0	24
	Unknown	0	8	1	5	0	1	15
Other (explain in narrative): No improper action	0	15	8	2	0	1	26	
Not Reported	0	0	0	0	0	0	0	

Percentage of crashes involving one or more SMVs in which an SMV is considered more responsible for the crash than any other vehicles involved in the crash	Animal	66.7%	100.0%	0.0%	100.0%	0.0%	0.0%	90.9%
	Ran Traffic Signal	0.0%	0.0%	0.0%	0.0%	0.0%	0.0%	0.0%
	Ran Stop Sign	0.0%	77.8%	100.0%	100.0%	0.0%	0.0%	71.4%
	Crossed centerline	0.0%	57.9%	40.0%	80.0%	0.0%	0.0%	58.6%
	FTYROW: At uncontrolled intersection	0.0%	60.0%	0.0%	100.0%	0.0%	0.0%	71.4%
	FTYROW: Making right turn on red signal	0.0%	0.0%	0.0%	0.0%	0.0%	0.0%	0.0%
	FTYROW: From stop sign	100.0%	75.0%	100.0%	100.0%	0.0%	0.0%	82.4%
	FTYROW: From yield sign	0.0%	100.0%	0.0%	0.0%	0.0%	0.0%	100.0%
	FTYROW: Making left turn	0.0%	91.7%	0.0%	100.0%	0.0%	0.0%	92.3%
	FTYROW: From driveway	0.0%	83.3%	100.0%	90.9%	0.0%	0.0%	87.5%
	FTYROW: From parked position	0.0%	100.0%	0.0%	100.0%	0.0%	0.0%	100.0%
	FTYROW: To pedestrian	0.0%	0.0%	0.0%	0.0%	0.0%	0.0%	0.0%
	FTYROW: Other (explain in narrative)	0.0%	38.7%	50.0%	100.0%	0.0%	100.0%	47.9%
	Traveling wrong way or on wrong side of road	0.0%	66.7%	0.0%	100.0%	0.0%	0.0%	84.6%
	Driving too fast for conditions	0.0%	31.6%	0.0%	100.0%	0.0%	0.0%	42.9%
	Exceeded authorized speed	0.0%	0.0%	0.0%	50.0%	0.0%	0.0%	25.0%
	Made improper turn	0.0%	92.9%	0.0%	100.0%	0.0%	0.0%	93.3%
	Improper Lane Change	0.0%	0.0%	0.0%	0.0%	0.0%	0.0%	0.0%
	Followed too close	0.0%	0.0%	0.0%	75.0%	0.0%	0.0%	15.0%
	Disregarded RR Signal	0.0%	0.0%	0.0%	0.0%	0.0%	0.0%	0.0%
	Disregarded Warning Sign	0.0%	0.0%	0.0%	0.0%	0.0%	0.0%	0.0%
	Operating vehicle in an erratic/reckless/careless/negligent/aggressive manner	0.0%	28.6%	0.0%	100.0%	0.0%	100.0%	72.7%
	Improper Backing	0.0%	0.0%	0.0%	0.0%	0.0%	0.0%	0.0%
	Illegally Parked/Unattended	0.0%	0.0%	0.0%	0.0%	0.0%	0.0%	0.0%
	Swerving/Evasive Action	100.0%	20.4%	40.0%	75.0%	0.0%	100.0%	35.6%
	Over correcting/over steering	0.0%	60.0%	0.0%	0.0%	0.0%	0.0%	60.0%
	Downhill runaway	0.0%	100.0%	0.0%	100.0%	0.0%	0.0%	66.7%
	Equipment failure	0.0%	90.9%	100.0%	100.0%	0.0%	0.0%	92.3%
	Separation of units	0.0%	50.0%	0.0%	0.0%	0.0%	0.0%	50.0%
	Ran off road - right	100.0%	91.3%	83.3%	100.0%	0.0%	0.0%	91.2%
	Ran off road - straight	0.0%	66.7%	0.0%	0.0%	0.0%	0.0%	66.7%
	Ran off road - left	0.0%	86.7%	0.0%	100.0%	0.0%	100.0%	90.0%
	Lost Control	0.0%	30.0%	0.0%	100.0%	0.0%	100.0%	45.5%
	Inattentive/distracted by: Passenger	0.0%	0.0%	0.0%	0.0%	0.0%	0.0%	0.0%
	Inattentive/distracted by: Use of phone or other device	0.0%	0.0%	0.0%	100.0%	0.0%	0.0%	25.0%
	Inattentive/distracted by: Fallen object	0.0%	0.0%	0.0%	0.0%	0.0%	0.0%	0.0%
	Inattentive/distracted by: Fatigued/asleep	0.0%	0.0%	0.0%	0.0%	0.0%	0.0%	0.0%
	Other (explain in narrative): Vision obstructed	0.0%	42.9%	0.0%	0.0%	0.0%	0.0%	30.0%

Percentage of crashes involving one or more SMVs in which an SMV is considered more responsible for the crash than any other vehicles involved in the crash (continued)	Oversized Load/Vehicle	0.0%	0.0%	100.0%	0.0%	0.0%	0.0%	100.0%
	Cargo/equipment loss or shift	0.0%	0.0%	0.0%	100.0%	0.0%	0.0%	100.0%
	Other (explain in narrative): Other improper action	0.0%	37.0%	50.0%	100.0%	0.0%	0.0%	43.6%
	Unknown	0.0%	66.7%	100.0%	100.0%	0.0%	100.0%	78.9%
	Other (explain in narrative): No improper action	0.0%	68.2%	100.0%	66.7%	0.0%	100.0%	76.5%
	Not Reported	0.0%	0.0%	0.0%	0.0%	0.0%	0.0%	0.0%
	Total	50.0%	51.7%	39.6%	91.9%	0.0%	100.0%	58.7%
Major cause of crashes involving one or more SMVs with matching circumstances from the Non-SMV involved that indicate more responsibility on the particular Non-SMV than any other vehicle involved in the crash	Animal	1	0	0	0	0	0	1
	Ran Traffic Signal	0	0	0	0	0	0	0
	Ran Stop Sign	0	2	0	0	2	0	4
	Crossed centerline	0	8	3	1	0	0	12
	FTYROW: At uncontrolled intersection	0	2	0	0	0	0	2
	FTYROW: Making right turn on red signal	0	0	0	0	0	0	0
	FTYROW: From stop sign	0	3	0	0	0	0	3
	FTYROW: From yield sign	0	0	0	0	0	0	0
	FTYROW: Making left turn	0	1	0	0	0	0	1
	FTYROW: From driveway	0	2	0	1	0	0	3
	FTYROW: From parked position	0	0	0	0	0	0	0
	FTYROW: To pedestrian	0	0	0	0	0	0	0
	FTYROW: Other (explain in narrative)	0	19	4	0	2	0	25
	Traveling wrong way or on wrong side of road	0	2	0	0	0	0	2
	Driving too fast for conditions	0	13	7	0	0	0	20
	Exceeded authorized speed	0	2	0	1	0	0	3
	Made improper turn	0	1	0	0	0	0	1
	Improper Lane Change	0	0	0	0	0	0	0
	Followed too close	1	11	3	1	1	0	17
	Disregarded RR Signal	0	0	0	0	0	0	0
	Disregarded Warning Sign	0	0	0	0	0	0	0
	Operating vehicle in an erratic/reckless/careless/negligent/aggressive manner	0	5	0	0	1	0	6
	Improper Backing	0	0	0	0	0	0	0
	Illegally Parked/Unattended	0	0	0	0	0	0	0
	Swerving/Evasive Action	0	39	3	4	1	0	47
	Over correcting/over steering	0	2	0	0	0	0	2
	Downhill runaway	0	0	1	0	0	0	1
	Equipment failure	0	1	0	0	0	0	1
	Separation of units	0	1	0	0	0	0	1
	Ran off road - right	0	2	1	0	0	0	3
Ran off road - straight	0	1	0	0	0	0	1	

Major cause of crashes involving one or more SMVs with matching circumstances from the Non-SMV involved that indicate more responsibility on the particular Non-SMV than any other vehicle involved in the crash (continued)	Ran off road - left	0	2	0	0	0	0	2
	Lost Control	1	7	4	0	0	0	12
	Inattentive/distracted by: Passenger	0	0	0	0	1	0	1
	Inattentive/distracted by: Use of phone or other device	0	3	0	0	0	0	3
	Inattentive/distracted by: Fallen object	0	0	0	0	0	0	0
	Inattentive/distracted by: Fatigued/asleep	0	0	1	0	0	0	1
	Other (explain in narrative): Vision obstructed	2	8	3	1	0	0	14
	Oversized Load/Vehicle	0	0	0	0	0	0	0
	Cargo/equipment loss or shift	0	0	0	0	0	0	0
	Other (explain in narrative): Other improper action	0	29	2	0	0	0	31
	Unknown	0	4	0	0	0	0	4
	Other (explain in narrative): No improper action	0	7	0	1	0	0	8
	Not Reported	0	4	0	1	0	0	5
Percentage of crashes involving one or more SMVs in which a Non-SMV is considered more responsible for the crash than any other vehicles involved in the crash	Animal	33.3%	0.0%	0.0%	0.0%	0.0%	0.0%	9.1%
	Ran Traffic Signal	0.0%	0.0%	0.0%	0.0%	0.0%	0.0%	0.0%
	Ran Stop Sign	0.0%	22.2%	0.0%	0.0%	100.0%	0.0%	28.6%
	Crossed centerline	0.0%	42.1%	60.0%	20.0%	0.0%	0.0%	41.4%
	FTYROW: At uncontrolled intersection	0.0%	40.0%	0.0%	0.0%	0.0%	0.0%	28.6%
	FTYROW: Making right turn on red signal	0.0%	0.0%	0.0%	0.0%	0.0%	0.0%	0.0%
	FTYROW: From stop sign	0.0%	25.0%	0.0%	0.0%	0.0%	0.0%	17.6%
	FTYROW: From yield sign	0.0%	0.0%	0.0%	0.0%	0.0%	0.0%	0.0%
	FTYROW: Making left turn	0.0%	8.3%	0.0%	0.0%	0.0%	0.0%	7.7%
	FTYROW: From driveway	0.0%	16.7%	0.0%	9.1%	0.0%	0.0%	12.5%
	FTYROW: From parked position	0.0%	0.0%	0.0%	0.0%	0.0%	0.0%	0.0%
	FTYROW: To pedestrian	0.0%	0.0%	0.0%	0.0%	0.0%	0.0%	0.0%
	FTYROW: Other (explain in narrative)	0.0%	61.3%	50.0%	0.0%	100.0%	0.0%	52.1%
	Traveling wrong way or on wrong side of road	0.0%	33.3%	0.0%	0.0%	0.0%	0.0%	15.4%
	Driving too fast for conditions	0.0%	68.4%	100.0%	0.0%	0.0%	0.0%	57.1%
	Exceeded authorized speed	0.0%	100.0%	0.0%	50.0%	0.0%	0.0%	75.0%
	Made improper turn	0.0%	7.1%	0.0%	0.0%	0.0%	0.0%	6.7%
	Improper Lane Change	0.0%	0.0%	0.0%	0.0%	0.0%	0.0%	0.0%
	Followed too close	100.0%	100.0%	100.0%	25.0%	100.0%	0.0%	85.0%
	Disregarded RR Signal	0.0%	0.0%	0.0%	0.0%	0.0%	0.0%	0.0%
Disregarded Warning Sign	0.0%	0.0%	0.0%	0.0%	0.0%	0.0%	0.0%	
Operating vehicle in an erratic/reckless/careless/negligent/aggressive manner	0.0%	71.4%	0.0%	0.0%	100.0%	0.0%	27.3%	

Percentage of crashes involving one or more SMVs in which a Non-SMV is considered more responsible for the crash than any other vehicles involved in the crash (continued)	Improper Backing	0.0%	0.0%	0.0%	0.0%	0.0%	0.0%	0.0%
	Illegally Parked/Unattended	0.0%	0.0%	0.0%	0.0%	0.0%	0.0%	0.0%
	Swerving/Evasive Action	0.0%	79.6%	60.0%	25.0%	100.0%	0.0%	64.4%
	Over correcting/over steering	0.0%	40.0%	0.0%	0.0%	0.0%	0.0%	40.0%
	Downhill runaway	0.0%	0.0%	100.0%	0.0%	0.0%	0.0%	33.3%
	Equipment failure	0.0%	9.1%	0.0%	0.0%	0.0%	0.0%	7.7%
	Separation of units	0.0%	50.0%	0.0%	0.0%	0.0%	0.0%	50.0%
	Ran off road - right	0.0%	8.7%	16.7%	0.0%	0.0%	0.0%	8.8%
	Ran off road - straight	0.0%	33.3%	0.0%	0.0%	0.0%	0.0%	33.3%
	Ran off road - left	0.0%	13.3%	0.0%	0.0%	0.0%	0.0%	10.0%
	Lost Control	100.0%	70.0%	100.0%	0.0%	0.0%	0.0%	54.5%
	Inattentive/distracted by: Passenger	0.0%	0.0%	0.0%	0.0%	100.0%	0.0%	100.0%
	Inattentive/distracted by: Use of phone or other device	0.0%	100.0%	0.0%	0.0%	0.0%	0.0%	75.0%
	Inattentive/distracted by: Fallen object	0.0%	0.0%	0.0%	0.0%	0.0%	0.0%	0.0%
	Inattentive/distracted by: Fatigued/asleep	0.0%	0.0%	100.0%	0.0%	0.0%	0.0%	100.0%
	Other (explain in narrative): Vision obstructed	100.0%	57.1%	100.0%	100.0%	0.0%	0.0%	70.0%
	Oversized Load/Vehicle	0.0%	0.0%	0.0%	0.0%	0.0%	0.0%	0.0%
	Cargo/equipment loss or shift	0.0%	0.0%	0.0%	0.0%	0.0%	0.0%	0.0%
	Other (explain in narrative): Other improper action	0.0%	63.0%	50.0%	0.0%	0.0%	0.0%	56.4%
	Unknown	0.0%	33.3%	0.0%	0.0%	0.0%	0.0%	21.1%
	Other (explain in narrative): No improper action	0.0%	31.8%	0.0%	33.3%	0.0%	0.0%	23.5%
	Not Reported	0.0%	100.0%	0.0%	100.0%	0.0%	0.0%	100.0%
	Total	50.0%	48.3%	60.4%	8.1%	100.0%	0.0%	41.3%
Multiple Vehicle Crashes								
	Multiple Vehicle Crashes	10	319	57	60	8	2	456
Major cause of multiple vehicle crashes involving one or more SMVs	Animal	3	0	0	0	0	0	3
	Ran Traffic Signal	0	0	0	0	0	0	0
	Ran Stop Sign	0	9	1	1	2	0	13
	Crossed centerline	0	18	5	5	0	0	28
	FTYROW: At uncontrolled intersection	0	5	0	2	0	0	7
	FTYROW: Making right turn on red signal	0	0	0	0	0	0	0
	FTYROW: From stop sign	1	12	2	2	0	0	17
	FTYROW: From yield sign	0	1	0	0	0	0	1
	FTYROW: Making left turn	0	12	0	1	0	0	13
	FTYROW: From driveway	0	12	1	11	0	0	24
	FTYROW: From parked position	0	0	0	1	0	0	1
	FTYROW: To pedestrian	0	0	0	0	0	0	0
FTYROW: Other (explain in narrative)	0	30	7	5	2	2	46	

Major cause of multiple vehicle crashes involving one or more SMVs (continued)	Traveling wrong way or on wrong side of road	0	6	0	6	0	0	12
	Driving too fast for conditions	0	14	7	2	0	0	23
	Exceeded authorized speed	0	2	0	1	0	0	3
	Made improper turn	0	14	0	1	0	0	15
	Improper Lane Change	0	0	0	0	0	0	0
	Followed too close	1	11	3	4	1	0	20
	Disregarded RR Signal	0	0	0	0	0	0	0
	Disregarded Warning Sign	0	0	0	0	0	0	0
	Operating vehicle in an erratic/reckless/careless/negligent/aggressive manner	0	6	0	7	1	0	14
	Improper Backing	0	0	0	0	0	0	0
	Illegally Parked/Unattended	0	0	0	0	0	0	0
	Swerving/Evasive Action	1	44	5	7	1	0	58
	Over correcting/over steering	0	2	0	0	0	0	2
	Downhill runaway	0	1	1	0	0	0	2
	Equipment failure	0	4	1	0	0	0	5
	Separation of units	0	2	0	0	0	0	2
	Ran off road - right	1	6	3	0	0	0	10
	Ran off road - straight	0	1	0	0	0	0	1
	Ran off road - left	0	6	0	0	0	0	6
	Lost Control	1	8	4	0	0	0	13
	Inattentive/distracted by: Passenger	0	0	0	0	1	0	1
	Inattentive/distracted by: Use of phone or other device	0	3	0	0	0	0	3
	Inattentive/distracted by: Fallen object	0	0	0	0	0	0	0
	Inattentive/distracted by: Fatigued/asleep	0	0	1	0	0	0	1
	Other (explain in narrative): Vision obstructed	2	13	3	1	0	0	19
	Oversized Load/Vehicle	0	0	0	0	0	0	0
	Cargo/equipment loss or shift	0	0	0	0	0	0	0
	Other (explain in narrative): Other improper action	0	45	4	1	0	0	50
	Unknown	0	11	1	1	0	0	13
	Other (explain in narrative): No improper action	0	18	8	1	0	0	27
Not Reported	0	3	0	0	0	0	3	

Major cause of multiple vehicle crashes involving one or more SMVs with matching circumstances from the SMV involved that indicate more responsibility on the SMV than any other vehicle involved in the crash	Animal	2	0	0	0	0	0	2
	Ran Traffic Signal	0	0	0	0	0	0	0
	Ran Stop Sign	0	7	1	1	0	0	9
	Crossed centerline	0	10	2	4	0	0	16
	FTYROW: At uncontrolled intersection	0	3	0	2	0	0	5
	FTYROW: Making right turn on red signal	0	0	0	0	0	0	0
	FTYROW: From stop sign	1	9	2	2	0	0	14
	FTYROW: From yield sign	0	1	0	0	0	0	1
	FTYROW: Making left turn	0	11	0	1	0	0	12
	FTYROW: From driveway	0	10	1	10	0	0	21
	FTYROW: From parked position	0	0	0	1	0	0	1
	FTYROW: To pedestrian	0	0	0	0	0	0	0
	FTYROW: Other (explain in narrative)	0	11	3	5	0	2	21
	Traveling wrong way or on wrong side of road	0	4	0	6	0	0	10
	Driving too fast for conditions	0	1	0	2	0	0	3
	Exceeded authorized speed	0	0	0	0	0	0	0
	Made improper turn	0	13	0	1	0	0	14
	Improper Lane Change	0	0	0	0	0	0	0
	Followed too close	0	0	0	3	0	0	3
	Disregarded RR Signal	0	0	0	0	0	0	0
	Disregarded Warning Sign	0	0	0	0	0	0	0
	Operating vehicle in an erratic/reckless/careless/negligent/aggressive manner	0	1	0	7	0	0	8
	Improper Backing	0	0	0	0	0	0	0
	Illegally Parked/Unattended	0	0	0	0	0	0	0
	Swerving/Evasive Action	1	5	2	3	0	0	11
	Over correcting/over steering	0	0	0	0	0	0	0
	Downhill runaway	0	1	0	0	0	0	1
	Equipment failure	0	3	1	0	0	0	4
	Separation of units	0	1	0	0	0	0	1
	Ran off road - right	1	4	2	0	0	0	7
	Ran off road - straight	0	0	0	0	0	0	0
	Ran off road - left	0	4	0	0	0	0	4
	Lost Control	0	1	0	0	0	0	1
Inattentive/distracted by: Passenger	0	0	0	0	0	0	0	
Inattentive/distracted by: Use of phone or other device	0	0	0	0	0	0	0	
Inattentive/distracted by: Fallen object	0	0	0	0	0	0	0	
Inattentive/distracted by: Fatigued/asleep	0	0	0	0	0	0	0	
Other (explain in narrative): Vision obstructed	0	5	0	0	0	0	5	

Major cause of multiple vehicle crashes involving one or more SMVs with matching circumstances from the SMV involved that indicate more responsibility on the SMV than any other vehicle involved in the crash (continued)	Oversized Load/Vehicle	0	0	0	0	0	0	0
	Cargo/equipment loss or shift	0	0	0	0	0	0	0
	Other (explain in narrative): Other improper action	0	16	2	1	0	0	19
	Unknown	0	7	1	1	0	0	9
	Other (explain in narrative): No improper action	0	11	8	0	0	0	19
	Not Reported	0	0	0	0	0	0	0
Percentage of multiple vehicle crashes involving one or more SMVs in which an SMV is considered more responsible for the crash than any other vehicles involved in the crash	Animal	66.7%	0.0%	0.0%	0.0%	0.0%	0.0%	66.7%
	Ran Traffic Signal	0.0%	0.0%	0.0%	0.0%	0.0%	0.0%	0.0%
	Ran Stop Sign	0.0%	77.8%	100.0%	100.0%	0.0%	0.0%	69.2%
	Crossed centerline	0.0%	55.6%	40.0%	80.0%	0.0%	0.0%	57.1%
	FTYROW: At uncontrolled intersection	0.0%	60.0%	0.0%	100.0%	0.0%	0.0%	71.4%
	FTYROW: Making right turn on red signal	0.0%	0.0%	0.0%	0.0%	0.0%	0.0%	0.0%
	FTYROW: From stop sign	100.0%	75.0%	100.0%	100.0%	0.0%	0.0%	82.4%
	FTYROW: From yield sign	0.0%	100.0%	0.0%	0.0%	0.0%	0.0%	100.0%
	FTYROW: Making left turn	0.0%	91.7%	0.0%	100.0%	0.0%	0.0%	92.3%
	FTYROW: From driveway	0.0%	83.3%	100.0%	90.9%	0.0%	0.0%	87.5%
	FTYROW: From parked position	0.0%	0.0%	0.0%	100.0%	0.0%	0.0%	100.0%
	FTYROW: To pedestrian	0.0%	0.0%	0.0%	0.0%	0.0%	0.0%	0.0%
	FTYROW: Other (explain in narrative)	0.0%	36.7%	42.9%	100.0%	0.0%	100.0%	45.7%
	Traveling wrong way or on wrong side of road	0.0%	66.7%	0.0%	100.0%	0.0%	0.0%	83.3%
	Driving too fast for conditions	0.0%	7.1%	0.0%	100.0%	0.0%	0.0%	13.0%
	Exceeded authorized speed	0.0%	0.0%	0.0%	0.0%	0.0%	0.0%	0.0%
	Made improper turn	0.0%	92.9%	0.0%	100.0%	0.0%	0.0%	93.3%
	Improper Lane Change	0.0%	0.0%	0.0%	0.0%	0.0%	0.0%	0.0%
	Followed too close	0.0%	0.0%	0.0%	75.0%	0.0%	0.0%	15.0%
	Disregarded RR Signal	0.0%	0.0%	0.0%	0.0%	0.0%	0.0%	0.0%
	Disregarded Warning Sign	0.0%	0.0%	0.0%	0.0%	0.0%	0.0%	0.0%
	Operating vehicle in an erratic/reckless/careless/negligent/aggressive manner	0.0%	16.7%	0.0%	100.0%	0.0%	0.0%	57.1%
	Improper Backing	0.0%	0.0%	0.0%	0.0%	0.0%	0.0%	0.0%
	Illegally Parked/Unattended	0.0%	0.0%	0.0%	0.0%	0.0%	0.0%	0.0%
	Swerving/Evasive Action	100.0%	11.4%	40.0%	42.9%	0.0%	0.0%	19.0%
	Over correcting/over steering	0.0%	0.0%	0.0%	0.0%	0.0%	0.0%	0.0%
	Downhill runaway	0.0%	100.0%	0.0%	0.0%	0.0%	0.0%	50.0%
Equipment failure	0.0%	75.0%	100.0%	0.0%	0.0%	0.0%	80.0%	
Separation of units	0.0%	50.0%	0.0%	0.0%	0.0%	0.0%	50.0%	

Percentage of multiple vehicle crashes involving one or more SMVs in which an SMV is considered more responsible for the crash than any other vehicles involved in the crash (continued)	Ran off road - right	100.0%	66.7%	66.7%	0.0%	0.0%	0.0%	70.0%
	Ran off road - straight	0.0%	0.0%	0.0%	0.0%	0.0%	0.0%	0.0%
	Ran off road - left	0.0%	66.7%	0.0%	0.0%	0.0%	0.0%	66.7%
	Lost Control	0.0%	12.5%	0.0%	0.0%	0.0%	0.0%	7.7%
	Inattentive/distracted by: Passenger	0.0%	0.0%	0.0%	0.0%	0.0%	0.0%	0.0%
	Inattentive/distracted by: Use of phone or other device	0.0%	0.0%	0.0%	0.0%	0.0%	0.0%	0.0%
	Inattentive/distracted by: Fallen object	0.0%	0.0%	0.0%	0.0%	0.0%	0.0%	0.0%
	Inattentive/distracted by: Fatigued/asleep	0.0%	0.0%	0.0%	0.0%	0.0%	0.0%	0.0%
	Other (explain in narrative): Vision obstructed	0.0%	38.5%	0.0%	0.0%	0.0%	0.0%	26.3%
	Oversized Load/Vehicle	0.0%	0.0%	0.0%	0.0%	0.0%	0.0%	0.0%
	Cargo/equipment loss or shift	0.0%	0.0%	0.0%	0.0%	0.0%	0.0%	0.0%
	Other (explain in narrative): Other improper action	0.0%	35.6%	50.0%	100.0%	0.0%	0.0%	38.0%
	Unknown	0.0%	63.6%	100.0%	100.0%	0.0%	0.0%	69.2%
	Other (explain in narrative): No improper action	0.0%	61.1%	100.0%	0.0%	0.0%	0.0%	70.4%
	Not Reported	0.0%	0.0%	0.0%	0.0%	0.0%	0.0%	0.0%
Total	50.0%	42.2%	33.3%	84.5%	0.0%	100.0%	46.7%	
Vehicle Action	Movement Essentially Straight	4	210	38	82	0	6	340
	Turning Left	1	115	7	10	0	0	133
	Turning Right	1	16	1	7	0	0	25
	Making U-Turn	0	3	0	4	0	3	10
	Overtaking/passing	0	4	0	2	0	0	6
	Changing Lanes	0	1	0	0	0	0	1
	Entering Traffic Lane	0	3	1	0	0	0	4
	Leaving Traffic Lane	0	0	0	0	0	0	0
	Backing	0	4	7	3	0	0	14
	Slowing/Stopping	0	6	0	6	0	0	12
	Stopped for Sign/Signal	0	1	3	0	0	0	4
	Legally Parked	0	1	0	0	0	0	1
	Illegally Parked/Unattended	0	5	0	1	0	0	6
	Not Reported	4	9	1	2	7	0	23
	Other (explain in narrative)	0	5	4	11	0	0	20
Unknown	0	3	0	3	1	0	7	

APPENDIX C: COMPLETE VARIABLE DESCRIPTIONS

Complete Variable Descriptions

Variable	Summary	Description	
x1	Report Type	1	1977 Officer
		2	1977 Driver
		3	Pre-1977 Driver
		4	1979 Officer
		5	1979 Driver
		6	2001 Driver
		7	2001 TraCS
		8	2001 Officer
x2	First Harmful Event	11	Non-collision events: Overturn/rollover
		12	Non-collision events: Jackknife
		13	Non-collision events: Other non-collision (explain in narrative)
		20	Collision with: Non-motorist (see non-motorist type)
		21	Collision with: Vehicle in traffic
		22	Collision with: Vehicle in/from other roadway
		23	Collision with: Parked motor vehicle
		24	Collision with: Railway vehicle/train
		25	Collision with: Animal
		26	Collision with: Other non-fixed object (explain in narrative)
		30	Collision with fixed object: Bridge/bridge rail/overpass
		31	Collision with fixed object: Underpass/structure support
		32	Collision with fixed object: Culvert
		33	Collision with fixed object: Ditch/embankment
		34	Collision with fixed object: Curb/island/raised median
		35	Collision with fixed object: Guardrail
		36	Collision with fixed object: Concrete barrier (median or right side)
		37	Collision with fixed object: Tree
		38	Collision with fixed object: Poles (utility, light, etc.)
		39	Collision with fixed object: Sign post
		40	Collision with fixed object: Mailbox
41	Collision with fixed object: Impact attenuator		
42	Collision with fixed object: Other fixed object (explain in narrative)		
50	Miscellaneous events: Fire/explosion		
51	Miscellaneous events: Immersion		
52	Miscellaneous events: Hit and run		
77	Not Reported		
99	Unknown		
x3	Manner of Crash/Collision	1	Non-collision
		2	Head-on
		3	Rear-end
		4	Angle, oncoming left turn
		5	Broadside
		6	Sideswipe, same direction
		7	Sideswipe, opposite direction
		9	Unknown
		77	Not Reported
x4	Major Cause	1	Animal
		2	Ran Traffic Signal
		3	Ran Stop Sign

	Major Cause (continued)	4	Crossed centerline		
		5	FTYROW: At uncontrolled intersection		
		6	FTYROW: Making right turn on red signal		
		7	FTYROW: From stop sign		
		8	FTYROW: From yield sign		
		9	FTYROW: Making left turn		
		10	FTYROW: From driveway		
		11	FTYROW: From parked position		
		12	FTYROW: To pedestrian		
		13	FTYROW: Other (explain in narrative)		
		14	Traveling wrong way or on wrong side of road		
		15	Driving too fast for conditions		
		16	Exceeded authorized speed		
		17	Made improper turn		
		18	Improper Lane Change		
		19	Followed too close		
		20	Disregarded RR Signal		
		21	Disregarded Warning Sign		
		22	Operating vehicle in an erratic/reckless/careless/negligent/aggressive manner		
		23	Improper Backing		
		24	Illegally Parked/Unattended		
		25	Swerving/Evasive Action		
		26	Over correcting/over steering		
		27	Downhill runaway		
		28	Equipment failure		
		29	Separation of units		
		30	Ran off road - right		
		31	Ran off road - straight		
		32	Ran off road - left		
		33	Lost Control		
		34	Inattentive/distracted by: Passenger		
		35	Inattentive/distracted by: Use of phone or other device		
		36	Inattentive/distracted by: Fallen object		
		37	Inattentive/distracted by: Fatigued/asleep		
		38	Other (explain in narrative): Vision obstructed		
		39	Oversized Load/Vehicle		
		40	Cargo/equipment loss or shift		
		41	Other (explain in narrative): Other improper action		
		42	Unknown		
		43	Other (explain in narrative): No improper action		
		77	Not Reported		
		x5	Environmental Contributing Circumstances	1	None apparent
				2	Weather conditions
				3	Physical obstruction
4	Pedestrian action				
5	Glare				
6	Animal in roadway				
7	Previous accident				
8	Other (explain in narrative)				
9	Unknown				
77	Not Reported				

x6	Weather Conditions	1	Clear
		2	Partly cloudy
		3	Cloudy
		4	Fog/smoke
		5	Mist
		6	Rain
		7	Sleet/hail/freezing rain
		8	Snow
		9	Severe winds
		10	Blowing sand/soil/dirt/snow
		77	Not Reported
		88	Other (explain in narrative)
99	Unknown		
x7	Light Conditions	1	Daylight
		2	Dusk
		3	Dawn
		4	Dark - roadway lighted
		5	Dark - roadway not lighted
		6	Dark - unknown roadway lighting
		9	Unknown
77	Not Reported		
x8	Crashwide Surface Conditions	1	Dry
		2	Wet
		3	Ice
		4	Snow
		5	Slush
		6	Sand/mud/dirt/oil/gravel
		7	Water (standing/moving)
		8	Other (explain in narrative)
		9	Unknown
77	Not Reported		
x9	County in which Crash Occurred	1	Adair
		2	Adams
		3	Allamakee
		4	Appanoose
		5	Audubon
		6	Benton
		7	Black Hawk
		8	Boone
		9	Bremer
		10	Buchanan
		11	Buena Vista
		12	Butler
		13	Calhoun
		14	Carroll
		15	Cass
		16	Cedar
17	Cerro Gordo		
18	Cherokee		
19	Chickasaw		
20	Clarke		
21	Clay		
22	Clayton		

County in which Crash Occurred (continued)	23	Clinton
	24	Crawford
	25	Dallas
	26	Davis
	27	Decatur
	28	Delaware
	29	Des Moines
	30	Dickinson
	31	Dubuque
	32	Emmet
	33	Fayette
	34	Floyd
	35	Franklin
	36	Fremont
	37	Greene
	38	Grundy
	39	Guthrie
	40	Hamilton
	41	Hancock
	42	Hardin
	43	Harrison
	44	Henry
	45	Howard
	46	Humboldt
	47	Ida
48	Iowa	
49	Jackson	
50	Jasper	
51	Jefferson	
52	Johnson	
53	Jones	
54	Keokuk	
55	Kossuth	
56	Lee	
57	Linn	
58	Louisa	
59	Lucas	
60	Lyon	
61	Madison	
62	Mahaska	
63	Marion	
64	Marshall	
65	Mills	
66	Mitchell	
67	Monona	
68	Monroe	
69	Montgomery	
70	Muscatine	
71	O'Brien	
72	Osceola	
73	Page	
74	Palo Alto	
75	Plymouth	

	County in which Crash Occurred (continued)	76	Pocahontas
		77	Polk
		78	Pottawattamie
		79	Poweshiek
		80	Ringgold
		81	Sac
		82	Scott
		83	Shelby
		84	Sioux
		85	Story
		86	Tama
		87	Taylor
		88	Union
		89	Van Buren
		90	Wapello
		91	Warren
		92	Washington
		93	Wayne
		94	Webster
		95	Winnebago
		96	Winneshiek
		97	Woodbury
		98	Worth
		99	Wright
x10	Month of Crash	1	January
		2	February
		3	March
		4	April
		5	May
		6	June
		7	July
		8	August
		9	September
		10	October
		11	November
		12	December
x11	Day of Month		Day of Month when crash occurred
x12	Year of Crash		Year in which crash took place
x13	Time of Crash		Time at which crash took place in 24 hour system
		7777	Not Reported
x14	Location of First Harmful Event	1	On Roadway
		2	Shoulder
		3	Median
		4	Roadside
		5	Gore
		6	Outside trafficway
		9	Unknown
		77	Not reported.
x15	Time of Sunrise		Sunrise time in State Center, IA, on 15th day of month the crash occurred
x16	Time of Sunset		Sunset time in State Center, IA, on 15th day of month the crash occurred

x17	Roadway Contributing Circumstances	1	None apparent
		2	Road surface condition
		3	Debris
		4	Ruts/holes/bumps
		5	Work Zone (construction/maintenance/utility)
		6	Worn/travel-polished surface
		7	Obstruction in roadway
		8	Traffic control device inoperative/missing/obscured
		9	Shoulders (none/low/soft/high)
		10	Non-highway work
		11	Non-contact vehicle
		77	Not reported.
		99	Unknown
x18	Type of Roadway Junction/Feature	1	Non-intersection: No special feature
		2	Non-intersection: Bridge/overpass/underpass
		3	Non-intersection: Railroad crossing
		4	Non-intersection: Business drive
		5	Non-intersection: Farm/residential drive
		6	Non-intersection: Alley intersection
		7	Non-intersection: Crossover in median
		8	Non-intersection: Other non-intersection (explain in narrative)
		11	Intersection: Four-way intersection
		12	Intersection: T - intersection
		13	Intersection: Y - intersection
		14	Intersection: Five-leg or more
		15	Intersection: Offset four-way intersection
		16	Intersection: Intersection with ramp
		17	Intersection: On-ramp merge area
		18	Intersection: Off-ramp diverge area
		19	Intersection: On-ramp
		20	Intersection: Off-ramp
		21	Intersection: With bike/pedestrian path
		22	Intersection: Other intersection (explain in narrative)
77	Not reported.		
99	Unknown		
x19	Crash Severity	1	Fatality
		2	Major Injury
		3	Minor Injury
		4	Possible/Unknown Injury
		5	Property Damage Only
x20	Number of Fatalities		Crashwide total of all fatalities.
x21	Number of Injuries		Crashwide total of all injuries, excluding fatalities.
x22	Number of Major Injuries		Crashwide total of all major injuries.
x23	Number of Minor Injuries		Crashwide total of all minor injuries.
x24	Number of Possible Injuries		Crashwide total of all possible injuries.
x25	Number of Unknown Injuries		Crashwide total of all unknown injuries.
x26	Amount of Property Damage		Crashwide total of property damage, including non-vehicular.

x27	Number of vehicles involved in crash		Number of vehicles involved in the crash.
x28	Number of Occupants		Crashwide total of occupants in all vehicles.
x29	Sequence of Events 1st Event	1	Ran off road, right
		2	Ran off road, straight
		3	Ran off road, left
		4	Crossed centerline/median
		5	Animal or object in roadway
		6	Evasive action (swerve, panic braking, etc.)
		7	Downhill runaway
		8	Cargo/equipment loss or shift
		9	Equipment failure (tires, brakes, etc.)
		10	Separation of units
		11	Non-collision events: Overturn/rollover
		12	Non-collision events: Jackknife
		13	Non-collision events: Other non-collision (explain in narrative)
		20	Collision with: Non-motorist (see non-motorist type)
		21	Collision with: Vehicle in traffic
		22	Collision with: Vehicle in/from other roadway
		23	Collision with: Parked motor vehicle
		24	Collision with: Railway vehicle/train
		25	Collision with: Animal
		26	Collision with: Other non-fixed object (explain in narrative)
		30	Collision with fixed object: Bridge/bridge rail/overpass
		31	Collision with fixed object: Underpass/structure support
		32	Collision with fixed object: Culvert
		33	Collision with fixed object: Ditch/embankment
		34	Collision with fixed object: Curb/island/raised median
		35	Collision with fixed object: Guardrail
		36	Collision with fixed object: Concrete barrier (median or right side)
		37	Collision with fixed object: Tree
		38	Collision with fixed object: Poles (utility, light, etc.)
		39	Collision with fixed object: Sign post
		40	Collision with fixed object: Mailbox
		41	Collision with fixed object: Impact attenuator
		42	Collision with fixed object: Other fixed object (explain in narrative)
		50	Miscellaneous events: Fire/explosion
		51	Miscellaneous events: Immersion
		52	Miscellaneous events: Hit and run
		77	Not reported
		99	Unknown
x30	Sequence of Events 2nd Event		See Sequence of Events 1st Event
x31	Sequence of Events 3rd Event		See Sequence of Events 1st Event
x32	Sequence of Events 4th Event		See Sequence of Events 1st Event
x33	Most Harmful Event		See Sequence of Events 1st Event
x34	Driver Age		Age of driver from Date of Birth and Crash Date

x35	Male	1	Male
		0	Other
x36	Female	1	Female
		0	Other
x37	Charged	1	Yes
		2	No
		3	Not applicable.
		9	Unknown
		77	Not reported.
x38	Alcohol Test Administered	1	None
		2	Blood
		3	Urine
		4	Breath
		5	Vitreous
		9	Refused
		77	Not reported.
x39	Alcohol Test Results		Blood Alcohol Content in decimal format
x40	Drug Test Administered	1	None
		2	Blood
		3	Urine
		9	Refused
		77	Not reported.
x41	Drug Test Results	1	Positive
		2	Negative
		77	Not reported.
x42	Driver Condition	1	Apparently normal
		2	Physical impairment
		3	Emotional (e.g. depressed/angry/disturbed)
		4	Illness
		5	Asleep/fainted/fatigued/etc.
		6	Under the influence of alcohol/drugs/medications
		8	Other (explain in narrative)
		9	Unknown
		77	Not reported.
x43	Driver Contributing Circumstances	1	Ran traffic signal
		2	Ran stop sign
		3	Exceeded authorized speed
		4	Driving too fast for conditions
		5	Made improper turn
		6	Traveling wrong way or on wrong side of road
		7	Crossed centerline
		8	Lost Control
		9	Followed too close
		10	Swerved to avoid: vehicle/object/non-motorist/or animal in roadway
		11	Over correcting/over steering
		12	Operating vehicle in an erratic/reckless/careless/negligent/aggressive manner
		13	FTYROW: From stop sign
		14	FTYROW: From yield sign
		15	FTYROW: Making left turn
		16	FTYROW: Making right turn on red signal
		17	FTYROW: From driveway

	Driver Contributing Circumstances (continued)	18	FTYROW: From parked position
		19	FTYROW: To pedestrian
		20	FTYROW: At uncontrolled intersection
		21	FTYROW: Other (explain in narrative)
		22	Inattentive/distracted by: Passenger
		23	Inattentive/distracted by: Use of phone or other device
		24	Inattentive/distracted by: Fallen object
		25	Inattentive/distracted by: Fatigued/asleep
		26	Other (explain in narrative): Vision obstructed
		27	Other (explain in narrative): Other improper action
		28	Other (explain in narrative): No improper action
		77	Not reported.
		99	Unknown
x44	Visions Obscurement	1	Not obscured
		2	Trees/crops
		3	Buildings
		4	Embankment
		5	Sign/billboard
		6	Hillcrest
		7	Parked vehicles
		8	Moving vehicles
		9	Person/object in or on vehicle
		10	Blinded by sun or headlights
		11	Frosted windows/windshield
		12	Blowing snow
		13	Fog/smoke/dust
		77	Not reported.
		88	Other (explain in narrative)
99	Unknown		
x45	Iowa Drivers License State	1	Drivers License State = Iowa
		0	Other Drivers License State or not reported
x46	Other Drivers License State	1	Drivers License State = State other than Iowa; excluding states not reported
		0	Other Drivers License State or not reported
x47	Driver Age bins	1	DriverAge < 14
		2	DriverAge = 14
		3	DriverAge = 15
		4	DriverAge = 16
		5	DriverAge = 17
		6	DriverAge = 18
		7	DriverAge = 19
		8	DriverAge = 20
		9	DriverAge >= 21 and DriverAge <= 24
		10	DriverAge >= 25 and DriverAge <= 29
		11	DriverAge >= 30 and DriverAge <= 34
		12	DriverAge >= 35 and DriverAge <= 39
		13	DriverAge >= 40 and DriverAge <= 44
		14	DriverAge >= 45 and DriverAge <= 49
		15	DriverAge >= 50 and DriverAge <= 54
		16	DriverAge >= 55 and DriverAge <= 59
		17	DriverAge >= 60 and DriverAge <= 64
		18	DriverAge >= 65 and DriverAge <= 69
		19	DriverAge >= 70 and DriverAge <= 74

	Driver Age bins (continued)	20	DriverAge >= 75 and DriverAge <= 79
		21	DriverAge >= 80 and DriverAge <= 84
		22	DriverAge >= 85 and DriverAge <= 89
		23	DriverAge >= 90 and DriverAge <= 94
		24	DriverAge >= 95 and DriverAge <= 98 (actually, 98 is 98 and greater)
		77	Not reported.
		99	Unknown
x48*	Driver License Class A	1	Driver License Class A Restriction
		0	Other Driver License Restriction Class
x49	Driver License Class B	1	Driver License Class B Restriction
		0	Other Driver License Restriction Class
x50	Driver License Class C	1	Driver License Class C Restriction
		0	Other Driver License Restriction Class
x51	Driver License Class D	1	Driver License Class D Restriction
		0	Other Driver License Restriction Class
x52	Speed Limit		Speed limit of road on which SMV was traveling.
x53	Traffic Control	1	No controls present
		2	Traffic signals
		3	Flashing traffic control signal
		4	Stop signs
		5	Yield signs
		6	No Passing Zone (marked)
		7	Warning sign
		8	School zone signs
		9	Railway crossing device
		10	Traffic director
		11	Workzone signs
		77	Not reported.
		88	Other control (explain in narrative)
		99	Unknown
x54	Vehicle Configuration	1	Passenger car
		2	Four-tire light truck (pick-up/panel)
		3	Van or mini-van
		4	Sport utility vehicle
		5	Single-unit truck (2-axle/6-tire)
		6	Single-unit truck (>= 3 axles)
		7	Truck/trailer
		8	Truck tractor (bobtail)
		9	Tractor/semi-trailer
		10	Tractor/doubles
		11	Tractor/triples
		12	Other heavy truck (cannot classify)
		13	Motor home/recreational vehicle
		14	Motorcycle
		15	Moped/All-Terrain Vehicle
		16	School bus (seats > 15)
		17	Small school bus (seats 9-15)
		18	Other bus (seats > 15)
		19	Other small bus (seats 9-15)
		20	Farm vehicle/equipment
		21	Maintenance/construction vehicle
		22	Train

	Vehicle Configuration (continued)	23	Other (explain in narrative)
		77	Not reported.
		99	Unknown
x55	Vehicle Year		Model Year of SMV in Crash
		7777	Not Reported
x56	Emergency Vehicle Type	1	Not applicable
		2	Police
		3	Fire
		4	Ambulance
		5	Towing
		6	Military
		7	Maintenance
		9	Unknown
		77	Not reported.
x57	Emergency Status	1	Yes - in emergency
		2	No - not in emergency
		3	Not applicable
		9	Unknown
		77	Not reported.
x58	Total Occupants		Occupants in SMV
		777	Not Reported
x59	Cargo Body Type	1	Not applicable
		2	Truck Cargo Type: Van/enclosed box
		3	Truck Cargo Type: Dump truck (grain/gravel)
		4	Truck Cargo Type: Cargo tank
		5	Truck Cargo Type: Flatbed
		6	Truck Cargo Type: Concrete mixer
		7	Truck Cargo Type: Auto transporter
		8	Truck Cargo Type: Garbage/refuse
		9	Truck Cargo Type: Other truck cargo type (explain in narrative)
		10	Trailer type: Small utility (one axle)
		11	Trailer type: Large utility (2+ axles)
		12	Trailer type: Boat
		13	Trailer type: Camper
		14	Trailer type: Large mobile home
		15	Trailer type: Oversize load
		16	Trailer type: Towed vehicle
		17	Trailer type: Pole
		18	Trailer type: Other trailer type (explain in narrative)
		77	Not reported.
		99	Unknown
x60	Vehicle Action	1	Movement essentially straight
		2	Turning left
		3	Turning right
		4	Making U-turn
		5	Overtaking/passing
		6	Changing lanes
		7	Entering traffic lane (merging)
		8	Leaving traffic lane
		9	Backing
		10	Slowing/stopping
		11	Stopped for stop sign/signal

	Vehicle Action (continued)	12	Legally Parked
		13	Illegally Parked/Unattended
		14	Other (explain in narrative)
		77	Not reported.
		99	Unknown
x61	Point of Initial Impact	1	Front
		2	Passenger side - front
		3	Passenger side - middle
		4	Passenger side - rear
		5	Rear
		6	Driver side - rear
		7	Driver side - middle
		8	Driver side - front
		9	Top
		10	Under-Carriage
		77	Not reported.
		99	Unknown
		x62	Most Damaged Area
2	Passenger side - front		
3	Passenger side - middle		
4	Passenger side - rear		
5	Rear		
6	Driver side - rear		
7	Driver side - middle		
8	Driver side - front		
9	Top		
10	Under-Carriage		
77	Not reported.		
99	Unknown		
x63	Extent of Damage		
		2	Minor damage
		3	Functional damage
		4	Disabling damage
		5	Severe - vehicle totaled
		9	Unknown
		77	Not reported.
x64	Underride/Override	1	None
		2	Underride - compartment intrusion
		3	Underride - no compartment intrusion
		4	Underride - compartment intrusion unknown
		5	Override - moving vehicle
		6	Override - parked/stationary vehicle
		9	Unknown
		77	Not reported.
x65	Approximate Cost to Repair or Replace		Estimated dollar value of repairs to vehicle
x66	Rural	1	Rural
		0	Other
x67	Urban	1	Urban
		0	Other
x68	Unknown	1	Unknown Location
		0	Other

x69	Motorcycle License	1	Driver of SMV had Motorcycle License
		0	Driver of SMV did not have Motorcycle License
SEVERITY	Crash Severity	0	x19=5; Property Damage Only
		1	x19=3 or x19=4; Minor Injury or Possible/Unknown Injury
		2	x19=2 or x19=1; Major Injury or Fatality
MULTVEH	More than 1 vehicle in Crash	1	x27>1; multiple vehicle collision
		0	x27=1; single vehicle collision
DARK	Dark Environmental Light Conditions	1	x7=4 or x7=5 or x7=6; dark condition with either roadway lighted, roadway not lighted, or unknown roadway lighting conditions
		0	Other conditions
REAREND	Rear-end Collision	1	X3=3; Manner of Collision = Rear-end
		0	Manner of collision was not rear-end
OLDCAR	Age of the vehicle is greater than 29 years (age of vehicle is year of accident minus year of car)	1	(x12-x55)>29; Vehicle is older than 29 years
		0	Vehicle is not older than 29 years
OLD	Age of Driver is older than 59 years	1	x34>59; Driver of SMV is over 59 years old
		0	Driver of SMV is not over 59 years old
STRAIGHT	Movement of SMV was Essentially Straight	1	x60=1; Essentially Straight Vehicle Movement
		0	Other Vehicle Movement
FSTHMOFF	First Harmful Event was off the roadway	1	x14>1 and x14<9; Location of First Harmful Event was either: on the shoulder, median, roadside, gore, or outside the trafficway
		0	x14=1 or x14=9 or x14=77; Location of first harmful event was either on the roadway, unknown, or not reported
FALL	Crash was during Fall Season	1	8<x10<12; Crash month is September, October, or November
		0	Crash Month was in a month other than September, October, or November
SUMMER	Crash was during Summer Season	1	5<x10<9; Crash month is June, July, August
		0	Crash month was in a month other than June, July, or August
YOUNG	Driver of Farm Vehicle is 25 years of age or under	1	x34<26; Driver of Farm Vehicle is 25 years of age or under
		0	Driver of Farm Vehicle is over 25 years of age or unknown
x48	Driver License Class A	1	Driver License Class A Restriction
		0	Other Driver License Restriction Class
x66	Rural	1	Rural
		0	Other

*variable is described in the CDL Vehicle/License Classification System

CDL Vehicle/License Classification System

Type "A" Vehicle/Class "A" CDL

Any combination of vehicles with a GCWR of 26,001 or more pounds, provided the GVWR of the vehicle(s) being towed is in excess of 10,000 pounds.

The holders of a Class A license may, with appropriate endorsements, operate vehicles within Types B and C.

Type "B" Vehicle/Class "B" CDL

Any single vehicle with a GVWR of 26,001 or more pounds, or any such vehicle towing a vehicle not in excess of 10,000 pounds GVWR. The holders of a Class B license may, with appropriate endorsements, operate vehicles within Type C.

Type "C" Vehicle/Class "C" CDL

Any single vehicle less than 26,001 pounds GVWR, or any such vehicle towing a vehicle not in excess of 10,000 pounds GVWR. This group applies only to vehicles which are placarded for hazardous material or designed to transport 16 or more persons, including the driver (and similar-size passenger vehicles designed to transport a fewer number of handicapped persons and has a GVWR of 10,001 or more pounds).

CDL fees: \$16 - 2 years / \$40 - 5 years (initial and renewal) plus applicable endorsement or restriction fees.

Single Vehicle Crashes Model for Transferability Test

```

-----+-----
Ordered Probability Model
Maximum Likelihood Estimates
Model estimated: Sep 30, 2008 at 09:57:26PM.
Dependent variable          SEVERITY
Weighting variable          None
Number of observations      80
Iterations completed        11
Log likelihood function     -78.43699
Restricted log likelihood   -83.60915
Chi squared                 10.34433
Degrees of freedom          6
Prob[ChiSqd > value] =    .1108805
Underlying probabilities based on Normal
Cell frequencies for outcomes
  Y Count Freq  Y Count Freq  Y Count Freq
  0      37 .462  1       27 .337  2       16 .200
-----+-----

```

```

-----+-----+-----+-----+-----+-----+
|Variable | Coefficient | Standard Error |b/St.Er.|P[|Z|>z] | Mean of X|
-----+-----+-----+-----+-----+-----+
Index function for probability
Constant  -.2464055339   .34018068   -.724   .4689
DARK      .1316365466   .39502247   .333   .7390   .13750000
X48      .6355093766E-01 .31991273   .199   .8425   .23750000
OLDCAR    .7856015672   .33172654   2.368   .0179   .20000000
OLD       .2014052532   .32188241   .626   .5315   .22500000
STRAIGHT -.1487391041   .32352111   -.460   .6457   .78750000
FSTHMOFF .4529181377   .27244689   1.662   .0964   .52500000
Threshold parameters for index
Mu(1)    1.024471978   .17163710   5.969   .0000
(Note: E+nn or E-nn means multiply by 10 to + or -nn power.)

```

[Matrix: Las](#)
[8,4]

```

-----+-----+-----+-----+-----+-----+-----+
| Cross tabulation of predictions. Row is actual, column is predicted.
| Model = Probit . Prediction is number of the most probable cell.
-----+-----+-----+-----+-----+-----+-----+
| Actual|Row Sum| 0 | 1 | 2 | 3 | 4 | 5 | 6 | 7 | 8 | 9 |
-----+-----+-----+-----+-----+-----+-----+
| 0 | 37 | 32 | 5 | 0 |
| 1 | 27 | 19 | 2 | 6 |
| 2 | 16 | 10 | 1 | 5 |
-----+-----+-----+-----+-----+-----+-----+
| Col Sum| 5154 | 61 | 8 | 11 | 0 | 0 | 0 | 0 | 0 | 0 | 0 |
-----+-----+-----+-----+-----+-----+-----+

```

Multiple Vehicle Crashes Model for Transferability Test

```

-----+-----
Ordered Probability Model
Maximum Likelihood Estimates
Model estimated: Sep 30, 2008 at 09:55:42PM.
Dependent variable          SEVERITY
Weighting variable          None
Number of observations      518
Iterations completed        11
Log likelihood function     -457.1571
Restricted log likelihood    -471.1244
Chi squared                 27.93448
Degrees of freedom          6
Prob[ChiSqd > value] =     .9666952E-04
Underlying probabilities based on Normal
Cell frequencies for outcomes
  Y Count Freq  Y Count Freq  Y Count Freq
  0   300 .579  1   167 .322  2   51 .098
-----+-----

```

```

-----+-----+-----+-----+-----+-----+
|Variable | Coefficient | Standard Error |b/St.Er.|P[|Z|>z] | Mean of X|
-----+-----+-----+-----+-----+-----+
Index function for probability
Constant  -.4048688910  .92886733E-01  -4.359  .0000
DARK      .3675166792   .13379980      2.747  .0060  .18918919
X48      -.2876888328  .12956214     -2.220  .0264  .23938224
OLDCAR   .2510433634   .15524755      1.617  .1059  .12355212
OLD       .1869284159   .12337949      1.515  .1298  .23552124
STRAIGHT .2638182154   .10826086      2.437  .0148  .48262548
FSTHMOFF -.3618854242E-01 .21925984     -1.165  .8689  .63706564E-01
Threshold parameters for index
Mu(1)    1.136748820  .77641390E-01  14.641  .0000
(Note: E+nn or E-nn means multiply by 10 to + or -nn power.)

```

[Matrix: Las](#)
[8,4]

```

-----+-----+-----+-----+-----+-----+
| Cross tabulation of predictions. Row is actual, column is predicted.
| Model = Probit . Prediction is number of the most probable cell.
-----+-----+-----+-----+-----+-----+
| Actual|Row Sum| 0 | 1 | 2 | 3 | 4 | 5 | 6 | 7 | 8 | 9 |
-----+-----+-----+-----+-----+-----+
| 0 | 300 | 292 | 8 | 0 |
| 1 | 167 | 155 | 12 | 0 |
| 2 | 51 | 45 | 6 | 0 |
-----+-----+-----+-----+-----+-----+
| Col Sum| 5074 | 492 | 26 | 0 | 0 | 0 | 0 | 0 | 0 | 0 | 0 |
-----+-----+-----+-----+-----+-----+

```

Total Data Initial Model for Transferability Test

```

-----+-----
Ordered Probability Model
Maximum Likelihood Estimates
Model estimated: Sep 30, 2008 at 09:51:08PM.
Dependent variable          SEVERITY
Weighting variable          None
Number of observations       598
Iterations completed        11
Log likelihood function     -540.1444
Restricted log likelihood    -558.3204
Chi squared                 36.35214
Degrees of freedom          6
Prob[ChiSqd > value] =     .2353880E-05
Underlying probabilities based on Normal
Cell frequencies for outcomes
  Y Count Freq  Y Count Freq  Y Count Freq
  0   337 .563  1   194 .324  2   67 .112
-----+-----

```

```

-----+-----+-----+-----+-----+-----+
|Variable | Coefficient | Standard Error |b/St.Er.|P[|Z|>z] | Mean of X|
-----+-----+-----+-----+-----+-----+
Index function for probability
Constant  -.5229656896   .10797170   -4.844   .0000
X66       .1962161376   .10277633    1.909   .0562   .64548495
DARK      .3188140578   .12510934    2.548   .0108   .18227425
X48      -.2407092699   .11918625   -2.020   .0434   .23913043
OLDCAR    .3929388205   .13783065    2.851   .0044   .13377926
OLD       .1713134473   .11445307    1.497   .1344   .23411371
STRAIGHT  .2656272924   .99700621E-01  2.664   .0077   .52341137
Threshold parameters for index
Mu(1)     1.103726747   .69597773E-01  15.859   .0000
(Note: E+nn or E-nn means multiply by 10 to + or -nn power.)

```

[Matrix: Last](#)
[8,4]

```

-----+-----+-----+-----+-----+-----+
|      Cross tabulation of predictions. Row is actual, column is predicted.
|      Model = Probit      . Prediction is number of the most probable cell.
|-----+-----+-----+-----+-----+-----+
| Actual|Row Sum| 0 | 1 | 2 | 3 | 4 | 5 | 6 | 7 | 8 | 9 |
|-----+-----+-----+-----+-----+-----+
| 0     | 337   | 313| 24| 0 |
| 1     | 194   | 166| 28| 0 |
| 2     | 67    | 52 | 15| 0 |
|-----+-----+-----+-----+-----+-----+
|Col Sum| 4556 | 531| 67| 0 | 0 | 0 | 0 | 0 | 0 | 0 |
|-----+-----+-----+-----+-----+-----+

```

Rural Vehicle Crashes Model for Transferability Test

```

-----+-----
Ordered Probability Model
Maximum Likelihood Estimates
Model estimated: Sep 30, 2008 at 09:48:35PM.
Dependent variable          SEVERITY
Weighting variable          None
Number of observations       386
Iterations completed        11
Log likelihood function     -359.7776
Restricted log likelihood   -371.5021
Chi squared                 23.44893
Degrees of freedom         5
Prob[ChiSqd > value] =    .2769708E-03
Underlying probabilities based on Normal
Cell frequencies for outcomes
  Y Count Freq  Y Count Freq  Y Count Freq
  0    205 .531  1    133 .344  2     48 .124
-----+-----

```

```

-----+-----+-----+-----+-----+-----+
|Variable | Coefficient | Standard Error | b/St.Er. | P[|Z|>z] | Mean of X|
-----+-----+-----+-----+-----+-----+
Index function for probability
Constant  -.3810407132   .10830809   -3.518   .0004
DARK      .3008707344   .15067273   1.997   .0458   .19430052
X48      -.1607732670   .14517255   -1.107   .2681   .24093264
OLDCAR   .3905008419   .16788740   2.326   .0200   .13989637
OLD      .2026780970   .14157314   1.432   .1523   .23316062
STRAIGHT .3338913567   .12355012   2.702   .0069   .54404145
Threshold parameters for index
Mu(1)    1.123426998   .84952972E-01  13.224   .0000
(Note: E+nn or E-nn means multiply by 10 to + or -nn power.)

```

[Matrix: Las](#)
[7,4]

```

-----+-----+-----+-----+-----+-----+-----+
| Cross tabulation of predictions. Row is actual, column is predicted.
| Model = Probit . Prediction is number of the most probable cell.
-----+-----+-----+-----+-----+-----+-----+
| Actual|Row Sum| 0 | 1 | 2 | 3 | 4 | 5 | 6 | 7 | 8 | 9 |
-----+-----+-----+-----+-----+-----+-----+
| 0 | 205 | 181 | 24 | 0 |
| 1 | 133 | 107 | 26 | 0 |
| 2 | 48 | 33 | 15 | 0 |
-----+-----+-----+-----+-----+-----+-----+
| Col Sum| 3958 | 321 | 65 | 0 | 0 | 0 | 0 | 0 | 0 | 0 | 0 |
-----+-----+-----+-----+-----+-----+-----+

```

Urban Crashes Model for Transferability Test

```

-----+-----
Ordered Probability Model
Maximum Likelihood Estimates
Model estimated: Sep 30, 2008 at 09:46:00PM.
Dependent variable          SEVERITY
Weighting variable          None
Number of observations      204
Iterations completed        10
Log likelihood function     -171.9083
Restricted log likelihood   -177.4383
Chi squared                 11.06008
Degrees of freedom          5
Prob[ChiSqd > value] =     .5020168E-01
Underlying probabilities based on Normal
Cell frequencies for outcomes
  Y Count Freq  Y Count Freq  Y Count Freq
  0   128 .627  1    57 .279  2    19 .093
-----+-----
|Variable | Coefficient | Standard Error |b/St.Er.|P[|Z|>z] | Mean of X|
-----+-----+-----+-----+-----+-----
Index function for probability
Constant  -.4396257258   .15210344  -2.890   .0038
DARK      .4560765578   .23287553   1.958   .0502   .15196078
X48      -.4139005134   .21166592  -1.955   .0505   .24509804
OLDCAR    .3342550134   .25275735   1.322   .1860   .11764706
OLD       .8794196051E-01 .20414187   .431   .6666   .22549020
STRAIGHT  .1577365795   .17339070   .910   .3630   .49509804
Threshold parameters for index
Mu(1)    1.041816551   .12319718   8.456   .0000
(Note: E+nn or E-nn means multiply by 10 to + or -nn power.)

```

[Matrix: Las](#)
[7,4]

```

-----+-----
Cross tabulation of predictions. Row is actual, column is predicted.
Model = Probit . Prediction is number of the most probable cell.
-----+-----+-----+-----+-----+-----+-----+-----+-----+-----+-----+-----+
|Actual|Row Sum| 0 | 1 | 2 | 3 | 4 | 5 | 6 | 7 | 8 | 9 |
-----+-----+-----+-----+-----+-----+-----+-----+-----+-----+-----+-----+
| 0 | 128 | 126 | 2 | 0 |
| 1 | 57 | 57 | 0 | 0 |
| 2 | 19 | 19 | 0 | 0 |
-----+-----+-----+-----+-----+-----+-----+-----+-----+-----+-----+-----+
|Col Sum| 3572 | 202 | 2 | 0 | 0 | 0 | 0 | 0 | 0 | 0 | 0 |
-----+-----+-----+-----+-----+-----+-----+-----+-----+-----+-----+-----+

```

Urban Crash Model Output

```

+-----+
| Ordered Probability Model
| Maximum Likelihood Estimates
| Model estimated: Sep 30, 2008 at 10:03:25PM.
| Dependent variable          SEVERITY
| Weighting variable          None
| Number of observations      204
| Iterations completed        10
| Log likelihood function     -167.0860
| Restricted log likelihood    -177.4383
| Chi squared                 20.70460
| Degrees of freedom          4
| Prob[ChiSqd > value] =     .3623565E-03
| Underlying probabilities based on Normal
|   Cell frequencies for outcomes
|   Y Count Freq  Y Count Freq  Y Count Freq
|   0   128 .627  1    57 .279  2    19 .093
+-----+

```

Variable	Coefficient	Standard Error	b/St.Er.	P[Z >z]	Mean of X
Index function for probability					
Constant	-.4840439973	.15107551	-3.204	.0014	
REAREND	.4630938685	.18660562	2.482	.0131	.28921569
FALL	.4658329383	.17516108	2.659	.0078	.39705882
X48	-.4595981493	.21740622	-2.114	.0345	.24509804
YOUNG	-.4713090160	.25636129	-1.838	.0660	.15686275
Threshold parameters for index					
Mu(1)	1.073768106	.12651977	8.487	.0000	

Matrix: Las
[6,4]

```

+-----+
| Marginal effects for ordered probability model
| M.E.s for dummy variables are Pr[y|x=1]-Pr[y|x=0]
| Names for dummy variables are marked by *.
+-----+

```

Variable	Coefficient	Standard Error	b/St.Er.	P[Z >z]	Mean of X
These are the effects on Prob[Y=00] at means.					
Constant	.0000000000				
*REAREND	-.1773941289	.28768566E-01	-6.166	.0000	.28921569
*FALL	-.1760150119	.27159047E-01	-6.481	.0000	.39705882
*X48	.1631453490	.42915011E-01	3.802	.0001	.24509804
*YOUNG	.1636877301	.43237989E-01	3.786	.0002	.15686275
These are the effects on Prob[Y=01] at means.					
Constant	.0000000000				
*REAREND	.1003752415	.31224026E-01	3.215	.0013	.28921569
*FALL	.1034814695	.31013277E-01	3.337	.0008	.39705882
*X48	-.1066883416	.12387178E-01	-8.613	.0000	.24509804
*YOUNG	-.1095914256	.12933794E-01	-8.473	.0000	.15686275
These are the effects on Prob[Y=02] at means.					
Constant	.0000000000				
*REAREND	.7701888735E-01	.14004986E-01	5.499	.0000	.28921569
*FALL	.7253354241E-01	.12916884E-01	5.615	.0000	.39705882
*X48	-.5645700745E-01	.19956137E-01	-2.829	.0047	.24509804
*YOUNG	-.5409630453E-01	.18952947E-01	-2.854	.0043	.15686275

(Note: E+nn or E-nn means multiply by 10 to + or -nn power.)

Summary of Marginal Effects for Ordered Probability Model (probit)

Variable	Y=00	Y=01	Y=02	Y=03	Y=04	Y=05	Y=06	Y=07
----------	------	------	------	------	------	------	------	------

```

ONE          .0000   .0000   .0000
*REAREND    -.1774   .1004   .0770
*FALL       -.1760   .1035   .0725
*X48        .1631  -.1067  -.0565
*YOUNG      .1637  -.1096  -.0541

```

```

+-----+
|      Cross tabulation of predictions. Row is actual, column is predicted.      |
|      Model = Probit      .      Prediction is number of the most probable cell.  |
+-----+
| Actual|Row Sum| 0 | 1 | 2 | 3 | 4 | 5 | 6 | 7 | 8 | 9 |
+-----+
|      0|   128|124| 4 | 0 |   |   |   |   |   |   |   |
|      1|    57| 51| 6 | 0 |   |   |   |   |   |   |   |
|      2|    19| 15| 4 | 0 |   |   |   |   |   |   |   |
+-----+
|Col Sum|  5744|190|14| 0 | 0 | 0 | 0 | 0 | 0 | 0 | 0 |
+-----+

```

Rural Crash Model Output

```

+-----+
| Ordered Probability Model
| Maximum Likelihood Estimates
| Model estimated: Sep 30, 2008 at 10:02:00PM.
| Dependent variable          SEVERITY
| Weighting variable          None
| Number of observations      386
| Iterations completed        11
| Log likelihood function     -355.5843
| Restricted log likelihood    -371.5021
| Chi squared                  31.83555
| Degrees of freedom          5
| Prob[ChiSqd > value] =     .6403042E-05
| Underlying probabilities based on Normal
| Cell frequencies for outcomes
| Y Count Freq  Y Count Freq  Y Count Freq
| 0   205 .531  1   133 .344  2   48 .124
+-----+

```

Variable	Coefficient	Standard Error	b/St.Er.	P[Z >z]	Mean of X
Index function for probability					
Constant	-.1583535805	.18351724	-.863	.3882	
OLDCAR	.3061131666	.17108260	1.789	.0736	.13989637
STRAIGHT	.2838471806	.12581828	2.256	.0241	.54404145
DARK	.4393932163	.15592898	2.818	.0048	.19430052
SUMMER	.4011187597	.14406042	2.784	.0054	.23575130
MULTVEH	-.3517517045	.16308638	-2.157	.0310	.83678756
Threshold parameters for index					
Mu(1)	1.142486576	.86510374E-01	13.206	.0000	
(Note: E+nn or E-nn means multiply by 10 to + or -nn power.)					

[Matrix: Last](#)
[7,4]

```

+-----+
| Marginal effects for ordered probability model
| M.E.s for dummy variables are Pr[y|x=1]-Pr[y|x=0]
| Names for dummy variables are marked by *.
+-----+

```

Variable	Coefficient	Standard Error	b/St.Er.	P[Z >z]	Mean of X
These are the effects on Prob[Y=00] at means.					
Constant	.0000000000(Fixed Parameter).....			
*OLDCAR	-.1215735976	.26028034E-01	-4.671	.0000	.13989637
*STRAIGH	-.1124263209	.24621054E-01	-4.566	.0000	.54404145
*DARK	-.1735968523	.26256344E-01	-6.612	.0000	.19430052
*SUMMER	-.1588840052	.25874983E-01	-6.140	.0000	.23575130
*MULTVEH	.1394810886	.24937458E-01	5.593	.0000	.83678756
These are the effects on Prob[Y=01] at means.					
Constant	.0000000000(Fixed Parameter).....			
*OLDCAR	.5539734629E-01	.18770178E-01	2.951	.0032	.13989637
*STRAIGH	.5922145837E-01	.19374213E-01	3.057	.0022	.54404145
*DARK	.7602061988E-01	.21275716E-01	3.573	.0004	.19430052
*SUMMER	.7251802699E-01	.20765090E-01	3.492	.0005	.23575130
*MULTVEH	-.6273058462E-01	.29626992E-02	-21.173	.0000	.83678756
These are the effects on Prob[Y=02] at means.					
Constant	.0000000000(Fixed Parameter).....			
*OLDCAR	.6617625128E-01	.30745633E-01	2.152	.0314	.13989637
*STRAIGH	.5320486257E-01	.26544237E-01	2.004	.0450	.54404145
*DARK	.9757623240E-01	.29113285E-01	3.352	.0008	.19430052
*SUMMER	.8636597820E-01	.28765436E-01	3.002	.0027	.23575130
*MULTVEH	-.7675050397E-01	.44434322E-01	-1.727	.0841	.83678756
(Note: E+nn or E-nn means multiply by 10 to + or -nn power.)					

Summary of Marginal Effects for Ordered Probability Model (probit)								
Variable	Y=00	Y=01	Y=02	Y=03	Y=04	Y=05	Y=06	Y=07
ONE	.0000	.0000	.0000					
*OLDCAR	-.1216	.0554	.0662					
*STRAIGH	-.1124	.0592	.0532					
*DARK	-.1736	.0760	.0976					
*SUMMER	-.1589	.0725	.0864					
*MULTVEH	.1395	-.0627	-.0768					

Cross tabulation of predictions. Row is actual, column is predicted. Model = Probit . Prediction is number of the most probable cell.											
Actual	Row Sum	0	1	2	3	4	5	6	7	8	9
0	205	190	15	0							
1	133	121	12	0							
2	48	29	18	1							
Col Sum	5540	340	45	1	0	0	0	0	0	0	0