



2016

# BRIDGE END SETTLEMENT EVALUATION AND PREDICTION

Jiwen Zhang

*University of Kentucky*, zd\_wen@126.com

Digital Object Identifier: <http://dx.doi.org/10.13023/ETD.2016.155>

**[Click here to let us know how access to this document benefits you.](#)**

---

## Recommended Citation

Zhang, Jiwen, "BRIDGE END SETTLEMENT EVALUATION AND PREDICTION" (2016). *Theses and Dissertations--Civil Engineering*. 40.

[https://uknowledge.uky.edu/ce\\_etds/40](https://uknowledge.uky.edu/ce_etds/40)

This Doctoral Dissertation is brought to you for free and open access by the Civil Engineering at UKnowledge. It has been accepted for inclusion in Theses and Dissertations--Civil Engineering by an authorized administrator of UKnowledge. For more information, please contact [UKnowledge@lsv.uky.edu](mailto:UKnowledge@lsv.uky.edu).

**STUDENT AGREEMENT:**

I represent that my thesis or dissertation and abstract are my original work. Proper attribution has been given to all outside sources. I understand that I am solely responsible for obtaining any needed copyright permissions. I have obtained needed written permission statement(s) from the owner(s) of each third-party copyrighted matter to be included in my work, allowing electronic distribution (if such use is not permitted by the fair use doctrine) which will be submitted to UKnowledge as Additional File.

I hereby grant to The University of Kentucky and its agents the irrevocable, non-exclusive, and royalty-free license to archive and make accessible my work in whole or in part in all forms of media, now or hereafter known. I agree that the document mentioned above may be made available immediately for worldwide access unless an embargo applies.

I retain all other ownership rights to the copyright of my work. I also retain the right to use in future works (such as articles or books) all or part of my work. I understand that I am free to register the copyright to my work.

**REVIEW, APPROVAL AND ACCEPTANCE**

The document mentioned above has been reviewed and accepted by the student's advisor, on behalf of the advisory committee, and by the Director of Graduate Studies (DGS), on behalf of the program; we verify that this is the final, approved version of the student's thesis including all changes required by the advisory committee. The undersigned agree to abide by the statements above.

Jiwen Zhang, Student

Dr. Timothy R.B. Taylor, Major Professor

Dr. Yi-Tin Wang, Director of Graduate Studies

---

BRIDGE END SETTLEMENT EVALUATION AND PREDICTION

---

DISSERTATION

---

A dissertation submitted in partial fulfillment of the requirements for the degree of  
Doctor of Philosophy in the College of Engineering  
at the University of Kentucky

By

Jiwen Zhang

Lexington, Kentucky

Director: Timothy R.B. Taylor, Professor of Civil Engineering  
Lexington, Kentucky 2016

Copyright© Jiwen Zhang 2016

## ABSTRACT OF DISSERTATION

### BRIDGE END SETTLEMENT EVALUATION AND PREDICTION

A bridge approach is usually built to provide a smooth and safe transition for vehicles from the roadway pavement to the bridge structure. However, differential settlement between the roadway pavement resting on embankment fill and the bridge abutment built on more rigid foundation often creates a bump in the roadway. Previous work examined this issue at a microscopic level and presented new methods for eliminating or minimizing the effects at specific locations.

This research studies the problem at a macroscopic level by determining methods to predict settlement severity to assist designers in developing remediation plans during project development to minimize the lifecycle costs of bridge bump repairs. The study is based on historic data from a wide range of Kentucky roads and bridges relating to bridge approach inspection and maintenance history. A macro method considering a combination of maintenance times, maintenance measures, and observed settlement was used to classify the differential settlement scale as minimal, moderate, and severe, corresponding to the approach performance status good, fair, and poor. A series of project characteristics influencing differential settlement were identified and used as parameters to develop a model to accurately predict settlement severity during preliminary design. Eighty-seven bridges with different settlement severities were collected as the first sample by conducting a survey of local bridge engineers in 12 transportation districts. Sample two was created by randomly selecting 600 bridges in the inspection history of bridges in Kentucky. Ordinal and/or multinomial logistic regression analyses were implemented to identify the relationships between the levels of differential settlement and the input variables. Two predictive models were developed. Prediction of bridge approach settlement can play an important role in selecting proper design, construction, and maintenance techniques and measures. The users can select one or two models to predict the approach settlement level for a new bridge or an existing bridge with different purposes.

The significance of this study lies in its identification of parameters that had the most influence on the settlement severity at bridge ends, and how those parameters interacted in developing of a prediction model. The important parameters include geographic regions, approach age, average daily traffic (ADT), the use of approach slabs, and the foundation

soil depth. The regression results indicate that the use of approach slabs can improve the performance of approaches on mitigating the problem caused by differential settlement. In addition, current practices regarding differential settlement prediction and mitigation were summarized by surveying the bridge engineers in 5 transportation districts.

**KEYWORDS:** bump at the end of the bridge, bridge approach, differential settlement, approach slab, prediction model, logistic regression

Jiwen Zhang  
\_\_\_\_\_  
Student's Signature

4/27/2016  
\_\_\_\_\_  
Date

BRIDGE END SETTLEMENT EVALUATION AND PREDICTION

By

Jiwen Zhang

Dr. Timothy R. B. Taylor

---

Director of Dissertation

Dr. Yi-Tin Wang

---

Director of Graduate Studies

4/27/2016

---

Date

*To my parents, wife, and the coming baby.*

## ACKNOWLEDGEMENTS

I am very grateful to everyone who has contributed and supported me during my doctoral studies. Firstly, I would like to express my gratitude to my advisor Dr. Timothy R. B. Taylor for his guidance, motivation, and incessant assistance from the beginning when I firstly entered into the United States to the completion of my program. I also would like to acknowledge the other two professors from the group of construction Dr. Gabriel B. Dadi and Dr. William F. Maloney for their support and encouragement at different phases of my stay at the University of Kentucky.

My gratitude is extended to the rest of my dissertation committee members, Dr. Issam Elias Harik, Dr. Arnold J. Stromberg, and the outside examiner Dr. Christina M. Payne for their valuable comments and advice. Appreciation is expressed to my colleague Roy Sturgill for his help during my doctoral studies. Sincere thanks to the graduate students in the department of Civil Engineering Ying Li, Huang Liu, Hossein Karimi, Elyas Jazayeri, Xi Wang, Yuxia Ji, and Chao Xu.

This research program SPR14-486 is funded by the Kentucky Transportation Center (KTC), and the financial support from KTC is greatly appreciated. Their generous support enabled me to pursue my Ph.D. degree as the sole professional focus during my graduate study as a research assistant.

I would like to acknowledge my parents Baofu Zhang and Hengxia Wang, my parents in law Jiaqiang Liu and Mingxiu Zhao, and my sister LiLi Zhang. It is their guidance,



encouragement, inspiration, and love that have made me overcome challenges and complete this work.

Finally, I would like to dedicate this work to my wife Li Liu and our coming baby who will see the world in July. She often came to the United States to accompany with me and do a lot for me by sacrificing her job and hobbies. She silently endured all the difficult times when I did not stay with her. Her companionship, encouragement, and support have been made me to strive for the best in our lives.

## Table of Contents

ACKNOWLEDGEMENTS.....	iii
LIST OF TABLES.....	viii
LIST OF FIGURES.....	xiii
1 INTRODUCTION.....	1
1.1 Background and Motivation.....	1
1.2 Definition of the “Bump” and Rating .....	5
1.3 Dissertation Objectives and Tasks .....	8
1.4 Research Structure.....	10
1.5 Dissertation Significance.....	11
2 LITERATURE REVIEW .....	14
2.1 Causes of Bridge Approach Settlement .....	14
2.2 Mitigation Methods .....	18
2.3 Application of Approach Slabs .....	20
2.4 Critical Review of Previous Studies.....	28
3 DATA COLLECTION .....	29
3.1 Model Inputs Identification.....	29
3.2 Other Lurking Variables.....	36
3.3 Collection Method.....	39
3.4 Model Output .....	40
3.5 Rating Output Levels .....	42
3.6 Bridge Selection .....	45
3.6.1 Information from a Survey.....	45
3.6.2 Information from the Transportation Cabinet.....	46
3.7 Limitations of Data.....	47
4 DATA ANALYSES .....	51
4.1 Approach Age .....	52
4.1.1 Sample One.....	52
4.1.2 Sample Two .....	62
4.1.3 Conclusions.....	67
4.2 Bridge Length and Width.....	68

4.2.1	Sample One.....	68
4.2.2	Sample Two .....	77
4.2.3	Conclusions.....	84
4.3	Average Daily Traffic .....	85
4.3.1	Sample One.....	85
4.3.2	Sample Two .....	89
4.3.3	Conclusions.....	93
4.4	Approach Type.....	94
4.4.1	Sample One.....	94
4.4.2	Sample Two .....	98
4.4.3	Conclusions.....	106
4.5	Abutment Type.....	107
4.5.1	Sample One.....	107
4.5.2	Sample Two .....	110
4.5.3	Conclusions.....	113
4.6	Embankment Height.....	114
4.6.1	Sample One.....	114
4.6.2	Sample Two .....	117
4.6.3	Conclusions.....	120
4.7	Foundation Soil Depth .....	121
4.7.1	Sample One.....	121
4.7.2	Sample Two .....	124
4.7.3	Conclusions.....	127
4.8	Foundation Soil Consistency.....	127
4.8.1	Sample One.....	127
4.8.2	Sample Two .....	131
4.8.3	Conclusions.....	134
4.9	Geographical Location .....	134
4.10	Comprehensive Model .....	141
4.10.1	Sample One.....	145
4.10.2	Sample Two .....	157
4.10.3	Comparison between Two Models .....	168

4.10.4	Conclusions.....	170
5	DISTIRCT INTERVIEWS.....	172
5.1	Foundation Soil .....	173
5.2	Embankment Backfill Material .....	176
5.3	Approach Slab.....	184
5.4	Abutments .....	186
5.5	Drainage .....	189
6	CONCLUSIONS AND RECOMMENDATIONS.....	196
6.1	Summary .....	196
6.2	Conclusions .....	198
6.3	Recommendations for Future Research .....	202
	APPENDICES .....	204
	Appendix A: Summary of Major Studies on Bridge Approach Settlement.....	204
	Appendix B: Survey of Requesting Bridges with Different Settlement Levels for Comprising Sample One .....	225
	Appendix C: Detailed Data Information of Sample One .....	228
	Appendix D: Detailed Data Information of Sample Two .....	234
	Appendix E: Output of the Ordinal Logistic Regression for Sample One.....	275
	Appendix F: Output of the Multinomial Logistic Regression for Sample One .....	279
	Appendix G: Output of the Ordinal Logistic Regression for Sample Two.....	284
	Appendix H: Output of the Multinomial Logistic Regression for Sample Two.....	288
	BIBLIOGRAPHY.....	293
	VITA.....	300

## List of Tables

Table 1.1 Is Approach slab settlement a significant problem? (Virginia DOT, 1999).....	4
Table 1.2 Bump Scale Ratings (Hun Soo Ha, 2002) .....	7
Table 1.3 Approach slab rating system developed by LTRC (Das et al. 1999) .....	8
Table 2.1 Summary of causes of bridge approach settlement (Helwany, 2007) .....	15
Table 2.2 Mitigation methods of bridge approach settlement (Helwany, 2007) .....	19
Table 2.3 Current use of approach slabs (%) state interstate system, primary system, and secondary system (Hoppe, 1999).....	22
Table 2.4 Advantage of Using Approach Slabs (Hoppe, 1999) .....	24
Table 2.5 Disadvantage of using approach slabs (Hoppe, 1999).....	26
Table 3.1 Connection between approach slab and bridge (Hoppe, 1999) .....	38
Table 3.2 Micro methods in determining differential settlement scale .....	44
Table 3.3 Macro method in determining differential settlement scale .....	44
Table 3.4 Distribution of the bridges with different settlement levels from each transportation district for sample one .....	46
Table 3.5 Distribution of the bridges with different settlement levels from each transportation district for sample two .....	47
Table 4.1 Code sheet for the variables in samples.....	52
Table 4.2 Sample One: Frequency table of age group (AGEG) by SEVERITY .....	55
Table 4.3 Sample One: Model fitting information of ordinal logistic regression between AGE and SEVERITY .....	57
Table 4.4 Sample One: Parameter estimates of ordinal logistic regression between AGE and SEVERITY .....	58
Table 4.5 Sample One: Test of parallel lines of ordinal logistic regression between AGE and SEVERITY .....	60
Table 4.6 Sample Two: Frequency table of age group (AGEG) by SEVERITY .....	64
Table 4.7 Sample Two: Model fitting information of ordinal logistic regression between AGE and SEVERITY .....	66
Table 4.8 Sample Two: Parameter estimates of ordinal logistic regression between AGE and SEVERITY .....	66
Table 4.9 Sample Two: Test of parallel lines of ordinal logistic regression between AGE and SEVERITY .....	67
Table 4.10 Sample One: Frequency table of length group (LENGTHG) by SEVERITY .....	69
Table 4.11 Sample One: Frequency table of width group (WIDTHG) by SEVERITY ...	72
Table 4.12 Sample One: Model fitting information of ordinal logistic regression between LENGTH and SEVERITY .....	74
Table 4.13 Sample One: Parameter estimates of ordinal logistic regression between Length and SEVERITY .....	75
Table 4.14 Sample One: Test of parallel lines of ordinal logistic regression between LENGTH and SEVERITY .....	75
Table 4.15 Sample One: Model fitting information of ordinal logistic regression between WIDTH and SEVERITY .....	76

Table 4.16 Sample One: Parameter estimates of ordinal logistic regression between WIDTH and SEVERITY .....	76
Table 4.17 Sample One: Test of parallel lines of ordinal logistic regression between WIDTH and SEVERITY .....	77
Table 4.18 Sample Two: Frequency table of length group (LENGTHG) by SEVERITY	78
Table 4.19 Sample Two: Frequency table of width group (WIDTHG) by SEVERITY ..	78
Table 4.20 Sample Two: Model fitting information of ordinal logistic regression between LENGTH and SEVERITY .....	81
Table 4.21 Sample Two: Parameter estimates of ordinal logistic regression between LENGTH and SEVERITY .....	82
Table 4.22 Sample Two: Test of parallel lines of ordinal logistic regression between LENGTH and SEVERITY .....	82
Table 4.23 Sample Two: Model fitting information of ordinal logistic regression between WIDTH and SEVERITY .....	83
Table 4.24 Sample Two: Parameter estimates of ordinal logistic regression between WIDTH and SEVERITY .....	83
Table 4.25 Sample Two: Test of parallel lines of ordinal logistic regression between WIDTH and SEVERITY .....	84
Table 4.26 Sample One: Model fitting information of ordinal logistic regression between ADT and SEVERITY .....	85
Table 4.27 Sample One: Parameter estimates of ordinal logistic regression between ADT and SEVERITY .....	86
Table 4.28 Sample One: Test of parallel lines of ordinal logistic regression between ADT and SEVERITY .....	86
Table 4.29 Sample One: Model fitting information of multinomial logistic regression between ADT and SEVERITY .....	87
Table 4.30 Sample One: Parameter estimates of multinomial logistic regression between ADT and SEVERITY .....	87
Table 4.31 Sample Two: Model fitting information of ordinal logistic regression between ADT and SEVERITY .....	90
Table 4.32 Sample Two: Parameter estimates of ordinal logistic regression between ADT and SEVERITY .....	90
Table 4.33 Sample Two: Test of parallel lines of ordinal logistic regression between ADT and SEVERITY .....	91
Table 4.34 Sample Two: Model fitting information of multinomial logistic regression between ADT and SEVERITY .....	91
Table 4.35 Sample Two: Parameter estimates of multinomial logistic regression between ADT and SEVERITY .....	92
Table 4.36 Sample Two: Classification table of multinomial logistic regression between ADT and SEVERITY .....	92
Table 4.37 Sample One: Frequency table of approach type (APPT) by SEVERITY .....	95
Table 4.38 Sample One: Model fitting information of ordinal logistic regression between APPT and SEVERITY .....	96

Table 4.39 Sample One: Parameter estimates of ordinal logistic regression between APPT and SEVERITY .....	97
Table 4.40 Sample One: Test of parallel lines of ordinal logistic regression between APPT and SEVERITY .....	97
Table 4.41 Sample Two: Frequency table of approach type (APPT) by SEVERITY.....	98
Table 4.42 Sample Two: Model fitting information of ordinal logistic regression between APPT and SEVERITY .....	99
Table 4.43 Sample Two: Parameter estimates of ordinal logistic regression between APPT and SEVERITY .....	100
Table 4.44 Sample Two: Test of parallel lines of ordinal logistic regression between APPT and SEVERITY .....	100
Table 4.45 Sample Two: APPT VS. SEVERITY cross tabulation.....	103
Table 4.46 Sample Two: Chi-square test for APPT VS. SEVERITY .....	104
Table 4.47 Sample Two: Rating system to quantify approach effectiveness .....	105
Table 4.48 Sample Two: Grade distribution for approach type in different settlement severity .....	106
Table 4.49 Sample One: Frequency table of abutment type (ABUT) by SEVERITY ..	107
Table 4.50 Sample One: Model fitting information of ordinal logistic regression between ABUT and SEVERITY .....	108
Table 4.51 Sample One: Parameter estimates of ordinal logistic regression between ABUT and SEVERITY .....	109
Table 4.52 Sample One: Test of parallel lines of ordinal logistic regression between ABUT and SEVERITY .....	109
Table 4.53 Sample Two: Frequency table of abutment type (ABUT) by SEVERITY .	110
Table 4.54 Sample Two: Model fitting information of ordinal logistic regression between ABUT and SEVERITY .....	111
Table 4.55 Sample Two: Parameter estimates of ordinal logistic regression between ABUT and SEVERITY .....	112
Table 4.56 Sample Two: Test of parallel lines of ordinal logistic regression between ABUT and SEVERITY .....	112
Table 4.57 Sample One: Frequency table of embankment height group (EHG) by SEVERITY .....	115
Table 4.58 Sample One: Model fitting information of ordinal logistic regression between EH and SEVERITY .....	116
Table 4.59 Sample One: Parameter estimates of ordinal logistic regression between EH and SEVERITY .....	116
Table 4.60 Sample One: Test of parallel lines of ordinal logistic regression between EH and SEVERITY .....	117
Table 4.61 Sample Two: Frequency table of embankment height group (EHG) by SEVERITY .....	118
Table 4.62 Sample Two: Model fitting information of ordinal logistic regression between EH and SEVERITY .....	119

Table 4.63 Sample Two: Parameter estimates of ordinal logistic regression between EH and SEVERITY .....	119
Table 4.64 Sample Two: Test of parallel lines of ordinal logistic regression between EH and SEVERITY .....	120
Table 4.65 Sample One: Frequency table of foundation soil depth (FSD) by SEVERITY .....	122
Table 4.66 Sample One: Model fitting information of ordinal logistic regression between FSD and SEVERITY .....	123
Table 4.67 Sample One: Parameter estimates of ordinal logistic regression between FSD and SEVERITY .....	123
Table 4.68 Sample One: Test of parallel lines of ordinal logistic regression between FSD and SEVERITY .....	124
Table 4.69 Sample Two: Frequency table of foundation soil depth (FSD) by SEVERITY .....	125
Table 4.70 Sample Two: Model fitting information of ordinal logistic regression between FSD and SEVERITY .....	126
Table 4.71 Sample Two: Parameter estimates of ordinal logistic regression between FSD and SEVERITY .....	126
Table 4.72 Sample Two: Test of parallel lines of ordinal logistic regression between FSD and SEVERITY .....	127
Table 4.73 Sample One: Frequency table of foundation soil consistency (FSC) by SEVERITY .....	128
Table 4.74 Sample One: Model fitting information of ordinal logistic regression between FSC and SEVERITY .....	129
Table 4.75 Sample One: Parameter estimates of ordinal logistic regression between FSC and SEVERITY .....	130
Table 4.76 Sample One: Test of parallel lines of ordinal logistic regression between FSC and SEVERITY .....	130
Table 4.77 Sample Two: Frequency table of foundation soil consistency (FSC) by SEVERITY .....	131
Table 4.78 Sample Two: Model fitting information of ordinal logistic regression between FSC and SEVERITY .....	132
Table 4.79 Sample Two: Parameter estimates of ordinal logistic regression between FSC and SEVERITY .....	133
Table 4.80 Sample Two: Test of parallel lines of ordinal logistic regression between FSC and SEVERITY .....	133
Table 4.81 Distribution of the Bridge Approaches from Each District .....	135
Table 4.82 Sample One: Test of parallel lines of ordinal logistic regression between DISTRICT and SEVERITY .....	137
Table 4.83 Sample One: Model fitting information of multinomial logistic regression between district and SEVERITY .....	137
Table 4.84 Sample One: Parameter estimates of multinomial logistic regression between DISTRICT and SEVERITY .....	138



Table 4.85 Sample One: Parameter estimates of multinomial logistic regression between DISTRICT and SEVERITY .....	138
Table 4.86 Sample Two: Model fitting information of ordinal logistic regression between DISTRICT and SEVERITY .....	139
Table 4.87 Sample Two: Parameter estimates of ordinal logistic regression between DISTRICT and SEVERITY .....	140
Table 4.88 Sample Two: Test of parallel lines of ordinal logistic regression between DISTRICT and SEVERITY .....	141
Table 4.89 Classification of the variables in the model.....	144
Table 4.90 Dummy variables definition in the model .....	144
Table 4.91 Sample One: Model fitting information of ordinal logistic regression.....	147
Table 4.92 Sample One: Goodness of fit of ordinal logistic regression .....	147
Table 4.93 Sample One: Pseudo R-square of ordinal logistic regression.....	147
Table 4.94 Sample One: Test of parallel lines of ordinal logistic regression .....	147
Table 4.95 Sample One: Model fitting information of multinomial logistic regression	151
Table 4.96 Sample One: Goodness of fit of ordinal logistic regression .....	151
Table 4.97 Sample One: Pseudo R-square of multinomial logistic regression.....	151
Table 4.98 Sample One: Likelihood ration tests of multinomial logistic regression.....	152
Table 4.99 Sample One: Classification table of multinomial logistic regression.....	153
Table 4.100 Sample Two: Model fitting information of multinomial logistic regression .....	160
Table 4.101 Sample Two: Goodness of fit of multinomial logistic regression .....	160
Table 4.102 Sample Two:: Pseudo R-square of multinomial logistic regression.....	160
Table 4.103 Sample Two: Likelihood ratio tests of multinomial logistic regression.....	161
Table 4.104 Sample Two: Classification table of multinomial logistic regression .....	161
Table 4.105 Percent correct of applying two model to each other dataset .....	169
Table 5.1 Summary of foundation soils improvement methods based on soil type .....	174
Table 5.2 Summary of foundation soils improvement methods based on soil type based on the function (Puppala, 2009).....	175
Table 5.3 Embankment material specifications (Hoppe, 1999).....	177
Table 5.4 Lift thickness and percent compaction requirements (Hoppe, 1999) .....	179
Table 5.5 Material requirements for flowable fill by Colorado DOT.....	183
Table 5.6 Drainage method used by various states (White et al., 2005).....	195

## List of Figures

Figure 1.1 The significance of bridge approach settlement (Virginia DOT, 2003).....	3
Figure 2.1 Schematic of various contributors leading to the existence of the bump at the bridge ends (Briaud et al. 1997).....	15
Figure 2.2 Schematic design of a typical approach slab (TxDOT, 2002).....	22
Figure 3.1 A typical full height closed or high abutment (bridge No. 094B00041N).....	31
Figure 3.2 A typical perched abutment (bridge No. 056B00454R).....	32
Figure 3.3 A typical spill-through abutment (bridge No. 056B00489N) .....	32
Figure 4.1 Sample One: Scatterplot of approach settlement levels by approach age .....	53
Figure 4.2 Sample One: Plot of the percentage of approaches with minimal SEVERITY in each age group .....	55
Figure 4.3 Sample One: Plot of the percentage of approaches with severe SEVERITY in each age group .....	56
Figure 4.4 Sample Two: Scatterplot of approach settlement levels by approach age .....	63
Figure 4.5 Sample One: Plot of the percentage of approaches with minimal SEVERITY in each age group .....	64
Figure 4.6 Sample Two: Plot of the percentage of approaches with severe SEVERITY in each age group .....	65
Figure 4.7 Sample One: Scatterplot of approach settlement levels by bridge length.....	70
Figure 4.8 Sample One: Scatterplot of approach settlement levels by bridge width.....	70
Figure 4.9 Sample One: Plot of the percentage of approaches with minimal SEVERITY in each length group.....	71
Figure 4.10 Sample One: Plot of the percentage of approaches with severe SEVERITY in each length group.....	71
Figure 4.11 Sample One: Plot of the percentage of approaches with minimal SEVERITY in each width group.....	73
Figure 4.12 Sample One: Plot of the percentage of approaches with severe SEVERITY in each width group.....	73
Figure 4.13 Sample Two: Plot of the percentage of approaches with minimal SEVERITY in each length group.....	79
Figure 4.14 Sample Two: Plot of the percentage of approaches with severe SEVERITY in each length group.....	79
Figure 4.15 Sample Two: Plot of the percentage of approaches with minimal SEVERITY in each width group.....	80
Figure 4.16 Sample Two: Plot of the percentage of approaches with severe SEVERITY in each width group.....	80
Figure 4.17 Sample One: Distribution of settlement levels across approach type .....	96
Figure 4.18 Sample Two: Distribution of settlement levels across approach type.....	99
Figure 4.19 Sample One: Distribution of settlement levels across abutment type .....	108
Figure 4.20 Sample Two: Distribution of settlement levels across abutment type .....	111
Figure 4.21 Sample One: Scatterplot of approach settlement levels by embankment height .....	115

Figure 4.22 Sample Two: Scatterplot of approach settlement levels by embankment height.....	118
Figure 4.23 Sample One: Scatterplot of approach settlement levels by foundation soil depth.....	122
Figure 4.24 Sample Two: Scatterplot of approach settlement levels by foundation soil depth.....	125
Figure 4.25 Sample One: Distribution of settlement levels across foundation soil consistency.....	129
Figure 4.26 Sample Two: Distribution of settlement levels across foundation soil consistency.....	132
Figure 4.27 Sample One: Distribution of settlement levels across transportation district .....	136
Figure 4.28 Sample Two: Distribution of settlement levels across transportation district .....	136
Figure 4.29 Sample One: Variation trend of the estimated probability of minimal versus approach age .....	154
Figure 4.30 Sample One: Variation trend of the estimated probability of minimal versus transportation districts.....	155
Figure 4.31 Sample One: Variation trend of the estimated probability of minimal versus foundation soil depth.....	156
Figure 4.32 Sample Two: Variation trend of the estimated probability of minimal versus transportation districts.....	164
Figure 4.33 Sample Two: Variation trend of the estimated probability of minimal versus approach age .....	165
Figure 4.34 Sample Two: Variation trend of the estimated probability of minimal versus average daily traffic .....	166
Figure 4.35 Sample Two: Variation trend of the estimated probability of minimal versus average approach type.....	167
Figure 5.1 The flowable mortar used under a roadway pavement (Smadi, 2001).....	183
Figure 5.2 Simplified cross section of non-integral abutment bridge (Greimann et al., 1987; White et al., 2005).....	188
Figure 5.3 Simplified cross section of integral abutment bridge (Greimann et al., 1987; White et al., 2005).....	188
Figure 5.4 Approach slab joint details at pavement edge (Briaud et al., 1997).....	191
Figure 5.5 Mechanically stabilized earth (MSE) walls system under sleeper slab (Abu-Hejleh et al., 2006).....	191
Figure 5.6 Drainage layer of granular material and collector pipe (Nassif, 2002) .....	192
Figure 5.7 Schematic of porous fill surrounding subdrain (Iowa DOT, 2005).....	193
Figure 5.8 Schematic of granular backfill wrapped with geotextile filter material (Wisconsin DOT, 2003).....	194
Figure 5.9 Schematic of geocomposite vertical drain wrapped with filter fabric (Missouri DOT, 2005).....	194

# 1 INTRODUCTION

## 1.1 Background and Motivation

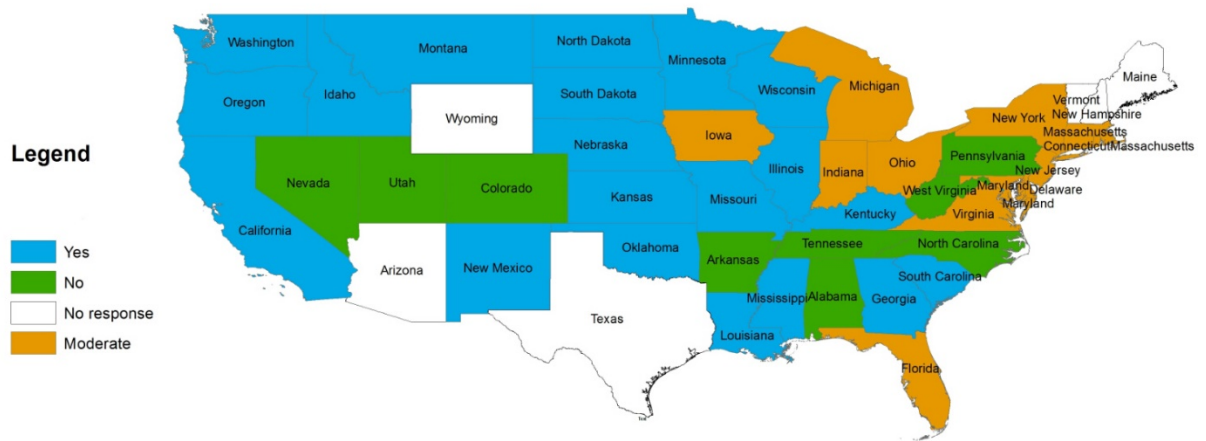
The differential settlement (also referred to approach settlement) between the bridge abutment and the adjacent roadway pavement usually creates a bump in the roadway. This differential settlement is commonly defined as “the difference in elevation of approach pavements and bridge upper-structures caused by unequal settlement of embankments and abutments.” (Sam Helwany et al., 2007). Settlement of the approach is an old and well recognized problem across most of the state transportation agencies. The Kentucky Transportation Cabinet (KYTC) has also identified bridge settlement and the formation of the bump as a significant problem due to its noticeable consequences. This heave/uneven transition may cause the following results:

- a) discomfort to passengers,
- b) damage to vehicles,
- c) a negative effect on public perception of the state infrastructure,
- d) damage to bridge structures,
- e) reduced steering control for drivers,
- f) increased traffic loading on the abutment,
- g) accidents,
- h) considerable maintenance costs/works, and
- i) delays and inconveniences caused by maintenance work.

In addition, the constant maintenance work, closure of lanes, traffic control resulted by bump problems would adversely interrupt the orderly flow of traffic and cause delay; or in some cases the maintenance works in heavy traffic roads are practically impossible without bringing traffic into a standstill. According to the report of Federal Highway Administration (FHWA) “Priority, Market-Ready Technologies and Innovations” (FHWA-HRT-04-053), the delay hours caused by traffic congestion due to road repair works average approximately 36 hours for each person per year. In other words, all kinds of repair work results in annually 5.7 billion of person-hours of delay. Maintenance work of bridge bumps takes up an important part of the whole amount of repair works for transportation agencies, and hence bump problems have gained more attention especially in this era where time is becoming more and more valuable to everybody.

Considerable amounts of annual maintenance cost to reduce differential settlement and bump problems consume a significant amount of budgets of state departments of transportation in the United States. National Cooperative Highway Research Program (NCHRP) synthesis 234 (Briaud et al., 1997) reported that 25 percent of the bridges nationwide, approximately 150,000 bridges, showed damage induced by differential bridge approach settlement and more than \$100 million is spent on maintenance or repair every year. A survey (Laguros et al., 1990) of 61 different transportation agencies concluded that almost 70% of the agencies considered bridge approach settlement or bump problems significant. Furthermore, a more detailed survey (Hoppe, 1999) reported that bridge approach settlement or bump problems were rated as a significant problem by 44% of the state Department of Transportation agencies (Figure 1.1). Kentucky is listed as having a “Yes” problem. Furthermore, interviews with the local bridge engineers also

conclude that the bridge approach settlement is extensive in Kentucky. Statistics gathered from KTC (Dupont and Allen, 2002) reported that nearly \$1000 is spent per bridge per year to address approach settlement problems, slightly higher than the national average cost of \$700 per bridge per year (Briaud et al., 1997).



**Figure 1.1 The significance of bridge approach settlement (Virginia DOT, 2003)**

A survey concerning the validity of using approach slab as one of the most effective measures for eliminating differential settlement at bridge ends was also conducted by Virginia DOT in 1999. The results as showed in Table 1.1 indicate that almost half states still consider the approach slab settlement as a significant problem.

**Table 1.1 Is Approach slab settlement a significant problem? (Virginia DOT, 1999)**

<b>State</b>	<b>Yes</b>	<b>No</b>	<b>Moderate</b>
AZ		X	
CA	X		
CT			X
DE	X		
FL			X
GA	X		
ID	X		
IN			X
IA			X
IL	X		
KS	X		
KY	X		
LA	X		
MA			X
MD			X
ME		X	
MI			X
MN	X		
MS	X		
MO	X		
MT	X		
ND	X		
NE	X		
NH		X	
NJ			X
NM	X		
NY			X
OH			X
OK	X		
OR	X		
SC	X		
SD	X		

TX		X	
VT		X	
VA			X
WA	X		
WI	X		
WY		X	

Because of the serious consequences caused by differential settlement, numerous studies have been funded to identify the mechanism of the formation of approach settlement, determine the mitigation methods, and seek advanced maintenance techniques to lessen maintenance budget. In an effort to reduce the effects of differential settlement, the present research is primarily aimed at developing a model that can predict settlement and determine remediation plans during project development based on given project characteristics. With this core objective in mind, one of the tasks of this research is to synthesize the causation of differential bridge end settlement and bump problems in Kentucky and then identify best practices to prevent differential settlement.

## 1.2 Definition of the “Bump” and Rating

Differential settlement originates from the fact that the bridge transition connects two structures with different supporting systems. A bridge abutment is usually constructed on relatively firm soil, rock, or piles driven to a dense or stiff deep soil stratum and generates slight settlement, which is negligible compared to the settlement of roadway pavement that is commonly supported on a natural or filled soil subgrade.

The “bump” typically can be defined as the differential settlement at the area between the bridge and roadway interfaces (Anand J., 2009). Differential settlement is an occurrence



ordinarily discovered where two foundations of two cooperating structures have been constructed under different concepts. For roadways, this occurrence can be found at the intersection between the roadway and the bridge, which is normally indicated as approach pavement/slab in the most cases. White et al. (2005) defined the term “bridge approach” as a larger area covering from the bridge structure/abutment to a distance of about 100 ft. away from the abutment. This definition refers to not only the approach slab alone but also the backfill and embankment areas beyond and under the approach slab as significant factors that contribute to the settlement around the bridge approach region.

Many researchers have studied the interface between bridge and roadway. Four methods have been summarized to define the approach settlement tolerance.

- a) Bump could be noticed with about 0.5 inches of approach settlement (Wahls, 1990), and may cause riding discomfort at about 2 to 2.5 inches (Stark et al. 1995). Walkinshaw (1978) suggested the differential settlement greater than 2.5 inches can result in a poor ride quality and maintenance is needed. Bozozuk (1978) concluded that differential settlement could be tolerated to 3.9 inches vertically and 2 inches horizontally. Hun Soo Ha et al (2002) suggested a range to rate the bump scale.

**Table 1.2 Bump Scale Ratings (Hun Soo Ha, 2002)**

Rating	Description	Range
0	No Bump	0
1	Slight Bump	~1 inch
2	Moderate Bump—Readily Recognizable	~2 inch
3	Significant Bump—Repair Needed	~3 inch
4	Large Bump—Safety Hazard	>3 inch

- b) Long et al. (1988) and Wahls (1990) recommended the use of a relative gradient, which is defined as a function of the length of the approach slab, of 1/125 as a criterion to begin a remedial action, and a gradient smaller than 1/200 may be considered as a satisfactory level for rider comfort. According to these thresholds, the required design length of an approach pavement/slab ( $L$ ) can be estimated as:
- $$L \geq 200(sf - sa)$$
- Where  $sf$  is the estimated total fill settlement at the end the approach pavement/slab, and  $sa$  is the estimated settlement of the bridge abutment.
- c) Several researchers used the International Roughness Index (IRI), which is defined as the accumulations of undulations under a given segment length and normally in the form of mm/m or m/km, to determine the allowable bumps. The highest IRI value would be used to rate the performance of an approach, and rating system of bridge approaches using IRI was developed by Louisiana Transportation and Research Center (LTRC) (Das et al. 1999).

**Table 1.3 Approach slab rating system developed by LTRC (Das et al. 1999)**

Range (IRI) m/km	Rating
0 to 3.9	Very Good
4.0 to 7.9	Good
8.0 to 9.9	Fair
10.0 to 11.9	Poor
12 and above	Very Poor

- d) In Australia, Hsi (2007) recommended differential settlement of 0.3 percent, grade change in transverse and longitudinal direction, and a residual settlement of 100 mm for a 40-year period as threshold to initiate maintenance procedures on transition zones.

### **1.3 Dissertation Objectives and Tasks**

The Kentucky Transportation Cabinet (KYTC), and many other state transportation agencies, continually struggle with differential settlement at bridge ends. Bump issues present a potential hazard at bridge ends for motorists, particularly motorcyclists. Additionally, bump issues are a constant source of maintenance spending, averagely \$1,000 per bridge per year in the commonwealth of Kentucky (Dupont and Allen, 2002). Many have deemed that it is a problem that is going to exist without resolution from some configurations of approach slabs, flooded backfills, or any other methods. This research does not study bump issues from the angle of developing engineering techniques that may minimize or eliminate the differential settlement at bridge ends. In contrast, this

study aims to identify the best practice of minimizing or eliminating bump issues by analyzing other states' experience regrading this issue and attempts to yield a model for estimating the severity of the phenomenon given specific project conditions based on nearly 50 years of highway and bridge construction in Kentucky. In this way, the transportation agency can be prepared to monitor and better repair the situation when it occurs.

The main objective of this research project is to develop a settlement predictive model at a macro level for estimating the severity of differential settlement at bridge ends.

Therefore, it is significant to identify major project characteristics that have an important impact on the formation of the approach settlement, and determine which characteristics could be qualitative or quantitative defined and regarded as inputs to build the model.

This methodology intends to provide project stakeholders with an overall understanding of monitoring and better repairing the differential settlement at bridge ends when it occur.

With this view in mind, the objectives of the study can be outlined as follows:

- a) Collect a body of design, construction and maintenance data that describes a relevant section of bridges and approaching roadways within Kentucky and the bridge end settlement that has occurred at these bridges,
- b) Identify recent developments in research associated with bridge ends, particularly those completed since the last study conducted by KTC,
- c) Analyze the collected macro data and conduct field interviews with each district to identify a subset of bridges and develop a predictive model for bridge end settlement during project planning and design.

## 1.4 Research Structure

This research can be accomplished through the following tasks:

- a) Review literature and publically available data in differential bridge end settlement and prediction. An extensive literature review related to causation of differential bridge end settlement should be completed in this phase. The review includes publically available resources for existing structures exhibiting differential bridge end settlement (geotechnical reports, project plans, United States Geological Survey, etc.), especially review literature related to prediction of differential bridge end settlement.
- b) Survey selected bridge approaches and qualitatively assess causative factors. An online survey form has been created by “Surveygizmo” to contact district engineers in the 12 districts to identify bridges within their districts that experience excessive approach settlement, moderate approach settlement, and minimal approach settlement, respectively. Project characteristics and geotechnical conditions of these bridges are also requested. Approximately 35 district bridge engineers responded to this survey, as well as more than 130 bridges with different approach settlement levels were collected. These bridges will be verified and used as the first sample to conduct regression analysis in the following tasks. Next, field interviews with each district representatives would be scheduled to verify the results of the survey and acquire an understanding of the whole picture of bump issues at each district.

Advice on how to select bridges is expected, as well as advice on which bridges can be used as sample to conduct regression analysis.

- c) Develop a multivariate regression model for prediction of approach settlement.
- d) Collect the best practices in the treatment of bridge approach settlement. This phase will review literature on best practices for corrective methods in treating differential bridge end settlement. Then collect KYTC practices used as corrective actions for treating the field interview with local district bridge engineers. Lastly, based on previous studies, collect KYTC methods to determine the timing for corrective measures.
- e) Develop a framework for application of settlement treatments to align with predicted settlement conditions. Based on the differential settlement prediction model, the future or past bump problems could be predicted into three levels-- severe, moderate, and minimal given a specific bridge. Then, compare this predicted level with the real bump conditions obtained by field interview to verify the validity of this model. If the correlation coefficient of this model is good, it can be used to develop a framework for prescriptive correction measures that could be applied to predicted differential settlement. In addition, procedures and implementation measures for using the framework also should be given.

## **1.5 Dissertation Significance**

This research expects to obtain a comprehensive picture of current bump problems in Kentucky. Identify design, construction, and maintenance practices to eliminate or minimize the differential settlement at bridge ends according to previous study review,

survey, and field interview with local bridge engineers in each district. Different variables that contribute to the formation of approach settlement would be identified and defined. Some bridges that have been experiencing different settlement levels would be asked from local bridge personnel according to a survey, which would generate the first sample with small quantity of bridges. Then the second sample with 600 bridges would be created by randomly selecting bridges from the inspective datum of Kentucky to conduct logistic statistical analysis to develop models for predicting the settlement status. Availability and reliability of these two models would be compared and verified. Next, develop an implementation resource to use as a model to predict bridge end settlement given project conditions and provide a framework for application of settlement treatments to align with predicted settlement conditions.

Numerous studies have been done on the topic of bridge bump issues; some of them were based on the theme of statistics. However, few researchers conducted the analysis according to systematic statistical method. Laguros and Zaman (1990) have established a linear numeric model to explain the relationships between the approach settlement and various causative factors by quantitatively defining these factors, but none of the categorical causing factors were included in this model. Most of previous studies on bump issues focused on only one contributing factor or some and did not study this issue account for all causative factors; or specific techniques for eliminating or minimizing the effects at specific locations/bridges; or conclusions were not based upon an in-depth statistical approach. This study focuses on the issue at a macro level and will develop a settlement predictive model by considering important factors based on historic data from a wide range of Kentucky roads and bridges. This work hopes to offer contributions to

researchers, engineers, and policy makers. Researchers and engineers will benefit from developing a rich understanding on the mechanism of formation of approach settlement and effective mitigation methods under different circumstances. In addition, this work will offer policy makers insight into effectively initiating guidelines on bridge design, construction, and maintenance work in order to minimize or eliminate approach settlement at bridge ends.

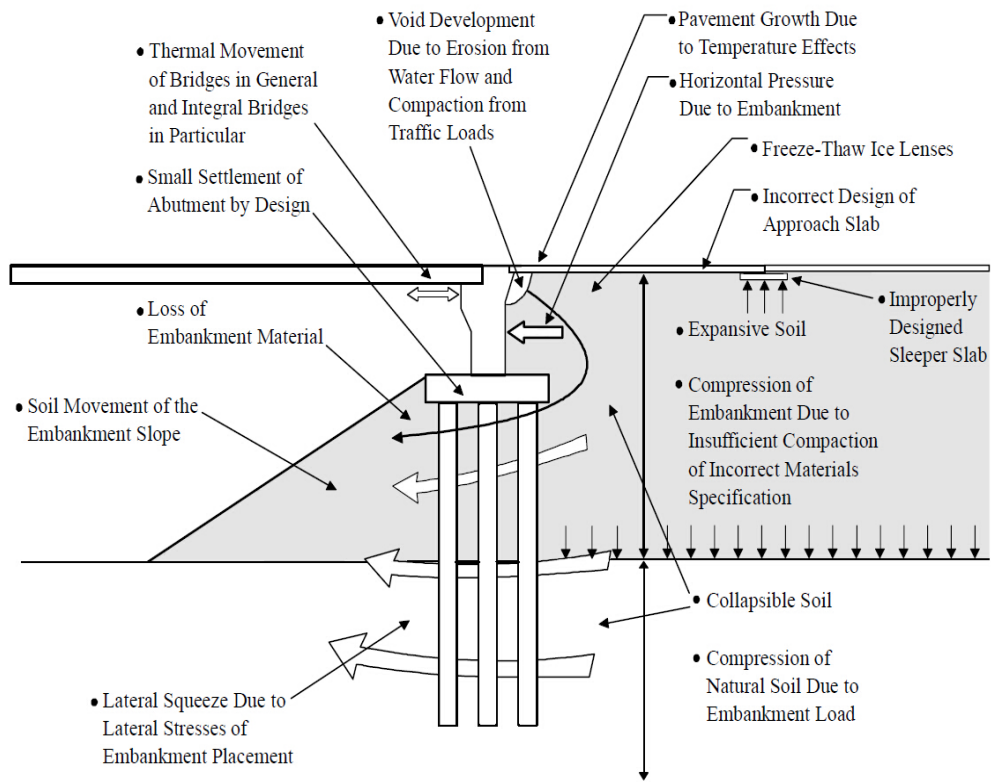


## **2 LITERATURE REVIEW**

In order to appreciate the causes of the failures occurring at bridge ends and to determine the best practices for solving bump problems, a good understanding of the mechanics of approach is warranted. A comprehensive literature review related to the causation of differential bridge ends settlement has been conducted, and general corrective actions for minimizing/eliminating this problem have been summarized. This section is aiming at providing a reference when a specific problem has emerged given Kentucky construction policies and project characteristics

### **2.1 Causes of Bridge Approach Settlement**

Many studies (Hopkins, 1969, 1985; Stewart, 1985; Greimann et al., 1987; Laguros et al., 1990; Kramer and Sajer, 1991; Ha et al., 2002; Jayawickrama et al., 2005; White et al., 2005, 2007, Puppala, 2009; AKM, A. I., 2010) have been undertaken to determine causes of the problem. A commonly accepted study conducted by Briaud et al. (1997) summarized various factors that contribute to differential settlement at bridge ends.



**Figure 2.1 Schematic of various contributors leading to the existence of the bump at the bridge ends (Briaud et al. 1997)**

Helwany (2007) classified different factors into five major categories. A summary of these factors is listed in Table 2.1.

**Table 2.1 Summary of causes of bridge approach settlement (Helwany, 2007)**

	Category	Causes
1	Poor Performance of Approach Pavement	Deformation in Flexible Pavement: Rutting, shoving or cracking
		Failures in Concrete Pavements: transverse cracking, joint faulting, corner breaks, or blowup
		Improper placement of roadway grades

2	Type of Bridge Abutments and Foundation Support	Lack of maintenance of expansion joints of Non-Integral Abutments causing temperature induced stresses on bridge abutment
		Ratcheting or cyclic movement of integral abutments resulting in lateral movement of abutment and increased lateral earth pressures
		Vertical movement of foundations (shallow vs. deep) in relationship to embankment stiffness
		Improper Abutment or Wingwall Design
3	Vertical and Lateral Deformation of Backfill	Inadequate compaction of backfill due to limited space, improper construction equipment, contractor care, soil type, and/or lift thickness
		Volumetric changes of backfill due to temperature differences and drainage (i.e., frost heaving, thaw, collapsible soils, and swelling)
		Post-construction consolidation of cohesive soils due to the embankment self-weight, traffic loads, and weight of asphalt overlays
		Bearing capacity failure of sleeper slab footing under approach slabs
4	Vertical and Lateral Deformation of Foundation Soil	Lateral squeeze of weak foundation soils due to increase vertical stresses (i.e., embankment weight)
		Consolidation settlement (primary & secondary) of silt, clay and organic soils due to increased effective stress
		Slope stability failures due to soils with low shear strengths

5	Poor Drainage	Erosion of side slopes at abutment causing localized movements of backfill behind and in front of abutment. Also, loss of fines through the granular construction layer/pad below the abutment (usually constructed to facilitate construction operations) and the subsequent movement due to fines migration
		Instability of slopes at the abutment from rise in water level
		Increase in hydrostatic pressure behind abutment
		Poor pavement drainage causing ice lensing, soft subgrades, and pumping that causes faulting in concrete pavements and cracking in flexible pavements

Puppala (2009) presented the following major factors that caused approach bumps by summarizing and reviewing of other investigations that addressed the bump problems:

- Consolidation settlement of foundation soil;
- Poor compaction and consolidation of backfill material;
- Poor drainage and soil erosion;
- Types of bridge abutments;
- Traffic volume;
- Age of the approach slab;
- Approach slab design;
- Skewness of the bridge; and

- Seasonal temperature variations.

Although it is easy to spot excessive settlement at bridge approaches, their causes are usually complex and difficult to figure out. Some studies attempted to solve this problem by addressing one or several causes. In general, approach settlement is a result of a combination of several factors that may vary from case to case. Very seldom can approach settlement be traced to a single cause.

## **2.2 Mitigation Methods**

In order to control or prevent problems induced by differential settlement, numerous mitigation methods have been considered. Most studies give similar recommendations for reducing or removing the effects of approach settlement. In general, mitigation methods can be classified into three major categories of improvements that correspond to the major contributing factors at bridge ends:

- a) enhancement of the foundation soil;
- b) improvement of the embankment fill; and
- c) erosion reduction.

Helwany (2007) summarized mitigation methods that have been used in an attempt to alleviate various factors that may cause approach settlement. One or more of mitigation techniques may be required because of different site conditions.

**Table 2.2 Mitigation methods of bridge approach settlement (Helwany, 2007)**

Causes	Mitigation Method
Enhancement of the foundation soil	Removal and Replacement of Weak Foundation Soils
	Ground Improvement (mechanical or chemical)
	Surcharging
	Supporting Embankment on Deep Foundations
Improvement of the embankment fill	More Stringent Backfill and Compaction Specification
	Scheduling a Delay in Construction Work
	Geosynthetic Reinforced Earth
	Controlled Low Strength Materials (CLSM)
	Lightweight Fills
	Reinforced Concrete Approach Slab
	Hydraulic Fills
Erosion reduction	Flatter Side Slopes
	Limiting P200 material
	Diverting Water away from the Abutment
	Geotextile Separators
	Backfill and Surface Drains
	Increasing Surface Drainage
	Maintaining Watertight Joints
	Extending Wingwalls
	Extending Limits of Backfill Prism

Although approach settlement has been commonly recognized, given plenty of attention, and its causes have been clearly identified in the past several decades, no unified set of engineering solutions has been proposed primarily due to the complexity of the factors

involved and varied situations case by case. Most previous research examined the bump issues at a micro level and presented new engineering techniques for minimizing or eliminating the effects at specific locations. However, the proposed research focuses the problem at a macro level and aims at providing guidelines to stakeholders for a specific project by the development of a settlement predictive model to evaluate the severity of approach settlement.

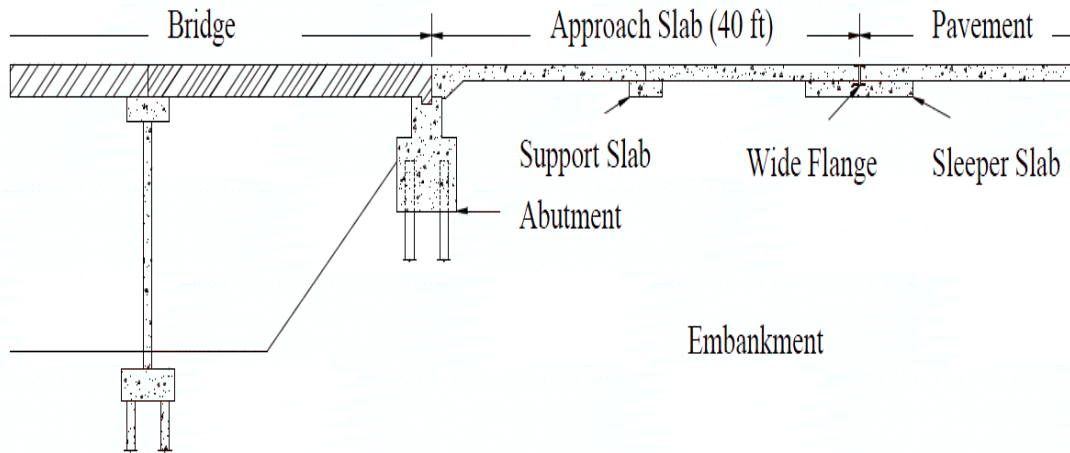
### **2.3 Application of Approach Slabs**

One of the most popular measures to solve bump problems is the application of approach slabs. Approach slabs refer to reinforced concrete slabs supported at one end on the bridge abutment and at the other end on the embankment fill, and aim to provide a gradual smooth transition or a ramp to span the problematic area between the roadway pavement and bridge structures. The schematic design of an approach slab is illustrated in Figure 2.2. A sleeper slab is sometimes used as a footing that extends the entire width of the roadway to equalize settlement beneath the roadway end, particularly in the case of Portland cement concrete pavements (Hoppe, 1999). Briaud (2002) summarized the function of an approach slab as:

- to span the void that may develop below the slab;
- to prevent slab deflection, which could result in settlement near the abutment;
- to provide a ramp for the differential settlement between the embankment and the abutment. This function is affected by the length of the approach slab and the magnitude of the differential settlement; and
- to provide a better seal against water percolation and erosion of the embankment

A survey (Schaefer and Koch, 1992) showed that 80 percent of new bridges would use approach slabs across the United States. Hoppe (1999) concluded that the frequency with which approach slabs are used varies drastically throughout the nation. 14 DOTs use approach slabs at all times for conventional abutments, while Kentucky is one of the only two DOTs (the other one is Maryland) that claims that approach slabs serve only to move the bump from the end of the bridge to the end of the approach slabs and practices a no-use policy. Obviously, there is no direct correlation between the application of approach slabs and the alleviation of bump effects, because no consensus has been obtained on the real benefits or drawbacks with regard to the use of approach slabs. Table 2.3 shows the percentage of approach slabs that are used in various states on interstate, primary, and secondary systems. It is evident that the use of approach slabs on the primary highway systems is prevalent, while Kentucky's response indicated that usage of approach slabs on interstate and primary systems is dramatically below the national average and also indicated low usage on secondary roads compared with most of other states. Hoppe (1999) also conducted a survey on the advantages and disadvantages of using approach slabs. Smooth ride, reduced impact on the backwall, and enhanced drainage control are commonly considered as the major benefits of approach slabs. On the other hand, initial high construction cost and maintenance problems with settling approach slabs are quoted as the main disadvantages. The reasons that no clearly defined benefits from the application of approach slabs was indicated by Kentucky will be investigated in this study. The primary benefits and drawbacks of using approach slabs are summarized in Table 2.4 and Table 2.5.





**Figure 2.2 Schematic design of a typical approach slab (TxDOT, 2002)**

**Table 2.3 Current use of approach slabs (%) state interstate system, primary system, and secondary system (Hoppe, 1999)**

State	Interstate System	Primary System	Secondary System
AL	100	100	20
AZ	100	100	80
CT	< 50	< 50	< 50
DE	90	65	20
FL	100	100	100
GA	100	100	100
ID	small	small	very small
IL	100	100	90
IN	100	100	100
IA	100	75	10
KS	90	50	20
KY	35	35	35
LA	100	100	100
ME	>50	>50	>50

MD	<1	<2	0
MA	100	100	100
MN	90	69	8
MO	100	100	10
MS	100	100	85
MT	<5	<5	<1
NE	100	100	100
NV	100	100	100
NH	95	30	7
NM	80	80	80
NY	100	100	100
ND	75	60	0
OH	100	95	75
OK	100	>90	0
OR	100	100	100
SC	100	100	30
SD	95	90	5
VT	100	100	100
VA	98	75	< 4
WA	75	50	25
WI	100	100	25
WY	90	75	50

**Table 2.4 Advantage of Using Approach Slabs (Hoppe, 1999)**

State	Smooth Ride	Reduced Impact	Control Drainage	Uniform Settlement	Lower Maint. Cost	Seismic Stability	Minimum Deviation at Joints	None
AL	Δ	Δ						
AZ	Δ	Δ						
CA	Δ							
CT	Δ							
DE	Δ							
FL	Δ							
GA	Δ							
ID		Δ		Δ				
IL			Δ	Δ				
IN	Δ			Δ				
IO	Δ	Δ					Δ	
KS	Δ	Δ	Δ					
KY								Δ
LA		Δ						
ME	Δ	Δ		Δ				
MD								Δ
MA	Δ							
MN	Δ	Δ						
MS	Δ							
MO	Δ					Δ		
MT	Δ	Δ						
NE	Δ		Δ	Δ	Δ			
NH				Δ				
NJ	Δ	Δ						
NM	Δ							
NY	Δ							

ND	Δ				Δ			
OH	Δ							
OK	Δ							
OR	Δ		Δ	Δ		Δ		
SD	Δ	Δ	Δ					
TX	Δ							
VT	Δ	Δ						
VA	Δ	Δ		Δ				
WA	Δ					Δ		
WI	Δ	Δ			Δ			
WY		Δ	Δ	Δ				

**Table 2.5 Disadvantage of using approach slabs (Hoppe, 1999)**

State	Higher Initial Cost	Maint.	Erosion	Bending Stress at Backwall	Problems w/Staged Construction	Joints	Rough Surface	Increased Construction Time
CA	Δ							
DE	Δ	Δ	Δ					
GA		Δ	Δ					
IL	Δ							
IN	Δ							
IO	Δ	Δ						
KS	Δ	Δ						
KY	Δ	Δ						
LA				Δ				
ME	Δ							
MN		Δ						
MO	Δ					Δ		
MT		Δ	Δ					
NE	Δ	Δ						
NJ		Δ						
ND	Δ							
OK	Δ							Δ
OR	Δ						Δ	Δ
SD	Δ	Δ						
VA		Δ	Δ					
WA	Δ				Δ			
WI	Δ	Δ						
WY	Δ							

It is a consensus that the usage of an approach slab cannot influence the magnitude of the differential settlement that will ultimately develop. In other words, embankment fill settlement would still occur even though approach slabs are used. In that situation, a void may be formed mainly due to soil erosion and fill deformation beneath the approach slab, and approach slabs would play a role as beams that provide smooth transitions between roadway pavement and bridge structures. A study (Zaman, 1990) concluded that approach slabs may alleviate bump problems to some extent in the short run. However, in the long run, the bump problem would get worse in the scenario that the void beneath the approach slabs is so big that they cannot experience the vehicle load due to fractures.

Another debate refers to a subject of when to initiate an approach slab, including design and construction details in various site conditions. Martin et al. (2013) considered that the structural design and construction issues, besides geotechnical in nature, have an important impact on the performance of approach slabs, and a basic design of approach slab is recommended. Most think whether an approach slab would be used or not primarily depends on traffic volume and/or functional classification of the road. A couple of factors are involved in approach slab usage criteria but no consensus have been reached. Improper design policies may generate two opposite results: if approach slabs are overdesigned, over-expenditure would be burdened; otherwise, cracking or complete failures of approach slabs due to insufficient reinforcement in the long term may cause an abrupt gradient. Due to the complexity of geotechnical conditions of different sites, pavement techniques, and joint expansion at approach slab ends, design and construction of approach slabs are being studied to achieve an equilibrium. Kentucky Structural Design Manual (2005) stipulates a general design criteria of approach slabs and states

that approach slabs should be used as directed by a project manager, however, no standard drawings or detailed design policies of approach slabs have been given and no issues have been indicated on when to initiate an approach slab. A survey conducted by Allen et al. (2002) indicated that only 5 out of 12 districts often place the approach slabs below grade as a prevention technique and only 2 districts have the experience in using sleeper slabs, which is dramatically below the national average. In an effort to further understand the two debatable subjects, effectiveness of approach slabs on mitigating the differential settlement is evaluated by statistical analysis between bridges with approach slabs and bridges without based on a large amount of bridges in Kentucky.

## **2.4 Critical Review of Previous Studies**

To provide detailed background information describing previous studies related to this topic, and to better understand the mechanisms leading to the formation of bridge approach settlement problems, an extensive literature review of previous major research was conducted. Because of the considerable cost spent on mitigating/eliminating bridge approach settlement, Federal Highway Administration (FHWA) and State Department of Transportation(s) (DOTs) have sponsored substantial studies to identify the causes, mitigation measures, and maintenance techniques on the topic of bridge approach settlement or bump problems at the ends of the bridge. Various state DOT studies in the last 50 years have been collected and major works of these studies are listed in Appendix A.

### **3 DATA COLLECTION**

#### **3.1 Model Inputs Identification**

As it is shown in the literature review, it is clear that a variety of opinions persists as to the causes of bridge approach settlements and mitigation methods. In order to obtain comprehensive and meaningful relationships between approach settlement levels and various contributors, it is necessary to identify as many initial causing factors as possible because no consensus has been reached on the role of each factor affecting the final approach settlement formation. In other words, all contributing factors need to be collected and analyzed to see the weight of each variable to the predictive model, and then select some of them to establish the optimum predictive model. A series of potential variables is identified and its collection methods are presented. The main model inputs include: (i) bridge length, width, and approach year; (ii) approach type; (iii) abutment type; (iv) embankment fill material and height; (v) foundation soil type (consistency) and thickness; (vi) transportation districts; (vii) Average Daily Traffic (ADT); (viii) drainage.

1. Basic project information

The basic quantitative variables that could be identified include bridge length, width, approach year (year built), and ADT. The age of the bridge approach could negatively affect the embankment fill performance in terms of controlling deformation underneath the approach, especially at the expansion joints next to the slab for those bridges with approach slabs (Laguros et al., 1990 and Bakeer et al., 2005). Traffic volume has been considered as a major factor in the performance of the bump severity, while the opinions regarding the effects of



traffic volume are divergent. High volume traffic has been found to be a compelling reason for the formation of approach settlement (Wong and Small, 1994). On the one hand, Lenke (2006) concluded that bump severity was found to increase with vehicle velocity, vehicle weight, especially heavy truck traffic, and ADT. On the other hand, Bakeer (2005) noted that speed limit and traffic volume almost have no effect on the performance of bridge approaches.

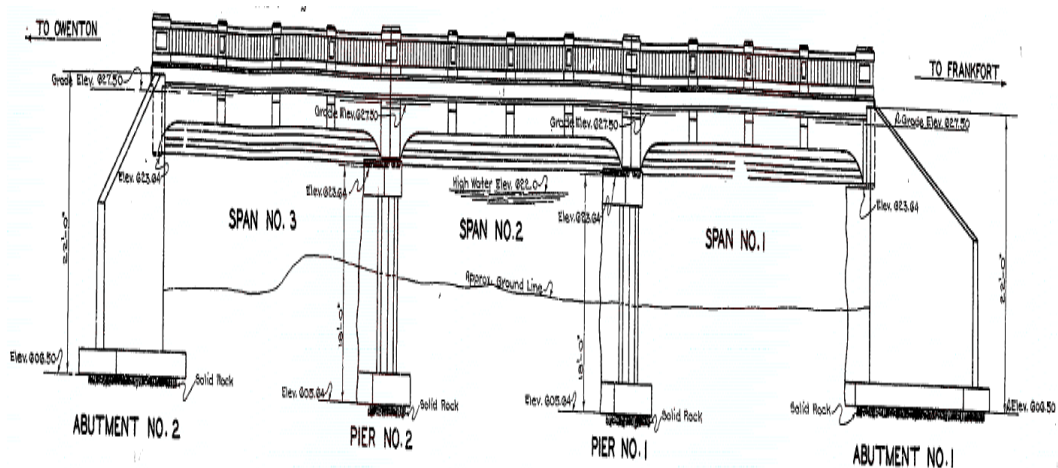
## 2. Approach Type

The bridge approaches are classified into two categories: (i) bridges with approach slabs or Portland cement concrete approaches are termed as rigid; (ii) bridges without approach slabs or approach built with asphaltic concrete cement are termed as flexible. Evaluation of approach slabs effect on mitigating differential settlement at bridge ends will be investigated in a separated section in this study.

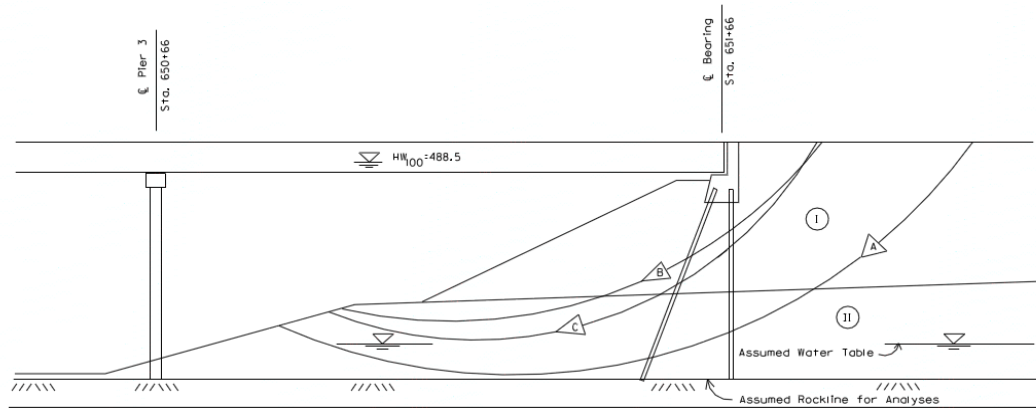
## 3. Abutment type

Abutment must have backwalls to keep the embankment from covering up the beam ends and to support possible approaches, for which compatibility between abutments and bridge approaches can be guaranteed. Generally, abutments can be classified into integral (movable) or non-integral (conventional or stub) types (Greimann, 1987). In order to characterize abutments more accurately, different types of abutments can be grouped into closed, perched, or spill-through. Closed abutments originate from the fact that tall walls are built to hold back the approach embankment, which results in higher lateral earth pressure. Closed

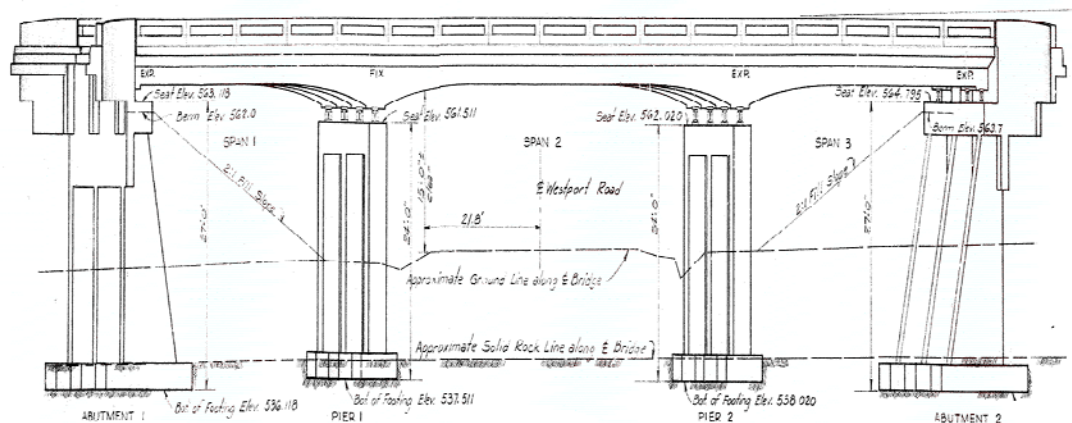
abutments must be constructed before the approach embankment, therefore there is a potential for closed abutment to settle more because it can be more difficult to bring large compaction equipment to compact the fill (Dupont and Allen, 2002). Perched abutments are usually construed on piles or shallow spread footings, so the embankment can be placed to the bottom elevation of the abutment. The embankment fill can be compacted to a good condition with an advantage that the lateral forces on perched abutments are the lowest of the other types, which leads to less lateral movement (Dupont and Allen, 2002). Spill-through abutments usually are placed on columns and must be constructed before the embankment. In this type, transmission of lateral force through columns is allowed. Embankment fill is also difficult to compact well since the abutments must be constructed before the embankment. Three typical bridges in different abutment types are illustrated in Figure 3.1, 3.2, and 3.3.



**Figure 3.1 A typical full height closed or high abutment (bridge No. 094B00041N)**



**Figure 3.2 A typical perched abutment (bridge No. 056B00454R)**



**Figure 3.3 A typical spill-through abutment (bridge No. 056B00489N)**

#### 4. Embankment fill material and height

The deformation of the backfill material has been perceived and proven to be one of the crucial factors to cause bridge approach settlement (Hopkins, 1973; Wahls, 1990; Lenke, 2006; Helwany, 2007). Sam Helwany (2007) concluded that the causes of vertical and horizontal deformation of the backfill material result from volumetric changes in the soil, lack of compaction, post-construction consolidation settlement, and bearing capacity failure of the embankment soil. In

addition to deformation, lateral stability and shear strength of backfill material should also be considered as important factors in determining the overall stability of backfill. Lateral confining forces are usually considered significant for foundation soil, while on embankment backfills, the confinement effects receive much less attention (Wahls, 1990). In general, cohesive soils are more difficult to compact to their optimum moisture content and density when compared to coarser or granular fill materials (Hopkins, 1973). Some studies (Hopkins, 1973; Wahls, 1990) indicated that thick embankments tend to settle more than shallow ones. It is difficult to retrieve the fill material type based on the current storing system due to a large time span. For old bridges, there are no detailed instructions on what kind of materials were used in the design plan. For new bridges, embankments are usually constructed according to standard drawings (Std. Drwg. RGX-100; 105) for most bridges in Kentucky unless there is a note specifying that. Such a standardized fill composed of stabilized soil is inappropriate to be classified as a normal fill such as clay, silt, or sand. Consequently, the embankment height is merely considered as the proper variable that reflects the contribution of the embankment fill.

##### 5. Foundation soil type (consistency) and thickness

Many studies (Hopkins, 1969; Wahls, 1990; Dupont and Allen, 2002) concluded that consolidation settlement of foundation soils contributed significantly to approach settlement. Foundation settlement typically results from a combination of dynamic traffic loads applied at the embankment surface and static load due to the weight of the embankment itself (Dupont and Allen, 2002). Although it is

easy to find the occurrence of settlement and determine its magnitude, the reasons for this problem are usually difficult to identify because of the variability of the engineering properties of foundation soils. In addition, it is difficult to access the foundation after construction because it is buried deep beneath the bridge approach/roadway surface (Wahls, 1990). More settlement would occur in cohesive soils after construction than non-cohesive soils because cohesive soils, such as soft or high plasticity clays, are more susceptible to soil plastic deformation, which can aggravate the approach settlement.

Foundation soil is usually a mixture of several types of soil, hence it is inappropriate to grossly categorize the foundation soil type as silt, clay, sand, or rock. However, the consistency of the foundation soil could be identified based on its engineering properties and composition of each type of soil. This research suggests that the consistency of the foundation soil could be classified as soft, stiff, very stiff, or hard, corresponding to different types of soil. The foundation soil thickness underneath the embankment is also considered as a variable to evaluate its effect, and it usually refers to the elevation difference between original ground and hard rock. The foundation soil depth is usually equal to zero for closed or perched abutments because they are usually built on hard soils/rock with stern borehole parameters. For pile-supported abutments, the foundation soil depth is normally equal to the length of the piles that are supported on hard rock.

## 6. District

When and how to initiate corrective measures when a differential approach settlement occurs vary from district to district. In addition, the current practice with regard to bridge maintenance is different between transportation districts. That is the main reason why the geographic regions are adopted as a major input factor.

## 7. Drainage

Poor drainage around the bridge abutments and under the approach pavements is a commonly perceived cause of bridge approach settlement. Many transportation agencies (such as Texas DOT, Virginia DOT, Iowa DOT, and Colorado DOT) documented the importance of the drainage and soil erosion. Improper, damaged, or blocked drainage systems can cause erosion in the abutment and embankment slope, which increases soil erosion and enlarges void formation (Hoyos, 2009). There are no uniform guidelines for the use, design, and construction of drainage systems nationwide. Therefore, it is tough to define drainage issues as numeric or categorical variables that are considered as inputs to develop a model to evaluate severity of approach settlement even though drainage has been perceived as one of the most important causing factors. Even if the drainage could be classified as a binary variable that whether the drainage design has been considered or not for an approach, it would make a futile effort of considering drainage as a factor in logistic regressions because almost every approach has adopted drainage design as required by KYTC. Another reasonable option defining drainage as a numerical variable is to assign different grades by rating different designs of

drainage, but this information is not always available in current storing system in KYTC.

### **3.2 Other Lurking Variables**

#### **1. Temperature cycle**

Most bridges are characterized as integral or non-integral abutment bridges with the main difference in the connection between the bridge superstructure and the abutment. The non-integral bridges are usually supported on bearing connections that allow the superstructure to move longitudinally without transferring lateral loads to the abutment. Generally, battered piles are typically installed to accommodate for lateral loads on the abutment backwall and expansion joints are used as connections to tolerate the relative movement between the superstructure and the abutment. While for integral bridges, the superstructure is rigidly connected to the abutment in order to eliminate the use of bearing plates and forbid the relative movement. Bridge superstructure and approach usually expand and contract because of concrete thermal strain characteristics when they are exposed to temperature fluctuations. Both integral and non-integral bridges are vulnerable to differential settlements. However, the integral bridges are more susceptible to temperature fluctuations as the abutment backfill is more affected by temperature changes for the two reported problems (Arsoy et al, 1999):

- Development of a void near the abutment face
- Differential settlement between the bridge superstructure and approach embankment

This research does not consider this variable as an important variables due to the following two reasons:

- Most bridges used as research subject are non-integral bridges that are more resistant to temperature fluctuations
- All the bridges are subjected to the same temperature changes, therefore, it is meaningless to list this variable as an input for statistical analysis. But the influence from the temperature changes is still exist

## 2. Connection between the approach slab and the bridge

Several issues are involved in the connection between the approach slab and the bridge, including the approach slab dimensions, paving notch, sleeper beam, etc. Kentucky is one of the two states that consider the application of approach slab has little effect on the elimination/mitigation of differential settlement even though approach slabs are widely used nationwide. In addition, Hoppe (1999) conducted a survey (Table 3.1) and concluded that most of the bridges in Kentucky are non-integral and no doveled or tied connection between approach slab and bridge are installed. Therefore, whether approach slabs were used or not, it is more significant to consider the use of approach slabs as a model input instead of considering this input in more detail.



**Table 3.1 Connection between approach slab and bridge (Hoppe, 1999)**

State	Non-integral Bridges		Integral Bridges		Integral Abutments Not Used
	Doweled or Tied	No Connection	Doweled or Tied	No Connection	
AL	×				×
AZ		×			
CA	×		×		
CT		×			
DE		×			×
FL	×				×
GA		×		×	
IA	×			×	
ID	×		×		
IL	×		×		
IN		×	×		
KS	×		×		
KY		×			
LA	×				
MA	×			×	
MD					×
ME		×	×		
MN		×	×		
MO	×				
MS		×			×
MT		×			
ND				×	

NJ		×			×
NH	×				
NV	×			×	
OH	×				
OK	×		×		
OR	×		×		
SC	×				
SD		×		×	
TN	×				
TX	×				×
VA		×	×		
VT	×				
WA	×		×		
WI		×			
WY	×		×		

### 3.3 Collection Method

Bridge length, width, year, and ADT could be easily retrieved from the KYTC online service “Bridge Data Miner” once a bridge is specified.

Once a bridge sample is determined, interviews with KYTC maintenance engineers would be conducted and bridge plans would be requested. Approach type for a bridge could be identified if the design plan for that bridge could be obtained and reviewed.

The abutment type can be identified explicitly from the site observation and verified from the design plan that are available in the design report at KYTC.

Embankment height refers to elevation difference between the original ground level and the surface of backfill. The estimated value could be determined from the bridge elevation plans at KYTC.

Foundation soil information is contained in sounding plans that are included in the design plans for most bridges. For other bridges, foundation soil type can be grossly determined by reviewing a geotechnical report for a given project that provided by Kentucky Geological Survey (KGS). Foundation thickness underneath the embankment here measures from the bottom of the embankment to a dense or stiff deep soil stratum. It is difficult to distinguish the bond between soft and dense soil; therefore, precision of foundation soil thickness would be controlled within 1~2 feet.

Drainage design has not been considered as a separate topic from the review of some old bridge plans. For newer bridges (less than 20 years), the drainage design varies from case to case. The proposed research will not consider this available as an input but discussion related to this issue will be involved in the section of the current practice that may effectively mitigate the bump problems.

The data base development was based on three sources: (I) basic bridge information from the KYTC online service “Bridge Data Miner”, (II) interview of local bridge maintenance personnel, and (III) bridge inspection records and design plans maintained at the KYTC.

### **3.4 Model Output**

Bridge approach settlement is the output of the anticipated model. The approach settlement here doesn't refer to the real settlement in the form of inches that the approach has experienced from the time it is opened to traffic. This study attempts to develop a

model by using ordinal/nominal logistic regression based on a large-scale sample. No records regarding the real approach settlement are available in the current maintenance system. It is impractical to measure the real approach settlement of every bridge in the selected sample (basically 600 bridges). It is a wise way of addressing the output from the macro angle that classify the approach settlement severity as three levels: minimal, moderate, and severe.

One study conducted by Kentucky Transportation Center (KTC) (Dupont and Allen, 2002) indicated that the best practice to alleviate the bridge bump problems is to establish up-to-date maintenance activities, by scheduling periodic repair activities as well as occasional required maintenance. Maintenance techniques to rectify distressed/faulted approach generally include local patching, mud/slab jacking, asphalt overlay, and replacement (Wahls, 1990; Briaud, 1997; Dupont and Allen, 2002; Hoyos, 2009). The term “local patching” refers to the maintenance performed at a specified spots on the approach pavement. Mud/slab jacking is generally performed on bridges with approach slabs. It refers to a quick, convenient, and economical technique of raising a settled rigid approach to a desired elevation by pressure injecting cement grout or mud-cement mixtures (Hoyos, 2009). Asphalt overlay is adopted to improve the riding conditions of the entire roadway. Replacement of an approach is necessary where a highly deteriorated bridge approach has occurred due to the differential settlement. This technique is normally more expensive and time-consuming than other correction techniques. A good understanding of the mechanisms of these maintenance techniques is an essential prerequisite to define the severity of a bridge approach settlement.

There are two methods used to identify the severity of an approach settlement:

1. One is determined by the frequency of maintenance or subjective judgment of district maintenance engineers based on their work experience. If more maintenance on correction approach settlement has been performed toward a bridge, the worse bump situation can be claimed. This method is used to judge the settlement levels of the first bridge sample from the survey.
2. After interviews with several KYTC maintenance engineers, there is no system or archive regarding maintenance history for a bridge even though some corrective actions were performed. However, there is an archive, named “Pontis”, of most of bridges in Kentucky which contains all inspective activities and suggested mitigation methods for the emerged problems, including suggestions of solving approach settlement. From the inspection history, the maintenance actions could be assumed to have been occurred. It is important to note that inspection history is not equal to maintenance history, and the validity of using inspection history instead of maintenance will be verified by statistical analysis in the next chapter. Therefore, the other method of rating the severity of an approach settlement is originated from the inspection history “Pontis.”

### **3.5 Rating Output Levels**

No uniform system has been established for rating bridge approaches due to a complicated mechanism leading to differential settlement. Four rating systems as illustrated in chapter one are derived from micro level perspectives, while this paper rates the riding quality of an approach from macro level perspectives. The macro level methods here refer to techniques that determine the differential settlement scale by assessing the inspection history from “Pontis”, basically an internal network server used

for storing inspection history of approaches of most bridges in Kentucky, or surveying the local bridge maintenance engineers . The “Pontis” database includes the last 6 to 8 years’ inspection history of most bridges in Kentucky except for a few bridges in district four and district eight, and could be acquired from the KYTC. The other macro method is performed by electronic survey and district interviews, and the differential settlement scale of bridges from the survey is verified by local bridge engineers based on their work experience.

According to the macro level evaluation methods, the differential settlement scale could be classified as minimal, moderate, and severe, which corresponds to the approach performance status good, fair, and poor. Table 9 and Table 10 are given to summarize the similarities and differences between micro and macro methods in determining the differential settlement scale.

**Table 3.2 Micro methods in determining differential settlement scale**

Rating	Description	Micro Method	
		Actual Settlement (Inch)	IRI (mm/m)
Very Good	No Bump	0	0~4
Good	Slight Bump	~1 inch	5~8
Fair	Moderate Bump – Readily Recognizable	~2 inch	9~12
Poor	Significant Bump – Repair Needed	~3 inch	13~16
Very Poor	Large Bump – Safety Hazard	> 3 inch	> 17

**Table 3.3 Macro method in determining differential settlement scale**

Rating	Description	Marco Method	
		Inspection History (Pontis): Characteristics	Survey: Characteristics
Good	No bump or minimal/slight bump	No or less than 1.5 inches approach settlement was detected and no maintenance work is needed to correct differential settlement.	No maintenance work has been performed on fixing differential settlement since opening.
Fair	Moderate bump	Settlement ranging from 1.5 to 3 inches was detected and repair work including wedging repair, local patching, and mud jack may be needed. Problem may repeat in periodical inspection reports.	Differential settlement can cause a minor impact and 1 to 3 times of maintenance work have been performed on fixing it.

Poor	Severe bump	Settlement more than 3 inches was detected and problem lasts for a long time. Transition have to be resurfaced or approach slabs need to be replaced.	Differential settlement can cause a major impact and maintenance work should be performed every couple of years.
------	-------------	---	--

### 3.6 Bridge Selection

#### 3.6.1 Information from a Survey

An electronic questionnaire was created by “Surveygizmo” and distributed to managers of each transportation district. Then these managers sent this link to the specific bridge engineers that are responsible for bridge inspection or maintenance to identify and quantify differential settlement at bridge ends throughout each district. The purpose of this survey is to obtain information regarding the existence of bridges with “bump” issues, identify major causes of differential settlement at bridge ends, and evaluate the existing record keeping procedures regarding maintenance of “bump” issues. There are 35 bridge engineers participated in this survey, but only 18 engineers provided the completed and feasible information as requested. 131 bridges with different settlement severity were obtained. The distribution of these bridges is shown in Table 3.4. No bridges from District two and District eight are fed back. The bridge plans for only 87 bridges were able to be identified in the current bridge archive from KYTC due to the reasons that the other bridges are too new to be included in the current archive or some information for these bridges are missed. These bridges are composed of sample one for



analysis the relationship between approach settlement levels and its predictors in the next chapter.

**Table 3.4 Distribution of the bridges with different settlement levels from each transportation district for sample one**

District	Settlement Levels			Total No.
	Minimal	Moderate	Severe	
1	2	2	2	6
3	0	0	3	3
4	0	2	3	5
5	0	9	1	10
6	6	23	26	55
7	0	4	5	9
9	0	3	3	6
10	2	2	2	6
11	10	6	9	25
12	0	0	6	6
	20	51	60	131

### **3.6.2 Information from the Transportation Cabinet**

The primary source of data from the KYTC is the inspection history named “Pontis”. It is basically an internal network server used for storing inspection history of approaches of most bridges in Kentucky. A simple random sample was created as sample two by randomly selecting 600 bridges from “Pontis”. If bridges without inspection history were selected, these bridges would be deleted, and the selection process would be iterated to obtain 600 bridges with completed inspection history.

A simple random sampling was used to generate sample two, which means every bridge with the equal opportunity to be selected. Therefore, a transportation district which contains more bridges in the “Pontis” would has a higher probability that more bridges would be selected in the sample two. The method also guarantees that the sample two includes bridges from every transportation district.

**Table 3.5 Distribution of the bridges with different settlement levels from each transportation district for sample two**

District	Settlement Levels			Total No.
	Minimal	Moderate	Severe	
1	97	65	5	167
2	0	6	12	18
3	11	13	4	28
4	0	0	1	1
5	1	17	18	36
6	11	39	18	68
7	7	25	40	72
8	0	1	1	2
9	3	16	11	30
10	21	13	0	34
11	5	31	39	45
12	36	47	16	99
	192	273	135	600

### **3.7 Limitations of Data**

Sampling is an important component of any piece of research because of the significant impact that it can have on the quality of your results/findings. The samples used in this research would be studied to obtained conclusions that stands for the entire population.

Hence the accuracy of the conclusions is usually dependent upon the reliability of the data. This section mainly discusses some of the limitations of the data for sample one and sample two, respectively.

#### 1. Limitation of the data for sample one

The biggest limitation of the data for sample one is the sample size. Even 131 bridges were collected for sample one, but only 87 with completed information can be used for analysis. Our research team had tried to contact as many bridge maintenance engineers as we can to obtain a sample with sufficient individuals. For logistic regression which discussed in the next chapter, a model constructed by a small sample size may lead to unreliable conclusions.

Several responders provided the same bridges with different settlement levels. This phenomenon can be explained by two aspects. First, the maintenance bridge engineers evaluate the settlement level for a bridge based on his or her work experience. The work experience for each respondent is different. In many cases, the maintenance engineer had been working for a particular district for a length of time that was much shorter than the age of the approach. Some engineers may work more than several decades in a district, while some engineers may just start their work life. If they judge the settlement level for a bridge based on maintenance times based on their work experience, they may conclude differently. In this scenario, a higher settlement level would be adopted for a bridge given different settlement levels by different respondents. For example, moderate and minimal settlement levels were given for the same bridge, moderate would be adopted for this bridge. Second, different rating criterion may be applied by different respondents. Some bridge maintenance engineers use the number of maintenance times to evaluate the

settlement levels, while some bridge maintenance engineers use the observed settlement in inches to evaluate the settlement levels. Different evaluation criterion may conclude different results.

Generally, the bridges with the worst settlement situations may impress the responders most. In this case, sample one may include more bridges with severe settlement than other settlement levels. The observed results verified this assumption. There are 60 bridges with severe settlement while 20 approaches in minimal and 51 approaches in moderate. In this sense, sample one may lead to selection bias.

## 2. Limitation of the data for sample two

A simple random sample is a subset of individuals chosen from a larger population. Each individual is chosen randomly and entirely by chance, such that each individual has the same probability of being chosen at any stage during the sampling process. It was envisioned that no one type or factor had significant dominance on the selection process. A simple random sample is an unbiased surveying technique. Based on the above considerations, the random sampling method was used to generate sample two. In this sense, sample two would not lead to selection bias.

The system “Ponits” only provides the inspection history for most of the bridges in Kentucky in the last ten years. The current situation of the settlement levels could be identified without giving earlier maintenance actives. Even if the settlement level for a bridge could be summarized by using last years’ maintenance history, there is still a chance that this bridge was rebuilt or approach slabs were replaced more than ten years

ago. In this case, the current settlement level for an approach cannot reflect the true settlement level.

In the inspection history “Pontis”, there are exact maintenance times and what kind of maintenance activities were undertaken for some bridges. While there are observed true settlement in inches were measured for some bridges. It is not a problem to evaluate the settlement level for an approach solely based on one evaluation criteria, maintenance times or observed settlement, shown in Table 3.3. For some bridges, the “Pontis” not only provides maintenance times but also observed accumulative settlement. There is a chance that two different settlement levels for an approach may be reached based on two evaluation criterion. In this situation, the higher settlement level would be selected for that bridge.

## 4 DATA ANALYSES

The major goal of this study is to estimate the probability of occurrence of each of the three settlement levels as well as to estimate the odds of severity choice as a function of the covariates and to express the results in terms of odds ratios for severity choice given bridge characteristics. The independent variables of interest both consist of count data and categorical (ordinal and nominal) variables. The outcome (response) variable is ternary: minimal, moderate, or severe, and it is assumed as ordinal under the assumption that the levels of approach settlement have a natural ordering (low to high), but the distances between adjacent levels are not consistent (see Table 3.3).

Logistic regression is a type of a probabilistic statistical classification model that is used for predicting the outcome of a categorical dependent variable based on one or more predictors or features. Two methods are usually used to conduct logistic regression analyses. The ordinal regression procedure is usually used to build models, generate predictions, and evaluate the importance of various predictor variables in cases where the dependent variable is ordinal in nature. Multinomial logistic regression is used to model nominal outcome variables, in which the log odds of the outcomes are modeled as a linear combination of the predictor variables. Because it is uncertain to treat settlement severities as a true ordering variable, ordinal logistic regression will be carried out at first, and then multinomial logistic regression will be implemented if the assumption that the slope coefficients in ordinal regression are the same across response categories is violated.

A code sheet for the variables that are included in data analyses for identifying the relationship between each parameter (all parameters) and dependent variable is given in Table 4.1.

**Table 4.1 Code sheet for the variables in samples**

Variable	Description	Codes/Values	Name
1	Geographical location	District Number 1=District 1 2=District 2 . . 12=District 12	DISTRICT
2	Age of bridge approaches	Years	AGE
3	Bridge length	Ft.	LENGTH
4	Bridge width	Ft.	WIDTH
5	Average daily traffic	Number/day	ADT
6	Abutment type	1=closed 2=spill-through 3=perched	ABUT
7	Approach type	1=flexible 2=rigid	APPT
8	Embankment height	Ft.	EH
9	Foundation soil depth	Ft.	FSD
10	Foundation soil consistency	1=soft 2=stiff 3=very stiff 4=hard	FSC
11	Bridge approach settlement	1=minimal 2=moderate 3=severe	SEVERITY

## 4.1 Approach Age

### 4.1.1 Sample One

This section is interested in the approach age that influence whether an approach is experiencing minimal settlement or severe settlement. It is helpful to start with exploring the relationship between approach age and the settlement severity for sample one. Had

the outcome variable been continuous rather than ternary (polytomous), a scatterplot of the outcome versus the independent variables was formed. This scatterplot may be used to provide an impression of the nature and strength of any relationship between the settlement severity and the causative variables. A scatterplot of the data in sample one is given in Figure 4.1. In this scatterplot, all points fall on one of three parallel lines representing the settlement levels. There is some tendency for the bridges with moderate or severe settlement to be younger than those with minimal settlement. While this plot does depict the polytomous nature of the settlement levels quite clearly, it is not able to provide a clear picture of the nature of the relationship between AGE and SEVERITY.

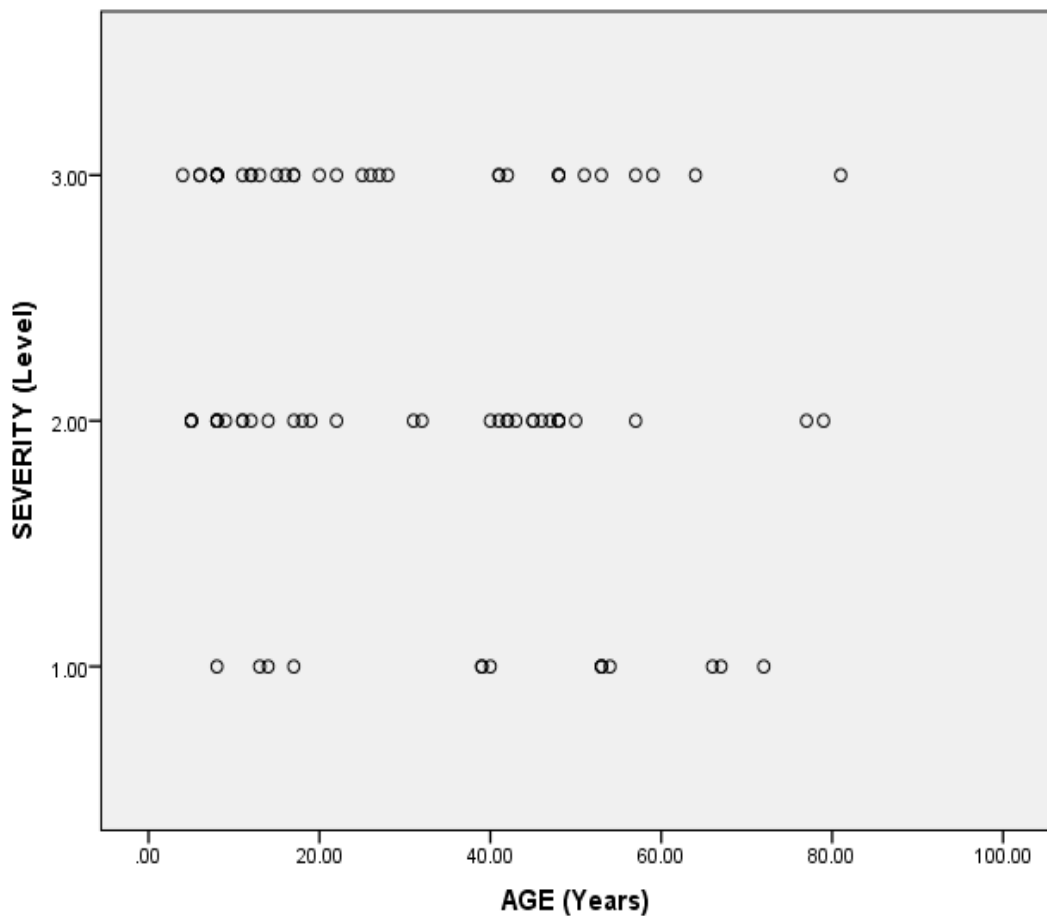


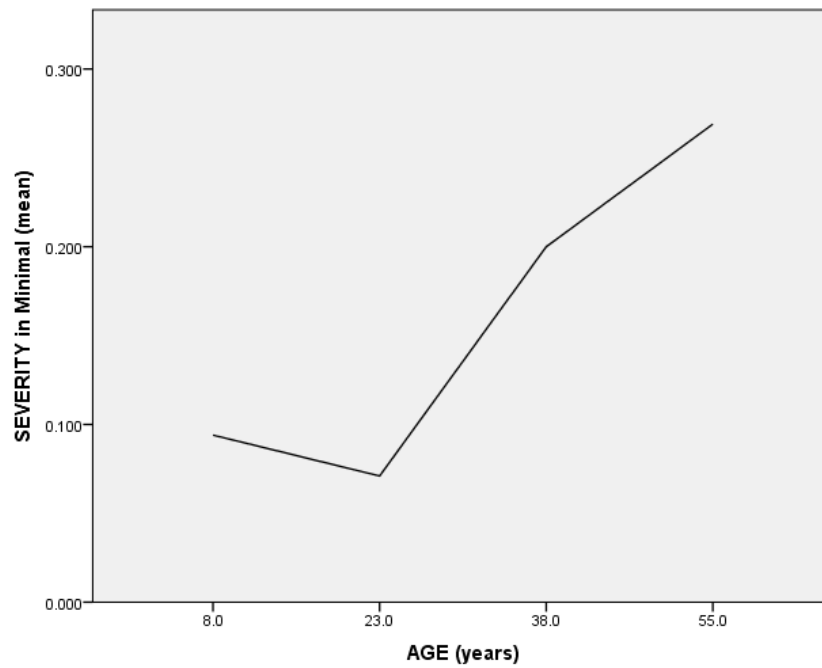
Figure 4.1 Sample One: Scatterplot of approach settlement levels by approach age



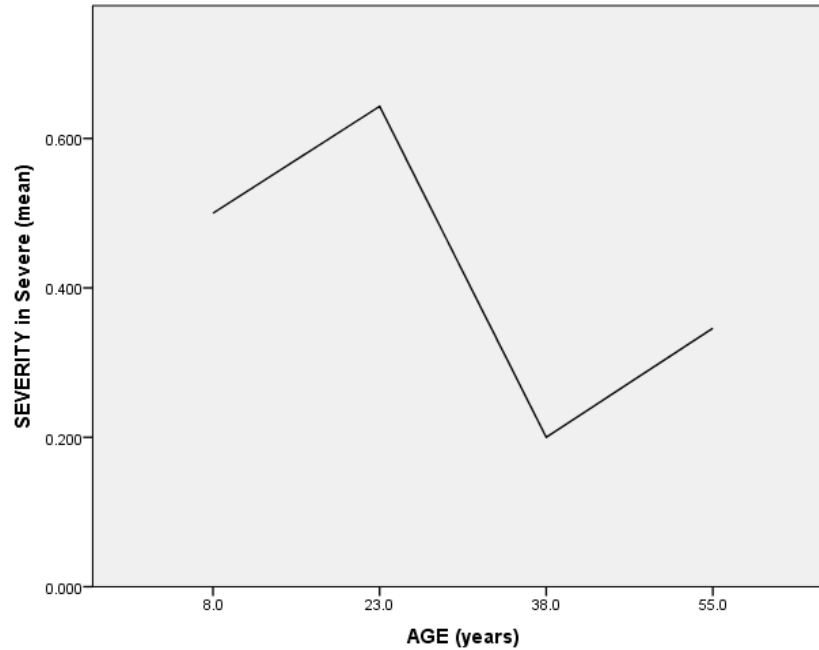
The main problem with this scatterplot is that the variability in SEVERITY at all ages is large, and it is difficult to see any functional relationship between AGE and SEVERITY. An effective way of solving this problem, while still maintaining the structure of the relationship between the dependent and the independent variable, is to create intervals for the independent variables by removing some variation and compute the mean of the response within each group. This strategy is used to group the independent variable AGE into four categories (AGEG) defined in Table 4.3. The percentage of SEVERITY with minimal and severe are also computed. Figure 4.2 and Figure 4.3 present two plots of the percent of approach with minimal or severe settlement versus the midpoint of each age interval. By examining Figure 4.2, it shows that as approach age increases within 0~30 years, the proportion of approaches with minimal settlement decrease, and then as approach age increase within 30~60 years, the proportion of approaches with minimal settlement increases. By examining Figure 4.3, the proportion of approaches with severe settlement increases as age increases during the stage of 0~30 years. Then, the proportion of approaches with severe settlement decreases as age increases within 30~45 years, and finally the proportion of approaches with severe settlement increases as age increases after 45 years. The variation of the proportion of approaches with minimal settlement shows an almost reverse tendency with the variation of the proportion of approaches with severe settlement. This strategy above provides, to some extent, considerable insight into the relationship between AGE and SEVERITY. However, the functional form for this relationship need to be analyzed by logistic regression.

**Table 4.2 Sample One: Frequency table of age group (AGEG) by SEVERITY**

Age group (year)	Severity			Total	Mean	
	Minimal	Moderate	Severe		Minimal	Severe
0~15	3	13	16	32	0.094	0.500
16~30	1	4	9	14	0.071	0.643
31~45	3	9	3	15	0.200	0.200
Above 45	7	10	9	26	0.269	0.346
	14	36	37	87		



**Figure 4.2 Sample One: Plot of the percentage of approaches with minimal SEVERITY in each age group**



**Figure 4.3 Sample One: Plot of the percentage of approaches with severe SEVERITY in each age group**

Many statistical packages are able to conduct logistic regression analyses. Statistical Package for the Social Sciences (SPSS) is employed to explore the relationship between AGE and SEVERITY as well as other relationships in the following logistic regressions. Since the outcome is an ordinal categorical variable with three levels, the program of ordinal logistic regression is adopted at first. Below the ordinal logistic regression command is used to run a model predicting the outcome variable SEVERITY, using AGE. The output is shown in Table 4.3 ~ Table 4.5, each of which is discussed below.

**Table 4.3 Sample One: Model fitting information of ordinal logistic regression  
between AGE and SEVERITY**

Model	-2 Log Likelihood	Chi-Square	df	Sig.
Intercept Only	129.841			
Final	125.172	4.668	1	.031

- **Model:** This indicates the parameters of the model for which the model fit is calculated. "Intercept Only" describes a model that does not control for any independent variables and simply fits an intercept to predict the outcome variable. "Final" describes a model that includes the specified independent variables and has been arrived at through an iterative process that maximizes the log likelihood of the outcomes seen in the outcome variable. By including the independent variables and maximizing the log likelihood of the outcomes seen in the data, the "Final" model should improve upon the "Intercept Only" model. This can be seen in the differences in the -2(Log Likelihood) values associated with the models.
- **-2(Log Likelihood):** This is the product of -2 and the log likelihoods of the null model and fitted "final" model. The likelihood of the model is used to test of whether all independent variables' regression coefficients in the model are simultaneously zero and in tests of nested models.
- **Chi-Square:** This is the Likelihood Ratio (LR) Chi-Square test that at least one of the predictors' regression coefficient is not equal to zero in the model.

- df: This indicates the degrees of freedom of the Chi-Square distribution used to test the LR Chi-Square statistic and is defined by the number of predictors in the model.
- Sig.: This is the probability of getting a LR test statistic as extreme as, or more so, than the observed under the null hypothesis; the null hypothesis is that all of the regression coefficients in the model are equal to zero.

The p-value for this regression model is 0.031 that is smaller than a specified alpha level (if 0.05 is set in this study). This would lead to conclude that this model fits better than an empty model (i.e., model with no independent variables). In other words, the relationship between AGE and SEVERITY can be described by this model.

**Table 4.4 Sample One: Parameter estimates of ordinal logistic regression between AGE and SEVERITY**

		Estimate	Std. Error	Wald	df	Sig.	95% Confidence Interval	
							Lower Bound	Upper Bound
Threshold	[SEVERITY = 1.00]	-2.349	.454	26.766	1	.000	-3.239	-1.459
	[SEVERITY = 2.00]	-.312	.363	.739	1	.390	-1.024	.400
Location	AGE	-.021	.010	4.661	1	.031	-.040	-.002

- SEVERITY=1.00: This is the estimated cutpoint on the latent variable used to differentiate low SEVERITY from middle and high SEVERITY when values of the independent variables are evaluated at zero. Subjects that had a value of -2.349 or less on the underlying latent variable (SEVERITY) that gave rise to

SEVERITY would be classified as low SEVERITY given the approaches' age were zero.

- SEVERITY=2.00: This is the estimated cutpoint on the latent variable used to differentiate low and middle SEVERITY from high severity when values of the independent variables are evaluated at zero. Subjects that had a value of -0.312 or greater on the underlying latent variable that gave rise to SEVERITY would be classied as high SEVERITY given the approaches' age were zero. Subjects that had a value between -2.349 and -0.312 on the underlying latent variable would be classified as middle SEVERITY.
- Estimate: These are the ordered log-odds (logit) regression coefficients. Standard interpretation of the ordered logit coefficient is that for a one unit increase in the predictor, the response variable level is expected to change by its respective regression coefficient in the ordered log-odds scale while the other variables in the model are held constant. Interpretation of the ordered logit estimates is not dependent on the ancillary parameters; the ancillary parameters are used to differentiate the adjacent levels of the response variable. However, since the ordered logit model estimates one equation over all levels of the outcome variable, a concern is whether our one-equation model is valid or a more flexible model is required. The odds ratios of the predictors can be calculated by exponentiating the estimate.
- Std. Error: These are the standard errors of the individual regression coefficients.
- Wald: This is the Wald chi-square test that tests the null hypothesis that the estimate equals zero.

- 95% Confidence Interval: This is the Confidence Interval (CI) for an individual regression coefficient given the other independent variables are in the model

In this model, if an approach were to increase AGE by one year, the ordered log-odds of being in a higher SEVERITY (i.e., from minimal to moderate, or from moderate to severe) category would decrease by 0.021 while the other variables in the model are held constant (only one dependent variable is used here). The Wald test statistic for the independent variable is 4.661 with an associated p-value of 0.031. If the alpha level 0.05 is selected, the null hypothesis would be rejected and conclude that the regression coefficient for AGE has been found to be statistically significant in estimating SEVERITY given other variables, although none others in this model, are in the model. In other words, AGE is found statistically associated with SEVERITY. For ordinal logistic regression, the null hypothesis states that the location parameters (slope coefficients) are the same across response categories. The SPSS output shows that this null hypothesis cannot be rejected due to a high significance level 0.342 as shown in table of test of parallel lines.

**Table 4.5 Sample One: Test of parallel lines of ordinal logistic regression between AGE and SEVERITY**

Model	-2 Log Likelihood	Chi-Square	df	Sig.
Null Hypothesis	125.172			
General	124.269	.903	1	.342

- General: This table is the output that tests the proportional odds assumption. This is commonly referred to as the test of parallel lines because the null hypothesis states that the slope coefficients in the model are the same across response categories (and lines of the same slope are parallel). Since the ordered logit model estimates one equation over all levels of the response variables, the test for proportional odds tests whether this one-equation model is valid. If a null hypothesis was rejected based on the significance of the Chi-Square statistic, it would conclude that ordered logit coefficients are not equal across the levels of the outcome, and a less restrictive model (i.e., multinomial logit model) may fit better. If the null hypothesis was failed to be rejected, the assumption would hold. The significance of Chi-Square statistic for this model is  $0.342 > 0.1$ , which implies that the ordinal logistic regression is appropriate for obtaining the relationship between AGE and SEVERITY.

Because this model is found statistically significant. The response Y in this study has three levels which are represented by 1, 2, and 3, and the associated probabilities are  $\pi_1$ ,  $\pi_2$ , and  $\pi_3$ . The relationship between AGE and SEVERITY for sample one can be described by the following equations:

$$\text{Logit} \frac{\pi_1}{1 - \pi_1} = \text{Logit} \frac{\pi_1}{\pi_2 + \pi_3} = -2.349 - 0.021AGE \quad (4.1)$$

$$\text{Logit} \frac{\pi_1 + \pi_2}{1 - (\pi_1 + \pi_2)} = \text{Logit} \frac{\pi_1 + \pi_2}{\pi_3} = -0.312 - 0.021AGE \quad (4.2)$$

Therefore,



$$\pi_1 = \frac{\exp(-2.349 - 0.021AGE)}{1 + \exp(-2.349 - 0.021AGE)} \quad (4.3)$$

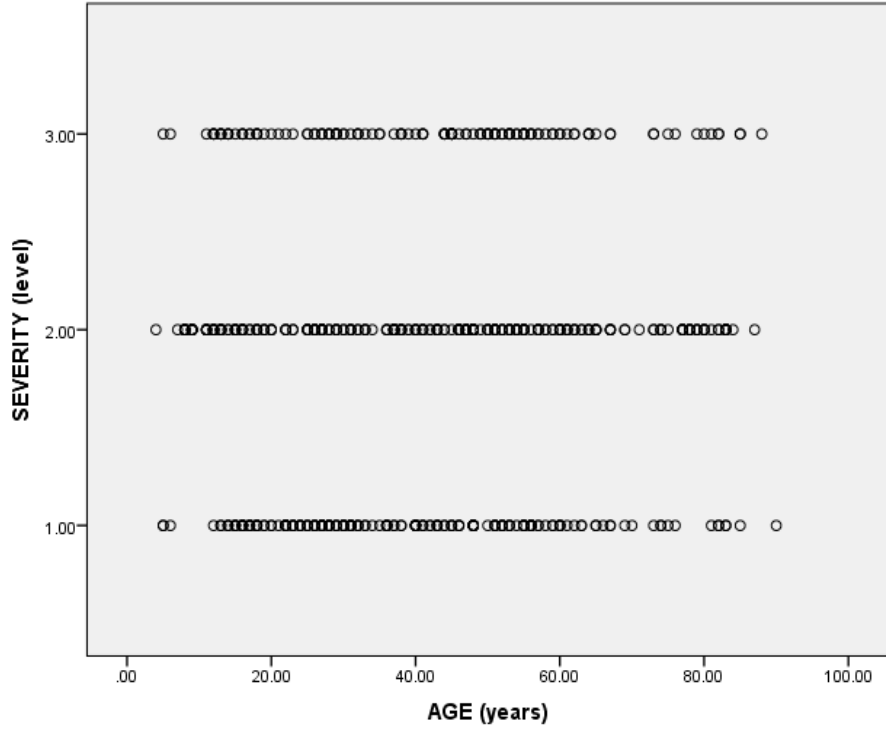
$$\pi_2 = \frac{\exp(-2.349 - 0.021AGE)}{1 + \exp(-2.349 - 0.021AGE)} - \pi_1 \quad (4.4)$$

$$\pi_3 = 1 - \pi_1 - \pi_2 \quad (4.5)$$

By using equations from 4.1 to 4.5, it is able to compute the probability that each settlement category may occur solely based on the independent variable AGE.

#### **4.1.2 Sample Two**

Had the dependent variable been continuous rather than ternary, a scatterplot of the SEVERITY versus the AGE was created for sample two to provide a descriptive impression of the nature and strength of any relationship between the outcome and the independent variable. The same as sample one, no clear relationship could be revealed by this scatterplot.

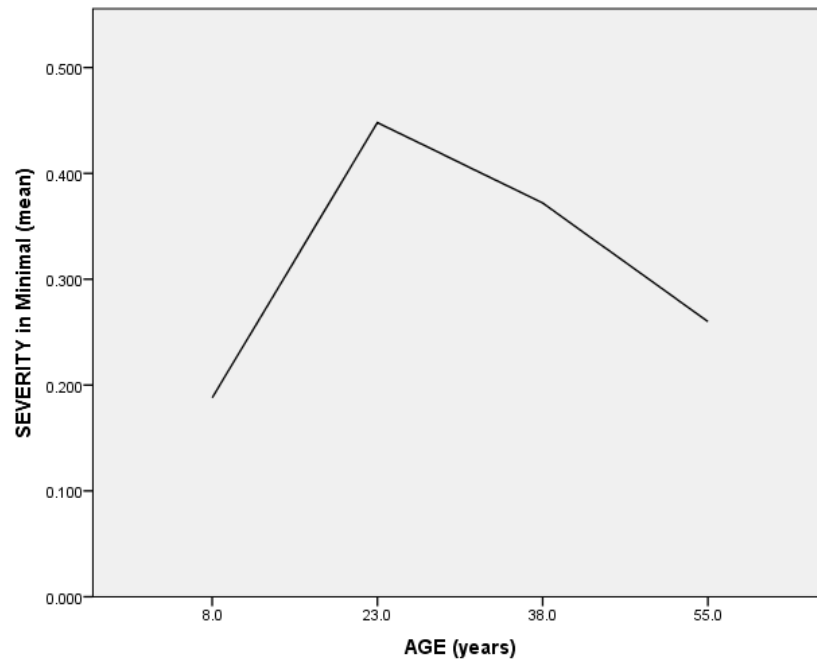


**Figure 4.4 Sample Two: Scatterplot of approach settlement levels by approach age**

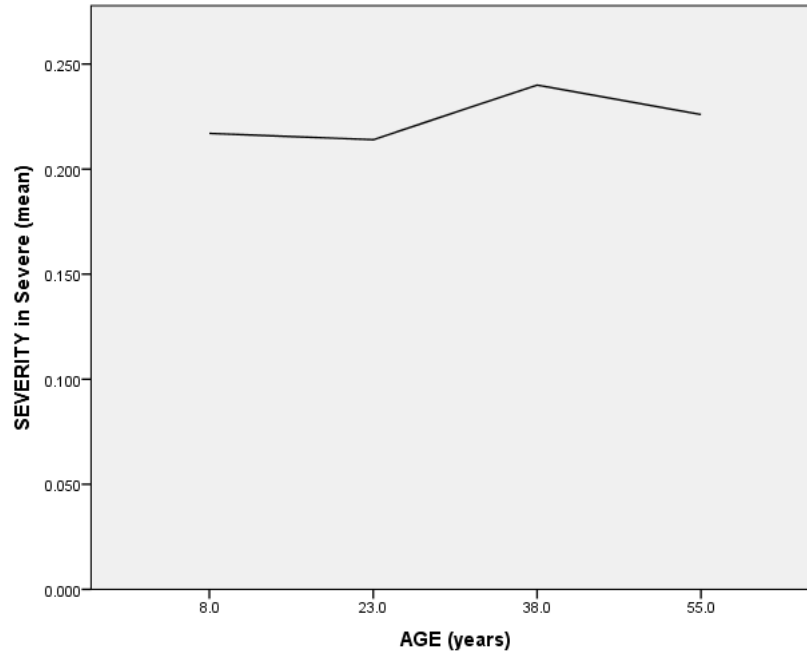
Then the data in the sample two was divided into four age groups to obtain the relationship between the percentage of SEVERITY with minimal (severe) and AGE. The result is shown in Table 4.6. Figure 4.5 shows that the proportion of approaches with minimal settlement increases as approach age increases within 30 years, while the proportion of approaches with minimal settlement decreases as approach age increases after 30 years. Figure 4.6 shows that the proportion of approaches with severe settlement varies slightly among different age groups. The changing tendency of the percentage of approaches in sample two with minimal settlement shows a contradictory trend with the sample one.

**Table 4.6 Sample Two: Frequency table of age group (AGEG) by SEVERITY**

Age group (year)	Severity			Total	Mean	
	Minimal	Moderate	Severe		Minimal	Severe
0~15	13	41	15	69	0.188	0.217
16~30	65	49	31	145	0.448	0.214
31~45	45	47	29	121	0.372	0.240
Above 45	69	136	60	265	0.260	0.226
	192	273	135	600		



**Figure 4.5 Sample One: Plot of the percentage of approaches with minimal SEVERITY in each age group**



**Figure 4.6 Sample Two: Plot of the percentage of approaches with severe SEVERITY in each age group**

An ordinal regression was also carried out to obtain the functional relationship between the settlement severity and the approach age for sample two. The p-value (Sig.) from the output of model fitting information is larger than 0.05 and indicates that this model is not better than a null model without any predictors. For sample two, if an approach were to increase AGE by one year, the ordered log-odds of being in a higher SEVERITY category would increase by 0.006 while the other variables in the model are held constant. The Wald test statistic for the variable AGE is 2.221 with an associated p-value of 0.136. If the alpha level 0.05 is selected, the null hypothesis cannot be rejected. In other words, the approach age is not statistically significant associated with settlement levels. The analysis of test of parallel lines indicates that the proportional odds assumption is not violated and the method of ordinal regression for identifying the relationship between the settlement severity and the approach age is applicable. If the

proportional odds assumption was violated, a less restrictive model, such as the multinomial logistic regression, would be used. Since this model cannot fit the relationship between AGE and SEVERITY well for sample two, no equations would be given to describe their functional relationship.

**Table 4.7 Sample Two: Model fitting information of ordinal logistic regression between AGE and SEVERITY**

Model	-2 Log Likelihood	Chi-Square	df	Sig.
Intercept Only	496.710			
Final	494.397	2.313	1	.128

Note: Link function: Logit

**Table 4.8 Sample Two: Parameter estimates of ordinal logistic regression between AGE and SEVERITY**

		Estimate	Std. Error	Wald	df	Sig.	95% Confidence Interval	
							Lower Bound	Upper Bound
Threshold	[SEVERITY = 1.00]	-.524	.176	8.910	1	.003	-.868	-.180
	[SEVERITY = 2.00]	1.473	.186	62.806	1	.000	1.108	1.837
Location	AGE	.006	.004	2.221	1	.136	-.002	.013

**Table 4.9 Sample Two: Test of parallel lines of ordinal logistic regression between AGE and SEVERITY**

Model	-2 Log Likelihood	Chi-Square	df	Sig.
Null Hypothesis	494.397			
General	492.923	1.474	1	.225

Note: The null hypothesis states that the location parameters (slope coefficients) are the same across response categories.

#### **4.1.3 Conclusions**

The ordinal regression is applicable to explore the relationship between the settlement severity and the approach age. The result of sample one is not exactly the same with sample two. Sample one shows that AGE is statistically significant while sample two is not. Furthermore, the changing tendency of proportion (mean) of approaches with minimal settlement of the sample one is different with sample two. This divergence could be explained from several aspects: (1) two samples were based on different evaluation criteria of settlement severity with different sample size, (2) the outcome of the sample one was determined by local bridge engineers depending on their work experience that may be varied by person to person, and (3) the predictor variable AGE was classified as continuous variable for both ordinal logistic regressions, however, 55.3% of cells (i.e., dependent variable levels by observed combinations of predictor variable values) with zero frequencies for sample one, which may lead to unstable model for sample one.

Most types of logistic regression, using maximum likelihood estimates, require sufficient sample size. How big is big is a topic of some debate. But a check for empty or small cells by doing a crosstab between categorical independent variables and the outcome

variable is needed. If a cell has very few cases, the model may become unstable or it might not run at all. In this sense, the output of sample two has a higher reliability than model of sample one while the sample two concludes that AGE is not significantly associated with SEVERITY. A comprehensive analysis including all predictor variables is absolutely needed for both samples to obtain a more complete answer for the relationship between the settlement severity and the approach age.

## **4.2 Bridge Length and Width**

No previous studies had listed bridge length or width as an important factor that may affect the bridge end settlement between the abutment and the roadway. This study collected the bridge length and width as the basic information as well as other important factors mentioned in other literatures. The variables LENGTH and WIDTH were treated the same as AGE. A descriptive relationship was depicted firstly, and then the changing tendency of proportion (mean) of approaches with minimal or severe settlement was illustrated. Finally, statistical package SPSS was used to obtain any functional relationship between the bridge length (width) and the settlement severity.

### **4.2.1 Sample One**

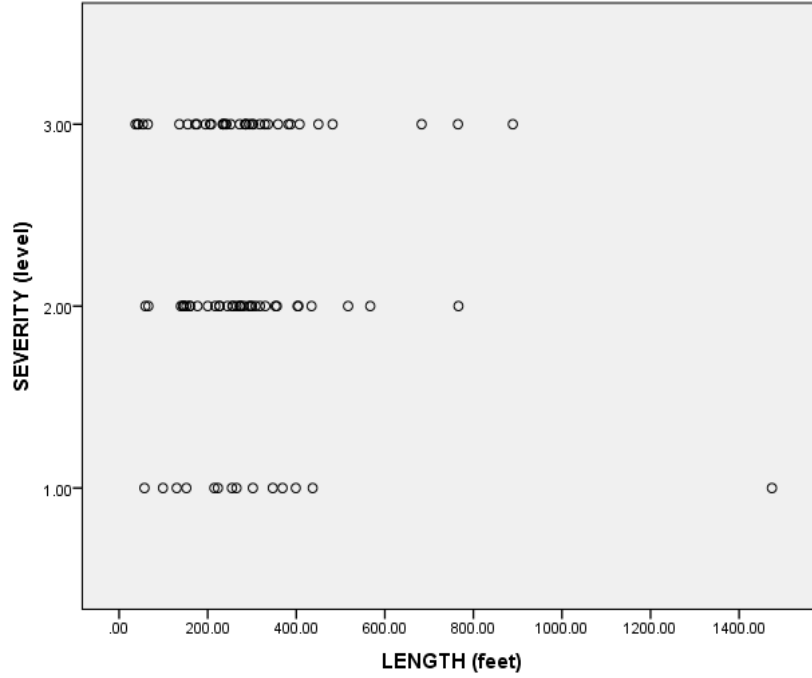
Scatterplots of the outcome versus the bridge length and width are given in Figure 4.7 and Figure 4.8, respectively. The approaches with bridge length between 100 and 300 feet seem to have been experiencing a higher severity level compared to the approaches with bridge length longer than 400 feet. But no distinct relationship between the approach settlement and the bridge length (width) could be perceived solely based on these scatterplots.

In order to further explore the relationship between LENGTH and SEVERITY, length group (LENGTHG) was created by dividing length into several groups shown in Table 4.10. Table 4.10 contains, for each length group, the frequency of occurrence of each settlement severity, as well as the presence of the percent with Minimal or Severe. Figure 4.9 presents a plot of the percent of approaches with minimal settlement versus the midpoint of each length interval. It shows that the approaches with bridge length between 300 and 400 feet have the highest proportion in minimal settlement while the approaches with bridge length between 200 and 300 feet have the lowest proportion in minimal settlement. Similarly, the percent of approaches with severe settlement versus the midpoint of each length interval is given in Figure 4.10. The highest proportion of approaches in severe settlement falls in the range between 0 and 100 feet, while the lowest proportion of approaches in severe settlement lies in the range between 100 and 200 feet.

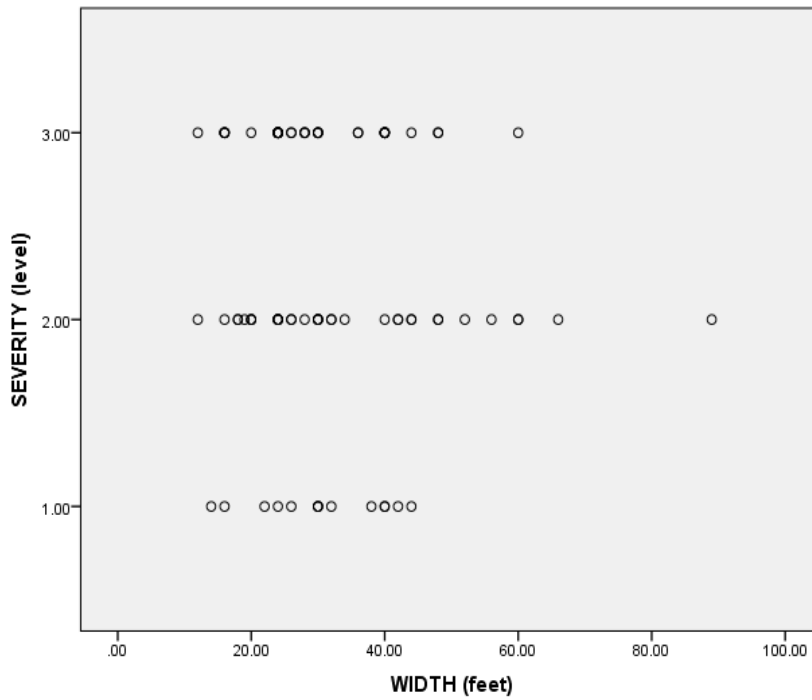
**Table 4.10 Sample One: Frequency table of length group (LENGTHG) by SEVERITY**

Length group (feet)	Severity			Total	Mean	
	Minimal	Moderate	Severe		Minimal	Severe
0~100	2	2	5	9	0.222	0.556
101~200	2	8	5	15	0.133	0.333
201~300	4	15	14	33	0.121	0.424
301~400	4	5	7	16	0.250	0.438
Above 400	2	6	6	14	0.143	0.429
Total	14	36	37	87		

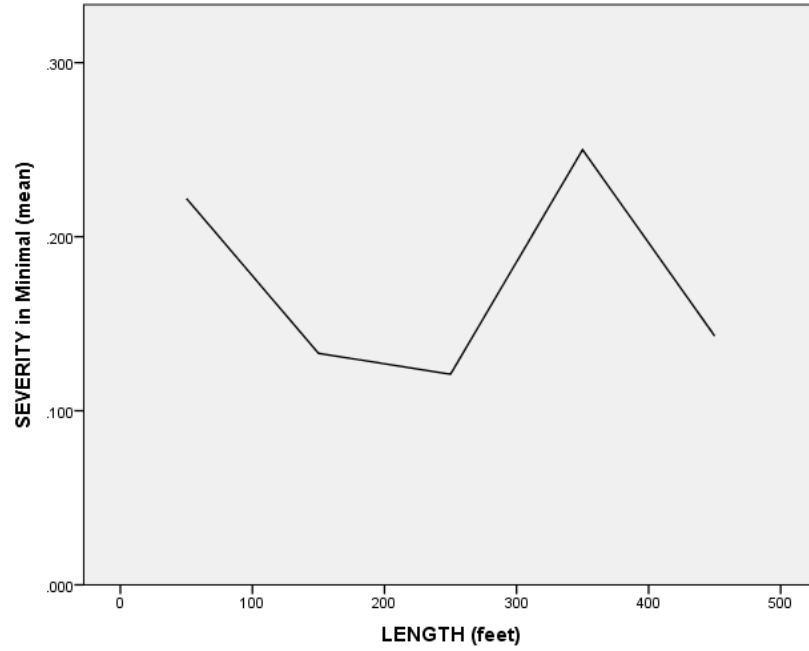




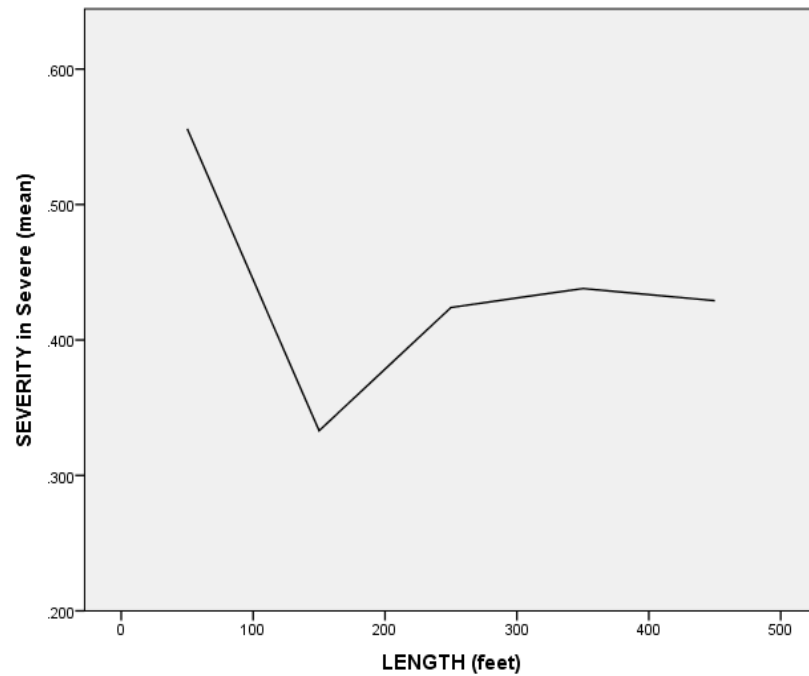
**Figure 4.7 Sample One: Scatterplot of approach settlement levels by bridge length**



**Figure 4.8 Sample One: Scatterplot of approach settlement levels by bridge width**



**Figure 4.9 Sample One: Plot of the percentage of approaches with minimal SEVERITY in each length group**

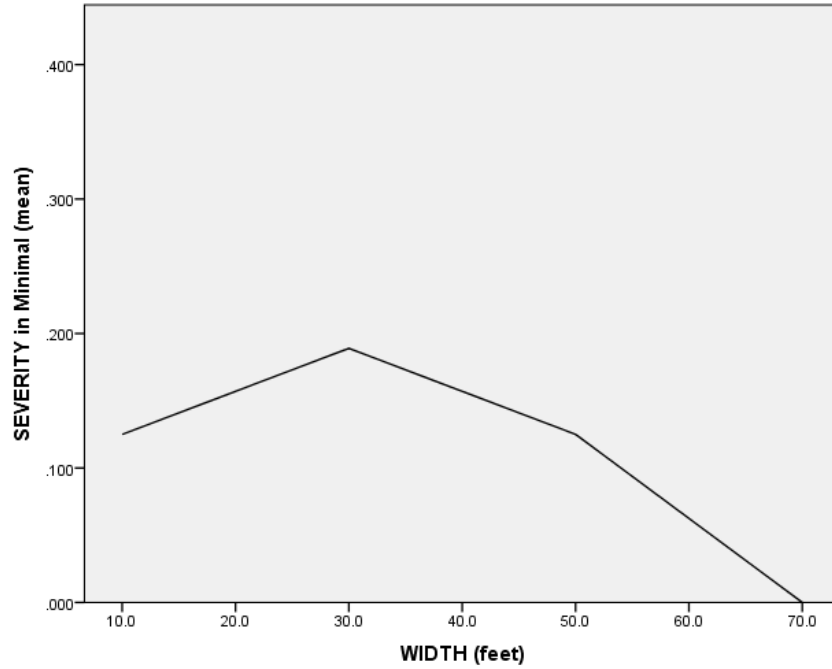


**Figure 4.10 Sample One: Plot of the percentage of approaches with severe SEVERITY in each length group**

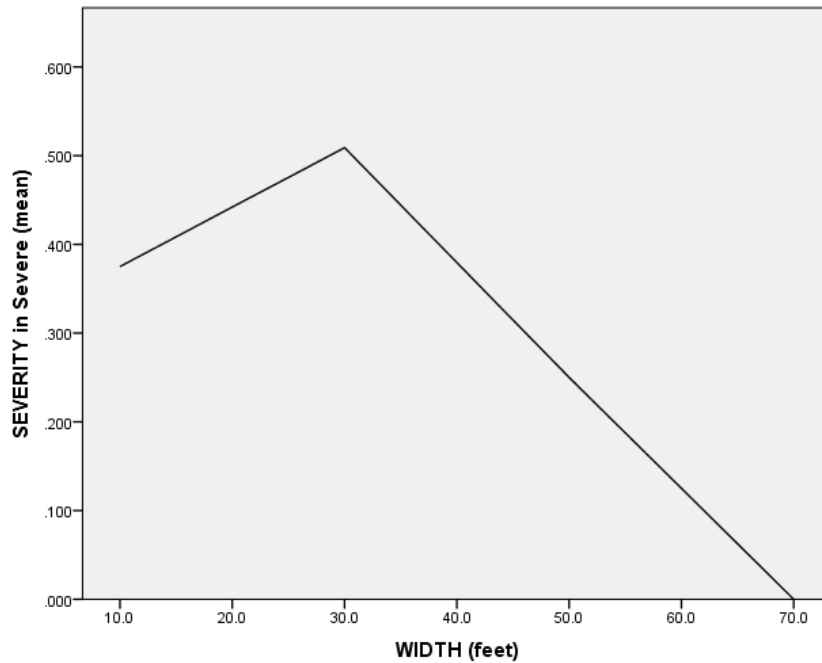
The frequency table of width group (WIDTHG) by SEVERITY is shown in Table 4.11. From Figure 4.11 and 4.12, it can be seen that both the proportions of approaches with minimal severity and severe severity increase as width increases before 40 feet and then decrease as width increases after 40 feet.

**Table 4.11 Sample One: Frequency table of width group (WIDTHG) by SEVERITY**

Width Group (feet)	Severity			Total	Mean	
	Minimal	Moderate	Severe		Minimal	Severe
0~20	2	8	6	16	0.125	0.375
21~40	10	16	27	53	0.189	0.509
41~60	2	10	4	16	0.125	0.250
Above 60	0	2	0	2	0	0
Total	14	36	37	87		



**Figure 4.11 Sample One: Plot of the percentage of approaches with minimal SEVERITY in each width group**



**Figure 4.12 Sample One: Plot of the percentage of approaches with severe SEVERITY in each width group**

Then the ordinal regressions were conducted to identify the functional relationship between the bridge length (width) and the settlement severity. The results are shown in Table 4.12 ~ Table 4.17. The p-value for the model of the relationship between LENGTH and SEVERITY is 0.630, which implies that this model is not better than a null model without any predictors and cannot fit the relationship well. The LENGTH is not statistically significant related with SEVERITY as the regression coefficient of length is 0.597. Likewise, the relationship between WIDTH and SEVERITY is also not statistically significant due to a high p-value 0.396. By examining the output of test of parallel lines for both the relationships between LENGTH and SEVERITY and between WIDTH and SEVERITY, the method of ordinal regression is applicable because the null hypothesis states that the slope coefficients in the model are the same across response categories cannot be rejected. Because these two models can not reflect the relationships in this section very well, the expressions of these two models in equations are not given here.

**Table 4.12 Sample One: Model fitting information of ordinal logistic regression between LENGTH and SEVERITY**

Model	-2 Log Likelihood	Chi-Square	df	Sig.
Intercept Only	173.194			
Final	173.563	0.231	1	.630

**Table 4.13 Sample One: Parameter estimates of ordinal logistic regression between Length and SEVERITY**

		Estimate	Std. Error	Wald	df	Sig.	95% Confidence Interval	
							Lower Bound	Upper Bound
Threshold	[SEVERITY = 1.00]	-1.807	.420	18.461	1	.000	-2.631	-.983
	[SEVERITY = 2.00]	.150	.362	.173	1	.678	-.558	.859
Location	LENGTH	-.001	.001	.280	1	.597	-.002	.001

**Table 4.14 Sample One: Test of parallel lines of ordinal logistic regression between LENGTH and SEVERITY**

Model	-2 Log Likelihood	Chi-Square	df	Sig.
Null Hypothesis	173.563			
General	172.842	.721	1	.396

**Table 4.15 Sample One: Model fitting information of ordinal logistic regression  
between WIDTH and SEVERITY**

Model	-2 Log Likelihood	Chi-Square	df	Sig.
Intercept Only	90.944			
Final	90.329	.615	1	.433

**Table 4.16 Sample One: Parameter estimates of ordinal logistic regression between  
WIDTH and SEVERITY**

		Estimate	Std. Error	Wald	df	Sig.	95% Confidence Interval	
							Lower Bound	Upper Bound
Threshold	[SEVERITY = 1.00]	-2.021	.579	12.199	1	.000	-3.155	-.877
	[SEVERITY = 2.00]	-.057	.517	.012	1	.913	-1.091	.976
Location	WIDTH	-.011	.015	.534	1	.465	-.041	0.019

**Table 4.17 Sample One: Test of parallel lines of ordinal logistic regression between WIDTH and SEVERITY**

Model	-2 Log Likelihood	Chi-Square	df	Sig.
Null Hypothesis	90.329			
General	88.596	1.733	1	.188

#### **4.2.2 Sample Two**

The analysis process for sample one was iterated in this section to analyze the relationship between the bridge length (width) and the settlement severity for sample two. The proportion of approaches with minimal settlement versus the midpoint of each length interval of sample two shows similar changing trend with sample one: the proportion of severity in minimal increases as the length increases at first, then decreases as the length increases in the middle, and then increases as the length increases after 400 feet. While the proportion of approaches with severe settlement changes within a small degree as the length varies.

The percentage of approaches with minimal SEVERITY in each width group of sample two increases as the bridge width increases if the bridge width less than 20 feet, and then decreases if the bridge width continues to increase. This changing trend is also similar with sample one.

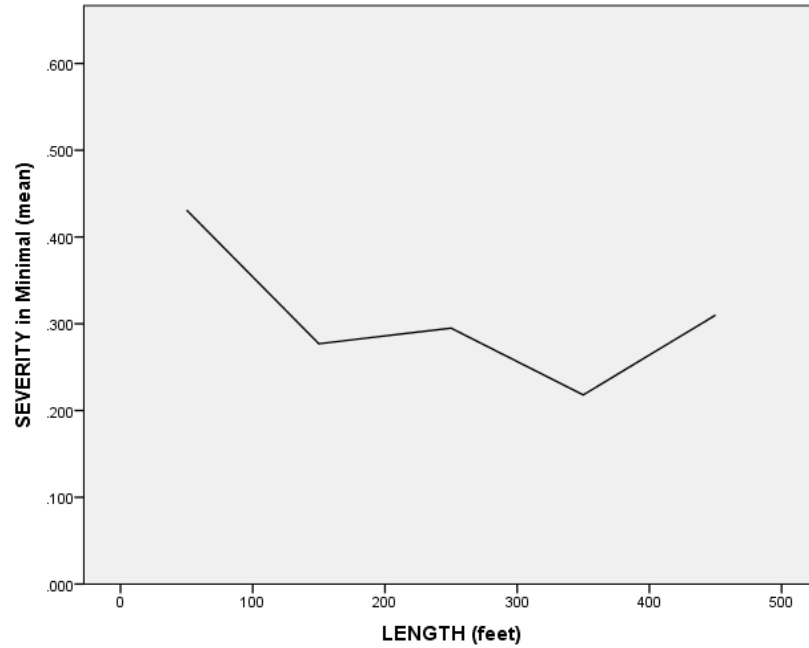


**Table 4.18 Sample Two: Frequency table of length group (LENGTHG) by SEVERITY**

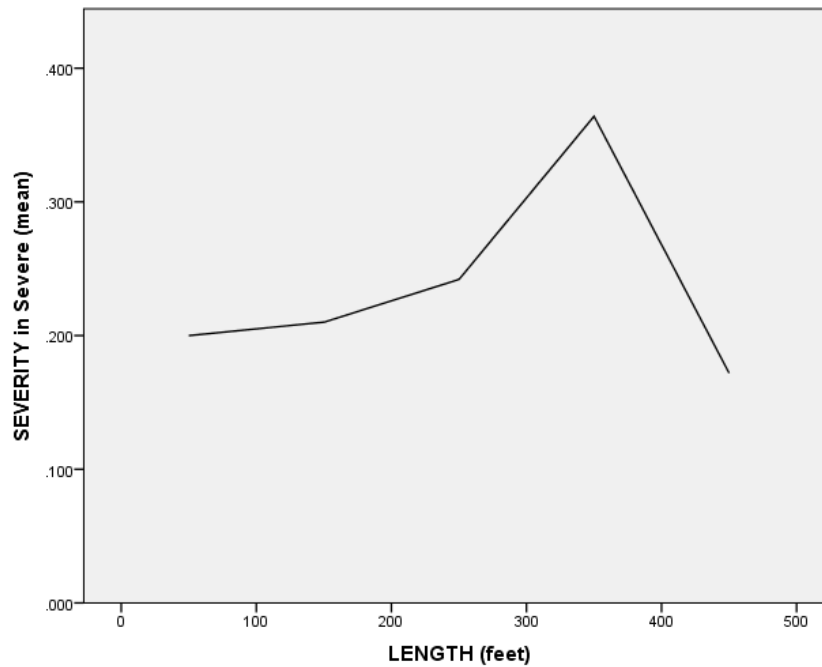
Length group (feet)	Severity			Total	Mean	
	Minimal	Moderate	Severe		Minimal	Severe
0~100	69	59	32	160	0.431	0.200
101~200	54	100	41	195	0.277	0.210
201~300	39	61	32	132	0.295	0.242
301~400	12	23	20	55	0.218	0.364
Above 400	18	30	10	58	0.310	0.172
	192	273	135	600		

**Table 4.19 Sample Two: Frequency table of width group (WIDTHG) by SEVERITY**

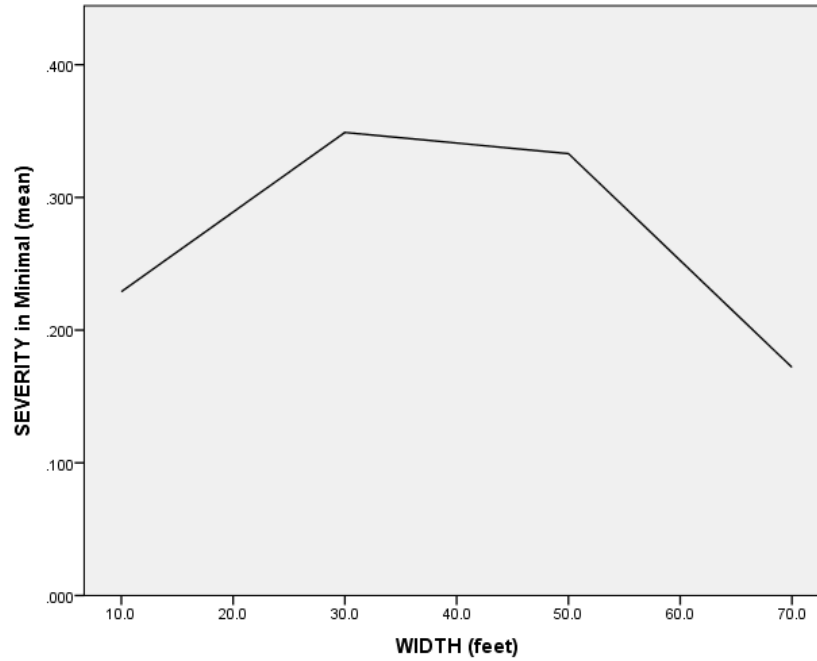
Width Group (feet)	Severity			Total	Mean	
	Minimal	Moderate	Severe		Minimal	Severe
0~20	11	24	13	48	0.229	0.271
21~40	141	177	86	404	0.349	0.213
41~60	30	41	19	90	0.333	0.211
Above 60	10	31	17	58	0.172	0.293
Total	192	273	135	600		



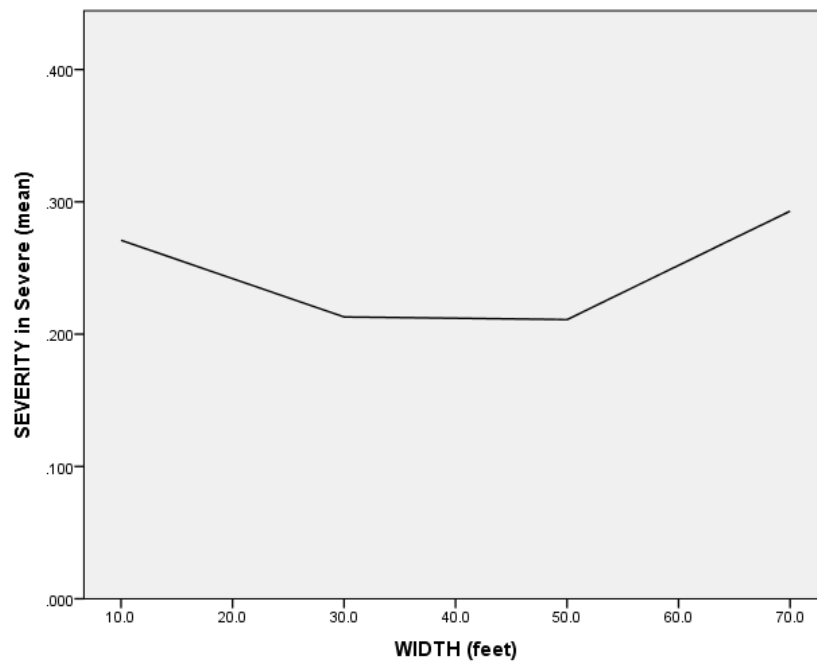
**Figure 4.13 Sample Two: Plot of the percentage of approaches with minimal SEVERITY in each length group**



**Figure 4.14 Sample Two: Plot of the percentage of approaches with severe SEVERITY in each length group**



**Figure 4.15 Sample Two: Plot of the percentage of approaches with minimal SEVERITY in each width group**



**Figure 4.16 Sample Two: Plot of the percentage of approaches with severe SEVERITY in each width group**

The following is the output from the statistical package SPSS. Table 4.20 shows that the model between LENGTH and SEVERITY is not statistically significant and cannot reflect the relationship well. However, the p-value of the model between WIDTH and SEVERITY is 0.02 that is smaller than 0.05, which indicates this model can fit the relationship between the bridge with and the settlement severity well. The regression coefficient 0.003 reveals that there is an association between WIDTH and SEVERITY for sample two. This relationship can be expressed in the following equations:

$$\text{Logit} \frac{\pi_1}{1 - \pi_1} = \text{Logit} \frac{\pi_1}{\pi_2 + \pi_3} = -0.355 + 0.011\text{WIDTH} \quad (4.6)$$

$$\text{Logit} \frac{\pi_1 + \pi_2}{1 - (\pi_1 + \pi_2)} = \text{Logit} \frac{\pi_1 + \pi_2}{\pi_3} = 1.661 + 0.011\text{WIDTH} \quad (4.7)$$

The probability relationship between different settlement levels are shown in equation 4.3, 4.4, and 4.5. By combining the equations 4.6 and 4.7, the probability that each settlement category may occur could be computed.

**Table 4.20 Sample Two: Model fitting information of ordinal logistic regression between LENGTH and SEVERITY**

Model	-2 Log Likelihood	Chi-Square	df	Sig.
Intercept Only	893.936			
Final	891.874	2.061	1	.151

**Table 4.21 Sample Two: Parameter estimates of ordinal logistic regression between  
LENGTH and SEVERITY**

		Estimate	Std. Error	Wald	df	Sig.	95% Confidence Interval	
							Lower Bound	Upper Bound
Threshold	[SEVERITY = 1.00]	-.660	.111	35.107	1	.000	-.878	-.442
	[SEVERITY = 2.00]	1.336	.123	118.743	1	.000	1.096	1.577
Location	LENGTH	.000	.000	1.760	1	.185	.000	.001

**Table 4.22 Sample Two: Test of parallel lines of ordinal logistic regression between  
LENGTH and SEVERITY**

Model	-2 Log Likelihood	Chi-Square	df	Sig.
Null Hypothesis	891.874			
General	888.733	3.141	1	.076

**Table 4.23 Sample Two: Model fitting information of ordinal logistic regression  
between WIDTH and SEVERITY**

Model	-2 Log Likelihood	Chi-Square	df	Sig.
Intercept Only	343.809			
Final	334.022	9.787	1	.002

**Table 4.24 Sample Two: Parameter estimates of ordinal logistic regression between  
WIDTH and SEVERITY**

		Estimate	Std. Error	Wald	df	Sig.	95% Confidence Interval	
							Lower Bound	Upper Bound
Threshold	[SEVERITY = 1.00]	-.355	.157	5.135	1	.023	-.662	-.048
	[SEVERITY = 2.00]	1.661	.172	93.352	1	.000	1.324	1.998
Location	WIDTH	.011	.004	9.025	1	.003	.004	.018

**Table 4.25 Sample Two: Test of parallel lines of ordinal logistic regression between WIDTH and SEVERITY**

Model	-2 Log Likelihood	Chi-Square	df	Sig.
Null Hypothesis	334.022			
General	331.729	2.293	1	.130

### 4.2.3 Conclusions

The ordinal regression results show that there is not significant relationship between the bridge length and the settlement severity both for sample one and sample two. The SPSS output shows that there is an association between WIDTH and SEVERITY for sample two, while no relationship exists for sample one. The statistical model of sample one cannot reflect the relationship between the bridge width and the settlement severity very well due to a little bit high model p-value  $0.151 > 0.05$ . But a significant relationship between WIDTH and SEVERITY is found if a sample has sufficient data. The functional relationship for sample two shows that for one unit increase in WIDTH, a 0.011 increase in the ordered log odds of being in a higher settlement level given all of the other variables in the model are held constant. This conclusion should be compare to the comprehensive model which is illustrated in the last section of this chapter.

### 4.3 Average Daily Traffic

The opinion on the relationship between the traffic volume and approach settlement is debatable. High volume traffic has been found to be a compelling reason for the formation of approach settlement (Wong and Small, 1994). On the one hand, Lenke (2006) concluded that bump severity was found to increase with vehicle velocity, vehicle weight, especially heavy truck traffic, and ADT. On the other hand, Bakeer (2005) noted that speed limit and traffic volume almost have no effect on the performance of bridge approaches. The relationship between ADT and Severity would be identified in this section.

#### 4.3.1 Sample One

It is not appropriate to process ADT as AGE because the variability in ADT is very considerable from several decades to hundreds of thousands. Therefore, no scatterplots or proportion changing tendency of approaches with different levels in different ADT were described here. The output from SPSS was used for inference the relationship between ADT and SEVERITY.

**Table 4.26 Sample One: Model fitting information of ordinal logistic regression between ADT and SEVERITY**

Model	-2 Log Likelihood	Chi-Square	df	Sig.
Intercept Only	170.786			
Final	170.221	.565	1	.452



**Table 4.27 Sample One: Parameter estimates of ordinal logistic regression between  
ADT and SEVERITY**

		Estimate	Std. Error	Wald	df	Sig.	95% Confidence Interval	
							Lower Bound	Upper Bound
Threshold	[SEVERITY = 1.00]	-1.764	.333	28.060	1	.000	-2.417	-1.111
	[SEVERITY = 2.00]	-.199	.258	.591	1	.442	-0.308	.705
Location	ADT	0.000	.000	.446	1	.504	-3.829E-5	1.833E-5

**Table 4.28 Sample One: Test of parallel lines of ordinal logistic regression between  
ADT and SEVERITY**

Model	-2 Log Likelihood	Chi-Square	df	Sig.
Null Hypothesis	170.221			
General	167.055	.3166	1	.075

Table 4.26 shows that the p-value of the model 0.452 lead to conclude that this model is not different with a null model. The regression coefficient for ADT is 0.504, which indicates ADT is not significantly related with SEVERITY. From Table 4.28, the null hypothesis that the slope coefficients in the model are the same across response

categories is violated if an alpha value 0.05 is specified. A less restrictive model (multinomial logistic regression) was used to verify the output from ordinal regression.

**Table 4.29 Sample One: Model fitting information of multinomial logistic regression between ADT and SEVERITY**

Model	Model Fitting Criteria	Likelihood Ratio Tests		
	-2 Log Likelihood	Chi-Square	df	Sig.
Intercept Only	170.786			
Final	166.511	4.275	2	.118

**Table 4.30 Sample One: Parameter estimates of multinomial logistic regression between ADT and SEVERITY**

SEVERITY		B	Std. Error	Wald	df	Sig.	Exp(B)	95% Confidence Interval for Exp(B)	
								Lower Bound	Upper Bound
1.00	Intercept	-.970	.404	5.764	1	.016			
	ADT	.000	.000	.000	1	.996	1.000	1.000	1.000
2.00	Intercept	-.373	.305	1.500	1	.221			
	ADT	.000	.000	2.706	1	.100	1.000	1.000	1.000

Note: The reference category is 3.00

- B: These are the estimated multinomial logistic regression coefficients for the models. An important feature of the multinomial logit model is that it estimates  $k-1$  models, where  $k$  is the number of levels of the outcome variable. In this instance, SPSS is treating the Severe as the referent group and therefore estimated a model for Minimal relative to Severe and a model for Moderate relative to Severe.
- Exp (B): These are the odds ratios for the predictors. They are the exponentiation of the coefficients. The odds ratio of a coefficient indicates how the risk of the outcome falling in the comparison group compared to the risk of the outcome falling in the referent group changes with the variable in question. An odds ratio  $> 1$  indicates that the risk of the outcome falling in the comparison group relative to the risk of the outcome falling in the referent group increases as the variable increases. In other words, the comparison outcome is more likely to occur. An odds ratio  $< 1$  indicates that the risk of the outcome falling in the comparison group relative to the risk of the outcome falling in the referent group decreases as the variable increases

Therefore, since the parameter estimates are relative to the referent group, the standard interpretation of the multinomial logistic regression is that for a unit change in the predictor variable, the logit of outcome SEVERITY relative to the referent group is expected to change by its respective parameter estimate (which is in log-odds units) given the variables in the model are held constant. In this model, (1) Minimal relative to Severe: for a one unit increase in ADT for Minimal relative to Severe given the other variables in the model are held constant, the multinomial log-odds of becoming Minimal

to Severe would be expected to be unchanged; (2) Moderate relative to Severe: for a one unit increase in ADT for moderate relative to Severe given the other variables in the model are held constant, the multinomial log-odds of becoming Moderate to Severe would be expected to be unchanged.

For Minimal relative to Severe, the Wald test statistic for the predictor ADT is 0 with an associated p-value of 0.996. Therefore, it would fail to reject the null hypothesis and conclude that for Minimal relative to Severe, the regression coefficient for ADT has not been found to be statistically different from zero. The same conclusions would be expected for Moderate relative to Severe.

Both ordinal and multinomial logistic regression show that there is no significant association between ADT and SEVERITY. But this conclusion should be verified by creating a comprehensive model considering all other predictors.

#### **4.3.2 Sample Two**

An ordinal regression was carried out at first and the output is shown in Table 4.31 ~ Table 4.33. Even though the model from the ordinal regression seems to fit the relationship well, the test of parallel lines shows that the null hypothesis that the slope coefficients in the model are the same across response categories is violated. Multinomial logistic regression was conducted as another analysis to compare with ordinal regression, and the results are shown in Table 4.34 and Table 4.35.

**Table 4.31 Sample Two: Model fitting information of ordinal logistic regression  
between ADT and SEVERITY**

Model	-2 Log Likelihood	Chi-Square	df	Sig.
Intercept Only	1234.091			
Final	1192.759	41.332	1	.000

**Table 4.32 Sample Two: Parameter estimates of ordinal logistic regression between  
ADT and SEVERITY**

		Estimate	Std. Error	Wald	df	Sig.	95% Confidence Interval	
							Lower Bound	Upper Bound
Threshold	[SEVERITY = 1.00]	-.520	.096	29.317	1	.000	-.709	-.332
	[SEVERITY = 2.00]	1.572	.116	183.621	1	.000	1.344	1.799
Location	ADT	3.322E-5	6.180E-6	28.903	1	.000	2.111E-5	4.534E-5

**Table 4.33 Sample Two: Test of parallel lines of ordinal logistic regression between  
ADT and SEVERITY**

Model	-2 Log Likelihood	Chi-Square	df	Sig.
Null Hypothesis	1192.759			
General	1185.952	6.807	1	.009

**Table 4.34 Sample Two: Model fitting information of multinomial logistic regression  
between ADT and SEVERITY**

Model	Model Fitting Criteria			Likelihood Ratio Tests		
	AIC	BIC	-2 Log Likelihood	Chi-Square	df	Sig.
Intercept Only	1238.091	1246.885	1234.091			
Final	1194.964	1212.552	1186.964	47.127	2	.000

- AIC: This is the Akaike information criterion.
- BIC: This is the Bayesian information criterion.

**Table 4.35 Sample Two: Parameter estimates of multinomial logistic regression  
between ADT and SEVERITY**

SEVERITY		B	Std. Error	Wald	df	Sig.	Exp(B)	95% Confidence Interval for Exp(B)	
								Lower Bound	Upper Bound
1.00	Intercept	.852	.141	36.785	1	.000			
	ADT	.000	.000	24.038	1	.000	1.000	1.000	1.000
2.00	Intercept	.905	.123	54.330	1	.000			
	ADT	.000	.000	10.356	1	.001	1.000	1.000	1.000

Note: The reference category is 3.

**Table 4.36 Sample Two: Classification table of multinomial logistic regression  
between ADT and SEVERITY**

Observed	Predicted			
	1.00	2.00	3.00	Percent Correct
1.00	0	191	1	0.0%
2.00	0	267	6	97.8%
3.00	0	122	13	9.6%
Overall Percentage	0.0%	96.7%	3.3%	46.7%

Table 4.36 indicates this multinomial logit model is statistically significant and fits the relationship well. For Minimal relative to Severe, the Wald test statistic for the predictor ADT is 24.038 with an associated p-value of 0.0001. Therefore, the null hypothesis would be rejected and conclude that for Minimal relative to Severe, the regression coefficient for ADT has been found to be statistically different from zero. The same conclusions would be expected for Moderate relative to Severe.

### **4.3.3 Conclusions**

The test of parallel lines of ordinal logistic regression between ADT and SEVERITY has shown that the null regression that the slope coefficients in the model are the same across response categories is violated both for sample one and sample two. Method of multinomial logistic regression was used to obtain the relationship between ADT and SEVERITY. The analysis for sample one shows the model cannot reflect the relationship between ADT and SEVERITY with an associated model p-value around 0.1. While the analysis for sample two demonstrates that ADT is statistically significant for the model. The table of parameter estimates for sample two shows that a 0.00003 increase in the ordered log odds of being in a higher level of settlement for a one unit increase in ADT, which means the higher of settlement level may occur as the ADT is larger.

The biggest difference between these two samples are data size. Therefore, this study believes that there is an association between ADT and SEVERITY given sufficient sample size. This conclusion should be compared to the conclusions from the comprehensive model taking all other predictors into account. Table 4.36 gives the classification table of multinomial logistic regression between ADT and SEVERITY. The



overall (correct) percentage of predicting the settlement levels solely based on ADT is 46.7%, which is not an ideal predicted accuracy in engineering area.

#### **4.4 Approach Type**

Many researchers, Ha et al. (2002), Luna et al. (2003), White et al. (2005), Puppla et al. (2009), applied approach slabs on selected sites to connect roadway and bridges and practiced the bump problems at bridge ends that could be minimized when an approach slab is used. Investigations from Dopont and Allen (2002) and Briaud et al. (1997) have illustrated that approach slabs are widely perceived as successful when they are designed longer to span the problematic area and stronger to prevent cracking as well as the fact that good pavement joints lead into them. However, these conclusions were derived from a specific survey or field tests, no systematic statistical method has been used to verify the good performance of approach slabs in solving bump issues.

Concerning fewer approach slabs are used in Kentucky, this section intends to verify whether approach slabs are useful or not on mitigating bump problem based on the performance of approach slabs that have been constructed in Kentucky.

##### **4.4.1 Sample One**

Table 4.37 presents the statistics of sample one that was used to explore the relationship between approach type and differential settlement scale. A mosaic plot (Figure 4.17) was created to explore the distribution of a categorical (nominal or ordinal) variable SEVERITY across the levels of a second categorical variable APPT. A mosaic plot is divided into rectangles, so that the area of each rectangle is proportional to the

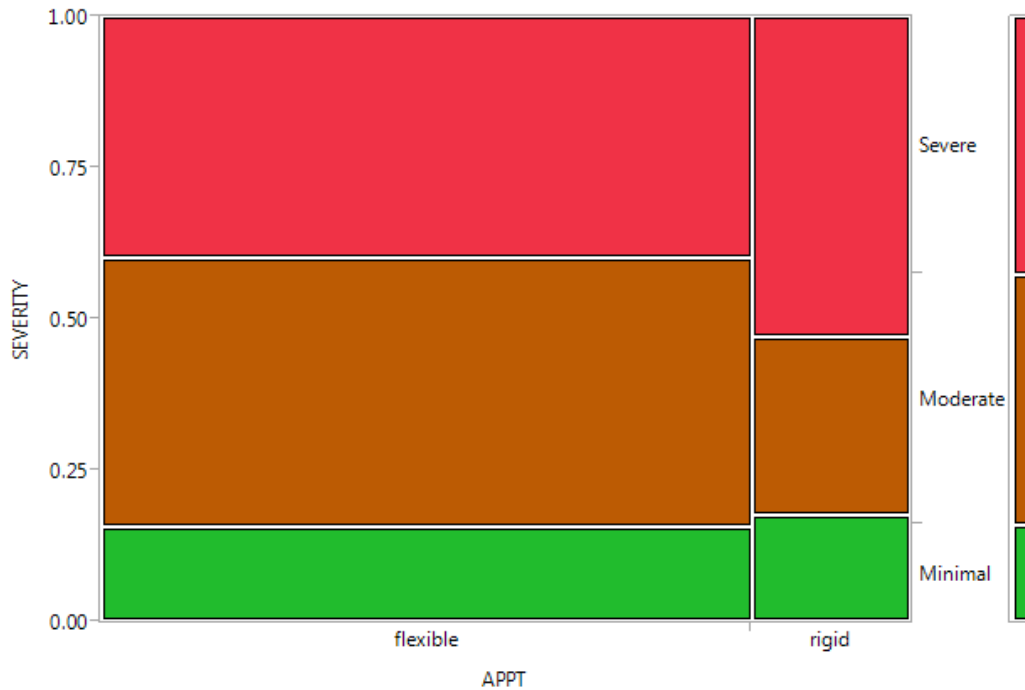
populations of the Y variable in each level of the x variable. The larger the rectangle area, the greater number of count data in it. Note the following about Figure 4.17:

- The proportions on the x-axis represent the number of observations for each level of the x variable, which is approach type (APPT).
- The proportions on the y-axis at right represent the overall proportions of Minimal, Moderate, and Severe settlements for the combined levels (All different approach types).
- The scale of the y-axis at left show the response probability, with the whole axis being a probability of one (representing the total sample).

The mosaic plot shows that the bridges with rigid approaches both have higher proportions of minimal settlement and severe settlement than the bridges with flexible approaches. While the bridges with flexible approaches have a higher proportion of moderate settlement.

**Table 4.37 Sample One: Frequency table of approach type (APPT) by SEVERITY**

Approach Type	Severity			Total
	Minimal	Moderate	Severe	
Flexible (0)	11	31	28	70
Rigid (1)	3	5	9	17
Total	14	36	37	87



**Figure 4.17 Sample One: Distribution of settlement levels across approach type**

A model was attempted to be created to describe the relationship between APPT and SEVERITY by SPSS, and the output is shown in Table 4.38 ~ Table 4.40. The results indicate that this model cannot fit the relationship well and there is no direct association between APPT and SEVERITY based on the regression coefficients of APPT for SEVERITY.

**Table 4.38 Sample One: Model fitting information of ordinal logistic regression between APPT and SEVERITY**

Model	-2 Log Likelihood	Chi-Square	df	Sig.
Intercept Only	15.796			
Final	15.309	.487	1	.485

**Table 4.39 Sample One: Parameter estimates of ordinal logistic regression between APPT and SEVERITY**

		Estimate	Std. Error	Wald	df	Sig.	95% Confidence Interval	
							Lower Bound	Upper Bound
Threshold	[SEVERITY = 1.00]	-1.957	.520	14.190	1	.000	-2.976	-.939
	[SEVERITY = 2.00]	.003	.468	.000	1	.995	-.913	.919
Location	[APPT=.00]	-.367	.516	.505	1	.477	-1.378	.645
	[APPT=1.00]	0 <sup>a</sup>	.	.	0	.	.	.

a. This parameter is set to zero because it is redundant.

**Table 4.40 Sample One: Test of parallel lines of ordinal logistic regression between APPT and SEVERITY**

Model	-2 Log Likelihood	Chi-Square	df	Sig.
Null Hypothesis	15.309			
General	14.461	.848	1	.357

Another method used to assess whether two categorical variables, APPT and SEVERITY, are independent or not is Chi-square test. The test procedure is appropriate when the following conditions are met:

1. The sampling method is simple random sampling.
2. The variables under study are each categorical.
3. If sample data are displayed in a contingency table, the expected frequency count for each cell of the table is at least 5.

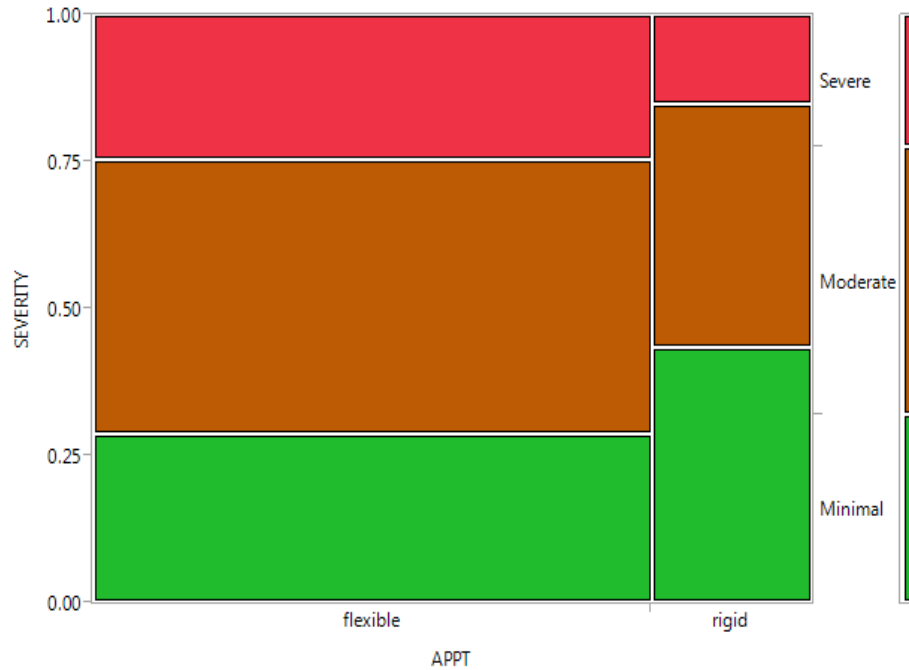
Sample one was created from a survey and cannot meet the condition 1. From contingency table 4.37, several cells have a small frequency count. Therefore, Chi-square test is not appropriate for sample one.

#### 4.4.2 Sample Two

A descriptive analysis was conducted by creating a frequency table of approach type by settlement levels and a mosaic plot of distribution of settlement levels across approach type. The mosaic plot reveals that the bridges with rigid approach tend to experience minimal settlement and have the lowest proportion of severe settlement. A measure to further explore the functional relationship between APPT and SEVERITY was analyzed by ordinal logistic regression in SPSS.

**Table 4.41 Sample Two: Frequency table of approach type (APPT) by SEVERITY**

Approach Type	Severity			Total
	Minimal	Moderate	Severe	
Flexible (0)	134	218	115	467
Rigid (1)	58	55	20	133
Total	192	273	135	600



**Figure 4.18 Sample Two: Distribution of settlement levels across approach type**

**Table 4.42 Sample Two: Model fitting information of ordinal logistic regression between APPT and SEVERITY**

Model	-2 Log Likelihood	Chi-Square	df	Sig.
Intercept Only	34.402			
Final	22.444	11.957	1	.001

**Table 4.43 Sample Two: Parameter estimates of ordinal logistic regression between APPT and SEVERITY**

		Estimate	Std. Error	Wald	df	Sig.	95% Confidence Interval	
							Lower Bound	Upper Bound
Threshold	[SEVERITY = 1.00]	-.265	.166	2.558	1	.110	-.591	.060
	[SEVERITY = 2.00]	1.756	.182	93.134	1	.000	1.399	2.113
Location	[APPT=.00]	.641	.186	11.835	1	.001	.276	1.007
	[APPT=1.00]	0 <sup>a</sup>	.	.	0	.	.	.

a. This parameter is set to zero because it is redundant

**Table 4.44 Sample Two: Test of parallel lines of ordinal logistic regression between APPT and SEVERITY**

Model	-2 Log Likelihood	Chi-Square	df	Sig.
Null Hypothesis	22.444			
General	22.422	.022	1	.881

This model can fit the relationship between APPT and SEVERITY well with a model p-value 0.001. The table of parameter estimates show the Wald test statistic for the predictor APPT is 11.835 with an associated p-value of 0.001. The null hypothesis that

the regression coefficient of APPT is zero given that the rest of the predictors are in the model (only one predictor in this model) would be rejected. In other words, APPT is statistically significant to this model and a relationship exists between APPT and SEVERITY.

To further verify there is a significant association between APPT and SEVERITY, Chi-square test has been undertaken. This method consists of four steps: (1) state the hypothesis, (2) formulate an analysis plan, (3) analyze sample data, and (4) interpret results.

1. State the hypothesis

The null hypothesis states that knowing the level of approach type is not helpful to predict the level of settlement severity. That is, the two categorical variables are independent.

*$H_0$ : Approach type and settlement severity are independent*

*$H_a$ : Approach type and settlement severity are not independent*

The alternative hypothesis is that knowing the approach type is helpful to predict the level of settlement severity. However, support for the alternative hypothesis suggests that APPT and SEVERITY are related, the relationship is not necessarily causal. In the sense that APPT “causes” the other.

2. Formulate an analysis plan

A significance level of 0.05 is specified and Chi-square test is used to examine whether these two variables are independent or not.

3. Analyze sample data



Using sample data, calculate the degrees of freedom, expected frequencies, test statistic, and the P-value associated with the test statistic.

Degrees of freedom: The degrees of freedom (DF) is equal to:

$$DF = (r - 1) * (c - 1) \quad (4.8)$$

where  $r$  is the number of levels for one categorical variable, and  $c$  is the number of levels for the other categorical variable. In this case, DF is equal to 2.

Expected frequencies: The expected frequency counts are computed separately for each level of one categorical variable at each level of the other categorical variable. Compute  $r * c$  expected frequencies by using the following equation.

$$E_{r,c} = (n_r * n_c) / n \quad (4.9)$$

where  $E_{r,c}$  is the expected frequency count for level of  $r$  of APPT and level  $c$  of SEVERITY,  $n_r$  is the total number of sample observations at level  $r$  of APPT,  $n_c$  is the total number of sample observations at level  $c$  of SEVERITY, and  $n$  is the total sample size. Table 4.45 shows the observed frequencies and expected frequencies.

**Table 4.45 Sample Two: APPT VS. SEVERITY cross tabulation**

			SEVERITY			Total
			Minimal	Moderate	Severe	
APPT	Flexible	Count	134	218	115	467
		Expected Count	149.4	212.5	105.1	467.0
	Rigid	Count	58	55	20	133
		Expected Count	42.6	60.5	29.9	133.0
Total		Count	192	273	135	600
		Expected Count	192.0	273.0	135.0	600.0

Test statistic: The test statistic is a Chi-square random variable ( $\chi^2$ ) defined by the following equation.

$$X^2 = \sum [(O_{r,c} - E_{r,c})^2 / E_{r,c}] \quad (4.10)$$

where  $O_{r,c}$  is the observed frequency count at level  $r$  of APPT and level  $c$  of SEVERITY. The test statistic in this case is 12.01. The p-value is the probability that a Chi-square statistic having two degrees of freedom is more extreme than 12.01. By using the Chi-square Distribution Calculator to find  $P(\chi^2 > 12.01) = 0.002$ .

P-value: The P-value is the probability of observing a sample statistic as extreme as the test statistic. Table 4.46 presents the result of Chi-square test using SPSS, which is the same with the result calculated by using Chi-square Distribution Calculator.

**Table 4.46 Sample Two: Chi-square test for APPT VS. SEVERITY**

	Value	df	Asymp. Sig. (2-sided)
Pearson Chi-Square	12.072	2	.002
Likelihood Ratio	11.980	2	.003
Linear-by-Linear Association	11.577	1	.001
N of Valid Cases	600		

4. Interpret results

Since the p-value (0.002) is much smaller than the significance level (0.05), we cannot accept the null hypothesis. Thus, 99.8% probability to conclude that there is a correlation between APPT and SEVERITY.

The Chi-square test has verified there is a significant relationship between approach type and settlement severity, however, a positive or negative impact is not specified, even with its effectiveness magnitude. A rating system as illustrated in Table 4.47 is defined to quantify the effectiveness of rigid approach on mitigating differential settlement. Grade 3, 2, and 1 would be assigned to settlement level minimal, moderate, and severe, respectively.

**Table 4.47 Sample Two: Rating system to quantify approach effectiveness**

Settlement Scale	Grade	Effective Ratio	Impact
Minimal	2	1	No impact
Moderate	1	<1	Negative
Severe	0	>1	Positive

An effective ratio (ER) is defined as:

ER

$$ER = \frac{\text{Total grade of rigid approaches in different settlement level} / \text{Count of rigid approach}}{\text{Total grade of flexible approaches in different settlement level} / \text{Count of flexible approach}} \quad (4.11)$$

By this method, it is appropriate to conclude the approach slab would generate a positive impact on mitigating differential settlement when ER is larger than 1, otherwise, a negative impact would take place when ER is less than 1, or no impact of approach slab use when ER equals 1. The ER of the sample two is equal to 1.24. Thus, the use of approach slab has a positive effect on mitigating the problem caused by differential settlement. In other words, the use of approach slabs could enhance the performance of approaches as transitions between roadway and the bridge. However, the effectiveness is not significant because the ER is slightly larger than 1.

**Table 4.48 Sample Two: Grade distribution for approach type in different settlement severity**

Category	Flexible			Rigid		
SEVERITY	Minimal	Moderate	Severe	Minimal	Moderate	Severe
Count	134	218	115	58	55	20
Grade	268	218	0	116	55	0

#### 4.4.3 Conclusions

The mosaic plots of sample one and sample two both show that the bridges with rigid approaches tend to present a higher proportion in minimal settlement than flexible approaches. The ordinal regression of sample one shows that there is no association between APPT and SEVERITY. While, the SPSS output of sample two indicates that APPT is statistically significant in the relationship between APPT and SEVERITY. The ordered logit for flexible approaches being in a higher settlement level is 0.641 more than rigid approaches when the other variable in the models are held constant (only one predictor for this model). In other words, the regression output of sample two indicates that rigid approaches behave better than flexible approaches in the treatment of the differential settlement at bridge ends. The results of Chi-square test for sample two verify the conclusion that there is a significant association between APPT and SEVERITY. An effective ration was defined to illustrate the impact of approach slabs on mitigating differential settlement. The result indicates that the use of approach slab has a positive effect on mitigating the problem caused by differential settlement at bridge ends.

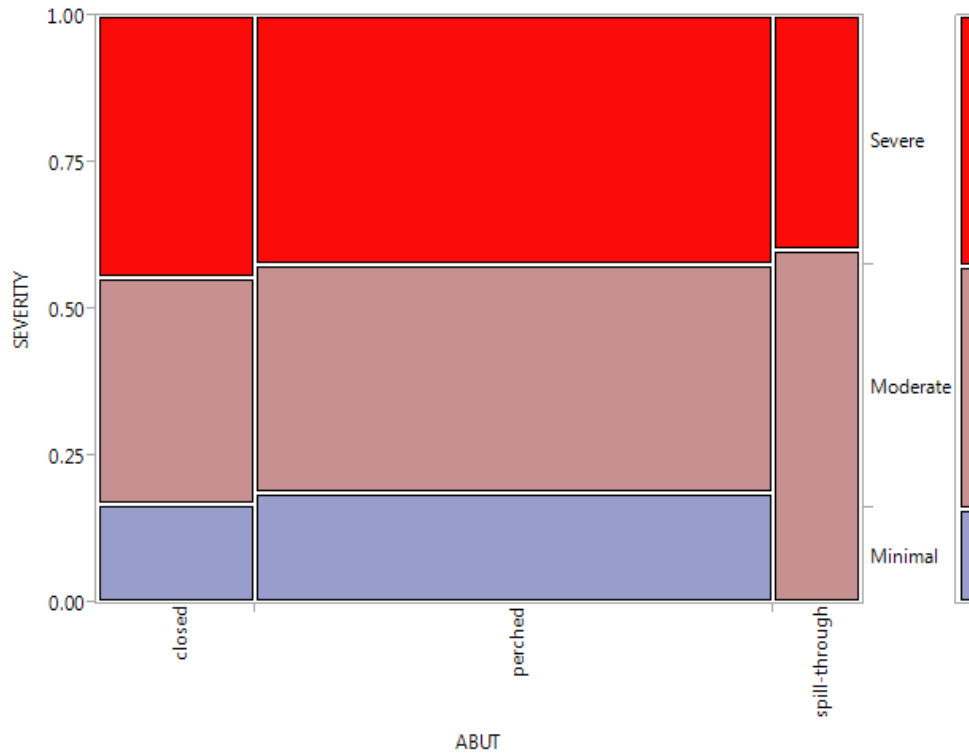
## 4.5 Abutment Type

### 4.5.1 Sample One

A descriptive analysis was conducted by creating a frequency table of abutment type by settlement levels and a mosaic plot of distribution of settlement levels across abutment type. The mosaic plot reveals that the bridges with perched abutments have the highest proportion of minimal settlement compared to other abutment types. A measure to further explore the relationship between ABUT and SEVERITY was analyzed by ordinal logistic regression in SPSS. The output shows that the model cannot fit the relationship between ABUT and SEVERITY well and concludes that ABUT and SEVERITY are two independent variables (no association between ABUT and SEVERITY).

**Table 4.49 Sample One: Frequency table of abutment type (ABUT) by SEVERITY**

Abutment Type	Severity			Total
	Minimal	Moderate	Severe	
Closed (1)	3	7	8	18
Spill-through (2)	0	6	4	10
Perched (3)	11	23	25	59
Total	14	36	37	87



**Figure 4.19 Sample One: Distribution of settlement levels across abutment type**

**Table 4.50 Sample One: Model fitting information of ordinal logistic regression between ABUT and SEVERITY**

Model	-2 Log Likelihood	Chi-Square	df	Sig.
Intercept Only	21.469			
Final	21.247	.222	2	.895

**Table 4.51 Sample One: Parameter estimates of ordinal logistic regression between  
ABUT and SEVERITY**

		Estimate	Std. Error	Wald	df	Sig.	95% Confidence Interval	
							Lower Bound	Upper Bound
Threshold	[SEVERITY = 1.00]	-1.596	.320	24.912	1	.000	-2.223	-.969
	[SEVERITY = 2.00]	.360	.259	1.936	1	.164	-.147	.867
Location	[ABUT=1.00]	.104	.507	.042	1	.838	-.890	1.097
	[ABUT=2.00]	.279	.650	.184	1	.668	-.994	1.552
	[ABUT=3.00]	0 <sup>a</sup>	.	.	0	.	.	.

a. This parameter is set to zero because it is redundant.

**Table 4.52 Sample One: Test of parallel lines of ordinal logistic regression between  
ABUT and SEVERITY**

Model	-2 Log Likelihood	Chi-Square	df	Sig.
Null Hypothesis	21.247			
General	17.143	4.104	2	.128



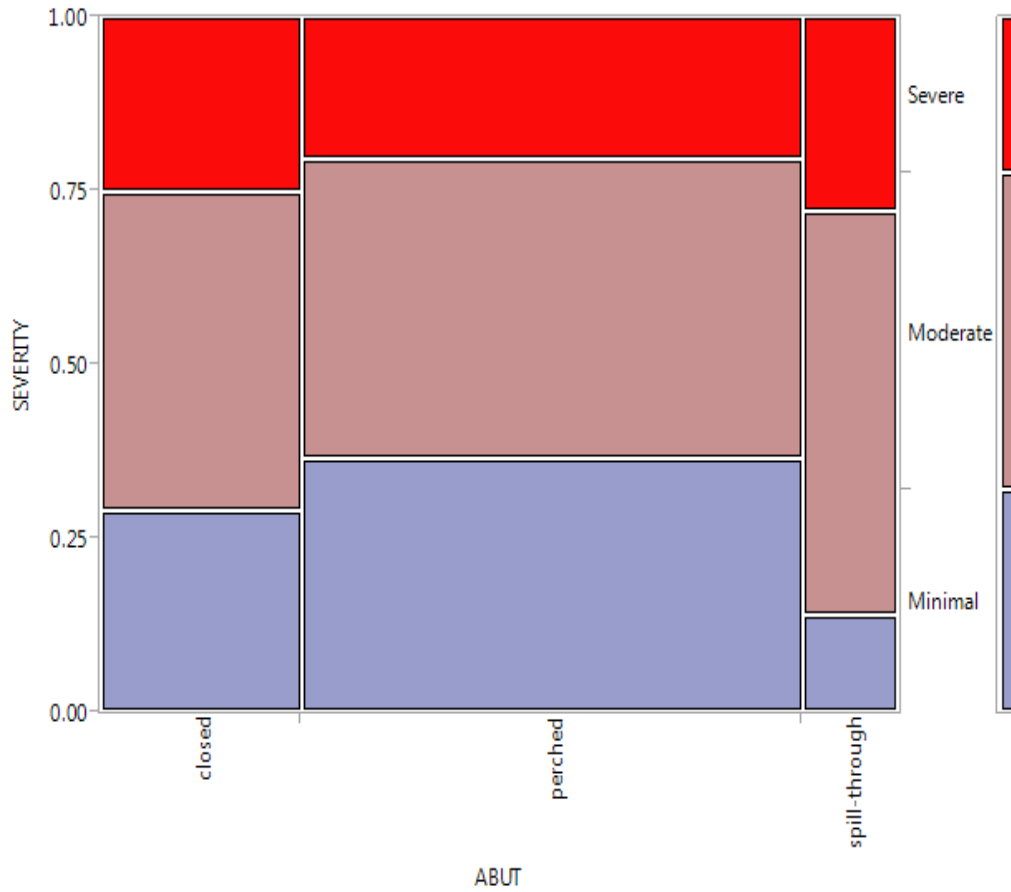
#### 4.5.2 Sample Two

Table 4.53 shows the frequency table of abutment type by severity levels for sample two.

Figure 4.20 presents a mosaic plot illustrating the distribution of SEVERITY across ABUT. It shows that the bridges with perched abutments have the highest proportion of minimal settlement.

**Table 4.53 Sample Two: Frequency table of abutment type (ABUT) by SEVERITY**

Abutment Type	Severity			Total
	Minimal	Moderate	Severe	
Closed (1)	44	69	38	151
Spill-through (2)	10	42	20	72
Perched (3)	138	162	77	377
Total	192	273	135	600



**Figure 4.20 Sample Two: Distribution of settlement levels across abutment type**

**Table 4.54 Sample Two: Model fitting information of ordinal logistic regression**

**between ABUT and SEVERITY**

Model	-2 Log Likelihood	Chi-Square	df	Sig.
Intercept Only	48.028			
Final	36.593	11.435	2	.003

**Table 4.55 Sample Two: Parameter estimates of ordinal logistic regression between ABUT and SEVERITY**

		Estimate	Std. Error	Wald	df	Sig.	95% Confidence Interval	
							Lower Bound	Upper Bound
Threshold	[SEVERITY = 1.00]	-.589	.103	32.456	1	.000	-.792	-.386
	[SEVERITY = 2.00]	1.433	.119	145.761	1	.000	1.200	1.665
Location	[ABUT=1.00]	.320	.180	3.139	1	.076	-.034	.673
	[ABUT=2.00]	.749	.242	9.572	1	.002	.275	1.224
	[ABUT=3.00]	0 <sup>a</sup>	.	.	0	.	.	.

**Table 4.56 Sample Two: Test of parallel lines of ordinal logistic regression between ABUT and SEVERITY**

Model	-2 Log Likelihood	Chi-Square	df	Sig.
Null Hypothesis	36.593			
General	30.892	5.701	2	.058

Ordinal regression was implemented to identify the functional relationship between ABUT and SEVERITY. The output is shown in Table 4.54 ~ Table 4.56. The model fit

information shows that this model fits significantly better than an empty model (i.e., a model with no predictors). The table of parameter estimates shows that ABUT=2 (spill-through) is statistically significant. The log odds of being in a higher settlement level will increase by 0.320 if moving from the ABUT=3 (perched) to the ABUT=1 (closed). Similarly, the log odds of being in a higher settlement level will increase by 0.749 if moving from the ABUT=3 (perched) to the ABUT=2 (spill-through). In other words, the bridges with perched abutment experience a lower level of settlement compared to other types of abutment given other independent variables are the same.

Generally, the interpretation for logistic regression between two nominal variables is very cumbersome, especially the outcome variable and independent variables have more than two levels. In this instance, the output from a mosaic plot can be helpful to explore the relationship between two categorical variables. The logistic regression can be used to define the functional relationship between two categorical variables.

### **4.5.3 Conclusions**

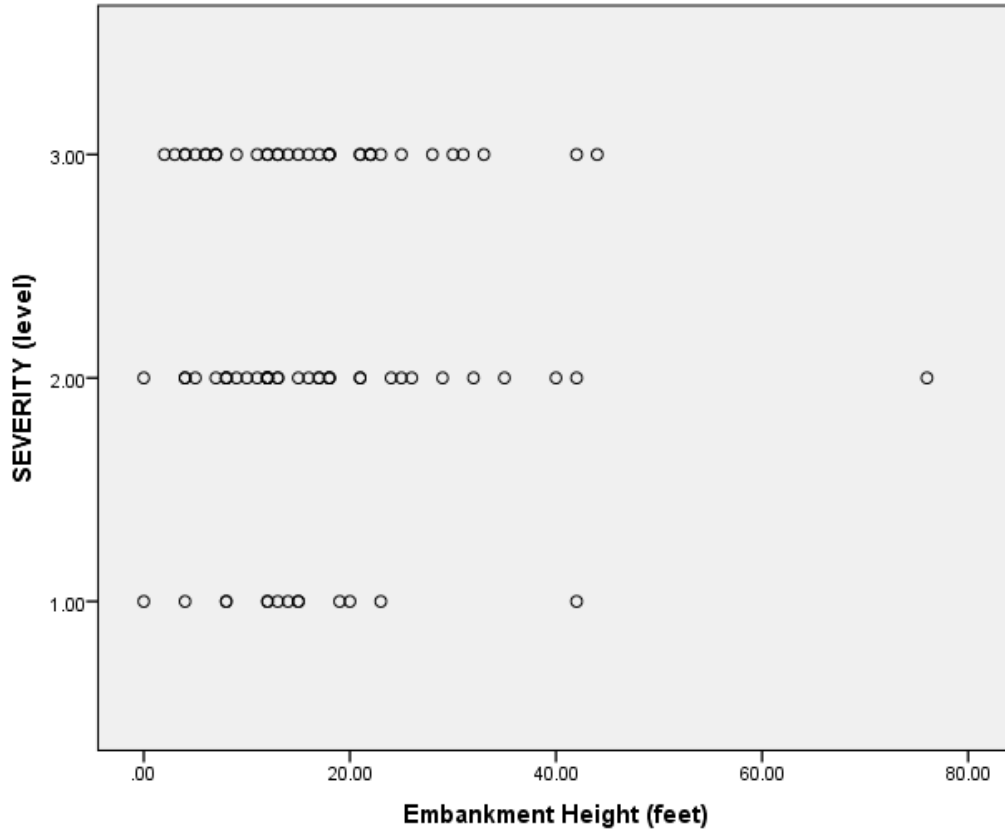
The mosaic plots of sample one and sample two both show that the bridges with perched abutment tend to present a higher proportion in minimal settlement than other types of abutment. The SPSS output of sample one indicates there is no association between ABUT and SEVERITY. While the output of sample two indicates a relationship exist between ABUT and SEVERITY. The interpretation of parameter estimates of sample two concludes that: (1) the log odds of being in a higher settlement level will increase by 0.320 if moving from the ABUT=3 (perched) to the ABUT=1 (closed), and (2) the log odds of being in a higher settlement level will increase by 0.749 if moving from the ABUT=3 (perched) to the ABUT=2 (spill-through). Sample two demonstrates that the

bridges with perched abutment experience a lower level of settlement compared to other types of abutment given other independent variables are the same.

## **4.6 Embankment Height**

### **4.6.1 Sample One**

A scatterplot of approach settlement levels by embankment height of sample one is given in Figure 4.21. This plot cannot provide a clear picture of the nature of the relationship between EH and SEVERITY. In addition, a frequency table of embankment height group (EHG) by SEVERITY is used to group the independent variable EG into four categories defined in Table 4.57. The EHG of 0~20 feet shows a higher proportion of settlement in minimal than the group of above 20 feet. While EHG of above 20 feet shows a higher proportion of settlement in severe than the group of 0~20 feet. The output from SPSS shows that the null hypothesis that the regression coefficient in the model is equal to zero cannot be rejected because the p-value of the model is 0.847. In other words, this model is not better than a null model without any predictors and cannot reflect the relationship between EH and SEVERITY.



**Figure 4.21 Sample One: Scatterplot of approach settlement levels by embankment height**

**Table 4.57 Sample One: Frequency table of embankment height group (EHG) by SEVERITY**

EH group (feet)	Severity			Total	Mean	
	Minimal	Moderate	Severe		Minimal	Severe
0~10	4	10	11	25	0.160	0.440
11~20	8	15	13	36	0.222	0.361
21~30	1	6	9	16	0.063	0.563
Above 30	1	5	4	10	0.100	0.400
Total	14	36	37	87		

**Table 4.58 Sample One: Model fitting information of ordinal logistic regression  
between EH and SEVERITY**

Model	-2 Log Likelihood	Chi-Square	df	Sig.
Intercept Only	111.179			
Final	111.142	.037	1	.847

**Table 4.59 Sample One: Parameter estimates of ordinal logistic regression between  
EH and SEVERITY**

		Estimate	Std. Error	Wald	df	Sig.	95% Confidence Interval	
							Lower Bound	Upper Bound
Threshold	[SEVERITY = 1.00]	-1.597	.407	15.373	1	.000	-2.396	-.799
	[SEVERITY = 2.00]	.356	.361	.970	1	.325	-.352	1.064
Location	EH	.003	.017	.034	1	.853	-.030	.036

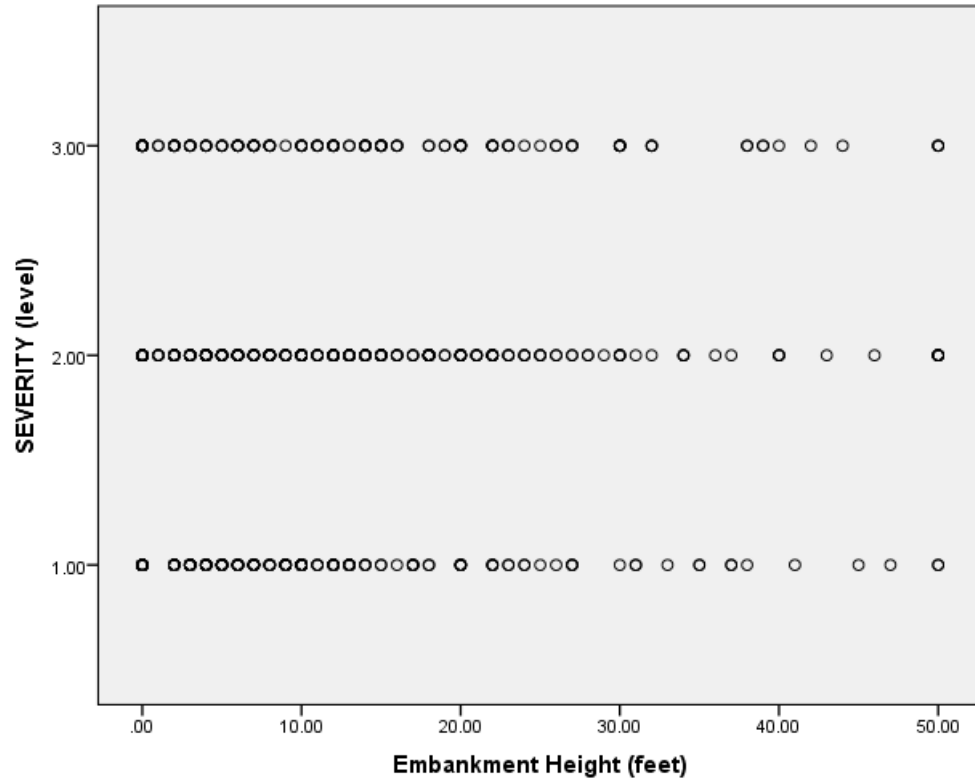
**Table 4.60 Sample One: Test of parallel lines of ordinal logistic regression between  
EH and SEVERITY**

Model	-2 Log Likelihood	Chi-Square	df	Sig.
Null Hypothesis	111.142			
General	110.380	.762	1	.383

#### **4.6.2 Sample Two**

A descriptive analysis was conducted by creating a scatterplot of approach settlement levels by embankment height and a frequency table of embankment height group (EHG) by SEVERITY. The EHG of 0~10 feet shows the highest proportion of settlement in minimal than the other groups. While EHG of above 20 feet shows a higher proportion of settlement in severe than the group of 0~20 feet. The output from SPSS shows that the null hypothesis that the regression coefficient in the model is equal to zero would be rejected because the p-value of the model is 0.003. In other words, this model is significantly better than a null model without any predictors. The relationship between EH and Severity should be identified by comparing to a comprehensive model considering all other independent variables.





**Figure 4.22 Sample Two: Scatterplot of approach settlement levels by embankment height**

**Table 4.61 Sample Two: Frequency table of embankment height group (EHG) by SEVERITY**

EH group (feet)	Severity			Total	Mean	
	Minimal	Moderate	Severe		Minimal	Severe
0~10	127	145	81	333	0.381	0.243
11~20	38	78	40	156	0.243	0.256
21~30	14	32	21	67	0.209	0.313
Above 30	13	18	13	44	0.295	0.295
Total	192	273	135	600		

**Table 4.62 Sample Two: Model fitting information of ordinal logistic regression  
between EH and SEVERITY**

Model	-2 Log Likelihood	Chi-Square	df	Sig.
Intercept Only	304.684			
Final	295.877	8.807	1	.003

**Table 4.63 Sample Two: Parameter estimates of ordinal logistic regression between  
EH and SEVERITY**

		Estimate	Std. Error	Wald	df	Sig.	95% Confidence Interval	
							Lower Bound	Upper Bound
Threshold	[SEVERITY = 1.00]	-.512	.119	18.577	1	.000	-.745	-.279
	[SEVERITY = 2.00]	1.502	.134	125.068	1	.000	1.239	1.766
Location	EH	.021	.007	8.846	1	.003	.007	.034

**Table 4.64 Sample Two: Test of parallel lines of ordinal logistic regression between EH and SEVERITY**

Model	-2 Log Likelihood	Chi-Square	df	Sig.
Null Hypothesis	295.877			
General	295.876	.001	1	.978

### 4.6.3 Conclusions

Scatterplots of approach settlement levels by embankment height for sample one and sample two cannot provide a clear picture of the relationship between EH and SEVERITY. For sample one, the embankment height group of 11~20 feet presents the highest proportion of approaches with minimal settlement. For sample two, the embankment height group of 0~10 feet presents the highest proportion of approaches with minimal settlement. Both samples show that shallow embankment tend to settle less than deep embankment. In return, group of above 30 feet presents the highest proportion of approaches with severe settlement for sample one and group of 21~30 feet presents the highest proportion of approaches with severe settlement for sample two. Both samples show that deep embankment tend to settle more than shallow embankment.

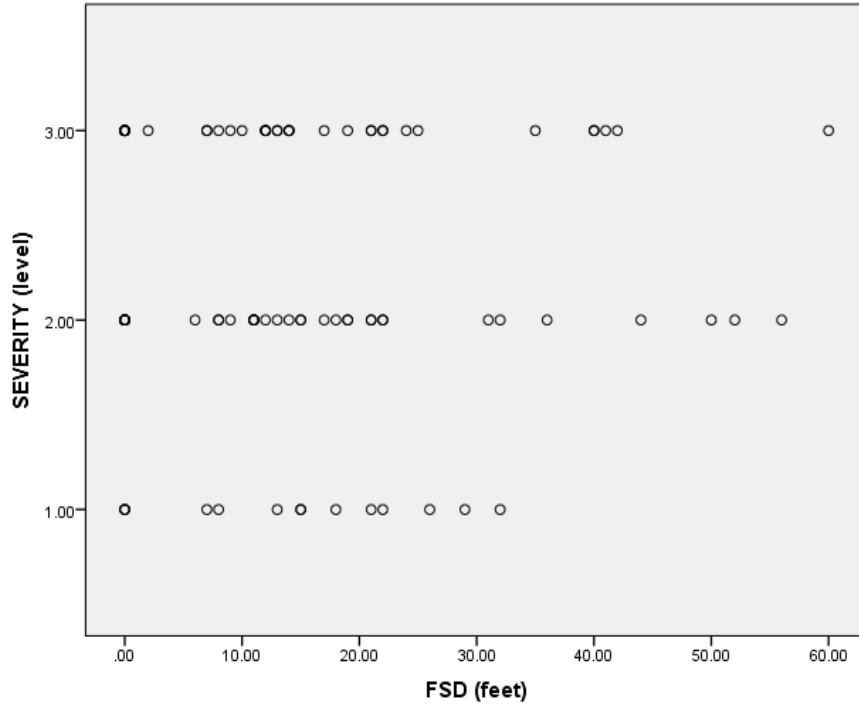
The SPSS output for sample one and sample two are different. The model of sample two is better to reflect a relationship between EH and SEVERITY than a null model without any predictors. The model of sample two shows that the ordered log odds of being in a higher level of settlement will increase 0.021 for a one unit increase in embankment height. In other words, the higher the embankment, the higher level of settlement may

occur. However, this model cannot identify the exact relationship between EH and SEVERITY. All other predictors should be considered to create a comprehensive model to define the relationship between EH and SEVERITY by comparing to other independent variables.

## **4.7 Foundation Soil Depth**

### **4.7.1 Sample One**

A scatterplot of approach settlement levels by foundation soil depth was given for a descriptive analysis, but this plot cannot provide a clear picture of the relationship between FSD and SEVERITY. Then a frequency table of foundation soil depth by severity was created to figure out the changing tendency of the proportion of approaches with minimal settlement and severe settlement. Table 4.65 shows that shallow foundations have a higher proportion of settlement in minimal than deep foundations. The functional relationship between FSD and SEVERITY was attempted to be identified by SPSS. The output shows that the regression coefficient of FSD for SEVERITY is 0.942, which implies that there is no association between FSD and SEVERITY. Moreover, the model is not different from a null model and cannot fit the relationship well.



**Figure 4.23 Sample One: Scatterplot of approach settlement levels by foundation soil depth**

**Table 4.65 Sample One: Frequency table of foundation soil depth (FSD) by SEVERITY**

FSD (feet)	Severity			Total	Mean	
	Minimal	Moderate	Severe		Minimal	Severe
0~10	5	12	14	31	0.161	0.452
11~20	4	13	11	28	0.143	0.393
21~30	4	4	6	14	0.286	0.429
31~40	1	3	3	7	0.143	0.429
Above 40	0	4	3	7	0	0.429
	14	36	37	87		

**Table 4.66 Sample One: Model fitting information of ordinal logistic regression  
between FSD and SEVERITY**

Model	-2 Log Likelihood	Chi-Square	df	Sig.
Intercept Only	102.216			
Final	102.211	.006	1	.940

**Table 4.67 Sample One: Parameter estimates of ordinal logistic regression between  
FSD and SEVERITY**

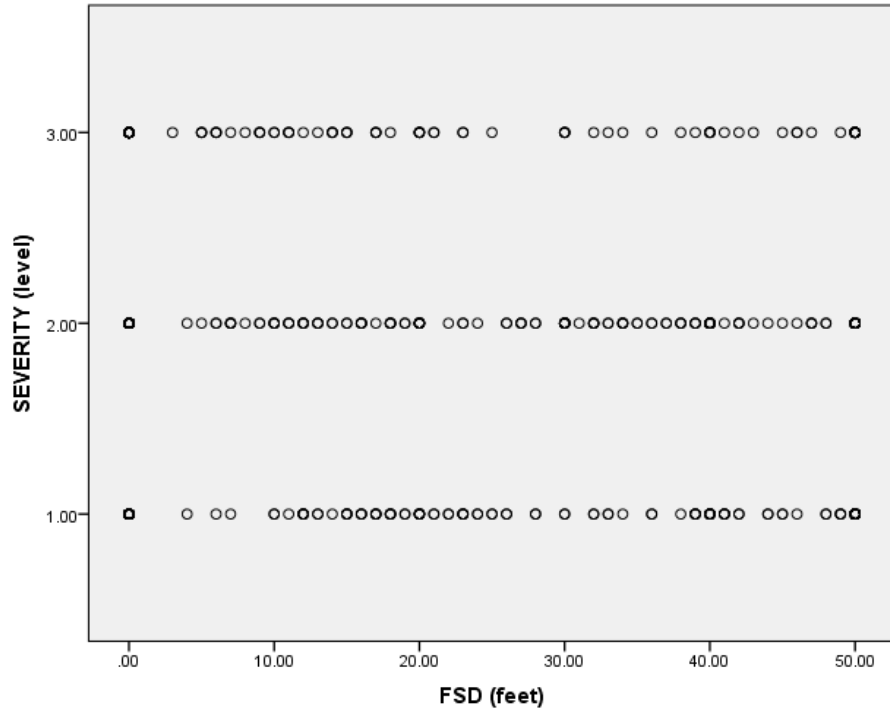
		Estimate	Std. Error	Wald	df	Sig.	95% Confidence Interval	
							Lower Bound	Upper Bound
Threshold	[SEVERITY = 1.00]	-1.635	.370	19.550	1	.000	-2.359	-.910
	[SEVERITY = 2.00]	.318	.315	1.017	1	.313	-.300	.936
Location	FSD	.001	.014	.005	1	.942	-.027	.029

**Table 4.68 Sample One: Test of parallel lines of ordinal logistic regression between FSD and SEVERITY**

Model	-2 Log Likelihood	Chi-Square	df	Sig.
Null Hypothesis	102.211			
General	101.998	.212	1	.645

#### **4.7.2 Sample Two**

No distinct relationship between FSD and SEVERITY is found by examining the scatterplot of approach settlement levels by foundation soil depth. The frequency table of FSD by SEVERITY shows that shallow foundations are more likely to present a higher settlement level than deep foundations. The output from the ordinal logistic regression indicates that there is an association between FSD and SEVERITY. For a unit increase in FSD, the log odds of being in a higher level of settlement would be expected to decrease 0.018.



**Figure 4.24 Sample Two: Scatterplot of approach settlement levels by foundation soil depth**

**Table 4.69 Sample Two: Frequency table of foundation soil depth (FSD) by SEVERITY**

FSD (feet)	Severity			Total	Mean	
	Minimal	Moderate	Severe		Minimal	Severe
0~10	59	127	75	261	0.226	0.287
11~20	32	33	20	85	0.376	0.235
21~30	18	21	9	48	0.375	0.188
31~40	21	37	10	68	0.309	0.147
Above 40	62	55	21	138	0.449	0.152
	192	273	135	600		



**Table 4.70 Sample Two: Model fitting information of ordinal logistic regression  
between FSD and SEVERITY**

Model	-2 Log Likelihood	Chi-Square	df	Sig.
Intercept Only	271.677			
Final	250.393	21.285	1	.000

**Table 4.71 Sample Two: Parameter estimates of ordinal logistic regression between  
FSD and SEVERITY**

		Estimate	Std. Error	Wald	df	Sig.	95% Confidence Interval	
							Lower Bound	Upper Bound
Threshold	[SEVERITY = 1.00]	-1.137	.124	84.670	1	.000	-1.379	-.895
	[SEVERITY = 2.00]	.910	.120	57.677	1	.000	.675	1.145
Location	FSD	-.018	.004	20.797	1	.000	-.026	-.010

**Table 4.72 Sample Two: Test of parallel lines of ordinal logistic regression between  
FSD and SEVERITY**

Model	-2 Log Likelihood	Chi-Square	df	Sig.
Null Hypothesis	250.393			
General	250.392	.001	1	.980

### 4.7.3 Conclusions

Descriptive analysis of sample one indicates that shallow foundations are tend to have a lower level of settlement compared to deep foundations. While the results from sample two reverse this conclusion. Ordinal logistic regression of sample one shows that there is no association between FSD and SEVERITY, while the sample two shows that for a one unit increase in FSD, a 0.018 decrease in the ordered log odds of being in a higher level of settlement would be expected. Note that the frequency table of FSD by SEVERITY of sample one has empty cells, which may lead to an unstable model for interpretation.

## 4.8 Foundation Soil Consistency

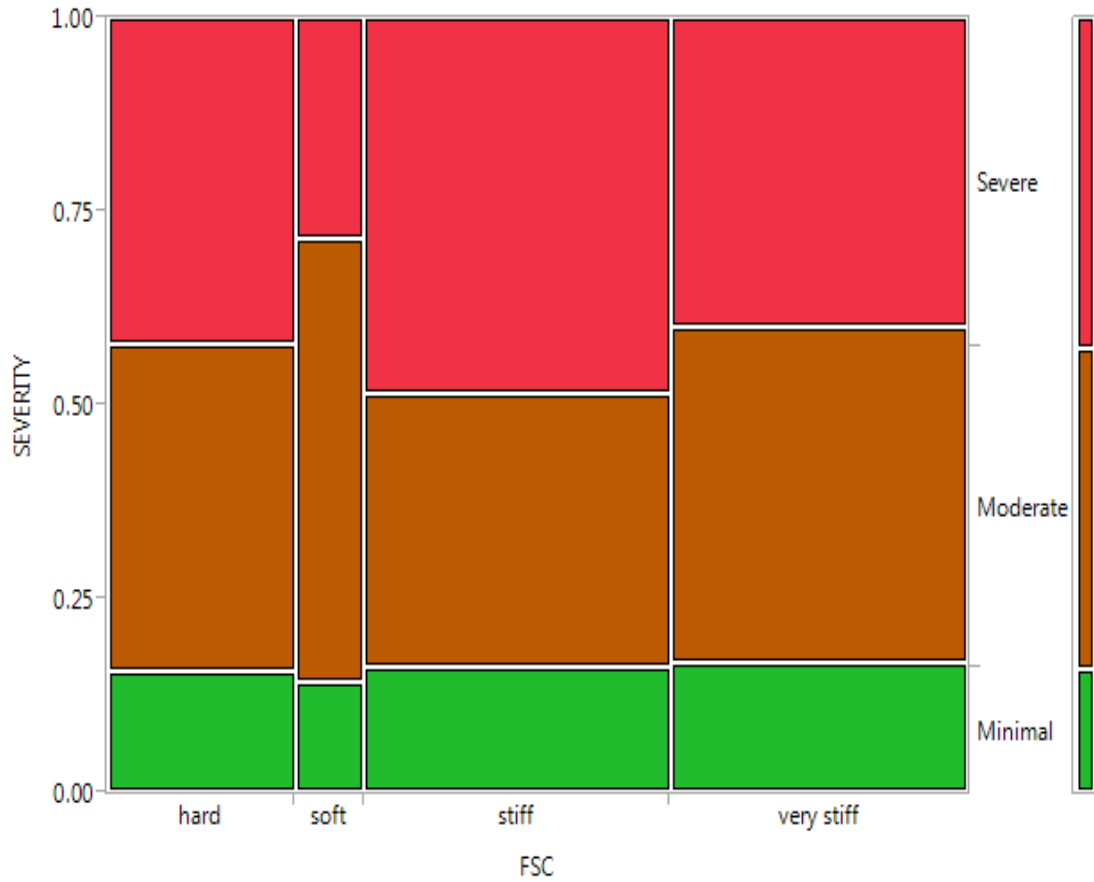
### 4.8.1 Sample One

No distinct relationship between FSC and SEVERITY is found by examining the scatterplot of approach settlement levels by foundation soil depth. The mosaic plot of settlement levels across foundation soil consistency shows that the proportion of approaches in minimal settlement varies slightly in each of group of consistency. In

addition, the model from ordinal logistic regression reveals that the model cannot reflect the relationship and there is no association between FSC and SEVERITY.

**Table 4.73 Sample One: Frequency table of foundation soil consistency (FSC) by SEVERITY**

FSC (level)	Severity			Total
	Minimal	Moderate	Severe	
Soft	1	4	2	7
Stiff	5	11	15	31
Very stiff	5	13	12	30
Hard	3	8	8	19
Total	14	36	37	87



**Figure 4.25 Sample One: Distribution of settlement levels across foundation soil consistency**

**Table 4.74 Sample One: Model fitting information of ordinal logistic regression between FSC and SEVERITY**

Model	-2 Log Likelihood	Chi-Square	df	Sig.
Intercept Only	25.498			
Final	24.904	.594	3	.898

**Table 4.75 Sample One: Parameter estimates of ordinal logistic regression between  
FSC and SEVERITY**

		Estimate	Std. Error	Wald	df	Sig.	95% Confidence Interval	
							Lower Bound	Upper Bound
Threshold	[SEVERITY = 1.00]	-1.652	.481	11.812	1	.001	-2.595	-.710
	[SEVERITY = 2.00]	.310	.439	.500	1	.480	-.550	1.171
Location	[FSC=1.00]	-.339	.827	.168	1	.682	-1.960	1.283
	[FSC=2.00]	.186	.550	.115	1	.735	-.892	1.264
	[FSC=3.00]	-.080	.551	.021	1	.885	-1.159	1.000
	[FSC=4.00]	0	.	.	0	.	.	.

**Table 4.76 Sample One: Test of parallel lines of ordinal logistic regression between  
FSC and SEVERITY**

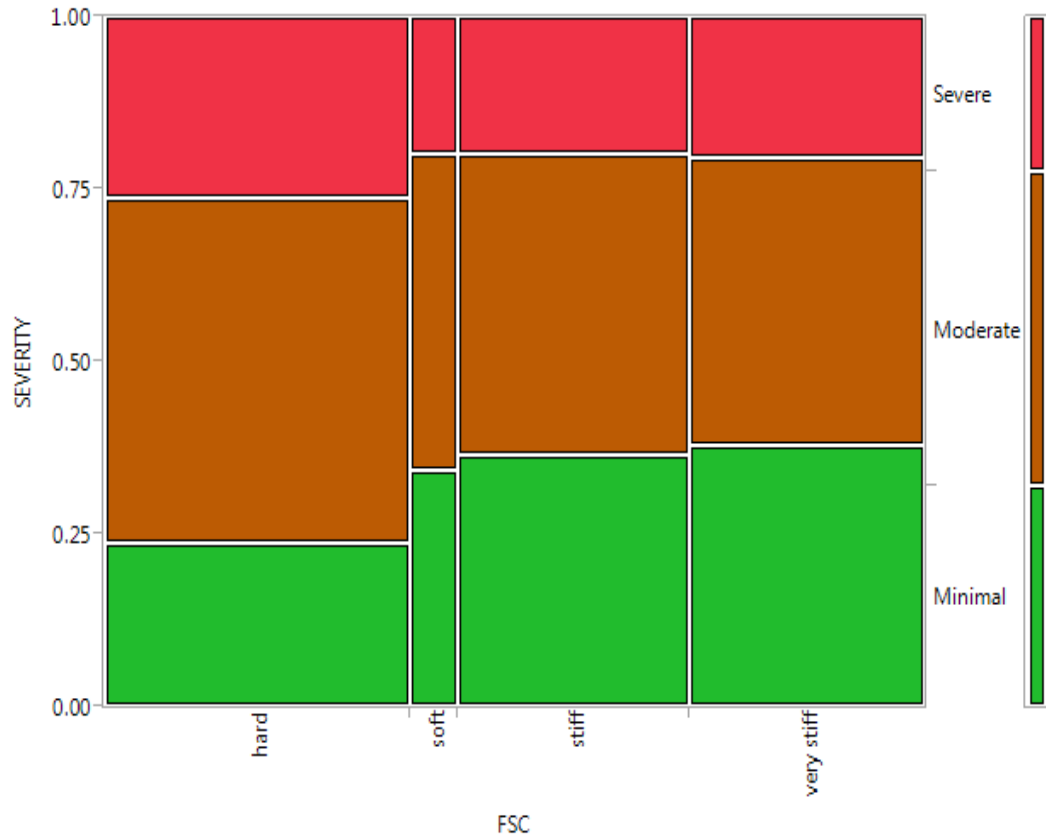
Model	-2 Log Likelihood	Chi-Square	df	Sig.
Null Hypothesis	24.904			
General	24.149	.756	3	.860

#### 4.8.2 Sample Two

The mosaic plot of settlement levels across foundation soil consistency shows that the group of hard of foundation soil consistency has the lowest proportion in minimal settlement while has the highest proportion in severe settlement. The SPSS output shows that there is an association between FSC and SVERITY and the model is significantly better than a null model without any predictors. The logit odds of being in a higher level of settlement will decrease by 0.432 if moving from FSC=4 (hard) to FSC=1 (soft). The logit odds of being in a higher level of settlement will decrease by 0.494 if moving from FSC=4 (hard) to FSC=2 (stiff). The logit odds of being in a higher level of settlement will decrease by 0.528 if moving from FSC=4 (hard) to FSC=3 (very stiff). In other words, the approaches with a higher level of foundation soil consistency tend to experience a lower level of settlement.

**Table 4.77 Sample Two: Frequency table of foundation soil consistency (FSC) by SEVERITY**

FSC (level)	Severity			Total
	Minimal	Moderate	Severe	
Soft	12	16	7	35
Stiff	62	74	34	170
Very stiff	65	71	35	171
Hard	53	112	59	224
Total	192	273	135	600



**Figure 4.26 Sample Two: Distribution of settlement levels across foundation soil consistency**

**Table 4.78 Sample Two: Model fitting information of ordinal logistic regression between FSC and SEVERITY**

Model	-2 Log Likelihood	Chi-Square	df	Sig.
Intercept Only	51.727			
Final	41.439	10.288	3	.016

**Table 4.79 Sample Two: Parameter estimates of ordinal logistic regression between FSC and SEVERITY**

		Estimate	Std. Error	Wald	df	Sig.	95% Confidence Interval	
							Lower Bound	Upper Bound
Threshold	[SEVERITY = 1.00]	-1.076	.137	62.020	1	.000	-1.344	-.808
	[SEVERITY = 2.00]	.942	.135	49.020	1	.000	.679	1.206
Location	[FSC=1.00]	-.432	.340	1.614	1	.204	-1.099	.235
	[FSC=2.00]	-.494	.191	6.680	1	.010	-.868	-.119
	[FSC=3.00]	-.528	.191	7.638	1	.006	-.902	-.153
	[FSC=4.00]	0	.	.	0	.	.	.

**Table 4.80 Sample Two: Test of parallel lines of ordinal logistic regression between FSC and SEVERITY**

Model	-2 Log Likelihood	Chi-Square	df	Sig.
Null Hypothesis	41.439			
General	39.446	1.993	3	.574



### **4.8.3 Conclusions**

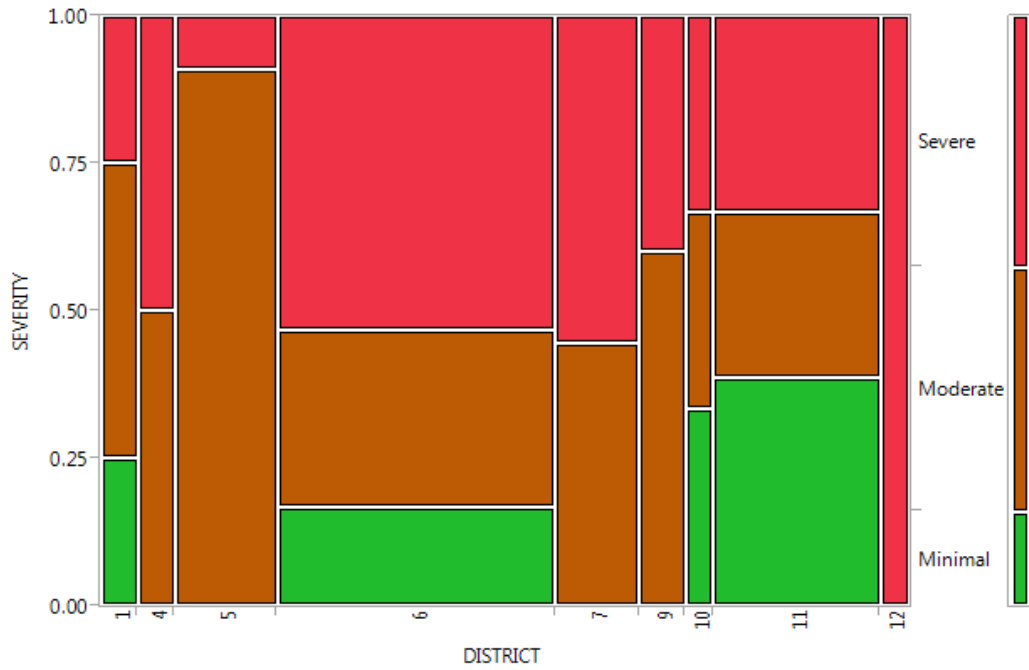
The descriptive analysis of sample one and sample two cannot provide a clear picture of the relationship between FSC and SEVERITY. The ordinal logistic regression of sample one shows that there is no association between FSC and SEVERITY, while the sample two shows that FSC is statistically significant. The mosaic plot of sample two shows that the group of hard foundation soil consistency has the lowest proportion in minimal settlement while has the highest proportion in severe settlement. But the functional relationship gained by SPSS indicates that the approaches with a higher level of foundation soil consistency tend to experience a lower level of settlement.

## **4.9 Geographical Location**

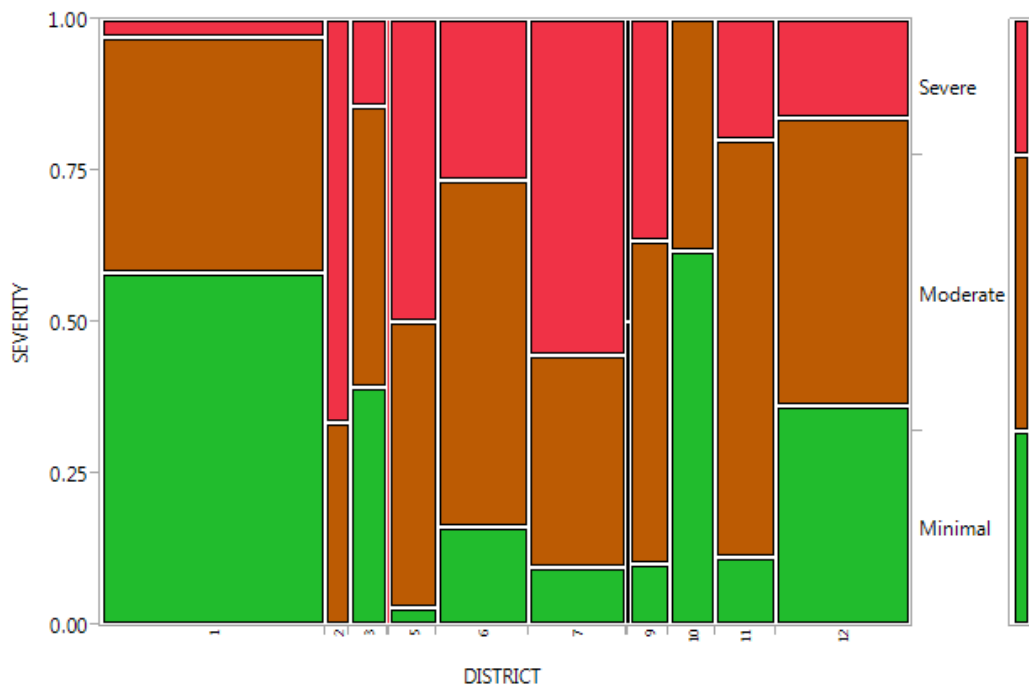
Table 4.81 lists the two samples with different approach settlement levels in each district. For sample one, there is no data from district two, three, and eight. For sample two, there are few data from district four and eight. From the mosaic plot of distribution of settlement levels across each district of sample one, district eleven presents the highest proportion of approaches with minimal settlement while the relatively small proportion of approaches with severe settlement. District twelve presents the highest proportion of approaches with severe settlement. The mosaic plot of sample two shows that the district one and district ten behaves much better than other districts with the highest proportion in minimal settlement while the lowest proportion in severe settlement.

**Table 4.81 Distribution of the Bridge Approaches from Each District**

District	Sample One				Sample Two			
	Severity			Total	Severity			Total
	Minimal	Moderate	Severe		Minimal	Moderate	Severe	
1	1	2	1	4	97	65	5	167
2	0	0	0	0	0	6	12	18
3	0	0	0	0	11	13	4	28
4	0	2	2	4	0	0	1	1
5	0	10	1	11	1	17	18	36
6	5	9	16	30	11	39	18	68
7	0	4	5	9	7	25	40	72
8	0	0	0	0	0	1	1	2
9	0	3	2	5	3	16	11	30
10	1	1	1	3	21	13	0	34
11	7	5	6	18	5	31	9	45
12	0	0	3	3	36	47	16	99
	14	36	37	87	192	273	135	600



**Figure 4.27 Sample One: Distribution of settlement levels across transportation district**



**Figure 4.28 Sample Two: Distribution of settlement levels across transportation district**

Ordinal logistic regression was performed at first for both samples to explore the functional relationship between DISTRICT and SEVERITY. The test of parallel lines of sample one shows that the null hypothesis states that the slope coefficients are the same across response categories is violated. Therefore, multinomial logistic regression was carried out for sample one. The output of multinomial logistic regression for sample one and ordinal logistic regression for sample two is shown in the following tables.

**Table 4.82 Sample One: Test of parallel lines of ordinal logistic regression between DISTRICT and SEVERITY**

Model	-2 Log Likelihood	Chi-Square	df	Sig.
Null Hypothesis	47.844			
General	28.160	19.684	8	.012

**Table 4.83 Sample One: Model fitting information of multinomial logistic regression between district and SEVERITY**

Model	Model Fitting Criteria			Likelihood Ratio Tests		
	AIC	BIC	-2 Log Likelihood	Chi-Square	df	Sig.
Intercept Only	64.942	69.873	60.942			
Final	63.434	73.297	55.434	5.508	2	.064

**Table 4.84 Sample One: Parameter estimates of multinomial logistic regression  
between DISTRICT and SEVERITY**

SEVERITY	B	Std. Error	Wald	df	Sig.	Exp(B)	95% Confidence Interval for Exp(B)	
							Lower Bound	Upper Bound
1.00	Intercept	-2.056	1.014	4.109	1	.043		
	DISTRICT	.137	.118	1.340	1	.247	1.146	.910 1.445
2.00	Intercept	.881	.667	1.742	1	.187		
	DISTRICT	-.130	.090	2.111	1	.146	.878	.736 1.047

Note: The reference category is: 3.00

**Table 4.85 Sample One: Parameter estimates of multinomial logistic regression  
between DISTRICT and SEVERITY**

Observed	Predicted			
	1.00	2.00	3.00	Percent Correct
1.00	0	6	8	0.0%
2.00	0	23	13	63.9%
3.00	0	20	17	45.9%
Overall Percentage	0.0%	56.3%	43.7%	46.0%

By analyzing the output from the multinomial logistic regression for sample one, the p-value of the model is slightly larger than 0.05. It is uncertain to conclude that there is an association between DISTRICT and SEVERITY for sample one. All other predictors should be considered to create a comprehensive model to evaluate the relationship between DISTRICT and SEVERITY. The interpretation of the parameter estimates is not given here because it may lead to ambiguity.

**Table 4.86 Sample Two: Model fitting information of ordinal logistic regression between DISTRICT and SEVERITY**

Model	-2 Log Likelihood	Chi-Square	df	Sig.
Intercept Only	297.488			
Final	84.835	212.653	11	.000

**Table 4.87 Sample Two: Parameter estimates of ordinal logistic regression between  
DISTRICT and SEVERITY**

		Estimate	Std. Error	Wald	df	Sig.	95% Confidence Interval	
							Lower Bound	Upper Bound
Threshold	[SEVERITY = 1.00]	-.699	.199	12.304	1	.000	-1.089	-.308
	[SEVERITY = 2.00]	1.992	.225	78.050	1	.000	1.550	2.434
Location	[DISTRICT=1.00]	-1.053	.251	17.606	1	.000	-1.544	-.561
	[DISTRICT=2.00]	2.733	.548	24.884	1	.000	1.659	3.806
	[DISTRICT=3.00]	-.150	.414	.131	1	.718	-.962	.662
	[DISTRICT=4.00]	20.763	.000	.	1	.	20.763	20.763
	[DISTRICT=5.00]	2.058	.392	27.584	1	.000	1.290	2.826
	[DISTRICT=6.00]	.961	.312	9.506	1	.002	.350	1.572
	[DISTRICT=7.00]	2.133	.318	44.891	1	.000	1.509	2.756
	[DISTRICT=8.00]	2.106	1.403	2.254	1	.133	-.643	4.856
	[DISTRICT=9.00]	1.457	.411	12.563	1	.000	.651	2.263
	[DISTRICT=10.00]	-1.240	.404	9.433	1	.002	-2.032	-.449
	[DISTRICT=11.00]	.900	.355	6.447	1	.011	.205	1.595
	[DISTRICT=12.00]	0	.	.	0	.	.	.

**Table 4.88 Sample Two: Test of parallel lines of ordinal logistic regression between  
DISTRICT and SEVERITY**

Model	-2 Log Likelihood	Chi-Square	df	Sig.
Null Hypothesis	84.835			
General	70.087	14.748	11	.194

The model from the ordinal logistic regression for sample two is statistically significant. There is a significant relationship between DISTRICT and SEVERITY. The ordered log-odds regression coefficients were obtained by comparing to DISTRICT=12. There are three districts (district one, three, and ten) behave better than district twelve with the interpretation as following:

- The log odds of being in a higher level of settlement severity will decrease by 1.053 if moving from the DISTRICT=12 TO DISTRICT=1,
- The log odds of being in a higher level of settlement severity will decrease by 0.150 if moving from the DISTRICT=12 TO DISTRICT=3,
- The log odds of being in a higher level of settlement severity will decrease by 1.240 if moving from the DISTRICT=12 TO DISTRICT=10.

#### **4.10 Comprehensive Model**

Based on the analyses between each parameter and dependent variable above, the dependent variable SEVERITY may not be ordinal in nature when analyzing the relationship between ADT and SEVERITY and the relationship between DISTRICT and



SEVERITY. Consequently, both ordinal logistic regression and multinomial logistic regression were carried out to develop comprehensive models for two samples, and these two different methods were compared to determine which one is better.

The model structure is shown in Table 4.89. For categorical variables (factors) in ordinal or multinomial logistic regression, dummy variables created to represent an attribute with two or more distinct categories/levels should be defined to interpret the SPSS output. For each categorical variable with K levels, K-1 dummy variables should be assumed.

Dummy variables in this study is defined in Table 4.90. According to different probability theory, output form of the models from ordinal logistic regression and multinomial logistic regression is different. Proportional-odds cumulative logit model is possibly the most popular model for ordinal data. This model uses cumulative probabilities upto a threshold, thereby making the whole range of ordinal categories binary at that threshold. The response Y in this study has three levels which are represented by 1, 2, and 3, and the associated probabilities are  $\pi_1$ ,  $\pi_2$ , and  $\pi_3$ . For ten independent variables, the following equations are supposed to be developed for ordinal logistic regression.

$$\text{Logit} \frac{\pi_1}{1 - \pi_1} = \text{Logit} \frac{\pi_1}{\pi_2 + \pi_3} = -\alpha_1 + \beta_1 x_1 + \dots + \beta_{10} x_{10} \quad (4.12)$$

$$\text{Logit} \frac{\pi_1 + \pi_2}{1 - (\pi_1 + \pi_2)} = \text{Logit} \frac{\pi_1 + \pi_2}{\pi_3} = -\alpha_2 + \beta_1 x_1 + \dots + \beta_{10} x_{10} \quad (4.13)$$

$$\pi_1 + \pi_2 + \pi_3 = 1 \quad (4.14)$$

Therefore,

$$\pi_1 = \frac{\exp(-\alpha_1 + \beta_1 x_1 + \cdots + \beta_{10} x_{10})}{1 + \exp(-\alpha_1 + \beta_1 x_1 + \cdots + \beta_{10} x_{10})} \quad (4.15)$$

$$\pi_2 = \frac{\exp(-\alpha_1 + \beta_1 x_1 + \cdots + \beta_{10} x_{10})}{1 + \exp(-\alpha_1 + \beta_1 x_1 + \cdots + \beta_{10} x_{10})} - \pi_1 \quad (4.16)$$

$$\pi_3 = 1 - \pi_1 - \pi_2 \quad (4.17)$$

When the assumption states that the slope coefficients in the model are the same across response categories for ordinal logistic regression is rejected, a less restrictive model of multinomial logistic regression is an optimal method. Multinomial logistic regression models how multinomial response variable depends on a set of explanatory variables. The following equations, if  $Y = 3$  is set as the referent, are supposed to be developed for multinomial logistic regression with ten independent variables. It is important to note that the parameter coefficients for different equations are different, which is the biggest difference of the output between the ordinal logistic regression and multinomial logistic regression.

$$\text{Logit} \frac{\pi_1}{\pi_3} = \alpha_1 + \beta_{11} x_1 + \cdots + \beta_{110} x_{10} \quad (4.18)$$

$$\text{Logit} \frac{\pi_2}{\pi_3} = \alpha_2 + \beta_{21} x_1 + \cdots + \beta_{210} x_{10} \quad (4.19)$$

$$\pi_1 + \pi_2 + \pi_3 = 1 \quad (4.20)$$

**Table 4.89 Classification of the variables in the model**

Covariates	Factors	Dependent
LENGTH	DISTRICT	SEVERITY
WIDTH	ABUT	
AGE	APPT	
ADT	FSC	
EH		
FSD		

**Table 4.90 Dummy variables definition in the model**

DISTRICT		ABUT	
Original	Dummy	Original	Dummy
District1=1;	DIS1=1, otherwise DIS1=0;	Perched=1;	ABUT1=1, otherwise ABUT1=0;
District2=2;	DIS2=1, otherwise DIS2=0;	Closed=2;	ABUT2=1, otherwise ABUT2=0;
District3=3;	DIS3=1, otherwise DIS3=0;	Spill- through=3	All ABUT=0
District4=4;	DIS4=1, otherwise DIS4=0;		
District5=5;	DIS5=1, otherwise DIS5=0;		
District6=6;	DIS6=1, otherwise DIS6=0;		
District7=7;	DIS7=1, otherwise DIS7=0;		
District8=8;	DIS8=1, otherwise DIS8=0;		
District9=9;	DIS9=1, otherwise DIS9=0;		
District10=10;	DIS10=1, otherwise DIS10=0;		
District11=11;	DIS11=1, otherwise DIS11=0;		
District11=12	All DIS=0		

APPT		FSC	
Original	Dummy	Original	Dummy
Flexible=1;  Rigid=2	APPT1=1, otherwise APPT1=0;  All APPT=0	Soft=1;  Stiff=2;  Very stiff=3;  Hard=4	FSC1=1, otherwise FSC1=0;  FSC2=1, otherwise FSC2=0;  FSC3=1, otherwise FSC3=0;  All FSC=0

#### 4.10.1 Sample One

An ordinal regression considering all predictors for prediction of approach settlement levels based on project characteristics was carried out. Some important model information are shown in Table 4.91 ~ Table 4.94, and the complete output for this ordinal logistic regression is shown in Appendix E. From the model fitting information table, p-value of this model is 0.056. If an alpha 0.05 is set, the assumption that all regression coefficients of predictors are zero cannot be violated and this model is not better than a null model (without any predictors). In other words, this comprehensive model cannot fit the relationship between all predictors and settlement levels well. The goodness of fit table presents two tests, Pearson and Deviance, of the null hypothesis that the model adequately fits the data. If the significance value is small (less than 0.05), then the model does not adequately fit the data. In this case, its value is greater than 0.05, so the data are consistent with the model assumptions.

From the table of pseudo R-square, there are three pseudo R-squared values computed by three different methods. Logistic regression does not have an equivalent to the R-squared that is found in ordinary least squares (OLS) regression. OLS is concerned with the squares of the errors. It tries to find a fitting line going through the sample data that

minimizes the sum of the squared errors; however, many people have tried to come up with one. There are a wide variety of pseudo R-squared statistics which can give contradictory conclusions. Because these statistics do not mean what R-squared means in OLS regression (the proportion of variance of the response variable explained by the predictors). Generally, these pseudo r-square values are not very high either not very low, it is suggested interpreting them with great caution. The test of parallel lines indicates that the proportional odds assumption is not violated and the method of ordinal regression for identifying the relationship between approach settlement and its causative factors is applicable. However, the model fitting information indicates that this model may not be better than a null model. Therefore, method of multinomial logistic regression was adopted.

**Table 4.91 Sample One: Model fitting information of ordinal logistic regression**

Model	-2 Log Likelihood	Chi-Square	df	Sig.
Intercept Only	177.953			
Final	147.035	30.918	20	.056

**Table 4.92 Sample One: Goodness of fit of ordinal logistic regression**

	Chi-Square	df	Sig.
Pearson	154.849	152	.421
Deviance	147.035	152	.599

**Table 4.93 Sample One: Pseudo R-square of ordinal logistic regression**

Method	Value
Cox and Snell	.299
Nagelkerke	.344
McFadden	.174

**Table 4.94 Sample One: Test of parallel lines of ordinal logistic regression**

Model	-2 Log Likelihood	Chi-Square	df	Sig.
Null Hypothesis	147.035			
General	116.451 <sup>b</sup>	30.584 <sup>c</sup>	20	.061

Another method of multinomial logistic regression was carried out aiming at developing a more accurate and parsimonious model. The complete output for this multinomial logistic regression is shown in Appendix F. The model fitting information of multinomial logistic regression shows that the p-value of model fitting information is smaller than 0.05, which means this model can fit the relationship between SEVERITY and all independent variables well. The goodness of fit table shows that the significance values from Pearson and Deviance tests are much higher than 0.05 and bigger than the results from ordinal logistic regression, which means this model adequately fits the data. The values of pseudo R-square are not very high or not very low. The likelihood ratio tests indicate AGE, DISTRICT, and FSD are statistically significant for this model. The interpretation of the parameter estimates is presented as following:

Minimal relative to Severe:

- AGE: If an approach was to increase AGE by one year, the multinomial log-odds of being minimal relative to severe would be expected to increase by 0.131 unit while holding all other variables in the model constant.
- DISTRICT: If a bridge was moved to district one from district twelve, the multinomial log-odds of being minimal relative to severe would be expected to increase by 21.483 unit while holding all other variables in the model constant. The estimated multinomial logistic regression coefficients for other districts can be interpreted in the same way.
- FSD: If the foundation soil depth for a bridge was to increase by one feet, the multinomial log odds of being minimal relative to severe would be expected to decrease by 0.175 unit while holding all other variables in the model constant.

Moderate relative to Severe:

- AGE: If an approach was to increase AGE by one year, the multinomial log-odds of being moderate relative to severe would be expected to increase by 0.014 unit while holding all other variables in the model constant.
- DISTRICT: If a bridge was moved to district one from district twelve, the multinomial log-odds of being moderate relative to severe would be expected to increase by 18.093 unit while holding all other variables in the model constant. The estimated multinomial logistic regression coefficients for other districts can be interpreted in the same way.
- FSD: If the foundation soil depth for a bridge was to increase by one feet, the multinomial log odds of being minimal relative to severe would be expected to decrease by 0.004 unit while holding all other variables in the model constant.

The probability that each settlement level may occur can be expressed in the following equations:



$$\begin{aligned}
\text{logit} \frac{\pi_1}{\pi_3} = & 11.246 + 0.003\text{LENGTH} - 0.013\text{WIDTH} + 0.131\text{AGE} \\
& + 0.000\text{ADT} - 0.084\text{EH} - 0.175\text{FSD} + 21.483\text{DIS1} \\
& + 0.000\text{DIS2} + 0.000\text{DIS3} + 1.767\text{DIS4} + 3.722\text{DIS5} \\
& + 17.908\text{DIS6} + 1.751\text{DIS7} + 0.000\text{DIS8} + 4.132\text{DIS9} \\
& + 24.518\text{DIS10} + 20.706\text{DIS11} + 0.000\text{DIS12} \\
& - 37.279\text{ABUT1} - 16.258\text{ABUT2} + 0.000\text{ABUT3} \\
& - 1.622\text{APPT1} + 0.000\text{APPT2} - 32.712\text{FSC1} \\
& - 29.828\text{FSC2} - 30.989\text{FSC3} + 0.000\text{FSC4} \quad (4.21)
\end{aligned}$$

$$\begin{aligned}
\text{logit} \frac{\pi_2}{\pi_3} = & -4.972 + 0.000\text{LENGTH} + 0.021\text{WIDTH} + 0.014\text{AGE} \\
& + 0.000\text{ADT} - 0.016\text{EH} - 0.004\text{FSD} + 18.093\text{DIS1} \\
& + 0.000\text{DIS2} + 0.000\text{DIS3} + 16.967\text{DIS4} + 19.462\text{DIS5} \\
& + 16.612\text{DIS6} + 17.134\text{DIS7} + 0.000\text{DIS8} + 17.776\text{DIS9} \\
& + 17.041\text{DIS10} + 16.859\text{DIS11} + 0.000\text{DIS12} \\
& - 13.840\text{ABUT1} - 0.075\text{ABUT2} + 0.000\text{ABUT3} \\
& + 0.898\text{APPT1} + 0.000\text{APPT2} - 13.082\text{FSC1} \\
& - 14.185\text{FSC2} - 13.552\text{FSC3} + 0.000\text{FSC4} \quad (4.22)
\end{aligned}$$

The probability relationship between three severity levels:

$$\pi_1 + \pi_2 + \pi_3 = 1 \quad (4.23)$$

By using these equations above, it is able to compute the probability that each settlement category may occur based on all predictors. The settlement category with the largest

probability will be selected as the predicted category. The classification table shows the predicted accuracy for each settlement level. The overall percentage of correct of predicting the settlement levels is 67.8%.

**Table 4.95 Sample One: Model fitting information of multinomial logistic regression**

Model	Model Fitting Criteria	Likelihood Ratio Tests		
	-2 Log Likelihood	Chi-Square	df	Sig.
Intercept Only	177.953			
Final	115.383	62.570	40	.013

**Table 4.96 Sample One: Goodness of fit of ordinal logistic regression**

	Chi-Square	df	Sig.
Pearson	120.916	132	.746
Deviance	115.383	132	.848

**Table 4.97 Sample One: Pseudo R-square of multinomial logistic regression**

Method	Value
Cox and Snell	.513
Nagelkerke	.589
McFadden	.352

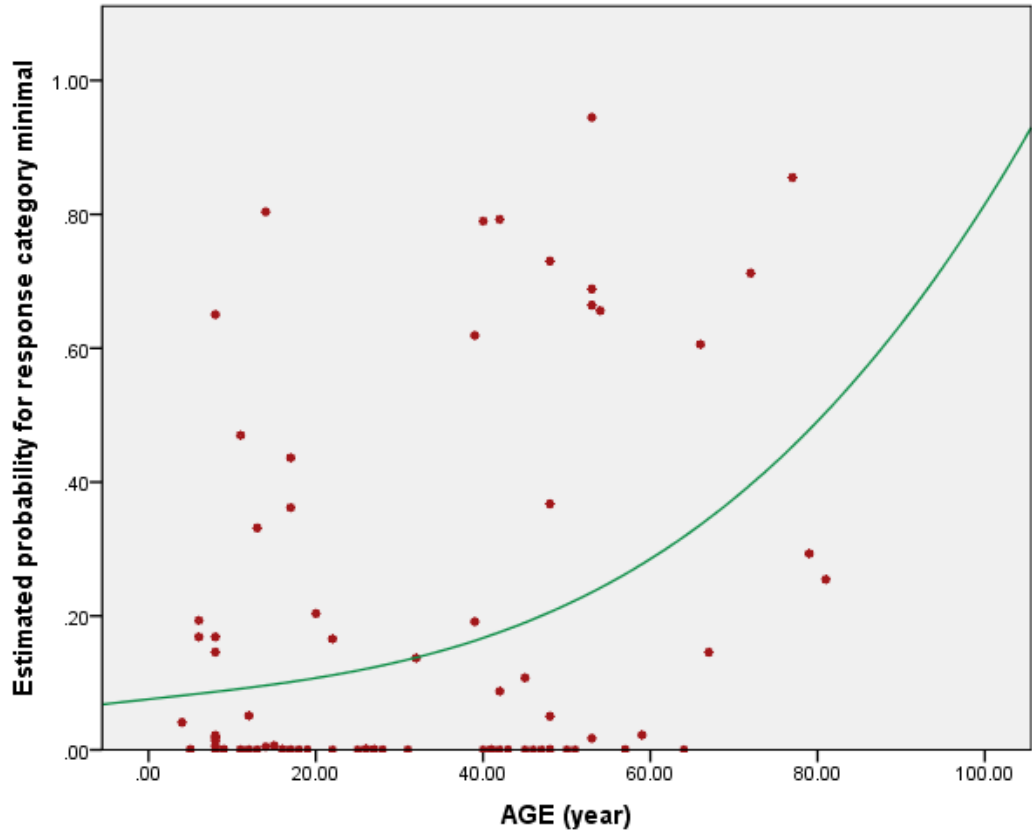
**Table 4.98 Sample One: Likelihood ration tests of multinomial logistic regression**

Effect	Model Fitting Criteria	Likelihood Ratio Tests		
	-2 Log Likelihood of Reduced Model	Chi-Square	df	Sig.
Intercept	115.383	.000	0	.
LENGTH	117.334	1.950	2	.377
WIDTH	116.110	.727	2	.695
AGE	129.661	14.278	2	.001
ADT	117.052	1.669	2	.434
EH	117.560	2.176	2	.337
FSD	121.448	6.065	2	.048
DISTRICT	152.321	36.938	16	.002
ABUT	120.157	4.773	4	.311
APPT	118.496	3.113	2	.211
FSC	119.905	4.521	6	.606

**Table 4.99 Sample One: Classification table of multinomial logistic regression**

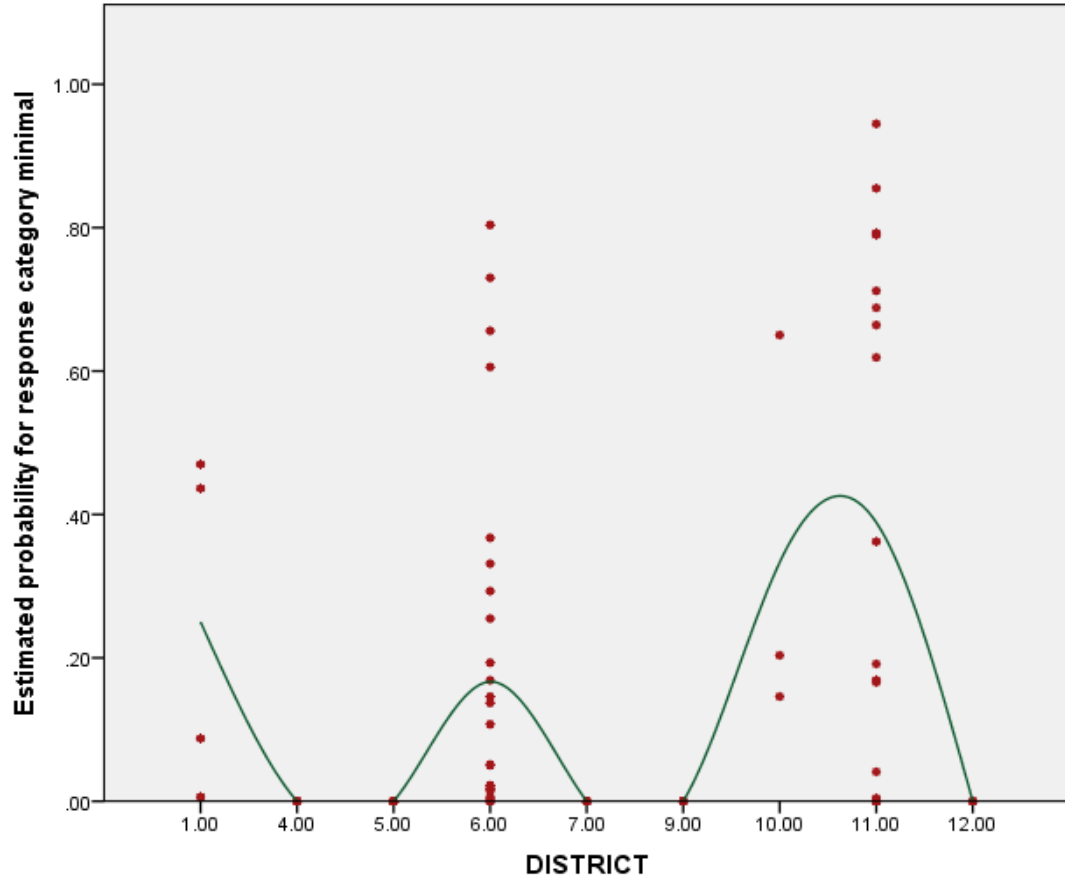
Observed	Predicted			
	1.00	2.00	3.00	Percent Correct
1.00	11	1	2	78.6%
2.00	2	22	12	61.1%
3.00	3	8	26	70.3%
Overall Percentage	18.4%	35.6%	46.0%	67.8%

With the purpose of better interpretation of the parameter estimates, the variation trends of the predicted probability of minimal versus the statistically significant predictors (AGE, DISTRICT, and FSD) were identified. From the variation trend of the estimated probability of minimal versus approach age, the probability of being in the settlement level of minimal will increase as approach age increases. From the variation trend of the estimated probability of minimal versus transportation districts, district one, ten, and eleven show a higher probability of being in the settlement level of minimal than other districts. Similarly, the variation trend of the estimated probability of minimal versus foundation soil depth indicates that the probability of being in the settlement level of minimal will increase at first as the foundation soil depth increase by 25 feet and then decrease as the foundation soil depth continues to increase.



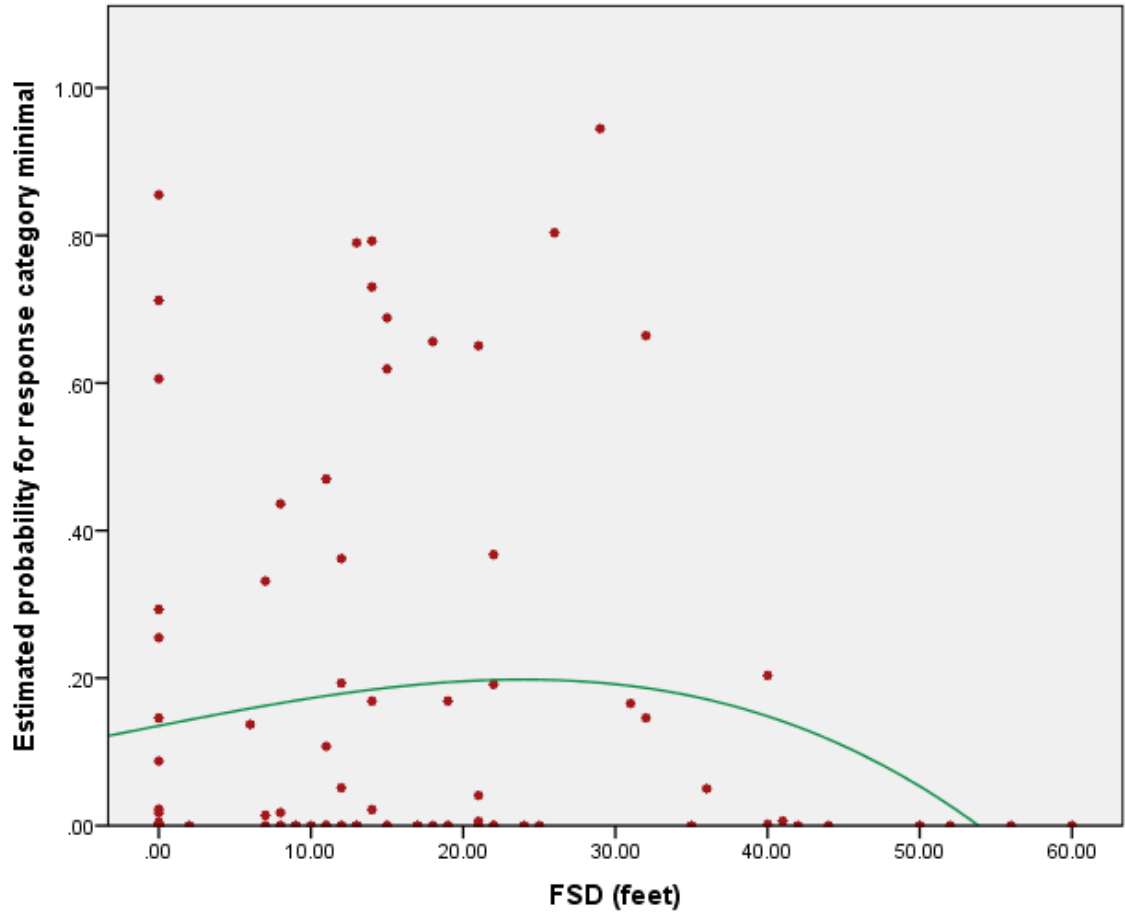
Footnote: interpolation line stands for variation trend at total

**Figure 4.29 Sample One: Variation trend of the estimated probability of minimal versus approach age**



Footnote: interpolation line stands for variation trend at total

**Figure 4.30 Sample One: Variation trend of the estimated probability of minimal versus transportation districts**



Footnote: interpolation line stands for variation trend at total

**Figure 4.31 Sample One: Variation trend of the estimated probability of minimal versus foundation soil depth**

From the interpretation of the parameter estimates for significant predictors and the variation trends of the predicted probability of minimal versus the statistically significant predictors, the following conclusions can be concluded:

- As age of an approach increases, the probability of being in a higher settlement level will decrease.
- The performance of approaches in the district one, district ten, and district eleven behaves better than other districts.

- As foundation soil depth for a bridge increases, the probability of being in a higher settlement level will decrease.

#### **4.10.2 Sample Two**

Both ordinal and multinomial logistic regressions were carried out for sample two, and their results are similar. Both models are applicable and reliable for this sample, and the same conclusions were obtained. The outputs of ordinal logistic regression and multinomial logistic regression for sample two are shown in Appendix G and Appendix H, respectively. Method of multinomial logistic regression is solely illustrated in this section in order to make it easier to compare with sample one. Some important model fitting information for this multinomial logistic regression are shown in Table 4.100 ~ Table 4.104,. This model is better than a null model from the model fitting information, which implies that at least one parameter estimate is not zero. From the table of goodness of fit, the null hypothesis that the model adequately fits the data is true due to the high significance values from Pearson and Deviance tests. In other words, this model is able to fit the relationship between all predictors and SEVERITY well. From the table of likelihood ratio tests, DISTRICT, AGE, ADT, and APPT are statistically significant, while the others are not. The interpretation of the parameter estimates is summarized as following:

Minimal relative to Severe:

- DISTRICT: If a bridge was moved to district one from district twelve, the multinomial log-odds of being minimal relative to severe would be expected to increase by 2.278 while holding all other variables in the model constant. The



estimated multinomial logistic regression coefficients for other districts can be interpreted in the same way.

- AGE: If an approach was to increase AGE by one year, the multinomial log-odds of being minimal relative to severe would be expected to decrease by 0.029 while holding all other variables in the model constant.
- ADT: If the ADT for an approach was to increase by one unit, the multinomial log odds of being minimal relative to severe would be expected to increase by 1.0E-8 while holding all other variables in the model constant.
- APPT: If a bridge approach was changed to flexible from rigid, the multinomial log-odds of being minimal relative to severe would be expected to decrease by 0.977 while holding all other variables in the model constant.

Moderate relative to Severe:

- DISTRICT: If a bridge was moved to district one from district twelve, the multinomial log-odds of being moderate relative to severe would be expected to increase by 1.549 while holding all other variables in the model constant. The results from ordinal logistic regression also concludes that the log odds of being in a higher level of settlement severity will decrease by 1.124 if moving from the district twelve to district one while the other variables in the model are held constant.
- AGE: If an approach was to increase AGE by one year, the multinomial log-odds of being moderate relative to severe would be expected to decrease by 0.009 while holding all other variables in the model constant. The ordinal logistic regression indicates: for a one unit increase in AGE on the expected SEVERITY

level given the other variables are held constant in the model, the ordered log-odds of being in a higher level of SEVERITY will increase by 0.017.

- ADT: If the ADT for an approach was to increase by one unit, the multinomial log odds of being moderate relative to severe would be expected to increase by  $1.2E-8$  unit while holding all other variables in the model constant. The parameter estimates from multinomial logistic regression show that the coefficient for ADT is approximately equal to zero due to a very small value. However, the ordinal logistic regression concludes that the ordered log-odds of being in a higher level of SEVERITY will increase by  $1.910E-5$  if increasing one unit in ADT on the expected SEVERITY level given the other variables are held constant in the model,.
- APPT: If a bridge approach was changed to flexible from rigid, the multinomial log-odds of being moderate relative to severe would be expected to decrease by 0.525 while holding all other variables in the model constant. Similarly, the ordinal logistic regression concludes that the log odds of being in a higher level of settlement severity will increase by 0.529 if changing from the rigid approach to flexible approach while the other variables in the model are held constant.

**Table 4.100 Sample Two: Model fitting information of multinomial logistic regression**

Model	Model Fitting Criteria	Likelihood Ratio Tests		
	-2 Log Likelihood	Chi-Square	df	Sig.
Intercept Only	1270.242			
Final	984.788	285.453	46	.000

**Table 4.101 Sample Two: Goodness of fit of multinomial logistic regression**

	Chi-Square	df	Sig.
Pearson	1128.538	1150	.669
Deviance	984.788	1150	1.000

**Table 4.102 Sample Two:: Pseudo R-square of multinomial logistic regression**

Methods	Value
Cox and Snell	.379
Nagelkerke	.430
McFadden	.225

**Table 4.103 Sample Two: Likelihood ratio tests of multinomial logistic regression**

Effect	Model Fitting Criteria	Likelihood Ratio Tests		
	-2 Log Likelihood of Reduced Model	Chi-Square	df	Sig.
Intercept	984.788	.000	0	.
LENGTH	987.497	2.709	2	.258
WIDTH	988.640	3.852	2	.146
AGE	999.009	14.220	2	.001
ADT	994.452	9.664	2	.008
EH	984.984	.196	2	.907
FSD	986.155	1.367	2	.505
DISTRICT	1169.284	184.496	22	.000
ABUT	988.706	3.917	4	.417
APPT	991.444	6.655	2	.036
FSC	987.878	3.089	6	.798

**Table 4.104 Sample Two: Classification table of multinomial logistic regression**

Observed	Predicted			
	1.00	2.00	3.00	Percent Correct
1.00	122	62	8	63.5%
2.00	70	168	35	61.5%
3.00	8	54	73	54.1%
Overall Percentage	33.3%	47.3%	19.3%	60.5%

The probability that each settlement level may occur can be expressed in the following equations:

$$\begin{aligned}
 \text{logit} \frac{\pi_1}{\pi_3} = & 4.624 - 0.001LENGTH - 0.015WIDTH - 0.29AGE + 1.0 \times 10^{-8}ADT \\
 & - 0.006EH - 0.003FSD + 2.278DIS1 - 18.812DIS2 + 0.452DIS3 \\
 & - 20.848DIS4 - 3.749DIS5 - 0.980DIS6 - 2.714DIS7 - 17.614DIS8 \\
 & - 2.427DIS9 + 16.495DIS10 - 1.356DIS11 + 0.000DIS12 \\
 & - 0.749ABUT1 - 1.246ABUT2 + 0.000ABUT3 - 0.977APPT1 \\
 & + 0.000APPT2 - 0.188FSC1 - 0.718FSC2 - 1.026FSC3 \\
 & + 0.000FSC4 \qquad (4.24)
 \end{aligned}$$

$$\begin{aligned}
 \text{logit} \frac{\pi_2}{\pi_3} = & 2.423 + 0.000LENGTH + 0.002WIDTH - 0.009AGE + 1.2 \times 10^{-8}ADT \\
 & - 0.005EH + 0.007FSD + 1.549DIS1 - 1.907DIS2 + 0.176DIS3 \\
 & - 20.103DIS4 - 0.969DIS5 - 0.140DIS6 - 1.580DIS7 - 1.072DIS8 \\
 & - 0.830DIS9 + 15.721DIS10 + 0.193DIS11 + 0.000DIS12 \\
 & - 0.319ABUT1 - 0.082ABUT2 + 0.000ABUT3 - 0.525APPT1 \\
 & + 0.000APPT2 - 0.383FSC1 - 0.662FSC2 - 0.846FSC3 \\
 & + 0.000FSC4 \qquad (4.25)
 \end{aligned}$$

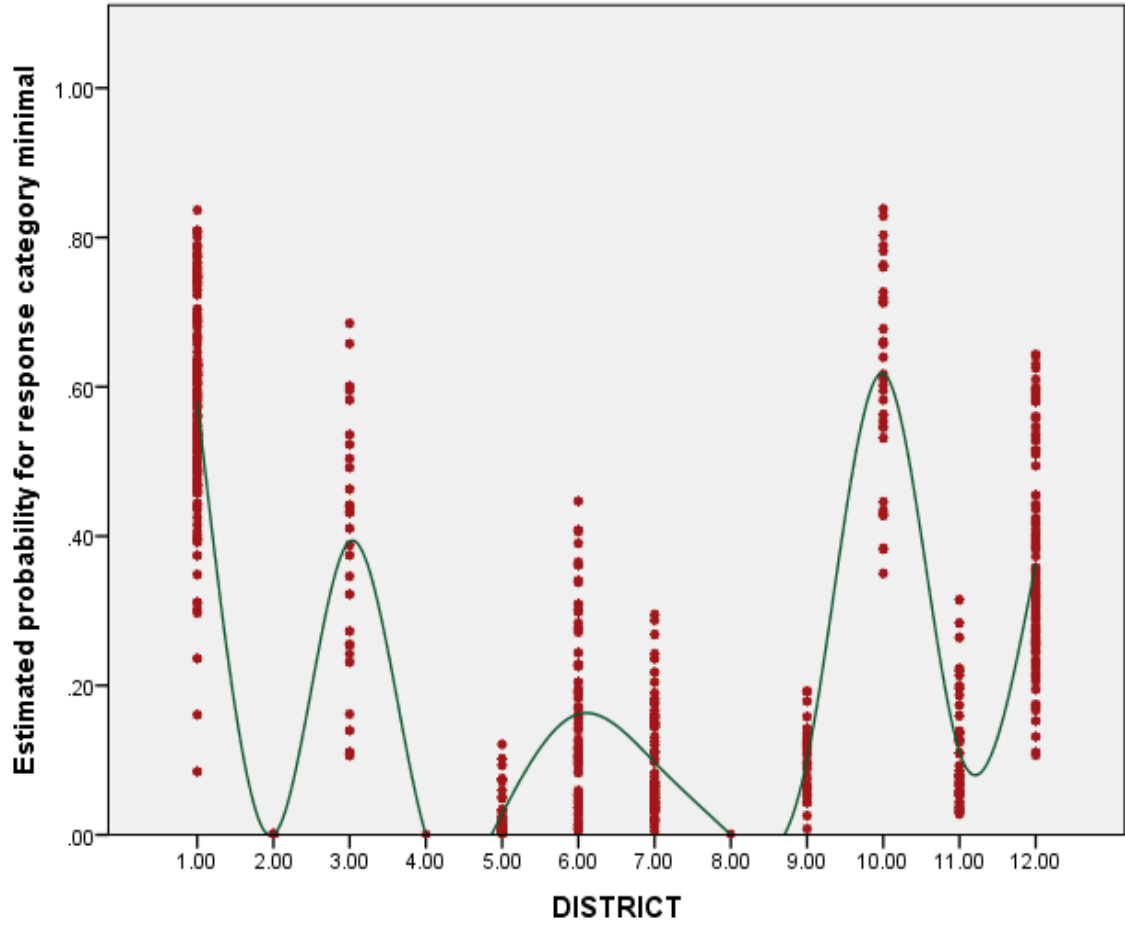
The probability relationship between three severity levels:

$$\pi_1 + \pi_2 + \pi_3 = 1 \qquad (4.26)$$

By using these three equations above, it is able to compute the probability that each settlement category may occur based on all predictors. The settlement category with the largest probability will be selected as the predicted category. The classification table

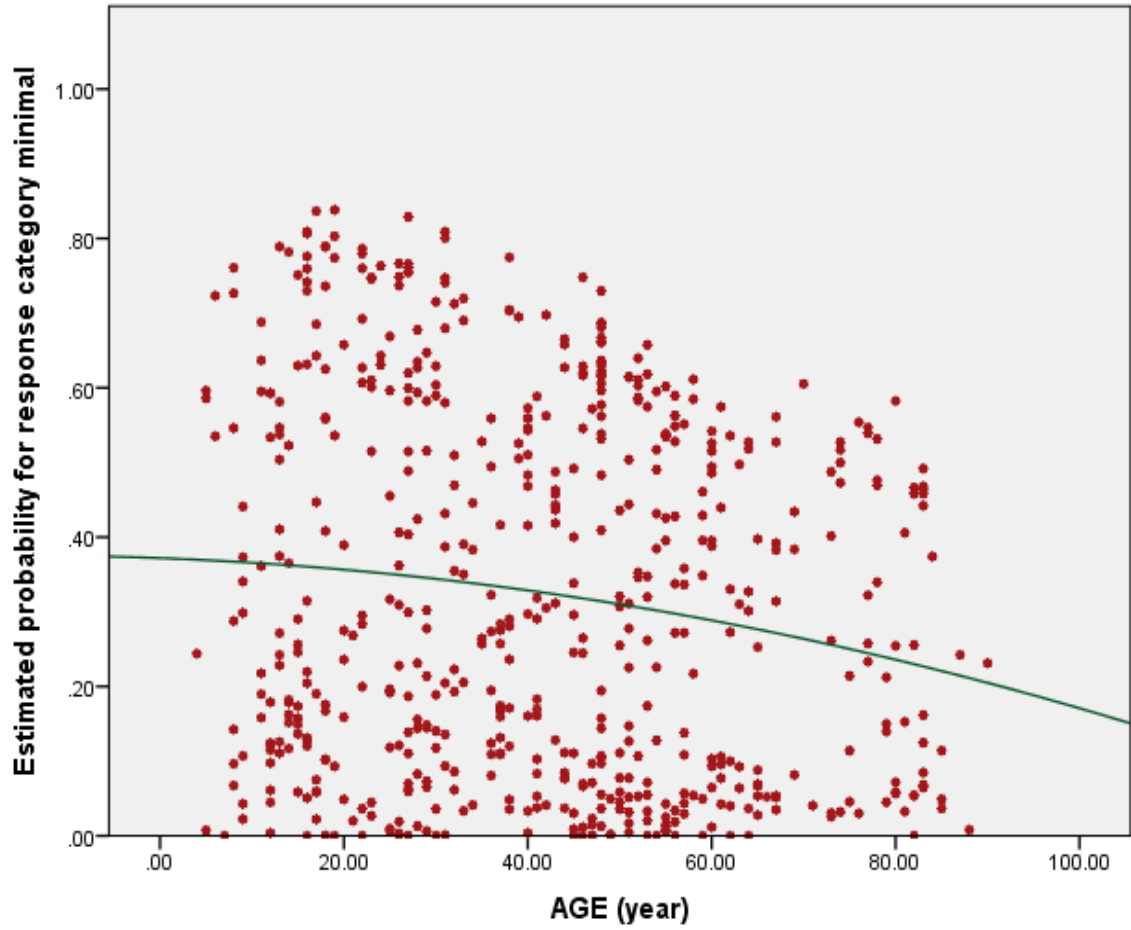
shows the predicted accuracy for each settlement level. The overall percentage of correct of predicting the settlement levels by using this model is 60.5%.

As the same way of dealing with sample one, the variation trends of the predicted probability of minimal versus the statistically significant predictors (DISTRICT, AGE, ADT, and APPT) were identified for sample two. From the variation trend of the estimated probability of minimal versus transportation districts, district one, three, and ten show a higher probability of being in the settlement level of minimal than other districts. From the variation trend of the estimated probability of minimal versus approach age, the probability of being in the settlement level of minimal will decrease as approach age increases. Similarly, the variation trend of the estimated probability of minimal versus average daily traffic indicates that the probability of being in the settlement level of minimal will decrease as the average daily traffic increase. Furthermore, it is distinct to conclude that rigid approaches tend to have a higher probability of experiencing settlement levels of minimal than flexible approaches.



Footnote: interpolation line stands for variation trend at total

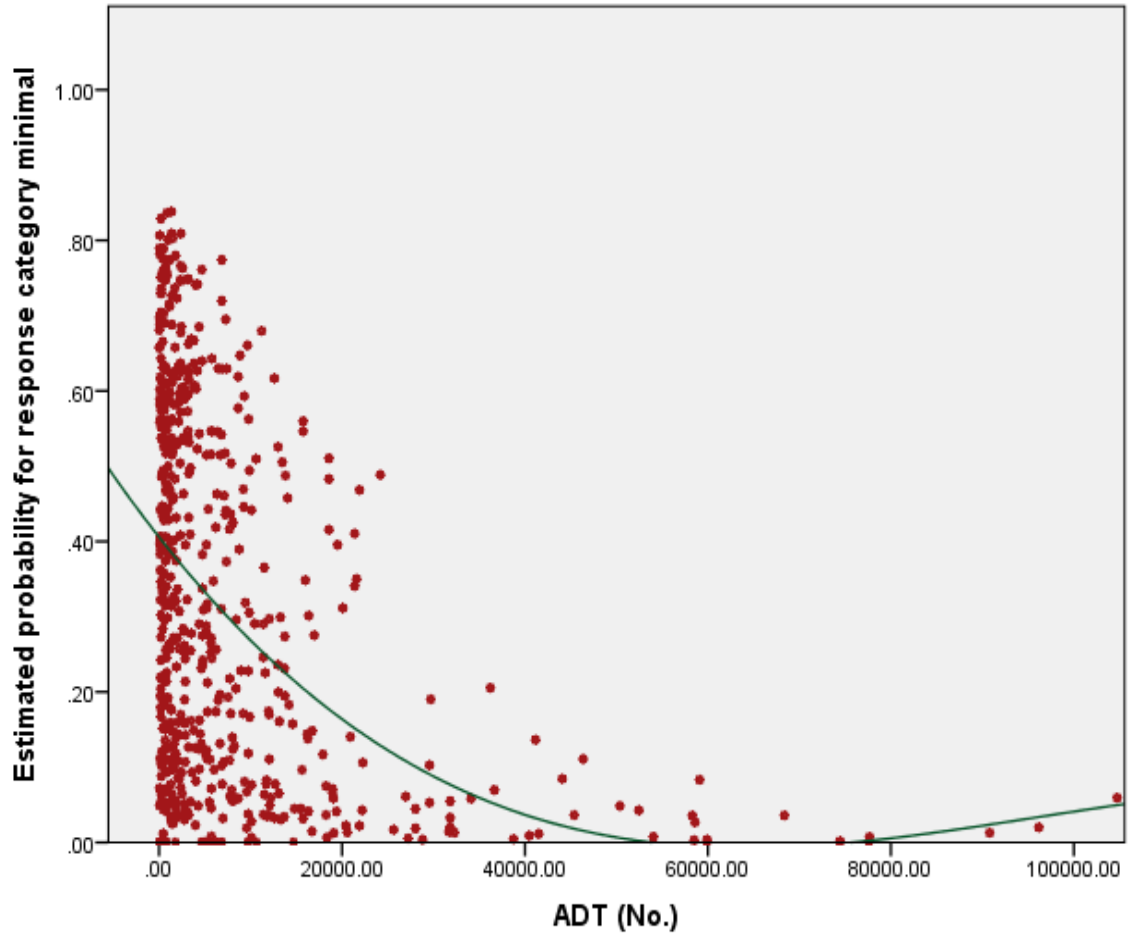
**Figure 4.32 Sample Two: Variation trend of the estimated probability of minimal versus transportation districts**



Footnote: interpolation line stands for variation trend at total

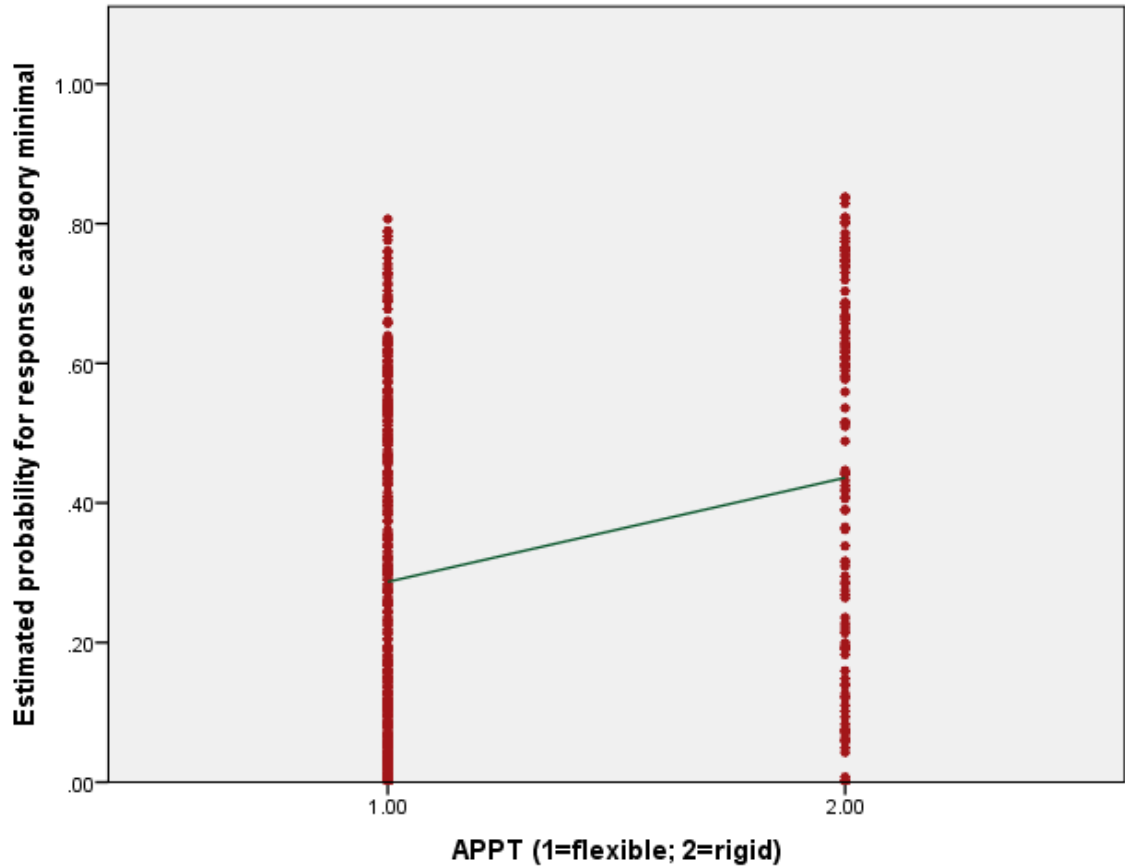
**Figure 4.33 Sample Two: Variation trend of the estimated probability of minimal versus approach age**





Footnote: interpolation line stands for variation trend at total

**Figure 4.34 Sample Two: Variation trend of the estimated probability of minimal versus average daily traffic**



Footnote: interpolation line stands for variation trend at total

**Figure 4.35 Sample Two: Variation trend of the estimated probability of minimal versus average approach type**

From the interpretation of the parameter estimates for significant predictors and the variation trends of the predicted probability of minimal versus the statistically significant predictors, the following conclusions can be concluded:

- The performance of approaches in the district one, district three, and district ten behaves better than other districts.
- As age of an approach increases, the probability of being in a higher settlement level will increase.

- As average daily traffic for an approach increases, the probability of being in a higher settlement level will increase.
- Flexible approaches tend to have a higher probability of being in a higher settlement level than rigid approaches.

#### **4.10.3 Comparison between Two Models**

The process of applying a predictive model to a set of data is referred to as scoring the data. SPSS has procedures for building predictive models of logistic regressions. Once a model has been built, the model specifications can be saved in a file that contains all of the information necessary to reconstruct the model. Then the model file can be used to generate predictive scores in other datasets. This section used the utility named Scoring Wizard in SPSS to apply the model created with sample one to dataset of sample two and generate predicted settlement category, and vice versa apply the model created with sample two to dataset of sample one. The scoring process consists of three basic steps:

1. Build the model and save the model file. A predictive model can be built by using a dataset for which the outcome of interest is known. For example, if a model that will predict the settlement levels for sample one is aimed to be developed, a dataset that already contains information on observed settlement levels is supposed to be possessed.
2. Apply that model to a different dataset to obtain predicted outcomes. For example, apply the model created from sample one to data of sample two, it needs to assume that the outcome of settlement levels for sample two is not known.
3. Finally, compare the predicted settlement category with the observed settlement category and obtain the accuracy rate for both models.

The comparison between the observed settlement category and the predicted settlement category is shown in Table 4.105. When applying the model created with sample one to dataset of sample two, the accuracy rate of predicting the right settlement category is 30.2%. Conversely, when applying the model created with sample two to dataset of sample one, the accuracy rate of predicting the right settlement category is 28.7%. Both accuracy rates are slightly lower than a stochastic probability of 33% that could be obtained by guessing the settlement category randomly. This is not surprising because it demonstrates these two models are different models that are developed from different samples based on different selection criteria. The users can decide which one to use by different requirements and purposes.

**Table 4.105 Percent correct of applying two model to each other dataset**

Category	Percent Correct
Apply model one to data of sample two	30.2%
Apply model two to data of sample one	28.7%

In logistic regressions, the count data (i.e., LENGTH and ADT) with a considerable variability are processed as continuous variables while they are not truly continuous. A check for empty or small cells by doing a crosstab between categorical independent variables and the outcome variable was conducted and shows that there are more than 65% cells (i.e., dependent variable levels by observed combinations of predictor variable values) with zero frequencies for both samples. If a cell has very few cases, the model may become unstable or it might not run at all. The size of sample two is much bigger

than sample one. In this instance, models developed from sample one may not be stable even if the model could gain a satisfied p-value.

#### **4.10.4 Conclusions**

The model developed from the method of ordinal logistic regression for sample one is found not statistically significant. In other words, this model is not better than a null model and cannot fit the relationship between settlement levels and all predictors well. Then a multinomial logistic regression was conducted on sample one. The results show that AGE, DISTRICT, and FSD are statistically significant while the others are not. This model indicates that there is a negative correlation between AGE and SEVERITY, which means the probability of being in a higher settlement level will decrease as the approach age increases. This conclusion is contrary to the relationship between AGE and SEVERITY of sample two. This reverse can be explained by the fact that a selection bias may be formed because the bridges with severe bump usually impress respondents most. Sample one shows that district one, district ten, and district eleven behave better than other districts in the treatment of differential settlement at bridge ends. In addition, the probability of being in a higher settlement level will decrease as foundation soil depth for a bridge increases.

Both ordinal and multinomial logistic regressions were implemented for sample two, and both methods yield the similar results. Both logistic regressions of sample two reveal that DISTRICT, AGE, ADT, and APPT are statistically significant for the relationship between the settlement severity and its causative predictors. District one, district three, and district ten behave better by comparing to other districts in the treatment of differential settlement at bridge ends. There is a positive correlation between AGE and

SEVERITY, which implies that the probability of being in a higher level of approach settlement will increase as the bridge age increases while holding all other predictors constant. As average daily traffic for an approach increases, the probability of being in a higher settlement level will increase. Furthermore, flexible approaches tend to have a higher probability of being in a higher settlement level than rigid approaches.

## **5 DISTRICT INTERVIEWS**

The research team visited five out of twelve districts to document various problems that are reported by local bridge personnel at bridge approaches. Bridge engineers in design, construction, and maintenance from district one, district three, district five, district eleven, and district twelve were interviewed in type of face to face or video conferences.

This section is a summary of current practices that have been adopted for mitigating settlements at bridge approaches, as well as suggested methods or measures for managing bridge approaches which may produce potential settlements based on the results of predictive models. These current practices and suggestions are listed based on various groups of treatments such as foundation soil, backfill materials, approach slab, abutments, and drainage.

The major purpose of this chapter is to provide bridge engineers the prescriptive correction measures that could be applied to predicted differential settlement. On the one hand, the bridge designers could use the models developed in Chapter four to predict the approach settlement level based on foundation, approach, embankment, and other bridge characteristics for a new bridge. And then apply corresponding techniques or measures to prevent or minimize the settlement problems that may occur in the future. On the other hand, the bridge maintenance engineers also could use the models to predict approach settlement level for a bridge that has been constructed. And then implement maintenance measures for different levels of distressed approaches.

## 5.1 Foundation Soil

Foundation soils beneath the embankment and embankment fill is one of the important factors that influence the performance of bridge approaches (Wahls, 1990). Many studies have demonstrated that the settlement mechanism and process are different between soil of granular material type and soil of cohesive material type. For granular soils, such as sand, gravel, and rock, it doesn't need to undergo long term settlements, and the differential settlement between roadway and bridge upper structure can be negligible. While for cohesive soils, the settlement process is much longer than granular soils. Large settlements either from primary and/or secondary consolidation settlement may be formed in a long term. Subsequently, the settlements of the foundation soils and embankment fill may lead to a poor performance of bridge approaches. Generally, the time period for the primary phase can range from a few months in very granular soils to seven to ten years for some clays (Hopkins, 1973). Hence different mitigation methods are supposed to be adopted to deal with these two different type of foundation soils.

Both predictive models developed from sample one and sample two show that there is no significant association between foundation soils and approach settlement levels. It does not equal to a deduction that the foundation soils cannot able to influence the approach settlement. However, it should be noted that the foundation soils information that was used to develop the models are foundation soils after improvement or special treatments, especially for highly compressible foundation soils. Appropriate treatment methods or measures for highly compressible foundation soils are necessary before the construction of the construction of bridge parts. Therefore, a full investigation about the foundation soils is needed prior to design and construction. After the literature review and interviews



with the local bridge engineers in these five districts, Table 5.1 summarizes the improvement/treatment techniques or measures for foundation soils in different soil types. According to the function of each stabilization technique, Puppala (2009) divided these techniques into three subcategories as shown in Table 5.2.

**Table 5.1 Summary of foundation soils improvement methods based on soil type**

Technique	Granular soils	Cohesive soils
Excavation and replacement	X	✓
Preloading with or without surcharge	✓	✓
Dynamic compaction	✓	✓
Grouting	✓	✓
Drains	X	✓
Grave/Stone columns	X	✓
Geosynthetics	✓	✓

**Table 5.2 Summary of foundation soils improvement methods based on soil type based on the function (Puppala, 2009)**

Mechanical	Hydraulic	Reinforcement
Excavation and replacement; Preloading and surcharge; Dynamic compaction	Sand drains; Prefabricated drains; Surcharge loading	Columns: Stone and lime columns; Geopiers; Concrete injected columns; Deep soil mixing columns
		Deep foundations: In-situ compacted piles; CFA piles; Driven piles
		Geosynthetics: Geotextiles/Geogrids; Geocells

The current practices regrading foundation preparation are summarized by interviewing local bridge engineers. The following conclusions can be obtained:

1. Most bridge design engineers consider that a reliable subsurface exploration information for a selected site is paramount. The importance of foundation exploration phase cannot be overemphasized. Responsible geotechnical personnel must be assigned with this task.
2. Several ground improvement methods are usually adopted as a combination to guarantee an adequate foundation for new bridges. The most common ways that have been using to improve highly compressible foundation soils are preloading the foundation soils and excavation and replacement. Some DOTs, such as Iowa

DOT and TxDOY, have implemented guidelines on foundation soils treatment. However, the KYTC has not given a manual that will guide designers and constructors how to carry out different ground improvement methods for a particular field situation.

3. The process of preloading and precompression the foundation soils usually spans a long time period. Many districts reported that they are not willing to accommodate the preloading and/or precompression periods since this process may lead to construction delay and drive initial construction costs higher.
4. Using the predictive models, if the approach settlement for a constructed bridge was classified as severe due to the problem of foundation soils. Two easy and reliable alternatives are proposed when situations do arise that the foundation soils are not adequate. One is to reduce the loads applied to the foundation, and the other method is to improve the properties of the foundation soil by grouting chemical.

## **5.2 Embankment Backfill Material**

Consensus of opinion that high quality granular engineered fill would influence the serviceability of the embankment, in the aspects of slope stability, compression, consolidation, or bearing capacity issues, has been reached. White et al. (2005) suggested that the embankment fill material should have these following properties:

- being easily compacted,
- not time-dependent,
- not sensitive to moisture,
- providing good drainage,

- erosion resistance, and
- shear resistance.

Hoppe (1999) summarized the embankment material specifications and lift thickness and percent compaction requirements from various DOTs as shown in Table 5.3 and Table 5.4, respectively.

**Table 5.3 Embankment material specifications (Hoppe, 1999)**

State	Same/Different from regular embankment	% passing 75mm (No. 200 sieve)	Miscellaneous
AL	Same		A-1 to A-7
AZ	Different		
CA		<4	Compacted pervious material
CT	Different	<5	Pervious material
DE	Different		Borrow type C
FL	Same		A-1, A-2-4 through A-2-7, A-4, A-5, A-6, A-7 (LL<50)
GA	Same		GA Class I, II or III
ID			A yielding material
IL	Different		Porous, granular
IN	Different	<8	
IO	Different		Granular; can use Geogrid
KS			Can use granular, flowable or light weight
KY		<10	Granular
LA			Granular
ME	Different	<20	Granular borrow
MA	Different	<10	Gravel borrow type B, M1.03.0

MI	Different	<7	Only top 0.9 m (3 ft) are different (granular material Class II)
MN		<10	Fairly clean granular
MO			Approved material
MS	Different		Sandy or loamy, non-plastic
MT	Different	<4	Pervious
NE			Granular
NV	Different		Granular
NH	Same	<12	
NJ	Different	<8	Porous fill (Soil Aggregate I-9)
NM	Same		
NY		<15	<30% Magnesium Sulfate loss
ND	Different		Graded mix of gravel and sand
OH	Same		Can use granular material
OK	Different		Granular just next to backwall
OR	Different		Better material
SC	Same		
SD	Varies		Different for integral; same for conventional
TX	Same		
VT	Same		Granular
VA	Same		Pervious backfill
WA			Gravel borrow
WI	Different	<15	Granular
WY	Different		Fabric reinforced

**Table 5.4 Lift thickness and percent compaction requirements (Hoppe, 1999)**

State	Lift Thickness, mm(inch)	% Compaction	Miscellaneous
AL	203(8)	95	
AZ	203(8)	100	
CA	203(8)	95	For top 0.76 m (2.5 ft)
CT	152(6)	100	Compacted lift indicated
DE	203(8)	95	
FL	203(8)	100	
GA		100	
ID	203(8)	95	
IL	203(8)	95	For top, remainder varies with embankment height
IN	203(8)	95	
IO	203(8)	None	One roller pass per inch thickness
KS	203(8)	90	
KY	152(6)	95	Compacted lift indicated; Moisture = +2% or -4% of optimum
LA	305(12)	95	
ME	203(8)		At or near optimum moisture
MD	152(6)	97	For top 0.30 m (1ft), remainder is 92%
MA	152(6)	95	
MI	230(9)	95	
MN	203(8)	95	
MO	203(8)	95	
MS	203(8)		
MT	152(6)	95	At or near optimum moisture
NE		95	

NV		95	
NH	305(12)	98	
NJ	305(12)	95	
NY	152(6)	95	Compacted lift indicated
ND	152(6)		
OH	152(6)		
OK	152(6)	95	
OR	203(8)	95	For top 0.91 m (3ft), remainder is 90%
SC	203(8)	95	
SD	203-305(8-12)	97	0.20 m (8 inch) for embankment, 0.30 m (12 inch) for bridge end backfill
TX	305(12)	None	
VT	203(8)	90	
VA	203(8)	95	+ or – 20% of optimum moisture
WA	102(4)	95	Top 0.61 m (2 ft), remainder is 0.20 m (8 inch)
WI	203(8)	95	Top 1.82 m (6 ft and within 60 m (200 ft), remainder is 90%
WY	305(12)		Use reinforced geotextiles layers

From the table of embankment material specifications, 49 percent of the DOTs use more rigorous material specifications for an approach fill than for a regular highway embankment fill. From Table 5.4, it can be drawn that a 95 percent of the standard proctor test compaction condition is generally specified for the compaction of approach fill. Since the embankment must provide a smooth transition between the roadway and the bridge, KYTC Structural Design Manual specifies the standards for design and construction considerations both in materials quality requirements and compaction specifications on the title sheet: Special Provision 69, “Embankment at Bridge End Bent

Structures,” and Standard Drawings RGX-100 and RGX-105, “Treatment of Embankment at Bridge End-Bent Structures.” In Kentucky, granular embankment is usually adopted except that special construction methods are specified when granular embankment materials are erodible or unstable.

Apart from the selection of embankment backfill material, precompression technique in embankment construction is cited by most bridge engineers in interviews as one of another important methods to minimize potential of settlement and lateral movement development in the approach embankments. The precompression in embankment construction is a process in which the weight of embankment will be considered as a load inducing the consolidation settlement and completing the process prior to the beginning of actual pavement or roadway construction (Puppala, 2009). Similar with the precompression method for foundation soils, this method may lead to delay, even up to one year, in most of the cases. Hence a reasonable schedule considering this step/process is necessary so as to allow embankment settlement prior to roadway construction before the placement of approach pavement (Cotton et al., 1987).

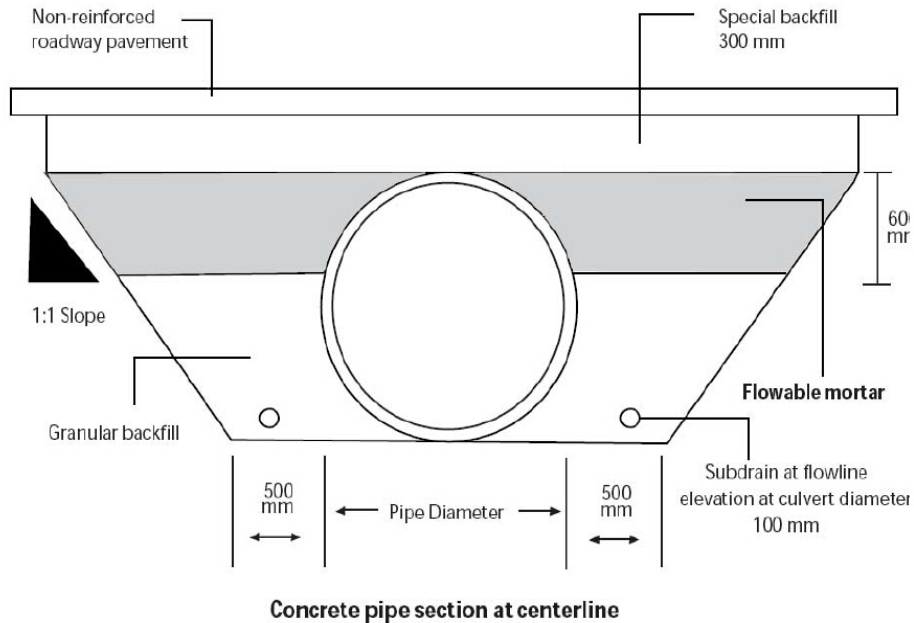
Another effective way, cited most by districts, of solving the excessive approach settlement is the use of flowable fills. The flowable fill has other common names, such as unshrinkable fill, controlled density fill, flowable mortar, flowable fill, plastic soil-cement, and soil-cement slurry (Du et al., 2006). Flowable fill is a low-strength mixing concrete used as a backfill behind the abutment wall to reduce the possibility of approach settlements near the surface, resulting from the compression of the backfill itself (Abu-Hejleh et al., 2006). Folliard et al. (2008) pointed out that the fluidity of flowable fill makes it a rapid and efficient backfilling material. This material could fill voids without



the need of any compaction, thus making the embankment as a whole uncompressible. The low-strength mixing concrete has been used by several districts in Kentucky and showed a good performance of preventing erosion of the backfill and enhancing the constructability of the fill behind the walls and its surrounding areas. Another advantage of this method is time-consuming (Snethen and Benson, 1998). This method is greatly appropriate for the bridge projects with urgent construction schedules. The interviewees also stated that this method is an expensive construction practice. In certain field and construction scenarios, the use of this practice would drive a higher construction cost. However, the benefits obtained by less approach settlement problems can balance the increased construction cost. Although flowable fill are widely used in Kentucky, no material requirements have been specified by KYTC. Various districts usually employ this method based on their experience. Colorado DOT provides exact specifications, on the material requirements for flowable fill. It stipulates the maximum lift thickness for flowable fill material is 3 ft and a placement of additional layers is not permitted until the flowable fill has lost sufficient moisture to be walked on without indenting more than 2 inches. Additionally Colorado DOT specifies that the flowable fill does not need any vibration because the vibration may stiffen the flowable fill by allowing the setting to occur faster in the field. The material requirements for flowable fill by Colorado DOT is shown in Table 5.5 as a reference for Kentucky use. In Iowa, the flowable fill has been frequently used as a placement under the existing bridges. Smadi (2001) suggested a flowable mortar that could be easily applied due to several advantages: fluidity, durability, less frequent maintenance, and easy excavation. Details of flowable mortar that are used by Iowa DOT are illustrated in Figure 5.1.

**Table 5.5 Material requirements for flowable fill by Colorado DOT**

Ingredient	Lb/C.Y.
Cement	50
Water	325 (or as needed)
Coarse aggregate (AASHTO No.57 or 67)	1700
Fine aggregate (AASHTO M6)	1845



Note: Illustration is not to scale.

**Figure 5.1 The flowable mortar used under a roadway pavement (Smadi, 2001)**

When the predictive models are used to evaluate the approach settlement for a new bridge as severe, a type of technique or a combination of backfill selection, precompression technique, and flowable fills can be employed to solve the problem of the excessive settlements induced by the embankment. If the predicted approach settlement for an existing bridge is severe, the technique of flowable fill is also an effective way of solving

the excessive approach settlement that has been demonstrated by different districts. A manual on flowable fill design and construction is supposed to be developed by KYTC to guide the employment of flowable fill.

### **5.3 Approach Slab**

The use of approach slabs is one of the most popular approach settlement abatement techniques. The bridge approach slab is a part of a bridge that rests on the abutment at one end and on the embankment or a sleeper slab on the other end (Wahls, 1990). The problem with approach slabs is that the voids beneath the approach slab are formed when approach settlement occurs. If the slab is not designed with enough reinforcement to support the unsupported span length, cracking or complete failures may lead to the approach impassable to traffic (Dupont and Allen, 2002).

A survey on over 131 bridges in Texas conducted by James et al. (1991) found that the bridges with flexible pavement had a smoother transition than those with rigid pavement. Another survey based on bridges in South Carolina (Pierce et al., 2001) showed that the approach slab with asphalt overlays tend to increase surface roughness. Most state agencies specify that the use of approach slabs is only an option, not required as a must. Although approach slabs are widely used nationwide, some state agencies (Kentucky and Maryland) argue that the use of approach slabs cannot minimize the approach settlement that will finally develop while increase the construction cost. Although, the use of approach slabs is an expensive construction practice, the analysis in chapter four indicates that the use of approach slabs is still a practical alternative in certain field and construction scenarios where the use of such practice justifies the higher costs.

The results from the Chi-square tests and the effective ratio prove that the approach slab use has a positive impact on alleviating bump issues caused by differential settlement. However, it does not equal that a bump caused by differential settlement could be eliminated by using approach slabs, and approach slabs should be adopted to every bridge by DOTs. Since the bump problem caused by differential settlement is the responsibility of DOTs, which operate under a certain budget, the cost of any methods for eliminating or minimizing this problem is a significant factor. Many solutions to this problem from design, construction, and maintenance have been proposed by DOTs, however, the total cost of approach slab and its life-cycle maintenance must not exceed the total cost of flexible approach and its life-cycle maintenance. A new approach slab is usually designed to last longer than 20 years with a cost range from \$5,000 to \$10,000 (Dupont and Allen, 2002), which is much more expensive than a flexible approach; while no statistics have demonstrated that the life-cycle maintenance of an approach slab is much lower than maintenance cost of a flexible approach during its service life. If a regular asphalt wedge tapering the gradient change to return a smooth transition cannot fix an improper approach slab, replacement of the slab is required. Dupont and Allen (2002) also concluded that the replacement of an approach slab may have a cost over \$10,000.

In an effort to figure out the low usage rate of approach slabs in Kentucky, district interviews with local bridge engineers and maintenance personnel from five districts (one, three, five, eleven, and twelve) were conducted. The feedback is summarized as:

- KYTC specifies the use of approach slabs as directed by the project manager.
- Approach slab use varies dramatically among districts. District three and five have used approach slabs as a prevention technique for minimizing differential

settlement, while the other three districts lag behind. Besides approach slabs, sleep slabs are usually placed transversally under approach slabs to disperse the load transmitted to the embankment. Good performance of approach slabs has been perceived in district three. District five indicated that approach slabs were used for most bridges two decades ago, but no distinct effect had been detected and slab use was abandoned due to high cost.

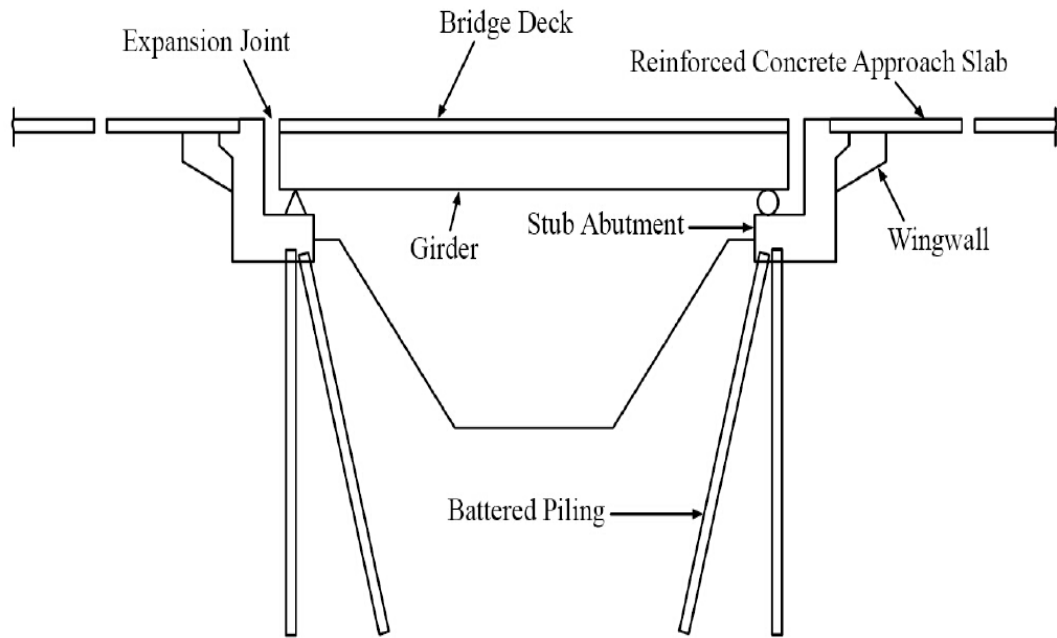
- The performance of the approach slabs depends on a series of factors including approach slab dimensions, steel reinforcement, use of a sleeper slab, and type of connection between the approach slab and the bridge. The mechanism that affects the performance of approach slabs is complex, and no specific manuals for approach slab have been established in Kentucky to specify some design or construction issues, such as joint, length, vertical place, reinforcement, etc.
- Most districts quote high construction cost as the most significant factor influencing the wide use of approach slabs.
- Approach slab use can be adopted as an effective measure for differential settlement problems, but it is not a panacea and other methods also can be used to mitigate this problem, such as embankment fill, compaction, drainage, etc.
- No maintenance record from Kentucky or other states has proven life-cycle maintenance cost for approach slabs are lower than flexible approaches.

## **5.4 Abutments**

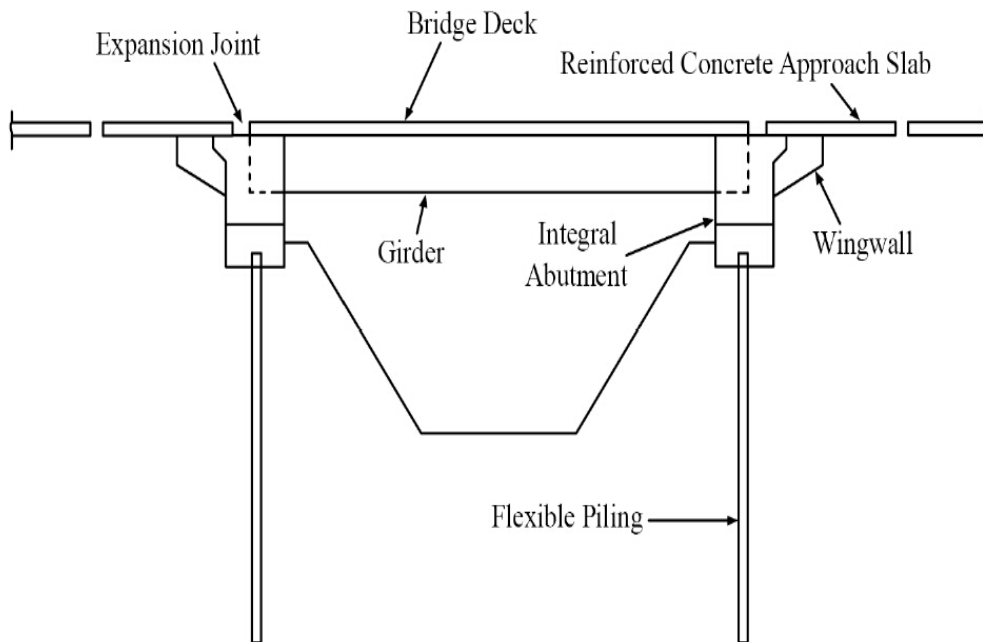
Many abutment designs exist and different abutment types have been tried on bridges throughout the United States, however, a consensus has not been reached on the best type of abutment to minimize and/or eliminate the bump problem caused by approach

settlement. Generally there are two types of abutments that are usually adopted widely by various DOTs: one-integral (conventional) and integral type. The non-integral or conventional type of bridge abutments (Figure 5.2) have bearing connections and expansion joints to provide the superstructures with a certain amount of lateral movement between the abutment and the bridge deck (Wahls, 1990). The integral bridge abutment type (Figure 5.3) was developed in order to eliminate the use of bearing plates and to reduce potential maintenance problems (Horvath, 2000). The integral abutment is a stub abutment connected to the bridge superstructure tightly without any expansion joints (Wahls, 1990). Both non-integral abutments and integral abutments are commonly employed by many state transportation agencies including Kentucky.

In chapter three, the abutment type is divided into three categories: closed, spill-through, and perched. Generally, closed and spill-through abutments fall into the category of non-integral abutments, while perched abutments can be classified as non-integral or integral abutments. In the chapter of data analysis, there is no significant association between abutment type and approach settlement levels. However, several studies have shown that the type of bridge abutments plays an important role in the form of approach settlement. Pierce et al. (2001) concluded that the bridge approaches with integral abutments tend to provide a smoother surface than the bridges with non-integral abutments. Another study (Wahls, 1990) reported a problem related to cracking and bulking at the approach pavement due to a lateral cyclic movement of the abutment from thermal movement induced stresses at the bridge decks. The biggest problem for integral abutments is the lateral movements. The bridge superstructure will be expanded and contracted by seasonal air temperature fluctuations because of concrete thermal strain properties.



**Figure 5.2 Simplified cross section of non-integral abutment bridge (Greimann et al., 1987; White et al., 2005)**



**Figure 5.3 Simplified cross section of integral abutment bridge (Greimann et al., 1987; White et al., 2005)**

According to the interview with bridge engineers from various districts, abutments supported on pile bent (perched) are generally more economical than spill-through (open column) abutments on spread footings. They usually adopt the pile bent abutments first when there is a choice between the two types of abutment. When non-integral abutments are necessary, piles that resist horizontal thrust by battering the front row of piles 1 to 3 are needed. For new bridges, the structural design manual of KYTC suggests that an integral abutment is preferable than non-integral abutments, and backwalls and expansion joints are recommended to be constructed for pile bent abutments. In addition, different abutments have different requirements for embankment backfill in design and construction in Kentucky.

## **5.5 Drainage**

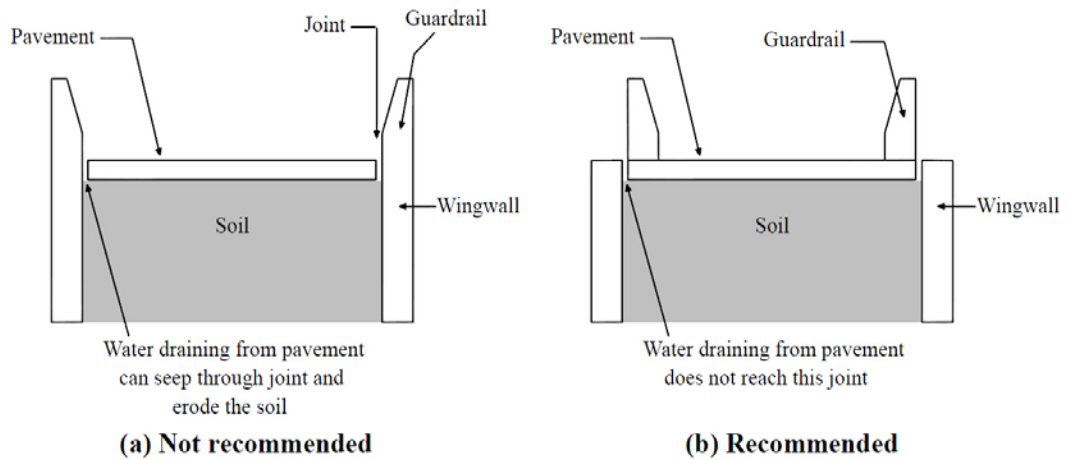
Approach drainage is another key factor that influence the occurrence of bump caused by approach settlement at the end of bridges. Water collected on the road surface and bridge pavement can flow into the underlying fill materials due to ineffective seals at the joints or cracks between the bridge approach and the abutments, and this infiltrated water can do significantly damage to the bridge approach. For bridge without approach slabs, the seeped water will immediately induce settlement, causing a bump. For bridges even with approach slabs, erosion can amplify the development of voids caused by compression of backfill and lateral deformations (Dupont and Allen, 2002). In this sense, the design of bridge approaches has to be incorporated with an efficient drainage system (Abu-Hejleh et al., 2006). Dupont and Allen (2002) also pointed out that the construction costs added to incorporate a good drainage system are not high when compared to the expensive maintenance costs that they might experience during the service life of the bridge.



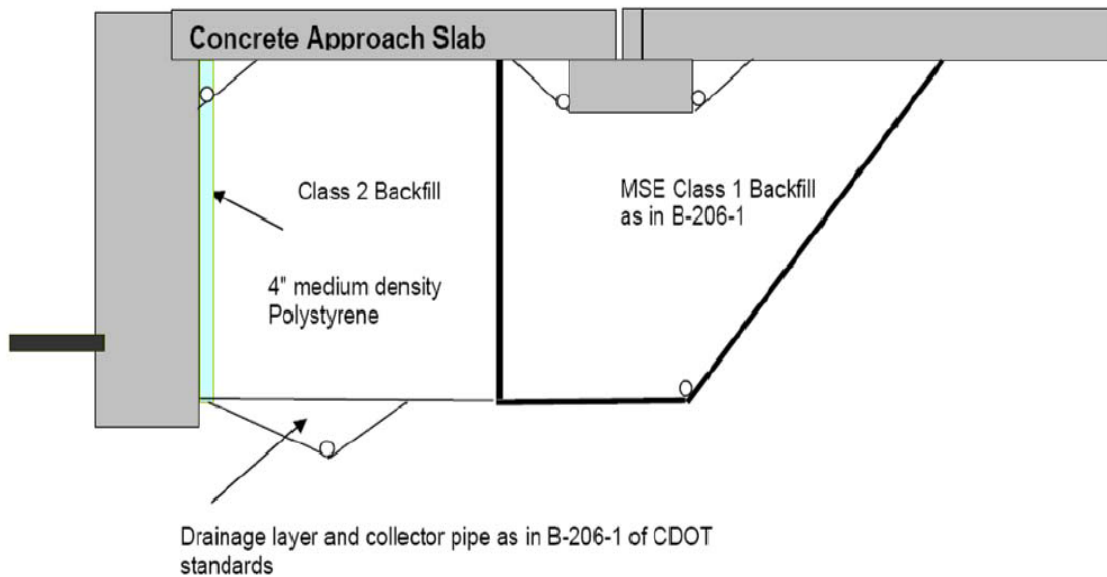
Therefore, the significance of designing bridge approaches with effective seals and good drainage conditions cannot be overemphasized.

In the last chapter, drainage design cannot be treated as a quantitative or qualitative variable included in the predictive models due to a fact that it is difficult to evaluate the performance of drainage plan for a bridge based on very limited record on this information in Kentucky. Also it is too simple to consider drainage as a binary variable (considered drainage design or not) because most bridges have considered drainage design. Thus this section mainly summarizes the current practices used by KYTC and other transportation agencies.

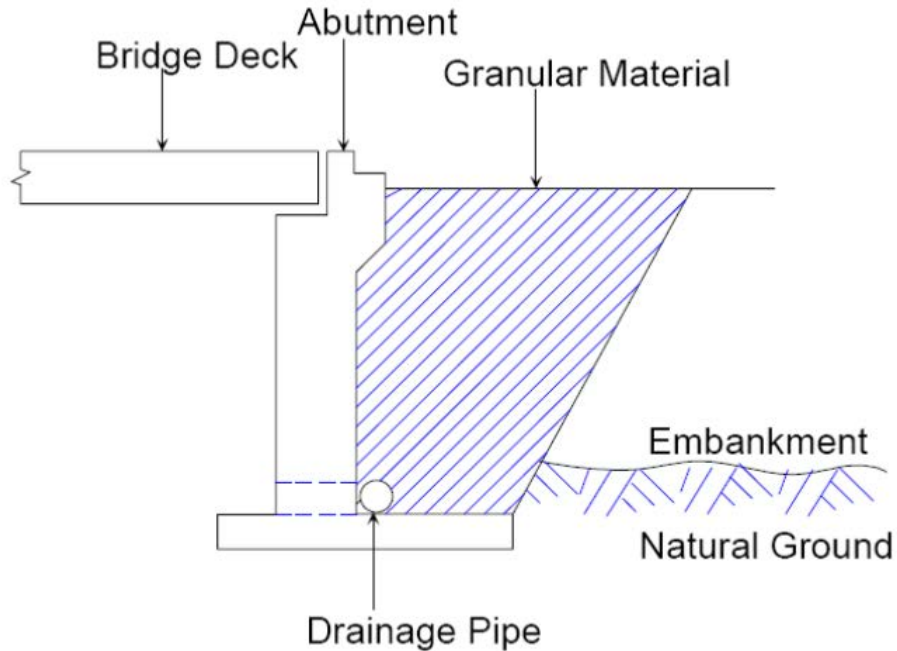
Generally, bridge approach must include both surface and subsurface drainage designs. For surface drainage design, Briaud et al. (1997) introduced a way of designing wingwalls curb-to-curb that could direct the water away from the bridge joints (Figure 5.4). For subsurface drainage design, a method that has been considered by most DOTs is the use of porous backfill material or limiting the percentage of fine particles in the fill material to reduce material plasticity and enhance drainage properties. Different layers of granular materials should be arranged with requirements in sequence and thickness in order to prevent water exiting the wall face and causing erosion. Furthermore, outlets should be installed to discharge of seepage away from the reinforced soil structure. Abu-Hejleh et al. suggested a drainage system by using mechanically stabilized earth (MSE) walls (Figure 5.5). Another subsurface drainage design introduced by Nassif (2002) is to construct a layer of filter material before placement of the backfill and then install perforated pipes at the bottom to discharge the collected water (Figure 5.6).



**Figure 5.4 Approach slab joint details at pavement edge (Briaud et al., 1997)**



**Figure 5.5 Mechanically stabilized earth (MSE) walls system under sleeper slab (Abu-Hejleh et al., 2006)**



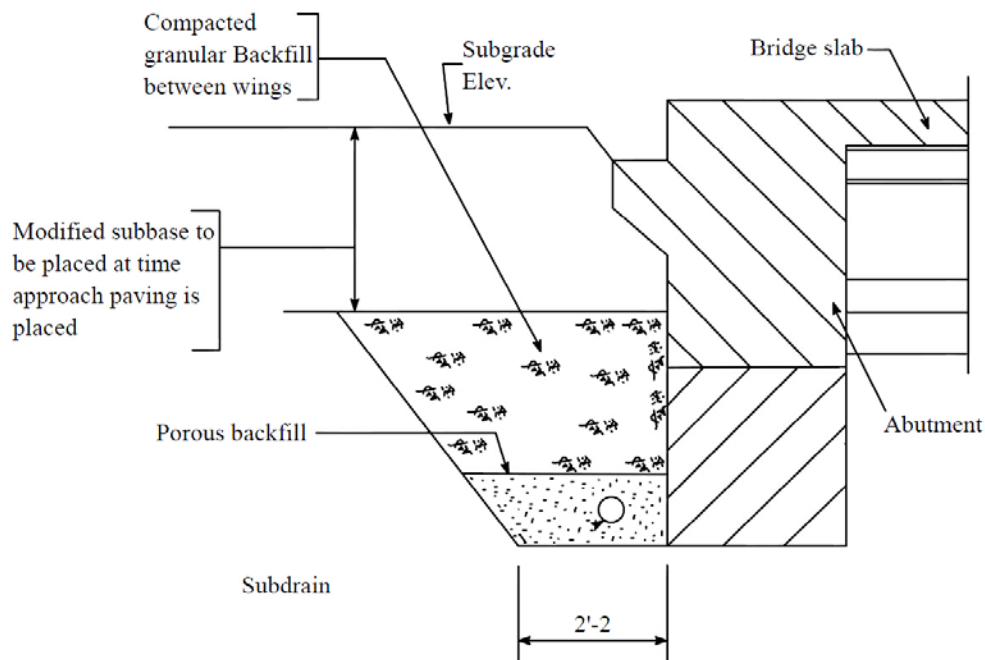
**Figure 5.6 Drainage layer of granular material and collector pipe (Nassif, 2002)**

Based on the recommendations reported in the literature, the techniques or measures to improve drainage conditions include:

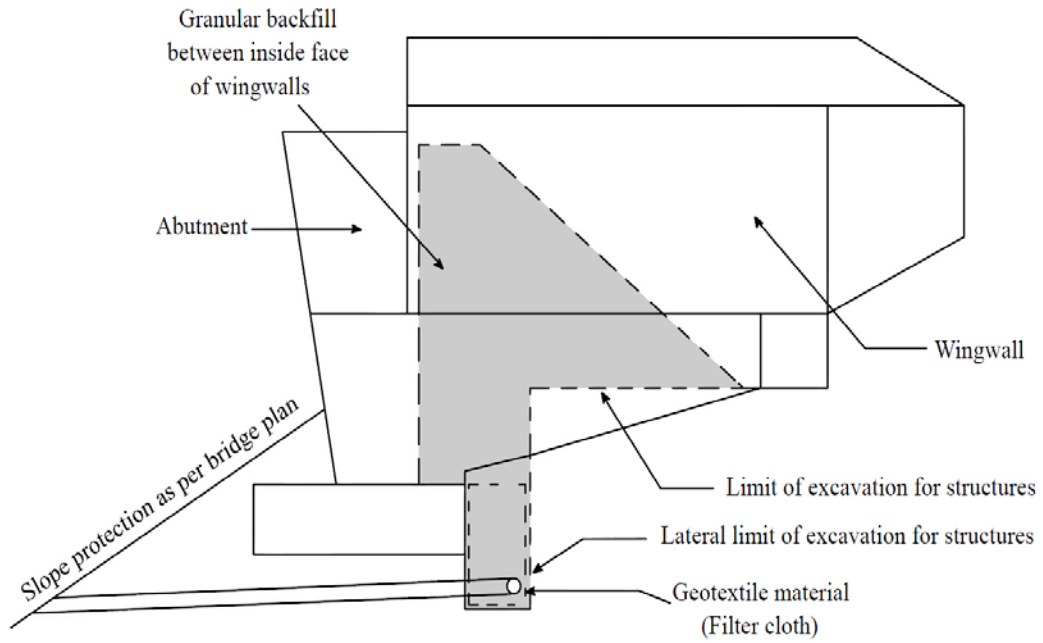
- use of porous backfill material,
- make side slopes flatter,
- use of a curb-to-curb design for erosion control and effective drainage of water away from the bridge structure and approach slab system (Figure 5.4),
- place drains at the back and/or low points of the embankment backfill in order to discharge groundwater,
- use of a large diameter surface drain and gutter system in the shoulder of the approach slab for bridges with approach slabs,
- use of a geo-composite vertical drainage system around the embankments,
- plastic drainpipes, weep holes in the abutments;

- use of a thick layer of tire chips as an elastic zone behind the abutment with a high capacity of drainage,
- use of interceptor drains on the back slope,
- perform periodic maintenance;
- mechanically stabilized earth (MSE) structures (Figure 5.5),
- construct a layer of filter material before placement of the backfill and then install

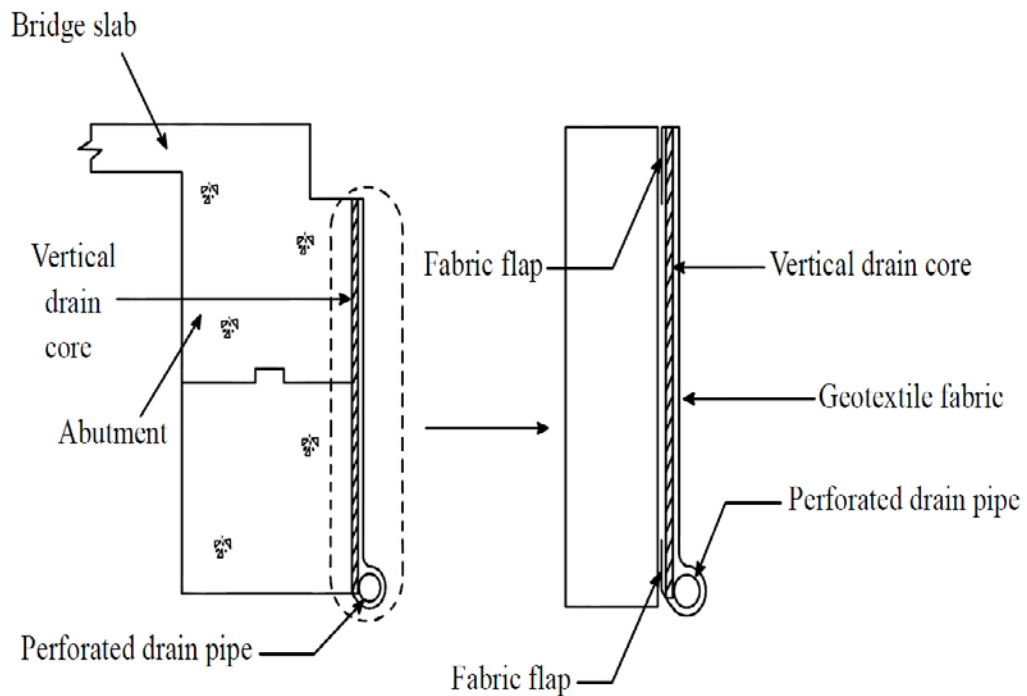
According to a review conducted by White et al. (2005), there main variations of drainage system were adopted across the nationwide: (1) porous backfill around a perforated drain pipe; (2) geotextiles wrapped around the porous fill; and (3) vertical geo-composite drainage system (Figures 5.7 to 5.10). From this study, approximately 14 out of 16 states have used a combination of two or more of the above three methods to increase the drainage efficiency (Table 5.6).



**Figure 5.7 Schematic of porous fill surrounding subdrain (Iowa DOT, 2005)**



**Figure 5.8 Schematic of granular backfill wrapped with geotextile filter material (Wisconsin DOT, 2003)**



**Figure 5.9 Schematic of geocomposite vertical drain wrapped with filter fabric (Missouri DOT, 2005)**

**Table 5.6 Drainage method used by various states (White et al., 2005)**

State	Porous Fill	Geotextile	Geocomposite Drainage System
Iowa	X	-	-
California	X	X	X
Colorado	-	X	X
Indiana	X	X	-
Louisiana	X	X	X
Missouri	-	X	X
Nebraska	-	X	X
New Jersey	X	X	X
New York	-	-	X
North Carolina	X	X	-
Oklahoma	X	X	-
Oregon	X	X	-
Tennessee	X	X	-
Texas	X	X	-
Washington	X	-	-
Wisconsin	X	X	-

By talking with the local bridge engineers in various districts, most engineers cited that the use of porous backfill behind the abutment would enhance the drainage capacity and would reduce the erosion around the abutment. In Kentucky, specifications from AASHTO govern the requirements of material type and use. Several districts sometimes adopt granular backfill wrapped with geotextile as drainage systems. Currently, no special provisions related to the design of bridge approach drainage are provided by KYTC.

## **6 CONCLUSIONS AND RECOMMENDATIONS**

### **6.1 Summary**

A bridge approach is usually built to provide a smooth and safe transition for vehicles from the roadway pavement to the bridge structure. However, differential settlement between the roadway pavement resting on embankment fill and the bridge abutment built on more rigid foundation often creates a bump in the roadway. In the United States, the highway agencies have been spending considerable amounts of their maintenance budgets to minimize or eliminate the bump problems caused by approach settlement at bridge ends. Moreover the maintenance work usually results in traffic delays and unsafe ride for motorists in heavy traffic areas. Prediction of bridge approach settlement can play an important role in selecting proper design, construction, and maintenance techniques and/or measures. On the one hand, bridge designers could use a predictive model to predict the approach settlement level based on foundation, approach, embankment, and other bridge characteristics for a new bridge. And then apply corresponding techniques and/or measures in the preliminary phase to prevent or minimize the settlement problems that may occur in the future. On the other hand, the bridge maintenance engineers could use a predictive model to evaluate the performance of an approach for an existing bridge based on the current situations in use such as approach year, geographic regions, Average Daily Traffic (ADT), and approach type. And then implement effective maintenance activities for correcting distressed approaches.

A study based on statistical methods was carried out to identify the predominant factors that may significantly influence the formation of the approach settlement and to figure

out how to develop a model for predicting approach settlement level by quantifying these count or categorical data as model inputs. Two samples were obtained by different selection methods: sample one with 87 bridges was formed by a survey of local bridge engineers from each transportation district, and sample two was randomly generated with 600 bridges from an internal network server “Pontis” which was used for storing the inspection history of approaches of most of the bridges in Kentucky. Previous studies usually adopted a micro method to evaluate the approach performance based on observed approach settlement. A macro method based on a combination of maintenance times, maintenance measures, and observed settlement was used to classify the differential settlement scale as minimal, moderate, and severe, corresponding to the approach performance status good, fair, and poor. Ten independent variables that may have an important contribution to the formation of approach settlement were identified. The independent variables of interest both consist of count data and categorical (ordinal and nominal) variables. The outcome (response) variable is ternary: minimal, moderate, or severe, and it is assumed as ordinal under the assumption that the levels of approach settlement have a natural ordering (low to high), but the distances between adjacent levels are not consistent. If the ordinal logistic analyses violates this assumption, a less restrictive method of multinomial logistic method would be adopted. Chi-square test was employed first to identify whether there is an association between each predictor and approach settlement levels. Then both methods of ordinal logistic regression and multinomial logistic regression were used to develop the comprehensive models to predict approach settlement levels considering all predictors. Two predictive models were developed to estimate the probability of occurrence of each of the three settlement levels



as well as to estimate the odds of severity choice as a function of the covariates and to express the results in terms of odds ratios for severity choice given bridge characteristics. The users can select one or two models to predict the approach settlement level for a new bridge or an existing bridge based on different purposes.

Five transportation districts were visited to obtain the current practices that have been using for alleviating the bump problems caused by approach settlement. A base of techniques and measures regarding bridge approaches in design, construction, and maintenance was developed for providing bridge engineers the prescriptive correction measures that could be applied to predicted differential settlement. Techniques and measures in the terms of foundation soil, embankment backfill material, approach slab, abutments, and drainage were collected and summarized.

## **6.2 Conclusions**

The primary objective was met through the statistical analyses performed that predict the approach settlement levels for a new or an existing bridge given bridge characteristics in terms of approach, embankment, abutment, traffic volume, and foundation. From the previous results, there are several key conclusions that can be made:

1. It is imperative that the approach system be treated as a stand-alone design objective in Kentucky. From the literature review, several states, such as Iowa, Texas, Wisconsin, have initiated a design manual regarding approach design. From the district interviews in Kentucky, most of issues related to approach design are directed by project manager. Maintenance techniques or measures are in a great variation among districts when excessive approach settlement occurs.

2. It is appropriate to use the macro method based on a combination of maintenance times, maintenance measures, and observed settlement to classify the differential settlement level. Observed settlements are not necessarily needed to evaluate the performance of approaches if a record regarding approach maintenance activities exists.
3. A legible, accurate, and accessible record keeping system regarding inspection/maintenance of bridge approaches is an effective and straightforward way of discovering and managing bridge approaches when excessive approach settlements occurs.
4. Sample one: The results from logistic regression show that approach age, transportation districts, and foundation soil depth are the three most important factors influencing the formation of approach settlement. The probability of being in a higher settlement level will decrease as the approach age increases. District one, district ten, and district eleven behave better than other districts in the treatment of differential settlement at bridge ends. In addition, the probability of being in a higher settlement level will decrease as foundation soil depth for a bridge increases.
5. Sample two: Transportation district, approach age, average daily traffic, and approach type are the four most important factors that contribute to the development of approach settlement. District one, district three, and district ten behave better by comparing to other districts in the treatment of differential settlement at bridge ends. There is a positive correlation between AGE and SEVERITY, which implies that the probability of being in a higher level of

approach settlement will increase as the bridge age increases while holding all other predictors constant. As average daily traffic for an approach increases, the probability of being in a higher settlement level will increase. Furthermore, flexible approaches tend to have a higher probability of being in a higher settlement level than rigid approaches.

6. There is a significant association between approach type and approach settlement levels. Concerning fewer approach slabs are used in Kentucky, the use of approach slabs was demonstrated to be useful on mitigating bump problem based on the performance of approach slabs that have been constructed in Kentucky. The use of approach slabs could enhance the performance of approaches as transitions between roadway and the bridge. However, the effectiveness is not significant because the effective ratio is slightly larger than 1.
7. The variation trends of the predicted probability of minimal versus the statistically significant predictors met well with the logistic regression results for sample one. The probability of being in the settlement level of minimal will increase as approach age increases. District one, ten, and eleven show a higher probability of being in the settlement level of minimal than other districts. The probability of being in the settlement level of minimal will increase at first as the foundation soil depth increase by 25 feet and then decrease as the foundation soil depth continues to increase.
8. The variation trends of the predicted probability of minimal versus the statistically significant predictors met well with the logistic regression results for sample two. District one, three, and ten show a higher probability of being in the settlement

level of minimal than other districts. The probability of being in the settlement level of minimal will decrease as approach age increases. The probability of being in the settlement level of minimal will decrease as the average daily traffic increases. Rigid approaches tend to have a higher probability of experiencing settlement levels of minimal than flexible approaches.

9. The most common ways that have been using by Kentucky to improve highly compressible foundation soils are preloading the foundation soils and excavation and replacement. Two easy and reliable alternatives are proposed when situations do arise that the foundation soils are not adequate. One is to reduce the loads applied to the foundation, and the other method is to improve the properties of the foundation soil by grouting chemical. KYTC has not given a manual that will guide designers and constructors how to carry out different ground improvement methods for a particular field situation.
10. Many districts reported that they are not willing to accommodate the preloading and/or precompression periods since this process may lead to construction delay and drive initial construction costs higher.
11. Precompression technique in embankment construction is reported as a successful practice by most bridge engineers. Another effective way of solving the excessive approach settlement is the use of flowable fills.
12. The use of Approach slab varies dramatically among districts. No specific manuals for approach slab have been established in Kentucky to specify some design and/or construction issues. Most districts quote high construction cost as the most significant factor influencing the wide use of approach slabs. No

maintenance record from Kentucky or other states has proven life-cycle maintenance cost for approach slabs are lower than flexible approaches.

13. Abutments supported on pile bent (perched) are generally more economical than spill-through (open column) abutments on spread footings. KYTC suggests that an integral abutment is preferable than non-integral abutments.
14. The use of porous backfill behind the abutment would enhance the drainage capacity and would reduce the erosion around the abutment. Several districts sometimes adopt granular backfill wrapped with geotextile as drainage systems. Currently, no special provisions related to the design of bridge approach drainage are provided by KYTC.

### **6.3 Recommendations for Future Research**

This research is limited in the construction engineering body of knowledge, which provides a great opportunity for growth in some areas such as structural engineering, transportation engineering, and statistics, both in depth and breadth. In view of the present study, there are several recommendations for additional research.

1. A sample with more bridges obtained by surveying bridge engineers should be used for logistic regression. In logistic regression, if the sample size is small, it may lead to an unstable model.
2. Other lurking variables, such as temperature cycle, connection between the approach and the bridge, compressibility characteristics of embankment, and drainage design of approaches, may be included in the present models.
3. The effect of drainage on the formation of approach settlement should be studied in depth based on bridge characteristics in Kentucky. A consensus has been

reached nationwide that drainage plays a very significant role in the development of differential settlements at bridge ends.

4. The developed models in this research are based on judgment of local bridge engineers or inspection record from KYTC. Field visits should be conducted to verify the results from the predictive models. The true approach settlement should be measured to compare with the results from the models. If there is a database for the record of the observed settlement for most of the bridges in Kentucky, other statistical methods can be used to predict the approach settlement in inches.
5. Predictive models are only built on the bridges from Kentucky, bridges from other states can be included to develop a more comprehensive use nationwide by this method.
6. Explore the potential of using the characteristics on construction of abutment and backfill as inputs to develop a model. Interviews with the construction engineers are recommended as well as frequent visits to observe the abutment and backfill construction.
7. Some information on foundation soil used for developing the models are not very accurate. Field tests need to be carried out to investigate the foundation soils when this information cannot be obtained from bridge design plans.

## APPENDICES

### Appendix A: Summary of Major Studies on Bridge Approach Settlement

No.	Author, Institution & Time	Title	Main Works & Key Findings
1	Elizabeth; TxDOT; 2012	The Bump at the End of the Railway Bridge	<ul style="list-style-type: none"> <li>• Investigate the complete track response resulting from a bump/dip</li> <li>• Quantify an acceptable slope for track geometry under freight traffic</li> <li>• Examine the influence of various design components on track response for the bump/dip</li> <li>• Develop a prototype track transition solution and assist in analyzing the performance of a full-scale field test. A 4-D dynamic numerical model was developed to simulate a train passing over a bridge approach system using the program LS-DYNA</li> <li>• The resulting impact forces, track deflection, ballast and subgrade pressures that were generated by the bump/dip were then evaluated. Based on the survey and simulation results, an acceptable slope can be defined.</li> </ul>

2	Ghorbanpoor, Al; Koutnik, Therese Ellen; Helwany, Sam; Wisconsin DOT; 2007	Evaluation of bridge approach settlement mitigation methods	<ul style="list-style-type: none"> <li>• Literature review of causes of bridge approach settlement, current mitigation methods and maintenance technique. Field test for some selected bridges. Introduction of backfill specification, field instrumentation plan</li> <li>• The movements of the approach fills that have granular foundation soils (Hemlock and Cranberry) and less than 5 to 7 feet of fill were insignificant over five years compared with the movements of the approach fills (Western and Beloit) with cohesive foundation soils over two years</li> <li>• Embankment side slopes that settle and slough (Western and Beloit) resulted in erosion and/or movement of backfill material</li> <li>• The cost of flowable fill is greater than geosynthetic reinforced fill for small quantity jobs</li> <li>• Laboratory and field tests need to be carried out to investigate the effectiveness of using hydraulic fills as a method for alleviating bridge approach settlements</li> </ul>
---	--	---	--



3	White et al; Iowa DOT; 2007	“Underlying” Causes for Settlement of Bridge Approach Pavement Systems	<ul style="list-style-type: none"> <li>• Void development from backfill collapse following saturation, severe backfill erosion, poor surface and subsurface water management, and poor construction practices mainly contribute to settlement problems of the approach pavements of bridges</li> <li>• Erosion can lead to problems including: exposure of the H-piles, failure of the slope protection cover, severe faulting in the approach pavement, and loss of backfill around subdrain elements</li> <li>• Problems in void development, water management, and pavement roughness were generally more pronounced with integral abutment bridges than non-integral</li> <li>• Backfill materials should be placed outside the range of bulking moisture contents and should be less susceptible to erosion</li> <li>• The surface water management system should be designed to shed water to the base of the embankment and the subsurface drainage system to provide an easy pathway for infiltrating water to escape</li> </ul>
---	-----------------------------------	---	--

4	Hoppe; Virginia DOT; 2006	Field Measurements on Skewed Semi- Integral Bridge with Elastic Inclusion: Instrumentation Report	<ul style="list-style-type: none"> <li>• Data obtained by monitoring earth pressure cells, load cells, and strain gages would be useful for future endeavors</li> </ul>
5	Abu-Hejleh et al; Colorado DOT; 2006	Flowfill and MSE bridge approaches: Performance, Cost and Recommendations for Improvements	<ul style="list-style-type: none"> <li>• Flowfill is recommended in certain difficult field conditions (e.g., to fill and close up voids, in areas where compaction is difficult, easier to place around an embankment slope)</li> <li>• The use of the MSE or GRS abutment system is the best system to alleviate the approach bridge bump problem</li> <li>• The high quality backfill materials should be placed under the sleeper slab</li> <li>• The length of the approach slab should be related to the depth of the abutment wall and the magnitude of the projected post-construction settlements</li> <li>• The drainage system is very important to collect and drain any surface water before it reaches and softens the soil layers located beneath or around the sleeper slab</li> </ul>

6	Lenke; New Mexico DOT; 2006	Settlement Issues – Bridge Approach Slabs	<ul style="list-style-type: none"> <li>• MSE walls have fewer problems with approach slab settlement issues than other types of bridge abutment systems</li> </ul>
7	Hoppe; Virginia Transportation Center (TRC)/Virginia DOT; 2005	Field Study of Integral Backwall with Elastic Inclusion	<ul style="list-style-type: none"> <li>• An elastic inclusion consisting of a layer of elasticized Expanded Polystyrene (EPS) 0.25 m significantly reduced earth pressures and approach settlements at the semi-integral bridge</li> <li>• The well-compacted select backfill material at bridge approaches is necessary</li> <li>• Short approach slabs could be sufficient to provide a grade transition</li> <li>• Shorter approach slabs would be easier for the superstructure to push and pull during cyclic movements, and would exert less stress on the backwall if they settle</li> <li>• Thermally induced lateral movements of the superstructure may not be equal at both abutments</li> </ul>

8	Jayawickrama et al.; TxDOT; 2005	Water intrusion in base/subgrade material at bridge ends	<ul style="list-style-type: none"> <li>• Saturated base/subgrade material at the end of bridge could be a major problem</li> <li>• Use of geotextiles fabric beneath the joints to avoid loss of material by erosion</li> <li>• Approach slab stabilization to control void development and cross/slot stitching of approach slabs and concrete pavements for controlling further development of cracks</li> </ul>
9	Cai et al.; Louisiana TRC/ LADOT; 2005	Determination of interaction between the bridge concrete approach slab and embankment settlement	<ul style="list-style-type: none"> <li>• After settlement is increased to a larger value, it no longer affects the performance of slab since approach slab completely loses its contact with soil and becomes a simple beam</li> <li>• The developed procedure can be used in designing the approach slab to meet the established deformation requirements</li> <li>• Due to over stress of bolts and dowel bars, cracking is seen</li> </ul>

10	David White, Sri Sritharan; Iowa DOT; 2005	Identification of the Best Practices for Design, Construction, and Repair of Bridge Approaches	<ul style="list-style-type: none"> <li>• Void development under the bridge approach is observed within one year of bridge construction, indicating insufficient moisture control/compaction and poor backfill material</li> <li>• Water management around the bridge is a major problem at most of the inspected bridges. Several abutment subdrains were observed to be either blocked with soil, dry, indicating no water flow, or collapsed</li> <li>• Grouting under the approach slab does not necessarily prevent further settlement or loss of backfill material due to erosion</li> <li>• Use a more effective joint sealing system at the joint between road and bridge approach</li> <li>• Reduce time-dependent post construction settlements</li> </ul>
11	Mekkawy et al.; Iowa DOT; 2005	Simple Design Alternatives to Improve Drainage and Reduce Erosion at Bridge Abutments	<ul style="list-style-type: none"> <li>• Three alternatives are recommended to improve drainage and alleviate erosion: 1) use geocomposite drain with granular backfill reinforcement, 2) use tire chips behind the bridge abutment, and 3) use porous backfill material</li> </ul>

12	M. Schmitz; Kansas DOT; 2004	Use of Controlled Low-Strength Material as Abutment Backfill	<ul style="list-style-type: none"> <li>• Use of Controlled Low-Strength Material (CLSM) behind bridge abutments to avoid the problem of settlement</li> <li>• Compressible soils beneath the fill may settle beneath the weight of the embankment, causing settlement of the embankment itself. This may lead to significant differential settlement between the approaches and bridges, which are usually built on drilled shafts or piles that extend to bedrock</li> <li>• Stone columns would not only accelerate consolidation but also transfer loads to less compressible units. CLSM would complement stone columns well, acting as a solid fill with little settlement.</li> </ul>
----	------------------------------------	--	---

13	Ronaldo Luna; MoDOT; 2004	Evaluation of Bridge Approach Slabs Performance and Design	<ul style="list-style-type: none"> <li>• Geotechnical (soil mechanics) techniques can be used to predict when the potential for a problem exists. The various means of reducing the settlement of the embankments need to be established on a case -by-case basis as determined by the design interactions between the geotechnical engineers and the bridge designers</li> <li>• Modern numerical method is used to determine the embankment settlement and it compared well with the general observed conditions. The use of typical geotechnical data for input parameters results in useful but relatively large ranges of the predicted settlement due to the inability of assessing modulus and related deformation parameters</li> <li>• The construction sequence has a significant effect on the final performance of the embankment and bridge approach slab</li> </ul>
----	------------------------------	--	---

14	Seo et al.; TxDOT; 2003	The bump at the end of the bridge: an Investigation	<ul style="list-style-type: none"> <li>• The compressibility of the soil is contributing to the development of the bump</li> <li>• The transition zone of the approach embankment is about 12 m with 80 percent of the maximum settlement occurring in the first 6 m for a uniform load case</li> <li>• The size of the sleeper slab and support slab influences the settlement of the slab. The optimum width of both slabs is 1.5 m</li> <li>• A single-slab at least 6 m long and 0.3 m thick is recommended for an approach slab</li> </ul>
15	Arsoy et al.; VTRC/VDOT; 2002	Performance of Piles Supporting Integral Bridges	<ul style="list-style-type: none"> <li>• Steel H-piles oriented in the weak-axis bending area is a good choice for support integral abutment bridges</li> <li>• Pipe Piles will cause higher stress in the abutments than steel H-piles</li> <li>• Concrete piles are not a suitable choice. Tension cracks due to cyclic lateral load can reduce their vertical load capacity</li> </ul>



16	Nassif; NJDOT; 2002	Finite element modeling of bridge approach, transition slabs using ABAQUS, and identifying the probable cause of cracking	<ul style="list-style-type: none"> <li>• The number one reason for the bump is the settlement of the embankment fill followed by the loss of fill by erosion</li> <li>• The settlement at the bridge approach is worse when the embankment is high and the fill is clay</li> <li>• The settlement at the bridge approach is lessened when an approach slab is used and the abutment fill is cement stabilized</li> </ul>
17	Dupont and Allen; Kentucky Transportation Center (KTC); 2002	Movements and settlements of highway bridge approaches	<ul style="list-style-type: none"> <li>• Lowered approach slabs with asphalt overlays</li> <li>• Require settlement periods and/or surcharges prior to final construction</li> <li>• Design Maintenance plans concurrent to construction plans</li> <li>• Implement specifications for select fill adjacent to abutments</li> <li>• Improve drainage designs on and around approached <ul style="list-style-type: none"> <li>• Require bridge approach warranties</li> <li>• Reduce the side slope of embankments</li> </ul> </li> <li>• Improve approach slab design</li> </ul>

18	Marquart, M.; NDDOT; 2002	Fabric Reinforced Backfill under Approach Slabs	<ul style="list-style-type: none"> <li>• A bump that is allowed to persist increases the chance of damage to the bridge deck from the dynamic impact of vehicles</li> <li>• Damage to the bridge deck can also be caused by snowplows in the winter</li> <li>• Integral bridge abutments appear to be a special case where a bump is consistently created resulting from temperature cycles and the associated compression and decompression of the approach fill by the abutment wall</li> </ul>
19	Ha and Briaud; TxDOT; 2002	Investigation of settlement at bridge approach slab expansion joint: survey and site investigations	<ul style="list-style-type: none"> <li>• The number one reason for the bump is the settlement of the embankment fill followed by the loss of fill by erosion</li> <li>• The soil near the abutment was weaker and wetter than the soil away from the abutment</li> <li>• The soil near the abutment had a relatively high Plasticity Index (PI) for an embankment fill</li> <li>• A bump rating number, BR, and a bump index number, BI, are proposed to document the severity of existing bumps and to evaluate the likelihood of developing a bump at a site, respectively</li> </ul>

20	Pierce, Charles E; SCDOT; 2001	Investigation into improvement of bridge approaches in South Carolina	<ul style="list-style-type: none"> <li>Conducted visual inspection and quantitative assessment of bridge approach slabs located at 25 bridges in 11 counties across South Carolina, and assessed the performance level of bridge approach slabs and determine the rideability of the road-to-bridge transition</li> </ul>
21	Parsons; Kansas DOT; 2001	Compaction and settlement of existing embankments	<ul style="list-style-type: none"> <li>Eight embankments constructed between 1994 and 2000 were selected for undisturbed field sampling. Two borings were drilled in each embankment and shelby tube samples were collected for testing at regular intervals. Samples of the cuttings were also collected for testing. A telephone survey of all state DOTs was conducted to assess current practice with regard to specifications for compaction of fills.</li> </ul>

22	Abu-Hejleh et al.; Colorado DOT; 2001	Results and Recommendations of Forensic Investigation of Three Full-Scale GRS Abutment and Piers in Denver, Colorado	<ul style="list-style-type: none"> <li>• GRS abutment and piers are practical alternatives used in bridge support</li> <li>• GRS should not be used in a scour situation</li> <li>• GRS piers are suitable for remote locations, since it can be constructed or repaired by using small construction equipment within a few days</li> </ul>
23	Hoppe; VTRC/VDOT; 1999	Guidelines for the use, design, and construction of bridge approach slabs	<ul style="list-style-type: none"> <li>• Full-width approach slabs are used. It reduces erosion of the approach fill</li> <li>• Placing approach slabs below the road surface facilitates resurfacing operations</li> <li>• Drainage system between the top of the approach slab and the surface of the road should be provided</li> <li>• Pre-cambering may be employed to compensate differential settlement at bridge approaches resulting from differing foundations beneath the bridge and the roadway</li> </ul>

24	Sankar; Louisiana TRC; 1999	Assessment of mitigating embankment settlement with pile-supported approach slabs	<ul style="list-style-type: none"> <li>Identified the factors that contribute to total approach settlement in pile supported approach slabs in southeastern Louisiana. The main factor affecting slab settlement is downdrag, or negative skin friction, load imposed on the pile due to the weight of the roadway embankment.</li> </ul>
25	Reid et al.; SDDOT; 1999	Use of fabric reinforced soil wall for integral abutment bridge end treatment and investigate the effectiveness of present design	<ul style="list-style-type: none"> <li>Voids reduced by using the rubber tire chips behind the integral abutment</li> <li>Cyclic movements do not affect the voids</li> </ul>
26	Snethen et al.; Ohio DOT; 1998	Construction of CLSM approach embankment to minimize the bump at the end of the bridge	<ul style="list-style-type: none"> <li>The use of Control Low-Strength Material (CLSM) as an approach embankment fill material as a simple and cost effective method to reduce the potential for developing the bump at the end of the bridge</li> </ul>

27	Hearn; Colorado DOT; 1997	Faulted pavements at bridge abutments	<ul style="list-style-type: none"> <li>• Synthesis on faulted pavements at bridge abutments; Occurrence of pavements faults. Reported causes; Mitigation of pavement faults; Observed total settlements; Prediction of total settlements; Differential settlement in bridges; Limits on tolerable settlements for bridges.</li> </ul>
28	Briaud and Jame; TxDOT; 1997	Settlement of bridge approaches : (the bump at the end of the bridge)	<ul style="list-style-type: none"> <li>• Identified and described techniques that have been used to alleviate the problem of the bump at the end of the bridge including the location and cause of settlement and methods used to reduce settlement</li> <li>• Types of interaction between various divisions of the DOTs in the design, construction, and maintenance of bridge approaches are addressed</li> </ul>

29	Schaefer and Koch; SDDOT; 1992	Survey done to isolate and determine the mechanisms controlling backfill to reduce void development under bridge approaches	<ul style="list-style-type: none"> <li>• Thermal induced movements of integral abutments are responsible for void development</li> <li>• No problem with the material used as a backfill</li> <li>• Voids are not developed due to erosion</li> <li>• Cracking is due to loss of support</li> <li>• Mud jacking does not affect the formation of voids</li> <li>• Non-integral abutment reduces the problem of voids</li> <li>• Maintenance cost increases by using integral abutments</li> </ul>
30	Laguros and Zaman; OKDOT; 1990	Evaluation of causes of excessive settlements of pavements behind bridge abutments and their remedies	<ul style="list-style-type: none"> <li>• Settlement problem is due to the absence of drainage</li> <li>• Major portion of the settlement occurs within first twenty years</li> <li>• Skewed approaches have higher approach settlement than non-skewed approaches</li> <li>• Regression techniques were used to develop an empirical relationship between the approach settlement and the causative parameters such as age of the approach, embankment height, traffic volume, and skewness of the approach.</li> </ul>

31	Wahls; NCDOT; 1990	Design and construction of bridge approaches and to revise and update the report of KYDOT (1969)	<ul style="list-style-type: none"> <li>• Bridge approach settlements are caused due to time dependent consolidation of embankment, poor compaction, drainage, and erosion of abutment backfill</li> <li>• Lateral creep of foundation soils and movements of the abutment</li> <li>• Type of abutment and foundation also affect the performance</li> <li>• Differential settlement can be minimized by using shallow foundations</li> </ul>
32	Greimann et al.; Iowa DOT; 1987	Pile design and tests for integral abutment bridges due to the effect of temperature changes	<ul style="list-style-type: none"> <li>• Horizontal displacement had no effect on the vertical load capacity</li> <li>• Use of a pre-drilled hole is recommended as a pile construction detail to reduce the pile stresses significantly when horizontal displacements of the pile occur</li> </ul>
33	Stewart; Caltrans; 1985	Survey of Highway structure approaches	<ul style="list-style-type: none"> <li>• Structure approach slab policy</li> <li>• Design policies and procedures</li> <li>• Structure approach slab design concepts</li> <li>• Construction sequence and details for rehabilitation projects</li> </ul>



34	Hopkins, KyDOT; 1985	Long term movements of highway bridge approach embankments and pavements by surveying and observation of six bridge sites from 1966 to 1985	<ul style="list-style-type: none"> <li>• Settlement of bridge approach foundations contributes significantly to settlements of approach pavements</li> <li>• Improper compaction, lateral movements, erosion of materials, and secondary compressions are the causes for long-term movement of bridge approaches</li> </ul>
35	Greimann et al.; Iowa DOT; 1984	Deign of Piles for Integral Abutment Bridge	<ul style="list-style-type: none"> <li>• The ultimate load capacity for frictional piles was not affected by lateral displacements of up to 4 in. for Hpiles and up to 2 in. for timber and concrete piles</li> <li>• The ultimate load capacity was considerably decreased if lateral displacements greater than 2 in. for end-bearing H- piles</li> </ul>
36	DiMillion; WSDOT; 1982	Performance of Highway Bridge Abutments Supported by Spread Footing on Compacted Fill	<ul style="list-style-type: none"> <li>• Spread footing on compacted fill supporting the bridge abutment is very reliable and inexpensive</li> <li>• The superstructure with a spread footing can withstand temperate settlement (1-3 in.) without distress</li> </ul>

37	Hopkins; KyDOT; 1969	<p>Preliminary survey done on the existing bridges to calculate settlement of highway bridge approaches and embankment foundations by using special experimental design and construction features at selected bridge sites</p>	<ul style="list-style-type: none"> <li>• Concrete bridge approaches are better than bituminous bridge approaches</li> <li>• Progressive failure or creep of the approach is a cause for the development of an approach fault</li> <li>• Erosion of soil from abutments contributes to development of defective bridges. <ul style="list-style-type: none"> <li>• Traffic is not a cause for the settlement</li> </ul> </li> <li>• Backfilling around abutments with a granular material did not arrest the development of faulted approaches <ul style="list-style-type: none"> <li>• Settlement of the approach foundation and embankment contributes significantly to settlement of bridge approaches and approach pavements</li> </ul> </li> <li>• Replacing the soft compressible material with rock or compacted material</li> <li>• Pre-consolidate using surcharge fill <ul style="list-style-type: none"> <li>• Allow sufficient time for consolidation of the foundation under the load of the embankment</li> <li>• Use of vertical sand drains and drainage system</li> </ul> </li> </ul>
----	-------------------------	--	--

			<ul style="list-style-type: none"><li>• Longitudinal camber is provided at the approaches</li></ul>
--	--	--	---

## **Appendix B: Survey of Requesting Bridges with Different Settlement Levels for Comprising Sample One**

Survey Designation:

One of the most important tasks of this project is to select bridges and conduct site visits to evaluate “bump” issues at bridge ends based on maintenance information. This survey will serve to help identify and quantify differential settlement at bridge ends throughout the state. The purpose of this survey is to:

- Obtain information regarding the existence of bridges with “bump” issues;
- Identify major causes of differential settlement at bridge ends;
- Evaluate the existing record keeping procedures regarding maintenance of “bump” issues.

1. THANK YOU FOR YOUR ASSISTANCE!

Name of Respondent:

Job Title:

E-mail Address:

2. Please list five bridges that you believe have the worst “bump” conditions in your district. (Fill in the information as thoroughly as convenient) Please use the following scale to rank the condition: 1= Major bump, 2= Moderate bump, 3= Minor or no bump.

Bridges	Bridge ID/Number/Mile post	Route	County	Condition	Remarks
Bridge 1					
Bridge 2					

Bridge 3					
Bridge 4					
Bridge 5					

3. In what cases does the “bump” problem appear to be minimized? Please list five bridges that you consider to be in good condition in your district. (Fill in the information as thoroughly as convenient) Please use the following scale to rank the condition: 1= Major bump, 2= Moderate bump, 3= Minor or no bump.

Bridges	Bridge ID/Number/Mile post	Route	County	Condition	Remarks
Bridge 1					
Bridge 2					
Bridge 3					
Bridge 4					
Bridge 5					

4. In what cases does the “bump” problem appear to be moderate? Please list five bridges that you consider to be in moderate condition in your district? Please list five bridges that you consider to be in good condition in your district. (Fill in the information as thoroughly as convenient) Please use the following scale to rank the condition: 1= Major bump, 2= Moderate bump, 3= Minor or no bump.

Bridges	Bridge ID/Number/Mile post	Route	County	Condition	Remarks
Bridge 1					

Bridge 2					
Bridge 3					
Bridge 4					
Bridge 5					

If you have any questions, please call Professor Timothy R. B. Taylor on (859) 323-3680 or contact him on E-mail at [tim.taylor@uky.edu](mailto:tim.taylor@uky.edu). We would appreciate your response by April 1st, 2014

## Appendix C: Detailed Data Information of Sample One

Bridge_ ID	Dist rict	Len gth	Wi dth	App Age	AD T	AbuT ype	AppT ype	EmbH eight	FSoilD epth	Consist ency	Seve rity
061B00 099N	11	136	24	4	246 0	3	1	7	21	2	3
056B00 495N	5	281 .5	66	5	582 00	3	1	32	15	2	2
056B00 489N	5	356 .2	30	5	800 00	2	1	29	8	2	2
056B00 492N	5	159 .7	24	5	582 00	1	1	17	0	4	2
056B00 494N	5	308	30	5	582 00	3	1	24	17	3	2
049B00 072N	6	889	24	6	122 00	3	2	22	12	3	3
118B00 123N	11	175 .9	40	6	401 0	3	2	18	19	2	3
115B00 065N	4	683	40	8	706	3	2	18	13	3	3
056B00 488N	5	353	60	8	174 00	2	1	18	0	4	2
041B00 062N	6	255 .6	18	8	296	3	1	5	14	2	2
041B00 065N	6	242 .5	28	8	393	3	1	18	8	2	3
039B00 048N	6	286 .5	24	8	294 00	3	1	21	14	2	3
041B00 069N	6	450	30	8	244 0	3	1	33	7	2	3

041B00 067N	6	236	24	8	484	3	1	4	21	2	3
041B00 064N	6	234 .7	24	8	393	2	1	3	2	2	3
076B00 111N	7	272	20	8	191 0	3	1	11	8	2	2
105B00 144R	7	482	60	8	176 00	1	2	22	0	4	3
105B00 145R	7	172	16	8	176 00	3	1	6	7	3	3
013B00 082R	10	437	42	8	229 0	3	1	19	21	2	1
013B00 083R	10	567	32	8	361 5	3	1	16	32	3	2
041B00 061N	6	257	18	9	565	3	1	18	11	1	2
079B00 146N	1	296 .9	24	11	224 0	3	2	18	11	3	2
041B00 058N	6	382	30	11	611 0	1	2	42	0	4	3
084B00 051N	7	177	34	11	631	3	1	8	19	3	2
096B00 040N	6	200 .1	56	12	112 00	3	2	17	12	3	2
076B00 105R	7	286 .1	20	12	269 50	3	2	5	12	2	3
045B00 081N	9	272	16	12	590 0	3	1	44	35	3	3
041B00 052N	6	223	16	13	348 0	3	2	0	7	3	1



076B00 107N	7	252	30	13	154 00	3	1	12	17	1	3
059B00 104N	6	147 4.1	22	14	132 00	3	2	8	26	2	1
048B00 181N	11	59. 1	12	14	358 0	1	1	4	0	4	2
073B00 159L	1	205	40	15	469 5	3	2	17	41	3	3
094B00 041N	6	765 .1	36	16	280 0	1	1	11	0	4	3
070B00 076N	1	57. 1	14	17	329 0	3	1	4	8	3	1
009B00 068R	7	146	24	17	860 0	1	1	7	0	4	2
048B00 176N	11	329	12	17	238 0	3	1	7	12	3	3
060B00 076N	12	54	16	17	671 0	1	1	6	0	4	3
056B00 454R	5	402 .7	42	18	135 00	3	2	25	22	3	2
081B00 067N	9	766 .1	60	19	511 0	3	2	76	52	3	2
097B00 116N	10	284 .1	40	20	420 0	3	2	2	40	1	3
011B00 055N	7	240	24	22	337 0	3	2	21	10	3	3
061B00 095N	11	517	48	22	861 0	3	2	35	31	2	2
061B00 091R	11	303	26	25	665 0	2	1	14	22	3	3

039B00 039N	6	387	24	26	397 0	3	1	18	40	2	3
021B00 054N	6	42. 3	16	27	534 0	1	1	7	0	4	3
068B00 101N	9	294	24	28	290 0	3	1	22	42	2	3
021B00 049N	6	265 .1	24	31	534 0	3	1	15	50	3	2
041B00 038N	6	146	16	32	398 0	3	1	21	6	3	2
048B00 103N	11	302	24	39	637	3	1	42	22	2	1
048B00 124N	11	130	40	39	602 0	3	1	12	15	3	1
009B00 052L	7	244 .4	26	40	615 0	1	1	9	0	4	2
048B00 110N	11	369	44	40	595 0	3	1	14	13	3	1
048B00 118N	11	226	48	41	602 0	2	1	12	19	3	2
048B00 117N	11	300	48	41	602 0	2	1	23	12	3	3
067B00 081N	12	358 .9	48	41	919 0	3	1	16	22	2	3
111B00 027R	1	151 .9	42	42	955 0	1	1	12	0	4	2
048B00 114N	11	217	44	42	595 0	2	1	21	21	3	2
048B00 113N	11	208	44	42	595 0	3	1	9	14	3	3

037B00 053R	5	299 .8	89	43	190 50	3	1	12	15	2	2
052B00 037N	5	139 .2	19	45	139 0	3	1	12	21	3	2
039B00 010N	6	404 .9	28	45	272 0	3	1	12	11	1	2
022B00 084L	9	227	40	46	600 0	3	1	13	9	3	2
052B00 051L	5	434 .4	32	47	169 50	3	1	42	18	2	2
056B00 167R	5	274 .5	52	48	340 50	3	1	40	56	1	2
039B00 017N	6	293	24	48	352	3	1	10	22	2	2
039B00 030N	6	274	26	48	93	3	1	8	36	2	2
021B00 038L	6	336	30	48	146 00	3	1	30	14	2	3
039B00 023R	6	154 .9	40	48	136 00	2	1	31	9	2	3
021B00 037L	6	233 .9	40	48	136 00	3	1	28	60	3	3
022B00 088L	9	144	44	48	735 0	2	1	4	11	2	2
090B00 019L	4	330 .1	30	50	495 0	3	1	26	13	1	2
050B00 030L	4	194 .9	24	51	185 00	3	1	13	24	2	3
094B00 001N	6	43	28	53	208	1	1	4	0	4	3

118B00 059R	11	399	30	53	127 00	3	1	15	29	2	1
118B00 058R	11	347	30	53	127 00	3	1	15	32	3	1
118B00 054R	11	99	40	53	127 00	3	1	13	15	1	1
041B00 007N	6	254 .8	32	54	694 0	3	1	20	18	2	1
047B00 036R	4	317 .9	30	57	182 00	2	1	0	44	2	2
108B00 010N	5	407 .4	28	57	486 0	3	1	25	25	2	3
039B00 022N	6	65	26	59	376	1	1	12	0	4	3
067B00 027N	12	317 .9	36	64	291 0	3	1	15	13	3	3
049B00 021N	6	265	26	66	142 00	1	2	23	0	4	1
009B00 002N	6	151 .9	30	67	517 0	1	1	8	0	4	1
118B00 040N	11	214 .9	38	72	315 0	1	1	12	0	4	1
048B00 012N	11	160	20	77	326 0	1	1	13	0	4	2
094B00 002N	6	65. 9	20	79	244	1	1	8	0	4	2
039B00 006N	6	37	24	81	119 0	1	1	13	0	4	3

## Appendix D: Detailed Data Information of Sample Two

Bridge_ID	District	Length	Width	App Age	ADT	AbuType	AppType	EmbHeight	FSoilDepth	Consistency	Severity
065B00 024N	10	133	28	30	1106	3	1	0	36	2	1
077B00 084N	10	156	56	8	5798	1	1	5	50	2	2
004B00 028N	1	693	28	73	1631	3	1	13	26	2	1
004B00 061N	1	99	44	22	4155	3	1	13	50	2	1
016B00 050N	3	130	22	60	232	3	1	13	50	2	1
018B00 020N	1	99	23	82	1612	3	1	4	40	2	1
018B00 109N	1	115	22	58	768	3	1	8	39	2	1
018B00 115N	1	90	44	24	2070	3	1	3	50	2	1
018B00 116N	1	90	44	24	2070	3	1	3	50	2	1
020B00 024N	1	198	22	67	894	3	1	3	24	2	1
021B00 048N	6	211	30	31	8400	3	1	13	45	2	1
021B00 050N	6	361	30	30	6460	3	1	20	50	2	1
028B00 051N	1	157	20	53	120	3	1	12	36	2	1

036B00 096N	12	203	44	36	307 0	3	1	13	50	2	1
038B00 011N	1	330	24	74	104 0	3	1	2	32	2	1
038B00 065N	1	99	24	56	81	3	1	2	41	2	1
038B00 078N	1	238	40	30	244 9	3	1	26	42	2	1
038B00 081N	1	71	44	27	205 0	3	1	6	50	2	1
042B00 031N	1	84	24	52	341	3	1	9	40	2	1
042B00 194N	1	99	24	51	235	3	1	2	40	2	1
042B00 195N	1	99	24	51	235	3	1	4	40	2	1
053B00 033N	1	114	24	56	118	3	1	11	50	2	1
053B00 047N	1	175	24	74	994	3	1	3	33	2	1
063B00 105N	11	34	22	15	411 62	3	1	0	14	2	1
065B00 026N	10	147	30	28	235 0	3	1	8	50	2	1
067B00 010N	12	237	44	45	842 7	3	1	31	19	2	1
072B00 020N	1	811	26	51	974	3	1	5	50	2	1
073B00 010N	1	389	28	51	230 0	3	1	27	50	2	1

073B00 048N	1	114	28	55	271 0	3	1	9	50	2	1
073B00 049N	1	132	28	55	277 4	3	1	10	50	2	1
073B00 108N	1	430	28	40	117 6	3	1	17	50	2	1
073B00 113N	1	337	44	40	311 9	3	1	10	20	2	1
073B00 114L	1	458	39	40	185 80	3	1	37	50	2	1
073B00 115R	1	143	39	40	185 80	3	1	6	50	2	1
073B00 116L	1	197	40	40	157 54	3	1	35	20	2	1
073B00 119L	1	172	40	40	157 54	3	1	45	15	2	1
073B00 121N	1	260	88	40	120 33	3	1	9	50	2	1
073B00 153N	1	214	30	16	375	3	1	3	12	2	1
079B00 013N	1	84	24	52	578	3	1	6	50	2	1
088B00 042N	10	186	30	52	469 0	3	1	20	13	2	1
097B00 089N	10	646	32	42	978 4	3	1	33	15	2	1
107B00 040N	3	173	44	14	416 5	3	1	27	41	2	1
111B00 045N	1	317	28	41	101 0	3	1	22	44	2	1

114B00 053R	3	220	30	43	632 2	3	1	0	20	2	1
004B00 027N	1	300	24	73	127 7	3	1	1	30	2	2
008B00 051N	6	234	44	43	820 7	3	1	18	50	2	2
008B00 066N	6	305	54	30	683 72	3	1	4	50	2	2
016B00 016N	3	264	24	80	263 0	3	1	12	50	2	2
019B00 066N	6	93	82	25	975 7	3	1	11	42	2	2
021B00 039R	6	336	30	48	146 00	3	1	4	10	2	2
021B00 058N	6	275	32	9	917	3	1	22	50	2	2
022B00 132N	9	63	28	31	673	3	1	0	27	2	2
034B00 039L	7	159	30	53	318 15	3	1	22	11	2	2
036B00 025N	12	114	44	51	519 0	3	1	10	20	2	2
036B00 104N	12	968	82	37	666 0	3	1	21	30	2	2
036B00 106N	12	409	82	37	919 0	3	1	34	32	2	2
036B00 142N	12	245	32	13	570 0	3	1	4	14	2	2
037B00 093R	5	766	32	26	957 1	3	1	18	44	2	2



039B00 027R	6	128	38	48	162 02	3	1	30	12	2	2
042B00 106N	1	208	31	54	722 0	3	1	0	40	2	2
042B00 190N	1	264	20	61	557	3	1	2	30	2	2
042B00 265N	1	77	22	16	89	3	1	6	18	2	2
045B00 053N	9	225	30	31	234 3	3	1	22	50	2	2
048B00 180N	11	204	44	15	529 4	3	1	10	17	2	2
051B00 133N	2	167	44	30	686 0	3	1	6	50	2	2
052B00 038N	5	294	32	47	395 2	3	1	18	10	2	2
053B00 021N	1	198	30	67	894	3	1	4	24	2	2
056B00 146L	5	72	29	45	275 9	3	1	23	9	2	2
058B00 044N	12	99	26	73	984	3	1	12	40	2	2
058B00 067N	12	202	82	28	137 11	3	1	34	16	2	2
063B00 107N	11	306	98	15	190 53	3	1	1	11	2	2
070B00 038N	1	99	24	74	740	3	1	7	32	2	2
070B00 063L	1	173 1	39	38	129 67	3	1	50	50	2	2

073B00 015N	1	66	22	46	137 9	3	1	14	50	2	2
073B00 054N	1	115	22	64	148 8	3	1	1	50	2	2
073B00 055N	1	152	22	64	148 8	3	1	8	50	2	2
073B00 104R	1	170	38	43	138 10	3	1	19	50	2	2
073B00 106N	1	115	88	43	200 78	3	1	5	32	2	2
073B00 111L	1	121	39	40	219 03	3	1	13	50	2	2
073B00 112R	1	196	39	40	185 80	3	1	0	35	2	2
079B00 017N	1	99	19	77	315 2	3	1	12	16	2	2
079B00 019N	1	165	19	77	315 2	3	1	4	15	2	2
079B00 056N	1	144	28	60	987 6	3	1	15	40	2	2
079B00 117R	1	216	39	39	134 55	3	1	21	46	2	2
079B00 146N	1	297	48	11	232 7	3	1	4	50	2	2
097B00 017L	10	265	30	46	126 00	3	1	24	13	2	2
097B00 105N	10	302	86	33	216 00	3	1	21	32	2	2
098B00 053N	12	280	29	50	220 8	3	1	4	50	2	2

098B00 152N	12	355	27	34	100	3	1	22	50	2	2
098B00 168N	12	269	32	31	144 2	3	1	21	50	2	2
098B00 176N	12	139	40	33	362 00	3	1	22	50	2	2
098B00 185L	12	223	51	27	132 50	3	1	18	42	2	2
106B00 034N	5	159	24	55	140 6	3	1	14	16	2	2
106B00 059R	5	226	30	55	205 77	3	1	5	13	2	2
114B00 052L	3	194	31	43	101 04	3	1	10	18	2	2
117B00 068N	2	221	26	47	79	3	1	22	23	2	2
119B00 049N	10	172	30	52	406 0	3	1	13	31	2	2
003B00 034N	7	129	26	44	104	3	1	13	15	2	3
008B00 018N	6	279	22	75	466	3	1	7	45	2	3
019B00 049L	6	354	56	38	503 74	3	1	50	15	2	3
019B00 053L	6	218	64	38	583 00	3	1	20	40	2	3
021B00 044N	6	285	44	41	235 0	3	1	26	25	2	3
025B00 058R	7	159	30	53	572 4	3	1	22	9	2	3

030B00 045N	2	32	13	53	106 08	3	1	1	40	2	3
034B00 026N	7	211	91	46	415 00	3	1	15	11	2	3
036B00 144N	12	242	40	13	133 3	3	1	2	15	2	3
045B00 057N	9	323	28	30	186 2	3	1	15	17	2	3
052B00 050L	5	360	32	47	167 09	3	1	39	6	2	3
054B00 095L	2	318	34	54	970 1	3	1	30	40	2	3
056B00 147R	5	72	38	45	404 66	3	1	10	20	2	3
056B00 251N	5	188	142	45	599 00	3	1	40	50	2	3
056B00 290N	5	940	72	40	288 00	3	1	23	43	2	3
056B00 478N	5	100	106	12	599 00	3	1	22	20	2	3
064B00 055L	12	312	43	38	437 5	3	1	23	50	2	3
073B00 095N	1	389	44	59	160 00	3	1	0	46	2	3
075B00 053N	2	241	20	62	92	3	1	15	42	2	3
075B00 057N	2	190	26	59	78	3	1	12	40	2	3
076B00 105L	7	320	60	12	269 50	3	1	10	20	2	3

081B00 068N	9	157	35	16	163 1	3	1	5	50	2	3
087B00 015N	7	165	20	61	128 1	3	1	11	17	2	3
105B00 120L	7	268	60	23	280 30	3	1	10	30	2	3
106B00 066L	5	195	30	55	190 78	3	1	22	23	2	3
036B00 084L	12	562	28	52	705 1	2	1	15	20	2	2
018B00 111N	1	88	82	27	241 85	3	2	3	42	2	1
018B00 113N	1	170	28	27	716	3	2	5	50	2	1
036B00 128N	12	319	82	25	525 4	3	2	35	50	2	1
037B00 099N	5	497	44	20	428 0	3	2	50	26	2	1
042B00 164N	1	198	26	48	75	3	2	17	50	2	1
042B00 216N	1	106	30	31	135 0	3	2	9	16	2	1
042B00 247N	1	30	43	23	233 8	3	2	3	50	2	1
042B00 249N	1	36	43	23	233 8	3	2	10	50	2	1
045B00 067N	9	294	28	25	968	3	2	18	44	2	1
053B00 068N	1	237	26	48	24	3	2	30	49	2	1

058B00 071N	12	68	25	24	214	3	2	2	46	2	1
064B00 070N	12	89	29	28	426	3	2	4	50	2	1
067B00 087N	12	120	38	36	211 9	3	2	12	23	2	1
070B00 045N	1	150	30	46	313 0	3	2	41	12	2	1
072B00 038N	1	234	28	38	124 0	3	2	31	15	2	1
073B00 131N	1	162	28	31	987	3	2	0	22	2	1
073B00 149N	1	33	34	22	179 0	3	2	8	50	2	1
079B00 076L	1	519	30	48	864 0	3	2	12	50	2	1
080B00 022N	12	312	42	29	567 3	3	2	22	25	2	1
004B00 060N	1	375	44	25	350 0	3	2	50	50	2	2
007B00 109N	11	326	28	32	697	3	2	6	34	2	2
018B00 119N	1	75	46	22	744	3	2	13	39	2	2
019B00 064N	6	77	26	27	104 720	3	2	0	38	2	2
028B00 052N	1	224	34	38	517	3	2	0	47	2	2
034B00 027L	7	135	38	46	366 47	3	2	18	10	2	2

036B00 135N	12	615	30	23	667 4	3	2	46	30	2	2
042B00 158R	1	97	38	48	380 5	3	2	8	40	2	2
042B00 168R	1	132	38	48	320 5	3	2	15	40	2	2
042B00 243N	1	68	32	26	233 8	3	2	0	50	2	2
054B00 014L	2	157	38	47	545 1	3	2	14	50	2	2
054B00 090N	2	174	24	46	354	3	2	12	19	2	2
061B00 078N	11	506	34	37	207 0	3	2	12	38	2	2
061B00 091L	11	303	40	25	665 0	3	2	30	30	2	2
079B00 075R	1	291	30	48	864 0	3	2	13	50	2	2
091B00 055N	9	402	28	25	810	3	2	43	28	2	2
093B00 054N	5	47	28	18	321	3	2	0	33	2	2
097B00 113N	10	344	28	27	468 5	3	2	0	40	2	2
098B00 257R	12	907	41	9	731 5	3	2	37	50	2	2
015B00 090N	5	331	40	17	122 00	3	2	6	20	2	3
036B00 120N	12	586	34	28	804 3	3	2	50	50	2	3

048B00 140N	11	189	24	35	117 4	3	2	8	20	2	3
056B00 414N	5	210	135	26	117 000	3	2	12	39	2	3
056B00 495N	5	282	124	5	540 47	3	2	2	23	2	3
057B00 025R	7	198	40	29	167 50	3	2	42	10	2	3
059B00 082N	6	281	70	30	208 97	3	2	14	50	2	3
108B00 037N	5	323	278	31	676	3	2	14	32	2	3
113B00 102N	2	173	39	18	175 3	3	2	3	17	2	3
004B00 057N	1	90	40	30	687 1	1	1	0	0	4	1
005B00 010N	3	25	35	90	462 0	1	1	4	0	4	1
009B00 024N	7	86	24	65	237	1	1	7	0	4	1
018B00 025N	1	443	30	59	711 5	1	1	2	0	4	1
020B00 066N	1	69	76	12	254 0	1	1	0	0	4	1
021B00 023N	6	34	23	85	161 0	1	1	7	0	4	1
028B00 013N	1	212	19	82	741	1	1	9	0	4	1
033B00 036N	10	81	28	32	116 0	1	1	10	0	4	1



034B00 154N	7	57	54	16	497 3	1	1	13	0	4	1
036B00 152N	12	200	24	5	219 2	1	1	24	0	4	1
064B00 031N	12	48	26	57	494	1	1	10	0	4	1
064B00 083N	12	38	29	18	90	1	1	2	0	4	1
067B00 046N	12	99	22	67	133 4	1	1	4	0	4	1
070B00 068N	1	83	28	33	617	1	1	0	0	4	1
073B00 122N	1	256	44	40	438 5	1	1	12	0	4	1
076B00 100N	7	40	43	15	376 0	1	1	13	0	4	1
076B00 101N	7	188	29	14	688	1	1	10	0	4	1
079B00 037N	1	67	23	83	266 7	1	1	5	0	4	1
083B00 039N	10	69	27	13	475	1	1	0	0	4	1
086B00 032N	3	38	20	61	787	1	1	6	0	4	1
087B00 008N	7	66	26	28	449 0	1	1	0	0	4	1
091B00 062N	9	131	48	13	391 0	1	1	0	0	4	1
095B00 003N	10	66	20	76	787	1	1	4	0	4	1

097B00 012L	10	504	30	46	641 8	1	1	0	0	4	1
097B00 042N	10	261	26	54	706	1	1	11	0	4	1
098B00 136N	12	76	26	56	473 0	1	1	7	0	4	1
098B00 138N	12	318	27	65	565 5	1	1	5	0	4	1
098B00 198N	12	88	40	25	146 0	1	1	10	0	4	1
099B00 049N	10	231	14	53	50	1	1	0	0	4	1
119B00 071N	10	88	28	14	77	1	1	0	0	4	1
001B00 084N	8	324	38	7	489 9	1	1	9	0	4	2
003B00 059N	7	37	33	11	277 0	1	1	12	0	4	2
005B00 011N	3	45	34	87	476 2	1	1	6	0	4	2
008B00 067N	6	65	28	29	351 6	1	1	5	0	4	2
008B00 089N	6	83	30	11	225	1	1	20	0	4	2
009B00 004N	7	132	26	67	550 0	1	1	8	0	4	2
019B00 038N	6	362	44	40	273 8	1	1	0	0	4	2
019B00 043R	6	240	84	41	295 52	1	1	5	0	4	2

019B00 050N	6	313	36	38	782 8	1	1	10	0	4	2
024B00 156N	2	40	23	16	732	1	1	16	0	4	2
025B00 105N	7	263	140	9	204 31	1	1	10	0	4	2
034B00 010N	7	443	16	60	137 0	1	1	20	0	4	2
035B00 095N	9	100	48	8	286 2	1	1	6	0	4	2
036B00 006N	12	159	20	77	272 6	1	1	10	0	4	2
036B00 105N	12	491	82	37	991 0	1	1	0	0	4	2
039B00 029N	6	245	26	48	141	1	1	20	0	4	2
040B00 040N	7	257	48	12	429 5	1	1	23	0	4	2
042B00 274N	1	134	65	12	931 4	1	1	2	0	4	2
048B00 030N	11	140	20	51	129 0	1	1	2	0	4	2
049B00 027N	6	34	14	79	679	1	1	4	0	4	2
049B00 036N	6	78	19	83	761	1	1	7	0	4	2
052B00 056N	5	63	23	40	128 5	1	1	0	13	4	2
055B00 007N	11	66	24	80	859	1	1	3	0	4	2

055B00 038N	11	68	27	27	415	1	1	5	0	4	2
056B00 367N	5	38	38	33	186 0	1	1	4	0	4	2
057B00 032N	7	111	35	14	123 0	1	1	0	0	4	2
058B00 047N	12	295	24	79	528 6	1	1	2	0	4	2
059B00 112N	6	28	14	9	213 79	1	1	0	0	4	2
060B00 042N	12	53	22	54	112 5	1	1	10	0	4	2
060B00 077N	12	48	38	12	230 0	1	1	13	0	4	2
061B00 016N	11	99	24	69	402 0	1	1	6	0	4	2
061B00 037N	11	144	19	83	625	1	1	14	0	4	2
061B00 081R	11	159	40	36	770 0	1	1	0	0	4	2
063B00 039R	11	185	38	47	189 60	1	1	0	0	4	2
063B00 043L	11	480	30	46	189 60	1	1	5	0	4	2
063B00 097N	11	108	32	36	805 4	1	1	12	0	4	2
066B00 033N	11	124	24	63	245 0	1	1	10	0	4	2
067B00 031N	12	116	19	82	714	1	1	8	0	4	2

072B00 005N	1	62	19	83	445	1	1	7	0	4	2
072B00 051N	1	26	14	39	728 8	1	1	7	0	4	2
073B00 026N	1	43	28	60	681 0	1	1	2	0	4	2
076B00 008N	7	172	28	59	121 00	1	1	17	0	4	2
077B00 085N	10	224	44	8	136 4	1	1	17	0	4	2
079B00 035N	1	129	23	83	136 0	1	1	4	0	4	2
079B00 047N	1	172	19	83	119 7	1	1	4	0	4	2
079B00 081N	1	141	28	44	836	1	1	14	0	4	2
081B00 047N	9	46	25	38	307	1	1	4	0	4	2
086B00 056N	3	92	40	11	276 0	1	1	15	0	4	2
094B00 031N	6	60	25	29	216	1	1	10	0	4	2
095B00 043N	10	101	40	8	607	1	1	15	0	4	2
097B00 058N	10	143	22	58	144 4	1	1	12	0	4	2
105B00 021N	7	53	29	75	569 0	1	1	0	0	4	2
105B00 129N	7	114	30	18	133 0	1	1	0	0	4	2

106B00 090N	5	165	48	17	219 00	1	1	12	0	4	2
110B00 018N	3	43	28	54	187 0	1	1	18	0	4	2
112B00 035N	5	269	28	16	253	1	1	3	0	4	2
118B00 022N	11	140	20	83	251 9	1	1	12	0	4	2
118B00 031N	11	120	24	80	796 0	1	1	26	0	4	2
003B00 011N	7	216	23	85	326 0	1	1	6	0	4	3
003B00 056N	7	264	28	20	124 1	1	1	0	0	4	3
005B00 045N	3	83	26	45	409	1	1	10	0	4	3
007B00 062N	11	60	18	54	813	1	1	19	0	4	3
008B00 075N	6	573	26	25	133 930	1	1	14	0	4	3
009B00 061N	7	35	27	28	113 9	1	1	2	0	4	3
009R00 605N	7	77	12	85	68	1	1	20	0	4	3
017B00 026N	2	48	19	82	303	1	1	15	0	4	3
022B00 035N	9	392	102	88	571 0	1	1	3	0	4	3
022B00 160N	9	36	40	11	281 0	1	1	1	0	4	3

024B00 064N	2	46	22	56	345	1	1	7	0	4	3
025B00 033N	7	152	24	65	593	1	1	4	0	4	3
025B00 102N	7	80	15	13	180	1	1	4	0	4	3
034B00 036N	7	112	58	56	136 70	1	1	14	0	4	3
034B00 123N	7	204	68	34	163 17	1	1	27	0	4	3
034B00 136N	7	32	28	29	195 9	1	1	9	0	4	3
040B00 028L	7	109 8	40	41	975 0	1	1	14	0	4	3
041B00 051N	6	330	35	13	572 0	1	1	12	0	4	3
057B00 024N	7	174	56	29	131 00	1	1	15	0	4	3
063B00 018N	11	108	24	80	842 4	1	1	8	0	4	3
064B00 038N	12	475	12	45	127 3	1	1	0	0	4	3
067B00 060N	12	48	24	64	160 0	1	1	6	0	4	3
067B00 096N	12	48	12	35	190 0	1	1	0	0	4	3
071B00 083N	3	125	26	27	90	1	1	5	0	4	3
075B00 072N	2	26	22	22	164	1	1	0	0	4	3

076B00 012N	7	111	24	81	126 00	1	1	7	0	4	3
084B00 043N	7	127	35	18	187	1	1	0	0	4	3
084B00 047N	7	52	26	16	187	1	1	0	0	4	3
098B00 058N	12	53	30	57	202 0	1	1	5	0	4	3
098B00 092N	12	46	22	48	338 2	1	1	0	0	4	3
105B00 046N	7	63	23	45	483	1	1	12	0	4	3
003B00 007R	7	108 8	30	50	864 3	3	1	50	0	4	2
019B00 044L	6	283	66	41	295 52	3	1	40	0	4	2
019B00 045N	6	494	25	41	591 03	3	1	50	0	4	2
057B00 012N	7	185	24	51	146 0	3	1	15	0	4	2
103B00 056L	9	156	40	47	600 0	3	1	50	0	4	2
019B00 048L	6	285	52	44	440 75	3	1	50	0	4	3
034B00 032L	7	159	30	53	318 14	3	1	38	0	4	3
067B00 008N	12	205	30	50	723 2	3	1	7	0	4	3
063B00 025N	11	132	26	73	133 01	2	1	6	0	4	3



002B00 012N	3	225	30	50	345 0	2	1	14	0	4	1
005B00 047N	3	100	20	62	204	2	1	6	0	4	1
012B00 017N	6	152	20	60	260	2	1	6	0	4	1
033B00 015N	10	189	24	56	546	2	1	5	0	4	1
033B00 023N	10	134	22	59	107 0	2	1	10	0	4	1
060B00 060N	12	231	25	45	801	2	1	5	0	4	1
061B00 049N	11	76	22	66	130	2	1	5	0	4	1
067B00 097N	12	67	40	35	118 5	2	1	12	0	4	1
097B00 046N	10	100	12	69	383	2	1	5	0	4	1
111B00 060N	1	448	39	6	704	2	1	0	0	4	1
005B00 095R	3	289	42	13	187 5	2	1	10	0	4	2
008B00 026N	6	66	22	62	155 7	2	1	4	0	4	2
008B00 032N	6	279	26	48	183 0	2	1	0	0	4	2
008B00 040L	6	159	107	55	316 92	2	1	6	0	4	2
008B00 042L	6	307	22	48	907 93	2	1	18	0	4	2

008B00 078L	6	159	73	22	453 97	2	1	12	0	4	2
008B00 080L	6	159	73	23	585 71	2	1	4	0	4	2
010B00 073L	9	246	42	8	958 0	2	1	8	0	4	2
021B00 006N	6	319	26	48	270	2	1	18	0	4	2
025B00 042N	7	192	22	61	762	2	1	2	0	4	2
026B00 049N	11	129	23	57	174 2	2	1	9	0	4	2
028B00 029N	1	89	20	65	74	2	1	4	0	4	2
032B00 020N	9	114	22	57	485	2	1	7	0	4	2
034B00 038L	7	199	30	56	280 38	2	1	15	0	4	2
039B00 014N	6	350	28	48	141 9	2	1	18	0	4	2
041B00 014N	6	321	24	82	145 0	2	1	8	0	4	2
049B00 017N	6	404	90	57	137 0	2	1	18	0	4	2
052B00 048N	5	144	24	60	460	2	1	5	0	4	2
055B00 020N	11	101	20	65	315	2	1	9	0	4	2
063B00 002N	11	252	24	74	696 7	2	1	19	0	4	2

066B00 013N	11	212	21	71	308 0	2	1	10	0	4	2
067B00 032N	12	116	19	81	714	2	1	8	0	4	2
096B00 001N	6	630	24	79	284 1	2	1	6	0	4	2
096B00 008N	6	133	26	4	285 1	2	1	16	0	4	2
096B00 026N	6	159	22	61	115 3	2	1	7	0	4	2
097B00 035N	10	99	22	67	473 7	2	1	3	0	4	2
097B00 043N	10	66	25	69	122 0	2	1	2	0	4	2
098B00 005N	12	159	22	58	267	2	1	4	0	4	2
106B00 062L	5	245	30	55	272 28	2	1	15	0	4	2
110B00 011N	3	121	28	83	349 7	2	1	3	0	4	2
114B00 005N	3	200	54	61	222 69	2	1	25	0	4	2
118B00 044N	11	530	26	65	101 00	2	1	30	0	4	2
118B00 046L	11	172	38	48	182 50	2	1	13	0	4	2
118B00 090N	11	192	26	67	117 73	2	1	0	0	4	2
003B00 022N	7	236	26	50	120 67	2	1	11	0	4	3

009B00 008N	7	129	20	76	132 0	2	1	12	0	4	3
009B00 032N	7	129	28	49	165 6	2	1	16	0	4	3
011B00 047N	9	70	26	32	777 0	2	1	6	0	4	3
019B00 030N	6	114	24	60	360 0	2	1	5	0	4	3
028B00 024N	1	198	14	67	198	2	1	3	0	4	3
034B00 003N	7	144	30	51	157 42	2	1	10	0	4	3
034B00 021L	7	134	24	53	318 14	2	1	18	0	4	3
034B00 049N	7	100	26	64	259 7	2	1	8	0	4	3
034B00 078R	7	132	50	51	256 48	2	1	20	0	4	3
037B00 060R	5	213	30	55	183 50	2	1	30	0	4	3
041B00 011N	6	241	24	82	343 0	2	1	12	0	4	3
045B00 025N	9	225	25	73	154 6	2	1	14	0	4	3
056B00 369N	5	282	84	29	100 98	2	1	11	0	4	3
061B00 084N	11	79	28	32	207 0	2	1	27	0	4	3
066B00 036N	11	185	24	58	530	2	1	8	0	4	3

071B00 047N	3	364	24	79	800 3	2	1	26	0	4	3
087B00 012N	7	100	25	62	188 1	2	1	7	0	4	3
105B00 020N	7	216	26	27	793 9	2	1	8	0	4	3
026B00 0108N	11	144	40	22	130 35	1	2	11	0	4	1
026B00 109N	11	63	32	22	379	1	2	9	0	4	1
028B00 058N	1	36	41	31	400 0	1	2	18	0	4	1
058B00 081N	12	68	41	18	165 0	1	2	0	0	4	1
059B00 098N	6	247	28	17	340	1	2	0	0	4	1
060B00 058N	12	341	33	43	536 8	1	2	50	0	4	1
063B00 110N	11	115	28	16	670	1	2	5	0	4	1
064B00 066N	12	240	30	31	566	1	2	0	0	4	1
067B00 111N	12	142	30	30	282 5	1	2	6	0	4	1
067B00 122N	12	213	33	23	778	1	2	4	0	4	1
076B00 089N	7	53	28	22	583	1	2	9	0	4	1
098B00 239N	12	108	30	17	576 0	1	2	10	0	4	1

110B00 040L	3	83	42	17	244 0	1	2	4	0	4	1
025B00 100N	7	87	40	20	473 3	1	2	17	0	4	2
028B00 063N	1	73	44	26	318 0	1	2	10	0	4	2
032B00 035N	9	906	44	16	320 0	1	2	20	0	4	2
049B00 069N	6	102	40	18	232 0	1	2	2	0	4	2
056B00 453N	5	46	31	19	784	1	2	3	0	4	2
097B00 118N	10	34	28	19	133 4	1	2	7	0	4	2
098B00 230N	12	102 3	44	20	876 0	1	2	0	0	4	2
101B00 017N	6	289	24	26	190	1	2	13	0	4	2
105B00 142R	7	78	42	8	515 0	1	2	8	0	4	2
008B00 009N	6	276	82	55	524 58	1	2	0	0	4	3
008B00 065N	6	67	28	33	912	1	2	16	0	4	3
041B00 047N	6	219	65	17	297 00	1	2	3	0	4	3
056B00 393N	5	99	149	27	171 000	1	2	0	0	4	3
093B00 049N	5	92	29	29	235 6	1	2	7	0	4	3

118B00 063R	11	485	30	57	162 46	3	2	40	0	4	2
070B00 075N	1	71	44	22	392 7	2	2	3	0	4	2
086B00 053N	3	140	32	19	276 0	2	2	5	0	4	2
103B00 077N	9	149	30	27	555 0	2	2	11	0	4	2
105B00 107R	7	296	47	28	117 53	2	2	5	0	4	2
105B00 108R	7	358	62	27	115 08	2	2	13	0	4	2
022B00 075N	9	185	11. 2	51	192 1	1	1	20	0	3	3
053B00 059N	1	231	24	60	275	3	1	10	50	3	1
040B00 004N	7	154	20	67	277 0	3	1	3	21	3	3
042B00 118N	1	99	23	81	775	1	1	6	0	3	1
042B00 093N	1	38	28	59	516 0	1	1	8	40	3	2
007B00 101N	11	96	23	37	119 1	1	1	20	0	3	3
002B00 009N	3	363	26	52	197	3	1	24	41	3	1
004B00 039N	1	99	24	57	254	3	1	5	40	3	1
004B00 051N	1	99	24	55	240	3	1	5	50	3	1

013B00 039N	10	406	24	56	141 0	3	1	25	24	3	1
018B00 102N	1	365	44	32	919 8	3	1	17	50	3	1
018B00 122N	1	54	22	18	392	3	1	10	12	3	1
018B00 124N	1	58	22	18	54	3	1	10	12	3	1
020B00 040N	1	99	24	53	194	3	1	2	39	3	1
028B00 049N	1	114	24	55	294	3	1	7	49	3	1
036B00 110N	12	798	44	37	218 3	3	1	20	13	3	1
036B00 125N	12	192	30	27	199	3	1	4	50	3	1
036B00 153N	12	200	24	5	219 2	3	1	12	23	3	1
038B00 015N	1	196	38	48	173 0	3	1	22	50	3	1
038B00 048N	1	159	22	44	40	3	1	3	20	3	1
038B00 084N	1	78	26	22	93	3	1	8	48	3	1
042B00 028N	1	208	26	48	341	3	1	23	50	3	1
042B00 057N	1	84	26	56	825	3	1	3	40	3	1
042B00 129N	1	114	24	56	673	3	1	3	50	3	1



042B00 172N	1	241	26	48	200	3	1	20	38	3	1
042B00 196N	1	114	24	55	730	3	1	4	49	3	1
042B00 222N	1	180	28	28	233 8	3	1	5	50	3	1
042B00 224N	1	135	28	28	233 8	3	1	5	50	3	1
042B00 261N	1	71	29	16	419	3	1	0	21	3	1
053B00 036N	1	87	19	83	130	3	1	12	40	3	1
053B00 098N	1	227	26	18	239	3	1	0	23	3	1
053B00 100N	1	212	28	16	140	3	1	2	28	3	1
059B00 053L	6	256	62	21	961 77	3	1	0	10	3	1
067B00 038N	12	411	20	75	778	3	1	0	32	3	1
067B00 082N	12	203	44	41	104 41	3	1	14	12	3	1
067B00 102N	12	149	77	36	137 54	3	1	10	20	3	1
067B00 103N	12	291	44	36	137 54	3	1	10	20	3	1
068B00 054N	9	76	20	63	245	3	1	7	22	3	1
071B00 086N	3	96	27	23	218	3	1	7	17	3	1

073B00 101L	1	133	38	43	140 45	3	1	23	50	3	1
073B00 158N	1	64	23	15	174	3	1	2	39	3	1
073B00 164R	1	506	42	15	646 1	3	1	3	17	3	1
079B00 089N	1	132	24	60	504	3	1	7	41	3	1
079B00 144R	1	232	28	16	419 0	3	1	9	11	3	1
097B00 100N	10	288	82	34	924 3	3	1	10	10	3	1
098B00 201R	12	157	45	37	169 69	3	1	8	17	3	1
006B00 050R	9	157	40	48	807 1	3	1	13	7	3	2
007B00 121N	11	208	30	27	185 4	3	1	0	37	3	2
010B00 074N	9	293	29	8	156 21	3	1	10	45	3	2
016B00 019N	3	76	24	77	147	3	1	8	20	3	2
018B00 090N	1	99	24	52	277	3	1	5	37	3	2
018B00 126N	1	163	34	11	139 3	3	1	0	50	3	2
028B00 048N	1	99	24	55	79	3	1	4	23	3	2
034B00 158N	7	262	56	12	439 7	3	1	3	26	3	2

035B00 097N	9	266	54	9	286 2	3	1	31	8	3	2
036B00 023N	12	114	44	51	519 0	3	1	20	14	3	2
036B00 060N	12	99	22	62	440	3	1	4	18	3	2
036B00 079N	12	436	30	46	575 6	3	1	12	50	3	2
036B00 090N	12	396	34	38	280 0	3	1	22	50	3	2
036B00 107N	12	235	82	37	120 22	3	1	28	20	3	2
036B00 109N	12	620	82	37	120 40	3	1	29	47	3	2
036B00 114N	12	187	70	37	119 70	3	1	23	47	3	2
036B00 139N	12	105	84	15	113 82	3	1	8	10	3	2
036B00 140N	12	250	86	15	113 82	3	1	2	22	3	2
042B00 009N	1	213	30	48	328 0	3	1	15	40	3	2
042B00 062N	1	228	22	60	139 0	3	1	3	40	3	2
042B00 185N	1	112	20	62	393	3	1	3	42	3	2
053B00 014N	1	132	20	78	765	3	1	8	30	3	2
053B00 015N	1	165	20	78	765	3	1	9	30	3	2

053B00 041N	1	195	30	84	707	3	1	13	38	3	2
056B00 153N	5	220	38	49	776 04	3	1	25	50	3	2
058B00 041N	12	827	30	53	620 4	3	1	2	50	3	2
058B00 050R	12	129	44	46	565 0	3	1	20	34	3	2
059B00 106L	6	479	40	13	894 8	3	1	18	7	3	2
059B00 108N	6	279	85	14	178 96	3	1	7	6	3	2
060B00 012N	12	161	24	77	190 5	3	1	14	18	3	2
061B00 068N	11	174	30	51	689 6	3	1	34	33	3	2
061B00 082R	11	225	40	36	935 0	3	1	7	43	3	2
064B00 027N	12	144	26	53	100 0	3	1	2	36	3	2
067B00 130N	12	451	82	15	625 0	3	1	0	20	3	2
073B00 009N	1	294	44	43	780 0	3	1	11	50	3	2
073B00 059N	1	204	42	55	805 0	3	1	0	41	3	2
073B00 079N	1	132	24	63	343 5	3	1	10	40	3	2
073B00 093N	1	238	50	64	163 64	3	1	30	40	3	2

079B00 011N	1	152	30	54	326 2	3	1	11	50	3	2
079B00 097N	1	114	28	47	235 1	3	1	11	39	3	2
079B00 118R	1	210 8	39	41	131 55	3	1	40	50	3	2
080B00 013N	12	200	24	57	156 0	3	1	6	50	3	2
080B00 018N	12	99	24	50	184 0	3	1	0	50	3	2
088B00 010N	10	84	20	78	200 0	3	1	4	26	3	2
103B00 093N	9	303	76	9	222 00	3	1	18	27	3	2
105B00 133N	7	171	40	16	459 0	3	1	3	5	3	2
114B00 087N	3	283	120	13	463 60	3	1	2	12	3	2
114B00 090R	3	128	59	13	213 80	3	1	1	12	3	2
118B00 045L	11	674	30	50	154 96	3	1	32	39	3	2
120B00 024L	7	165	39	42	194 00	3	1	20	20	3	2
007B00 143N	11	99	31	16	156	3	1	2	11	3	3
008B00 021N	6	318	30	57	196 6	3	1	25	50	3	3
008B00 073N	6	640	26	25	133 930	3	1	32	18	3	3

011B00 038L	7	509	44	44	114 00	3	1	39	3	3	3
018B00 137R	1	345	42	6	193 6	3	1	6	13	3	3
035B00 091N	9	95	30	12	148	3	1	2	8	3	3
036B00 021N	12	114	44	51	116 00	3	1	20	30	3	3
036B00 036N	12	99	28	56	198 9	3	1	15	50	3	3
036B00 078N	12	371	24	53	274 0	3	1	0	50	3	3
036B00 138N	12	98	26	18	600	3	1	0	14	3	3
040B00 038N	7	153	30	14	412	3	1	11	30	3	3
045B00 077N	9	236	48	12	520 9	3	1	7	5	3	3
056B00 156L	5	284	30	49	744 44	3	1	22	50	3	3
056B00 158N	5	385	30	49	148 888	3	1	38	50	3	3
056B00 372R	5	151	40	28	322 85	3	1	18	9	3	3
057B00 031N	7	128	28	14	441 0	3	1	4	9	3	3
059B00 038L	6	159	88	55	776 69	3	1	30	46	3	3
064B00 063N	12	201	34	32	484	3	1	15	50	3	3

073B00 061N	1	214	30	55	195 00	3	1	0	50	3	3
079B00 114R	1	193	47	39	130 00	3	1	24	11	3	3
081B00 036N	9	210	26	52	109 1	3	1	32	49	3	3
084B00 046N	7	172	35	15	698	3	1	2	6	3	3
087B00 059N	7	354	40	18	685 4	3	1	12	5	3	3
100B00 029N	8	120 8	26	64	586 4	3	1	0	12	3	3
114B00 085L	3	496	41	13	787 5	3	1	7	6	3	3
118B00 056R	11	141	38	50	127 00	3	1	30	5	3	3
004B00 067N	1	90	23	13	325	2	1	3	0	3	2
034B00 094L	7	117	62	51	387 54	2	1	5	4	3	2
012B00 030N	6	244	44	26	483 3	3	2	22	18	3	1
013B00 071N	10	122	24	27	206	3	2	9	18	3	1
021B00 034N	6	150	24	45	291	3	2	7	17	3	1
028B00 064N	1	41	45	26	171 0	3	2	10	33	3	1
041B00 041N	6	403	24	26	121	3	2	10	30	3	1

042B00 159L	1	97	38	48	380 5	3	2	12	40	3	1
042B00 217N	1	245	28	31	691	3	2	0	34	3	1
042B00 238N	1	83	28	27	668	3	2	4	50	3	1
042B00 239N	1	80	28	27	891	3	2	4	50	3	1
042B00 254N	1	70	30	17	877	3	2	0	16	3	1
060B00 056N	12	633	32	43	619 1	3	2	38	4	3	1
060B00 070N	12	168	32	27	112 5	3	2	10	18	3	1
070B00 046N	1	216	30	46	313 0	3	2	47	50	3	1
071B00 097L	3	204	43	20	173 1	3	2	14	15	3	1
073B00 064N	1	228	27	44	386	3	2	20	50	3	1
073B00 138N	1	140	31	31	112 00	3	2	17	48	3	1
076B00 099N	7	93	93	17	341 00	3	2	2	6	3	1
079B00 128N	1	223	40	29	884 2	3	2	13	50	3	1
079B00 135N	1	51	28	22	255	3	2	7	45	3	1
088B00 072N	10	141	46	33	685 0	3	2	15	18	3	1



088B00 081N	10	252	40	24	255 0	3	2	3	23	3	1
098B00 186N	12	289	28	29	182 0	3	2	15	16	3	1
119B00 062N	10	74	40	19	150 7	3	2	3	25	3	1
015B00 071N	5	289	24	29	50	3	2	18	6	3	2
030B00 155N	2	206	86	18	146 80	3	2	8	50	3	2
034B00 164L	7	195	43	11	772 8	3	2	18	16	3	2
042B00 154R	1	208	24	48	740 0	3	2	26	50	3	2
042B00 162R	1	189	38	48	320 5	3	2	14	40	3	2
042B00 163L	1	97	38	48	320 5	3	2	12	50	3	2
042B00 165L	1	97	38	48	320 5	3	2	13	50	3	2
042B00 166R	1	208	38	48	320 5	3	2	9	50	3	2
042B00 170R	1	310	30	48	377 5	3	2	16	50	3	2
042B00 257N	1	67	39	16	237 9	3	2	0	19	3	2
045B00 082N	9	464	60	12	520 9	3	2	20	30	3	2
049B00 068N	6	310	52	20	474 0	3	2	6	34	3	2

058B00 058N	12	190	44	37	771 5	3	2	15	36	3	2
058B00 064N	12	134	32	32	106 00	3	2	8	27	3	2
058B00 068N	12	83	41	25	115 0	3	2	6	15	3	2
066B00 061N	11	324	30	29	288 0	3	2	16	20	3	2
098B00 196N	12	142	40	27	518 0	3	2	4	35	3	2
107B00 035N	3	170	76	31	323 8	3	2	27	28	3	2
021B00 045N	6	259	44	41	142 00	3	2	19	36	3	3
022B00 083R	9	357	38	44	101 23	3	2	16	47	3	3
041B00 048N	6	290	41	14	115 00	3	2	4	7	3	3
047B00 156N	4	303	44	19	555 9	3	2	44	14	3	3
056B00 426L	5	103 0	85	26	585 00	3	2	32	41	3	3
120B00 038N	7	182	25	21	171 0	3	2	13	10	3	3
018B00 024N	1	87	23	70	272 0	3	1	7	30	1	1
042B00 201N	1	159	23	38	207	3	1	0	50	1	1
059B00 081L	6	547	36	32	753 7	3	1	10	50	1	1

064B00 058N	12	93	34	36	457	3	1	9	39	1	1
067B00 083N	12	343	62	41	941 6	3	1	37	7	1	1
070B00 065N	1	146 7	25	63	679 4	3	1	7	50	1	1
080B00 039N	12	164	33	16	385	3	1	0	21	1	1
097B00 056N	10	159	36	48	966 3	3	1	20	19	1	1
111B00 043N	1	262	27	42	61	3	1	27	28	1	1
003B00 060N	7	254	133	12	148 00	3	1	14	11	1	2
012B00 008N	6	159	26	54	826	3	1	22	40	1	2
026B00 061N	11	178	76	44	117 24	3	1	27	7	1	2
032B00 012N	9	114	24	65	250	3	1	2	40	1	2
033B00 019N	10	165	22	80	157 0	3	1	5	30	1	2
036B00 037L	12	308	45	42	985 0	3	1	24	50	1	2
036B00 077N	12	246	30	53	593 0	3	1	0	50	1	2
042B00 128N	1	215	26	48	673	3	1	25	50	1	2
053B00 022N	1	185	24	74	132 0	3	1	6	48	1	2

059B00 073N	6	207	40	37	260 3	3	1	28	9	1	2
064B00 018N	12	121	20	78	808	3	1	4	34	1	2
079B00 023N	1	349 6	20	83	220 0	3	1	10	30	1	2
098B00 256L	12	127 6	42	9	735 0	3	1	50	20	1	2
036B00 008N	12	84	30	60	289 0	3	1	2	30	1	3
036B00 086N	12	358	28	52	127 0	3	1	30	50	1	3
051B00 073R	2	191	26	45	500 0	3	1	27	34	1	3
051B00 074N	2	270	34	45	461 0	3	1	23	33	1	3
051B00 076N	2	240	30	45	672	3	1	22	38	1	3
054B00 012R	2	174	38	47	633 7	3	1	30	21	1	3
084B00 014R	7	200	30	50	525 0	3	1	20	14	1	3
018B00 120N	1	140	44	19	686 1	3	2	7	50	1	1
019B00 067N	6	165	82	26	975 7	3	2	17	40	1	1
053B00 050N	1	222	28	48	278	3	2	16	50	1	1
042B00 177L	1	211	38	48	435 5	3	2	9	48	1	2

052B00 075N	5	175	27	26	362	3	2	24	12	1	2
056B00 314L	5	170	46	17	182 50	3	2	36	7	1	2

## Appendix E: Output of the Ordinal Logistic Regression for Sample One

```
GET
  FILE='C:\Users\jzh252\Desktop\Sample1.sav'.
DATASET NAME DataSet1 WINDOW=FRONT.
PLUM SEVERITY BY DISTRICT ABUT APPT FSC WITH LENGTH WIDTH AGE ADT EH
FSD
  /CRITERIA=CIN(95) DELTA(0) LCONVERGE(0) MXITER(100) MXSTEP(5)
PCONVERGE(1.0E-6) SINGULAR(1.0E-8)
  /LINK=LOGIT
  /PRINT=FIT PARAMETER SUMMARY TPARALLEL.
```

### PLUM - Ordinal Regression

#### Warnings

There are 174 (66.7%) cells (i.e., dependent variable levels by observed combinations of predictor variable values) with zero frequencies.

Unexpected singularities in the Fisher Information matrix are encountered. There may be a quasi-complete separation in the data. Some parameter estimates will tend to infinity.

The PLUM procedure continues despite the above warning(s). Subsequent results shown are based on the last iteration. Validity of the model fit is uncertain.

#### Case Processing Summary

		N	Marginal Percentage
SEVERITY	1.00	14	16.1%
	2.00	36	41.4%
	3.00	37	42.5%
DISTRICT	1.00	4	4.6%
	4.00	4	4.6%
	5.00	11	12.6%
	6.00	30	34.5%
	7.00	9	10.3%
	9.00	5	5.7%
ABUT	1.00	18	20.7%
	2.00	10	11.5%
	3.00	59	67.8%
	APPT	1.00	70

	2.00	17	19.5%
FSC	1.00	7	8.0%
	2.00	31	35.6%
	3.00	30	34.5%
	4.00	19	21.8%
Valid		87	100.0%
Missing		0	
Total		87	

#### Model Fitting Information

Model	-2 Log Likelihood	Chi-Square	df	Sig.
Intercept Only	177.953			
Final	147.035	30.918	20	.056

Link function: Logit.

#### Goodness-of-Fit

	Chi-Square	df	Sig.
Pearson	154.849	152	.421
Deviance	147.035	152	.599

Link function: Logit.

#### Pseudo R-Square

Cox and Snell	.299
Nagelkerke	.344
McFadden	.174

Link function: Logit.

#### Parameter Estimates

	Estimate	Std. Error	Wald	df	Sig.	95% Confidence Interval	
						Lower Bound	Upper Bound
Threshold [SEVERITY = 1.00]	-22.103	2.653	69.404	1	.000	-27.303	-16.903

	[SEVERITY = 2.00]	-19.557	2.661	54.024	1	.000	-24.772	-14.342
Location	LENGTH	-.003	.001	4.263	1	.039	-.005	.000
	WIDTH	.000	.020	.000	1	.988	-.039	.038
	AGE	-.050	.015	10.820	1	.001	-.079	-.020
	ADT	-4.102E-5	2.284E-5	3.226	1	.072	-8.578E-5	3.739E-6
	EH	.024	.024	1.009	1	.315	-.022	.070
	FSD	.028	.022	1.641	1	.200	-.015	.070
	[DISTRICT=1.00]	-22.056	1.145	370.988	1	.000	-24.300	-19.812
	[DISTRICT=4.00]	-19.315	1.194	261.665	1	.000	-21.655	-16.975
	[DISTRICT=5.00]	-20.446	1.018	403.198	1	.000	-22.442	-18.451
	[DISTRICT=6.00]	-20.195	.662	931.737	1	.000	-21.492	-18.899
	[DISTRICT=7.00]	-20.271	.926	478.701	1	.000	-22.086	-18.455
	[DISTRICT=9.00]	-20.858	1.069	380.390	1	.000	-22.954	-18.762
	[DISTRICT=10.00]	-22.022	1.335	271.945	1	.000	-24.639	-19.405
	[DISTRICT=11.00]	-21.657	.000	.	1	.	-21.657	-21.657
	[DISTRICT=12.00]	0 <sup>a</sup>	.	.	0	.	.	.
	[ABUT=1.00]	3.555	2.474	2.065	1	.151	-1.293	8.404
	[ABUT=2.00]	1.646	.849	3.756	1	.053	-.019	3.311
	[ABUT=3.00]	0 <sup>a</sup>	.	.	0	.	.	.
	[APPT=1.00]	-.348	.678	.264	1	.607	-1.678	.981
	[APPT=2.00]	0 <sup>a</sup>	.	.	0	.	.	.
	[FSC=1.00]	2.226	2.483	.803	1	.370	-2.641	7.093
	[FSC=2.00]	2.502	2.329	1.154	1	.283	-2.062	7.067
	[FSC=3.00]	2.151	2.328	.854	1	.355	-2.412	6.714
	[FSC=4.00]	0 <sup>a</sup>	.	.	0	.	.	.

Link function: Logit.

a. This parameter is set to zero because it is redundant.

#### Test of Parallel Lines<sup>a</sup>

Model	-2 Log Likelihood	Chi-Square	df	Sig.
Null Hypothesis	147.035			
General	116.451 <sup>b</sup>	30.584 <sup>c</sup>	20	.061



The null hypothesis states that the location parameters (slope coefficients) are the same across response categories.

a. Link function: Logit.

b. The log-likelihood value cannot be further increased after maximum number of step-halving.

c. The Chi-Square statistic is computed based on the log-likelihood value of the last iteration of the general model. Validity of the test is uncertain.

## Appendix F: Output of the Multinomial Logistic Regression for Sample One

```

NOMREG SEVERITY (BASE=LAST ORDER=ASCENDING) BY DISTRICT ABUT APPT FSC
WITH LENGTH WIDTH AGE ADT EH FSD
  /CRITERIA CIN(95) DELTA(0) MXITER(100) MXSTEP(5) CHKSEP(20)
LCONVERGE(0) PCONVERGE(0.000001) SINGULAR(0.00000001)
  /MODEL
  /STEPWISE=PIN(.05) POUT(0.1) MINEFFECT(0) RULE(SINGLE)
ENTRYMETHOD(LR) REMOVALMETHOD(LR)
  /INTERCEPT=INCLUDE
  /PRINT=CLASSTABLE FIT PARAMETER SUMMARY LRT CPS STEP MFI IC.

```

### Nominal Regression

#### Warnings

There are 174 (66.7%) cells (i.e., dependent variable levels by subpopulations) with zero frequencies.

Unexpected singularities in the Hessian matrix are encountered. This indicates that either some predictor variables should be excluded or some categories should be merged.

The NOMREG procedure continues despite the above warning(s). Subsequent results shown are based on the last iteration. Validity of the model fit is uncertain.

#### Case Processing Summary

		N	Marginal Percentage
SEVERITY	1.00	14	16.1%
	2.00	36	41.4%
	3.00	37	42.5%
DISTRICT	1.00	4	4.6%
	4.00	4	4.6%
	5.00	11	12.6%
	6.00	30	34.5%
	7.00	9	10.3%
	9.00	5	5.7%
	10.00	3	3.4%
ABUT	11.00	18	20.7%
	12.00	3	3.4%
	1.00	18	20.7%
	2.00	10	11.5%
	3.00	59	67.8%

APPT	1.00	70	80.5%
	2.00	17	19.5%
FSC	1.00	7	8.0%
	2.00	31	35.6%
	3.00	30	34.5%
	4.00	19	21.8%
Valid		87	100.0%
Missing		0	
Total		87	
Subpopulation		87 <sup>a</sup>	

a. The dependent variable has only one value observed in 87 (100.0%) subpopulations.

#### Model Fitting Information

Model	Model Fitting Criteria			Likelihood Ratio Tests		
	AIC	BIC	-2 Log Likelihood	Chi-Square	df	Sig.
Intercept Only	181.953	186.885	177.953			
Final	199.383	302.951	115.383	62.570	40	.013

#### Goodness-of-Fit

	Chi-Square	df	Sig.
Pearson	120.916	132	.746
Deviance	115.383	132	.848

#### Pseudo R-Square

Cox and Snell	.513
Nagelkerke	.589
McFadden	.352

**Likelihood Ratio Tests**

Effect	Model Fitting Criteria			Likelihood Ratio Tests		
	AIC of Reduced Model	BIC of Reduced Model	-2 Log Likelihood of Reduced Model	Chi-Square	df	Sig.
Intercept	199.383	302.951	115.383 <sup>a</sup>	.000	0	.
LENGTH	197.334	295.970	117.334	1.950	2	.377
WIDTH	196.110	294.746	116.110	.727	2	.695
AGE	209.661	308.297	129.661	14.278	2	.001
ADT	197.052	295.689	117.052	1.669	2	.434
EH	197.560	296.196	117.560	2.176	2	.337
FSD	201.448	300.084	121.448	6.065	2	.048
DISTRICT	204.321	268.434	152.321	36.938	16	.002
ABUT	196.157	289.861	120.157	4.773	4	.311
APPT	198.496	297.133	118.496	3.113	2	.211
FSC	191.905	280.677	119.905	4.521	6	.606

The chi-square statistic is the difference in -2 log-likelihoods between the final model and a reduced model. The reduced model is formed by omitting an effect from the final model. The null hypothesis is that all parameters of that effect are 0.

a. This reduced model is equivalent to the final model because omitting the effect does not increase the degrees of freedom.

**Parameter Estimates**

SEVERITY <sup>a</sup>	B	Std. Error	Wald	df	Sig.	Exp(B)	95% Confidence Interval for Exp(B)	
							Lower Bound	Upper Bound
1.00 Intercept	11.264	2463.658	.000	1	.996			
LENGTH	.003	.002	1.663	1	.197	1.003	.998	1.007
WIDTH	-.013	.058	.047	1	.829	.988	.881	1.107
AGE	.131	.048	7.457	1	.006	1.140	1.038	1.252
ADT	.000	.000	1.870	1	.172	1.000	1.000	1.000
EH	-.084	.063	1.809	1	.179	.919	.813	1.039
FSD	-.175	.091	3.709	1	.054	.839	.702	1.003
[DISTRICT=1.00]	21.483	2463.657	.000	1	.993	2137345651.087	.000	. <sup>b</sup>
[DISTRICT=4.00]	1.767	3096.612	.000	1	1.000	5.852	.000	. <sup>b</sup>
[DISTRICT=5.00]	3.722	2894.902	.000	1	.999	41.327	.000	. <sup>b</sup>

[DISTRICT=6.00]	17.908	2463.656	.000	1	.994	59907624.950	.000	.b
[DISTRICT=7.00]	1.751	2717.319	.000	1	.999	5.758	.000	.b
[DISTRICT=9.00]	4.132	2913.733	.000	1	.999	62.309	.000	.b
[DISTRICT=10.00]	24.518	2463.658	.000	1	.992	44467382271.204	.000	.b
[DISTRICT=11.00]	20.706	2463.656	.000	1	.993	982595954.472	.000	.b
[DISTRICT=12.00]	0 <sup>c</sup>	.	.	0	.	.	.	.
[ABUT=1.00]	-	2.821	174.608	1	.000	6.457E-17	2.563E-19	1.627E-14
[ABUT=2.00]	-	1288.134	.000	1	.990	8.695E-8	.000	.b
[ABUT=3.00]	0 <sup>c</sup>	.	.	0	.	.	.	.
[APPT=1.00]	-1.622	1.493	1.181	1	.277	.197	.011	3.681
[APPT=2.00]	0 <sup>c</sup>	.	.	0	.	.	.	.
[FSC=1.00]	-	2.060	252.053	1	.000	6.212E-15	1.095E-16	3.525E-13
[FSC=2.00]	-	1.434	432.457	1	.000	1.111E-13	6.680E-15	1.848E-12
[FSC=3.00]	-	.000	.	1	.	3.480E-14	3.480E-14	3.480E-14
[FSC=4.00]	0 <sup>c</sup>	.	.	0	.	.	.	.
2.00 Intercept	-4.972	4161.044	.000	1	.999			
LENGTH	.000	.002	.055	1	.814	1.000	.996	1.004
WIDTH	.021	.029	.528	1	.467	1.022	.964	1.082
AGE	.014	.018	.606	1	.436	1.014	.978	1.052
ADT	.000	.000	.001	1	.973	1.000	1.000	1.000
EH	-.016	.030	.279	1	.598	.985	.929	1.043
FSD	-.004	.026	.027	1	.869	.996	.947	1.047
[DISTRICT=1.00]	18.093	2349.030	.000	1	.994	72037379.865	.000	.b
[DISTRICT=4.00]	16.967	2349.029	.000	1	.994	23373245.447	.000	.b
[DISTRICT=5.00]	19.462	2349.030	.000	1	.993	283228462.428	.000	.b
[DISTRICT=6.00]	16.612	2349.029	.000	1	.994	16392243.251	.000	.b
[DISTRICT=7.00]	17.134	2349.029	.000	1	.994	27625984.370	.000	.b
[DISTRICT=9.00]	17.776	2349.029	.000	1	.994	52474867.233	.000	.b
[DISTRICT=10.00]	17.041	2349.030	.000	1	.994	25171888.908	.000	.b
[DISTRICT=11.00]	16.859	2349.029	.000	1	.994	20970639.872	.000	.b
[DISTRICT=12.00]	0 <sup>c</sup>	.	.	0	.	.	.	.

[ABUT=1.00]	-	3434.581	.000	1	.997	9.762E-7	.000	.b
	13.840							
[ABUT=2.00]	-.075	.993	.006	1	.940	.927	.132	6.493
[ABUT=3.00]	0 <sup>c</sup>	.	.	0	.	.	.	.
[APPT=1.00]	.898	.878	1.045	1	.307	2.453	.439	13.716
[APPT=2.00]	0 <sup>c</sup>	.	.	0	.	.	.	.
[FSC=1.00]	-	3434.581	.000	1	.997	2.083E-6	.000	.b
	13.082							
[FSC=2.00]	-	3434.581	.000	1	.997	6.914E-7	.000	.b
	14.185							
[FSC=3.00]	-	3434.581	.000	1	.997	1.301E-6	.000	.b
	13.552							
[FSC=4.00]	0 <sup>c</sup>	.	.	0	.	.	.	.

a. The reference category is: 3.00.

b. Floating point overflow occurred while computing this statistic. Its value is therefore set to system missing.

c. This parameter is set to zero because it is redundant.

#### Classification

Observed	Predicted			Percent Correct
	1.00	2.00	3.00	
1.00	11	1	2	78.6%
2.00	2	22	12	61.1%
3.00	3	8	26	70.3%
Overall Percentage	18.4%	35.6%	46.0%	67.8%

## Appendix G: Output of the Ordinal Logistic Regression for Sample Two

```

GET
  FILE='C:\Users\jzh252\Desktop\Sample2.sav'.
DATASET NAME DataSet1 WINDOW=FRONT.
PLUM SEVERITY BY DISTRICT ABUT APPT FSC WITH LENGTH WIDTH AGE ADT EH
FSD
  /CRITERIA=CIN(95) DELTA(0) LCONVERGE(0) MXITER(100) MXSTEP(5)
PCONVERGE(1.0E-6) SINGULAR(1.0E-8)
  /LINK=LOGIT
  /PRINT=FIT PARAMETER SUMMARY TPARALLEL.

```

### PLUM - Ordinal Regression

#### Warnings

There are 1198 (66.7%) cells (i.e., dependent variable levels by observed combinations of predictor variable values) with zero frequencies.

Unexpected singularities in the Fisher Information matrix are encountered. There may be a quasi-complete separation in the data. Some parameter estimates will tend to infinity.

The PLUM procedure continues despite the above warning(s). Subsequent results shown are based on the last iteration. Validity of the model fit is uncertain.

#### Case Processing Summary

		N	Marginal Percentage
SEVERITY	1.00	192	32.0%
	2.00	273	45.5%
	3.00	135	22.5%
DISTRICT	1.00	167	27.8%
	2.00	18	3.0%
	3.00	28	4.7%
	4.00	1	0.2%
	5.00	36	6.0%
	6.00	68	11.3%
	7.00	72	12.0%
	8.00	2	0.3%
	9.00	30	5.0%
	10.00	34	5.7%

	11.00	45	7.5%
	12.00	99	16.5%
ABUT	1.00	151	25.2%
	2.00	72	12.0%
	3.00	377	62.8%
APPT	1.00	467	77.8%
	2.00	133	22.2%
FSC	1.00	35	5.8%
	2.00	170	28.3%
	3.00	171	28.5%
	4.00	224	37.3%
Valid		600	100.0%
Missing		0	
Total		600	

#### Model Fitting Information

Model	-2 Log Likelihood	Chi-Square	df	Sig.
Intercept Only	1270.242			
Final	1009.932	260.310	23	.000

Link function: Logit.

#### Goodness-of-Fit

	Chi-Square	df	Sig.
Pearson	1159.928	1173	.601
Deviance	1009.932	1173	1.000

Link function: Logit.

#### Pseudo R-Square

Cox and Snell	.352
Nagelkerke	.400
McFadden	.205

Link function: Logit.



Parameter Estimates

	Estimate	Std. Error	Wald	df	Sig.	95% Confidence Interval	
						Lower Bound	Upper Bound
Threshold [SEVERITY = 1.00]	1.533	.656	5.462	1	.019	.247	2.819
[SEVERITY = 2.00]	4.380	.682	41.194	1	.000	3.043	5.718
Location LENGTH	.000	.000	1.101	1	.294	.000	.001
WIDTH	.006	.005	1.729	1	.189	-.003	.015
AGE	.017	.005	13.194	1	.000	.008	.026
ADT	1.910E-5	6.424E-6	8.841	1	.003	6.510E-6	3.169E-5
EH	.005	.008	.307	1	.580	-.012	.021
FSD	.002	.008	.085	1	.771	-.013	.017
[DISTRICT=1.00]	-1.124	.269	17.487	1	.000	-1.651	-.597
[DISTRICT=2.00]	2.992	.566	27.896	1	.000	1.881	4.102
[DISTRICT=3.00]	-.258	.428	.363	1	.547	-1.097	.581
[DISTRICT=4.00]	21.369	.000	.	1	.	21.369	21.369
[DISTRICT=5.00]	1.870	.432	18.748	1	.000	1.023	2.716
[DISTRICT=6.00]	.753	.336	5.029	1	.025	.095	1.411
[DISTRICT=7.00]	2.234	.341	42.970	1	.000	1.566	2.902
[DISTRICT=8.00]	2.170	1.492	2.115	1	.146	-.754	5.094
[DISTRICT=9.00]	1.699	.424	16.091	1	.000	.869	2.529
[DISTRICT=10.00]	-1.236	.417	8.790	1	.003	-2.054	-.419
[DISTRICT=11.00]	.850	.369	5.302	1	.021	.126	1.573
[DISTRICT=12.00]	0 <sup>a</sup>	.	.	0	.	.	.
[ABUT=1.00]	.570	.530	1.155	1	.282	-.469	1.609
[ABUT=2.00]	.706	.554	1.626	1	.202	-.379	1.792
[ABUT=3.00]	0 <sup>a</sup>	.	.	0	.	.	.
[APPT=1.00]	.529	.219	5.825	1	.016	.099	.958
[APPT=2.00]	0 <sup>a</sup>	.	.	0	.	.	.
[FSC=1.00]	.316	.636	.247	1	.619	-.931	1.564
[FSC=2.00]	.601	.558	1.158	1	.282	-.493	1.694
[FSC=3.00]	.731	.541	1.826	1	.177	-.329	1.791

[FSC=4.00]	0 <sup>a</sup>	.	.	0	.	.	.
------------	----------------	---	---	---	---	---	---

Link function: Logit.

a. This parameter is set to zero because it is redundant.

**Test of Parallel Lines<sup>a</sup>**

Model	-2 Log Likelihood	Chi-Square	df	Sig.
Null Hypothesis	1009.932			
General	978.310	31.621	23	.108

The null hypothesis states that the location parameters (slope coefficients) are the same across response categories.

a. Link function: Logit.

## Appendix H: Output of the Multinomial Logistic Regression for Sample Two

```

NOMREG SEVERITY (BASE=LAST ORDER=ASCENDING) BY DISTRICT ABUT APPT FSC
WITH LENGTH WIDTH AGE ADT EH FSD
  /CRITERIA CIN(95) DELTA(0) MXITER(100) MXSTEP(5) CHKSEP(20)
LCONVERGE(0) PCONVERGE(0.000001) SINGULAR(0.00000001)
 /MODEL
 /STEPWISE=PIN(.05) POUT(0.1) MINEFFECT(0) RULE(SINGLE)
ENTRYMETHOD(LR) REMOVALMETHOD(LR)
 /INTERCEPT=INCLUDE
 /PRINT=CLASSTABLE FIT PARAMETER SUMMARY LRT CPS STEP MFI IC.

```

### Nominal Regression

#### Warnings

There are 1198 (66.7%) cells (i.e., dependent variable levels by subpopulations) with zero frequencies.

Unexpected singularities in the Hessian matrix are encountered. This indicates that either some predictor variables should be excluded or some categories should be merged.

The NOMREG procedure continues despite the above warning(s). Subsequent results shown are based on the last iteration. Validity of the model fit is uncertain.

#### Case Processing Summary

		N	Marginal Percentage
SEVERITY	1.00	192	32.0%
	2.00	273	45.5%
	3.00	135	22.5%
DISTRICT	1.00	167	27.8%
	2.00	18	3.0%
	3.00	28	4.7%
	4.00	1	0.2%
	5.00	36	6.0%
	6.00	68	11.3%
	7.00	72	12.0%
	8.00	2	0.3%
	9.00	30	5.0%
	10.00	34	5.7%

	11.00	45	7.5%
	12.00	99	16.5%
ABUT	1.00	151	25.2%
	2.00	72	12.0%
	3.00	377	62.8%
APPT	1.00	467	77.8%
	2.00	133	22.2%
FSC	1.00	35	5.8%
	2.00	170	28.3%
	3.00	171	28.5%
	4.00	224	37.3%
Valid		600	100.0%
Missing		0	
Total		600	
Subpopulation		599 <sup>a</sup>	

a. The dependent variable has only one value observed in 599 (100.0%) subpopulations.

#### Model Fitting Information

Model	Model Fitting Criteria			Likelihood Ratio Tests		
	AIC	BIC	-2 Log Likelihood	Chi-Square	df	Sig.
Intercept Only	1274.242	1283.035	1270.242			
Final	1080.788	1291.841	984.788	285.453	46	.000

#### Goodness-of-Fit

	Chi-Square	df	Sig.
Pearson	1128.538	1150	.669
Deviance	984.788	1150	1.000

#### Pseudo R-Square

Cox and Snell	.379
Nagelkerke	.430
McFadden	.225

### Likelihood Ratio Tests

Effect	Model Fitting Criteria			Likelihood Ratio Tests		
	AIC of Reduced Model	BIC of Reduced Model	-2 Log Likelihood of Reduced Model	Chi-Square	df	Sig.
Intercept	1080.788	1291.841	984.788 <sup>a</sup>	.000	0	.
LENGTH	1079.497	1281.756	987.497	2.709	2	.258
WIDTH	1080.640	1282.899	988.640	3.852	2	.146
AGE	1091.009	1293.268	999.009	14.220	2	.001
ADT	1086.452	1288.711	994.452	9.664	2	.008
EH	1076.984	1279.243	984.984	.196	2	.907
FSD	1078.155	1280.414	986.155	1.367	2	.505
DISTRICT	1221.284	1335.604	1169.284	184.496	22	.000
ABUT	1076.706	1270.171	988.706	3.917	4	.417
APPT	1083.444	1285.703	991.444	6.655	2	.036
FSC	1071.878	1256.549	987.878	3.089	6	.798

The chi-square statistic is the difference in -2 log-likelihoods between the final model and a reduced model. The reduced model is formed by omitting an effect from the final model. The null hypothesis is that all parameters of that effect are 0.

a. This reduced model is equivalent to the final model because omitting the effect does not increase the degrees of freedom.

### Parameter Estimates

SEVERITY <sup>a</sup>	B	Std. Error	Wald	df	Sig.	Exp(B)	95% Confidence Interval for Exp(B)	
							Lower Bound	Upper Bound
1.00 Intercept	4.624	1.157	15.986	1	.000			
LENGTH	-.001	.001	.731	1	.393	.999	.998	1.001
WIDTH	-.015	.010	2.507	1	.113	.985	.966	1.004
AGE	-.029	.008	12.243	1	.000	.972	.956	.987
ADT	.000	.000	4.229	1	.040	1.000	1.000	1.000
EH	-.006	.015	.150	1	.699	.994	.966	1.023
FSD	-.003	.013	.056	1	.813	.997	.972	1.023
[DISTRICT=1.00]	2.278	.576	15.612	1	.000	9.754	3.151	30.188

[DISTRICT=2.00]	-	1870.596	.000	1	.992	6.761E-9	.000	. <sup>b</sup>
	18.812							
[DISTRICT=3.00]	.452	.696	.422	1	.516	1.571	.402	6.146
[DISTRICT=4.00]	-	.000	.	1	.	8.827E-10	8.827E-10	8.827E-10
	20.848							
[DISTRICT=5.00]	-3.749	1.130	11.006	1	.001	.024	.003	.216
[DISTRICT=6.00]	-.980	.548	3.193	1	.074	.375	.128	1.099
[DISTRICT=7.00]	-2.714	.562	23.316	1	.000	.066	.022	.199
[DISTRICT=8.00]	-	4267.729	.000	1	.997	2.241E-8	.000	. <sup>b</sup>
	17.614							
[DISTRICT=9.00]	-2.427	.745	10.619	1	.001	.088	.021	.380
[DISTRICT=10.00]	16.495	1218.838	.000	1	.989	14581852.469	.000	. <sup>b</sup>
[DISTRICT=11.00]	-1.356	.674	4.055	1	.044	.258	.069	.964
[DISTRICT=12.00]	0 <sup>c</sup>	.	.	0	.	.	.	.
[ABUT=1.00]	-.749	.901	.690	1	.406	.473	.081	2.767
[ABUT=2.00]	-1.246	.963	1.676	1	.196	.288	.044	1.898
[ABUT=3.00]	0 <sup>c</sup>	.	.	0	.	.	.	.
[APPT=1.00]	-.977	.392	6.215	1	.013	.376	.175	.811
[APPT=2.00]	0 <sup>c</sup>	.	.	0	.	.	.	.
[FSC=1.00]	-.188	1.088	.030	1	.863	.829	.098	6.988
[FSC=2.00]	-.718	.950	.572	1	.450	.488	.076	3.137
[FSC=3.00]	-1.026	.915	1.257	1	.262	.359	.060	2.154
[FSC=4.00]	0 <sup>c</sup>	.	.	0	.	.	.	.
2.00 Intercept	2.423	.913	7.050	1	.008			
LENGTH	.000	.001	.052	1	.820	1.000	.999	1.001
WIDTH	.002	.005	.094	1	.759	1.002	.991	1.012
AGE	-.009	.007	2.041	1	.153	.991	.978	1.004
ADT	.000	.000	5.707	1	.017	1.000	1.000	1.000
EH	-.005	.012	.176	1	.675	.995	.972	1.019
FSD	.007	.011	.423	1	.515	1.007	.986	1.029
[DISTRICT=1.00]	1.549	.561	7.631	1	.006	4.708	1.568	14.134
[DISTRICT=2.00]	-1.907	.606	9.893	1	.002	.149	.045	.487
[DISTRICT=3.00]	.176	.656	.072	1	.788	1.193	.330	4.311
[DISTRICT=4.00]	-	.000	.	1	.	1.859E-9	1.859E-9	1.859E-9
	20.103							
[DISTRICT=5.00]	-.969	.504	3.696	1	.055	.380	.141	1.019

[DISTRICT=6.00]	-.140	.452	.096	1	.756	.869	.358	2.109
[DISTRICT=7.00]	-1.580	.423	13.946	1	.000	.206	.090	.472
[DISTRICT=8.00]	-1.072	1.529	.491	1	.483	.342	.017	6.860
[DISTRICT=9.00]	-.830	.504	2.709	1	.100	.436	.162	1.171
[DISTRICT=10.00]	15.721	1218.838	.000	1	.990	6720042.522	.000	. <sup>b</sup>
[DISTRICT=11.00]	.193	.501	.149	1	.700	1.213	.455	3.235
[DISTRICT=12.00]	0 <sup>c</sup>	.	.	0	.	.	.	.
[ABUT=1.00]	-.319	.690	.214	1	.644	.727	.188	2.812
[ABUT=2.00]	-.082	.708	.014	1	.907	.921	.230	3.689
[ABUT=3.00]	0 <sup>c</sup>	.	.	0	.	.	.	.
[APPT=1.00]	-.525	.343	2.344	1	.126	.592	.302	1.159
[APPT=2.00]	0 <sup>c</sup>	.	.	0	.	.	.	.
[FSC=1.00]	-.383	.846	.205	1	.651	.682	.130	3.583
[FSC=2.00]	-.662	.722	.841	1	.359	.516	.125	2.123
[FSC=3.00]	-.846	.694	1.486	1	.223	.429	.110	1.672
[FSC=4.00]	0 <sup>c</sup>	.	.	0	.	.	.	.

a. The reference category is: 3.00.

b. Floating point overflow occurred while computing this statistic. Its value is therefore set to system missing.

c. This parameter is set to zero because it is redundant.

#### Classification

Observed	Predicted			Percent Correct
	1.00	2.00	3.00	
1.00	122	62	8	63.5%
2.00	70	168	35	61.5%
3.00	8	54	73	54.1%
Overall Percentage	33.3%	47.3%	19.3%	60.5%

## BIBLIOGRAPHY

Abendroth, R. E., Greimann, L.F., and LaViolette, M. D. (2007). "An Integral Abutment Bridge With Precast Concrete Piles." *Final Rep., IHRB Project TR-438, CTRE Project No. 99-48*, IOWA Department of Transportation, Ames, Iowa.

Abu-Hejleh, N., Hanneman, D., White, D. J., and Ksouri, I. (2006). "Flowfill and MSE Bridge Approaches: Performance, Cost and Recommendations for Improvements." *Report No. CDOT-DTD-R-2006-2*. Colorado Department of Transportation, Denver.

Albajar, L., Gascón, C., Hernando, A., and Pacheco, J. (2005). "Transiciones de Obra de Paso-Terraplén. Aproximación al Estado del Arte y Experiencias Españolas." Asociación Técnica de Carreteras, Ministerio de Fomento.

Anand J. Puppala, Sireesh Saride, and Ekarut Archeewa (2009). "Recommendations for Design, Construction, and Maintenance of Bridge Approach Slabs." *Synthesis Report, FHWA/TX-09/0-6022-1*, Texas Department of Transportation, El Paso, Texas.

Ardani, A. (1987). "Bridge Approach Settlement", *Report No. CDOT-DTP-R-87-06*, Colorado Department of Highways, Denver, CO.

Arsoy, S., Barker, R.M. and Duncan, J.M. (1999). "The behavior of Integral Abutment Bridges (Final Report)." *Report No. FHWA/VTRC00-CR3*. Virginia Department of Transportation.

Arsoy, S., Duncan, J.M. and Barker, R.M. (2002). "Performance of Piles Supporting Integral Bridges." *Transportation Research Record 1808*, Washington, D.C.

Bakeer, M., Shutt, M., Zhong, J., Das, S., and Morvant, M. (2005). "Performance of Pile-Supported Bridge Approach Slabs." *Journal of Bridge Engineering*, ASCE, 10.1061/(ASCE) 1084-0702(2005)10:2(228), 228-237

Bozozuk, M. (1978). "Bridge Foundations Move. Transportation Research Record 678: Tolerable Movements of Bridge Foundations, Sand Drains, K-Test, Slopes, and Culverts." *Transportation Research Board, National Research Council, Washington, D.C. 17-21*.

Briaud, J. L., James, R. W., and Hoffman, S. B. (1997). "Settlement of Bridge Approaches (the bump at the end of the bridge)." *NCHRP Rep. No. 234*, Transportation Research Board, National Research Council, Washington, D.C.

Burke, M.P. (1993). "Integral bridges: attributes and limitations." *Transportation Research Record 1393 p. 1-8*. Transportation Research Board, 75th Annual Meeting.

Chini, S.A., Wolde-Tinsae, A.M., and Aggour, M. S. (1992). "Drainage and Backfill Provisions for Approaches to Bridges." Maryland Department of Transportation.



Cotton, D. M., Kilian, A. P., and Allen, T. (1987). "Westbound Embankment Preload on Rainier Avenue, Seattle, Washington." *Transportation Research Record No. 1119*, Transportation Research Board, Washington D.C., 61-75.

Das, S. C., Bakeer, R., Zhong, J., and Schutt, M. (1990). "Assessment of mitigation embankment settlement with pile supported approach slabs." Louisiana Transportation and Research Center, Baton Rouge, LA.

Du, L., Arellano, M., K. J. Folliard, Nazarian, S., and Trejo, D. (2006). "Rapid-Setting CLSM for Bridge Approach Repair: A Case Study." *ACI Material Journal*. September-October 2006, 312-318.

Dupont, B., and D. L. Allen. (2002). "Movements and settlements of highway bridge approaches." *KTC-02-18/SPR-220-00-1F*, Kentucky Transportation Center, Lexington, KY.

Federal Highway Administration (2000). "Priority, Market-Ready Technologies and Innovations", *Rep. No. FHWA-HRT-04-053*, Transportation Research Board, Washington, D.C.

Folliard, K.J., Du, L., Trejo, D., Halmen, C., Sabol, S., and Leshchinsky, D. (2008). "Development of a Recommended Practice for Use of Controlled Low-Strength Material in Highway Construction." *NCHRP Synthesis of Highway Practice No. 597*, Transportation Research Board, Washington D.C.

Gaorbanpoor, Al, Koutnik, Therese Ellen, Helwany, Sam (2007), "Evaluation of Bridge Approach Settlement Mitigation Methods." *Wisconsin Highway Research Program*, Wisconsin Department of Transportation, Milwaukee, WI.

Girton, D.D, Hawkinson, T.R and Greimann, L.F. (1991). "Validation of Design Recommendations for Integral-Abutment Piles." *Journal of Structural Engineering*, Vol. 117, No.7.

Greimann, L. F., Yang, Pe-Shen, Wolde-Tinsae, and made M. (1986). "Nonlinear Analysis of Integral Abutment Bridges." *Journal of Structural Engineering*, Vol. 112, No. 10, 2263-2280.

Greimann, L. F. and Wolde-Tinsae, A. M. (1988). "Design model for piles in jointless bridges." *Journal of Structural Engineering*, ASCE, 114(6), 1354-1371.

Grover, R. A. (1978), "Movements of bridge abutments and settlements of approach pavements in Ohio." *Journal of Transportation Research Record*, N678, pp. 12—17.

Hannigan, P.J., Goble, G.G., Thendean, G., Likins, G.E., and Rausche, F. (1998). "Design and Construction of Driven Pile Foundations – Volume I." *Report No. FHWA-HI-97-013*, Federal Highway Administration, Washington, D.C.

Hannon, J. B. and Walsh, T. J. (1982), "Wick drains, membrane reinforcement, and lightweight fill for embankment construction at Dumbarton." *Transportation Research Record, TRB, N897*, pp. 37—42.

Hearn, George (1997), "Faulted pavements at bridge abutments." *Report CDOT-DTD-97-11*, Colorado Department of Transportation, Boulder, CO.

Holtz, R. (1982). *Treatment of Problem Foundation for Highway Embankments*. Transportation Research Board, Washington, D.C.

Hopkins, T.C. (1969), "Settlement of highway bridge approaches and embankment foundations." *Interim Report, KYHPR-64-17; HPR-1(4), Part II*, Dept. of Highways, Lexington, KY.

Hopkins, T.C. (1973). "Settlement of highway bridge approaches and embankment foundations, Bluegrass Parkway Bridges over Chaplin River." Kentucky Dept. of Highway, N 356, Feb. 1973, Interim 39, PP 35.

Hopkins, T.C. (1985), "Long-term movements of high-way bridge approach embankments and pavements." *A draft report, UKTRP-85-12*, Kentucky Transportation Research Program, Lexington, KY.

Hoppe, E. J. (1999). "Guidelines for the Use, Design, and Construction of Bridge Approach Slabs." Virginia Department of Transportation, Charlottesville, VA.

Horvath, J. S. (1991). "Using Geosynthetics to Reduce Surcharge-Induced Stresses on Rigid Earth Retaining Structures." *Transportation Research Record 1330*, PP 47-53.

Horvath, J. S. (2000). "Integral Abutment Bridges: Problem and Innovative Solutions Using EPS Geofoam and other Geosynthetics." *Research Report No. CE/GE-00-2*, Bronx, New York

Horvath, J. S. (2005). "Integral-Abutment Bridges: Geotechnical Problems and Solutions Using Geosynthetics and Ground Improvement." *IAJB 2005 - The 2005 FHWA Conference on Integral Abutment and Jointless Bridges*. 16-18 March, Baltimore, Maryland, USA.

Hsi, J. and Martin, J. (2005). "Soft Ground Treatment and Performance, Yelgun to Chinderah Freeway, New South Wales, Australia." *In Ground Improvement-Case Histories*, Elsevier Geo-Engineering Book Series, Volume 3, 563-599.

Hughes, F. H. (1981), "Vertical drains accelerate consolidation settlement under bridge approach embankments." *Highways and Public Works*, Vol. 49, No. 1858, P. 8.

Irick, P. E. and Copas, T. L. (1969), "Bridge approach design and construction practices", *NCHRP Synthesis of Highway Practice 2*, Highway Research Board, Washington, D.C.

James, R.W., Zhang, H., and Zollinger, D.G. (1991). "Observations of severe abutment backwall damage." *Transportation Research Record 1319*, Transportation Research Board, 55-61.

Jayawickrama, P., Nash, P., Leaverton, M. and Mishra, D. (2005). "Water Intrusion in Base/Subgrade Materials at Bridge Ends." *TxDOT Report, FHWA/TX-06/0-5096-1*, Texas Tech University, Lubbock, TX.

Kentucky Transportation Cabinet. (2005). "Kentucky Structural Design Manual." Frankfort, KY.

Kentucky Transportation Cabinet. (2005). "Kentucky Structural Design Manual, Special Provision 69, Embankment at Bridge End Bent Structures." Kentucky Transportation Cabinet, Frankfort, KY

Kentucky Transportation Cabinet.(2005). Standard Drawings RGX-100 and RGX-105, "Treatment of Embankment at Bridge End-Bent Structures." Kentucky Transportation Cabinet, Frankfort, KY.

Kramer, S.L., and Sajer, P. (1991). "Bridge Approach Slab Effectiveness." Washington State Transportation Center, Seattle, WA.

Kemahli, A. S. (1971), "A different approach to bridge approach slabs." *Highway Focus*, Vol. 3, No. 3, pp. 23-80.

Laguros, J. G., Zaman, M. M., and Mahmood, I. U. (1990). "Evaluation of Causes of Excessive Settlements of Pavements Behind Bridge Abutments and their Remedies; Phase II. (Executive Summary)." *Rep. No. FHWA/OK 89 (07)*, Oklahoma Department of Transportation, OK.

Laguros, J. G., Zaman, M. M., and Mahmood, I. U. (1990b). "Evaluation of Causes of Excessive Settlements of Pavements Behind Bridge Abutments and their Remedies; Phase I". Oklahoma Department of Transportation, OK.

Lawver, A., French, C. and Shield, C.K. (2000). "Field Performance of Integral Abutment Bridges." *Transportation Research Record 1740*, Washington D.C.

Lenke, L. R. (2006). "Settlement Issues-Bridge Approach Slabs." *Rep. No. NM04MNT-02*, New Mexico Department of Transportation. NM.

Long, J.H., Olson, S.M. and Stark, T.D. (1998). "Differential Movement at Embankment/Bridge Structure Interface in Illinois." *Transportation Research Record No. 1633*, Transportation Research Board, Washington, D.C., 53-60.

Margason, G.A. (1963), "A study of settlement at a number of bridge approaches on the Maidenhead By-Pass." *Chartered Mun. Eng. (England)*, Vol. 90, pp. 134-138.

- Margason, G.A. (1970), "Settlement behind bridge abutments. The performance of a stony clay fill in an approach embankment to an overbridge on the M4 Motorway." Ministry of Transport, London, UK, RRL Rept, Lr 311.
- MaLaren, D. (1967), "Settlement behind bridge abutments." *RRL Report LR 76*, Road Research Laboratory, Crowthorn, Gt. Britain, 18 pp.
- Mahmood, I.U. (1990). "Evaluation of Causes of Bridge Approach Settlement and Development of Settlement Prediction Models." Ph.D. Thesis, University of Oklahoma, Norman.
- Martin, R. D., and Kang, T. (2013). "Structural Design and Construction Issues of Approach Slabs." *Pract. Period. Struct. Des. Constr*, 10.1061/(ASCE)SC.1943-5576.0000133, 12-20.
- Michael, E. Schmitz (2004), "Use of Controlled Low-Strength Material as Abutment Backfill." *Report No. K-TRAN: KU-02-6*, Kansas Department of Transportation, Lawrence, KA.
- Nassif, H. (2002). "Finite Element Modeling of Bridge Approach and Transition Slabs." *Rep. No. FHWA-NJ-2002-007*, Department of Civil and Environmental Engineering, Center for Advanced Infrastructure and Transportation (CAIT), Rutgers, New Jersey.
- Nicks, Jennifer Elizabeth (2012), "The Bump at the End of the Railway Bridge." PhD Thesis Research Report, Texas A&M University.
- Pierce, C. E., Baus, R. L., Harries, K. A., and Yang, W. (2001). "Investigation into Improvement of Bridge Approaches in South Carolina," *Summary Report, Rep. No. FHWA-SC-01-02*, South Carolina Department of Transportation.
- Puppala, A. J., Saride, S., Archeewa, E., Hoyos, L. R. and Nazarian, S. (2008), "Recommendations for Design, Construction, and Maintenance of Bridge Approach Slabs: Synthesis Report." *Report No. 0-6022-1*, Texas Department Transportation.
- Robert L. Parsons, Stephen A. Cross (2001), "Compaction and settlement of existing embankments", *Report KTRAN: KU-00-8*, Kansas Department of Transportation, Topeka, Kansas.
- Ronaldo Luna, Jonathan L. Robison, Andrew Wilding, "Evaluation of bridge approach slabs, performance and design." *Report No. UTC R80*, Center for Infrastructure Engineering Studies/UTC program, Rolla, MO.
- Sabatini, P.J., Elisa, V., Schmertmann, G.R., and Bonaparte, R. (February 1997). "Geotechnical Engineering Circular No. 2" *Report No. FHWA-SA-96-038*, Federal Highway Administration, Washington, D.C.

Sam Helwany, Therese E. K., Al Ghorbanpoor (2007), "Evaluation of Bridge Approach Settlement Mitigation Methods". Wisconsin Department of Transportation, Milwaukee, WI.

Sankar, C. Das, Reda Barkeer (1999), "Assessment of mitigating embankment settlement with pile supported approach slabs." *Report 97-4GT*, Louisiana Transportation and Research Center, Baton Rouge, Louisiana.

Schaefer, V. R. and Koch, J. C. (November 1992). "Void Development under Bridge Approaches." *Report No. SD90-03*, South Dakota Department of Transportation, Pierre, 147 pp.

Shields, D. H.; Deschenes, J. H.; Scott, J. D.; Bauer, G. E. and Young, F. D. (1980), "Advantages of founding bridge abutments on approach fills – with discussion." *RTAC Forum*, Road and Transportation Association of Canada, Vol. 3, No. 1, pp. 7—16.

Smadi, O. (2001). "The strength of flowable mortar."  
[http://www.ctre.iastate.edu/PUBS/tech\\_news/2001/julaug/flowable\\_mortar.pdf](http://www.ctre.iastate.edu/PUBS/tech_news/2001/julaug/flowable_mortar.pdf)

Snethen, D. R. and Benson, J. M. (1998). "Construction of CLSM Approach Embankment to Minimize the Bump at the End of the Bridge." *The Design and Application of Controlled Low-Strength Materials (Flowable Fill)*, ASTM STP 1331.

Stark, T.D., Olson, S. M., Long, J.H. (1995). "Differential Movement at the Embankment/Structure Interface – Mitigation and Rehabilitation," *Report No. IAB-H1, FY 93*, Illinois Department of Transportation, Springfield, Illinois.

Steward, C. F. (1985), "Highway Structure approaches." *Report No. FHWA/CA/SD-85-05*, Federal Highway Administration,.

Tadros, M. K, and Benak, J. V. (1989). "Bridge Abutment and Bridge Approach slab Settlement, Phase I". Final Report, Nebraska Department of Roads.

Unified Facilities Criteria (UFC). (2004). "Pavement Design For Roads, Streets, Walk, and Open Storage Area." *Rep. No. UFC 3-250-01FA*, US Army Corps of Engineers.

Valtonen, M. and Faerkkilae, H. (1984), "A reinforced road embankment on soft soil." *Proc. Nordic Geotechnical Congress*, Swedish Geotechnical Institute, pp. 215—222.

Wahls, H. E. (1990). "Design and Construction of Bridge Approaches." *NCHRP No. 159*, Transportation Research Board, National Research Council, Washington, D.C.

Walkinshaw, J. L. (1978). "Survey of Bridge Movements in the Western United States, Transportation Research Record 678: Tolerable Movements of Bridge Foundations, Sand Drains, K-Test, Slopes, and Culverts." Transportation Research Board, National Research

Council, Washington, D. C.

White, D., Sritharan, S., Suleiman, M., Mohamed M., and Sudhar, C. (2005). "Identification of the Best Practices for Design, Construction, and Repair of Bridge Approaches." *CTRE. Project 02-118*, Iowa Department of Transportation. Ames, Iowa.

Wicke, M. and Stoelhorst, D. (1982), "Problems associated with the design and construction of concrete pavements on approach embankments." Concrete Society Terminal House, Grosvenor Gardens, London, England.

Wong, H. K. W. and Small, J. C. (1994). "Effect of Orientation of Bridge Slabs on Pavement Deformation." *Journal of Transportation Engineering*, 120(4), 590-602.

Yates, D. S., and Moore, D. S. (2010). *The Practice of Statistics, 4th Ed.* Macmillan, New York, NY.

Yee, W.S. (1974), "Long term settlement study at bridge approaches (North Maxwell)." California Dept. of Transportation, Sacramento, CA.

## VITA

Jiwen Zhang was born to Bofu Zhang and Hengxia Wang in Linyi, Shandong, China. After graduating from No. 2 High School in Linyi, he attended Ludong University pursuing a Bachelor of Science degree in civil engineering, where he received several awards and assistantships to support his studies. During the process of pursuing a bachelor degree, he has gained a rich experience in bridge and road construction. After graduation from Ludong University, he continued to pursue a Master of Science in geotechnical engineering both in the Institute of Engineering Mechanics (IEM), China Earthquake Administration and Harbin Institute of Technology under the guidance of Professor Lingxin Zhang. IEM covered all expenses that he spent during master studies. He completed all necessary courses as required by this program in Harbin Institute of Technology, and then focused on structural seismic design and completed one project in the area of soil-structure interaction when he was in IEM. With the dream of learning the most advanced and most cutting-edge knowledge in construction engineering and project management, he entered into United States and continued to be a doctoral student as a research assistant in civil engineering at the University of Kentucky. He has completed one project related to bridge end settlement evaluation and prediction with his advisor Professor Tim Taylor. Two journal papers regarding this topic are going to be sent out for peer review. His research interests include logistic regression, structural seismic design, and deep excavation and support system.

Jiwen Zhang