

2010

# Willingness to Seek Professional Psychological Help Among Canadians of African Descent: a Culturally Based Help-Seeking Model

Justine Joseph  
*University of Windsor*

Follow this and additional works at: <https://scholar.uwindsor.ca/etd>

---

## Recommended Citation

Joseph, Justine, "Willingness to Seek Professional Psychological Help Among Canadians of African Descent: a Culturally Based Help-Seeking Model" (2010). *Electronic Theses and Dissertations*. 487.  
<https://scholar.uwindsor.ca/etd/487>

This online database contains the full-text of PhD dissertations and Masters' theses of University of Windsor students from 1954 forward. These documents are made available for personal study and research purposes only, in accordance with the Canadian Copyright Act and the Creative Commons license—CC BY-NC-ND (Attribution, Non-Commercial, No Derivative Works). Under this license, works must always be attributed to the copyright holder (original author), cannot be used for any commercial purposes, and may not be altered. Any other use would require the permission of the copyright holder. Students may inquire about withdrawing their dissertation and/or thesis from this database. For additional inquiries, please contact the repository administrator via email ([scholarship@uwindsor.ca](mailto:scholarship@uwindsor.ca)) or by telephone at 519-253-3000ext. 3208.

WILLINGNESS TO SEEK PROFESSIONAL PSYCHOLOGICAL HELP  
AMONG CANADIANS OF AFRICAN DESCENT:  
A CULTURALLY BASED HELP-SEEKING MODEL

by

Justine Joseph

A Dissertation  
Submitted to the Faculty of Graduate Studies  
through the Department of Psychology  
in Partial Fulfillment of the Requirements for  
the Degree of Doctor of Philosophy at the  
University of Windsor

Windsor, Ontario, Canada

2010

© 2010 Justine Joseph

Willingness to Seek Professional Psychological Help among Canadians of African Descent:  
A Culturally Based Help-seeking Model

by

Justine Joseph

APPROVED BY:

---

Dr. M. Mobley, External Examiner  
Rutgers University

---

Dr. S. N. Dlamini  
Department of Education

---

Dr. K. Cramer  
Department of Psychology

---

Dr. R. Menna  
Department of Psychology

---

Dr. B. C. H. Kuo  
Department of Psychology

---

Dr. E. Maticka-Tyndale, Chair of Defense  
Faculty of Graduate Studies

## AUTHOR'S DECLARATION OF ORIGINALITY

I hereby certify that I am the sole author of this dissertation and that no part of this dissertation has been published or submitted for publication.

I certify that, to the best of my knowledge, my dissertation does not infringe upon anyone's copyright nor violate any proprietary rights and that any ideas, techniques, quotations, or any other material from the work of other people included in my dissertation, published or otherwise, are fully acknowledged in accordance with the standard referencing practices. Furthermore, to the extent that I have included copyrighted material that surpasses the bounds of fair dealing within the meaning of the Canada Copyright Act, I certify that I have obtained a written permission from the copyright owner(s) to include such material(s) in my dissertation and have included copies of such copyright clearances to my appendix.

I declare that this is a true copy of my dissertation, including any final revisions, as approved by my dissertation committee and the Graduate Studies office, and that this thesis has not been submitted for a higher degree to any other University or Institution.

## ABSTRACT

Attempts to address systemic barriers to accessing mental health services have often been unable to generate adequate credibility and improve service use among members of ethnic minority communities. Such outcomes have resulted in calls to consider the role of psychological and cultural factors in the underutilization of mental health services. The present study examines psychological and cultural antecedents to seeking professional psychological help among Canadians of African descent ( $N=193$ ). Using path analysis, Cramer's (1999) model of psychological help-seeking behaviour was tested for its generalizability to Canadians of African descent. Overall, Cramer's model did not fit the data however the majority of the help-seeking pathways were replicated. Culture-specific variables (i.e., cultural mistrust, Africentrism, and afri-cultural coping) were introduced to expand Cramer's original model. Two culturally based models were tested for improved model fit. Although these culturally based models did not adequately fit the data, the cultural pathways demonstrated a significant influence on the help-seeking process. A respecified model based on the results of these analyses adequately fit the data ( $\chi^2(39, N=193) = 50.103, p = .110$ ; CFI = .969; RMSEA = .039; GFI = .957; TLI = .957), providing additional support for culturally indicated pathways to seeking professional psychological help. Implications of these findings are discussed and form the basis of recommendations for mental health promotion campaigns and the delivery of culturally competent mental health services in Canadian communities of African descent. Recommendations are made for future investigations.

## DEDICATION

For my family and fiancé whose unconditional love and enduring support have brought blessings  
abound.

## ACKNOWLEDGEMENTS

My sincere gratitude to Dr. Ben Kuo whose trusted guidance, invaluable insights, and refreshing optimism have contributed to making my research pursuits a truly rewarding endeavour. I would also like to extend many thanks to my committee members whose consummate expertise and constructive feedback have been an indispensable resource throughout this process.

## TABLES OF CONTENTS

AUTHOR’S DECLARATION OF ORIGINALITY .....	iii
ABSTRACT .....	iv
DEDICATION .....	v
ACKNOWLEDGEMENTS .....	vi
LIST OF TABLES .....	x
LIST OF FIGURES .....	xi
CHAPTER I: Introduction .....	1
Statement of the Problem.....	1
Psychological Antecedents of Help-Seeking Behaviour .....	2
The Impact of Culture on Psychological Antecedents of Help-Seeking Behaviour .....	5
Culturally Revised Help-Seeking Models Among Minority Populations.....	12
Rationale for the Present Study.....	15
Definition of Variables.....	19
Hypothesized Help-Seeking Path Models.....	21
CHAPTER II: Review of the Literature .....	28
Attitudes Toward Seeking Professional Psychological Help.....	28
The Impact of Attitudes on Willingness to Seek Professional Psychological Help .....	29
Attitudes Toward Seeking Professional Psychological Services Among People of African Descent.....	32
Attitudinal Barriers to Seeking Professional Psychological Help.....	35
Self-Concealment and Attitudes Toward Seeking Professional Psychological Help .....	38
Psychological Distress and Attitudes Toward Seeking Professional Psychological Help.....	41
Cultural Mistrust.....	44
From Healthy Cultural Paranoia to Cultural Mistrust.....	45
Cultural Mistrust and Psychological Distress .....	50
Cultural Mistrust and Self-Concealment.....	53
Cultural Mistrust and Attitudes Toward Seeking Professional Psychological Help.....	57



Culture & Africentric Values.....	63
Africentrism .....	64
An Africentric Paradigm for Mental Health .....	66
African Self-Consciousness and Behavioural Prediction .....	70
Africentric Values and Mental Health Beliefs .....	73
Formal and Informal Help-Seeking Behaviours Among People of African Descent.....	77
Africultural Coping Behaviour .....	83
CHAPTER III: Methodology.....	88
Recruitment and Administration Procedure.....	88
Description of the Sample.....	90
Instrumentation .....	94
Self-Concealment Scale .....	94
Attitudes Toward Seeking Professional Psychological Help scale – Short Form .....	96
Africentrism Scale .....	98
Cultural Mistrust Inventory .....	101
Integrated Coping Measure .....	103
Brief Symptom Inventory 18 .....	108
Intentions to Seek Counseling Inventory – Cultural Revision .....	111
Social Provisions Scale .....	113
Demographic Questionnaire.....	115
CHAPTER IV: Results .....	117
Data Screening and Preparation.....	117
Descriptive Statistics .....	117
Missing Data .....	117
Multivariate Normality.....	118
Preliminary Analyses .....	121
Main Analyses .....	123
Hypothesized Path Model 1 .....	123
Hypothesized Path Model 2 .....	126

Hypothesized Path Model 3 .....	129
Model Respecification .....	132
Summary .....	135
CHAPTER V: Discussion .....	136
Cramer's (1999) Help-Seeking Model.....	136
Culturally Based Help-Seeking Models.....	140
Respecified Model .....	143
Limitations .....	144
Recommendations for Future Research.....	146
Clinical Implications.....	149
REFERENCES .....	152
APPENDIX A.....	198
APPENDIX B .....	203
VITA AUCTORIS .....	219

## LIST OF TABLES

Table 1. Demographic Characteristics .....	92
Table 2. Internal Consistency Reliability ( $\alpha$ ) .....	115
Table 3. Summary Table of Correlations, Means, and Standard Deviations.....	119
Table 4. Fit Indices of Hypothesized Path Models .....	124
Table 5. Squared Multiple Correlations ( $R^2$ ) .....	125

## LIST OF FIGURES

Figure 1. Hypothesized Path Model 1: Cramer's (1999) Model .....	21
Figure 2. Hypothesized Path Model 2: Culture-Based Modification of Cramer's (1999) Model .....	23
Figure 3. Hypothesized Path Model 3: Alternate Culture-Based Modification of Cramer's (1999) Model .....	26
Figure 4. Hypothesized Path Model 1 (Cramer's (1999) Path Model): Standardized Regression Weights .....	125
Figure 5. Hypothesized Path Model 2 (Culture-Based Modification): Standardized Regression Weights .....	128
Figure 6. Hypothesized Path Model 3 (Alternate Culture-Based Modification): Standardized Regression Weights .....	131
Figure 7. Respecified Model: Standardized Regression Weights and Squared Multiple Correlations ( $R^2$ ) .....	134

## CHAPTER I: Introduction

### Statement of the Problem

Recent research on the provision of mental health services has identified cultural differences in psychological help-seeking behaviour as a major factor that impacts mental health service utilization. Demands for appropriate care have pushed for better understanding of the role of race, ethnicity, and culture in the provision of mental health services for minority populations (Nouroozifar & Zangeneh, 2006). In particular, the cultural incongruity of mental health services and poor perceived availability of culturally competent providers have been identified as possible barriers to professional help-seeking for personal problems or emotional difficulties among underserved racial and ethnic minority groups (Blank, Tetrick, Brinkley, Smith, & Doherty, 1994; Flaskerund, 1986; Nickerson, Helms, & Terrell, 1994). Consequently, advancements in the provision of mental health services to underserved minority populations have been grounded in the assumption that utilization rates will improve when services are congruent with the beliefs of prospective minority clients (Carten, 2006).

However, campaigns aimed at incorporating culturally competent practice into the organization and delivery of mental health services have often failed to establish and maintain a constructive working relationship between mental health service providers and minority communities (Davis, 2006). Canadians of African descent<sup>1</sup>, in particular, often do not use these specialty services in spite of strategies to improve their accessibility (i.e., awareness campaigns, availability of interpreters, persons to accompany service users, community organization involvement; Centre for Addiction and Mental Health [CAMH] Insite News, 2006). Limited improvements in the use of mental health services by Canadians of African descent despite the

---

<sup>1</sup>In the present study, the term “Canadian of African descent” refers to individuals of Black African heritage with several generations of ancestors who have lived in Canada, immigrants of Black/African heritage (e.g., from continental Africa, the Caribbean), and their Canadian-born children. It is often used synonymously with the term

reduction of such external access barriers, have called increasing attention to the potential role of internal psychological factors in their underutilization of mental health services. These psychological factors likely play a significant role in creating and perpetuating the service gap because they “may act as important intervening variables between the recognition of distressing psychological problems and one’s actual decision to seek help” (Kushner & Sher, 1991, p. 196).

### Psychological Antecedents of Help-Seeking Behaviour

Among the many psychological factors that have been associated with the utilization of professional mental health services, several robust findings point to critical constructs that appear to be central to a person’s decision to seek professional help for psychological problems. First and foremost, the psychological help-seeking literature indicates that negative *attitudes toward professional psychological services* are strongly associated with avoidance of mental health services and less *willingness to seek professional psychological help* (Cepeda-Benito & Short, 1998; Cramer, 1999; Deane & Chamberlain, 1994; Deane & Todd, 1996; Kelly & Achter, 1995; Leaf & Bruce, 1987; Rickwood & Braithwaite, 1994). Second, the literature in this area of research clearly indicates that individuals become motivated to seek psychological help when their *psychological distress* taxes or exceeds their personal coping resources (Cepeda-Benito & Short, 1998; Cramer, 1999; Ingham & Miller, 1986; Kelly & Achter, 1995; Rickwood & Braithwaite, 1994) and when their *social support* network is impaired or ineffective (e.g., Sherbourne, 1988).

A number of studies have demonstrated a positive relationship between deliberately concealing sensitive personal information from others and poor psychological well-being (Pennebaker, 1985; Pennebaker & Beall, 1986; Pennebaker, Hughes, & O’Heeron, 1987). This

predisposition to actively conceal personal information perceived as distressing or negative, referred to as *self-concealment* (Larson & Chastain, 1990), has garnered increasing attention in the help-seeking literature because of its implications for these key findings in the literature. Due to the expectation of disclosing sensitive personal information during psychological treatment, high self-concealers have been found to report unfavourable attitudes toward seeking professional psychological help and thus be less willing to seek professional psychological help than low self-concealers (Cramer, 1999). However, negative attitudes toward professional psychological services notwithstanding, poor psychological adjustment may motivate high self-concealers to seek mental health services. Moreover, high self-concealers are likely to have weak informal support networks such as family and friends (Cepeda-Benito & Short, 1998; Kelly & Achter, 1995; Larson & Chastain, 1990; Rickwood & Braithwaite, 1994), effectively reducing the protective benefits of informal social support for psychological well-being (Brown, Bhrolchain, & Harris, 1975; Miller & Ingham, 1976) and further increasing the likelihood that psychological distress may necessitate the need for professional psychological services.

On the basis of these empirically supported relations between psychological distress, attitudes toward seeking professional psychological help, social support, self-concealment and willingness to seek professional psychological help, Cramer (1999) proposed a path model of professional psychological help-seeking behaviour. The hypothesized paths represented an integration of published findings concerning the interrelations among these key constructs and a resolution of discrepancies between the regression models of Kelly and Achter (1995) and Cepeda-Benito and Short (1998). Kelly and Achter (1995) found that high levels of self-concealment were associated with both unfavourable attitudes toward seeking professional psychological help and greater willingness to seek professional psychological help. Kelly and

Achter (1995) speculated that the latter finding was indicative of a possible influence of social support on high self-concealers' willingness to seek professional psychological help. However, in a follow-up to Kelly and Achter's (1995) study, Cepeda-Benito and Short (1998) found no indication that high-self concealers were more willing to seek professional psychological help than low self-concealers. Moreover, they found no evidence that weak social support increased the willingness of high self-concealers to seek professional psychological help.

Cramer's (1999) model of help-seeking behaviour reconciled this apparent inconsistency. This model suggests that the predominant tendency for high self-concealers to conceal intimate and potentially embarrassing personal information leads to greater distress because this personality trait is representative of an interpersonal style that diminishes the buffering effect of social support networks. Therefore, high self-concealers are likely willing to seek professional psychological help because they experience high levels of psychological distress. A simultaneous, yet weaker, tendency for high self-concealers to harbour unfavourable attitudes toward seeking professional psychological services inhibits their willingness to seek help for mental health reasons. Therefore, high self-concealers are also less likely to seek professional psychological help. These findings suggest ambivalence toward seeking professional psychological help among high self-concealers, involving a conflict between greater psychological distress and an aversion to engaging in psychological treatment. Cramer's (1999) synthesis of these findings provides a theoretically and conceptually informed framework of professional help-seeking for mental health reasons.

#### *The Impact of Culture on Psychological Antecedents of Help-Seeking Behaviour*

Although the specific constructs included in Cramer's (1999) model have been implicated in psychological help-seeking behaviours among people of African descent,



additional culturally relevant factors are likely to affect the psychological help-seeking behaviour of this population. For instance, psychological distress has been found to be an important predictor of psychological help-seeking behaviour among people of African descent (Ingham & Miller, 1986). For example, African Americans experiencing higher levels of psychological distress have been found to be more willing to seek professional psychological services currently or in the near future than those with lower levels of psychological distress (Constantine, Chen, & Ceesay, 1997). However, even after controlling for the effects of education and levels of psychological distress, African Americans continue to be less likely to seek psychological services than their White counterparts (Ayalon & Young, 2005).

Social support networks have been found to be a significant moderator of psychological distress and help-seeking behaviour among people of African descent (Constantine, Wilton, & Caldwell, 2003). This finding is consistent with the social support literature reporting that African Americans often rely on family members and other informal social support networks to help address their concerns before seeking professional psychological help (e.g., Constantine et al., 1997; Harris & Mollock, 2000; McMiller & Weisz, 1996). The communal nature of these interpersonal contacts is particularly relevant to investigations of cultural influences on psychological help-seeking behaviour. The values of people of African descent may influence their coping resources (Constantine, Myers, Kindaichi, & Moore, 2004; Utsey, Adams, & Bolden, 2000). These values are based on an Africentric worldview, also referred to as *Africentrism*, which embodies the principles of communalism, collectivism, unity, cooperation, harmony, spirituality, balance, creativity, and authenticity (Constantine, Gainor, Ahluwalia, & Berkel, 2003; Jackson & Sears, 1992; Myers, 1993; Utsey et al., 2000). Consistent with the familial, social, and spiritual emphases of the Africentric orientation, people of African descent

may view their informal social support networks as the primary resource for assistance when experiencing emotional difficulties. In doing so, people of African descent tend to utilize their social support networks both as an alternative and a supplement to professional mental health services (Caldwell, 1996; Neighbors & Jackson, 1984; Snowden, 1998). However, people of African descent do not appear to be inclined to seek help from social support networks when their concerns may be considered mental health problems as opposed to physical health problems (Snowden, 2001). For instance, African Americans are reportedly less likely than Whites to request assistance from family, friends, and religious figures for mental health problems (Snowden, 1998). Furthermore, African Americans who define the nature of their problems as disturbances of feelings, emotions, and mood are reluctant to seek either informal or professional help (Neighbors & Jackson, 1984).

These findings are consistent with the literature suggesting that people of African descent may prefer indirect assistance (e.g., general encouragement, companionship, social and spiritual advice) rather than direct assistance (e.g., recognition and discussion of problems framed in psychological and psychiatric terms; Taylor & Chatters, 1991) from informal and professional helpers. While this pattern of psychological help-seeking behaviour may be explained by a tendency for self-concealment, it may also be shaped by an Africentric orientation or experiences with racism and oppression. For example, people of African descent who strongly identify with Africentrism may not seek direct assistance for emotional difficulties from their social support network due to concerns about destabilizing their relationships and maintaining the well-being of important others by minimizing the burden of their own problems (Wallace & Constantine, 2005). They may also be reluctant to seek direct assistance for emotional difficulties from mental health professionals due to concerns that: a) their presenting problems could be misunderstood or

dismissed by treatment providers who lack cultural competence, b) the disclosure of negative information may contribute to cultural stereotyping of their larger ethnic or cultural group, and c) psychological services will not address their needs in a holistic manner (Constantine et al., 2004; Sanders-Thompson, Bazile, & Akbar, 2004). In addition, cultural sanctions concerning the impropriety of ‘airing dirty laundry’ in public and expectations of personal strength and courage in the face of adversity may deter people of African descent from seeking psychological services (Wallace & Constantine, 2005).

Research has established the impact of culture on the endorsement of specific coping strategies (Daly, Jennings, Beckett, & Leashore, 1995; Parks, 1998; Plummer & Slane, 1996). With regard to individuals of African descent, the literature suggests that members of this minority group have access to coping resources outside of the mainstream (i.e., Eurocentric) coping schema, which may serve to reduce psychological distress in some important way (Williams, 1994). For example, the practice of rituals such as prayer, meditation, candle lighting, are promoted as a means of coping with adversity. While individuals of African descent may employ mainstream coping strategies in certain situations (e.g., high levels of psychological distress may necessitate professional help-seeking), the full range of culture-specific and mainstream coping responses available to people of African descent are not adequately represented in the current literature (Joseph & Kuo, 2009). To fill this gap, Utsey and colleagues (2000) compiled an inventory of coping strategies derived from African culture that are utilized by African Americans in their efforts to manage stress. These *africultural coping* strategies represent four types of coping behaviours characteristic of this population: (a) cognitive and emotional debriefing (e.g., hoping for things to get better) (b) spiritual-centred coping (e.g., praying that things will work themselves out), (c) collective coping (e.g., resolution and comfort

sought from others or a group), and (d) ritual-centred coping (e.g., burning incense for strength or guidance in dealing with a problem) (Utsey, Brown, & Bolden, 2004). These culture-specific coping strategies are often utilized and depleted before turning to formal coping strategies, such as seeking professional mental health services, to cope with psychological distress (Constantine, Myers, Kindaichi, & Moore, 2004; Utsey et al., 2000).

Furthermore, the history of substandard treatment provided to people of African descent in many mental health contexts (Toldson & Toldson, 2001) may have contributed to a mistrust of mental health systems (Whaley, 2001a). Indeed, fear of treatment (i.e., apprehension arising from aversive expectations about seeking and using mental health services; Kushner & Sher, 1991) and fear of being hospitalized are major reasons for not seeking psychological help cited by people of African descent (Sussman et al., 1987). Psychological literature corroborates these concerns with reports that people of African descent are often misdiagnosed and overrepresented among involuntary hospital admissions (Garb, 1997, 1998; Lindsay & Paul, 1989; Neighbors, Jackson, Campbell, & Williams, 1989). Such bias in the provision of mental health services may contribute to people of African descent's lack of confidence in the mental health care system as they might suspect that they are vulnerable to racist mistreatment in what is perceived as a White-dominated institution. This disillusionment with the mental healthcare system may partially explain the underutilization of mental health services by people of African descent (McLean, Campbell, & Cornish, 2003).

The tendency for people of African descent to distrust Whites has been referred to as *cultural mistrust* (Terrell & Terrell, 1981). Cultural mistrust has been described as an adaptive and psychologically healthy response developed by people of African descent to protect their self-esteem in a racist social environment (Grier & Cobbs, 1968). Cramer (1999) indicated that

those who tend to self-conceal are likely caught in an approach-avoidance conflict, where skepticism about mental health services may effectively inhibit help-seeking behaviour. With regard to people of African descent, this conflict may be rife with issues of cultural mistrust. In addition, the degree to which talking to others has generally helped in the past is an important indicator of whether a person decides to seek professional psychological help (Vogel & Wester, 2003). Thus, in considering professional psychological services, individuals of African descent may be generally inclined to mistrust White therapists due to a history of negative experiences with White individuals perceived as culturally insensitive, prejudicial, or discriminatory in nature (Klonoff & Landrine, 1999; Klonoff, Landrine, & Ullman, 1999). Given that the majority of mental health professionals are White, issues of cultural mistrust may result in strong negative views and perceptions of professional psychological services by people of African descent (Whaley, 2001a).

Such perceptions of professional psychological services are increasingly recognized as valuable and important indicators of whether individuals of African descent seek professional psychological services (Constantine, 2002a). In particular, the perceived stigma of mental illness has been found to influence attitudes and behaviour toward seeking mental health services (Fabian & Edwards, 2005). Among people of African descent, the stigma associated with illness in combination with feelings of shame and embarrassment related to having psychological concerns is a key barrier to seeking professional psychological help (Snowden, 2001). For example, African Americans have been found to avoid seeking professional psychological help because these mental health resources are seen as unfamiliar or only intended for use by people with serious mental health concerns (i.e., schizophrenia, depression, and suicidal ideation; Constantine et al., 1997; Sanders-Thompson et al., 2004).

The stigma associated with psychological help-seeking behaviour among people of African descent may be magnified by cultural beliefs concerning mental health care treatment. African Americans with a strong sense of Africentrism have been found to perceive greater stigma associated with mental health services than African Americans with a weaker Africentric orientation (Wallace & Constantine, 2005). This stigma is expressed by greater discomfort with the idea of seeking 'psychotherapy' as opposed to 'counseling' because of the stigma of mental instability associated with the former term (Sanders-Thompson et al., 2004). African Americans are also more willing to seek academic counseling for educational and vocational concerns than personal counseling for interpersonal and mental health concerns (Constantine et al., 1997; June, Pope Curry, & Gear, 1990). Furthermore, higher levels of perceived stress and depression among African Americans have been associated with more unfavourable attitudes toward seeking professional psychological help (Nobles, 1998). Consequently, African Americans may tend to seek mental health services from general health care practitioners or informal support sources such as churches, rather than from specialized clinicians. Regardless of the type or the severity of problem, African Americans who initially seek spiritual counsel are less likely to seek help from any other professionals (Neighbors, Musick, & Williams, 1998).

Considering that the acknowledgement of personal concerns may not necessarily motivate people of African descent to seek professional mental health services (Davies et al., 2000; Diala et al., 2000; Lopez, Melendez, Sauer, Berger, & Wyssmann, 1998), it seems reasonable to argue the individuals who ultimately seek professional psychological help will possess somewhat favourable attitudes toward seeking professional psychological help (Cramer, 1999). Although people of African descent are less inclined to seek professional psychological services than their White counterparts, they have been found to endorse more favourable

attitudes toward professional psychological services prior to receiving psychological treatment (Diala et al., 2000). However, people of African descent have been found to endorse less favourable attitudes toward mental health services after receiving treatment than their White counterparts (Diala et al., 2000; Kessler et al., 1996).

The stigma of mental illness has been identified as a major barrier to adequate treatment and life opportunities for individuals involved in the mental health system (U.S. DHHS, 1999). Moreover, the stigma toward mental illness has been found to disproportionately affect people of African descent diagnosed with serious mental illnesses (Cooper-Patrick et al., 1997; Sussman et al., 1987). For example, African Americans are more likely to be escorted to hospital emergency rooms by police and have higher rates of involuntary hospitalization (Takeuchi, Sue, & Yeh, 1995). African Americans residing in community group homes are more frequently under suspicion by neighbours and tend to be questioned more frequently by police (Garland, Ellis-MacLeod, Landsverk, Gasnger, & Johnson, 1998). In addition, African Americans with serious mental illness perceive more stigma and experience heightened discrimination, especially in the areas of employment, housing, and health care (Corrigan et al., 2003).

Taken together, the above-mentioned findings suggest that the decision to seek professional help for psychological difficulties likely depends on both psychological and cultural factors. This position is in agreement with the existing research on pathways toward seeking professional mental health care. This body of research suggests that the pathway toward seeking professional psychological help likely begins at some identifiable point in the social network, initiated by culturally mediated help-seeking interactions between a distressed individual and his or her significant others (Rogler & Cortes, 1993). Although the nature and severity of the distress prompts the distressed individual to seek professional psychological services (Greenley &

Mechanic, 1976; Horwitz, 1977b), the process involved in the decision to seek professional psychological services are shaped by both psychological and cultural factors (Horwitz, 1977a; Lin, Tardiff, Donetz, & Goresky, 1978; Link & Dohrenwend, 1980; Sue, 1977).

*Culturally Revised Help-Seeking Models Among Minority Populations*

To date, few studies have evaluated the influence of cultural factors on Cramer's (1999) help-seeking model. Morgan, Ness, and Robinson (2003) extended Cramer's (1999) model by adding racial background (i.e., self-identified Asian and White Canadian background) as an exogenous variable. Morgan and colleagues (2003) pointed to empirical reports of racial differences in the help-seeking attitudes and behaviours to justify their examination of ethnocultural determinants on Asian Americans' willingness to seek professional psychological help for mental health issues. For example, Asian Americans' tend to underutilize mental health services compared to their White counterparts (Leong, Wagner, & Tata, 1995; Suan & Tyler, 1990; Sue & Sue, 2002). Asian Americans tend to endorse less favourable attitudes toward professional help-seeking for personal problems than their White counterparts (Sue, 1994). Furthermore, highly acculturated Asian Americans tend to endorse more favourable attitudes toward professional psychological help-seeking than less acculturated Asian Americans (Atkinson & Gim, 1989; Tata & Leong, 1994). Together, this literature provided a reasonable basis to seriously consider the impact of ethnocultural influences on the willingness of racial and ethnic minority group members to seek professional mental health services. Although Morgan and colleagues (2003) reported findings consistent with this literature, methodological limitations precluded a more fine-grained analysis.

Liao, Rounds, and Klein (2005) tested a) the generalizability of Cramer's model to Asian and Asian American students, and b) whether the addition of the within-group cultural variable



of acculturation (i.e., the changes in attitudes and behaviours in one culture as a result of continuous contact with another culture) to Cramer's model would better explain the help-seeking processes of Asians and Asian Americans. According to Liao and colleagues (2005), acculturation is an important aspect of the professional help-seeking behaviour of Asians and Asian Americans because the process can often explain within-group differences within racial and ethnic immigrant groups and has also been related to several of the psychological variables in Cramer's model (Ponterotto, Baluch, & Carielli, 1998). Liao and colleagues (2005) adopted both a behavioural and value approach to operationalize the acculturation construct. The behavioural approach included the assessment of friendship choice, language usage, and movie, music, and food preferences; the value approach included the assessment of Asian values such as filial piety, collectivism, and conformation to norms.

The results of Liao and colleagues (2005) study indicated that although Cramer's model could explain both the help-seeking processes of Asians/Asian Americans and White Americans, the model performed differently for these two groups. For example, self-concealment was more negatively related to attitudes toward seeking professional psychological help for the Asian/Asian American group than for the White group. Liao and colleagues (2005) argued that cultural-based norms regarding interpersonal relationships might be the key to explaining the strong relation between self-concealment and attitudes toward counseling. More specifically, this connection may be more salient for Asians and Asian Americans because self-concealment may be viewed as a way of avoiding *loss of face* (i.e., damage to one's social status gained by performing roles that are valued by others), and subsequently maintaining one's social roles and integrity within the Asian culture. In other words, the influence of self-concealment on Asians' and Asian Americans' attitudes toward professional help-seeking behaviour for psychological

reasons appears to be effectively shaped by Asian cultural norms regarding social relations. The findings of the study also indicated that acculturation does not directly influence one's willingness to seek professional psychological help but rather influences one's attitude toward professional psychological services, which in turn influences one's willingness to seek professional psychological help. In particular, adherence to Asian values was a better predictor of attitudes toward seeking professional psychological help than behavioural acculturation. Although self-concealment explained more of the variance in attitudes toward seeking professional psychological help than adherence to Asian values, both constructs made independent contributions. These findings suggest that both self-concealment and adherence to Asian values are important to the professional help-seeking behaviours for Asians and Asian Americans for personal concerns.

The studies of Morgan et al. (2003) and Liao et al. (2005) provide an empirical and conceptual basis for the cultural extension of Cramer's (1999) model to Canadians of African descent. That is, cultural factors may influence the help-seeking behaviour among people of African descent in a manner similar to that demonstrated among people of Asian descent. Thus far, only one empirical study has adapted the conclusions of Liao and colleagues (2005) to examine the relations between self-concealment, adherence to culture-based values, and attitudes toward seeking professional psychological help among people of African descent. Wallace and Constantine (2005) investigated the extent to which Africentrism predicted attitudes toward seeking professional psychological help and self-concealment in a sample of African American university students. The findings indicated that an Africentric orientation was not significantly predictive of attitudes toward seeking professional psychological help. However, an Africentric orientation was significantly predictive of self-concealment tendencies and perceived counseling

stigma. Furthermore, the results indicated that neither perceived counseling stigma nor favourable psychological help-seeking attitudes significantly mediated the relation between Africentrism and self-concealment. This finding suggests that perhaps other cultural factors (e.g., cultural mistrust) and psychological help-seeking behaviours (e.g., afri-cultural coping) may impact the self-concealment behaviour of people of African descent and are worthy of empirical examination.

Thus, although Cramer's (1999) model may capture the psychological factors (i.e., social support, self-concealment, psychological distress, and attitudes toward seeking professional psychological help) that influence psychological help-seeking behaviour among people of African descent, this model does not account for the potential impact of Africentric worldview (i.e., cultural mistrust, Africentrism, afri-cultural coping behaviour) on the help-seeking process. While Cramer's original model may offer an adequate explanation for professional psychological help-seeking behaviours among people of African descent, it is the interest of the present study to determine whether a cultural extension of Cramer's model would provide an improved explanatory framework for professional psychological help-seeking in this population.

### Rationale for the Present Study

Major shifts in the cultural and ethnic composition of Canada has increased dialogue devoted to multicultural mental health issues, especially concerning how mental health services are being organized and delivered (Davis, 2006). The health of Canada's minority population is of prime concern to researchers and policymakers for two main reasons. As a major immigrant-receiving nation, the large number of ethnocultural minorities in Canada represents an important sector of the general population. This population's health is a central concern that has

implications for the cost and adequacy of Canada's health care system. The health of Canada's ethnocultural minorities is also an important index of the effectiveness of Canadian immigration policy (i.e., potential burden on Canada's taxpayer-funded healthcare system). It is a major factor in evaluating whether Canada is benefiting from its investment into large-scale immigration program (McDonald & Kennedy, 2004).

In general, Canadian minority group members use fewer mental health services than their non-minority counterparts (Munroe-Blum, Boyle, Offord, & Kates, 1989). In 2002, Statistics Canada conducted the first national survey of mental health and well-being of Canadians -- the Canadian Community Health Survey: Mental Health and Well-Being (CCHS 1.2). This survey provided the first compilation of data concerning the prevalence of mental health disorders, the incidence of mental health disorders, and individual determinants (e.g., sociodemographic factors, psychological distress, self-rated health, social support, barriers) of mental health service use across Canada (Statistics Canada, 2004). In an examination of sociodemographic variables on the CCHS 1.2, Vasiliadis, Lesage, Adair and Boyer (2005) found that country of birth and ethnic background were significant predictors of mental health service use. Furthermore, they demonstrated that ethnic status remained a significant predictor of mental health service use even after accounting for attitudes toward seeking mental health services. Vasiliadis and colleagues (2005) suggested that the availability of mental health resources might play a role in professional help-seeking behaviours for mental health reasons among cultural and ethnic minority groups.

Canadian research has documented specific problems in providing mental health services to cultural and ethnic minority groups (Williams, 2002). Following the publication of the report titled *After the Door has been Opened: Mental Health Issues Affecting Immigrants and Refugees in Canada* (Canadian Task Force on Mental Health Issues Affecting Immigrants and Refugees,

1988), several policy papers have addressed the marginalization of cultural and ethnic minority groups in the Canadian mental health care system (e.g., Barwick & Campbell, 1993; Metropolitan Toronto District Health Council, 1992; Ontario Ministry of Mental Health, 1992; Ontario Ministry of Health, 1995; Reitz, 1995). The systemic inequities affecting the cultural and ethnic minority groups are apparent and the disparities seem to be most pronounced among racial minority individuals and community. These findings highlight the need to prioritize issues of race and ethnicity in efforts to improve the accessibility of mental health care for ethnic minority individuals in Canada (Williams, 2002).

Canadians of African descent have been described as the most underserved group in the Canadian health care system (Health Canada, 2000). Anecdotal claims of Canadian mental health providers who have treated people of African ancestry present a clear dichotomy. They assert that Canadians of African descent are overrepresented in mandatory services such as those provided in correctional facilities, youth treatment centers, forensic treatment in psychiatric facilities, or other institutional services. However, Canadians of African descent are typically underrepresented in voluntary services such as psychiatric outpatient clinics and drug treatment facilities (CAMH Insite News, 2006). The unavailability of quantitative data to investigate these claims is reflected in the overall lack of empirical studies on mental health issues affecting Canadians of African descent. Consequently, Canadian mental health researchers have begun to look toward similar documented discrepancies among African Americans in the U.S. to help inform hypotheses about the psychological treatment-seeking behaviour of Canadians of African descent. Although, there may be differences in the historical and contemporary milieu that have independently shaped these populations, there are also common cultural norms, values, experiences and attitudes associated with their shared minority status that make it reasonable to

presume that the factors affecting the psychological treatment-seeking behaviour of African Americans may extend to Canadians of African descent.

Empirical investigations of mental health service utilization among African Americans have replicated this dichotomy. These studies have documented African Americans' overrepresentation in inpatient and emergency mental health settings (e.g., Maynard, Ehreth, Cox, Peterson, & McGann, 1997; Scheffler & Miller, 1991; Snowden & Cheung, 1990) and underrepresentation in outpatient treatment-seeking for mental health problems (e.g., Alvidrez, 1999; Freiman, Cunningham & Cornelius, 1994, as cited in Snowden, 2001; Pumariega, Glover, Holzer, & Nguyen, 1998; Snowden, 1999a). Given these similarities, the factors influencing mental health service utilization among African Americans are likely suited to illuminate issues that affect mental health service utilization among Canadians of African descent.

Cross-national comparisons of mental health service utilization in Canada and the United States demonstrate that, in both countries, race and ethnicity are significantly associated with treatment seeking (Mojtabai & Olfson, 2006). Although the overall incidence of mental health disorders are similar for African Americans and White Americans (Kessler et al., 1996), there are marked disparities in the utilization of services (Hu, Snowden, Jerrell, & Nguyen, 1991). African Americans who need mental health services are less likely to receive them compared to White Americans (U.S. DHHS, 2001, as cited in Fabian & Edwards, 2005). Moreover, the percentage of African Americans who received mental health treatment from any source was only half the rate of White Americans (Swartz et al., 1998).

The gap between service need and service utilization among African Americans has often been explained by systemic barriers to equal treatment such as financial burden, lack of health care insurance, lack of access to treatment programs, poorer quality of treatment, and consequent

early termination, as a result of individual and institutional racism and discrimination (Snowden, 2003). However, even after adjusting for socioeconomic differences that may attenuate the impact of these systemic barriers, the service gap remains (Padgett, Patrick, Burns, & Schlesinger, 1994; Swartz et al., 1998).

The enduring disparities in the utilization of mental health services in the United States and Canada point to the potential importance of ethnocultural and individual differences in willingness to seek professional psychological services (Mojtabai & Olfson, 2006). Hence, the present study intends to examine psychological and cultural variables that may contribute to the ongoing service gap. The purpose of the present study is to evaluate a) the generalizability of Cramer's (1999) framework of psychological help-seeking behaviour to Canadians of African descent and b) the applicability of a culturally-revised help-seeking model based on Cramer's (1999) original framework.

#### *Definition of Variables*

The outcome variable involved in this investigation was:

- a) **Willingness to seek professional psychological help (WTSPPH)**: The perceived effort one intends to invest in obtaining professional mental health services if experiencing personal problems or emotional difficulties.

The predictor variables included:

- b) **Africentrism (AFR)**: Attitudes, beliefs, and behaviours consistent with an Africentric orientation.
- c) **Africultural coping (AC)**: Mainstream and culture-specific coping behaviours employed by people of African descent to manage stressful situations.

- d) **Attitudes toward seeking professional psychological help (ATSPPH)**: Positive or negative evaluations concerning the prospect of obtaining mental health services for personal problems or emotional difficulties.
- e) **Cultural mistrust (CM)**: The tendency of people of African descent to be suspicious of people of European descent, Eurocentric organizations, and Eurocentric institutions.
- f) **Psychological distress (PD)**: A range of feelings and emotions individuals experience in reaction to adverse events.
- g) **Self-concealment (SC)**: The predisposition to purposefully conceal private information that is negative, distressing, or potentially embarrassing.
- h) **Social support (SS)**: An individual's perception that family, friends, neighbours, or community members will be available to provide support if needed.

The empirical literature suggests that previous experience with mental health services (e.g., Diala et al., 2000) and preferences for same-race therapists (e.g., Nickerson et al., 1994) possibly impact attitudes toward and willingness to seek professional psychological services among people of African descent (see Chapter II for further details). Therefore, the following covariates are included in this investigation:

- i) **CV1**: I have seen a counselor, therapist, or psychologist for help in dealing with serious personal or emotional problems.
- j) **CV2**: If I was considering therapy for help in dealing with a serious personal or emotional problem, the race of the therapist would be important to me.
- k) **CV3**: If I was experiencing serious personal or emotional problems, I would be more willing to seek therapy if I knew the therapist was Black.



### *Hypothesized Help-Seeking Path Models*

Three path models were hypothesized to test the research questions posed by the present study. Figure 1 illustrates Path Model 1, which replicates the paths originally indicated by Cramer (1999) and will be evaluated for its generalizability to Canadians of African descent.

Figure 1

#### *Hypothesized Path Model 1: Cramer's (1999) Model*

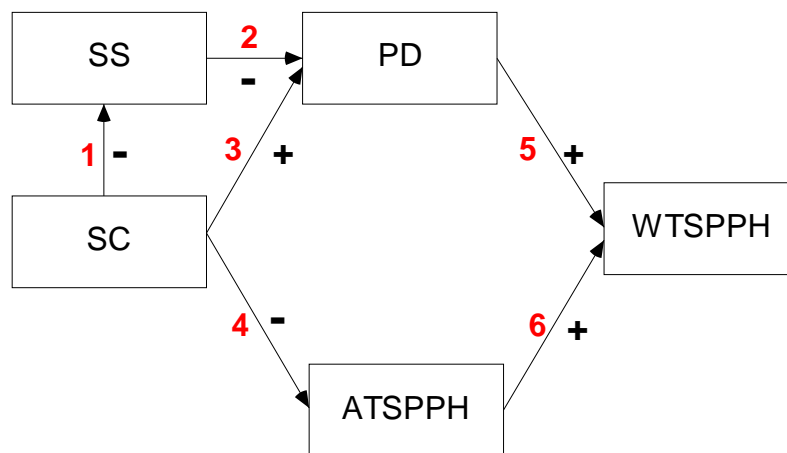

*Note.* *ATSPPH* = Attitudes Toward Seeking Professional Psychological Help, *PD* = Psychological Distress, *SC* = Self-concealment, *SS* = Social Support, *WTSPPH* = Willingness to Seek Professional Psychological Help.

1. *Self-concealment leads to less social support.* Individuals who tend to withhold personally distressing information experience little or no social support. This is likely due to the fact that their behavioural style results in them eschewing the help of others.
2. *Less social support leads to more psychological distress.* Individuals who perceive poor availability of social support are more susceptible to experiencing significant psychological distress.
3. *Self-concealment leads to more psychological distress.* Individuals who tend to withhold personally distressing information are inclined to experience significant psychological distress.
4. *Self-concealment leads to negative attitudes toward seeking professional psychological help.* Individuals who tend to withhold personally distressing information are likely to be wary of the psychotherapy process and thus hold unfavourable attitudes toward that seeking professional psychological help.
5. *Psychological distress leads to a greater willingness to seek professional psychological help.* Individuals are more likely to seek professional psychological help if their personal or emotional problems are sufficiently distressing.
6. *Positive attitudes toward professional psychological help lead to a greater willingness to seek professional psychological help.* Individuals are more likely to seek professional psychological help if they harbor favourable attitudes toward psychotherapy or believe that the psychotherapy process is valuable and effective.

Figure 2 illustrates the second path model, which supplements Cramer's (1999) original model by including cultural constructs that represent the heterogeneity among Canadians of African descent and covariates that may help to further understand professional psychological help-seeking behaviours in this population. The hypothesized directions of the additional paths

are specified, with the exception of the pathway between Africentrism and attitudes toward seeking professional psychological help (i.e., 11a/b) because the theoretical literature equally supports a positive and negative relationship and empirical evidence for either hypothesized direction is unavailable.

Figure 2

*Hypothesized Path Model 2: Culture-Based Modification of Cramer's (1999) Model*

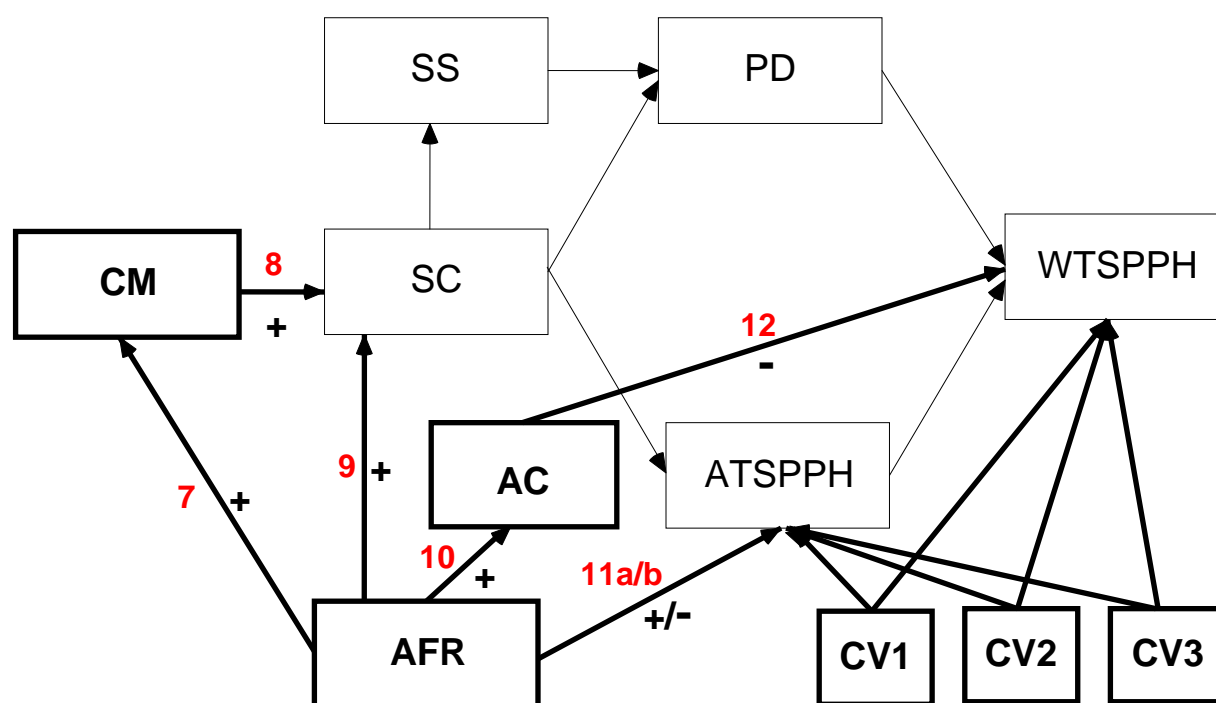

*Note.* Cultural constructs, covariates, and pathways added to Cramer's (1999) model appear in boldface. *AC* = Africultural Coping, *AFR* = Africentrism, *ATSPPH* = Attitudes Toward Seeking Professional Psychological Help, *CM* = Cultural Mistrust, *CV1* = I have seen a counselor, therapist, or psychologist for help in dealing with serious personal or emotional problems, *CV2* = If I was considering therapy for help in dealing with a serious personal or emotional problem, the race of the therapist would be important to me, *CV3* = If I was experiencing serious personal or emotional problems, I would be more willing to seek therapy if I knew the therapist was Black, *PD* = Psychological Distress, *SC* = Self-concealment, *SS* = Social Support, *WTSPPH* = Willingness to Seek Professional Psychological Help.

7. *Stronger identification with Africentrism leads to a greater sense of cultural mistrust.*

Individuals who possess a strong Africentric orientation tend to be increasingly suspicious of the intentions and motivations of White people, Eurocentric organizations and institutions.

8. *Cultural mistrust leads to increased self-concealing behaviour.*

Increasing levels of suspicion concerning the intentions and motivations of White people, Eurocentric organizations, and Eurocentric institutions contributes to more self-concealing tendencies, particularly in situations that amplify power dynamics (e.g., the therapist-client relationship).

9. *Stronger identification with Africentrism leads to increased self-concealing behaviour.*

Individuals who possess a strong Africentric orientation are more likely to abide by cultural sanctions against revealing distressing or embarrassing personal information.

10. *Stronger identification with Africentrism leads to a greater likelihood of using afri-cultural coping behaviours.*

A strong Africentric orientation promotes culturally-derived ways of living, such as the utilization of afri-cultural coping behaviours.

11. a) *Stronger identification with Africentrism leads to more favourable attitudes toward seeking professional psychological help.*

A strong Africentric orientation supports efforts to maintain psychological well-being (including the use of professional psychological help when necessary) in order to maximize individual contributions to collective goals.

11. b) *Stronger identification with Africentrism leads to unfavourable attitudes toward seeking professional psychological help.*

Individuals who possess a strong Africentric orientation find themselves at odds with the perspectives of Eurocentric-based institutions such as the mental health system, thus engendering negative attitudes toward seeking professional psychological help.

12. *Increased use of african cultural coping strategies leads to decreased willingness to seek professional psychological help.* Increased engagement in culture-specific coping strategies derived from African culture decreases one's willingness to seek professional psychological help.

Figure 3 depicts that third path model, which offers a modification of the second path model. It features two additional pathways between cultural mistrust and psychological distress, and cultural mistrust and attitudes toward seeking professional psychological help. A reversal of the pathway between cultural mistrust and Africentrism is also specified.

Figure 3

*Hypothesized Path Model 3: Alternate Culture-Based Modification of Cramer's (1999) Model*

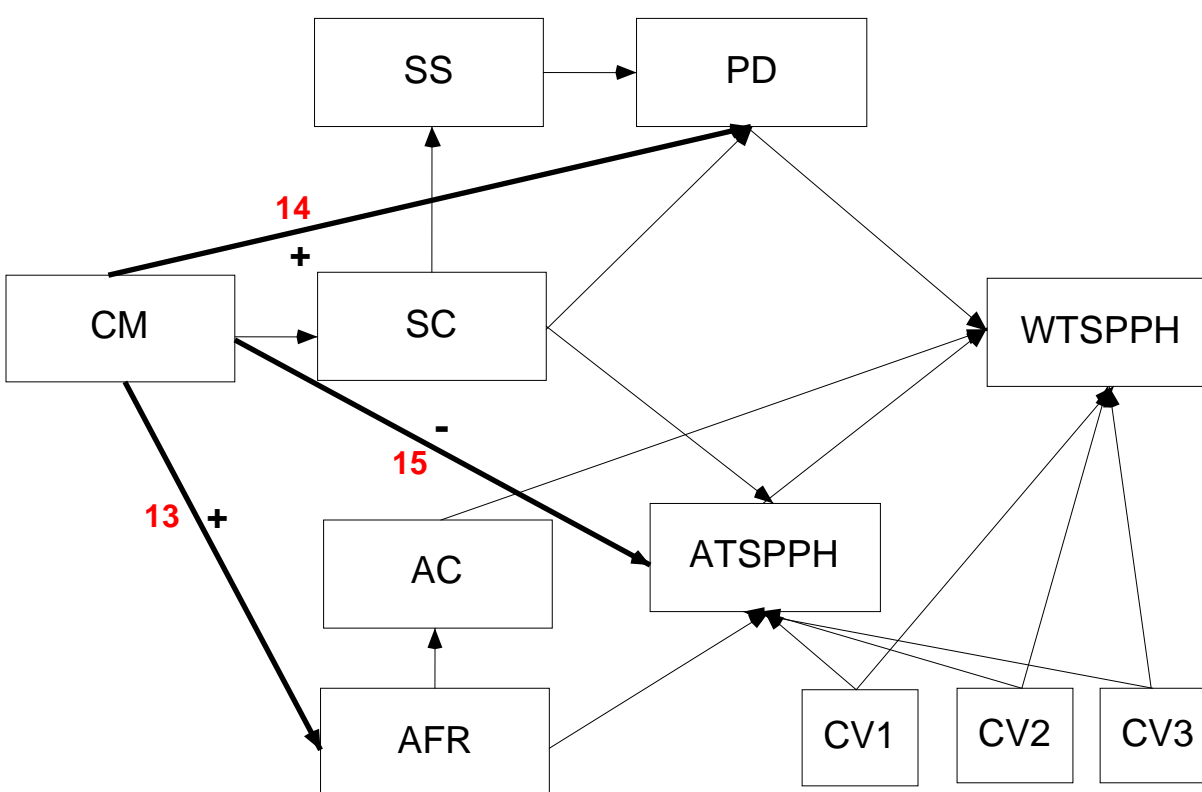

*Note.* Featured pathways appear in boldface. *AC* = Africultural Coping, *AFR* = Africentrism, *ATSPPH* = Attitudes Toward Seeking Professional Psychological Help, *CM* = Cultural Mistrust, *CV1* = I have seen a counselor, therapist, or psychologist for help in dealing with serious personal or emotional problems, *CV2* = If I was considering therapy for help in dealing with a serious personal or emotional problem, the race of the therapist would be important to me, *CV3* = If I was experiencing serious personal or emotional problems, I would be more willing to seek therapy if I knew the therapist was Black, *PD* = Psychological Distress, *SC* = Self-concealment, *SS* = Social Support, *WTSPPH* = Willingness to Seek Professional Psychological Help.

13. *Increased cultural mistrust contributes to a stronger sense of Africentrism.* Individuals who tend to be suspicious of the intentions and motivations of White people, Eurocentric organizations, and Eurocentric institutions experience increasing affiliation with the Africentric orientation.

14. *Increased cultural mistrust leads to greater psychological distress.* The tendency to be suspicious of the intentions and motivations of White people, Eurocentric organizations, and Eurocentric institutions likely contributes to emotional strain.

15. *Increased cultural mistrust contributes to unfavourable attitudes toward seeking professional psychological help.* Greater suspiciousness of the intentions and motivations of White people, Eurocentric organizations, and Eurocentric institutions increases the likelihood that individuals will harbour negative attitudes toward seeking professional psychological services.

## **CHAPTER II: Review of the Literature**

This chapter outlines the literature pertaining to the relationships between the constructs investigated in this present study, with particular attention given to how cultural factors shape these relationships for people of African descent. Accordingly, this chapter summarizes the empirical research on attitudes toward seeking professional psychological help, psychological distress, self-concealment, and social support constructs that served as the foundation for Cramer's (1999) model of professional help-seeking for psychological problems. Furthermore, this chapter presents research that has reexamined these essential constructs as they specifically relate to the experiences of people of African descent. Lastly, a case is made for the consideration of cultural mistrust, Africentrism, and aficultural coping behaviours in formulating an improved explanatory model of people of African descent's professional help-seeking behaviour for personal or psychological difficulties.

### **Attitudes Toward Seeking Professional Psychological Help**

The process of seeking help for emotional and psychological problems has long been recognized as part of a complex myriad of influences that contribute to the mental health service gap. From the early research indicating that the help-seeking process is tightly linked to social class (e.g., Hollingshead & Redlich, 1958; Rogler, Malgady, & Rodriguez, 1989) emerged a contemporary understanding of professional help-seeking for mental health concerns that is inextricably linked to cultural factors. Informed by the converging literature on racial differences in mental health service utilization, researchers have explored attitudinal considerations involved in the decision to seek professional psychological services. Together, this literature suggests that minority and majority group members tend to differ in their attitudes toward professional help-



seeking for mental health concerns despite a common need for mental health services (Leong et al., 1995).

Early research identified African Americans as a minority group that demonstrated inconsistent use of professional psychological services (Kessler et al., 1994; Sue & Sue, 2002). Unlike other ethnic minority groups such as Hispanic and Asian Americans, the literature documented the overutilization of inpatient services and the over- and underutilization of outpatient services depending on the clinical setting and presenting problems (Atkinson, Morten, & Sue, 1998; Sue, Zane, & Young, 1994). As research on the mental health service utilization of African Americans evolved, more consistent evidence emerged. Most notably, Snowden (1999a) reported findings that indicated mixed patterns of service use typically occurred when sociodemographic differences and diagnoses were not accounted for among community samples of African Americans. Using controlled analyses, Snowden demonstrated that African Americans were consistently less likely than their White counterparts to seek mental health services.

#### *The Impact of Attitudes on Willingness to Seek Professional Psychological Help*

One's willingness to exert effort in performing a behaviour is the most immediate and important cognitive antecedent of actual behavioural performance (e.g., Ajzen, 1991; Fishbein & Ajzen, 1975; Fischer & Fischer, 1992; Gollwitzer, 1993; Triandis, 1977). Therefore, one's willingness to engage in a specific behaviour should predict the actual behaviour with considerable accuracy. The findings from a number of studies have demonstrated that behavioural intentions explain a significant proportion of the variance in actual behaviour, thus substantiating the predictive validity of behavioural intentions (e.g., Ajzen & Fishbein, 2005; Albarracín, Johnson, Fishbein, & Muellerleile, 2001; Armitage & Conner, 2001; Notani, 1998;

Randall & Wolff, 1994; Sheeran, 2002). Accordingly, the present study has operationalized psychological help-seeking behaviour as one's willingness to seek professional psychological help rather than their actual action of seeking professional psychological help.

The theory of planned behaviour (TPB; Ajzen, 1991) lends theoretical support to utilize willingness to perform a behaviour rather than engagement in the actual behaviour as a proxy outcome variable. The TPB provides a social-cognitive framework for explaining how deliberative decisions that involve consideration of the advantages and disadvantages of a target behaviour (Fazio, 1990) influence the actual performance of that behaviour (Ajzen, 1991). The TPB posits that an individual's willingness to perform a behaviour (e.g., 'I intend to do X next week) is a key predictor of behavioral performance (Sheeran, Norman, Ordell, 1999). Furthermore, one's willingness to perform a behaviour is thought to be determined by three variables: attitudes (positive or negative evaluations of performing the behaviours, e.g., 'Therapy is what I need to help me with my problem), subjective norms (perceived social pressure from significant others to perform the behaviour; e.g., 'If I seek therapy, my friends may think I am weak'), and perceived behavioural control (perceived self-efficacy in relation to the performance of the behaviour, e.g., 'I know how to request professional psychological services if needed'; Ajzen, 1991; Chatzisarantis & Hagger, 1997; Sheeran, Norman, & Orbell, 1999).

Although the 'perceived behavioural control' construct has contributed to furthering the understanding of behavioural prediction, the 'attitudes' and 'subjective norms' constructs are the most important features of the TPB. The importance of attitudes and subjective norms in explaining behaviour has been demonstrated by a number of empirical investigations of their relationship with willingness to perform behaviours and the actual performance of behaviours. Fishbein and Ajzen (1975) proposed that the relative weights attached to attitudes and subjective

norms in the prediction of willingness vary for different behaviours. This hypothesis has been supported by the existing literature examining the links between attitudes and subjective norms and a range of diverse behaviours (e.g., Ajzen & Fishbein, 1980; Fishbein & Ajzen, 1975; Kraus, 1995; Miniard & Cohen, 1981; Triandis, 1994). These studies have generally found that attitudes are more related to willingness (and thus behaviour) than subjective norms. That is, behaviours tend to be determined more by attitudinal factors than normative factors (Trafimow & Finlay, 1996). Moreover, attitudinal factors remain the best predictors of behaviour regardless of individual personality differences (i.e., internally vs. externally motivated people; Sheeran, Norma, & Orbell, 1999).

Even though the majority of people and behaviours are attitudinally controlled, there is a small proportion of the population whose willingness to engage in behaviours is governed by normative influences (Trafimow & Finlay, 1996). Stronger associations between subjective norms and willingness are usually found among people with a higher sense of the collective self (Trafimow & Finlay, 1996) and people with stronger interdependent construal (Park & Levine, 1999). These cultural value orientations are inherently linked to conceptions of the self (Markus & Kitayama, 1991). Individualism is defined as a tendency to place one's own needs above the needs of one's in-group, whereas collectivism is defined as the tendency to place the needs of one's in-group above one's own needs (Hofstede 1980). Like the individualism-collectivism construct (a cultural variable), the independent and interdependent self-construal construct (an individual difference variable) is concerned with the relationship of the individual to the collective (Singelis, 1994). The independent self-construal refers to individuals who perceive themselves as autonomous and tend to utilize social context primarily as standard for appraisal or as sources that can verify and affirm the internal attributes of the individual. Conversely, the

interdependent self-construal refers to individuals who view themselves in connection to others and try to find ways to maintain harmony within the group. These individuals tend to place a high importance on relationships and are more likely to act in accordance with the anticipated expectations of others and social norms rather than their own individual wishes and personal attributes (Markus & Kitayama, 1991; Singelis, 1994). Individuals who are collectively oriented are more likely than their individually oriented counterparts to report sensitivity to embarrassment (Sharkey & Singelis, 1995) such as that brought on by stigma, and to display relational and conversational constraints (Kim et al., 1996) consistent with self-concealment. This collectivist orientation is a core element of the values of many minority groups (e.g., African, Asian, and Latino). Thus, for people of African descent who ascribe to Africentric ideals, help-behaviours may be strongly shaped by cultural norms. Thus, subjective (or cultural) norms appear to be an important factor to consider when exploring the dynamic involved in professional help-seeking for mental health reasons among people of African descent.

#### *Attitudes Toward Seeking Professional Psychological Services Among People of African Descent*

In accordance with the literature linking behavioural intention with actual behaviour, investigations of attitudes toward professional psychological services among African Americans gained increasing importance as a predictor of African Americans' willingness to seek professional psychological help and, by extension, African Americans' actual help-seeking behaviour. For example, Gary (1987) examined the attitudes of African American adults toward community mental health centers, which revealed a recent shift toward more positive attitudes toward mental health services. An earlier review by Parker and McDavis (1983) revealed that African Americans associated shame with the use of professional psychological services and endorsed beliefs that professional psychological services are ineffective and only necessary for

those who were severe mental illness. Using a random sample of community households, Gary (1987) demonstrated that African American adults were more knowledgeable about mental health services than suggested by the findings of Parker and McDavis (1983), and that mental health services were perceived as increasingly available. Respondents who were married, endorsed higher levels of racial consciousness, and those who reported higher educational levels also reported more positive attitudes toward community mental health centers. However, approximately half of Gary's (1987) sample reported neutral attitudes toward seeking professional psychological services, primarily as a reaction to experiences with culturally insensitive mental health providers.

Diala and colleagues (2000) explored the racial differences in attitudes toward seeking professional psychological treatment and its association with the use of mental health services in a representative sample of the US population. Diala et al. (2000) found that African American respondents were more likely than their White counterparts to endorse positive attitudes toward seeking professional psychological services, feeling comfortable discussing personal problems with a mental health professional, and less embarrassment about informing friends that they were seeking professional psychological services before actual service use. However, African Americans identified as being in need of services and had received them held more negative attitudes about professional psychological services and were less likely to continue using them than their White counterparts with similar needs and usage. In both cases, African American respondents reportedly used fewer mental health services than their White counterparts.

Diala et al. (2000) argued that, in the context of cross-racial therapeutic relationships, racially dissimilar mental health providers may display racial microaggressions (i.e., subtle interactions that communicate insulting or demeaning messages about racial minorities;

Franklin, 1999) such as engaging in colour blindness, blaming the victim, and overidentification toward clients of African descent that create difficulties in the form of poor working relationships, therapeutic impasses, premature termination from counseling, and client dissatisfaction with treatment (Helms & Cook, 1999) - thus negatively influencing attitudes toward seeking professional psychological treatment among former consumers of mental health services. Moreover, across ethnic groups, previous use of mental health services by individuals or their family members is related to the likelihood of current service use (Padgett et al., 1994; Robbins & Greenley, 1983), the frequency of service use, and the duration of service use (DeFigueredo & Boerslter, 1988). Therefore, negative attitudes toward seeking professional psychological help among previous mental health consumers of African descent are not only detrimental to the future help-seeking behaviour of that individual but also the future help-seeking behaviour of their family members.

In a qualitative study, Sanders-Thompson, Bazile, and Akbar (2004) explored African American's attitudes toward professional psychological services. Using a focus group format, several themes emerged providing insight into the attitudes and beliefs about professional psychological services among communities of African descent. General agreement existed regarding the need for psychological intervention for individuals with serious psychopathology (i.e., suicidal ideation, schizophrenia, and depression), substance abuse, and trauma (e.g., sexual abuse, domestic violence). Less emergent difficulties (i.e., problems managing grief, relationship difficulties) were also identified as appropriate reasons to seek professional psychological services. However, there was little consensus regarding willingness to seek professional psychological help for these life stressors. These results suggest that serious mental illness, as

opposed to everyday stressors and problems, is most likely to precipitate professional treatment seeking for psychological problems among African Americans

### *Attitudinal Barriers to Seeking Professional Psychological Help*

The remarkable insight of Sanders-Thompson and colleagues' (2004) African American discussants regarding the barriers to seeking professional psychological help culminated in a nuanced perspective on this literature (e.g., Alvidrez, 1999; Gary, 1987; Hall & Tucker, 1985; Priest, 1991; Whaley, 1997). The results suggested that although African Americans have recently been reported to seek professional psychological services to a greater extent than in the past, many attitudes remain unchanged. First, feelings of shame and embarrassment were linked with seeking professional psychological services. Individuals with mental illness, as well as their families, were noted to hide their illness because of the fear of rejection. Psychotherapy, in particular, was viewed as unfamiliar and associated with the stigma of mental illness (i.e., being labeled as 'crazy'). The term 'counseling' was deemed more acceptable because it appealed to lay notions of help, assistance, and problem solving.

Individuals who believe that mental illness is highly stigmatizing are not likely to seek professional help for personal or emotional problems on a voluntary basis. Moreover, there is evidence that psychiatric disorders have greater stigma attributed to them in ethnic minority populations (Alvidrez, 1999). For example, Silva de Crane and Spielberger (1981) found that African American college students endorsed more negative views of mental illness (i.e., mentally ill individuals are morally inferior or should be isolated from the general public) than their White counterparts. Social class also appeared to be important, whereby low-income and less educated individuals tend to be more concerned about the reactions of friends and family if they sought professional psychological help than middle class or more education individuals (Leaf, Bruce,

Tischler, & Holzer, 1987). Whaley (1997) found that a nationally representative sample of African Americans perceived individuals with mental illness as more dangerous and violent than their White counterparts, regardless of their previous level of contact with people with mental illnesses.

Using a community sample of African Americans and White Americans, Anglin, Link, and Phelan (2006) demonstrated that African Americans were more likely to believe that people with mental illness would act in a violent manner but also less likely to believe these individuals should be blamed or punished for violent acts; these differences could not be explained by sociodemographic differences between the two groups. Based on their findings, Anglin and colleagues (2006) posited that these types of stigmatizing attitudes alone could not explain lower rates of psychological treatment-seeking among people of African descent. First, they surmised that there may be something particularly salient for people of African descent about the fear of being labeled as violent that motivates them to avoid the label of mental illness associated with psychological treatment, as opposed to the fear of being punished or blamed for their behaviour. Second, they reasoned that individuals of African descent may be less apt to blame and punish people with mental illnesses who may have been violent because they can relate to the experience of being stereotyped as violent. Lastly, Anglin and colleagues (2006) applied attribution theory (that people try to determine causes to behavior; Weiner, 1993, 1995) to explain how mental illness may elicit a more sympathetic response among people of African descent, despite its' association with violent behaviour. They argued that the increased perception of violent behaviour attributed to the mentally ill might be part of a more general perception that absolves a mentally ill person of responsibility for illness-related behaviour.



Sanders-Thompson and colleagues' (2004) African American discussants also noted the potential role of cultural beliefs in inhibiting help-seeking behaviour. For example, the Africentric worldview emphasizes collectiveness. Historically speaking, the collective refers to the clan or the tribe; in contemporary society, the collective reflects the family unit or community (Akbar, 1985; Nobles, 1986). Within communities of African descent, psychotherapy is often perceived as a process that requires the client to "tell [his or her] business to a stranger" and relinquish his or her independence (Priest, 1991, p. 214). Cultural objections to sharing information with individuals outside the extended kinship network encourage the resolution of personal concerns within the social network and discourage the pursuit of assistance outside of this group. Furthermore, among people of African descent, historically-based expectations that adversity will be endured and overcome through demonstrations of strength and pride may contribute to an implicit belief that seeking help is a sign of weakness. Accordingly, seeking psychological treatment is also perceived as a sign of weakness (Sanders-Thompson et al., 2004).

Thus, the degree to which individuals of African descent adhere to this cultural dictum discourages the disclosure of personal or family business to strangers. This tendency may strongly influence individuals of African descent's willingness to seek professional psychological help (Priest, 1991). As such, the relationship between attitudes toward seeking professional psychological help and willingness to seek professional psychological help among people of African descent is partially embedded in culture-based norms. Cultural sanctions to withhold negative, distressing, or intimate information conflict with the expectation in psychotherapy to explicitly discuss difficult matters that often include one's personal and family history.

*Self-Concealment and Attitudes Toward Seeking Professional Psychological Help*

In the general mental health literature, the tendency to actively conceal from others information perceived as highly intimate, distressing, or negative is called self-concealment (Larson & Chastain, 1990). More recently, researchers have begun to conceptualize self-concealment as a personality trait characterized by a predisposition to deliberately conceal distressing and potentially embarrassing information (Cepeda-Benito & Short, 1998; Cramer, 1999; Larson & Chastain, 1990; Wallace & Constantine, 2005). Accordingly, the extent to which individuals endorse favourable attitudes toward seeking professional psychological help should, at least in part, be influenced by their aversion to revealing sensitive personal information in a therapeutic setting. For example, high self-concealers may generally have unfavourable attitudes toward professional help-seeking for personal problems or emotional difficulties because they are concerned about revealing their most intimate and disturbing experiences.

Kelly and Achter (1995) investigated the relations between self-concealment, attitudes toward seeking professional psychological help, and willingness to seek professional psychological help. They found that even though high levels of self-concealment were associated with more negative attitudes toward professional psychological services, high levels of self-concealment were also associated with greater willingness to seek professional psychological services. Kelly and Achter reasoned that the unfavourable attitudes of high self-concealers were a reflection of their fear of having to reveal intimate information to the therapist. Ironically, it speculated that these individuals were also more willing to seek help from professionals, presumably because they are even more reluctant to seek help from their non-professional social network. That is, their predisposition for self-concealment prevents them from experiencing the

mental health benefits of informal social support (Evans & Katona, 1995; McCartney, 1995; Straits-Troster et al., 1994).

Cepeda-Benito and Short (1998) attempted to reconcile these paradoxical findings by exploring the relations between willingness to seek professional psychological help, attitudes toward professional psychological help, fears of psychological services, psychological distress, social support, and self-concealment. In contrast to the findings of Kelly and Achter (1995), Cepeda-Benito and Short found that high self-concealers were three times more likely than low self-concealers to report needing but not intending to seek professional help. Moreover, high self-concealers were less willing to seek professional psychological help than low self-concealers, regardless of the high self-concealers reported levels of social support.

Cramer (1999) consolidated the findings of these two studies in a model indicating that self-concealment tendencies have an indirect effect on help-seeking via social support, psychological distress, and attitudes toward seeking professional psychological help. In effect, high self-concealers who do not develop strong social support networks experience higher levels of psychological distress. In a parallel process, high self-concealers have more negative attitudes toward seeking help. Simultaneously, these high self-concealers have a greater need for counseling because of high levels of distress but are inhibited from seeking help because of their negative attitudes towards seeking professional psychological help (Kahn & Williams, 2003); willingness to seek professional psychological help is a product of these opposing forces.

In the only published empirical study examining the relationship between self-concealment and attitudes toward seeking professional psychological help within a sample of African descent, Wallace and Constantine (2005) investigated the moderating role of Africentrism. The findings of this study indicated that stronger identification with Africentrism,

for both African American men and women, was associated with greater perceived stigma about professional psychological services and greater self-concealment. Furthermore, stronger identification with Africentrism did not predict attitudes toward seeking professional psychological help but did predict greater perceived stigma associated with seeking professional psychological help. However, neither favourable attitudes toward seeking professional psychological help nor perceived stigma associated with professional psychological services moderated the relationship between Africentrism and self-concealment. Given the complex attitudinal, behavioural, and cultural issues involved in the help-seeking behaviour people of African descent, perhaps a path model incorporating all of these factors may better illuminate the impact of Africentrism on the relation between attitudes toward seeking professional help and willingness to seek professional psychological help.

Lack of knowledge about the symptoms of mental illness and the threshold for seeking professional psychological services for personal difficulties was cited as another barrier to seeking mental health services by Sanders-Thompson and colleagues' (2004) discussants. This noted lack of information reportedly resulted in seeking consultation from emergency departments and churches for resources and referrals. Concerns about the therapeutic relationship were also identified as a major barrier to seeking professional psychological services. Psychologists were described as "older White males" who were "impersonal", "elitist", and "too far removed from the community [of African descent] to be of assistance" (p. 23). The educational status of psychologists was also viewed as "intimidating" and believed to limit the ability of psychologists to relate to their clients.

In addition, trust was noted as a major challenge to the therapeutic relationship. Concerns about stereotypes about people of African descent infiltrating the therapy room, were

manifested in this group's fear surrounding misdiagnosis, labeling, and brainwashing. Men of African descent, in particular, may be particularly likely to view psychotherapy in this manner. For example, the literature suggests that African American men have internalized the idea that to be perceived as weak or unstable represents a major threat to survival (Hobbs, 1985; Kirk, 1986; Warfield & Marion, 1985). Consequently, African American men tend to demonstrate extreme reluctance toward participation in psychotherapy. African American men are generally found to be reluctant to participate in psychotherapy as compared to African American women. The reluctance of African American men, as compared to their White counterparts, is uniquely characterized by a strong need to be independent and a conscious effort to avoid situations where Whites (e.g., therapists) are experienced as more powerful than themselves. Accordingly, prospective male clients of African descent may perceive themselves as less powerful than a presumably White therapist. Such power imbalances are seen by African American men to foster dependence and vulnerability that may leave them susceptible to mistreatment.

#### *Psychological Distress and Attitudes Toward Seeking Professional Psychological Help*

Generally speaking, empirical studies examining help-seeking intentions have found that psychological distress is significantly and positively related to a person's willingness to seek mental health services (e.g., Cepeda-Benito & Short, 1998; Cramer, 1999). In other words, experiencing psychological distress appears to be a prerequisite for seeking professional psychological help (Vogel & Wei, 2005). Individuals who seek professional psychological help tend to report greater levels of psychological distress (Veroff, Kulka, & Douvan, 1981) and more symptoms of psychopathology (Boyd, 1986; Yokopenic, Clark, & Aneshensal, 1983) than those who do not seek professional psychological help. The literature in this area also indicates that individuals who perceive their own problems as more severe than the problems of others

(Goodman, Sewell, & Jampol, 1984) and believe that participating in psychological treatment may reduce their feelings of distress (Mechanic, 1975) tend to be more willing to seek professional psychological help. Furthermore, the literature suggests that individuals' perceived symptom severity is positively correlated with their willingness to seek professional psychological help (Robbins & Greenley, 1983) and their actual use of professional psychological services (Norcross & Prochaska, 1986). For example, Cepeda-Benito & Short (1998) found that current distress predicted the perceived likelihood of seeking professional psychological help to the point that the reported type of distress coincided with the specific reasons for which help would have been sought. When considering the potential influence of self-concealment, which has long been noted to have negative implications for mental health outcomes (Brown, Bhrolchain, & Harris, 1975; Lowenthal & Haven, 1968; Miller & Ingham, 1976; Pennebaker, 1985; Pennebaker & Beall, 1986), Cepeda-Benito and Short (1998) found a positive relation between self-concealment and current psychological distress. These high self-concealers reported lower rates of seeking professional psychological help than their low self-concealing counterparts. In fact, high self-concealers were three times more likely than low self-concealers to report need but not seeking professional psychological help.

Professional help-seeking for emotional difficulties has been associated with expressions of psychological distress among people of African descent. In particular, Heurtin-Roberts, Snowden, and Miller (1997) demonstrated that the endorsement of African American folk symptoms (i.e., anxiety-related concerns, somatic complaints) are strongly associated with the likelihood of having received mental health care whether from a mental health practitioner in private or public practice, from a physician, or in an emergency room. However, African Americans who report receiving professional psychological services have most likely received

emergency psychiatric care (Hu et al., 1991). Such crisis-oriented treatment might preclude participation in outpatient psychotherapy. This reliance on emergency psychiatric health care may be indicative of the importance of distress severity as a predictor of professional psychological help-seeking behaviour among people of African descent. Repeated, crisis-oriented treatment might preclude participation in regular outpatient treatment and predispose the entry into inpatient psychiatric care. This suggests that, similar to the general population, high levels of distress are a precursor to seeking mental health care among people of African descent.

In an extension of this study, Snowden (1999b) investigated whether the endorsement of African American folk-symptoms (i.e., anxiety-related concerns and somatic complaints) is more strongly associated with the use of mental health services among African Americans than their White counterparts. Snowden (1999b) hypothesized that the expression of these culturally sanctioned idioms of distress lessens the stigma associated with help-seeking behaviour, leading to increased help-seeking behaviour among African Americans endorsing these symptoms. As hypothesized, the results indicated that African Americans who reported seeking professional help for personal or emotional difficulties were more likely than their White counterparts to cite anxiety-related symptoms and somatic complaints as their presenting complaints. Furthermore, these racial differences in mental health service use remained after accounting for respondents who met diagnostic criteria for a mental disorder. Snowden (1999b) also included symptoms of demoralization and estrangement that are atypical of African American folk symptoms; these symptoms included feelings of hopelessness, loss of sexual interest, trouble concentrating, and thought problems indicative of depressive symptomatology. The results indicated that the association between demoralization-estrangement and help-seeking behaviour was stronger for White respondents as compared to their African American counterparts. The findings from these

studies suggest that the endorsement of symptoms indicative of anxiety and somatization disorders may be a particularly important step for people of African descent considering professional assistance for personal or emotional problems. That is, the expression of anxiety symptoms and somatic complaints may be a culturally acceptable way for people of African descent to assert their desire for professional consultation concerning personal problems and emotional difficulties while reducing the risk of violating cultural mores for psychological help-seeking.

Thus, the research has consistently demonstrated underutilization of professional mental health services by individuals of African descent (e.g., Kessler et al., 1994; Snowden, 1999a). This pattern of mental health utilization has been mainly attributed to attitudes toward professional psychological services. The accumulating evidence suggests that these attitudes interact with self-concealment, psychological distress, and social support (Cepeda-Benito & Short, 1998; Cramer, 1999; Kelly & Achter, 1995) to influence one's willingness to seek professional assistance for personal and emotional problems. Together, these constructs constitute the foundation of the present study's proposed cultural extension of Cramer's model of professional help-seeking for psychological reasons.

### Cultural Mistrust

The literature points to trust as a highly important variable to consider in prospective cross-cultural therapeutic relationships (Dixon & Glover, 1984; Nickerson et al., 1994; Ponterotto, Alexander, & Hinkston, 1988; Watkins & Terrell, 1988; Watkins, Terrell, Miller, Terrell, 1989; Vontress, 1971). As a result of an extensive history of race-related mistreatment by Whites, people of African descent may have developed a generalized suspicion of Whites.



This notion of cultural mistrust (Terrell & Terrell, 1981) can be conceptualized as the degree to which people of African descent mistrust Whites. Accordingly, cultural mistrust may play a crucial role in cross-cultural therapy involving White therapists and clients of African descent. Indeed, the theoretical and empirical literature suggests that cultural mistrust may have a deleterious impact on people of African descent's willingness to establish therapeutic relationships with White therapists, which in turn may serve as a barrier for seeking professional psychological help (Nickerson et al., 1994).

#### *From Healthy Cultural Paranoia to Cultural Mistrust*

The underutilization of mental health services by people of African descent has been regarded as a reflection of cultural attitudes and beliefs about White society resulting from historical and contemporary experiences of racism and oppression (Ashby, 1986; Bronstein, 1986; Terrell & Terrell, 1981). Grier and Cobbs (1968) first introduced the idea that people of African descent have developed paranoid-like behaviours due to such interracial encounters. This cultural response style, termed 'healthy cultural paranoia', has been used to describe the apprehension experienced by people of African descent in interracial clinical situations; it is characterized by sensitivities regarding issues of trust, suspicion, and self-consciousness (Grier & Cobbs, 1968; Ridley, 1984, 1986). However, researchers disputed the propriety of using the term *paranoia* to describe this adaptive behaviour, arguing that this term should exclusively refer to beliefs and perceptions reflecting genuine pathology (Ashby, 1986; Bronstein, 1986). This controversy was drawn along the lines of the categorical-dimensional debate about the nature of psychopathology in general, with proponents of reserving the term for psychopathology subscribing to a categorical model and those advocating flexible usage of the term to encompass

cultural behaviours and nonclinical situations championing a dimensional perspective (Whaley, 2001b).

Ridley (1984) proposed a dimensional approach to resolve the debate whereby cultural paranoia and clinical (or pathological) paranoia are orthogonal dimensions that combine to produce different paranoid presentations. According to Ridley's (1984) typology, a person of African descent may endorse: 1) low cultural paranoia and low clinic paranoia representing a nonparanoid type, 2) high cultural paranoia but low clinical paranoia representing a culturally paranoid type, 3) low cultural paranoia but high clinical paranoia reflecting a functionally paranoid type, and 4) simultaneous high cultural and clinical paranoia reflecting a confluent paranoid type (Ridley, 1984). Based on this typology, the types of experiences considered paranoid could range from mistrust in nonclinical populations to delusions and hallucinations involving ideas of persecution and grandiosity found in psychotic disorders. This model suggests that paranoia at the mild end of the continuum represents interactions between individuals and a threatening social environment, whereas severe paranoia reflects delusional beliefs that are independent of social reality. The organizing principle of these ranges of experiences is the fear of victimization (Fenigstein & Vanable, 1992; Zigler & Glick, 1998). This dimensional approach advanced the conceptualization of paranoia as occurring along a continuum of severity, on which cultural aspects of paranoia (i.e., mistrust, suspiciousness, self-consciousness) are located at the mild or nonclinical end of the severity continuum (Whaley, 2001b).

Researchers on both sides of the debate agreed that the term 'cultural mistrust' was a more appropriate description of the phenomenon. The reformulation of healthy cultural paranoia as cultural mistrust has been further supported by research demonstrating its' differential manifestation in nonclinical and clinical populations of African descent and their White

counterparts (Whaley, 1998, 2001b). According to this research, subclinical forms of paranoia like mistrust, suspiciousness, and self-consciousness may be more susceptible to environmental influences than clinical forms of paranoia that can include delusions of persecution or personality traits of pervasive suspiciousness and extreme mistrust (American Psychiatric Association, 1994). For example, Terrell and Barrett (1979) found that subclinical paranoia in the form of low interpersonal trust tends to be stronger in women, people of African descent, and individuals of low socioeconomic status as compared to men, Whites, and individuals of high socioeconomic status. Furthermore, Fenigstein and Vanable (1992) demonstrated that subclinical paranoia in normal populations is often manifested in environmental contexts that heighten self-consciousness.

Based on studies of ethnoracial differences in prevalence rates of affective and psychotic disorders in the U.S. population, Whaley (1997) pointed to the apparent overdiagnosis of schizophrenia and underdiagnosis of depression among African Americans in clinical settings. He also called attention to mounting evidence that African Americans with affective disorders are often misdiagnosed with schizophrenia (Simon et al, 1973; Bell & Mehta, 1980, 1981; Mukherjee, Shukla, Woodle, Rosen, & Olarte, 1983). After controlling for purported clinician bias (e.g., lack of adherence to diagnostic criteria in unstructured clinical interviews), Whaley (1997) found that ethnoracial differences in the diagnosis of paranoid processes among African Americans and their White counterparts remained. Further findings illustrated the role of cultural variations in paranoid symptom expression, particularly the role of mistrust as a mechanism used by African Americans with depressive disorders to protect their self-esteem (Bentall, Kinderman, & Kaney, 1994; Ridley, 1984). These findings suggest that even among clinical populations,

cultural influences on paranoid symptoms expressions are an important consideration in the provision of mental health services.

Combs, Penn, and Fenigstein (2002) found that African Americans scored significantly higher than Whites on a scale of subclinical paranoia. More specifically, they found that African Americans highly endorsed lack of trust in others, a mistrust of the motives of others, being on guard with others, and perceived criticism by others. The African American respondents in this study also had significantly higher scores on clinical self-report measures of paranoia, suggesting consistent differences in paranoid ideation across the two ethnic groups. These results do not suggest that African Americans are more pathologically paranoid than other ethnic groups; rather, the group differences reflect interpersonal mistrust likely caused by pervasive discrimination and perceived racism. Together, these findings suggest that cultural contexts that promote feelings of alienation and powerlessness are more likely to engender mistrust (Whaley, 1998, 2004). Mirowsky and Ross (1983) argued that belief in the external control of others contributes to feelings of mistrust, which can ultimately lead to paranoid ideation among those who are powerless. Thus, the threat of victimization or exploitation is likely to be a major cause of paranoid symptoms. As such, paranoia at the mild end of the continuum (i.e., mistrust) may not only be culturally-determined but also based on realistic concerns about victimization and exploitation based on direct and vicarious experiences with racism and oppression.

Terrell and Terrell (1981) proposed that people of African descent become mistrustful of White people as a result of being treated unfairly by White people. According to Terrell and Terrell (1981), the tendency to be suspicious of White people is prevalent in four major areas. First, people of African descent are often viewed as being mistrustful in educational and training settings. For example, Cooley (2006) argued that the racialization within the education system

has transformed beliefs about the academic and intellectual abilities of students of African descent into instruments of categorization and judgment, whereby students of African descent are constantly confronted with negative messages about their supposed inadequacies and pathologies. Consequently, students of African descent become disillusioned and mistrustful of what is perceived to be a white-dominated educational system (Terrell & Terrell, 1981). Russell (1971) also proposed that the content of the curriculum and evaluation process are culturally biased. As a result, people of African descent become wary of what they learn and the value of their learning experience.

Second, theorists have suggested that people of African descent are leery of the political and legal system. For example, Kitano (1974) proposed that limited participation of people of African descent in political activities brings about mistrust toward political and legal systems that seem closed to them. Furthermore, Warren's (1969) contention that the police, political, and legal systems are primarily concerned with controlling rather than servicing people of African descent lead to feeling of helplessness and alienation.

Third, people of African descent tend to be cautious in their work and business interactions involving White people. Rutledge and Gass (1967) maintained that people of African descent often terminate their employment because they do not trust Whites to treat them fairly. As a consequence, people of African descent are more interested in job security than obtaining intrinsic satisfaction from their jobs. Lastly, people of African descent tend to be suspicious of Whites in interpersonal or social contexts. For example, Kitano (1974) argued that people of African descent prefer to live in neighbourhoods and municipalities where other people of African descent reside because their predisposition to mistrust Whites influences the extent to which they are willing to interact with them. These theories suggest that cultural mistrust among

people of African descent may be generalized to a variety of situations. Accordingly, the White-oriented context of the therapeutic setting may lead to mistrust and suspiciousness among people of African descent (Terrell & Terrell, 1984).

### *Cultural Mistrust and Psychological Distress*

Paranoia related to cultural factors, or cultural mistrust, has been an increasing area of study in research concerning people of African descent (Combs et al., 2006; Whaley, 1998). Paranoia at this lower end of the continuum can be defined as a relatively stable relational style that is characterized by mistrust, suspiciousness, ill will or resentment, and beliefs in external control or influence (Fenigstein & Venable, 1992). Cognitive and behavioural investigations of paranoia indicate that it serves as a self-protective function whereby personal failures are attributed to external factors in order to avoid feelings anxiety, guilt, depression, or low self-esteem (Bentell, Kinderman, & Kaney, 1994; Kramer, 1998; Kramer & Messick, 1998; Ridley, 1984; Trower & Chadwick, 1995; Vinogradov, King, & Huberman, 1992; Zigler & Glick, 1988). The association between paranoia and psychological distress can be better understood from the perspective of experiences of victimization and exploitation of racial and ethnic minorities. Members of minority groups that continue to be victimized and exploited by the dominant culture may develop paranoid tendencies as a way of adapting to their environmental circumstances. For instance, this cautious approach to interacting with the world may prevent minority group members from attributing interracial experiences of rejection and disappointment to personal inadequacies rather than prejudice and discrimination, thus maintaining their psychological well-being (Collins & Lightsey Jr., 2001; Hughes & Demo, 1989; Mizell, 1999, Whaley, 2001b).

Cultural mistrust has been conceptualized as a reaction to everyday racism that is perceived in a self-referential and threatening manner (Combs et al., 2002; Thompson, Neville, Weathers, Poston & Atkinson, 1990; Whaley, 1998). Visible minority status may contribute to a heightened sense of self-consciousness among people of African descent (Kramer, 1998). Self-consciousness refers to an individual's perception of the self as a social object (Fenigstein, Scheier, & Buss, 1975). There is evidence for a relationship between higher levels of self-consciousness and paranoid-like behaviour, especially in public situations where the person feels scrutinized by others. For example, Bodner and Mickulincer (1998) demonstrated that increased self-focused attention following personal failure produced depressive-like responses, whereas increased other-focused attention following the same circumstances produced paranoid-like responses. This finding is consistent with research showing similarities between patients with clinical paranoia and patients with depression in terms of negative self-relevant information but differences in terms of external attributions for personal failures (Bentall, Kinderman, & Kaney, 1994). Combs and Penn (2004) found that respondents with high levels of nonclinical paranoia endorsed more negative attitudes toward a neutral-behaving experimenter than respondents with low levels of nonclinical paranoia. This finding suggests that people with elevated levels of paranoid-like behaviours tend to perceive greater hostility in ambiguous situations due to the lack of contextual cues with regard to intentions (Freeman, Garety, Kuipers, Fowler, & Bebbington, 2002).

The relation between paranoia-like behaviour and higher levels of self-consciousness may explain the unusual relation between high self-esteem and low personal efficacy in people of African descent (e.g., Collins & Lightsey Jr., 2001; Hughes & Demo, 1989; Mizell, 1999). For instance, individuals of African descent may attribute lack of personal efficacy to sociostructural

barriers rather than dispositional factors (Whaley, 2001b). Thus, cultural mistrust may work to reconcile the dissonance caused by a gap between the ideal self and the actual self that has been limited by the constraints of reality. By attributing underachievement of the ideal self and other threats to the self to external causes, cultural mistrust may indeed serve to protect the psychological well-being of people of African descent (Whaley, 1998).

Although the relation between cultural mistrust and psychological well-being is generally assumed to be positive and linear (Grier & Cobbs, 1968; Sue & Sue, 2002; Triandis, 1976; White, 1980), this relationship has rarely been examined. According to the linear model, low cultural mistrust is associated with poor psychological health and high cultural mistrust is associated with good psychological health. Bell and Tracy (2006) explored the relation between cultural mistrust and psychological health using a curvilinear model. Similar to the linear model, the curvilinear model demonstrated that high levels of trust for Whites (relative to people of African descent) was not conducive to psychological well-being, but low levels of trust for Whites were also associated with poor psychological well-being. Furthermore, the curvilinear model demonstrated that people of African descent with moderate mistrust of Whites exhibit the greatest levels of psychological well-being. While these findings only lend partial support to the notion that mistrust of Whites is a healthy and adaptive characteristic, they do suggest that a moderate level of trust in Whites is related to personal well-being. This conclusion makes intuitive sense given the racial composition of North America, which necessitates a certain degree of trust in the White majority group for effective daily functioning (e.g., school, work, commerce) and psychological health.



### *Cultural Mistrust and Self-Concealment*

Ridley (1984) speculated that cultural mistrust might play a significant role in self-concealment among prospective clients of African descent. Implicit in the task of psychotherapy is that therapeutic progress is achieved through ongoing dialogue-based interactions between the therapist and the client. Ideally, the client should be unguarded and open to freely discussing intimate or sensitive personal information. However, these conditions are dependent upon the client's ability to trust the therapist with potentially distressing or shameful information. The act of disclosing sensitive information can be conceptualized as a willingness on the part of the discloser to become more vulnerable. Clients who trust their therapist likely feel free to openly disclose because they perceive the risks of revealing the self as minimal. By contrast, clients who do not trust their therapist will feel compelled to deliberately censor or limit their disclosure, which is an act of self-concealment. These mistrustful clients likely perceive considerable risk in revealing the self. As such, mistrust and self-concealment likely work together, both in the interest of protecting the individual's self-esteem.

People of African descent may be especially reluctant to disclose personal information to White counselors because of the hardship they have experienced as a result of racism and oppression (Vontress, 1971). People of African descent have been socialized to hide their true feelings when interacting with White people because they are apprehensive that what they say will be used against them or distorted in a way that disparages them (Ridley, 1984). Kadushin (1983) suggested that concealment is an adaptive mechanism that works to minimize feelings of oppression and powerlessness, and has thus become a transgenerational coping mechanism deemed necessary for survival. However, this adaptive mechanism becomes problematic for people of African descent seeking mental health services because deliberate self-concealment

runs counter to successful therapeutic outcomes; in this context, self-concealment as a survival technique may have detrimental consequences for psychological well-being. Given the underrepresentation of professional counselors and psychologists of African descent (compared with the representation of people of African descent in the general population), prospective clients of African descent will likely be seen by White mental health clinicians in order to receive treatment (Poston, Craine, & Atkinson, 1991). Thus, for clients of African descent who generally do not trust White people but whose experiences of psychological distress demand professional psychological attention, the idea of being treated by a White mental health clinician may become a major barrier to therapeutic progress (Ridley, 1984).

Several studies have provided support for the influence of cultural mistrust on self-concealment in interpersonal interactions, especially the therapeutic relationship. For instance, Watkins and Terrell (1988) found that highly mistrust African American respondents rated a White counselor less favourably on a measure of self-disclosure than did African American respondents with low levels of mistrust. Poston and colleagues (1991) explored the relationship between cultural mistrust, counselor's ability to openly discuss racial differences (i.e., counselor dissimilarity confrontation), and willingness to disclose intimate and sensitive personal information among a sample of African Americans. Using a stepwise regression that included income, education, participants' sex, cultural mistrust in interpersonal relationships, counselors' sex, and counselor confrontation as predictor variables, Poston et al. (1991) found that only income and education level were significant predictors of self-disclosures. More specifically, willingness to disclose personal information to a White counselor improved with increasing income and diminishes with more education. Poston and colleagues (1991) reasoned that people of African descent with higher levels of income have likely been successful within their

respective occupational domains, which might be an indicator of their ability to establish rapport and trust White people. With respect to education, they speculated that increased knowledge about the history of oppression of African peoples by Whites by means of higher education might lead to decreased willingness to disclose to a White mental health provider. Although these interpretations are at odds with Poston and colleagues' (1991) finding that cultural mistrust is not a predictor of disclosures in a therapeutic setting, these researchers did not address the potential limitations of using a subset of items from a measure of cultural mistrust that focused solely on interpersonal relations. For example, Whaley (1998) has advised against utilizing interpersonal distrust as a proxy measure for cultural mistrust because, depending on the interracial context, these constructs may or may not overlap.

Thompson, Worthington, and Atkinson (1994) examined the effects of counselor content orientation (i.e., attending to racial issues vs. universal issues in a counseling session), counselor race (i.e., African American vs. White), and respondent's levels of cultural mistrust on the frequency and depth of self-disclosures, ratings of counselor credibility, and willingness to seek professional psychological help among African American female undergraduate students. Thompson and colleagues (1994) hypothesized that the therapeutic relationship would be enhanced when counselors attended to racial issues while eliciting information from African American clients about the daily functioning, as indicated by ratings of client credibility and attempts to disclose personal information. These researchers predicted that African American clients would respond favourably to culturally oriented counselors and be more willing to reveal intimate aspects of themselves because this approach reflects openness to understanding the client in the context of subtly racist and alienating settings.

The findings of the study indicated that participants exposed to the racial content generally disclosed more intimate information about themselves and endorsed a greater willingness to seek professional psychological help than the students in the universal content condition. Moreover, the results also indicated that highly mistrustful participants disclosed the least amount of information to White counselors; participants who demonstrated low levels of cultural disclosed the most amount of information when paired with African American counselors. Thompson and colleagues (1994) speculated that the low-mistrustful participants were able to easily forge a therapeutic relationship with the African American counselor due to similarities to themselves or their ideals (i.e., high-achieving and functioning in predominantly White institution). By contrast, highly mistrustful participants may have tempered their self-disclosures with African American counselors because they generalize their mistrust to all counselors in a predominantly White university setting.

Ward (2005) conducted a qualitative study investigating the subjective experiences in counseling among African American clients by assessing the impact of the respondents' sense of trust and emotional comfort (i.e., safety) in the therapeutic relationship and perception of the counselor's personal experience, professional experiences, and responsiveness (i.e., counselor effectiveness) on their intentional disclosure and concealment of personal information. Twelve of the respondents were being treated by a White therapist, and one of the respondents was being treated by an African American therapist. The qualitative analyses indicated that the African American clients in this study deliberately monitored and managed the flow of personal information as they evaluated their counselor's experience and responsiveness (i.e., counselor effectiveness) and their level of safety. Ward (2005) concluded that counselors' responsiveness, particularly with regard to race-related matters, influenced the African American respondents'

perception of the counselor as effective. Moreover, the African American respondents' perception of their counselor as effective positively impact their sense of safety in the therapeutic relations, which translated into open disclosures of personal and sensitive information about themselves and their families.

### *Cultural Mistrust and Attitudes Toward Seeking Professional Psychological Help*

Empirical studies investigating whether minority clients are better served by or prefer therapists of the same race have resulted in mixed findings (Ponterotto, Alexander, Hinkston, 1988). However, the results of empirical studies focusing on the preferences of African Americans (as opposed to Hispanics, Asian American, and Native Americans; e.g., Proctor & Rosen, 1981; Thompson & Cimboric, 1978) are one exception to these general findings. Reviews of the empirical literature have supported the conclusion that clients of African descent frequently and consistently prefer to see therapists of African descent than White therapists (e.g., Atkinson, 1983; Harrison, 1975). Despite the consistent findings concerning African Americans subjects' preference for a same-race therapist, the preference for race of a therapist is not necessarily attributable to the client's race but rather a function of within-group variables such as cultural mistrust. Therefore, it seems that within-group differences (e.g., levels of cultural mistrust) likely underlie preferences for therapist race among people of African descent and may contribute to a greater understanding of attitudes toward seeking professional psychological help among this population (Nickerson et al., 1994).

That being said, cultural mistrust may explain why people of African descent underutilize professional mental health services (Nickerson et al., 1994). For instance, Thompson and Cimboric (1978) found that the likelihood of utilizing psychological services was greater among African American students if they thought they would see an African American, rather than a

White therapist. Generally speaking, prospective clients' perceived ability to trust a therapist is strongly linked with their expectations for therapy (Watkins & Terrell, 1988). However, in addition to these more general issues concerning trust, the minority client's perceived ability to trust a White therapist may weigh heavily on their expectations of cross-cultural therapy. For example, clients of African descent who are distrustful of Whites may have lower expectations for therapy when assigned to a White therapist than when assigned to a therapist of African descent (Watkins & Terrell, 1988). As such, the preference for racially similar therapists by prospective clients of African descent may be driven by a higher-order relationship between their perceived ability to trust a therapist and their expectations for therapy (Dixon & Glover, 1984; Rotter, 1978).

Using a sample of African American college students, Watkins and Terrell (1988) conducted an analogue study to examine the relationship between cultural mistrust among African Americans and expectations for therapy from therapists of European and African descent. Cultural mistrust was found to have a main effect on expectations for therapy. These results suggested that people of African descent who were highly mistrustful of White people generally tend to expect less from therapy than their less mistrustful counterparts, regardless of the race of the therapist. This finding supported the existing literature underscoring the importance of establishing a therapeutic relationship based on trust (Benjamin, 1974; Marmour, 1976; Okun, 1976). A significant interaction effect was also found between the race of the therapist and level of cultural mistrust. These results suggested that highly mistrustful people of African descent who are assigned to a White therapist will expect less from therapy than if they are assigned to a Black therapist. Furthermore, highly mistrustful people of African descent expect a White therapist to be less accepting and trustworthy and have less expertise as a

professional helper; they also expect that therapy will be less successful if treated by a White therapist. Together, the results of this study demonstrate that the therapist's race in conjunction with the client's level of cultural mistrust negatively affects therapy expectations (Watkins & Terrell, 1988).

Therapist credibility, which consists of characteristics such as trustworthiness, expertise, reliability, and sincerity, is integral to establishing effective therapeutic relationships and rationales for psychological intervention (Atkinson & Wampold, 1982). Watkins and colleagues (1989) conducted an analogue study examining the effects of cultural mistrust on perceptions of the credibility of therapists of European and African descent. The results demonstrated that highly mistrustful African Americans viewed White therapists as less credible than therapists of African descent. Vontress (1971) noted the potential for barriers to the therapeutic process when clients of African descent have difficulty trusting White therapists. For example, clients of African descent may present White therapists with a number of 'tests' (e.g., open resentment, ingratiation) in order to assess the therapist's attitudes toward people of African descent (Greene, 1985). Such behaviours are consistent with the argument that the therapeutic context, reflecting the culture, values, and power dynamics of larger society, may elicit cultural mistrust among people of African descent (Maultsby, 1982; Ridley, 1984).

Watkins and colleagues (1989) also found a main effect for cultural mistrust on the perceived confidence of therapists in assisting with various problem areas. These results demonstrated that highly mistrustful African Americans viewed both therapists of European and African descent as least able to help them with sexual functioning concerns. The authors argued that trust in the working relationship was integral to raising and discussing such sensitive matters in therapy. Considering that clients of African descent with high levels of cultural mistrust may

also have a distrust of people of African descent working in white-oriented settings, they may subsequently be reluctant to reveal such sensitive matters to therapists of African descent. An interaction effect was also found between cultural mistrust, the therapist's race, and the perceived confidence of therapists in assisting with various problem areas. Highly mistrustful people of African descent were found to view the White therapist as less able to help them in dealing with general anxiety, shyness, dating difficulties, and feelings of inferiority.

Thus, highly mistrustful people of African descent may be particularly reluctant to seek professional psychological services because their mistrust of the White-oriented therapeutic environment. The reluctance of highly mistrustful people of African descent to seek professional psychological services may be further intensified by the prospect of being treated by a White therapist who is perceived as less capable of helping them with their problems. Although there were a number of presenting problems where this interaction was not significant, these four identified problems are commonly cited presenting problems for individuals requesting professional psychological services. High cultural mistrust may present a major barrier to psychological treatment-seeking among people of African descent.

Research assessing therapist preferences among people of African descent have indicated preferences for a variety of other therapist characteristics. Atkinson, Furlong, and Poston (1986) examined the relative preference for therapists of the same race, religion, sex, age, education, socioeconomic status, personality, attitudes, and values, using a sample of African American students attending a predominantly African American post-secondary institution. Atkinson and colleagues (1986) found that even though African American students preferred a same-race therapist over a different-race therapist, they also preferred an older, more educated therapist with similar attitudes and personality over a therapist of the same race. Furthermore, the ranking



of preferences did not differ between participants who endorsed a strong Africentric orientation and those who endorsed a weak Africentric orientation. Ponterotto, Alexander, and Hinkston (1988) replicated and extended Atkinson et al.'s (1986) study by testing its generalization on a demographically different sample of African Americans. Ponterotto and colleagues (1988) demonstrated a high correlation between the rankings of therapist characteristics by their sample of African American students attending a predominantly Anglo-American post-secondary institution and Atkinson and colleagues' (1986) sample of African Americans attending a predominantly African American post-secondary institution.

Despite the overall similarity between the findings of these studies, there were two notable differences concerning the major variable of interest of both studies – ethnicity. First, therapist ethnicity was ranked second by Ponterotto et al.'s (1988) sample; this characteristic had been ranked fifth by Atkinson et al.'s (1986) sample. This differential ranking could not be attributed to differences in commitment to African American culture between the study samples because both samples endorsed similar levels of Africentric orientation. Second, Africentric orientation affected the ranking of an ethnically similar therapist within Ponterotto et al.'s (1988) sample. Respondents who endorsed a strong Africentric orientation ranked an ethnically similar counselor second, whereas respondents with a weak Africentric orientation ranked an ethnically similar counselor fifth. This preference for an ethnically similar therapist over an ethnically dissimilar therapist by strongly Africentric respondents is inconsistent with Atkinson et al.'s (1986) findings.

Ponterotto and colleagues (1988) explained these differential preferences as a function of environmental stimuli that accompanied the geographical setting of the respective samples. They argued that the availability of a same-race therapist might have been a non-issue for Atkinson et

al.'s (1986) sample because their experience at a predominantly African American institution may have created the expectation of psychological treatment by an African American mental health professional. Consequently, Atkinson et al.'s (1986) sample may not have perceived therapist race as a salient variable. However, the potential availability of African American mental health professionals may have served as a more salient cue for Ponterotto et al.'s sample who were attending a predominantly White institution -- especially for respondents with a strong Africentric orientation.

Nickerson et al. (1994) explored the relationship between African American students' mistrust of Whites, opinions about mental illness, and attitudes toward seeking professional psychological help from White mental health providers. Nickerson and colleagues (1994) found cultural mistrust to be a consistent and powerful predictor of attitudes toward seeking professional psychological help among people of African descent. More specifically, high cultural mistrust was a stronger and more reliable predictor of negative attitudes toward psychological treatment-seeking than gender or opinions about mental illness. Furthermore, high levels of cultural mistrust were associated with an expectation that services provided by White mental health providers would be less relevant, impactful, and gratifying. These results demonstrate that cultural mistrust might be an important consideration affecting psychological treatment-seeking decisions among people of African descent. In particular, the results suggest that people of African descent who are more mistrustful of Whites might have more negative attitudes regarding seeking therapy from a White therapist.

In light of these findings, cultural mistrust in the therapeutic relationships appears to be an important dynamic that warrants special attention in studies of minority clients' attitudes toward professional psychological services (Watkins & Terrell, 1988). Researchers and

clinicians alike have hypothesized that interracial dyads in the therapeutic context are influenced by the broader cultural milieu (Ridley, 1984; Whaley, 1998). For example, Whaley (2001a) found no significant differences in effect sizes for cultural mistrust between African Americans in studies of counseling and therapy and African and Americans in studies concerning other interracial situation. Therefore, cultural mistrust appears to influence attitudes and behaviours in the mental health context to the same extent as it influences other psychosocial domains (Maultsby, 1982; Ridley, 1984). In other words, this broad cultural phenomenon seems to pervade the everyday lives of people of African descent (Essed, 1991). Given that White mental health professionals will likely continue to constitute the majority of clinical staff in mental health centers (Whiteley, Mahaffey, & Greer, 1987), cultural mistrust might serve as a barrier for people of African descent seeking psychological services even before the first contact is made between the potential client and therapist. More specifically, cultural mistrust might foster negative attitudes among people of African descent about entering therapy with presumably White therapists (e.g., low perceived credibility, competence, etc.). Consequently, potential clients of African descent may be less willing to seek professional psychological help. Thus, it seems reasonable to speculate that cultural mistrust is an influential variable affecting prospective cross-cultural therapeutic relationships (Nickerson et al., 1994).

### Culture & Africentric Values

Culture can be conceptualized as those components of an ethnic or racial group's history, values, knowledge, and behavioural norms that become implicitly or explicitly meaningful in social interactions (Betancourt & Lopez, 1993). In other words, culture is lived experience interpreted through principles and assumptions that form a blueprint for understanding. The

existing literature exploring cultural differences suggest that, for people of African descent, these principles and assumptions have been derived from an African-centred (or Africentric) value system (e.g., Asante, 1998; Azibo, 1992; Kambon, 1998; Nobles, 1990). At the group-level, Africentric values (e.g., spirituality, communalism) are regarded as collective attributes that provide the conceptual foundations for living and understanding (Nobles, 1986). However, manifestations of such group-level patterns are evident among individual members to varying degrees. Accounting for Africentric values as a within-group variability factor adds an element of precision to Cramer's (1999) model of seeking professional psychological help, as it may have considerable implications for value-based behavioural norms that may include seeking professional psychological help.

### *Africentrism*

The intellectual and philosophical principles that serve as the foundation for the cultural image, life experiences, history and traditions of the African diaspora has been termed *Africentrism* (Grills & Longshore, 1996). This African-centred perspective proposes that African epistemologies, ideals, and values should be at the centre of any analyses involving people of African descent. It is these principles that have been cited as the appropriate basis on which to develop scientific criteria for authenticating the reality of (Hill, 1995) and informing the provision of mental health services for (Grills & Longshore, 1996) people of African descent.

The term Africentrism has been used to describe an Africentric worldview that encompasses the culture-based values of people of African descent throughout the world (Graham, 1999). Mbiti (1970) contended that traditional African ways of understanding the world and people continue to constitute a major part of the philosophical and value system throughout the African Diaspora, despite a longstanding history of oppression of people of

African descent in Western societies. Furthermore, Karenga (1988) argued that these are core beliefs, ideals, and assumptions that represent the values that people of African descent need to build and maintain their families, community and culture.

The Africentric worldview represents a fusion of traditional African philosophies and values and lessons learned from historical experiences of the African Diaspora (Constantine, Lewis, Conner, & Sanchez, 2000; Myers, 1993; Nobles, 1990). It is characterized by a holistic approach to the human condition that includes cosmological, ontological, and axiological perspectives on the origin and general structure of the universe, the existence of God, and the nature of value and value judgments, respectively. The principles and values that define the Africentric worldview paradigm emphasize: a) spirituality (i.e., the belief that the spiritual resides over the material, which can be expressed through worship, prayer, and other rituals that are symbolic and strengthen one's spiritual connection; b) affect sensitivity (i.e., the importance of sensitivity to the feelings and emotional needs of others that may be expressed and perceived by both verbal and nonverbal means); c) expressive communication (i.e., oral communication is ideal, and considered as important as written communication, as well as indirect ways of conveying thoughts and ideas such as art, speech, music, and body movements); d) harmony (i.e., the balance between physical, spiritual, emotional, and vocational elements of one's life fosters optimal functioning); e) time as a social phenomenon (i.e., in accordance with the belief that all things are fluid and that events are not discrete and unconnected, events are dictated by the will of the people not by the clock or calendar); f) communalism (i.e., the self is perceived as a part of a collective phenomenon in a way that encourages the importance of the group over the individual, cooperation rather than competition, and interpersonal and affiliative relationships over materialistic or production-oriented activities); g) multidimensional perception (i.e., a

preference for a variety of stimuli and methods of learning that simultaneously engage visual, auditory, tactile perceptions, and motor skills); and h) negativity to positivity (i.e., the ability to see the good in all situations and to create a positive situation from a negative one).

These core elements, while not exhaustive, mark the Africentric worldview as culturally distinct (Randolph & Banks, 1993). The beliefs, values, assumptions, and philosophical orientations from Africa, modified by contemporary experiences, have been transmitted to people of African descent today – including Canadians of African descent. Indeed, the Africentrism construct, as conceptualized by the principles and values noted above, has been reliably assessed in a heterogeneous sample of Black Canadians of varying generation status and ethnic origins (Joseph & Kuo, 2009). Given that identification with the Africentric worldview may shape the mental health-related attitudes of people of African descent, appreciating this worldview is essential to understanding the psychological treatment-seeking behaviour of Canadians of African descent (Asante, 1998; Azibo, 1992; Nobles, 1990).

#### *An Africentric Paradigm for Mental Health*

Kobi K. K. Kambon (1992; also known as Joseph A. Baldwin, 1976, 1981) employed the philosophical principles of ancient Africa as a foundation for the investigation, articulation, and operationalization of a model of mental health for people of African descent. The resultant ‘Africentric Model of Black Personality’ lies in stark contrast to the traditional, non-Africentric models of mental health that are characterized by conceptual frameworks developed from European-centred (or Eurocentric) worldview that emphasizes mastery over nature by promoting competition, individual rights, independence, materialism, external knowledge, dichotomous thinking, and achievement through intervention (Jackson & Sears, 1992; Kambon, 1998). Rather, Kambon’s model of African personality relies on the Africentric worldview as the conceptual

framework for understanding mental health, a belief system that promotes values, attitudes, and customs that encourage collective responsibility, cooperation, interdependence, spirituality, self-knowledge, diurnal thinking, and achievement through human and spiritual networks. This model highlights the value of positive-affirmative energy and proactive motivational tendencies, and emphasizes the affirmation of Africentric culture values as key to healthy psychological functioning among people of African descent (Kambon, 1998).

According to Kambon's (1992; Baldwin, 1976, 1981) model, the African personality is comprised of two core components called the African Self-Extension Orientation (ASEO) and African Self-Consciousness (ASC). The ASEO is a biogenetically determined unconscious trait that is operationally likened to spirituality (Kambon, 1998). This spirituality is a dynamic, relational energy that allows the self to achieve a collective and communal consciousness (Baldwin, Brown & Rackley, 1990). The ASC is a derivative of the ASEO in that it represents the conscious level of expression of the ASEO. The origins of the ASC are partly biogenetically determined because it is derived from the ASEO, but also partly environmental determined because consciousness develops partly through experience. Within the African personality system, the ASEO defines and energizes the African personality organization and the ASC directs the system toward the fulfillment and maintenance of African 'survival thrust' (Kambon, 1998). This notion of survival is grounded in the universal principle of 'organismic survival maintenance', which posits that all functionally normal organisms seek to secure, protect, maintain and advance their own survival (Baldwin, 1984, 1985; Kambon, 1998). Due to the communal nature of people of African descent, African survival thrust can be more specifically characterized as an intrinsic motivation to secure, protect, maintain and advance African "collective" survival (Kambon, 1998)

Given the immutable and inherently nurturing quality of the ASEO, Kambon (1998) linked mental health outcomes to the ASC's vulnerability to experiential influence. For instance, Kambon contended that healthy psychological functioning among people of African descent can be explained by early socialization experiences, and institutional and systemic processes that work to actively cultivate and reinforce the Africentric worldview. He argued that it is necessary for individuals of African descent to develop awareness and knowledge of their cultural identity and cultural heritage, and to recognize factors that affirm their cultural reality in order to maintain their psychological well-being (Baldwin 1981, 1984; Kambon, 1992). Furthermore, he encouraged people of African descent to resist Eurocentric values and institutions that threaten the development of ASC. Resistance to their Eurocentric social forces may include maintaining Africentric values (e.g., collectivism) and institutions (e.g., Black churches) rather than integrating into White-dominated institutions or embracing Eurocentric values (e.g., individualism; Pierre & Mahalik, 2005).

Baldwin (1981, 1984) also asserted that optimal functioning of the ASC engenders self-awareness and self-affirmative behaviours, which serve a protective function for the psychological well-being of people of African descent. He proposed four basic characteristics for fully operational ASC, including: awareness of African identity and cultural heritage, and pursuit of self-knowledge; prioritizing African survival through adherence to Africentric values and participation in Africentric institutions; active participation in the survival, liberation, and proactive development of people of African descent, and the defense of their worth, dignity, and integrity; and recognition and active resistance of oppressive forces that are detrimental the survival of people of African descent (Baldwin, 1981).



By contrast, Kambon (1992) argued that a sociocultural context characterized by pervasive cultural oppression and imposition of a Eurocentric worldview (or other worldviews that conflict with Africentrism) serves to weaken the ASC. Consequently, conscious-level Africentrism (i.e., ASC) becomes distorted by conscious-level Eurocentrism, creating intrapsychic conflict between the ASC and the unconscious-level Africentrism of the ASEO. Kambon (1998) referred to this latter set of psychological circumstances as an abnormal and unnatural relationship between the core components of the African personality system that constitutes “a case of basic African mental disorder” (p. 39), also known as African personality disorder. The African personality disorder is best described as a cultural misorientation. Cultural misorientation refers to Eurocentric self-consciousness among people of African descent that is sanctioned, nurtured, and reinforced by the social forces and institutional support systems of White dominated society. This Eurocentric self-consciousness among people of African descent supports the European survival thrust, and thus cannot foster the self-affirmative behaviours that are essential to maintaining the psychological well-being among people of African descent.

To date, only one empirical study has specifically addressed Kambon’s (1992, 1998; Baldwin, 1976, 1981, 1984) contention that ASC promotes psychological well-being among people of African descent. In a study investigating ASC and Black racial identity as predictor of psychological distress for a sample of African American men, Pierre and Mahalik (2005) hypothesized that increasing levels of ASC would predict less psychological distress. The results of this study partially supported Kambon’s notions about the psychological benefits of ASC for people of African descent. In support of Kambon’s encouragement of resistances against Eurocentric values and institutions, respondents had higher self-esteem and lower psychological distress when they endorsed attitudes in favour of opposition against threats toward the

development and survival of people of African descent (e.g., “It is not within the best interest of Blacks to depend on Whites for anything, no matter how religious and decent they purport to be”). Pierre and Mahalik (2005) proposed two explanations for this finding. First, they suggested that the respondents who had higher self-esteem and experienced less psychological distress might be better equipped to resist Eurocentric forces. Second, they suggested that the respondents who endorsed attitudes favouring the active resistance of Eurocentric values and institutions felt better about themselves and experienced less psychological distress, ostensibly because they were protecting themselves against harmful influences. This latter interpretation is consistent with Kambon’s understanding of how resistance to Eurocentric forces works to promote psychological well-being. However, it is possible that both explanations may account for the inverse relationship between ASC and psychological well-being.

#### *African Self-Consciousness and Behavioural Prediction*

Within Kambon’s (1992, 1998; Baldwin, 1981, 1984) theory, not only is there recognition of the role of ASC on the psychological functioning of people of African descent but there is also a clear implication for ASC on the behaviour of people of African descent. In particular, Kambon (1992) asserted that the “African survival thrust inherent in ASC represents the affirmation and self-determination of African life” (p. 54). Inferences can be made about specific behaviours that should be expressed by people individuals expressing varying levels of ASC. For instance, people with high ASC should exhibit a strong sense of African identity, resist Eurocentric influences, recognize the importance of collective survival and development of people of African descent, and respect and actively maintain African life (Thompson & Chambers, 2000).

In a study investigating the relationship between African self-consciousness and health-promoting behaviours among African American college students, Thompson and Chambers (2000) reasoned that if the ASC represents a basic African survival thrust, then higher levels of ASC should be associated with increased agency. They predicted that people of African descent with high ASC would take more preventative and proactive measures with their health (e.g., proper diet, regular exercise, avoid substance use) as compared to their lower ASC counterparts because they valued their continued existence as African descents. Furthermore, they hypothesized that this relationship would be mediated by the degree to which individuals focus on their health through states of attention to cognitive and affective cues, or health consciousness (Gould, 1990). Accordingly, individuals with low ASC and high health consciousness may engage in health-promoting behaviour for aesthetic reasons rather than for cultural reasons. Thus, individuals of African descent with high ASC and high health consciousness were expected to engage in more intense and consistent health promoting behaviours than counterparts who exhibited low ASC and high health consciousness.

Thompson and Chambers (2000) found that ASC and health consciousness independently contribute to health-promoting behaviour. Although no relationship was found between ASC and health consciousness, ASC was significantly correlated with health responsibility, interpersonal relations, and spiritual growth components of health-promoting behaviour. From a theoretical standpoint, these findings suggest that high ASC may promote both informal (e.g., assistance from friend, family member, or religious figure) and formal help-seeking behaviours (i.e., professional assistance). The endorsement of interpersonal relations and spiritual growth can be conceptualized as an expression of ASC, as indicated by the promotion of Africentric values (i.e., spirituality and collectivism) and institutions (i.e., church and extended kinship groups) that

affirm the cultural reality of people of African descent. The relationship between ASC and health responsibility, which involves being mindful and accepting responsibility for one's health through education and requests for professional services when necessary, may be a manifestation of African survival thrust (Kambon, 1992; Walker, Sechrist, & Pender, 1987).

Accordingly, people of African descent with high ASC may be intrinsically motivated to exercise agency and preserve their individual integrity so that they are able to maximally contribute to the goals of the collective (Thompson & Chambers, 2000). In so far as the maintenance of African survival thrust is central to this pursuit, both informal *and* professional help-seeking may be envisioned as self-affirmative behaviours that serve to maintain optimal psychological functioning. On the other hand, Africentric values that emphasize the maintenance of interpersonal harmony may promote self-concealment behaviours that are incompatible with seeking help from both informal *and* professional resources. That is, individuals of African descent may be reluctant to use either informal or professional resources due to concerns about burdening others with their problems. Thus, self-concealment appears to be consistent with the Africentric ideals that have been theoretically linked to psychological well-being. There are no empirical studies examining the role of ASC as a moderator of the relationship between self-concealment and psychological functioning among people of African descent. However, self-concealment has been linked to poor psychological health and adjustment in the general population (Cepeda-Benito & Short, 1998; Ichiyama, Colbert, Laramore, Heim, Carone, & Schmidt, 1993; Kelly & Achter, 1995; Kahn & Hessling, 2001; Kelly, 1998; King, Emmons, & Woodley, 1992; Larson & Chastain, 1990). Furthermore, self-concealment continues to predict psychological distress regardless of perceived social support (Kelly & Yip, 2006). Therefore, it stands to reason that even though self-concealment tendencies may inhibit help-seeking

behaviours, the deleterious consequences of self-concealment for psychological well-being may necessitate professional help-seeking for personal and emotional difficulties.

Kambon (1992; Baldwin, 1987; Baldwin & Bell, 1985) maintained that virtually all functionally significant behavioural patterns among people of African descent are at least partly influenced by ASC. As demonstrated by the above-noted studies, there are many important differences between the behaviours of people of African descent with high and low levels of ASC. Given these findings, it seems that ASC, or some aspect of it, may play a role as either an independent or moderator variable in the analyses of psychological help-seeking behaviour among people of African descent.

#### *Africentric Values and Mental Health Beliefs*

The underutilization of professional psychological services by people of African descent has often been attributed to the incompatibility between Eurocentric value system implicit in professional psychological treatment and the Africentric value orientation among prospective clients of African descent (Sue & Sue, 2002). Existing research suggests that the path to initiation of psychological treatment is influenced by family members' interpretations of the prospective client's symptoms (e.g., Rogler & Cortes, 1993). In particular, the cultural background and social class of the family has been associated with how the prospective client, family, and mental health professionals perceive the illness and formulate treatment plans (Boyd-Franklin & Shenouda, 1990; Neighbors, 1985; Rogler & Cortes, 1993). Nickerson and colleagues (1994) argued that it is both the unique history and culture, and generalized experiences that shape people of African descent's beliefs about mental illness. In particular, people of African descent tend to identify more closely to their ingroup members, which may

prompt them to view social issues from the perspective of their ingroup members even if the issues do not personally affect them (Hunt, 1996).

The extent to which oppressive social conditions have affected people of African descent within the mental health system (e.g., racism and discrimination in the diagnosis of schizophrenia; Whaley, 2004) may strongly affect the beliefs about mental illness. In a qualitative study, Guarnaccia and Parra (1996) compared the experiences of Hispanic-American, African-American, and European-American families' experiences of caring for a seriously mentally ill family member (i.e., predominantly diagnosed with schizophrenia) and how the family's cultural background influenced the recognition of symptoms, labeling of the illness, and response to the family member's behavior. The African American families were most likely to describe their family member's problem as one of difficulties with social interactions. They were also tended to report their family member's problem as stemming from medical causes and negative personality traits. Furthermore, the African American families expressed a strong expectation that their family member's mental illness would be cured. The African American families were more likely to disagree with the professional diagnosis of their family members' illness than the Hispanic-American and European-American families. These findings were attributed to greater mistrust of professionals (particularly White professionals) and strong beliefs in the healing power of God (Boyd-Franklin & Shenouda, 1990). Together, these findings suggest a tendency for people of African descent to favour alternative etiological models of mental illness and their associated remedies (e.g., prayer and willpower often prescribed by religion) and reject traditional etiological models of mental illness and their affiliated treatments (e.g., professional psychological treatment).

Thus, it appears that beliefs about the causes of mental illness in communities of African descent are incompatible with the disease model that is often promoted in the community mental health services field (Neighbors, 1990; Vega & Murphy, 1990). People of African descent are more likely to endorse spiritual causes of mental illness than either biological or environmental causes (Taylor & Chatters, 1991; Taylor, Chatters, Jayakody, & Levin, 1996). Furthermore, empirical studies have demonstrated that people of African descent choose to pray or consult with religious leaders for help with personal or emotional problems (Milstein, Guarnaccia, & Midlarsky; Taylor & Chatters, 1991). The importance of prayer and willpower in managing personal and emotional difficulties is emphasized in the teachings of Black religious leaders. Consequently, people of African descent may be more likely than their White counterparts to believe that mental disorders are caused by bad character or lack of will power (Hall & Tucker, 1985). Such attributions may serve a self-enhancing function for individuals of African descents, as suggested by qualitative reports that people of African descent “perceive their race as having less need for psychological help than Whites, that is, as being strong people who can cope with life problems” (Hall & Tucker, 1985, p. 908).

Schnittker, Freese, and Powell (2000) tested whether racial differences in etiological beliefs were linked to racial differences in attitudes toward seeking professional mental health treatment. The results partially supported the contention that racial differences in etiological beliefs influence racial differences in the endorsement of professional treatment. The results revealed mixed findings concerning racial differences in biological explanations for mental illness. The African American respondents were less likely to accept genetic reasons but equally as likely to endorse a chemical imbalance as an explanation for mental illness. Furthermore, the results indicated that there was no general tendency for the African American respondents to

endorse environmental explanations for personal and emotional problems more so than their White counterparts. Rather, racial differences were limited to a greater reluctance by the African American respondents to accept family upbringing as an explanation for mental illness. Schnittker and colleagues (2000) argued that the rejection of genetic and family upbringing explanations among their African American respondents might be a result of public debate regarding the social advancement of people of African descent based on the premise of supposed genetic and familial problems among people of African descent (e.g., inheritance of poor cognitive ability, faulty parenting in families of African descent). Consequently, the African American respondents may have reacted more negatively than their White counterparts when presented with genetics or family upbringing as potential causes for mental health problems, even when the explanations were not specifically directed to people of African descent. As predicted by previous theoretical and empirical literature, the African American respondents were indeed significantly more likely than their White counterparts to endorse the “God’s will” explanation for mental illness.

Schnittker and colleagues (2000) conducted regression analyses demonstrated that a stronger belief in genetics, chemical imbalance, or poor family upbringing as a cause of personal or emotional difficulties predicted strong endorsement of professional treatment for these problems. By contrast, a stronger belief that personal and emotional difficulties are a product of God’s will predicted weak endorsement of professional treatment for these problems. Supplementary regression analyses indicated that more than 40% of the racial difference in attitudes toward seeking professional psychological help might be explained by differences in the etiology of psychiatric disorders. These results are consistent with the rationale that people of African descent are less likely to use professional mental health services because they have



different beliefs about the causes of mental illness. These racial differences cannot be further accounted for by socioeconomic differences (i.e., education, income, marital status) or other confounding variables (i.e., geographical location).

Given that people of African descent are disproportionately exposed to environmental stimuli that may be considered sources of chronic and acute stress, people of African descent may be more attuned to the social origins of mental illness, (Outlaw, 1993; Sears, 1991; Thompson, 1996). People of African descent may be more dissatisfied with professional mental health services than their White counterparts because they do not believe enough credence is given to environmental conditions that contribute to the onset of psychiatric disorders (Neighbours, 1985). Furthermore, the salience of environmental explanations for emotional or personal problems among people of African descent might contribute to the perception that emotional or personal problems are primarily a consequence of hard times rather than illness (Sussman et al., 1987). Such beliefs may explain the tendency for people of African descent to consult their family and community members when seeking help for personal and emotional problems than their White counterparts (Schnittker et al., 2000).

#### *Formal and Informal Help-Seeking Behaviour Among People of African Descent*

Researchers have sought to understand African American psychological help-seeking behaviours in the context of supportive community-based processes (e.g., Neighbors & Jackson, 1984; Neighbors et al., 1998). Metaphysical approaches to coping based on religious and/or spiritual belief systems have been consistently noted in community samples of African Americans (Constantine, Lewis, Conner, & Sanchez, 2000; Dressler, 1991; Ellison, 1993; Jagers & Smith, 1996; Lukoff, Turner, & Lu, 1992). Research has suggested that African Americans, when compared to other racial and ethnic groups, often endorse religious coping activities

(Bourjolly, 1998; Jenkins, 1995; Koenig, 1998) when dealing with serious personal difficulties (e.g., Ellison & Taylor, 1996), illness (e.g., Ellison, 1993), and the loss of a family member (Thompson & Vardaman, 1997). For instance, African Americans have been found to prefer the avoidance of morbid thoughts and exertion of willpower over professional psychological treatment as the best ways to manage emotional difficulties (Hall & Tucker, 1985). This regard for spiritually-based coping strategies is likely derived from an Africentric worldview, which holds spirituality as a central feature (Myers, 1993). These spiritual values have provided communities of African descent with the tools to make effective responses without the risk of being exposed to oppressive forces within the established authority (Daly et al., 1995; Milstein, Guarnaccia, and Midlarsky, 1995). Thus, it appears that people of African descent have learned to rely on internal and external coping behaviors that offer an indigenous structure and means to deal with adversity (Pinderhughes, 1992).

A growing body of literature has demonstrated links between religious involvement and human service professions. Communities of African descent, in particular, have a long history of human services delivery in the context of religious institutions (Taylor, Ellison, Chatters, Levin, & Lincoln, 2000). Based on this tradition of faith-based initiatives in communities of African descent, the influence of the church in communities of African descent have become crucial for developing models of mental health service delivery. In particular, the role of the minister or pastor has been critical to understanding the delivery of mental health services to communities of African descent (Veroff, Douvan, & Kulka, 1981). Neighbors, Jackson, Bowman and Gurin (1983) found that ministers are frequent sources of help for African Americans facing personal problems. It has been argued that the clergy in Black religious institutions are an extremely accessible source of help by virtue of the fact that they are positioned within an organization that

is perceived as a source of comfort and support (Taylor & Chatters, 1986, 1988). This affiliation removes a major barrier for people of African descent considering professional mental health care – the stigma of being labeled as ‘crazy’ or mentally ill (Snowden, 2001). Regardless of attempts by professional mental health providers to make services more culturally relevant, people of African descent still perceive these formal environments as foreign and hostile places (Neighbors et al., 1998).

Clergy have traditionally played a role in the delivery of mental health services (Veroff, Douvan, & Kulka, 1981), however little is known about the types of services provided, the circumstances surrounding referrals to clinicians, and the factors associated with those referrals (Williams, 1994). Mollica, Streets, Boscarino, and Redlich (1986) found that Black clergy emphasized the use of theological beliefs (e.g., sin, guilt, forgiveness, penance, redemption, salvation) and religious practices (prayer, meditation, exorcism, confession, faith healing, quoting scripture, and church attendance) in counseling. In addition, Black clergy reported that they often sought out troubled individuals rather than waiting for self-referral. In addition to a role of family counselor, diagnostician, and therapist, Levin (1986) suggested that clergy also has the role of referral agent. However, Mollica et al. (1986) found that when that when Black clergy reported referral to mental health professionals, they were often referring to other clergy members for pastoral counseling. This finding is consistent with more recent studies suggesting limited contact between Black clergy and professional mental health services. For example, Neighbors and colleagues (1998) found that people who first sought help from clergy were less likely to contact other professionals, especially if their presenting difficulties involved death, illness, or emotional adjustment issues. Consequently, they speculated that either: a) individuals of African descent experiencing emotional distress receive exactly what they need from the

clergy member and, thus, feel no motivation to turn elsewhere, or b) folk remedies and indigenous therapies substantially reduce the perceived need to use professional mental health services. Neighbors and colleagues (1998) concluded that their analyses supported the latter interpretation. Thus, for people of African descent, seeking religious counsel for emotional and personal difficulties appears to forestall the pathway to seeking professional psychological services.

An emerging body of research has also pointed to the role of extended kinship networks (i.e., family, friends, church members, fictive kin, neighbours) in African American communities as sources of informal help (Billingsley, 1992; Chatters, Taylor, & Neighbors, 1989; Dilworth-Anderson, Burton, & Johnson, 1993; Dillworth-Anderson, Williams, & Cooper, 1999; Hatchett, Cochran, & Jackson, 1991; Taylor, Chatters, Tucker, & Lewis, 1990). Particularly when confronted with stressful situations, people of African descent have been noted to rely on family, community, and social support networks (Daly et al., 1995). These extended social networks provide a variety of support including instrumental and tangible aid, emotional supports, and sources of advice or information (Hatchett et al., 1991).

Furthermore informal support appears to play a prominent role in the maintenance of psychological well-being of individuals of African descent (Taylor, Chatters, Hardison, & Riley, 2001). For example, Hughes and Demo (1989) found that African Americans without supportive family and friends had lower self-esteem and personal efficacy. Dressler (1985) found that African Americans who perceive their kin to be unsupportive reported more depressive symptoms. Brown and Gary (1987) found that poor perceived social support from family and friends significantly increased psychological distress among African American women. On the other hand, satisfactory social support has been associated with better overall well-being

(Chatters, 2000), self esteem (Ellison, 1993; Miller, Moen, & Dempster-McClain, 1991), increased satisfaction with life (Levin, Chatters, & Taylor, 1995; Miller et al., 1991; Taylor, Chatters, Hardison, & Riley, 2001), and less depression (Ensel & Lin, 1991; Hong & Seltzer, 1995; Peirce, Frone, Russell, Cooper, & Mudar, 2000).

Informal support has also been linked to professional help-seeking behavior in the general population. For example, individuals with weaker social support networks are more likely to seek professional help (Birkel & Reppucci, 1983; Bosmajian & Mattson, 1980; Goodman et al., 1984; Linn & McGranahan, 1980). Researchers have argued that people with less social support tend to seek professional help more often because social support influences one's vulnerability to psychological distress, which predicts professional help-seeking behaviour for emotional problems (Cramer, 1999). Informal support impacts the help-seeking process by shaping how an individual evaluates and responds to distressing symptoms (Angermeyer, Matschinger, & Riedel-Heller, 2001; Pescosolido & Boyer, 1999; Rickwood & Braithwaite, 1994). Alternatively, the decision to seek professional help may be influenced by individuals' perception that they have a problem that they cannot manage individually or collectively with assistance of their social support network. In the absence of benefits incurred by a strong social support network, psychological distress may continue or intensify, which in turn increases the likelihood that professional psychological services will be sought (Powell & Kotschessa, 1995).

Few studies have investigated how people of African descent use informal and professional help in combination. Using data from the National Survey of Black Americans, Neighbors et al. (1983) found that informal social networks were used substantially more than formal sources of help for all socio-demographic groups of African American adults. Neighbors and Jackson (1984) reported that the majority of respondents used only informal help (41%) or

both informal and professional help (33%), while 9% of respondents sought only professional help and 16.3% did not receive any assistance for problems described as emotional in nature. The utilization of solely professional psychological services did not differ by gender; however, women were more likely than men to use both informal and professional psychological help. Older respondents were more likely than younger respondents to have sought either informal or professional assistance. Compared to problems involving physical ailments, interpersonal difficulties, death, and financial concerns, respondents with emotional problems were least likely to seek either informal or professional assistance. These findings suggest that people of African descent with emotional difficulties are reluctant to seek any help at all.

Snowden (1998) found that African Americans were less likely than their White counterparts to seek help from family, friends, or religious figures when troubled by mental health problems. This finding may be attributed to stigma concerning disclosures about emotional difficulties. However, the African American respondents were more likely than their White counterparts to disclose their mental health problems to informal helpers in conjunction with seeking help from professional mental health providers. These findings support the 'help-seeking facilitation' interpretation of informal helpers in communities of African descent, in the form of assistance with recognizing psychological distress or recommendations for professional intervention. In particular, the African American respondents who sought informal help (whether solely or in conjunction with professional support) were more likely than their White counterparts to report anxiety-related symptoms, consistent with the literature suggesting that disclosures of anxiety-related symptomatology are perceived as culturally acceptable.

Cultural differences lead to differential thoughts, feelings, and actions of individuals from different cultures (Markus & Kitayama, 1991). Accordingly, the extent that Africentric values

influence mental-health related beliefs will likely be reflected in the attitudes and willingness of people of Africa descent toward seeking professional psychological help for mental health problems (Millet, Sullivan, Schwebel, & Myers, 1996). In other words, culturally influenced explanatory models of mental illness influence attitudes toward professional psychological services, which in turn shape intentions to seek professional psychological services (Kleinman, 1980). Thus, how these views are associated with perceptions of psychological help-seeking behaviour warrant consideration when devising a model of professional treatment seeking for mental health problems that will better accommodate people of African descent.

#### *Africultural Coping Behaviour*

The impact of psychological distress on willingness to seek professional psychological help has been well documented (e.g., Cepeda-Benito & Short, 1998; Cramer, 1999; Vogel & Wei, 2005). In light of these findings, the coping construct has garnered considerable attention in the help-seeking literature, mainly due to its benefits to psychological well-being (Wong, 2002). Coping refers to “efforts, both action oriented and intra psychic, to manage (i.e., master, tolerate, reduce, minimize) environmental and internal demands and conflicts” (Lazarus & Launier, 1978, pg. 311) caused by external events (e.g., major life changes, minor discrete events, and ongoing life circumstances; Billings & Moos, 1981; Folkman, 1984; Folkman & Lazarus, 1980; McCrae, 1984).

Generally speaking, coping has been conceptualized as a multidimensional construct with at least two broad categories: problem-focused and emotion-focused coping. The problem-focused coping strategies resemble problem-solving tactics (Lazarus, 2000). These strategies involve efforts of an individual to obtain information and mobilize actions with the intention of changing the reality of the person-environment interaction (Lyon, 2000). Such strategies include

attempts to define the problem, contemplate alternative solutions, weigh the advantages and disadvantages of possible actions, implement actions to change what is changeable, and if necessary, learn new skills. These problem-focused actions may be directed at either the environment (e.g., planning, taking control of the situation) or the self (e.g., changing the meaning of an event, recognizing personal resources or strengths) (Lazarus, 2000). By contrast, the emotion-focused strategies are aimed at regulating one's emotional responses to stressful situations without changing the realities of the stressful situation. These strategies include distancing, avoiding, selective attention, blaming, minimizing, wishful thinking, venting emotions, seeking social support, exercising, and meditating. Unlike the problem-focused techniques, emotion-focused tactics do not alter the meaning of an event directly (Lyon, 2000).

Much of the coping research on people of African descent has focused on generalizing Eurocentric-based coping paradigms (e.g., problem-focused and emotion-focused coping) to the experiences of this specific population while overlooking culture-based coping resources at the disposal of this particular population (e.g., Plummer & Slane, 1996; Krieger & Sidney, 1996). While individuals of African descent may use the coping strategies outlined by general coping frameworks, these paradigms inadequately represent the breadth of coping strategies utilized by people of African descent (Utsey et al., 2000) -- particularly those that reflect the transmission of African belief systems and values (Daly et al., 1995). Africentric values may provide an indigenous structure and culture-specific means for minority group members to effectively maintain their psychological well-being (Daly et al., 1995). Furthermore, these culture-specific behaviours may reflect the perceived normative coping strategies (i.e., subjective norms) within communities of African descent, and are thus important factors to consider when exploring



willingness to seek professional psychology help among people of African descent (Ajzen, 1991).

Informed by Africentric theoretical frameworks and empirical literature, Utsey et al. (2000) documented various culture-specific coping behaviours utilized by people of African descent during stressful encounters, coined 'aficultural coping'. Aficultural coping can be defined as the extent to which individuals of African descent adopt coping behaviours specifically derived from African culture (Utsey et al., 2000). Utsey and colleagues (2000) conceptualized Aficultural coping behaviours as comprising of four primary dimensions: cognitive/emotional debriefing, spiritual-centred coping, collective coping, and ritual-centred coping. Spiritual-centred coping reflects the degree to which beliefs about God or a supernatural power are used to manage stressors (e.g., praying that things will work themselves out). Collective coping refers to a tendency to rely on family and social networks to manage stressful situations (e.g., resolution and comfort sought from others or a group). Cognitive/emotional debriefing refers to cognitive efforts to evaluate the risk and adversity associated with stressors in order to regulate emotional responding (e.g., hoping for things to get better). Ritual-centred coping represents African-based cultural practices that involve the performance of rituals such as lighting candles or burning incense, to deal with stressful situations (e.g., burning incense for strength or guidance in dealing with a problem). These coping strategies are shaped, at least in part, by cultural patterns and characteristics.

Indigenous coping resources are often utilized and exhausted before turning to professional mental health providers to cope with psychological distress (Constantine, Myers, Kindaichi, & Moore, 2004; Utsey et al., 2000). More specifically, culture-specific coping strategies tend first increase with mounting psychological distress and then decrease in response

to more severe psychological distress. Simultaneously, professional help for psychological reasons is increasingly sought with growing psychological distress. This pattern of help-seeking behavior can be accounted for by two explanations. First, individuals who can effectively use culture-specific coping resources may effectively prevent themselves from increasing levels of psychological distress. Second, culture-specific coping strategies may be abandoned as ineffective in the face of increasing psychological distress, which in turn increases one's motivation to seek professional assistance (Jorm, Griffiths, Christensen, Parslow, & Rogers, 2004).

Thus, the manner in which people of African descent approach and participate in mental health services appears to be determined more by social structures and community traditions than clinical and administrative decision-making. Such cultural resources represent a fund of knowledge that influences the personal and collective coping behaviours of people of African descent. These culture-specific strategies are presumably derived from historical and cultural experiences of communities in the African diaspora that have engendered rightful suspicion of social systems and reliance on social support networks and Black churches. Consequently, attempts to seek help from outside the extended kinship network and community could be perceived as a sign of weakness and a betrayal, thus decreasing willingness to seek professional psychological help in communities of African descent.

Indeed, people of African descent tend to be more reluctant to seek help from mental health professionals than their White counterparts (e.g., McMiller & Weisz, 1996; Snowden & Cheung, 1990; Takeuchi, Leaf, & Kuo, 1988; Takeuchi, Uehara, & Maramba, 1999). However, extenuating circumstances that burden these personal and collective resources present a real threat to well-being, which appears to be a compelling reason to seek professional psychological

help. For these reasons, the present study's inclusion of afri-cultural coping behaviours will likely add a valuable dimension to models of seeking professional psychological help by accounting for the impact of culture on coping with psychological distress, and ultimately willingness to seek professional psychological help.

### **CHAPTER III: Methodology**

This chapter summarizes the process of conducting the present study, which includes an overview of the recruitment and administration procedure, a description of the sample, a review of the instruments used, and an outline of the statistical analyses.

#### **Recruitment and Administration Procedure**

Self-identified Canadians of African descent were recruited for participation in the present study. Individuals who did not have Black African ancestry, were not currently living in Canada, and were younger than eighteen years of age were not eligible to participate. Two hundred potential participants were sought among psychology courses at the University of Windsor, Black student associations at the University of Windsor, Black Canadian associations (e.g., Caribbean Teacher's Federation, City of Windsor Race and Ethnic Cultural Relations Committee, Congress of Black Women, Canadian Alliance of Black Educators), and referrals (i.e., snowball technique). Prospective participants were invited in person, by phone, or electronic mail to participate in a research project that was described as a study exploring Black Canadians' attitudes toward psychotherapy. Interested respondents were advised of two available options for participation: completing a paper-and-pencil version of the questionnaire package in person or accessing the internet survey service PsychData.com to complete the questionnaires in an electronic format. Participants who were enrolled in a psychology course at the University of Windsor were eligible to receive one bonus mark toward one psychology course of their choice. As a token of appreciation for volunteering their time, all other participants were entered in a draw to win one of the five twenty-dollar gift certificates to Chapters Books, which were distributed when the recruitment for the study was completed.

Before the questionnaire package was administered, all participants were instructed to review an information letter and consent form (see Appendix A) outlining the terms under which the research was being conducted. Consent was obtained via the participant's authorization on the consent form or selecting a response option on the electronic form indicating agreement with the terms of the study. All participants were given the opportunity to obtain a copy of the information letter and consent form for their personal records; participants who completed the paper-pencil version of the questionnaire were supplied with a copy and participants who completed the electronic version were plainly instructed to print a copy or contact the investigator to have a copy forwarded to them. After the questionnaires were completed, arrangements were made for the participants to receive one bonus mark toward the psychology course of their choice or to be entered into the draw. As part of an informal debriefing process, participants were thanked for volunteering their time and encouraged to ask questions and offer their comments about the present study. This recruitment and administration procedure was approved by the University of Windsor research ethics board.

A total of 207 protocols were completed using this recruitment procedure. Fifty-six (27%) of these protocols were paper-and-pencil questionnaire packages completed in person (90% response rate)<sup>2</sup> and 151 (73%) of the protocols were completed using online administration (78% response rate)<sup>3</sup>. Of the 207 protocols completed, 14 protocols were deemed invalid because: the participant did not have Black African ancestry ( $N=3$ ), the participant completed a valid protocol twice ( $N=3$ ), and an administrative error ( $N= 8$ ). It has been recommended that an

---

<sup>2</sup> The completion rate for questionnaire packages completed in person is calculated by dividing the number of participants who completed at least 80% of the questionnaire package in person divided by the number of participants who arranged an appointment with the investigator to complete the questionnaire package in person (Council of American Survey Research Organizations [CASRO], 1982).

<sup>3</sup> The completion rate for the online administration is calculated by dividing the number of participants who completed at least 80 % of questionnaire package using the electronic format by the number of participants who started the questionnaire package using the electronic format (CASRO, 1982).

appropriate sample size for conducting path analysis should have a ratio of at least 10:1 to the number of observed variables in order to ensure precision for parameter estimates and confidence in fit indices (Mueller, 1997). The resultant sample size ( $N=193$ ) meets this criteria and is thus suitable for testing the hypothesized path models.

### Description of the Sample

The sample consisted of 193 participants (75.1 % females, 24.9 % males), ranging in age from 18 to 61 ( $M=21.0$ ,  $SD=6.889$ ). One hundred and forty-six (75.6 %) of the participants indicated that both their parents were of Black African descent and the remaining 47 (24.4 %) participants identified as biracial or multiracial individuals of African descent. Approximately half of the sample (49.2 %) was born in Canada while the remaining participants were born outside Canada (e.g., United States, Europe, Caribbean, Africa, Central America, Middle East). The participants' highest level of education varied widely: 0.5% partially completed high school, 26.4% completed high school or received the diploma equivalent, 4.7% partially completed a 2-year college program, 7.3% completed a 2-year college program, 46.7% had partially completed university, 6.2% completed a Bachelor's degree, 2.1% partially completed graduate or professional school, and 2.6 % completed graduate or professional school. Household income was determined by accessing Canadian census tract (CT) profiles (Statistics Canada, 2006) organized by postal code. The median household income for the census tracts encompassing the participants' permanent addresses was normally distributed, ranging from \$24,297 to \$110,329 (median=\$52,110,  $SD=21,105$ ). When reporting employment status, participants were instructed to endorse multiple responses if applicable. Approximately 9% of the sample was employed full-time, 28.0% were employed part-time, 10.9% were unemployed, 67.4% held student status, and

0.5 % indicated that they had alternative employment arrangements. In terms of marital status, 90.7% of the sample was single, 5.2% were married, 1% were widowed, 1.6% were either separated or divorced, and 1.6% were cohabiting. Generation status refers to whether the participant or the participants' parents were born in or outside Canada. Approximately 20% of the sample claimed 1<sup>st</sup> generation status (born outside of Canada and immigrated to Canada after the age of 12), 15% identified themselves as 1.5 generation (born outside of Canada and immigrated to Canada before the age of 12), 36.8% declared 2<sup>nd</sup> generation status (born in Canada and have at least one parent who was born outside of Canada), 3.1% declared 3<sup>rd</sup> generation status (born in Canada and have at least one parent who was born in Canada), 3.1% claimed that they were beyond 3<sup>rd</sup> generation (born in Canada and have at least one grandparent who was born in Canada), and 17.6% stated that they were international students. With regards to citizenship, 72.0% of the sample held Canadian citizenship, 8.8% held landed immigrant status, 17.1% held student visas, and 0.5% held visitor's visas. Sixty-three (32.6%) of the participants had received professional (i.e., counselor, therapist, psychologist, or psychiatrist) mental health services for a personal or emotional reason and 130 (67.4%) had never sought professional psychological help. Table 1 summarizes these demographic characteristics.

Table 1

*Demographic Characteristics (N = 193)*

	<i>N</i>	<i>%</i>
Gender		
Men	48	24.9
Women	145	75.1
Racial Background		
Black/African	146	75.6
Biracial/Multiracial	47	24.4
Age ( <i>Mean</i> = 21.0, <i>SD</i> = 6.889)		
18-24	144	74.6
25-34	33	17.1
35-44	11	5.7
45-54	3	1.6
55-64	1	0.5
65+	0	0.0
Missing	1	0.5
Place of Birth		
Canada	95	49.2
United States	1	0.5
Europe	7	3.6
Caribbean	14	7.3
Africa	69	35.8
Other	3	1.6
Missing	4	2.1
Highest Level of Education		
Partially Completed High School	1	0.5
Completed High School or GED	51	26.4
Partially Completed 2 year College Program	9	4.7
Completed 2 year College Program	14	7.3
Partially Completed University Degree	96	46.7
Completed Bachelor's Degree	12	6.2
Partially Completed Graduate or Professional School	4	2.1
Completed Graduate or Professional School	5	2.6
Missing	1	0.5
Household Income ( <i>Median</i> =\$52,110, <i>SD</i> =\$21,105)		
Below \$19,999	0	0.0
\$20,000+ - \$39,999	31	16.1
\$40,000+ - \$59,999	84	43.5
\$60,000+ - \$79,999	31	16.1
Above \$80,000	35	18.1
Missing	12	6.2



Table 1 Continued

*Demographic Characteristics (N = 193)*

	<i>N</i>	<i>%</i>
<b>Employment Status<sup>4</sup></b>		
Full Time	18	9.3
Part Time	54	28.0
Unemployed	21	10.9
Student	130	67.4
Other	1	0.5
Missing	0	0.0
<b>Marital Status</b>		
Single	175	90.7
Married	10	5.2
Widowed	2	1.0
Separated/Divorced	3	1.6
Cohabiting	3	1.6
Missing	0	0.0
<b>Generation Status</b>		
1 <sup>st</sup> Generation	38	19.7
1.5 Generation	29	15.0
2 <sup>nd</sup> Generation	71	36.8
3 <sup>rd</sup> Generation	6	3.1
Beyond 3 <sup>rd</sup> Generation or Later	15	7.8
International Student	34	17.6
Missing	0	0.0
<b>Immigration Status</b>		
Canadian Citizen	139	72.0
Landed Immigrant	17	8.8
Student Visa	33	17.1
Visitor's Visa	1	0.5
Missing	3	1.6
<b>Previous Psychological Services</b>		
Yes	63	32.6
No	130	67.4

<sup>4</sup> Respondents were instructed to endorse all employment descriptors that applied to them (e.g., student and part-time employment). Consequently, the cumulative frequency (*N*) does not sum to 193 and the cumulative frequency (%) does not sum to 100.

### Instrumentation

Each participant was administered a questionnaire package (see Appendix B) consisting of: (a) the Self-Concealment Scale (SCS; Larson & Chastain, 1990); b) the Attitudes Toward Seeking Professional Psychological Help Scale – Short Form (ATSPPH-S; Fischer & Farina, 1995); (c) the Africentrism Scale (AS; Grills & Longshore, 1996); (d) the Cultural Mistrust Inventory (CMI; Terrell & Terrell, 1981); (e) the Integrated Coping Measure (Amirkhan, 1990; Utsey et al., 2000); (f) the Brief Symptom Inventory 18 (BSI-18; Derogatis, 2000); (g) the Intentions to Seek Counseling Inventory – Cultural Revision (adapted from the ISCI; Cash, Begley, McCown, & Weise, 1975), (h) the Social Provisions Scale (SPS; Cutrona & Russell, 1987), and (i) a demographic questionnaire. The demographic characteristics of the sample in the present study have been presented in Table 1. The psychometric properties of the remaining instruments are presented in Table 2.

#### *Self-Concealment Scale (SCS)*

The Self-Concealment Scale (SCS; Larson & Chastain, 1990) is a 10-item measure that assesses the predisposition to actively conceal personal information from others. The SCS was developed using a sample of 306 human service workers (e.g., nurses, physical therapists, social workers, and clergy), conference attendees, and counselling psychology graduate students. There was no evidence of recruitment group differences in the total sample. Although the sample was primarily female (90%), there was no evidence of sex differences in the total sample. Ten scale items were generated to reflect: a tendency to keep things to oneself, possession of personally distressing or negative information that has been shared with few others, and apprehension about revealing private information. The items administered to the development sample demonstrated

favourable psychometric properties and constitute the final version of the SCS utilized in the present study.

The SCS (Larson & Chastain, 1990) instructs respondents to rate their level of endorsement of positively worded items (e.g., “I have a secret that is so private I would lie if anybody asked me about it”) using a 5-point Likert scale (1 = Strongly Disagree, 2 = Disagree, 3 = Neutral, 4 = Agree, 5 = Strongly Agree). The SCS yields a total score (ranging from 10 to 50) by summing the responses to each item. Higher scores on the SCS indicate greater self-concealment. Using a sample of human service professional and trainees, Larson and Chastain (1990) reported good internal consistency reliability ( $\alpha = .83$ ) for the SCS. The authors also reported test-retest reliability over four weeks and inter-item reliability as  $r = .81$  and  $r = .83$ , respectively. Discriminant validity was evidenced by a significant negative correlation with self-disclosure scores ( $r = -.27$ ). Predictive validity of the SCS was supported by a significantly improved prediction of anxiety ( $R^2$  Increment = .052,  $p < .001$ ) and depression scores ( $R^2$  Increment = .074,  $p < .001$ ).

Cramer and Barry (1999) further evaluated the psychometric properties of the SCS among a university student samples. The results of the study provided additional support for the internal consistency reliability ( $\alpha = .83 - .87$ ) and test-retest reliability ( $r = .74$ ). Other studies that have used the Self-Concealment Scale among various university student samples report similar psychometric properties (e.g., Cepeda-Benito & Short, 1998; Cramer & Lake, 1998; Ichiyama et al., 1993; Kelly & Achter, 1995; King, Emmons, & Woodley, 1992; Wallace & Constantine, 2005; Ritz & Dahme, 1996). In particular, Wallace and Constantine’s (2005) reported good internal consistency reliability ( $\alpha = .85$ ) among a sample of African American college students. No studies to this author’s knowledge have evaluated the psychometric

properties of the SCS among a community sample of African descent. In the present study, which features a mixed community and student sample, the internal consistency reliability was good ( $\alpha = .87$ ).

*Attitudes Toward Seeking Professional Psychological Help scale – Short Form (ATSPPH-S)*

Attitudes toward seeking professional psychological help were measured using the Attitudes Toward Seeking Professional Psychological Help – Short Form (ATSPPH-S; Fischer & Farina, 1995). The ATSPPH-S is a 10-item self-report measure that assesses an overall belief in the value of psychotherapy for assistance with personal and emotional problems and receptivity to the notion of seeking psychotherapy for assistance with personal or emotional problems. Respondents are instructed to rate their agreement to positively worded items (e.g., “If I were experiencing a serious emotional crisis at this point in my life, I would be confident that I could find relief in psychotherapy”) and negatively worded items (e.g., “There is something admirable in the attitude of a person who is willing to cope with his or her conflicts and fears *without* resorting to professional help”) using a 4-point Likert scale (0 = Disagree, 1 = Partly disagree, 2 = Partly agree, 3 = Agree). The ATSPPH-S yields a total score (ranging from 0 to 30) that is obtained by summing the positively keyed responses and negatively keyed responses for each positively and negatively worded item, respectively. Higher scores on the ATSPPH-S indicate more favourable attitudes toward seeking professional psychological help.

The ATSPPH-S was derived from the original, 29-item ATSPPH (Fischer & Turner, 1970). The items on the ATSPPH were developed by a panel of mental health professionals, refined through various phases in the test construction, and validated using 960 male and female participants from a variety of educational settings in three separate samples. Internal consistency and test-retest reliability (ranging from 5 days to 2 months) for the 29-item measure ranged from

$\alpha = .83$  to  $.86$  and  $r = .73$  to  $.89$ , respectively. Results of a factor-analysis revealed a four-factor solution, as follows: Recognition for Personal Need for Professional Psychological Help (Need), Tolerance of Stigma Associated with Psychiatric Help (Stigma), Interpersonal Openness Regarding One's Problems (Openness), and Confidence in the Mental Health Profession (Confidence). However, the subscales yielded poor to moderate internal consistency ( $\alpha = .62$  to  $.74$ ). Accordingly, Fischer and Turner (1970) cautioned against the independent interpretation of the subscale scores.

Consequently, Fischer and Farina (1995) devised a shortened version of the ATSPPH (i.e., ATSPPH-S) intended to produce a single score to measure attitudes toward seeking professional psychological help. The ATSPPH-S was created by selecting 14 items from the original ATSPPHS with the highest item-to-total score correlation coefficient. The results of a factor analyses yielded a two-factor solution. The 10 items that loaded on Factor 1 sufficiently described the help-seeking construct and demonstrated good internal consistency ( $\alpha = .84$ ) and test-retest reliability after 1 month ( $r = .80$ ). The four remaining items, which loaded on Factor 2, formed an interpersonal openness subscale; these four items were dropped due to low internal consistency ( $\alpha = .64$ ). Fischer and Farina (1995) reported evidence of convergent validity, as indicated by the correlation between the 10-item ATSPPH-S and the original 29-item measure ( $r = .87$ ).

Few studies utilizing the ATSPPH-S among samples of African descent have further commented on the psychometric properties of this measure. However, there are a few notable exceptions. For example, Wallace and Constantine (2005) report good internal consistency reliability ( $\alpha = .83$ ) for the ATSPPH-S among samples of African American university students. Furthermore, inferences about the likely performance of the ATSPPH-S among the sample of

African descent can be drawn from reports of the ATSPPH-S's performance among other communally-oriented minority groups (e.g., Asian, Latino). Members of largely communal cultural groups tend to prefer informal to formal support in understanding and addressing their problems and concerns. Because this common cultural value (i.e., communalism) may interact with the ATSPPH-S in a similar manner, it stands to reason that psychometric support for the use of the ATSPPH-S among communally-oriented samples of non-African descent may translate to samples of African descent. For example, Moore and Constantine (2005) reported good internal consistency reliability ( $\alpha = .81$ ) in a study of collectivistic coping among a sample of international students from Africa, Asia, and Latin America. Constantine (2002b) also reported good internal consistency reliability ( $\alpha = .83$ ) among a sample of university students who identified as either African American, Asian American, Latino(a) American, American Indian, or biracial American. Other studies of attitudes toward seeking professional psychological help using non-integrated samples of minority group members provide psychometric support for the use of the ATSPPH-S among these minority populations (e.g. Kim & Omizo, 2003; Miville & Constantine, 2006; Zhang & Dixon, 2003). In the present study, the internal consistency reliability of the ATSPPH-S was good ( $\alpha = .81$ ).

#### *Africentrism Scale (AS)*

The Africentrism Scale (AS; Grills & Longshore, 1996) is a 15-item self-report measure that assesses the extent to which respondents endorse the Africentric worldview, based on the seven principles of the *Nguzo Saba* that represent African values for daily healthy living (Karenga, 1988). These principles include: unity (to strive for and maintain unity in the family, community, nation and race); self-determination (to define ourselves, name ourselves, create for ourselves and speak for ourselves); collective work and responsibility (to build and maintain our

community together and to make our brother's and sister's problems, our problems and to solve them together); cooperative economics (to build and maintain our own stores, shops and other businesses and to profit from them); purpose (to collectively work toward building and developing of our community in order to restore our people to their traditional greatness); creativity (to do always as much as we can, in the way that we can, in order to leave our community more beautiful than when we inherited it); and faith (to believe with all our hearts in our parents, our teachers, our leaders, our people and the righteousness and victory of our struggle). Respondents are asked to respond to positively worded items that are consistent with Africentrism (e.g., “Black people should make are community better than it was when they found it”) and negatively worded items that were inconsistent with Africentrism (e.g., “The problems of other Black people are their problems, not mine”) using a 4-point Likert scale (1 = Strongly disagree, 2 = Disagree, 3 = Agree, 4 = Strongly agree). The AS yields a total score that is obtained by summing the scale-coded responses and reverse-coded responses for each positively and negatively worded item, respectively. Higher scores on the AS reflect a stronger adherence to an Africentric values.

In the development of the AS, Grills and Longshore (1996) conducted a series of four studies to determine the psychometric properties of three versions of this measure. Based on the results of these studies, the authors recommended the use of the final, 15-item version of the AS (i.e., Form C) for future studies. Grills and Longshore (1996) reported that the internal consistency of  $\alpha = .79$  for this 15-item AS. In a demonstration of known-groups validity, Grills and Longshore (1996) found that African American participants scored significantly higher on the AS than their White counterparts, and African American participants who were members of a community group devoted to the study of African American history and culture scored higher on

the AS than African American participants who were not members of this group. The construct validity of the AS was evaluated by examining the convergent validity between the AS and the Multigroup Ethnic Identity Measure (MEIM; Phinney, 1992), a measure which assesses several dimensions of racial identity. African American respondents who scored higher on the AS also scored higher on the ethnic identity achievement ( $r=.53$ ,  $p<.001$ ), ethnic behaviour ( $r=.56$ ,  $p=.001$ ), and affirmation ( $r=.59$ ,  $p<.001$ ) subscales of the MEIM, thus indicating moderate convergent validity. The construct validity was also examined using factor analysis. Grills and Longshore (1996) concluded that a one-factor solution was the most meaningful way to account for the Africentrism construct. Cokley and Williams (2005) addressed the limitations of the factor analysis (e.g., marked nonrepresentative sampling, small sample size, unclear statistical logic in making decisions) conducted by Grills and Longshore (1996) and similarly concluded that the AS is best conceptualized as measuring a global, unitary construct of Africentrism than measuring orthogonal dimensions that yield subscale scores.

In a cross-validation study, Kwate (2003) demonstrated that Africentrism is inversely related ( $r=-.48$ ,  $p=.0001$ ) to cultural misorientation. Cultural misorientation refers to various manifestations of African-centered psychopathology caused by institutionalized imposition of Eurocentric worldviews among people of African descent) as measured by the Cultural Misorientation Scale (CMS; Kambon, 1997). Africentrism scores were significantly higher among older respondents, respondents with higher educational levels, and respondents who identified as African or African American (Kwate, 2003). Kwate (2003) also examined the psychometric properties of the AS among a diverse sample of African descent who identified as African, African American, and Caribbean/West Indian. Kwate (2003) reported that the AS demonstrated good internal consistency for the overall sample ( $\alpha=.81$ ), and maintained adequate



to good overall internal consistency reliability for the individual ethnic groups (i.e., Africans,  $\alpha=.71$ ; Caribbeans,  $\alpha=.83$ ; African Americans,  $\alpha=.81$ ); the Cronbach alphas for the measure were not significantly different. In the present study, the AS demonstrated adequate internal consistency reliability ( $\alpha = .74$ ) for the overall sample; the internal consistency reliability for individual ethnic groups was not calculated because the data was not available.

### *Cultural Mistrust Inventory (CMI)*

The Cultural Mistrust Inventory (CMI; Terrell & Terrell, 1981) is an instrument that measures lack of trust for White society among people of African descent. The concept of cultural mistrust is based on the assumptions that people of African descent have developed and maintained a healthy suspicion of White people and White-related organizations in order to protect themselves from racial discrimination and persecution (Grier & Cobbs, 1968). Terrell and Terrell (1981) posited that cultural mistrust was apparent in everyday facets of life, particularly education and training, business and work, interpersonal relations, and politics and law. Accordingly, the CMI is composed of four subscales that represent these four domains. The authors generated a pool of items that reflected suspicions of White society in the context of these domains. These items were independently reviewed by four Black psychologists with regard to its clarity and suitability for each domain, resulting in an initial pool of 81 items. The validation sample consisted of 172 African American males completing the first and second years of post-secondary education. Items frequently endorsed by the majority of the participants were eliminated through item-discrimination analysis, resulting in the elimination of 9 items. The remaining items were tested for contamination by socially desirable responding; twenty-three items were eliminated because they correlated significantly with scores of social desirability. The outstanding items were tested for convergent validity with the Racial Discrimination Index (RDI;

Terrell & Miller, 1980), which assesses the frequency and severity of experiences of racial discrimination within the past year; one item correlated more with the RDI than the CMI and was thus eliminated.

The final, 48-item version of the CMI is utilized in the present study. Respondents are instructed to respond items that are consistent with the cultural mistrust construct (i.e., “Blacks should be suspicious of advice given by White politicians”) and items that are inconsistent with cultural mistrust construct (i.e., “Whites are usually fair to all people regardless of race”) using a 7-point Likert scale (1 = Strongly Disagree, 2 = Disagree, 3 = Slightly Disagree, 4 = Neither Agree Nor Disagree, 5 = Slightly Agree, 6 = Agree, 7 = Strongly Agree). Total scores (ranging from 1 to 7) are obtained by calculating the average item response (i.e., summing the ratings across the 48 positively and negatively keyed items, and dividing by the number of items). Higher scores on the CMI indicate a tendency to mistrust Whites. Terrell and Terrell (1981) reported that the CMI demonstrated adequate item-total correlations (ranging from  $r = .34$  to  $.47$ ) and good test-retest reliability within a two-week period ( $r = .86$ ). The authors also reported that the CMI demonstrated good concurrent validity with the RDI, whereby respondents reporting frequent experiences of racial discrimination obtained significantly higher scores on the CMI as compared to respondents who reported less frequent experiences of racial discrimination. The subscale intercorrelations ranged from  $.11$  to  $.23$ , however no psychometric data was reported for the individual subscales.

Terrell and Terrell (1981) did not report internal consistency estimates for the four subscales, however Thompson et al. (1994) reported the internal consistency estimates for two subscales utilized in their study, Interpersonal Relations ( $\alpha = .54$ ) and Education and Training ( $\alpha = .54$ ). There is a trend in the cultural mistrust literature to use the scores from these two subscales

instead of the total score (e.g., Gilbert, 1997; Grant-Thompson & Atkinson, 1997; Poston et al., 1991; Thompson et al., 1990; Thompson et al., 1994) because these are the only two subscales that were significantly intercorrelated in Terrell and Terrell's (1981) original sample. However, Whaley (2002) argued that this may be an artifact of using a university population, based on an earlier study (Whaley, 1998) in which the Interpersonal Relations subscale demonstrated the poorest internal consistency reliability of the CMI subscales among African American psychiatric patients. There has also been some concern about the generalizability of the CMI as a measure of cultural mistrust in community and female samples. Whaley (2001a) found that the effect sizes for the CMI were not significantly larger in studies using university or exclusively male samples. This finding suggests that the initial development of the CMI using a sample of African American, male university students does not limit the applicability of the measure to more diverse populations of African descent. Thus, the CMI is likely a reliable and valid measure for people of African descent, in general.

Although Terrell and Terrell (1981) did not provide internal consistency estimates for the CMI but subsequent studies have provided additional support for the validity of the CMI. For instance, Nickerson et al. (1994) and Bell and Tracey (2006) reported that the full scale CMI demonstrated good internal consistency,  $\alpha = .89$  and  $\alpha = .95$  respectively. In the present study, the CMI demonstrated good internal consistency ( $\alpha = .93$ ).

#### *Integrated Coping Measure (ICM)*

For the purposes of the present study, subscales from the Coping Strategy Indicator (CSI; Amirkhan, 1990) and the Africultural Coping Systems Inventory (ACSI; Utsey et al., 2000) were combined to create one measure that reflects the mainstream and culture-specific repertoire of coping strategies used by people of African descent. The original CSI was composed of three

subscales (i.e., Problem Solving, Avoidance, and Social Support) and the original ACSI was composed of four subscales (i.e., Cognitive/Emotional Debriefing, Spiritual-Centred Coping, Collective Coping, and Ritual-Centred Coping). However, due to overlapping item content between the CSI's Social Support subscale and the ACSI's Collective Coping subscale, and the CSI's narrow operationalization of the emotion-focused coping construct (i.e., Avoidance), the CSI's Avoidance and Social Support subscale were deemed unnecessary for the purposes of the present study. Thus, the following subscales were retained for the ICM: Problem Solving (CSI), Cognitive/Emotional Debriefing (ACSI), Spiritual-Centred Coping (ACSI), Collective Coping (ACSI), and Ritual-Centred Coping (ACSI). The items comprising the Problem Solving and Cognitive/Emotional Debriefing subscales were considered to adequately represent the strategies outlined in the conventional coping paradigms (i.e., problem-focused coping and emotion-focused coping, respectively), while the items comprising the Spiritual-Centred, Collective, and Ritual-Centred Coping subscales were considered to adequately represent the strategies outlined in the aficultural coping paradigm. Total scores for the integrated coping measure were calculated by converting the raw scores for each subscales to z-scores, and then summing the z-scores for each subscale; higher total scores indicated for frequent use of conventional and aficultural coping strategies.

Descriptions of the CSI, the ACSI, and their psychometric properties are as follows:

The CSI is a 33-item measure of coping strategies used by individuals in dealing with stressful situations. It is conceptualized as a situation-specific instrument that assesses individuals' preferences for coping strategies regarding a specific stressful episode. An exhaustive list of coping items was collected from existing coping measures, previous research, and recommendations from students and colleagues of the test developer (Amirkhan, 1990). The

items were then reduced in a series of factor analyses with independent samples, as suggested by Schwarzer and Schwarzer (1996). The resultant CSI revealed three coping dimensions: Problem-Solving (11 items), Seeking Social Support (11 items), and Avoidance (11 items). These coping dimensions mirror the approach and avoidance strategies mentioned frequently in the coping literature, and more specifically, the problem-focused and emotion-focused strategies proposed by Lazarus and Folkman (1980). The Problem-Solving subscale assesses the use of instrumental strategies involving manipulation of stressors instead of merely being aware of the stressor; the Seeking Social Support subscale reflects attempts to seek human contact for reasons apart from instrumental or palliative aid; and the Avoidance subscale evaluates emotion-focused responses involving efforts to withdraw oneself from the stressor.

For the purposes of the present study, the administration instructions were modified. The standard administration of the CSI instructs participants to select a problem that occurred within the last six months that caused them to worry. In the present study, each participant was presented with a scenario that described a serious emotional crisis (e.g., the death of one's mother and ensuing depressive symptomatology) in order to elicit a full range of potential coping responses. Participants were instructed to indicate the extent to which they would use the coping strategies to deal with the vignette using a 3-point Likert type scale (1 = not at all, 2 = a little, 3 = a lot), as indicated by the standard administration procedure. Scores for each subscale (ranging from 3 to 33) were calculated by summing the values of the corresponding items, with higher scores on any given subscale indicating a tendency to utilize the associated type of coping strategy. Amirkhan (1990) reported good internal consistency reliabilities of the CSI subscales with a Cronbach's  $\alpha$  of: .89 for Problem-Solving, .84 for Avoidance, and .93 for Seeking Social Support. An analysis of test-retest reliability conducted on a student sample and community

sample over a 4 to 8 week period were found to be adequate: .83 and .77 for the Problem-Solving subscale, .80 and .86 for Seeking Social Support, and .82 and .79 for Avoidance, respectively.

Among the various available coping instruments, the CSI was selected for the present study for three important reasons. First and foremost, the CSI is grounded in theoretical framework posited by Lazarus and Folkman, sharing many items with the Ways of Coping Questionnaire (WCQ; Folkman & Lazarus, 1988). The CSI was been developed and validated based on a large, heterogeneous sample and has, thus, been extended for use with culturally diverse populations (e.g., Utsey et al., 2000). Second, when compared to other coping measures, the CSI has been reported to be relatively resistant to the influence of demographic variables (e.g., age, gender, and socioeconomic status), recall problems, and social desirability biases. Lastly, in comparison to other available coping measures, the CSI offers improved orthogonality of coping strategy subscales, indicating that the coping dimensions of the CSI are relatively independent of each other (Amirkhan, 1990). This is an important feature considering the value of capturing distinct coping strategies.

In the present study, only the Problem Solving subscale of the CSI was included in the Integrated Coping Measure. Joseph and Kuo (2009) reported good internal consistency reliability ( $\alpha = .87$ ) for the Problem Solving subscale among a sample of Canadians of African descent. The Problem Solving subscale also demonstrated good internal consistency reliability ( $\alpha = .85$ ) in the present study.

The ACSI is a 30-item self-report instrument that measures the use of afri-cultural coping strategies; that is, culture-specific coping behaviours employed by people of African descent in everyday stressful situations. Utsey and colleagues (2000) utilized Azibo's (1996) theory-derived steady-state approach to develop this instrument. This approach involves utilizing constructs

derived from Africentric psychological theory, assessing those constructs with reliable and valid instruments, and gathering data in order to evaluate hypotheses. The ACSI is also a situation-specific measure; respondents are first asked to identify a stressful situation they experienced and respond to the items on the ACSI using a 4-point Likert-type scale (0=does not apply or did not use, 1=used a little, 2=used a lot, 3=used a great deal). The items describe various coping strategies that represent four coping dimensions: Cognitive/Emotional Debriefing (11 items), Spiritual-Centred Coping (8 items), Collective Coping (8 items), and Ritual-Centred Coping (3 items). The Cognitive/Emotional Debriefing subscale measures adaptive reactions to environmental stressors that have evolved out of centuries of racial oppression. The Spiritual-Centred Coping subscale measures coping behaviours that are utilized to maintain a sense of harmony with the universe. The Collective Coping subscale evaluates the respondents' attempts to seek resolution and comfort from others or a group. The last subscale, Ritual-Centred Coping, determines the extent to which individuals of African descent perform African-based cultural practices (e.g., lighting candles or burning incense) to deal with stressful situations (Utsey et al., 2004).

Utsey et al. (2000) reported adequate internal consistency reliability (Cronbach's  $\alpha$ ) for the four ACSI subscales: .80 for Cognitive/Emotional Debriefing, .79 for Spiritual-Centred Coping, .71 for Collective Coping, and .75 for Ritual-Centred Coping. Similarly, Lewis-Coles and Constantine (2006) reported satisfactory internal consistency reliability (i.e., Cronbach's  $\alpha$ ) ranging from .74 to .84. Findings in support of concurrent validity indicated that the ACSI scores were positively and significantly correlated to scores on the Ways of Coping Questionnaire (Folkman & Lazarus, 1988). Exploratory and confirmatory factor analyses revealed that a four-factor oblique model delivered the best fitting representation of coping dimensions for the ACSI.

With regard to the convergent validity, the subscales of the ACSI were positively and significantly correlated with the Religious Problem Solving Scale – Short Form (Pargament et al., 1988), and the Spirituality Scale (Jagers & Smith, 1996).

Utsey and colleagues (2004) examined the structural invariance of scores on the ACSI across three separate samples of African descent – African American (parents of African ancestry born in the United States), African Caribbean (parents of African ancestry born in the Caribbean), and continental African (born in Africa). The results of confirmatory factor analyses revealed the underlying factor structure of the ACSI varied across the three samples, suggesting that the ACSI retains limited utility beyond African American populations. However, a number of methodological limitations (e.g., small sample size inappropriate for CFA) might have contributed to this finding of structural invariance.

Furthermore, the ACSI has demonstrated good psychometric properties among samples of African descent outside of the United States. For example, Joseph and Kuo (2009) reported good internal consistency among Canadians of African descent (Cognitive/Emotional Debriefing,  $\alpha = .90$ ; Spiritual-Centred Coping,  $\alpha = .90$ ; Collective Coping,  $\alpha = .87$ ; Ritual-Centred Coping,  $\alpha = .85$ ). In the present study, the ACSI demonstrated adequate to good internal consistency (Cognitive/Emotional Debriefing,  $\alpha = .82$ ; Spiritual-Centred Coping,  $\alpha = .89$ ; Collective Coping,  $\alpha = .71$ ; Ritual-Centred Coping,  $\alpha = .70$ ).

#### *Brief Symptom Inventory 18 (BSI-18)*

In the present study, psychological distress is evaluated using the Brief Symptom Inventory 18 (BSI-18; Derogatis, 2000). This measure is an 18-item standardized self-report inventory designed primarily to screen for psychological disintegration and psychiatric disorders in medical and community populations. It is the latest version of an integrated series of test



instruments (i.e., BSI, Derogatis, 1993; SCL-90-R, Derogatis, 1983) designed to measure psychological distress. The BSI-18 (Derogatis, 2000) was selected because it measures mental health outcomes that have been associated with exposure to race-related stressors, namely depression, anxiety, somatization (physiological manifestations of distress) and overall psychological distress. The BSI-18 (Derogatis, 2000) consists of three primary symptom dimensions (depression [DEP], anxiety [ANX], somatization [SOM]; six items each) and one global severity index [GSI] or total score. Depression items assess clinical depression symptoms such as dysphoria, anhedonia, and self-deprecation; anxiety items measure symptoms of nervousness, tension, motor restlessness, and apprehension; somatization items reflect distress caused by perceived bodily dysfunction, focusing on symptoms arising from cardiovascular and gastrointestinal systems, and other physiologic symptoms that have powerful autonomic mediation; the global severity index summarizes the respondent's overall level of psychological distress.

In the administration of the BSI-18 (Derogatis, 2000), participants are instructed to indicate the degree to which they have experienced psychological symptoms for at least one-week (7 days) during the past year, using a 5-point scale ranging from not at all (0) to extremely (4). To compute subscale scores, the values for the six item responses for each dimension are summed and the resultant raw scores are converted to standardized T scores. To calculate the GSI, the raw scores for the symptom dimensions are summed and converted to standardized T scores. The BSI-18 (Derogatis, 2000) offers satisfactory internal consistency reliability: SOM (.74), DEP (.84), ANX (.89). Joseph and Kuo (2009) reported good internal consistency reliability for these subscales in the context of psychological symptoms experienced in the past year among a sample of Canadians of African descent: .81 (SOM), .87(DEP), and .85 (ANX).

Joseph and Kuo (2009) also reported good internal consistency for the same sample referencing lifetime psychological symptoms: .83(SOM), .88(DEP), and .85(ANX). In the present study, the subscales demonstrated good internal consistency reliability in a similar sample reporting psychological symptoms experienced over the past year: .76 (SOM), .86 (DEP), .83 (ANX). The internal consistency reliability for the total scale score (GSI) was .91.

Tests of construct validity between the BSI-18 and its longer predecessor, the SCL-90-R (Derogatis, 1983), demonstrate a strong, highly significant correspondence between the two sets of subscale scores, suggesting that their measurement of the construct has suffered little or no alteration. An additional validation study was conducted on a community sample ( $N=1,134$ ) utilized factor analysis; the results confirmed the hypothesized dimensional structure of the BSI-18 (Derogatis, 2000). Although test-retest reliability studies have not been conducted for the BSI-18 (Derogatis, 2000), studies of the corresponding BSI (Derogatis, 1993) scales report satisfactory test-retest reliability: SOM (.68), DEP (.84), ANX (.79), GSI (.90). Convergent-discriminant validity studies have also only been reported for the BSI-18's parent measures, the SCL-90 (Derogatis, Rickels, & Rock, 1976) and the BSI (Derogatis, 1993). In these studies, scores on the nine primary symptom dimensions were correlated with MMPI scores on the clinical scale (Dahlstrom, 1969), the Wiggins content scale (Wiggins, 1966), and the Tryon cluster scale (Tryon, 1996) from a sample of symptomatic individuals ( $N=209$ ). The SCL-90-R (Derogatis, 1983) dimensions that are represented on the BSI-18 (somatization, anxiety, depression; Derogatis, 2000) revealed convergent coefficients approaching .60 and greater; a replication of the comparison with the BSI (Derogatis, 1993) instrument revealed a similar pattern of convergence and discrimination.

*Intentions to Seek Counseling Inventory – Cultural Revision (ISCI-CR)*

The Intentions to Seek Counseling Inventory (ISCI) is Robertson and Fitzgerald's (1992) modified version of Cash et al.'s (1975) Personal Problem Inventory. The inventory lists seventeen common personal problems that are frequently cited as reasons for seeking professional psychological services. These issues include weight control, excessive alcohol use, relationship difficulties, concerns about sexuality, depression, conflicts with parents, speech anxiety, difficulties dating, choosing a major, difficulty in sleeping, drug problems, feelings of inferiority, test anxiety, difficulties with friends, academic work procrastination, self-understanding, and loneliness. For each personal problem, respondents are instructed to rate how likely they would be to seeking professional psychological help if they were experiencing that problem using a 6-point Likert scale (1 = Very Unlikely, 2 = Unlikely, 3 = Doubtful, 4 = Possibly, 5 = Likely, 6 = Very Likely). The ratings are summed to derive a total score (ranging from 17 to 102), with higher scores indicating a greater likelihood of seeking professional psychological help for various personal and emotional problems. Internal consistency estimates of the ISCI range from  $\alpha = .84$  to  $.90$  (Cepeda-Benito & Short, 1998; Kelly & Achter, 1995; Kahn & Williams, 2003). Kelly and Achter (1995) reported a correlation of  $.36$  between the ISCI and favourable attitudes toward seeking professional psychological help. Factor analyses of the ISCI yielded a three-factor solution, which accounts for 59% of the variability in the ISCI scores. These factors were representative of Psychological and Interpersonal Concerns (10 items,  $\alpha = .90$ ), Academic Concerns (4 items,  $\alpha = .71$ ), and Drug Use Concerns (2 items,  $\alpha = .86$ ). The 'weight control' item did not load highly on any of the three factors. Intercorrelations among the three subscales ranged from  $.18$  to  $.50$  (Cepeda-Benito & Short, 1998).

There are no empirical reports of the ISCI's psychometric properties among people of African descent. To this author's knowledge, Morgan and colleagues (2003) published the only report of internal consistency ( $\alpha = .88$ ) for the ISCI among a sample consisting of primarily ethnic minority group members. However, there are several reports of psychometric properties for culture-specific modifications of the Personal Problem Inventory among samples of ethnic minority group members. For example, Liao et al. (2005) and Solberg, Ritsma, Davis, Tata, and Jolly (1994) reported good internal consistency reliability estimates ( $\alpha = .94 - .97$ ) among samples of Asian descent. Ponce and Atkinson (1989) and Gim, Atkinson, and Whiteley (1990) demonstrated consistent factor structure for the original items on the PPI among Mexican American and African American samples, respectively.

Despite the lack of psychometric evidence specifically supporting the use of the ISCI among people of African descent, reports of good psychometric properties among other minority groups and methodological concerns regarding instrumental consistency with the studies used to develop Cramer's (1999) model informed the decision include the ISCI in the present study. However, the ISCI was further modified in two ways. First, three of the ISCI items that were specific to academic concerns (i.e., choosing a major, test anxiety, academic work procrastination) were excluded from the present study in order generalize the measure to the experiences of the community and student population that will comprise the study sample. Second, in reviewing the literature with regard to the types of problems experienced by people of African descent (e.g., Heurtin-Roberts et al., 1997; June et al., 1990; Sue & Sue, 2002), six additional items were included in the ISCI: financial difficulties, poor living conditions, anxiety, health problems, exploring racial identity, and emotional reactions to racism and prejudice. In the

present study, the modified version of the ISCI demonstrated good internal consistency reliability ( $\alpha = .91$ ).

### *Social Provisions Scale (SPS)*

The Social Provisions Scale (SPS; Cutrona & Russell, 1987) is a 24-item self-report instrument that measures perceived social support. The measure was designed to assess the six social functions or provisions of social relationships identified by Weiss (1974). Accordingly, the instrument is comprised of six subscales, each consisting of four items: Reliable Alliance, indicated by confidence that others will be available in times of stress (e.g., “There are people I can depend on to help me if I really need it”); Attachment, in the form of emotional closeness (e.g., “I feel a strong emotional bond with at least one other person”); Guidance, provided through advice or information (e.g., “There is a trustworthy person I could turn to for advice if I were having problems”); Nurturance, through providing support to others (e.g., “There are people who depend on me for help”); Social Integration, via a sense of belonging to a group of friends (e.g., “There are people who enjoy the same social activities I do”); and Reassurance of Worth, through the recognition of one’s competence (e.g., “There are people who admire my talents and abilities”). Respondents are instructed to indicate the extent to which each statement describes their current social network using a 4-point Likert scale (1 = Strongly Disagree, 2 = Disagree, 3 = Agree, 4 = Strongly Agree). The SPS yields a total score (ranging from 24 to 96) that is obtained by summing the positively keyed and negatively keyed responses for each positively and negatively worded item, respectively. Subscale scores can also be derived for each of the social provisions by summing the representative items. Higher scores on the SPS indicate a greater degree of perceived social support.

Construct validity of the SPS global score has been evidenced by significant correlations ranging from .35 to .46 with other self-report measures of social support (Cutrona & Russell, 1987). With regards to predictive validity, Cutrona (1984) found that scores on the SPS were predictive of postpartum depression. That is, women without relational supports were more likely to become depressed after their pregnancy. Cutrona (1982) demonstrated the convergent validity of social provision scores with scores on the UCLA Loneliness Scale (Russell, Peplau, & Cutrona, 1980) among first-year university students. Lack of social support accounted for 66% of the variability in UCLA Loneliness scores. Confirmatory factor analyses of the SPS have revealed a six-factor structure that is consistent with the six relational provisions identified by Weiss (Cutrona & Russell, 1987; Russell & Cutrona, 1984). However, subsequent analyses of the factor structure have identified a strong second-order factor that represents a global measure of social support; this overall factor was reported to account for 92% of the association among the first-order factors that correspond to the six subscales (Russell & Cutrona, 1991). As such, the present study will use the global social support score as an aggregate measure of social support.

A number of studies have reported good internal consistency reliability for the SPS across a variety of samples (e.g., Cutrona, 1982; Cutrona, 1984; Cutrona & Russell, 1987; Cutrona, Russell, & Rose, 1986; Cutrona & Troutman, 1986; Morgan et al., 2003; Russell, Altmaier, & Van Velzen, 1987). Internal consistency reliability estimates range from .85 to .92 for the full-scale score. The studies that have used the SPS to explore perceptions of social support among samples that primarily consist of minority group members have reported similar internal consistency estimates as the studies using the SPS among primarily Caucasian samples. For example, Morgan et al. (2003) reported good internal consistency for the SPS full-scale score

( $\alpha = .91$ ) among a sample consisting of 65.25% non-Caucasians. Furthermore, Mosher, Prelow, Chen, and Yackel (2006) reported good internal consistency for the SPS full-scale score ( $\alpha = .90$ ) among a sample of university students of African descent. In the present study, the SPS also demonstrated good internal consistency ( $\alpha = .91$ ).

### *Demographic Questionnaire*

Participants with self-identified African ancestry were administered a short demographic questionnaire requesting background information. Specifically, the questionnaire was designed to obtain information about the following characteristics: gender, age, country of birth, immigration status, racial background of parents, generation status, marital status, employment status, highest level of education completed, and family socioeconomic status (as indicated by postal code of the participants' primary or permanent residence). Participants were also instructed to respond to questions concerning their history of seeking professional psychological services and general perceptions of psychological service providers using a forced-choice and Likert response format. These questions included: (a) If I was considering therapy for help in dealing with a serious personal or emotional problem, the race of the therapist would be important to me, (b) If I was experiencing serious personal or emotional problems, I would be more willing to seek therapy if I knew the therapist was Black, and (c) I have seen a counselor, therapist, or psychologist for help in dealing with serious personal or emotional problems.

Table 2

### *Internal Consistency Reliability ( $\alpha$ )*

	<i>SCS</i> ( <i>SC</i> )	<i>ATSPPH-S</i> ( <i>ATSPPH</i> )	<i>AS</i> ( <i>AFR</i> )	<i>CMI</i> ( <i>CM</i> )	<i>ICM</i> ( <i>AC</i> )	<i>BSI-18</i> ( <i>PD</i> )	<i>ISCI-CR</i> ( <i>WTSPPH</i> )	<i>SPS</i> ( <i>SS</i> )
<i><math>\alpha</math></i>	.87	.81	.74	.93	.79	.91	.91	.91

*Note.* Acronyms for each measure are followed by corresponding variable labels, in parentheses.

## CHAPTER IV: Results

AMOS 17.0 (Analysis of Moment Structures; Arbuckle, 2008) was utilized to test the hypothesized path models (Figures 1 to 3) using path analysis. Path analysis was conducted to assess whether the relations between self-concealment [SM], social support [SS], psychological distress [PD], attitudes toward seeking professional psychological help [ATSPPH], and willingness to seek professional psychological help [WTSPPH] specified in Cramer's (1999) path model (Figure 1, on page 31) provided an adequate explanation for the psychological help-seeking behaviour of Canadians of African descent. The revised models (Figures 2 and 3, on pages 33 and 35 respectively) were also tested using path analysis in order to examine whether adding culture-specific variables (Cultural Mistrust [CM], Africentrism [AFR], Africultural Coping [AC]) to Cramer's (1999) model while controlling the covariates would better explain the professional psychological help-seeking behaviour for Canadians of African descent. The covariates were: a) I have seen a counselor, therapist, or psychologist for help in dealing with serious personal or emotional problems [CV1]<sup>5</sup>, b) If I was considering therapy for help in dealing with a serious personal or emotional problem, the race of the therapist would be important to me [CV2], and c) If I was experiencing serious personal or emotional problems, I would be more willing to seek therapy if I knew the therapist was Black [CV3]. After examining the relative fit of the hypothesized path models, the parameter estimates were evaluated to determine their consistency with theoretical expectations. The empirical tests (i.e., modification indices [MIs] and standardized residual matrix) were inspected for signs of specification errors and areas of poor fit.

---

<sup>5</sup> Although CV1 is a dichotomous variable, AMOS 17.0 (Arbuckle, 2008) can perform ML estimation providing that it is being treated as a predictor (K. Preacher, personal communication, October 2, 2009), which is the case in the present study.



### Data Screening and Preparation

The data were first screened for data entry errors and missing data (Kline, 2005). In conducting the path analyses for the present study, the estimates of the specified relationships between the variables (i.e., the hypothesized paths) in the model were calculated using the maximum likelihood (ML) method, which requires the assumption of multivariate normality (MacDonald & Ho, 2002). Accordingly, the data was examined to determine whether the assumption of multivariate normality was satisfied. Careful consideration and resolution of these issues were fundamental to an honest analysis and interpretation of the data.

#### *Descriptive Statistics*

Summary statistics (i.e., mean, median, standard deviation, minimum, maximum, range) and bivariate correlations were generated for the main variables (Self-Concealment, Psychological Distress, Social Support, Attitudes Toward Seeking Professional Psychological Help, Willingness Toward Seeking Professional Psychological Help, Cultural Mistrust, Africentrism, Africultural Coping) and the covariates. The summary statistics were assessed and the means, medians, standard deviations appeared acceptable. The range of values for each variable was inspected to ensure the values within the appropriate range; there were no out-of-range values. A summary correlation table is presented in Table 3. An inspection of the correlation table did not uncover any apparent inflated, deflated, or inaccurately calculated correlation coefficients.

#### *Missing Data*

Missing data was managed using listwise deletion and mean item replacement. Individual cases were excluded from the analysis if more than 20% of items were missing on any given measure. Due to an administrative error, eight cases were deleted using this method. When less

than 20% of items were missing on a measure, the missing item scores were substituted with the participant's mean score on the measure in question and the case was retained.

### *Multivariate Normality*

The assumption of multivariate normality is met when all univariate distributions are normal, the distribution of any pair of variables is bivariate normal, and all bivariate scatterplots are linear and homoscedastic. Most instances of multivariate nonnormality are detected through an examination of univariate distributions (Kline, 2005). The presence of outliers often contributes to violations of normality. An examination of boxplots for each of the main variables in the hypothesized models (i.e., excluding the covariates) did not suggest the presence of any extreme outliers. Further examination of the z-scores for each of the main variables revealed several extreme positive outliers (i.e., z-score > 3.29) – one among the Cultural Mistrust scores, two among the Psychological Distress scores, and one among in the Africultural Coping scores.

Table 3  
*Summary Table of Correlation, Means, and Standard Deviations*

	<i>SC</i>	<i>ATSPPH</i>	<i>AFR</i>	<i>CM</i>	<i>PD</i>	<i>WTSPPH</i>	<i>SS</i>	<i>AC</i>	<i>CV1</i>	<i>CV2</i>	<i>CV3</i>
Self-concealment ( <i>SC</i> )	--										
Attitudes Toward Seeking Professional Psychological Help ( <i>ATSPPH</i> )	-.03	--									
Africentrism ( <i>AFR</i> )	-.15*	-.02	--								
Cultural Mistrust ( <i>CM</i> )	.21**	-.13	.09	--							
Psychological Distress ( <i>PD</i> )	.50**	.03	-.07	.27**	--						
Willingness to Seek Professional Psychological Help ( <i>WTSPPH</i> )	.16*	.40*	-.07	-.03	.20**	--					
Social Support ( <i>SS</i> )	-.43**	-.10	.28**	.16*	-.20**	-.49	--				
Africultural Coping ( <i>AC</i> )	-.09	-.02	.39**	.12	-.00	.06	.28**	--			
Previous Therapy Services ( <i>CV1</i> )	-.12	-.25**	-.06	.01	-.19**	-.19**	.08	-.028	--		
Race of therapist important ( <i>CV2</i> )	.12	-.25**	.10	.34**	.09	-.16*	.01*	.20**	.04	--	
More willing to see Black therapist ( <i>CV3</i> )	.18*	-.08	.06	.34**	.11	.06	-.06	.14	-.07	.64**	--
Mean	29.07	16.08	43.43	3.29	49.84	59.85	78.89	.00	1.67	1.10	1.08
Standard Deviation	8.20	5.87	5.30	.66	9.96	21.20	10.07	3.03	.47	2.38	2.34

Note. \* $p < .05$ , \*\* $p < .01$ .

In the interest of preserving the sample size, the cases that contained these outliers were not deleted and transformations (i.e., log, square root, reciprocal) were attempted to reduce the impact of outliers. The transformations did not effectively rein in the outliers. Consequently, the outlier values were replaced with values that estimated a z-score of 3, as recommended by Field (2005). An examination of the shape and density of the bivariate scatterplots for the main variables in the model (i.e., excluding the covariates) indicated that the assumptions of linearity and homoscedasticity were met (Tabachnick & Fidell, 2001).

An inspection of histograms of the main variables in the hypothesized models (with outliers corrected) suggested that the scores approximated a normal distribution. However the results of the Shapiro-Wilk test, an objective measure of normal distribution, identified non-normal distributions for Social Support [ $W(193) = .964, p < .05$ ], Willingness to Seek Professional Psychological Help [ $W(193) = .983, p < .05$ ], Psychological Distress [ $W(193) = .934, p < .05$ ], and Attitudes toward Seeking Professional Psychological Distress [ $W(193) = .986, p < .05$ ]. An examination of the skewness and kurtosis statistics for these variables indicated that the distribution for Social Support was negatively skewed and platykurtic while the distributions for Willingness to Seek Professional Psychological Help, Psychological Distress, and Attitudes toward Seeking Professional Psychological Help were positively skewed and platykurtic (i.e., flat).

Although non-normal, the distribution of these variables is consistent with what is known in the literature about the characteristics of these variables among samples of African descent. For example, communalism and collectivism has been identified as a core cultural value among people of African descent (Constantine, Gainor, Ahluwalia, & Berkel, 2003; Jackson & Sears, 1992; Myers, 1993; Utsey et al., 2000). This sample characteristic may have positively impacted

the participants' perception of their social support networks, resulting in a tendency to endorse higher scores (i.e., negative skewness) on the measure of social support. Similarly, the literature suggests that people of African descent tend to endorse negative attitudes toward mental health services (Alvidrez, 1999; Sanders-Thompson et al., 2004), and are reluctant to report psychological distress (e.g., Neighbors & Jackson, 1984; Wallace & Constantine, 2005) and seek professional mental health services (e.g., Constantine et al., 2004; Sanders-Thompson, Bazile, & Akbar, 2004). These characteristics may have been reflected in the sample's endorsement of psychological distress, attitudes and willingness to seek professional psychological services, resulting in a tendency to endorse lower scores (i.e., positive skewness) on the respective measures. Given that ML estimation is fairly robust against violations of normality (MacDonald & Ho, 2002) and the non-normal distribution of Social Support, Psychological Distress, Attitudes Toward Seeking Professional Psychological Help, and Willingness to Seek Professional Psychological Help are likely accurate representations of the constructs within this sample, the variables were not transformed to more closely approximate a normal distribution.

### Preliminary Analyses

The main variables were examined to determine whether any significant mean differences existed due to socioeconomic status, as indicated by gender (male versus female), education (secondary versus postsecondary<sup>6</sup>), age (24 years old and younger versus 25 and older), and household income. The results of an independent t-test and one-way ANOVA revealed no significant differences on the main variables by gender or household income, respectively. The results of an independent t-test showed that participants who had at least

---

<sup>6</sup> The categories for education and age were modified for mean comparison analyses in order to obtain greater statistical power.

partially completed post-secondary education reported less self-concealment tendencies ( $t(190) = 2.33, p < .05, d = .34$ ) and more available social support than participants who partially or fully completed secondary education ( $t(190) = 2.94, p < .01, d = .43$ ). The results of a subsequent independent t-test showed that younger participants reported more self-concealment tendencies ( $t(190) = 2.08, p < .05, d = .30$ ), less favourable attitudes toward seeking professional psychological help ( $t(190) = 1.98, p < .05, d = .29$ ), less adherence to Africentric values ( $t(190) = 2.92, p < .01, d = .42$ ), and reported more psychological distress ( $t(190) = 1.93, p < .05, d = .28$ ) than their older counterparts. The small magnitude of these effect sizes, as determined by Cohen's (1988) guidelines, did not justify multiple group (secondary versus postsecondary education) analysis of the data.

Independent t-tests were also performed to determine whether significant differences in the main variables existed due to the covariates. An analysis of mean differences indicated that participants who had previously sought professional mental health services (CV1) had more positive attitudes toward seeking professional mental health services ( $t(191) = 3.61, p < .01, d = .52$ ), reported more psychological distress ( $t(191) = 2.72, p < .01, d = .39$ ), and endorsed more willingness to seek professional mental health services ( $t(191) = 2.68, p < .01, d = .39$ ) than participants who had not previously sought professional mental health services. Participants who believed that the race of the therapist would be important if they were considering seeking therapy (CV2<sup>7</sup>) used more afri-cultural coping strategies ( $t(37.22) = 3.12, p < .01, d = .54$ ), were less willing to seek professional mental health services ( $t(191) = 2.10, p < .01, d = .30$ ), endorsed higher levels of cultural mistrust ( $t(191) = 3.02, p < .01, d = .44$ ), endorsed more Africentric beliefs ( $t(191) = 2.38, p < .01, d = .34$ ), and reported less favourable attitudes toward

---

<sup>7</sup> Cutpoints were used to categorize respondents on the continuous covariates, CV2 and CV3. Higher scores (i.e., 4, 5) represented agreement with the belief that the race of the therapist would be important in considering seeking therapy and increased willingness to seek therapy if the therapist was Black, respectively.

seeking professional mental health services ( $t(191) = 2.49, p < .01, d = .36$ ) than participants who indicated they would be indifferent to the therapist's race or deemed it unimportant. Participants who indicated they would be more willing to seek therapy if the therapist was black (CV3) were more likely to use afri-cultural coping strategies ( $t(191) = 1.95, p < .05, d = .28$ ), endorsed higher levels of cultural mistrust ( $t(191) = 3.59, p < .01, d = .52$ ), and endorsed higher self-concealment tendencies ( $t(191) = 1.88, p < .05, d = .27$ ) than participants who indicated that they would not be more willing to seek professional mental health services if the therapist was Black. The medium effect size for these group differences, greater than .05 according to Cohen (1988), support the inclusion of the three covariates in the hypothesized path models to reduce error variation.

## Main Analyses

### *Hypothesized Path Model 1*

Path analysis was performed to evaluate the adequacy of Cramer's (1999) model (i.e., Hypothesized Model 1). The overall fit of the model was evaluated using the fit indices displayed in Table 4. The chi-square statistic ( $\chi^2$ ) indicates good fit when non-significant (Joreskog, 1993). Values of .06 or less on the root-mean-square error of approximation (RMSEA), an absolute fit index, indicate good fit (Hu & Bentler, 1999). The comparative fit index (CFI), goodness of fit index (GFI), and Tucker-Lewis index are normed statistics that indicate good fit when their values are greater than .95 (Hu & Bentler, 1995). According to these benchmarks, model 1 demonstrated adequate overall fit for Canadians of African descent.

Table 4

*Fit Indices of Hypothesized Path Models*

	$\chi^2$	df	<i>P</i>	CFI	RMSEA	GFI	TLI
Model 1	6.68	4	.15	.98	.06	.99	.95
Model 2	198.00	37	<.001	.56	.12	.85	.34
Model 3	195.45	36	<.001	.56	.15	.85	.33

Although model 1 appeared promising, an examination of the path coefficients (Figure 4) indicated that several relationships specified within the model did not accurately reproduce the data. While the parameter estimates for paths 1 (self-concealment  $\rightarrow$  social support), 3 (self-concealment  $\rightarrow$  psychological distress), 5 (psychological distress  $\rightarrow$  willingness to seek professional psychological help), and 6 (attitudes toward seeking professional psychological help  $\rightarrow$  willingness to seek professional psychological help) were significant, of considerable magnitude, and in the hypothesized direction, the parameter estimates for paths 2 (social support  $\rightarrow$  psychological distress) and 4 (self-concealment  $\rightarrow$  attitudes toward seeking professional psychological help) were not significant, thus compromising the overall utility of the model. Given that fit indices provide only an “average” fit of the model (Kline, 1991), it is likely that acceptable fit indices were obtained because some paths coefficients were not significantly different from zero whereas others were relatively high. In other words, while there was considerable overall agreement between the model and the data, the predictive accuracy of the model was poor. The overall model explained only 19% of the variance in willingness to seek professional psychological help. Among the squared multiple correlations for the remaining endogenous variables (Table 5), it was particularly interesting to note that none of the variance (0%) in attitudes toward seeking professional psychological help was explained by self-concealment.



Figure 4

*Hypothesized Path Model 1 (Cramer's (1999) Path Model): Standardized Regression Weights*

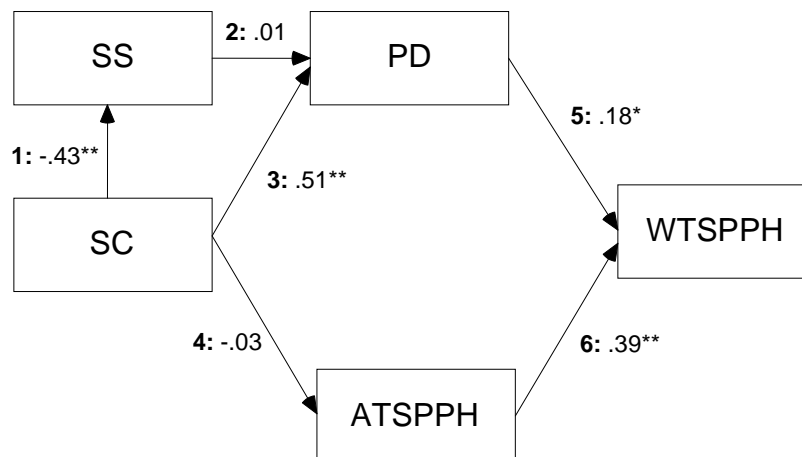

*Note.* \* $p < .05$ , \*\* $p < .01$ . Standardized regression weights are preceded by the path numbers which appear in boldface. *ATSPPH* = Attitudes Toward Seeking Professional Psychological Help, *PD* = Psychological Distress, *SC* = Self-concealment, *SS* = Social Support, *WTSPPH* = Willingness to Seek Professional Psychological Help.

Table 5

*Squared Multiple Correlations ( $R^2$ )*

Endogenous Variables	$R^2$		
	Model 1	Model 2	Model 3
Willingness to Seek Professional Psychological Help (WTSPPH)	.19	.31	.31
Self Concealment (SC)	--	.07	.05
Social Support (SS)	.18	.18	.18
Psychological Distress (PD)	.25	.25	.28
Attitudes Toward Seeking Professional Psychological Help (ATSPPH)	.00	.15	.15
Africultural Coping (AC)	--	.15	.15
Cultural Mistrust (CM)	--	.01	--
Africentrism (AFR)	--	--	.01

The modification index (MI) and standardized residual matrix provide information that is helpful in detecting model misspecification. The MI estimates the change in  $\chi^2$  if fixed parameters were allowed to be freely estimated and is accompanied by an estimate of the expected parameter change (Byrne, 2001). Joreskog (1993) recommended freeing parameters with the largest MI and anticipated parameter change, but only if the specific relationship was theoretically meaningful. Model 1 did not specify any fixed or constrained parameters, therefore MIs could not be generated and examined for evidence of misfit. Alternatively, the standardized residual matrix was inspected for indications of pockets of poor fit. Standardized residuals are estimates of the distance, in standard deviations, between the observed residuals and a perfectly fitting model containing zero residuals (Byrne, 2001); standard deviations greater than 2.58 are considered large (Joreskog & Sorbom, 1988). However, there were no large values identified in the standardized residual matrix, suggesting that there were no statistically significant specification errors in the model.

### *Hypothesized Path Model 2*

Path analysis was performed on model 2 to examine whether the addition of cultural constructs (i.e., paths 7 to 12) and covariates to account for any pre-existing heterogeneity among Black Canadians improved the fit of Cramer's (1999) model. An examination of the fit indices for model 2 (Table 4) indicated that the overall model did not fit the data.

The parameter estimates for model 2 were examined in order to determine which hypothesized relations were supported by the data. An inspection of the path coefficients (Figure 5) revealed that paths 2 (social support  $\rightarrow$  psychological distress) and 4 (self-concealment  $\rightarrow$  attitudes toward seeking professional psychological help), also specified in hypothesized model

1, remained nonsignificant. Among the paths implicating cultural mistrust, Africentrism, and afri-cultural coping, only paths 8 (cultural mistrust → self-concealment), 9 (Africentrism → self-concealment), and 10 (Africentrism → afri-cultural coping) were significant, of considerable magnitude, and in the hypothesized direction.

The covariates also demonstrated substantial interaction with the willingness to seek professional psychological help (WTSPPH), and this variable's strongest predictor, attitudes toward seeking professional psychological help (ATSPPH). The following covariate paths were significant: CV1 (i.e., previous therapy service) → ATSPPH, CV2 (i.e., race of therapist important) → ATSPPH, CV2 → WTSPPH, CV3 (i.e., more willing to seek treatment from Black therapist) → WTSPPH. As compared to hypothesized model 1, the specified relations involving CV2 and CV3 considerably improved the proportion of variance in willingness to seek professional psychological help explained by the model, increasing the  $R^2$  from .19 to .31. Furthermore, the inclusion of CV1 and CV2 explained an additional 15 % of the variation in attitudes toward seeking professional psychological help (Table 4).

The modification indices and standardized residual matrix were examined to identify pockets of poor fit and misspecification errors. Model 2 generated MIs because the correlations among the exogenous variables (Africentrism, CV1, CV2, CV3) were fixed at zero (i.e., uncorrelated). The expected parameter changes for the largest MIs (CV2 and CV3, CM error variance and CV3, CM error variance and CV2) were small (.24 - .76), and thus of little concern (Byrne, 2001). However, the parameter change expected if the correlation between Africentrism and the error variance for social support was large (11.62). Although the MI for this path was the fourth largest, the relationship makes theoretical sense - that is, variations in the measurement of

perceived availability of social support might be accounted for by identification with Africentric values such as communalism.

Figure 5

*Hypothesized Path Model 2 (Culture-Based Modification): Standardized Regression Weights*

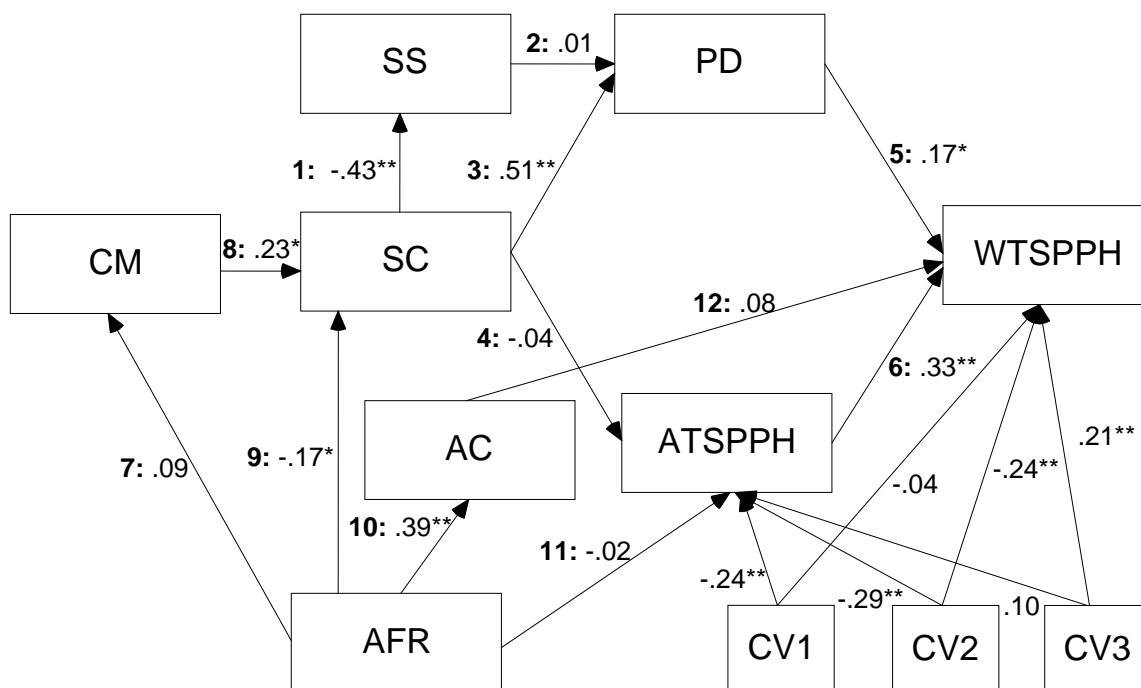

*Note.* \* $p < .05$ , \*\* $p < .01$ . Standardized regression weights are preceded by the path numbers which appear in boldface. *AC* = Africultural Coping, *AFR* = Africentrism, *ATSPPH* = Attitudes Toward Seeking Professional Psychological Help, *CM* = Cultural Mistrust, *CV1* = I have seen a counselor, therapist, or psychologist for help in dealing with serious personal or emotional problems, *CV2* = If I was considering therapy for help in dealing with a serious personal or emotional problem, the race of the therapist would be important to me, *CV3* = If I was experiencing serious personal or emotional problems, I would be more willing to seek therapy if I knew the therapist was Black, *PD* = Psychological Distress, *SC* = Self-concealment, *SS* = Social Support, *WTSPPH* = Willingness to Seek Professional Psychological Help.

An examination of the standardized residual covariances for model 2 revealed significant points of strain in the hypothesized model, as follows (listed from highest to lowest significant standardized residual covariance values): CV2 and CV3, CV2 and cultural mistrust, CV3 and

cultural mistrust, aficultural coping and social support, Africentrism and social support, CV2 and aficultural coping, CV1 and psychological distress. This finding suggests the covariances between each pair of observed variables in the hypothesized model are significantly different than what would exist if the model fit were perfect.

Although no pathways between these pairs of variables were specified in hypothesized model 2, they are all theoretically consistent. For instance, it would be reasonable to expect that Black Canadians would be more willing to seek therapy with a Black therapist (CV3) if they believed that a therapist's race was important when seeking therapy. Likewise, Canadians of African descent who are suspicious of White people and Eurocentric institutions (CM) may be more likely to consider the race of the therapist as an important factor in seeking therapy services (CV2) and more willing to seek therapy with a same-race therapist (CV3). In addition, Canadians of African descent who tend to use aficultural coping strategies (AC) may be more likely to take the race of the therapist into consideration when deciding to seek therapy. Furthermore, Canadians of African descent who value collectivism and communalism (AFR) might be more likely to perceive greater availability of social support (SS), which may also be reflected in their use of aficultural coping strategies (AC). Lastly, individuals of African descent who have previously used therapy services (CV1) may experience greater levels of psychological distress (PD) in the past as well as in the present, as compared to individuals of African descent who have never used therapy services.

### *Hypothesized Path Model 3*

Path analysis was also performed on model 3, an alternate culture-based modification of Cramer's (1999) model. Model 3 contained the same cultural constructs and covariates as model

2 but removed the path between Africentrism and self-concealment (path 9), specified the path between cultural mistrust and Africentrism in the direction opposite to path 7 (path 13), and included paths between cultural mistrust and psychological distress (path 14) and cultural mistrust and attitudes toward seeking professional psychological help (path 15). An examination of the fit indices for model 3, presented in Table 4, indicated that the overall model did not fit the data.

The parameter estimates for specified paths in model 3 are presented in Figure 6. Among the paths originally specified in Cramer's (1999) model, paths 2 (social support → psychological distress) and path 4 (self-concealment → attitudes toward seeking professional psychological help) remained nonsignificant. In addition, the following culture-specific pathways were significant, substantially large, and in the hypothesized direction: path 14 (cultural mistrust → psychological distress), path 8 (cultural mistrust → self-concealment), and path 10 (Africentrism → self-concealment).

Similarly to hypothesized model 2, the covariates demonstrated substantial interaction with WTSPPH and ATSPPH. The following covariate paths were significant: CV1 → ATSPPH, CV2 → ATSPPH, CV2 → WTSPPH, and CV3 → WTSPPH. Overall, hypothesized model 3 explained 31% of the variance in willingness to seek professional psychological help and the inclusion of the specified relations between CV1 and CV2 improved the proportion of variance in attitudes to seeking professional psychological help by 15% (Table 5).

Figure 6

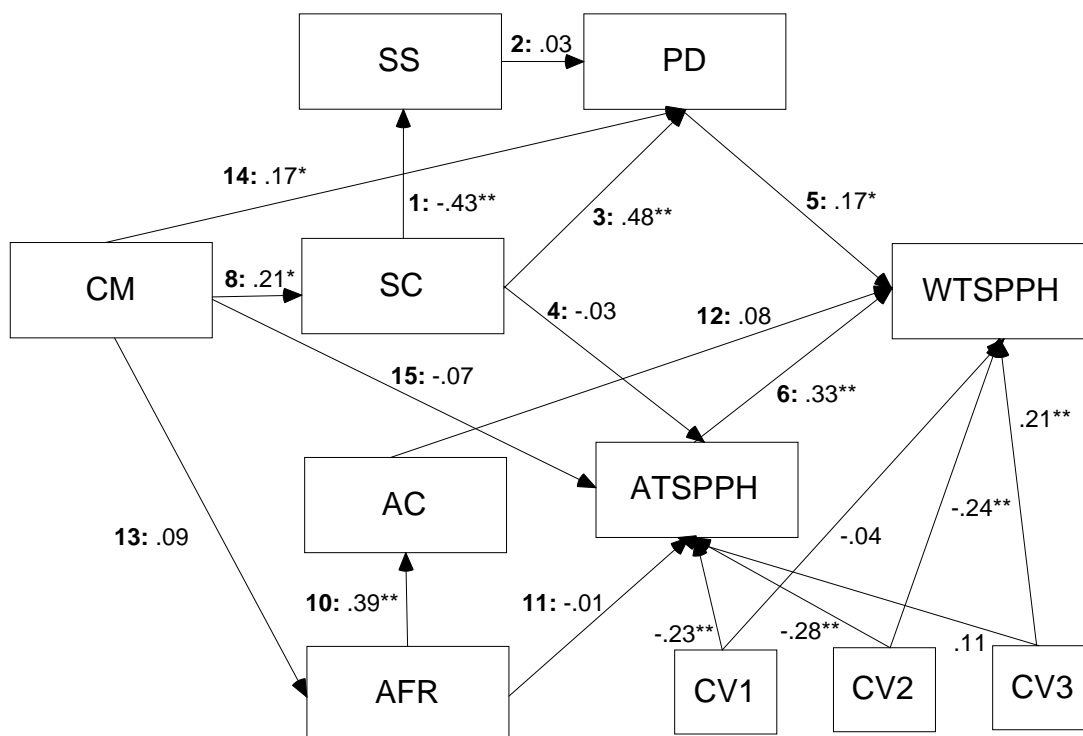
*Hypothesized Path Model 3 (Alternate Culture-Based Modification): Standardized Regression**Weights*

*Note.* \* $p < .05$ , \*\* $p < .01$ . Standardized regression weights are preceded by the path numbers which appear in boldface. *AC* = Africultural Coping, *AFR* = Africentrism, *ATSPPH* = Attitudes Toward Seeking Professional Psychological Help, *CM* = Cultural Mistrust, *CV1* = I have seen a counselor, therapist, or psychologist for help in dealing with serious personal or emotional problems, *CV2* = If I was considering therapy for help in dealing with a serious personal or emotional problem, the race of the therapist would be important to me, *CV3* = If I was experiencing serious personal or emotional problems, I would be more willing to seek therapy if I knew the therapist was Black, *PD* = Psychological Distress, *SC* = Self-concealment, *SS* = Social Support, *WTSPPH* = Willingness to Seek Professional Psychological Help.

In order to clarify which areas of the model were ill-fitting, the modification indices and standardized residual matrix were examined. An examination of the available MIs indicated that the anticipated parameter changes for the largest MIs (CV2 and CV3, CM error variance and CV3, CM error variance and CV2) were small (.24 - .76); however, the parameter change

expected with the specification of covariance between Africentrism and the error variance for social support was large (11.62) and theoretically consistent. An inspection of the standardized residual covariances for model 3 revealed the following significant points of strain (listed from highest to lowest significant standardized residual covariance values): CV2 and CV3, CV2 and cultural mistrust, CV3 and cultural mistrust, aficultural coping and social support, Africentrism and social support, CV1 and psychological distress. These are the same points of strain identified in hypothesized model 2.

### *Model Respecification*

Based on the indicators of poor fit identified in the path analyses of the hypothesized model (i.e., nonsignificant path coefficients, large MIs and associated parameter changes, significant standardized residual covariances) and theoretical considerations, the culture-based model was respecified and reestimated (Figure 7). To create the respecified model, all of the pathways with nonsignificant path coefficients were trimmed. Paths 8 (cultural mistrust → self concealment), 10 (Africentrism → aficultural coping), and 14 (cultural mistrust → psychological distress), the significant culturally-indicated pathways, were retained in the model. Using the information from the empirical tests (i.e., MIs, standardized residual matrix), the following new pathways were specified: a direct positive pathway from Africentrism → social support; an indirect relationship between Africentrism and social support was indicated with path 10 (Africentrism → aficultural coping) and the addition of a direct, positive pathway from aficultural coping → social support; positive covariances between CV2 and CV3, CV2 and cultural mistrust, CV3 and cultural mistrust were indicated. A pathway from social support to self-concealment was specified to represent the post hoc hypothesis that Black Canadians who perceive low availability of social support are more likely to conceal negative or potentially



embarrassing personal information. In the interest of parsimony, path 9 (Africentrism → self-concealment) and the covariance between CV1 and psychological distress were not indicated in the respecified model. An examination of the fit indices for the respecified model indicated acceptable fit ( $\chi^2(39, N=193) = 50.103, p = .110$ ; CFI = .969; RMSEA = .039; GFI = .957; TLI = .957). All path coefficients demonstrated statistical significance and the overall model explained 21% of the variance in willingness to seek professional psychological help.

Figure 7

Respecified Model: Standardized Regression Weights and Squared Multiple Correlations ( $R^2$ )

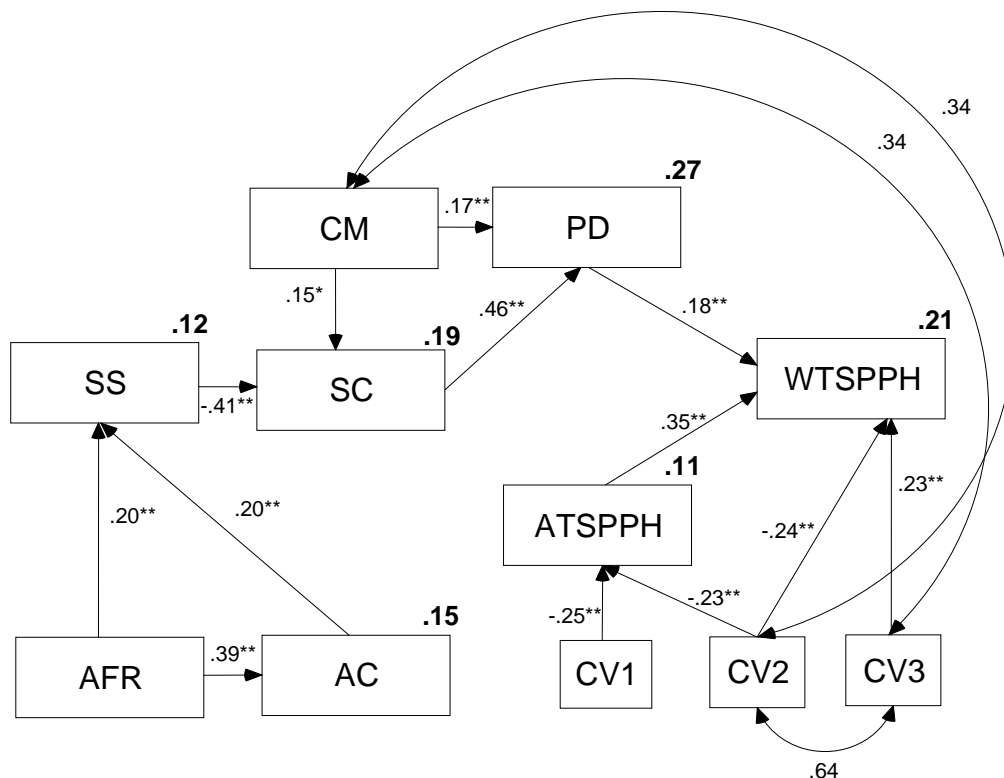

Note. \* $p < .05$ , \*\* $p < .01$ . Squared multiple correlations ( $R^2$ ) appear in boldface. AC = Africultural Coping, AFR = Africentrism, ATSPPH = Attitudes Toward Seeking Professional Psychological Help, CM = Cultural Mistrust, CV1 = I have seen a counselor, therapist, or psychologist for help in dealing with serious personal or emotional problems, CV2 = If I was considering therapy for help in dealing with a serious personal or emotional problem, the race of the therapist would be important to me, CV3 = If I was experiencing serious personal or emotional problems, I would be more willing to seek therapy if I knew the therapist was Black, PD = Psychological Distress, SC = Self-concealment, SS = Social Support, WTSPPH = Willingness to Seek Professional Psychological Help.

### Summary

The results of the present study indicated that Cramer's (1999) model of psychological help-seeking (i.e., hypothesized model 1) did not adequately reproduce the data in the present study. Although the model fit indices were indicative of good overall fit, the specified relations between social support and psychological distress (path 2) and self-concealment and attitudes toward seeking professional psychological help (path 4) were not statistically significant.

The overall fit of both culturally-based models (i.e., hypothesized models 2 and 3) was also poor. Among the pathways originally specified in Cramer's (1999) model, paths 2 and 4 remained nonsignificant. Among the culturally indicated pathways, only paths 8 (cultural mistrust → self-concealment), 9 (Africentrism → self-concealment), 10 (Africentrism → afri-cultural coping), and 14 (cultural mistrust → psychological distress) were significant -- the former and latter paths having a direct effect on variables contained in Cramer's (1999) original model. Furthermore, the inclusion of the covariates in the culturally-based models considerably increased the proportion of variance in attitudes and willingness to seek professional psychological distress explained by the model.

A review of the empirical tests (i.e., MIs, standardized residual matrix) pointed to areas of strain within the culturally-based models. After considering the theoretical implications of each possible revision to the model, the culture-based model was respecified and reanalyzed. The model fit statistics and statistically significant parameter estimates provided support for the respecified model.

## CHAPTER V: Discussion

The purpose of the present study was to determine whether Cramer's (1999) model of psychological treatment-seeking could be extended to Canadians of African descent and examine cultural influences on the process of seeking professional psychological help. Cramer's model outlined two parallel yet conflicting processes for people who tend to conceal personally distressing or negative information from others. According to Cramer (1999), high self-concealers' unfavourable attitudes toward seeking professional psychological help and consequent unwillingness to seek psychological treatment is likely due to an aversion to disclosing personal problems. However, this disposition precludes the protective benefits of social support, which increases high self-concealers' susceptibility to experiencing psychological distress that may necessitate psychological treatment-seeking. The theoretical and empirical literature has implicated culture-specific values (i.e., Africentrism), attitudes (i.e., cultural mistrust), and behaviours (i.e., aficultural coping strategies) at multiple points during the help-seeking process. Based on this knowledge, the present study proposed two culture-based adaptations to Cramer's (1999) help-seeking model to further understand the psychological treatment-seeking behaviour of Canadians of African descent.

### Cramer's (1999) Help-Seeking Model

Overall, the results of the present study indicated that Cramer's (1999) model cannot adequately explain the psychological treatment-seeking behaviour of Canadians of African descent. Although the fit indices indicated that the model provided a good fit to the data, an examination of the path coefficients revealed that the relations between a) social support and psychological distress and b) self-concealment and attitudes toward seeking professional

psychological help were not supported. However, the remaining relations originally proposed by Cramer (1999) were replicated in the present study. Self-concealment predicted social support and psychological distress such that high self-concealers tended to perceive low availability of social support and experience psychological distress. Psychological distress and favourable attitudes toward seeking psychological treatment both predicted willingness to seek psychological treatment. Attitudes toward seeking professional psychological help were a stronger predictor of willingness to seek professional psychological help than psychological distress. Furthermore, the indirect effect of self-concealment on willingness to seek psychological treatment was moderated by psychological distress. This finding suggests that psychological distress is an important motivating factor for seeking professional psychological help among high self-concealers.

Cramer's (1999) findings also identified unfavourable attitudes toward seeking professional psychological help as an impediment to high self-concealers' willingness to seek psychological treatment. However, this finding was not fully supported in the current study, as there was no relation between self-concealment and attitudes toward seeking psychological treatment. Wallace and Constantine (2005) also found no significant relation between self-concealment and attitudes toward seeking psychological treatment in a sample of African American university students. Thus, even though unfavourable attitudes toward treatment seeking among Canadians of African descent predicted less willingness to seek psychological treatment for personal and emotional problems, these negative attitudes were not associated with concerns about disclosing distressing or potentially embarrassing personal information.

Other factors, such as concerns about being associated with the stigma of mental illness (e.g., labeled "crazy," "weak," "morally inferior," "dangerous," and "violent"; Anglin et al.,

2006; Sanders-Thompson et al., 2004; Silva de Crane & Spielberger, 1981; Snowden, 2001), may be more salient among communities of African descent. Mental illness is highly stigmatized in communities of African descent (Alvidrez, 1999; Hall & Tucker, 1985; Snowden, 2001) even though attitudes toward seeking professional psychological help are not less favourable than the mainstream population (Diala et al., 2000; Hall & Tucker, 1985). Stigmatizing views that place personal responsibility on individuals with mental illness have been associated with decreased willingness to seek professional psychological help (Cooper, Corrigan, & Watson, 2003). However, the negative impact of mental illness stigma on willingness to seek professional psychological treatment tends to be lessened by favourable attitudes toward seeking professional psychological help (Meltzer et al., 2003). In other words, people who endorse mental illness stigma are less likely to seek psychological help for themselves unless they have favourable views of the appropriateness and effectiveness of psychological treatment. Accordingly, positive attitudes toward seeking professional psychological treatment may mediate the relation between mental illness stigma and willingness to seek professional psychological help, serving to counteract a significant barrier to psychological treatment seeking for populations of African descent.

Furthermore, social support did not moderate the relation between self-concealment and psychological distress, despite being negatively associated with psychological distress. At first glance, this finding appears to be a departure from the well-documented buffering effects of social support on psychological distress in the general stress-coping literature. However, empirical studies that have explicitly investigated the role of social support networks in maintaining the psychological well-being of populations of African descent are limited and have resulted in mixed findings (e.g., Lincoln, Chatters, & Taylor, 2003; Warheit, Vega, Shimizu, &

Meinhardt, 1982). Such findings suggest that available supports do not provide any direct emotional benefit for people of African descent (Snowden, 1998). Although the specific mechanisms underlying the relationship between perceived social support and psychological distress are not well-understood (Lincoln et al., 2003), these findings are still unexpected given theoretical considerations about the role of strong kinship bonds (familial and nonfamilial) in promoting and maintaining the emotional well-being of people of African descent, on a family and community level (Jones, 1990; Morris, 2001; Nobles, 1997), and how this may apply to informal help-seeking for emotional and psychological problems.

It may be that competing culture-specific influences temper the protective benefits of social support among populations of African descent. On the one hand, strong social support networks are highly valued within communities of African descent, which may reinforce individuals of African descent's perceptions of available social support. At the same time, cultural beliefs concerning the impropriety of 'airing dirty laundry' and expectations of personal strength and courage in the face of adversity (Wallace & Constantine, 2005) may discourage individuals of African descent from confiding distressing or negative personal information to the people in their lives so that they can receive social support. Furthermore, individuals of African descent, particularly those who strongly identify with Africentric values, may hesitate to disclose their emotional problems in the interest of maintaining social harmony and not transferring their burdens to others (Constantine, Okazaki, & Utsey, 2004; Markus & Kitayama, 1991; Wallace & Constantine, 2005). Alternatively, it is possible that the perception that support would be available if needed enhances the sense of personal control among individuals of African descent, thus enabling them to cope without direct assistance from their support network (Lincoln et al., 2003; Reinhardt, Boerner, & Horowitz, 2006).

### Culturally Based Help-Seeking Models

The alternative culture-based models proposed in the present study also did not adequately explain the psychological treatment-seeking behaviour of Canadians of African descent. However, they provided support for cultural antecedents to help-seeking behaviour. Africentrism was predictive of self-concealment tendencies (path 9) but was not predictive of attitudes toward seeking psychological treatment (path 11 a/b). The former finding supports the above-noted contention that self-concealment tendencies among people of African descent may be associated with value-directed cultural norms. Unlike the theoretical literature, the latter finding indicates that an Africentric orientation does not predict either positive or negative attitudes toward psychological treatment seeking among Canadians of African descent. Nevertheless, it is consistent with the literature examining the relation between Africentrism and attitudes toward seeking psychological treatment. Similar to the present study, Wallace and Constantine (2005) found no relation between Africentrism and attitudes seeking professional psychological help.

Africentrism also predicted the use of aficultural coping strategies (path 10). This finding corresponds with the theoretical underpinnings of the aficultural coping construct, which propose that the repertoire of coping strategies utilized by individuals of African descent has grown out of African traditions, beliefs and value systems (Utsey et al., 2000). However, the use of aficultural coping strategies did not predict willingness to seek professional psychological help (path 12). Accordingly, the pathway between the use of informal, indigenous coping strategies and professional psychological services should be reexamined, as it appears that the willingness of Canadians of African descent to seek psychological treatment is not associated with the effectiveness of or disaffection caused by aficultural coping strategies.



As hypothesized, cultural mistrust predicted self-concealment (path 8). Thus, Canadians of African descent who are particularly wary of the motivations and intentions of Eurocentric institutions and their representatives, such as mental health services and clinicians, are less likely to disclose their vulnerabilities. It may be that suspiciousness of the dominant culture exacerbates existing self-concealment tendencies. Those with higher levels of cultural mistrust may anticipate greater risk in disclosing personal information due to concerns about making oneself vulnerable to racial microaggressions (Sue et al., 2007) in addition to judgment or embarrassment. Therefore, characterological tendencies to withhold personal information may be reinforced as an effective strategy for coping with cultural mistrust. As noted above, Africentrism predicted self-concealment; however, no relation was found between Africentrism and cultural mistrust (paths 7 and 13). This finding suggests that a strong Africentric orientation and high levels of cultural mistrust may independently predict self-concealment tendencies.

Cultural mistrust also predicted psychological distress (path 14) but did not predict attitudes toward seeking psychological treatment (path 15). These findings provide new evidence for two areas of the empirical literature where the implications for help-seeking behaviour are unclear. First, cultural mistrust may be a healthy adaptation for coping with concerns about potential mistreatment (e.g., Sue & Sue, 2002) but there appear to be limits to its protective benefits. The findings from the present study indicate that high levels of cultural mistrust are detrimental to the emotional well-being of people of African descent, providing further support for a curvilinear relationship between cultural mistrust and psychological distress (Bell & Tracey, 2006). Moreover, if high levels of cultural mistrust exacerbates psychological distress then cultural mistrust may both indirectly motivate (at high levels) and inhibit (at moderate levels) psychological treatment-seeking behaviour.

Second, although cultural mistrust has been linked to negative attitudes toward seeking psychological treatment from White clinicians (e.g., Nickerson et al., 1994), the general attitudes of people of African descent toward seeking psychological treatment do not tend to be more negative than mainstream attitudes (e.g., Diala et al., 2000; Hall & Tucker, 1985). The findings of the present study indicated that lack of trust for White society does not directly influence general attitudes about the benefits of psychotherapy for treating emotional problems and mental illness among Canadians of African descent. However, strong beliefs that a therapist's race is important when considering psychotherapy (CV2) negatively influenced attitudes toward seeking treatment and willingness to seek treatment; preference for a therapist of African descent (CV3) did not impact attitudes toward seeking psychological treatment but did increase willingness to seek professional psychological help.

Thus, it appears there may be specific qualities attributed to White therapists that go beyond a general suspicion. For example, highly mistrustful African Americans tend to perceive White therapists as less credible and less capable of dealing with their problems than Black therapists (Watkins et al., 1999), and report lower expectations for therapy conducted by White therapists (Thompson et al., 1994). Such negative perceptions about White therapists may magnify cultural mistrust and, in turn, heighten skepticism about the value and effectiveness of psychological treatment. These same perceptions may be validated by early experiences in therapy, further eroding attitudes toward seeking psychological treatment. Gibbs (1985) argued that clients of African descent enter therapy with reservations about White therapists and spend the early phase of therapy evaluating the interpersonal process for evidence of racist or color-blind attitudes that are incompatible with understanding their realities. Perhaps experiencing White therapists as insensitive or naïve about racial matters undermines confidence in the

therapist's competence and likelihood of treatment success. Although speculative, this interpretation is supported in the existing literature. For example, African Americans' attitudes toward seeking psychological treatment have been found to be more favourable than Whites before seeking psychotherapy and less favourable than Whites after seeking psychotherapy (Diala et al., 2000).

### Respecified Model

A post hoc model was specified based on the results from the hypothesized models (e.g., indicators of poor fit) and theoretical considerations. The respecified model fit the observed data. The model fit indices were in the acceptable range and each of the pathways was statistically significant. Africultural coping mediated the relationship between Africentrism and perceived availability of social support. Thus, it appears that individuals who identify with an Africentric orientation are more likely to perceive greater availability of social support, which is enhanced by their use of indigenous coping strategies. Furthermore, greater perceived availability of social support predicted more openness to revealing personally distressing or embarrassing problems.

These relationships may be explained by a cultural preference for providing indirect support for emotional problems that does not involve explicit discussion of the problem. For instance, close others may make efforts to engage and interact with individuals who appear to be distressed or are suspected of being troubled in order to distract them from their problems and reinforce their sense of self-worth. Similarly, religious figures may make efforts to reaffirm the religious beliefs or encourage prayer for individuals who appear to be distressed or are suspected of being troubled (Snowden, 1998). Such africultural coping strategies may serve to increase

perceptions of available social support and help soften reluctance to discussing personal problems.

Furthermore, self-concealment mediated the relationship between cultural mistrust and psychological distress. This finding replicates the relationships in hypothesized path model 3, further supporting the earlier supposition that mistrust of the dominant culture may compound self-concealment tendencies and intensify emotional distress. Like the hypothesized models, both direct pathways from psychological distress and attitudes toward seeking psychological distress toward willingness to seek psychological treatment remained significant - the latter pathway demonstrating a stronger relationship. The covariates also predicted attitudes toward seeking psychological treatment and willingness to seek psychological treatment to a similar degree as demonstrated in hypothesized models 2 and 3.

### Limitations

The findings of the present study represent a major contribution to the existing literature regarding professional treatment-seeking behaviour for emotional and psychological issues among populations of African descent. Despite the poor overall fit of the hypothesized models, the explanatory value of cultural antecedents for psychological treatment seeking behaviour was evident. However, any conclusions drawn from these findings should be balanced with consideration of the methodological limitations.

One major limitation of path analysis is that specified models that fit the data well can never be truly proven or confirmed (Kline, 1991). Thus, even though the respecified model provided a good fit to the data, there may be other, yet to be tested models that explain the data equally well or better. Another major limitation is that the observed variables are assumed to be

measured without error, which is unrealistic in social sciences research. In future investigations, structural equation modeling using multiple indicators for latent variables may reduce the impact of measurement error.

Although the clinical outcome of interest is actual psychological treatment seeking, it was not possible to track future help-seeking behaviour of the participants. Accordingly, willingness to seek professional psychological help, the primary determinant of actual help-seeking behaviour, was used as a proxy measure. Another limitation is that cross-sectional data was collected to test hypothesized path models that specify the process of seeking psychological help, which unfolds over a period of time. Retesting the help-seeking pathways using longitudinal data may provide additional support for the interpretation of the results of the present study (e.g., cultural mistrust → psychological distress) by clarifying the proposed temporal relationship between the variables. While the results of path analyses cannot be used to definitively determine causation, retesting the proposed models using structural equation modeling may also enhance confidence in the causal hypotheses supported and rejected in the current study.

Although gender differences in help-seeking variables are frequently documented in the literature (Rogler & Cortes, 1993), they were not present in the current study. Gender invariance in the hypothesized path models cannot be assumed however, due to the relatively small sample size of males and females in the sample, multi-group analyses (i.e., male vs. female) of the hypothesized path models would have been underpowered. For the same reason, multi-group analyses comparing individuals who have previously sought psychological treatment versus individuals who have never sought psychological treatment were not conducted. The medium effect size of this covariate suggests that psychological help-seeking pathways may differentially predict willingness to seek psychological treatment for these two groups.

Even though participants in the present study were recruited from the community in addition to the university population, the age distribution of the sample did not adequately represent Canadians of African descent. Thus, the generalizability of the findings may be circumscribed. Furthermore, socially desirable responding was not accounted for in the present study. It is possible that the participants did not genuinely report their attitudes in an effort to enhance their self-image or make an impression that was consistent with their presumed intentions of the study.

#### Recommendations for Future Research

Future investigations of psychological treatment-seeking behaviour among people of African descent should test alternative models that build on the findings from the present study. Although the majority of the relationships specified in Cramer's (1999) model of help-seeking behaviour generalized to Canadians of African descent, the overall model did not adequately explain the process of seeking professional psychological treatment in this group. Specifically, the relationship between a) social support and psychological distress and b) self-concealment and attitudes toward seeking professional psychological help were not replicated. Other empirical studies of psychological help-seeking behaviour (e.g., Leech, 2007; Liao et al., 2005; Morgan, Ness, & Robinson, 2003) have replicated these relationships among samples of non-African descent (e.g., Asian, Asian American, White). The absence of these relationships in the present study suggests that the conditions that motivate psychological treatment-seeking among Canadians of African descent differs from those of other ethnoracial backgrounds. However, given that this study is the first to test a model of help-seeking in a population of African

descent, it is first necessary to retest the paths proposed in the present study with other populations of African descent to determine whether these findings are generalizable.

As noted in the summary and interpretation section of this chapter, differences in racial socialization, values, and mental health related stigma may account for differences in the help-seeking process and these should also be explicitly tested. For example, a closer examination of how culture impacts self-concealment tendencies among people of African descent may help identify the disconnect between self-concealment and attitudes toward seeking professional psychological help. Similarly, the lack of association between social support and psychological distress may also be clarified by investigations of how the perceived availability of different types of social resources (e.g., social outreach, affective support, instrumental support, informational support) may differentially affect psychological distress among people of African descent.

The role of mental health related stigma should also be given larger consideration in future investigations of psychological help-seeking behaviour among people of African descent, especially since mental health stigma is a highly salient issue in communities of African descent. Mental-health stigma may prove to be a more robust predictor of attitudes toward seeking professional psychological help than self-concealment in this population. As such, the source of the approach-avoidance conflict for people of African descent may look quite different than what has been previously conceptualized (e.g., Cramer, 1999; Kushner & Sher, 1989, 1991).

Future model testing should also include multi-group analyses to further examine the influence of extraneous variables on the help-seeking process among people of African descent. For example, although the empirical literature suggests that matching therapists and clients by race does not improve therapeutic outcomes (Norcross, 2002), the findings of the current study

suggest that concerns about the therapist's race negatively influences attitudes about seeking and willingness to seek professional psychological treatment. While a therapist's race may not be integral to the treatment process, it may constitute a significant barrier to seeking treatment for those with high levels of cultural mistrust and other related characteristics such as anti-White racial identity attitudes. Thus, it is possible that the aspects of the help-seeking process may differ for those who identify the race of the therapist as an important factor. Other extraneous factors that might impact the help-seeking process include previous experience seeking professional psychological help, gender, and education.

The findings of the current study also point to theoretical reconsiderations -- most notably, the relationship between perceived social support and psychological distress. For Canadians of African descent, perceived social support did not exhibit a buffering effect on psychological distress. Perhaps the temporal relation of these variables is misspecified for this population. As indicated earlier, it may be that individuals of African descent who exhibit signs of poor emotional well-being mobilize close others to engage them socially in an effort to subtly communicate that support is available if needed (Snowden, 1998). It may also be that the role of social support has been misspecified for this population. For instance, the respecified model demonstrated that perceived social support attenuates self-concealment tendencies, which for people of African descent may partially attributed to an inherent trait as well as cultural conditioning.

The link between informal and formal help-seeking should also be reconsidered. The empirical literature suggests that professional psychological help is typically sought when informal resources have been exhausted. However, the findings of the present study do not support a link between informal, afri-cultural coping and willingness to seek professional



psychological help. It is possible that psychological distress mediates this relationship, in that professional help-seeking depends on the effectiveness of informal coping strategies in managing psychological distress. It is also possible that informal coping resources serve to complement rather than substitute professional help-seeking behaviour. Future research should test the viability of these alternative pathways to psychological treatment seeking.

### Clinical Implications

The findings of the present study speak to the importance of cultural, attitudinal, and dispositional perspectives in deciding to seek professional psychological help. For Canadians African descent, in particular, identification with Africentric values and difficulty trusting the mental health care system appears to modulate characterological tendencies and beliefs that directly influence psychological help-seeking behaviour. Before clients enter the therapy room, they must overcome access and psychological barriers to seeking professional help. As the psychological barriers to seeking professional help may be rooted in culture-based rules, norms, and expectations, mental health promotion and prevention efforts need to address community concerns about what it means to seek outside help and counterbalance these issues with information about how professional mental health services may specifically benefit people in their community. Targeting fears and negative perceptions about seeking professional mental health services and reframing mental health services in a way that is consistent with culturally accepted goals may be the most effective approach to reducing psychological barriers and improving the utilization of services (Komiya, Good, & Sherrod, 2000). Such efforts may also help to reduce the service gap in other communities of colour.

The apparent cultural antecedents to mental health care decision making lends support to the cultural safety approach to improving mental health service delivery for marginalized populations. Beyond providing culturally competent services, the cultural safety approach recognizes how the national, political, cultural history of marginalized groups have contributed to power imbalances that negatively affect health care behaviours. The cultural safety approach reflects a shift in the power dynamics in that the recipients of mental health services define which practices are safe or unsafe. Any practice that alienates or discourages individuals from seeking necessary treatment is regarded as unsafe (Anderson et al., 2003; National Aboriginal Health Organization [NAHO], 1996). Through this process, communities can assert their specific needs by prioritizing resources and establishing the standards for appropriate, accessible care. Such a process may transform the opinions of members of marginalized groups, facilitating their identification with mental health services as a viable option for assistance with personal and emotional problems.

Primary health providers, rather than specialized mental health providers such as psychologists or psychiatrists (Mojtabai & Olfson, 2006), are often the first professionals sought by Canadians seeking help for mental health concerns. Mental health capacity-building efforts oriented toward a) improving cultural competency and safety practices within the primary health care setting to reduce the social distance that can hinder the communication of emotional distress and b) increasing awareness of referral services specifically designed for particular ethnic minority communities may also be required to improve the utilization of mental health care services by ethnic minorities. Research has demonstrated that mental health programs oriented to specific minority communities effectively promote the utilization of mental health services by members of these communities (Takeuchi et al., 1995).

Greater ethnic minority representation among mental health practitioners in these specialized services has been identified as one of the factors that encourage service utilization and treatment retention (Snowden, 1999a; Sue, Fujino, Hu, Takeuchi, & Zane, 1991; Wu & Windle, 1980). Given the importance of a therapist's race for Canadians of African descent who are considering seeking professional mental health services, specialized mental health services with racially similar staff may be more successful than mainstream programs in attracting clientele. It may be that the presence of ethnic minority mental health providers is perceived as an indicator of a culturally safe environment where the professionals, by virtue of their shared racial and/or cultural background, are more likely to share a worldview, inherently understand the sociocultural subtleties underlying minority clients' presenting problems, and provide treatment that is consistent with minority clients' values.

## REFERENCES

- Ajzen, I. (1991). The theory of planned behavior. *Organizational Behavior and Human Decision Processes*, 50, 179-211.
- Ajzen, I., & Fishbein, M. (1980). Understanding attitudes and predicting social behaviour. Englewood Cliffs, NJ: Prentice Hall.
- Ajzen, I., & Fishbein, M. (2005). The influence of attitudes on behaviour. In D. Albarracín, B. Johnson, T. Blair, & M. Zanna (Eds.) *The Handbook of Attitudes* (pp. 173-221. Mahwah, NJ: Lawrence Erlbaum Associates Publishers.
- Akaike, H. (1974). A new look at the statistical model identification. *IEEE Transactions on Automatic Control*, 19(6), 716-723.
- Akbar, N. (1985). Our destiny: Authors of a scientific revolution. In H. McAdoo & J. McAdoo (Eds.), *Black Children* (pp. 17-31). Newbury Park, CA: Sage.
- Albarracín, D., Johnson, B. T., Fishbein, M., & Muellerleile, P. A. (2001). Theories of reasoned action and planned behavior as models of condom use: A meta-analysis. *Psychological Bulletin*, 127, 142-161.
- Alvidrez, J. (1999). Ethnic variation in mental health attitudes and help-seeking behaviours among low income African American, Latina, and European American young women. *Community Mental Health Journal*, 35, 515-530.
- Amirkhan, J. H. (1990). A factor analytically derived measure of coping: The Coping Strategy Indicator. *Journal of Personality and Social Psychology*, 23, 36-49.
- Anderson, J., Perry, J., Blue, C., Browne, A., Henderson, A., Khan, K., Kirkham, S., Lynam, J., Semeniuk, P., & Smye, V. (2003). "Rewriting" cultural safety within the postcolonial and

- postnational feminist project: Toward new epistemologies of healing. *Advances in Nursing Science*, 26(3), 196-214.
- Angermeyer, M. C., Matschinger, H., & Riedel-Heller, S. G. (2001). What to do about mental disorder help-seeking recommendations of the lay public. *Acta Psychiatrica Scandinavica*, 103, 220–225.
- Anglin, D. M., Link, B. G., Phelan, J. C. (2006). Racial differences in stigmatizing attitudes toward people with mental illness. *Psychiatric Services*, 57(6), 857-862.
- Arbuckle, J. L. (2008): AMOS 17.0 User's Guide. Chicago: SPSS/Erlbaum.
- Armitage, C. J., & Conner, M. (2001). Efficacy of the theory of planned behavior: A meta-analytic review. *British Journal of Social Psychology*, 40, 471-499.
- Asante, M. K. (1998). The Afrocentric idea. Philadelphia, PA: Temple University Press.
- Ashby, H. U. (1986). Mislabeled the Black client: A reply to Ridley. *American Psychologist*, 41, 224-225.
- Atkinson, D. R. (1983). Ethnic similarity in counseling psychology: A review of research. *The Counseling Psychologist*, 11(3), 79-92.
- Atkinson, D. R., & Gim, R. H. (1989). Asian-American cultural identity and attitudes toward mental health services. *Journal of Counseling Psychology*, 36, 209-212.
- Atkinson, D. R., & Wampold, B. E. (1982). A comparison of the Counselor Rating Form and Counselor Effectiveness Rating Scale. *Counselor Education and Supervision*, 22, 25-36.
- Atkinson, D. R., Furlong, M. J., & Poston, W. C. (1986). Afro-American preferences for counselor characteristics. *Journal of Counseling Psychology*, 33, 326-330.

- Atkinson, D. R., Morten, G., & Sue, D. W. (1998). Addressing the mental health needs of racial/ethnic minorities. In D. R. Atkinson et al., (Ed.), *Counseling American minorities* (5<sup>th</sup> ed., pp. 51-80). Boston: McGraw-Hill.
- Ayalon, L., & Young, M. A. (2005). Racial group differences in help-seeking behaviors. *The Journal of Social Psychology, 145*(4), 391-403.
- Azibo, D. A. (1992). Understanding the proper and improper usage of the comparative research framework. In D. A. Azibo, A. Burlew, W. C. Banks, H. P. McAdoo (Eds.), *African American psychology: Theory, research, and practice* (pp. 18-27). Thousand Oaks, CA, US: Sage Publications, Inc.
- Azibo, D. A. (1996). Personality, clinical, and social psychological research on Blacks: Appropriate and inappropriate research frameworks. In D. A. Azibo (Ed.), *African psychology in historical perspective and related commentary* (pp. 203-234). Trenton, NJ: Africa World Press.
- Baldwin, J. A. (1984). African self-consciousness and the mental health of African-Americans. *The Journal of Black Studies, 15*, 177-194.
- Baldwin, J. A., Brown, R., & Rackley, R. (1990). Some socio-behavioral correlates of African self-consciousness in African American college students. *Journal of Black Psychology, 17*(1), 1-17.
- Baldwin, J. A. (1976). Black psychology and Black personality. *Black Books Bulletin, 4*(3), 6-11, 65.
- Baldwin, J. A. (1981). Notes on an Africentric theory of Black personality. *Western Journal of Black Studies, 5*(3), 172-179.

- Baldwin, J. A. (1985). Psychological aspects of European cosmology in American society. *The Western Journal of Black Studies*, 9(4), 216-223.
- Baldwin, J. A. (1987). African psychology and Black personality testing. *The Negro Educational Review*, 38(3-4), 56-66.
- Baldwin, J. A., & Bell, Y. A. (1985). The African self-consciousness scale: An Africentric personality questionnaire. *The Western Journal of Black Studies*, 9, 61-68.
- Barwick, C. L., & Campbell, J. (1993). *Implementing a shared vision: A symposium on models of care in a pluralistic Canada*. Toronto: Cultural, Community and Health Studies, the Clarke Institute of Psychiatry and The Addiction Research Foundation.
- Bell, C. C., & Mehta, H. (1980). The misdiagnosis of black patients with manic depressive illness. *Journal of the National Medical Association*, 72, 141-145.
- Bell, C. C., & Mehta, H. (1981). Misdiagnosis of black patients with manic depressive illness: Second in a series. *Journal of the National Medical Association*, 73, 101-107.
- Bell, T. J., & Tracy, T. J. (2006). The relation of cultural mistrust and psychological health. *Journal of Multicultural Counseling and Development*, 34, 2-14.
- Benjamin, A. (1974). *The helping interview*. Boston: Houghton Mifflin.
- Bentall, R. P., Kinderman, P., Kaney, S. (1994). The self, attribution processes and abnormal beliefs: Towards a model of persecutory delusions. *Behavior Research and Therapy*, 32, 331-341.
- Betancourt, H., & Lopez, S. R. (1993). The study of culture, ethnicity, and race in American psychology. *American Psychologist*, 48, 629-637.

- Billings, A. G., & Moos, R. H. (1981). The role of coping responses and social resources in attenuating the impact of stressful life events. *Journal of Behavioral Medicine, 4*, 139-157.
- Billingsley, A. (1992). *Climbing Jacob's ladder: The enduring legacy of African-American families*. New York: Simon & Schuster.
- Birkel, R. C., & Reppucci, N. D. (1983). Social networks, information seeking, and the utilization of services. *American Journal of Community Psychology, 11*, 185-205.
- Blank, M. B., Tetrick, F. L., Brinkley, D. F., Smith, H. O., & Doheny, V. (1994). Racial matching and service utilization among seriously mentally ill consumers in the rural south. *Community Mental Health Journal, 30*, 271-280.
- Bodner, E., & Mikulincer, M. (1998). Learned helplessness and the occurrence of depressive-like and paranoid-like responses: The role of attentional focus. *Journal of Personality and Social Psychology, 74*, 1010-1023.
- Bosmajian, C. P., & Mattson, R. E. (1980). A controlled study of variables related to counseling center use. *Journal of Counseling Psychology, 27*, 510-519.
- Bourjolly, J. N. (1998). Differences in religiousness among black and white women with breast cancer. *Social work in health care, 28*(1), 21-39.
- Boyd, J. H. (1986). Use of mental health services for the treatment of panic disorder. *American Journal of Psychiatry, 143*, 1569-1574.
- Boyd-Franklin, N., & Shenouda, N. T. (1990). A multisystems approach to the treatment of a Black, inner-city family with a schizophrenic mother. *American Journal of Orthopsychiatry, 60*(2), 186-195.



- Bronstein, P. (1986). Self-disclosure, paranoia, and unaware racism: Another look at the Black client and White therapist. *American Psychologist*, 41, 225-226.
- Brown, D. R., & Gary, L. E. (1987). Stressful life events, social support networks, and the physical and mental health of urban Black adults. *Journal of Human Stress*, 165–174.
- Brown, G. W., Bhrolchain, M. H., & Harris, T. (1975). Social class and psychiatric disturbance among women in an urban population. *Sociology*, 9, 225-254.
- Byrne, B. M. (2001). *Structural equation modeling with Amos: Basic concepts, applications, and programming*. Mahwah, NJ: Erlbaum.
- Caldwell, C. H. (1996). Predisposing, enabling, and need factors related to patterns of help-seeking among African America women. In H. W. Neighbors and J. S. Jackson (Eds.), *Mental Health in Black America* (pp. 146-160). Thousand Oaks, CA: Sage Publications.
- Canadian Task Force on Mental Health Issues Affecting Immigrants and Refugees (1988). *After the door has been opened: Mental health issues affecting immigrants and refugees in Canada*. Ottawa: Multiculturalism and Citizenship Canada.
- Carten, A. J. (2006). African Americans and mental health. In Rosenberg, J., & Rosenberg, S. (Eds.), *Community mental health: Challenges for the 21<sup>st</sup> century*. New York: Taylor & Francis Group.
- Cash, P. J., Begley, D. A., McCown, & Weise, B. C. (1975). When counselors are heard but not seen: Initial impact of physical attractiveness, *Journal of Counseling Psychology*, 22(4), 273–279.
- Centre for Addiction and Mental Health [CAMH] Insite News (2006). *Developing a New Service Model for Canadians of African Descent: Enslavement, Colonialism, Racism, Identity, and Mental Health*, November-December Issue, 17-18.

- Cepeda-Benito, A., & Short, P., (1998). Self-concealment, avoidance of psychological services, and perceived likelihood of seeking professional help. *Journal of counseling Psychology*, *45*, 58-64.
- Chatters, L. M. (2000). Religion and health: Public health research and practice. *Annual Review of Public Health*, *21*, 335–367.
- Chatters, L. M., Taylor, R. J., & Neighbors, H. W. (1989). Size of the informal helper network mobilized in response to serious personal problems. *Journal of Marriage and the Family*, *51*, 667-676.
- Chatzisarantis, N. L. & Hagger, M. S. (2007). Mindfulness and the intention-behavior relationship within the theory of planned behavior. *Personality and Social Psychology Bulletin*, *33*(5), 663-676.
- Chou, C. P., & Bentler, P. M. (1995). Estimates and tests in structural equation modeling. In R. Hoyle (Ed.), *Structural equation modeling: Issues, concepts, and applications* (pp. 37-55). Newbury Park, CA: Sage.
- Cokley, K., & Williams, W. (2005). A psychometric examination of the Africentric Scale: Challenges in measuring Afrocentric values. *Journal of Black Studies*, *35*(6), 827-843.
- Collins, K.W., & Lightsey, O. R., Jr. (2001). Racial identity, generalized self-efficacy, and self-esteem: A pilot study of a mediation model for African American women. *Journal of Black Psychology*, *27*(3), 272-287.
- Combs, D. R., & Penn, D. L. (2004). The role of sub-clinical paranoia on social perception and behavior. *Schizophrenia Research*, *69*, 93-104.

- Combs, D. R., Penn, D. L., & Fenigstein, A. (2002). Ethnic differences in subclinical paranoia: An expansion of the norms for the paranoia scale. *Cultural Diversity and Ethnic Minority Psychology, 8*, 248-256.
- Combs, D. R., Penn, D. L., Cassisi, J., Michael, C., Wood, T., Tanner, J., & Adams, C. (2006). Perceived racism as a predictor of paranoia among African Americans. *Journal of Black Psychology, 32*(1), 87-104.
- Constantine, M. G. (2002a). The intersection of race, ethnicity, gender, and social class in counseling: Examining selves in cultural contexts. *Journal of Multicultural Counseling and Development. Special Issues: Race, ethnicity, gender, and social class in counseling, 30*(4), 210-215.
- Constantine, M. G. (2002b). Predictors of satisfaction with counseling: Racial and ethnic minority clients' attitudes toward counseling and ratings of their counselors' general and multicultural counseling competence. *Journal of Counseling Psychology, 49*(2), 255-263.
- Constantine, M. G., Chen, E. C., & Ceesay, P. (1997). Intake concerns of racial and ethnic minority students at a university counseling center: Implications for developmental programming and outreach. *Journal of Multicultural Counseling and Development, 25*, 210-218.
- Constantine, M. G., Gainor, K. A., Ahluwalia, M. L., & Berkel, L. A. (2003). Independent and interdependent self-construals, individualism, collectivism, and harmony control in African Americans. *Journal of Black Psychology, 29*, 87-101.
- Constantine, M.G., Okazaki, S., & Utsey, S.O. (2004). Self-concealment, social self-efficacy, acculturative stress, and depression in African, Asian, and Latin American International College Students. *American Journal of Orthopsychiatry, 74*(3), 230-241.

- Constantine, M. G., Lewis, E. L., Conner, L. C., & Sanchez, D. (2000). Addressing spiritual and religious issues in counseling African Americans: Implications for counselor training and practice. *Counseling and Values, 45*, 28-38.
- Constantine, M. G., Myers, L. J., Kindaichi, M., & Moore, J. L. (2004). Exploring indigenous mental health practices: The roles of healers and helpers in promoting well-being in people of color. *Counseling and Values, 48*, 110-125.
- Constantine, M. G., Wilton, L., & Caldwell, L. D. (2003). The role of social support in moderating the relationship between psychological distress and willingness to seek psychological help among Black and Latino college students. *Journal of College Counseling, 6*(2), 155-165.
- Cooley, K. (2006). The impact of racialized schools and racist (mis)education on African American students' academic identity. In M.G. Constantine & D.W. Sue, *Addressing racism: Facilitating cultural competence in mental health and educational settings* (pp. 127-144). Hoboken, NJ: John Wiley & Sons, Inc.
- Cooper, A.E., Corrigan, P.W., & Watson, A.C. (2003). Mental illness stigma and care seeking. *The Journal of Nervous and Mental Disease, 191*(5), 339-341.
- Cooper-Patrick, L., Gallo, J. J., Power, N. R., Steinwachs, D., Eaton, W. W., & Ford, D. E. (1999). Identification of patient attitudes and preferences regarding treatment for depression. *Journal of General Internal Medicine, 12*, 431-438.
- Council of American Survey Research Organizations [CASRO]. (1982). *On the definition of response rates* (special report of the CASRO task force on completion rates, Lester R. Frankel, Chair). Port Jefferson, NY: CASRO.

- Cramer, K. M. (1999). Psychological antecedents to help-seeking behavior: A reanalysis using path modeling structures. *Journal of Counseling Psychology, 46*(3), 381-387.
- Cramer, K. M., & Barry, J. E. (1999). Psychometric properties and confirmatory factor analysis of the Self-Concealment Scale. *Personality and Individual Differences, 27*(4), 629-637.
- Cramer, K. M., & Lake, R. P. (1998). The Preference for Solitude Scale: psychometric properties and factor structure. *Personality and Individual Differences, 24*, 193-199.
- Cutrona, C. E. (1982). Transition to college: Loneliness and the process of social adjustment. In L. A. Peplau & D. Perlman (Eds.), *Loneliness: A sourcebook of current research, theory, and therapy* (pp. 291-309). New York: Wiley Interscience.
- Cutrona, C. E. (1984). Social support in the transition to parenthood. *Journal of Abnormal Psychology, 93*, 378-390.
- Cutrona, C. E., & Russell, D. W. (1987). The provisions of social relationships and adaptation to stress. In W. H. Jones & D. Perlman (Eds.), *Advances in personal relationships* (Vol. 1, pp. 37-67). Greenwich, CT: JAI Press.
- Cutrona, C. E., & Troutman, B. R. (1986). Social support, infant temperament, and parenting self-efficacy: A mediational model of postpartum depression. *Child Development, 57*, 1507-1518.
- Cutrona, C. E., Russell, D., & Rose, J. (1986). Social support and adaptation to stress by the elderly. *Psychology and Aging, 1*, 47-54.
- Dahlstrom, W.G. (1969). Recurrent issues in the development of the MMPI. In J.N. Butcher (Ed.), *MMPI: Research development and clinical applications*. New York: McGraw-Hill.
- Daly, A., Jennings, J., Beckett, J. O., & Leashore, B. R. (1995). Effective coping strategies of African Americans. *Social Work, 40*, 240-248.

- Davies, J., McCrae, B.P., Frank, J., Dochnahl, A., Pickering, T., Harrison, B., Zakrzewski, M., & Wilson, K. (2000). Identifying male college students' perceived health needs, barriers to seeking help, and recommendations to help men adopt healthier lifestyles. *Journal of American College Health, 48*, 259-267.
- Davis, S. (2006). *Community Mental Health in Canada: Policy, Theory, and Practice*. Vancouver: UBC Press.
- Deane, F. P., & Chamberlain, K. (1994). Treatment fearfulness and distress as predictors of professional psychological help-seeking. *British Journal of Guidance and Counseling, 22*, 207-217,
- Deane, F. P., & Todd, D. M. (1996). Attitudes and perceived likelihood of seeking professional help for personal problems or suicidal thinking. *Journal of College Student Psychotherapy, 10*, 45-59.
- DeFigueredo, J. M., & Boerstler, H. (1988). The relationship of presenting complaints to the use of psychiatric services in a low-income group. *American Journal of Psychiatry, 145*, 1145-1148.
- Derogatis L. R. (1983). SCL-90-R administration, scoring, and procedures manual. 2nd ed. Baltimore: Clinical Psychometric Research.
- Derogatis, L. R. (1993). *BSI Brief Symptom Inventory. Administration, Scoring, and Procedures Manual (4th Ed.)*. Minneapolis, MN: National Computer Systems.
- Derogatis, L. R. (2000). *BSI-18: Brief Symptom Inventory 18: Administration, scoring, and procedures manual*. Minneapolis, MN: National Computer Systems.
- Derogatis, L.R., Rickels, K., & Rock, A. (1976). The SCL-90 and the MMPI: A step in the validation of a new self-report scale. *British Journal of Psychiatry, 128*, 280-289.

- Diala, C., Muntaner, C., Walrath, C., Nickerson, K. J., LaVeist, T. A., Leaf, P. J. (2000). Racial differences in attitudes toward professional mental health care and in the use of services. *American Journal of Orthopsychiatry*, 70(4), 455-464.
- Dilworth-Anderson, P., Burton, L. M., & Johnson, L. B. (1993). Reframing theories for understanding race, ethnicity, and families. In P. G. Boss, W. J. Doherty, R. LaRossa, W. R. Schumm, & S. K. Steinmetz (Eds.), *Sourcebook of family theories and methods: A conceptual approach* (pp. 627-645). New York: Plenum.
- Dilworth-Anderson, P., Williams, S. W., & Cooper, T. (1999). The contexts of experiencing emotional distress among family caregivers to elderly African Americans. *Family relations Special Issue: Interventions for family caregivers*, 48(4), 391-396.
- Dixon, D. N., & Glover, J. A. (1984). *Counseling: A problem solving approach*. New York: Wiley.
- Dressler, W. W. (1985). Extended family relationships, social support, and mental health in a southern Black community. *Journal of Health and Social Behavior*, 26, 39 - 48.
- Dressler, W. W. (1991). *Stress and adaptation in the context of culture: Depression in a southern Black community*. Albany: State University of New York Press.
- Ellison, C. G. (1993). Religious involvement and self perception among Black Americans. *Social Forces*, 71, 1027-1055.
- Ellison, C. G., & Taylor, R. J. (1996). Turning to prayer: Social and situation antecedents of religious coping among African Americans. *Review of Religious Research*, 38, 111-131.
- Ensel, W., & Lin, N. (1991). The life stress paradigm and psychological distress. *Journal of Health and Social Behavior*, 32, 321-341.

- Essed, P. (1991). *Understanding everyday racism: An interdisciplinary theory*. Newbury Park, CA: Sage Publications.
- Evans, S., & Katona, C. (1995). Epidemiology of depressive symptoms in elderly primary care attenders. *Dementia, 4*, 327-333.
- Everett, J. E., Chipungu, S. S., & Leashore, B. R. (1991). *Child welfare: An Africentric perspective*. New Brunswick, NJ: Rutgers University Press.
- Fabian, E. S., & Edwards, Y. V. (2005). Community mental health and African Americans. In D. A. Harley & J. M. Dillard (Eds.), *Contemporary Mental Health Issues Among African Americans* (pp. 225-235). Alexandria, VA: American Counseling Association.
- Fazio, R. H. (1990). Multiple processes by which attitudes guide behavior: The mode model as an integrative framework. *Advances in Experimental Social Psychology, 23*, 75-109.
- Fenigstein, A. & Vanable, P. A. (1992). Paranoia and self-consciousness. *Journal of Personality and Social Psychology, 62*, 129-138.
- Fenigstein, A., Scheier, M. F., & Buss, A. H. (1975). Public and private self-consciousness: Assessment and theory. *Journal of Consulting and Clinical Psychology, 43*, 522-527.
- Fischer, E. H., & Farina, A. (1995). Attitudes toward seeking professional psychological help: A shortened form and considerations for research. *Journal of College Student Development, 36*(4), 368-373.
- Fischer, E. H., & Turner, J. L. (1970). Orientations to seeking professional help. *Journal of Consulting and Clinical Psychology, 35*, 70-90.
- Fishbein, M., & Ajzen, I. (1975). *Belief, attitude, intention, and behavior: An introduction to theory and research*. Reading, MA: Addison-Wesley.



- Fisher, J. D., & Fisher, W. A. (1992). Changing AIDS-risk behaviour. *Psychological Bulletin*, *111*, 455-474.
- Flaskerund, J. H. (1986). The effects of culture-compatible interventions on the utilization of mental health services by minority clients. *Community Mental Health Journal*, *22*, 127-141.
- Folkman, S. (1984). Personal control and stress and coping processes: A theoretical analysis. *Journal of Personality and Social Psychology*, *46*, 839-852.
- Folkman, S., & Lazarus, R. (1988). *Manual for the Ways of Coping questionnaire* [Research Edition]. Palo Alto, CA: Consulting Psychologists.
- Folkman, S., & Lazarus, R. S. (1980). An analysis of coping in a middle-aged community sample. *Journal of Health and Social Behavior*, *21*, 219-239.
- Franklin, A. J. (1999). Invisibility syndrome and racial identity development in psychotherapy and counseling African American men. *Counseling Psychologist*, *27*, 761-793.
- Freeman, D., Garety, P. A., Kuipers, E., Fowler, D., & Bebbington, P. E. (2002). A cognitive model of persecutory delusions. *British Journal of Clinical Psychology*, *41*, 331-347.
- Garb, H. N. (1997). Race bias, social class bias, and gender bias in clinical judgment. *Clinical Psychology: Science and Practice*, *4*, 99-120.
- Garb, H. N. (1998). *Studying the clinician*. Washington, DC: American Psychological Association.
- Garland, A., Ellis-MacLeod, W., Landsverk, J., Gasnger, W., & Johnson, I., (1998). Minority populations in the child welfare system: The visibility hypothesis reexamined. *American Journal of Orthopsychiatry*, *68*, 283-294.

- Gary, L. E. (1987). Attitudes of Black adults toward community health centers. *Hospital and Community Psychiatry, 38*, 110-1105.
- Gibbs, J.T., (1985). Treatment relationships with black clients: Interpersonal vs. instrumental strategies. In C. Germain (Ed.), *Advances in Clinical Social Work Practice* (pp. 188). Silver Spring, MD: National Association of Social Workers, Inc.
- Gilbert, D. J. (1997). The Prejudice Perception Assessment Scale: Measuring stigma vulnerability among African-American students at predominantly Euro-American universities. *Journal of Black Psychology, 24*, 305-321.
- Gim, R. H., Atkinson, D. R., & Whiteley, S. (1990). Asian-American acculturation, severity of concerns, and willingness to see a counselor. *Journal of Counseling Psychology, 37*(3), 281–285.
- Gollwitzer, P. M. (1993). Goal achievement: The role of intentions. In W. Stroebe & M. Hewstone (Eds.), *European review of social psychology*, Vol. 4 (pp. 141-185). Chichester, UK: Wiley.
- Goodman, S. H., Sewell, D. R., & Jampol, R. C. (1984). On going to the counselor: Contributions of life stress and social supports to the decision to seek psychological counseling. *Journal of Counseling Psychology, 31*, 306–313.
- Gould, S. J. (1990). Health consciousness and health behavior: The application of a new Health Consciousness Scale. *American Journal of Preventive Medicine, 6*(4), 288-237.
- Graham, M. J. (1999). The African-centred worldview: Toward a paradigm for social work. *Journal of Black Studies, 30*(1), 103-122.
- Grant-Thompson, S. K., & Atkinson, D. R. (1997). Cross-cultural mentor effectiveness and African American male students. *Journal of Black Psychology, 23*, 120-134.

- Greene, B. A. (1985). Considerations in the treatment of Black patients by White therapists. *Psychotherapy, 22*, 389-393.
- Greenley, J. R., & Mechanic, D. (1976). Social selection in seeking help for psychological problems. *Journal of Health and Social Behaviour, 17*(3), 249-262.
- Grier, W. H., & Cobbs, P. M. (1968). *Black Rage*. New York: Basic Books.
- Grills, C., & Longshore, D. (1996). Africentrism: Psychometric analyses of self-report measure. *Journal of Black Psychology, 22*(1), 86-106.
- Guarnaccia, P. J., & Parra, P. (1996). Ethnicity, social status, and families' experiences of caring for a mentally ill family member. *Community Mental Health Journal, 32*(3), 243-260.
- Hall, L. E., & Tucker, C. M. (1985). Relationships between ethnicity, conceptions of mental illness, and attitudes associated with seeking psychological help. *Psychological Reports, 57*, 97-106.
- Harris, T. L., & Molock, S. D. (2000). Cultural orientation, family cohesion, and family support in suicide ideation and depression among African American college students. *Suicide and Life Threatening Behavior, 30*, 341-353.
- Harrison, D. K. (1975). Race as a counselor-client variable in counseling and psychotherapy: A review of the research. *The Counseling Psychologist, 5*(1), 124-133.
- Hatchett, S. J., Cochran, D., & Jackson, J. S. (1991). Family life. In J. S. Jackson (Ed.), *Life in Black America* (pp. 46-83). Newbury Park, CA: Sage.
- Health Canada (2000). "Certain Circumstances": Issues in equity and responsiveness in access to health care in Canada. Ottawa: Health Canada.
- Helms, J. E., & Cook, D. A. (1999). *Using race and culture in counseling and psychotherapy: Theory and process*. Needham Heights, MA: Allyn & Bacon.

- Heurtin-Roberts, S., Snowden, L. R., & Miller, L. (1997). Expressions of anxiety in African Americans: Ethnography and the epidemiological catchment area studies. *Culture, Medicine, and Psychiatry, 21*, 337-363.
- Hill, P. (1995). African-centred paradigm. *The Drum, 2*(1), 4.
- Hobbs, S. R. (1985). Issues in psychotherapy with Black male adolescents in the inner city: A Black clinician's perspective. *Journal of Non-White Concerns, 13*, 79 – 87.
- Hofstede, G. (1980). *Culture's Consequences: International differences in Work-Related Values*. London, UK: Sage.
- Hollingshead, A. B., & Redlich, F. C. (1958). *Social class and mental illness*. New York: John Wiley.
- Hong, J., & Seltzer, M. M. (1995). The psychological consequences of multiple roles: The nonnormative case. *Journal of Health and Social Behavior, 36*, 386–398.
- Horwitz, A. V. (1977a). Social networks and pathways to psychiatric treatment. *Social Forces, 56*, 86-105.
- Horwitz, A. V. (1977b). The pathways into psychiatric treatment: Some differences between men and women. *Journal of Health and Social Behavior, 18*, 169-178.
- Hu, L. T., & Bentler, P. M. (1995). Evaluating model fit. In R. H. Hoyle (Ed.), *Structural Equation Modeling. Concepts, Issues, and Applications* (pp. 76-99). London: Sage.
- Hu, L. T., & Bentler, P. M. (1999). Cutoff criteria for fit indices in covariance structure analysis: Conventional criteria versus new alternatives. *Structural Equation Modeling, 6*, 1-55.
- Hu, T. W., Snowden, L. R., Jerrell, J. M., & Nguyen, T. D. (1991). Ethnic populations in public mental health: Service choice and level of use. *American Journal of Public Health, 81*, 1429-1434.

- Hughes, M., & Demo, D. H. (1989). Self-perception of Black Americans: Self-esteem and personal efficacy. *American Journal of Sociology, 95*, 132-159.
- Hunt, M. O. (1996). The individual, society, or both? A comparison of Black, Latino, and White Beliefs about the Causes of Poverty. *Social Forces, 75*, 293-322.
- Ichiyama, M. A., Colbert, D., Laramore, H., Heim, M., Carone, K., & Schmidt, J. (1993). Self-concealment and correlates of adjustment in college students. *Journal of College Student Psychotherapy, 7*, 55-68.
- Ingham, J. G., & Miller, P. M. (1986). Self-referral to primary care: Symptoms and social factors. *Journal of Psychosomatic Research, 30*, 49-56.
- Jackson, A. P., & Sears, S. J. (1992). Implications of an Africentric worldview in reducing stress for African American women. *Journal of Counseling and Development, 71*(2), 184-190.
- Jagers, R. J., & Smith, P. (1996). Further examination of the spirituality scale. *Journal of Black Psychology, 22*, 429-442.
- Jenkins, R. A. (1995). Religion and HIV: Implications for research and intervention. *Journal of Social Issues, 51*, 131-144.
- Jones, N.C. (1990). Black/White issues in psychotherapy: A framework for clinical practice. *Journal of Social Behavior and Personality, 5*(5), 305-322.
- Joreskog, K. G. (1993). Testing structural equation models. In K. A. Bollen & J. S. Lang (Eds.), *Testing structural equation models* (pp. 294 – 316). Newbury Park, CA: Sage.
- Joreskog, K. G., & Sorbom, D. (1988). *LISREL7: A Guide to the Program and Applications*, SPSS Inc., Chicago, IL: National Education Resources.

- Jorm, A. F., Griffiths, K. M., Christensen, H., Parslow, R. A., & Rogers, B. (2004). Actions taken to cope with depression at different levels of severity: A community survey. *Psychological Medicine, 34*(2), 293-299.
- Joseph, J., & Kuo, B. C. H. (2009). Black Canadians' coping responses to racial discrimination. *Journal of Black Psychology, 35*(1), 78-101.
- June, L. N., Pope Curry, B., & Gear, C. L. (1990). An eleven-year analysis of Black students' experience of problems and use of services: Implications for counseling professionals. *Journal of Counseling Psychology, 37*, 21-39.
- Kadushin, A. (1983). *The social work interview*. New York: Columbia University Press.
- Kahn, J. H., & Hessling, R. M. (2001). Measuring the tendency to conceal versus disclose psychological distress. *Journal of Social and Clinical Psychology, 20*, 41-65.
- Kahn, J. H., & Williams, M. N. (2003). The impact of prior counseling on predictors of college counseling center use. *Journal of College Counseling, 6*, 144-154.
- Kambon, K. K. (1992). An introduction to the African Self-Consciousness Scale. In R.L. Jones (Ed.), *Handbook of tests and measurements for research on Black populations* (207-215). Berkeley, CA: Cobb & Henry.
- Kambon, K. K. (1997). *The Cultural Misorientation Scale manual*. Tallahassee, FL: Nubian Nation.
- Kambon, K. K. (1998). An African-centered paradigm for understanding the mental health of Africans in America. In R. Jones (Ed.), *African American mental health: Theory, research and intervention*. Hampton, VA: Cobb and Henry Publishers.
- Karenga, M. (1988). Black studies and the problem of paradigm: The philosophical dimension. *Journal of Black Studies, 18*, 395-414.

- Kelly, A. E. (1998). Clients' secret keeping in outpatient therapy. *Journal of Counseling Psychology, 45*, 50–57.
- Kelly, A. E., & Achter, J.A. (1995). Self-concealment and attitudes toward counseling in university students. *Journal of Counseling Psychology, 42*, 40-46.
- Kelly, A. E., & Yip, J.J. (2006). Is keeping a secret or being a secretive person linked to psychological symptoms? *Journal of Personality, 75*(5), 1349-1370.
- Kessler, R. C., Berglund, P. A., Zhao, S., Leaf, P. J., Kouzis, A. C., Bruce, M. L., et al. (1996). The 12-month prevalence and correlates of serious mental illness. In R. W. Manderscheid & M.A. Sonnenschein (Eds.), *Mental health, United States* (pp. 59 – 70). Rockville, MD: Center for Mental Health Services.
- Kessler, R. C., McGonagle, K., Zhao, S., Nelson, C., Hughes, M., Eshleman, S., et al. (1994). Lifetime and 12-month prevalence of DSM-III-R psychiatric disorders in the United States: Results from the National Comorbidity Survey. *Archives of General Psychiatry, 51*, 8-19.
- Kim, B. S., & Omizo, M. M. (2003). Asian cultural values, attitudes toward seeking professional psychological help, and willingness to see a counselor. *Counseling Psychologist, 31*(3), 343-361.
- Kim, M. S., Hunter, J. E., Miyahara, A., Horvath, A. M., Bresnahan, M., & Yoon, H. J. (1996). Individual vs. culture-level dimensions of individualism-collectivism: Effects on preferred conversational styles. *Communication Monographs, 63*, 29-39.
- King, L. A., Emmons, R. A., & Woodley, S. (1992). The structure of inhibition. *Journal of Research in Personality, 26*, 85–102.

- Kirk, A. R. (1986). Destructive behaviors among members of the Black community with a special focus on males: Causes and methods of intervention. *Journal of Multicultural Counseling and Development, 14*, 3-9.
- Kitano, H. H. (1974). *Race Relations*. Englewood Cliffs, NJ: Prentice-Hall.
- Kleinman, A. (1980). *Patients and healers in the context of culture*. Berkeley, CA: University of California Press.
- Kline, R.B., (1991). Latent variable path analysis in clinical research: A beginner's tour guide. *Journal of Clinical Psychology, 47*(4), 471-484.
- Kline, R. B. (2005). *Principles and practice of structural equation modeling*. NY: Guilford Press.
- Klonoff, E. A., & Landrine, H. (1999). Cross-validation of the Schedule of Racist Events. *Journal of Black Psychology, 25*(2), 231-254.
- Klonoff, E. A., Landrine, H., & Ullman, J. B. (1999). Racial discrimination and psychiatric symptoms among Blacks. *Cultural Diversity & Ethnic Minority Psychology, 5*(4), 329-339.
- Koenig, H. G. (1998). Religious attitudes and practices of hospitalized medically ill older adults. *International Journal of Geriatric Psychiatry, 13*, 213-224.
- Komiya, N., Good, G.E., & Sherrod, N.B. (2000). Emotional openness as a predictor of college students' attitudes toward seeking psychological help. *Journal of Counseling Psychology, 47*, 138 – 143.
- Kramer, R. M. (1998). Paranoid cognition in social systems: Thinking and acting in the shadow of doubt. *Personality and Social Psychology Review, 2*, 251-275.



- Kramer, R. M., & Messick, D. M. (1998). Getting by with a little help from our enemies: Collective paranoia and its role in intergroup relations. In C. Sedikides, J. Schopler, & C. A. Insko (Eds.), *Intergroup cognition and intergroup behavior* (pp. 233-255). Mahwah, NJ: Erlbaum.
- Kraus, S. J. (1995). Attitudes and the prediction of behaviour: A meta-analysis of the empirical literature. *Personality and Social Psychology Bulletin*, *21*, 58-75.
- Krieger, N. & Sidney, S. (1996). Racial discrimination and blood pressure: The CARDIA study of young Black and White adults. *American Journal of Public Health*, *86*, 1370-1378.
- Kushner, M. G., & Sher, K. J. (1989). Fear of psychological treatment and its relation to mental health service avoidance. *Professional Psychology: Research and Practice*, *20*, 196-203.
- Kushner, M.G., & Sher, K..J. (1991). The relation of treatment fearfulness and psychological service utilization: An overview. *Professional Psychology: Research and Practice*, *22*(3), 196-203.
- Kwate, N. O. (2003). Cross-validation of the Africentrism Scale. *Journal of Black Psychology*, *29*(3), 308-324.
- Larson, D. G., & Chastain, R. L. (1990). Self-concealment: Conceptualization, measurement, and health implications. *Journal of Social and Clinical Psychology*, *9*(4), 439-455.
- Lazarus, R. S. & Folkman, S. (1980). An Analysis of Coping in a Middle-Aged Community Sample. *Journal of Health and Social Behavior*, *21*, 219-239.
- Lazarus, R. S. (2000). Evolution of a Model of Stress, Coping, and Discrete Emotion. In V. H. Rice (Ed.), *Handbook of Stress, Coping, and Health: Implications for Nursing Research, Theory, and Practice* (pp. 195-222). Thousand Oaks, CA: Sage.

- Lazarus, R., & Launier, R. (1978). Stress related transactions between person and environment. In A. Pervin & M. Lewis (Eds.), *Perspectives in international psychology* (pp. 284-327).
- Leaf, P. J., & Bruce, M. L. (1987). Gender differences in the use of mental-health related services: A reexamination. *Journal of Health and Social Behavior*, 28, 171-183.
- Leaf, P. J., Bruce, M. L., Tischler, G. L., & Holzer, C. E. (1987). The relationship between demographic factors and attitudes towards mental health services. *Journal of Community Psychology*, 15, 275-284.
- Leech, N.L. (2007). Cramer's model of willingness to seek counseling: A structural equation model for counseling students. *Journal of Psychology: Interdisciplinary and Applied*, 141(4), 435-445.
- Leong, F. T., Wagner, N. S., & Tata, S. P. (1995). Racial and ethnic variations in help-seeking attitudes. In J. G. Ponterotto, J. M. Casas, L. A. Suzuki, & C. M. Alexander (Eds.), *Handbook of multicultural counseling* (pp. 415 – 438). Thousand Oaks, CA, US: Sage Publications.
- Levin, J. S. (1986). Roles for the Black Pastor in Preventive Medicine. *Pastoral Psychology*, 35, 94-103.
- Levin, J. S., Chatters, L. M., & Taylor, R. J. (1995). Religious effects on health status and life satisfaction among Black Americans. *Journal of Gerontology: Social Sciences*, 50B, S154–S163.
- Lewis-Coles, M. E., & Constantine, M. G. (2006). Racism-related stress, afri-cultural coping, and religious problem-solving among African Americans. *Cultural Diversity and Ethnic Minority Psychology*, 12(3), 433-443.

- Liao, H., Rounds, J., & Klein, A. G. (2005). A test of Cramer's (1999) help-seeking model and acculturation effects with Asian and Asian American college students. *Journal of Counseling Psychology, 52*(3), 400-411.
- Lin, T.Y., Tardiff, K., Donetz, G., & Goresky, W. (1978). Ethnicity and patterns of help-seeking. *Culture, Medicine, & Psychiatry, 2*(1), 3-13.
- Lincoln, K. D., Chatters, L. M., & Taylor, R. J. (2003). Psychological distress among Black and white Americans: Differential effects of social support, negative interaction and personal control. *Journal of Health and Social Behavior 44*(3), 390-407.
- Lindsay, K. P., & Paul, G. L. (1989). Involuntary commitment to public mental institutions: Issues involving the overrepresentation of Blacks and assessment of relevant functioning. *Psychological Bulletin, 106*, 171-183.
- Link, B., & Dohrenwend, B. P. (1980). Formulation of hypotheses about the ratio of untreated and treated cases in the true prevalence studies of functional disorders in adults in the United States. In B. P. Dohrenwend, B. S. Dohrenwend, M. S. Gould, B. Link, R. Neugebauer, & R. Wunsch-Hitzig (Eds.), *Mental Illness in the United States: Epidemiological Estimates* (pp. 133 – 149). New York: Praeger.
- Linn, J. G., & McGranahan, D. A. (1980). Personal disruptions, social integration, subjective well-being, and predisposition toward the use of counseling services. *American Journal of Community Psychology, 8*, 87–100.
- Lopez, F. G., Melendez, M. C. Sauer, E. M.; Berger, E., & Wyssmann, J. (1998). Internal working models, self-reported problems, and help-seeking attitudes among college students. *Journal of Counseling Psychology, 45*(1), 7983.

- Lowenthal, M. F., & Haven, C. (1968). Interaction and adaptation: Intimacy as a critical variable. *American Sociological Review*, 33, 20-30.
- Lukoff, D., Turner, R., & Lu, F. (1992). Transpersonal psychology research review: Psychoreligious dimensions of healing. *Journal of Transpersonal Psychology*, 24, 41-60.
- Lyon, B. L. (2000). Stress, Coping, and Health: A Conceptual Overview. In V.H. Rice (Ed.), *Handbook of Stress, Coping, and Health: Implications for Nursing Research, Theory, and Practice* (pp. 3-23).
- Markus, H., & Kitayama, S. (1991). Culture and the self: Implications for cognition, emotion, and motivation. *Psychological Review*, 98, 224-253.
- Marmour, J. (1976). Common operational factors in diverse approaches to behaviour change. In A. Burton (Ed.), *What makes behavior change possible?* (pp. 3-12). New York: Brunner/Mazel.
- Maultsby, M. C., Jr. (1982). A historical view of Blacks' distrust of psychiatry. In S.M. Turner & R.T. Jones (Eds.), *Behavior modification in Black populations* (pp. 39-55). New York: Plenum.
- Maynard, C., Ehreth, J., Cox, G. B., Peterson, P.D., & McGann, M. E. (1997). Racial differences in the utilization of public mental health services in Washington state. *Administration and Policy in Mental Health*, 24, 335-356.
- Mbiti, J. S. (1970). *African religions and philosophy*. Garden City, NY: Anchor Books.
- McAdoo, H. (2007). *Black Families*. Sage Publications: Thousand Oaks, California.
- McCartney, J. (1995). Addictive behaviors: Relationship factors and their perceived influence on change. *Genetic, Social, & General Psychology Monographs*, 121, 39-64.

- McCrae, R. R. (1984). Situational determinants of coping responses: Loss, threat, challenge. *Journal of Personality and Social Psychology, 46*, 919-928.
- McDonald, J. T., & Kennedy, S. (2004). Insights into the 'healthy immigrant effect': health status and health service use of immigrants to Canada. *Social Science and Medicine, 59*, 1613-1627.
- McDonald, R. P., & Ho, M. R. (2002). Principles and practice in reporting structural equation analyses. *Psychological Methods, 7*, 64-82.
- McLean, C., Campbell, C., & Cornish, F. (2003). African-Caribbean interactions with mental health services in the UK: experiences and expectations of exclusion as (re)productive of health inequalities. *Social Science & Medicine, 56*(3), 657-669
- McMiller, W. P., & Weisz, J. R. (1996). Help-seeking preceding mental health intake among African American, Latino, and Caucasian youths. *Journal of the American Academy of Child and Adolescent Psychiatry, 35*, 1086-1094.
- Mechanic, D. (1975). Sociocultural and social-psychological factors affecting personal responses to psychological disorder. *Journal of Health and Social Behavior, 16*, 393-405.
- Meltzer, H., Bebbington, P., Brugha, T., Farrell, M., Jenkins, R., & Lewis, G. (2003). The reluctance to seek treatment for neurotic disorders. *International Review of Psychiatry, 15*, 123-128.
- Metropolitan Toronto District Health Council. (1992). *Improving mental health support for diverse ethnoracial communities in Metro Toronto*. Toronto: Metropolitan Toronto District Health Council.
- Meyers, L.S., Gamst, G., & Guarino, A.J. (2006). *Applied multivariate research: Design and interpretation*. Sage Publications: Thousand Oaks, California.

- Miller, M. L., Moen, P., & Dempster-McClain, D. (1991). Motherhood, multiple roles, and maternal well-being: Women of the 1950's. *Gender & Society, 5*, 565–582.
- Miller, P., & Ingham, J. G. (1976). Friends, confidants, and symptoms. *Social Psychiatry, 11*, 51-68.
- Millet, P. E., Sullivan, B. F., Schwebel, A. I., Myers, L. J. (1996). Black Americans' and White Americans' views on the etiology and treatment of mental health problems. *Community Mental Health Journal, 32*(3), 235-242.
- Milstein, G., Guarnaccia, P., and Midlarsky, E. (1995). Ethnic differences in the interpretation of mental illness: Perspectives of caregivers. *Research in community and mental health, 8*, 155-178.
- Miniard, P. W., & Cohen, J. B. (1995). An examination of the Fishbein's behavioral intentions model concept and measures. *Journal of Experimental Social Psychology, 17*, 309-329.
- Mirowsky, J., & Ross, C. E. (1983). Paranoia and the structure of powerlessness. *American Sociological Review, 48*, 228-239.
- Miville, M. L., & Constantine, M. G. (2006). Sociocultural predictors of psychological help-seeking attitudes and behavior among Mexican American college students. *Cultural Diversity & Ethnic Minority Psychology, 12*(3), 420-432.
- Mizell, C. A. (1999). African American men's personal sense of mastery: The consequences of the adolescent environment, self-concept, and adult achievement. *Journal of Black Psychology, 25*(2), 210-230.
- Mojtabai, R., & Olfson, M. (2006). Treatment seeking for depression in Canada and the United States. *Psychiatric Services, 57*(5), 631-639.

- Mollica, R. F., Streets, F. J., Boscarino, J., & Redlich, F. C. (1986). A community study of formal pastoral counseling activities of the clergy. *American Journal of Psychiatry*, *143*, 323-328.
- Monroe-Blum, H., Boyle, M. H., Offord, D., & Kates, N. (1989). Immigrant children: Psychiatric disorders, school performance, and service utilization. *American Journal of Orthopsychiatry*, *59*(4), 510-519.
- Moore, J. L., & Constantine, M. G. (2005). Development and initial validation of the Collectivistic Coping Styles Measure with African, Asian, and Latin American international students. *Journal of Mental Health Counseling*, *27*(4), 329-347.
- Morgan, T., Ness, D., & Robinson, M. (2003). Students' help-seeking behaviours by gender, racial background, and student status. *Canadian Journal of Counseling*, *37*(2), 151-166.
- Morris, E.G. (2001). Clinical practices with African American juxtaposition of standard clinical practices and africentrism. *Professional Psychology: Research and Practice*, *32*(6), 563-572.
- Mosher, C. E., Prelow, H. M., Chen, W. W., & Yackel, M. E. (2006). Coping and social support as mediators of the relation of optimism to depressive symptoms among Black college students. *Journal of Black Psychology*, *32*(1), 72-86.
- Mukherjee, S., Shukla, S., Woodle, J., Rosen, A.M., & Olarte, S. (1983). Misdiagnosis of schizophrenia in bipolar patients: a multiethnic comparison. *The American Journal of Psychiatry*, *140*, 1571 – 1574.
- Myers, L. J. (1993). *Understanding an Afrocentric worldview: Introduction to an optimal psychology* (2<sup>nd</sup> ed.). Dubuque, IA. Kendall/Hunt.

- National Aboriginal Health Organization (2006). *Fact Sheet: Cultural Safety*. Retrieved December 23, 2009, from <http://www.naho.ca/english/documents/Culturalsafetyfactsheet.pdf> .
- Neighbors, H. W. (1985). Seeking professional help for personal problems: Black Americans Use of Health and Mental Health Services. *Community Mental Health Journal, 21*, 156-166.
- Neighbors, H. W. (1990). The prevention of psychopathology in African Americans: An epidemiological perspective. *Community Mental Health Journal, 26*, 167-179.
- Neighbors, H. W., & Jackson, J. S. (1984). The use of informal and formal help: Four patterns of illness behavior in the Black community. *American Journal of Community Psychology, 12*(6), 629-644.
- Neighbors, H. W., Jackson, J. S., Bowman, P., Gurin, G. (1983). Stress, coping, and black mental health: Preliminary findings from a national study. *Prevention in Human Services, 2*, 4-29.
- Neighbors, H. W., Jackson, J. S., Campbell, L., & Williams, D. (1989). The influence of racial factors on psychiatric diagnosis: A review and suggestions for research. *Community Mental Health Journal, 25*, 301-311.
- Neighbors, H. W., Musick, M. A., & Williams, D. R. (1998). The African American minister as a source of help for serious personal crises: Bridge or barrier to mental health care. *Health Education and Behavior, 25*, 759-777.
- Nickerson, K. J., Helms, J. E., Terrell, F. (1994). Cultural mistrust, opinions about mental illness, and Black students' attitudes toward seeking psychological help from White counselors. *Journal of Counseling Psychology, 41*, 378-385.



- Nobles, W. W. (1986). *African psychology: Toward its reclamation, reascension, and revitalization*. Oakland, CA: Black Family Institute Publication.
- Nobles, W. W. (1990). African philosophy: Foundations of Black psychology. In R.E. Jones (Ed.), *Black Psychology* (pp. 47-63). Berkeley, CA: Cobb & Henry.
- Nobles, W. W. (1998). To be African or not to be: The question of identity or authenticity—some preliminary thoughts. In R. L. Jones (Ed.), *African American identity development* (pp. 185-206). Hampton, VA: Cobb & Henry.
- Norcross, J. C., & Prochaska, J. O. (1986). The psychological distress and self-change of psychologists, counselors, and laypersons. *Psychotherapy*, 23, 102–114.
- Norcross, J. C. (2002). Cultural and demongraphic diversity. In J.C. Norcross (ed.) *Psychotherapy relationships that work: Therapist contributions and responsiveness to patients*. New York: Oxford University Press.
- Notani, A. S. (1998). Moderators of perceived behavioral control's predictiveness in the theory of planned behavior: A meta-analysis. *Journal of Consumer Psychology*, 7, 247-271.
- Nouroozifar, M., & Zangeneh, M. (2006). Mental health and addiction state of ethnocultural/racial communities. *International Journal of Mental Health and Addiction*, 4, 288-193.
- Okun, B. F. (1976). *Effective helping: Interviewing and counseling techniques*. North Scituate, MA: Duxbury.
- Ontario Ministry of Health (1995). *Strengthening voices: Ministry of health anti-racism strategy*. Toronto: Ministry of Health.

- Ontario Ministry of Mental Health. (1992). *Let's work together: Guidelines to promote cultural/racial sensitivity and awareness in health care programs and services*. Toronto: Ministry of Health.
- Outlaw, F. H. (1993). Stress and coping: The influence of racism on the cognitive appraisal processing of African-Americans. *Issues in Mental Health Nursing, 14*, 399-409.
- Padgett, D. K., Patrick, C., Burns, B. J., & Schlesinger, H. J. (1994). Ethnicity and the use of outpatient mental health services in a national insured population. *American Journal of Public Health, 84*, 222-226.
- Pargament, K. I., Kennell, J., Hathaway, W., Grevengoed, N., Newman, J., & Jones, W. (1988). Religion and the problem-solving process: Three styles of coping. *Journal for the Scientific Study of Religion, 27*, 90-104.
- Park, H. S., & Levine, T. R. (1999). The theory of reasoned action and self-construal: Evidence from three cultures. *Communication Monographs, 66*, 199-218.
- Parker, W. M., & McDavis, R. J. (1983). Attitudes toward mental health agencies and counselor. *Journal of Non-White Concerns, 11*, 89-98.
- Parks, F. M. (1998). Models of helping and coping: A transgenerational theory of African-American traditional healing. *Revista Interamericana de Psicologia, 32*, 95-110.
- Peirce, R. S., Frone, M. R., Russell, M., Cooper, M. L., & Mudar, P. (2000). A longitudinal model of social contact, social support, depression and alcohol use. *Health Psychology, 19*, 28-38.
- Pennebaker, J. W. (1985). Traumatic experience and psychosomatic disease: Exploring the roles of behavioural inhibition, obsession, and confiding. *Canadian Psychology, 26*, 82-95.

- Pennebaker, J. W., & Beall, S. K. (1986). Confronting a traumatic event: Toward an understanding of inhibition and disease. *Journal of Abnormal Psychology, 95*, 274 – 281.
- Pennebaker, J. W., Hughes, C. F., & O' Heeron, R. C. (1987). The psychophysiology of confession: linking inhibitory and psychosomatic processes. *Journal of Personality and Social Psychology, 52*, 781-79.
- Pescosolido, B. A., & Boyer, C. A. (1999). How do people come to use mental health services? Current knowledge and changing perspectives. In A. V. Horwitz & T. L. Scheid (Eds.), *A handbook for the study of mental health: Social contexts, theories, and systems* (pp. 392–411). New York: Cambridge University Press.
- Phinney, J. S. (1992). The Multigroup Ethnic Identity Measure: A new scale for use with diverse groups. *Journal of Adolescent Research, 7*, 156-176.
- Pierre, M. R., & Mahalik, J. R. (2005). Examining African Self consciousness and Black racial identity as predictors of Black men's psychological well-being. *Cultural Diversity and Ethnic Minority Psychology, 11*, 28-40.
- Pinderhughes, E. (1992). Afro-American families and the victim system. In M. McGoldrick, J.K. Pearce, and J. Giordano (Eds.), *Ethnicity and Family Therapy*. New York, NY: The Guilford Press.
- Plummer, D. L., & Slane, S. (1996). Patterns of coping in racially stressful situations. *Journal of Black Psychology, 22*, 302-315.
- Ponce, F. Q., & Atkinson, D. R. (1989). Mexican-American acculturation, counselor ethnicity, counseling style, and perceived counselor credibility. *Journal of Counseling Psychology, 36*, 203-208.

- Ponterotto, J. G., Alexander, C. M., Hinkston, J. A. (1988). Afro-American preferences for counselor characteristics: A replication and extension. *Journal of Counseling Psychology*, 35(2), 175-182.
- Ponterotto, J. G., Baluch, S., & Carielli, D. (1998). The Suinn-Lew Asian Self-Identity Acculturation Scale (SL-ASIA): Critique and research recommendations. *Measurement and Evaluation in Counseling and Development*, 31(2), 109-124.
- Poston, C. W. S., Craine, M., & Atkinson, D. R. (1991). Counselor dissimilarity confrontation, client cultural mistrust, and willingness to self-disclose. *Journal of multicultural counseling and development*, 19(2).
- Potocny-Tripodi, M. (2002). *Best practices for social work with refugees and immigrants*. New York: Columbia University Press.
- Powell, G. N., & Kotschessa, B. (1995). Factors that influence professional employees' willingness to seek counseling. *Psychological Reports*, 77, 872-874.
- Priest, R. (1991). Racism and prejudice as negative impacts on African American clients in therapy. *Journal of Counseling & Development. Special Issue: Multiculturalism as a fourth force in counseling*, 70(1), 213 – 215.
- Proctor, E. K., & Rosen, A. (1981). Expectations and preferences for counselor race and their relation to intermediate treatment outcomes. *Journal of Counseling Psychology*, 28, 40-46.
- Pumariega, A. J., Glover, S., Holzer, C. E., & Nguyen, H. (1998). Utilization of mental health services in a tri-ethnic sample of adolescents. *Community Mental Health Journal*, 34, 145-156.

- Randall, D. M., & Wolff, J. A. (1994). The time interval in the intention-behavior relationship: Meta-analysis. *British Journal of Social Psychology, 33*, 405-418.
- Randolph, S. M., & Banks, D. (1993). Making a way out of no way: The promise of Africentric approaches to HIV prevention. *Journal of Black Psychology, 19*, 406-422.
- Reinhardt, J.P., Boerner, K., Horowitz, A. (2006). Good to have but not to use: Differential impact of perceived and received support on well-being. *Journal of Social and Personal Relationships, 23*(1), 117-129.
- Reitz, J. G. (1995). *A review of the literature on aspects of ethno-racial access, utilization and delivery of social services*. Toronto: Multicultural Coalition for Access to Family Services, Toronto, and the Ontario Ministry of Community and Social Services.
- Rickwood, D. J. & Braithwaite, V. A. (1994). Social-psychological factors affecting help-seeking for emotional problems. *Social Science and Medicine, 39*, 563-572.
- Ridley, C. R. (1984). Clinical treatment of the nondisclosing Black client: A therapeutic paradox. *American Psychologist, 39*, 1234-1244.
- Ridley, C. R. (1986). Optimum service delivery to the Black client. *American Psychologist, 41*, 226-226.
- Ritz, T., & Dahme, B. (1996). Repression, self-concealment and rationality/emotional defensiveness: the correspondence between three questionnaire measures of defensive coping. *Personality and Individual Differences, 20*, 95-102.
- Robbins, J. M., & Greenley, J. R. (1983). Thinking about what's wrong: Attributions of severity, cause, and duration in the problem definition stage of psychiatric help-seeking. *Research in Community & Mental Health, 3*, 209-232.

- Robertson, J. M. & Fitzgerald, L. F. (1992). Overcoming the masculine mystique: Preferences for alternative forms of assistance among men who avoid counseling. *Journal of Counseling Psychology*, 39, 240-246.
- Rogler, L. H., & Cortes, D. E. (1993). Help-seeking pathways: A unifying concept in mental health care. *The American Journal of Psychiatry*, 150(4), 554-561.
- Rogler, L. H., Malgady, R. G., & Rodriguez, O. (1989). *Hispanics and mental health: A framework for research*. Malabar, FL: Robert E. Krieger.
- Rotter, J.N. (1978). Generalized expectancies for problem solving and psychotherapy. *Cognitive Therapy & Research*, 2(1), 1 - 10.
- Russell, D. & Cutrona, C. (1984, August). The provision of social relationships and adaptation to stress. Paper presented at the American Psychological Association, Toronto, ON, Canada.
- Russell, D., & Cutrona, C. E. (1991). Social support, stress, and depressive symptoms among the elderly: Test of a process model. *Psychology and Aging*, 6, 190-201.
- Russell, D., Altmaier, E., & Van Velzen, D. (1987). Job-related stress, social support, and burnout among classroom teachers. *Journal of Applied Psychology*, 72, 269-274.
- Russell, D., Peplau, L. A., & Cutrona, C. E. (1980). The Revised UCLA Loneliness Scale: Concurrent and discriminant validity evidence. *Journal of Personality and Social Psychology*, 39, 472-480.
- Russell, M. (1971). "Erased, Debased, and Encased: The dynamics of African education colonization in America." In J.W. Blassingame (Ed.), *New Perspectives on Black Studies*. Chicago, IL: University of Illinois Press.
- Rutledge, A. L., & Gass, G. Z. (1967). *Nineteen Negro Men*. Jossey-Bass.

- Sanders-Thompson, V. L., Bazile, A., & Akbar, M. (2004). African Americans' perceptions of psychotherapy and psychotherapists. *Professional Psychology: Research and Practice*, 35(1), 19-26.
- Scheffler, R. M., & Miller, A. B. (1991). Differences in mental health service utilization among ethnic subpopulations. *International Journal of Law and Psychiatry. Special Issue: Law, psychiatry, and mental health policy*, 14(4), 363-376.
- Schnittker, J., Freese, J., & Powell, B. (2000). Nature, nature, neither, nor: Black-White differences in beliefs about the causes and appropriate treatment of mental illness. *Social Forces*, 78(3), 1101-1130.
- Schwarzer, R., & Schwarzer, C. (1996). A critical survey of coping instruments. In M. Zeidner & N. S. Endler (Eds.), *Handbook of Coping*. New York: Wiley.
- Sears, D. O. (1991). Symbolic racism. In P.A. Katz & D.A. Taylor (Eds.), *Eliminating racism: Profiles in controversy* (pp. 53-84). New York: Plenum.
- Sharkey, W. F., & Singelis, T. M. (1995). Embarrassability and self-construal: A theoretical integration. *Personality and Individual Differences*, 19, 919-926.
- Sheeran, P. (2002). Intention-behavior relations: A conceptual and empirical review. In W. Stroebe & M. Hewstone (Eds.), *European review of social psychology* (Vol. 12, pp/ 1-36). Chichester, UK: Wiley.
- Sheeran, P., Norman, P., & Orbell, S. (1999). Evidence that intentions based on attitudes better predict behaviour than intentions based on subjective norms. *European Journal of Social Psychology*, 29(2-3), 403-406.
- Sherbourne, C. D. (1988). The role of social support and life stress in the use of mental health services. *Social Science and Medicine*, 27, 1393-1400.

- Silva de Crane, R., & Spielberger, C. D. (1981). Attitudes of Hispanic, Black, and Caucasian university students toward mental illness. *Hispanic Journal of Behavioral Sciences, 3*, 241-255.
- Simon, R. J., Fleiss, J. L., Gurland, B. J., Stiller, P. R., Sharpe, L. (1973). Depression and schizophrenia in hospitalized Black and White mental patients. *Archives of General Psychiatry, 28*, 509-512.
- Singelis, T. N. (1994). The measurement of independent and interdependent self-construals. *Personality and Social Psychological Bulletin, 20*, 580-591.
- Snowden, L. R. & Cheung, F. K. (1990). Use of inpatient mental health services by members of ethnic minority groups. *American Psychologist, 45*(3), 347-355.
- Snowden, L. R. (1998). Racial differences in informal help-seeking for mental health problems. *Journal of Community Psychology, 26*, 429-438.
- Snowden, L. R. (1999a). African American service use for mental health problems. *Journal of Community Psychology 27*(3), 303-313.
- Snowden, L. R. (1999b). African American folk idiom and mental health service use. *Cultural Diversity and Ethnic Minority Psychology, 5*(4), 364-370.
- Snowden, L. R. (2001). Barriers to effective mental health services for African Americans. *Mental Health Services Research, 3*(4), 181-187.
- Snowden, L. R. (2003). Bias in mental health assessment and intervention: Theory and evidence. *American Journal of Public Health, 93*, 239-243.
- Solberg, V. S., Ritsma, S., Davis, B. J., Tata, S. P., & Jolly, A. (1994). Asian-American students' severity of problems and willingness to seek help from university counseling centers:



- Role of previous counseling experience, gender, and ethnicity. *Journal of Counseling Psychology*, 41(3), 275-279.
- Statistics Canada (2004). The 2002 Canadian Community Health Survey (CCHS) Cycle 1.2: Mental Health and Well-Being. *The Daily*, Catalogue No. 11-001-XIE. Ottawa: Statistics Canada.
- Statistics Canada (2006). *Census Tract (CT) Profiles*, Catalogue number 95-597-XWE. Retrieved September 20, 2009, from <http://www12.statcan.gc.ca/census-recensement/2006/dp-pd/prof/92-597/index.cfm?Lang=E> .
- Statistics Canada (2008). Canada's Ethnocultural Mosaic, 2006 Census, Catalogue number 97-562-X. Retrieved February 27, 2010, from <http://www12.statcan.ca/census-recensement/2006/as-sa/97-562/pdf/97-562-XIE2006001.pdf>.
- Steiger, J. H. (1990). Structural model evaluation and modification: An interval estimation approach. *Multivariate Behavioral Research*, 25, 173-180.
- Straits-Troster, K. A., Patterson, T. L., Semple, S. J., Temoshok, L., et al. (1994). The relationship between loneliness, interpersonal competence, and immunological status in HIV-infected men. *Psychology & Health*, 9(3), 205-219.
- Suan, L. V., & Tyler, J. D. (1990). Mental health values and preference for mental health resources of Japanese-American and Caucasian-American students. *Professional Psychology: Research and Practice*, 21(4), 291-296.
- Sue, D. W. (1994). Asian-American mental health and help-seeking behavior: Comment on Solberg et al. (1994), Tata and Leong (1994), and Lin (1994). *Journal of Counseling Psychology*, 41, 292-295.

- Sue, D. W., & Sue, D. (2002). *Counseling the culturally diverse: Theory and practice* (4th ed.). New York, NY: Wiley.
- Sue, D.W., Capodilupo, C.M., Torino, G.C., Bucceri, J.M., Holder, A.M.B., Nadal, K.L., & Esquilin, M. (2007). Racial microaggressions in everyday life: Implications for clinical practice. *American Psychology*, 62(4), 271-286.
- Sue, S. (1977). Community mental health services to minority groups: Some optimism, some pessimism. *American Psychologist*, 32(6), 616-624.
- Sue, S., Fujino, D., Hu, L., Takeuchi, D., & Zane, N. (1991). Community mental health services for ethnic minority groups: A test of the cultural responsiveness hypothesis. *Journal of Consulting and Clinical Psychology*, 59(4), 533-540.
- Sue, S., Zane, N., & Young, K. (1994). Research on psychotherapy with culturally diverse populations. In A. E. Bergin & S. L. Garfield (Eds.), *Handbook of psychotherapy and behaviour change* (4th ed., pp. 783-817). New York: John Wiley & Sons.
- Sussman, L. K., Robins, L. N., & Earls, F. (1987). Treatment-seeking for depression by Black and White Americans. *Social science and medicine*, 24, 187-196.
- Swartz, M. S., Wagner, H. R., Swanson, J. W., Burns, B. J., George, L. K., & Padgett, D. K. (1998). Comparing use of public and private mental health services: The enduring barriers of race and age. *Community Mental Health Journal*, 34, 133-144.
- Tabachnick, B.G., & Fidell, L. S. (2001). *Using Multivariate Statistics* (4<sup>th</sup> ed.). Boston, MA: Allyn & Bacon.
- Takeuchi, D. T., Leaf, P. J., & Kuo, H. (1988). Ethnic differences in the perception of barriers to help-seeking. *Social Psychiatry and Psychiatric Epidemiology*, 23, 273-280.

- Takeuchi, D. T., Sue, S., & Yeh, M. (1995). Return rates and outcomes from ethnicity-specific mental health programs in Los Angeles. *American Journal of Public Health, 85*, 638-643.
- Takeuchi, D. T., Uehara, E. S., Maramba, G. G. (1999). Cultural diversity and mental health treatment. In A.V. Horwitz and T.L. Scheid (Eds.), *A Hand Book for the Study of Mental Health*. Cambridge.
- Tata, S. P., & Leong, F. T. L. (1994). Individualism-collectivism, social-network orientation, and acculturation as predictors of attitudes toward seeking professional psychological help among Chinese Americans. *Journal of Counseling Psychology, 41*(3), 280-287,
- Taylor, R. J., & Chatters, L. M. (1986). Church-based informal support networks among elderly blacks. *The Gerontologist, 26*, 637-642.
- Taylor, R. J., & Chatters, L. M. (1988). Church members as a source of informal social support. *Review of Religious Research, 30*, 193-202.
- Taylor, R. J., & Chatters, L. M. (1991). Religious life. In J.S. Jackson (Ed.), *Life in Black America* (pp. 105-123). Thousand Oaks, CA: Sage.
- Taylor, R. J., Chatters, L. M., Hardison, C. B., & Riley, A. (2001). Informal social support networks and subjective well-being among African Americans. *Journal of Black Psychology, 27*, 439-463.
- Taylor, R. J., Chatters, L. M., Jayakody, R., & Levin, J. S. (1996). Black and White differences in religious participation: A multisample comparison. *Journal for the scientific study of religion, 35*, 403-410.
- Taylor, R. J., Chatters, L. M., Tucker, M. B., & Lewis, E. (1990). Developments in research on Black families: A decade review. *Journal of Marriage and the Family, 52*, 993-1014.

- Taylor, R. J., Ellison, C. G., Chatters, L. M., Levin, J. S., & Lincoln, K. D. (2000). Mental health services in faith communities: The role of clergy in Black church. *Social Work, 45*(1), 73-87.
- Terrell, F., & Barrett, R. K. (1979). Interpersonal trust among college students as a function of race, sex, and socioeconomic class. *Perceptual and Motor Skills, 48*, 1194.
- Terrell, F., & Miller, F. S. (1980). The Racial Discrimination Index. In Reginald L. Jones (Ed.) (1996). *Handbook of Tests and Measurements for Black Populations*. (Volume 2, pp. 321-331). Hampton, VA: Cobb & Henry.
- Terrell, F., & Terrell, S. (1981). An inventory to measure cultural mistrust among Blacks. *The Western Journal of Black Studies, 5*(3), 180-185.
- Terrell, F., & Terrell, S. (1984). Race of counselor, client sex, cultural mistrust level, and premature termination from counseling among Black clients. *Journal of Counseling Psychology, 31*(3), 371-375.
- Thompson, C. E., Neville, H., Weathers, P. L., Poston, W. C., & Atkinson, D. R. (1990). Cultural mistrust and racism reaction among African-American students. *Journal of College Student Development, 31*(2), 162-168.
- Thompson, C. E., Worthington, R., & Atkinson, D. R. (1994). Counselor content orientation, counselor race, and Black women's cultural mistrust and self-disclosures. *Journal of counseling psychology, 41*(2), 155-161.
- Thompson, M. P., & Vardaman, P. J. (1997). The role of religion in coping with the loss of a family member to homicide. *Journal for the Scientific Study of Religion, 36*(1), 44-51.

- Thompson, R. A., & Chambers, J. W., Jr. (2000). African self-consciousness and health-promoting behaviors among African American college students/ *Journal of Black Psychology, 26*, 330-345.
- Thompson, R. A., & Cimboric, P. (1978). Black students' counselor preference and attitudes toward counseling center use. *Journal of Counseling Psychology, 25*, 570-575.
- Thompson, V. L. (1996). Perceived experiences of racism as stressful life events. *Community Mental Health, 32*(3), 223-233.
- Thompson, V. L., Bazile, A., & Akbar, M. (2004). African Americans' perceptions of psychotherapy and psychotherapists. *Professional Psychology: Research and Practice, 35*, 19-26.
- Toldson, I. L., & Toldson, L. A. (2001). Biomedical ethics: An African-centered psychological perspective. *Journal of Black Psychology, 27*, 401-423.
- Trafimow, D., & Finlay, K. A. (1996). The importance of subjective norms for a minority of people: Between subjects and within subjects analysis. *Personality and Social Psychology Bulletin, 22*, 820-828.
- Triandis, H. C. (1976). *Variations in Black and White perceptions of the social environment*. Urbana: University of Illinois Press.
- Triandis, H. C. (1977). *Interpersonal behavior*. Monterey, CA: Brooks/Cole.
- Triandis, H. C. (1994). *Culture and social behavior*. New York, NY: McGraw-Hill.
- Trower, P., & Chadwick, P. (1995). Pathways to defense of self: A theory of two types of paranoia. *Clinical Psychology: Science and Practice, 2*, 263-278.
- Tryon, R. C. (1996). Unrestricted cluster and factor analysis with application to the MMPI and Holzinger-Harman problems. *Multivariate Behavioral Research, 1*, 229-244.

- U.S. Department of Health and Human Services. (1999). *Mental Health: A report of the Surgeon General*. Rockville, MD: U.S. Department of Health and Human Services, Substance Abuse and Mental Health Services Administration, Center for Mental Health Services, National Institutes of Health, National Institute of Mental Health.
- Utsey, S. O., Adams, E. P., & Bolden, M. (2000). Development and initial validation of the Africultural Coping Systems Inventory. *Journal of Black Psychology, 26*, 194-215.
- Utsey, S.O., Brown, C., & Bolden, M. A. (2004). Testing the structural invariance of the Africultural Coping Systems Inventory Across Three Samples of African Descent Populations. *Educational and Psychological Measurement, 64*(1), 185-195.
- Vasiliadis, H., Lesage, A., Adair, C., & Boyer, R. (2005). Service use for mental health reasons: Cross-provincial differences in rates, determinants, and equity of access. *The Canadian Journal of Psychiatry, 50*(10), 614 – 619.
- Vega, W. A., & Murphy, J. W. (1990). *Culture and the restructuring of community mental health*. Greenwood.
- Veroff, J. B., Douvan, E., & Kulka, R. A. (1981). *Mental health in America: Patterns of help-seeking 1957–1976*. New York: Basic Books.
- Vinogradov, S., King, R. J., & Huberman, B. A. (1992). An associationist model of the paranoid process: Application of phase transition in spreading activation networks. *Psychiatry, 55*, 79 – 94.
- Vogel, D. L., & Wei, M. (2005). Adult attachment and help-seeking intent: The mediating roles of psychological distress and perceived social support. *Journal of Counseling Psychology, 52*(3), 347-357.

- Vogel, D. L., & Wester, S. R. (2003). To seek help or not to seek help: The risks of self-disclosure. *Journal of Counseling Psychology, 50*(3), 351-361.
- Vontress, C. E. (1971). Racial differences: Impediments to rapport. *Journal of Counseling Psychology, 18*, 7-13.
- Walker, S. N., Sechrist, K. R., Pender, N. J. (1987). The Health-promoting lifestyle profile: Development and psychometric characteristics. *Nursing Research, 36*(2), 76-81.
- Wallace, B. D., & Constantine, M. G. (2005). Africentric cultural values, psychological help-seeking attitudes, and self-concealment in African American college students. *Journal of Black Psychology, 31*(4), 369-385.
- Ward, E. C. (2005). Keeping it real: A grounded theory study of African American clients engaging in counseling at a community mental health agency. *Journal of Counseling Psychology, 52*, 471-481.
- Warfield, J. L., & Marion, R. L. (1985). Counseling the Black male. *Journal of Non-White Concerns, 13*, 54-71.
- Warheit, G., Vega, W., Shimizu, D., & Meinhardt, K. (1982). Interpersonal coping networks and mental health problems among four race-ethnic groups. *Journal of Community Psychology, 10*(4), 312 – 324.
- Warren, R. L. (1969). Politics and the ghetto system. In R. L. Warren (Ed.), *Politics and the ghettos* (pp. 11-30). New York: Atherton Press.
- Watkins, C. E., Jr, Terrell, F., Miller, F. S., & Terrell, S. L. (1989). Cultural mistrust and its effects on expectational variables in Black client – White counselor relationships. *Journal of Counseling Psychology, 36*(4), 447-450.

- Watkins, C. E., Jr., & Terrell, F. (1988). Mistrust level and its effects on counseling expectations in Black client – White counselor relationships: An analogue study. *Journal of Counseling Psychology, 35*(2), 194-197.
- Weiner, B. (1993). On sin versus sickness, a theory of perceived responsibility and social motivation. *American Psychologist, 48*, 957-965.
- Weiner, B. (1995). *Judgments of responsibility: A foundation for a theory of social conduct*. New York, NY: Guilford.
- Weiss, R. S. (1974). The provisions of social relationships. In Z. Rubin (Ed.), *Doing unto others* (pp. 17-26). Englewood Cliffs, NJ: Prentice-Hall.
- Whaley, A. L. (1997). Ethnic and racial differences in perceptions of dangerousness of persons with mental illness. *Psychiatric Services, 48*, 1339-1330.
- Whaley, A. L. (1998). Cross-cultural perspective on paranoia: A focus on the Black American experience. *Psychiatric Quarterly, 69*(4), 325-343.
- Whaley, A. L. (2001a). Cultural mistrust and mental health services for African Americans: A review and meta-analysis. *The Counseling Psychologist, 29*, 513-531.
- Whaley, A. L. (2001b). Cultural mistrust: An important psychological construct for diagnosis and treatment of African Americans. *Professional Psychology: Research and Practice, 32*(6), 55-562.
- Whaley, A. L. (2002). Psychometric analysis of the Cultural Mistrust Inventory with a Black Psychiatric Inpatient Sample. *Journal of Clinical Psychology, 58*(4), 383-396.
- Whaley, A. L. (2004). A two-stage method for the study of cultural bias in the diagnosis of schizophrenia in African Americans. *Journal of Black Psychology, 30*, 167-186.



- White, J. L. (1980). Toward a Black psychology. In R.L. Jones (Ed.), *Black Psychology* (pp. 1-12). New York: Harper & Row.
- Whiteley, S. M., Mahaffey, P. J., & Greer, C. A. (1987). The campus counseling center: A profile of staffing patterns and services. *Journal of College Student Personnel*, 28, 71-81.
- Wiggins, J. S. (1966). Substantive dimensions of self-report in the MMPI item pool. *Psychological Monographs*, 80 (22, Whole No. 630).
- Williams, C. C. (2002). A rationale for an anti-racist entry point to anti-oppressive social work in mental health services. *Critical Social Work*, 2(2), 20-31.
- Williams, D. R. (1994). The measurement of religion in epidemiologic studies: Problems and prospects. In J.S. Levin (Ed.), *Religion in aging and health: Theoretical foundations and methodological frontiers* (pp. 125-148). Thousand Oaks, CA: Sage.
- Wong, D. F. K. (2002). Stage-specific and culture-specific coping strategies used by Mainland Chinese immigrants during resettlement in Hong Kong: A qualitative analysis. *Social Work in Health Care*, 35(1-2), 479-499.
- Wu, I., & Windle, C. (1980). Ethnic specificity in the relationship of minority use and staffing of community mental health centers. *Community Mental Health Journal*, 16, 156 – 168.
- Yokopenic, P. A., Clark, V. A., & Aneshensel, C. S. (1983). Depression, problem recognition, and professional consultation. *Journal of Nervous & Mental Disease*, 171, 15–23.
- Zhang, N., & Dixon, D. N. (2003). Acculturation and attitudes of Asian international students toward seeking psychological help. *Journal of Multicultural Counseling & Development*, 31(3), 205-222.
- Zigler, E., & Glick, M. (1988). Is paranoid schizophrenia really camouflaged depression? *American Psychologist*, 43, 284-290.

## APPENDIX A



### LETTER OF INFORMATION FOR CONSENT TO PARTICIPATE IN RESEARCH

**Title of Study:** Black Canadians' Attitudes toward Seeking Psychotherapy

You are asked to participate in a research study conducted by Justine Joseph, MA (Student Investigator) and Dr. Ben Kuo, PhD, CPsych (Faculty Supervisor), from the Department of Psychology at the University of Windsor, the results of which will contribute to the completion of a doctoral dissertation.

If you have any questions or concerns about the research, please feel free to contact Dr. Ben Kuo, PhD, C. Psych. ([benkuo@uwindor.ca](mailto:benkuo@uwindor.ca); (519)253-3000, Ext. 2238).

#### PURPOSE OF THE STUDY

The purpose of the present study is to explore how cultural influences may impact Black Canadians' attitudes toward seeking psychotherapy for assistance in dealing with personal difficulties or emotional problems.

#### PROCEDURES

If you volunteer to participate in this study, we would ask you to do the following things:

- a) Volunteer up to approximately one hour of your time.
- b) Carefully read and honestly answer the questions presented to you.

#### POTENTIAL RISKS AND DISCOMFORTS

The present study requires you to imagine a potentially upsetting situation and report on recent emotional experiences, which may cause you some emotional discomfort (e.g., worry, sadness, anger). If you require assistance in addressing such difficulties, please contact the following organizations for consultation and referral to community resources:

- The University of Windsor Student Counseling Centre ([www.uwindsor.ca/scc](http://www.uwindsor.ca/scc)) - (519)253-3000 x. 4616
- Canadian Mental Health Association of Windsor-Essex Country ([www.cmha-weeb.on.ca](http://www.cmha-weeb.on.ca)) - (519)255-7440
- Canadian Mental Health Association of Toronto ([www.toronto.cmha.ca](http://www.toronto.cmha.ca)) - (416)789-7957

You may also contact the supervisor of this research study (Dr. Ben Kuo, Ph.D., C. Psych. @ [benkuo@uwindor.ca](mailto:benkuo@uwindor.ca) or (519)253-3000, x. 2238), for further questions or consultation.

#### POTENTIAL BENEFITS TO SUBJECTS AND/OR TO SOCIETY

Involvement in this research project may benefit you by satisfying personal interest in the subject matter, instilling pride in your contribution to a better understanding of Black Canadians' perceptions of mental health services and developing recommendations for improved mental health services among minority populations, attaining educational goals, and possibly winning a \$20 gift certificate to Chapters Books.

#### PAYMENT FOR PARTICIPATION

If you are currently enrolled in a psychology course at the University of Windsor, you are eligible to receive credit toward bonus marks in the eligible psychology course(s). If you are not participating in the present study for the purpose of receiving course credit, you will automatically be entered in a draw to win one of five, twenty-dollar gift certificates to Chapters Books. The gift certificates will be delivered electronically to the prize winners by June 2009.

If you have chosen to receive bonus marks as compensation for your time, you will be forfeiting your entry into the aforementioned draw.

## CONFIDENTIALITY

All necessary precautions will be made to protect your privacy and confidentiality. Any personal information that is obtained in connection with this study and that can be identified with you (e.g., consent, compensation for participation) will remain confidential. Each individual who participates in this study will be assigned an ID number representing a record of their participation that is not linked to their identity. In no case will responses from individual participants be identified; that is, all data is analyzed and published anonymously.

If you complete the online version of this study using psychdata.com, the information you submit will be stored temporarily on PsychData's server located in the United States and may be accessed by the U.S. legal and government officials during this time, in accordance with the U.S. Patriot's Act. All electronic data files will be stored in secured database that can only be accessed by a researcher with the correct password. Paper-based materials relating to this study will be stored in a locked file cabinet in a storage space that is only accessible by the researchers conducting this study. The researchers have full control over the data, including the ability to delete and/or dispose of all data at the study's completion. Both the electronic database and paper-based materials are scheduled to be deleted after five years.

## PARTICIPATION AND WITHDRAWAL

You can choose whether to be in this study or not. If you volunteer to be in this study, you may withdraw at any time without consequences of any kind. You may also refuse to answer any questions you don't want to answer and still remain in the study. Due to the anonymity of the data (i.e., the data provided by any particular participant is unidentifiable, even by the researcher), it is not possible to request withdrawal of your data after completing the study.

The investigator may withdraw you from this research if circumstances arise which warrant doing so. There are three circumstances under which the investigator will withdraw you from this research without your consent:

- a) You are not an individual of African or African-Caribbean.
- b) You are under 18 years of age.
- c) You are not currently residing in Canada.

## FEEDBACK OF THE RESULTS OF THIS STUDY TO THE SUBJECTS

For your personal interest, the results of this study will be available at [www.uwindsor.ca/reb](http://www.uwindsor.ca/reb) under Study Results (Participants/Visitors) by June 2009.

## SUBSEQUENT USE OF DATA

The data collected from this project may be used in subsequent studies.

## RIGHTS OF RESEARCH SUBJECTS

You may withdraw your consent at any time and discontinue participation without penalty. If you have questions regarding your rights as a research subject, contact: Research Ethics Coordinator, University of Windsor, Windsor, Ontario N9B 3P4; Telephone: 519-253-3000, ext. 3948; e-mail: [ethics@uwindsor.ca](mailto:ethics@uwindsor.ca)

## SIGNATURE OF INVESTIGATOR

These are the terms under which I will conduct research.

\_\_\_\_\_  
Signature of Investigator

\_\_\_\_\_  
Date

Revised November 2007



## CONSENT TO PARTICIPATE IN RESEARCH

**Title of Study:** Black Canadians' Attitudes toward Seeking Psychotherapy

You are asked to participate in a research study conducted by Justine Joseph, MA (Student Investigator) and Dr. Ben Kuo, PhD, C. Psych (Faculty Supervisor), from the Department of Psychology at the University of Windsor, the results of which will contribute to the completion of a doctoral dissertation.

If you have any questions or concerns about the research, please feel free to contact Dr. Ben Kuo, PhD, C. Psych ([benkuo@uwindor.ca](mailto:benkuo@uwindor.ca); (519)253-3000, Ext. 2238).

### PURPOSE OF THE STUDY

The purpose of the present study is to explore how cultural influences may impact Black Canadians' attitudes toward seeking psychotherapy for assistance in dealing with personal difficulties or emotional problems.

### PROCEDURES

If you volunteer to participate in this study, we would ask you to do the following things:

- a) Volunteer up to approximately one hour of your time.
- b) Carefully read and honestly answer the questions presented to you.

### POTENTIAL RISKS AND DISCOMFORTS

The present study requires you to imagine a potentially upsetting situation and report on recent emotional experiences, which may cause you some emotional discomfort (e.g., worry, sadness, anger). If you require assistance in addressing such difficulties, please contact the following organizations for consultation and referral to community resources:

- The University of Windsor Student Counseling Centre ([www.uwindsor.ca/scc](http://www.uwindsor.ca/scc)) - (519)253-3000 x. 4616
- Canadian Mental Health Association of Windsor-Essex Country ([www.cmha-wecb.on.ca](http://www.cmha-wecb.on.ca)) - (519)255-7440
- Canadian Mental Health Association of Toronto ([www.toronto.cmha.ca](http://www.toronto.cmha.ca)) - (416)789-7957

You may also contact the supervisor of this research study (Dr. Ben Kuo, Ph.D., C. Psych. @ [benkuo@uwindor.ca](mailto:benkuo@uwindor.ca) or (519)253-3000, Ext. 2238), for further questions or consultation.

### POTENTIAL BENEFITS TO SUBJECTS AND/OR TO SOCIETY

Involvement in this research project may benefit you by satisfying personal interest in the subject matter, instilling pride in your contribution to a better understanding of Black Canadians' perceptions of mental health services and developing recommendations for improved mental health services among minority populations, attaining educational goals, and possibly winning a \$20 gift certificate to Chapters Books.

### PAYMENT FOR PARTICIPATION

If you are currently enrolled in a psychology course at the University of Windsor, you are eligible to receive credit toward bonus marks in the eligible psychology course(s). If you are not participating in the present study for the purpose of receiving course credit, you will automatically be entered in a draw to win one of five, twenty-dollar gift certificates to Chapters Books. The gift certificates will be delivered electronically to the prize winners by June 2009. If you have chosen to receive bonus marks as compensation for your time, you will be forfeiting your entry into the aforementioned draw.

## CONFIDENTIALITY

All necessary precautions will be made to protect your privacy and confidentiality. Any personal information that is obtained in connection with this study and that can be identified with you (e.g., consent, compensation for participation) will remain confidential. Each individual who participates in this study will be assigned an ID number representing a record of their participation that is not linked to their identity. In no case will responses from individual participants be identified; that is, all data is analyzed and published anonymously.

If you complete the online version of this study using psychdata.com, the information you submit will be stored temporarily on PsychData's server located in the United States and may be accessed by the U.S. legal and government officials during this time, in accordance with the U.S. Patriot's Act. All electronic data files will be stored in secured database that can only be accessed by a researcher with the correct password. Paper-based materials relating to this study will be stored in a locked file cabinet in a storage space that is only accessible by the researchers conducting this study. The researchers have full control over the data, including the ability to delete and/or dispose of all data at the study's completion. Both the electronic database and paper-based materials are scheduled to be deleted after five years.

## PARTICIPATION AND WITHDRAWAL

You can choose whether to be in this study or not. If you volunteer to be in this study, you may withdraw at any time without consequences of any kind. You may also refuse to answer any questions you don't want to answer and still remain in the study. Due to the anonymity of the data (i.e., the data provided by a particular participant is unidentifiable, even by the researcher), it is not possible to request withdrawal of your data after completing the study.

The investigator may withdraw you from this research if circumstances arise which warrant doing so. There are three circumstances under which the investigator will withdraw you from this research without your consent:

- d) You are not an individual of African or African-Caribbean descent.
- e) You are under 18 years of age.
- f) You are not currently residing in Canada.

## FEEDBACK OF THE RESULTS OF THIS STUDY TO THE SUBJECTS

For your personal interest, the results of this study will be available at [www.uwindsor.ca/reb](http://www.uwindsor.ca/reb) under Study Results (Participants/Visitors) by June 2009.

## SUBSEQUENT USE OF DATA

The data collected from this project may be used in subsequent studies.

## RIGHTS OF RESEARCH SUBJECTS

You may withdraw your consent at any time and discontinue participation without penalty. If you have questions regarding your rights as a research subject, contact: Research Ethics Coordinator, University of Windsor, Windsor, Ontario, N9B 3P4; Telephone: 519-253-3000, ext. 3948; e-mail: [ethics@uwindsor.ca](mailto:ethics@uwindsor.ca)

## SIGNATURE OF RESEARCH SUBJECT/LEGAL REPRESENTATIVE

I understand the information provided for the study '**Black Canadians' Attitudes Toward Seeking Psychotherapy**' as described herein. My questions have been answered to my satisfaction, and I agree to participate in this study. I have been given a copy of this form.

\_\_\_\_\_  
Name of Subject

\_\_\_\_\_  
Signature of Subject

\_\_\_\_\_  
Date

SIGNATURE OF INVESTIGATOR

These are the terms under which I will conduct research.

\_\_\_\_\_  
Signature of Investigator

\_\_\_\_\_  
Date

Revised November 2007

## APPENDIX B

### Self-Concealment Scale

Read each statement carefully and indicate how closely each statement applies to you using the following scale:

Strongly Disagree      Disagree      Neutral      Agree      Strongly Agree  
*1* ----- *2* ----- *3* ----- *4* ----- *5*

Remember, there are no “wrong” answers, and the only right ones are whatever is true for you. Circle the response that seems to best apply to you. It is important that you answer every item.

	<i>Strongly Disagree</i>	<i>Disagree</i>	<i>Neutral</i>	<i>Agree</i>	<i>Strongly Agree</i>
1. I have an important secret that I haven't shared with anyone.	1	2	3	4	5
2. If I shared all my secrets with my friends, they'd like me less.	1	2	3	4	5
3. There are lots of things about me that I keep to myself.	1	2	3	4	5
4. Some of my secrets have really tormented me.	1	2	3	4	5
5. When something bad happens to me, I tend to keep it to myself.	1	2	3	4	5
6. I'm often afraid I'll reveal something I don't want to.	1	2	3	4	5
7. Telling a secret often backfires and I wish I hadn't told it.	1	2	3	4	5
8. I have a secret that is so private I would lie if anybody asked me about it.	1	2	3	4	5
9. My secrets are too embarrassing to share with others.	1	2	3	4	5
10. I have negative thoughts about myself that I never share with anyone.	1	2	3	4	5

### Attitudes Toward Seeking Professional Psychological Help – Short Form (ATSPPH-S)

Below are a number of statements concerning psychology and mental health issues. Read each statement carefully and indicate whether you agree, partly agree, partly disagree, or disagree. Please express your frank opinion in rating the statements. Remember, there are no “wrong” answers, and the only right ones are whatever you honestly feel or believe. It is important that you answer every item.

1. If I believed I was having a mental breakdown, my first inclination would be to get professional attention.	Disagree	Partly Disagree	Partly Agree	Agree
2. The idea of talking about problems with a psychologist strikes me as a poor way to get rid of emotional conflicts.	Disagree	Partly Disagree	Partly Agree	Agree
3. If I were experiencing a serious emotional crisis at this point in my life, I would be confident that I could find relief in psychotherapy.	Disagree	Partly Disagree	Partly Agree	Agree
4. There is something admirable in the attitude of a person who is willing to cope with his or her conflicts and fears <i>without</i> resorting to professional help.	Disagree	Partly Disagree	Partly Agree	Agree
5. I would want to get psychological help if I were worried or upset for a long period of time.	Disagree	Partly Disagree	Partly Agree	Agree
6. I might want to have psychotherapy in the future.	Disagree	Partly Disagree	Partly Agree	Agree
7. A person with an emotional problem is not likely to solve it alone; he or she <i>is</i> likely to solve it with professional help.	Disagree	Partly Disagree	Partly Agree	Agree
8. Considering the time and expense involved in psychotherapy, it would have doubtful value for a person like me.	Disagree	Partly Disagree	Partly Agree	Agree
9. A person should work out his or her own problems; getting psychotherapy would be a last resort.	Disagree	Partly Disagree	Partly Agree	Agree
10. Personal and emotional troubles, like many things, tend to work out by themselves.	Disagree	Partly Disagree	Partly Agree	Agree



### Africentrism Scale (AS)

Read each statement carefully and indicate whether you strongly disagree, disagree, agree, or strongly agree. Please express your honest opinion in rating the statements. Remember, there are no “wrong” answers, and the only right ones are whatever you honestly feel or believe. If in doubt, circle the response that seems closest to your feelings about the statement. It is important that you answer every item.

<b>1.</b> Black people should make their community better than it was when they found it.	Strongly Disagree	Disagree	Agree	Strongly Agree
<b>2.</b> The problems of other Black people are their problems, not mine.	Strongly Disagree	Disagree	Agree	Strongly Agree
<b>3.</b> The unity of the African race is very important to me.	Strongly Disagree	Disagree	Agree	Strongly Agree
<b>4.</b> I am more concerned with reaching my own goals than with working for the Black community.	Strongly Disagree	Disagree	Agree	Strongly Agree
<b>5.</b> I have very little faith in Black people.	Strongly Disagree	Disagree	Agree	Strongly Agree
<b>6.</b> I owe something to the Black people who have suffered before me.	Strongly Disagree	Disagree	Agree	Strongly Agree
<b>7.</b> I owe something to those who have tried to make things better for me.	Strongly Disagree	Disagree	Agree	Strongly Agree
<b>8.</b> Black people need to stop worrying so much about “the community” and take care of their own needs	Strongly Disagree	Disagree	Agree	Strongly Agree
<b>9.</b> I am doing a lot to improve my neighborhood.	Strongly Disagree	Disagree	Agree	Strongly Agree
<b>10.</b> The success I have had I mainly because of me, not anyone else.	Strongly Disagree	Disagree	Agree	Strongly Agree
<b>11.</b> I have more confidence in White professionals, like doctors and teachers, than in Black professionals.	Strongly Disagree	Disagree	Agree	Strongly Agree
<b>12.</b> Black people should build and maintain their own communities.	Strongly Disagree	Disagree	Agree	Strongly Agree
<b>13.</b> I must do all I can to restore Black people to their position of respect in the world.	Strongly Disagree	Disagree	Agree	Strongly Agree
<b>14.</b> I make it a point to shop at Black businesses and use Black owned services.	Strongly Disagree	Disagree	Agree	Strongly Agree
<b>15.</b> It is important that Black people decide for themselves what to be called and what their needs are.	Strongly Disagree	Disagree	Agree	Strongly Agree

### Cultural Mistrust Inventory (CMI)

Read each statement carefully and indicate your honest feelings about each statement using the following scale:

*Strongly Disagree*      *Disagree*      *Slightly Disagree*      *Neither Agree nor Disagree*      *Slightly Agree*      *Agree*      *Strongly Agree*  
 1-----2-----3-----4-----5-----6-----7

Remember, there are no “wrong” answers, and the only right ones are whatever you honestly feel or believe. Circle the response that seems closest to your feelings about the statement. It is important that you answer every item.

	Strongly Disagree	Disagree	Slightly Disagree	Neither Agree Nor Disagree	Slightly Agree	Agree	Strongly Agree
1. Whites are usually fair to all people regardless of race.	1	2	3	4	5	6	7
2. White teachers teach subjects so that it favours Whites.	1	2	3	4	5	6	7
3. White teachers are more likely to slant the subject matter to make Blacks look inferior.	1	2	3	4	5	6	7
4. White teachers deliberately ask Black students questions which are difficult so they will fail.	1	2	3	4	5	6	7
5. There is no need for a Black person to work hard to get ahead financially because Whites will take what you earn anyway.	1	2	3	4	5	6	7
6. Black citizens can rely on White lawyers to defend them to the best of his or her ability.	1	2	3	4	5	6	7
7. Black parents should not trust White teachers.	1	2	3	4	5	6	7
8. White politicians will promise Blacks a lot but deliver little.	1	2	3	4	5	6	7
9. White policemen will slant a story to make Blacks appear guilty.	1	2	3	4	5	6	7
10. White politicians usually can be relied on to keep the promises they make to Blacks.	1	2	3	4	5	6	7
11. Blacks should be suspicious of a White person who tries to be friendly.	1	2	3	4	5	6	7
12. Whether you should trust a person or not is not based on his race.	1	2	3	4	5	6	7
13. Probably the biggest reason Whites want to be friendly with Blacks is so they can take advantage of them.	1	2	3	4	5	6	7

	Strongly Disagree	Disagree	Slightly Disagree	Neither Agree nor Disagree	Slightly Agree	Agree	Strongly Agree
14. A Black person can usually trust his or her White co-workers.	1	2	3	4	5	6	7
15. If a White person is honest in dealing with Blacks it is because of fear of being caught.	1	2	3	4	5	6	7
16. A Black person cannot trust a White judge to evaluate him fairly.	1	2	3	4	5	6	7
17. A Black person can feel comfortable making a deal with a White person simply by a handshake.	1	2	3	4	5	6	7
18. Whites deliberately pass laws designed to block the progress of Blacks.	1	2	3	4	5	6	7
19. There are some Whites who are trustworthy enough to have as close friends.	1	2	3	4	5	6	7
20. Blacks should not have anything to do with Whites since they cannot be trusted.	1	2	3	4	5	6	7
21. It is best for Blacks to be on their guard when among Whites.	1	2	3	4	5	6	7
22. Of all ethnic groups, Whites are really the 'Indian-givers'.	1	2	3	4	5	6	7
23. White friends are least likely to break their promise.	1	2	3	4	5	6	7
24. Blacks should be cautious about what they say in the presence of White since Whites will try to use it against them.	1	2	3	4	5	6	7
25. Whites can rarely be counted on to do what they say.	1	2	3	4	5	6	7
26. Whites are usually honest with Blacks.	1	2	3	4	5	6	7
27. Whites are as trustworthy as members of any other ethnic group.	1	2	3	4	5	6	7
28. Whites will say one thing and do another.	1	2	3	4	5	6	7
29. White politicians will take advantage of Blacks every change they get.	1	2	3	4	5	6	7
30. When a White teacher asks a Black student a question, it is usually to get information which can be used against him or her.	1	2	3	4	5	6	7
31. White policemen can be relied on to exert an effort to apprehend those who commit crimes against Blacks.	1	2	3	4	5	6	7

	Strongly Disagree	Disagree	Slightly Disagree	Neither Agree nor Disagree	Slightly Agree	Agree	Strongly Agree
<b>32.</b> Black students can talk to a White teacher in confidence without fear that the teacher will use it against him or her later.	1	2	3	4	5	6	7
<b>33.</b> Whites will usually keep their word.	1	2	3	4	5	6	7
<b>34.</b> White policemen usually do not try to trick Blacks into admitting they committed a crime which they didn't.	1	2	3	4	5	6	7
<b>35.</b> There is no need for Blacks to be more cautious with White businessmen than with Blacks.	1	2	3	4	5	6	7
<b>36.</b> There are some White businessmen who are honest in business transactions with Blacks.	1	2	3	4	5	6	7
<b>37.</b> White store owners, salesmen, and other White businessmen tend to cheat Blacks whenever they can.	1	2	3	4	5	6	7
<b>38.</b> Since Whites cannot be trusted, the old saying "one in the hand is worth two in the bush" is a good policy to follow.	1	2	3	4	5	6	7
<b>39.</b> Whites who establish businesses in Black communities do so only so that they can take advantage of Blacks.	1	2	3	4	5	6	7
<b>40.</b> Blacks have often been deceived by White politicians.	1	2	3	4	5	6	7
<b>41.</b> White politicians are equally honest with Blacks and Whites.	1	2	3	4	5	6	7
<b>42.</b> Blacks should not confide in Whites because they will use it against you.	1	2	3	4	5	6	7
<b>43.</b> A Black person can loan money to a White person and feel confident it will be repaid.	1	2	3	4	5	6	7
<b>44.</b> White businessmen usually will not try to cheat Blacks.	1	2	3	4	5	6	7
<b>45.</b> White business executives will steal the ideas of their Black employees.	1	2	3	4	5	6	7
<b>46.</b> A promise from a White is about as good as a three dollar bill.	1	2	3	4	5	6	7
<b>47.</b> Blacks should be suspicious of advice given by White politicians.	1	2	3	4	5	6	7
<b>48.</b> If a Black student tries, he will get the grade he deserves from a White teacher.	1	2	3	4	5	6	7

### Integrated Coping Measure (ICM)

The statements below are intended to represent some of the strategies people use to cope with personal problems and emotional difficulties. In responding to these statements, please **imagine yourself in the following situation:**

*Two years after the unexpected death of your mother, you've noticed that you still aren't feeling like yourself. You can't recall the last time you felt happy. It seems like you always feel sad and tired no matter what you do. You rarely socialize anymore and are constantly irritable. You realize all the activities that you once gave you pleasure have lost their appeal. Your performance at work/school has suffered horribly because of these emotional difficulties. You've been called to a meeting to discuss your future at your workplace / school. Since your mother's death, you've received multiple warnings about your poor performance and you are worried that this time you will be asked to resign your position / drop out of school. You do not want to leave your workplace / school, but are beginning to feel like things are never going to get better.*

Now, keeping this situation in mind, read each statement carefully and then circle the response that seems to best describe how often you would use the strategy to help you feel better. Remember, there are no "wrong" answers, and the only right ones are whatever you honestly feel or believe. It is important that you answer every item.

	Not At All	Used A Little	Used A Lot
1. Rearranged things around you so that your problem had the best chance of being resolved.	1	2	3
2. Brainstormed all possible solutions before deciding what to do.	1	2	3
3. Set some goals for yourself to deal with the situation.	1	2	3
4. Weighed your options very carefully.	1	2	3
5. Tried different ways to solve the problem until you found one that worked.	1	2	3
6. Thought about what needed to be done to straighten things out.	1	2	3
7. Turned your full attention to solving the problem.	1	2	3
8. Formed a plan of action in your mind.	1	2	3
9. Stood firm and fought for what you wanted in the situation.	1	2	3
10. Tried to solve the problem.	1	2	3
11. Tried to carefully plan a course of action rather than acting on impulse.	1	2	3

	Does not apply or would not use.	Would use a little.	Would use a lot.	Would use a great deal.
12. Prayed that things would work themselves out.	0	1	2	3
13. Got a group of family or friends together to help with the problem.	0	1	2	3
14. Shared your feelings with a friend or family member.	0	1	2	3
15. Remembered what a parent (or other relative) once said about dealing with these kind of situations.	0	1	2	3
16. Tried to forget about the situation.	0	1	2	3
17. Went to church (or other religious meeting) to get help from the group.	0	1	2	3
18. Thought of all the struggles Black people have had to endure and this gave me strength to deal with the situation.	0	1	2	3
19. To keep from thinking about the situation I found other things to keep me busy.	0	1	2	3
20. Sought advice about how to handle the situation from an older person in my family or community.	0	1	2	3
21. Read a scripture from the Bible (or similar book) for comfort and/or guidance.	0	1	2	3
22. Asked for suggestions on how to deal with the situation during a meeting of my organization or club.	0	1	2	3
23. Tried to convince myself that it wasn't that bad.	0	1	2	3
24. Asked someone to pray for me.	0	1	2	3
25. Spent more time than usual doing group activities.	0	1	2	3
26. Hoped that things would get better with time.	0	1	2	3
27. Read passage from a daily meditation book.	0	1	2	3
28. Spent more time than usual doing things with friends and family.	0	1	2	3
29. Tried to remove myself from the situation.	0	1	2	3
30. Sought out people I thought would make me laugh.	0	1	2	3
31. Got dressed up in my best clothing.	0	1	2	3

	Does not apply or would not use.	Would use a little.	Would use a lot.	Would use a great deal.
32. Attended a social event (dance, party, movie) to reduce stress caused by the situation.	0	1	2	3
33. Asked for blessings from a spiritual or religious person.	0	1	2	3
34. Helped others with their problems.	0	1	2	3
35. Lit a candle for strength and guidance in dealing with the problem.	0	1	2	3
36. Sought emotional support from family and friends.	0	1	2	3
37. Burned incense for strength or guidance in dealing with the problem.	0	1	2	3
38. Sang a song to myself to help reduce the stress.	0	1	2	3
39. Used a cross or other object for its special powers in dealing with the problem.	0	1	2	3
40. Found myself watching more comedy shows on TV.	0	1	2	3
41. Left matters in God's hands.	0	1	2	3

**Brief Symptom Inventory – 18 (BSI-18)**

The BSI-18 is copyrighted and not to be reproduced or transmitted in any form or by any means without permission of the publisher, Pearson Assessments Inc.



### Intentions of Seek Counseling Inventory – Cultural Revision (ISCI-CR)

The following list states a number of reasons why people decide to seek therapy. Read each item carefully and **imagine** that you were experiencing the same problem. Please indicate how likely you would be to seek therapy if you were experiencing the same problem using the following scale:

Very Unlikely      Unlikely      Doubtful      Possibly      Likely      Very Likely

1 ----- 2 ----- 3 ----- 4 ----- 5 ----- 6

Remember, there are no “wrong” answers, and the only right ones are whatever applies to you. Circle the response that seems to best apply to you. It is important that you answer every item.

	Very Unlikely	Unlikely	Doubtful	Possibly	Likely	Very Likely
1. Weight control	1	2	3	4	5	6
2. Excessive alcohol use	1	2	3	4	5	6
3. Relationship difficulties (i.e., romantic partners)	1	2	3	4	5	6
4. Concerns about sexuality	1	2	3	4	5	6
5. Depression	1	2	3	4	5	6
6. Conflicts with parents	1	2	3	4	5	6
7. Speech anxiety	1	2	3	4	5	6
8. Difficulties dating	1	2	3	4	5	6
9. Difficulty sleeping	1	2	3	4	5	6
10. Drug problems	1	2	3	4	5	6
11. Feelings of inferiority	1	2	3	4	5	6
12. Difficulties with friends	1	2	3	4	5	6
13. Self-understanding (i.e., personal growth)	1	2	3	4	5	6
14. Loneliness	1	2	3	4	5	6
15. Financial difficulties	1	2	3	4	5	6
16. Poor living conditions	1	2	3	4	5	6
17. Anxiety	1	2	3	4	5	6
18. Health Problems	1	2	3	4	5	6
19. Exploring racial identity	1	2	3	4	5	6
20. Emotional reactions to racism or prejudice	1	2	3	4	5	6

### Social Provisions Scale (SPS)

In answering the following questions, think about your current relationships with friends, family members, co-workers, community members, and so on. Please indicate to what extent each statement describes your current relationships with other people. Use the following scale to indicate your opinion:

Strongly Disagree                      Disagree                      Agree                      Strongly Agree  
*1* ----- *2* ----- *3* ----- *4*

Remember, there are no “wrong” answers, and the only right ones are whatever is true for you. Circle the response that seems to best apply to you. It is important that you answer every item.

	Strongly Disagree	Disagree	Agree	Strongly Agree
<b>1.</b> There are people I can depend on to help me if I really need it.	1	2	3	4
<b>2.</b> I feel that I do not have close personal relationships with other people.	1	2	3	4
<b>3.</b> There is no one I can turn to for guidance in times of stress.	1	2	3	4
<b>4.</b> There are people who depend on me for help.	1	2	3	4
<b>5.</b> There are people who enjoy the same social activities I do.	1	2	3	4
<b>6.</b> Other people do not view me as competent.	1	2	3	4
<b>7.</b> I feel personally responsible for the well-being of another person.	1	2	3	4
<b>8.</b> I feel part of a group of people who share my attitudes and beliefs.	1	2	3	4
<b>9.</b> I do not think other people respect my skills and abilities.	1	2	3	4
<b>10.</b> If something went wrong, no one would come to my assistance.	1	2	3	4
<b>11.</b> I have close relationships that provide me with a sense of emotional security and well-being.	1	2	3	4
<b>12.</b> There is someone I could talk to about important decisions in my life.	1	2	3	4

	<b>Strongly Disagree</b>	<b>Disagree</b>	<b>Agree</b>	<b>Strongly Agree</b>
<b>13.</b> I have relationships where my competence and skill are recognized.	1	2	3	4
<b>14.</b> There is no one who shares my interests and concerns.	1	2	3	4
<b>15.</b> There is no one who really relies on me for their well-being.	1	2	3	4
<b>16.</b> There is a trustworthy person I could turn to for advice if I were having problems.	1	2	3	4
<b>17.</b> I feel a strong emotional bond with at least one other person.	1	2	3	4
<b>18.</b> There is no one I can depend on for aid if I really need it.	1	2	3	4
<b>19.</b> There is no one I feel comfortable talking about problems with.	1	2	3	4
<b>20.</b> There are people who admire my talents and abilities.	1	2	3	4
<b>21.</b> I lack a feeling of intimacy with another person.	1	2	3	4
<b>22.</b> There is no one who likes to do the things I do.	1	2	3	4
<b>23.</b> There are people I can count on in an emergency.	1	2	3	4
<b>24.</b> No one needs me to care for them.	1	2	3	4

### Demographic Questionnaire

Please complete the following information as accurately as possible:

1. Gender (*specify if necessary*):

- Male  
 Female  
 Other: \_\_\_\_\_

2. Age: \_\_\_\_\_

3. Were you born in Canada?

- YES  
 NO

*If NO*, please specify your country of birth:

\_\_\_\_\_

*If NO*, how many years have you lived in Canada:

\_\_\_\_\_

4. Immigration Status:

- Canadian Citizen  
 Landed Immigrant  
 Student Visa  
 Visitor's Visa

5. Your mother's racial background is:

- White  
 Black  
 Latino  
 Aboriginal/First Nations  
 East Asian (e.g., China, Korea, Taiwan, etc.)  
 Southeast Asian (e.g., Cambodia, Indonesia, Laos, Vietnam, etc.)  
 South Asian (e.g., India, Pakistan, Sri Lanka, etc.)  
 Biracial (*specify*):  
 \_\_\_\_\_  
 Multiracial (*specify*):  
 \_\_\_\_\_  
 Other (*specify*):  
 \_\_\_\_\_

Your father's racial background is:

- White  
 Black  
 Latino  
 Aboriginal/First Nations  
 East Asian (e.g., China, Korea, Taiwan, etc.)  
 Southeast Asian (e.g., Cambodia, Indonesia, Laos, Vietnam, etc.)  
 South Asian (e.g., India, Pakistan, Sri Lanka, etc.)  
 Biracial (*specify*):  
 \_\_\_\_\_  
 Multiracial (*specify*):  
 \_\_\_\_\_  
 Other (*specify*):  
 \_\_\_\_\_

What cultural group do you most closely identify with (e.g. West Indian, Jamaican, African, Ghanaian, African Canadian, Canadian)?

---

6. What is your generation status in Canada?

- 1st generation (born outside of Canada & immigrated to Canada after the age of 12)
- 1.5 generation (born outside of Canada & immigrated to Canada before the age of 12)
- 2nd generation (born in Canada & have at least one parent who was born outside of Canada)
- 3rd generation (born in Canada and have at least on parent who was born in Canada)
- Beyond 3rd or later generation
- I am an international student who was born outside of Canada

7. Marital Status:

- Single
- Married
- Widowed
- Separated or Divorced
- Cohabiting

8. Employment Status (*Check all that apply*):

- Full-time
- Part-time
- Unemployed
- Student

9. Highest level of education completed (*Specify where necessary*)

- Grade school (*Highest grade completed e.g. 1 – 8: \_\_\_\_\_*)
- Partially completed High School (*Highest grade completed: \_\_\_\_\_*)
- Completed High School or GED
- Partially completed college program
- Completed 2 year college program
- Partially completed University degree
- Completed University degree
- Partially completed graduate or professional school
- Completed graduate or professional school

10. Postal Code of primary (i.e., permanent) Canadian residence: \_\_\_\_\_

11. **If** I was considering therapy for help in dealing with serious personal or emotional problems, the race of the therapist would be important to me.
- 1 ----- 2 ----- 3 ----- 4 ----- 5  
Strongly Disagree    Disagree            Neutral            Agree            Strongly Agree
12. **If** I was experiencing serious personal or emotional problems, I would be more willing to seek therapy if I knew the therapist was Black.
- 1 ----- 2 ----- 3 ----- 4 ----- 5  
Strongly Disagree    Disagree            Neutral            Agree            Strongly Agree
13. I have seen a counselor, therapist, psychologist, or psychiatrist for help in dealing with a personal or emotional problem.             NO             YES

## VITA AUCTORIS

NAME: Justine Joseph  
PLACE OF BIRTH: Toronto, Ontario  
YEAR OF BIRTH: 1981  
EDUCATION: Bayview Glen Secondary School, Toronto,  
Ontario  
1987-1999  
University of Toronto, Toronto, Ontario  
1999-2003 Hon.B.Sc.  
University of Windsor, Windsor, Ontario  
2003-2006 M.A.  
University of Windsor, Windsor, Ontario  
2006-2010 Ph.D.