

Thesis Report

**Topic: A comparative study of DC/AC
pure sine wave inverters.**

N.B: This report is submitted to the Department of Electrical & Electronics Engineering (EEE), BRAC University.

Submitted By-

Nusrat Khan Bintu-09210021

Labiba Muhammad-09210019

&

Navid Anjum-11310015

Thesis Supervisor:

Supriyo Shafkat Ahmed

Lecturer of BRAC University

Declaration

We do hereby declare that the thesis titled “A comparative study of DC/AC pure sine wave inverters” is submitted to the Department of Electrical & Electronics Engineering (EEE) of BRAC University in partial fulfillment of the Bachelor of Science in Electronics & Communication Engineering. This is our original work and was not submitted elsewhere for the award of any other degree or any other publication.

Date:

Supervisor

(Student Name)

Student ID:

(Student Name)

Student ID:

(Student Name)

Student ID:

Acknowledgement

We are greatly thankful to our supervisor Supriyo Shafkat Ahmed for his proper guidance and support during this exercise. His inspiration and encouragement made it easier for us to finish the pre-thesis work properly in proper time.

Abstract

A power inverter or inverter is an electrical power converter that changes direct current (DC) to alternating current (AC). The converted AC can be at any required voltage and frequency with appropriate transformer, switching and control system. In under developed countries, the ever increasing reliance on electrical and electronic devices which utilize AC power highlights the problem associated with the unexpected or sudden loss of power due to electrical load shedding. Therefore, there is a need of inexpensive and reliable pure sine wave inverter to backup sophisticated electronic devices like medical devices and as well as for household appliances like fan, television, tube-lights etc.

It has been noted that today's pure sine wave inverter produces total harmonic distortion (THD) of about 3% ^[1]. It is due to this THD, the lifetime of other electrical devices like fan, tube-light etc. decreases significantly ^[2]. This thesis aims to compare and analyze the total harmonic distortion, efficiency and cost effectiveness of different inverters from different renowned companies and finally to propose a design of a pure sine wave inverter with less total harmonic distortion and with greater efficiency than usual. Thus, it will have less effect on the lifetime of any electrical devices such as fan, tube lights etc.

TABLE OF CONTENTS

	Page
TITLE.....	I
DECLARATION.....	II
ACKNOWLEDGEMENTS.....	III
ABSTRACT.....	IV
TABLE OF CONTENTS.....	V
LIST OF TABLES.....	VIII
LIST OF FIGURES.....	IX
Chapter 1: INTRODUCTION	1
1.1 Inverter	3
1.2 Inverter and UPS	
1.3 Automation Section	6
1.3.1 Relay	7
1.3.2 Transformer	7
1.3.3 Wet Lead-Acid Battery	8
1.3.4 IC's of the inverter	8

Chapter 2: Circuit Description of PWM based 500W MOSFET Inverter	16
2.1 Making of 50Hz frequency by the oscillator section	16
2.2 Driver Section	17
2.3 Output Section	17
2.4 PWM or Pulse Width Modulation section	18
2.5 Extra Protection Circuits	19
2.6 High Voltage Spike Protection Circuit	21
2.7 Shutdown Section Inside the IC2 (SG3524)	21
2.8 Overload Section	22
2.9 Overload Protection Circuit	23
2.10 Function of overload protection circuit in overload condition	24
2.11 changeovers Section	25
2.12 Changeover Circuit	26
2.13 changeovers when AC mains are available	27
2.14 Low battery cut section	28
2.15 Battery charging section	30
2.15.1 AC Mains Sensing Section	31
2.15.2 Soft Start Section (Charging Delay Circuit)	31
2.15.3 Charging Ampere Sensing Section/Battery Current Sensing Section	33
Chapter 3: Elaborate description of the project	35
3.1 Block Diagram of our inverter Digital Inverter (625VA/12V)	35
3.2 Different sections of our inverter digital inverter	37
3.2.1 Main inverter transformer	37
3.2.2 Switching output section	37
3.2.3 Oscillator section	37
3.2.4 Low-battery protector section	37
3.2.5 Overload protector section	37

3.2.6 Battery charging control section	37
3.2.7 Driver transformer	37
3.2.8 Main input sensor section	37
3.2.9 MCB switch (miniature circuit breaker)	37
3.2.10 AC/DC Selector Section	38
3.2.11 Main Input Sensor Section	38
3.2.12 MCB Switch	38
3.2.13 Output socket	38
3.3 Detail explanation of our inverter circuit	38
3.3.1 AC/DC and charging selector section	38
3.3.2 Voltage double and regulator section	39
3.3.3 Voltage Doublers	39
3.3.4 Voltage regulator	39
3.3.5 Mains input sensor section	40
3.3.6 Oscillator section	40
3.3.7 Switching output section	41
3.3.8 Charging section	42
3.3.9 AC/DC selector (change over) section	43
3.3.10 AC/DC selector and battery charging control section	43
3.3.11 Overload and over changing protector section	45
3.3.12 over load protector	45
3.3.13 Battery charging control and low battery protector section	46
Chapter 4: Formulas and Calculations	48
Chapter 5: Result	55
Chapter 7: Conclusion	66
References	67

List of Tables

Table: 2 voltage when ac mains return and voltage when charging start	32
Table: 4 THD% by voltage for every inverters output including AC Mains	51
Table: 5 .1 THD in voltage	62
Table: 5.2 THD in different load current	64
Table: 5.3 Efficiency Change	65

LIST OF FIGURE

Figure	page
Fig:1: block diagram of inverter	2
Fig:1.1 block diagram of IPS and Inverter	3
Fig:1.2 Basic diagram of an inverter	5
Fig: 1.3. 1Internal block diagram of ICLM339	9
Fig: 1.3.2 Internal block diagram of IC SG3524	10
Fig:1.3.3 Internal Block diagram of IC NE555/LM555	12
Fig:1.3.4 Internal block diagram of IC 4N35	13
Fig 1.3.5 diagram of MOC3021	15
Fig:2 oscillator, PWM,error amplifier ®ulator supplysection	17
Fig:2.1 output section (using MOSFET)	18
Fig:2.2 circuit diagram of overload protection section	20
Fig:2.4 change over section	22
Fig:2.5 low battery cut section	23
Fig:2.6 charging section power section	25
Fig:2.7 charging control & soft start charging section	26
Fig:2.8 circuit diagram of battery level sensing & charging ampere section	29
Fig: 2.9 circuit diagram of charging control section using SCR	31
Fig 3 block diagram of inverter Digital Inverter (625W/12V)	36
Fig: 4 THD in voltage for the output of Pure Sine Wave Inverter of Rahimafrooz	49
Fig: 4.1 THD in voltage for the output of Pure Sine Wave Inverter manufactured by SINGER	49
Fig: 4.2 THD in voltage for the output of Pure Sine Wave Inverter manufactured by NAVANA	50
Fig: 4.3 THD in voltage for the output of Pure Sine Wave Inverter of Butter Fly	50
Fig:4.4 THD in voltage for the output of Pure Sine Wave Inverter as a BU project	51
Fig:4.5 THD by voltage in DB versus harmonics graph	52
Fig:4.6 Output of the sine wave inverter manufactured by Rahimafrooz	52
Fig:4.7 Output of the sine wave inverter manufactured by SINGER	52

Fig:4.8 Output of the sine wave inverter manufactured by NAVANA	53
Fig: 4.9 Output of the sine wave inverter manufactured by Butter Fly	53
Fig:4.10 Output of the AC Mains	54
Fig:4.11 Output of our BU project inverter	54
Fig:5 block diagram of the project inverter	56
Fig:5.1 BU project inverter's THD of voltage in Spectrum Analyzer	59
Fig:5.2 BU project inverter's THD of voltage in Spectrum Analyzer after 30 days	59
Fig: 5.3Rahimafrooz manufactured inverter's THD of voltage in Spectrum Analyzer	60
Fig: 5.4 Rahimafrooz manufactured inverter's THD of voltage after 30 days	60
Fig: 5.5 BU Project inverter's output in digital oscilloscope	61
Fig:5.6 Project inverter's output in digital oscilloscope after 30 days	61
Fig:5.7Rahimafrooz manufactured inverter's output in Digital oscilloscope	61
Fig:5.8Rahimafrooz manufactured inverter's output in Digital Oscilloscope after 30 days	62
Fig:5.9 Distortion in different Harmonics	63
Fig:5.10 Difference between THD percentages	63
Fig:5.11 THD in different load current	64
Fig:5.12 Efficiency Change	65

INTRODUCTION

1.1 Inverter

Currently whatever work you do, in each and every field you will find some electrical or electronic device, be it in general household use or in some special industrial use.

These electrical or electronic devices require electrical power for their operation and most of these devices are very particular about the quality of the power given to them. If the power given to these electrical/electronic devices are not according to their required quality then these devices can get damaged.

Also these devices will not be of any use if you do not provide them with proper power supply. In Bangladesh standard electrical or electronic equipment works on 220V/50Hz AC power supply ^[3].

This power supply should not contain any problems such as spike, noise etc., otherwise it could damage the equipment.

In development countries the power provided by the power supplying companies are of good quality, without any of the above given problems, but in a developing country like Bangladesh the power provided by the electricity supply department contain a lot of problems.

Also, power cuts and line problems are very frequent in these countries. This situation gets worse in some specific seasons such a in summer, when the electricity generated by the hydro-electrical plant go down and the power requirement, because of increased use of A.Cs coolers, fans etc., increase, so frequent power cuts become common. In rainy seasons due to thunder storms electrical line/polls get damages, increasing the power problems.

In this type of situation some kind of device which could provide power supply to the electrical/electronic devices during the mains power breakdown becomes a necessity.

We have already said that in India most of the electrical/electronic devices work in the 220V AC supply provide be the electricity department. Internally the circuit in most of the electronic equipment works on DC supply.

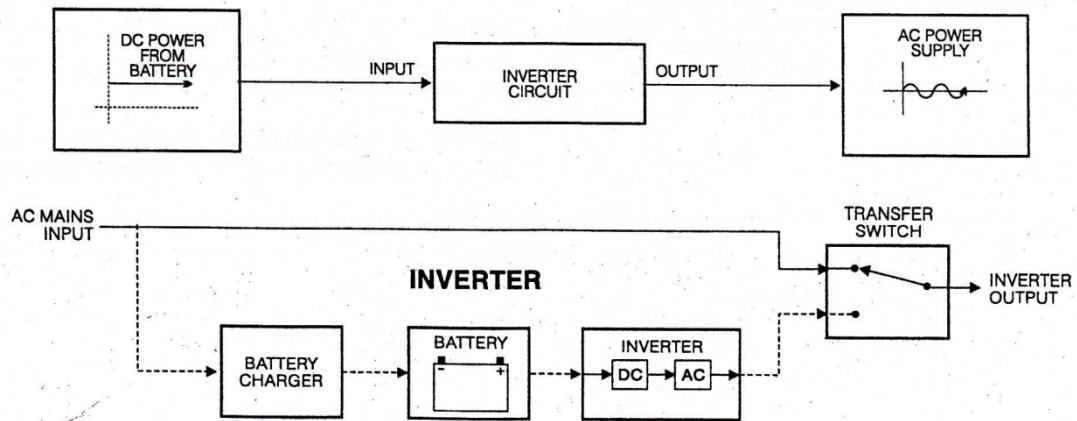

Fig: 1: block diagram of inverter

The external AC supply is converted into DC supply by the power supply provided on this equipment. Any devices which work on DC supply can be used during the mains power breakdown by connecting them to batteries.

The lead-acid batteries used in the automobiles are very good for this purpose they provide good quality power for long duration and can be recharged once the power stored in them are consumed. Any device which has facility to connect a DC power source can be made to work on the DC power provided by the batteries but if a device does not have any option to connect to a DC power source, or if a device requires AC power source for its operation then what should be done.

For this, device such as an inverter or a generator is used. Generators are generally used in shops or business offices as a power source, when the mains AC supply is not available, but at homes and small offices etc. inverters are more commonly used.

An inverter is a device which can convert the DC supply required by most of the electrical/electronic equipment.

The process through which these inverters convert DC into AC supply is called “inversion”. This inversion process is reverse of the rectification process, where the AC power is converted into DC power.

Generally when one talks about the “Inverter”, he talks about a combination of inverter circuit, charger circuit and a battery.

The charger circuit keeps the battery charged when the mains power supply is available and when the mains AC

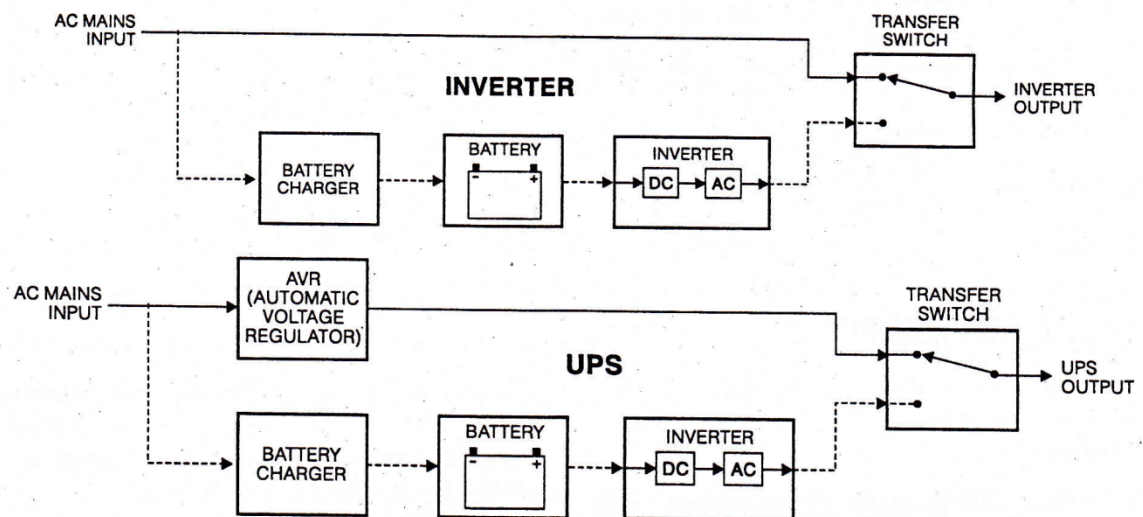

Fig: 1.1 block diagram of IPS and Inverter

Supply fails; the inverter circuit takes the DC power stored in the battery and converts it into 220v/50Hz AC supply, which can be used to power any common electrical/electronic equipment.

1.2 Inverter and UPS

The inverter and UPS generally do the same job of providing uninterrupted AC supply, when the AC supply, when the AC mains fail.

An Inverter contains the following sections

- Charging Section

- Inverter Section

An UPS has the following sections

- Charging Section
- Inverter Section
- AVR (Automatic Voltage Regulation) Section

The AVR section is an additional section in the UPS. When the AC mains is available, the inverter sends the AC mains to its output socket, without any correction. For example, if the input AC supply is 180V, it will be directly sent to the output socket by the inverter, and if the input AC supply is 260V, this will also be directly sent to the output socket.

No correction is done by the inverter on the input AC supply to bring it into 220-230V range. In the UPS when the AC mains are available, the AVR section regulates the incoming AC supply and provides a regulated output at its output socket. This AVR section regulates the incoming AC mains supply (varying from 140V to 270V) and provides a supply in the range of 220V to 240V at its output socket^[4].

If sensitive equipment such as a computer is operated on inverter output, the fluctuation in the input AC mains supply will reach the output and could damage the equipment. If the same equipment is operated on UPS, a regulated output by the UPS makes sure that the equipment works without any trouble.

Another difference between the UPS and inverter is in the changeover time, i.e. in the time taken by the UPS or inverter to switch between the AC mains supply to battery mode and from battery mode to AC mains supply.

In an inverter, this changeover time is not very small, these results in a reboot of the computer connected to the inverter output. In an UPS this changeover time is so small that the load connected to the UPS output works without any interruption. Generally in a low battery or overload condition the inverter shuts down without any indication or warning. UPS uses buzzer and LEDs to inform the user about these conditions, before shutting down.

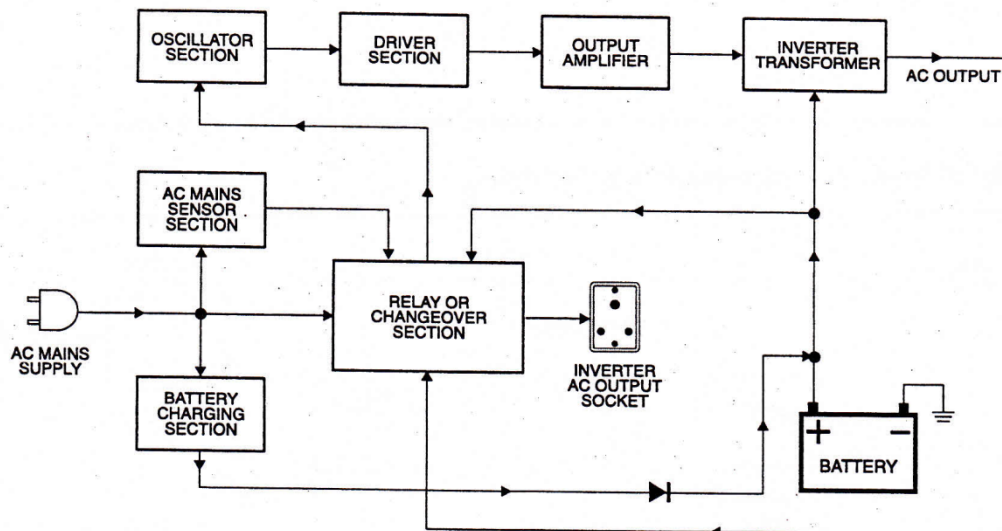

Fig: 1.2 Basic diagram of an inverter

These warning signals make sure that the user can safely save his works and shutdown the computer, before the UPS switches off. Because of these differences, the UPS is more suited for such applications, where some critical load such as computer or medical equipment requires uninterrupted supply.

An inverter can be safely used to provide uninterrupted supply to the household electrical equipment such as fans, lights etc.

Basic Working Principle of the Inverter

An Inverter is used to provide uninterrupted 220V AC supply to the load connected at its output socket. Inverter provides constant AC supply at its output socket, even when the AC mains supply is not available.

Let us see how the Inverter does this. To understand the working of inverter, we shall consider inverter in the following situations:

- When the AC mains supply is available
- When the AC mains supply is not available (Inverter operating on battery supply)

When the AC main supply is available

When the AC mains supply is available, this AC mains supply goes to the AC mains sensor, Relay, and Battery charging section of the inverter. AC mains sensor informs the relay about availability of the AC mains supply. When this relay receives AC mains available signal from the AC mains sensor, it directly passes the AC mains signals to the inverter output socket^[5].

The battery charging section converts this AC mains supply into DC supply this DC supply is then regulated to provide required voltage and current to charge the inverter battery.

When the AC mains supply is not available

When the AC mains supply is not available, an oscillator section inside the inverter generates 50Hz frequency MOS drive signal. This MOS drive signal is amplified by driver section and sent to the output section. Output section used MOSFET devices for switching operation.

These MOSFETs are connected to the primary winding of the inverter transformer. When these MOSFETs receive the MOS drive signal from the driver section, they start to switch on/off at the speed of 50Hz.

This switching on/off of MOSFET starts an alternating current with 50Hz frequency at the primary winding of the inverter transformer. This results in a 220V AC supply (with 50Hz frequency) at the secondary winding of the inverter transformer. This 220V AC supply at the secondary winding is sent to the output socket of the inverter through a changeover relay.

1.3 Automation Section

Inverter contains an Automation Section to automatically tackle various special conditions that may arise during the running of the Inverter. This section takes care of conditions such as low battery, overload, overcharge etc.

Based on the condition this section may switch the Inverter to battery mode or may completely switch off the Inverter and inform about the situation to the user by sounding buzzer and glowing LED indicators.

Components of the Inverter

An Inverter requires various components for its proper operation. Some of these components are

- Relay
- Transformer
- Transistor
- MOSFETs
- ICs
- Battery

1.3.1 Relay

Relay is an electromagnetic switch. Switching on/off of relay is based on the flow of current through its coil. Relay is used for switching on/off various high voltage circuits. In Inverter, relay is used in various cut circuits and to switch the output between AC main supply and inverter generated supply.

1.3.2 Transformer

A step up transformer with layers winding has been used as the main transformer for this inverter. This transformer core original cold rolled Nickel Grain Oriented (CRNGO). In the primary side of this transformer have 23 turns of winding and secondary side has 650 turns of winding. The layer is insulated by a paper and the second layers wound on it, this process is considered till the 650 turns is completed. We have used 5SWG blue channeled wire for winding. This transformer has higher load leading capability.

1.3.3 Wet Lead-Acid Battery

To make this inverter use wet lead-acid battery. In these batteries, the electrolyte is in liquid form, therefore these batteries are known as “wet cell”. This battery is made of combination of several lead-acid cells, each cell delivering 2.1V^[6].

To get 12V from a lead-acid battery, one needs to connect 6 lead-acid cells in series. A 6V battery would require 3 lead-acid cells.

These cells are connected together using thick metal strips, as large current is involved. Each cell has a removable cap to check/add the water/acid level of the cell. In a lead-acid cell the positive electrode is made of lead-peroxide, and the negative electrode is made of spongy lead.

A combination of sulfuric acid and water is used as electrolyte in these batteries. The negative and positive electrodes are immersed in a combination of 8 parts of water and 3 parts of concentrated sulfuric acid. The specific gravity of the electrolyte of a fully charged battery is about 1.25 to 1.28.

As the battery gets discharged the sulfuric acid gets reduced and the water content increase. This reduces the specific gravity of the battery to around 1.13 to 1.15, when the battery is fully discharged. When the battery is recharged, the sulfuric acid content and water level is again restored to its fully charged state.

1.3.4 ICs' of the Inverter^[9]

In this project PWM is used, Inverter based on PWM (Pulse Width Modulation) technology and MOSFET device use the following ICs

- LM324N – operational Amplifier (Op-Amp)
- SG3524 – PWM Controller and Oscillator
- LM339 – Quad Comparator
- NE555 – Timer
- 4N35 – Opto-Coupler

- MOC3021 – Opto-Coupler
- LM7812 – 12V Voltage Regulator
- LM317 – Adjustable Regulator

LM324N - operational Amplifier (Op-Amp)

LM324N is an Operational Amplifier (Op-Amp) IC. It has four different Op-Amp units, which can be used individually. One can use LM124/224/324A/524A or

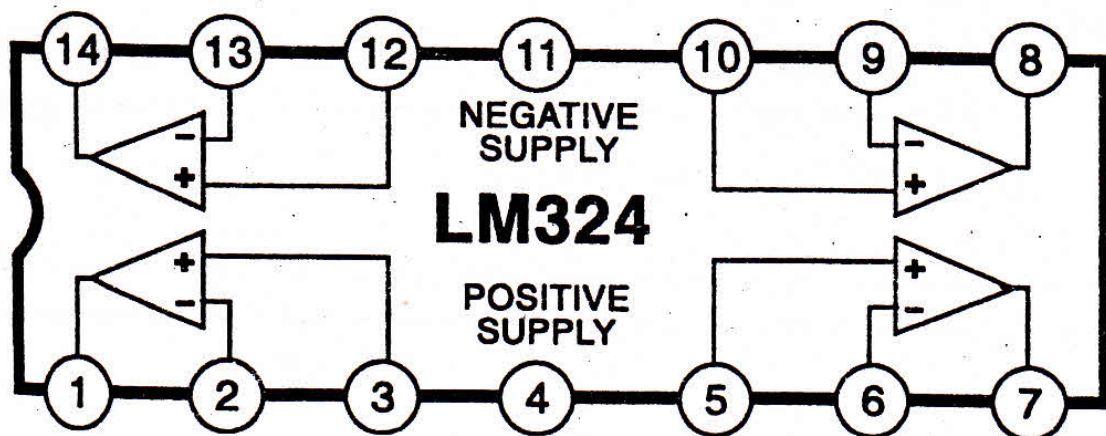

LM2902 in place of the LM324N IC. Pin description of IC LM324N is given below:

Pin-1 – Output 1

Pin -2 – Inverting (-) Input 1

Pin-3 – Non-Inverting (+) Input 2

Pin-4 – Positive Supply

Pin-5 – Non-Inverting (+) Input 2

Pin-6 – Inverting (-) Input 2

Pin-7 – Output 2

Pin-8 – Output 3

Pin-9 – Inverting (-) Input 3

Pin-10 – Non-Inverting (+) Input 3

Pin-11 – Negative Supply

Pin-12 – Non-Inverting (+) Input 4

Pin-13 – Inverting (-) Input 4

Pin-14 – Output 4

Operational Amplifier lays a big role in the PWM based Inverter. The Op-Amp is used as a comparator in the Inverter circuit. Four different Op-amps in the LM324N can be used for four different works.

LM339 – Low power Low Offset Voltage Quad Comparators

This IC fig 1.3 consists of four independent decision precision voltage comparators with an offset voltage specification as low as 2mVmax for all four comparators. These are designed specifically to operate from a single power supply over a wide range of voltages. Operation from split power supplies is also possible and the low power supply current drain is independent of the magnitude of the power supply voltage. Pin description of IC LM339 is given below:

Pin-1 – Output 2

Pin -2 – output 1

Pin-3 – Positive Supply

Pin-4 – Inverting (-) Input 1

Pin-5 – Non-Inverting (+) Input 1

Pin-6 – Inverting (-) Input 2

Pin-7 – Non-Inverting (+) Input

Pin-8 – Inverting (-) Input 3

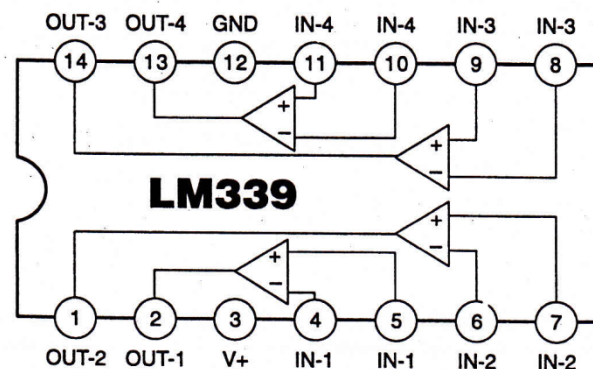

Fig: 1.3.1 Internal block diagram of ICLM339

Pin-9 – Non-Inverting (+) Input 3

Pin-10 – Inverting (-) Input 4

Pin-11 – Non-Inverting (+) Input 4

Pin-12 – Negative Supply

Pin-13 – Output

Pin-14 – Output 3

SG3524 – PWM Controller and Oscillator

SG3524 is a 16 pin PWM (Pulse Width Modulation) controller fig 1.3.2 IC. It is a very common IC in MOSFET based Inverter device. This IC contains various sections such as oscillator output, error amplifier, shutdown and +5V regulator. All these section are used to control the Inverter. Pin description of IC KA3524/SG3524 is given below:

Pin-1 – this is inverting input pin for error amplifier. This pin is given feedback signal for output regulation.

Pin-2 – This is non-inverting input for error amplifier. This pin is given a constant reference voltage from pin-16 of this same IC.

Pin-3 – This is output pin for oscillator section

Pin-4 – this pin related to amplifier.

Pin-5 – This pin is related to amplifier section.

Pin-6 – This pin is related to oscillator section. Resistor at this pin sets the frequency of the oscillator.

Pin-7 – This is oscillator section time constant capacitor input pin. Value of capacitor at this pin sets the oscillator frequency.

Pin-8 – Ground

Pin-9 –pulse Width Control input. It is also known as compensation input pin. Width of the drive signal of compensation input pin. Width of the drive signal of PWM IC output depends on the voltage at this pin.

Pin-10 – Shutdown input. More than 0.6V to this pin shuts down the oscillation section inside the IC.

Pin-11 – Oscillator section output. MOS drive signal is output at this pin.

Pin-12 – Positive supply for oscillator section

Pin-13 – Positive supply for oscillator section.

Pin-14 – Oscillator section output. MOS drive signal is output at this pin.

Pin-15 – positive supply for IC.

Pin-16 – output of voltage regulator. A constant, regulated +5V is output from this pin.

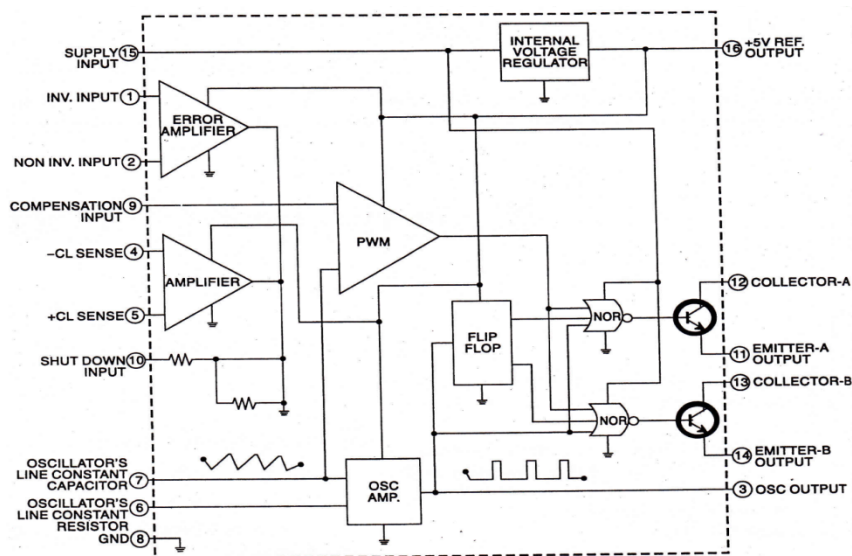

Fig: 1.3.2 internal block diagram of IC SG3524

NE555 – Timer

This is a very common 8 pin timer IC in fig 1.3.3. This IC can output various timing pulse at its output based on the value of the components at its various pins. This IC can work with a DC supply is given below:

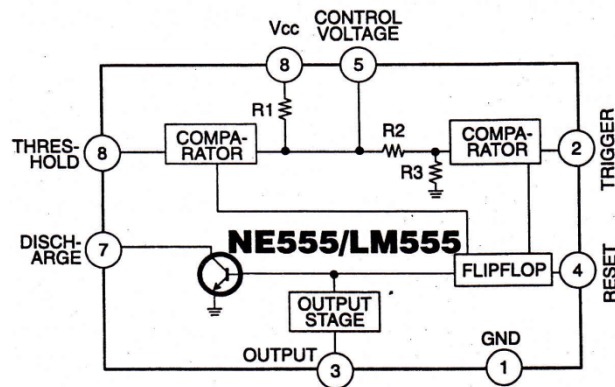

Fig: 1.3.3 Internal Block diagram of IC NE555-timer

Pin-1 – Negative Supply (Ground)

Pin-2 – Trigger Input

Pin-3 – Output

Pin-4 – Reset

Pin-5 – Control

Pin-6 – Threshold

Pin-7- Discharge

Pin-8 – positive Supply

The status of the signal at its output pin-3 can be changed by giving a low or high trigger pulse as input at its pin-2.

4N35 – Opto-Coupler

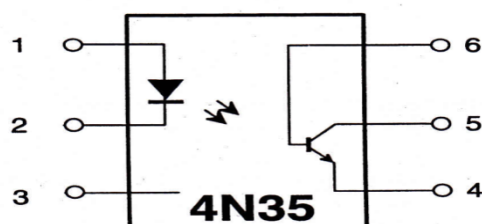

Fig: 1.3.4 Internal block diagram of IC 4N35

IN 4N35 is a 6pin opto-coupler IC in fig 1.3.4. It contains a LED and a photo transistor. Pin-1 and 2 are connected to the LED, pin-1 is given positive supply and pin-2 is given negative supply to light the LED.

Pin-4, 5 and 6 are connected to this photo transistor. Light falling on the vase conducts the photo transistor and output from the transistor and output from the transistor is made available at its emitter.

Pin description of IC 4N35 is given below:

Pin-1 – This pin is connected to the anode of the LED.

Pin-2 – This pin is connected to the cathode of the LED.

Pin-3 – this pin is not used.

Pin-4 – This pin is connected to the emitter of the photo transistor.

Pin-5 – This pin is connected to the collector of the photo transistor.

Pin-6 – This pin is connected to the vase of the photo transistor.

MOC3021 – Opto-Coupler GaAs Infrared Emitted Diode and Light Activated Triac Driver

The MOC3021 series consists of Gallium Arsenide infrared emitting diode coupled with a light activated silicon bilateral switch, which functions like a triac in a dual in line package. These devices are especially designed for triggering power triacs while maintaining dielectric isolation from the trigger control circuit. They are mounted in dual in line packages. These devices are also available in surface mount packaging. Pin description of IC MOC3021 is given below:

Pin- 1 – This pin is connected to the anode of the LED.

Pin-2 – this pin is connected to the cathode of the LED.

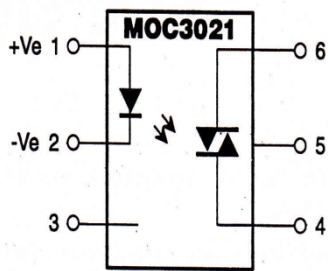

Fig 1.3.5 diagram of MOC3021

Pin-3 – This pin not used.

Pin-4 – this pin is connected to Triac.

Pin-5 – This pin is not used.

Pin-6 – This pin is connected to Triac.

LM7812 – 12V Voltage Regulator

This is a 3 pin 12V voltage regulator IC.

Pin-1 is input

Pin-2 is ground

Pin-3 is the regulated output pin.

LM317 – Adjustable Regulator

This is a 3 pin adjustable regulator IC.

Pin-1 is a control pin. This pin is connected to the ground through a reset.

Pin-2 is output pin.

Pin-3 is input pin.

This IC has better current limiting capacity and line & load regulation capacity compared to other regulator ICs. This IC also has an overload protection section. This IC does not require any filter, because of its high ripple rejection capability.

2. Circuit Description of PWM based 500W/625VA-12V MOSFET Inverter

2.1 Making of 50Hz frequency by the oscillator section [8].

This is a 500VA/625VA PMW MOSFET technology based inverter. Oscillation section of this inverter uses a very common PWM controller IC SG3524 (KA3524/CA3524) [7].

This IC is used to generate the 50HZ frequency required to generate AC supply by the inverter.

To start this process, battery supply is given to pin-15 of IC2 (SG3524), through inverter on/off switch, and diode D17, D18.

Pin-8 of IC2 is connected to negative terminal of the battery .IC9 is used to regulate the 12V supply from battery.

Pin-6 and 7 of IC2 are oscillation section pins. Frequency produced by IC2 depends on the value of the capacitor and resistance at these pins.

Two capacitors C27 and C28 (each 0.1uF) are connected to pin-7. This capacitor decides the 50Hz frequency output by IC2.

Pin-6 is timing resistance pin. A resistance at this pin keeps the oscillator frequency constant. Present VR5 (20K) is connected to ground from pin-6 of IC2. A preset is used at this pin, so that the value of the output frequency can be adjusted to a constant 50Hz.

With the frequency adjustment preset VR4, another resistance R23 is connected to pin-6.

Signal generated by oscillator section of IC2, reach the flip-flop section of IC2. This section converts the incoming signal into signal with changing polarity.

In a two signals with changing polarity, when the first signal is positive, the second signal will be negative and when the second signal becomes positive the first signal will become negative.

This process is repeated 50 times per second, i.e. an alternating signal with 50Hz frequency is generated inside the flip-flop section of IC2.

This 50Hz frequency alternating signal is output at pin-11 and 14 of IC2. This alternating signal is known as "MOS drive signal".

This MOS drive signal at pin-11 and 14 are between 3-4V. Voltage at these pins should be same; any difference in the voltage at these pins could damage the MOSFET at the output.

2.2 Driver Section

MOS drive signal from pin-11 and 14 of ic2 are given to the base of MOS driver T1 and T2. This results in the MOS drive signal getting separated into two different channels.

Transistor T1 and T2 amplify the 50 HZ MOS drive signal at their base to a sufficient level and output them from emitter.

50Hz signal from the emitter of T1 is given to the gate (G) of each MOSFET in the first MOSFET channel, through resistance RA19 (2K2). Each MOSFET gate (G) receives the 50Hz signal through a resistor (RA14~RA9).

50Hz signal from the emitter of T2 is given to the gate (G) of each MOSFET in the second MOSFET channel, through resistance RA14 (2K2). Each MOSFET gate (G) receives the 50 Hz signal through a resistor (RA6~RA9).

2.3 Output Section

The 50Hz alternating MOS drive signal reach each MOSFET channel separately.

This results in the MOSFET channels being alternatively on and off. When first channel is on, the second will be off, and when the second channel is on, the first will be off. This on/off switching process is repeated 50 times per second.

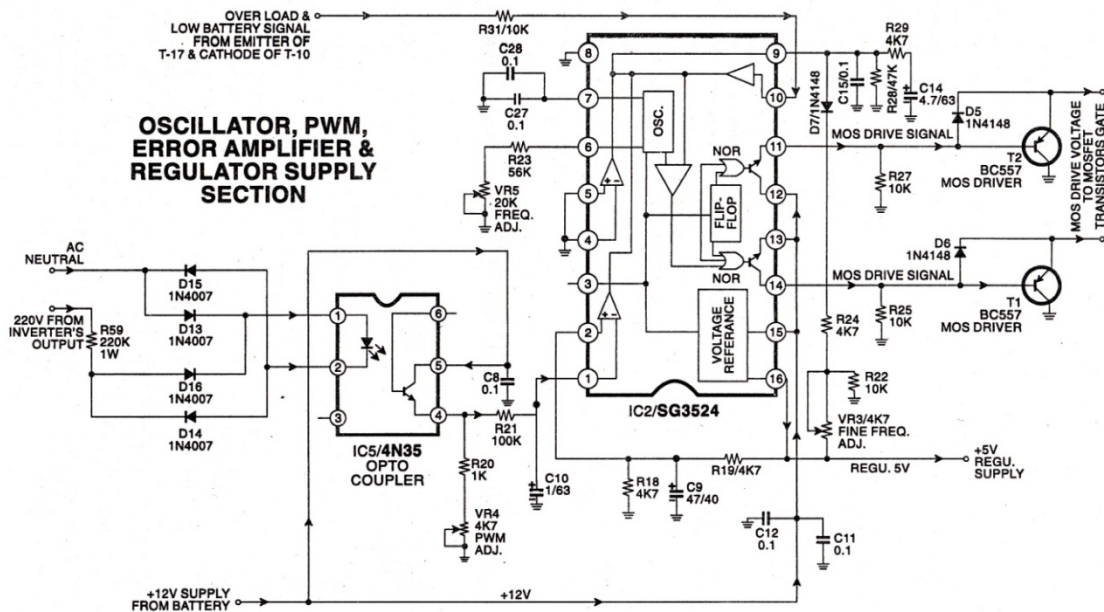

Fig: 2 Oscillator, PWM, error amplifier & regulator supply section

Drain (D) of all MOSFET of the second channel is also connected together and the other end of the inverter transformer's bifilar winding is connected to this connection.

Positive terminal of the battery is connected to the center tapping of the bifilar winding. The results in the positive supply reaching drain (D) of each MOSFET transistor, through a shunt (low value resistance).

Because polarity of the 50Hz MOS drive signal at pin-11 and 14 are different, at a time only one channel from the output channel remains on, the other channel stays off.

When first MOSFET channel is on, the current flows through first half of the inverter transformer layer winding. When second MOSFET channel turns on, the current flows through second half of the inverter transformer winding.

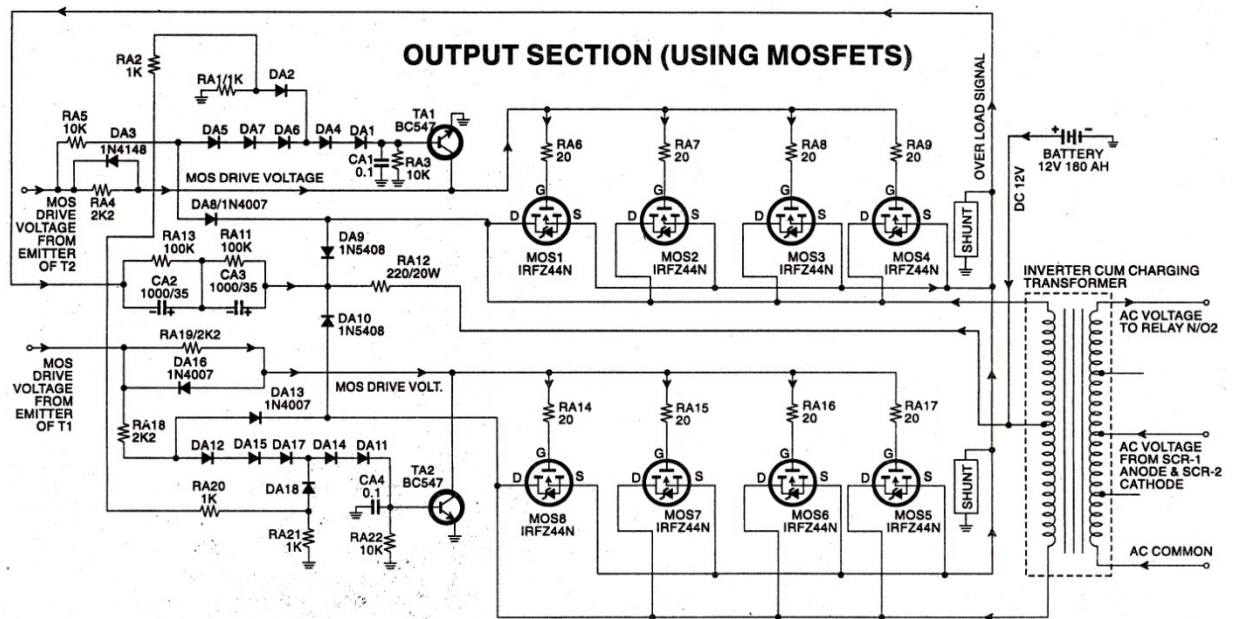

Fig: 2.1 Output section (using MOSFET)

This switching on/off of MOSFET channels will start an alternating current in the bifilar winding will induce an AC current of 50Hz, in the 270V tapping of the transformer.

AC voltage output from 270V tapping of secondary winding is connected to N/O-2 terminal of relay. When the AC mains is not available, pole P-2 of the relay is connected to N/O-2 terminal.

The AC voltage produced by the inverter reaches the inverter output socket through N/O-2 and P-2 terminals of the relay.

2.4 PWM or Pulse Width Modulation section ^[10]

PWM or pulse width modulation is used to keep the inverter output to a constant 220V AC.

To make the PWM work, the PWM IC2 (SG3524) should always receive a feedback of AC supply generated by the inverter circuit.

If IC2 does not receive feedback, then as value of load connected to the inverter output socket change, the pulse width output from pin-11 and 14 will also change. This result in fluctuation of the inverter output socket.

To provide feedback to the PWM controller IC2, the AC voltage generated at the 270V winding of the inverter transformer is given to pin-3 of the controller CN-4.

This AC voltage at pin-3 of CN-4 is given to dropping resistance R59 and then converter into DC voltage by bridge rectifier D13~D16.

DC voltage from the bridge rectifier is sent to pin-1 and 2 of opto-coupler IC (4N35). When pin-1 and 2 receive supply, a LED inside the IC starts to glow; the light from this LED falls on the base of a photo-transistor inside the IC5.

This will conduct the photo-transistor.

Controller of photo-transistor is connected to pin-5 of IC5, and emitter is connected to pin-4.

Pin-5 of IC5 receives 12V supply from the battery. When the photo-transistor conducts, the supply at collector of photo-transistor is output as feedback at its emitter, i.e. pin-4 of IC5.

Feedback signal at pin-4 of IC5 is given to pin-1 of IC2 (SG3524), through a potential divider circuit made of R21, and PWM adjustment preset VR4.

Pin-1, 2 and 9 IC2 are three pins of an Op-Amp, pin-1 and 2 are input pins and pin-9 is output pin.

As explained earlier, pin-1 of IC2 is given feedback signal from the output supply; pin-2 is given 5V regulated supply as reference voltage is taken from pin-16 of IC2.

When the value of the load connected at the inverter output change, voltage at pin-4 of IC5 will also change.

This will result in variations in the feedback voltage reaching pin-1 of IC2 (SG3524). Any change in the feedback signal reaching pin-1 of IC2 will result in change in output from pin-9.

Pin-9 of IC2 is internally connected to the section, which controls the width of the oscillating frequency.

Change in the signal at pin-9 will result in change in the width of the output frequency. This will in turn result in change in the 50Hz frequency output at pin-11 and 14.

This change in the width of 50Hz frequency will bring back the inverter output by changing the width of the 50Hz frequency signal.

2.5 Extra Protection Circuits ^[11]

If there is some fault in the PWM fails, the MOS drive voltage at pin-11 and 14 will increase and the MOSFET could get damaged.

2.6 High Voltage Spike Protection Circuit

Sometimes “high voltage spikes” is output from the pin-11 and 14 of the PWM controller IC2.

When this spike reach drain or gate of MOSFET it could damage the MOSFET transistor.

To remove the spike from MOS drive signal, a filter circuit is used in the circuit.

50HZ signal from pin-11 of IC2 is amplified by T2 and output at its emitter. This signal from the emitter of T2 reaches anode of DA9, through DA8. Anode of DA9 is also connected to drain of the MOSFET.

In this same manner, 50Hz signal from the emitter of T2 and output at its emitter. This signal from the emitter of T2 reaches DA9, through DA8. Anode of DA9 is also connected to drain of the MOSFET.

In this same manner, 50Hz signal from pin-14 of IC2 is amplified by T1 and output at its emitter. This signal from the emitter of T1 reaches anode of DA10, through DA13. Anode of DA10 is also connected together, and its junction is connected to the positive terminal of battery RA12. A filter circuit is also connected to this junction.

This filter circuit has two resistors RA11 and RA13 and two capacitors CA3 and CA2. RA13 and CA2 are joined together and their junction point is connected to the negative terminal of the battery through a shunt.

Any spike in the MOS drive signal reach this junction point through DA9 and DA10 and are sent to ground by the filter circuit.

So, the MOSFET transistors in the output section are protected from the high voltage spike, by sending the spike to ground.

2.7 Shutdown Section Inside the IC2 (SG3524)

IC2 contains a shutdown section to protect the Inverter. This shutdown section is connected to pin-10.

In any special situation, a voltage can be sent to the pin-10 to shut down the inverter. Signal at pin-10 stops the oscillation process inside the IC, and MOS drive signal output from IC2 stops, this in turn stops the inverter.

Shutdown section turns off the inverter.

- When the battery voltage reach a minimum level. Further use of battery could permanently damage the battery. This is known as “low battery shutdown”. When the battery is low, a low battery shutdown section sends 2~4V supply to this shutdown pin. This shutdown the inverter.
- When load of higher than inverter capacity is connected to inverter, the overload shutdown section shuts down the inverter by giving signal to pin-10. This is known as “overload shutdown”.

This overload protection circuit switches off the inverter, if a high load is connected at inverter output.

Let us see how this overload protection circuit works.

2.9 Overload Protection Circuit

Overload protection circuit uses two op-amps made of pin-6, 7, 1 and pin-10, 11, 13 of IC7 (LM339). It also uses two transistors T16 and T17.

Pin-6 and 7 are input pins and pin-1 is output pin of first op-amp, pin-10 and 11 are input pins and pin-13 is output pin of the second op-amp.

Source(s) of the MOSFET in the output section is connected to the ground through three 0.1E shunts. The voltage generated on these shunts is used as "overload sensing voltage".

Voltage generated on these shunts increase as the load connected to the output increase.

Pin-1 of IC7 is connected to base of overload-sensing voltage generated by the shunt, through R70, VR6.

Pin-6 of IC7 receives overload sensing voltage generated by the shunt, through R26.

Pin-7 of IC7 receives a constant 5V reference voltage from pin-16 of IC2, through R70, VR6.

Preset VR6 is used to set the overload shutdown load value.

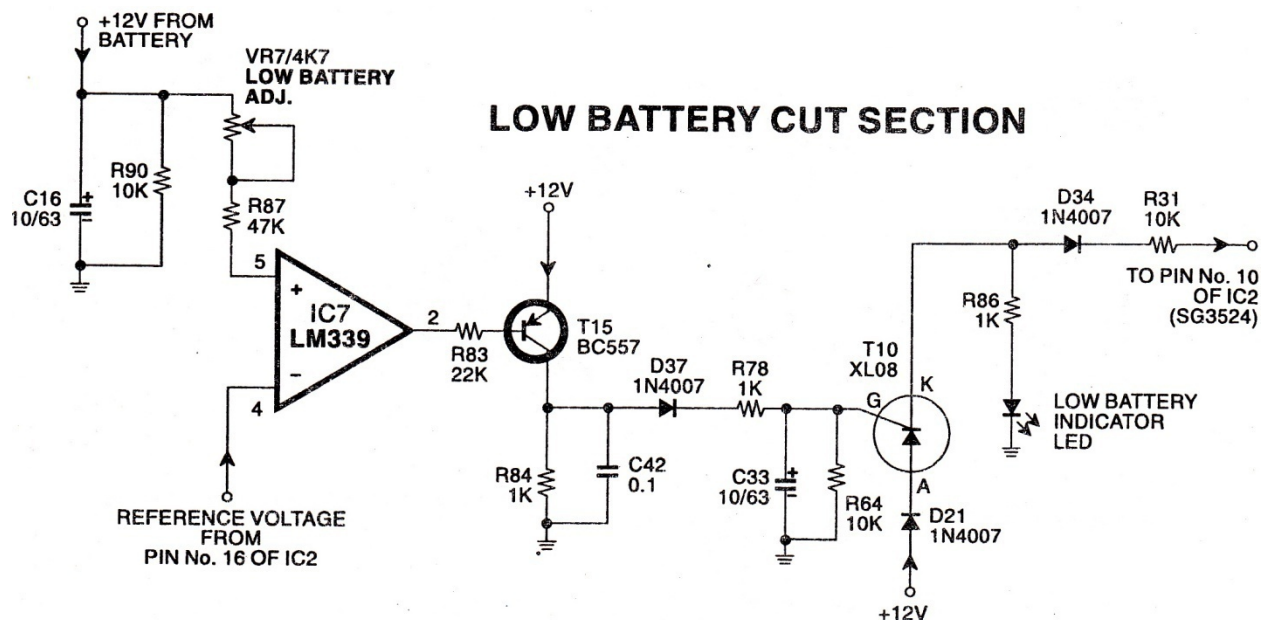

Fig: 2.5 low battery cut section

When normal load is connected at the inverter output, voltage at pin-7 of IC7 is higher than the voltage at its pin-6. This will output high voltage at the pin-1.

This high voltage at pin-1 of IC7 is given to base of PNP transistor T16, through R88. High voltage at its base will switch off the T16, and the voltage at its collector will become 0V.

This result is for normal operation of the inverter.

2.10 Function of overload protection circuit in overload condition

In overload condition, an “overload sensing voltage” is generated at the shunt connected at the MOSFET source. This “overload sensing voltage” reaches the pin-6 of IC7.

In overload condition, the voltage at pin-6 of IC7 becomes higher than the voltage at pin-7 of IC7.

When the voltage at pin-6 becomes higher than the voltage at pin-7, the voltage at pin-1 becomes low. This low signal is called “Overload signal”.

From pin-1 this signal reaches the base of overload transistor T16, through R88. A low overload signal at base of T16 will switch the transistor on. This results in 6V at the collector of T16.

R91 and C43 at the collector of T16 will not allow the 6V supply to stay for more than a few seconds.

This voltage at collector of T16 is given to pin-10 of IC7 (LM339) through D38, R81.

Pin-10, 11 and 13 of IC7 are three pins of an Op-Amp. Pin-11 of IC7 is given a constant 5V reference voltage through R73.

In overload situation, pin-10 of IC7 receives 6V and pin-13 of IC7. This low signal is used a “overload signal”.

This low level signal at its base will switch on the T17, through R82.

Low level signal at its base will switch on the T17, and T17 starts operating. This will provide a 4V overload signal at the collector of transistor T17.

4V overload signal at the collector of T17 is used to

- Glows overload indicator LED5, by giving overload signal to the LED through R89
- Sound buzzer by giving overload signal to the buzzer through D36.
- Shutdown the inverter by giving overload signal to the shutdown pin-10 of PWM controller IC2 (SG3524), through D35 and R31.

When the pin-10 of IC2 receives overload signal, the oscillator section inside the IC stops its operation and the inverter output stops.

One important point about the overload shutdown is, this shutdown happens only for a few seconds, after which the inverter turns on once again.

This process is repeated until the load at the inverter becomes normal. If the load at the inverter output is not reduced the output section MOSFET could get damaged.

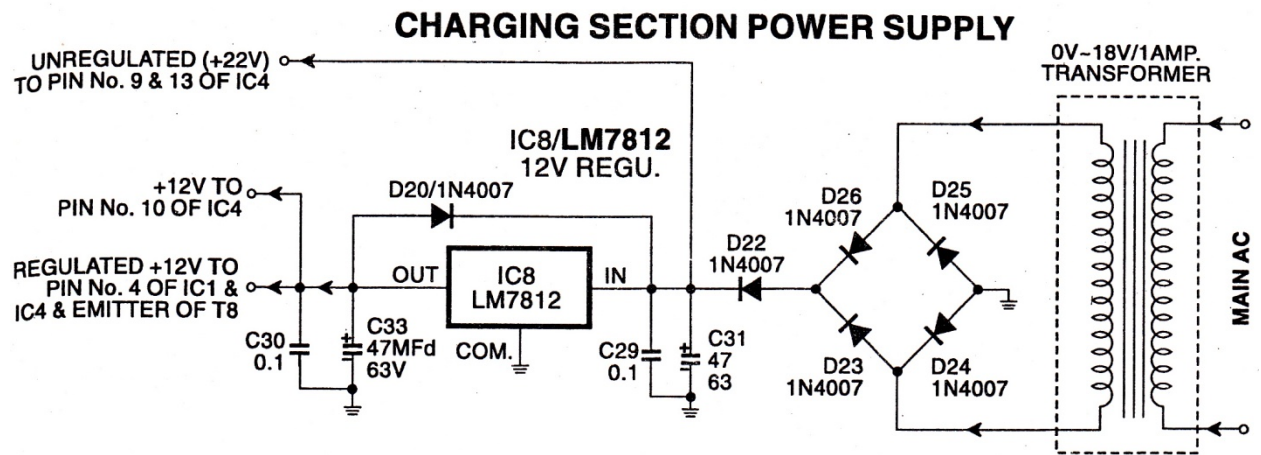

Fig: 2.6 charging section power supply

2.11 changeovers Section

Changeover section is used to

- Switch on the inverter when the AC mains supply switch off and to switch off the inverter when the AC mains supply return.
- During the changeover, when the inverter receives AC mains supply, it stops drawing the battery supply, and the AC mains supply at the inverter input is directly sent to the inverter output socket.

2.12 Changeover Circuit

The changeover circuit of this inverter uses one 2-pole relay, pin-8, 9, 14 of IC7 (LM339), opto-coupler IC6 (4N35) and four transistors T11~T14.

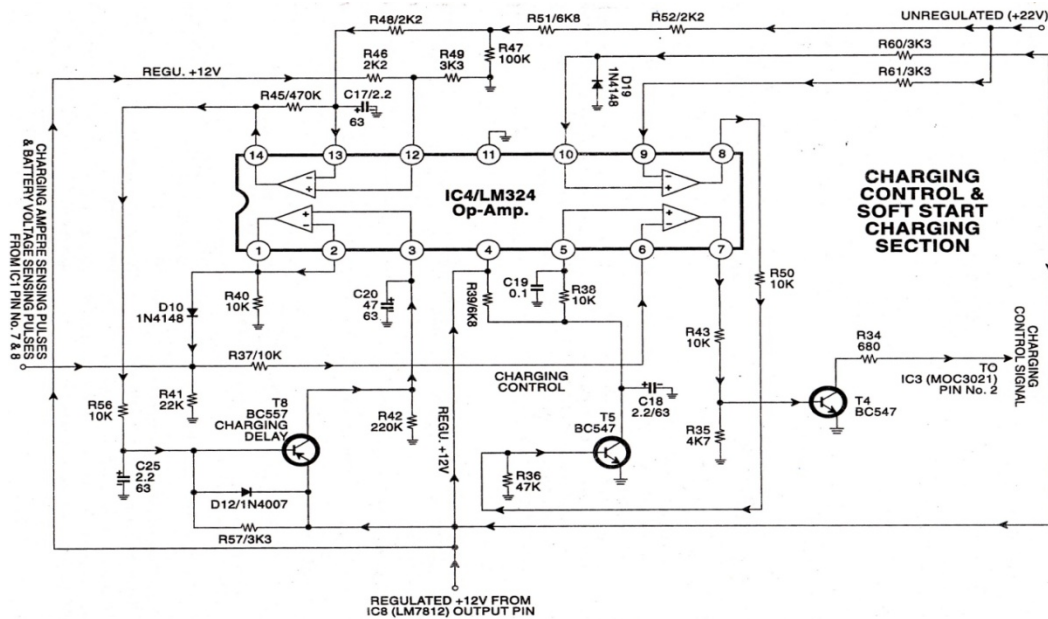

Fig: 2.7 charging control & soft start charging section

2.13 Changeovers when AC mains are available

When the AC main supply is available, mains supply is available at pin-1 and 2 of connector CN4. Resistance R58 at pin-1 is used to drop the supply.

Now, the AC mains supply is converted into DC supply by the bridge rectifier (D27~D30). Positive of this DC supply is given to the pin-1 of opto-coupler IC6 (4N35), and the negative is given to the pin-2 of IC6.

Pin-1 and pin-2 of the IC6 are connected to the LED inside the opto-coupler. When supply is given to the pin-1 and pin-2, the LED starts to glow. The light from LED falls on the base of photo-transistor inside this opto-coupler IC.

Collector of the phototransistor is connected to pin-5. This pin-5 is given 12V supply from IC9. Emitter of this phototransistor is connected to pin-4 of IC6.

When the LED inside the IC6 glows, the phototransistor starts to conduct. This results in 12V output at pin-4 of IC6.

This 12V output is given to pin-8 of IC7 (LM339), through R67 and R71. Pin-8 of IC7 receives around 7.9V. Pin-9 of IC7 is given a constant 5V reference voltage from pin-16 of IC2, through R72.

Pin-8, 9 and 14 of IC7 are pins of an Op-Amp. As the voltage at pin-8 is higher than the voltage at pin-9, the Op-Amp output at pin-14 will be a low level "changeover" signal.

This low level changeover signal is given to base of T14, through R75. This changeover signal will turn on the transistor T14.

When the transistor T14 turn on, the changeover signal is output at its collector. This changeover signal is given

to AC on indicator LED, through R85. This will glow the LED to indicate availability of AC mains supply.

Signal at collector of T14 is also given to shutdown pin-10 of IC2, through D33 and R31. This will stop the oscillation section of IC2, and the inverter shuts down.

Changeover signal at the base of T13 will switch on the transistor. This will switch off T12. Switching off of T12 will result in relay driver transistor T11 being turned off.

When the T11 is off, its collector will not show any output voltage.

Collector of T11 is connected to the inverter ON LED through R32. This is also directly connected to relay coil. When T11 is off, the inverter on LED will remain off and current will not flow in the relay coil.

2.14 Low battery cut section

For its operations the inverter gets voltage and current from battery. When the battery becomes fully discharged any further withdrawal of voltage could damage the battery.

When the voltage goes below a set limit the inverter should be switched off. This will protect the battery from discharging further and getting damaged. "Low battery cut" section of the inverter does the job of switching off inverter, when battery voltage becomes low. A fully charged battery will show voltage of around 13.5V, when this voltage reaches 9~10V, the battery is considered discharged. If the battery voltage goes below 9V, the battery could get permanently damaged. Recharging this battery could be impossible.

To switch off the inverter in low battery condition Op-Amp made of pin-4, 5, 2 of IC7 (LM339), T15, SCR T10 and low battery indicator LED is used.

Pic-4 if IC7 is given constant reference voltage +5V from pin-16 of IC2, through R33, VR7 and R87.

When the battery voltage is more than 10V, pin-2 of IC7 will output a high voltage, which is around 7V. This 7V output is given to the base of low battery transistor T-15, through R83. This high voltage at base of T15 will switch off the transistor and a 0V is made available at collector of T15. 0V at the collector of T15 will stop the following circuits of low-battery cut section from operating and the inverter operates normally.

When the battery voltage goes lower than 10V, the voltage reaching pin-5 of IC7 becomes lower than the voltage at pin-4 of IC7.

This results in a low voltage at output pin-2 of IC7. Low voltage at pin-2 will switch on the transistor T15 and a "low battery signal" is output at the transistor's collector. This low battery signal is given to the gate of SCR T10, through D37 and low battery signal is made available at cathode. This signal at the gate of T10 will make the SCR conduct and 8V low battery signal is made available at cathode (K).

This low battery signal at the cathode of SCR T10 does the following jobs.

- Switch on the low battery indicator LED, through R86.
- Low battery signal is given to shutdown pin-10 of IC2 through R31, D34. This signal at pin-10 of IC2 will stop the oscillation section of the IC2, and the inverter will switch off.

When the inverter is switched off, it stops drawing voltage from battery and the battery is protected from further discharging.

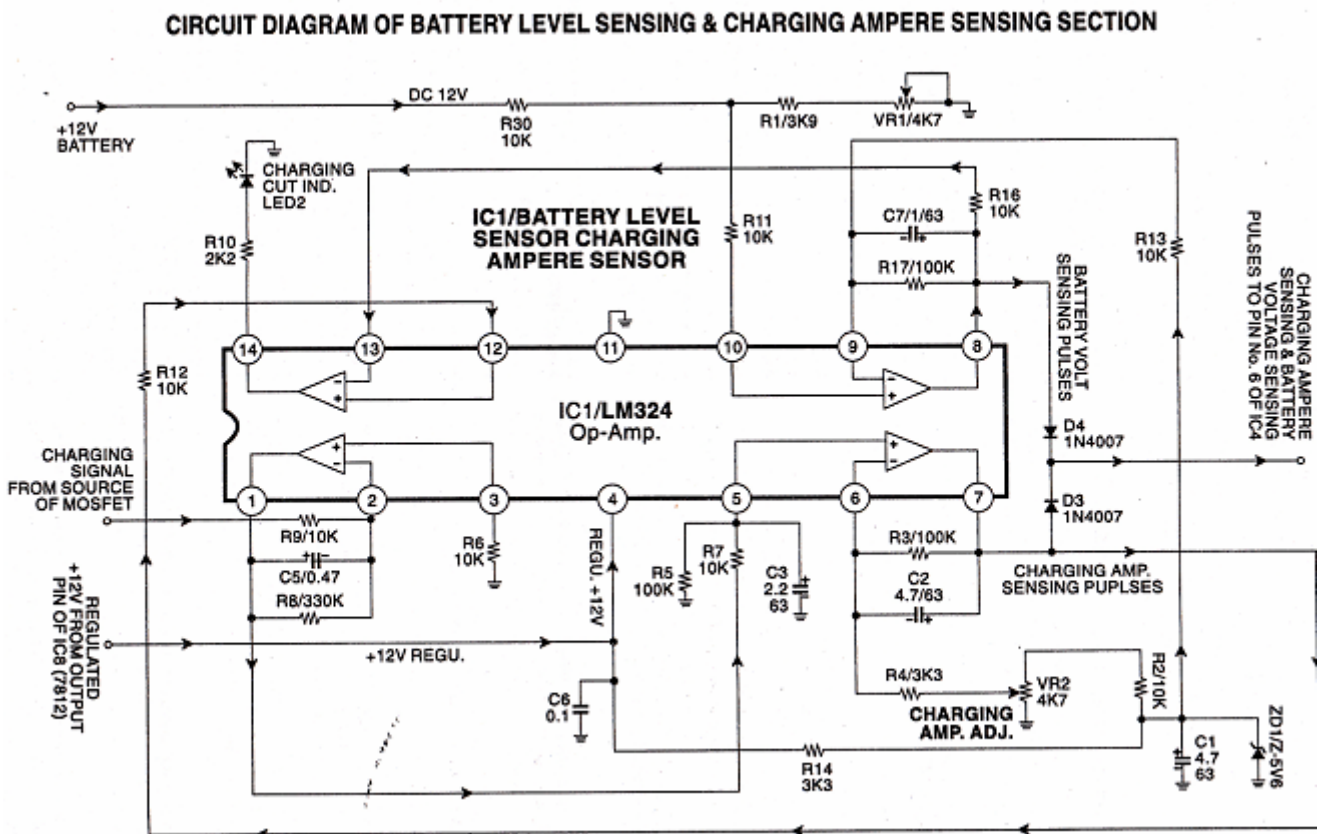

Fig: 2.8 circuit diagram of battery level sensing & charging ampere section

2.15 Battery charging section

When the inverter section receives AC mains supply, it stops operation, but the charger section in the inverter starts its operation and start charging the battery. When the inverter receives AC mains supply, two LED's starts to glow:

- One LED, to indicate AV mains available and
- Second LED to indicate battery charging.

When the AC mains supply is available (in charging mode), inverter transformer is used for charging. In this mode, the inverter transformer works as a step-down transformer and outputs 12V supply at its secondary winding.

During the charging, MOSFET transistors at the output section works as rectifiers. MOSFET drain (D) works as cathode and source (S) works as anode.

During charging the center tapping of the transformer receives positive supply and the MOSFET source (S) receives negative supply.

Center tapping of the transformer is connected to the positive terminal of the battery and the MOSFET source (S) is connected to the negative terminal of battery through 0.1E resistance as a shunt.

When the inverter receives AC mains supply, inverter transformer and MOSFET together work as a charger and charge the battery. One needs to add some additional circuits in a simple charging arrangement like this to protect the battery.

For example

- A soft-start section to protect the MOSFET.
- A “battery voltage sensing circuit” to protect the battery from high current when the battery voltage becomes low.
- A “battery charging ampere sensing circuit” to keep charging current constant, etc.

For all these works, control circuit of two Op-Amp ICs (IC1 & IC4), IC3, IC8, two SCRs (SCR1 & SCR2) and one triggering transformer is used.

To understand the complete charging process, we can divide it into the following sections

- AC mains sensing section
- Soft Start Section
- Charging Voltage Sensing Section
- Charging Current Sensing Section
- Charging Process

2.15.1 AC Mains Sensing Section

To sense the AC mains supply, this inverter uses 0~18V/1Amp. Triggering transformer, regulator IC8 (7812), pin 8, 9, 10 of IC4 (LM324).

When the AC mains supply is available by the changeover section, this supply is given to the primary winding of 0~18V triggering transformer. This results in 18V AC supply at the secondary winding.

This 18V AC supply is rectified by bridge rectifier (D23-D26) and given to filter capacitors C29, C31, through D22.

Rectified and filtered DC supply by IC8 (L7812). C30 and C32 further filter this 12V supply. This 12V regulated supply stays constant even when there is change in the AC mains supply. This constant 12V supply is given as a reference voltage to pin-10 of IC4 (LM324) through R60, D19. Pin-8, 9, 10 of IC4 (LM324) makes an Op-Amp unit. Unregulated DC supply at the positive terminal of the bridge rectifier is given to pin-9 of IC4 (LM324), through a potential divider made of R61 and R62. When the AC mains supply is available, voltage at pin-9 is around 3.5V.

In this condition output at op-amp output will be high. This high signal at op-amp output pin-8 is known as "AC mains sensing pulse". This "AC mains sensing pulse" at pin-8 is given to the base of transistor T5, through R50. Collector of this transistor is given 12V DC supply through R39. AC mains sensing pulse at the base of T15, turns on the transistor. When the T15 turns on, amplified AC mains sensing signal is made available at its collector.

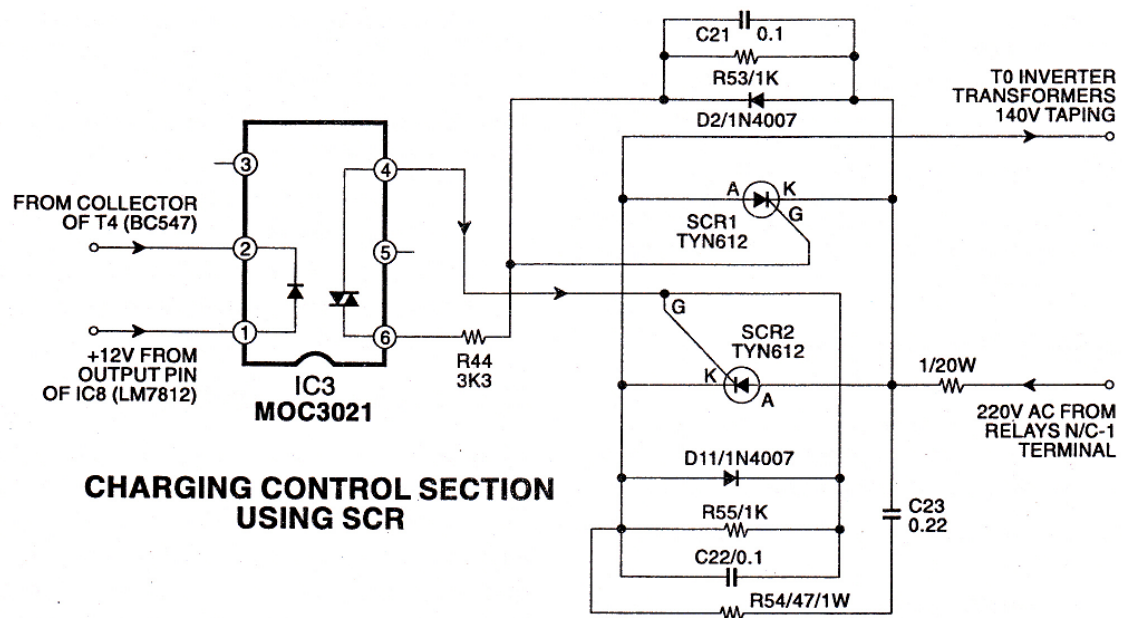

Fig: 2.9 Circuit diagram of charging control section using SCR

This signal at the collector of T15 is sent to pin-5 of Op-amp IC4. This signal informs the inverter about availability of AC mains supply.

2.15.2 Soft Start Section (Charging Delay Circuit)

After a power cut, when the AC mains supply returns, i.e. when the inverter switch from battery mode to AC mains mode (i.e. charging mode), the charging process is not started immediately and current to the MOSFET may suddenly increase and the MOSFET could get damaged.

The soft-start or charging delay circuit is used to protect the MOSFET from this sudden increase in current. This circuit uses an op-amp made of pin-12, 13, 14 and pin-1, 2, 3 of IC4 (LM7812). This 12V supply is given to pin-12 of IC4, through D22, R52, R51, and potential divider circuit made of R47 and R48.

These signals at pin-12 and 13 of IC4 will provide output from pin-14 of IC4. This output is given to the base of charging delay transistor T8, through R56.

Emitter of charging delay transistor T8 is given 12V regulated supply. This supply is given as base biasing to the base of T8, through R57. Capacitor C25 is connected to the base of T8. When the AC mains supply is restored the capacitor C25 starts to charge. When the C25 charge reaches 11V, the T8 will switch on.

When the T8 switches on, 10V is produced at its collector. This 10V is given to pin-3 of IC4.

Pin-1, 2, 3 of IC4 is pins of one op-amp inside the IC4. Pin-2 is given a negative reference voltage through R40. When the pin-3 of IC4 receives 10V from collector of T8, the output at pin-1 of IC4 is also around 10V.

This soft start pulse output at pin-1 of IC4 is given to input pin-6 of another op-amps on the same IC4, through D10, R37.

Soft start pulse of around 10V at the pin-6 of IC4, will output 0V at its output pin-7. This 0V is given to the base of T4, through R43. 0V at the base will switch off the T4.

When the T4 switches off, opto-coupler IC3 will not receive any pulse from the collector of T4, and the IC3 will stop the charging process.

After some delay when the C25 gets discharged T8 will switch off. When the T8 switches off, its collector contains 0V. This 0V is output by pin-1 of IC4. Voltage at pin-6 of IC4 will reduce to 4V. 4V at pin-6 will result in an output of 2V from output pin-7.

2V from pin-7 of IC4 will switch on T4 and the IC3 (MOC3021) starts operating. This will start the charging process. Voltage at various pins of IC4 (LM324), when the AC mains supply and charging starts is given in the following table

Table 2 voltage when AC mains returns and voltage when charging starts

Pin	Voltage when AC mains return	Voltage when charging starts
1	10V	0V
2	10V	0V
3	10V	0V
5	3V	3V
6	10V	4V
7	0V	2V
12	7V	7V
13	4V	4V
14	3V	11V

To sense the battery voltage a battery voltage sensing or charging voltage sensing section is used. This section uses an Op-Amp made of pin-8, 9, and 10 of IC1 (LM324). Pin-9 and 10 are input pins of Op-Amp and pin-8 is output pin.

Pin-10 is given 12V~battery supply through a potential divider network made of R30, R1, VR1, R11.

Reset VR1 (4K7) is used to set the battery charging voltage. If we want to charge the battery charging voltage then we need to charge the battery up to 13V, then VR1 is set for 13V, so that the battery will not charge for more than 13V. Pin-9 of IC1 is given a reference voltage from 12V regulated supply (received from IC8-7812), through R14, R13.

C4 (4.7uF/63V) at the junction of R13, R14 is used to filter the supply and ZD1 (5.6V) is used to keep this supply constant. A negative feedback is given to the pin-9 of IC1, from pin-1 through C7 and R17. Based on the voltage reaching pin-9 and 10 the output pin-8 will contain a "battery voltage sensing pulse". This pulse is given to pin-6 of IC4 (LM324), through D4, R37.

Battery voltage sensing pulse reaching pin-6 of IC4 helps in charging the battery to a fixed voltage. This battery voltage sensing pulse is also used to switch on the charging indicator LED. Signal at pin-8 of IC1 is given to pin-13 of IC1, through R16. Charging ampere pulse at pin-7 of IC1 is given to pin-12 of IC1 through R12. Pin-12, 13, 14 are pins of another Op-Amp inside the IC1. As the voltage at pin-12 is higher than the voltage at pin-13, the op-amp output pin-14 will contain about 10V output.

Output voltage at pin-14 is given to the charging indicator LED, through R10. This will switch on the LED to indicate us that the charging is going on as the battery gets charged the battery voltage sensing pulse increase. When the battery becomes fully charged, voltage at pin-12 becomes lower than the voltage at pin-13. This result in allow voltage at pin-14, i.e. the voltage reach 0V.

0V at pin-14 of IC1 means it will stop supply to the charging indicator LED will stop glowing. This indicated that now the battery is fully charged.

2.15.3 Charging Ampere Sensing Section or Battery Current Sensing Section

To sense the battery charging current, two op-amps made of pin-1, 2, 3 and pin-5, 6, 7 of IC1 (LM234) are used. Charging ampere sensing section gets the charging sensing pulse from the source (S) of MOSFET in the output section. This "charging sensing pulse" is given to pin-2 of IC1, through R9. Pin-3 of IC1 is connected to the ground through R9. Pin-3 of IC1 is connected to the ground through R6, to give a negative reference voltage at this pin.

Positive output at pin-1 of IC is given as feedback signal to pin-2 of this IC through R8. Positive charging sensing pulse at pin-1 of IC1 through pulse at pin-1 IC1 is given to pin-5 of IC1 through a potential divider circuit made of R7 and R5.

pin-6 of IC1 is given 12V regulated supply (receive from IC8) through a potential divider circuit made of R14, R2, VR2, R4. Preset VR2 is used to set the charging current by charging the voltage reaching pin-6 of IC1.

Pin-7 of IC1 outputs “charging ampere pulses” based on the voltage reaching pin-5 and 6 of IC1. This “charging ampere pulse” is used in the following places:

- “Charging ampere pulses” produced at pin-7 of IC1 is given as feedback at pin-6 of IC1, through R3, C2.
- “Charging ampere pulses” produced at pin-7 of IC1 is given to pin-12 of IC1 through R12. This is used to turn on the indicator LED.
- “Charging ampere pulses” produced at pin-7 of IC1 is given to pin-6 of IC4 (LM324) through D3, R37.

Use of “charging ampere pulse” reaching pin-6 of IC4

As we have seen IC1 and IC4 are used during the charging process to control various conditions. As explained earlier pin-5 of IC4 receives “AC mains sensing pulse” and pin-6 of IC4 (LM324) receives the following pulses:

- “Soft start pulse” from pin-1 of IC4 through D10, R37.
- “Battery voltage sensing pulse” from pin-8 of IC1 (LM324) through D4, R37.
- “Battery charging ampere pulse” from pin-7 of IC1 through D3, R37.

Pin-5, 6, 7 of IC4 is pins of op-amp inside this IC. This IC provides output at pin-7 based on the various inputs at its pin-5 and 6. This output from pin-7 of IC4 is used to start the charging process.

3. Elaborate description of the project

This inverter operates on 12V battery. This inverter has almost all the characteristics of any modern digital inverter. The main technical characteristics of this digital inverter are:

- 1. AC mains lo/high voltage protection.
- 2. Overload protection.
- 3. Low battery protection.
- 4. Soft start on heavy load.
- 5. Four stage battery charger.

3.1 Block Diagram of inverter Digital Inverter (625VA/12V) [12]

The digital inverter has amplifier PWM controller IC U6 (SG3525A), operational amplifier IC U3, U5, U8 and U7 (LM 324), regular IC (LA7812), timer IC U1 and U4, opto-coupler IC U2 (4N35), SCR Q6 and Q7, 15 transistor and 8 MOSFET's are used.

The input AC mains supply is first supplied to AC/DC selector (changeover) relay and input AC mains sensor section.

The signal for the presence of input AC mains supply from input AC mains sensor is supplied to AC/DC selector section.

The AC/DC selector section selects AC state and glows mains on indicator LED. The change over relay is selected for AC state and the input AC supply from changeover relay is supplied to output socket through MCB switch.

The input AC mains supply from change over relay is supplied to AC control and transfer section.

When the input AC mains supply is present then charging control and AC/DC selector section controls the pulses generated from charging pulse generator section and switch OFF (shut down) the oscillator section to stop the switching frequency output.

The charging pulses generated from charging pulse generator section are amplified and supplied to driver transformer.

The charging pulses from driver transformer are supplied to AC control and transfer section. The AC control and transfer section with the help of these pulses controls the input AC mains supply from change over relay and supplied it to charging selector relay.

The "battery charging control and low battery protector" section control the changing selection relay and thus the input mains supply at charging selector relay is supplied to different tapping of main inverter transformer.

The voltage induced across the layering winding of main inverter transformer is converted to DC by rectifier and supplied to battery positive terminal for charging.

The DC supply from battery is supplied to voltage doublers, main inverter transformer and voltage regulator section.

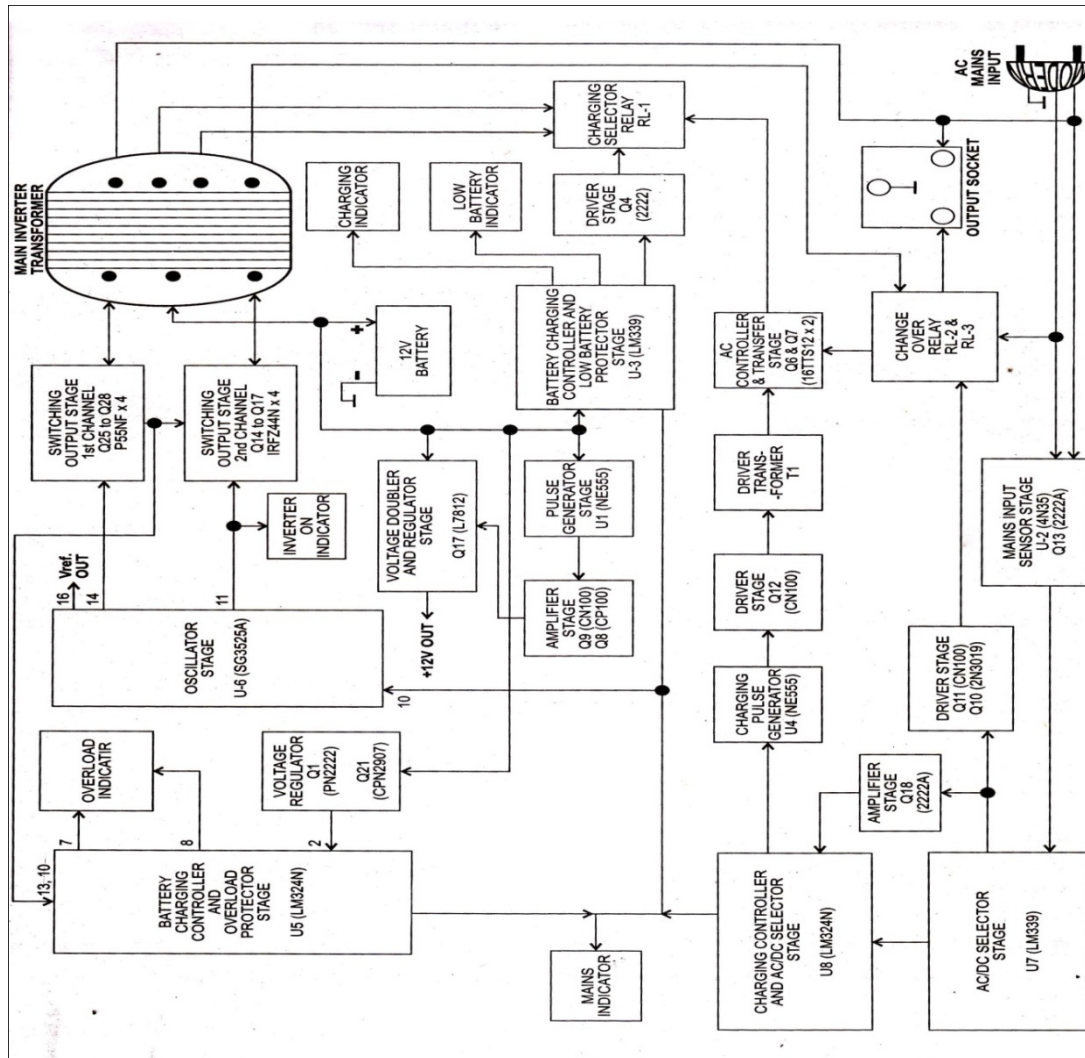

Fig 3 block diagram of inverter Digital Inverter (625VA/12V)

The supply from battery is boosted and supplied to regulator IC Q17 (LA7812). The 12V regulated DC output from IC Q17 is supplied to different sections of inverter.

When there is no input AC mains supply (power fail) then change over section (AC/DC selector) selects Dc state (battery mode).

When DC State is selected then oscillator sections starts operating and generates switching signal output from pin-11 and 14 of IC U6 (SG33525).

3.2 Different sections of our inverter digital inverter

The different sections of our inverter digital inverter can be detected by the description given below:

3.2.1 Main inverter transformer

The heavy and largest transformer in the inverter is main inverter transformer. The positive terminal of battery is connected to this transformer.

3.2.2 Switching output section

The section connected to the layering winding of main inverter transformer is switching output section. This section has heat and number of MOSFET's connected on heat sink.

3.2.3 Oscillator section

The section having IC U4 (SG3525A) is called as oscillator section. This section has one frequency adjustment preset.

3.2.4 Low-battery protector section

The section having low battery indicator LED and low- battery adjustment preset is called as low-battery protector section.

3.2.5 Overload protector section

The section connected to source of MOSFET's in switching output section is called as over load protector section. The over load indicator LED is also connected to this section.

3.2.6 Battery charging control section

The section connected to battery charging indicator LED, battery charging voltage adjustment preset and charging ampere adjustment preset (IC U3, LM339) is called as battery charging control section.

3.2.7 Charging pulse generator

The section having IC U4 (NE555) is called as charging pulse generator section. This section is connected to driver transformer T1.

3.2.8 Driver transformer

The small transformer connected to SCR is called as driver transformer.

3.2.9 AC control and transfer section

The section having SCR Q6, Q7 and transformer T1 is called as AC control and transfer section.

3.2.10 AC/DC selector section

The section connected to “mains indicator LED” , change over relay and IC U8 (LM324) is called AC/DC selector section.

3.2.11 Main input sensor section

The section connected to opto-coupler IC U2 (4N35) is called mains input sensor section. The input AC mains supply is directly supplied to mains input sensor section.

3.2.12 MCB switch (miniature circuit breaker)

This switch is connected on the back panel of inverter. The Ac supply on output socket of inverter is available through MCB switch. Usually this switch is bigger than ON/OFF switch. The voltage and current capacity of this switch is printed on the body.

3.2.13 Output socket

The load driven by inverter is connected to this socket. The output AC supply from inverter is available on this socket.

3.3 Detail explanation of our inverter circuit

The working of circuit and different sections are explained below:

3.3.1 AC/DC and charging selector section

The neutral from input AC mains supply is directly supplied to inverter output socket, mains input sensor section and mains inverter transformer.

The earthling from input AC mains supply is connected to inverter output socket and inverter cabinet.

The phase from input AC mains supply is directly supplied to N/C terminal of relay RL-3, pole of relay RL-2 through fuse (7 amp) and mains sensor section.

When the input AC mains supply is present, the transistor Q10 remains OFF and relays RL-2 RL-3 are also OFF.

Thus the input AC mains supply at N/C terminal of relay RL-3 is supplied to inverter output socket through MCB switch

The input AC mains supply at the pole of relay RL-2 is supplied to SCR Q6 and Q7 in “AC control and transfer” section through N/C terminal of relay.

The mains input sensor section supplies the signal to AC/DC selector section (IC U7) and battery charging control section (IC U3).

The relay RL-1 is used to select the charging voltage level of battery. This relay is controlled to select either tapping 145V or 195V of main inverter transformer.

When there is no input AC mains supply then relay driver transistor Q10 switches ON and drivers the relay RL-2 and RL-3 (i.e. pole connected to O/C terminal).

Thus the relay RL-3 switches ON and supply from 250V tapping of main transformer is supplied to inverter output socket through O/C terminal, pole and MCB switch.

The relay RL-2 switches ON (pole connected to O/C terminal) and stops the supply to AC controller and transfer section to stop the charging process.

The MCB switch is connected in series with inverter output supply for safety of internal circuit.

If the load connected to inverter is short circuited or the load connected is more than inverter capacity then this MCB switch automatically breaks the circuit to prevent the internal circuit from excess current and heat.

The resistor (220E/20W) and capacitor (.22MF/275V) Connected between phase and neutral of inverter output socket are used as filters.

If the capacitor is damaged then there is humming sound from fan, stereo amplifier etc when inverter operates on battery mode.

3.3.2 Voltage double and regulator section

The supply from battery is unregulated. Hence 12V regulator IC Q17 (LA7812), IC U1 (NE555) and transistor Q8 and Q9 are used.

3.3.3 Voltage doublers

This section has timer IC U1 (NE555) and transistor Q8 and Q9.

The IC U1 (NE555) operates on battery positive supply at pin-8 and 4 through diode D3 and r26. The pin-1 of IC U1 is connected to ground.

The supply at pin-8 is supplied to pin-7 through R27 and the supply at pin07 is supplied to pin-6 through R28. The pins-6 and 2 are connected to capacitor C6 and pin-5 is connected to capacitor C3.

The IC U1 (NE555) generated switching signals from pin-3. These switching signals are supplied to the base of transistor Q8 and Q9. The transistors start switching and the amplified output (boost voltage) from emitter of Q8 and q9 are supplied to diode D15 through C15.

The diode converts it into DC voltage and this voltage is stored by capacitor C11 (47MFd/50V). Thus the 12V supply from voltage double section is boosted up to 18V to 24V.

3.3.4 Voltage regulator

This section generates 12V regulated supply. This section has regulator IC Q17 (LA7812). The input voltage to pin-1 of regulator IC Q17 is supplied from

- Battery positive terminal through fuse (80 amp), R29 ,D16 and R57.
- 2. Boost voltage across the capacitor C11.

The regular IC Q17 regulates the above input voltage and generates 12V regulated output from pin-3. This regulated voltage is supplied to different sections of inverter.

3.3.5 Mains input sensor section ^[12]

This section supplies signal to different section for the presence/absence of input AC mains supply. This section has one opto-coupler IC U2 (4N35) , bridge rectifier (D5,D6,and D8) and transistor Q13.

When input AC mains supply is present then neutral from AC mains line is supplied to one terminal of bridge rectifier through R14 and phase from AC mains line is supplied to second terminal of bridge rectifier through R13.

This supply is rectified and supplied pin-1 of opto-coupler IC U2 and negative voltage is supplied to pin-2 of IC. The positive voltage from regulator IC Q17 is supplied to pin-5 of IC U2.

The photo –transistor in IC operates and the output from pin-4 is supplied as feedback to pin-6 through R31. The pin-6 is internally connected to the base of built-in photo-transistor.

The pin-4 is connected to potential divider formed by R30 and VR4. The preset VR4 is used to set minimum level of input AC mains supply.

When the input Ac mains supply is preset the output from pin-4 of IC U2 is supplied to pin-5 of IC U8 in “AC /DC selector section and battery are charging control” through D43, D42, and R110 in “AC/DC selector section”.

The transistor Q13 switches ON and the positive supply from emitter is supplied to pin-5 of IC U& (LM339) through D43, D42, R111 and R110 in “AC/DC selector section”.

The positive output from emitter of transistor Q13 is supplied to pin-9 of IC U3 (LM339) through D43, D35 and R43 in “battery charging control and low battery protection section”.

3.3.6 Oscillator section

This section generates 50 Hz switching frequency to operate the inverter circuit in battery mode. The oscillator section has one PWM (pulse width modulation) controller IC U6.

This IC has built-in oscillator section, error section voltage reference section and output section.

This IC operates on 12V supply at pin-15 and 13 from regulator IC Q13. The built-in voltage reference section in IC generates +5V regulated output from pin-16.

The built-in oscillator section is related to pin-5, 6, 7 and 8 and the components C41, R69, preset VR3, R133 and C35 connected to these pins are timing components to generate the 50Hz switching signal. The preset VR3 connected to pin-6 is used to set the 50Hz frequency.

The switching signal output from pin-11 & 14 has 180 degree phase difference.

These switching signals are generated only when low voltage is supplied to pin-10 (shut down pin).

When the inverter switch is in OFF position then 12V supply from supply line is supplied to pin-10 through R88 & D38 to stop the switching signal output.

When inverter switch is in OFF position then the switching signal from pin-11 & 14 are supplied to the gate terminal of MOSFET's in output section. The switching signal from pin-11 is supplied to "inverter ON" indicator LED.

The shut down signal to pin-10 of IC U6 is supplied from:

- Pin-8 of IC U8 through R105 & D46
- Pin-7 of IC U5 through D34 & R74
- Pin-13 of IC U3 through D2 & R19
- Inverter switch through R188 & D38

3.3.7 Switching output section ^[12]

The switching section converts DC voltage from battery into AC voltage. The switching output section has two similar channels that are switched ON and OFF alternately. This section has 8 MOSFET's (4 in each channel) and one main inverter transformer.

The positive DC supply from battery is supplied to from battery into AC voltage. The switching output section has two similar channels that are switched ON and OFF alternately.

This section has * MOSFET's (4 in each channel) and one main inverter transformer.

The positive DC supply from battery is supplied to center tapping of bi-filler winding in main inverter transformer through fuse (80amp).

This 12V from one terminal of bi-filler winding is supplied to drain terminal of MOSFET's Q25, Q26, Q27 and Q28 in one channel.

The source of terminal MOSFET's in both the channels are connected to negative terminal of battery through R70, R71, R72 and R73.

When there is no input AC mains supply and inverter switches in ON position then PWM controller IC U6 generates 50Hz frequency switching signals from pin-11 and 14. The switching signal from pin-14 of IC U6 is supplied to MOSFET's (Q25, Q26, Q27 and Q28) in one channel through R117, D29, R118, R128, R132, R134 and R136.

Similarly the switching signal from pin-11 of IC U6 is supplied to MOSFET's (Q29, Q30, Q31 and Q32) in second channel through R106, D39, R107, R137, R140, R144 and R145.

The MOSFET's in each channel start switching according to the input switching signals from PWM controller IC U6.

This switching of MOSFET's flow the AC current across the bi-filler winding of main inverter transformer and the AC voltage induced across the secondary winding is supplied to inverter output socket through O/C terminal and pole of relay RL-3 and MCB switch.

The regulator zener diodes D52 and D53 are connected to gate of MOSFET's in each channel to keep the switching signal level stable and prevent the MOSFET's.

The diodes D48 and D49 connected to drain of MOSFET's to prevent the MOSFET's from high voltage spikes.

3.3.8 Charging section ^[12]

The charging section charges the battery when the input AC mains supply is present. The charging section has one timer IC U4 (NE 555), SCR, Q5, Q7 and driver transformer T1. The control circuit formed by SCR and transistor control the level of AC mains supply.

The timer IC U4 (NE 555) generates the changing pulse. When the input AC mains supply is present then the control voltage from pin-1 of IC U8 in "charging control section" is supplied as trigger to pin-2 and 6 of timer IC U4 through D44.

The transistor starts switching according to the input signal and the changing current flows across the primary winding of driver transformer.

The driver transformer T1 has two secondary windings. The voltage induced in one secondary winding is supplied to cathode of SCR Q6 and SCR Q7.

The voltage from this secondary winding is rectified by D10 and supplied as trigger signal to the gate of SCR Q6 through R37.

Similarly the voltage induced in other in other secondary winding is supplied to cathode of SCR Q7 and anode of SCR Q6. The voltage from this secondary winding is rectified by D9 and supplied as trigger signal to the gate of SCR Q7 through R36.

The phase from input AC mains supply is supplied to code of SCR Q7 and anode of SCR Q7 through fuse (7amp) and AC/DC selector relay RL-2.

Thus when input AC mains supply is present voltage induced across the secondary of driver transformer T1 triggers both SCR Q6 and Q7. The SCR Q6 and Q7 operate as trial and controls the AC mains supply voltage level.

The AC supply from cathode of SCR Q7 and anode of SCR Q6 is supplied to the primary winding of main inverter transformer through pole of charging selector relay RL-1.

The AC voltage is induced across the bi-filler winding of main inverter transformer.

The positive supply from center tapping of layering winding is supplied to positive terminal of battery and negative supply room internal diode connected between drain and source of MOSFET's is supplied to negative terminal of battery through R70,R71,R72 and R73 and thus battery starts charging.

When there is no input AC mains supply then high voltage output from pin-1 of IC U8 (LM324) is supplied as trigger pulse to pin-2 and 6 of IC U4 to stop the charging pulse generation and battery charging.

3.3.9 AC/DC selector (change over) section

The main function of this section is to select the AC state when the input AC mains supply is present and select battery mode when the input AC mains supply is absent.

This section has one operational amplifier IC U& (LM339) and three transistors Q10, Q11 and Q18. This 8 pin IC U7 has two built-in operational amplifiers.

The IC U7 operates on 12V supply at pin-8 from supply line. The reference voltage from pin-16 of IC U6 (SG3525A) is supplied to pin-6 (inverting pin) of IC U7 through D40 and potential divider formed by R89 and R90.

The supply from emitter of transistor Q13 (in mains input sensor section) is supplied to pin-5(non-inverting pin) of IC U7 through D43, D42 and potential divider formed by R111,R110 and R112.

When input mains supply is present then high voltage is supplied at pin-5(non-inverting pin) and low voltage is supplied to pin-6(inverting pin) and the high output from pin-7 is supplied to pin-8 of IC U7 through D45 and R102. The high output from pin-7 is also supplied to transistors Q18 and Q11.

The transistor Q11 switches ON and the relay driver Q10 connected to transistor Q11 also switches ON and both the relays RL-2 and RL3 and thus DC State is selected.

3.3.10 AC/DC selector and battery charging control section

This section selects the AC or DC state and controls the battery charging process. The section has 14 pin operational amplifier IC U8 (LM324) and one transistor Q3. This IC has four built-in operational amplifiers.

The IC U8 operates on 12V supply at pin-4 from regulator IC Q17. The reference voltage from pin-16 of IC U6 (SG3525A) is supplied to pin-9 of IC U8.

The supply from pin-7 of IC U7 is supplied to pin-10 of IC U8 through D45, R101 and R102.

When input mains supply is present then high voltage is supplied at pin-10(non-inverting pin) and low voltage is supplied to pin-9(inverting pin) and high output from pin-8 is supplied to:

- Pin-10 (shut down) of IC U6 (PWM controller) through R105, D46.
- 2. Base of transistor Q3 through Q3 R4. The transistor Q3 switches ON to glow the Mains On indicator LED.
- 3. Base of transistor Q16 through R119.
- 4. Pin-10 of IC U8 (as feedback) through R103.

The supply from pin-3 of IC U5 is supplied to pin-12 of IC U8 through potential divider formed by R129 and R130. The 12V supply from supply line is supplied to pin-13 through R147 and R114.

Thus low voltage is supplied at pin-12(non inverting pin) and high voltage is supplied to pin-14 is supplied to pin-3 of this IC U8.

The positive supply from 12V supply line supplied to pin-2 through potential divider formed by R148, R156 and R155.

Thus low voltage is supplied at pin-12 (non-inverting pin) and high voltage is supplied to pin pin-13(inverting pin) and low voltage is supplied to pin-3 of this IC U8.

The positive supply from 12V supply line is supplied to pin-2 through potential divider formed by R148, R156 and R155.

Thus low voltage is supplied at pin-3 (non-inverting pin) and high voltage is supplied to pin-2 (inverting pin) and the low output from pin-1 is supplied to pin-2 and 6 of this IC U4 (NE555) through D44.

The positive supply from 12V supply line is supplied to pin-6 through potential divider formed by R147 and R158. The voltage supply at pin-5 is supplied from pin-4 of IC U2 through R113 only when the input AC mains supply is present.

Thus when input AC mains supply is present then voltage at pin-5 (non-inverting) is greater than voltage at pin-6 (inverting pin) and the output from pin-7 is high.

When there is no input AC mains supply (power fail) then voltage at pin-5(non-inverting pin) is lower than voltage at pin-6(inverting pin) and he output from pin-7 is low.

When there is no input AC mains supply (power fail) then the output from pin-1 is high. This high output is supplied to the base of transistor Q18. The transistor Q18 switches ON and the output from collector is low.

Thus when there is no input AC mains supply (power fail) then the low output from pin-7 of IC U8 and collector of transistor Q18 is supplied to pin-12 and 13 of IC U8.

Thus when there is no input AC mains supply then voltage at pin-12 (non-inverting pin) is greater than voltage at pin-13(inverting pin) and the high output from pin-14 is supplied to pin-3 of IC U8 through R116.

Thus when there is no input AC mains supply then voltage at pin-3 (non-inverting pin)of IC U8 is greater than voltage at pin_2(inverting pin) and the high output from pin-1 is supplied to pin-2 and 6 of charging pulse generation.

When there is no input ACX mains supply then the low output from pin-7 is supplied to pin-10 of IC U8 (LM324) through R101 and R102.

Thus the voltage at pin-10 (non-inverting pin) is lower than voltage at pin-9(inverting pin) and the low output from pin-7 is supplied to the base of transistor Q3 , transistor Q16 and pin-10 of PWM controller IC U6 (SG3525A).

The transistor Q3 switches OFF and also switches OFF the mains normal indicator LED. The transistor Q16 switches OFF and also switches OFF the changing indicator LED.

The low voltage from pin-7 is supplied to pin-10 (shut down) of PWM controller IC U6 (SG3525A) to generate the switching pulse from pin-11 and 14. The switching pulse output from pin-11 is glows the inverter ON indicator LED.

3.3.11 Overload and over charging protector section

This section prevents the inverter circuit when there over load (load connected more that the maximum capacity of inverter) or there is short circuit in load. This section also prevents the battery from over charging.

This section has 14 pin operational amplifier IC U5 (LM234) and two transistors Q21 and Q14. This IC has four built –in operational amplifiers.

The operational amplifiers connected between pin-1,2,3 and pin-12,13,14 are used for overcharging protection and the operational amplifiers connected between pin-8,9,10 and pin-5,6,7 are used for over load protection. This IC operates on 12V supply at pin-4 from supply line.

3.3.12 Overload protector

The negative supply to pin-5 of IC U5 is supplied through R83. The output from pin-8 is supplied as feedback to pin-9 through R86 and R84. The voltage developed at source of MOSFET's is supplied to pin-10 of IC U5 through R82.

When inverter is connected to normal load then the voltage at pin-10(non-inverting pin) is lower than voltage at pin-9 (inverting pin) and the output from pin-8 is low.

The reference voltage from pin-16 of IC U6 (SG3525A) is supplied to pin-6 of IC U5 through R61. The supply from pin-7 is supplied as feedback to pin-5 through D18 and R85.

Thus at normal load the voltage at pin-5 (non-inverting pin) is lower than voltage at pin-6 (inverting pin) and the output from pin-7 is low.

The low output from pin-7 is supplied to pin-10 (shut down pin) of IC U6 through D34 and R74 and the IC U6 continues to generate the pulses from pin-11 and 14.

The low output from pin-8 of IC U5 is supplied to the base of transistor Q14. The transistor Q14 switches OFF to switches OFF the overload indicator LED.

When there is over load or load short circuited then more current flows across the MOSFET's and the positive voltage from source of MOSFET's is supplied to pin-10 of IC U5 through R82.

Thus the voltage at pin-10 (non-inverting pin) is greater than voltage at pin-9 (inverting pin) and the output from pin-8 is high. This high voltage is supplied to pin-10 (shut down) of IC U6 (SG3525A) to stop the switching signal output from pin-11 and 14.

Similarly the high output from pin-7 is supplied to the base of transistor Q14 through R76. The switches ON and glow the overload indicator LED.

When the inverter is in over load condition then reset switch is pressed to reset the circuit and switch ON the circuit.

When the reset switch is on then the voltage at pin-5 of U5 are reduced by negative supply through R159 and D57 similarly the voltage at pin-8 of U5 are reduced by negative supply through R63 and D19. This switches OFF the OVER Load indicator LED and switches ON the inverter.

3.3.13 Battery charging control and low battery protector section

This section has 14 pin operational amplifiers IC U3 (LM339). This IC has four built-in operational amplifiers. The operational amplifiers connected between pin-7,6,1 and pin 8,9,14 are used for battery charging control and the operational amplifiers connected between pin-10,11,13 is used for low- battery protection.

This IC operates on 12V supply at pin-3 from pin-3 of IC Q17. The positive supply from battery is supplied to the base of transistor Q1 through potential divider R6 and R7. The high output from the emitter of transistor Q1 is supplied to pin-7 of IC U3 through R50 and R48.

The voltage at pin-7 can be adjusted by R51, R60 and preset VR-1. The regulated supply from zanier shunt regulator Q5 is supplied to pin-6.

When the battery voltage is normal then voltage at pin-7 (non-inverting pin) is greater than voltage at pin-6 (inverting pin) and the high output from pin-1 is supplied to the base of transistor Q15 through R121.

The low output from collector is supplied to the emitter of transistor Q16 .the base basing to transistor Q16 is supplied from pin-8 of IC U8. The transistor Q15 and Q16 switch ON to glow the charging ON indicator LED.

The positive supply to pin-11 of IC U3 is supplied from pin-3 of Q17 through R39 and R40. The positive supply to pin-10 is supplied from battery through D3, R46, and R45.

Thus when the battery voltage is normal then voltage at pin-10 (non-inverting pin) is greater than voltage at pin-11 (inverting pin) and the output from pin-13 low.

When the battery voltage is low then high output form pin-13 of IC U3 is supplied to pin-10 (shut down pin) of IC U6 to stop the switching signal output from pin-11 and 14.

The high output from pin-13 is supplied to the base of transistor Q2 through R20. The transistor switches ON to glow low-battery indicator LED.

4. Formulas and Calculations:

Formulas^[14]:

The formulas we have used for the calculation is given below:

- 1) For THD in voltage calculation:

$$THD_v = \sqrt{\left(\frac{v_s}{v_{s1}}\right)^2 - 1}$$

Where,

v_{s1} =Fundamental voltage

v_s =Total voltage

- 2) For THD in current calculation:

$$THD_i = \sqrt{\left(\frac{i_s}{i_{s1}}\right)^2 - 1}$$

Where,

i_{s1} =Fundamental current

i_s =Total current

- 3) For Efficiency calculation:

$$\text{(\% Efficiency)} = \frac{p_{out}}{p_{in}} \times 100$$

p_{out} =Power at the output of the transformer

p_{in} =Power at the output of the MOSFET Driver Circuit

Calculation:

We checked four renowned companies' pure sine wave inverters output in Spectrum Analyzer. From the spectrum analyzer we got the following information for Total Harmonic Distortion analysis:

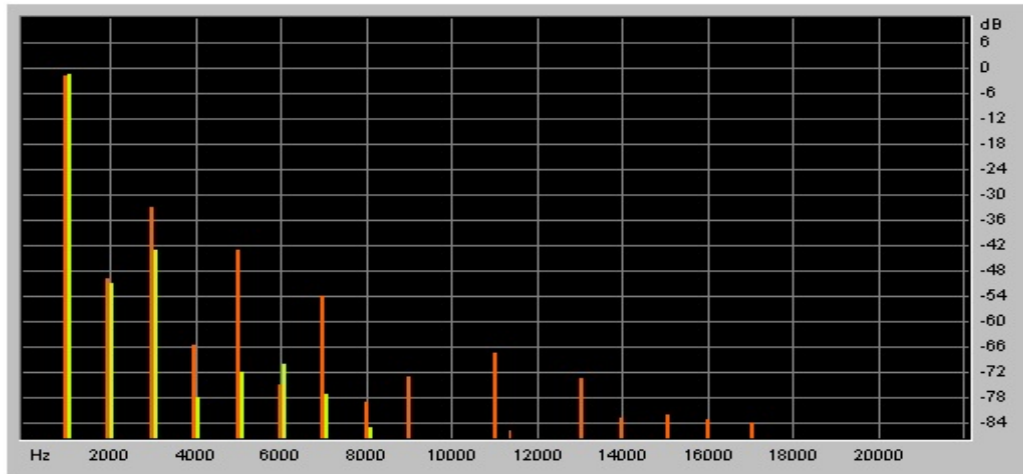

Fig: 4 THD in voltage for the output of Pure Sine Wave Inverter manufactured by Rahimafrooz

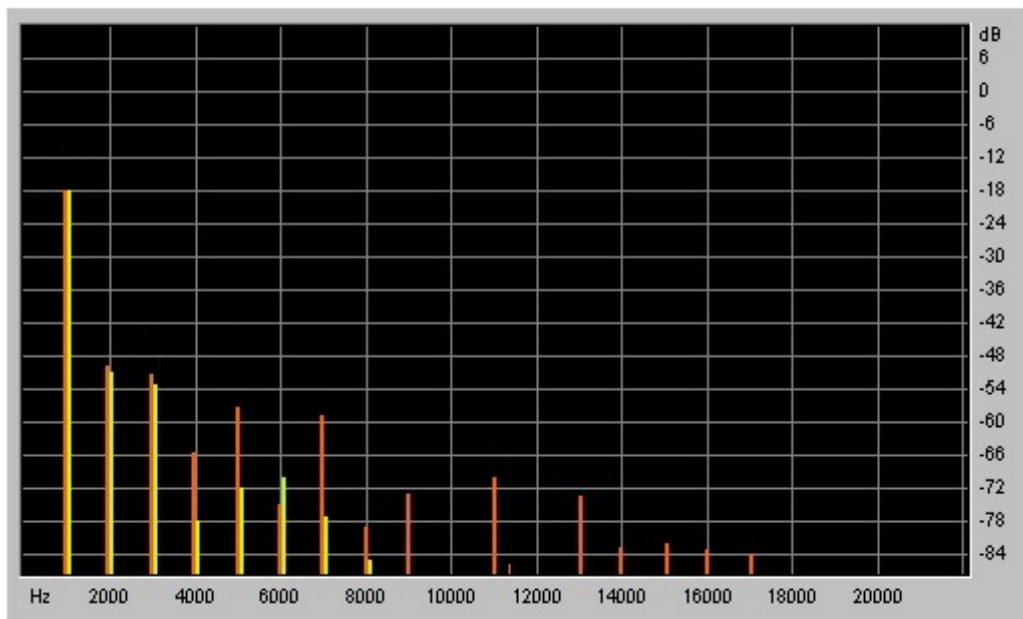

Fig: 4.1 THD in voltage for the output of Pure Sine Wave Inverter manufactured by SINGER

Finally, after checking the output of BU project inverter's output in Spectrum Analyzer .output

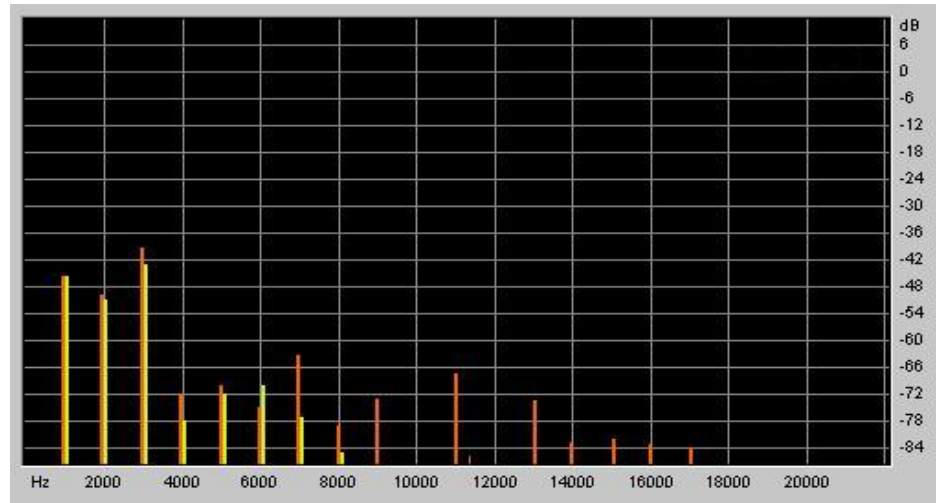

Fig: 4.4 THD in voltage for the output of Pure Sine Wave Inverter of BU project

By using spectrum analyzer and digital oscilloscope we found the following data for every inverter:

Table: 4 THD% by voltage for every inverters output including AC Mains

HARMONI C	Our Inverter	Singer	RAHIMAFRO OZ	NAVANA	Butter Fly	AC Main
1	5.61E-04	7.44E-06	5.61E-04	6.16E-03	5.61E-04	2.51E-07
2	5.00E-07	6.92E-16	3.91E-09	3.85E-09	2.50E-07	1.00E-11
3	2.50E-07	5.28E-21	3.91E-09	5.28E-21	3.91E-09	1.00E-11
4	1.25E-07	6.92E-16	3.91E-09	3.85E-09	2.50E-07	1.00E-11
5	3.91E-09	8.65E-17	7.81E-09	8.65E-17	7.81E-09	1.00E-11
6	3.13E-08	6.92E-16	1.56E-08	8.65E-17	2.50E-07	1.00E-11
7	1.56E-08	3.85E-09	3.13E-08	6.92E-16	3.13E-08	1.00E-11
8	7.81E-09	1.16E-08	6.25E-08	6.92E-16	2.50E-07	1.00E-11
9	3.91E-09	6.92E-16	6.25E-08	6.92E-16	6.25E-08	1.00E-11
10	6.25E-08	6.44E-25	1.25E-07	6.92E-16	1.25E-07	1.00E-11
11	3.91E-09	5.28E-21	1.25E-07	6.92E-16	1.25E-07	1.00E-11
12	3.91E-09	8.65E-17	2.50E-07	3.85E-09	2.50E-07	1.00E-11
13	6.25E-08	6.15E-31	5.00E-07	1.16E-08	5.28E-21	1.00E-10
14	1.25E-07	6.92E-16	3.91E-09	7.44E-06	2.50E-07	1.00E-10
SUMMATI ON	5.62E-04	7.45E-06	5.62E-04	6.17E-03	5.63E-04	2.51E-07
THD% by voltage	2.67E+00	3.67E+00	2.70E+00	4.02E+00	4.02E+00	8.93E-02

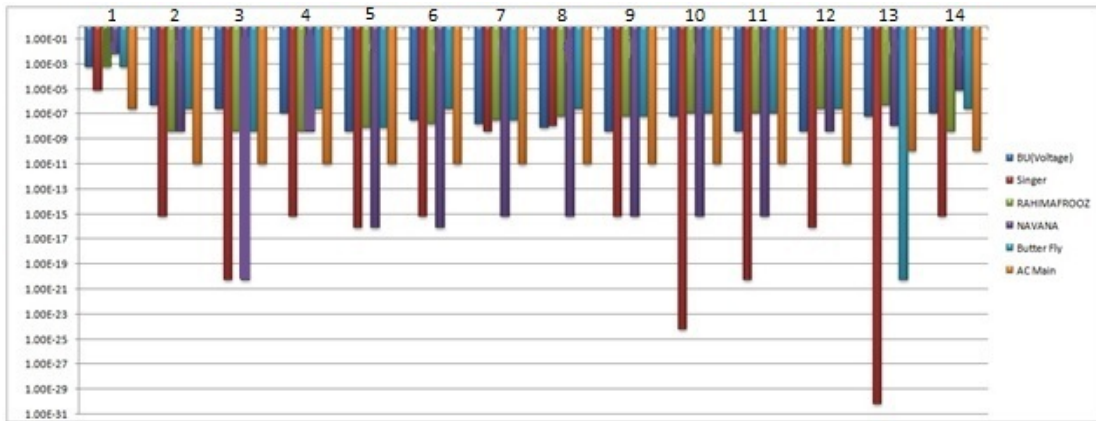

Fig: 4.5 THD by voltage in dB vs. harmonics graph

The sine wave outputs of those inverters including AC Mains are given below:

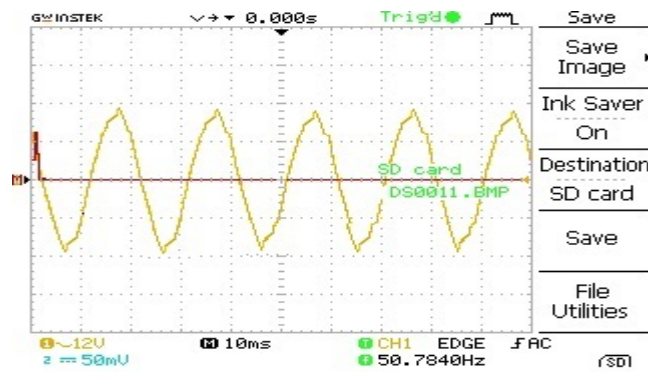

Fig: 4.6 Output of the sine wave inverter manufactured by Rahimafrooz

N.B: This Company use random winding transformer, relay switches in changeover section in their inverter which creates distortion.

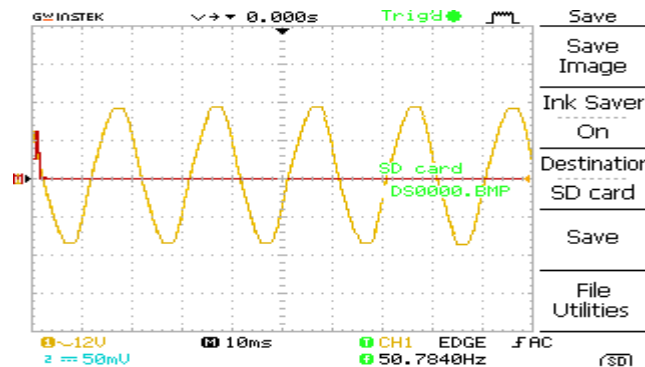

Fig: 4.7 Output of the sine wave inverter manufactured by SINGER

N.B: This Company use Bifilar winding transformer and do not use protection circuit like Battery charging current sensing circuit, Battery voltage sensing circuit section in their inverter which creates distortion.

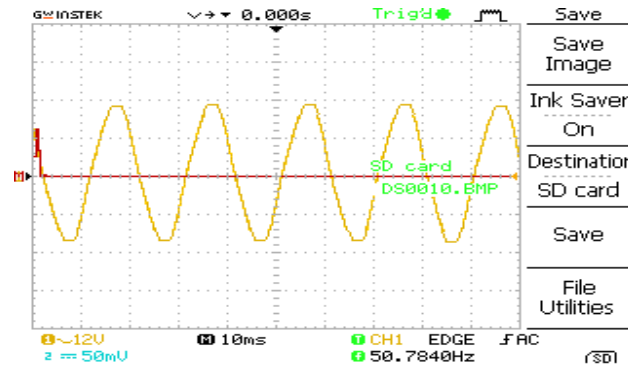

Fig: 4.8 Output of the sine wave inverter manufactured by NAVANA

N.B: This Company use random winding transformer and do not use protection circuit like Battery charging current sensing circuit, Battery voltage sensing circuit section in their inverter which creates distortion.

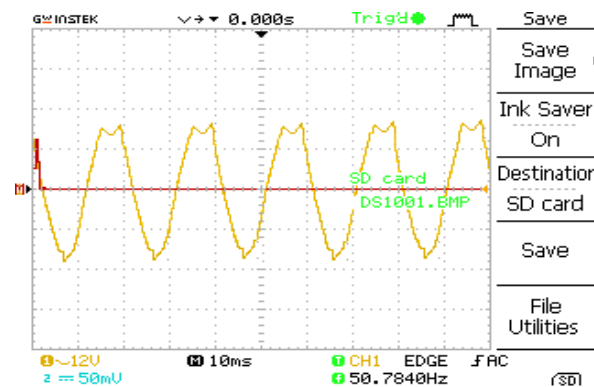

Fig4.9: Output of the sine wave inverter manufactured by Butter Fly

N.B: This Company use bifilar winding transformer and do not use any protection circuit in their inverter which creates distortion.

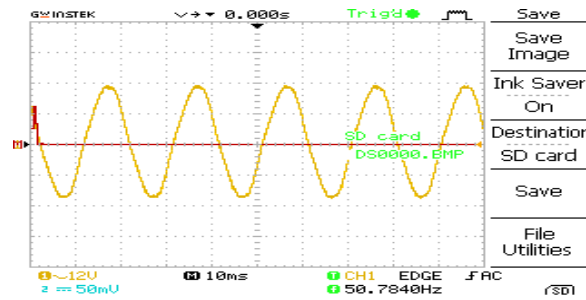

Fig :4.10 Output of the AC Mains

BU project inverter's output is given below:

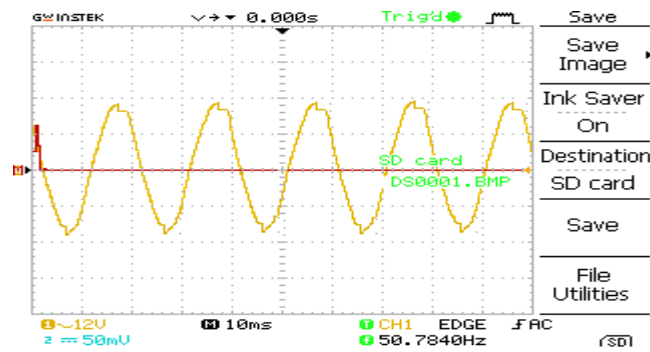

Fig: 4.11 BU project inverter

N.B: We tried to solve all the problems which have been discussed above by making some changes. These changes have been discussed in the result part including the reasons behind the lowest distorted output of the inverter designed by us.

5. Result:

After the calculation we have understood that among the renowned companies of Bangladesh, Rahimafrooz Company manufactures the best pure sine wave inverter. But this inverter has some drawbacks which are the main causes behind the distorted sine wave output. Although it shows only 2.70% THD but the percentages of THD will be increased significantly. So we need to remove the drawbacks for getting better sine wave output. At first we will discuss about the drawbacks:

- This inverter does not regulate the AC mains supply reaching the inverter transformer during the charging process. As a result, the MOSFETs used in the MOSFET driver circuit can be damaged. Any fault in MOSFET driver circuit will increase the THD of the output.
- Current flowing through the battery can not be controlled during battery charging which creates distortion in the output. This could result in damage to the battery and the oscillator circuit of the inverter.
- A battery is considered fully charged at 13.5v and fully discharged at 10v. If the inverter draws current from a discharged battery, the battery will be permanently damaged. Any fault in battery will create the oscillator circuit output more distorted.
- If full load is connected at the inverter output socket, high current will flow through the inverter. But the transformer has layer winding and Dynamo grade laminated core. This type of transformer has higher load bearing capability with distortion in sine wave output.
- This inverter has 3 relay switches for changeover section which can perform the changeover operation faster but creates distortion in output.

With these drawbacks the circuit diagram:

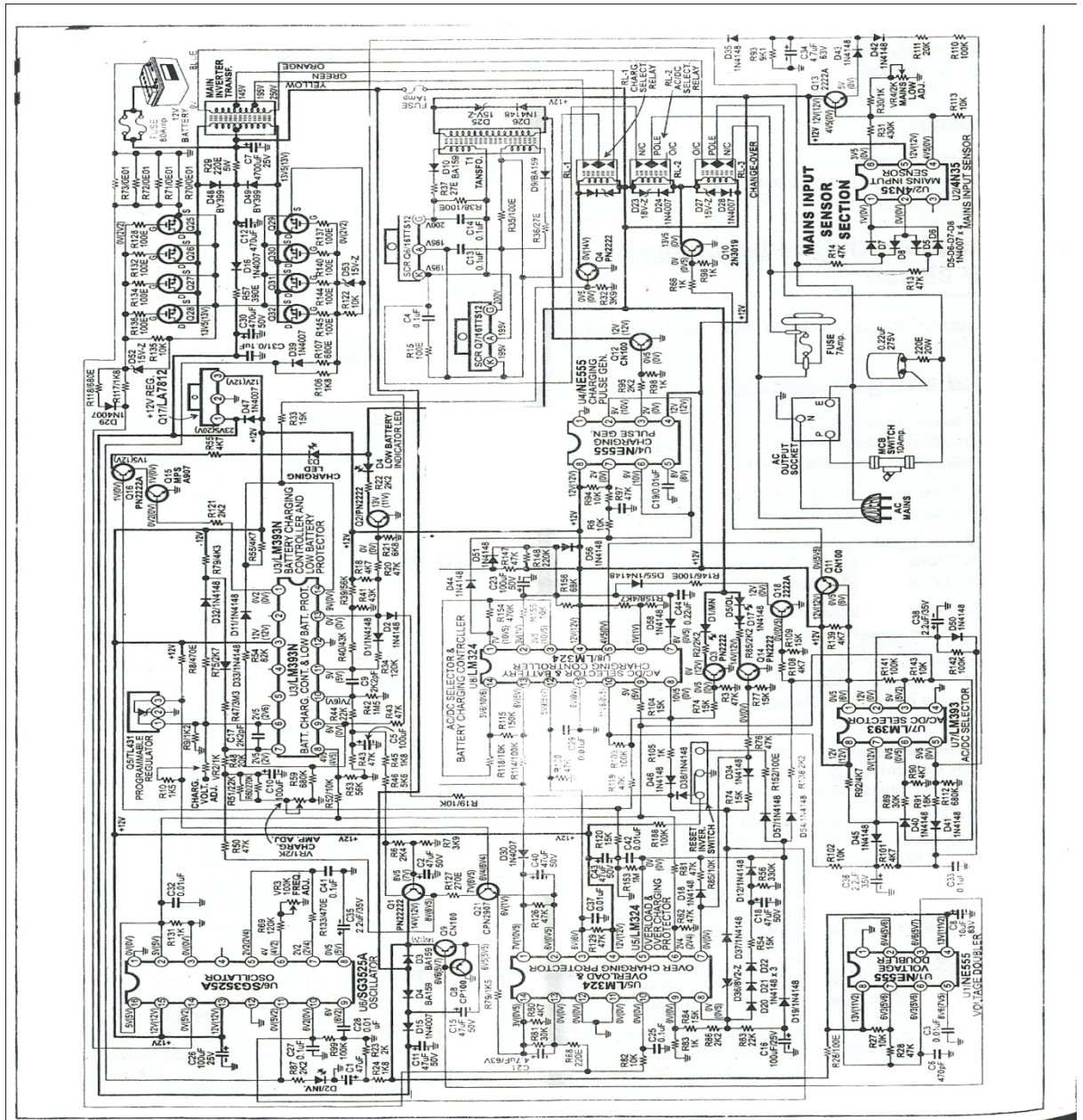

For reducing the THD and removing the drawbacks described above we have some components and added various protection circuits in our pure sine wave inverter. Those are:

Protection circuits:

- Battery charging current sensing circuit
- Battery voltage sensing circuit

- AC mains sensing circuit
- Soft start circuit
- Low battery cut circuit
- Changeover circuit
- Shutdown section
- PWM section to regulate output supply

Components changes:

- We have used a step up transformer with Random winding and original cold rolled Nickel Grain Oriented Core which is unavailable in the markets of this country. That is why, we collected the original core first and then we built the transformer by ourselves.
- We have used SCR in every part of the changeover circuit instead of using relay switch.
- We have used IC KA3525A instead of IC SG3524A in the oscillator circuit for reducing THD in the oscillator circuit output.
- We have used IC 4N35 instead of IC MOC3021 in the oscillator circuit for reducing THD in output.
- We did not use any Micro-controller in any part of the inverter. Although it makes circuit simpler and rarely defective during normal operation but they develop faults due to high voltage and creates more distorted output than traditionally designed pure sine wave inverter. For example, Butter Fly company manufacture their inverters based on PIC 16F72 which provide the most distorted pure sine wave output among the renowned companies of Bangladesh according to our calculation part.

That is why; our inverter shows the lowest THD percentages in the Spectrum analyzer and greater efficiency according to our calculation part.

So, the final circuit diagram which has been used by us for designing a pure sine wave inverter with less total harmonic distortion and with greater efficiency than usual is:

various protection circuits, then inverter's THD percentage and efficiency change will very low.

For this experiment, we have used our inverter and an inverter manufactured by Rahimafrooz Company Ltd. for about 30 days with full load. Then we have found the following result:

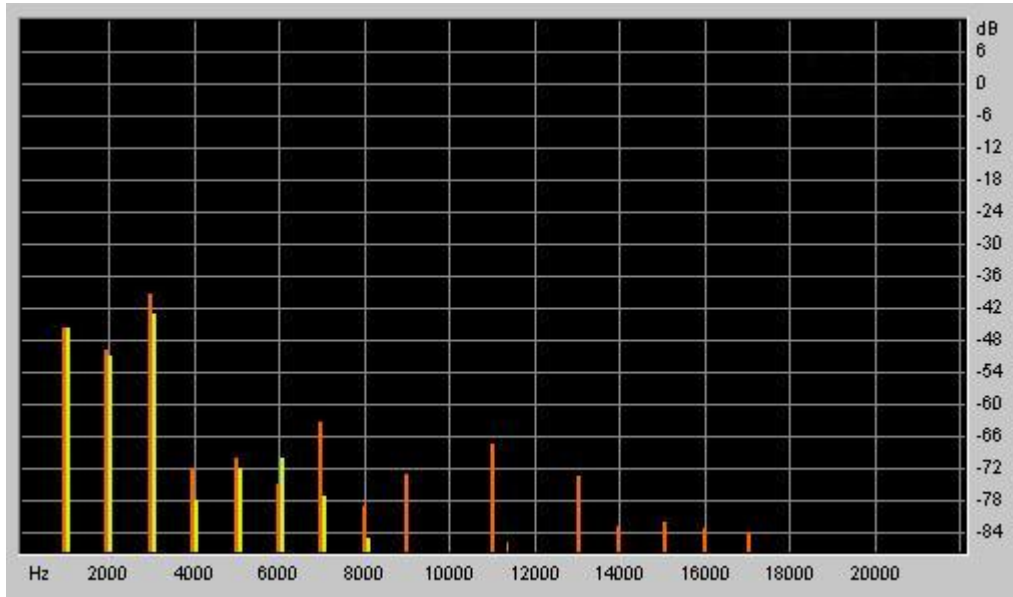

Fig: 5.1 BU Project inverter's THD of voltage in Spectrum Analyzer

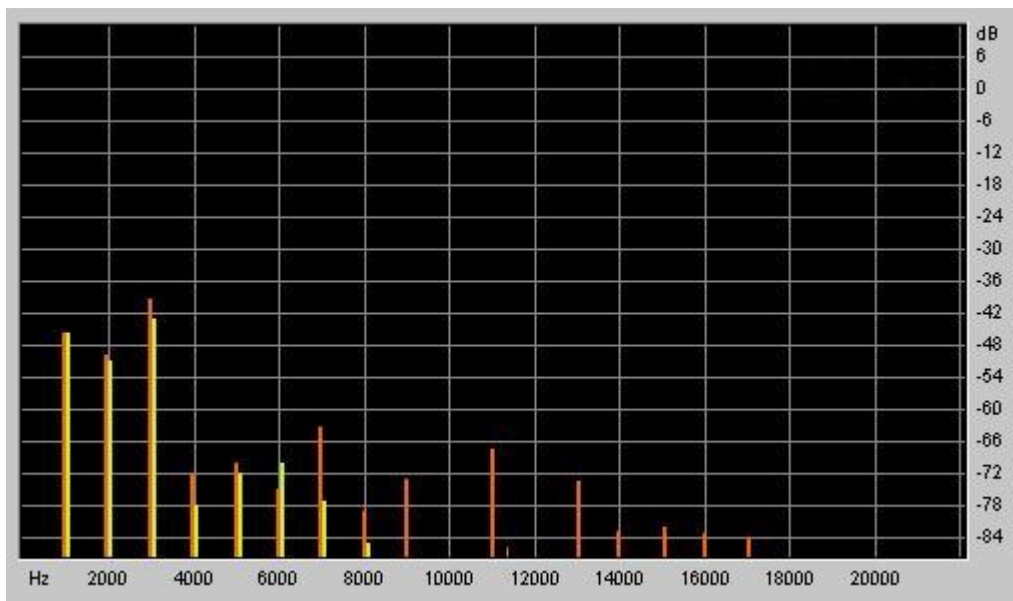

Fig: 5.2 BU project inverter's THD of voltage in Spectrum Analyzer after 30 days

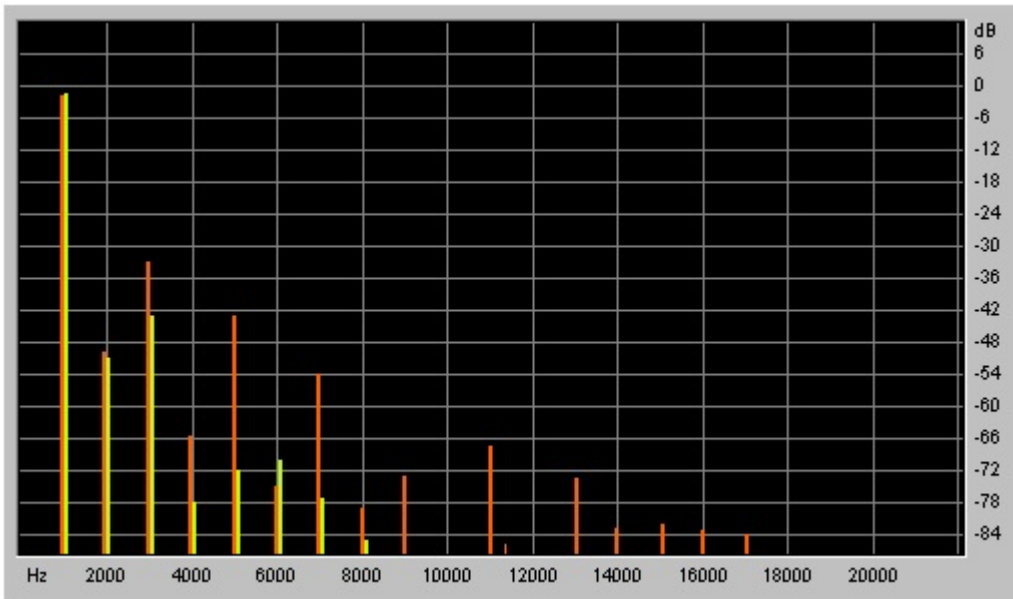

Fig: 5.3 Rahimafrooz manufactured inverter's THD of voltage in Spectrum Analyzer

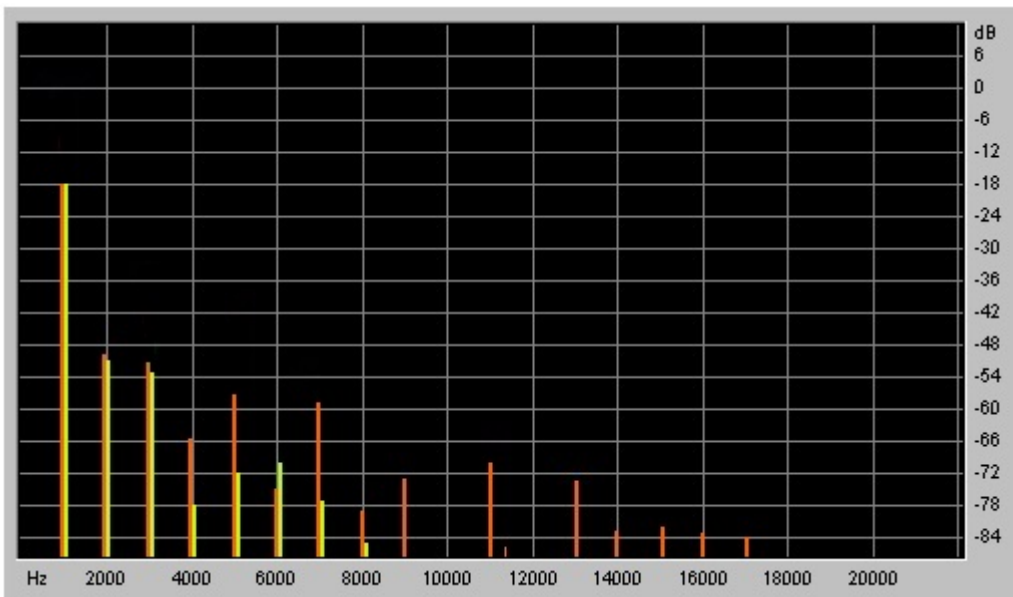

Fig: 5.4 Rahimafrooz inverter's THD of voltage in Spectrum Analyzer after 30 days

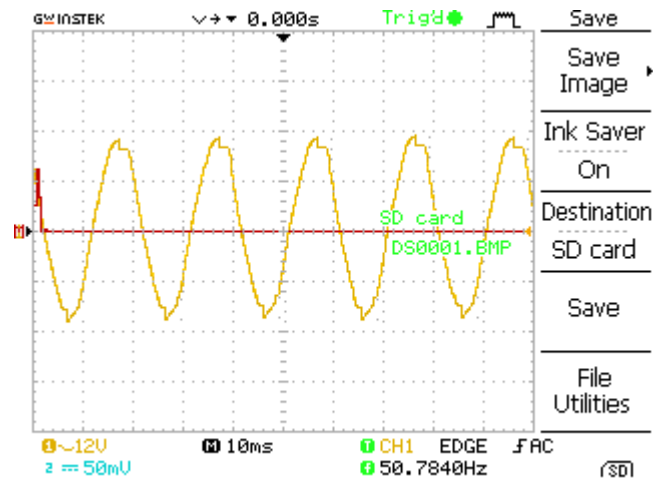

Fig: 5.5 BU project inverter's output in digital oscilloscope

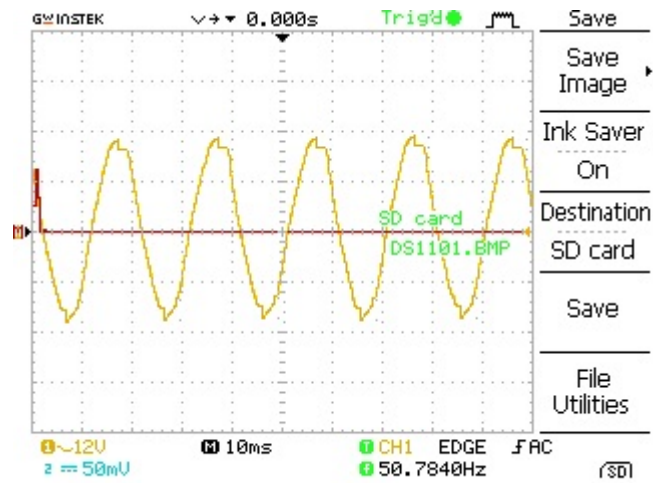

Fig: 5.6 BU project inverter's output in digital oscilloscope after 30 days

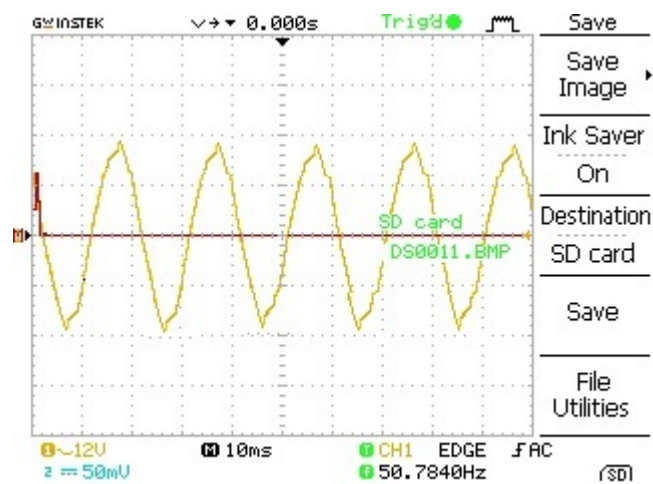

Fig: 5.7 Rahimafrooz inverter's output in Digital oscilloscope

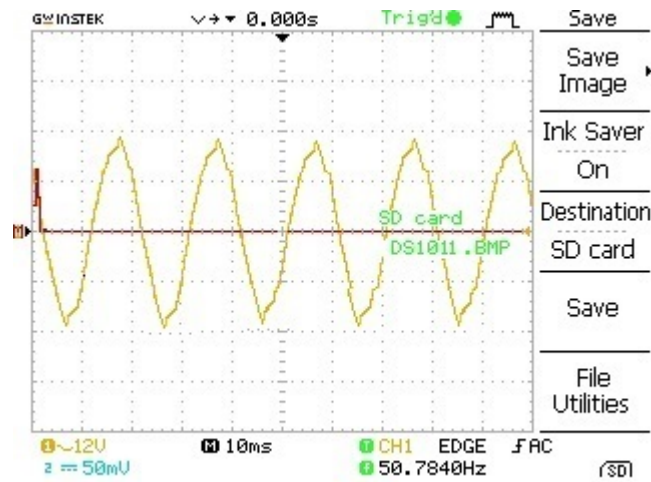

Fig: 5.8 Rahimafrooz manufactured inverter's output in Digital Oscilloscope after 30 days

Table: 5 .1 THD in voltage

HARMONIC	BU (new)	BU (30 days later)	RAHIMAFROOZ (new)	Rahimafrooz (30 days later)
1	5.61E-04	5.61E-04	5.61E-04	8.44E-06
2	5.00E-07	3.91E-09	3.91E-09	6.92E-16
3	2.50E-07	3.91E-09	3.91E-09	5.28E-21
4	1.25E-07	3.91E-09	3.91E-09	6.92E-16
5	3.91E-09	7.81E-09	7.81E-09	8.65E-17
6	3.13E-08	1.56E-08	1.56E-08	6.92E-16
7	1.56E-08	3.13E-08	3.13E-08	3.85E-09
8	7.81E-09	6.25E-08	6.25E-08	1.16E-08
9	3.91E-09	6.25E-08	6.25E-08	6.92E-16
10	6.25E-08	1.25E-07	1.25E-07	6.44E-25
11	3.91E-09	1.25E-07	1.25E-07	5.28E-21
12	3.91E-09	2.50E-07	2.50E-07	8.65E-17
13	6.25E-08	5.00E-07	5.00E-07	6.15E-31
14	1.25E-07	3.91E-09	3.91E-09	6.92E-16
SUMMATION	5.62E-04	5.62E-04	5.62E-04	8.45E-06
THD% by voltage	2.67E+00	2.69E+00	2.70E+00	3.60E+00

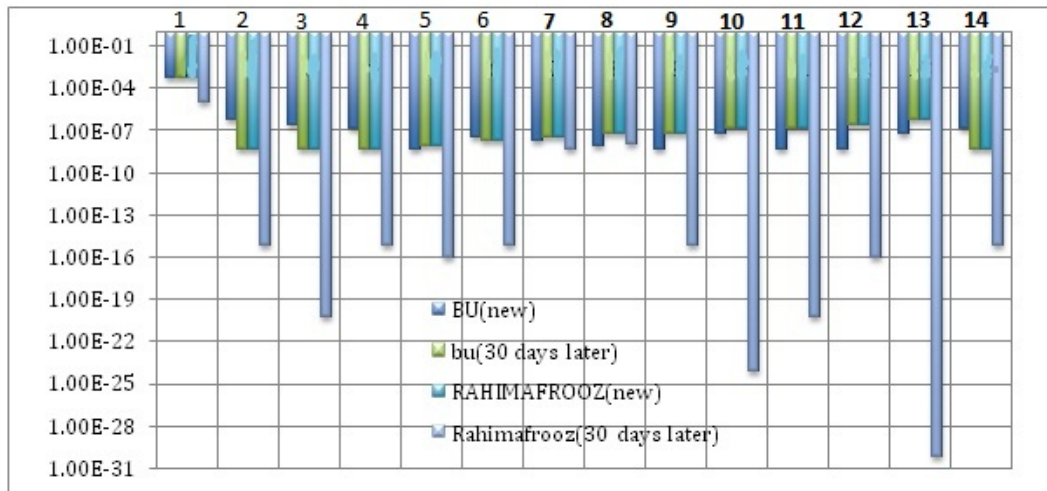

Fig: 5.9 Distortion in voltage vs. different Harmonics

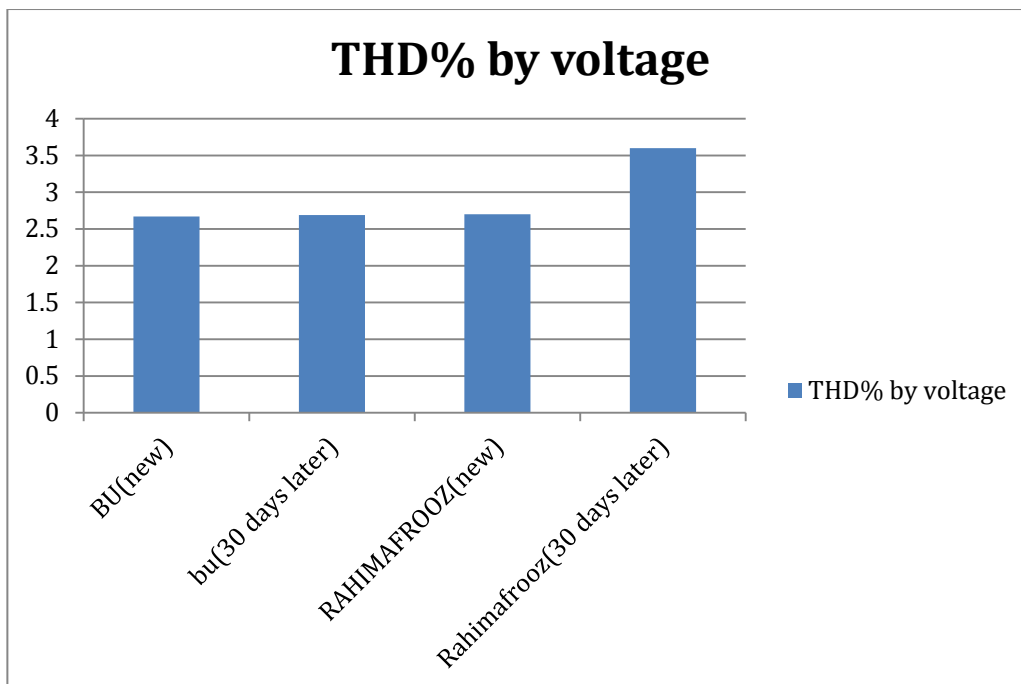

Fig: 5.10 Difference between THD percentages

Table: 5.2 THD in different load current

Load Current(A)	BU (new)	BU (30 days later)	Rahimafrooz (new)	Rahimafrooz (30 days later)
0.32	0.855	0.855	0.855	1.71
0.64	1.7088	1.7088	1.7087	2.021
0.96	2.5632	2.5632	2.62	2.5632
1.28	2.6	2.6	0.8016	2.666
1.6	2.62	2.62	0.8009	0.855

**Fig: 5.11 THD in different load current for different companies' inverters**

Table: 5.3 Efficiency Change

	BU (new)	BU (30 days later)	RAHIMAFROOZ (new)	RAHIMAFROOZ (30 days later)
%EFFICIENCY	99.98064	99.98064	99.97604	98

**Fig: 5.12 Efficiency Change**

According to the results, increasing rate of THD and decreasing rate of efficiency is smaller in our inverter than the inverter manufactured by Rahimafrooz Company Ltd, because we have added various protection circuits and changed some important components which have been described above.

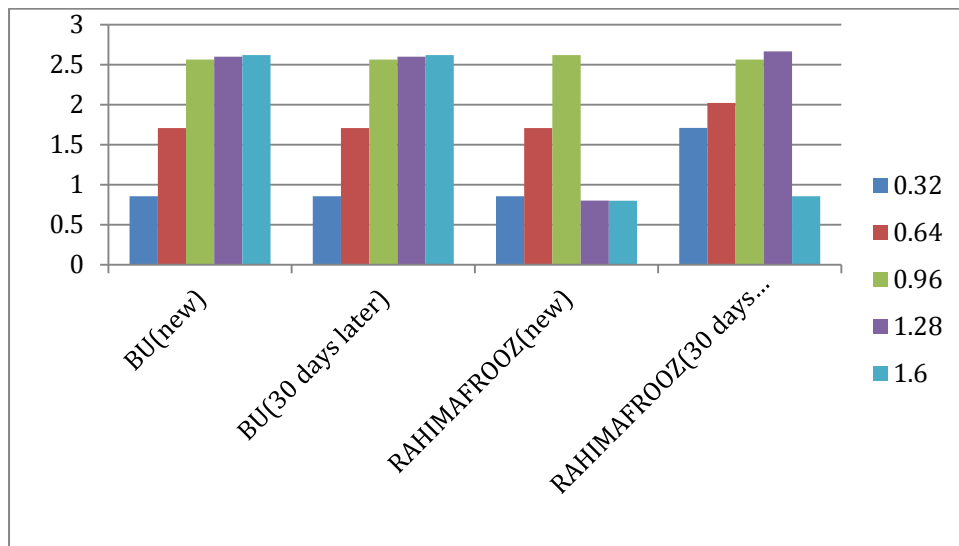
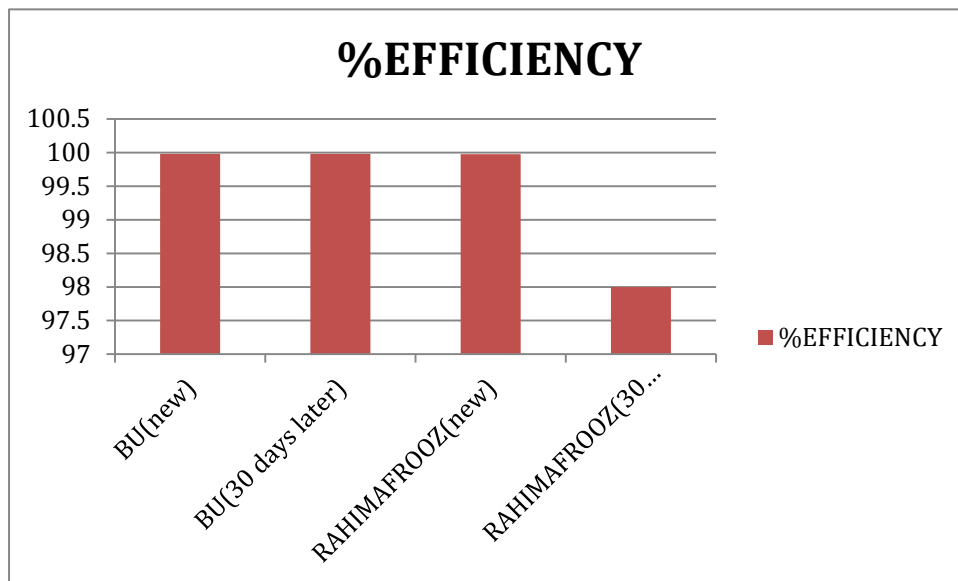
6. Conclusion:

We compare and analyze the total harmonic distortion, efficiency and cost effectiveness of different inverters from different renowned companies and finally we propose a design of a pure sine wave inverter with less total harmonic distortion and with greater efficiency than usual. Thus, it will have less affect on the lifetime of any electrical devices such as fan, tube lights etc.

References:

- [1] Modified Sine-Wave Inverter Enhanced - Docstoc. Retrieved November 3, 2010
<http://www.docstoc.com/docs/28649128/Modified-Sine-Wave-Inverter-Enhanced>
- [2] Power Inverter for Home. Retrieved November 7, 2012
<http://www.electroschematics.com/5645/home-inverter>
- [3] World Electricity Standards - QuantumBalancing.com. Retrieved December 8, 2012
<http://www.quantumbalancing.com/worldelectricity/electricityif.htm>
- [4] Eaton UPS and Power Management Fundamentals Handbook. Retrieved December 17, 2010
http://pqlit.eaton.com/ll_download_bylitcode.asp?doc_id=16991
- [5] High-frequency power supply: Topics by Science.gov. Retrieved May 2009
www.science.gov/topicpages/h/high-frequency+power+supply.html
- [6] Battery Stuff Articles. Retrieved June 26, 2010
<http://www.batterystuff.com/kb/articles/battery-articles/battery-basics.html>
- [7] Accurate 50Hz Oscillator Circuit Using 555 And 7490. Retrieved April 6, 2011
www.electroniccircuits.com/electronic-circuits/accurate-50hz-oscillator-circuit-using-555-and-7490
- [8] AIMS 300 Watt Pure Sine 12 Volt Power Inverter. Retrieved April 23, 2012
<http://findpdf.net/documents/about-Modern-Digital-Inverter-Modern-Digital-Inverter-download.html>
- [9] Modern Digital Inverter [English]. Retrieved May 9, 2013
<http://www.lynx-india.com/index.php?productID=19135>
- [10] Design and construction of a 2-kva inverter. Retrieved December 17, 2010
www.dottedpages.org/index.php/icons/engr?download=28:design-and-construction-of-inverter
- [11] Grounding and Circuit Protection for Inverters and Battery Chargers. Retrieved October 13, 2009
<http://www.blueseas.com/resources/101>.

[12] Pure Sine wave Inverter. Retrieved August 23, 2010

<http://www.bpbonline.com/download>

[13] Fundamentals of Electricity. Retrieved April 10, 2010

<http://epb.apogee.net/foe/fsgo.asp>

[14] N. Mohan "Power Electronics: Converters, Applications and Design", 3rd edition, Wiley, 2002.

<http://as.wiley.com/WileyCDA/WileyTitle/productCd-EHEP002026.html>