

January 2013

Novel Models and Algorithms for Uncertainty Management in Power Systems

Long Zhao

University of South Florida, longzhao@mail.usf.edu

Follow this and additional works at: <http://scholarcommons.usf.edu/etd>



Part of the [Oil, Gas, and Energy Commons](#), and the [Operational Research Commons](#)

Scholar Commons Citation

Zhao, Long, "Novel Models and Algorithms for Uncertainty Management in Power Systems" (2013). *Graduate Theses and Dissertations*.

<http://scholarcommons.usf.edu/etd/4971>

This Dissertation is brought to you for free and open access by the Graduate School at Scholar Commons. It has been accepted for inclusion in Graduate Theses and Dissertations by an authorized administrator of Scholar Commons. For more information, please contact scholarcommons@usf.edu.

Novel Models and Algorithms for Uncertainty Management in Power Systems

by

Long Zhao

A dissertation submitted in partial fulfillment
of the requirements for the degree of
Doctor of Philosophy
Department of Industrial and Management Systems Engineering
College of Engineering
University of South Florida

Major Professor: Bo Zeng, Ph.D.
José Zayas-Castro, Ph.D.
Tapas Das, Ph.D.
Kaushal Chari, Ph.D.
Lingling Fan, Ph.D.

Date of Approval:
November 8, 2013

Keywords: Stochastic Programming, Robust Optimization, Mixed-integer
Programming, Unit Commitment, Transmission Vulnerability Analysis

Copyright © 2013, Long Zhao

Acknowledgments

First, I dedicate this dissertation work to my family which is the most significant in my life. I would like to dedicate this work to my parents, Peiwen Zhao and Xianglan Sun, for their support and help in the past many years, more precisely, since I was born. And I give a special feeling of gratitude to my lovely wife, Yazhuo Liu, for going through all those years with me. Many of my research ideas were inspired, unexpectedly, when I was having dinner, going shopping, or walking on campus with her. To be with her makes me peaceful in my heart.

Second, I would like to dedicate this dissertation to my major advisor, Dr. Bo Zeng, who has been like my old brother since 2009. This work cannot be done without his help and support. Sometimes we agreed, and sometimes we argued. Sometimes we succeeded, and sometimes we failed. I am very happy that I have the opportunity to spend several years working with him at USF. And I will keep working with him in future.

Third, my many thanks go to Dr. José Zayas-Castro who has been giving me great advices in the past four years. I still remember that he walked me around the college of engineering at my very first day at University of South Florida. And he has been taking care of me like a father to a son since then. I am very grateful for the experience working with and learning from him.

Finally, I would dedicate this work to Dr. Tapas Das, Dr. Kaushal Chari, and Dr. Lingling Fan who gave me valuable suggestions; to Dr. Ali Yalcin, a great and funny gentleman, that I really enjoy working with; to my fellows at USF including Wei Yuan, Anna Danandeh, Yu An, Seyed Javad Sajjadi, and Jasper Quach; to my friend, Mr. Brian Buckley at Tampa Electric Company for the research in Chapter 2; and to my supervisors at ISO New England this summer: Dr. Jinye Zhao, Dr. Tongxin Zheng, and Dr. Eugene Litvinov.

Table of Contents

List of Tables	iii
List of Figures	iv
Abstract	v
1 Introduction	1
2 A Stochastic Unit Commitment Model with Cooling Systems	3
2.1 Note to Reader	3
2.2 Background	3
2.3 Characteristics and Operations of Cooling Systems	7
2.4 Stochastic UC-cooling Models	8
2.4.1 Optimal Stochastic UC-cooling Model	8
2.4.2 UC Models without Optimal Cooling Operations	12
2.4.3 Solution and Model Improvement	13
2.5 Computational Study	14
3 Robust Unit Commitment Problem with Demand Response and Wind Energy	18
3.1 Note to Reader	18
3.2 Background	18
3.3 Wind-UC Model	20
3.4 Solution Methods	25
3.5 Wind-UC-DR Model	29
3.6 Computational Results	30
3.6.1 BD vs. C&CG	30
3.6.2 One Uncertainty Budget Constraint	31
3.6.3 Multiple Uncertainty Budget Constraints	31
4 Vulnerability Analysis of Power Grids with Line Switching	35
4.1 Note to Reader	35
4.2 Background	35
4.3 Min-Max Attack-Defend Model	39
4.4 The Global Optimal Solution by C&CG Algorithm	42
4.5 Algorithm Description	48
4.6 Computational Study	50

5 Conclusion	59
References	61
Appendices	71
Appendix A Reprint Permissions from IEEE	72
A.1 Reprint Permissions for Chapter 2	72
A.2 Reprint Permissions for Chapter 3	73
A.3 Reprint Permissions for Chapter 4	74

List of Tables

Table 1 Nomenclature Used in Chapter 2	6
Table 2 Characteristics of Gas Generators	16
Table 3 Commitment Percentage for Different Spinning Reserve Levels	17
Table 4 Nomenclature Used in Chapter 3	21
Table 5 The Performance Comparison of Two Methods	31
Table 6 The Wind-UC Results with One Budget Constraint	32
Table 7 The Wind-UC-DR Results with One Budget Constraint	32
Table 8 The Wind-UC Results with Multiple Budget Wind Constraints	33
Table 9 The Wind-UC-DR Results with Multiple Budget Wind Constraints	33
Table 10 Nomenclature Used in Chapter 4	39
Table 11 Load Shedding on 7-Bus System with and without Line Switching	51
Table 12 C&CG versus Enumeration on 7-Bus System with Line Switching	52
Table 13 Configurations of Computing Facilities	52
Table 14 Algorithm Performance Comparison for IEEE One-Area RTS-96 Systems	54
Table 15 Load Shedding (MW) to IEEE One-Area RTS-96 System Caused by Attacks	55
Table 16 Optimal Attack and Switching in One-Area RTS-96 for $K=8,10$ by C&CG	55
Table 17 Results of Three-Area RTS-96 System Attacks with Cardinality 1-6	58
Table 18 Results of IEEE 118-bus System	58

List of Figures

Figure 1 Cooler Inlet Air Yields Higher Turbine Output	5
Figure 2 Demand and Capacity versus Air Temperature	5
Figure 3 Piecewise Linear Fuel Cost Function	10
Figure 4 Random Demand Prediction with Three Scenarios	15
Figure 5 Total Costs Changes for Different Demand Levels	16
Figure 6 A 7-bus Power System	51
Figure 7 Comparison of Best Attacks Obtained using C&CG and MSBD for $K = 8$	53

Abstract

This dissertation is a collection of previously-published manuscript and conference papers. In this dissertation, we will deal with a stochastic unit commitment problem with cooling systems for gas generators, a robust unit commitment problem with demand response and uncertain wind generation, and a power grid vulnerability analysis with transmission line switching. The latter two problems correspond to our theoretical contributions in two-stage robust optimization, i.e., how to efficiently solve a two-stage robust optimization, and how to deal with mixed-integer recourse in robust optimization. Due to copyright issue, this dissertation does not include any methodology papers written by the author during his PhD study. Readers are referred to the author's website for a complete list of publications.

1 Introduction

Many gas generators, especially in warm areas, are equipped with cooling systems that can significantly improve power output efficiencies. However, the operations of cooling systems and their impact on unit commitment problems have not been investigated analytically. In chapter 2, we build mathematical forms to capture the operations and costs of running cooling systems. Then we develop a stochastic unit commitment model with operations and costs from cooling systems for stochastic demand. Finally, computation results from a real power system are presented.

On the other hand, both demand response (DR) strategy and renewable energy have been adopted to improve power generation efficiency and reduce greenhouse gas emission. However, the uncertainty and intermittent generation pattern in wind farms and the complexity of demand side management pose huge challenges. In chapter 3, we analytically investigate how to integrate DR and wind energy with fossil fuel generators to (1) minimize power generation cost; and (2) fully take advantage of the wind energy with the managed demand to reduce greenhouse emission. We first build a two-stage robust unit commitment (UC) model to obtain day-ahead generator schedules where wind uncertainty is captured by a polytopic uncertainty set. Then, we extend our model to include DR strategy such that both price levels and generator schedules will be derived for the next day. For these two challenging models, we derive their mathematical properties and develop a novel solution method. Our computational study on an IEEE 118-bus system with 36 units shows that robust UC models can fully make use of wind generation with less generation cost. Also, the developed algorithm is computationally superior to classical Benders decomposition method.

Finally, vulnerability analysis of a power grid, especially in its static status, is often performed through solving a bi-level optimization problem, which, if solved to optimality,

yields the most destructive interdiction plan with the worst loss. As one of the most effective operations to mitigate deliberate outages or attacks, transmission line switching recently has been included and modeled by a binary variable in the lower level decision model. Because this bi-level (or an equivalent min-max) problem is a challenging nonconvex discrete optimization problem, no exact algorithm has been developed, and only a few recent heuristic procedures are available. In chapter 4, we present an equivalent single-level reformulation of this problem, and describe a column-and-constraint generation algorithm to derive the global optimal solution. Numerical study confirms the quality of solutions and the computational efficiency of the proposed algorithm. Discussion and analysis of the mitigation effect of line switching are also presented in the chapter.

This dissertation is organized as follows. Chapter 2 describes our work in a stochastic unit commitment problem with cooling systems for gas generators; Chapter 3 presents a robust unit commitment problem with demand response and uncertain wind generation; Chapter 4 corresponds to a power grid vulnerability analysis with transmission line switching.

2 A Stochastic Unit Commitment Model with Cooling Systems

2.1 Note to Reader

This chapter has been previously published ©2013 IEEE. Reprinted, with permission, from Long Zhao, Bo Zeng and Brian Buckley, A Stochastic Unit Commitment Model With Cooling Systems, IEEE Transactions on Power Systems, Feb. 2013 [85]. The second author, Dr. Bo Zeng, contributed for part of technical section; and the third author, Mr. Brian Buckley, identified the background and significance of this application.

2.2 Background

Unit commitment (UC) problem determines generators' on/off statuses and output levels to satisfy forecasted customer demand (or system load) with the least generation cost, consisting of generator start-up costs, fixed costs (no load costs), and fuel costs ([46, 65, 86]). Given the importance of power generators and the fact that fuel cost accounts for up to 60 percent of total operating cost, the unit commitment problem is arguably the most important operation problem in the power industry. Extended from a basic unit commitment model that considers only generators and the deterministic load information, many variants have been developed and studied, including SCUC with transmission security requirements ([40, 48, 77]), UC with stochastic demands and integration of renewable energy supplies ([25, 71, 73]). See [55] for a review of unit commitment problems.

Although numerous papers have been published on modeling and fast solution methods for UC problems, to the best of our knowledge, none have considered one practical problem: gas generator efficiency related to inlet air temperature. Given the fact that many cooling systems have been installed for gas turbine generators to change the inlet air temperature and thus improve their efficiency, the authors believe it is important to incorporate analytically the operations and impacts of cooling systems into current UC models. The authors are not

aware of any papers on UC that consider the effect of temperature on gas generators, or UC with cooling systems operations.

In practice, the actual power generation of a gas generator is directly affected by the temperature of the inlet air to the turbine. This relationship can be described linearly as in Figure 1 ([76]), which suggests that cooling inlet air leads to higher efficiency. The reason is that physically cool air is denser and can give the turbine a higher mass-flow rate, resulting in an increase in turbine output and efficiency. So, on a hot day, the high temperature will significantly reduce the performance of a gas turbines. For example, a gas turbine generator that produces 200MW per hour when the ambient temperature is 50°F may produce only 150MW per hour when the inlet air temperature rises to 100°F. The 50MW loss, at a price of approximately \$50 to more than \$100 per MWh means as much as a \$12500 to \$25000 loss of revenue for the power producer in 5 hours. Actually, during hot summers, according to a local power plant in Florida, the largest loss in generating capacity coincides with the peak load (see Figure 2). A similar observation is reported in [59], and the lost capacity is treated as “*hidden treasure*”. Such a situation poses a great challenge to system operators in managing generators, controlling generation cost, and satisfying green house gas emission restrictions. To address this issue, cooling systems that cool the turbine inlet air have been developed and commercialized. Because reducing the temperature of the turbine inlet air even by just a few degrees can increase power output substantially, many gas generators, especially those working in warm or hot environments, have had cooling systems installed to compensate for the efficiency loss caused by high air temperatures. In spite of the importance of cooling systems on power generators, the authors are not aware of any research on UC involving the operations and impact of cooling systems. The lack of technical support to the operations of cooling systems often leads them to be operated under simple rules in an *ad hoc* fashion. For example, one policy used by a local power plant in Florida states that “if a gas generator is running below the maximum generating level, then keep the cooling system off; otherwise, the cooling system can be turned on if necessary.” Obviously, such a

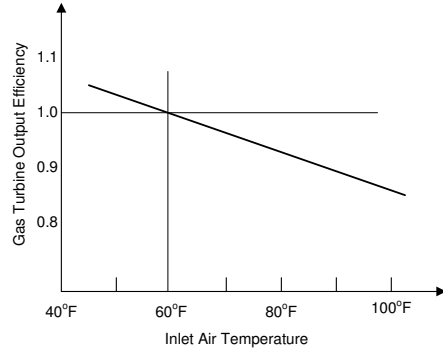

Figure 1: Cooler Inlet Air Yields Higher Turbine Output ([76])

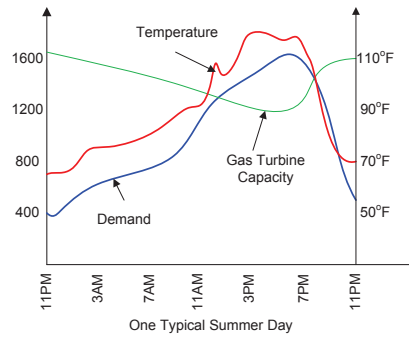

Figure 2: Demand and Capacity versus Air Temperature

rule is not optimal because generator schedules and cost factors are ignored. Also, without explicitly considering the operations and impact of cooling systems, a UC model probably cannot yield an optimal schedule for a set of generators with the least generation cost. Thus, there is a clear need to extend the research on UC models to incorporate the operations and effects of cooling systems.

To address this need and to bridge the gap between industrial practice and academic research, the authors systematically studied a unit commitment problem with consideration of cooling systems. Because we believe that load is a critical factor in determining the operations of cooling systems and that forecasting often is inaccurate, we performed our research with a 2-stage stochastic unit commitment model where the forecasted load is represented by a set of probabilistic scenarios. As a result, we built a novel UC model by integrating a 2-stage stochastic UC formulation with the operations and costs of cooling

Table 1: Nomenclature Used in Chapter 2

i	Gas generator
t	Time period
k	Breaking point of piecewise linear approximation of generation cost
s	Scenario
A_{it}^T	Ambient temperature at time t at generator i 's location
A_{it}^D	Dew temperature at time t at generator i 's location
d_t^s	Demand at time t in scenario s
l_i, u_i	Minimum/maximum generation limits of unit i
m_+^i, m_-^i	Minimum up/down limits
Δ_+^i, Δ_-^i	Ramping up/down limits of unit i
p_{ik}^G	Output level at breaking point k in piecewise linear approximation of generator i
c_i^{NL}	No-load(fixed) cost of unit i
c_i^{SU}	Startup cost of unit i
c_{ik}	Fuel cost at output level p_{ik}
ρ	Cooling system efficiency
c_i^{OM}	Operating and maintenance cost of cooling system i for an extra unit of power generation
c_i^{Fix}	Fixed cost of operating cooling system i
$p(s)$	Probability of scenario s
Q_i	Maximum spinning reserve contribution from unit i
R_t^s	Spinning reserve requirement of time t in scenario s
x_{it}^s	Planned generation level of unit i at time t in scenario s
v_{it}	Binary variable, (if 1) unit i is started up at time t
w_{it}	Binary variable, (if 1) unit i is shut down at time t
y_{it}	Binary variable, (if 1) unit i is running at time t
λ_{itk}^s	Positive linear combination of k breaking points of generator i at time t in scenario s
z_{it}^s	Binary cooling system on/off variable for unit i at time t in scenario s
r_{it}^s	Spinning reserve from generator i at time t in scenario s

systems. We denoted it by a 2-stage stochastic *UC-cooling* model. To the best of our knowledge, it is the first analytical model to consider a UC model with the operations and costs of cooling systems. We performed a set of experiments on a real power system operated by a local utility company. In particular, the performance, including generation cost decrease and robustness of the system obtained from using the integrated stochastic model, was compared with that obtained from using the practical decision rule.

The chapter is organized as follows. In Section 2.3, mathematical forms for the impact of cooling systems on generator performances are abstracted. Section 2.4 describes the developed integrated stochastic UC-cooling model. Section 2.5 presents a set of computational results to demonstrate the economic benefits that derive from considering the operations and impacts of cooling systems. Nomenclature used in this chapter is listed in Table 1.

2.3 Characteristics and Operations of Cooling Systems

In this section, the background and operations of cooling systems are described analytically. In practice, different kinds of cooling systems have inherent advantages and disadvantages, and the most widely used are evaporative coolers and chiller coils ([29]). This paper focuses on evaporative coolers, and cooling systems are used in the remainder of this paper for convention. Chiller coils with a stronger cooling ability at a relatively high cost can be analyzed in a similar way.

Unlike the commitment of generators, which has to be determined day-ahead, the operations of cooling systems are made in real time. That is, the system operators can decide the on/off statuses of cooling systems according to actual demand. By using cooling systems, the inlet air temperature can be reduced from ambient temperature A^T towards dew-point A^D by $100\rho\%$, where ρ is the cooling efficiency taking values between 0.85 and 0.9 ([44, 76]). Consequently, the inlet air temperature into a gas turbine will be reduced to $A^T - \rho(A^T - A^D)$ degrees. In this paper, $\rho = 0.9$. For example, given the 100°F ambient air temperature and the 70°F dew-point, the inlet air temperature will be $100 - 0.9(100 - 70) = 73^\circ\text{F}$ departing from the cooling systems.

As shown in Figure 1 ([76]), the power output of a gas turbine is a linear inverse function of the inlet air temperature. We sampled two points of the straight line and built the linear function such that the *scheduled* output of a gas turbine x MW will turn out to be an *actual* $x \left(1.2 - \frac{A'}{300}\right)$ MW, where A' is the inlet air temperature. For example, if the inlet air temperature is 60°F, the real output of a gas turbine is the same as the scheduled value but will be less if the inlet air temperature is higher.

There exist a fixed cost and some operating and maintenance (O&M) cost for running a cooling system. The O&M cost usually is regarded as a proportion of the extra power output due to the use of cooling systems ([32]). Therefore, in this paper, we assume a linear O&M cost of the extra power generation. Formally, each time a cooling system is turned on, a fixed cost c^{Fix} will be incurred; if the planned output is x MW, by using cooling systems the actual generation will increase from $x \left(1.2 - \frac{A^T}{300}\right)$ MW to $x \left(1.2 - \frac{AT - \rho(A^T - A^D)}{300}\right)$ MW, and the extra generation will be $x \left(\frac{\rho(A^T - A^D)}{300}\right)$ MW with the cost of c^{OM} per MW.

2.4 Stochastic UC-cooling Models

2.4.1 Optimal Stochastic UC-cooling Model

In this section, a general stochastic UC model with cooling systems is formulated, aptly named SUC-C, to minimize the total cost.

$$\begin{aligned}
min \quad & \sum_{t=0}^{T-1} \sum_{i=0}^{I-1} (c_i^{NL} y_{it} + c_i^{SU} v_{it}) + \sum_i \sum_t \sum_{s=0}^{S-1} p(s) c_i^{Fix} z_{it}^s \\
& + \sum_{t=0}^{T-1} \sum_{i=0}^{I-1} \sum_{k=0}^{K-1} \sum_{s=0}^{S-1} p(s) c_{ik} \lambda_{itk}^s \\
& + \sum_{t=0}^{T-1} \sum_i \sum_{s=0}^{S-1} p(s) x_{it}^s z_{it}^s \rho \left(\frac{A_{it}^T - A_{it}^D}{300} \right) c_i^{OM} \tag{2.1}
\end{aligned}$$

$$st. \quad v_{it} - w_{it} = y_{it} - y_{i,t-1}, \forall i, t \geq 1; \tag{2.2}$$

$$v_{i0} = y_{i0}, \forall i \tag{2.3}$$

$$\sum_{h=t-m_+^i+1}^t v_{ih} \leq y_{it}, \forall i, t \geq m_+^i - 1; \tag{2.4}$$

$$\sum_{h=t-m_-^i+1}^t w_{ih} \leq 1 - y_{it}, \forall i, t \geq m_-^i - 1; \quad (2.5)$$

$$\begin{aligned} x_{i,t+1}^s &\leq x_{it}^s + y_{it}\Delta_+^i + (1 - y_{it})u_i, \\ \forall i, s, t &= 0, 1, \dots, T - 2 \end{aligned} \quad (2.6)$$

$$\begin{aligned} x_{it}^s &\leq x_{i,t+1}^s + y_{i,t+1}\Delta_-^i + (1 - y_{i,t+1})u_i, \\ \forall i, s, t &= 0, 1, \dots, T - 2 \end{aligned} \quad (2.7)$$

$$x_{it}^s = \sum_{k=0}^{K-1} \lambda_{itk}^s p_{ik}^G, \forall i, t, s \quad (2.8)$$

$$\sum_{k=0}^{K-1} \lambda_{itk}^s = y_{it}, \forall i, t, s \quad (2.9)$$

$$\sum_i x_{it}^s \left(1.2 - \frac{A_{it}^T - z_{it}\rho(A_{it}^T - A_{it}^D)}{300} \right) \geq d_t^s, \forall t, s \quad (2.10)$$

$$x_{it}^s + r_{it}^s \leq u_i y_{it}, \forall i, t, s \quad (2.11)$$

$$r_{it}^s \leq Q_i, \forall i, t, s \quad (2.12)$$

$$\sum_i r_{it}^s \left(1.2 - \frac{A_{it}^T - z_{it}\rho(A_{it}^T - A_{it}^D)}{300} \right) \geq R_t^s, \forall t, s \quad (2.13)$$

$$y_{it}, z_{it}^s \in \{0, 1\}; x_{it}^s, r_{it}^s, \lambda_{itk}^s \geq 0, v_{it}, w_{it} \in [0, 1]. \quad (2.14)$$

The objective function (2.1) consists of start-up costs, no-load costs, fuel costs of gas generators, and the fixed costs and O&M costs of cooling systems. Piecewise linear functions are used to approximate the actual quadratic fuel cost functions of gas generators. To be specific, the piecewise linear function for each generator i has $K - 1$ segments, with the minimum/maximum generation limits (l_i, u_i) as the end points, as shown in Figure 3.

Constraints (2.2-2.3) stand for start-up operations; that is, unit i is started up at the beginning of period t if its status is off at time $t - 1$ and is on at time t . Constraints (2.4-2.5) are minimum up/down constraints. If the unit $i \in I$ is turned on(off) in one period, it has to stay in the on(off) status for a minimum number of periods, denoted by $m_+^i(m_-^i)$. Simultaneously, the variables v_{it} and w_{it} can be relaxed to be continuous since

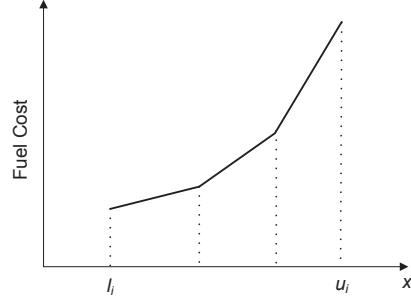

Figure 3: Piecewise Linear Fuel Cost Function

they will be forced to be binary due to (2.2-2.5). Constraints (2.2-2.5) with continuous v_{it} and w_{it} are proposed and investigated in [60], stating that those constraints are strong (sometimes facet-defining) valid inequalities for UC problems. Constraints (2.6-2.7) are ramping up/down limits in UC models ([36]). These constraints require that the maximal increase in the generation level of the unit i from one period to the next cannot be more than Δ_+^i . Similarly, Δ_-^i is introduced to restrict the maximal decrease of the unit i from period to period. Constraints (2.8-2.9) illustrate the generation efficiency of each unit. If the generator i at time t is off ($y_{it} = 0$), then there is no power output ($x = 0$); otherwise ($y_{it} = 1$), the power output is a convex combination of the breakpoints of the piecewise linear cost function. The minimization objective will force a unique combination. Constraint (2.10) ensures that customer demand will be satisfied by actual power generation. Constraints (2.11-2.13) state the spinning reserve requirement ([81]). After substituting x_{it}^s by the RHS of (2.8) and linearizing $\lambda_{itk}^s z_{it}^s$ and $r_{it}^s z_{it}^s$ by introducing new variables θ_{itk}^s and π_{it}^s for all i, t, k, s respectively, there is a mixed integer programming (MIP) problem as follows. Please note that the nonnegativity of x_{it}^s is always true with the RHS of (2.8).

$$\begin{aligned}
\min \quad & \sum_{t=0}^{T-1} \sum_{i=0}^{I-1} (c_i^{NL} y_{it} + c_i^{SU} v_{it}) + \sum_{t=0}^{T-1} \sum_{i=0}^{I-1} \sum_{k=0}^{K-1} \sum_{s=0}^{S-1} p(s) c_{ik} \lambda_{itk}^s \\
& + \sum_{t=0}^{T-1} \sum_i \sum_{k=0}^{K-1} \sum_{s=0}^{S-1} p(s) \theta_{itk}^s p_{ik}^G \rho \left(\frac{A_{it}^T - A_{it}^D}{300} \right) c_i^{OM}
\end{aligned}$$

$$+ \sum_i \sum_t \sum_{s=0}^{S-1} p(s) c_i^{Fix} z_{it}^s; \quad (2.15)$$

st. (2.2 – 2.5), (2.12)

$$\sum_{k=0}^{K-1} \lambda_{i,t+1,k}^s p_{ik}^G \leq \sum_{k=0}^{K-1} \lambda_{itk}^s p_{ik}^G + y_{it} \Delta_+^i + (1 - y_{it}) u_i, \quad \forall i, s, t = 0, 1, \dots, T-2 \quad (2.16)$$

$$\sum_{k=0}^{K-1} \lambda_{itk}^s p_{ik}^G \leq \sum_{k=0}^{K-1} \lambda_{i,t+1,k}^s p_{ik}^G + y_{i,t+1} \Delta_-^i + (1 - y_{i,t+1}) u_i, \quad \forall i, s, t = 0, 1, \dots, T-2 \quad (2.17)$$

$$\sum_{k=0}^{K-1} \lambda_{itk}^s = y_{it}, \forall i, t, s \quad (2.18)$$

$$\sum_i \sum_{k=0}^{K-1} \lambda_{itk}^s p_{ik}^G \left(1.2 - \frac{A_{it}^T}{300} \right) + \sum_i \sum_{k=0}^{K-1} \theta_{itk}^s p_{ik}^G \frac{\rho(A_{it}^T - A_{it}^D)}{300} \geq d_t^s, \forall t, s \quad (2.19)$$

$$\theta_{itk}^s \leq \lambda_{itk}^s, \forall i, t, k, s \quad (2.20)$$

$$\theta_{itk}^s \leq z_{it}^s, \forall i, t, k, s \quad (2.21)$$

$$\theta_{itk}^s \geq \lambda_{itk}^s + z_{it}^s - 1, \forall i, t, k, s \quad (2.22)$$

$$\sum_{k=0}^{K-1} \lambda_{itk}^s p_{ik}^G + r_{it}^s \leq u_i y_{it}, \forall i, t, s \quad (2.23)$$

$$\sum_i r_{it}^s \left(1.2 - \frac{A_{it}^T}{300} \right) + \sum_i \pi_{it}^s \frac{\rho(A_{it}^T - A_{it}^D)}{300} \geq R_t^s, \forall t, s \quad (2.24)$$

$$\pi_{it}^s \leq r_{it}^s, \forall i, t, s \quad (2.25)$$

$$\pi_{it}^s \leq z_{it}^s Q_i, \forall i, t, s \quad (2.26)$$

$$\pi_{it}^s \geq r_{it}^s + (z_{it}^s - 1) Q_i, \forall i, t, s \quad (2.27)$$

$$y_{it} \in \{0, 1\}, v_{it}, w_{it} \in [0, 1], \forall i, t;$$

$$z_{it}^s \in \{0, 1\}; \theta_{itk}^s, r_{it}^s, \pi_{it}^s \geq 0, \forall i, t, s, k$$

$$\lambda_{itk}^s \geq 0, \forall i, t, s, k \quad (2.28)$$

In particular, the nonlinear terms $\lambda_{itk}^s z_{it}^s$ in (2.10) are replaced by nonnegative variables θ_{itk}^s with extra constraints (2.20-2.22). If $z_{it}^s = 0$, constraint (2.21) and the nonnegativity of θ_{itk}^s will force θ_{itk}^s to be 0, while if $z_{it}^s = 1$, constraints (2.20) and (2.22) will force $\theta_{itk}^s = \lambda_{itk}^s$. Similarly, the terms $r_{it}^s z_{it}^s$ are linearized by introducing variables π_{it}^s with constraints (2.25-2.27).

2.4.2 UC Models without Optimal Cooling Operations

Note that a regular stochastic UC model with the temperature consideration can be obtained simply by setting z_{it}^s to 0 in the optimal stochastic UC-cooling model defined in (2.15-2.28). We call this model SUC-0 for short.

As mentioned, the operations of cooling systems are not incorporated in daily UC scheduling decisions of the local utility company. The system operators manually select and turn on cooling systems if needed according to the previously-stated decision rule: “if a gas generator is running below maximum generating level, then keep the cooling system off; otherwise, the cooling system can be turned on if necessary.” To simulate that rule in generator scheduling, one constraint is added to the SUC-C model:

$$(1 - z_{its})u_i \geq u_i - x_{its}, \forall i, t, s. \quad (2.29)$$

This constraint can guarantee that when $y_{it} = 1$, if the generating level $x_{its} < u_i$, z_{its} will be forced to be 0, i.e., the cooling system will be kept off; otherwise, z_{its} could be either 0 or 1. The decision-rule-induced UC model defined in (2.15-2.28) and (2.29) is called RUC-C for short.

RUC-C is used as a benchmark to justify SUC-C model. In fact, RUC-C provides an analytical solution that should be better than the ad hoc operation fashion in practice. Therefore, the performance improvement of SUC-C, compared with RUC-C, will be more significant with respect to real practice.

2.4.3 Solution and Model Improvement

Benders decomposition has been widely used to solve stochastic UC problems ([37, 48–50]). Thus, we first implemented Benders decomposition with a Pareto-optimal cut ([51]) in which all the binary variables including cooling systems decisions z_{it}^s are incorporated into the first stage to balance the decomposed subsystems. Unfortunately, based on the testing instances described in next section, we found that the performance of Benders decomposition to these problems is significantly slower than CPLEX 12.2, a state-of-the-art commercial solver ([1]). One possible reason is that Benders cuts are not so effective as the cuts added by CPLEX, i.e., the flow cuts, in our specific problem. In Benders decomposition, the relative gap will decrease to 1-2 percent in one or several minutes; however, the cuts provided by CPLEX can reduce the gap less than 1 percent in one minute. For refining the gap from 1 percent to 0.01 percent, LP-based Branch-and-Bound used by the solver is more efficient in our problem than cutting planes, ie., Benders cuts. Therefore, CPLEX was selected as the basic solution approach.

In the computational study, it was observed that the commercial solver will encounter some trouble in dealing with RUC-C. To address this issue, the RUC-C model was modified by replacing (2.29) the following two constraints. Because the y_{it} and z_{its} are binary variables, it is easy to see that the new model after this replacement is equivalent to the previous one.

$$(1 - z_{its})(u_i - l_i) \geq (u_i - x_{its})y_{it}, \forall i, t, s \quad (2.30)$$

$$z_{its} \leq y_{it}, \forall i, t, s. \quad (2.31)$$

Note that the nonlinear term $x_{its}y_{it}$ (or after x_{its} is replaced by $\sum_{k=0}^{K-1} \lambda_{itk}^s p_{ik}^G$) can be linearized easily in a way similar to (2.20-2.22) or (2.25-2.27).

Although neither (2.29) nor (2.30-2.31) can dominate the other one, the latter is stronger when $y_{it} = 1$ or $y_{it} = 0$. For example, when $y_{it} = 1$, the latter dominates the former since $u_i \geq u_i - l_i$. When $u_i - l_i$ is small, the dominance is very significant. Such results indicate that, in the Branch-and-Bound algorithm, the model with (2.30-2.31) should have better

computational performance. This was confirmed by our computational study on a real power system. Using the commercial solver CPLEX, which implements the LP based Branch-and-Bound method, the model with (2.30-2.31) performs drastically faster, approximately by 5 to 10 times, than the one with (2.29).

2.5 Computational Study

In this section, a computational study is presented and investigated the impact of cooling systems on a stochastic day-ahead UC model ($T=24$ hours) by comparing the performance of SUC-0, SUC-C, and RUC-C. The models were implemented in C++ with CPLEX 12.2 on a PC desktop with an Intel Core(TM) 2Duo 3.00GHz CPU and 3.25GB memory. The relative gap is set to be $1e - 4$ for terminating all problems.

The experiments were conducted on a real power system operated by a local utility company in Florida. The system has 16 generators, including 11 gas-fired and 5 coal-fired units, to generate electric power to meet customer demand. The total capacity is approximately 4600MW and the average demand per hour is around a half of the capacity. In particular, the 5 coal-fired generators are must-run units to meet the base load (about 1100MW) in each hour, while the remaining 11 gas generators are committed in daily operations to meet variable demand. The experiment was conducted on the gas generators with respect to variable demand. Because the performance of cooling systems depends heavily on the ambient temperatures and dew points, the gas generators are grouped according to their physical locations. To be specific, 1 gas unit (GU1) is at the first location, and 6 (GS1-GS6) and 4 gas units (GK2-GK5) are located at the second and third places, respectively. All gas generators are equipped with cooling systems.

The physical characteristics of the 11 gas generators are listed in Table 2, including the maximum/minimum output levels, minimum up/down restrictions, and ramp rates. Note that the ramp rates are only applicable to GS1 and GS2. The hourly ambient temperatures and dew points at those locations were obtained from a local weather forecasting web site ([2]). The day-ahead prediction of non-base load was taken for a typical summer day with

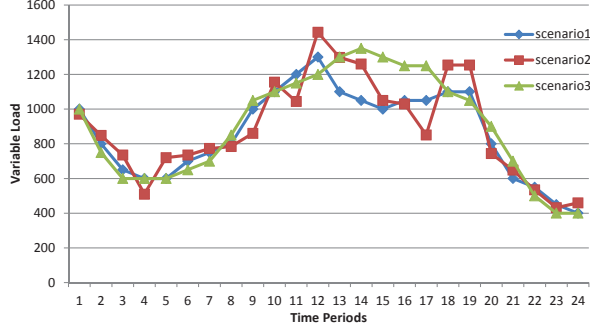

Figure 4: Random Demand Prediction with Three Scenarios

three scenarios, see Figure 4. Three ($K=4$) segments were adopted for the piecewise linear fuel cost functions of all generators. To be specific, every quadratic cost function $\phi(x) = \alpha x^2 + \beta x$ where $l \leq x \leq u$ was averagely divided into three segments with breaking points $\{l, \frac{u+2l}{3}, \frac{2u+l}{3}, u\}$. The related cost for any breaking point x of the piecewise linear cost function was computed as $\phi(x)$. To protect the confidential information, the start-up costs, no-load costs and fuel costs of the generators were randomly selected in our experiment. For example, the parameters α_i and β_i were randomly generated in a range $[0.019, 0.024]$ and $[14, 18]$ respectively. The start-up costs and no-load costs were randomly generated in $[2000, 4000]$ and $[100, 200]$. The maximum spinning reserve contribution from unit i is 20% of the maximum generation level, that is $Q_i = 0.2u_i$ for all i . And the spinning requirement was 90MW for each hour. The fixed costs and O&M costs of cooling systems were estimated to be \$50 and \$3 respectively.

In our numerical study, we focused on three aspects: commitment statuses, savings in expected generation cost and cost robustness; and commitment stability to variable spinning reservation. Commitment statuses indicate the utilization of gas generators, which affects the flexibility of operating decisions and scheduled maintenance of the system. Savings in expected generation cost indicate the economic efficiency of UC decisions; cost robustness shows the sensitivity of the power system to different levels of demand. Commitment stability to variable spinning reservations indicates how consistent the commitment of the system will be to different reserve requirements.

Table 2: Characteristics of Gas Generators

Characteristic	GU1	GS1	GS2	GS3-6	GK2-5
Max Output	57	710	940	57	155
Min Output	32	130	135	32	105
Min UP	6	4	4	6	2
Min Down	2	1	1	2	1
Ramp Rate	57	267	267	57	160

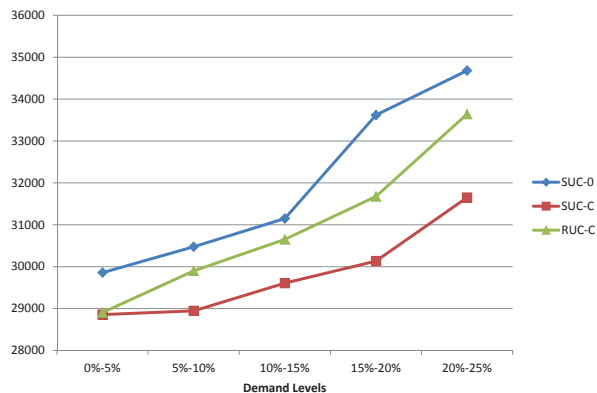

Figure 5: Total Costs Changes for Different Demand Levels

The commitment statuses of the generators are shown in [85]. We note that SUC-C reduces 19 running statuses of all gas generators compared with SUC-0 and reduces 6 running statuses compared with RUC-C. The observation indicates that with cooling systems, the utilization of gas generators will decrease significantly. This reduction also makes system operation and potential maintenance scheduling more flexible. Also, it shows that the decision rule is not an optimal solution for the system.

The expected total generation cost for SUC-0 is \$524,438, compared with \$508,493 for SUC-C and \$513,901 for RUC-C. The 3.05 percent savings indicate that the cooling systems can significantly improve the economic efficiency of the unit commitment decisions, and the optimization model SUC-C is better than the decision rule based RUC-C by 0.89 percent savings. Therefore, the cooling systems, if operated effectively, will lead to a clear cost reduction.

We also investigated how sensitive the expected total costs could be for different levels of extra demands. Specifically, we tested the system performance for 5,10,15,20 and 25 percent

Table 3: Commitment Percentage for Different Spinning Reserve Levels

	5%	15%	25%
SUC-0	81.06%	81.06%	84.09%
SUC-C	73.86%	73.86%	75.00%
RUC-C	75.38%	76.14%	79.55%

extra demand in all scenarios. That is, we recomputed the commitment statuses for the new forecasted demand $d_t^{s'} = (1 + l)d_t^s$ for all s, t where $l = 5\%, 10\%, 15\%, 20\%, 25\%$. We define

$$\Delta_{cost}(l_1 - l_2) = \text{Total cost at level } l_2 - \text{Total cost at level } l_1.$$

Figure 5 depicts the change in total costs between the different levels. We observed that (1) without cooling systems, total costs will increase dramatically as in the case of SUC-0, and (2) costs for RUC-C fluctuate more compared to those for SUC-C, which indicates that the optimization approach is less sensitive to demand changes than the decision rule.

Unlike a fixed spinning reservation, i.e., 90MW, variable reservations (usually a proportion of the demand) also are used by many utility companies or ISOs ([16, 70]) to deal with supply disruptions. We investigated the commitment percentage, the ratio of committed units for all time periods, with respect to different spinning reservation levels, such as 5,15,25 percent. As seen in Table 3, in all levels, the commitment percentage of SUC-0 is consistently the highest and that of SUC-C is the least, which can be explained by the benefits gained from using cooling systems. Also, we note that RUC-C is less stable in commitment percentage than SUC-0 and SUC-C. This likely is due to the fact that the simple operating rule makes the generator very sensitive to demand and reserve requirements. Finally, it is worth pointing out that SUC-C has a slight increase in commitment percentage when the reservation level increases from 5 to 25 percent, which shows a clear benefit of the optimization model of cooling systems in dealing with different reservation levels.

3 Robust Unit Commitment Problem with Demand Response and Wind Energy

3.1 Note to Reader

This chapter has been previously published ©2012 IEEE. Reprinted, with permission, from Long Zhao and Bo Zeng, Robust unit commitment problem with demand response and wind energy, Power and Energy Society General Meeting, Jul. 2012 [83]. The second author, Dr. Bo Zeng, contributed for part of technical sections.

3.2 Background

Unit commitment (UC) problem, i.e., scheduling generators to meet demands, is a well-known challenging discrete optimization problem. Given that generation cost is a major component of the whole system operating cost, it is critical to derive optimal solution to achieve economic savings. However, various factors, including uncertain customer demands, system reliability requirement, technical and application restrictions, have to be included in UC models. Consequently, many deterministic and stochastic UC extensions have been proposed and solved to address different issues ([25, 40, 48, 71, 73, 77]).

Recently, renewable and low-carbon energy sources such as wind, wave-power, and solar are introduced into the power system and are expected to have a significant increase in future years to reduce or avoid the environmental impacts of fossil-fuels. Among those resources, wind energy is of special importance as it is expected to provide 20% of U.S. electricity market by 2030 ([28]) starting from 2.4% in 2009 ([35]). However, wind power is uncontrollable and highly intermittent. Therefore it is risky to introduce large amount of wind energy into current power systems because the intermittency nature of wind can raise costs for regulation and hamper the reliability of the power system. To address this issue, various stochastic programming models have been developed by assuming wind output

scenarios and related probabilities ([25, 64, 72, 74]). However, this kind of assumption may not be realistic as in most cases the exact wind distribution is rarely available day-ahead. It remains as a challenging problem that how to integrate this intermittent energy into current power system with a soft prediction that no exact probability information can be provided.

On the other hand, demand response, which enables customers to respond to variable prices at different time periods, is emerging in the demand side management of power market. Because many utilities have daily demand patterns which vary between peak and off-peak hours, e.g. people use more electricity in the afternoon than in the evening. The demand response provides a feasible approach to reduce peak time load by allowing customers to decide when and how to curtail or shift their electric consumption based on retail rate plans, which may charge higher prices during high-demand hours and lower prices at other times. That is, to some reasonable extent, the power system operators can control the demand increase/decrease at different times by adjusting the electricity price to customers. Since late 1990s, more and more technical reports in various states have shown its effectiveness based on results of experiments or simulations, including [33], [54] and [45]. A few research projects were performed to investigate the impact of DR on unit commitment problem, including [66], [67] and [56].

Ideally, if wind generation is certain or probabilistic information is available, unit commitment with DR can be formulated using stochastic programming techniques. As discussed, however, it is highly uncertain and distribution information is not reliable. To address this issue, we propose to use a recent optimization approach, (two-stage) robust optimization, to model and compute generators' schedules, generation level, as well as optimal electricity rate. Specifically, we first consider day-ahead unit commitment problem based on intermittent wind energy which is captured by a polyhedral uncertainty set. Different from probabilistic scenarios, the uncertainty set modeling method captures the randomness nature without any explicit description of distribution function. Given this advantage, robust optimization has been adopted to model and compute decisions for a few real systems where

the uncertainty is clear but difficult to capture or infeasibility is extremely costly, see [10–15] for detailed technical discussion and applications. Then, our model is extended to include demand response, where a set of price levels and related demand increase/decrease percentages are predefined for each hour to seek optimal price-assigning strategy. Overall, we look for a solution that fully utilizes wind energy with the maximized return or minimized cost.

Related to our independent research using robust optimization, papers [43] and [16] also develop robust models for unit commitment. In [43], a robust model with transmission constraint is developed with consideration of demand uncertainty, which is described by an polytopic uncertainty set, and is exactly solved with a Benders decomposition method. In [16], another robust model with both demand uncertainty and reserve requirements is solved by a heuristic procedure within a Benders decomposition framework. Compared to related research work, our have the following contributions. First, to the best of our knowledge, it is the first time that the two-stage robust optimization model is developed to the next generation unit commitment problem with uncertain wind energy supply and demand response; Second, a novel solution algorithm has been developed to exactly solve two-stage robust UC models; Finally, a set of numerical experiments shows that the proposed algorithm performs an order of magnitude better than Benders method and our model also leads to clear economic benefits.

The chapter is organized as follows. We first present the two-stage robust UC model with wind uncertainty in Section 3.3. In Section 3.4, this model is studied and a novel cutting plane algorithm is developed and analyzed. In Section 3.5, the model of UC with wind is extended to incorporate DR strategy. The computational results are presented in Section 3.6. Nomenclature used in this chapter is listed in Table 4.

3.3 Wind-UC Model

Day-ahead UC problems typically involve different sets of decisions that need to be determined in two stages. In the first stage, the generators' on/off status need to be determined for the next day such that the resulting plan for those generators meets their physical restric-

Table 4: Nomenclature Used in Chapter 3

i	Generator, $i = 0, 1, \dots, N - 1$
t	Planning period, $t = 0, 1, \dots, T - 1$
l	Price and demand change level, $l = 0, 1, \dots, L - 1$
\mathbb{V}	The polyhedron uncertainty set
a_i	Start up cost of unit i
r_i	Running cost of unit i
c_i	Fuel cost of unit i
e_t	Purchase price at time t in power market
q_t	Sale price at time t in power market
v_t	Wind output at time t
\underline{v}_t	Minimum wind output prediction at time t
\bar{v}_t	Maximum wind output prediction at time t
θ_t	Weight of wind prediction at time t in budget constraints
l_i	Lower bound output of unit i
u_i	Upper bound output of unit i
Δ_+^i	Ramping up limit of unit i
Δ_-^i	Ramping down limit of unit i
d_t	Demand at time t
m_+^i	Minimum up time limit of unit i
m_-^i	Minimum down time limit of unit i
p_l	Price level l
$d_l\%$	Demand level l
β	Custom bill amount before implementing demand response
y_{it}	Binary on/off status of unit i at time t
z_{it}	Binary start up of unit i at time t
x_{it}	Continuous generation of unit i at time t
b_t	Continuous purchased power at time t
s_t	Continuous sold power at time t
w_{tl}	Binary price level selection at time t

tions. Then, for each particular hour of the next day, the generation level of each spinning generator will be determined, which actually is performed in a real time or nearly real-time environment. Given the penetration of wind energy, such a working fashion gives us a chance to integrate wind energy supply in the second stage so that partial demand can be met by wind energy, and the expensive fossil fuel power generation can be reduced. However, two prominent issues need to be considered: wind energy generation is random, and power supply must be very reliable while purchasing power from spot market to cover the unsatisfied demand (i.e. energy deficit) is typically very expensive. Such a situation motivates us to build a two-stage robust optimization model for unit commitment with uncertain wind energy supply whose optimal solution can hedge again all possible scenarios and work well in the worst case.

We consider the day-ahead unit commitment problem with I thermal units for T time periods. In the remainder of this paper, we follow the convention that one period stands for 60 mins and therefore T equals to 24. Note that our models and solution method are applicable to any time scale as well. To minimize the operating cost and to meet physical requirements, the generator on/off status as well as start up operation needs to be determined day-ahead while the actual generation outputs and market sell/buy decisions will be made in a real-time fashion.

Assuming that precise wind energy generation in the next T periods is known, we present Wind-UC Model in (3.1-3.9) by integrating wind energy into classical day-ahead UC-model([24],[36],[68]), which also serves as the nominal model to its robust counterpart.

$$\min \sum_{t=0}^{T-1} \sum_{i=0}^{N-1} (c_i x_{it} + r_i y_{it} + a_i z_{it}) + \sum_{t=0}^{T-1} (e_t b_t - q_t s_t); \quad (3.1)$$

$$st. \quad -y_{i(t-1)} + y_{it} - y_{ih} \leq 0, \quad (3.2)$$

$$\forall i, t \geq 1, t \leq h \leq \min(m_+^i + t - 1, T - 1);$$

$$y_{i(t-1)} - y_{it} + y_{ih} \leq 1, \quad (3.3)$$

$$\forall i, t \geq 1, t \leq h \leq \min(m_-^i + t - 1, T - 1);$$

$$-y_{i(t-1)} + y_{it} - z_{it} \leq 0, \forall i, t \geq 1; \quad (3.4)$$

$$l_i y_{it} \leq x_{it} \leq u_i y_{it}, \forall i, t; \quad (3.5)$$

$$\sum_{i=0}^{N-1} x_{it} + v_t + b_t - s_t = d_t, \forall t; \quad (3.6)$$

$$x_{i,t+1} \leq x_{it} + y_{it} \Delta_+^i + (1 - y_{it}) u_i, \quad (3.7)$$

$$\forall i, t = 0, 1, \dots, T - 2$$

$$x_{it} \leq x_{i,t+1} + y_{i,t+1} \Delta_-^i + (1 - y_{i,t+1}) u_i, \quad (3.8)$$

$$\forall i, t = 0, 1, \dots, T - 2$$

$$y_{it}, z_{it} = \{0, 1\}, x_{it}, b_t, s_t \geq 0, \forall i, t. \quad (3.9)$$

The objective function of Wind-UC model is to minimize total operating cost consisting of start up cost, running cost, fuel cost, and market cost (the cost is positive if buying power from spot market and negative if selling power to spot market). Constraints (2) and (3) are minimum up/down constraints ([68]). If the unit $i \in I$ is turned on(off) in one period, it has to stay in the on(off) status for a minimum number of periods, denoted by $m_+^i (m_-^i)$. Constraint (4) stands for start up operation ([24]), that is, unit i is started up at the beginning of period t if its status is off at time $t - 1$ and is on at time t . Constraint (5) illustrates the generation capacity of each unit ([36]), where l_i and u_i stand for the minimum and maximum output of unit i respectively. Constraint (6) ensures that the customer demand d_t should be satisfied. Constraints (7) and (8) are ramping up/down limits in unit commitment system ([36]). These constraints require that the maximum increase in generation level of unit i from one period to the next cannot be more than Δ_+^i . Similarly, Δ_-^i is introduced to restrict the maximum decrease of unit i from period to period.

As discussed earlier, wind energy generation for next T periods in general cannot be precisely estimated. To describe its randomness in our derivation of reliable schedules for

generators, we introduce a polyhedral uncertainty set for wind energy generation. Specifically, the wind output v_t at each time t is restricted by a least value \underline{v}_t and a largest value \bar{v}_t . Aggregated effect over multiple periods are modeled by a *budget* constraint such that the overall wind generation over these periods are greater than a specific value. To capture the intermittent nature of wind energy generation, we also introduce multiple budget constraints over partitions of the next T hours.

Next, we present the robust counterpart of Wind-UC model, namely Robust Wind-UC model. The most significant difference is that the first-stage decisions $\{\mathbf{y}, \mathbf{z}\}$ should be made day-ahead to hedge against all possible wind energy supply scenarios that are unknown at this time, while the second-stage decisions $\{\mathbf{x}, \mathbf{b}, \mathbf{s}\}$ should be made after wind energy supply is revealed in every period. The optimal solution to the robust counterpart, due to the min – max – min form of the objective function, is feasible for all possible scenarios and performs well for the worst case.

$$\begin{aligned} \min_{\mathbf{y}, \mathbf{z} \in \mathbb{Y}} \sum_{t=0}^{T-1} \sum_{i=0}^{N-1} (a_i z_{it} + r_i y_{it}) + \max_{\mathbf{v} \in \mathbb{V}} \min_{\mathbf{x}, \mathbf{b}, \mathbf{s} \in \mathbb{X}} \sum_{t=0}^{T-1} \sum_{i=0}^{N-1} c_i x_{it} \\ + \sum_{t=0}^{T-1} (e_t b_t - q_t s_t); \end{aligned} \quad (3.10)$$

where $\mathbb{Y} = \{\mathbf{y}, \mathbf{z} : (2) - (4); y_{it}, z_{it} = \{0, 1\}, \forall i, t; \}$

$\mathbb{X} = \{\mathbf{x} : (5) - (8), x_{it} \geq 0, \forall i, t\}$.

And the uncertainty set is constructed as follows:

$$\begin{aligned} \mathbb{V} = \{ \mathbf{v} : \underline{v}_t \leq v_t \leq \bar{v}_t, \sum_{t \in T_1} \theta_t v_t \geq V'_1, \sum_{t \in T_2} \theta_t v_t \geq V'_2, \dots, \\ \sum_{t \in T_N} \theta_t v_t \geq V'_N, \{T_n\} \text{ is a partion of } \{0, 1, \dots, T-1\} \}, \end{aligned}$$

where θ_t is the weight of wind output prediction at t in budget constraints, although they often are assumed to be one in real life applications. For example, $\{2 \leq v_1 \leq 4, 1 \leq v_2 \leq$

$3, v_1 + v_2 \geq 5\}$ specifies a predicted wind output in individual and consecutive time periods. Also, since the uncertainty set can be constructed in an appropriately conservative way, e.g., shifting the prediction interval into a lower level and/or increasing the conservative level (i.e., reduce V 's) of the budget constraints, the desired reliability can be achieved without incorporating reserve constraints.

Given that robust Wind-UC reduces to the classical UC problem if no wind power generation is present and the classical UC is NP-hard ([69]), robust Wind-UC problem is NP-hard. So, it poses a great computational challenge.

3.4 Solution Methods

Computing the exact solution to the aforementioned two-stage robust Wind-UC model is very difficult. Two-level algorithm is an effective method due to the two-stage natural of the problem. Hence, we develop and implement two algorithms within a two-level framework.

The first one is a Bender decomposition type algorithm (BD), which is also used in [16, 43, 83]. The inner-level max – min problem is converted into a monolithic bilinear programming problem by dualizing the innermost minimization problem. Solving this bilinear program will enable us to generate a Benders type cutting plane from the revealed uncertainty set and dual information of the innermost second-stage linear programming problem. Then, the outer-level algorithm will then be used to refine a first-stage decision after adding Benders cuts from inner-level.

Specifically, after dualizing the innermost linear program of max – min problem, we have the following bilinear program, which serves as our inner-level problem. Note that (\mathbf{y}, \mathbf{z}) are fixed and $\lambda, \pi, \rho, \delta, \mu, \gamma, \varphi$ are the dual variables of constraints for the innermost linear program.

$$\begin{aligned} \max \quad & \sum_{i=0}^{I-1} \sum_{t=0}^{T-1} (l_i y_{it} \lambda_{it} - u_i y_{it} \pi_{it}) + \sum_{t=0}^{T-1} (d_t - v_t) \varphi_t \\ & - \sum_{i=0}^{I-1} \sum_{t=0}^{T-2} \rho_{it} (y_{it} \Delta_+^i + (1 - y_{it}) u_i) \end{aligned}$$

$$- \sum_{i=0}^{I-1} \sum_{t=0}^{T-2} \delta_{it} (y_{i,t+1} \Delta_-^i + (1 - y_{i,t+1}) u_i) \quad (3.11)$$

$$st.c_i \geq \lambda_{i0} - \pi_{i0} + \varphi_0 + \rho_{i0} - \delta_{i0}, \forall i \in I, t = 0 \quad (3.12)$$

$$c_i \geq \lambda_{it} - \pi_{it} + \varphi_t - \rho_{i,t-1} + \delta_{i,t-1} + \rho_{it} - \delta_{it}, \\ \forall i \in I, t \in \{1, \dots, T-2\} \quad (3.13)$$

$$c_i \geq \lambda_{i,T-1} - \pi_{i,T-1} + \varphi_{T-1} - \rho_{i,T-2} + \delta_{i,T-2}, \\ \forall i \in I, t = T-1 \quad (3.14)$$

$$\mu_t + \varphi_t \leq e_t, \forall t \in T \quad (3.15)$$

$$\gamma_t - \varphi_t \leq -q_t, \forall t \in T \quad (3.16)$$

$$\lambda_{it}, \pi_{it}, \rho_{it}, \delta_{it}, \mu_t, \gamma_t \geq 0, \varphi_t \text{ free}; \mathbf{v} \in \mathbb{V}. \quad (3.17)$$

Note that the uncertainty polyhedron is not complicated. In fact, we have the following observation.

Remark 1. *For any given first-stage decision (\mathbf{y}, \mathbf{z}) , the worst-case wind is a vertex of \mathbb{V} , and in any worst case the wind output takes value at either minimum or maximum except (at most) one in each partition piece taking values between the bounds.*

With this observation, we can convert the bilinear inner-level problem into a mixed integer program (MIP) and solve it by any off-the-shelf MIP solver. We mention that if the uncertainty set is a general polyhedron, max – min problem can be converted into an MIP based on the strong KKT-conditions of the innermost linear program. This topic is beyond the scope of this paper.

After linearization and computing an optimal solution, $(\mathbf{v}^k, \lambda^k, \pi^k, \rho^k, \delta^k, \mu^k, \gamma^k, \varphi^k)$, to the inner-level problem, we can add the following k -th Benders cuts,

$$\vartheta \geq \sum_{i=0}^{I-1} \sum_{t=0}^{T-1} (l_i y_{it} \lambda_{it}^k - u_i y_{it} \pi_{it}^k) + \sum_{t=0}^{T-1} (d_t - v_t^k) \varphi_t^k$$

$$\begin{aligned}
& - \sum_{i=0}^{I-1} \sum_{t=0}^{T-2} \rho_{it}^k (y_{it} \Delta_+^i + (1 - y_{it}) u_i) \\
& - \sum_{i=0}^{I-1} \sum_{t=0}^{T-2} \delta_{it}^k (y_{i,t+1} \Delta_-^i + (1 - y_{i,t+1}) u_i)
\end{aligned} \tag{3.18}$$

into our outer-level problem.

$$\min \sum_{t=0}^{T-1} \sum_{i=0}^{N-1} (a_i z_{it} + r_i y_{it}) + \vartheta \tag{3.19}$$

$$st. \mathbf{y}, \mathbf{z} \in \mathbb{Y} \tag{3.20}$$

$$1, 2, \dots, k-1 \text{ cuts} \tag{3.21}$$

Although it can be shown that Bender decomposition converges an optimal solution finitely, we note that this method is not computationally effective. We then use a different scheme to generate cuts. Our idea is to create a set of new extra variables $\{\mathbf{x}^k, \mathbf{b}^k, \mathbf{s}^k\}$ and the corresponding constraints, i.e.,

$$\vartheta \geq \sum_{t=0}^{T-1} \sum_{i=0}^{N-1} c_i x_{it}^k + \sum_{t=0}^{T-1} (e_t b_t^k - q_t s_t^k); \tag{3.22}$$

$$l_i y_{it} \leq x_{it}^k \leq u_i y_{it}, \forall i, t; \tag{3.23}$$

$$\sum_{i=0}^{N-1} x_{it}^k + v_t^k + b_t^k - s_t^k = d_t, \forall t, k; \tag{3.24}$$

$$x_{i,t+1}^k \leq x_{it}^k + y_{it} \Delta_+^i + (1 - y_{it}) u_i, \forall i, \forall t = 0, 1, \dots, T-2 \tag{3.25}$$

$$\begin{aligned}
x_{it}^k & \leq x_{i,t+1}^k + y_{i,t+1} \Delta_-^i + (1 - y_{i,t+1}) u_i, \\
& \forall i, \forall t = 0, 1, \dots, T-2
\end{aligned} \tag{3.26}$$

$$x_{it}^k, b_t^k, s_t^k \geq 0, \tag{3.27}$$

and add them to the outer-level problem to refine the first stage decisions. Since the newly-created variables are primal to decision makers and the cuts are generated in primal space

of the second stage problem, we denote this procedure *column-and-constraint generation* (C&CG) algorithm. Although a large number of extra variables and constraints will be generated, we emphasize that the C&CG procedure reveals the nature of two-stage robust optimization problem compared with Benders decomposition by the following observation.

Remark 2. *Given a certain number of revealed uncertainty points, the value function of the two-stage robust Wind-UC model is exactly constructed by the outer-level problem of C&CG, while that of BD is only an underestimation.*

The algorithmic description is as follows.

- (1) Set $UB = \infty$, $LB = -\infty$, tolerance $\varepsilon \geq 0$, $k = 1$. Find any $\{\mathbf{y}^k, \mathbf{z}^k\} \in \mathbb{Y}$.
- (2) Solve the inner-level problem (3.11-3.17) given $\mathbf{y}^k, \mathbf{z}^k$, obtain worst case wind output \mathbf{v}^k , update $UB = \min\{UB, obj^* + \sum_{t=0}^{T-1} \sum_{i=0}^{N-1} (r_i y_{it}^k + a_i z_{it}^k)\}$ where obj^* is the optimal objective value of the subproblem in this iteration. Add new variables and constraints (3.22)-(3.27) to outer-level problem (3.19)-(3.21).
- (3) Solve the updated outer-level problem, let $\mathbf{y}^{k+1} = \mathbf{y}^*$, $\mathbf{z}^{k+1} = \mathbf{z}^*$, where \mathbf{y}^* and \mathbf{z}^* are optimal solutions. Update LB to be the optimal objective value of outer-level problem in this iteration.
- (4) If $UB - LB \leq \varepsilon$, then stop. Otherwise $k = k + 1$, go to step 2.

Finally, we conclude that the proposed C&CG algorithm can find the optimal solution in finite steps, that is, the algorithm is finitely convergent. Since any repeated first stage decision *or* the extreme point in the uncertainty set will lead to $LB = UB$ in the above procedure, the finite set \mathbb{Y} and the finite number of extreme points in \mathbb{V} implies that the algorithm will terminate at the optimal solution in finite steps. In fact, let $\alpha = |\mathbb{Y}|$ and $\gamma = |\tilde{\mathbb{V}}|$ where $\tilde{\mathbb{V}}$ is the set of all extreme points in \mathbb{V} , the number of iterations will be bounded by $\min\{\alpha, \gamma\}$.

3.5 Wind-UC-DR Model

If demand response is considered, the price level which should be selected as the rate at each time is the decision to be made, where L levels price p_l and demand increase/decrease percentage $d_l\%$ are pre-defined for each time period. Therefore we have the following Wind-UC-DR model with additional decision variables $w_{tl} \in \{0, 1\}$. Since the power rate in each time period can be different, the objective function is to maximize the profit or minimize the negative profit. The right-hand side of constraint (3.29) is the predicted demand after demand response; Constraint (3.30) guarantees that after applying demand response the bill of ratepayers will not increase; Constraint (3.31) states that only one price level can be selected in each time. In real applications the price and demand increase/decrease level can be obtained from historical data or experiments like in previous technical reports ([33]).

$$\min \sum_{t=0}^{T-1} \sum_{i=0}^{N-1} (a_i z_{it} + r_i y_{it} + c_i x_{it}) + \sum_{t=0}^{T-1} (e_t b_t - q_t s_t) - \sum_t d_t \sum_{l=0}^{L-1} w_{tl} p_l (1 + d_l\%) \quad (3.28)$$

$$st. (2) - (5), (7) - (8);$$

$$\sum_{i=0}^{N-1} x_{it} + v_t + b_t - s_t = d_t \sum_{l=0}^{L-1} w_{tl} (1 + d_l\%), \forall t; \quad (3.29)$$

$$\sum_t d_t \sum_{l=0}^{L-1} w_{tl} p_l (1 + d_l\%) \leq \beta; \quad (3.30)$$

$$\sum_{l=0}^{L-1} w_{tl} = 1, \forall t; \quad (3.31)$$

$$x_{it}, b_t, s_t \geq 0; y_{it}, z_{it}, w_{tl} = \{0, 1\}, \forall i, t, l; v_t \in V.$$

The following formulation is the corresponding robust counterpart of Wind-UC-DR model.

$$\min_{\mathbf{y}, \mathbf{z}, \mathbf{w} \in \mathbb{Y}'} \sum_{t=0}^{T-1} \sum_{i=0}^{N-1} (a_i z_{it} + r_i y_{it}) + \max_{\mathbf{v} \in \mathbb{V}} \min_{\mathbf{x}, \mathbf{b}, \mathbf{s} \in \mathbb{X}'} \sum_{t=0}^{T-1} \sum_{i=0}^{N-1} c_i x_{it}$$

$$+ \sum_{t=0}^{T-1} (e_t b_t - q_t s_t) - \sum_t d_t \sum_{l=0}^{L-1} w_{tl} p_l (1 + d_l \%); \quad (3.32)$$

where $\mathbb{Y}' = \mathbb{Y} \cap \{(3.30 - 3.31)\}$;

$$\mathbb{X}' = \{\mathbf{x}, \mathbf{b}, \mathbf{s} : (5), (7) - (8), (3.29), \mathbf{x}, \mathbf{b}, \mathbf{s} \geq 0\}$$

Similarly, the first stage decision variables $\{\mathbf{y}, \mathbf{z}, \mathbf{w}\}$ should be made day-ahead while the second stage decision variables $\{\mathbf{x}, \mathbf{b}, \mathbf{s}\}$ should be made after wind uncertainty is revealed. Note that it can also be solved by the column-and-constraint generation algorithm presented in previous section.

3.6 Computational Results

In this section, the computational performance of C&CG and BD is compared, and the economic benefit from wind integration and demand response is presented. The experiment is conducted on a power system of IEEE 118-bus system with 36 thermal units, and the parameters are mostly adopted from [49] with some changes for convenience: first, the fuel cost is linear instead of quadratic form ([16, 43]), and second, the ramping up/down parameters are adjusted according to the rule in [36]. The fixed price without demand response is set to be 15, and price levels and related demand increase/decrease are pre-defined at each time and the values are sampled from experiment results in ([33]). The minimum wind output is randomly generated in $[0, 100]$ and maximum in $[100, 200]$ at each hour. All the parameters used in this section are listed in [83]. The algorithm is implemented in CPLEX12.1 on Dell OPTIPLEX 760 with 3.00GHz CPU and 3GB of RAM. Profit is calculated to be 558616, obtained from a return based on the fixed price minus the generation cost, without wind energy and demand response.

3.6.1 BD vs. C&CG

The performances of BD with pareto-optimal cuts([51]) and C&CG are compared in Wind-UC model. The gap is set to be within 0.5%, one budget constraint for twenty-four

Table 5: The Performance Comparison of Two Methods

		BA			C&CG	
cases	profit	time(s)	iterations	profit	time(s)	iterations
case1	596669	2239	80	594674	50	3
case2	589931	4619	70	589478	243	3
case3	581290*	>20000*	120*	583293	803	3
case4	578362	12670	59	575876	324	2
case5	572166*	>20000*	70*	571181	27	2

hours is used. To simplify our comparison, we let $\theta = \bar{1}$ in budget constraint $\sum_{t \in T} \theta_t v_t \geq V'$. We use ξ in budget constraints to control the conservative level, i.e., $V' = \xi \sum_t \underline{v}_t + (1 - \xi) \sum_t \bar{v}_t$. We take $\xi = 0.1, 0.3, 0.5, 0.7, 0.9$ in case 1-5 respectively. From the computation results shown in Table 5, we can see that C&CG is computationally superior to BD in the sense of less computational time and fewer iteration number.

3.6.2 One Uncertainty Budget Constraint

Using the same parameters and with a single budget constraint in wind uncertainty, the economical benefit of wind-UC and wind-UC-DR is further investigated as well as the performance of the C&CG algorithm. As shown in Table 6, the profit will be significantly improved by integrating wind into unit commitment model even if we prepare for the worst case. Table 7 shows that the system will benefit more if demand response is also considered.

3.6.3 Multiple Uncertainty Budget Constraints

We use four budget constraints that evenly partition twenty-four hours, i.e., $\mathbf{v} \in \mathbb{V} = \{\mathbf{v} : \underline{v}_t \leq v_t \leq \bar{v}_t, \sum_{t \in T_1} \theta_t v_t \geq V'_1, \sum_{t \in T_2} \theta_t v_t \geq V'_2, \sum_{t \in T_3} \theta_t v_t \geq V'_3, \sum_{t \in T_4} \theta_t v_t \geq V'_4\}$, and $(\xi_1, \xi_2, \xi_3, \xi_4)$ is used to capture the uncertainty budget in each period. Let $(\xi_1, \xi_2, \xi_3, \xi_4)$ be $(0.9, 0.8, 0.7, 0.6)$, $(0.8, 0.3, 0.7, 0.6)$, $(0.5, 0.9, 0.1, 0.7)$, $(0.4, 0.8, 0.2, 0.6)$, and $(0.7, 0.8, 0.3, 0.5)$ in five cases. Table 8 and Table 9 indicate similar insights that the system will benefit from wind and demand response.

The “NA”s in Table 7 and 9 correspond to the cases with the global gap $1e - 4$, in which the CPLEX solver was out-of-memory when the branch-and-bound trees became too large for

Table 6: The Wind-UC Results with One Budget Constraint

cases	gap	profit	time(s)	iterations	profit increase
case1	0.5%	594674	50	3	6.45%
	0.1%	596215	383	5	6.73%
	optimal	596669	2160	8	6.81%
case2	0.5%	589478	243	3	5.52%
	0.1%	589478	245	3	5.52%
	optimal	589931	1293	5	5.61%
case3	0.5%	583293	803	3	4.42%
	0.1%	583293	803	3	4.42%
	optimal	583811	1427	4	4.51%
case4	0.5%	575876	324	2	3.09%
	0.1%	578513	759	3	3.56%
	optimal	578513	759	3	3.56%
case5	0.5%	571181	27	2	2.25%
	0.1%	573279	55	3	2.62%
	optimal	573279	55	3	2.62%

Table 7: The Wind-UC-DR Results with One Budget Constraint

cases	gap	profit	time(s)	iterations	profit increase
case1	0.5%	610479	212	4	9.28%
	0.1%	611379	2106	9	9.45%
	optimal	NA	NA	NA	NA
case2	0.5%	604162	404	3	8.15%
	0.1%	604993	1391	6	8.30%
	optimal	NA	NA	NA	NA
case3	0.5%	598270	1383	3	7.10%
	0.1%	598870	8646	8	7.21%
	optimal	NA	NA	NA	NA
case4	0.5%	593255	1104	3	6.20%
	0.1%	593311	1844	4	6.21%
	optimal	NA	NA	NA	NA
case5	0.5%	587606	85	2	5.19%
	0.1%	588110	165	3	5.28%
	optimal	588165	1838	3	5.29%

Table 8: The Wind-UC Results with Multiple Budget Wind Constraints

cases	gap	profit	time(s)	iterations	profit increase
case1	0.5%	575010	206	2	2.93%
	0.1%	577648	420	3	3.41%
	optimal	577648	420	3	3.41%
case2	0.5%	582337	1141	3	4.25%
	0.1%	582337	1141	3	4.25%
	optimal	582505	2430	5	4.28%
case3	0.5%	581942	117	2	4.18%
	0.1%	584579	257	3	4.65%
	optimal	584579	257	3	4.65%
case4	0.5%	582720	491	2	4.31%
	0.1%	585357	873	3	4.79%
	optimal	585357	873	3	4.79%
case5	0.5%	580419	622	2	3.90%
	0.1%	583057	1237	3	4.38%
	optimal	583057	1237	3	4.38%

Table 9: The Wind-UC-DR Results with Multiple Budget Wind Constraints

cases	gap	profit	time(s)	iterations	profit increase
case1	0.5%	590076	237	2	5.63%
	0.1%	592339	595	3	6.04%
	optimal	NA	NA	NA	NA
case2	0.5%	597313	839	3	6.93%
	0.1%	597313	1323	4	6.93%
	optimal	NA	NA	NA	NA
case3	0.5%	600869	127	2	7.56%
	0.1%	601391	339	4	7.66%
	optimal	601441	8318	8	7.67%
case4	0.5%	599721	265	2	7.36%
	0.1%	599896	480	3	7.39%
	optimal	NA	NA	NA	NA
case5	0.5%	597016	970	2	6.87%
	0.1%	597398	1698	3	6.94%
	optimal	NA	NA	NA	NA

the master problems with a number of binary demand response decisions. This is one of the drawbacks of the proposed algorithm that the size of the master problems will grow very fast, although it dominates Benders decomposition both theoretically, as stated in Observation 2, and computationally, see Table 5. Noting that the feasible space of the masters problems in the proposed algorithm are identical to general two-stage stochastic programming (TSSP) problems, one can adopt effective methods to TSSP to solve the master problems.

4 Vulnerability Analysis of Power Grids with Line Switching

4.1 Note to Reader

This chapter has been previously published ©2013 IEEE. Reprinted, with permission, from Long Zhao and Bo Zeng, Vulnerability Analysis of Power Grids With Line Switching, IEEE Transactions on Power Systems, Aug. 2013 [84]. The second author, Dr. Bo Zeng, contributed for part of technical sections in this chapter.

4.2 Background

Vulnerability analysis of power grid, especially in its static status, often is modeled as a bi-level interdiction model (aka. an attack-defend model) or sometime as a tri-level defend-attack-defend model, if some defending decisions can be made before attacks [20, 21, 61, 63]. In those multi-level models, different decision makers will make decisions, according to their own objective functions, in a sequential way where each individual decision maker must wait and consider the constraints imposed by the decisions made by previous ones [5, 75]. For example, in the attack-defend model, the attacker seeks to minimize the satisfied load demand by removing up to K transmission lines; after the attack, the system operators try to mitigate the loss in the environment of K lines down by adjusting nodal generation, load shedding, and other dispatching parameters. Identifying such a group of lines whose removal will lead to the severe loss of demand is critical for system daily operations and long-term security. Interested readers are referred to [7, 18, 21, 61] and references therein for its applications in power systems. For example, limited protective or hardening resources can be allocated to those lines to enhance the reliability of the system or reduce the probability of successfulness of the attacks. Also, those critical lines are of interest in the transmission network capacity expansion problem to better balance risk and economic advantages. In

fact, when $K = 1$ and 2 , the problem is closely related to $N - 1$ and $N - 2$ security criteria adopted in the power industry.

Because of its significance to the power industry, emergency planning centers, and homeland security, as well as its complexity from the underlining network/flow characteristics, an extensive amount of research effort has been dedicated to the power grid interdicting problem since 2000. As a result, many algorithms have been developed to address variants with different considerations and scales. Salmeron et al. [61] formulate the problem of optimal interdiction of an electric power network as a max-min problem and develop a heuristic algorithm to solve the problem. Later, they extend the model to multiple periods with the considerations of repair times of the power grid after attack and the demand variation over time [63]. They propose and implement a *global Benders decomposition* method that can solve large-scale problems with high-quality solutions in a reasonable time. In parallel, Motto et al. [53] convert the max-min power interdicting problem into an equivalent single-level mixed integer programming (MIP) model through dualizing the lower-level linear programming (LP) problem and linearizing resulting binary-binary or binary-continuous terms. They also employ Karush-Kuhn-Tucker (KKT) optimality conditions of the lower-level LP problem to achieve a similar transformation [7, 9]. Using the duality of LP and linearization techniques, Janjarassuk and Linderoth [42] also convert a stochastic network interdiction problem into an equivalent MIP. Due to the stochastic structure, they are able to apply an L-shaped decomposition technique with a sampling-based approach to solve their problem. To reduce the computational complexity, Bier et al. [18] develop a greedy-based algorithm to derive interdiction strategies, and report a set of vulnerable transmission lines that are different from those in [61]. Different from the above classical mathematical programming based approach, graph theory-based methods, in conjunction with KKT conditions, are developed in [30, 31, 57] to solve power grid interdicting problem. As a result, instances of large-scale power grids can be solved approximately within a short time [58].

It is noted the lower-level problems (or defending problems) are assumed to be LP or NLP problems in all the aforementioned studies. This assumption is essential for them in that duality theory and KKT conditions play the central role in formulation transformations or algorithm development. Recently, transmission line switching has been analytically studied in order to reduce dispatch cost in power system scheduling. It is observed that up to 25 percent dispatch savings can be achieved [34, 39, 40, 47]. Given the fact that the topology of the power grid will be changed if one or more transmission lines are attacked or disconnected, transmission line switchings can also be incorporated into system operator’s post-disruption decision for a better mitigation effect. For example, in Pennsylvania-New Jersey-Maryland Interconnection (PJM), Special Protection Schemes have included transmission line switching as one operation during contingencies [41]. Nevertheless, line-switching decisions are made with pre-defined rules, which are not analytical and could be less effective. Recently, this idea, i.e., including line switching into the lower level decision problem, is quantitatively studied by Arroyo and Fernandez [8] and Delgadillo et al. [27]. Because it is necessary to represent line-switching decisions by binary variables, the lower-level problem becomes non-convex, and strong duality theory or KKT conditions is not valid anymore. As a result, the previously-developed techniques to convert bi-level to single-level are not applicable. Given the difficulties to solve this problem exactly, two heuristic procedures, a genetical algorithm and a *multi-start Benders decomposition* method, are developed to identify high-quality solutions [8, 27]. Nevertheless, the power grid interdiction problem with line switching, especially the pursuit of its global optimal solution, remains an open problem for researchers in the power systems as well as operations research communities.

On the other hand, some recent research on robust optimization could be used to solve this open problem. To provide a solution method to this challenging problem that is of critical interest to the power industry, governmental organizations, and security agencies, we developed an exact algorithm based on strategies used to solve 2-stage robust optimization problems [80, 82]. Specifically, we separate binary line switching variables from other

continuous dispatching decisions in the lower level so that an equivalent single-level reformulation can be obtained. Then, a column-and-constraint generation (C&CG) method within a master-subproblem framework is used to dynamically identify significant attacks and corresponding line switching decisions. Because the whole procedure provides an upper bound and a lower bound, the quality of the best feasible solution found so far can be estimated, and a user-defined tolerance can be supplied to achieve a computational tradeoff, which provides a flexible mechanism for system operators in practice. Our major contributions are listed as follows.

Mathematically, we provide an equivalent single-level reformulation of the bi-level power grid vulnerability analysis problem. This reformulation is obtained by explicitly enumerating line switching decisions and (dual decisions of) their corresponding dispatching problems. However, such a cumbersome enumeration can be avoided by the proposed algorithm in deriving an optimal solution.

Algorithmically, we develop a finitely-convergent algorithm that dynamically identifies and includes critical line switching decisions and generates (dual decisions of) their corresponding dispatching problems into the single-level reformulation. As it only considers a partial enumeration of most effective line switching decisions, the barrier of enumeration can be successfully removed.

Computationally, we perform a set of preliminary experiments. Results show that the proposed algorithm outperforms existing algorithms and can derive global optimal solutions within a reasonable computation time. As a new solution method, we believe that it can be further extended to solve this challenging problem on larger instances. Please note that the most realistic models that capture the post-attack behaviors often involve the dynamically-induced transients and/or the nonlinearity of alternative current (AC) power flow, which may lead to a cascading or blackout in the grid. Therefore, those models are more complicated and comprehensive than the static one with direct current (DC) flow presented in this paper. See, for example, [3, 6, 17, 22, 23, 26, 52] and references therein.

Table 10: Nomenclature Used in Chapter 4

i	Generator
j	Demand
l	Transmission line
n	Node
m	Alias of n
\mathcal{A}	Set of attack decisions
\mathcal{C}	Set of switching decisions
H	$ \mathcal{C} - 1$ where $h \in \{0, \dots, H\}$
\mathcal{U}	Subset of $\{0, \dots, H\}$
x_l	Reactance at line l
M_l	A big number for line l
F_l	Flow limit at line l
P_i^{max}	Maximal generation of generator i
D_j^n	Demand at node n
K	Cardinality of attack
$\bar{\theta}$	Maximum difference of connected phase angles
d_j^n	Satisfied demand at node n
Δd_j^n	Load shedding at node n
θ_n	Phase angle at node n
f_l^{mn}	Power flow on line l from node m to n
z_l	Line switching, 0 if l is switched off
p_i^n	Generation level of generator at node n
w_l	Attack, 0 if line l is removed by attacker

The chapter is organized as follows. In Section 4.3, we review the bi-level formulation of power grid interdiction problem with transmission line switching. In Section III we give the equivalent single-level formulation and the column-and-constraint generation algorithm with a master-subproblem framework. In Section 4.6 we report the results of the computational study. Nomenclature used in this chapter is listed in Table 10.

4.3 Min-Max Attack-Defend Model

In the following, we present a bi-level formulation of the power grid interdiction problem with transmission line switching. We mention that our model has the same nature as the one proposed by Delgado et al. [27]. In this model, the higher-level decision is made by the attacker, which seeks to minimize the served load (or equivalently, maximize the load shedding) by disconnecting transmission lines. Then, after some lines are disrupted by the

attacker, system operator solves the lower decision problem to compute the optimal operations, including line switching and other dispatching operations, to maximize the load that can be served (or equivalently, minimize the unmet demand). The mathematical formulation is listed as follows. We represent a vector of variables by using the boldface of the corresponding variable.

$$\min_{\mathbf{w} \in \mathcal{A}} \max_{\{\mathbf{p}, \mathbf{d}, \mathbf{f}, \theta, \mathbf{z}\}} \sum_j d_j^n \quad (4.1)$$

$$st. z_l w_l (\theta_m - \theta_n - x_l f_l^{mn}) = 0, \forall l \quad (4.2)$$

$$-F_l z_l w_l \leq f_l^{mn} \leq z_l w_l F_l, \forall l \quad (4.3)$$

$$p_i^n \leq P_i^{max}, \forall i \quad (4.4)$$

$$d_j^n \leq D_j^n, \forall j \quad (4.5)$$

$$\sum_l f_l^n + p_i^n = \sum_l f_l^n + d_j^n, \forall n \quad (4.6)$$

$$p_i^n \geq 0, d_j^n \geq 0, f_l^{mn}, \theta_n \text{ free}, z_l \in \{0, 1\} \quad (4.7)$$

where $\mathcal{A} = \{\mathbf{w} \in \mathbb{B}^L : w_l \in \{0, 1\}, \sum_l (1 - w_l) \leq K\}$.

As reflected in objective function (4.1), the attacker can remove no more than K transmission lines trying to minimize the served demand. After the attack, the system operator tries to maximize the served demand (or equivalently minimize the loss of load) by adjusting network topology through line switching, phase angles and generation levels. Note that $\Delta d_j^n = D_j^n - d_j^n$. So, this objective function is equivalent to that of [27] where a max – min formulation is employed, as

$$\max_{\mathbf{w} \in \mathcal{A}} \min \sum_j \Delta d_j^n = \sum_j D_j^n - \min_{\mathbf{w} \in \mathcal{A}} \max \sum_j d_j^n.$$

Constraints in (4.2) are to ensure DC power flow approximations that follow Kirchhoff's Laws with additional attack and switching decisions [4, 27, 62]. So, whenever the line exists, i.e. $w_l = z_l = 1$, the classical traditional power flow equation, $\theta_m - \theta_n - x_l f_l^{mn} = 0$, must hold. Given that (4.2) are nonlinear equations, [4, 62] propose a linearization method to convert such type of constraints into linear formulations that are computationally friendly. By adopting that method, we obtain

$$\theta_m - \theta_n - x_l f_l^{mn} + (1 - z_l w_l) M_l \geq 0, \forall l \quad (4.8)$$

$$\theta_m - \theta_n - x_l f_l^{mn} - (1 - z_l w_l) M_l \leq 0, \forall l \quad (4.9)$$

where M_l is a sufficiently large number. Hence, in the remainder of this paper, constraints (4.8-4.9) will be used to replace (4.2).

Constraint (4.3) forces the power flow on a transmission line to be zero when the line is attacked or disconnected; otherwise, the flow will be restricted within $[-F, F]$ [27, 40]. Based on the joint restriction of constraints (4.3) and (4.8-4.9), the parameter M_l can be specified [4, 62], and the maximal difference of two phase angles at buses m, n connected by a line l , $\bar{\theta} = \theta_m^{max} - \theta_n^{min}$, can be implicitly incorporated. To be specific, assume $\bar{\theta}$ is explicitly given and a line l is available (that is, $\theta_m - \theta_n - x_l f_l^{mn} = 0$), then if $F_l \leq \bar{\theta}/x_l$, $|\theta_n - \theta_m| \leq \bar{\theta}$ will always be reductant; On the other hand, if $F_l > \bar{\theta}/x_l$, we replace F_l by a new value of $\bar{\theta}/x_l$ and then the difference of angular separation, i.e., $\theta_m - \theta_n$, could be automatically restricted. Meanwhile, we can have a valid value $\bar{\theta} + x_l F_l$ for parameter M_l . Therefore, unlike the model in [27], we do not explicitly include phase angle limits.

For simplicity, we follow the convention in [18, 53, 61] to aggregate multiple generators at one bus into a single generation limit in constraint (4.4). Similarly, constraint (4.5) guarantees that the satisfied demand does not exceed the nominal demand value at load buses. The nonnegativity constraints on generation and demand variables ensure that generation/demand will always be generation/demand. Finally, constraint (4.6) is the traditional

node balance equation such that the inflow and outflow of any node are equal [4, 27, 40, 62]. In the next section, we first present a single-level equivalent formulation of the bi-level power grid interdiction problem. Then, we describe the column-and-constraint generation method that dynamically builds and solves the single-level equivalent form. We use $\hat{\cdot}$ to denote a decision variable with a fixed value, i.e., it becomes a parameter when its value is given.

4.4 The Global Optimal Solution by C&CG Algorithm

Note that the objective function in the original min-max formulation in (4.1-4.6) (with (4.2) replaced by (4.8-4.9)) can be equivalently expressed as

$$\min_{\mathbf{w} \in \mathcal{A}} \max_{\mathbf{z}, \mathbf{p}, \mathbf{f}, \theta, \mathbf{d}} \sum_j d_j^n = \min_{\mathbf{w} \in \mathcal{A}} \max_{z \in \mathcal{C}} \max_{\mathbf{p}, \mathbf{f}, \theta, \mathbf{d}} \sum_j d_j^n \quad (4.10)$$

where \mathcal{C} is the binary set including all possible line switching decisions. Although such an extension from a bi-level model into tri-level is counterintuitive as it seems, at least temporarily, to increase the complexity of the problem, it provides a mechanism to isolate the line switching set from other dispatching decisions. In particular, it can be further converted into a single-level problem and solved by the recent methods proposed in [80, 82].

To see this, for any given attack $\hat{\mathbf{w}} \in \mathcal{A}$ and switching decision $\hat{\mathbf{z}}$, the remaining problem, which is actually the classical dispatching problem, is a pure LP problem. Furthermore, this LP problem is always feasible in that the solution with $\{\mathbf{p}, \mathbf{f}, \theta, \mathbf{d}\} = \mathbf{0}$ is feasible in all cases. Therefore, the strong duality holds, and the maximization dispatching problem can be equivalently replaced by its minimization dual problem. Next, we present the corresponding dual problem in (4.11-4.16), where $\lambda^1 - \lambda^7$ are dual variables for constraints (4.8-4.9), (4.3-4.6), respectively. Note that $n|i@n$ and $n|j@n$ denote the bus n with generator i or demand j , respectively. Also, $l|m \rightarrow \cdot$ and $l|l = \cdot \rightarrow m$ denote the transmission line with bus m as the start and end bus, respectively.

$$\begin{aligned}
\min \quad & \sum_l \lambda_l^1 (1 - \hat{z}_l \hat{w}_l) M_l + \sum_l \lambda_l^2 (1 - \hat{z}_l \hat{w}_l) M_l \\
& + \sum_l \lambda_l^3 F_l \hat{z}_l \hat{w}_l + \sum_l \lambda_l^4 F_l \hat{z}_l \hat{w}_l \\
& + \sum_i \lambda_i^5 P_i^{max} + \sum_j \lambda_j^6 D_j^n
\end{aligned} \tag{4.11}$$

$$st. \lambda_i^5 + \lambda_{n|i@n}^7 \geq 0, \forall i \tag{4.12}$$

$$\lambda_j^6 - \lambda_{n|j@n}^7 \geq 1, \forall j \tag{4.13}$$

$$x_l \lambda_l^1 - x_l \lambda_l^2 - \lambda_l^3 + \lambda_l^4 - \lambda_m^7 + \lambda_n^7 = 0, \forall l(m \rightarrow n) \tag{4.14}$$

$$\sum_{l|m \rightarrow \cdot} (\lambda_l^2 - \lambda_l^1) + \sum_{l|\cdot \rightarrow m} (\lambda_l^1 - \lambda_l^2) = 0, \forall m \tag{4.15}$$

$$\lambda^7 \text{ free}, \lambda^1, \dots, \lambda^6 \geq 0 \tag{4.16}$$

Then, we can reformulate the min-max power network interdiction model into an equivalent single-level model through Proposition 1-3 in the following.

Proposition 1. *The min-max problem defined in (4.1-4.7) is equivalent to the following tri-level programming problem:*

$$\begin{aligned}
\min_{\mathbf{w} \in \mathcal{A}} \max_{\mathbf{z} \in \mathcal{C}} \min_{\lambda^1, \dots, \lambda^7} \quad & \sum_l \lambda_l^1 (1 - z_l w_l) M_l + \sum_l \lambda_l^2 (1 - z_l w_l) M_l \\
& + \sum_l \lambda_l^3 F_l z_l w_l + \sum_l \lambda_l^4 F_l z_l w_l \\
& + \sum_i \lambda_i^5 P_i^{max} + \sum_j \lambda_j^6 D_j^n \\
& st. (4.12 - 4.16)
\end{aligned} \tag{4.17}$$

Note that it can easily be proven by strong duality of the linear program of the innermost maximization problem in equation (4.10).

Proposition 2. *The tri-level model defined above is equivalent to the single-level form defined in (4.18-4.24).*

$$\min \quad \eta \tag{4.18}$$

$$\begin{aligned} \text{st. } \eta \geq & \sum_l \lambda_l^{1(h)} (1 - \hat{z}_l^{(h)} w_l) M_l + \sum_l \lambda_l^{2(h)} (1 - \hat{z}_l^{(h)} w_l) M_l \\ & + \sum_l \lambda_l^{3(h)} F_l \hat{z}_l^{(h)} w_l + \sum_l \lambda_l^{4(h)} F_l \hat{z}_l^{(h)} w_l \\ & + \sum_i \lambda_i^{5(h)} P_i^{max} + \sum_j \lambda_j^{6(h)} D_j^n, \forall \hat{\mathbf{z}}^{(h)} \in \mathcal{C} \end{aligned} \tag{4.19}$$

$$\lambda_i^{5(h)} + \lambda_{n|i@n}^{7(h)} \geq 0, \forall i, h \tag{4.20}$$

$$\lambda_j^{6(h)} - \lambda_{n|j@n}^{7(h)} \geq 1, \forall j, h \tag{4.21}$$

$$\begin{aligned} x_l \lambda_l^{1(h)} - x_l \lambda_l^{2(h)} - \lambda_l^{3(h)} + \lambda_l^{4(h)} - \lambda_m^{7(h)} + \lambda_n^{7(h)} = 0, \\ \forall l(m \rightarrow n), h \end{aligned} \tag{4.22}$$

$$\begin{aligned} \sum_{l|m \rightarrow \cdot} (\lambda_l^{2(h)} - \lambda_l^{1(h)}) + \sum_{l|\cdot \rightarrow m} (\lambda_l^{1(h)} - \lambda_l^{2(h)}) = 0, \\ \forall m, h \end{aligned} \tag{4.23}$$

$$\mathbf{w} \in \mathcal{A}, \eta, \lambda^{7(h)} \text{ free}, \lambda^{1(h)}, \dots, \lambda^{6(h)} \geq 0 \tag{4.24}$$

where $\{\hat{\mathbf{z}}^{(h)}\}_{h=0}^H = \mathcal{C}$.

Proof. The tri-level programming problem in Proposition 1 is equivalent to the following program:

$$\begin{aligned} \min_{\mathbf{w} \in \mathcal{A}} \quad & \eta \\ \text{st. } \eta \geq & \max_{\mathbf{z} \in \mathcal{C}} \min_{\lambda^1, \dots, \lambda^7} \sum_l \lambda_l^1 (1 - z_l w_l) M_l + \sum_i \lambda_i^5 P_i^{max} \\ & + \sum_l \lambda_l^2 (1 - z_l w_l) M_l + \sum_l \lambda_l^3 F_l z_l w_l + \sum_l \lambda_l^4 F_l z_l w_l + \sum_j \lambda_j^6 D_j^n, \end{aligned} \tag{4.12 - 4.16}.$$

Note that \mathcal{C} is a finite discrete set that contains all the line switching decisions, i.e., $\mathcal{C} = \{\hat{\mathbf{z}}^{(h)}\}_{h=0}^H$. By enumeration, it follows that the above program is equivalent to the following formulation:

$$\begin{aligned}
& \min_{\mathbf{w} \in \mathcal{A}} \eta \\
& \text{st. } \eta \geq \min_{\lambda^{(h)}} \sum_l \lambda_l^{1(h)} (1 - \hat{z}_l^{(h)} w_l) M_l \\
& + \sum_l \lambda_l^{2(h)} (1 - \hat{z}_l^{(h)} w_l) M_l + \sum_l \lambda_l^{3(h)} F_l \hat{z}_l^{(h)} w_l \\
& + \sum_l \lambda_l^{4(h)} F_l \hat{z}_l^{(h)} w_l + \sum_i \lambda_i^{5(h)} P_i^{max} \\
& + \sum_j \lambda_j^{6(h)} D_j^n, \forall \hat{\mathbf{z}}^{(h)} \in \mathcal{C} \\
& \lambda_i^{5(h)} + \lambda_{n|i@n}^{7(h)} \geq 0, \forall i, h \\
& \lambda_j^{6(h)} - \lambda_{n|j@n}^{7(h)} \geq 1, \forall j, h \\
& x_l \lambda_l^{1(h)} - x_l \lambda_l^{2(h)} - \lambda_l^{3(h)} + \lambda_l^{4(h)} - \lambda_m^{7(h)} + \lambda_n^{7(h)} = 0, \\
& \forall l(m \rightarrow n), h \\
& \sum_{l|m \rightarrow \cdot} (\lambda_l^{2(h)} - \lambda_l^{1(h)}) + \sum_{l|\cdot \rightarrow m} (\lambda_l^{1(h)} - \lambda_l^{2(h)}) = 0, \\
& \forall m, h \\
& \mathbf{w} \in \mathcal{A}, \eta, \lambda^{7(h)} \text{ free}, \lambda^{1(h)}, \dots, \lambda^{6(h)} \geq 0
\end{aligned}$$

Note that $\lambda^{(h)}$ are independent for different h in the sense that each set of $\lambda^{(h)}$ is generated for a feasible line switching decision. Then, by removing the “min” in the first set of constraints, which does not change the optimal value, we obtain the equivalent program in Proposition 2.

In the above single-level equivalent form, decision variables are \mathbf{w} and $(\lambda^{1(h)}, \dots, \lambda^{7(h)})$ for all h . We note that constraint (4.19) involves terms that are products of one binary variable, w_l , and one continuous variable $\lambda^{k(h)}$ with $k = 1, \dots, 4$. The mathematical programming

problems with mixed-integer nonlinear constraints are in general very difficult. So, it would be natural to linearize those terms using standard linearization techniques [9, 53] so that professional MIP solvers can be called to solve this problem. Assume that M'_{kl} is a sufficiently large number that provides an upper bound to optimal values of $\lambda_l^{k(h)}$ in (4.11-4.16), we can have the following equivalent linear constraints.

Proposition 3. *Constraints defined in (4.19) can be linearized as (4.25-4.38).*

$$\begin{aligned} \eta \geq & \sum_l (\lambda_l^{1(h)} - \hat{z}_l^{(h)} \alpha_l^{(h)}) M_l + \sum_l (\lambda_l^{2(h)} - \hat{z}_l^{(h)} \beta_l^{(h)}) M_l \\ & + \sum_l \pi_l^{(h)} F_l \hat{z}_l^{(h)} + \sum_l \mu_l^{(h)} F_l \hat{z}_l^{(h)} + \sum_i \lambda_i^{5(h)} P_i^{max} \\ & + \sum_j \lambda_j^{6(h)} D_j^n, \forall \hat{\mathbf{z}}^{(h)} \in \mathcal{C} \end{aligned} \quad (4.25)$$

$$\alpha_l^{(h)} \leq \lambda_l^{1(h)}, \forall h, l \quad (4.26)$$

$$\alpha_l^{(h)} \geq \lambda_l^{1(h)} - (1 - w_l) M'_{1l}, \forall h, l \quad (4.27)$$

$$\alpha_l^{(h)} \leq w_l M'_{1l}, \forall h, l \quad (4.28)$$

$$\beta_l^{(h)} \leq \lambda_l^{2(h)}, \forall h, l \quad (4.29)$$

$$\beta_l^{(h)} \geq \lambda_l^{2(h)} - (1 - w_l) M'_{2l}, \forall h, l \quad (4.30)$$

$$\beta_l^{(h)} \leq w_l M'_{2l}, \forall h, l \quad (4.31)$$

$$\pi_l^{(h)} \leq \lambda_l^{3(h)}, \forall h, l \quad (4.32)$$

$$\pi_l^{(h)} \geq \lambda_l^{3(h)} - (1 - w_l) M'_{3l}, \forall h, l \quad (4.33)$$

$$\pi_l^{(h)} \leq w_l M'_{3l}, \forall h, l \quad (4.34)$$

$$\mu_l^{(h)} \leq \lambda_l^{4(h)}, \forall h, l \quad (4.35)$$

$$\mu_l^{(h)} \geq \lambda_l^{4(h)} - (1 - w_l) M'_{4l}, \forall h, l \quad (4.36)$$

$$\mu_l^{(h)} \leq w_l M'_{4l}, \forall h, l \quad (4.37)$$

$$\pi_l^{(h)}, \mu_l^{(h)}, \alpha_l^{(h)}, \beta_l^{(h)} \geq 0 \quad (4.38)$$

As a result, the bi-level power interdiction problem defined in (4.1-4.7) can be reformulated as a mixed-integer programming problem.

Corollary 1. *The equivalent single-level linear MIP formulation of the bi-level power grid interdiction problem is the one obtained by replacing (4.19) with (4.25-4.38) in the formulation of (4.18- 4.24).*

We have successfully converted the min-max power interdiction problem into a single-level MIP problem. However, this single-level equivalent form is of theoretical interest only. As a set of $(\lambda^{1(h)}, \dots, \lambda^{7(h)})$ and their corresponding constraints must be introduced for any possible $\hat{\mathbf{z}}^h$ in set \mathcal{C} , which is actually exponential with respect to the number of lines in the grid, therefore it is not feasible to enumerate all possible line switching decisions for any real instances. Instead of using the complete enumeration to obtain the equivalent form, we next describe an algorithm that dynamically identifies and includes significant line switching decisions (and dual decisions of their corresponding dispatching decisions), i.e., the barrier of complete enumeration can be removed.

Based on observations made in [80, 82] on solving 2-stage robust optimization problems, it is anticipated that only a very small part of \mathcal{C} is critical in determining an optimal solution. So, one idea is to start with a single-level formulation with a small subset of \mathcal{C} (i.e., their variables and constraints) and then gradually expand the formulation by including more significant components (i.e., their variables and constraints) of \mathcal{C} . Note from (4.18-4.24) that a single-level formulation with a subset of \mathcal{C} , which is named the *partial single-level formulation*, yields a lower bound to the actual optimal value. Also, any feasible solution to the min-max formulation, which can be obtained for any attack plan, yields an upper bound, given that the ultimate objective function is minimization. Therefore, the expansion process can be terminated with an optimal solution whenever upper and lower bounds match. This idea is implemented within a master-subproblem framework using a column-and-constraint generation approach as follows.

4.5 Algorithm Description

To simplify our exposition, we use the compact forms of all problems in this subsection. Specifically, let $\mathbf{y} = \{\mathbf{p}, \mathbf{d}, \mathbf{f}, \theta, \mathbf{z}\}$ denote the set of decision variables, including line switching and other dispatching variables, made by system operator, then the lower level decision model given any attack $\hat{\mathbf{w}} \in \mathcal{A}$ will be

$$\max \mathbf{c}\mathbf{y} \quad (4.39)$$

$$st. \mathbf{B}\mathbf{y} \leq \mathbf{g} - \mathbf{A}\hat{\mathbf{w}} \quad (4.40)$$

$$\text{variable restrictions on } \mathbf{y}, \quad (4.41)$$

where $\mathbf{c}, \mathbf{g}, \mathbf{B}, \mathbf{A}$ are appropriate vectors or matrices defined in (4.1-4.6). Similarly, for some known $\{\mathbf{z}^{(h)}\}_{h \in \mathcal{U}} \subseteq \mathcal{C}$, the partial single-level formulation is

$$\min \eta \quad (4.42)$$

$$st. \mathbf{Q}\eta + \mathbf{E}\lambda^{(h)} + \mathbf{G}\mathbf{w} \leq \mathbf{h}\hat{\mathbf{z}}^{(h)} + \mathbf{a}, \forall h \in \mathcal{U} \quad (4.43)$$

$$\mathbf{w} \in \mathcal{A} \quad (4.44)$$

$$\text{variable restrictions on } \mathbf{w}, \eta, \lambda^{(\mathbf{h})}, \quad (4.45)$$

where $\mathbf{h}, \mathbf{a}, \mathbf{Q}, \mathbf{E}, \mathbf{G}$ are appropriate vectors or matrices defined in (4.20-4.23, 4.25-4.38).

Next we describe the algorithm in steps.

Steps of C&CG Algorithm are listed below.

(1) Set $LB = -\infty$, $UB = +\infty$, $h = 0$, $U = \emptyset$ and an optimality tolerance ϵ .

(2) Solve the partial single-level formulation defined in (4.42-4.45) (as the *master problem*).

Derive an optimal solution $(\mathbf{w}^{*h}, \eta^{*h}, \lambda^{*h})$ and update $LB = \eta^{*h}$.

(3) Solve the lower level problem defined in (4.39-4.41) (as the *subproblem*) with $\hat{\mathbf{w}} = \mathbf{w}^{*h}$ and update $UB = \min\{UB, \mathbf{c}\mathbf{y}^*\}$ where \mathbf{y}^* , including the optimal line switching \mathbf{z}^* , is the optimal solution of the lower level problem.

(4) If $UB - LB \leq \epsilon$, return \mathbf{w}^{*h} as an optimal attack plan and terminate. Otherwise, update $U = U \cup \{h\}$ with $\hat{\mathbf{z}}^{(h)} = \mathbf{z}^*$, create new recourse decision variables $\lambda^{(h)}$, and add the corresponding constraints defined in (4.43) to the partial single-level problem. Let $h = h + 1$ and go to step (2).

As proven in [82], given the fact that \mathcal{C} is a finite binary set, it follows directly that the number of iterations of C&CG algorithm is finite and it converges to an optimal solution. For completeness, we present the proof here:

Proof. We claim that any repeated \mathbf{z}^* in above procedure implies global optimality, i.e., $LB = UB$. Then the conclusion follows immediately due to the finite number of points in \mathcal{C} . Suppose at iteration q an optimal attack \mathbf{w}^* is obtained by solving the (master) problem in Step 2) of the algorithm in Section 4.4. And for this given \mathbf{w}^* , let \mathbf{y}^* which includes \mathbf{z}^* and \mathbf{d}^* be the optimal solution to the subproblem in Step 3). It follows that $UB \leq \mathbf{c}\mathbf{y}^* = \sum_j d_j^{n*}$. Assume \mathbf{z}^* has been identified at or before iteration $q - 1$, it will have two consequences. First, \mathbf{w}^* will be the optimal solution to the (master) problem in Step 2) at iteration $q + 1$ because the problems at these two iterations are identical. Second, since the constraints and variables (4.19-2.21) related to \mathbf{z}^* are already added to the master problem, we will have for iteration $q + 1$ that $LB = \eta^* \geq \min\{ \sum_l \lambda_l^1(1 - z_l^* w_l^*)M_l + \sum_l \lambda_l^2(1 - z_l^* w_l^*)M_l + \sum_l \lambda_l^3 F_l z_l^* w_l^* + \sum_l \lambda_l^4 F_l z_l^* w_l^* + \sum_i \lambda_i^5 P_i^{max} + \sum_j \lambda_j^6 D_j^n : (4.12 - 4.16)\} = \sum_j d_j^{n*}$, where the inequality comes from constraint (4.19) and the last equality results from the strong duality of a linear programming problem. Now we have $\sum_j d_j^{n*} \leq LB \leq UB \leq \sum_j d_j^{n*}$, so the equality will go through, i.e., $LB = UB$.

Note from the algorithm description that many variables and constraints probably will be introduced in each iteration, which increases the complexity of the master problem and may cause the algorithm less efficient to deal with large scale instances. However, the strength of the newly-added constraints is strong [80], and the algorithm usually derives an optimal solution after a small number of iterations. The numerical study in Section 4.6 confirms this where a global optimal solution can be obtained after a few iterations for all instances.

4.6 Computational Study

In this section, we conduct computational experiments on several power systems of different scales. Note that the performance of the algorithm varies to different selections of M' in (4.26-4.37). And the values of M' that are used in all experiments throughout this paper are selected as follows. Assume that line l connects bus m and n . If line l_1 and l_2 have a common bus m , we call $l_1(l_2, \textit{respectively})$ is a neighborhood of line $l_2(l_1, \textit{respectively})$ at bus m . And let $Ne(l(m))$ denote the set of all neighborhoods of line l at bus m in the power network with the complete topology. A selection of the big-M's for any line $l = (m \rightarrow n)$ is as follows with $\vartheta \in \mathbb{N}$. In our experiments, ϑ is set to one.

$$M'_{1l} = M'_{2l} = \vartheta \max \left\{ \sum_{l' \in Ne(l(m))} \frac{1}{x_{l'}}, \sum_{l^* \in Ne(l(n))} \frac{1}{x_{l^*}}, \frac{1}{x_l} \right\}$$

$$M'_{3l} = M'_{4l} = 1 + \vartheta \max \left\{ \sum_{l' \in Ne(l(m))} \frac{x_l}{x_{l'}}, \sum_{l^* \in Ne(l(n))} \frac{x_l}{x_{l^*}} \right\}$$

The experiments include: First, on a simple 7-bus system, we compare the C&CG algorithm with the enumeration of all possible attacks. Since the enumeration does not involve big-M linearization technique, the result confirms the correctness of the proposed algorithm with the selection of M' ; Second, On the IEEE one-area RTS-96 system, the performance of the C&CG algorithm benchmarks the best known results obtained by multi-start Benders decomposition method [27] to show its effectiveness; Third, on the IEEE three-area RTS-96 system, we apply combinatorial optimization based on the result of one-area system, reporting an islanding phenomenon in a relatively large network when it is attacked; Finally, on the IEEE 118-bus system, we compare the C&CG algorithm with enumeration again to show the correctness and effectiveness of the former one in a relatively complicated power network.

The solution was implemented in C++ on a PC desktop, and the commercial solver IBM ILOG CPLEX 12.4 was used as the MIP solver for all problems with $\epsilon = 1 \times 10^{-4}$. We

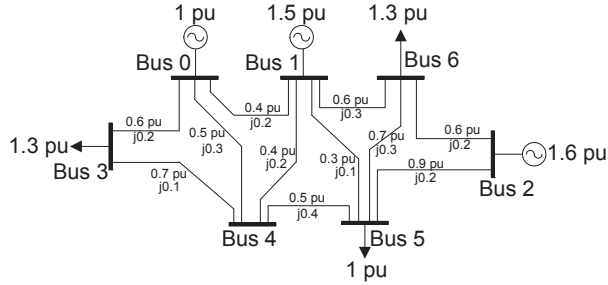

Figure 6: A 7-bus Power System

Table 11: Load Shedding on 7-Bus System with and without Line Switching

K	Load Shedding with Line Switching (MW)	Load Shedding without Line Switching (MW)
1	90	131
2	150	189
3	210	222
4	260	264
5	290	320

mention that one strategy, which may accelerate the computational speed for experiments, is to start from the master problem with respect to the full topology of the power network in the first iteration [27].

The C&CG is applied to a simple 7-bus system whose topology and parameters are shown in Figure 6. Table 11 presents the maximal load shedding with and without line switching operations, which agrees with the conclusion in [27] that the system can benefit from line switching to satisfy custom demand. We also enumerate all possible attacks and compare the results with C&CG in Table 12. The maximal load shedding provided by enumeration is identical to that by C&CG, so it is omitted. Table 12 not only confirms the correctness of the proposed algorithm from an empirical point of view, but also shows that C&CG is more efficient as it only involves a few iterations (attack scenarios) to obtain a global optimal solution.

Now we present a case study based on IEEE One-Area [38]. The system has 24 buses, 11 of which are equipped with generators and 16 of which are load buses. There are, in

Table 12: C&CG versus Enumeration on 7-Bus System with Line Switching

K	Iteration of C&CG	Time (s) of C&CG	Time (s) of Enumeration	Number of Possible Attacks
1	4	1.34	1.75	11
2	7	2.64	7.11	55
3	4	1.40	18.86	165
4	5	1.64	34.92	330
5	3	0.84	47.83	462

Table 13: Configurations of Computing Facilities

Platform	MSBD [27]	C&CG
CPU	4 processors at 2.6GHz	1 processor at 3GHz
RAM	32G	3.25G
CPLEX	11.0.1	12.4
Global Opt. Tolerance ϵ	NA	1×10^{-4}
ϵ for Master/Sub-Problem	1×10^{-2}	1×10^{-4}

total, 38 transmission lines, and the cardinality of attacks is from 1 to 12. We compare the computational result for One-Area RTS-96 system with that in [27], by noting that [27] is the only study providing an analytical algorithm for this type of interdiction problem with line switching (binary decisions) in lower level. All the parameters are adopted from [27]. And, as in [27], two lines connected with the same towers were treated as independent lines, and only connected transmission lines can be switched off. In addition, we set bus 1 to be the reference bus, that is, $\theta_1 = 0$. To achieve a fair comparison on the algorithm performance, differences between computing facilities used in this study and in [27] are listed in Table 13. In the remainder of the section, to avoid confusion, we use *MSBD* to denote the multi-start Benders decomposition method and the associated research presented in [27].

The computational speed and complexity are shown in Table 14. It can be observed that C&CG can derive optimal solutions in all instances within a reasonable time, saving an average of more than 95% of computational effort of MSBD. One interesting observation is that the number of iterations is larger when K is small. One possible reason is that the network is small so that the problem becomes less challenging after removing many lines.

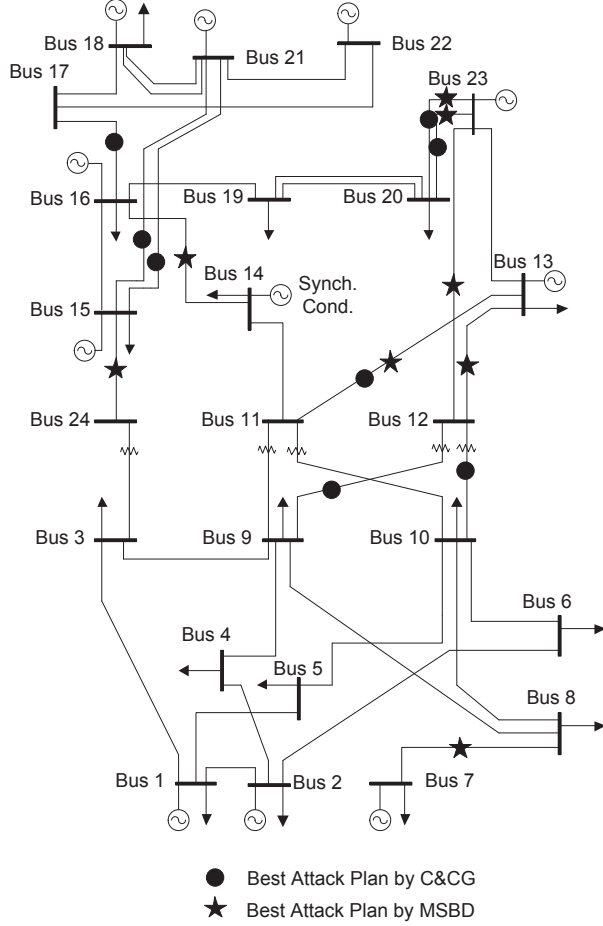

Figure 7: Comparison of Best Attacks Obtained using C&CG and MSBD for $K = 8$

We observe again from Table 14 that the number of iterations in C&CG is very small, in spite of the fact that the size of this 24-bus system is much larger than that of the aforementioned 7-bus system. For example, for case $K = 10$, there are $\binom{38}{10} \geq 400$ million possible attacks and $2^{38} \geq 200$ billion possible line switching decisions, while the proposed algorithm only needs 2 of them to obtain the global optimality. Therefore, our *partial* enumeration strategy is very effective and the proposed algorithm is computationally efficient.

The optimal values in terms of load shedding, rounding to integers, are presented in Table 15 and compared with those obtained by MSBD method in [27]. It is observed that the solutions obtained by MSBD are actually of high qualities in that optimal values can be achieved in most cases except cases $K = 8$ and $K = 10$ (although the authors mentioned

Table 14: Algorithm Performance Comparison for IEEE One-Area RTS-96 Systems

K	Time (s) of MSBD [27]	Time (s) of C&CG	Iterations of C&CG
1	18.48	23.48	7
2	293.31*	22.01	6
3	2261.59*	20.51	6
4	2180.67*	19.42	4
5	1610.35*	17.92	2
6	1520.47*	17.04	2
7	0.89	16.24	1
8	1312.42*	15.65	3
9	1155.64*	14.77	2
10	1029.01*	14.28	2
11	0.85	13.48	1
12	0.88	12.85	1
Average Time	948.71	17.30	

that the distance of the solution to the global optimal one is unknown in [27]). Indeed, if we use the attack provided by MSBD, we have exactly the same load shedding, i.e., 905MW and 1017MW, for cases $K = 8$ and $K = 10$.

As most optimal attack and switching decisions are presented in [27], we simply provide the optimal solutions for cases $K = 8$ and $K = 10$ in Table 16. For example, when the lines in the second column are attacked, another set of lines in the third column needs to be switched off to minimize the load shedding. Note that although the quality of solutions obtained by MSBD are good in cases $K = 8$ and $K = 10$, they may be very different from optimal attack plans. For example, Figure 7 shows the optimal attack and line switching decisions derived by C&CG and those obtained by MSBD, when $K = 8$.

We also applied our algorithm to IEEE Three-Area RTS-96 system [38] which has 73 buses and 185 transmission lines. Five interconnecting transmission lines merge three single areas: three lines between the first two areas, one line joining the second and the third area, and one transmission line connects the first and the third area. The parameters in each area are inherited from the above One-Area system[27]. The reactance of those inter-area lines is adopted from [38].

Table 15: Load Shedding (MW) to IEEE One-Area RTS-96 System Caused by Attacks

K	MSBD [27]	C&CG
1	131	131
2	279	279
3	429	429
4	538	538
5	688	688
6	775	775
7	855	855
8*	905*	915*
9	1002	1002
10*	1017*	1051*
11	1131	1131
12	1194	1194

Table 16: Optimal Attack and Switching in One-Area RTS-96 for $K=8,10$ by C&CG

K	Global optimal attack	Optimal switching
8	9-12, 10-12, 11-13, 15-21A, 15-21B, 16-17, 20-23A, 20-23B	3-9, 4-9, 8-10, 9-11, 12-13, 12-23, 13-23, 15-16, 19-20
10	1-3, 1-5, 2-4, 2-6, 7-8, 11-13, 12-13, 12-23, 20-23A, 20-23B	1-2, 3-9, 4-9, 5-10, 6-10, 8-10, 9-11, 10-12, 13-23, 15-21, 17-22, 19-20

Instead of starting from sketch, we take advantage of the result of one-area system. The strategy is similar to but different from the one mentioned at the beginning of this section that it starts from the master problem with respect to the full topology of the power network [27]. We start from the master problem with all five inter-areas lines switched-off at the beginning, i.e., $\hat{z}_l = 0$, if line l is one of the five lines, namely, the restricted master problem. Therefore, the restricted initial master problem can be decomposed into three small attack-defend problems that are solved to optimality.

Formally, let ϖ_1, ϖ_2 , and $\varpi_3 \in \mathbb{Z}_+$ denote the number of lines attacked in each single area, and let $LoadS(\varpi)$ be a function defined from the number of attacked lines to the maximum load shedding in a single area. For example, $LoadS(1) = 131$, $LoadS(2) = 279$, and etc. Then the maximum load shedding corresponding to the restricted master problem is equivalent to the optimal objective value of the following ‘‘knapsack’’ problem:

$$\max LoadS(\varpi_1) + LoadS(\varpi_2) + LoadS(\varpi_3) \quad (4.46)$$

$$st. \varpi_1 + \varpi_2 + \varpi_3 \leq K, \quad (4.47)$$

$$\varpi_1, \varpi_2, \varpi_3 \in \mathbb{Z}_+, \quad (4.48)$$

Let I_b^A, I_b^B , and I_b^C denote the collection of buses in each of the three areas, respectively, with $I_b^3 = I_b^A \cup I_b^B \cup I_b^C$. Similarly, let I_l^A, I_l^B , and I_l^C denote the collection of transmission lines in each of the three areas, respectively, with $I_l^3 = I_l^A \cup I_l^B \cup I_l^C$. Let I_p denote the set of inter-area lines. The master problem is

$$\min_{\mathbf{w} \in \mathcal{A}'} \max_{\{\mathbf{p}, \mathbf{d}, \mathbf{f}, \theta, \mathbf{z}\}} \sum_{j \in I_b^3} d_j^n \quad (4.49)$$

$$st. z_l w_l (\theta_m - \theta_n - x_l f_l^{mn}) = 0, \forall l \in I_l^3 \cup I_p \quad (4.50)$$

$$-F_l z_l w_l \leq f_l^{mn} \leq z_l w_l F_l, \forall l \in I_l^3 \cup I_p \quad (4.51)$$

$$p_i^n \leq P_i^{max}, \forall i \in I_b^3 \quad (4.52)$$

$$d_j^n \leq D_j^n, \forall j \in I_b^3 \quad (4.53)$$

$$\sum_l f_l^n + p_i^n = \sum_l f_l^n + d_j^n, \forall n \in I_b^3 \quad (4.54)$$

$$p_i^n \geq 0, d_j^n \geq 0, f_l^{mn}, \theta_n \text{ free}, z_l \in \{0, 1\} \quad (4.55)$$

where $\mathcal{A}' = \{\mathbf{w} \in \mathbb{B}^{|I_b^3|+|I_p|} : w_l \in \{0, 1\}, \sum_l (1 - w_l) \leq K\}$.

Clearly, the optimal objective value of the *restricted master problem* defined in (4.49)-(4.55) with parameters $z_l = 0, \forall l \in I_p$ in the lower level, is a lower bound of the virtual master problem, i.e., the one defined with variables $z_l \in \{0, 1\}, \forall l \in I_p$. The maximum load shedding is

$$\sum_{j \in I_b^3} D_j^n - \min_{\mathbf{w} \in \mathcal{A}'} \max_{\{\mathbf{p}, \mathbf{d}, \mathbf{f}, \theta, \mathbf{z}\} \in (4.50)-(4.55)} \sum_{j \in I_b^3} d_j^n, \quad (4.56)$$

which is equivalent to

$$\max_{\mathbf{w} \in \mathcal{A}'} \min_{\{\mathbf{p}, \mathbf{d}, \mathbf{f}, \theta, \mathbf{z}\} \in (4.50)-(4.55)} \sum_{j \in I_b^3} D_j^n - \sum_{j \in I_b^3} d_j^n. \quad (4.57)$$

Noting that the three areas are isolated in the *restricted master problem*, i.e., $z_l = 0, \forall l \in I_p$, the lower level can be decomposed into three independent problems. By applying $\varpi_1 = \sum_{l \in I_l^A} (1 - w_l)$, $\varpi_2 = \sum_{l \in I_l^B} (1 - w_l)$, and $\varpi_3 = \sum_{l \in I_l^C} (1 - w_l)$, it follows from the definition of $LoadS(\varpi)$ that the maximum load shedding corresponding to the restricted master problem is equivalent to the optimal objective value of the “knapsack” problem defined in (4.46)-(4.48).

For example, if the optimal solution to the above problem is $\varpi_1 = 1, \varpi_2 = 2, \varpi_3 = 1$ for $K = 4$, the maximal load shedding is 131+279+131(MW) and the optimal attack corresponds to $K = 1, K = 2$, and $K = 1$ for each single area, respectively. Then the algorithm continues with the subproblem, and the global optimality can be obtained when lower and

Table 17: Results of Three-Area RTS-96 System Attacks with Cardinality 1-6

K	Maximal Load Shedding (MW)	Computational Time (s)
1	131+0+0	0.56
2	279+0+0	0.36
3	429+0+0	0.47
4	131+429+0	0.46
5	279+429+0	0.32
6	429+429+0	0.39

Table 18: Results of IEEE 118-bus System

K	Maximum Load Shedding (MW)	Iterations of C&CG	Computational Time (s) of C&CG	Computational Time (s) of Enumeration
1	190	2	10.01	104.02
2	440	1	20.54	20571.66

upper bounds match. Interestingly, for all instances with $K \leq 6$, numerical results show that an optimal attack does not remove inter-area lines and actually those lines are switched off defensively by an optimal system operators, as shown in Table 17. Hence, a clear islanding phenomenon is observed here. One of the reasons may be that each single area is balanced in generation and load, i.e., the power generation can successfully satisfy the demand. This feature is related to that in [58] where a sub-area is generation rich but another is demand rich and the attacker will tend to remove the inter-areas lines.

We also want to emphasize that the above strategy can be used in a system with different subsystems, in which case multiple functions $LoadS_{\xi}(\cdot), \xi = 1, 2, \dots$, will be defined instead of a single one. Therefore it provides an idea to address a large-scale network problem given that its sub-area problems can be solved efficiently.

On IEEE 118-bus system, the C&CG algorithm is compared with the enumeration of all possible attacks again to show the correctness and effectiveness of the former one on a relatively complicated power network. This network has 185 lines, 19 generation bus, and a total peak load of 4519MW. All the data is adopted from [19]. The result of C&CG agrees with enumeration, and is much more efficient as shown in Table 18.

5 Conclusion

In Chapter 2, mathematical models were formulated for temperature-modulated generation and characterized cooling system operations for gas-fired generators. Cooling decisions were integrated into a UC model with uncertain demands, and a 2-stage stochastic UC model was developed. A set of experiments was performed on a real power system to evaluate the benefits that derive from operating cooling systems. The performance, robustness of generation costs, and commitment stability of the optimization model were compared with respect to a decision-rule-induced UC model. The results show that cooling systems are economically efficient and that the optimization approach is more stable and reliable than the decision rule in daily operations management. One future research direction is to apply this model in a cost-benefit analysis if a cooling system is under consideration in a capacity expansion plan. Another future research direction is to study the two-stage robust optimization model with cooling systems. The latter is more difficult than those in [16, 43, 83] because it includes cooling system on/off decisions in the recourse problem.

In Chapter 3 By introducing wind output and demand response, we construct two-stage robust optimization problems and derive mathematical properties of optimal solutions. We develop a novel cutting plane method to this problem. Our study shows that the robust unit commitment model can significantly reduce total cost accounting for demand response and the uncertainty of wind energy and the cutting plane method can dramatically decrease the computation time compared with traditional Benders decomposition.

In Chapter 4, we study a static power grid vulnerability issue by considering a bi-level power grid interdiction problem with line switching. We first proposed an equivalent single-level reformulation to this bi-level min-max problem. Then, we developed a column-and-constraint generation algorithm to derive the global optimal solution within a

master-subproblem framework. The reformulation is nontrivial, and the algorithm is novel. In particular, a set of preliminary computational results show that it performs better than existing work. In fact, the method can be readily modified to deal with other bi-level problems with binary or integer decision variables in the lower level model, which could yield an impact on a larger scope methodology. Moreover, given that the bi-level interdiction problem can be effectively solved using our method, it is anticipated that the challenging extended tri-level problems, such as defend-attack-defend (DAD) problems arising from power, military logistics, or other infrastructure systems [21, 78], can be solved with advanced algorithm development based on the current one [79]. Particular efforts will be extended to advance our algorithms to study large-scale power grids with a consideration of dynamic behaviors to address the cascading issue.

References

- [1] <http://www-01.ibm.com/software/integration/optimization/cplex-optimizer/>, IBM ILOG cplex solver package.
- [2] <http://weather.tbo.com/>, weather from tampa bay online.
- [3] Réka Albert, István Albert, and Gary L. Nakarado. Structural vulnerability of the north american power grid. *Phys. Rev. E*, 69:025103, Feb 2004.
- [4] R. Alvarez. Interdicting electrical power grids. Master’s thesis, Department of Operations Research, U.S. Naval Postgraduate School, Monterey, CA, 2004.
- [5] G. Anandalingam. A mathematical programming model of decentralized multi-level systems. *Journal of the Operational Research Society*, pages 1021–1033, 1988.
- [6] G. Andersson, P. Donalek, R. Farmer, N. Hatziaargyriou, I. Kamwa, P. Kundur, N. Martins, J. Paserba, P. Pourbeik, J. Sanchez-Gasca, R. Schulz, A. Stankovic, C. Taylor, and V. Vittal. Causes of the 2003 major grid blackouts in north america and europe, and recommended means to improve system dynamic performance. *Power Systems, IEEE Transactions on*, 20(4):1922 – 1928, 2005.
- [7] J.M. Arroyo. Bilevel programming applied to power system vulnerability analysis under multiple contingencies. *Generation, Transmission & Distribution, IET*, 4(2): 178–190, 2010.
- [8] JM Arroyo and FJ Fernandez. A genetic algorithm approach for the analysis of electric grid interdiction with line switching. In *Intelligent System Applications to Power Systems, 2009. ISAP’09. 15th International Conference on*, pages 1–6. IEEE, 2009.

- [9] J.M. Arroyo and F.D. Galiana. On the solution of the bilevel programming formulation of the terrorist threat problem. *Power Systems, IEEE Transactions on*, 20(2):789–797, 2005.
- [10] A. Atamturk and M. Zhang. Two-stage robust network flow and design under demand uncertainty. *Operations Research*, 55(4):662–673, 2007.
- [11] A. Ben-Tal and A. Nemirovski. Robust convex optimization. *Mathematics of Operations Research*, 23(4):769–805, 1998.
- [12] A. Ben-Tal and A. Nemirovski. Robust solutions of uncertain linear programs. *Operations Research Letters*, 25(1):1–14, 1999.
- [13] A. Ben-Tal and A. Nemirovski. Robust solutions of linear programming problems contaminated with uncertain data. *Mathematical Programming*, 88(3):411–424, 2000.
- [14] D. Bertsimas and M. Sim. Robust discrete optimization and network flows. *Mathematical Programming*, 98(1):49–71, 2003.
- [15] D. Bertsimas and M. Sim. The price of robustness. *Operations Research*, 52(1):35–53, 2004.
- [16] D. Bertsimas, E. Litvinov, X.A. Sun, J. Zhao, and T. Zheng. Adaptive robust optimization for the security constrained unit commitment problem. *Power Systems, IEEE Transactions on*, 28(1):52–63, 2013.
- [17] D. Bienstock and S. Mattia. Using mixed-integer programming to solve power grid blackout problems. *Discrete Optimization*, 4(1):115 – 141, 2007.
- [18] V.M. Bier, E.R. Gratz, N.J. Haphuriwat, W. Magua, and K.R. Wierzbicki. Methodology for identifying near-optimal interdiction strategies for a power transmission system. *Reliability Engineering & System Safety*, 92(9):1155–1161, 2007.

- [19] S. Blumsack. *Network Topologies and Transmission investment Under Electric-Industry Restructuring*. Phd thesis, Carnegie Mellon University, 2006.
- [20] Gerald G. Brown. Defending critical infrastructure. Technical report, DTIC Document, 2006.
- [21] Gerald G. Brown, W. Matthew Carlyle, Javier Salmeron, and Kevin Wood. Analyzing the vulnerability of critical infrastructure to attack and planning defenses. In *Tutorials in Operations Research. INFORMS*, pages 102–123. INFORMS, 2005.
- [22] B.A. Carreras, V.E. Lynch, I. Dobson, and D.E. Newman. Critical points and transitions in an electric power transmission model for cascading failure blackouts. *Chaos: An Interdisciplinary Journal of Nonlinear Science*, 12(4):985–994, 2002.
- [23] B.A. Carreras, V.E. Lynch, I. Dobson, and D.E. Newman. Complex dynamics of blackouts in power transmission systems. *Chaos: An Interdisciplinary Journal of Nonlinear Science*, 14(3):643–652, 2004.
- [24] S. Cerisola, A. Baillo, J.M. Fernandez-Lopez, A. Ramos, and R. Gollmer. Stochastic power generation unit commitment in electricity markets: A novel formulation and a comparison of solution methods. 57(1):32–46, 2009.
- [25] E.M. Constantinescu, V.M. Zavala, M. Rocklin, S. Lee, and M. Anitescu. A computational framework for uncertainty quantification and stochastic optimization in unit commitment with wind power generation. *Power Systems, IEEE Transactions on*, 26(1):431–441, 2011.
- [26] Paolo Crucitti, Vito Latora, and Massimo Marchiori. Model for cascading failures in complex networks. *Phys. Rev. E*, 69:045104, Apr 2004.
- [27] A. Delgadillo, J.M. Arroyo, and N. Alguacil. Analysis of electric grid interdiction with line switching. *Power Systems, IEEE Transactions on*, 25(2):633–641, 2010.

- [28] DoE. 20u.s. electricity supply. Technical report, 2008.
- [29] Inc. Donaldson Company. Cooling inlet air improves turbine output, 2005.
- [30] V. Donde, V. Lopez, B. Lesieutre, A. Pinar, C. Yang, and J. Meza. Identification of severe multiple contingencies in electric power networks. In *Power Symposium, 2005. Proceedings of the 37th Annual North American*, pages 59–66. IEEE, 2005.
- [31] V. Donde, V. López, B. Lesieutre, A. Pinar, C. Yang, and J. Meza. Severe multiple contingency screening in electric power systems. *Power Systems, IEEE Transactions on*, 23(2):406–417, 2008.
- [32] J. Elliott. Inlet air cooling optimizes plant flexibility. *Diesel & Gas Turbine Worldwide*, 2004.
- [33] A. Faruqui and S. Sergici. Household response to dynamic pricing of electricity- a survey of experiment evidence. Technical report, 2009.
- [34] E.B. Fisher, R.P. O’Neill, and M.C. Ferris. Optimal transmission switching. *Power Systems, IEEE Transactions on*, 23(3):1346–1355, 2008.
- [35] L. Flowers. Wind powering america update, 2010.
- [36] A. Frangioni and C. Gentile. Solving nonlinear single-unit commitment problems with ramping constraints. *Operations Research*, 54(4):767–775, 2006.
- [37] Y. Fu, M. Shahidehpour, and Z. Li. Ac contingency dispatch based on security-constrained unit commitment. *Power Systems, IEEE Transactions on*, 21(2): 897–908, 2006.
- [38] C. Grigg, P. Wong, P. Albrecht, R. Allan, M. Bhavaraju, R. Billinton, Q. Chen, C. Fong, S. Haddad, S. Kuruganty, W. Li, R. Mukerji, D. Patton, N. Rau, D. Reppen, A. Schneider, M. Shahidehpour, and C. Singh. The IEEE reliability test system–1996. *Power Systems, IEEE Transactions on*, 14(3):1010–1020, 1999.

- [39] K.W. Hedman, R.P. O’Neill, E.B. Fisher, and S.S. Oren. Optimal transmission switching with contingency analysis. *Power Systems, IEEE Transactions on*, 24(3): 1577–1586, 2009.
- [40] K.W. Hedman, M.C. Ferris, R.P. O’Neill, E.B. Fisher, and S.S. Oren. Co-optimization of generation unit commitment and transmission switching with n-1 reliability. *Power Systems, IEEE Transactions on*, 25(2):1052–1063, 2010.
- [41] PJM Interconnection. Transmission operations - PJM, 2009.
- [42] U. Janjarassuk and J. Linderoth. Reformulation and sampling to solve a stochastic network interdiction problem. *Networks*, 52(3):120–132, 2008.
- [43] R. Jiang, M. Zhang, G. Li, and Y. Guan. Benders decomposition for the two-stage security constrained robust unit commitment problem, available at www.optimization-online.org. Technical report, 2010.
- [44] RS Johnson Sr. The theory and operation of evaporative coolers for industrial gas turbine installations. *Journal of engineering for gas turbines and power*, 111:327, 1989.
- [45] David Kathan, Caroline Daly, Eric Eversole, Maria Farinella, Jignasa Gadani, Ryan Irwin, Cory Lankford, Adam Pan, Christina Switzer, and Dean Wright. National action plan on demand response. Technical report, 2010.
- [46] S.A. Kazarlis, AG Bakirtzis, and V. Petridis. A genetic algorithm solution to the unit commitment problem. *Power Systems, IEEE Transactions on*, 11(1):83–92, 1996.
- [47] A. Khodaei and M. Shahidehpour. Transmission switching in security-constrained unit commitment. *Power Systems, IEEE Transactions on*, 25(4):1937–1945, 2010.
- [48] A. Lotfjou, M. Shahidehpour, Y. Fu, and Z. Li. Security-constrained unit commitment with ac/dc transmission systems. *Power Systems, IEEE Transactions on*, 25(1): 531–542, 2010.

- [49] H. Ma and S. M. Shahidehpour. Unit commitment with transmission security and voltage constraints. *Power Systems, IEEE Transactions on*, 14(2):757–764, 1999.
- [50] H. Ma and SM Shahidehpour. Transmission-constrained unit commitment based on benders decomposition. *International Journal of Electrical Power & Energy Systems*, 20(4):287–294, 1998.
- [51] T.L. Magnanti and R.T. Wong. Accelerating benders decomposition: Algorithmic enhancement and model selection criteria. *Operations Research*, 29(3):464–484, 1981.
- [52] Adilson E. Motter and Ying-Cheng Lai. Cascade-based attacks on complex networks. *Phys. Rev. E*, 66:065102, Dec 2002.
- [53] A.L. Motto, J.M. Arroyo, and F.D. Galiana. A mixed-integer LP procedure for the analysis of electric grid security under disruptive threat. *Power Systems, IEEE Transactions on*, 20(3):1357–1365, 2005.
- [54] Bernie Neenan, Donna Pratt, Peter Cappers, James Doane, Jeremy Anderson, Richard Boisvert, Charles Goldman, Osman Sezgen, Galen Barbose, Ranjit Bharvirkar, Michael K. Meyer, Steve Shankle, and Derrick Bates. How and why customers respond to electricity price variability: A study of nyiso and nyserda 2002 prl program performance. Technical report, 2003.
- [55] Narayana P. Padhy. Unit commitment—a bibliographical survey. *Power Systems, IEEE Transactions on*, 19(2):1196–1205, 2004.
- [56] M. Parvania and M. Fotuhi-Firuzabad. Demand response scheduling by stochastic scuc. *Smart Grid, IEEE Transactions on*, 1(1):89–98, 2010.
- [57] A. Pinar, A. Reichert, and B. Lesieutre. Computing criticality of lines in power systems. In *Circuits and Systems, 2007. ISCAS 2007. IEEE International Symposium on*, pages 65–68. IEEE, 2006.

- [58] A. Pinar, J. Meza, V. Donde, and B. Lesieutre. Optimization strategies for the vulnerability analysis of the electric power grid. *SIAM Journal on Optimization*, 20(4):1786–1810, 2010.
- [59] D.V. Punwani and C.M. Hurlbert. Unearthing hidden treasure. *Power Engineering*, 2005.
- [60] D. Rajan and S. Takriti. Minimum up/down polytopes of the unit commitment problem with start-up costs. *IBM Research Report*, 2005.
- [61] J. Salmeron, K. Wood, and R. Baldick. Analysis of electric grid security under terrorist threat. *Power Systems, IEEE Transactions on*, 19(2):905–912, 2004.
- [62] J. Salmeron, K. Wood, and R. Baldick. Optimizing electric grid design under asymmetric threat (II). Technical Report NPS-OR-04-001, Naval Postgraduate School, 2004.
- [63] J. Salmeron, K. Wood, and R. Baldick. Worst-case interdiction analysis of large-scale electric power grids. *Power Systems, IEEE Transactions on*, 24(1):96–104, 2009.
- [64] Ramteen Sioshansi and Walter Short. Evaluating the impacts of real-time pricing on the usage of wind generation. *Power Systems, IEEE Transactions on*, 24(2):516–524, 2009.
- [65] W.L. Snyder, H.D. Powell, and J.C. Rayburn. Dynamic programming approach to unit commitment. *Power Systems, IEEE Transactions on*, 2(2):339–348, 1987.
- [66] Chua-Liang Su. *Optimal Demand-Side Participation in Day-Ahead Electricity Markets*. PhD thesis, University of Mathester, 2007.
- [67] Chua-Liang Su and Daniel Kirschen. Quantifying the effect of demand response on electricity markets. *Power Systems, IEEE Transactions on*, 24(3):1199–1207, 2009.

- [68] Samer Takriti, Benedikt Krasenbrink, and Lilian S. Y. Wu. Incorporating fuel constraints and electricity spot prices into the stochastic unit commitment problem. 48(2):268–280, 2000.
- [69] Chuang-Li Tseng. *On power system generation unit commitment problems*. Ph.d., University of California, Berkeley, 1996.
- [70] C.L. Tseng, S.S. Oren, A.J. Svoboda, and R.B. Johnson. Price-based adaptive spinning reserve requirements in power system scheduling¹. *International Journal of Electrical Power & Energy Systems*, 21(2):137–145, 1999.
- [71] A. Tuohy, P. Meibom, E. Denny, and M. O’Malley. Unit commitment for systems with significant wind penetration. *Power Systems, IEEE Transactions on*, 24(2):592–601, 2009.
- [72] Aidan Tuohy, Peter Meibom, Eleanor Denny, and Mark O’Malley. Unit commitment for systems with significant wind penetration. *Power Systems, IEEE Transactions on*, 24(2):592–601, 2009.
- [73] J. Wang, M. Shahidehpour, and Z. Li. Security-constrained unit commitment with volatile wind power generation. *Power Systems, IEEE Transactions on*, 23(3):1319–1327, 2008.
- [74] Jianhui Wang, Audun Botterud, Vladimiro Miranda, Claudio Monteiro, and Gerald Sheble. Impact of wind power forecasting on unit commitment and dispatch. Technical report, 2009.
- [75] U.P. Wen and S.T. Hsu. Linear bi-level programming problems—a review. *Journal of the Operational Research Society*, pages 125–133, 1991.
- [76] E.S. William. Turbine inlet air cooling. *ASHRAE Journal article*, 1998.

- [77] L. Wu, M. Shahidehpour, and T. Li. Cost of reliability analysis based on stochastic unit commitment. *Power Systems, IEEE Transactions on*, 23(3):1364–1374, 2008.
- [78] Yiming Yao, T. Edmunds, D. Papageorgiou, and R. Alvarez. Trilevel optimization in power network defense. *Systems, Man, and Cybernetics, Part C: Applications and Reviews, IEEE Transactions on*, 37(4):712–718, july 2007.
- [79] Wei Yuan, Long Zhao, and Bo Zeng. Optimal power grid protection through a defender-attacker-defender model. *Reliability Engineering & System Safety*, 121:83–89, 2014.
- [80] Bo Zeng and Long Zhao. Solving two-stage robust optimization problems using a column-and-constraint generation method. *Operations Research Letters*, 41(5):457–461, 2013.
- [81] Qiaozhu Zhai, Xiaohong Guan, Jinghui Cheng, and Hongyu Wu. Fast identification of inactive security constraints in SCUC problems. *Power Systems, IEEE Transactions on*, 25(4):1946–1954, 2010.
- [82] L. Zhao and B. Zeng. An exact algorithm for two-stage robust optimization with mixed integer recourse problems. Under review, available in *optimization-online*, University of South Florida, 2011.
- [83] Long Zhao and Bo Zeng. Robust unit commitment problem with demand response and wind energy. In *Power and Energy Society General Meeting, 2012 IEEE*, pages 1–8, 2012. ©2013 IEEE. Reprinted with Permission.
- [84] Long Zhao and Bo Zeng. Vulnerability analysis of power grids with line switching. *Power Systems, IEEE Transactions on*, 28(3):2727–2736, 2013. ©2013 IEEE. Reprinted with Permission.

- [85] Long Zhao, Bo Zeng, and B. Buckley. A stochastic unit commitment model with cooling systems. *Power Systems, IEEE Transactions on*, 28(1):211–218, 2013. ©2013 IEEE. Reprinted with Permission.
- [86] F. Zhuang and F.D. Galiana. Towards a more rigorous and practical unit commitment by lagrangian relaxation. *Power Systems, IEEE Transactions on*, 3(2):763–773, 1988.

Appendices

Appendix A Reprint Permissions from IEEE

A.1 Reprint Permissions for Chapter 2

[Home](#)[Account Info](#)[Help](#)

Title: A Stochastic Unit Commitment Model With Cooling Systems
Author: Long Zhao; Bo Zeng; Buckley, B.
Publication: Power Systems, IEEE Transactions on
Publisher: IEEE
Date: Feb. 2013
Copyright © 2013, IEEE

Logged in as:
Long Zhao
Account #:
3000707802

[LOGOUT](#)

Thesis / Dissertation Reuse

The IEEE does not require individuals working on a thesis to obtain a formal reuse license, however, you may print out this statement to be used as a permission grant:

Requirements to be followed when using any portion (e.g., figure, graph, table, or textual material) of an IEEE copyrighted paper in a thesis:

- 1) In the case of textual material (e.g., using short quotes or referring to the work within these papers) users must give full credit to the original source (author, paper, publication) followed by the IEEE copyright line © 2011 IEEE.
- 2) In the case of illustrations or tabular material, we require that the copyright line © [Year of original publication] IEEE appear prominently with each reprinted figure and/or table.
- 3) If a substantial portion of the original paper is to be used, and if you are not the senior author, also obtain the senior author's approval.

Requirements to be followed when using an entire IEEE copyrighted paper in a thesis:

- 1) The following IEEE copyright/ credit notice should be placed prominently in the references: © [year of original publication] IEEE. Reprinted, with permission, from [author names, paper title, IEEE publication title, and month/year of publication]
- 2) Only the accepted version of an IEEE copyrighted paper can be used when posting the paper or your thesis on-line.
- 3) In placing the thesis on the author's university website, please display the following message in a prominent place on the website: In reference to IEEE copyrighted material which is used with permission in this thesis, the IEEE does not endorse any of [university/educational entity's name goes here]'s products or services. Internal or personal use of this material is permitted. If interested in reprinting/republishing IEEE copyrighted material for advertising or promotional purposes or for creating new collective works for resale or redistribution, please go to http://www.ieee.org/publications_standards/publications/rights/rights_link.html to learn how to obtain a License from RightsLink.

If applicable, University Microfilms and/or ProQuest Library, or the Archives of Canada may supply single copies of the dissertation.

[BACK](#)[CLOSE WINDOW](#)

A.2 Reprint Permissions for Chapter 3

[Home](#)[Account Info](#)[Help](#)

Title: Robust unit commitment problem with demand response and wind energy
Conference Proceedings: Power and Energy Society General Meeting, 2012 IEEE
Author: Long Zhao; Bo Zeng
Publisher: IEEE
Date: 22-26 July 2012
Copyright © 2012, IEEE

Logged in as:
Long Zhao
Account #:
3000707802

[LOGOUT](#)

Thesis / Dissertation Reuse

The IEEE does not require individuals working on a thesis to obtain a formal reuse license, however, you may print out this statement to be used as a permission grant:

Requirements to be followed when using any portion (e.g., figure, graph, table, or textual material) of an IEEE copyrighted paper in a thesis:

- 1) In the case of textual material (e.g., using short quotes or referring to the work within these papers) users must give full credit to the original source (author, paper, publication) followed by the IEEE copyright line © 2011 IEEE.
- 2) In the case of illustrations or tabular material, we require that the copyright line © [Year of original publication] IEEE appear prominently with each reprinted figure and/or table.
- 3) If a substantial portion of the original paper is to be used, and if you are not the senior author, also obtain the senior author's approval.

Requirements to be followed when using an entire IEEE copyrighted paper in a thesis:

- 1) The following IEEE copyright/ credit notice should be placed prominently in the references: © [year of original publication] IEEE. Reprinted, with permission, from [author names, paper title, IEEE publication title, and month/year of publication]
- 2) Only the accepted version of an IEEE copyrighted paper can be used when posting the paper or your thesis on-line.
- 3) In placing the thesis on the author's university website, please display the following message in a prominent place on the website: In reference to IEEE copyrighted material which is used with permission in this thesis, the IEEE does not endorse any of [university/educational entity's name goes here]'s products or services. Internal or personal use of this material is permitted. If interested in reprinting/republishing IEEE copyrighted material for advertising or promotional purposes or for creating new collective works for resale or redistribution, please go to http://www.ieee.org/publications_standards/publications/rights/rights_link.html to learn how to obtain a License from RightsLink.

If applicable, University Microfilms and/or ProQuest Library, or the Archives of Canada may supply single copies of the dissertation.

[BACK](#)[CLOSE WINDOW](#)

A.3 Reprint Permissions for Chapter 4



Title: Vulnerability Analysis of Power Grids With Line Switching
Author: Long Zhao; Bo Zeng
Publication: Power Systems, IEEE Transactions on
Publisher: IEEE
Date: Aug. 2013
Copyright © 2013, IEEE

Logged in as:
Long Zhao
Account #:
3000707802



Thesis / Dissertation Reuse

The IEEE does not require individuals working on a thesis to obtain a formal reuse license, however, you may print out this statement to be used as a permission grant:

Requirements to be followed when using any portion (e.g., figure, graph, table, or textual material) of an IEEE copyrighted paper in a thesis:

- 1) In the case of textual material (e.g., using short quotes or referring to the work within these papers) users must give full credit to the original source (author, paper, publication) followed by the IEEE copyright line © 2011 IEEE.
- 2) In the case of illustrations or tabular material, we require that the copyright line © [Year of original publication] IEEE appear prominently with each reprinted figure and/or table.
- 3) If a substantial portion of the original paper is to be used, and if you are not the senior author, also obtain the senior author's approval.

Requirements to be followed when using an entire IEEE copyrighted paper in a thesis:

- 1) The following IEEE copyright/ credit notice should be placed prominently in the references: © [year of original publication] IEEE. Reprinted, with permission, from [author names, paper title, IEEE publication title, and month/year of publication]
- 2) Only the accepted version of an IEEE copyrighted paper can be used when posting the paper or your thesis on-line.
- 3) In placing the thesis on the author's university website, please display the following message in a prominent place on the website: In reference to IEEE copyrighted material which is used with permission in this thesis, the IEEE does not endorse any of [university/educational entity's name goes here]'s products or services. Internal or personal use of this material is permitted. If interested in reprinting/republishing IEEE copyrighted material for advertising or promotional purposes or for creating new collective works for resale or redistribution, please go to http://www.ieee.org/publications_standards/publications/rights/rights_link.html to learn how to obtain a License from RightsLink.

If applicable, University Microfilms and/or ProQuest Library, or the Archives of Canada may supply single copies of the dissertation.

