

2011

# Fabrication and Characterization of Electrospun Cactus Mucilage Nanofibers

Yanay Pais

*University of South Florida, [ypais@mail.usf.edu](mailto:ypais@mail.usf.edu)*

Follow this and additional works at: <http://scholarcommons.usf.edu/etd>

 Part of the [American Studies Commons](#), [Electrical and Computer Engineering Commons](#),  
[Materials Science and Engineering Commons](#), and the [Nanoscience and Nanotechnology Commons](#)

---

## Scholar Commons Citation

Pais, Yanay, "Fabrication and Characterization of Electrospun Cactus Mucilage Nanofibers" (2011). *Graduate Theses and Dissertations*.  
<http://scholarcommons.usf.edu/etd/3279>

This Thesis is brought to you for free and open access by the Graduate School at Scholar Commons. It has been accepted for inclusion in Graduate Theses and Dissertations by an authorized administrator of Scholar Commons. For more information, please contact [scholarcommons@usf.edu](mailto:scholarcommons@usf.edu).

Fabrication and Characterization of Electrospun Cactus Mucilage Nanofibers

by

Yanay Pais

A thesis submitted in partial fulfillment  
of the requirements for the degree of  
Master of Science in Electrical Engineering  
Department of Electrical Engineering  
College of Engineering  
University of South Florida

Major Professor: Sylvia Thomas, Ph.D.  
Norma Alcantar, Ph.D.  
Maria Celis, Ph.D.

Date of Approval:  
June 23, 2011

Keywords: nopal, prickly pear, *Opuntia ficus-indica*, polyvinyl alcohol,  
electrospin

Copyright © 2011, Yanay Pais

## **DEDICATION**

I would like to dedicate this thesis and all that may come after to my wonderful parents Mr. Jose Pais and Mrs. Ana Pais, and to the rest of my big and lovely family.

Thank you all the support and love you have shown me. Know that I am grateful that you have and always been there to push me and inspire me to work harder and reach higher.

## **ACKNOWLEDGMENTS**

I am forever grateful to my major professor, Dr. Sylvia Thomas for always having time to listen and give words of direction or encouragement. Thank you for all the help, insight, faith and support you have shown me.

Thank you to Dr. Norma Alcantar for giving understanding and reassuring advice.

Dr. Maria Celis I have to thank for all the time and effort she spent teaching me and working alongside me.

Multiple thanks go to my fellow Ambir research group members and friends, especially to Mr. Brandon Richard and his knowledge of electrospinning and Mr. Samuel Perez for assistance in characterization.

Thank you to Dr. Alcantar's research group. Especially to Mrs. Dawn Fox who always had time to listen and help in the lab.

Also thank you to ESTARS and NSF RAPID grant for funding in this project.

## TABLE OF CONTENTS

LIST OF TABLES	iii
LIST OF FIGURES	iv
ABSTRACT	vii
CHAPTER 1: INTRODUCTION	1
1.1. Thesis Structure	1
1.2. Introduction	1
1.3. Significance of This Study	2
1.4. Research Goals	3
1.4.1. Goal 1: Mucilage Mixture Study	3
1.4.2. Goal 2: Electrospinning Mucilage	3
1.4.3. Goal 3: Characterization of Mucilage Nanofibers	3
CHAPTER 2: WATER CONTAMINATION	4
2.1. The Current Water Situation	4
2.2. Present Water Treatment Methods	4
2.2.1. Filtration	5
2.3. Implications of This Project	7
CHAPTER 3: THE STUDY OF CACTUS MUCILAGE	8
3.1. Characteristics of the Cactus	8
3.2. Cactus Mucilage	9
3.3. The Chemical Structure of Mucilage	9
3.4. Studies on Water Treatment Using Mucilage	11
CHAPTER 4: ELECTROSPINNING NANOFIBERS	13
4.1. Producing Nanofibers	13
4.2. The Electrospinning Process	14
4.3. Polymers	15
4.3.1. Polyvinyl Alcohol	16
4.3.2. Biological Polymers	17
4.4. Application of Electrospun Nanofibers	18
4.4.1. Nanofibers in Water Treatment	19

CHAPTER 5: EXPERIMENTAL PROCEDURE	21
5.1. Mucilage Extraction	21
5.2. Mucilage Solution Mixture	22
5.3. Polyvinyl Alcohol Mixtures	22
5.4. The Mucilage and PVA Mixtures	22
5.5. Electrospinning Experiment Setup	23
CHAPTER 6: RESULTS AND DISCUSSION	25
6.1. Mucilage Extraction	25
6.2. Mixtures	25
6.3. Mucilage and PVA Ratio Nanofiber Results	26
6.4. PVA Molecular Weight Nanofiber Results	31
6.5. NaOH and Water Washes	37
6.6. Differential Scanning Calorimetry Test	39
6.7. FT-IR Spectroscopy Attenuated Total Reflectance	40
CHAPTER 7: CONCLUSION AND FUTURE WORK	42
7.1. Summary of Findings	42
7.2. Future Work	43
7.3. Final Remarks	43
REFERENCES	44

## LIST OF TABLES

Table 1:	Overview of Commercial Nanofiltration Membranes [10]	7
Table 2:	PVA and Mucilage Ratio Mixtures	23
Table 3:	Parameters Set for Electrospinning Setup	24
Table 4:	PVA Experimental Mixtures	26

## LIST OF FIGURES

Figure 1:	Filtration Types Versus Size of Common Contaminants [4]	6
Figure 2:	Naturally Growing Prickly Pear Cactus with Flowers and Fruit	9
Figure 3:	The Partial Structure of <i>Ofi</i> Mucilage[14, 15]	10
Figure 4:	Fluorescent Images of <i>E. coli</i> With and Without Mucilage [16]	12
Figure 5:	A Follicle of Human Hair Overlaid a Nanofiber Mesh [27]	13
Figure 6:	Electrospinning Diagram [20]	16
Figure 7:	SEM Images of Defects Formed at Lower Levels of Polymer Concentration [17]	17
Figure 8:	Potential Applications for Electrospun Nanofibers [17]	19
Figure 9:	A Depiction of Filtration Membranes Using a Support or Scaffold [28]	20
Figure 10:	Mucilage Extraction Process Flow [5]	21
Figure 11:	A) Electrospinning Setup B) Close Up of Syringe and Collector Plate	24
Figure 12:	SEM Image at 11Kx 9% PVA and Mucilage (70:30) PVA:Mucilage	27
Figure 13:	SEM Image at 100Kx 9% PVA and Mucilage (70:30) PVA:Mucilage	27
Figure 14:	Microscope Image at 50x 9% PVA and Mucilage (30:70) PVA:Mucilage	28
Figure 15:	Microscope Image at 100x 9% PVA and Mucilage (50:50) PVA:Mucilage	28



Figure 16:	Microscope Image at 100x 9% PVA and Mucilage (70:30) PVA:Mucilage	29
Figure 17:	Microscope Image at 100x 11% PVA and Mucilage (70:30) PVA:Mucilage	29
Figure 18:	SEM Image Top View of 11% PVA and Mucilage (70:30) PVA:Mucilage	30
Figure 19:	SEM Image at 70Kx of 11% PVA and Mucilage (70:30) PVA:Mucilage Fiber Measured at 52nm.	30
Figure 20:	SEM Image at 6Kx of 11% PVA and Mucilage (70:30) PVA:Mucilage Fiber Measured at 7.8 $\mu$ m.	31
Figure 21:	AFM Image at 10 $\mu$ m for 9% Low M PVA and Mucilage (70:30) PVA:Mucilage	32
Figure 22:	AFM Image at 1 $\mu$ m for 9% Low M PVA and Mucilage (70:30) PVA:Mucilage	32
Figure 23:	AFM Sectional Analysis Image at 1 $\mu$ m for 9% Low M PVA and Mucilage (70:30) PVA:Mucilage Fiber Diameter 177nm	33
Figure 24:	AFM Image at 10 $\mu$ m for 9% High M PVA and Mucilage (70:30) PVA:Mucilage	34
Figure 25:	AFM Image at 1 $\mu$ m for 9% High M PVA and Mucilage (70:30) PVA:Mucilage	34
Figure 26:	Sectional Analysis Image at 1 $\mu$ m for 9% High M PVA and Mucilage (70:30) PVA:Mucilage Fiber Diameter 460 nm	35
Figure 27:	Sectional Analysis Image at 1 $\mu$ m for 9% High M PVA and Mucilage (70:30) PVA:Mucilage Fiber Diameter 4 $\mu$ m	35
Figure 28:	3D AFM Image at 1 $\mu$ m for 9% Low M PVA and Mucilage (70:30) PVA:Mucilage	36
Figure 29:	3D AFM Image at 1 $\mu$ m for 9% High M PVA and Mucilage (70:30) PVA:Mucilage	36
Figure 30:	Mucilage and PVA Nanofiber Mesh Used in Washes	37
Figure 31:	NaOH Crystals and Pure Mucilage Nanofibers Microscope 20x	38

Figure 32:	Pure Mucilage Nanofibers a) Microscope 50x b) Microscope 100x	38
Figure 33:	DSC Test of Nanofibers	39
Figure 34:	Absorbance of Pure Mucilage	40
Figure 35:	Absorbance of PVA and Mucilage Nanofibers	41

## ABSTRACT

This work seeks to fabricate, optimize, and characterize nanofibers of cactus *Opuntia ficus-indica* mucilage and Poly (vinyl alcohol) (PVA) by electrospinning. Mucilage is a neutral mixture of sugars produced by cactus and PVA is a non-toxic, water-soluble, synthetic polymer, which is widely used as a co-spinning agent for polymers. Mucilage was extracted from the cactus pad and prepared for electrospinning by mixing with acetic acid. Two types of PVA were used differentiating in high and low molecular weights. Concentrations of PVA were varied to find an adequate threshold for fiber formation. Changing the ratio of PVA to cactus mucilage produced fibers of different diameter and quality. The optimizations of the parameters used in the electrospinning setup were also a factor in creating quality fibers without deformity. An acceptable PVA to mucilage ratio mixture was reached for the use of the electrospinning process and consistent nanofibers were accomplished with the use of both the low and high molecular weight PVA. The fibers were observed using a Scanning Electron Microscope, Atomic Force Microscopy, and Differential Scanning Calorimetry. In this project we were able to obtain nanofiber meshes made with environmentally friendly materials with fiber diameters ranging from 50nm to 7 $\mu$ m sized. The produced nanofibers were made in the hope that it can be utilized in the future as an inexpensive, biocompatible, and biodegradable water filtration system.

## **CHAPTER 1: INTRODUCTION**

### **1.1. Thesis Structure**

The following thesis will introduce the concept of mucilage nanofibers made from the cactus *Opuntia ficus-indica* mucilage by way of electrospinning and the uses this material can serve. Chapter One is an overall introduction to the project. Chapter Two outlines the current use of nanofibers in water treatment and filtration. Chapter Three introduces cactus mucilage and the reason it was chosen for this project. Chapter Four explains the method of electrospinning and its current uses. The experimental procedures and characterization are detailed in Chapters Five. In Chapter Six the results are discussed and Chapter Seven serves as conclusions and recommendations for future work.

### **1.2. Introduction**

Water is fundamental for life on earth and clean water is a necessity for everyone. Unfortunately getting clean water is a hardship many people still face. Although access to potable water has improved in the last hundred years, communities in developing countries are still affected by unhygienic drinking water. According to the World Health Organization 1.4 million children die from diarrhea annually [1]. These unfortunate deaths could be prevented by increasing access to safe drinking water but the process of cleaning contaminated water is sometimes difficult and costly.

Researchers are always looking for new and affordable methods of getting rid of water contaminants. To help maintain global sustainability of human health and welfare we must develop ways to filter and clean our existing water resources. Of particular interest is the filtration of environmental contaminants with inexpensive, non-toxic, natural materials.

Nanofiber meshes are being used as water filtration devices but are mostly made up of non-organic materials that are not biodegradable. In this project we wish to obtain nanofiber meshes that are made with environmentally friendly materials.

### **1.3. Significance of This Study**

This research aims to investigate cactus mucilage based fibers as a possible treatment for water purification. These non-woven nanofibers are to be spun using an electrospinning technique and further studied for an optimization of nanofiber mesh production. Electrospinning is a safe, simple, and reliable method of producing nanofibers meshes. In this study we chose the *Opuntia ficus-indica* also known as the prickly pear because it is an abundant plant that can be found almost anywhere in the world. It has also been studied for its water purification abilities.

Apart from water filtration the mucilage nanofibers can be utilized for many other applications such as; air and gas filtration, absorption, sensors, tissue scaffolding, tissue engineering, drug delivery, catalyst, enzyme carrier, food additive, and textiles among other uses.

This study will hopefully increase the body of knowledge in the field of electrospun natural fibers and the capabilities of cactus mucilage. This method to producing nanofiber meshes out of plant material is in the process of being patented. It

will also lead to a future water filtration system that is affordable, biodegradable, sustainable, and can be utilized worldwide to help millions.

#### **1.4. Research Goals**

The goals of this work are as follows.

##### **1.4.1. Goal 1: Mucilage Mixture Study**

The first goal of this project is to find a method of mixing a mucilage solution that is capable of being electrospun. Different percentages of mucilage and solutions will be used to find the best balanced mixtures for optimal electrospinning.

##### **1.4.2. Goal 2: Electrospinning Mucilage**

There are many parameters that can affect the outcome of electrospun nanofibers. This study will find a set of parameters that are best for electrospinning nanofibers composed of cactus mucilage. Changing parameters that are part of the electrospinning set up greatly effects the characteristics of the fibers that are formed.

##### **1.4.3. Goal 3: Characterization of Mucilage Nanofibers**

Once nanofibers are formed they must be studied to determine which fiber formations work best for our purposes. Nanofibers were characterized using Scanning Electron Microscope, Atomic Force Microscopy, and Differential Scanning Calorimetry.

## **CHAPTER 2: WATER CONTAMINATION**

### **2.1. The Current Water Situation**

Access to clean water is necessary for continuity of a healthy life. About 1.1 billion people in developing countries struggle with the challenge of cleaning contaminated water in their communities [1]. Water is also essential in industries such as electronics, pharmaceuticals and food [2]. It is clear that obtaining water free of contaminants is a major concern as the availability of fresh water is decreased [2]. Contaminants in water can be chemical, biological, either naturally occurring in the environment or man-made.

### **2.2. Present Water Treatment Methods**

Since ancient times, people have tried different methods of cleaning water. It has always been important to remove the smell, taste, turbidity, metals and pathogens that can exist in water [3]. Some of the methods to reduce contamination are basic sedimentation, chemical treatment and filtration.

Sedimentation is a method of waiting for the particles in water to settle to the bottom by means of gravity and then removing the clean supernatant water. While this method has been used for thousands of years and is inexpensive, it is incapable of removing small microbes and metals that remain in the water [3].

Chemical treatment is also used to kill off viruses and bacteria living in water. The chemicals most widely used are chlorine and iodine. While these chemicals are easy to come by, getting the exact dosage to disinfect can be difficult. In addition these chemicals are poisonous and adding too much in drinking water can cause illnesses, organ damage, and even death [4].

Filtration is commonly used in conjunction with sedimentation and chemical treatments [3].

### **2.2.1. Filtration**

Water filtration by definition means to sift out the impurities found in water. The size of the filtering pore is important to determine the size of particles that can be separated.

Traditionally filters can be made of sand, gravel, and charcoal. Newer filtering methods are made from ceramics, carbon, and woven and non-woven fibers. Below in Figure 1 are listed several types of filtering processes including conventional filtration, microfiltration, ultrafiltration, nanofiltration, and reverse osmosis. Filtration membranes are much needed and highly utilized in water purification, waste treatment and in clarification and concentration processes [6].

The size of the pores in the filters dictates the size of the materials that can be filtered out of the water. Nanofiltration and reverse osmosis are able to remove the smallest 0.001 microns sized particles, including pesticides, dyes, and other organic contaminants [5, 7]. Reverse osmosis is generally used in conjunction to carbon filtration for desalination processes. Unfortunately reverse osmosis requires a large amount of



energy to operate and water is lost in the process as well as some dissolved natural occurring minerals that are needed for human nutrition [7, 8].

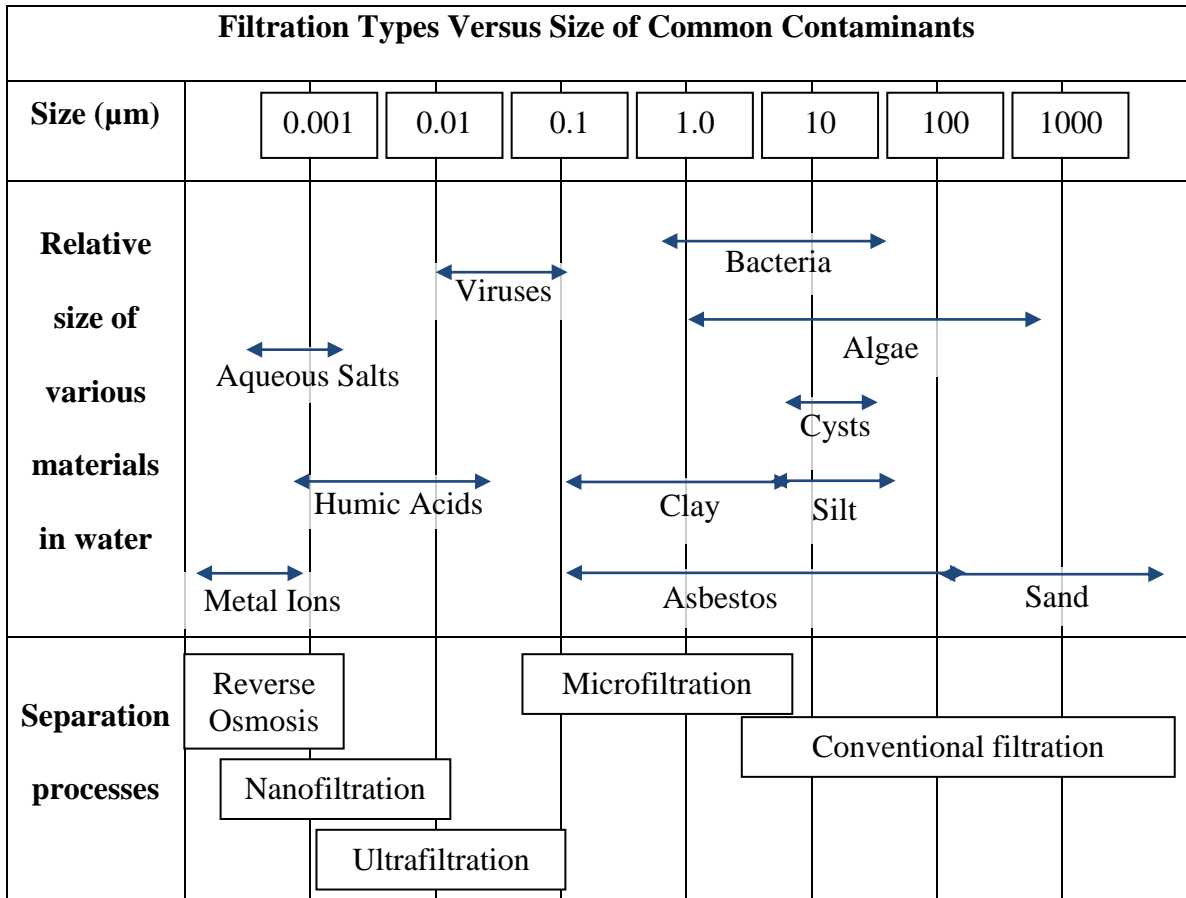

Figure 1: Filtration Types Versus Size of Common Contaminants [4]

Nanofiltration has been around since the 1970s and has been known as “low pressure reverse osmosis” [9]. It is seen as a combinatory process capable of removing hardness and a wide range of other components in one step [9]. These small membranes are hailed for their compactness, low-cost operation, energy-efficiency and high throughput [6]. Unfortunately most of the commercially available membranes are made

with synthetic materials and are not biodegradable [10]. See Table 1 for an overview of the nanofiltration membranes by manufacturer and composition.

Table 1: Overview of Commercial Nanofiltration Membranes [10]

Membrane	UTC20	Desal5DL	Desal5HL	NTR7450	N30F	NFPES10
Manufacturer	Toray <sup>a</sup>	GE Osmonics <sup>b</sup>	GE Osmonics <sup>b</sup>	Nitto-Denko <sup>c</sup>	Nadir <sup>d</sup>	Nadir <sup>d</sup>
MWCO (Da)	180	150-300	150-300	600-800	400	1000
Max. Temp (°C)	35	90	50	40	95	95
pH range	3-10	1-11	3-9	2-14	0-14	0-14
Composition top layer	Polypiperazineamide	Cross-linked aromatic polyamide	Cross-linked aromatic polyamide	Sulfonated polyether-sulfone	Permanently hydrophilic polyether-sulfone	Permanently hydrophilic polyether-sulfone

<sup>a</sup>Tokyo, Japan; <sup>b</sup>Lee Mee sur Seine, Frankrijk; <sup>c</sup>Somicon AG, Basel, Switzerland; <sup>d</sup>Wiesbaden, Germany.

### 2.3. Implications of This Project

It has been established that nanofiltration will become a critical components of industrial and public water purification systems as more progress is made toward the synthesis of cost-effective and environmentally acceptable functional materials [2]. This project hopes to create a nanofiltration system made from mucilage of a cactus.

The project itself would help enhance the knowledge of water remediation. Introduce an environmentally friendly, non-toxic, and biodegradable method of water treatment. It would also provide a sustainable technology for water filtration that is economically competitive and affordable across the world.

## CHAPTER 3: THE STUDY OF CACTUS MUCILAGE

### 3.1. Characteristics of the Cactus

The genus *Opuntia* is the largest under the *Cactaceae* family [11]. Domestication of *Opuntia ficus-indica* (*Ofi*) started in Mexico about 9000 years ago [12]. After the colonization of the Americas the *Ofi* plant was introduced to Spain and then the rest of the Mediterranean [12]. Varieties of *Opuntia* can now be found all around the world [11]. Figure 2 is an example of a flowering *Ofi* plant.

*Ofi* or prickly pear is a very versatile plant. *Ofi* leaves and fruits have been used in rural Mexico for their medicinal benefits, such as for treating arteriosclerosis, diabetes, and gastritis and hyperglycemia [11]. Studies have been made to use the prickly pear for cultivation as an alternative to cereal and forage crops. The fruits of the cactus were to be used for human consumption and the green pads for livestock feeding [13]. The cactus has been also studied for its antioxidant properties. It is also being studied for its ability to reduce turbidity and other contaminants in water [5].



Figure 2: Naturally Growing Prickly Pear Cactus with Flowers and Fruit

### 3.2. Cactus Mucilage

The mucilage inside the *Ofi* plant is a thick, gummy clear substance. Like mucilage from other plants, it aids in retaining and storing water for the cactus. Mucilage swells when in contact with water giving it the ability to precipitate ions and particles from aqueous solutions [5]. Most of the mucilage is found on the cladodes or pads of the cactus. The mucilage content in the cladodes is influenced not only by the handling of the crop but is also dependent on the temperature, and irrigation [13].

### 3.3. The Chemical Structure of Mucilage

Mucilage is a neutral, complex carbohydrate composed of 55 sugar residues including arabinose (67.3%), galactose (6.3%), rhamnase (5.4%), and xylose (20.4%),

and a galacturonic acid [13, 14]. It also contains organic species which give the capacity to interact with metals, cations and biological substances such as K, Ca, Mg, Fe, Na, and others [14]. This unique surface activity enhances dispersion, creates emulsifications, and reduces tension of high polarity fluids.

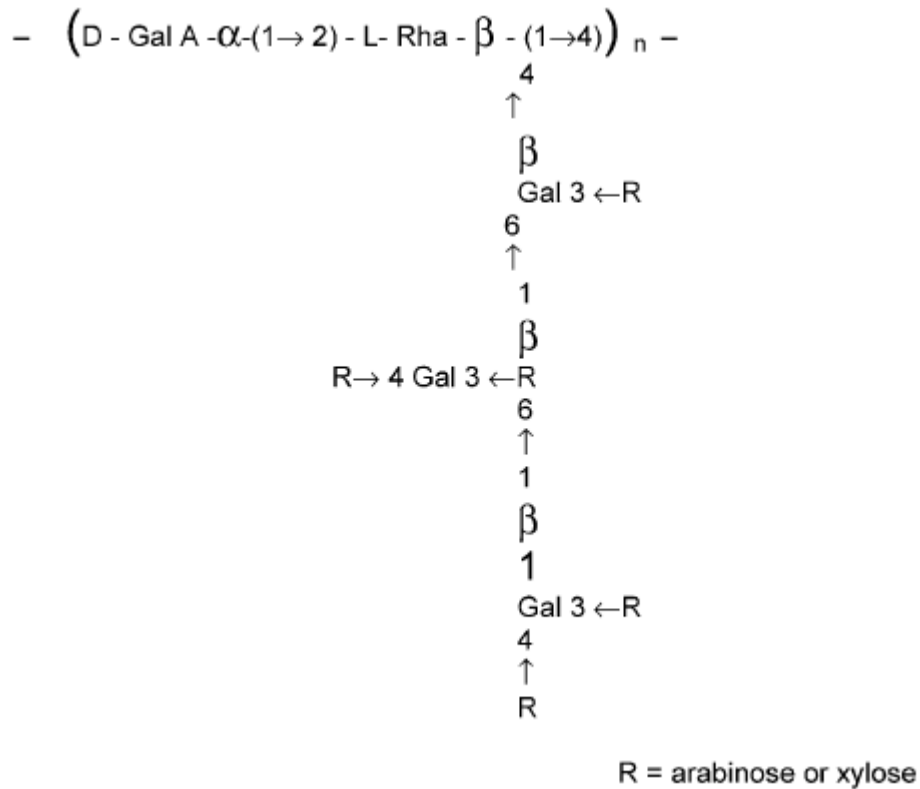

Figure 3: The Partial Structure of *Ofi* Mucilage [14, 15]

Figure 3 shows a partial structure of mucilage as proposed by McGarvie and Parolis [14, 15]. R indicates the presence of different arabinose and xylose forms, D-Gal indicating D-galacturonic acid, Gal indicating galactose, and Rha indicating Rhamnose [13, 14, 15].

### **3.4. Studies on Water Treatment Using Mucilage**

Studies have been made on the use of the *Ofi* mucilage as a treatment for water. A study by Alcantar and Young proved that mucilage has a flocculating ability that is comparative to the widely used aluminum sulphate. The ability to remove turbidity has also shown promising results with mucilage [5]. In the same laboratory trials and others following it mucilage has also been shown as a promising arsenic removal agent [5]. Other researchers have proven to remove hard substances such as lime, from water [13].

In another study by Alcantar and Buttice, it was proven that by using mucilage (C in Figure 4) bigger flocs of *E. coli* formed when suspended in water [16]. Flocs were also formed with mucilage and *B. cereus* in water [16]. Giving to the conclusion that *Ofi* mucilage is able to remove bacteria from water.

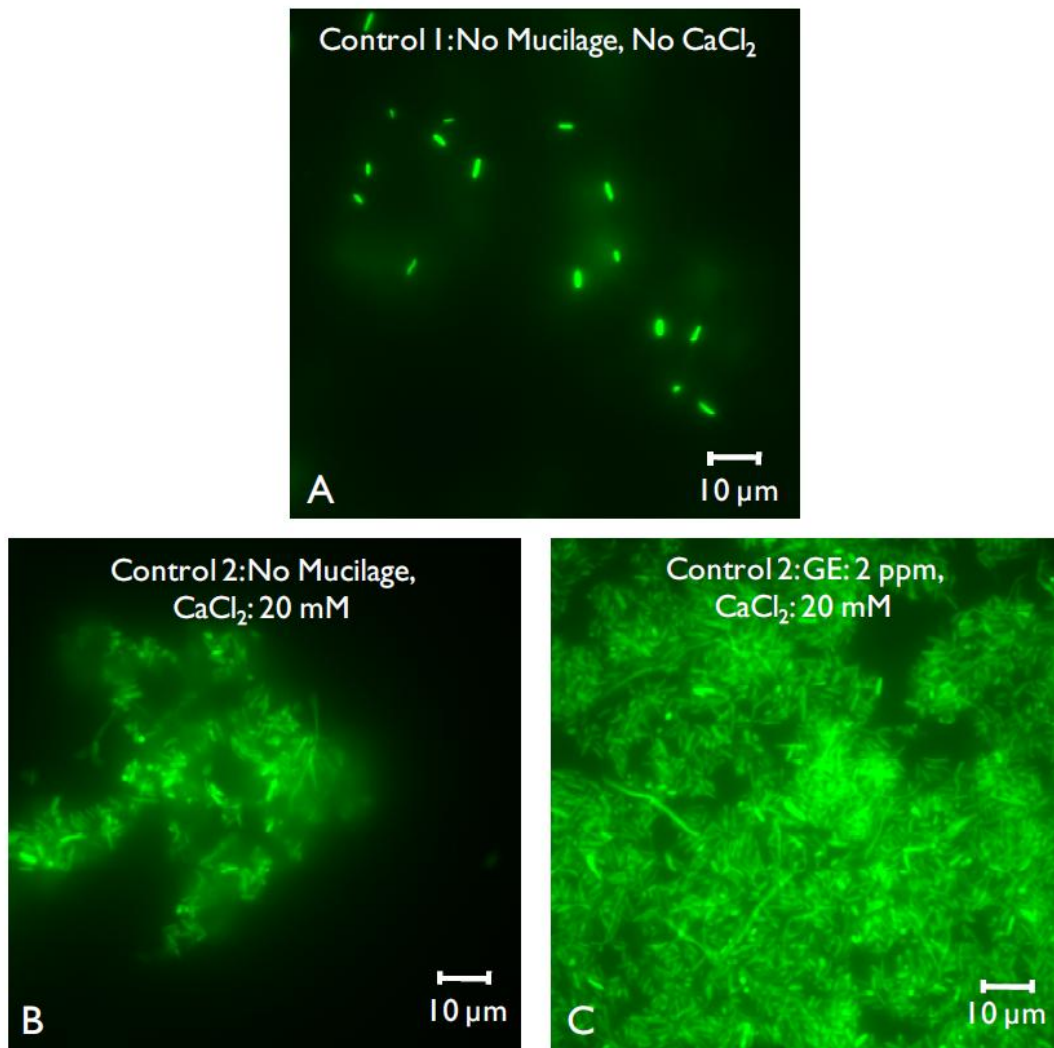

Figure 4: Fluorescent Images of *E. coli* With and Without Mucilage [16]

Research has also recently been conducted by Alcantar with mucilage's ability to absorb/adsorb, disperse, and emulsify oil in salinized and fresh water with promising results.

## CHAPTER 4: ELECTROSPINNING NANOFIBERS

### 4.1. Producing Nanofibers

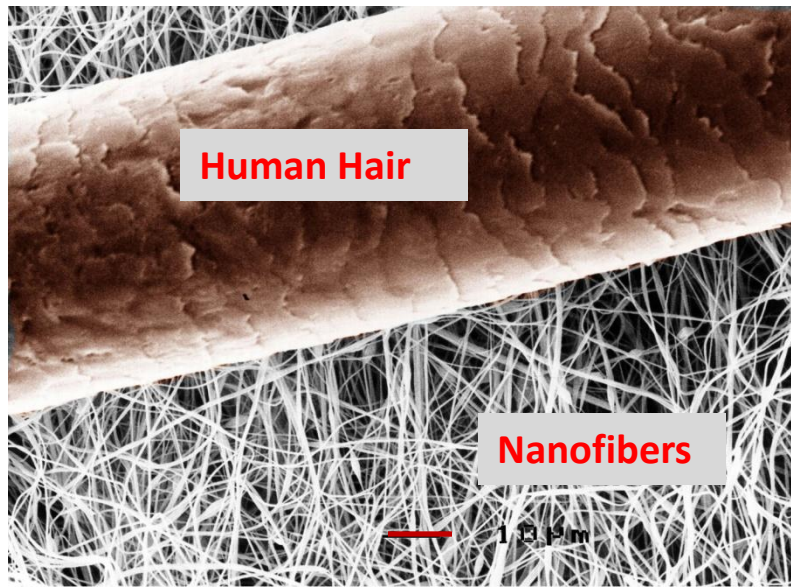

Figure 5: A Follicle of Human Hair Overlaid a Nanofiber Mesh [27]

Electrospinning is a simple and inexpensive method of fabricating nanofibers from synthetic or natural polymers. The procedure of electrospinning was first patented in 1934, describing an experimental setup for producing polymer filaments using electrostatic force [16, 17]. In recent years electrospinning has been increasingly researched because of the growing interest in nanotechnology and the construction of nanofiber meshes [16].



Other forms of producing nanofibers include template synthesis and phase separation. Template synthesis uses a nanoporous membrane as a template to make nanofiber shapes, either hollow or solid. This method is not able to continuously create nanofibers. Phase separation nanofibers are created by dissolution, gelation, extraction with different solvents, freezing, and drying resulting in nanoscale porous foam. This process takes a relatively long period of time to create the nanoscale porous foam [16].

The electrospinning process seems to be the preferable method to further develop the mass production of one-by-one continuous nanofibers from polymers and produce two-dimensional nanostructures [16, 18].

#### **4.2. The Electrospinning Process**

The electrospinning or electro static process is fairly simple. A high voltage is used to create a charged jet of polymer solution to come out of a needle. An electrode is placed on the needle and a collector is grounded, driving a high voltage electric field between them. The charged polymers evaporate and solidify into a network of tiny fibers that are collected onto the grounded plate [16, 19].

Solutions of polymers are mixed by dissolving solid polymers with a proper solvent. Mixtures are different depending on the polymer but once liquid is attained it is transferred to a syringe with needle. This dissolving process and the electrospinning can take place at room temperature at atmospheric conditions.

Usually a syringe pump is used to help push the polymer solution to the tip of the needle. A capillary is formed and held at the end of the needle by surface tension [16]. A DC voltage supply of several kilovolts is used to create an electric field between needle tip and collector. The electric field helps to induce a charge on the surface of the liquid

and causes a force directly opposite to the surface tension directed towards the grounded collector plate [19]. Increasing the electric field, forces the hemispherical shape of the capillary into a cone shape. This cone shape is known as the Taylor cone [16]. A critical value is attained in which the electric field force surpasses the surface tension, and the fluid is ejected from the Taylor cone tip [16]. The expelled polymer solution becomes unstable and elongates allowing the jet to become very thin and long [16]. The solvents evaporate leaving behind charged polymers fibers that solidify at the collector plate [19]. See Figure 6 for a diagram of the electrospinning process [20].

There are many aspects of the electrospinning process that need to be taken into consideration to get the wanted nanofibers. These parameters include: voltage, syringe size, needle size, syringe infusion rate, and distance from collector plate. All of these parameters had to be closely monitored in this project to achieve the desired results.

### **4.3. Polymers**

To electrospin cactus mucilage a co-spinning polymer must be added to help start forming the polymer chains needed for nanofiber formation.

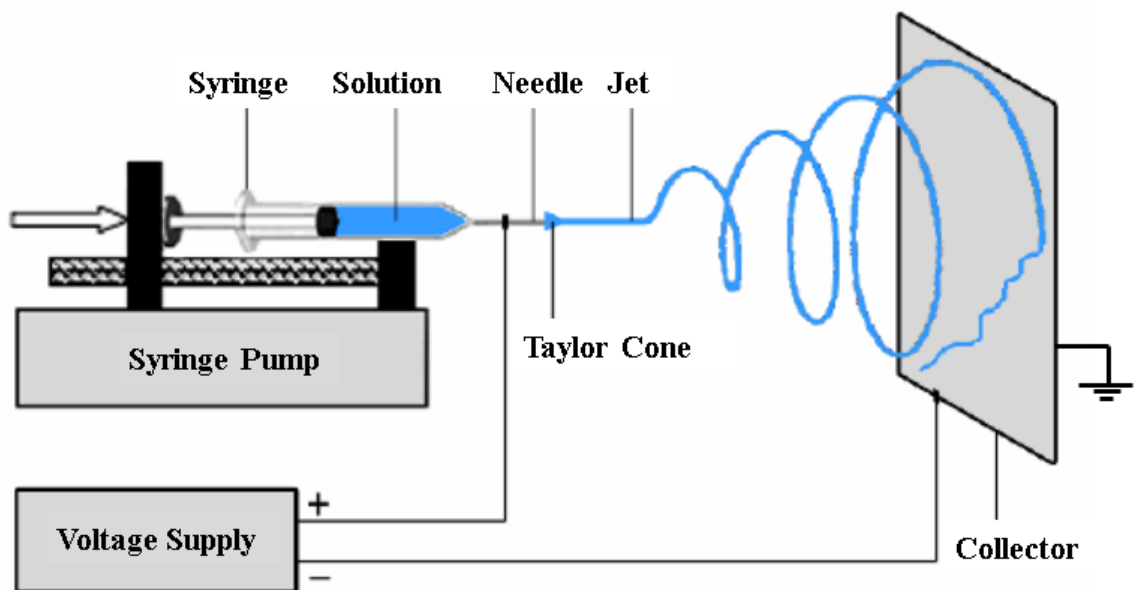

Figure 6: Electrospinning Diagram [20]

#### 4.3.1. Polyvinyl Alcohol

For the purpose of this study, polyvinyl alcohol (PVA) was used as a co-spinning polymer. Although there are many polymers that have been used for electrospinning PVA was chosen because it is a water soluble polymer that is odorless, non-toxic, biodegradable, and biocompatible [21]. It is also resistant to oil and solvents and has high tensile strength and flexibility.

PVA was a good choice considering other natural polymers and carbohydrates that have been successfully spun with PVA [21-24]. When spinning PVA as a co-spinning agent with carbohydrates it is important to monitor the concentration and ratios of carbohydrates to PVA.

The percent concentration of the solution had to be closely monitored in this project to achieve defect free fiber formation. If the polymer concentration is too low many defects or no fibers would be formed. The viscosity of the solution is related to the

number of polymer chains in the solution [17]. See Figure 7 for a diagram of how the polymer concentration affects defects found in fiber formation.

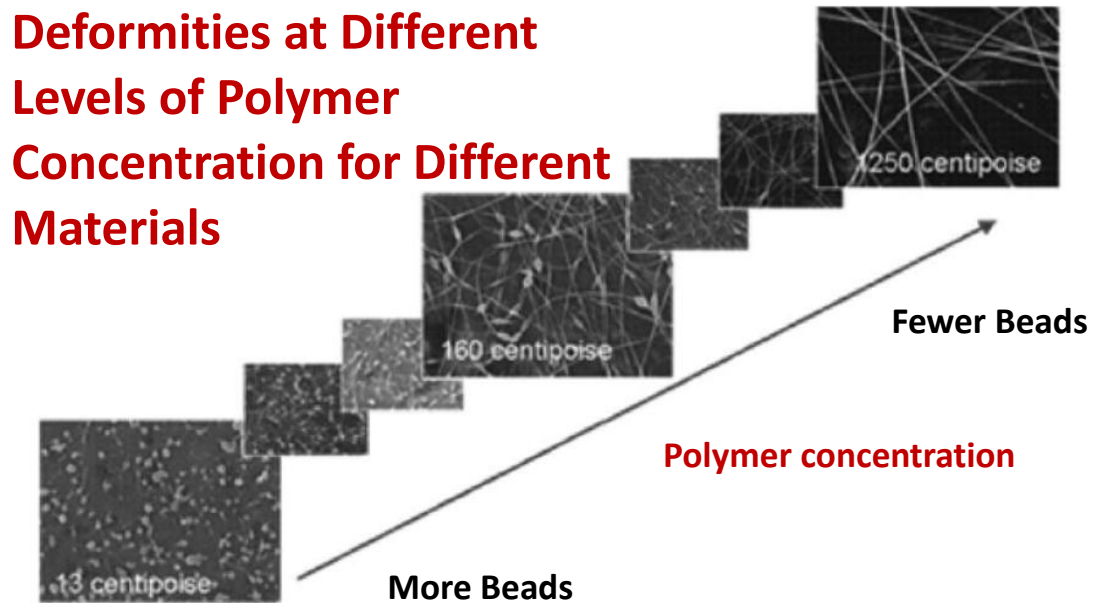

Figure 7: SEM Images of Defects Formed at Lower Levels of Polymer Concentration [17]

#### 4.3.2. Biological Polymers

It is troublesome spinning carbohydrates and other biological components alone because the need for a co-spinning agent such as PVA and a solvent to help dissolution. Many studies have used acetic acid or other acids to help break down carbohydrates such as chitosan [21, 23], cellulose [24, 25], and levan [26].

Acetic acid was chosen for this research because it is a weak acid that can easily be diluted and still be harmless and biocompatible when mixed in the mucilage and PVA electrospinning solution.

#### **4.4. Application of Electrospun Nanofibers**

Electrospun nanofibers are prominent because of their small diameter, large surface area per unit mass, extremely small pore size, and superior mechanical properties [20]. These features make them an ideal material for many applications.

Other studies have been made to fabricate fibers that are not only non-woven meshed but also aligned, patterned, twisted yarn, and three-dimensional structures [18]. Recently several methods have been developed to control the deposition behavior of the fibers either by rotating drums, disk collectors, parallel electrodes, among others that were able to align nanofiber arrays [18].

Fibers can be made from a few nanometers to a couple of micrometers and have many uses in industry [17, 20]. These applications include but are not limited to water filters, air filters, composites, drug delivery, tissue scaffolds, MEMS devices, and sensors. See Figure 8 for a chart of the many uses for electrospun nanofibers [17].

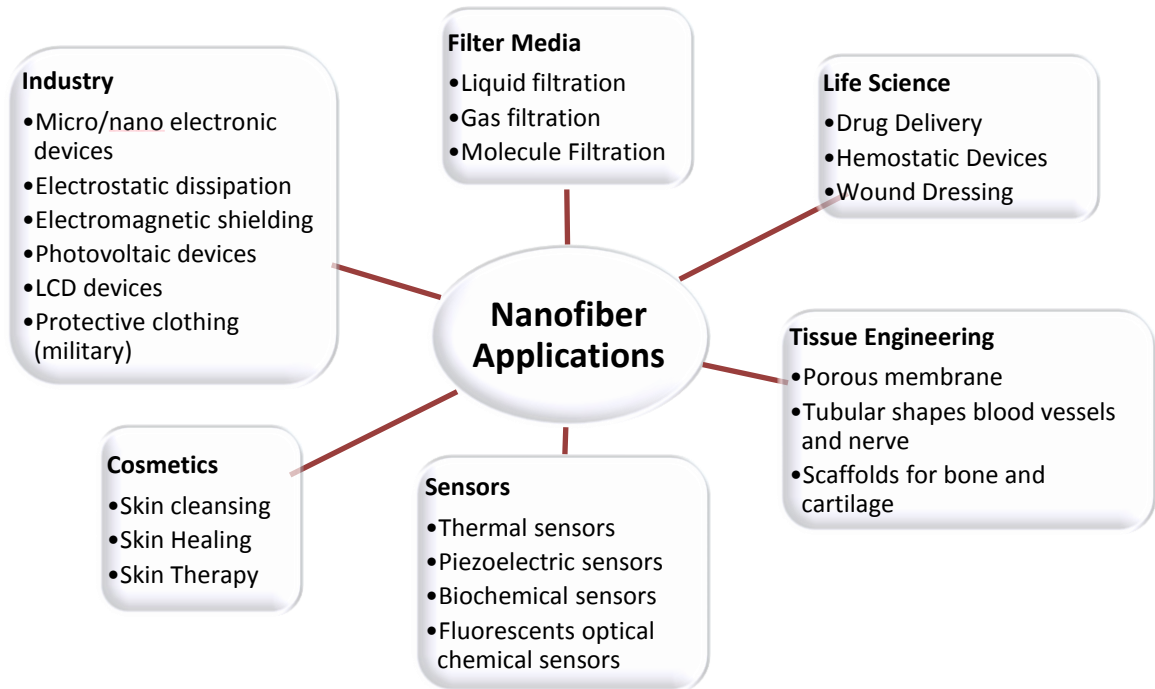

Figure 8: Potential Applications for Electrospun Nanofibers [17]

#### 4.4.1. Nanofibers in Water Treatment

Electrospun nanofibrous membranes possess several attributes that make them very attractive in water filtration technology. They have high porosity, pore sizes ranging from tens of nanometer to several micrometers, interconnected open pore structure, and a large surface area per unit volume [6].

One of the drawbacks from using electrospun nanofiber meshes is that they require additional support and are usually placed either over a support as seen in commercial air filters [17], ‘sandwiched’ between various layers [17] or blended together with micron fibers [18]. Figure 9 can be seen as a depiction of a electrospun filtration setup with scaffolding supports [28].

Layering different size of nanopore fiber meshes has the advantage of creating low fouling nanofilters [6, 28]. This is a highly effective in helping the structures filter for a longer period of time, extending their shelf life [6].

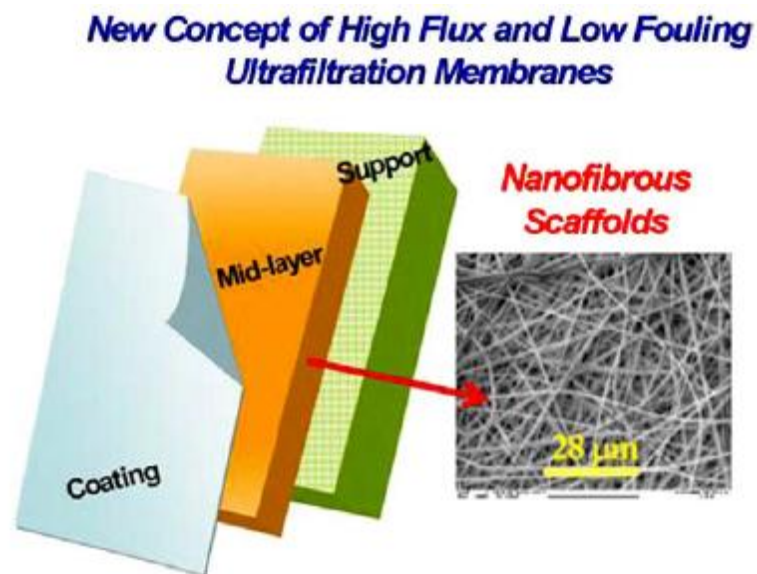

Figure 9: A Depiction of Filtration Membranes Using a Support or Scaffold [28]

## CHAPTER 5: EXPERIMENTAL PROCEDURE

### 5.1. Mucilage Extraction

The procedure for extracting mucilage from the *Opuntia-ficus indica* can be followed in Figure 10.

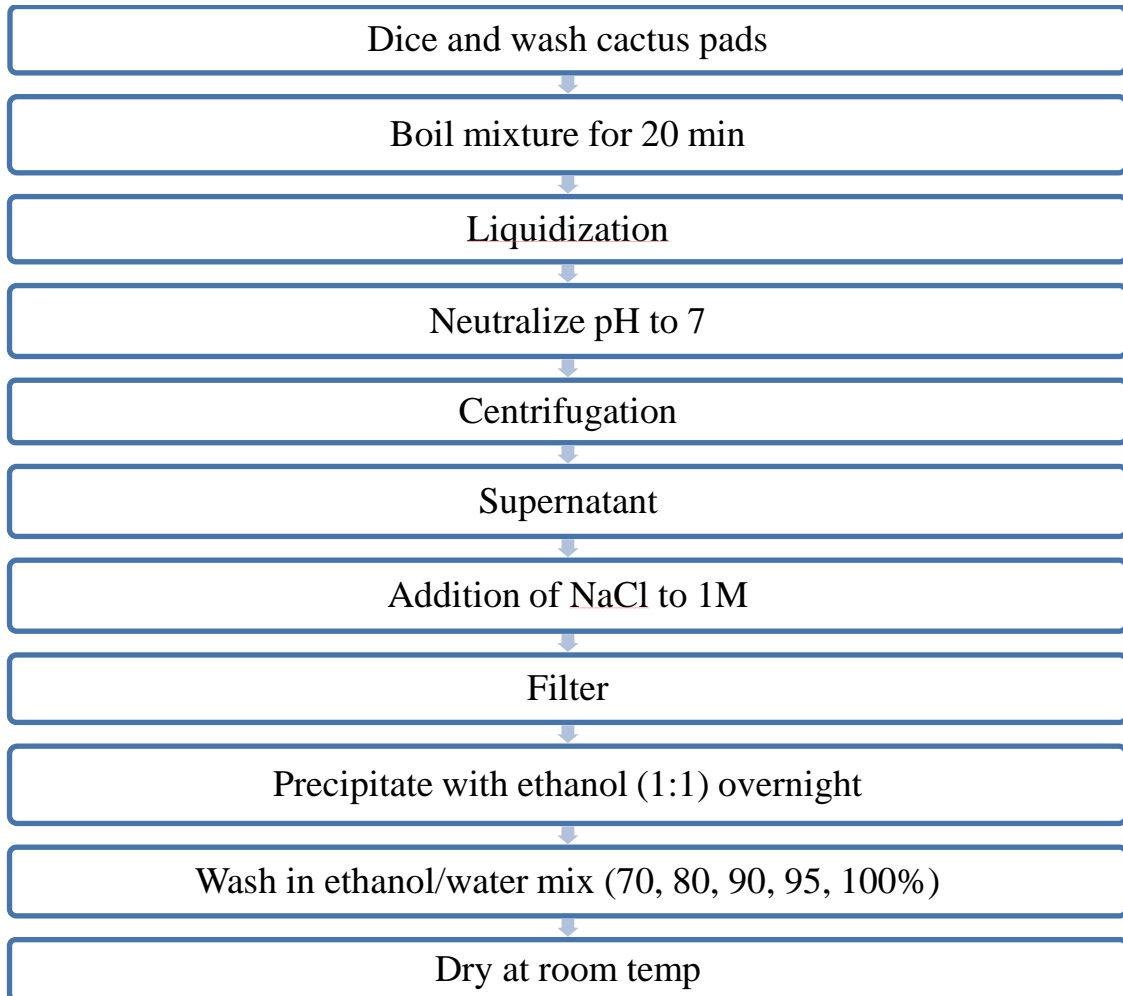

Figure 10: Mucilage Extraction Process Flow [5]



This is a general method for extraction that was adapted from a study by Cárdenas [14]. Details and adaptations of this process for optimal extraction are patented by Alcantar and her research group [5, 16]. All mucilage extracted was stored and dried at room temperature and then grounded into powder form in a mortar and pestle. The resulting mucilage powder is used in the following experiment to create nanofibers.

## **5.2. Mucilage Solution Mixture**

The mucilage powder is mixed at a 4% w/w with a solution of acetic acid and deionized water. The acetic acid is mixed with deionized water at a 50% w/w. Mucilage and acid are mixed at 60°C at 600 rpm and covered to avoid evaporation for 8-10 hours or until the solution is a consistent mixture. To help evenly mix the mucilage acid solution and reduce the size of clusters that form, a tissue grinder was used.

## **5.3. Polyvinyl Alcohol Mixtures**

The polyvinyl alcohol (PVA) was used with two types of molecular weight. The lower molecular weight 28.4 M was mixed in four different concentrations, at 7%, 9%, 11%, 20%. The higher molecular weight PVA at 80 M was mixed at a 9% concentration solution. All solutions were mixed with deionized water at 125°C at 900 rpm covered for approximately 1.25 hours or until PVA had thorough consistency.

## **5.4. The Mucilage and PVA Mixtures**

PVA solutions were mixed with different ratio of mucilage and acetic acid mixtures. The 9% PVA solutions were mixed by volumetric ratios of 70:30, 50:50, and 30:70 with mucilage for the lower molecular weight of 27,000 PVA. The higher molecular weight PVA of 85,000-124,000 was mixed at a ratio of 70:30 with the

mucilage solution. All of these mixtures were heated to 60°C at 600 rpm for 30 minutes.

See Table 2 for experiments performed with different ratio mixtures.

Table 2: PVA and Mucilage Ratio Mixtures

<b>PVA (28.4 M)</b>	<b>Ratios (PVA:Mucilage)</b>
7%	70:30
9%	70:30
	50:50
	30:70
11%	70:30
<b>PVA (80 M)</b>	<b>Ratios (PVA:Mucilage)</b>
9%	70:30

### 5.5. Electrospinning Experiment Setup

The electrospinning field is set inside an enclosed box to reduce electrostatic interference, other electric fields, and other factors that may impede the optimum formation of fibers. See Figure 11 for a view of the experimental set up.

The power supply used was a Spectrovision DA-30. The syringe pump was a Harvard Apparatus PHD 2000.

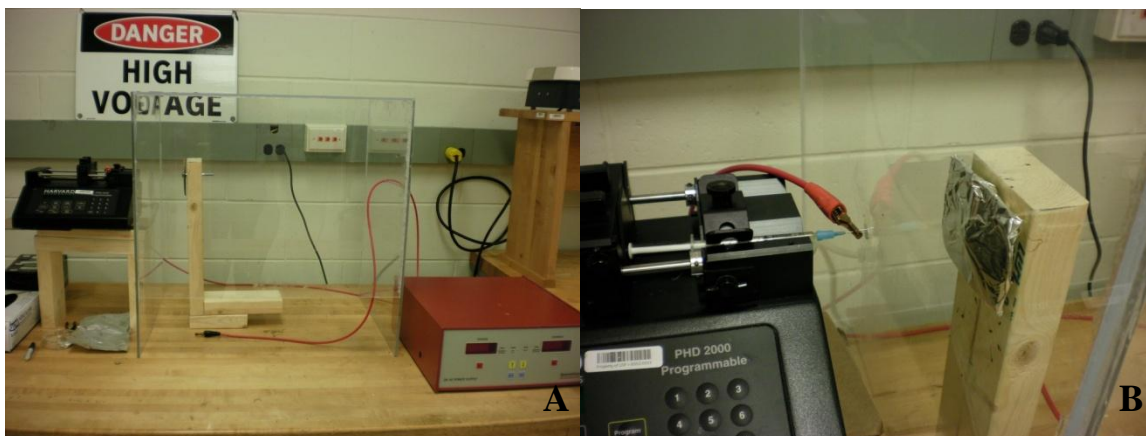

Figure 11: A) Electrospraying Setup B) Close Up of Syringe and Collector Plate

The parameters for electrospraying were set as shown on Table 3. Earlier experiments showed that the following parameters were ideal for our set up and produced good fibers. The distance between the needle tip and collector plate were changed during experiments to see the differences in fiber diameter and shape.

Table 3: Parameters Set for Electrospraying Setup

Electrospraying Parameters	Values
Voltage	20~22 kV
Syringe	1 mL
Syringe Diameter	4 mm
Needle*	18 1/2" gauge 22 1" gauge
Infusion Rate	2.5 $\mu$ L/min
Distance (needle tip and collector plate)*	7-13 cm
* Changed between experiments	

## CHAPTER 6: RESULTS AND DISCUSSION

### 6.1. Mucilage Extraction

Mucilage extraction relied very heavily on the cactus pad. Cactus pads had different extraction rates and it was difficult to guess the amount extracted would be following the described procedure.

### 6.2. Mixtures

It was fairly simple to achieve 4% w/w mucilage with a 50% w/w acetic acid. At the beginning of the experiment 90% w/w acetic acid mix was used and then 50% there seemed no difference in fiber formation. 50% w/w was kept because it was less caustic. A thorough study could be performed with FTIR to see at which point of acetic acid mixture is ideal for forming polymer mixture. A tissue grinder was a necessity to get a good homogeneous mixture even after several hours of magnetic stirring.

Achieving a well-mixed PVA was difficult at some percentages. 7%, 9%, and 11% were used. 20% solution of the lower PVA was too thick and burned before being thoroughly mixed. See Table 4 for summary of PVA mixtures.

Table 4: PVA Experimental Mixtures

<b>PVA 28.4 M</b>	
7%	good solution
9%	good solution
11%	good solution
20%	solution did not mix
<b>PVA 80 M</b>	
9%	good solution

The PVA and mucilage solutions were mixed together but it was observed that after several hours the mucilage and PVA would start to separate. More mixing and agitation would bring them back together.

### 6.3. Mucilage and PVA Ratio Nanofiber Results

Nanofiber results were viewed by microscope and then later by SEM imaging. At 7% PVA solution no fibers formed so it became difficult to take pictures of the dots and deformities that formed. At 9% few thin flat looking fibers formed that measured about 180nm. See Figure 12 for a SEM image of 9% PVA fibers at 11Kx. Figure 13 shows an SEM image of 9% PVA fibers at 100Kx. For SEM images the samples were sputtered with gold.

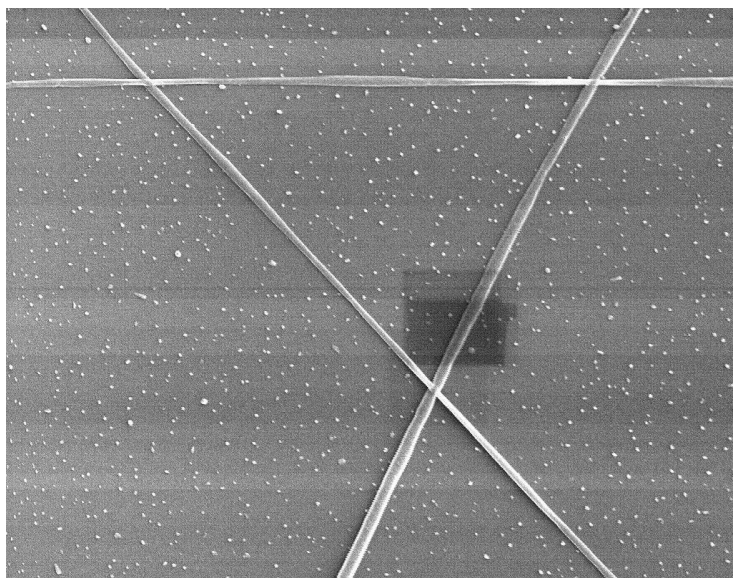

Figure 12: SEM Image at 11Kx 9% PVA and Mucilage (70:30) PVA:Mucilage

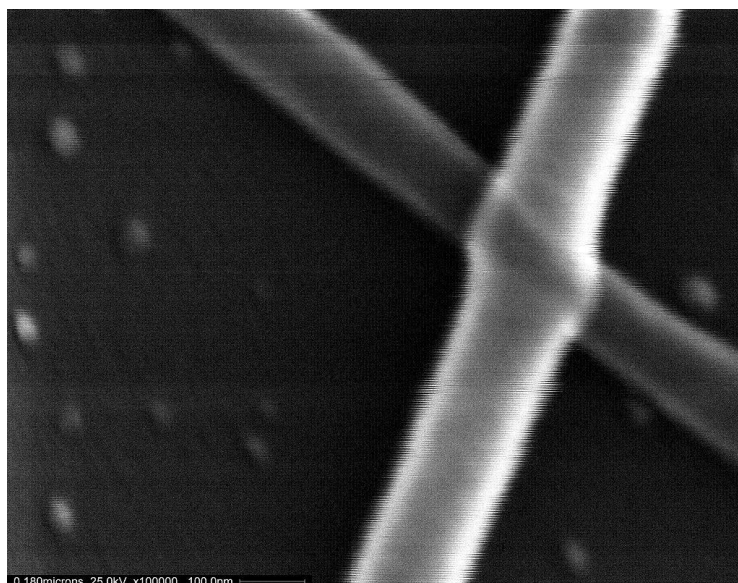

Figure 13: SEM Image at 100Kx 9% PVA and Mucilage (70:30) PVA:Mucilage

The 9% PVA was mixed with different ratios of mucilage 70:30, 50:50, and 30:70. At 30:70 ratio there appeared to be not enough polymer mixtures because there were many dots and deformities although some fibers still formed, see Figure 14. At

50:50 ratio fibers appeared also with deformities but at a much higher quality, see Figure 15. At 70:30 a larger amount of fibers were formed with fewer deformities, see Figure 16. These results lead to the conclusion that at a higher PVA ratio more polymers were present in order to start forming a fiber with little deformities.

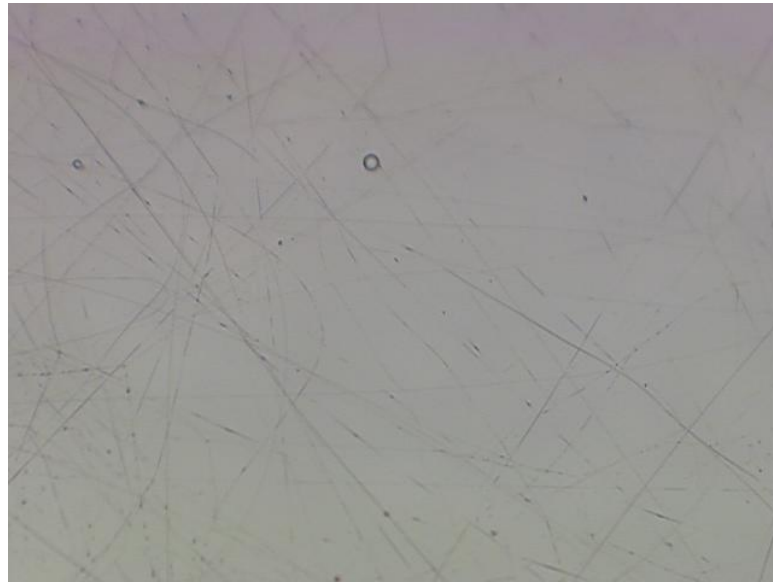

Figure 14: Microscope Image at 50x 9% PVA and Mucilage (30:70) PVA:Mucilage

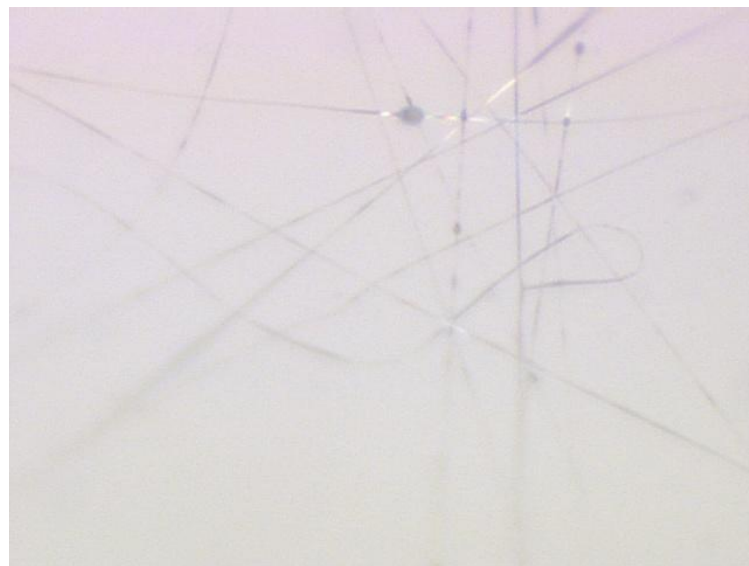

Figure 15: Microscope Image at 100x 9% PVA and Mucilage (50:50) PVA:Mucilage

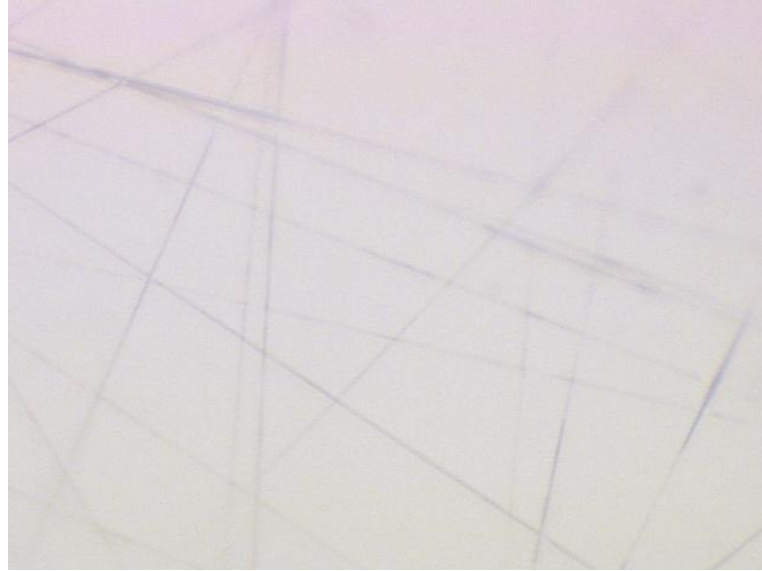

Figure 16: Microscope Image at 100x 9% PVA and Mucilage (70:30) PVA:Mucilage

PVA solution mix at 11% gave many more fibers that were measured as thin as 52nm to 8 $\mu$ m much thicker see Figure 17, 18, 19 and 20. A top view of the fiber mesh can be seen in Figure 18, cavities were formed that were about 4 microns in diameter. This might be from dust particles that contaminated the surface of the glass substrate. Therefore in future production of fiber meshes the substrate must be cleaned.

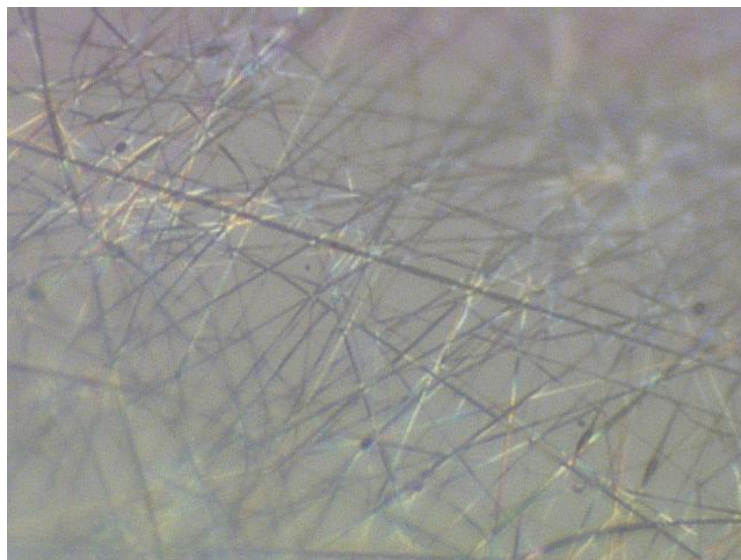

Figure 17: Microscope Image at 100x 11% PVA and Mucilage (70:30) PVA:Mucilage



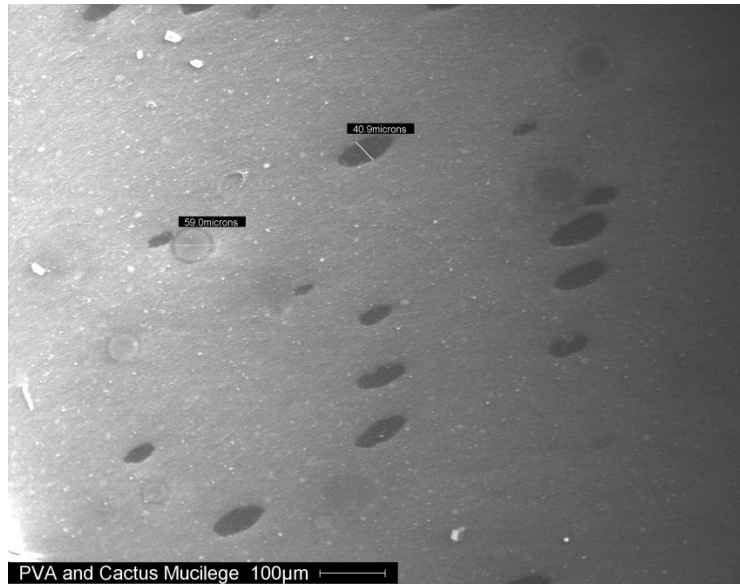

Figure 18: SEM Image Top View of 11% PVA and Mucilage (70:30) PVA:Mucilage



Figure 19: SEM Image at 70Kx of 11% PVA and Mucilage (70:30) PVA:Mucilage Fiber  
Measured at 52nm.

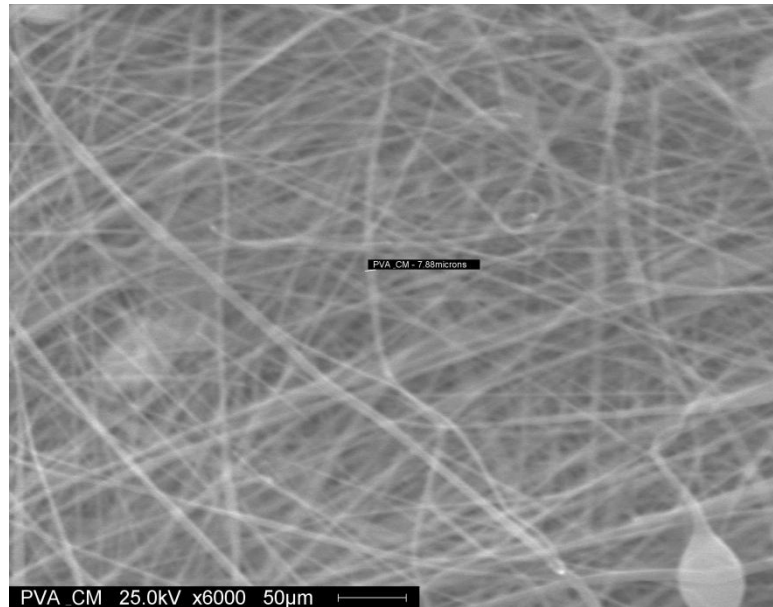

Figure 20: SEM Image at 6Kx of 11% PVA and Mucilage (70:30) PVA:Mucilage Fiber Measured at 7.8  $\mu\text{m}$ .

#### 6.4. PVA Molecular Weight Nanofiber Results

Mixtures of PVA at 9% w/w with ratios of 70:30 PVA to mucilage were deemed more stable because they produced fibers of the same size more consistently than 11% PVA mixtures. See Figure 21 and 22 for AFM images of low molecular weight PVA mixtures at 10 $\mu\text{m}$  samples and at 1 $\mu\text{m}$  respectively. Figure 23 shows a sectional analysis of the low molecular PVA fibers samples at 1 $\mu\text{m}$ . From the sectional analysis we got a measurement of about 177nm which is close to the previous measurement received at 180nm from the former mixture taken with an SEM image.

This is comparable to other nanofibers formed with biological substances which diameter size ranges from 100 - 600 nm [21-26].

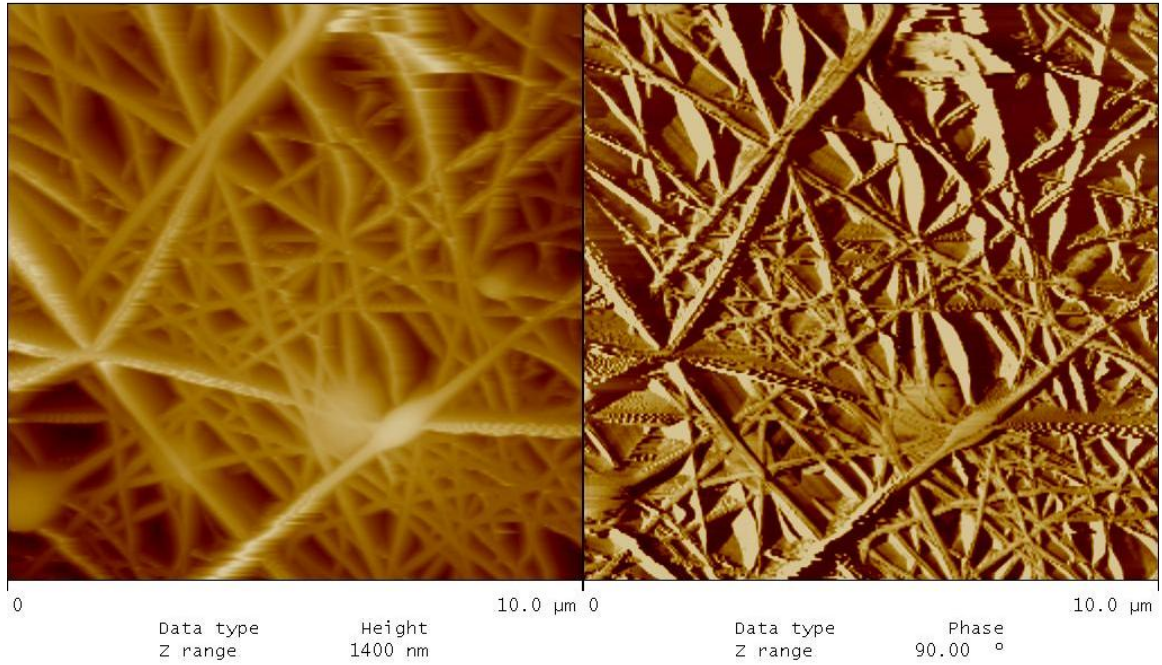

Figure 21: AFM Image at 10µm for 9% Low M PVA and Mucilage (70:30)

PVA:Mucilage

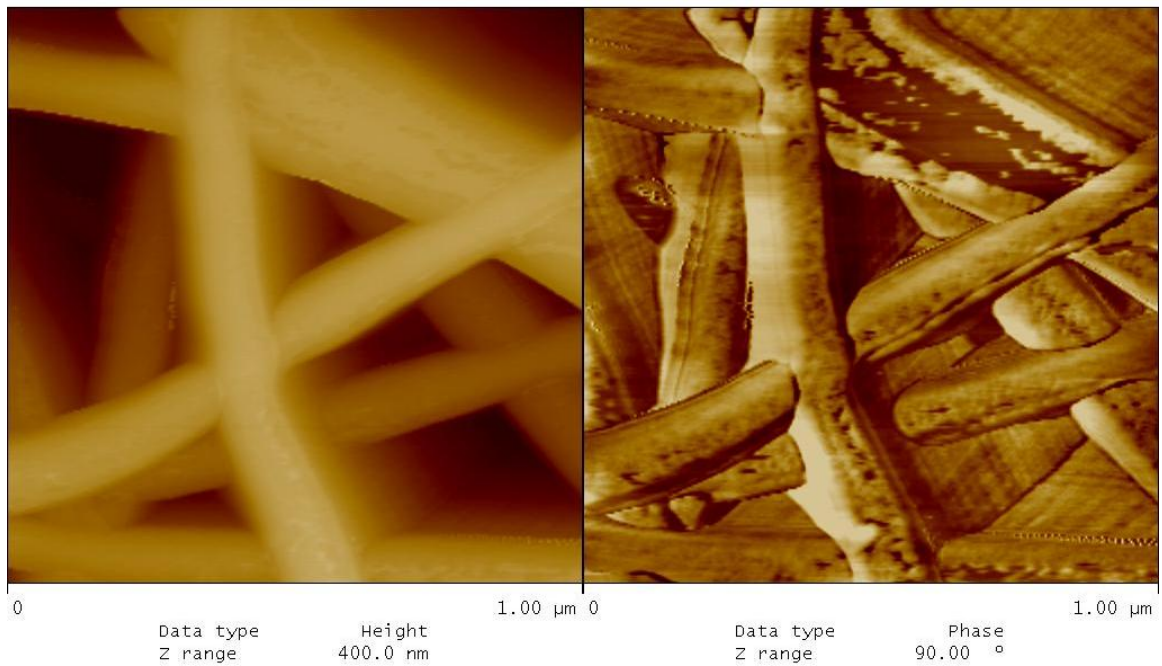

Figure 22: AFM Image at 1µm for 9% Low M PVA and Mucilage (70:30)

PVA:Mucilage

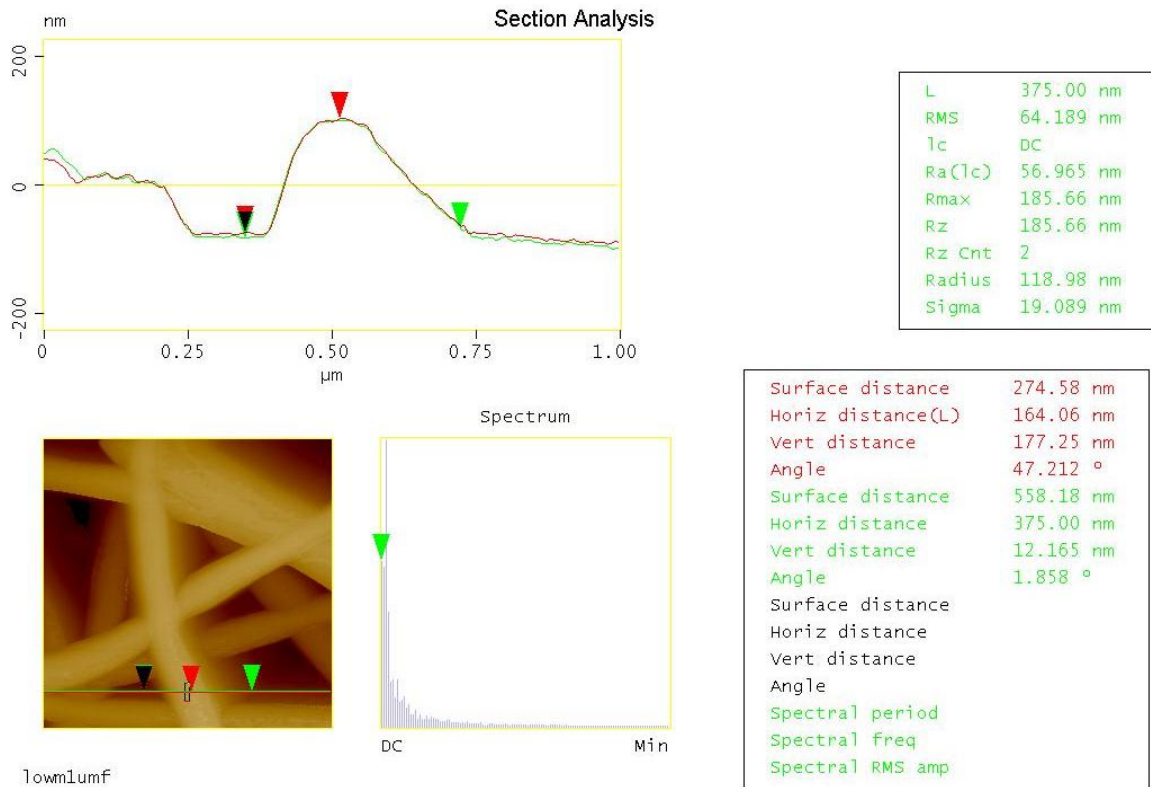

Figure 23: AFM Sectional Analysis Image at 1µm for 9% Low M PVA and Mucilage (70:30) PVA:Mucilage Fiber Diameter 177nm

See Figure 24 and 25 for high molecular weight PVA mixtures at 10µm samples and at 1µm respectively. The AFM images show that the high molecular weight PVA produces a bigger mix of fibers with different diameters and that the diameters are overall much larger than the fibers made with lower molecular weight. Two samples were collected of the high molecular weight measuring 460nm and 4µm respectively, see Figure 26 and 27.

It is also noted that the fibers of both low and high molecular weight seem very smooth and lack porosity, this might change if PVA is removed, see Figure 28 and 29.

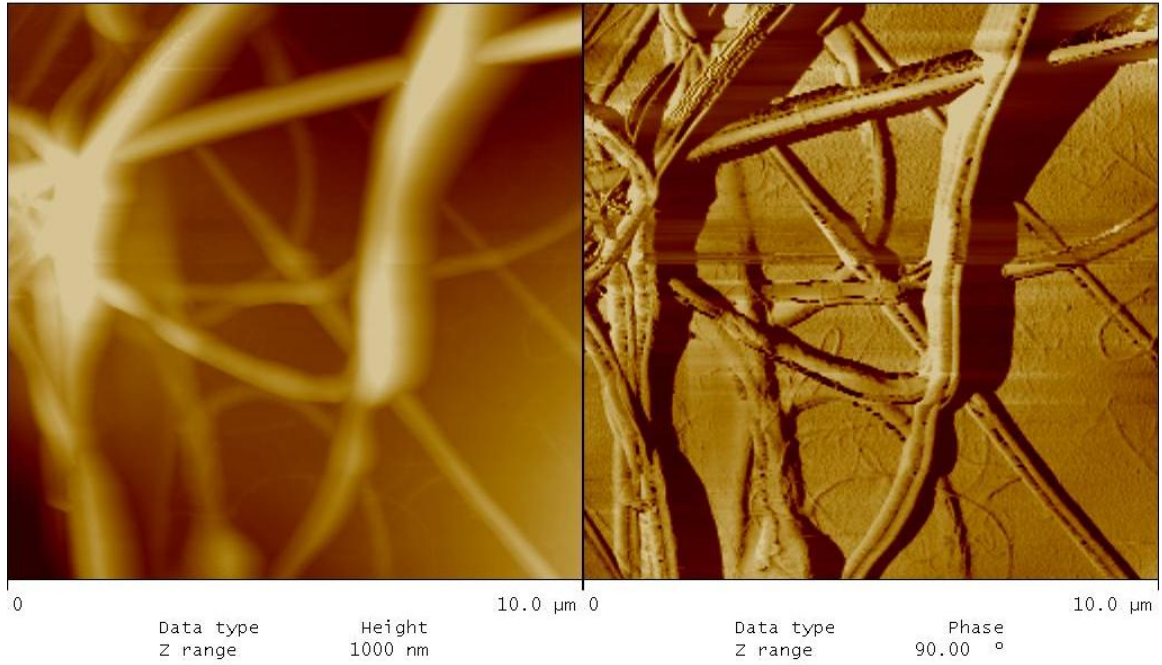

Figure 24: AFM Image at 10µm for 9% High M PVA and Mucilage (70:30)

PVA:Mucilage

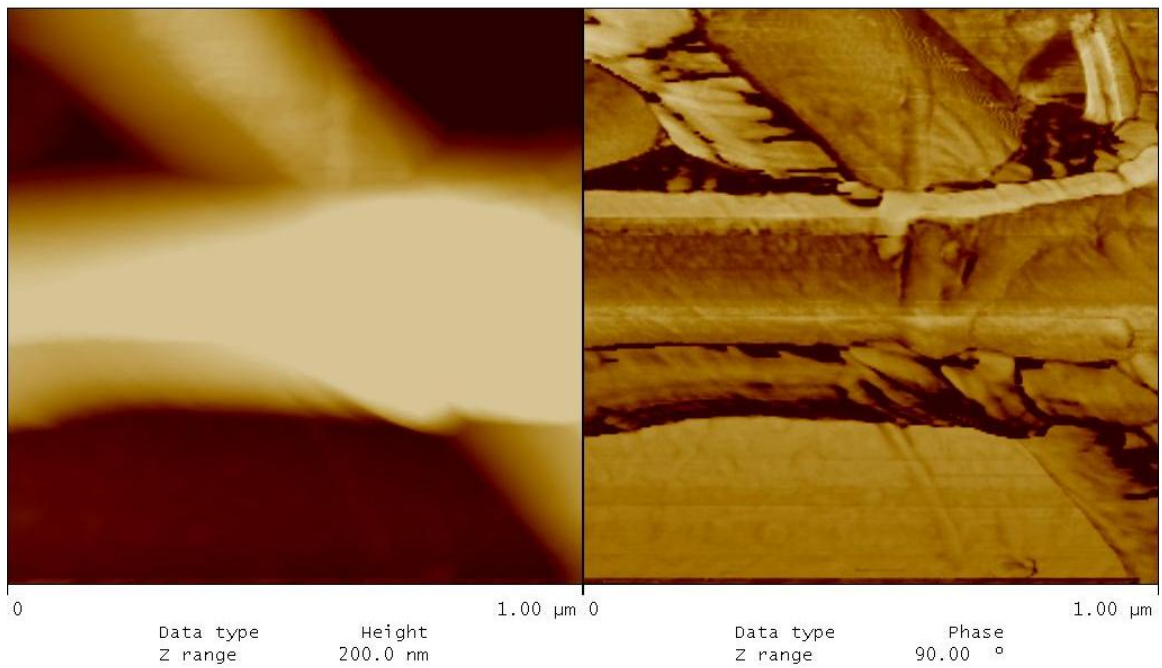

Figure 25: AFM Image at 1µm for 9% High M PVA and Mucilage (70:30)

PVA:Mucilage

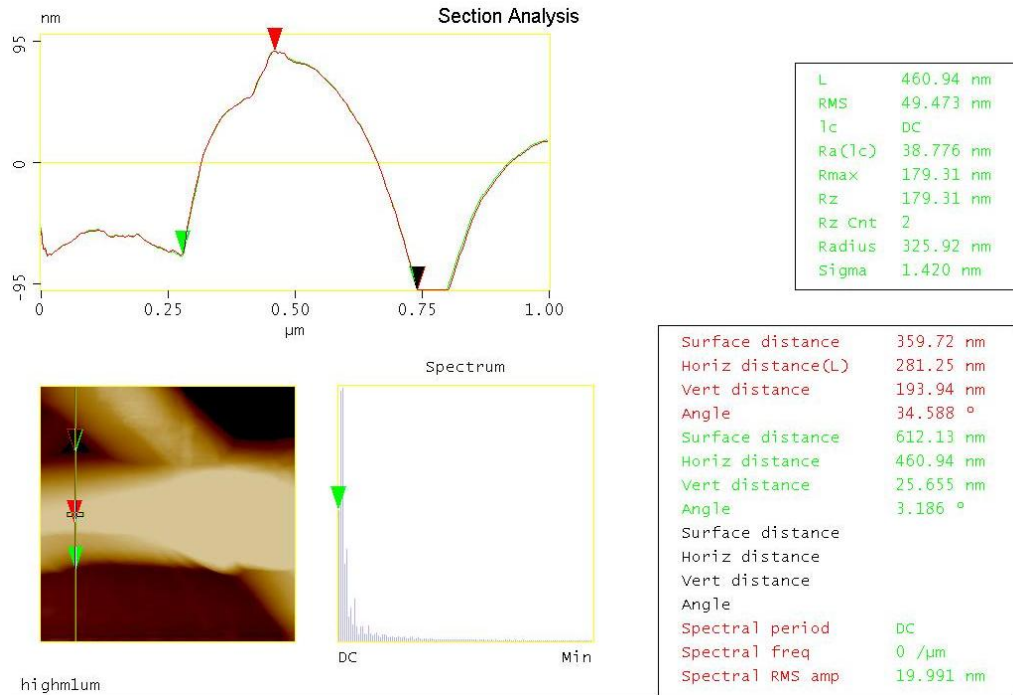

Figure 26: Sectional Analysis Image at 1µm for 9% High M PVA and Mucilage (70:30)

PVA:Mucilage Fiber Diameter 460 nm

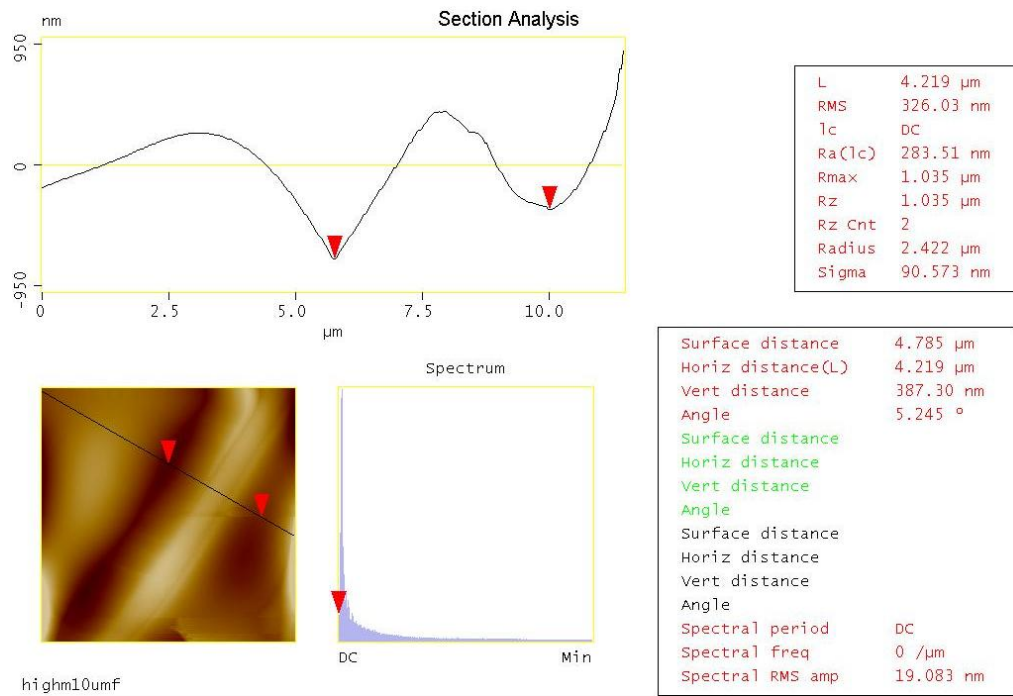

Figure 27: Sectional Analysis Image at 1µm for 9% High M PVA and Mucilage (70:30)

PVA:Mucilage Fiber Diameter 4 µm

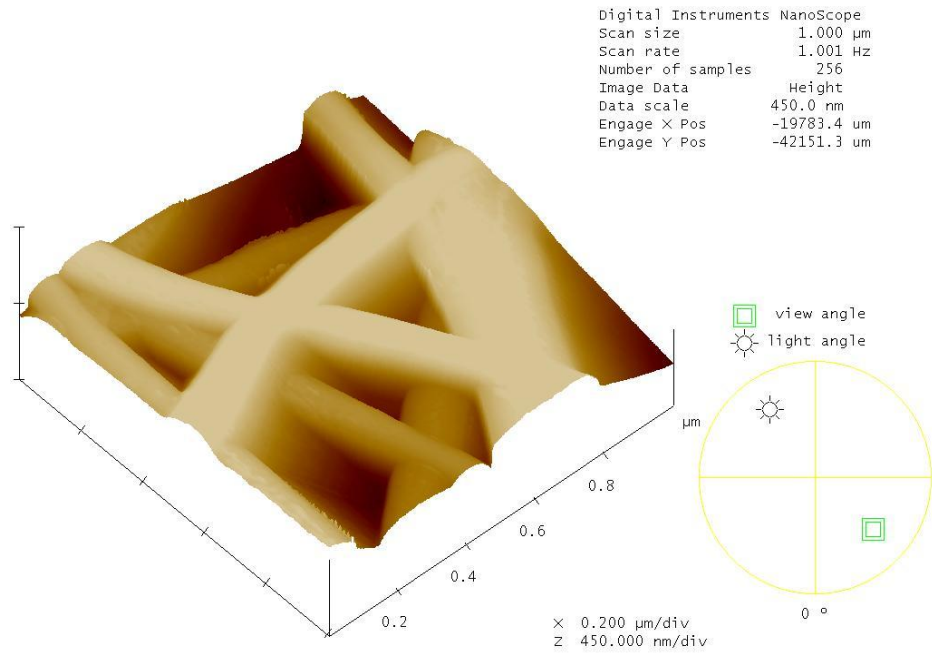

Figure 28: 3D AFM Image at  $1\mu\text{m}$  for 9% Low M PVA and Mucilage (70:30)

PVA:Mucilage

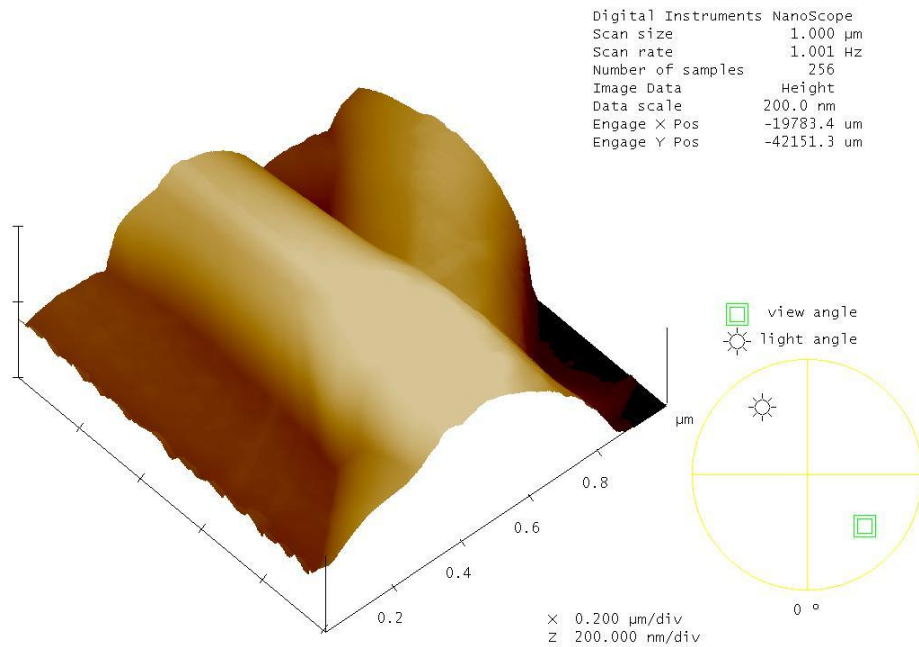

Figure 29: 3D AFM Image at  $1\mu\text{m}$  for 9% High M PVA and Mucilage (70:30)

PVA:Mucilage

## 6.5. NaOH and Water Washes

A simple experiment was performed to remove PVA from the nanofiber structures. This is done so that pure mucilage fibers can be obtained. The experiment had very promising results. See Figure 30 for a view of the pretreated mesh.

First a 0.5 M NaOH wash was performed on a PVA only and a PVA mucilage nanofiber mesh and set to dry over 24 hours in an oven at 30°C. The NaOH seemed to remove the PVA particles but crystalline formations were observed after drying in both meshes. See Figure 31 for a depiction of the crystals and the still intact mucilage mesh.

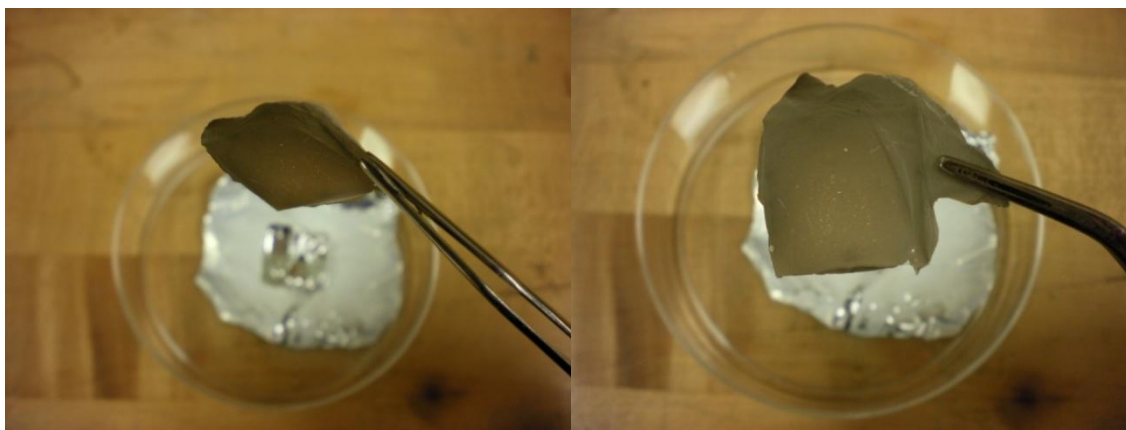

Figure 30: Mucilage and PVA Nanofiber Mesh Used in Washes

Then a second set of experiments were performed with just deionized water on the PVA only and PVA and mucilage mesh. The water seemed to wash away all the PVA since no nanofiber structures were seen in the PVA only mesh. Nanofibers were still intact in the PVA and mucilage mesh although the mesh seemed to lose most of its content. This was expected since 70% of the mesh is composed of PVA. See Figure 32 for a depiction of pure mucilage nanofibers.



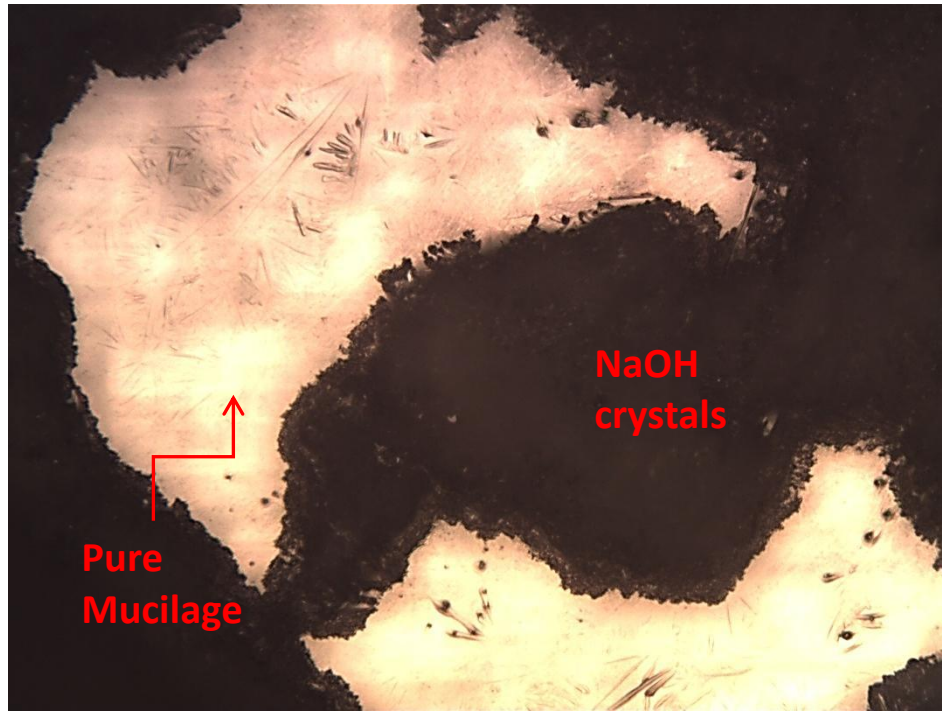

Figure 31: NaOH Crystals and Pure Mucilage Nanofibers Microscope 20x

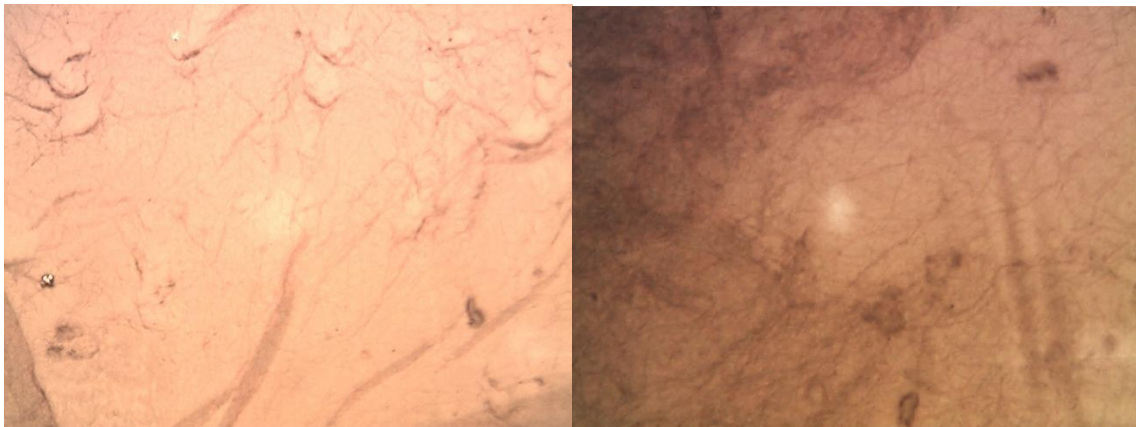

Figure 32: Pure Mucilage Nanofibers (a) Microscope 50x (b) Microscope 100x

## 6.6. Differential Scanning Calorimetry Test

A differential scanning calorimetry test was also performed on nanofiber mesh. PVA at 9% (w/w) alone gave a melting point of 222.53°C. Mucilage and PVA high molecular weight at 9% melting point was 214.89°C. Also mucilage and PVA low molecular weight at 9% melting point was 216.27°C.

Both PVA and mucilage mixtures were at a ratio of 70:30. These two mixtures had a melting point difference of 2°C which is considered insignificant. The pure PVA at 222.53°C is higher than the other two samples but not a very considerable difference. This tells us that the mucilage is lowering the melting point of the PVA nanofibers but not by a significant amount. See Figure 33 for DSC results.

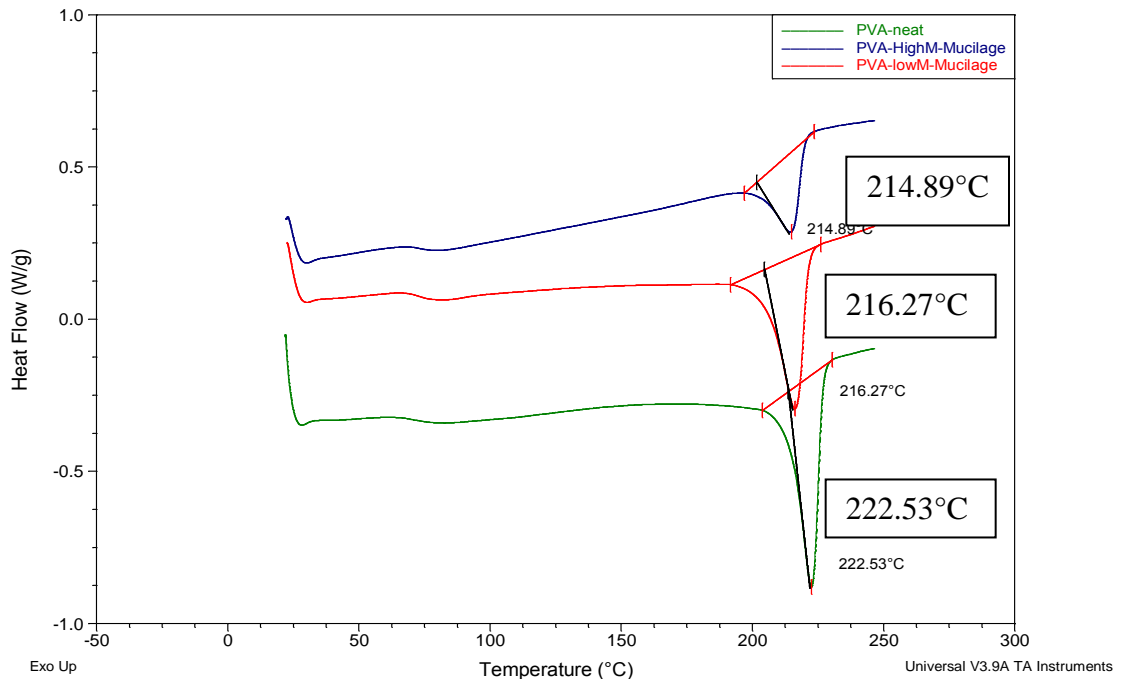

Figure 33: DSC Test of Nanofibers

## 6.7. FT-IR Spectroscopy Attenuated Total Reflectance

Attenuated total reflectance test were also performed. Most of the peaks identified for the PVA alone spectrum corresponded to CH groups. The test shows some similarities between the pure mucilage and the PVA mucilage mixed nanofibers both having strong peaks around 1080-1040  $\text{cm}^{-1}$ . Unfortunately these tests were inconclusive and a broader test must be performed with solely PVA, PVA in nanofiber form, and Mucilage in nanofiber form. See Figures 34 and 35 for ATR results.

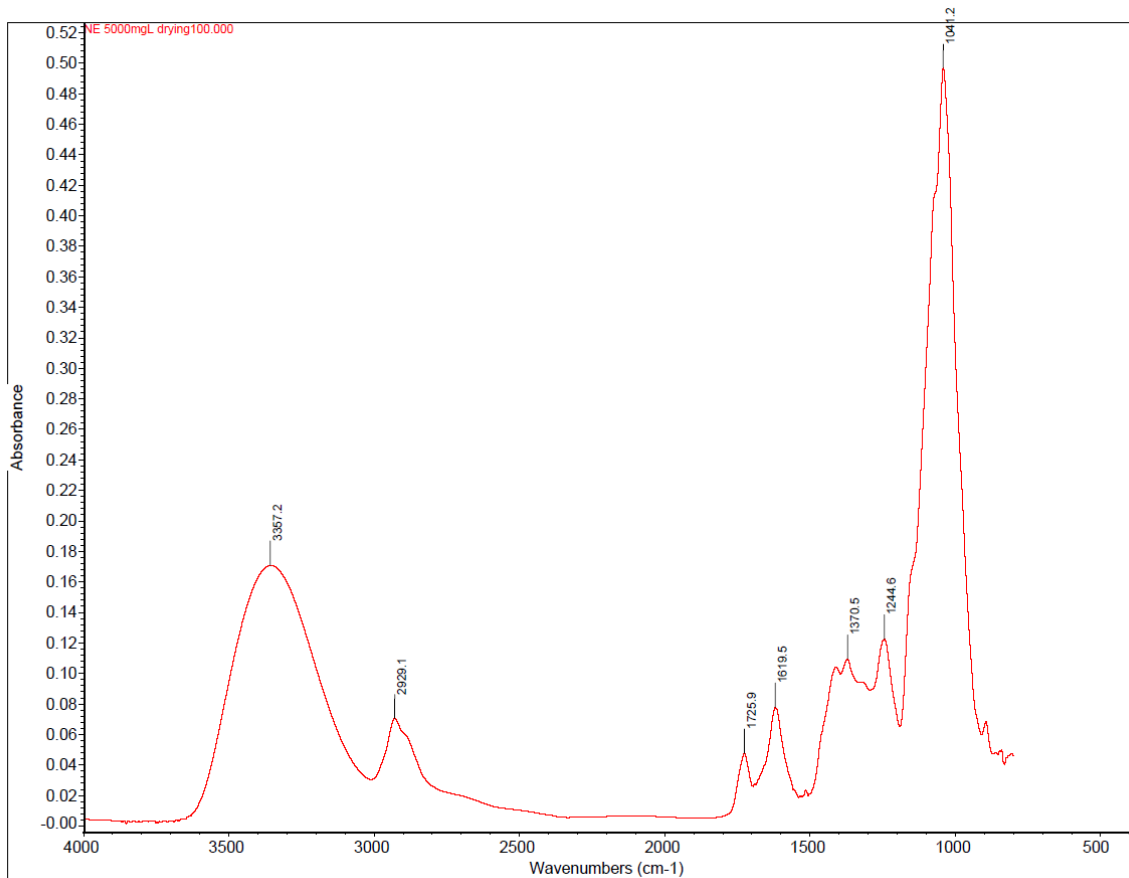

Figure 34: Absorbance of Pure Mucilage

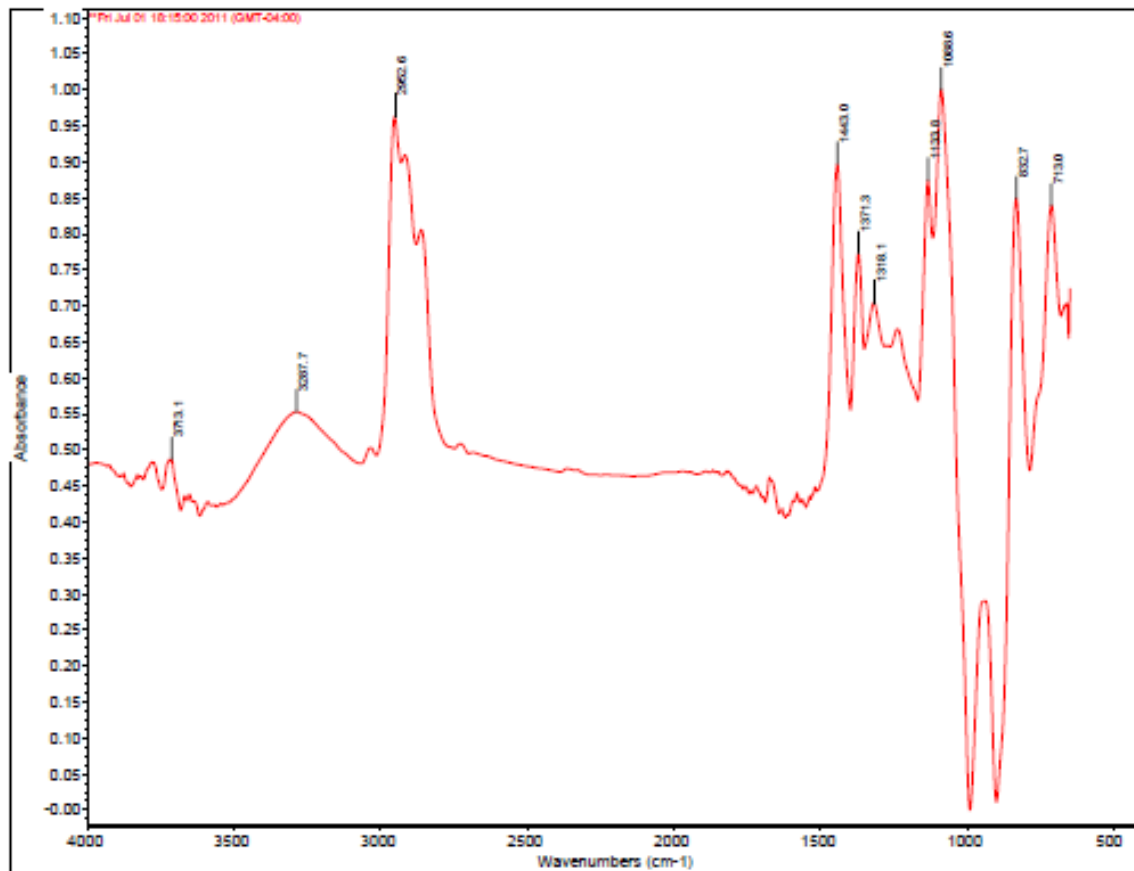

Figure 35: Absorbance of PVA and Mucilage Nanofibers

## CHAPTER 7: CONCLUSION AND FUTURE WORK

### 7.1. Summary of Findings

Through the work presented in this thesis a process for making electrospun nanofibers out of cactus mucilage and polyvinyl alcohol was found and studied.

Electrospun fibers at 9% w/w low molecular weight PVA ratio mixed with mucilage at 4% w/w at a ratio of 70:30 were formed with constant diameters of around 180 nm.

Electrospun fibers at higher than 9% PVA ratios or higher molecular weights produced fibers with larger sizes with varying diameters.

Electrospun fibers at lower than 9% PVA ratios were short and produced deformities.

Nanofiber meshes of cactus mucilage can now be formed with ranging diameter sizes from 50 nm to 7  $\mu\text{m}$ . This gives way to meshes with variable sizes of pores.

The fiber distribution is deposited with various round and oval cavities with approximately 4 micrometers in diameter.

Fibers formed were smooth and had little to no porosity.

The melting point of the fibers was around 215°C with PVA. Mucilage had no adverse effects on melting point.

## **7.2. Future Work**

More optimization could still be made by finding exact viscosities of mixtures before they are electrospun.

Studies can also be made on mucilage and acetic acid mixture properties.

To produce a filter studies have to be produced in filter manufacturing and to verify if the mucilage nanofiber mesh filter can compete with filters that are currently out in the market.

Research and implement other uses for mucilage nanofiber meshes.

## **7.3. Final Remarks**

*Opuntia ficus-indica* mucilage is a versatile and unique substance. It was exciting to be able to produce nanofiber meshes that could potentially become biodegradable water filters. It is moving to work on a project that could help many people and improve sustainability of water management.

## REFERENCES

- [1] A. Prüss-Üstün, R. Bos, F. Gore, and J. Bartram, *Safer water, better health: costs, benefits and sustainability of interventions to protect and promote health*, Geneva: World Health Organization, 2008.
- [2] N. Savage and M.S. Diallo, “Nanomaterials and Water Purification: Opportunities and Challenges,” *Journal of Nanoparticle Research*, vol. 7, Oct. 2005, pp. 331-342.
- [3] L. Pasteur, “The History of Drinking Water Treatment,” *Public Health*, 2000.
- [4] APEC, “Different Water Filtration Methods Explained,” *Freedrinkingwater.com*.
- [5] K.A. Young, “The Mucilage of *Opuntia Ficus Indica*: A Natural, Sustainable, and Viable Water Treatment Technology for Use in Rural Mexico for Reducing Turbidity and Arsenic Contamination in Drinking Water,” University of South Florida, 2006.
- [6] R. Gopal, S. Kaur, Z. Ma, C. Chan, S. Ramakrishna, and T. Matsuura, “Electrospun nanofibrous filtration membrane,” *Journal of Membrane Science*, vol. 281, Sep. 2006, pp. 581-586.
- [7] B. Van der Bruggen and C. Vandecasteele, “Removal of pollutants from surface water and groundwater by nanofiltration: overview of possible applications in the drinking water industry.,” *Environmental Pollution*, vol. 122, Jan. 2003, pp. 435-445.
- [8] H. Nicoll, “Water Needs, Unique Research Arrangement Lead to Membrane Development,” *Water Quality Products*, vol. 6, 2001.
- [9] “The Past, Present, and Future of Water Filtration Technology,” *Historyof Water Filters.com*.

- [10] K. Boussu, B. Vanderbruggen, a Volodin, C. Vanhaesendonck, J. Delcour, P. Vandermeeren, and C. Vandecasteele, "Characterization of commercial nanofiltration membranes and comparison with self-made polyethersulfone membranes," *Desalination*, vol. 191, May. 2006, pp. 245-253.
- [11] J.-C. Lee, H.-R. Kim, J. Kim, and Y.-S. Jang, "Antioxidant property of an ethanol extract of the stem of *Opuntia ficus-indica* var. *saboten.*," *Journal of agricultural and food chemistry*, vol. 50, Oct. 2002, pp. 6490-6.
- [12] R. Kiesling, "Origen , Domesticación y Distribución de *Opuntia ficus-indica*," *America*, vol. 22, 1995, pp. 4747-4748.
- [13] G.K. Jani, D.P. Shah, V.D. Prajapati, and V.C. Jain, "Gums and mucilages : versatile excipients for pharmaceutical formulations," *Journal of Pharmaceutical Sciences*, vol. 4, 2009, pp. 309-323.
- [14] A. Cárdenas and F.M. Goycoolea, "Rheology and Aggregation of Cactus ( *Opuntia ficus-indica* ) Mucilage in Solution," 1997, pp. 152-159.
- [15] C. Saenz, "Opuntia spp mucilage's: a functional component with industrial perspectives," *Journal of Arid Environments*, vol. 57, May. 2004, pp. 275-290.
- [16] A.L. Buttice, "Reducing Sediment and Bacterial Contamination in Water Using Mucilage Extracted from the," University of South Florida, 2009.
- [17] Z. Huang, "A review on polymer nanofibers by electrospinning and their applications in nanocomposites," *Composites Science and Technology*, vol. 63, Nov. 2003, pp. 2223-2253.
- [18] H. Yan, L. Liu, and Z. Zhang, "Alignment of electrospun nanofibers using dielectric materials," *Applied Physics Letters*, vol. 95, 2009, p. 143114.
- [19] Y. Zhang, X. Huang, B. Duan, L. Wu, S. Li, and X. Yuan, "Preparation of electrospun chitosan/poly(vinyl alcohol) membranes," *Colloid and Polymer Science*, vol. 285, Jan. 2007, pp. 855-863.
- [20] M. Ziabari, V. Mottaghtalab, and a K. Haghi, "Application of direct tracking method for measuring electrospun nanofiber diameter," *Brazilian Journal of Chemical Engineering*, vol. 26, Mar. 2009, pp. 53-62.
- [21] Y. Jia, J. Gong, X. Gu, H. Kim, J. Dong, and X. Shen, "Fabrication and characterization of poly (vinyl alcohol)/chitosan blend nanofibers produced by electrospinning method," *Carbohydrate Polymers*, vol. 67, Feb. 2007, pp. 403-409.



- [22] L. Buttafoco, N.G. Kolkman, P. Engbers-Buijtenhuijs, a a Poot, P.J. Dijkstra, I. Vermes, and J. Feijen, "Electrospinning of collagen and elastin for tissue engineering applications.," *Biomaterials*, vol. 27, Feb. 2006, pp. 724-34.
- [23] G. Ma, D. Yang, Y. Zhou, Y. Jin, and J. Nie, "Preparation and characterization of chitosan/poly(vinyl alcohol)/poly(vinyl pyrrolidone) electrospun fibers," *Frontiers of Materials Science in China*, vol. 1, Oct. 2007, pp. 432-436.
- [24] A. Frenot, M.W. Henriksson, and P. Walkenstro, "Electrospinning of Cellulose-Based Nanofibers," *Polymer*, 2006.
- [25] H. Qi, X. Sui, J. Yuan, Y. Wei, and L. Zhang, "Electrospinning of Cellulose-Based Fibers From NaOH/Urea Aqueous System," *Macromolecular Materials and Engineering*, vol. 295, Aug. 2010, pp. 695-700.
- [26] S. Manandhar, S. Vidhate, and N. D'Souza, "Water soluble levan polysaccharide biopolymer electrospun fibers," *Carbohydrate Polymers*, vol. 78, Nov. 2009, pp. 794-798.
- [27] R.R. Hegde, A. Dahiya, and M.G. Kamath, "NANOFIBER NONWOVENS," *MATERIALS SCIENCE & ENGINEERING 554*, 2004.
- [28] K. Yoon, K. Kim, X. Wang, D. Fang, B.S. Hsiao, and B. Chu, "High flux ultrafiltration membranes based on electrospun nanofibrous PAN scaffolds and chitosan coating," *Polymer*, vol. 47, Mar. 2006, pp. 2434-2441.