

2007

Cooperative localization in wireless networked systems

Mauricio Castillo-Effen
University of South Florida

Follow this and additional works at: <http://scholarcommons.usf.edu/etd>

 Part of the [American Studies Commons](#)

Scholar Commons Citation

Castillo-Effen, Mauricio, "Cooperative localization in wireless networked systems" (2007). *Graduate Theses and Dissertations*.
<http://scholarcommons.usf.edu/etd/662>

This Dissertation is brought to you for free and open access by the Graduate School at Scholar Commons. It has been accepted for inclusion in Graduate Theses and Dissertations by an authorized administrator of Scholar Commons. For more information, please contact scholarcommons@usf.edu.

Cooperative Localization In Wireless Networked Systems

by

Mauricio Castillo-Effen

A dissertation submitted in partial fulfillment
of the requirements for the degree of
Doctor of Philosophy
Department of Electrical Engineering
College of Engineering
University of South Florida

Co-Major Professor: Wilfrido A. Moreno, Ph.D.
Co-Major Professor: Kimon P. Valavanis, Ph.D.
Miguel A. Labrador, Ph.D.
James T. Leffew, Ph.D.
Fernando Falquez, Ph.D.

Date of Approval:
October 22, 2007

Keywords: inertial navigation, monte carlo methods, position estimation, cooperative systems, wireless networks, protocols

© Copyright 2007 , Mauricio Castillo-Effen

Dedication

“Perfection is achieved, not when there is nothing more to add, but when there is nothing left to take away.” –Antoine de Saint-Exupéry

To each and every member of my beloved family...

Acknowledgements

I would like to express my most sincere gratitude to my two co-major professors, Dr. Wilfrido Moreno and Dr. Kimon Valavanis. I thank them for their direction, support and for creating the ideal research environment. The environment they have created for their students possessed all the challenges, freedom and resources required for completion of my research. They complemented each other perfectly.

During this research endeavor, I had the privilege of working with Dr. Miguel Labrador. Dr. Labrador always provided important insight and guidance. In his subtle and expert manner he showed me the beauty of academic rigor and good scientific practices.

I also thank the other members of my committee. Dr. James Leffew and Dr. Fernando Falquez read my documentation and provided important feedback from the time of my research proposal until the completion of this dissertation.

I must also extend by deep appreciation to my fellow Master and Doctoral students. With these people I worked on projects, performed experiments, wrote papers and engaged in discussions. If it could only be true that such enjoyable pursuits will comprise the rest of my professional life. They have all become dear friends to me.

This research was also partially supported by two grants: ARO W911NF-06-1-0069 and SPAWAR N00039-06-C-0062.

Table of Contents

List of Tables	vi
List of Figures	vii
Abstract	xi
Chapter 1 Introduction	1
1.1. Technologies on the Rise and the Emergence of Computing Paradigms	1
1.1.1. Everywhere Computing	1
1.1.2. Everything Networked	2
1.1.3. Open Spectrum	4
1.1.4. The Inertial Sensor Revolution	5
1.2. The Need for Location Information	7
1.2.1. Wireless Sensor Networks for Flash-Flood Alerting	7
1.2.2. Multi-Robot Teams With Cooperation and Coordination	11
1.3. Research Question	14
1.4. Contributions	15
1.5. Methodology	16
1.6. Document structure	17
Chapter 2 Related Work	19
2.1. A Taxonomy of Solutions for Localization	19
2.1.1. Definitions of Location	20
2.1.2. Research Communities	20
2.1.2.1. Navigation	20

2.1.2.2. Robotics	21
2.1.2.3. Wireless Networking	21
2.1.2.4. Localization Theory	22
2.1.3. Categories According to Processing and Infrastructure	22
2.1.3.1. Centralized Localization	22
2.1.3.2. Infrastructure-Based Localization	23
2.1.3.3. Cooperative Localization	23
2.1.4. Sensors and Measurements	24
2.2. Salient Work	25
2.2.1. The Localization Problem from the Robotics Perspective	26
2.2.1.1. Thrun, Burgard and Fox	26
2.2.1.2. Kurazume and Nagata	26
2.2.1.3. Roumeliotis and Bekey	27
2.2.1.4. Howard, Mataric and Sukhatme	28
2.2.2. Projects in Radio-Localization	29
2.2.2.1. Active Badge and Active Office	29
2.2.2.2. Cricket	30
2.2.2.3. Radar	30
2.2.2.4. Calamari	31
2.2.2.5. Place Lab	31
2.2.3. Localization in Wireless Sensor Networks	32
2.2.4. Contributions from Inertial Navigation	33
2.2.4.1. Gustafson	33
2.2.4.2. Sukkarieh	34
2.3. Some Commercially Available Products	34
2.3.1. Northstar Robot Localization System	35
2.3.2. Liberty Latus	35
2.3.3. Vicon MX	35
2.3.4. IS900 Precision Motion Tracker	36
2.3.5. Navizon	36
2.3.6. Motorola's Mesh Enabled Architecture	36

2.4. Conclusions	37
Chapter 3 A Flexible Localization Solution	39
3.1. Definition of Localization	39
3.2. The Systems Engineering Approach	40
3.3. Requirements and Metrics	43
3.4. Structuring the Cooperative Localization Problem	48
3.4.1. Challenges and Issues in Localization	48
3.4.1.1. A Trilateration Experiment	48
3.4.1.2. Inertial Measurement Experiment	52
3.4.1.3. Summary of Challenges and Issues	55
3.4.2. Cooperative Localization and Distributed Estimation	56
3.5. Functional Analysis and Allocation	58
3.5.1. The “Localizer” – A Conceptual Solution for Cooperative Localization	60
3.5.2. Application Examples	62
3.5.2.1. A Localizer-Enabled Cell Phone	62
3.5.2.2. UAV–WSN Cooperative Localization	63
3.5.2.3. A Swarm of Ground Robots	65
3.6. The Role of Ranging	66
3.7. Summary	66
Chapter 4 Cooperative Localization in the Case of Fixed Nodes	68
4.1. Probabilistic Approach to Localization	69
4.1.1. Bayes Filter	71
4.1.1.1. Illustrating the Experiment	72
4.1.2. Particle Filters	75
4.1.3. Implementation of Resampling	79
4.2. General Assumptions	81
4.3. Varying the Number of Particles	83
4.4. Adapting Particle Filters	84
4.4.1. Tuning parameters	91

4.5. Experimental Results	92
4.5.1. Experiment 1: Sensor Characterization	92
4.5.2. Experiment 2: Three Beacons and Twenty Listeners in Range	95
4.5.3. Experiment 3: Incremental Localization	97
4.6. Summary	99
Chapter 5 Localization of Mobile Nodes	101
5.1. Navigation Structure	101
5.1.1. The INS Module	104
5.1.2. The Navigation Aiding Module	105
5.1.3. The Wireless Network Interface Module	106
5.2. Assumptions	106
5.3. Probabilistic Motion Model	108
5.3.1. Preliminary Analysis of the Probabilistic Motion Model	110
5.3.2. Basic Navigation Aiding	115
5.4. Measurement Update with Respect to Non-Deterministic Reference Nodes	121
5.4.1. Gaussian Measurement: Uniform Landmark Position	123
5.4.2. Gaussian Measurement, Gaussian Reference Node Position	124
5.5. Experiments in Cooperative Localization	130
5.5.1. Cooperative Localization of Two “Passing-By” Nodes	130
5.5.2. Cooperative Localization of a Robot Swarm Moving in Formation	132
5.6. Summary	135
Chapter 6 The Role of Protocols	136
6.1. The Cricket Platform	138
6.1.1. Cricket V2.0 Protocol	138
6.1.2. The RobustLoc Application	142
6.2. Chirp Reception Frequency	143
6.3. Basic Outline of the Protocol	148
6.4. Summary	150

Chapter 7 Conclusions and Future Work	151
7.1. Conclusions	151
7.2. Future Work	154
References	156
About the Author	End Page

List of Tables

Table 1: Requirements for Localization	45
Table 2: Bayes Filter Algorithm	71
Table 3: Particle Filter Algorithm	76
Table 4: Particle Adaptation Algorithm	87
Table 5: Measurement Errors for Range Readings	94
Table 6: Quantitative Results of Experiments with the Motion Model	114
Table 7: Quantitative Results of Experiments with the Motion Model and Range Measurements	120
Table 8: Experiment Conditions for two Moving and Cooperating Nodes	131
Table 9: Experimental Results Showing the Effect of Cooperation and no Cooperation for a Mobile Node	132
Table 10: Experimental Conditions for Localization of a Robot Swarm	133
Table 11: Results of Cooperative Localization in a Robot Swarm	134

List of Figures

Figure 1: Ubiquitous Computing Example	2
Figure 2: A Wireless Sensor Node for Flash-flood Alerting	3
Figure 3: Conceptual SDR Platform	5
Figure 4: Analog Devices' ADIS16350 Block Diagram	6
Figure 5: Flash-Flood Prone Zone in Venezuela	8
Figure 6: Wireless Sensor Network-Based Flash-Flood Alert System	10
Figure 7: Robots and Sensors for Cooperative Exploration of Occluded Spaces	14
Figure 8: Block Diagram of a GNC System	42
Figure 9: Setup for a Trilateration Experiment	49
Figure 10: Results of a Trilateration Experiment	50
Figure 11: The Microstrain's 3DM-GX1 Inertial Measurement Unit	52
Figure 12: Measured Acceleration with Basic Statistical Parameters	53
Figure13: Measured Angular Rate with Basic Statistical Parameters	53
Figure 14: "Virtual" Motion of a Static Object Due to Errors	54
Figure 15: Three Aspects of Cooperative Localization	56
Figure16: Cooperative Estimation	58
Figure 17: Main Functions of the Cooperative Estimation Solution	58
Figure 18: Simplified Representation of the "Localizer"	61
Figure 19: A Localizer-Enabled Cell Phone for Pedestrian Navigation	63

Figure 20: UAV-WSN Cooperative Localization	64
Figure 21: A Swarm of Ground Robots Equipped with Localizers	65
Figure 22: Localization as a Hidden Markov Model	70
Figure 23: Configuration of Beacons and a Listener	72
Figure 24: Belief after one Range Measurement	73
Figure 25: Belief after two Range Measurements	73
Figure 26: Belief after three Range Measurements	74
Figure 27: Particle Filter Initialization	77
Figure 28: Particles after the First Range Measurement	77
Figure 29: Particles after a Second Range Measurement	78
Figure 30: Particles after a Third Range Measurement	78
Figure 31: Set of Uniformly Distributed Particles and Their Histogram	79
Figure 32: Weighted Particles	80
Figure 33: Cumulative Weight of Weighted Particles	80
Figure 34: Resampled Set of Particles with Corresponding Histogram	81
Figure 35: Convergence as a Function of Particle Size	83
Figure 36: Particle Updating	86
Figure 37: Measurement Distributions	93
Figure 38: Position of the COGs of Particles after 12 Chirps, (1 unit \equiv 0.3m)	96
Figure 39: Convergence of the Average Position Error	97
Figure 40: Incremental Localization Experiment: Estimates after 100 Chirps, (1 unit \equiv 0.3m)	98
Figure 41: Convergence of Position Error in Incremental Localization	99
Figure 42: A Common GPS/INS Integration Topology	102

Figure 43: Proposed Structure for Aided Navigation	103
Figure 44: PMM for $v = 1\text{m/s}$ and $\omega = 0\text{rad/s}$	111
Figure 45: PMM for $v = 1\text{m/s}$ and $\omega = 0.05\text{rad/s}$	112
Figure 46: PMM for $v = 1\text{m/s}$ and $\omega = [0.1(t < 10) + (-0.1)(t \geq 10)]\text{rad/s}$	112
Figure 47: PMM with Greater Uncertainty in v : $\alpha_{1,2} = 0.5$, $\alpha_{3,4,5,6} = 0.05$	113
Figure 48: PMM with Greater Uncertainty in ω : $\alpha_{3,4} = 0.5$, $\alpha_{1,2,5,6} = 0.05$	113
Figure 49: PMM with Greater Uncertainty in γ : $\alpha_{5,6} = 0.5$, $\alpha_{1,2,3,4} = 0.05$	114
Figure 50: Measurement Probability, $p(z_t x_t)$	116
Figure 51: PMM for $v = 1\text{m/s}$ and $\omega = 0\text{rad/s}$ with Measurement Updates	117
Figure 52: PMM for $v = 1\text{m/s}$ and $\omega = 0.05\text{rad/s}$ with Measurement Updates	117
Figure 53: PMM for $v = 1\text{m/s}$ and Varying ω with Measurement Updates	118
Figure 54: PMM with Greater Uncertainty in v With Measurement Updates	118
Figure 55: PMM with Greater Uncertainty in ω with Measurement Updates	119
Figure 56: PMM with Greater Uncertainty in γ with Measurement Updates	119
Figure 57: Combination of Measurement Distributions with Position Belief	124
Figure 58: Position Belief of the Reference Node	128
Figure 59: PDF of the Range Measurement	128
Figure 60: PDF of the Range Measurement Obtained from Convolution	129
Figure 61: Belief after Applying a Measurement Update with a Convolved PDF	130
Figure 62: Two “Passing-by” Nodes $v = 1\text{m/s}$ and $\omega = 0\text{rad/s}$	131
Figure 63: Robots moving in a Square-Shaped Formation	132
Figure 64: Cooperative Localization in a Robot Swarm	134

Figure 65: The Two Lower Layers of the OSI Model	137
Figure 66: Cricket V2.0 Configuration	140
Figure 67: Cricket V2.0 Protocols	142
Figure 68: RobustLoc Protocol	143
Figure 69: Histograms for the Inter-Arrival Time from Six Nodes	146
Figure 70: Probability of, n , Chirps Received; $P\{N(1s) = n\}$	147
Figure 71: Basic Localization Protocol for a WSN	150

Localization in Wireless Networked Systems

Mauricio Castillo Effen

Abstract

A novel solution for the localization of wireless networked systems is presented. The solution is based on cooperative estimation, inter-node ranging and strap-down inertial navigation. This approach overrides limitations that are commonly found in currently available localization/positioning solutions. Some solutions, such as GPS, make use of previously deployed infrastructure. In other methods, computations are performed in a central fusion center. In the robotics field, current localization techniques rely on a simultaneous localization and mapping, (SLAM), process, which is slow and requires sensors such as laser range finders or cameras.

One of the main attributes of this research is the holistic view of the problem and a systems-engineering approach, which begins with analyzing requirements and establishing metrics for localization. The all encompassing approach provides for concurrent consideration and integration of several aspects of the localization problem, from sensor fusion algorithms for position estimation to the communication protocols required for enabling cooperative localization. As a result, a conceptual solution is presented, which is flexible, general and one that can be adapted to a variety of application scenarios. A major advantage of the solution resides in the utilization of wireless network interfaces for communications and for exteroceptive sensing. In

addition, the localization solution can be seamlessly integrated into other localization schemes, which will provide faster convergence, higher accuracy and less latency.

Two case-studies for developing the main aspects of cooperative localization were employed. Wireless sensor networks and multi-robot systems, composed of ground robots, provided an information base from which this research was launched. In the wireless sensor network field, novel nonlinear cooperative estimation algorithms are proposed for sequential position estimation. In the field of multi-robot systems the issues of mobility and proprioception, which uses inertial measurement systems for estimating motion, are contemplated. Motion information, in conjunction with range information and communications, can be used for accurate localization and tracking of mobile nodes. A novel partitioning of the sensor fusion problem is presented, which combines an extended Kalman filter for dead-reckoning and particle filters for aiding navigation.

Chapter 1

Introduction

1.1. Technologies on the Rise and the Emergence of Computing Paradigms

Cooperative localization, as presented in this dissertation, lies at the heart of the rise of technological advances, which are poised to change the day-to-day life of the world's societies. In order to allow for the reader to place this research in its proper context, the current technological developments, which motivate and enable the practical realization of the ideas and concepts presented, are summarized.

1.1.1. Everywhere Computing

As in the realm of Mark Weiser's vision of "Ubiquitous Computing", currently, people come into contact with objects that incorporate embedded processors, without giving any consideration to how things work internally, [1]. Advances in semiconductor fabrication capabilities provide the verification that Moore's law still holds. Larger computing power, larger memory capacity in ever-shrinking electronic packaging and reduction of prices are reported daily. Inevitably, the pervasiveness of these devices will provide for the creation of, so called, *smart* or *situation-aware environments*, [2]. Smart environments work on behalf of humans. The attempt to serve their occupants needs and fulfill their expressed desires. In addition, smart environments are conceived, which will attempt to deduce their occupants desires and requirements. Embedded computers may

someday become a part of a person’s physical makeup. Currently, computers, which are veiled in clothing, are available to be carried by people. Such capability has, in the last few years, been extensively researched in the *wearable computing* field, [3]. Figure 1, presents an experimental office environment with, what the authors term, “roomware” components, [4].



Figure 1: Ubiquitous Computing Example:
Streitz et al., 2005, [4]

Roomware components such as computers and their interfaces form part of the walls and furniture and provide interactive collaboration tools. The ultimate goal consists in having people not perceive of computers as such. Rather, people, while performing their activities, will interact intuitively with their computational assistants to produce more efficient and error free activities.

1.1.2. Everything Networked

Developments do not stop at *everywhere computing*. The latest communications and networking technologies have enabled *embedded systems* to communicate among

each other and to connect to and through the largest interconnected system in the world, the Internet. The communications modality with the fastest pace of growth is *wireless* with its key thrust stemming from personal communications. Aside from the rather trivial personal communications applications, it is widely accepted that, in a not so distant future, hordes of tiny and low-cost sensors will be pervasively installed for collecting data related to physical quantities of every imaginable kind [5]. This development has already started, [6]. The usefulness of the, so called, *Wireless Sensor Networks*, (WSNs), has been studied extensively presented and in several publications. For instance, WSNs were used for disaster management purposes, as explained in section 1.2.1, [7]. Figure 2 pictures a wireless sensor node, which is equipped with a Global Positioning System receiver. These types of WSNs may be used extensively in disaster management projects.



Figure 2: A Wireless Sensor Node for Flash-flood Alerting:
Castillo-Effen et al., 2004, [7]

Another product based on wireless technology is the *radio frequency ID* or RF-ID. The RF-ID is destined to become ubiquitous due to its applicability within a wide variety of scenarios such as tracking people, commodities and sensing key parameters of perishable food, [8].

While technical issues with respect to spectrum band allocation are being resolved, it seems that the, so-called, Fixed to Mobile Convergence, (FMC), and the Mobile to Mobile Convergence, (MMC), are imminent, [9]. As a result, these technologies will provide for a high degree of integration of cell phones into corporate fixed line telecommunications/networking infrastructures. These infrastructures will allow services to be provided to users regardless of location, the terminals, physical radio technology or protocols they may employ.

1.1.3. Open Spectrum

The constant growth of users of wireless communication devices has generated a congested and inadequately utilized electromagnetic spectrum, which is considered by many as a “precious natural resource” [10]. This development has generated a completely new approach to the use of the radiofrequency spectrum. Ideally, this new approach should fulfill some basic requirements such as, [10]:

- Provide highly reliable communication channels between users,
- Use the electromagnetic frequency spectrum efficiently,
- Do not interfere with communications of frequency bands licensed to primary users.

Undoubtedly, the achievement of these goals can only be obtained if communication devices have a degree of “intelligence” and if they are aware of the presence of other communication parties by sensing the event of instantaneous spectrum occupation.

These concepts have been summarized and well documented under the definition of *cognitive radio* [11]. The key enabler, at the core of cognitive radio, is a highly

flexible platform, which is known as *Software Defined Radio*, (SDR). Conceptually, SDR is nothing more than a digital signal processing device. Together with a wideband receiving and transmitting front-end and wideband signal converters, the SDR processes signals at the baseband. Figure 3 depicts this conceptual platform.

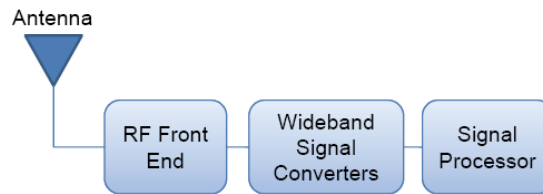

Figure 3: Conceptual SDR Platform

Developments in reconfigurable computing indicate that the best way to perform signal processing within the SDR platform may be based on programmable hardware such as Field-Programmable Gate Arrays, (FPGAs). Reconfigurable computing will make the basic objectives of cognitive radio possible. In addition, reconfigurable computing opens up new possibilities of having full interoperability among devices equipped with wireless communications interfaces. These capabilities are currently being tested in the Joint Tactical Radio System, (JTRS), military research program, [12]. These efforts are important steps towards the “everything networked” future.

1.1.4. The Inertial Sensor Revolution

The MEMS, (Micro Electro-Mechanical Systems), revolution has engendered a wide variety of devices aimed at sensing motion in all things that move. *Inertial sensors* is the term applied to these motion sensors. These devices have experienced a drop in their cost. Therefore, they are used more and more in everyday life. The price drop has

been tenfold in the past five years and the market grew by almost 10% in 2006, [13]. As a result, these devices are found in applications such as gaming devices, cameras, cell phones and portable computers. Additionally, applications that were restricted to expensive gimballed inertial navigation sensing units may now be handled by strap-down platforms at very low costs, [14]. Figure 4 presents a diagram of an Inertial Measurement Unit, (IMU).

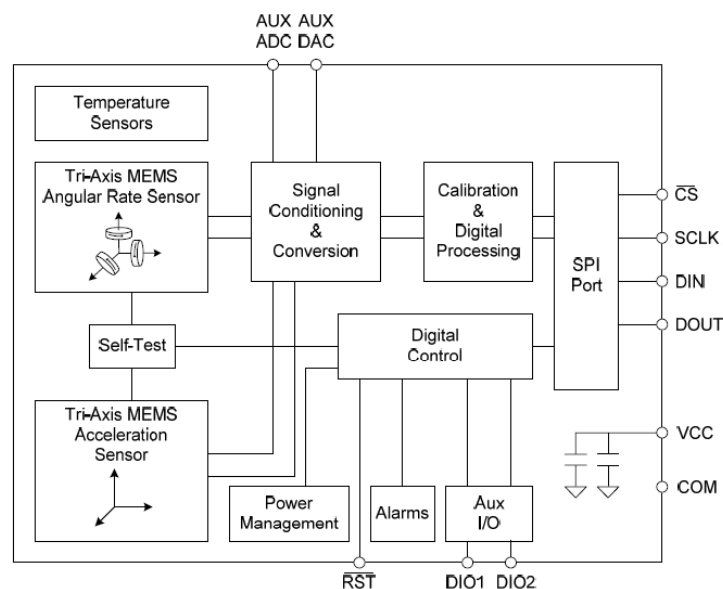

Figure 4: Analog Devices' ADIS16350 Block Diagram:
Taken from the Data Sheet

The IMU contains six motion sensors. Three of the sensors are orthogonal accelerometers and three are orthogonal gyroscopes. Physically, the IMU looks like a cube with an edge of 23mm. Currently, this device sells for \$275 when purchased in quantities between 1000 and 5000.

1.2. The Need for Location Information

The possibility exists of having mobile computing devices, which build wireless networks spontaneously or in an *ad-hoc* manner. Such a possibility has generated a multiplicity of potential applications. Furthermore, “location-awareness” is supposed to become mainstream as part of the pervasive computing revolution [15]. Location aware computing encompasses applications such as everyday office productivity, personal navigation, emergency preparedness and intelligent transportation systems.

Two research projects, where localization plays a crucial role, are presented next. They are introduced to highlight the need for real-time location information. Such data is crucial in applications where devices incorporate wireless networking interfaces. These projects, wherein this author was actively involved, served also as motivation for pursuing this research.

1.2.1. Wireless Sensor Networks for Flash-Flood Alerting

The primary purpose of the Rapid Organization and Situation Assessment project was to aid the population of the Andean region of Venezuela. Specifically, the city of Merida and its neighboring towns were chosen as the area for development of an Early Alert System based on a WSN. Large amounts of property damage and resident casualties caused by flash-floods were reported over the years. Additionally, hydrological and geological studies had shown that the region was highly prone to similar events in near future.

A flash-flood is a sudden discharge of large amounts of water. It results from a particular confluence and chain of meteorological and geological events. The mountains

that surround the borders of the rivers have geologically unstable characteristics. In the event of high precipitation levels, some zones of the mountains provide origin to landslides that fall into the rivers, which occludes the flow of water. Eventually, these naturally built barriers cannot sustain the high potential energy of the accumulated water. When the barriers finally break, a rush of water occurs, which affects the villages downstream. This chain of events happens in a short period of time, (few hours), which poses a serious challenge for authorities who try to protect the population. Figure 5 pictures a set of houses, which are prone to be wiped out by the interaction between the mountains and the rivers in the formation of a flash-flood.



Figure 5: Flash-Flood Prone Zone in Venezuela:
Matthew C. Larsen, USGS

The solution to this problem involves the application of several communication and information technologies. The flash-flood alert system is presented in Figure 6.

Basically, the alert system consists of three major components:

- A WSN for collecting information in the places where variables need to be measured. The self-healing/self-forming multi-hopping nature of a WSN

allows for a robust low-cost sensing solution that can be deployed swiftly and easily. The main variables to be measured are:

- Soil humidity, for detecting landslides,
 - Precipitation, (rainfall),
 - Water level sensors, situated in strategic locations of the rivers,
 - Other meteorological sensors, such as wind speed, temperature, sun radiation and barometric pressure, for disaster prediction.
- A sink node, located close to the sensor network whose function is collecting data from the wireless sensor nodes. Periodically, or in case of abnormal conditions, the sink sends information via cellular network to a central location.
 - A central location or command center. At the command center, emergency preparedness authorities make decisions with the help of a computer system. The computer system collects data and augments a Geographical Information System, (GIS), with a layer of live data incoming from the distant WSN.

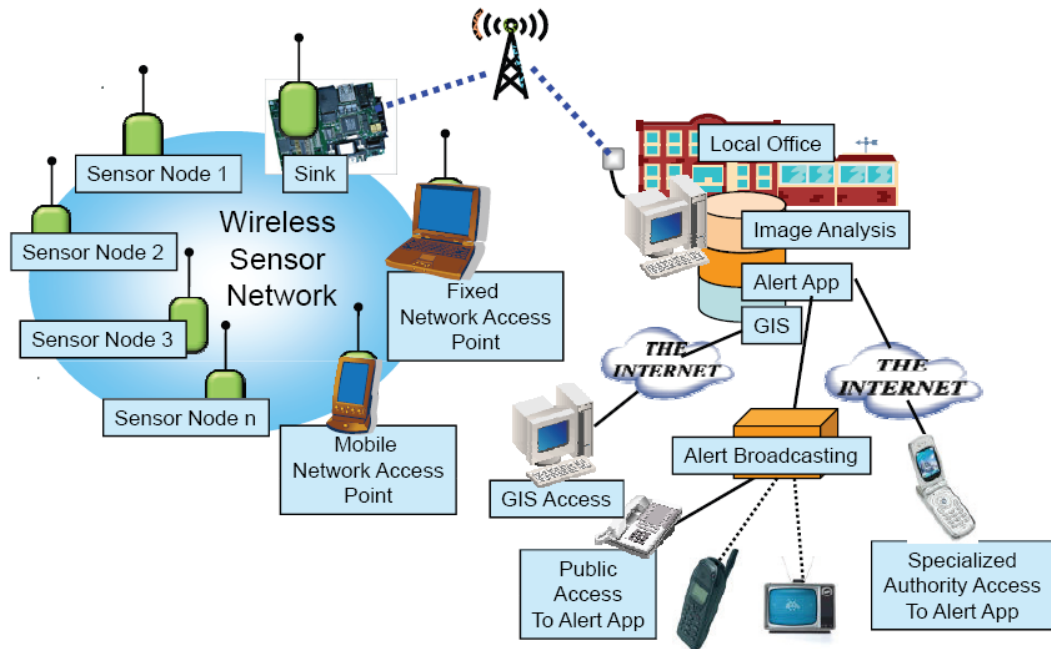

Figure 6: Wireless Sensor Network-Based Flash-Flood Alert System

It is critical that the location of the nodes be known with good accuracy for achieving a successful overlay of sensor data with the GIS maps. As a consequence, the decision makers have access to relevant information in order to take appropriate mitigation measures. In some cases, sensors nodes are located in places with Line of Sight, (LOS), access to GPS satellites. Therefore, they can determine their location with little error and almost no effort. However, there are places where mountains or vegetation obstruct the direct LOS between sensor nodes and some of the GPS satellites. These conditions cause a *loss of fix* condition, which prevents the nodes from determining their location.

The research, presented in this dissertation, was directed towards providing means for localization in a distributed fashion, without the requirement of having GPS receivers in all the nodes. In wireless sensor networks, “strength is in numbers”. Sensors are deployed in large quantities. Therefore, they need to be low in cost. Having a GPS

receiver in every unit would increase the cost of the system unnecessarily. Ideally, nodes with GPS receivers should cooperate with nodes that do not possess GPS receivers. After some time and through several information exchanges, all nodes will have good position estimates.

Location information is essential for the usefulness of the data provided by the nodes. Location information is also important for implementing important algorithms for network management. Network management algorithms such as power management, node addressing and the implementation of efficient location aware routing protocols may be simplified to a great extent using location information. Solutions to these types of localization requirements are explored initially in Chapter 3. Afterwards, localization in sensor networks is expounded in Chapter 4.

1.2.2. Multi-Robot Teams With Cooperation and Coordination

The ability of a robot to localize itself is an essential prerequisite for autonomy. For this reason, localization is also regarded as the most basic perceptual problem in robotics, [16]. A robot needs to estimate its current position in order to determine the next action. The position estimate with respect to local features determines the immediate actions performed by the robot. On the other hand, the position with respect to some semi-global coordinate system helps the robot establish the actions to take within a longer time-horizon or broader scope, such as part of a plan or mission within a team. For multi-robot teams, relative location with respect to other members of the team is fundamental for achieving coordination and cooperation during such activities as formation control, swarming, cooperative search and exploration. Localization in a

multi-robot system is fundamental for exploiting redundancy and complementarities inherent to a system composed of multiple heterogeneous individuals. When ground robots navigate in an unknown environment, it has been shown that it is advantageous to perform the action in a specific formation [17]. Different formations adapt to particular goals such as exploration and surveillance. In addition, formations can help in keeping a required node degree in a network topology. Moreover, if every robot is aware of its location, resource sharing and task allocation can be enacted more efficiently. Some mechanisms for task allocation, such as auction-based methods, have been reported extensively in the current literature [18].

One major contribution of this research consists in enabling localization in scenarios where multi-robot systems have to be deployed in an ad-hoc manner and execute missions with minimal human intervention. Chiefly, occluded and unstructured environments where no prior knowledge is easily accessible, such as maps, pose a great challenge to currently used localization schemes. For example, GPS-based solutions do not work in environments surrounded by objects that intermittently block the line of sight to GPS-satellites. As a consequence, equipping each robot or sensor node with a GPS-receiver does not assure correct positioning in all situations and/or at all times.

Simultaneous Localization and Mapping, (SLAM), techniques studied profusely in current literature are known to give good results in structured environments such as the indoors, [16]. SLAM techniques assume the availability of relatively accurate exteroceptive sensing such as the one obtained from laser range-finders. At the same time, the proposed solutions usually make extensive use of computational resources onboard the robots. It will be shown in Chapter 5, that there are not many solutions,

reported in the literature, that make use of SLAM techniques in multi-robot systems in the context of unstructured outdoor locations. Moreover, in such applications, a map is an outcome of the relatively slow SLAM process. In many cases, a map is neither needed nor required within the scope of a mission with severe time constraints.

Figure 7 presents an example of the use of a multi-robot system for cooperative exploration of occluded spaces. In order to maximize the information acquisition over time, entropy maximization algorithms may guide robot navigation while exploring the confined space. There are no maps of the environment, there is no access to the Global Positioning System and pure odometer information would diverge quickly due to high level of uncertainty in the motion patterns of the robot. While all these adverse factors put the success of the mission in jeopardy, communications can remain functional. The robots may drop disposable nodes that remain fixed for the duration of the mission. The fact of the sensors being immobile makes them act as “anchor nodes” or “landmarks”. While the disposable nodes cooperatively enhance their location information, they also serve as reference points for the robots that explore in the inside of the restrained space. These sensor nodes allow for localization. They also may act as relay nodes for the ground robots to maintain the communications infrastructure with the outside. In such a situation one of the robots would act as a gateway to the command center. The relative localization computed inside of the restrained space can even be enhanced with absolute coordinates obtained from members of the robot team with access to the GPS system.

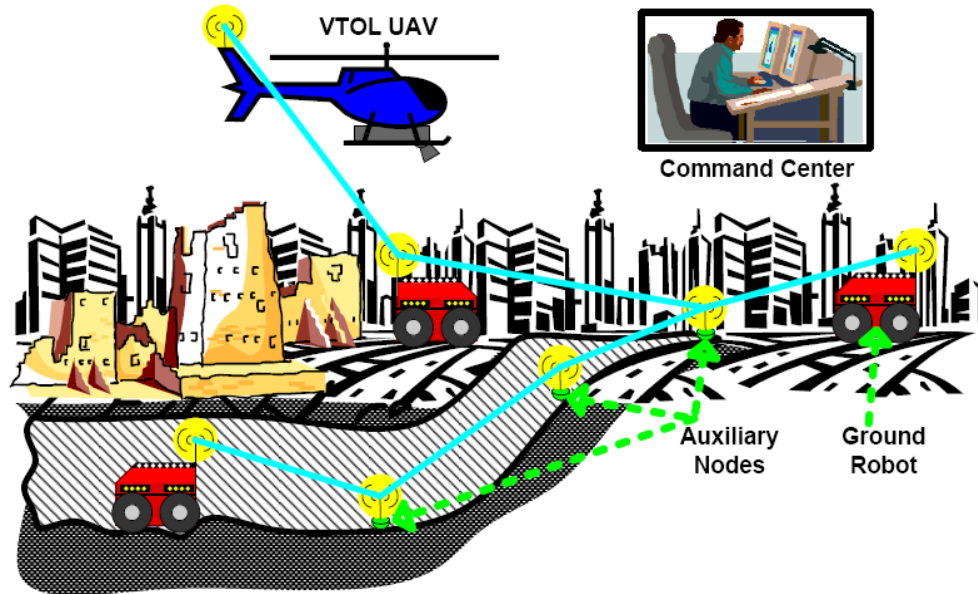

Figure 7: Robots and Sensors for Cooperative Exploration of Occluded Spaces

The description above does not point to the specific techniques used for localization. Rather, it illustrates a hypothetical scenario where localization can be enabled through collaboration of on-site deployed nodes and robots. The particular techniques needed for implementing such a cooperative localization scenario are the ones covered within the scope of this dissertation.

1.3. Research Question

The main question that guided this research can be stated as:

What resources and mechanisms are necessary for enabling real-time cooperative localization in wireless networked systems?

1.4. Contributions

The main contributions of this research are:

- A novel flexible solution to localization, which is based on distributed cooperative localization. This approach unifies networking and inertial navigation in a way that has neither been reported elsewhere in the current literature nor implemented in commercial solutions.
- Structuring of the cooperative localization problem. A systems-engineering analysis of the main localization function with allocated sub-functions is presented.
- Simple cooperative nonlinear distributed estimation laws were developed, which are amenable for localization of devices with constraints in computational resources and power, such as Wireless Sensor Nodes. Most standard approaches resource on optimal estimation techniques. However, they do not suggest simple suboptimal nonlinear estimation laws for WSNs such as the ones described in this document.
- Data fusion algorithms were developed to enable cooperative localization of wireless networked systems with mobile nodes. A concrete partitioning of the problem is presented, which provides for incorporating single range measurements and inertial measurements. Incorporation of these capabilities makes it a trilateration-free approach.
- A protocol was developed, which enables cooperative localization. The protocols required, for cooperative localization have not been explicitly analyzed in other research.

- A taxonomy of current localization solutions and a comprehensive review of the state of the art in localization. A holistic approach such as the one attempted in this work requires an all-encompassing taxonomy, which has not been presented elsewhere in the current literature.

1.5. Methodology

One of the main features of this work is the application of Systems Engineering principles to a research problem. Hence, the focus is not placed on solving the problem in an ad-hoc manner, but rather on analyzing all its aspects and their interactions in order to create a solution space, from which a particular solution may be drawn fitting a specific application. Due to the application of SE, the problem transforms from an amorphous whole into manageable pieces which may be investigated separately. SE also allows for engendering a vision of how localization should ideally work in the near or long term future, without technological constraints. Hence, novel and long-standing ideas may be generated that could be realized gradually, as technology progresses.

After the application of the SE process, each particular aspect may be analyzed by abstracting all the others. Abstracting means creating simplified models or making reasonable assumptions. In order to isolate certain problems, specific scenarios are studied where other aspects do not play any role. For instance, when considering the cooperative position estimation aspect, mobility may be taken “out of the equation” if nodes are assumed to be fixed. On the other hand, when dealing with mobility the networking aspects may be also abstracted, allowing all nodes to exchange information seamlessly. Novel contributions have arisen as a result of the application of this

methodology. For example, applying the conceptual cooperative localization solution to the particular case when nodes are fixed and limited in energy and computational resources, unique nonlinear recursive estimation techniques have been proposed. Lifting the restrictions on computational resources on mobile nodes, computational intensive but elegant solutions have been offered for cooperative localization of wireless networked systems.

1.6. Document structure

Chapter 2 presents a comprehensive report of relevant available solutions for localization, which are comparable to the solution presented in this document. Furthermore, related work is presented following a taxonomical classification.

Chapter 3 covers the main localization solution proposed from a systems-engineering point of view. The localization problem is initially structured and analyzed at the conceptual level. Relevant metrics and requirements are defined. Afterwards, a conceptual solution is presented, which guides the development of specific algorithms and techniques presented in subsequent chapters.

Chapter 4 focuses on cooperative localization as applied to Wireless Sensor Networks. In order to isolate the cooperative aspect of the estimation process, cooperative localization of fixed nodes with limited ranging capability is analyzed. Particular constraints and needs of WSN are also addressed.

Chapter 5 presents the central idea of this research, which is cooperative localization in mobile wireless networked systems. The analysis begins with an introduction to a navigation structure, which provides for the incorporation of mobility

into the position estimation process. A probabilistic motion model is introduced as well as fusion of range estimates. The chapter concludes with a series of simulation experiments, which show different situations where cooperative localization yields better position estimates than the non-cooperative variant.

Chapter 6 presents several alternatives and aspects of the protocol necessary for enabling cooperative localization in wireless mobile networks.

Chapter 7 summarizes the material presented and highlights the objectives that were achieved. It also points to several topics and areas for possible future research in cooperative localization of wireless networks.

Chapter 2

Related Work

Localization is a vast field of research with many technological applications. This is the reason why it has evolved in different directions, each in its own realm and sometimes within a very limited perspective. As a result, a broad variety of tools and techniques have been generated. However, due to the constrained vision employed by the different research communities some opportunities have been overlooked. Since one of the main features of this research was its unifying nature, in the following sections, major contributions from different fields will be presented in a structured manner. In this manner the reader can obtain a clear picture of who are the current key players in localization and their respective contributions.

2.1. A Taxonomy of Solutions for Localization

The localization field may be categorized according to different criteria. For instance:

- Definition of location,
- Research communities that have an interest in the localization problem,
- Processing and infrastructure required by the technological solutions,
- Sensors and measurements.

2.1.1. Definitions of Location

There are two main interpretations of location and according to them there are two categories for localization:

- **Qualitative:** Numbers or sets of coordinates are not necessary. Information, in the form of location qualifiers, such as “in room ENB151” or “in front of the Hall of Flags” is sufficient to describe the position of an object or agent. In robotics, locations described in this form are also known as *topological*.
- **Quantitative:** Coordinates with respect to a map or to an inertial reference system are the result of quantitative localization schemes. Position descriptions may be *absolute*, as in the case of latitude and longitude coordinates obtained from a GPS receiver; or *relative*, such as the ones obtained from SLAM in robotics. In robotics, quantitative location information is also known as *metric*.

2.1.2. Research Communities

Currently there are four main research communities that deal with the localization problem.

2.1.2.1. Navigation

The navigation community has handled the localization problem for many years. Consequently, their methods have evolved to a high degree of maturity. Numerous textbooks treat the inertial navigation problem, particularly from the optimal estimation

perspective, [19], [20], [21]. Specifically, defense-related applications such as target tracking and long-range weapon guidance have driven the field to its current state of the art. In addition, numerous other areas benefited and contributed to these developments such as geodesy and vehicle navigation. The current Global Positioning System and its derivatives can be viewed as one of the main products of navigation.

2.1.2.2. Robotics

Localization is a central topic in autonomous robotic navigation. Localization is the process of determining a coordinate transformation that provides a means of finding the correspondence between the robot's coordinate system and a map that is described in a global coordinate system, [16].

There is a profuse number of publications on the *Simultaneous Localization and Mapping*, (SLAM), problem. In SLAM, neither the map nor its location is known to the robot, which has to infer both, as it traverses the unknown location where it was placed. In most cases, robots possess accurate exteroceptive sensing capabilities such as range finders and cameras that provide for the identification of features in the environment. The greatest degree of complexity is reached when multiple robots need to exchange information for performing SLAM in unstructured environments.

2.1.2.3. Wireless Networking

Localization in the wireless communications community is also known as “radio-localization” or “positioning”. It is defined as the process of determining the position of a node, which is the *target node*, from information collected from radio signals traveling

between the target node and a number of *reference nodes*. There are three types of widely used wireless networks where localization is important. Mobile ad-hoc networks, cellular networks and wireless sensor networks require localization information. The articles presented in [22] show, in a tutorial fashion, several aspects of localization from the wireless networks perspective.

2.1.2.4. Localization Theory

There are some groups of researchers that have focused their interest on the theoretical aspects of the localization problem. For instance, the computational complexity of finding the nodes of a network, given the internode distances, has been proven to be NP-complete, [23]. Aspnes also studied graph rigidity for unambiguous localization. Distributed consensus and distributed/cooperative estimation schemes are studied in [24] and [25].

2.1.3. Categories According to Processing and Infrastructure

Solutions for localization may be categorized into three groups.

2.1.3.1. Centralized Localization

In this case, the localization routines are executed in a *data fusion center*, which collects all necessary information to determine the location of the target node. Most localization schemes proposed for cellular and ad-hoc networks require some previously deployed infrastructure and data fusion centers. The most common approach consists of collecting measurements from mobile nodes in a central platform and executing a multi-

lateration type of algorithm to determine their position. Centralized localization schemes are sometimes unfeasible due to limitations in scalability and reliability.

2.1.3.2. Infrastructure-Based Localization

Network-based or infrastructure-based solutions may not require a central data fusion center. However, previously deployed infrastructure in the form of beacons or landmarks is necessary. The Global Positioning System may be regarded as an infrastructure-based system, [26]. Such a classification is possible since satellites send out signals to GPS receivers, which basically compute their location based on the location of the satellites and the distances to them. Similarly the “Cricket” localization system in its original conception was also an infrastructure based system. In Cricket, the *beacons* send out ultrasound pulses, which may be used by *listeners* to determine their location. Computations are carried out at the client’s location, which is the reason why these solutions may be regarded as *client-based* or *mobile-based*.

2.1.3.3. Cooperative Localization

Cooperative localization methods may be termed as *fully distributed* since nodes in a network collaborate to estimate their position. In some cases nodes rely on a few nodes with absolute position information to infer their absolute location. After nodes have determined their position, they help other nodes to infer their location. This type of localization is known as *incremental*. However, if all nodes start the localization process simultaneously, the localization process is termed to be *concurrent*.

2.1.4. Sensors and Measurements

Basically, there are two major categories of sensors that may help in achieving localization and tracking of a moving node:

- **Proprioceptive Sensors:** Provide information about the position and movement of the different internal parts of an object. Typically, accelerometers, gyroscopes and encoders are considered proprioceptive sensors since they do not provide information with respect to external reference points. Odometry or *deduced reckoning* (DR) (“dead reckoning”) is based on proprioceptive sensing.
- **Exteroceptive Sensors:** These sensors help establish relationships of distance and bearing with respect to external inertial reference frames. Most radio signals could be considered within this category, as well as vision-based sensors, sun-sensors, star trackers, magnetometers that measure the Earth’s magnetic field, laser range finders, etc. In inertial navigation terms, exteroceptive sensors are also known as *aids*.

A taxonomy of radio-localization techniques according to measurements where the following types of measurements are distinguished is treated in [27]:

- **Received Signal Strength, (RSS):** If the power of the transmitter and receiver together with a propagation model are known, it is possible to estimate the distance between nodes.
- **Time of Arrival, (TOA):** Synchronization is required in order to use the signal’s travel time to estimate distance.
- **Time Difference of Arrival, (TDOA):** This is equivalent to taking

differences of TOA measurements. With respect to pure TOA, it has the advantage that clock bias can be eliminated.

- Angle of Arrival, (AOA): These measurements are possible when antennae are directionally sensitive or when multiple receiver antennas are used.
- Digital Map Information: In this case, RSS measurements are collected a-priori in a specific area and associated with a map. RSS real-time measurements are used by the receiver for finding the most likely position that matches the stored RSS data. Higher resolution maps may improve positioning accuracy. However, they require more memory and more elaborate calibration procedures.
- Direct Estimates: Corresponds to information that is available in direct form. For instance, it can be obtained from GPS receivers in outdoor environments.

The use of different measurements or combinations of them affects the localization accuracy and implies different limitations as described in [27].

2.2. Salient Work

Important developments and research, which have had a key impact on this dissertation, are described next.

2.2.1. The Localization Problem from the Robotics Perspective

2.2.1.1. Thrun, Burgard and Fox

A comprehensive treatment on localization in robotics is presented in [16]. This report also contains bibliographical remarks to earlier work. The main contribution of Thrun consisted in providing a structured framework for localization using probabilistic techniques. The term probabilistic refers to the idea of incorporating uncertainty in the localization process and taking into consideration the noise inherent to sensor measurements.

Collaborative multi-robot localization is explored and some practical results demonstrated in [28]. Although it is assumed that all robots are initially given a model of the environment; they are also equipped with accurate exteroceptive sensors, (laser range-finders), and they can exchange information seamlessly. While these assumptions might be realistic in some environments, they may not hold in unstructured and uncertain environments. The positive aspects of this work show that the multi-robot localization problem can be decomposed into smaller problems that can be handled by each member of the team. Faster convergence is achieved by leveraging on collaboration.

2.2.1.2. Kurazume and Nagata

Kurazume's research, previous to the research mentioned in last section, is seminal in the area of multi-robot localization, [29]. In Kurazume's research, for the first time, the idea of collaboration among robots of a team is exposed and a concrete technique described. In the approach presented, the robot team is divided into two

groups. The groups serve as landmarks to each other. The “landmark” group remains stationary while the other group moves. Even though this research can only be classified as an interesting research exercise, it demonstrated that the position error derived from pure proprioception can be reduced in a collaborative scenario.

2.2.1.3. Roumeliotis and Bekey

The research carried out by Roumeliotis provided one of the most appealing approaches to the multi-robot localization problem, [30]. Collaboration is based on the temporal exchange of information between pairs of robots, which always achieves better accuracy than the individual members of the team. Robots with better sensors help other robots to improve their location estimates. The core of Roumeliotis’ work is the decomposition of a central Kalman filter into smaller communicating filters. Each filter consumes only measurements produced by the host robot. Convergence of the Kalman filters is tested extensively in different scenarios. All equations are derived and demonstrated for the specific case when the number of robots is three. Finally, experimental results are presented where an overhead camera is used to record the ground truth position of three Pioneer II robots.

In the experimental setup, the relative position and orientation required for the proper function of the algorithm is “simulated” by the overhead camera. It is not clear how each robot would be able to estimate its relative position and orientation in a real scenario. Furthermore, the communications infrastructure required for the exchange of information among robots is not handled in proper detail. In addition, the need for explicitly taking into account the number of robots for deriving the Kalman filter

equations constitutes a serious restriction for scenarios where robots should have the ability to join and leave the team in an ad-hoc manner.

2.2.1.4. Howard, Mataric and Sukhatme

Howard et al. developed a localization method applicable to environments presenting a high degree of uncertainty, [31]. They assume that each robot makes use of its proprioceptive sensing units and that they also can detect each other's position and identity. The team localization problem is reduced to a combination of maximum likelihood estimation and optimization procedures. Optimization is used for maximizing the likelihood that a set of estimates give rise to the set of observations obtained by measurement. This is equivalent to maximizing the conditional probability of the observations given the estimates. Due to the nonlinear nature of the problem, steepest descent and conjugate gradient optimization algorithms were employed. The experimental results with four robots utilized are presented. The problem of estimating the position of other robots is solved by attaching retro-reflective poles to each robot, which make them appear as "moving landmarks". The approach offered is essentially centralized and account neither for scalability nor reliability issues.

In their most recent work, Howard et al., lift the assumption of having a centralized computer to perform the optimization, [32]. In addition they make use of the Bayesian formalism and the particle filter implementation to enable "cooperative relative localization". As stressed in the reactive paradigm school of robotics, the approach is "ego-centric", which means the robot is always at the origin of its coordinate system. With the new additions, the work shares more attributes with the work by Roumeliotis

and provides various improvements. Limitations of the Kalman filter are revoked due to the ability to maintain non-parametric distributions, (particle-filter), with the reasonable consequence of enhancing the robustness of the algorithm. The explanations regarding the use of UDP broadcast sockets for sharing observations among members of the robot team are welcome additions to the literature. Consequently, they offer a glimpse of the communication problems that arise when trying to implement different forms of coordination or collaboration. Experimental results with four robots are presented for validating the correctness of the method. In addition, the “robot sensor” proposed is based on cameras and special artifacts that increase the computational burden and cost of implementation.

2.2.2. Projects in Radio-Localization

2.2.2.1. Active Badge and Active Office

The Active Badge and Active Office projects represent two of the earliest documented localization projects, which were oriented towards ubiquitous computing and pervasive sensing, [33], [34]. In both cases, the localization is rather centralized. The nodes act passively by sending pulses to a network of receivers, which pass the information to a master station where the information is processed. In the Active Badge case, infrared pulses were used, which provided only for symbolic location information retrieval. In the Active Office case, nodes send ultrasound and RF pulses. The receivers compute distances based on the time difference of arrival, (TDOA). Distance information is passed to the master station, which can determine the nodes position.

2.2.2.2. Cricket

The Cricket project represents an evolution towards decentralized schemes, [35]. In its original conception, Cricket allowed each node to determine its physical position. In a way, similar to the active office project, cricket is based on ultrasound and range estimates obtained from TDOA measurements. Reference nodes send RF and ultrasound pulses continuously. The listener calculates the distance to each beacon from the TDOA. The cricket hardware is basically a sensor node, (“MICA2 Mote”), equipped with a pair of piezoelectric transducers. One transducer generates ultrasound pulses and the other transducer receives the ultrasound pulses.

The work by Priyantha was extended and improved in [36] by applying graph theory. The notion of robust quadrilaterals is introduced to allow for scalable and accurate distributed localization. Up to date, Moore’s work is perhaps the most complete in the area of wireless sensor network localization employing the Cricket platform, [36]. Mobility is also introduced through the application of Kalman filter techniques.

2.2.2.3. Radar

The RADAR project focused mainly on localization in wireless local area networks, (LAN, IEEE 802.11 Standard), [37]. This research was characterized by the use of RF measurements. The Radio Signal Strength, (RSS), was used to obtain range estimates. Furthermore, it leveraged on the readily available hardware of standard off-the-shelf wireless LAN equipment, focused attention on the double use of the wireless communications hardware. Another important aspect of this project was the creation of a “Radio Map”, which is explained in the section describing radio-location measurements.

2.2.2.4. Calamari

Calamari started after the Cricket project and possessed several interesting features, [38]. It allowed for the fusion of different ranging techniques such as connectivity, Received Signal Strength, (RSS), and TDOA from ultrasound. The hardware was very similar to the cricket platform. The main difference was that it worked at a much lower frequency, 25khz in contrast to 40khz, which enabled an almost omni-directional propagation of sound. Furthermore, only one transducer was used for transmission and reception of ultrasound pulses. The advantages of having simpler hardware and a wider cone angle have to be traded for a lower achievable precision.

2.2.2.5. Place Lab

The Place Lab project started in 2003 with the goal of providing ubiquitous location capability to mobile computing platforms, [39]. After some years of experiments and practical deployment, the lessons learned from this project were reported in [40]. The technology relied on mobile computers making use of a large database containing positions of Wi-Fi and GSM access points. These databases were built from so-called *war driving* tours where “war-drivers” collect position and MAC address information from wireless access points, which constantly broadcast their identifier such as the MAC address. It is not necessary for a receiver to have authorization to use the network in order to receive the beacon message. Then, if several access points are in range, based on the received signal strength, it is possible to apply triangulation to determine the receiver’s position with an accuracy of approximately 25m [41]. Currently, there are several cities that have been mapped. In addition, there is a

commercial product, Navizon, which takes advantage of the databases built by the war-driving community and the methodology of Place Lab.

2.2.3. Localization in Wireless Sensor Networks

Localization algorithms for WSNs have been studied and decomposed into three procedures, [42]:

- Determining distances between unknown and anchor nodes,
- Deriving a position for each node from the anchor distances,
- Refining node positions using information about the range.

Three prototypical algorithms that fall into this scheme are:

- *Ad-hoc positioning*, [43],
- *N-hop multi-lateration*, [44],
- *Robust positioning*, [45].

All three algorithms use different methods for determining distances. The derivation of position is through trilateration in the first two cases, whereas bounding boxes are used in the third case, which provide results similar to those obtained through trilateration but with fewer computations. In the final step, the last two algorithms provide for refinement, while the first one does not provide for refinement.

Simulation studies and practical results have shown a great level of discordance in the field of localization. As a consequence, many papers published recently:

- Revisit trilateration schemes [46],
- Look for theoretic foundations and assess the computational complexity of localization [47],

- Investigate error bounds [48], [49], [50],
- Investigate robustness [51],
- Provide comprehensive experimental studies [52], [53].

One last research effort, which should be mentioned, is the one proposed by Ramadurai, [54]. The main feature of Ramadurai's research was the departure from the use of deterministic models for computing the position of the nodes. In addition, he evaded the use of lateration or similar geometric approximations. Instead, range measurements and the position of the nodes were described by probability density functions, (PDFs). The final position estimate was computed from the convolution of PDFs. The results were not very promising since the localization error presented considerable variations. In addition, the convolutions required considerable computational power that was provided in the experimental setup by Personal Digital Assistants, (PDAs), which acted as sensor nodes.

2.2.4. Contributions from Inertial Navigation

2.2.4.1. Gustafson

The work of Fredrik Gustafson stands out from the extensive amount of work in inertial navigation, [55]. Gustafson's work formally introduces the use of Bayesian statistical techniques for the almost "classical" problem of GPS/INS integration. Moreover, it proves that *sequential Monte Carlo estimation*, (SMCE), which are also known as *particle filter* methods, can be applied to a variety of similar problems such as positioning, navigation and tracking.

A major problem associated with particle filters is the large amount of particles necessary for accurate belief representation when the dimension of the state vector to be estimated is greater than three. Gustafson applied particle filters to inertial navigation with a state vector of 27 states. The solution to this problem stems from the application of a procedure called *Rao-Blackwellization*, which essentially decomposes the estimation problem into a standard Kalman filter for 24 states and a particle filter for the three remaining states. The Rao-Blackwellization procedure is also known as the *marginalized particle filter*.

2.2.4.2. Sukkarieh

The impact of Sukkarieh's work on the application of inertial navigation to the autonomous vehicles community is substantial. Sukkarieh analyzes several aspects of inertial navigation, [56]. He provides comprehensive coverage of statistical estimation, error analysis and fault detection in low-cost inertial navigation systems. More recent work focuses on incorporating cameras for inertial navigation aiding and on cooperative SLAM in unknown environments, [57], [58].

2.3. Some Commercially Available Products

A few products are mentioned in order for the reader to gain an overview of commercially available solutions for localization.

2.3.1. Northstar Robot Localization System

The Northstar Robot Localization System is a localization system commercialized by the Evolution Robotics Company. The system uses infrared, (IR), landmarks, which are projected onto a flat ceiling. Nodes to be localized incorporate detectors that identify the marks on the ceiling and determine their own position and heading by means of triangulation. Northstar may be categorized as an infrastructure-based system. The main applications envisioned for this product are primarily mobile robot navigation, asset tracking and tracking of people.

2.3.2. Liberty Latus

Liberty Latus is a “6-DOF magnetic tracking solution” which was commercialized by the company Polhemus. The system tracks up to 12 magnetic markers, which have the size of a matchbox and a weight of two ounces, (battery included). Receptors need to be deployed for detecting magnetic signals emitted by the markers. All receptors connect to a central computer. Each receptor has coverage of approximately 5 m². The low latency, 5 ms, makes this solution very appropriate for high performance motion tracking. Such requirements are found in the analysis of human motion, in the animation industry or in the design of attitude control systems.

2.3.3. Vicon MX

Vicon MX is a camera-based motion capture system. Several cameras are necessary for tracking the motion of highly reflective markers. Up to eight cameras may be connected through a high-speed network. The applications are very similar to the ones

offered by the Liberty Latus system. However, the markers are lighter and do not require a battery. The Vicon MX system is more expensive than Liberty Latus.

2.3.4. IS900 Precision Motion Tracker

Intersense is a company that competes in the market with the previous two companies mentioned, Polhemus and Vicon. The main application scenarios for the IS900 system are augmented reality, immersive technologies and other novel human-computer interfaces. The major characteristic of the IS900 system consists of the incorporation of inertial measurements aided by ultrasound. According to the product documentation, better tracking accuracy can be achieved due to the inclusion of inertial measurements in the position and attitude estimation process.

2.3.5. Navizon

Navizon is a personal localization system combining GPS, Wi-Fi and cellular phone positioning. The principle of operation was elucidated in the previous exposition of the Place Lab project. According to their product documentation, Navizon may be categorized as a “software only GPS”. Navizon users possessing GPS receivers collect wireless data and share the data with other users by accessing the Navizon central server.

2.3.6. Motorola’s Mesh Enabled Architecture

Fast and accurate localization is just one of the capabilities of Motorola’s Mesh Enabled Architecture, (MEA). MEA is based on mobile, ad-hoc networking technology, offering high bandwidth and excellent coverage even in scenarios where nodes move at

high speed. Nodes require a specialized wireless network interface card. Fixed mesh wireless routers may be installed to guarantee coverage in large geographic areas. This technology is proprietary and information about specifications with respect to the localization function as well as its operational principles is limited.

2.4. Conclusions

After presenting a large collection of related work in localization and a comprehensive taxonomy, it may be concluded that there still exist many areas open to further scrutiny and study. Current solutions seem to be based on divergent approaches and plagued by limitations such as:

- They work only in specific environments, such as outdoors or indoors.
- Some are based on centralized computation, giving rise to scalability limitations.
- Many methods depend strictly on previously deployed infrastructure which is mostly proprietary.
- Other methods are based on the simultaneous construction of maps using bulky exteroceptive sensors.

Four key developments have substantially changed the shape of the field in recent times:

- The wireless communications field has allowed for the spontaneous creation of networks where nodes can exchange information seamlessly.

- The inertial navigation field has moved away from gimbaled inertial measurement units towards strap-down configurations, which take advantage of the low costs enabled by advances in MEMS.
- The robotics field has contributed substantially to the solution of nonlinear estimation problems with important results in probabilistic estimation techniques.
- There is enormous pressure for the advancement of location-aware computing and ubiquitous location systems with big commercial opportunities.

There are no localization solutions that explicitly take advantage of cooperation, radio-localization and inertial sensors for localization. The integration of these three aspects is the central subject of study in this research, which will be developed in the next chapters.

Chapter 3

A Flexible Localization Solution

3.1 Definition of Localization

Within the scope of this research, localization is defined as the process of determining the position of an object, which in this case is a node in a wireless network, relative to a given reference frame of coordinates. The terms *localization*, *positioning*, *geolocation* and *navigation* can be used synonymously. However, in some of the robotics and autonomous vehicle literature, the terms *localization* and *navigation* have different meanings. For instance, according to Bekey, localization refers to the ability of a robot to “know where it is,” while navigation may be understood as the process of planning and executing maneuvers necessary to move from point A to point B, [59]. In this document, the more traditional interpretation of the term navigation will be used, which refers to “accurately determining position and velocity relative to a known reference” [19]. Some authors, in the robotics literature, also distinguish between *global localization* and *position tracking*, [16]. A robot needs global localization when it needs to estimate its coordinates with respect to a known reference frame. The robot is said to need position tracking when the position estimates have to be kept current as it wanders. The semantics of localization in this research encompasses both problems. It is assumed implicitly that all activities from proper position initialization to real-time updating are contained within the localization concept.

3.2. The Systems Engineering Approach

This research is a reflection of the, ever more frequent, appearance of technical problems involving several disciplines. In this case, an integrative understanding of networking, control, signal processing and computing is necessary to approach the problem in the most effective way. The application of a holistic view to these types of problems can be considered as one the main contributions of this research. Considering the diversity and variety of aspects of the problems treated, only the Systems Engineering, (SE), approach can provide the common ground for an adequate formulation of a solution to a multifaceted and interdisciplinary problem such as localization

The main focus and goal of the SE approach is to yield a tangible product or system, as required in the development of a project, [60]. It is widely accepted that the main objective of research is the generation of knowledge. Apparently, the application of a SE approach to research may seem arguable. However, one of the main weaknesses, which were identified during the collection of sources of related work, was the fact that most researchers observe the localization problem from a very narrow perspective. For instance, the roboticist is concentrated on solving the simultaneous localization and mapping, (SLAM), problem, which in its pure form, may be restricted to only few application scenarios.

In many real-life applications of mobile robots, the generation of a map is not strictly necessary. Other means to obtain location information, at least in rough form, may be available. Conversely, scientists in the communications areas count only on radio-location techniques. They are in many cases oblivious to the advances of inertial

measurement systems, which may provide a key complement to techniques currently employed in radio-localization. Consequently, it appears that the application of SE to structuring research endeavors is perfectly feasible. In addition, the SE approach may give rise to innovative and optimal solutions to particular applications. Therefore, it is argued that the application of SE principles results in a more focused and structured generation of knowledge. The SE process is a sequential, top-down, process with the main objective of delivering a “*Solution Space*” that fits the needs of particular missions and/or applications. Within the solution space, the role of the SE process is translating requirements into a system that solves the problem. The SE process accounts for all the restrictions, requirements and needs initially specified. The SE process may be divided into four basic steps:

- Requirement analysis,
- Functional analysis and allocation,
- Design synthesis,
- Verification.

Figure 8 presents the block diagram of the guidance, navigation, and control, (GNC), problem from the SE approach as applied to autonomous vehicles, [19].

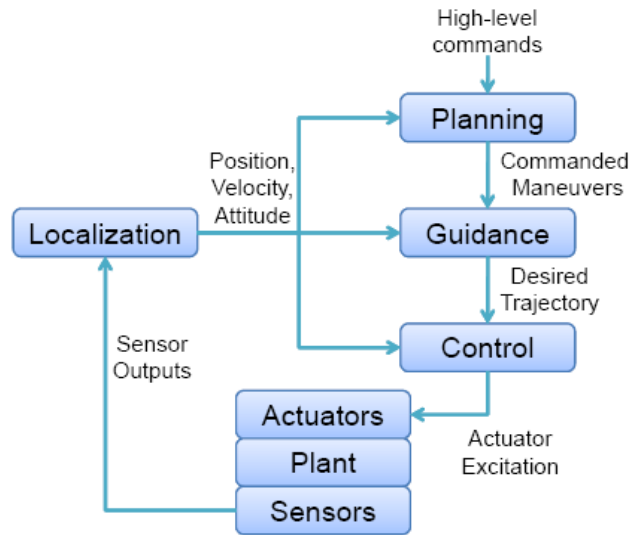

Figure 8: Block Diagram of a GNC System:
Modified from [19]

The SE approach to research planning indicates that through proper structuring of a problem, conceptual solutions can be obtained that are free of technological constraints. The diagram presented in Figure 8 is the result of the application of the first two steps of the SE process. It shows the different functions that are required in a GNC application and their interactions. However, the diagrammed process does not reference actual solutions or particular implementations since they may vary according to application, available resources or the stage of technological development. Concrete implementation factors will be considered in the design synthesis and verification steps, which are iterated until reaching a solution that fulfills all the requirements specified in step one of the process.

3.3. Requirements and Metrics

The development of a localization system is proposed, which lifts the limited applicability and restrictions of solutions previously formulated. A requirements analysis considering different aspects of localization solutions is listed below:

- Coverage: One major drawback of currently available localization schemes is their limited coverage. For instance, GPS receivers work only outdoors. Other indoor systems work only within a specific range and with severe constraints. For example, the “Cricket” and NorthStar systems are severely constrained by the fact that signals can be easily blocked by obstacles.
- Processing: Because of privacy issues and due to scalability constraints, centralized solutions are not desirable. For example, current localization services offered by cellular communications providers are based on centralized trilateration schemes, which allow them to pinpoint the location of mobile communication devices. A distributed cooperative estimation process is desired, which provides a capability for nodes to determine their position locally with the help of close-by neighbors.
- Sensing: Researchers from the mobile communications community see the problem as a “radio-localization” problem since radio signals alone are used to determine position information. However, the roboticist incorporates sensors such as laser range-finders and cameras. These sensors improve the localization process but are too bulky and expensive to be installed in every networked wireless system. Navigation scientists

are especially concerned with the process of augmenting inertial sensing with external aids. However, they do not consider the potential cooperation that can take place due to networking. The solution should provide a balance between the compactness found in radio-localization with the comprehensiveness of robotics and navigation.

- **Applicability:** Some currently available methods work only for specific applications. For instance, localization systems designed for mobile communications cannot be used in robotics applications. What is sought is a solution, which can be used in all applications such as personal navigation, vehicular navigation and robotics with some adaptations.
- **Infrastructure:** Many localization systems rely heavily on previously deployed infrastructure. Such is the case with GPS, which needs a set of dedicated satellites. Other systems require direct communication to anchor nodes, beacons, or visual landmarks. The proposed system should work without relying only on external infrastructure. However, it should benefit from such infrastructure when available.
- **Previous knowledge:** Some localization designs require a map with signature patterns such as visual or RF signal strength. These maps are built prior to the deployment of the devices to be localized. However, it is desirable that no previous mapping should be necessary. Storing large amounts of information locally should also be avoided.
- **Integration:** The localization solution should be easily integrated into the vehicles, robots or objects to be localized. If other types of localization

systems are in place, the system should integrate into their computational and communications resources use them and enhance them to the maximum extent possible.

Table 1 summarizes the desired characteristics of the localization solution compared to characteristics, which have been reported in related scientific literature or to commercially available characteristics.

Table 1: Requirements for Localization

	Features	
	Proposed	Common
Location	Anywhere	Either outdoors or, indoors
Processing	Local, distributed	Centralized
Sensing	Compact and comprehensive	Radio-loc. only, cameras, range-finders
Applicability	Universal	Specific (robotics, cellular, vehicles).
Infrastructure	Benefit from it when available	Ref. points, beacons, anchor nodes
Prev. Knowledge	Minimum	Maps, databases
Integration	“Embeddable”	Stand-alone

Requirements involve all desired features of the localization solution to be proposed. However, it is highly relevant to determine concrete quantitative metrics in order to compare the proposed solution to other solutions. The comparative relevance of each metric depends on the particular application. A list of metrics that can be used to assess the quality of a localization method follows:

- Accuracy: This metric can be viewed as the uncertainty associated with a position estimate. Accuracy may be measured in units of longitude. Estimation bounds, such as the Cramer-Rao lower bound, indicate the minimum variance achievable using particular proprioceptive and exteroceptive sensing hardware.
- Lag, Latency: Many localization system vendors indicate latency as one of the main parameters of their products. The position estimation process is not instantaneous. Therefore, results are obtained a short time interval after the platform has passed through a given position. Hence, this parameter defines the ability of the system to perform *dynamic tracking*.
- Coverage: Coverage could be measured in units of area in the case of two-dimensional solutions. Coverage is highly dependent on the technology used for exteroceptive sensing. For instance, ultrasound ranging technology, which is used in the Cricket localization system, has a wedge-formed coverage area with an approximate radius of five meters and an approximate angle of 150° . Cooperative localization methods present better coverage metrics than trilateration solutions, which require nodes to be within the coverage area of anchor nodes. Coverage can be categorized according to the application environment since exteroceptive sensing technologies, such as ranging, depend on the propagation patterns of RF-Signals. Some authors distinguish indoor-to-indoor, (ITI), indoor-to-outdoor, (ITO), and outdoor-to-indoor, (OTI), coverage metrics.

- **Cost:** The cost can be divided into two main categories. These categories comprise costs at the local level and the cost of infrastructure. Some localization schemes such as GPS do not imply any costs to the user. However, certain methods specify a minimum number of reference nodes for the solution to work within certain error bounds. Some solutions require expensive sensors at the node level. Others may only use hardware that is already in place such as wireless network interface cards, (WNICs).
- **Computational complexity:** Computational complexity of localization algorithms can vary with such parameters as the number of sensors employed, the number of nodes in the network and the accuracy of the models used for navigation.
- **Message complexity:** Distributed computations involve the exchange of messages. This exchange of messages can be observed as communications “overhead”. Therefore, it is desirable for localization methods to possess a limited usage bandwidth and that the amount of localization-related messages does not grow exponentially with the number of nodes.

3.4. Structuring the Cooperative Localization Problem

3.4.1. Challenges and Issues in Localization

After the requirements have been analyzed and metrics established, the systems engineering approach usually includes a step, which consists of analyzing the challenges that are involved in solving the main problem. Exploratory practical experiments may be carried out to discover the challenges and issues of localization. Two preliminary “naïve” experiments that elucidate the challenges of localization are described next.

3.4.1.1. A Trilateration Experiment

There are many alternatives for the determination of the location of a node based on external measurements or through the application of geometric principles. The most widely used method is *trilateration*, which is defined as “a method to determine the position of an object based on simultaneous range measurements from three stations located at known sites”, [46]. A straight-forward numerical implementation of trilateration is through the application of Cayley-Menger determinants, [46]. However, trilateration is highly sensitive to errors in the range measurements as well as in the position of the reference nodes.

A practical experiment was performed with the help of the Cricket localization system, (presented in Chapter 5), to assess the trilateration method. The setup consisted of three *beacons*, which sent ultrasound pulses and a mobile platform equipped with a *listener*, [61]. The setup is pictured in Figure 9.

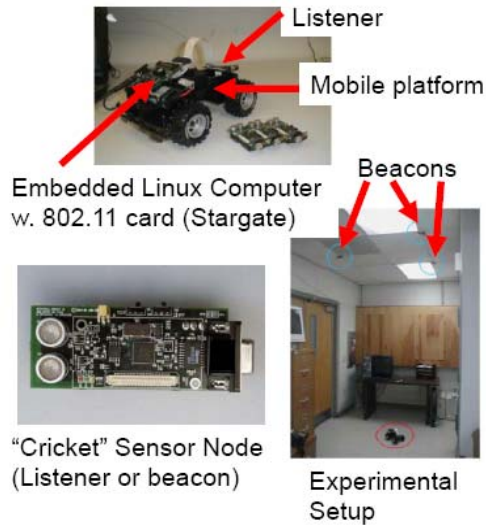

Figure 9: Setup for a Trilateration Experiment

When a beacon sends an ultrasound pulse, it also simultaneously sends an RF packet with a beacon identifier, which may be associated with a specific position. This combination of ultrasound pulse and RF packet is interpreted as a single *chirp*. A chirp possesses information about the location where the chirp originates such as the position of the beacon and the distance from that location to the listener. In reality several listeners can make use of a chirp since each listener needs to compute its distance to the beacon. The distance can be determined, using the speed of sound for the ultrasound pulse and the speed of light for the RF packet, from the time difference of arrival, (TDOA).

This particular experiment deals with a mobile platform that obtains chirps from the beacons and forwards them to a computer where the position is calculated. No two beacons can emit chirps at the same time. Therefore, a protocol was required. A *medium access control*, (MAC), protocol was employed, which enabled the beacons to share the acoustic medium where the ultrasound propagated.

Figure 10 presents the results obtained from this experiment and the positions of

the beacons. The x-marks indicate the trilateration estimates. The smooth curve, which can be used as ground-truth, shows the trajectory of the mobile platform obtained through a-posteriori smoothing of the data.

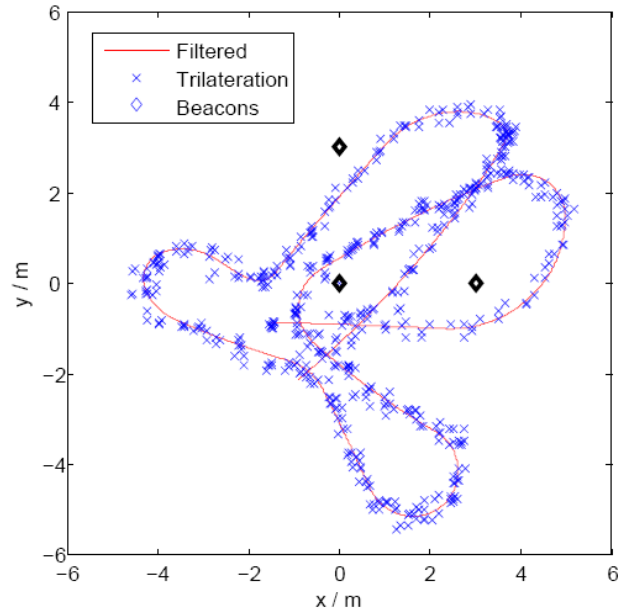

Figure 10: Results of a Trilateration Experiment

Although the experiment was simple, the degree of error, which was an average of approximately 0.2m in the position estimates, highlights several drawbacks of the trilateration approach. Most of the drawbacks can be attributed to the fact that the Cricket localization system was designed for *static* localization. However, in this case, it was applied to *dynamic tracking* of a mobile platform. Salient points, from an analysis of the experiment, were:

- In order to perform trilateration, three simultaneous measurements are required. In this case, because of the MAC protocol, the chirps arrive at different instants of time. If absolutely no filtering is applied, the best possible result can be obtained using the three most recent chirps. This

means that if the listener is moving, only one range measurement is valid and the other two are outdated. The error is exacerbated considering that range measurements also have some degree of noise. The solution to this problem requires projecting the past measurements through a motion model of the mobile platform in order to apply trilateration to one current measurement and two past measurements. Hence, filtering is required.

- Sensitivity and error analysis indicate that results are highly dependent on the configuration of the beacons and on the position of the listener, [46]. For instance, beacons that are almost collinear do not yield good results. Similarly, when the listener is close to the barycenter of the triangle formed by the beacons, the sensitivity and errors behave better than when the listener is in faraway locations.
- The problem of lack of consistency in the error and sensitivity could be alleviated by placing higher numbers of beacons. However, the listener would have to choose the best configurations of three beacons to optimize the error performance of the position estimates.
- At least three measurements from three different beacons are required in order to obtain a valid position estimate. However, intuitively, one or two beacons could be used to obtain a raw estimate of position.

3.4.1.2. Inertial Measurement Experiment

An Inertial Measurement Unit, (IMU), should improve the location estimation results obtained in the previous experiment since it contains information about the motion of the mobile platform. A simple experiment demonstrates the challenges involved in the use of inertial sensing devices. The experiment consists of simply collecting data from a static IMU. Six variables were measured with the help of accelerometers and gyroscopes contained in the IMU. The accelerometers provided three orthogonal accelerations. The gyroscopes provided three orthogonal angular rates. The IMU used in this experiment is pictured in Figure 11, which also depicts the measurement axes for the available signals.

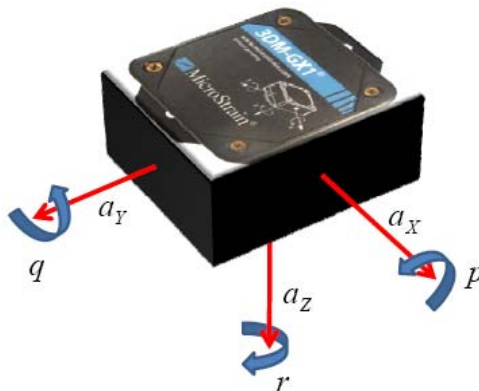

Figure 11: The Microstrain's 3DM-GX1 Inertial Measurement Unit

Figure 12 presents the measured acceleration data and Figure 13 presents the measured angular rate data. From these results it can be inferred that the position or attitude of the IMU cannot be determined from the measurements in a straightforward manner. Acquired measurements present bias and a considerable noise component. The noise component is especially large in the case of the accelerometers. The accelerometers also sense the Earth's gravitation, which makes it difficult to distinguish the true acceleration from noise and gravity.

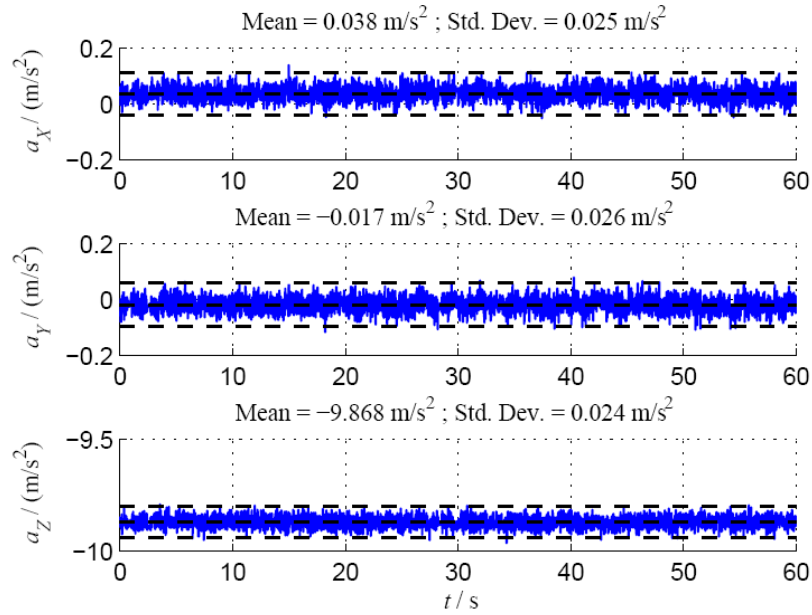

Figure 12: Measured Acceleration with Basic Statistical Parameters

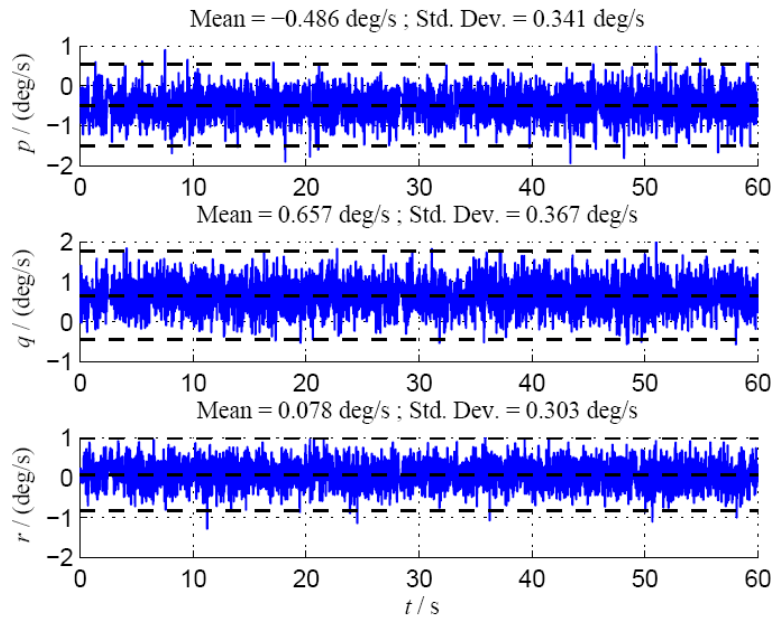

Figure13: Measured Angular Rate with Basic Statistical Parameters

Basic zero-phase digital filtering was applied to the data presented in Figures 12 and 13 after removing the mean. The resulting signals were integrated, with the objective of obtaining position and attitude, in accordance with:

$$\ddot{x}_j(t) = \tilde{a}_j(t), \quad (1)$$

where $\tilde{a}_j(t)$ is the measured acceleration, $x_j(t)$ is position along the j axis, and

$$\begin{bmatrix} \dot{\phi} \\ \dot{\theta} \\ \dot{\psi} \end{bmatrix} = \begin{bmatrix} 1 & \sin(\phi) \tan(\theta) & \cos(\phi) \tan(\theta) \\ 0 & \cos(\phi) & -\sin(\phi) \\ 0 & \sin(\phi)/\cos(\theta) & \cos(\phi)/\cos(\theta) \end{bmatrix} \begin{bmatrix} \tilde{p} \\ \tilde{q} \\ \tilde{r} \end{bmatrix}, \quad (2)$$

where ϕ , θ and ψ are roll, pitch, and yaw, respectively. \tilde{p} , \tilde{q} , \tilde{r} are measured angular rates around the X, Y and Z axes respectively. Figure 14 presents, in a summarized way, the computed position and attitude for a time interval of 60s.

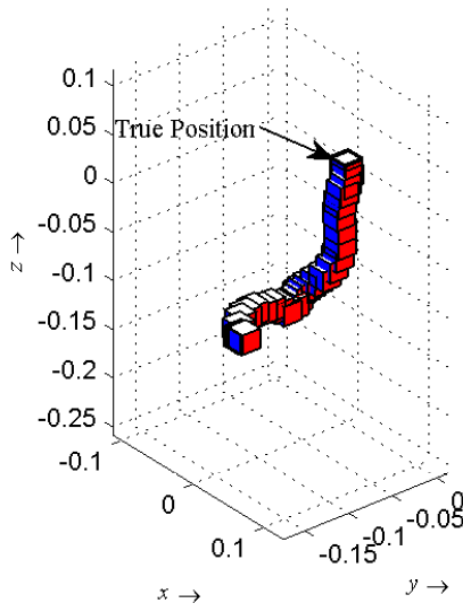

Figure 14: “Virtual” Motion of a Static Object Due to Errors

The results presented indicate that the error due to drift in the accelerometers can grow very quickly even when the average is subtracted. However, attitude errors were much smaller since the orientation of the object did not change noticeably.

3.4.1.3. Summary of Challenges and Issues

The following main challenges have been identified:

- The localization problem based on range measurements is a difficult problem, [62]. It has been proven that, in the presence of noise, the localization problem is NP-Hard.
- As seen from the trilateration experiment, measurements may arrive asynchronously. For instance, in trilateration, at least three simultaneous range readings are required.
- When using trilateration, choosing different groups of three reference nodes yields different sensitivity and accuracy.
- Ranging technologies have limited coverage.
- Inertial sensors have significant errors that are non-stationary. If calculations do not account for these errors the estimation results may diverge quickly.
- Kinematics of a rigid body is highly nonlinear, as equation 2 indicates.
- Variables of interest in rigid body kinematics are tightly coupled.
- The most practical and inexpensive way to do inertial navigation is with strap-down inertial measurements systems. However, it may be much easier to employ gimballed inertial measurement units, which are more accurate and sensitive, but bulkier and more expensive.

3.4.2. Cooperative Localization and Distributed Estimation

In networked systems, centralized solutions may not be optimal due to several constraints, which are associated with scalability, robustness and flexibility. This fact is well known, for instance in ad-hoc networks, which require routing algorithms to build routes for shuttling information between nodes. Therefore, it is highly desirable to elaborate a distributed localization solution where the computational and communications load is distributed evenly among the members of the network.

Making localization a cooperative distributed task improves its coverage, scalability, flexibility and robustness. The central idea in this research is the possibility of posing localization as a distributed estimation problem. Figure 15 presents the cooperative localization process, which takes in a network of four nodes. As indicated in Figure 15, the problem can be partitioned into three major aspects.

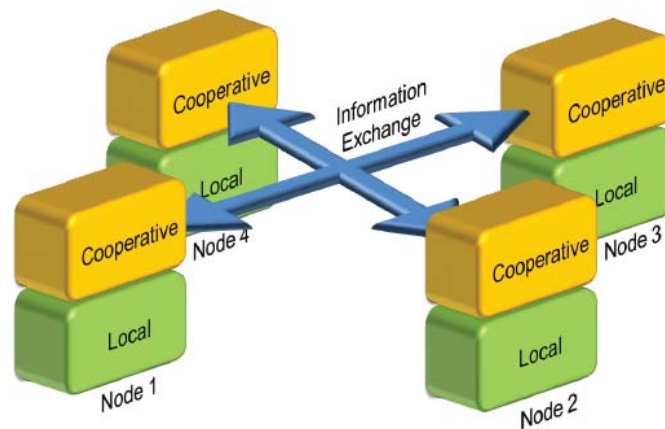

Figure 15: Three Aspects of Cooperative Localization

Each aspect is depicted in different color and represents:

- Local Aspect: The lower blocks represent processing taking place in each node for the estimation of the node's position,

- Cooperative Aspect: The upper blocks depict the processing component, which is executed on behalf of other nodes in order to enable cooperative distributed estimation,
- Information Exchange Aspect: The exchange arrows represent the information that each node sends to their neighbors as part of the cooperative estimation process.

The main question consists in finding the appropriate boundaries of problem partitions.

Three questions arise:

- How much processing is going to be performed at the local level?
- What portion of the processing is going to be solved in a distributed manner?
- What type of information is going to be exchanged?

The more weight that is placed on pure distributed estimation, the greater will be the amount of information to be exchanged. However, pure local processing will disable the potential of having more accuracy due to the possibility of exchanging information since the systems may have to exchange information under any circumstance. Ideally, the estimation process should allow for a refinement of estimates in a loop such as the one depicted in Figure 16.

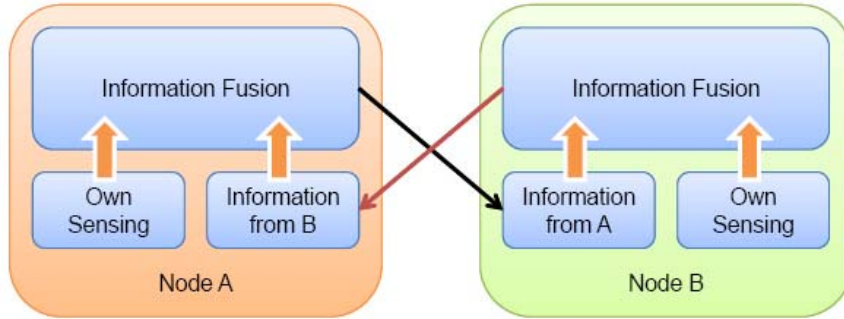

Figure16: Cooperative Estimation

3.5. Functional Analysis and Allocation

Following the SE approach, a more detailed functional analysis of the localization solution yields the main functional modules, which are depicted in Figure 17. The overall general solution has three main components.

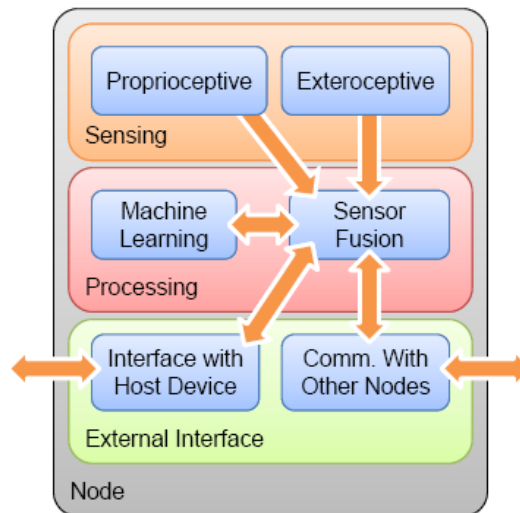

Figure 17: Main Functions of the Cooperative Estimation Solution

Each of the main components is comprised of several sub-units:

- Sensing: This unit is in charge of obtaining physical measurements, which will enable the system to determine its location. There are two main categories of sensing devices, which were introduced in section 2.1.4:

- Proprioceptive: These are devices that can be used by the system to register its own motion. Sensors of this category are the ones that provide for performing dead-reckoning, which is also known as odometry. It can be assumed that proprioceptive measurements are available at higher sampling rates than measurements from the complementary exteroceptive category. The proprioceptive module is only necessary when nodes possess mobility.
 - Exteroceptive: Odometry cannot be used for long-term position tracking, due to modeling errors and measurement noise. However, exteroceptive sensors provide for keeping errors, which stem from odometry, within bounds. In navigation terms, sensors of this category are also known as *navigation aids*.
- Processing: To allow for combining data incoming from the sensing module and information gathered through the communication interfaces, a processing device is required. The processing device is required to execute procedures, which, most likely, would consist of sensor fusion filters. Accurate positioning of mobile nodes with minimum latency demands much higher computational power than static node localization. An additional *machine learning* module is suggested for localization of mobile nodes. The learning module would perform online identification of certain parameters such as drift rates of the inertial sensors, particular motion patterns of the host vehicle or node carrier, the non-orthogonality of inertial measurements and lever-arm compensation

- Interface: Localization of a wireless node serves an application-specific purpose. Therefore, there must be a user for the location information.

This module consists of the elements that enable the wireless localization solution to pass this information to a user or to other nodes. In the latter case, a node may contribute to the cooperative localization process by providing its own position estimate to other nodes. Thus, it should be stressed at this point, that the most viable way to implement cooperative localization is by making each node share its own position estimate.

Additional to the position estimate, it is important for other nodes to have a measure of confidence of their position estimate since they may use it in their own position estimation process.

3.5.1. The “Localizer” – A Conceptual Solution for Cooperative Localization

The third step in the systems engineering approach is design synthesis. Following these guidelines a conceptual solution for cooperative localization is presented. This solution can be considered as the vision for this research, which opens the possibility for generating concrete measurable contributions to the state of the art.

A localizer is an abstraction of the conceptual solution for localization presented in this work. The “localizer” may exploit hardware already available in its carrier, such as power, communications interfaces, antennae or even the processing unit. In one extreme case, the localizer may have the appearance of a small rugged device comprising all the hardware and software, as presented, in simplified form, in Figure 18.

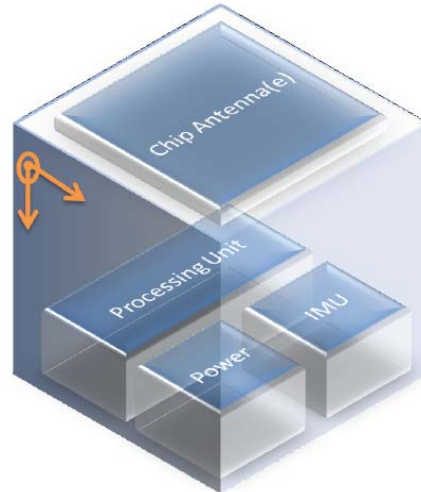

Figure 18: Simplified Representation of the “Localizer”

NOTE: After coining the term “localizer” for illustrating the conceptual localization solution, the author became aware of a device also termed “localizer”, introduced by the science-fiction author Vernor Vinge in the novel “A Deepnes in the Sky” published in 1999. Vinge describes localizers as tiny devices bearing some resemblance to one of the possible solutions expounded in this document.

In another extreme case, the “localizer” may include all the software algorithms and use all the hardware resources available in the host device. The “localizer” comprises the following elements:

- An inertial measurement unit, which may minimally incorporate a six-degree-of-freedom inertial measurement configuration such as three accelerometers and three gyroscopes.
- A processing unit comprising all processing functions explained previously. For its physical realization, the processing unit may be realized as a system of parallel processors or multi-threaded software modules. Each module would be dedicated to different tasks such as:
 - A sensor fusion processing module for executing sensor fusion algorithms and cooperative estimation tasks.

- A communications module for performing all communications tasks and protocols. This module may also use a signal processor for assistance in managing software defined radio functions and range determination. Possibly, only one communications interface may be necessary for communication with other localizers and with host devices querying position information.
- A management processing module, which may be in charge of machine learning routines and coordination among the different processors.
- An antenna or set of antennas in case the communications system is realized as a MIMO system or in case other geometric relationships are used for location determination, such as the angle of arrival, (AOA), of a “chirp.”

The localizer might represent a viable solution for the two motivating examples expounded in Chapter 1. Additional application scenarios are described below with the purpose of understanding the function of each module of the localizer.

3.5.2. Application Examples

3.5.2.1. A Localizer-Enabled Cell Phone

One possible application scenario of the localizer may involve incorporating it in cellular phones for accurate pedestrian navigation. Due to seamless interoperability, cell

phones of the future may establish communication links with indoor and outdoor network access points. They may even use other phones in a multi-hop configuration. Multiple channels and specific protocols may be used for synchronization and accurate range estimation. The main feature of this futuristic phone is the incorporation of a strap-down inertial measurement unit. The measurement unit would provide for motion tracking and substantially reduce information exchanges associated with cooperative localization. A high degree of dead-reckoning precision is achieved due to the identification of the motion patterns of the users. These parameters may be acquired after a continuous identification process through machine learning techniques. Static cell-phone towers and wireless access points would have their location estimated with high accuracy, which would make navigation aids very accurate. This situation is illustrated in Figure 19.

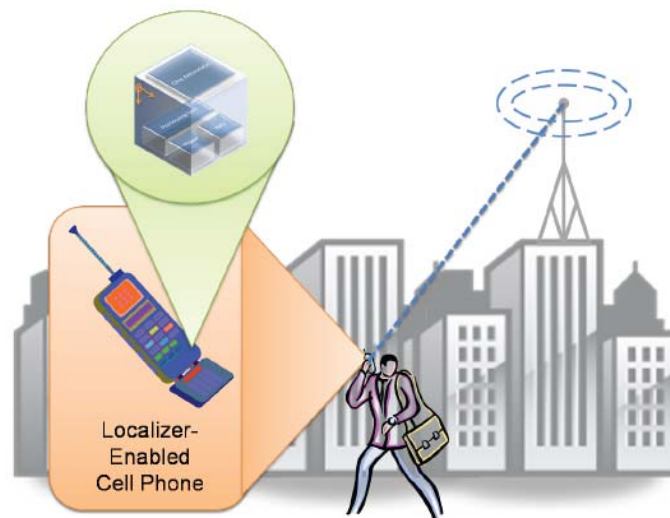

Figure 19: A Localizer-Enabled Cell Phone for Pedestrian Navigation

3.5.2.2. UAV-WSN Cooperative Localization

A scenario, where the proposed localization solution would be applicable, involves an unmanned aerial vehicle, (UAV), aided cooperative localization of wireless

sensor networks. For instance, an environmental monitoring WSN may be deployed randomly by UAVs in a location with severe LOS obstruction with respect to GPS-satellites. WSN nodes may be equipped with a localizer, which would allow them to cooperatively find their relative location. However, if data needs to be collected using absolute location information, there should be a mechanism that would allow the nodes to determine their absolute location. A localizer-enabled UAV could be used for “spreading” location information among the WSN nodes just after deployment. This situation is illustrated in Figure 20.

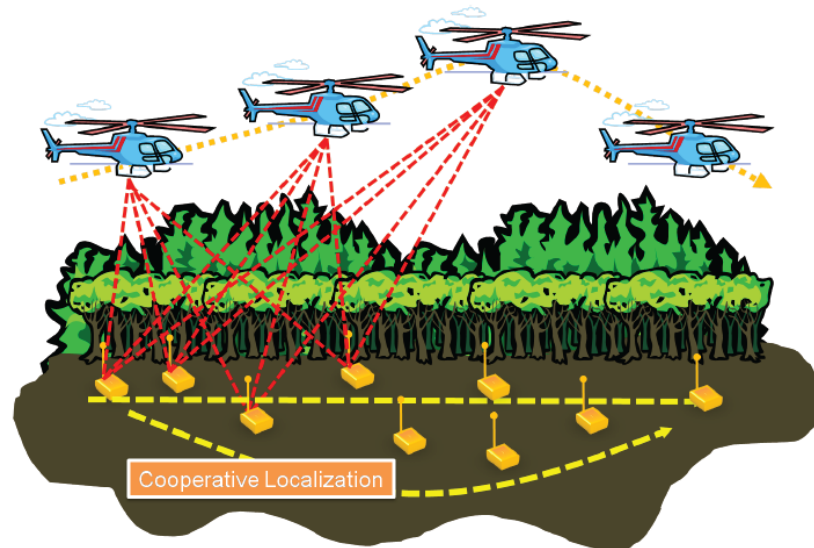

Figure 20: UAV-WSN Cooperative Localization

The motion of the UAV would allow it to broadcast chirps from different locations. The chirps would allow the WSN nodes to estimate their own position information. Not all nodes would need to find their location. Certain nodes could use similar cooperative localization mechanisms for refining the position estimates independently of the UAV. The cooperative localization mechanisms would provide for achieving complete coverage of the network.

3.5.2.3. A Swarm of Ground Robots

The localizer can be also used in a network of ground vehicles, which need to move in a specific formation. Figure 21 pictures such a network. Since each robot is equipped with a localizer, they can communicate with each other. Therefore, they can determine their relative distances. Due to the inertial sensing capability included in each localizer, the robots do not need to exchange location information continuously.

Formation control algorithms will use the relative position information for maintaining a specific geometric pattern.

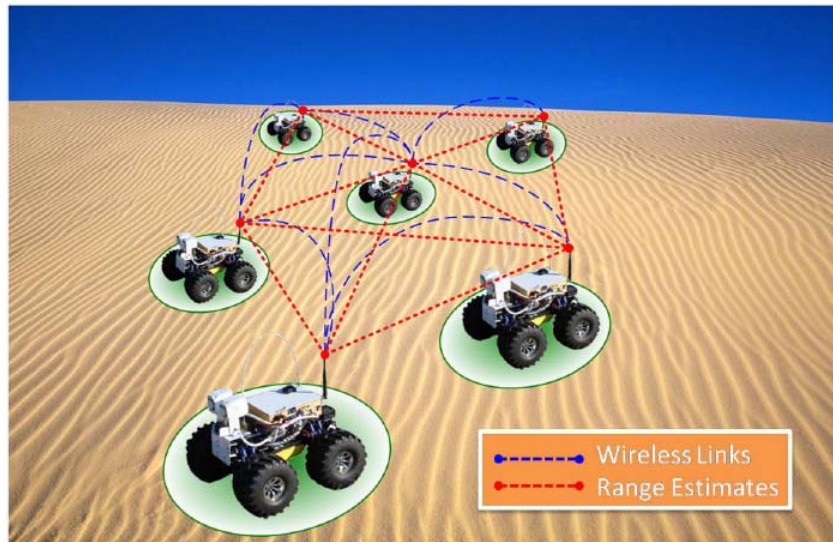

Figure 21: A Swarm of Ground Robots Equipped with Localizers

The machine learning algorithms may learn the holonomic constraints of the robots, which would enhance their dead-reckoning ability. Position estimates obtained from the localizers may be further refined in case more sensing magnitudes had to be integrated such as velocities and position changes stemming from wheel encoders.

3.6. The Role of Ranging

Navigation aids used in this research used range measurements such as inter-node distances. In the remainder of this document, it is assumed that range measurements are available, even under adverse conditions, which is the primary situation in indoor environments. Indoor environments pose the main challenge to current ranging methods due to the difficulty of range estimation under Undetected Direct Path, (UDP), conditions, [63]. These conditions arise in cluttered environments with severe multi-path propagation characteristics. Under these conditions nodes do not have Line of Sight, (LOS), connectivity. The cooperative nature of the localization scheme proposed in this research makes the estimation of very long ranges unnecessary. However, most researchers agree that, due to intense research work in Ultra-Wideband, (UWB), modulation techniques, in the near future range measurements may be available as a byproduct of the networking functionality of wireless networking interfaces, [64]. The main advantages and challenges of UWB localization, as well as an outline of techniques and error bounds, are covered in a tutorial manner in, [65].

3.7. Summary

The localization problem was analyzed and considered most relevant aspects from the systems engineering perspective. Initially, requirements and metrics were defined. Two preliminary experiments served for identifying key issues in localization, which showed it to be a non-trivial problem. Function allocation exposed the structure and modules necessary for creating a conceptual solution, which may be applied to a variety of scenarios. Finally, the “localizer” was presented with some examples illustrating its

use and capabilities. A localizer may be realized as a stand-alone device. Alternatively, its functions may be embedded in the computers of the host vehicle or carrier. The main characteristic of the localizer consists of the integration of three aspects:

- A wireless network interface with the functions of communications and range measurements,
- An inertial measurement unit,
- One or more processing devices executing routines for the implementation of protocols, for recursive state estimation and for continuous on-line calibration.

Chapter 4

Cooperative Localization in the Case of Fixed Nodes

Several aspects of the conceptual solution were presented in the previous chapter. The best way to approach solving a complex problem, which includes many functional components and fields, is to isolate the different aspects of the problem by applying a “divide and conquer” approach. In the divide phase, the nodes were considered to be fixed. The fixed node assumption allowed key aspects of the problem to be isolated. However, the fixed node idea is not an assumption but the relevant condition in certain problems. The problem of localization in Wireless Sensor Networks, (WSNs), which was outlined in the introduction, is a fixed node localization problem.

This chapter develops two main ideas that were key in this research:

- Probabilistic estimation: It is shown that probabilistic approaches can override limitations inherent to deterministic solutions such as those using graph rigidity, trilateration or other similar ideas.
- Cooperative localization: It is proven that devices can exchange information and use it for determining their own location in a cooperative and distributed manner.

The associated aspects of mobility and the protocols underlying cooperative localization are handled in subsequent chapters. For practical implementation of the localization algorithms, which are presented in this chapter, additional aspects are explored.

Computational and energy constraints inherent to WSN nodes, which were used while seeking to minimize the complexity of the estimation algorithms, are presented.

Additionally, the number of messages, required to be exchanged, between nodes to achieve accurate localization was investigated.

4.1. Probabilistic Approach to Localization

In section 3.4.1.1, it was shown that trilateration may not be the best solution for determining the position of a node. Obtaining the position from pure geometry in a closed form expression or through an iterative solution is regarded as the *deterministic* approach to localization. *Probabilistic* techniques constitute an alternative approach. One of the main advantages of probabilistic techniques is that they facilitate the consideration of uncertainty, which is always present in real-world applications. The main sources of uncertainty reside in the inaccuracy of dynamic models and in the measurement of noise.

This section introduces the probabilistic estimation framework as applied to localization. The approach follows the one presented in, [16]. In general, and not only for fixed nodes, the localization problem can be viewed as a continuous Markov process. The state of the system, (x_t) , evolves with time and is driven by the controls, (u_t) . The system is Markovian because the current state depends only on the previous state, (x_{t-1}) , and the control action. In other words, to predict the next state, it is only necessary to know the current state, the control that is being applied and the conditional probability functions. The state is not directly observable. Only measurements, (z_t) , are available. The measurements are probabilistic projections of the state. Measurements contain noise.

Since the state is “hidden behind” the measurements, the model of the evolution of the position in time can be regarded as a *Hidden Markov Model*, (HMM), or as a *Dynamic Bayes Network*, (DBN). It is important to note that the state is not the position. The state is a collection of variables that completely describe the system. Hence, the state may also incorporate the current velocity and rotational speed in the case of moving nodes. A diagrammatic depiction of a HMM is presented in Figure 22.

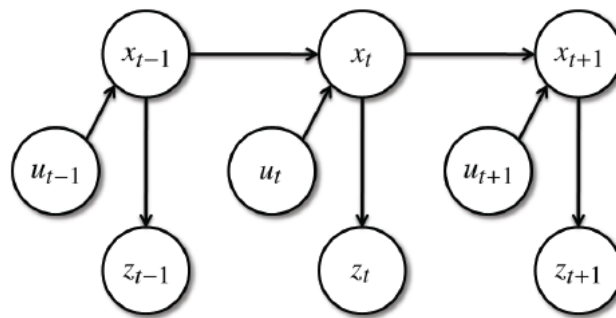

Figure 22: Localization as a Hidden Markov Model:
From [16]

A paramount change in perception occurs when applying probabilistic methods to the problem of localization. The position of an object or node cannot be viewed as possessing a fixed value, which can be directly measured. Instead, position is viewed as stochastic in nature and, the value associated with position, is termed *belief*. A belief can be understood as the node’s internal knowledge about the state. The belief also incorporates the uncertainty inherent to the non-absolute knowledge about the state. In statistical terms, a belief is simply a probability density function. The belief distribution represents the probability of any hypothetical state value.

4.1.1. Bayes Filter

The Bayes filter is a tool that can be applied for determining belief with almost no restrictions outside the assumption of the process being Markovian. Table 2 presents the Bayes filter algorithm. Table 2 lists the main steps invoked in assessing the belief, the *posterior*, after the application of the control and the measurement. Measurement and control are not applied at the same time. The *prediction* is the result of the incorporation of the control. The posterior is calculated from the prediction after the *measurement update* step.

Table 2: Bayes Filter Algorithm

$$\begin{aligned}
 & \text{BayesFilter}(bel(x_{t-1}), u_t, z_t) \\
 & \overline{bel}(x_t) = \int p(x_t | u_t, x_{t-1}) bel(x_{t-1}) dx_{t-1} \\
 & bel(x_t) = \eta p(z_t | x_t) \overline{bel}(x_t) \\
 & \text{return } bel(x_t)
 \end{aligned}$$

In Table 2, $bel(x_t)$ stands for the conditional probability distribution:

$$bel(x_t) = p(x_t | z_{1:t}, u_{1:t}) \quad (3)$$

Similarly:

$$\overline{bel}(x_t) = p(x_t | z_{1:t-1}, u_{1:t}) \quad (4)$$

For calculating the posterior, three probability distributions are required:

- The initial belief: $p(x_0)$,
- The transition probability: $p(x_t | u_t, x_{t-1})$,
- The measurement probability: $p(z_t | x_t)$.

4.1.1.1. Illustrating the Experiment

In an experiment similar to the one performed in Section 3.4.1.1, beacon nodes send chirps to a static listener. Given that the device to be localized is static makes the prediction calculation step unnecessary. Figure 23 depicts the configuration of the beacons and the listener.

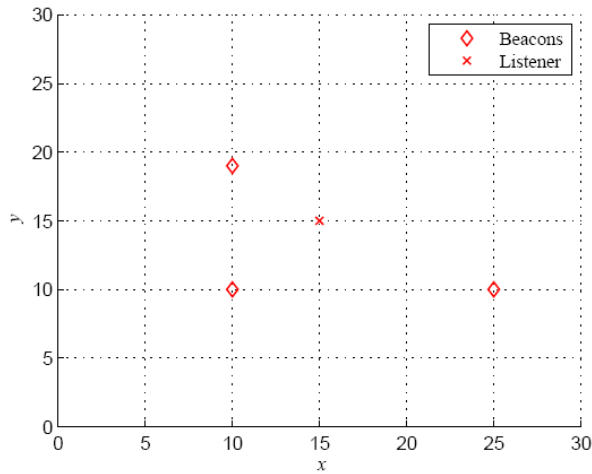

Figure 23: Configuration of Beacons and a Listener

Figures 24 through 26 show the sequential application of the Bayes filter. The assumptions are that range measurements are always noisy and that the measurement noise has Gaussian distribution. Therefore, the location of a listener belief can be represented by an annular distribution centered on the beacon. The belief after one range measurement is presented in Figure 24.

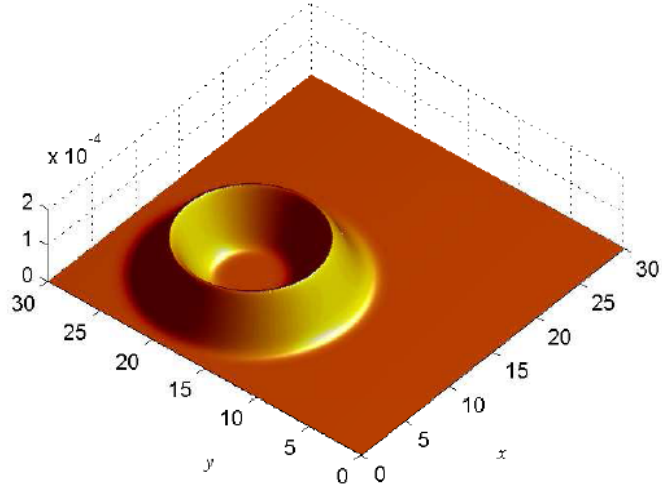

Figure 24: Belief after one Range Measurement

Every time a range measurement from a beacon is available, the position belief is updated. In this example, three measurements were processed. Noise in the range measurements displayed a standard deviation of one, ($\sigma = 1.0$). The belief after two range measurements is presented in Figure 25.

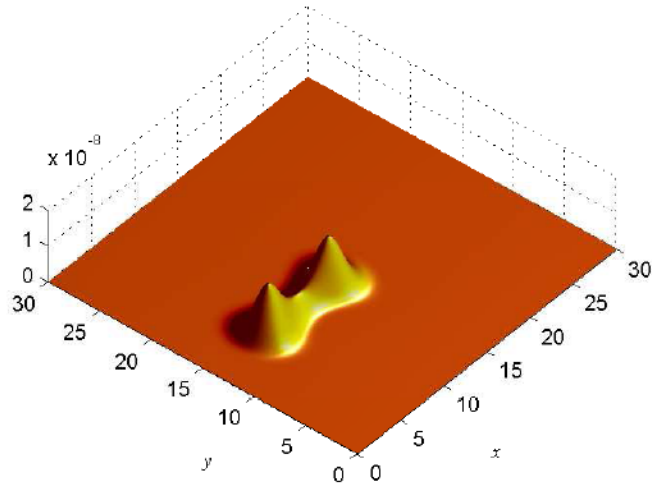

Figure 25: Belief after two Range Measurements

Figure 26 presents the belief obtained after three range measurements.

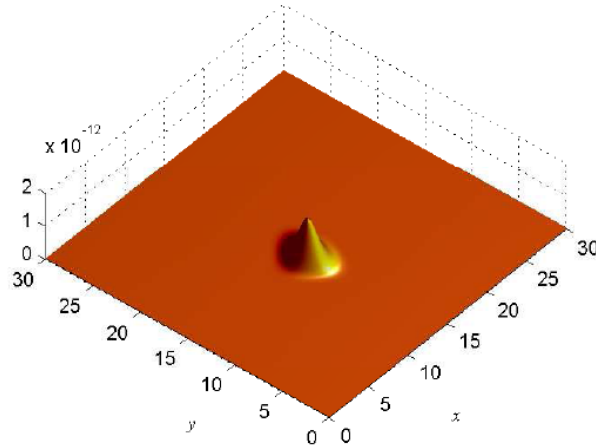

Figure 26: Belief after three Range Measurements

This example shows several important aspects of the probabilistic approach:

- What is calculated is the belief, which is the Probability Density Function, (PDF), of a node being at a particular position. Specific techniques could be used to extract from this PDF a position estimate and the degree of uncertainty. If the PDF was Gaussian, the position would correspond to the mean of the PDF and the uncertainty to the covariance matrix.
- The PDFs resulting from the application of the Bayes filter to range measurements are not normally distributed. This could be a major hurdle when trying to apply optimal estimation methods that assume normal distributions.
- It is possible to obtain position estimates without the need for three chirps from different beacons. For instance, after the second chirp, as shown in Figure 25, the PDF has a strong bimodal character, which indicates that there is equal probability for the node being at one of the peaks.
- All measurements are useful. Even two measurements from the same node produce a refining effect on the resulting belief.

4.1.2. Particle Filters

Graphs in previous sections were computed using the generic Bayes filter, which was evaluated numerically on a grid with almost 300 cells per side. However, localization needs to be implemented in embedded devices. Therefore, working with such a degree of resolution or even symbolically may not be feasible as a result of memory and computational constraints. There are two main possibilities for the practical representation of beliefs; Gaussian and non-parametric. Due to the non-Gaussian nature of the beliefs resulting from applying measurement updates stemming from range measurements, this section considers only non-parametric belief representations. Non-parametric belief representations work with sampled versions of the distributions. The two popular varieties of sampled representations are *histogram filters* and *particle filters*. The particle filter representation is known to possess a high level of robustness and there are a number of techniques that make it computationally tractable. The generic particle filter algorithm, which can be viewed as a Monte Carlo approximation of the Bayes filter, is listed in Table 3.

Table 3: Particle Filter Algorithm

```

Particle_Filter( $X_{t-1}, u_t, z_t$ )
 $\bar{X}_t = X_t = \emptyset$ 
for  $m = 1$  to  $M$  do
sample  $x_t^{[m]} \sim p(x_t | u_t, x_{t-1}^{[m]})$ 
 $w_t^{[m]} = p(z_t | x_t^{[m]})$ 
 $\bar{X}_t = \bar{X}_t \cup \langle x_t^{[m]}, w_t^{[m]} \rangle$ 
endfor
for  $m = 1$  to  $M$  do
draw  $i$  with probability  $\propto w_t^{[i]}$ 
add  $x_t^{[i]}$  to  $X_t$ 
endfor
return  $X_t$ 

```

The first for-loop implements the Bayes filter using samples of the distributions. The second for-loop is termed *importance sampling* and is relevant for keeping a larger amount of particles at places with higher probabilities. After the first for-loop, particles are still spread according to the prior concentration. However, after the second for-loop, particles will have higher concentration where the posterior had higher weight. Each particle is one hypothesis of the possible position of the listener. The weight of a particle can also be interpreted as the probability of the hypothetical position.

The experiment for localization from three range measurements was repeated using particle filters. The results are presented in Figures 27 through 30. The number of particles, M , in the experiment was 5000. Since there was no previous knowledge about the location of the listener, the belief was initialized by sampling a two-dimensional uniform distribution. Figure 27 presents the result.

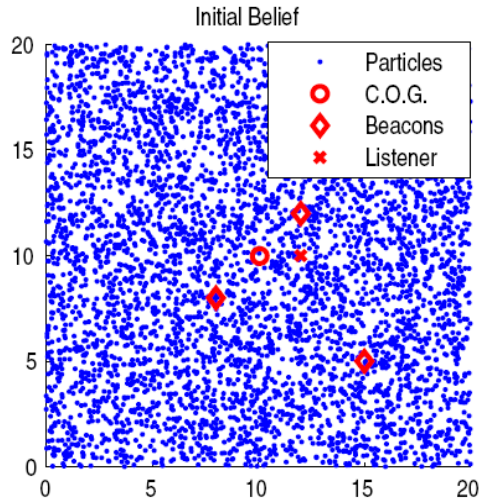

Figure 27: Particle Filter Initialization

Figure 28 shows the belief after the first range measurement and after resampling, which is also known as *importance sampling*.

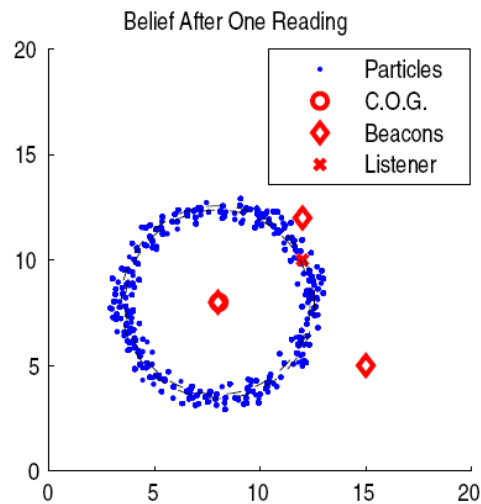

Figure 28: Particles after the First Range Measurement

Figure 29 presents the belief after the second range measurement.

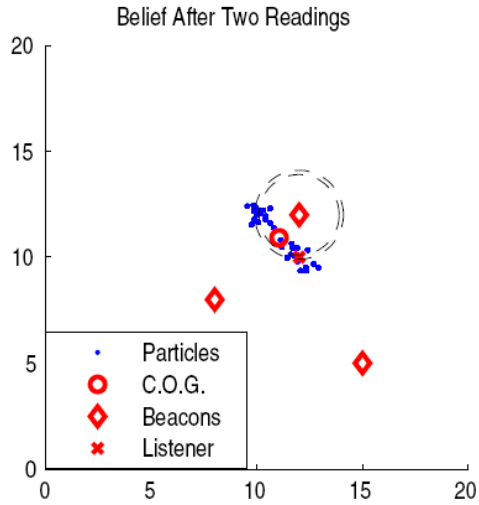

Figure 29: Particles after a Second Range Measurement

The red cross, and the red circle are displayed in each of the steps of the iterative process to represent the true and the estimated position of the listener respectively. The estimated position was calculated as the Center Of Gravity, (COG), of all particles. A comparison of the estimated and true positions demonstrates that the estimation converges to the true position.

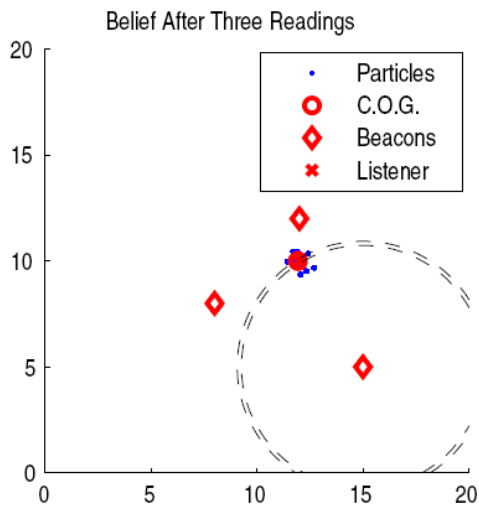

Figure 30: Particles after a Third Range Measurement

4.1.3. Implementation of Resampling

The resampling process consists in drawing a specific number of particles from an original set of particles \bar{X}_t to conform a new set of particles X_t representing a particular belief, that is, a probability density function. The process of “drawing” particles is governed by the weight of each particle of the set \bar{X}_t . The way this was implemented is illustrated by an example, where the distribution of \bar{X}_t is uniform and the weighting distribution is normal, as seen in Figures 31 through 34.

First, in Figure 31, the original set comprising 1000 particles is shown. Particles are distributed uniformly over the interval (0, 10). This fact can be corroborated by observing the histogram.

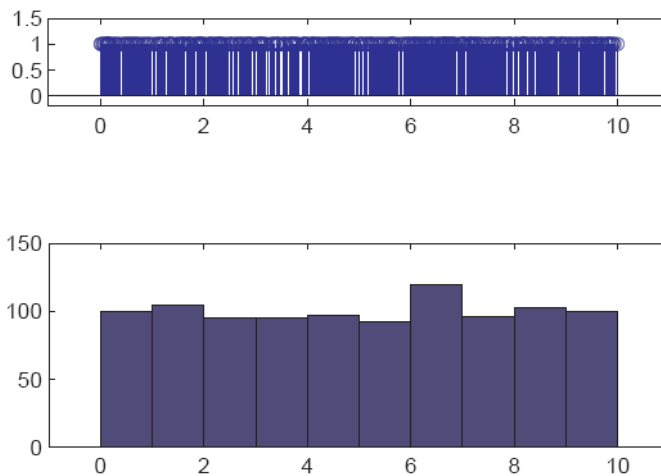

Figure 31: Set of Uniformly Distributed Particles and Their Histogram

Then, the particles are weighted according to a normal distribution given by $N(5, 2)$. The weighted particles are shown in Figure 32.

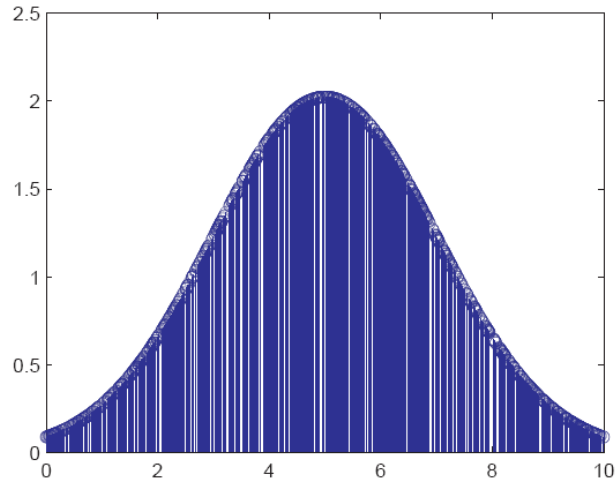

Figure 32: Weighted Particles

Figure 33 shows the cumulative sum of the weights. After that, N random values are generated according to a uniform distribution $U(0, 1)$. These values are used to perform an interpolation finding the indexes of the corresponding particles. This can be thought as finding the x value for each y generated value. The concrete MATLAB command used is:

```
newix = interp1(cumul, 1:N, ix, 'nearest', 'extrap')
```

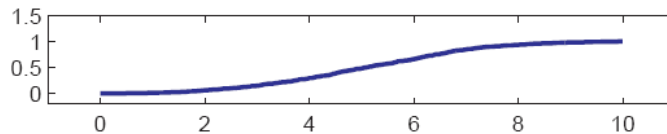

Figure 33: Cumulative Weight of Weighted Particles

Then, the new particle set consists of the particles with the indexes obtained from the function mentioned above. The new set is depicted in Figure 34. The corresponding histogram shows that the particles are distributed according to the weighting distribution $N(5, 2)$.

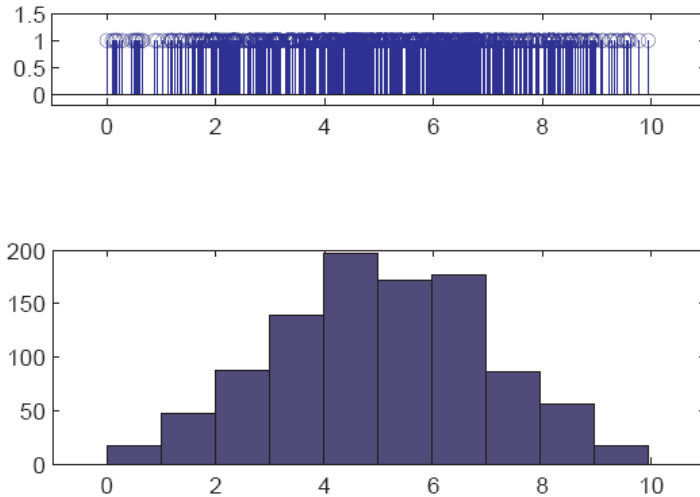

Figure 34: Resampled Set of Particles with Corresponding Histogram

4.2. General Assumptions

WSN nodes are assumed to host range-based measurement devices. A “chirp” sent by a node comprises a distance measurement pulse and a short message, (standard wireless packet). The message contains the location of the beacon and a measure of uncertainty of its own position. Nodes can act alternatively either as transmitters of chirps, (beacons), or as receivers, (listeners). In the transmitting state a node broadcasts chirps to neighboring nodes. Listeners compute their distance from the transmitting node and use the position transmitted by the beacon to update their own position estimates. Listeners obtain readings from different beacons at random. The ranging technology may require a particular randomized MAC arbitration scheme. Hence, this research is applicable to platforms with different ranging technologies such as Received Signal Strength, (RSS), to other more sophisticated ranging techniques, for instance those described in [66] and [67].

Two scenarios, *incremental* localization and *concurrent* localization, are analyzed in order to define the localization problem, [68]. In both scenarios, the ranging device has a specific coverage area. In the *incremental* localization scenario, reference nodes broadcast their position to nodes within their coverage area. As soon as a node has a good position estimate it begins to broadcast its position to other nodes, which expands the region of coverage for localization. In concurrent localization all nodes start the localization process simultaneously. In both scenarios, nodes cooperate to obtain the final position estimates, which leads to the term cooperative localization. Therefore, in cooperative localization, WSN nodes do not rely on a central platform to assist in the localization process. Consequently, the algorithms are characterized as *distributed*. In both scenarios, it is assumed that there is an underlying MAC layer protocol striving to minimize the overhead of information packets exchanged for coordination. It is also assumed that localization packets, (chirps), constitute the core of the information exchange necessary for enabling localization.

Given that communications was the key factor impacting network lifetime in WSNs, the main metric considered, to reach final localization estimates, was the total number of chirps broadcasted, [69]. The main concern was the *convergence time* of the algorithm measured by the number of chirps. Slower convergence implies that more messages must be exchanged. Thus, the *message complexity* of the distributed algorithm employed for localization was crucial to assess its impact on the energy consumption and the lifetime of the WSN.

4.3. Varying the Number of Particles

In Section 4.1.2 the localization process using a particle filter, which consisted of 5000 particles was illustrated. The large amount of memory required for localization motivated an investigation of the effect of changing the amount of particles. Reduction of the number of particles required would make the method applicable to devices with constrained computational and memory storage resources. However, convergence time is severely affected by the number of particles, which will be demonstrated in subsequent paragraphs.

In the experiments performed, the Crámer-Rao bound was not calculated, [48]. Therefore, convergence was assumed to be reached when the COG of the particles was within one standard deviation of the measurements. The experiment was run twenty times with different random seeds. The results presented in Figure 35 are the averages of twenty runs.

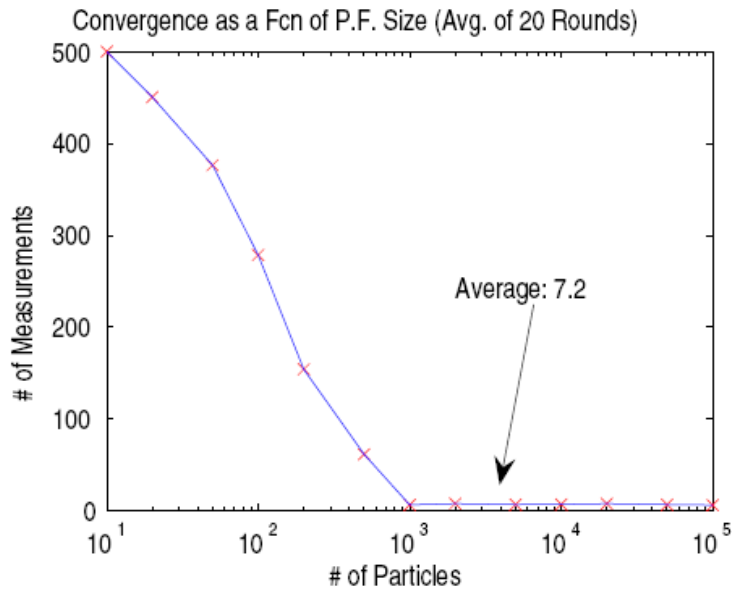

Figure 35: Convergence as a Function of Particle Size

On average, approximately seven chirps are required in order to reach final estimates. These results were corroborated by applying the binomial distribution. The problem is that fast convergence, (7 chirps in this case), can only be obtained with a number of particles greater than 1000. Other experiments demonstrated that approximately 500 particles were necessary if they were initialized with a flat annular distribution around the beacon, after the first reading, instead of a uniform distribution. However, even 500 particles impose a significant burden on the reduced memory and computational resources available in WSN nodes.

Significant memory and computational requirements exist to yield fast convergence in sequential Monte-Carlo estimation. Reducing the number of particles slows convergence. Slow convergence is particularly undesirable when faced with the prospect of trying to apply this method to tracking mobile nodes. Slow convergence would also increase the amount of chirps required, which would incur high energy expenditures. An additional problem related to reducing the number of particles is that particle filters base their robustness on keeping particles, (hypothesis) with low probability, (weight).

4.4. Adapting Particle Filters

The two elements that are essential to estimation are the belief representation and the estimation law. When the belief is approximated by a Gaussian distribution, the optimal estimation law, which minimizes the sum of the squared errors, is given by the Kalman filter. When the belief is strongly non-Gaussian the belief may be approximated by a set of particles. The main objective pursued in this research was to reduce the

amount of particles used in particle filters while maintaining their positive properties such as simplicity, robustness and fast convergence. Previous experimentation has shown that a reduction in the number of particles causes an increment in the amount of chirps necessary to achieve localization. The main reason for this degradation lies in the fact that fewer particles cannot represent the actual belief with sufficient accuracy. Therefore, if fewer particles are used, they should not be generated “randomly” as in the original formulation of the Monte Carlo approximation. Hence, a smoother trade-off of accuracy and convergence versus number of particles is sought, (graceful degradation).

This research proposed a nonlinear estimation algorithm. The algorithm is based on a suboptimal update rule. The rule yields extreme simplicity and flexibility due to its straightforward geometric interpretation. Since it handles position as a belief, the algorithm conserves the probabilistic nature of sequential estimation methods. Furthermore, it incorporates a heuristic certainty measure, which resembles the covariance measure of belief in a parametric implementation of the Bayes filter.

If a WSN node is static, the hypotheses of a particle filter do not move. Therefore, particles are only subject to the importance resampling process. In the resampling process the most likely hypothesis is drawn, with higher probability, to generate a new set of particles. Due to this research, it is proposed that particles not be resampled. Instead, particles should be moved to relevant spots as the sequential estimation process proceeds, (*adaptation*). The term “particle” is kept and it is still used for representing a hypothesis of the state that needs to be estimated, which is the position of the node. It is possible to determine the optimal next estimate by applying optimal filtering theory. This approach would lead to a parametric implementation of the Bayes

filter, which manifests itself as a Multi-Hypothesis Kalman filter, (KF), with the consequent computational overhead and limitations. In this research a sub-optimal nonlinear estimation algorithm was introduced that provided good results. The nonlinear estimation algorithm can be viewed as the counterpart of simple nonlinear control algorithms such as “bang-bang” control or three-point control.

The belief updating algorithm is illustrated geometrically using only one particle in a 2-D space. However, this principle works analogously in a 3-D space and also with different numbers of particles. Every range measurement “moves” the particle from its current position, in a greedy approach, to minimize the error with respect to the latest measurement. Figure 36 illustrates the 2-D configuration where three steps of the estimation process are presented: the initialization and two updates.

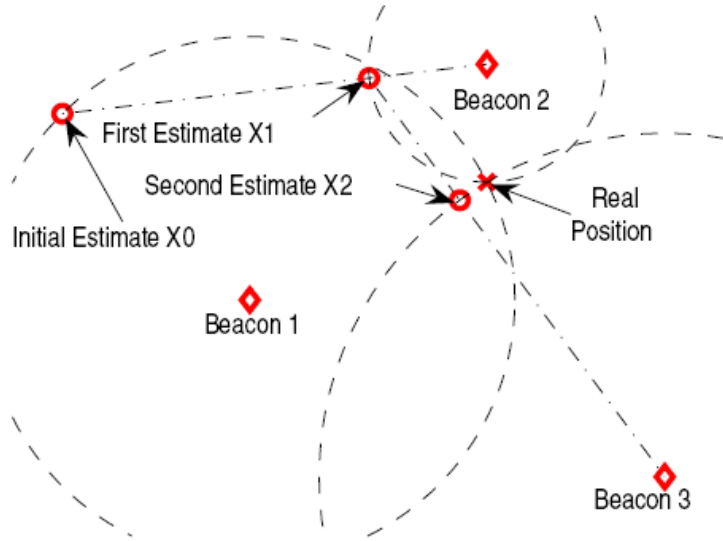

Figure 36: Particle Updating

Since particle filters represent samples of a probability distribution, (PDF), the small numbers of particles used have to be representative. If the range measurements

noise is assumed to be Gaussian, the PDF in the two-dimensional space, has an annular distribution around the beacon node. This situation was depicted in Figure 24. In a 3-D space, a sphere is realized with higher “concentration” of probability in the vicinity of the radius corresponding to the measurement. For illustration, in the 2-D space, a few representative particles were positioned around a circle of radius, r , which represents the measured range. An advantageous configuration of particles was simply that of a regular polygon inscribed in the circle. The orientation of the particles was left to randomization. This configuration was used for initializing the particles. Using this information, a basic form of the few-particle algorithm, for the adaptation of one particle, was constructed and is presented in Table 4.

The adaptation algorithm consists of two basic steps. In the first step, the, v , parameter finds the direction from the previous position of the particle, x_{t-1} , towards the position of the beacon, x_{ref} . The second calculation consists of finding a point in space, x_t , which is collinear with the previous particle position and the position of the beacon. The new point lies at a distance, r_t , from the beacon, which provided the most recent measurement.

Table 4: Particle Adaptation Algorithm

1-Particle_Adaptation($x_{t-1}, r_t, x_{\text{ref}}$)

if $t = 1$

$x_{t-1} = \text{rand}(x \in R^n)$

$$v = \frac{x_{\text{ref}} - x_{t-1}}{\|x_{\text{ref}} - x_{t-1}\|}$$

$x_t = x_{t-1} + v(\|x_{\text{ref}} - x_{t-1}\| - r_t)$

return x_t

If more particles are used, the particle adaptation algorithm is performed on each of the particles. Actual position estimates can be computed via the weighted average, (center of gravity), of the particles and is given by:

$$\hat{x} = \sum_{i=1}^{N_p} w_i \cdot x_i. \quad (5)$$

If only the Table 4 update rule is used, nodes holding just one particle, which are surrounded by beacons, estimate their location rather quickly. In addition, if the node degree is high the location estimate is derived even more quickly. However, localization converges rather slowly in the case where beacons are positioned on one side only. This situation occurs always at the borders of the network. Therefore, several particles are required to have more hypotheses and to find convergence. The weight, w , of a particle is proportional to the probability of the distance of the particle to the beacon, (d_p).

Assuming that range measurements, $N(r, \sigma_r)$ are distributed normally, with r , the range measurement and σ_r the standard deviation of the measurement, the weight can be calculated by:

$$w = \Pr(d_p | r, \sigma_r) = \frac{1}{\eta} \exp\left(-\frac{(d_p - r)^2}{2\sigma_r^2}\right). \quad (6)$$

The factor $1/\eta$ is used for normalization of the particles. The particles conform to a discrete distribution, which approximates a Gaussian, $N(r, \sigma_r)$ on the distance to the beacon. In order to avoid numerical issues, a probability threshold, w_{Thr} , can be defined to eliminate particles with very low probability. This method would work in a similar

way even if a different unimodal distribution is assumed, for instance a triangular distribution, which would yield significant computational simplicity for wireless sensor nodes.

Parameters r and σ_r can be used when the position of the beacon is assumed to be known with 100% certainty. However, in cooperative localization, imperfectly localized nodes act as beacons for other nodes, which have more uncertainty in their location estimates. Therefore, the uncertainty in the position of the beacon has to be taken into account. Assuming that nodes possess a heuristic “certainty” measure, $c \in [0, 1]$, the standard deviation used to evaluate the weight of the particles can be updated using:

$$\sigma = \sigma_r \sqrt{1 - \alpha \log(c)}. \quad (7)$$

The factor α depends on the application and the certainty measure adopted. It can be verified that if the beacon knows its position with absolute certainty, ($c = 1$), the standard deviation used in the weight evaluation is simply the same as the one corresponding to the measurements, σ_r . However, if the certainty is low, the weighting Gaussian is wider. Such a Gaussian has the effect of keeping particles that would be otherwise eliminated if a more constrained distribution was used.

As mentioned before, the significance of the location certainty, c , becomes apparent in the situation of incremental localization. Unlocalized nodes start with a certainty of zero and reference nodes start with certainty close to one since their location is assumed to be known. It is expected that every update helps to increase the location certainty of a node. This expectation is reasonable in view of the assumption that there

are no malicious nodes, which purposefully sabotage the cooperative localization process. The certainty factor is also essential since it is used as the stopping criterion for the sequential estimation process.

There are several choices for the calculation of, c . Two simple measures that can be used for computing c are:

- The degree of spread of the particles: A simple measure of spread is the variance of the discrete distribution along each of the dimensions, j , of the position. If the weight of the particles is considered, it can be calculated by:

$$\text{Var}(x_j) = \sum_{i=1}^{N_p} w_i \cdot (x_j - \bar{x}_j)^2. \quad (8)$$

- Another simple and effective measure of spread of the particles is the size of the bounding box that encloses all particles, which is given by:

$$D_j = \max(x_j) - \min(x_j). \quad (9)$$

The change in two consecutive estimates is computed from equation 5. However, if the change is small, it is assumed that the estimation process is close to reaching convergence. Therefore, the measure of closeness is approximated by:

$$\Delta \hat{x}_j = |\hat{x}_{j,t} - \hat{x}_{j,t-1}|. \quad (10)$$

The best results were obtained using a certainty measure based on both criteria. In both cases, the quantities, used in the measure of spread, need to be compared with

respect to a reference value. A reference value that can be used is the standard deviation of the measurements. The standard deviation quantifies the highest achievable accuracy of the technology being used. A certainty heuristic, which was successfully implemented, is given by:

$$c = \min \left(1, \exp \left(-\beta \frac{\max(\text{Var}(x_j))}{\sigma_r} \right), \gamma \frac{\sigma_r}{\max_j(\Delta \hat{x}_j)} \right). \quad (11)$$

In equation 11, β and γ are parameters that can be tuned freely. The effect of these parameters is that of slowing down the convergence while achieving better accuracy. Conversely, β and γ speed up the localization process while sacrificing accuracy. In practice, the sequential update procedure is terminated when a certainty threshold, c_{Thr} , is reached.

4.4.1. Tuning parameters

To this point, several parameters have been identified, which govern the achievable accuracy and speed of convergence of the algorithm. Final values of these parameters depend on several factors that are specific to the concrete application envisioned. The main factors are:

- Node density: Usually, higher density gives faster convergence and better accuracy since nodes have more neighbors with whom to exchange chirps.
- Range measurement technology: The two main factors that have a major impact are the measurement error and the maximum range.

- Computational resources: WSN platforms with more computational resources can handle more particles. Therefore, the accuracy and speed of convergence of the location estimation can be improved. More computational power can also help in implementing more sophisticated certainty calculation, which will also improve accuracy and convergence speed.
- Energy resources: More energy available means an increased ability to exchange more chirps, which improves the accuracy of the final location estimates.
- Accuracy requirements: It has been demonstrated experimentally that the localization algorithm presented can fully exploit the accuracy of the ranging technology, which provides for the best accuracy. However, better accuracy is usually paid for in terms of more chirps, which requires more energy expenditure.

4.5. Experimental Results

4.5.1. Experiment 1: Sensor Characterization

Preliminary tests of experimental data were performed in order to validate the basic assumptions. The main goal was to provide a basic sensor characterization of a candidate range-measurement technology. The data used stemmed from experiments performed with the Cricket system, [70]. In the initial experiment, 12 beacons sent chirps to a listener for 1.48 hours. Distance measurements were computed at the listener and

transferred to a PC. The PC time stamped the distance readings as well as the beacon identifiers.

Figure 37 illustrates the statistical nature of the distance measurements for two randomly selected beacons.

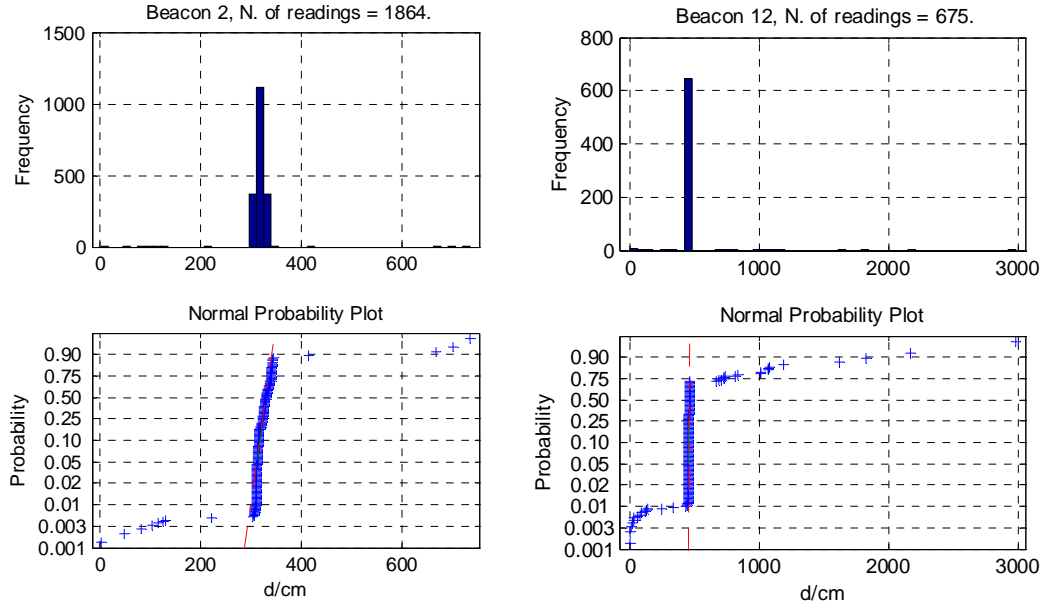

Figure 37: Measurement Distributions

In Figure 37, the upper plots depict histograms of the readings and the lower diagrams present normal probability plots. The lower plots were used to evaluate how well the data fit a normal distribution. In most cases, using standard statistical tests, such as the Kolomogorov Smirnof test or the Lilliefors test, the null hypothesis that the data stemmed from a normal family distribution could be rejected at the 5% significance level. This fact indicated that the range measurement distributions were not necessarily normal. However, normality is not a strict condition for the methods presented in this research to work. In fact, it was hinted previously that even if particles are evaluated with triangular distributions, the distributed cooperative localization algorithm would converge

appropriately. Hence, the only condition for convergence is that measurements shall be distributed unimodally.

Table 5 presents the mean and standard deviation of the measurements for each of the twelve beacons. These results were obtained with version V1 of the Cricket firmware. Researchers have reported much better accuracy with the new firmware version, (V2). With the V2 firmware version, measurement errors consisted of 1 cm on average and 3 cm most of the time, [71].

Table 5: Measurement Errors for Range Readings

Beacon Nr.	N. of readings	Std. dev. (cm)	Mean (cm)
1	1969	8.0	390
2	1864	7.2	317
3	1835	7.6	453
4	1743	7.0	455
5	1659	7.2	441
6	2014	7.0	328
7	1848	6.9	344
8	1824	7.4	312
9	1587	7.0	352
10	1528	4.6	310
11	1773	8.4	408
12	675	5.4	456

The Gaussian approximation of range measurements is meant for giving a measure of the spread or precision. It is also remarkable that the measurement accuracy is highly dependent on the range determination algorithms, even when the same transducers are used.

4.5.2. Experiment 2: Three Beacons and Twenty Listeners in Range

The simulations presented were developed as MATLAB scripts. The simulations consist of iterations of a basic step where a beacon sends a chirp to its neighboring nodes. Nodes were deployed randomly within the field. Beacons that sent chirps were picked at random in order to simulate a randomized MAC protocol such as the one used in the Cricket system. Nodes within the range of a beacon used the range reading to update their particles as explained previously.

In the experiment presented in this section, twenty listener nodes estimated their positions by using range readings from three beacons. One unit is equivalent to 0.3 m. In this setup, it was assumed that all nodes were in the region of coverage of the beacons. Each node managed 20 particles that were initialized after the first reading. Range measurements contained a noise component, which followed a normal distribution with a standard deviation one half unit, ($\sigma = 0.5$). A standard deviation of 15 cm, (0.5 units), is relatively conservative when compared to the accuracy achievable with the technology presented in previous section.

Figure 38, depicts positions for beacons, nodes and the COG of particles after 12 beacon chirps were received by all nodes. The dotted circles show approximate bounds, which were defined by the error in the range measurements.

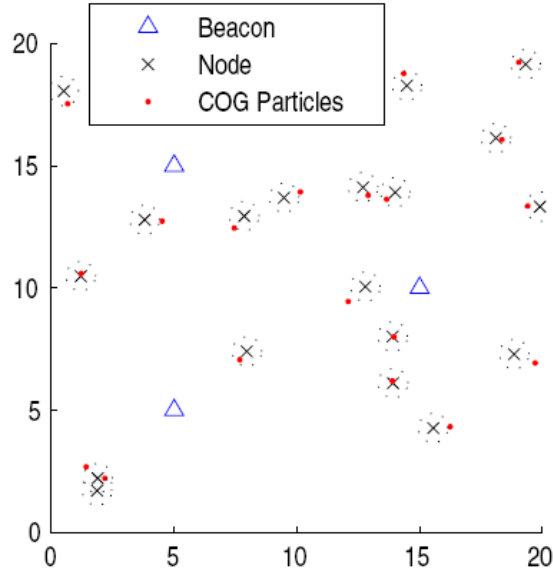

Figure 38: Position of the COGs of Particles After 12 Chirps, (1 unit \equiv 0.3m)

By analyzing the average location error per node, which is given, as a function of message number, (beacon chirp), by:

$$\bar{E} = \frac{1}{n} \left(\sum_i^n \|x_{\text{TRUE}} - \hat{x}_i\| \right). \quad (12)$$

the convergence of the algorithms was assessed. The convergence curve is presented in Figure 39. Twenty, (20), different experiments were averaged to obtain the position error plot. The plotted data yielded the smooth monotonically decaying curve presented in Figure 39.

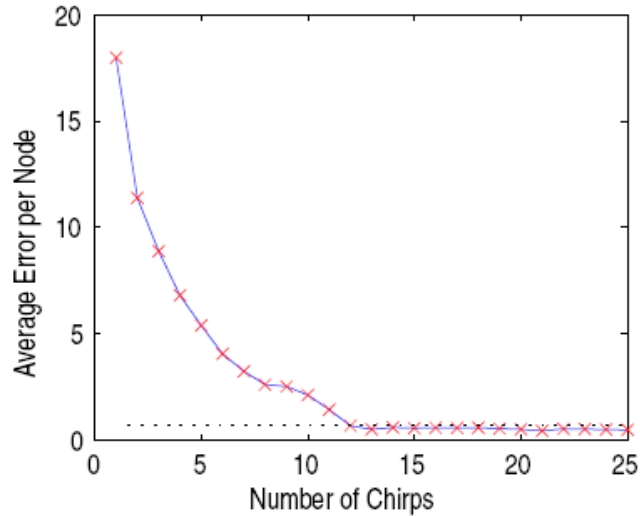

Figure 39: Convergence of the Average Position Error

Figure 39 illustrates the fact that, on average, 12 beacon chirps are necessary for achieving localization. This total number of chirps divided by the number of beacons yields approximately 4 chirps per beacon, which is an excellent result in terms of energy expenditure. The minimum average error was slightly higher than the standard deviation of the measurement noise. The chirps were generated at random and the measurements were noisy. Therefore, the number of chirps necessary was more than the minimal number of chirps, which a complete particle filter would predict. However, it must be reiterated that these results were obtained with only 20 particles.

4.5.3. Experiment 3: Incremental Localization

In a second experiment, the feasibility of cooperative localization using the proposed algorithm was tested by limiting the range of the beacon chirps to a specific distance. Therefore, listeners that were outside the range of the beacons had to wait until nearby listeners could act as beacons. Listeners could act as beacons only after they had localized themselves, at least partially, (*incremental localization*). In this experiment the

heuristic certainty factor was employed. In addition, 78 nodes were randomly deployed in a square field with a side of 60 units. Four nodes were used as reference nodes and their locations were chosen in a regular pattern. Figure 36 presents the setup parameters and the results. Once again, 20 particles are used in the sequential estimation process. When sending chirps, nodes were assumed to have a radius of coverage of 15 units. The noise in the readings had a standard deviation of one half unit, ($\sigma = 0.5$).

Analogously to the previous experiment, two figures characterize the development and results of the experiment. Figure 40 presents the configuration of the nodes, the reference nodes and estimates of position after most of the nodes had found their location.

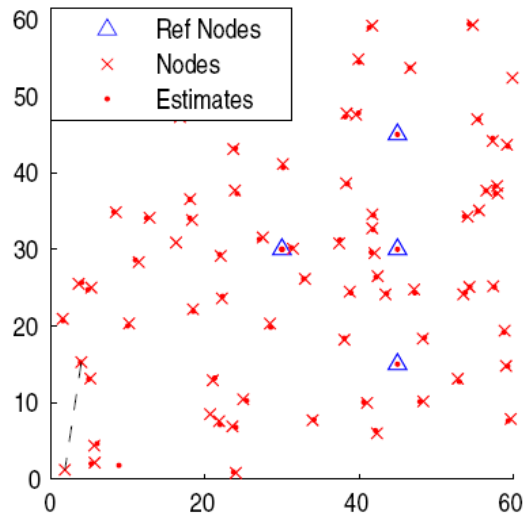

Figure 40: Incremental Localization Experiment: Estimates after 100 Chirps, (1 unit \equiv 0.3m)

Convergence results are illustrated in Figure 41. Figure 41 illustrates that the average error per node is a function of the number of total chirps that were emitted from all beacons. The data indicate that approximately 150 chirps were required to reach convergence. This means that, on average, each beacon sends approximately two chirps.

It is possible that this distribution may not be uniform for all beacons. Some beacons, especially the reference nodes, may incur higher energy expenditures than nodes located at the border of the WSN.

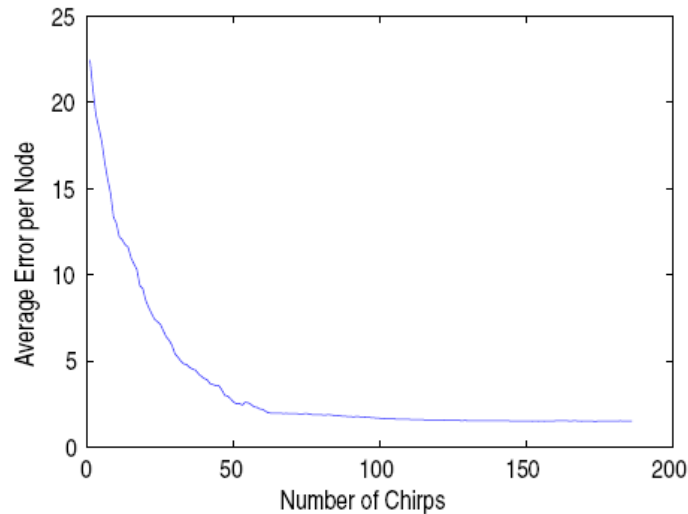

Figure 41: Convergence of Position Error in Incremental Localization

4.6. Summary

Commonly employed methods for localization are based on deterministic/trilateration-based techniques. The methods present drawbacks that have been identified and explained. However, optimal probabilistic estimation techniques require computational and energy resources not available in constrained WSN nodes. To bridge this gap, a new probabilistic distributed algorithm was outlined, which is based on a simple nonlinear estimation procedure. This algorithm provides promising results and should establish a new direction in location estimation techniques in Wireless Sensor Networks. The approach gives rise to flexible algorithms for solving the localization problem in WSNs in a wide variety of application scenarios. The strength of the algorithm lies in its simplicity and flexibility. The flexibility stems from the ability to

tune, using very few parameter, the convergence and accuracy of the localization process.

Given that the algorithm parameters depend on the specific application, computer simulation studies can help in the determination of optimal values for typical scenarios.

The WSN case study helped in introducing the two main aspects of cooperative localization and the probabilistic framework that were fundamental to this research.

Chapter 5

Localization of Mobile Nodes

5.1. Navigation Structure

The main objective of this chapter is to demonstrate the feasibility of cooperative localization in mobile wireless networked systems. The conceptual solution introduced in Chapter 3 will be developed in more detail with an emphasis on practical implementation. This chapter can be considered as an in-depth analysis of the “Sensor Fusion” module, the core of the localization solution, which was presented in Figure 17, and reproduced here for ease of reference.

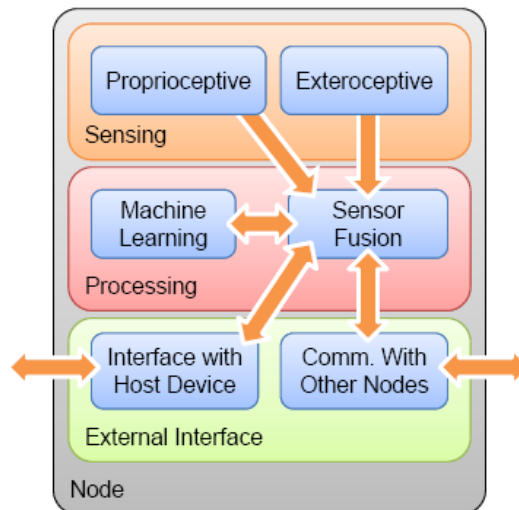

Figure 17: Main Functions of the Cooperative Estimation Solution

Aided navigation constitutes the basis for the development of the localization method offered in this dissertation. Therefore, the integration of GPS and an Inertial Navigation System, (INS), through a complementary filter, which was applied to navigation of vehicles with different locomotion modalities, was used as the basic inspiration. Figure 42, illustrates how such a complementary filter works, [19].

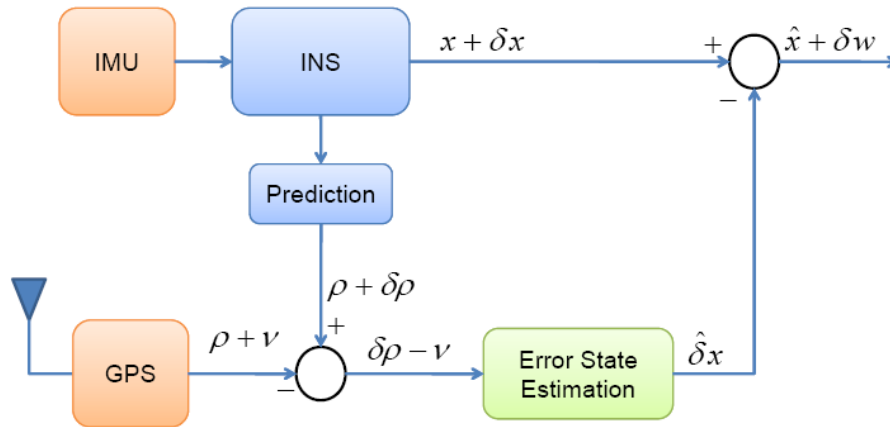

Figure 42: A Common GPS/INS Integration Topology

The INS receives signals from an inertial measurement unit, which are integrated to produce an estimate of state, termed $x + \delta x$. Due to sensor errors and the integrating feature of the INS, the output signals possess low-frequency noise. Concurrently, the INS produces estimates of the GPS measurement, termed $\rho + \delta\rho$, where $\delta\rho$ represents error due to noise. The GPS receiver also produces, at lower rates than the INS, position estimates, which are termed $\rho + \nu$. The spectral content of the GPS noise occurs at higher frequencies than that of the INS. The combination of the predicted GPS output with the actual GPS measurement yields a signal, termed $\delta\rho - \nu$, which is used to drive a filter that estimates the INS state error, $\hat{\delta x}$. The frequency content of the GPS and INS

errors can be modeled with accuracy. Therefore, it is possible to design the error estimation filter such that it attenuates the GPS noise while providing accurate estimates of the INS state error. Once estimated, the error can be subtracted from the INS estimate to yield the final state estimate, which will still possess a small residual error, termed δw . Variants of this method and additional details with respect to GPS/INS integration techniques are covered in detail in, [19]. Figure 43 presents the aided navigation method proposed in this research.

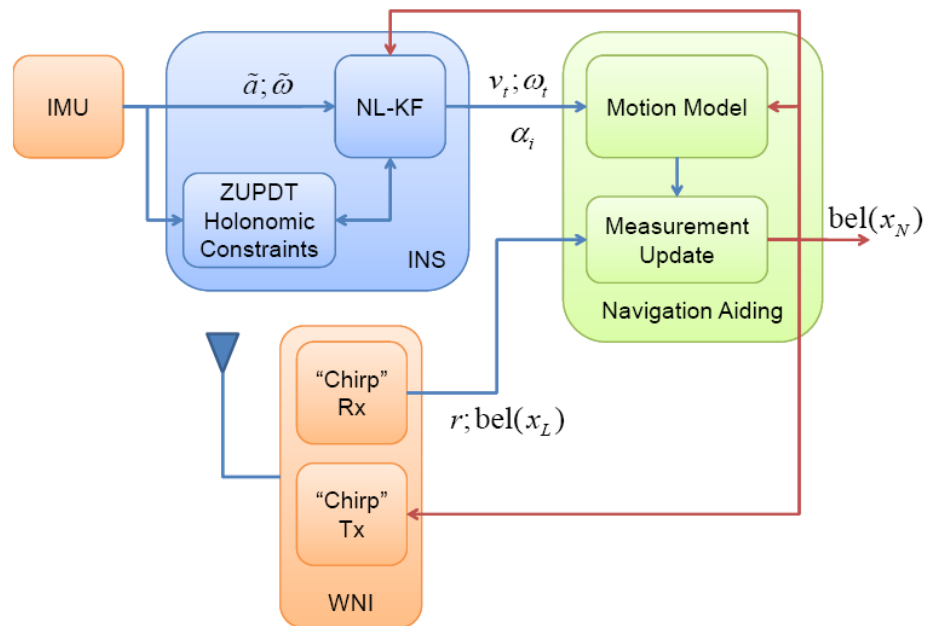

Figure 43: Proposed Structure for Aided Navigation

Figure 47 can also be attributed to the application of the functional allocation method, which stems from the Systems Engineering approach. This navigation solution presents three principal modules.

5.1.1. The INS Module

The core of the INS module consists of a filter, which performs sensor fusion of the proprioceptive sensors. An IMU measures accelerations with a set of three orthogonal accelerometers and measures angular rates with a set of three orthogonal gyroscopes. The acceleration and angular rate signals, produced by the IMU, are provided to the INS module. Most IMUs also incorporate a set of magnetometers, which assist in initializing the INS. In addition the IMU's magnetometer signals assist in maintaining attitude estimates current. However, magnetometers are very sensitive to the proximity of ferromagnetic materials, which is a major concern in their application.

The main function of the INS module is to provide optimal estimates of speed and angular velocity, which is projected onto the configuration space of the moving node. In addition, the INS module produces confidence parameters of a simplified motion model operating in the configuration space, which are represented as α_i in Figure 43.

Therefore, it is implicitly assumed that optimal attitude estimation is to be performed. Due to the nonlinear nature of rigid body motion, the sensor fusion filter needs to be realized as a nonlinear variant of an optimal estimator, which possesses the capability to handle several states. The Extended Kalman Filter (EKF), which is proposed in this research, represents such an optimal estimator.

The combined effect of the absence of external aids in conjunction with the non-stationary nature of sensor errors renders estimates unusable after a relatively short period of time. The time frame associated with usable estimates depends on the quality of the IMU. This is the reason external updating has to be provided by the navigation aiding module. The external updating is provided in the form of position estimates, which

prevent INS errors from growing without bounds. Additionally, certain techniques such as zero updating and the incorporation of constraints in the filtering process help with reducing the negative effects of inertial sensor errors. The machine learning function introduced in Chapter 3 can also be considered as an add-on improvement, which was left for future research.

5.1.2. The Navigation Aiding Module

The Navigation Aiding module is where the position estimation process is performed. In concert with the Bayesian approach to the problem, actual estimates are not as important as the PDF of position, which is the position belief given by, $\text{bel}(x_N)$. There are several techniques for extracting an actual numeric position estimate from belief. Subsequent section will explain how the Bayesian approach provides an elegant way of handling uncertainty. In addition, the Bayesian approach also paves the way for solutions that do not deal with issues related to graph rigidity. The two main components, predication and cooperation, of a Bayesian Filter were utilized in the navigation aiding module. Prediction was incorporated in the form of a probabilistic motion model and in measurement updates. The probabilistic motion model was based on velocity estimates and parameters provided by the INS module. The parameters of the motion model are essentially a function of the measures of confidence of the velocity estimates such as covariance or variances. Cooperation is provided by the measurement update function. Information is provided by other nodes in the form of range measurements, r , and reference node position belief, $\text{bel}(x_L)$, which are termed collectively as “chirps.”

The Navigation Aiding module updates its internal predicted position belief, which is obtained from the motion model, by using incoming chirps. The combination of uncertain range measurements along with the position belief of the chirp originator is one of the main topics and contributions of this dissertation, which will be presented in Section 5.4. After the combination of these two pieces of information, the resulting PDF is used for updating the predicted belief, which is returned to the motion model, in a recursive procedure. The Navigation Aiding module is presented in greater detail in subsequent sections of this chapter.

5.1.3. The Wireless Network Interface Module

The function of the Wireless Network Interface, (WNI), module is twofold. The WNI module is used as an exteroceptive sensor for obtaining range estimates. In addition, the WNI module is employed as a means for communication. Chirps are generated and received by the WNI. Additionally, the WNI module directly influences the measurement updating function of the navigation aiding module. The concrete protocols required to handle these two aspects are elucidated in Chapter 6.

5.2. Assumptions

The structure presented in previous section has explained how sensor fusion can yield an optimal estimate of the main states associated with the kinematics of a rigid body. The main objective of this chapter is to present the advantages of cooperative localization when applied to mobile nodes.

During the development of this section, the reader may visualize the localization process, which takes place in a multi-robot system, as presented in Chapter 1. The underlying assumptions, which are associated with the problem of localization presented in this chapter, are:

- The localization problem is presented for the two-dimensional case. That is, a mobile node in a two-dimensional plane with three degrees of freedom will be considered. The degrees of freedom are concerned with the nodes position, which is given by the x and y coordinates and the nodes heading, which is represented by the angle, θ . A vector of these parameters is termed the node's pose, p . However, the methods proposed may be extended to three-dimensional localization.
- Each mobile node possesses an inertial navigation system, (INS), which receives information from six sensors. The sensors consist of three orthogonal accelerometers and three orthogonal gyros. The INS is initialized correctly and provides optimal estimates of horizontal linear speed, v , and angular speed, ω . That is, the result of odometry calculations are optimal estimates of, v , and, ω . Current pose estimates are fed-back to the INS in order to compensate for errors inherent to inertial sensors.
- As in the case of fixed nodes, mobile nodes have the ability to exchange "chirps". A chirp is a signaling mechanism, which allows nodes to determine inter-node range and to exchange belief information.
- In contrast to the problem analyzed for fixed nodes, it is assumed that there are no restrictions with respect to energy, computational power or memory.

- Doppler effects due to relative motion of the mobile nodes were neglected.
- Additional errors, which may arise from lack of clock synchronization in the process of measuring range, were neglected.

5.3. Probabilistic Motion Model

Localization can be analyzed as a hidden Markov model, (HMM). The HMM was presented in Figure 22. In this framework, the state transition probability, $p(x_t | u_t, x_{t-1})$, is determined by the motion model of the mobile node. Most of the development in this section is based on the probabilistic methods presented in [16]. According to the decomposition presented in previous section, the state of the robot, handled by the particle filter, is assumed to be its pose, p , which is given by:

$$p_t = \begin{bmatrix} x_t \\ y_t \\ \theta_t \end{bmatrix}. \quad (13)$$

The inputs are the estimated translational velocity, $\hat{v}_{INS,t}$, and rotational velocity, $\hat{\omega}_{INS,t}$, which are provided by the INS system. The control vector, u , is comprised of the two estimated magnitudes, which are given by:

$$v_t = \hat{v}_{INS,t}, \quad (14)$$

and

$$\omega_t = \hat{\omega}_{INS,t}. \quad (15)$$

Thus:

$$u_t = \begin{bmatrix} v_t \\ \omega_t \end{bmatrix}. \quad (16)$$

The deterministic motion model is given by:

$$\begin{bmatrix} x_t \\ y_t \\ \theta_t \end{bmatrix} = \begin{bmatrix} x_{t-1} \\ y_{t-1} \\ \theta_{t-1} \end{bmatrix} + \begin{bmatrix} -v_t/\omega_t \sin \theta_{t-1} + v_t/\omega_t \sin(\theta_{t-1} + \omega_t \Delta t) \\ v_t/\omega_t \cos \theta_{t-1} - v_t/\omega_t \cos(\theta_{t-1} + \omega_t \Delta t) \\ \omega_t \Delta t \end{bmatrix}. \quad (17)$$

In practice, the dead-reckoning process enabled by a coasting INS possesses errors and is subject to noise and uncertainty. Therefore, the input variables can be modeled as the estimated quantities plus a random variable, ε_b , with finite variance, b^2 , and zero mean. It can be assumed that such a random variable is distributed according to a normal distribution with parameters obtained from an error analysis of the INS system. It has proven useful, to model the standard deviation of the noise, ε_b , as dependent on the magnitude of, v , and, ω . Therefore, u_t :

$$\begin{bmatrix} \hat{v}_t \\ \hat{\omega}_t \end{bmatrix} = \begin{bmatrix} v_t \\ \omega_t \end{bmatrix} + \begin{bmatrix} \varepsilon_{\alpha_1|v|+\alpha_2|\omega|} \\ \varepsilon_{\alpha_3|v|+\alpha_4|\omega|} \end{bmatrix}. \quad (18)$$

To obtain a complete probabilistic model of the motion of the mobile node, an additional source of error was considered. The additional source of error results from a random rotation after the node has moved for the discrete time interval, Δt .

This error is calculated from:

$$\hat{\gamma} = \mathcal{E}_{\alpha_5|\nu|+\alpha_6|\omega|}. \quad (19)$$

The complete probabilistic motion model, (PMM), is given by:

$$\begin{bmatrix} x_t \\ y_t \\ \theta_t \end{bmatrix} = \begin{bmatrix} x_{t-1} \\ y_{t-1} \\ \theta_{t-1} \end{bmatrix} + \begin{bmatrix} -\hat{v}_t/\hat{\omega}_t \sin \theta_{t-1} + \hat{v}_t/\hat{\omega}_t \sin(\theta_{t-1} + \hat{\omega}_t \Delta t) \\ \hat{v}_t/\hat{\omega}_t \cos \theta_{t-1} - \hat{v}_t/\hat{\omega}_t \cos(\theta_{t-1} + \hat{\omega}_t \Delta t) \\ \omega_t \Delta t + \hat{\gamma} \Delta t \end{bmatrix}. \quad (20)$$

The noise and uncertainty, in the motion of the mobile node, depend on the parameters, $\alpha_1, \alpha_2, \dots, \alpha_6$. The larger these constants, the less accurate will be the predictions. The growth of these constants will also be reflected in “wider” belief distributions. These constants can be obtained from the motion model.

For particle filters, it is not necessary to compute, $p(x_t | u_t, x_{t-1})$, for arbitrary x_t , u_t and x_{t-1} . It is sufficient to have the ability to sample from the conditional probability density function. This will ensure that even when using identical particles for x_{t-1} , the predicted values will have enough diversity before applying the measurement update.

5.3.1. Preliminary Analysis of the Probabilistic Motion Model

Several experiments were carried out to observe the effect of the parameters and since there was no navigation aiding, the uncertainty grew. Figures 44 through 46 illustrate the overall effect of the parameters, α , for different trajectories. These results certify that the model possesses more uncertainty with greater values of the α

parameters. In Figures 44 through 46 snapshots of the current state of the particles are presented. Internally, the robot updates the particles, according to the PMM, more often than depicted. Covariance ellipses with a width of 3σ , in the respective eigen-directions, results from the Gaussian approximation for the particles. The center of the ellipses corresponds to the center of gravity of the particles, which can also be considered as a good approximation of the actual position derived from the set of particles.

Figure 46 presents results for fixed v and ω and an increase in the α values. These results were obtained without measurement updates.

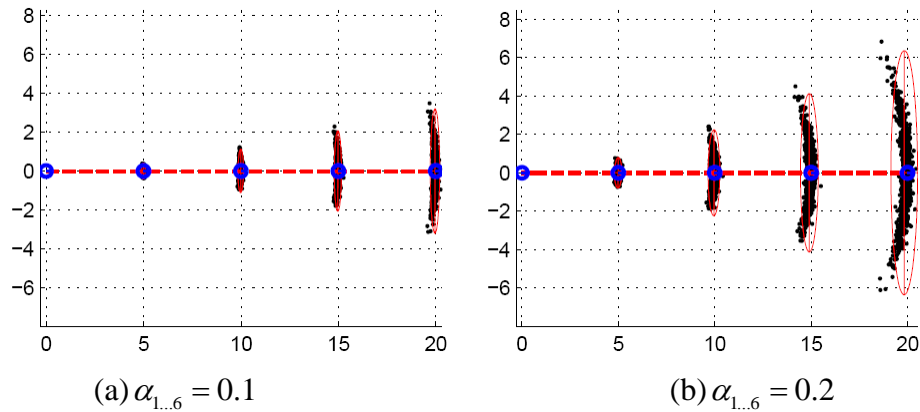

Figure 44: PMM for $v = 1\text{m/s}$ and $\omega = 0\text{rad/s}$

Figure 45 presents results for the same v and α values but with an increase in the value of the ω parameter. These results were obtained without measurement updates.

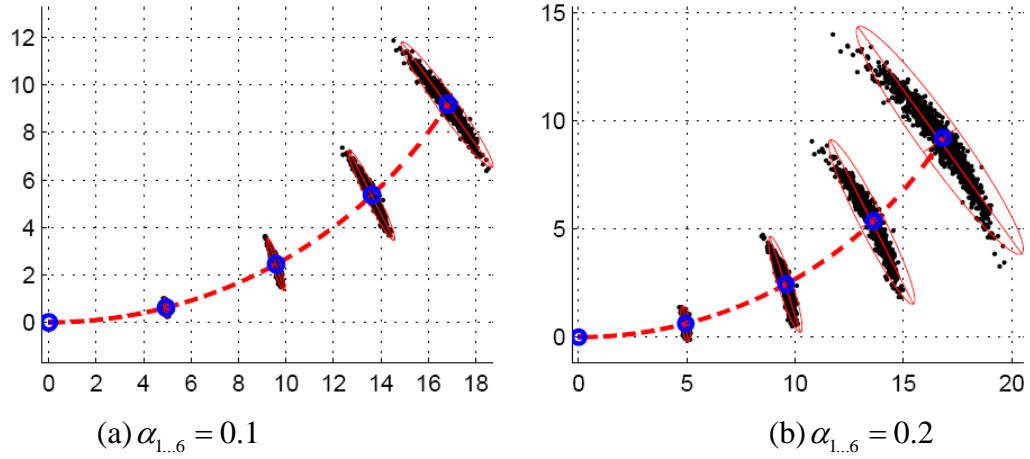

Figure 45: PMM for $v = 1\text{m/s}$ and $\omega = 0.05\text{rad/s}$

Figure 46 presents results for the same v and α values but with an increase in the value of the ω parameter. These results were obtained without measurement updates.

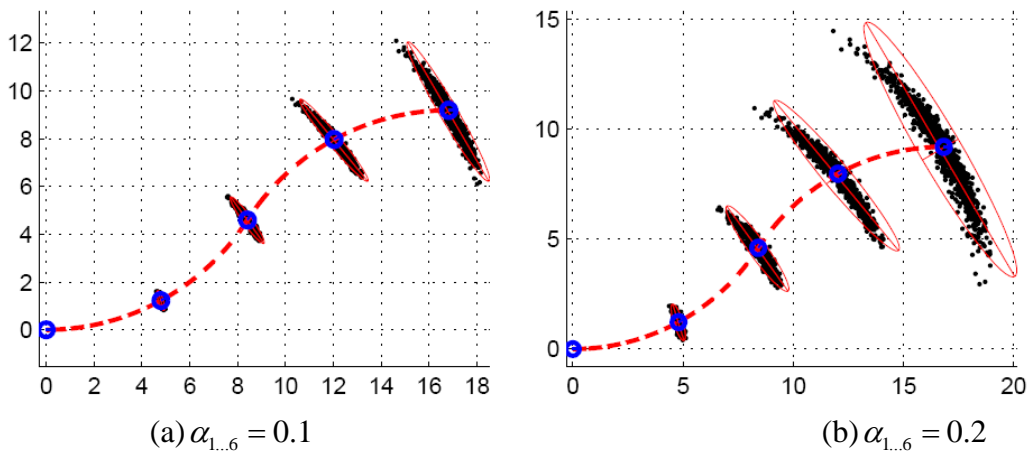

Figure 46: PMM for $v = 1\text{m/s}$ and $\omega = [0.1(t < 10) + (-0.1)(t \geq 10)]\text{rad/s}$

The effect of the individual α parameters is presented in Figures 47 through 49 using similar conditions to those presented in Figure 44. These results indicate that the model is highly sensitive to the parameters, which define the uncertainty in rotational motion, $(\alpha_3 \dots \alpha_6)$. However, the uncertainty in the translational velocity, (α_1, α_2) , does not produce any significant spread in the belief. Figure 47 presents the results obtained

for an increase in the uncertainty in the ν parameter but with fixed values for the α parameters.

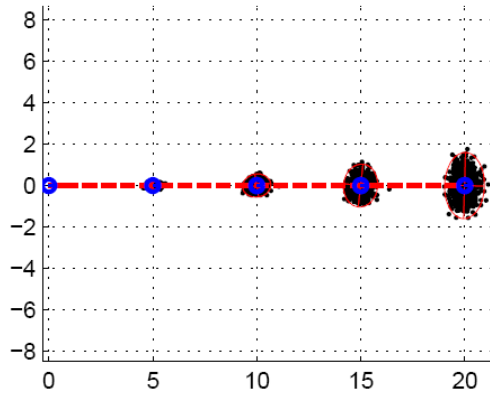

Figure 47: PMM with Greater Uncertainty in ν :
 $\alpha_{1,2} = 0.5, \alpha_{3,4,5,6} = 0.05$

Figure 48 presents the results obtained for an increase in the uncertainty in the ω parameter but with fixed values for the α parameters.

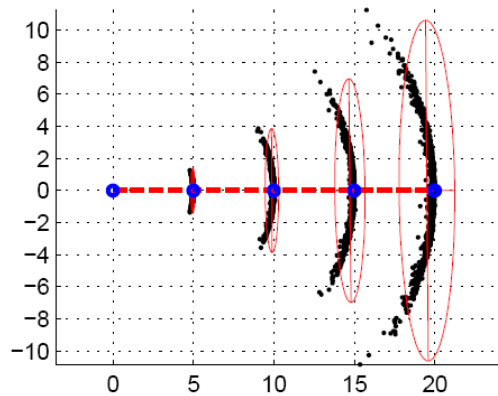

Figure 48: PMM with Greater Uncertainty in ω :
 $\alpha_{3,4} = 0.5, \alpha_{1,2,5,6} = 0.05$

Figure 49 presents the results obtained for an increase in the uncertainty in the γ parameter but with fixed values for the α parameters.

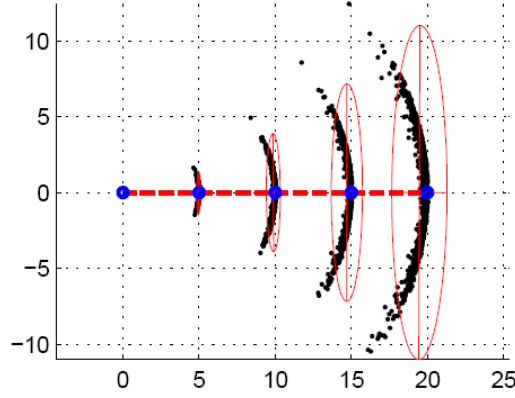

Figure 49: PMM with Greater Uncertainty in γ :
 $\alpha_{5,6} = 0.5, \alpha_{1,2,3,4} = 0.05$

It is also indicated that the distributions of the belief, after the prediction, are not Gaussian. Therefore, particle filters offer a very appropriate way to represent belief.

With growing uncertainty, greater spread, in the position of the robot, is expected since it is only subject to prediction through dead-reckoning. Table 6 summarizes the results of these preliminary experiments. The maximum error and spread, (3σ), of the particles was produced at the end of the experiment. Both values are presented in the last column of Table 6.

Table 6: Quantitative Results of Experiments
 With the Motion Model

Trajectory	α_1, α_2	α_3, α_4	α_5, α_6	$3\sigma_{\text{MAX}}$ (m)	Error (m)
Straight Line	0.10	0.10	0.10	3.20	0.04
Straight Line	0.20	0.20	0.20	6.35	0.17
Straight Line	0.50	0.05	0.05	1.60	0.01
Straight Line	0.05	0.50	0.05	10.6	0.49
Straight Line	0.05	0.05	0.50	11.0	0.53
Curve	0.10	0.10	0.10	3.26	0.05
Curve	0.20	0.20	0.20	6.46	0.18
S-Shaped	0.10	0.10	0.10	3.38	0.06
S-Shaped	0.20	0.20	0.20	6.69	0.20

5.3.2. Basic Navigation Aiding

In particle filtering, the measurement update is performed through computation of the weight of the particles and through the resampling procedure. The weight of the particles is given by:

$$w_t^{[m]} = p(z_t | x_t^{[m]}). \quad (21)$$

In this specific example, it was assumed that the moving node can measure its distance to reference nodes with known positions. Since the experiment was preliminary, the position of the reference nodes was assumed to be known with perfect certainty. In latter sections, the uncertainty in the positions of the reference nodes will be taken into account. The uncertainty of the reference nodes had to be taken into account since other mobile nodes become reference nodes for the mobile node, which is to be localized.

Range measurements were assumed to possess normally distributed noise with a specific standard deviation. The standard deviation was chosen so that the associated probability density function, $p(z_t | x_t)$, would resemble the curve presented in Figure 50. The PDF presented in Figure 50 is for a “beacon”, reference node, located at, (8m, 8m). In the illustrated example, the measured range was 5m and the standard deviation was 1m.

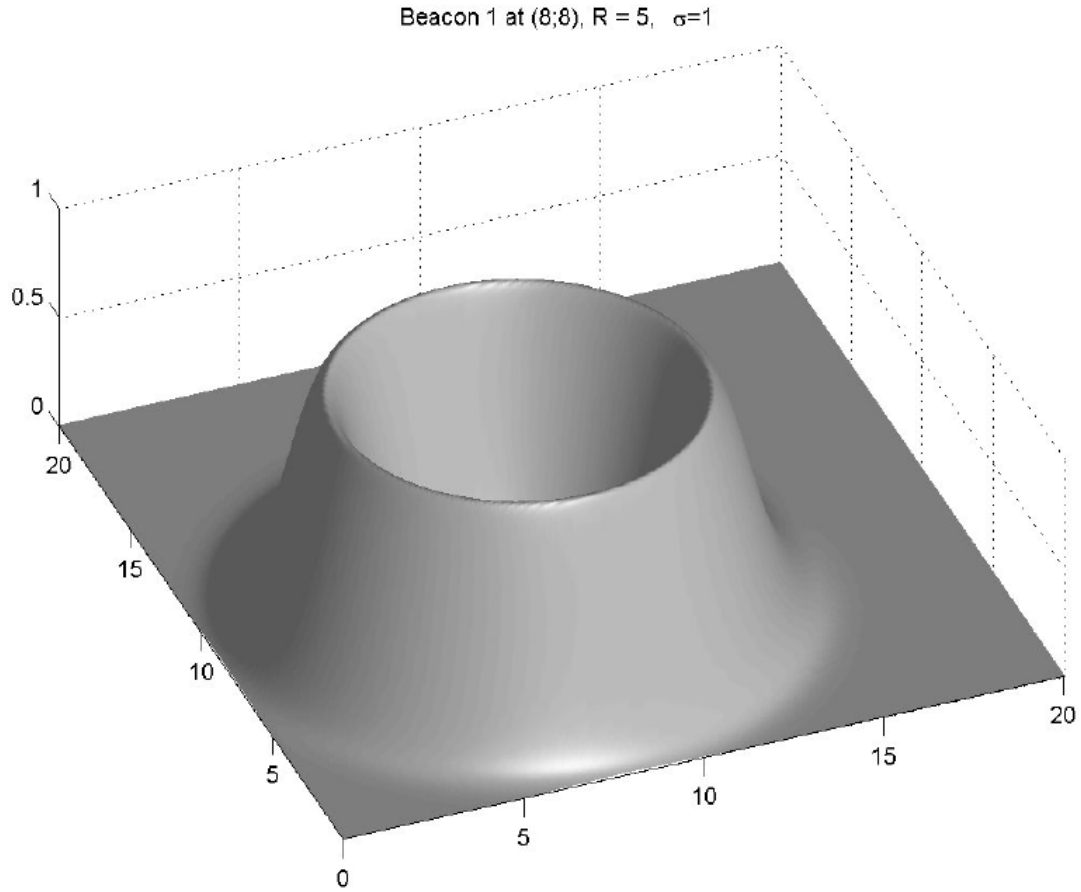

Figure 50: Measurement Probability, $p(z_t | x_t)$

To analyze improvements for the measurement of range to the reference node, it was established that range readings were to be taken with respect to a beacon located at (0, 10m), with noise distributed according to, $N(0, 0.05m)$. The results of the experiment are presented in Figures 51 through 56. In addition, the center of gravity of the particles is also presented for the reader to observe the estimated position after the measurement update, which is indicated by the red robot mark. Measurements were available every 5 seconds and the robot kept computing dead-reckoning based on the velocity model. Figure 51 presents results for fixed v and ω with measurement updates and an increase in the α values.

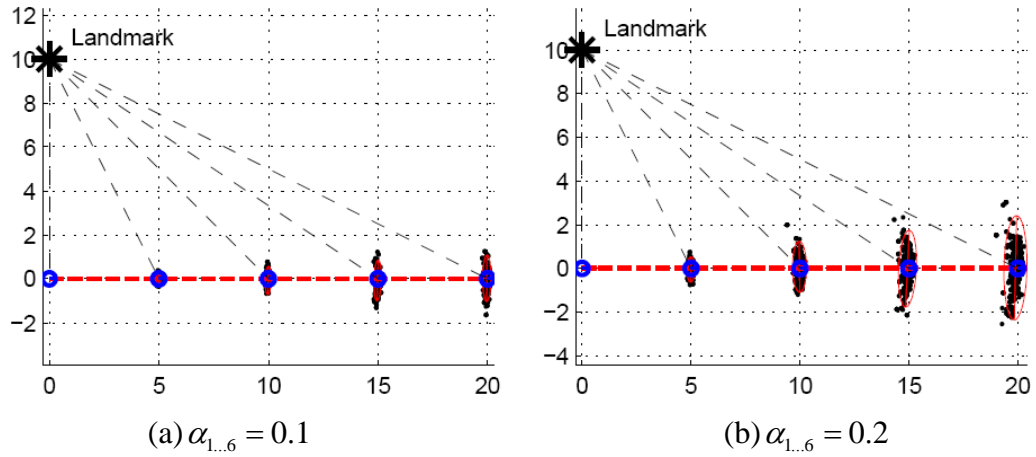

Figure 51: PMM for $v = 1\text{m/s}$ and $\omega = 0\text{rad/s}$ with Measurement Updates

Figures 51 and 44 should be compared since they present results for different experiments with the same parameter values. Figure 52 presents, with measurement updates, results for the same v and α values but with an increase in the value of the ω parameter.

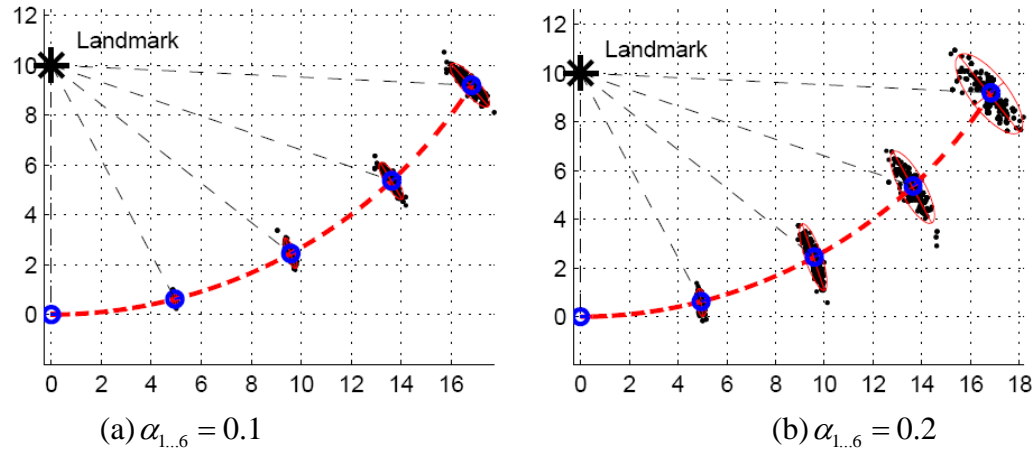

Figure 52: PMM for $v = 1\text{m/s}$ and $\omega = 0.05\text{rad/s}$ with Measurement Updates

Figures 52 and 45 should be compared since they present results for different experiments with the same parameter values. Figure 53 presents, with measurement updates, results for the fixed v and α values but with a varying value ω parameter.

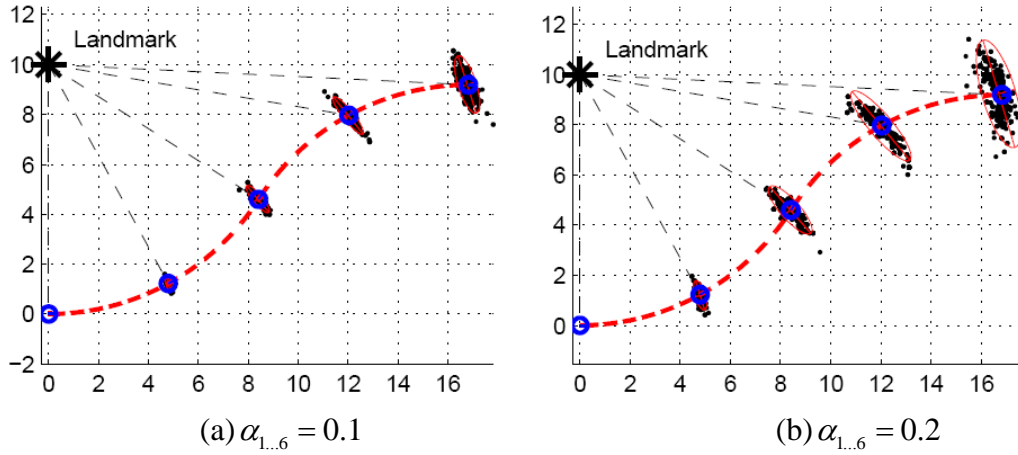

Figure 53: PMM for $v = 1\text{m/s}$ and Varying ω with Measurement Updates

Figures 53 and 46 should be compared since they present results for different experiments with the same parameter values. Figure 54 presents results for an increased uncertainty in the v parameter with measurement updates.

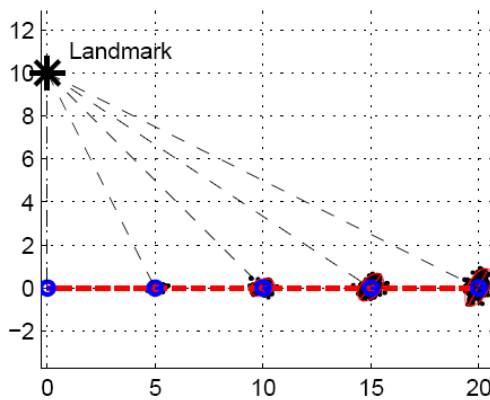

Figure 54: PMM with Greater Uncertainty in v With Measurement Updates

Figures 54 and 47 should be compared since they present results for experiments with and without measurement updates but with increased uncertainty in the v parameter. Figure 55 presents results for an increased uncertainty in the ω parameter with measurement updates.

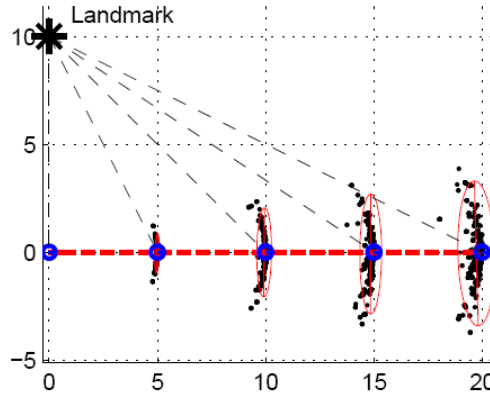

Figure 55: PMM with Greater Uncertainty in ω With Measurement Updates

Figures 55 and 48 should be compared since they present results for experiments with and without measurement updates but with increased uncertainty in the ω parameter. Figure 56 presents results for an increased uncertainty in the γ parameter with measurement updates.

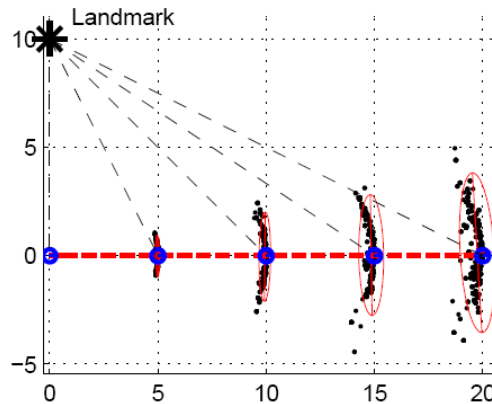

Figure 56: PMM with Greater Uncertainty in γ With Measurement Updates

Figures 56 and 49 should be compared since they present results for experiments with and without measurement updates but with increased uncertainty in the γ parameter.

In all cases, even though the measurements were noisy, the uncertainty was reduced due to the measurements obtained from the reference node. It is also indicated that if measurements were available more often, the divergence of the particles would be much reduced. Another way to reduce divergence would be to have reference nodes located at different places in order to yield a trilateration-like effect. In such a situation the robot would keep the spread of the location belief within bounds. Table 7 summarizes the experiments considering the measurement update. For comparison purposes, the results listed in Table 6 have also been included.

Table7: Quantitative Results of Experiments with the Motion Model and Range Measurements

Trajectory	α_1, α_2	α_3, α_4	α_5, α_6	w. Range Meas.		w.o. Range Meas.	
				$3\sigma_{MAX}$ (m)	Δ (m)	$3\sigma_{MAX}$ (m)	Δ (m)
Straight Line	0.10	0.10	0.10	1.05	0.04	3.20	0.04
Straight Line	0.20	0.20	0.20	2.38	0.12	6.35	0.17
Straight Line	0.50	0.05	0.05	0.96	0.05	1.60	0.01
Straight Line	0.05	0.50	0.05	3.36	0.27	10.6	0.49
Straight Line	0.05	0.05	0.50	3.70	0.30	11.0	0.53
Curve	0.10	0.10	0.10	1.14	0.07	3.26	0.05
Curve	0.20	0.20	0.20	2.01	0.09	6.46	0.18
S-Shaped	0.10	0.10	0.10	1.20	0.05	3.38	0.06
S-Shaped	0.20	0.20	0.20	2.23	0.13	6.69	0.20

5.4. Measurement Update with Respect to Non-Deterministic Reference Nodes

In section 5.3, the positive effect of range measurements on the position belief was presented. The position of the reference node was assumed to be known with perfect certainty. In this section, this assumption is relaxed. In order to gain insight into the problem, the analysis will be reduced to the one-dimensional case. That is, nodes are only allowed to move along the, x , direction. However, initially, distributions are not assumed to follow a Gaussian distribution. The range measurement is a random variable, R , given by the probability density function:

$$f_R(r) = p(z | x), \quad (22)$$

with the corresponding cumulative distribution, $F_R(r)$, given by:

$$P\{R \in (-\infty, a]\} = F_R(a) = \int_{-\infty}^a f_R(r) dr. \quad (23)$$

Analogously, the position of the reference node is a random variable, L , given by its belief, $\text{bel}(x_L)$, which is a probability density function, $f_L(l)$, with its respective cumulative distribution, $F_L(l)$, which is given by:

$$P\{L \in (-\infty, b]\} = F_L(b) = \int_{-\infty}^b f_L(x) dx. \quad (24)$$

Using these two distributions, equations 23 and 24, the distribution for the measurement update is sought, given that the reference node is no longer a set of numbers. Instead the reference node is a belief. Therefore, the PDF of P is sought from:

$$f_P(x) = p(z, \text{bel}(x_L) | x). \quad (25)$$

These three variables P , L and R are related geometrically by:

$$P = L + R. \quad (26)$$

The cumulative distribution function of P satisfies:

$$F_P(x) = F_{L+R}(x) = \iint_{l+r \leq x} f_R(r) f_L(l) dr dl. \quad (27)$$

This expression may be manipulated to obtain a definitive expression given by:

$$\begin{aligned} F_{L+R}(x) &= \int_{-\infty}^{\infty} \int_{-\infty}^{x-l} f_R(r) f_L(l) dr dl \\ &= \int_{-\infty}^{\infty} \left(\int_{-\infty}^{x-l} f_R(r) dr \right) f_L(l) dl. \\ &= \int_{-\infty}^{\infty} F_R(x-l) f_L(l) dl \end{aligned} \quad (28)$$

To obtain $f_P(x)$, equation 28 may be differentiated, which yields:

$$\begin{aligned} f_P(x) = f_{L+R}(x) &= \frac{d}{dx} \int_{-\infty}^{\infty} F_R(x-l) f_L(l) dl \\ &= \int_{-\infty}^{\infty} \frac{d}{dx} [F_R(x-l)] f_L(l) dl. \\ &= \int_{-\infty}^{\infty} f_R(x-l) f_L(l) dl \\ f_P(x) &= f_R(x) * f_L(x) \end{aligned} \quad (29)$$

Equation 29 states that the resulting PDF for P is the convolution of the individual PDFs for R and L . This result is corroborated in the statistical literature; for instance, [72]. The PDF for measurement updates, which is given by equation 25, can be rewritten as:

$$p(z, \text{bel}(x_L) | x) = \text{bel}(x_L) * R. \quad (30)$$

5.4.1. Gaussian Measurement: Uniform Landmark Position

The previous results obtained will be applied to a concrete example in this section. In the example, the distance measurement from the position of node, p_N , to the nominal position of the reference node, p_L , is distributed according to:

$$r = |p_N - p_L| \sim N(15, 1). \quad (31)$$

The PDF of the reference node is given by:

$$p_L = \begin{cases} 0.1 & x \in (-5, 5) \\ 0 & \text{otherwise} \end{cases} \quad (32)$$

The resulting PDF for the position of the node to be localized is given by:

$$p_N = p_L * r. \quad (33)$$

Figure 57 presents the three distributions pictorially.

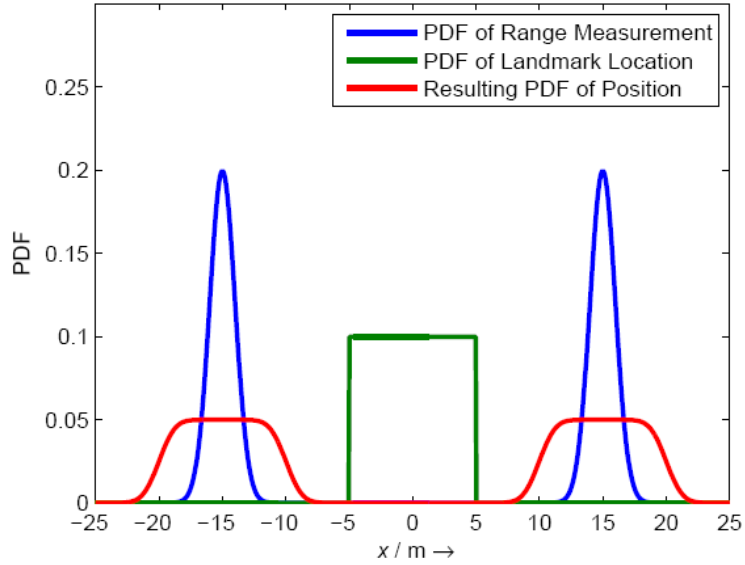

Figure 57: Combination of Measurement Distributions With Position Belief

Figure 57 indicates that, due to the flatness of the uniform distribution representing the belief of the reference node, the measurement updating PDF has more spread.

5.4.2. Gaussian Measurement, Gaussian Reference Node Position

The derivation developed for one dimension could also be easily extended to two dimensions by applying a two-dimensional convolution. However, since nodes need to transmit position belief information to other nodes, complex non-Gaussian PDFs represent a complexity issue. For instance, if a particle filter implementation is employed, the transmitting node would need to transmit all the particles as part of the “chirp”. Upon reception, the receiving node would need to calculate the convolution of the position belief of the transmitting node with the PDF of the range measurement in order to update its own particles. However, if the node could transmit a Gaussian

approximation of belief, less parameters would be required. In addition, the fact that a Gaussian is obtained from the convolution of two Gaussian could be also exploited.

It can be easily shown that if the range measurement, $N(r_m, \sigma_m)$, and the position belief of the reference node, $N(\mu_L, \sigma_L)$, are distributed normally, the resulting PDF is also Gaussian, $N(\mu_N, \sigma_N)$. The standard deviation of the new Gaussian can be determined from:

$$\sigma_N = \sqrt{\sigma_m^2 + \sigma_L^2} . \quad (34)$$

This relationship, given by equation 34, was applied in order to simplify the method for computing the convolution of a Gaussian range measurement in the two-dimensional case. In the two dimensional case the range measurement possesses a bivariate Gaussian belief of position of the reference node. This convolution was handled in polar coordinates, where all random variables are normally distributed.

The position belief of the reference node, $\text{bel}(\mathbf{x}_L)$, is described by a Gaussian bivariate distribution with mean vector, μ_L , and covariance matrix, Σ_L , and is given as:

$$\text{bel}(\mathbf{x}_L) \sim N(\mu_L, \Sigma_L) . \quad (35)$$

The range measurement is given by:

$$r = \|\mathbf{x}_N - \mathbf{x}_L\| \sim N(r_m, \sigma_m) . \quad (36)$$

The distribution is sought, which will be applied for weighting the belief of a node using the range measurement, for localization. The required distribution is given by:

$$p(r, \text{bel}(\mathbf{x}_L) | \mathbf{x}_N) = f_R(\mathbf{x}). \quad (37)$$

The covariance matrix, Σ_L , can be decomposed into its eigenvectors and eigenvalues such that:

$$\Sigma_L \mathbf{v} = \lambda \mathbf{v}. \quad (38)$$

Therefore, unitary eigenvectors \mathbf{v}_1 and \mathbf{v}_2 are obtained with corresponding eigenvalues λ_1 and λ_2 . A unit vector can also be obtained from the mean to an arbitrary point, which is given by:

$$\mathbf{u} = \frac{\mathbf{x} - \mu_L}{\|\mathbf{x} - \mu_L\|}. \quad (39)$$

The angle θ between \mathbf{u} and the eigenvector \mathbf{v}_1 can be calculated from:

$$\cos(\theta) = \mathbf{u} \cdot \mathbf{v}_1, \quad (40)$$

and since \mathbf{v}_1 and \mathbf{v}_2 are orthogonal, $\sin(\theta)$ can be obtained from:

$$\sin(\theta) = \mathbf{u} \cdot \mathbf{v}_2. \quad (41)$$

Using equation 34, equation 40 and equation 41, the new variance for any given angle θ can be computed from:

$$\sigma^2(\theta) = \sigma_m^2 + \frac{\lambda_1^2 \lambda_2^2}{\lambda_2^2 (\mathbf{u} \cdot \mathbf{v}_1)^2 + \lambda_1^2 (\mathbf{u} \cdot \mathbf{v}_2)^2}. \quad (42)$$

The probability as a function of angle and distance can then be computed from the Gaussian distribution and is given by:

$$\begin{aligned} p(r, \text{bel}(\mathbf{x}_L) | \mathbf{x}_N) &= f_R(\theta, \|\mathbf{x} - \mu_L\|) \\ &= \frac{1}{\sqrt{2\pi}\sigma(\theta)} \exp\left\{-\frac{1}{2(\sigma(\theta))^2} (\|\mathbf{x} - \mu_L\| - r_m)^2\right\} \end{aligned} \quad (43)$$

This analysis, equations 34 through 43, was applied to the computation of the distribution of the measurement update for the specific case where the position belief of the reference node was given by:

$$\text{bel}(\mathbf{x}_L) \sim \left(\begin{bmatrix} 0 \\ 0 \end{bmatrix}, \begin{bmatrix} 4 & 1 \\ 1 & 1 \end{bmatrix} \right), \quad (44)$$

and the range measurement was given by:

$$r \sim N(15, 1). \quad (45)$$

Figure 58 presents the results for the position belief of the reference node.

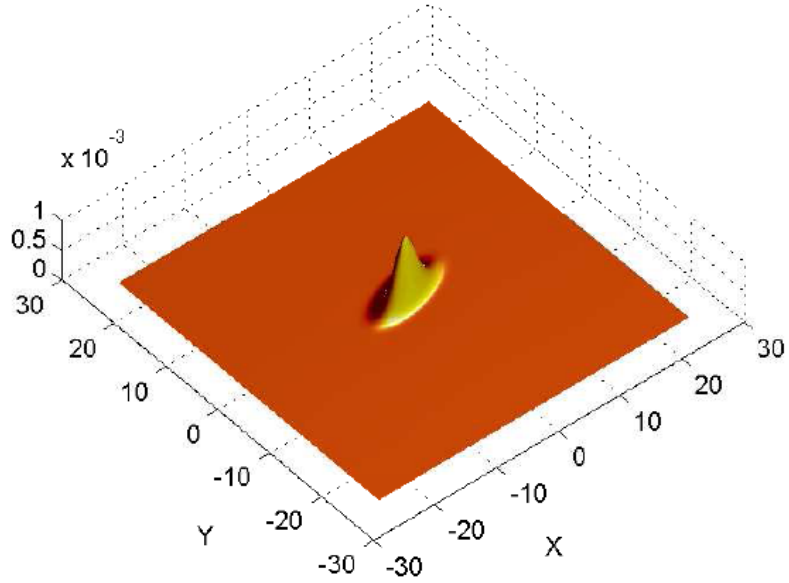

Figure 58: Position Belief of the Reference Node

Figure 59 presents the results for PDF of the measurement update distribution without considering the position uncertainty of the reference node.

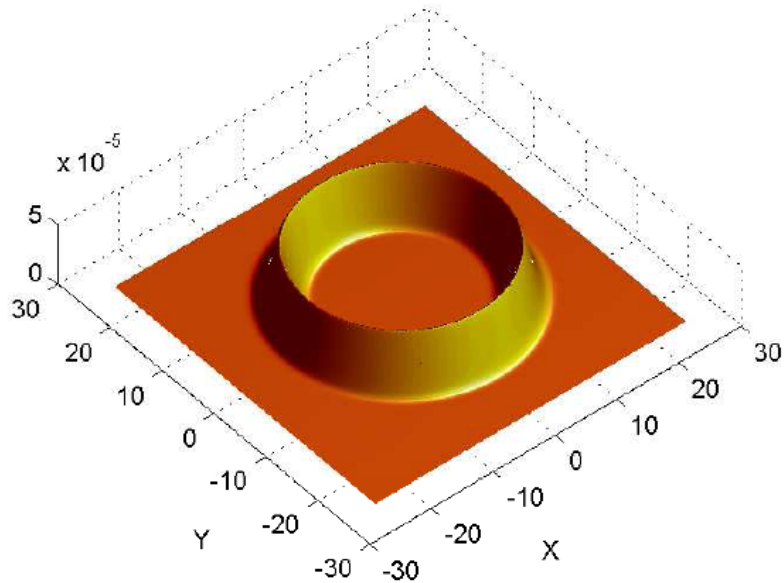

Figure 59: PDF of the Range Measurement

Figure 60 presents the results for the PDF of the convolved distribution.

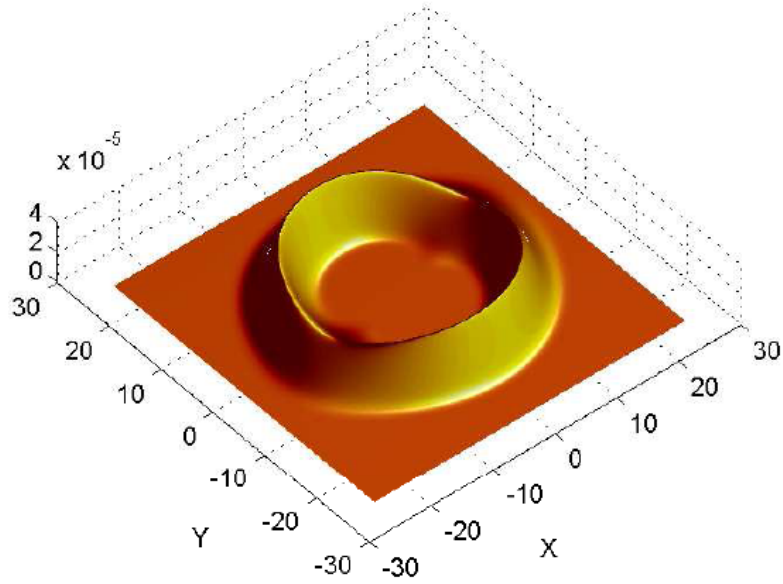

Figure 60: PDF of the Range Measurement Obtained from Convolution

These results illustrate that a wider spread for the reference node's belief also widens the spread of the convolved distribution and reduces the height. In general, the convolved PDF presents more spread than the measurement PDF, which does not consider the belief of the reference node. If this distribution was applied for weighting a set of uniformly distributed particles, the configuration presented in Figure 61 would be obtained after resampling.

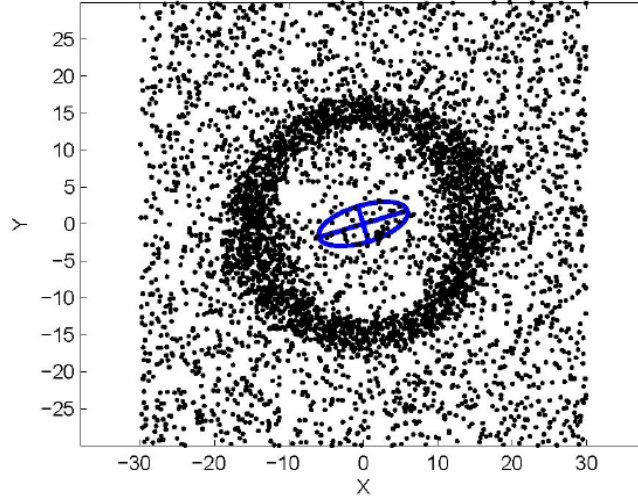

Figure 61: Belief after Applying a Measurement Update with a Convolved PDF

5.5. Experiments in Cooperative Localization

In order to isolate the estimation aspect from the protocols required for localization, in all the examples studied in this section, perfect networking was assumed. Nodes were able to exchange chirps simultaneously at specified time intervals. Nodes were not required to contend with medium access conflicts or the establishment of networking links. However, the limitations of ranging technology were taken into account. Therefore, chirps could not be transmitted to nodes that were beyond the coverage area for ranging.

5.5.1. Cooperative Localization of Two “Passing-By” Nodes

In this experiment, two nodes moved towards one another. Both nodes maintained the same speed. For comparison purposes, the experiment was conducted with and without cooperation. When the nodes cooperated, chirps were exchanged every,

$$T_{\text{chirp}} = 5 \text{ s.}$$

The measurement update mechanism presented in section 5.4 was employed for processing chirps. The experimental conditions are summarized in Table 8.

Table 8: Experiment Conditions for two Moving and Cooperating Nodes

	Robot 1	Robot 2
$[x(\text{m}), y(\text{m}), \theta(\text{rad})]$	$[0, -4, 0]$	$[23, 4, \pi]$
v (m/s)	1	1
ω (rad/sec)	0	0
$\alpha_{1,2}$	0.2	0.2
$\alpha_{3,4}$	0.2	0.2
$\alpha_{5,6}$	0.2	0.2
N of Particles	1000	1000
T_s for Odometry (ms)	20	20

The results obtained for running the experiment under cooperating conditions and conditions of no cooperation are presented in Figure 62.

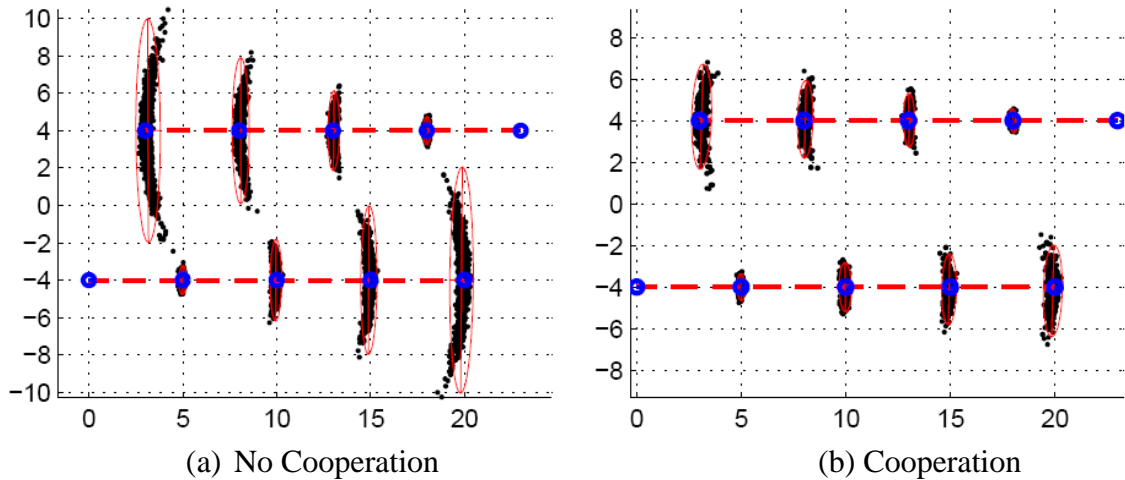

Figure 62: Two “Passing-by” Nodes $v = 1\text{m/s}$ and $\omega = 0\text{rad/s}$

Numerical results for experiments involving no cooperation, cooperation with of the other moving node and cooperation with a fixed reference node are presented in Table 9. The results for only one of the nodes are presented, since the results for both nodes were very similar.

Table 9: Experimental Results Showing the Effect of Cooperation and no Cooperation for a Mobile Node

No Cooperation		Cooperation w Moving Node		Cooperation with Fixed Node	
$3\sigma_{MAX}$	Δ	$3\sigma_{MAX}$	Δ	$3\sigma_{MAX}$	Δ
6.05m	0.17m	2.53m	0.15m	2.38m	0.12m

5.5.2. Cooperative Localization of a Robot Swarm Moving in Formation

The goal of this experiment was to demonstrate the effect of cooperative localization for a swarm of robots. The robot team consisted of four robots, which moved in a square-shaped formation. The formation of the swarm is presented in Figure 63.

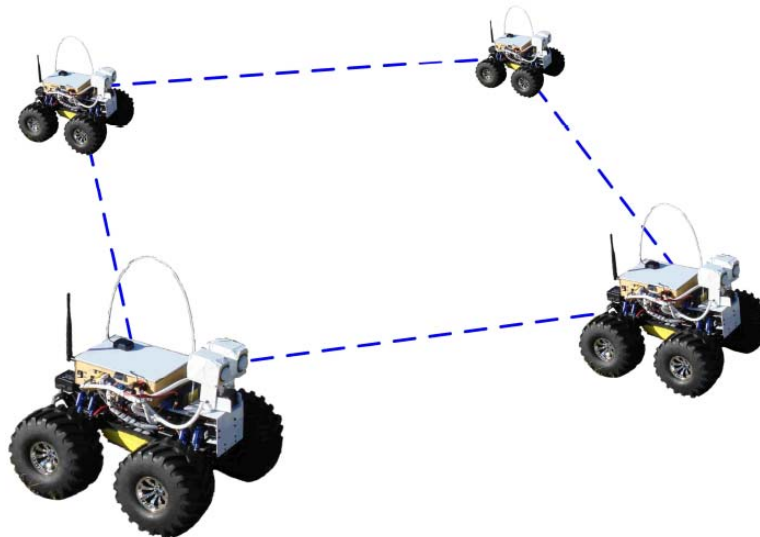

Figure 63: Robots moving in a Square-Shaped Formation

The algorithms required to build such a formation are beyond the scope of this analysis. The robots used pre-computed controls, which allowed them to maintain the formation. The conditions of the experiment are presented succinctly in Table 10 and are similar to the conditions presented in Figures 46 and 53 where one node followed an s-shaped trajectory.

Table 10: Experimental Conditions for Localization of a Robot Swarm

	Robot 1	Robot 2	Robot 3	Robot 4
$[x(\text{m}), y(\text{m}), \theta(\text{rad})]$	[4,1,0]	[0,-1,0]	[1,2,0]	[3,-2,0]
v (m/s)	1	1	1	1
ω (rad/sec)	0.1,-0.1	0.1,-0.1	0.1,-0.1	0.1,-0.1
$\alpha_{1,2}$	0.2	0.2	0.2	0.2
$\alpha_{3,4}$	0.2	0.2	0.2	0.2
$\alpha_{5,6}$	0.2	0.2	0.2	0.2
N. of Particles	1000	1000	1000	1000
T_s for Odometry (ms)	20	20	20	20
T_c for Chirps (s)	5	5	5	5

Figure 64 depicts snapshots of the particles, of each robot every five seconds, while traversing the s-shaped path. The actual results are presented in Table 11. Table 11 contains results for unaided and reference-node-aided localization for purposes of comparison.

Table 11: Results of Cooperative Localization
In a Robot Swarm

	Cooperation w Moving Nodes		No Cooperation		Cooperation with Fixed Node	
	$3\sigma_{MAX}$	Δ	$3\sigma_{MAX}$	Δ	$3\sigma_{MAX}$	Δ
Robot 1	1.92m	0.12m	6.69m	0.20m	2.23m	0.13m
Robot 2	1.73m	0.15m				
Robot 3	1.65m	0.14m				
Robot 4	1.54m	0.13m				

From Table 11, it can be inferred that cooperation among the four robots is comparable to receiving chirps from a fixed reference node with perfect position knowledge. However, the degree of uncertainty after traversing the trajectory for 20s is better in the case of cooperative localization. The results of the swarm experiment are presented graphically in Figure 64.

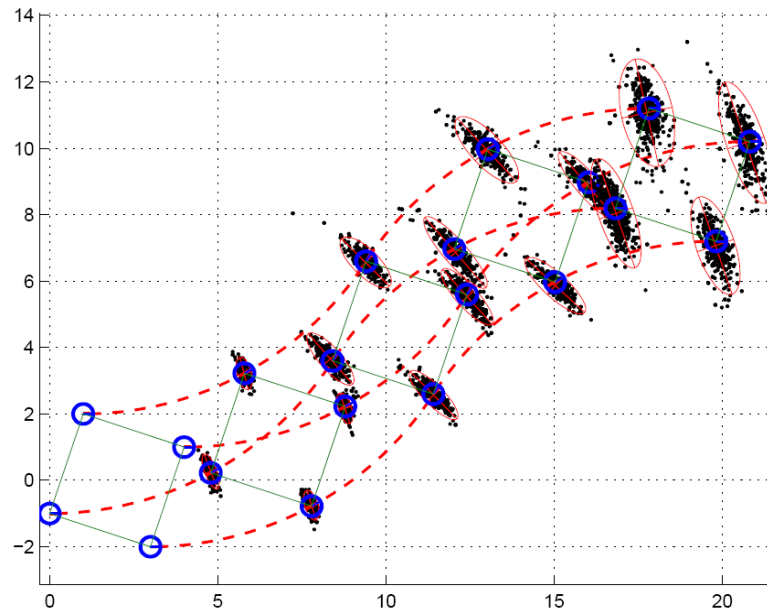

Figure 64: Cooperative Localization in a Robot Swarm

5.6. Summary

This chapter has presented the principal results and contributions of this dissertation, which are:

- A novel navigation principle, which integrates an INS with range readings for cooperative localization. The navigation principle is based on particle filtering techniques and a probabilistic motion model,
- A detailed development of the conceptual notion of “chirp” in cooperative localization,
- The measurement update from a reference node with a given position belief was found to be equal to the convolution of the measurement PDF with the PDF of the belief,
- A simplified, exact, algorithm for computing the convolution of the measurement PDF with the PDF of the belief. The convolution is specific to the case when range measurement noise and the position belief of the reference node can be assumed to be Gaussian,
- Several experimental scenarios, where the usefulness of the cooperative localization techniques, were highlighted.

Chapter 6

The Role of Protocols

In this chapter, the exchange of chirps will be investigated in more detail. Some of the assumptions made in previous chapters will be relaxed. Communication protocols provide for efficient medium utilization, for the creation of communication links and for establishing paths for packet delivery. In a similar way, localization protocols provide for efficient and fair swapping of chirps among nodes, which are to be localized.

The main goal of the networking function in a wireless networked system is to transmit data. The transmitted data is not simply limited to that used for localization. The transmission of operational data related to the mission of the WSN is paramount. Therefore, in cases when the localization function shares the wireless network interfaces, (WNI), with the main data transmission function, it cannot have higher priority. Therefore, the localization function needs to use the WNI sparingly, which forces a careful design of the localization protocols.

Localization protocols deal mainly with the two lower layers of the OSI model of networking. The layers associated with cooperative localization are presented in Figure 65.

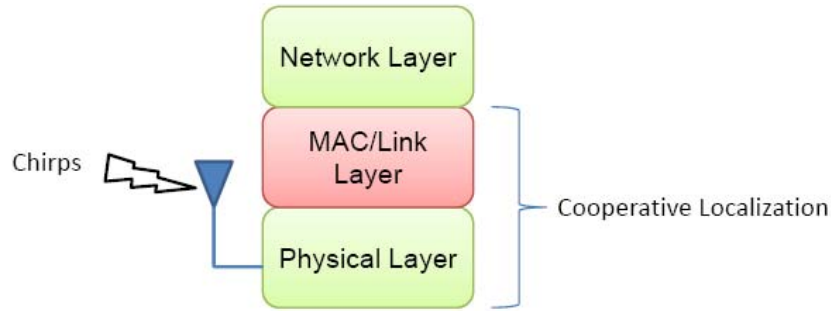

Figure 65: The Two Lower Layers of the OSI Model

At the physical layer, certain signal processing functions may be implemented, which would provide for the determination of range between two nodes. In more basic platforms, such as the Cricket Platform, this is achieved by using the Time Difference of Arrival of an ultrasound pulse and an RF packet. Since ranging, as such, is not within the scope of this dissertation, the physical layer will not be treated in further detail.

In order to guarantee any type of communication, nodes need to work within the same communication channels and share the wireless medium. A Medium Access Control Protocol, (MAC), creates the necessary signaling mechanisms, for usage of a medium, which is efficient and fair to all nodes. Subsequent sections will demonstrate how the MAC can encompass several channels. At the link layer, acknowledgement mechanisms are implemented to guarantee delivery of chirps. Due to the strong ad-hoc nature of the networks under consideration, protocols that require synchronization may not be appropriate. Randomized protocols will usually represent a better alternative. Therefore, with respect to this dissertation and from the point of view of protocols, the MAC/Link layer represents the main object of study.

6.1. The Cricket Platform

The Cricket localization system, which was developed at MIT and commercialized by the Crossbow Company, constitutes an ideal platform for investigating the issues related to protocols. The main advantage of the Cricket system is that it is based on the TinyOS operating system. The TinyOS operating system is widely popular, open-source and targeted to Wireless Sensor Networks. TinyOS provides abstractions that allow for the selective customization of specific functions within the package of functions available. In this research TinyOS was particularly suitable since it provided for the notion of a chirp to be embodied in a very direct manner.

6.1.1. Cricket V2.0 Protocol

A chirp, in the Cricket system, comprises an ultrasound pulse and an RF packet with the position information of the transmitting node. Therefore, a chirp requires an ultrasound channel and a RF channel. Nodes cannot transmit ultrasound pulses simultaneously since such activity would create a collision. The receivers would not be able to determine the source of the chirp from the signal mixture. The situation is resolved by employing the Carrier Sense Multiple Access, (CSMA), technique. In CSMA, a node uses its ultrasound receiver to detect whether other nodes are transmitting. In case a signal is detected, the node waits for a random time, which is termed random back-off, before attempting a transmission. A similar mechanism is employed for the RF-channel.

The, off-the-shelf, Cricket localization function possesses modes for transmitting and receiving. The transmitting mode is termed “beacon” and the receiving mode is

termed “listener”. Nodes may be set to work in only one mode. Therefore, nodes can be setup to be beacons or listeners but not both at the same time. Beacons are placed at known positions, which means that they do not perform any localization activities. However, listeners use chirps from beacons to find their location via trilateration.

Figure 66 presents a graphical representation, component diagram, of the main Cricket V2.0 software configuration, which details all of its main components.

In Figure 66, the `UltrasoundControlM` module performs the function of controlling the ultrasound channel by providing the `UltrasoundControl` interface. The `UltrasoundControl` interface is comprised of several commands and events such as:

- `command result_t UltrasoundControl.StartDetector,`
- `command result_t UltrasoundControl.StopDetector,`
- `event result_t UltrasoundControl.PulseDetected,`
- `event result_t UltrasoundControl.DetectorTimeout,`
- `command result_t UltrasoundControl.SendPulse,`
- `command result_t UltrasoundControl.SetGain.`

Control of the RF channel is analyzed in a similar manner. The RF channel contains the `CC1000RadioIntM` module. The `CC1000RadioIntM` module provides several interfaces for setting a node to either the listening mode or the receiving mode. In addition, the `CC1000RadioIntM` module possesses capabilities for receiving and transmitting messages.

The protocols for the, off-the-shelf, Cricket V2.0 application are depicted, in simplified form, in Figure 67.

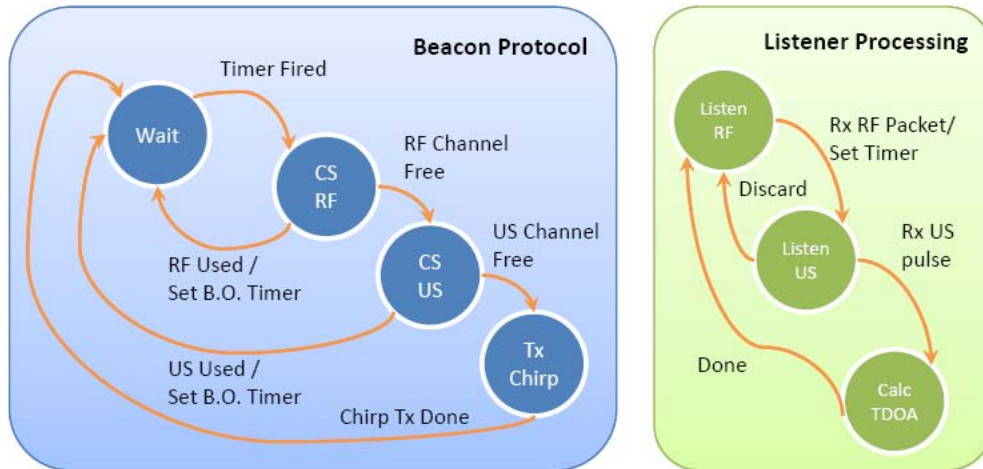

Figure 67: Cricket V2.0 Protocols

NOTE: The terms *provide*, *use*, *module*, *configuration*, *interface*, *command* and *event* have a special interpretation in the NesC language of TinyOS.

Although modules for using the Cricket platforms in both modes are available, as Figure 66 indicates, the main application does not accommodate all the requirements for the simultaneous exchange of chirps. Nodes need to function both as listeners *and* beacons for cooperative localization to occur. However, the main Cricket application does not provide for both modes to be active at the same time.

6.1.2. The RobustLoc Application

The RobustLoc application was developed by Moore, [36]. In the RobustLoc application, nodes act as both beacons and listeners. In addition, nodes are not limited simply to transmitting range information to the external serial port of the platform. In RobustLoc nodes also perform localization functions.

Nodes are usually in receiver mode and convert to beacon mode at fixed time intervals for short periods of time. The interactions of the RF and ultrasound channels with respect to beacon and listener functions are presented in Figure 68.

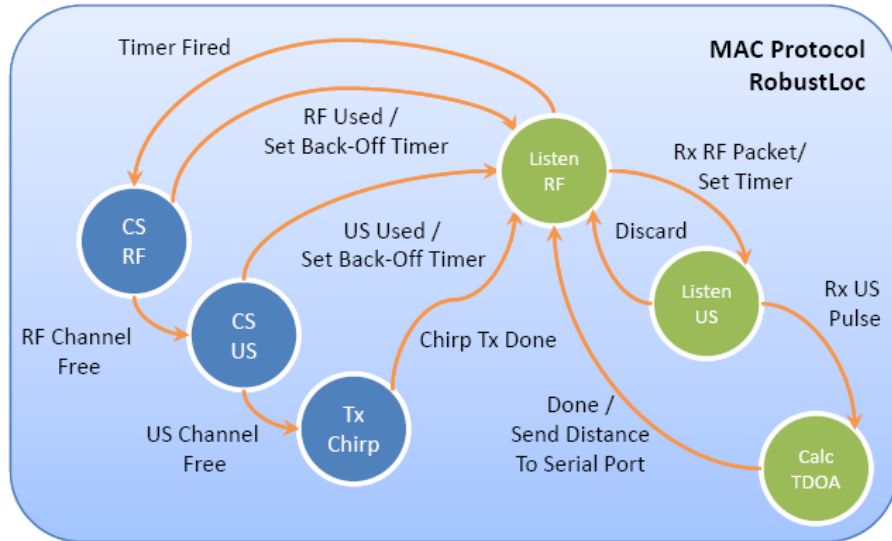

Figure 68: RobustLoc Protocol

6.2. Chirp Reception Frequency

The effort to maintain odometry errors within prescribed bounds is substantially reduced at higher frequencies. Therefore, the integrated navigation perspective considers higher frequency navigation aids as superior. However, medium allocation is not instantaneous. A definitive time is required to transmit chirps. Thus, the frequency at which nodes receive chirps is an important metric that measures the efficiency of the protocol.

The goal in this section is to develop the nature of the chirp reception process from the statistical perspective. The distribution of the range errors for this specific technology was scrutinized in section 4.5.1. Instead of modeling the protocols theoretically, an empirical model is sought. The model can later be incorporated into the navigation and motion models, which provides for a more realistic prediction functions such as accuracy and latency.

In pursuit of this objective, the question is posed:

- Assuming a network of n nodes, with every node having the ability to see all the others, what maximum chirp rate is achievable?

A perfect Time Division Multiple Access, (TDMA), protocol can be taken as an ideal case, which may yield the highest possible chirp rate. Two channels, ultrasound and RF, are shared by Cricket nodes. The channel, which defines the maximum chirp frequency, is the ultrasound channel since it operates in the slower medium. The maximum range of the Cricket ultrasound transducer was found to be approximately 5m. Therefore, each chirp allocates the ultrasound medium for at least a time, which is given by:

$$\Delta t = \frac{r}{v_{\text{Sound}}} = \frac{5m}{340m/s} = 15ms . \quad (46)$$

If nodes would take turns in a highly synchronized manner, they would need to wait to use the channel for a time given by:

$$\Delta T = n\Delta t . \quad (47)$$

For a network with $n = 6$, this represents a waiting time of $\Delta T = 90ms \approx 10\text{Chirps/s}$.

Hence, the performance of the TDMA protocol deteriorates with higher numbers of nodes.

To study the statistical nature of the chirps, an experiment similar to the one described in section 4.5.1 was performed. The main focus, of the experiment, was the frequency at which chirps were transmitted. Therefore, the listener registered the time of arrival in microseconds and the beacon number.

The histograms in Figure 69 depict the inter-arrival times of the chirps. In each case, an exponential distribution of the form $e^{-t/\mu}$ was fitted to the data and the parameter μ determined. As expected, μ was similar for all beacons since they all used the same protocol and the physical propagation conditions were similar. An average μ was determined to be:

$$\bar{\mu} = 525 \mu s . \quad (48)$$

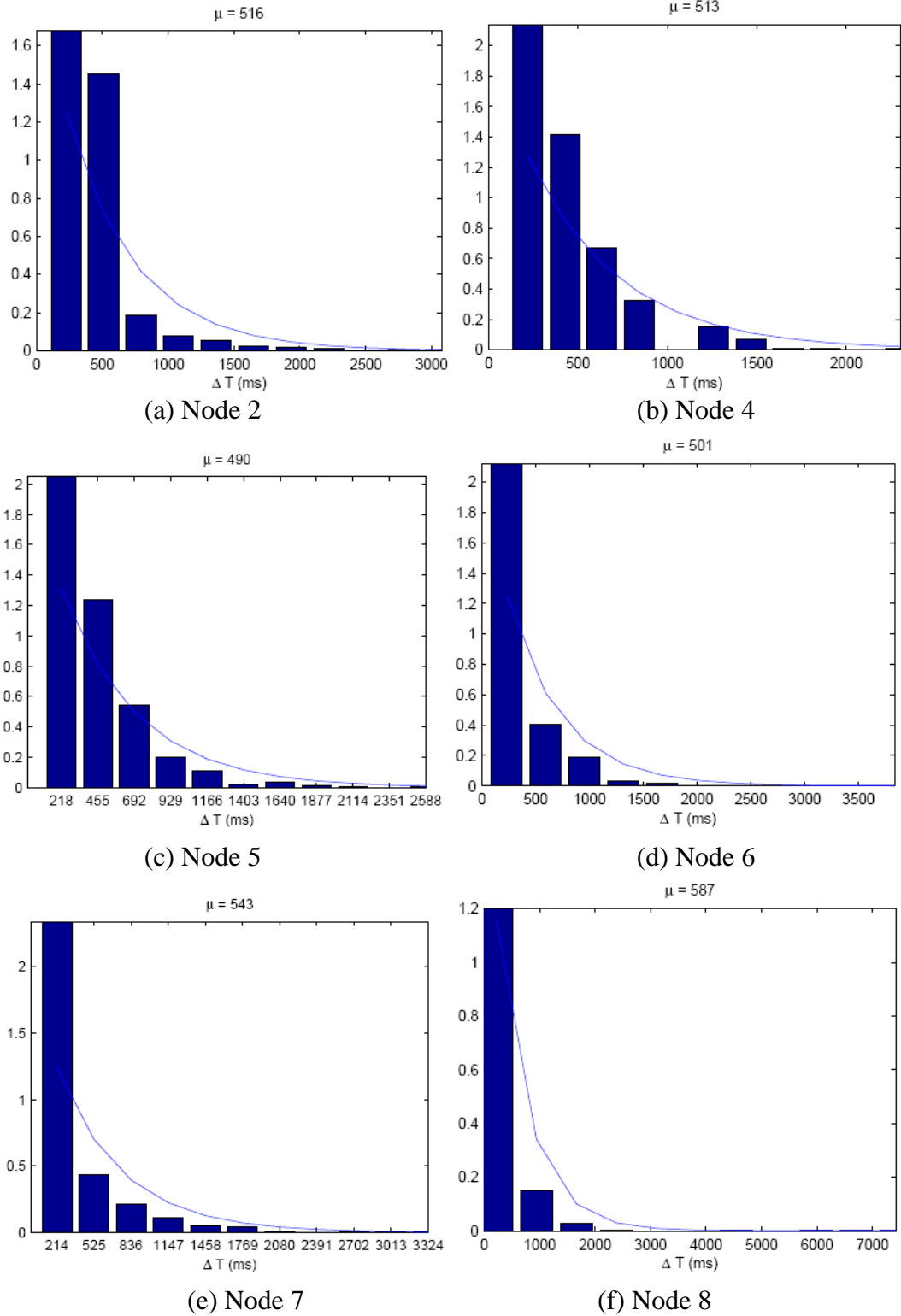

Figure 69: Histograms for the Inter-Arrival Time from Six Nodes

Since inter-arrival times can be modeled as an exponential distribution, the probability of a certain number of chirps, n , arriving at a listener within a specific time interval can be modeled as a Poisson process of the form:

$$P\{N(\Delta t) = n\} = e^{-\lambda t} \frac{(\lambda t)^n}{n!}, \quad (49)$$

where

$$\lambda = 1/\mu, \quad (50)$$

was determined to be:

$$\lambda = 1.9 \text{Chirps/s}. \quad (51)$$

In accordance with the Poisson model, the theoretical probabilities for different numbers, n , of received chirps within a time interval of 1s are presented in Figure 70.

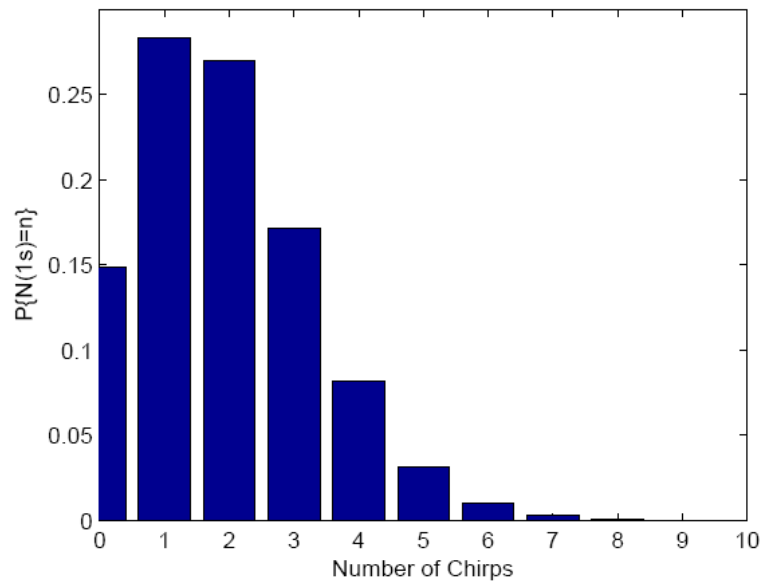

Figure 70: Probability of, n , Chirps Received; $P\{N(1s) = n\}$

6.3. Basic Outline of the Protocol

The protocols to handle cooperative localization can vary significantly since they are highly dependent on the role and characteristics of the node. For example:

- A wireless access point, which is fixed and considered part of the infrastructure. Upon its initial installation, the access point infers a basic zone from other wireless access points with which it communicates by the exchange of chirps. Lack of access to a sufficient number of other access points can leave the location belief with a substantial spread. However, it may “pick up” information from cell phones, lap-tops and vehicles, which are passing by or located in the near vicinity, in a continuous improvement process. Such a process would be limited by the nodes ability to measure range.
- A cell phone tower, due to GPS access and GPS augmentation systems, could quickly become a “pseudo-light” or beacon, which broadcasts chirps within its area of coverage.
- A vehicle would rely on its localizer in GPS/INS mode when driving in open landscapes. However, in urban canyons a vehicle could communicate with cell phone towers and access points to keep its position errors within bounds. On the highway, a vehicle can communicate with other vehicles in order to guarantee accurate position estimates, which are necessary for safe driving and purposeful navigation.

- A pedestrian with cell phone would exchange chirps with cell phone towers, other cell phones and passing robots in order to keep its error bounds within limits.
- A wireless sensor node would work in a way very similar to a wireless access point.

The operation of a cooperative localization protocol, for a wireless sensor network, yields itself to a simple outline type description. It is assumed that a few reference nodes are initially positioned in the area of interest.

After deployment, listener nodes put themselves in *unlocalized* mode. Concurrently, reference nodes enter their *localized* mode and wait for *chirp-request* messages. In the *unlocalized* mode, nodes wait for chirps for a specified time. If no chirps are heard, after the wait time has elapsed, a *chirp-request* message is broadcast.

Listener nodes, in the *process-chirp* state, use chirps to estimate their location and update their uncertainty measure, c . When a threshold certainty level, c_{Thr} , is achieved, the node assumes it has a good location estimate and moves into the *localized* state. When a node receives a chirp request, while still in the *unlocalized* state, it compares its current certainty level with a threshold certainty level by checking if the condition $c'_{\text{Thr}} < c_{\text{Thr}}$ holds. If this condition is true, the node transmits a chirp. However, nodes with very low certainty values should be prevented from sending chirps in order to avoid contention.

The sooner the nodes start cooperating as beacons, even when their location estimate is not perfect, the sooner the nodes, distant from the original reference nodes, will reach convergence.

In the *localized* state a node either puts itself to sleep or performs its usual duties. While awake, the node listens for chirp requests. The long preamble technique may be used in order to reach sleeping neighbors. In every case, the techniques used in the MAC randomized protocols can be used to allow for sharing the ultrasound and RF channels necessary for collision free chirp exchange. Figure 71 presents, in state-diagram form, the protocol, which is comprised of the different states and messages.

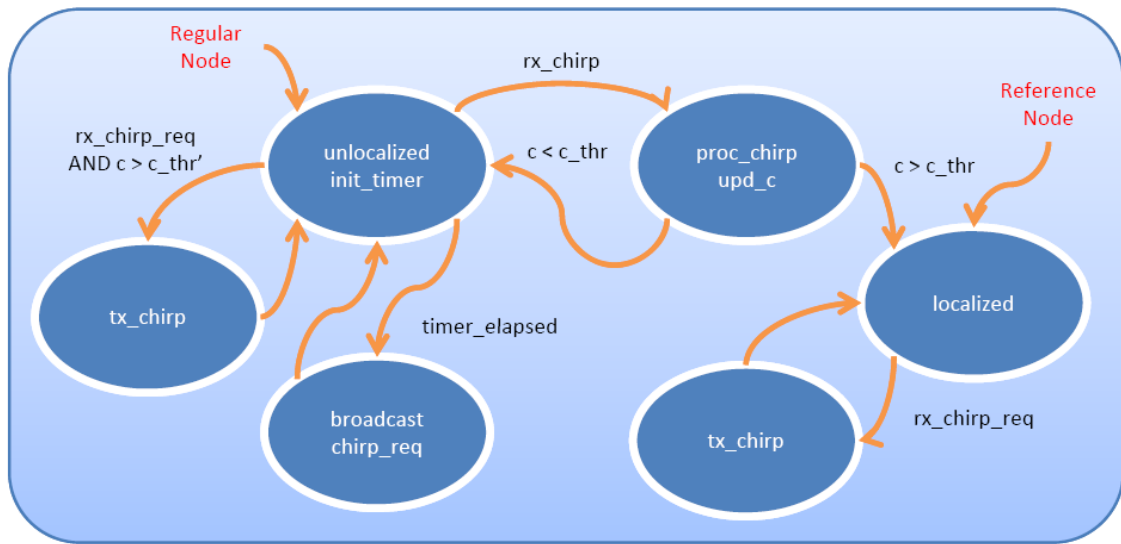

Figure 71: Basic Localization Protocol for a WSN

6.4. Summary

This chapter has briefly presented a few aspects related to protocols that are necessary to enable cooperative localization. The Cricket system served as the basis for the analysis. Basic MAC techniques employed in two known applications were studied. The inter-arrival time of chirps was quantified and modeled statistically. Finally, a protocol applicable to localization of Wireless Sensor Networks was outlined.

Chapter 7

Conclusions and Future Work

7.1. Conclusions

This research investigated the process of forging an original vision of how localization in wireless networked systems could work in the future. The result was the development of a novel localization solution. This result was achieved primarily due to the application of Systems Engineering principles. In addition, the results of this research were based on solid foundations of previous work in the areas of navigation, networking, robotics and estimation. The *chirp*, was introduced as a unit for one-to-one interactions. Also introduced was the *localizer*, as a device, which encompassed networking, ranging and inertial measurement functionalities. These two concepts were central to the success of this research.

The three main pillars of the novel localization solution are:

- Cooperative estimation,
- Introduction of a probabilistic framework,
- Incorporation of inertial measurements.

These three aspects have not been unified in any previous solution.

Cooperation refers to the purposeful interactions among nodes of a network such that nodes with lower position uncertainty assist other nodes to perform self-localization. Through cooperation, localization becomes a distributed estimation task. It also remedies coverage and reliability issues, due to the inherent redundancy enabled by cooperation.

The probabilistic framework lays the foundation for handling measurement errors in a very elegant way. Additionally, it provides the mechanism for breaking away from trilateration and other graph rigidity related approaches. Within the probabilistic view, position is not a set of coordinates. Instead, position becomes a *belief*. The *belief* provides the mechanism for the extraction of an actual estimate of position. Due to the application of probabilistic estimation techniques, every measurement and interaction with other nodes is useful, which avoids the “no fix” condition common in trilateration. A product of this framework is also the particle filter, also known as a Sequential Monte Carlo Estimation or Bootstrap filter, which was used extensively in this research.

Strapdown Inertial Navigation Systems, (SINS), are becoming common place due to the abruptly sinking prices of MEMS-based inertial sensors. The combination of SINS and inter-node range measurements for navigation aiding was one of the fundamental ideas put forward in this research.

Two main issues of particle filters were addressed and effective solutions proposed. The need for large numbers of particles to produce convergence of the sequential estimation process was investigated and a heuristic adaptation rule proposed. The adaptation rule wireless sensor nodes with limited computational resources to benefit from the advantages and simplicity of particle filters. The resulting non-linear estimation law is flexible and can be tuned according to the metric with the highest relevance in a

specific application. Secondly, the applicability restrictions when handling problems with a state vector of higher than three dimensions was investigated. The problem was partitioned. The odometry partition employed an optimal filter to handle a large number of states. The aiding partition assumes responsibility for producing position estimates and fusing range measurements. This navigation structure proved useful in diverse example scenarios, which were presented in chapter 5.

Another highlight of the research, presented in this dissertation, was the elegant solution to the problem of performing the convolution of the annular measurement update probability density function with the position belief of the chirp originator. This was achieved through representation of the problem in polar coordinates and by exploiting the fact that both PDFs possess Gaussian sections, whose convolution yields another normal distribution.

Many problems that possess a NP-complete nature, such as the localization of nodes in a network using noisy measurement readings, have been solved in approximate form through the application randomization techniques. It appears that, with the increasing computational power of embedded networked systems, the use of randomization techniques will expand dramatically. Randomization techniques are particularly applicable to those many real problems, which are, by their very nature, highly uncertain and noisy.

7.2. Future Work

A few of the many lines of inquiry that this research has unveiled and could or possibly should attract research attention in the future are:

- Consideration of vehicles, which incorporate an integrated INS/GPS system. In such a vehicle there exists the possibility of exchanging chirps for communication and to measure inter-node range. How would this additional capability improve the INS/GPS estimation process?
- How can priors such as holonomic constraints and maps be incorporated into the cooperative localization process?
- What are the observabilities and sensitivities of different geometric configurations of localizers? What is the effect of using redundant localizers?
- How can the techniques, outlined in this dissertation, be improved by machine learning techniques? For example, over time the localizer “gets to know” its carrier. Tracking a person is different from tracking a vehicle.
- How can the parameters of the probabilistic motion model be determined?

There seems to be three possibilities:

- Via theoretical error analysis of the inertial navigation system,
- Empirically, by performing system identification or expectation maximization-type algorithms,
- Via continuous on-line parameter learning.

- What is the effect of malicious nodes, which try to “delocalize” a network? Similarly, what happens when one node presents severe measurement failures? Since localization is a cooperative process, much like a distributed routing algorithm, techniques for identifying malicious nodes in localization may be drawn from the distributed computation area.
- A careful analysis of the Lower bounds of estimation, such as the Cramer-Rao lower bound used for Gaussian distributions, could help in quantifying the exact benefits of cooperative localization.

References

- [1] Mark Weiser, “The Computer for the Twenty-First Century”, *Scientific American*, pp. 94–100, September, 1991
- [2] V. Coroama, J. Bohn, and F. Mattern, “Living in a Smart Environment – Implications for the Coming Ubiquitous Information Society”, In 2004 IEEE International Conference on Systems, Man and Cybernetics, vol. 6, pp. 5633–5638, 2004
- [3] IBM Research, “Pervasive, Mobile and Wearable Computing”, <http://researchweb.watson.ibm.com/WearableComputing/>, May 2005.
- [4] N. Streitz, C. Magerkurth, T. Prante and C. Roecker, “From Information Design to Experience Design: Smart Artefacts and the Disappearing Computer”, *Interactions*, vol. 12(4), pp. 21–25, 2005
- [5] D. Estrin, D. Culler, K. Pister and G. Sukhatme, “Connecting the Physical World with Pervasive Networks”, *Pervasive Computing, IEEE*, vol. 1(1), pp 59–69, 2002
- [6] D. Estrin, “Reflections on Wireless Sensing Systems - From Ecosystems to Human Systems”, In *IEEE Radio and Wireless Symposium 2007*, pp. 1–4, January, 2007
- [7] M. Castillo-Effen, D.H. Quintela, W. Moreno, R. Jordan and W. Westhoff, “Wireless Sensor Networks for Flash-Flood Alerting”, In *Proceedings of the Fifth IEEE International Caracas Conference on Devices, Circuits and Systems*, vol. 1, pp 142–146, 3-5 November, 2004
- [8] R. Want, “An Introduction to RFID Technology”, *Pervasive Computing, IEEE*, vol. 5(1), pp. 25–33, 2006
- [9] M. Vrdoljak, S. I. Vrdoljak and G. Skugor, “Fixed-Mobile Convergence Strategy: Technologies and Market Opportunities”, *Communications Magazine, IEEE*, vol. 38(2), pp.116– 121, 2000
- [10] S. Haykin. “Cognitive Radio: Brain-Empowered Wireless Communications”, *IEEE Journal on Selected Areas in Communications*, vol. 23(2), pp. 201–220, 2005

- [11] J. Mitola and G. Maguire, “Cognitive Radio: Making Software Radios More Personal”, *Personal Communications*, IEEE [see also *IEEE Wireless Communications*], vol. 6(4), pp. 13–18, 1999
- [12] D. Scaperth, B. Lee, T. Rondeau, D. Maldonado, C. W. Bostian and S. Harrison, “Cognitive Radio Platform Development for Interoperability”, In *Military Communications Conference, MILCOM 2006*, pp. 1–6, 2006
- [13] W. M. Bulkeley, “Profit in Motion – Tiny Sensors Take Off”, *The Wall Street Journal* online, page B3, May 10th, 2007
- [14] L. Kincaid, “Analog Devices Breakthrough MEMS Sensor Brings Sophisticated Motion and Navigation Control to Industrial Applications”, *Analog Devices*, Press Release, June 11th, 2007
- [15] M. Hazas, J. Scott and J. Krumm, “Location-Aware Computing Comes of Age”, *Computer*, vol. 37(2), pp. 95–97, 2004
- [16] S. Thrun, W. Burgard, and D. Fox, “Probabilistic Robotics (Intelligent Robotics and Autonomous Agents)”, *The MIT Press*, September, 2005
- [17] T. Balch and R. C. Arkin, “Behavior-Based Formation Control for Multirobot Teams”, *IEEE Transactions on Robotics and Automation*, vol. 14(6), pp. 926–939, 1998
- [18] R. M. Zlot, “An Auction-Based Approach to Complex Task Allocation for Multirobot Teams”, PhD thesis, Robotics Institute, Carnegie Mellon University, Pittsburgh, PA, December, 2006
- [19] J. Farrel and M. Barth, “The Global Positioning System and Inertial Navigation”, *McGraw-Hill*, NY 10011, 1999
- [20] M. S. Grewal, L. R. Weill and A. P. Andrews, “Global Positioning Systems, Inertial Navigation, and Integration”, *Wiley-Interscience*, December, 2000
- [21] J. L. Crassidis and J. L. Junkins, “Optimal Estimation of Dynamic Systems”, *Chapman & Hall/CRC*, April, 2004
- [22] A. Dogandzic, J. Riba, G. Seco and A. L. Swindlehurst, “Positioning and Navigation with Applications to Communications (from the guest editors)”, *IEEE Signal Processing Magazine*, vol. 22(4), pp. 10–11, 2005
- [23] J. Aspnes, T. Eren, D.K. Goldenberg, A.S. Morse, W. Whiteley, Y.R. Yang, B.D.O. Anderson and P.N. Belhumeur, “A Theory of Network Localization”, *IEEE Transactions on Mobile Computing*, vol. 5(12), pp. 1663–1678, 2006

- [24] J. Xiao, A. Ribeiro, Z. Luo, and G. B. Giannakis, “Distributed Compression-Estimation Using Wireless Sensor Networks”, *IEEE Signal Processing Magazine*, vol. 23(4), pp. 27–41, 2006
- [25] R. Olfati-Saber and R. M. Murray, “Consensus Problems in Networks of Agents with Switching Topology and Time-Delays”, *IEEE Transactions on Automatic Control*, vol. 49(9), pp. 1520–1533, 2004
- [26] I. A. Getting, “The Global Positioning System”, *IEEE Spectrum*, pp. 36–47, December, 1993
- [27] F. Gustafsson and F. Gunnarsson, “Mobile Positioning Using Wireless Networks: Possibilities and Fundamental Limitations Based on Available Wireless Network Measurements”, *IEEE Signal Processing Magazine*, vol. 22(4), pp. 41–53, 2005
- [28] D. Fox, W. Burgard, H. Kruppa and S. Thrun, “A Probabilistic Approach to Collaborative Multi-Robot Localization”, *Autonomous Robots*, vol. 8(3), pp. 325– 344, 2000
- [29] R. Kurazume, S. Nagata and S. Hirose, “Cooperative Positioning with Multiple Robots”, vol.2, pp. 1250–1257, 1994
- [30] S. I. Roumeliotis and G. A. Bekey, “Distributed Multirobot Localization”, *IEEE Transactions on Robotics and Automation*, vol. 18(5), pp. 781–795, October, 2002
- [31] A. Howard, M. Matari, and G. Sukhatme, “Localization for Mobile Robot Teams using Maximum Likelihood Estimation”, In *Proceedings of the IEEE/RSJ International Conference on Intelligent Robots and Systems*, 2002
- [32] A. Howard, M. Mataric, and G. Sukhatme, “Cooperative Relative Localization for Mobile Robot Teams: An Ego-Centric Approach”, In *Proceedings of the Naval Research Laboratory Workshop on Multi-Robot Systems*, Washington, D.C., March, 2003
- [33] R. Want, A. Hopper, V. Falcao and J. Gibbons, “The Active Badge Location System”, *ACM Transactions on Information Systems*, vol. 10(1), pp. 91–102, 1992
- [34] A. Ward, A. Jones and A. Hopper, “A New Location Technique for the Active Office”, *IEEE Personal Communications* [see also *IEEE Wireless Communications*], vol. 4(5), pp. 42– 47, 1997
- [35] N. Priyantha, A. Chakraborty, and H. Balakrishnan, “The Cricket Location-Support System”, In *Proceedings of the 6th Annual ACM International Conference on Mobile Computing and Networking (MobiCom ’00)*, August, 2000

- [36] D. Moore, J. Leonard, D. Rus and S. Teller, “Robust Distributed Network Localization with Noisy Range Measurements”, In SenSys ’04: Proceedings of the 2nd International Conference on Embedded Networked Sensor Systems, New York, USA, ACM Press, pp. 50–61 , 2004
- [37] V. Padmanabhan P. Bahl and A. Balachandran, “Enhancements to the RADAR User Location and Tracking System”, Technical report, Microsoft Research, Microsoft Corporation, One Microsoft Way, Redmond, WA98052, February, 2000
- [38] C. D. Whitehouse, “The Design of Calamari: An Ad-Hoc Localization System for Sensor Networks”, Master’s thesis, University of California at Berkeley, Fall 2002
- [39] J. Hightower and G. Borriello, “Location Systems for Ubiquitous Computing”, Computer, vol. 34(8), pp. 57–66, 2001
- [40] J. Hightower, A. LaMarca, and I. Smith, “Practical Lessons from PlaceLab”, IEEE Pervasive Computing, vol. 5(3), pp. 32–39, 2006
- [41] A. LaMarca, Y. Chawathe and I. Smith, “Finding Yourself: Experimental Location Technology Relies on Wi-Fi and Cell Phone Signals Instead of Orbiting Satellites”, IEEE Spectrum, vol. 41(12), pp. 51–54, December, 2004
- [42] K. Langendoen and N. Reijers, “Embedded Systems Handbook”, CRC Press, 2005
- [43] D. Niculescu and B. Nath, “Ad-Hoc Positioning System”, In IEEE Globecom ’01, November, 2001
- [44] A. Savvides, H. Park, and M. B. Srivastava, “The N-Hop Multilateration Primitive for Node Localization Problems”, Mobile Networks and Applications Journal, August, 2003
- [45] C. Savarese, K. Langendoen, and J. Rabaey, “Robust Positioning Algorithms for Distributed Ad-Hoc Wireless Sensor Networks”, In USENIX Conference, Monterey, CA, June, 2002
- [46] F. Thomas and L. Ros, “Revisiting Trilateration for Robot Localization”, IEEE Transactions on Robotics, vol. 21(1), pp. 93–101, February, 2005
- [47] T. Eren, D. K. Goldenberg, W. Whiteley, Y. R. Yang, A. S. Morse, B. D. O. Anderson and P. N. Belhumeur, “Rigidity, Computation, and Randomization in Network Localization”, In IEEE Infocom 04, March, 2004
- [48] N. Patwari, J. N. Ash, S. Kyperountas, III Hero, R. L. Moses and N. S. Correal, “Locating the Nodes: Cooperative Localization in Wireless Sensor Networks” IEEE Signal Processing Magazine, vol. 22(4), pp. 54–69, 2005

- [49] R. L. Moses A. Savvides, W. L. Garberand and M. B. Srivastava, “An Analysis of Error Inducing Parameters in Multihop Sensor Node Localization”, IEEE Transactions on Mobile Computing, vol. 4, pp. 567–577, November/December, 2005
- [50] D. Moore, J. Leonard, D. Rus, and S. Teller, “Robust Distributed Network Localization with Noisy Range Measurements”, In SenSys '04: Proceedings of the 2nd International Conference on Embedded Networked Sensor Systems, New York, USA, ACM Press, pp. 50–61, 2004
- [51] K. Whitehouse and D. Culler, “A Robustness Analysis of Multi-Hop Ranging-Based Localization Approximations”, In The Fifth International Conference on Information Processing in Sensor Networks (IPSN '06), Nashville, TN, April 19-21, 2006
- [52] K. Whitehouse, C. Karlof, A. Woo, F. Jiang, and D. Culler, “The Effects of Ranging Noise on Multihop Localization: an Empirical Study”, In The Fourth International Conference on Information Processing in Sensor Networks (IPSN '05), Los Angeles, CA, April 25-27, 2005
- [53] J. Ash and R. Moses, “Acoustic Time Delay Estimation and Sensor Network Self-Localization: Experimental Results”, Journal of the Acoustical Society of America, August, 2004
- [54] V. Ramadurai and M. Sichitiu, “Localization in Wireless Sensor Networks: A Probabilistic Approach”, In Proceedings of the 2003 International Conference on Wireless Networks (ICWN 2003), Las Vegas, NV, pp. 275-281, June, 2003
- [55] F. Gustafsson, F. Gunnarsson, N. Bergman, U. Forssell, J. Jansson, R. Karlsson and P. J. Nordlund, “Particle Filters for Positioning, Navigation, and Tracking, IEEE Transactions on Signal Processing, [see also IEEE Transactions on Acoustics, Speech, and Signal Processing], vol. 50(2), pp.425–437, 2002
- [56] S. Sukkarieh, “Low Cost, High Integrity, Aided Inertial Navigation Systems for Autonomous LandVehicles”, PhD thesis, Australian Centre for Field Robotics, The University of Sidney, March, 2000
- [57] M. George and S. Sukkarieh, “Camera Aided Inertial Navigation in Poor GPS Environments”, In IEEE Aerospace Conference, pages 1–12, 2007
- [58] M. Bryson and S. Sukkarieh, “Co-operative Localisation and Mapping for Multiple UAVs in Unknown Environments”, In Aerospace Conference, 2007 IEEE, pages 1–12, 2007
- [59] G. A. Bekey, “Autonomous Robots–From Biological Inspiration to Implementation and Control”, The MIT Press, Cambridge, MA 02142, 2005

- [60] Department of Defense, “Systems Engineering Fundamentals”, Defense Acquisition University Press, Fort Belvoir, VA22060-5565, 2001
- [61] S. K. Rupanagudi, “A Platform for Research on Localization and Tracking using Wireless Sensor Networks”, Master’s Thesis, University of South Florida, March, 2006
- [62] A. Basu, J. Gao, J. S. B. Mitchell and G. Sabhnani, “Distributed Localization using Noisy Distance and Angle Information”, In *MobiHoc ’06: Proceedings of the Seventh ACM International Symposium on Mobile Ad Hoc Networking and Computing*, New York, USA, ACM Press, pp. 262–273, 2006
- [63] K. Pahlavan, F. O. Akgul, M. Heidari, A. Hatami, J. M. Elwell and R. D. Tingley, “Indoor Geolocation in the Absence of Direct Path”, *IEEE Wireless Communications*, [see also *IEEE Personal Communications*], vol. 13(6), pp. 50–58, 2006
- [64] S. Galler, J. Schroeder, G. Rahmatollahi, K. Kyamakya, and K. Jobmann, “Analysis and Practical Comparison of Wireless LAN and Ultra-Wideband Technologies for Advanced Localization”, In *Position, Location, And Navigation Symposium*, 2006 IEEE/ION, pp. 198–203, 2006
- [65] S. Gezici, T. Zhi, G. B. Giannakis, H. Kobayashi, A. F. Molisch, H. V. Poor and Z. Sahinoglu, “Localization via Ultra-Wideband Radios: a Look at Positioning Aspects for Future Sensor Networks”, *IEEE Signal Processing Magazine*, vol. 22(4), pp. 70–84, 2005
- [66] K. Sunwoo, A.P. Brown, T. Pals, R.A. Iltis, and L. Hua, “Geolocation in Ad Hoc Networks Using DS-CDMA and Generalized Successive Interference Cancellation”, *IEEE Journal on Selected Areas in Communications*, vol. 23(5), pp. 984–998, 2005
- [67] Motorola, “Mesh Networks -Position Paper”, www.motorola.com/mesh/pages/technology/, 2005
- [68] N. B. Priyantha, “The Cricket Indoor Location System”, Ph.D. Thesis, Massachusetts Institute of Technology, June, 2005
- [69] H. Karl and A. Willig, “Protocols and Architectures for Wireless Sensor Networks”, Wiley, 2005
- [70] A. L. Miu, “Design and Implementation of an Indoor Mobile Navigation System”, Master’s Thesis, Massachusetts Institute of Technology, January 2002

- [71] H. Balakrishnan, R. Baliga, D. Curtis, M. Goraczko, A. Miu, B. Priyantha, A. Smith, K. Steele, S. Teller and K. Wang, “Lessons from Developing and Deploying the Cricket Indoor Location System”, Technical Report, Massachusetts Institute of Technology, 2003
- [72] Sheldon M. Ross, “Introduction to Probability Models”, Eighth Edition, Academic Press, January, 2003

About the Author

Mauricio Castillo-Effen obtained the Dipl. Ing. Degree in Electrical Engineering from the University of Applied Sciences of Hannover, Germany in 1993 and the M.Sc. degree in Modern Control Systems from Universidad Mayor de San Simon, (UMSS), Cochabamba , Bolivia in 2001. The M.Sc. program was developed and administered by Delft University of Technology, The Netherlands. Mauricio worked in Germany and in Bolivia as Engineer, consultant and as Associate Professor at the Universidad Privada Boliviana. Mauricio also worked as Research Assistant, Teaching Assistant and Adjunct Faculty at the University of South Florida, Department of Electrical Engineering. Additionally, he was Research Assistant for the Center of Robot Assisted Search and Rescue and for the Unmanned Systems Laboratory. Mauricio has published and presented his work at conferences, in journals and in book chapter contributions in the fields of Unmanned Aerial Vehicles, Control, Robotics and Wireless Networks. Mauricio is an IEEE and ION member.