

ABSTRACT

BOND, BENJAMIN DANIEL. A Comparative Study of Partial Least Squares (PLS) Regression and Artificial Neural Network (ANN) Methods for Determining Elemental Weights in Sheet Metal. (Under the direction of Dr. Robin P. Gardner).

The in-situ determination of elemental weights in various materials is highly desirable for a number of manufacturing processes. Energy dispersive X-ray fluorescence (EDXRF) leverages the physics of electron binding energy and the characteristic X-rays emitted from low energy photoelectric absorption to interrogate material surfaces, which can lead to the prediction of element composition. This study looks at two different methods for determining the elemental weights in sheet metal using spectroscopic data generated from EDXRF. The first method, partial least squares (PLS) regression, develops latent variables through orthogonal decomposition of the spectroscopic and elemental weight matrices. These components and loadings are then rotated such that the variation in the spectroscopic data is used to explain the variation in the elemental compositions. The second method used, artificial neural networks (ANN), acts as a non-linear fitting function, whereby the weights are found using the Levenberg Marquardt algorithm. Both of these methods yielded mixed results, however in general the predictions were positive for identifying major elemental constituents in each sample. It is apparent that the selection of a particular tool is application dependent, and thus the study was inconclusive whether one technique was better over another. The results presented in this study should simply reflect the possibilities of each method; however, optimization is recommended for any industrial application.

© Copyright 2014 Benjamin Daniel Bond

All Rights Reserved

A Comparative Study of Partial Least Squares (PLS) Regression and Artificial Neural Network (ANN) Methods for Determining Elemental Weights in Sheet Metal

by
Benjamin Daniel Bond

A thesis submitted to the Graduate Faculty of
North Carolina State University
in partial fulfillment of the
requirements for the degree of
Master of Science

Nuclear Engineering

Raleigh, North Carolina

2014

APPROVED BY:

Dr. Robin P. Gardner
Committee Chair

Dr. John Mattingly

Dr. Ralph Smith

Dedication

This work is dedicated to my beautiful wife Halima, who willingly accepted a drastic change in lifestyle to allow me this pursuit, and deftly handled all the logistics of home life so I could apply my full energy to this degree.

Biography

Benjamin Bond was born in the spring of 1977 to Daniel Kartheiser and Lauren Mara Miller. A few years later, Lauren was remarried Scott G. Bond, and in 1981 Benjamin was adopted into the Bond family household. Benjamin grew up largely in the Bangor/Brewer area of Maine, and graduated from Brewer High School in 1995. He later studied at the University of Maine, Orono and obtained a B.S. degree in Business Administration. In 2009, Benjamin chose to pursue a new career in Nuclear Engineering, and was admitted on a full time basis to North Carolina State University in the summer of 2010. Since then he has had numerous achievements which include obtaining a Nuclear Reactor Operator's License for the PULSTAR reactor, graduating Magna Cum Laude with a B.S. in Nuclear Engineering, and acceptance into the graduate program as part of an accelerated Bachelor-Master's Program (ABM). In unconventional fashion (for those in the ABM), he chose to pursue the M.S. degree (thesis option) in lieu of the M.N.E. degree (non-thesis option), a decision that has proved to be quite challenging yet very rewarding.

Acknowledgements

I would like to extend my thanks to Dr. Robin Gardner for allowing me the opportunity and latitude to work on this topic. It is rare that one can pursue something out of pure intellectual curiosity, but you were able to allow me this experience, so thank you very much. I would also like to thank Dr. John Mattingly; your knowledge and expertise was immensely helpful and I've learned so much from you over this past year. My only regret is not taking more of your classes. Dr. Smith, thank you for taking me on as an advisee on such late notice. I really appreciate your openness and desire to help me achieve this goal.

I would also like to thank the numerous students that played a special role in my work. This honor goes to Mital Zalavadia, Dr. Kyoung Lee, Adan Calderon, and Guojing Hou for their in-depth instruction, late night discussions, hands on help, and moral support.

There are a few professors who made a profound impact on me, and without their help none of this would have been possible. They deserve mentioning and include Dr. Mohammad Bourham, Dr. Hany Abdel-Khalik, Dr. Dmitry Anistratov, Dr. Joseph Doster, Dr. Moody Chu, Dr. Jerome Lavell, Dr. Yara Yingling, and Mr. Scott Lassel. Thank you for everything.

Special thanks to the Rick Lamy and Terry Briggs at the precision instrument machine shop for making the custom laser mounts needed for this experiment.

A big thank you to those at the NC State Craft Center who gave me guidance in my construction of the target, source, and detector holding device; not only was it functional, but it came out quite beautifully for a novice craftsman.

Like all NE students, my relationship with Lisa Marshall is quite special. She has played a huge role in my success that stems all the way back to when I was a prospective student. She can be given credit for single handedly contributing the most to my financial success

by means of my first internship opportunity, access and help in obtaining scholarships, and exclusive access to research opportunities. Beyond that, she has been a staunch supporter of my education and she and Sherry Bailey were the first to make me realize that graduate school was a very real possibility for me.

Thank you to my friends and family for your undying support and encouragement. You make crossing the finish line so much more enjoyable.

Table of Contents

List of Tables.....	viii
List of Figures.....	xii
Motivation and Background.....	1
Theory.....	5
Physical Interactions of X-rays.....	5
Detector Selection and Operation.....	6
Review and Application of Artificial Neural Networks (ANNs).....	9
The Neural Network Algorithm.....	12
Backpropagation using the Levenberg-Marquardt Algorithm.....	16
Review and Application of Partial Least Squares Regression.....	21
The PLS Algorithm.....	21
Simulation Methods and Design.....	26
Experimental Methods and Design.....	31
Experimental Design.....	31
Uncertainty Analysis and Error Quantification.....	39
Uncertainty in the Spectroscopic Data.....	39
Residual Error.....	39
Sensitivity Studies.....	40
Results.....	41
Conclusion.....	57
References.....	58
Appendices.....	63
Appendix A – X-ray Spectroscopic Data (Simulated and Experimental).....	64
Appendix B – ASTM Standards.....	70
Appendix C – LV Study Results on Scaled and Centered Data.....	73
Appendix D – Estimates of Elemental Weight Fractions for Set 1.....	74

Appendix E – ANN Algorithm (in matlab).....	108
Appendix F – PLS Algorithm (in matlab)	115
Appendix G – Sample MCNP File	119
Appendix H – More results.....	125

List of Tables

Table 1 – Select X-ray transition energies (in KeV)	8
Table 2 – Metals used in the simulation	30
Table 3 – Settings for the Experimental Equipment	32
Table 4 – Characteristic Xray and gamma ray emissions for Cd ¹⁰⁹ and Am ²⁴¹	35
Table 5 – Gaussian broadening parameters	36
Table 6 – Metals used in the experiment	37
Table 7 – Performance Table for the Stainless Steel Set of X-ray spectroscopic data	44
Table 8 – PLS Model – LV Study (w/o Scaling or Centering)	46
Table 9 – Mean of Square Error between Model Estimates and Data	48
Table 10 – Selected Results for aluminum 1100 and 7075	49
Table 11 – Selected Results for stainless steel 316	50
Table 12 – Selected Results for stainless steel 434 and 660, using all of the metals as a basis for training	51
Table 13 – Number of elements predicted in the steel samples that were within the range of the ASTM Standard*	53
Table 14 – Fraction of elements predicted in the steel within the range of the ASTM Standard* multiplied by their contribution	54
Table 15 – Fraction of elements predicted in the aluminum within the range of the ASTM Standard* multiplied by their contribution	55
Table 16 – Fraction of elements predicted in the copper based metals within the range of the ASTM Standard* multiplied by their contribution	56
Table 17 – ASTM Standards for Select Types of Copper Based Metals	70
Table 18 – ASTM Standards for Select Types of Copper Based Metals	71
Table 19 – ASTM Standards for Select Types of Aluminum	72
Table 20 – PLS Model - LV Study - Centered and Scaled Data Input	73
Table 21 – Estimate of Set 1 Aluminum Element Weight Fractions (8 Node ANN Model with Set 2 Simulated Data)	74
Table 22 – Estimate of Set 1 Aluminum Element Weight Fractions (8 Node ANN Model with Set 2 Simulated Data*)	75

Table 23 – Estimate of Set 1 Copper Based Metal Element Weight Fractions (4 LV PLS Model with Set 2 Simulated Data)	76
Table 24 – Estimate of Set 1 Copper Based Metal Element Weight Fractions (4 LV PLS Model with Set 2 Simulated Data*)	77
Table 25 – Estimate of Set 1 Stainless Steel Element Weight Fractions (8 Node ANN Model with Set 2 Simulated Data)	78
Table 26 – Estimate of Set 1 Stainless Steel Element Weight Fractions (8 Node ANN Model with Set 2 Simulated Data*)	79
Table 27 – Estimate of Set 1 Element Weight Fractions (for all metals using 8 Node ANN Model with Set 2 Simulated Data).....	80
Table 28 – Estimate of Set 1 Element Weight Fractions (for all metals using 8 Node ANN Model with Set 2 Simulated Data*)	81
Table 29 – Estimate of Set 1 Element Weight Fractions (for all metals using 4 LV PLS Model with Set 2 Simulated Data)	82
Table 30 – Estimate of Set 1 Element Weight Fractions (for all metals using 4 LV PLS Model with Set 2 Simulated Data*)	83
Table 31 – Estimate of Set 2 Aluminum Element Weight Fractions (8 Node ANN Model with Set 1 Simulated Data)	84
Table 32 – Estimate of Set 2 Aluminum Element Weight Fractions (8 Node Model with Set 1 Simulated Data*).....	85
Table 33 – Estimate of Set 2 Aluminum Element Weight Fractions (4 LV PLS Model with Set 1 Simulated Data)	86
Table 34 – Estimate of Set 2 Aluminum Element Weight Fractions (4 LV PLS Model with Set 1 Simulated Data*)	87
Table 35 – Estimate of Set 2 Copper Based Metal Element Weight Fractions (8 Node ANN Model with Set 1 Simulated Data).....	88
Table 36 – Estimate of Set 2 Copper Based Metal Element Weight Fractions (8 Node ANN Model with Set 1 Simulated Data*).....	89
Table 37 – Estimate of Set 2 Copper Based Metal Element Weight Fractions (4 LV PLS Model with Set 1 Simulated Data)	90

Table 38 – Estimate of Set 2 Copper Based Metal Element Weight Fractions (4 LV PLS Model with Set 1 Simulated Data*)	91
Table 39 – Estimate of Set 2 Stainless Steel Element Weight Fractions (8 Node ANN Model with Set 1 Simulated Data)	92
Table 40 – Estimate of Set 2 Stainless Steel Element Weight Fractions (8 Node ANN Model with Set 1 Simulated Data*)	93
Table 41 – Estimate of Set 2 Stainless Steel Element Weight Fractions (4 LV PLS Model with Set 1 Simulated Data)	94
Table 42 – Estimate of Set 2 Stainless Steel Element Weight Fractions (4 LV PLS Model with Set 1 Simulated Data*)	95
Table 49 – Estimate of Set 2 Element Weight Fractions (for all metals using 4 LV PLS Model with Set 1 Simulated Data)	96
Table 50 – Table 49 Continued.....	97
Table 51 – Table 49 Continued.....	98
Table 52 – Estimate of Set 2 Element Weight Fractions (for all metals using 4 LV PLS Model with Set 1 Simulated Data*)	99
Table 53 – Table 52 Continued.....	100
Table 54 – Table 52 Continued.....	101
Table 55 – Estimate of Aluminum Element Weight Fractions (8 Node ANN Model with Experimental Data)	102
Table 56 – Estimate of Aluminum Element Weight Fractions (4 LV PLS Model with Experimental Data)	103
Table 57 – Estimate of Copper Based Metal Element Weight Fractions (8 Node ANN Model with Experimental Data).....	104
Table 58 – Estimate of Copper Based Metal Element Weight Fractions (4 LV PLS Model with Experimental Data).....	104
Table 59 – Estimate of Stainless Steel Element Weight Fractions (8 Node ANN Model with Experimental Data).....	105
Table 60 – Estimate of Stainless Steel Element Weight Fractions (4 LV PLS Model with Experimental Data)	105

Table 61 – Estimate of Element Weight Fractions (for all metals using 8 Node ANN Model with Experimental Data).....106

Table 62 – Estimate of Element Weight Fractions (for all metals using 4 LV PLS Model with Experimental Data).....107

Table 63 - Number of Elements predicted in the aluminum samples that were within the Range of the ASTM Standard*125

Table 64 - Number of Elements predicted in the copper based metal samples that were within the Range of the ASTM Standard*126

List of Figures

Figure 1 – Typical Features seen in a Gamma Spectra of Co-60	3
Figure 2 – Typical Structure of a Feed-Forward Neural Network.....	10
Figure 3 – Structure of Neural Net used in this study and its transformation functions.	11
Figure 4 – X and Y data block structure	12
Figure 5 – Sigmoid function Figure 6 – Error Function	13
Figure 7 – Flow Diagram of the ANN Algorithm.....	20
Figure 8 – MCNP Model of a LEGe Detector, Metal Target, Cd-109 X-ray Source, and Lead Collimator	27
Figure 9 – Russian Roulette Psuedo Code	29
Figure 10 – Block Diagram of the Experimental Setup.....	31
Figure 11 – Perspective view of lead collimator.....	32
Figure 12 – Side view of detector, target, and collimator	33
Figure 13 – View of Experimental setup with lasers mounted	34
Figure 14 – Experimental setup with laser dots aligned on the metal surface	34
Figure 15 – Full view of the experimental apparatus	38
Figure 16 – MCNP Simulated Data	41
Figure 17 – MCNP Simulated Data (Gaussian Broadened).....	42
Figure 18 – Experimental Data with relevant peaks identified.....	43
Figure 19 – Reduction of SS 302 data from 1024 channels to 128 channels.....	45
Figure 20 – MCNP Data for Al-1100, Al-2011, Al-2024, and Al-7075.....	64
Figure 21 – MCNP Data for Al-3003, Al-5052, Al-5086, and Al-5454.....	64
Figure 22 – MCNP Data for Al-6061, Al-6063, Al-6101, and Al-6262.....	65
Figure 23 – Gaussian Broadened MCNP Data for Al-1100, Al-2011, Al-2024, and Al- 7075.....	65
Figure 24 – Gaussian Broadened MCNP Data for Al-3003, Al-5052, Al-5086, and Al- 5454.....	66
Figure 25 – MCNP Data for Al-6061, Al-6063, Al-6101, and Al-6262.....	66
Figure 26 – MCNP Data for C101, C110, C122, C260, C260, C353, C464, C510	67

Figure 27 – Gaussian broadened MCNP Data for C101, C260, C260, C353, C464, and C510	67
Figure 28 – MCNP Data for Stainless Steel 302, 304, 316, 321, and 330	68
Figure 29 – MCNP Data for Stainless Steel 405, 430, 434, and 660	68
Figure 30 – Gaussian broadened MCNP Data for Stainless Steel 302, 304, 316, 321, and 330	69
Figure 31 – Gaussian broadened MCNP Data for Stainless Steel 405, 430, 434, and 660	69

Motivation and Background

The need and for fast and accurate elemental analysis is a problem faced by many different industries. In manufacturing processes, it is very useful to have an inline (or in situ) elemental detection system rather than batch testing. When inline elemental detection systems are integrated with quality controls, adjustments to manufacturing processes can be made in real time and with much less adverse effect on the final product. Many applications can benefit from an inline elemental analysis system, but a couple of examples will illustrate this point. In oil applications, it is important to determine the sodium, chlorine, and sulfur content while the oil is being pumped from the ground. These varying levels will ultimately determine how the oil is refined, what end products it makes, and what markets it is sold to. In coal applications there are rigorous EPA limits on sulfur concentrations that can be burned with coal. An inline system for determining the sulfur content of different veins would allow real-time classification and down mixing of over sulfurized coal tailings. This study looks at processes for real time classification of different metals in recycling applications. Since the 1970s, the amount of scrap metal reprocessed into new steel products has constantly risen [Pflaum]. Scrap metal represents a source of residual materials that may be undesirable in new products. Therefore careful classification of scrap will play an important factor in future manufacturing. The physical description (such as density, color, elasticity, ferrouisity) can often be enough to broadly classify metals in categories such as steel, copper, aluminum, and brass. However, this description is often inadequate for distinguishing between highly similar metals such as stainless steel(SS) 304 and SS 316 which can be important in the re-smelting process because most stainless steels are not allowed to contain molybdenum (per ASTM A240) except for SS 316, which contains 2% – 3%. While there are methods for removing unwanted elements, it is more cost efficient and productive to begin with scrap of the same stock as that of the desired result.

Identifying trace elements is a difficult proposition, and the pursuit can be elusive. There are several different techniques that currently exist such as chemical analysis, direct combustion, and peak analysis (using spectroscopic data) [ASTM E34, ASTM E350,

ASTM E827-08]. The holy grail of element analysis is an in situ process that can provide near instantaneous and reliable results. For this requirement, spectroscopy is really the only method that offers a solution. Generation of spectroscopic data can occur in a multitude of ways, but it essentially works on the fundamental principle that the target materials are irradiated with either photons or particles inducing a nuclear or electron shell reaction. These reactions then emit characteristic photons that can be captured using a detector. Among the most popular methods are Energy Dispersive X-Ray Fluorescence (EDXRF), Neutron Activation Analysis (NAA), Prompt Gamma Neutron Activation Analysis (PGNAA), Laser Induced Breakdown Spectroscopy (LIBS), and Particle Induced X-Ray Emission (PIXE).

With spectra in hand, the next challenge is to decipher the data contained within. In the past most analysis has focused on peak analysis. Peak analysis in its most simple form simply looks for the peaks associated with elements of interest, identifies them, then tries to make an assessment as to their concentration based on the amplitude of these peaks. Peak analysis works well when peaks are well resolved and are not convolved with other features within the spectra. These other spectral features can include other full energy absorption peaks, backscatter peaks, positron annihilation, the Compton edge and continua, and pair production just to name a few. In other words, peak analysis only takes advantage of a small amount of information present in the spectra and ignores a host of other data contained in these other features. The ASTM standards for the aluminum, copper, brass, bronze, and steel samples can be found in “Appendix B – ASTM Standards.”

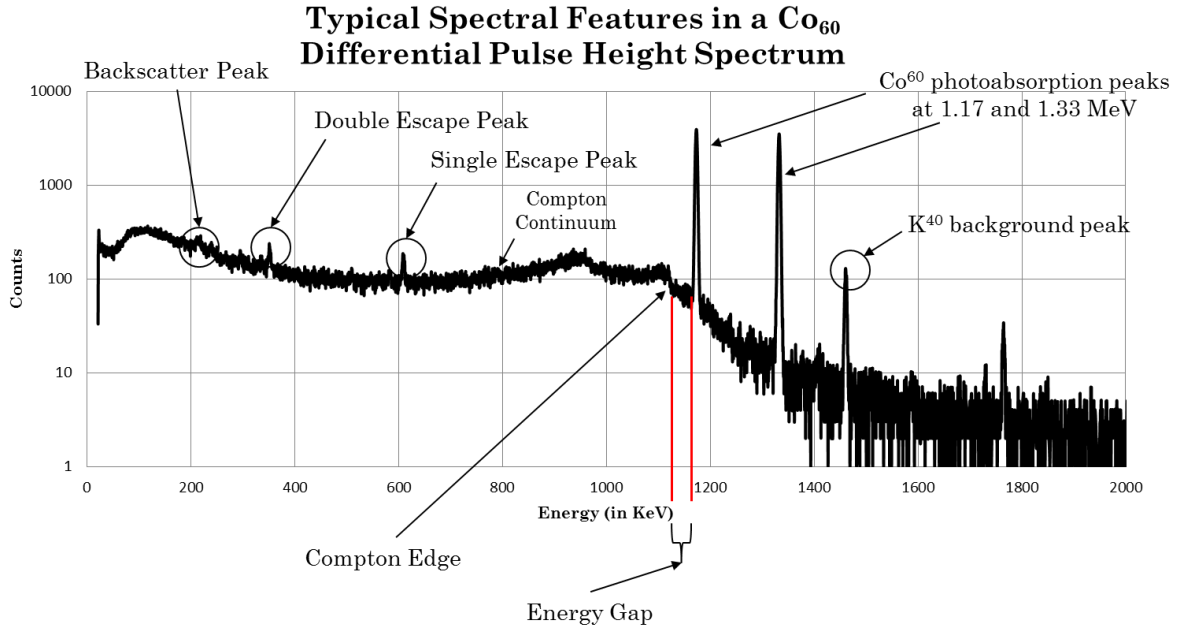

Figure 1 – Typical Features seen in a Gamma Spectra of Co-60

Monte Carlo Library Least Squares (MCLLS) developed by the Center for Engineering Applications of Radioisotopes (CEAR) at NC State offers a method for including all of the spectral information. This method has evolved through several iterations over the years; however, the general approach has always been to use Monte Carlo to generate a response (or spectrum) for each element given a particular source. These libraries are then concatenated into a matrix \mathbf{A} and can used to solve the equation

$$\mathbf{Ax} = \mathbf{y} \tag{1.1}$$

where the vector \mathbf{x} contains the elemental weights, and \mathbf{y} contains the experimental spectra. \mathbf{x} can be found by either using regression by calculating the covariance matrix,

$$\mathbf{A}^T \mathbf{Ax} = \mathbf{A}^T \mathbf{y} \tag{1.2}$$

$$\mathbf{x} = [\mathbf{A}^T \mathbf{A}]^{-1} \mathbf{A}^T \mathbf{y} \tag{1.3}$$

or through a non-linear search techniques to find the elemental weights by minimizing the residuals of $\text{abs}[\hat{\mathbf{y}} - \mathbf{y}]$.

$$\min_{\mathbf{x} \in \mathbb{R}} \left\{ \text{abs} \left[\left(\mathbf{a}_1 x_1 + \mathbf{a}_2 x_2 + \mathbf{a}_3 x_3 + \dots + \mathbf{a}_N x_N \right) - \mathbf{y} \right] \right\} \quad (1.4)$$

There are a couple of challenges one can encounter when using the MCLS method. Those include the covariance matrix $\mathbf{A}^T \mathbf{A}$ being ill-conditioned where there is a high degree of covariance between libraries, generating negative weights for some of the elements, or having large residuals for areas of the spectra that are not well simulated.

The purpose of this work is to look at two additional techniques for analyzing spectroscopic data to overcome some of the issues with the MCLS method. These techniques include Artificial Neural Networks and Partial Least Squares. Both methods present an opportunity to build mathematical models that not only describe the spectroscopic data of the calibrated samples, but will also help predict the properties within new samples. The first method implemented is the Artificial Neural Network (ANN). A Back Propagation Neural Network will be employed that uses the Levenberg-Marquardt algorithm for finding local minima within the solution, with a Levy Flight Random Walk process to handle the global minimization search. The second method is to use Partial Least Squares (PLS), a technique widely used in the field of chemometrics, to rotate the principle components (PCA) of the spectroscopic data such that a linear model can be formed to predict elemental weights.

Theory

Physical Interactions of X-rays

When dealing with thin, dense materials such as aluminum or steel, one of the most appropriate methods for generating spectra is through energy dispersive X-ray fluorescence (EDXRF). X-ray spectroscopy is possible because it leverages the atomic structure of an element. The quantum model of the nucleus suggests that electrons orbit the nucleus in a series of shells (or states). Each shell exists at a discrete energy level and can be described by the principal quantum number (n), the angular momentum quantum number (l); the number of electrons that can exist within each shell and how they are arranged are described by these plus the magnetic quantum number (m_l) and the electron spin quantum number (m_s). In traditional chemistry, this would be equivalent to the $n=1,2,3$, and s, p, d, f orbitals notation seen in introductory chemistry texts (see Chang). Energy can be added to an atom by exciting an electron from one state (or shell) and elevating an electron to a higher energy shell. Atoms will always tend toward their most stable state and will shed excess energy to do so. An excited atom de-excites by emitting an X-ray as an electron drops from an elevated orbital state into a lower one. The energy of that X-ray is dictated by the conservation of energy and the difference between the final and initial energy of the host atom.

$$X^* = X + \gamma \quad (2.1)$$

In X-ray spectroscopy applications, the principal quantum number is replaced by the convention of K, L, M,... radiations or emissions [Markowicz], where K represents the lowest energy state available to an electron. For example, a $K\alpha$ emission is an X-ray that was born as a result of an electron transition from the L to the K level, K being the final state and α meaning from 1 level above. Likewise, an $L\beta$ X-ray is a photon emitted from the N to L transition.

In this paper there will be wide reference to “matrix effects” that occur within an irradiated sample. Essentially this phrase refers to the effect where the intensity for any

given photon (K α of Cr for example) is correlated to the concentrations of all the other materials in the sample. X-ray spectroscopy in particular is unique because the photons from elements of higher atomic number (or Z value) have the propensity for initiating X-rays in lower Z materials [Sherman].

In 1955 Jacob Sherman published a paper that derived theoretical equations to explain the matrix effects seen in two- and three- element mixtures. Due to the complexity of this charge he made a couple simplifications in his analysis. First, he limited the Z values of the materials he was evaluating to 22 – 50 so that only K α emissions would be present. Secondly, he assumed a monodirectional, monochromatic source. Lastly, he neglected tertiary effects (meaning anything beyond the second ionization was ignored). In 1978 Gardner and Doster found through the use of Monte Carlo simulation that ignoring tertiary effects was non-trivial when determining elemental concentrations [Gardner]. Given Sherman's challenges, we can see that derivation of the theoretical yield for complex (anything beyond three elements) mixtures is impractical. Development of Monte Carlo simulation coupled with computational methods poses the best capability to tackle these challenges.

Detector Selection and Operation

Measurement of low energy photons (e.g. below 100KeV) requires that a detector have very little material between the measurement medium (e.g. crystal, gas, etc.) and the source; otherwise, the photons will attenuate in the structural material and never ionize the detection medium. As a result, it is necessary to use a detector that has a thin, low density window between the outer can material and the crystal. For practical purposes, the detector choice is limited to semi-conductor detectors such as low energy germanium detectors (LEGe), silicon lithium drifted detectors (SiLi), and silicon surface barrier detectors.

The detector selected for this experiment is a low energy germanium detector containing a 15mm thick crystal, 45mm in diameter. The crystal was doped with a p-type material

(Ge/B) on the front face $3\mu\text{m}$ in thickness. The side and back walls were doped with an n-type material (Ge/Li) 0.5mm in thickness. The purpose of the doping material is to apply a bias to the crystal. The high voltage (HV) supply applies a reverse bias to the crystal such that the crystal is devoid of electron-hole pairs. When ionizing radiation interacts with the crystal, electron-hole pairs are easily formed within the crystal and are quickly swept to the anode and cathode and the charge is collected. At room temperature the electrons can freely move from the valence to the conductance bands through thermal excitation. This is undesirable since the charge collection process should reflect the ionization of the material from external sources. Semi-conductor materials must be cryogenically cooled to prevent electrons from moving to the conductance band under thermal excitation. A much more detailed discussion of detector physics can be found in referenced texts (see Knoll). Table 1 includes a list of all the X-ray transmissions that are related to this thesis work with their respective energy and relative intensity.

Table 1 – Select X-ray transition energies (in KeV)

Select X-ray Transition Energies (in KeV)																	
Atomic #	Element	K α -1		K α -2		K β (β -1 & β -3)		K β -2		L α -1		L α -2		L β -1		L β -2	
		E(KeV)	I%	E(KeV)	I%	E(KeV)	I%	E(KeV)	I%	E(KeV)	I%	E(KeV)	I%	E(KeV)	I%	E(KeV)	I%
5	B**	0.183	0.11	0.183	0.0560	----	----	----	----	----	----	----	----	----	----	----	----
6	C*	0.277	0.19	0.277	0.0900	----	----	----	----	----	----	----	----	----	----	----	----
7	N*	0.392	0.35	0.392	0.1700	----	----	----	----	----	----	----	----	----	----	----	----
8	O*	0.525	0.55	0.525	0.2800	----	----	----	----	----	----	----	----	----	----	----	----
12	Mg	1.254	2.00	1.254	1.0000	1.302	????	----	----	----	----	----	----	----	----	----	----
13	Al	1.488	2.60	1.487	1.2900	1.558	0.023	----	----	----	----	----	----	----	----	----	----
14	Si	1.741	3.30	1.740	1.2900	1.836	0.084	----	----	----	----	----	----	----	----	----	----
15	P	2.015	4.10	2.013	2.0400	2.141	0.184	----	----	----	----	----	----	----	----	----	----
16	S	2.309	5.00	2.307	2.4900	2.468	0.345	----	----	----	----	----	----	----	----	----	----
22	Ti	4.510	12.80	4.504	6.4000	4.934	2.140	----	----	0.452	0.063	0.456	0.007	0.462	0.050	----	----
23	V	4.952	14.50	4.944	7.3000	5.430	2.480	----	----	0.511	0.120	0.514	0.013	0.522	0.096	----	----
24	Cr	5.414	16.40	5.404	8.3000	5.947	2.780	----	----	0.577	0.190	0.573	0.021	0.583	0.150	----	----
25	Mn	5.898	18.30	5.886	9.3000	6.493	3.230	----	----	0.640	0.260	0.639	0.029	0.651	0.200	----	----
26	Fe	6.403	20.20	6.390	10.2000	7.060	3.630	----	----	0.708	0.410	0.707	0.045	0.721	0.250	----	----
28	Ni	7.478	24.00	7.460	12.2000	8.268	4.360	----	----	0.854	0.500	0.853	0.056	0.871	0.340	----	----
29	Cu	8.048	26.00	8.028	13.3000	8.907	4.690	----	----	0.930	0.600	0.929	0.066	0.949	0.390	----	----
30	Zn	8.639	28.00	8.616	14.3000	9.574	5.130	9.658	0.194	1.012	0.650	1.012	0.072	1.035	0.420	----	----
33	As	10.543	32.70	10.508	16.8000	11.727	6.440	11.866	0.323	1.282	0.870	1.282	0.096	1.317	0.520	----	----
34	Se	11.223	34.10	11.182	17.6000	12.497	6.880	12.655	1.250	1.380	0.980	1.379	0.108	1.420	0.580	----	----
40	Zr	15.775	41.00	15.691	21.4000	17.667	9.320	17.971	1.330	2.043	1.660	2.040	0.190	2.125	0.900	2.219	0.012
41	Nb	16.616	41.80	16.521	21.9000	18.624	9.630	18.956	1.450	2.167	1.800	2.163	0.200	2.257	0.930	2.367	0.056
42	Mo	17.479	42.60	17.374	22.4000	19.607	10.020	19.967	1.880	2.294	1.900	2.290	0.210	2.395	1.000	2.521	0.100
47	Ag	22.163	45.60	21.991	24.2000	24.943	11.420	25.458	1.980	2.985	2.500	2.979	0.280	3.151	1.390	3.348	0.320
48	Cd	23.174	46.10	22.984	24.5000	26.095	11.680	26.644	2.190	3.134	2.600	3.128	0.290	3.317	1.510	3.529	0.380
50	Sn	25.271	45.70	25.044	24.7000	28.486	12.140	29.109	2.280	3.444	2.900	3.436	0.320	3.663	1.750	3.905	0.460
51	Sb	26.359	46.00	26.111	24.9000	29.726	12.290	30.388	2.370	3.605	3.000	3.596	0.340	3.844	1.840	4.101	0.520
52	Te	27.472	46.20	27.202	25.0000	30.996	12.470	31.699	3.910	3.770	3.200	3.760	0.360	4.030	1.960	4.302	0.580
82	Pb	74.970	46.20	72.807	27.7000	84.940	16.280	87.362	3.930	10.551	12.800	10.450	1.440	12.613	8.500	12.623	3.180
83	Bi	77.109	46.20	74.817	27.7000	87.351	16.290	89.849	0.000	10.839	13.200	10.731	1.480	13.023	8.800	12.979	3.280

Sources National Institute of Science and Technology: <http://physics.nist.gov/PhysRefData/XrayTrans/Html/search.html>

Lawrence Berkeley National Laboratory: <http://ie.lbl.gov/atomic/x2.pdf>

Review and Application of Artificial Neural Networks (ANNs)

Artificial Neural Networks (ANNs) are information processing models composed of densely interconnected computational units. They are modeled after highly parallelized biological computing systems such as the brain. These systems are well suited for problems such as pattern recognition, association, classification, and predictive modeling. There are a wide range of neural network models, each specialized to handle a certain set of the problems mentioned above. While this discussion will only focus on one type (the backpropagation network) an exhaustive discussion of artificial networks can be found in many of the referenced texts [Hagan, Freeman, etc.]. For the purposes of analyzing spectroscopic data, a neural network ideally suited for predictive modeling is needed. As in the case of spectroscopy, the goal is to use a spectrum of known data to predict the elemental composition of an unknown material. An overly simplified model would be:

$$\mathbf{f}(\mathbf{x}) = \hat{\mathbf{y}} \quad (3.1)$$

where \mathbf{x} represents a one column vector containing all of the spectroscopic data for one sample, and $\mathbf{f}(\cdot)$ is the set of mathematical operations applied to \mathbf{x} to produce an estimate of the elemental weights which we call $\hat{\mathbf{y}}$. The backpropagation network (BPN) represents one such choice that allows this and will be discussed shortly.

Neural networks represent an ideal way for solving the “elemental analysis” problem for three reasons. The first is their adaptive programming, where processing models are learned by example rather than being pre-programmed (also referred to as supervised learning); this is especially useful when the nature of the problem is not well understood but there is abundant calibration data. The second is the ANN’s ability to model non-linear behavior. The “matrix effects” associated with the elemental analysis problem are by the very nature non-linear, and so it is apt to have a non-linear prediction model. Lastly, if structured properly, ANNs can ignore noise in strepitous environments.

The bases of the neural network (NN) are the individual processing units called nodes. These can be thought of as the biological equivalent to neurons. The metastructure of the

nodes are layers, broken up into three distinct types – the input layer, the hidden layer, and the output layer – with each node interconnected with every other node in the succeeding layer as seen in Figure 2. A BPN can comprise a minimum of three layers, and in this study a three layer neural network is employed. In general, there is no restriction to the number of layers used; however computational costs and over fitting data to noise are considerations to be made when selecting the number of layers.

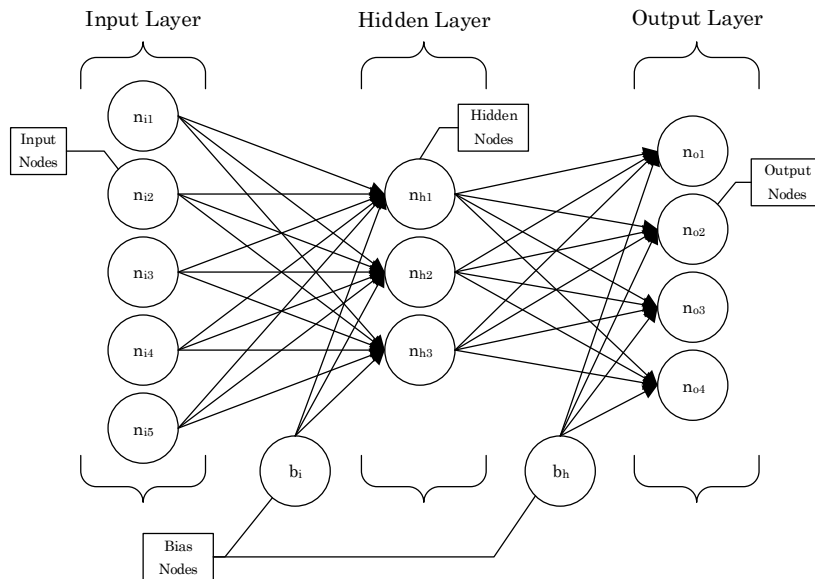

Figure 2 – Typical Structure of a Feed-Forward Neural Network

The interconnection between each node is called a weight and is synonymous with the term “synaptic gap.” The term aptly applies since the weights scale the amount each parent node contributes to the numerical value of each interconnecting child node.

In a simple three-layer feed-forward network, the input data are scaled by the weights and are summed at each node in the hidden layer. In order for the non-linear modelling capability to exist, these values are then normalized by a non-linear function such as the sigmoid or error function. After the hidden nodes take on these new values, they are fed

through a second set of weights and the process is repeated. The only difference is that the transformation function before the output layer is linear.

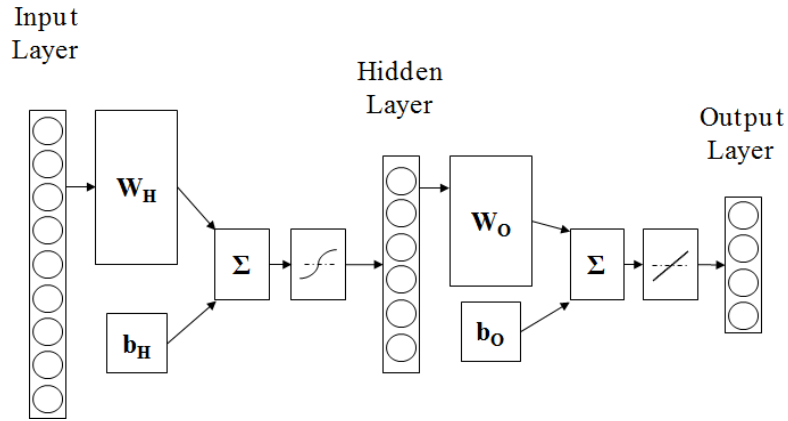

Figure 3 – Structure of Neural Net used in this study and its transformation functions.

A BPN is identical with respect to the feed-forward network approach but supplements it with a correction step. When building the model, the weights necessary for accurate prediction must be determined. Using calibrated data, we can feed X-ray spectra of known compositions into the network and then correct the weights based on the calibrated response that we expect to see. The term *backpropagation* refers to the process of taking the differences (or errors) between the ANN prediction and the true value, and then propagating corrections to the weights, beginning with the weights connected at the output layer, and then updating the next set of upstream weights, repeating the process until arrival at the input layer. Aside from a few rare cases, ANNs are not ideally suited for extrapolation but can handle interpolation quite well [Marsland]. As a result, training data that encompass the full range of possible data sets are required for optimum results.

When generating the network, one of the most important aspects is to determine the appropriate number of hidden nodes. The number of nodes should roughly correspond to the number of inflection points (of interest) present in the spectroscopic data [Hagan].

Too many hidden nodes will mean that the solution will fit itself to the noise contained within the X-ray spectra, which is not desirable.

Since the author developed a specific purpose neural network program for this application, a formal mathematical description of the backpropagation network employed will be presented, along with the update methods and the various enhancements used for optimizing the global search that minimizes the errors between the model and the calibration data. Figure 3 and Figure 4 will serve as the reference for this network.

The Neural Network Algorithm

In an effort to be consistent in notation and treatment of vectors and matrices in both the Neural Network algorithm and the Partial Least Squares (PLS) algorithm, the following convention will apply. All vectors (e.g. \mathbf{x}) will be in bold lowercase font and should be considered single column vectors. All matrices (e.g. \mathbf{X}) will be in bold uppercase font. \mathbf{x} represents the X-ray spectra of a single sample, and \mathbf{y} is a vector containing the elemental weights of that sample. The matrix \mathbf{X} will contain the transposed vectors of \mathbf{x}_i where each row corresponds to the i^{th} sample of a set of N samples and M energy bins. Likewise, the matrix \mathbf{Y} will contain the transposed vectors of \mathbf{y}_i for N samples and L elements as seen in Figure 4.

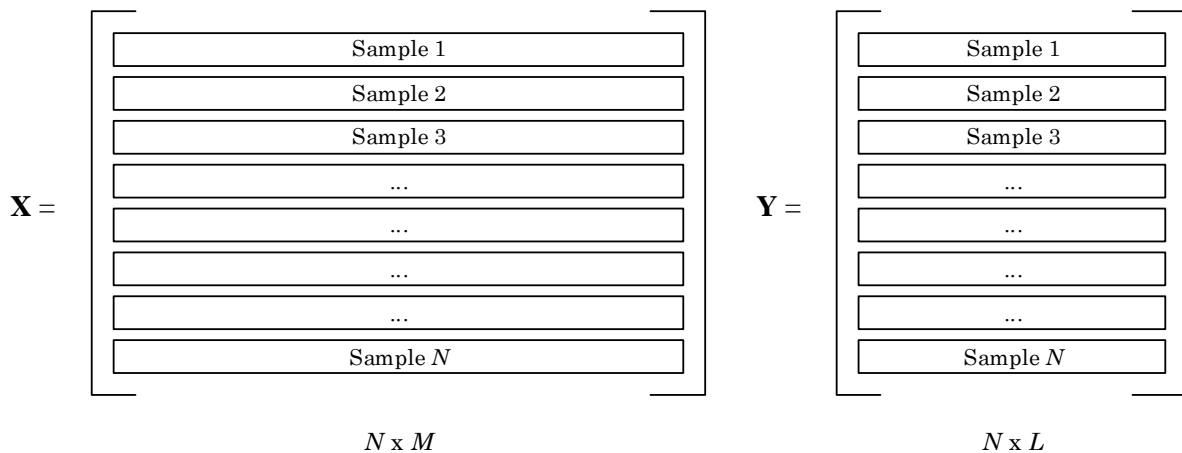

Figure 4 – X and Y data block structure

In general, the samples are handled one at a time in BP Networks where X-ray spectroscopic data is fed to the input layer. The inputs are transformed by a set of weights and a bias node from the input layer to the hidden layer. These weights are initialized as random numbers at the outset of the algorithm.

To simplify the notation we can treat the weights as an $I \times H$ matrix \mathbf{W}_H where I represents the number of input nodes, and H represents the number of hidden nodes. In essence, each row represents the contribution of the i^{th} input node on each hidden node.

At each node in the hidden layer, the weighted contributions from each input node are summed and added to a bias. These weights and bias are called the “hidden weights” and “hidden bias” respectively since they operate from the input to the hidden layer.

$$net_j^h = \sum_{i=1}^I w_{ij} x_i + b_h \quad (3.2)$$

In matrix notation

$$\mathbf{net}^h = \mathbf{W}_H^T \mathbf{x} + b_h \quad (3.3)$$

All sums (\mathbf{net}^h) are then non-linearly transformed using either a Sigmoid function which ranges from 0 to 1 or an Error function which ranges from -1 to 1. For this algorithm, the Sigmoid function was chosen since we would like the weights to keep the same sign during the transformation.

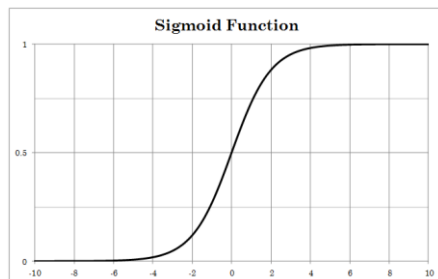

Figure 5 – Sigmoid function

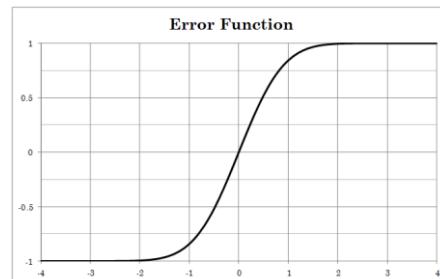

Figure 6 – Error Function

The Sigmoid function is $\frac{1}{1+e^{-x}}$ and is defined as the operator f_j^h , such that at each j^{th} node in the hidden layer, the superposition of weighted inputs is operated on in the following way.

$$f_j^h(\text{net}_j^h) = \frac{1}{1 + \exp(-\text{net}_j^h)} \quad (3.4)$$

The final values taken at the j^{th} node of the hidden layer are then:

$$h_j = f_j(\text{net}_j^h) \quad (3.5)$$

The transformed data now become the input to the output layer. Another array of weights and bias node (“output weights” and “output bias” respectively) facilitates the summation of the hidden nodes into the output nodes.

$$\text{net}_k^o = \sum_{j=1}^H w_{jk} h_j + b_o \quad (3.6)$$

$$\mathbf{net}^o = \mathbf{W}_o^T \mathbf{h} + b_o \quad (3.7)$$

A final transformation takes place at the output layer. Since the non-linearity parameters have already been built in at the hidden layer, there is no need for a second non-linear transformation. We can simply treat f_k^o as a constant multiplier. For simplicity, $f_k^o = 1$. It has been shown that for two layer networks a sigmoid transformation at the hidden layer and linear transformation at the output layer can approximate almost any function [Hornick].

$$f_k(\text{net}_k^o) = 1 \cdot (\text{net}_k^o) \quad (3.8)$$

$$o_k = f_k(\text{net}_k^o) \quad (3.9)$$

Once final values have been calculated at the output layer, the output of the network is compared to the calibrated answers. If the requirements of the performance index have not been met, then the differences are backpropagated through the weights \mathbf{W}_O and then \mathbf{W}_H and a new final answer is calculated.

Choice of performance index is limited to a couple of different options. Most common is the sum of squared errors $SSE = \sum (y - o)^2$, the mean square error $MSE = \frac{1}{N} \sum (y - o)^2$

, and the χ^2 test where $\chi^2 = \sum \frac{(y - o)^2}{y}$, where y is the expected value (calibrated value)

and o is the network's output value. Any other choices are usually variations on these themes. This algorithm uses the SSE as the performance index.

Backpropagation using the Levenberg-Marquardt Algorithm

The Levenberg-Marquardt Algorithm was used to optimize the correction step in our backpropagation. This is a variation of Newton's method which is a second-order method based on the second-order Taylor series where a quadratic approximation is made to $F(\mathbf{x})$ [Hagan]. The notation is where \mathbf{g} is the gradient $[\nabla F(\mathbf{x})]$, and \mathbf{H} is the Hessian of \mathbf{x} $[\nabla^2 F(\mathbf{x})]$.

$$F(\mathbf{w}_{k+1}) = F(\mathbf{w}_k + \Delta\mathbf{w}_k) \simeq F(\mathbf{w}_k) + \mathbf{g}_k^T \Delta\mathbf{w}_k + \frac{1}{2} \Delta\mathbf{w}_k^T \mathbf{H}_k \Delta\mathbf{w}_k \quad (3.10)$$

Find the minimum by setting the derivative of the update equal to zero.

$$\mathbf{g}_k + \mathbf{H}_k \Delta\mathbf{w}_k = 0 \quad (3.11)$$

$$\Delta\mathbf{w}_k = -\mathbf{H}_k^{-1} \mathbf{g}_k \quad (3.12)$$

$$\mathbf{w}_{k+1} = \mathbf{w}_k - \mathbf{H}_k^{-1} \mathbf{g}_k \quad (3.13)$$

Finding and inverting the Hessian matrix can be extremely expensive in computational terms and may not be possible depending on how well conditioned the Hessian matrix is. The Levenberg Marquardt method approximates the Hessian Matrix using the Covariance matrix of the Jacobian (First order derivative).

$$\begin{aligned} \mathbf{H} &= 2\mathbf{J}^T \mathbf{J} + 2\mathbf{S} \\ \mathbf{H} &\simeq 2\mathbf{J}^T \mathbf{J} \end{aligned} \quad (3.14)$$

$$\mathbf{w}_{k+1} = \mathbf{w}_k - \left(2\mathbf{J}^T \mathbf{J}\right)_k^{-1} \mathbf{g}_k \quad (3.15)$$

It may be found that $\mathbf{J}^T \mathbf{J}$ is not invertible as well. To make the approximated Hessian invertible we simply need to make $\mathbf{J}^T \mathbf{J}$ positive definite by adding a symmetric positive definite contribution $\mu \mathbf{I}$. We know this works because if we assume that the eigenvalues and eigenvectors of \mathbf{H} are $\{\lambda_1, \lambda_2, \lambda_3, \dots, \lambda_n\}$ and $\{\mathbf{z}_1, \mathbf{z}_2, \mathbf{z}_3, \dots, \mathbf{z}_n\}$ respectively, then

$$\mathbf{G} = \mathbf{H} + \mu \mathbf{I} \quad (3.16)$$

$$\mathbf{G}\mathbf{z}_i = [\mathbf{H} + \mu \mathbf{I}]\mathbf{z}_i = \mathbf{H}\mathbf{z}_i + \mu \mathbf{z}_i = \lambda \mathbf{z}_i + \mu \mathbf{z}_i = (\lambda_i + \mu) \mathbf{z}_i \quad (3.17)$$

Thus the eigenvectors of \mathbf{G} remain the same with only the magnitude of the eigenvalues changing.

$$\mathbf{w}_{k+1} = \mathbf{w}_k - \left[2(\mathbf{J}^T \mathbf{J} + \mu \mathbf{I}) \right]_k^{-1} \mathbf{g}_k \quad (3.18)$$

If we choose the performance index to be the sum of squares, then:

$$F(\mathbf{w}) = \sum_{i=1}^N e_i^2 = \mathbf{e}^T \mathbf{e} \quad (3.19)$$

Where $e_i = y_i - o_i$ then the gradient is:

$$\mathbf{g}_k = \nabla F(\mathbf{w})_j = 2 \sum_{i=1}^N e_i \cdot \frac{\partial e_i}{\partial w_j} = 2 \mathbf{J}^T \mathbf{e} \quad (3.20)$$

The Jacobian represents the first order derivative of the error with respect to the weights.

$$\mathbf{J}_s = \begin{bmatrix} \frac{\partial e_1}{\partial w_{o,1,1}} & \dots & \frac{\partial e_1}{\partial w_{o,H,O}} & \frac{\partial e_1}{\partial w_{h,1,1}} & \dots & \frac{\partial e_1}{\partial w_{h,I,H}} & \frac{\partial e_1}{\partial b_o} & \frac{\partial e_1}{\partial b_h} \\ \frac{\partial e_2}{\partial w_{o,1,1}} & \dots & \frac{\partial e_2}{\partial w_{o,H,O}} & \frac{\partial e_2}{\partial w_{h,1,1}} & \dots & \frac{\partial e_2}{\partial w_{h,I,H}} & \frac{\partial e_2}{\partial b_o} & \frac{\partial e_2}{\partial b_h} \\ \vdots & & \vdots & \vdots & & \vdots & \vdots & \vdots \\ \frac{\partial e_O}{\partial w_{o,1,1}} & \dots & \frac{\partial e_O}{\partial w_{o,H,O}} & \frac{\partial e_O}{\partial w_{h,1,1}} & \dots & \frac{\partial e_O}{\partial w_{h,I,H}} & \frac{\partial e_O}{\partial b_o} & \frac{\partial e_O}{\partial b_h} \end{bmatrix} \quad (3.21)$$

To evaluate the SSE across all samples at the same time, the Jacobian becomes the concatenation of all the Jacobian matrices of each sample.

$$\mathbf{J} = \begin{bmatrix} \mathbf{J}_1 \\ \mathbf{J}_2 \\ \vdots \\ \mathbf{J}_s \end{bmatrix} \quad (3.22)$$

To find the elements of the Jacobian, the chain rule differentiates the hidden layer weights, the output layer weights, and both bias nodes.

$$e_k = y_k - o_k \quad (3.23)$$

The derivative of the error with respect to the output weights is

$$-\frac{\partial e_k}{\partial w_{jk}^o} = -\frac{\partial o_k}{\partial (net_k^o)} \frac{\partial (net_k^o)}{\partial w_{jk}^o} \quad (3.24)$$

Where the partial derivatives for the output weights are simply:

$$\frac{\partial o_k}{\partial (net_k^o)} = 1 \quad (3.25)$$

$$\frac{\partial (net_k^o)}{\partial w_{jk}^o} = \frac{\partial}{\partial w_{jk}^o} \sum_{j=1}^H w_{jk}^o h_j = h_j \quad (3.26)$$

The derivative of the error with respect to the output bias is

$$-\frac{\partial e_k}{\partial b^o} = -\frac{\partial o_k}{\partial (net_k^o)} \frac{\partial (net_k^o)}{\partial b^o} \quad (3.27)$$

$$\frac{\partial (net_k^o)}{\partial b^o} = -1 \quad (3.28)$$

$$-\frac{\partial e_k}{\partial b^o} = 1 \quad (3.29)$$

Since there is no correction data available for the hidden layer values, we must backpropagate the errors contained in the output layer to the hidden layer weights using the chain rule.

$$-\frac{\partial e_k}{\partial w_{ij}^h} = -\frac{\partial o_k}{\partial (net_k^o)} \frac{\partial (net_k^o)}{\partial h_j} \frac{\partial h_j}{\partial (net_j^h)} \frac{\partial (net_j^h)}{\partial w_{ij}^h} \quad (3.30)$$

$$\frac{\partial o_k}{\partial (net_k^o)} = 1 \quad (3.31)$$

$$\frac{\partial (net_k^o)}{\partial h_j} = w_{ij}^h \quad (3.32)$$

$$\frac{\partial h_j}{\partial(\text{net}_j^h)} = \frac{-\exp(-\text{net}_j^h)}{(1 + \exp(-\text{net}_j^h))^2} \quad (3.33)$$

$$\frac{\partial(\text{net}_j^h)}{\partial w_{ij}^h} = \frac{\partial}{\partial w_{ij}^h} \sum_{i=1}^I w_{ij}^h x_i = x_i \quad (3.34)$$

$$-\frac{\partial e_k}{\partial w_{ij}^h} = -w_{jk}^o \frac{-\exp(-\text{net}_j^h)}{(1 + \exp(-\text{net}_j^h))^2} x_i \quad (3.35)$$

Repeating the same steps above for the hidden bias, the final partial derivative is

$$-\frac{\partial e_k}{\partial b^h} = \sum_{j=1}^H w_{jk}^o \cdot \frac{-\exp(-\text{net}_j^h)}{(1 + \exp(-\text{net}_j^h))^2} \quad (3.36)$$

The update method can now be generalized to the following: If all of the weights and biases from every layer are arranged into one column array \mathbf{w} , then

$$\mathbf{w}_{k+1} = \mathbf{w}_k - \left[(\mathbf{J}^T \mathbf{J} + \mu \mathbf{I}) \right]_k^{-1} \mathbf{J}^T \mathbf{e} \quad (3.37)$$

The power in the Levenberg Marquardt method is in the selection of μ . When μ is large the update procedure is slow, so if the corrections implemented reduce the SSE, then we would like to scale μ down so that that it will reach the minimum faster. An arbitrary constant can be used, but a common selection is $c = 10$, where $\mu = \mu/c$. However, if the selection of μ results in an increase in the SSE, then it means the step size is too large and μ should be increased $\mu = c \cdot \mu$.

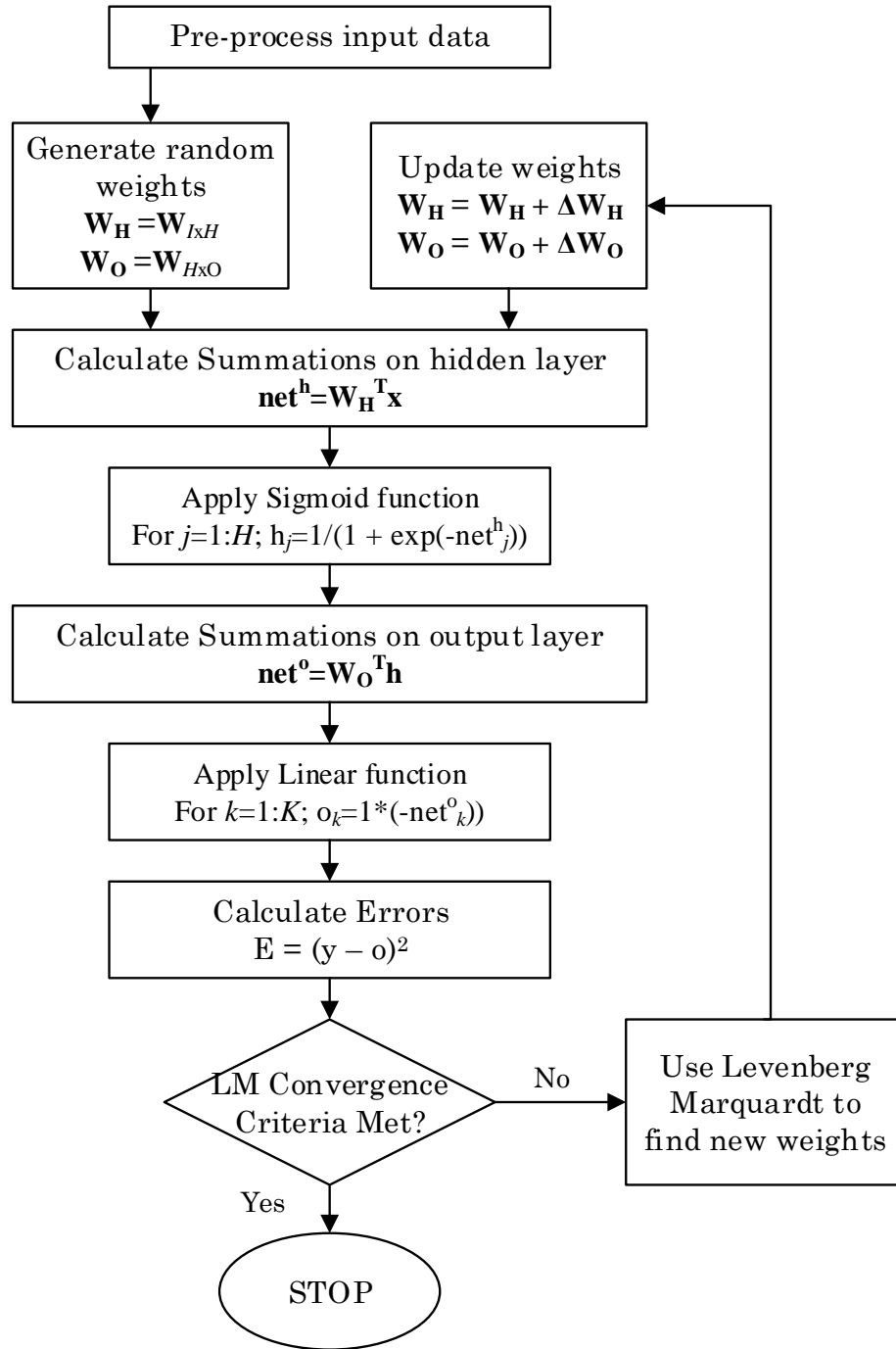

Figure 7 – Flow Diagram of the ANN Algorithm

Review and Application of Partial Least Squares Regression

Partial Least Squares (PLS) is a linear regression technique developed by H. Wold in the 1960s. It is used to maximize the correlation between the explanatory variables in one data set and the response variables in another data set. In model building, it is often helpful to functionalize explanatory variables so that the response variables can be predicted.

$$\mathbf{Y} = \mathbf{f}(\mathbf{X}) \quad (4.1)$$

In PLS Regression, \mathbf{X} and \mathbf{Y} can be considered the composition of two matrices where the decompositions are a set of orthogonal factors $\mathbf{X} = \mathbf{TP}^T + \mathbf{R}_X$ and $\mathbf{Y} = \mathbf{UQ}^T + \mathbf{R}_Y$, where \mathbf{T} and \mathbf{U} are the scores, \mathbf{P} and \mathbf{Q} the loadings, and \mathbf{R}_X and \mathbf{R}_Y the residuals. Principal Component Analysis (PCA), a forbearer to PLS, uses the latent structure of these matrices to find a set of scores and loadings that best describes the variation in the \mathbf{X} and \mathbf{Y} data blocks. PLS differs only in the sense in that it also seeks regression coefficients (the diagonal entries of \mathbf{B}) such that the combination of scores, loadings, and regression coefficients best use the variation in \mathbf{X} to explain the variation in \mathbf{Y} [Bro].

In gamma ray and X-ray spectroscopy, this method can be leveraged as long as there are an adequate number of verifiable samples. With known \mathbf{X} and \mathbf{Y} data blocks, the scores, loadings, and regression coefficients can be generated and then used to predict the response variables from new samples. Equation 4.1 can be reformulated to project the scores of \mathbf{X} onto the loadings of \mathbf{Y} through a set of regression coefficients \mathbf{B} .

$$\hat{\mathbf{Y}} = \mathbf{TBQ}^T \quad (4.2)$$

Where $\hat{\mathbf{Y}}$ is an estimate of \mathbf{Y} .

The PLS Algorithm

In this description of the PLS Algorithm, it will be implied that the row vectors of \mathbf{X} and \mathbf{Y} will represent each individual sample. The column vectors in \mathbf{X} will correspond to a predictor variable (i.e. channel number or energy). The column vectors in \mathbf{Y} are the response variables and represent the different possible elements in each sample.

We begin by scaling and centering the \mathbf{X} and \mathbf{Y} data blocks by converting each matrix element into a Z-score. The purpose of this is to allow data with different magnitudes and units to be put on equal footing. Each column vector contains all the values for one variable; therefore, the mean and standard deviation are calculated for each. Hence the variations in the elements of \mathbf{X} and \mathbf{Y} are normalized and converted into units of per standard deviation. To avoid confusion, we define the matrices \mathbf{E} and \mathbf{F} as the scaled and centered data of \mathbf{X} and \mathbf{Y} .

$$x_{ij} = \frac{x_{ij} - \mu_j}{\sigma_j} \quad (4.3)$$

$$y_{ik} = \frac{y_{ik} - \mu_k}{\sigma_k} \quad (4.4)$$

$$\begin{aligned} \mathbf{E} &= \mathbf{X}_{\text{Scaled_ \& _Centered}} \\ \mathbf{F} &= \mathbf{Y}_{\text{Scaled_ \& _Centered}} \end{aligned} \quad (4.5)$$

To decompose \mathbf{E} to \mathbf{F} into its respective scores and loadings, an iterative approach is used to determine the vectors for \mathbf{T} , \mathbf{P} , \mathbf{U} , and \mathbf{Q} one component at a time. (Note the terms component and latent variable are used interchangeably). If the number of components chosen is equal to the rank of \mathbf{X} , then all of the variation of \mathbf{X} is explained in the component scores (Bro). This is often undesirable, since \mathbf{X} often contains noise that limits the full utilization of \mathbf{X} from being the best predictor. An optimization method for choosing the right number of components will be discussed later, but is an important part of the PLS model. For the first iteration of each component, the vector \mathbf{u} is populated with random numbers.

$$\mathbf{w} = \frac{\mathbf{E}^T \mathbf{u}}{\|\mathbf{E}^T \mathbf{u}\|_2} \quad (4.6)$$

$$\mathbf{t} = \frac{\mathbf{E} \mathbf{w}}{\|\mathbf{E} \mathbf{w}\|_2} \quad (4.7)$$

$$\mathbf{q} = \frac{\mathbf{F}\mathbf{t}}{\|\mathbf{F}\mathbf{t}\|_2} \quad (4.8)$$

$$\mathbf{u} = \mathbf{F}\mathbf{q} \quad (4.9)$$

Perform the above iteration until \mathbf{t} converges to the desired convergence criteria. The vector \mathbf{p} and regression coefficient b are then calculated so that the contribution of a particular component can be deducted from the \mathbf{E} and \mathbf{F} matrices.

$$\mathbf{p} = \frac{\mathbf{E}^T\mathbf{t}}{\|\mathbf{t}\|_2} \quad (4.10)$$

$$b = \frac{\mathbf{t}^T\mathbf{u}}{\|\mathbf{t}^T\mathbf{t}\|_2} = \mathbf{t}^T\mathbf{u} \quad (4.11)$$

$$\mathbf{E} = \mathbf{E} - \mathbf{t}\mathbf{p}^T \quad (4.12)$$

$$\mathbf{F} = \mathbf{F} - b\mathbf{t}\mathbf{q}^T \quad (4.13)$$

To determine how much a particular component explains \mathbf{X} and \mathbf{Y} , the following relations can be used, where SS_E and SS_F denote the sum of squares for \mathbf{E} and \mathbf{F} respectively, and LV_E and LV_F represent the amount each Latent Variable explains \mathbf{E} and \mathbf{F} respectively.

$$LV_E = \frac{\mathbf{p}^T\mathbf{p}}{SS_E} \quad (4.14)$$

$$LV_F = \frac{b^2}{SS_F}$$

$$SS_E = \sum (e_{ij} - \bar{e})^2 = \sum (e_{ij})^2$$

$$SS_F = \sum (f_{ik} - \bar{f})^2 = \sum (f_{ik})^2 \quad (4.15)$$

As components are generated, they will always explain a decreasing amount of the parent matrices. The vectors \mathbf{t} , \mathbf{u} , \mathbf{w} , \mathbf{q} , and \mathbf{p} are stored as the column vectors of \mathbf{T} , \mathbf{U} , \mathbf{W} , \mathbf{Q} , and \mathbf{P} respectively during the component generation process. The values of b are stored

as the diagonal entries of \mathbf{B} . This process is repeated until \mathbf{E} and \mathbf{F} are nearly equivalent to the **NULL** matrix.

Using equation 4.16, the optimum number of components for the model is where the residuals between \mathbf{F} and $\hat{\mathbf{F}}$ are minimized.

$$\hat{\mathbf{F}} = \mathbf{TBQ}^T \quad (4.16)$$

$$LV_{optimum} = \min \left\{ \text{abs} \left[\mathbf{F} - \hat{\mathbf{F}}_i \right] \right\} \quad (4.17)$$

For convenience when evaluating unknown data sets, the t scores and weighting factors call be lumped into one term.

$$\hat{\mathbf{F}}_{\text{Unk}} = \mathbf{E}_{\text{Unk}} \mathbf{B}_{\text{PLS}} \quad (4.18)$$

$$\mathbf{B}_{\text{PLS}} = \mathbf{P}^\dagger \mathbf{BQ}^T \quad (4.19)$$

Where \mathbf{P}^\dagger is the Penrose Moore inverse of \mathbf{P} .

Keep in mind that $\mathbf{E} = e_{ij} = \frac{x_{ij} - \mu_j}{\sigma_j}$ which means that the results of $\hat{\mathbf{F}}$ are not direct

evaluations of $\hat{\mathbf{Y}}$. To functionalize \mathbf{B}_{PLS} into terms of \mathbf{X}_{Cal} and \mathbf{Y}_{Cal} , a multiple linear regression (MLR) must be completed on each vector in $\hat{\mathbf{Y}}_{\text{Cal}}$. Completion of the PLS Algorithm determines the optimal number of latent variables that explains the \mathbf{X} and \mathbf{Y} data. Assuming that the optimum number of latent variables is L, the multivariate regression that occurs can be expressed as:

$$\hat{\mathbf{y}}_i = a_i + b_i \mathbf{v}_1 + c_i \mathbf{v}_2 + \dots + m_i \mathbf{v}_L \quad (4.20)$$

$$\mathbf{v}_j = \mathbf{x}_j \mathbf{B}_{\text{PLS}} \quad (4.21)$$

The goal is now to find the set of coefficients $[a_i \dots l_i]$ such that $(y_i - \hat{y}_i)^2$ is minimized. To do this M normal equations are generated. To generate these equations the following method is used.

The first normal equation is:

$$\sum_{j=1}^n y_{jk} = an + b \sum_{j=1}^n x_{j1} + c \sum_{j=1}^n x_{j2} + \dots + m \sum_{j=1}^n x_{jL} \quad (4.22)$$

The second normal equation is:

$$\sum_{j=1}^n x_{j1} \cdot y_{jk} = a \sum_{j=1}^n x_{j1} + b \sum_{j=1}^n x_{j1} \cdot x_{j1} + c \sum_{j=1}^n x_{j1} \cdot x_{j2} + \dots + m \sum_{j=1}^n x_{j1} \cdot x_{jL} \quad (4.23)$$

The third normal equation is:

$$\sum_{j=1}^n x_{j2} \cdot y_{jk} = a \sum_{j=1}^n x_{j2} + b \sum_{j=1}^n x_{j2} \cdot x_{j1} + c \sum_{j=1}^n x_{j2} \cdot x_{j2} + \dots + m \sum_{j=1}^n x_{j2} \cdot x_{jL} \quad (4.24)$$

This pattern is repeated through to the Mth normal equation:

$$\sum_{j=1}^n x_{jL} \cdot y_{jk} = a \sum_{j=1}^n x_{jL} + b \sum_{j=1}^n x_{jL} \cdot x_{j1} + c \sum_{j=1}^n x_{jL} \cdot x_{j2} + \dots + m \sum_{j=1}^n x_{jL} \cdot x_{jL} \quad (4.25)$$

With M equations in hand, we can solve for the coefficients $[a..m]$. Arranging the coefficients $[b..m]$ into an N by L matrix \mathbf{B}_{SCL} (where N is the number of samples), the $\hat{\mathbf{Y}}$ estimate can be directly solved for:

$$\hat{\mathbf{Y}} = \mathbf{X}\mathbf{B}_{\text{PLS_NEW}} + \mathbf{A} \quad (4.26)$$

$$\mathbf{B}_{\text{PLS_NEW}} = \mathbf{B}_{\text{PLS}}\mathbf{B}_{\text{MLR}} \quad (4.27)$$

$$\mathbf{A}_{\text{N} \times \text{L}} = \begin{pmatrix} a_1 & \dots & a_L \\ a_1 & \dots & a_L \\ a_1 & \dots & a_L \end{pmatrix} \quad (4.28)$$

Simulation Methods and Design

To supplement the experimental data, simulated X-ray spectra were generated using the Monte Carlo Method. The Monte Carlo approach simulates the random walk of a particle by sampling the probability density functions (PDF) for each phase space the particle enters. Since photon transport and its interactions with matter is viewed as a stochastic process, it follows that this sampling method is well suited for this application.

MCNP 5, a General Purpose Monte Carlo Neutron Transport Code developed by the Los Alamos National Laboratory with origins going back to the Manhattan Project, was the code chosen to generate the spectra. MCNP itself is considered one of the gold standards in general purpose Monte Carlo (Along with Geant4 and others). The version MCNP 5 was observed to have significantly better figures of merit over MCNP 6, hence that was the software chosen.

MCNP 5 uses two different types of treatments for photon physics and can be specified by the user. The simple physics model accounts for incoherent (Compton) scattering, photoelectric absorption, and pair production and is well suited for higher energy physics problems. The detailed physics model additionally includes coherent (Thomson) scattering, fluorescent photon emission, auger electron transport, plus bremsstrahlung. Detailed mathematical descriptions of these transport processes can be found in the *MCNP User Manual Vol I*. The detailed physics model was chosen for fluorescent emission and auger electron physics which is critical for this particular application. Figure 8 shows the geometry of the simulated experiment using the geometry visualizer VISED.

The power of the Monte Carlo method lies within the variance reduction techniques that can be brought to bear to preferentially sample interactions that will contribute to the parameter of interest. For instance, a large amount of time can be spent tracking particles that will never contribute to the energy deposited in the detector.

For this particular simulation, the probability of an X-ray being emitted towards the target, hitting the material, resulting in a new photon directed towards the detector and ultimately being absorbed was relatively small. For this reason a number of variance reduction techniques had to be employed in order to obtain statistically viable results. These variance reduction techniques include: direction biasing, collision forcing (aka implicit capture), particle splitting, and weight cutoff limits with Russian roulette.

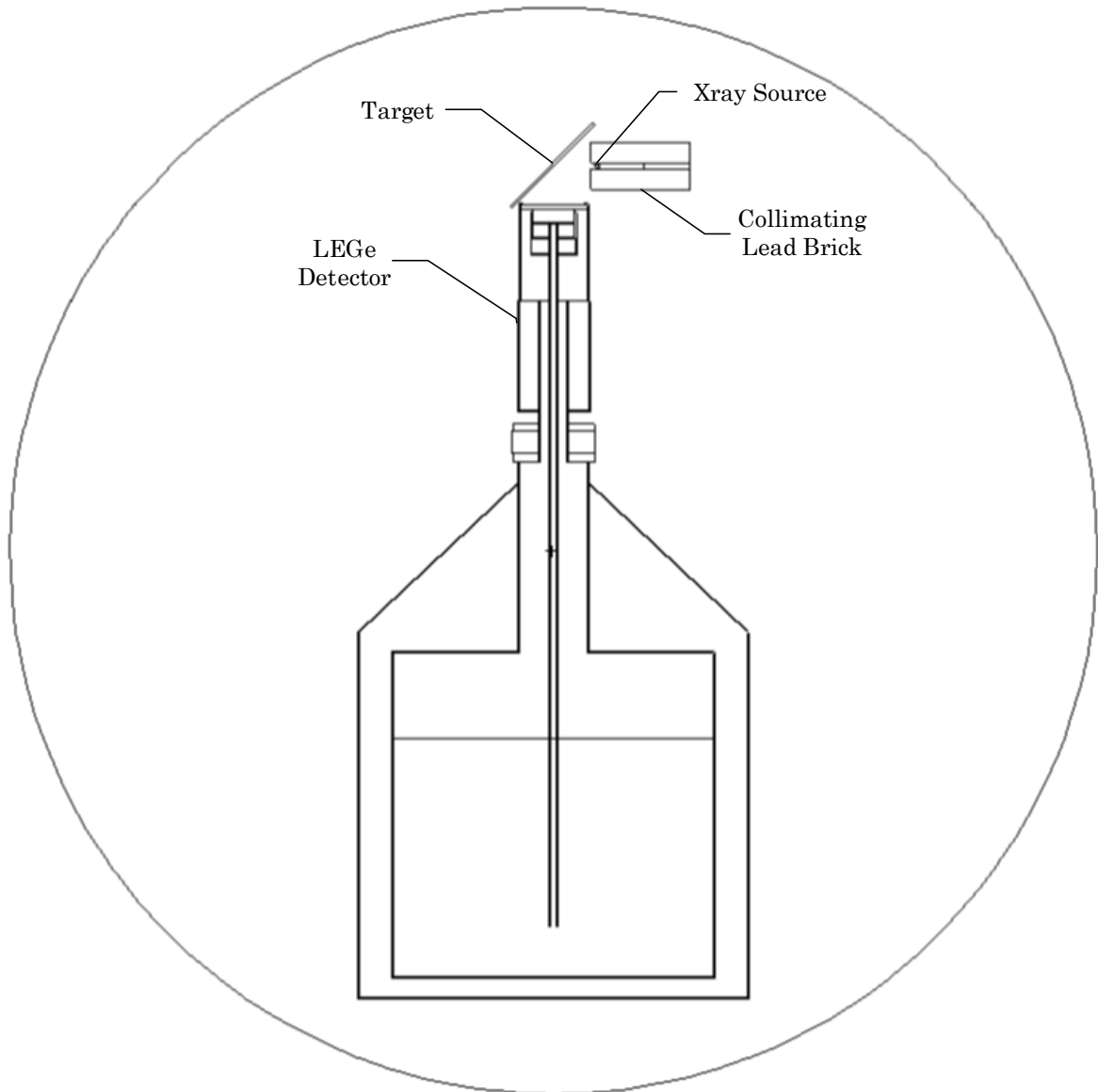

Figure 8 – MCNP Model of a LEGe Detector, Metal Target, Cd-109 X-ray Source, and Lead Collimator

To demonstrate how this works, the initial particle is emitted from a 60° cone that lies centered on the x axis and directed towards the target. The base weight is updated with the probability that an isotropic source would have emitted a photon in this direction in the first place which is equal to the fraction of the solid angle over the unit sphere or $w = \frac{\Omega}{4\pi}$. If the photon passes the surface of the target, a collision is forced and is sampled from the PDF given in equation 5.1

$$1 - \exp(-\Sigma_t d) \quad (5.1)$$

The distance a particle travels before interacting can be directly sampled from a uniform distribution by integrating equation 5.1 and normalizing it:

$$x = \frac{1}{\Sigma_t} \cdot \ln(1 - \varphi(1 - \exp(-\Sigma_t d))) \quad (5.2)$$

where x is the distance traveled into the material, Σ_t is the total cross section, d is the cord length of the material along the vector of travel, and where φ is a uniformly distributed random number on the range $[0,1)$. The base weight is subsequently updated to $w = w \cdot (1 - \exp(-\Sigma_t d))$.

If any subsequent particles resulting from this interaction are directed towards the detector face, then the information yield from that particle is maximized by splitting it as it crosses the crystal surface. The base weight for each split photon becomes $w = w/n$ where n is the number of split particles. Collision forcing is applied again inside the detector to take full advantage of particles that have arrived at the detector. In Monte Carlo simulation, a good deal of time is spent tracking particles that will never make it to the detector and never contribute statistically to the answer. A wise choice of cutoff parameters can be used to kill particles that fit this description. The cutoff limits can be based on energy and/or weight. A weight cutoff was used to kill particles with a weight below 0.0001; this would allow for all of the weight adjustments used in the variance

reduction techniques described above, and still allow final particles to be counted towards the tally. Any further weight reduction would suggest that the particle was on a track not likely to enter the detector. After the weight cutoff limit is reached, Russian roulette is performed in such a way that the mean of each tally is preserved. Russian roulette can be summed up in this simple algorithm

```
If  $w_{\text{Base}} < w_{\text{Limit}}$ 
   $\phi \leftarrow \text{rand}[0,1)$ 
  If  $\phi < w_{\text{Limit}}$  then
     $w_{\text{Base}} := w_{\text{Limit}}$ 
  Else
    Particle is killed
  End
End
```

Figure 9 – Russian Roulette Pseudo Code

Table 2 – Metals used in the simulation

Metal Samples used in Simulation	
Material	ASTM Standard
Aluminum	1100
	2024
	3003
	5086
	5454
	6061
	6063
	6101
	7075
Steel	302
	304
	316
	321
	405
	430
	434
	660
Copper/Brass/ Bronze	C101
	C110
	C122
	C260
	C353
	C464
	C510

Experimental Methods and Design

Experimental Design

An experiment was developed to test the ANN and PLS methods using experimental data rather than simulated data. Figure 10 shows a block diagram of the experimental set up, which includes the following pieces of equipment:

Equipment:

1. Various Al, SS, and Cu Metal Samples
2. Low Energy Germanium Detector (LEGe) - Canberra GL1515R with:
 - a. Built in pre-amplifier (Canberra 2002CPSL)
 - b. Cryostat Configuration 7500SL
 - c. Dewar Model DWR-30
3. HV Supply (Ortec 459)
4. Amplifier (Canberra 2026)
5. Oscilloscope (Tektronix TDS 2012)
6. 750 μCi Cd^{109} Source
7. ORTEC Easy-MCA-8K
8. Sample/Source holder
9. Lead Collimator

Data Collection Software:

1. ORTEC GammaVision-32 v7.01

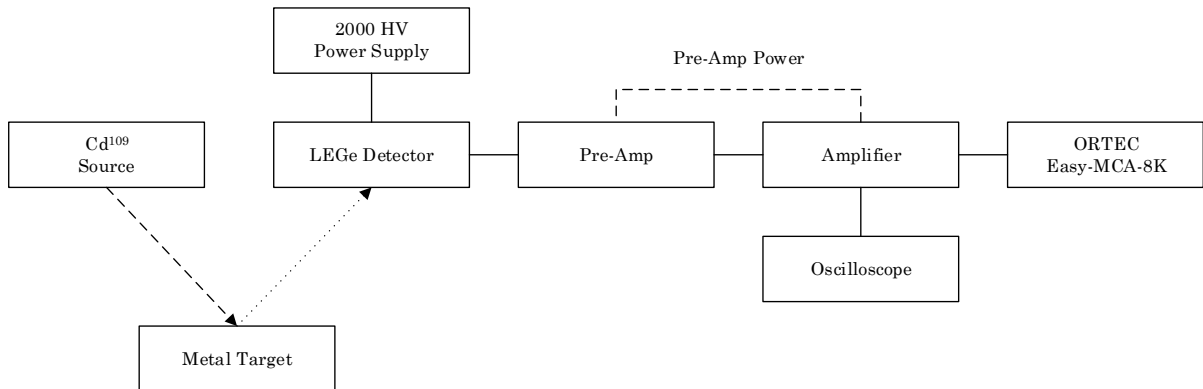

Figure 10 – Block Diagram of the Experimental Setup

Table 3 – Settings for the Experimental Equipment

Power Supply	Amplifier Settings		
	Voltage	Gain	Shaping Time
-2000V	100 X .5	6 μ s	Uni-Polar

Each sample is laid on the wooden frame at a 45° angle above the LEGe Detector. On the opposing side of the frame, a collimated Cd109 source is used to irradiate the sample as seen in Figure 11 and Figure 12.

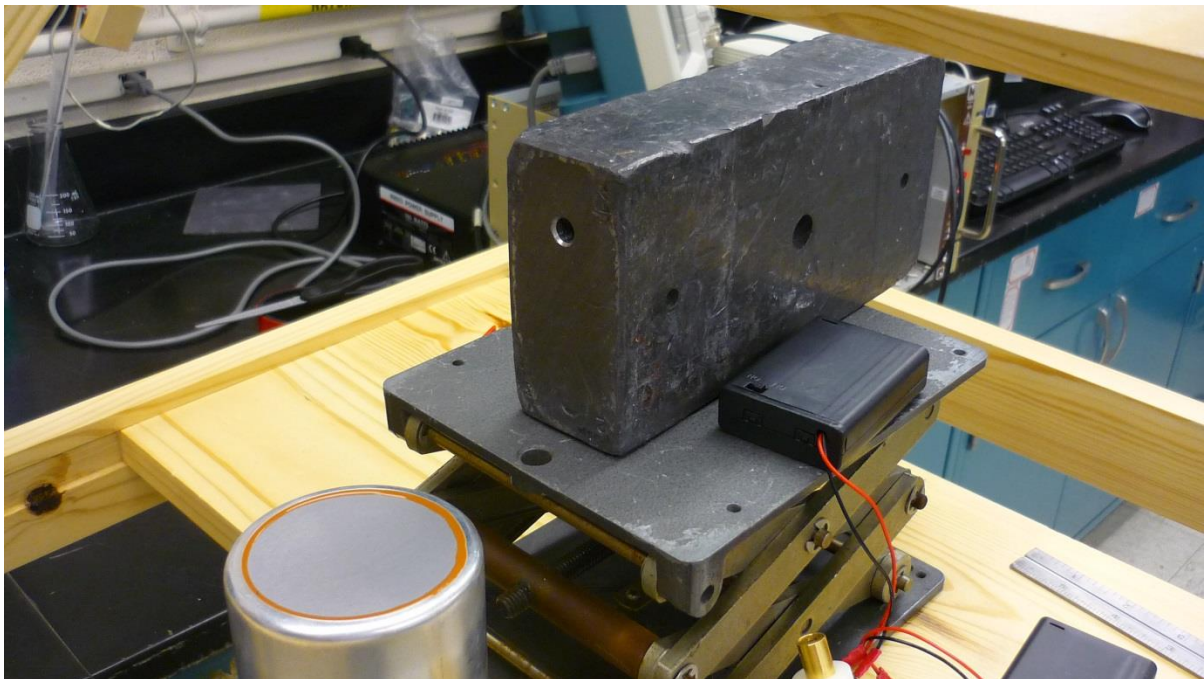

Figure 11 – Perspective view of lead collimator

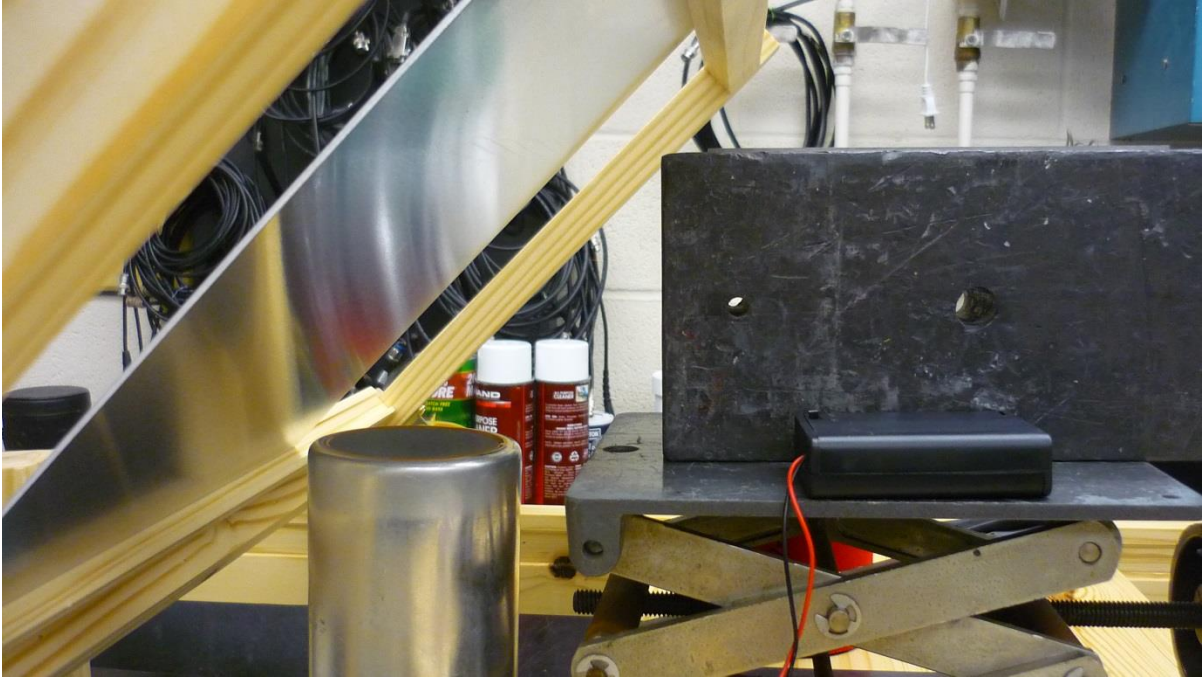

Figure 12 – Side view of detector, target, and collimator

To ensure the optimum placement, lasers are mounted to the collimator and detector face and aligned so that they intersect at the target's surface as seen in Figure 13 and Figure 14.

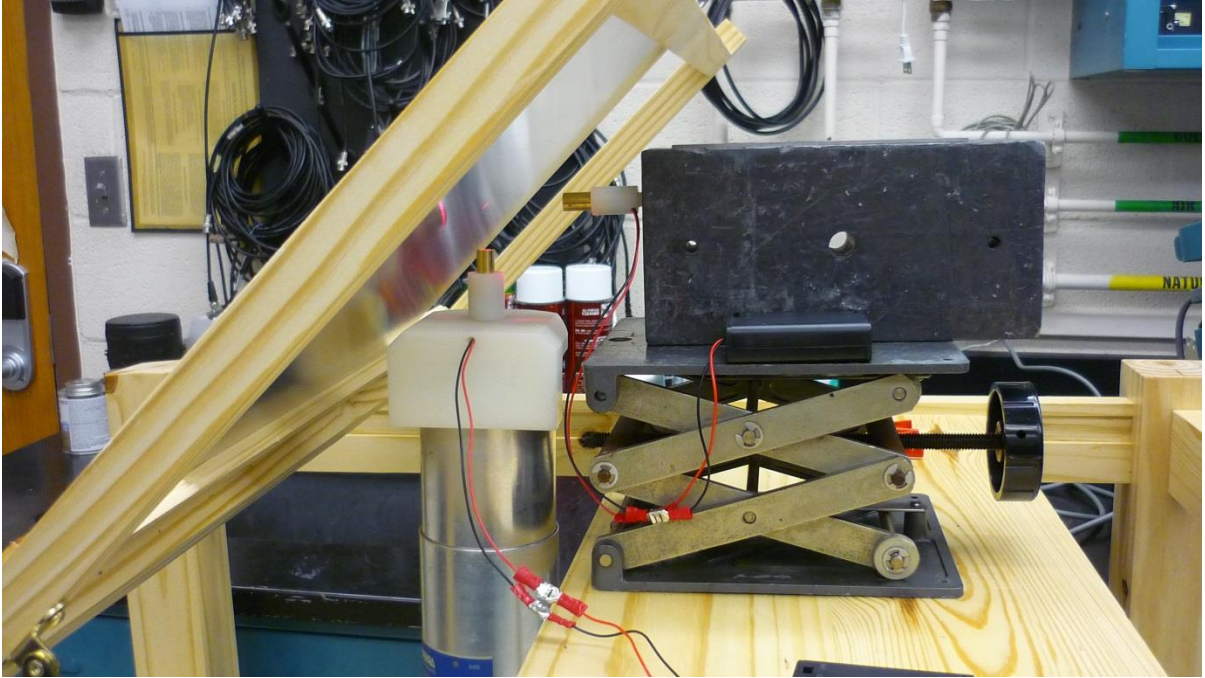

Figure 13 – View of Experimental setup with lasers mounted

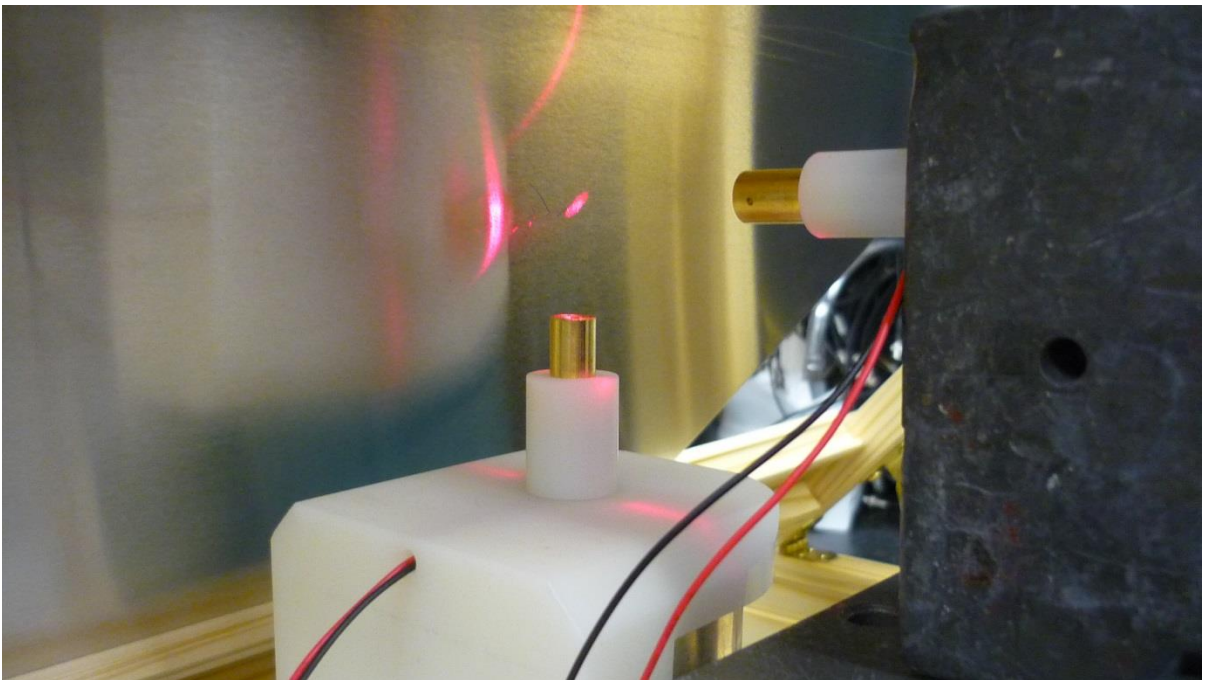

Figure 14 – Experimental setup with laser dots aligned on the metal surface

The detector was calibrated and its resolution characterized using two different sources, the first being Cd^{109} and the second source being Am^{241} . The two sources emit a number of different gamma and X-rays as seen in Table 4.

Table 4 – Characteristic X-ray and gamma ray emissions for Cd^{109} and Am^{241}

Characteristic X-Ray and γ -Ray Emissions (Partial List)				
Radioisotope	Energy(KeV)	Yield(%)	Used for Calibration	Type
Cd^{109}	2.978	4.5	No	$L\alpha_1$
	3.151	2.6	No	$L\beta_1$
	21.990	29.5	No	$K\alpha_2$
	22.163	55.7	No	$K\alpha_1$
	24.912	4.76	No	$K\beta_3$
	24.943	9.2	No	$K\beta_1$
	25.455	2.3	Yes	$K\beta_2$
	88.04	3.61	Yes	γ
Am^{241}	13.761	1.07	No	$L\alpha_2$
	13.946	9.6	No	$L\alpha_1$
	16.816	2.5	No	$L\beta_2$
	17.061	1.5	No	$L\beta_4$
	17.751	5.78	No	$L\beta_1$
	17.992	1.37	No	$L\beta_3$
	20.784	1.39	No	$L\gamma_1$
	26.3448	2.40	No	γ
	59.5412	35.9	Yes	γ

Due to the number of convolved peaks only three peaks could be found which correlated to a discrete energy. Those included the 26.3448 and 59.5412 KeV gamma rays from Am^{241} and the 88.04 KeV photon from Cd^{109} . These three energy peaks were used to characterize the resolution of the detector. For calibration purposes the number of peaks used was expanded to include the 13.761/13.946 convolved peak from Am^{241} and the 21.990/22.163 convolved peak from Cd^{109} .

The following model as seen in equation 6.1 was used to fit these data points and collect the necessary parameters for the GEB card in MCNP. Although the experiment and first round of simulations were independent of each other (meaning the simulation was not meant to replicate the experiment), the GEB parameters did provide a means to add noise to the simulated data that was consistent with the experiment and could be used in a second round of simulations that does replicate the experiment.

$$fwhm(E) = B \cdot \text{sqrt}(E + C \cdot E^2) + A \quad (6.1)$$

A non-linear search was performed to find the coefficients A, B, and C.

Table 5 – Gaussian broadening parameters

FWHM(E) Coefficients	
A	7.003E-4
B	9.931E-5
C	265

The following metals were used in the experiment and are different from the Simulation data due to accessibility of materials.

Table 6 – Metals used in the experiment

Metal Samples used in Experiment	
Material	ASTM Standard
Aluminum	1100
	2024
	2036
	3003
	5086
	5454
	6061
	6063
	6101
	7050
7075	
Steel	302
	304
	316
	321
	430
	A569
	A653
Copper/Brass/ Bronze	C101
	C110
	C260
	C353
	C464
	C510



Figure 15 – Full view of the experimental apparatus

Uncertainty Analysis and Error Quantification

To determine the error bounds of the solutions proposed by the ANN and PLS algorithms the uncertainty in the Spectroscopic data (the X block), the uncertainty in our calibration data (the Y block), and the error in the predictions (the Yest Block) must be considered. Adding to this complexity is that when building our model we will also have residual error, meaning that if $\mathbf{X}_{\text{Cal}}, \mathbf{Y}_{\text{Cal}}$ are the original data blocks used to determine the model parameters and \mathbf{X}_{Cal} is plugged into the model, it does not necessarily mean that \mathbf{Y}_{Cal} is retrieved, but rather an estimate of \mathbf{Y}_{Cal} is calculated called $\hat{\mathbf{Y}}_{\text{Cal}}$

$$f(\mathbf{X}_{\text{Cal}}) = \hat{\mathbf{Y}}_{\text{Cal}} \neq \mathbf{Y}_{\text{Cal}} \quad (6.2)$$

$$\mathbf{E}_{\text{residual}} = \text{abs}(\hat{\mathbf{Y}} - \mathbf{Y}_{\text{Cal}}) \quad (6.3)$$

Uncertainty in the Spectroscopic Data

Counting statistics in the nuclear field can be characterized as a Poisson distributed process which is a special case of the Binomial distribution, where the probability of an event approaches zero while the total number of trials approaches infinity. As a result, the expected number of counts in the i^{th} given channel can be considered to have a mean equal to the number of observed counts with a standard deviation equal to the square root of observed counts. [Knoll].

$$C_i^{\text{expected}} = C_i^{\text{observed}} \pm \sqrt{C_i^{\text{observed}}} \quad (6.4)$$

Residual Error

As mentioned before the residual error is simply the amount calculated in equation 7.2. In this study, the model error was the largest source of error and as a result in the uncertainty in the Y data could be ignored, since it is much smaller than the model error.

$$\mathbf{E}_{\text{residual}} \gg \sigma_Y \quad (6.5)$$

In the case of both the ANN and PLS methods, the model is built using an iterative process. Where that process ends is somewhat arbitrary and can be controlled by the experimentalist. This means that a typical variance calculation using propagation of error as seen in equation 7.5 is not practical.

$$\begin{aligned} \text{e.g.} \quad & Y = f(a) + f(b) \\ \text{then} \quad & \sigma_Y^2 = \sigma_a^2 \left(\frac{\partial Y}{\partial f(a)} \right)^2 + \sigma_b^2 \left(\frac{\partial Y}{\partial f(b)} \right)^2 \end{aligned} \quad (6.6)$$

assuming a and b are independent

As a result an alternative method is needed to quantify the bounds of uncertainty.

Sensitivity Studies

Sensitivity studies can be performed by perturbing the spectroscopic data, applying it to the model and then observing how the elemental weights change. If enough of these studies are done, the results can be placed into a histogram and a distribution of errors can be found. These sensitivity studies inherently incorporate both the residual error and the uncertainty in the spectroscopic data into its results. To apply uncertainty bounds to an unknown sample the maximum error found in the sensitivity study can be used as the upper and lower error limits of the unknown sample.

$$\sigma_{\hat{Y}_i}^2 = \max \left(\left(\hat{Y}(X_{\text{Perturbed}})_i - Y_{\text{Cal}_i} \right)^2 \right) \quad (6.7)$$

Results

To best convey the results, only a small subset will be presented in this section. Any omitted results will be included in a corresponding appendix. The results will be presented chronologically so the reader will gain the best understanding for how the pieces are interconnected.

The first step in this research was to generate both simulated and experimental spectra for the aluminum, steel, and copper based metals. Figure 16 through Figure 18 show one sample from each of the representative metal types.

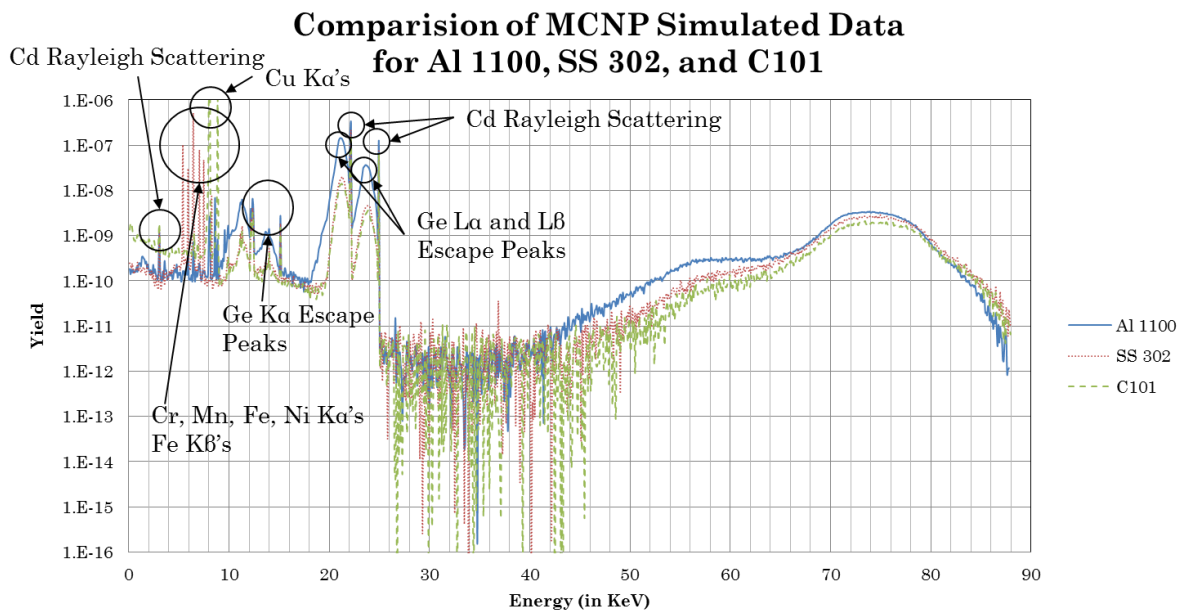

Figure 16 – MCNP Simulated Data

Figure 16 shows the standard F8 tally output from MCNP. Here the discrete energies emitted by major elements can be clearly seen. The K α emission from Cr, Mn, Fe, and Ni are all quite visible and distinct for the SS302 sample. The peaks for the trace metals are not immediately apparent to the naked eye; however, there is evidence of their existence in the smaller peaks.

Comparison of MCNP Gaussian Broadened Simulated Data for Al 1100, SS 306, and C101

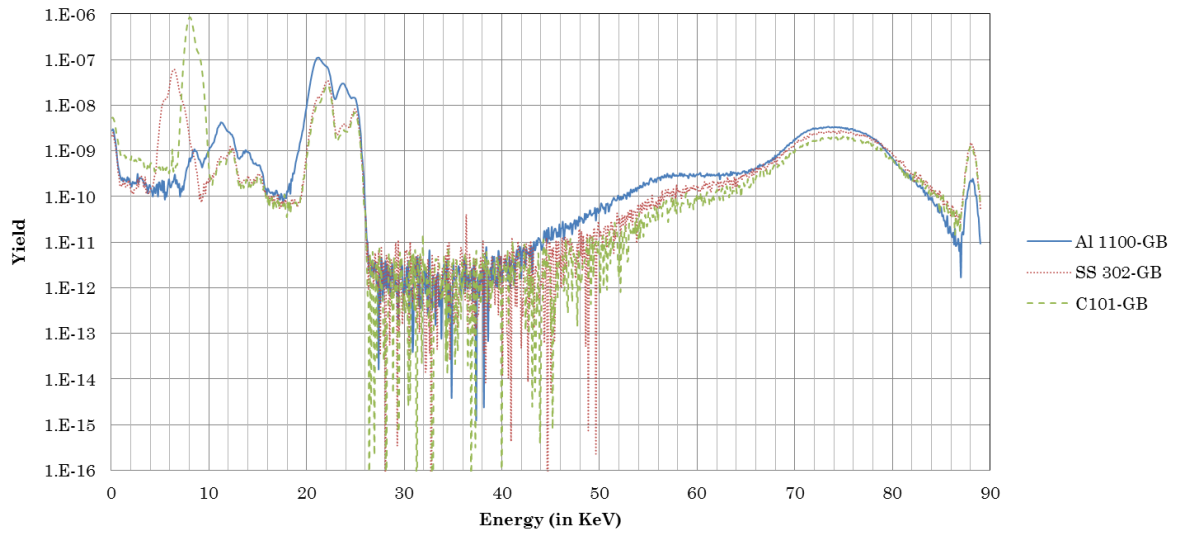

Figure 17 – MCNP Simulated Data (Gaussian Broadened)

In Figure 17 MCNP uses the model described in equation 6.1 to spread counts amongst channels. The fine resolution is lost, but now looks much more similar to the experimental data seen in Figure 18.

Comparison of Experimental Data for Al 1100, SS 302, and C101

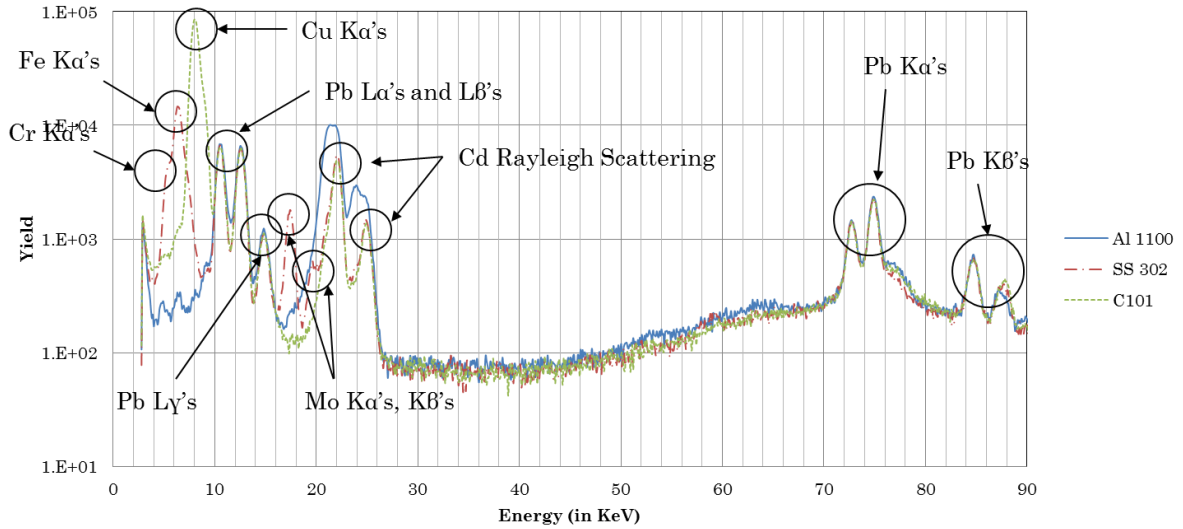

Figure 18 – Experimental Data with relevant peaks identified

The experimental data and simulation data have striking similarities and differences. One thing to notice is the absence of lead(Pb) X-rays in the simulation. In the experiment there are several peaks related to lead(Pb) excitation. The largest contributor to this discrepancy is the direction forcing scheme used in the simulation. By forcing all particles towards the target, the simulation eliminates the possibility of backscattered photons from inside the collimator reaching the detector. Fortunately, this study treats the simulation and experimental data as separate entities and uses each spectroscopic set as its own set of predictors for the elemental weights.

One of the challenges related to the Neural Network method is the amount of computation time related to the weight update procedure. To get a sense of scale for the calculations involved, a study was run on the stainless steel simulated spectra. The study was performed on a standard desktop computer with an Intel i7 processor and 8GB of ram. The results are provided in Table 7. The average time before a solution is converged upon can range from several hundred iterations to tens of thousands of iterations.

Table 7 – Performance Table for the Stainless Steel Set of X-ray spectroscopic data

Performance Table of ANN Network					
Set	Nodes	Channels	Dim of Jacobian covariance matrix	Total # of Elements	Run time per Iteration (s)
SS Simulation Set 8 Samples	8	128	9296 x 9296	86,415,616	1.3
		256	17488 x 17488	305,830,144	11
		512	33872 x 33872	1,147,312,384	88
		1024	66640 x 66640	4,440,889,600	652
	10	128	11616 x 11616	134,931,456	2.7
		256	21856 x 21856	477,684,736	20
		512	42336 x 42336	1,792,336,896	155
		1024	83296 x 83296	6,938,223,616	1,147

As can be inferred from Table 7, if it takes 10,000 iterations to converge, then with a 10 node network using a standard multi-channel analyzer setting of 1024 channels, it would take approximately 132 days to reach a solution. As a result a reduction in the data set is necessary. Figure 19 shows what a re-binned spectrum looks like when going from 1024 channels to 128 channels.

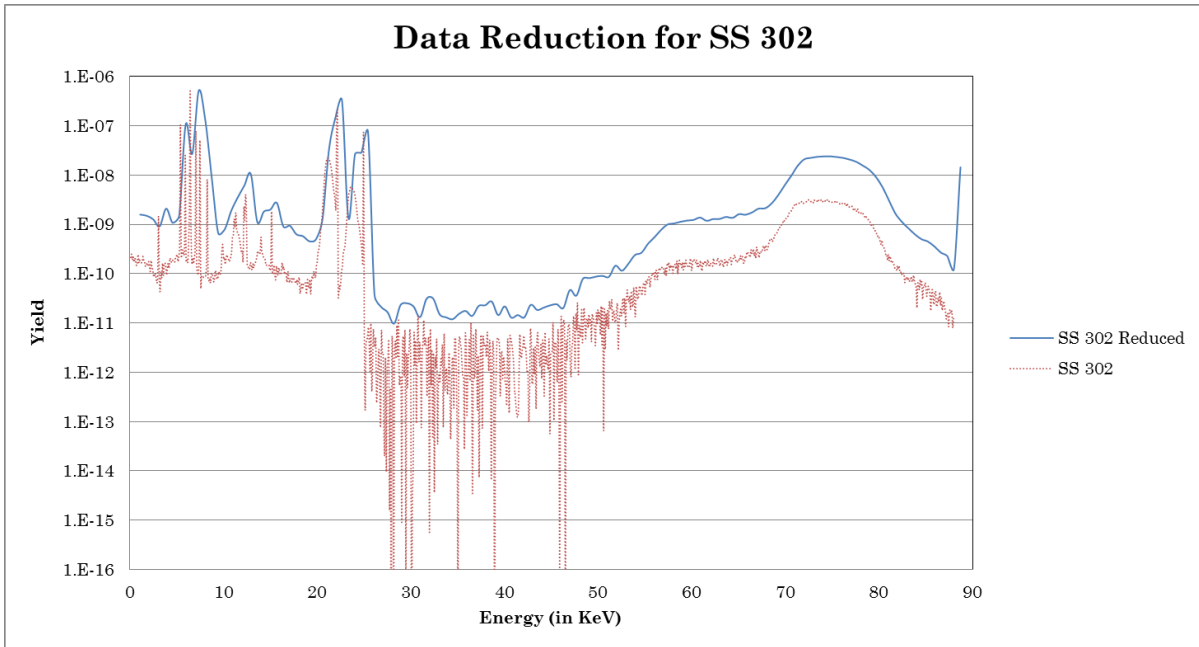

Figure 19 – Reduction of SS 302 data from 1024 channels to 128 channels

As can be seen in Figure 19, resolution is lost during the re-binning process. This step is critical to achieve solutions in a reasonable amount of time. After re-binning the data from 1024 channels to 128 channels, the same task can be reduced from 132 days of computation time to 7.5 hours. When optimizing the ANN for computational performance, the number of hidden nodes and number of input nodes should be kept as low as possible without compromising the SSE. With this in mind 8, 9, and 10 node models were examined using 128 channel spectroscopic data.

To determine the optimum number of Latent Variables in the PLS model, the data in Table 8 was generated. Table 8 shows how much each latent variable explains both the X and Y data block as a function of their linear correlation.

Table 8 – PLS Model – LV Study (w/o Scaling or Centering)

		The proportion of the data explained by a Latent Variable (LV)											
	Data Block	LV1	LV2	LV3	LV4	LV5	LV6	LV7	LV8	LV9	LV10	Total Explained	
Aluminum Samples													
	Simulated Data - Set 1	X	0.96395445	0.02714547	0.00831160	0.00056399	0.00002355	0.00000046	0.00000037	0.00000007	0.00000001	0.00000003	0.99999999
		Y	0.98447438	0.01212174	0.00187868	0.00106356	0.00016957	0.00015720	0.00002729	0.00002242	0.00007341	0.00001005	0.99999830
	Simulated Data - Set 1 - GB	X	0.97096844	0.02434481	0.00431027	0.00035658	0.00001901	0.00000035	0.00000010	0.00000027	0.00000005	0.00000003	0.99999994
		Y	0.98400233	0.01331805	0.00123420	0.00097762	0.00017993	0.00018942	0.00003426	0.00001117	0.00001527	0.00001306	0.99997529
	Simulated Data - Set 2	X	0.95987172	0.03050827	0.00873778	0.00084559	0.00003492	0.00000023	0.00000106	0.00000039	0.00000002	0.00000002	0.99999999
		Y	0.98432879	0.01182381	0.00199116	0.00123783	0.00026721	0.00022473	0.00001453	0.00001002	0.00006229	0.00001813	0.99997850
	Simulated Data - Set 2 - GB	X	0.96845204	0.02641485	0.00458840	0.00051373	0.00002975	0.00000026	0.00000050	0.00000018	0.00000011	0.00000010	0.99999993
		Y	0.98345463	0.01341238	0.00138852	0.00112092	0.00026600	0.00023195	0.00001581	0.00002307	0.00001702	0.00001600	0.99994630
	Experimental Data	X	0.58989897	0.16025378	0.07406176	0.04127128	0.03298088	0.02236196	0.01399490	0.01984710	0.01623515	0.01616213	0.98706792
		Y	0.15182340	0.19302104	0.11195467	0.13825114	0.12144204	0.08353320	0.11815813	0.02856368	0.03016561	0.01332558	0.99023847
Copper Based Metal Samples													
	Simulated Data - Set 1	X	0.92376240	0.07619183	0.00002286	0.00002201	0.00000032	0.00000058	0.00000000	0.00000000	0.00000000	0.00000000	1.00000000
		Y	0.93724012	0.05841720	0.00229474	0.00070589	0.00133073	0.00001130	0.00000002	0.00000000	0.00000000	0.00000000	1.00000000
	Simulated Data - Set 1 - GB	X	0.96034697	0.03961684	0.00001742	0.00001780	0.00000047	0.00000044	0.00000006	0.00000000	0.00000000	0.00000000	1.00000000
		Y	0.91802660	0.07767164	0.00241967	0.00060587	0.00125430	0.00002187	0.00000004	0.00000000	0.00000000	0.00000000	1.00000000
	Simulated Data - Set 2	X	0.92376198	0.07619310	0.00002361	0.00002036	0.00000039	0.00000054	0.00000000	0.00000000	0.00000000	0.00000000	1.00000000
		Y	0.93519732	0.06043548	0.00241747	0.00087258	0.00107601	0.00000109	0.00000006	0.00000000	0.00000000	0.00000000	1.00000000
	Simulated Data - Set 2 - GB	X	0.96034799	0.03961645	0.00001783	0.00001672	0.00000055	0.00000040	0.00000006	0.00000000	0.00000000	0.00000000	1.00000000
		Y	0.91569442	0.07998140	0.00258434	0.00073903	0.00097582	0.00002484	0.00000015	0.00000000	0.00000000	0.00000000	1.00000000
	Experimental Data	X	0.36430576	0.21274024	0.15775445	0.13162468	0.13357487	0.00000000	0.00000000	0.00000000	0.00000000	0.00000000	1.00000000
		Y	0.30519715	0.43861044	0.14808320	0.09815992	0.00994928	0.00000000	0.00000000	0.00000000	0.00000000	0.00000000	1.00000000
Stainless Steel Samples													
	Simulated Data - Set 1	X	0.91085331	0.04010517	0.04148006	0.00699129	0.00056617	0.00000349	0.00000049	0.00000001	0.00000000	0.00000000	1.00000000
		Y	0.84167396	0.13197198	0.01200417	0.01159476	0.00063554	0.00165067	0.00041099	0.00005613	0.00000180	0.00000000	1.00000000
	Simulated Data - Set 1 - GB	X	0.90869850	0.03783171	0.04686512	0.00614804	0.00045076	0.00000545	0.00000013	0.00000017	0.00000012	0.00000000	1.00000000
		Y	0.83215831	0.14167176	0.00940059	0.01391263	0.00068006	0.00161292	0.00055493	0.00000529	0.00000351	0.00000000	1.00000000
	Simulated Data - Set 2	X	0.90786658	0.04243094	0.03809423	0.01136715	0.00020995	0.00002697	0.00000412	0.00000005	0.00000001	0.00000000	1.00000000
		Y	0.83745525	0.13086507	0.01546856	0.01344321	0.00077275	0.00121327	0.00053238	0.00024710	0.00000239	0.00000000	1.00000000
	Simulated Data - Set 2 - GB	X	0.90583188	0.03986369	0.04453832	0.00959936	0.00015293	0.00001097	0.00000242	0.00000022	0.00000020	0.00000000	1.00000000
		Y	0.82806642	0.14129648	0.00993627	0.01775631	0.00092338	0.00149164	0.00025798	0.00025006	0.00002145	0.00000000	1.00000000
	Experimental Data	X	0.59346554	0.39234338	0.01037491	0.00371640	0.00008631	0.00000986	0.00000361	0.00000000	0.00000000	0.00000000	1.00000000
		Y	0.82770442	0.14876591	0.01678753	0.00428187	0.00231079	0.00012516	0.00002450	0.00000000	0.00000000	0.00000000	1.00000000
Total Samples													
	Simulated Data - Set 1	X	0.25268735	0.65247813	0.02215357	0.07005981	0.00097687	0.00110522	0.00040299	0.00011187	0.00001246	0.00000968	0.99999795
		Y	0.50682843	0.14908138	0.25793564	0.01497035	0.04126766	0.00419963	0.00487289	0.00546533	0.00506496	0.00217875	0.99186502
	Simulated Data - Set 1 - GB	X	0.27942889	0.66116034	0.02136395	0.03585706	0.00080125	0.00101647	0.00027577	0.00007564	0.00001000	0.00000723	0.99999661
		Y	0.49975326	0.16066670	0.25085595	0.01508677	0.04008500	0.00593430	0.00560435	0.00621294	0.00593762	0.00268461	0.99282151
	Simulated Data - Set 2	X	0.27312646	0.63191393	0.02195548	0.07019068	0.00106192	0.00100403	0.00058562	0.00014796	0.00000638	0.00000456	0.99999704
		Y	0.48925749	0.16542849	0.25650218	0.01560855	0.03901802	0.00492499	0.00437170	0.00813012	0.00791425	0.00185880	0.99301460
	Simulated Data - Set 2 - GB	X	0.29275903	0.64775922	0.02128990	0.03586804	0.00084435	0.00099956	0.00037664	0.00009149	0.00000475	0.00000277	0.99999574
		Y	0.48947952	0.17104269	0.24844276	0.01560858	0.03800083	0.00526307	0.00559664	0.00926255	0.00946785	0.00185494	0.99401943
	Experimental Data	X	0.82499300	0.09124737	0.03699632	0.04392497	0.00142708	0.00039044	0.00033336	0.00038744	0.00019626	0.00004957	0.99994582
		Y	0.19510404	0.45615025	0.27247627	0.03403397	0.01069141	0.01530698	0.00683044	0.00486775	0.00158004	0.00029754	0.99733870

It appears that across all cases and samples, most of the variation in the X and Y data blocks can be explained with 4 to 6 latent variables.

The first indication of performance for both the ANN and PLS models are the sum of square errors (SSE). To get an indication of the amount of error per element the mean square error (MSE) is collected. The MSE for 8, 9, and 10 node ANN models, along with the 4, 5, and 6 latent variable PLS models are reported in Table 9. Poor performers are marked in red, and better performers are marked in blue.

Table 9 – Mean of Square Error between Model Estimates and Data

$$\frac{1}{n} \sum (Y - Y_{est})^2$$

	Mean Square Error										EXP N/A
	Self Prediction					Opposite Set Prediction					
	MCNP		MCNP-GEB		EXP	MCNP		MCNP-GEB		EXP	
	Set 1	Set 2	Set 1	Set 2	Set 1	Set 1	Set 2	Set 1	Set 2		
ANN - 8 Nodes											
Aluminum	3.28E-04	4.06E-04	1.52E-03	1.59E-03	1.53E-03	5.03E-04	4.66E-04	1.59E-03	1.52E-03	*	
Copper/Brass/Bronze	2.29E-04	1.78E-04	2.64E-04	1.95E-04	2.16E-02	1.68E-04	2.80E-04	1.98E-04	2.96E-04	*	
Stainless Steel	4.28E-04	4.56E-04	1.57E-02	1.66E-02	1.13E-02	3.89E-04	5.82E-04	1.67E-02	1.57E-02	*	
All Metals	7.21E-04	1.30E-03	1.60E-03	2.28E-03	4.39E-01	4.57E-03	3.53E-03	2.36E-03	2.71E-03	*	
ANN - 9 Nodes											
Aluminum	3.12E-04	4.11E-04	1.51E-03	1.59E-03	1.53E-03	5.23E-04	5.37E-04	1.58E-03	1.52E-03	----	
Copper/Brass/Bronze	2.56E-04	1.97E-04	2.69E-04	2.25E-04	2.16E-02	1.95E-04	2.93E-04	2.17E-04	3.26E-04	----	
Stainless Steel	4.67E-04	6.02E-04	1.57E-02	1.66E-02	1.13E-02	5.08E-04	6.82E-04	1.67E-02	1.57E-02	----	
All Metals	4.66E-03	1.12E-02	7.23E-04	1.59E-03	4.39E-01	6.65E-03	1.19E-02	1.02E-03	1.78E-03	----	
ANN - 10 Nodes											
Aluminum	2.78E-04	2.50E-03	1.52E-03	1.59E-03	1.53E-03	8.28E-04	2.61E-03	1.59E-03	1.52E-03	----	
Copper/Brass/Bronze	2.43E-04	3.66E-04	3.43E-04	2.13E-04	2.16E-02	1.87E-04	4.39E-04	2.70E-04	3.13E-04	----	
Stainless Steel	3.27E-04	9.48E-04	1.57E-02	1.66E-02	1.13E-02	3.14E-04	1.01E-03	1.67E-02	1.57E-02	----	
All Metals	2.68E-03	2.50E-03	8.87E-03	6.92E-03	4.39E-01	4.30E-03	3.44E-03	9.83E-03	6.73E-03	----	
PLS - 4 LV's											
Aluminum	3.16E-04	2.72E-04	3.16E-04	2.72E-04	2.30E-04	3.46E-04	4.13E-04	3.22E-04	3.89E-04	*	
Copper/Brass/Bronze	4.86E-07	4.84E-06	6.75E-07	4.19E-03	3.14E-06	2.39E-05	2.94E-05	2.26E-05	4.13E-03	*	
Stainless Steel	4.95E-04	5.25E-04	4.29E-04	4.71E-04	7.54E-04	5.24E-04	5.68E-04	4.90E-04	5.20E-04	*	
All Metals	2.79E-02	2.65E-02	2.82E-02	2.69E-02	2.81E-02	2.69E-02	2.84E-02	2.69E-02	2.83E-02	*	
PLS - 5 LV's											
Aluminum	3.04E-04	2.65E-04	3.03E-04	2.55E-04	2.16E-04	9.37E-02	4.12E-02	2.76E-02	6.83E-02	----	
Copper/Brass/Bronze	2.34E-08	7.92E-09	6.99E-08	6.39E-09	3.78E-25	4.20E-05	3.62E-05	2.51E-05	3.51E-05	----	
Stainless Steel	4.05E-04	1.70E-04	3.70E-04	1.66E-04	2.07E-05	5.94E-04	6.68E-04	4.96E-04	5.20E-04	----	
All Metals	1.56E-02	1.45E-02	2.21E-02	2.16E-02	2.28E-02	1.52E-02	1.68E-02	2.13E-02	2.32E-02	----	
PLS - 6 LV's											
Aluminum	2.35E-04	1.10E-04	1.27E-04	9.58E-05	2.12E-04	5.86E-02	4.55E-01	8.69E-02	2.78E-02	----	
Copper/Brass/Bronze	8.58E-21	9.74E-24	1.04E-21	3.19E-25	5.30E-15	2.57E-03	3.47E-05	3.50E-03	3.77E-05	----	
Stainless Steel	1.24E-04	9.20E-07	4.10E-05	4.71E-06	4.97E-26	2.97E-04	3.02E-04	5.37E-04	3.76E-04	----	
All Metals	1.42E-02	1.29E-02	1.50E-02	1.34E-02	8.74E-03	1.36E-02	1.61E-02	1.40E-02	1.59E-02	----	

* See individual results

Oddly enough, some of the best and worst performing solutions come from the PLS model. It appears that the copper based metals are well predicted under the PLS model, while the aluminum and the total metal PLS models performed poorly. Since not all errors carry equal weight it is important to look at the individual values to see where the errors originated. Table 31 through Table 56 show the individual results for the 8 node ANN models and the 4 LV PLS models for simulated data set two and the experimental data set (results for simulated set one are contained in “Appendix D – Estimates of Elemental Weight Fractions for Set 1”).

Looking at some of the select cases in close detail, the results from Aluminum 1100 and 7075 both reveal errors in the major elemental components of only a couple percent, while the trace element predictions range from a few percent to several orders of magnitude in error. The ASTM standard calls for a minimum of 99% aluminum for Al 1100, and with a guess at 97.3% Al it would be very easy to misclassify this material.

Table 10 – Selected Results for aluminum 1100 and 7075

Metal Typ Set Type/Number			Algorithm		Elements															
					Al		B		Bi		Cr		Cu		Fe		Mg			
					Est	Act	Est	Act	Est	Act	Est	Act	Est	Act	Est	Act	Est	Act		
Aluminum 7075																				
1100	Sim Set 2 - Al Only	ANN	0.972953	0.994795	-0.000326	-	-0.000654	-	0.002928	-	-0.001683	0.000673	0.004161	0.000471	0.017130	-				
1100	Sim Set 2 - Al Only	PLS	0.979349	0.994795	0.000015	-	0.000891	-	0.001173	-	-0.004378	0.000673	0.002448	0.000471	0.013759	-				
1100	Experiment - Al Only	ANN	0.956081	0.993250	0.000836	-	0.009661	-	0.002465	-	0.014937	0.001250	0.002828	0.003000	0.000211	-				
1100	Experiment - Al Only	PLS	0.966966	0.993250	0.001827	-	0.005404	-	0.001605	-	0.024286	0.001250	-0.004443	0.003000	-0.000274	-				
7075	Sim Set 2 - Al Only	ANN	0.888112	0.892454	0.002764	-	-0.005681	-	0.006059	0.002280	0.016317	0.014880	-0.000549	0.001896	0.027100	0.028569				
7075	Sim Set 2 - Al Only	PLS	0.895865	0.892454	-0.000004	-	-0.000135	-	0.002214	0.002280	0.012253	0.014880	0.002463	0.001896	0.027559	0.028569				
7075	Experiment - Al Only	ANN	0.956081	0.893700	0.000836	-	0.009661	-	0.002465	0.002300	0.014937	0.016000	0.002828	0.002500	0.000211	0.025000				
7075	Experiment - Al Only	PLS	0.945957	0.893700	-0.000925	-	0.005893	-	0.004149	0.002300	-0.001635	0.016000	0.015957	0.002500	0.000828	0.025000				
			Mn		Ni		Pb		Si		Ti		Zn							
			Est	Act	Est	Act	Est	Act	Est	Act	Est	Act	Est	Act						
1100	Sim Set 2 - Al Only	ANN	0.006471	0.000274	-	-	-0.008546	-	0.001328	0.002894	-0.002178	-	-0.000127	0.000893						
1100	Sim Set 2 - Al Only	PLS	0.003337	0.000274	-	-	0.000749	-	0.002803	0.002894	0.000184	-	-0.000330	0.000893						
1100	Experiment - Al Only	ANN	0.002140	0.000250	0.000453	-	0.010311	0.001750	0.000099	-	0.000011	0.000500	-	-						
1100	Experiment - Al Only	PLS	0.004619	0.000250	0.000453	-	-0.000388	0.001750	-0.000039	-	0.000001	0.000500	-	-						
7075	Sim Set 2 - Al Only	ANN	0.006404	0.000208	-	-	-0.002524	-	-0.000289	0.002902	0.003412	0.000731	0.050089	0.056080						
7075	Sim Set 2 - Al Only	PLS	0.001665	0.000208	-	-	-0.000105	-	0.002843	0.002902	0.000617	0.000731	0.054765	0.056080						
7075	Experiment - Al Only	ANN	0.002140	0.001500	0.000453	-	0.010311	0.002000	0.000099	0.001000	0.000011	0.056000	-	-						
7075	Experiment - Al Only	PLS	-0.002265	0.001500	0.000453	-	0.031353	0.002000	0.000371	0.001000	0.000022	0.056000	-	-						

To get a sense of the results between the different data sets of the same material, we examine the results for stainless steel 316 as seen in Table 11. Here we see that on an individual element level there is not much difference between the Gaussian Broadened and normal simulation data. However for the experimental data there is much greater accuracy in the PLS solution than in the ANN solution.

Table 11 – Selected Results for stainless steel 316

Metal Type	Set Type/Number	Algorithm	Elements													
			Al		B		C		Cr		Cu		Fe			
			Est	Act	Est	Act	Est	Act	Est	Act	Est	Act	Est	Act		
SS-316	Sim Set 2 - SS Only	ANN	-0.001913	-	0.001762	-	0.000744	0.000396	0.158857	0.168609	-0.002208	-	0.653837	0.673076		
		PLS	0.000787	-	0.000008	-	0.000559	0.000396	0.170616	0.168609	-0.001323	-	0.633375	0.673076		
	Sim Set 2 - GB - SS Only	ANN	0.000254	-	-0.000197	-	0.000663	0.000396	0.169174	0.168609	0.001493	-	0.688699	0.673076		
		PLS	0.001016	-	0.000009	-	0.000568	0.000396	0.167968	0.168609	-0.001427	-	0.636295	0.673076		
	Sim Set 1 - SS Only	ANN	-0.000365	-	-0.000976	-	-0.000936	0.000400	0.160013	0.170000	0.000276	-	0.652022	0.669975		
		PLS	0.000128	-	0.000015	-	0.000422	0.000400	0.171285	0.170000	-0.000522	-	0.637419	0.669975		
	Sim Set 1 - GB - SS Only	ANN	0.000391	-	-0.000046	-	0.000605	0.000400	0.168688	0.170000	0.000563	-	0.693553	0.669975		
		PLS	0.000255	-	0.000017	-	0.000418	0.000400	0.168593	0.170000	-0.000574	-	0.638642	0.669975		
	Experiment - SS Only	ANN	0.000419	-	0.000012	-	0.000496	0.000400	0.120326	0.170000	0.000026	-	0.806513	0.669975		
		PLS	-0.000213	-	0.000000	-	0.000414	0.000400	0.173380	0.170000	0.000000	-	0.657072	0.669975		
				Pb		Mn		Mo		Nb		Ni		N		
				Est	Act	Est	Act	Est	Act	Est	Act	Est	Act	Est	Act	
		Sim Set 2 - SS Only	ANN	0.001245	-	0.007440	0.006579	0.016924	0.024833	-	-	0.136597	0.121661	-0.002597	0.000375	
			PLS	-0.000004	-	0.010116	0.006579	0.024971	0.024833	-	-	0.146033	0.121661	0.000395	0.000375	
		Sim Set 2 - GB - SS Only	ANN	-0.000380	-	0.009931	0.006579	0.004986	0.024833	-	-	0.115049	0.121661	0.000098	0.000375	
			PLS	-0.000004	-	0.010609	0.006579	0.024977	0.024833	-	-	0.144188	0.121661	0.000352	0.000375	
		Sim Set 1 - SS Only	ANN	0.000300	-	0.006870	0.010000	0.015803	0.025000	-	-	0.136499	0.120000	-0.000080	0.000500	
			PLS	-0.000003	-	0.010670	0.010000	0.024823	0.025000	-	-	0.144701	0.120000	0.000479	0.000500	
		Sim Set 1 - GB - SS Only	ANN	0.000028	-	0.008390	0.010000	0.005244	0.025000	-	-	0.113868	0.120000	0.000286	0.000500	
			PLS	-0.000003	-	0.010565	0.010000	0.024855	0.025000	-	-	0.145418	0.120000	0.000456	0.000500	
		Experiment - SS Only	ANN	-	-	0.007584	0.010000	0.003583	0.025000	0.000015	-	0.056897	0.120000	0.000294	0.000500	
			PLS	-	-	0.010397	0.010000	0.024167	0.025000	0.000000	-	0.129708	0.120000	0.000552	0.000500	
					P		Si		S		Sn		Ti		V	
					Est	Act	Est	Act	Est	Act	Est	Act	Est	Act	Est	Act
Sim Set 2 - SS Only			ANN	-0.002214	0.000105	0.006374	0.004179	-0.002112	0.000187	0.001656	-	0.003120	-	-0.001106	-	
			PLS	0.000243	0.000105	0.005470	0.004179	0.000298	0.000187	-0.000014	-	0.006920	-	0.001549	-	
Sim Set 2 - GB - SS Only			ANN	0.000193	0.000105	0.006044	0.004179	0.000097	0.000187	0.000130	-	0.003001	-	0.000934	-	
			PLS	0.000249	0.000105	0.005506	0.004179	0.000301	0.000187	-0.000015	-	0.007657	-	0.001750	-	
Sim Set 1 - SS Only			ANN	0.000833	0.000225	0.003966	0.003750	-0.000544	0.000150	-0.002067	-	0.002848	-	0.001012	-	
			PLS	0.000229	0.000225	0.003150	0.003750	0.000150	0.000150	-0.000013	-	0.006224	-	0.000842	-	
Sim Set 1 - GB - SS Only			ANN	0.000330	0.000225	0.005159	0.003750	0.000187	0.000150	0.000107	-	0.002930	-	0.000318	-	
			PLS	0.000229	0.000225	0.003142	0.003750	0.000150	0.000150	-0.000014	-	0.006904	-	0.000946	-	
Experiment - SS Only			ANN	0.000216	0.000225	0.002992	0.003750	0.000146	0.000150	-	-	0.000659	-	0.000016	-	
			PLS	0.000222	0.000225	0.003547	0.003750	0.000147	0.000150	-	-	0.000607	-	0.000000	-	

Table 12 – Selected Results for stainless steel 434 and 660, using all of the metals as a basis for training

Metal Type	Set Type/Number	Algorithm	Elements													
			Al		B		C		Cr		Cu		Fe			
			Est	Act	Est	Act	Est	Act	Est	Act	Est	Act	Est	Act		
434	Sim Set 1 - SS Only	ANN	0.001834	-	-0.003343	-	-0.001689	0.000600	0.156541	0.170000	0.001131	-	0.847763	0.809050		
		PLS	-0.000059	-	-0.000012	-	0.000606	0.000600	0.168142	0.170000	0.000544	-	0.847412	0.809050		
	Sim Set 1 - GB - SS Only	ANN	0.000391	-	-0.000045	-	0.000603	0.000600	0.168688	0.170000	0.000563	-	0.693554	0.809050		
		PLS	-0.000112	-	-0.000012	-	0.000609	0.000600	0.169563	0.170000	0.000551	-	0.844019	0.809050		
660	Sim Set 1 - SS Only	ANN	0.003651	0.001750	-0.005348	0.000055	-0.001708	0.000400	0.170425	0.147500	0.005385	-	0.509546	0.543195		
		PLS	0.001121	0.001750	0.000029	0.000055	0.000355	0.000400	0.157208	0.147500	0.000917	-	0.547021	0.543195		
	Sim Set 1 - GB - SS Only	ANN	0.000391	0.001750	-0.000046	0.000055	0.000604	0.000400	0.168688	0.147500	0.000563	-	0.693554	0.543195		
		PLS	0.000957	0.001750	0.000026	0.000055	0.000360	0.000400	0.160664	0.147500	0.000995	-	0.545097	0.543195		
			Pb		Mn		Mo		Ni		N		P			
			Est	Act	Est	Act	Est	Act	Est	Act	Est	Act	Est	Act		
434	Sim Set 2 - SS Only	ANN	-0.002230	-	0.005757	0.005000	0.014226	0.010000	-0.021734	-	0.001271	-	0.002208	0.000200		
		PLS	0.000003	-	0.003756	0.005000	0.008383	0.010000	-0.029272	-	-0.000070	-	0.000191	0.000200		
	Sim Set 2 - GB - SS Only	ANN	0.000027	-	0.008391	0.005000	0.005243	0.010000	0.113867	-	0.000285	-	0.000329	0.000200		
		PLS	0.000003	-	0.003923	0.005000	0.008367	0.010000	-0.027211	-	-0.000049	-	0.000192	0.000200		
660	Sim Set 1 - SS Only	ANN	-0.004945	-	0.010286	0.010000	0.006932	0.012500	0.268523	0.255000	0.001379	-	0.001280	0.000200		
		PLS	0.000005	-	0.010676	0.010000	0.013300	0.012500	0.250316	0.255000	0.000213	-	0.000201	0.000200		
	Sim Set 1 - GB - SS Only	ANN	0.000028	-	0.008390	0.010000	0.005243	0.012500	0.113867	0.255000	0.000285	-	0.000329	0.000200		
		PLS	0.000005	-	0.010800	0.010000	0.013271	0.012500	0.249737	0.255000	0.000240	-	0.000202	0.000200		
			Si		S		Sn		Ti		V					
			Est	Act	Est	Act	Est	Act	Est	Act	Est	Act				
434	Sim Set 2 - SS Only	ANN	0.000603	0.005000	0.000952	0.000150	-0.004350	-	-0.000086	-	0.001490	-				
		PLS	0.005855	0.005000	0.000150	0.000150	0.000014	-	-0.004990	-	-0.000654	-				
	Sim Set 2 - GB - SS Only	ANN	0.005158	0.005000	0.000186	0.000150	0.000105	-	0.002929	-	0.000317	-				
		PLS	0.005813	0.005000	0.000150	0.000150	0.000014	-	-0.005138	-	-0.000680	-				
660	Sim Set 1 - SS Only	ANN	0.004958	0.005000	0.002603	0.000150	-0.003053	-	0.006974	0.021250	0.000730	0.003000				
		PLS	0.005613	0.005000	0.000150	0.000150	0.000023	-	0.011274	0.021250	0.001577	0.003000				
	Sim Set 1 - GB - SS Only	ANN	0.005158	0.005000	0.000187	0.000150	0.000106	-	0.002930	0.021250	0.000318	0.003000				
		PLS	0.005644	0.005000	0.000150	0.000150	0.000025	-	0.010385	0.021250	0.001441	0.003000				

Looking at the data in Table 12 where all of the metal is used to serve as the training set, we notice that again the ANN sometimes give poor predictions for the amount of iron for the Gaussian broadened set, but predictions that are in alignment with the PLS predictions for the normal simulation set. To better characterize all of the data, Table 13 through Table 16 were generated to give an overall picture of the performance. As was seen in Table 10 sometimes negative answers can be given. If it is assumed that a negative answer indicates zero presence of a material, then the results of this study can be summed up by the following tables.

Table 13 seems to indicate that PLS is clearly the better model to use, since it has a higher number of correctly predicted models. However, not all correctly predicted elements should be treated equally. For example if a number of elements not in the material are correctly predicted as being absent, it still does not give us all of the information needed to correctly classify the material. Table 14, Table 15, and Table 16 look at the how much a correctly identified material contributes to the total elemental weight of that material. In other words, it places more weight on accurate predictions of principle elements, little value on trace elements, and no weight on absent elements.

We can then begin to see trends in the predictions where PLS performs well in most of the studies, but not all. It tends to give its best predictions when the training set is narrow in focus and the metals analyzed fall into the same grouping. However, in the steel samples the ANN method demonstrates its capability when there are large numbers of elements, many of which are not present, and there is high variability in the data sets. The ANN is able to take all of these parameters and significantly outperform the PLS predictions.

Table 13 – Number of elements predicted in the steel samples that were within the range of the ASTM Standard*

		302		304		316		321		330		405		430	
# of Elements		ANN	PLS	ANN	PLS	ANN	PLS	ANN	PLS	ANN	PLS	ANN	PLS	ANN	PLS
Steel															
Sim set 1	17	12	13	11	14	11	12	11	13	12	12	10	10	12	10
Sim set 1 - GB	17	9	14	9	13	10	12	11	14	7	11	7	10	8	9
Sim set 2	17	15	15	15	15	11	12	16	15	12	13	9	10	10	9
Sim set 2 - GB	17	8	13	8	15	11	11	10	15	8	13	6	10	7	10
Exp		-	-	6	11	6	12	-	-	-	-	-	-	-	-
All Metals															
Sim set 1	27	13	14	12	14	14	21	13	15	11	17	7	13	10	13
Sim set 1 - GB	27	6	14	7	14	14	20	7	15	10	16	6	14	7	14
Sim set 2	27	3	14	4	14	11	21	5	15	7	17	4	13	3	13
Sim set 2 - GB	27	9	14	9	14	12	20	10	15	11	16	9	14	8	14
Exp	29	-	-	15	18	15	19	-	-	-	-	-	-	-	-
		434		660		A569		A653							
# of Elements		ANN	PLS	ANN	PLS	ANN	PLS	ANN	PLS						
Steel															
Sim set 1	17	8	13	6	12	-	-	-	-						
Sim set 1 - GB	17	7	13	6	11	-	-	-	-						
Sim set 2	17	15	12	10	9	-	-	-	-						
Sim set 2 - GB	17	8	13	7	9	-	-	-	-						
Exp		-	-	-	-	-	-	-	-						
All Metals															
Sim set 1	27	12	19	13	17	-	-	-	-						
Sim set 1 - GB	27	15	18	7	17	-	-	-	-						
Sim set 2	27	9	19	10	18	-	-	-	-						
Sim set 2 - GB	27	18	18	8	17	-	-	-	-						
Exp	29	-	-	-	-	-	-	-	-						

*Elements not present in the material were considered "correctly estimated" if the estimate was negative, or less than 1E-4

Table 14 – Fraction of elements predicted in the steel within the range of the ASTM Standard* multiplied by their contribution

		302		304		316		321		330		405		430	
# of Elements		ANN	PLS	ANN	PLS	ANN	PLS	ANN	PLS	ANN	PLS	ANN	PLS	ANN	PLS
Steel															
Sim set 1	17	0.91	0.92	0.82	1.00	0.96	0.85	0.99	1.00	0.99	1.00	0.01	0.01	0.97	0.81
Sim set 1 - GB	17	0.71	1.00	0.71	1.00	0.99	0.85	0.82	1.00	0.01	0.62	0.01	0.01	0.18	0.82
Sim set 2	17	0.99	1.00	0.82	1.00	0.80	0.85	0.99	1.00	0.99	0.99	0.01	0.02	0.18	0.80
Sim set 2 - GB	17	0.71	0.90	0.71	1.00	0.99	0.85	0.82	1.00	0.01	0.99	0.02	0.01	0.19	0.82
Exp		-	-	0.01	0.75	0.01	0.97	-	-	-	-	-	-	-	-
All Metals															
Sim set 1	27	0.74	0.01	0.80	0.01	0.67	0.72	0.81	0.01	0.84	0.01	0.85	0.01	0.82	0.01
Sim set 1 - GB	27	0.75	0.01	0.73	0.01	0.79	0.72	0.72	0.01	0.83	0.01	0.84	0.01	0.82	0.01
Sim set 2	27	0.72	0.02	0.71	0.02	0.80	0.71	0.71	0.02	0.46	0.01	0.84	0.02	0.01	0.02
Sim set 2 - GB	27	0.73	0.02	0.72	0.02	0.77	0.71	0.71	0.02	0.82	0.01	0.84	0.02	0.02	0.02
Exp	29	-	-	0.00	0.01	0.00	0.67	-	-	-	-	-	-	-	-
		434		660		A569		A653							
# of Elements		ANN	PLS	ANN	PLS	ANN	PLS	ANN	PLS						
Steel															
Sim set 1	17	0.01	0.19	0.28	0.99	-	-	-	-						
Sim set 1 - GB	17	0.18	0.19	0.02	0.83	-	-	-	-						
Sim set 2	17	0.84	1.00	0.59	0.61	-	-	-	-						
Sim set 2 - GB	17	0.19	0.85	0.02	0.59	-	-	-	-						
Exp		-	-	-	-	-	-	-	-						
All Metals															
Sim set 1	27	0.02	0.02	0.29	0.01	-	-	-	-						
Sim set 1 - GB	27	0.01	0.02	0.26	0.01	-	-	-	-						
Sim set 2	27	0.83	0.02	0.60	0.02	-	-	-	-						
Sim set 2 - GB	27	0.84	0.02	0.58	0.02	-	-	-	-						
Exp	29	-	-	-	-	-	-	-	-						

*Elements not present in the material were considered "correctly estimated" if the estimate was negative, or less than 1E-4

Table 15 – Fraction of elements predicted in the aluminum within the range of the ASTM Standard* multiplied by their contribution

		1100		2011		2024		2036		3003		5052		5086	
		ANN	PLS	ANN	PLS	ANN	PLS	ANN	PLS	ANN	PLS	ANN	PLS	ANN	PLS
Aluminum															
Sim set 1	12	0.00	0.00	0.94	0.94	0.93	0.95	-	-	0.00	0.02	0.00	0.97	0.00	0.01
Sim set 1 - GB	12	0.01	0.00	0.01	0.94	0.02	0.95	-	-	0.01	0.02	0.96	0.98	0.97	0.01
Sim set 2	12	0.01	0.01	1.00	0.94	0.94	1.00	-	-	0.01	0.99	0.98	0.00	0.01	0.01
Sim set 2 - GB	12	0.00	0.01	0.00	0.94	0.02	1.00	-	-	0.00	0.99	0.96	0.00	0.97	0.02
Exp	12	0.01	0.00	-	-	-	-	0.97	0.98	-	-	-	-	-	-
All Metals															
Sim set 1	27	0.00	0.00	0.00	0.00	0.02	0.01	-	-	0.00	0.00	0.00	0.00	0.00	0.01
Sim set 1 - GB	27	0.00	0.00	0.00	0.00	0.01	0.05	-	-	0.00	0.01	0.97	0.00	0.95	0.01
Sim set 2	27	0.00	0.00	0.00	0.00	0.95	0.01	-	-	1.00	0.00	0.00	0.00	0.00	0.01
Sim set 2 - GB	27	0.00	0.00	0.92	0.00	0.92	0.01	-	-	0.98	0.98	0.00	0.00	0.01	0.01
Exp	29	0.00	0.00	-	-	-	-	0.01	0.01	-	-	-	-	-	-
		5454		6061		6063		6101		6262		7075-unk		7075	
		ANN	PLS	ANN	PLS	ANN	PLS	ANN	PLS	ANN	PLS	ANN	PLS	ANN	PLS
Aluminum															
Sim set 1	12	0.00	0.97	0.98	0.97	0.98	0.01	0.98	0.01	0.01	0.98	-	-	0.99	1.00
Sim set 1 - GB	12	0.96	0.97	0.96	0.97	0.01	0.01	0.01	0.01	0.96	0.98	-	-	0.01	1.00
Sim set 2	12	0.98	0.01	0.97	0.98	0.97	0.99	0.98	0.98	0.98	0.00	-	-	0.93	1.00
Sim set 2 - GB	12	0.96	0.01	0.96	0.98	0.00	0.98	0.00	0.98	0.96	0.00	-	-	0.01	1.00
Exp	12	-	-	-	-	-	-	-	-	-	-	0.01	0.00	0.01	1.00
All Metals															
Sim set 1	27	0.00	0.00	0.01	0.97	0.00	0.00	0.01	0.00	0.01	0.00	-	-	0.00	0.02
Sim set 1 - GB	27	0.95	0.00	0.01	0.98	0.00	0.00	0.00	0.00	0.97	0.00	-	-	0.00	0.02
Sim set 2	27	0.00	0.01	0.00	0.00	0.00	0.00	0.00	0.00	0.01	0.00	-	-	0.06	0.02
Sim set 2 - GB	27	0.00	0.00	0.00	0.00	0.00	0.00	0.00	0.00	0.00	0.00	-	-	0.00	0.02
Exp	29	-	-	-	-	-	-	-	-	-	-	0.00	0.00	0.00	0.00

*Elements not present in the material were considered "correctly estimated" if the estimate was negative, or less than 1E-4

Table 16 – Fraction of elements predicted in the copper based metals within the range of the ASTM Standard* multiplied by their contribution

		C101		C110		C122		C260		C353		C464		C510	
# of Elements		ANN	PLS	ANN	PLS	ANN	PLS	ANN	PLS	ANN	PLS	ANN	PLS	ANN	PLS
Copper Based Metals															
Sim set 1	17	0.00	0.00	0.00	1.00	0.00	1.00	0.99	1.00	0.99	1.00	0.99	1.00	0.00	1.00
Sim set 1 - GB	17	0.00	0.00	0.00	0.00	0.00	0.00	0.99	0.98	0.36	0.99	0.99	0.38	0.00	0.00
Sim set 2	17	0.00	0.00	0.00	1.00	0.00	1.00	0.00	1.00	0.99	1.00	0.99	1.00	0.00	1.00
Sim set 2 - GB	17	0.00	0.00	0.00	0.00	0.00	1.00	0.31	1.00	0.36	1.00	0.99	1.00	0.00	1.00
Exp	17	-	-	0.00	0.00	-	-	-	-	-	-	-	-	-	-
All Metals															
Sim set 1	27	0.00	0.00	0.00	0.00	0.00	0.00	0.29	0.31	0.36	0.35	0.39	0.99	0.00	0.94
Sim set 1 - GB	27	0.00	0.00	0.00	0.00	0.00	0.00	0.00	0.31	0.00	0.35	0.39	0.99	0.00	0.94
Sim set 2	27	0.00	0.00	0.00	0.00	0.00	0.00	0.30	0.31	0.37	0.36	0.39	0.99	0.00	0.94
Sim set 2 - GB	27	0.00	0.00	0.00	0.00	0.00	0.00	0.00	0.31	0.35	0.36	0.39	0.99	0.00	0.94
Exp	29	-	-	0.00	0.00	-	-	-	-	-	-	-	-	-	-

*Elements not present in the material were considered "correctly estimated" if the estimate was negative, or less than 1E-4

Conclusion

In conclusion it is apparent that there are number of predictions from both the ANN and PLS that range from poor to excellent. In most cases, they could easily distinguish the presence of major components such as copper, iron, and zinc concentrations. Unfortunately, for both methods the amount of model error simply drowns out the possibility of identifying trace elements. Since the average error as seen in Table 9 is on the order of 10^{-3} , any reasonable predictions for the presence of an element would only be possible for elemental concentrations that make up at least 1% of the total material.

A few other general observations are noted. First it appears that when there are a large range of response variables and a number of them have zero for a value, the ANN method tends to provide better predictions than the PLS method. Counter to that, when the training data is more precise and limited in scope, such as only using copper samples to predict the composition of copper metals, the PLS model performs better.

The reason may be related to the additional non-linear parameters introduced by highly variable training sets. In the more narrow studies the PLS performs very well because the relationships exhibit more linear correlation and thus the model error can be reduced vs. a non-linear model that may not have converged as precisely.

Since most of the predictions were at least in the rough area of actual concentrations, a more precise analysis would include some statistical testing to see the likelihood a particular metal is one type over another. This could be done with variations on the goodness to fit studies but work with limited samples and statistics.

The final recommendation is that both models exhibit potential but are flawed if applied blindly. For each application of interest there needs to be an optimization step in the course of its implementation to ensure that results are consistent, repeatable, and precise.

References

- ASTM A568 / A568M - 13ae1 standard specification for steel, sheet, carbon, structural, and high-strength, low-alloy, hot-rolled and cold-rolled, general requirements for* . (2013). ().ASTM International.
- ASTM A653 / A653M - 13 standard specification for steel sheet, zinc-coated (galvanized) or zinc-iron alloy-coated (galvannealed) by the hot-dip process* . (2013). ().ASTM International.
- Abdi, H. (1999). In Edelman B., Valentin D. (Eds.), *Neural networks electronic resource*]. Thousand Oaks, Calif.: Sage Publications. Retrieved from <http://www2.lib.ncsu.edu/catalog/record/NCSU2803258>;
- Abdi, H. (2003). Partial least square regression (PLS regression). *Encyclopedia of social science research methods* (pp. 792-795) Sage.
- ASTM A240/A240M-13c standard specification for chromium and chromium-nickel stainless steel plate, sheet, and strip for pressure vessels and for general applications* . (2013). ().ASTM International.
- ASTM A36 / A36M - 12 standard specification for carbon structural steel*. (2012). ().ASTM International.
- ASTM A480 / A480M - 14 standard specification for general requirements for flat-rolled stainless and heat-resisting steel plate, sheet, and strip*. (2014). ().ASTM International.
- ASTM A480 / A480M - 14 standard specification for general requirements for flat-rolled stainless and heat-resisting steel plate, sheet, and strip* . (2014). ().ASTM International.
- ASTM A569/A569M-91a(1993)e1 historical standard: ASTM A569/A569M-91a(1993)e1 standard specification for steel, carbon (O. 15 maximum, percent), hot-rolled sheet and strip commercial quality* . (1993). ().ASTM International.
- ASTM B103/B103M-10 standard specification for phosphor bronze plate, sheet, strip, and rolled bar*. (2010). ().ASTM International.

ASTM B122 / B122M - 11 standard specification for copper-nickel-tin alloy, copper-nickel-zinc alloy (nickel silver), and copper-nickel alloy plate, sheet, strip, and rolled bar . (2011). ().ASTM International.

ASTM B152 / B152M - 13 standard specification for copper sheet, strip, plate, and rolled bar . (2013). ().ASTM International.

ASTM B171/B171M-12 standard specification for copper-alloy plate and sheet for pressure vessels, condensers, and heat exchangers . (2012). ().ASTM International.

ASTM B209 - 10 standard specification for aluminum and aluminum-alloy sheet and plate. (2010). ().ASTM International.

ASTM B248 - 12 standard specification for general requirements for wrought copper and copper-alloy plate, sheet, strip, and rolled bar. (2012). ().ASTM International.

ASTM B36 / B36M - 13 standard specification for brass plate, sheet, strip, and rolled bar. (2013). ().ASTM International.

ASTM B370 - 12 standard specification for copper sheet and strip for building construction . (2012). ().ASTM International.

ASTM B453/B453M-11e1 standard specification for copper-zinc-lead alloy (leaded-brass) rod, bar, and shapes . (2011). ().ASTM International.

ASTM E478 - 08 standard test methods for chemical analysis of copper alloys . (2008). ().ASTM International.

Bevington, P. R., 1933-. (1969). *Data reduction and error analysis for the physical sciences* New York, McGraw-Hill 1969]. Retrieved from <http://www2.lib.ncsu.edu/catalog/record/NCSU58240>

Bro, R., Rinnan, Å., & Faber, N. K. M. (2005). Standard error of prediction for multilinear PLS: 2. practical implementation in fluorescence spectroscopy. *Chemometrics and Intelligent Laboratory Systems*, 75(1), 69-76.

- Bro, R., & Smilde, A. K. (2003). Centering and scaling in component analysis. *Journal of Chemometrics*, 17(1), 16-33.
- Chang, R. (1998). *Chemistry*. Boston, Mass.: McGraw-Hill. Retrieved from <http://www2.lib.ncsu.edu/catalog/record/NCSU1399425>
- Deslattes, R. D., Kessler Jr, E. G., Indelicato, P., De Billy, L., Lindroth, E., & Anton, J. (2003). X-ray transition energies: New approach to a comprehensive evaluation. *Reviews of Modern Physics*, 75(1), 35.
- Doster, J. M., & Gardner, R. P. (1982). The complete spectral response for EDXRF systems— calculation by monte carlo and analysis applications. 1—homogeneous samples. *X-Ray Spectrometry*, 11(4), 173-180.
- Doster, J. M., & Gardner, R. P. (1982). The complete spectral response for EDXRF systems— calculation by monte carlo and analysis applications. 2—heterogeneous samples. *X-Ray Spectrometry*, 11(4), 181-186.
- Dunn, W. L. (. L., 1944-. (2012). In Shultis J. K. (Ed.), *Exploring monte carlo methods electronic resource*. Amsterdam ; Burlington, MA: Academic Press. Retrieved from <http://www2.lib.ncsu.edu/catalog/record/NCSU2504149>;
- Evans, R. D., 1907-. (1955). *The atomic nucleus*. Malabar, Fla.: R.E. Krieger, 1982. Retrieved from <http://www2.lib.ncsu.edu/catalog/record/NCSU955734>
- Freeman, J. A. (1991). In Skapura D. M. (Ed.), *Neural networks : Algorithms, applications, and programming techniques*. Reading, Mass.: Addison-Wesley. Retrieved from <http://www2.lib.ncsu.edu/catalog/record/NCSU771546>
- Gardner, R. P. (1978). In Doster J. M. (Ed.), *Corrections to the third-order formula for x-ray fluorescence intensities* American Chemical Society. doi:10.1021/ac50034a034
- Geladi, P., & Kowalski, B. R. (1986). Partial least-squares regression: A tutorial. *Analytica Chimica Acta*, 185, 1-17.

- Geladi, P., & Kowalski, B. R. (1986). Partial least-squares regression: A tutorial. *Analytica Chimica Acta*, 185(0), 1-17. doi:[http://dx.doi.org/10.1016/0003-2670\(86\)80028-9](http://dx.doi.org/10.1016/0003-2670(86)80028-9)
- Hagan, M. T., & Menhaj, M. -. (1994). Training feedforward networks with the marquardt algorithm. *Neural Networks, IEEE Transactions on*, 5(6), 989-993. doi:10.1109/72.329697
- Hagan, M. T. (1996). In Beale M. H., , Demuth H. B. and (Eds.), *Neural network design*. Boston: PWS Pub. Retrieved from <http://www2.lib.ncsu.edu/catalog/record/UNCb2911330>
- Helland, I. S. (1990). Partial least squares regression and statistical models. *Scandinavian Journal of Statistics*, , 97-114.
- Höskuldsson, A. (1988). PLS regression methods. *Journal of Chemometrics*, 2(3), 211-228.
- Knoll, G. F. (2010). *Radiation detection and measurement*. Hoboken, N.J.: John Wiley. Retrieved from <http://www2.lib.ncsu.edu/catalog/record/UNCb6478572>
- Lorber, A., Wangen, L. E., & Kowalski, B. R. (1987). A theoretical foundation for the PLS algorithm. *Journal of Chemometrics*, 1(1), 19-31.
- Manne, R. (1987). Analysis of two partial-least-squares algorithms for multivariate calibration. *Chemometrics and Intelligent Laboratory Systems*, 2(1), 187-197.
- Marsland, S. (2009). *Machine learning : An algorithmic perspective*. Boca Raton: CRC Press. Retrieved from <http://www2.lib.ncsu.edu/catalog/record/NCSU2244782>
- Marti, W. (1961). Determination of the interelement effect in the X-ray fluorescence analysis of cr in steels. *Spectrochimica Acta*, 17(4), 379-383.
- Mattingly, J. (2009). Polyethylene-reflected plutonium metal sphere: Subcritical neutron and gamma measurements. *SAND2009-5804 Revision, 2*
- McConn Jr., R. J., Gesh, C. J., Pagh, R. T., Rucker, R. A., & Williams III, R. G. (2011). *RADIATION PORTAL MONITOR PROJECT: Compendium of material composition data for radiation transport modeling*. (No. PIET-43741-TM-963, PNNL-15870 Rev. 1). Alexandria, VA: National Technical Information Service.

- Ng, K. S. (2013). *A simple explanation of partial least squares*. <http://users.cecs.anu.edu.au/~kee/>:
- Sherman, J. (1956). The theoretical derivation of fluorescent X-ray intensities from mixtures. *Spectrochimica Acta*, 7, 283-306.
- Shultis, J. K., & Faw, R. (2006). An MCNP primer. *Dept.of Mechanical and Nuclear*,
- Tobias, R. D. (1995). An introduction to partial least squares regression. Paper presented at the *Proc. Ann. SAS Users Group Int. Conf., 20th, Orlando, FL, 2-5*.
- X-5 Monte Carlo Team. (2008). *MCNP — A general monte carlo N-particle transport code, version 5 volume I: Overview and theory*. (User Manual No. LA-UR-03-1987). Los Alamos National Laboratory.
- Younger, M. S. (1979). *Handbook for linear regression*. North Scituate, Mass.: Duxbury Press. Retrieved from <http://www2.lib.ncsu.edu/catalog/record/NCSU896999>
- Zabinsky, S., Rehr, J., Ankudinov, A., Albers, R., & Eller, M. (1995). Multiple-scattering calculations of X-ray-absorption spectra. *Physical Review B*, 52(4), 2995.

Appendices

Appendix A – X-ray Spectroscopic Data (Simulated and Experimental)

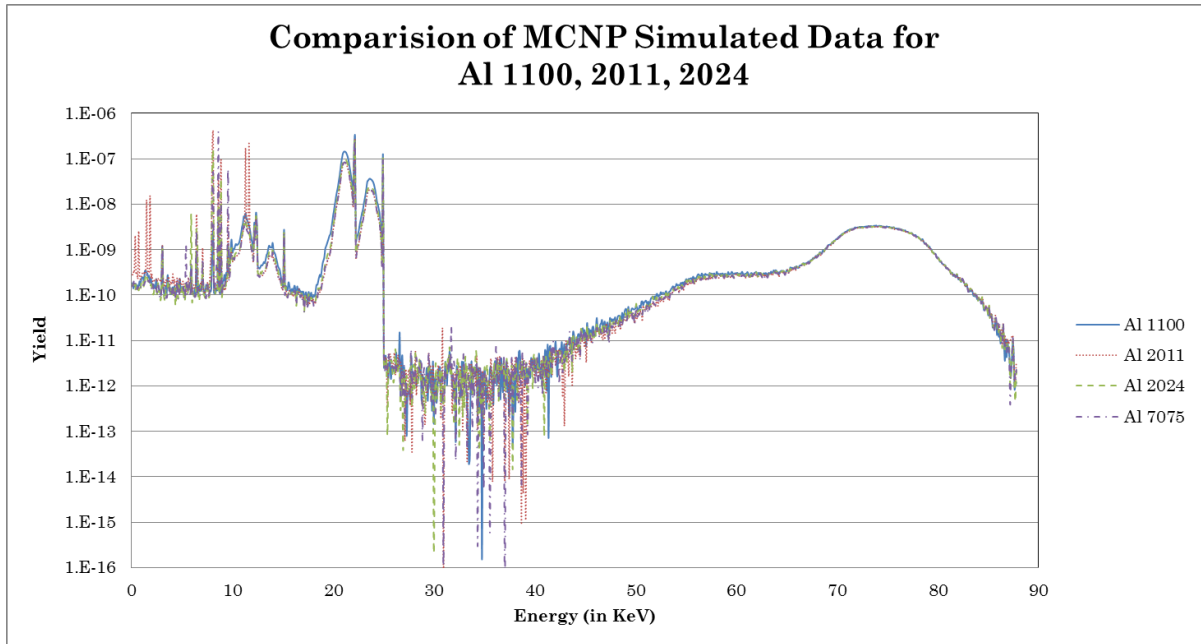

Figure 20 – MCNP Data for Al-1100, Al-2011, Al-2024, and Al-7075

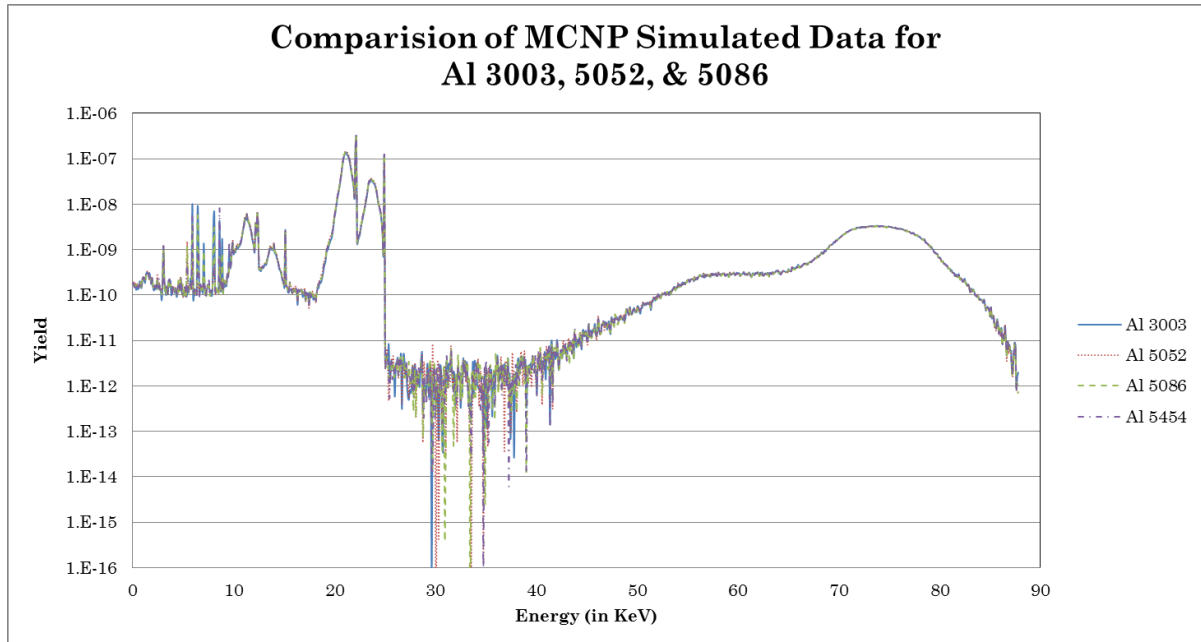

Figure 21 – MCNP Data for Al-3003, Al-5052, Al-5086, and Al-5454

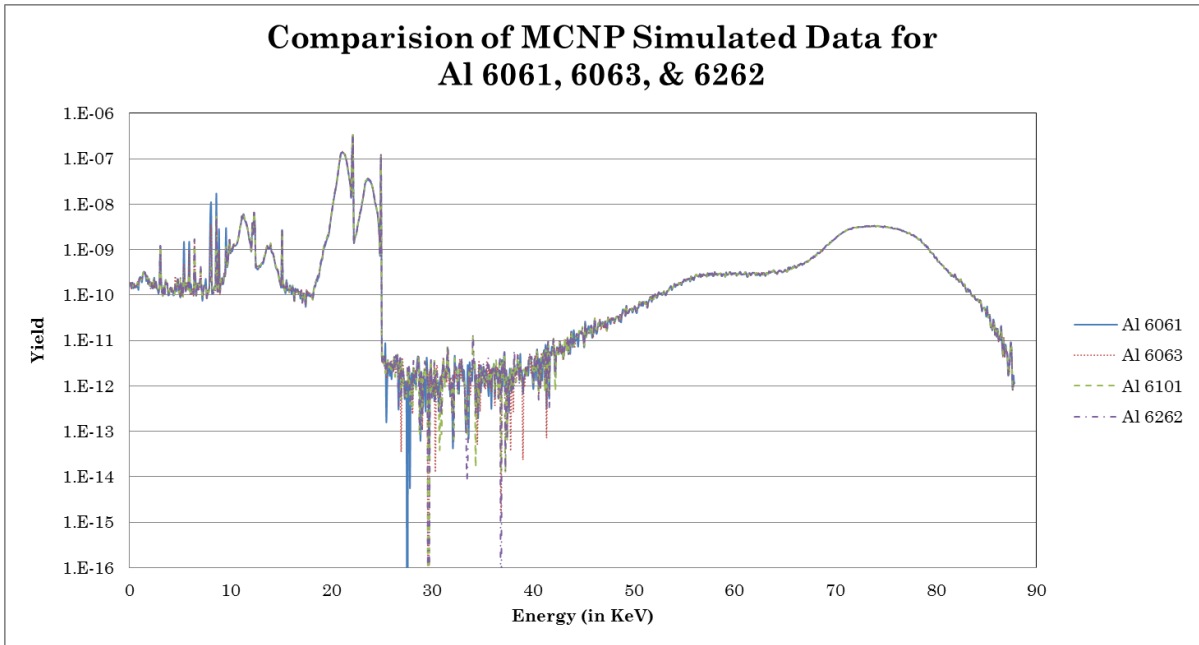

Figure 22 – MCNP Data for Al-6061, Al-6063, Al-6101, and Al-6262

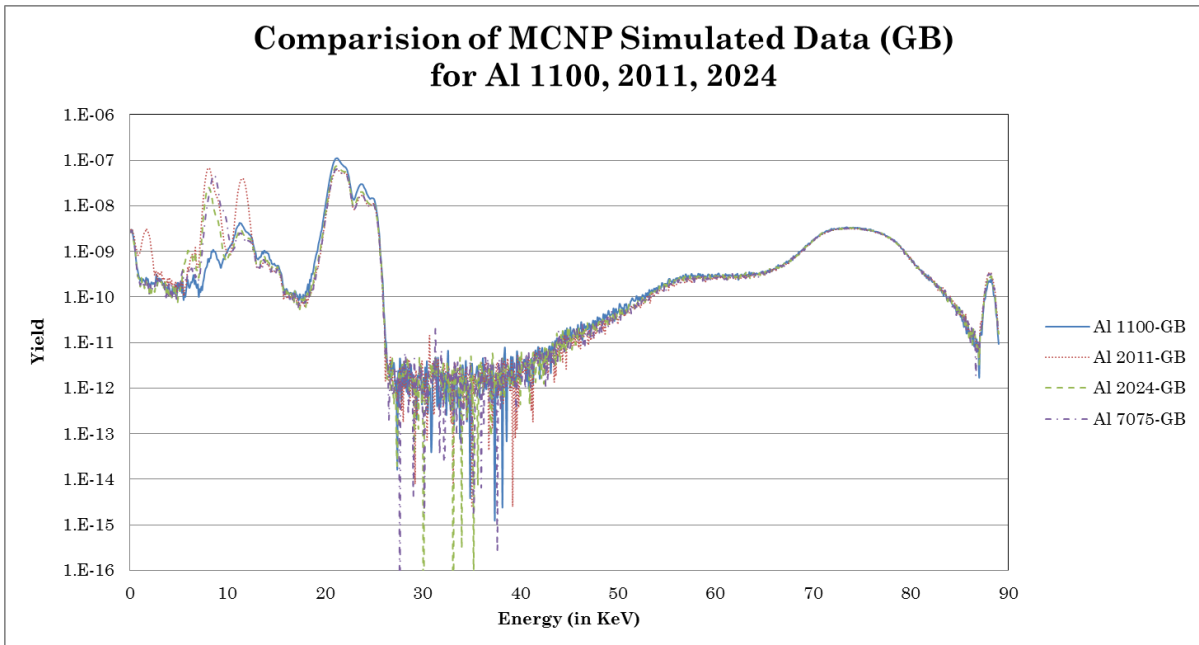

Figure 23 – Gaussian Broadened MCNP Data for Al-1100, Al-2011, Al-2024, and Al-7075

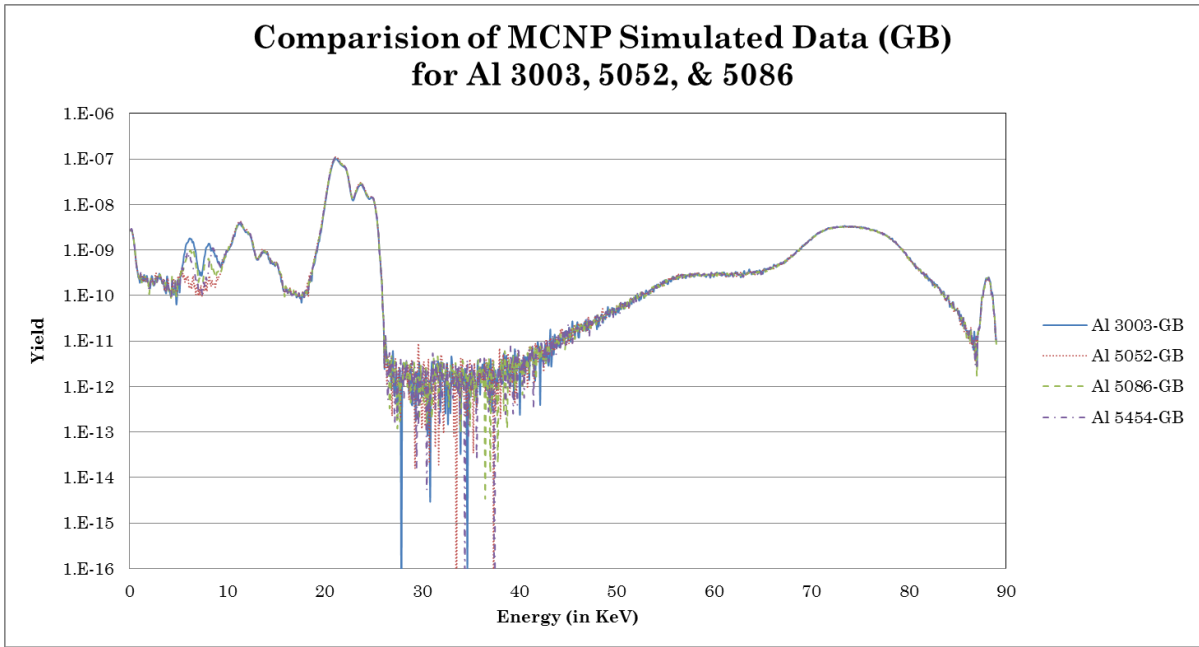

Figure 24 – Gaussian Broadened MCNP Data for Al-3003, Al-5052, Al-5086, and Al-5454

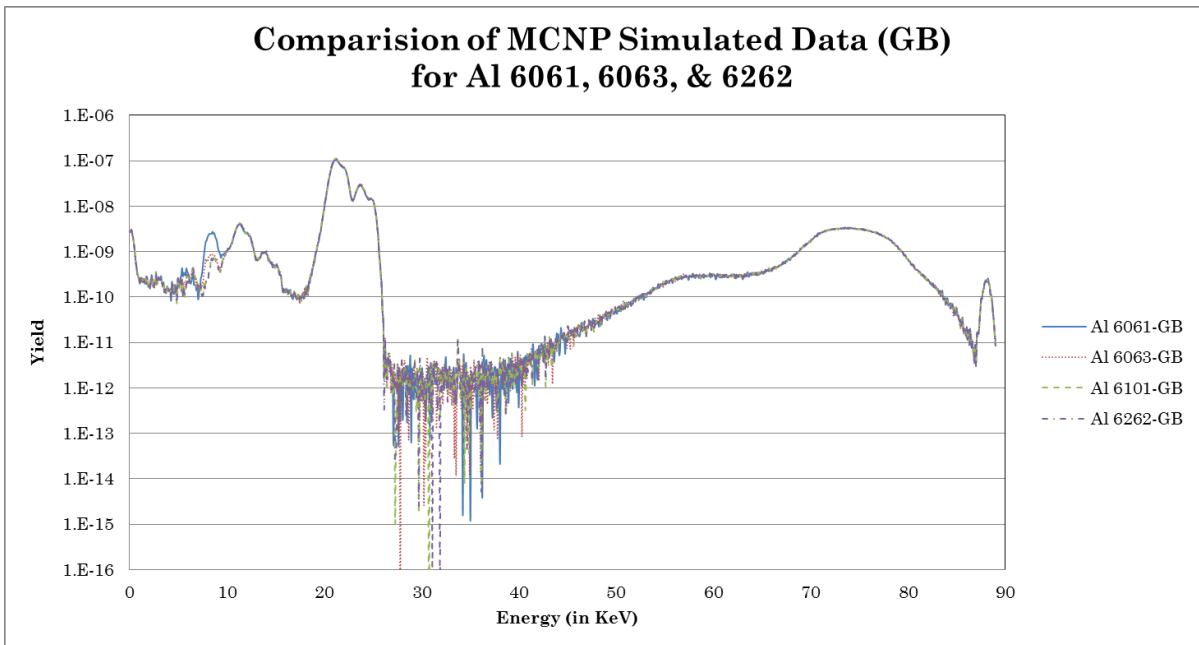

Figure 25 – MCNP Data for Al-6061, Al-6063, Al-6101, and Al-6262

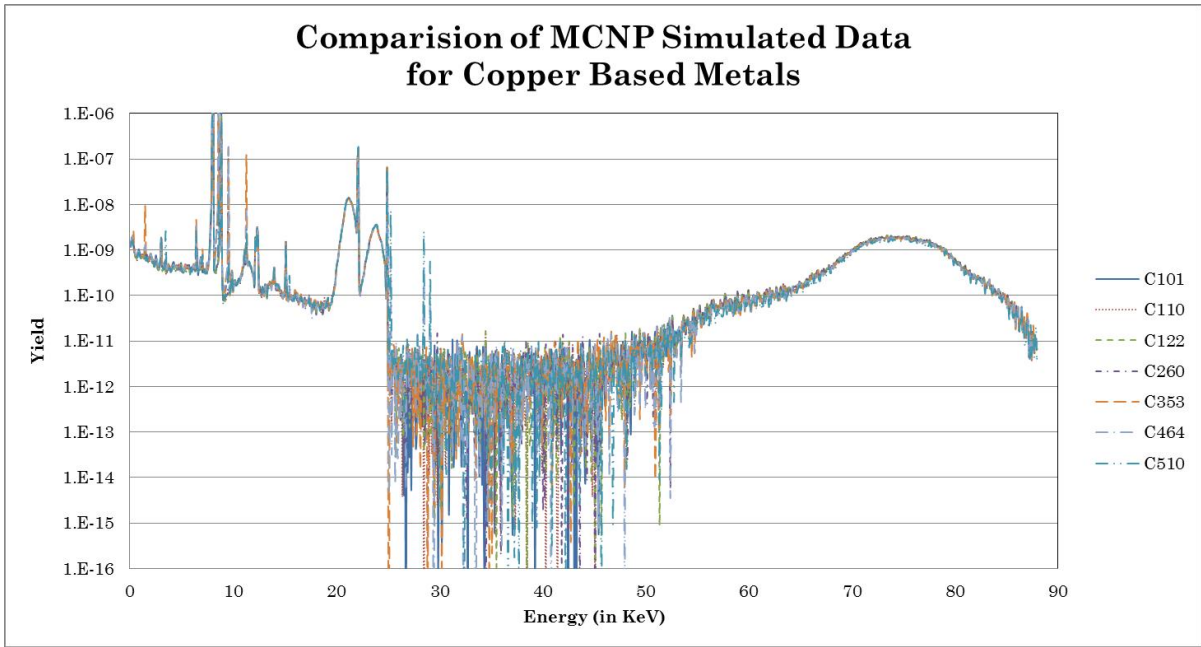

Figure 26 – MCNP Data for C101, C110, C122, C260, C260, C353, C464, C510

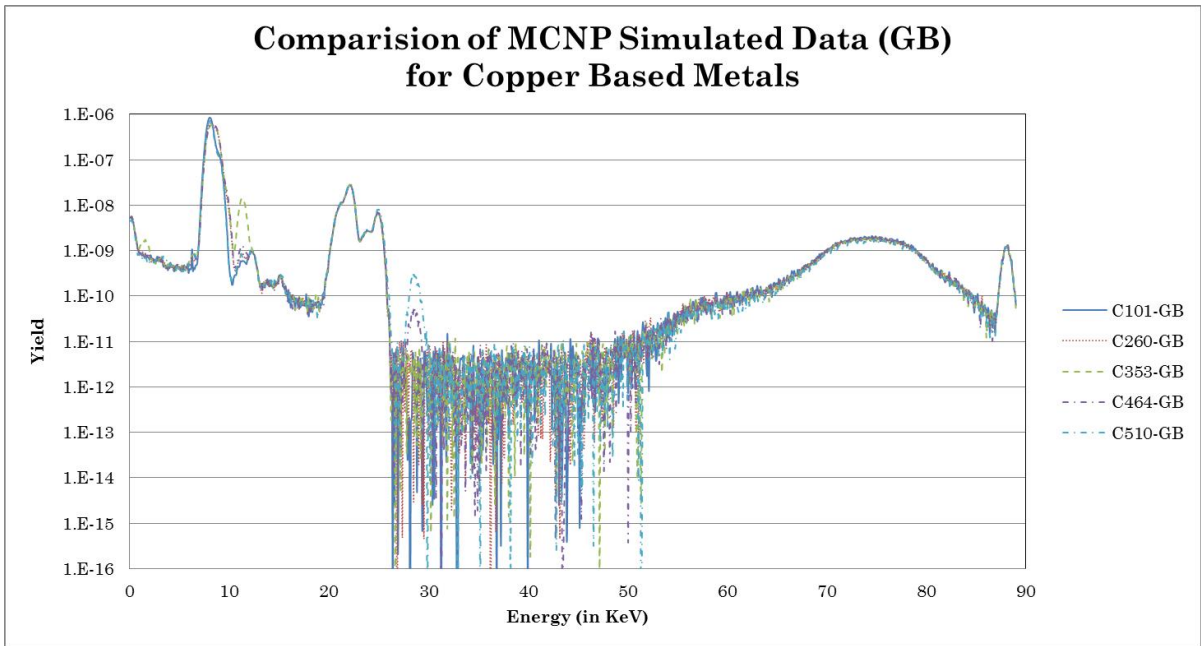

Figure 27 – Gaussian broadened MCNP Data for C101, C260, C260, C353, C464, and C510

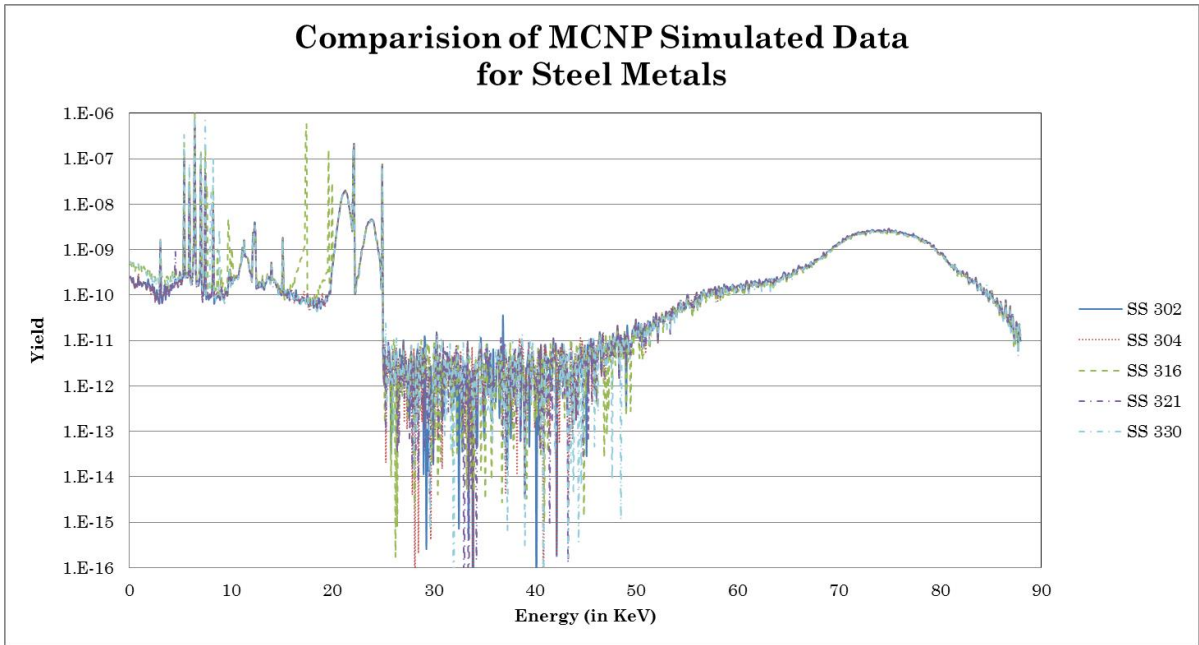

Figure 28 – MCNP Data for Stainless Steel 302, 304, 316, 321, and 330

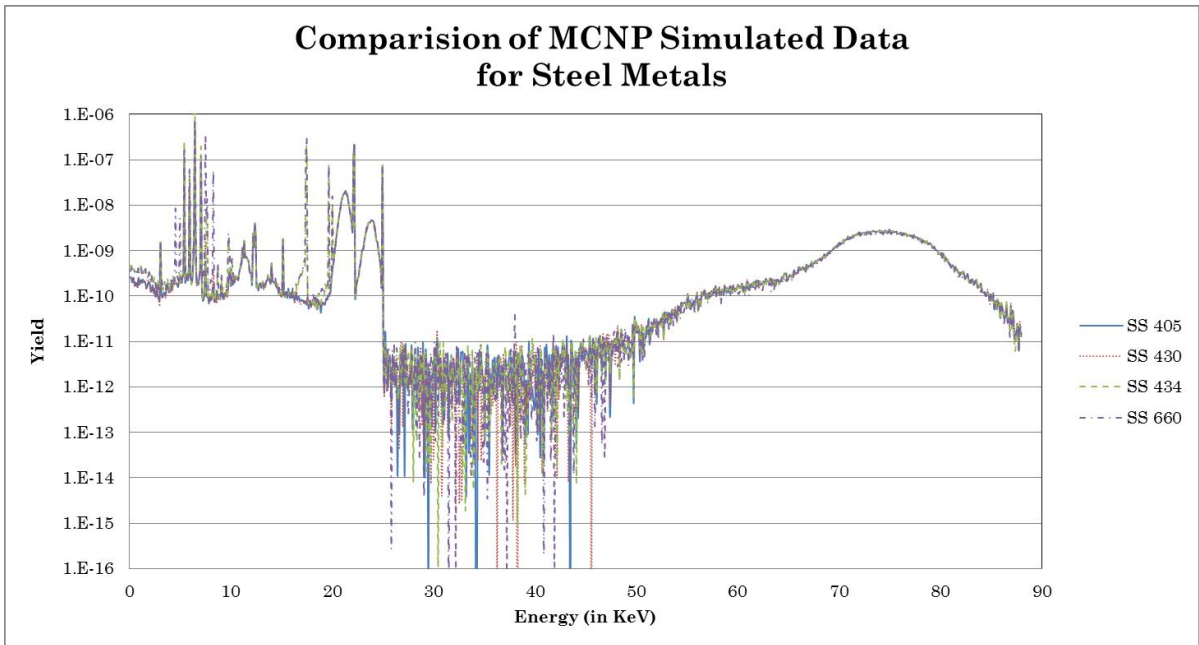

Figure 29 – MCNP Data for Stainless Steel 405, 430, 434, and 660

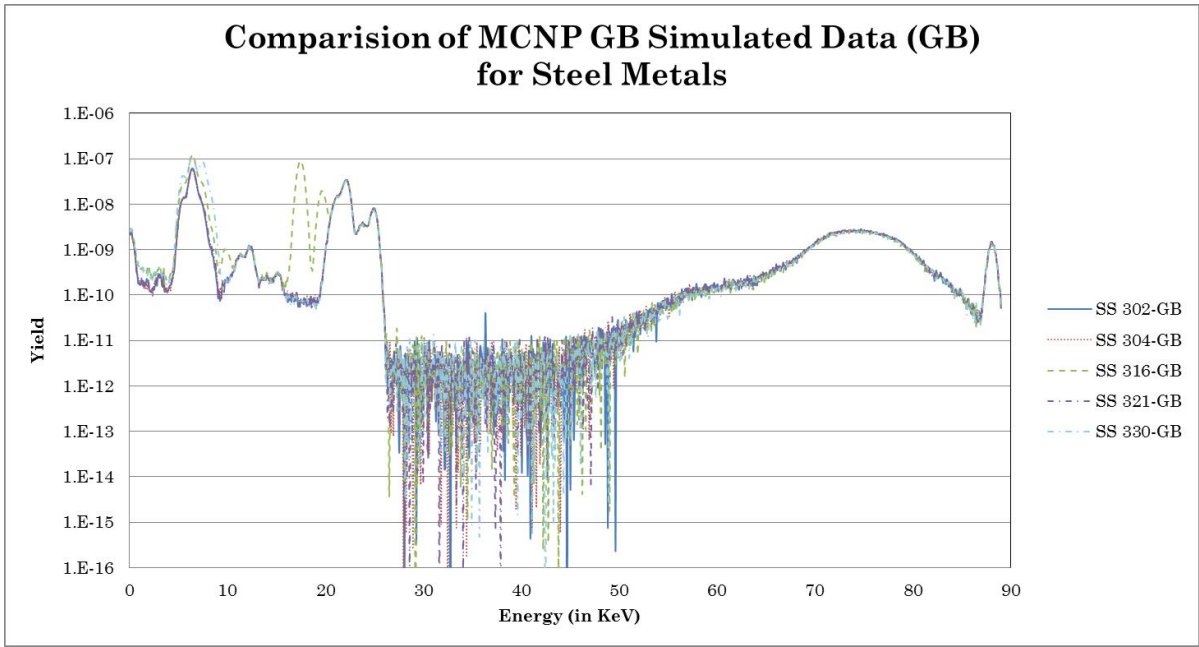

Figure 30 – Gaussian broadened MCNP Data for Stainless Steel 302, 304, 316, 321, and 330

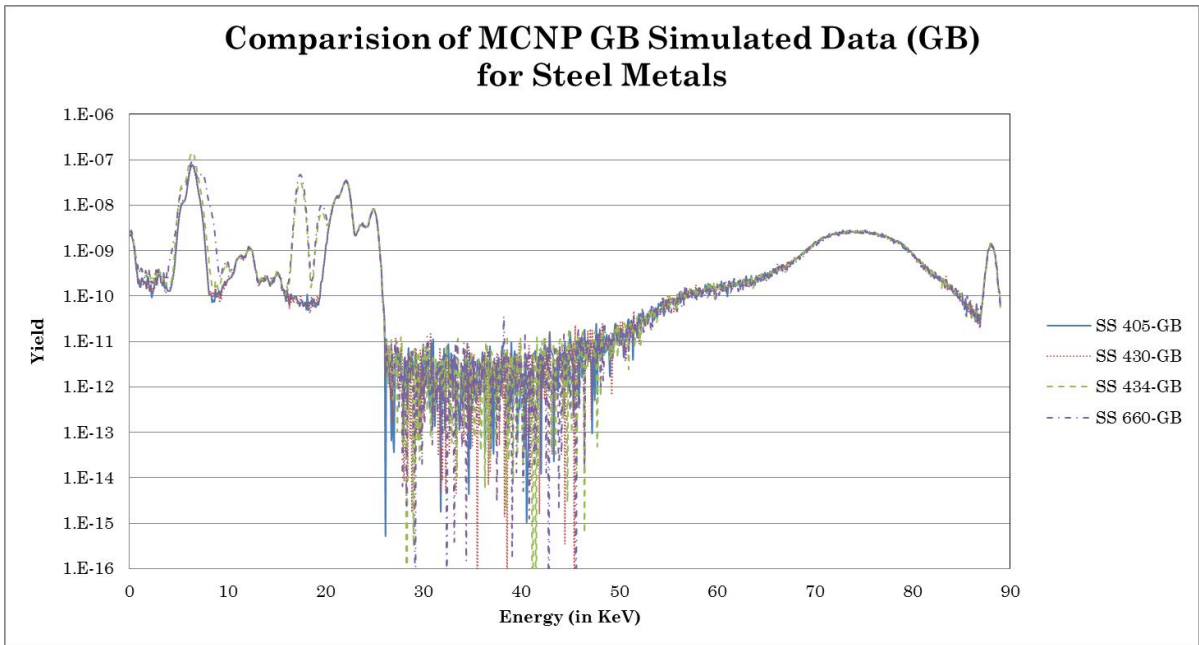

Figure 31 – Gaussian broadened MCNP Data for Stainless Steel 405, 430, 434, and 660

Appendix B – ASTM Standards

Table 17 – ASTM Standards for Select Types of Copper Based Metals

Element	C10100		C11000		C12200		C26000		C35300		C46400		C51000	
	min%	max%	min%	max%	min%	max%	min%	max%	min%	max%	min%	max%	min%	max%
Cu*	99.9900	100.0000	99.9000	----	99.9000	----	68.500	71.500	61.000	63.000	59.000	62.000	<i>Remainder</i>	
Ag	----	0.0025	----	0.1000	----	0.1000	----	----	----	----	----	----	----	----
As	----	0.0005	----	----	----	----	----	----	----	----	----	----	----	----
Bi	----	0.0001	----	----	----	----	----	----	----	----	----	----	----	----
Cd	----	0.0001	----	----	----	----	----	----	----	----	----	----	----	----
Fe	----	0.0010	----	----	----	----	----	0.050	----	0.150	----	0.100	----	0.100
Mn	----	0.0005	----	----	----	----	----	----	----	----	----	----	----	----
Ni	----	0.0010	----	----	----	----	----	----	----	----	----	----	----	----
O	----	0.0005	----	0.0400	----	----	----	----	----	----	----	----	----	----
P	----	0.0003	----	----	0.0150	0.0400	----	----	----	----	----	----	0.030	0.350
Pb	----	0.0005	----	----	----	----	----	0.070	1.500	2.500	----	0.200	----	0.050
S	----	0.0015	----	----	----	----	----	----	----	----	----	----	----	----
Sb	----	0.0004	----	----	----	----	----	----	----	----	----	----	----	----
Se	----	0.0003	----	----	----	----	----	----	----	----	----	----	----	----
Sn	----	0.0002	----	----	----	----	----	----	----	----	0.500	1.000	4.200	5.800
Te	----	0.0002	----	----	----	----	----	----	----	----	----	----	----	----
Zn	----	0.0001	----	----	----	----	<i>Remainder</i>		<i>Remainder</i>		<i>Remainder</i>		----	0.300

*Includes Ag for C26000, C35300, and C46400

sources: ASTM B36, B171, B453, B103

Table 18 – ASTM Standards for Select Types of Copper Based Metals

ASTM Standards for Steel												
Element	302		304		316		321		330		405	
	min%	max%	min%	max%	min%	max%	min%	max%	min%	max%	min%	max%
Al	----	----	----	----	----	----	----	----	----	----	0.100	0.300
B	----	----	----	----	----	----	----	----	----	----	----	----
C	----	0.150	----	0.070	----	0.080	----	0.080	----	0.080	----	0.080
Cr	17.000	19.000	17.500	19.500	16.000	18.000	17.000	19.000	17.000	20.000	11.500	14.500
Cu	----	----	----	----	----	----	----	----	----	1.000	----	----
Fe	<i>Remainder</i>		<i>Remainder</i>		<i>Remainder</i>		<i>Remainder</i>		<i>Remainder</i>		<i>Remainder</i>	
Mn	----	----	----	----	----	----	----	----	----	0.005	----	----
Mo	----	2.000	----	2.000	----	2.000	----	2.000	----	2.000	----	1.000
Nb	----	----	----	----	2.000	3.000	----	----	----	----	----	----
Ni	8.000	10.000	8.000	10.500	10.000	14.000	9.000	12.000	34.000	37.000	----	0.600
N	----	0.100	----	0.100	----	0.100	----	0.100	----	----	----	----
P	----	0.045	----	0.045	----	0.045	----	0.045	----	0.030	----	0.040
Si	----	0.750	----	0.750	----	0.750	----	0.750	0.750	1.500	----	1.000
S	----	0.030	----	0.030	----	0.030	----	0.030	----	0.030	----	0.030
Sn	----	----	----	----	----	----	----	----	----	0.025	----	----
Ti	----	----	----	----	----	----	----	0.700	----	----	----	----
V	----	----	----	----	----	----	----	----	----	----	----	----
Element	430		434		660		A569		A653			
	min%	max%	min%	max%	min%	max%	min%	max%	min%	max%		
Al	----	----	----	----	----	0.350	----	----				
B	----	----	----	----	0.001	0.010	----	----				
C	----	0.120	0.000	0.120	0.000	0.080	----	0.150				
Cr	16.000	18.000	16.000	18.000	13.500	16.000	----	0.150				
Cu	----	----	----	----	----	----	----	0.200				
Fe	<i>Remainder</i>		<i>Remainder</i>		<i>Remainder</i>		<i>Remainder</i>					
Mn	----	----	----	----	----	----	----	0.600				
Mo	----	1.000	----	1.000	----	2.000	----	0.060				
Nb	----	----	0.750	1.250	1.000	1.500	----	0.008	see ASTM A653			
Ni	----	0.750	0.000	0.000	24.000	27.000	----	----				
N	----	----	----	----	----	----	----	----				
P	----	0.040	----	0.040	----	0.040	----	0.035				
Si	----	1.000	----	1.000	----	1.000	----	----				
S	----	0.030	----	0.030	----	0.030	----	0.035				
Sn	----	----	----	----	----	----	----	----				
Ti	----	----	----	----	1.900	2.350	----	----				
V	----	----	----	----	0.100	0.500	----	0.008				

sources: ASTM A240, A638, A569, A653

Table 19 – ASTM Standards for Select Types of Aluminum

ASTM Standards for Aluminum														
Element	1100		2011		2024		2036		3003		5052		5086	
	min%	max%	min%	max%	min%	max%	min%	max%	min%	max%	min%	max%	min%	max%
Al	99.000	----	<i>Remainder</i>		<i>Remainder</i>		<i>Remainder</i>		<i>Remainder</i>		<i>Remainder</i>		<i>Remainder</i>	
B	----	----	----	----	----	----	----	----	----	----	----	----	----	----
Bi	----	----	0.200	0.600	----	----	----	----	----	----	----	----	----	----
Cr	----	----	----	----	----	0.100	----	0.100	----	----	0.150	0.350	0.050	0.250
Cu	0.050	0.200	5.000	6.000	3.800	4.900	2.200	3.000	0.050	0.200	----	0.100	----	0.100
Fe	----	0.950*	----	0.700	----	0.500	----	0.500	----	0.700	----	0.400	----	0.500
Mg	----	----	----	0.050	1.200	1.800	0.300	0.600	----	----	2.200	2.800	3.500	4.500
Mn	----	0.050	----	----	0.300	0.900	0.100	0.400	1.000	1.500	----	0.100	0.200	0.700
Pb	----	----	0.200	0.600	----	----	----	----	----	----	----	----	----	----
Si	----	inc.	----	0.400	----	0.500	----	0.500	----	0.600	----	0.250	----	0.400
Ti	----	----	----	----	----	0.150	----	0.150	----	----	----	----	----	0.150
Zn	----	0.100	----	0.300	----	0.250	----	0.250	----	0.100	----	0.100	----	0.250
Zr	----	----	----	----	----	----	----	----	----	----	----	----	----	----
V	----	----	----	----	----	----	----	----	----	----	----	----	----	----
Other - Each	----	0.05	----	0.05	----	0.05	----	0.05	----	0.05	----	0.05	----	0.05
Other - Total	----	0.15	----	0.15	----	0.15	----	0.15	----	0.15	----	0.15	----	0.15
Element	5454		6061		6063		6101		6262		7050		7075	
	min%	max%	min%	max%	min%	max%	min%	max%	min%	max%	min%	max%	min%	max%
Al	<i>Remainder</i>		<i>Remainder</i>		<i>Remainder</i>		<i>Remainder</i>		<i>Remainder</i>		<i>Remainder</i>		<i>Remainder</i>	
B	----	----	----	----	----	----	----	0.060	----	----	----	----	----	----
Bi	----	----	----	----	----	----	----	----	0.400	0.700	----	----	----	----
Cr	0.050	0.200	0.040	0.350	----	0.100	----	0.030	0.040	0.140	----	0.040	0.180	0.280
Cu	----	0.100	0.150	0.400	----	0.100	----	0.100	0.150	0.400	2.000	2.600	1.200	2.000
Fe	----	0.400	----	0.700	----	0.350	----	0.500	----	0.700	----	0.150	----	0.500
Mg	2.400	3.000	0.800	1.200	0.450	0.900	0.350	0.800	0.800	1.200	1.900	2.600	2.100	2.900
Mn	0.500	1.000	----	0.150	----	0.100	----	0.030	----	0.150	----	0.100	----	0.300
Pb	...	----	----	----	----	----	----	----	0.400	0.700	----	----	----	----
Si	----	0.250	0.400	0.800	0.200	0.600	0.300	0.700	0.400	0.800	----	0.120	----	0.400
Ti	----	0.200	----	0.150	----	0.100	----	----	----	0.150	----	0.060	----	0.200
Zn	----	0.250	----	0.250	----	0.100	----	0.100	----	0.250	5.700	6.700	5.100	6.100
Zr	----	----	----	----	----	----	----	----	----	----	0.080	0.150	----	----
V	----	----	----	----	----	----	----	----	----	----	----	----	----	----
Other - Each	----	0.05	----	0.05	----	0.05	----	0.03	----	0.05	----	0.05	----	0.05
Other - Total	----	0.15	----	0.15	----	0.15	----	0.10	----	0.15	----	0.15	----	0.15

sources: ASTM B209

* includes Si

Appendix C – LV Study Results on Scaled and Centered Data

Table 20 – PLS Model - LV Study - Centered and Scaled Data Input

		The proportion of the data explained by a Latent Variables (LV's)										Total Explained
Data Block		LV1	LV2	LV3	LV4	LV5	LV6	LV7	LV8	LV9	LV10	
Aluminum Samples												
Simulated Data - Set 1	X	0.66681022	0.11381101	0.05356314	0.06254005	0.03019404	0.02008871	0.01327245	0.01406172	0.00822442	0.01172996	0.99429571
	Y	0.18090173	0.26575070	0.10949717	0.06677348	0.05299204	0.07091337	0.06967161	0.04416349	0.05569181	0.03462312	0.95097853
Simulated Data - Set 1 - GB	X	0.61063925	0.10190439	0.06563250	0.05204019	0.03460687	0.04685248	0.02584673	0.03024690	0.01070546	0.01111927	0.98959403
	Y	0.17819865	0.26992484	0.10831652	0.09392055	0.06214679	0.04081893	0.05423861	0.02451629	0.07391350	0.06272738	0.96872207
Simulated Data - Set 2	X	0.66907164	0.08846008	0.07384510	0.05838274	0.03095802	0.02331685	0.01960093	0.00894230	0.01124932	0.01117216	0.99499915
	Y	0.16452409	0.21492336	0.11938149	0.11166975	0.07322907	0.07578058	0.06646846	0.10549909	0.02940420	0.02013114	0.98101123
Simulated Data - Set 2 - GB	X	0.61324178	0.09587541	0.05467767	0.07309296	0.03848573	0.02501539	0.03040170	0.02224128	0.01242061	0.01919891	0.98465145
	Y	0.16558244	0.20565018	0.17001966	0.10210122	0.06238364	0.06438705	0.03688981	0.06211234	0.09078621	0.02668476	0.98659732
Experimental Data	X	0.58989897	0.16025378	0.07406176	0.04127128	0.03298088	0.02236196	0.01399490	0.01984710	0.01623515	0.01616213	0.98706792
	Y	0.15182340	0.19302104	0.11195467	0.13825114	0.12144204	0.08353320	0.11815813	0.02856368	0.03016561	0.01332558	0.99023847
Copper Based Metal Samples												
Simulated Data - Set 1	X	0.39559775	0.25236388	0.19497697	0.07296808	0.02884983	0.05524348	0.00000000	0.00000000	0.00000000	0.00000000	1.00000000
	Y	0.39559775	0.25236388	0.19497697	0.07296808	0.02884983	0.05524348	0.00000000	0.00000000	0.00000000	0.00000000	1.00000000
Simulated Data - Set 1 - GB	X	0.34138078	0.24382634	0.22287611	0.08463152	0.05480040	0.05248485	0.00000000	0.00000000	0.00000000	0.00000000	1.00000000
	Y	0.56985017	0.17996151	0.16452623	0.04056835	0.04008650	0.00500723	0.00000000	0.00000000	0.00000000	0.00000000	1.00000000
Simulated Data - Set 2	X	0.48788797	0.21655227	0.11385579	0.07836531	0.05515227	0.04818639	0.00000000	0.00000000	0.00000000	0.00000000	1.00000000
	Y	0.25228790	0.22767859	0.35391614	0.09660418	0.03580025	0.03371294	0.00000000	0.00000000	0.00000000	0.00000000	1.00000000
Simulated Data - Set 2 - GB	X	0.42767255	0.24917731	0.08905316	0.09523866	0.07759920	0.06125912	0.00000000	0.00000000	0.00000000	0.00000000	1.00000000
	Y	0.27422626	0.21196455	0.38763447	0.05542220	0.04915263	0.02159988	0.00000000	0.00000000	0.00000000	0.00000000	1.00000000
Experimental Data	X	0.36430576	0.21274024	0.15775445	0.13162468	0.13357487	0.00000000	0.00000000	0.00000000	0.00000000	0.00000000	1.00000000
	Y	0.30519715	0.43861044	0.14808320	0.09815992	0.00994928	0.00000000	0.00000000	0.00000000	0.00000000	0.00000000	1.00000000
Stainless Steel Samples												
Simulated Data - Set 1	X	0.51916729	0.19024792	0.11811305	0.06802477	0.03914910	0.02481394	0.02252264	0.01796128	0.00000000	0.00000000	1.00000000
	Y	0.28189188	0.26768631	0.17187465	0.17949644	0.05529728	0.02768331	0.01261552	0.00345461	0.00000000	0.00000000	1.00000000
Simulated Data - Set 1 - GB	X	0.48202208	0.17365463	0.07623583	0.08873316	0.06047142	0.04020780	0.04052879	0.03814629	0.00000000	0.00000000	1.00000000
	Y	0.27499763	0.24749174	0.21197179	0.15358863	0.06336996	0.03017316	0.01257106	0.00583602	0.00000000	0.00000000	1.00000000
Simulated Data - Set 2	X	0.57042074	0.15426885	0.07594070	0.07626822	0.03681289	0.03945409	0.02845631	0.01837820	0.00000000	0.00000000	1.00000000
	Y	0.24996092	0.22011235	0.24906394	0.11021289	0.06976282	0.04230580	0.04019469	0.01898658	0.00000000	0.00000000	1.00000000
Simulated Data - Set 2 - GB	X	0.49751644	0.12687245	0.09748661	0.07601515	0.07094753	0.04957660	0.04189890	0.03968632	0.00000000	0.00000000	1.00000000
	Y	0.23510703	0.27207024	0.21322595	0.10852831	0.05822705	0.04976072	0.04349386	0.01958686	0.00000000	0.00000000	1.00000000
Experimental Data	X	0.48119112	0.18256059	0.13247530	0.08704756	0.05810605	0.05861938	0.00000000	0.00000000	0.00000000	0.00000000	1.00000000
	Y	0.52104331	0.13898672	0.11634303	0.11030084	0.07035193	0.04297418	0.00000000	0.00000000	0.00000000	0.00000000	1.00000000
Total Samples												
Simulated Data - Set 1	X	0.60609330	0.17213097	0.03691798	0.03138291	0.03752325	0.02222304	0.02050898	0.01794851	0.01265131	0.00723828	0.96461853
	Y	0.13522703	0.17246566	0.14141003	0.07556631	0.05795792	0.04723891	0.04941115	0.04307412	0.03053300	0.03335940	0.78624353
Simulated Data - Set 1 - GB	X	0.58699951	0.17300975	0.03031791	0.04072089	0.05012592	0.02868826	0.01716173	0.01046147	0.01040772	0.00741373	0.95530690
	Y	0.13538501	0.17328136	0.14048778	0.06748178	0.04731036	0.04614885	0.05220228	0.05895606	0.03146247	0.03707028	0.78978622
Simulated Data - Set 2	X	0.61743480	0.16922216	0.04087444	0.03273403	0.02323378	0.01994481	0.01689024	0.01375911	0.01530560	0.00597499	0.95537395
	Y	0.13331700	0.17169491	0.07299177	0.06136033	0.05772654	0.05953278	0.04978675	0.05948277	0.03100550	0.05893167	0.75583002
Simulated Data - Set 2 - GB	X	0.59960384	0.16555481	0.04611545	0.03984083	0.02537254	0.01847382	0.01624001	0.01017152	0.01122708	0.00996429	0.94256420
	Y	0.13335788	0.17567328	0.05526755	0.05270098	0.06024289	0.05638585	0.05868100	0.06031663	0.04381875	0.03737655	0.73382136
Experimental Data	X	0.48119112	0.18256059	0.13247530	0.08704756	0.05810605	0.05861938	0.00000000	0.00000000	0.00000000	0.00000000	1.00000000
	Y	0.52104331	0.13898672	0.11634303	0.11030084	0.07035193	0.04297418	0.00000000	0.00000000	0.00000000	0.00000000	1.00000000

Appendix D – Estimates of Elemental Weight Fractions for Set 1

Table 21 – Estimate of Set 1 Aluminum Element Weight Fractions (8 Node ANN Model with Set 2 Simulated Data)

Aluminum	Al		B		Bi		Cr		Cu		Fe	
	Est	Act	Est	Act	Est	Act	Est	Act	Est	Act	Est	Act
1100	0.972953	0.994795	-0.000326	-	-0.000654	-	0.002928	-	-0.001683	0.000673	0.004161	0.000471
2011	0.932185	0.929975	-0.002384	-	0.004839	0.004970	-0.000184	-	0.055494	0.054141	0.003496	0.001678
2024	0.921214	0.927149	-0.002906	-	0.001439	-	0.003253	0.000217	0.022982	0.045485	0.000513	0.001813
3003	0.959082	0.978023	-0.000064	-	-0.001005	-	0.002178	-	-0.000065	0.001955	0.003167	0.006083
5052	0.973642	0.970739	-0.000349	-	-0.000588	-	0.002985	0.003057	-0.002348	0.000084	0.004308	0.000103
5086	0.967806	0.944737	-0.000133	-	-0.000852	-	0.002716	0.002031	-0.001785	0.000890	0.003989	0.003745
5454	0.964930	0.962812	-0.000110	-	-0.000913	-	0.002529	0.000693	-0.001330	0.000093	0.003703	0.000222
6061	0.965837	0.973882	-0.000173	-	-0.000812	-	0.002694	0.002653	-0.000385	0.003021	0.003781	0.000136
6063	0.974605	0.987111	-0.000353	-	-0.000630	-	0.002968	0.000749	-0.002274	0.000920	0.004281	0.000916
6101	0.974772	0.985162	-0.000346	0.000142	-0.000629	-	0.002986	0.000295	-0.002253	0.000061	0.004297	0.001100
6262	0.974932	0.958337	-0.000350	-	-0.000630	0.006893	0.003000	0.000949	-0.002142	0.002721	0.004261	0.005531
7075	0.888112	0.892454	0.002764	-	-0.005681	-	0.006059	0.002280	0.016317	0.014880	-0.000549	0.001896
Aluminum	Mg		Mn		Pb		Si		Ti		Zn	
	Est	Act	Est	Act	Est	Act	Est	Act	Est	Act	Est	Act
1100	0.017130	-	0.006471	0.000274	-0.008546	-	0.001328	0.002894	-0.002178	-	-0.000127	0.000893
2011	0.004409	0.000480	0.002538	-	-0.003611	0.004484	0.000046	0.001578	-0.004024	-	0.002665	0.002694
2024	0.017119	0.015577	0.009784	0.007033	-0.007426	-	-0.002301	0.000634	-0.005475	0.000875	0.003200	0.001217
3003	0.016612	-	0.005681	0.011896	-0.007666	-	0.001510	0.001436	-0.001778	-	0.000623	0.000607
5052	0.016982	0.024779	0.006374	0.000488	-0.008650	-	0.001482	0.000714	-0.002060	-	-0.000452	0.000036
5086	0.016953	0.042255	0.006083	0.004171	-0.008334	-	0.001498	0.001497	-0.001869	0.000603	0.000319	0.000071
5454	0.016800	0.027198	0.005854	0.007047	-0.008064	-	0.001543	0.000788	-0.001742	0.000055	0.000520	0.001092
6061	0.017078	0.010750	0.006386	0.001421	-0.008312	-	0.001298	0.005677	-0.002185	0.000119	0.000488	0.002341
6063	0.017059	0.005403	0.006361	0.000828	-0.008610	-	0.001396	0.002605	-0.002047	0.000785	-0.000308	0.000683
6101	0.017109	0.007651	0.006417	0.000212	-0.008592	-	0.001383	0.004663	-0.002102	-	-0.000253	0.000714
6262	0.017151	0.011513	0.006455	0.000211	-0.008599	0.005699	0.001375	0.004412	-0.002116	0.001269	-0.000168	0.002465
7075	0.027100	0.028569	0.006404	0.000208	-0.002524	-	-0.000289	0.002902	0.003412	0.000731	0.050089	0.056080

Table 22 – Estimate of Set 1 Aluminum Element Weight Fractions (8 Node ANN Model with Set 2 Simulated Data*)

*Gaussian Broadened												
Al		B		Bi		Cr		Cu		Fe		
Aluminum	Est	Act	Est	Act	Est	Act	Est	Act	Est	Act	Est	Act
1100	0.958769	0.994795	0.000006	-	0.000978	-	0.001066	-	0.010405	0.000673	0.001965	0.000471
2011	0.958771	0.929975	0.000014	-	0.000985	0.004970	0.001081	-	0.010417	0.054141	0.001981	0.001678
2024	0.958755	0.927149	0.000023	-	0.001006	-	0.001098	0.000217	0.010417	0.045485	0.001991	0.001813
3003	0.958766	0.978023	0.000004	-	0.000979	-	0.001062	-	0.010401	0.001955	0.001959	0.006083
5052	0.958769	0.970739	0.000006	-	0.000978	-	0.001065	0.003057	0.010405	0.000084	0.001964	0.000103
5086	0.958768	0.944737	0.000006	-	0.000979	-	0.001064	0.002031	0.010404	0.000890	0.001963	0.003745
5454	0.958768	0.962812	0.000005	-	0.000979	-	0.001064	0.000693	0.010403	0.000093	0.001962	0.000222
6061	0.958768	0.973882	0.000006	-	0.000979	-	0.001065	0.002653	0.010404	0.003021	0.001964	0.000136
6063	0.958770	0.987111	0.000006	-	0.000978	-	0.001065	0.000749	0.010405	0.000920	0.001965	0.000916
6101	0.958770	0.985162	0.000006	0.000142	0.000978	-	0.001065	0.000295	0.010405	0.000061	0.001965	0.001100
6262	0.958770	0.958337	0.000006	-	0.000978	0.006893	0.001065	0.000949	0.010405	0.002721	0.001965	0.005531
7075	0.958739	0.892454	0.000051	-	0.001059	-	0.001159	0.002280	0.010449	0.014880	0.002047	0.001896
Mg		Mn		Pb		Si		Ti		Zn		
Aluminum	Est	Act	Est	Act	Est	Act	Est	Act	Est	Act	Est	Act
1100	0.014513	-	0.002828	0.000274	0.000853	-	0.002465	0.002894	0.000344	-	0.005726	0.000893
2011	0.014496	0.000480	0.002839	-	0.000836	0.004484	0.002475	0.001578	0.000345	-	0.005731	0.002694
2024	0.014523	0.015577	0.002790	0.007033	0.000848	-	0.002521	0.000634	0.000422	0.000875	0.005771	0.001217
3003	0.014524	-	0.002815	0.011896	0.000862	-	0.002469	0.001436	0.000355	-	0.005730	0.000607
5052	0.014513	0.024779	0.002828	0.000488	0.000853	-	0.002464	0.000714	0.000343	-	0.005726	0.000036
5086	0.014517	0.042255	0.002823	0.004171	0.000856	-	0.002466	0.001497	0.000348	0.000603	0.005727	0.000071
5454	0.014519	0.027198	0.002821	0.007047	0.000858	-	0.002467	0.000788	0.000350	0.000055	0.005728	0.001092
6061	0.014517	0.010750	0.002823	0.001421	0.000856	-	0.002467	0.005677	0.000349	0.000119	0.005728	0.002341
6063	0.014512	0.005403	0.002829	0.000828	0.000853	-	0.002464	0.002605	0.000342	0.000785	0.005725	0.000683
6101	0.014512	0.007651	0.002829	0.000212	0.000853	-	0.002464	0.004663	0.000342	-	0.005725	0.000714
6262	0.014512	0.011513	0.002829	0.000211	0.000853	0.005699	0.002464	0.004412	0.000342	0.001269	0.005725	0.002465
7075	0.014516	0.028569	0.002742	0.000208	0.000807	-	0.002607	0.002902	0.000543	0.000731	0.005842	0.056080

Table 23 – Estimate of Set 1 Copper Based Metal Element Weight Fractions (4 LV PLS Model with Set 2 Simulated Data)

	Cu		Ag		As		Bi		Cd		Fe	
	Est	Act	Est	Act	Est	Act	Est	Act	Est	Act	Est	Act
C101	1.0031337	0.9999320	0.0000700	0.0000241	0.0000038	0.0000040	0.0000008	0.0000008	0.0000005	0.0000005	0.0000553	0.0000089
C110	0.9993038	0.9990166	0.0005649	0.0008444	0.0000000	-	0.0000000	-	0.0000000	-	0.0000031	-
C122	0.9991192	0.9994759	0.0005643	0.0002851	0.0000000	-	0.0000000	-	0.0000000	-	0.0000033	-
C260	0.6905907	0.6887690	0.0000165	-	0.0000007	-	0.0000001	-	0.0000001	-	0.0002995	0.0004667
C353	0.6185593	0.6185066	0.0000004	-	0.0000000	-	0.0000000	-	0.0000000	-	0.0002547	0.0002595
C464	0.6023515	0.6038520	-0.0000135	-	-0.0000006	-	-0.0000001	-	-0.0000001	-	0.0003679	0.0002302
C510	0.9555950	0.9552920	0.0000015	-	0.0000001	-	0.0000000	-	0.0000000	-	0.0001072	0.0001349
	Mn		Ni		O		P		Pb		S	
	Est	Act	Est	Act	Est	Act	Est	Act	Est	Act	Est	Act
C101	0.0000004	0.0000004	0.0000061	0.0000065	0.0000079	0.0000021	-0.0000250	0.0000007	0.0001401	0.0000027	0.0000114	0.0000121
C110	0.0000000	-	0.0000000	-	0.0000695	0.0001390	0.0001193	-	0.0000051	-	0.0000000	-
C122	0.0000000	-	0.0000000	-	0.0000695	-	0.0001215	0.0002390	0.0000097	-	-0.0000001	-
C260	0.0000001	-	0.0000012	-	0.0000019	-	-0.0000502	-	0.0002783	0.0006686	0.0000022	-
C353	0.0000000	-	0.0000000	-	0.0000000	-	-0.0000014	-	0.0175272	0.0175385	0.0000001	-
C464	-0.0000001	-	-0.0000010	-	-0.0000016	-	0.0000413	-	0.0008926	0.0005711	-0.0000018	-
C510	0.0000000	-	0.0000002	-	0.0000000	-	0.0005707	0.0005785	-0.0000278	0.0000368	0.0000004	-
	Sb		Se		Sn		Te		Zn			
	Est	Act	Est	Act	Est	Act	Est	Act	Est	Act	Est	Act
C101	0.0000016	0.0000017	0.0000011	0.0000012	-0.0037241	0.0000013	0.0000008	0.0000008	0.0003158	0.0000002		
C110	0.0000000	-	0.0000000	-	-0.0000764	-	0.0000000	-	0.0000109	-		
C122	0.0000000	-	0.0000000	-	0.0001055	-	0.0000000	-	0.0000071	-		
C260	0.0000003	-	0.0000002	-	-0.0007645	-	0.0000001	-	0.3096227	0.3100957		
C353	0.0000000	-	0.0000000	-	-0.0000221	-	0.0000000	-	0.3636817	0.3636954		
C464	-0.0000003	-	-0.0000002	-	0.0076170	0.0069873	-0.0000001	-	0.3887490	0.3883594		
C510	0.0000001	-	0.0000000	-	0.0430244	0.0431514	0.0000000	-	0.0007281	0.0008064		

Table 24 – Estimate of Set 1 Copper Based Metal Element Weight Fractions (4 LV PLS Model with Set 2 Simulated Data*)

*Gaussian Broadened												
	Cu		Ag		As		Bi		Cd		Fe	
	Est	Act	Est	Act	Est	Act	Est	Act	Est	Act	Est	Act
C101	1.0022168	0.9999320	0.0000587	0.0000241	0.0000038	0.0000040	0.0000008	0.0000008	0.0000005	0.0000005	0.0000571	0.0000089
C110	0.9987400	0.9990166	0.0005622	-	0.0000000	-	0.0000000	-	0.0000000	-	0.0000029	-
C122	0.9996922	0.9994759	0.0005654	-	0.0000000	-	0.0000000	-	0.0000000	-	0.0000018	-
C260	0.6908884	0.6887690	0.0000130	-	0.0000007	-	0.0000001	-	0.0000001	-	0.0002994	0.0004667
C353	0.6185691	0.6185066	0.0000006	-	0.0000000	-	0.0000000	-	0.0000000	-	0.0002546	0.0002595
C464	0.6021114	0.6038520	-0.0000104	-	-0.0000006	-	-0.0000001	-	-0.0000001	-	0.0003676	0.0002302
C510	0.9556174	0.9552920	0.0000034	-	0.0000001	-	0.0000000	-	0.0000000	-	0.0001093	0.0001349
	Mn		Ni		O		P		Pb		S	
	Est	Act	Est	Act	Est	Act	Est	Act	Est	Act	Est	Act
C101	0.0000004	0.0000004	0.0000061	0.0000065	0.0000064	0.0000021	-0.0000166	0.0000007	0.0001528	0.0000027	0.0000114	0.0000121
C110	0.0000000	-	0.0000000	-	0.0000691	0.0001390	0.0001216	-	0.0000138	-	0.0000000	-
C122	0.0000000	-	0.0000000	-	0.0000695	-	0.0001194	-	-0.0000027	-	0.0000000	-
C260	0.0000001	-	0.0000012	-	0.0000014	-	-0.0000469	-	0.0002712	0.0006686	0.0000022	-
C353	0.0000000	-	0.0000000	-	0.0000001	-	-0.0000015	-	0.0175268	0.0175385	0.0000001	-
C464	-0.0000001	-	-0.0000010	-	-0.0000011	-	0.0000384	-	0.0008975	0.0005711	-0.0000018	-
C510	0.0000000	-	0.0000002	-	0.0000006	-	0.0005707	0.0005785	-0.0000240	0.0000368	0.0000003	-
	Sb		Se		Sn		Te		Zn			
	Est	Act	Est	Act	Est	Act	Est	Act	Est	Act		
C101	0.0000016	0.0000017	0.0000011	-	-0.0029792	0.0000013	0.0000008	-	0.0004777	0.0000002		
C110	0.0000000	-	0.0000000	-	0.0001213	-	0.0000000	-	0.0003693	-		
C122	0.0000000	-	0.0000000	-	-0.0001075	-	0.0000000	-	-0.0003380	-		
C260	0.0000003	-	0.0000002	-	-0.0004745	-	0.0000001	-	0.3090428	0.3100957		
C353	0.0000000	-	0.0000000	-	-0.0000140	-	0.0000000	-	0.3636642	0.3636954		
C464	-0.0000003	-	-0.0000002	-	0.0073770	0.0069873	-0.0000001	-	0.3892239	0.3883594		
C510	0.0000000	-	0.0000000	-	0.0430782	0.0431514	0.0000000	-	0.0006436	0.0008064		

Table 25 – Estimate of Set 1 Stainless Steel Element Weight Fractions (8 Node ANN Model with Set 2 Simulated Data)

	Al		B		C		Cr		Cu		Fe	
	Est	Act	Est	Act	Est	Act	Est	Act	Est	Act	Est	Act
302	-0.000947	-	0.000038	-	0.000013	0.000805	0.172062	0.175570	-0.000759	-	0.725203	0.717547
304	-0.000850	-	-0.000081	-	-0.000109	0.000185	0.172638	0.189038	-0.000539	-	0.720007	0.696584
316	-0.001913	-	0.001762	-	0.000744	0.000396	0.158857	0.168609	-0.002208	-	0.653837	0.673076
321	-0.000619	-	-0.000419	-	-0.000161	0.000095	0.172888	0.183709	0.000044	-	0.713243	0.693149
330	-0.000469	-	0.000730	-	0.000440	0.000678	0.180835	0.180042	0.004130	0.009962	0.418111	0.434682
405	-0.002779	0.002252	0.002090	-	0.001379	0.000100	0.163413	0.141206	-0.003943	-	0.815462	0.844097
430	-0.002566	-	0.002135	-	0.000722	0.000026	0.167698	0.162736	-0.003672	-	0.786560	0.819053
434	-0.000679	-	-0.000328	-	-0.000260	0.000439	0.157470	0.160370	-0.002956	-	0.829103	0.819363
660	0.001507	0.003691	-0.001566	0.000027	0.000377	0.000789	0.166549	0.159546	0.003087	-	0.561010	0.500662
	Pb		Mn		Mo		Ni		N		P	
	Est	Act	Est	Act	Est	Act	Est	Act	Est	Act	Est	Act
302	-0.000301	-	0.009410	0.017760	-0.002200	-	0.081410	0.083273	-0.000763	0.000366	-0.001457	0.000083
304	-0.000345	-	0.009542	0.012737	-0.002604	-	0.086229	0.094231	-0.000680	0.000456	-0.001214	0.000258
316	0.001245	-	0.007440	0.006579	0.016924	0.024833	0.136597	0.121661	-0.002597	0.000375	-0.002214	0.000105
321	-0.000544	-	0.009901	0.001188	-0.002858	-	0.091266	0.109590	-0.000344	0.000728	-0.001134	0.000268
330	-0.000512	0.000027	0.014115	0.010673	0.006337	-	0.361657	0.355840	-0.001506	-	-0.001282	0.000060
405	0.000600	-	0.006892	0.008266	0.003208	-	0.001762	0.001010	-0.001579	-	-0.004001	0.000219
430	0.000688	-	0.007461	0.006258	0.000336	-	0.029660	0.003672	-0.001932	-	-0.002572	0.000090
434	-0.000343	-	0.005325	0.005619	0.014099	0.008436	-0.000016	-	-0.001279	-	-0.001019	0.000364
660	-0.002786	-	0.012070	0.020275	0.010301	0.013169	0.215193	0.264885	-0.000903	-	-0.001877	0.000381
	Si		S		Sn		Ti		V			
	Est	Act	Est	Act	Est	Act	Est	Act	Est	Act	Est	Act
302	0.005745	0.004345	-0.001114	0.000251	-0.000356	-	0.000633	-	-0.000868	-	-	-
304	0.005699	0.006388	-0.001068	0.000123	-0.000517	-	0.000693	-	-0.000727	-	-	-
316	0.006374	0.004179	-0.002112	0.000187	0.001656	-	0.003120	-	-0.001106	-	-	-
321	0.005509	0.006889	-0.000840	0.000295	-0.001048	-	0.000628	0.004089	-0.000455	-	-	-
330	0.008932	0.007908	-0.001779	0.000021	0.000949	0.000107	0.009215	-	0.000704	-	-	-
405	0.005908	0.002703	-0.002362	0.000147	0.001787	-	-0.000164	-	-0.002190	-	-	-
430	0.006208	0.008052	-0.002562	0.000113	0.001748	-	0.000214	-	-0.001881	-	-	-
434	0.003988	0.005117	-0.000774	0.000292	-0.000198	-	-0.000346	-	-0.001130	-	-	-
660	0.006583	0.009507	0.000432	0.000344	-0.001083	-	0.004918	0.021632	-0.000269	0.005092	-	-

Table 26 – Estimate of Set 1 Stainless Steel Element Weight Fractions (8 Node ANN Model with Set 2 Simulated Data*)

	*Gaussian Broadened											
	Al		B		C		Cr		Cu		Fe	
	Est	Act	Est	Act	Est	Act	Est	Act	Est	Act	Est	Act
302	0.000989	-	0.000158	-	0.000162	0.000805	0.168817	0.175570	0.000799	-	0.688673	0.717547
304	0.000990	-	0.000161	-	0.000160	0.000185	0.168816	0.189038	0.000795	-	0.688672	0.696584
316	0.000254	-	-0.000197	-	0.000663	0.000396	0.169174	0.168609	0.001493	-	0.688699	0.673076
321	0.000994	-	0.000165	-	0.000156	0.000095	0.168812	0.183709	0.000790	-	0.688671	0.693149
330	0.000281	-	-0.000184	-	0.000646	0.000678	0.169163	0.180042	0.001468	0.009962	0.688697	0.434682
405	0.000905	0.002252	0.000103	-	0.000233	0.000100	0.168869	0.141206	0.000899	-	0.688677	0.844097
430	0.000946	-	0.000129	-	0.000199	0.000026	0.168844	0.162736	0.000851	-	0.688675	0.819053
434	0.000273	-	-0.000190	-	0.000650	0.000439	0.169166	0.160370	0.001477	-	0.688699	0.819363
660	0.000268	0.003691	-0.000192	0.000027	0.000654	0.000789	0.169168	0.159546	0.001482	-	0.688699	0.500662
	Pb		Mn		Mo		Ni		N		P	
	Est	Act	Est	Act	Est	Act	Est	Act	Est	Act	Est	Act
	302	0.000316	-	0.009918	0.017760	0.005308	-	0.114820	0.083273	0.000319	0.000366	0.000230
304	0.000317	-	0.009921	0.012737	0.005311	-	0.114816	0.094231	0.000317	0.000456	0.000233	0.000258
316	-0.000380	-	0.009931	0.006579	0.004986	0.024833	0.115049	0.121661	0.000098	0.000375	0.000193	0.000105
321	0.000322	-	0.009923	0.001188	0.005316	-	0.114813	0.109590	0.000317	0.000728	0.000235	0.000268
330	-0.000356	0.000027	0.009931	0.010673	0.004995	-	0.115038	0.355840	0.000104	-	0.000190	0.000060
405	0.000229	-	0.009902	0.008266	0.005245	-	0.114864	0.001010	0.000303	-	0.000192	0.000219
430	0.000271	-	0.009908	0.006258	0.005275	-	0.114845	0.003672	0.000312	-	0.000209	0.000090
434	-0.000363	-	0.009929	0.005619	0.004992	0.008436	0.115044	-	0.000104	-	0.000192	0.000364
660	-0.000368	-	0.009930	0.020275	0.004991	0.013169	0.115045	0.264885	0.000102	-	0.000193	0.000381
	Si		S		Sn		Ti		V			
	Est	Act	Est	Act	Est	Act	Est	Act	Est	Act		
	302	0.006168	0.004345	0.000290	0.000251	-0.000061	-	0.002734	-	0.000266	-	
304	0.006172	0.006388	0.000287	0.000123	-0.000061	-	0.002730	-	0.000265	-		
316	0.006044	0.004179	0.000097	0.000187	0.000130	-	0.003001	-	0.000934	-		
321	0.006173	0.006889	0.000287	0.000295	-0.000060	-	0.002725	0.004089	0.000261	-		
330	0.006051	0.007908	0.000102	0.000021	0.000119	0.000107	0.002995	-	0.000911	-		
405	0.006141	0.002703	0.000280	0.000147	-0.000061	-	0.002802	-	0.000347	-		
430	0.006153	0.008052	0.000286	0.000113	-0.000062	-	0.002771	-	0.000307	-		
434	0.006046	0.005117	0.000103	0.000292	0.000125	-	0.002997	-	0.000918	-		
660	0.006046	0.009507	0.000101	0.000344	0.000126	-	0.002998	0.021632	0.000923	0.005092		

Table 27 – Estimate of Set 1 Element Weight Fractions (for all metals using 8 Node ANN Model with Set 2 Simulated Data)

	Al		Ag		As		B		Bi		C		Cd		Cr		Cu		
	Est	Act	Est	Act	Est	Act	Est	Act	Est	Act	Est	Act	Est	Act	Est	Act	Est	Act	
302	0.016374	-	0.003105	-	0.003224	-	0.003617	-	0.003046	-	0.002548	0.000805	0.002520	0.000001	0.002385	-	-	0.001093	-
304	0.020496	-	0.003410	-	0.003252	-	0.003280	-	0.002992	-	0.002534	0.000185	0.002702	-	0.002575	-	-	0.001967	-
316	0.007134	-	0.004078	-	-0.007239	-	0.004573	-	-0.001386	-	-0.000451	0.000396	-0.001046	-	-0.002296	-	-	0.009752	-
321	0.022728	-	0.003536	-	0.003371	-	0.003796	-	0.002945	-	0.002602	0.000095	0.002900	-	0.002821	-	-	-0.001264	-
330	-0.004125	-	-0.000373	-	0.007825	-	0.000695	-	0.005612	-	0.004843	0.000678	0.002543	-	0.002891	-	-	0.007923	0.000962
405	-0.031258	0.002252	-0.000949	-	0.004244	-	0.000639	-	0.004212	-	0.003273	0.000100	0.000847	-	0.000835	-	-	0.001900	-
430	-0.010151	-	0.001578	-	0.003046	-	0.002685	-	0.003364	-	0.002572	0.000026	0.001539	-	0.001330	-	-	-0.000422	-
434	0.010990	-	-0.005234	-	0.004739	-	-0.001926	-	0.005836	-	0.003892	0.000439	-0.001572	-	-0.001612	-	-	0.008491	-
660	-0.001867	0.003691	0.000157	-	-0.000508	-	0.001524	0.000027	0.002022	-	0.002025	0.000789	-0.000428	-	-0.000921	-	-	0.010611	-
1100	1.029737	0.994795	-0.001976	-	0.000694	-	0.003154	-	0.006031	-	0.000776	-	-0.003532	-	-0.003663	-	-	0.010220	0.000673
2011	0.952464	0.929975	-0.004354	-	-0.003486	-	-0.004086	-	0.001090	0.004970	0.001923	-	-0.002132	-	-0.001046	-	-	0.031588	0.054141
2024	0.930051	0.927149	-0.003318	-	0.003722	-	-0.002435	-	0.004509	-	0.003578	-	0.000416	-	0.001883	0.000217	0.020524	0.045485	-
3003	0.984195	0.978293	-0.001190	-	0.004377	-	0.002670	-	0.006772	-	0.002238	-	-0.000929	-	-0.000450	-	-	0.008153	0.001955
5052	1.032968	0.970739	-0.002059	-	0.000801	-	0.003213	-	0.006174	-	0.000770	-	-0.003628	-	-0.003780	0.003057	0.009987	0.000084	-
5086	1.016585	0.944737	-0.001782	-	0.001933	-	0.002967	-	0.006311	-	0.001261	-	-0.002714	-	-0.002644	0.002031	0.009572	0.000890	-
5454	1.007052	0.962812	-0.001504	-	0.002771	-	0.002895	-	0.006441	-	0.001598	-	-0.002044	-	-0.001826	0.000693	0.009605	0.000693	-
6061	1.011424	0.973882	-0.001582	-	0.001805	-	0.002794	-	0.006006	-	0.001326	-	-0.002415	-	-0.002269	0.002653	0.010171	0.003021	-
6063	1.036242	0.987111	-0.002056	-	0.000519	-	0.003260	-	0.006083	-	0.000666	-	-0.003765	-	-0.003954	0.000749	0.010139	0.000020	-
6101	1.035359	0.985162	-0.002048	-	0.000398	-	0.003274	0.000142	0.006033	-	0.000626	-	-0.003813	-	-0.004017	0.000295	0.010197	0.000061	-
6262	1.035114	0.985337	-0.001993	-	0.000356	-	0.003310	-	0.006001	0.000893	0.000610	-	-0.003796	-	-0.004004	0.000949	0.010167	0.002721	-
7075	0.920150	0.892454	0.003887	-	-0.007666	-	-0.000617	-	-0.004081	-	0.000703	-	0.002527	-	0.003848	0.002280	0.028457	0.014880	-
C101	-0.019091	-	0.000873	0.000024	0.007102	0.000004	0.002051	-	0.005639	0.000001	0.003660	-	0.002474	-	0.002559	-	-	0.002610	-
C110	0.017861	-	0.003860	0.000844	0.001100	-	0.003569	-	0.002013	-	0.001795	-	0.002306	-	0.002034	-	-	0.005162	-
C122	0.018035	-	0.003845	0.000285	0.001070	-	0.003569	-	0.002010	-	0.001782	-	0.002279	-	0.002001	-	-	0.005179	-
C260	-0.024097	-	-0.003389	-	0.006817	-	-0.000004	-	0.006545	-	0.003614	-	-0.000396	-	-0.000444	-	-	0.000633	-
C353	0.016207	-	0.005503	-	0.001568	-	0.003057	-	0.003040	-	0.002512	-	0.004952	-	0.005393	-	-	0.000984	-
C464	0.011709	-	0.001871	-	0.001920	-	0.001970	-	0.002137	-	0.002338	-	0.002906	-	0.002064	-	-	0.001118	-
C510	0.011850	-	0.003042	-	0.001308	-	0.003338	-	0.002483	-	0.001796	-	0.001679	-	0.001322	-	-	0.005085	-
	Fe		Mg		Mn		Mo		Ni		N		O		P		Pb		
	Est	Act	Est	Act	Est	Act	Est	Act	Est	Act	Est	Act	Est	Act	Est	Act	Est	Act	
302	0.710827	0.717475	0.002399	-	0.011912	0.017760	0.005990	-	0.071879	0.083273	0.003013	0.000366	0.003483	-	0.002680	0.000083	0.003007	-	
304	0.702796	0.696584	0.002387	-	0.011836	0.012737	0.005990	-	0.075147	0.094231	0.003080	0.000456	0.003795	-	0.002600	0.000258	0.003097	-	
316	0.648000	0.673076	0.005330	-	0.012128	0.006579	0.011122	0.024833	0.138997	0.121661	0.005112	0.000375	0.003510	-	0.000163	0.000105	0.002786	-	
321	0.696244	0.693149	0.002318	-	0.011730	0.011188	0.005970	-	0.079036	0.109500	0.003029	0.000728	0.003897	-	0.002565	0.000268	0.003104	-	
330	0.422035	0.434682	0.001512	-	0.019960	0.010673	0.009079	-	0.377668	0.355840	0.001208	-	0.000264	-	0.004691	0.000060	0.002233	0.000027	
405	0.834219	0.844097	0.002223	-	0.012539	0.008266	0.005880	-	0.014420	0.001010	0.001799	-	-0.000643	-	0.004080	0.000219	0.001770	-	
430	0.785460	0.819053	0.002447	-	0.012038	0.006258	0.005254	-	0.033043	0.003672	0.002763	-	0.001940	-	0.003131	0.000090	0.002594	-	
434	0.832118	0.819363	0.003972	-	0.014979	0.005619	0.007439	0.008436	0.011012	-	0.001012	-	0.004925	-	0.005740	0.000364	0.002058	-	
660	0.571201	0.500662	0.003826	-	0.015487	0.002975	0.010462	0.013169	0.218469	0.264885	0.002766	-	0.000067	-	0.002616	0.000031	0.001918	-	
1100	-0.059660	0.000471	0.020549	-	0.010614	0.000274	-0.000439	-	0.000899	-	0.003491	-	-0.000883	-	0.003871	-	0.003428	-	
2011	-0.052954	0.001678	0.018940	0.000490	0.003479	-	0.009704	-	-0.010094	-	0.000520	-	-0.005753	-	0.002455	-	-0.000457	0.004484	
2024	-0.042395	0.000183	0.016681	0.015377	0.005935	0.007033	0.004798	-	0.013726	-	0.000156	-	-0.003633	-	0.004008	-	0.000958	-	
3003	-0.029952	0.000083	0.018339	-	0.010040	0.011896	-0.000862	-	0.011055	-	0.002617	-	-0.000098	-	0.004374	-	0.003460	-	
5052	-0.062945	0.000103	0.020625	0.024779	0.010800	0.004088	-0.000615	-	0.001584	-	0.003514	-	-0.000917	-	0.003942	-	0.003454	-	
5086	-0.052908	0.003745	0.019856	0.042255	0.010457	0.004171	-0.000604	-	0.004636	-	0.003188	-	-0.000682	-	0.004060	-	0.003431	-	
5454	-0.046131	0.000222	0.019339	0.027198	0.010256	0.007047	-0.000694	-	0.006815	-	0.003001	-	-0.000413	-	0.004144	-	0.003456	-	
6061	-0.050573	0.000136	0.019661	0.010750	0.009996	0.001421	-0.000202	-	0.004715	-	0.003093	-	-0.000601	-	0.003912	-	0.003353	-	
6063	-0.064097	0.000916	0.020768	0.005403	0.010777	0.000828	-0.000562	-	0.000537	-	0.003581	-	-0.000924	-	0.003881	-	0.003459	-	
6101	-0.063062	0.001100	0.020790	0.007651	0.010768	0.000212	-0.000518	-	0.000088	-	0.003606	-	-0.000925	-	0.003851	-	0.003459	-	
6262	-0.062404	0.005531	0.020788	0.011513	0.010743	0.000211	-0.000511	-	-0.000034	-	0.003626	-	-0.000873	-	0.003827	-	0.003474	0.005899	
7075	-0.041755	0.001896	0.017137	0.028569	-0.002677	0.000208	0.011317	-	-0.007834	-	0.002906	-	0.001542	-	-0.001413	-	0.001671	-	
C101	0.001803	0.000009	0.001023	-	0.004598	0.000000	0.000553	-	0.004046	0.000007	0.001743	-	0.001334	0.000002	0.004482	0.000001	0.002196	0.000003	
C110	-0.000924	-	0.002504	-	0.001998	-	0.002888	-	-0.001129	-	0.003102	-	0.003648	0.000139	0.002941	-	-	0.003043	-
C122	-0.000925	-	0.002521	-	0.002007	-	0.002891	-	-0.001283	-	0.003108	-	0.003634	-	0.002940	0.000239	0.003041	-	
C260	0.009346	0.000467	0.002884	-	0.006885	-	0.000303	-	-0.002906	-	0.001114	-	-0.002576	-	0.005459	-	0.006750	0.000669	
C353	0.003020	0.000260	0.002315	-	-0.000208	-	0.003725	-	0.010696	-	0.002573	-	0.004955	-	0.001103	-	0.006907	0.017539	
C464	-0.005466	0.000020	0.003379	-	0.002274	-	0.002638	-	-0.004087	-	0.002314	-	0.001793	-	0.002419	-	0.009114	0.000571	
C510	0.003362	0.000135	0.002634	-	0.002702	-	0.002641	-	-0.002046	-	0.003035	-	0.002952	-	0.002377	0.000570	0.002954	0.000037	
	S		Sb		Se		Si		Sn		Te		Ti		Zn		V		
	Est	Act	Est	Act	Est	Act	Est	Act	Est	Act	Est	Act	Est	Act	Est	Act	Est	Act	
302	0.002312	0.000251	0.001926	-	0.001793	-	0.000898	0.004345	0.003176	-	0.003318	-	0.003639	-	0.001158	-	0.001853	-	
304	0.002475	0.000123	0.001702	-	0.001639	-	0.009337	0.006388	0.003236	-	0.003510	-	0.003617	-	-0.000105	-	0.001691	-	

Table 29 – Estimate of Set 1 Element Weight Fractions (for all metals using 4 LV PLS Model with Set 2 Simulated Data)

	Al		Ag		As		B		Bi		C		Cd		Cr		Cu	
	Est	Act	Est	Act	Est	Act	Est	Act	Est	Act	Est	Act	Est	Act	Est	Act	Est	Act
302	0.1179171	-	0.000185	-	-0.000002	-	-0.000019	-	0.0002875	-	0.0002610	0.0008050	0.0000001	0.0000005	0.0000911	-	0.0105331	-
304	0.1203222	-	0.0000189	-	-0.0000002	-	-0.0000021	-	0.0002939	-	0.0002570	0.0001850	0.0000001	-	0.0000929	-	0.0107379	-
316	0.0202461	-	-0.0000125	-	0.0000001	-	0.0000066	-	-0.0001576	-	0.0005393	0.0003960	0.0000000	-	-0.0000505	-	-0.0054516	-
321	0.1210465	-	0.0000192	-	-0.0000002	-	-0.0000021	-	0.0002966	-	0.0002551	0.0000950	0.0000001	-	0.0000933	-	0.0108403	-
330	-0.0656415	-	-0.0000077	-	0.0000001	-	0.0000067	-	-0.0001625	-	0.0005371	0.0006780	0.0000000	-	-0.0000550	-	-0.0056229	0.0009820
405	0.0827421	0.0022520	0.0000106	-	-0.0000001	-	0.0000002	-	0.0000189	-	0.0003243	0.0001000	0.0000001	-	0.0000662	-	0.0072611	-
430	0.1056459	-	0.0000147	-	-0.0000001	-	-0.0000009	-	0.0002462	-	0.0002283	0.0000260	0.0000001	-	0.0000841	-	0.0090674	-
434	-0.0658389	-	-0.0000173	-	0.0000001	-	0.0000079	-	-0.0001942	-	0.0005659	0.0004390	0.0000000	-	-0.0000470	-	-0.0050101	-
660	-0.0252975	0.0036910	-0.0000035	-	0.0000000	-	0.0000046	0.0000270	-0.0000591	-	0.0004753	0.0007890	0.0000000	-	-0.0000237	-	-0.0002964	-
1100	1.0528657	0.9947950	-0.0000053	-	0.0000000	-	0.0000061	-	0.0009630	-	-0.0000110	-	0.0000000	-	0.0011233	-	0.0059119	0.0006730
2011	0.6505305	0.9299750	0.0000354	-	0.0000000	-	0.0000054	-	0.0007567	0.0049700	0.0000121	-	0.0000000	-	0.0007206	-	0.0111524	0.0541410
2024	0.7625893	0.9271490	0.0000187	-	-0.0000001	-	-0.0000075	-	0.0008316	-	0.0000050	-	0.0000000	-	-0.0008451	0.0002170	0.0109120	0.0454850
3003	0.9895810	0.9780230	-0.0000016	-	0.0000000	-	0.0000141	-	0.0009359	-	-0.0000059	-	0.0000000	-	0.0011324	-	0.0070943	0.0019550
5052	1.0586953	0.9707390	-0.0000057	-	0.0000000	-	0.0000162	-	0.0009692	-	-0.0000118	-	0.0000000	-	-0.0012196	0.0003570	0.0058391	0.0000840
5086	1.0322184	0.9447370	-0.0000044	-	0.0000000	-	0.0000154	-	0.0009545	-	-0.0000097	-	0.0000000	-	0.0011862	0.0002310	0.0063229	0.0008900
5454	1.0185336	0.9628120	-0.0000036	-	0.0000000	-	0.0000150	-	0.0009490	-	-0.0000089	-	0.0000000	-	0.0011687	0.0006830	0.0065992	0.0000630
6061	1.0173197	0.9738820	-0.0000032	-	0.0000000	-	0.0000150	-	0.0009472	-	-0.0000085	-	0.0000000	-	0.0011674	0.0026530	0.0065547	0.0003010
6063	1.0631864	0.9871110	-0.0000059	-	0.0000000	-	0.0000163	-	0.0009683	-	-0.0000123	-	0.0000000	-	0.0012252	0.0007490	0.0057636	0.0009200
6101	1.0631240	0.9851620	-0.0000060	-	0.0000000	-	0.0000164	0.0001420	0.0009678	-	-0.0000119	-	0.0000000	-	0.0012253	0.0002950	0.0057397	0.0000610
6262	1.0632420	0.9858370	-0.0000060	-	0.0000000	-	0.0000164	-	0.0009678	0.0068930	-0.0000119	-	0.0000000	-	0.0012254	0.0009490	0.0057392	0.0027210
7075	0.6490932	0.8924540	-0.0000019	-	-0.0000002	-	0.0000040	-	0.0000940	-	0.0000098	-	0.0000001	-	0.0007119	0.0022800	0.0127909	0.0004800
C101	-0.0194779	-	0.0003023	0.0000241	0.0000013	0.0000040	0.0000013	-	0.0002620	0.0000008	-0.0000042	-	0.0000000	-	-0.0000646	-	-0.0015649	-
C110	0.0118567	-	0.0002622	0.0008444	0.0000010	-	-0.0000007	-	0.0001187	-	0.0000031	-	0.0000000	-	-0.0000389	-	0.0023957	-
C122	0.0119812	-	0.0002621	0.0002851	0.0000010	-	-0.0000008	-	0.0001190	-	0.0000032	-	0.0000000	-	-0.0000388	-	0.0024074	-
C260	0.0001247	-	0.0000440	-	0.0000002	-	-0.0000002	-	-0.0000204	-	-0.0000031	-	0.0000000	-	-0.0000355	-	-0.0004787	-
C353	0.0204264	-	-0.0000092	-	0.0000000	-	-0.0000004	-	0.0000076	-	0.0000007	-	0.0000000	-	-0.0000675	-	0.0009376	-
C464	0.0125345	-	-0.0000288	-	-0.0000001	-	-0.0000003	-	-0.0000170	-	-0.0000013	-	0.0000000	-	-0.0000683	-	0.0003908	-
C510	0.0186898	-	0.0002905	-	0.0000010	-	-0.0000003	-	0.0001152	-	0.0000049	-	0.0000000	-	-0.0000284	-	0.0010723	-
	Fe		Mg		Mn		Mo		Ni		N		O		P		Pb	
	Est	Act	Est	Act	Est	Act	Est	Act	Est	Act	Est	Act	Est	Act	Est	Act	Est	Act
302	0.6299783	0.7117540	0.0022874	-	0.00093350	0.0177600	0.0012510	-	0.0730526	0.0882730	0.0002661	0.00003660	0.0000023	-	0.0001808	0.0000830	0.0003221	-
304	0.6291635	0.6965840	0.0023360	-	0.00093255	0.0127370	0.0011157	-	0.0717277	0.0942310	0.0002685	0.0004560	0.0000024	-	0.0001803	0.0002580	0.0003289	-
316	0.6935959	0.6730760	-0.0012625	-	0.0101215	0.0065790	0.0105149	0.0248330	0.1645435	0.1216610	0.0001100	0.0003750	-0.0000015	-	0.0002214	0.0001050	-0.0001569	-
321	0.6290046	0.6931490	0.0023531	-	0.00093224	0.011880	0.0010489	-	0.0710981	0.0950000	0.0002697	0.0007280	0.0000024	-	0.0001801	0.0002680	0.0003317	-
330	0.6860294	0.4346820	-0.0013376	-	0.0100664	0.0106730	0.0105313	-	0.1639693	0.3558400	0.0001062	-	-0.0000010	-	0.0002229	0.0000600	-0.0001941	0.0000270
405	0.6409581	0.8440970	0.0015597	-	0.0094832	0.0082660	0.0034031	-	0.0939258	0.0010100	0.0002281	-	0.0000013	-	0.0001888	0.0002190	0.0002169	-
430	0.6327948	0.8190530	0.0020131	-	0.0093815	0.0062580	0.0020575	-	0.0821075	0.0036720	0.0002483	-	0.0000018	-	0.0001836	0.0000900	0.0002784	-
434	0.6913074	0.8193630	-0.0014170	-	0.0101202	0.0056190	0.0115088	0.0084390	0.1734480	-	0.0000890	-	-0.0000021	-	-0.0002223	0.0003640	-0.0001955	-
660	0.6787997	0.5006920	-0.0005204	-	0.0099290	0.0292750	0.0083491	0.0131600	0.1435086	0.2648850	0.0001459	-	-0.0000004	-	-0.0002133	0.0003810	-0.0000821	-
1100	-0.0601587	0.0004710	0.0157130	-	0.0021694	0.0002740	0.0004391	-	-0.0025582	-	-0.0000386	-	-0.0000007	-	-0.0000168	-	0.0007510	-
2011	0.1833974	0.0016780	0.0102466	0.0004800	0.0044095	-	-0.0019337	-	-0.0001114	-	0.0001224	-	0.0000044	-	0.0000625	-	0.0007173	0.0044840
2024	0.1491712	0.0018130	0.0117639	0.0155770	0.0042228	0.0070330	-0.0017329	-	-0.0017880	-	0.0001024	-	0.0000023	-	0.0000429	-	0.0007292	-
3003	-0.0096595	0.0006830	0.0148638	-	0.0028863	0.0118960	-0.0000402	-	-0.0019801	-	-0.0000055	-	0.0000002	-	-0.0000036	-	0.0007457	-
5052	-0.0642734	0.0001030	0.0157931	0.0247790	0.0021287	0.0004880	0.0004654	-	-0.0027240	-	-0.0000410	-	-0.0000007	-	-0.0000180	-	0.0007523	-
5086	-0.0434343	0.0037450	0.0154373	0.0422550	0.0023403	0.0004170	0.0002672	-	-0.0024927	-	-0.0000273	-	0.0000006	-	-0.0000128	-	0.0007600	-
5454	-0.0323099	0.0022230	0.0152543	0.0271980	0.0024530	0.0070470	0.0001515	-	-0.0024668	-	-0.0000199	-	-0.0000004	-	-0.0000099	-	0.0007593	-
6061	-0.0329181	0.0001360	0.0152329	0.0107500	0.0024431	0.0014210	0.0001703	-	-0.0023405	-	-0.0000205	-	-0.0000004	-	-0.0000097	-	0.0007579	-
6063	-0.0678385	0.0009160	0.0158541	0.0054030	0.0020921	0.0008280	0.0004941	-	-0.0028119	-	-0.0000432	-	-0.0000007	-	-0.0000189	-	0.0007529	-
6101	-0.0679134	0.0001030	0.0158516	0.0076510	0.0020915	0.0002120	0.0005089	-	-0.0028834	-	-0.0000436	-	-0.0000007	-	-0.0000189	-	0.0007523	-
6262	-0.0680140	0.0005310	0.0158531	0.0115130	0.0020905	0.0002110	0.0005106	-	-0.0028778	-	-0.0000436	-	-0.0000007	-	-0.0000189	-	0.0007523	0.0056990
7075	0.2291194	0.0018600	0.0103318	0.0285690	0.0049751	0.0002080	-0.0025927	-	0.0002659	-	0.0001569	-	-0.0000002	-	0.0000447	-	0.0014303	-
C101	-0.0825804	0.0000089	-0.0010282	-	-0.0011026	0.0000004	0.0007856	-	0.0014539	0.0000065	-0.0000543	-	0.0000369	0.0000021	0.0001959	0.0000007	-0.0001415	0.0000027
C110	0.0227704	-	-0.0002302	-	0.0005583	-	-0.0004317	-	0.0011667	-	0.0000235	-	0.0000320	0.0001290	0.0000192	-	-0.0000096	-
C122	0.0331301	-	-0.0002273	-	0.0005636	-	-0.0004349	-	0.0011709	-	0.0000237	-	0.0000320	-	0.0001912	0.0002390	-0.0000091	-
C260	-0.0351415	0.0004667	0.0002852	-	-0.0005795	-	0.0003611	-	-0.0003626	-	-0.0000235	-	0.0000054	-	0.0000249	-	0.0054509	0.0006886
C353	0.0092661	0.0002505	0.0008452	-	0.0000586	-	-0.0000476	-	-0.0002612	-	-0.0000052	-	-0.0000011	-	-0.0000031	-	0.0063182	0.0175385
C464	-0.0063728	0.0002302	0.0007794	-	-0.0001975	-	0.0000950	-	-0.0006747	-	-0.0000048	-	-0.0000035	-	-0.0000201	-	0.0069029	0.0005711
C510	0.0227545	0.0001349	-0.0001521	-	0.0004428	-	-0.0002368	-	0.0001939	-	0.0000149	-	0.0000018	-	0.0001884	0.0000575	0.0000282	0.0000368
	S		Sb		Se		Si		Sn		Te		Ti		Zn		V	

Table 30 – Estimate of Set 1 Element Weight Fractions (for all metals using 4 LV PLS Model with Set 2 Simulated Data*)

	*Gaussian Broadened																			
	Al		Ag		As		B		Bi		C		Cd		Cr		Cu			
	Est	Act	Est	Act	Est	Act	Est	Act	Est	Act	Est	Act	Est	Act	Est	Act	Est	Act		
302	0.113226	-	0.0000176	-	-0.0000001	-	-0.0000020	-	0.0002903	-	0.0002572	0.0008050	0.0000001	0.0000005	0.00000853	-	0.0104069	-		
304	0.1154449	-	0.0000181	-	-0.0000002	-	-0.0000021	-	0.0002960	-	0.0002535	0.0001850	0.0000001	-	0.0000869	-	0.0105810	-		
316	-0.0631323	-	-0.0000156	-	0.0000001	-	0.0000069	-	-0.0001720	-	-0.0005515	0.0003960	8.149E-09	-	-0.0000506	-	-0.0036249	-		
321	0.1166525	-	0.0000188	-	-0.0000002	-	-0.0000022	-	0.0003000	-	0.0002507	0.0000950	0.0000001	-	0.0000876	-	0.0107077	-		
330	-0.0690867	-	0.0000037	-	1.484E-07	-	0.0000066	-	-0.0001706	-	-0.0005355	0.0006780	6.911E-09	-	-0.0000620	-	-0.0036313	0.0099620		
405	0.0831156	0.0022520	0.0000085	-	-0.0000001	-	-0.0000002	-	0.0002025	-	0.0003157	0.0001000	0.0000001	-	0.0000644	-	0.0076596	-		
430	0.1028531	-	0.0000125	-	-0.0000001	-	-0.0000012	-	0.0002530	-	0.0002834	0.0000260	0.0000001	-	0.0000798	-	0.0091893	-		
434	-0.0649555	-	-0.0000238	-	6.065E-08	-	0.0000076	-	-0.0001958	-	0.0005725	0.0004390	3.269E-09	-	-0.0000468	-	-0.0045196	-		
660	-0.0243885	0.0036910	0.0000007	-	0.0000000	-	0.0000045	0.0000270	-0.0000589	-	-0.0004730	0.0007890	2.614E-08	-	-0.0000246	-	-0.0001497	-		
1100	1.0402717	0.9947950	-0.0000045	-	0.0000000	-	0.0000157	-	0.0009538	-	-0.0000080	-	0.0000000	-	0.0011971	-	0.0061230	0.0006730		
2011	0.6472704	0.9299750	0.0000359	-	0.0000000	-	0.0000052	-	0.0007515	0.0049700	0.0000119	-	0.0000000	-	0.0007062	-	0.0110966	0.0541410		
2024	0.7508962	0.9271490	0.0000192	-	-0.0000001	-	0.0000073	-	0.0008237	-	0.0000066	-	0.0000000	-	0.0008320	0.0002170	0.0107316	0.0454850		
3003	0.9757805	0.9789230	-0.0000011	-	0.0000000	-	0.0000139	-	0.0009238	-	-0.0000014	-	0.0000000	-	0.0011161	-	0.0071366	0.0019550		
5052	1.0460420	0.9707300	-0.0000049	-	0.0000000	-	0.0000159	-	0.0009568	-	-0.0000086	-	0.0000000	-	0.0012043	0.0030570	0.0060484	0.0000840		
5086	1.0189019	0.9447370	-0.0000038	-	0.0000000	-	0.0000000	-	0.0009441	-	-0.0000061	-	0.0000000	-	0.0011703	0.0009490	0.0064766	0.0008900		
5454	1.0045562	0.9628120	-0.0000030	-	0.0000000	-	0.0000147	-	0.0009379	-	-0.0000049	-	0.0000000	-	0.0011526	0.0008930	0.0067104	0.0000930		
6061	1.0043388	0.9738820	-0.0000025	-	0.0000000	-	0.0000147	-	0.0009380	-	-0.0000058	-	0.0000000	-	0.0011519	0.0026530	0.0067255	0.0003020		
6063	1.0506888	0.9871110	-0.0000051	-	0.0000000	-	0.0000160	-	0.0009591	-	-0.0000092	-	0.0000000	-	0.0012101	0.0007490	0.0059803	0.0000920		
6101	1.0506868	0.9851620	-0.0000052	-	0.0000000	-	0.0000160	0.0001420	0.0009588	-	-0.0000090	-	0.0000000	-	0.0012104	0.0002950	0.0059619	0.0000610		
6262	1.0510271	0.9583370	-0.0000052	-	0.0000000	-	0.0000166	-	0.0009588	0.0068930	-0.0000090	-	0.0000000	-	0.0012106	0.0009490	0.0059573	0.0027210		
7075	0.6389584	0.8924540	-0.0000018	-	-0.0000002	-	0.0000040	-	0.0007628	-	-0.0000086	-	5.575E-08	-	0.0007071	0.0022890	0.0124557	0.0148800		
C101	-0.0187564	-	0.0000317	0.0000241	0.0000013	0.0000040	0.0000013	-	0.0002754	0.0000008	0.0000028	-	-1.879E-08	-	-0.0000645	-	-0.0012219	-		
C110	0.0127571	-	0.0002618	0.0008444	0.0000010	-	-0.0000006	-	0.0001202	-	0.0000083	-	7.930E-09	-	-0.0000379	-	0.0024900	-		
C122	0.0131341	-	0.0002624	0.0002851	0.0000010	-	-0.0000006	-	0.0001216	-	0.0000075	-	8.117E-09	-	-0.0000379	-	0.0025275	-		
C290	0.0004307	-	0.0000441	-	0.0000002	-	0.0000002	-	-0.0000211	-	-0.0000044	-	-8.222E-09	-	0.0000363	-	-0.0004961	-		
C353	0.0192012	-	-0.0000083	-	-3.657E-08	-	-0.0000005	-	0.0000062	-	-0.0000025	-	-1.895E-09	-	0.0000666	-	-0.0008246	-		
C464	0.0123864	-	-0.0000293	-	-0.0000001	-	-0.0000004	-	-0.0000183	-	-0.0000053	-	-1.628E-09	-	0.0000692	-	0.0002400	-		
C510	0.0191301	-	-0.0002604	-	0.0000010	-	-0.0000003	-	0.0001179	-	-0.0000091	-	-5.318E-09	-	-0.0000284	-	0.0021615	-		
	Fe		Mg		Mn		Mo		Ni		N		O		P		Pb			
	Est	Act	Est	Act	Est	Act	Est	Act	Est	Act	Est	Act	Est	Act	Est	Act	Est	Act		
302	0.6376474	0.7175470	0.0021825	-	0.0092882	0.0177600	0.0011506	-	0.0703353	0.0832730	0.0002966	0.0003660	0.0000022	-	0.0001825	0.0000830	0.0003274	-		
304	0.6368278	0.6965840	0.0022241	-	0.0092540	0.0127370	0.0010277	-	0.0690905	0.0942310	0.0002985	0.0004560	0.0000022	-	0.0001821	0.0002580	0.0003332	-		
316	0.6948036	0.6730760	-0.0012559	-	0.0102724	0.0065790	0.0109371	0.0248330	0.1688249	0.1210610	0.0001090	0.0003750	-0.0000019	-	0.0002205	0.0001050	-0.0001378	-		
321	0.6360604	0.6931490	0.0022486	-	0.0092405	0.011880	0.0009352	-	0.0681505	0.1095900	0.0002699	0.0007280	0.0000023	-	0.0001819	0.0002680	0.0003337	-		
330	0.6694086	0.4346820	-0.0013928	-	0.0099058	0.0106730	0.0106481	-	0.1643552	0.3558400	0.0001029	-	0.0000004	-	0.0002262	0.0000930	-0.0003128	0.0000020		
405	0.6496770	0.8440970	0.0015797	-	0.0094875	0.0082660	0.0030924	-	0.0898526	0.0010100	0.0002356	-	0.0000011	-	0.0001884	0.0002190	0.0002618	-		
430	0.6422887	0.8190530	0.0019594	-	0.0093641	0.0062580	0.0020291	-	0.0790556	0.0036720	0.0002522	-	0.0000016	-	0.0001843	0.0000900	0.0003088	-		
434	0.7009710	0.8193630	-0.0013218	-	0.0103954	0.0056190	0.016244	0.0084360	0.1757374	-	0.0000989	-	-0.0000029	-	0.0002195	0.0003840	-0.0001095	-		
660	0.6721264	0.9006920	-0.0004978	-	0.0098933	0.0292570	0.0084037	0.0131690	0.1428676	0.2648850	0.0001462	-	0.0000001	-	0.0002140	0.0003810	-0.0000991	-		
1100	-0.0510329	0.0004710	0.0155546	-	0.0022970	0.0002740	0.0004084	-	-0.0012099	-	-0.0000322	-	-0.0000006	-	-0.0000144	-	0.0007466	-		
2011	0.1933464	0.0016780	0.0100399	0.0004800	0.0044101	-	-0.0020203	-	0.0009797	-	0.0001244	-	0.0000044	-	0.0000657	-	0.0007088	0.0044840		
2024	0.1579091	0.0018130	0.0115637	0.0155770	0.0042231	0.0070330	-0.0017353	-	-0.0020134	-	0.0001029	-	0.0000024	-	0.0000460	-	0.0007140	-		
3003	0.0003297	0.0008830	0.0146672	-	0.0027959	0.0118960	-0.0000601	-	-0.0006303	-	-0.0000011	-	-0.0000001	-	-0.0000007	-	0.0007359	-		
5052	-0.0551453	0.0001030	0.0156382	0.0247790	0.0022584	0.0004880	0.0004394	-	-0.0016171	-	-0.0000346	-	-0.0000006	-	-0.0000156	-	0.0007480	-		
5086	-0.0338635	0.0037450	0.0152633	0.0225550	0.0024627	0.0041710	0.0002593	-	-0.0013420	-	-0.0000216	-	-0.0000005	-	-0.0000101	-	0.0007536	-		
5454	-0.0226383	0.0022200	0.0150708	0.0271980	0.0025713	0.0070470	0.0001602	-	-0.0012279	-	-0.0000146	-	-0.0000004	-	-0.0000071	-	0.0007516	-		
6061	-0.0234017	0.0003360	0.0150634	0.0107500	0.0025581	0.0014210	0.0001389	-	-0.0014891	-	-0.0000146	-	-0.0000003	-	-0.0000071	-	0.0007521	-		
6063	-0.0588578	0.0009160	0.0156994	0.0054030	0.0022224	0.0008280	0.0004690	-	-0.0017117	-	-0.0000368	-	-0.0000006	-	-0.0000165	-	0.0007486	-		
6101	-0.0590583	0.0011000	0.0157009	0.0076510	0.0022207	0.0002120	0.0004772	-	-0.0016246	-	-0.0000371	-	-0.0000006	-	-0.0000166	-	0.0007481	-		
6262	-0.0591953	0.0055310	0.0157030	0.0115130	0.0022194	0.0002110	0.0004796	-	-0.0016148	-	-0.0000372	-	-0.0000006	-	-0.0000166	-	0.0007480	0.0005690		
7075	0.2374206	0.0018900	0.0101359	0.0285690	0.0048923	0.0002080	-0.0026005	-	-0.0030591	-	-0.0001553	-	-0.0000002	-	0.0000477	-	0.0014187	-		
C101	-0.0882633	0.0000089	-0.0009920	-	-0.0009365	0.0000004	0.0007026	-	0.0070877	0.0000005	-0.0000534	-	0.0000368	0.0000021	0.0001938	0.0000007	-0.0001091	0.0000027		
C110	0.0278791	-	-0.0002223	-	0.0006352	-	-0.0004866	-	0.0052442	-	0.0000214	-	0.0000320	0.0001390	0.0001899	-	0.0000085	-		
C122	0.0276676	-	-0.0002167	-	0.0006322	-	-0.0005129	-	0.0049973	-	0.0000218	-	0.0000321	-	0.0001902	0.0002390	-0.0000030	-		
C290	-0.0338732	0.0004667	0.0002997	-	-0.0005076	-	0.0003981	-	-0.0014688	-	-0.0000229	-	0.0000054	-	0.0000251	-	0.0054377	0.0006866		
C353	0.0128144	0.0002505	0.0008255	-	-0.0000063	-	-0.0000030	-	-0.0002974	-	-0.0000010	-	-0.0000010	-	-0.0000016	-	0.0062823	0.0175385		
C464	-0.0027959	0.0002302	0.0007840	-	-0.0002737	-	0.0001512	-	-0.0039256	-	-0.0000041	-	-0.0000036	-	-0.0000197	-	0.0068973	0.0005711		
C510	0.0185792	0.0001349	-0.0001437	-	0.0005330	-	-0.0003354	-	0.0057698	-	0.0000144	-	0.0000318	-	0.0001872	0.0005785	0.0000442	0.0000388		
	S		Sh		Se		Si		Sn		Te		Ti		Zn					

Table 31 – Estimate of Set 2 Aluminum Element Weight Fractions (8 Node ANN Model with Set 1 Simulated Data)

Aluminum	Al		B		Bi		Cr		Cu		Fe	
	Est	Act	Est	Act	Est	Act	Est	Act	Est	Act	Est	Act
1100	0.978962	0.993250	-0.001246	-	-0.000343	-	-0.002673	-	0.004472	0.001250	-0.000904	0.003000
2011	0.929254	0.929750	0.000163	-	0.002443	0.004000	-0.004619	-	0.060176	0.055000	0.002772	0.003500
2024	0.922029	0.928000	-0.002969	-	0.001167	-	-0.000846	0.000500	0.031999	0.043500	-0.003177	0.002500
3003	0.958489	0.979250	-0.000605	-	-0.000990	-	-0.003404	-	0.007796	0.001250	-0.002084	0.003500
5052	0.979683	0.967750	-0.001264	-	-0.000276	-	-0.002742	0.002500	0.004004	0.000500	-0.000893	0.002000
5086	0.970928	0.947000	-0.000938	-	-0.000578	-	-0.003023	0.001500	0.005364	0.000500	-0.001254	0.002500
5454	0.972626	0.958250	-0.001057	-	-0.000535	-	-0.002911	0.001250	0.004770	0.000500	-0.001183	0.002000
6061	0.969466	0.973050	-0.001078	-	-0.000469	-	-0.002719	0.001950	0.006273	0.002750	-0.001133	0.003500
6063	0.976621	0.985000	-0.001160	-	-0.000413	-	-0.002787	0.000500	0.004797	0.000500	-0.001028	0.001750
6101	0.979334	0.985150	-0.001197	0.000300	-0.000383	-	-0.002747	0.000150	0.004199	0.000500	-0.000908	0.002500
6262	0.979513	0.963100	-0.001199	-	-0.000384	0.005500	-0.002733	0.000900	0.004317	0.002750	-0.000938	0.003500
7075	0.895728	0.893700	-0.000310	-	-0.001830	-	0.000962	0.002300	0.016904	0.016000	-0.000424	0.002500
Aluminum	Mg		Mn		Pb		Si		Ti		Zn	
	Est	Act	Est	Act	Est	Act	Est	Act	Est	Act	Est	Act
1100	0.009979	-	-0.002166	0.000250	0.008080	-	0.003320	0.001750	0.000918	-	-0.000142	0.000500
2011	-0.004880	0.000250	-0.007009	-	0.008256	0.004000	0.004090	0.002000	0.002370	-	0.001455	0.001500
2024	0.010637	0.015000	0.003639	0.006000	0.006099	-	-0.000227	0.002500	-0.003173	0.000750	0.001352	0.001250
3003	0.009903	-	-0.002261	0.012500	0.008755	-	0.003367	0.003000	0.000822	-	0.000863	0.000500
5052	0.009641	0.025000	-0.002306	0.000500	0.008187	-	0.003486	0.001250	0.000992	-	-0.001117	0.000500
5086	0.009719	0.040000	-0.002232	0.004500	0.008345	-	0.003432	0.002000	0.000830	0.000750	-0.000646	0.001250
5454	0.009803	0.027000	-0.002450	0.007500	0.008248	-	0.003454	0.001250	0.001139	0.001000	0.000121	0.001250
6061	0.010048	0.010000	-0.002016	0.000750	0.007943	-	0.003263	0.006000	0.000834	0.000750	0.000881	0.001250
6063	0.009873	0.006750	-0.002197	0.000500	0.008161	-	0.003351	0.004000	0.000905	0.000500	-0.000360	0.000500
6101	0.009931	0.005750	-0.002256	0.000150	0.008187	-	0.003364	0.005000	0.000946	-	-0.000285	0.000500
6262	0.009976	0.010000	-0.002213	0.000750	0.008170	0.005500	0.003361	0.006000	0.000924	0.000750	-0.000196	0.001250
7075	0.021852	0.025000	-0.000684	0.001500	0.005501	-	0.001238	0.002000	0.001869	0.001000	0.054119	0.056000

Table 32 – Estimate of Set 2 Aluminum Element Weight Fractions (8 Node Model with Set 1 Simulated Data*)

*Gaussian Broadened												
Al		B		Bi		Cr		Cu		Fe		
Aluminum	Est	Act	Est	Act	Est	Act	Est	Act	Est	Act	Est	Act
1100	0.958604	0.993250	0.000048	-	0.000800	-	0.000934	-	0.010449	0.001250	0.002721	0.003000
2011	0.958589	0.929750	0.000031	-	0.000823	0.004000	0.000971	-	0.010380	0.055000	0.002754	0.003500
2024	0.958613	0.928000	-0.000057	-	0.000766	-	0.001045	0.000500	0.010340	0.043500	0.002744	0.002500
3003	0.958614	0.979250	0.000053	-	0.000781	-	0.000918	-	0.010484	0.001250	0.002702	0.003500
5052	0.958605	0.967750	0.000050	-	0.000799	-	0.000932	0.002500	0.010453	0.000500	0.002719	0.002000
5086	0.958609	0.947000	0.000052	-	0.000791	-	0.000925	0.001500	0.010467	0.000500	0.002712	0.002500
5454	0.958607	0.958250	0.000051	-	0.000794	-	0.000928	0.001250	0.010462	0.000500	0.002715	0.002000
6061	0.958607	0.973050	0.000046	-	0.000794	-	0.000935	0.001950	0.010453	0.002750	0.002718	0.003500
6063	0.958605	0.985000	0.000049	-	0.000797	-	0.000933	0.000500	0.010453	0.000500	0.002719	0.001750
6101	0.958605	0.985150	0.000049	0.000300	0.000799	-	0.000933	0.000150	0.010451	0.000500	0.002720	0.002500
6262	0.958604	0.963100	0.000049	-	0.000800	0.005500	0.000934	0.000900	0.010450	0.002750	0.002721	0.003500
7075	0.958587	0.893700	-0.000090	-	0.000802	-	0.001072	0.002300	0.010302	0.016000	0.002781	0.002500
Mg		Mn		Pb		Si		Ti		Zn		
Aluminum	Est	Act	Est	Act	Est	Act	Est	Act	Est	Act	Est	Act
1100	0.013773	-	0.002896	0.000250	0.000750	-	0.003102	0.001750	0.000439	-	0.005566	0.000500
2011	0.013721	0.000250	0.002926	-	0.000772	0.004000	0.003201	0.002000	0.000410	-	0.005615	0.001500
2024	0.013606	0.015000	0.002930	0.006000	0.000917	-	0.002894	0.002500	0.000532	0.000750	0.005356	0.001250
3003	0.013793	-	0.002881	0.012500	0.000749	-	0.003024	0.003000	0.000463	-	0.005519	0.000500
5052	0.013777	0.025000	0.002895	0.000500	0.000747	-	0.003099	0.001250	0.000439	-	0.005566	0.000500
5086	0.013785	0.040000	0.002889	0.004500	0.000746	-	0.003068	0.002000	0.000449	0.000750	0.005547	0.001250
5454	0.013781	0.027000	0.002891	0.007500	0.000747	-	0.003079	0.001250	0.000445	0.001000	0.005553	0.001250
6061	0.013771	0.010000	0.002894	0.000750	0.000755	-	0.003077	0.006000	0.000447	0.000750	0.005548	0.001250
6063	0.013775	0.006750	0.002895	0.000500	0.000749	-	0.003093	0.004000	0.000441	0.000500	0.005561	0.000500
6101	0.013774	0.005750	0.002896	0.000150	0.000748	-	0.003101	0.005000	0.000439	-	0.005566	0.000500
6262	0.013774	0.010000	0.002896	0.000750	0.000749	0.005500	0.003103	0.006000	0.000438	0.000750	0.005567	0.001250
7075	0.013559	0.025000	0.002955	0.001500	0.000945	-	0.002951	0.002000	0.000509	0.001000	0.005375	0.056000

Table 33 – Estimate of Set 2 Aluminum Element Weight Fractions (4 LV PLS Model with Set 1 Simulated Data)

Aluminum	Al		B		Bi		Cr		Cu		Fe	
	Est	Act	Est	Act	Est	Act	Est	Act	Est	Act	Est	Act
1100	0.970008	0.993250	0.000083	-	0.001374	-	0.001070	-	0.007971	0.001250	0.002225	0.003000
2011	0.928821	0.929750	-0.000087	-	0.003030	0.004000	-0.000072	-	0.043513	0.055000	0.004372	0.003500
2024	0.923152	0.928000	0.000009	-	0.000069	-	0.000503	0.000500	0.050005	0.043500	0.002392	0.002500
3003	0.957138	0.979250	-0.000035	-	-0.000810	-	0.000793	-	0.007685	0.001250	0.003067	0.003500
5052	0.971253	0.967750	0.000081	-	0.001326	-	0.001044	0.002500	0.007401	0.000500	0.002253	0.002000
5086	0.965465	0.947000	0.000031	-	0.000399	-	0.000929	0.001500	0.007417	0.000500	0.002610	0.002500
5454	0.966242	0.958250	0.000044	-	0.000636	-	0.000995	0.001250	0.006873	0.000500	0.002516	0.002000
6061	0.962622	0.973050	0.000047	-	0.000716	-	0.001013	0.001950	0.009717	0.002750	0.002460	0.003500
6063	0.968615	0.985000	0.000069	-	0.001108	-	0.001029	0.000500	0.008002	0.000500	0.002330	0.001750
6101	0.970573	0.985150	0.000081	0.000300	0.001328	-	0.001064	0.000150	0.007301	0.000500	0.002251	0.002500
6262	0.970585	0.963100	0.000081	-	0.001336	0.005500	0.001065	0.000900	0.007348	0.002750	0.002246	0.003500
7075	0.890300	0.893700	0.000013	-	0.000140	-	0.002374	0.002300	0.019035	0.016000	0.002340	0.002500
Aluminum	Mg		Mn		Pb		Si		Ti		Zn	
	Est	Act	Est	Act	Est	Act	Est	Act	Est	Act	Est	Act
1100	0.012921	-	-0.003836	0.000250	0.001374	-	0.004156	0.001750	0.000424	-	0.002229	0.000500
2011	0.001739	0.000250	0.011048	-	0.003030	0.004000	0.000466	0.002000	-0.000042	-	0.004181	0.001500
2024	0.014015	0.015000	0.004224	0.006000	0.000069	-	0.002789	0.002500	0.000795	0.000750	0.001977	0.001250
3003	0.016618	-	0.012082	0.012500	-0.000810	-	0.002212	0.003000	0.000604	-	0.001456	0.000500
5052	0.012842	0.025000	-0.003382	0.000500	0.001326	-	0.004129	0.001250	0.000417	-	0.001310	0.000500
5086	0.014434	0.040000	0.003376	0.004500	0.000399	-	0.003297	0.002000	0.000496	0.000750	0.001148	0.001250
5454	0.014258	0.027000	0.001549	0.007500	0.000636	-	0.003499	0.001250	0.000481	0.001000	0.002271	0.001250
6061	0.014292	0.010000	0.000779	0.000750	0.000716	-	0.003533	0.006000	0.000502	0.000750	0.003605	0.001250
6063	0.013324	0.006750	-0.001866	0.000500	0.001108	-	0.003920	0.004000	0.000444	0.000500	0.001917	0.000500
6101	0.012974	0.005750	-0.003444	0.000150	0.001328	-	0.004119	0.005000	0.000422	-	0.002003	0.000500
6262	0.012960	0.010000	-0.003516	0.000750	0.001336	0.005500	0.004128	0.006000	0.000421	0.000750	0.002009	0.001250
7075	0.025544	0.025000	-0.000471	0.001500	0.000140	-	0.002208	0.002000	0.001045	0.001000	0.057334	0.056000

Table 34 – Estimate of Set 2 Aluminum Element Weight Fractions (4 LV PLS Model with Set 1 Simulated Data*)

*Gaussian Broadened												
	Al		B		Bi		Cr		Cu		Fe	
Aluminum	Est	Act	Est	Act	Est	Act	Est	Act	Est	Act	Est	Act
1100	0.972800	0.993250	0.000090	-	0.001518	-	0.001051	-	0.007122	0.001250	0.002197	0.003000
2011	0.930697	0.929750	-0.000085	-	0.003079	0.004000	-0.000056	-	0.042386	0.055000	0.004374	0.003500
2024	0.925133	0.928000	0.000013	-	0.000153	-	0.000488	0.000500	0.049292	0.043500	0.002383	0.002500
3003	0.959717	0.979250	-0.000028	-	-0.000677	-	0.000796	-	0.006955	0.001250	0.003028	0.003500
5052	0.974112	0.967750	0.000087	-	0.001467	-	0.001024	0.002500	0.006480	0.000500	0.002228	0.002000
5086	0.968150	0.947000	0.000037	-	0.000531	-	0.000919	0.001500	0.006589	0.000500	0.002581	0.002500
5454	0.969007	0.958250	0.000050	-	0.000763	-	0.000983	0.001250	0.005922	0.000500	0.002492	0.002000
6061	0.965269	0.973050	0.000053	-	0.000840	-	0.001000	0.001950	0.008828	0.002750	0.002436	0.003500
6063	0.971409	0.985000	0.000074	-	0.001232	-	0.001012	0.000500	0.006963	0.000500	0.002312	0.001750
6101	0.973399	0.985150	0.000087	0.000300	0.001463	-	0.001045	0.000150	0.006341	0.000500	0.002230	0.002500
6262	0.973399	0.963100	0.000088	-	0.001475	0.005500	0.001045	0.000900	0.006437	0.002750	0.002223	0.003500
7075	0.891934	0.893700	0.000015	-	0.000194	-	0.002368	0.002300	0.018219	0.016000	0.002339	0.002500
	Mg		Mn		Pb		Si		Ti		Zn	
Aluminum	Est	Act	Est	Act	Est	Act	Est	Act	Est	Act	Est	Act
1100	0.012452	-	-0.004604	0.000250	0.001518	-	0.004269	0.001750	0.000396	-	0.001192	0.000500
2011	0.001540	0.000250	0.010858	-	0.003079	0.004000	0.000532	0.002000	-0.000061	-	0.003659	0.001500
2024	0.013725	0.015000	0.003828	0.006000	0.000153	-	0.002845	0.002500	0.000776	0.000750	0.001211	0.001250
3003	0.016217	-	0.011241	0.012500	-0.000677	-	0.002353	0.003000	0.000580	-	0.000493	0.000500
5052	0.012370	0.025000	-0.004107	0.000500	0.001467	-	0.004237	0.001250	0.000388	-	0.000247	0.000500
5086	0.014007	0.040000	0.002631	0.004500	0.000531	-	0.003416	0.002000	0.000469	0.000750	0.000139	0.001250
5454	0.013833	0.027000	0.000868	0.007500	0.000763	-	0.003609	0.001250	0.000454	0.001000	0.001257	0.001250
6061	0.013879	0.010000	0.000109	0.000750	0.000840	-	0.003638	0.006000	0.000476	0.000750	0.002631	0.001250
6063	0.012896	0.006750	-0.002475	0.000500	0.001232	-	0.004015	0.004000	0.000417	0.000500	0.000912	0.000500
6101	0.012514	0.005750	-0.004116	0.000150	0.001463	-	0.004220	0.005000	0.000393	-	0.000962	0.000500
6262	0.012494	0.010000	-0.004221	0.000750	0.001475	0.005500	0.004233	0.006000	0.000393	0.000750	0.000959	0.001250
7075	0.025351	0.025000	-0.000689	0.001500	0.000194	-	0.002244	0.002000	0.001028	0.001000	0.056803	0.056000

Table 35 – Estimate of Set 2 Copper Based Metal Element Weight Fractions (8 Node ANN Model with Set 1 Simulated Data)

	Cu		Ag		As		Bi		Cd		Fe	
	Est	Act	Est	Act	Est	Act	Est	Act	Est	Act	Est	Act
C101	1.0007487	0.9999515	-0.0031791	0.0000125	-0.0017008	0.0000025	0.0025026	0.0000005	0.0002556	0.0000005	0.0003868	0.0000050
C110	0.9837990	0.9995000	0.0012416	0.0003000	0.0004753	-	-0.0007401	-	0.0000817	-	0.0000027	-
C122	0.9837890	0.9993000	0.0012602	0.0004250	0.0004819	-	-0.0007495	-	0.0000839	-	0.0000011	-
C260	0.6883904	0.7000000	0.0006321	-	0.0008695	-	0.0001104	-	-0.0012203	-	0.0017040	0.0002500
C353	0.6232066	0.6200000	0.0000307	-	-0.0002952	-	0.0004772	-	0.0003263	-	0.0008689	0.0007500
C464	0.6112013	0.6050000	-0.0006796	-	-0.0004941	-	-0.0003760	-	0.0007650	-	-0.0007336	0.0005000
C510	0.9769125	0.9458500	0.0014665	-	0.0007152	-	-0.0010441	-	-0.0001769	-	-0.0000556	0.0005000
	Mn		Ni		O		P		Pb		S	
	Est	Act	Est	Act	Est	Act	Est	Act	Est	Act	Est	Act
C101	0.0036874	0.0000025	-0.0023214	0.0000050	0.0004748	0.0000025	0.0009029	0.0000015	0.0004880	0.0000025	0.0012646	0.0000075
C110	-0.0012745	-	0.0010109	-	-0.0001608	0.0002000	0.0003312	-	-0.0000709	-	-0.0003600	-
C122	-0.0012938	-	0.0010305	-	-0.0001652	-	0.0003258	0.0002750	-0.0000677	-	-0.0003670	-
C260	0.0021263	-	-0.0024222	-	0.0013436	-	0.0007816	-	0.0039869	0.0003500	-0.0006685	-
C353	0.0002049	-	0.0006167	-	-0.0000092	-	-0.0004028	-	0.0085371	0.0200000	-0.0000116	-
C464	-0.0017065	-	0.0013494	-	-0.0010453	-	-0.0001878	-	0.0093559	0.0010000	0.0006353	-
C510	-0.0015225	-	0.0007898	-	-0.0001072	-	0.0004877	0.0019000	-0.0004785	0.0002500	-0.0004096	-
	Sb		Se		Sn		Te		Zn			
	Est	Act	Est	Act	Est	Act	Est	Act	Est	Act	Est	Act
C101	-0.0029314	0.0000020	0.0009552	0.0000015	0.0020876	0.0000010	-0.0037355	0.0000010	-0.0047210	0.0000005		
C110	0.0008174	-	-0.0000183	-	0.0151660	-	0.0010811	-	0.0004857	-		
C122	0.0008311	-	-0.0000175	-	0.0152170	-	0.0010954	-	0.0004430	-		
C260	0.0022551	-	-0.0029328	-	0.0045529	-	0.0012251	-	0.3027580	0.2994000		
C353	0.0001641	-	0.0006395	-	0.0025709	-	-0.0003774	-	0.3655286	0.3592500		
C464	-0.0021328	-	0.0018990	-	0.0018763	0.0075000	-0.0008289	-	0.3766040	0.3860000		
C510	0.0011317	-	-0.0004435	-	0.0158190	0.0500000	0.0015645	-	0.0070814	0.0015000		

Table 36 – Estimate of Set 2 Copper Based Metal Element Weight Fractions (8 Node ANN Model with Set 1 Simulated Data*)

*Gaussian Broadened												
	Cu		Ag		As		Bi		Cd		Fe	
	Est	Act	Est	Act	Est	Act	Est	Act	Est	Act	Est	Act
C101	1.0037910	0.9999515	0.0001721	0.0000125	-0.0037835	0.0000025	-0.0009584	0.0000005	-0.0019947	0.0000025	-0.0005435	0.0000050
C110	0.9813367	0.9995000	0.0002215	0.0003000	0.0015291	-	0.0003578	-	0.0008645	0.0002000	0.0003832	-
C122	0.9811383	0.9993000	0.0001798	0.0004250	0.0016011	-	0.0003741	-	0.0009033	-	0.0004020	-
C260	0.6876851	0.7000000	0.0001521	-	-0.0009746	-	-0.0001419	-	-0.0004502	-	0.0003414	0.0002500
C353	0.6307766	0.6200000	-0.0001600	-	0.0001700	-	0.0000555	-	0.0000612	-	0.0004940	0.0007500
C464	0.6045615	0.6050000	0.0000838	-	0.0004421	-	0.0000495	-	0.0002215	-	0.0006772	0.0005000
C510	0.9793333	0.9458500	0.0001895	-	0.0011862	-	0.0003438	-	0.0006984	-	0.0003695	0.0005000
	Mn		Ni		O		P		Pb		S	
	Est	Act	Est	Act	Est	Act	Est	Act	Est	Act	Est	Act
C101	-0.0007053	0.0000025	-0.0013237	0.0000050	-0.0019947	0.0000025	0.0036890	0.0000015	-0.0008502	0.0000025	-0.0009650	0.0000075
C110	0.0002762	-	0.0005643	-	0.0008645	0.0002000	-0.0006420	-	0.0002333	-	0.0003818	-
C122	0.0002860	-	0.0005787	-	0.0009033	-	-0.0007157	0.0002750	0.0002585	-	0.0003696	-
C260	-0.0001498	-	-0.0004181	-	-0.0004502	-	0.0008323	-	0.0062408	0.0003500	-0.0001543	-
C353	0.0000559	-	0.0000951	-	0.0000612	-	-0.0000431	-	0.0074603	0.0200000	0.0000642	-
C464	0.0000729	-	0.0002193	-	0.0002215	-	-0.0003954	-	0.0080495	0.0010000	0.0000707	-
C510	0.0002538	-	0.0004200	-	0.0006984	-	-0.0004975	0.0019000	0.0003286	0.0002500	0.0003512	-
	Sb		Se		Sn		Te		Zn			
	Est	Act	Est	Act	Est	Act	Est	Act	Est	Act		
C101	0.0022606	0.0000020	-0.0000662	0.0000015	0.0114200	0.0000010	-0.0022634	0.0000010	-0.0106012	0.0000005		
C110	-0.0009165	-	0.0000190	-	0.0122816	-	0.0008828	-	0.0035014	-		
C122	-0.0009334	-	0.0000581	-	0.0122982	-	0.0009537	-	0.0036184	-		
C260	0.0005487	-	-0.0001095	-	0.0041298	-	-0.0005893	-	0.3026449	0.2994000		
C353	0.0000383	-	0.0001956	-	0.0028813	-	0.0002420	-	0.3579412	0.3592500		
C464	-0.0003098	-	-0.0000702	-	0.0023364	0.0075000	0.0001536	-	0.3842910	0.3860000		
C510	-0.0006387	-	0.0000684	-	0.0121182	0.0500000	0.0007746	-	0.0059168	0.0015000		

Table 37 – Estimate of Set 2 Copper Based Metal Element Weight Fractions (4 LV PLS Model with Set 1 Simulated Data)

	Cu		Ag		As		Bi		Cd		Fe	
	Est	Act	Est	Act	Est	Act	Est	Act	Est	Act	Est	Act
C101	0.9911795	0.9999515	-0.0000579	0.0000125	0.0000023	0.0000025	0.0000005	0.0000005	0.0000005	0.0000005	0.0000887	0.0000050
C110	0.9994227	0.9995000	0.0003625	0.0003000	0.0000000	-	0.0000000	-	0.0000000	-	-0.0000002	-
C122	0.9992084	0.9993000	0.0003623	0.0004250	0.0000000	-	0.0000000	-	0.0000000	-	0.0000019	-
C260	0.6949005	0.7000000	-0.0000044	-	0.0000005	-	0.0000001	-	0.0000001	-	0.0003029	0.0002500
C353	0.6198421	0.6200000	-0.0000001	-	0.0000000	-	0.0000000	-	0.0000000	-	0.0007516	0.0007500
C464	0.6092075	0.6050000	0.0000036	-	-0.0000004	-	-0.0000001	-	-0.0000001	-	0.0004564	0.0005000
C510	0.9453831	0.9458500	-0.0000002	-	0.0000000	-	0.0000000	-	0.0000000	-	0.0005048	0.0005000
	Mn		Ni		O		P		Pb		S	
	Est	Act	Est	Act	Est	Act	Est	Act	Est	Act	Est	Act
C101	0.0000023	0.0000025	0.0000047	0.0000050	-0.0000166	0.0000025	0.0003957	0.0000015	-0.0000221	0.0000025	0.0000070	0.0000075
C110	0.0000000	-	0.0000000	-	0.0001000	0.0002000	0.0001323	-	-0.0000050	-	0.0000000	-
C122	0.0000000	-	0.0000000	-	0.0001000	-	0.0001394	0.0002750	0.0000019	-	0.0000000	-
C260	0.0000005	-	0.0000009	-	-0.0000013	-	-0.0000990	-	0.0002576	0.0003500	0.0000014	-
C353	0.0000000	-	0.0000000	-	-0.0000001	-	-0.0000030	-	0.0199971	0.0200000	0.0000000	-
C464	-0.0000004	-	-0.0000008	-	0.0000011	-	0.0000817	-	0.0010762	0.0010000	-0.0000011	-
C510	0.0000000	-	0.0000001	-	-0.0000005	-	0.0018914	0.0019000	0.0002415	0.0002500	0.0000001	-
	Sb		Se		Sn		Te		Zn			
	Est	Act	Est	Act	Est	Act	Est	Act	Est	Act		
C101	0.0000019	0.0000020	0.0000014	0.0000015	0.0100183	0.0000010	0.0000009	0.0000010	-0.0016071	0.0000005		
C110	0.0000000	-	0.0000000	-	-0.0000808	-	0.0000000	-	0.0000682	-		
C122	0.0000000	-	0.0000000	-	0.0001104	-	0.0000000	-	0.0000757	-		
C260	0.0000004	-	0.0000003	-	0.0008948	-	0.0000002	-	0.3037448	0.2994000		
C353	0.0000000	-	0.0000000	-	0.0000277	-	0.0000000	-	0.3593845	0.3592500		
C464	-0.0000003	-	-0.0000002	-	0.0067618	0.0075000	-0.0000002	-	0.3824152	0.3860000		
C510	0.0000000	-	0.0000000	-	0.0500816	0.0500000	0.0000000	-	0.0018978	0.0015000		

Table 38 – Estimate of Set 2 Copper Based Metal Element Weight Fractions (4 LV PLS Model with Set 1 Simulated Data*)

*Gaussian Broadened												
	Cu		Ag		As		Bi		Cd		Fe	
	Est	Act	Est	Act	Est	Act	Est	Act	Est	Act	Est	Act
C101	0.9258629	0.9999515	-0.0000768	0.0000125	0.0000046	0.0000025	0.0000006	0.0000005	0.0000006	0.0000005	0.0000302	0.0000050
C110	1.1119579	0.9995000	0.0002956	0.0003000	0.0000023	-	0.0000001	-	0.0000001	-	-0.0000306	-
C122	1.1129172	0.9993000	0.0002981	0.0004250	0.0000023	-	0.0000001	-	0.0000001	-	-0.0000349	-
C260	0.6924683	0.7000000	-0.0000918	-	0.0000025	-	0.0000003	-	0.0000003	-	0.0002634	0.0002500
C353	0.6152078	0.6200000	-0.0001186	-	0.0000019	-	0.0000001	-	0.0000001	-	0.0007174	0.0007500
C464	0.6570771	0.6050000	-0.0001028	-	0.0000016	-	0.0000001	-	0.0000001	-	0.0004195	0.0005000
C510	1.1025444	0.9458500	-0.0000591	-	0.0000022	-	0.0000002	-	0.0000002	-	0.0004715	0.0005000
	Mn		Ni		O		P		Pb		S	
	Est	Act	Est	Act	Est	Act	Est	Act	Est	Act	Est	Act
C101	0.0000046	0.0000025	0.0000092	0.0000050	-0.0000530	0.0000025	0.0002249	0.0000015	0.0000084	0.0000025	0.0000060	0.0000075
C110	0.0000023	-	0.0000045	-	0.0000640	0.0002000	0.0000061	-	-0.0000268	-	-0.0000008	-
C122	0.0000023	-	0.0000046	-	0.0000647	-	-0.0000048	0.0002750	-0.0000462	-	-0.0000008	-
C260	0.0000025	-	0.0000050	-	-0.0000195	-	-0.0001740	-	0.0002211	0.0003500	0.0000006	-
C353	0.0000019	-	0.0000039	-	-0.0000122	-	-0.0000511	-	0.0199565	0.0200000	-0.0000005	-
C464	0.0000016	-	0.0000031	-	-0.0000116	-	0.0000042	-	0.0010262	0.0010000	-0.0000019	-
C510	0.0000022	-	0.0000043	-	-0.0000399	-	0.0017285	0.0019000	0.0002140	0.0002500	-0.0000010	-
	Sb		Se		Sn		Te		Zn			
	Est	Act	Est	Act	Est	Act	Est	Act	Est	Act		
C101	0.0000026	0.0000020	0.0000024	0.0000015	0.0176151	0.0000010	0.0000013	0.0000010	-0.0639564	0.0000005		
C110	0.0000005	-	0.0000010	-	0.0081833	-	0.0000003	-	-0.0436116	-		
C122	0.0000005	-	0.0000010	-	0.0078363	-	0.0000003	-	-0.0442068	-		
C260	0.0000011	-	0.0000012	-	0.0107634	-	0.0000005	-	0.2853104	0.2994000		
C353	0.0000005	-	0.0000010	-	0.0080489	-	0.0000003	-	0.3590230	0.3592500		
C464	0.0000004	-	0.0000007	-	0.0170152	0.0075000	0.0000002	-	0.3751680	0.3860000		
C510	0.0000008	-	0.0000010	-	0.0612664	0.0500000	0.0000004	-	-0.0679641	0.0015000		

Table 39 – Estimate of Set 2 Stainless Steel Element Weight Fractions (8 Node ANN Model with Set 1 Simulated Data)

	Al		B		C		Cr		Cu		Fe	
	Est	Act	Est	Act	Est	Act	Est	Act	Est	Act	Est	Act
302	0.001046	-	-0.002788	-	-0.001200	0.000750	0.172049	0.180000	0.001036	-	0.730516	0.714625
304	0.001566	-	-0.003336	-	-0.001770	0.000350	0.174557	0.185000	0.002086	-	0.712098	0.707525
316	-0.000365	-	-0.000976	-	-0.000936	0.000400	0.160013	0.170000	0.000276	-	0.652022	0.669975
321	0.001809	-	-0.003487	-	-0.002080	0.000400	0.173417	0.180000	0.002658	-	0.703411	0.695475
330	-0.002613	-	0.001142	-	0.000305	0.000400	0.182377	0.185000	0.000999	0.005000	0.429578	0.432900
405	-0.001209	0.002000	0.000318	-	0.000385	0.000400	0.160846	0.130000	-0.002984	-	0.816583	0.854250
430	-0.000851	-	0.000065	-	-0.000194	0.000600	0.165150	0.170000	-0.002255	-	0.796810	0.815300
434	0.001834	-	-0.003343	-	-0.001689	0.000600	0.156541	0.170000	0.001131	-	0.847763	0.809050
660	0.003651	0.001750	-0.005348	0.000055	-0.001708	0.000400	0.170425	0.147500	0.005385	-	0.509546	0.543195
	Pb		Mn		Mo		Ni		N		P	
	Est	Act	Est	Act	Est	Act	Est	Act	Est	Act	Est	Act
302	-0.001435	-	0.007794	0.010000	-0.002683	-	0.079672	0.090000	0.000510	0.000500	0.001004	0.000225
304	-0.001812	-	0.008651	0.010000	-0.004462	-	0.095322	0.092500	0.000971	0.000500	0.002224	0.000225
316	0.000300	-	0.006870	0.010000	0.015803	0.025000	0.136499	0.120000	-0.000080	0.000500	0.000833	0.000225
321	-0.002406	-	0.008654	0.010000	-0.004796	-	0.100149	0.105000	0.001288	0.000500	0.002911	0.000225
330	0.002067	0.000025	0.010560	0.010000	0.006429	-	0.360499	0.355000	-0.000786	-	-0.001608	0.000150
405	-0.000392	-	0.004457	0.005000	0.003407	-	0.003641	0.003000	-0.001307	-	-0.001829	0.000200
430	-0.000376	-	0.005619	0.005000	0.000899	-	0.021479	0.003750	-0.001167	-	-0.000485	0.000200
434	-0.002230	-	0.005757	0.005000	0.014226	0.010000	-0.021734	-	0.001271	-	0.002208	0.000200
660	-0.004945	-	0.010286	0.010000	0.006932	0.012500	0.268523	0.255000	0.001379	-	0.001280	0.000200
	Si		S		Sn		Ti		V			
	Est	Act	Est	Act	Est	Act	Est	Act	Est	Act	Est	Act
302	0.002681	0.003750	0.000827	0.000150	-0.002579	-	-0.000189	-	-0.000006	-	-	-
304	0.002195	0.003750	0.001108	0.000150	-0.004028	-	-0.000854	-	0.000815	-	-	-
316	0.003966	0.003750	-0.000544	0.000150	-0.002067	-	0.002848	-	0.001012	-	-	-
321	0.002018	0.003750	0.001027	0.000150	-0.004205	-	-0.000164	0.004500	0.001291	-	-	-
330	0.008299	0.011250	-0.001908	0.000150	0.000104	0.000125	0.006166	-	0.000360	-	-	-
405	0.004118	0.005000	-0.001352	0.000150	0.002548	-	0.002293	-	-0.002040	-	-	-
430	0.003726	0.005000	-0.001198	0.000150	0.000890	-	0.000822	-	-0.001278	-	-	-
434	0.000603	0.005000	0.000952	0.000150	-0.004350	-	-0.000086	-	0.001490	-	-	-
660	0.004958	0.005000	0.002603	0.000150	-0.003053	-	0.006974	0.021250	0.000730	0.003000	-	-

Table 40 – Estimate of Set 2 Stainless Steel Element Weight Fractions (8 Node ANN Model with Set 1 Simulated Data*)

*Gaussian Broadened												
Al		B		C		Cr		Cu		Fe		
Est	Act	Est	Act	Est	Act	Est	Act	Est	Act	Est	Act	
302	0.000444	-	0.000055	-	0.000376	0.000750	0.168538	0.180000	0.000552	-	0.693594	0.714625
304	0.000452	-	0.000061	-	0.000367	0.000350	0.168523	0.185000	0.000550	-	0.693587	0.707525
316	0.000391	-	-0.000046	-	0.000605	0.000400	0.168688	0.170000	0.000563	-	0.693553	0.669975
321	0.000456	-	0.000066	-	0.000364	0.000400	0.168519	0.180000	0.000553	-	0.693587	0.695475
330	0.000392	-	-0.000047	-	0.000605	0.000400	0.168687	0.185000	0.000564	0.005000	0.693553	0.432900
405	0.000414	0.002000	0.000031	-	0.000426	0.000400	0.168594	0.130000	0.000555	-	0.693603	0.854250
430	0.000421	-	0.000041	-	0.000399	0.000600	0.168573	0.170000	0.000553	-	0.693604	0.815300
434	0.000391	-	-0.000045	-	0.000603	0.000600	0.168688	0.170000	0.000563	-	0.693554	0.809050
660	0.000391	0.001750	-0.000046	0.000055	0.000604	0.000400	0.168688	0.147500	0.000563	-	0.693554	0.543195
Pb		Mn		Mo		Ni		N		P		
Est	Act	Est	Act	Est	Act	Est	Act	Est	Act	Est	Act	
302	-0.000011	-	0.008290	0.010000	0.005314	-	0.113756	0.090000	0.000170	0.000500	0.000090	0.000225
304	0.000000	-	0.008281	0.010000	0.005316	-	0.113748	0.092500	0.000161	0.000500	0.000080	0.000225
316	0.000028	-	0.008390	0.010000	0.005244	0.025000	0.113868	0.120000	0.000286	0.000500	0.000330	0.000225
321	-0.000003	-	0.008288	0.010000	0.005318	-	0.113738	0.105000	0.000160	0.000500	0.000070	0.000225
330	0.000028	0.000025	0.008392	0.010000	0.005245	-	0.113867	0.355000	0.000287	-	0.000329	0.000150
405	-0.000031	-	0.008317	0.005000	0.005298	-	0.113796	0.003000	0.000203	-	0.000144	0.000200
430	-0.000030	-	0.008301	0.005000	0.005306	-	0.113784	0.003750	0.000189	-	0.000120	0.000200
434	0.000027	-	0.008391	0.005000	0.005243	0.010000	0.113867	-	0.000285	-	0.000329	0.000200
660	0.000028	-	0.008390	0.010000	0.005243	0.012500	0.113867	0.255000	0.000285	-	0.000329	0.000200
Si		S		Sn		Ti		V				
Est	Act	Est	Act	Est	Act	Est	Act	Est	Act			
302	0.005128	0.003750	0.000118	0.000150	-0.000074	-	0.002811	-	0.000337	-		
304	0.005130	0.003750	0.000126	0.000150	-0.000077	-	0.002816	-	0.000343	-		
316	0.005159	0.003750	0.000187	0.000150	0.000107	-	0.002930	-	0.000318	-		
321	0.005128	0.003750	0.000119	0.000150	-0.000092	-	0.002814	0.004500	0.000337	-		
330	0.005158	0.011250	0.000187	0.000150	0.000107	0.000125	0.002930	-	0.000318	-		
405	0.005130	0.005000	0.000111	0.000150	-0.000044	-	0.002815	-	0.000318	-		
430	0.005127	0.005000	0.000108	0.000150	-0.000058	-	0.002805	-	0.000325	-		
434	0.005158	0.005000	0.000186	0.000150	0.000105	-	0.002929	-	0.000317	-		
660	0.005158	0.005000	0.000187	0.000150	0.000106	-	0.002930	0.021250	0.000318	0.003000		

Table 41 – Estimate of Set 2 Stainless Steel Element Weight Fractions (4 LV PLS Model with Set 1 Simulated Data)

	Al		B		C		Cr		Cu		Fe	
	Est	Act	Est	Act	Est	Act	Est	Act	Est	Act	Est	Act
302	-0.000117	-	-0.000004	-	0.000509	0.000750	0.182190	0.180000	0.000111	-	0.723984	0.714625
304	-0.000347	-	-0.000006	-	0.000509	0.000350	0.188177	0.185000	0.000186	-	0.706161	0.707525
316	0.000128	-	0.000015	-	0.000422	0.000400	0.171285	0.170000	-0.000522	-	0.637419	0.669975
321	-0.000361	-	-0.000006	-	0.000506	0.000400	0.188767	0.180000	0.000242	-	0.699231	0.695475
330	0.000085	-	0.000009	-	0.000412	0.000400	0.185572	0.185000	0.004710	0.005000	0.413602	0.432900
405	0.001253	0.002000	0.000009	-	0.000504	0.000400	0.147315	0.130000	-0.000355	-	0.819629	0.854250
430	0.001002	-	0.000007	-	0.000501	0.000600	0.154047	0.170000	-0.000336	-	0.799385	0.815300
434	-0.000059	-	-0.000012	-	0.000606	0.000600	0.168142	0.170000	0.000544	-	0.847412	0.809050
660	0.001121	0.001750	0.000029	0.000055	0.000355	0.000400	0.157208	0.147500	0.000917	-	0.547021	0.543195
	Pb		Mn		Mo		Ni		N		P	
	Est	Act	Est	Act	Est	Act	Est	Act	Est	Act	Est	Act
302	0.000001	-	0.009378	0.010000	0.000011	-	0.079522	0.090000	0.000463	0.000500	0.000222	0.000225
304	0.000001	-	0.010102	0.010000	0.000008	-	0.091541	0.092500	0.000547	0.000500	0.000225	0.000225
316	-0.000003	-	0.010670	0.010000	0.024823	0.025000	0.144701	0.120000	0.000479	0.000500	0.000229	0.000225
321	0.000001	-	0.010234	0.010000	0.000027	-	0.097536	0.105000	0.000553	0.000500	0.000225	0.000225
330	0.000024	0.000025	0.010399	0.010000	0.000013	-	0.369792	0.355000	-0.000012	-	0.000152	0.000150
405	-0.000002	-	0.005446	0.005000	0.000008	-	0.016957	0.003000	-0.000006	-	0.000203	0.000200
430	-0.000002	-	0.006380	0.005000	-0.000006	-	0.030542	0.003750	0.000104	-	0.000209	0.000200
434	0.000003	-	0.003756	0.005000	0.008383	0.010000	-0.029272	-	-0.000070	-	0.000191	0.000200
660	0.000005	-	0.010676	0.010000	0.013300	0.012500	0.250316	0.255000	0.000213	-	0.000201	0.000200
	Si		S		Sn		Ti		V			
	Est	Act	Est	Act	Est	Act	Est	Act	Est	Act	Est	Act
302	0.003982	0.003750	0.000150	0.000150	0.000003	-	-0.000189	-	-0.000216	-	-	-
304	0.003865	0.003750	0.000150	0.000150	0.000005	-	-0.000792	-	-0.000331	-	-	-
316	0.003150	0.003750	0.000150	0.000150	-0.000013	-	0.006224	-	0.000842	-	-	-
321	0.003920	0.003750	0.000150	0.000150	0.000006	-	-0.000710	0.004500	-0.000321	-	-	-
330	0.010916	0.011250	0.000150	0.000150	0.000118	0.000125	0.003575	-	0.000484	-	-	-
405	0.004570	0.005000	0.000150	0.000150	-0.000009	-	0.003811	-	0.000514	-	-	-
430	0.004319	0.005000	0.000150	0.000150	-0.000008	-	0.003302	-	0.000404	-	-	-
434	0.005855	0.005000	0.000150	0.000150	0.000014	-	-0.004990	-	-0.000654	-	-	-
660	0.005613	0.005000	0.000150	0.000150	0.000023	-	0.011274	0.021250	0.001577	0.003000	-	-

Table 42 – Estimate of Set 2 Stainless Steel Element Weight Fractions (4 LV PLS Model with Set 1 Simulated Data*)

	*Gaussian Broadened											
	Al		B		C		Cr		Cu		Fe	
	Est	Act	Est	Act	Est	Act	Est	Act	Est	Act	Est	Act
302	-0.000134	-	-0.000004	-	0.000511	0.000750	0.182922	0.180000	0.000103	-	0.721033	0.714625
304	-0.000197	-	-0.000004	-	0.000505	0.000350	0.185120	0.185000	0.000119	-	0.707400	0.707525
316	0.000255	-	0.000017	-	0.000418	0.000400	0.168593	0.170000	-0.000574	-	0.638642	0.669975
321	-0.000201	-	-0.000003	-	0.000501	0.000400	0.185572	0.180000	0.000159	-	0.699533	0.695475
330	0.000086	-	0.000009	-	0.000410	0.000400	0.185884	0.185000	0.004728	0.005000	0.408491	0.432900
405	0.001254	0.002000	0.000009	-	0.000502	0.000400	0.146772	0.130000	-0.000320	-	0.823097	0.854250
430	0.001142	-	0.000009	-	0.000496	0.000600	0.150286	0.170000	-0.000357	-	0.808224	0.815300
434	-0.000112	-	-0.000012	-	0.000609	0.000600	0.169563	0.170000	0.000551	-	0.844019	0.809050
660	0.000957	0.001750	0.000026	0.000055	0.000360	0.000400	0.160664	0.147500	0.000995	-	0.545097	0.543195
	Pb		Mn		Mo		Ni		N		P	
	Est	Act	Est	Act	Est	Act	Est	Act	Est	Act	Est	Act
302	0.000001	-	0.009514	0.010000	0.000004	-	0.081592	0.090000	0.000477	0.000500	0.000223	0.000225
304	0.000001	-	0.009999	0.010000	0.000015	-	0.092450	0.092500	0.000522	0.000500	0.000225	0.000225
316	-0.000003	-	0.010565	0.010000	0.024855	0.025000	0.145418	0.120000	0.000456	0.000500	0.000229	0.000225
321	0.000001	-	0.010178	0.010000	0.000037	-	0.099369	0.105000	0.000532	0.000500	0.000225	0.000225
330	0.000024	0.000025	0.010530	0.010000	0.000032	-	0.374225	0.355000	-0.000004	-	0.000153	0.000150
405	-0.000002	-	0.005257	0.005000	0.000020	-	0.014357	0.003000	-0.000024	-	0.000202	0.000200
430	-0.000002	-	0.005948	0.005000	0.000020	-	0.025275	0.003750	0.000051	-	0.000206	0.000200
434	0.000003	-	0.003923	0.005000	0.008367	0.010000	-0.027211	-	-0.000049	-	0.000192	0.000200
660	0.000005	-	0.010800	0.010000	0.013271	0.012500	0.249737	0.255000	0.000240	-	0.000202	0.000200
	Si		S		Sn		Ti		V			
	Est	Act	Est	Act	Est	Act	Est	Act	Est	Act		
302	0.003937	0.003750	0.000150	0.000150	0.000003	-	-0.000118	-	-0.000212	-		
304	0.003844	0.003750	0.000150	0.000150	0.000003	-	0.000052	-	-0.000204	-		
316	0.003142	0.003750	0.000150	0.000150	-0.000014	-	0.006904	-	0.000946	-		
321	0.003869	0.003750	0.000150	0.000150	0.000004	-	0.000252	0.004500	-0.000179	-		
330	0.010920	0.011250	0.000150	0.000150	0.000118	0.000125	0.003740	-	0.000504	-		
405	0.004661	0.005000	0.000150	0.000150	-0.000008	-	0.003581	-	0.000490	-		
430	0.004425	0.005000	0.000150	0.000150	-0.000009	-	0.003662	-	0.000474	-		
434	0.005813	0.005000	0.000150	0.000150	0.000014	-	-0.005138	-	-0.000680	-		
660	0.005644	0.005000	0.000150	0.000150	0.000025	-	0.010385	0.021250	0.001441	0.003000		

Table 43 – Estimate of Set 2 Element Weight Fractions (for all metals using 4 LV PLS Model with Set 1 Simulated Data)

	Al		Ag		As		B		Bi		C		Cd		Cr		Cu	
	Est	Act	Est	Act	Est	Act	Est	Act	Est	Act	Est	Act	Est	Act	Est	Act	Est	Act
302	0.1179171	-	0.0000185	-	-0.0000002	-	-0.0000019	-	0.0002875	-	0.0002610	0.0008050	0.0000001	0.0000005	0.0000911	-	0.0058566	-
304	0.1203223	-	0.0000189	-	-0.0000002	-	-0.0000021	-	0.0002939	-	0.0002570	0.0001850	0.0000001	-	0.0000929	-	0.0060926	-
316	-0.0620461	-	-0.0000125	-	0.0000001	-	0.0000066	-	-0.0001576	-	0.0005393	0.0003960	9.465E-09	-	-0.0000505	-	-0.0052530	-
321	0.1210466	-	0.0000192	-	-0.0000002	-	-0.0000021	-	0.0002966	-	0.0002551	0.0000950	0.0000001	-	0.0000933	-	0.0063699	-
330	-0.0656389	-	-0.0000077	-	0.0000001	-	0.0000067	-	-0.0001625	-	0.0005371	0.0006780	8.206E-09	-	-0.0000550	-	0.0100563	0.0099620
405	0.0827412	0.0022520	0.0000106	-	-0.0000001	-	0.0000002	-	0.0001889	-	0.0003243	0.0001000	0.0000001	-	0.0000662	-	0.0015360	-
430	0.1056452	-	0.0000147	-	-0.0000001	-	-0.0000009	-	0.0002462	-	0.0002883	0.0000260	0.0000001	-	0.0000841	-	0.0032606	-
434	-0.0658412	-	-0.0000173	-	0.0000001	-	0.0000079	-	-0.0001942	-	0.0005659	0.0004390	3.808E-10	-	-0.0000470	-	-0.0101419	-
660	-0.0252963	0.0036910	-0.0000035	-	0.0000000	-	0.0000046	0.0000270	-0.0000591	-	0.0004753	0.0007890	2.602E-08	-	-0.0000237	-	0.0028540	-
1100	1.0528659	0.9947950	-0.0000053	-	0.0000000	-	0.0000161	-	0.0009630	-	-0.0000110	-	0.0000000	-	0.0012123	-	-0.0007521	0.0006730
2011	0.6595290	0.9299750	0.0000354	-	0.0000000	-	0.0000054	-	0.0007567	0.0049700	0.0000121	-	4.365E-08	-	0.0007206	-	0.0929507	0.0541410
2024	0.7625900	0.9271490	0.0000187	-	-0.0000001	-	0.0000075	-	0.0008316	-	0.0000050	-	0.0000000	-	0.0008451	0.0002170	0.0350531	0.0454850
3003	0.9898514	0.9780230	-0.0000016	-	0.0000000	-	0.0000141	-	0.0009359	-	-0.0000059	-	0.0000000	-	0.0011324	-	0.0004953	0.0019550
5052	1.0586955	0.9707390	-0.0000057	-	0.0000000	-	0.0000162	-	0.0009662	-	-0.0000118	-	0.0000000	-	0.0012196	0.0030570	-0.0013941	0.0000840
5086	1.0322187	0.9447370	-0.0000044	-	0.0000000	-	0.0000154	-	0.0009545	-	-0.0000097	-	0.0000000	-	0.0011862	0.0020310	-0.0009680	0.0008900
5454	1.0185339	0.9628120	-0.0000036	-	0.0000000	-	0.0000150	-	0.0009490	-	-0.0000089	-	0.0000000	-	0.0011687	0.0006930	-0.0006519	0.0000930
6061	1.0173200	0.9738820	-0.0000032	-	0.0000000	-	0.0000150	-	0.0009472	-	-0.0000085	-	0.0000000	-	0.0011674	0.0026530	0.0010234	0.0030210
6063	1.0631866	0.9871110	-0.0000059	-	0.0000000	-	0.0000163	-	0.0009683	-	-0.0000123	-	0.0000000	-	0.0012252	0.0007490	-0.0014669	0.0009200
6101	1.0631242	0.9851620	-0.0000060	-	0.0000000	-	0.0000164	0.0001420	0.0009678	-	-0.0000119	-	0.0000000	-	0.0012253	0.0002950	-0.0014763	0.0000610
6262	1.0632422	0.9583370	-0.0000060	-	0.0000000	-	0.0000164	-	0.0009678	0.0068930	-0.0000119	-	0.0000000	-	0.0012254	0.0009490	-0.0014796	0.0027210
7075	0.6490941	0.8924540	-0.0000019	-	-0.0000002	-	0.0000040	-	0.0007690	-	0.0000098	-	0.0000001	-	0.0007119	0.0022800	0.0120166	0.0148800
C101	-0.0194781	-	0.0003023	0.0000241	0.0000013	0.0000040	0.0000013	-	0.0000260	0.0000008	-0.0000042	-	-1.919E-08	-	-0.0000646	-	1.1098451	0.9999320
C110	0.0118568	-	0.0002622	0.0008444	0.0000010	-	-0.0000007	-	0.0001187	-	0.0000031	-	8.501E-09	-	-0.0000389	-	0.9370122	0.9990166
C122	0.0119813	-	0.0002621	0.0002851	0.0000010	-	-0.0000008	-	0.0001190	-	0.0000032	-	8.582E-09	-	-0.0000388	-	0.9364380	0.9994759
C260	0.0001249	-	0.0000440	-	0.0000002	-	0.0000002	-	-0.0000203	-	-0.0000031	-	-8.369E-09	-	0.0000355	-	0.7215233	0.6887690
C353	0.0204260	-	-0.0000092	-	-4.343E-08	-	-0.0000004	-	0.0000076	-	0.0000007	-	1.776E-09	-	0.0000675	-	0.6005437	0.6185066
C464	0.0125348	-	-0.0000288	-	-0.0000001	-	-0.0000003	-	-0.0000170	-	-0.0000013	-	-1.767E-09	-	0.0000683	-	0.5941088	0.6038520
C510	0.0186807	-	0.0002605	-	0.0000010	-	-0.0000003	-	0.0001152	-	0.0000049	-	5.309E-09	-	-0.0000284	-	0.9388117	0.9552920

Table 44 – Table 49 Continued

	Fe		Mg		Mn		Mo		Ni		N		O		P		Pb	
	Est	Act	Est	Act	Est	Act	Est	Act	Est	Act	Est	Act	Est	Act	Est	Act	Est	Act
302	0.6299789	0.7175470	0.0022874	-	0.0093359	0.0177600	0.0012510	-	0.0730521	0.0832730	0.0002661	0.0003660	0.0000023	-	0.0001808	0.0000830	0.0003221	-
304	0.6291641	0.6965840	0.0023360	-	0.0093254	0.0127370	0.0011157	-	0.0717272	0.0942310	0.0002685	0.0004560	0.0000024	-	0.0001803	0.0002580	0.0003289	-
316	0.6935955	0.6730760	-0.0012625	-	0.0101215	0.0065790	0.0105149	0.0248330	0.1645439	0.1216610	0.0001100	0.0003750	-0.0000015	-	0.0002214	0.0001050	-0.0001569	-
321	0.6290051	0.6931490	0.0023531	-	0.0093224	0.0011880	0.0010489	-	0.0710976	0.1095900	0.0002697	0.0007280	0.0000024	-	0.0001801	0.0002680	0.0003317	-
330	0.6860183	0.4346820	-0.0013376	-	0.0100064	0.0106730	0.0105313	-	0.1639968	0.3558400	0.0001062	-	-0.0000010	-	0.0002229	0.0000600	-0.0001941	0.0000270
405	0.6409591	0.8440970	0.0015597	-	0.0094832	0.0082660	0.0034030	-	0.0939254	0.0010100	0.0002281	-	0.0000013	-	0.0001888	0.0002190	0.0002169	-
430	0.6327957	0.8190530	0.0020131	-	0.0093815	0.0062580	0.0022057	-	0.0821070	0.0036720	0.0002483	-	0.0000018	-	0.0001836	0.0000900	0.0002784	-
434	0.6913082	0.8193630	-0.0014170	-	0.0101202	0.0056190	0.0115088	0.0084360	0.1734483	-	0.0000890	-	-0.0000021	-	0.0002223	0.0003640	-0.0001954	-
660	0.6787988	0.5006620	-0.0005203	-	0.0099260	0.0202750	0.0083849	0.0131690	0.1435089	0.2648850	0.0001459	-	-0.0000004	-	0.0002133	0.0003810	-0.0000621	-
1100	-0.0601592	0.0004710	0.0157120	-	0.0021694	0.0002740	0.0004391	-	-0.0025579	-	-0.0000386	-	-0.0000007	-	-0.0000168	-	0.0007510	-
2011	0.1833985	0.0016780	0.0102466	0.0004800	0.0044096	-	-0.0019337	-	-0.0001115	-	0.0001224	-	0.0000044	-	0.0000625	-	0.0007173	0.0044840
2024	0.1491710	0.0018130	0.0117639	0.0155770	0.0042228	0.0070330	-0.0017329	-	-0.0017882	-	0.0001024	-	0.0000023	-	0.0000429	-	0.0007292	-
3003	-0.0096563	0.0060830	0.0148638	-	0.0026863	0.0118960	-0.0000402	-	-0.0019799	-	-0.0000055	-	-0.0000002	-	-0.0000036	-	0.0007457	-
5052	-0.0642739	0.0001030	0.0157931	0.0247790	0.0021287	0.0004880	0.0004654	-	-0.0027237	-	-0.0000410	-	-0.0000007	-	-0.0000180	-	0.0007523	-
5086	-0.0434348	0.0037450	0.0154374	0.0422550	0.0023403	0.0041710	0.0002672	-	-0.0024925	-	-0.0000273	-	-0.0000006	-	-0.0000128	-	0.0007600	-
5454	-0.0324004	0.0002220	0.0152543	0.0271980	0.0024530	0.0070470	0.0001515	-	-0.0024666	-	-0.0000199	-	-0.0000004	-	-0.0000099	-	0.0007593	-
6061	-0.0329185	0.0001360	0.0152329	0.0107500	0.0024431	0.0014210	0.0001703	-	-0.0023403	-	-0.0000205	-	-0.0000004	-	-0.0000097	-	0.0007579	-
6063	-0.0678390	0.0009160	0.0158541	0.0054030	0.0020922	0.0008280	0.0004941	-	-0.0028116	-	-0.0000432	-	-0.0000007	-	-0.0000189	-	0.0007529	-
6101	-0.0679139	0.0011000	0.0158516	0.0076510	0.0020915	0.0002120	0.0005089	-	-0.0026831	-	-0.0000436	-	-0.0000007	-	-0.0000189	-	0.0007523	-
6262	-0.0680145	0.0055310	0.0158531	0.0115130	0.0020905	0.0002110	0.0005106	-	-0.0026775	-	-0.0000436	-	-0.0000007	-	-0.0000189	-	0.0007522	0.0056990
7075	0.2291195	0.0018960	0.0103318	0.0285690	0.0049751	0.0002080	-0.0025927	-	-0.0020663	-	0.0001569	-	-0.0000002	-	0.0000447	-	0.0014303	-
C101	-0.0825811	0.0000089	-0.0010282	-	-0.0011026	0.0000004	0.0007856	-	0.0014546	0.0000065	-0.0000543	-	0.0000369	0.0000021	0.0001959	0.0000007	-0.0001415	0.0000027
C110	0.0327700	-	-0.0002301	-	0.0005583	-	-0.0004317	-	0.0011670	-	0.0000235	-	0.0000320	0.0001390	0.0001912	-	-0.0000096	-
C122	0.0331296	-	-0.0002273	-	0.0005636	-	-0.0004349	-	0.0011712	-	0.0000237	-	0.0000320	-	0.0001912	0.0002390	-0.0000091	-
C260	-0.0351410	0.0004667	0.0002852	-	-0.0005796	-	0.0003611	-	-0.0003331	-	-0.0000235	-	0.0000054	-	0.0000249	-	0.0054509	0.0006686
C353	0.0092673	0.0002595	0.0008451	-	0.0000585	-	-0.0000476	-	-0.0002619	-	0.0000052	-	-0.0000011	-	-0.0000031	-	0.0063182	0.0175385
C464	-0.0063720	0.0002302	0.0007794	-	-0.0001976	-	0.0000950	-	-0.0006755	-	-0.0000048	-	-0.0000035	-	-0.0000201	-	0.0069029	0.0005711
C510	0.0227540	0.0001349	-0.0001521	-	0.0004428	-	-0.0002368	-	0.0019643	-	0.0000149	-	0.0000318	-	0.0001884	0.0005785	0.0000282	0.0000368

Table 45 – Table 49 Continued

	S		Sb		Se		Si		Sn		Te		Ti		Zn	
	Est	Act	Est	Act	Est	Act	Est	Act	Est	Act	Est	Act	Est	Act	Est	Act
302	0.0001718	0.0002510	-0.0000001	-	0.0000000	-	0.0053467	0.0043450	0.0004376	-	0.0000000	-	0.0022440	-	0.0012877	-
304	0.0001713	0.0001230	-0.0000001	-	0.0000000	-	0.0053282	0.0063880	0.0004483	-	0.0000000	-	0.0022250	-	0.0013090	-
316	0.0002111	0.0001870	0.0000000	-	0.0000000	-	0.0066348	0.0041790	-0.0002371	-	1.602E-08	-	0.0035650	-	-0.0003025	-
321	0.0001711	0.0002950	-0.0000001	-	0.0000000	-	0.0053197	0.0068890	0.0004557	-	0.0000000	-	0.0022163	0.0040890	0.0012990	-
330	0.0002092	0.0000210	4.406E-08	-	3.110E-08	-	0.0065689	0.0079080	-0.0000712	0.0001070	2.073E-08	-	0.0035417	-	-0.0020164	-
405	0.0001799	0.0001470	0.0000000	-	0.0000000	-	0.0056342	0.0027030	0.0002587	-	0.0000000	-	0.0025408	-	0.0010707	-
430	0.0001749	0.0001130	-0.0000001	-	0.0000000	-	0.0054672	0.0080520	0.0003490	-	0.0000000	-	0.0023701	-	0.0012673	-
434	0.0002129	0.0002920	0.0000000	-	0.0000000	-	0.0067438	0.0051170	-0.0003570	-	0.0000000	-	0.0036824	-	-0.0001870	-
660	0.0002021	0.0003440	0.0000000	-	0.0000000	-	0.0063250	0.0095070	-0.0000190	-	0.0000000	-	0.0032593	0.0216320	-0.0005968	-
1100	-0.0000158	-	0.0000000	-	0.0000000	-	0.0023845	0.0028940	-0.0001072	-	0.0000000	-	0.0002224	-	0.0009676	0.0008930
2011	0.0000444	-	0.0000000	-	0.0000000	-	0.0028958	0.0015780	0.0011498	-	0.0000000	-	0.0005784	-	0.0049881	0.0026940
2024	0.0000355	-	0.0000000	-	0.0000000	-	0.0029325	0.0006340	0.0005499	-	0.0000000	-	0.0005269	0.0008750	0.0024519	0.0012170
3003	-0.0000033	-	0.0000000	-	0.0000000	-	0.0025415	0.0014360	-0.0000242	-	0.0000000	-	0.0003038	-	0.0011050	0.0006070
5052	-0.0000168	-	0.0000000	-	0.0000000	-	0.0023718	0.0007140	-0.0001184	-	0.0000000	-	0.0002144	-	0.0009444	0.0000360
5086	-0.0000117	-	0.0000000	-	0.0000000	-	0.0024353	0.0014970	-0.0000911	-	0.0000000	-	0.0002477	0.0006030	0.0015814	0.0000710
5454	-0.0000090	-	0.0000000	-	0.0000000	-	0.0024683	0.0007880	-0.0000718	-	0.0000000	-	0.0002641	0.0000550	0.0016122	0.0010920
6061	-0.0000091	-	0.0000000	-	0.0000000	-	0.0024637	0.0056770	-0.0000568	-	0.0000000	-	0.0002645	0.0001190	0.0016378	0.0023410
6063	-0.0000177	-	0.0000000	-	0.0000000	-	0.0023601	0.0026050	-0.0001238	-	0.0000000	-	0.0002080	0.0007850	0.0009365	0.0006830
6101	-0.0000177	-	0.0000000	-	0.0000000	-	0.0023614	0.0046630	-0.0001249	-	0.0000000	-	0.0002096	-	0.0009359	0.0007140
6262	-0.0000177	-	0.0000000	-	0.0000000	-	0.0023612	0.0044120	-0.0001251	-	0.0000000	-	0.0002095	0.0012690	0.0009356	0.0024650
7075	0.0000546	-	-0.0000001	-	-0.0000001	-	0.0031323	0.0029020	0.0000110	-	0.0000000	-	0.0006361	0.0007310	0.0432116	0.0560800
C101	-0.0000166	0.0000121	0.0000006	0.0000017	0.0000004	0.0000012	-0.0005901	-	0.0111195	0.0000013	0.0000003	0.0000008	-0.0001471	-	-0.0011203	0.0000002
C110	0.0000108	-	0.0000004	-	0.0000003	-	0.0002173	-	0.0095362	-	0.0000002	-	0.0000791	-	-0.0006009	-
C122	0.0000109	-	0.0000004	-	0.0000003	-	0.0002200	-	0.0095309	-	0.0000002	-	0.0000799	-	-0.0005976	-
C260	-0.0000081	-	0.0000001	-	0.0000001	-	-0.0002175	-	0.0039770	-	0.0000000	-	-0.0000619	-	0.3123084	0.3100957
C353	0.0000022	-	-1.846E-08	-	-1.303E-08	-	0.0001252	-	0.0023318	-	-8.686E-09	-	0.0000325	-	0.3584659	0.3636954
C464	-0.0000019	-	0.0000000	-	0.0000000	-	0.0000043	-	0.0018880	0.0069873	-2.214E-08	-	-0.0000043	-	0.3926028	0.3883594
C510	0.0000086	-	0.0000004	-	0.0000003	-	0.0001849	-	0.0095072	0.0431514	0.0000002	-	0.0000737	-	0.0019083	0.0008064

Table 46 – Estimate of Set 2 Element Weight Fractions (for all metals using 4 LV PLS Model with Set 1 Simulated Data*)

	*Gaussian Broadened																	
	Al		Ag		As		B		Bi		C		Cd		Cr		Cu	
	Est	Act	Est	Act	Est	Act	Est	Act	Est	Act	Est	Act	Est	Act	Est	Act	Est	Act
302	0.1133220	-	0.0000176	-	-0.0000001	-	-0.0000020	-	0.0002903	-	0.0002572	0.0008050	0.0000001	0.0000005	0.0000853	-	0.0051339	-
304	0.1154439	-	0.0000181	-	-0.0000002	-	-0.0000021	-	0.0002960	-	0.0002535	0.0001850	0.0000001	-	0.0000869	-	0.0055915	-
316	-0.0631444	-	-0.0000156	-	0.0000001	-	0.0000069	-	-0.0001720	-	0.0005515	0.0003960	8.144E-09	-	-0.0000506	-	-0.0135709	-
321	0.1166510	-	0.0000188	-	-0.0000002	-	-0.0000022	-	0.0003000	-	0.0002507	0.0000950	0.0000001	-	0.0000876	-	0.0067149	-
330	-0.0690779	-	0.0000037	-	0.0000001	-	0.0000066	-	-0.0001706	-	0.0005355	0.0006780	0.0000000	-	-0.0000620	-	0.0388809	0.0099620
405	0.0831222	0.0022520	0.0000085	-	-1.166E-07	-	-0.0000002	-	0.0002025	-	0.0003157	0.0001000	0.0000001	-	0.0000644	-	-0.0055220	-
430	0.1028364	-	0.0000125	-	-0.0000001	-	-0.0000012	-	0.0002530	-	0.0002834	0.0000260	0.0000001	-	0.0000798	-	-0.0022953	-
434	-0.0649704	-	-0.0000238	-	0.0000001	-	0.0000076	-	-0.0001957	-	0.0005725	0.0004390	3.270E-09	-	-0.0000468	-	-0.0310577	-
660	-0.0243943	0.0036910	0.0000007	-	0.0000000	-	0.0000045	0.0000270	-0.0000589	-	0.0004730	0.0007890	2.614E-08	-	-0.0000246	-	0.0126409	-
1100	1.0402724	0.9947950	-0.0000045	-	0.0000000	-	0.0000157	-	0.0009538	-	-0.0000080	-	-1.120E-08	-	0.0011971	-	-0.0007254	0.0006730
2011	0.6472613	0.9299750	0.0000359	-	0.0000000	-	0.0000052	-	0.0007515	0.0049700	0.0000119	-	4.450E-08	-	0.0007062	-	0.0951010	0.0541410
2024	0.7508899	0.9271490	0.0000191	-	-0.0000001	-	0.0000073	-	0.0008237	-	0.0000066	-	3.698E-08	-	0.0008320	0.0002170	0.0373762	0.0454850
3003	0.9757799	0.9780230	-0.0000011	-	0.0000000	-	0.0000139	-	0.0009238	-	-0.0000014	-	-3.068E-10	-	0.0011161	-	0.0008085	0.0019550
5052	1.0460427	0.9707390	-0.0000049	-	0.0000000	-	0.0000159	-	0.0009568	-	-0.0000086	-	-1.206E-08	-	0.0012043	0.0030570	-0.0014323	0.0000840
5086	1.0189020	0.9447370	-0.0000038	-	0.0000000	-	0.0000151	-	0.0009441	-	-0.0000061	-	-7.473E-09	-	0.0011703	0.0020310	-0.0008185	0.0008900
5454	1.0048561	0.9628120	-0.0000030	-	0.0000000	-	0.0000147	-	0.0009379	-	-0.0000049	-	-5.020E-09	-	0.0011526	0.0006930	-0.0004324	0.0000930
6061	1.0043386	0.9738820	-0.0000025	-	0.0000000	-	0.0000147	-	0.0009380	-	-0.0000058	-	-4.951E-09	-	0.0011519	0.0026530	0.0013400	0.0030210
6063	1.0506896	0.9871110	-0.0000051	-	0.0000000	-	0.0000160	-	0.0009591	-	-0.0000092	-	-1.282E-08	-	0.0012101	0.0007490	-0.0014967	0.0009200
6101	1.0508676	0.9851620	-0.0000052	-	0.0000000	-	0.0000160	0.0001420	0.0009588	-	-0.0000090	-	-1.294E-08	-	0.0012104	0.0002950	-0.0015107	0.0000610
6262	1.0510279	0.9583370	-0.0000052	-	0.0000000	-	0.0000160	-	0.0009588	0.0068930	-0.0000090	-	-1.298E-08	-	0.0012106	0.0009490	-0.0015166	0.0027210
7075	0.6389513	0.8924540	-0.0000018	-	-0.0000002	-	0.0000040	-	0.0007628	-	0.0000086	-	0.0000001	-	0.0007011	0.0022800	0.0153700	0.0148800
C101	-0.0187631	-	0.0003017	0.0000241	0.0000013	0.0000040	0.0000013	-	0.0000008	0.0000008	0.0000028	-	-1.879E-08	-	-0.0000645	-	1.1074140	0.9999320
C110	0.0127478	-	0.0002618	0.0008444	0.0000010	-	-0.0000006	-	0.0001202	-	0.0000082	-	7.932E-09	-	-0.0000379	-	0.9363641	0.9990166
C122	0.0131248	-	0.0002624	0.0002851	0.0000010	-	-0.0000006	-	0.0001215	-	0.0000075	-	8.119E-09	-	-0.0000379	-	0.9373019	0.9994759
C260	0.0004402	-	0.0000441	-	0.0000002	-	0.0000002	-	-0.0000211	-	-0.0000044	-	-8.223E-09	-	0.0000363	-	0.7212148	0.6887690
C353	0.0192117	-	-0.0000083	-	-3.658E-08	-	-0.0000005	-	0.0000063	-	-0.0000025	-	1.892E-09	-	0.0000666	-	0.6022046	0.6185066
C464	0.0123998	-	-0.0000293	-	-0.0000001	-	-0.0000004	-	-0.0000183	-	-0.0000053	-	-1.630E-09	-	0.0000692	-	0.5934916	0.6038520
C510	0.0191216	-	0.0002604	-	0.0000010	-	-0.0000003	-	0.0001179	-	0.0000091	-	5.319E-09	-	-0.0000284	-	0.9382932	0.9552920

Table 47 – Table 52 Continued

	Fe		Mg		Mn		Mo		Ni		N		O		P		Pb	
	Est	Act	Est	Act	Est	Act	Est	Act	Est	Act	Est	Act	Est	Act	Est	Act	Est	Act
302	0.6376504	0.7175470	0.0021825	-	0.0092681	0.0177600	0.0011503	-	0.0703330	0.0832730	0.0002666	0.0003660	0.0000022	-	0.0001825	0.0000830	0.0003273	-
304	0.6368311	0.6965840	0.0022241	-	0.0092539	0.0127370	0.0010274	-	0.0690883	0.0942310	0.0002685	0.0004560	0.0000022	-	0.0001821	0.0002580	0.0003331	-
316	0.6948065	0.6730760	-0.0012560	-	0.0102726	0.0065790	0.0109382	0.0248330	0.1688342	0.1216610	0.0001090	0.0003750	-0.0000019	-	0.0002204	0.0001050	-0.0001372	-
321	0.6360640	0.6931490	0.0022485	-	0.0092404	0.0011880	0.0009349	-	0.0681483	0.1095900	0.0002699	0.0007280	0.0000023	-	0.0001819	0.0002680	0.0003337	-
330	0.6693987	0.4346820	-0.0013927	-	0.0099058	0.0106730	0.0106484	-	0.1643562	0.3558400	0.0001029	-	0.0000004	-	0.0002262	0.0000600	-0.0003130	0.0000270
405	0.6496736	0.8440970	0.0015798	-	0.0094874	0.0082660	0.0030920	-	0.0898493	0.0010100	0.0002356	-	0.0000011	-	0.0001884	0.0002190	0.0002616	-
430	0.6422883	0.8190530	0.0019594	-	0.0093641	0.0062580	0.0020287	-	0.0790527	0.0036720	0.0002522	-	0.0000016	-	0.0001843	0.0000900	0.0003086	-
434	0.7009553	0.8193630	-0.0013216	-	0.0103955	0.0056190	0.0116245	0.0084360	0.1757375	-	0.0000989	-	-0.0000029	-	0.0002195	0.0003640	-0.0001098	-
660	0.6721274	0.5006620	-0.0004979	-	0.0098934	0.0202750	0.0084043	0.0131690	0.1428724	0.2648850	0.0001462	-	0.0000001	-	0.0002140	0.0003810	-0.0000988	-
1100	-0.0510336	0.0004710	0.0155546	-	0.0022970	0.0002740	0.0004084	-	-0.0015208	-	-0.0000322	-	-0.0000006	-	-0.0000144	-	0.0007466	-
2011	0.1933557	0.0016780	0.0100398	0.0004800	0.0044101	-	-0.0020204	-	-0.0009800	-	0.0001244	-	0.0000044	-	0.0000657	-	0.0007089	0.0044840
2024	0.1579159	0.0018130	0.0115636	0.0155770	0.0042230	0.0070330	-0.0017354	-	-0.0020137	-	0.0001029	-	0.0000024	-	0.0000460	-	0.0007141	-
3003	0.0003304	0.0060830	0.0146672	-	0.0027959	0.0118960	-0.0000061	-	-0.0006303	-	-0.0000011	-	-0.0000001	-	-0.0000007	-	0.0007359	-
5052	-0.0551461	0.0001030	0.0156352	0.0247790	0.0022585	0.0004880	0.0004395	-	-0.0016170	-	-0.0000346	-	-0.0000006	-	-0.0000156	-	0.0007480	-
5086	-0.0338638	0.0037450	0.0152633	0.0422550	0.0024627	0.0041710	0.0002593	-	-0.0013419	-	-0.0000216	-	-0.0000005	-	-0.0000101	-	0.0007536	-
5454	-0.0226383	0.0002220	0.0150708	0.0271980	0.0025713	0.0070470	0.0001603	-	-0.0012278	-	-0.0000146	-	-0.0000004	-	-0.0000071	-	0.0007517	-
6061	-0.0234016	0.0001360	0.0150633	0.0107500	0.0025581	0.0014210	0.0001389	-	-0.0014890	-	-0.0000146	-	-0.0000003	-	-0.0000071	-	0.0007521	-
6063	-0.0588388	0.0009160	0.0156994	0.0054030	0.0022224	0.0008280	0.0004660	-	-0.0017116	-	-0.0000368	-	-0.0000006	-	-0.0000165	-	0.0007486	-
6101	-0.0590593	0.0011000	0.0157009	0.0076510	0.0022207	0.0002120	0.0004773	-	-0.0016245	-	-0.0000371	-	-0.0000006	-	-0.0000166	-	0.0007481	-
6262	-0.0591963	0.0055310	0.0157030	0.0115130	0.0022194	0.0002110	0.0004797	-	-0.0016146	-	-0.0000372	-	-0.0000006	-	-0.0000166	-	0.0007480	0.0056990
7075	0.2374270	0.0018960	0.0101358	0.0285690	0.0048923	0.0002080	-0.0026004	-	-0.0039582	-	0.0001553	-	-0.0000002	-	0.0000477	-	0.0014189	-
C101	-0.0882509	0.0000089	-0.0009921	-	-0.0009367	0.0000004	0.0007018	-	0.0070822	0.0000065	-0.0000534	-	0.0000368	0.0000021	0.0001938	0.0000007	-0.0001092	0.0000027
C110	0.0279114	-	-0.0002225	-	0.0006350	-	-0.0004873	-	0.0052395	-	0.0000214	-	0.0000320	0.0001390	0.0001899	-	0.0000085	-
C122	0.0276819	-	-0.0002169	-	0.0006320	-	-0.0005136	-	0.0049925	-	0.0000218	-	0.0000321	-	0.0001902	0.0002390	-0.0000030	-
C260	-0.0338877	0.0004667	0.0002999	-	-0.0005975	-	0.0003988	-	-0.0014641	-	-0.0000228	-	0.0000054	-	0.0000251	-	0.0054377	0.0006686
C353	0.0127968	0.0002595	0.0008257	-	-0.0000061	-	-0.0000020	-	-0.0029808	-	0.0000058	-	-0.0000010	-	-0.0000016	-	0.0062824	0.0175385
C464	-0.0028172	0.0002302	0.0007842	-	-0.0002734	-	0.0001524	-	-0.0039182	-	-0.0000041	-	-0.0000036	-	-0.0000197	-	0.0068973	0.0005711
C510	0.0185926	0.0001349	-0.0001439	-	0.0005329	-	-0.0003361	-	0.0057651	-	0.0000144	-	0.0000318	-	0.0001872	0.0005785	0.0000442	0.0000368

Table 48 – Table 52 Continued

	S		Sb		Se		Si		Sn		Te		Ti		Zn		V	
	Est	Act	Est	Act	Est	Act	Est	Act	Est	Act	Est	Act	Est	Act	Est	Act	Est	Act
302	0.0001730	0.0002510	-0.0000001	-	0.0000000	-	0.0053397	0.0043450	0.0004514	-	0.0000000	-	0.0021471	-	0.0012999	-	0.0003195	-
304	0.0001725	0.0001230	-0.0000001	-	0.0000000	-	0.0053217	0.0063880	0.0004639	-	0.0000000	-	0.0021274	-	0.0013026	-	0.0003124	-
316	0.0002133	0.0001870	0.0000000	-	0.0000000	-	0.0066973	0.0041790	-0.0003746	-	0.0000000	-	0.0036926	-	0.0016046	-	0.0008764	-
321	0.0001721	0.0002950	-0.0000001	-	0.0000000	-	0.0053060	0.0068890	0.0004831	-	0.0000000	-	0.0021121	0.0040890	0.0011074	-	0.0003071	-
330	0.0002060	0.0000210	0.0000001	-	0.0000000	-	0.0064539	0.0079080	0.0002576	0.0001070	0.0000000	-	0.0035832	-	-0.0080901	-	0.0008535	-
405	0.0001812	0.0001470	0.0000000	-	0.0000000	-	0.0056260	0.0027030	0.0002044	-	0.0000000	-	0.0024558	-	0.0026368	-	0.0004298	-
430	0.0001765	0.0001130	-0.0000001	-	0.0000000	-	0.0054712	0.0080520	0.0003073	-	0.0000000	-	0.0022848	-	0.0024161	-	0.0003689	-
434	0.0002166	0.0002920	0.0000000	-	0.0000000	-	0.0068345	0.0051170	-0.0006249	-	0.0000000	-	0.0038075	-	0.0045205	-	0.0009153	-
660	0.0002009	0.0003440	0.0000000	-	0.0000000	-	0.0062704	0.0095070	0.0000926	-	0.0000000	-	0.0032713	0.0216320	-0.0026240	-	0.0007304	0.0050920
1100	-0.0000132	-	0.0000000	-	0.0000000	-	0.0024240	0.0028940	-0.0001030	-	0.0000000	-	0.0002695	-	0.0010845	0.0008930	-0.0000019	-
2011	0.0000463	-	0.0000000	-	0.0000000	-	0.0029141	0.0015780	0.0011938	-	0.0000000	-	0.0005307	-	0.0046019	0.0026940	-0.0000314	-
2024	0.0000374	-	0.0000000	-	0.0000000	-	0.0029537	0.0006340	0.0005893	-	0.0000000	-	0.0004937	0.0008750	0.0019158	0.0012170	-0.0000324	-
3003	-0.0000005	-	0.0000000	-	0.0000000	-	0.0025872	0.0014360	-0.0000178	-	0.0000000	-	0.0003424	-	0.0010831	0.0006070	-0.0000035	-
5052	-0.0000142	-	0.0000000	-	0.0000000	-	0.0024122	0.0007140	-0.0001156	-	0.0000000	-	0.0002635	-	0.0010864	0.0000360	-0.0000019	-
5086	-0.0000090	-	0.0000000	-	0.0000000	-	0.0024773	0.0014970	-0.0000859	-	0.0000000	-	0.0002920	0.0006030	0.0016546	0.0000710	-0.0000031	-
5454	-0.0000063	-	0.0000000	-	0.0000000	-	0.0025119	0.0007880	-0.0000662	-	0.0000000	-	0.0003067	0.0000550	0.0016583	0.0010920	-0.0000039	-
6061	-0.0000065	-	0.0000000	-	0.0000000	-	0.0025018	0.0056770	-0.0000476	-	0.0000000	-	0.0003014	0.0001190	0.0016786	0.0023410	-0.0000053	-
6063	-0.0000152	-	0.0000000	-	0.0000000	-	0.0024000	0.0026050	-0.0001209	-	0.0000000	-	0.0002578	0.0007850	0.0010697	0.0006830	-0.0000020	-
6101	-0.0000152	-	0.0000000	-	0.0000000	-	0.0024004	0.0046630	-0.0001219	-	0.0000000	-	0.0002588	-	0.0010595	0.0007140	-0.0000014	-
6262	-0.0000152	-	0.0000000	-	0.0000000	-	0.0024001	0.0044120	-0.0001222	-	0.0000000	-	0.0002588	0.0012690	0.0010574	0.0024650	-0.0000014	-
7075	0.0000561	-	-0.0000001	-	-0.0000001	-	0.0031279	0.0029020	0.0000613	-	0.0000000	-	0.0005468	0.0007310	0.0429735	0.0560800	-0.0000529	-
C101	-0.0000181	0.0000121	0.0000006	0.0000017	0.0000004	0.0000012	-0.0005241	-	0.0110816	0.0000013	0.0000003	0.0000008	-0.0000044	-	-0.0001989	0.0000002	0.0000442	-
C110	0.0000093	-	0.0000004	-	0.0000003	-	0.0002633	-	0.0095260	-	0.0000002	-	0.0001594	-	-0.0003311	-	0.0000196	-
C122	0.0000092	-	0.0000004	-	0.0000003	-	0.0002591	-	0.0095447	-	0.0000002	-	0.0001554	-	-0.0010535	-	0.0000182	-
C260	-0.0000075	-	0.0000001	-	0.0000001	-	-0.0002302	-	0.0039738	-	0.0000000	-	-0.0000797	-	0.3122330	0.3100957	-0.0000025	-
C353	0.0000033	-	0.0000000	-	0.0000000	-	0.0000951	-	0.0023622	-	0.0000000	-	-0.0000289	-	0.3573978	0.3636954	-0.0000155	-
C464	-0.0000008	-	0.0000000	-	0.0000000	-	-0.0000321	-	0.0018754	0.0069873	0.0000000	-	-0.0000740	-	0.3933685	0.3883594	-0.0000180	-
C510	0.0000072	-	0.0000004	-	0.0000003	-	0.0002299	-	0.0095035	0.0431514	0.0000002	-	0.0001547	-	0.0019747	0.0008064	0.0000239	-

Table 49 – Estimate of Aluminum Element Weight Fractions (8 Node ANN Model with Experimental Data)

	Al		B		Bi		Cr		Cu		Fe	
Aluminum	Est	Act	Est	Act	Est	Act	Est	Act	Est	Act	Est	Act
1100	0.956081	0.993250	0.000836	-	0.009661	-	0.002465	-	0.014937	0.001250	0.002828	0.003000
2036	0.956081	0.959500	0.000836	0.000500	0.009661	0.026000	0.002465	0.002500	0.014937	0.004500	0.002828	0.002500
7075	0.956081	0.893700	0.000836	-	0.009661	-	0.002465	0.002300	0.014937	0.016000	0.002828	0.002500
Unk-F75	0.956081	0.893700	0.000836	-	0.009661	-	0.002465	0.002300	0.014937	0.016000	0.002828	0.002500
Unk-1	0.956081		0.000836		0.009661		0.002465		0.014937		0.002828	
	Mg		Mn		Ni		Pb		Si		Ti	
Aluminum	Est	Act	Est	Act	Est	Act	Est	Act	Est	Act	Est	Act
1100	0.000211	-	0.002140	0.000250	0.000453	-	0.010311	0.001750	0.000099	-	0.000011	0.000500
2036	0.000211	0.002500	0.002140	0.000750	0.000453	0.001250	0.010311	-	0.000099	-	0.000011	-
7075	0.000211	0.025000	0.002140	0.001500	0.000453	-	0.010311	0.002000	0.000099	0.001000	0.000011	0.056000
Unk-F75	0.000211	0.025000	0.002140	0.001500	0.000453	-	0.010311	0.002000	0.000099	0.001000	0.000011	0.056000
Unk-1	0.000211		0.002140		0.000453		0.010311		0.000099		0.000011	
	Zn		Zr		V							
Aluminum	Est	Act	Est	Act	Est	Act	Est	Act	Est	Act	Est	Act
1100	-	-	-	-	-	-	-	-	-	-	-	-
2036	-	-	-	-	-	-	-	-	-	-	-	-
7075	-	-	-	-	-	-	-	-	-	-	-	-
Unk-F75	-	-	-	-	-	-	-	-	-	-	-	-
Unk-1	-	-	-	-	-	-	-	-	-	-	-	-

Table 50 – Estimate of Aluminum Element Weight Fractions (4 LV PLS Model with Experimental Data)

	Al		B		Bi		Cr		Cu		Fe	
Aluminum	Est	Act	Est	Act	Est	Act	Est	Act	Est	Act	Est	Act
1100	0.966966	0.993250	0.001827	-	0.005404	-	0.001605	-	0.024286	0.001250	-0.004443	0.003000
2036	0.950444	0.959500	0.000638	0.000500	0.027158	0.026000	0.002834	0.002500	0.008948	0.004500	0.005918	0.002500
7075	0.945957	0.893700	-0.000925	-	0.005893	-	0.004149	0.002300	-0.001635	0.016000	0.015957	0.002500
Unk-F75	0.895657	0.893700	0.001178	-	0.015279	-	0.001140	0.002300	0.024207	0.016000	0.000036	0.002500
Unk-1	0.988484		-0.006490		0.050513		0.011342		-0.075025		0.061997	
	Mg		Mn		Ni		Pb		Si		Ti	
Aluminum	Est	Act	Est	Act	Est	Act	Est	Act	Est	Act	Est	Act
1100	-0.000274	-	0.004619	0.000250	0.000453	-	-0.000388	0.001750	-0.000039	-	0.000001	0.000500
2036	0.000966	0.002500	0.002008	0.000750	0.000453	0.001250	0.000106	-	-0.000021	-	0.000001	-
7075	0.000828	0.025000	-0.002265	0.001500	0.000453	-	0.031353	0.002000	0.000371	0.001000	0.000022	0.056000
Unk-F75	-0.000069	0.025000	0.001051	0.001500	0.000453	-	0.060494	0.002000	0.000653	0.001000	0.000045	0.056000
Unk-1	0.005244		-0.012099		0.000453		-0.025607		-0.000183		-0.000021	
	Zn		Zr		V							
Aluminum	Est	Act	Est	Act	Est	Act						
1100	-	-	-	-	-	-						
2036	-	-	-	-	-	-						
7075	-	-	-	-	-	-						
Unk-F75	-	-	-	-	-	-						
Unk-1	-	-	-	-	-	-						

Table 51 – Estimate of Copper Based Metal Element Weight Fractions (8 Node ANN Model with Experimental Data)

	Cu		Ag		As		Bi		Cd		Fe	
	Est	Act	Est	Act	Est	Act	Est	Act	Est	Act	Est	Act
C110	0.813608	0.999500	0.000022	0.000300	0.000020	-	0.000020	-	0.000023	-	0.000204	-
	Mn		Ni		O		P		Pb		S	
	Est	Act	Est	Act	Est	Act	Est	Act	Est	Act	Est	Act
C110	0.000019	-	0.000033	-	0.000069	0.000200	0.000217	-	0.003370	-	0.000019	-
	Sb		Se		Sn		Te		Zn			
	Est	Act	Est	Act	Est	Act	Est	Act	Est	Act		
C110	0.000020	-	0.000019	-	0.008553	-	0.000021	-	0.174093	-		

Table 52 – Estimate of Copper Based Metal Element Weight Fractions (4 LV PLS Model with Experimental Data)

	Cu		Ag		As		Bi		Cd		Fe	
	Est	Act	Est	Act	Est	Act	Est	Act	Est	Act	Est	Act
C110	0.967753	0.999500	0.000015	0.000300	0.000001	-	0.000001	-	2.33E-07	-	0.000379	-
	Mn		Ni		O		P		Pb		S	
	Est	Act	Est	Act	Est	Act	Est	Act	Est	Act	Est	Act
C110	3.33E-07	-	2.85E-07	-	-0.000049	0.000200	-0.000002	-	0.001323	-	0.000005	-
	Sb		Se		Sn		Te		Zn			
	Est	Act	Est	Act	Est	Act	Est	Act	Est	Act		
C110	0.000001	-	0.000001	-	-0.004528	-	0.000002	-	0.035098	-		

Table 53 – Estimate of Stainless Steel Element Weight Fractions (8 Node ANN Model with Experimental Data)

	Al		B		C		Cr		Cu		Fe	
	Est	Act	Est	Act	Est	Act	Est	Act	Est	Act	Est	Act
304	0.956081	0.993250	0.000836	-	0.009661	-	0.002465	-	0.014937	0.001250	0.002828	0.003000
316	0.956081	0.959500	0.000836	0.000500	0.009661	0.026000	0.002465	0.002500	0.014937	0.004500	0.002828	0.002500
	Mn		Mo		Nb		Ni		N		P	
	Est	Act	Est	Act	Est	Act	Est	Act	Est	Act	Est	Act
304	0.000211	-	0.002140	0.000250	0.000453	-	0.010311	0.001750	0.000099	-	0.000011	0.000500
316	0.000211	0.002500	0.002140	0.000750	0.000453	0.001250	0.010311	-	0.000099	-	0.000011	-
	Si		S		Ti		V					
	Est	Act	Est	Act	Est	Act	Est	Act				
304	-	-	-	-	-	-	-	-				
316	-	-	-	-	-	-	-	-				

Table 54 – Estimate of Stainless Steel Element Weight Fractions (4 LV PLS Model with Experimental Data)

	Al		B		C		Cr		Cu		Fe	
	Est	Act	Est	Act	Est	Act	Est	Act	Est	Act	Est	Act
304	0.966966	0.993250	0.001827	-	0.005404	-	0.001605	-	0.024286	0.001250	-0.004443	0.003000
316	0.950444	0.959500	0.000638	0.000500	0.027158	0.026000	0.002834	0.002500	0.008948	0.004500	0.005918	0.002500
	Mn		Mo		Nb		Ni		N		P	
	Est	Act	Est	Act	Est	Act	Est	Act	Est	Act	Est	Act
304	-0.000274	-	0.004619	0.000250	0.000436	-	-0.000388	0.001750	-0.000039	-	0.000001	0.000500
316	0.000966	0.002500	0.002008	0.000750	0.001000	0.001250	0.000106	-	-0.000021	-	0.000001	-
	Si		S		Ti		V					
	Est	Act	Est	Act	Est	Act	Est	Act				
304	-	-	-	-	-	-	-	-				
316	-	-	-	-	-	-	-	-				

Table 55 – Estimate of Element Weight Fractions (for all metals using 8 Node ANN Model with Experimental Data)

	Al		Ag		As		B		Bi		C		Cd		Cr		Cu		Fe	
	Est	Act	Est	Act	Est	Act	Est	Act	Est	Act	Est	Act	Est	Act	Est	Act	Est	Act	Est	Act
304	0.459056	-	0.000025	-	0.000024	-	0.000024	-	0.000024	-	0.000160	0.000350	0.000025	-	0.199926	-	0.227071	0.707525	0.007193	-
316	0.459056	-	0.000025	-	0.000024	-	0.000024	-	0.000024	-	0.000160	0.000400	0.000025	-	0.199926	-	0.227071	0.669975	0.007193	-
1100	0.459056	0.993250	0.000025	-	0.000024	-	0.000024	-	0.000024	-	0.000160	-	0.000025	-	0.199926	0.001250	0.227071	0.003000	0.007193	-
2036	0.459056	0.959500	0.000025	-	0.000024	-	0.000024	0.000500	0.000024	0.026000	0.000160	-	0.000025	-	0.199926	0.004500	0.227071	0.002500	0.007193	0.002500
7075	0.459056	0.893700	0.000025	-	0.000024	-	0.000024	-	0.000024	-	0.000160	-	0.000025	-	0.199926	0.016000	0.227071	0.002500	0.007193	0.025000
Unk-F75	0.459056	0.893700	0.000025	-	0.000024	-	0.000024	-	0.000024	-	0.000160	-	0.000025	-	0.199926	0.016000	0.227071	0.002500	0.007193	0.025000
Unk-1	0.459056	-	0.000025	-	0.000024	-	0.000024	-	0.000024	-	0.000160	-	0.000025	-	0.199926	-	0.227071	-	0.007193	-
C110	0.459056	-	0.000025	0.000300	0.000024	-	0.000024	-	0.000024	-	0.000160	-	0.000025	-	0.199926	0.999500	0.227071	-	0.007193	-
	Mg		Mn		Mo		N		Nb		Ni		O		P		Pb		S	
	Est	Act	Est	Act	Est	Act	Est	Act	Est	Act	Est	Act	Est	Act	Est	Act	Est	Act	Est	Act
304	0.003500	0.010000	0.001024	-	0.000103	0.000500	0.000025	-	0.015956	0.092500	0.000036	-	0.000129	0.000225	0.000928	-	0.000062	0.000150	0.000024	-
316	0.003500	0.010000	0.001024	0.025000	0.000103	0.000500	0.000025	-	0.015956	0.120000	0.000036	-	0.000129	0.000225	0.000928	-	0.000062	0.000150	0.000024	-
1100	0.003500	0.000250	0.001024	-	0.000103	-	0.000025	-	0.015956	-	0.000036	-	0.000129	-	0.000928	0.001750	0.000062	-	0.000024	-
2036	0.003500	0.000750	0.001024	-	0.000103	-	0.000025	-	0.015956	0.001250	0.000036	-	0.000129	-	0.000928	-	0.000062	-	0.000024	-
7075	0.003500	0.001500	0.001024	-	0.000103	-	0.000025	-	0.015956	-	0.000036	-	0.000129	-	0.000928	0.002000	0.000062	-	0.000024	-
Unk-F75	0.003500	0.001500	0.001024	-	0.000103	-	0.000025	-	0.015956	-	0.000036	-	0.000129	-	0.000928	0.002000	0.000062	-	0.000024	-
Unk-1	0.003500	-	0.001024	-	0.000103	-	0.000025	-	0.015956	-	0.000036	-	0.000129	-	0.000928	-	0.000062	-	0.000024	-
C110	0.003500	-	0.001024	-	0.000103	-	0.000025	-	0.015956	-	0.000036	0.000200	0.000129	-	0.000928	-	0.000062	-	0.000024	-
	Sb		Se		Si		Sn		Te		Ti		V		Zn		Zr			
	Est	Act	Est	Act	Est	Act	Est	Act	Est	Act	Est	Act	Est	Act	Est	Act	Est	Act	Est	Act
304	0.000024	-	0.001885	0.003750	0.002072	-	0.000024	-	0.000422	-	0.000029	-	0.046750	-	0.000070	-	-	-	-	-
316	0.000024	-	0.001885	0.003750	0.002072	-	0.000024	-	0.000422	-	0.000029	-	0.046750	-	0.000070	-	-	-	-	-
1100	0.000024	-	0.001885	-	0.002072	-	0.000024	-	0.000422	0.000500	0.000029	-	0.046750	-	0.000070	-	-	-	-	-
2036	0.000024	-	0.001885	-	0.002072	-	0.000024	-	0.000422	-	0.000029	-	0.046750	-	0.000070	-	-	-	-	-
7075	0.000024	-	0.001885	0.001000	0.002072	-	0.000024	-	0.000422	0.056000	0.000029	-	0.046750	-	0.000070	-	-	-	-	-
Unk-F75	0.000024	-	0.001885	0.001000	0.002072	-	0.000024	-	0.000422	0.056000	0.000029	-	0.046750	-	0.000070	-	-	-	-	-
Unk-1	0.000024	-	0.001885	-	0.002072	-	0.000024	-	0.000422	-	0.000029	-	0.046750	-	0.000070	-	-	-	-	-
C110	0.000024	-	0.001885	-	0.002072	-	0.000024	-	0.000422	-	0.000029	-	0.046750	-	0.000070	-	-	-	-	-

Table 56 – Estimate of Element Weight Fractions (for all metals using 4 LV PLS Model with Experimental Data)

	Al		Ag		As		B		Bi		C		Cd		Cr		Cu		Fe	
	Est	Act	Est	Act	Est	Act	Est	Act	Est	Act	Est	Act	Est	Act	Est	Act	Est	Act	Est	Act
304	0.108031	-	-6.06E-08	-	-2.28E-09	-	1.74E-07	-	-3.91E-09	-	0.000440	0.000350	0.136195	0.185000	0.004063	-	0.667414	0.707525	0.002851	-
316	0.108216	-	8.57E-08	-	3.22E-09	-	2.55E-07	-	5.53E-09	-	0.000441	0.000400	0.127521	0.170000	0.020714	-	0.665578	0.669975	0.002493	-
1100	1.054909	0.993250	1.27E-07	-	4.77E-09	-	1.90E-07	-	8.18E-09	-	-0.000021	-	-0.029472	-	0.003169	0.001250	-0.031491	0.003000	0.014836	-
2036	0.902257	0.959500	1.10E-07	-	4.13E-09	-	-8.06E-08	0.000500	7.07E-09	0.026000	0.000010	-	0.015791	0.002500	0.031700	0.004500	0.014065	0.002500	0.013884	0.002500
7075	0.746181	0.893700	-4.29E-07	-	-1.62E-08	-	-3.91E-07	-	-2.77E-08	-	0.000063	-	0.066498	0.002300	-0.007769	0.016000	0.116851	0.002500	0.013203	0.025000
Unk-F75	0.713734	0.893700	-4.72E-07	-	-1.78E-08	-	-3.19E-07	-	-3.05E-08	-	0.000067	-	0.054346	0.002300	0.004711	0.016000	0.143753	0.002500	0.012465	0.025000
Unk-1	0.103598	-	2.89E-08	-	1.09E-09	-	2.18E-07	-	1.86E-09	-	0.000442	-	0.132128	-	0.014834	-	0.668231	-	0.002595	-
C110	-0.018576	-	0.000005	0.000300	1.75E-07	-	3.18E-08	-	3.00E-07	-	-0.000025	-	-0.001735	-	0.957197	0.999500	-0.080709	-	-0.000627	-
	Mg		Mn		Mo		N		Nb		Ni		O		P		Pb		S	
	Est	Act	Est	Act	Est	Act	Est	Act	Est	Act	Est	Act	Est	Act	Est	Act	Est	Act	Est	Act
304	0.008229	0.010000	0.003816	-	0.000311	0.000500	0.000001	-	0.064163	0.092500	-0.000002	-	0.000240	0.000225	-0.000229	-	0.000135	0.000150	-3.26E-09	-
316	0.007880	0.010000	0.003635	0.025000	0.000291	0.000500	0.000001	-	0.059940	0.120000	0.000001	-	0.000230	0.000225	-0.000181	-	0.000129	0.000150	4.61E-09	-
1100	0.001800	0.000250	-0.000642	-	-0.000067	-	0.000001	-	-0.014509	-	0.000003	-	-0.000054	-	0.000337	0.001750	-0.000022	-	6.82E-09	-
2036	0.003380	0.000750	0.000420	-	0.000034	-	-0.000001	-	0.007423	0.001250	0.000002	-	0.000034	-	0.000193	-	0.000011	-	5.89E-09	-
7075	0.005270	0.001500	0.001581	-	0.000148	-	-0.000002	-	0.031890	-	-0.000008	-	0.000109	-	0.000130	0.002000	0.000050	-	-2.31E-08	-
Unk-F75	0.004695	0.001500	0.001282	-	0.000122	-	-0.000001	-	0.025974	-	-0.000009	-	0.000087	-	0.000441	0.002000	0.000044	-	-2.54E-08	-
Unk-1	0.008060	-	0.003735	-	0.000302	-	0.000001	-	0.062178	-	0.000000	-	0.000236	-	-0.000205	-	0.000132	-	1.55E-09	-
C110	-0.000203	-	0.000092	-	-0.000004	-	-0.000001	-	-0.000294	-	0.000076	0.000200	0.000247	-	0.002458	-	-0.000005	-	2.50E-07	-
	Sb		Se		Si		Sn		Te		Ti		V		Zn		Zr			
	Est	Act	Est	Act	Est	Act	Est	Act	Est	Act	Est	Act	Est	Act	Est	Act	Est	Act	Est	Act
304	-2.28E-09	-	3.08E-03	0.003750	0.001222	-	-6.51E-09	-	0.000757	-	0.000010	-	-0.000826	-	0.000100	-	-	-	-	-
316	3.22E-09	-	3.02E-03	0.003750	0.001162	-	9.21E-09	-	0.000718	-	0.000008	-	-0.001873	-	0.000074	-	-	-	-	-
1100	4.77E-09	-	2.26E-03	-	-0.000782	-	1.36E-08	-	0.000360	0.000500	0.000002	-	-0.000605	-	-0.000014	-	-	-	-	-
2036	4.13E-09	-	2.40E-03	-	0.000674	-	1.18E-08	-	0.000504	-	0.000006	-	0.007132	-	0.000077	-	-	-	-	-
7075	-1.62E-08	-	2.58E-03	0.001000	0.001255	-	-4.62E-08	-	0.000669	0.056000	0.000012	-	0.021101	-	0.000190	-	-	-	-	-
Unk-F75	-1.78E-08	-	2.35E-03	0.001000	0.000861	-	-5.08E-08	-	0.000594	0.056000	0.000011	-	0.034308	-	0.000168	-	-	-	-	-
Unk-1	1.09E-09	-	3.05E-03	0.001220	0.001220	-	3.10E-09	-	0.000737	-	0.000009	-	-0.001369	-	0.000086	-	-	-	-	-
C110	1.75E-07	-	-3.42E-05	-	0.010485	-	5.00E-07	-	0.000000	-	-0.000001	-	0.131671	-	-0.000022	-	-	-	-	-

Appendix E – ANN Algorithm (in matlab)

```
function [wH, wO, bH, bO] = myANN(X, Y, hNodes, scaleFactor, outputName)
% Benjamin Bond
% Master's Research
% ANN Algorithm
%
% myANN.m is a Neural Net used to Analyze Spectra which employs
% backpropagation as the correction step.
%
% X = Spectroscopic data as described in the thesis
% Y = Calibrated Weights as described in the thesis
% Dimensions of X and Y:  X(n_samp,ch)  Y(n_samp,wgts)
% hnodes = the number of hidden nodes desired
% outputName = outputName for results.  Not all results are returned in the function
%-----

%-----
% Process Training Data
iNodes = size(X,2); % Number of Input Nodes
oNodes = size(Y,2); O = oNodes;
                H = hNodes;

nMats = size(Y,2);
samples = size(X,1); % Number of Samples
IHHO2 = iNodes*hNodes+hNodes*oNodes+2;
IH = iNodes*hNodes;
HO = hNodes*oNodes;
SM = samples*nMats;
w = zeros(IHHO2,1);
y = (1:1:nMats);
sigmaY = std(Y,1);
I = eye(IHHO2);

% -----
% Initialize input, hidden, and output layers, and initialize Jacobian.
inputLayer = X;
hiddenLayer = zeros(samples,hNodes); % Initialize Hidden Layer
outputLayer = zeros(samples,oNodes); % Initialize Output Layer
J = zeros(samples*nMats,IHHO2);
    YTemp = Y;
    for i = 1:size(YTemp,1)
        for j = 1:size(YTemp,2)
            if YTemp(i,j) == 0
                YTemp(i,j) = max(max(Y));
            end
        end
    end
    bTemp = min(min(YTemp));
    biasMax = bTemp %
% End of Data Processing function
%-----

%-----
% Training Phase

icount = 0;
SSE = 10;
mu = .01;
C = 10;

% Seed weight matrices either with random numbers or previous iteration
weightMatrixIbyH = rand(iNodes,hNodes); % Seed first weight matrix
```

```

weightMatrixHbyO = rand(hNodes,oNodes); % Seed second weight matrix
bWHidden = bTemp*rand(1); bWHmatrix = ones(samples,hNodes);
bWOutput = bTemp*rand(1); bWMatrix = ones(samples,oNodes);

icount = icount + 1;
weightMatrixIbyHold = weightMatrixIbyH;
weightMatrixHbyOold = weightMatrixHbyO;
bWHiddenold = bWHidden;
bWOutputold = bWOutput;

%=====

% START OF SECOND WHILE LOOP - THIS IS THE LM ALGORITHM
icountR = 0;
dError = 1;
LMConvCrit = 1E-8; % Levenberg-Marquardt Algorithm convergence criteria
while dError > LMConvCrit
    %tic
    icountR = icountR + 1;
    % If this is the first time through, then calculate everything
    if icountR == 1
        weightMatrixIbyH = weightMatrixIbyHold; % Seed first weight matrix
        weightMatrixHbyO = weightMatrixHbyOold; % Seed second weight matrix
        % Map data from inputLayer to hiddenLayer
        % Use Sigmoid Transformation (a.k.a logistic curve) after finding nodal sums
        [~,hiddenLayer,outputLayer,netlbyH,netlbyO] = getLayers(inputLayer, bWHidden,
bWOutput, weightMatrixIbyH, weightMatrixHbyO, Y, samples, Cutoff, hNodeCutoff, oNodeCutoff);
    end

    % Construct the weight vector
    w = transpose(weightMatrixHbyO(1,:));
    for h = 2:hNodes
        w = vertcat(w,transpose(weightMatrixHbyO(h,:)));
    end
    for i = 1:iNodes
        w = vertcat(w, transpose(weightMatrixIbyH(i,:)));
    end
    w = vertcat(w,bWHidden);
    w = vertcat(w,bWOutput);

    % Calculate the Weight updates
    % Step 1 - Construct the Jacobian
    for s = 1:samples
        % Construct the temporary Jacobian
        Jtemp = zeros(oNodes,IHHO2);

        % First populate the first HxO columns with de/dw for the
        % hidden layer weights
        ct = 0;
        for i = 1:oNodes
            ct = ct + 1;
            jt = 0;
            for j=0:H-1
                Jtemp(i,jt+ct) = -hiddenLayer(s,j+1);
                jt = jt + oNodes;
            end
        end

        % Step 2 - Populate the next IxH columns with de/dw for the
        % input layer weights
        for i = 1:oNodes
            xt = 0;
            for x = 1:iNodes
                for k = 1:H

```

```

        Jtemp(i,H0+xt+k) = -weightMatrixHbyO(k,i)*inputLayer(s,x)*exp(-
netlbyH(s,k))/(1 + exp(-netlbyH(s,k)))^2);
    end
    xt = xt + hNodes;
end
end

% Step 3 - Populate the hidden bias node column
for i = 1:oNodes
Jtemp(i,IHHO2-1) = 0;
    for j = 1:H
        Jtemp(i,IHHO2-1) = Jtemp(i,IHHO2-1) + Jtemp(i,j+H0)/inputLayer(s,1);
    end
end

% Step 4 - Populate the output bias node column
for i = 1:oNodes
    Jtemp(i,IHHO2) = -1;
end

if s == 1
J = Jtemp;
else
J = vertcat(J,Jtemp);
end
end

% Construct the error vector
for s = 1:samples
    etemp = Y - outputLayer;
    if s == 1
        e = transpose(etemp(s,:));
    else
        e = vertcat(e,transpose(etemp(s,:)));
    end
end

% Check the conditioning of the Inverse
JtJ = transpose(J)*J;
JtJmuI = JtJ + mu*I;

if cond(JtJmuI) > 2 && icount == 1
    while cond(JtJmuI) > 2 && mu <= 1E20
        mu = mu * C;
        JtJmuI = JtJ + mu*I;
    end
elseif cond(JtJmuI) > 1000 && icount ~= 1
    while cond(JtJmuI) > 1000 && mu <= 1E20
        mu = mu * C;
        JtJmuI = JtJ + mu*I;
    end
end

% Test for positive definiteness
positivedefinite = all(eig(JtJmuI) > 0);
if positivedefinite == true
    JtJmuIinvJe = -JtJmuI\((transpose(J) * e);
else
    stop 'error in inversion'
end

[F4] = findSSE(inputLayer, bWHidden, bWOutput, weightMatrixIbyH, weightMatrixHbyO, Y,
samples, Cutoff, hNodeCutoff, oNodeCutoff);
% Update the weights
w = w + JtJmuIinvJe;

```

```

ct = 0;
for h = 1:hNodes
    for o = 1:oNodes
        ct = ct + 1;
        weightMatrixHbyO(h,o) = w(ct,1);
    end
end
for i = 1:iNodes
    for h = 1:hNodes
        ct = ct + 1;
        weightMatrixIbyH(i,h) = w(ct,1);
    end
end
bWHidden = w(IHHO2-1,1);
bWOutput = w(IHHO2,1);
    if bWHidden < 0
        bWHidden = 0;
    elseif bWHidden >= biasMax
        bWHidden = biasMax;
    end
    if bWOutput < 0
        bWOutput = 0;
    elseif bWOutput >= biasMax
        bWOutput = biasMax;
    end
end

% Recalculate the errors
[F5] = findSSE(inputLayer, bWHidden, bWOutput, weightMatrixIbyH, weightMatrixHbyO, Y,
samples, Cutoff, hNodeCutoff, oNodeCutoff);
dError = (F5 - F4)/F5;
if dError < 0 && mu >= 1E-9
    mu = mu/C;
    weightMatrixIbyHold = weightMatrixIbyH; % Seed first weight matrix
    weightMatrixHbyOold = weightMatrixHbyO; % Seed second weight matrix
    bWHiddenold = bWHidden;
    bWOutputold = bWOutput;
elseif dError > 0 && mu <= 1E22
    mu = mu*C;
    weightMatrixIbyH = weightMatrixIbyHold;
    weightMatrixHbyO = weightMatrixHbyOold;
    bWHidden = bWHiddenold;
    bWOutput = bWOutputold;
elseif dError > 0 && mu > 1E22
    weightMatrixIbyH = weightMatrixIbyHold;
    weightMatrixHbyO = weightMatrixHbyOold;
    bWHidden = bWHiddenold;
    bWOutput = bWOutputold;
    dError = 0;
end

[F10,hiddenLayer,outputLayer,netlbyH,netlbyO] = getLayers(inputLayer, bWHidden,
bWOutput, weightMatrixIbyH, weightMatrixHbyO, Y, samples, Cutoff, hNodeCutoff, oNodeCutoff);
dError = abs(dError);
dErrorArray(1,icountR) = dError;
SSEarray(1,icountR) = F10;

if mod(icountR,10) == 0
    %{
    y = 1:size(dErrorArray,2);
    figure(1)
    semilogy(y,dErrorArray)
    figure(2)
    semilogy(y,SSEarray)
    %}
    F10
    %toc

```

```

end
if mod(icountR,10) == 0
    dlmwrite(outputName,F10,'delimiter',' ','precision',15);
    dlmwrite(outputName,scaleFactor,'delimiter',' ','-
append','roffset',1,'precision',15);
    dlmwrite(outputName,weightMatrixIbyH,'delimiter',' ','-
append','roffset',1,'precision',15);
    dlmwrite(outputName,bWHidden,'delimiter',' ','-
append','roffset',1,'precision',3);
    dlmwrite(outputName,weightMatrixHbyO,'delimiter',' ','-
append','roffset',1,'precision',15);
    dlmwrite(outputName,bWOutput,'delimiter',' ','-
append','roffset',1,'precision',15);
end

end
icountR;

% END OF LM WHILE LOOP
% -----

[F11] = findSSE(inputLayer, bWHidden, bWOutput, weightMatrixIbyH, weightMatrixHbyO, Y,
samples, Cutoff, hNodeCutoff, oNodeCutoff);

wH = weightMatrixIbyH;
wO = weightMatrixHbyO;
bH = bWHidden;
bO = bWOutput;

dlmwrite(outputName,SSE,'delimiter',' ','precision',15);
dlmwrite(outputName,scaleFactor,'delimiter',' ','-append','roffset',1,'precision',15);
dlmwrite(outputName,weightMatrixIbyH,'delimiter',' ','-append','roffset',1,'precision',15);
dlmwrite(outputName,bWHidden,'delimiter',' ','-append','roffset',1,'precision',3);
dlmwrite(outputName,weightMatrixHbyO,'delimiter',' ','-append','roffset',1,'precision',15);
dlmwrite(outputName,bWOutput,'delimiter',' ','-append','roffset',1,'precision',15);

end

```

```

function [SSE,hL,oL,nIH,nHO] = getLayers(inputLayer, bWHidden, bWOutput, weightMatrixIbyH,
weightMatrixHbyO, Y, samples, Cutoff, hNodeCutoff, oNodeCutoff)

hNodes = size(weightMatrixHbyO,1);
oNodes = size(weightMatrixHbyO,2);
% Recalculate the errors
% Map data from inputLayer to hiddenLayer
% Use Sigmoid Transformation (a.k.a logistic curve) after finding nodal sums
bWHmatrix = bWHidden * ones(samples,hNodes);
netlbyH = (inputLayer * weightMatrixIbyH) + bWHmatrix;
if Cutoff == 1
    for i = 1:size(netlbyH,1)
        for j = 1:size(netlbyH,2)
            if weightMatrixIbyH(i,j) < hNodeCutoff
                netlbyH(i,j) = 0;
            end
        end
    end
end
% Apply Logistic Curve
hiddenLayer = 1./(1 + exp(-1.*netlbyH));
hL = hiddenLayer;
nIH = netlbyH;

%-----
% Map data from hiddenLayer to outputLayer
% Use a linear transformation after finding nodal sums f(net) = net
bWMatrix = bWOutput * ones(samples,oNodes);
netlbyO = (hiddenLayer * weightMatrixHbyO) + bWMatrix;
if Cutoff == 1
    for i = 1:size(netlbyO,1)
        for j = 1:size(netlbyO,2)
            if weightMatrixHbyO(i,j) < oNodeCutoff
                netlbyO(i,j) = 0;
            end
        end
    end
end
outputLayer = netlbyO;
oL = outputLayer;
nHO = netlbyO;

SSEarray = (Y - outputLayer).^2;
SSE = sum(sum(SSEarray,1),2);

end

```



```

function [SSE] = findSSE(inputLayer, bWHidden, bWOutput, weightMatrixIbyH, weightMatrixHbyO,
Y, samples, Cutoff, hNodeCutoff, oNodeCutoff)
    hNodes = size(weightMatrixHbyO,1);
    oNodes = size(weightMatrixHbyO,2);
    % Recalculate the errors
    % Map data from inputLayer to hiddenLayer
    % Use Sigmoid Transformation (a.k.a logistic curve) after finding nodal sums
    bWHmatrix = bWHidden * ones(samples,hNodes);
    netlbyH = (inputLayer * weightMatrixIbyH) + bWHmatrix;
    if Cutoff == 1
        for i = 1:size(netlbyH,1)
            for j = 1:size(netlbyH,2)
                if weightMatrixIbyH(i,j) < hNodeCutoff
                    netlbyH(i,j) = 0;
                end
            end
        end
    end
    % Apply Logistic Curve
    hiddenLayer = 1./(1 + exp(-1.*netlbyH));

    %-----
    % Map data from hiddenLayer to outputLayer
    % Use a linear transformation after finding nodal sums f(net) = net
    bWomatrix = bWOutput * ones(samples,oNodes);
    netlbyO = (hiddenLayer * weightMatrixHbyO) + bWomatrix;
    if Cutoff == 1
        for i = 1:size(netlbyO,1)
            for j = 1:size(netlbyO,2)
                if weightMatrixHbyO(i,j) < oNodeCutoff
                    netlbyO(i,j) = 0;
                end
            end
        end
    end
    outputLayer = netlbyO;

    SSEarray = (Y - outputLayer).^2;
    SSE = sum(sum(SSEarray,1),2);

end

```

Appendix F – PLS Algorithm (in matlab)

```
function [C] = myPLS_f(pcrit,rcrit,n,scaleCenter,X,Y,outputName)
% Benjamin Bond
% Master's Research
% PLS Algorithm

% pcrit is the convergence criteria for the predictor variables
% (between 0 and 1)
% rcrit is the convergence criteria for the response variables
% (between 0 and 1)
% n = the number of latent variables you want to use.
% scaleCenter = 'yes' and 'no' and are used to indicate whether or not you
% want to scale and center your data.
% X = the X block as discussed in the Thesis
% Y = the Y block as discussed in the Thesis
% outputName = outputName for results. Not all results are returned in the function

% Initialize starting matrices

XBlock = X
YBlock = Y

nSamples = size(XBlock,1);
nChannel = size(XBlock,2);
nElement = size(YBlock,2);
if nSamples ~= size(YBlock,1)
    'Stop Error';
end

T = zeros(size(Y,1),1);
U = zeros(size(Y,1),1);
W = zeros(size(X,2),1);
P = zeros(size(X,2),1);
Q = zeros(size(Y,2),1);
B = zeros(1);
bmatrix = zeros(size(Y,2));
btemp = zeros(size(Y,2),1);
Amatrix = zeros(size(Y,2)+1);
Ymatrix = zeros(size(Y,2)+1,1);
yintercept = zeros(1,size(Y,2));

L = size(X,1);

if strcmp(scaleCenter,'yes')
    Ebar = mean(X,1);
    Fbar = mean(Y,1);

    E = X;
    F = Y;

    for i = 1:L
        E(i,:) = X(i,:) - Ebar(1,:);
        F(i,:) = Y(i,:) - Fbar(1,:);
    end

    sigE = std(E);
    sigF = std(F);

    for i = 1:size(X,1)
        for j = 1:size(X,2)
            if sigE(1,j) ~= 0
                E(i,j) = E(i,j)/sigE(1,j);
            end
        end
    end
end
```

```

end
for i = 1:size(Y,1)
    for j = 1:size(Y,2)
        if sigF(1,j) ~= 0
            F(i,j) = F(i,j)/sigF(1,j);
        end
    end
end
elseif strcmp(scaleCenter,'no')
    E = X;
    F = Y;
end

E0 = E;
F0 = F;

SX = E.^2;
SSX = sum(sum(SX,1),2);

SY = F.^2;
SSY = sum(sum(SY,1),2);

%-----

%-----
% Training Phase
%
tconvcrit = 1E-6;
pconv = 0.0;
pconvcrit = pcrit;
rconv = 0.0;
rconvcrit = rcrit;
k = 0;

while pconv < pconvcrit && rconv < rconvcrit && k < n;
    k = k + 1;

    tconv = 1;
    icount = 0;

    while tconv > tconvcrit
        icount = icount + 1;

        if icount == 1
            u = rand(size(Y,1),1);
            told = 1000*u;
        end

        w = transpose(E)*u/(norm(transpose(E)*u,2));
        t = E*w/(norm(E*w,2));
        q = transpose(F)*t/(norm(transpose(F)*t,2));
        u = F*q;

        tconv = max(abs(t - told));
        told = t;
    end;

    p = (transpose(E)*t/(norm(t,2)));
    b = transpose(t)*u/(transpose(t)*t);

    E = E - t*transpose(p);
    F = F - b*t*transpose(q);

    T(:,k) = t;
    U(:,k) = u;
end;

```

```

        W(:,k) = w;
        P(:,k) = p;
        Q(:,k) = q;
        B(k,k) = b;

        ptp(k,1) = transpose(p)*p;
        b2(k,1) = b^2;
        LVX(k,1) = ptp(k,1)/SSX;
        LVY(k,1) = b2(k,1)/SSY;

        pconv = sum(LVX,1);
        rconv = sum(LVY,1);
end
LV = k;

LVXTotal = sum(LVX);
LVYTotal = sum(LVY);

Eprime = T*transpose(P);
Eresid = E0 - Eprime;

% End of Training function
%-----

%-----
% Application Phase
% Predict the Y Values
Bpls = pinv(transpose(P))*B*transpose(Q);
Fest = E*Bpls;

y = (1:1:size(Y,2));
delta = Fest - F;
RelDelta = delta./F;

% Create the Normal Equations for MLR
XB = X*Bpls;
coffa = ones(size(XB,1),1);
XB2 = horzcat(coffa,XB);
bmatrix = zeros(size(Y,2)+1,size(Y,2));
for kk = 1:size(Y,2)
    Ytemp = Y(:,kk);
    for i = 1:size(Y,2)+1
        XB2itemp = XB2(:,i);
        Ymatrix(i,1) = sum(XB2itemp.*Ytemp,1);
        for j = 1:size(Y,2)+1
            XB2jtemp = XB2(:,j);
            Amatrix(i,j) = sum(XB2itemp.*XB2jtemp,1);
        end
    end
    btemp = Amatrix\Ymatrix;
    bmatrix(:,kk) = btemp;
end

for i = 1:size(Y,1)
    yintercept(i,:) = bmatrix(1,:);
end

bmatrix2 = removerows(bmatrix,[1]);

Yest = X*Bpls*bmatrix2 + yintercept;
Ydif = Yest - Y;

delta = Yest - Y;
RelDelta = delta./Y;

```

```

        BplsScl = Bpls*bmatrix2;
        yint = yintercept;
        if size(X,1) == 1
            SSE = sum((Yest - Y).^2);
        elseif size(X,1) > 1
            SSE = sum(sum((Yest - Y).^2))
        end

        dlmwrite(outputName,SSE,'delimiter',' ','precision',15);
        dlmwrite(outputName,BplsScl,'delimiter',' ','-
append','roffset',1,'precision',15);
        dlmwrite(outputName,yint,'delimiter',' ','-
append','roffset',1,'precision',15);
        dlmwrite(outputName,Y,'delimiter',' ','-
append','roffset',1,'precision',15);
        dlmwrite(outputName,Yest,'delimiter',' ','-
append','roffset',1,'precision',15);
        dlmwrite(outputName,Ydif,'delimiter',' ','-
append','roffset',1,'precision',15);
        dlmwrite(outputName,LV,'delimiter',' ','-
append','roffset',1,'precision',15);
        dlmwrite(outputName,LVXTotal,'delimiter',' ','-
append','roffset',1,'precision',15);
        dlmwrite(outputName,transpose(LVX),'delimiter',' ','-
append','roffset',1,'precision',15);
        dlmwrite(outputName,LVYTotal,'delimiter',' ','-
append','roffset',1,'precision',15);
        dlmwrite(outputName,transpose(LVY),'delimiter',' ','-
append','roffset',1,'precision',15);

        C = 'complete'
end

```

Appendix G – Sample MCNP File

```
LEGe Detector Model GL1515R
c   Created on: Saturday, January 18, 2014
c   Created by: Benjamin Bond
c
c
c Standard Units used throughout this code include:
c  1. lengths in centimeters,
c  2. energies in MeV,
c  3. time in shakes (10-8 sec),
c  4. temperatures in MeV (kT),
c  5. atomic densities in units of atoms/barn-cm,
c  6. mass densities in g/cm3,
c  7. cross sections in barns (10-24 cm2),
c  8. heating numbers in MeV/collision, and
c  9. atomic weight ratio based on a neutron mass of 1.008664967 amu.
c   In these units, Avogadro's number is 0.59703109 x 10+24.
c
c LEGe Detector by Canberra; Model #GL1515R; Serial #5954147
c Dewar Model          DWR-30
c Crystat Configuration 7500SL
c Preamplifier Model   2002CPSL
c
c This File contains a target located at (0, 0, 0)
c The source sits on the X axis, and the detector
c lies along the Z axis underneath the (0, 0, 0) point.
c
c ***** BLOCK 1 Cell Definitions *****
c **** Source Cells
100 0      (-1001 1002 -1003)
c
c **** Collimator
912 12 -11.35 (-9000 9001 -9002 9003)    $ Cylinder
913 12 -11.35 (-9000 9004 -9003)        $ Plug
c
c **** Detector Cells
200 1 -5.33 (-2001 2002 -2003)
201 7 -2.95 (-2001 2002 -2005 2003):
      (-2002 2004 -2005)
202 8 -3.80 (-2006 2001 -2005)
c **** Housing Cells
400 2 -2.70 (-4001 4004 -4009 4007):
      (-4004 4012 -4009 4008):
      (-4011 4013 -4010 4009):
      (-4013 4014 -4010 5001)
401 13 -1.85 (-4002 4003 -4007)
402 11 -.001 (-4012 4013 -4009 5001)
c
c **** Peripherals
300 4 -8.96 (-2004 3000 -3001 3002)    $ Copper Tubing
301 14 -.048 (-3003 3004 -3008 2005):  $ Insulation
      (-3004 3005 -3008 3001)
302 2 -2.70 (-3005 3006 -3008 3009):
      (-3006 3007 -3008 3001)
303 0      (-2004 3004 -2005 3001)
304 0      (-3005 3006 -3009 3001)
305 0      (-4003 4004 -4007):
      (-4004 2006 -4008)
306 0      (-2006 3007 -4008 3008):
      (-3007 4011 -4008 3001):
      (-2006 3003 -3008 2005)
500 5 -8.00 (-4012 5007 -5001 5002):  $ SS
      (-4011 4012 -4008 3001)
```

```

501 9 -1.02 (-5000 5003 -5004 5001) $Nylon Cap
502 6 -0.92 (-5003 5005 -5006 5001) $Butyl Ring
503 5 -8.00 (-5005 5007 -5008 5001) $$SS
c
c **** Dewar
600 2 -2.70 (-5007 6006 -6001 6000)
601 2 -2.70 (-6006 6012 -6010 6011): $ Cone
(-6012 6019 -6002 6003): $ Barrell
(-6019 6020 -6002): $ Bot Plate
(-6011 6012 6003):
(-6012 6011 -6003)
602 2 -2.70 (-6013 6017 -6004 6005): $ Barrell
(-6013 6014 -6004 6000): $ Top Plate
(-6017 6018 -6004) $ Bot Plate
603 2 -2.70 (-6011 -6006 6013 -6001 6000)$ Stem
604 3 -1.00 (-6015 6017 -6005 3001): $ Liquid Nitrogen
(-6015 3000 -3002):
(-3000 6017 -3001)
605 3 -.001 (-4012 5007 -5002 3001): $ Gaseous Nitrogen in neck
(-5007 6014 -6000 3001):
(-6014 6015 -6005 3001)
606 3 -.001 (-2004 6015 -3002) $ " " in Tube
607 0 (-6011 -6006 6013 -6003 6001):$ Vacuum Inside Dewar - Top
(-6013 6019 -6003 6004): $ Vacuum Inside Dewar - Side
(-6018 6019 -6004) $ Vacuum Inside Dewar - Bot
c **** Target
3300 304 -8.00 (-8000 8001 -8002 8003 -8004 8005) $ Plate
c
c **** Universe
997 11 -.001 (-7000 #3300 #912 #913 #100 #400) &
(#401 #402 #200 #201 #202 #300 #301 #302) &
(#303 #304 #305 #306 #500 #501 #502 #503) &
(#600 #601 #602 #603 #604 #605 #606 #607)
999 0 7000
c ***** BLOCK 2 Surface Definitions *****
c **** Source Geometry (If Point Source this is not used)
1001 cx 0.20 $ Bottom Edge of Source
1002 px 4.48 $ Top Edge of Source
1003 px 4.98 $ Cylinder
c
c **** Collimator Geometry
9000 px 15.00 $ Top of Collimator
9001 px 4.00 $ Bottom of Collimator
9002 cx 2.54 $ Outside of Collimator
9003 cx 0.25 $ Inside of Collimator
9004 px 10.00 $ Plug
c
c **** Target Geometry $ half thickness is currently 0.15875 cm
8000 2 pz 0.3175 $ Bottom of Target
8001 2 pz 0.00 $ Top of Target
8002 2 px 6.5 $ Sides of Target
8003 2 px -6.5 $ " "
8004 2 py 6.5 $ " "
8005 2 py -6.5 $ " "
c
c **** Detector Geometry
c **** Outer Aluminum Can
4001 pz -4.125 $ Top - Bottom Edge
4002 pz -4.175 $ Top - Top Edge
4003 pz -4.225 $ Top - Bottom Edge
4004 pz -4.275 $ Top - Top Edge
4007 cz 3.35 $ Inner Surface (assume 8mm gap to Inner Can)
4008 cz 3.70
4009 cz 3.85 $ Outer Surface (1mm)
4010 cz 4.00 $

```

```

4011 pz -14.80      $
4012 pz -14.90      $
4013 pz -26.95
4014 pz -27.10      $
c
c **** Bulk Crystal
2001 pz -4.70      $ Crystal - Top
2002 pz -6.25      $ Crystal - Bottom
2003 cz 2.25      $ Crystal Diameter
c
c **** Ge/Li Layer - Side and Back
2004 pz -6.30      $ Ge/Li dead layer Top (.5mm) (3004)
2005 cz 2.30      $ Ge/Li dead layer Side(.5mm) (3001)
c
c **** Ge/B Layer - Front
2006 pz -4.6999997 $ Ge/B dead layer Side(.3microns)
c
c **** Copper Cold Finger
3000 pz -84.0      $ Estimated Height of Copper Tube
3001 cz .4900
3002 cz .3655      $ Inner Wall of Copper Tubing
c
c **** Insulation and Cup
3003 pz -5.10
3004 pz -7.8
3005 pz -8.05
3006 pz -9.6
3007 pz -9.75
3008 cz 2.55
3009 cz 2.40
c
c **** Stainless Steel, Nylong Ring, and Butyl Ring
5000 pz -28.4
5003 pz -29.2
5005 pz -31.7
5007 pz -32.6
5001 cz 1.65
5002 cz 1.50
5004 cz 4.50
5006 cz 4.61
5008 cz 4.48
c
c **** Dewar
6006 pz -34.9
6000 cz 03.75      $ Inner Neck - Inside Surface
6001 cz 03.90      $ Inner Neck - Outside Surface
6002 cz 21.60      $ Outer Wall of Dewar - Outside
6003 cz 21.45      $ Outer Wall of Dewar - Inside (assume 1.5mm of Al)
6004 cz 17.80      $ Inner Wall of Dewar - Outside
6005 cz 17.65      $ Inner Wall of Dewar - Inside (assume 1.5mm of Al)
6010 kz -31.25 1.15 -1 $ Outside Cone of Dewar
6011 kz -31.40 1.15 -1 $ Inside Cone of Dewar
6012 pz -51.40      $ Bottom of Cone
6013 pz -53.60      $ Inner Wall of Dewar - Top
6014 pz -53.75      $ Inner Wall of Dewar - Bottom (assume 1.5mm Al)
6015 pz -63.20      $ Estimated Height of Nitrogen (approx 3/4 full)
6017 pz -89.55      $ Inside Bottom of Dewar - Inside
6018 pz -89.70      $ Inside Bottom of Dewar - Outside (assume 1.5mm Al)
6019 pz -91.75      $ Outside Wall of Dewar - Inside
6020 pz -91.90      $ Outside Wall of Dewar - Outside (assume 1.5mm Al)
c
c **** Universe
7000 sz -42.5 60    $ Outside Universe
c
c ***** BLOCK 3 Data Block Definitions *****

```



```

c **** BLOCK 3 (A) Problem type (MODE) Card 3-24
mode p e
c
c **** BLOCK 3 (B) Geometry Cards 3-24 to 3-33
*TR2 0 0 0 225 90 135 90 0 90 135 90 225 $ CW 45 deg
c
c **** BLOCK 3 (C) Variance Reduction 3-33
c imp:p 1 29r 0 $ 101, 998
c imp:e 1 29r 0 $ 101, 998
c 200 401 305 3300
imp:p 1 0 1 12 1 25r 0
imp:e 1 0 1 12 1 25r 0
fcl:p 0 2r 0.9 0 23r -1 0 1r $ 100, 999
c
c **** BLOCK 3 (D) Source Specification 3-53
c For Americium 241
c sdef par=2 erg=D1 pos=4.73 0 0 cel=100 wgt=0.0669873 &
c vec=-1 0 0 dir=D2 $ 30 degrees, 60 degree spread
c si1 L .0139 .0263448 .033196 .05954121
c sp1 D .42 .024 .00126 .359
c si2 -1 0.8660254 1
c sp2 0 0.9330127 0.0669873
c sb2 0 0 1
c For Cadmium 109
sdef par=2 erg=D1 pos=4.73 0 0 cel=100 wgt=0.0669873 &
vec=-1 0 0 dir=D2 $ 30 degrees, 60 degree spread
si1 L .00298 .0219903 .0221629 .0249 .0880341
sp1 D .112 .291 .552 .178 .0361
si2 -1 0.8660254 1
sp2 0 0.9330127 0.0669873
sb2 0 0 1
c
c **** BLOCK 3 (E) Tally Specification 3-80
f8:p 200 $ Cell number of Detector
f18:p 200
ft18: GEB 7.003E-4 9.931E-5 265
e8 0.0 1E-5 8.70E-5 1022i 0.089 $ Zero_bin Junk_bin Beg_Erg #chn's End_Erg
e18 0.0 1E-5 8.70E-5 1022i 0.089 $ Zero_bin Junk_bin Beg_Erg #chn's End_Erg
c
c **** BLOCK 3 (G) Energy and Thermal Treatment Spec. 3-131
c N/A
c **** BLOCK 3 (H) Problem Cutoff Cards 3-139
c cut:ptype, time cutoff, lower energy cutoff, weight cutoffs 1&2, minimum source weight
cut:p 100000 1.0E-3 -.3333 -.0001 .25
cut:e 100000 1.0E-3 -.3333 -.0001 .25
nps 1000000000
c
c **** BLOCK 3 (I) User Data Arrays 3-142
c N/A
c **** BLOCK 3 (J) Peripheral Cards 3-143
c ptrac file=asc max=50 write=all event=sur type=p & $ event=src,sur,ter &
c nps=5001,5050
c Note - The PTRAC card can only be used if processing on one node
c
c ***** BLOCK 3 (F) Material Specification 3-121 *****
c **** Germanium rho = 5.323 g/cc
m1 32000. -1
c
c **** Aluminum rho = 2.70 g/cc
m2 13000. -1
c
c **** Air
m11 07000. -.7500 $ Nitrogen
08000. -.2500 $ Oxygen
c
c **** Nitrogen, Liquid - rho = 1.00 g/cc

```

```

m3 07000. -1
c
c **** Copper, rho = 8.9600 g/cc
m4 29000. -1
c
c **** Stainless Steel, rho = 8.0000 g/cc
m5 06000. -.000400 $ Carbon
    14000. -.005000 $ Silicon
    15000. -.000230 $ Phosphorous
    16000. -.000150 $ Sulfur
    24000. -.190000 $ Chromium
    25000. -.010000 $ Manganese
    26000. -.701720 $ Iron
    28000. -.092500 $ Nickel
c
c **** Butyl Rubber
m6 01000. -0.144 $ Hydrogen
    06000. -0.856 $ Carbon
c
c **** Ge/Li Dead Layer  eff rho = 2.90 g/cc
m7 32000. -0.5 $ Germanium rho = 5.323 g/cc
    03000. -0.5 $ Lithium rho = 0.534 g/cc
c
c **** Ge/B Dead Layer  eff rho = 3.80 g/cc
m8 32000. -0.5 $ Germanium rho = 5.323 g/cc
    05000. -0.5 $ Boron rho = 2.370 g/cc
c
c **** Silicon Rubber  rho = 1.0185 g/cc
m9 01000. -0.0807 $ Hydrogen
    06000. -0.3212 $ Carbon
    08000. -0.2235 $ Oxygen
    14000. -0.3746 $ Silicon
c
c **** Charcoal
m10 06000. -1.000 $ Carbon
c
c **** Lead Sheild
m12 82000. -1. $ Lead
c
c **** Beryllium
m13 04000. -1. $ Beryllium
c
c **** Polyisocyanurate (PIR)  rho = 0.048 g/cc
m14 01000. -.04 $ Hydrogen
    06000. -.72 $ Carbon
    07000. -.11 $ Nitrogen
    08000. -.13 $ Oxygen
c
c **** Americium 241  rho = 13.6 g/cc
m15 95241. -1.0 $ Americium
c
c **** 302 Stainless Steel  density = 7.86 g/cc Ref EPS
m302 06000. -.000750 $ 0.001500 Max Carbon
    24000. -.180000 $ 0.18000 +/- 0.01000 Chromium
    26000. -.714625 $ .714625 +/- 0.03900 Iron
    25000. -.010000 $ 0.02000 Max Manganese
    28000. -.090000 $ 0.09000 +/- 0.01000 Nickel
    07000. -.000500 $ 0.00100 Max Nitrogen
    15000. -.000225 $ 0.00045 Max Phosphorous
    14000. -.003750 $ 0.00750 Max Silicon
    16000. -.000150 $ 0.00030 Max Sulphur
c
c **** 304 Stainless Steel  density = 8.0 g/cc Ref EPS
m304 06000. -.000350 $ 0.00070 Max Carbon
    24000. -.185000 $ 0.18500 +/- 0.01000 Chromium
    26000. -.707525 $ .707525 +/- .037475 Iron

```

25000.	-.010000	\$ 0.02000	Max Manganese
28000.	-.092500	\$ 0.09250 +/-	0.01250 Nickel
07000.	-.000500	\$ 0.00100	Max Nitrogen
15000.	-.000225	\$ 0.00045	Max Phosphorous
14000.	-.003750	\$ 0.00750	Max Silicon
16000.	-.000150	\$ 0.00030	Max Sulphur
C			
c ****	316 Stainless Steel	density = 8.0 g/cc	Ref EPS
m316	06000.	-.000400	\$ 0.00080 Max Carbon
	24000.	-.170000	\$ 0.17000 +/- 0.01000 Chromium
	26000.	-.669975	\$.669975 +/- .050025 Iron
	25000.	-.010000	\$ 0.02000 Max Manganese
	42000.	-.025000	\$ 0.02500 +/- 0.00500 Molybdenum
	28000.	-.120000	\$ 0.12000 +/- 0.02000 Nickel
	07000.	-.000500	\$ 0.00100 Max Nitrogen
	15000.	-.000225	\$ 0.00045 Max Phosphorous
	14000.	-.003750	\$ 0.00750 Max Silicon
	16000.	-.000150	\$ 0.00030 Max Sulphur
C			
c ****	321 Stainless Steel	density = 8.0 g/cc	Ref EPS
m321	06000.	-.000400	\$ 0.00080 Max Carbon
	24000.	-.180000	\$ 0.18000 +/- 0.01000 Chromium
	26000.	-.695475	\$.696475 +/- .043525 Iron
	25000.	-.010000	\$ 0.02000 Max Manganese
	28000.	-.105000	\$ 0.10500 +/- 0.01500 Nickel
	07000.	-.000500	\$ 0.00100 Max Nitrogen
	15000.	-.000225	\$ 0.00045 Max Phosphorous
	14000.	-.003750	\$ 0.00750 Max Silicon
	16000.	-.000150	\$ 0.00030 Max Sulphur
	22000.	-.004500	\$ 0.00700 Max Titanium
C			
C ***** END OF MATERIALS *****			
C			
C ***** END OF FILE *****			

Appendix H – More results

Table 57 - Number of Elements predicted in the aluminum samples that were within the Range of the ASTM Standard*

		1100		2011		2024		2036		3003		5052		5086	
# of Elements		ANN	PLS	ANN	PLS	ANN	PLS	ANN	PLS	ANN	PLS	ANN	PLS	ANN	PLS
Aluminum															
Sim set 1	12	7	4	8	8	8	11	-	-	6	6	5	5	6	9
Sim set 1 - GB	12	4	4	4	8	5	11	-	-	4	7	4	6	7	7
Sim set 2	12	7	5	9	10	7	12	-	-	7	9	9	5	9	10
Sim set 2 - GB	12	4	5	4	10	5	12	-	-	4	9	5	5	7	10
Exp	12	6	7	-	-	-	-	9	9	-	-	-	-	-	-
All Metals															
Sim set 1	27	6	17	8	14	8	17	-	-	7	17	6	18	8	21
Sim set 1 - GB	27	10	17	9	14	7	19	-	-	6	18	13	18	14	21
Sim set 2	27	9	19	11	15	9	19	-	-	10	19	8	20	8	22
Sim set 2 - GB	27	10	18	11	15	10	19	-	-	14	21	9	19	14	22
Exp	29	15	25	-	-	-	-	16	20	-	-	-	-	-	-
		5454		6061		6063		6101		6262		7075-unk		7075	
		ANN	PLS	ANN	PLS	ANN	PLS	ANN	PLS	ANN	PLS	ANN	PLS	ANN	PLS
Aluminum															
Sim set 1	12	5	6	8	6	9	5	8	4	6	8	-	-	10	12
Sim set 1 - GB	12	5	6	5	6	5	6	3	5	5	8	-	-	5	12
Sim set 2	12	10	9	8	8	7	7	8	6	5	5	-	-	7	12
Sim set 2 - GB	12	6	9	5	8	4	7	2	6	5	5	-	-	5	12
Exp	12	-	-	-	-	-	-	-	-	-	-	7	5	7	10
All Metals															
Sim set 1	27	7	19	7	19	6	19	7	17	9	18	-	-	9	17
Sim set 1 - GB	27	11	19	10	18	10	18	11	17	11	18	-	-	7	17
Sim set 2	27	7	21	7	19	9	20	9	19	10	19	-	-	13	18
Sim set 2 - GB	27	12	20	12	19	10	19	9	18	10	19	-	-	10	18
Exp	29	-	-	-	-	-	-	-	-	-	-	14	16	14	17

*Elements not present in the material were considered "correctly estimated" if the estimate was negative, or less than 1E-4

Table 58 - Number of Elements predicted in the copper based metal samples that were within the Range of the ASTM Standard*

	# of Elements	C101		C110		C122		C260		C353		C464		C510	
		ANN	PLS	ANN	PLS	ANN	PLS	ANN	PLS	ANN	PLS	ANN	PLS	ANN	PLS
Copper Based Metals															
Sim set 1	17	6	13	6	15	7	11	6	15	8	16	11	14	9	17
Sim set 1 - GB	17	11	12	4	10	3	9	11	11	5	13	7	11	4	11
Sim set 2	17	10	11	5	13	4	11	6	13	6	17	8	16	7	16
Sim set 2 - GB	17	11	11	5	11	4	14	11	13	5	17	7	16	5	16
Exp	17	-	-	2	11	-	-	-	-	-	-	-	-	-	-
All Metals															
Sim set 1	27	11	19	1	18	1	17	12	18	3	19	3	22	9	17
Sim set 1 - GB	27	6	19	5	16	5	16	9	18	1	19	5	22	5	16
Sim set 2	27	2	19	2	16	2	16	10	18	3	17	3	23	2	15
Sim set 2 - GB	27	10	19	9	14	8	15	10	18	3	19	8	22	10	14
Exp	29	-	-	5	23	-	-	-	-	-	-	-	-	-	-

*Elements not present in the material were considered "correctly estimated" if the estimate was negative, or less than 1E-4