

Abstract

MUTISO, ATHANAS. Investigation of Prompt Gamma-Ray Neutron Activation Analysis for Determining Phase Amounts in Multiphase Flow. (Under the direction of Professor Robin P. Gardner).

Prompt Gamma Neutron Activation Analysis (PGNAA) is established on basic nuclear reactions, the radioactive capture of neutrons. This nuclear reaction takes place for each isotope of every element, with the simple exception of ^4He . Therefore, in principle, a complete elemental and isotopic analysis can be performed using PGNAA. The analysis is a rapid, non-destructive, instrumental and nuclear technique for determining elemental composition of bulk and other samples. However, due to PGNAA inherent large background, the accuracy and sensitivity of the process is limited because of the detectors used and the structural materials in the geometry.

Furthermore, the technique is sensitive to entire periodic table to varying degrees though, the chemical form and shape of the sample are relatively unimportant. This work is basely focused on how to utilize prompt gamma-rays that are from the formation of two products that is-the light one and heavier product to determine phase amounts in multiphase flow. A Cf-252 source and a NaI detector are used for this purpose.

Simulates are *in-silico* by utilizing a CEARCPG code, developed in the Center for Engineering Application of Radioisotopes (CEAR) of North Carolina State University. The algorithm for sampling the prompt gamma rays, which are produced from the neutron reaction and inelastic scattering reaction, accounts all the prompt gamma-rays.

In this work, nine elements that yield reasonable PGNAA responses and are included in oil, water and gas are simulated and quantitative spectrum analysis is done by using Monte Carlo-Least-Squares (MCLLS) approach to measure the three phase amounts in hypothesized realistic samples. A background that was previously obtained experimentally in bulk analysis

applications was added to the response here to make the calculations more reasonable.

The MCLLS mainly consists of using Monte Carlo code with fundamental parameters to simulate the prompt gamma ray spectra response to a sample composition. In this course of simulation, elemental library spectra are also generated and consequently used in linear library least square (LLS) calculation for elemental composition. Hydrogen, carbon and oxygen are of particular interest in the simulations. These elements appear in all the three phases i.e., oil, water and gas. Basically, the most important gamma rays emitted from carbon and oxygen range from 4.445 to 6.13 MeV whilst gamma rays resulting from capture of thermal neutrons with ranges of 1.6 to 4.8MeV are of lesser important.

With high energies, pair production interaction dominates the interaction of gamma rays. The rays emitted outside the detector can contribute to the lower range of the response spectra. CEARCPG takes care of this effect and makes the simulated elemental library spectra more accurate. This has contributed of the usage of all of information of the measured sample in the MCLLS analysis.

Moreover, the calculated weight fraction of oxygen from neutron capture is larger than the other elements with 53.9445%. This might be caused by extreme high neutron capture cross section. As observed, the calculated weight fraction of all the elements agrees well with the true weight fraction. Since the cross section of neutron inelastic scattering is zero, the component of hydrogen and sulphur can not be determined by using neutron inelastic spectrum. Compared to the simulation results from neutron inelastic spectrum, the results from neutron capture spectra is closer to the real one because of its non interference with the “unknown” spectrum. In general if the “unknown” spectrum is large, the possibility of blowing up the fitting is high. The results indicate that this approach would be accurate and is feasible.

Investigation of Prompt Gamma-Ray Neutron Activation Analysis for Determining Phase Amounts in Multiphase Flow

By

Athanas Makau Mutiso

A thesis submitted to the Graduate Faculty of North Carolina State University in
partial fulfillment of the requirements of the Degree of
Master of Science

NUCLEAR ENGINEERING

Raleigh, North Carolina

2007

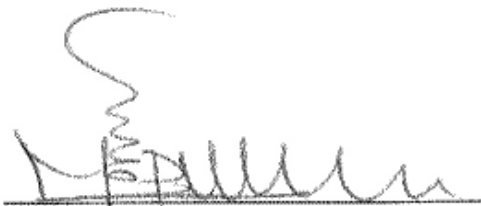

Prof. Mohamed A. Bourham



Dr. Sharon Lubkin

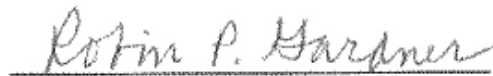

Chair of Advisory Committee
Prof. Robin P. Gardner

Dedication

This thesis is dedicated to my beloved daughter
Theresia Nzisa

Biography

Athanas Mutiso was born in Machakos, Kenya on August 21st 1970. He finished his elementary school, middle school and high school education in his home town and enrolled at the Mombasa Polytechnic and Kenya Polytechnic Institute where he was granted a Diploma and Higher National diploma (HND) in Mechanical Engineering in 1992 and 1998 respectively.

In 1997, Mutiso was employed by Exxon Mobil Kenya Ltd, as Aviation Engineering Supervisor until 1999 when he relocated to United States of America. In 2001, he was accepted by the department of Mechanical and Nuclear Engineering of Kansas State University. He earned his B.S. in Mechanical (Nuclear Engineering Option) in May 2004.

In August, 2004, he began his graduate study in Nuclear Engineering Department at North Carolina State University and worked as Research assistant and Library Representative in the Burlington Nuclear Laboratory.

Acknowledgements

I am deeply indebted to my teacher and advisor Dr. Robin P. Gardner for his continued guidance throughout the course of this work. His style of advising is unique. I appreciate the rare opportunity granted to me to undertake this research work and also given the chance to work with so diligent members of CEAR group at North Carolina State University. I would also like to extend my gratitude to Dr. Bourham (Interim Head of Nuclear Department) and Dr. Sharon Lubkin (Professor in Math Department) for agreeing to be my thesis committee members until completion of this work.

Special thanks to Dr. Geir Johansen (University of Bergen) for the initial set up of this work. It was an honor for me to work under his guidance. Dr Libai, I would like to say thank you for your helpful instruction, discussion and assistance with CEARCPG code and MCNP in this work. I also would like to thank Dr. Xiaogang Han (former CEAR group member, NCSU), for his work in developing CEARCPG code which as made this work a success. Further; I would like to extend my thanks to all those who assisted, faculties and staff members of the Department of Nuclear Engineering, graduate students and my friends. Finally, I need to express my deepest and most sincere appreciation to my family, for the love and encouragement.

Table of Contents

	Page
List of Tables.....	viii
List of Figures.....	ix
Chapter 1 Introduction	1
1.1 Background.....	1
1.2 Overview of simulation code	5
1.3 Overview of multiphase flow	7
Chapter 2 Physics	9
2. 1 Neutron physics.....	9
2.1.1 Neutron source	9
2.1.2 Interaction of neutrons.....	9
2.1.3 Energy of neutrons.....	11
2. 2 Photon physics.. ..	12
2.2.1 Interaction of gamma-rays in matter	12
2.2.2 The Photoelectric effect	13
2.2.3 Compton scattering	14
2.2.4 Pair production.....	15
2.2.5 The total attenuation coefficient	17
2. 3 Prompt gamma-ray spectroscopy.....	18
2. 4 Scintillation detectors	20
2. 5 PGAA with radioisotopic sources.....	23
2.5. 1 Discussion overview	23
2.5. 2 ²⁵² Cf sources.....	24
Chapter 3 PGNAA Application	25
3.1 Industrial application of prompt-gamma ray neutron activation (PGNAA) technique.....	25

3. 2 Monte Carlo CEARCPG code simulations for thermal neutron intensity calculations	26
3.2.1 CEARCPG flow chart.....	30
3.2. 2 Example of CEARCPG benchmarking	32
3. 3 Energy discrimination	33
3. 4 General view of multiphase flow	33
3.4.1 Background.....	34
3.4. 2 The SOFA Project.....	35
3.4. 3 Water Salinity.....	36
Chapter 4	38
4.1 Overview of PGNAA.....	38
4.2 Simulation geometry	39
4.2.1 Geometry specification.....	39
4.2. 2 CEARCPG surface cards.....	41
4.2. 3 Input file for simulation design.....	43
4.2. 4 Mixture Sample (Oil, Water and Gas)	46
4. 3 Simulation procedure	47
Chapter 5 Results	50
5. 1 Simulation Results & Analysis.....	50
5. 2 Simulated elemental spectrum for seawater sample.....	53
5. 3 CEARCPG code benchmarking for fitted library spectra and total simulation	55
5.3.1 Total simulation and fitted library spectra.....	58
5.3. 2 General discussion of the benchmarking	58
5.3. 3 MCLLS approach	59
5.3. 4 Total spectrum with added background spectrum	62
5.3. 5 Quntitative analysis.....	64

5. 4 Discussion and conclusion.....	71
5. 5 Future work.....	73
References	75
Appendix A	80
Data with added background for inelastic & Capture interaction.....	81
Appendix B	95
Data for program CURLLS, Sigma and Residue.....	96
Appendix C	107
CEARCPG Input Card and Data for Oil, Water and Gas Libraries.....	108

List of Tables

Table 2- 1: The characteristics of spontaneous fission source ^{252}Cf	9
Table 2- 2: Nuclides exhibited internal pair production, gamma radiations, and relative intensities of the positron-negatron pairs.....	17
Table 2- 3: Photopeak energy resolution for various detectors.....	20
Table 3- 1: Typical contents of ions in oil field brines and seawater	36
Table 4- 1: Nine (9) elements in the multiphase flow mixture of seawater	38
Table 4- 2: CEARCPG surface cards.....	42
Table 4- 3: Input geometry of CEARCPG created to run the simulation1.....	44
Table 4- 4: Input geometry of CEARCPG created to run the simulation2.....	45
Table 5- 1: The assumed elemental composition for the nine elements.....	52
Table 5- 2: The assumed elemental composition for oil, water and gas	55
Table 5- 3: Identified elemental energy peaks of the sample	59
Table 5- 4: MCLLS quantitative results by fitting the total spectra from neutron capture	65
Table 5- 5: MCLLS quantitative results by fitting the total spectra from neutron inelastic scattering reaction	65
Table 5- 6: Results for the standard deviation (Sigma) for neutron capture.....	66
Table 5- 7: Results for the standard deviation (Sigma) for neutron inelastic scattering	66
Table 5- 8: MCLLS quantitative results by fitting the total spectra for oil.....	69
Table 5- 9: MCLLS quantitative results by fitting the total spectra for water	69
Table 5- 10: MCLLS quantitative results by fitting the total spectra for gas	70
Table 5- 11: Results for the standard deviation (Sigma) for oil	70
Table 5- 12: Results for the standard deviation (Sigma) for water	70
Table 5- 13: Results for the standard deviation (Sigma) for gas	70
Table 5- 14: Some definition of the used variables in the analysis.....	71

List of Figures

Figure 1- 1: Neutron capture and gamma emission process	2
Figure 1- 2: PGNAA analysis spectrum	4
Figure 2- 1: Incident photon energy with recoil electron and scattered photons .	14
Figure 2- 2: Distribution of some energies.	15
Figure 2- 3: Conversion of gamma-ray photon into a negatron and positron pair	16
Figure 2- 4: The relative importance of different attenuation coefficient as a function of photon energy and the Z-number of the absorbe	18
Figure 2- 5: Absolute efficiency curves of prompt gamma-ray detecting systems using the BGO, NaI, and HPGe detectors	22
Figure 3- 1: The flow chart of CEARCPG	31
Figure 3- 2: Schematic of ETI prototype	32
Figure 3- 3: The TRACERCO - Profiler TM installed in gravitational separator with typical phase distribution.....	34
Figure 3- 4: Sketch of CMR's patented SOFA concept of Continuous.....	35
Figure 3- 5: Sketch of the vertical cross section of the experimental set-up to characterize produced water.....	37
Figure 4- 1: Geometry design concept.....	39
Figure 4- 2: Sketch of vertical cross section of the geometry set-up used to characterize seawater.....	40
Figure 4- 3: The generic design tool (X-Z plane) for 3 phase flow simulation	46
Figure 4- 4: Elemental libraries from neutron capture interaction	48
Figure 4- 5: Elemental libraries from neutron inelastic scattering interaction.....	49

Figure 5- 1: Simulated elemental spectra from neutron capture interaction.....	53
Figure 5- 2: Simulated elemental spectra from inelastic scattering interaction ...	53
Figure 5- 3: Total sample spectra from neutron capture interaction.....	54
Figure 5- 4: Total sample spectra from neutron inelastic scattering.....	54
Figure 5- 5: Total sample spectra from neutron capture for crude oil.....	55
Figure 5- 6: Total sample spectra from neutron capture for water.....	56
Figure 5- 7: Total sample spectra from neutron capture for gas.....	56
Figure 5- 8: Schematic Y-Z plane design for sample simulation, where (1) is the ²⁵² Cf neutron source, (2) lead to hold source, (3) sample, (4) vacuum, (5) NaI detector, (6) lead shield, and (7) stainless steel cylinder tank.....	57
Figure 5- 9: Total simulation vs. fitted library spectra for both inelastic scattering interaction and capture interaction	58
Figure 5- 10: Total simulation with added background spectrum.....	63
Figure 5- 11: Total simulation vs. fitted library spectra with added background spectrum	63
Figure 5- 12: Results for the SIGMA Y(I) and RESDUE for neutron capture	67
Figure 5- 13: Results for the SIGMA Y(I) and RESDUE for neutron inelastic	67
Figure 5- 14: Results showing the Y(I), YFIT(I), SIGMAY(I) and RESDUE from neutron capture for crude oil	68
Figure 5- 15: Results showing the Y(I), YFIT(I), SIGMAY(I) and RESDUE from neutron capture for water	68
Figure 5- 16: Results showing the Y(I), YFIT(I), SIGMAY(I) and RESDUE from neutron capture for gas.....	69

Chapter 1

1.0 Introduction

1.1 Background

The fundamental aspects of all nuclear techniques of chemical analysis involve the interaction between an incoming projectile (neutron, charged particles, or gamma-photons) and a target nucleus. Consequently, the interaction is a formation of two products-that is the light one and the heavier product. In the case of Prompt Gamma Neutron Activation Analysis (PGNAA), the projectile is a neutron and the light product is a gamma-ray photon (Alfassi and Chung, 1995).

Prompt Gamma Neutron Activation Analysis (PGNAA) is a technique that is widely used for determining the presence and amount of many elements simultaneously in samples ranging in size from micrograms to many grams. It is a non-destructive, instrumental nuclear method. The method is also a nuclear analytical technique used for identifying trace and major components of bulk samples, as well as determining their concentrations (Gardner and Metwally, CEAR 2004). It is due to these facts that this work entails determination of phase amounts in multiphase flow on sea waters by utilizing PGNAA.

In addition, other methods have been used to characterize by dual modality gamma-ray measurements. Dual modality densitometry (DMD) (Holstad 2000, Johansen 2000, *et al* 2001) is an example of how measurements of transmitted and scattered gamma radiation can be combined to get more information about the flow being investigated. Prompt Gamma Neutron Activation Analysis (PGNAA) phenomenon is based on the radioactive capture between a

neutron and the nucleus of an atom. The reaction is written $T(n,\gamma)P$ where the T is the target nucleus and P is the product, thus radioactive capture. Then the excited nucleus that is formed by capturing the incident neutrons decays very fast in a matter of 10^{-14} seconds to ground level emitting gamma rays (Molnár, 2004).

Because Prompt Gamma Neutron Activation Analysis (PGNAA) and Neutron Activation Analysis (NAA), both are important techniques in analyzing of trace elements (Molnár, 2004), they still have fundamental difference. Neutron induced prompt gamma-rays depend on prompt capture gamma-rays while the Neutron Activation Analysis use the delayed gamma-rays from radioactive daughter nucleus. Figure 1-1 below better demonstrates this phenomena concept. The figure illustrates the neutron capture by a target nucleus followed by the emission of gamma rays.

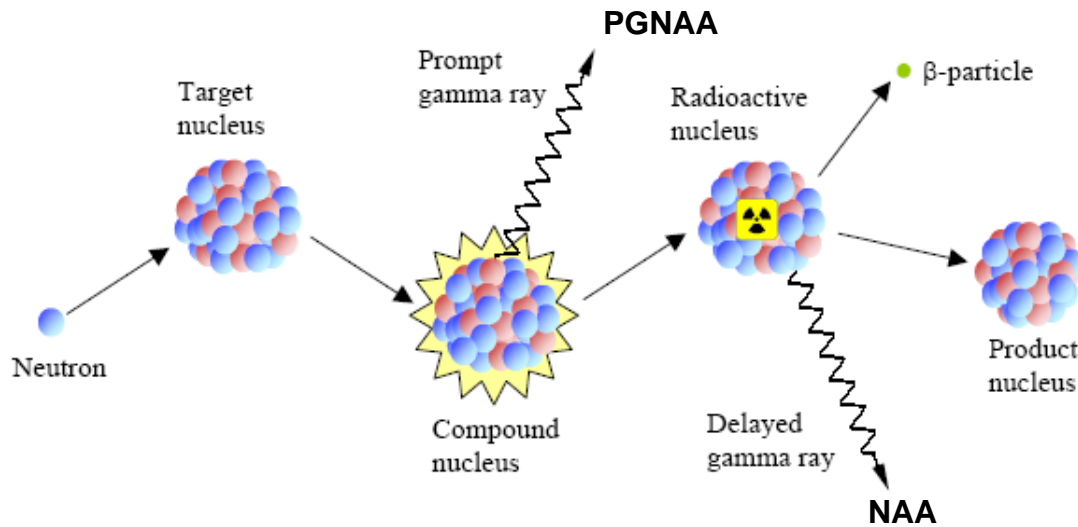

Figure 1- 1: Neutron capture and gamma emission process
 (Reprinted with permission from Gardner and Han, CEAR Group 2004)

In characterizing of prompt gamma spectra, the highest energy prompt gamma lines are close to 12MeV, unlike delay lines which are mostly below

3MeV. Thus the energy range may cause spectroscopic problems (Molnár, 2004). This indication show that prompt gamma spectra has a wider range than that used in NAA. Prompt gamma spectra usually contain several hundred peaks, at least an order of magnitude more than in gamma spectra of radioactive nuclides. Due to the high energies, the Compton plateaus are much longer in prompt gamma spectra, and thus the largest fraction of counts appears in the background, not in characteristic peaks. The sources of this background are as following:

- a. Gamma rays produced by neutron interaction from the source within the detector,
- b. Gamma rays emitted by the neutrons sources
- c. Gamma rays produced from non sample materials of the surroundings

Also, there is an additional natural background due to potassium-40, natural uranium and thorium and the cosmic radiation.

In the case of PGNAA, no sample preparation is required i.e. the irradiation does not change the elemental composition of the sample. In NAA the samples can be irradiated in an isotropic neutron field, and the delayed gamma-rays from the sample can be detected. While hydrogen (from sample and /or non sample material) is a common element, it causes problems in many typical cases of PGNAA. After its activation, hydrogen de-excites by emitting a single prompt gamma-ray with energy of 2.223 MeV. It follows that the magnitude of the peak from a sample spectrum is usually one to two orders of magnitude larger than other elements of concern. Thus this causes complexity of the spectra and

sensitivity setback. Moreover PGNAA is a unique and specific tool for determination of hydrogen or water contents in trace amount (Molnár, 2004).

Prompt Gamma Neutron Activation Analysis (PGNAA) complexity is also caused by the summing and pulse pile-up effect (Han, 2005). The pulses may lead to overlap between pulses when counting rates are high and therefore results to distortions in the taken spectrum (Metwally, 2003). It may lead to false amounts when elemental analysis using full peaks or Library Least Squares (LLS) method is performed (Han, 2005).

A typical example is as shown in Figure 1-2.

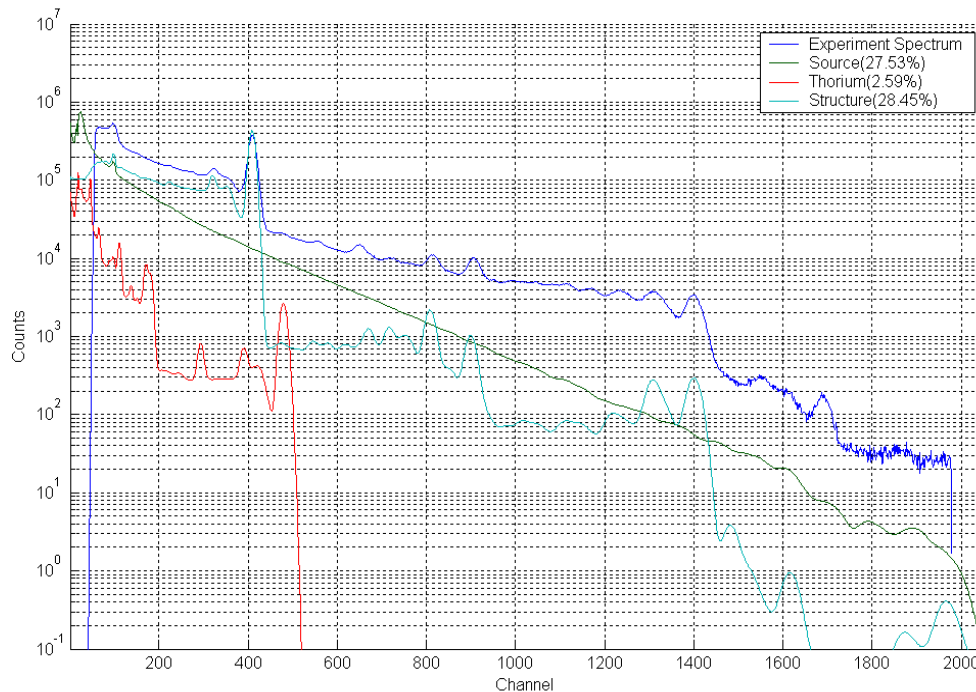

**Figure 1- 2: PGNAA analysis spectrum
(Reprinted with permission from Metwally,
CEAR 2003)**

Consequently, PGAA is a complimentary technique to NAA by allowing determination of elements that form radioactive products after irradiation (e.g., H

and B), and for elements with a long half-life to be measured by NAA (e.g., C). In addition, boron is the only exception to the usual prompt gamma gamma-rays measurement, in which the gamma measured is not due to the (n, γ) reaction. Actually just like (lithium), boron reacts with neutrons by emission of α -particles, i.e. $^{10}\text{B}(n, \alpha)^7\text{Li}$ reaction. ^7Li mostly are formed in the excited state and de-excited instantaneously ($7.3 \cdot 10^{-14}$ s) by emission of 477 keV gamma-rays.

The PGNAA technique requires a source of neutrons and high-resolution spectrometers for measurement of gamma rays with energies over the range from about 100 keV to 11MeV. The energies of the prompt rays identify the neutron-capturing elements, while the intensities of the peaks at these energies show their concentrations.

1. 2 Overview of simulation code

The CEARCPG that is used in this work is a Monte Carlo code, developed in the Center for Engineering Application of Radioisotopes (CEAR) of North Carolina State University. The code models the spectra response of Prompt gamma-Ray Neutron Activation Analysis (PGNAA). It is a Monte Carlo Code for Normal and Coincidence Prompt Gamma-Ray Neutron Activation Analysis (Han, Xiongang, Metwally and Gardner, 2006). All the prompt gamma rays are taken into account by using this algorithm.

Before the development of this code, work was done by interpolating the prompt gamma rays from pre-calculated gamma-ray table (Han, 2005). While the calculation was for single spectrum and could not simulate the coincidence,

nevertheless, CEARCPG is able to sample gamma rays from the nucleus scheme. The code (Han, 2005) simulates three cases that are:

- a. A prototype for ETI PGNAA application that is designed to ensure the capability of CEARCPG for single spectrum simulation and,
- b. The second and third designed for coincidence simulation.

The code also is utilized to optimize the design of coincidence PGNAA devices. In my work, the CEARCPG code is used for single spectrum simulation.

The most mathematical analysis approach with PGNAA systems is the library least-square approach (Zhang, 2003). Its postulation is that any unknown sample spectrum is the sum of the products of the elemental amount and the library spectrum of each element for every channel. The Monte Carlo-library least squares (MCLLS) that analyze the contents of sample material in prompt gamma-ray activation analysis (PGNAA, takes advantage of Monte Carlo simulation to generate the required elemental library spectra for the sample of interest as opposed to using experimental methods. Thus the MCLLS resolves unnecessary work and cost of setting experimental work (Gardner and Zhang, 2003).

Consequently, CEARCPG code has proven to be more reliable in giving better results than the previous methods used. Moreover, the algorithm for sampling the prompt gamma rays, which are produced from the neutron reaction and inelastic scattering reaction, is used in this work and accounts all the prompt gamma-rays. In this work, nine elements with oil, water and gas are simulated and qualitative and quantitative spectrum analysis is done by using Monte Carlo-

Least-Squares (MCLLS) approach to measure phase amounts in the sample. The MCLLS mainly consists of using Monte Carlo code with fundamental parameters to simulate the prompt gamma ray spectra response to a sample composition. In this course of simulation, elemental library spectra are also generated and consequently used in linear library least square (LLS) calculation for elemental composition.

1. 3 Overview of multiphase flow

Another process in the work is the determination of the phase amounts in multiphase flow. Multiphase flow is the simultaneous flow of gas, liquid and/or solid phases in different combinations. Multiphase flows, particularly two-phase flows, are probably the most common flow cases in nature, examples being the flow of blood in our body and the drift of clouds in the sky. Multiphase flow problems can vary considerably depending on the constituents and the topology of the flow (Power and Brebbia, 2001). One of the most important flow types in technical applications is dispersed flow, with bubbles, drops or solid particles spread out in a continuous liquid or gaseous phase. With modern computer technology, however, it is possible to numerically solve the partial differential equations describing multidimensional, time-dependent multiphase flow problems. There are many ways to model a multiphase flow problem using partial differential equations, depending on the physical phenomena of interest and the nature of the problem (Celik, Hughes, Crone and Lankford, 1990). For dilute dispersed flows, so-called Lagrangian particle tracking is often employed. Using this approach, the motion of the continuous fluid is described by the Navier-

Stokes equations in an Eulerian frame, while the bubbles, drops are also important in most industrial applications, such as energy conversion, paper manufacturing, food manufacturing and medical applications. The bubbles rising in a glass of cold beer provide another good example of multiphase flow (Power and Brebbia, 2001).

Even though multiphase flows are very common, the subject is still relatively new as a specific research area. In my work, the multiphase flow in sea waters is a mixture of different components of mixture of gas, oil and water.

Chapter 2

2. 1 Neutron physics

2.1. 1 Neutron source

Neutrons are known to be powerful tool for particle and nuclear physics. There are several neutron sources (nuclear reactor, accelerator, and radioisotope neutron emitter) that can be used for PGNAA analysis. Because of the high neutron flux, nuclear reactor is the best choice of all as it offers high sensitivity for most elements (Gardner and Han, 2004). However, this work uses radioisotope neutron emitter of ^{252}Cf as a source. Refer Figure 1-1 for some basic information about the ^{252}Cf source. In Table 2-1, shows the characteristics of spontaneous fission source ^{252}Cf .

**Table 2- 1: The characteristics of spontaneous fission source ^{252}Cf
(Courtesy of CEAR Group, 2003)**

Half life	2.645 y
Decay Method	Alpha decay (96.0%) Spontaneous fission (3.1%)
Average neutron produced per fission	3.76
Average energy of neutrons	2.348 MeV
Energy distribution of neutrons	Watt fission spectrum $f(E) = Ce^{-E/a} \sinh(bE)^{1/2}$
Average gamma particle per fission	6.95
Average energy of Alpha particles	6.117 MeV

2.1. 2 Interaction of neutrons

Because neutrons are electrically neutral, they are not affected by the electron or positive charge of the nucleus in an atom. As a result, neutrons

penetrate through the atomic electron cloud and interact directly with the nucleus (Lamarsh and Baratta, 2001). So the neutrons collide with nuclei but not with atom. The process can be expressed as follows, $X+n \rightarrow [X+n]^* \rightarrow$ decomposition of the compound nucleus. Where X is the target nucleus and $[X+n]^*$ is the compound nucleus. Neutrons may interact with nuclei in one or more process. These processes are as the following:

- a. *Elastic Scattering*: In this process, the conservation of the sum of the kinetic energies of the nucleus and neutron is preserved both before and after reaction. The neutron strikes the nucleus that is almost in its ground state and then the neutron reappears and lastly left in its ground state. At this stage, neutron is said to be elastically scattered by the nucleus. The reaction is denoted by (n, n) .
- b. *Inelastic Scattering*: After the interaction of type (n, n) which is identical to scattering, the resulting nucleus remains in an excited state after the emission of the neutron. The excited nucleus decays by the emission of gamma rays. In this case, the sum of the kinetic energy of the neutron is not conserved before and after the reaction. The reaction is denoted by (n, n') and is an endothermic interaction.
- c. *Radioactive capture*: The neutron in this case is captured by nucleus and absorbed; one or more capture gamma rays are emitted. This is an exothermic interaction and is denoted by (n, γ) . Most importantly, nuclear reaction for prompt gamma-ray neutron activation analysis are transformation by the (n, γ) reaction, where the excited nucleus passes to a

lower energy state by emission of gamma-rays. The reactions are non-threshold and occur with high probability especially when thermal neutrons are used. The products are usually radioactive.

- d. *Charged particle Reaction*: Due to absorption reactions of the type (n, α) and (n, p) neutron may disappear. These reactions may be exothermic or endothermic.
- e. *Neutron-Producing Reactions*: These reactions are endothermic and occur with energetic neutrons. The type $(n, 2n)$ and $(n, 3n)$ represent one neutron reaction and two neutrons reaction respectively. The one neutron reaction is especially important in reactors containing heavy water or beryllium since ^2H and ^9Be have loosely bound neutron that can easily be ejected.
- f. *Fission*: These are the process of nucleus splitting apart to under-go *fission* after the neutrons collide with certain nuclei. The process is the principle source of nuclear energy for practical application. Although *fusion* reaction is being studied extensively, it has not yet been set to practicality.

2.1. 3 Energy of neutrons

Neutrons can be separated into two categories: These are fast-energy neutrons and low-energy neutrons. First neutrons have energies higher than 0.5 MeV while slow neutrons have energies lower than 0.5 MeV. Specifically, neutrons can be classified as follows: Thermal energies of about 0.4 eV, epithermal energies of about 0.2 eV, cadmium energy of 0.4 eV, epicadmium of 0.5 eV, slow neutrons of 1-10 eV, resonance of 1-300 eV, middle of 500 eV to 0.5 MeV, fast neutrons of above 0.5 MeV, ultrafast of energies over 20 MeV. For

neutrons of less energy of 939.5766 MeV (neutron rest mass), the wavelength, velocity and temperature is described as follows:

$$V(\text{m/s}) = 1.38 \times 10^4 \sqrt{E_n(\text{eV})} \quad (1)$$

$$\lambda(\text{\AA}) = \frac{0.286}{\sqrt{E_n(\text{eV})}} \quad (2)$$

$$T(\text{K}) = 1.16 \times 10^4 E_n(\text{eV}) \quad (3)$$

2. 2 Photon physics

The gamma rays in CEARCPG code are found mainly from (1) the neutron radioactive capture, (2) gamma rays from the neutron source, (3) the neutron inelastic scattering reaction (4) the natural background and, (5) the NaI(Tl) detector activation. CEARCPG code uses a similar simple mode that is used in MCNP. It ignores the coherent scattering and fluorescence photon from the photoelectric absorption. CEARCPG only considers the photoelectric effect, pair production, Compton scattering from free electron. The total cross section is considered to be the sum of the three components ($\sigma_c + \sigma_p + \sigma_{pp}$).

2.2. 1 Interaction of gamma-rays in matter

There are several types of photon interaction mechanism. However, three main interactions are discussed in this paper. These are: photoelectric absorption, compton scattering and pair production. These types of interaction of photons in a medium of density ρ and atomic number Z are discussed below. The probability per target atom is described by the cross-section in barns (10^{-24}cm^2).

2.2. 2 The Photoelectric effect

In the photoelectric absorption process, a photon undergoes interaction with an absorber atom where the photon completely disappears. Photon energy is transferred to one of the bound electrons of the atom. As the energetic photoelectron is ejected by the atom from its bound shell, the atom is left in an excited state. This excitation energy is dispersed as an Auger electron or as fluorescence (a characteristic X-ray).

The photoelectron appears with an energy given by:

$$E_{e^-} = E_{\gamma} - E_b \quad (4)$$

where E_{γ} is the energy of the incident photon and E_b is the binding energy of the photo-electron. The ejected photoelectric will leave a vacancy in its original shell which is quickly filled through capture of an electron from an outer shells. Therefore one or more characteristic X rays (fluorescence) may also be generated (Gardner and Han, 2004). The cross section for the photoelectric effect is approximately given by:

$$\tau \cong c_{\tau} \cdot \frac{Z^n}{E_{\gamma}^{3.5}} \quad (5)$$

where c_{τ} is a constant for a given material and n is a typical variable between 4 to 5 depending on incident gamma ray (Knoll 2000). In general, more tightly bound electrons have larger cross sections so that the inner electrons with energies less than E_{γ} are likely to be ejected as photoelectrons. CEARCPG considers the ejected free electron to deposit its all energy locally.

2.2. 3 Compton scattering

Compton scattering interaction is an inelastic process and takes place between the incident gamma-rays and an electron in an absorbing material. Consequently, scattered photon and recoil electron are generated. The photon is scattered at an angle θ relative to its original direction while the recoil electron is scattered at an angle ϕ to the incident direction of the photon.

Figure 2-1 demonstrates the incident photon energy that produces a recoil electron and the scattered photons.

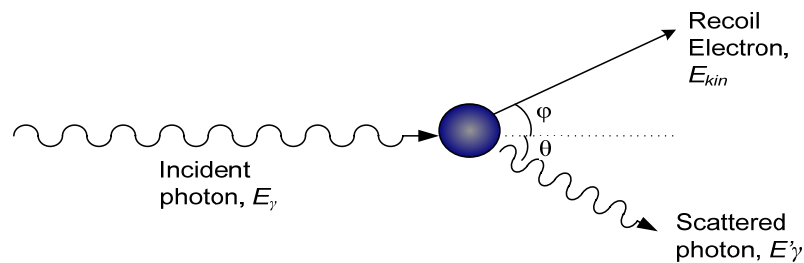

Figure 2- 1: Incident photon energy with recoil electron and scattered photons

The energy of the scattered photon can be found from conservation of energy and momentum and can be described by the following equation:

$$E'_\gamma = \frac{E_\gamma}{1 + \frac{E_\gamma}{m_e c^2} (1 - \cos \theta)} \quad (6)$$

where m_e is the rest mass energy of an electron (0.511 MeV) and θ is the angle between the incident photon and scattered photon. This analysis neglects the atomic binding of the electron and assumes that the gamma-ray photons interact with a free electron (Gardner and Han, 2004).

The angular distribution of scattered photon is predicted by the Klein-Nishin formula for the differential scattering cross section (Knoll 2000):

$$\frac{d\sigma}{d\Omega} = Zr_o^2 \left(\frac{1}{1 + \alpha(1 - \cos\theta)} \right)^2 \left(\frac{1 + \cos^2\theta}{2} \right) \left(1 + \frac{\alpha^2(1 - \cos\theta)^2}{(1 + \cos^2\theta)[1 + \alpha(1 - \cos\theta)]} \right) \quad (7)$$

where $\alpha \equiv E_\gamma / m_e c^2$ and r_o is the classical electron radius.

Figure 2-2 shows distribution of some of these energies. The polar plot of the number of photons (incident from the left) illustrate Compton scattering to a unit solid angle at the scattering angle θ . The indicated curves show initial energies.

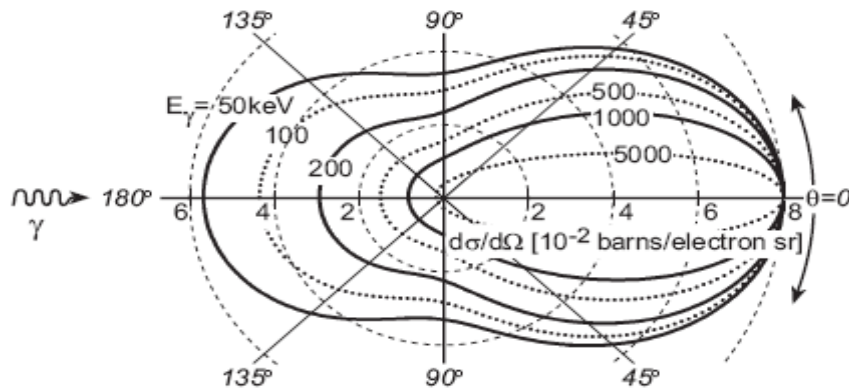

Figure 2- 2: Distribution of some energies (Courtesy Johansen and Jackson, 2004)

2.2. 4 Pair production

The interaction of gamma radiation with matter involves the transfer of gamma energy, in a whole or part, to atomic electrons of the irradiated material. This mechanism of gamma energy dissipation in matter, results in the creation of nuclear particles from the gamma particles (L'Annunziata, 1998). Pair production is only possible if the gamma-ray energy exceeds twice the rest-mass energy of an electron (1.02 MeV). The excess energy carried by the incident particle is shared between the electron and the positron as kinetic energy. The positron will subsequently annihilate after slowing down in the absorbing media (Gardner and

Han, 2004). Two annihilation photons are usually produced as secondary products of this interaction. Each annihilation photon has energy of 0.511 MeV.

The nuclear particles are an electron (negatron) and positron from an individual gamma ray photon that interacts with Compton field of the nucleus. As a result of this interaction, mass from the energy is created. The formation of an electron can be calculated according to Einstein's equation for equivalency of mass and energy.

$$E=mc^2 \quad (8)$$

where E is the energy, m is mass, and c is the speed of light.

Figure 2-3 shows the conversion of gamma-ray photon into a negatron and positron pair.

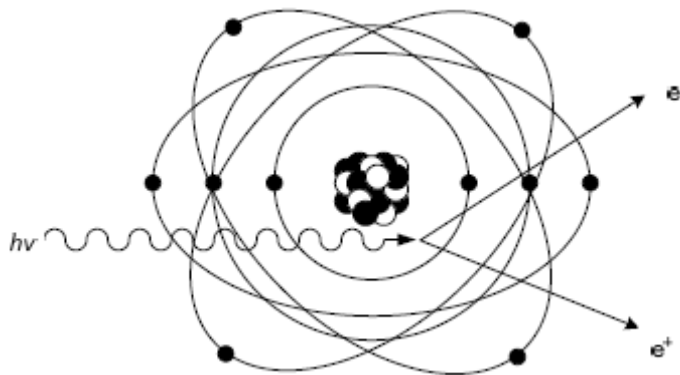

Figure 2- 3: Conversion of gamma-ray photon into a negatron and positron pair (L'Annunziata, 1998)

The table below shows example of nuclides that exhibit internal pair production, the gamma radiations, and relative intensities of the positron-negatron pairs.

Table 2- 2: Nuclides exhibiting internal pair production, gamma radiations, and relative intensities of the positron-negatron pairs

Nuclides	Gamma radiation		
	Energy(MeV)	Abundance (%)	Pair/gamma rate(e/γ)
Na-24	1.369, 2.754	100	6.00E-05
	1.81	100	7.00E-04
Mn-56	2.11	29	5.60E-04
	1.099	15	4.60E-04
Fe-59	1.292	57	1.40E-04
	1.17	43	1.1E--4
Co-60	1.33	100	3.70E-05
Pr-142	1.576	100	(combined)
	1.489	4	1.10E-04
Pr-144	2.186	0.3	1.90E-04
	1.274	0.7	6.70E-04
154-Eu	1.274	37	8.00E-05

2.2. 5 The total attenuation coefficient

The interaction of radiation with matter is always statistical in nature, and therefore, is described in probabilistic terms. Moreover, total interaction probabilities per unit path length, u_t , is fundamental in describing how indirect-ionizing radiation interacts with matter. Thus the probability, per unit length, that a neutral particle undergoes some sort of reaction, u_t , is the sum of the probabilities, per unit path length of travel, for each type of possible reaction (Shultis and Faw, 2002), that is.,

$$u_t(E) = \sum_i u_i(E) \quad (9)$$

Where u_i is the linear coefficient for reaction i , these coefficients generally depend on the particle's kinetic energy E .

The total linear attenuation coefficient is a contribution of Photoelectric effect (u_p), Compton scattering (u_c), Pair production (u_k) and Rayleigh scattering (u_r).

As depicted in Figure 2-4, the total linear coefficient is dominated by photoelectric effect at lower energies, Compton scattering at middle energies and pair production at high energies. One chooses the source depending on the energy required for the work.

Figure 2-4 is the relative importance of different attenuation coefficient as a function of photon energy and the Z-number of the absorber.

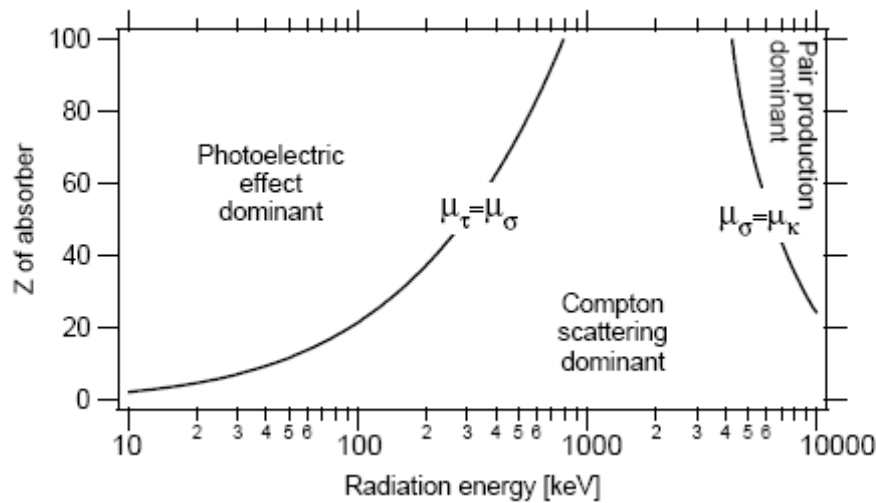

Figure 2- 4: The relative importance of different attenuation coefficient as a function of photon energy and the Z-number of the absorber. (Reprinted with permission from Johansen and Jackson, 2004)

The relation between the attenuation coefficient and the cross section is well described by the following equation:

$$u_t = u_\tau + u_k + u_\sigma + u_r = \frac{N_A}{A} \rho (r + \tau + k + \sigma) = \frac{N_A}{A} \rho_{tot} = N \sigma_{tot} \quad (10)$$

Where N_A is the Avogadro's number, A is the average atomic mass, N is the number of atoms and σ_{tot} is the sum of cross sections.

2. 3 Prompt gamma-ray spectroscopy

The basic equipment for detection of prompt gamma rays is the gamma-ray spectrometer. In order to detect and analyze the gamma-ray in prompt

gamma-ray activation analysis (PGAA), a photon detector is required. The detector converts the energy of the gamma ray to an electronic signal. This signal is amplified, shaped, digitized and stored in a histogram that makes up a spectrum of gamma peaks. The choice of a particular detector type for PGAA application depends upon the gamma-ray energy range of interest and the application's resolution and efficiency requirements (Alfasi and Chung, 1995). The detector must have adequate material to absorb a large fraction of gamma-ray energy. Thus, any gas-filled counter is not suitable for detecting full-energy gamma-rays energies because the probability of absorbing all the gamma-ray energy is too low. Further, the higher gamma-ray energies, as frequently encountered in PGAA, are more effectively absorbed by higher Z materials. Other considerations are count rate capability, resolution, and if timing applications are involved, pulse rise time.

The types of detectors usually used in PGAA are scintillation detectors and semi conducting detectors. In this work, NaI(Tl) scintillation detector is used to detect the prompt gamma-rays. Scintillation detectors are used in conjunction with multiplier tube (PMT) to convert the scintillation light pulse into an electric pulse. A typical scintillation spectroscopy system consists of the NaI(Tl) detector, high voltage supply, a preamplifier (PA), an amplifier, an analog-to digital converter (ADC), and a multi-channel analyzer (MCA).

The table below shows photopeak energy resolution for various detectors used in PGAA experiments.

Table 2- 3: photopeak energy resolution for various detectors used in PGAA experiments (Ref: Alfassi and Chung, 1995)

Detector type and size (Diameter x Height)	Resolution:		FWHM (KeV)	
	122 KeV	662 KeV	1332 KeV	10829 KeV
HPGe (2"x2.3")	0.8	1.2	1.8	6
Nal (2"x 2")	23	53	7.50E+01	214
BGO (2"x 2")	40	85	1.25E+02	450

2. 4 Scintillation detectors

The energy range of prompt gamma radiation extends from practically zero to 12MeV. There are two detector types in practice that are able to detect gamma rays over this range. These are scintillation and the germanium semiconductors detectors (Molnár, 2004). Because industrial applications require durable, shock and vibration resistant, easy to use equipment, which may be operated in a wide range of temperature, humidity and pressure environment (Alfassi and Chung 1995), scintillation detectors are widely suited for this purpose. In my simulations, I have considered the usage of scintillation detectors because they are good in monitoring the composition of nearly identical objects.

The gamma-ray interacting with a scintillator produces a pulse of light that is converted to an electric pulse by PMT. The PMT consists of photocathode, a focusing electrode and 10 or more dynodes that multiply the number of electrons striking them several times each. The anode and dynodes are biased by a chain of resistors typically located in a plug-on tube base assembly (Alfasi and Chung, 1995). Thallium-activated Nal and BGO crystals are commonly used as scintillator materials. The properties of this two are transparent, available in large size, and give large light output proportional to gamma-ray energy.

The high Z of iodine in NaI(Tl) gives good efficiency for gamma-ray detection. In order to activate the crystal, a small amount of thallium (Tl) is added to the material. The best resolution expected is about 8.0% for the 662-keV gamma-ray from ^{137}Cs for a 2"x2" crystal, and is slightly better for smaller sizes. NaI(Tl) detector has high detecting efficiency particularly in high-energy region. The light decay time constant in NaI(Tl) is about 0.25 μs . Typical charge-sensitive Pas translate this into an output pulse rise time of about 0.50 μs . The NaI(Tl) detector is the dominant material for gamma-detection used for spectroscopy and pair spectroscopy systems because of its relative economical cost in terms of spectral resolution and detecting efficiency.

In Figure 2-5 shows the prompt gamma-ray spectra taken by the BGO, NaI(Tl), and HPGe detectors with similar size *in vivo* PGAA scan using the 0.1-W Tsiang Mobile Education Reactor (THMER) in Taiwan (Alfasi and Chung, 1995).

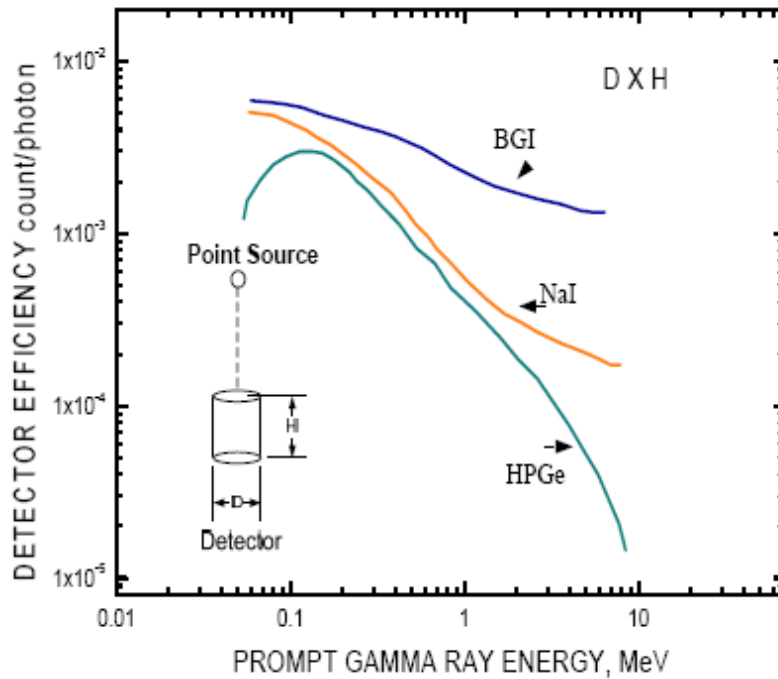

Figure 2- 5: Absolute efficiency curves of prompt gamma-ray detecting systems using the BGO, NaI, and HPGe detectors with size indicated; the curve for the pair spectrometer using the HPGe and 9”X10” NaI(Tl) shield is also plotted (Alfassi, Chung 1995)

Although the high-energy resolution HPGe detector yields excellent quality of the prompt photon spectrum, it takes however many histories of 50,000s to collect enough counts. BGO only needs 1800s. For 1800s, the NaI(Tl) detector is impractical for on-line measurements of nitrogen prompt gamma-rays because the incidental sum in 9 MeV to 11 MeV regions shown in Figure 2-5. Hence, NaI(Tl) detector crystal for medium-energy and BGO for high-energy prompt gamma-rays, are useful in PGAA experiment. In this work, NaI(Tl) detector is considered for measuring prompt gamma-ray neutron activation analysis (PGNAA).

2. 5 PGAA with radioisotopic sources

There are usually three radionuclide sources used in PGAA. Two of this are of the types α -emitters embedded in Be, using the ${}^9\text{Be}(\alpha,n) {}^{12}\text{C}$ reaction. The α -emitting source is either ${}^{241}\text{Am}$ or ${}^{238,239}\text{Pu}$. The third source is the ${}^{252}\text{Cf}$ spontaneous fission source which is considered in this work.

Several factors influence the choice of the source. For bulk samples, (α,n) is used because it has higher energy neutron that lead to better uniformity of the activation flux., however for PGAA, this is not the case because ${}^{252}\text{Cf}$ spontaneous fission neutrons have neutrons with average of 2.35 MeV and mostly use thermal neutrons. The most abundant energy is about 1 to 2MeV and has low-gamma dose rates. Since my work was entirely simulation, I did not experience this problematic dose rate.

To make the quantitative analysis of the measured PGNAA gamma spectrum, there are two popular methods. They are peak analysis and Library Least Squares (LLS). Robin. P. Gardner compared these two methods in 1997. (Robin. P. Gardner 1997). In his study, analyses for elements Al, Si, and Fe were made by using the single peak analysis and the elemental library least-squares method. It shows that the library least-squares method is about 2.5 times better than the single peak analysis method.

2.5. 1 Discussion overview

In this paper, I will only discuss ${}^{252}\text{Cf}$ source. It is the only source I have used to examine PGNAA in determining phase amounts of different elements in

multi-phase flow. Because of its low-gamma dose rates, it will also be viable if the work is done experimentally.

2.5. 2 ^{252}Cf sources

Most PGNAA investigation is done using ^{252}Cf due to its low gamma-ray fluence. Another advantage of ^{252}Cf source is the higher integrated exposure before onset of neutron-induced damage in NaI(Tl) detector. Neutrons from ^{252}Cf source are placed on a lead plate and then neutrons are directed to hit a container which is made of stainless steel and thus scatter while moderating in the sample. The lead is placed just above the source in order to reduce the low-energy gamma-rays originating in the ^{252}Cf . The prompt gammas are measured using NaI(Tl) detector. The detector is shielded with lead. More discussion of this is found in chapter 3.

Chapter 3

3. 1 Industrial application of prompt-gamma ray neutron activation (PGNAA) technique

Prompt gamma ray neutron activation analysis (PGNAA) technique is a powerful multi-elemental analysis technique however; the technique is new in industrial process control. The typical examples of its industrial application are: PGNAA based cement analyzer, PGNAA based slurry analyzers for mines. The PGNAA analyzers utilize radioisotope neutron ^{252}Cf or ^{241}Am -Be sources as well as accelerator based T(d,n) and D(d,n) neutron sources to excite the sample atoms. Accelerator based neutron sources have some advantages over radioisotope sources. They have radiation on-off capability and less γ -ray background. Also some of the radioisotope sources have short half-lives such as that of ^{252}Cf source, which is 2.64 years. D(d,n) source, in spite of its 100 times lower neutron yield than T(d,n) source, is still preferred for its use in thermal neutron capture based PGNAA studies. This is due to higher moderation probability of lower energy neutrons from D(d,n)source.

Various methods have been applied for exploration of neutron capture prompt gamma rays in multielemental analytical work, by utilizing research reactors or isotopic neutron sources as sources of thermal neutrons. Reactor based neutron sources generally provide much higher sensitivity for those particular applications which can be performed in the laboratory environment. The portable neutron sources, both isotopic and neutron generating, offer a wide range of industrial and field applications with some lower sensitivity. Two distinct geometrical arrangements of target and detector are possible. One can either

use internal target geometry by placing the sample inside the reactor or the assembly used and observing the gamma rays outside these facilities, or by streaming neutrons to a sample mounted close to the detector. The internal geometry has advantage of high neutron flux but poor counting geometry. The external geometry does the opposite to the internal geometry. The theoretical basis and design consideration of PGNAA facilities using these different methods was reviewed by different authors (Clark et al 1982).

This work does not involve all this experimental setups but does advanced simulations by using neutron capture gamma rays for estimating different elemental signature in seawater, while utilizing ^{252}Cf neutron source.

3. 2 Monte Carlo CEARCPG code simulations for thermal neutron intensity calculations

The PGNAA setup in industrial process applications are designed for elemental analysis using prompt γ -rays emitted due to thermal neutron capture (n,γ) reactions. Therefore optimization of thermal neutron intensity at sample locations is of primary interest for the design of the PGNAA setup. Because of the random nature of scattering processes, it is usually impossible to solve the transport of radiation analytically. Thus the Monte-Carlo (MCNP) simulations are used to approximate the behavior of the radiation. MCNP are pseudo-random number generators and known probability distributions in radiation physics to simulate trajectories for individual's particles. The trajectories are simulated from the photon that is emitted and is absorbed. With a constructed geometry, energy deposition and flux within a cell, pulse-height spectrum or flux in a detector can

be simulated (Johansen and Jackson 2004). Chapter 5 explains better the simulation geometry in this work. In this work, the MCNP code has been substituted to Monte Carlo code CEARCPG for the purpose of simulation.

The Monte Carlo code CEARCPG is a new code which predicts the counting in coincidence PGNAAs and also optimizes the design of PGNAAs gauges that utilize this approach. CEARCPG is a specific-purpose, continuous-energy, generalized geometry, coupled neutron,/photon Monte Carlo transport code. The neutron energy regime is from 10^{-11} to 20MeV. The photon energy regime is from 0.01 to 20MeV. The CEARCPG can be used to analyze 97 isotopes of practical interest (Gardner, Han 2005). PGNAAs can be used in on-line bulk sample analysis, small sample neutron beam elemental analysis, oil well logging elemental analysis and aluminum alloy sorting. CEARCPG has been tested on the on-line bulk sample and now this work is using the code on seawater sample characterization. Initializing segment that is used to define the geometry, required neutron cross section, photon cross sections, angular distributions of scattered neutrons, and nuclei excited structure used to sample the prompt gamma rays.

1. Neutron source segment that samples the energy and direction of the source neutrons. The default neutron source is ^{252}Cf . It also supports user-defined neutron source.
2. Neutron tracking segment that tracks the flight of neutrons and sample collision positions as well as neutron interaction types.

3. Prompt gamma-ray sampling segment which is used to sample the prompt gamma rays generated by neutron radioactive capture reactions and neutron inelastic scattering reactions.
4. Gamma-ray tracking segment that tracks the flight of gamma rays and the collision positions as well as the photon interaction types.
5. Tally segment that records the spectra detected by detectors as well as single coincidence spectra of each element of interest.

Also, the CEARCPG code features are:

1. The neutron library includes 97 isotopes of practical interest. The neutron energy ranges from 10^{-11} to 20 MeV. Three sub-libraries are included.
 - a) The neutron cross-section library is extracted from the ENDF/B-VI. 8 300k and the JENDL-3. 3 300k libraries. The angular distribution data of neutron elastic scattering and neutron inelastic scattering of each isotope is also in the library.
 - b) The (n, γ) scheme library that is extracted from the ENSDF library. This library is used to sample prompt gamma rays caused by the (n, γ) reaction and
 - c) The neutron inelastic scattering library. This library is used to sample the gamma rays that are induced by neutrons inelastic scattering.
2. The library for gamma-rays include the elements $z=1$ to 100, which come from the EPDL97 library. The gamma-ray energy range is from 0.01 to 20 MeV.

3. CEARCPG code input is similar to those of MCNP. By using the platform VisED of MCNP, it is easy for user to design and check the geometry part used for the simulation.
4. CEARCPG also records the following gamma-ray spectra separately:
 - a) Prompt gamma rays from neutron radioactive capture interaction in the sample zone
 - b) Gamma rays from neutron inelastic scattering interaction in the sample zone
 - c) Coincidence gamma rays from the sample zone
 - d) Prompt gamma rays from neutron radioactive capture interactions in the zones other than the sample region
 - e) Coincidence gamma rays from the zones other than the sample region
 - f) Gamma rays from neutron capture
 - g) Gamma rays from the natural background due to the ^{40}K decay chain
 - h) Gamma rays from the natural background due to the Th decay chain
 - i) Gamma rays from the natural background due to the U decay chain
 - j) Prompt gamma rays from ^{127}I and ^{23}Na detector neutron activation
 - k) Decay gamma rays from the ^{23}Na resulting from NaI detector neutron activation
 - l) Decay gamma rays from the ^{123}I resulting from NaI detector neutron activation

The uniqueness of CEARCPG vs. MCNP is that CEARCPG uses the same format of ENDF/B-VI and ENDSDF library. The user does not transfer the data format as is required when using MCNP. This format makes the CEACPG

code more flexible and extensible. The free gas model describes the thermal neutron scatter (Gardner, Hans 2005). For more details concerning the gamma-ray sampling and code benchmarking refer [32].

3.2. 1 CEARCPG flow chart

CEARCPG code is written by Compaq Visual Fortran in FORTRAN 95. The data is stored by dynamic memory allocation technique for data storage during problem set-up. The code is integrated by several modules that can carry different function (Hans, 2005). Figure 3-1 shows the flow chart. The code is composed of several major parts. These are: 1) initializing part which reads the geometry input; 2) set up variable dimensions and the dynamically allocated storage; 3)neutron transport part; 4)the gamma rays transportation part and 5) the recording part. The public memory lots and public common memory block stores the data that are exchanged among the different part.

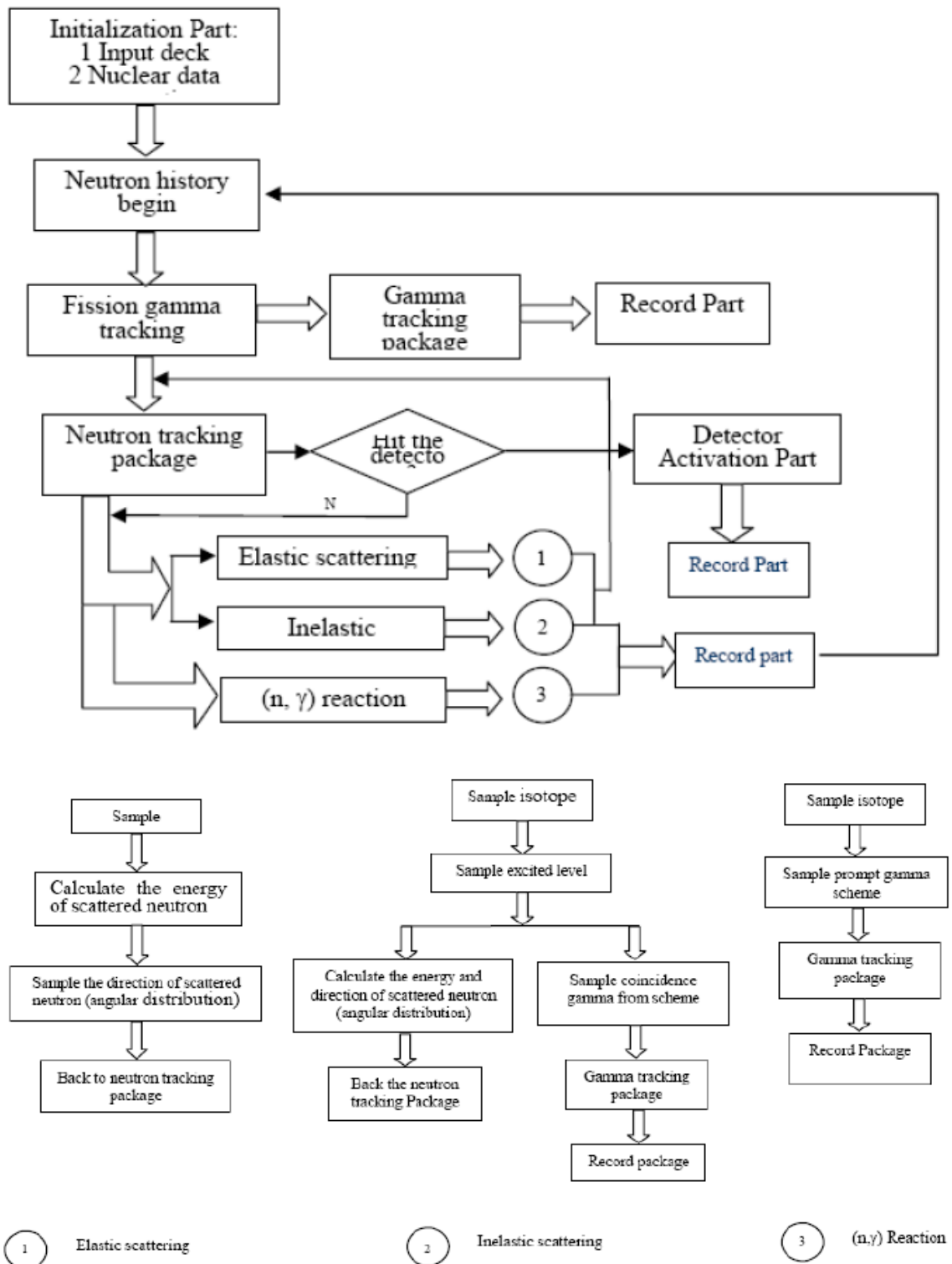

Figure 3- 1: The flow chart of CEARCPG (Reprinted with permission from Han, 2005)

3.2. 2 Example of CEARCPG benchmarking

Several experiments have been performed to benchmark the CEARCPG code. This includes the bulk coal sample where the geometry schematic measurement is as shown in Figure 3-1. The geometry is plotted using a Visual Editor of MCNP5. The prompt gamma rays are measured by 5"x5" NaI detector. The coal sample contains 17 elements. With only one NaI detector, the experiment can be used to validate single spectra simulation of the CEARCPG code.

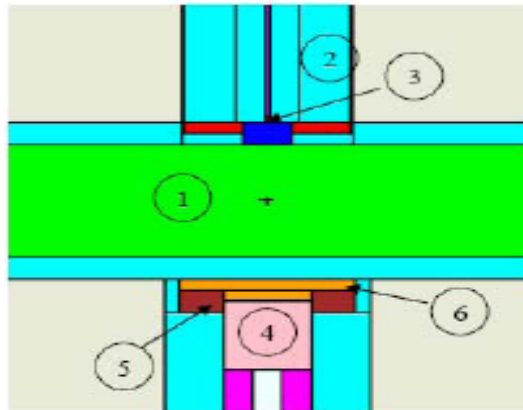

Figure 3- 2: Schematic of ETI prototype (CEARCPG 2005)

The ETI prototype consist of (1) coal sample, (2) polyethylene, (3) ^{252}Cf neutron source, (4) the NaI detector, (5) the lead shield, and (6) the Lithium loaded polyethylene. The simulated spectra are normalized at the Neutron peak. CEARCPG also utilizes the fission gamma rays of ^{252}Cf neutron source, NaI detector activation gamma rays and the gamma rays from the natural background. The difference between the above prototype and this work is that the sample is seawater and lithium loaded polyethylene is not used. More details are found in chapter 4.

3. 3 Energy discrimination

Because a photon can scatter many times, and in a different direction each time, it becomes difficult to detect that scattered radiation at a specific volume. Also it turns out to be difficult to develop a geometry that can allow detection only of scattered radiation with certain energies. Due to this problem, collimators and energy discrimination are used to prevent some of the unwanted scattered radiation from being detected. In this work, the use of collimators is not necessary because prompt gamma rays travel in straight paths.

The energy of scattered photon will vary with the scattering angle (refer eq. 6). If energy-sensitive detector systems are used, one can select radiation that has been scattered at a given angle by choosing the given energies with the positioning of the detector. The limiting factor of this technique is that scattered radiation at small angles may have the same energies as that of once scattered photons at larger angle. This makes it difficult to use discrimination energies at low energies with the use of detectors that have poor resolution.

3. 4 General view of multiphase flow

As mentioned in Section 1.3, multiphase flow is the simultaneous flow of gas, liquid and/or solid phases in different combinations. Multiphase flows, particularly two-phase flows, are probably the most common flow cases in nature and are essential in most industrial applications, such as energy conversion, paper manufacturing, and food manufacturing and medical applications. In this work, seawater is passed through a small cylindrical tank for measurement. Chapter 4 discusses this in details.

3.4. 1 Background

The background of this work is due to an increased demand for accurate level measurements and improved process control in gravitational gas/oil/water separators.

In Figure 3-2, a mixture of water, oil, gas and sand/sludge flows in through the inlet at the top left of the separator. In the petroleum industry, sand, water, emulsion, oil, form and gas are commonly referred to as different phases in the flow (Holstad 2004). Figure 3-3 shows separation of the phases as the mixture flows through the separator. There are three outlets in the weir. One is for the gas at the top of the tank and two are for water and oil separated at the bottom by weir.

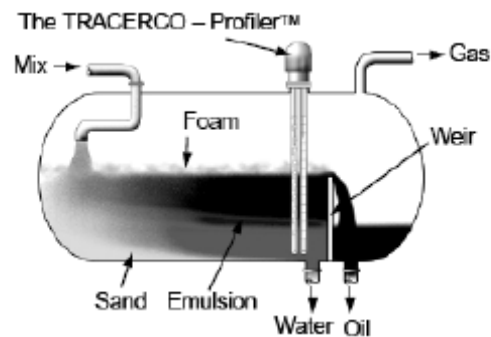

Figure 3- 3: The TRACERCO - Profiler™ installed in gravitational separator with typical phase distribution. (Reprinted with permission from Johansen and Jackson 2004)

Chemicals are used to enhance reduction of high amounts of foam and emulsion. The Tracerco-profiler™ is also installed to monitor the interfaces. This is level-monitoring system utilizes attenuation of gamma-radiation to give the density profile in the separator (Hjertaker et al 2001; Olhmat 2003).

3.4. 2 The SOFA Project

The use of sub-sea production and processing facilities is now commonly used in off-shore industry. The SOFA project for sub-sea multiphase metering is a new concept that is used to optimize oil fields operations (Johansen and Jackson 2000; paper 1). Figure 3-4 shows a sketch of the SOFA design where a sample is taken from the flow and the phases are allowed to separate and stabilize in a measurement chamber that acts as a gravitational separator tank. When the phases are allowed to stabilize, multiple measurements are carried out to characterize the fluid before it is reinjected to the pipeline. This is a continuous process where a new sample is taken each time. The volume fraction of the phases is found by level measurement with CMR's Ultrasonic Interface Level Detector (UID) (Hjertaker et al 2001). These level measurements are by ultrasound (Hjertaker et al 2001) and detection of attenuation coefficients by the use of transmitted radiation (Johansen and Jackson 2004)

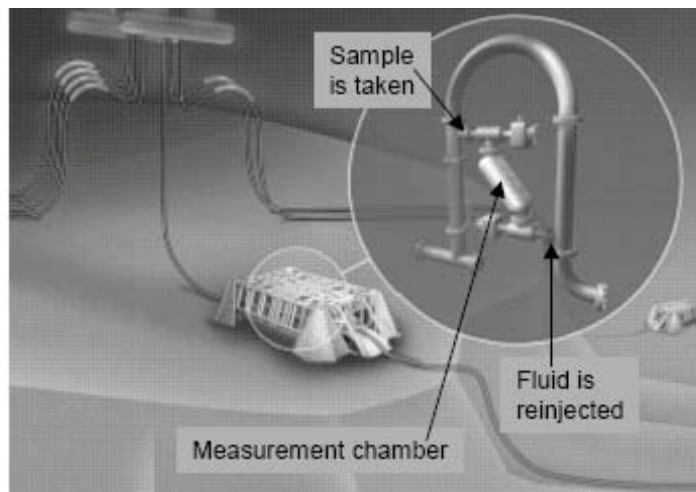

Figure 3- 4: Sketch of CMR's patented SOFA concept of Continuous sampling analysis of multiphase flow. (Reprinted with permission from Johansen and Jackson 2004)

3.4. 3 Water Salinity

Produced water contains various types of salts and can have a mixture of formation water and injected seawater. Typically, seawater and formation water have different composition. Also the formation water may change from one well to another. Due to this the salinity and the composition of produced water may change thus a relative change is an indicative of changes in the production conditions. Contents of ions for formation water and seawater are as shown in Table 3-1.

Table 3- 1: Typical contents of ions in oil field brines and seawater (Wright et al 1994, Barlow 2003)

Ions		Formation water [mg/l]	Seawater [mg/l]
Sodium	Na ⁺	30730	10500
Potassium	K ⁺	710	390
Magnesium	Mg ²⁺	470	1350
Chlorine	Cl ⁻	59640	19000
Calcium	Ca ²⁺	5300	410
Barium	Ba ²⁺	420	< 1
Strontium	Sr ²⁺	840	8
Sulphate	SO ₄ ⁻	4	2700

In the petroleum industry, various measurement systems depend on the salinity of the water (Thorn et al 1997, Miller et al 1999). Due to the change noted in salinity or composition of the produced water, the density and conductivity is altered and thus induces a drift in measurement results in the system based on detection of density or electrical impedance. In this work nine (9) elements are considered in seawater. Chapter 4 discusses this in details. Figure 3-5 is a sketch of the vertical cross section of the experimental set-up used to characterize produced water.

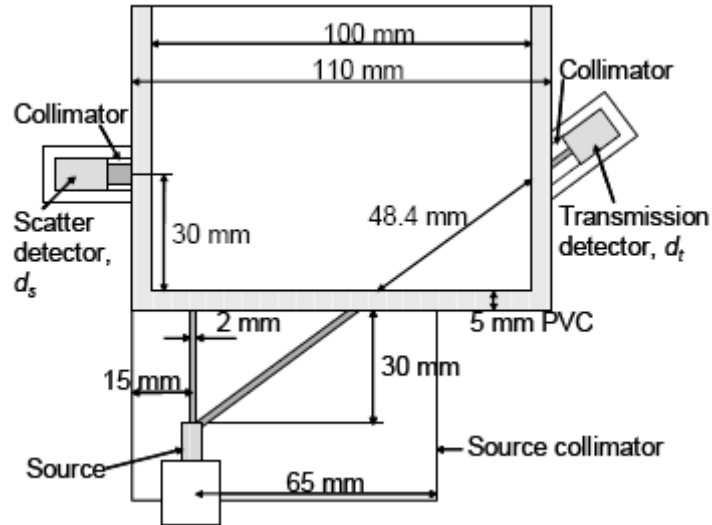

Figure 3- 5: Sketch of the vertical cross section of the experimental set-up used to characterize produced water (Johansen and Jackson 2004)

Two detectors are positioned on opposite sides of the measurement chamber. Detector (d_1) detects transmitted radiation and detector (d_2) detects scattered radiation. Both detectors use $10 \times 10 \times 3 \text{ mm}^3$ cadmium zinc telluride (CdZnTe) semiconductor detectors in aluminum housing. There are also removable collimators at the front of the detectors.

Chapter 4

4. 1 Overview of PGNAA

As mentioned in Section 1.1, prompt gamma-ray activation analysis (PGNAA) is a non-destructive technique to identify elements and determine their concentration in a sample. The method is based on the detection of capture gamma rays emitted by a sample during neutron irradiation. The principle of the technique involves the measurement of characteristic gamma rays which follow the absorption of thermal neutrons. This provides information on some nuclear data such as the level schemes of particular nuclei, and can offer a nondestructive analytical technique. Table 4-1 shows the capture gamma ray production yield for 9 elements in seawater. These elements have been used in this work and are H, C, O, Na, Cl, K, S, Ca, and Mn.

Table 4- 1: Nine (9) elements in the multiphase flow mixture of seawater

#	Elements	Symbol	Atomic Number	Radioisotope	[g/cm-3]	σ_v [barns]	N_v	Seawater(%)
1	Hydrogen	H	1	¹ H(99.985)	Gas	0.3326(7)	2	26.0658
2	Carbon	C	6	¹² C(98.9)	1.6	0.00351(5)	13	10.1886
3	Oxygen	O	8	¹⁶ O(99.76)	Gas	1.90e-04(19)	37	53.9392
4	Sodium	Na	11	²³ Na(100)	0.97	0.530(5)	240	3.073
5	Sulphur	S	16	³² S(95.02)	2.07	0.534(10)	427	0.1264
6	Chlorine	Cl	17	³⁵ Cl(75.77)	Gas	33.1(3)	455	5.964
7	Potassium	K	19	³⁹ K(93.2581)	0.86	2.06(19)	1436	0.071
8	Calcium	Ca	20	⁴⁰ Ca(96.941)	1.55	0.431(19)	288	0.53
9	Manganese	Mn	25	⁵⁵ Mn(100)	7.43	13.36(5)	126	0.042

4. 2 Simulation geometry

Simulations were carried out with various geometries and qualitative and quantitative analysis done to identify the best simulation for the work. Figure 4-1 shows the geometry design used to investigate prompt gamma-ray neutron activation analysis for determining the phase amounts in seawater sample multiphase flow.

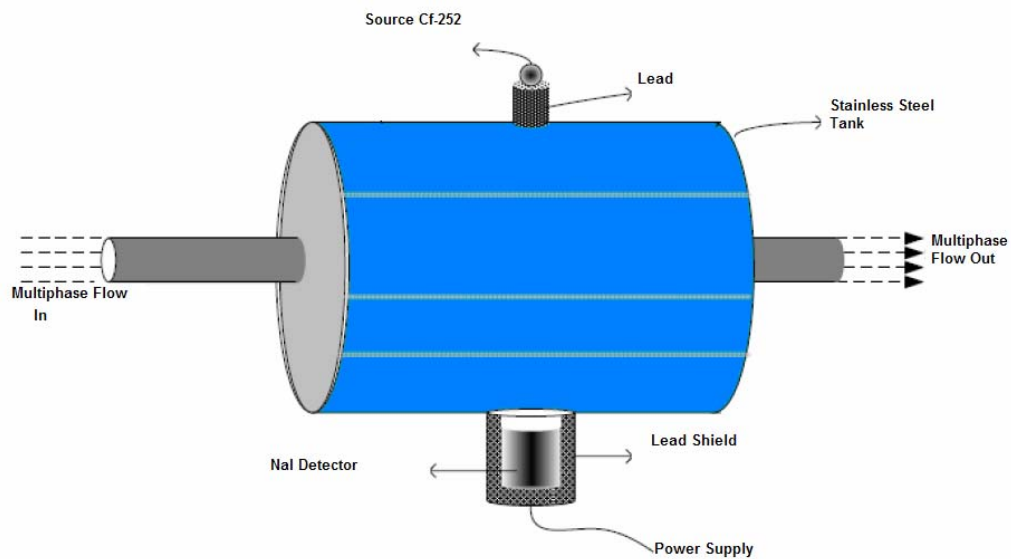

Figure 4- 1: Geometry design for the concept of continuous analysis of multiphase flow

4.2. 1 Geometry specification

The source (^{252}Cf) was positioned at the top on a cylindrical lead holder. The transmission NaI detector was positioned at the bottom of the rotating cylindrical tank at the measurement chamber as shown below. Figure 4-3 shows a principle sketch of the simulation geometry. The detector is 6 by 6 inches sodium iodide (NaI) detector in a lead casing. The outside and inside diameter of the rotating cylindrical tank is 25.8 cm and 25.4 cm respectively. The length of

the tank is 38.1 cm and is made of stainless steel. The detector is shielded by a lead of thickness 0.4 cm. Seawater sample is let to pass through the tank and the flow is assumed to be uniform.

The simplified simulation model was used because it allowed easier implementation of different geometries and also easy to change the geometry parameters. In the simulation, the detector is made of heavy alloy to get close to 100% stopping efficiency. All the simulations were carried out with the Monte Carlo CEARCPG code. This code was developed by the CEAR group at North Carolina State University. It is a powerful code that is able to predict the experimental spectrum and optimize the various coincidence PGNAA applications (Hans, 2005)

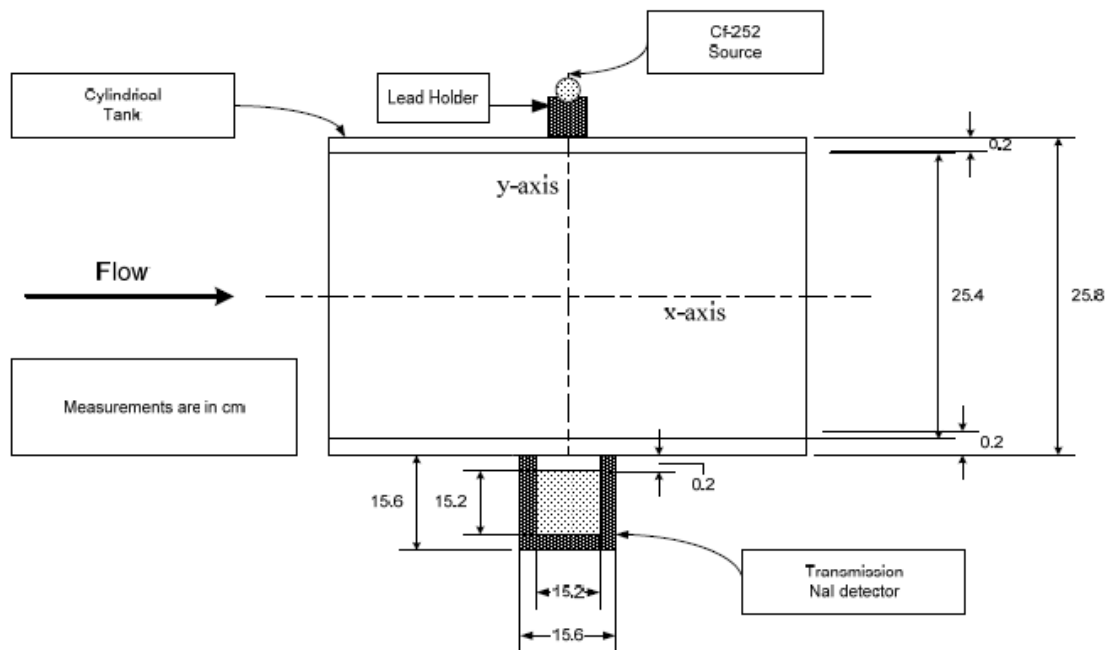

Figure 4- 2: Sketch of vertical cross section of the geometry set-up used to characterize seawater

4.2. 2 CEARCPG surface cards

The geometry specification in CEARCPG code is done through surface card and cell card. The surface card specifies the surface number, surface type, and the equation coefficients parameters specific to the surface type. The cell card specifies cell number, material intensity, and surfaces forming the cell. The geometry description is given for the plane, sphere, cylinder, cone, ellipsoid, and hyperboloid, paraboloid and torus. Note that the geometry specification for CEARCPG is copied from MCNP. This means that it is specified just like that for MCNP.

In Table 4-2 shows a detailed description of the surface type and associated parameters. The sense of a surface is defined as positive or negative sign along with surface number. The negative sign for the plane surface is when the center of the cell is on the left side or below the plane and vice versa. If the cell is inside for sphere, cylinder, cone and torus, the corresponding surface will be negative and vice versa. Also the cells are not allowed to overlap each other or be left over without explicit definition and are specified with use of intersection operator. The details of how to prepare the input file for the geometry of PGNAA analyzer can be found in the CEARCPG user's guide (Han, Gardner, 2005).

Table 4- 2: CEARCPG surface cards (CEARCPG 2005)

Surface Type		Description	Equation	Card Entries
Plane	<i>P</i>	General plane	$Ax+By+Cz-D=0$	\overline{ABCD}
	<i>PX</i>	Plane normal to <i>X</i>	$x-D=0$	\overline{D}
	<i>PY</i>	Plane normal to <i>Y</i>	$y-D=0$	\overline{D}
	<i>PZ</i>	Plane normal to <i>Z</i>	$z-D=0$	\overline{D}
Sphere	<i>SO</i>	Sphere centered at origin	$x^2 + y^2 + z^2 - R^2 = 0$	\overline{R}
	<i>S</i>	General	$(x-\bar{x})^2 + (y-\bar{y})^2 + (z-\bar{z})^2 - R^2 = 0$	$\overline{\bar{x}\bar{y}\bar{z}R}$
	<i>SX</i>	Centered on <i>X</i> -axis	$(x-\bar{x})^2 + y^2 + z^2 - R^2 = 0$	$\overline{\bar{x}R}$
	<i>SY</i>	Centered on <i>Y</i> -axis	$x^2 + (y-\bar{y})^2 + z^2 - R^2 = 0$	$\overline{\bar{y}R}$
	<i>SZ</i>	Centered on <i>Z</i> -axis	$x^2 + y^2 + (z-\bar{z})^2 - R^2 = 0$	$\overline{\bar{z}R}$
Cylinder	<i>CX</i>	Parallel to <i>X</i> -axis	$(y-\bar{y})^2 + (z-\bar{z})^2 - R^2 = 0$	$\overline{\bar{y}\bar{z}R}$
	<i>CY</i>	Parallel to <i>Y</i> -axis	$(x-\bar{x})^2 + (z-\bar{z})^2 - R^2 = 0$	$\overline{\bar{x}\bar{z}R}$
	<i>CZ</i>	Parallel to <i>Z</i> -axis	$(x-\bar{x})^2 + (y-\bar{y})^2 - R^2 = 0$	$\overline{\bar{x}\bar{y}R}$
	<i>CX</i>	On <i>X</i> -axis	$y^2 + z^2 - R^2 = 0$	\overline{R}
	<i>CY</i>	On <i>Y</i> -axis	$x^2 + z^2 - R^2 = 0$	\overline{R}
	<i>CZ</i>	On <i>Z</i> -axis	$x^2 + y^2 - R^2 = 0$	\overline{R}
Cone	<i>KX</i>	Parallel to <i>X</i> -axis	$\sqrt{(y-\bar{y})^2 + (z-\bar{z})^2} - t(x-\bar{x}) = 0$	$\overline{\bar{x} \bar{y} \bar{z} t^2 \pm 1}$
	<i>KY</i>	Parallel to <i>Y</i> -axis	$\sqrt{(y-\bar{y})^2 + (z-\bar{z})^2} - t(y-\bar{y}) = 0$	$\overline{\bar{x} \bar{y} \bar{z} t^2 \pm 1}$
	<i>KZ</i>	Parallel to <i>Z</i> -axis	$\sqrt{(y-\bar{y})^2 + (z-\bar{z})^2} - t(z-\bar{z}) = 0$	$\overline{\bar{x} \bar{y} \bar{z} t^2 \pm 1}$
	<i>KX</i>	On <i>X</i> -axis	$\sqrt{y^2 + z^2} - t(x-\bar{x}) = 0$	$\overline{\bar{x} t^2 \pm 1}$
	<i>KY</i>	On <i>Y</i> -axis	$\sqrt{y^2 + z^2} - t(y-\bar{y}) = 0$	$\overline{\bar{y} t^2 \pm 1}$
	<i>KZ</i>	On <i>Z</i> -axis	$\sqrt{y^2 + z^2} - t(z-\bar{z}) = 0$	$\overline{\bar{z} t^2 \pm 1}$
Ellipsoid Hyperboloid Paraboloid	<i>GQ</i>	Axes parallel to <i>X</i> , <i>Y</i> , or <i>Z</i> axis	$A(x-\bar{x})^2 + B(y-\bar{y})^2 + C(z-\bar{z})^2 +$ $D(x-\bar{x}) + E(y-\bar{y}) + F(z-\bar{z}) + G = 0$	$\overline{ABCDEFG}$ \overline{xyz}
Cylinder/ Cone Ellipsoid Hyperboloid Paraboloid	<i>C</i>	Axes not parallel to <i>X</i> , <i>Y</i> , or <i>Z</i> axis	$Ax^2 + By^2 + Cz^2 + Dxy + Eyz$ $Fzx + Gx + Hy + Jz + K = 0$	\overline{ABCDE} \overline{FGHJK}
Elliptical or circular torus. (Axes parallel to <i>X</i> , <i>Y</i> , or <i>Z</i> axis)	<i>K</i>		$(x-\bar{x})^2 / B^2 + (\sqrt{(y-\bar{y})^2 + (z-\bar{z})^2} - A)^2 / C^2 - 1 = 0$ $(y-\bar{y})^2 / B^2 + (\sqrt{(x-\bar{x})^2 + (z-\bar{z})^2} - A)^2 / C^2 - 1 = 0$ $(z-\bar{z})^2 / B^2 + (\sqrt{(x-\bar{x})^2 + (y-\bar{y})^2} - A)^2 / C^2 - 1 = 0$	$\overline{xyz ABC}$

4.2. 3 Input file for simulation design

The CEARCPG format of input card is very similar to the input card of MCNP. Most of the input card is the same as input file of MCNP (MCNP manual 2004). The following is some specific cards used in CEARCPG.

- 1) Sdef card, which is used to define the neutron source. The default neutron source in CEARCPG is ^{252}Cf . CEARCPG also support the point neutron source, beam neutron and user-defined neutron source.
- 2) Number detectors card is used to define the number of detectors used in simulation.
- 3) Detector card is used to define the geometry information of detector, such as the size of the detector, position and so on.
- 4) Spect card is used to define the parameters of the output spectra, such as the number of channel for single and coincidence spectrum and the calibration of the spectrum.
- 5) Detcoin card is used to define the relationship among the detectors. In this work, only one detector is used to record the single spectrum.

Tables 4-3 and Table 4-4 represent a typical input of CEARCPG created to run the simulation.

Table 4- 3: Input geometry of CEARCPG created to run the simulation 1

Created on: Saturday, August 21st, 2006 at 16:32 PM

C	# of cells	# mat	Density	Surface
1 -	1	1	-0.92	3 -4 -1
2 -	2	2	-8.03	1 -2 3 -4
3 -	3	3	-11.34	-6 5 -9 7
4 -	4	4	-3.667	-5 -8 7
5 -	5	5	-0.001193	8 -9 -5
6 -	6	3	-11.34	-12 -11 10
7 -	7	5	-0.001193	-14 11 13
8 -	8	5	-0.001193	-14 11 -12 10
9 -	9	5	-0.001193	-14 -10 9 2
10 -	10	5	-0.001193	-14 -3 -2
11 -	11	5	-0.001193	-14 4 -2
12 -	12	5	-0.001193	-14 -9 7 6
13 -	13	5	-0.001193	-14 -7
14 -	14	5	-0.001193	-13 -11 12
15 -	15	5	-0.001193	-14 11 -13 12
16 -	16	5	-0.001193	-14 -11 13
17 -	17	5	-0.001193	14

C18 - Surface X Y Z plane dimensions (cm)

19 -	1	cx	12.7
20 -	2	cx	12.9
21 -	3	px	-19.05
22 -	4	px	19.05
23 -	5	cz	7.62
24 -	6	cz	7.82
25 -	7	pz	-30.49
26 -	8	pz	-15.25
27 -	9	pz	-14.85
28 -	10	pz	13.3
29 -	11	cz	1
30 -	12	pz	13.7
31 -	13	pz	14.7
32 -	14	so	100

C33 - Atomic # Weight Fraction

34 -m1	01001	-0.260658
35 -	06012	-0.101886
36 -	08016	-0.539392
37 -	11023	-0.03073
38 -	16032	-0.001264
39 -	17035	-0.05964
40 -	19039	-0.00071
41 -	20040	-0.0053
42 -	25055	-0.00042
43 -m2	26054	-1
44 -m3	82207	-1
45 -m4	11023	-0.1548278
46 -	53127	-0.8451722
47 -m5	07014	-0.767
48 -	08016	-0.233

exponential probability density function; discrete importance function Stratified (Han, 2005).

4.2. 4 Mixture Sample of Oil, Water and Gas

The geometry schematic of the seawater sample measurement is plotted in Figure 4-4. The geometry is plotted by using the Visual Editor of MCNP5. The prompt gamma rays are measured by a 6" X 6" NaI detector. The seawater sample contains 9 elements. Because there is only one detector, this work is used to validate the capability of single spectra simulation of the CEACPG code.

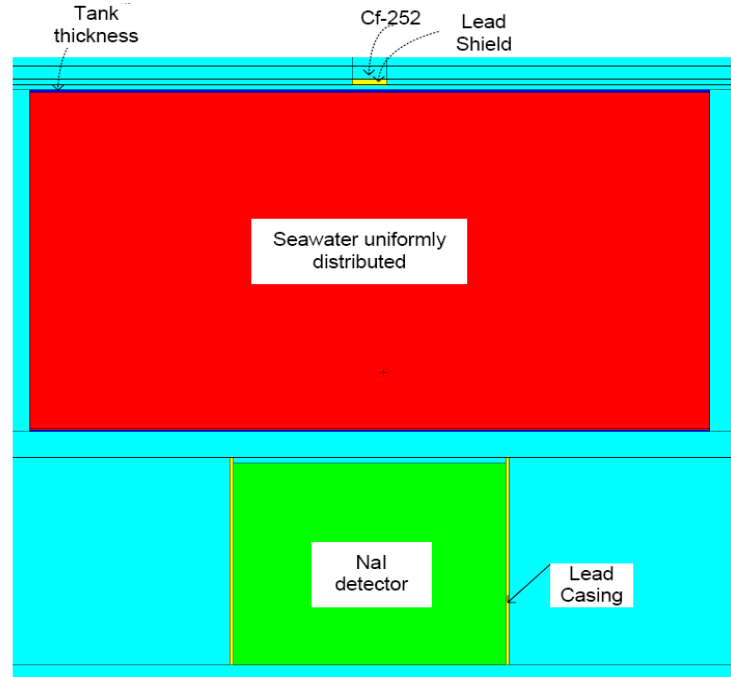

Figure 4- 3: The generic design tool (X-Z plane) for 3 phase flow simulation

The detector arrangement can record the coincidence and single spectra at the same time. Fittings can be applied for single and coincidence spectrum. This work involves only the fitted single spectra.

4. 3 Simulation procedure

The following steps were undertaken: 1) Generated elemental libraries from neutron capture interaction, 2) Generated elemental libraries from neutron inelastic scattering interaction and, 3) The generated libraries were then benchmarked with the simulated total sample (seawater) spectra of the nine (9) elements for both elastic and inelastic capture interaction. The same geometry was used to generate these libraries. The generated libraries were also compared to the previously stored libraries from Dr. Gardner's locker.

Although the geometry and the sample used for this work and Dr. Gardner's libraries are different, the spectrum signature (figure print) holds similarities. Moreover, the libraries from Dr. Gardner's locker are generated by using Monte Carlo simulations whilst for this work CEACPG code is used. Figure 4-5 and 4-6 are the calculated elemental libraries from neutron capture and inelastic capture interaction respectively.

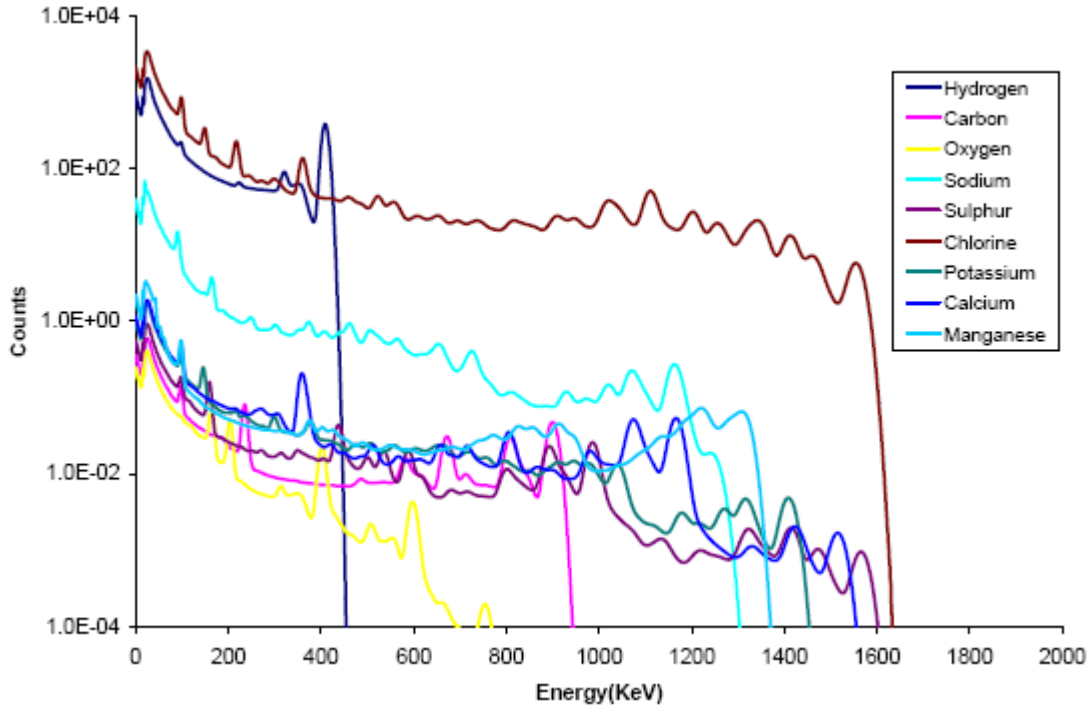

Figure 4-4: Elemental libraries from neutron capture interaction

In Figure 4-4, 2048 channels were used to simulate the elemental libraries from neutron capture interaction. The counts are mostly concentrated on 10^{-4} to 10^{+04} . Hydrogen has the highest count and oxygen has the lowest count as compared to the other seven elements. In addition, the channels used for both hydrogen and oxygen are 450 and 800 respectively. As shown in Figure 4-4, the number of channels used for sulphur and chlorine is around 1650. This shows a difference of 390 channels from the maximum channels used for the elemental library simulation.

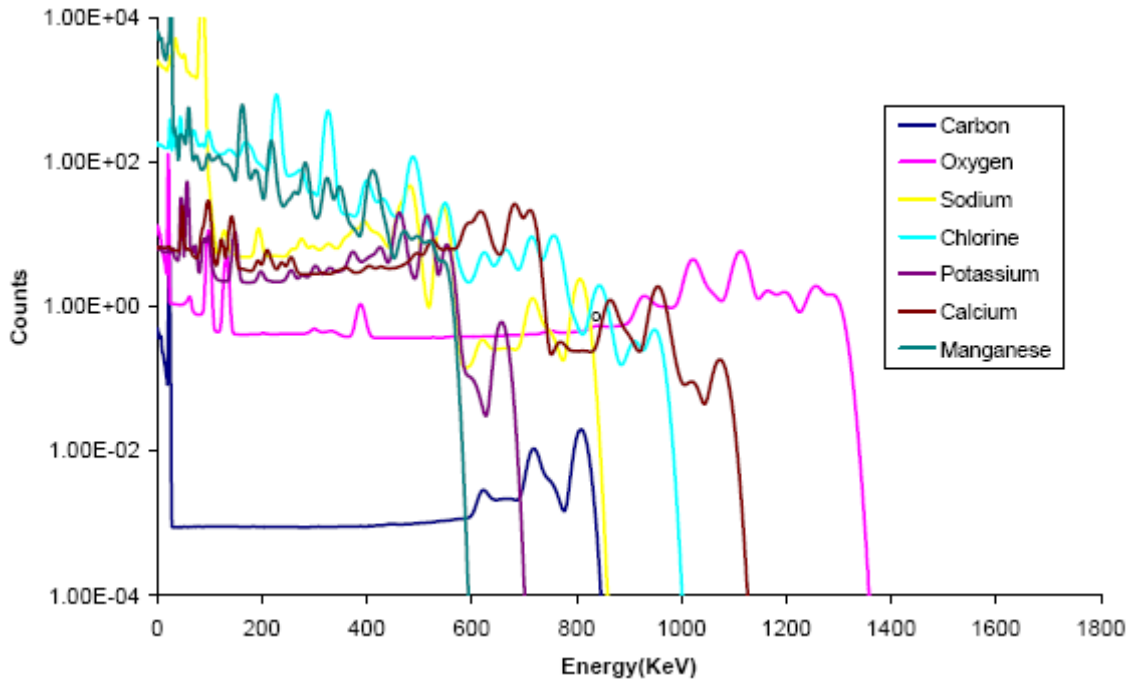

Figure 4- 5: Elemental libraries from neutron inelastic scattering interaction

The elemental libraries for neutron inelastic scattering interaction also have 2048 channels. The counts are mostly concentrated on 10^{-04} to 10^{+04} . The spectrum has a magnitude of around 10^8 . Hydrogen spectrum is missing because it has zero cross-sections from the neutron inelastic capture interaction.

In addition, manganese has the highest peak with few 580 channels. The lowest count is carbon with 850 channels. In Figure 4-6, the number of channels used for oxygen is around 1380. This shows a difference of 668 channels from the maximum channels used for the elemental library from neutron inelastic simulation. The output data for both elastic and inelastic capture spectrums are found in appendix A.

Chapter 5

5.1 Simulation Results & Analysis

The investigation of prompt gamma-ray neutron activation analysis for determining the phase amounts in seawater has been possible due to the powerful use of CEARCPG code. The CEARCPG code is a specific purpose Monte Carlo code developed at the Center for Engineering Applications of Radioisotopes (CEAR) of North Carolina State University and is used to model the spectra response of Prompt Gamma-Ray Neutron Activation Analysis (PGNAA) systems. The features of this code are discussed in section 3.

This code has been previously used to perform elemental analysis for bulk materials such as coal and concrete. In this work, the code has been used to characterize the elemental analysis for seawater in a multiphase flow.

When the simulation is complete, the CEARCPG code gives output data for coincidence, single and inputcheck text. For this case, data is collected for single and has 3 sets. i.e., fission, sample and unsample. Here, sample gives data for detector response function (DRF) and the original calculated data with no DRF.

The detector response function (DRF) is the probability density distribution of the deposited energy of an incident gamma ray. It is that pulse-height energy spectrum gotten for incident mono-energetic photons. There are other methods DRF's are applied besides Monte-Carlo simulation as variance reduction method. These methods are with incident photon spectra from each element for the production of elemental libraries spectra. Moreover, an incident

gamma ray on the detector will have one interaction inside the detector i.e., incident gamma ray is tracked until its first interaction is forced to take place, and its accumulated weight is tallied the same way as a normal incident gamma ray. The approach reduces the tracking time of gamma-ray transports and enhances the precision (Metwally, 2003). The incident gamma-ray spectra and gamma-ray pulse height spectra are listed as follows:

1. The elemental prompt gamma ray library spectra in the sample where the gamma rays emitted from neutron radioactive capture interactions of the elements in the sample is contributed by each library spectrum.
2. Source gamma ray spectrum contains the contributions from the gamma rays generated from ^{252}Cf fission interactions.
3. The extra spectrum includes the contributions of all the gamma rays from neutron induced interactions (neutron radioactive capture interaction and neutron inelastic scattering) and radioisotope decays that take place in the non- In the sample zone, all elemental gamma ray spectra. Each spectrum includes the contributions from the gamma rays emitted from neutron radioactive capture interactions of the seawater sample.
4. For inelastic gamma ray spectra, each spectrum only accounts for the contributions from the gamma rays emitted from neutron inelastic scatterings of the element of the sample.
5. With the decay gamma ray spectra, each spectrum only accounts for the contributions from the radioisotope decay of the sample.

6. Total spectrum is the contribution of gamma rays emitted from ^{252}Cf fission interactions, neutron induced interactions and radioisotope decays that occur in both sample and unsample.
7. The natural background spectrum includes three generated spectra that have gamma rays from Uranium decay chains, Thorium decay chains and ^{40}K decay. Note that only the shapes and relative intensities of these spectra are meaningful since they do not have actual weight fractions in the sample.
8. Background Spectra from NaI detector activation are the prompt gamma-ray spectrum of both Iodine (I) and Sodium (Na), the ^{24}Na decay spectrum and the ^{128}I decay spectrum. Gardner et al. (2000) have measured this background spectrum experimentally.

Table 5-1: The assumed elemental composition for the nine elements in the multiphase flow sample used for CEARCPG simulation with a density of 0.92 g/cm^3

Element	Weight fraction
Hydrogen	0.26065
Carbon	0.101886
Oxygen	0.539392
Sodium	0.030373
Sulphur	0.001264
Chlorine	0.05964
Potassium	0.00071
Calcium	0.0053
Manganese	0.00042

5.2 Simulated elemental spectrum for nine elements sample

The simulated elemental spectrum for both neutron capture interaction and inelastic scattering inelastic are shown in Figure 5-1 and Figure 5-2. Note that background spectrum is not included in the sample spectrum.

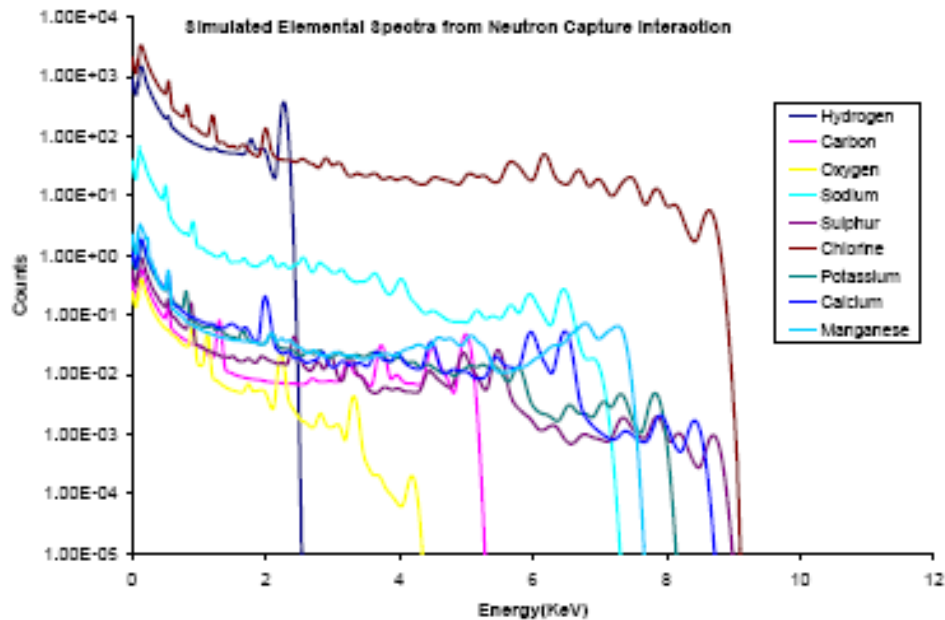

Figure 5- 1: Simulated elemental spectra from neutron capture interaction

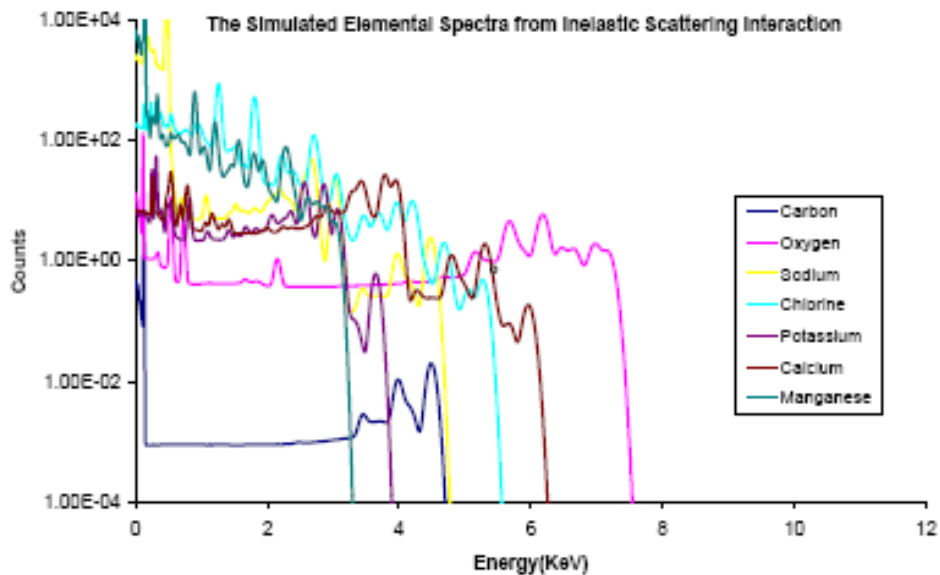

Figure 5- 2: Simulated elemental spectra from inelastic scattering interaction

The total sample spectrum for both capture and inelastic interaction is as shown in Figure 5-3 and Figure 5-4.

Note that background spectrum is not included in the total sample spectrum.

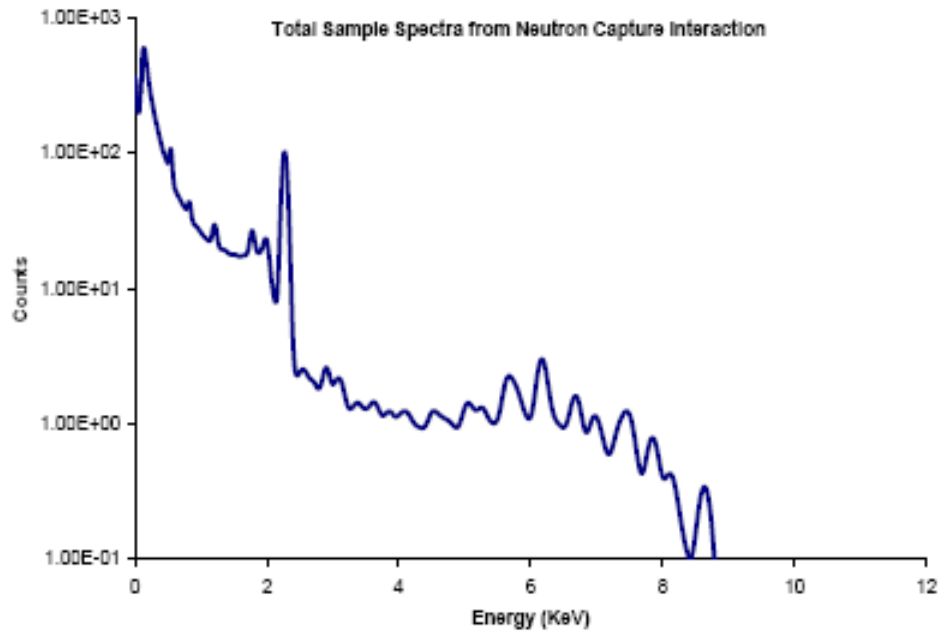

Figure 5- 3: Total sample spectra from neutron capture interaction

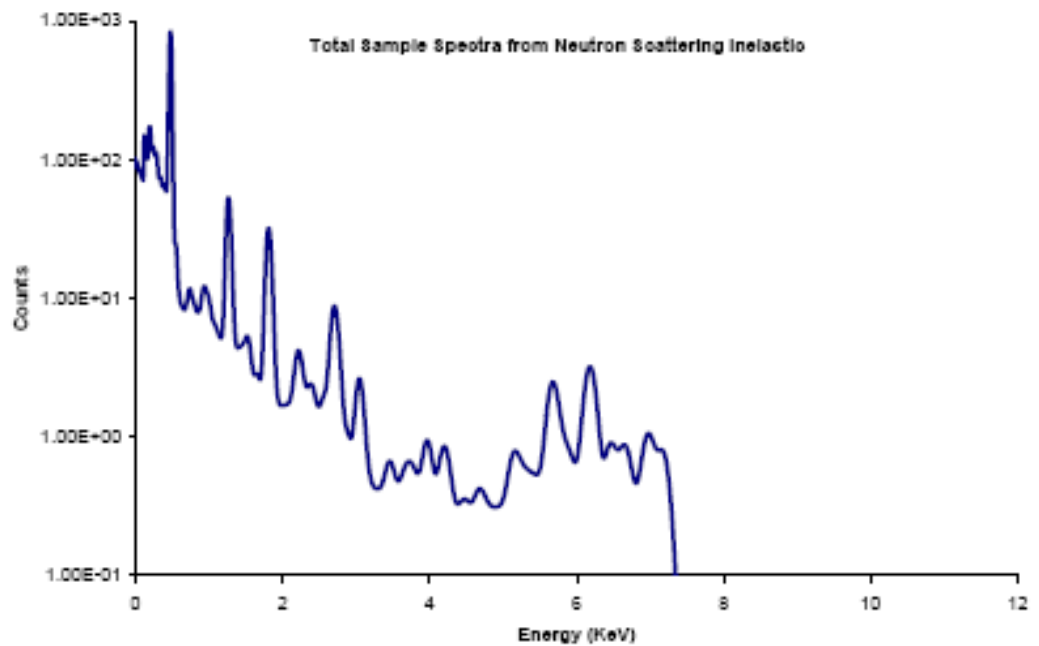

Figure 5- 4: Total sample spectra from neutron inelastic scattering

Table 5-2: The assumed elemental composition for oil, water and Gas samples used for CEARCPG simulation with densities: (1) 0.8 g/cm³ for oil. (2) 1.025 g/cm³ water and, (3) 0.031 g/cm³ for gas

Sample	Element	Weight fraction
Oil	Hydrogen	0.153
	Carbon	0.847
Water	Hydrogen	0.10854
	Oxygen	0.86146
	Sodium	0.01181
	Chlorine	0.01819
Gas	Hydrogen	0.01921
	Oxygen	0.30498
	Chlorine	0.67581

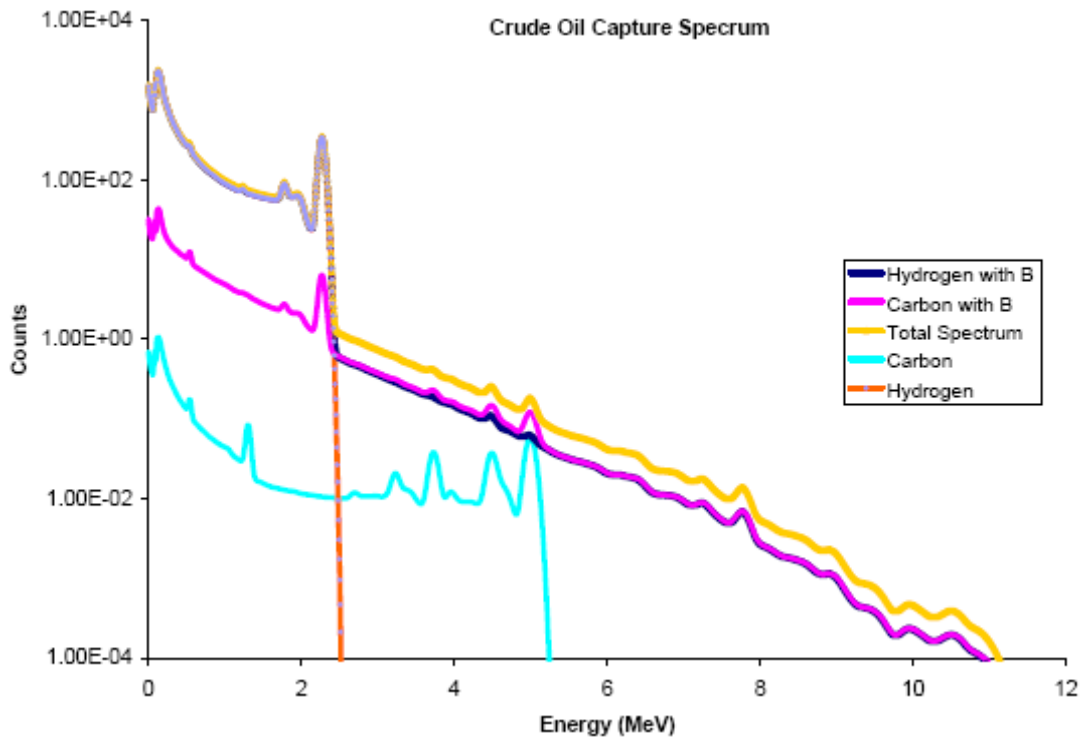

Figure 5- 5: Total sample spectra from neutron capture for crude oil

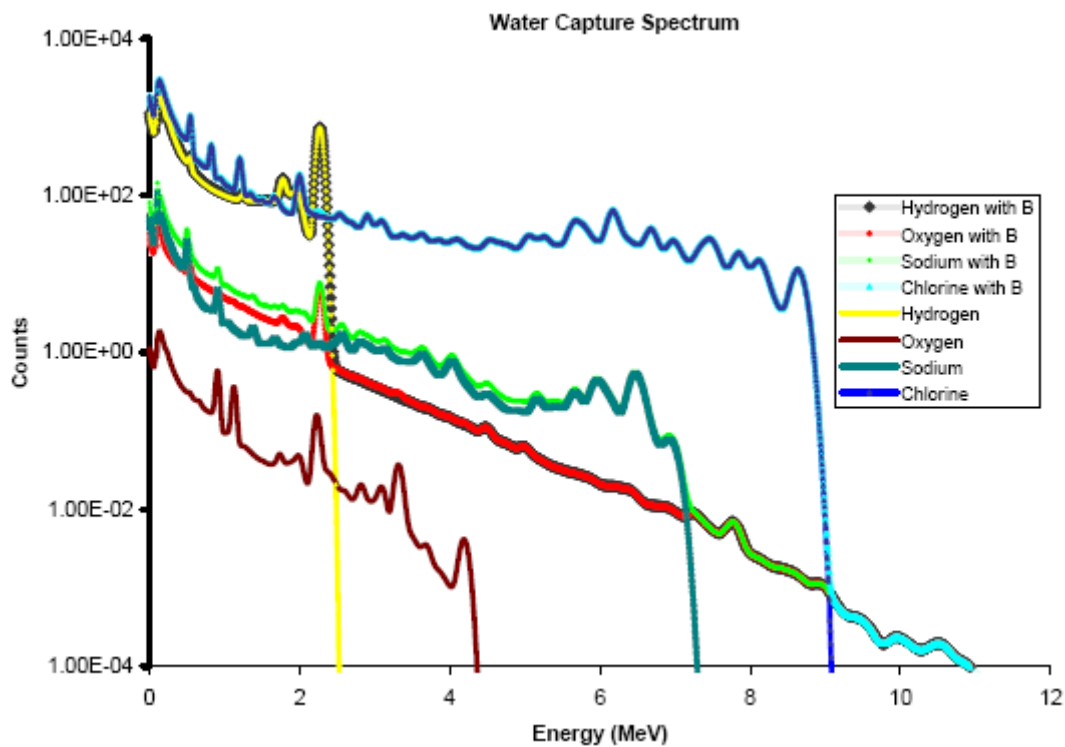

Figure 5-6: Total sample spectra from neutron capture for water

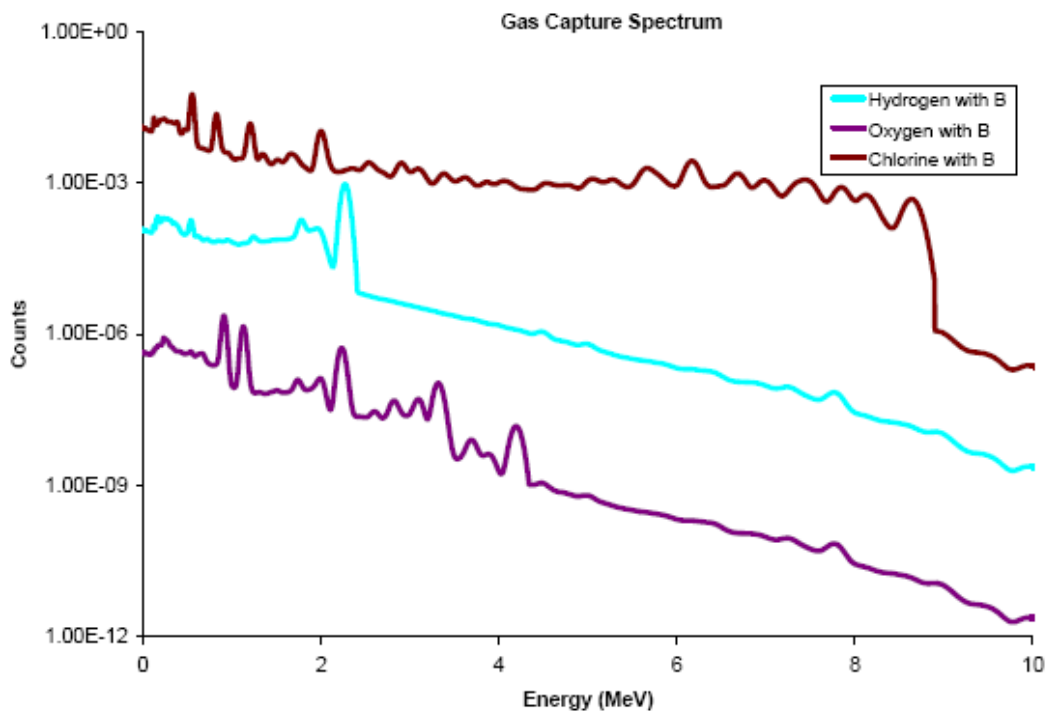

Figure 5-7: Total sample spectra from neutron capture for gas

5.3 CEARCPG code benchmarking for fitted library spectra and total simulation

The use of prompt-gamma neutron activation analysis (PGNAA) and neutron inelastic scattering (NIS) technique in measuring elemental composition in seawater has shown positive results in determining the phase amounts in multiphase flow. In this technique, a sample is bombarded with neutrons, produced by a radioisotope source ^{252}Cf .

When these neutrons interact with the elemental constituents of the seawater sample, they produce gamma rays that are then measured. The energies of the gamma rays then give a fingerprint of the elements in the sample, and the intensities of the gamma rays give concentration information. The figure shows the prototype unit which has been used to simulate elemental spectrum. The geometry is plotted by using the Visual Editor of MCNP. The prompt gamma rays are measured by a 6"X6" NaI detector. The seawater sample contains nine (9) elements.

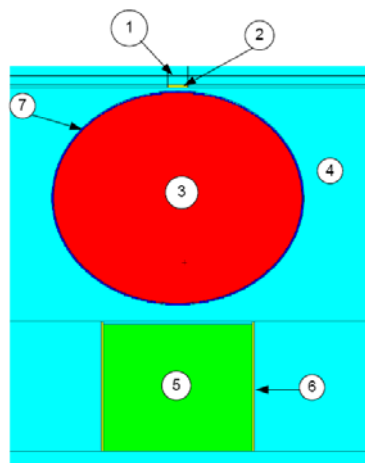

Figure 5- 8: Schematic Y-Z plane design for seawater simulation, where (1) is ^{252}Cf neutron source, (2) lead to hold source, (3) seawater sample, (4) vacuum, (5) NaI detector, (6) lead shield, and (7) Stainless steel cylindrical tank

5.3. 1 Total simulation and fitted library spectra

The total simulation and the fitted library spectra have been benchmarked to compare and identify the phase amounts in the multiphase flow. Figure 5-6 shows the benchmark of the simulated results from CEARCPG code that is performed by comparing the simulated total sample spectra with the fitted library spectra. Note that the total spectrum is not added the background spectrum.

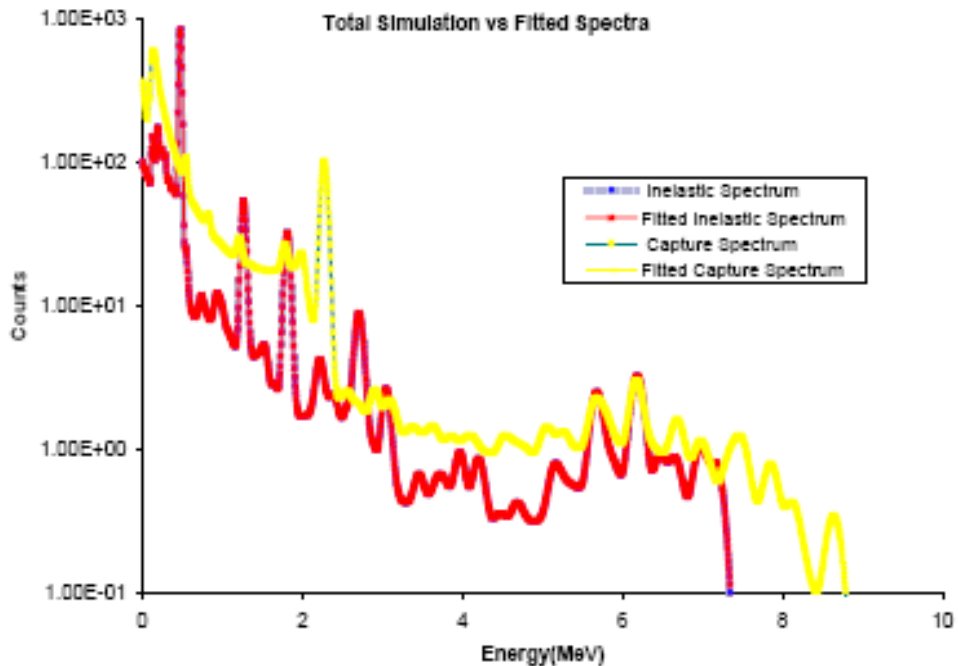

Figure 5- 9: Total simulation vs. fitted library spectra for both inelastic scattering interaction and capture interaction

5.3. 2 General discussion of the benchmarking

In Figure 5-6, the calculated spectrum of the sample and the fitted library spectrum clearly show that no big weight peaks are found in the simulated spectrum, and it agrees very well with the fitted library spectra with respect to the corresponding energy peak position and there heights as well as overall spectra shape. It is also noticed that the magnitude of the count in most of the channels

are very well fitted with almost less than 5% magnitude for both capture and inelastic spectrum. As noted there is no overall spectral shift because of 100% alignment of the spectrum. Also this is in effect because only one geometry configuration and same sample have been used for the work.

CEARCPG code seems to give a better result has compared to previously used MCNP code. CEARCPG gives detector respond function (DRF) to the spectrum and performs MCLLS for quantitative and qualitative analysis. It is a perfect code that employs coincidence and single data. CEARCPG seems to be accurate and efficient because it tracks pair production gamma rays, can incorporate neutron activation background a spectrum, takes account the non-linearity of the NaI a detector, adopting a general geometry package and eliminates the big weight problem. Table 5-3 shows the elemental energy peaks of the given sample.

Table 5- 3: Identified elemental energy peaks of the sample

Elements	Abundance (%)	σ_{γ} (barns)	$g(293^U)$ K)	N(gamma)	Energy(MeV) for capture gamma rays
Hydrogen	99.9885(70)	0.3326	0.999	1	2.2223
Carbon	98.93(8)	0.00353	1	6	4.95(0.00261), 1.26(0.00124),3.68(0.00122)
Oxygen	99.757(16)	0.00019	1	4	0.87(1.77e-4), 2.84(1.64e-4), 1.09(1.58e-4)
Sodium	100	0.53	1	240	1.369(0.53), 2.754, 0.472
Sulphur	94.93(31)	0.548	1	101	0.81(0.347), 5.420.57(0.308),2.379(0.206)
Chlorine	75.78(4)	43.5	1	384	1.164(8.91), 0.517(7.58), 6.111(6.59)
Potassium	93.25(44)	2.1	1.001	308	0.02983(1.38), 0.77(0.903), 1.158(0.16)
Calcium	96.94(16)	0.41	1.001	49	1.943(0.352), 6.4196(0.176), 4.418(0.0708)
Manganese	100	13.36	1	126	0.846(13.1), 1.810(3.62), 4.418(0.0708)

5.3. 3 MCLLS approach

MCLLS approach is designed to utilize Monte-Carlo code which has parameters to simulate the gamma-ray spectra response to a sample of known composition. MCLLS also produces simulation of individual elemental library

spectra that are subsequently used in linear library-least squares (LLS) calculation for elemental composition. Further, more iterations can be performed incase accurate or desired results are not achieved. As discussed earlier, CEARCPG Monte-Carlo code has several features that suits MCLLS approach. These includes: a geometry package, use of detector response function for increased accuracy and variance reduction, and use of other methods for the best efficiency.

There are three important steps the Monte-Carlo Library Least-Square (MCLLS) approach. These steps are:

Step 1. Given an assumed sample composition with suitable qualitative and approximate quantitative analysis, Monte Carlo simulation is done to produce the predicted spectrum of the unknown sample mixture, the individual library spectra of each element in the sample, and differential operators for each spectrum with respect to each element.

Step 2. Step two includes using library least-squares to give a calculated set of elemental amounts in the sample. These library spectra can be found in step 1 or step 3.

Step 3. Step3 involves doing more iteration incase the elemental amounts of step2 are largely different from initial assumed amounts. When the calculated amounts are near the assumed one, then differential operator method is performed to correct the elemental library spectra obtained. A repetitive iteration is encouraged in order to

achieve the best results. If this is achieved, then the work becomes non-problematic.

The Library least-squares (LLS) approach consists of the following: (1) it is the most fundamental approach, (2) gives most accurate results, (3) gives an estimate of standard deviation of each calculated elemental amount, (4) peak interference are automatically accounted for. The Library least-squares (LLS) have only one disadvantage i.e., the elemental libraries must be available for all elements present in the sample of concerned (Marshall and Zumberge, 1989).

In a closer look, LLS approach will assume that the measurement process is linear in that the intensities of each element times the counts in each channel or pulse-height energy bin unit intensity added together for all elements equals counts in the unknown mixture sample. The following equation describes these phenomena.

$$y_i = \sum_{j=1}^m x_j a_{ij} + E_i \quad \text{for } i=1,n \quad (11)$$

where y_i is the variance is the counts of unknown sample mixture in the channel I, and a_{ij} are the library spectra or counts in the channel I of the element j in the unknown sample mixture. E_i is the random errors in counts in channel i.

A set of linear equations can be generated from Equation (11). The linear equations can be solved for x_i through minimizing the corresponding reduced Chi-square χ^2_v .

The reduced chi-square value (χ^2_v) is evaluated as shown below:

$$\chi^2_v = \sum_{i=1}^n E_i^2 / [\sigma_i^2 (n - m)] \quad (12)$$

Where σ_i^2 is the variance of y_i and is considered as Poisson distribution and thus equal to y_i . The x_i are found by minimizing the chi-square value. LLS provide the calculated elemental amounts and their standard deviations, the reduced chi-square value, and the residuals of the experimental minus the calculated sample spectra. Ref: paper by Arinc, Wielopolski, and Gardner [2].

5.3. 4 Total spectrum with added background spectrum

The total spectrum can be used to test the algorithm of Library-Square fitting. Thus MCLLS code is used for this purpose (Shyu, 1993). An experimental measured background spectrum is added to the simulated total spectra. These unknown background accounts for fission background, NaI prompt background and any extra background.

The modified total spectra are plotted in Figure 5-7 and the unknown part takes a 5.5% in the total inelastic spectrum and 6% in the total capture spectrum. Also the fitted spectra are plotted in Figure 5-8.

Further, elemental prediction can be well done with the simulated spectrum but can not predict the continuous tail at high energy region. In order to get better results fitting results, the background library based on experiment takes care of the continuous tail at high energies. For this work, background spectrum was added from a different experimental geometry with different sample. The continuous tail is not assumed to be 100% due the different geometries. Thus this work proves that the logarithm of Library Least-square fit could be used for elemental libraries if the generated libraries are near to accurate.

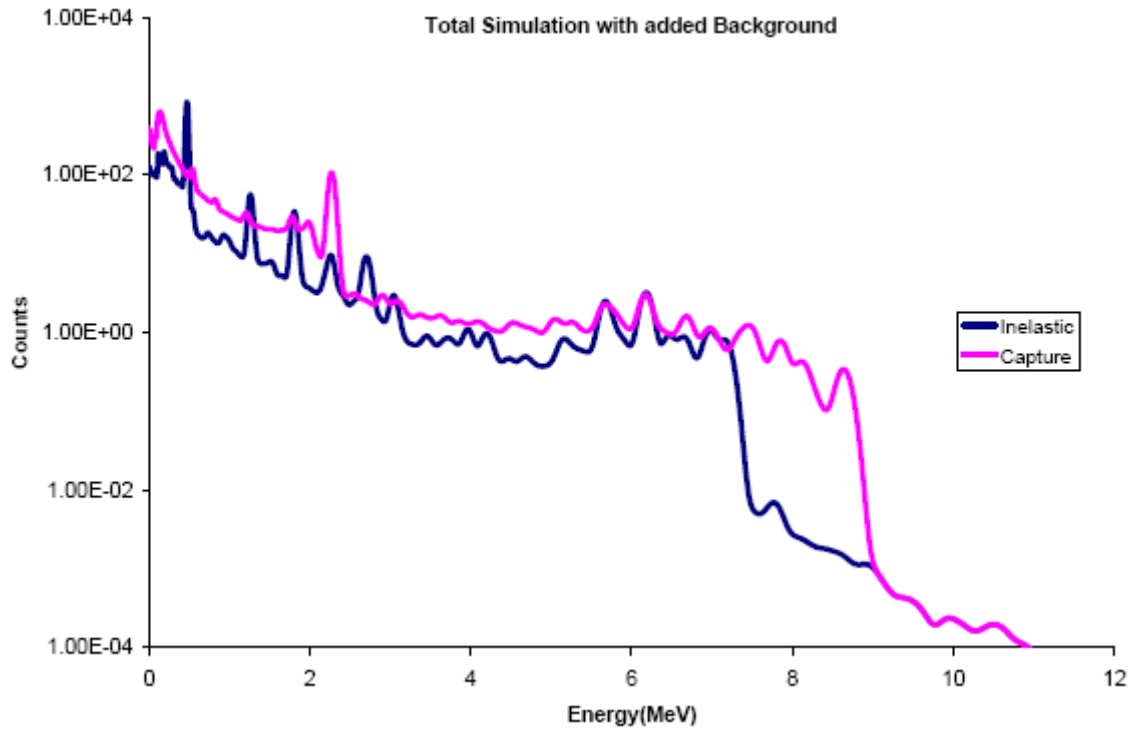

Figure 5- 10: Total simulation with added background spectrum

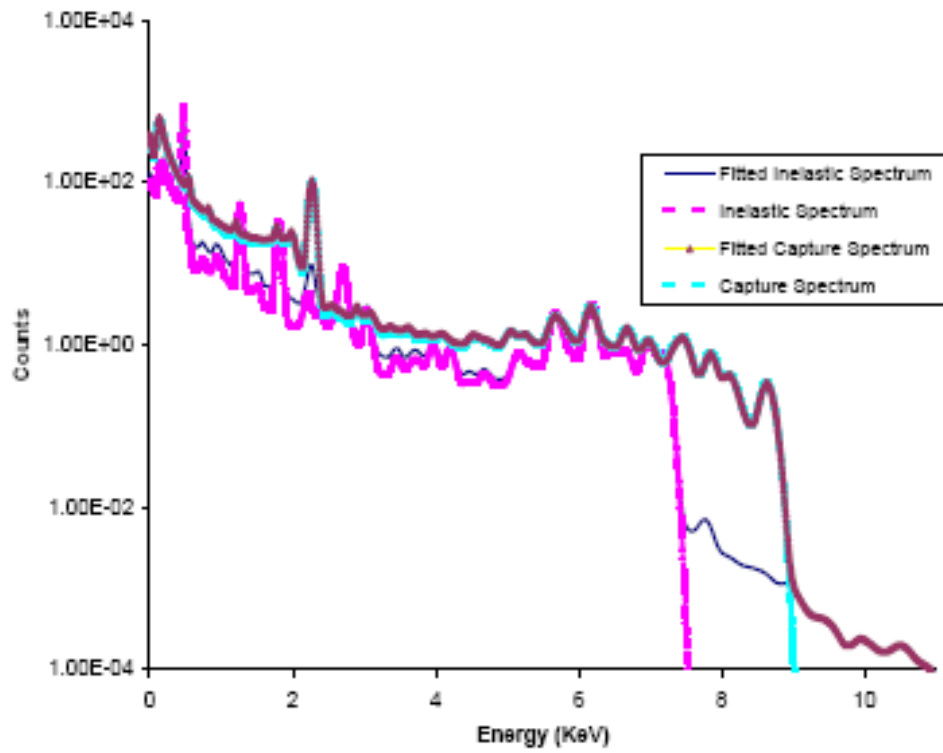

Figure 5- 11: Total simulation vs. fitted library spectra with added background spectrum

5.3. 5 Quantitative analysis

In order to get the accurate elemental analysis from gamma spectrum measured with NaI detector, the simulated spectra is fitted with elemental library spectra based on neutron interaction type. This simulated spectrum is then compared to the elemental libraries spectra and then benchmarked. As earlier discussed, the simulated spectrum can predict the elemental peak well although it can not predict the continuous tail at high energy regions.

The MCLLS approach discussed in section 4, has the advantage of using all the available spectral data and is capable of analyzing spectra with unresolved peaks. However by applying the MCLLS approach, the elemental library spectra must be available. This work was first to generate elemental library spectra before doing the total simulations. Although these elemental library spectra might vary from the sample to other due to the matrix effects, sample density, sample moisture, MCLLS method can overcome this.

As shown below, the calculated weight fraction of oxygen from neutron capture is larger than the other elements with 53.9445%. This might be caused by extreme high neutron capture cross section. As observed in Tables 5-2 and 5-3, the calculated weight fraction of all the elements agree well with the true weight fraction. Since the cross section of neutron inelastic scattering is zero, the component of hydrogen and sulphur can not be determined by using neutron inelastic spectrum. Compared to the simulation results from neutron inelastic spectrum, the results from neutron capture spectra is closer to the real one

because of its non interference with the “unknown” spectrum. In general if the “unknown” spectrum is large, the possibility of blowing up the fitting is high.

Table 5- 4: MCLLS quantitative results by fitting the total spectra from neutron capture

Number	Library	Neutron Capture		Error(%)
		True weight fraction %	Calculated weight fraction%	
1	Hydrogen	26.0658	26.0742	0.00109847
2	Carbon	10.1886	10.227	0.361341
3	Oxygen	53.9392	53.9445	0.00043144
4	Sodium	3.073	3.01991	0.199225
5	Sulphur	0.1264	0.126364	0.002661
6	Chlorine	5.964	5.96331	0.00090784
7	Potassium	0.071	0.0648947	0.224376
8	Calcium	0.53	0.529603	0.00596943
9	Manganese	0.042	0.0415427	0.0270249
Total		100	99.9913244	

Table 5- 5: MCLLS quantitative results by fitting the total spectra from neutron inelastic scattering reaction

Number	Library	Neutron Inelastic Scattering		Error(%)
		True weight fraction %	Calculated weight fraction%	
1	Hydrogen	26.0658	-	-
2	Carbon	10.1886	10.227	0.361341
3	Oxygen	53.9392	52.2977	0.00043144
4	Sodium	3.073	3.07309	0.00127836
5	Sulphur	0.1264	-	-
6	Chlorine	5.964	5.9647	0.00090784
7	Potassium	0.071	0.0648947	0.224376
8	Calcium	0.53	0.529603	0.00596943
9	Manganese	0.042	0.0415427	0.0270249
Total		100	72.1985304	-

Table 5- 6: Results for the standard deviation (Sigma) for neutron capture

I	A(I)	SIGMAA(I) %	R(I)	AREA(I) %
Hydrogen	2.61E-01	1.10E-03	6.06E-01	6.17E+01
Carbon	9.27E-02	5.81E-01	4.56E-01	1.00E-02
Oxygen	3.08E-01	2.25E+00	5.04E-01	1.95E-02
Sodium	3.02E-02	1.48E-01	6.80E-01	2.53E-01
Sulphur	1.26E-03	2.66E-03	9.14E-02	2.03E-04
Chlorine	5.96E-02	9.08E-04	8.54E-01	3.21E+01
Potassium	8.57E-03	1.06E+01	7.41E-01	2.56E-03
Calcium	9.05E-03	3.86E+00	6.57E-01	3.07E-03
Manganese	8.14E-03	1.83E+00	6.21E-01	3.91E-03

CHISQR= 0.355280E+03
The sum of all library areas is: 99.9963815 %
MO= 1 SIGY (Y multiplier)= 1.0E-002
NBEGIN= 1 NEND= 2048 SIGMUL= 1.00E-002

Table 5- 7: Results for the standard deviation (Sigma) for neutron inelastic scattering

I	A(I)	SIGMAA(I) %	R(I)	AREA(I) %
Carbon	1.02E-01	3.61E-01	2.90E-01	1.22E-02
Oxygen	5.39E-01	4.31E-04	7.70E-01	5.23E+00
Sodium	3.07E-02	1.28E-03	4.18E-01	7.01E+01
Chlorine	5.96E-02	9.08E-04	7.20E-01	2.36E+01
Potassium	6.49E-04	2.24E-01	3.50E-01	1.18E-02
Calcium	5.30E-03	5.97E-03	3.98E-01	1.65E-01
Manganese	4.15E-04	2.70E-02	2.10E-01	8.47E-01

The sum of all library areas is: 100.012680%
CHISQR= 0.204029E+03 CHIZRO= 0 MODE= 1
MO= 1 SIGY (Y multiplier)= 0.01
RES(I)=(Y(I)-YFIT(I))/SIGMAY(I).
NBEGIN= 1 NEND= 2048 SIGMUL= 0.01

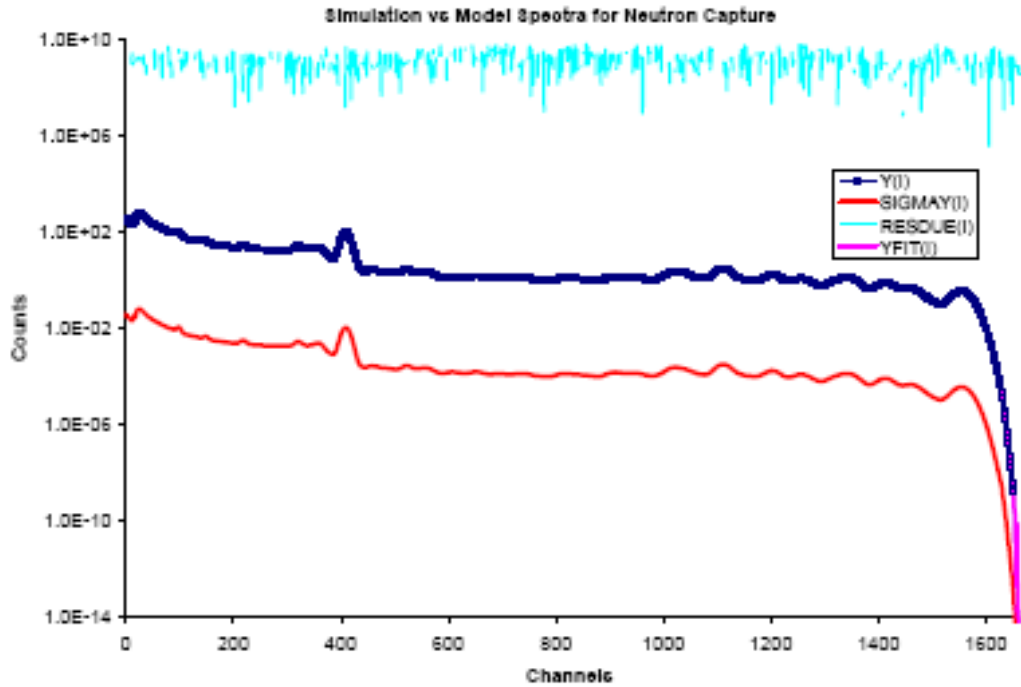

Figure 5- 12: Results showing the SIGMAY(I) and RESDUE for neutron capture

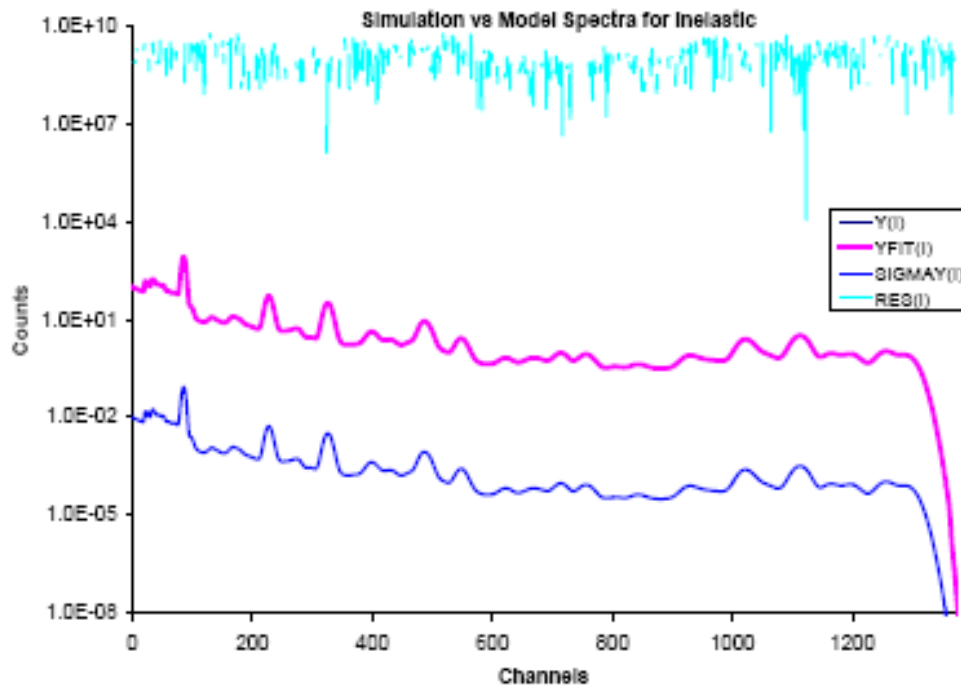

Figure 5- 13: Results showing the SIGMAY(I) and RESDUE for neutron inelastic interaction

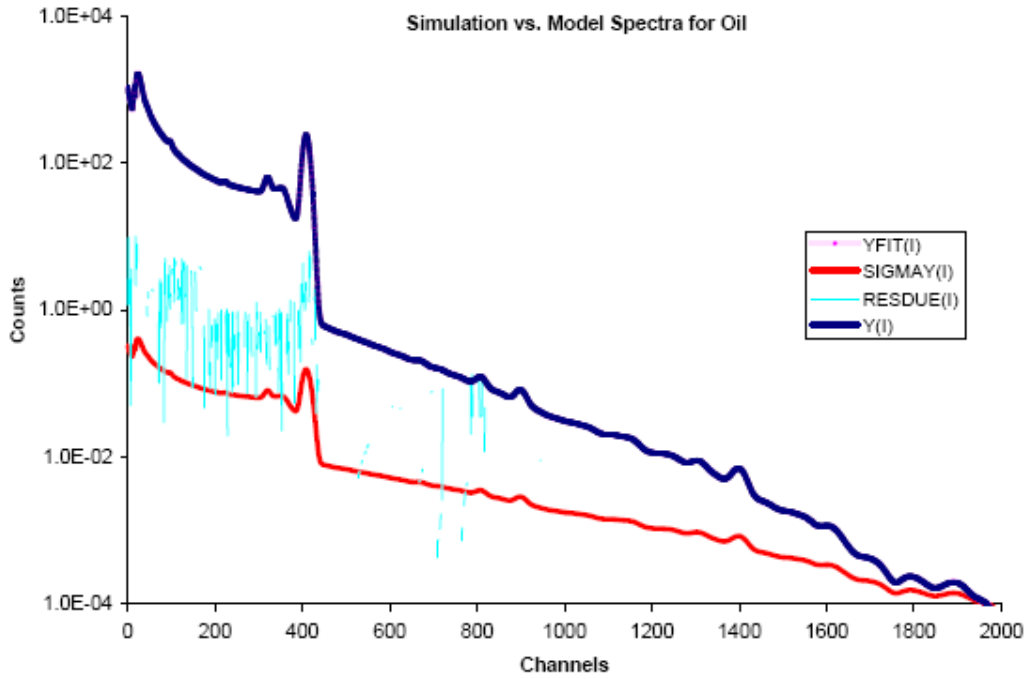

Figure 5- 14: Results showing the Y(I), YFIT (I), SIGMAY(I) and RESDUE from neutron capture for crude oil

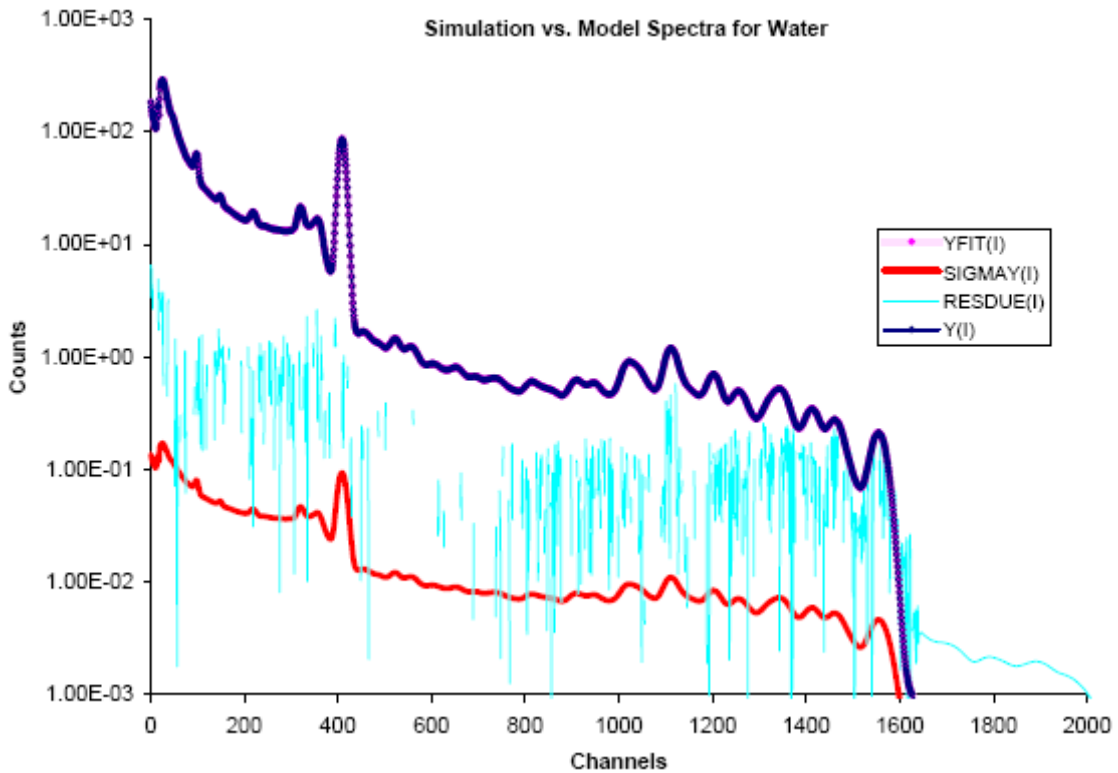

Figure 5- 15: Results showing the Y(I), YFIT (I), SIGMAY(I) and RESDUE from neutron capture for water

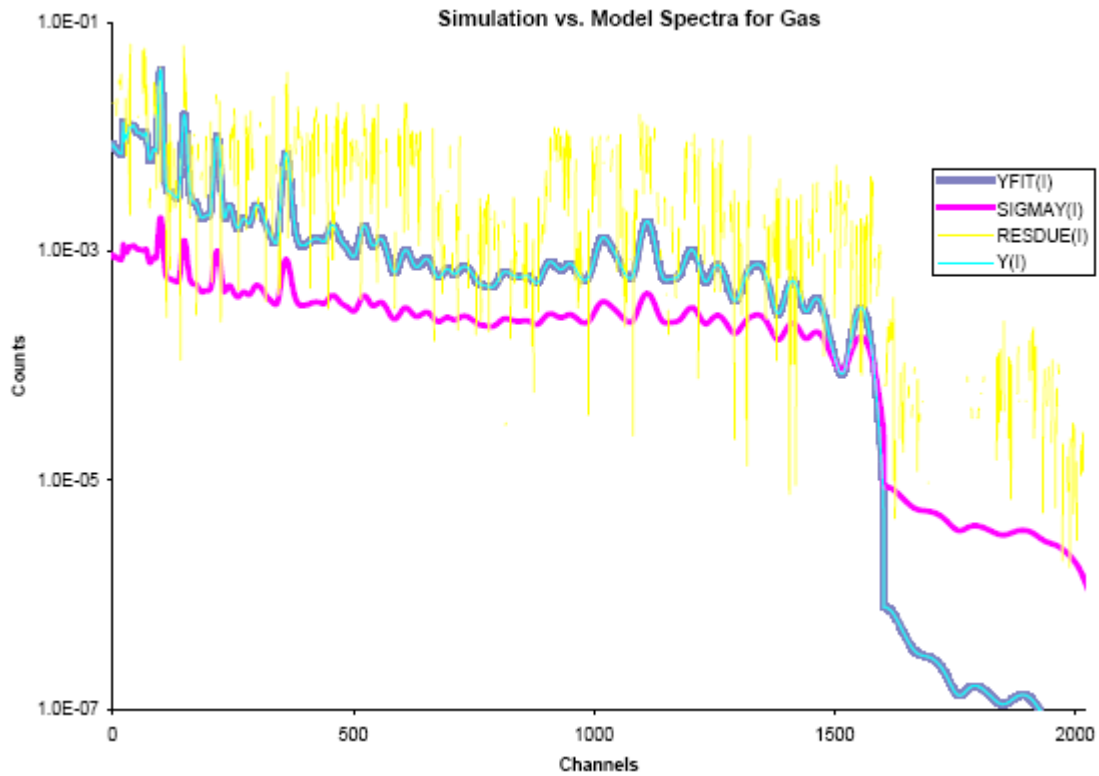

Figure 5- 16: Results showing the Y(I), YFIT (I), SIGMAY(I) and RESDUE from neutron capture for gas.

Table 5- 8: MCLLS quantitative results by fitting the total spectra for oil

Number	Library	Neutron capture for oil		Error(%)
		True weight fraction (%)	Calculated weight fraction (%)	
1	Hydrogen	15.3	15.4	0.25835
2	carbon	84.7	84.5	0.00482
		100	99.9	

Table 5-9: MLLS quantitative results by fitting the total spectra for water

Number	Library	Neutron capture for water		Error (%)
		True weight fraction %	Calculated weight fraction %	
1	Hydrogen	10.854	10.8553	0.023708
2	Oxygen	86.146	85.8451	0.184149
3	Sodium	1.181	1.34262	0.510584
4	Chlorine	1.819	1.81763	0.060947
		100	99.86065	

Table 5-10: MCLLS quantitative results by fitting the total spectra for gas

Number	Library	Neutron capture for gas		Error (%)
		True weight fraction %	Calculated weight fraction %	
1	Hydrogen	1.92	1.84	0.02128
2	Oxygen	30.49	31.23	0.01199
3	Chlorine	67.59	67.53	0.00044
		100	100.6	

Table 5- 11: Results for the standard deviation (Sigma) for oil
For OIL

I	A(I)	SIGMAA(I) %	R(I)	AREA(I) %
1	6.84E-01	4.82E-03	1.00E+00	9.87E+01
2	3.17E-01	2.58E-01	6.95E-01	1.28E+00

CHISQR= 0.159646E+01
The sum of all library areas is: 99.99961 %
MO= 2 SIGY (Y multiplier)= 1.0E-002
NBEGIN= 1 NEND= 2048 SIGMUL= 1.0E-02

Table 5- 12: Results for the standard deviation (Sigma) for water
For Water

I	A(I)	SIGMAA(I) %	R(I)	AREA(I) %
1	1.09E-01	2.37E-02	9.76E-01	6.60E+01
2	8.58E-01	1.84E-01	9.48E-01	1.44E+01
3	1.34E-02	5.11E-01	9.13E-01	4.89E-01
4	1.82E-02	6.09E-02	8.18E-01	1.92E+01

CHISQR= 0.323756E+00
The sum of all library areas is: 99.999675 %
MO= 2 SIGY (Y multiplier)= 1.0E-002
NBEGIN= 1 NEND= 2048 SIGMUL= 1.0E-02

Table 5- 13: Results for the standard deviation (Sigma) for gas
For Gas

I	A(I)	SIGMAA(I)%	R(I)	AREA(I) %
1	1.84E-02	2.12E-02	3.07E-01	3.47E-02
2	5.54E-01	1.20E-02	4.82E-01	2.69E-03
3	6.76E-01	4.40E-04	1.00E+00	1.00E+02

CHISQR= 0.742893E+00
The sum of all library areas is: 99.9994998 %
MO= 2 SIGY (Y multiplier)= 1.0E-002
NBEGIN= 1 NEND= 2048 SIGMUL= 1.0E-02

Table 5- 14: Some definition of the used variables in the analysis

$$\text{RES}(I)=Y(I)-Y\text{FIT}(I)/\text{SIGMAY}(I)$$

Y(I) is the input vector of data points for the dependant variable

SIGMAY(I) is the input vector of standard deviations for the Y data points when available

YFIT(I) is the output vector calculated values of Y with final model or function

CHISQR is the output calculated value of the reduced chi-square value.

The value of SIGMAA are also affected by this CHISQR

5. 4 Discussion and conclusion

The intent of this work was to investigate prompt gamma-ray activation analysis (PGNAA) for determining the phase amounts in multiphase flow. PGNAA technique is a non-destructive method and has been widely used for measuring elemental composition in bulk samples. Because it has advantage of producing high energies (high penetrating) gamma rays, it allows the analysis of large sample volumes. The coal and oil well logging industries are two examples where this technique is applied. In the oil logging industry, the logging tool consists of a fast neutron source and one or more radiation detectors at different spacing from the source.

Further, the process works as the radiation source emitting fast neutrons undergoes collisions with formation elements. This collision emits inelastic gamma rays and subsequently slows down the neutrons. Upon slowing down, the neutrons may be captured and other set of gamma rays may be emitted. Thus the resulting gamma rays before or after the interaction is detected by radiation detectors and the resulting spectra are analyzed to obtain the information or signature of the elemental amounts in the formation. The same

process has been applied in this work and the phase amounts evaluated and analyzed. As shown in Tables 5-4 to 5-5, carbon and oxygen are of particular interest in the simulations. Basically, the most important gamma rays emitted from these elements range from 4.445 to 6.13 MeV whilst gamma rays resulting from capture of thermal neutrons with ranges of 1.6 to 4.8MeV are of lesser important.

With high energies, pair production interaction dominates the interaction of gamma rays. The rays emitted outside the detector can contribute to the lower range of the response spectra. CEARCPG takes care of this effect and makes the simulated elemental library spectra more accurate. This has contributed of the usage of all of information of the measured sample in the MCLLS analysis. Moreover, neutron activation backgrounds are caused by neutron activation in the NaI detector. Gardner et al (2000) has measured three spectra from the gamma-ray spectrum of I and Na, the ^{24}Na decay spectrum and ^{128}I decay spectrum.

As discussed in section 5.3.5, CEARCPG code and MCLLS have proven to be very effective in this simulation and qualitative analysis work. CEARCPG calculates detector response function (DRF) and deals with the prompt gamma-ray transport inside the detector to make use of the detector response functions. As mentioned before, the approach is expected to reduce the tracking time of gamma-ray transports and enhance the precision.

As shown in section 5.3.5, Tables 5-2 and 5.3, the calculated weight fraction of oxygen from neutron capture is larger than the other elements with

53.9445%. This might be caused by extreme high neutron capture cross section. As observed, the calculated weight fraction of all the elements agrees well with the true weight fraction. Since the cross section of neutron inelastic scattering is zero, the component of hydrogen and sulphur can not be determined by using neutron inelastic spectrum. Compared to the simulation results from neutron inelastic spectrum, the results from neutron capture spectra is closer to the real one because of its non interference with the “unknown” spectrum. In general if the “unknown” spectrum is large, the possibility of blowing up the fitting is high.

To surmise this work, PGNA method has identified the phase amounts in seawater through a powerful use of CEARCPG code and MCLLS application. In order to deal with the prompt gamma-ray transport inside the detector, CEARCPG calculates the detector response function (DRF). As mentioned earlier, detector respond function (DRF) is the probability density distribution of the deposited energy of the incident gamma ray.

5. 5 Future work

In order to improve and obtain the most accurate phase amounts in this work, the following is proposed:

- 1) A proposed experimental work is necessary.
- 2) Improve the geometry package further to make sure that the simulated geometry is equivalent to the model geometry for expected greater efficiency.
- 3) The sample to be all inclusive to cater for oil logging.

- 4) The CEARCPG to be modified in order to cater more effectively for the above.

The experiment ought to be set and phase amounts measured in order to account for background spectrum. The results will then be benchmarked with the simulated spectrum in order to check if the results will agree with precision. In this way, the experimental spectrum will be able to predict elemental peak well and also predict the continuous tail at the high energy regions. The background library based on the experiment will take care of the continuous tail.

References

1. Alfassi, Z. B and Chung. C, PROMPT GAMMA NEUTRON ACTIVATION ANALYSIS, CRC Press, Inc., 1995.
2. Arinc, F., Gardner, R. P., Wielopolski, L., and Stiles, A. R. (1975). "Applications of the least-squares method to the analysis of XRF spectral intensities from atmospheric particulates collected on filters." *Advances in X-ray Analysis*, 19, pp. 367-380.
3. Borsaru, M., Biggs, Nichol, W. Bos F. 2001. THE APPLICATION OF PROMPT GAMMA NEUTRON ACTIVATION ANALYSIS TO BOREHOLE LOGGING FOR COAL, *Applied Radiation and Isotopes* 54(2001)335-343.
4. C.M. Shyu, R.P. Gardner, K. Verghese. *Nuclear Geophys.* 7 (2) 1993 241.
5. Clark, T. C., Gardner, R. P., and Verghese, K., 1982. A Monte Carlo Model for In-Situ Prompt Gamma-Ray Analysis Probs, *Nucl. Instru. Methods*, 193, 365, (1982).
6. Crowe, C. T., and R. Johnson, NUMERICAL METHODS IN MULTIPHASE FLOWS 1994, FED-Vol. 185, The American Society of Mechanical Engineers, USA.
7. Database for Prompt Gamma-ray Neutron Activation Analysis, <http://www-nds.iaea.org/pgaa/>
8. Brookhaven National Laboratory, Evaluated Nuclear Structure Data File (ENSDF) <http://www.nndc.bnl.gov/ensdf/> (2005).
9. G.A. Johansen and P. Jackson, RADIOISOTOPE GAUGES FOR INDUSTRIAL PROCESS MEASUREMENTS, John Wiley & Sons, Ltd., West Sussex, England, 2004.
10. Gardner, R. P., 2002. A Monte Carlo Simulation Approach for Generating NaI Detector Response Functions (DRF's) that Accounts for Nonlinearity and Variable Flat Continua, A Report to Sabia, Inc, North Carolina State University.
11. Gardner, R. P., and Mayo, C. W., 1999, NaI DETECTOR NONLINEARITY FOR PGNA APPLICATIONS, *Applied Radiation and Isotopes*, 51 (1999) 189-195.

12. Gardner, R.P. and R.L. Ely, Jr., 1967, RADIOISOTOPE MEASUREMENT APPLICATIONS IN ENGINEERING, Reinhold Publishing Corporation, New York.
13. Heydorn, K., NEUTRON ACTIVATION ANALYSIS FOR CLINICAL TRACE ELEMENT RESEARCH, Volume 1, CRC Press, Inc., 1984.
14. Hoste, J, R. Gijbels, and D. De Soete, NEUTRON ACTIVATION ANALYSIS, John Wiley & Sons, Ltd., West Sussex, England, 1972.
15. Hughes, D., I. Celk, C. Crowe and D Lankford, 1990, NUMERICAL METHODS FOR MULTIPHASE FLOWS, FED-Vol. 91, The American Society of Mechanical Engineers, USA.
16. IAEA Database for Prompt Gamma-ray Neutron Activation Analysis, <http://www-nds.iaea.org/pgaa> (2005).
17. K.E. Stephenson, J. W. J. Ferguson, B. Fitzgerald, A. R. H. Goodwin, G.H. Meeten, and S. E Pelham, FLOW METER FOR MULTIPHASE-PHASE MIXTURES, UK Patent GB2351810B, 2001.
18. Knoll, G.F., 2000, RADIATION DETECTION AND MEASUREMENT, 3rd Edition John Wiley & Sons, New York.
19. L'Annunziata, M. F., HANDBOOK OF RADIOACTIVITY ANALYSIS, Academic Press, San Diego, California, 1998.
20. Lamarsh, J. R and A. J. Baratta, INTRODUCTION TO NUCLEAR ENGINEERING, Third Edition, Prentice-Hall, Inc., New Jersey 2001.
21. M. B. Holstand and G. A. Johansen, PRODUCED WATER CHARACTERIZATION BY DUAL MODALITY GAMMA-RAY MEASUREMENTS, Measurement Science Technology 16(2005)1007-1013, IOP Publishing Ltd, UK.
22. M. Mickael, Robin P. Gardner and K. Verghese, McDNL: A new Specific Purpose Monte Carlo Code for Simulation of Dual Spaced Neutron Porosity Logd. SPWLA 29th Annual logging Symposium, San Antonio, TX, June 1988.
23. Marie Bueie Holstand PhD Dissertation, University of Bergen, Noway 2004.

24. Marshall III, J. H., and Zumberge, J.F., 1989. On-line Measurements of Bulk Coal Using Prompt Gamma Neutron Activation Analysis, Nucl. Geophys, 3(4), 445.
25. Molnar, G.L., Rólyay, Zs., Veres, A., Simonits, A., Rausch, H., 1993. Cold neutron facility for prompt gamma neutron activation analysis. J. Radioanal. Nucl. Chem. 167, 133-137.
26. P. Ember, T. Belgya, J. L. Weil and G. L. Molnar, Coincidence measurement setup for PGAA and nuclear structure studies, Applied Radiation and Isotopes, Volume 57, Issue 4, October 2002, Pages 573-577.
27. P. P. Ember, T. Belgya and G. L. Molnar, Improvement of the capabilities of PGAA by coincidence techniques, Applied Radiation and Isotopes, Volume 56, Issue 3, March 2002, Pages 535-541.
28. P.P. Ember , T. Belgya, J.L Weil, G.L. Molnar, Coincidence measurement setup for PGAA and nuclear structure studies. Applied Radiation and Isotopes 57 (2002) 573-577.
29. Power, H. and C.A. Brebbia, COMPUTATIONAL METHODS IN MULTIPHASE FLOW, WITPRESS Southampton, Boston 2001.
30. Price, W.J., 1958, NUCLEAR RADIATION DETECTION, McGraw-Hill Book Company, Inc., New York.
31. R. P. Gardner, C. W. Mayo, E. S. El-Sayyed, W. A. Metwally, Y. Zheng and M. Poertz, A feasibility study of a coincidence counting approach for PGAA applications, Applied Radiation and Isotopes, Volume 53, Issues 4-5, 15 November 2000, Pages 515-526.
32. R.P. Gardner, A. Sood, Y. Y. Wang, L. Liu, P. Guo, and R. J. Cehrek, Single Peak Versus Library Least-Squares Analysis Method for PGAA Analysis of Vitrified Waste. Appl. Radiat. Isot. Vol. 48, No. 10-12, pp. 1331-1335, 1997.
33. R.P. Gardner. A Report on the Contract: Software Design for a PGAA Coal Analyzer Prototype, North Carolina State University. 2000 Radioisotopes, Department of Nuclear Engineering, North Carolina State University.
34. Robin P. Gardner, A Monte Carlo Simulation Approach for Generating NaI Detector Response Function(DRF's) that Accounts for Nonlinearity and Variable Flat Continua. A report to Sabia. Inc. North Carolina State University 2002.

35. Robin P. Gardner, El Sayyed, Yuanshui Zheng, Stephanie Hayden and Charles W. Mayo, NaI detector neutron activation spectra for PGNAA applications, Applied Radiation and Isotopes, Volume 53, Issues 4-5, 15 November 2000, Pages 483-497.
36. Shyu C. M., Gardner R. P. and Verghese K. (1993) Development of the Monte Carlo library least-squares method of analysis for neutron capture prompt gamma-ray analyzers. Nuclear Geophysics 7(2), 241-268.
37. Shyu, C.M., He, T., Verghese, K. and Gardner, R.P. (1988) Monte Carlo-library least-squares principle for nuclear analyzers. Transactions of the American Nuclear Society, Suppl. 3, 56, 4446.
38. V. V. Verbinski, Hans Weber, and R. E. Sund, Prompt Gamma Rays from $^{236}\text{U}(n,f)$, $^{239}\text{Pu}(n,f)$, and spontaneous fission of ^{252}Cf . Physics Review C, Volume 7, number 3, March 1973.
39. Vourvopolulos, G., 1994, NEUTRON AND THEIR APPLICATION, The International Society for Optical Engineering, Volume 23339, Crete, Greece, 1994.
40. W. A. Metwally, R. P. Gardner and C. W. Mayo, Two-dimensional diagonal summing of coincidence spectra for bulk PGNAA applications, Nuclear Walid A. Metwally, Robin P. Gardner, Charles W. Mayo, Elemental PGNAA analysis using gamma-gamma coincidence counting with the library least-squares approach, Nucl. Instru. Methods, B, In press, 2004.
41. Walid A. Metwally, Ph.D thesis, North Carolina State University, 2003.
42. Walid A. Metwally, Robin P. Gardner and Charles W. Mayo, Elemental PGNAA analysis using gamma-gamma coincidence counting with the library least-squares approach, Nuclear Instruments and Methods in Physics Research Section B: Beam Interactions with Materials and Atoms, Volume 213, January 2004, Pages 394-399.
43. Walid A. Metwally, Robin. P. Gardner, Charles W. Mayo. Elemental PGNAA analysis using gamma-gamma coincidence counting with the library least-squares approach. Nuclear Instrument and Methods in Physics Research B 213 (2004) 394-399.
44. Weijun Guo, Ph.D thesis, North Carolina State University. 2004.
45. Wenchao Zhang, Robin P. Gardner. The analog linear interpolation approach for Monte Carlo simulation of PGNAA: The CEARPGA code.

Nuclear Instruments and Methods in physics Research B. 213 (2004)
116-123.

46. Wenchao Zhang, The analog Linear Interpolation Approach for Monte Carlo Simulation of Prompt Gamma-Ray Neutron Activation Analysis, Ph.D Thesis, North Carolina State University, 2003.

47. Xiaogang Han PhD Thesis, North Carolina State University, 2005.

Appendix A

Data with added Background for Inelastic and Capture Interaction

<i>Ch</i>	<i>Added B</i> <i>Inelastic</i>	<i>Added B</i> <i>Capture</i>	<i>Ch</i>	<i>Added B</i> <i>Inelastic</i>	<i>Added B</i> <i>Capture</i>	<i>Ch</i>	<i>Added B</i> <i>Inelastic</i>	<i>Added B</i> <i>Capture</i>
1	1.31E-06	3.90E-06	691	7.13E-09	1.40E-08	1381	5.76E-11	4.43E-09
2	1.21E-06	3.50E-06	692	7.14E-09	1.40E-08	1382	5.86E-11	4.39E-09
3	1.18E-06	3.24E-06	693	7.17E-09	1.40E-08	1383	5.95E-11	4.37E-09
4	1.12E-06	3.02E-06	694	7.22E-09	1.40E-08	1384	6.06E-11	4.37E-09
5	1.10E-06	2.86E-06	695	7.30E-09	1.40E-08	1385	6.13E-11	4.40E-09
6	1.09E-06	2.74E-06	696	7.41E-09	1.39E-08	1386	6.24E-11	4.43E-09
7	1.06E-06	2.61E-06	697	7.55E-09	1.39E-08	1387	6.34E-11	4.49E-09
8	1.04E-06	2.47E-06	698	7.71E-09	1.39E-08	1388	6.43E-11	4.57E-09
9	1.00E-06	2.33E-06	699	7.92E-09	1.38E-08	1389	6.53E-11	4.67E-09
10	9.89E-07	2.23E-06	700	8.14E-09	1.37E-08	1390	6.60E-11	4.78E-09
11	9.85E-07	2.18E-06	701	8.38E-09	1.36E-08	1391	6.68E-11	4.91E-09
12	9.89E-07	2.22E-06	702	8.64E-09	1.36E-08	1392	6.74E-11	5.05E-09
13	1.01E-06	2.42E-06	703	8.91E-09	1.35E-08	1393	6.82E-11	5.20E-09
14	1.02E-06	2.78E-06	704	9.19E-09	1.34E-08	1394	6.88E-11	5.37E-09
15	1.03E-06	3.27E-06	705	9.46E-09	1.33E-08	1395	6.90E-11	5.54E-09
16	1.04E-06	3.76E-06	706	9.75E-09	1.32E-08	1396	6.94E-11	5.72E-09
17	1.00E-06	3.59E-06	707	1.00E-08	1.31E-08	1397	6.95E-11	5.91E-09
18	9.29E-07	3.00E-06	708	1.03E-08	1.31E-08	1398	6.97E-11	6.10E-09
19	1.06E-06	4.27E-06	709	1.05E-08	1.30E-08	1399	6.95E-11	6.29E-09
20	1.49E-06	5.35E-06	710	1.07E-08	1.30E-08	1400	6.94E-11	6.48E-09
21	1.90E-06	5.81E-06	711	1.08E-08	1.28E-08	1401	6.91E-11	6.67E-09
22	1.62E-06	6.10E-06	712	1.09E-08	1.29E-08	1402	6.85E-11	6.86E-09
23	1.49E-06	6.28E-06	713	1.10E-08	1.28E-08	1403	6.79E-11	7.03E-09
24	1.64E-06	6.37E-06	714	1.10E-08	1.28E-08	1404	6.73E-11	7.20E-09
25	1.82E-06	6.37E-06	715	1.10E-08	1.28E-08	1405	6.63E-11	7.35E-09
26	1.85E-06	6.32E-06	716	1.09E-08	1.29E-08	1406	6.53E-11	7.49E-09
27	1.65E-06	6.23E-06	717	1.08E-08	1.29E-08	1407	6.43E-11	7.61E-09
28	1.44E-06	6.04E-06	718	1.06E-08	1.30E-08	1408	6.31E-11	7.71E-09
29	1.36E-06	5.76E-06	719	1.04E-08	1.30E-08	1409	6.19E-11	7.80E-09
30	1.43E-06	5.45E-06	720	1.01E-08	1.31E-08	1410	6.06E-11	7.87E-09
31	1.60E-06	5.16E-06	721	9.87E-09	1.32E-08	1411	5.92E-11	7.92E-09
32	1.78E-06	4.89E-06	722	9.58E-09	1.32E-08	1412	5.76E-11	7.94E-09
33	1.93E-06	4.64E-06	723	9.28E-09	1.33E-08	1413	5.61E-11	7.94E-09
34	1.98E-06	4.41E-06	724	8.95E-09	1.34E-08	1414	5.45E-11	7.91E-09
35	1.97E-06	4.20E-06	725	8.64E-09	1.33E-08	1415	5.29E-11	7.87E-09
36	1.87E-06	3.97E-06	726	8.34E-09	1.34E-08	1416	5.13E-11	7.81E-09
37	1.70E-06	3.76E-06	727	8.04E-09	1.35E-08	1417	4.99E-11	7.72E-09
38	1.55E-06	3.57E-06	728	7.77E-09	1.35E-08	1418	4.83E-11	7.62E-09
39	1.45E-06	3.43E-06	729	7.53E-09	1.36E-08	1419	4.67E-11	7.49E-09
40	1.38E-06	3.29E-06	730	7.31E-09	1.36E-08	1420	4.54E-11	7.35E-09
41	1.35E-06	3.16E-06	731	7.13E-09	1.37E-08	1421	4.37E-11	7.19E-09
42	1.37E-06	3.04E-06	732	6.98E-09	1.37E-08	1422	4.24E-11	7.02E-09
43	1.40E-06	2.92E-06	733	6.88E-09	1.37E-08	1423	4.09E-11	6.84E-09
44	1.40E-06	2.83E-06	734	6.81E-09	1.38E-08	1424	3.97E-11	6.65E-09

45	1.36E-06	2.75E-06	735	6.77E-09	1.37E-08	1425	3.85E-11	6.46E-09
46	1.29E-06	2.65E-06	736	6.78E-09	1.37E-08	1426	3.72E-11	6.26E-09
47	1.24E-06	2.57E-06	737	6.83E-09	1.37E-08	1427	3.61E-11	6.06E-09
48	1.23E-06	2.48E-06	738	6.90E-09	1.37E-08	1428	3.51E-11	5.86E-09
49	1.24E-06	2.39E-06	739	7.01E-09	1.37E-08	1429	3.40E-11	5.65E-09
50	1.26E-06	2.32E-06	740	7.16E-09	1.36E-08	1430	3.32E-11	5.46E-09
51	1.27E-06	2.25E-06	741	7.33E-09	1.36E-08	1431	3.24E-11	5.27E-09
52	1.24E-06	2.18E-06	742	7.52E-09	1.35E-08	1432	3.16E-11	5.09E-09
53	1.17E-06	2.12E-06	743	7.73E-09	1.35E-08	1433	3.10E-11	4.93E-09
54	1.08E-06	2.06E-06	744	7.93E-09	1.34E-08	1434	3.03E-11	4.77E-09
55	9.78E-07	2.00E-06	745	8.16E-09	1.33E-08	1435	2.98E-11	4.62E-09
56	9.09E-07	1.93E-06	746	8.38E-09	1.32E-08	1436	2.93E-11	4.49E-09
57	8.77E-07	1.88E-06	747	8.60E-09	1.31E-08	1437	2.88E-11	4.38E-09
58	8.74E-07	1.84E-06	748	8.82E-09	1.30E-08	1438	2.84E-11	4.28E-09
59	8.83E-07	1.79E-06	749	9.02E-09	1.29E-08	1439	2.79E-11	4.19E-09
60	8.89E-07	1.75E-06	750	9.21E-09	1.28E-08	1440	2.75E-11	4.12E-09
61	8.82E-07	1.71E-06	751	9.37E-09	1.26E-08	1441	2.73E-11	4.06E-09
62	8.59E-07	1.66E-06	752	9.51E-09	1.24E-08	1442	2.70E-11	4.01E-09
63	8.28E-07	1.62E-06	753	9.62E-09	1.23E-08	1443	2.68E-11	3.98E-09
64	7.97E-07	1.58E-06	754	9.70E-09	1.22E-08	1444	2.66E-11	3.96E-09
65	7.76E-07	1.54E-06	755	9.75E-09	1.21E-08	1445	2.64E-11	3.96E-09
66	7.68E-07	1.50E-06	756	9.76E-09	1.19E-08	1446	2.61E-11	3.96E-09
67	7.72E-07	1.46E-06	757	9.74E-09	1.18E-08	1447	2.60E-11	3.97E-09
68	7.82E-07	1.43E-06	758	9.68E-09	1.17E-08	1448	2.59E-11	3.99E-09
69	7.89E-07	1.39E-06	759	9.59E-09	1.16E-08	1449	2.58E-11	4.02E-09
70	7.87E-07	1.35E-06	760	9.46E-09	1.15E-08	1450	2.55E-11	4.05E-09
71	7.77E-07	1.32E-06	761	9.30E-09	1.14E-08	1451	2.54E-11	4.08E-09
72	7.61E-07	1.29E-06	762	9.11E-09	1.13E-08	1452	2.51E-11	4.12E-09
73	7.40E-07	1.26E-06	763	8.90E-09	1.12E-08	1453	2.50E-11	4.16E-09
74	7.18E-07	1.23E-06	764	8.66E-09	1.11E-08	1454	2.50E-11	4.19E-09
75	7.04E-07	1.20E-06	765	8.41E-09	1.11E-08	1455	2.48E-11	4.21E-09
76	7.14E-07	1.18E-06	766	8.14E-09	1.10E-08	1456	2.48E-11	4.24E-09
77	7.86E-07	1.15E-06	767	7.87E-09	1.09E-08	1457	2.46E-11	4.27E-09
78	9.97E-07	1.13E-06	768	7.57E-09	1.09E-08	1458	2.43E-11	4.28E-09
79	1.46E-06	1.12E-06	769	7.30E-09	1.08E-08	1459	2.43E-11	4.29E-09
80	2.30E-06	1.10E-06	770	7.01E-09	1.08E-08	1460	2.41E-11	4.30E-09
81	3.53E-06	1.08E-06	771	6.73E-09	1.07E-08	1461	2.39E-11	4.29E-09
82	5.03E-06	1.06E-06	772	6.45E-09	1.07E-08	1462	2.39E-11	4.28E-09
83	6.55E-06	1.05E-06	773	6.19E-09	1.06E-08	1463	2.38E-11	4.26E-09
84	7.78E-06	1.03E-06	774	5.95E-09	1.06E-08	1464	2.35E-11	4.23E-09
85	8.46E-06	1.01E-06	775	5.72E-09	1.06E-08	1465	2.33E-11	4.19E-09
86	8.42E-06	9.92E-07	776	5.50E-09	1.05E-08	1466	2.31E-11	4.14E-09
87	7.63E-06	9.76E-07	777	5.31E-09	1.05E-08	1467	2.31E-11	4.08E-09
88	6.25E-06	9.61E-07	778	5.13E-09	1.05E-08	1468	2.29E-11	4.01E-09
89	4.63E-06	9.51E-07	779	4.97E-09	1.04E-08	1469	2.27E-11	3.94E-09
90	3.11E-06	9.46E-07	780	4.83E-09	1.04E-08	1470	2.25E-11	3.86E-09
91	1.92E-06	9.51E-07	781	4.71E-09	1.04E-08	1471	2.23E-11	3.78E-09
92	1.14E-06	9.70E-07	782	4.60E-09	1.04E-08	1472	2.21E-11	3.69E-09
93	6.88E-07	1.00E-06	783	4.52E-09	1.04E-08	1473	2.19E-11	3.59E-09
94	4.73E-07	1.05E-06	784	4.46E-09	1.04E-08	1474	2.18E-11	3.49E-09

95	3.92E-07	1.10E-06	785	4.39E-09	1.04E-08	1475	2.16E-11	3.39E-09
96	3.73E-07	1.15E-06	786	4.36E-09	1.04E-08	1476	2.14E-11	3.28E-09
97	3.73E-07	1.18E-06	787	4.33E-09	1.04E-08	1477	2.12E-11	3.18E-09
98	3.71E-07	1.20E-06	788	4.31E-09	1.04E-08	1478	2.11E-11	3.07E-09
99	3.59E-07	1.18E-06	789	4.31E-09	1.05E-08	1479	2.09E-11	2.96E-09
100	3.37E-07	1.13E-06	790	4.31E-09	1.05E-08	1480	2.06E-11	2.86E-09
101	3.08E-07	1.05E-06	791	4.33E-09	1.06E-08	1481	2.05E-11	2.75E-09
102	2.77E-07	9.65E-07	792	4.34E-09	1.06E-08	1482	2.03E-11	2.65E-09
103	2.49E-07	8.79E-07	793	4.37E-09	1.07E-08	1483	2.02E-11	2.55E-09
104	2.26E-07	8.04E-07	794	4.39E-09	1.08E-08	1484	2.01E-11	2.45E-09
105	2.08E-07	7.44E-07	795	4.43E-09	1.10E-08	1485	1.99E-11	2.36E-09
106	1.97E-07	7.01E-07	796	4.46E-09	1.11E-08	1486	1.98E-11	2.27E-09
107	1.89E-07	6.71E-07	797	4.50E-09	1.13E-08	1487	1.97E-11	2.18E-09
108	1.83E-07	6.50E-07	798	4.52E-09	1.14E-08	1488	1.96E-11	2.10E-09
109	1.78E-07	6.35E-07	799	4.56E-09	1.16E-08	1489	1.95E-11	2.02E-09
110	1.75E-07	6.23E-07	800	4.59E-09	1.17E-08	1490	1.94E-11	1.94E-09
111	1.72E-07	6.12E-07	801	4.62E-09	1.19E-08	1491	1.92E-11	1.87E-09
112	1.70E-07	6.03E-07	802	4.63E-09	1.20E-08	1492	1.91E-11	1.80E-09
113	1.68E-07	5.96E-07	803	4.66E-09	1.22E-08	1493	1.89E-11	1.74E-09
114	1.66E-07	5.88E-07	804	4.66E-09	1.24E-08	1494	1.89E-11	1.68E-09
115	1.64E-07	5.81E-07	805	4.67E-09	1.25E-08	1495	1.88E-11	1.62E-09
116	1.62E-07	5.74E-07	806	4.67E-09	1.27E-08	1496	1.87E-11	1.57E-09
117	1.61E-07	5.68E-07	807	4.66E-09	1.29E-08	1497	1.87E-11	1.51E-09
118	1.59E-07	5.62E-07	808	4.65E-09	1.30E-08	1498	1.86E-11	1.47E-09
119	1.59E-07	5.56E-07	809	4.64E-09	1.31E-08	1499	1.86E-11	1.42E-09
120	1.59E-07	5.49E-07	810	4.62E-09	1.32E-08	1500	1.85E-11	1.38E-09
121	1.59E-07	5.44E-07	811	4.59E-09	1.33E-08	1501	1.84E-11	1.34E-09
122	1.59E-07	5.37E-07	812	4.56E-09	1.34E-08	1502	1.84E-11	1.30E-09
123	1.61E-07	5.30E-07	813	4.53E-09	1.35E-08	1503	1.84E-11	1.27E-09
124	1.62E-07	5.24E-07	814	4.50E-09	1.35E-08	1504	1.84E-11	1.23E-09
125	1.64E-07	5.18E-07	815	4.46E-09	1.34E-08	1505	1.83E-11	1.20E-09
126	1.67E-07	5.12E-07	816	4.43E-09	1.34E-08	1506	1.83E-11	1.18E-09
127	1.70E-07	5.06E-07	817	4.40E-09	1.34E-08	1507	1.83E-11	1.15E-09
128	1.74E-07	5.01E-07	818	4.37E-09	1.34E-08	1508	1.83E-11	1.13E-09
129	1.78E-07	4.95E-07	819	4.34E-09	1.34E-08	1509	1.81E-11	1.11E-09
130	1.82E-07	4.91E-07	820	4.33E-09	1.34E-08	1510	1.81E-11	1.09E-09
131	1.84E-07	4.85E-07	821	4.31E-09	1.32E-08	1511	1.81E-11	1.07E-09
132	1.85E-07	4.80E-07	822	4.31E-09	1.32E-08	1512	1.80E-11	1.06E-09
133	1.85E-07	4.76E-07	823	4.31E-09	1.31E-08	1513	1.80E-11	1.05E-09
134	1.83E-07	4.71E-07	824	4.32E-09	1.30E-08	1514	1.80E-11	1.04E-09
135	1.80E-07	4.66E-07	825	4.34E-09	1.30E-08	1515	1.79E-11	1.04E-09
136	1.76E-07	4.61E-07	826	4.35E-09	1.29E-08	1516	1.79E-11	1.04E-09
137	1.73E-07	4.58E-07	827	4.39E-09	1.27E-08	1517	1.78E-11	1.05E-09
138	1.68E-07	4.54E-07	828	4.41E-09	1.27E-08	1518	1.78E-11	1.06E-09
139	1.66E-07	4.52E-07	829	4.46E-09	1.26E-08	1519	1.77E-11	1.07E-09
140	1.63E-07	4.51E-07	830	4.50E-09	1.25E-08	1520	1.77E-11	1.09E-09
141	1.60E-07	4.53E-07	831	4.55E-09	1.25E-08	1521	1.76E-11	1.12E-09
142	1.58E-07	4.56E-07	832	4.60E-09	1.24E-08	1522	1.76E-11	1.15E-09
143	1.55E-07	4.62E-07	833	4.66E-09	1.24E-08	1523	1.74E-11	1.18E-09
144	1.53E-07	4.70E-07	834	4.71E-09	1.23E-08	1524	1.73E-11	1.22E-09

145	1.50E-07	4.79E-07	835	4.76E-09	1.23E-08	1525	1.73E-11	1.27E-09
146	1.48E-07	4.87E-07	836	4.81E-09	1.22E-08	1526	1.72E-11	1.32E-09
147	1.46E-07	4.94E-07	837	4.85E-09	1.22E-08	1527	1.71E-11	1.37E-09
148	1.44E-07	4.97E-07	838	4.89E-09	1.21E-08	1528	1.71E-11	1.44E-09
149	1.42E-07	4.94E-07	839	4.92E-09	1.21E-08	1529	1.69E-11	1.50E-09
150	1.40E-07	4.86E-07	840	4.94E-09	1.19E-08	1530	1.69E-11	1.58E-09
151	1.39E-07	4.74E-07	841	4.95E-09	1.19E-08	1531	1.68E-11	1.66E-09
152	1.38E-07	4.57E-07	842	4.96E-09	1.18E-08	1532	1.67E-11	1.74E-09
153	1.37E-07	4.40E-07	843	4.97E-09	1.18E-08	1533	1.67E-11	1.83E-09
154	1.37E-07	4.22E-07	844	4.96E-09	1.17E-08	1534	1.66E-11	1.92E-09
155	1.37E-07	4.06E-07	845	4.94E-09	1.17E-08	1535	1.65E-11	2.02E-09
156	1.38E-07	3.92E-07	846	4.92E-09	1.16E-08	1536	1.65E-11	2.12E-09
157	1.40E-07	3.80E-07	847	4.89E-09	1.16E-08	1537	1.64E-11	2.22E-09
158	1.42E-07	3.72E-07	848	4.85E-09	1.16E-08	1538	1.63E-11	2.32E-09
159	1.45E-07	3.65E-07	849	4.81E-09	1.15E-08	1539	1.63E-11	2.42E-09
160	1.48E-07	3.60E-07	850	4.76E-09	1.15E-08	1540	1.62E-11	2.52E-09
161	1.53E-07	3.56E-07	851	4.71E-09	1.15E-08	1541	1.61E-11	2.63E-09
162	1.57E-07	3.52E-07	852	4.65E-09	1.14E-08	1542	1.61E-11	2.73E-09
163	1.62E-07	3.50E-07	853	4.60E-09	1.14E-08	1543	1.60E-11	2.82E-09
164	1.67E-07	3.48E-07	854	4.55E-09	1.13E-08	1544	1.58E-11	2.92E-09
165	1.70E-07	3.45E-07	855	4.48E-09	1.13E-08	1545	1.57E-11	3.00E-09
166	1.72E-07	3.43E-07	856	4.43E-09	1.13E-08	1546	1.56E-11	3.09E-09
167	1.74E-07	3.41E-07	857	4.36E-09	1.12E-08	1547	1.55E-11	3.16E-09
168	1.75E-07	3.39E-07	858	4.31E-09	1.12E-08	1548	1.55E-11	3.23E-09
169	1.73E-07	3.36E-07	859	4.26E-09	1.11E-08	1549	1.54E-11	3.29E-09
170	1.72E-07	3.34E-07	860	4.20E-09	1.11E-08	1550	1.53E-11	3.34E-09
171	1.70E-07	3.32E-07	861	4.15E-09	1.10E-08	1551	1.51E-11	3.38E-09
172	1.67E-07	3.29E-07	862	4.11E-09	1.09E-08	1552	1.50E-11	3.40E-09
173	1.66E-07	3.27E-07	863	4.07E-09	1.09E-08	1553	1.49E-11	3.42E-09
174	1.64E-07	3.25E-07	864	4.02E-09	1.08E-08	1554	1.48E-11	3.43E-09
175	1.61E-07	3.22E-07	865	3.99E-09	1.07E-08	1555	1.47E-11	3.43E-09
176	1.59E-07	3.20E-07	866	3.95E-09	1.06E-08	1556	1.46E-11	3.42E-09
177	1.56E-07	3.17E-07	867	3.92E-09	1.05E-08	1557	1.43E-11	3.40E-09
178	1.53E-07	3.14E-07	868	3.88E-09	1.05E-08	1558	1.42E-11	3.36E-09
179	1.50E-07	3.11E-07	869	3.86E-09	1.04E-08	1559	1.41E-11	3.32E-09
180	1.47E-07	3.09E-07	870	3.83E-09	1.03E-08	1560	1.39E-11	3.26E-09
181	1.44E-07	3.07E-07	871	3.81E-09	1.02E-08	1561	1.38E-11	3.19E-09
182	1.40E-07	3.03E-07	872	3.79E-09	1.02E-08	1562	1.37E-11	3.12E-09
183	1.36E-07	3.01E-07	873	3.78E-09	1.01E-08	1563	1.35E-11	3.04E-09
184	1.32E-07	2.99E-07	874	3.77E-09	1.01E-08	1564	1.34E-11	2.95E-09
185	1.28E-07	2.96E-07	875	3.75E-09	1.00E-08	1565	1.33E-11	2.85E-09
186	1.24E-07	2.94E-07	876	3.74E-09	1.00E-08	1566	1.31E-11	2.74E-09
187	1.21E-07	2.92E-07	877	3.74E-09	9.99E-09	1567	1.30E-11	2.63E-09
188	1.18E-07	2.90E-07	878	3.74E-09	9.99E-09	1568	1.28E-11	2.52E-09
189	1.16E-07	2.88E-07	879	3.73E-09	1.00E-08	1569	1.27E-11	2.40E-09
190	1.14E-07	2.87E-07	880	3.73E-09	1.00E-08	1570	1.25E-11	2.28E-09
191	1.13E-07	2.84E-07	881	3.73E-09	1.01E-08	1571	1.23E-11	2.16E-09
192	1.11E-07	2.83E-07	882	3.74E-09	1.01E-08	1572	1.22E-11	2.04E-09
193	1.10E-07	2.80E-07	883	3.74E-09	1.02E-08	1573	1.21E-11	1.92E-09
194	1.09E-07	2.79E-07	884	3.74E-09	1.03E-08	1574	1.20E-11	1.80E-09

195	1.08E-07	2.77E-07	885	3.76E-09	1.04E-08	1575	1.19E-11	1.68E-09
196	1.06E-07	2.75E-07	886	3.76E-09	1.06E-08	1576	1.18E-11	1.56E-09
197	1.05E-07	2.74E-07	887	3.77E-09	1.07E-08	1577	1.17E-11	1.45E-09
198	1.04E-07	2.72E-07	888	3.78E-09	1.09E-08	1578	1.17E-11	1.34E-09
199	1.02E-07	2.70E-07	889	3.79E-09	1.11E-08	1579	1.16E-11	1.24E-09
200	1.01E-07	2.69E-07	890	3.82E-09	1.13E-08	1580	1.15E-11	1.14E-09
201	9.92E-08	2.68E-07	891	3.83E-09	1.15E-08	1581	1.15E-11	1.04E-09
202	9.78E-08	2.66E-07	892	3.86E-09	1.18E-08	1582	1.14E-11	9.49E-10
203	9.64E-08	2.65E-07	893	3.88E-09	1.20E-08	1583	1.15E-11	8.63E-10
204	9.52E-08	2.65E-07	894	3.91E-09	1.22E-08	1584	1.15E-11	7.82E-10
205	9.41E-08	2.65E-07	895	3.94E-09	1.25E-08	1585	1.15E-11	7.07E-10
206	9.31E-08	2.67E-07	896	3.99E-09	1.27E-08	1586	1.13E-11	6.36E-10
207	9.22E-08	2.69E-07	897	4.03E-09	1.30E-08	1587	1.13E-11	5.71E-10
208	9.14E-08	2.73E-07	898	4.08E-09	1.32E-08	1588	1.13E-11	5.10E-10
209	9.13E-08	2.79E-07	899	4.14E-09	1.35E-08	1589	1.13E-11	4.55E-10
210	9.15E-08	2.84E-07	900	4.21E-09	1.37E-08	1590	1.13E-11	4.05E-10
211	9.25E-08	2.92E-07	901	4.29E-09	1.39E-08	1591	1.13E-11	3.59E-10
212	9.49E-08	3.01E-07	902	4.37E-09	1.41E-08	1592	1.13E-11	3.17E-10
213	9.92E-08	3.10E-07	903	4.47E-09	1.43E-08	1593	1.15E-11	2.79E-10
214	1.06E-07	3.18E-07	904	4.57E-09	1.44E-08	1594	1.15E-11	2.45E-10
215	1.18E-07	3.24E-07	905	4.70E-09	1.46E-08	1595	1.15E-11	2.15E-10
216	1.34E-07	3.30E-07	906	4.83E-09	1.47E-08	1596	1.15E-11	1.88E-10
217	1.57E-07	3.33E-07	907	4.98E-09	1.47E-08	1597	1.15E-11	1.64E-10
218	1.87E-07	3.33E-07	908	5.13E-09	1.48E-08	1598	1.15E-11	1.43E-10
219	2.25E-07	3.31E-07	909	5.29E-09	1.48E-08	1599	1.15E-11	1.24E-10
220	2.71E-07	3.26E-07	910	5.47E-09	1.49E-08	1600	1.15E-11	1.09E-10
221	3.22E-07	3.20E-07	911	5.66E-09	1.48E-08	1601	1.15E-11	9.42E-11
222	3.77E-07	3.11E-07	912	5.85E-09	1.48E-08	1602	1.15E-11	8.20E-11
223	4.32E-07	3.02E-07	913	6.05E-09	1.47E-08	1603	1.15E-11	7.11E-11
224	4.83E-07	2.92E-07	914	6.26E-09	1.46E-08	1604	1.15E-11	6.18E-11
225	5.26E-07	2.82E-07	915	6.46E-09	1.45E-08	1605	1.15E-11	5.39E-11
226	5.54E-07	2.71E-07	916	6.68E-09	1.44E-08	1606	1.15E-11	4.69E-11
227	5.69E-07	2.63E-07	917	6.88E-09	1.43E-08	1607	1.15E-11	4.11E-11
228	5.67E-07	2.55E-07	918	7.08E-09	1.42E-08	1608	1.13E-11	3.59E-11
229	5.48E-07	2.48E-07	919	7.28E-09	1.41E-08	1609	1.13E-11	3.17E-11
230	5.17E-07	2.43E-07	920	7.46E-09	1.40E-08	1610	1.12E-11	2.82E-11
231	4.74E-07	2.39E-07	921	7.63E-09	1.38E-08	1611	1.12E-11	2.51E-11
232	4.25E-07	2.36E-07	922	7.79E-09	1.37E-08	1612	1.11E-11	2.25E-11
233	3.71E-07	2.33E-07	923	7.93E-09	1.36E-08	1613	1.10E-11	2.04E-11
234	3.20E-07	2.32E-07	924	8.05E-09	1.35E-08	1614	1.09E-11	1.85E-11
235	2.72E-07	2.31E-07	925	8.15E-09	1.34E-08	1615	1.09E-11	1.70E-11
236	2.30E-07	2.30E-07	926	8.24E-09	1.33E-08	1616	1.08E-11	1.59E-11
237	1.93E-07	2.29E-07	927	8.31E-09	1.32E-08	1617	1.07E-11	1.46E-11
238	1.63E-07	2.28E-07	928	8.34E-09	1.32E-08	1618	1.06E-11	1.39E-11
239	1.40E-07	2.28E-07	929	8.37E-09	1.31E-08	1619	1.04E-11	1.30E-11
240	1.22E-07	2.27E-07	930	8.37E-09	1.31E-08	1620	1.03E-11	1.23E-11
241	1.08E-07	2.27E-07	931	8.35E-09	1.31E-08	1621	1.02E-11	1.20E-11
242	9.83E-08	2.26E-07	932	8.32E-09	1.30E-08	1622	1.00E-11	1.12E-11
243	9.09E-08	2.26E-07	933	8.27E-09	1.30E-08	1623	9.91E-12	1.11E-11
244	8.55E-08	2.26E-07	934	8.20E-09	1.30E-08	1624	9.76E-12	1.05E-11

245	8.17E-08	2.24E-07	935	8.13E-09	1.31E-08	1625	9.60E-12	1.03E-11
246	7.93E-08	2.23E-07	936	8.04E-09	1.31E-08	1626	9.45E-12	9.99E-12
247	7.76E-08	2.23E-07	937	7.94E-09	1.32E-08	1627	9.30E-12	9.71E-12
248	7.64E-08	2.22E-07	938	7.84E-09	1.32E-08	1628	9.14E-12	9.51E-12
249	7.58E-08	2.21E-07	939	7.74E-09	1.33E-08	1629	8.97E-12	9.19E-12
250	7.53E-08	2.19E-07	940	7.63E-09	1.34E-08	1630	8.82E-12	9.03E-12
251	7.51E-08	2.18E-07	941	7.52E-09	1.34E-08	1631	8.66E-12	8.78E-12
252	7.50E-08	2.17E-07	942	7.42E-09	1.35E-08	1632	8.51E-12	8.59E-12
253	7.50E-08	2.16E-07	943	7.31E-09	1.35E-08	1633	8.35E-12	8.41E-12
254	7.49E-08	2.15E-07	944	7.20E-09	1.36E-08	1634	8.20E-12	8.24E-12
255	7.50E-08	2.13E-07	945	7.11E-09	1.36E-08	1635	8.03E-12	8.05E-12
256	7.51E-08	2.12E-07	946	7.02E-09	1.36E-08	1636	7.89E-12	7.91E-12
257	7.50E-08	2.11E-07	947	6.92E-09	1.36E-08	1637	7.74E-12	7.75E-12
258	7.51E-08	2.10E-07	948	6.84E-09	1.36E-08	1638	7.58E-12	7.59E-12
259	7.52E-08	2.10E-07	949	6.77E-09	1.35E-08	1639	7.43E-12	7.43E-12
260	7.52E-08	2.08E-07	950	6.70E-09	1.35E-08	1640	7.30E-12	7.30E-12
261	7.54E-08	2.08E-07	951	6.62E-09	1.34E-08	1641	7.14E-12	7.15E-12
262	7.55E-08	2.07E-07	952	6.56E-09	1.33E-08	1642	7.01E-12	7.01E-12
263	7.58E-08	2.07E-07	953	6.51E-09	1.32E-08	1643	6.89E-12	6.89E-12
264	7.61E-08	2.07E-07	954	6.45E-09	1.31E-08	1644	6.75E-12	6.75E-12
265	7.65E-08	2.06E-07	955	6.40E-09	1.29E-08	1645	6.62E-12	6.62E-12
266	7.71E-08	2.06E-07	956	6.36E-09	1.28E-08	1646	6.51E-12	6.51E-12
267	7.77E-08	2.06E-07	957	6.32E-09	1.26E-08	1647	6.38E-12	6.38E-12
268	7.83E-08	2.06E-07	958	6.27E-09	1.25E-08	1648	6.27E-12	6.27E-12
269	7.90E-08	2.07E-07	959	6.24E-09	1.23E-08	1649	6.16E-12	6.16E-12
270	7.96E-08	2.07E-07	960	6.20E-09	1.22E-08	1650	6.03E-12	6.03E-12
271	8.01E-08	2.07E-07	961	6.17E-09	1.20E-08	1651	5.94E-12	5.94E-12
272	8.02E-08	2.05E-07	962	6.14E-09	1.19E-08	1652	5.83E-12	5.83E-12
273	8.04E-08	2.05E-07	963	6.11E-09	1.17E-08	1653	5.72E-12	5.72E-12
274	8.01E-08	2.05E-07	964	6.08E-09	1.16E-08	1654	5.63E-12	5.63E-12
275	7.95E-08	2.04E-07	965	6.05E-09	1.14E-08	1655	5.55E-12	5.55E-12
276	7.85E-08	2.04E-07	966	6.03E-09	1.13E-08	1656	5.46E-12	5.46E-12
277	7.72E-08	2.03E-07	967	6.00E-09	1.12E-08	1657	5.38E-12	5.38E-12
278	7.53E-08	2.03E-07	968	5.97E-09	1.11E-08	1658	5.29E-12	5.29E-12
279	7.33E-08	2.01E-07	969	5.94E-09	1.10E-08	1659	5.21E-12	5.21E-12
280	7.10E-08	2.01E-07	970	5.92E-09	1.09E-08	1660	5.13E-12	5.13E-12
281	6.86E-08	2.00E-07	971	5.89E-09	1.07E-08	1661	5.07E-12	5.07E-12
282	6.61E-08	2.00E-07	972	5.87E-09	1.07E-08	1662	5.00E-12	5.00E-12
283	6.36E-08	1.99E-07	973	5.84E-09	1.06E-08	1663	4.94E-12	4.94E-12
284	6.13E-08	1.99E-07	974	5.81E-09	1.05E-08	1664	4.87E-12	4.87E-12
285	5.91E-08	1.99E-07	975	5.79E-09	1.05E-08	1665	4.83E-12	4.83E-12
286	5.72E-08	1.97E-07	976	5.76E-09	1.05E-08	1666	4.77E-12	4.77E-12
287	5.58E-08	1.97E-07	977	5.74E-09	1.04E-08	1667	4.72E-12	4.72E-12
288	5.46E-08	1.97E-07	978	5.72E-09	1.04E-08	1668	4.68E-12	4.68E-12
289	5.38E-08	1.97E-07	979	5.71E-09	1.04E-08	1669	4.64E-12	4.64E-12
290	5.31E-08	1.98E-07	980	5.70E-09	1.04E-08	1670	4.62E-12	4.62E-12
291	5.28E-08	1.98E-07	981	5.69E-09	1.04E-08	1671	4.57E-12	4.57E-12
292	5.27E-08	1.98E-07	982	5.68E-09	1.04E-08	1672	4.55E-12	4.55E-12
293	5.27E-08	1.99E-07	983	5.69E-09	1.05E-08	1673	4.51E-12	4.51E-12
294	5.28E-08	1.99E-07	984	5.72E-09	1.05E-08	1674	4.49E-12	4.49E-12

295	5.29E-08	1.99E-07	985	5.75E-09	1.06E-08	1675	4.47E-12	4.47E-12
296	5.29E-08	1.99E-07	986	5.80E-09	1.07E-08	1676	4.45E-12	4.45E-12
297	5.30E-08	1.99E-07	987	5.87E-09	1.08E-08	1677	4.42E-12	4.42E-12
298	5.27E-08	2.00E-07	988	5.95E-09	1.09E-08	1678	4.40E-12	4.40E-12
299	5.23E-08	2.00E-07	989	6.07E-09	1.10E-08	1679	4.40E-12	4.40E-12
300	5.17E-08	2.00E-07	990	6.21E-09	1.12E-08	1680	4.38E-12	4.38E-12
301	5.12E-08	2.00E-07	991	6.39E-09	1.14E-08	1681	4.38E-12	4.38E-12
302	5.06E-08	2.00E-07	992	6.60E-09	1.16E-08	1682	4.36E-12	4.36E-12
303	5.01E-08	2.01E-07	993	6.85E-09	1.19E-08	1683	4.36E-12	4.36E-12
304	4.97E-08	2.02E-07	994	7.15E-09	1.21E-08	1684	4.34E-12	4.34E-12
305	4.96E-08	2.03E-07	995	7.49E-09	1.25E-08	1685	4.34E-12	4.34E-12
306	5.01E-08	2.05E-07	996	7.87E-09	1.28E-08	1686	4.32E-12	4.32E-12
307	5.12E-08	2.07E-07	997	8.31E-09	1.32E-08	1687	4.32E-12	4.32E-12
308	5.33E-08	2.11E-07	998	8.81E-09	1.36E-08	1688	4.30E-12	4.30E-12
309	5.65E-08	2.15E-07	999	9.37E-09	1.40E-08	1689	4.30E-12	4.30E-12
310	6.15E-08	2.21E-07	1000	9.98E-09	1.45E-08	1690	4.30E-12	4.30E-12
311	6.85E-08	2.27E-07	1001	1.06E-08	1.50E-08	1691	4.27E-12	4.27E-12
312	7.80E-08	2.36E-07	1002	1.14E-08	1.55E-08	1692	4.27E-12	4.27E-12
313	9.02E-08	2.45E-07	1003	1.21E-08	1.61E-08	1693	4.25E-12	4.25E-12
314	1.05E-07	2.55E-07	1004	1.29E-08	1.66E-08	1694	4.23E-12	4.23E-12
315	1.24E-07	2.64E-07	1005	1.38E-08	1.72E-08	1695	4.23E-12	4.23E-12
316	1.46E-07	2.74E-07	1006	1.47E-08	1.77E-08	1696	4.21E-12	4.21E-12
317	1.70E-07	2.81E-07	1007	1.56E-08	1.83E-08	1697	4.19E-12	4.19E-12
318	1.96E-07	2.87E-07	1008	1.66E-08	1.88E-08	1698	4.19E-12	4.19E-12
319	2.25E-07	2.93E-07	1009	1.75E-08	1.94E-08	1699	4.17E-12	4.17E-12
320	2.53E-07	2.95E-07	1010	1.84E-08	1.99E-08	1700	4.15E-12	4.15E-12
321	2.79E-07	2.94E-07	1011	1.94E-08	2.04E-08	1701	4.12E-12	4.12E-12
322	3.02E-07	2.91E-07	1012	2.03E-08	2.08E-08	1702	4.10E-12	4.10E-12
323	3.22E-07	2.86E-07	1013	2.11E-08	2.12E-08	1703	4.08E-12	4.08E-12
324	3.37E-07	2.79E-07	1014	2.19E-08	2.16E-08	1704	4.06E-12	4.06E-12
325	3.44E-07	2.70E-07	1015	2.26E-08	2.19E-08	1705	4.02E-12	4.02E-12
326	3.45E-07	2.62E-07	1016	2.33E-08	2.22E-08	1706	4.00E-12	4.00E-12
327	3.39E-07	2.52E-07	1017	2.39E-08	2.24E-08	1707	3.97E-12	3.97E-12
328	3.26E-07	2.43E-07	1018	2.43E-08	2.26E-08	1708	3.95E-12	3.95E-12
329	3.09E-07	2.35E-07	1019	2.47E-08	2.28E-08	1709	3.91E-12	3.91E-12
330	2.86E-07	2.27E-07	1020	2.50E-08	2.28E-08	1710	3.89E-12	3.89E-12
331	2.61E-07	2.21E-07	1021	2.51E-08	2.29E-08	1711	3.85E-12	3.85E-12
332	2.34E-07	2.16E-07	1022	2.52E-08	2.29E-08	1712	3.82E-12	3.82E-12
333	2.07E-07	2.12E-07	1023	2.51E-08	2.28E-08	1713	3.78E-12	3.78E-12
334	1.80E-07	2.09E-07	1024	2.49E-08	2.28E-08	1714	3.74E-12	3.74E-12
335	1.56E-07	2.07E-07	1025	2.46E-08	2.27E-08	1715	3.70E-12	3.70E-12
336	1.34E-07	2.06E-07	1026	2.43E-08	2.25E-08	1716	3.67E-12	3.67E-12
337	1.15E-07	2.05E-07	1027	2.38E-08	2.24E-08	1717	3.63E-12	3.63E-12
338	9.81E-08	2.05E-07	1028	2.33E-08	2.22E-08	1718	3.59E-12	3.59E-12
339	8.44E-08	2.04E-07	1029	2.27E-08	2.20E-08	1719	3.55E-12	3.55E-12
340	7.33E-08	2.05E-07	1030	2.20E-08	2.18E-08	1720	3.50E-12	3.50E-12
341	6.46E-08	2.05E-07	1031	2.13E-08	2.16E-08	1721	3.46E-12	3.46E-12
342	5.78E-08	2.07E-07	1032	2.06E-08	2.14E-08	1722	3.42E-12	3.42E-12
343	5.25E-08	2.08E-07	1033	1.98E-08	2.11E-08	1723	3.35E-12	3.35E-12
344	4.87E-08	2.10E-07	1034	1.91E-08	2.09E-08	1724	3.31E-12	3.31E-12

345	4.57E-08	2.12E-07	1035	1.83E-08	2.07E-08	1725	3.27E-12	3.27E-12
346	4.35E-08	2.14E-07	1036	1.75E-08	2.04E-08	1726	3.20E-12	3.20E-12
347	4.19E-08	2.17E-07	1037	1.68E-08	2.02E-08	1727	3.16E-12	3.16E-12
348	4.08E-08	2.21E-07	1038	1.61E-08	1.99E-08	1728	3.12E-12	3.12E-12
349	3.99E-08	2.25E-07	1039	1.54E-08	1.97E-08	1729	3.05E-12	3.05E-12
350	3.93E-08	2.29E-07	1040	1.48E-08	1.94E-08	1730	3.01E-12	3.01E-12
351	3.87E-08	2.34E-07	1041	1.42E-08	1.91E-08	1731	2.95E-12	2.95E-12
352	3.84E-08	2.39E-07	1042	1.36E-08	1.88E-08	1732	2.90E-12	2.90E-12
353	3.81E-08	2.43E-07	1043	1.31E-08	1.85E-08	1733	2.84E-12	2.84E-12
354	3.80E-08	2.47E-07	1044	1.26E-08	1.83E-08	1734	2.80E-12	2.80E-12
355	3.77E-08	2.51E-07	1045	1.21E-08	1.79E-08	1735	2.73E-12	2.73E-12
356	3.75E-08	2.53E-07	1046	1.17E-08	1.76E-08	1736	2.69E-12	2.69E-12
357	3.73E-08	2.54E-07	1047	1.14E-08	1.73E-08	1737	2.62E-12	2.62E-12
358	3.71E-08	2.53E-07	1048	1.10E-08	1.70E-08	1738	2.58E-12	2.58E-12
359	3.68E-08	2.51E-07	1049	1.08E-08	1.67E-08	1739	2.54E-12	2.54E-12
360	3.66E-08	2.47E-07	1050	1.05E-08	1.64E-08	1740	2.47E-12	2.47E-12
361	3.63E-08	2.41E-07	1051	1.02E-08	1.60E-08	1741	2.43E-12	2.43E-12
362	3.59E-08	2.34E-07	1052	9.98E-09	1.57E-08	1742	2.39E-12	2.39E-12
363	3.55E-08	2.26E-07	1053	9.77E-09	1.54E-08	1743	2.35E-12	2.35E-12
364	3.52E-08	2.16E-07	1054	9.58E-09	1.51E-08	1744	2.30E-12	2.30E-12
365	3.48E-08	2.06E-07	1055	9.40E-09	1.48E-08	1745	2.26E-12	2.26E-12
366	3.44E-08	1.94E-07	1056	9.24E-09	1.45E-08	1746	2.22E-12	2.22E-12
367	3.40E-08	1.84E-07	1057	9.09E-09	1.41E-08	1747	2.17E-12	2.17E-12
368	3.37E-08	1.74E-07	1058	8.94E-09	1.38E-08	1748	2.14E-12	2.14E-12
369	3.34E-08	1.63E-07	1059	8.79E-09	1.35E-08	1749	2.11E-12	2.11E-12
370	3.30E-08	1.54E-07	1060	8.65E-09	1.33E-08	1750	2.09E-12	2.09E-12
371	3.28E-08	1.46E-07	1061	8.50E-09	1.30E-08	1751	2.06E-12	2.06E-12
372	3.27E-08	1.38E-07	1062	8.36E-09	1.28E-08	1752	2.03E-12	2.03E-12
373	3.25E-08	1.31E-07	1063	8.21E-09	1.26E-08	1753	2.01E-12	2.01E-12
374	3.23E-08	1.25E-07	1064	8.07E-09	1.24E-08	1754	1.99E-12	1.99E-12
375	3.23E-08	1.19E-07	1065	7.93E-09	1.22E-08	1755	1.98E-12	1.98E-12
376	3.22E-08	1.14E-07	1066	7.78E-09	1.20E-08	1756	1.97E-12	1.97E-12
377	3.22E-08	1.10E-07	1067	7.64E-09	1.19E-08	1757	1.96E-12	1.96E-12
378	3.24E-08	1.06E-07	1068	7.51E-09	1.17E-08	1758	1.96E-12	1.96E-12
379	3.26E-08	1.03E-07	1069	7.38E-09	1.16E-08	1759	1.96E-12	1.96E-12
380	3.29E-08	9.95E-08	1070	7.25E-09	1.15E-08	1760	1.96E-12	1.96E-12
381	3.35E-08	9.70E-08	1071	7.14E-09	1.14E-08	1761	1.96E-12	1.96E-12
382	3.41E-08	9.47E-08	1072	7.03E-09	1.13E-08	1762	1.96E-12	1.96E-12
383	3.49E-08	9.32E-08	1073	6.94E-09	1.12E-08	1763	1.97E-12	1.97E-12
384	3.59E-08	9.22E-08	1074	6.88E-09	1.12E-08	1764	1.98E-12	1.98E-12
385	3.70E-08	9.19E-08	1075	6.83E-09	1.11E-08	1765	1.99E-12	1.99E-12
386	3.84E-08	9.29E-08	1076	6.81E-09	1.11E-08	1766	2.00E-12	2.00E-12
387	4.00E-08	9.52E-08	1077	6.82E-09	1.12E-08	1767	2.02E-12	2.02E-12
388	4.17E-08	9.95E-08	1078	6.86E-09	1.12E-08	1768	2.03E-12	2.03E-12
389	4.36E-08	1.06E-07	1079	6.95E-09	1.13E-08	1769	2.06E-12	2.06E-12
390	4.57E-08	1.16E-07	1080	7.08E-09	1.15E-08	1770	2.08E-12	2.08E-12
391	4.81E-08	1.30E-07	1081	7.25E-09	1.16E-08	1771	2.10E-12	2.10E-12
392	5.06E-08	1.49E-07	1082	7.49E-09	1.19E-08	1772	2.12E-12	2.12E-12
393	5.34E-08	1.74E-07	1083	7.78E-09	1.21E-08	1773	2.14E-12	2.14E-12
394	5.63E-08	2.06E-07	1084	8.12E-09	1.25E-08	1774	2.15E-12	2.15E-12

395	5.95E-08	2.45E-07	1085	8.54E-09	1.29E-08	1775	2.17E-12	2.17E-12
396	6.29E-08	2.92E-07	1086	9.02E-09	1.33E-08	1776	2.20E-12	2.20E-12
397	6.63E-08	3.48E-07	1087	9.57E-09	1.38E-08	1777	2.22E-12	2.22E-12
398	7.01E-08	4.12E-07	1088	1.02E-08	1.44E-08	1778	2.24E-12	2.24E-12
399	7.39E-08	4.84E-07	1089	1.09E-08	1.50E-08	1779	2.26E-12	2.26E-12
400	7.78E-08	5.62E-07	1090	1.17E-08	1.57E-08	1780	2.28E-12	2.28E-12
401	8.16E-08	6.43E-07	1091	1.25E-08	1.64E-08	1781	2.30E-12	2.30E-12
402	8.53E-08	7.27E-07	1092	1.34E-08	1.72E-08	1782	2.30E-12	2.30E-12
403	8.86E-08	8.08E-07	1093	1.44E-08	1.80E-08	1783	2.32E-12	2.32E-12
404	9.15E-08	8.84E-07	1094	1.54E-08	1.89E-08	1784	2.32E-12	2.32E-12
405	9.39E-08	9.52E-07	1095	1.65E-08	1.98E-08	1785	2.35E-12	2.35E-12
406	9.55E-08	1.01E-06	1096	1.77E-08	2.07E-08	1786	2.35E-12	2.35E-12
407	9.61E-08	1.05E-06	1097	1.89E-08	2.17E-08	1787	2.37E-12	2.37E-12
408	9.59E-08	1.07E-06	1098	2.01E-08	2.26E-08	1788	2.37E-12	2.37E-12
409	9.49E-08	1.08E-06	1099	2.13E-08	2.36E-08	1789	2.37E-12	2.37E-12
410	9.26E-08	1.06E-06	1100	2.25E-08	2.45E-08	1790	2.37E-12	2.37E-12
411	8.96E-08	1.04E-06	1101	2.37E-08	2.54E-08	1791	2.37E-12	2.37E-12
412	8.58E-08	9.94E-07	1102	2.49E-08	2.63E-08	1792	2.37E-12	2.37E-12
413	8.14E-08	9.35E-07	1103	2.61E-08	2.70E-08	1793	2.37E-12	2.37E-12
414	7.66E-08	8.66E-07	1104	2.72E-08	2.78E-08	1794	2.37E-12	2.37E-12
415	7.16E-08	7.90E-07	1105	2.82E-08	2.84E-08	1795	2.37E-12	2.37E-12
416	6.65E-08	7.11E-07	1106	2.91E-08	2.90E-08	1796	2.35E-12	2.35E-12
417	6.16E-08	6.29E-07	1107	2.99E-08	2.94E-08	1797	2.35E-12	2.35E-12
418	5.68E-08	5.50E-07	1108	3.07E-08	2.98E-08	1798	2.35E-12	2.35E-12
419	5.25E-08	4.73E-07	1109	3.13E-08	3.01E-08	1799	2.32E-12	2.32E-12
420	4.88E-08	4.04E-07	1110	3.18E-08	3.02E-08	1800	2.32E-12	2.32E-12
421	4.52E-08	3.39E-07	1111	3.21E-08	3.02E-08	1801	2.30E-12	2.30E-12
422	4.24E-08	2.83E-07	1112	3.23E-08	3.02E-08	1802	2.30E-12	2.30E-12
423	3.99E-08	2.35E-07	1113	3.23E-08	3.00E-08	1803	2.28E-12	2.28E-12
424	3.81E-08	1.94E-07	1114	3.22E-08	2.97E-08	1804	2.26E-12	2.26E-12
425	3.65E-08	1.59E-07	1115	3.20E-08	2.93E-08	1805	2.26E-12	2.26E-12
426	3.52E-08	1.30E-07	1116	3.16E-08	2.88E-08	1806	2.24E-12	2.24E-12
427	3.42E-08	1.07E-07	1117	3.10E-08	2.82E-08	1807	2.22E-12	2.22E-12
428	3.34E-08	8.83E-08	1118	3.04E-08	2.76E-08	1808	2.22E-12	2.22E-12
429	3.28E-08	7.37E-08	1119	2.96E-08	2.69E-08	1809	2.20E-12	2.20E-12
430	3.21E-08	6.23E-08	1120	2.87E-08	2.61E-08	1810	2.17E-12	2.17E-12
431	3.16E-08	5.36E-08	1121	2.77E-08	2.53E-08	1811	2.15E-12	2.15E-12
432	3.11E-08	4.70E-08	1122	2.67E-08	2.45E-08	1812	2.14E-12	2.14E-12
433	3.05E-08	4.20E-08	1123	2.55E-08	2.36E-08	1813	2.12E-12	2.12E-12
434	2.99E-08	3.82E-08	1124	2.43E-08	2.28E-08	1814	2.11E-12	2.11E-12
435	2.93E-08	3.55E-08	1125	2.31E-08	2.19E-08	1815	2.09E-12	2.09E-12
436	2.86E-08	3.35E-08	1126	2.19E-08	2.10E-08	1816	2.08E-12	2.08E-12
437	2.80E-08	3.20E-08	1127	2.06E-08	2.02E-08	1817	2.06E-12	2.06E-12
438	2.72E-08	3.09E-08	1128	1.94E-08	1.94E-08	1818	2.03E-12	2.03E-12
439	2.65E-08	3.02E-08	1129	1.81E-08	1.86E-08	1819	2.02E-12	2.02E-12
440	2.59E-08	2.97E-08	1130	1.70E-08	1.78E-08	1820	2.00E-12	2.00E-12
441	2.52E-08	2.93E-08	1131	1.58E-08	1.71E-08	1821	1.98E-12	1.98E-12
442	2.46E-08	2.91E-08	1132	1.47E-08	1.65E-08	1822	1.97E-12	1.97E-12
443	2.40E-08	2.89E-08	1133	1.37E-08	1.58E-08	1823	1.95E-12	1.95E-12
444	2.36E-08	2.90E-08	1134	1.27E-08	1.53E-08	1824	1.93E-12	1.93E-12

445	2.31E-08	2.90E-08	1135	1.18E-08	1.47E-08	1825	1.92E-12	1.92E-12
446	2.29E-08	2.91E-08	1136	1.10E-08	1.42E-08	1826	1.90E-12	1.90E-12
447	2.27E-08	2.93E-08	1137	1.03E-08	1.38E-08	1827	1.87E-12	1.87E-12
448	2.25E-08	2.94E-08	1138	9.64E-09	1.34E-08	1828	1.86E-12	1.86E-12
449	2.25E-08	2.97E-08	1139	9.08E-09	1.30E-08	1829	1.84E-12	1.84E-12
450	2.26E-08	2.99E-08	1140	8.60E-09	1.27E-08	1830	1.82E-12	1.82E-12
451	2.27E-08	3.01E-08	1141	8.19E-09	1.24E-08	1831	1.81E-12	1.81E-12
452	2.29E-08	3.03E-08	1142	7.86E-09	1.21E-08	1832	1.79E-12	1.79E-12
453	2.32E-08	3.05E-08	1143	7.61E-09	1.19E-08	1833	1.78E-12	1.78E-12
454	2.34E-08	3.06E-08	1144	7.43E-09	1.17E-08	1834	1.76E-12	1.76E-12
455	2.38E-08	3.08E-08	1145	7.31E-09	1.15E-08	1835	1.75E-12	1.75E-12
456	2.42E-08	3.09E-08	1146	7.24E-09	1.13E-08	1836	1.73E-12	1.73E-12
457	2.45E-08	3.09E-08	1147	7.23E-09	1.11E-08	1837	1.71E-12	1.71E-12
458	2.48E-08	3.10E-08	1148	7.27E-09	1.10E-08	1838	1.70E-12	1.70E-12
459	2.52E-08	3.10E-08	1149	7.34E-09	1.09E-08	1839	1.69E-12	1.69E-12
460	2.54E-08	3.09E-08	1150	7.45E-09	1.08E-08	1840	1.68E-12	1.68E-12
461	2.58E-08	3.08E-08	1151	7.58E-09	1.07E-08	1841	1.67E-12	1.67E-12
462	2.60E-08	3.06E-08	1152	7.73E-09	1.06E-08	1842	1.66E-12	1.66E-12
463	2.64E-08	3.05E-08	1153	7.90E-09	1.05E-08	1843	1.65E-12	1.65E-12
464	2.69E-08	3.03E-08	1154	8.07E-09	1.04E-08	1844	1.65E-12	1.65E-12
465	2.74E-08	3.00E-08	1155	8.24E-09	1.03E-08	1845	1.64E-12	1.64E-12
466	2.81E-08	2.98E-08	1156	8.41E-09	1.02E-08	1846	1.64E-12	1.64E-12
467	2.91E-08	2.95E-08	1157	8.57E-09	1.01E-08	1847	1.63E-12	1.63E-12
468	3.03E-08	2.92E-08	1158	8.72E-09	1.01E-08	1848	1.63E-12	1.63E-12
469	3.19E-08	2.89E-08	1159	8.86E-09	9.99E-09	1849	1.63E-12	1.63E-12
470	3.39E-08	2.86E-08	1160	8.98E-09	9.92E-09	1850	1.63E-12	1.63E-12
471	3.62E-08	2.83E-08	1161	9.08E-09	9.87E-09	1851	1.63E-12	1.63E-12
472	3.91E-08	2.80E-08	1162	9.14E-09	9.80E-09	1852	1.64E-12	1.64E-12
473	4.25E-08	2.77E-08	1163	9.19E-09	9.75E-09	1853	1.64E-12	1.64E-12
474	4.63E-08	2.74E-08	1164	9.22E-09	9.70E-09	1854	1.65E-12	1.65E-12
475	5.05E-08	2.72E-08	1165	9.23E-09	9.66E-09	1855	1.65E-12	1.65E-12
476	5.52E-08	2.70E-08	1166	9.21E-09	9.63E-09	1856	1.66E-12	1.66E-12
477	6.00E-08	2.68E-08	1167	9.17E-09	9.59E-09	1857	1.66E-12	1.66E-12
478	6.49E-08	2.66E-08	1168	9.12E-09	9.57E-09	1858	1.67E-12	1.67E-12
479	6.99E-08	2.64E-08	1169	9.05E-09	9.57E-09	1859	1.68E-12	1.68E-12
480	7.47E-08	2.63E-08	1170	8.97E-09	9.57E-09	1860	1.69E-12	1.69E-12
481	7.92E-08	2.62E-08	1171	8.88E-09	9.59E-09	1861	1.70E-12	1.70E-12
482	8.31E-08	2.60E-08	1172	8.78E-09	9.61E-09	1862	1.71E-12	1.71E-12
483	8.66E-08	2.60E-08	1173	8.69E-09	9.66E-09	1863	1.72E-12	1.72E-12
484	8.94E-08	2.59E-08	1174	8.59E-09	9.72E-09	1864	1.73E-12	1.73E-12
485	9.14E-08	2.58E-08	1175	8.50E-09	9.80E-09	1865	1.74E-12	1.74E-12
486	9.25E-08	2.57E-08	1176	8.42E-09	9.90E-09	1866	1.76E-12	1.76E-12
487	9.27E-08	2.54E-08	1177	8.35E-09	1.00E-08	1867	1.77E-12	1.77E-12
488	9.21E-08	2.53E-08	1178	8.28E-09	1.01E-08	1868	1.78E-12	1.78E-12
489	9.07E-08	2.51E-08	1179	8.24E-09	1.03E-08	1869	1.80E-12	1.80E-12
490	8.85E-08	2.49E-08	1180	8.21E-09	1.05E-08	1870	1.81E-12	1.81E-12
491	8.57E-08	2.47E-08	1181	8.19E-09	1.07E-08	1871	1.82E-12	1.82E-12
492	8.22E-08	2.45E-08	1182	8.20E-09	1.09E-08	1872	1.83E-12	1.83E-12
493	7.82E-08	2.42E-08	1183	8.21E-09	1.12E-08	1873	1.84E-12	1.84E-12
494	7.40E-08	2.40E-08	1184	8.23E-09	1.15E-08	1874	1.85E-12	1.85E-12

495	6.94E-08	2.37E-08	1185	8.28E-09	1.18E-08	1875	1.87E-12	1.87E-12
496	6.48E-08	2.35E-08	1186	8.33E-09	1.21E-08	1876	1.88E-12	1.88E-12
497	6.00E-08	2.32E-08	1187	8.40E-09	1.24E-08	1877	1.89E-12	1.89E-12
498	5.53E-08	2.31E-08	1188	8.47E-09	1.27E-08	1878	1.91E-12	1.91E-12
499	5.08E-08	2.29E-08	1189	8.54E-09	1.31E-08	1879	1.92E-12	1.92E-12
500	4.64E-08	2.28E-08	1190	8.61E-09	1.34E-08	1880	1.92E-12	1.92E-12
501	4.24E-08	2.28E-08	1191	8.68E-09	1.38E-08	1881	1.93E-12	1.93E-12
502	3.85E-08	2.27E-08	1192	8.75E-09	1.41E-08	1882	1.94E-12	1.94E-12
503	3.50E-08	2.28E-08	1193	8.80E-09	1.44E-08	1883	1.95E-12	1.95E-12
504	3.19E-08	2.29E-08	1194	8.85E-09	1.47E-08	1884	1.95E-12	1.95E-12
505	2.91E-08	2.31E-08	1195	8.88E-09	1.50E-08	1885	1.96E-12	1.96E-12
506	2.65E-08	2.32E-08	1196	8.89E-09	1.53E-08	1886	1.96E-12	1.96E-12
507	2.44E-08	2.35E-08	1197	8.88E-09	1.55E-08	1887	1.97E-12	1.97E-12
508	2.26E-08	2.39E-08	1198	8.85E-09	1.57E-08	1888	1.97E-12	1.97E-12
509	2.10E-08	2.42E-08	1199	8.81E-09	1.59E-08	1889	1.97E-12	1.97E-12
510	1.97E-08	2.47E-08	1200	8.74E-09	1.60E-08	1890	1.97E-12	1.97E-12
511	1.87E-08	2.52E-08	1201	8.65E-09	1.61E-08	1891	1.97E-12	1.97E-12
512	1.79E-08	2.58E-08	1202	8.54E-09	1.62E-08	1892	1.97E-12	1.97E-12
513	1.72E-08	2.63E-08	1203	8.41E-09	1.62E-08	1893	1.97E-12	1.97E-12
514	1.66E-08	2.68E-08	1204	8.26E-09	1.61E-08	1894	1.97E-12	1.97E-12
515	1.62E-08	2.74E-08	1205	8.10E-09	1.60E-08	1895	1.96E-12	1.96E-12
516	1.59E-08	2.80E-08	1206	7.91E-09	1.59E-08	1896	1.96E-12	1.96E-12
517	1.56E-08	2.86E-08	1207	7.72E-09	1.57E-08	1897	1.95E-12	1.95E-12
518	1.53E-08	2.89E-08	1208	7.51E-09	1.55E-08	1898	1.95E-12	1.95E-12
519	1.51E-08	2.94E-08	1209	7.29E-09	1.52E-08	1899	1.94E-12	1.94E-12
520	1.48E-08	2.97E-08	1210	7.07E-09	1.50E-08	1900	1.93E-12	1.93E-12
521	1.46E-08	2.99E-08	1211	6.85E-09	1.46E-08	1901	1.92E-12	1.92E-12
522	1.43E-08	3.00E-08	1212	6.62E-09	1.43E-08	1902	1.91E-12	1.91E-12
523	1.42E-08	3.00E-08	1213	6.40E-09	1.39E-08	1903	1.89E-12	1.89E-12
524	1.40E-08	2.99E-08	1214	6.18E-09	1.36E-08	1904	1.87E-12	1.87E-12
525	1.38E-08	2.97E-08	1215	5.97E-09	1.32E-08	1905	1.86E-12	1.86E-12
526	1.37E-08	2.94E-08	1216	5.77E-09	1.28E-08	1906	1.85E-12	1.85E-12
527	1.37E-08	2.89E-08	1217	5.58E-09	1.24E-08	1907	1.83E-12	1.83E-12
528	1.38E-08	2.84E-08	1218	5.41E-09	1.20E-08	1908	1.82E-12	1.82E-12
529	1.39E-08	2.79E-08	1219	5.25E-09	1.16E-08	1909	1.80E-12	1.80E-12
530	1.42E-08	2.74E-08	1220	5.11E-09	1.12E-08	1910	1.78E-12	1.78E-12
531	1.46E-08	2.68E-08	1221	4.99E-09	1.09E-08	1911	1.77E-12	1.77E-12
532	1.51E-08	2.62E-08	1222	4.90E-09	1.05E-08	1912	1.75E-12	1.75E-12
533	1.58E-08	2.56E-08	1223	4.82E-09	1.02E-08	1913	1.72E-12	1.72E-12
534	1.66E-08	2.51E-08	1224	4.77E-09	9.93E-09	1914	1.70E-12	1.70E-12
535	1.76E-08	2.47E-08	1225	4.75E-09	9.67E-09	1915	1.68E-12	1.68E-12
536	1.87E-08	2.43E-08	1226	4.75E-09	9.44E-09	1916	1.66E-12	1.66E-12
537	1.98E-08	2.39E-08	1227	4.78E-09	9.25E-09	1917	1.64E-12	1.64E-12
538	2.10E-08	2.37E-08	1228	4.83E-09	9.08E-09	1918	1.62E-12	1.62E-12
539	2.23E-08	2.35E-08	1229	4.91E-09	8.95E-09	1919	1.60E-12	1.60E-12
540	2.37E-08	2.34E-08	1230	5.02E-09	8.86E-09	1920	1.57E-12	1.57E-12
541	2.50E-08	2.34E-08	1231	5.15E-09	8.79E-09	1921	1.55E-12	1.55E-12
542	2.61E-08	2.33E-08	1232	5.31E-09	8.76E-09	1922	1.54E-12	1.54E-12
543	2.72E-08	2.34E-08	1233	5.50E-09	8.76E-09	1923	1.52E-12	1.52E-12
544	2.82E-08	2.35E-08	1234	5.70E-09	8.79E-09	1924	1.50E-12	1.50E-12

545	2.89E-08	2.36E-08	1235	5.93E-09	8.85E-09	1925	1.48E-12	1.48E-12
546	2.95E-08	2.38E-08	1236	6.18E-09	8.94E-09	1926	1.46E-12	1.46E-12
547	2.98E-08	2.40E-08	1237	6.44E-09	9.05E-09	1927	1.43E-12	1.43E-12
548	2.98E-08	2.41E-08	1238	6.72E-09	9.18E-09	1928	1.41E-12	1.41E-12
549	2.97E-08	2.44E-08	1239	7.01E-09	9.33E-09	1929	1.39E-12	1.39E-12
550	2.93E-08	2.46E-08	1240	7.31E-09	9.49E-09	1930	1.38E-12	1.38E-12
551	2.87E-08	2.48E-08	1241	7.62E-09	9.66E-09	1931	1.36E-12	1.36E-12
552	2.79E-08	2.49E-08	1242	7.93E-09	9.84E-09	1932	1.34E-12	1.34E-12
553	2.68E-08	2.50E-08	1243	8.24E-09	1.00E-08	1933	1.33E-12	1.33E-12
554	2.57E-08	2.51E-08	1244	8.55E-09	1.02E-08	1934	1.31E-12	1.31E-12
555	2.44E-08	2.52E-08	1245	8.84E-09	1.04E-08	1935	1.29E-12	1.29E-12
556	2.31E-08	2.52E-08	1246	9.12E-09	1.06E-08	1936	1.28E-12	1.28E-12
557	2.17E-08	2.51E-08	1247	9.39E-09	1.07E-08	1937	1.27E-12	1.27E-12
558	2.03E-08	2.50E-08	1248	9.64E-09	1.09E-08	1938	1.26E-12	1.26E-12
559	1.90E-08	2.49E-08	1249	9.87E-09	1.11E-08	1939	1.25E-12	1.25E-12
560	1.77E-08	2.48E-08	1250	1.01E-08	1.12E-08	1940	1.24E-12	1.24E-12
561	1.65E-08	2.46E-08	1251	1.03E-08	1.13E-08	1941	1.23E-12	1.23E-12
562	1.54E-08	2.43E-08	1252	1.04E-08	1.14E-08	1942	1.22E-12	1.22E-12
563	1.44E-08	2.40E-08	1253	1.05E-08	1.15E-08	1943	1.21E-12	1.21E-12
564	1.34E-08	2.36E-08	1254	1.06E-08	1.15E-08	1944	1.20E-12	1.20E-12
565	1.26E-08	2.32E-08	1255	1.07E-08	1.15E-08	1945	1.20E-12	1.20E-12
566	1.18E-08	2.28E-08	1256	1.07E-08	1.15E-08	1946	1.19E-12	1.19E-12
567	1.11E-08	2.23E-08	1257	1.07E-08	1.15E-08	1947	1.18E-12	1.18E-12
568	1.06E-08	2.19E-08	1258	1.06E-08	1.15E-08	1948	1.18E-12	1.18E-12
569	1.01E-08	2.14E-08	1259	1.06E-08	1.14E-08	1949	1.16E-12	1.16E-12
570	9.61E-09	2.08E-08	1260	1.05E-08	1.13E-08	1950	1.15E-12	1.15E-12
571	9.23E-09	2.04E-08	1261	1.04E-08	1.12E-08	1951	1.14E-12	1.14E-12
572	8.93E-09	1.99E-08	1262	1.02E-08	1.11E-08	1952	1.13E-12	1.13E-12
573	8.66E-09	1.94E-08	1263	1.01E-08	1.09E-08	1953	1.14E-12	1.14E-12
574	8.42E-09	1.90E-08	1264	9.90E-09	1.07E-08	1954	1.13E-12	1.13E-12
575	8.21E-09	1.85E-08	1265	9.73E-09	1.06E-08	1955	1.12E-12	1.12E-12
576	8.03E-09	1.81E-08	1266	9.55E-09	1.04E-08	1956	1.11E-12	1.11E-12
577	7.89E-09	1.77E-08	1267	9.37E-09	1.02E-08	1957	1.10E-12	1.10E-12
578	7.75E-09	1.74E-08	1268	9.20E-09	9.95E-09	1958	1.09E-12	1.09E-12
579	7.64E-09	1.71E-08	1269	9.03E-09	9.73E-09	1959	1.08E-12	1.08E-12
580	7.55E-09	1.69E-08	1270	8.87E-09	9.51E-09	1960	1.07E-12	1.07E-12
581	7.46E-09	1.66E-08	1271	8.72E-09	9.28E-09	1961	1.07E-12	1.07E-12
582	7.39E-09	1.63E-08	1272	8.59E-09	9.06E-09	1962	1.05E-12	1.05E-12
583	7.34E-09	1.62E-08	1273	8.47E-09	8.83E-09	1963	1.05E-12	1.05E-12
584	7.28E-09	1.61E-08	1274	8.36E-09	8.60E-09	1964	1.03E-12	1.03E-12
585	7.22E-09	1.60E-08	1275	8.27E-09	8.38E-09	1965	1.02E-12	1.02E-12
586	7.19E-09	1.59E-08	1276	8.20E-09	8.16E-09	1966	1.01E-12	1.01E-12
587	7.15E-09	1.59E-08	1277	8.16E-09	7.95E-09	1967	1.00E-12	1.00E-12
588	7.11E-09	1.58E-08	1278	8.12E-09	7.74E-09	1968	9.87E-13	9.87E-13
589	7.10E-09	1.57E-08	1279	8.10E-09	7.55E-09	1969	9.76E-13	9.76E-13
590	7.08E-09	1.58E-08	1280	8.09E-09	7.36E-09	1970	9.64E-13	9.64E-13
591	7.05E-09	1.58E-08	1281	8.10E-09	7.18E-09	1971	9.50E-13	9.50E-13
592	7.05E-09	1.59E-08	1282	8.11E-09	7.02E-09	1972	9.37E-13	9.37E-13
593	7.02E-09	1.59E-08	1283	8.12E-09	6.86E-09	1973	9.23E-13	9.23E-13
594	7.01E-09	1.60E-08	1284	8.13E-09	6.72E-09	1974	9.09E-13	9.09E-13

595	6.98E-09	1.60E-08	1285	8.15E-09	6.58E-09	1975	8.96E-13	8.96E-13
596	6.99E-09	1.61E-08	1286	8.16E-09	6.46E-09	1976	8.82E-13	8.82E-13
597	6.99E-09	1.62E-08	1287	8.15E-09	6.36E-09	1977	8.66E-13	8.66E-13
598	7.00E-09	1.63E-08	1288	8.14E-09	6.27E-09	1978	8.53E-13	8.53E-13
599	7.01E-09	1.64E-08	1289	8.12E-09	6.19E-09	1979	8.39E-13	8.39E-13
600	7.03E-09	1.65E-08	1290	8.08E-09	6.14E-09	1980	8.25E-13	8.25E-13
601	7.07E-09	1.66E-08	1291	8.02E-09	6.10E-09	1981	8.11E-13	8.11E-13
602	7.11E-09	1.66E-08	1292	7.94E-09	6.07E-09	1982	7.97E-13	7.97E-13
603	7.16E-09	1.67E-08	1293	7.84E-09	6.06E-09	1983	7.82E-13	7.82E-13
604	7.22E-09	1.68E-08	1294	7.72E-09	6.06E-09	1984	7.66E-13	7.66E-13
605	7.31E-09	1.69E-08	1295	7.58E-09	6.08E-09	1985	7.53E-13	7.53E-13
606	7.40E-09	1.69E-08	1296	7.41E-09	6.11E-09	1986	7.39E-13	7.39E-13
607	7.50E-09	1.68E-08	1297	7.22E-09	6.16E-09	1987	7.25E-13	7.25E-13
608	7.63E-09	1.68E-08	1298	7.01E-09	6.23E-09	1988	7.10E-13	7.10E-13
609	7.74E-09	1.68E-08	1299	6.79E-09	6.32E-09	1989	6.96E-13	6.96E-13
610	7.86E-09	1.68E-08	1300	6.54E-09	6.41E-09	1990	6.82E-13	6.82E-13
611	8.01E-09	1.67E-08	1301	6.28E-09	6.53E-09	1991	6.68E-13	6.68E-13
612	8.14E-09	1.67E-08	1302	6.01E-09	6.65E-09	1992	6.55E-13	6.55E-13
613	8.29E-09	1.66E-08	1303	5.73E-09	6.79E-09	1993	6.41E-13	6.41E-13
614	8.42E-09	1.65E-08	1304	5.44E-09	6.94E-09	1994	6.25E-13	6.25E-13
615	8.56E-09	1.64E-08	1305	5.14E-09	7.10E-09	1995	6.10E-13	6.10E-13
616	8.67E-09	1.62E-08	1306	4.84E-09	7.26E-09	1996	5.96E-13	5.96E-13
617	8.79E-09	1.61E-08	1307	4.54E-09	7.44E-09	1997	5.82E-13	5.82E-13
618	8.87E-09	1.60E-08	1308	4.24E-09	7.62E-09	1998	5.66E-13	5.66E-13
619	8.96E-09	1.59E-08	1309	3.94E-09	7.81E-09	1999	5.52E-13	5.52E-13
620	9.01E-09	1.58E-08	1310	3.66E-09	8.00E-09	2000	5.37E-13	5.37E-13
621	9.06E-09	1.57E-08	1311	3.37E-09	8.20E-09	2001	5.23E-13	5.23E-13
622	9.06E-09	1.57E-08	1312	3.10E-09	8.39E-09	2002	5.07E-13	5.07E-13
623	9.05E-09	1.56E-08	1313	2.84E-09	8.59E-09	2003	4.94E-13	4.94E-13
624	9.01E-09	1.55E-08	1314	2.58E-09	8.78E-09	2004	4.78E-13	4.78E-13
625	8.96E-09	1.55E-08	1315	2.34E-09	8.97E-09	2005	4.64E-13	4.64E-13
626	8.86E-09	1.53E-08	1316	2.12E-09	9.16E-09	2006	4.49E-13	4.49E-13
627	8.77E-09	1.53E-08	1317	1.91E-09	9.35E-09	2007	4.33E-13	4.33E-13
628	8.64E-09	1.53E-08	1318	1.72E-09	9.54E-09	2008	4.19E-13	4.19E-13
629	8.52E-09	1.52E-08	1319	1.54E-09	9.72E-09	2009	4.04E-13	4.04E-13
630	8.36E-09	1.52E-08	1320	1.37E-09	9.90E-09	2010	3.88E-13	3.88E-13
631	8.22E-09	1.53E-08	1321	1.22E-09	1.01E-08	2011	3.74E-13	3.74E-13
632	8.05E-09	1.53E-08	1322	1.08E-09	1.03E-08	2012	3.59E-13	3.59E-13
633	7.90E-09	1.53E-08	1323	9.50E-10	1.04E-08	2013	3.45E-13	3.45E-13
634	7.75E-09	1.53E-08	1324	8.35E-10	1.06E-08	2014	3.32E-13	3.32E-13
635	7.60E-09	1.53E-08	1325	7.32E-10	1.08E-08	2015	3.16E-13	3.16E-13
636	7.46E-09	1.54E-08	1326	6.41E-10	1.09E-08	2016	3.03E-13	3.03E-13
637	7.34E-09	1.54E-08	1327	5.60E-10	1.11E-08	2017	2.90E-13	2.90E-13
638	7.24E-09	1.55E-08	1328	4.88E-10	1.12E-08	2018	2.77E-13	2.77E-13
639	7.14E-09	1.56E-08	1329	4.25E-10	1.14E-08	2019	2.65E-13	2.65E-13
640	7.07E-09	1.57E-08	1330	3.70E-10	1.15E-08	2020	2.52E-13	2.52E-13
641	7.00E-09	1.57E-08	1331	3.23E-10	1.17E-08	2021	2.41E-13	2.41E-13
642	6.96E-09	1.58E-08	1332	2.82E-10	1.18E-08	2022	2.28E-13	2.28E-13
643	6.94E-09	1.59E-08	1333	2.46E-10	1.19E-08	2023	2.18E-13	2.18E-13
644	6.94E-09	1.61E-08	1334	2.15E-10	1.20E-08	2024	2.06E-13	2.06E-13

645	6.95E-09	1.62E-08	1335	1.88E-10	1.21E-08	2025	1.97E-13	1.97E-13
646	6.98E-09	1.63E-08	1336	1.67E-10	1.22E-08	2026	1.87E-13	1.87E-13
647	7.02E-09	1.64E-08	1337	1.48E-10	1.23E-08	2027	1.76E-13	1.76E-13
648	7.07E-09	1.64E-08	1338	1.31E-10	1.24E-08	2028	1.68E-13	1.68E-13
649	7.13E-09	1.65E-08	1339	1.18E-10	1.24E-08	2029	1.59E-13	1.59E-13
650	7.21E-09	1.66E-08	1340	1.07E-10	1.25E-08	2030	1.51E-13	1.51E-13
651	7.30E-09	1.65E-08	1341	9.71E-11	1.25E-08	2031	1.43E-13	1.43E-13
652	7.39E-09	1.65E-08	1342	8.93E-11	1.25E-08	2032	1.36E-13	1.36E-13
653	7.48E-09	1.65E-08	1343	8.29E-11	1.25E-08	2033	1.28E-13	1.28E-13
654	7.57E-09	1.65E-08	1344	7.71E-11	1.25E-08	2034	1.22E-13	1.22E-13
655	7.67E-09	1.64E-08	1345	7.32E-11	1.24E-08	2035	1.15E-13	1.15E-13
656	7.78E-09	1.63E-08	1346	6.90E-11	1.23E-08	2036	1.10E-13	1.10E-13
657	7.88E-09	1.62E-08	1347	6.61E-11	1.22E-08	2037	1.04E-13	1.04E-13
658	7.98E-09	1.61E-08	1348	6.36E-11	1.21E-08	2038	9.92E-14	9.92E-14
659	8.07E-09	1.60E-08	1349	6.09E-11	1.19E-08	2039	9.43E-14	9.43E-14
660	8.16E-09	1.58E-08	1350	5.97E-11	1.18E-08	2040	8.98E-14	8.98E-14
661	8.25E-09	1.56E-08	1351	5.77E-11	1.16E-08	2041	8.56E-14	8.56E-14
662	8.33E-09	1.55E-08	1352	5.68E-11	1.14E-08	2042	8.15E-14	8.15E-14
663	8.40E-09	1.53E-08	1353	5.55E-11	1.11E-08	2043	7.79E-14	7.79E-14
664	8.46E-09	1.51E-08	1354	5.45E-11	1.09E-08	2044	7.43E-14	7.43E-14
665	8.50E-09	1.49E-08	1355	5.39E-11	1.06E-08	2045	7.08E-14	7.08E-14
666	8.55E-09	1.47E-08	1356	5.29E-11	1.03E-08	2046	6.76E-14	6.76E-14
667	8.57E-09	1.44E-08	1357	5.25E-11	1.00E-08	2047	6.48E-14	6.48E-14
668	8.59E-09	1.44E-08	1358	5.20E-11	9.70E-09	2048	6.18E-14	6.18E-14
669	8.60E-09	1.41E-08	1359	5.13E-11	9.39E-09			
670	8.59E-09	1.40E-08	1360	5.09E-11	9.07E-09			
671	8.56E-09	1.38E-08	1361	5.08E-11	8.75E-09			
672	8.53E-09	1.37E-08	1362	5.05E-11	8.44E-09			
673	8.50E-09	1.36E-08	1363	5.02E-11	8.12E-09			
674	8.46E-09	1.36E-08	1364	5.01E-11	7.81E-09			
675	8.39E-09	1.35E-08	1365	5.00E-11	7.50E-09			
676	8.33E-09	1.35E-08	1366	5.00E-11	7.20E-09			
677	8.25E-09	1.33E-08	1367	5.00E-11	6.91E-09			
678	8.16E-09	1.33E-08	1368	5.01E-11	6.63E-09			
679	8.07E-09	1.34E-08	1369	5.03E-11	6.36E-09			
680	7.98E-09	1.34E-08	1370	5.06E-11	6.10E-09			
681	7.89E-09	1.34E-08	1371	5.09E-11	5.86E-09			
682	7.79E-09	1.35E-08	1372	5.13E-11	5.64E-09			
683	7.68E-09	1.35E-08	1373	5.18E-11	5.43E-09			
684	7.59E-09	1.36E-08	1374	5.22E-11	5.24E-09			
685	7.49E-09	1.36E-08	1375	5.28E-11	5.06E-09			
686	7.41E-09	1.36E-08	1376	5.34E-11	4.91E-09			
687	7.33E-09	1.37E-08	1377	5.42E-11	4.77E-09			
688	7.25E-09	1.38E-08	1378	5.51E-11	4.66E-09			
689	7.19E-09	1.39E-08	1379	5.58E-11	4.56E-09			
690	7.15E-09	1.39E-08	1380	5.66E-11	4.49E-09			

Appendix B

Data for Program CURLLS, Sigma and Residue

This is data from Program CURLLS.

This is data from mixture file: S.T

This data file is originally named curlls.out.

Additional data for each channel is stored in the file named curlls.plt. This includes I, Y(I), YFIT(I), SIGMAY(I), and RES(I).

The individual library file names are:

- 1 Carbon
- 2 Hydrogen
- 3 Oxygen
- 4 Sodium
- 5 Sulphur
- 6 Chlorine
- 7 Potassium
- 8 Calcium
- 9 Manganese

The model is:

```

SUBROUTINE MODEL(X,I,A,ZI,YFI)
IMPLICIT REAL*8(A-H,O-Z)
DIMENSION X(25,17000),A(25),ZI(25)
COMMON/BLOCKA/NLS
YFI=0.0E+00
DO 10 J=1,NLS
  ZI(J)=X(J,I)
  YFI=YFI+A(J)*ZI(J)
10 CONTINUE
RETURN
END
  
```

```

NBEGIN= 1 NEND= 2048 SIGMUL= 1.0E-002
CHISQR= 0.359552E+03 CHIZRO= 0 MODE= 1 NW= 1
MO= 1 SIGY (Y multiplier)= 1.0E-002
  
```

SIGMAA(I) and AREA(I) are in %.

I	A(I)	SIGMAA(I)	R(I)	AREA(I)
1	0.806752E-01	0.104654E+01 %	0.5620E+00	0.7202E+00 %
2	0.260671E+00	0.109847E-02 %	0.6061E+00	0.6171E+02 %
3	0.522977E+00	0.248985E+00 %	0.5576E+00	0.4543E+01 %
4	0.307106E-01	0.199225E+00 %	0.6764E+00	0.4993E+00 %
5	0.173145E-02	0.650699E+02 %	0.5635E+00	0.1520E-01 %
6	0.596335E-01	0.907841E-03 %	0.8536E+00	0.3213E+02 %
7	0.179762E-01	0.798746E+01 %	0.5662E+00	0.1600E+00 %
8	0.228248E-01	0.215194E+01 %	0.5703E+00	0.2041E+00 %
9	0.282032E-02	0.788661E+01 %	0.5822E+00	0.2558E-01 %

The sum of all library areas is: 100.003451319636 %

RES(I)=(Y(I)-YFIT(I))/SIGMAY(I).

I, Y(I), YFIT(I), SIGMAY(I), and RES(I) are in file curlls.plt.

<i>Ch</i>	<i>Sigma</i>	<i>Resdue</i>	<i>Ch</i>	<i>Sigma</i>	<i>Resdue</i>
1	3.50E-10	-1.17E+01	513	2.25E-12	-1.29E-01
2	3.02E-10	3.46E+00	514	2.22E-12	9.37E-01
3	2.75E-10	2.89E+00	515	2.18E-12	1.06E+01
4	2.48E-10	9.09E+00	516	2.13E-12	-2.63E+01
5	2.23E-10	4.31E+00	517	2.09E-12	1.17E+01
6	2.22E-10	1.82E-01	518	2.04E-12	2.76E+00
7	2.78E-10	-4.78E+00	519	1.99E-12	-7.05E+00
8	3.76E-10	-9.68E+00	520	1.94E-12	1.24E+01
9	3.00E-10	-3.56E+00	521	1.88E-12	1.20E+01
10	5.35E-10	-5.95E+00	522	1.82E-12	-2.17E+01
11	6.11E-10	8.55E+00	523	1.76E-12	1.04E+01
12	6.37E-10	-5.70E+00	524	1.70E-12	7.92E+00
13	6.32E-10	-2.08E+01	525	1.63E-12	-1.91E+01
14	6.05E-10	2.31E+01	526	1.57E-12	1.53E+01
15	5.45E-10	2.30E+01	527	1.50E-12	-1.47E+01
16	4.89E-10	6.88E-01	528	1.44E-12	-1.89E+01
17	4.42E-10	3.18E+01	529	1.39E-12	4.84E+01
18	3.97E-10	-5.22E+00	530	1.33E-12	-4.25E+01
19	3.57E-10	-3.62E-01	531	1.29E-12	1.47E+01
20	3.29E-10	-1.48E+00	532	1.24E-12	-5.22E+01
21	3.04E-10	-4.03E+00	533	1.21E-12	4.40E+01
22	2.83E-10	-1.40E+01	534	1.18E-12	4.48E+01
23	2.65E-10	-2.34E+01	535	1.15E-12	-6.20E+00
24	2.48E-10	1.03E+01	536	1.13E-12	-2.18E+01
25	2.32E-10	-1.25E+01	537	1.12E-12	-1.59E+00
26	2.18E-10	-2.49E+01	538	1.12E-12	3.13E+00
27	2.06E-10	1.76E+01	539	1.13E-12	4.34E+01
28	1.94E-10	-3.38E+00	540	1.15E-12	1.42E+01
29	1.84E-10	1.74E+01	541	1.19E-12	3.44E+00
30	1.75E-10	2.29E+00	542	1.25E-12	1.07E+01
31	1.67E-10	2.57E+01	543	1.33E-12	-1.20E+01
32	1.58E-10	7.71E+00	544	1.44E-12	1.07E+01
33	1.50E-10	2.36E+01	545	1.57E-12	4.96E+00
34	1.42E-10	-3.09E+01	546	1.72E-12	1.24E+01
35	1.36E-10	2.64E+01	547	1.89E-12	-2.35E+00
36	1.29E-10	-1.26E+01	548	2.07E-12	-2.37E+01
37	1.23E-10	2.18E+01	549	2.26E-12	-2.44E+01
38	1.18E-10	4.10E+01	550	2.45E-12	-6.20E-01
39	1.14E-10	3.67E+01	551	2.63E-12	2.71E+01
40	1.10E-10	6.02E+00	552	2.78E-12	8.15E+00
41	1.06E-10	-4.67E+01	553	2.90E-12	1.10E+01
42	1.03E-10	3.00E+01	554	2.98E-12	-4.56E-01
43	9.92E-11	-1.25E+01	555	3.02E-12	-5.64E+00
44	9.61E-11	-5.96E-01	556	3.02E-12	1.50E+01
45	9.46E-11	1.13E+01	557	2.97E-12	7.97E+00
46	9.70E-11	-3.73E-01	558	2.88E-12	7.18E+00
47	1.05E-10	-3.07E+00	559	2.76E-12	5.66E+00
48	1.15E-10	-3.63E+01	560	2.61E-12	2.92E+00
49	1.20E-10	9.03E+00	561	2.45E-12	8.36E+00
50	1.13E-10	1.96E+01	562	2.27E-12	-2.05E+01

51	9.64E-11	-1.16E+01	563	2.10E-12	-7.61E+00
52	8.04E-11	1.45E+01	564	1.94E-12	2.81E+01
53	7.01E-11	-1.67E+01	565	1.78E-12	-3.05E+01
54	6.50E-11	-9.52E+00	566	1.65E-12	9.78E+00
55	6.23E-11	-5.31E+00	567	1.53E-12	4.41E+01
56	6.03E-11	5.98E+00	568	1.42E-12	-1.51E+01
57	5.88E-11	1.64E+01	569	1.34E-12	8.25E+00
58	5.74E-11	-2.37E+01	570	1.27E-12	1.90E+01
59	5.62E-11	1.71E+01	571	1.21E-12	1.27E+01
60	5.50E-11	2.19E+01	572	1.17E-12	2.38E+01
61	5.37E-11	1.16E+01	573	1.13E-12	3.53E+01
62	5.24E-11	9.35E+00	574	1.10E-12	2.94E+01
63	5.12E-11	2.46E+01	575	1.07E-12	-3.18E+01
64	5.00E-11	-2.34E+01	576	1.05E-12	-5.69E+01
65	4.90E-11	6.76E+00	577	1.04E-12	1.42E+01
66	4.80E-11	-2.73E+01	578	1.02E-12	-8.91E+00
67	4.71E-11	-2.86E+01	579	1.01E-12	6.67E+01
68	4.62E-11	1.36E+01	580	9.92E-13	6.58E+00
69	4.54E-11	-5.95E+00	581	9.80E-13	8.09E+00
70	4.51E-11	-1.98E+01	582	9.70E-13	-2.98E+01
71	4.56E-11	2.50E+01	583	9.62E-13	1.59E+01
72	4.70E-11	1.60E+01	584	9.58E-13	-2.03E+01
73	4.88E-11	1.35E+01	585	9.57E-13	-2.16E+01
74	4.97E-11	3.71E+00	586	9.61E-13	-3.29E+01
75	4.87E-11	3.32E+00	587	9.72E-13	-3.35E+01
76	4.58E-11	-7.91E-01	588	9.90E-13	-2.18E+01
77	4.22E-11	-1.31E+01	589	1.02E-12	4.92E+01
78	3.92E-11	4.33E+00	590	1.05E-12	1.80E+00
79	3.72E-11	1.04E+01	591	1.10E-12	3.07E+01
80	3.60E-11	4.35E+00	592	1.15E-12	4.34E+00
81	3.53E-11	-1.60E+00	593	1.21E-12	1.42E+01
82	3.48E-11	1.72E+01	594	1.28E-12	5.25E+01
83	3.43E-11	3.45E+00	595	1.34E-12	-3.13E+01
84	3.38E-11	-1.44E+01	596	1.41E-12	5.58E+00
85	3.34E-11	2.13E+00	597	1.47E-12	-2.97E+01
86	3.30E-11	1.09E+01	598	1.53E-12	1.53E+01
87	3.25E-11	-6.61E+00	599	1.57E-12	-3.25E+01
88	3.20E-11	-8.16E-01	600	1.60E-12	-2.89E+01
89	3.14E-11	-6.45E+00	601	1.62E-12	2.29E+01
90	3.09E-11	-4.14E+00	602	1.61E-12	-1.14E+00
91	3.04E-11	-1.79E+00	603	1.59E-12	-1.37E+01
92	2.99E-11	1.60E+01	604	1.55E-12	-1.56E+00
93	2.94E-11	-1.31E+01	605	1.50E-12	2.34E+01
94	2.90E-11	-1.03E+01	606	1.43E-12	-5.82E+00
95	2.86E-11	-9.77E+00	607	1.36E-12	5.73E+00
96	2.83E-11	1.95E+01	608	1.28E-12	3.43E+01
97	2.79E-11	1.14E+01	609	1.20E-12	1.63E+01
98	2.75E-11	-2.05E+01	610	1.12E-12	-4.43E+00
99	2.72E-11	5.48E+00	611	1.05E-12	-4.64E+01
100	2.69E-11	9.79E+00	612	9.93E-13	-2.25E+01
101	2.66E-11	-8.92E+00	613	9.44E-13	-3.62E+01
102	2.65E-11	2.63E+00	614	9.08E-13	2.57E+01

103	2.67E-11	2.45E+00	615	8.86E-13	-2.00E+01
104	2.73E-11	-9.35E+00	616	8.76E-13	2.88E+00
105	2.85E-11	4.49E+00	617	8.79E-13	-3.07E+01
106	3.01E-11	1.16E+01	618	8.94E-13	5.21E+00
107	3.18E-11	2.10E+01	619	9.18E-13	6.77E+00
108	3.30E-11	-7.80E-01	620	9.49E-13	2.00E+01
109	3.33E-11	-1.79E+01	621	9.84E-13	1.24E+01
110	3.26E-11	-9.02E+00	622	1.02E-12	-4.42E+01
111	3.11E-11	2.06E+00	623	1.06E-12	-1.65E+00
112	2.91E-11	-1.99E+01	624	1.09E-12	1.91E+00
113	2.71E-11	-2.78E+01	625	1.12E-12	4.52E+00
114	2.55E-11	7.99E+00	626	1.14E-12	2.40E+01
115	2.43E-11	1.68E+01	627	1.15E-12	8.72E+00
116	2.36E-11	1.85E+01	628	1.15E-12	-4.16E+01
117	2.32E-11	1.69E+01	629	1.15E-12	6.38E+01
118	2.30E-11	1.81E+01	630	1.13E-12	-4.93E+00
119	2.28E-11	-1.88E+01	631	1.10E-12	-5.93E+01
120	2.27E-11	-1.78E+01	632	1.07E-12	-5.22E+00
121	2.27E-11	2.70E+01	633	1.04E-12	5.19E+01
122	2.25E-11	-6.34E+00	634	9.94E-13	1.31E+01
123	2.23E-11	-1.58E+01	635	9.50E-13	-8.42E+00
124	2.21E-11	-2.08E+01	636	9.05E-13	2.25E+01
125	2.19E-11	-1.27E+01	637	8.60E-13	-1.28E+01
126	2.17E-11	4.62E+00	638	8.16E-13	-4.00E+01
127	2.14E-11	-8.72E+00	639	7.75E-13	-3.17E+01
128	2.12E-11	-2.17E+00	640	7.36E-13	4.52E+00
129	2.10E-11	5.14E+00	641	7.02E-13	3.03E+01
130	2.08E-11	-2.02E+01	642	6.72E-13	2.87E+01
131	2.07E-11	-1.25E+01	643	6.47E-13	1.17E+01
132	2.07E-11	1.04E+01	644	6.27E-13	-2.23E+01
133	2.07E-11	1.86E+01	645	6.14E-13	-4.16E+01
134	2.06E-11	-2.76E+01	646	6.06E-13	2.15E+01
135	2.06E-11	-2.25E+01	647	6.05E-13	3.64E+00
136	2.06E-11	3.43E+00	648	6.11E-13	2.76E+00
137	2.05E-11	4.44E+00	649	6.23E-13	2.78E+00
138	2.04E-11	4.11E+00	650	6.41E-13	3.49E+00
139	2.02E-11	-2.35E+01	651	6.65E-13	5.05E+00
140	2.01E-11	-5.00E+00	652	6.94E-13	-7.00E+00
141	2.00E-11	7.55E+00	653	7.26E-13	2.38E+01
142	1.99E-11	1.92E+01	654	7.62E-13	2.62E+01
143	1.98E-11	1.60E+01	655	8.00E-13	-2.05E+01
144	1.97E-11	-2.59E+01	656	8.39E-13	2.01E+01
145	1.98E-11	1.33E+01	657	8.78E-13	-1.00E+01
146	1.98E-11	-1.39E+01	658	9.17E-13	2.73E+01
147	1.99E-11	9.00E+00	659	9.54E-13	-2.16E+01
148	1.99E-11	-2.00E+01	660	9.90E-13	-1.63E+01
149	2.00E-11	9.34E+00	661	1.02E-12	-7.04E+01
150	2.00E-11	9.18E+00	662	1.06E-12	3.01E+01
151	2.00E-11	5.75E-01	663	1.09E-12	-2.17E+01
152	2.01E-11	-1.39E+01	664	1.12E-12	-1.75E+01
153	2.04E-11	-4.88E+00	665	1.15E-12	-1.39E+01
154	2.10E-11	-1.53E+01	666	1.18E-12	4.02E+01

155	2.21E-11	1.22E+01	667	1.20E-12	8.85E+00
156	2.36E-11	6.16E+00	668	1.22E-12	2.72E+01
157	2.54E-11	-1.44E+01	669	1.23E-12	-3.59E+01
158	2.73E-11	-1.02E+01	670	1.24E-12	-5.00E+01
159	2.88E-11	1.14E+01	671	1.25E-12	3.14E+01
160	2.94E-11	-1.45E+01	672	1.24E-12	2.02E-01
161	2.91E-11	6.59E-01	673	1.23E-12	1.68E+01
162	2.79E-11	1.02E+01	674	1.21E-12	4.98E+01
163	2.61E-11	-1.34E+01	675	1.17E-12	-3.46E+01
164	2.43E-11	3.87E-01	676	1.13E-12	-1.95E+01
165	2.27E-11	-2.19E+01	677	1.08E-12	-4.08E+01
166	2.16E-11	-1.08E+01	678	1.03E-12	-6.27E+00
167	2.09E-11	2.35E+00	679	9.70E-13	-9.73E+00
168	2.06E-11	2.03E+01	680	9.07E-13	1.90E+01
169	2.05E-11	2.50E+01	681	8.44E-13	-1.91E+01
170	2.05E-11	-3.77E+00	682	7.81E-13	1.30E+01
171	2.07E-11	6.62E+00	683	7.20E-13	-4.76E+00
172	2.10E-11	-3.22E+00	684	6.63E-13	3.44E+01
173	2.15E-11	1.97E+01	685	6.10E-13	-5.01E+01
174	2.21E-11	-1.46E+01	686	5.64E-13	6.61E+00
175	2.30E-11	2.18E+01	687	5.24E-13	4.62E+00
176	2.39E-11	1.13E+01	688	4.91E-13	-1.50E+00
177	2.47E-11	-1.40E+01	689	4.66E-13	8.73E+00
178	2.53E-11	1.17E+01	690	4.48E-13	-9.88E+00
179	2.53E-11	2.78E-01	691	4.39E-13	-2.11E+00
180	2.47E-11	1.22E+00	692	4.37E-13	-1.13E+01
181	2.34E-11	1.27E+01	693	4.44E-13	8.27E+00
182	2.16E-11	6.56E+00	694	4.57E-13	-1.17E+01
183	1.95E-11	-2.75E-01	695	4.78E-13	5.44E-01
184	1.74E-11	2.22E+01	696	5.05E-13	1.04E+00
185	1.54E-11	-2.79E+01	697	5.37E-13	5.74E+00
186	1.38E-11	9.33E-01	698	5.72E-13	1.06E+00
187	1.25E-11	2.87E+01	699	6.10E-13	1.72E+01
188	1.14E-11	-1.68E+01	700	6.48E-13	-4.12E+01
189	1.06E-11	6.77E+00	701	6.85E-13	-2.00E+01
190	9.95E-12	-1.53E+01	702	7.20E-13	-2.84E+01
191	9.48E-12	7.23E-01	703	7.49E-13	-3.58E+01
192	9.22E-12	2.59E+00	704	7.72E-13	3.41E+01
193	9.29E-12	-4.77E+00	705	7.87E-13	-3.11E-01
194	9.95E-12	-1.27E+01	706	7.94E-13	1.63E+01
195	1.16E-11	-7.69E+00	707	7.92E-13	-5.22E+00
196	1.49E-11	9.16E+00	708	7.81E-13	1.04E+01
197	2.05E-11	-1.78E+01	709	7.62E-13	-1.27E-01
198	2.92E-11	-9.74E+00	710	7.35E-13	-3.92E+01
199	4.13E-11	-1.12E+01	711	7.02E-13	2.69E+00
200	5.62E-11	-8.83E+00	712	6.65E-13	-1.16E+01
201	7.27E-11	-1.25E+01	713	6.26E-13	3.54E+01
202	8.84E-11	-1.32E+01	714	5.85E-13	-7.09E+00
203	1.01E-10	2.65E+01	715	5.46E-13	2.39E+00
204	1.07E-10	-2.18E+01	716	5.09E-13	-6.59E+00
205	1.07E-10	3.13E+01	717	4.77E-13	-7.55E-02
206	9.94E-11	1.02E+01	718	4.49E-13	-1.05E+01

207	8.67E-11	-8.05E+00	719	4.27E-13	-7.38E+00
208	7.10E-11	1.86E-01	720	4.11E-13	-3.01E+00
209	5.49E-11	-1.09E+01	721	4.01E-13	1.66E+00
210	4.03E-11	-1.34E+00	722	3.96E-13	-3.03E+00
211	2.84E-11	1.65E+01	723	3.96E-13	1.33E+01
212	1.93E-11	-1.19E+01	724	3.99E-13	-7.03E-01
213	1.30E-11	3.11E+00	725	4.05E-13	1.59E+01
214	8.83E-12	-3.63E+00	726	4.12E-13	1.29E+01
215	6.23E-12	-2.39E+01	727	4.19E-13	9.19E+00
216	4.70E-12	-2.55E+00	728	4.25E-13	1.04E+01
217	3.83E-12	1.05E+01	729	4.29E-13	7.38E+00
218	3.35E-12	8.92E+00	730	4.30E-13	-1.05E+01
219	3.09E-12	-1.48E+01	731	4.28E-13	-1.11E+00
220	2.96E-12	-1.01E+01	732	4.23E-13	8.48E+00
221	2.91E-12	4.14E+00	733	4.14E-13	-6.15E+00
222	2.90E-12	9.43E+00	734	4.02E-13	7.16E+00
223	2.91E-12	-1.01E+01	735	3.86E-13	-4.39E+00
224	2.94E-12	-1.04E+01	736	3.69E-13	4.40E+00
225	2.99E-12	-2.78E+00	737	3.49E-13	-3.73E+00
226	3.03E-12	-1.23E+01	738	3.28E-13	-6.73E+00
227	3.07E-12	5.84E+00	739	3.07E-13	-1.05E+01
228	3.09E-12	-1.22E+01	740	2.86E-13	6.78E+00
229	3.10E-12	-1.06E+00	741	2.65E-13	3.53E+00
230	3.09E-12	-1.09E+01	742	2.45E-13	-8.54E+00
231	3.07E-12	1.19E+00	743	2.27E-13	1.34E+01
232	3.03E-12	-1.14E+01	744	2.10E-13	9.37E-01
233	2.98E-12	-7.76E+00	745	1.94E-13	-2.36E+01
234	2.92E-12	-5.82E+00	746	1.80E-13	-6.63E+00
235	2.86E-12	5.80E-01	747	1.68E-13	2.50E+01
236	2.80E-12	4.06E+00	748	1.56E-13	-1.49E+01
237	2.74E-12	-1.19E+01	749	1.46E-13	-4.68E+01
238	2.70E-12	2.00E+01	750	1.38E-13	1.94E+01
239	2.66E-12	3.33E-01	751	1.30E-13	2.13E+00
240	2.63E-12	4.68E+00	752	1.23E-13	-3.37E+01
241	2.61E-12	1.52E+01	753	1.17E-13	-3.79E+01
242	2.59E-12	-6.43E+00	754	1.12E-13	-6.03E+01
243	2.56E-12	-1.31E+01	755	1.09E-13	4.74E+01
244	2.53E-12	4.09E+00	756	1.06E-13	-8.47E+00
245	2.49E-12	9.28E-01	757	1.04E-13	-2.90E+01
246	2.45E-12	1.30E+01	758	1.04E-13	-2.80E+01
247	2.40E-12	1.50E+01	759	1.06E-13	4.96E+01
248	2.35E-12	-4.10E+00	760	1.09E-13	-3.87E+00
249	2.31E-12	1.62E+01	761	1.14E-13	-3.49E+01
250	2.28E-12	-2.62E+01	762	1.22E-13	3.90E+01
251	2.27E-12	-2.69E+01	763	1.31E-13	-4.96E+01
252	2.29E-12	4.97E+00	764	1.43E-13	-3.95E+01
253	2.33E-12	1.29E+01	765	1.58E-13	4.69E+01
254	2.39E-12	9.41E+00	766	1.74E-13	3.71E+00
255	2.47E-12	-4.65E+00	767	1.92E-13	9.72E+00
256	2.57E-12	-1.64E+01	768	2.11E-13	-2.28E+01
257	2.69E-12	7.39E+00	769	2.31E-13	-3.18E+01
258	2.80E-12	-4.16E+00	770	2.52E-13	8.47E-02

259	2.90E-12	6.04E+00	771	2.72E-13	-9.62E+00
260	2.97E-12	-2.94E+00	772	2.91E-13	-1.08E+01
261	3.00E-12	-6.05E+00	773	3.08E-13	2.86E-01
262	2.99E-12	-5.28E+00	774	3.23E-13	2.19E+01
263	2.94E-12	2.17E+01	775	3.34E-13	1.19E+01
264	2.85E-12	1.76E+01	776	3.41E-13	7.92E+00
265	2.74E-12	2.25E+01	777	3.44E-13	8.96E+00
266	2.62E-12	-9.50E+00	778	3.42E-13	-1.40E+01
267	2.51E-12	-1.47E-01	779	3.37E-13	1.55E+01
268	2.43E-12	4.67E+00	780	3.26E-13	-9.58E+00
269	2.37E-12	1.93E+01	781	3.12E-13	-1.85E+01
270	2.34E-12	9.97E+00	782	2.95E-13	1.16E+01
271	2.33E-12	-1.43E+01	783	2.75E-13	2.35E+01
272	2.35E-12	2.89E+00	784	2.52E-13	-1.04E+01
273	2.38E-12	-6.59E+00	785	2.29E-13	2.71E+01
274	2.42E-12	2.62E+00	786	2.04E-13	-2.45E+01
275	2.45E-12	-2.66E+01	787	1.80E-13	-1.70E+00
276	2.49E-12	-2.65E+00	788	1.57E-13	1.56E+01
277	2.51E-12	-4.30E+00	789	1.34E-13	-5.08E+01
278	2.52E-12	3.63E+00	790	1.14E-13	1.84E+01
279	2.51E-12	4.59E+00	791	9.50E-14	3.18E+01
280	2.48E-12	1.09E+01	792	7.83E-14	3.71E+01
281	2.43E-12	1.59E+01	793	6.36E-14	-1.24E+01
282	2.36E-12	7.43E+00	794	5.11E-14	8.23E-01
283	2.28E-12	1.74E+01	795	4.05E-14	4.71E+00
284	2.18E-12	-2.00E+01	796	3.17E-14	-4.65E+00
285	2.09E-12	2.48E+01	797	2.46E-14	9.17E+00
286	1.99E-12	1.55E+01	798	1.89E-14	2.51E+01
287	1.90E-12	3.83E+00	799	1.44E-14	1.39E+01
288	1.81E-12	-5.31E+00	800	1.09E-14	3.53E+01
289	1.74E-12	-1.65E+01	801	8.20E-15	2.68E+01
290	1.68E-12	-4.08E+01	802	6.18E-15	-3.94E-01
291	1.64E-12	-5.30E+00	803	4.69E-15	1.41E+01
292	1.61E-12	7.43E+00	804	3.60E-15	7.93E+00
293	1.59E-12	1.28E+01	805	2.82E-15	2.67E+01
294	1.58E-12	1.34E+01	806	2.25E-15	6.77E+00
295	1.58E-12	-1.04E+01	807	1.85E-15	1.08E+01
296	1.59E-12	2.96E+01	808	1.59E-15	-3.15E+00
297	1.60E-12	7.13E+00	809	1.39E-15	3.57E+01
298	1.61E-12	-2.30E+01	810	1.23E-15	1.61E+01
299	1.63E-12	-2.17E+01	811	1.12E-15	-4.44E+00
300	1.65E-12	1.51E+01	812	1.05E-15	-2.47E+01
301	1.67E-12	3.90E+00	813	9.99E-16	-5.88E+00
302	1.68E-12	2.05E+01	814	9.51E-16	8.84E+00
303	1.69E-12	2.30E+01	815	9.03E-16	-4.06E+00
304	1.69E-12	3.17E+01	816	8.59E-16	-7.73E+00
305	1.68E-12	-5.76E+00	817	8.24E-16	5.78E-01
306	1.67E-12	1.64E+01	818	7.91E-16	3.22E+00
307	1.65E-12	1.79E+01	819	7.59E-16	3.52E+00
308	1.63E-12	2.23E+01	820	7.30E-16	-3.47E+00
309	1.61E-12	2.12E+01	821	7.01E-16	-1.90E+00
310	1.58E-12	-4.24E+01	822	6.75E-16	-1.09E+00

311	1.56E-12	-4.42E+01	823	6.51E-16	-2.02E-01
312	1.55E-12	1.86E+01	824	6.27E-16	-2.02E-01
313	1.54E-12	8.55E+00	825	6.03E-16	-2.02E-01
314	1.53E-12	-6.07E+00	826	5.83E-16	-2.02E-01
315	1.52E-12	-1.46E+01	827	5.63E-16	-2.02E-01
316	1.52E-12	-4.25E+01	828	5.46E-16	-2.02E-01
317	1.53E-12	-4.62E+00	829	5.29E-16	-2.02E-01
318	1.54E-12	8.07E-01	830	5.13E-16	-2.02E-01
319	1.55E-12	-1.82E+00	831	5.00E-16	-2.02E-01
320	1.57E-12	2.72E+01	832	4.87E-16	-2.02E-01
321	1.59E-12	1.75E+01	833	4.77E-16	-2.02E-01
322	1.61E-12	6.06E+00	834	4.68E-16	-2.02E-01
323	1.63E-12	2.67E+01	835	4.62E-16	-2.02E-01
324	1.64E-12	-1.30E+01	836	4.55E-16	-2.02E-01
325	1.65E-12	-1.94E+01	837	4.49E-16	-2.02E-01
326	1.66E-12	1.21E+01	838	4.45E-16	-2.02E-01
327	1.65E-12	-3.16E-01	839	4.40E-16	-2.02E-01
328	1.63E-12	-4.67E+01	840	4.38E-16	-2.02E-01
329	1.61E-12	-1.65E+01	841	4.36E-16	-2.02E-01
330	1.58E-12	-8.40E+00	842	4.34E-16	-2.02E-01
331	1.54E-12	-3.36E+01	843	4.32E-16	-2.02E-01
332	1.51E-12	1.76E+01	844	4.30E-16	-2.02E-01
333	1.47E-12	-5.78E-01	845	4.30E-16	-2.02E-01
334	1.43E-12	-1.95E+01	846	4.27E-16	-2.02E-01
335	1.40E-12	-3.99E+00	847	4.23E-16	-2.02E-01
336	1.37E-12	-2.33E+01	848	4.21E-16	-2.02E-01
337	1.35E-12	-2.70E+01	849	4.19E-16	-2.02E-01
338	1.34E-12	-3.15E+01	850	4.15E-16	-2.02E-01
339	1.34E-12	3.48E+01	851	4.10E-16	-2.02E-01
340	1.34E-12	1.40E+01	852	4.06E-16	-2.02E-01
341	1.35E-12	1.83E+01	853	4.00E-16	-2.02E-01
342	1.36E-12	2.91E+01	854	3.95E-16	-2.02E-01
343	1.37E-12	3.17E+01	855	3.89E-16	-2.02E-01
344	1.38E-12	-1.53E+00	856	3.82E-16	-2.02E-01
345	1.39E-12	6.37E+00	857	3.74E-16	-2.02E-01
346	1.40E-12	1.09E+00	858	3.67E-16	-2.02E-01
347	1.40E-12	-2.72E+01	859	3.59E-16	-2.02E-01
348	1.40E-12	2.81E+01	860	3.50E-16	-2.02E-01
349	1.39E-12	7.92E+00	861	3.42E-16	-2.02E-01
350	1.37E-12	-4.86E+01	862	3.31E-16	-2.02E-01
351	1.36E-12	1.48E+01	863	3.20E-16	-2.02E-01
352	1.34E-12	1.03E+01	864	3.12E-16	-2.02E-01
353	1.32E-12	4.36E+01	865	3.01E-16	-2.02E-01
354	1.30E-12	-2.13E+01	866	2.90E-16	-2.02E-01
355	1.29E-12	3.29E+00	867	2.80E-16	-2.02E-01
356	1.29E-12	4.51E+01	868	2.69E-16	-2.02E-01
357	1.28E-12	-2.90E+01	869	2.58E-16	-2.02E-01
358	1.29E-12	4.97E+00	870	2.47E-16	-2.02E-01
359	1.30E-12	-6.91E+00	871	2.39E-16	-2.02E-01
360	1.31E-12	-4.55E+00	872	2.30E-16	-2.02E-01
361	1.32E-12	-1.37E+01	873	2.22E-16	-2.02E-01
362	1.33E-12	-8.27E+00	874	2.14E-16	-2.02E-01

363	1.34E-12	-1.45E+01	875	2.09E-16	-2.02E-01
364	1.35E-12	-6.21E+00	876	2.03E-16	-2.02E-01
365	1.36E-12	-3.83E+00	877	1.99E-16	-2.02E-01
366	1.37E-12	8.00E-01	878	1.97E-16	-2.02E-01
367	1.37E-12	-3.10E+01	879	1.96E-16	-2.02E-01
368	1.37E-12	-1.27E+01	880	1.96E-16	-2.02E-01
369	1.37E-12	7.13E+00	881	1.96E-16	-2.02E-01
370	1.37E-12	1.93E+01	882	1.98E-16	-2.02E-01
371	1.35E-12	-2.83E+01	883	2.00E-16	-2.02E-01
372	1.34E-12	4.23E+00	884	2.03E-16	-2.02E-01
373	1.32E-12	-8.64E-01	885	2.08E-16	-2.02E-01
374	1.30E-12	-6.80E+00	886	2.12E-16	-2.02E-01
375	1.27E-12	-4.53E+01	887	2.15E-16	-2.02E-01
376	1.25E-12	4.21E+01	888	2.20E-16	-2.02E-01
377	1.22E-12	2.39E+00	889	2.24E-16	-2.02E-01
378	1.20E-12	4.39E+01	890	2.28E-16	-2.02E-01
379	1.17E-12	2.27E+00	891	2.30E-16	-2.02E-01
380	1.15E-12	-6.33E+00	892	2.32E-16	-2.02E-01
381	1.13E-12	-7.61E+00	893	2.35E-16	-2.02E-01
382	1.11E-12	-1.58E+01	894	2.37E-16	-2.02E-01
383	1.10E-12	1.90E+01	895	2.37E-16	-2.02E-01
384	1.09E-12	5.93E-01	896	2.37E-16	-2.02E-01
385	1.08E-12	2.89E+01	897	2.37E-16	-2.02E-01
386	1.07E-12	1.05E+01	898	2.35E-16	-2.02E-01
387	1.06E-12	-1.59E+01	899	2.35E-16	-2.02E-01
388	1.05E-12	-3.62E+01	900	2.32E-16	-2.02E-01
389	1.05E-12	3.18E+01	901	2.30E-16	-2.02E-01
390	1.04E-12	1.12E+01	902	2.26E-16	-2.02E-01
391	1.04E-12	2.04E+01	903	2.24E-16	-2.02E-01
392	1.04E-12	2.14E+01	904	2.22E-16	-2.02E-01
393	1.04E-12	2.96E+01	905	2.17E-16	-2.02E-01
394	1.04E-12	-2.87E+01	906	2.14E-16	-2.02E-01
395	1.05E-12	7.90E+00	907	2.11E-16	-2.02E-01
396	1.06E-12	-2.14E+01	908	2.08E-16	-2.02E-01
397	1.08E-12	-1.21E+01	909	2.03E-16	-2.02E-01
398	1.11E-12	2.47E+01	910	2.00E-16	-2.02E-01
399	1.14E-12	1.40E+01	911	1.97E-16	-2.02E-01
400	1.17E-12	-2.75E+00	912	1.93E-16	-2.02E-01
401	1.20E-12	-6.18E+01	913	1.90E-16	-2.02E-01
402	1.24E-12	1.29E+01	914	1.86E-16	-2.02E-01
403	1.27E-12	1.31E+01	915	1.82E-16	-2.02E-01
404	1.30E-12	1.37E+01	916	1.79E-16	-2.02E-01
405	1.32E-12	-8.43E+00	917	1.76E-16	-2.02E-01
406	1.34E-12	2.22E+01	918	1.73E-16	-2.02E-01
407	1.35E-12	2.38E+01	919	1.70E-16	-2.02E-01
408	1.35E-12	1.63E+00	920	1.68E-16	-2.02E-01
409	1.34E-12	-5.69E-01	921	1.66E-16	-2.02E-01
410	1.33E-12	-3.64E+00	922	1.65E-16	-2.02E-01
411	1.32E-12	3.70E+01	923	1.64E-16	-2.02E-01
412	1.30E-12	7.07E-01	924	1.63E-16	-2.02E-01
413	1.29E-12	3.97E+01	925	1.63E-16	-2.02E-01
414	1.27E-12	-1.83E+00	926	1.64E-16	-2.02E-01

415	1.26E-12	3.12E+01	927	1.65E-16	-2.02E-01
416	1.24E-12	-1.85E+01	928	1.66E-16	-2.02E-01
417	1.23E-12	1.06E+01	929	1.67E-16	-2.02E-01
418	1.22E-12	3.73E+01	930	1.69E-16	-2.02E-01
419	1.21E-12	1.30E+01	931	1.71E-16	-2.02E-01
420	1.20E-12	3.56E+01	932	1.73E-16	-2.02E-01
421	1.19E-12	8.81E+00	933	1.76E-16	-2.02E-01
422	1.18E-12	2.93E+01	934	1.78E-16	-2.02E-01
423	1.17E-12	2.26E+00	935	1.81E-16	-2.02E-01
424	1.16E-12	2.29E+01	936	1.83E-16	-2.02E-01
425	1.15E-12	-5.66E+00	937	1.85E-16	-2.02E-01
426	1.14E-12	-3.62E+01	938	1.88E-16	-2.02E-01
427	1.13E-12	-1.32E+01	939	1.91E-16	-2.02E-01
428	1.12E-12	-4.19E+01	940	1.92E-16	-2.02E-01
429	1.11E-12	-6.99E+01	941	1.94E-16	-2.02E-01
430	1.10E-12	-4.54E+01	942	1.95E-16	-2.02E-01
431	1.09E-12	-1.92E+01	943	1.96E-16	-2.02E-01
432	1.08E-12	6.42E+00	944	1.97E-16	-2.02E-01
433	1.06E-12	-4.85E+00	945	1.97E-16	-2.02E-01
434	1.05E-12	2.31E+01	946	1.97E-16	-2.02E-01
435	1.03E-12	-4.76E+01	947	1.97E-16	-2.02E-01
436	1.02E-12	3.62E+01	948	1.96E-16	-2.02E-01
437	1.01E-12	2.08E+00	949	1.95E-16	-2.02E-01
438	1.00E-12	-3.50E+01	950	1.93E-16	-2.02E-01
439	9.99E-13	1.45E+01	951	1.91E-16	-2.02E-01
440	1.00E-12	-3.56E+01	952	1.87E-16	-2.02E-01
441	1.01E-12	-5.63E+01	953	1.85E-16	-2.02E-01
442	1.03E-12	-4.14E+01	954	1.82E-16	-2.02E-01
443	1.06E-12	9.84E+00	955	1.78E-16	-2.02E-01
444	1.09E-12	4.43E+00	956	1.75E-16	-2.02E-01
445	1.13E-12	-1.88E+01	957	1.70E-16	-2.02E-01
446	1.18E-12	-5.00E+00	958	1.66E-16	-2.02E-01
447	1.23E-12	9.82E+00	959	1.62E-16	-2.02E-01
448	1.28E-12	2.37E+01	960	1.57E-16	-2.02E-01
449	1.33E-12	4.00E+01	961	1.54E-16	-2.02E-01
450	1.37E-12	-1.42E+01	962	1.50E-16	-2.02E-01
451	1.41E-12	-2.15E+01	963	1.46E-16	-2.02E-01
452	1.44E-12	-1.22E+01	964	1.41E-16	-2.02E-01
453	1.47E-12	3.75E+01	965	1.38E-16	-2.02E-01
454	1.48E-12	-4.61E+00	966	1.34E-16	-2.02E-01
455	1.48E-12	-3.42E+01	967	1.31E-16	-2.02E-01
456	1.48E-12	1.80E+01	968	1.28E-16	-2.02E-01
457	1.46E-12	-2.45E+01	969	1.26E-16	-2.02E-01
458	1.44E-12	-2.82E+01	970	1.24E-16	-2.02E-01
459	1.42E-12	8.48E+00	971	1.22E-16	-2.02E-01
460	1.40E-12	4.64E+01	972	1.20E-16	-2.02E-01
461	1.37E-12	1.10E+01	973	1.19E-16	-2.02E-01
462	1.35E-12	3.12E+01	974	1.18E-16	-2.02E-01
463	1.32E-12	-5.61E+00	975	1.17E-16	-2.02E-01
464	1.31E-12	-2.57E+01	976	1.16E-16	-2.02E-01
465	1.34E-12	3.49E+01	977	1.16E-16	-2.02E-01
466	1.36E-12	-2.75E+01	978	1.11E-16	-2.02E-01

472	1.36E-12	4.25E+01	984	9.87E-17	-2.02E-01
473	1.36E-12	2.95E+00	985	9.64E-17	-2.02E-01
474	1.36E-12	5.15E+01	986	9.37E-17	-2.02E-01
475	1.35E-12	2.60E+01	987	9.09E-17	-2.02E-01
476	1.33E-12	1.56E+01	988	8.82E-17	-2.02E-01
477	1.30E-12	-2.83E+01	989	8.53E-17	-2.02E-01
478	1.28E-12	6.58E+00	990	8.25E-17	-2.02E-01
479	1.25E-12	8.87E+00	991	7.97E-17	-2.02E-01
480	1.21E-12	-2.30E+01	992	7.66E-17	-2.02E-01
481	1.18E-12	-2.24E+01	993	7.39E-17	-2.02E-01
482	1.15E-12	-2.11E+01	994	7.10E-17	-2.02E-01
483	1.13E-12	1.53E+01	995	6.82E-17	-2.02E-01
484	1.10E-12	-3.90E+01	996	6.55E-17	-2.02E-01
485	1.09E-12	3.61E+01	997	6.25E-17	-2.02E-01
486	1.07E-12	1.85E+01	998	5.96E-17	-2.02E-01
487	1.06E-12	-1.53E+01	999	5.66E-17	-2.02E-01
488	1.05E-12	4.74E+00	1000	5.37E-17	-2.02E-01
489	1.05E-12	6.34E+01	1001	5.07E-17	-2.02E-01
490	1.04E-12	-2.84E+01	1002	4.78E-17	-2.02E-01
491	1.05E-12	1.27E+01	1003	4.49E-17	-2.02E-01
492	1.06E-12	5.36E+01	1004	4.19E-17	-2.02E-01
493	1.07E-12	-1.82E+01	1005	3.88E-17	-2.02E-01
494	1.09E-12	5.28E+00	1006	3.59E-17	-2.02E-01
495	1.12E-12	-4.44E+01	1007	3.32E-17	-2.02E-01
496	1.16E-12	-5.61E+01	1008	3.03E-17	-2.02E-01
497	1.22E-12	2.53E+00	1009	2.77E-17	-2.02E-01
498	1.28E-12	-4.02E+01	1010	2.52E-17	-2.02E-01
499	1.36E-12	-1.92E+01	1011	2.28E-17	-2.02E-01
500	1.45E-12	-1.24E+01	1012	2.06E-17	-2.02E-01
501	1.55E-12	-1.99E+01	1013	1.87E-17	-2.02E-01
502	1.66E-12	-2.34E+00	1014	1.68E-17	-2.02E-01
503	1.77E-12	-2.08E+01	1015	1.51E-17	-2.02E-01
504	1.88E-12	-3.71E+01	1016	1.36E-17	-2.02E-01
505	1.99E-12	7.72E+00	1017	1.22E-17	-2.02E-01
506	2.08E-12	-1.86E+01	1018	1.10E-17	-2.02E-01
507	2.16E-12	-6.72E+00	1019	9.92E-18	-2.02E-01
508	2.22E-12	-4.63E+00	1020	8.98E-18	-2.02E-01
509	2.26E-12	-1.23E+01	1021	8.15E-18	-2.02E-01
510	2.28E-12	-1.88E+00	1022	7.43E-18	-2.02E-01
511	2.29E-12	1.65E+01	1023	6.76E-18	-2.02E-01
512	2.28E-12	2.57E+01	1024	6.18E-18	-2.02E-01

APPENDIX C

CEARCPG Input Card and Data for Oil, Water and Gas Libraries

CEARCPG INPUT FOR OIL		
33 -	Number	Wt. Fraction
34 - m1	1001	-0.153
35 -	6012	-0.847

CEARCPG INPUT FOR WATER		
33 -	Number	Wt. Fraction
34 - m1	1001	-0.10854
35 -	8016	-0.86146
36 -	11023	-0.01181
37 -	17035	-0.1819

CEARCPG INPUT FOR GAS		
33 -	Number	Wt. Fraction
34 -m1	1001	-0.01921
35 -	8016	-0.30498
36 -	17035	-0.67581

Channels	Energy (KeV)	H+C Oil	H+O+Na+Cl Water	H+O+Cl Gas
1	0.0027787	1.16E+03	5.78E+02	1.45E-01
2	0.0083362	1.03E+03	5.19E+02	1.36E-01
3	0.0138937	9.34E+02	4.80E+02	1.36E-01
4	0.0194512	8.62E+02	4.49E+02	1.33E-01
5	0.0250087	8.09E+02	4.26E+02	1.33E-01
6	0.0305662	7.67E+02	4.09E+02	1.33E-01
7	0.0361237	7.23E+02	3.90E+02	1.32E-01
8	0.0416813	6.80E+02	3.70E+02	1.29E-01
9	0.0472387	6.41E+02	3.52E+02	1.27E-01
10	0.0527963	6.16E+02	3.38E+02	1.25E-01
11	0.0583537	6.24E+02	3.34E+02	1.25E-01
12	0.0639113	6.75E+02	3.42E+02	1.23E-01
13	0.0694687	7.73E+02	3.69E+02	1.22E-01
14	0.0750263	8.99E+02	4.17E+02	1.21E-01
15	0.0805837	1.06E+03	4.83E+02	1.20E-01
16	0.0861413	1.19E+03	5.48E+02	1.20E-01
17	0.0916987	1.10E+03	5.25E+02	1.19E-01
18	0.0972563	8.83E+02	4.45E+02	1.18E-01
19	0.1028137	1.26E+03	6.27E+02	1.27E-01
20	0.1083712	1.56E+03	7.79E+02	1.42E-01
21	0.1139287	1.66E+03	8.29E+02	1.76E-01
22	0.1194862	1.72E+03	8.59E+02	2.22E-01
23	0.1250438	1.74E+03	8.83E+02	1.92E-01
24	0.1306012	1.74E+03	8.94E+02	1.54E-01
25	0.1361587	1.72E+03	9.00E+02	1.58E-01
26	0.1417162	1.69E+03	9.06E+02	1.76E-01
27	0.1472738	1.63E+03	9.01E+02	1.76E-01

28	0.1528312	1.55E+03	8.82E+02	1.64E-01
29	0.1583887	1.46E+03	8.51E+02	1.60E-01
30	0.1639462	1.37E+03	8.14E+02	1.63E-01
31	0.1695038	1.28E+03	7.77E+02	1.71E-01
32	0.1750612	1.20E+03	7.38E+02	1.80E-01
33	0.1806187	1.12E+03	7.02E+02	1.88E-01
34	0.1861762	1.06E+03	6.70E+02	1.96E-01
35	0.1917338	9.94E+02	6.41E+02	2.00E-01
36	0.1972912	9.35E+02	6.11E+02	1.99E-01
37	0.2028487	8.79E+02	5.79E+02	1.99E-01
38	0.2084062	8.33E+02	5.51E+02	2.02E-01
39	0.2139638	7.97E+02	5.28E+02	2.03E-01
40	0.2195212	7.65E+02	5.08E+02	2.03E-01
41	0.2250787	7.35E+02	4.91E+02	2.06E-01
42	0.2306362	7.09E+02	4.76E+02	2.11E-01
43	0.2361938	6.84E+02	4.63E+02	2.12E-01
44	0.2417512	6.61E+02	4.54E+02	2.09E-01
45	0.2473087	6.41E+02	4.48E+02	2.05E-01
46	0.2528662	6.21E+02	4.43E+02	2.02E-01
47	0.2584238	6.02E+02	4.36E+02	1.98E-01
48	0.2639812	5.83E+02	4.25E+02	1.93E-01
49	0.2695387	5.63E+02	4.11E+02	1.88E-01
50	0.2750962	5.45E+02	3.97E+02	1.83E-01
51	0.2806537	5.28E+02	3.82E+02	1.82E-01
52	0.2862112	5.13E+02	3.69E+02	1.82E-01
53	0.2917688	4.99E+02	3.55E+02	1.82E-01
54	0.2973262	4.87E+02	3.43E+02	1.83E-01
55	0.3028838	4.74E+02	3.31E+02	1.83E-01
56	0.3084412	4.63E+02	3.19E+02	1.83E-01
57	0.3139987	4.51E+02	3.09E+02	1.82E-01
58	0.3195562	4.41E+02	3.00E+02	1.80E-01
59	0.3251137	4.30E+02	2.91E+02	1.78E-01
60	0.3306712	4.20E+02	2.83E+02	1.76E-01
61	0.3362288	4.11E+02	2.75E+02	1.75E-01
62	0.3417862	4.02E+02	2.67E+02	1.74E-01
63	0.3473438	3.94E+02	2.59E+02	1.72E-01
64	0.3529012	3.87E+02	2.52E+02	1.70E-01
65	0.3584587	3.81E+02	2.45E+02	1.69E-01
66	0.3640162	3.74E+02	2.39E+02	1.70E-01
67	0.3695737	3.67E+02	2.33E+02	1.75E-01
68	0.3751312	3.60E+02	2.28E+02	1.80E-01
69	0.3806888	3.54E+02	2.23E+02	1.83E-01
70	0.3862462	3.46E+02	2.17E+02	1.79E-01
71	0.3918038	3.40E+02	2.12E+02	1.69E-01
72	0.3973612	3.33E+02	2.07E+02	1.55E-01
73	0.4029187	3.26E+02	2.01E+02	1.40E-01
74	0.4084762	3.19E+02	1.96E+02	1.27E-01
75	0.4140337	3.13E+02	1.91E+02	1.17E-01
76	0.4195912	3.08E+02	1.86E+02	1.10E-01
77	0.4251488	3.04E+02	1.83E+02	1.06E-01
78	0.4307062	3.00E+02	1.80E+02	1.05E-01
79	0.4362638	2.97E+02	1.77E+02	1.07E-01
80	0.4418212	2.92E+02	1.74E+02	1.10E-01
81	0.4473787	2.88E+02	1.71E+02	1.14E-01
82	0.4529362	2.83E+02	1.68E+02	1.19E-01
83	0.4584937	2.79E+02	1.66E+02	1.24E-01
84	0.4640512	2.74E+02	1.63E+02	1.28E-01
85	0.4696088	2.70E+02	1.61E+02	1.30E-01
86	0.4751662	2.67E+02	1.60E+02	1.31E-01
87	0.4807238	2.63E+02	1.59E+02	1.29E-01
88	0.4862812	2.60E+02	1.58E+02	1.27E-01
89	0.4918387	2.57E+02	1.57E+02	1.25E-01

90	0.4973962	2.55E+02	1.56E+02	1.26E-01
91	0.5029537	2.54E+02	1.57E+02	1.34E-01
92	0.5085112	2.55E+02	1.58E+02	1.55E-01
93	0.5140687	2.57E+02	1.61E+02	1.94E-01
94	0.5196262	2.61E+02	1.65E+02	2.54E-01
95	0.5251837	2.65E+02	1.69E+02	3.34E-01
96	0.5307412	2.69E+02	1.73E+02	4.27E-01
97	0.5362988	2.70E+02	1.74E+02	5.20E-01
98	0.5418563	2.68E+02	1.73E+02	5.97E-01
99	0.5474138	2.63E+02	1.68E+02	6.43E-01
100	0.5529713	2.54E+02	1.60E+02	6.47E-01
101	0.5585288	2.43E+02	1.50E+02	6.08E-01
102	0.5640862	2.31E+02	1.40E+02	5.31E-01
103	0.5696438	2.21E+02	1.31E+02	4.33E-01
104	0.5752012	2.12E+02	1.23E+02	3.33E-01
105	0.5807587	2.05E+02	1.17E+02	2.44E-01
106	0.5863162	2.00E+02	1.13E+02	1.75E-01
107	0.5918737	1.97E+02	1.11E+02	1.27E-01
108	0.5974312	1.93E+02	1.09E+02	9.64E-02
109	0.6029887	1.90E+02	1.07E+02	7.85E-02
110	0.6085462	1.88E+02	1.05E+02	6.84E-02
111	0.6141037	1.86E+02	1.04E+02	6.27E-02
112	0.6196612	1.83E+02	1.03E+02	5.95E-02
113	0.6252188	1.81E+02	1.01E+02	5.76E-02
114	0.6307763	1.79E+02	1.00E+02	5.66E-02
115	0.6363338	1.77E+02	9.90E+01	5.62E-02
116	0.6418913	1.75E+02	9.79E+01	5.59E-02
117	0.6474488	1.73E+02	9.69E+01	5.58E-02
118	0.6530062	1.71E+02	9.59E+01	5.56E-02
119	0.6585638	1.69E+02	9.49E+01	5.53E-02
120	0.6641212	1.67E+02	9.40E+01	5.48E-02
121	0.6696787	1.65E+02	9.30E+01	5.43E-02
122	0.6752362	1.63E+02	9.20E+01	5.37E-02
123	0.6807937	1.61E+02	9.10E+01	5.32E-02
124	0.6863512	1.59E+02	9.00E+01	5.27E-02
125	0.6919087	1.57E+02	8.90E+01	5.22E-02
126	0.6974662	1.55E+02	8.81E+01	5.18E-02
127	0.7030237	1.54E+02	8.72E+01	5.14E-02
128	0.7085812	1.52E+02	8.63E+01	5.10E-02
129	0.7141388	1.51E+02	8.56E+01	5.05E-02
130	0.7196963	1.49E+02	8.48E+01	5.01E-02
131	0.7252538	1.48E+02	8.41E+01	4.97E-02
132	0.7308113	1.46E+02	8.34E+01	4.94E-02
133	0.7363688	1.45E+02	8.26E+01	4.91E-02
134	0.7419262	1.43E+02	8.19E+01	4.89E-02
135	0.7474838	1.42E+02	8.12E+01	4.90E-02
136	0.7530412	1.40E+02	8.04E+01	4.95E-02
137	0.7585987	1.39E+02	7.97E+01	5.09E-02
138	0.7641562	1.38E+02	7.90E+01	5.38E-02
139	0.7697137	1.36E+02	7.83E+01	5.90E-02
140	0.7752712	1.35E+02	7.76E+01	6.77E-02
141	0.7808287	1.33E+02	7.70E+01	8.08E-02
142	0.7863862	1.32E+02	7.64E+01	9.93E-02
143	0.7919437	1.31E+02	7.57E+01	1.23E-01
144	0.7975012	1.30E+02	7.52E+01	1.51E-01
145	0.8030588	1.29E+02	7.45E+01	1.82E-01
146	0.8086163	1.27E+02	7.39E+01	2.12E-01
147	0.8141738	1.26E+02	7.33E+01	2.37E-01
148	0.8197312	1.25E+02	7.28E+01	2.54E-01
149	0.8252888	1.24E+02	7.22E+01	2.60E-01
150	0.8308462	1.23E+02	7.16E+01	2.53E-01
151	0.8364038	1.22E+02	7.11E+01	2.36E-01

152	0.8419612	1.21E+02	7.05E+01	2.11E-01
153	0.8475187	1.20E+02	7.01E+01	1.82E-01
154	0.8530762	1.19E+02	6.96E+01	1.53E-01
155	0.8586337	1.18E+02	6.92E+01	1.26E-01
156	0.8641912	1.17E+02	6.89E+01	1.03E-01
157	0.8697487	1.16E+02	6.86E+01	8.57E-02
158	0.8753062	1.15E+02	6.83E+01	7.29E-02
159	0.8808637	1.14E+02	6.81E+01	6.40E-02
160	0.8864212	1.13E+02	6.78E+01	5.78E-02
161	0.8919788	1.12E+02	6.77E+01	5.36E-02
162	0.8975363	1.11E+02	6.75E+01	5.07E-02
163	0.9030938	1.10E+02	6.73E+01	4.86E-02
164	0.9086512	1.09E+02	6.70E+01	4.71E-02
165	0.9142088	1.08E+02	6.65E+01	4.61E-02
166	0.9197662	1.08E+02	6.60E+01	4.53E-02
167	0.9253238	1.07E+02	6.55E+01	4.49E-02
168	0.9308812	1.06E+02	6.48E+01	4.47E-02
169	0.9364387	1.05E+02	6.42E+01	4.47E-02
170	0.9419962	1.04E+02	6.35E+01	4.47E-02
171	0.9475537	1.03E+02	6.29E+01	4.46E-02
172	0.9531112	1.03E+02	6.24E+01	4.44E-02
173	0.9586687	1.02E+02	6.18E+01	4.40E-02
174	0.9642262	1.01E+02	6.14E+01	4.34E-02
175	0.9697837	1.00E+02	6.09E+01	4.24E-02
176	0.9753412	9.98E+01	6.06E+01	4.13E-02
177	0.9808988	9.90E+01	6.02E+01	4.00E-02
178	0.9864563	9.83E+01	5.98E+01	3.87E-02
179	0.9920138	9.78E+01	5.95E+01	3.74E-02
180	0.9975712	9.71E+01	5.92E+01	3.62E-02
181	1.0031287	9.65E+01	5.88E+01	3.52E-02
182	1.0086863	9.59E+01	5.85E+01	3.44E-02
183	1.0142437	9.51E+01	5.82E+01	3.38E-02
184	1.0198012	9.45E+01	5.78E+01	3.33E-02
185	1.0253588	9.40E+01	5.76E+01	3.30E-02
186	1.0309162	9.33E+01	5.73E+01	3.29E-02
187	1.0364738	9.24E+01	5.69E+01	3.29E-02
188	1.0420312	9.19E+01	5.67E+01	3.30E-02
189	1.0475888	9.12E+01	5.64E+01	3.32E-02
190	1.0531462	9.05E+01	5.61E+01	3.34E-02
191	1.0587038	8.98E+01	5.58E+01	3.36E-02
192	1.0642612	8.91E+01	5.55E+01	3.38E-02
193	1.0698188	8.84E+01	5.52E+01	3.40E-02
194	1.0753762	8.78E+01	5.49E+01	3.41E-02
195	1.0809338	8.72E+01	5.47E+01	3.42E-02
196	1.0864912	8.66E+01	5.44E+01	3.42E-02
197	1.0920488	8.59E+01	5.41E+01	3.42E-02
198	1.0976062	8.54E+01	5.39E+01	3.42E-02
199	1.1031637	8.48E+01	5.37E+01	3.43E-02
200	1.1087212	8.42E+01	5.35E+01	3.45E-02
201	1.1142787	8.36E+01	5.33E+01	3.49E-02
202	1.1198363	8.31E+01	5.31E+01	3.57E-02
203	1.1253937	8.24E+01	5.29E+01	3.70E-02
204	1.1309513	8.19E+01	5.27E+01	3.91E-02
205	1.1365087	8.13E+01	5.24E+01	4.23E-02
206	1.1420663	8.09E+01	5.22E+01	4.70E-02
207	1.1476237	8.03E+01	5.20E+01	5.34E-02
208	1.1531813	7.97E+01	5.17E+01	6.18E-02
209	1.1587387	7.95E+01	5.16E+01	7.25E-02
210	1.1642963	7.90E+01	5.14E+01	8.52E-02
211	1.1698537	7.85E+01	5.12E+01	9.97E-02
212	1.1754113	7.82E+01	5.11E+01	1.15E-01
213	1.1809687	7.79E+01	5.11E+01	1.31E-01

214	1.1865263	7.76E+01	5.12E+01	1.45E-01
215	1.1920837	7.76E+01	5.14E+01	1.57E-01
216	1.1976412	7.77E+01	5.19E+01	1.65E-01
217	1.2031988	7.79E+01	5.24E+01	1.68E-01
218	1.2087562	7.81E+01	5.31E+01	1.67E-01
219	1.2143138	7.83E+01	5.37E+01	1.61E-01
220	1.2198712	7.86E+01	5.44E+01	1.50E-01
221	1.2254288	7.88E+01	5.50E+01	1.37E-01
222	1.2309862	7.91E+01	5.55E+01	1.22E-01
223	1.2365438	7.89E+01	5.56E+01	1.06E-01
224	1.2421012	7.86E+01	5.55E+01	9.03E-02
225	1.2476588	7.81E+01	5.51E+01	7.63E-02
226	1.2532162	7.74E+01	5.45E+01	6.41E-02
227	1.2587738	7.67E+01	5.37E+01	5.42E-02
228	1.2643312	7.58E+01	5.28E+01	4.64E-02
229	1.2698888	7.48E+01	5.19E+01	4.07E-02
230	1.2754462	7.40E+01	5.11E+01	3.67E-02
231	1.2810037	7.33E+01	5.04E+01	3.43E-02
232	1.2865612	7.28E+01	4.99E+01	3.31E-02
233	1.2921187	7.23E+01	4.94E+01	3.28E-02
234	1.2976763	7.18E+01	4.90E+01	3.33E-02
235	1.3032337	7.13E+01	4.87E+01	3.43E-02
236	1.3087913	7.09E+01	4.85E+01	3.56E-02
237	1.3143487	7.04E+01	4.83E+01	3.70E-02
238	1.3199063	7.00E+01	4.82E+01	3.85E-02
239	1.3254637	6.96E+01	4.80E+01	3.98E-02
240	1.3310213	6.92E+01	4.79E+01	4.09E-02
241	1.3365787	6.90E+01	4.79E+01	4.16E-02
242	1.3421363	6.86E+01	4.78E+01	4.20E-02
243	1.3476937	6.82E+01	4.77E+01	4.19E-02
244	1.3532513	6.77E+01	4.75E+01	4.15E-02
245	1.3588087	6.73E+01	4.74E+01	4.07E-02
246	1.3643663	6.70E+01	4.74E+01	3.96E-02
247	1.3699237	6.68E+01	4.73E+01	3.84E-02
248	1.3754812	6.63E+01	4.72E+01	3.70E-02
249	1.3810388	6.61E+01	4.71E+01	3.55E-02
250	1.3865962	6.57E+01	4.70E+01	3.41E-02
251	1.3921538	6.54E+01	4.69E+01	3.28E-02
252	1.3977112	6.51E+01	4.68E+01	3.15E-02
253	1.4032688	6.47E+01	4.67E+01	3.04E-02
254	1.4088262	6.43E+01	4.65E+01	2.95E-02
255	1.4143838	6.40E+01	4.64E+01	2.86E-02
256	1.4199412	6.38E+01	4.63E+01	2.80E-02
257	1.4254988	6.34E+01	4.61E+01	2.74E-02
258	1.4310562	6.31E+01	4.60E+01	2.70E-02
259	1.4366138	6.28E+01	4.59E+01	2.68E-02
260	1.4421712	6.25E+01	4.57E+01	2.67E-02
261	1.4477288	6.22E+01	4.57E+01	2.68E-02
262	1.4532862	6.19E+01	4.55E+01	2.70E-02
263	1.4588437	6.17E+01	4.55E+01	2.74E-02
264	1.4644012	6.14E+01	4.54E+01	2.79E-02
265	1.4699587	6.11E+01	4.53E+01	2.85E-02
266	1.4755163	6.09E+01	4.52E+01	2.92E-02
267	1.4810737	6.06E+01	4.51E+01	3.00E-02
268	1.4866313	6.04E+01	4.51E+01	3.07E-02
269	1.4921887	6.02E+01	4.50E+01	3.13E-02
270	1.4977463	6.00E+01	4.50E+01	3.18E-02
271	1.5033037	5.98E+01	4.50E+01	3.22E-02
272	1.5088613	5.94E+01	4.49E+01	3.24E-02
273	1.5144187	5.92E+01	4.48E+01	3.24E-02
274	1.5199763	5.89E+01	4.48E+01	3.22E-02
275	1.5255337	5.88E+01	4.48E+01	3.19E-02

276	1.5310913	5.86E+01	4.47E+01	3.14E-02
277	1.5366487	5.84E+01	4.47E+01	3.10E-02
278	1.5422063	5.81E+01	4.46E+01	3.05E-02
279	1.5477637	5.80E+01	4.46E+01	3.00E-02
280	1.5533212	5.78E+01	4.46E+01	2.96E-02
281	1.5588788	5.76E+01	4.45E+01	2.93E-02
282	1.5644362	5.74E+01	4.44E+01	2.91E-02
283	1.5699938	5.72E+01	4.44E+01	2.91E-02
284	1.5755512	5.70E+01	4.43E+01	2.92E-02
285	1.5811088	5.67E+01	4.42E+01	2.95E-02
286	1.5866662	5.65E+01	4.41E+01	3.01E-02
287	1.5922238	5.63E+01	4.40E+01	3.08E-02
288	1.5977812	5.61E+01	4.39E+01	3.16E-02
289	1.6033388	5.59E+01	4.38E+01	3.27E-02
290	1.6088962	5.57E+01	4.38E+01	3.39E-02
291	1.6144538	5.55E+01	4.37E+01	3.51E-02
292	1.6200112	5.53E+01	4.37E+01	3.65E-02
293	1.6255688	5.52E+01	4.36E+01	3.77E-02
294	1.6311262	5.51E+01	4.36E+01	3.89E-02
295	1.6366837	5.49E+01	4.36E+01	4.00E-02
296	1.6422412	5.48E+01	4.36E+01	4.09E-02
297	1.6477987	5.48E+01	4.36E+01	4.16E-02
298	1.6533563	5.46E+01	4.37E+01	4.21E-02
299	1.6589137	5.46E+01	4.37E+01	4.23E-02
300	1.6644713	5.44E+01	4.37E+01	4.24E-02
301	1.6700287	5.43E+01	4.38E+01	4.23E-02
302	1.6755863	5.43E+01	4.39E+01	4.21E-02
303	1.6811437	5.45E+01	4.42E+01	4.17E-02
304	1.6867013	5.46E+01	4.46E+01	4.13E-02
305	1.6922587	5.48E+01	4.51E+01	4.08E-02
306	1.6978163	5.53E+01	4.58E+01	4.02E-02
307	1.7033737	5.59E+01	4.68E+01	3.95E-02
308	1.7089313	5.67E+01	4.81E+01	3.88E-02
309	1.7144887	5.78E+01	4.97E+01	3.79E-02
310	1.7200462	5.92E+01	5.17E+01	3.70E-02
311	1.7256037	6.09E+01	5.42E+01	3.61E-02
312	1.7311612	6.30E+01	5.70E+01	3.50E-02
313	1.7367188	6.52E+01	6.00E+01	3.39E-02
314	1.7422762	6.74E+01	6.32E+01	3.29E-02
315	1.7478338	6.98E+01	6.65E+01	3.18E-02
316	1.7533912	7.20E+01	6.96E+01	3.07E-02
317	1.7589488	7.39E+01	7.23E+01	2.97E-02
318	1.7645062	7.55E+01	7.45E+01	2.88E-02
319	1.7700638	7.67E+01	7.62E+01	2.79E-02
320	1.7756212	7.72E+01	7.70E+01	2.72E-02
321	1.7811788	7.71E+01	7.70E+01	2.65E-02
322	1.7867362	7.64E+01	7.63E+01	2.59E-02
323	1.7922938	7.51E+01	7.49E+01	2.53E-02
324	1.7978512	7.35E+01	7.29E+01	2.48E-02
325	1.8034088	7.14E+01	7.04E+01	2.44E-02
326	1.8089662	6.93E+01	6.78E+01	2.39E-02
327	1.8145237	6.70E+01	6.50E+01	2.35E-02
328	1.8200812	6.48E+01	6.23E+01	2.31E-02
329	1.8256387	6.28E+01	5.98E+01	2.27E-02
330	1.8311963	6.10E+01	5.76E+01	2.22E-02
331	1.8367537	5.95E+01	5.58E+01	2.18E-02
332	1.8423113	5.83E+01	5.43E+01	2.14E-02
333	1.8478687	5.73E+01	5.31E+01	2.11E-02
334	1.8534263	5.64E+01	5.22E+01	2.07E-02
335	1.8589837	5.60E+01	5.17E+01	2.03E-02
336	1.8645413	5.55E+01	5.13E+01	2.00E-02
337	1.8700987	5.52E+01	5.11E+01	1.98E-02

338	1.8756563	5.52E+01	5.11E+01	1.96E-02
339	1.8812137	5.51E+01	5.11E+01	1.96E-02
340	1.8867713	5.51E+01	5.12E+01	1.97E-02
341	1.8923287	5.52E+01	5.15E+01	2.01E-02
342	1.8978862	5.53E+01	5.17E+01	2.08E-02
343	1.9034437	5.53E+01	5.20E+01	2.20E-02
344	1.9090012	5.56E+01	5.24E+01	2.36E-02
345	1.9145588	5.56E+01	5.27E+01	2.60E-02
346	1.9201162	5.58E+01	5.30E+01	2.91E-02
347	1.9256738	5.59E+01	5.33E+01	3.32E-02
348	1.9312312	5.61E+01	5.37E+01	3.82E-02
349	1.9367888	5.62E+01	5.39E+01	4.42E-02
350	1.9423462	5.63E+01	5.42E+01	5.13E-02
351	1.9479038	5.62E+01	5.43E+01	5.91E-02
352	1.9534612	5.62E+01	5.44E+01	6.77E-02
353	1.9590188	5.60E+01	5.43E+01	7.68E-02
354	1.9645762	5.58E+01	5.41E+01	8.59E-02
355	1.9701338	5.53E+01	5.37E+01	9.47E-02
356	1.9756912	5.48E+01	5.31E+01	1.03E-01
357	1.9812488	5.41E+01	5.22E+01	1.10E-01
358	1.9868062	5.32E+01	5.12E+01	1.15E-01
359	1.9923637	5.20E+01	4.99E+01	1.19E-01
360	1.9979212	5.09E+01	4.85E+01	1.21E-01
361	2.0034788	4.95E+01	4.68E+01	1.20E-01
362	2.0090362	4.81E+01	4.50E+01	1.18E-01
363	2.0145937	4.65E+01	4.31E+01	1.14E-01
364	2.0201513	4.49E+01	4.12E+01	1.08E-01
365	2.0257088	4.33E+01	3.92E+01	1.01E-01
366	2.0312662	4.17E+01	3.72E+01	9.37E-02
367	2.0368237	4.02E+01	3.53E+01	8.57E-02
368	2.0423813	3.87E+01	3.35E+01	7.76E-02
369	2.0479388	3.73E+01	3.17E+01	6.98E-02
370	2.0534962	3.60E+01	3.01E+01	6.25E-02
371	2.0590537	3.47E+01	2.86E+01	5.57E-02
372	2.0646113	3.36E+01	2.71E+01	4.97E-02
373	2.0701688	3.25E+01	2.58E+01	4.45E-02
374	2.0757262	3.16E+01	2.46E+01	4.00E-02
375	2.0812837	3.07E+01	2.35E+01	3.62E-02
376	2.0868412	2.99E+01	2.25E+01	3.30E-02
377	2.0923988	2.91E+01	2.15E+01	3.04E-02
378	2.0979563	2.84E+01	2.07E+01	2.82E-02
379	2.1035137	2.77E+01	1.99E+01	2.64E-02
380	2.1090712	2.71E+01	1.92E+01	2.49E-02
381	2.1146288	2.66E+01	1.86E+01	2.37E-02
382	2.1201863	2.62E+01	1.81E+01	2.27E-02
383	2.1257437	2.58E+01	1.77E+01	2.18E-02
384	2.1313012	2.56E+01	1.75E+01	2.11E-02
385	2.1368588	2.56E+01	1.76E+01	2.06E-02
386	2.1424163	2.59E+01	1.80E+01	2.01E-02
387	2.1479737	2.64E+01	1.88E+01	1.97E-02
388	2.1535312	2.74E+01	2.02E+01	1.94E-02
389	2.1590888	2.89E+01	2.24E+01	1.92E-02
390	2.1646463	3.12E+01	2.55E+01	1.90E-02
391	2.1702037	3.45E+01	2.99E+01	1.88E-02
392	2.1757612	3.88E+01	3.59E+01	1.88E-02
393	2.1813187	4.46E+01	4.37E+01	1.87E-02
394	2.1868763	5.20E+01	5.36E+01	1.87E-02
395	2.1924338	6.12E+01	6.58E+01	1.87E-02
396	2.1979912	7.23E+01	8.07E+01	1.87E-02
397	2.2035487	8.54E+01	9.81E+01	1.87E-02
398	2.2091063	1.01E+02	1.18E+02	1.87E-02
399	2.2146638	1.17E+02	1.41E+02	1.88E-02

400	2.2202212	1.36E+02	1.65E+02	1.88E-02
401	2.2257787	1.55E+02	1.90E+02	1.89E-02
402	2.2313363	1.75E+02	2.16E+02	1.90E-02
403	2.2368938	1.94E+02	2.42E+02	1.91E-02
404	2.2424512	2.12E+02	2.65E+02	1.92E-02
405	2.2480087	2.28E+02	2.86E+02	1.93E-02
406	2.2535662	2.41E+02	3.04E+02	1.94E-02
407	2.2591238	2.51E+02	3.17E+02	1.96E-02
408	2.2646812	2.56E+02	3.24E+02	1.97E-02
409	2.2702387	2.58E+02	3.27E+02	1.99E-02
410	2.2757962	2.54E+02	3.23E+02	2.01E-02
411	2.2813538	2.47E+02	3.14E+02	2.02E-02
412	2.2869113	2.36E+02	3.01E+02	2.04E-02
413	2.2924687	2.22E+02	2.83E+02	2.06E-02
414	2.2980262	2.05E+02	2.61E+02	2.08E-02
415	2.3035838	1.87E+02	2.38E+02	2.09E-02
416	2.3091413	1.68E+02	2.13E+02	2.11E-02
417	2.3146987	1.48E+02	1.88E+02	2.12E-02
418	2.3202562	1.29E+02	1.63E+02	2.14E-02
419	2.3258138	1.11E+02	1.40E+02	2.15E-02
420	2.3313713	9.43E+01	1.18E+02	2.16E-02
421	2.3369287	7.91E+01	9.84E+01	2.16E-02
422	2.3424862	6.57E+01	8.10E+01	2.17E-02
423	2.3480437	5.41E+01	6.59E+01	2.17E-02
424	2.3536013	4.43E+01	5.31E+01	2.17E-02
425	2.3591588	3.61E+01	4.23E+01	2.17E-02
426	2.3647162	2.94E+01	3.35E+01	2.16E-02
427	2.3702737	2.39E+01	2.64E+01	2.15E-02
428	2.3758313	1.96E+01	2.07E+01	2.14E-02
429	2.3813888	1.62E+01	1.62E+01	2.13E-02
430	2.3869462	1.35E+01	1.27E+01	2.12E-02
431	2.3925037	1.15E+01	1.01E+01	2.11E-02
432	2.3980613	9.92E+00	8.05E+00	2.09E-02
433	2.4036188	8.76E+00	6.55E+00	2.08E-02
434	2.4091762	7.91E+00	5.44E+00	2.06E-02
435	2.4147337	7.27E+00	4.62E+00	2.05E-02
436	2.4202913	6.80E+00	4.04E+00	2.04E-02
437	2.4258488	6.47E+00	3.62E+00	2.04E-02
438	2.4314062	6.22E+00	3.32E+00	2.04E-02
439	2.4369637	6.04E+00	3.12E+00	2.04E-02
440	2.4425212	5.91E+00	2.97E+00	2.05E-02
441	2.4480788	5.81E+00	2.87E+00	2.07E-02
442	2.4536363	5.74E+00	2.80E+00	2.10E-02
443	2.4591937	5.68E+00	2.74E+00	2.14E-02
444	2.4647512	5.62E+00	2.71E+00	2.19E-02
445	2.4703088	5.57E+00	2.68E+00	2.25E-02
446	2.4758663	5.54E+00	2.66E+00	2.31E-02
447	2.4814237	5.50E+00	2.65E+00	2.38E-02
448	2.4869812	5.46E+00	2.63E+00	2.44E-02
449	2.4925388	5.44E+00	2.63E+00	2.52E-02
450	2.4980963	5.40E+00	2.62E+00	2.58E-02
451	2.5036537	5.37E+00	2.62E+00	2.65E-02
452	2.5092112	5.35E+00	2.63E+00	2.70E-02
453	2.5147687	5.30E+00	2.62E+00	2.75E-02
454	2.5203263	5.27E+00	2.62E+00	2.79E-02
455	2.5258837	5.25E+00	2.63E+00	2.82E-02
456	2.5314412	5.22E+00	2.63E+00	2.84E-02
457	2.5369987	5.17E+00	2.63E+00	2.84E-02
458	2.5425563	5.15E+00	2.63E+00	2.84E-02
459	2.5481138	5.12E+00	2.62E+00	2.82E-02
460	2.5536712	5.08E+00	2.62E+00	2.80E-02
461	2.5592287	5.06E+00	2.61E+00	2.76E-02

462	2.5647863	5.02E+00	2.59E+00	2.72E-02
463	2.5703438	4.99E+00	2.57E+00	2.68E-02
464	2.5759012	4.97E+00	2.56E+00	2.63E-02
465	2.5814587	4.93E+00	2.53E+00	2.58E-02
466	2.5870163	4.89E+00	2.51E+00	2.52E-02
467	2.5925738	4.88E+00	2.48E+00	2.46E-02
468	2.5981312	4.84E+00	2.45E+00	2.41E-02
469	2.6036887	4.80E+00	2.42E+00	2.35E-02
470	2.6092462	4.78E+00	2.40E+00	2.30E-02
471	2.6148038	4.75E+00	2.37E+00	2.24E-02
472	2.6203612	4.73E+00	2.35E+00	2.19E-02
473	2.6259187	4.70E+00	2.32E+00	2.15E-02
474	2.6314762	4.67E+00	2.29E+00	2.11E-02
475	2.6370338	4.64E+00	2.27E+00	2.07E-02
476	2.6425913	4.62E+00	2.25E+00	2.03E-02
477	2.6481487	4.60E+00	2.23E+00	2.00E-02
478	2.6537062	4.59E+00	2.21E+00	1.98E-02
479	2.6592638	4.54E+00	2.18E+00	1.95E-02
480	2.6648213	4.53E+00	2.17E+00	1.93E-02
481	2.6703787	4.51E+00	2.15E+00	1.91E-02
482	2.6759362	4.49E+00	2.14E+00	1.89E-02
483	2.6814938	4.47E+00	2.13E+00	1.87E-02
484	2.6870513	4.47E+00	2.12E+00	1.85E-02
485	2.6926087	4.45E+00	2.11E+00	1.83E-02
486	2.6981662	4.43E+00	2.10E+00	1.81E-02
487	2.7037237	4.41E+00	2.09E+00	1.78E-02
488	2.7092813	4.39E+00	2.08E+00	1.76E-02
489	2.7148388	4.37E+00	2.08E+00	1.73E-02
490	2.7203962	4.35E+00	2.08E+00	1.70E-02
491	2.7259537	4.33E+00	2.08E+00	1.68E-02
492	2.7315113	4.33E+00	2.08E+00	1.65E-02
493	2.7370688	4.31E+00	2.08E+00	1.62E-02
494	2.7426262	4.29E+00	2.09E+00	1.59E-02
495	2.7481837	4.26E+00	2.09E+00	1.57E-02
496	2.7537413	4.24E+00	2.09E+00	1.54E-02
497	2.7592988	4.23E+00	2.10E+00	1.52E-02
498	2.7648562	4.21E+00	2.10E+00	1.51E-02
499	2.7704137	4.19E+00	2.11E+00	1.50E-02
500	2.7759713	4.17E+00	2.11E+00	1.50E-02
501	2.7815288	4.15E+00	2.11E+00	1.50E-02
502	2.7870862	4.12E+00	2.11E+00	1.51E-02
503	2.7926437	4.09E+00	2.10E+00	1.53E-02
504	2.7982012	4.07E+00	2.10E+00	1.56E-02
505	2.8037588	4.05E+00	2.10E+00	1.60E-02
506	2.8093163	4.03E+00	2.09E+00	1.64E-02
507	2.8148737	4.02E+00	2.08E+00	1.69E-02
508	2.8204312	3.99E+00	2.07E+00	1.76E-02
509	2.8259888	3.95E+00	2.05E+00	1.83E-02
510	2.8315463	3.94E+00	2.04E+00	1.90E-02
511	2.8371037	3.92E+00	2.03E+00	1.99E-02
512	2.8426612	3.90E+00	2.02E+00	2.07E-02
513	2.8482188	3.88E+00	2.00E+00	2.17E-02
514	2.8537763	3.85E+00	1.99E+00	2.26E-02
515	2.8593337	3.82E+00	1.97E+00	2.35E-02
516	2.8648912	3.80E+00	1.96E+00	2.44E-02
517	2.8704487	3.78E+00	1.95E+00	2.53E-02
518	2.8760063	3.76E+00	1.94E+00	2.60E-02
519	2.8815637	3.75E+00	1.93E+00	2.67E-02
520	2.8871212	3.72E+00	1.91E+00	2.72E-02
521	2.8926787	3.70E+00	1.91E+00	2.76E-02
522	2.8982363	3.68E+00	1.90E+00	2.78E-02
523	2.9037938	3.67E+00	1.89E+00	2.79E-02

524	2.9093512	3.65E+00	1.88E+00	2.78E-02
525	2.9149087	3.63E+00	1.87E+00	2.75E-02
526	2.9204663	3.61E+00	1.86E+00	2.71E-02
527	2.9260238	3.59E+00	1.84E+00	2.66E-02
528	2.9315812	3.57E+00	1.83E+00	2.60E-02
529	2.9371387	3.55E+00	1.82E+00	2.52E-02
530	2.9426963	3.54E+00	1.81E+00	2.45E-02
531	2.9482538	3.52E+00	1.80E+00	2.37E-02
532	2.9538112	3.50E+00	1.78E+00	2.29E-02
533	2.9593687	3.49E+00	1.77E+00	2.21E-02
534	2.9649262	3.46E+00	1.76E+00	2.14E-02
535	2.9704838	3.45E+00	1.75E+00	2.07E-02
536	2.9760412	3.43E+00	1.74E+00	2.01E-02
537	2.9815987	3.41E+00	1.73E+00	1.96E-02
538	2.9871562	3.40E+00	1.72E+00	1.92E-02
539	2.9927138	3.38E+00	1.71E+00	1.89E-02
540	2.9982713	3.36E+00	1.70E+00	1.87E-02
541	3.0038287	3.34E+00	1.69E+00	1.86E-02
542	3.0093862	3.32E+00	1.68E+00	1.86E-02
543	3.0149438	3.32E+00	1.68E+00	1.86E-02
544	3.0205013	3.31E+00	1.67E+00	1.87E-02
545	3.0260587	3.29E+00	1.67E+00	1.89E-02
546	3.0316162	3.27E+00	1.66E+00	1.91E-02
547	3.0371738	3.25E+00	1.65E+00	1.94E-02
548	3.0427313	3.23E+00	1.65E+00	1.97E-02
549	3.0482887	3.21E+00	1.64E+00	2.00E-02
550	3.0538462	3.19E+00	1.63E+00	2.03E-02
551	3.0594037	3.19E+00	1.63E+00	2.05E-02
552	3.0649613	3.17E+00	1.63E+00	2.08E-02
553	3.0705188	3.15E+00	1.62E+00	2.10E-02
554	3.0760762	3.13E+00	1.62E+00	2.12E-02
555	3.0816337	3.11E+00	1.61E+00	2.14E-02
556	3.0871913	3.10E+00	1.61E+00	2.14E-02
557	3.0927488	3.07E+00	1.60E+00	2.15E-02
558	3.0983062	3.05E+00	1.60E+00	2.14E-02
559	3.1038637	3.05E+00	1.60E+00	2.13E-02
560	3.1094213	3.03E+00	1.60E+00	2.11E-02
561	3.1149788	3.02E+00	1.59E+00	2.08E-02
562	3.1205362	3.00E+00	1.59E+00	2.05E-02
563	3.1260937	3.00E+00	1.59E+00	2.01E-02
564	3.1316512	2.99E+00	1.58E+00	1.97E-02
565	3.1372088	2.97E+00	1.57E+00	1.92E-02
566	3.1427662	2.95E+00	1.56E+00	1.87E-02
567	3.1483237	2.93E+00	1.55E+00	1.81E-02
568	3.1538812	2.94E+00	1.54E+00	1.75E-02
569	3.1594388	2.93E+00	1.53E+00	1.69E-02
570	3.1649963	2.91E+00	1.52E+00	1.63E-02
571	3.1705537	2.90E+00	1.50E+00	1.57E-02
572	3.1761112	2.91E+00	1.50E+00	1.52E-02
573	3.1816688	2.90E+00	1.48E+00	1.46E-02
574	3.1872263	2.88E+00	1.47E+00	1.41E-02
575	3.1927837	2.86E+00	1.45E+00	1.36E-02
576	3.1983412	2.85E+00	1.44E+00	1.31E-02
577	3.2038988	2.86E+00	1.44E+00	1.27E-02
578	3.2094563	2.84E+00	1.42E+00	1.23E-02
579	3.2150137	2.83E+00	1.41E+00	1.20E-02
580	3.2205712	2.83E+00	1.41E+00	1.17E-02
581	3.2261287	2.81E+00	1.40E+00	1.14E-02
582	3.2316863	2.80E+00	1.39E+00	1.12E-02
583	3.2372437	2.80E+00	1.39E+00	1.11E-02
584	3.2428012	2.78E+00	1.38E+00	1.10E-02
585	3.2483587	2.75E+00	1.37E+00	1.10E-02

586	3.2539163	2.74E+00	1.37E+00	1.09E-02
587	3.2594738	2.72E+00	1.36E+00	1.10E-02
588	3.2650312	2.70E+00	1.36E+00	1.11E-02
589	3.2705887	2.69E+00	1.36E+00	1.12E-02
590	3.2761463	2.67E+00	1.35E+00	1.14E-02
591	3.2817038	2.64E+00	1.34E+00	1.16E-02
592	3.2872612	2.64E+00	1.34E+00	1.19E-02
593	3.2928187	2.61E+00	1.34E+00	1.22E-02
594	3.2983763	2.59E+00	1.33E+00	1.25E-02
595	3.3039338	2.56E+00	1.32E+00	1.29E-02
596	3.3094912	2.56E+00	1.31E+00	1.32E-02
597	3.3150487	2.53E+00	1.30E+00	1.37E-02
598	3.3206062	2.51E+00	1.29E+00	1.41E-02
599	3.3261638	2.49E+00	1.29E+00	1.45E-02
600	3.3317212	2.47E+00	1.28E+00	1.49E-02
601	3.3372787	2.47E+00	1.27E+00	1.53E-02
602	3.3428362	2.45E+00	1.26E+00	1.57E-02
603	3.3483938	2.44E+00	1.25E+00	1.61E-02
604	3.3539513	2.41E+00	1.24E+00	1.64E-02
605	3.3595087	2.41E+00	1.23E+00	1.67E-02
606	3.3650662	2.39E+00	1.23E+00	1.69E-02
607	3.3706238	2.37E+00	1.22E+00	1.70E-02
608	3.3761813	2.37E+00	1.21E+00	1.71E-02
609	3.3817387	2.36E+00	1.20E+00	1.72E-02
610	3.3872962	2.34E+00	1.19E+00	1.71E-02
611	3.3928538	2.34E+00	1.19E+00	1.70E-02
612	3.3984113	2.32E+00	1.18E+00	1.69E-02
613	3.4039687	2.32E+00	1.18E+00	1.67E-02
614	3.4095262	2.30E+00	1.17E+00	1.64E-02
615	3.4150837	2.30E+00	1.17E+00	1.61E-02
616	3.4206413	2.28E+00	1.16E+00	1.58E-02
617	3.4261988	2.28E+00	1.16E+00	1.55E-02
618	3.4317562	2.26E+00	1.15E+00	1.51E-02
619	3.4373137	2.26E+00	1.15E+00	1.48E-02
620	3.4428713	2.24E+00	1.14E+00	1.44E-02
621	3.4484288	2.24E+00	1.14E+00	1.41E-02
622	3.4539862	2.22E+00	1.13E+00	1.38E-02
623	3.4595437	2.21E+00	1.13E+00	1.35E-02
624	3.4651013	2.19E+00	1.12E+00	1.32E-02
625	3.4706588	2.19E+00	1.12E+00	1.29E-02
626	3.4762162	2.17E+00	1.11E+00	1.27E-02
627	3.4817737	2.17E+00	1.11E+00	1.26E-02
628	3.4873312	2.15E+00	1.10E+00	1.24E-02
629	3.4928888	2.15E+00	1.10E+00	1.23E-02
630	3.4984462	2.12E+00	1.09E+00	1.22E-02
631	3.5040037	2.12E+00	1.09E+00	1.22E-02
632	3.5095612	2.10E+00	1.09E+00	1.22E-02
633	3.5151188	2.09E+00	1.09E+00	1.22E-02
634	3.5206763	2.08E+00	1.09E+00	1.22E-02
635	3.5262337	2.07E+00	1.08E+00	1.23E-02
636	3.5317912	2.05E+00	1.08E+00	1.24E-02
637	3.5373488	2.04E+00	1.08E+00	1.25E-02
638	3.5429063	2.03E+00	1.08E+00	1.26E-02
639	3.5484637	2.01E+00	1.07E+00	1.27E-02
640	3.5540212	2.00E+00	1.07E+00	1.29E-02
641	3.5595788	1.98E+00	1.07E+00	1.31E-02
642	3.5651363	1.97E+00	1.07E+00	1.32E-02
643	3.5706937	1.95E+00	1.07E+00	1.34E-02
644	3.5762512	1.95E+00	1.07E+00	1.36E-02
645	3.5818087	1.94E+00	1.07E+00	1.37E-02
646	3.5873663	1.93E+00	1.07E+00	1.39E-02
647	3.5929237	1.93E+00	1.08E+00	1.40E-02

648	3.5984812	1.92E+00	1.08E+00	1.42E-02
649	3.6040387	1.92E+00	1.08E+00	1.42E-02
650	3.6095963	1.92E+00	1.08E+00	1.43E-02
651	3.6151538	1.91E+00	1.08E+00	1.44E-02
652	3.6207112	1.91E+00	1.08E+00	1.44E-02
653	3.6262687	1.92E+00	1.08E+00	1.43E-02
654	3.6318263	1.91E+00	1.08E+00	1.43E-02
655	3.6373838	1.91E+00	1.07E+00	1.42E-02
656	3.6429412	1.93E+00	1.07E+00	1.40E-02
657	3.6484987	1.93E+00	1.07E+00	1.39E-02
658	3.6540563	1.94E+00	1.07E+00	1.37E-02
659	3.6596138	1.95E+00	1.06E+00	1.34E-02
660	3.6651712	1.96E+00	1.06E+00	1.32E-02
661	3.6707287	1.97E+00	1.05E+00	1.29E-02
662	3.6762862	1.99E+00	1.05E+00	1.27E-02
663	3.6818438	2.00E+00	1.04E+00	1.24E-02
664	3.6874012	2.01E+00	1.04E+00	1.21E-02
665	3.6929587	2.02E+00	1.03E+00	1.18E-02
666	3.6985162	2.02E+00	1.02E+00	1.16E-02
667	3.7040738	2.03E+00	1.01E+00	1.13E-02
668	3.7096313	2.04E+00	1.01E+00	1.11E-02
669	3.7151887	2.04E+00	9.98E-01	1.08E-02
670	3.7207462	2.04E+00	9.90E-01	1.06E-02
671	3.7263038	2.02E+00	9.76E-01	1.04E-02
672	3.7318613	2.01E+00	9.67E-01	1.03E-02
673	3.7374187	2.00E+00	9.57E-01	1.01E-02
674	3.7429762	1.99E+00	9.50E-01	1.00E-02
675	3.7485337	1.97E+00	9.39E-01	9.95E-03
676	3.7540913	1.95E+00	9.29E-01	9.91E-03
677	3.7596487	1.93E+00	9.18E-01	9.89E-03
678	3.7652062	1.91E+00	9.07E-01	9.89E-03
679	3.7707637	1.88E+00	8.96E-01	9.93E-03
680	3.7763213	1.86E+00	8.85E-01	9.99E-03
681	3.7818788	1.84E+00	8.77E-01	1.01E-02
682	3.7874362	1.81E+00	8.67E-01	1.02E-02
683	3.7929937	1.78E+00	8.56E-01	1.03E-02
684	3.7985513	1.76E+00	8.46E-01	1.04E-02
685	3.8041088	1.73E+00	8.36E-01	1.06E-02
686	3.8096662	1.71E+00	8.30E-01	1.07E-02
687	3.8152237	1.69E+00	8.21E-01	1.09E-02
688	3.8207813	1.66E+00	8.09E-01	1.10E-02
689	3.8263388	1.64E+00	8.02E-01	1.12E-02
690	3.8318962	1.62E+00	7.95E-01	1.13E-02
691	3.8374537	1.60E+00	7.88E-01	1.14E-02
692	3.8430112	1.59E+00	7.86E-01	1.15E-02
693	3.8485688	1.58E+00	7.81E-01	1.16E-02
694	3.8541262	1.56E+00	7.76E-01	1.17E-02
695	3.8596837	1.55E+00	7.73E-01	1.17E-02
696	3.8652412	1.54E+00	7.69E-01	1.17E-02
697	3.8707988	1.53E+00	7.67E-01	1.17E-02
698	3.8763563	1.52E+00	7.65E-01	1.16E-02
699	3.8819137	1.53E+00	7.67E-01	1.15E-02
700	3.8874712	1.52E+00	7.66E-01	1.15E-02
701	3.8930288	1.52E+00	7.66E-01	1.14E-02
702	3.8985863	1.51E+00	7.66E-01	1.13E-02
703	3.9041437	1.51E+00	7.66E-01	1.11E-02
704	3.9097012	1.49E+00	7.64E-01	1.10E-02
705	3.9152588	1.49E+00	7.65E-01	1.09E-02
706	3.9208163	1.49E+00	7.67E-01	1.08E-02
707	3.9263737	1.49E+00	7.72E-01	1.07E-02
708	3.9319312	1.49E+00	7.75E-01	1.07E-02
709	3.9374887	1.49E+00	7.77E-01	1.06E-02

710	3.9430463	1.48E+00	7.80E-01	1.06E-02
711	3.9486037	1.48E+00	7.83E-01	1.06E-02
712	3.9541612	1.48E+00	7.89E-01	1.06E-02
713	3.9597187	1.47E+00	7.92E-01	1.07E-02
714	3.9652763	1.47E+00	7.95E-01	1.07E-02
715	3.9708338	1.47E+00	8.01E-01	1.08E-02
716	3.9763912	1.46E+00	8.03E-01	1.09E-02
717	3.9819487	1.45E+00	8.06E-01	1.10E-02
718	3.9875063	1.45E+00	8.11E-01	1.12E-02
719	3.9930638	1.44E+00	8.12E-01	1.13E-02
720	3.9986212	1.42E+00	8.12E-01	1.15E-02
721	4.0041788	1.42E+00	8.15E-01	1.16E-02
722	4.0097362	1.41E+00	8.13E-01	1.17E-02
723	4.0152937	1.40E+00	8.15E-01	1.19E-02
724	4.0208512	1.38E+00	8.08E-01	1.20E-02
725	4.0264087	1.37E+00	8.04E-01	1.21E-02
726	4.0319662	1.36E+00	8.03E-01	1.22E-02
727	4.0375238	1.35E+00	7.97E-01	1.22E-02
728	4.0430813	1.34E+00	7.90E-01	1.23E-02
729	4.0486388	1.33E+00	7.86E-01	1.23E-02
730	4.0541963	1.32E+00	7.78E-01	1.23E-02
731	4.0597537	1.31E+00	7.70E-01	1.23E-02
732	4.0653112	1.30E+00	7.61E-01	1.23E-02
733	4.0708687	1.29E+00	7.55E-01	1.23E-02
734	4.0764262	1.28E+00	7.45E-01	1.22E-02
735	4.0819838	1.27E+00	7.35E-01	1.22E-02
736	4.0875413	1.27E+00	7.28E-01	1.21E-02
737	4.0930988	1.26E+00	7.18E-01	1.20E-02
738	4.0986563	1.25E+00	7.08E-01	1.19E-02
739	4.1042137	1.25E+00	6.99E-01	1.18E-02
740	4.1097712	1.25E+00	6.92E-01	1.17E-02
741	4.1153287	1.24E+00	6.84E-01	1.15E-02
742	4.1208862	1.23E+00	6.75E-01	1.14E-02
743	4.1264437	1.23E+00	6.69E-01	1.13E-02
744	4.1320013	1.21E+00	6.57E-01	1.11E-02
745	4.1375588	1.21E+00	6.52E-01	1.10E-02
746	4.1431163	1.21E+00	6.45E-01	1.08E-02
747	4.1486738	1.20E+00	6.37E-01	1.06E-02
748	4.1542312	1.20E+00	6.33E-01	1.05E-02
749	4.1597887	1.19E+00	6.26E-01	1.03E-02
750	4.1653462	1.19E+00	6.22E-01	1.02E-02
751	4.1709037	1.18E+00	6.15E-01	9.99E-03
752	4.1764613	1.18E+00	6.12E-01	9.83E-03
753	4.1820188	1.17E+00	6.06E-01	9.68E-03
754	4.1875763	1.17E+00	6.03E-01	9.54E-03
755	4.1931338	1.17E+00	5.99E-01	9.40E-03
756	4.1986912	1.16E+00	5.93E-01	9.27E-03
757	4.2042487	1.16E+00	5.90E-01	9.15E-03
758	4.2098062	1.15E+00	5.84E-01	9.04E-03
759	4.2153637	1.15E+00	5.81E-01	8.95E-03
760	4.2209212	1.14E+00	5.74E-01	8.86E-03
761	4.2264788	1.14E+00	5.70E-01	8.78E-03
762	4.2320363	1.13E+00	5.64E-01	8.72E-03
763	4.2375938	1.12E+00	5.61E-01	8.66E-03
764	4.2431513	1.11E+00	5.54E-01	8.61E-03
765	4.2487087	1.11E+00	5.51E-01	8.57E-03
766	4.2542662	1.10E+00	5.44E-01	8.54E-03
767	4.2598237	1.09E+00	5.40E-01	8.51E-03
768	4.2653812	1.08E+00	5.33E-01	8.48E-03
769	4.2709388	1.08E+00	5.28E-01	8.46E-03
770	4.2764963	1.07E+00	5.23E-01	8.44E-03
771	4.2820538	1.06E+00	5.18E-01	8.43E-03

772	4.2876113	1.05E+00	5.13E-01	8.41E-03
773	4.2931687	1.05E+00	5.07E-01	8.39E-03
774	4.2987262	1.04E+00	5.03E-01	8.37E-03
775	4.3042837	1.03E+00	4.98E-01	8.35E-03
776	4.3098412	1.03E+00	4.94E-01	8.33E-03
777	4.3153987	1.02E+00	4.89E-01	8.31E-03
778	4.3209563	1.01E+00	4.85E-01	8.28E-03
779	4.3265138	1.01E+00	4.81E-01	8.26E-03
780	4.3320713	1.00E+00	4.78E-01	8.23E-03
781	4.3376288	1.00E+00	4.75E-01	8.21E-03
782	4.3431862	9.99E-01	4.72E-01	8.19E-03
783	4.3487437	9.98E-01	4.70E-01	8.17E-03
784	4.3543012	9.99E-01	4.68E-01	8.15E-03
785	4.3598587	9.99E-01	4.66E-01	8.14E-03
786	4.3654162	1.00E+00	4.66E-01	8.13E-03
787	4.3709738	1.01E+00	4.66E-01	8.13E-03
788	4.3765313	1.02E+00	4.67E-01	8.14E-03
789	4.3820888	1.02E+00	4.67E-01	8.16E-03
790	4.3876462	1.03E+00	4.69E-01	8.19E-03
791	4.3932037	1.05E+00	4.72E-01	8.23E-03
792	4.3987612	1.06E+00	4.74E-01	8.29E-03
793	4.4043187	1.08E+00	4.78E-01	8.36E-03
794	4.4098762	1.09E+00	4.81E-01	8.44E-03
795	4.4154338	1.11E+00	4.86E-01	8.54E-03
796	4.4209913	1.13E+00	4.90E-01	8.65E-03
797	4.4265488	1.15E+00	4.95E-01	8.78E-03
798	4.4321063	1.18E+00	5.01E-01	8.91E-03
799	4.4376637	1.19E+00	5.05E-01	9.06E-03
800	4.4432212	1.21E+00	5.10E-01	9.22E-03
801	4.4487787	1.23E+00	5.15E-01	9.38E-03
802	4.4543362	1.25E+00	5.20E-01	9.55E-03
803	4.4598937	1.27E+00	5.23E-01	9.72E-03
804	4.4654513	1.28E+00	5.26E-01	9.89E-03
805	4.4710088	1.29E+00	5.29E-01	1.01E-02
806	4.4765663	1.29E+00	5.30E-01	1.02E-02
807	4.4821237	1.30E+00	5.30E-01	1.04E-02
808	4.4876812	1.30E+00	5.30E-01	1.05E-02
809	4.4932387	1.30E+00	5.29E-01	1.07E-02
810	4.4987962	1.29E+00	5.26E-01	1.08E-02
811	4.5043537	1.28E+00	5.23E-01	1.09E-02
812	4.5099113	1.26E+00	5.19E-01	1.10E-02
813	4.5154688	1.25E+00	5.14E-01	1.10E-02
814	4.5210263	1.23E+00	5.07E-01	1.11E-02
815	4.5265838	1.21E+00	5.00E-01	1.11E-02
816	4.5321412	1.18E+00	4.94E-01	1.11E-02
817	4.5376987	1.16E+00	4.86E-01	1.11E-02
818	4.5432562	1.13E+00	4.78E-01	1.11E-02
819	4.5488137	1.11E+00	4.69E-01	1.11E-02
820	4.5543712	1.08E+00	4.60E-01	1.10E-02
821	4.5599288	1.05E+00	4.52E-01	1.10E-02
822	4.5654863	1.03E+00	4.44E-01	1.09E-02
823	4.5710438	1.00E+00	4.36E-01	1.09E-02
824	4.5766012	9.80E-01	4.28E-01	1.08E-02
825	4.5821587	9.59E-01	4.21E-01	1.07E-02
826	4.5877162	9.36E-01	4.13E-01	1.07E-02
827	4.5932737	9.16E-01	4.06E-01	1.06E-02
828	4.5988312	8.98E-01	4.00E-01	1.05E-02
829	4.6043888	8.83E-01	3.94E-01	1.05E-02
830	4.6099463	8.68E-01	3.89E-01	1.04E-02
831	4.6155038	8.55E-01	3.84E-01	1.03E-02
832	4.6210613	8.43E-01	3.79E-01	1.03E-02
833	4.6266187	8.32E-01	3.75E-01	1.02E-02

834	4.6321762	8.21E-01	3.71E-01	1.02E-02
835	4.6377337	8.13E-01	3.67E-01	1.01E-02
836	4.6432912	8.04E-01	3.64E-01	1.01E-02
837	4.6488487	7.98E-01	3.61E-01	1.01E-02
838	4.6544063	7.91E-01	3.58E-01	1.00E-02
839	4.6599638	7.85E-01	3.55E-01	1.00E-02
840	4.6655213	7.79E-01	3.53E-01	9.98E-03
841	4.6710788	7.73E-01	3.50E-01	9.97E-03
842	4.6766362	7.68E-01	3.48E-01	9.95E-03
843	4.6821937	7.64E-01	3.46E-01	9.94E-03
844	4.6877512	7.59E-01	3.44E-01	9.94E-03
845	4.6933087	7.55E-01	3.42E-01	9.94E-03
846	4.6988663	7.48E-01	3.39E-01	9.94E-03
847	4.7044238	7.43E-01	3.37E-01	9.96E-03
848	4.7099813	7.39E-01	3.35E-01	9.97E-03
849	4.7155388	7.34E-01	3.34E-01	1.00E-02
850	4.7210962	7.27E-01	3.31E-01	1.00E-02
851	4.7266537	7.22E-01	3.29E-01	1.00E-02
852	4.7322112	7.17E-01	3.27E-01	1.01E-02
853	4.7377687	7.10E-01	3.25E-01	1.01E-02
854	4.7433262	7.05E-01	3.23E-01	1.01E-02
855	4.7488838	6.98E-01	3.21E-01	1.02E-02
856	4.7544413	6.92E-01	3.19E-01	1.02E-02
857	4.7599988	6.85E-01	3.17E-01	1.02E-02
858	4.7655563	6.78E-01	3.14E-01	1.02E-02
859	4.7711137	6.73E-01	3.13E-01	1.02E-02
860	4.7766712	6.66E-01	3.10E-01	1.02E-02
861	4.7822287	6.59E-01	3.08E-01	1.02E-02
862	4.7877862	6.53E-01	3.06E-01	1.02E-02
863	4.7933438	6.47E-01	3.04E-01	1.01E-02
864	4.7989013	6.42E-01	3.02E-01	1.01E-02
865	4.8044588	6.37E-01	3.01E-01	1.00E-02
866	4.8100163	6.33E-01	2.99E-01	9.92E-03
867	4.8155737	6.29E-01	2.97E-01	9.84E-03
868	4.8211312	6.25E-01	2.95E-01	9.75E-03
869	4.8266887	6.22E-01	2.94E-01	9.65E-03
870	4.8322462	6.21E-01	2.93E-01	9.54E-03
871	4.8378037	6.20E-01	2.92E-01	9.44E-03
872	4.8433613	6.21E-01	2.91E-01	9.33E-03
873	4.8489188	6.24E-01	2.90E-01	9.23E-03
874	4.8544763	6.28E-01	2.90E-01	9.14E-03
875	4.8600338	6.33E-01	2.90E-01	9.05E-03
876	4.8655912	6.40E-01	2.91E-01	8.97E-03
877	4.8711487	6.50E-01	2.91E-01	8.91E-03
878	4.8767062	6.63E-01	2.93E-01	8.86E-03
879	4.8822637	6.75E-01	2.94E-01	8.83E-03
880	4.8878213	6.90E-01	2.96E-01	8.82E-03
881	4.8933788	7.07E-01	2.98E-01	8.82E-03
882	4.8989363	7.25E-01	3.00E-01	8.85E-03
883	4.9044938	7.48E-01	3.03E-01	8.91E-03
884	4.9100512	7.70E-01	3.06E-01	8.98E-03
885	4.9156087	7.95E-01	3.10E-01	9.08E-03
886	4.9211662	8.19E-01	3.13E-01	9.20E-03
887	4.9267237	8.45E-01	3.17E-01	9.35E-03
888	4.9322812	8.70E-01	3.20E-01	9.51E-03
889	4.9378388	8.97E-01	3.24E-01	9.70E-03
890	4.9433963	9.21E-01	3.27E-01	9.90E-03
891	4.9489538	9.45E-01	3.30E-01	1.01E-02
892	4.9545113	9.69E-01	3.33E-01	1.04E-02
893	4.9600687	9.90E-01	3.36E-01	1.06E-02
894	4.9656262	1.01E+00	3.38E-01	1.09E-02
895	4.9711837	1.02E+00	3.40E-01	1.11E-02

896	4.9767412	1.04E+00	3.41E-01	1.14E-02
897	4.9822987	1.05E+00	3.42E-01	1.16E-02
898	4.9878563	1.05E+00	3.42E-01	1.19E-02
899	4.9934138	1.05E+00	3.42E-01	1.21E-02
900	4.9989713	1.05E+00	3.41E-01	1.24E-02
901	5.0045287	1.05E+00	3.39E-01	1.26E-02
902	5.0100862	1.04E+00	3.37E-01	1.28E-02
903	5.0156437	1.02E+00	3.35E-01	1.30E-02
904	5.0212012	1.00E+00	3.32E-01	1.31E-02
905	5.0267587	9.85E-01	3.28E-01	1.33E-02
906	5.0323163	9.64E-01	3.25E-01	1.34E-02
907	5.0378738	9.39E-01	3.21E-01	1.35E-02
908	5.0434313	9.11E-01	3.17E-01	1.35E-02
909	5.0489888	8.82E-01	3.13E-01	1.35E-02
910	5.0545462	8.53E-01	3.09E-01	1.35E-02
911	5.0601037	8.22E-01	3.04E-01	1.35E-02
912	5.0656612	7.91E-01	3.00E-01	1.35E-02
913	5.0712187	7.59E-01	2.96E-01	1.34E-02
914	5.0767762	7.29E-01	2.92E-01	1.33E-02
915	5.0823338	6.99E-01	2.89E-01	1.32E-02
916	5.0878913	6.70E-01	2.85E-01	1.31E-02
917	5.0934488	6.43E-01	2.82E-01	1.30E-02
918	5.0990062	6.17E-01	2.79E-01	1.29E-02
919	5.1045637	5.92E-01	2.77E-01	1.27E-02
920	5.1101212	5.69E-01	2.74E-01	1.26E-02
921	5.1156787	5.48E-01	2.72E-01	1.24E-02
922	5.1212362	5.28E-01	2.70E-01	1.23E-02
923	5.1267938	5.11E-01	2.69E-01	1.22E-02
924	5.1323513	4.95E-01	2.67E-01	1.20E-02
925	5.1379088	4.80E-01	2.65E-01	1.19E-02
926	5.1434663	4.67E-01	2.64E-01	1.18E-02
927	5.1490237	4.58E-01	2.63E-01	1.18E-02
928	5.1545812	4.46E-01	2.61E-01	1.17E-02
929	5.1601387	4.37E-01	2.59E-01	1.16E-02
930	5.1656962	4.29E-01	2.58E-01	1.16E-02
931	5.1712537	4.22E-01	2.56E-01	1.16E-02
932	5.1768113	4.16E-01	2.54E-01	1.16E-02
933	5.1823688	4.11E-01	2.52E-01	1.16E-02
934	5.1879263	4.03E-01	2.49E-01	1.17E-02
935	5.1934837	3.99E-01	2.47E-01	1.17E-02
936	5.1990412	3.95E-01	2.45E-01	1.18E-02
937	5.2045987	3.91E-01	2.42E-01	1.19E-02
938	5.2101562	3.88E-01	2.40E-01	1.20E-02
939	5.2157137	3.85E-01	2.38E-01	1.21E-02
940	5.2212713	3.79E-01	2.34E-01	1.23E-02
941	5.2268288	3.77E-01	2.32E-01	1.24E-02
942	5.2323863	3.74E-01	2.29E-01	1.25E-02
943	5.2379438	3.72E-01	2.27E-01	1.26E-02
944	5.2435012	3.68E-01	2.24E-01	1.27E-02
945	5.2490587	3.66E-01	2.22E-01	1.28E-02
946	5.2546162	3.63E-01	2.20E-01	1.29E-02
947	5.2601737	3.59E-01	2.17E-01	1.30E-02
948	5.2657312	3.57E-01	2.16E-01	1.30E-02
949	5.2712888	3.55E-01	2.14E-01	1.31E-02
950	5.2768463	3.53E-01	2.13E-01	1.31E-02
951	5.2824038	3.48E-01	2.10E-01	1.31E-02
952	5.2879612	3.46E-01	2.09E-01	1.30E-02
953	5.2935187	3.44E-01	2.08E-01	1.30E-02
954	5.2990762	3.42E-01	2.07E-01	1.29E-02
955	5.3046337	3.39E-01	2.06E-01	1.28E-02
956	5.3101912	3.37E-01	2.05E-01	1.26E-02
957	5.3157488	3.34E-01	2.04E-01	1.25E-02

958	5.3213063	3.32E-01	2.04E-01	1.23E-02
959	5.3268638	3.30E-01	2.03E-01	1.22E-02
960	5.3324213	3.29E-01	2.03E-01	1.20E-02
961	5.3379787	3.27E-01	2.02E-01	1.18E-02
962	5.3435362	3.25E-01	2.02E-01	1.16E-02
963	5.3490937	3.23E-01	2.02E-01	1.14E-02
964	5.3546512	3.20E-01	2.01E-01	1.12E-02
965	5.3602087	3.19E-01	2.01E-01	1.10E-02
966	5.3657663	3.17E-01	2.00E-01	1.08E-02
967	5.3713238	3.17E-01	2.01E-01	1.06E-02
968	5.3768813	3.15E-01	2.00E-01	1.05E-02
969	5.3824388	3.13E-01	2.00E-01	1.03E-02
970	5.3879962	3.12E-01	1.99E-01	1.01E-02
971	5.3935537	3.10E-01	1.99E-01	1.00E-02
972	5.3991112	3.10E-01	1.99E-01	9.87E-03
973	5.4046687	3.07E-01	1.98E-01	9.76E-03
974	5.4102263	3.05E-01	1.97E-01	9.66E-03
975	5.4157838	3.05E-01	1.97E-01	9.57E-03
976	5.4213413	3.04E-01	1.96E-01	9.50E-03
977	5.4268988	3.02E-01	1.96E-01	9.44E-03
978	5.4324562	3.02E-01	1.95E-01	9.40E-03
979	5.4380137	3.00E-01	1.94E-01	9.37E-03
980	5.4435712	2.98E-01	1.93E-01	9.35E-03
981	5.4491287	2.98E-01	1.93E-01	9.36E-03
982	5.4546862	2.97E-01	1.92E-01	9.37E-03
983	5.4602438	2.94E-01	1.91E-01	9.41E-03
984	5.4658013	2.94E-01	1.90E-01	9.47E-03
985	5.4713588	2.92E-01	1.89E-01	9.54E-03
986	5.4769163	2.92E-01	1.89E-01	9.63E-03
987	5.4824737	2.90E-01	1.88E-01	9.75E-03
988	5.4880312	2.89E-01	1.87E-01	9.89E-03
989	5.4935887	2.89E-01	1.87E-01	1.01E-02
990	5.4991462	2.87E-01	1.87E-01	1.02E-02
991	5.5047038	2.85E-01	1.86E-01	1.05E-02
992	5.5102613	2.85E-01	1.86E-01	1.07E-02
993	5.5158188	2.83E-01	1.86E-01	1.10E-02
994	5.5213763	2.81E-01	1.86E-01	1.13E-02
995	5.5269337	2.81E-01	1.86E-01	1.17E-02
996	5.5324912	2.79E-01	1.86E-01	1.21E-02
997	5.5380487	2.77E-01	1.87E-01	1.25E-02
998	5.5436062	2.77E-01	1.88E-01	1.29E-02
999	5.5491637	2.76E-01	1.89E-01	1.34E-02
1000	5.5547213	2.74E-01	1.90E-01	1.39E-02
1001	5.5602788	2.74E-01	1.91E-01	1.44E-02
1002	5.5658363	2.72E-01	1.93E-01	1.50E-02
1003	5.5713938	2.71E-01	1.94E-01	1.55E-02
1004	5.5769512	2.71E-01	1.96E-01	1.61E-02
1005	5.5825087	2.68E-01	1.97E-01	1.67E-02
1006	5.5880662	2.69E-01	2.00E-01	1.73E-02
1007	5.5936237	2.67E-01	2.02E-01	1.79E-02
1008	5.5991812	2.67E-01	2.04E-01	1.84E-02
1009	5.6047388	2.65E-01	2.06E-01	1.90E-02
1010	5.6102963	2.66E-01	2.09E-01	1.95E-02
1011	5.6158538	2.64E-01	2.10E-01	2.00E-02
1012	5.6214112	2.64E-01	2.13E-01	2.04E-02
1013	5.6269687	2.63E-01	2.14E-01	2.08E-02
1014	5.6325262	2.63E-01	2.16E-01	2.12E-02
1015	5.6380837	2.61E-01	2.17E-01	2.15E-02
1016	5.6436412	2.62E-01	2.19E-01	2.17E-02
1017	5.6491988	2.60E-01	2.19E-01	2.19E-02
1018	5.6547563	2.60E-01	2.20E-01	2.20E-02
1019	5.6603138	2.61E-01	2.21E-01	2.21E-02

1020	5.6658713	2.58E-01	2.21E-01	2.21E-02
1021	5.6714287	2.58E-01	2.21E-01	2.21E-02
1022	5.6769862	2.57E-01	2.20E-01	2.20E-02
1023	5.6825437	2.55E-01	2.19E-01	2.19E-02
1024	5.6881012	2.55E-01	2.18E-01	2.17E-02
1025	5.6936587	2.54E-01	2.16E-01	2.15E-02
1026	5.6992163	2.54E-01	2.15E-01	2.13E-02
1027	5.7047738	2.52E-01	2.13E-01	2.10E-02
1028	5.7103313	2.51E-01	2.10E-01	2.07E-02
1029	5.7158887	2.51E-01	2.08E-01	2.04E-02
1030	5.7214462	2.49E-01	2.06E-01	2.01E-02
1031	5.7270037	2.50E-01	2.04E-01	1.98E-02
1032	5.7325612	2.47E-01	2.01E-01	1.95E-02
1033	5.7381187	2.46E-01	1.98E-01	1.92E-02
1034	5.7436763	2.46E-01	1.96E-01	1.89E-02
1035	5.7492338	2.44E-01	1.94E-01	1.85E-02
1036	5.7547913	2.43E-01	1.91E-01	1.82E-02
1037	5.7603488	2.43E-01	1.89E-01	1.79E-02
1038	5.7659062	2.41E-01	1.87E-01	1.76E-02
1039	5.7714637	2.42E-01	1.86E-01	1.73E-02
1040	5.7770212	2.40E-01	1.85E-01	1.70E-02
1041	5.7825787	2.39E-01	1.83E-01	1.67E-02
1042	5.7881362	2.39E-01	1.83E-01	1.64E-02
1043	5.7936938	2.36E-01	1.82E-01	1.61E-02
1044	5.7992513	2.37E-01	1.83E-01	1.58E-02
1045	5.8048088	2.35E-01	1.83E-01	1.55E-02
1046	5.8103662	2.34E-01	1.83E-01	1.52E-02
1047	5.8159237	2.34E-01	1.84E-01	1.49E-02
1048	5.8214812	2.33E-01	1.86E-01	1.46E-02
1049	5.8270387	2.32E-01	1.88E-01	1.43E-02
1050	5.8325962	2.31E-01	1.90E-01	1.40E-02
1051	5.8381538	2.30E-01	1.92E-01	1.37E-02
1052	5.8437113	2.29E-01	1.95E-01	1.34E-02
1053	5.8492688	2.28E-01	1.98E-01	1.32E-02
1054	5.8548263	2.27E-01	2.01E-01	1.29E-02
1055	5.8603837	2.25E-01	2.04E-01	1.26E-02
1056	5.8659412	2.24E-01	2.08E-01	1.24E-02
1057	5.8714987	2.22E-01	2.11E-01	1.21E-02
1058	5.8770562	2.21E-01	2.15E-01	1.19E-02
1059	5.8826137	2.20E-01	2.19E-01	1.16E-02
1060	5.8881713	2.18E-01	2.22E-01	1.14E-02
1061	5.8937288	2.17E-01	2.26E-01	1.12E-02
1062	5.8992863	2.15E-01	2.29E-01	1.10E-02
1063	5.9048437	2.14E-01	2.33E-01	1.08E-02
1064	5.9104012	2.13E-01	2.36E-01	1.07E-02
1065	5.9159587	2.10E-01	2.38E-01	1.05E-02
1066	5.9215162	2.09E-01	2.41E-01	1.03E-02
1067	5.9270737	2.07E-01	2.43E-01	1.02E-02
1068	5.9326313	2.06E-01	2.45E-01	1.01E-02
1069	5.9381888	2.04E-01	2.46E-01	9.97E-03
1070	5.9437463	2.03E-01	2.48E-01	9.88E-03
1071	5.9493038	2.01E-01	2.48E-01	9.80E-03
1072	5.9548612	1.99E-01	2.49E-01	9.73E-03
1073	5.9604187	1.98E-01	2.49E-01	9.68E-03
1074	5.9659762	1.97E-01	2.48E-01	9.65E-03
1075	5.9715337	1.94E-01	2.47E-01	9.65E-03
1076	5.9770912	1.93E-01	2.46E-01	9.67E-03
1077	5.9826488	1.92E-01	2.44E-01	9.73E-03
1078	5.9882063	1.91E-01	2.43E-01	9.81E-03
1079	5.9937638	1.89E-01	2.41E-01	9.94E-03
1080	5.9993212	1.88E-01	2.39E-01	1.01E-02
1081	6.0048787	1.87E-01	2.36E-01	1.03E-02

1082	6.0104362	1.86E-01	2.34E-01	1.06E-02
1083	6.0159937	1.85E-01	2.31E-01	1.09E-02
1084	6.0215512	1.84E-01	2.28E-01	1.13E-02
1085	6.0271088	1.84E-01	2.26E-01	1.17E-02
1086	6.0326663	1.83E-01	2.23E-01	1.22E-02
1087	6.0382238	1.82E-01	2.20E-01	1.27E-02
1088	6.0437813	1.81E-01	2.17E-01	1.34E-02
1089	6.0493387	1.80E-01	2.14E-01	1.41E-02
1090	6.0548962	1.80E-01	2.11E-01	1.48E-02
1091	6.0604537	1.80E-01	2.08E-01	1.56E-02
1092	6.0660112	1.79E-01	2.05E-01	1.65E-02
1093	6.0715687	1.79E-01	2.02E-01	1.74E-02
1094	6.0771263	1.79E-01	2.00E-01	1.84E-02
1095	6.0826838	1.79E-01	1.97E-01	1.94E-02
1096	6.0882413	1.78E-01	1.94E-01	2.04E-02
1097	6.0937988	1.78E-01	1.91E-01	2.14E-02
1098	6.0993562	1.78E-01	1.89E-01	2.25E-02
1099	6.1049137	1.78E-01	1.86E-01	2.35E-02
1100	6.1104712	1.78E-01	1.84E-01	2.45E-02
1101	6.1160287	1.78E-01	1.82E-01	2.55E-02
1102	6.1215863	1.78E-01	1.79E-01	2.64E-02
1103	6.1271438	1.78E-01	1.77E-01	2.73E-02
1104	6.1327013	1.78E-01	1.74E-01	2.81E-02
1105	6.1382588	1.78E-01	1.72E-01	2.88E-02
1106	6.1438162	1.78E-01	1.70E-01	2.94E-02
1107	6.1493737	1.78E-01	1.68E-01	2.98E-02
1108	6.1549312	1.78E-01	1.65E-01	3.02E-02
1109	6.1604887	1.78E-01	1.63E-01	3.05E-02
1110	6.1660462	1.78E-01	1.61E-01	3.06E-02
1111	6.1716038	1.78E-01	1.59E-01	3.06E-02
1112	6.1771613	1.77E-01	1.57E-01	3.05E-02
1113	6.1827188	1.77E-01	1.54E-01	3.02E-02
1114	6.1882763	1.77E-01	1.52E-01	2.99E-02
1115	6.1938337	1.76E-01	1.50E-01	2.94E-02
1116	6.1993912	1.76E-01	1.48E-01	2.88E-02
1117	6.2049487	1.76E-01	1.46E-01	2.81E-02
1118	6.2105062	1.75E-01	1.44E-01	2.74E-02
1119	6.2160637	1.75E-01	1.43E-01	2.65E-02
1120	6.2216213	1.75E-01	1.41E-01	2.56E-02
1121	6.2271788	1.74E-01	1.39E-01	2.47E-02
1122	6.2327363	1.74E-01	1.38E-01	2.37E-02
1123	6.2382937	1.73E-01	1.36E-01	2.27E-02
1124	6.2438512	1.71E-01	1.34E-01	2.17E-02
1125	6.2494087	1.71E-01	1.33E-01	2.07E-02
1126	6.2549662	1.70E-01	1.33E-01	1.97E-02
1127	6.2605237	1.70E-01	1.32E-01	1.88E-02
1128	6.2660813	1.69E-01	1.32E-01	1.78E-02
1129	6.2716388	1.69E-01	1.32E-01	1.69E-02
1130	6.2771963	1.68E-01	1.32E-01	1.61E-02
1131	6.2827538	1.69E-01	1.33E-01	1.53E-02
1132	6.2883112	1.68E-01	1.34E-01	1.45E-02
1133	6.2938687	1.68E-01	1.35E-01	1.38E-02
1134	6.2994262	1.67E-01	1.36E-01	1.32E-02
1135	6.3049837	1.67E-01	1.38E-01	1.26E-02
1136	6.3105412	1.67E-01	1.41E-01	1.21E-02
1137	6.3160988	1.67E-01	1.44E-01	1.16E-02
1138	6.3216563	1.66E-01	1.47E-01	1.12E-02
1139	6.3272138	1.66E-01	1.51E-01	1.09E-02
1140	6.3327712	1.65E-01	1.54E-01	1.06E-02
1141	6.3383287	1.64E-01	1.59E-01	1.03E-02
1142	6.3438862	1.64E-01	1.64E-01	1.01E-02
1143	6.3494437	1.63E-01	1.69E-01	9.90E-03

1144	6.3550012	1.64E-01	1.74E-01	9.75E-03
1145	6.3605588	1.63E-01	1.80E-01	9.63E-03
1146	6.3661163	1.63E-01	1.86E-01	9.53E-03
1147	6.3716738	1.62E-01	1.92E-01	9.47E-03
1148	6.3772313	1.62E-01	1.98E-01	9.42E-03
1149	6.3827887	1.61E-01	2.04E-01	9.39E-03
1150	6.3883462	1.61E-01	2.11E-01	9.38E-03
1151	6.3939037	1.59E-01	2.17E-01	9.37E-03
1152	6.3994612	1.58E-01	2.23E-01	9.38E-03
1153	6.4050187	1.58E-01	2.29E-01	9.39E-03
1154	6.4105763	1.57E-01	2.35E-01	9.41E-03
1155	6.4161338	1.56E-01	2.40E-01	9.43E-03
1156	6.4216913	1.54E-01	2.45E-01	9.46E-03
1157	6.4272487	1.54E-01	2.50E-01	9.48E-03
1158	6.4328062	1.52E-01	2.54E-01	9.51E-03
1159	6.4383637	1.51E-01	2.57E-01	9.53E-03
1160	6.4439212	1.49E-01	2.60E-01	9.56E-03
1161	6.4494787	1.47E-01	2.62E-01	9.58E-03
1162	6.4550363	1.46E-01	2.63E-01	9.60E-03
1163	6.4605938	1.44E-01	2.64E-01	9.62E-03
1164	6.4661513	1.42E-01	2.65E-01	9.64E-03
1165	6.4717088	1.41E-01	2.64E-01	9.66E-03
1166	6.4772662	1.39E-01	2.63E-01	9.68E-03
1167	6.4828237	1.37E-01	2.62E-01	9.70E-03
1168	6.4883812	1.36E-01	2.59E-01	9.72E-03
1169	6.4939387	1.34E-01	2.57E-01	9.75E-03
1170	6.4994962	1.32E-01	2.53E-01	9.79E-03
1171	6.5050538	1.30E-01	2.49E-01	9.83E-03
1172	6.5106113	1.28E-01	2.45E-01	9.89E-03
1173	6.5161688	1.27E-01	2.40E-01	9.96E-03
1174	6.5217262	1.25E-01	2.35E-01	1.00E-02
1175	6.5272837	1.24E-01	2.30E-01	1.01E-02
1176	6.5328412	1.22E-01	2.24E-01	1.03E-02
1177	6.5383987	1.20E-01	2.18E-01	1.04E-02
1178	6.5439562	1.19E-01	2.12E-01	1.06E-02
1179	6.5495138	1.17E-01	2.05E-01	1.07E-02
1180	6.5550713	1.16E-01	1.99E-01	1.09E-02
1181	6.5606288	1.15E-01	1.92E-01	1.12E-02
1182	6.5661863	1.13E-01	1.86E-01	1.14E-02
1183	6.5717437	1.12E-01	1.80E-01	1.17E-02
1184	6.5773012	1.11E-01	1.73E-01	1.20E-02
1185	6.5828587	1.10E-01	1.67E-01	1.23E-02
1186	6.5884162	1.09E-01	1.61E-01	1.27E-02
1187	6.5939737	1.08E-01	1.55E-01	1.30E-02
1188	6.5995313	1.07E-01	1.49E-01	1.34E-02
1189	6.6050888	1.06E-01	1.44E-01	1.38E-02
1190	6.6106463	1.06E-01	1.38E-01	1.41E-02
1191	6.6162037	1.05E-01	1.33E-01	1.45E-02
1192	6.6217612	1.04E-01	1.28E-01	1.49E-02
1193	6.6273187	1.04E-01	1.23E-01	1.53E-02
1194	6.6328762	1.03E-01	1.19E-01	1.56E-02
1195	6.6384337	1.03E-01	1.14E-01	1.59E-02
1196	6.6439913	1.03E-01	1.10E-01	1.62E-02
1197	6.6495488	1.02E-01	1.07E-01	1.65E-02
1198	6.6551063	1.02E-01	1.03E-01	1.67E-02
1199	6.6606638	1.02E-01	9.95E-02	1.69E-02
1200	6.6662212	1.01E-01	9.63E-02	1.71E-02
1201	6.6717787	1.01E-01	9.32E-02	1.72E-02
1202	6.6773362	1.01E-01	9.04E-02	1.73E-02
1203	6.6828937	1.01E-01	8.78E-02	1.73E-02
1204	6.6884512	1.01E-01	8.54E-02	1.72E-02
1205	6.6940088	1.00E-01	8.31E-02	1.72E-02

1206	6.6995663	1.00E-01	8.10E-02	1.70E-02
1207	6.7051238	1.00E-01	7.90E-02	1.68E-02
1208	6.7106812	9.99E-02	7.72E-02	1.66E-02
1209	6.7162387	9.98E-02	7.55E-02	1.63E-02
1210	6.7217962	9.98E-02	7.40E-02	1.60E-02
1211	6.7273537	9.98E-02	7.27E-02	1.57E-02
1212	6.7329112	9.96E-02	7.14E-02	1.53E-02
1213	6.7384688	9.94E-02	7.02E-02	1.49E-02
1214	6.7440263	9.93E-02	6.91E-02	1.45E-02
1215	6.7495838	9.93E-02	6.82E-02	1.40E-02
1216	6.7551413	9.90E-02	6.73E-02	1.36E-02
1217	6.7606987	9.91E-02	6.66E-02	1.32E-02
1218	6.7662562	9.89E-02	6.59E-02	1.27E-02
1219	6.7718137	9.88E-02	6.53E-02	1.23E-02
1220	6.7773712	9.88E-02	6.48E-02	1.19E-02
1221	6.7829287	9.85E-02	6.44E-02	1.15E-02
1222	6.7884863	9.83E-02	6.40E-02	1.11E-02
1223	6.7940438	9.84E-02	6.38E-02	1.07E-02
1224	6.7996013	9.84E-02	6.36E-02	1.04E-02
1225	6.8051588	9.81E-02	6.34E-02	1.01E-02
1226	6.8107162	9.81E-02	6.34E-02	9.83E-03
1227	6.8162737	9.80E-02	6.34E-02	9.60E-03
1228	6.8218312	9.78E-02	6.34E-02	9.42E-03
1229	6.8273887	9.78E-02	6.36E-02	9.27E-03
1230	6.8329462	9.76E-02	6.37E-02	9.15E-03
1231	6.8385038	9.74E-02	6.38E-02	9.08E-03
1232	6.8440613	9.73E-02	6.41E-02	9.05E-03
1233	6.8496188	9.71E-02	6.43E-02	9.05E-03
1234	6.8551762	9.68E-02	6.45E-02	9.08E-03
1235	6.8607337	9.67E-02	6.48E-02	9.15E-03
1236	6.8662912	9.64E-02	6.50E-02	9.25E-03
1237	6.8718487	9.63E-02	6.53E-02	9.38E-03
1238	6.8774062	9.59E-02	6.55E-02	9.54E-03
1239	6.8829638	9.59E-02	6.58E-02	9.71E-03
1240	6.8885213	9.53E-02	6.58E-02	9.91E-03
1241	6.8940788	9.51E-02	6.60E-02	1.01E-02
1242	6.8996363	9.47E-02	6.61E-02	1.03E-02
1243	6.9051937	9.43E-02	6.62E-02	1.06E-02
1244	6.9107512	9.40E-02	6.62E-02	1.08E-02
1245	6.9163087	9.35E-02	6.61E-02	1.10E-02
1246	6.9218662	9.31E-02	6.60E-02	1.13E-02
1247	6.9274237	9.27E-02	6.58E-02	1.15E-02
1248	6.9329813	9.19E-02	6.54E-02	1.17E-02
1249	6.9385388	9.14E-02	6.51E-02	1.19E-02
1250	6.9440963	9.09E-02	6.46E-02	1.21E-02
1251	6.9496537	9.01E-02	6.41E-02	1.22E-02
1252	6.9552112	8.95E-02	6.35E-02	1.24E-02
1253	6.9607687	8.89E-02	6.29E-02	1.25E-02
1254	6.9663262	8.83E-02	6.22E-02	1.26E-02
1255	6.9718837	8.77E-02	6.14E-02	1.26E-02
1256	6.9774413	8.69E-02	6.05E-02	1.27E-02
1257	6.9829988	8.62E-02	5.96E-02	1.27E-02
1258	6.9885563	8.54E-02	5.86E-02	1.26E-02
1259	6.9941138	8.47E-02	5.76E-02	1.26E-02
1260	6.9996712	8.39E-02	5.65E-02	1.25E-02
1261	7.0052287	8.31E-02	5.54E-02	1.24E-02
1262	7.0107862	8.25E-02	5.43E-02	1.22E-02
1263	7.0163437	8.17E-02	5.31E-02	1.21E-02
1264	7.0219012	8.11E-02	5.19E-02	1.19E-02
1265	7.0274588	8.05E-02	5.08E-02	1.17E-02
1266	7.0330163	7.97E-02	4.96E-02	1.15E-02
1267	7.0385738	7.89E-02	4.83E-02	1.12E-02

1268	7.0441312	7.84E-02	4.72E-02	1.10E-02
1269	7.0496887	7.78E-02	4.60E-02	1.07E-02
1270	7.0552462	7.73E-02	4.48E-02	1.05E-02
1271	7.0608037	7.68E-02	4.37E-02	1.02E-02
1272	7.0663612	7.63E-02	4.26E-02	9.92E-03
1273	7.0719188	7.57E-02	4.15E-02	9.64E-03
1274	7.0774763	7.54E-02	4.05E-02	9.36E-03
1275	7.0830338	7.51E-02	3.96E-02	9.08E-03
1276	7.0885913	7.48E-02	3.86E-02	8.81E-03
1277	7.0941487	7.45E-02	3.77E-02	8.54E-03
1278	7.0997062	7.43E-02	3.69E-02	8.28E-03
1279	7.1052637	7.40E-02	3.61E-02	8.03E-03
1280	7.1108212	7.40E-02	3.54E-02	7.79E-03
1281	7.1163787	7.39E-02	3.47E-02	7.57E-03
1282	7.1219363	7.40E-02	3.42E-02	7.35E-03
1283	7.1274938	7.40E-02	3.36E-02	7.15E-03
1284	7.1330513	7.43E-02	3.32E-02	6.97E-03
1285	7.1386087	7.44E-02	3.27E-02	6.80E-03
1286	7.1441662	7.47E-02	3.24E-02	6.65E-03
1287	7.1497237	7.48E-02	3.20E-02	6.53E-03
1288	7.1552812	7.52E-02	3.18E-02	6.42E-03
1289	7.1608387	7.56E-02	3.16E-02	6.33E-03
1290	7.1663963	7.60E-02	3.14E-02	6.26E-03
1291	7.1719538	7.63E-02	3.12E-02	6.21E-03
1292	7.1775113	7.67E-02	3.11E-02	6.19E-03
1293	7.1830688	7.70E-02	3.10E-02	6.19E-03
1294	7.1886262	7.75E-02	3.10E-02	6.21E-03
1295	7.1941837	7.79E-02	3.10E-02	6.25E-03
1296	7.1997412	7.83E-02	3.09E-02	6.31E-03
1297	7.2052987	7.86E-02	3.09E-02	6.39E-03
1298	7.2108562	7.90E-02	3.09E-02	6.50E-03
1299	7.2164138	7.91E-02	3.09E-02	6.62E-03
1300	7.2219713	7.95E-02	3.09E-02	6.77E-03
1301	7.2275288	7.96E-02	3.09E-02	6.93E-03
1302	7.2330862	7.97E-02	3.08E-02	7.10E-03
1303	7.2386437	7.97E-02	3.08E-02	7.30E-03
1304	7.2442012	7.97E-02	3.07E-02	7.50E-03
1305	7.2497587	7.97E-02	3.07E-02	7.72E-03
1306	7.2553162	7.94E-02	3.05E-02	7.94E-03
1307	7.2608738	7.91E-02	3.04E-02	8.18E-03
1308	7.2664313	7.90E-02	3.03E-02	8.42E-03
1309	7.2719888	7.85E-02	3.01E-02	8.66E-03
1310	7.2775463	7.79E-02	2.98E-02	8.90E-03
1311	7.2831037	7.73E-02	2.96E-02	9.15E-03
1312	7.2886612	7.68E-02	2.94E-02	9.39E-03
1313	7.2942187	7.61E-02	2.91E-02	9.63E-03
1314	7.2997762	7.52E-02	2.88E-02	9.87E-03
1315	7.3053337	7.45E-02	2.85E-02	1.01E-02
1316	7.3108913	7.37E-02	2.82E-02	1.03E-02
1317	7.3164488	7.28E-02	2.79E-02	1.05E-02
1318	7.3220063	7.21E-02	2.76E-02	1.07E-02
1319	7.3275637	7.09E-02	2.71E-02	1.09E-02
1320	7.3331212	6.99E-02	2.67E-02	1.11E-02
1321	7.3386787	6.90E-02	2.64E-02	1.13E-02
1322	7.3442362	6.81E-02	2.60E-02	1.14E-02
1323	7.3497937	6.72E-02	2.57E-02	1.16E-02
1324	7.3553513	6.64E-02	2.54E-02	1.17E-02
1325	7.3609088	6.54E-02	2.50E-02	1.19E-02
1326	7.3664663	6.44E-02	2.46E-02	1.20E-02
1327	7.3720238	6.35E-02	2.43E-02	1.21E-02
1328	7.3775812	6.25E-02	2.39E-02	1.22E-02
1329	7.3831387	6.18E-02	2.36E-02	1.23E-02

1330	7.3886962	6.09E-02	2.33E-02	1.24E-02
1331	7.3942537	6.01E-02	2.30E-02	1.25E-02
1332	7.3998112	5.94E-02	2.27E-02	1.26E-02
1333	7.4053688	5.87E-02	2.24E-02	1.27E-02
1334	7.4109263	5.78E-02	2.21E-02	1.27E-02
1335	7.4164838	5.73E-02	2.19E-02	1.28E-02
1336	7.4220412	5.66E-02	2.16E-02	1.28E-02
1337	7.4275987	5.60E-02	2.14E-02	1.29E-02
1338	7.4331562	5.53E-02	2.11E-02	1.29E-02
1339	7.4387137	5.45E-02	2.08E-02	1.29E-02
1340	7.4442712	5.41E-02	2.07E-02	1.29E-02
1341	7.4498287	5.35E-02	2.05E-02	1.29E-02
1342	7.4553863	5.30E-02	2.02E-02	1.29E-02
1343	7.4609438	5.24E-02	2.00E-02	1.28E-02
1344	7.4665013	5.18E-02	1.98E-02	1.28E-02
1345	7.4720587	5.14E-02	1.97E-02	1.27E-02
1346	7.4776162	5.08E-02	1.94E-02	1.26E-02
1347	7.4831737	5.05E-02	1.93E-02	1.24E-02
1348	7.4887312	4.99E-02	1.91E-02	1.23E-02
1349	7.4942887	4.92E-02	1.88E-02	1.21E-02
1350	7.4998463	4.89E-02	1.87E-02	1.20E-02
1351	7.5054038	4.84E-02	1.85E-02	1.18E-02
1352	7.5109613	4.79E-02	1.83E-02	1.15E-02
1353	7.5165188	4.76E-02	1.82E-02	1.13E-02
1354	7.5220762	4.71E-02	1.80E-02	1.11E-02
1355	7.5276337	4.68E-02	1.79E-02	1.08E-02
1356	7.5331912	4.63E-02	1.77E-02	1.05E-02
1357	7.5387487	4.62E-02	1.76E-02	1.02E-02
1358	7.5443062	4.58E-02	1.75E-02	9.95E-03
1359	7.5498638	4.54E-02	1.73E-02	9.64E-03
1360	7.5554213	4.51E-02	1.72E-02	9.34E-03
1361	7.5609788	4.50E-02	1.72E-02	9.03E-03
1362	7.5665362	4.48E-02	1.71E-02	8.72E-03
1363	7.5720937	4.46E-02	1.71E-02	8.42E-03
1364	7.5776512	4.46E-02	1.70E-02	8.11E-03
1365	7.5832087	4.45E-02	1.70E-02	7.81E-03
1366	7.5887662	4.45E-02	1.70E-02	7.52E-03
1367	7.5943238	4.45E-02	1.70E-02	7.23E-03
1368	7.5998813	4.45E-02	1.70E-02	6.96E-03
1369	7.6054388	4.47E-02	1.71E-02	6.70E-03
1370	7.6109963	4.50E-02	1.72E-02	6.45E-03
1371	7.6165537	4.53E-02	1.73E-02	6.21E-03
1372	7.6221112	4.56E-02	1.74E-02	5.99E-03
1373	7.6276687	4.61E-02	1.76E-02	5.78E-03
1374	7.6332262	4.64E-02	1.77E-02	5.59E-03
1375	7.6387837	4.70E-02	1.80E-02	5.42E-03
1376	7.6443413	4.76E-02	1.82E-02	5.27E-03
1377	7.6498988	4.83E-02	1.85E-02	5.14E-03
1378	7.6554563	4.91E-02	1.88E-02	5.02E-03
1379	7.6610137	4.97E-02	1.90E-02	4.93E-03
1380	7.6665712	5.04E-02	1.93E-02	4.86E-03
1381	7.6721287	5.13E-02	1.96E-02	4.81E-03
1382	7.6776862	5.22E-02	2.00E-02	4.78E-03
1383	7.6832437	5.30E-02	2.03E-02	4.77E-03
1384	7.6888013	5.40E-02	2.06E-02	4.79E-03
1385	7.6943588	5.46E-02	2.09E-02	4.83E-03
1386	7.6999163	5.56E-02	2.12E-02	4.89E-03
1387	7.7054738	5.65E-02	2.16E-02	4.97E-03
1388	7.7110312	5.73E-02	2.19E-02	5.07E-03
1389	7.7165887	5.82E-02	2.22E-02	5.19E-03
1390	7.7221462	5.88E-02	2.25E-02	5.33E-03
1391	7.7277037	5.95E-02	2.27E-02	5.49E-03

1392	7.7332612	6.00E-02	2.29E-02	5.67E-03
1393	7.7388188	6.07E-02	2.32E-02	5.86E-03
1394	7.7443763	6.13E-02	2.34E-02	6.06E-03
1395	7.7499338	6.15E-02	2.35E-02	6.27E-03
1396	7.7554912	6.18E-02	2.36E-02	6.50E-03
1397	7.7610487	6.19E-02	2.37E-02	6.73E-03
1398	7.7666062	6.21E-02	2.37E-02	6.96E-03
1399	7.7721637	6.19E-02	2.37E-02	7.20E-03
1400	7.7777212	6.17E-02	2.36E-02	7.43E-03
1401	7.7832788	6.15E-02	2.35E-02	7.67E-03
1402	7.7888363	6.09E-02	2.33E-02	7.89E-03
1403	7.7943938	6.04E-02	2.31E-02	8.11E-03
1404	7.7999513	5.99E-02	2.29E-02	8.31E-03
1405	7.8055087	5.90E-02	2.25E-02	8.50E-03
1406	7.8110662	5.81E-02	2.22E-02	8.67E-03
1407	7.8166237	5.72E-02	2.19E-02	8.82E-03
1408	7.8221812	5.61E-02	2.15E-02	8.95E-03
1409	7.8277387	5.50E-02	2.10E-02	9.05E-03
1410	7.8332963	5.39E-02	2.06E-02	9.13E-03
1411	7.8388538	5.26E-02	2.01E-02	9.19E-03
1412	7.8444113	5.12E-02	1.96E-02	9.22E-03
1413	7.8499687	4.99E-02	1.91E-02	9.22E-03
1414	7.8555262	4.85E-02	1.85E-02	9.19E-03
1415	7.8610837	4.70E-02	1.80E-02	9.14E-03
1416	7.8666412	4.56E-02	1.74E-02	9.06E-03
1417	7.8721987	4.44E-02	1.70E-02	8.95E-03
1418	7.8777563	4.29E-02	1.64E-02	8.82E-03
1419	7.8833138	4.15E-02	1.59E-02	8.67E-03
1420	7.8888713	4.04E-02	1.54E-02	8.50E-03
1421	7.8944288	3.89E-02	1.49E-02	8.31E-03
1422	7.8999862	3.77E-02	1.44E-02	8.10E-03
1423	7.9055437	3.64E-02	1.39E-02	7.89E-03
1424	7.9111012	3.53E-02	1.35E-02	7.66E-03
1425	7.9166587	3.42E-02	1.31E-02	7.43E-03
1426	7.9222162	3.32E-02	1.27E-02	7.19E-03
1427	7.9277738	3.22E-02	1.23E-02	6.96E-03
1428	7.9333313	3.13E-02	1.20E-02	6.73E-03
1429	7.9388888	3.03E-02	1.16E-02	6.50E-03
1430	7.9444462	2.95E-02	1.13E-02	6.28E-03
1431	7.9500037	2.88E-02	1.10E-02	6.07E-03
1432	7.9555612	2.82E-02	1.08E-02	5.88E-03
1433	7.9611187	2.76E-02	1.05E-02	5.70E-03
1434	7.9666762	2.70E-02	1.03E-02	5.54E-03
1435	7.9722338	2.65E-02	1.01E-02	5.40E-03
1436	7.9777913	2.61E-02	9.96E-03	5.27E-03
1437	7.9833488	2.57E-02	9.81E-03	5.17E-03
1438	7.9889063	2.53E-02	9.67E-03	5.09E-03
1439	7.9944637	2.48E-02	9.48E-03	5.03E-03
1440	8.0000212	2.45E-02	9.37E-03	5.00E-03
1441	8.0055787	2.43E-02	9.27E-03	4.98E-03
1442	8.0111362	2.40E-02	9.19E-03	4.99E-03
1443	8.0166937	2.38E-02	9.11E-03	5.01E-03
1444	8.0222513	2.37E-02	9.05E-03	5.05E-03
1445	8.0278088	2.35E-02	8.99E-03	5.11E-03
1446	8.0333663	2.32E-02	8.87E-03	5.18E-03
1447	8.0389238	2.31E-02	8.83E-03	5.27E-03
1448	8.0444813	2.30E-02	8.80E-03	5.36E-03
1449	8.0500388	2.29E-02	8.77E-03	5.46E-03
1450	8.0555963	2.27E-02	8.67E-03	5.57E-03
1451	8.0611538	2.26E-02	8.65E-03	5.68E-03
1452	8.0667112	2.23E-02	8.53E-03	5.80E-03
1453	8.0722687	2.23E-02	8.52E-03	5.91E-03

1454	8.0778262	2.23E-02	8.51E-03	6.01E-03
1455	8.0833837	2.21E-02	8.43E-03	6.11E-03
1456	8.0889412	2.20E-02	8.43E-03	6.20E-03
1457	8.0944987	2.19E-02	8.35E-03	6.29E-03
1458	8.1000562	2.17E-02	8.28E-03	6.36E-03
1459	8.1056137	2.17E-02	8.28E-03	6.41E-03
1460	8.1111712	2.15E-02	8.21E-03	6.46E-03
1461	8.1167288	2.13E-02	8.15E-03	6.48E-03
1462	8.1222863	2.13E-02	8.15E-03	6.49E-03
1463	8.1278438	2.11E-02	8.08E-03	6.49E-03
1464	8.1334013	2.09E-02	7.98E-03	6.46E-03
1465	8.1389588	2.07E-02	7.92E-03	6.42E-03
1466	8.1445163	2.05E-02	7.85E-03	6.37E-03
1467	8.1500738	2.06E-02	7.86E-03	6.30E-03
1468	8.1556313	2.04E-02	7.79E-03	6.21E-03
1469	8.1611887	2.02E-02	7.73E-03	6.11E-03
1470	8.1667462	2.01E-02	7.67E-03	5.99E-03
1471	8.1723037	1.99E-02	7.60E-03	5.87E-03
1472	8.1778612	1.96E-02	7.51E-03	5.73E-03
1473	8.1834187	1.95E-02	7.44E-03	5.58E-03
1474	8.1889762	1.94E-02	7.41E-03	5.43E-03
1475	8.1945337	1.92E-02	7.35E-03	5.27E-03
1476	8.2000912	1.90E-02	7.28E-03	5.10E-03
1477	8.2056487	1.89E-02	7.21E-03	4.93E-03
1478	8.2112063	1.88E-02	7.18E-03	4.76E-03
1479	8.2167638	1.86E-02	7.12E-03	4.59E-03
1480	8.2223213	1.84E-02	7.02E-03	4.41E-03
1481	8.2278788	1.83E-02	6.98E-03	4.24E-03
1482	8.2334363	1.81E-02	6.91E-03	4.07E-03
1483	8.2389938	1.80E-02	6.88E-03	3.91E-03
1484	8.2445513	1.79E-02	6.85E-03	3.75E-03
1485	8.2501088	1.77E-02	6.78E-03	3.59E-03
1486	8.2556662	1.76E-02	6.74E-03	3.44E-03
1487	8.2612237	1.75E-02	6.70E-03	3.30E-03
1488	8.2667812	1.74E-02	6.67E-03	3.16E-03
1489	8.2723387	1.73E-02	6.63E-03	3.03E-03
1490	8.2778962	1.72E-02	6.59E-03	2.90E-03
1491	8.2834537	1.71E-02	6.52E-03	2.78E-03
1492	8.2890112	1.70E-02	6.48E-03	2.66E-03
1493	8.2945687	1.69E-02	6.44E-03	2.56E-03
1494	8.3001262	1.68E-02	6.44E-03	2.45E-03
1495	8.3056838	1.67E-02	6.40E-03	2.36E-03
1496	8.3112413	1.66E-02	6.36E-03	2.27E-03
1497	8.3167988	1.66E-02	6.36E-03	2.18E-03
1498	8.3223563	1.65E-02	6.32E-03	2.10E-03
1499	8.3279138	1.65E-02	6.31E-03	2.03E-03
1500	8.3334713	1.65E-02	6.31E-03	1.96E-03
1501	8.3390288	1.64E-02	6.27E-03	1.89E-03
1502	8.3445863	1.64E-02	6.27E-03	1.83E-03
1503	8.3501437	1.64E-02	6.26E-03	1.77E-03
1504	8.3557012	1.64E-02	6.26E-03	1.72E-03
1505	8.3612587	1.63E-02	6.22E-03	1.67E-03
1506	8.3668162	1.63E-02	6.22E-03	1.63E-03
1507	8.3723737	1.63E-02	6.21E-03	1.58E-03
1508	8.3779312	1.62E-02	6.21E-03	1.55E-03
1509	8.3834887	1.61E-02	6.17E-03	1.51E-03
1510	8.3890462	1.61E-02	6.17E-03	1.49E-03
1511	8.3946037	1.61E-02	6.17E-03	1.46E-03
1512	8.4001613	1.60E-02	6.13E-03	1.44E-03
1513	8.4057188	1.60E-02	6.13E-03	1.43E-03
1514	8.4112763	1.60E-02	6.13E-03	1.42E-03
1515	8.4168338	1.59E-02	6.09E-03	1.42E-03

1516	8.4223913	1.59E-02	6.09E-03	1.43E-03
1517	8.4279488	1.58E-02	6.05E-03	1.44E-03
1518	8.4335063	1.58E-02	6.05E-03	1.45E-03
1519	8.4390638	1.57E-02	6.02E-03	1.48E-03
1520	8.4446212	1.57E-02	6.01E-03	1.51E-03
1521	8.4501787	1.56E-02	5.98E-03	1.55E-03
1522	8.4557362	1.56E-02	5.98E-03	1.60E-03
1523	8.4612937	1.55E-02	5.91E-03	1.66E-03
1524	8.4668512	1.54E-02	5.87E-03	1.72E-03
1525	8.4724087	1.54E-02	5.87E-03	1.80E-03
1526	8.4779662	1.53E-02	5.84E-03	1.88E-03
1527	8.4835237	1.52E-02	5.80E-03	1.97E-03
1528	8.4890812	1.52E-02	5.80E-03	2.08E-03
1529	8.4946388	1.51E-02	5.77E-03	2.19E-03
1530	8.5001963	1.51E-02	5.77E-03	2.31E-03
1531	8.5057538	1.50E-02	5.73E-03	2.44E-03
1532	8.5113113	1.49E-02	5.70E-03	2.57E-03
1533	8.5168688	1.49E-02	5.69E-03	2.71E-03
1534	8.5224263	1.48E-02	5.66E-03	2.86E-03
1535	8.5279838	1.47E-02	5.62E-03	3.02E-03
1536	8.5335413	1.47E-02	5.62E-03	3.18E-03
1537	8.5390987	1.46E-02	5.59E-03	3.34E-03
1538	8.5446562	1.45E-02	5.55E-03	3.51E-03
1539	8.5502137	1.45E-02	5.55E-03	3.68E-03
1540	8.5557712	1.44E-02	5.52E-03	3.84E-03
1541	8.5613287	1.43E-02	5.48E-03	4.01E-03
1542	8.5668862	1.43E-02	5.48E-03	4.17E-03
1543	8.5724437	1.42E-02	5.44E-03	4.33E-03
1544	8.5780012	1.41E-02	5.38E-03	4.48E-03
1545	8.5835587	1.40E-02	5.34E-03	4.62E-03
1546	8.5891163	1.39E-02	5.31E-03	4.76E-03
1547	8.5946738	1.38E-02	5.27E-03	4.88E-03
1548	8.6002313	1.38E-02	5.27E-03	5.00E-03
1549	8.6057888	1.37E-02	5.23E-03	5.10E-03
1550	8.6113463	1.36E-02	5.20E-03	5.18E-03
1551	8.6169038	1.34E-02	5.13E-03	5.25E-03
1552	8.6224613	1.33E-02	5.10E-03	5.31E-03
1553	8.6280188	1.32E-02	5.06E-03	5.34E-03
1554	8.6335762	1.31E-02	5.03E-03	5.36E-03
1555	8.6391337	1.31E-02	4.99E-03	5.37E-03
1556	8.6446912	1.30E-02	4.96E-03	5.35E-03
1557	8.6502487	1.27E-02	4.85E-03	5.32E-03
1558	8.6558062	1.26E-02	4.82E-03	5.26E-03
1559	8.6613637	1.25E-02	4.79E-03	5.20E-03
1560	8.6669212	1.23E-02	4.72E-03	5.11E-03
1561	8.6724787	1.22E-02	4.68E-03	5.01E-03
1562	8.6780362	1.22E-02	4.65E-03	4.90E-03
1563	8.6835938	1.20E-02	4.58E-03	4.77E-03
1564	8.6891513	1.19E-02	4.54E-03	4.63E-03
1565	8.6947088	1.18E-02	4.51E-03	4.47E-03
1566	8.7002663	1.16E-02	4.44E-03	4.31E-03
1567	8.7058238	1.15E-02	4.41E-03	4.14E-03
1568	8.7113813	1.13E-02	4.34E-03	3.96E-03
1569	8.7169388	1.13E-02	4.30E-03	3.78E-03
1570	8.7224963	1.11E-02	4.24E-03	3.59E-03
1571	8.7280537	1.10E-02	4.20E-03	3.40E-03
1572	8.7336112	1.09E-02	4.17E-03	3.21E-03
1573	8.7391687	1.08E-02	4.13E-03	3.02E-03
1574	8.7447262	1.07E-02	4.10E-03	2.83E-03
1575	8.7502837	1.06E-02	4.06E-03	2.64E-03
1576	8.7558412	1.05E-02	4.03E-03	2.46E-03
1577	8.7613987	1.05E-02	4.00E-03	2.28E-03

1578	8.7669562	1.05E-02	4.00E-03	2.11E-03
1579	8.7725137	1.04E-02	3.96E-03	1.94E-03
1580	8.7780712	1.03E-02	3.93E-03	1.78E-03
1581	8.7836288	1.03E-02	3.93E-03	1.63E-03
1582	8.7891863	1.02E-02	3.90E-03	1.49E-03
1583	8.7947438	1.02E-02	3.90E-03	1.35E-03
1584	8.8003013	1.02E-02	3.90E-03	1.22E-03
1585	8.8058588	1.02E-02	3.90E-03	1.10E-03
1586	8.8114163	1.00E-02	3.83E-03	9.90E-04
1587	8.8169738	1.00E-02	3.83E-03	8.87E-04
1588	8.8225312	1.00E-02	3.83E-03	7.91E-04
1589	8.8280887	1.00E-02	3.83E-03	7.04E-04
1590	8.8336462	1.00E-02	3.83E-03	6.24E-04
1591	8.8392037	1.00E-02	3.83E-03	5.51E-04
1592	8.8447612	1.00E-02	3.83E-03	4.85E-04
1593	8.8503187	1.02E-02	3.90E-03	4.25E-04
1594	8.8558762	1.02E-02	3.90E-03	3.72E-04
1595	8.8614337	1.02E-02	3.90E-03	3.24E-04
1596	8.8669912	1.02E-02	3.91E-03	2.81E-04
1597	8.8725487	1.02E-02	3.91E-03	2.43E-04
1598	8.8781063	1.02E-02	3.91E-03	2.10E-04
1599	8.8836638	1.02E-02	3.91E-03	1.80E-04
1600	8.8892213	1.02E-02	3.91E-03	1.54E-04
1601	8.8947788	1.02E-02	3.91E-03	1.31E-04
1602	8.9003363	1.02E-02	3.91E-03	1.30E-05
1603	8.9058938	1.02E-02	3.91E-03	1.30E-05
1604	8.9114513	1.02E-02	3.91E-03	1.30E-05
1605	8.9170087	1.02E-02	3.92E-03	1.30E-05
1606	8.9225662	1.02E-02	3.92E-03	1.30E-05
1607	8.9281237	1.02E-02	3.92E-03	1.30E-05
1608	8.9336812	1.01E-02	3.85E-03	1.28E-05
1609	8.9392387	1.01E-02	3.85E-03	1.28E-05
1610	8.9447962	9.99E-03	3.82E-03	1.27E-05
1611	8.9503537	9.99E-03	3.82E-03	1.27E-05
1612	8.9559112	9.90E-03	3.78E-03	1.26E-05
1613	8.9614687	9.81E-03	3.75E-03	1.25E-05
1614	8.9670262	9.72E-03	3.72E-03	1.24E-05
1615	8.9725838	9.72E-03	3.72E-03	1.24E-05
1616	8.9781413	9.64E-03	3.68E-03	1.23E-05
1617	8.9836988	9.55E-03	3.65E-03	1.22E-05
1618	8.9892563	9.46E-03	3.62E-03	1.20E-05
1619	8.9948138	9.28E-03	3.55E-03	1.18E-05
1620	9.0003713	9.19E-03	3.51E-03	1.17E-05
1621	9.0059288	9.10E-03	3.48E-03	1.16E-05
1622	9.0114862	8.94E-03	3.42E-03	1.14E-05
1623	9.0170437	8.82E-03	3.37E-03	1.12E-05
1624	9.0226012	8.68E-03	3.32E-03	1.11E-05
1625	9.0281587	8.55E-03	3.27E-03	1.09E-05
1626	9.0337162	8.41E-03	3.22E-03	1.07E-05
1627	9.0392737	8.27E-03	3.16E-03	1.05E-05
1628	9.0448312	8.14E-03	3.11E-03	1.04E-05
1629	9.0503887	7.98E-03	3.05E-03	1.02E-05
1630	9.0559462	7.85E-03	3.00E-03	9.99E-06
1631	9.0615037	7.71E-03	2.95E-03	9.82E-06
1632	9.0670613	7.57E-03	2.89E-03	9.64E-06
1633	9.0726188	7.44E-03	2.84E-03	9.47E-06
1634	9.0781763	7.30E-03	2.79E-03	9.29E-06
1635	9.0837338	7.14E-03	2.73E-03	9.10E-06
1636	9.0892913	7.02E-03	2.69E-03	8.94E-06
1637	9.0948488	6.89E-03	2.63E-03	8.77E-06
1638	9.1004063	6.75E-03	2.58E-03	8.59E-06
1639	9.1059637	6.61E-03	2.53E-03	8.42E-06

1640	9.1115212	6.49E-03	2.48E-03	8.27E-06
1641	9.1170787	6.36E-03	2.43E-03	8.10E-06
1642	9.1226362	6.24E-03	2.39E-03	7.94E-06
1643	9.1281937	6.13E-03	2.34E-03	7.80E-06
1644	9.1337512	6.01E-03	2.30E-03	7.65E-06
1645	9.1393087	5.89E-03	2.25E-03	7.50E-06
1646	9.1448662	5.79E-03	2.21E-03	7.38E-06
1647	9.1504237	5.67E-03	2.17E-03	7.23E-06
1648	9.1559812	5.58E-03	2.13E-03	7.11E-06
1649	9.1615388	5.48E-03	2.10E-03	6.98E-06
1650	9.1670963	5.37E-03	2.05E-03	6.83E-06
1651	9.1726538	5.28E-03	2.02E-03	6.73E-06
1652	9.1782113	5.19E-03	1.99E-03	6.61E-06
1653	9.1837688	5.09E-03	1.95E-03	6.49E-06
1654	9.1893263	5.01E-03	1.92E-03	6.38E-06
1655	9.1948838	4.94E-03	1.89E-03	6.29E-06
1656	9.2004412	4.86E-03	1.86E-03	6.19E-06
1657	9.2059987	4.79E-03	1.83E-03	6.09E-06
1658	9.2115562	4.71E-03	1.80E-03	5.99E-06
1659	9.2171137	4.63E-03	1.77E-03	5.90E-06
1660	9.2226712	4.57E-03	1.75E-03	5.82E-06
1661	9.2282287	4.52E-03	1.73E-03	5.75E-06
1662	9.2337862	4.45E-03	1.70E-03	5.67E-06
1663	9.2393437	4.40E-03	1.68E-03	5.60E-06
1664	9.2449012	4.34E-03	1.66E-03	5.52E-06
1665	9.2504587	4.30E-03	1.64E-03	5.47E-06
1666	9.2560163	4.25E-03	1.62E-03	5.41E-06
1667	9.2615738	4.20E-03	1.61E-03	5.35E-06
1668	9.2671313	4.17E-03	1.59E-03	5.30E-06
1669	9.2726888	4.13E-03	1.58E-03	5.26E-06
1670	9.2782463	4.11E-03	1.57E-03	5.23E-06
1671	9.2838038	4.07E-03	1.55E-03	5.18E-06
1672	9.2893613	4.05E-03	1.55E-03	5.15E-06
1673	9.2949188	4.01E-03	1.53E-03	5.11E-06
1674	9.3004762	3.99E-03	1.53E-03	5.09E-06
1675	9.3060337	3.98E-03	1.52E-03	5.06E-06
1676	9.3115912	3.96E-03	1.51E-03	5.04E-06
1677	9.3171487	3.93E-03	1.50E-03	5.01E-06
1678	9.3227062	3.91E-03	1.50E-03	4.98E-06
1679	9.3282637	3.91E-03	1.50E-03	4.98E-06
1680	9.3338212	3.90E-03	1.49E-03	4.96E-06
1681	9.3393787	3.90E-03	1.49E-03	4.96E-06
1682	9.3449362	3.88E-03	1.48E-03	4.94E-06
1683	9.3504938	3.88E-03	1.48E-03	4.94E-06
1684	9.3560513	3.86E-03	1.48E-03	4.92E-06
1685	9.3616088	3.86E-03	1.48E-03	4.92E-06
1686	9.3671663	3.84E-03	1.47E-03	4.89E-06
1687	9.3727238	3.84E-03	1.47E-03	4.89E-06
1688	9.3782813	3.82E-03	1.46E-03	4.87E-06
1689	9.3838388	3.82E-03	1.46E-03	4.87E-06
1690	9.3893963	3.82E-03	1.46E-03	4.87E-06
1691	9.3949537	3.80E-03	1.45E-03	4.84E-06
1692	9.4005112	3.80E-03	1.45E-03	4.84E-06
1693	9.4060687	3.78E-03	1.44E-03	4.81E-06
1694	9.4116262	3.76E-03	1.44E-03	4.79E-06
1695	9.4171837	3.76E-03	1.44E-03	4.79E-06
1696	9.4227412	3.74E-03	1.43E-03	4.77E-06
1697	9.4282987	3.73E-03	1.42E-03	4.74E-06
1698	9.4338562	3.73E-03	1.42E-03	4.74E-06
1699	9.4394137	3.71E-03	1.42E-03	4.72E-06
1700	9.4449713	3.69E-03	1.41E-03	4.70E-06
1701	9.4505288	3.66E-03	1.40E-03	4.67E-06

1702	9.4560863	3.65E-03	1.39E-03	4.64E-06
1703	9.4616438	3.63E-03	1.39E-03	4.62E-06
1704	9.4672013	3.61E-03	1.38E-03	4.60E-06
1705	9.4727588	3.58E-03	1.37E-03	4.55E-06
1706	9.4783163	3.56E-03	1.36E-03	4.53E-06
1707	9.4838738	3.53E-03	1.35E-03	4.50E-06
1708	9.4894312	3.51E-03	1.34E-03	4.47E-06
1709	9.4949887	3.48E-03	1.33E-03	4.43E-06
1710	9.5005462	3.46E-03	1.32E-03	4.40E-06
1711	9.5061037	3.42E-03	1.31E-03	4.36E-06
1712	9.5116612	3.40E-03	1.30E-03	4.33E-06
1713	9.5172187	3.36E-03	1.28E-03	4.28E-06
1714	9.5227762	3.33E-03	1.27E-03	4.23E-06
1715	9.5283337	3.29E-03	1.26E-03	4.19E-06
1716	9.5338912	3.26E-03	1.25E-03	4.16E-06
1717	9.5394488	3.23E-03	1.23E-03	4.11E-06
1718	9.5450063	3.19E-03	1.22E-03	4.06E-06
1719	9.5505638	3.16E-03	1.21E-03	4.02E-06
1720	9.5561213	3.11E-03	1.19E-03	3.96E-06
1721	9.5616788	3.08E-03	1.18E-03	3.92E-06
1722	9.5672363	3.04E-03	1.16E-03	3.87E-06
1723	9.5727938	2.98E-03	1.14E-03	3.79E-06
1724	9.5783513	2.94E-03	1.13E-03	3.75E-06
1725	9.5839087	2.91E-03	1.11E-03	3.70E-06
1726	9.5894662	2.85E-03	1.09E-03	3.62E-06
1727	9.5950237	2.81E-03	1.07E-03	3.58E-06
1728	9.6005812	2.77E-03	1.06E-03	3.53E-06
1729	9.6061387	2.71E-03	1.04E-03	3.45E-06
1730	9.6116962	2.68E-03	1.02E-03	3.41E-06
1731	9.6172537	2.62E-03	1.00E-03	3.34E-06
1732	9.6228112	2.58E-03	9.85E-04	3.28E-06
1733	9.6283687	2.52E-03	9.65E-04	3.21E-06
1734	9.6339263	2.49E-03	9.51E-04	3.17E-06
1735	9.6394838	2.43E-03	9.28E-04	3.09E-06
1736	9.6450413	2.39E-03	9.14E-04	3.04E-06
1737	9.6505988	2.33E-03	8.90E-04	2.97E-06
1738	9.6561563	2.29E-03	8.77E-04	2.92E-06
1739	9.6617138	2.26E-03	8.63E-04	2.87E-06
1740	9.6672713	2.20E-03	8.39E-04	2.80E-06
1741	9.6728288	2.16E-03	8.26E-04	2.75E-06
1742	9.6783862	2.12E-03	8.12E-04	2.70E-06
1743	9.6839437	2.09E-03	7.98E-04	2.66E-06
1744	9.6895012	2.04E-03	7.81E-04	2.60E-06
1745	9.6950587	2.01E-03	7.68E-04	2.56E-06
1746	9.7006162	1.97E-03	7.54E-04	2.51E-06
1747	9.7061737	1.93E-03	7.37E-04	2.46E-06
1748	9.7117312	1.90E-03	7.27E-04	2.42E-06
1749	9.7172887	1.87E-03	7.17E-04	2.39E-06
1750	9.7228462	1.86E-03	7.10E-04	2.36E-06
1751	9.7284038	1.83E-03	7.00E-04	2.33E-06
1752	9.7339613	1.80E-03	6.90E-04	2.30E-06
1753	9.7395188	1.79E-03	6.83E-04	2.27E-06
1754	9.7450763	1.77E-03	6.76E-04	2.25E-06
1755	9.7506338	1.76E-03	6.73E-04	2.24E-06
1756	9.7561913	1.75E-03	6.69E-04	2.23E-06
1757	9.7617488	1.74E-03	6.66E-04	2.22E-06
1758	9.7673063	1.74E-03	6.66E-04	2.22E-06
1759	9.7728637	1.74E-03	6.66E-04	2.22E-06
1760	9.7784212	1.74E-03	6.66E-04	2.22E-06
1761	9.7839787	1.74E-03	6.66E-04	2.22E-06
1762	9.7895362	1.74E-03	6.66E-04	2.22E-06
1763	9.7950937	1.75E-03	6.69E-04	2.23E-06

1764	9.8006512	1.76E-03	6.73E-04	2.24E-06
1765	9.8062087	1.77E-03	6.76E-04	2.25E-06
1766	9.8117662	1.78E-03	6.80E-04	2.26E-06
1767	9.8173237	1.80E-03	6.87E-04	2.29E-06
1768	9.8228813	1.81E-03	6.90E-04	2.30E-06
1769	9.8284388	1.83E-03	7.00E-04	2.33E-06
1770	9.8339963	1.85E-03	7.07E-04	2.36E-06
1771	9.8395538	1.87E-03	7.14E-04	2.38E-06
1772	9.8451113	1.89E-03	7.21E-04	2.40E-06
1773	9.8506688	1.90E-03	7.28E-04	2.42E-06
1774	9.8562263	1.91E-03	7.31E-04	2.44E-06
1775	9.8617838	1.93E-03	7.38E-04	2.46E-06
1776	9.8673412	1.96E-03	7.48E-04	2.49E-06
1777	9.8728987	1.97E-03	7.55E-04	2.51E-06
1778	9.8784562	1.99E-03	7.62E-04	2.54E-06
1779	9.8840137	2.01E-03	7.69E-04	2.56E-06
1780	9.8895712	2.03E-03	7.75E-04	2.58E-06
1781	9.8951287	2.05E-03	7.82E-04	2.61E-06
1782	9.9006862	2.05E-03	7.82E-04	2.61E-06
1783	9.9062437	2.06E-03	7.89E-04	2.63E-06
1784	9.9118012	2.06E-03	7.89E-04	2.63E-06
1785	9.9173588	2.09E-03	7.99E-04	2.66E-06
1786	9.9229163	2.09E-03	7.99E-04	2.66E-06
1787	9.9284738	2.11E-03	8.06E-04	2.68E-06
1788	9.9340313	2.11E-03	8.06E-04	2.68E-06
1789	9.9395888	2.11E-03	8.06E-04	2.68E-06
1790	9.9451463	2.11E-03	8.06E-04	2.68E-06
1791	9.9507038	2.11E-03	8.06E-04	2.68E-06
1792	9.9562613	2.11E-03	8.06E-04	2.68E-06
1793	9.9618187	2.11E-03	8.06E-04	2.68E-06
1794	9.9673762	2.11E-03	8.06E-04	2.68E-06
1795	9.9729337	2.11E-03	8.06E-04	2.68E-06
1796	9.9784912	2.09E-03	7.99E-04	2.66E-06
1797	9.9840487	2.09E-03	7.99E-04	2.66E-06
1798	9.9896062	2.09E-03	7.99E-04	2.66E-06
1799	9.9951637	2.06E-03	7.89E-04	2.63E-06
1800	10.0007212	2.06E-03	7.89E-04	2.63E-06
1801	10.0062787	2.05E-03	7.82E-04	2.60E-06
1802	10.0118362	2.05E-03	7.82E-04	2.60E-06
1803	10.0173938	2.03E-03	7.75E-04	2.58E-06
1804	10.0229513	2.01E-03	7.68E-04	2.56E-06
1805	10.0285088	2.01E-03	7.68E-04	2.56E-06
1806	10.0340663	1.99E-03	7.61E-04	2.54E-06
1807	10.0396238	1.97E-03	7.55E-04	2.51E-06
1808	10.0451813	1.97E-03	7.55E-04	2.51E-06
1809	10.0507388	1.96E-03	7.48E-04	2.49E-06
1810	10.0562962	1.93E-03	7.38E-04	2.46E-06
1811	10.0618537	1.91E-03	7.31E-04	2.43E-06
1812	10.0674112	1.90E-03	7.27E-04	2.42E-06
1813	10.0729687	1.88E-03	7.21E-04	2.40E-06
1814	10.0785262	1.88E-03	7.17E-04	2.39E-06
1815	10.0840837	1.86E-03	7.10E-04	2.37E-06
1816	10.0896412	1.85E-03	7.07E-04	2.35E-06
1817	10.0951987	1.83E-03	7.00E-04	2.33E-06
1818	10.1007562	1.80E-03	6.90E-04	2.30E-06
1819	10.1063137	1.80E-03	6.86E-04	2.29E-06
1820	10.1118713	1.78E-03	6.80E-04	2.26E-06
1821	10.1174288	1.76E-03	6.73E-04	2.24E-06
1822	10.1229863	1.75E-03	6.69E-04	2.23E-06
1823	10.1285438	1.73E-03	6.63E-04	2.21E-06
1824	10.1341013	1.72E-03	6.56E-04	2.18E-06
1825	10.1396588	1.71E-03	6.52E-04	2.17E-06

1826	10.1452163	1.69E-03	6.46E-04	2.15E-06
1827	10.1507737	1.66E-03	6.36E-04	2.12E-06
1828	10.1563312	1.65E-03	6.32E-04	2.11E-06
1829	10.1618887	1.64E-03	6.25E-04	2.08E-06
1830	10.1674462	1.62E-03	6.19E-04	2.06E-06
1831	10.1730037	1.61E-03	6.15E-04	2.05E-06
1832	10.1785612	1.59E-03	6.09E-04	2.03E-06
1833	10.1841187	1.58E-03	6.05E-04	2.02E-06
1834	10.1896762	1.57E-03	5.98E-04	1.99E-06
1835	10.1952337	1.56E-03	5.95E-04	1.98E-06
1836	10.2007912	1.54E-03	5.88E-04	1.96E-06
1837	10.2063488	1.52E-03	5.82E-04	1.94E-06
1838	10.2119063	1.51E-03	5.78E-04	1.93E-06
1839	10.2174638	1.50E-03	5.75E-04	1.92E-06
1840	10.2230213	1.50E-03	5.72E-04	1.90E-06
1841	10.2285788	1.49E-03	5.68E-04	1.89E-06
1842	10.2341363	1.48E-03	5.65E-04	1.88E-06
1843	10.2396938	1.47E-03	5.62E-04	1.87E-06
1844	10.2452512	1.47E-03	5.62E-04	1.87E-06
1845	10.2508087	1.46E-03	5.59E-04	1.86E-06
1846	10.2563662	1.46E-03	5.59E-04	1.86E-06
1847	10.2619237	1.45E-03	5.56E-04	1.85E-06
1848	10.2674812	1.45E-03	5.56E-04	1.85E-06
1849	10.2730387	1.45E-03	5.56E-04	1.85E-06
1850	10.2785962	1.45E-03	5.56E-04	1.85E-06
1851	10.2841537	1.46E-03	5.56E-04	1.85E-06
1852	10.2897112	1.46E-03	5.56E-04	1.85E-06
1853	10.2952687	1.46E-03	5.56E-04	1.85E-06
1854	10.3008263	1.47E-03	5.60E-04	1.87E-06
1855	10.3063838	1.47E-03	5.60E-04	1.87E-06
1856	10.3119413	1.47E-03	5.64E-04	1.88E-06
1857	10.3174988	1.48E-03	5.64E-04	1.88E-06
1858	10.3230563	1.48E-03	5.67E-04	1.89E-06
1859	10.3286138	1.49E-03	5.71E-04	1.90E-06
1860	10.3341713	1.50E-03	5.74E-04	1.91E-06
1861	10.3397287	1.51E-03	5.78E-04	1.93E-06
1862	10.3452862	1.52E-03	5.82E-04	1.94E-06
1863	10.3508437	1.53E-03	5.85E-04	1.95E-06
1864	10.3564012	1.54E-03	5.89E-04	1.96E-06
1865	10.3619587	1.55E-03	5.92E-04	1.97E-06
1866	10.3675162	1.57E-03	5.99E-04	1.99E-06
1867	10.3730737	1.58E-03	6.02E-04	2.01E-06
1868	10.3786312	1.58E-03	6.06E-04	2.02E-06
1869	10.3841887	1.60E-03	6.13E-04	2.04E-06
1870	10.3897462	1.61E-03	6.16E-04	2.05E-06
1871	10.3953038	1.62E-03	6.20E-04	2.06E-06
1872	10.4008613	1.63E-03	6.23E-04	2.08E-06
1873	10.4064188	1.64E-03	6.26E-04	2.09E-06
1874	10.4119763	1.65E-03	6.30E-04	2.10E-06
1875	10.4175338	1.67E-03	6.37E-04	2.12E-06
1876	10.4230913	1.67E-03	6.40E-04	2.13E-06
1877	10.4286488	1.68E-03	6.43E-04	2.14E-06
1878	10.4342062	1.70E-03	6.50E-04	2.17E-06
1879	10.4397637	1.71E-03	6.54E-04	2.18E-06
1880	10.4453212	1.71E-03	6.54E-04	2.18E-06
1881	10.4508787	1.72E-03	6.57E-04	2.19E-06
1882	10.4564362	1.73E-03	6.60E-04	2.20E-06
1883	10.4619937	1.74E-03	6.64E-04	2.21E-06
1884	10.4675512	1.74E-03	6.63E-04	2.21E-06
1885	10.4731087	1.74E-03	6.67E-04	2.22E-06
1886	10.4786662	1.74E-03	6.67E-04	2.22E-06
1887	10.4842237	1.75E-03	6.70E-04	2.23E-06

1888	10.4897813	1.75E-03	6.70E-04	2.23E-06
1889	10.4953388	1.75E-03	6.70E-04	2.23E-06
1890	10.5008963	1.75E-03	6.70E-04	2.23E-06
1891	10.5064538	1.75E-03	6.70E-04	2.23E-06
1892	10.5120113	1.75E-03	6.70E-04	2.23E-06
1893	10.5175688	1.75E-03	6.69E-04	2.23E-06
1894	10.5231263	1.75E-03	6.69E-04	2.23E-06
1895	10.5286837	1.74E-03	6.66E-04	2.22E-06
1896	10.5342412	1.74E-03	6.66E-04	2.22E-06
1897	10.5397987	1.73E-03	6.62E-04	2.21E-06
1898	10.5453562	1.73E-03	6.62E-04	2.21E-06
1899	10.5509137	1.72E-03	6.59E-04	2.19E-06
1900	10.5564712	1.71E-03	6.55E-04	2.18E-06
1901	10.5620287	1.70E-03	6.52E-04	2.17E-06
1902	10.5675862	1.70E-03	6.48E-04	2.16E-06
1903	10.5731437	1.68E-03	6.41E-04	2.14E-06
1904	10.5787012	1.67E-03	6.38E-04	2.12E-06
1905	10.5842588	1.66E-03	6.34E-04	2.11E-06
1906	10.5898163	1.65E-03	6.31E-04	2.10E-06
1907	10.5953738	1.63E-03	6.24E-04	2.08E-06
1908	10.6009313	1.62E-03	6.21E-04	2.07E-06
1909	10.6064888	1.61E-03	6.14E-04	2.04E-06
1910	10.6120463	1.59E-03	6.07E-04	2.02E-06
1911	10.6176038	1.58E-03	6.04E-04	2.01E-06
1912	10.6231612	1.56E-03	5.97E-04	1.99E-06
1913	10.6287187	1.53E-03	5.87E-04	1.95E-06
1914	10.6342762	1.52E-03	5.80E-04	1.93E-06
1915	10.6398337	1.50E-03	5.73E-04	1.91E-06
1916	10.6453912	1.48E-03	5.66E-04	1.89E-06
1917	10.6509487	1.46E-03	5.59E-04	1.86E-06
1918	10.6565062	1.45E-03	5.53E-04	1.84E-06
1919	10.6620637	1.43E-03	5.46E-04	1.82E-06
1920	10.6676212	1.40E-03	5.36E-04	1.78E-06
1921	10.6731787	1.38E-03	5.29E-04	1.76E-06
1922	10.6787363	1.37E-03	5.22E-04	1.74E-06
1923	10.6842938	1.35E-03	5.16E-04	1.72E-06
1924	10.6898513	1.33E-03	5.09E-04	1.69E-06
1925	10.6954088	1.31E-03	5.02E-04	1.67E-06
1926	10.7009663	1.30E-03	4.96E-04	1.65E-06
1927	10.7065238	1.27E-03	4.86E-04	1.62E-06
1928	10.7120813	1.25E-03	4.79E-04	1.60E-06
1929	10.7176388	1.24E-03	4.72E-04	1.57E-06
1930	10.7231962	1.23E-03	4.69E-04	1.56E-06
1931	10.7287537	1.21E-03	4.63E-04	1.54E-06
1932	10.7343112	1.19E-03	4.56E-04	1.52E-06
1933	10.7398687	1.18E-03	4.53E-04	1.51E-06
1934	10.7454262	1.17E-03	4.46E-04	1.49E-06
1935	10.7509837	1.15E-03	4.40E-04	1.47E-06
1936	10.7565412	1.14E-03	4.37E-04	1.46E-06
1937	10.7620987	1.13E-03	4.30E-04	1.43E-06
1938	10.7676562	1.12E-03	4.27E-04	1.42E-06
1939	10.7732138	1.11E-03	4.24E-04	1.41E-06
1940	10.7787713	1.10E-03	4.21E-04	1.40E-06
1941	10.7843288	1.09E-03	4.18E-04	1.39E-06
1942	10.7898863	1.09E-03	4.15E-04	1.38E-06
1943	10.7954438	1.08E-03	4.13E-04	1.37E-06
1944	10.8010013	1.07E-03	4.10E-04	1.36E-06
1945	10.8065588	1.06E-03	4.07E-04	1.35E-06
1946	10.8121163	1.06E-03	4.04E-04	1.34E-06
1947	10.8176737	1.05E-03	4.01E-04	1.33E-06
1948	10.8232312	1.05E-03	4.01E-04	1.34E-06
1949	10.8287887	1.03E-03	3.95E-04	1.31E-06

1950	10.8343462	1.02E-03	3.92E-04	1.30E-06
1951	10.8399037	1.02E-03	3.89E-04	1.29E-06
1952	10.8454612	1.01E-03	3.86E-04	1.28E-06
1953	10.8510187	1.01E-03	3.86E-04	1.29E-06
1954	10.8565762	1.00E-03	3.83E-04	1.28E-06
1955	10.8621337	9.94E-04	3.80E-04	1.27E-06
1956	10.8676913	9.86E-04	3.77E-04	1.26E-06
1957	10.8732488	9.78E-04	3.74E-04	1.25E-06
1958	10.8788063	9.70E-04	3.71E-04	1.24E-06
1959	10.8843638	9.62E-04	3.68E-04	1.22E-06
1960	10.8899213	9.54E-04	3.65E-04	1.21E-06
1961	10.8954788	9.54E-04	3.65E-04	1.21E-06
1962	10.9010363	9.37E-04	3.58E-04	1.19E-06
1963	10.9065938	9.32E-04	3.56E-04	1.19E-06
1964	10.9121512	9.20E-04	3.52E-04	1.17E-06
1965	10.9177087	9.12E-04	3.49E-04	1.16E-06
1966	10.9232662	9.02E-04	3.45E-04	1.15E-06
1967	10.9288237	8.90E-04	3.40E-04	1.13E-06
1968	10.9343812	8.79E-04	3.36E-04	1.12E-06
1969	10.9399387	8.69E-04	3.32E-04	1.11E-06
1970	10.9454962	8.58E-04	3.28E-04	1.09E-06
1971	10.9510537	8.46E-04	3.23E-04	1.08E-06
1972	10.9566112	8.34E-04	3.19E-04	1.06E-06
1973	10.9621688	8.22E-04	3.14E-04	1.05E-06
1974	10.9677263	8.09E-04	3.09E-04	1.03E-06
1975	10.9732838	7.97E-04	3.05E-04	1.01E-06
1976	10.9788413	7.85E-04	3.00E-04	9.99E-07
1977	10.9843988	7.71E-04	2.95E-04	9.81E-07
1978	10.9899563	7.59E-04	2.90E-04	9.67E-07
1979	10.9955138	7.47E-04	2.85E-04	9.51E-07
1980	11.0010713	7.34E-04	2.81E-04	9.35E-07
1981	11.0066287	7.22E-04	2.76E-04	9.19E-07
1982	11.0121862	7.09E-04	2.71E-04	9.03E-07
1983	11.0177437	6.96E-04	2.66E-04	8.87E-07
1984	11.0233012	6.82E-04	2.61E-04	8.68E-07
1985	11.0288587	6.70E-04	2.56E-04	8.53E-07
1986	11.0344162	6.58E-04	2.51E-04	8.37E-07
1987	11.0399737	6.45E-04	2.47E-04	8.21E-07
1988	11.0455312	6.32E-04	2.42E-04	8.05E-07
1989	11.0510887	6.20E-04	2.37E-04	7.89E-07
1990	11.0566463	6.07E-04	2.32E-04	7.73E-07
1991	11.0622038	5.94E-04	2.27E-04	7.57E-07
1992	11.0677613	5.83E-04	2.23E-04	7.42E-07
1993	11.0733188	5.70E-04	2.18E-04	7.26E-07
1994	11.0788763	5.56E-04	2.12E-04	7.08E-07
1995	11.0844338	5.43E-04	2.08E-04	6.92E-07
1996	11.0899913	5.31E-04	2.03E-04	6.76E-07
1997	11.0955488	5.18E-04	1.98E-04	6.60E-07
1998	11.1011062	5.04E-04	1.93E-04	6.42E-07
1999	11.1066637	4.92E-04	1.88E-04	6.26E-07
2000	11.1122212	4.77E-04	1.83E-04	6.08E-07
2001	11.1177787	4.65E-04	1.78E-04	5.92E-07
2002	11.1233362	4.51E-04	1.72E-04	5.74E-07
2003	11.1288937	4.40E-04	1.68E-04	5.60E-07
2004	11.1344512	4.26E-04	1.63E-04	5.42E-07
2005	11.1400087	4.13E-04	1.58E-04	5.26E-07
2006	11.1455662	3.99E-04	1.53E-04	5.08E-07
2007	11.1511238	3.85E-04	1.47E-04	4.91E-07
2008	11.1566813	3.73E-04	1.43E-04	4.75E-07
2009	11.1622388	3.59E-04	1.37E-04	4.57E-07
2010	11.1677963	3.45E-04	1.32E-04	4.40E-07
2011	11.1733538	3.33E-04	1.27E-04	4.24E-07

2012	11.1789113	3.19E-04	1.22E-04	4.07E-07
2013	11.1844688	3.07E-04	1.17E-04	3.91E-07
2014	11.1900263	2.95E-04	1.13E-04	3.76E-07
2015	11.1955837	2.81E-04	1.08E-04	3.58E-07
2016	11.2011412	2.69E-04	1.03E-04	3.43E-07
2017	11.2066987	2.58E-04	9.87E-05	3.29E-07
2018	11.2122562	2.46E-04	9.42E-05	3.14E-07
2019	11.2178137	2.36E-04	9.03E-05	3.01E-07
2020	11.2233712	2.24E-04	8.57E-05	2.85E-07
2021	11.2289287	2.14E-04	8.18E-05	2.73E-07
2022	11.2344862	2.03E-04	7.76E-05	2.58E-07
2023	11.2400437	1.94E-04	7.41E-05	2.47E-07
2024	11.2456012	1.84E-04	7.02E-05	2.34E-07
2025	11.2511588	1.75E-04	6.70E-05	2.23E-07
2026	11.2567163	1.66E-04	6.35E-05	2.11E-07
2027	11.2622738	1.57E-04	6.00E-05	2.00E-07
2028	11.2678313	1.49E-04	5.71E-05	1.90E-07
2029	11.2733888	1.41E-04	5.40E-05	1.80E-07
2030	11.2789463	1.35E-04	5.15E-05	1.71E-07
2031	11.2845038	1.27E-04	4.87E-05	1.62E-07
2032	11.2900612	1.21E-04	4.62E-05	1.54E-07
2033	11.2956187	1.14E-04	4.37E-05	1.46E-07
2034	11.3011762	1.09E-04	4.16E-05	1.38E-07
2035	11.3067337	1.02E-04	3.91E-05	1.30E-07
2036	11.3122912	9.76E-05	3.73E-05	1.24E-07
2037	11.3178487	9.29E-05	3.55E-05	1.18E-07
2038	11.3234062	8.83E-05	3.38E-05	1.12E-07
2039	11.3289637	8.39E-05	3.21E-05	1.07E-07
2040	11.3345212	7.99E-05	3.05E-05	1.02E-07
2041	11.3400787	7.62E-05	2.91E-05	9.70E-08
2042	11.3456363	7.25E-05	2.77E-05	9.23E-08
2043	11.3511938	6.93E-05	2.65E-05	8.82E-08
2044	11.3567513	6.61E-05	2.53E-05	8.42E-08
2045	11.3623088	6.30E-05	2.41E-05	8.02E-08
2046	11.3678663	6.02E-05	2.30E-05	7.66E-08
2047	11.3734238	5.76E-05	2.20E-05	7.34E-08
2048	11.3789813	5.50E-05	2.10E-05	5.26E-07